

## N O T I C E

THIS DOCUMENT HAS BEEN REPRODUCED FROM  
MICROFICHE. ALTHOUGH IT IS RECOGNIZED THAT  
CERTAIN PORTIONS ARE ILLEGIBLE, IT IS BEING RELEASED  
IN THE INTEREST OF MAKING AVAILABLE AS MUCH  
INFORMATION AS POSSIBLE

WDL-TR9153  
8 JULY 1981

# 34-METER ANTENNA DRIVE CONTROL SYSTEM

(NASA-CR-164683) THE 34-METER ANTENNA DRIVE	N81-30442
CONTROL SYSTEM (Ford Aerospace and	
Communications Corp.) 30 p HC A03/MF A01	
CSSL 131	Unclas
	27204
G3/37	

SUBMITTED TO:  
 JET PROPULSION LABORATORY  
 CALIFORNIA INSTITUTE OF TECHNOLOGY  
 PASADENA, CALIFORNIA



WDL TECHNICAL REPORT 9153

8 JULY 1981

34-METER ANTENNA  
DRIVE CONTROL SYSTEM

SUBMITTED TO:

JET PROPULSION LABORATORY  
CALIFORNIA INSTITUTE OF TECHNOLOGY  
PASADENA, CALIFORNIA

IN COMPLIANCE WITH:

JPL CONTRACT NO. 955945

This work was performed for the Jet Propulsion  
Laboratory, California Institute of Technology  
sponsored by the National Aeronautics and Space  
Administration under Contract NAS7-100.

FORD AEROSPACE & COMMUNICATIONS CORPORATION  
WESTERN DEVELOPMENT LABORATORIES DIVISION  
PALO ALTO, CALIFORNIA

## TECHNICAL CONTENT STATEMENT

This document contains information prepared by Ford Aerospace & Communications Corporation under JPL subcontract. Its content is not necessarily endorsed by the Jet Propulsion Laboratory, California Institute of Technology, or its sponsors.

No reportable new technology was developed during the course of this study effort.

## ABSTRACT

This report defines in detail the baseline antenna drive and control/instrumentation equipment for new 34 meter antennas included in the Network Consolidation Program of the DSN. The overall antenna control and monitor system is described along with its interfaces with other higher level control and monitor equipment. Explicit descriptions of the antenna axis drive motors and motor controllers, the axis angle encoding systems, and miscellaneous antenna located components are presented, and related to system functional and performance requirements. Some potential alternates to the baseline system configuration are described and discussed.

## TABLE OF CONTENTS

<u>SECTION</u>		<u>PAGE</u>
1	INTRODUCTION	1-1
	1.1 OVERALL SYSTEM DESCRIPTION	1-1
	1.2 SCOPE OF REPORT COVERAGE	1-5
2	REQUIREMENTS	2-1
3	EQUIPMENT DESCRIPTION	3-1
	3.1 ELECTRIC DRIVE SYSTEM	3-1
	3.1.1 Control Loop Configurations	3-1
	3.1.2 Status and Controls	3-4
	3.1.3 Equipment Description	3-6
	3.1.3.1 Drive Controller	3-6
	3.1.3.2 Hand Held Controller	3-9
	3.2 ENCODING SYSTEM	3-10
	3.3 SUBREFLECTOR CONTROLLER	3-11
	3.3.1 Description of Subreflector Controller	3-13
	3.3.2 Subreflector Controller Software	3-15

## SECTION 1

### INTRODUCTION

This report summarizes the study performed as an addendum to JPL contract 955945.

The purpose of this effort was to define in greater detail the elements of the baseline servo control system which constituted the basis for the budgetary cost estimates provided on an earlier phase of this program. Requirements as defined by JPL preliminary specifications and direct contact with JPL personnel are summarized and related to the WDL equipment described herein.

#### 1.1 OVERALL SYSTEM DESCRIPTION

The Antenna Control System is illustrated in Figure 1.1-1 with the basic interfaces between elements shown. The system consists of the following major elements.

- o Motor Assemblies - consisting of a dc drive motor, tachometer, brake and cooling blower motor mounted on each axis (2 assemblies for elevation, 4 assemblies for azimuth).
- o Drive Motor Controller - consisting of an electronic rack located in the equipment room on the antenna. This unit includes the SCR power amplifiers for each motor assembly, the electronics to control current and rate loops for each motor, the status monitor electronics, the safety and operating interlocks for each axis, the controls for auxiliary drive equipment, and the

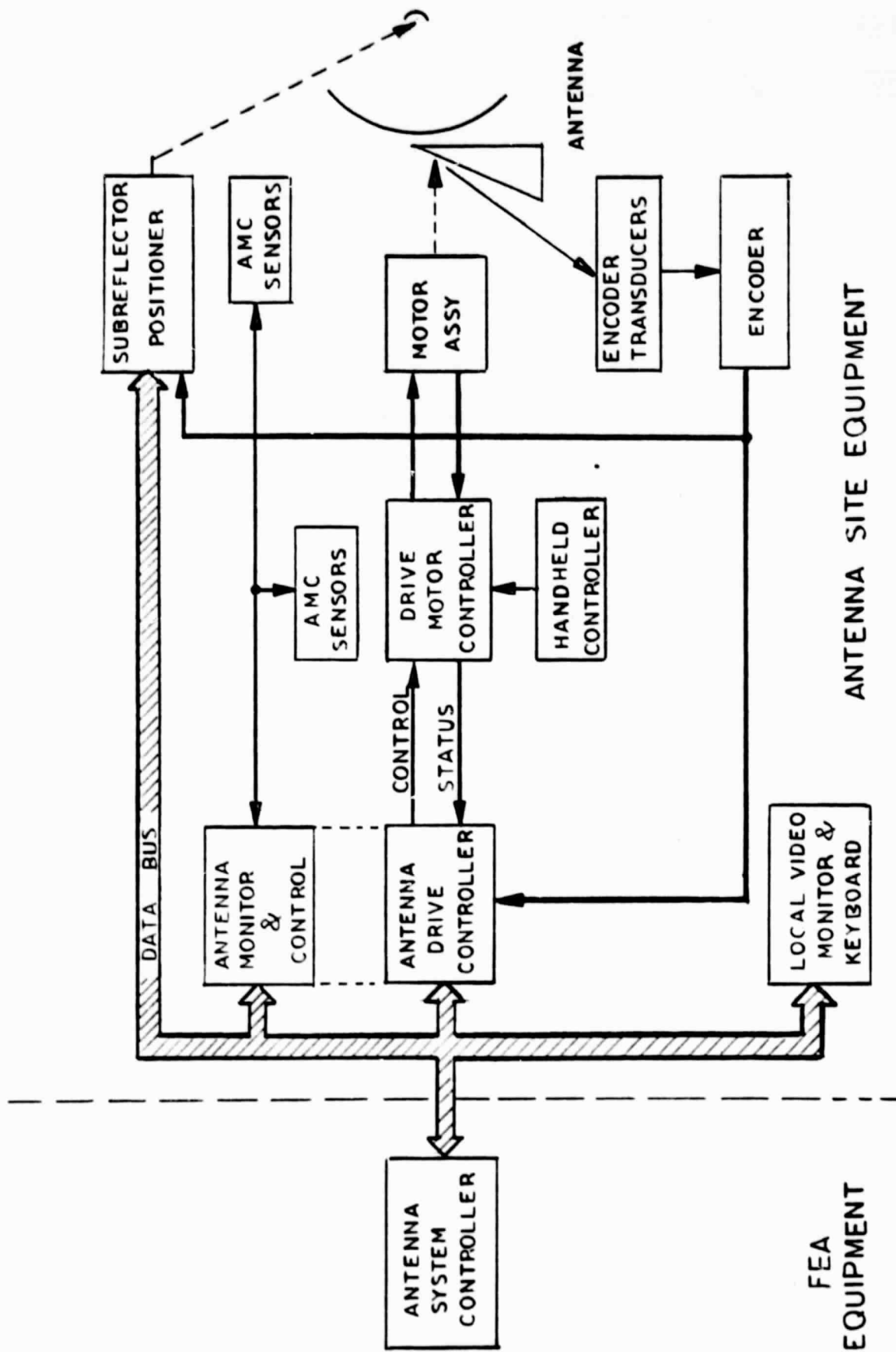

ANTENNA SITE EQUIPMENT

FIGURE 1.1-1



## 1.1 OVERALL SYSTEM DESCRIPTION (Continued)

required power handling, braking and protection equipment for the drive system.

- o Hand Held Controller - consisting of a remote control box and cable for operating the drive controller in each axis at the antenna.
- o Subreflector Position System - consisting of a three axis micro-computer control system for the subreflector which automatically compensates for antenna deflections at all orientations.
- o Encoding System - consisting of transducers on each axis and an electronics chassis to provide position display and feedback for each axis.
- o Antenna Drive Controller (ADC) - controls the position of the antenna in each axis; receives position commands, ephemeris data, offsets, corrections, conscan parameters, and mode commands from the Antenna System Controller; receives antenna position from the encoding system; and generates rate commands to the drive motor controller. This unit is located at the antenna and communicates with other computerized controllers and monitors via a common data bus.
- o Antenna Monitor and Control (AMC) - monitors the status of the antenna via distributed sensor multiplexers; determines correct operation; and communicates status to the antenna system controller. This unit is also located at the antenna.

## 1.1 OVERALL SYSTEM DESCRIPTION (Continued)

- o Video Monitor - a local monitor which monitors communications on the data bus and displays status of the computerized controllers. Also generates commands for individual controllers for local operation modes (maintenance, calibration, manual positioning, etc.).
  
- o Communications Bus - Figure 1.1-1 illustrates a communication bus between the antenna systems controller, the computer based controllers and monitors and the video monitor unit. It is envisioned the command, status, or data transfer from one unit to another would contain an address unique to each unit. This bus would be a standardized format such as RS232-C using ASCII character communications. A sending unit would label a message or command with the destination address. The receiving unit would echo the message to command back to the sending address, both checking for accuracy. Therefore, units could communicate with the system controller, another unit, or video monitor on the same bus. The system controller would be required to resolve conflicts in priorities. This concept has an impact on the video monitor in that it must contain an interface unit to communicate with the bus. It also requires the video monitor to format its displayed information. However, the monitor can "steal" information from the bus which is transmitted between two units without interfering with the communication i.e., antenna positions, antenna commands, subreflector positions, etc.

The equipment will be located in the antenna equipment room. The drive motor control rack is a separately enclosed unit as illustrated in Figure 3.1-2. The computerized controllers, encoder electronics and video monitor should

## 1.1 OVERALL SYSTEM DESCRIPTION (Continued)

be located in the same or closely located racks for ease of maintenance. An artists conception of this rack-up is shown in Figure 1.1-2.

## 1.2 SCOPE OF REPORT COVERAGE

This report summarizes WDL's study of the following control elements for the 34-meter antenna control system.

- o DC Drive Motors
- o Drive Motor Controller
- o Hand-Held Controller
- o Subreflector Controller

These elements constituted the baseline for the Cost and Schedule Report addendum to contract number 955945 given to JPL April 15, 1981.

The following units, described conceptually in the introduction, are not discussed in detail in this report because they were not part of the baseline scope and because JPL specifications for them were not finalized at the time of this study.

- o ADC - Antenna Drive Controller
- o AMC - Antenna Monitor and Controller
- o Video Display Unit

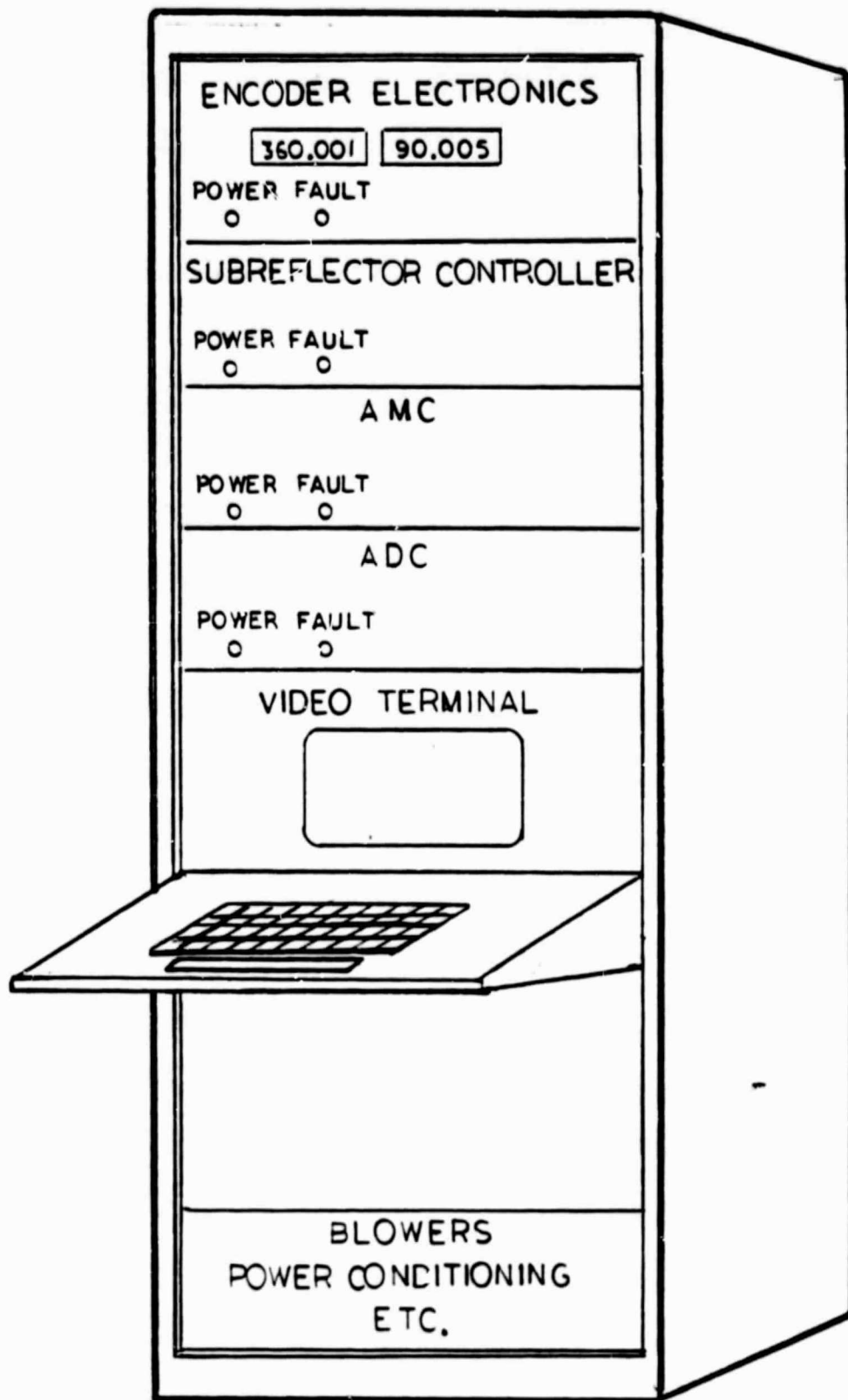

FIGURE 1.1-2

## SECTION 2

### REQUIREMENTS

The basic X-Band performance requirements are summarized in Table 2-1. The critical antenna parameters are presented in Table 2-2. The equipment described herein is capable of meeting the rate and acceleration requirements in the specific environments, and the pointing and tracking accuracy in conjunction with a sufficiently rigid antenna structure.

TABLE 2-1

CONTROL SYSTEM REQUIREMENTS

Maximum Slew Rates	± 0.5 deg/sec
Acceleration	± 0.4 deg/sec
Pointing Loss (total including structural and mechanical losses)	
10 mi/h wind (0.1 dB)	0.007°
30 mi/h wind (0.8 dB)	0.02°
Tracking Loss (total including structural and microwave losses)	
10 mi/h wind (0.2 dB)	0.010°
30 mi/h wind (0.3 dB)	0.012°

TABLE 2-2

ANTENNA PARAMETERS

Diameter	34 meters
Frequency	X-Band
Beamwidth	0.075 degrees
Motion Limits	
Azimuth	<u>±</u> 200 degrees
Elevation	10 to 90 degrees
Estimated Inertia	
Azimuth	$10 \times 10^6 \text{ lb}\cdot\text{ft}\cdot\text{s}^2$
Elevation	TBD
Estimated Wind Torques (Both axes)	
Operational (30 mi/h)	$350 \times 10^3 \text{ lb}\cdot\text{ft}$
Drive to stow (50 mi/h)	$1200 \times 10^3 \text{ lb}\cdot\text{ft}$
Gear Ratios	
Azimuth	21,000:1
Elevation	21,000:1

SECTION 3  
EQUIPMENT DESCRIPTION

3.1 ELECTRIC DRIVE SYSTEM

The drive motor controller is a self-contained unit which provides all the interface necessary between the antenna drive controller (ADC) and the drive motor assemblies. The controller includes a closed tach loop for each axis to provide speed control and a closed current loop for each motor to provide torque control.

The drive motor amplifier is a bidirectional, three-phase, half-wave SCR amplifier to provide full motoring and braking. The drive motors are arranged in an aiding-opposing configuration to provide antibacklash operation of the drive assemblies and bull gear.

Auxiliary functions include field power supplies, brake control logic, safety interlock logic, and comprehensive status and fault information.

A small hand held controller provides velocity control of the antenna anywhere within the length of the controller cord.

3.1.1 Control Loop Configurations

The elevation axis will be controlled in the conventional manner. The two torque-controlled motors will have equal and opposite torque bias to provide opposition at low loads and equal torque sharing at full load (accomplished by putting the current limit circuits after the bias injection point).



### 3.1.1 Control Loop Configurations (Continued)

The azimuth axis drive configurations has two motors on each of two wheels. The two motors on each driven wheel must be biased against each other to take out the gearbox backlash. There are several ways that the complete set of four motors can be controlled, including:

- o The two motors on each wheel can be controlled in the same manner as the elevation axis control system with feedback from both tachs to a common summing junction and use a common velocity command signal for each wheel.
- o Each motor can have its own independent tach loop and appropriate bias for antibacklash operation.

The disadvantage of this configuration is that it requires four complete power amplifiers and torque control loops. An alternative which eliminates two of the power amplifiers is to run the motors in series pairs. This configuration is shown in Figure 3.1.1-1. To maintain the same general motor size the motors must be rated at 120V rather than the 240V standard used for the conventional two motor drive. As shown in Figure 3.1.1-1, the series pairs are on opposite wheels to permit antibacklash biasing which is done in the standard way. The speed from all four of the tachs is fed back to a common summing junction and compared to the velocity command signal to generate a system velocity (previous experience with similar high-ratio drive controllers has shown that if all tachs are not fed back, undamped drive train resonances can occur during slew operations).

The series motor, two amplifier configuration was selected as the baseline drive control configuration because it is the most cost-effective for this application. The motors with the lowered voltage rating may be slightly

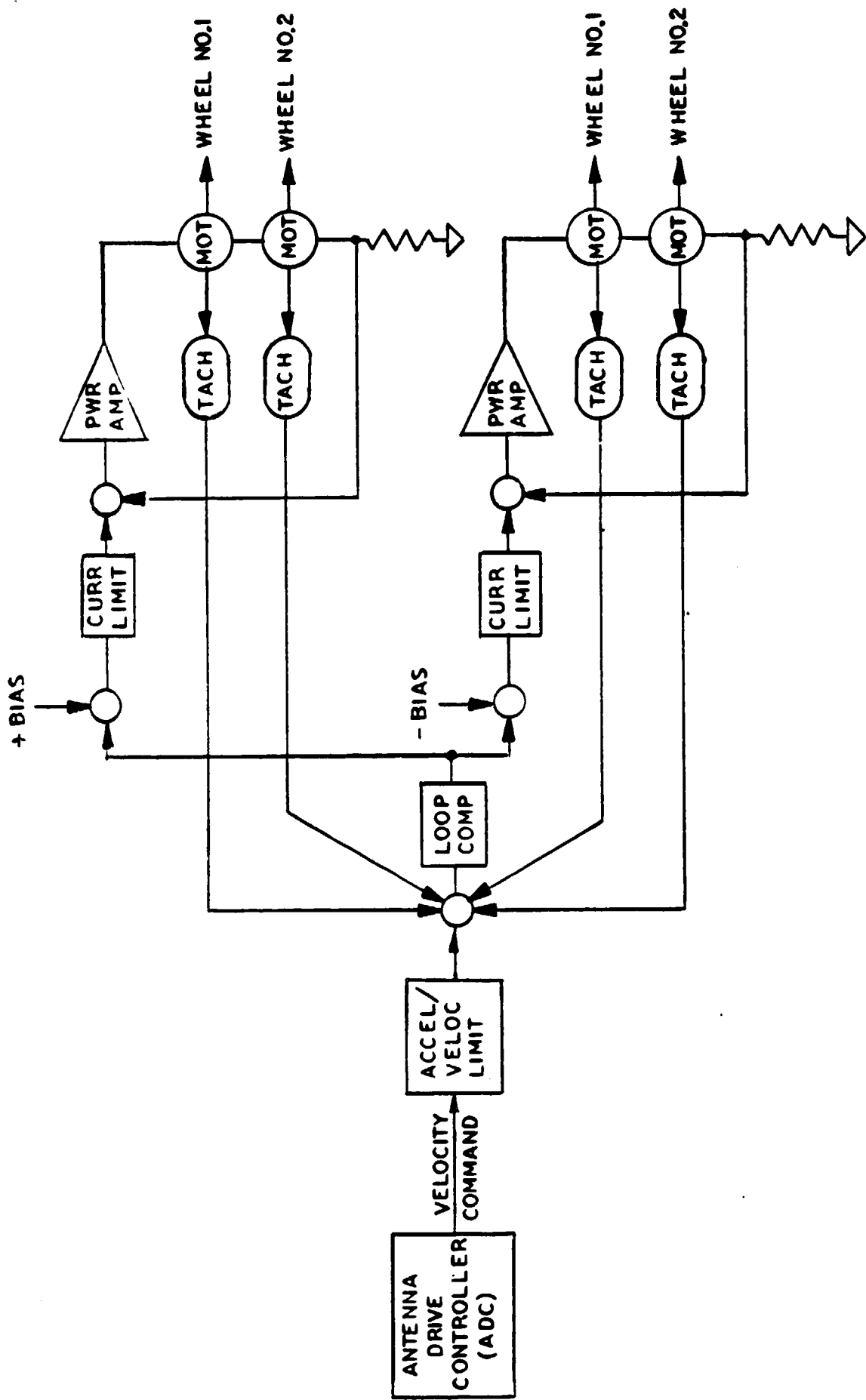

AZIMUTH AXIS 4 - MOTOR DRIVE MOTOR CONTROL

FIGURE 3.1-1

### 3.1.1 Control Loop Configurations (Continued)

more expensive because of their double current requirement, but this is easily offset by the cost reduction due to eliminating two power amplifiers.

### 3.1.2 Status and Controls

The necessary external controls for the drive controller from the ADC consist of an enable contact closure which functions as the main power disconnect control, individual axis on-off contact closures for releasing the brakes and enabling the SCR amplifiers, and the azimuth and elevation analog velocity control signals.

The enable control is interlocked with the various emergency off switches, final limits, hand crank interlocks, stow pin interlocks and cabinet rear door. This prevents any antenna movement under unsafe conditions by completely removing power from the drive controller.

The Az and El on-off controls release the brake, uncage the various integrators, and enable the SCR triggers to allow drive control. The brake interlock prevents any drive torque against an unreleased brake. The analog velocity control signal is a  $\pm 10$  Vdc input terminated into a differential input operational amplifier with 20K Ohms impedance. The velocity of the drive motors is proportional to the magnitude of the signal with direction of rotation determined by the polarity of the command.

There are various automatic controls internal to the drive controller; these include:

### 3.1.2 Status and Controls (Continued)

- a) Reduced current limit if one of the rectifier fuses blows. This allows continued operation at a reduced torque capability without overloading the remaining fuses.
- b) Phase sensing and phase reversal. This circuitry prevents operation if the phase of the power line is reversed or if one of the phases is missing.
- c) Power supply loss. The various dc power supplies are monitored and operation is prevented if any power supply is missing or out of adjustment.
- d) Field loss. The field current is monitored and operation of the affected motor is inhibited if the field current is incorrect.
- e) Motor overload. Each motor is protected with a thermal overload sized to the motor rms heating capability. An overload disconnects the affected motor from the armature power.
- f) Motor overheat. Each motor contains an internal thermostat which protects the motor from cumulative long term overload. Operation of the thermostat disconnects the affected motor.

The above parameters are statused by internal LED indicators on the electronic board and externally statused with isolated contact closures for remote fault sensing. In addition, the various analog control signals of the tach and torque loop are available on test points for monitoring.

### 3.1.2 Status and Controls (Continued)

In the area of status and control, it might be desirable to pursue some alternative methods such as direct data bus connection to the ADC controller. As presently envisioned (Figure 1.1-1), the ADC will be computing the position error or velocity command and producing drive motor control signals with an A/D as well as receiving the various controller status signals and converting them to bus level signals and/or format through some sort of interface electronics.

The more desirable method would be a direct connection of the drive motor controller to the data bus with all decoding of commands and formatting of status performed by the motor controller. This would simplify the ADC by eliminating the special input/output requirements of the drive controller and would make the drive controller appear as another addressable unit on the data bus.

### 3.1.3 Equipment Description

#### 3.1.3.1 Drive Controller

The drive controller consists of an RFI right Nema 12 cabinet measuring 24" deep by 36" wide by 90" high, weighing approximately 1800 lb and housing the following equipment for control of the six drive motors (see Figure 3.1-2).

- a) Power Supply Control Panel
- b) Two Motor Control Amplifier Panels (Az and E1)
- c) Servo Control Panel
- d) Four Armature Inductors
- e) Power Line RFI Filter
- f) 480-120 V Transformer