

19

DOE/NASA/1062-9
NASA TM-82670 ✓

A Program-Management Plan with Critical-Path Definition for Combustion Augmentation with Thermionic Energy Conversion (CATEC)

James F. Morris
National Aeronautics and Space Administration
Lewis Research Center

Owen S. Merrill
U.S. Department of Energy

and

Harsha K. Reddy
The Aerospace Corporation

Work performed for
U.S. DEPARTMENT OF ENERGY
Fossil Energy
Office of Coal Utilization

Prepared for
International Conference on Plasma Science
sponsored by the Institute of Electrical
and Electronics Engineers
Santa Fe, New Mexico, May 18-20, 1981

NOTICE

This report was prepared to document work sponsored by the United States Government. Neither the United States nor its agent, the United States Department of Energy, nor any Federal employees, nor any of their contractors, subcontractors or their employees, makes any warranty, express or implied, or assumes any legal liability or responsibility for the accuracy, completeness, or usefulness of any information, apparatus, product or process disclosed, or represents that its use would not infringe privately owned rights.

A Program-Management Plan with Critical-Path Definition for Combustion Augmentation with Thermionic Energy Conversion (CATEC)

James F. Morris
National Aeronautics and Space Administration
Lewis Research Center
Cleveland, Ohio 44135

Owen S. Merrill
U.S. Department of Energy
Washington, D.C. 20545

and

Harsha K. Reddy
The Aerospace Corporation
Los Angeles, California 90009

Work performed for
U.S. DEPARTMENT OF ENERGY
Fossil Energy
Office of Coal Utilization
Washington, D.C. 20545
Under Interagency Agreement EC-77-A-31-1062

International Conference on Plasma Science
sponsored by the Institute of Electrical
and Electronics Engineers
Santa Fe, New Mexico, May 18-20, 1981

A PROGRAM-MANAGEMENT PLAN WITH CRITICAL-PATH DEFINITION FOR COMBUSTION
AUGMENTATION WITH THERMIONIC ENERGY CONVERSION (CATEC)

James F. Morris, NASA Lewis Research Center;
Owen S. Merrill, U. S. Department of Energy; and
Harsha K. Reddy, The Aerospace Corporation

ABSTRACT

Thermionic energy conversion (TEC) deserves consideration for topping any conversion or process system that receives heat from an energy source at much higher temperatures: In recent TEC-topping analyses, overall plant efficiency (OPE) and cost of electricity (COE) improve slightly with current capabilities and substantially with fully matured technologies. And enhanced credibility derives from proven hot-corrosion protection for TEC by silicon-carbide clads in fossil-fuel combustion products.

Combustion augmentation with TEC (CATEC) affords minimal cost and plant perturbation, but with smaller OPE and COE improvements than more conventional topping applications. However risk minimization as well as comparative simplicity and convenience favor CATEC for early market penetration. Therefore a program-management plan is apropos. That plan, its inputs, characteristics, outputs and capabilities are subjects of this report.

Executive Summary

The demonstration of hot-corrosion protection by silicon-carbide clads in fossil-fuel combustion products confers credibility on proposed terrestrial applications of thermionic energy conversion (TEC): Now the gamut of TEC topping and process-heating proposals commands the respect of reality. And topping-study results predicting higher overall plant efficiency (OPE) and lower cost of electricity (COE) for current TEC technology mean savings of fuel and funds - here and now.

An interesting concept generalizes topping through combustion augmentation with TEC (CATEC): In this approach TEC protects combustor walls, preheats combustion air, delivers suitably cooled effluent to lower-temperature conversion or process systems, and generates additional electric power. All these desirable effects derive from modifying or replacing combustors, not from building new topping plants. Of course CATEC operates on a relatively small fraction of the total plant energy throughput. But it increases OPE and reduces COE with demonstrated TEC capability and minimal plant perturbation. Furthermore this method of skimming the high-temperature cream off combustion Carnot cycles applies to fluid-fueled atmospheric, pressurized and even coal-fired combustors.

In fact those three phases constitute a program proposed to develop CATEC in atmospheric, pressurized and coal-fired versions. Near the end of July 1980 developmental steps detailed by DOE project management underwent review and revision of precedences and durations by the program management in consultation with primary contractors (Rasor Associates Incorporated (RAI) and Thermo Electron Corporation (TECO)). At that time condensed critical-path Gantt charts for the three CATEC Program phases were available, projecting through applications development and support (ADS). Then cooperative efforts with Aerospace Corporation (AC) began to adapt CATEC plans to the computerized Program Management System (PMS) that they provide to DOE.

In the interim (early December 1980) TECO, Brown Boveri Turbomachinery (BBT) and RAI, United Technologies Corporation (UTC) teams presented results from separate studies of CATEC used with combined cycles and integrated coal gasification: Although the approaches differed considerably, the findings were consistent - higher OPE and lower COE with current TEC capabilities. The gains for existing pressurized-CATEC technologies are equivalent to about a 200°F increase in gas-turbine-inlet temperatures initially ranging up to 2200°F (over 370°F for second-generation TEC and still higher for the third generation).

Now various AC PMS outputs are available for CATEC ADS. This report presents and discusses some of these computerized implementations for programmatic guidance and control.

Topping with Thermionic Energy Conversion (TEC)

Several years ago a paucity of TEC-topping papers existed. Although the number of such publications available today is not plethoric, it is adequate to project TEC-topping potentialities (refs 1 to 21). Analyses indicate definite improvements in overall plant efficiency (OPE) and cost of electricity (COE) with TEC topping of plants (TEC TOP) for lower-temperature conversion or process systems energized by fossil-fuel combustion: These predicted gains are small for current TEC-TOP capabilities but substantial for fully matured technologies.

Such implications encourage the inference that terrestrial applications of TEC are assured. But without hot-corrosion protection from fossil-fuel combustion products, TEC TOP and its high-temperature, high-power-density benefits (refs 12, 13 and 17) are inaccessible. However the technology evolution necessary to break the hot-corrosion barrier is apparently at hand as reference 21 indicates:

Silicon-carbide (SiC) clads for TEC in topping of powerplants arose as a promising solution to this hot-corrosion problem (refs. 1, 13 to 17 and 22 to 28) during pre-1970 Office of Coal Research contract studies. Reference 1 reports on the thermal-shock stability, thermal-expansion compatibility, molten-slag resistance and hot-corrosion protection of SiC-clad TEC. Recent EPRI-supported work on coal-fired recuperators and regenerators further supports SiC as a high-temperature heat-receiving surface.

Now Thermo Electron Corporation (TECO) is testing a series of SiC-clad TEC diodes in fossil-fuel combustion products. One with a 1730 KW emitter passed 3500 hours (early December 1980) and is continuing (over 4700 hours in mid January 1981). Tests after over 5000 hours for another SiC-clad converter with a 1630 KW emitter yielded gratifying results (ref. 28):

"Electron microprobe analysis showed no evidence of any reaction between the interfaces of the tungsten, graphite, and silicon carbide. X-ray diffraction patterns of the silicon carbide were compared to those from unfired silicon carbide. The patterns were essentially identical and showed primarily silicon carbide. Knoop microhardness tests indicated there was no change in the hardness during the life test. The hardness at the dome was KHN 2600. The

following impurities were found on the dome area of the hot shell: aluminum, magnesium, potassium, and iron. The first three probably originated from the furnace firebrick and the iron from the melted flue pipe. Significantly, no chemical reactions between these elements and the silicon carbide were indicated. Apparently, no change or degradation to the composite shell resulted from the 5000 hours operation."

TECO also revealed that TEC fabrication based on chemical vapor deposition (CVD) with suitable SiC cladding is more economical than conventional fabrication for lower-temperature superalloy protection. The laminar W, graphite (C), SiC dome (emitter, thermal-expansion adapter, protective coating) can also be manufactured on reusable mandrels. So directly-fired TEC appears cost-effective as well as feasible. TECO has also demonstrated adaptability of their methods to produce SiC-clad MFHP (metallic-fluid heat pipe) envelopes.

Now TEC TOP definitely appears credible.

A special adaption with broad applicability is combustion augmentation with TEC (CATEC): Here combustor wall protection, combustion-air preheating, supply of appropriately cooled effluent to lower-temperature conversion or process systems and additional power generation all derive from TEC. And although the heat passing through TEC in CATEC is a relatively small fraction of the total plant thermal power, existing capabilities allow definite OPE and COE improvements that increase substantially for fully matured technology. Furthermore fluid-fueled and coal-fired atmospheric CATEC as well as pressurized versions enable TEC TOP with minimal cost and facility perturbation. Therefore the market-penetration probability appears promising for CATEC.

For these reasons this report presents a brief description of CATEC and a pertinent program-management plan with critical-path definition.

Current CATEC Capability for Combined Cycles with Integrated Gasifiers

Most OPE, COE evaluations for advanced conversion systems compare results derived from projections of fully matured technologies (fig. 1, ref 17). Perhaps this comparison is as equitable as any because all specimens are cut after ramming them against technological end-stops which are subject to detailed examination and discussion. The other extreme of the comparative distribution includes those conversion systems already in operation. The spectrum between these limits is variegated with differing degrees of completion, competitiveness and conscience. So the "take your best shot" approach seems a legitimate one.

But estimating near-term market-penetration probabilities requires determinations based on current capabilities. Operating under such a mandate Rasor Associates, Incorporated (RAI) and Thermo Electron Corporation (TECO) presented conceptual analyses of pressurized CATEC with gas turbines and combined cycles to Department of Energy (DOE) representatives in the spring of 1980: Existing TEC performance and fabrication technologies enable small improvements in gas-turbine and combined-cycle OPE's and COE's. The gains for current pressurized-CATEC capabilities can also be characterized as equivalent to about a 200°F increase in gas-turbine-inlet temperatures

initially ranging up to 2200°F. For second-generation TEC this effective gain is over 370°F - still higher for the third generation.

More detailed analyses of effects for existing pressurized-CATEC technologies utilized with combined cycles having integrated gasifiers became available to DOE in December 1981: Then TECO (Brown Boveri Turbomachinery, Stone and Webster Engineering) and RAI (United Technologies Corporation, Foster Wheeler Development Corporation, Bechtel National Incorporated) teams presented findings for initial design studies and cost evaluations. Those results with descriptions and discussions will be issued shortly as RAI and TECO topical reports for DOE.

Interim indications of improvements possible for current CATEC capabilities used with combined cycles having integrated gasifiers are a 3.7% increase in OPE (70% marginal efficiency) and a 2.5% decrease in COE (marginal COE 15% lower than baseline). Fully matured CATEC technologies should effect half-order-of-magnitude gains over these enhancements.

As previously observed only about 10% of the total plant thermal-power throughput enters the TEC in CATEC. So large TEC-TOP improvements like those of figure 1 and the increase from 43.4% to over 51% (ref. 17) for MHD, steam "reference plant 3" (ref. 29) are impossible. And CATEC performance is even further from efficiencies over 40% predictable for fully matured high temperature, high-power-density TEC used alone to convert fossil-fuel combustion directly to bath-side low-voltage direct current for electrolytic plants. But CATEC requires only combustor modification or replacement - not complete new plants. CATEC offers relatively low cost, low plant perturbation: low risk.

A CATEC Program-Management Plan

The CATEC concept originated in the TEC applied-research and technology (ART) program supported by DOE. When conceptual CATEC analyses revealed feasibility, even for current TEC capabilities, more intensive work began on an expansion of that section of the program-management plan:

100000	TEC ART
110000	TEC Materials
120000	TEC Interfaces
130000	TEC-Material Deposition
140000	TEC Plasmas
150000	TEC Electrodes
160000	TEC Enhancement
170000	TEC-Converter Performance (Efficiency and Life)
180000	TEC-Module Performance
190000	TEC-Applications Analyses
200000	TEC-Heating ART
210000	Combustor Innovations
220000	Furnace Adaptations
230000	Repowering Developments
240000	Heat-Transfer Intensifiers
250000	Compatible Protective-Clad Systems
260000	Heat Pipes
270000 to 290000	To Be Assigned
300000	TEC Applications Development and Support (ADS)
310000	CATEC
320000	TEC TOP: Steam Turbines
330000	TEC TOP: Advanced Conversion Systems

340000	TEC Process Heating
350000	TEC Cogeneration
360000	MHD, TEC, Steam Systems
370000	Advanced TEC Applications (Lasers, Fusion...)
380000 and 390000	To Be Assigned
400000	TEC Field Evaluation and Demonstration (FED)
410000 to 490000	Similar to 310000 to 390000 at Expanded Level
500000	TEC Commercial Activation and Operation (CAO)
510000 to 590000	Similar to 410000 to 490000 at Expanded Level
600000 to 900000	To Be Assigned

Of course the program-management-plan section of interest in this report is 310000: CATEC.

Project Management for the DOE TEC Program fleshed out a three-phase CATEC ADS plan for fluid-fueled atmospheric, pressurized and coal-fired versions (refs. 30 to 33). In July 1980 DOE Program Management in consultation with primary contractors (RAI and TECO) reviewed precedences and durations for the numerous steps of the proposed CATEC ADS schedule. And by the end of July 1980 condensed Gantt charts for the three phases of the CATEC ADS plan were available.

Subsequently cooperation with The Aerospace Corporation (AC) initiated adaptation of the three-phase CATEC-ADS plan to the computerized Program Management System (PMS) provided to DOE. A brief report by AC project professional Harsha Reddy follows directly.

ABSTRACT

A project to provide the DOE, Division of Fossil Energy, with a Critical Path Method (CPM) Program Management System (PMS) for the Thermionic Energy Conversion Program is described. This system will be used to facilitate mission-oriented program planning, replanning; program management, redirection; resource allocation, reallocation; and response to (1) higher levels within DOE, (2) congressional inquiries, (3) executive department requests (for example OMB) and (4) other sources of question or interest.

INTRODUCTION

The Aerospace Corporation has performed computer modeling activities for the Manager of the Thermionic Energy Conversion Program in Fossil Energy by structuring the program management system for thermionic energy conversion research, development and demonstration (RD&D). This management system will be used for subsequent replanning, management and control.

This system has been applied to other energy RD&D programs and generally includes (1) program modeling, (2) network analysis, (3) special network activities and (4) requirements analysis for critical-path-method (CPM) transition. In the case of thermionic energy conversion only program modeling and network analysis were performed; further effort has been postponed until program funding uncertainties are settled.

OBJECTIVE

This project was undertaken to provide a program planning and management tool to facilitate mission oriented program planning, replanning, program direction, redirection; resource allocation, reallocation; and response to (1) higher levels within DOE, (2) congressional inquiries, (3) executive department requests (for example OMB) and (4) other sources of question or interest.

IMPLEMENTATION

A proprietary CPM software package called "Project 2" was used. This package was originally used for planning and management of construction projects. Aerospace has pioneered its use for RD&D program planning, replanning and management.

The system comprises a primary data base and eight processors for basic network analysis, CPM scheduling, target (schedule) processing, network graphics, resource and cost allocation, resource constraining, multi-project processing and project cost processing. This combination enables the user to conduct a wide spectrum of planning, scheduling, and resource requirement analyses, as well as providing a program and project progress tracking capability. Over 60 different reporting formats may be generated, allowing the individual user to select those which are most useful and which are consistent with the printing and graphics equipment available.

The following five formats were generated for the Thermionic Energy Conversion Program:

1. Planning Schedule - a format lists activity numbers, descriptions (titles), activity durations, early and late start and finish times by calendar date, as well as month number (within the program calendar), and "float" or allowable slippage time. It also identifies "successor" activities by assigned number.
2. Network Analysis - this format displays activity chronology (duration, start and finish, float) as well as precedent and successor data (number, name and nature of relationship).
3. Network Listing - a basic listing by numbers of activities in the network gives durations.
4. Network Plot - a graphic displays activities and milestones, giving chronology and depicting the interties between activities. Critical paths are identified.
5. Gantt (Bar) Chart - various forms can be generated showing early and late starts and durations.

STATUS

To initiate the program modeling activity NASA LeRC, Cleveland, who are the technical coordinators of the DOE Thermionic Energy Conversion Program, provided a work-breakdown structure. Using this structure a network was generated. Later in the development, detailed descriptions of activities pertaining to research, development and technology (RD&T) and combustor augmentation with thermionic energy conversion (CATEC) were made available. Some modifications of the original network make it consistent with the descriptions. No detailed work-breakdown structure for the alternate applications of thermionic energy conversion were available; therefore they were not included in the network. A code structure for the activities of the Thermionic Energy Conversion Program was developed based on that of the Phosphoric Acid and Molten Carbonate Fuel Cell programs.

At this juncture funding issues for the TEC Program are not resolved and the future of the program is uncertain; therefore DOE directed Aerospace to suspend the program modeling activities until further notice.

The enclosed set of reports includes the latest information received from the program participants. This information is also stored on computer tape at the Aerospace Corporation for future reference.

Selected Outputs from the CATEC-ADS Management Plan

Of the various AC PMS outputs for CATEC ADS three epitomize the scheduler guidance and control with comparative compactness: The "Planning Schedule," "Bar Chart Graphics" (Gantt Chart) and "Activity-on-the-Node Network Diagrams" project accomplishments required to complete the three-phase CATEC-FED Program by November 1, 1989 after initiation on January 1, 1982. Although the practical and desired approach requires beginning all three CATEC phases (31...0, fluid-fueled atmospheric 31...1, pressurized 31...2 and coal-fired 31...3) at once and finishing each as soon as possible (Planning Schedule "early" dates and Gantt Chart closed bars), the outputs also show "lag" times corresponding to a simultaneous finish (Planning Schedule "late" dates and Gantt Chart open-top bars). These are exemplary demonstrations of PMS versatility and adaptability.

In addition to 31... designating CATEC and 31...0 to 31...3 relating to all or each of the CATEC phases the third digit from the left indicates a generic activity category; the fourth, a specific activity area; and the fifth, the particular activity serial number. For example 3110.. means CATEC Feasibility Studies; 3111.., CATEC Performance Inputs; and 311110, TEC Performance Inputs and Modeling, which apply to all three phases. This activity 311110 stands at the beginning of all the PMS outputs for CATEC ADS included here.

Perhaps the most informative of these but also the most cumbersome is the Activity-on-the-Node Network Diagram. This form clearly shows the program flow as well as the critical-path characteristics and activities.

Individual activity sheets for AC PMS also carry detailed resource and accounting information as well as technical descriptions and accomplishments. Thus in addition to program planning, management and adjustment this form of computer implementation facilitates effective archival capability.

Initiating and maintaining such a PMS project absorb substantial resources for some time. And this may not be advisable for all programs - particularly small, strongly ART types struggling to maintain a critical activity level. But after the throes of initiation, debugging and submission to the reporting regimen, PMS offers some definite guidance and control advantages.

Essential TEC ART (100000 series) and TEC-Heating ART (200000 series) are absent in all PMS outputs related to the "critical path method" (CPM). This absence derives from a primary premise (Project 2 Basic Manual): "CPM was designed for and is useful on projects where the duration of each activity can be estimated with reasonable certainty." And research defies scheduling.

REFERENCES

1. A. J. Cassano and J. R. Bedell, "Thermionic Topping Converter for a Coal-Fired Power Plant," Consolidated Controls Corp., Bethel, CT, CCC-60-6445-17, 1970.
2. F. N. Huffman, T. O. P. Speidel, and J. P. Davis, "Topping Cycle Applications of Thermionic Conversion," Energy 10; Annual Intersociety Energy Conversion Engineering Conference, IEEE, New York, 1975, pp. 496-502.
3. E. J. Britt, G. O. Fitzpatrick, and N. S. Rasor, "Thermionic Topping of Electric Power Plants," Energy 10; Annual Intersociety Energy Conversion Conference, IEEE, New York, 1975, pp. 503-512.
4. O. S. Merrill and J. J. Cuttica, "ERDA's Bicentennial Thermionic Research and Technology Program," Eleventh Intersociety Energy Conversion Engineering Conference, Vol. 2, American Institute of Chemical Engineers, New York, 1976, pp. 1635-1644.
5. E. J. Britt and G. O. Fitzpatrick, "Thermionic Topping for Central Station Power Plants," Eleventh Intersociety Energy Conversion Engineering Conference, Vol. 2, American Institute of Chemical Engineering, New York, 1976, pp. 1040-1045.
6. G. Miskolczy and T. O. P. Speidel, "Thermionic Topping of a Steam Power Plant," Eleventh Intersociety Energy Conversion Engineering Conference, Vol. 2, American Institute of Chemical Engineers, New York, 1976, pp. 1050-1055.
7. E. J. Britt, G. O. Fitzpatrick, and G. Carnasciali, "Increased Central Station Power Plant Efficiency with a Thermionic Topping System," Proceedings of the 12th Intersociety Energy Conversion Conference, Vol. 2, American Nuclear Society, Inc., LaGrange Park, IL, 1977, pp. 1602-1609.

8. G. Miskolczy and F. N. Huffman, "Evaluation of MHD-Thermionic-Steam Cycles," Proceedings of the 12th Intersociety Energy Conversion Conference, Vol. 2, American Nuclear Society, LaGrange Park, IL, 1977, pp. 1610-1616.
9. G. O. Fitzpatrick and E. J. Britt, "Thermionic Power Plant Design Point Selection: The Economic Impact," Proceedings of the 13th Intersociety Energy Conversion Engineering Conference, Vol. 3, Society of Automotive Engineers, Inc., Warrendale, Pa., 1978, pp. 1887-1892.
10. G. Carnasciali, G. O. Fitzpatrick, and E. J. Britt, "Performance and Cost Evaluation for a Thermionic Topping Power Plant," ASME Paper 77-WA/ENER-7, Nov. 1977.
11. F. N. Huffman and G. Miskolczy, "Thermionic Energy Conversion Topping System," ASME Paper 77-WA/ENER-6, Nov. 1977.
12. J. F. Morris, "Comments on TEC Trends," Conference Record-Abstracts, International Conference on Plasma Science, Institute of Electrical and Electronics Engineers, IEEE, New York, 1979, Abstract 6D10, p. 166. Also NASA TM-79317, 1979.
13. J. F. Morris, "Potentialities of TEC Topping: A Simplified View of Parametric Effects," IEEE Conference Record-Abstracts, International Conference on Plasma Science, IEEE, New York, 1980, Abstract 1E8, p. 16. Also NASA TM-81468, 1980.
14. O. S. Merrill, "The Changing Emphasis of the DOE Thermionic Program," IEEE Conference Record-Abstracts, 1980 IEEE International Conference on Plasma Science, IEEE, New York, 1980, Abstract 1E3, p. 14.
15. G. Miskolczy and F. N. Huffman, "Terrestrial Applications Using a Thermionic Array Module (TAM) Combustor," IEEE Conference Record Abstracts, 1980 IEEE International Conference on Plasma Science, IEEE, New York, 1980, Abstract 1E6, pp. 15-16.
16. R. S. Dick, E. J. Britt, and G. O. Fitzpatrick, "Electric Utility and Cogeneration Systems Applications of Thermionic Energy Conversion," IEEE Conference Record-Abstracts, 1980 IEEE International Conference on Plasma Science, IEEE, New York, 1980, Abstract 1E7, p. 16.
17. J. F. Morris, "Optimal Thermionic Energy Conversion with Established Electrodes for High-Temperature Topping and Process Heating," DOE/NASA/1062-6, NASA TM-81555, 1980.
18. G. Miskolczy, C. C. Wang, A. E. Margulies, and L. J. Fusegni, "Thermionic Topping of Combined Cycle Powerplants and Cogeneration Applications," Energy to the 21st Century, Proceedings of the 15th Intersociety Energy Conversion Engineering Conference, Vol. 3, AIAA, Inc., New York, 1980, pp. 1783-1787.

19. R. S. Dick, Jr. B. M. Bunda, and J. W. Starr, "Design Study of a Coal-Fired Thermionic (THX) - Topped Power Plant," Energy to the 21st Century, Proceedings of the 15th Intersociety Energy Conversion Engineering Conference, Vol. 3, AIAA, Inc., New York, 1980, pp. 1775-1782.
20. J. F. Morris, "Thermionic Energy Conversion (TEC) Topping Thermoelectrics," International IEEE Conference on Plasma Science; Conference Record-Abstracts, May 18-19, 1981; Santa Fe, New Mex. DOE/NASA-1062-8, NASA TM-81677, 1981.
21. J. F. Morris, "High Power Densities from High-Temperature Materials Interactions," AIAA Sixteenth Thermophysics Conference; June 23-25, 1981; Palto Alto, Calif.; DOE/NASA/1062-7, NASA TM-81626, 1981.
22. "DOE/JPL Advanced Thermionic Technology Program" Thermo Electron Corp., Waltham, Mass., Progress Report No.'s 33 and Higher, 1978-1980.
23. "Development and Evaluation of Tubular SiC Recuperators," Heat Exchanger Technology Program Newsletter, Department of Energy, Office of Fossil Energy Technology, May 1978, pp. 9-10.
24. J. C. Freche and G. M. Ault, "Progress in Advanced High Temperature Turbine Materials, Coatings, and Technology," High Temperature Problems in Gas Turbine Engines, AGARD-CP-229, 1978, pp.3-1 to 3.31.
25. "Coal-Fired Prototype High-Temperature Continuous-Flow Heat Exchanger," Electric Power Research Institute, Palo Alto, CA, EPPRI-AF-684, Feb. 1978.
26. V. J. Tennery and G. C. Wei, "Recuperator Materials Technology Assessment," Oak Ridge National Laboratory, Oak Ridge, TN, ORNL/TM-6227, Feb. 1978.
27. D. B. Goodale, D. Lieb, P. Reagan, G. Miskolczy, and F. N. Huffman, "Characteristics of Flame-Heated Chemical Vapor Deposited Thermionic Combustors," IEEE Conference Record-Abstracts, 1980 IEEE International Conference on Plasma Science, IEEE, New York, 1980, Abstract 1E9, p. 17.
28. D. B. Goodale, P. Reagan, G. Miskolczy, D. Lie, and F. N. Huffman, "Combustion Performance of CVD Silicon Carbide Thermionic Diodes," Energy to the 21st Century, Proceedings of the 15th Intersociety Energy Conversion Engineering Conference, Vol. 3, IEEE, New York, 1980, pp. 2095-2097.
29. F. A. Hals, "Parametric Study of Potential Early Commercial MHD Power Plants," Avco Corp., Wilmington, MA, Dec. 1979. DOE/NASA/0051-79/1, NASA CR-159633..
30. "Project/2 Basic Manual," Project Software & Development, Inc., Cambridge, MA, June 1979.

31. "Project/2 Sample Run: Activity-on-Node," Project Software & Development, Inc., Cambridge, MA, Revised June 1978.
32. "Project/2 Sample Run: Activity-on-Arrow," First Edition, Project Software & Development, Inc., Cambridge, MA, Sep. 1976, Reprinted Apr. 1978.
33. "Project/2 Sample Run: Outage Control," Project Software & Development, Inc., Cambridge, MA, July 1979.

APPENDIX - SYMBOLS

Demo	demonstration
Des	design
DP	decision point
Estin	estimation
Eval	evaluation
Fab	fabrication
Fac, facil	facility, facilities
Facil(s)	facilitation(s)
FED	field evaluation and demonstration
GT	gas turbine(s)
Heat exch	heat exchanger(s)
HP	heat pipe(s)
HX	heat exchanger(s)
Ident	identification
Indus	industry, industries, industrial
Install	installation(s)
Instr(s)	instrument(s), instrumentation
Integ, integ	integration
I/F	interface
Maint	maintenance
Modif	modification(s)
P&C, P and C	performance and cost
P&L, P and L	performance and life
Perf	performance
Prog	program
Proto	prototype(s)
Seg	segment(s)
Sel	selection(s)
Spec	specification(s)
ST	steam turbine(s)
Syst	system(s)
TEC	thermionic energy conversion
TEC ART	TEC applied research and technology
Verif	verification(s)

TABLE I - Continued.

SORT NODES											PAGE	2
ACTIVITY	DESCRIPTION	MODE=O/F	CODE	DURATION	START		FINISH		FF	TF		
					EARLY	LATE	EARLY	LATE				
311541	CATEC-COMPONENTS COST INPUTS(COMBUSTOR) PRECEDES 311711 311721		0	2	1JAN82	1FEB84	1FEB82	1MAR84	0	25		
					1	26	2	27				
311542	CATEC-COMPONENTS COST INPUTS(COMBUSTOR) PRECEDES 311712 311722		0	2	1JAN82	1MAR83	1FEB82	1APR83	0	14		
					1	15	2	16				
C 311543	CATEC-COMPONENTS COST INPUTS(COMBUSTOR) PRECEDES 311713 311723		0	2	1JAN82	1JAN82	1FEB82	1FEB82	0	0		
					1	1	2	2				
311611	GT,ST,CC AND INDUS P&C INPUTS PRECEDES 311711 311721		0	2	1JAN82	1FEB84	1FEB82	1MAR84	0	25		
					1	26	2	27				
311612	GT,ST,CC AND INDUS P&C INPUTS PRECEDES 311712 311722		0	2	1JAN82	1MAR83	1FEB82	1APR83	0	14		
					1	15	2	16				
C 311613	GT,ST,CC AND INDUS P&C INPUTS PRECEDES 311713 311723		0	2	1JAN82	1JAN82	1FEB82	1FEB82	0	0		
					1	1	2	2				
311711	CONCEPTUAL DESIGNS AND REVISIONS PRECEDES 311721 311731		0	4	1MAR82	1APR84	1JUN82	1JUL84	0	25		
					3	28	6	31				
311712	CONCEPTUAL DESIGN AND REVISIONS PRECEDES 311722 311732		0	6	1MAR82	1MAY83	1AUG82	1OCT83	0	14		
					3	17	8	22				
C 311713	CONCEPTUAL DESIGN AND REVISIONS PRECEDES 311723 311733		0	10	1MAR82	1MAR82	1DEC82	1DEC82	0	0		
					3	3	12	12				
311721	CONCEPTUAL P AND C APPROX AND ITERATIONS PRECEDES 311731		0	4	1MAR82	1APR84	1JUN82	1JUL84	0	25		
					3	28	6	31				
311722	CONCEPTUAL P&C APPROX AND ITERATIONS PRECEDES 311732		0	6	1MAR82	1MAY83	1AUG82	1OCT83	0	14		
					3	17	8	22				
C 311723	CONCEPTUAL P&C APPROX AND ITERATIONS PRECEDES 311733		0	10	1MAR82	1MAR82	1DEC82	1DEC82	0	0		
					3	3	12	12				
311731	CRITICAL CONCEPTUAL DESIGN REVIEW PRECEDES 311811		0	3	1JUL82	1AUG84	1SEP82	1OCT84	0	25		
					7	32	9	34				
311732	CRITICAL CONCEPTUAL DESIGN REVIEW PRECEDES 311812		0	3	1SEP82	1NOV83	1NOV82	1JAN84	0	14		
					9	23	11	25				
C 311733	CRITICAL CONCEPTUAL DESIGN REVIEW PRECEDES 311813		0	3	1JAN83	1JAN83	1MAR83	1MAR83	0	0		
					13	13	15	15				
311811	UPGRADED DESIGNS,P&C CALCS PRECEDES 311911 312111		0	2	1OCT82	1NOV84	1NOV82	1DEC84	0	25		
					10	35	11	36				
311812	UPGRADED DESIGNS,P&C CALCS PRECEDES 311912 312112		0	2	1DEC82	1FEB84	1JAN83	1MAR84	0	14		
					12	26	13	27				

TABLE I - Continued.

SORT NODES											PAGE 3	
ACTIVITY	DESCRIPTION	MODE=O/F	CODE	DURATION	START		FINISH		FF	TF		
					EARLY	LATE	EARLY	LATE				
C 311813	UPGRADED DESIGNS,P&C CALCS PRECEDES 311913 312113		0	2	1APR83 16	1APR83 16	1MAY83 17	1MAY83 17	0	0		
311911	EVAL BY INDUS ORG, NASA, DOE ETC PRECEDES 311921 318221		0	2	1DEC82 12	1JAN85 37	1JAN83 13	1FEB85 38	0	25		
311912	EVAL BY INDUS ORG, NASA, DOE ETC PRECEDES 311922 318222		0	2	1FEB83 14	1APR84 28	1MAR83 15	1MAY84 29	0	14		
C 311913	EVAL BY INDUS ORG, NASA, DOE ETC PRECEDES 311923 318223		0	2	1JUN83 18	1JUN83 18	1JUL83 19	1JUL83 19	0	0		
311921	CATEC PROG DP PRECEDES 312111 315111 315211 315311 315611 315711 315811 315911 316111 316211 316311 316411 316511 316611 316711 316811 316911		0		EVENT		1JAN83 13	1FEB85 38		25		
311922	CATEC PROG DP PRECEDES 312112 315112 315212 315312 315612 315712 315812 315912 316112 316212 316312 316412 316512 316612 316712 316812 316912		0		EVENT		1MAR83 15	1MAY84 29		14		
C 311923	CATEC PROG DP PRECEDES 312113 315113 315213 315313 315613 315713 315813 315913 316113 316213 316313 316413 316513 316613 316713 316813 316913		0		EVENT		1JUL83 19	1JUL83 19		0		
312111	INTEG ANAL MODELING,PARAMETRIC CALCS,COMP. SEL. PRECEDES 312311		0	3	1FEB83 14	1MAR85 39	1APR83 16	1MAY85 41	0	25		
312112	INTEG ANAL MODELING,PARAMETRIC CALCS,COMP. SEL. PRECEDES 312312		0	3	1APR83 16	1JUN84 30	1JUN83 18	1AUG84 32	0	14		
C 312113	INTEG ANAL MODELING,PARAMETRIC CALCS,COMP. SEL. PRECEDES 312313		0	3	1AUG83 20	1AUG83 20	1OCT83 22	1OCT83 22	0	0		
312311	PROTO TEC DES & FAB MODIF PRECEDES 312321 312411 313111		0	6	1FEB83 14	1MAR85 39	1JUL83 19	1AUG85 44	0	25		
312312	PROTO TEC DES & FAB MODIF PRECEDES 312322 312412 313112		0	6	1APR83 16	1JUN84 30	1SEP83 21	1NOV84 35	0	14		
C 312313	PROTO TEC DES & FAB MODIF PRECEDES 312323 312413 313113		0	10	1AUG83 20	1AUG83 20	1MAY84 29	1MAY84 29	0	0		

TABLE I - Continued.

		SORT NODES								PAGE 4	
ACTIVITY	DESCRIPTION	MODE=O/F	CODE	DURATION	START EARLY	START LATE	FINISH EARLY	FINISH LATE	FF	TF	
312321	P&L TESTS OF TEC MODULES PRECEDES 313111		0	18	1AUG83 20	1MAY88 77	1JAN85 37	1OCT89 94	1	57	
312322	P&L TESTS OF TEC MODULES PRECEDES 313112		0	18	1OCT83 22	1MAY88 77	1MAR85 39	1OCT89 94	1	55	
312323	P&L TESTS OF TEC MODULES PRECEDES 313113		0	18	1JUN84 30	1MAY88 77	1NOV85 47	1OCT89 94	0	47	
312411	OVERALL CATEC APPL DESIGN PRECEDES 312511 312611		0	3	1APR83 16	1MAY85 41	1JUN83 18	1JUL85 43	0	25	
312412	OVERALL CATEC APPL DESIGN PRECEDES 312512 312612		0	3	1JUN83 18	1AUG84 32	1AUG83 20	1OCT84 34	0	14	
C 312413	OVERALL CATEC APPL DESIGN PRECEDES 312513 312613		0	3	1OCT83 22	1OCT83 22	1DEC83 24	1DEC83 24	0	0	
312511	CATEC APPL INTERACTIONS STUDIES PRECEDES 312611		0	2	1JUL83 19	1AUG85 44	1AUG83 20	1SEP85 45	0	25	
312512	CATEC APPL INTERATIONS STUDIES PRECEDES 312612		0	2	1SEP83 21	1NOV84 35	1OCT83 22	1DEC84 36	0	14	
C 312513	CATEC APPL INTERATIONS STUDIES PRECEDES 312613		0	2	1JAN84 25	1JAN84 25	1FEB84 26	1FEB84 26	0	0	
312611	DETAILED DWGS OF CATEC APPL DESIGNS PRECEDES 312711 312911 313111 313211		0	3	1SEP83 21	1OCT85 46	1NOV83 23	1DEC85 48	0	25	
312612	DETAILED DWGS OF CATEC APPL DESIGNS PRECEDES 312712 312912 313112 313212		0	3	1NOV83 23	1JAN85 37	1JAN84 25	1MAR85 39	0	14	
C 312613	DETAILED DWGS OF CATEC APPL DESIGNS PRECEDES 312713 312913 313113 313213		0	3	1MAR84 27	1MAR84 27	1MAY84 29	1MAY84 29	0	0	
312711	DETAILED EST OF COMPS, OVERALL P&L, MAINT NEEDS PRECEDES 312811 312911		0	3	1DEC83 24	1JAN86 49	1FEB84 26	1MAR86 51	0	25	
312712	DETAILED EST OF COMPS, OVERALL P&L, MAINT NEEDS PRECEDES 312812 312912		0	3	1FEB84 26	1APR85 40	1APR84 28	1JUN85 42	0	14	
C 312713	DETAILED EST OF COMPS, OVERALL P&L, MAINT NEEDS PRECEDES 312813 312913		0	3	1JUN84 30	1JUN84 30	1AUG84 32	1AUG84 32	0	0	
312811	DETAILED CATEC APPL COST ANALY PRECEDES 312911		0	3	1DEC83 24	1MAR86 51	1FEB84 26	1MAY86 53	2	27	
312812	DETAILED CATEC APPL COST ANAL PRECEDES 312912		0	3	1FEB84 26	1JUN85 42	1APR84 28	1AUG85 44	2	16	

TABLE I - Continued.

ACTIVITY	DESCRIPTION	MODE=O/F	CODE	DURATION	START		FINISH		PAGE	
					EARLY	LATE	EARLY	LATE	FF	TF
312813	DETAILED CATEC APPL COST ANAL PRECEDES 312913		0	3	1JUN84 30	1AUG84 32	1AUG84 32	1OCT84 34	2	2
312911	CATEC APPL DESIGN REVIEW AND REFINE PRECEDES 313211		0	2	1MAR84 27	1APR86 52	1APR84 28	1MAY86 53	0	25
312912	CATEC APPL DESIGN REVIEW AND REFINE PRECEDES 313212		0	2	1MAY84 29	1JUL85 43	1JUN84 30	1AUG85 44	0	14
C 312913	CATEC APPL DESIGN REVIEW AND REFINE PRECEDES 313213		0	2	1SEP84 33	1SEP84 33	1OCT84 34	1OCT84 34	0	0
313111	D AND F OF TEC PROTOTYPES PRECEDES 313121 313131		0	4	1DEC83 24	1AUG88 80	1MAR84 27	1NOV88 83	0	56
313112	D AND F OF TEC PROTOTYPES PRECEDES 313122 313132		0	4	1FEB84 26	1AUG88 80	1MAY84 29	1NOV88 83	0	54
313113	D AND F OF TEC PROTOTYPES PRECEDES 313123 313133		0	4	1SEP84 33	1AUG88 80	1DEC84 36	1NOV88 83	0	47
313121	INTEG ADAPS, FACILS, INSTRS, & CTRL INSTALL PRECEDES 313131		0	4	1DEC83 24	1AUG88 80	1MAR84 27	1NOV88 83	0	56
313122	INTEG ADAPS, FACILS, INSTRS, & CTRL INSTALL PRECEDES 313132		0	4	1FEB84 26	1AUG88 80	1MAY84 29	1NOV88 83	0	54
313123	INTEG ADAPS, FACILS, INSTRS, & CTRL INSTALL PRECEDES 313133		0	4	1SEP84 33	1AUG88 80	1DEC84 36	1NOV88 83	0	47
313131	INTEG PROTO TESTG(DOE CONTROL) SINK ACTIVITY		0	12	1APR84 28	1DEC88 84	1MAR85 39	1NOV89 95	56	56
313132	INTEG PROTO TESTG(DOE CONTROL) SINK ACTIVITY		0	12	1JUN84 30	1DEC88 84	1MAY85 41	1NOV89 95	54	54
313133	INTEG PROTO TESTG(DOE CONTROL) SINK ACTIVITY		0	12	1JAN85 37	1DEC88 84	1DEC85 48	1NOV89 95	47	47
313211	CATEC SEGMENT DESIGN AND FACIL IDENT PRECEDES 313311 313411		0	3	1MAY84 29	1JUN86 54	1JUL84 31	1AUG86 56	0	25
313212	CATEC SEGMENT DESIGN AND FACIL INDENT PRECEDES 313312 313412		0	3	1JUL84 31	1SEP85 45	1SEP84 33	1NOV85 47	0	14
C 313213	CATEC SEGMENT DESIGN AND FACIL INDENT PRECEDES 313313 313413		0	3	1NOV84 35	1NOV84 35	1JAN85 37	1JAN85 37	0	0
313311	CATEC SEG FAB PRECEDES 313511		0	5	1JUN84 30	1SEP86 57	1OCT84 34	1JAN87 61	2	27

TABLE I - Continued.

SORT NODES											PAGE 6	
ACTIVITY	DESCRIPTION	MODE=0/F	CODE	DURATION	START		FINISH		FF	TF		
					EARLY	LATE	EARLY	LATE				
313312	CATEC SEG FAB PRECEDES 313512		0	6	1AUG84 32	1FEB86 50	1JAN85 37	1JUL86 55	4	18		
313313	CATEC SEG FAB PRECEDES 313513		0	12	1DEC84 36	1FEB85 38	1NOV85 47	1JAN86 49	2	2		
313411	CATEC SEG FAC ADAP PRECEDES 313511		0	5	1AUG84 32	1SEP86 57	1DEC84 36	1JAN87 61	0	25		
313412	CATEC SEG FAC ADAP PRECEDES 313512		0	8	1OCT84 34	1DEC85 48	1MAY85 41	1JUL86 55	0	14		
C 313413	CATEC SEG FAC ADAP PRECEDES 313513		0	12	1FEB85 38	1FEB85 38	1JAN86 49	1JAN86 49	0	0		
313511	CATEC SEG INSTAL AND INSTRN PRECEDES 313611 313811 313911		0	3	1JAN85 37	1FEB87 62	1MAR85 39	1APR87 64	0	25		
313512	CATEC SEG INSTAL AND INSTRN PRECEDES 313612 313812 313912		0	3	1JUN85 42	1AUG86 56	1AUG85 44	1OCT86 58	0	14		
C 313513	CATEC SEG INSTAL AND INSTRN PRECEDES 313613 313813 313913		0	3	1FEB86 50	1FEB86 50	1APR86 52	1APR86 52	0	0		
313611	CATEC SEG SHAKEDOWNS,MODIF PRECEDES 313711 313811 313911		0	2	1APR85 40	1MAY87 65	1MAY85 41	1JUN87 66	0	25		
313612	CATEC SEG SHAKEDOWNS,MODIF PRECEDES 313712 313812 313912		0	2	1SEP85 45	1NOV86 59	1OCT85 46	1DEC86 60	0	14		
C 313613	CATEC SEG SHAKEDOWNS,MODIF PRECEDES 313713 313813 313913		0	2	1MAY86 53	1MAY86 53	1JUN86 54	1JUN86 54	0	0		
313711	CATEC SEG PERF MAPPING PRECEDES 314111		0	3	1JUN85 42	1JUL87 67	1AUG85 44	1SEP87 69	0	25		
313712	CATEC SEG PERF MAPPING PRECEDES 314112		0	3	1NOV85 47	1JAN87 61	1JAN86 49	1MAR87 63	0	14		
C 313713	CATEC SEG PERF MAPPING PRECEDES 314113		0	3	1JUL86 55	1JUL86 55	1SEP86 57	1SEP86 57	0	0		
313811	CATEC SEGMENT P&L TESTS SINK ACTIVITY		0	18	1APR85 40	1JUN88 78	1SEP86 57	1NOV89 95	38	38		
313812	CATEC SEGMENT P&L TESTS SINK ACTIVITY		0	18	1SEP85 45	1JUN88 78	1FEB87 62	1NOV89 95	33	33		
313813	CATEC SEGMENT P&L TESTS SINK ACTIVITY		0	18	1MAY86 53	1JUN88 78	1OCT87 70	1NOV89 95	25	25		

TABLE I - Continued.

.....										
-----+-----+-----+-----+-----+-----+-----+-----+-----+-----										
.....										
-----+-----+-----+-----+-----+-----+-----+-----+-----+-----										
ACTIVITY	DESCRIPTION	SORT MODES		DURATION	START		FINISH		PAGE	
		MODE=O/F	CODE		EARLY	LATE	EARLY	LATE	FF	TF
-----+-----+-----+-----+-----+-----+-----+-----+-----+-----										
313911	CATEC SEG EVAL, REFINE, RERUNS & REPORTS SINK ACTIVITY		0	18	1JUN85 42	1JUN88 78	1NOV86 59	1NOV89 95	36	36
313912	CATEC SEG EVAL, REFINE, RERUNS & REPORTS SINK ACTIVITY		0	18	1NOV85 47	1JUN88 78	1APR87 64	1NOV89 95	31	31
313913	CATEC SEG EVAL, REFINE, RERUNS & REPORTS SINK ACTIVITY		0	18	1JUL86 55	1JUN88 78	1DEC87 72	1NOV89 95	23	23
314111	IDENT TEST FACIL & MODIF OF CATEC DESIGNS PRECEDES 314211 314311		0	2	1JUN85 42	1JUL87 67	1JUL85 43	1AUG87 68	0	25
314112	IDENT TEST FACIL & MODIF OF CATEC DESIGNS PRECEDES 314212 314312		0	2	1NOV85 47	1JAN87 61	1DEC85 48	1FEB87 62	0	14
C 314113	IDENT TEST FACIL & MODIF OF CATEC DESIGNS PRECEDES 314213 314313		0	2	1JUL86 55	1JUL86 55	1AUG86 56	1AUG86 56	0	0
314211	CATEC FAB PRECEDES 314411		0	6	1AUG85 44	1SEP87 69	1JAN86 49	1FEB88 74	0	25
314212	CATEC FAB PRECEDES 314412		0	12	1JAN86 49	1MAR87 63	1DEC86 60	1FEB88 74	0	14
C 314213	CATEC FAB PRECEDES 314413		0	18	1SEP86 57	1SEP86 57	1FEB88 74	1FEB88 74	0	0
314311	CATEC FACIL ADAP PRECEDES 314411		0	6	1AUG85 44	1SEP87 69	1JAN86 49	1FEB88 74	0	25
314312	CATEC FACIL ADAP PRECEDES 314412		0	12	1JAN86 49	1MAR87 63	1DEC86 60	1FEB88 74	0	14
C 314313	CATEC FACIL ADAP PRECEDES 314413		0	18	1SEP86 57	1SEP86 57	1FEB88 74	1FEB88 74	0	0
314411	CATEC INSTAL & INSTR PRECEDES 314511 314711 314811		0	3	1FEB86 50	1MAR88 75	1APR86 52	1MAY88 77	0	25
314412	CATEC INSTAL & INSTR PRECEDES 314512 314712 314812		0	3	1JAN87 61	1MAR88 75	1MAR87 63	1MAY88 77	0	14
C 314413	CATEC INSTAL & INSTR PRECEDES 314513 314713 314813		0	3	1MAR88 75	1MAR88 75	1MAY88 77	1MAY88 77	0	0
314511	CATEC SHAKEDOWNS & MODIF PRECEDES 314611 314711		0	2	1MAY86 53	1JUN88 78	1JUN86 54	1JUL88 79	0	25
314512	CATEC SHAKEDOWNS & MODIF PRECEDES 314612 314712		0	2	1APR87 64	1JUN88 78	1MAY87 65	1JUL88 79	0	14
.....										

TABLE I - Continued.

		SORT NODES					PAGE			
ACTIVITY	DESCRIPTION	MODE=O/F	CODE	DURATION	START EARLY	START LATE	FINISH EARLY	FINISH LATE	FF	TF
C 314513	CATEC SHAKEDOWNS & MODIF PRECEDES 314613 314713		0	2	1JUN88 78	1JUN88 78	1JUL88 79	1JUL88 79	0	0
314611	CATEC PERF MAPPING SINK ACTIVITY		0	3	1JUL86 55	1SEP89 93	1SEP86 57	1NOV89 95	38	38
314612	CATEC PERF MAPPING SINK ACTIVITY		0	3	1JUN87 66	1SEP89 93	1AUG87 68	1NOV89 95	27	27
314613	CATEC PERF MAPPING SINK ACTIVITY		0	3	1AUG88 80	1SEP89 93	1OCT88 82	1NOV89 95	13	13
314711	CATEC PERF. VERIF & LIFE ESTIM TESTS SINK ACTIVITY		0	18	1MAY86 53	1JUN88 78	1OCT87 70	1NOV89 95	25	25
314712	CATEC PERF. VERIF & LIFE ESTIM TESTS SINK ACTIVITY		0	18	1APR87 64	1JUN88 78	1SEP88 81	1NOV89 95	14	14
C 314713	CATEC PERF. VERIF & LIFE ESTIM TESTS SINK ACTIVITY		0	18	1JUN88 78	1JUN88 78	1NOV89 95	1NOV89 95	0	0
314811	CATEC EVAL, REFINE, RERUNS & REPORTS PRECEDES 314911		0	18	1MAY86 53	1JUN88 78	1OCT87 70	1NOV89 95	0	25
314812	CATEC EVAL, REFINE, RERUNS & REPORTS PRECEDES 314912		0	18	1APR87 64	1JUN88 78	1SEP88 81	1NOV89 95	0	14
C 314813	CATEC EVAL, REFINE, RERUNS & REPORTS PRECEDES 314913		0	18	1JUN88 78	1JUN88 78	1NOV89 95	1NOV89 95	0	0
314911	PUBLIC DEMO AND FED SINK ACTIVITY		0		EVENT		1APR86 52	1NOV89 95		43
314912	PUBLIC DEMO AND FED SINK ACTIVITY		0		EVENT		1MAR87 63	1NOV89 95		32
314913	PUBLIC DEMO AND FED SINK ACTIVITY		0		EVENT		1MAY88 77	1NOV89 95		18
315111	PROTECTIVE CLAD E&D(PILOT LINE) PRECEDES 315121 315411		0	18	1FEB83 14	1JUN86 54	1JUL84 31	1NOV87 71	0	40
315112	PROTECTIVE CLAD E&D(PILOT LINE) PRECEDES 315122 315412		0	18	1APR83 16	1JUN86 54	1SEP84 33	1NOV87 71	0	38
315113	PROTECTIVE CLAD E&D(PILOT LINE) PRECEDES 315123 315413		0	18	1AUG83 20	1JUN86 54	1JAN85 37	1NOV87 71	0	34
315121	PROTECTIVE CLAD E&D(PRODUCTION LINE) SINK ACTIVITY		0	24	1AUG84 32	1DEC87 72	1JUL86 55	1NOV89 95	40	40

TABLE I - Continued.

		SORT NODES						PAGE 9		
ACTIVITY	DESCRIPTION	MODE=O/F	CODE	DURATION	START EARLY	START LATE	FINISH EARLY	FINISH LATE	FF	TF
315122	PROTECTIVE CLAD E&D(PRODUCTION LINE) SINK ACTIVITY		0	24	1OCT84 34	1DEC87 72	1SEP86 57	1NOV89 95	38	38
315123	PROTECTIVE CLAD E&D(PRODUCTION LINE) SINK ACTIVITY		0	24	1FEB85 38	1DEC87 72	1JAN87 61	1NOV89 95	34	34
315211	RESERVOIR E&D SINK ACTIVITY		0	18	1FEB83 14	1JUN88 78	1JUL84 31	1NOV89 95	64	64
315212	RESERVOIR E&D SINK ACTIVITY		0	24	1APR83 16	1DEC87 72	1MAR85 39	1NOV89 95	56	56
315213	RESERVOIR E&D SINK ACTIVITY		0	30	1AUG83 20	1JUN87 66	1JAN86 49	1NOV89 95	46	46
315311	HP COMPONENTS E AND D SINK ACTIVITY		0	18	1FEB83 14	1JUN88 78	1JUL84 31	1NOV89 95	64	64
315312	HP COMPONENTS E AND D SINK ACTIVITY		0	24	1APR83 16	1DEC87 72	1MAR85 39	1NOV89 95	56	56
315313	HP COMPONENTS E AND D SINK ACTIVITY		0	30	1AUG83 20	1JUN87 66	1JAN86 49	1NOV89 95	46	46
315411	TEC HP FAB AND ASSLY PRECEDES 315511		0	18	1AUG83 20	1DEC87 72	1JAN85 37	1MAY89 89	0	52
315412	TEC HP FAB AND ASSLY PRECEDES 315512		0	24	1OCT83 22	1JUN87 66	1SEP85 45	1MAY89 89	0	44
315413	TEC HP FAB AND ASSLY PRECEDES 315513		0	30	1FEB84 26	1DEC86 60	1JUL86 55	1MAY89 89	0	34
315511	TEC HP PROCESSING AND TESTING SINK ACTIVITY		0	18	1FEB84 26	1JUN88 78	1JUL85 43	1NOV89 95	52	52
315512	TEC HP PROCESSING AND TESTING SINK ACTIVITY		0	24	1APR84 28	1DEC87 72	1MAR86 51	1NOV89 95	44	44
315513	TEC HP PROCESSING AND TESTING SINK ACTIVITY		0	30	1AUG84 32	1JUN87 66	1JAN87 61	1NOV89 95	34	34
315611	COMBUSTOR E&D SINK ACTIVITY		0	18	1FEB83 14	1JUN88 78	1JUL84 31	1NOV89 95	64	64
315612	COMBUSTOR E & D SINK ACTIVITY		0	24	1APR83 16	1DEC87 72	1MAR85 39	1NOV89 95	56	56
315613	COMBUSTOR E & D SINK ACTIVITY		0	30	1AUG83 20	1JUN87 66	1JAN86 49	1NOV89 95	46	46

TABLE I - Continued.

ACTIVITY	DESCRIPTION	MODE=O/F	SORT NODES		DURATION	START		FINISH		PAGE 10	
			CODE			EARLY	LATE	EARLY	LATE	FF	TF
315711	CATEC FAB, ASSLY, INTEGRITY CHECKS SINK ACTIVITY		0	18	1FEB83 14	1JUN88 78	1JUL84 31	1NOV89 95	64	64	
315712	CATEC FAB, ASSLY, INTEGRITY CHECKS SINK ACTIVITY		0	24	1APR83 16	1DEC87 72	1MAR85 39	1NOV89 95	56	56	
315713	CATEC FAB, ASSLY, INTEGRITY CHECKS SINK ACTIVITY		0	30	1AUG83 20	1JUN87 66	1JAN86 49	1NOV89 95	46	46	
315811	CATEC INSTR, CONTROLS, SAFETY E&D SINK ACTIVITY		0	18	1FEB83 14	1JUN88 78	1JUL84 31	1NOV89 95	64	64	
315812	CATEC INSTR, CONTROLS, SAFETY E&D SINK ACTIVITY		0	24	1APR83 16	1DEC87 72	1MAR85 39	1NOV89 95	56	56	
315813	CATEC INSTR, CONTROLS, SAFETY E&D SINK ACTIVITY		0	30	1AUG83 20	1JUN87 66	1JAN86 49	1NOV89 95	46	46	
315911	SYS INTEG E&D AND ANAL MODELING SINK ACTIVITY		0	18	1FEB83 14	1JUN88 78	1JUL84 31	1NOV89 95	64	64	
315912	SYS INTEG E&D AND ANAL MODELING SINK ACTIVITY		0	24	1APR83 16	1DEC87 72	1MAR85 39	1NOV89 95	56	56	
315913	SYS INTEG E&D AND ANAL MODELING SINK ACTIVITY		0	30	1AUG83 20	1JUN87 66	1JAN86 49	1NOV89 95	46	46	
316111	NON-TEC CONVERSION SYSTEMS E&D SINK ACTIVITY		0	18	1FEB83 14	1JUN88 78	1JUL84 31	1NOV89 95	64	64	
316112	NON-TEC CONVERSION SYSTEMS E&D SINK ACTIVITY		0	24	1APR83 16	1DEC87 72	1MAR85 39	1NOV89 95	56	56	
316113	NON-TEC CONVERSION SYSTEMS E&D SINK ACTIVITY		0	30	1AUG83 20	1JUN87 66	1JAN86 49	1NOV89 95	46	46	
316211	POWER CONDITIONING SYSTEMS E&D SINK ACTIVITY		0	18	1FEB83 14	1JUN88 78	1JUL84 31	1NOV89 95	64	64	
316212	POWER CONDITIONING SYSTEMS E&D SINK ACTIVITY		0	24	1APR83 16	1DEC87 72	1MAR85 39	1NOV89 95	56	56	
316213	POWER CONDITIONING SYSTEMS E&D SINK ACTIVITY		0	30	1AUG83 20	1JUN87 66	1JAN86 49	1NOV89 95	46	46	
316311	POLLUTION CONTROL SYSTEMS E&D SINK ACTIVITY		0	18	1FEB83 14	1JUN88 78	1JUL84 31	1NOV89 95	64	64	
316312	POLLUTION CONTROL SYSTEMS E&D SINK ACTIVITY		0	24	1APR83 16	1DEC87 72	1MAR85 39	1NOV89 95	56	56	

TABLE I - Continued.

ACTIVITY	DESCRIPTION	MODE=0/F	CODE	DURATION	START		FINISH		PAGE 11	
					EARLY	LATE	EARLY	LATE	FF	TF
316313	POLLUTION CONTROL SYSTEMS E&D SINK ACTIVITY		0	30	1AUG83 20	1JUN87 66	1JAN86 49	1NOV89 95	46	46
316411	FUEL SYSTEMS E&D SINK ACTIVITY		0	18	1FEB83 14	1JUN88 78	1JUL84 31	1NOV89 95	64	64
316412	FUEL SYSTEMS E&D SINK ACTIVITY		0	24	1APR83 16	1DEC87 72	1MAR85 39	1NOV89 95	56	56
316413	FUEL SYSTEMS E&D SINK ACTIVITY		0	30	1AUG83 20	1JUN87 66	1JAN86 49	1NOV89 95	46	46
316511	HEAT EXCH E&D SINK ACTIVITY		0	18	1FEB83 14	1JUN88 78	1JUL84 31	1NOV89 95	64	64
316512	HEAT EXCH E&D SINK ACTIVITY		0	24	1APR83 16	1DEC87 72	1MAR85 39	1NOV89 95	56	56
316513	HEAT EXCH E&D SINK ACTIVITY		0	30	1AUG83 20	1JUN87 66	1JAN86 49	1NOV89 95	46	46
316611	I/F SYSTEMS E&D SINK ACTIVITY		0	18	1FEB83 14	1JUN88 78	1JUL84 31	1NOV89 95	64	64
316612	I/F SYSTEMS E&D SINK ACTIVITY		0	24	1APR83 16	1DEC87 72	1MAR85 39	1NOV89 95	56	56
316613	I/F SYSTEMS E&D SINK ACTIVITY		0	30	1AUG83 20	1JUN87 66	1JAN86 49	1NOV89 95	46	46
316711	PROCESS INSTR, CNTRLS, SAFETY E&D SINK ACTIVITY		0	18	1FEB83 14	1JUN88 78	1JUL84 31	1NOV89 95	64	64
316712	PROCESS INSTR, CNTRLS, SAFETY E&D SINK ACTIVITY		0	24	1APR83 16	1DEC87 72	1MAR85 39	1NOV89 95	56	56
316713	PROCESS INSTR, CNTRLS, SAFETY E&D SINK ACTIVITY		0	30	1AUG83 20	1JUN87 66	1JAN86 49	1NOV89 95	46	46
316811	SYS INTG E&D & ANAL MODELING SINK ACTIVITY		0	18	1FEB83 14	1JUN88 78	1JUL84 31	1NOV89 95	64	64
316812	SYS INTG E&D & ANAL MODELING SINK ACTIVITY		0	24	1APR83 16	1DEC87 72	1MAR85 39	1NOV89 95	56	56
316813	SYS INTG E&D & ANAL MODELING SINK ACTIVITY		0	30	1AUG83 20	1JUN87 66	1JAN86 49	1NOV89 95	46	46
316911	AUX SYS TESTING & MODIF SINK ACTIVITY		0	18	1FEB83 14	1JUN88 78	1JUL84 31	1NOV89 95	64	64

TABLE I - Concluded.

		SORT		NODES						PAGE 12	
ACTIVITY	DESCRIPTION	MODE=0/F	CODE	DURATION	START		FINISH		FF	TF	
					EARLY	LATE	EARLY	LATE			
316912	AUX SYS TESTING & MODIF SINK ACTIVITY		0	24	1APR83 16	1DEC87 72	1MAR85 39	1NOV89 95	56	56	
316913	AUX SYS TESTING & MODIF SINK ACTIVITY		0	30	1AUG83 20	1JUN87 66	1JAN86 49	1NOV89 95	46	46	
317111	COMBUSTOR SPEC PRECEDES 311711		0	2	1JAN82 1	1FEB84 26	1FEB82 2	1MAR84 27	0	25	
317112	COMBUSTOR SPEC PRECEDES 311712		0	2	1JAN82 1	1MAR83 15	1FEB82 2	1APR83 16	0	14	
317113	COMBUSTOR SPEC PRECEDES 311713		0	2	1JAN82 1	1JAN82 1	1FEB82 2	1FEB82 2	0	0	
318111	IMPACT IDENTIFICATION PRECEDES 311921		0	4	1JAN82 1	1NOV84 35	1APR82 4	1FEB85 38	9	34	
318112	IMPACT IDENTIFICATION PRECEDES 311922		0	4	1JAN82 1	1FEB84 26	1APR82 4	1MAY84 29	11	25	
318113	IMPACT IDENTIFICATION PRECEDES 311923		0	4	1JAN82 1	1APR83 16	1APR82 4	1JUL83 19	15	15	
318211	PRELIM MARKET SURVEY PRECEDES 311911		0	4	1JAN82 1	1SEP84 33	1APR82 4	1DEC84 36	7	32	
318212	PRELIM MARKET SURVEY PRECEDES 311912		0	4	1JAN82 1	1DEC83 24	1APR82 4	1MAR84 27	9	23	
318213	PRELIM MARKET SURVEY PRECEDES 311913		0	4	1JAN82 1	1FEB83 14	1APR82 4	1MAY83 17	13	13	
318221	MARKET ANALYSIS SINK ACTIVITY		0	12	1FEB83 14	1DEC88 84	1JAN84 25	1NOV89 95	70	70	
318222	MARKET ANALYSIS SINK ACTIVITY		0	12	1APR83 16	1DEC88 84	1MAR84 27	1NOV89 95	68	68	
318223	MARKET ANALYSIS SINK ACTIVITY		0	12	1AUG83 20	1DEC88 84	1JUL84 31	1NOV89 95	64	64	

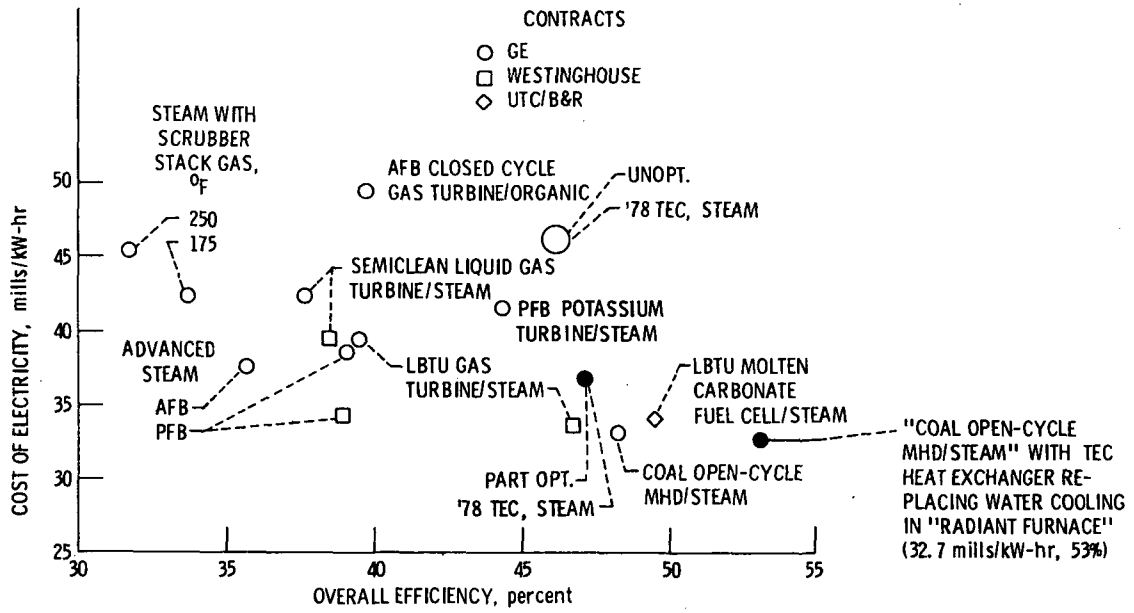

Figure 1. - ECAS Phase 2 results using 30-year levelized cost in mid-1975 dollars. Fuel cost assumed constant in fixed dollars.

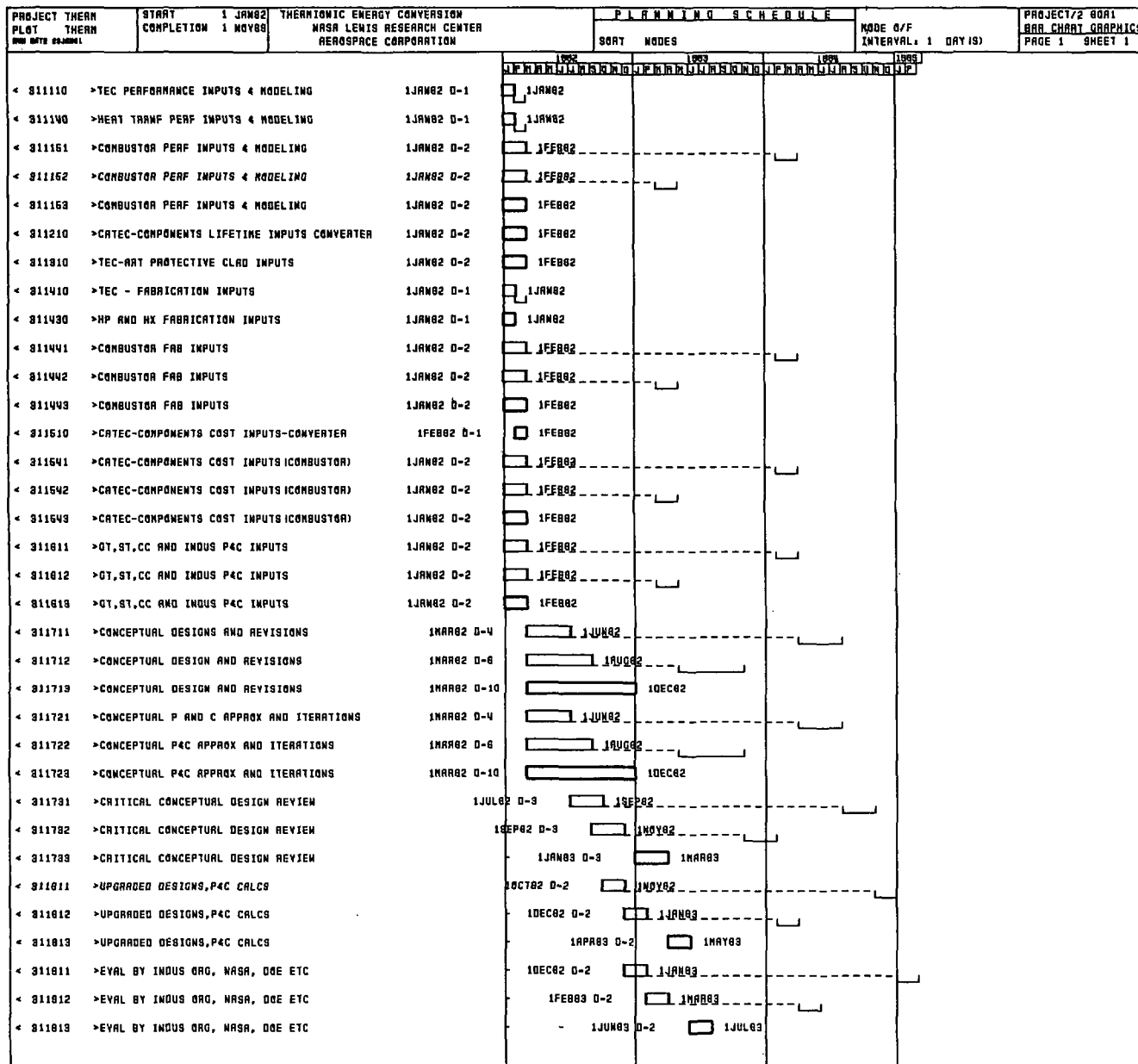

Figure 2

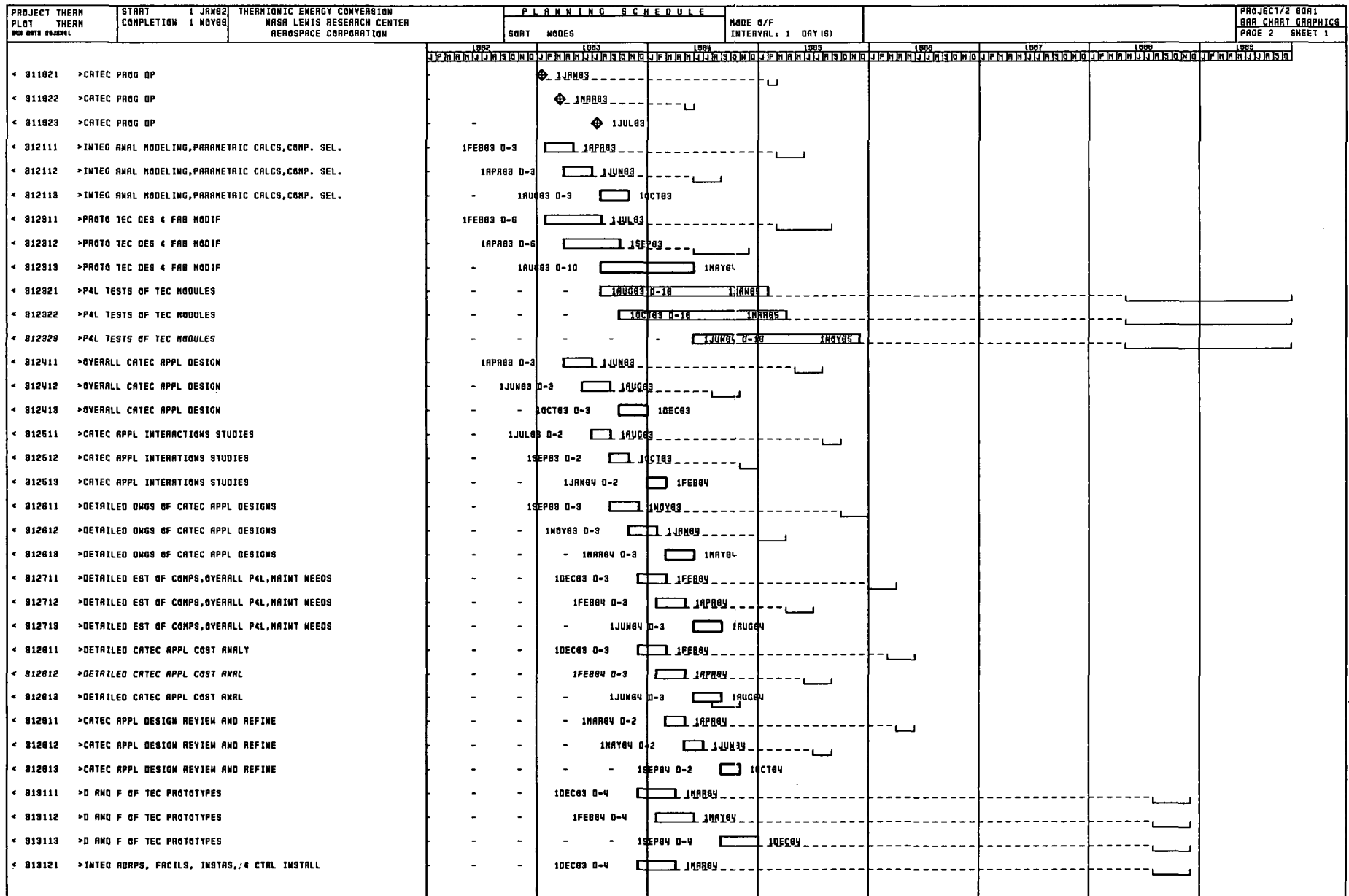

Figure 2. - Continued.

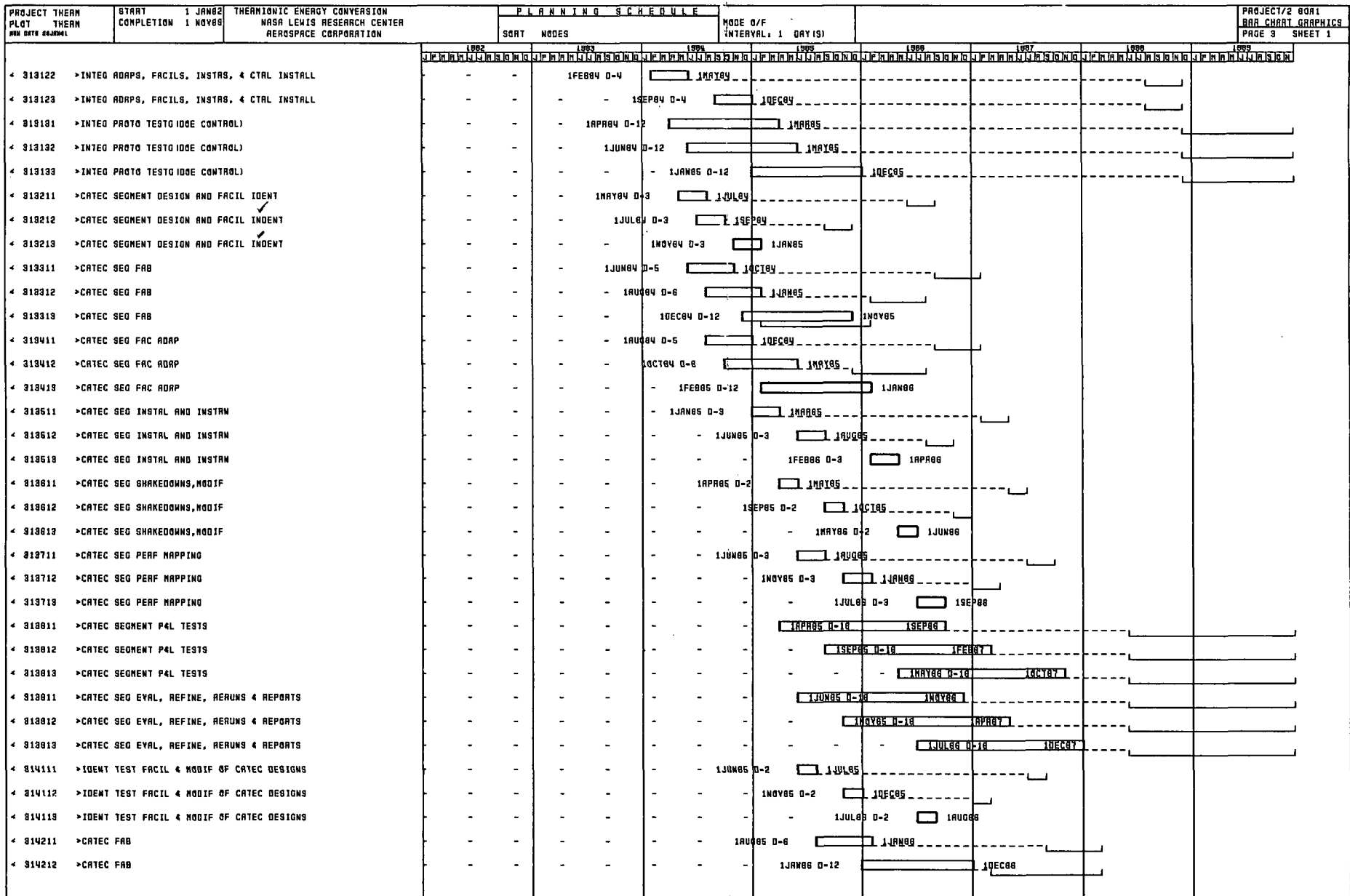

Figure 2 - Continued.

PROJECT THEM PLOT THEM WDR WDR 044041	START COMPLETION 1 NOV86	THERMIONIC ENERGY CONVERSION NASA LEWIS RESEARCH CENTER AEROSPACE CORPORATION	P L A N N I N G S C H E D U L E						MODE O/F INTERVAL: 1 DAY(S)		PROJECT/2 00A1 BAR CHART GRAPHICS PAGE 6 SHEET 1				
			1982	1983	1984	1985	1986	1987	1988	1989					
< 316411	>TEC HP FAB AND ASSLY	-	-	-	1AUG83 D-18	1JAN85	-	-	-	-	-	-	-		
< 316412	>TEC HP FAB AND ASSLY	-	-	-	1AUG83 D-24	1SEP85	-	-	-	-	-	-	-		
< 316413	>TEC HP FAB AND ASSLY	-	-	-	1FEB84 D-30	1JUL85	-	-	-	-	-	-	-		
< 316511	>TEC HP PROCESSING AND TESTING	-	-	-	1FEB84 D-18	1JUL85	-	-	-	-	-	-	-		
< 316512	>TEC HP PROCESSING AND TESTING	-	-	-	1APR84 D-24	1MAY85	-	-	-	-	-	-	-		
< 316513	>TEC HP PROCESSING AND TESTING	-	-	-	1AUG84 D-30	1JAN86	-	-	-	-	-	-	-		
< 316811	>COMBUSTOR E40	-	-	-	1FEB83 D-18	1JUL84	-	-	-	-	-	-	-		
< 316812	>COMBUSTOR E 4 0	-	-	-	1APR83 D-24	1MAY85	-	-	-	-	-	-	-		
< 316813	>COMBUSTOR E 4 0	-	-	-	1AUG83 D-30	1JAN86	-	-	-	-	-	-	-		
< 316711	>CATEC FAB, ASSLY, INTEGRITY CHECKS	-	-	-	1FEB83 D-18	1JUL84	-	-	-	-	-	-	-		
< 316712	>CATEC FAB, ASSLY, INTEGRITY CHECKS	-	-	-	1APR83 D-24	1MAY85	-	-	-	-	-	-	-		
< 316713	>CATEC FAB, ASSLY, INTEGRITY CHECKS	-	-	-	1AUG83 D-30	1JAN86	-	-	-	-	-	-	-		
< 316811	>CATEC INSTR, CONTROLS, SAFETY E40	-	-	-	1FEB83 D-18	1JUL84	-	-	-	-	-	-	-		
< 316812	>CATEC INSTR, CONTROLS, SAFETY E40	-	-	-	1APR83 D-24	1MAY85	-	-	-	-	-	-	-		
< 316813	>CATEC INSTR, CONTROLS, SAFETY E40	-	-	-	1AUG83 D-30	1JAN86	-	-	-	-	-	-	-		
< 316811	>SYS INTEO E40 AND ANAL MODELING	-	-	-	1FEB83 D-18	1JUL84	-	-	-	-	-	-	-		
< 316812	>SYS INTEO E40 AND ANAL MODELING	-	-	-	1APR83 D-24	1MAY85	-	-	-	-	-	-	-		
< 316813	>SYS INTEO E40 AND ANAL MODELING	-	-	-	1AUG83 D-30	1JAN86	-	-	-	-	-	-	-		
< 316111	>NON-TEC CONVERSION SYSTEMS E40	-	-	-	1FEB83 D-18	1JUL84	-	-	-	-	-	-	-		
< 316112	>NON-TEC CONVERSION SYSTEMS E40	-	-	-	1APR83 D-24	1MAY85	-	-	-	-	-	-	-		
< 316113	>NON-TEC CONVERSION SYSTEMS E40	-	-	-	1AUG83 D-30	1JAN86	-	-	-	-	-	-	-		
< 316211	>POWER CONDITIONING SYSTEMS E40	-	-	-	1FEB83 D-18	1JUL84	-	-	-	-	-	-	-		
< 316212	>POWER CONDITIONING SYSTEMS E40	-	-	-	1APR83 D-24	1MAY85	-	-	-	-	-	-	-		
< 316213	>POWER CONDITIONING SYSTEMS E40	-	-	-	1AUG83 D-30	1JAN86	-	-	-	-	-	-	-		
< 316311	>POLLUTION CONTRL SYSTEMS E40	-	-	-	1FEB83 D-18	1JUL84	-	-	-	-	-	-	-		
< 316312	>POLLUTION CONTRL SYSTEMS E40	-	-	-	1APR83 D-24	1MAY85	-	-	-	-	-	-	-		
< 316313	>POLLUTION CONTRL SYSTEMS E40	-	-	-	1AUG83 D-30	1JAN86	-	-	-	-	-	-	-		
< 316411	>FUEL SYSTEMS E40	-	-	-	1FEB83 D-18	1JUL84	-	-	-	-	-	-	-		
< 316412	>FUEL SYSTEMS E40	-	-	-	1APR83 D-24	1MAY85	-	-	-	-	-	-	-		
< 316413	>FUEL SYSTEMS E40	-	-	-	1AUG83 D-30	1JAN86	-	-	-	-	-	-	-		
< 316511	>HEAT EXCH E40	-	-	-	1FEB83 D-18	1JUL84	-	-	-	-	-	-	-		
< 316512	>HEAT EXCH E40	-	-	-	1APR83 D-24	1MAY85	-	-	-	-	-	-	-		
< 316513	>HEAT EXCH E40	-	-	-	1AUG83 D-30	1JAN86	-	-	-	-	-	-	-		
< 316611	>I/F SYSTEMS E40	-	-	-	1FEB83 D-18	1JUL84	-	-	-	-	-	-	-		

Figure 2. - Continued

PROJECT THERM PLOT THERM WDR DATE 0408901		START COMPLETION 1 NOV98	THERMIONIC ENERGY CONVERSION NASA LEWIS RESEARCH CENTER AEROSPACE CORPORATION	PLANNING SCHEDULE			PROJECT/2 QOR1 BAR CHART GRAPHICS PAGE 8 SHEET 1								
				SOFT	MODES	MODE O/F	INTERVAL: 1 DAY (S)								
				1992	1993	1994	1995	1996	1997	1998	1999				
				JAN	FEB	MAR	APR	MAY	JUN	JUL	AUG	SEP	OCT	NOV	DEC
<	316812	>I/F SYSTEMS E40													
<	316813	>I/F SYSTEMS E40													
<	316711	>PROCESS INSTR. CNTLS, SAFETY E40													
<	316712	>PROCESS INSTR. CNTLS, SAFETY E40													
<	316713	>PROCESS INSTR. CNTLS, SAFETY E40													
<	316811	>SYS INTO E40 & ANAL MODELING													
<	316812	>SYS INTO E40 & ANAL MODELING													
<	316813	>SYS INTO E40 & ANAL MODELING													
<	316811	>AUX SYS TESTING & MODIF													
<	316812	>AUX SYS TESTING & MODIF													
<	316813	>AUX SYS TESTING & MODIF													
<	317111	>COMBUSTOR SPEC	1 JAN 92 D-2												
<	317112	>COMBUSTOR SPEC	1 JAN 92 D-2												
<	317113	>COMBUSTOR SPEC	1 JAN 92 D-2												
<	318111	>IMPACT IDENTIFICATION	1 JAN 92 D-4												
<	318112	>IMPACT IDENTIFICATION	1 JAN 92 D-4												
<	318113	>IMPACT IDENTIFICATION	1 JAN 92 D-4												
<	318211	>PRELIM MARKET SURVEY	1 JAN 92 D-4												
<	318212	>PRELIM MARKET SURVEY	1 JAN 92 D-4												
<	318213	>PRELIM MARKET SURVEY	1 JAN 92 D-4												
<	318221	>MARKET ANALYSIS													
<	318222	>MARKET ANALYSIS													
<	318223	>MARKET ANALYSIS													

Figure 2. - Concluded.

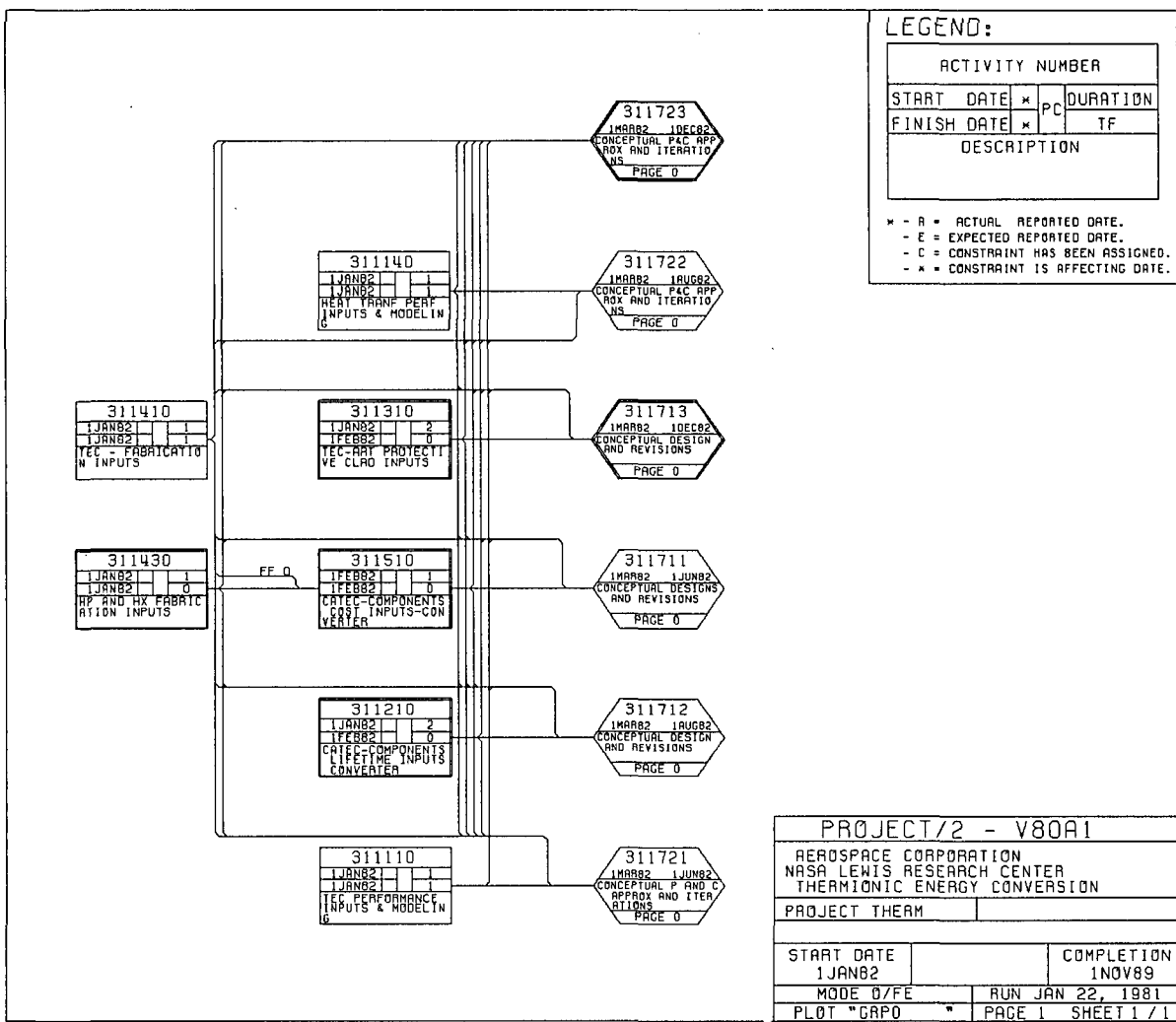

LEGEND:

ACTIVITY NUMBER	
START DATE * PC	DURATION
FINISH DATE * PC	TF
DESCRIPTION	

* - A = ACTUAL REPORTED DATE.
 - E = EXPECTED REPORTED DATE.
 - C = CONSTRAINT HAS BEEN ASSIGNED.
 - * = CONSTRAINT IS AFFECTING DATE.

PROJECT/2 - V80A1	
AEROSPACE CORPORATION NASA LEWIS RESEARCH CENTER THERMIONIC ENERGY CONVERSION	
PROJECT TEAM	
START DATE 1 JAN 82	COMPLETION 1 NOV 89
MODE 0/FE	RUN JAN 22, 1981
PLOT *CAPO	PAGE 1 SHEET 1 / 1

Figure 3(a).

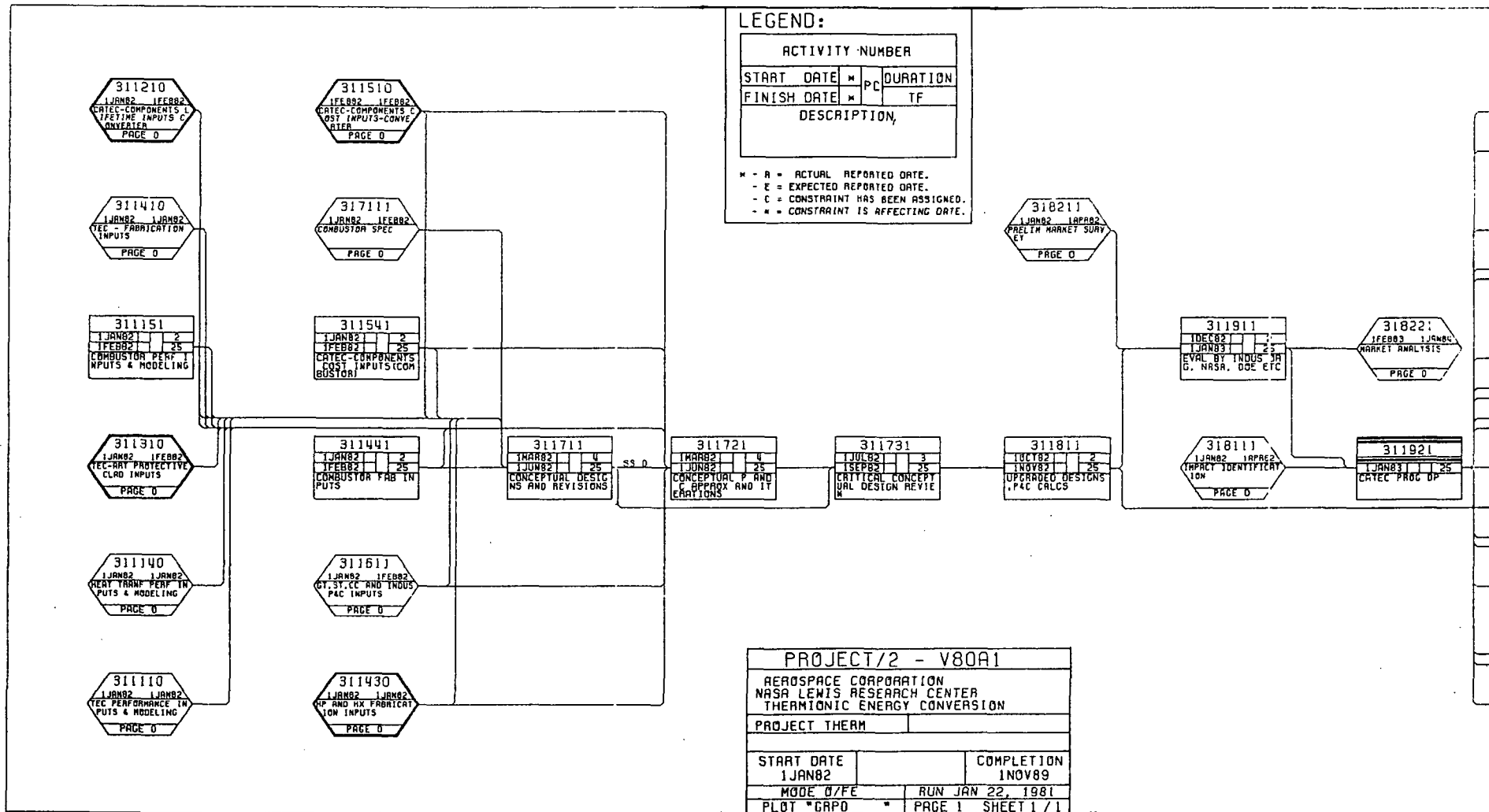

Figure 3(b). - Phase L

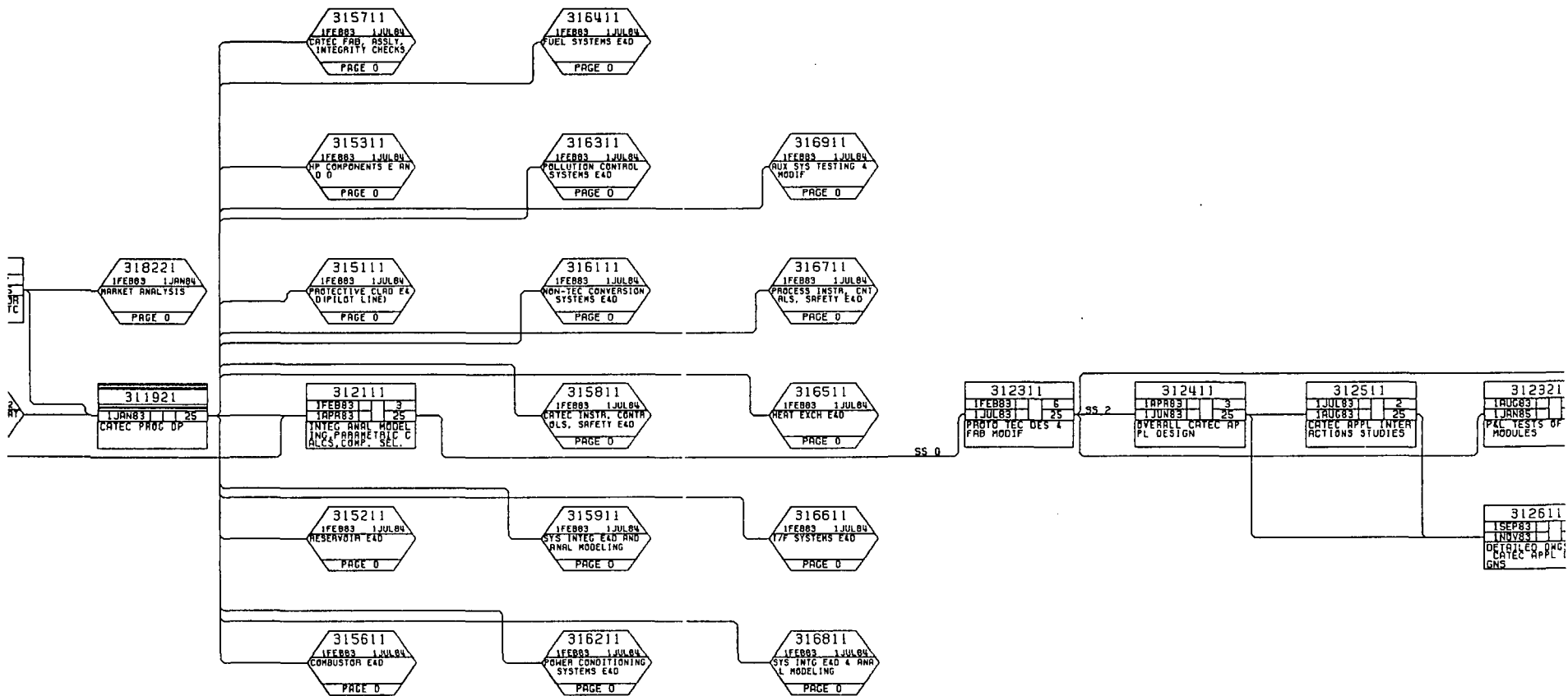

Figure 3(b). - Continued.

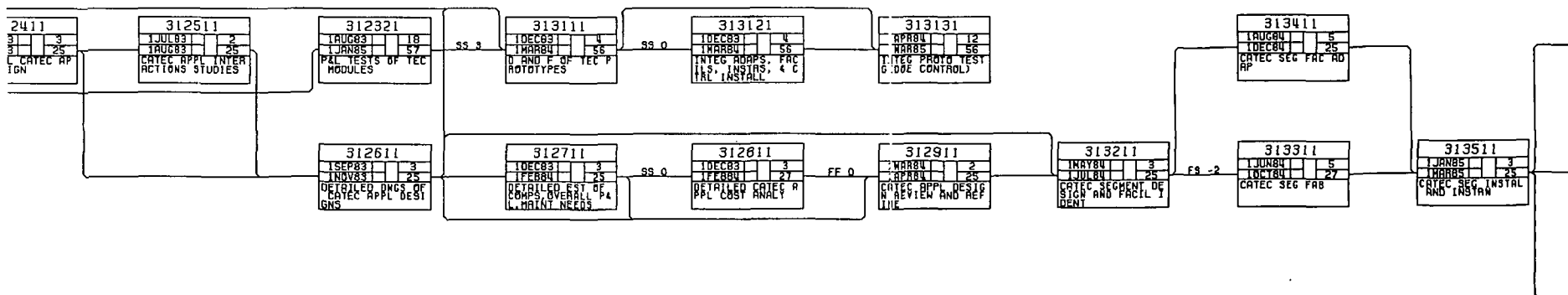

Figure 3(b). - Continued.

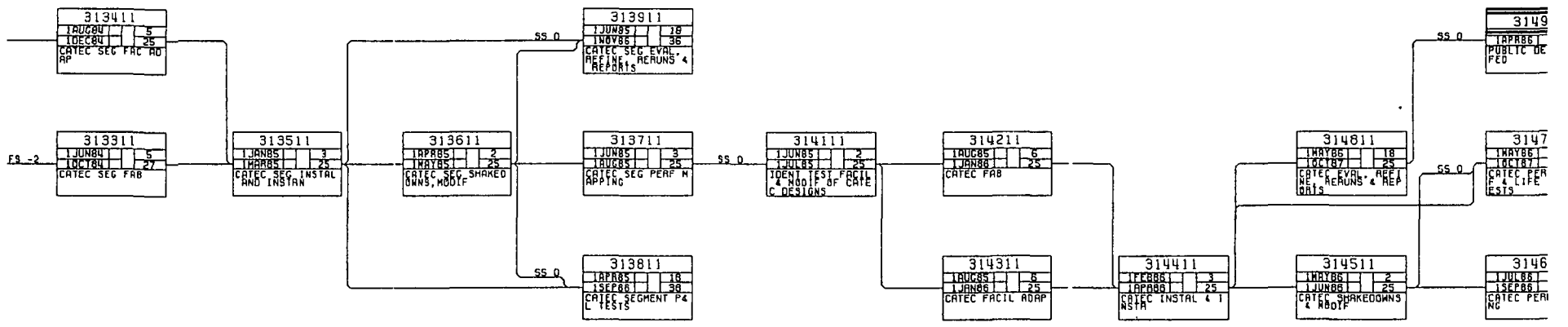

Figure 3(b). - Continued.

LEGEND:

ACTIVITY NUMBER			
START DATE	*	PC	DURATION
FINISH DATE	*		TF
DESCRIPTION			

- * - A - ACTUAL REPORTED DATE.
- E - EXPECTED REPORTED DATE.
- C - CONSTRAINT HAS BEEN ASSIGNED.
- * - CONSTRAINT IS AFFECTING DATE.

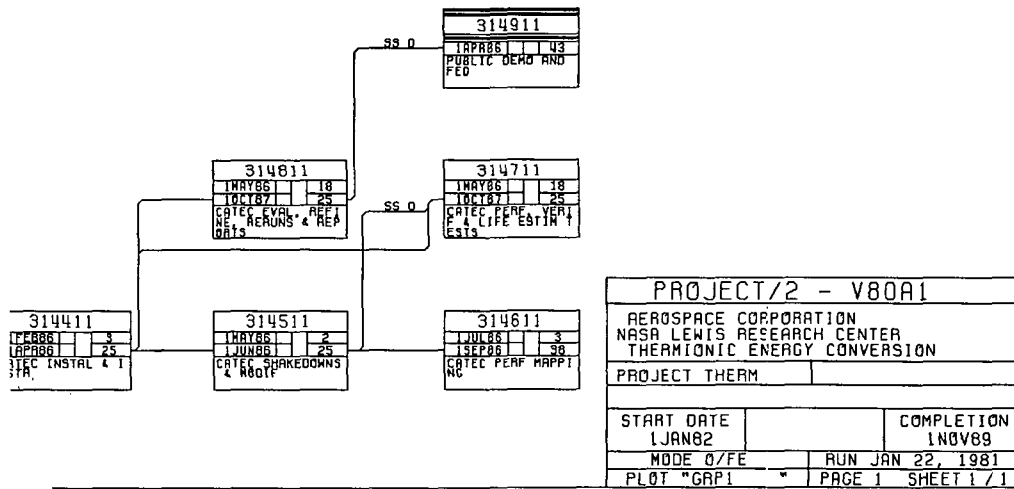

Figure 3(b). - Concluded.

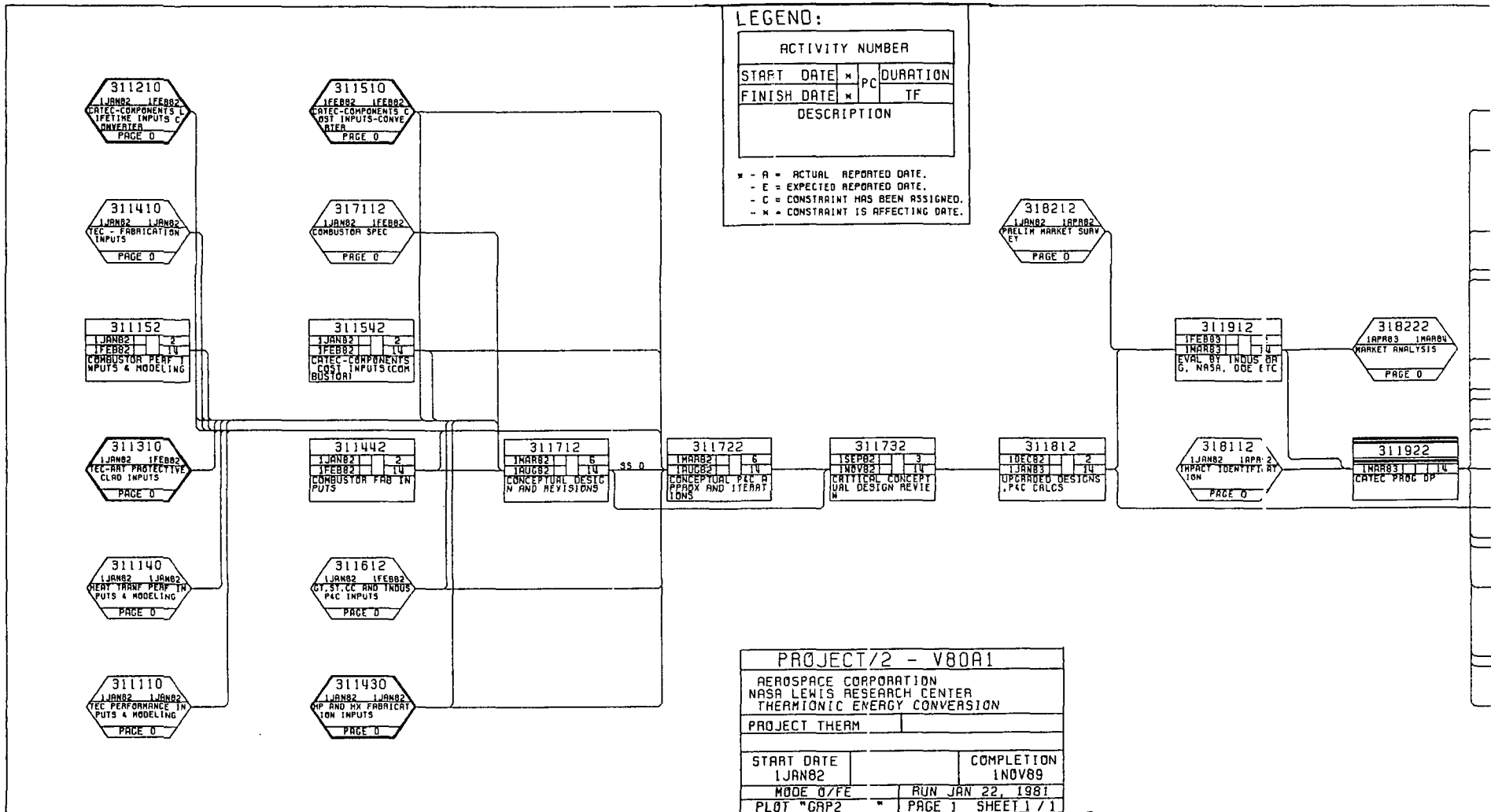

Figure 3(c). - Phase 2

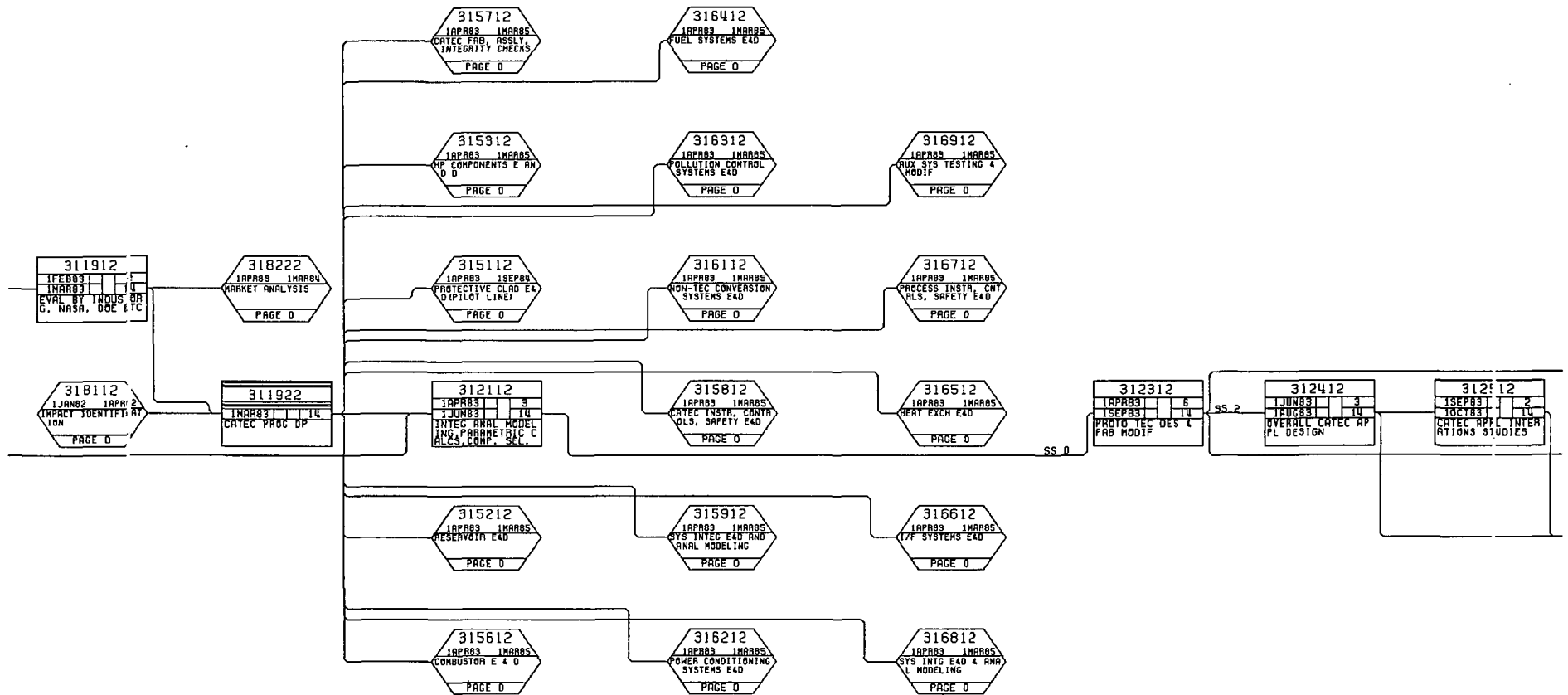

Figure 3(c). - Continued.

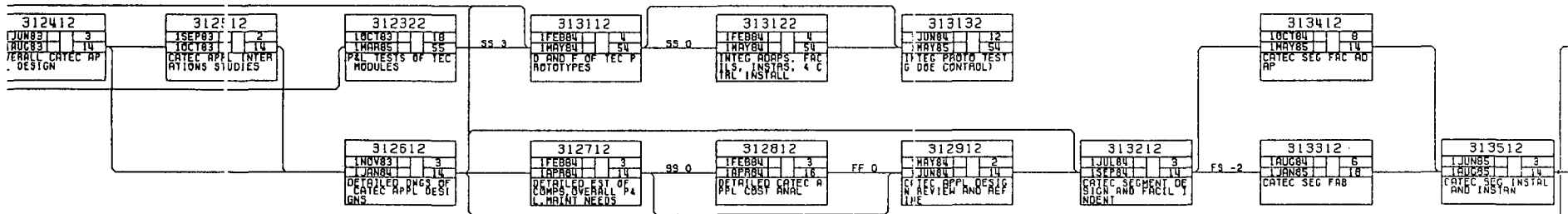

Figure 3(c). - Continued.

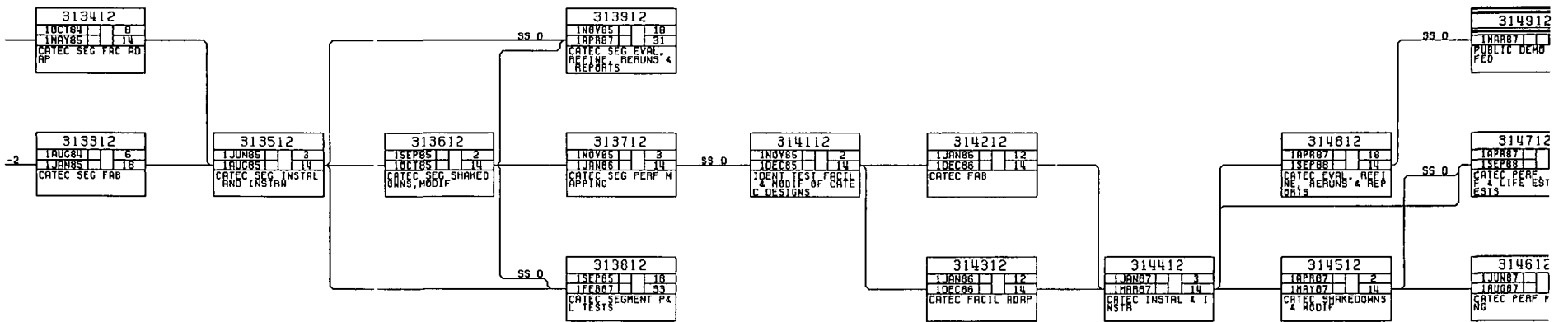
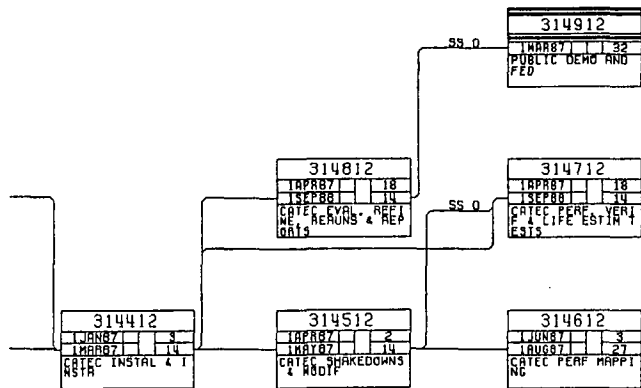

Figure 3(c). - Continued.

LEGEND:

ACTIVITY NUMBER			
START DATE	*	PC	DURATION
FINISH DATE	*		TF
DESCRIPTION			

- * - A - ACTUAL REPORTED DATE.
- E - EXPECTED REPORTED DATE.
- C - CONSTRAINT HAS BEEN ASSIGNED.
- * - CONSTRAINT IS AFFECTING DATE.



PROJECT/2 - V80A1	
AEROSPACE CORPORATION NASA LEWIS RESEARCH CENTER THERMIONIC ENERGY CONVERSION	
PROJECT THEM	
START DATE	COMPLETION
1 JAN 82	1 NOV 89
MODE 0/FE	RUN JAN 22, 1981
PLOT *GRP2	PAGE 1 SHEET 1/1

Figure 3(c). - Concluded.

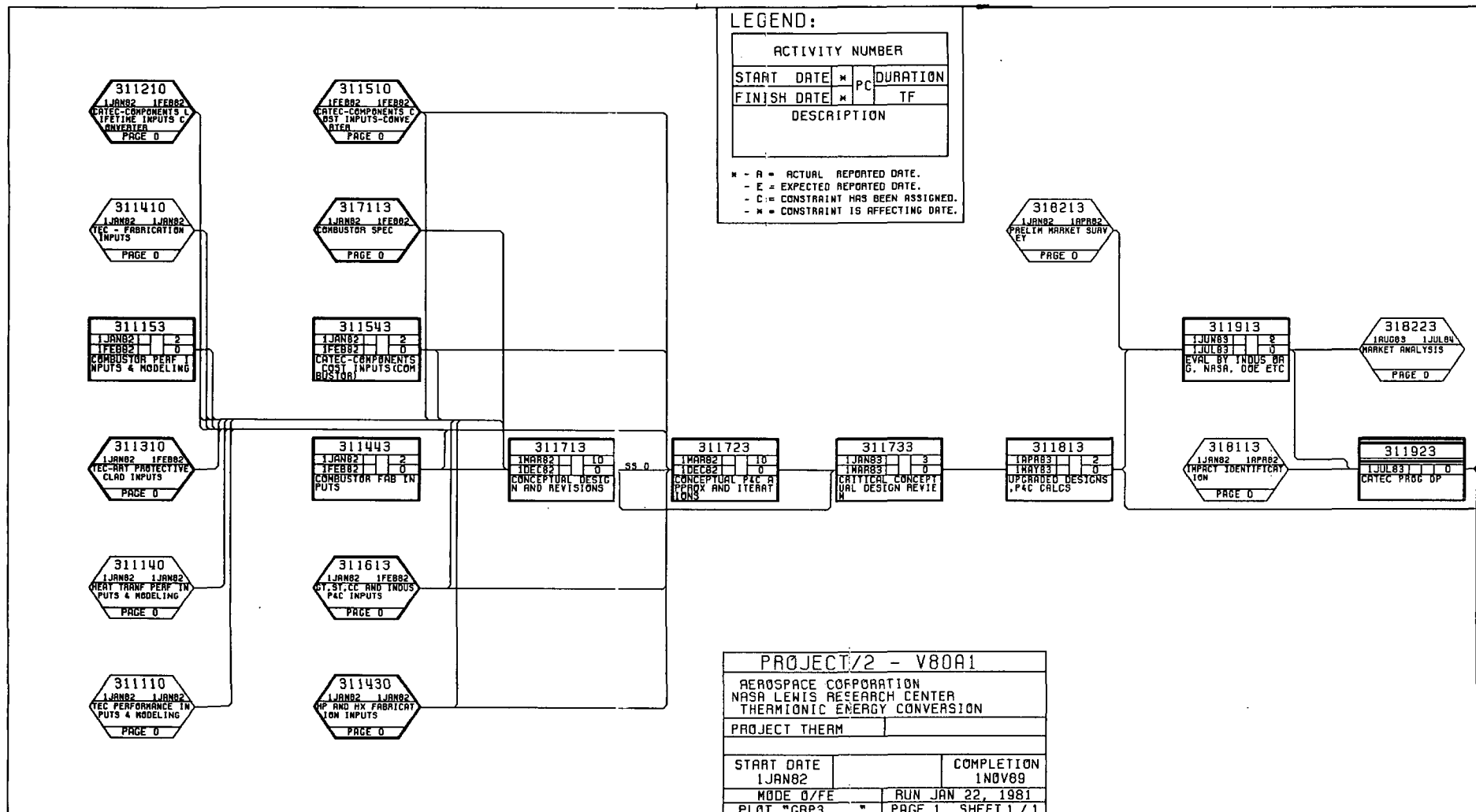

Figure 3(d). - Phase 3.

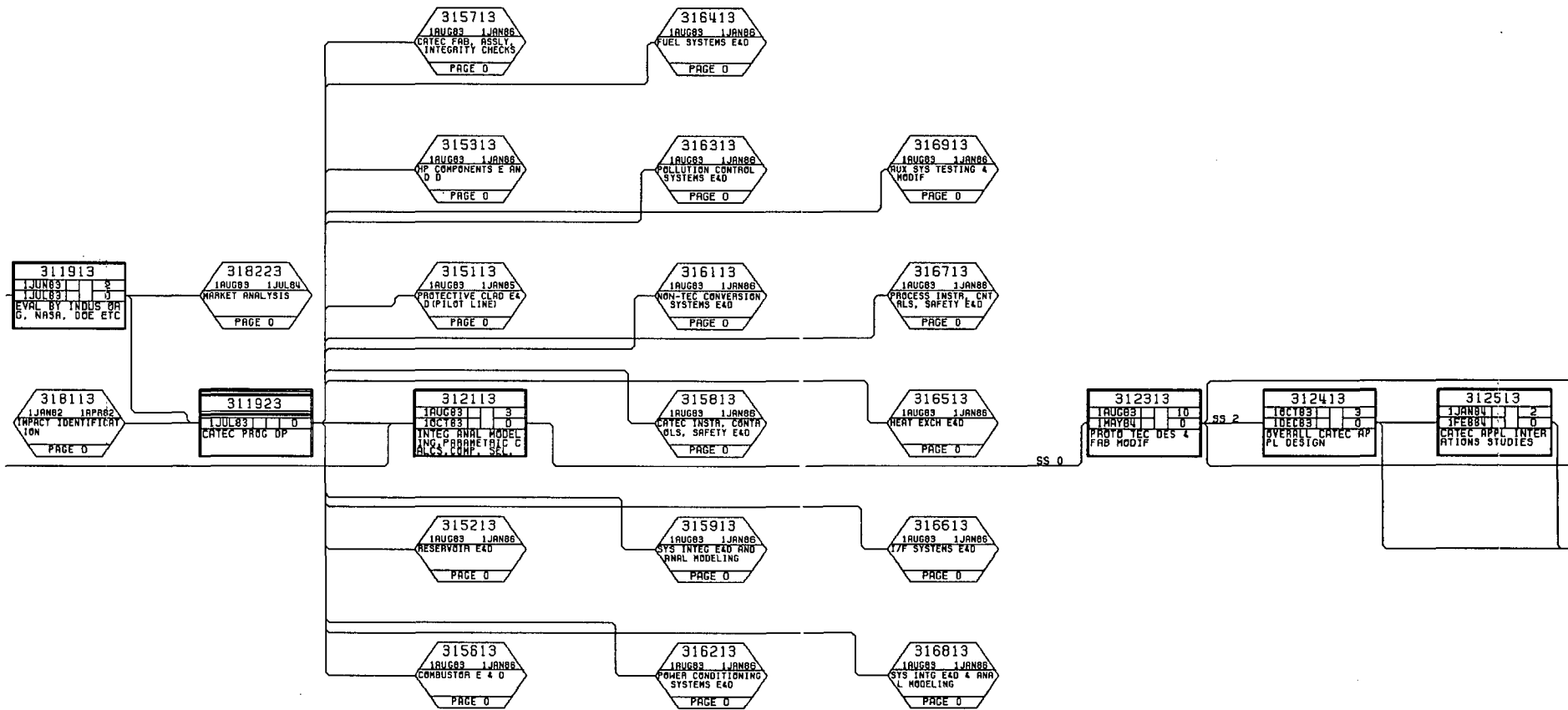

Figure 3(d). - Continued.

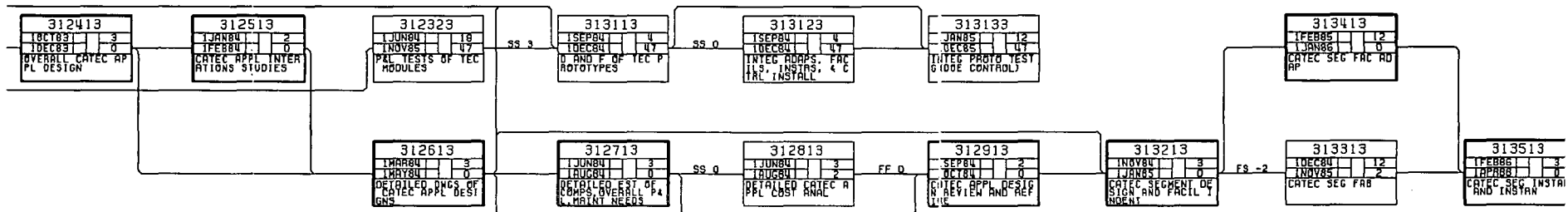

Figure 3(d). - Continued.

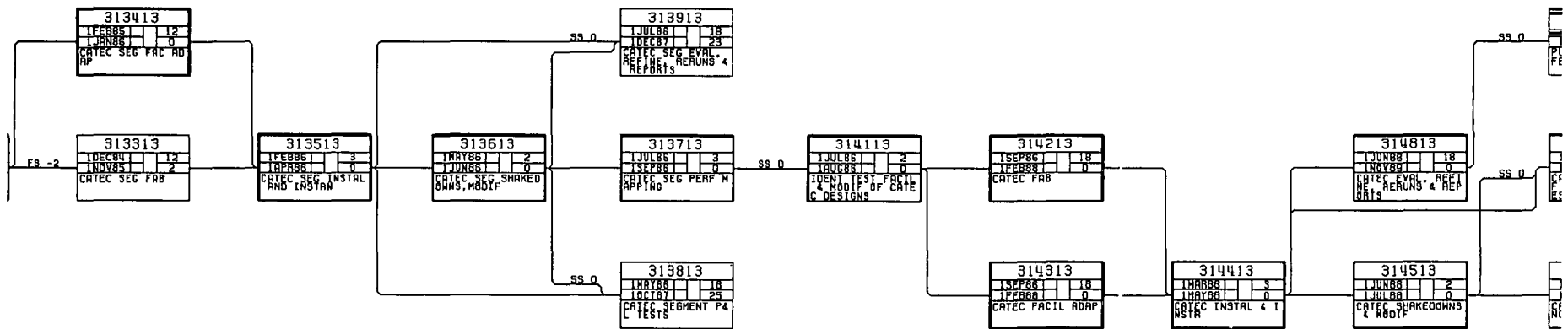

Figure 3(d). - Continued.

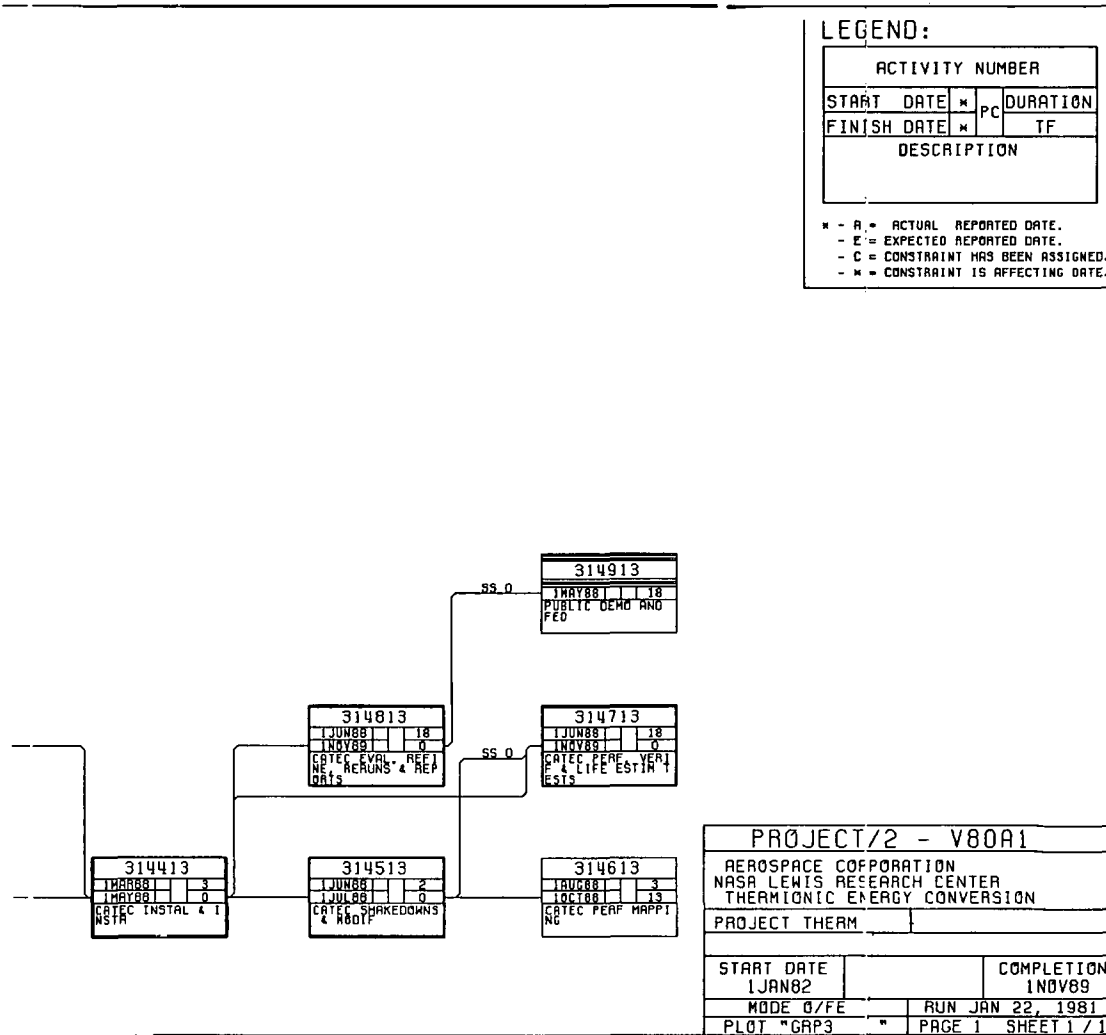

Figure 3(d), - Concluded.

1. Report No. NASA TM-82670	2. Government Accession No.	3. Recipient's Catalog No.	
4. Title and Subtitle A PROGRAM-MANAGEMENT PLAN WITH CRITICAL-PATH DEFINITION FOR COMBUSTION AUGMENTATION WITH THERMIONIC ENERGY CONVERSION (CATEC)		5. Report Date	
		6. Performing Organization Code 778-14-10	
7. Author(s) James F. Morris, Lewis Research Center; Owen S. Merrill, U.S. Department of Energy, Washington, D.C.; and Harsha K. Reddy, The Aerospace Corp., Los Angeles, California		8. Performing Organization Report No. E-950	
		10. Work Unit No.	
9. Performing Organization Name and Address National Aeronautics and Space Administration Lewis Research Center Cleveland, Ohio 44135		11. Contract or Grant No.	
		13. Type of Report and Period Covered Technical Memorandum	
12. Sponsoring Agency Name and Address U.S. Department of Energy Office of Coal Utilization Washington, D.C. 20545		14. Sponsoring Agency Code Report No. DOE/NASA/1062-9	
		15. Supplementary Notes Prepared under Interagency Agreement EC-77-A-31-1062. Prepared for International Conference on Plasma Science sponsored by the Institute of Electrical and Electronics Engineers, Santa Fe, New Mexico, May 18-20, 1981.	
16. Abstract Thermionic energy conversion (TEC) deserves consideration for topping any conversion or process system that receives heat from an energy source at much higher temperatures: In recent TEC-topping analyses, overall plant efficiency (OPE) and cost of electricity (COE) improve slightly with current capabilities and substantially with fully matured technologies. And enhanced credibility derives from proven hot-corrosion protection for TEC by silicon-carbide clads in fossil-fuel combustion products. Combustion augmentation with TEC (CATEC) affords minimal cost and plant perturbation, but with smaller OPE and COE improvements than more conventional topping applications. However risk minimization as well as comparative simplicity and convenience favor CATEC for early market penetration. Therefore a program-management plan is apropos. That plan, its inputs, characteristics, outputs and capabilities are subjects of this report.			
17. Key Words (Suggested by Author(s)) Thermionic energy conversion (TEC) Combustion augmentation with TEC (CATEC) Terrestrial application Combined-cycle with coal gasification High temperatures high power densities		18. Distribution Statement Unclassified - unlimited STAR Category 75 DOE Category UC-90f	
19. Security Classif. (of this report) Unclassified	20. Security Classif. (of this page) Unclassified	21. No. of Pages	22. Price*