

NASA Technical Memorandum 81356

NASA-TM-81356 19810023573

**Historical Background and Design
Evolution of the Transonic Aircraft
Technology Supercritical Wing**

FOR REFERENCE

NOT TO BE TAKEN FROM THIS ROOM

Theodore G. Ayers and James B. Hallissy

AUGUST 1981

NASA

NASA Technical Memorandum 81356

Historical Background and Design Evolution of the Transonic Aircraft Technology Supercritical Wing

Theodore G. Ayers
*Dryden Flight Research Center
Edwards, California*

James B. Hallissy
*Langley Research Center
Hampton, Virginia*

NASA

National Aeronautics
and Space Administration

**Scientific and Technical
Information Branch**

1981

HISTORICAL BACKGROUND AND DESIGN
EVOLUTION OF THE TRANSONIC AIRCRAFT TECHNOLOGY
SUPERCritical WING

Theodore G. Ayers
Dryden Flight Research Center

and

James B. Hallissy
Langley Research Center

INTRODUCTION

The military requirements of the mid-1960's placed heavy emphasis on fighter aircraft capable of achieving high maneuver load factors for air-to-air combat at high subsonic speeds. This emphasis created a need for basic research to reduce the drag and buffeting associated with the shock-induced boundary layer separation of the wing flow at high maneuvering lift coefficients. Although twist, camber, and sweep had been demonstrated to improve the wing flow characteristics, these design methods alone were not sufficient to solve the basic supercritical flow phenomenon. Research initiated by Richard T. Whitcomb at the NASA Langley Research Center in early 1964 led to the development of the NASA supercritical airfoil and demonstrated that high subsonic speed flight could be efficient (refs. 1 to 4). Research was then undertaken to extend the application of supercritical technology to maneuvering fighter aircraft.

Following these exploratory investigations, NASA, in cooperation with the General Dynamics Corporation, initiated wind-tunnel tests to demonstrate the aerodynamic advantages in aircraft maneuverability that could be realized through the application of supercritical airfoil technology to the F-111 airplane. This paper traces the history of these supercritical airfoil developments, with emphasis on the application to maneuvering aerodynamics.

The paper also addresses the specific design approach taken in the development of the supercritical wing for the transonic aircraft technology (TACT) airplane.

SYMBOLS

The results presented herein are for the stability-axis system. The moment reference center was located along the fuselage reference line at a point corresponding to $0.45 \bar{c}$ for a wing sweep angle of 16° . All coefficients are based on the geometry of the wing with a leading-edge sweep of 16° . A common reference area and wingspan were used for all data; the reference area and wingspan used are those of the F-111A airplane for 16° of leading-edge sweep. Transition trips were located on the wing surfaces using the methods described in reference 5 in an attempt to scale the flight boundary layer characteristics.

b	wing reference span, 1920.2 cm (756 in.)
C_D	drag coefficient, $\frac{\text{Drag}}{qS}$
C_L	lift coefficient, $\frac{\text{Lift}}{qS}$
C_{L_b}	buffet onset lift coefficient
C_m	pitching-moment coefficient, $\frac{\text{Pitching moment}}{qS\bar{c}}$
C_T	thrust coefficient, $\frac{\text{Thrust}}{qS}$
\bar{c}	reference mean aerodynamic chord, 275.6 cm (108.5 in.)
e	aerodynamic efficiency factor
L/D	lift-to-drag ratio
M	Mach number
M(L/D)	aerodynamic cruise range factor
p_s	specific excess power, m/sec
q	free stream dynamic pressure, N/m^2 (lb/ft^2)
S	reference wing area, $48.8 m^2$ ($525 ft^2$)

t/c wing section thickness ratio
 α angle of attack referred to wing manufacturing chord plane, deg
 δ_{fr} flap rotation, deg, positive trailing edge down
 δ_{ft} flap track rotation, deg, positive trailing edge down
 δ_h horizontal tail deflection, deg, positive trailing edge down
 δ_s spoiler deflection, deg, positive trailing edge up
 Λ leading-edge sweep of outboard wing panel, deg
 λ taper ratio

Subscripts:

dd drag divergence
 max maximum

EXPLORATORY STUDIES

Slotted Airfoil

Whitcomb's research in 1964, which was directed toward improving the aerodynamic efficiency of wings through the use of slotted supercritical airfoils (ref. 1), showed promising results for cruise flight near sonic speeds. The success of this research generated an experimental wind-tunnel program in early 1966 to test an approximation of the NASA slotted supercritical airfoil, which was installed on a model of the F-111 airplane to improve cruise performance. This approximation was obtained by modifying the F-111 high-lift system as shown in figure 1. Various airfoil shapes were obtained by rotating and extending the trailing-edge flaps to provide the desired rear camber, deflecting the spoiler to provide an upper surface slot, and positioning the flap vane and air director door to provide the desired slot geometry. Tests were conducted in the Langley 8-Foot Transonic Pressure Tunnel with a 1/15-scale model of the F-111 airplane. The results of these tests are documented in reference 6 and indicated that because of existing wing high-lift features, the full potential of the supercritical airfoil concept could not be realized. The increased wetted area of the slot and the severe aerodynamic obstructions of the flap tracks caused a subcritical drag level for the slotted configuration which was significantly higher than for the basic wing (fig. 2). At the selected design condition ($M = 0.80$ and $C_L = 0.5$), the drag levels for the two configurations were essentially the same. However, the subcritical

drag increment between the basic and slotted-flap configurations would be decreased if the wind-tunnel data were extrapolated to full-scale conditions because of the much lower effective Reynolds number on the flap at the model test conditions. Further reductions in this drag increment could have been realized by aerodynamic improvements to the flap track system on the airplane. Although the use of the slotted flaps did not improve the aerodynamic range factor ($M(L/D)$) at the design point, the data in figure 3 show that it improved the lift-to-drag ratio for the higher lift coefficients. These drag improvements were the result of a delay in shock-induced separation for the slotted-flap configuration.

The cruise drag characteristics for the model with unslotted flaps and 4° and 8° of simple flap rotation, that is, rotation about the center of curvature of the flap upper surface, are also summarized in figure 2. The unslotted flaps were not tested at Mach numbers higher than 0.79, so no comparison can be made with the basic wing or slotted flaps at the design point ($M = 0.80$ and $C_L = 0.5$). The data obtained with the 4° unslotted flap at $M = 0.79$ (fig. 3) do, however, indicate an improvement as compared with the basic configuration. The unslotted flaps also provided significant improvements over the basic configuration at higher lift coefficients. The data in reference 5 indicate that these trends existed throughout the Mach number range for which the data were obtained.

The pitching-moment characteristics for the basic wing, slotted flap, and rotated flap configurations at a Mach number of 0.79 are also presented in figure 3. As would be expected, the slotted flap resulted in a more negative pitching moment than the basic airfoil because of the more rearward center-of-pressure location on the wing. Of more significance, however, was the substantial increase in usable lift coefficient (delay in pitchup) at a Mach number of 0.79 for the slotted flap configuration as compared with the basic configuration. The trends were generally the same for the model with unslotted flaps, although the indicated increase in usable lift coefficient was not as large as for the model with the 4° slotted flap. The data included in reference 6 show that these trends were generally the same throughout the Mach number range of the tests.

Integral Airfoil

Although the results obtained by Whitcomb for the slotted two-dimensional airfoil and its application to airplane configurations showed significant improvements in the drag-divergence characteristics, manufacturing wings with the necessary slot geometry and tolerance is difficult from a practical standpoint. After the results described above were obtained for the unslotted F-111 flap configurations, two-dimensional wind-tunnel research was initiated which led in late 1966 to the development of the integral supercritical airfoil (ref. 2).

In mid-1967, NASA initiated an exploratory program to investigate the three-dimensional aerodynamic characteristics of a fighter airplane model

that incorporated the integral supercritical airfoil. At this point in the development of the NASA supercritical airfoil, a very generous leading-edge radius was desired to permit the proper development of supercritical flow for high drag-divergence Mach numbers. Because of this large leading-edge radius, a variable-wing-sweep model (fig. 4) was chosen which allowed the wing leading edge to be swept behind the Mach lines for more efficient operation at supersonic speeds. The F-111 configuration represented the only variable-sweep airplane in the inventory at that time.

Design. - The fundamental objective of this research effort was to evaluate the potential of the supercritical airfoil for improving fighter aircraft maneuver performance. To eliminate as many variables as possible, a direct airfoil substitution was made. Two sets of 1/24-scale model wing panels, identical in planform and thickness to the F-111 wing, were constructed, one set incorporating the supercritical airfoil and the other incorporating a conventional NACA 64A-series airfoil with 0.40 camber (fig. 5). Both wings had 6° of linear twist (washout), as compared with 4° of linear twist for the F-111 wing, to improve the span load distribution for the high-lift maneuver conditions at the higher Mach numbers and to reduce the more negative pitching moments of the supercritical wing. The wing incorporating the 64A-4XX airfoil was investigated because this airfoil represented the design camber being considered by the aerospace industry at that time to meet the requirements for fighter airplanes (ref. 7). Figure 5 also shows the cross sections of the supercritical wing with flap rotations of 5°, 10°, and -5°. These flap deflections represent a 20-percent chord simple flap. The negative flap deflection was tested because it reduced the rear camber slopes for the high-sweep supersonic flight configurations where strong shock interactions might exist. A comprehensive description of this research, which was completed in 1968, is given in reference 8; therefore, it is only summarized briefly in this paper.

Drag characteristics. - The untrimmed lift-drag polars for the NACA 64A-2XX (basic F-111), 64A-4XX, and the supercritical wing with 0° and 5° of flap rotation at a Mach number of 0.85 and a wing leading-edge sweep of 26 are presented in figure 6. These data show the substantial reductions in drag at the moderate and high lift ranges which were achieved with the supercritical airfoil. The results obtained for the conventional wing with 0.40 camber did show some reduction in drag over the wing with 0.20 camber at lift coefficients above 0.60. Similar gains were noted for the supercritical wing with 5° of flap rotation, which was essentially an increase in camber. The corresponding lift and moment characteristics, also shown in figure 6, indicated no adverse trim problems for the supercritical wing. The values of the lift-curve slope for the supercritical wing are high, the result of an increasing rearward movement of the shock wave with angle of attack. When the shock wave reached its rearmost position, the C_{L_α} values were nearly the same as those for the conventional NACA 64A-series airfoils ($C_L > 0.60$).

The trimmed maneuver drag characteristics are summarized in figure 7, where the drag coefficient is plotted as a function of Mach number for a wing

sweep of 26° and a lift coefficient of 0.90. These data showed reductions in C_D of about 0.20 to 0.30 through the Mach number range for the conventional wing with 0.40 camber below the values obtained for the wing with 0.20 camber. Also shown in this figure is a data point obtained for the 0.20 cambered wing with a simple flap rotation of 8° . This point was included to illustrate the fact that simple flaps can provide drag reductions similar to the higher design camber wings without off-design penalties. It should be noted, however, that these drag reductions may not be realized at higher Mach numbers, where the shock wave moves rearward to the wing flap juncture. The data obtained for the supercritical wing with 0° of flap rotation show reductions in C_D of approximately 0.03 to 0.07, as compared with the conventional wing (0.20 camber) through the Mach number range from 0.75 to 0.91. Although no subsonic data are included herein for wing sweeps greater than 26° , similar results were obtained for leading-edge sweep angles of 33° and 39° . The data obtained for the supercritical wing with 5° of flap rotation further reduced the drag levels throughout the Mach number range. Increasing the flap rotation of the supercritical wing to 10° resulted in the lowest subsonic drag levels ($M \leq 0.75$) for the supercritical wings. Also included in this figure is the ideal drag level for an aerodynamic efficiency of 1.00. This indicates the minimum subsonic ($M = 0.70$) drag levels achievable.

Figure 8 is similar to figure 7 except that these data are summarized for a lift coefficient of 0.50. The significant point is the 0.10 delay in drag-divergence Mach number for the supercritical wing ($\delta_{fr} = 0^\circ$) over that obtained for the wings with the NACA 64A-series airfoils. The 5° flap deflection data presented in this figure indicated a small penalty at the flaps-up cruise Mach number or a reduction in cruise Mach number of about 0.01.

Buffet characteristics. - The buffet onset lift coefficients for the various wings as determined from fluctuating wing-root bending-moment data are summarized in figure 9. Following the trends of the previously discussed characteristics, the 0.40 cambered wing buffet characteristics were somewhat better than those of the basic 0.20 cambered wing and about the same as those obtained for the 0.20 cambered wing with 8° of simple flap rotation. The higher buffet onset lift coefficient for the wing with 0.40 camber than for the 0.20 camber at the higher Mach numbers is the result of increased twist and is not a camber effect. The supercritical wing with 0° of flap deflection showed buffet onset lift coefficients 40 to 50 percent higher than those obtained for the 0.40 cambered wing in the Mach number range from 0.80 to 0.91. Instrumentation limitations precluded the determination of buffet onset for the supercritical wing with 5° of flap rotation. However, maximum lift coefficients achieved for that configuration were higher than those obtained with 0° of flap deflection throughout the Mach number range. At Mach numbers below 0.75, 10° flaps were used for the supercritical wing to correspond to the drag results in figure 7. The wing with 0.40 camber

showed somewhat better buffet onset characteristics than either the 0.20 cambered wing or the supercritical wing in the Mach number range from 0.60 to 0.72.

Supersonic characteristics. - Limited supersonic data were obtained up to a Mach number of 2.50 for the three wings with a leading-edge sweep of 72.5° . The results obtained for $M = 1.20$ and 2.16 are shown in figures 10(a) and 10(b). Because of the close proximity of the wing and horizontal tail in the wing chord plane at high angles of sweep, there is considerable wing-tail interference. To accurately assess the wing alone, the supersonic data ($\Lambda = 72.5^\circ$) are presented for the model with the horizontal tail off. The longitudinal aerodynamic characteristics obtained for a Mach number of 1.20 are presented in figure 10 and indicated no adverse effects for the supercritical wing as compared with the wing with the 64A-series airfoil and 0.20 camber. The 0.40 cambered wing had somewhat better drag characteristics at moderate lift coefficients than either the 0.20 cambered wing or the supercritical wing. At the higher supersonic Mach number of 2.16, the 0.20 and 0.40 cambered wings had almost identical untrimmed characteristics and the supercritical wing had slightly higher drag throughout the lift coefficient range for which data were obtained. The more positive values of pitching-moment coefficient associated with the rear camber supercritical wing indicate less trim penalty than for either the 0.20 or 0.40 cambered wings. The supercritical wing data are presented for a flap rotation of -5° to reduce the trailing-edge camber and thus reduce the drag penalties which might be incurred at supersonic speeds, where the Mach angle approaches the trailing-edge sweep angle.

DEVELOPMENT OF TRANSONIC AIRCRAFT TECHNOLOGY WING

Planform Selection

Objectives. - On the basis of the preceding exploratory three-dimensional investigation, NASA and the General Dynamics Corporation initiated a wind-tunnel program to demonstrate the aerodynamic advantages in aircraft maneuverability that could be realized through the application of supercritical airfoil technology to the F-111 airplane. In anticipation of an eventual full-scale flight validation of the wind-tunnel results, program objectives and design constraints were established that insured a practical design. The objectives of the program were to improve the transonic maneuverability and cruise Mach number of the F-111 airplane without degrading its cruise efficiency, sea level dash capability, supersonic performance, or low speed characteristics. The specific flight conditions established for this effort are shown in figure 11(a). In general, the design constraints (fig. 11(b)) limited major airframe modifications to the outboard wing panels and the overwing fairing rearward of the crew capsule. The new wing was to represent a practical wet-wing configuration with a high-lift system capable of satisfying the landing and takeoff requirements. A further requirement was that any new wing remain within the structural and physical limits of the existing wing pivot and carrythrough structure. As indicated in figure 11(b),

extensions of the wing chord forward of those for the basic F-111 wing were limited by stability requirements, whereas rearward chord extensions and maximum wing-sweep angles were restricted by the horizontal tail and fuselage structure. Wingspan and area variations were constrained by the wing pivot and carrythrough structure.

Within these constraints, three wing planforms, each consisting of supercritical and conventional 64A-4XX-series airfoils, were designed and fabricated for tests in the Langley 8-Foot Transonic Pressure Tunnel. These wings, shown in figure 12, were referred to as planforms A, B, and C and provided a matrix of aspect ratio (span), area, taper ratio, and airfoil data for selecting the wing which best met the design objectives and constraints.

Tradeoffs. - An analysis of the high subsonic speed stability, control, and performance characteristics of the model with supercritical and conventional airfoils for each of the three planforms was used to select one wing for further testing. Although many factors were considered in this process, the actual selection can be readily ascertained from the data in figure 13. This figure summarizes maneuver performance in terms of specific excess power, p_s , and aerodynamic range factor, $M(L/D)$, as a function of wing semi-span (planform shape). As would be expected, the wing with the largest area and lowest aspect ratio (planform A) provided the greatest maneuver capability and the poorest cruise capability. In contrast, planform C, which had the highest aspect ratio and smallest area, provided the greatest cruise performance and the poorest maneuver performance. The data obtained for planform B were considered to be a satisfactory compromise between maneuver and cruise performance, and therefore planform B was selected for further testing. This configuration was approved for full-scale flight evaluation in the joint NASA/Air Force TACT program in 1969.

The Langley wind-tunnel test phase of the TACT program consisted of approximately 1774 hours of wind-tunnel testing, slightly more than 1300 hours of which were in the 8-Foot Transonic Pressure Tunnel. The first results from these tests are reported in reference 9. Although a discussion of all the variables tested is beyond the scope of this paper, they included variations in wing twist, incidence, and trailing-edge and tip geometry; fuselage, nacelle, and inlet modifications; and external stores. Most of these variables were investigated in an attempt to provide a better aerodynamic match between the existing F-111 airframe and the higher subsonic speed capability afforded by the supercritical wing. The remainder of this paper addresses only the pertinent cruise and maneuver characteristics of the selected planform (planform B).

Wing Characteristics

The final Langley wind-tunnel tests in the development of the TACT configuration consisted primarily of evaluating small refinements of wing twist and camber to increase the aerodynamic cruise range factor, $M(L/D)$,

and reduce the maneuver drag. The final wing configuration is shown in figure 14(a), where it is compared with the basic F-111 geometry. The wing area was increased from 48.8 square meters (525 square feet) to 56.1 square meters (603.9 square feet), and aspect ratio was reduced from 8.56 at a wing-sweep position of 16° to 5.83 to improve the maneuver characteristics. The wing twist was increased from 4° for the F-111 configuration to 7.5° to accommodate the higher design Mach number and lift coefficient of the TACT wing. The average thickness-to-chord ratio for the TACT wing was lower than that for the F-111 wing (0.074 as compared with 0.105). This was a direct result of maintaining the F-111 wing box physical depth dimensions for compatibility with the wing pivot while increasing the chord to increase wing area. This reduced thickness was also advantageous in terms of drag at the higher subsonic speeds. The increased chord for the TACT wing also limited the maximum wing sweep to 58° , as compared with 72.5° for the F-111 configuration. The photograph in figure 14(b) shows the 1/24-scale model of the final TACT configuration.

Drag divergence. - The drag-divergence characteristics for the F-111 and TACT configurations are presented in figure 15 for a wing leading-edge sweep of 26° . At all lift coefficients, but particularly at lift coefficients of 0.50 and above, the TACT configuration exhibited an increased drag-divergence Mach number which improved both cruise and maneuver potential. The expected cruise lift coefficient based on a common reference area of 48.8 square meters (525 square feet) (the basic F-111 reference area) is identified as a reference point; it indicates an increase of approximately 0.12 in drag-divergence Mach number for the TACT configuration. The rapidly decreasing increment in drag divergence for the supercritical wing at lift coefficients below 0.30 can be attributed to lower-surface wing flow separation caused by the increased twist and rear camber.

Cruise performance. - The cruise characteristics of the two configurations are summarized in figure 16, where the cruise drag and aerodynamic range factor are presented as a function of Mach number. The previously noted drag-divergence gain is also apparent in this figure. The significant points are the $M = 0.88$ indicated drag divergence for the TACT configuration (fig. 16(a)) and substantial drag creep ($\Delta C_D = 0.0045$) before drag divergence.

Although some of this drag creep can be attributed to the geometry of the F-111 configuration, most of it results from the supercritical airfoil, which was designed to provide a high drag-divergence Mach number. Refinements of supercritical airfoil technology since the initiation of the TACT program have essentially eliminated this drag creep. The data in figure 16(b) indicate that even though drag creep is substantial, the cruise aerodynamic range factor, $M(L/D)$, for the TACT configuration is about 6 percent higher than that for the basic configuration. As stated previously, maintaining F-111 cruise capability was one of the objectives of the TACT development program.

The lower surface of the supercritical airfoil was designed to match Mach number with lift requirements. As a result, a large pressure gradient existed over the rear portion of the lower surface of the airfoil. Because

of this design characteristic, the aerospace community expressed concern about the effect of externally carried stores on the performance of aircraft with supercritical wings. Therefore, two store configurations were investigated in the TACT wind-tunnel tests. These configurations, shown in figure 17(a), were selected to provide data for representative stores that were aerodynamically clean (2271-liter (600-gallon) fuel tanks) and dirty (M-117 bombs). These store tests were conducted for an inboard pivoting pylon location only (fig. 17(b)). The incremental drag data indicate no significant adverse effects on the drag-divergence Mach number (fig. 16(a)). The only basis for comparing the incremental drag values for the TACT and F-111 configurations was the two data points obtained for M-117 bombs on a 1/24-scale model of the F-111 configuration with its reference area adjusted to 48.8 square meters (525 square feet). Although these data were obtained from unrelated wind-tunnel tests, they indicate comparable values for the conditions at which data were obtained. It was concluded from these tests that the drag penalties incurred with standard pylon-mounted external stores on supercritical wings are essentially the same as for conventional wings. Reduced spacing between the stores and wings (pylon height) was not investigated.

Maneuverability. - The lift-drag polar for the design maneuver Mach number of 0.90 is presented in figure 18. The drag reduction resulting from a delay in shock-induced separation for the supercritical wing can be seen by comparing the polars for the F-111 and TACT configurations at a wing leading-edge sweep of 26° . The significance of this improvement is illustrated by the increment at the maximum thrust level, $C_{T_{max}}$, of the F-111 airplane with TF30-P100 engines for $M = 0.90$ and an altitude of 3048 meters (10,000 feet). The increment shows a reduction in drag for the TACT configuration of about 46 percent, or an increase in usable lift of about 50 percent as compared with the F-111 configuration. These improvements can be directly related to maneuverability by expressing them in terms of constant altitude turn capability. The TACT configuration would have a turn radius of 1713 meters (5620 feet) as compared with the F-111 turn radius of 2183 meters (7165 feet). This increased capability may be converted into a 1829-meter (6000-foot) altitude gain in a 180° turn at the F-111F sustained load factor of 4.2 g's.

Buffet boundary. - An indication of the buffet onset characteristics associated with the above aerodynamics was obtained from fluctuating wing root bending moments (fig. 19). Although buffet data obtained from fluctuating wing root bending moment characteristics are subject to interpretation, the results shown were obtained in a consistent manner. Therefore the incremental values between the F-111 and TACT configurations should be valid. Wind-tunnel data for the F-111 configuration are presented for wing-sweep angles of 26° , 35° , and 45° to indicate the favorable effect of increased sweep on buffet onset lift coefficients for conventional airfoils. This figure indicates that a wing leading-edge sweep of 45° provides the highest buffet-free lift coefficient above Mach 0.85 for the F-111 configuration. However, this wing sweep would also produce the greatest static margin and would therefore incur a much greater trim drag penalty than the lower wing-sweep angles. In contrast, variations in the wing sweep of the TACT wing,

which was designed for efficient supercritical operation, cause only small differences in buffet onset at lift coefficients greater than the TACT maneuver design point. As a result of the TACT maneuver design Mach number, the predicted buffet onset for the TACT configuration was about 100 percent higher than the F-111 configuration.

Transonic acceleration. - As discussed in the section pertaining to the planform selection, maximum wing-sweep angle was limited by the wing chord extension and the fuselage-empennage structure. For the TACT configuration, this maximum leading-edge sweep was restricted to 58° . This restriction, combined with the relatively high camber requirements for obtaining good transonic maneuver performance, resulted in the possibility of the aircraft drag characteristics being degraded at very low lift coefficients and transonic speeds. However, the reduction in wing thickness-to-chord ratio combined with a somewhat improved normal cross-sectional area distribution for the TACT configuration actually improved the aircraft's drag characteristics at Mach numbers below about 1.05 (fig. 20). The data in figure 20 are for the maximum wing sweep of each configuration and are untrimmed ($\delta_h = 0^\circ$). The actual trim requirements for this condition, however, are small, and would not change the conclusions.

Supersonic performance. - At the higher supersonic speeds and lower lift coefficients, where there is a potential for strong interactions between the wing trailing shock and the high wing camber, the TACT configuration suffers a basic (untrimmed) drag penalty with $\Lambda = 58^\circ$ as compared with the F-111 aircraft with $\Lambda = 7.25^\circ$ (fig. 21). Although this drag penalty does exist, the improved drag-due-to-lift characteristics and less positive zero lift pitching moment associated with the less highly swept supercritical wing of the TACT configuration resulted in predicted trimmed supersonic drag ($C_L = 0.15$) only 3 percent higher than that for the F-111 configuration. As pointed out previously, this camber drag could be substantially reduced or eliminated by rotating the trailing edge upward (reducing the camber).

Although 58° was determined to be the maximum sweep angle for the TACT airplane without performing major airframe modifications, it was desirable to assess the supersonic drag characteristics of the configuration at wing-sweep angles more comparable to those of the F-111 aircraft. Data were therefore obtained for 65° of leading-edge sweep (the maximum sweep capability of the 1/24-scale model). These data, shown in figure 21, indicate the same basic lift-drag trends as for 58° of sweep. However, the trimmed supersonic drag values are about 2 percent lower than those for the more highly swept wing ($\Lambda = 72.5^\circ$) of the F-111 aircraft.

CONCLUDING REMARKS

The military requirements of the mid-1960's brought about an emphasis on maneuverability as a design objective for the emerging fighter aircraft.

Although the use of twist, camber, and sweep had been demonstrated to improve wing flow characteristics, these methods alone were not sufficient to resolve the basic supercritical flow phenomenon. Research initiated by Richard T. Whitcomb at the NASA Langley Research Center in early 1964 led to the development of the NASA slotted supercritical airfoil and a demonstration that high subsonic speed flight could be efficient. Research was then initiated to apply supercritical technology to maneuvering fighter aircraft.

Exploratory wind-tunnel studies using an F-111 model with the existing flap system modified to approximate the slotted supercritical airfoil proved to be unsatisfactory. Existing wing high-lift features resulted in subcritical drag levels which were significantly higher than those of the basic F-111 model and offset the improved drag-divergence characteristics at the design point. Closing the slot eliminated the subcritical drag penalty and improved cruise performance, which led to the development of an integral or unslotted supercritical airfoil. The initial application of this airfoil to a 1/24-scale variable-sweep model of the F-111 airplane significantly improved the model's drag-divergence Mach number, maneuver drag, and buffet onset characteristics. No significant penalties at supersonic speeds were indicated.

After these tests, cooperative NASA/General Dynamics wind-tunnel tests were initiated to demonstrate the advantages in aircraft maneuverability that could be realized through the application of supercritical airfoil technology to the F-111 airplane. Several wing planforms were investigated to provide the optimum tradeoff between maneuver and cruise performance. One planform was selected for further testing and was approved for full-scale flight validation in a joint NASA/Air Force transonic aircraft technology (TACT) program in 1969. Wind-tunnel tests indicated that relative to the basic F-111 configuration the TACT configuration resulted in an increase in drag-divergence Mach number of 0.12, an increase in aerodynamic cruise range efficiency of 6 percent, external store effects which were nearly identical, an increase in the maneuver lift coefficient of 50 percent at maximum power, a 46-percent reduction in maneuver drag at maximum thrust, a 100-percent increase in the buffet onset lift coefficient, transonic drag characteristics which were nearly identical for the wing sweep angles investigated, and trimmed supersonic drag levels which were about 3 percent higher for 58° of wing leading-edge sweep and about 2 percent lower for 65° of leading-edge sweep.

Dryden Flight Research Center
National Aeronautics and Space Administration
Edwards, California 93523
March 4, 1981

REFERENCES

1. Whitcomb, Richard T.; and Clark, Larry R.: An Airfoil Shape for Efficient Flight at Supercritical Mach Numbers. NASA TM X-1109, 1965.
2. Whitcomb, Richard T.: Review of NASA Supercritical Airfoils. ICAS Paper No. 74-10, Internat. Council of the Aeronaut. Sci., Aug. 1974.
3. Supercritical Wing Technology - A Progress Report on Flight Evaluations. NASA SP-301, 1972.
4. Ayers, Theodore G.: Supercritical Aerodynamics. Astronaut. & Aeronaut., vol. 10, no. 8, Aug. 1972, pp. 32-36.
5. Blackwell, James A., Jr.: Preliminary Study of Effects of Reynolds Number and Boundary-Layer Transition Location on Shock-Induced Separation. NASA TN D-5003, 1969.
6. Ayers, Theodore G.: Effect of Wing-Transition Location and Slotted and Unslotted Flaps on Aerodynamic Characteristics of a Fighter Model at High Subsonic Speeds. NASA TM X-1849, 1969.
7. Langley, Ames, Lewis, and Flight Research Center Support of DOD VFAX/FX Projects: A Progress Report. NASA SP-178, 1968.
8. Ayers, Theodore G.: A Wind-Tunnel Investigation of the Application of the NASA Supercritical Airfoil to a Variable-Wing-Sweep Fighter Airplane. NASA TM X-2759, 1973.
9. Hallissy, James B.; and Ayers, Theodore G.: Transonic Wind-Tunnel Investigation of the Maneuver Potential of the NASA Supercritical Wing Concept - Phase I. NASA TM X-3534, 1977.

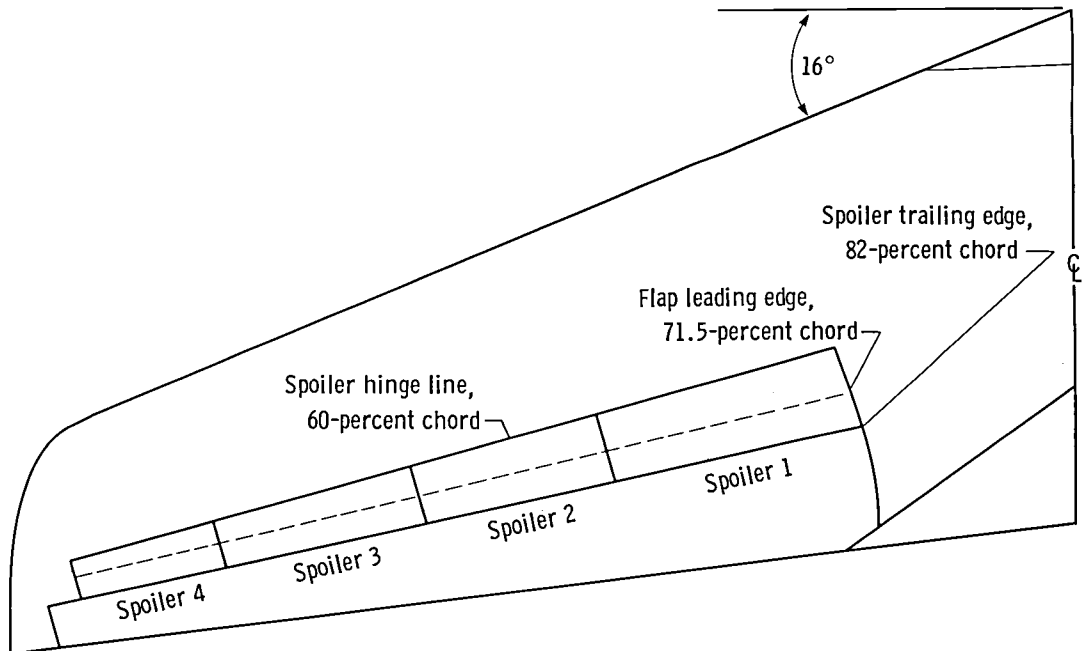
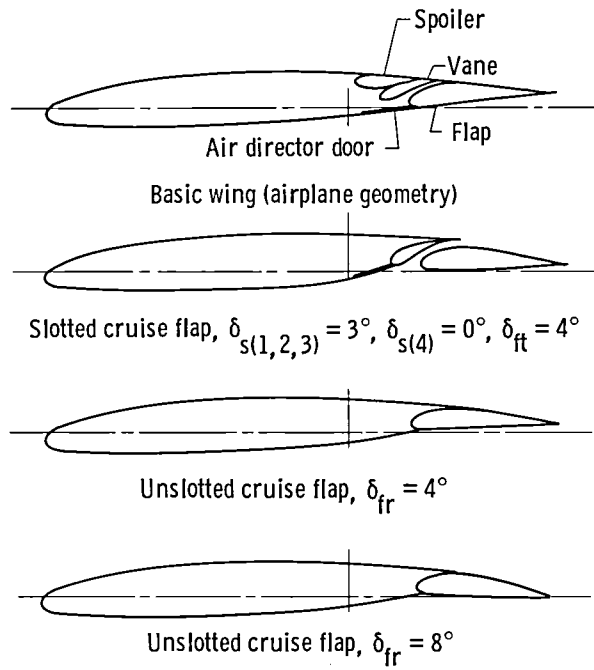

Figure 1. F-111 model wing details.

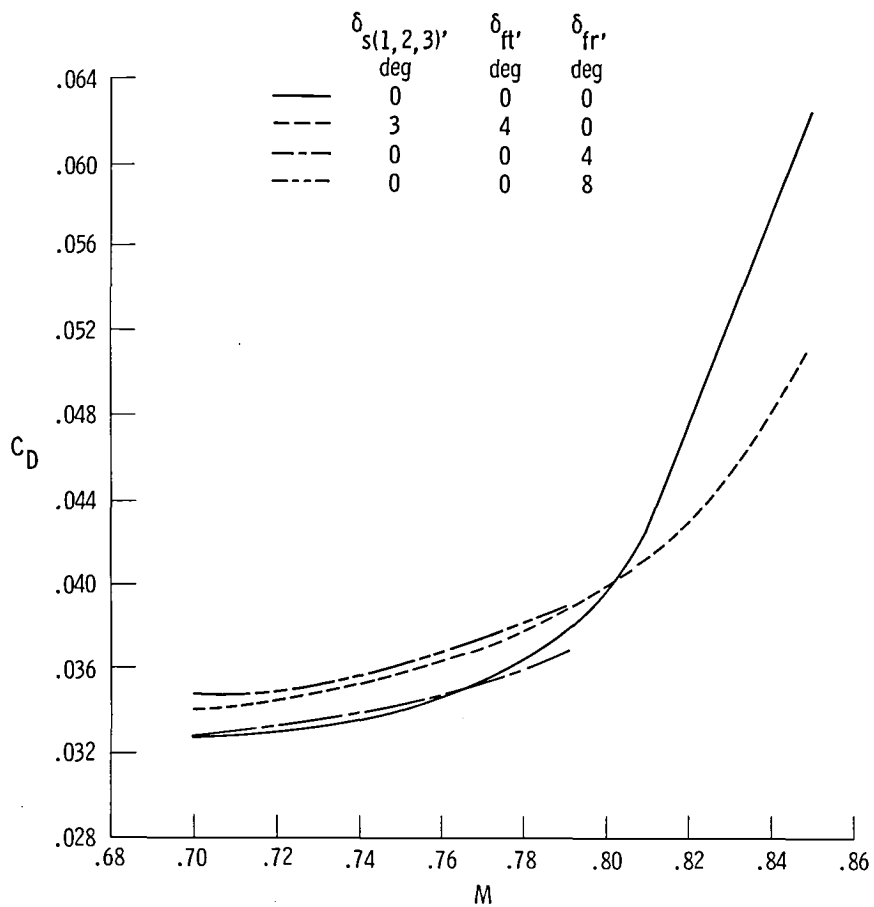

Figure 2. Effect of cruise flaps on drag characteristics of the 1/15-scale model. $\Lambda = 26^\circ$, $\delta_h = 0^\circ$, $C_L = 0.50$.

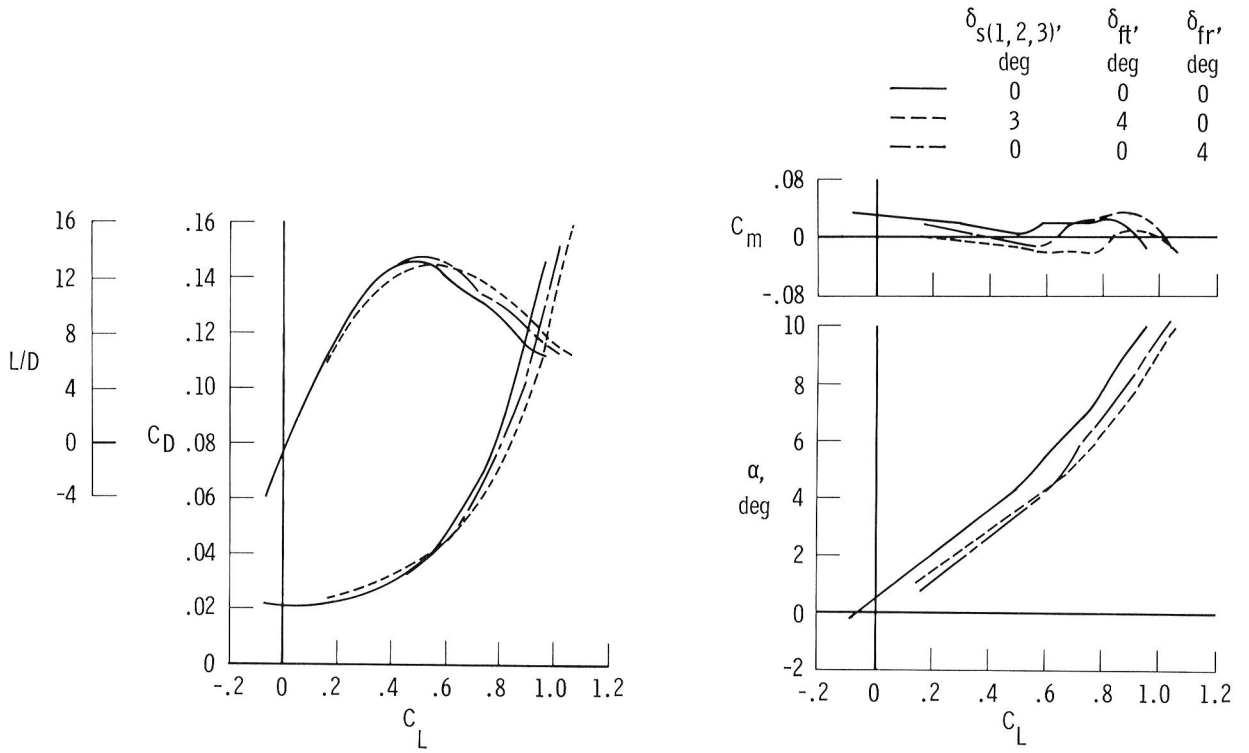

Figure 3. Effect of cruise flaps on longitudinal aerodynamic characteristics of model. $M = 0.79$, $\Lambda = 26^\circ$, $\delta_h = 0^\circ$.

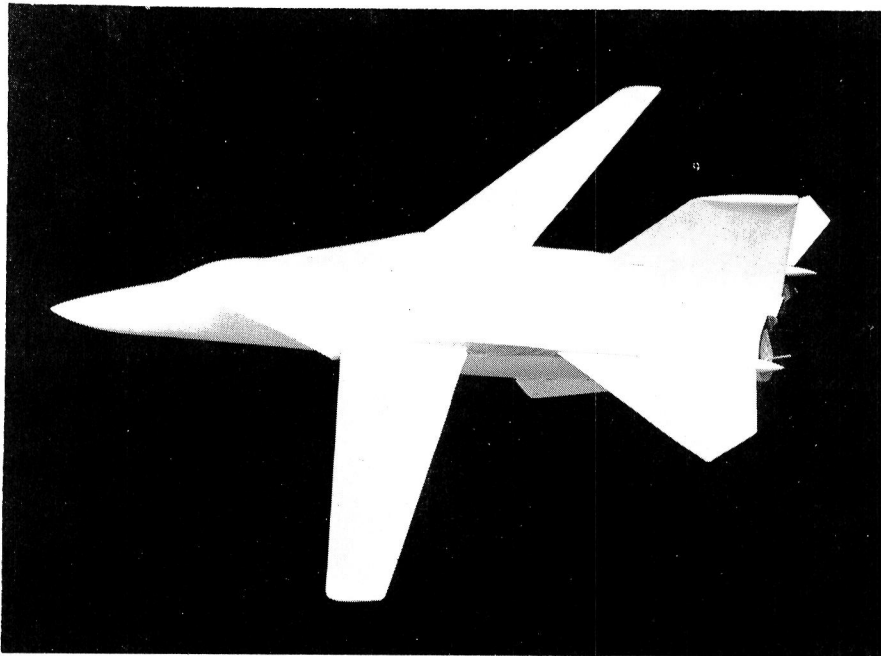

Figure 4. 1/24-scale F-111 wind-tunnel model.

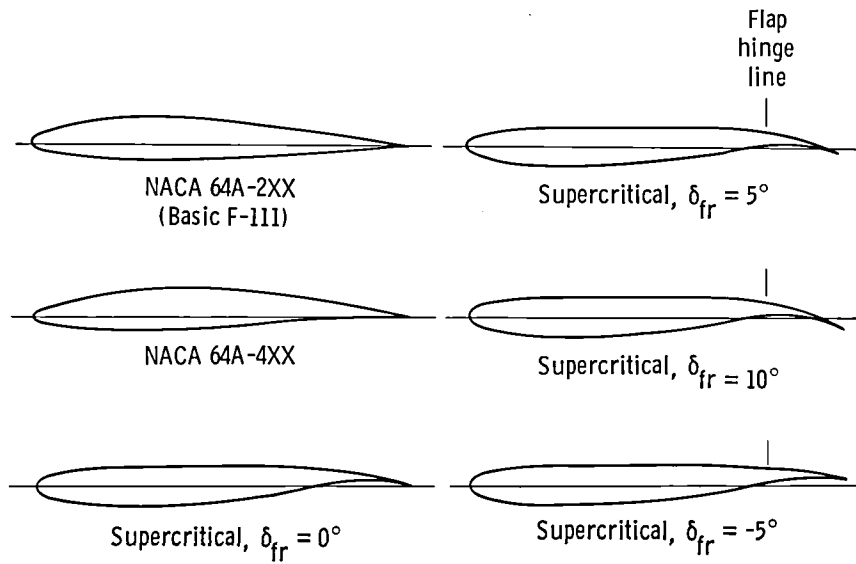

Figure 5. Airfoil shapes for exploratory investigation.

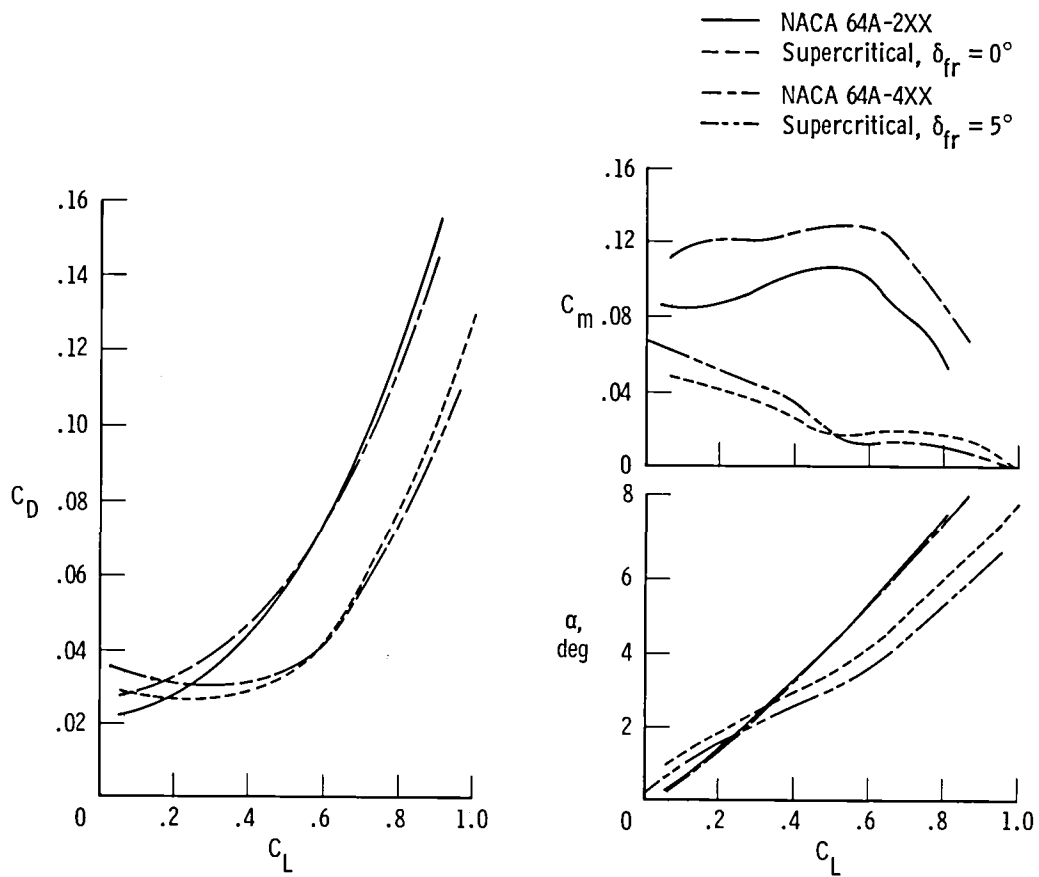

Figure 6. Effect of airfoil geometry on longitudinal aerodynamic characteristics. $M = 0.85$, $\Lambda = 26^\circ$, $\delta_h = 0^\circ$.

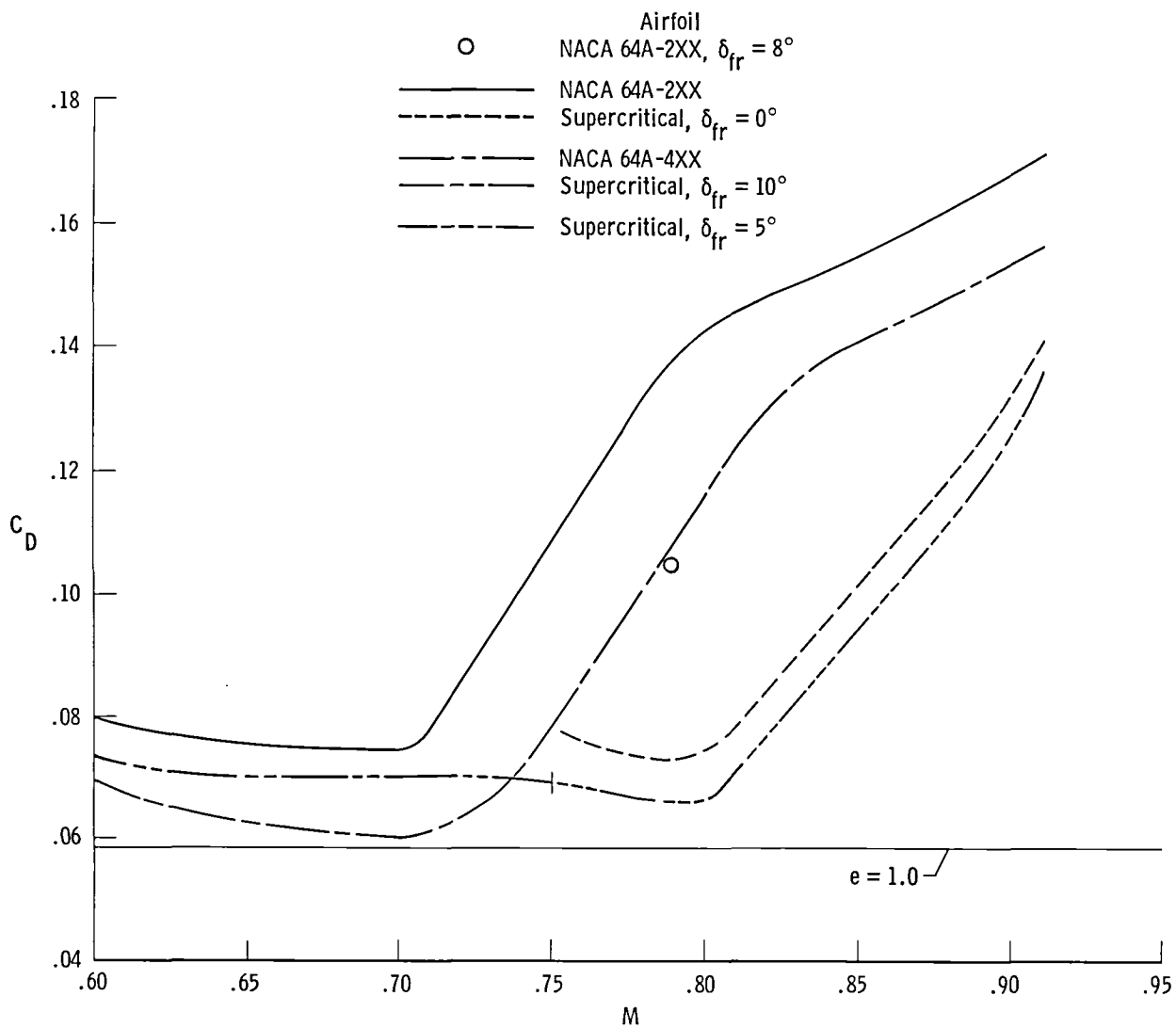

Figure 7. Effect of airfoil geometry on the trimmed maneuver drag characteristics. $\Lambda = 26^\circ$, $C_L = 0.90$.

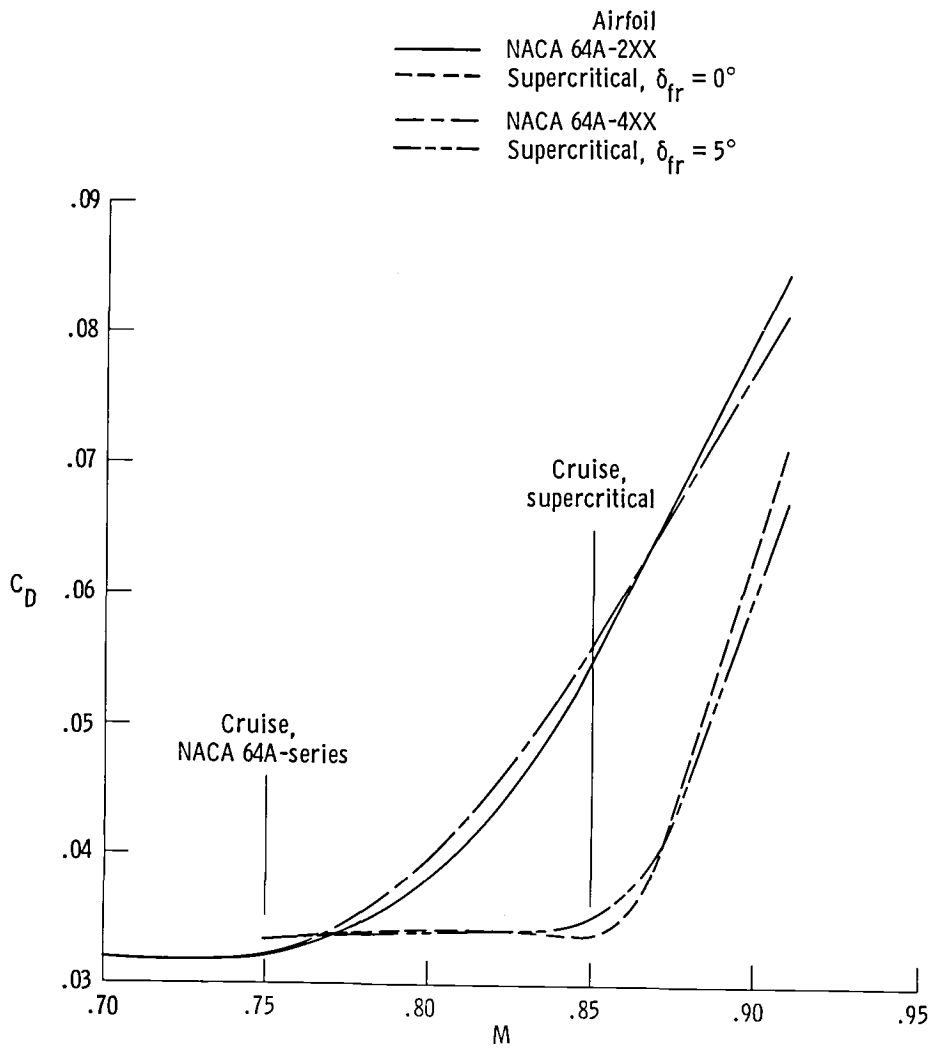

Figure 8. Effect of airfoil geometry on trimmed cruise drag characteristics. $\Lambda = 26^\circ$, $C_L = 0.50$.

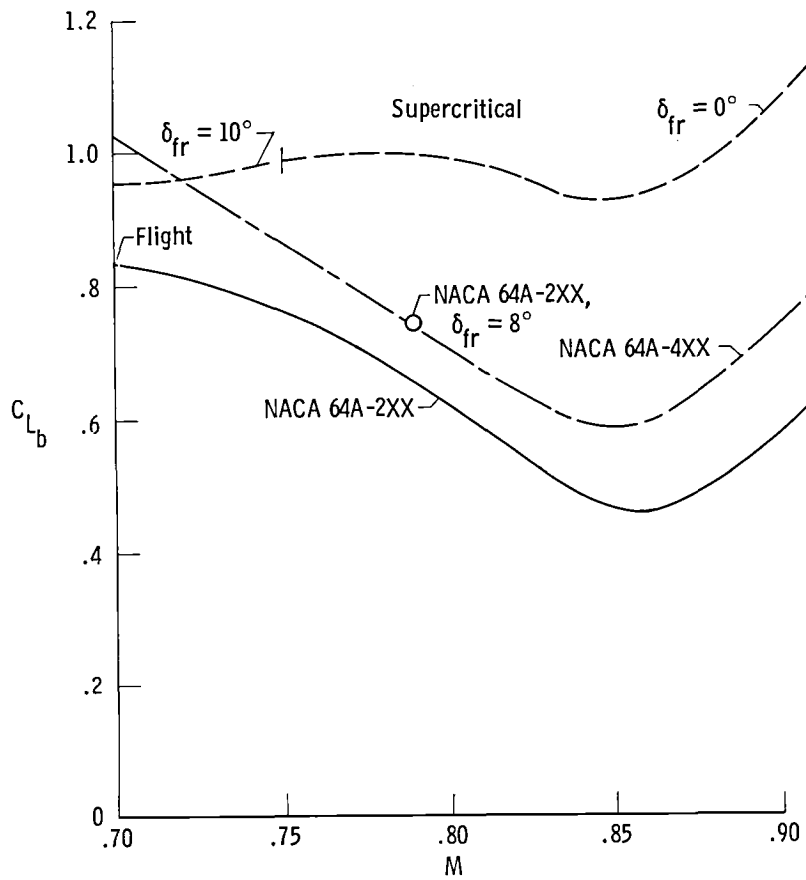
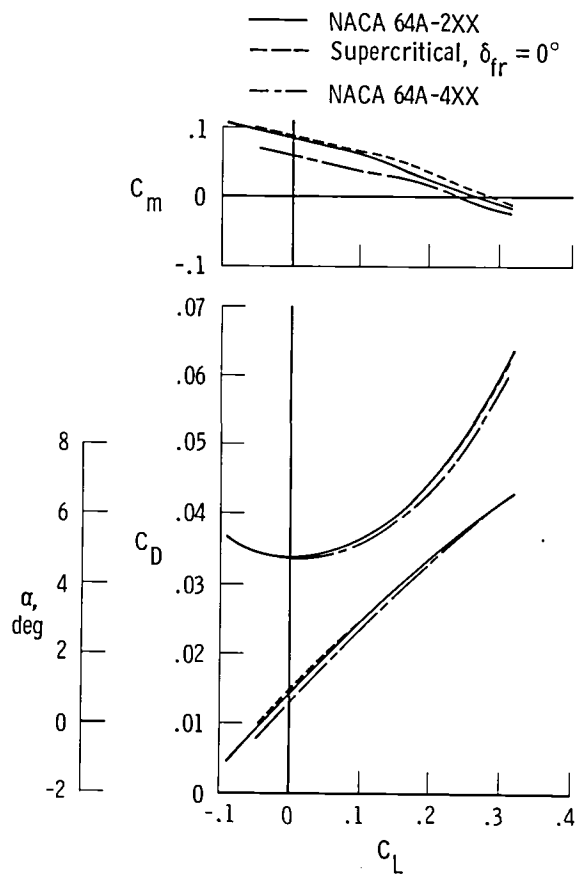
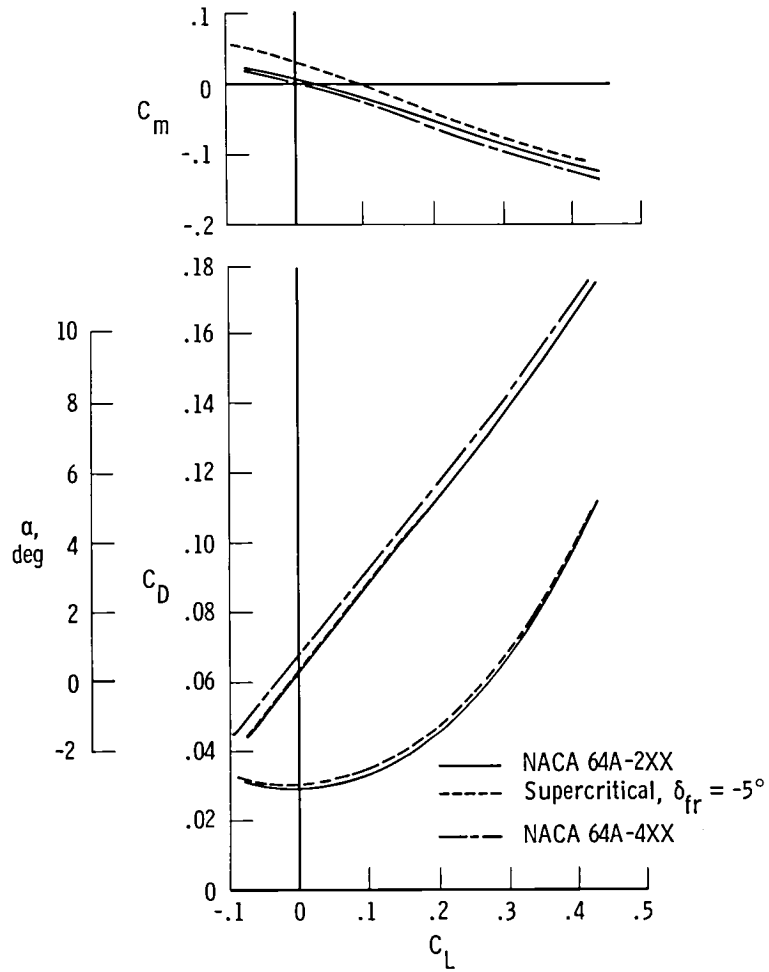

Figure 9. Effect of airfoil geometry on buffet onset lift coefficient. $\Lambda = 26^\circ$, $\delta_h = 0^\circ$.



(a) $M = 1.20$.

Figure 10. Effect of airfoil geometry on supersonic aerodynamic characteristics. $\Lambda = 72.5^\circ$, horizontal tail off.



(b) $M = 2.16$.

Figure 10. Concluded.

	Mach number	C_L	Δ , deg
Cruise	0.85	0.536	26
Maneuver	0.90	0.765	26
Takeoff ($\alpha = 12.8^\circ$)	0.20	-----	16

(a) Design criteria.

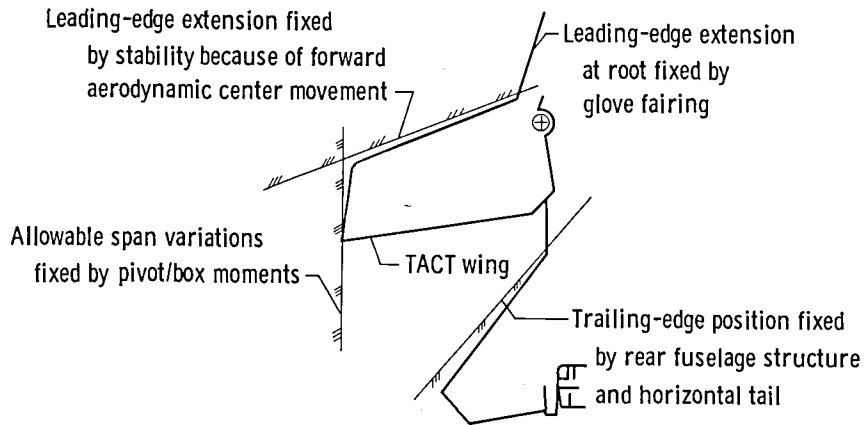

(b) Wing design.

Figure 11. TACT wing design approach.

Planform	Area, m ² (ft ²)	b/2, cm (in.)	λ	(t/c) _{tip}	Δ_{max} , deg
Basic F-111	56.51 (525)	960.1 (378)	0.325	0.098	72.50
A	67.27 (625)	868.7 (342)	0.742	0.042	54.75
B	65.01 (604)	904.2 (356)	0.541	0.055	58.00
C	63.25 (587.6)	922.0 (363)	0.435	0.066	60.75

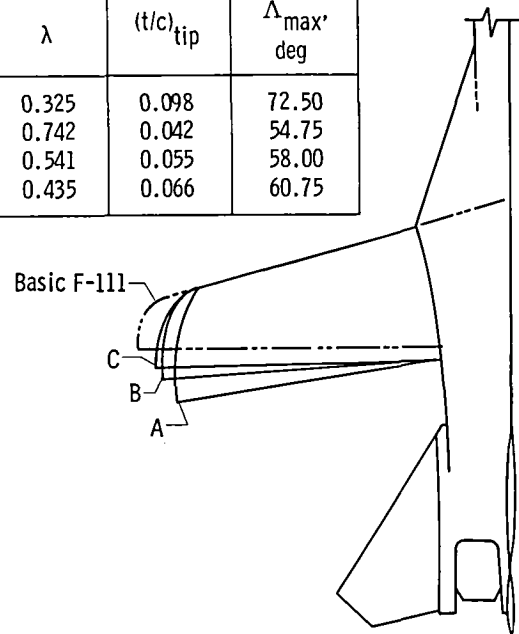

Figure 12. Candidate TACT planforms. $\Lambda = 16^\circ$.

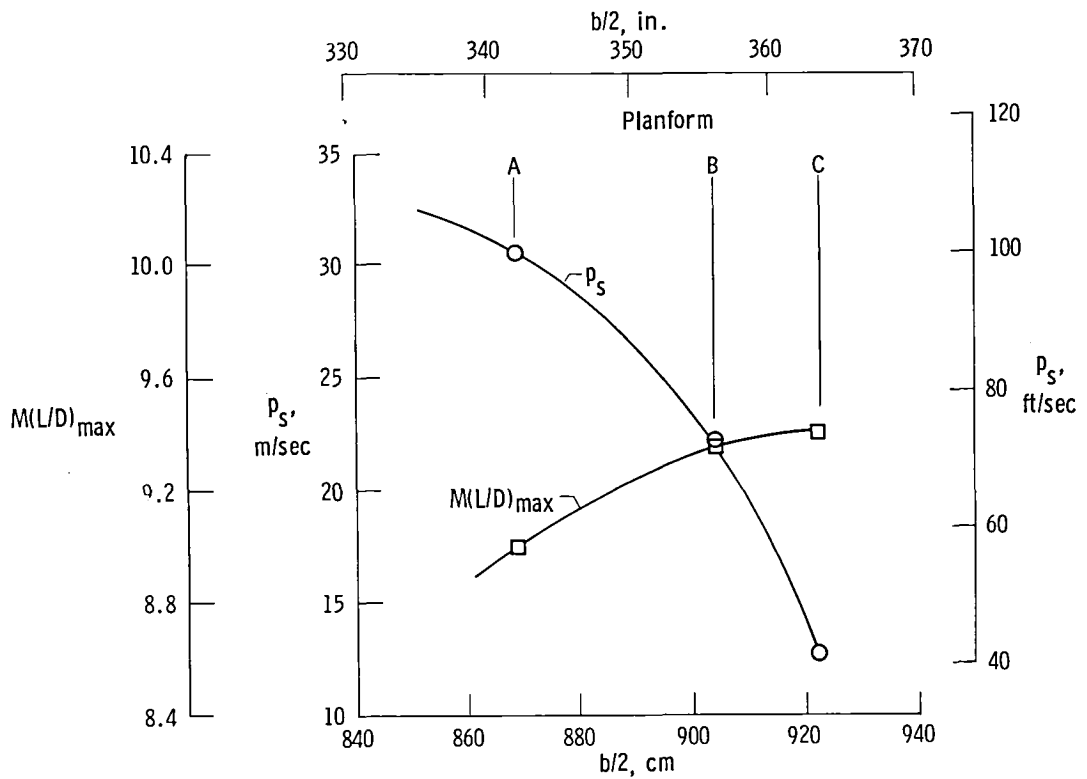
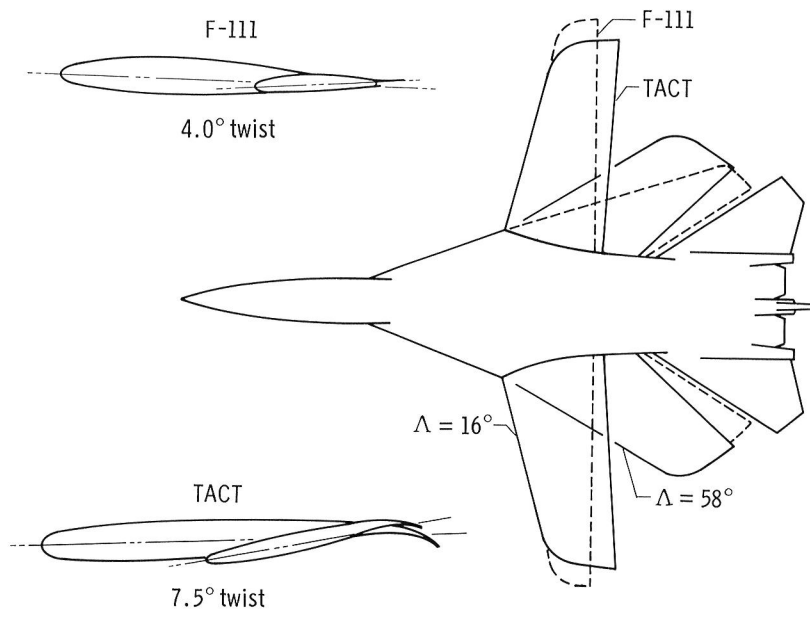
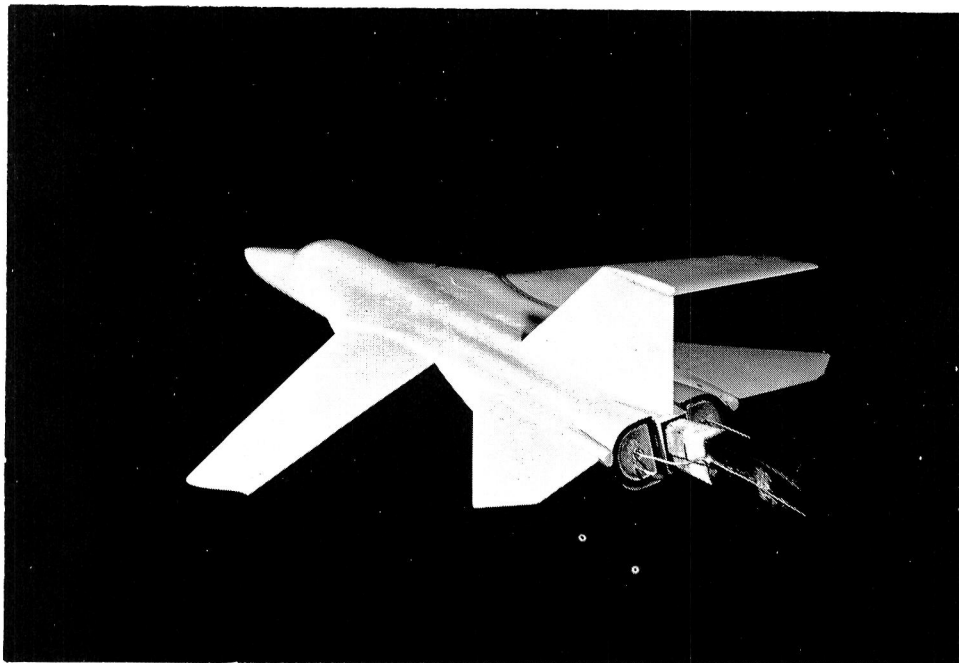

Figure 13. TACT wing planform selection. $\Lambda = 16^\circ$.



(a) Final wing configuration.



(b) 1/24-scale model of final TACT configuration.

Figure 14. Comparison of F-111 and TACT planforms.

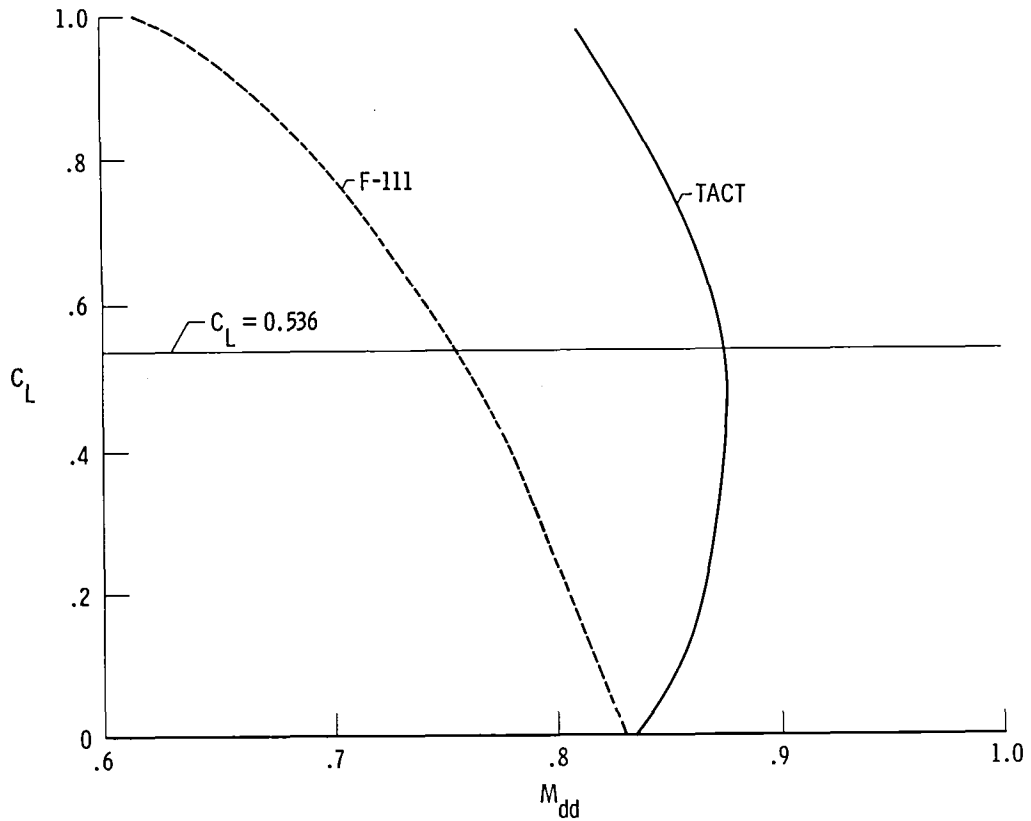
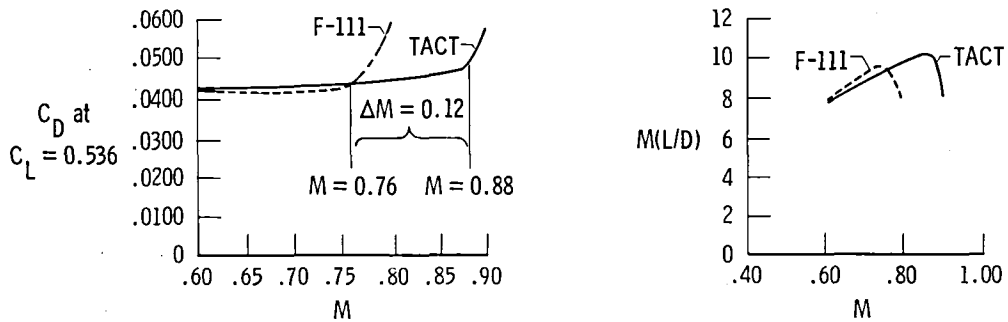

Figure 15. Comparison of F-111 and TACT drag-divergence Mach numbers. $\Lambda = 26^\circ$.



(a) Cruise drag.

(b) Cruise aerodynamics.

Figure 16. Comparison of F-111 and TACT cruise characteristics. $\Lambda = 26^\circ$, $\delta_h = 0^\circ$.

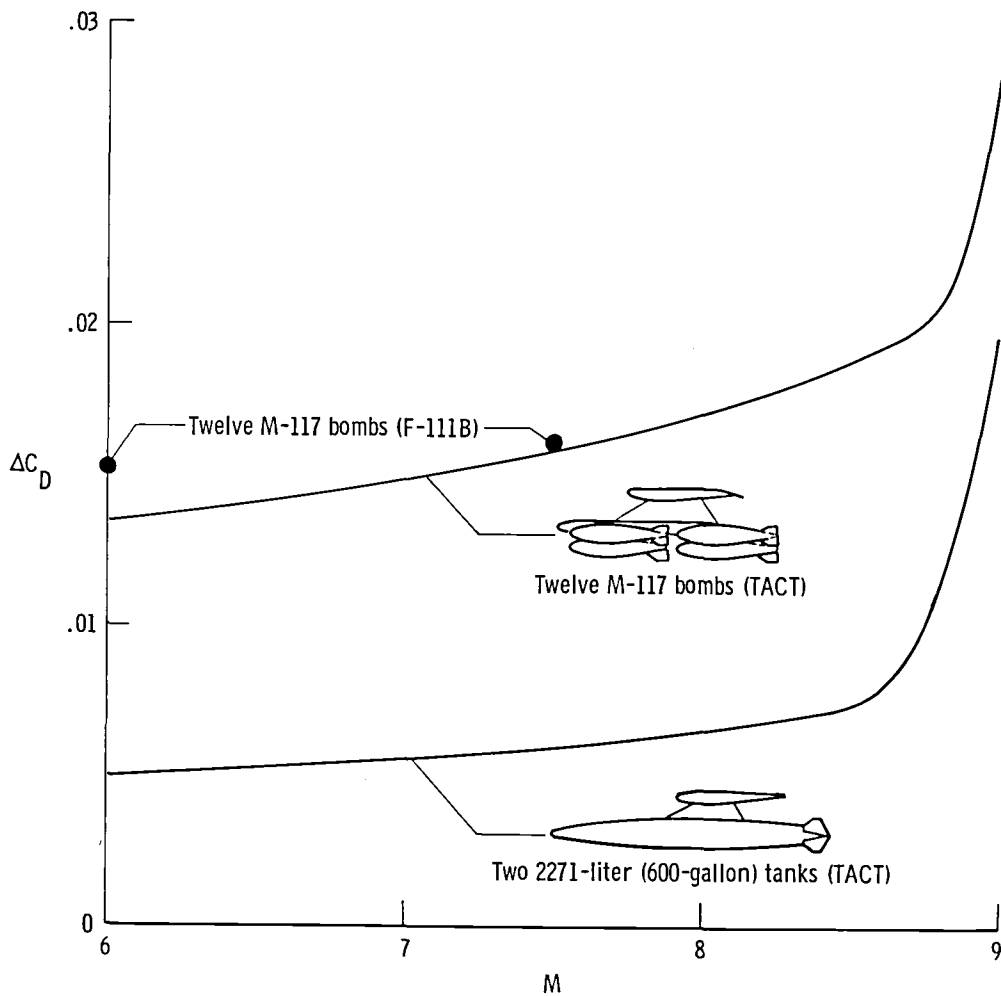

(a) Incremental stores drag.

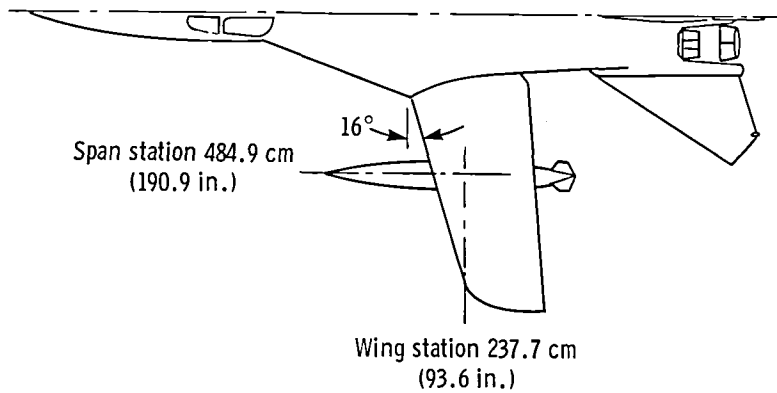

(b) Store location.

Figure 17. Effect of external stores on TACT drag characteristics. $\Lambda = 26^\circ$, $\delta_h = 0^\circ$, $C_L = 0.535$.

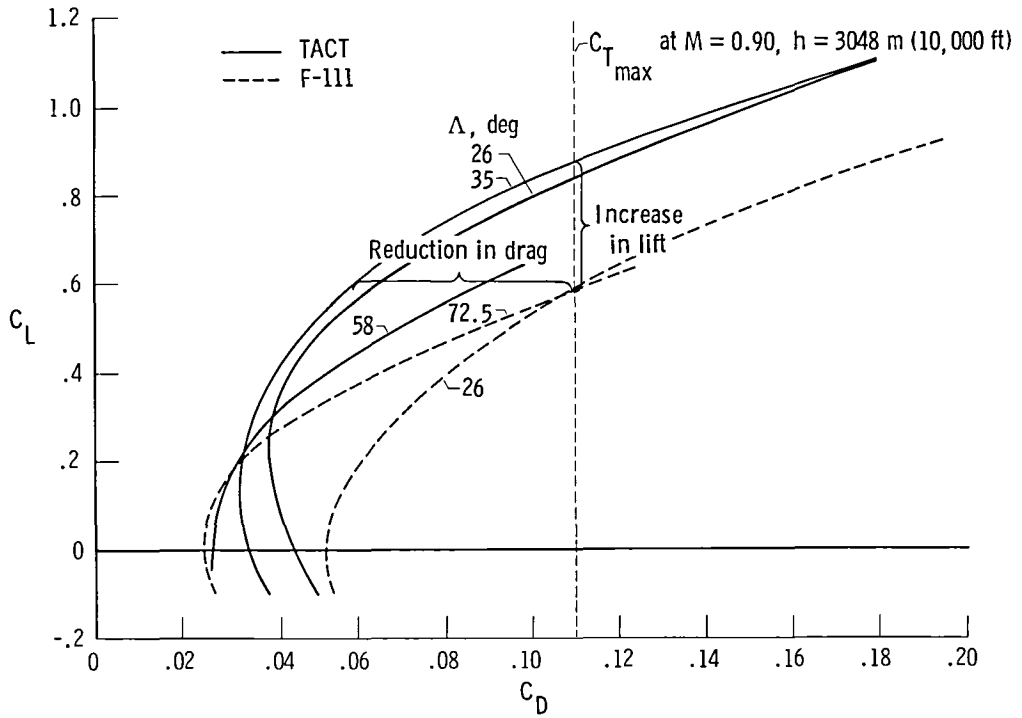

Figure 18. Comparison of F-111 and TACT maneuver drag characteristics. $M = 0.90$, $\delta_h = 0^\circ$.

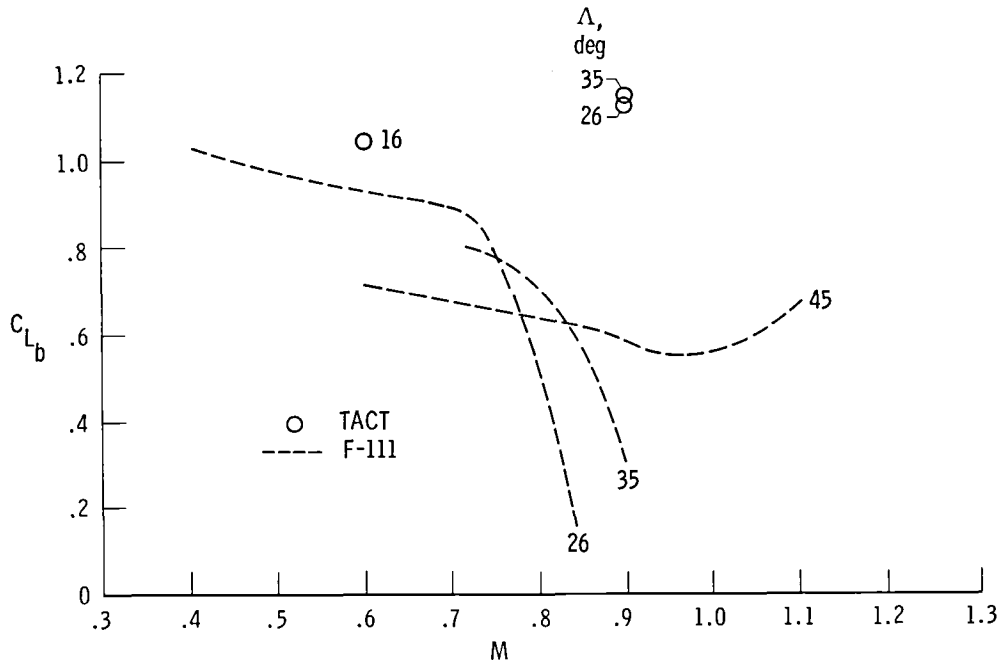

Figure 19. Comparison of buffet onset lift coefficients. $\delta_h = 0^\circ$.

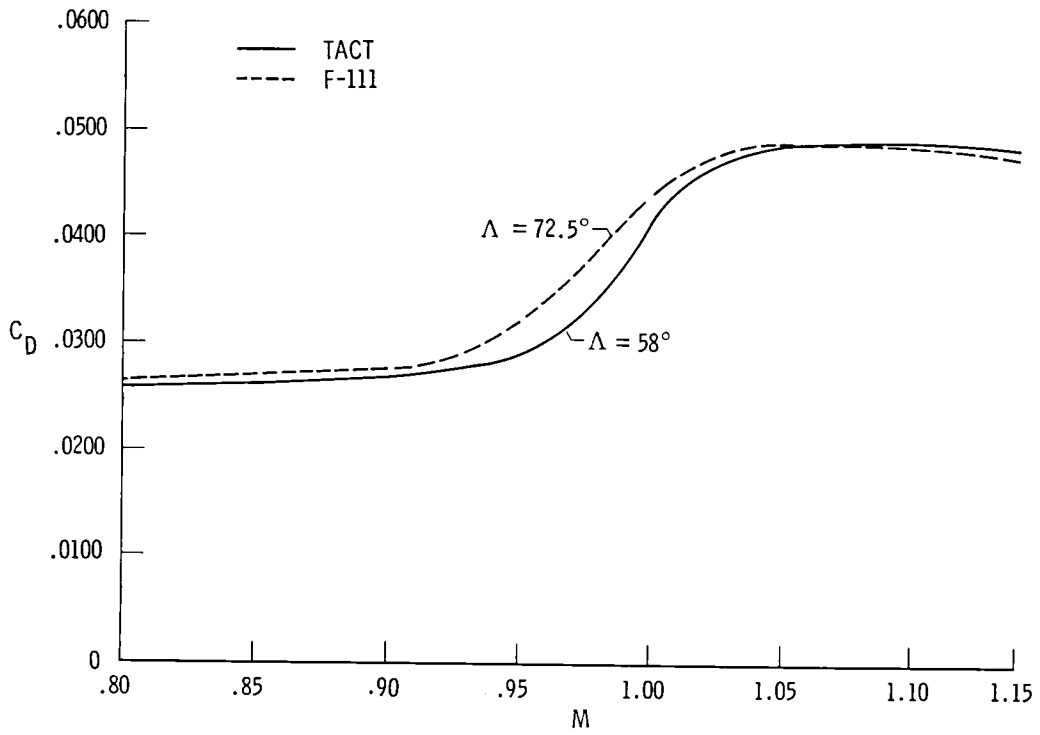
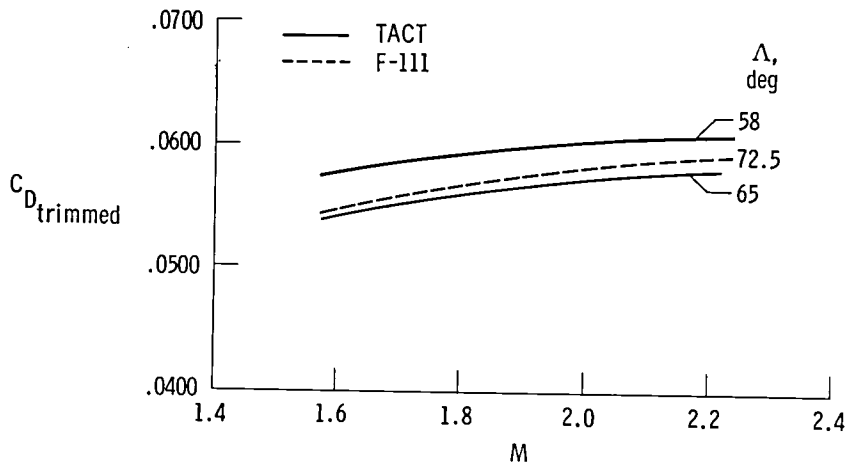
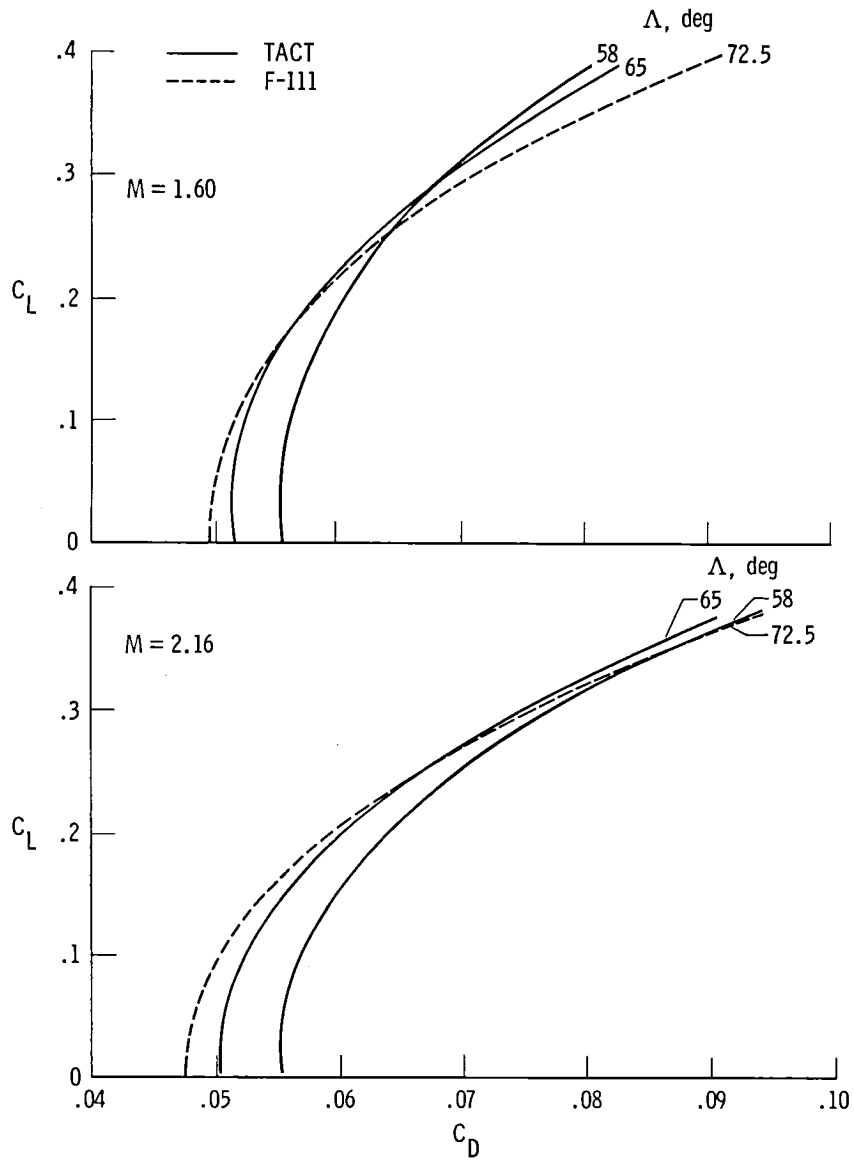

Figure 20. Comparison of sea level dash drag. $\delta_h = 0^\circ$, $C_L = 0.119$.



(a) Trimmed.

Figure 21. Comparison of supersonic drag characteristics.



(b) Untrimmed.

Figure 21. Concluded.



1. Report No. NASA TM-81356	2. Government Accession No.	3. Recipient's Catalog No.	
4. Title and Subtitle Historical Background and Design Evolution of the Transonic Aircraft Technology Supercritical Wing		5. Report Date August 1981	
		6. Performing Organization Code RTOP 505-31-44	
7. Author(s) Theodore G. Ayers and James B. Hallissy		8. Performing Organization Report No. H-1148	
		10. Work Unit No.	
9. Performing Organization Name and Address NASA Dryden Flight Research Center P.O. Box 273 Edwards, California 93523		11. Contract or Grant No.	
		13. Type of Report and Period Covered Technical Memorandum	
12. Sponsoring Agency Name and Address National Aeronautics and Space Administration Washington, D.C. 20546		14. Sponsoring Agency Code	
		15. Supplementary Notes Theodore G. Ayers: Dryden Flight Research Center. James B. Hallissy: Langley Research Center.	
16. Abstract Two-dimensional wind-tunnel test results obtained for supercritical airfoils indicated that substantial improvements in aircraft performance at high subsonic speeds could be achieved by shaping the airfoil to improve the supercritical flow above the upper surface. Significant increases in the drag-divergence Mach number, the maximum lift coefficient for buffet onset, and the Mach number for buffet onset at a given lift coefficient have been demonstrated for the supercritical airfoil, as compared with a NACA 6-series airfoil of comparable thickness. These trends have been corroborated by results from three-dimensional wind-tunnel and flight tests. Because these indicated extensions of the buffet boundaries could provide significant improvements in the maneuverability of a fighter airplane, NASA initiated an exploratory wind-tunnel investigation which demonstrated that significant aerodynamic improvements could be achieved from the direct substitution of a supercritical airfoil on a variable-wing-sweep multimission airplane model.			
17. Key Words (Suggested by Author(s)) Supercritical wing Maneuverability		18. Distribution Statement Unclassified-Unlimited STAR category 02	
19. Security Classif. (of this report) Unclassified	20. Security Classif. (of this page) Unclassified	21. No. of Pages 33	22. Price* A03

*For sale by the National Technical Information Service, Springfield, Virginia 22161

National Aeronautics and
Space Administration

THIRD-CLASS BULK RATE

Postage and Fees Paid
National Aeronautics and
Space Administration
NASA-451



Washington, D.C.
20546

Official Business

Penalty for Private Use, \$300

NASA

POSTMASTER: If Undeliverable (Section 158
Postal Manual) Do Not Return
