

N O T I C E

THIS DOCUMENT HAS BEEN REPRODUCED FROM
MICROFICHE. ALTHOUGH IT IS RECOGNIZED THAT
CERTAIN PORTIONS ARE ILLEGIBLE, IT IS BEING RELEASED
IN THE INTEREST OF MAKING AVAILABLE AS MUCH
INFORMATION AS POSSIBLE

(NASA-CR-161869) COAL/ROCK INTERFACE
DETECTION BY SENSITIZED PICK, PART A Final
Report (General Electric Co.) 99 p
HC A05/MF A01

N81-32582

CSSL 081

Unclass

H2/43 36736

COAL/ROCK INTERFACE DETECTION BY SENSITIZED PICK

Contract NAS8-33064

Part A

Final Report

August 1981

by Peter T.K. Wu and Joseph W. Erkes

General Electric Company
Corporate Research and Development
P.O. Box 8
Schenectady, NY 12301

Prepared for

National Aeronautics and Space Administration
George C. Marshall Space Flight Center
Alabama 35812

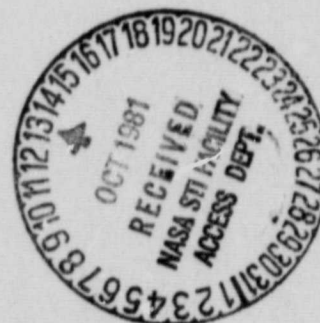

SRD-81-048

TABLE OF CONTENTS

Section	Page
	i
CONTENTS	
	iii
LIST OF ILLUSTRATIONS.....	
1.0 SUMMARY.....	1
2.0 INTRODUCTION.....	4
3.0 DEVELOPMENT OF THE SENSITIZED PICK BLOCK AND LOAD CELL.....	6
3.1 Design Modifications	6
3.2 Laboratory Testing	7
3.2.1 Static Calibration Tests	7
3.2.2 The Effect of Preload	7
3.2.3 Hysteresis.....	9
3.2.4 Cutting Test.....	9
3.2.5 Design Used in Simulated Longwall Facility at Bruceton, Pa.	10
3.2.6 Design Used in York Canyon Mine.....	11
4.0 DEVELOPMENT OF THE TELEMETRY SYSTEM	13
4.1 Original Shaker Research System	13
4.2 Modification of the Telemetry System	14
4.2.1 Isolation of the Output Stage of the Transmitter	14
4.2.2 Antenna Development	14
4.3 Description of the Final System and Its Performance	17
5.0 DEVELOPMENT OF PICK LOAD PROCESSOR	18
5.1 Background.....	18
5.2 Coal/Rock Detection System	18
5.3 Pick Signal Processor	18
5.4 Mine Safety Design.....	19
5.4.1 Voltage Safety Factors.....	19
5.4.2 Current—Limiting Resistors	20
5.4.3 Filter Capacitors	20
6.0 MSHA PERMIT OF TEST EQUIPMENT.....	21
6.1 Introduction	21
6.2 Modification of the Tape Recorder.....	21
6.3 Modification of the PAR Amplifier	21

TABLE OF CONTENTS (Cont'd)

Section	Page
7.0 MINE TEST RESULTS	22
7.1 Test Setup	22
7.2 York Canyon Mine Tests	22
8.0 CONCLUSIONS AND RECOMMENDATIONS	25
8.1 Sensitized Pick Hardware	25
8.2 Telemetry System	25
8.3 Signal Processing Module	26
APPENDIX A—Report on Improvements to Coal Cutting Hardware	
APPENDIX B—MSHA Correspondence	

LIST OF ILLUSTRATIONS

Figure

- 1 Original Shaker Research Labs design
- 2 Modified pick design
- 3 Photograph of facilities for static test of the sensitized pick
- 4 Instrumentation for calibration of the load cell and sensitized pick
- 5 Receiver output calibration curves for load cell alone and sensitized pick
- 6 SCO frequency vs. loading on sensitized pick for different preload
- 7 Simple spring model of the pick block showing the effect of preload
- 8 Typical hysteresis curves for sensitized pick block
- 9 Photograph of the sensitized pick block on a shaper machine
- 10 Average cutting force and power vs. cutting speed for cutting sandstone sample, depth of cut 1/8 in.
- 11 Average cutting force vs. cutting speed for cutting sandstone sample, depth of cut 3/16 in. and 1/4 in.
- 12 Strip chart of pick loads for 1/8 in.-deep cut in sandstone
- 13 Average cutting force vs. depth of cut for sandstone, cutting speed ≈ 0.5 ft/s.
- 14 Drawing of mounting fixture for sensitized pick block and transmitter assembly
- 15 The sensitized pick assembly ready for welding to the Joy longwall shearer
- 16 Samples of pick load signals for rock and coal
- 17 Photograph of the damaged pick block
- 18 The square short beam load cell and the pick block
- 19 Calibration curve for No. 2 load cell
- 20 The sensitized pick with square beam load cell, prior to welding to the Eickhoff shearer
- 21 Close-up view of the pick and pick block mounted on the Eickhoff shearer
- 22 Sensitized pick assembly as installed on the Eickhoff shearer
- 23 Improved transmitter system
- 24 Transmitter hardware prior to mounting on the Eickhoff shearer

ILLUSTRATIONS (Cont'd)

Figure

- 25 Receiver and analysis hardware in use on the Eickhoff shearer
- 26 Photograph of the PC board and transmitter housing
- 27 Sketch of the modified quarter wave loop antenna
- 28 Schematic of the final design of the telemetry system
- 29 RF signal strength measured in York Canyon mine
- 30 Cutting depth vs. drum position
- 31 Block diagram of sensitized pick processor
- 32 Block diagram of mine test instrumentation system
- 33 Drawing of accelerometer mounting cone
- 34 Cutting force signals measured at York Canyon mine

COAL/ROCK INTERFACE DETECTION BY SENSITIZED PICK

1.0 SUMMARY

General Electric Company's Corporate Research and Development Center (CRD), under contract to the National Aeronautics and Space Administration (NASA), and to the Department of Energy (DOE), developed and mine-tested a sensitized pick coal seam interface detector (originally developed by Shaker Research Corporation); in addition, CRD mine-tested a vibration-based coal seam interface detector (originally developed by CRD).

In order to increase the operating margins of the sensitized pick interface detector for safe, reliable operation under difficult in-mine conditions, a number of improvements were introduced.

Telemetry improvements:

1. The transmitted signal strength was increased to provide additional signal margin for in-mine conditions.
2. The transmitter section was redesigned to reduce "frequency pulling" of the transmitter frequency with variations in antenna load.

These improvements were accomplished by making several changes in the telemetry system. A buffer amplifier was introduced to drive the antenna and provide more isolation between the RF oscillator and the antenna load. In addition, a 10 dB attenuator pad was inserted between the RF section and the buffer amplifier to further improve the isolation. Finally, the original 68 Ω resistive antenna was replaced by an impedance matched, quarter wavelength shunt-fed antenna, consisting of a robust section of 1 in.-diameter steel rod welded to the drum surface.

These changes reduced "frequency pulling" by a factor of 50 (so that phase-lock was maintained under all conditions experienced in actual in-mine tests) and improved the received signal strength by nearly two orders of magnitude over sections of the drum rotation.

Mechanical improvements:

1. The linearity of the pick load SCO signal with true pick load was increased, and hysteresis effects were minimized.
2. The sensitized pick hardware was ruggedized for rough in-mine use.

These improvements were accomplished by a complete redesign of the pick block and load cell. The redesigned pick block provided a controlled pivot point, a "soft spring" to minimize transients caused by pick motion during use, and eliminated the preload responsible for changes in the sensitivity curve slope. Finally, the pick block

and load cell were redesigned to provide the large increase in strength necessary for use on a long wall shearer under typical mining conditions.

After those changes, the sensitized pick and telemetry system provided excellent, high quality signals proportional to cutting load under all conditions experienced during testing at the Bruceon Research Center and at the York Canyon mine.

CRD was also responsible for the development of a sensitized pick load signal processor, capable of processing the pick load signals and determining whether the cutting drum was cutting roof rock or coal.

The pick load processor development was based on data obtained with the new telemetry hardware at Bruceon Research Center on the mock longwall facility; after development, the processor was tested at the mock longwall facility and was used as the primary horizon control sensor during a successful automated cutting pass down the mock longwall by the Joy shearer.

In addition, because MSHA had altered its safety requirement and voided the earlier MSHA certification for the instrumentation recorder and associated equipment, CRD had to meet new MSHA certification requirements for all the old test instrumentations as well as for the newly developed equipment. This required extensive changes particularly to the instrumentation recorder, which were successfully completed in time for the York Canyon tests.

Finally, CRD was responsible for carrying out side-by-side testing of the sensitized pick coal seam interface detector and the vibration-based coal seam interface detector. These tests were carried out at York Canyon mine in Raton, N.M., in July of 1980. Unfortunately, because of an unexpected geological condition (a large middleman, or rocky inclusion in the coal), the vibration-based coal seam indicator detected (quite correctly) rock most of the time; thus, the York Canyon mine during that period was not suitable for an intercomparison of the two sensor systems.

The extensive data set obtained under actual mining conditions at York Canyon showed conclusively that prefacturing of both rock and coal is a more serious problem than had been anticipated on the basis of the tests at the mock longwall facility at Bruceon Research Center. Because of the extensive prefacturing, the sensitized pick would occasionally measure no large cutting loads for several revolutions after a major fracture. As a result, the pick processor would interpret this phenomena as a "coal cutting condition," even though the condition was temporary, until the shearer was trammed to an undisturbed roof section. It is recommended therefore that care be taken in interpreting processor "coal cutting signals," and it is probably prudent not to raise the cutting drum until a series of sequential "coal cutting signals" are obtained.

Finally, although the signal-derived artificial timing signals required by the pick processor seem to be adequate, it is recommended that the timing signals be derived directly from a tachometer generator on the cutting drum shaft, in order to further improve the reliability of the process.

In summary, the sensitized pick coal seam interface detector system provides high quality signals directly proportional to the cutting loads experienced. With care in choosing an interpretation algorithm, the problems introduced by the tendency of natural rock and coal to prefracture extensively can be overcome.

2.0 INTRODUCTION

Longwall mining of coal was developed about 40 years ago in Britain and Europe, where today it has become almost the exclusive method of coal mining. However, modern longwall mining in the United States did not begin until 1960. Up to 1977, about 72 longwall systems were used in U.S. mines, accounting for about 4% of the underground and 2% of the total material production. Among the reasons for the relatively slow growth of longwall mining in the U.S. have been the shallow, flat-lying coal beds which can be mined easily and efficiently by room-and-pillar methods, and the development of continuous mining machines. All these factors have contributed to major increases in coal output and worker productivity.

However, due to the recent energy crisis, the picture is changing. More and more emphasis has been placed on coal utilization. It is increasingly recognized that longwall mining with powered shearer or plow, armored face conveyors, and powered self-advancing roof supports has the potential for mining coal continuously at extremely high production rates. This method can also achieve coal bed recoveries approaching 90% as compared to 50% with room-and-pillar techniques. It is estimated that longwall mining will increase rapidly and account for about 28% of the underground and 12% of the total U.S. coal production by the year 1985.

Horizon control on the ranging arm of the longwall shearer is presently performed by operators who follow the machine and adjust the cutting drum position using visual observation, cutting noise characteristics, and the "feel" of the shearer as indicators of coal/rock cutting. If the horizon control can be automated, operators can then be moved from a very hazardous area (high coal dust concentration) to a safer, remote area. In addition to the safety consideration, the automatic horizon control system would yield a purer coal product (containing less rock) and reduce the downtime and the maintenance cost of the shearer.

Probably the single greatest impediment to automating the cutting function of the longwall shearer is the lack of sensors that can determine accurately when the shearer drum is cutting at the desirable upper and lower coal horizon.

CRD is under contract from NASA and DOE to develop and mine-test sensitized pick and vibration coal seam interface detection systems. The sensitized pick system uses signals of loading force on a special pick, called a sensitized pick, to determine whether the drum of the shearer is cutting rock or coal. The vibration system uses signals of surface vibration measured at the end of the ramping arm to differentiate between coal and rock cutting. These two sensor systems are part of the horizon control system which, when fully developed, would be used to automatically control the drum to cut along the coal-rock interface.

The sensitized pick system is expected to be a more sensitive system than the vibration system. The implementation of the sensitized pick, however, is much more complicated than that of the vibration system. Part of the purpose of the current study is to investigate the relative merit of the two systems under coal mine conditions.

The sensitized pick system was initially developed by Shaker Research Corporation under NASA Contract NAS8-32538. However, there are three key areas which need further development before the system can be used to obtain valid mine test data. These three areas are the following:

1. Modification of the load-carrying capacity of the load cell and preload design.
2. Improvement of the stability and the antenna efficiency of the telemetry transmitter system.
3. Modification of the instrumentation system to comply with new MSHA standards.

The vibration sensor system was developed earlier by the General Electric Company for the U.S. Bureau of Mines under Contract No. H0155120. However, field evaluation of this system is needed to reduce the system to practical use.

The above items, together with the development work on a real-time signal processor for the sensitized system and field tests of both systems, form the major portion of the current contract work.

3.0 DEVELOPMENT OF THE SENSITIZED PICK BLOCK AND LOAD CELL

3.1 Design Modifications

The current sensitized pick block has evolved through several design changes. The initial Shaker Research design is shown in Figure 1. Careful examination indicated that there were several areas where design improvements could be made. These areas are as follows:

1. The loading on the sensitized pick was transmitted to the load cell through a pivot joint which was not controlled. Due to normal wear, slight differences in dimensions of replacement picks and the exact manner in which the pick was seated in the pick block, the pivot point could shift and the shifting would produce errors in pick load measurement.
2. The load cell employed by Shaker Research was in a form of split cylinder with 0.45 in. O.D., 0.3 in. I.D. and a slot of 0.25 in. wide cut along a diameter line. This configuration has a load-carrying surface of roughly 0.05 in.² The exact material of which the load cell was made is not known. Assuming the material has a yield strength of 100 ksi and that there is an amplification factor of 2 due to the difference in length of the lever arms, the maximum static loading on the pick before yielding of the load cell would be 2500 lb. Although there were no data available on what maximum loading the sensitized pick should be designed for, it was felt that this upper limit was too low, especially under impact loading expected under actual mining conditions.
3. The preload bolt had a load-carrying surface of about 0.05 in.² which again was considered to be insufficient to support the load cell.
4. The preload bolt was physically located at the leading edge of the pick block. At that location, it would receive a lot of abuse due to cutting action. It was very difficult, if not impossible, to prevent the preload from shifting under impact excitation.
5. Shaker Research's report stated that the sensitized pick was operated under 2100 lb preload. This weight of preload was higher than it should have been. It will be shown later in this section that the effect of preload is to create a second slope at the low loading end of the calibration curve (output voltage vs. loading force). This second slope is different from the one expected from the elastic properties of the load cell. The value of this second slope greatly depends on the exact manner in which the leading edge of the pick contacts the

pick block. For stable and accurate pick load measurements, it is therefore undesirable to apply preload.

To correct for the deficiencies stated above, the following design modifications were proposed to and accepted by NASA:

1. Moving the preload bolt to the trailing edge of the pick block for more protection
2. Increasing the diameter of the preload bolt to 3/4 in. for larger load-carrying surface
3. Using SPIRALOCK* thread pattern for better locking of the preload bolt
4. Changing the load cell to a solid cylindrical configuration to increase the load-carrying capacity
5. Adding a soft spring pin at the leading interface between the pick and the pick block so that the preload can be reduced to a minimum
6. Controlling the pivot point on the pick

The modified design is shown in Figure 2.

3.2 Laboratory Testing

A set of sensitized pick hardware alloy with a test fixture was fabricated, and two different types of tests were performed.

3.2.1 Static Calibration Tests

The static calibration tests were done with a BALDWIN-SOUTHWARD hydraulic loading machine. Figure 3 is a picture showing the test setup.

Two foil strain gauges (350 Ω with gauge factor 2.09) were mounted in the axial direction of the load cell to form a half bridge. The load cell was connected to two dummy gauges, which were mounted on a separate steel block, to form a 4-arm bridge circuit. Shown on Figure 4 is a diagram of test instrumentation. Two calibration curves obtained using this equipment are plotted on Figure 5. The first curve is for loading directly at the 3/8 in.-diameter load cell, and the second one is for loading at the tip of the sensitized pick assembly. For loading at the load cell, the sensitivity was 3.46 mV/lb. While loading at the top of the sensitized pick, the sensitivity was 10.75 mV/lb. The difference between these two sensitivities is due to the mechanical amplification of the pick acting as a lever.

3.2.2 The Effect of Preload

Shown in Figure 6 are curves of SCO frequency vs. loading at the tip of the pick for various preload settings. It clearly indicates that there exist two slopes (i.e., two sensitivities). The lower pick load section has a smaller slope (less sensitive), and the

* Trademark of the Detroit Tap and Tool Company

higher pick load section has a larger slope, which corresponds to the expected sensitivity from the load cell. The location of the changeover point depends on the amount of preload: the higher the preload, the higher the changeover point. This nonlinearity in calibration curve is a very undesirable effect of preload. This can be explained using the simple model shown in Figure 7. The load cell is modeled by a spring with constant K_1 and relaxed length L_1 . The interface between the loading face of the pick and the block is modeled by two springs with spring constants K_2 and K_3 and the respective relaxed lengths L_2 and L_3 . The three springs are assumed to be confined together by the preload force F_0 and sustain a contraction of ΔL_1 , ΔL_2 and ΔL_3 , respectively. The force and torque balance equations can be written as

$$K_2 L_2 + K_3 L_3 = K_1 L_1 - F_0$$

$$K_2 L_2 l_3 + K_3 L_3 l_2 = K_1 L_1 l_2$$

If the pick is loaded by a horizontal force, F , which results in a horizontal displacement, S , from the current equilibrium position, we have the following force and torque balance equations:

$$F + K_2(L_2 - S_2) + K_3(L_3 - S_3) = K_1(L_1 + S_1)$$

$$F l_1 + K_2(L_2 - S_2) l_3 + K_3(L_3 - S_3) l_2 = K_1(L_1 + S_1) l_2$$

Solving for S_1/F , we have

$$\frac{S_1}{F} = \frac{l_1 - l_3}{(l_2 - l_3)(K_1 + K_3)}$$

For $S \leq L_2$

If $S \geq \Delta L_2$ (which means that the force F is so great that the pick is detached from the block at the leading face), the external force is then balanced solely against the load cell, and the incremental change in force and the displacement follows the relation,

$$\frac{dS_1}{dF} = \frac{l_1 - l_3}{(l_2 - l_3) K_1}$$

which is the force vs. displacement relation for the load cell alone. Normally, the spring constant for the leading interface between the pick and block is much larger than that of the load cell. This is the reason that the slope at lower pick load,

$$\frac{dS_1}{dF} = \frac{(l_1 - l_3)}{(l_2 - l_3)(K_1 + K_3)}$$

is much smaller than the slope

$$\frac{dS_1}{dS} = \frac{l_1 - l_3}{(l_2 - l_3) K_1}$$

for the load all alone, obtained after the leading interface is detached.

The conclusion from this analysis is that, if the preload is used to mount the sensitized pick, it must be large enough that the pick does not separate from the block at the leading face during loading. However, in this case the calibration of the pick load is then dependent on the interface between the shank of the pick and the block. Surface roughness, dirt, or a multitude of other conditions would affect the calibration. Another possibility would be to place a soft spring at the leading interface between the pick shank and the block. This would apply some preload to the pick but would have a longer travel so that the pick would not separate. Also, if the stiffness of the additional spring element is much less than the stiffness of the load cell, the load cell will dominate and there will be little effect on the calibration. The ideal solution would be not to use preload at all, but instead use other methods to prevent the pick from rattling in the block.

3.2.3 Hysteresis

For the load cell, the same calibration curve was obtained regardless of whether the loading was stepping up or down. However, for the sensitized pick assembly, there existed some hysteresis effect. A typical hysteresis curve is shown in Figure 8. In the range 0 to 1000 lb loading at the sensitized pick, the maximum width of the hysteresis loop is about 0.1 V. This is equivalent to about 50 lb of measurement uncertainty due to hysteresis.

3.2.4 Cutting Test

One important design consideration for the sensitized pick system is to match the dynamic range of the load cell and electronics to the range of the loading force to be measured. Since the range of the loading force on the pick was not known at that time, a cutting test was performed to obtain an estimation of cutting force. Sandstone and shale being the two most common roof materials in American coal mines, sandstone was used in the cutting test because it was more readily available. During the cutting tests, the vibrational effects on the transmitter assembly were also studied.

A clapper box was made to hold the sensitized pick block on a shaper machine, thus enabling the pick to make a linear cut at any selected depth on the sample rock. The transmitter assembly, including the battery, was mounted on a circuit board glued on top of the clapper box. Figure 9 shows the system mounted on the shaper machine.

The surface of the sandstone sample was machined smooth so that a uniform depth of cut over the face of the sample could be achieved. At the leading edge of the sample stone, a 30 degree ramp (30 degrees from horizontal) was cut out so that the cutting depth could be increased smoothly to the preset value.

Two parameters, cutting speed and cutting depth, were changed systematically within allowable range during the test. The range of cutting speed was controlled by that of the shaper machine. The speed varied from a minimum setting of 10 strokes per minute to the maximum setting of 160 strokes per minute. The real cutting speed could then be calculated in terms of feet per second from the known length of the cut and the chart recorder paper speed.

Shown in Figure 10 are curves of averaged cutting force and averaged power vs. cutting speed for an 1/8 in.-deep cut on sandstone. The cutting force decreases as the cutting speed increases. However, the average cutting power increases almost linearly with speed. As the depth of cut increases, the cutting force vs. cutting speed curve becomes irregular. Shown in Figure 11 are two curves for 3/16 in. and 1/4 in. cutting depth, respectively. The cutting force appears to fluctuate up and down depending on how the stone is breaking up in a particular test. It is likely that this variability is dependent on the internal properties of the sandstone being cut, and thus is not repeatable from test to test.

For all the cutting tests, cutting force always has a larger fluctuation at low speed than at high speed. Shown in Figure 12 are two strip charts of pick load for an 1/8 in.-deep cut on sandstone. The top chart is for cutting speed at 0.48 ft/s and the bottom chart is at 3.2 ft/s. At higher speed (3.2 ft/s), the cut-away portion of the sample stone was broken off into small pieces. However, at lower speed (0.48 ft/s) the rock cracked and broke into bigger chunks. The prominent peaks and valleys on the low cutting speed chart always corresponded to big pieces broken off from the sample stone.

For cutting speed at around 0.5 ft/s, the averaged cutting force vs. cutting depth data were plotted in Figure 13, the force increasing rapidly as the cutting depth increased. At this speed, the peak cutting force was much higher than the averaged value. Using Figure 11(a) as an example, the maximum peak is 279 lb, while the averaged value is about 100 lb.

These cutting tests were obtained by using a load cell of 3/8 in. in diameter. The maximum pick load for this load cell before yield is about 1000 lb. For 1/2 in. deep in sandstone at 0.5 ft/s, the average cutting force is around 600 lb (Figure 13), with the peak values approaching 1000 lb. It is therefore felt that the diameter of the load cell should be increased to 0.6 in. to accommodate severe mine conditions.

Throughout the cutting tests, the T-20 B transmitter assembly was subjected to varying degrees of vibrational excitations. The maximum vibration level observed on the pick block was 200 g_{p-p} (1 kHz low pass) when a 1/2 in. cut in sandstone was being made at 110 strokes/min shaper speed. No indication of major problems was observed.

3.2.5 Design Used in Simulated Longwall Facility at Bruceton, Pa.

The cutting tests indicated that the original 3/8 in.-diameter load cell could withstand only a 1/2 in. cut on sandstone. It was felt that, for real mine environment, the load-carrying capacity of the load cell should be increased. A new load cell of 0.6 in. diameter was adopted. This new load cell has more than 2.5 times more load-carrying capacity than the old one.

A series of tests of the sensitized pick were conducted using the DOE longwall simulations facility at Bruceton, Pa. At this facility, a special mixture of loose coal of various sizes, fly ash, and a special cement was poured to form a 40 ft-wide, 80 ft-long, and 8 ft-high simulated coal block. A cap approximately 6 ~ 8 in. thick and made of higher density material was poured on top to simulate roof rock. A Joy

shearer with chain-link face conveyor was used to cut this simulated coal block along its long dimension.

The design of the sensitized pick system used in these tests is shown in Figures 14 and 15. The sensitized pick block was welded onto a 1/2 in.-thick steel plate which in turn was welded on a 4 in.-square steel tube. The 4 in.-square steel tube is fitted, in a telescoping fashion, into a 5 in.-square steel tube which in turn is welded on the cutting drum of the shear. The location of this sensitized pick column was such that the sensitized pick was aligned with a leading normal pick. The height of the column was adjusted to extend the sensitized pick 1/4 in. higher than the normal pick. The transmitter electronics package was mounted on a plate and bolted onto the opening of the column to seal the transmitter electronics inside the column. The antenna of the system was extended out from the trailing side of the sensitized pick column and protected by the column. The design of the pick block incorporated all 6 modifications discussed in Section 2.1.

This design was tested 6 times at the DOE mock longwall facility. Stable and satisfactory results were obtained. Shown in Figure 16 are samples of the pick load signals for cutting pure coal and coal with roof rock. For best D.C. stability of the pick load signals, the preload bolt should only be hand tightened to eliminate free play and then welded onto the pick block.

3.2.6 Design Used in York Canyon Mine

The design used at the Bruceton mock longwall facility was tested at York Canyon from June 9 to June 13, 1980. The longwall face was advanced to an area where there was a thick "middle man" rock layer embedded in the coal seam. There was also a substantial amount of rock being cut both at the floor and the roof. Due to the excessive rock-cutting force, the sensitized pick block was damaged severely after only a few minutes of cutting. The damage was limited to pick and pick block. The supporting column and the antenna appeared to be free of damage. Shown in Figure 17 is a photograph of the damaged sensitized pick block. The dimensions of the rectangular hole at the center originally were 1.25 in. \times 0.75 in. Under the loading force of cutting through rock, the hole was deformed and the dimensions were changed to 1.65 in. \times 0.875 in. The surface of the pick block was also eroded severely.

Mr. Dan Brown of Carmet (manufacturer of the block) was contacted for specification of the material properties of the block. He indicated that the block was made of SAE 4140 steel and should have been factory heat-treated to a hardness of $R_c 38-45$. However, our laboratory test indicated that the actual hardness of the block was much less than $R_c 20$. This is part of the reason that the pick block was damaged to such an extent. A report from R.N. Johnson, detailing the nature of the failure mechanism, can be found in Appendix A.

To cope with this especially harsh environment in the coal mine, the load cell and the pick block were redesigned for a greater load-carrying capacity. The following changes were made:

1. The original cylindrical load cell which has a load-bearing surface of 0.385 in.² was replaced with a rectangular short-beam type of load cell with a load-bearing surface of 1.225 in.² A drawing of this load cell is shown in Figure 18.
2. The pick block was also replaced with one (also shown in Figure 18) designed to accommodate the new load cell. This pick block was made from a Carmet CG-61 pick block and then hardened to $R_c \approx 32$.

A typical calibration curve of this load cell is shown in Figure 19. The load cell used with the telemetry system has an overall sensitivity of 0.375 mV/lb. The overall sensitized pick hardware used at York Canyon is shown in Figures 20 through 22.

4.0 DEVELOPMENT OF THE TELEMETRY SYSTEM

4.1 Original Shaker Research System

In Shaker Research's original design,* the Inmet T-20B FM-FM strain transmitter was used to transmit the pick load signal. The transmitter is designed to operate in the normal FM band, i.e., 88-108 MHz. The strain gauge bridge on the load cell is excited by a closely regulated source within the transmitter. The output of the strain gauge bridge is amplified by a low drift, temperature compensated, instrumentation amplifier which maintains accuracy within $\pm 2\%$ of the measurement range from 0°C to 125°C . The output of the instrumentation amplifier is then used to deviate a sub-carrier oscillator (SCO). The full scale deviation is $\pm 10\%$ from the nominal frequency of 10,000 Hz. The SCO output is buffered and used to modulate the radio frequency oscillator (RFO), which has a tunable center frequency in the FM band. The output of the RFO was used to drive the antenna, which consisted of a 68Ω carbon resistor mounted over the ground plane of the transmitter enclosure box.

This system was used to produce two reels of data tape from Jane mine. These two reels of data were analyzed extensively. The following conclusions were reached:

1. Voice comments on the tape were not sufficiently clear to conclusively indicate which portions of the tape contained coal cutting signals, and which portions of the tape contained rock cutting signals.
2. The data on the tape contained many episodes of signal "drop-out." During a typical "drop-out" period, the signals became uniformly high amplitude, two-sided and wide band noise signals. The drop-outs were widely distributed over the whole data tape. Almost every cutting cycle contained one or more drop-out periods. Normally, the pick load signals should be one-sided signals with amplitude changing cyclically according to the revolution of the drum. The drop-out signals will occur if the transmitting antenna radiates a signal too weak for the receiver to capture, or if the RF carrier frequency of the transmitting shifts to a larger amount, one that is out of the capture range of the receiver.

The Shaker Research telemetry system was tested extensively in the laboratory. The tests confirmed that the system indeed had output level and stability problems responsible for the drop-outs experienced under actual mining conditions. Since the 68Ω resistor was almost buried in the ground plane, the radiation efficiency was relatively low; when measured at 5 ft distance by a $1/4$ wave whip antenna, the output was less than $10 \mu\text{V}$. Because the output stage of the transmitter was not buffered, a

* Final Report for NAS8-32538, "Development of Sensitized Pick Coal Rock Interface Detector System."

300 kHz shift in RF carrier frequency was easily obtained by placing a hand near the assembly body. As a result of these tests, it was concluded that the Shaker Research telemetry system should be improved prior to further testing.

4.2 Modification of the Telemetry System

4.2.1 Isolation of the Output Stage of the Transmitter

An OPTIMAX AH402 RF amplifier was used to isolate the output stage of the transmitter. This amplifier has an essentially flat frequency response in the range 5~400 MHz. It has a 14.5 dB gain, and maximum power output is 8 dBm. Within the FM band, the reverse isolation is about -21.5 dB.

A 10 dB π attenuator network was inserted between the output of the T20B transmitter and the input of the AH402 RF amplifier to match the impedance and reduce the reflections and mismatching responsible for the anomalous frequency shifts. The output of the AH402 is used to drive the antenna. A transformer circuit to match the AH402 RF amplifier to the antenna load was inserted between the output of the AH402 and the 1/4 wave shunt-fed antenna rod for impedance matching.

Shown in Figure 23 is a circuit block diagram of the modified antenna system. A picture of the transmitter hardware system prior to mounting is shown in Figure 24. Figure 25 is a picture of the receiver and analysis hardware mounted on an Eickhoff longwall shearer at York Canyon mine. The antenna is a 1 in.-diameter solid steel rod, one end of which is welded onto the drum, the other end attached through an insulated standoff tube to the back of the sensitized pick column.

This modified transmitter system is much superior in performance to the previous one. Laboratory tests indicated that the stability of the RF frequency was improved by 50 times (typically from 300 kHz RF carrier frequency shift to 6 kHz shift). The output power was increased by a factor of 20 dB.

4.2.2 Antenna Development

The radiation efficiency of the 68 Ω carbon resistor antenna in the original Shaker Research design was relatively low; even with the added amplification from the AH402 amplifier, it could not produce a signal strength sufficient for reliable signal transmission under anticipated in-mine conditions. An effort was made to develop a short rugged antenna of higher efficiency. The key consideration in the design is to determine the proper trade-off between better radiating efficiency and structural ruggedness. Several configurations were tested. The results were summarized in Table 4-1. For proper structural ruggedness, the length of the antenna, L, should be as short as possible. Table 4-1 shows that for L=2.5 in. a top hat capacitive antenna would produce the best result. The RF signal strength measured at the output of a quarter-wave whip antenna 15 ft from the transmitter was about 200 MV. This is more than a factor of 10 improvement over the carbon resistor antenna. A top hat capacitive antenna was built and tested with the sensitized pick system at Bruceton. Shown in Figure 26 is a picture of the transmitter assembly including the top hat capacitive antenna. Table 4.2 shows the RF signal strength at the output of the receiving antenna as function of the drum phase angle. The receiving antenna had a quarter-

Table 4.1

RECEIVER ANTENNA OUTPUT (IN MICRO VOLTS MEASURED 15 FT. AWAY FROM TRANSMITTER) AS A FUNCTION OF DIFFERENT ANTENNA CONFIGURATIONS

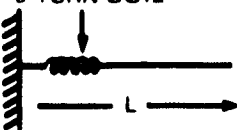
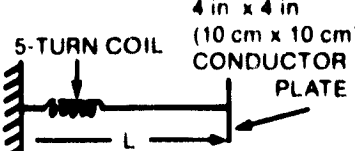
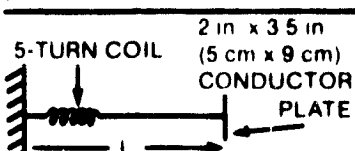
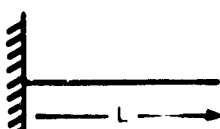
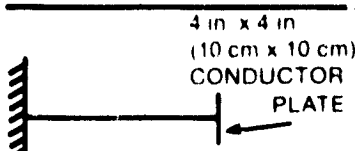
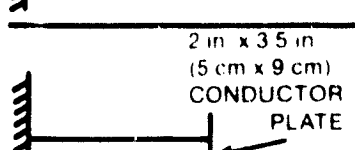
CONFIGURATION	LENGTH OF L (INCH)											
	95	85	75	65	55	45	35	25	15	10	05	
 <p>5-TURN COIL*</p>	180	170	130	110	90	65	50	35	—	—	—	
 <p>5-TURN COIL 4 in x 4 in (10 cm x 10 cm) CONDUCTOR PLATE</p>	1000	330	250	250	300	350	400	200	—	—	—	
 <p>5-TURN COIL 2 in x 3.5 in (5 cm x 9 cm) CONDUCTOR PLATE</p>	500	500	370	400	350	330	300	200	—	—	—	
					55	45	38	25	15	8	?	
 <p>4 in x 4 in (10 cm x 10 cm) CONDUCTOR PLATE</p>					450	300	330	180	200	130	75	
 <p>2 in x 3.5 in (5 cm x 9 cm) CONDUCTOR PLATE</p>					300	150	145	180	180	100	85	

*The 5-coil inductor is made of gauge 14 copper wire and the coil has a diameter of about 2.5".

Table 4.2
RF SIGNAL STRENGTH
FOR DIFFERENT DRUM PHASE LOCATIONS

<u>Top</u>	<u>250μV</u>
45° Forward	150
90° Forward	120
135° Forward	50
180°	100
225°	140
270°	210
315°	210

wave whip antenna attached at the end of the ranging arm. The signal strength varied from a minimum of 50 μV to a maximum of 210 μV .

Although a significant improvement in signal strength was obtained by using a top hat capacitive antenna, it was still felt that the 50 μV signal strength did not provide enough safety margin for a reliable signal transmission, especially because the RF absorption of coal slurry, which was an unknown, had not been taken into consideration. A decision was then made to develop a closely coupled loop antenna for higher radiation efficiency. Several types were investigated, including complete loop, half-wave partial loop, quarter-wave partial loop, shunt-fed and series-fed. Again, the major design considerations are radiation efficiency, structural ruggedness, and ease in implementation.

After several tests both at laboratory and on the Joy shearer at Bruceton, a final design was adopted. Shown in Figure 27 is a sketch of the quarter-wave shunt-fed antenna used in the mine test. The antenna is a 30 in.-long solid steel rod, 1 in. in diameter. The rod is bent into a shape more or less in conformance with the radius of the drum surface. One end of the antenna is attached to the downstream side of the sensitized pick column at about 2 in. from the drum surface, through a fiberglass reinforced epoxy insulator jacket of 0.25 in. wall thickness. The other end of the antenna is welded to the drum surface. The average distance from the antenna to the drum surface is about 3-4 in., well inside the shadow of the leading picks.

4.3 Description of the Final System and Its Performance

The final design of the transmitter portion of the telemetry system is shown in Figure 28. The variable capacitor in the antenna tuning circuit can be adjusted such that the optimum impedance matching between the output of the AH402 amplifier (50 Ω) and the antenna can be obtained. This is done by tuning the capacitor until a maximum signal strength at the receiving antenna is obtained.

The final system was tested on the longwall shearers at the DOE Bruceton facility and at York Canyon with a satisfactory result. A stable RF signal was obtained while the shearer drum was cutting. The field strengths measured at York Canyon using a quarter-wave length whip antenna attached at the end of the water spray pipe are listed in Figure 29. The signal strength varied from minimum 750 μV to maximum 4500 μV at the output of the receiving whip antenna. This is a strong and stable RF signal which is sufficient for a sound data transmission.

5.0 DEVELOPEMENT OF PICK LOAD PROCESSOR

5.1 Background

The original plan for this contact was to develop a pick load processor based on the Jane mine data tapes obtained by Shaker Research. However, the Jane mine data tapes were undesirable for this purpose because of the occurrence of RF carrier drop-out. Lacking adequate mine test data, the design of the pick load processor was therefore based primarily on the test data obtained from the simulated coal block at Bruce-ton.

5.2 Coal/Rock Detection Strategy

Shown in Figure 16 are sections of typical coal and rock cutting signals obtained from measurements on the simulated coal block at Bruce-ton. The distinctive characteristics of coal and rock signals are the following:

1. When cutting rock at the roof, the rock signals are contained only in the leading section of the signal cycle. Figure 30 is a diagram showing the relations between the depth of the cut into rock and the fraction of the drum cycle which will be occupied by rock signals for various pick extensions.
2. In the leading portion of the signal cycle, the rock signal has a sharper rise time and higher amplitude compared with signals for pure coal cutting. This is a direct result of cutting harder material at the roof.
3. The rock signals have fewer large-scale fluctuations than the coal signal, because the coal is prefractured. The mechanism of coal removal from the mine face is by large-scale fracture. Therefore, the cutting force shows large-scale fluctuation corresponding to the separation of big chunks of coal from the face.

Within the testing range of the Joy shearer parameters (such as tramming speed, the drum rotating speed, and the vertical speed of the ranging arm), the coal/rock signals retain similar characteristics as described above. However, the overall magnitude of the signals will change as those parameters are changed. For example, slower tramming speed produces a smaller overall signal than that of a faster tramming speed. To normalize most of these variations, which result from changes in machine operating parameters, a ratio scheme was adopted in addition to a simple level detection scheme.

5.3 Pick Signal Processor

The block diagram of the coal/rock interface detection scheme used for the processor is shown in Figure 38. There are two detection schemes, the first of which is intended to detect whether or not the shearer is cutting at all. It amplifies the signals and then removes most of the extraneous noise by employing a four pole low pass

filter. The remaining signals are then input to 10 comparators, which in turn drive 10 light emitting diodes (LED). When the signals are small (weak cutting forces) only the lower level LEDs will be on. As the signals become larger, higher level LEDs will be turned on. In addition to these signal-strength indicating LED outputs, there is also a comparator output available to indicate when the shearer is cutting. When the level of the filtered signal exceeds a pre-adjusted level, a 5 V D.C. signal will be at the output, otherwise there are 0 V at the output, implying an idle state.

The actual coal/rock interface detection scheme employs a ratio technique, and is somewhat independent of the machine operating parameters, such as slew rate, rotation speed, etc. This scheme also uses a low pass filter at the front end to reduce high frequency noise. Then the peak value of the signal is measured during a time window at the leading edge of the signal cycle. The length of this time window is adjustable. In parallel, the longtime average of the entire signal is also measured. Then the peak value is divided by the averaged value. The quotient signal is then threshold detected. If this quotient exceeds a pre-set level, a red LED will be turned on, indicating that rock is being cut. If the quotient drops below the pre-set level, a green light will be turned on, indicating a coal cutting condition.

To prevent false alarms due to drift in all instrumentation, including the load cell, telemetry transmitter, receiver, etc, a differentiation scheme is also designed into the front end of the circuit to compensate for the slow change in D.C. level of the signal. Again, in addition to the red/green light output, a TTL output is available. At this output, high (5 V) is for rock and low (0 V) is for coal.

Although this detection scheme worked reasonably well in its tests at Bruceton and York Canyon, it is recommended that when the next stage of development of the system is undertaken the timing signals be derived directly from a once/rev. sensor mounted in the cutting drum, instead of being derived indirectly from the coal/rock cutting signals themselves.

5.4 Mine Safety Design

All circuits are designed to be intrinsically safe using Underwriter Laboratories standard UL 913, dated January 20, 1976, revised April 8, 1976.

The power for the detector was provided by mercury batteries because they have the highest energy density of any commercially available type. When new they generate as much as 1.4 V per cell. All of the safety factors are based on the maximum voltage. All batteries have current limiting resistances connected at the battery terminals.

Figure 15.1 and 15.6 of UL 913 were used to determine the maximum allowable short circuit currents and capacitances. The calculations are listed below.

5.4.1 Voltage Safety Factors

The signal processing requires both positive and negative supplies. The calculations for the signal supplies assume that a short circuit can occur between the positive and negative supplies. Voltage with safety factor = [Batt. V \times No. of Batt. \times 1.1] \times 1.25 = [1.4 \times 24 \times 1.1] \times 1.25 = 46.2 V.

For the LEDs and the comparator, a separate supply is used. This keeps the on-off surges from interfering with the signal processing.

$$\text{LED Voltage} = (1.4 \times 5 \times 1.1) \times 1.25 = 9.6 \text{ V.}$$

5.4.2 Current Limiting Resistors

For the signal processing battery the current limit is .3 A using the methane curve of Figure 15.1. The limiting resistance is:

$$R = \frac{46.2}{.3} = 154 \Omega$$

This will be accomplished as shown in the drawing using four 39 Ω resistors. The power dissipated in each is:

$$P = I^2 R = (.3)^2 \times 39 = 3.5 \text{ W}$$

For a 100% safety factor 10 W resistors will be used.

According to Figure 15.1 there is no current limit for the LED battery, but a limit of .5 A will be used.

$$R = \frac{9.6}{.5} = 19.2 \Omega$$

Two 10 Ω resistors will be used

$$P = (.5)^2 \times 10 = 2.5 \text{ W}$$

For 100% safety factor 5 W resistors will be used.

All resistors will be wire wound or metal film.

5.4.3 Filter Capacitors

Using Figure 16.6 and the C + 0 Ω curve, the maximum allowable capacitance is 3 uf. A safety factor of 100% lowers this to 1.5 uf.

The voltage rating of the capacitor should be

$$V \times 1.1 \times 1.5 = 32.4 \times 1.1 \times 1.5 = 53.43 \text{ V.}$$

6.0 MSHA PERMIT OF TEST EQUIPMENT

6.1 Introduction

Shown in Figure 32 is a block diagram of the test instrumentation for mine test of the sensitized pick. This system was originally approved by the Mine Safety and Health Administration (MSHA) on Permit No. 351. Due to the recent change in safety standards, recertification of the entire instrumentation system was required by MSHA. A major portion of this effort was directed toward changing the circuit of the Lockheed 417 WB tape recorder to conform with MSHA safety standards. A considerable amount of effort was also directed toward modifying other test equipment, including the instrumentation amplifier and power supply for the receiver.

MSHA Permit No. 439 was obtained on 5/14/80. The permit covered the entire test instrumentation totalling 12 items. Shown in Appendix B is the official approval letter from MSHA and permit stickers, as well as other correspondence with MSHA.

6.2 Modification of the Tape Recorder

Extensive modification was done on the Lockheed tape recorder. Basically, all capacitive elements over $1\mu\text{F}$ need some kind of protection. All inductive elements, including the coil winding of motors and relays, need to be protected. Insertion of a protection circuit sometimes may hamper the normal operation of the tape recorder. Therefore, modification was done in a time-consuming step-by-step trial and test fashion.

An elaborate protection scheme was also developed to limit the current of the battery power supply of the tape recorder under various fault conditions.

All modifications to the tape recorder were documented in a drawing submitted from P. Wu to R. Bradburn of MSHA, dated 5/8/80.

6.3 Modification of the PAR Amplifier

Similar protection schemes for the capacitor and inductor were inserted in the circuit for the PAR Amplifier. A schematic of the modified version can be found in the drawings submitted with the application letter to MSHA, dated 5/8/80.

7.0 MINE TEST RESULTS

7.1 Test Setup

A mine test was conducted during July 21 to 28, 1980 at York Canyon mine, Raton, N.M. A sensitized pick assembly was mounted on the Eickhoff shearer at the drum facing the head gate. The sensitized pick column was located such that it followed a leading pick at about a 90 degree lag angle. Considering the amount of rock being cut at that time, it was decided not to extend the height of the sensitized pick beyond that of the normal pick. We were, in effect, trading sensitivity for more protection.

Figures 20 and 21 show pictures of the sensitized pick assembly as installed on the Eickhoff shearer. Figure 21 is a closeup view of the sensitized pick and pick block. The load cell has a raised loading pad at the front face that contacts with the pick. On the opposite face, there is a raised support area 1 cm wide on each side of the strain gauge mounting area.

The attenuation resistor network on the transmitter circuit board was set at values $R_s = 158\Omega$ and $R_p = 24.5\Omega$. This is equivalent to dividing the pick load signals by a factor of 12. With the CAL adjustment at the R-10B receiver set at 5.0, the overall system calibration was found to be 0.6 mV/lb.

In addition to the sensitized pick system, an accelerometer was also installed at the mounting cone shown in Figure 33 (welded at the end of the ranging arm) to measure vibration data. Pick load and SCO outputs from the receiver, amplified accelerometer signals, pick load processor output, and voice comments were recorded on the Lockheed 417 tape recorder. The tape recorder was set up to run at a speed of 15 in./s. The frequency responses of the machine at these speeds are 100-50,000 Hz and 0-5,000 Hz for direct record and FM record, respectively. Figure 32 is a block diagram showing the instrumentation system for this test.

Installation of the sensitized pick and instrumentation system were completed in one maintenance shift. In addition, numbers were marked on the cable rail every 20 inches for position reference purposes. We received excellent cooperation from the mine personnel in doing the welding work for us.

7.2 York Canyon Mine Tests

At the beginning of the first production shift on 7/23/80, the first set of data, taken while cutting the last 100 ft toward the head gate, was obtained.

This initial set of data was examined on site. The following conclusions were reached:

1. The quality of the data was excellent. The sensitized pick and instrumentation system were working properly.
2. Due to poor visibility during cutting, it was extremely difficult for our tape recorder operator to monitor several channels of instrumentation and in the meantime provide an adequate

voice comment for coal/rock cutting. It was decided, for the next data recording, to use two channels of voice comment from two observers to help improve this situation.

3. The major differences noted between the signatures of coal/rock cutting obtained from Bruceton and from York Canyon were the following:
 - a. The roof rock in the real mine has a much greater variation in properties such as hardness and degree of prefracture, than that of the roof cap at Bruceton. Therefore, in rock area, the rock signals at the leading edge of the signal cycle were much less uniform than had been seen at Bruceton. Under cutting force, roof rock often broke up into chunks and fell off the roof. For one or more cycles after the roof rock fell off, the sensitized pick might not make contact with rock, and therefore would produce "coal" signals, although the drum was ostensibly cutting into a rock layer. This is illustrated by a sample of "rock-cutting" signals, shown in Figure 34(a).
 - b. The characteristic signatures of coal cutting in a real mine also have much greater variation than those of the simulated coal at Bruceton. In the same general location of the coal seam, some coal was very loose and would crumble readily, whereas other sections of coal were tightly packed and hard. Sometimes there were hard materials other than coal embedded in the coal seam in a random manner. Therefore, isolated "rock" signals may appear while cutting in coal. These features can be seen in the sample of "coal-cutting" signals shown in Figure 34(b).
4. To establish a quantitative assessment of the percentage of "coal" signals while cutting in rock layer and the percentage of "rock" signals while cutting in coal, two long sections of continuous data, one for cutting into rock layer and the other into coal layer, were needed.
5. The vibration signals measured at the end of the ranging arm were fed to the vibration CID processor. Since the data contain the effect of a huge "middle man" rock layer, the vibration CID processor detected rock almost all the time. York Canyon mine in its current condition is therefore not a suitable test site for the vibration CID. As can be seen in Figures 34(c) and (d), the "middleman," although almost

always present, varied considerably in thickness, (and in the forces required to cut it); it should also be noted that the middleman layer, like the roof rock material, would occasionally prefracture, producing weak signals for a drum rotation or two.

During the first production shift of 7/25/80, a long section of pick load data corresponding to 300 ft of cutting was obtained. These new data contained two long sections of coal cutting and one long section of cutting into rock. Two voice channels were used to annotate the test conditions during recording. However, the visibility at the face was too poor to allow accurate observation of the depth of the rock cutting. As a supplement to the voice comments on the tape, after the shearer reached the head gate a brief visual examination of the coal/rock interface was made to record on a notebook the amount of rock cutting at each reference position.

8.0 CONCLUSIONS AND RECOMMENDATIONS

The program resulted in the development of a rugged mine-safe horizon sensor system capable of making high-accuracy measurements of the actual cutting forces experienced by an instrumented pick. That sensor system was tested under actual mining conditions in a series of tests at Raton N.M. and revealed new information about the nature of coal and rock prefracture under normal cutting conditions.

Each of the major technical areas where we made a significant effort will be summarized individually, and specific recommendations will be made.

8.1 Sensitized Pick Hardware

A series of modifications were made to the sensitized pick which materially improved its performance. The basic design of the pick was changed to provide

1. **Linear response** — the geometry was altered to eliminate the need for preload and to provide a controlled pivot point. The new design worked very well, and no improvements appear to be necessary.
2. **Improved Load Cell** — the load cell was redesigned to provide additional load-carrying capacity and to eliminate temperature stability problems by providing room to mount the dummy reference bridge strain gauge. The new design proved to be rugged and dependable, and no further changes are recommended.
3. **Increased Ruggedness** — the entire sensitized pick hardware system was redesigned to provide additional strength and durability under potentially rigorous underground mining conditions. The system proved to be sufficiently rugged to stand up under difficult conditions experienced at York Canyon mine, where an occasionally thick middleman severely taxed the longwall shearer. Further measures to increase the ruggedness of the sensitized pick hardware are probably unnecessary.

8.2 Telemetry System

A series of improvements were made to the telemetry system to improve its performance margins, stability, and accuracy.

1. **Improved Margins** — the telemetry transmitter system was extensively modified to increase signal strength to the point where the operating margins were large enough to guarantee adequate S/N at the telemetry receiver. An additional gain stage was introduced, and the transmitting antenna was changed from a terminating resistor buried in the ground plane to a large, robust, shunt-fed quarter wavelength antenna. These changes provided between two and three orders of magnitude improvement in S/N ratio at the receiver. It is recommended that the present receiving antenna be replaced with one which has similar electrical properties, but is considerably more rugged. The whip antenna used for the in-mine tests,

although it performed flawlessly, would probably not stand up to a roof rock fall.

2. **Stable Performance** – the telemetry system was also modified extensively to improve its stability and imperviousness to unusual cutting conditions (rock/coal overburden, coal slurry, accumulations of dirt and water, etc.). The stability was increased by nearly two orders of magnitude by padding the oscillator stage and by a careful redesign of the transmitting antenna.

No further improvements in the telemetry system are recommended, other than the replacement of the whip antenna.

8.3 Signal Processing Module

The signal processor module design was based on data obtained in a series of tests on the mock longwall facility at Bruceton Research Center. It performed well in tests at Bruceton, and in January 1980 was used successfully as the primary horizon control sensor in an automated cut down the longwall face. In tests at York Canyon mine it did not function as reliably for several reasons:

1. The algorithm chosen for interface sensing requires a tachometer signal as one of its input variables. Unfortunately, it was not possible to obtain a direct tachometer signal from either the Joy shearer at Bruceton or the Eickoff shearer at York Canyon mine. Instead, a subsystem was designed to create an artificial tachometer signal, derived from the original telemetered vibration signal. Although the artificial tachometer generator subsystem worked very well at Bruceton, it was less reliable at York Canyon because of the tendency of natural coal and rock to prefracture and fall away in large sections, so that the instrumented pick might experience no cutting forces for several drum rotations. As a result, the tachometer generator would occasionally lose "lock" with the drum rotation for a rotation or two.
2. In addition, the tendency for prefracturing to occur creates unresolvable ambiguities in the signal. Since there may be no rock signal (because of prefracture), even though the drum is high enough for other teeth to be cutting rock, there is no basis (with the existing data) for determining whether or not the shearer is in contact with the roof rock.

It is recommended therefore that wherever possible a direct tachometer signal be obtained from the instrumented shearer. This should eliminate any problems due to inaccurate timing signals.

The signal loss due to prefracture of the roof material is a more difficult problem. An approach which may help resolve the problem is suggested:

Improved interpretive algorithms – since geological formations tend to be relatively smooth over the distances trammed by the shearer during one or two rotations,

a reasonable guess, when the apparent signal changes from rock to coal (particularly if the drum has not been raised during that interval), is that it is due to prefracturing. A good procedure under those circumstances would be to wait for several rotations to confirm that the rock signal does not reappear, before further raising the drum. This could easily be accomplished by a minor change in the control algorithm.

In conclusion, the sensitized pick horizon control sensor system worked very well under actual mine conditions. The tendency of roof rock and coal to prefracture limits the accuracy of the system at present. A "smarter" control algorithm would help eliminate this problem.

Appendix A
Report on Improvements to
Coal Cutting Hardware

GENERAL ELECTRIC

CORPORATE RESEARCH AND DEVELOPMENT

P. O. BOX 8
SCHENECTADY, N. Y. 12301

DIAL COMM 8*236-

Building K1, 2S17
October 9, 1980

Dr. P.T. Wu
37 - 680

Sub: Report of Instrumented Coal Cutting Hardware
Improvements - Transmittal of.

Per your request, I prepared the attached brief report which describes
requested development of the improved design during June and July 1980.

Rn J

R. N. Johnson
Design Engineering

cc: Dr. J. Erkes
R.J. Stupp

REPORT OF
INSTRUMENTED COAL CUTTING HARDWARE IMPROVEMENTS

INTRODUCTION

On June 20, 1980, Design Engineering was requested by Dr. J. Erkes, Manager of Process and Product Diagnostics Program of the Quality Assurance Technology Branch, to assist Dr. P. Wu with redesign and fabrication of the subject hardware to replace equipment damaged during a coal mining test. The function of the equipment is measurement of tangential force transmitted to a commercial single-point tool operating in a coal mine on a rotating drum-type mining machine. The tool holder block (Fig. 1) of the original hardware (Fig. 2), was badly damaged (by compressive yielding) and the brazed carbide tip broken off the tool holder (Fig. 3) during a cutting test. A force transducer had been mounted in a threaded hole in a highly loaded region of the block which significantly reduced the bearing area. An analysis of these forces is attached.

Time was essential. One month was available from the initial communication until the revamped hardware was to be in a New Mexico coal mine for a test (July 21, 1980). The new hardware was delivered to Dr. Wu on July 17, 1980.

DISCUSSION

A visual inspection of the original hardware revealed no evidence of deformation of the tool holder while the block experienced gross compressive deformation, indicating a material of much lower strength. Both parts are standard components for mining equipment and are manufactured by Carmet Co., King's Mountain, N.C. A conversation (Ref.1) with a Carmet engineer revealed that both the tool holder and block should be 4140 steel, hardened to R_C 38-45. In fact, the block should be approximately 3 points harder than the holder. Hardness measurements were performed at CR&D (Physical Metallurgy Branch) on one of each of used and new components :

Tool holders (Ident."T") - $R_C = 33,34$

Tool holder blocks (Ident.3-206) - Below R_C scale

The latter result indicated that the blocks were essentially in the as-forged condition.

Regarding hardware redesign, Dr. Wu suggested measuring cutting forces by having the tool holder bear against a "short" strain-gaged beam mounted in a slot cut across the block, thereby eliminating the transducer. He furnished a bar of highly cold worked 300 series stainless steel for fabrication of the load sensors.

After the block was rough machined, it was heat treated by the K-1 Glassshop per a procedure (similar to other commercial processes) furnished by John Hughes, metallurgist, to achieve hardness in the R_C 38-45 range. A subsequent hardness measurement produced the same result as before, i.e. less than R_C 20. A sample of the block material was sent to the Materials Characterization Branch for analysis.

Result:

<u>Element</u>	<u>In Sample</u>	<u>In 4140 Steel (AISI)</u>
C	0.38%	0.38 - 0.43%
Cr	0.45%	0.80 - 1.10%
Mn	0.77%	0.75 - 1.00%
Si	0.24%	0.20 - 0.35%
Mo	0.26%	0.15 - 0.25%

Note that the measured content of chromium is only approximately half of the specified nominal content which undoubtedly explains the lack of response to heat treatment. Fortunately, in the new design, the bearing area between the beam and block is sufficiently large that yielding did not occur during the New Mexico test, per Dr. Wu.

Two complete assemblies (Fig. 4) were fabricated in the K-1 Machine Shop and delivered to Dr. Wu on July 17, 1980, in time for the scheduled test date.

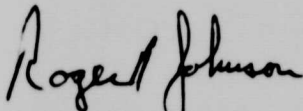

Roger N. Johnson
Design Engineering

Ref. 1 : Memo of telephone conversation with Dan Brown of Carmet Co.
dated 6/26/80.

RNJ:pb
10-6-80

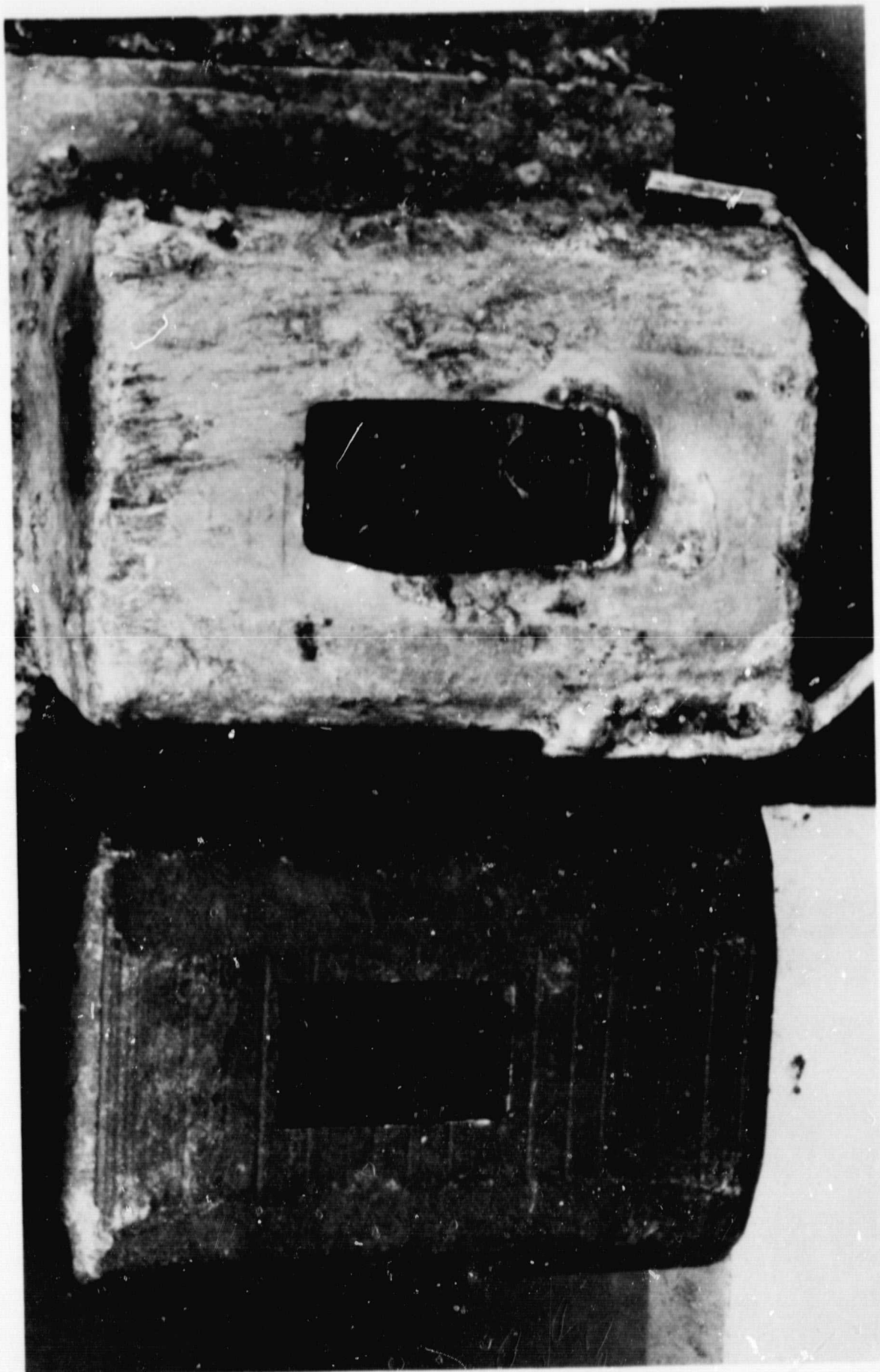

FIGURE 1. TOOL HOLDER BLOCKS

ORIGINAL PAGE IS
OF POOR QUALITY

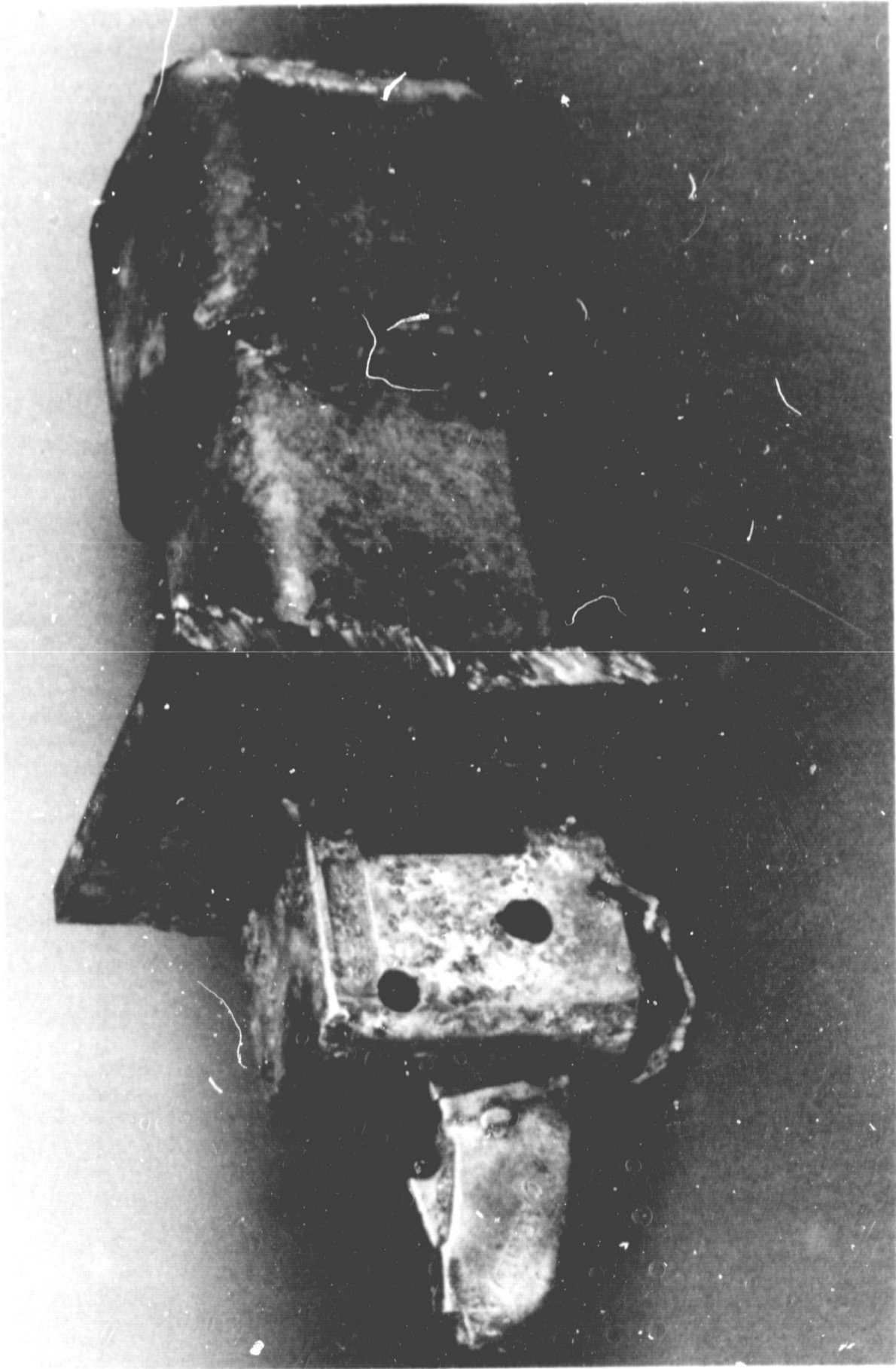

FIGURE 2. ORIGINAL COAL CUTTER ASSEMBLY.

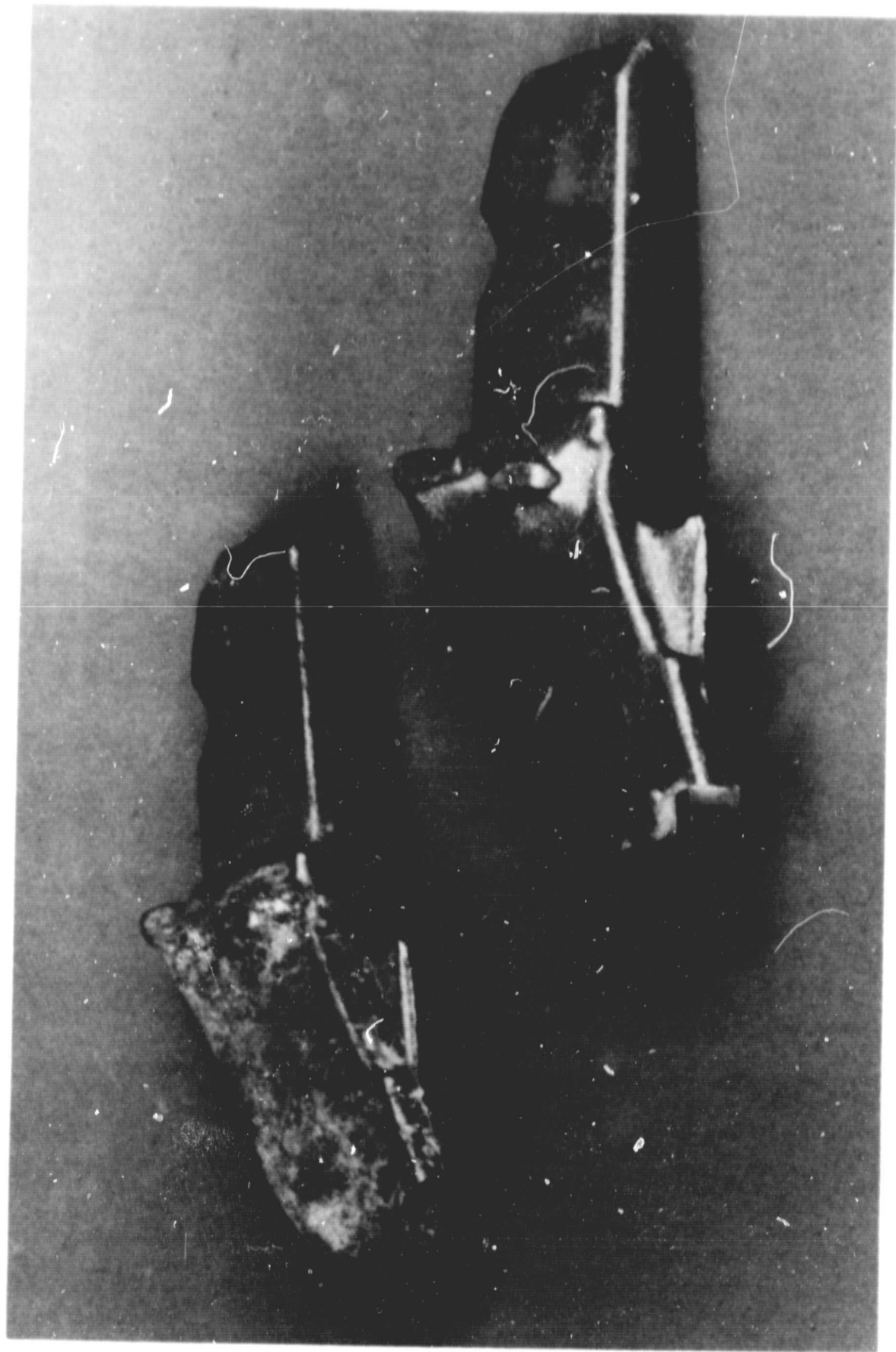

FIGURE 3. TOOL HOLDERS.

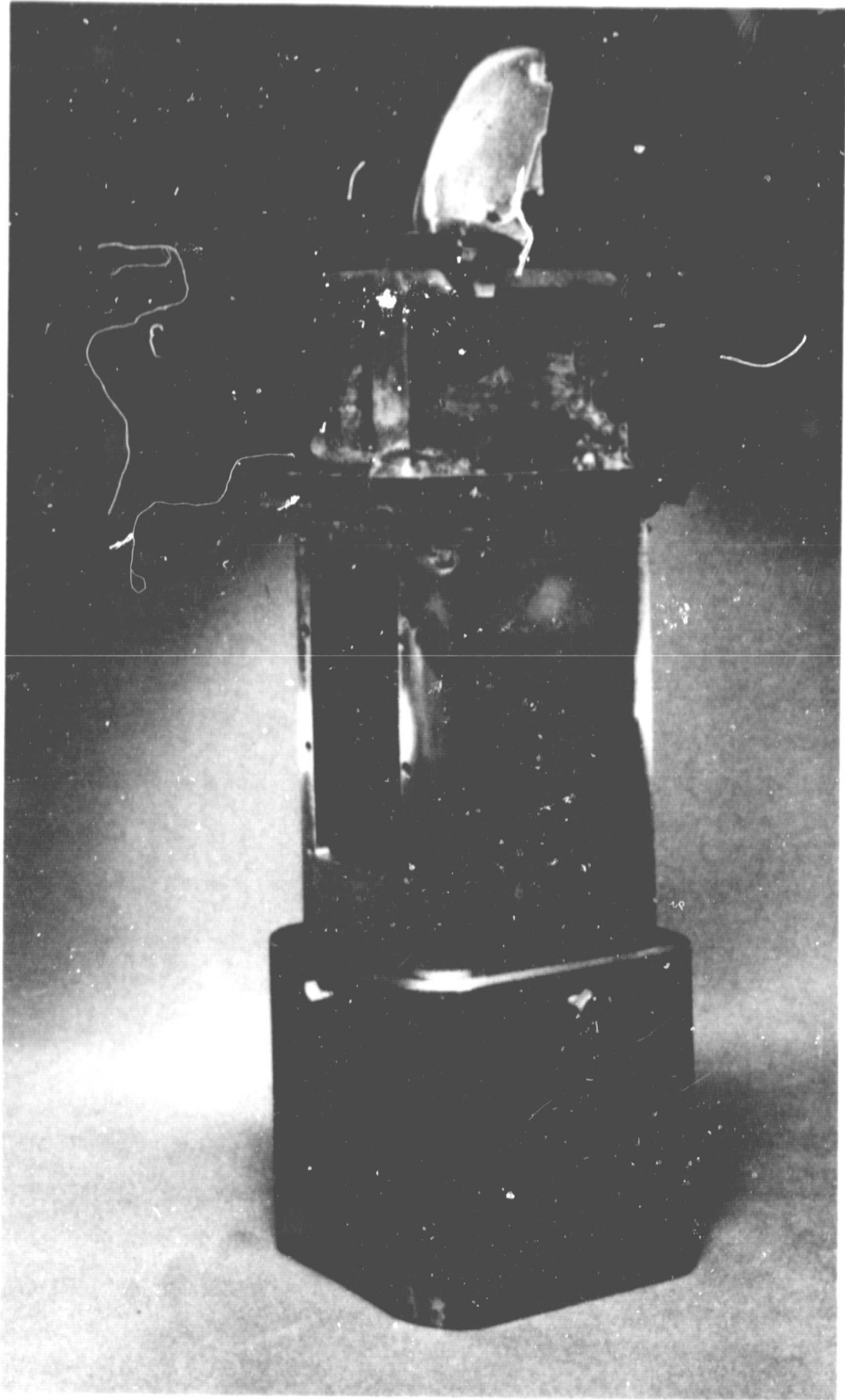
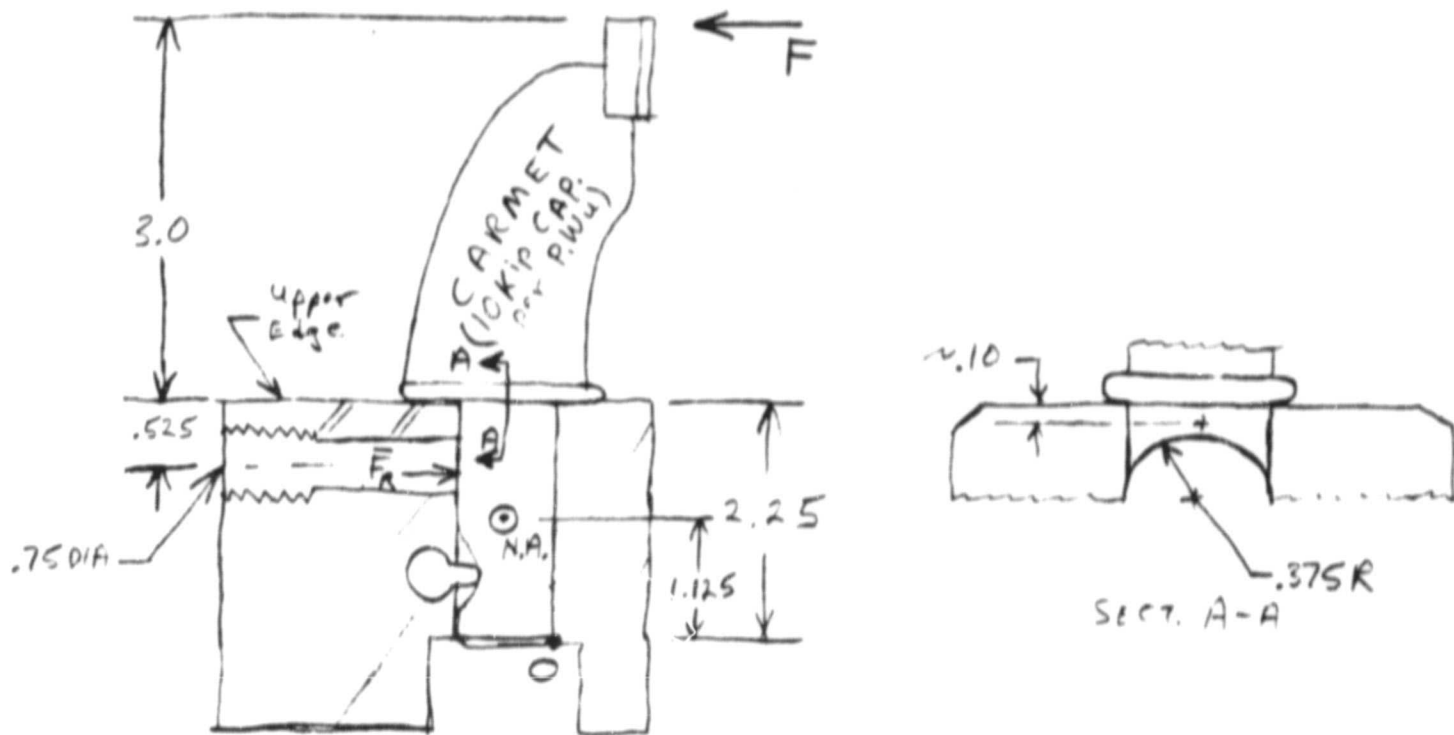

FIGURE 4. IMPROVED COAL CUTTER ASSEMBLY.

Cool Cutter Failure Analysis

6/2/01

1/



EQUIVALENT MOMENT AND FORCE AT N.A.:

$$F = F_{NA} + M_{NA}$$

$$M_{NA} = F \times D_{NA} = (3.0 + 1.125)F = 4.125 F$$

$$M_{NA} = \bar{F}_r \times \frac{h}{2}$$

$$\Rightarrow \bar{F}_r \times \frac{h}{2} = 4.125 F$$

$$h = 2.25$$

$$\bar{F}_r = \frac{8.25 F}{2.25} = 3.67 F$$

$$\bar{F}_R = \bar{F}_r + \frac{F}{2}$$

$$\text{If } F = 10^4 \text{ lb}$$

$$\bar{F}_R = (3.67 + .5) 10^4 \text{ lb} = 4.17 \times 10^4 \text{ lb}$$

$$A = \frac{h}{2} \times W = 1.125" \times 0.75" = 0.84 \text{ in}^2$$

$$\bar{S}_R = \frac{\bar{F}_R}{A} = \frac{4.17 \times 10^4 \text{ lb}}{0.84 \text{ in}^2} = 5.0 \times 10^4 \text{ lb/in}^2$$

At upper Edge assuming no loss in capacity due to the transducer:

$$\text{Max } S_r = 2 \bar{S}_r = 10^5 \text{ lb/in}^2$$

Note: It is most likely that the transducer and .75 dia insert are not as stiff as the base material which could make the bearing stress adjacent to the "upper edge" significantly $> 10^5 \text{ lb/in}^2$

Recommendations

1. Make new tool holder of a tough, weldable alloy having a minimum compressive yield strength of at least 150 KSI.
2. Evaluate smaller diameter force transducer and/or smaller load transfer rod.

Appendix B
MSHA Correspondence

U.S. DEPARTMENT OF LABOR
MINE SAFETY AND HEALTH ADMINISTRATION
4015 Wilson Boulevard
Arlington, Virginia 22203



MAY 14 1978

Mr. William D. Schmidt
Acting Deputy Director
Division of Fossil Fuel Extraction
Department of Energy
Mail Station D-107
Germantown, Maryland 20767

Dear Mr. Schmidt:

This refers to Mr. Thomas J. Fisher's letter of December 1, 1977, requesting an experimental permit for a Coal Seam Interface Detection System to be used on a longwall shearer. The Coal Seam Interface Detection System consists of the following:

1. A GE Vibration CID mounted in an explosion-proof enclosure (XP-1735), Serial No. 001.
2. A B&K Model 4344 Accelerometer previously accepted by MSHA under Permit No. 351, Serial No. 002.
3. A Princeton Applied Research Amplifier, Model PAR 113, with a battery power supply modified for intrinsic safety, all housed within enclosure Serial No. 003.
4. An FM radio link consisting of:
 - a. Inmet T20B and T20G transmitters operated from a 12V intrinsically safe battery power supply and housed within enclosure Serial No. 004.
 - b. Inmet R10A and R10B receivers operated from 6V intrinsically safe battery power supplies and housed within enclosure Serial No. 003.
5. A B and K Model 4344 Accelerometer mounted on a sensitized pick assembly, Serial No. 005.
6. A Load Cell on a sensitized pick assembly, Serial No. 006.
7. A Drum Phase Sensor (Electro Corporation Proximity Switch Model 55505-7), Serial No. 007.
8. A Pick Processor, Serial No. 008.
9. A Tektronix 211 Oscilloscope in an explosion-proof enclosure (X/P-1776) previously accepted by MSHA under Permit No. 351, Serial No. 009.

10. A Lockheed Microphone previously accepted by MSHA under Permit No. 351, Serial No. 010.

11. A mechanical switch box, Serial No. 011.

12. A Lockheed Tape Recorder, modified to be intrinsically safe as per Drawing Nos. 4-1 through 4-20(a), Serial No. 139.

The Mine Safety and Health Administration has examined the subject Coal Seam Interface Detection System and has determined that it meets the requirements of 30 CFR, Section 18.82 provided that it is constructed, wired, and maintained in accordance with drawings and specifications on file at the Approval and Certification Center. A list of those drawings is enclosed.

A complete report of this evaluation is filed under Investigation EP-439 at the Approval and Certification Center.

The enclosed permit labels, No. 439, must be attached to the system component indicated on the label as follows:

1. Vibration CID Component, Serial No. 001.
2. Accelerometer Component, Serial No. 002.
3. PAR 113 Amplifier and Inmet Receiver Component, Serial No. 003.
4. Transmitter Component, Serial No. 004.
5. Accelerometer/Sensitized Pick Component, Serial No. 005.
6. Load Cell Component, Serial No. 006.
7. Drum Phase Sensor Component, Serial No. 007.
8. Pick Processor Component, Serial No. 008.
9. Oscilloscope Component, Serial No. 009.
10. Microphone Component, Serial No. 010.
11. Mechanical Switch Component, Serial No. 011.
12. Tape Recorder Component, Serial No. 139.

The Mine Safety and Health Administration reserves the right to rescind for cause, at any time, the permission to use this Coal Seam Interface Detection System.

Sincerely,

Signed Robert B. Lagather

Robert B. Lagather
Assistant Secretary for
Mine Safety and Health

Enclosures

cc: R. B. Lagather (w/copy incoming & enclosure)
D. P. Schlick (w/copy incoming & enclosure)
E. R. Palowitch, DOE
M. J. Pazuchanics, DOE ✍
S. G. Sawyer
R. E. Marshall
R. P. Lenart
D. M. Abel
P. C. Zingo
Files (EP-439)
A&CC
MT Files (w/copy incomings)
MSHA Files, Room 737, Code 5001, Permit (w/incoming)

MSHA:MT:A&CC:RABradburn:pcz:FTS-923-1039

<u>TITLE</u>	<u>DRAWING NO.</u>	<u>REVISION</u>
Meter Amplifier Schematic	4-11	-
Resistor Board Schematic	4-12	-
Voice Trac Record Amplifier Schematic	4-15	-
Voice Track Reproduce Amplifier Schematic	4-16	-
Remote Control Schematic	4-17	-
Current Limited Battery Power Supply	4-20	-
SCR Crowbar for Encore Current Limiter	4-20(a)	-
FM Record Speed Module (15ips)	4-21	-
FM Reproduce Speed Module (15ips)	4-22	-
Direct Reproduce Speed Module (15ips)	4-23	-
Schematic of B and K 4344 Accelerometer and its equivalent electrical circuit	5	-
Schematic for Voice Microphone of the Tape Recorder	6	-
Drum Mounted Sensitized Pick Data Transmitting System	7	-
Electro Corp. Model 55505-7 Proximity Switch Circuit Diagram	8	-
Coal Seam Sensor Electronics for Sensitized Pick	9	1/24/80
Labeling	10	-



Permit 439

Issued to DOE-Pgh. Mining Tech. Cntr.

Date of Expiration Indefinite

Instrument Coal Seam Interface Detection

Model/Serial No. 001 Vibration CID Component
System



Permit 439

Issued to DOE-Pgh. Mining Tech. Cntr.

Date of Expiration Indefinite

Instrument Coal Seam Interface Detection

Model/Serial No. 002 Accelerometer Component
System



Permit 439

Issued to DOE-Pgh. Mining Tech. Cntr.

Date of Expiration Indefinite

Instrument Coal Seam Interface Detection

Model/Serial No. 003 PAR 113 Ampl. and Inmet
Receiver Component.

ORIGINAL PAGE IS
OF POOR QUALITY



Permit 439
Issued to DOE-Pgh. Mining Tech. Cntr.
Date of Expiration Indefinite
Instrument Coal Seam Interface Detection
Model/Serial No. 004 Transmitter Component System

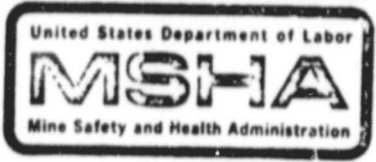

Permit 439
Issued to DOE-Pgh. Mining Tech. Cntr.
Date of Expiration Indefinite
Instrument Coal Seam Interface Detection
Model/Serial No. 005 Accelerometer/Sensitized System
Pick Component



Permit 439
Issued to DOE-Pgh. Mining Tech. Cntr.
Date of Expiration Indefinite
Instrument Coal Seam Interface Detection
Model/Serial No. 006 Load Cell Component System



Permit 439

Issued to DOE-Pgh. Mining Tech. Cntr.

Date of Expiration Indefinite

Instrument Coal Seam Interface Detection

Model/Serial No. 007 Drum Phase Sensor
Component System



Permit 439

Issued to DOE-Pgh. Mining Tech. Cntr.

Date of Expiration Indefinite

Instrument Coal Seam Interface Detection

Model/Serial No. 008 Pick Processor
Component System



Permit 439

Issued to DOE-Pgh. Mining Tech. Cntr.

Date of Expiration Indefinite

Instrument Coal Seam Interface Detection

Model/Serial No. 009 Oscilloscope
Component System



Permit 439

Issued to DOE-Pgh. Mining Tech. Cntr.

Date of Expiration Indefinite

Instrument Coal Seam Interface Detection
System

Model/Serial No. 010 Microphone Component



Permit 439

Issued to DOE-Pgh. Mining Tech. Cntr.

Date of Expiration Indefinite

Instrument Coal Seam Interface Detection
System

Model/Serial No. 011 Mechanical Switch
Component



Permit 439

Issued to DOE-Pgh. Mining Tech. Cntr.

Date of Expiration Indefinite

Instrument Coal Seam Interface Detection
System

Model/Serial No. 139 Tape Recorder Component

GENERAL ELECTRIC

APPENDIX II

GENERAL ELECTRIC COMPANY, RESEARCH AND DEVELOPMENT CENTER, P.O. BOX 43
SCHENECTADY, NEW YORK 12301, Phone (518) 385-2211

CORPORATE
RESEARCH AND
DEVELOPMENT

Building 37, Room 680
July 19, 1979

cc: R. Bradburn, MSHA
4800 Brobes Ave., Bldg. F
Pittsburgh, PA 15213
F. Ahlgren, CRD 37-680
B. Darrel, CRD 37-680

Mr. Michael J. Pzauchanics
Dept. of Energy
Pittsburgh Energy Research Center
4800 Farbes Ave.
Pittsburgh, PA 15213

Dear Mr. Pazuchanics:

The following is information requested by MSHA for the approval process of in mine use of test equipments for the NASA/DOE-GE vibrational CID contract work. This information is referenced to letters from me to Robert Bradburn of MSHA dated 4/23/79 and from Robert L. Lenart of MSHA to M. Pazuchanics dated 5/11/79.

1. Overall system (Figure I of letter from P. Wu to R. Bradburn)
 - (a) A schematic drawing of the B&K 4344 accelerometers and its equivalent electrical circuit is shown in Figure 1. Also shown in Figure 1 is the resistance and capacitance of the accelerometers.
 - (b) The cable entering the oscilloscope housing (XP-1776) is not a RG58/U (a mistake in the drawing). Rather, it is a coaxial cable of 1/4" in diameter. The cables entering the Hubbell enclosure (XP-1735) are RG58/U of 3/8" diameter and BELDOW8445 of 5/16" diameter.
 - (c) The microphone that provide voice comment to the Lockheed tape recorder is made by Shure Brother Inc. (Model 488A). The circuit diagram is shown in Figure 2.
2. GE Vibration CID sub-system (Figure II of letter from P. Wu to R. Bradburn).

The 100 PF capacitor which couples the accelerometer to the vibration sensor amplifier is replaced with a Centralab's high voltage disk capacitor rated 100 PF at 3000 VDCW, +20% tolerance.
3. PAR AMPLIFIER (Figure IV-5 of letter from P. Wu to R. Bradburn).

The voltage that appears across C101 (100 μ F) capacitor is normally 4.2 volt. However, if:

GENERAL ELECTRIC

Mr. Michael J. Pzauchanics

-2-

July 19, 1979

- (a) Q102 shorted from emitter to collector, this voltage becomes 9.6 volt.
 - (b) Q103 shorted from emitter to collector, it becomes 6 volts.
 - (c) Q104 shorted from emitter to collector, it becomes 4.2 volts.
- None of the voltage measured above exceeds 12 volts.

4. PAR Amplifier (continue) (Figure III-6 of letter from P. Wu to R. Bradburn).

The voltage across C202 normally is 3.9 volts.

However, if

- (a) Q202 shorted from emitter to collector, it becomes 5.8 volts.
- (b) Q203A shorted from collector to base, it becomes 7.1 volts.
- (c) Q203B shorted from collector to base, it becomes 7.5 volts.
- (d) Q206 shorted from collector to emitter, it becomes 2.2 volts.

5. PAR Amplifier (continue) Figure III-7 of letter from P. Wu to R. Bradburn)

The battery current can be limited to 0.7 amp in both the positive and negative leg by insert WW resistor of 50 Ω or more without interference with the normal function of the amplifier.

6. Lockheed Tape Recorder

The inductance and resistance of each inductive element except the recorder head in the Lockheed tape recorder have been measured using a General Radio Impedance bridge Type 1650-B. The inductances for the recorder head are furnished by Lockheed. These values together with the readable tolerance from capacitors rated 1 μ F or higher is listed in Table 1 following the order as they appear in the schematic of the tape recorder. Some of the tolerance of capacitance are not printed on the capacitor. We can further measure them if necessary. This involves further disassembling of the circuitry of the tape recorder which is highly undesirable.

7. Lockheed Tape Recorder (Figure IV-1 of letter from P. Wu to R. Bradburn)

- (a) Two 10 Ω , +1% WW resistor have been inserted in series with capacitors C8 and C9 and the common connection between the capacitor and resistor is insulated.
- (b) Battery package BT1 have been replaced by specially designed battery package made by ENCORE Electron Inc. The totally potted battery package contains dual redundant active current limiting circuit. The specification sheet is shown in Figure 3 and circuit diagram is shown in Figure 4.

GENERAL  ELECTRIC

Mr. Michael J. Pzauchanics

-3-

July 19, 1979

8. Lockheed Tape Recorder (Figure IV-3 of letter from P. Wu to P. Bradburn).

A 5Ω , $\pm 1\%$ WW resistor have been inserted in series with capacitor C3 for protection. The common connection between the capacitor and the resistor is insulated.

9. Lockheed Tape Recorder (Figure IV-9 of letter from P. Wu to R. Bradburn)

The value of capacitor C7 is misprinted as 1000 (μF) on the drawing. The examination of the tape recorder shown that C7 is actually a 1000 PF capacitor. Because of its small capacitance, it may not need protection.

10. Lockheed Tape Recorder (Figure IV-13 of letter from R. Lenart to M. Pzauchanics).

There is no such drawing on the owner's instruction manual for the particular tape recorder we want to use in the mine because we will be operated from battery power supply. Figure B-13 is schematic for auxiliary power supply which convert 110 VAC to DC power.

11. Lockheed Tape Recorder (Figure IV-14 of letter from P. Wu to R. Bradburn).

This schematic is for DC-DC converter. Again, the tape recorder we want to use in the mine does not have this because we use battery power supply.

12. Lockheed Tape Recorder (Figure IV-15 of letter from P. Wu to R. Bradburn).

There are only two indicator bulbs on the tape recorder. They were both No. 327 bulbs by GE rated 40 mA at 28 volts.

If MSHA request more information about the system or have any questions, please feel free to call me.

Sincerely yours,

Peter Wu

P. Wu
Staff Member, CRD
General Electric Co.
Bldg. 37, Room 680
1 River Rd.
Schenectady, NY 12345
Tel: (518) 385-9768

PW:jsb
Enclosures

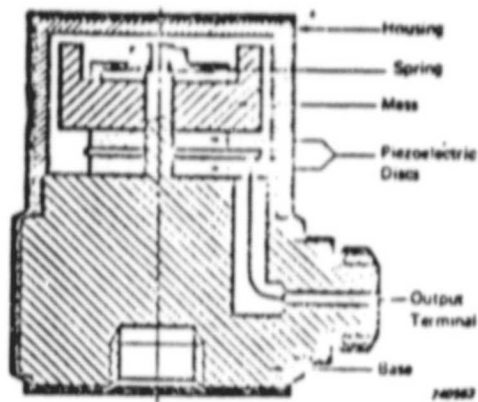

Schematic of piezoelectric accelerometer

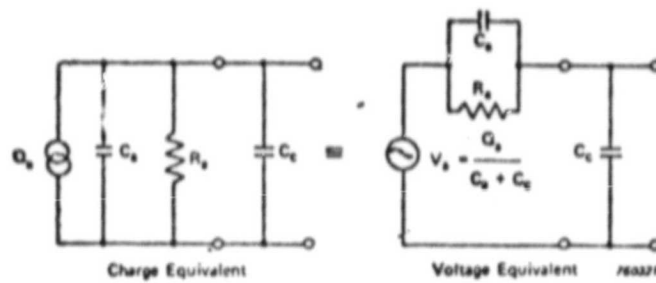

Equivalent circuits of piezoelectric accelerometer with connection cable

C_c = Cable capacitance = 103 PF

C_a = Capacitance of the sensing element = 993 PF

R_a = (Resistance over the crystal) > 20,000 M Ω at room temp.

Voltage sensitivity 3.14×10^{-3} v/g

Charge sensitivity 3.44 pc/g

FIGURE 1. Schematic of B&K 4344 accelerometer and its equivalent electrical circuit.

ORIGINAL PAGE IS
OF POOR QUALITY

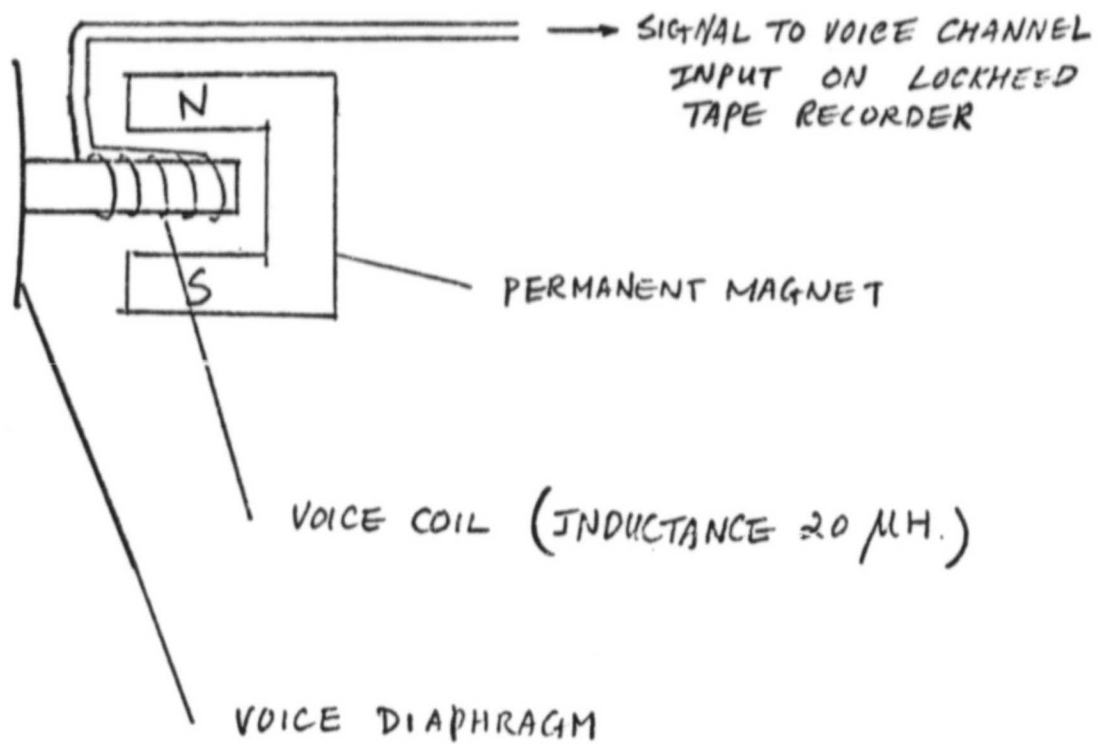

FIGURE 2. Schematic for voice microphone of the tape recorder.



ENCORE
ELECTRONICS, INC.

R. D. 2, MAPLE AVENUE
SARATOGA SPRINGS, NEW YORK 12866

(516) 584-5354

FIGURE 3. SPECIFICATIONS
EN221 ELECTRONIC CURRENT LIMITER

INPUT VOLTAGE RANGE: 2 to 40V DC at full load.

LOAD CURRENT RANGE: 0 to 0.75A DC full load.

CURRENT LIMIT & SHORT CIRCUIT CURRENT: $0.9A \pm 0.1A$.

MAX. POWER DISSIPATION: 5 watts continuous 36 watts momentary.

INPUT/OUTPUT VOLTAGE DIFFERENTIAL: 1.5V MAX. @ FL.

CONTROLS: OFF/O.N Toggle.

UNDERVOLTAGE INDICATOR LED: Extinguishes when output is less than 18V DC.

MECHANICAL:

SIZE: 4" L x 2 1/8" W x 1 5/8" H.

WEIGHT: 5 ounces.

CONNECTIONS: Three terminal barrier strip for + input, common, and + output.

January, 1976

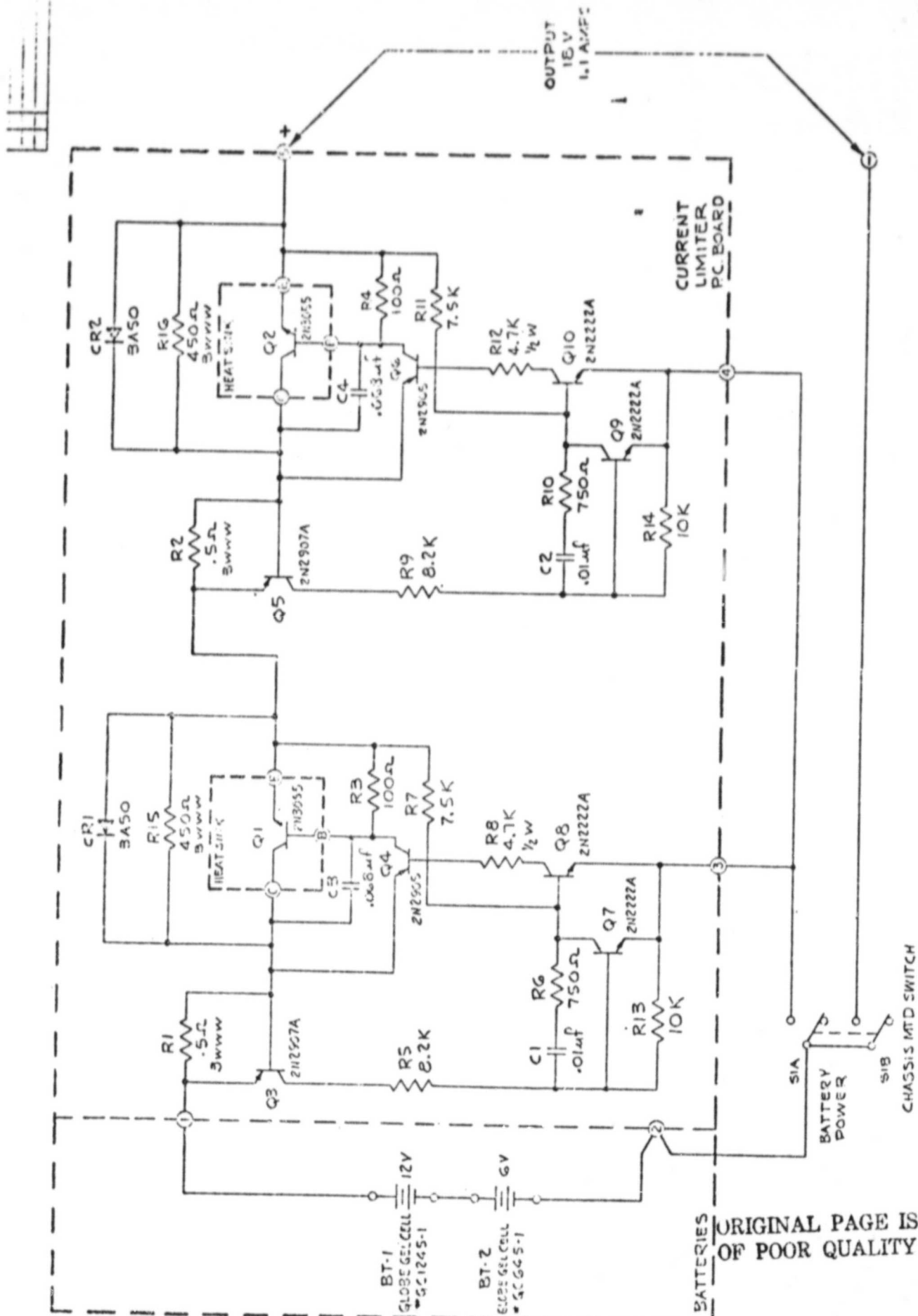

FIGURE 4. Schematic for the battery package BT1.

ENCORE ELECTRONICS, INC. SARATOGA SPRINGS, N. Y. 12158	DATE: 12-02	BY: BBA-005	SCALE: 1/16
JOB MATERIAL	DESIGNER	DATE: 12-02	BY: BBA-005
ENCORE ELECTRONICS, INC.	ENCORE ELECTRONICS, INC.	ENCORE ELECTRONICS, INC.	ENCORE ELECTRONICS, INC.
ENCORE ELECTRONICS, INC.	ENCORE ELECTRONICS, INC.	ENCORE ELECTRONICS, INC.	ENCORE ELECTRONICS, INC.

NOTE(S):
1. UNLESS OTHERWISE SPECIFIED ALL RESISTORS TO BE METAL FILM OR WIRE WOUND
2. POTTING MATERIAL: BLM CO.

ENCORE ELECTRONICS, INC. 12/2/72

TABLE I. INDUCTANCE & CAPACITANCE OF THE PARTS IN LOCKHEED 417D RECORDER

Reference Figure	Inductive Element		Measured Resistance	Capacitor Over 1 μ F		Rated Voltage (VDC)
	Code	Measured Inductance		Code	Capacitance Tolerance	
Fig. IV-1 System Schematic	RWD Motor B1	3.86 mH	36.5 Ω	C8	500 μ F Unknown	25
	RWD Motor B2	3.5 mH	44.7 Ω	C9	500 μ F Unknown	25
	L1, L2, L3, L4, L5	30 μ H	2.8 Ω			
	Cap Motor B3	0.57 mH	9.8 Ω			
Magnetic pick-up Of B3						
Fig. IV-2 Control Schematic	T1, T2	30 mH	70.9 Ω	C5, C6	47 μ F Unknown	25
	Tap 1 to 3 Tap 4 to 6	16 mH	9.9 Ω	C7, C8, C9	500 μ F -10% +150%	25
Fig. IV-3 Servo Schematic	Relay K1 & K2	6.5 mH	154.7 Ω	C3	35 μ F Unknown	25
	Tap 1 to 5 Tap 6 to 12	6.2 mH	154.7 Ω	C14, C15, C17	8 μ F Unknown	25
	Relay K3	55mH	161.5 Ω	C1, C12	10 μ F +10%	15
	Relay K4	58mH	161.5 Ω	C13	20 μ F Unknown	16
	Relay K5	56.5 mH	161.5 Ω			
	Relay K6	54 mH	161.5 Ω			
	Relay K7	39 mH	689 Ω			
Fig. IV-3 Servo Schematic	L 1	63 mH	23.3 Ω	C2	68 μ F +10%	15
				C3	3.3 μ F +10%	15
				C11	39 μ F +10%	10
				C8	33 μ F +10%	10

TABLE I (Continued)

Reference Figure	Inductive Element		Measured Inductance	Measured Resistance	Code	Capacitor Over 1 μ F		Rated Voltage (VDC)
	Code	Inductance				Capacitance	Tolerance	
Fig. IV-4 Direct Record Schematic					C2, C7	3.3 μ F	+10%	15
					C8	3.9 μ F	+10%	10
					C3, C5, C6	10 μ F	+10%	20
					C4	68 μ F	+10%	15
Fig. IV-5 Direct Reproduce Schematic					C18	100 μ F	Unknown	16
					C7	200 μ F	Unknown	12
					C21	75 μ F	Unknown	15
					C3, C19, C20	22 μ F	+10%	15
					C6, C10, C13	10 μ F	+10%	20
					C1	1 μ F	+10%	35
					C11	3.9 μ F	+10%	10
					C15	3.3 μ F	+10%	15
				C14	6.8 μ F	+10%	6	
Fig. IV-6 FM Record Schematic	L1	12.5 mH	14.7 Ω	C11, C12, C4	1 μ F	+10%	35	
	L2	15 mH	43.9 Ω	C6	35 μ F	Unknown	25	
				C1, C5	47 μ F	Unknown	20	
Fig IV-7 FM Reproduce Schematic	L1	120 mH	183 Ω	C2, C4, C6	1 μ F	+10%	35	
	L2	44 μ H	6.9 Ω	C8, C16	10 μ F	+10%	20	
				C9, C10	22 μ F	+10%	15	
Fig. IV-8 Head Assembly Schematic	Record head	3.4 mH \pm 5%	10 Ω	C3	68 μ F	Unknown	15	
	Track 1-8			C14	8 μ F	Unknown	25	
	Reproduce head	less than	80 Ω					
Fig. IV-9 BIAS Oscillator Assembly Schematic	Track 1-8	100 mH						
	L1	380 μ H	3.3 Ω					
	TI & Blue to Blue	71 μ H	0.7 Ω					
	T2	41 μ H	0.6 Ω					
	Brown to White	1.44mH	12.5 Ω					

TABLE I (Continued)

Reference Figure	Inductive Element		Measured Inductance	Measured Resistance	Capacitor Over 1 μF		
	Code	Code			Code	Capacitance	Tolerance
Fig. IV-10 BIAS TRAP Schematic	L1		0.26 mH	7.4 Ω			
	L2		0.27 mH	7.6 Ω			
	L3		0.26 mH	7.4 Ω			
	L4		0.27 mH	7.4 Ω			
	L5		0.35 mH	11.1 Ω			
	L6		0.28 mH	8.1 Ω			
	L7		0.27 mH	7.5 Ω			
Fig. IV-11 Meter Amplifier Schematic		C3			330 μF	Unknown	6
		C4			22 μF	Unknown	15
		C5, C6			10 μF	Unknown	20
Fig. IV-15 Voice Track Record Amplifier Schematic		C2			2.2 μF	+10%	20
		C5, C6			100 μF	+10%	20
		C7			22 μF	+10%	35
Fig. IV-16 Voice Track Reproduce Amplifier Schematic		C6			1 μF	Unknown	20
		C1, C3			10 μF	Unknown	20
		C8, C9, C14			100 μF	+10%	20
		C15			22 μF	+10%	20
		C2			47 μF	+10%	20
	C5			1.8 μF	Unknown	20	

ORIGINAL PAGE IS
OF POOR QUALITY

U.S. DEPARTMENT OF LABOR
MINE SAFETY AND HEALTH ADMINISTRATION
APPROVAL AND CERTIFICATION CENTER

R. R. 1, Box 201B
Industrial Park Blvd.
Triadelphia, West Virginia 26039



SEP 06 1979

Department of Energy
Pittsburgh Energy Research Center
Attn: Mr. Michael J. Pazuchinics
4800 Forbes Avenue
Pittsburgh, PA 15213

Reply to Attn of
MSHA:A&CC PAR21626

*Received 9/17/79
1 00*

Dear Mr. Pazuchanics:

With reference to your request for an experimental permit to use a Horizon Control Sensor for Longwall Mining, the following items are required to continue the investigation in addition to those items submitted to you in my letter of May 11, 1979:

A. Many of the components are not intrinsically safe under specified fault conditions. The following is a listing of the components and suggested remedies:

1. Figure IV-1. Capstan Motor. Insert two appropriately rated reverse-biased diodes across the motor at the brush terminals, if practical, or as close as possible to the brush terminals.
2. Figure IV-1. Other motors. Insert one diode across all other motors in the same manner as above.
3. Figure IV-2. Relays K1 through K7. Insert one reverse-biased diode across each relay coil near the coil terminals.
4. Figure IV-3. Capacitor C8 (500 microfarad) and C9 (500 microfarad). Insert a 6 ohm (minimum) resistor in series with each of the capacitors. Insulate common connection between resistor and capacitor.
5. Figure IV-4. Capacitor C4 (68 microfarad). Insert 6 ohm (minimum) resistor in series with C4 in same manner as above.
6. Figure IV-5. Capacitor C7 (200 microfarad) and C21 (75 microfarad). Insert 6 ohm (minimum) resistor in series with these capacitors in same manner as above.

7. Figure IV-5. Capacitor C18 (100 microfarad) and R33 (100 ohm). Assure that the common connection between those components is well insulated to preclude shorting the capacitor terminal to ground.
 8. Figure IV-6. Capacitors C1 (47 microfarad), C5 (47 microfarad), and C6 (35 microfarad). Insert a 6 ohm (minimum) resistor in series with each of those capacitors. Insulate the common connection between the resistor and capacitor in each case.
 9. Figure IV-7. Capacitor C3 (68 microfarad). Insert a 6 ohm resistor in series in same manner as above.
 10. Figure IV-16. Capacitor C2 (47 microfarad) and C14 (100 microfarad). Insert 6 ohm resistors in the same manner as above.
- B. Submit a schematic diagram or other descriptive drawing on the Speed Module which appears on several of the Lockheed drawings.
- C. Figure IV-15. Submit inductance and resistance specifications on inductor L1.
- D. Figure IV-10. Verify whether the values of the capacitors are rated in picofarad or microfarad.
- E. Reference the applicable figure numbers in the blocks of figure IV-1.
- F. On figure IV-14 indicate that this circuit is not used.
- G. All added protective resistors must be wirewound or metal film.
- H. Label all drawings with the following warning labels:
1. "Do not change without MSHA approval".
 2. "Warning: Any substitution, addition, or elimination of components may result in an unsafe condition".
- I. Send the battery power supply used with the Lockheed tape recorder to the Approval and Certification Center for testing.
- J. Document all changes on the appropriate drawings.
- K. Place a warning label on each enclosure stating - "Warning: Any substitution, addition, or elimination of components may result in an unsafe condition".

L. The complete system will be inspected by MSHA-A&CC. Preferably, this will take place at Bruceton.

M. Assign drawing numbers to each of the drawings. Preferably, the same numbers as presently used for designating the figures will be assigned except Arabic numerals should replace the Roman numerals.

N. If none exists, install an appropriately rated fuse in series with the battery used with the Lockheed tape recorder. Label the fuse holder with the fuse rating.

If you have any questions in regard to the above information, contact the investigator assigned to this project, Robert A. Bradburn, at (304) 547-0400, extension 26, or FTS 923-1039.

Sincerely,

Robert P. Lenart

Robert P. Lenart
Chief, Intrinsic Safety and Instrumentation Branch

cc: Files
A&CC
T.K. Wu, G.E. *A&B 9/4/79*

MSHA:A&CC:RABradburn:pcz:9/4/79

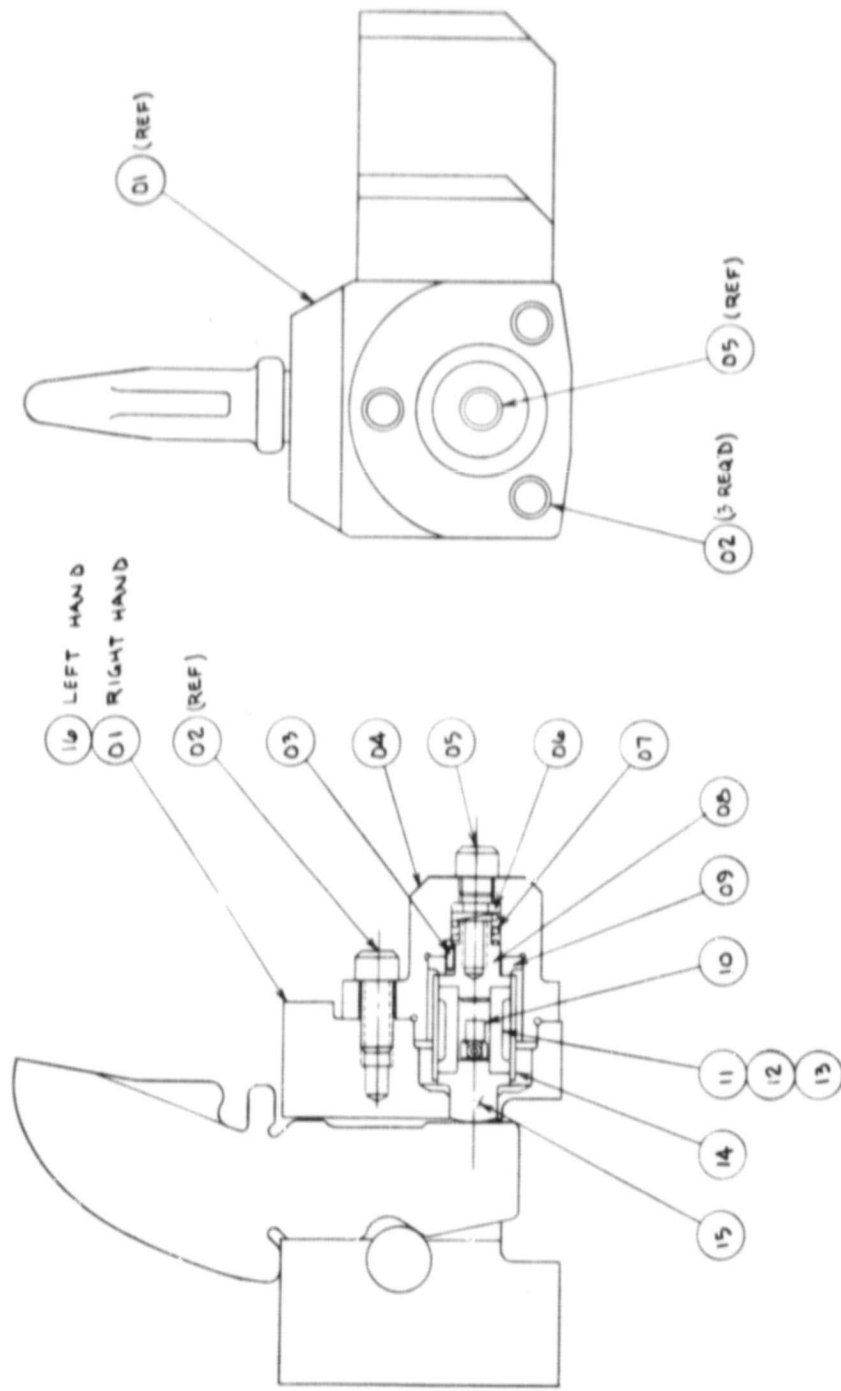

01 LEFT HAND
01 RIGHT HAND

G1 RIGHT HAND
G2 LEFT HAND

2-3

SHAKER RESEARCH CORPORATION <small>INCORPORATED IN CALIFORNIA 1950</small>		ASSEMBLY, INSTRUMENTED <i>PKK</i>	
<small>DIMENSIONAL TOLERANCES UNLESS OTHERWISE SPECIFIED DECIMAL FRACTIONS</small> <small>FRACTIONS BY 16</small> <small>ANGLES BY 5</small> <small>UNLESS OTHERWISE SPECIFIED</small> <small>UNLESS OTHERWISE SPECIFIED</small>		<small>DATE</small> 7/28/57	<small>SCALE</small> 1/1
<small>DRAWN</small> G.W.K.	<small>CHECKED</small> W.D.W.	<small>ISSUED</small> 1/1	<small>DRAWING NUMBER</small> 117-C-125
<small>REWORK ALL DIMS</small>		<small>EO</small>	<small>REV</small>

Figure 1. Original Shaker Research Labs design

SENSITIZED PICK/BLOCK DESIGN

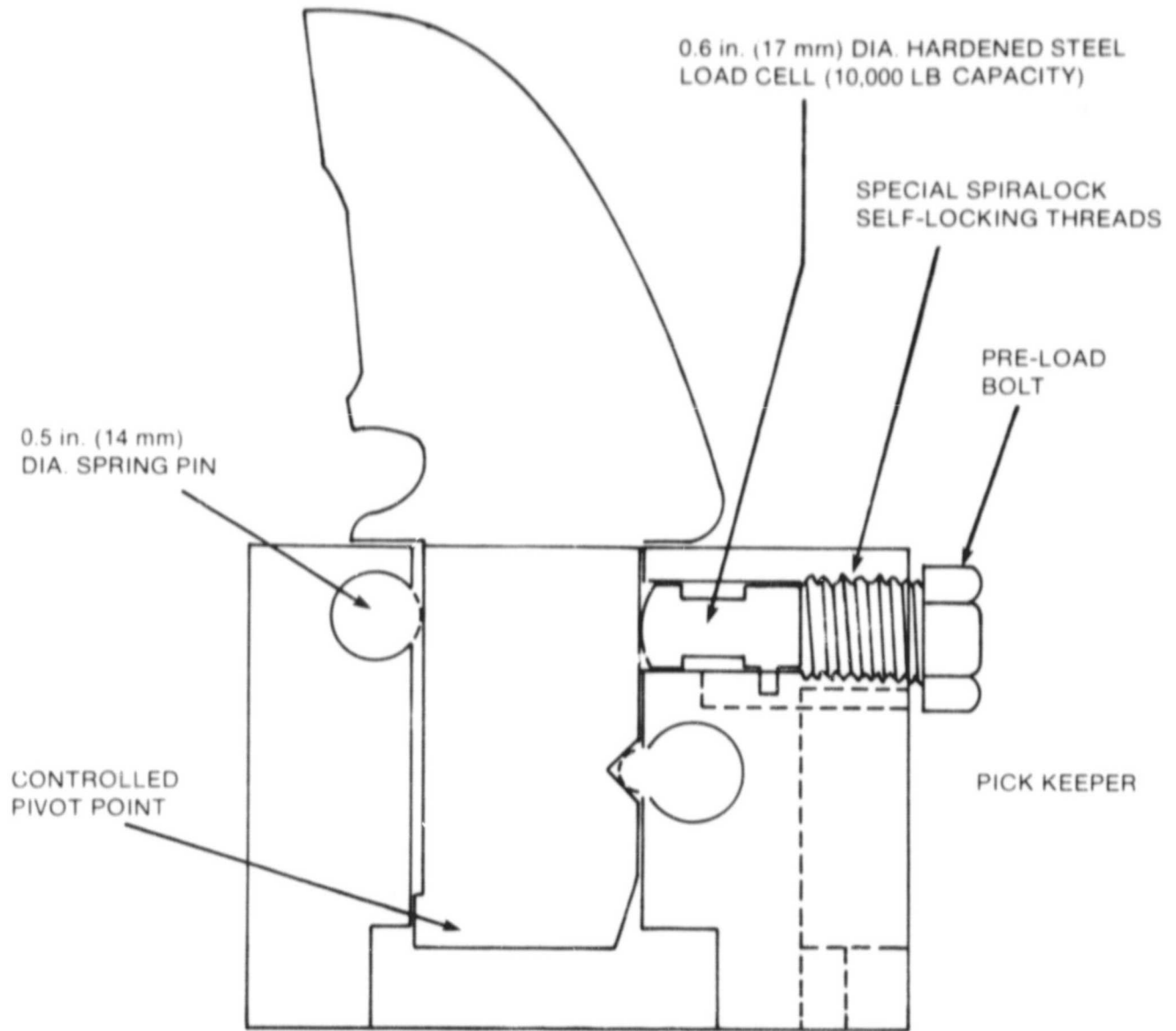

Figure 2. Modified pick design

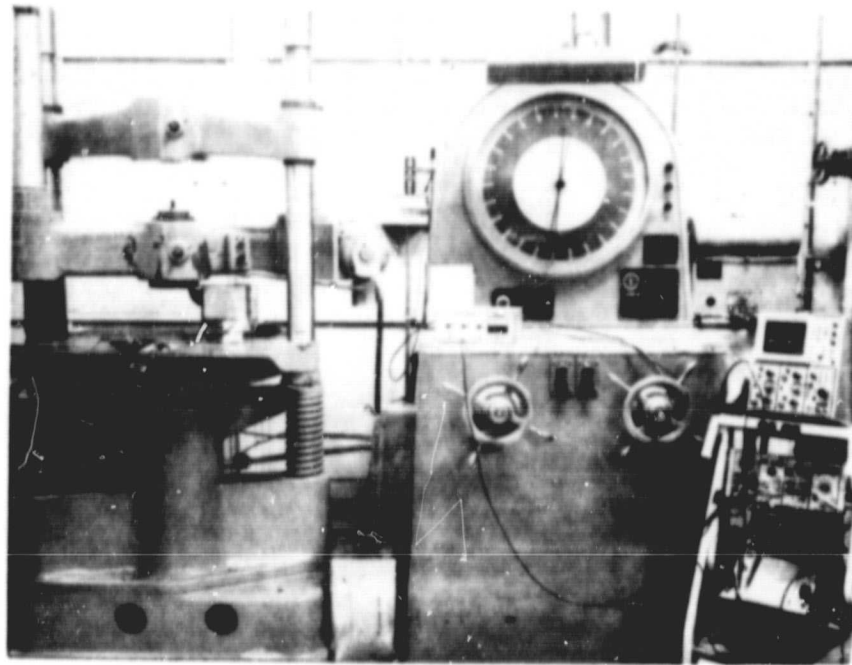

Figure 3. Photograph of facilities for static test of the sensitized pick

ORIGINAL PAGE IS
OF POOR QUALITY

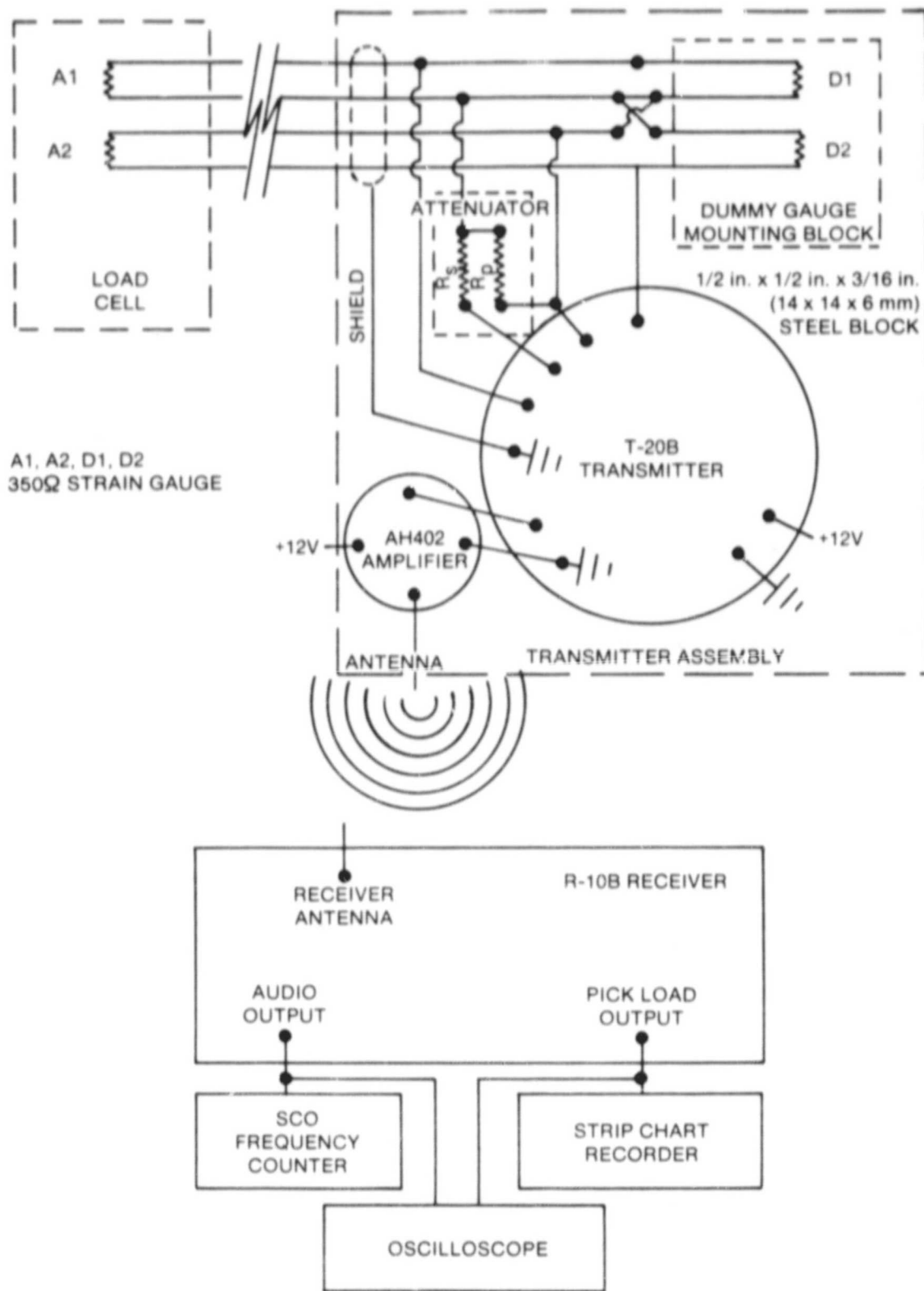

Figure 4. Instrumentation for calibration of the load cell and sensitized pick

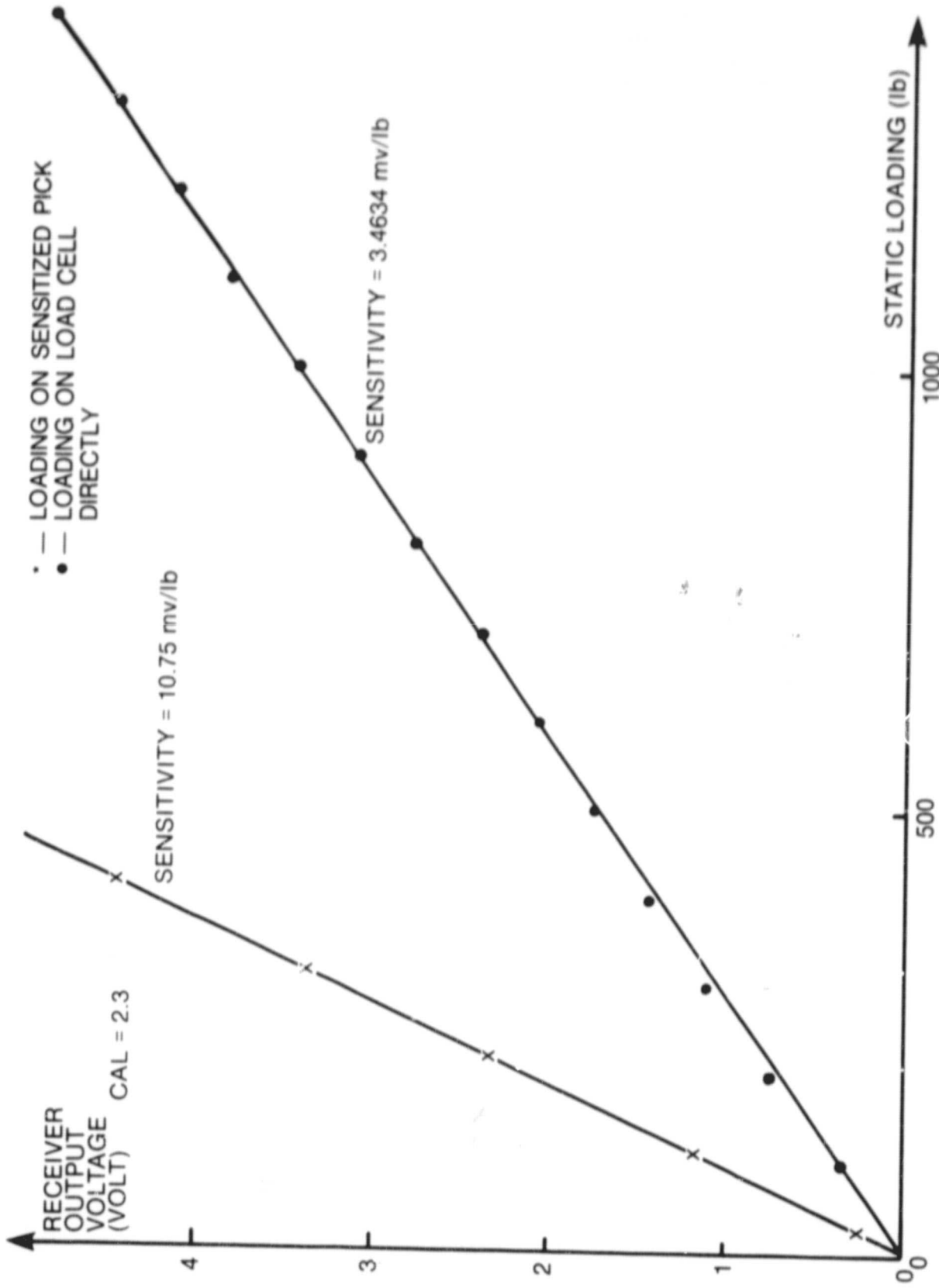

Figure 5. Receiver output calibration curves for load cell alone and sensitized pick

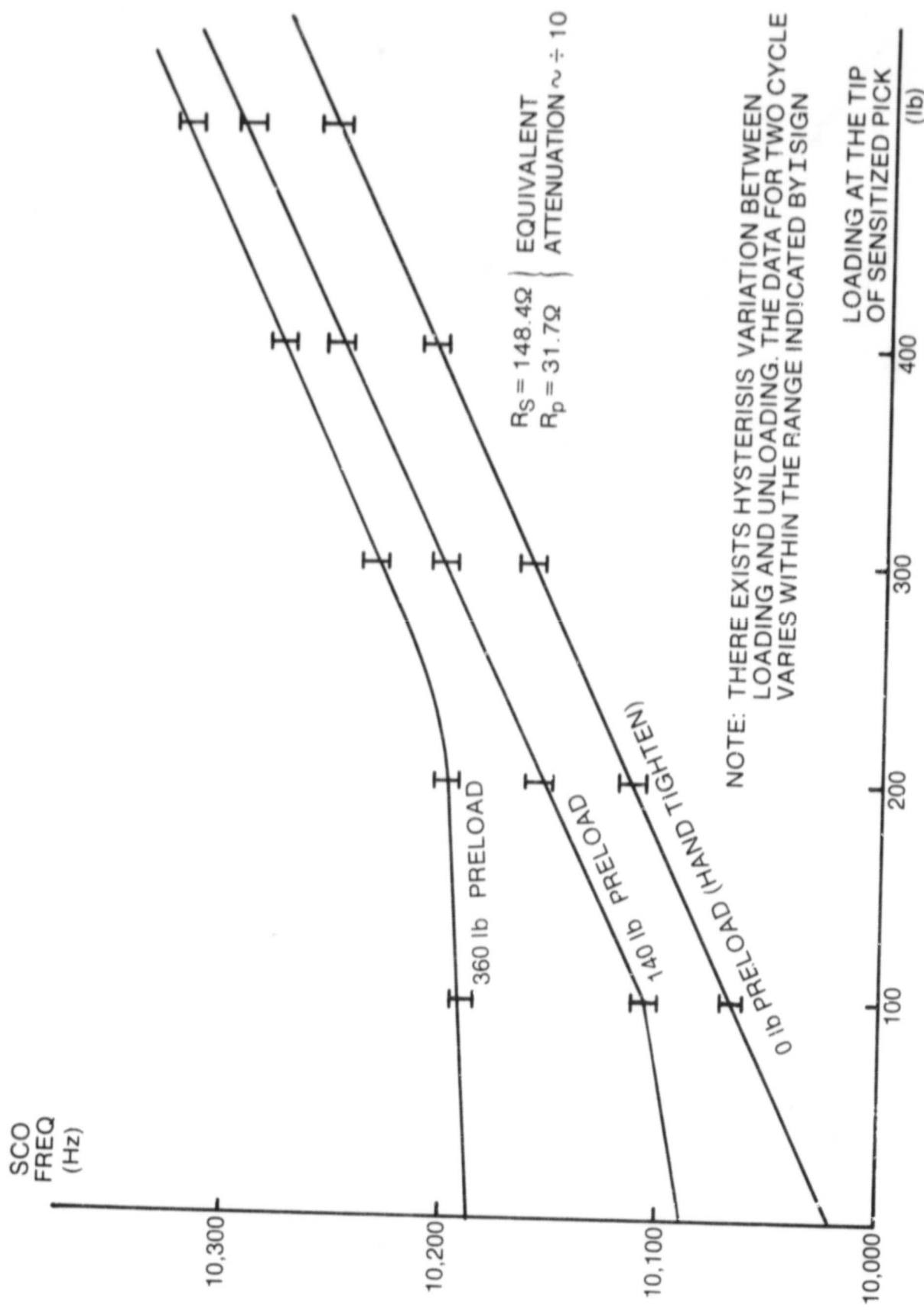

Figure 6. SCO frequency vs. loading on sensitized pick for different preload

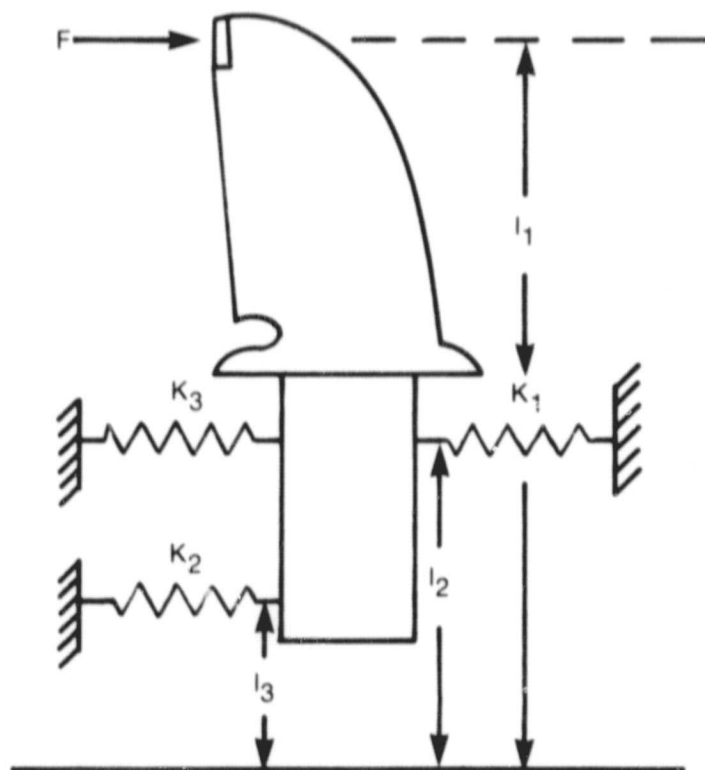
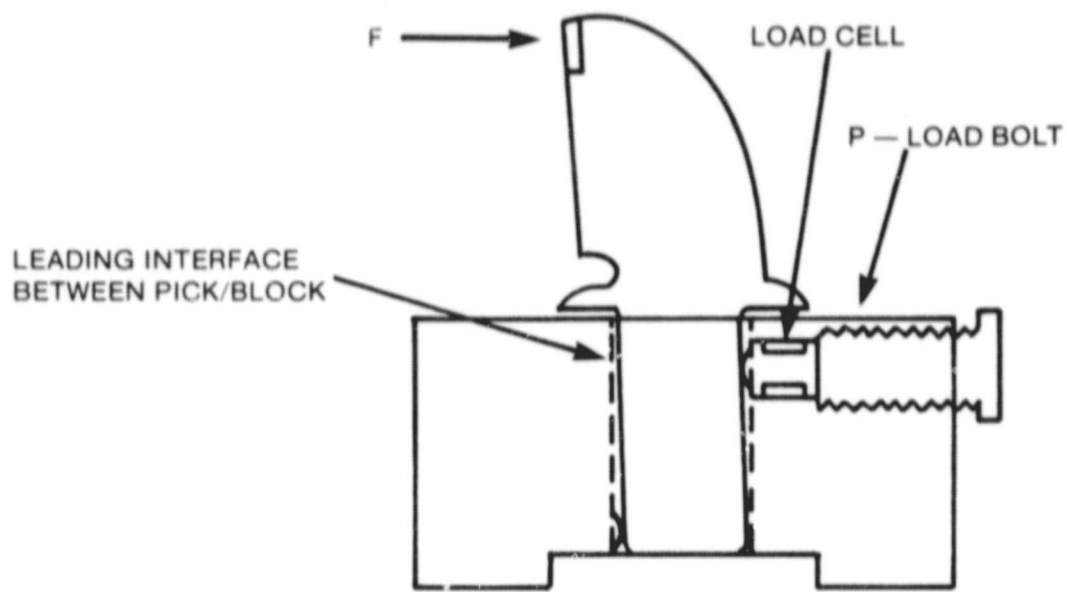

Figure 7. Simple spring model of the pick block showing the effect of preload

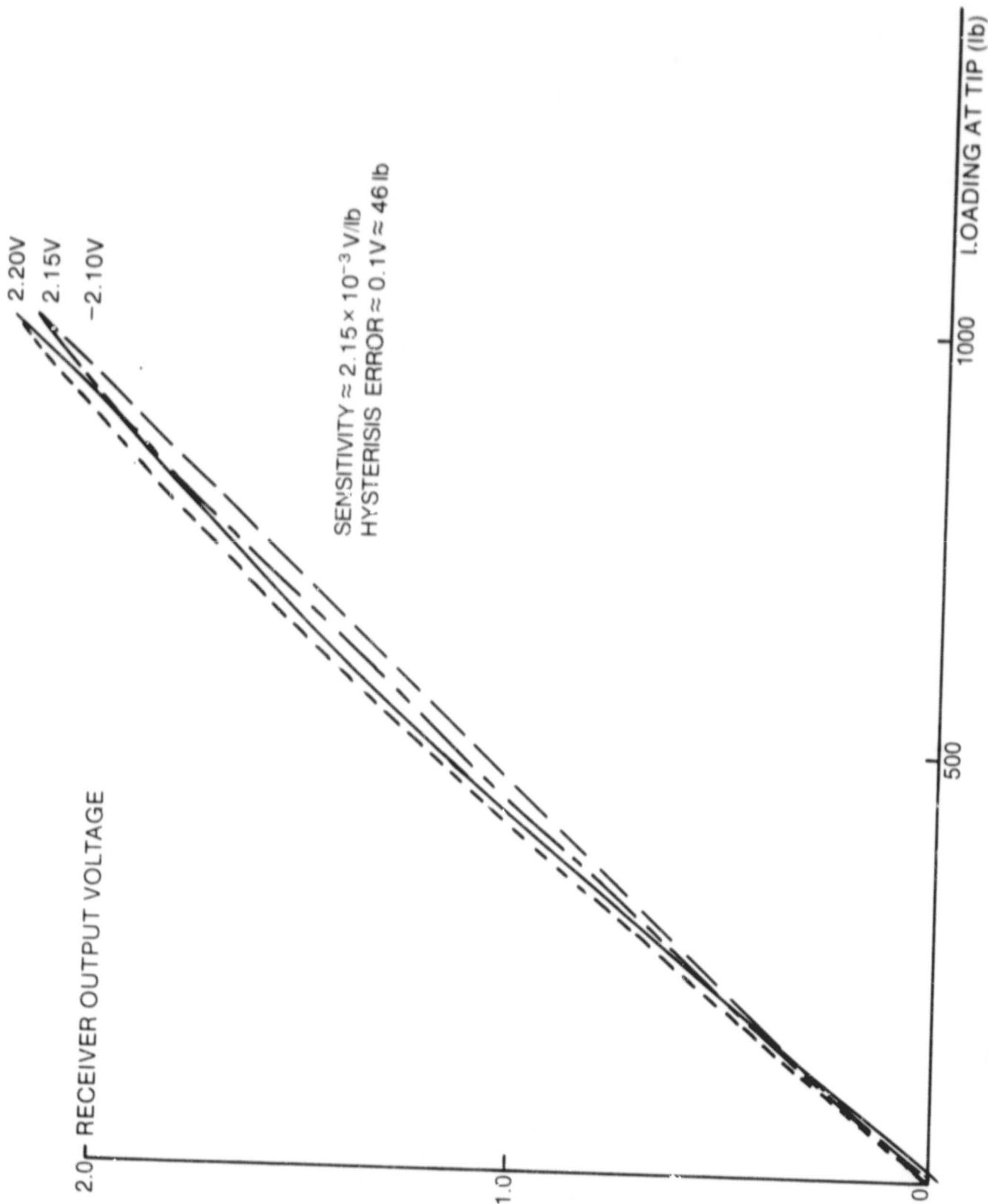

Figure 8. Typical hysteresis curves for sensitized pick block (Load cell #1, DIVISION 2 CAT - 25)

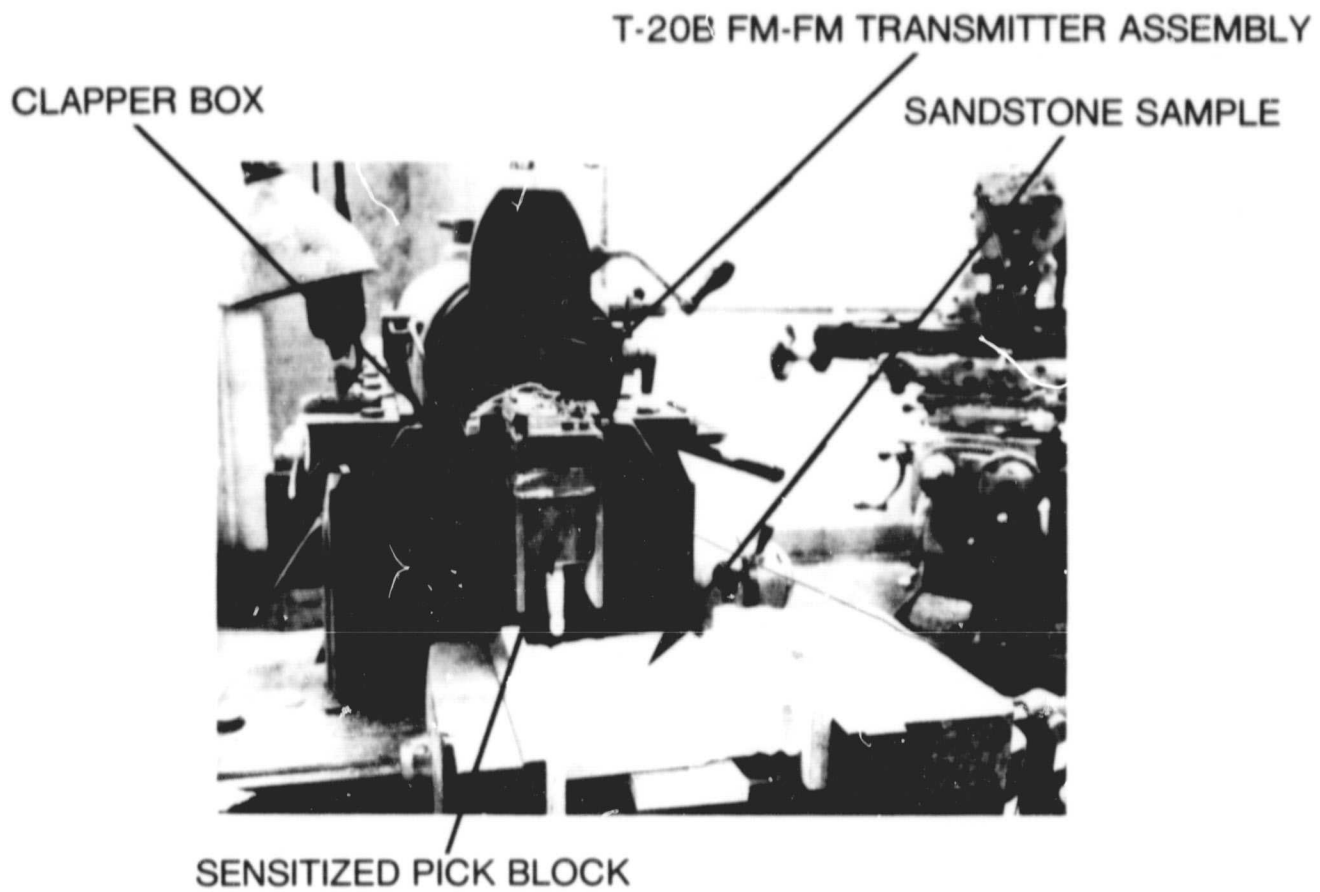

Figure 9. Photograph of the sensitized pick block on a shaper machine

ORIGINAL PAGE IS
OF POOR QUALITY

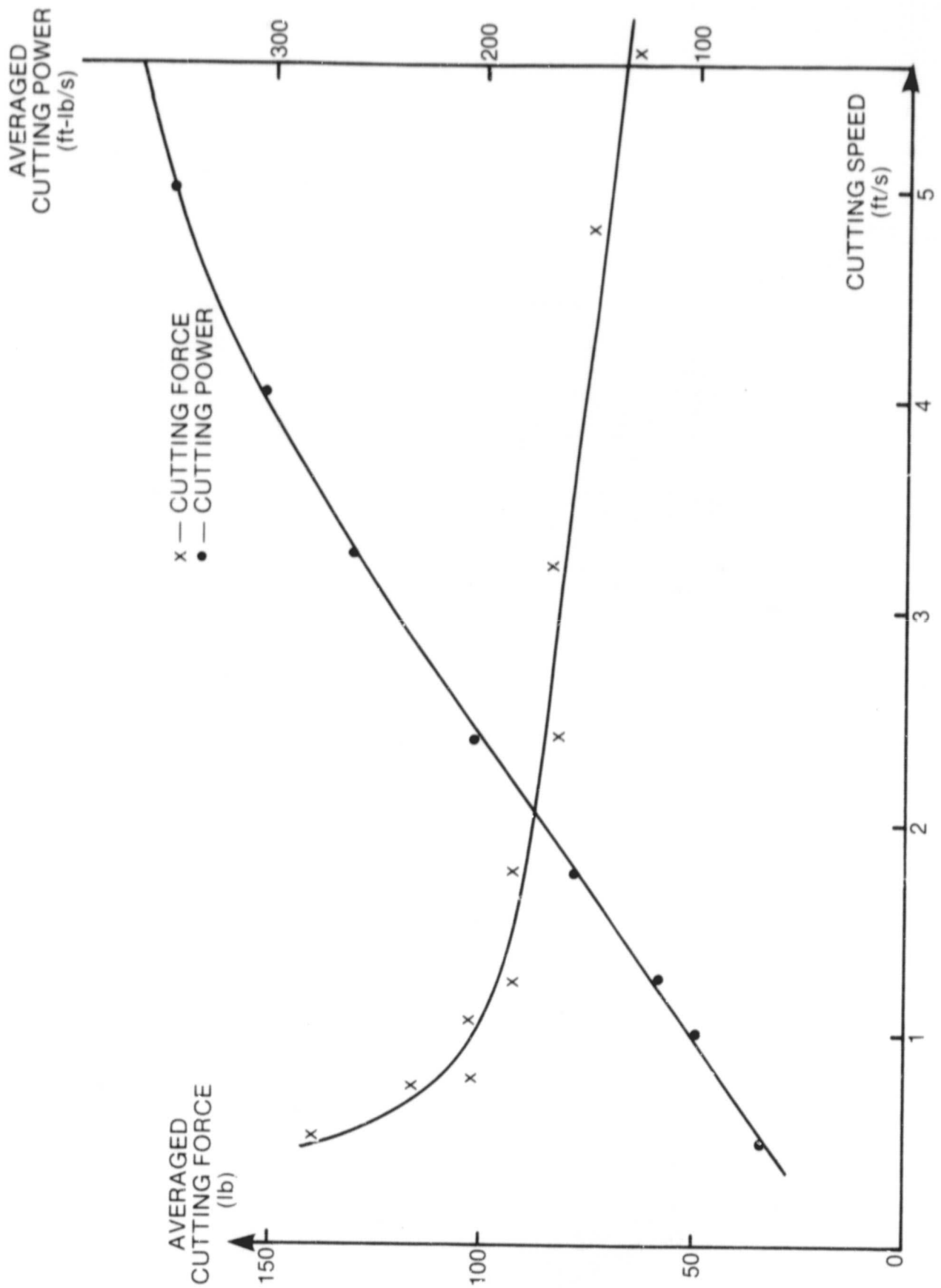

Figure 10. Average cutting force and power vs. cutting speed for cutting sandstone complete depth of cut 1/8 in.

ORIGINAL PAGE IS OF POOR QUALITY

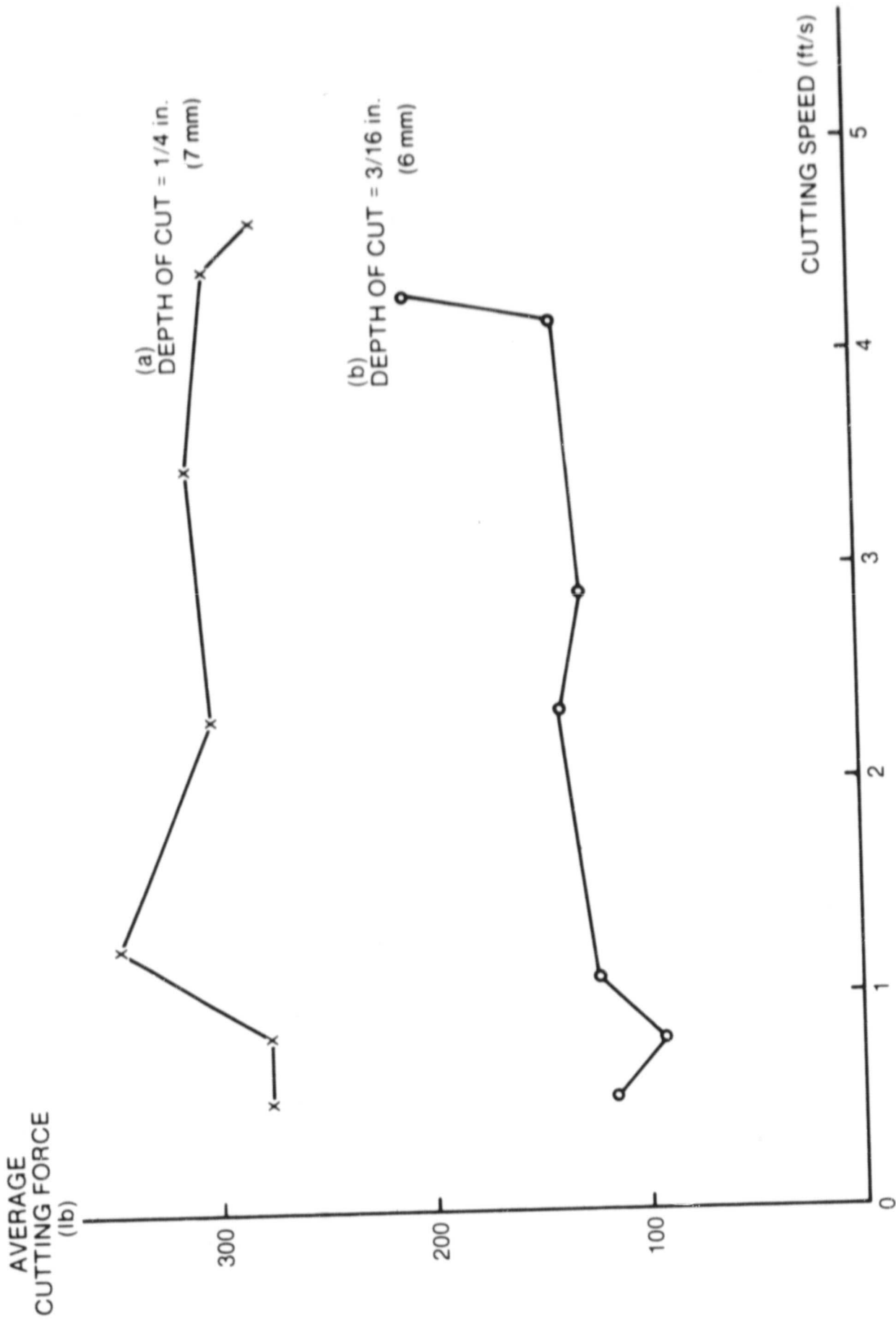

Figure 11. Average cutting force vs. cutting speed for cutting sandstone sample, depth of cut 3/16 in. and 1/4 in.

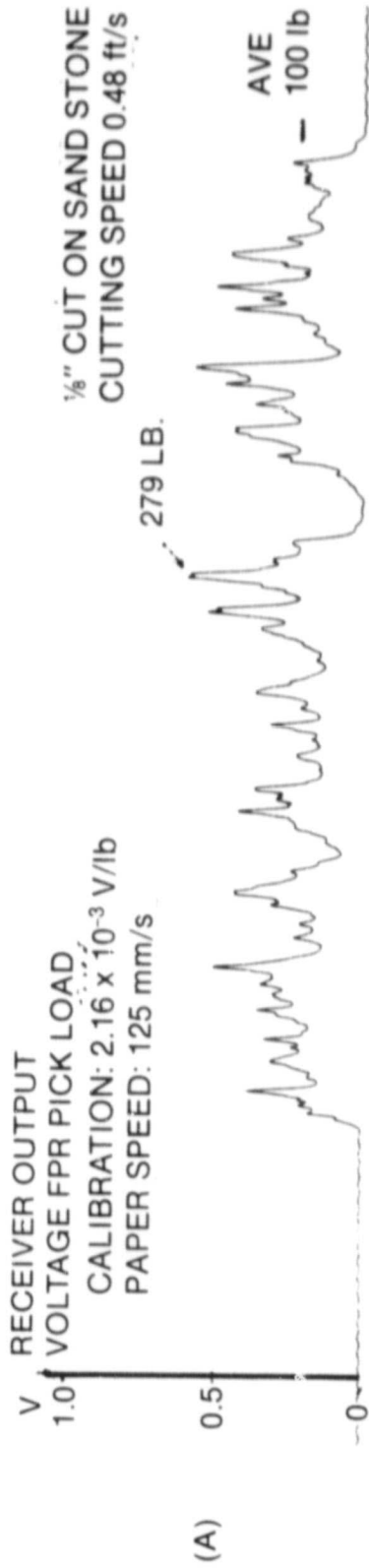

Figure 12. Strip chart of pick loads for 1/8 in.-deep cut in sandstone,
(a) cutting speed = 0.48 ft/s.
(b) cutting speed = 3.2 ft/s.

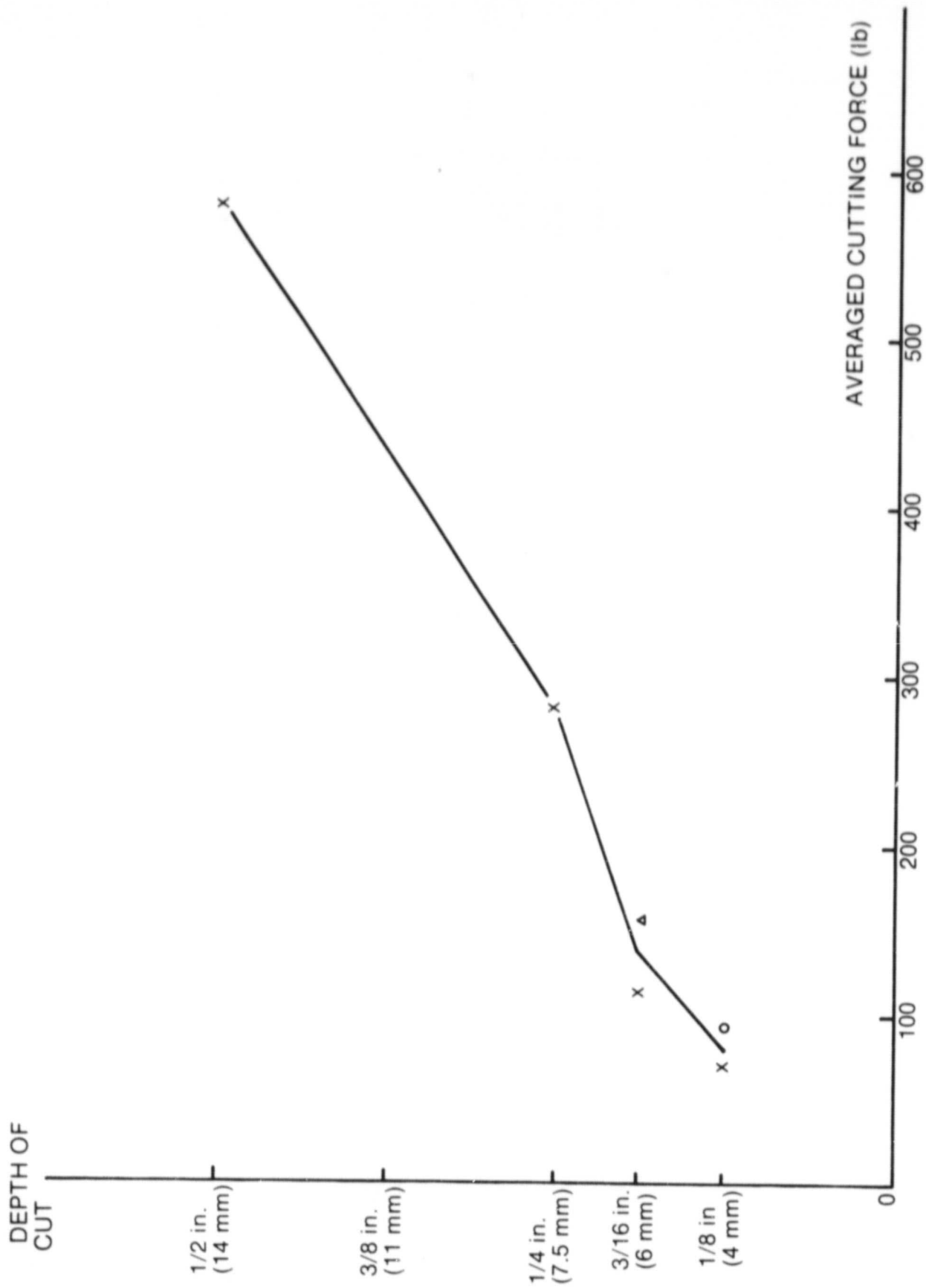

Figure 13. Average cutting force vs. depth of cut for sandstone, cutting speed ≈ 0.5 ft/s.

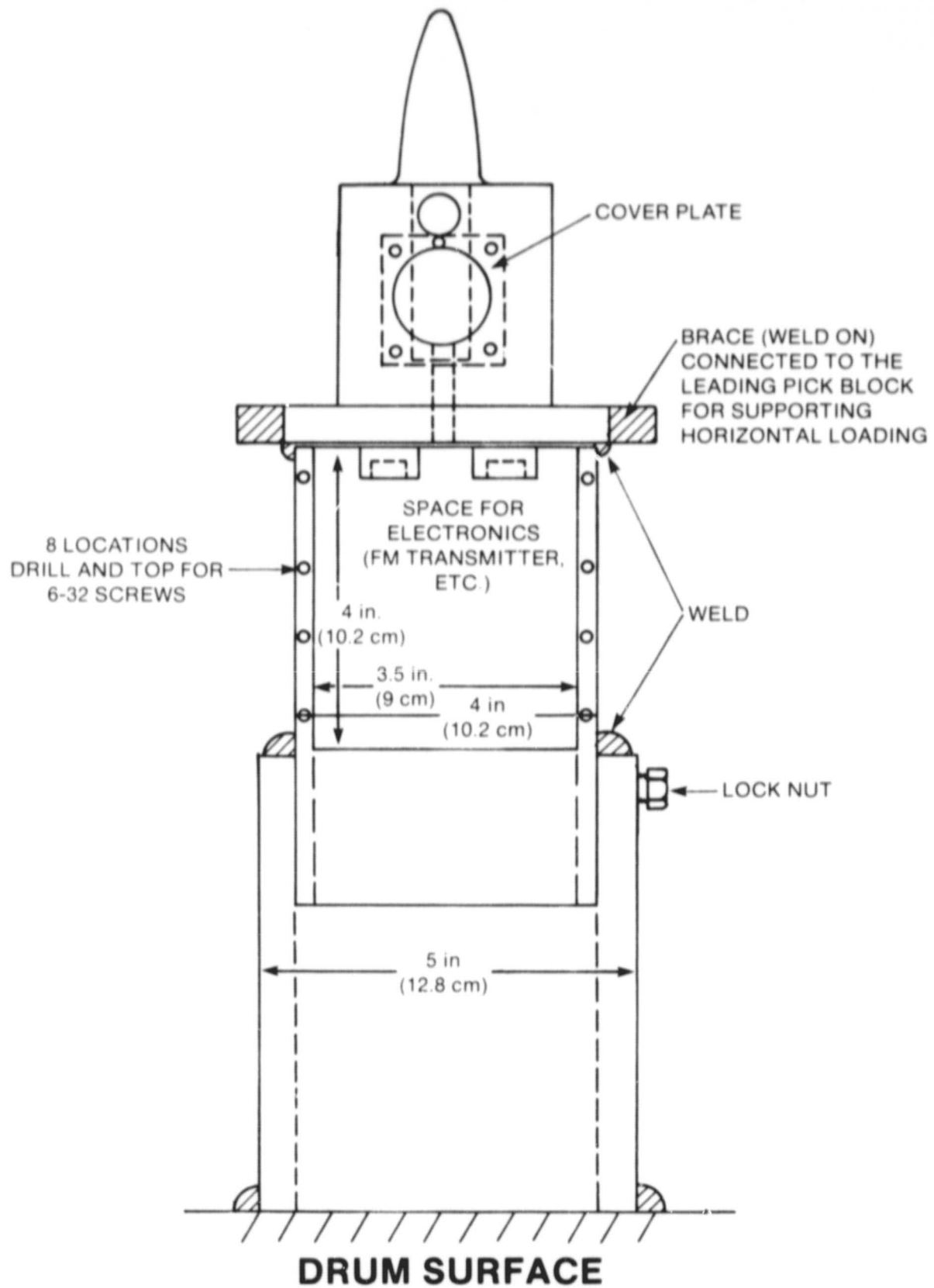

Figure 14. Drawing of mounting fixture for sensitized pick block and transmitter assembly

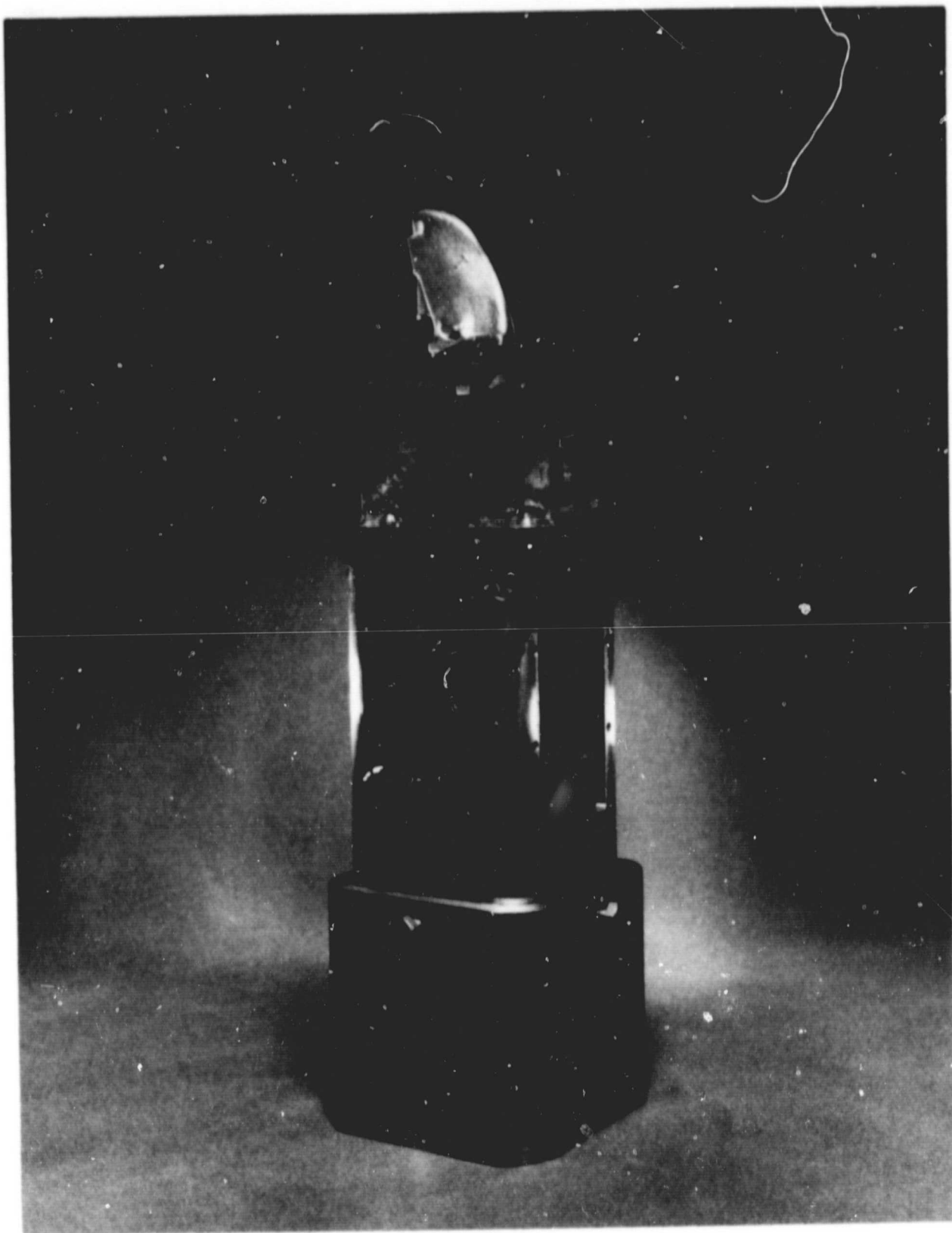

Figure 15. The sensitized pick assembly ready for welding to the Joy longwall shearer

ORIGINAL PAGE IS
OF POOR QUALITY

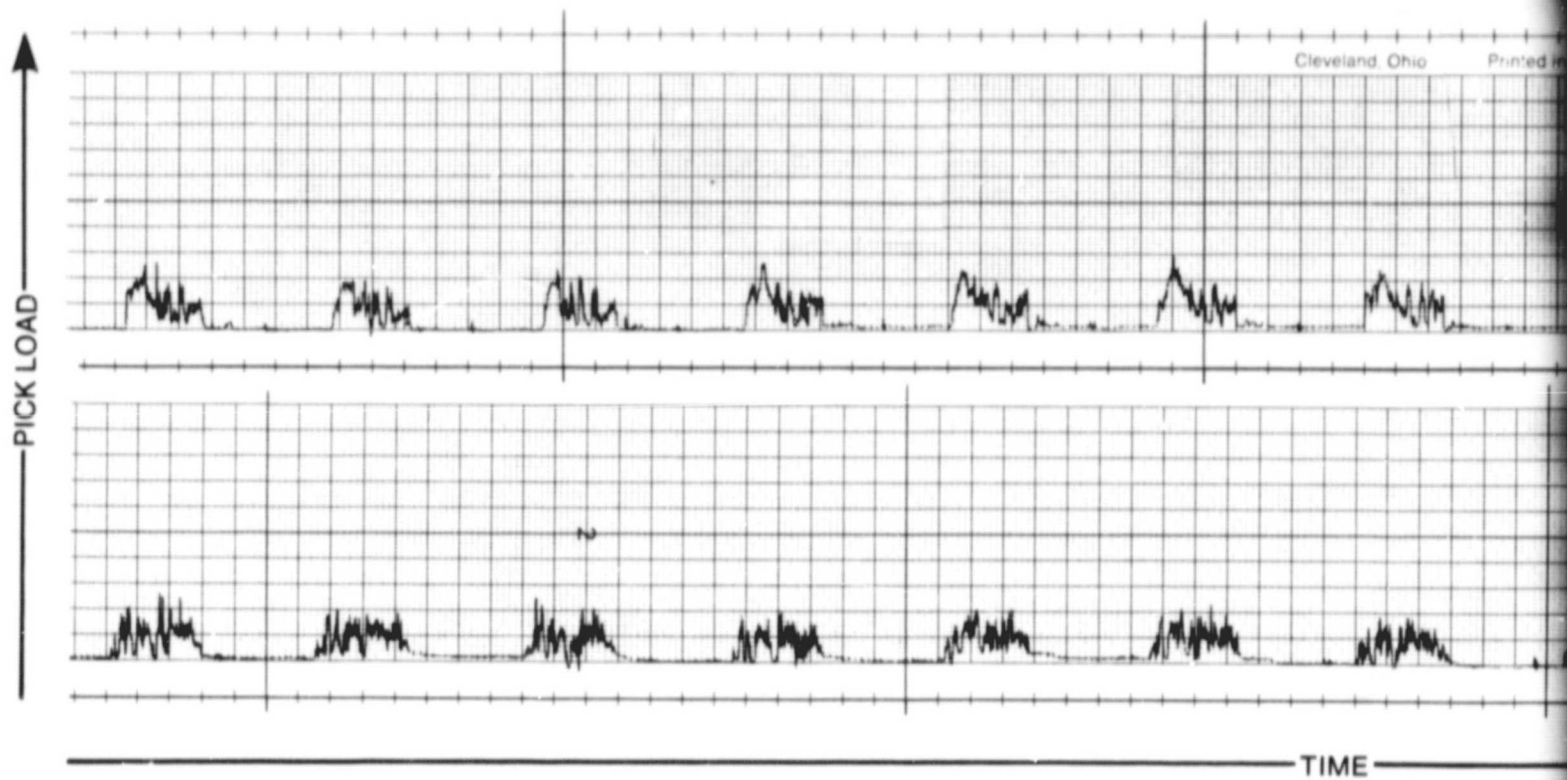

Figure 16. Samples of pick load signals for rock (upper

FOLDOUT FRAME

Cleveland Ohio Printed in U.S.A.

ROCK

COAL

TIME

oad signals for rock (upper curve) and coal (lower curve)

FOLDOUT FRAME 2

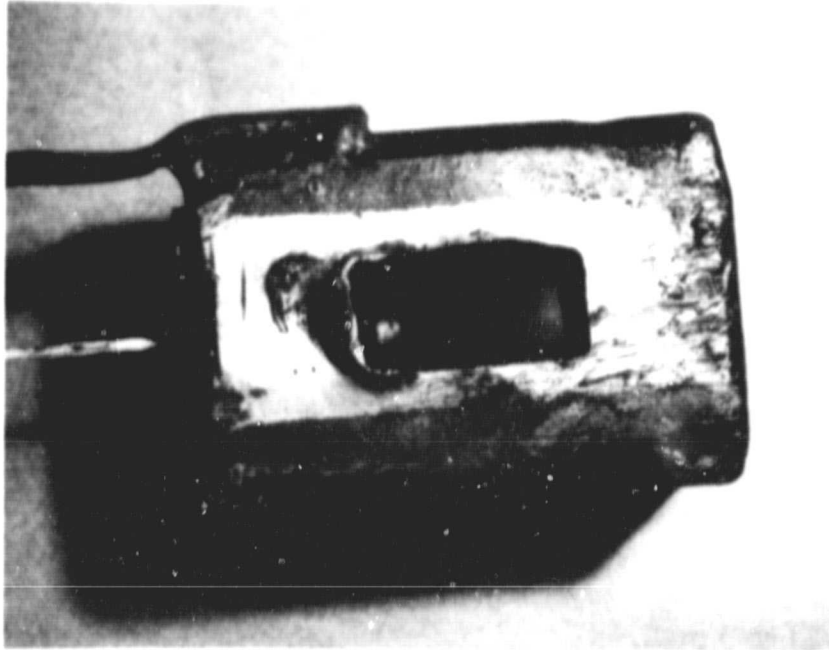

Figure 17. Photograph of the damaged pick block

ORIGINAL PAGE IS
OF POOR QUALITY

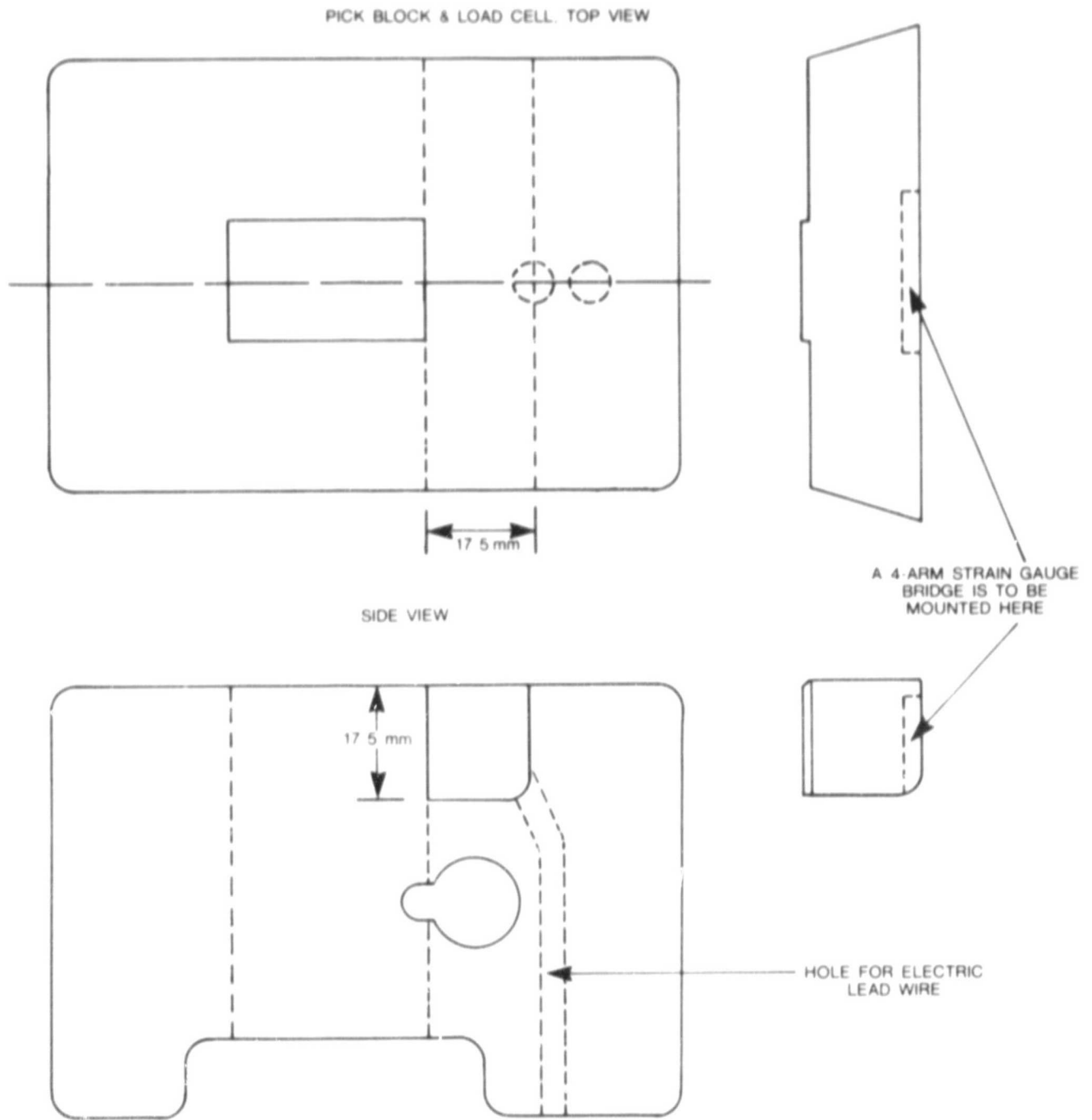

Figure 18. The square short beam load cell and the pick block

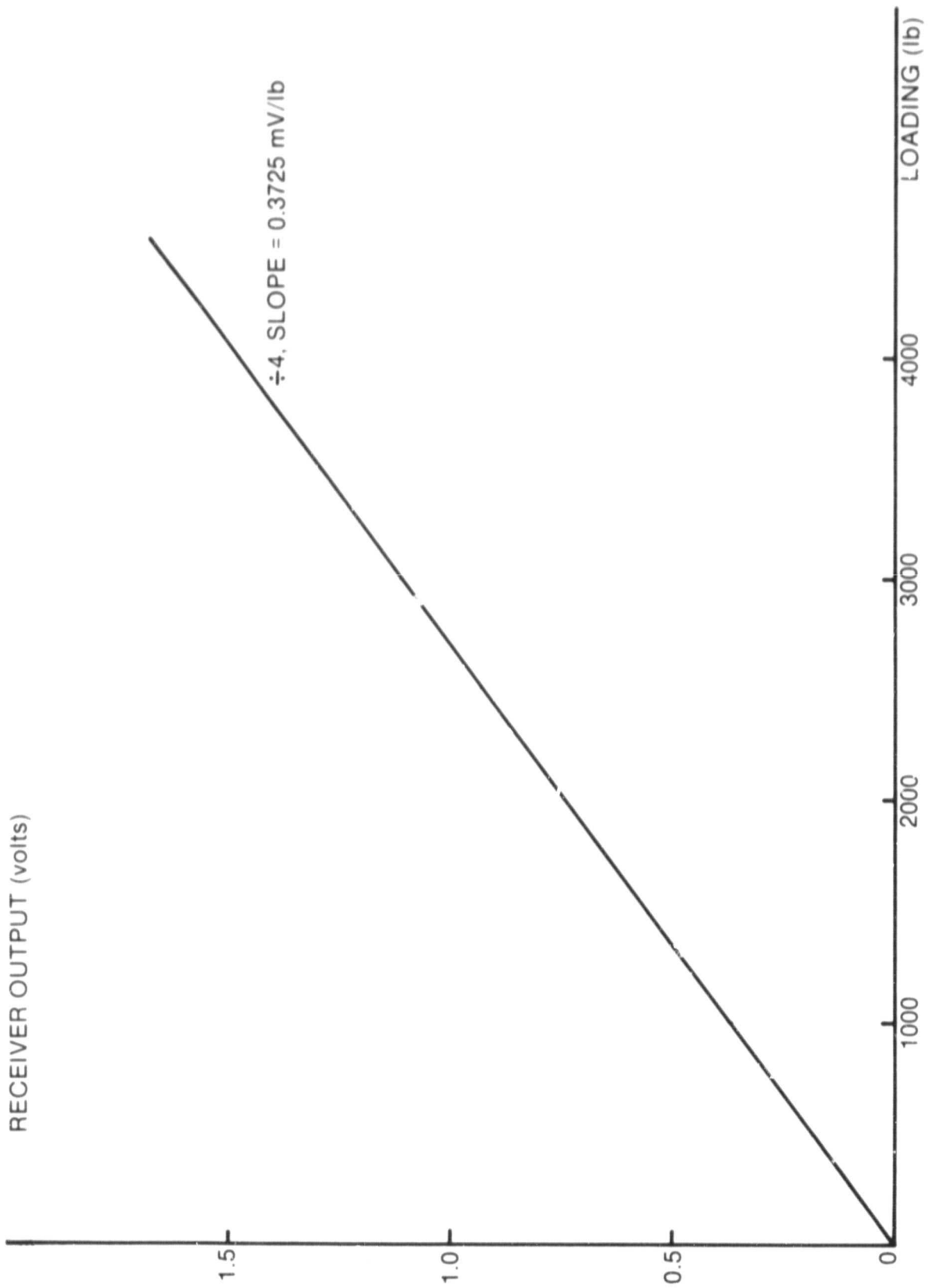

Figure 19. Calibration curve for No. 2 load cell (CAL = 2.5)



Figure 20. The sensitized pick with square beam load cell, prior to welding to the Eickhoff shearer



Figure 21. Close-up view of the pick and pick block mounted on the Eickhoff shearer

ORIGINAL PAGE IS
OF POOR QUALITY

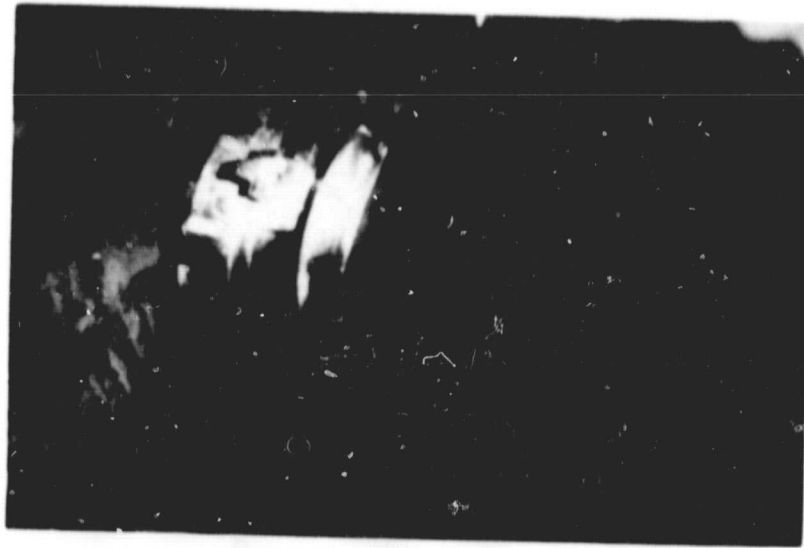
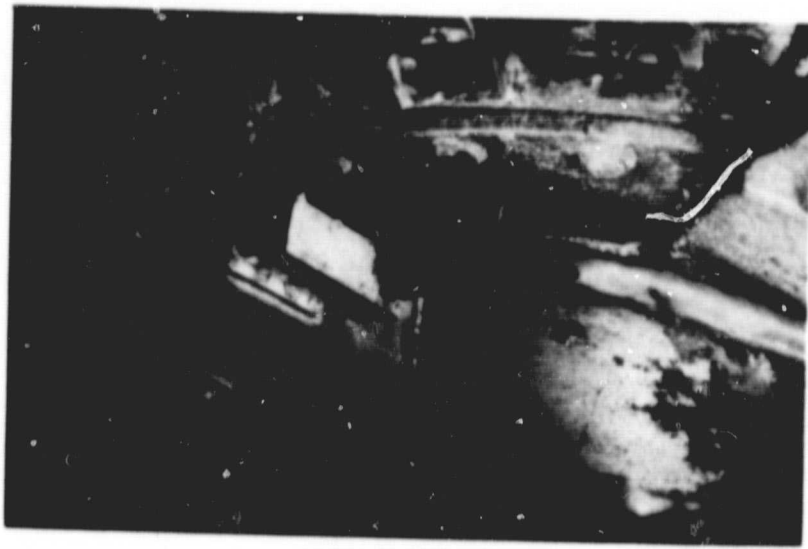

Figure 22. Sensitized pick assembly as installed on the Eickhoff shearer

ORIGINAL PAGE IS
OF POOR QUALITY

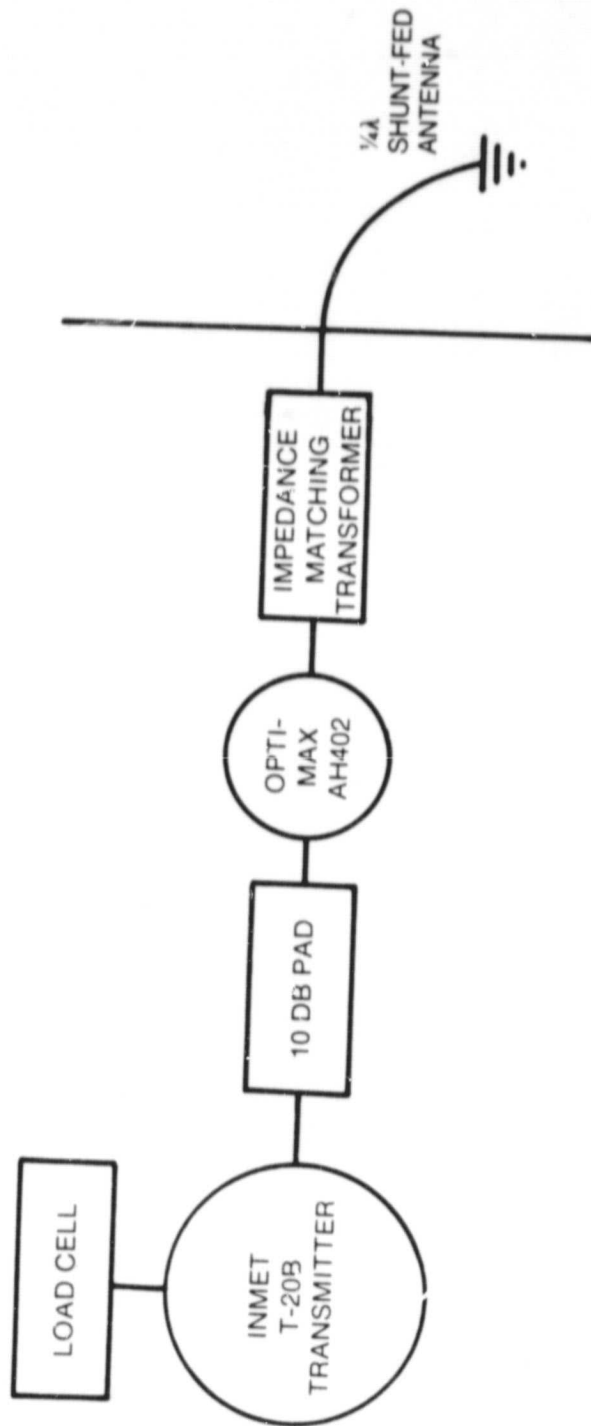

Figure 23. Improved transmitter system

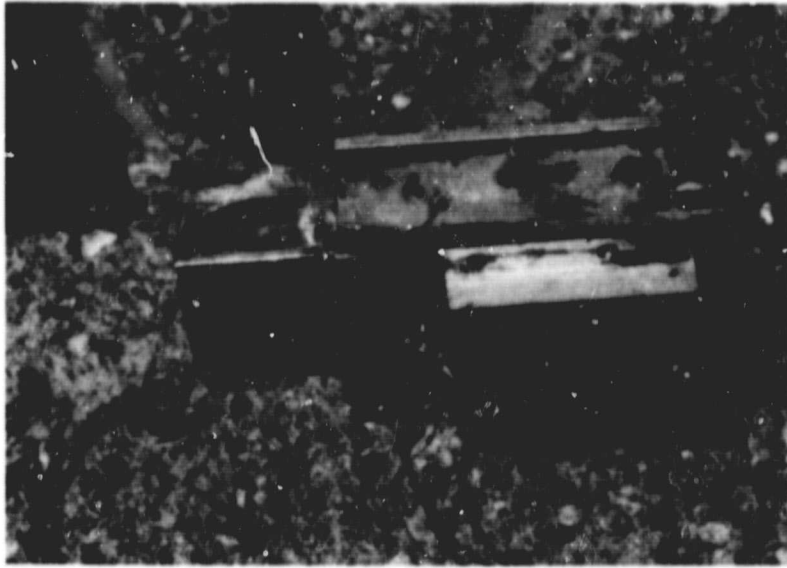

Figure 24. Transmitter hardware prior to mounting on the Eickhoff shearer

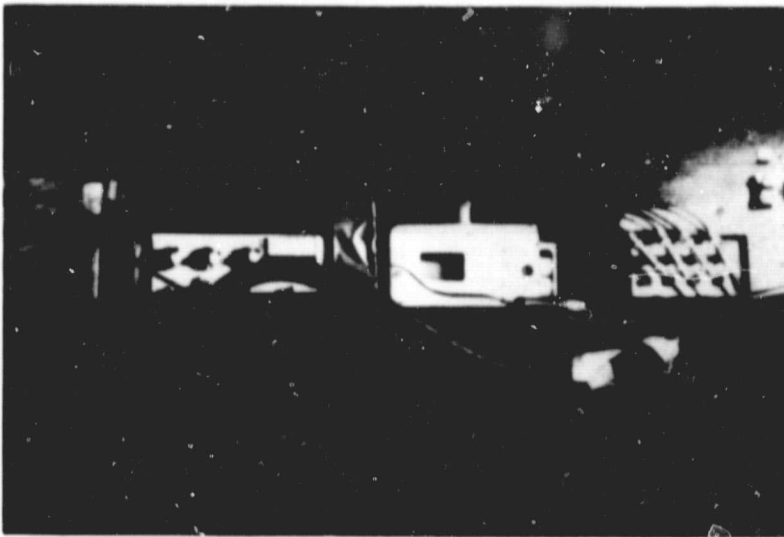

Figure 25. Receiver and analysis hardware in use on the Eickhoff shearer

ORIGINAL PAGE IS
OF POOR QUALITY

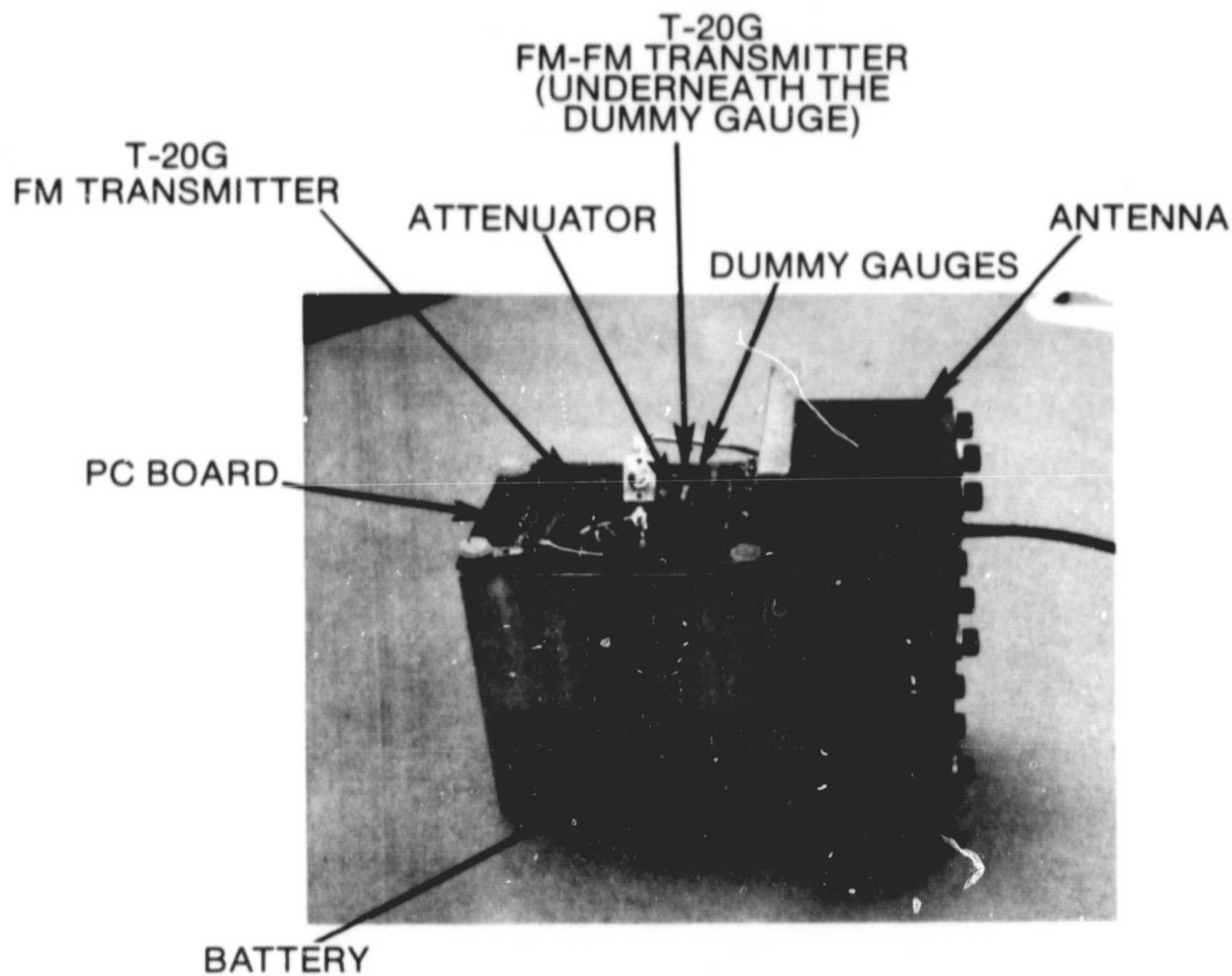

Figure 26. Photograph of the PC board and transmitter housing

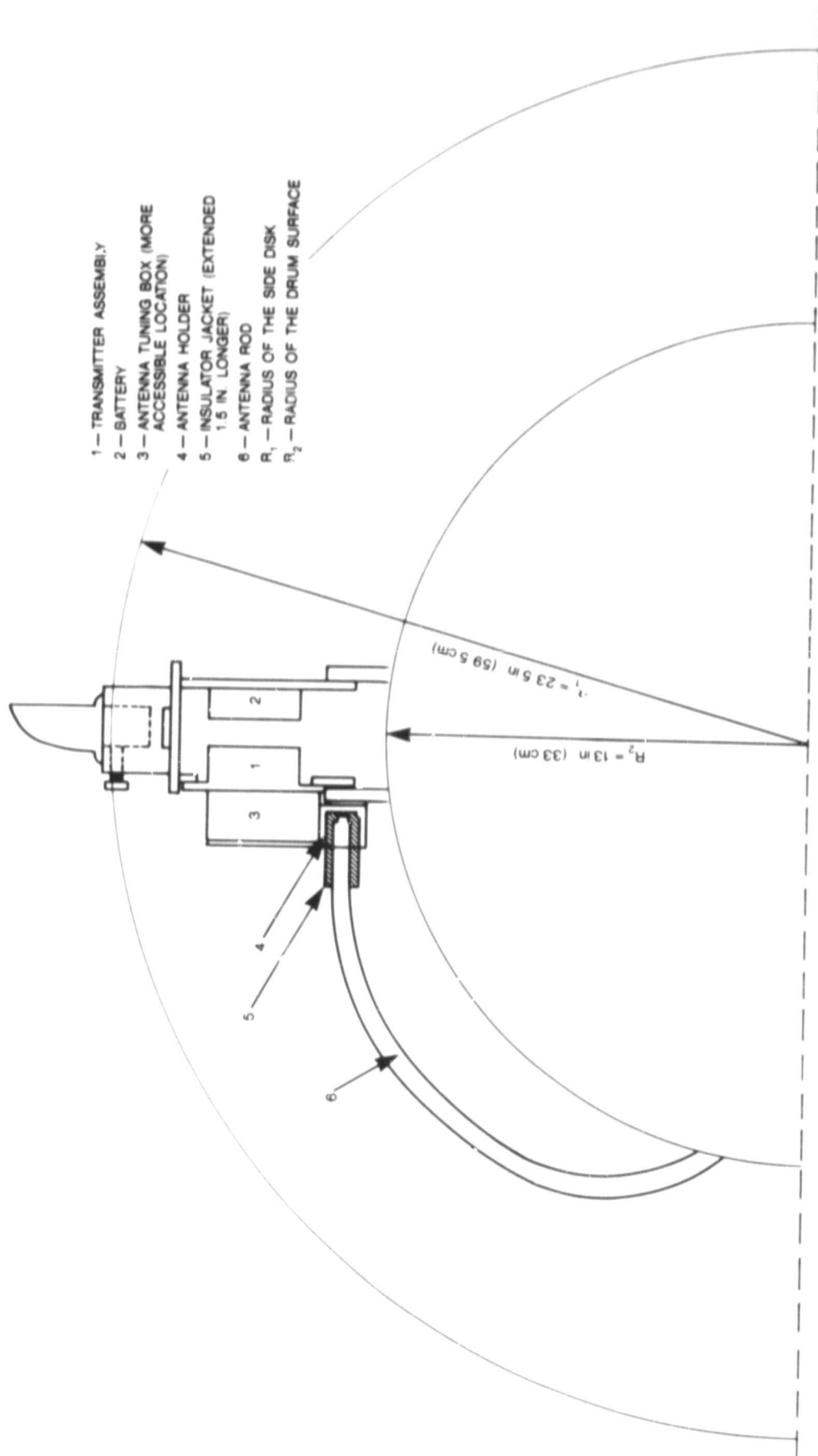

Figure 27. Sketch of the modified quarter wave loop antenna

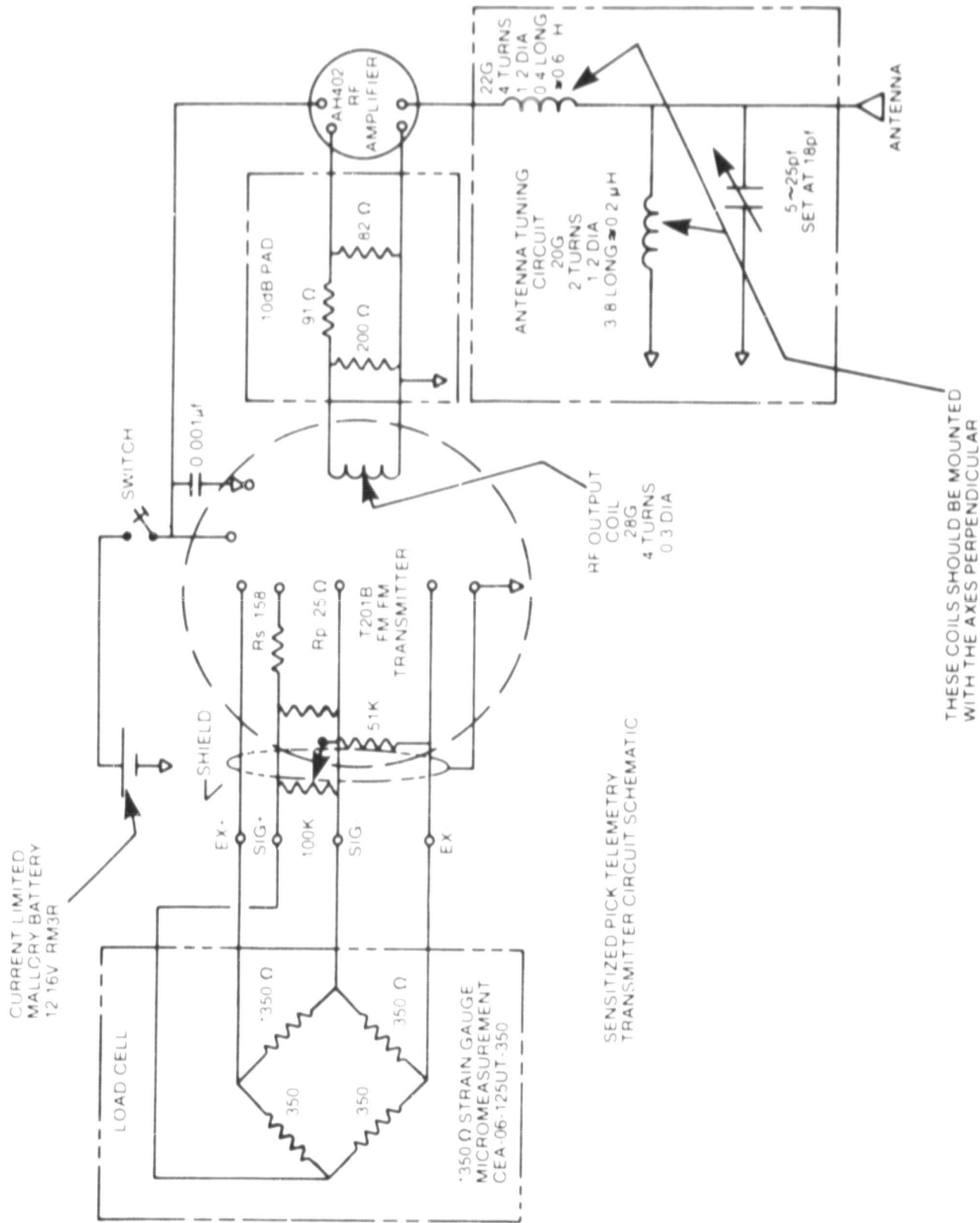
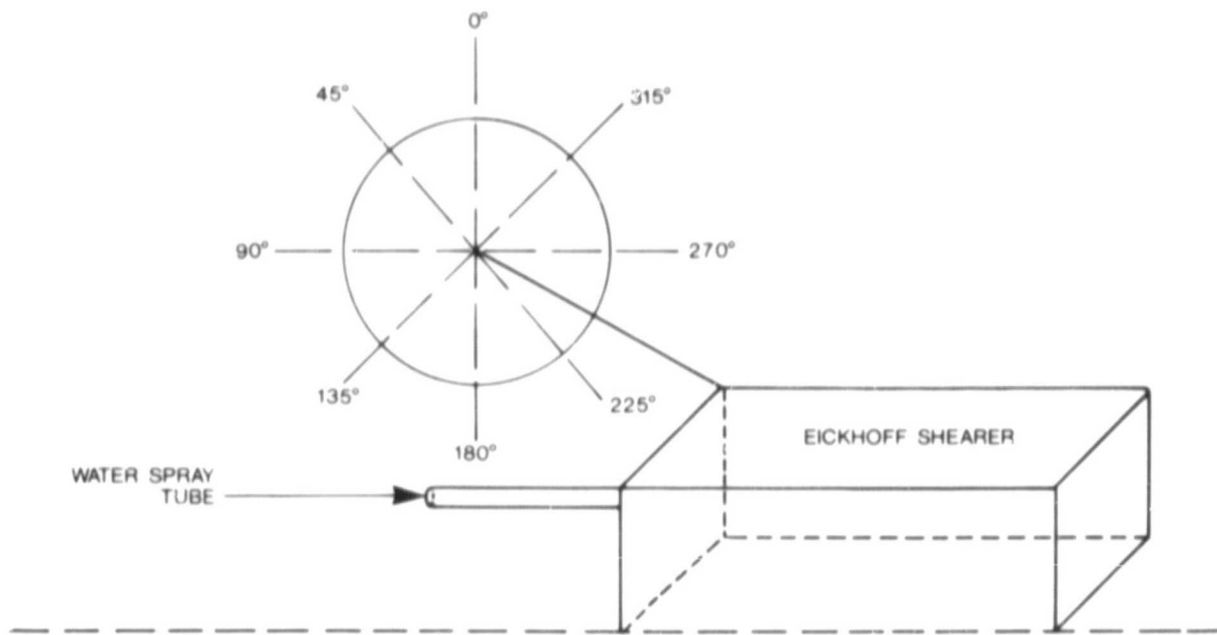

Figure 28. Schematic of the final design of the telemetry system



<u>DRUM PHASE ANGLE (DEGREE)</u>	<u>SIGNAL STRENGTH (μV)</u>
0	2000
45	750
90	1750
135	2000
180	1500
225	4500
270	4000
300	3750
315	4000

Figure 29. RF signal strength measured in York Canyon Mine

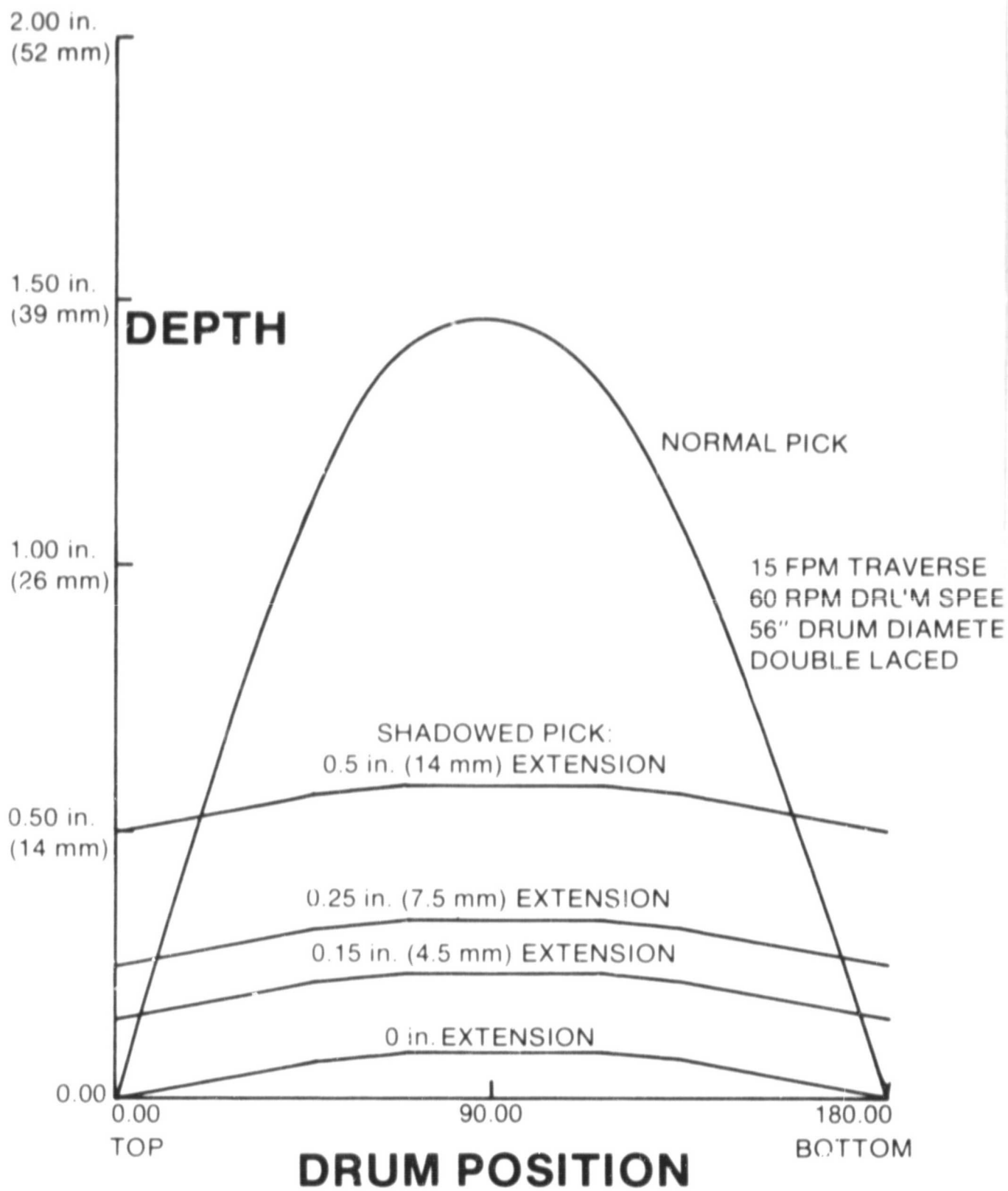

Figure 30. Cutting depth vs. drum position (15° lag shadow pick) Block diagram of sensitized pick processor

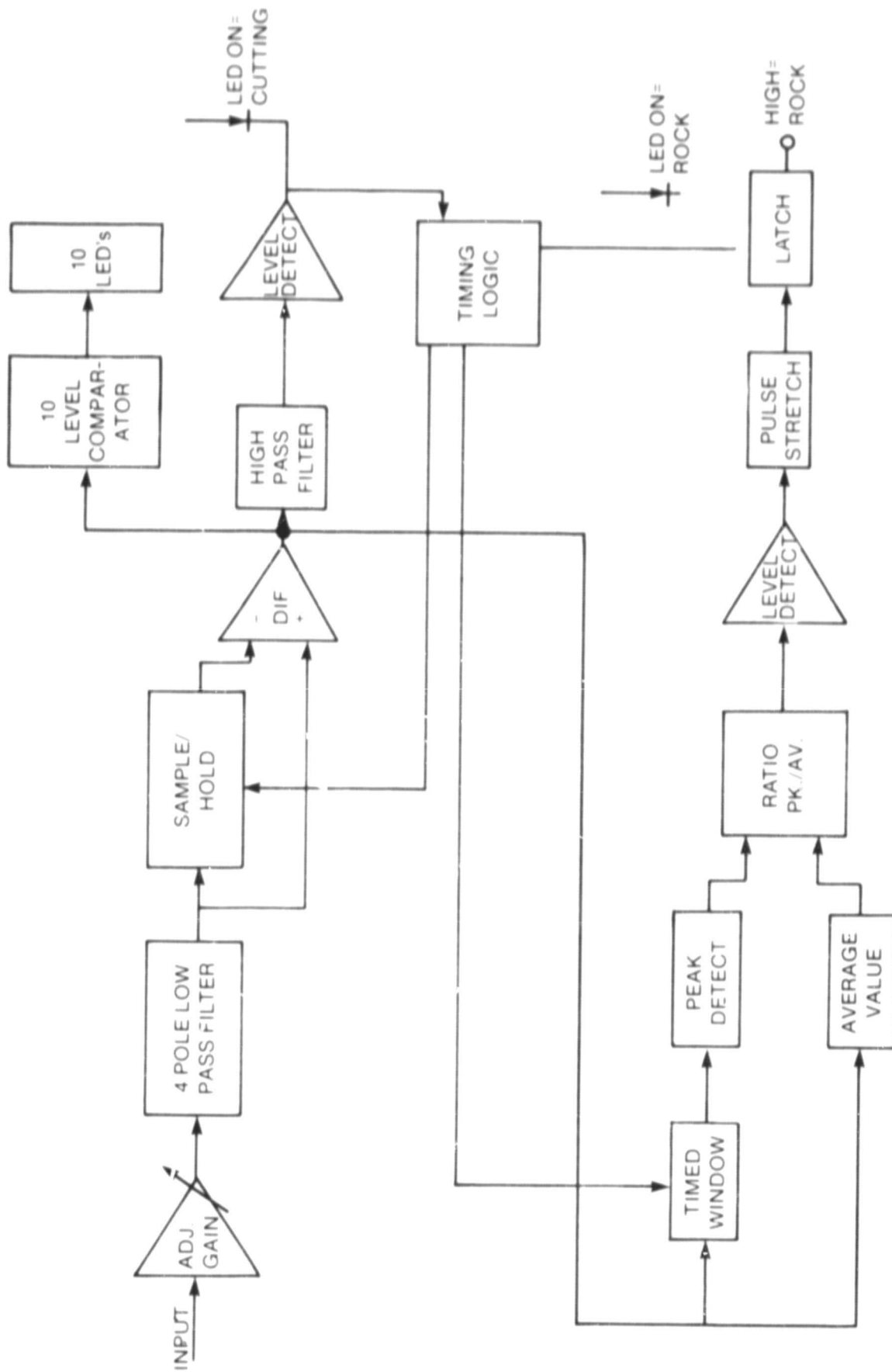

Figure 31. Block diagram of sensitized pick processor

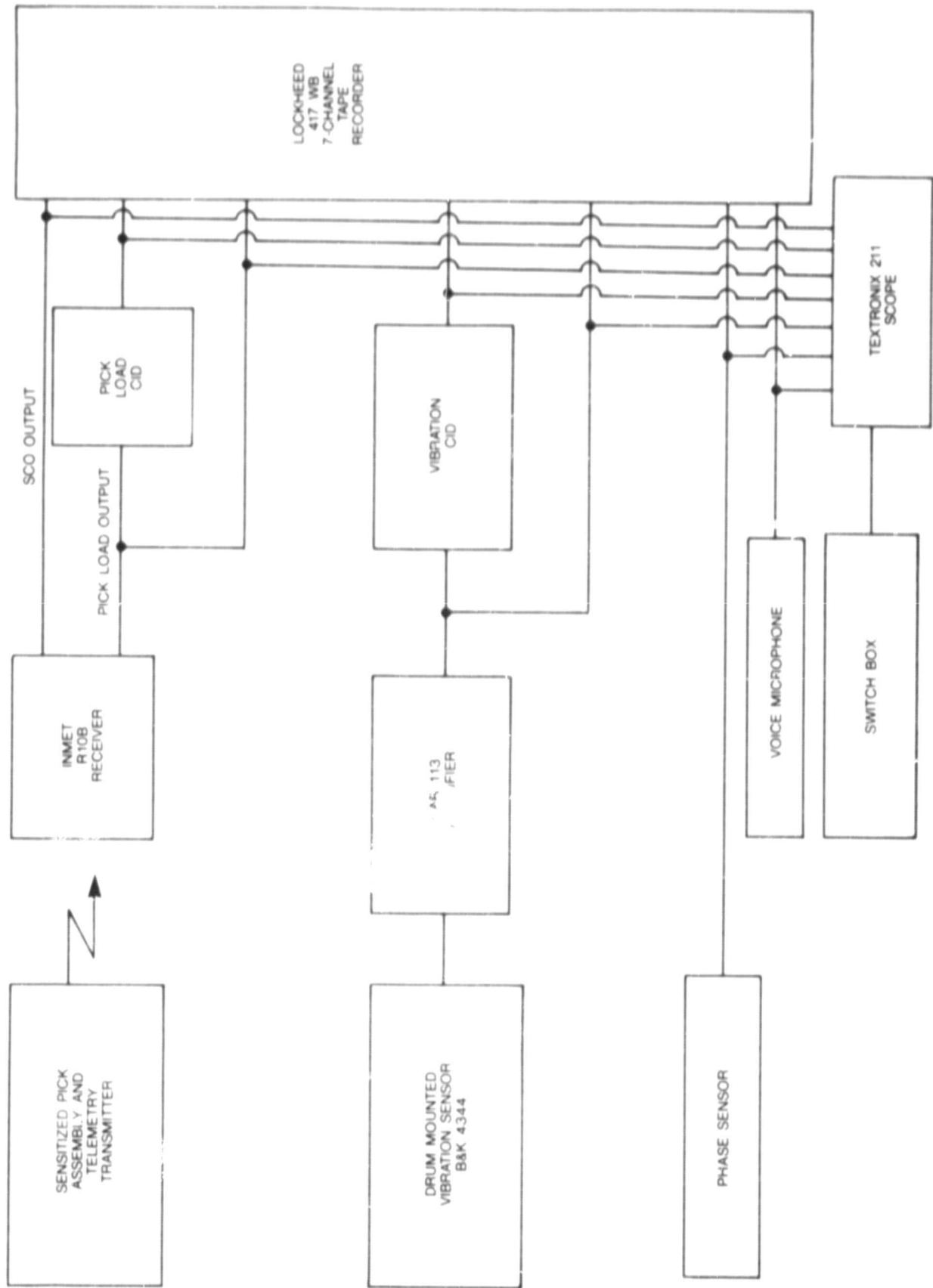

Figure 32. Block diagram of mine test instrumentation system

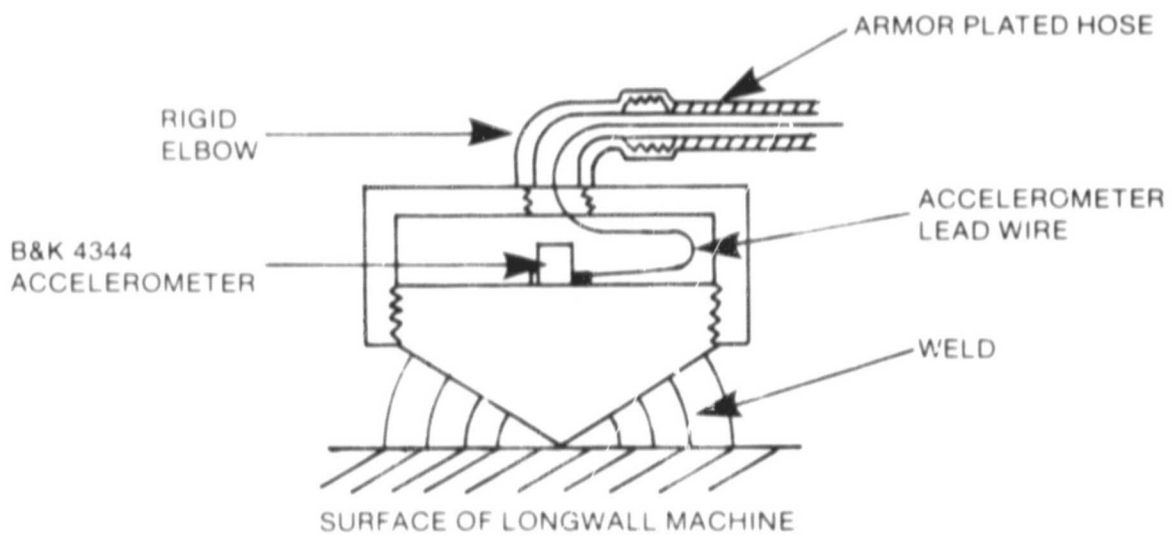
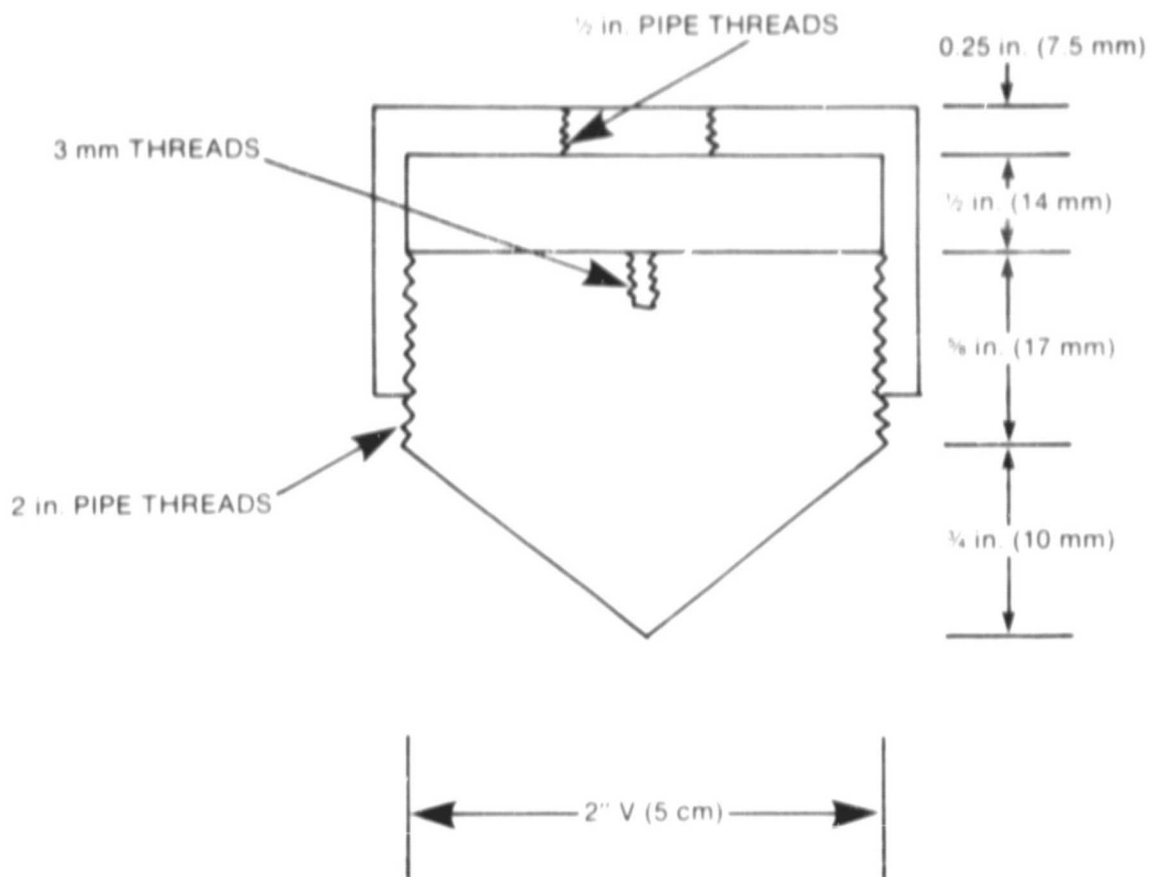

Figure 33. Drawing of accelerometer mounting cone

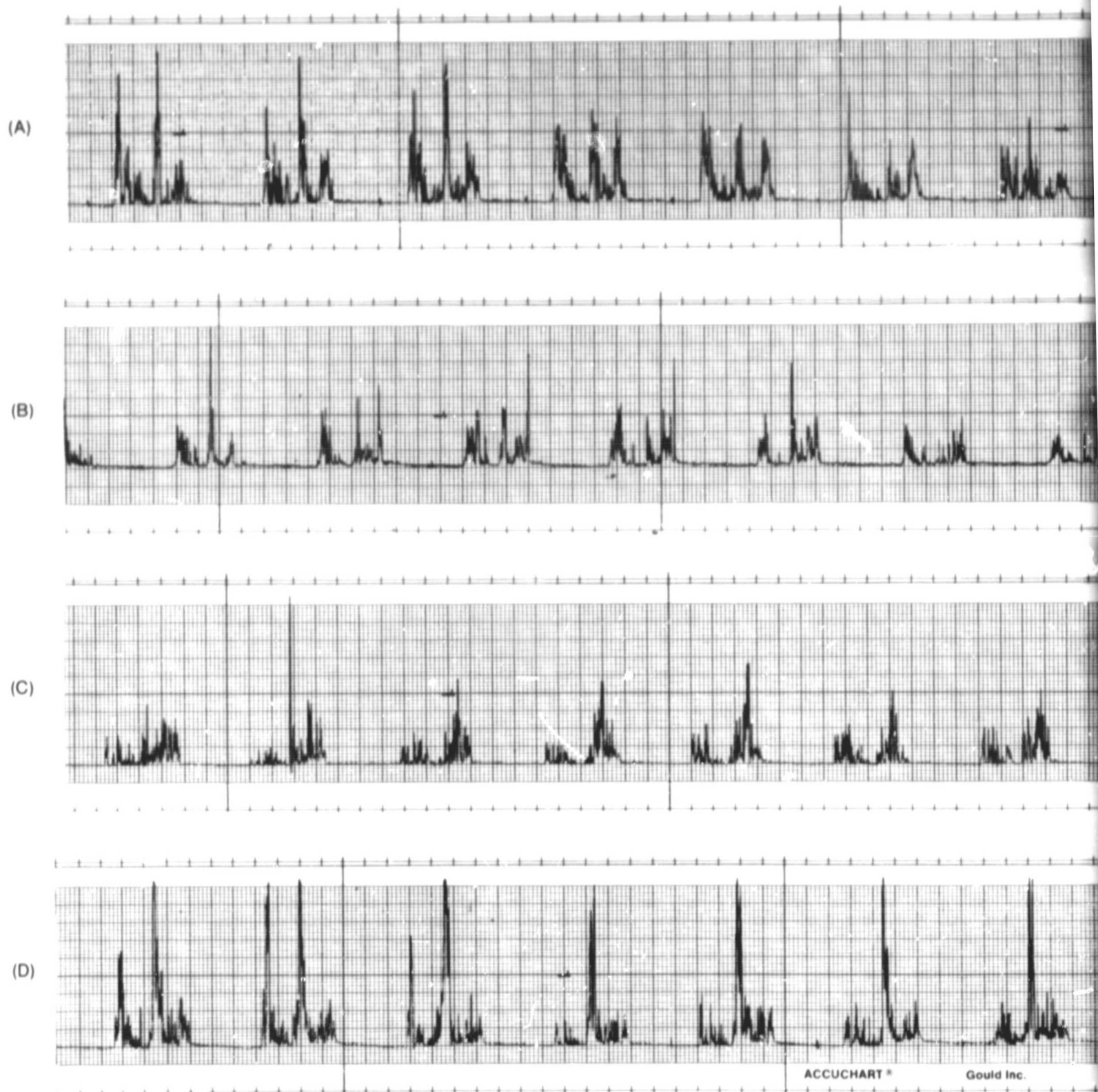
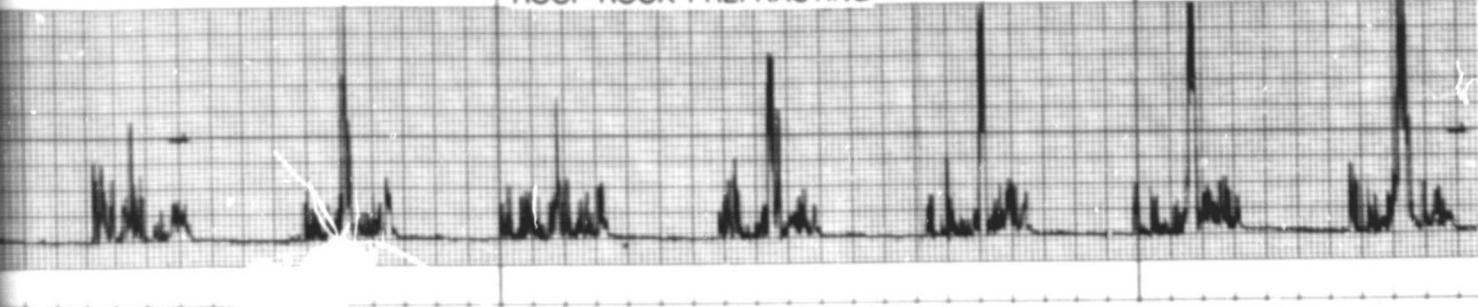

Figure 34. Cutting force signals measured
 (a) Typical "rock-cutting" signal
 (b) Typical "coal-cutting" signal
 (c) Typical signals where the "rock" is
 (d) Typical signals where the "coal" is

FOLDOUT FRAME

ROOF ROCK PREFRACTING



ROCK INCLUSION



ACCUCHART®

Gould Inc.

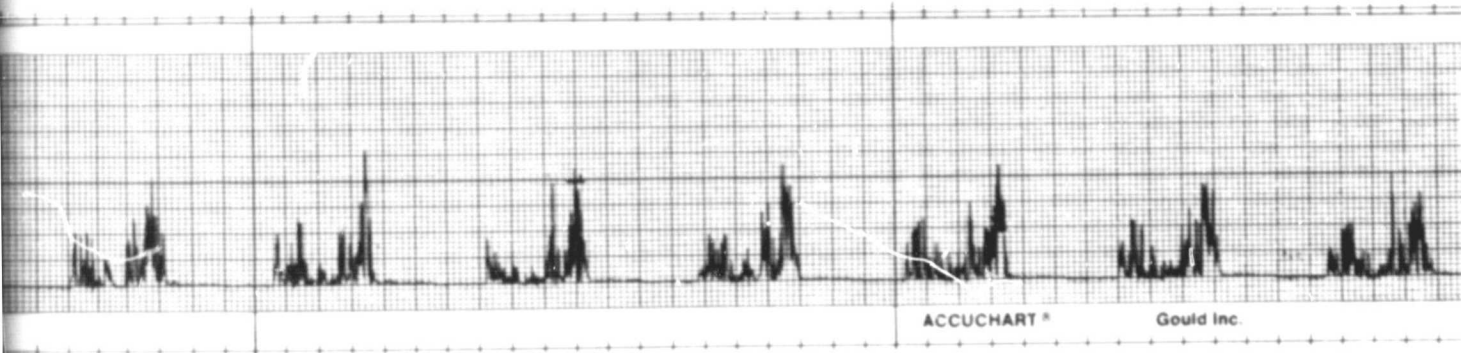

ACCUCHART®

Gould Inc.

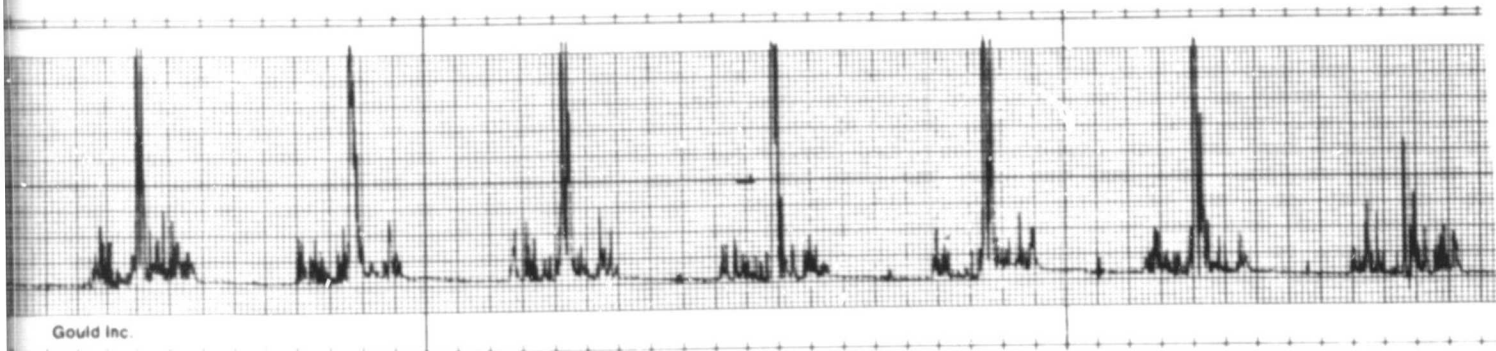

Gould Inc.

signals measured at York Canyon mine
"rock-cutting" signals
"ice-cutting" signals
signals where the "middleman" was small
signals where the "middleman" was thick

ORIGINAL PAGE IS
OF POOR QUALITY

FOLDED COPY

C-2

2