

RM-E52J06

RM E52J06

NACA RM E52J06

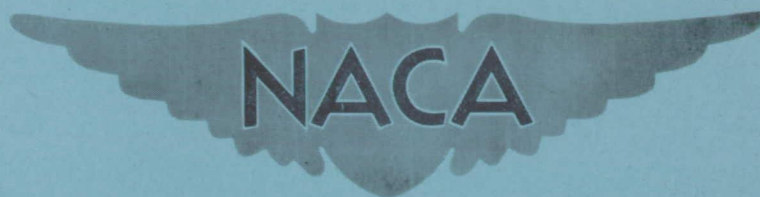

RESEARCH MEMORANDUM CASE FILE COPY

PRELIMINARY SURVEY OF ICING CONDITIONS MEASURED DURING
ROUTINE TRANSCONTINENTAL AIRLINE OPERATION

By Porter J. Perkins

Lewis Flight Propulsion Laboratory
Cleveland, Ohio

NATIONAL ADVISORY COMMITTEE
FOR AERONAUTICS

WASHINGTON
December 16, 1952

JPL LIBRARY
CALIFORNIA INSTITUTE OF TECHNOLOGY

DEC 23 1952

NATIONAL ADVISORY COMMITTEE FOR AERONAUTICS

RESEARCH MEMORANDUMPRELIMINARY SURVEY OF ICING CONDITIONS MEASURED DURING
ROUTINE TRANSCONTINENTAL AIRLINE OPERATION

By Porter J. Perkins

SUMMARY

Icing data collected on routine operations by four DC-4-type aircraft equipped with NACA pressure-type icing-rate meters are presented as preliminary information obtained from a statistical icing data program sponsored by the NACA with the cooperation of many airline companies and the United States Air Force. The program is continuing on a much greater scale to provide large quantities of data from many air routes in the United States and overseas. Areas not covered by established air routes are also being included in the survey.

The four aircraft which collected the data presented in this report were operated by United Air Lines over a transcontinental route from January through May, 1951. An analysis of the pressure-type icing-rate meter was satisfactory for collecting statistical data during routine operations. Data obtained on routine flight icing encounters from these four instrumented aircraft, although insufficient for a conclusive statistical analysis, provide a greater quantity and considerably more realistic information than that obtained from random research flights. A summary of statistical data will be published when the information obtained during the 1951-52 icing season and that to be obtained during the 1952-53 season can be analyzed and assembled. The 1951-52 data already analyzed indicate that the quantity, quality, and range of icing information being provided by this expanded program should afford a sound basis for ice-protection-system design by defining the important meteorological parameters of the icing cloud.

INTRODUCTION

The meteorological phase of the icing research program conducted by the NACA has been previously confined to research flights into icing conditions. These in-flight measurements of the meteorological quantities associated with aircraft icing (summarized in reference 1) have been limited to a relatively small number of flights over confined sections of the country and have thus provided only tentative design criteria for ice-protection systems.

The majority of the research flights into icing conditions were made by attempting to select weather conditions, flight paths, and altitudes, which would yield heavy or continuous icing. Multiple traverses were often made when such conditions were found. It is impossible, therefore, to determine from this information the extent or frequency of specified icing conditions that would be encountered during normal flight operations such as those experienced by airlines on routine schedules. Additional data are needed to substantiate or to modify the ice-protection-system design conditions in order that all-weather protective designs can be accomplished with the lowest possible penalties in terms of performance and payload. Statistical icing data obtained from routine operations could serve both as a basis for optimum design of ice-protection systems and as an aid to the operator in prescribing flight-control procedures, such as preferred altitudes, which would avoid or minimize hazardous icing conditions.

With the realization of this need for additional information, the NACA Lewis laboratory has initiated a program in cooperation with the major airlines and the United States Air Force to obtain measured icing data encountered during routine operations. These data include measurements of icing rate, liquid-water content computed from icing rate and airspeed, temperature, duration of icing, observations of the geographic location, type of ice, and effect of icing on the aircraft. Although cloud droplet-size values are needed to complete the meteorological variables associated with aircraft icing, a knowledge of the liquid-water content without knowledge of the droplet sizes can be useful in establishing ice-protection-design criteria for cases where droplet-size variations do not significantly affect the rate of ice collection.

This report presents the data collected by four transport aircraft equipped with pressure-type icing-rate meters supplied to United Air Lines by the NACA. These aircraft were flown over a transcontinental route across the central part of the United States between San Francisco and New York City during the period from early January to about the end of May, 1951. This survey covers only the initial phase of a program which will use over 50 meters to collect statistical icing data over many air routes both in the United States and overseas. Areas outside of established air routes are also being included in the program which will be continued for at least two subsequent icing seasons.

These data are presented in this preliminary report to show the type of data that can be obtained from the pressure-type icing-rate meter installed on airline aircraft and to provide some tentative information which may be of importance in view of the lack of any previous information of this type. The quantity of data is insufficient for a conclusive statistical analysis, but is presented herein for possible use by aircraft designers and operators before additional data can be collected.

APPARATUS AND PROCEDURE

Description and operation of icing-rate meter. - The icing-rate meter used on the airline transports was developed specifically for the purpose of collecting icing data by the NACA Lewis laboratory and is fully described in reference 2. A photograph of the individual units of this meter is shown in figure 1.

The principle of operation of the icing-rate meter is illustrated in figure 2, which shows an ice-collecting element containing total-pressure holes mounted in the air stream and connected to a differential pressure switch. The total pressure from the element is balanced against an ice-free total-pressure system (the conventional pressure system in the aircraft). When the holes in the ice-collecting element start to plug because of ice accretion, the pressure in the system becomes unbalanced and at a given value of differential pressure, the switch energizes an electric heater which de-ices the ice-plugged holes. The heat-off time of this cyclic process is an inverse function of the rate of ice accumulation on the element and can be used as a measure of the icing rate provided that the ice thickness required to plug the holes is known. This ice thickness was determined from previous calibrations in the Lewis Icing Research Tunnel. The calibration curve for the instrument is shown in figure 3. The icing rate on the sensing element is determined by the cloud liquid-water content, the air velocity, and the collection efficiency of the element.

An NACA flight-type recorder was used to record on photographic film the icing rate (in terms of heat-off time), the indicated airspeed, and the pressure altitude. The recorder started automatically at the initial plugging of the holes and continued until turned off manually after an icing encounter. A set of indicating lights was mounted on the pilot's instrument panel for visual indications of the icing intensity, of the operation of the recorder, and of when the film supply in the recorder was exhausted. An icing encounter was immediately revealed to the pilot by periodic flashing of the icing-rate light which was connected in parallel with the heating circuit. The icing intensity could be determined by the time between flashes of this light.

Installation of icing-rate meters on aircraft. - The icing-rate meters were installed on four engine (DC-4-type) aircraft. The ice-collecting element was mounted on the top left side of the fuselage about 4 feet back from the pilot's windshield. The airspeed and the altitude pressures for the recorder were obtained from the conventional total and static-pressure systems in the aircraft. The recorder was so positioned that the film supply could be replaced easily either in flight or on the ground.

Recording and assembling of data. - The data obtained with the instrument were recorded on photographic film $2\frac{7}{16}$ -inches wide and 20-feet long contained in a magazine or drum which mounted on the recorder unit. An electric motor advanced the film at a constant speed of about 1 inch per minute; this provided approximately 4 hours of data recording. When the indicating light showed that the film had been completely exposed, the drum was replaced at a ground station and shipped to the Lewis laboratory for developing and reloading. Replacement drums were kept at four line stations along the route in order to minimize the flight time of a meter with an exhausted film supply.

Supplemental information was obtained from the pilot's reports of the icing conditions. A special data sheet was made available in the pilot's compartment with instructions to fill in the information each time the icing indicating light from the meter detected an icing condition. These data for each icing encounter included notations of date, geographic location, temperature, altitude, airspeed, duration of icing, and any remarks concerning the type and intensity of icing and the effects of the icing conditions on the aircraft. The altitude and airspeed were included for purposes of cross reference in correlating the film data with the supplemental information. This was necessary because the flight crew did not always note all icing encounters that were in sequence on the film. Also, considerable data were noted by the pilot which were not recorded on the film because either the film had been exhausted earlier or the recorder was inoperative at the time.

Analysis of data. - A section of a typical data film taken during an icing encounter is shown in figure 4. The five traces which appear on the film include the airspeed and altitude traces with their respective reference lines and the icing-rate trace. This icing trace is shown recorded as a series of variable length dashes which correspond to the heat-off times. The icing rate is obtained from these heat-off or sensing-element icing periods using the calibration shown in figure 3 (see example in fig. 4). When the film was analyzed, 1-minute intervals were marked off, and icing rate, altitude, and airspeed were averaged and computed for each 1-minute period. Each icing encounter was identified by a break in the film record. It was therefore possible to consider each icing encounter separately and to associate the individual records with the supplemental data.

2371

The accuracy of the icing-rate measurements was limited particularly at the higher rates because of the inverse function of icing rate to the measured icing period as shown in the calibration curve of figure 3. The maximum value of reliable data was considered to be 12 inches per hour. Icing rates exceeding this amount were considered beyond the range of the meter and are tabulated as 12+ inches per hour in tables I and II. The minimum icing rate considered significant was 1/2 inch per hour. Rates of icing between 1/2 and 1 inch per hour were called traces of icing and were not assigned a specified value in order to minimize the computing effort and yet not disregard any icing that could be of any interest.

The pressure altitude was measured to an accuracy of ± 100 feet using NACA standard atmosphere. This altitude was generally within a few hundred feet of the mean sea-level altitude noted by the pilot. The indicated airspeed was recorded within ± 1 mile per hour although the average airspeed for a 1-minute period was calculated within only about ± 3 miles per hour because of the fluctuations of the total pressure experienced by the aircraft in the air stream.

Most of the icing conditions were found to have large variations of water concentrations during the encounter. In many encounters long distances of no icing were noted which were probably associated with broken-cloud formations. In order to separate these excessive periods of no icing from periods during which ice is accumulating and to provide a convenient analysis of the various icing conditions, an arbitrary maximum distance of about 50 miles (about 15 min) between areas of icing was established. Therefore, any period of nonicing greater than 50 miles was considered as separating the icing condition into individual icing encounters. This rule could not always be followed because of insufficient information for the determination of whether the recorder had been shut off and started again within this maximum period.

The data collected from the icing meters installed on the four transport aircraft and the supplemental pilot reports were analyzed by following a statistical approach, although it was realized that the quantity of information was insufficient for a conclusive analysis of this type. These data have shown that this type meter is satisfactory for a program of collecting statistical icing data on airline aircraft in routine service.

RESULTS AND DISCUSSION

During the 5-month period when data were collected, a total of 100 icing encounters were logged on the data film and in the pilot's reports. These data are summarized in tables I and II. Table I contains the information computed from the film records and is associated with the corresponding pilot's reports wherever possible. A total of 45 encounters were correlated from these combined sources. Table II presents

the data from encounters where film records were not obtained and only the pilot's reports were available. These data, which are restricted to visual observations of icing, are included in order to add to the quantity of information available for the statistical analysis of the frequency of occurrence of icing with respect to date, geographical location, altitude, temperature, and duration of the icing conditions.

The data in tables I and II should not be considered as a thorough investigation of the range of meteorological variables associated with aircraft icing because of the manner in which the data were collected. The aircraft collecting the data were following normal flight operations which, if possible, avoided icing, and without exception, no aircraft were dispatched into known severe icing conditions.

Frequency of Occurrence of Icing Conditions

Total flight time. - The flight time in the icing conditions reported in table I totals approximately 16 hours. The four aircraft flew a total of 1120 hours during the period when these conditions were encountered. These flight times show that approximately $1\frac{1}{2}$ percent of the total flying time of the four aircraft was in icing conditions. This percentage may be slightly lower than the true value because the total time logged by the aircraft was obtained for the period during which the film drums were on the aircraft. If a drum was not replaced shortly after the film had been exhausted, some icing may have been encountered and not recorded.

Geographical area. - The transcontinental route followed by these four aircraft was essentially the civil airway across the central part of the United States from San Francisco through Denver, Colorado; Chicago, Illinois; and Cleveland, Ohio to New York city. This route was divided into five areas in an attempt to associate the icing encounters with the topography of the geographical areas covered by this one transcontinental route. The approximate mileage within these areas, the corresponding percentage of encounters with relation to the total number of encounters over the entire route, and the percentage of total encounters per mile for each area are given in table III. This information quite accurately establishes the frequency of occurrence of icing in these areas with respect to the entire route, because of the equal coverage provided by the aircraft operating only on a complete transcontinental basis. It will be noted that almost one-half of all the icing encounters were within the Great Lakes region. This fact correlates with U.S. Weather Bureau records which show this region to have an exceptionally large amount of cloud cover caused by excessive moisture picked up by air flowing over the large lakes area during the winter months. The Rocky Mountain area contributed the next largest percentage

of icing over the route, although the percentage of encounters per mile shows that the East Coast area has the second greatest frequency of icing encounter.

Altitude. - The probability of encountering icing at any particular altitude cannot be determined from these data because the aircraft, in following the normal flight procedures, would not properly survey a wide range of altitudes. It is of interest, however, to relate the frequency of icing at the altitudes flown in order to consider the data representative of routine flight operations during which icing was probably avoided wherever possible with this type of aircraft, except during climb or descent. The graph of figure 5 shows that icing occurred most frequently between 6000 and 9000 feet and that the maximum altitude at which icing was obtained was 15,000 feet, a height which was limited by the altitude restrictions of the aircraft. All icing encountered above 9000 feet was in the Rocky Mountains area, which was the result of the higher flight altitudes required.

In a further study of the icing data with respect to altitude, it was noted that over one-half of the recorded data were obtained during either climbing or descending. From these records a measure of the vertical extent, or depth, of the icing clouds was determined and plotted as a cumulative frequency curve (fig. 6). This curve shows that the maximum icing cloud depth was about 4000 feet and that for 80 percent of all the measurements the cloud depth was less than 2200 feet. It is not possible to determine whether these data are for single cloud layers or whether multiple-cloud-layer data are included; however, the values agree closely with information presented in reference 3 for the thickness of single cloud layers. The vertical extent of multiple cloud layers from reference 3 is plotted in figure 6 in order to compare the greater extent of multiple cloud layers with the data of this report, which are apparently the depths of single cloud layers. The cloud-depth records may not be entirely correct because of the impossibility of determining whether the aircraft entered or emerged from the icing cloud at a point other than the top or the bottom of the cloud layer. Further analysis of the cloud depths showed a trend toward increased thickness with increasing pressure altitude. This trend may be the result of orographic effects since all measurements above 9000 feet were entirely in the Rocky Mountain area. No information was obtained as to the types of cloud formation that these data cover but it can probably be assumed, because of the seasonal aspects of the data, that the clouds were predominantly of the stratiform type.

Probability of Encountering Specified Values of Icing Parameters

Temperature. - The data on air temperature in the icing encounters were obtained from pilot's notations using the conventional outside air

temperature indicator on the aircraft. These indicators have rather limited accuracy, particularly in icing clouds, and the temperature data tabulated (tables I and II) are therefore uncorrected because of this uncertainty. In the analysis of the data, however, an adiabatic heating correction of -2°C was applied, which is approximately equivalent to the temperature rise in wet air at 200 miles per hour, the normal air-speed of these aircraft. A cumulative frequency curve of these data is plotted in figure 7, which shows that the lowest temperature encountered was -21°C (-6°F) and the highest temperature associated with an icing cloud was -2°C (28°F). From this figure it will also be noted that in 80 percent of the observations the temperatures were above -12°C (10°F) and that the average of the temperatures was -5°C (23°F). These data are of fundamental importance with respect to the heat requirements for thermal ice-protection systems.

Icing rate. - The average measured rate of ice accumulation, given in table I (column 7), is the average rate for a complete encounter excluding periods of nonicing which exceeded 1 minute. Because of the high collection efficiency of the meter element, this value is probably the maximum rate for any aircraft component subject to ice accretions. For large bodies, such as wings, the collection may be only 30 percent of this value, depending on other factors, particularly droplet size and airspeed. A cumulative frequency curve of the average icing rate as measured by the icing-rate meter is shown in figure 8. The largest average icing rate was about 10 inches per hour, whereas 80 percent of the measurements were less than 5 inches per hour. The maximum icing rate for any 1-minute period within the encounter is given in table I (column 9). This value is presented because of its possible significance with respect to certain aircraft components which may be particularly vulnerable to high rates of icing for short periods of time. A specific part may be adequately protected for a low rate of ice accretion over comparatively long periods, but such protection could fail under sudden and heavy accumulations. Unfortunately, about 25 percent of the maximum icing rates were beyond the reliable range of the meter (12 in./hr). The data, up to this limit, are also shown as a cumulative frequency curve in figure 8.

Liquid-water content. - An approximation of the liquid-water content of the icing clouds encountered was computed from the icing-rate indications using values of 0.9 gram per cubic centimeter as the density of ice collected on the element and 90 percent as the collection efficiency of the element. This collection-efficiency value was assumed constant for the range of airspeeds and droplet sizes encountered. Liquid-water-content values obtained by the meter in this manner have been compared in research flights by other means (rotating multicylinders) and were found to agree within 0.1 gram per cubic meter over a range of liquid-water content up to 0.5 gram per cubic meter.

2371

The average and maximum values of liquid-water content given in table I (columns 8 and 10) were computed from the corresponding average and maximum icing rates. A cumulative frequency curve of these values is shown in figure 9. The data for average values of liquid-water content for each encounter are shown to compare quite closely with previous observations presented in reference 3. From both sources, the average liquid-water contents per encounter are less than 0.4 gram per cubic meter in 80 percent of the observations and the maximum values are less than 1.0 gram per cubic meter. The data for maximum values of liquid-water content measured for any 1-minute period exceed the range of the meter for 25 percent of the observations. The 12-inches-per-hour limitation of the maximum icing rate measured by the meter and the true airspeed of the aircraft of slightly over 200 miles per hour determined the upper measurable limit of the liquid-water content to be approximately 1.0 gram per cubic meter. The maximum values of liquid-water content, compared with the corresponding average values, illustrate the extremely wide range of water content that exists in most of the individual icing encounters. The close correlation of these data to previous information obtained from limited research measurements are considered useful in further substantiating the validity of the previous data for proper design considerations. More information is needed, however, to substantiate the apparently close agreement of these data. Also, with considerable additional data, water contents of the icing clouds can be related to wide ranges of altitudes over various geographical areas.

Probable Duration of Specified Icing Conditions

Horizontal extent. - The duration of a given icing condition should be considered as a significant factor in the design and operation of ice-protection systems. Previous data on the horizontal extent of icing conditions have shown an inverse relation between the average liquid-water content and the extent of the conditions. This information was not considered completely reliable because of the unusual flight procedures used in obtaining the data. In most cases, the particular icing condition encountered was not surveyed to obtain the extent in any one direction. Many observations relied on surface reports of the extent of the cloud cover associated with the particular icing condition to determine the maximum extent of the icing clouds. The data presented in this report provide a more accurate survey of the straight-line extent of an icing encounter, although these data are subject to flight procedures which may have necessitated deviations from straight-line flight. This information is useful in the consideration of routine flight operations by this particular airline aircraft.

Average values of liquid-water content for each encounter are plotted in figure 10 against the total distance flown in measurable icing during the encounter. These data do not define clearly the inverse relation between liquid-water content and horizontal extent obtained from previous data. High values of liquid-water content exist over distances in excess of 100 miles as well as over much shorter distances. Additional data may show that liquid-water content does reduce with increasing horizontal extent as outlined by the envelope taken from reference 3. The data shown in figure 10 indicate that the majority of icing encounters will be over short distances (under 50 miles). It will be noted that most of the data fall within the reference envelope of maximum values except for two points which fall beyond the 125-mile-distance (extreme conditions).

The actual duration or time in icing conditions has been a rather difficult quantity to determine from reports received from transport or airline operations. Pilot's estimates of the extent of icing encounters have in many cases been considerably longer than the actual conditions because of their inability to distinguish between intermittent and continuous icing, particularly at night. To determine the relation of the pilot's estimates of the extent of icing to the actual period in which ice is accumulating, the flight crews were asked to include their judgment of the icing time on the supplemental data sheets. These times are compared with the corresponding measured time in icing in table I (columns 12 and 14). From this comparison it was found that if the icing time was short (less than 15 min) the pilot's estimate agreed quite well with the actual value. If, however, the icing time was considerably longer (1/2 hr or more), the actual duration of icing was less than 50 percent of the pilot's estimate. This discrepancy shows the difficulty of distinguishing intermittent icing, which is common for prolonged icing encounters. From the data in table I it was also found that the actual time in icing averages only about 60 percent of the total duration of the encounter (column 13); this substantiates the fact that most icing is intermittent and seldom continuous except for short encounters. It should be noted that an icing encounter as considered in this report does not contain periods of nonicing greater than about 15 minutes since periods greater than this amount were considered as separate encounters. The total time in icing, tabulated in table I (column 11), has been reduced to the total time in measurable icing (column 12) by the exclusion of periods with an icing rate of less than 1 inch per hour, which is considered insignificant and therefore omitted in computing the actual time in icing conditions.

Total ice accumulation. - The effects of an icing encounter on most aircraft components are determined largely by the concentrations of liquid-water encountered and the extent or time which the aircraft spends in the icing area. The combination of these two variables determines the total amount of ice that any component collects, excluding collection

2371

efficiency effects. The total ice thickness that would accumulate on the sensing element of the icing-rate meter for the entire encounter, if allowed to ice continuously, can be considered a measure of the largest amount of ice that any component collects because of the high collection efficiency of the meter sensing element. Multiplication of the average icing rate measured by the meter by the time in measurable icing gives a reference ice thickness assumed to collect on the sensing element. These total ice-thickness values were calculated (table I, column 15) and are plotted as a cumulative frequency curve in figure 11. This curve shows that in 90 percent of the icing encounters, the total quantity of ice accumulated was less than 2 inches thick. In three cases, however, the total thickness was over 4 inches, and the maximum accumulation was slightly over 6 inches.

The possibility of using the total ice accumulation measured by the meter as a reference to establish a criterion for determining the over-all effects of icing on a particular aircraft was investigated by comparison of the total ice accretion values with the pilot's comments of the icing intensity. It is assumed that the pilot's judgment of the icing intensity was determined largely by his observations of the accumulations on the aircraft and the corresponding effects on the aircraft performance. Most reports by pilots of the icing encountered referred to the icing conditions as trace, light, moderate, heavy, or severe.

The measured total ice accumulations were associated with their respective flight observations and were found to separate into categories as shown in figure 11. The dividing lines are only approximate but the correlations were quite consistent. Measured ice accumulations less than 1 inch were considered by pilots as traces of ice or, in many cases, not reported. The division between reported light and moderate icing seems to be about 2 inches, whereas heavy icing measured over 4 inches of ice accumulation. The one point of over 6 inches was considered severe in that the pilot requested an emergency landing because of the adverse effects on the aircraft. The measured values with respect to these observed categories of icing are confined to the four-engine DC-4-type aircraft with which these observations were obtained.

The severe condition which caused a total ice accumulation of over 6 inches was a combination of high average liquid-water content (0.8 g/cu m) and extensive distance flown in the icing (150 miles). The data on this icing condition are summarized in table I as record 1, encounters 1 and 2. The recorded data showed the condition to be of a cumulus-cloud nature which caused intermittent heavy icing over relatively short distances. The air temperature was estimated from radiosonde data which gave an exceptionally low temperature for these high values of liquid-water content. It is suspected that this encounter approaches the magnitude of other encounters (in this same general area) where icing has been reported as causing considerable adverse effects on aircraft performance.

SUMMARY OF RESULTS

The icing data collected by four transport aircraft equipped with pressure-type icing-rate meters have shown that this type meter is satisfactory for a program of collecting statistical icing data on airline aircraft in routine service. Considerable additional data are needed and will be obtained from the program which has been expanded to cover many air routes both in the United States and overseas.

The following preliminary results were obtained from the four aircraft operated by United Air Lines, from January through May, 1951, in routine service over a transcontinental route:

1. Approximately $1\frac{1}{2}$ percent of the total flying time of the four aircraft was in icing conditions.

2. Along the routes used by the civil airways across the central part of the United States, almost one-half of all the icing encounters were within the geographical areas where the weather is influenced by the Great Lakes.

3. Over one-half of the icing conditions were encountered during either climbing or descending. Measurements of icing cloud depth from these data showed that maximum cloud depths were about 4000 feet and that 80 percent of the icing conditions were less than 2200 feet in vertical extent. These results agree with previous measurements of single cloud layers.

4. The lowest air temperature reported in icing was -21°C (-6°F), whereas 80 percent of the observations were in air temperatures above -12°C (10°F).

5. The average liquid-water content in an icing encounter did not exceed 1.0 gram per cubic meter, and 80 percent of the measurements had less than 0.4 gram per cubic meter. The close correlations between these data and previous observations help to establish the validity of the earlier information.

6. The total ice accumulation from an icing encounter (product of average icing rate and duration of icing) was found to agree approximately with the pilot's estimates of the icing intensity based on observation and effects of the ice accretions on the aircraft. Pilot notations of light icing usually measured less than 2 inches of ice accumulation, whereas accumulations over 4 inches were indicative of heavy icing and those over 6 inches were called severe icing.

REFERENCES

1. Hacker, Paul T., and Dorsch, Robert G.: A Summary of Meteorological Conditions Associated with Aircraft Icing and a Proposed Method of Selecting Design Criteria for Ice-Protection Equipment. NACA TN 2569, 1951.
2. Perkins, Porter J., McCullough, Stuart, and Lewis, Ralph D.: A Simplified Instrument for Recording and Indicating Frequency and Intensity of Icing Conditions Encountered in Flight. NACA RM E51E16, 1951.
3. Kline, Dwight B., and Walker, Joseph A.: Meteorological Analysis of Icing Conditions Encountered in Low-Altitude Stratiform Clouds. NACA TN 2306, 1951.

2371

TABLE I - SUMMARY OF ICING DATA MEASURED BY ICING-RATE METER AND REPORTED

1	2	3	4	5	6	7	8	9	10	11	12	13	14	
Record number	Encounter number	Date	Pressure altitude (ft)	True airspeed (mph)	Indicated temperature (°C)	Average icing rate ^a (in./hr)	Average liquid-water content ^a (g/cu m)	Maximum icing rate ^b (in./hr)	Maximum liquid-water content ^b (g/cu m)	Total time in icing (min)	Total time in measurable icing ^e (min)	Total duration of encounter (min)	Total time in icing by pilot (min)	
1	1	1/16/51	9,600 ^c 12,400	181	-5to-12	7.2	0.5	12+	1.0+	26	6	26	180	
	2	1/17/51 (g)	13,000	200	-15	10.0	.8	12+	1.0+	51	38	61	(g)	
	3		7,600 ^c 9,600 ^d 7,300	223	(g)	11.0	.8	12+	1.0+	11	8	11		
2	1	(g)	7,300 ^c 9,200	232	(g)	4.4	0.2	4.9	0.3	3	3	9	(g)	
	2	(g)	5,500	230	(g)	2.9	.2	5.4	.4	4	3	4	(g)	
	3	(g)	10,200	225	(g)	4.2	.3	11.5+	.8	17	14	35	(g)	
	4	(g)	8,200 ^d 6,400	214	(g)	6.0	.4	12.0	.9	19	19	19	(g)	
3	1	1/24/51	6,500	205	-7	1.8	0.1	2.4	0.2	12	7	21	5	
	2	1/25/51	5,800 ^d 3,900	245	-14	3.5	.2	7.8	.5	6	6	6	5	
	3	1/25/51	3,700 ^c 5,800	194	-11	3.0	.2	4.9	.4	6	4	12	10	
4	1	2/15/51	7,700	223	-1	2.3	0.2	6.3	0.4	17	12	17	20	
	2	2/16/51	9,100 ^d 7,300	220	-1to-2	5.6	.4	9.2	.7	53	44	60	70	
	3	2/16/51	7,800 ^c 9,500 ^d 7,300	230	-4to-1	4.4	.3	12+	.8+	16	15	16	15	
	4	2/16/51	9,000	221	0	4.2	.3	6.7	.5	23	22	58	70	
	5	2/16/51	9,000	(e)	0	(g)	(g)	(g)	(g)	(g)	(g)	(g)	15	
	6	2/17/51	8,000	225	0	2.5	.2	10.0	.7	34	29	106	70	
5	1	(g)	3,200	221	(g)	5.6	0.4	12+	0.9+	8	8	8	(g)	
	2	2/6/51	2,200 ^c 4,000	205	0	2.2	.2	6.3	.5	29	21	51	60	
	3	2/6/51	4,100	207	-1	6.0	.5	10.0	.8	17	17	17	10	
	4	2/7/51	10,000 ^c 13,800	212	-12	7.2	.5	12+	.9+	9	8	17	3	
	5	2/7/51	13,000	223	-12	4.8	.3	9.0	.6	5	5	5	3	
	6	2/9/51	3,700 ^d 3,000	220	-20	4.6	.3	8.5	.6	4	4	5	3	
6	1	1/18/51	8,000	201	0	7.2	0.6	12+	0.9+	44	43	46	50	
	2	(g)	3,000 ^c 5,600	195	(g)	3.4	.3	12.0	1.0	5	5	8	(g)	
	3	(g)	3,900 ^c 5,100	192	(g)	1.9	.2	3.5	.3	4	4	4	(g)	
7	4	(g)	7,100	221	(g)	1.5	0.1	2.0	0.1	4	4	8	(g)	
	5	1/20/51	6,200	210	-4	4.2	.3	12+	.9+	17	17	24	45	
	6	(g)	4,200 ^c 6,100	161	(g)	2.5	.2	4.9	.5	4	4	6	(g)	
	7	(g)	11,000	238	(g)	7.8	.5	12+	.8+	5	5	5	(g)	
	8	(g)	5,600 ^c 7,100	197	(g)	4.2	.3	8.5	.7	7	7	10	(g)	
	9	(g)	7,100 ^c 6,600 ^c 8,000	225	(g)	6.7	.5	12+	.8+	8	8	21	(g)	
	8	1	3/14/51	2,400 ^c 2,800	193	0	3.0	0.2	3.5	0.3	3	3	15	20
	2	3/14/51	4,500 ^c 5,100	225	0	2.2	.2	3.5	.2	8	7		(g)	
	3	3/14/51	4,400 ^d 2,600	220	0	3.5	.3	8.5	.6	10	9	11	15	
4	3/14/51	2,400 ^c 3,400	188	0	4.1	.3	5.6	.5	6	6	6	10		
5	3/14/51	8,400	200	-9	2.0	.2	5.7	.5	6	6	7	5		
6	3/14/51	3,600	186	(g)	3.8	.3	9.2	.8	4	4	5	(g)		
9	1	(g)	7,000	219	(g)	3.3	0.2	4.6	0.3	4	4	4	(g)	
	2	5/5/51	15,300	226	-2	1.3	.1	4.4	.3	4	2	12	4	
	3	5/5/51	11,900 ^d 9,700 ^c	233	-1	2.9	.2	6.0	.4	9	8	15	5	
	4	5/5/51	10,600 ^c 12,800 ^d	198	0	5.0	.4	12+	.9	5	5	10	(g)	
	5	5/5/51	12,000 ^d 8,000	217	0	5.3	.4	12+	.9	13	11	15	5	
	6	(g)	6,300	246	(g)	1.8	.1	12+	.9	8	3	12	(g)	
	7	5/12/51	13,700	230	-12	1.9	.1	7.9	.8	10	6	36	26	
	8	5/12/51	10,600 ^d 7,100	219	-12	1.9	.1	3.0	.2	6	6	24	7	

^aAverage values for complete encounter.
^bMaximum value for 1-minute period during encounter.
^cClimb.
^dDescent.
^eGreater than 1 in./hr.
^fProduct of average icing rate and time in measurable icing.
^gNo data available.



23/1

DURING ROUTINE AIRLINE OPERATIONS FROM JANUARY THROUGH JUNE, 1951

15	16	17	18	19
Calculated total ice accumulation (in.)	Distance flown in icing (miles)	Distance flown in measurable icing ^e (miles)	Geographic location	Pilot comments and notes
0.7 6.3 • 1.3	78 170 41	18 127 30	Oakland, Calif. to Sacramento, Calif. 50 miles east Reno, Nev. to Elko, Nev. (g)	(Encounters 1 and 2 same flight) Pilot reported severe icing, requested emergency landing. (g)
0.2 1.1 1.0 1.9	12 12 64 68	12 8 52 68	(g) (g) (g) (g)	(No pilot data with this data film.) (g) (g) (g)
0.2 .4 .2	41 24 19	24 24 13	Youngstown, Ohio Elyria, Ohio Archbold, Ohio	(g) (Encounters 2 and 3 probably same icing condition broken by landing at Cleveland.)
0.5 4.1 1.1 1.5 (g) 1.2	63 195 61 85 (g) 127	45 162 58 81 (g) 109	Near Lexington, Nebr. Des Moines, Iowa to Chicago, Ill. Archbold, Ohio to Toledo, Ohio Cleveland, Ohio to Philipsburg, Pa. Allentown, Pa. Newark, N. J. to Philipsburg, Pa.	Trace of ice. Trace Des Moines, Iowa to Moline, Ill. - Light Chicago, Ill. Light to moderate ice. Light ice. Trace - (Pilot considered encounters 4 and 5 separate.) Trace of ice.
0.7 .8 1.7 1.0 .4 .3	29 100 59 32 19 15	29 72 59 28 19 15	(g) Chicago, Ill. to Moline, Ill. Iowa City, Iowa to Des Moines, Iowa Grand Island, Nebr. Grand Island, Nebr. to Omaha, Nebr. Over Milwaukee, Wis.	(g) Light rime. Light rime. Light rime. (g) Very light rime.
5.2 .3 .1	147 16 13	144 16 13	Philipsburg, Pa. to Youngstown, Ohio (g) (g)	(g) (g) (g)
0.1 1.2 .2 .7 .5 .9	15 60 11 20 23 30	15 60 11 20 23 30	(g) South Bend, Ind. to Chicago, Ill. (g) (g) (g) (g)	(g) (g) (g) (g) (g) (g)
0.2 .3 .5 .4 .2 .3	10 30 37 19 20 12	10 26 33 19 20 12	Chicago, Ill. to South Bend, Ind. Chicago, Ill. to South Bend, Ind. Sandusky, Ohio to Cleveland, Ohio Cleveland, Ohio to Akron, Ohio Altoona, Pa. (g)	Ice accumulation very slight. (Pilot considered 1 and 2 same encounter.) Trace only. Trace only. Trace only. (g)
0.2 .1 .4 .4 1.1 .2 .3 .2	15 15 35 17 54 29 38 22	15 8 31 17 45 11 23 22	(g) Blue Canyon, Calif. Auburn, Calif. area (g) Near Roseville, Calif. (g) Southwest of Fort Bridger, Wyo. (g)	(g) Moderate to heavy for about 30 seconds. Trace of ice. (Pilot considered 3 and 4 same encounter.) Trace of ice. (g) Trace to light ice. (g)



2571



TABLE II - SUMMARY OF ICING ENCOUNTERS AS OBSERVED BY FLIGHT CREWS
 [Icing-rate meter measurements unavailable]

Data Number	Encounter number	Date	Indicated altitude (ft)	True airspeed (mph)	Indicated temperature (°C)	Time in icing (min)	Distance flown icing (miles)	Geographic location	Pilot comments and notes
1	1	1/17/51	13,000	235	-10	30	117	Auburn, Calif. to Reno, Nev.	(b)
2	1	1/24/51	6,000	185	(b)	4	12	San Francisco, Calif.	(b)
	2	2/16/51	5,000	195	0	40	129	Goshen, Ind.	Tops of strato-cumulus.
	3	2/17/51	7,000	210	-6	10	40	Cleveland, Ohio eastbound	Tops of cumulus. Trace of rime.
	4	2/18/51	13,000	242	-16	3	56	Battle Mountain, Nev. area	Trace of rime.
	5	2/19/51	13,000	247	-16	13	12	Wells, Nev. to Lucin, Utah	Tops of cumulus. Trace of rime.
	6	2/19/51	13,000	253	-13	4	17	Rock Springs, Wyo.	Trace of rime.
	7	2/19/51	6,000	195	0	2	6	Toledo, Ohio	Mixture of rain and snow. Tops at 4000 ft.
	8	2/21/51	6,000 ^c	170	0	4	11	(b)	Climb through overcast. Tops at 4000 ft.
	9	3/2/51	14,000	230	-20	(b)	(b)	Sherman Hill, Wyo. area -	(b)
	10	3/2/51	10,000	210	-10	(b)	(b)	Lyman, Wyo. area	(b)
	11	3/2/51	6,000	205	-5	(b)	(b)	Poughkeepsie, N. Y. to Wilkes-Barre, Pa.	Light to moderate rough ice.
	12	3/8/51	6,000	205	-5	(b)	(b)	(b)	(b)
3	1	2/19/51	7,000	227	0	42	159	Akron, Ohio to Hayes Center, Nebr.	Trace of smooth rime.
	2	2/20/51	14,000	176	-15	10	15	Reno, Nev. to Donner Summit, Calif.	Light rime.
	3	3/7/51	12,000	244	-10	30	255	Phillipsburg, Pa. to Newark, N. J.	1 inch of rough mixture of ice and snow.
	4	3/7/51	12,000	244	-10	3	22	Elk Mountain, Nebr.	Trace of ice.
	5	3/9/51	6,000	170	-9	4	11	Akron, Ohio	Light rime.
	6	3/9/51	6,000 ^c	170	-9	6	4	Cleveland, Ohio to Youngstown, Ohio	Light rime.
	7	3/15/51	9,000	228	-5	3	11	South Bend, Ind.	Trace of ice.
	8	3/15/51	9,000	228	-5	3	11	Goshen, Ind. area	Trace of ice.
	9	3/15/51	9,000	222	-7	5	16	Toledo, Ohio	Light of ice.
	10	3/15/51	9,000	227	-8	3	11	Toledo, Ohio to Cleveland, Ohio	Trace of ice.
	11	3/15/51	9,000	226	-5	5	16	Wesley, Pa.	Trace of ice.
	12	3/16/51	12,000	212	-5	10	38	Port Bridger, Wyo. area	Light rime.
	13	3/19/51	17,000	203	-5	10	34	Grand Island, Nebr. area	Trace of smooth mixture of ice and snow.
	14	3/19/51	7,000	203	-5	10	34	Grand Island, Nebr. area	Trace of light rime.
	15	3/17/51	7,000	205	-1	36	123	Omaha, Nebr.	Trace of clear ice.
	16	3/20/51	10,000	217	0	12	43	Harrisburg, Pa. to Phillipaburg, Pa.	Trace of light rime.
	17	3/21/51	9,000	210	-8	10	35	Sellinggrove, Pa. area	Less than a trace.
4	1	3/31/51	4,000 ^c	170	-2	5	14	Climbing Chicago, Ill. to South Bend, Ind	(b)
	2	4/3/51	8,000 ^c	177	-1	15	44	Hartford, Conn. to Poughkeepsie, N. Y.	Trace of ice.
	3	4/3/51	8,000	212	-7	15	53	Brookville, Pa. to Youngstown, Ohio	Medium icing.
	4	4/4/51	9,000	209	-9	45	157	Archbold, Ohio to Cleveland, Ohio	Light to moderate ice.
	5	4/4/51	9,000	209	-10	80	279	Youngstown, Ohio to Sellingsgrove, Pa.	Light to moderate ice.
	6	4/4/51	7,000 ^d	224	-9	10	37	Allentown, Pa. area	Trace of ice.
5	1	4/6/51	7,000	230	0	(b)	(b)	Imperial, Nebr. to Omaha, Nebr.	Trace of rime.
	2	4/7/51	10,000 ^d	212	-1	10	37	Akron, Ohio to Denver, Colo.	Light rime.
	3	4/7/51	10,000	212	-1	40	141	Phillipsburg, Pa. to Cleveland, Ohio	(b)
	4	4/21/51	(b)(c)	150	-4	5	12	Denver, Colo.	Hardly visible trace during take-off.
	5	4/21/51	11,000	227	0	55	190	Grand Island, Nebr. to Iowa City, Iowa	Light trace of rime.
6	1	3/31/51	4,000 ^c	170	-2	5	14	Climb out of Chicago, Ill.	(b)
	2	4/4/51	8,000	196	-5	21	69	Goshen, N. Y. to Wilkes-Barre, Pa.	Varied from light trace to light-moderate.
	3	4/7/51	8,000 ^d	209	-9	11	38	Akron, Ohio to Denver, Colo.	Trace to light rime ice.
	4	4/12/51	8,000	209	0	23	80	Youngstown, Ohio to Cleveland, Ohio	Trace to light ice.
	5	4/12/51	6,000	188	-3	35	110	Goshen, Ind. to Chicago, Ill.	Light to moderate.
	6	4/13/51	7,000	214	-4	10	36	Toledo, Ohio	Trace to light rime.
	7	4/17/51	9,000	216	-7	10	36	South Bend, Ind. to Goshen, Ind.	Trace to light rime.
	8	4/25/51	14,500	228	-7	10	36	Denver, Colo. to Goshen, Ind.	Trace at 10 minute intervals.
	9	4/10/51	9,000	223	-4	(b)	(b)	Phillipsburg, Pa.	(b)
	10	4/10/51	9,000	223	-4	(b)	(b)	Phillipsburg, Pa.	(b)
	11	4/10/51	9,000	223	-4	(b)	(b)	Phillipsburg, Pa.	(b)
	12	5/1/51	12,000	225	-2	5	19	Chicago, Ill. to Goshen, Ind.	(b)
	13	6/1/51	14,500	225	(b)	8	(b)	West of Grand Junction, Colo.	In alto-cumulus clouds.

^aMean sea level.
^bBy data available.
^cClimb.
^dDescent.

TABLE III - RELATION OF ICING ENCOUNTERS TO GEOGRAPHICAL AREAS



Area	Approximate extent of area	Approximate mileage	Percentage of total number of encounters	Percentage of total number of encounters per mile
West Coast	San Francisco, Calif. to Donner Summit, Calif.	170	4	0.024
Rocky Mountains	Donner Summit, Calif. to North Platte, Nebr.	1160	25	.022
Central Plains	North Platte, Nebr. to Moline Ill.	520	14	.027
Great Lakes	Moline, Ill. to Philipsburg, Pa.	670	43	.064
East Coast	Philipsburg, Pa. to New York, N. Y.	240	14	.058

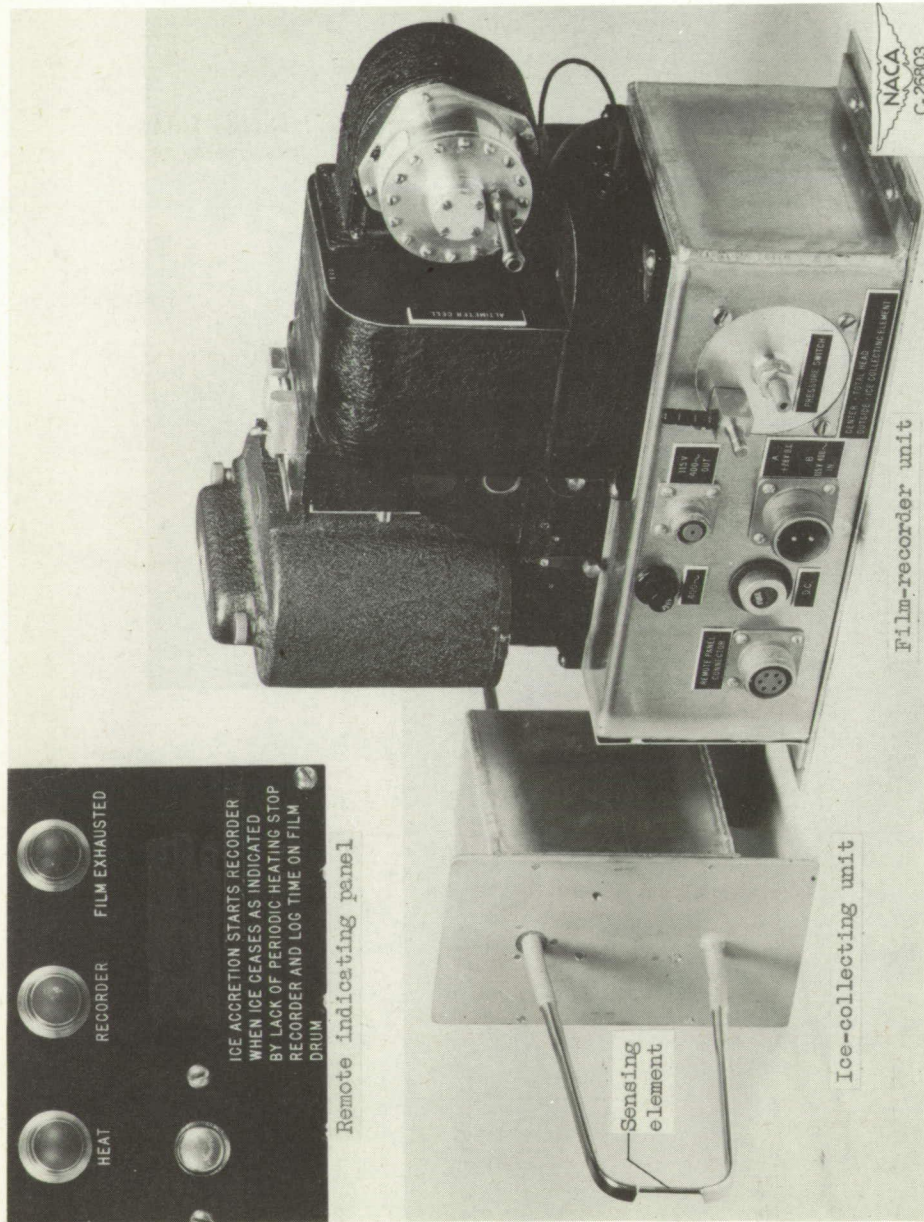

Figure 1. - NACA pressure-type icing-rate meter.

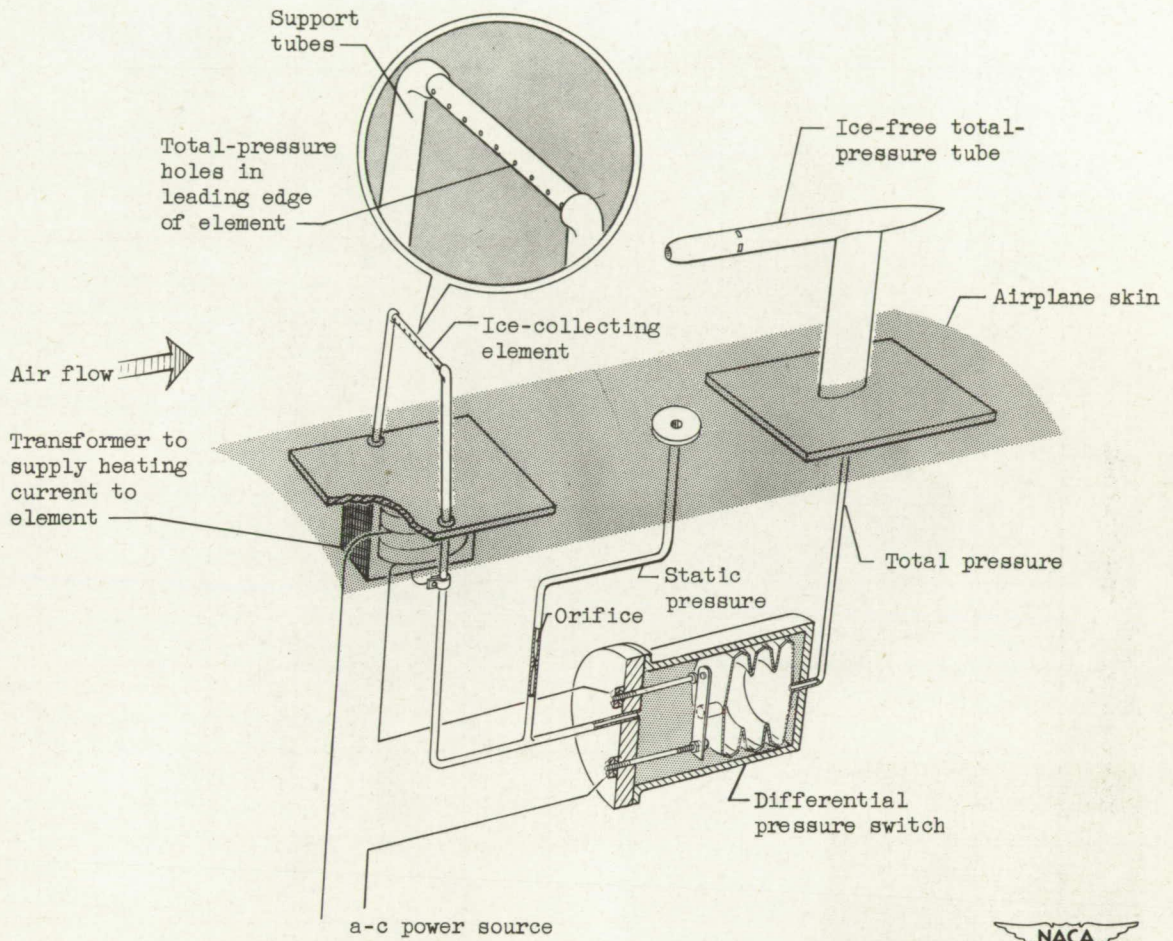

Figure 2. - Principle of operation of NACA pressure-type icing-rate meter.

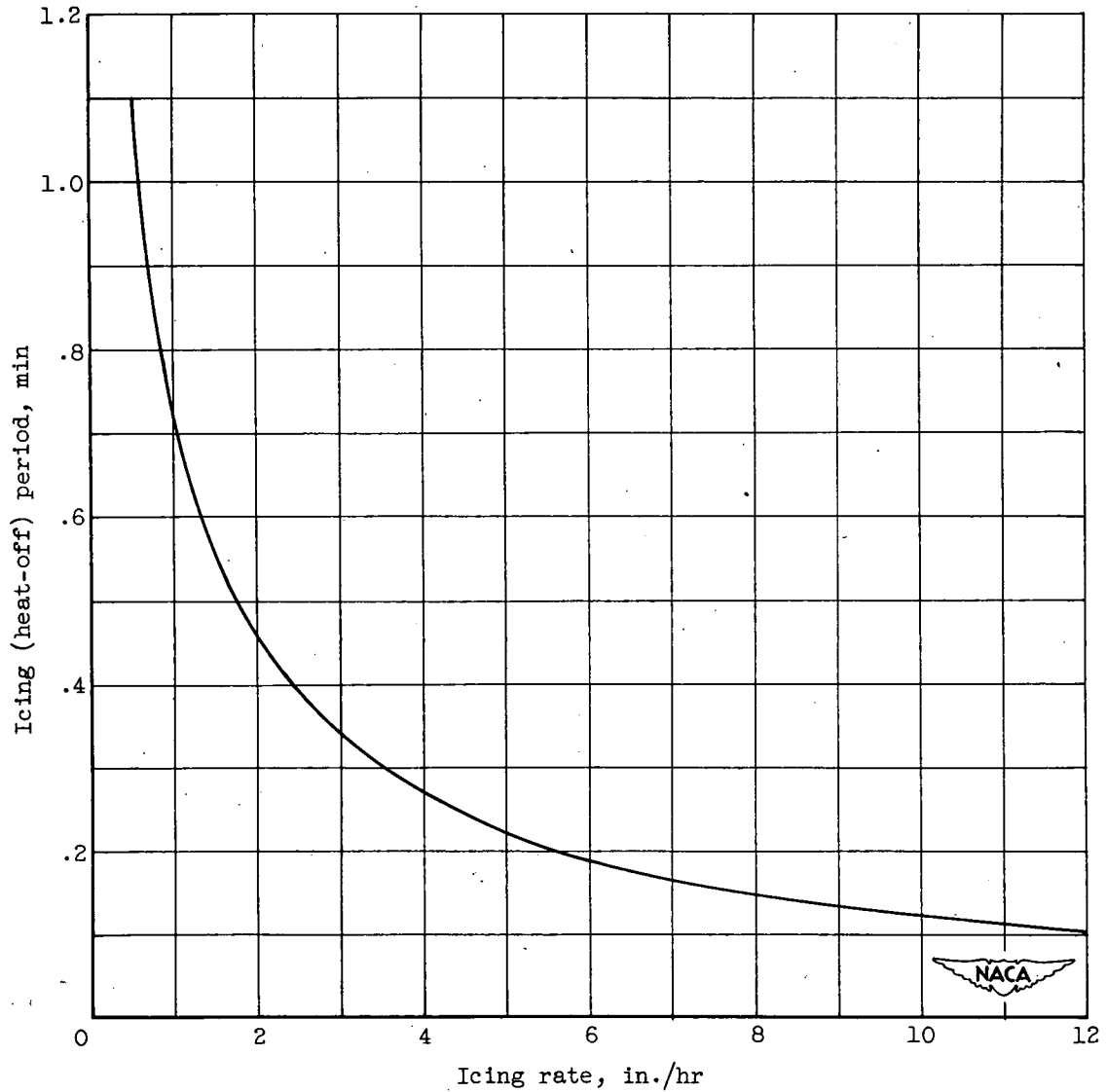

Figure 3. - Calibration of rate of ice accumulation on sensing element of pressure-type icing-rate meter at 200 miles per hour.

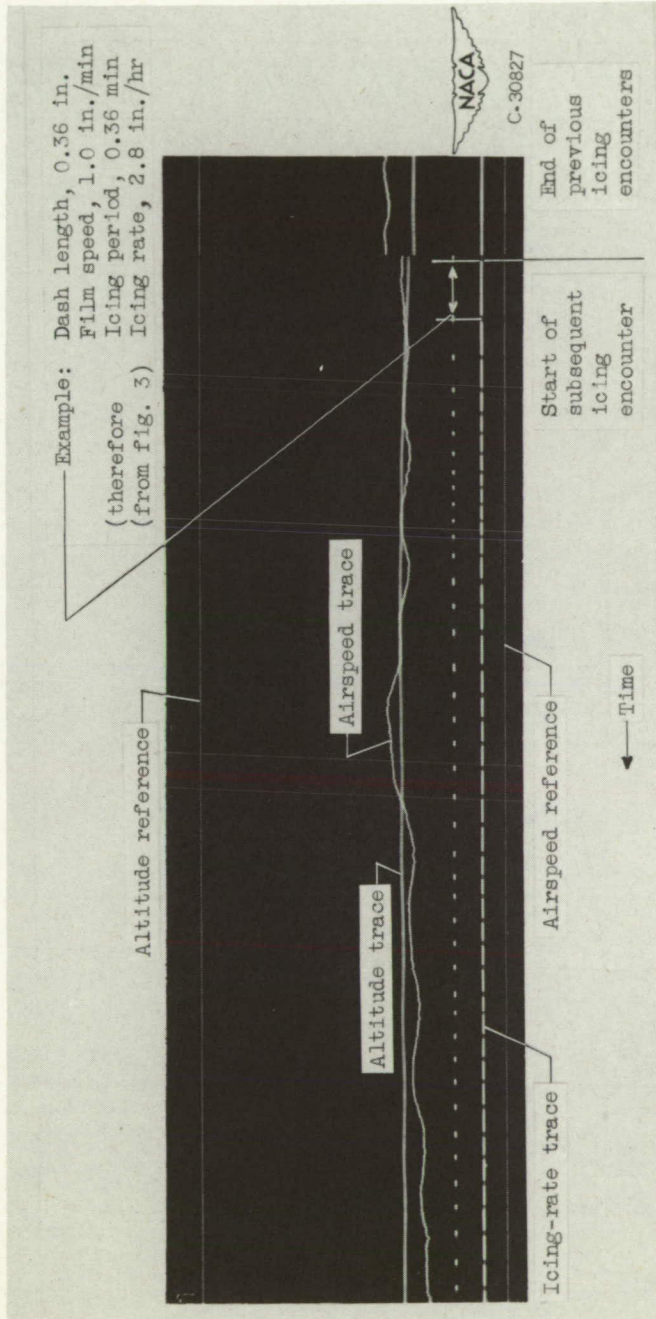

Figure 4. - Section of data film from pressure-type icing-rate meter recorded during icing encounter by airline aircraft.

2371

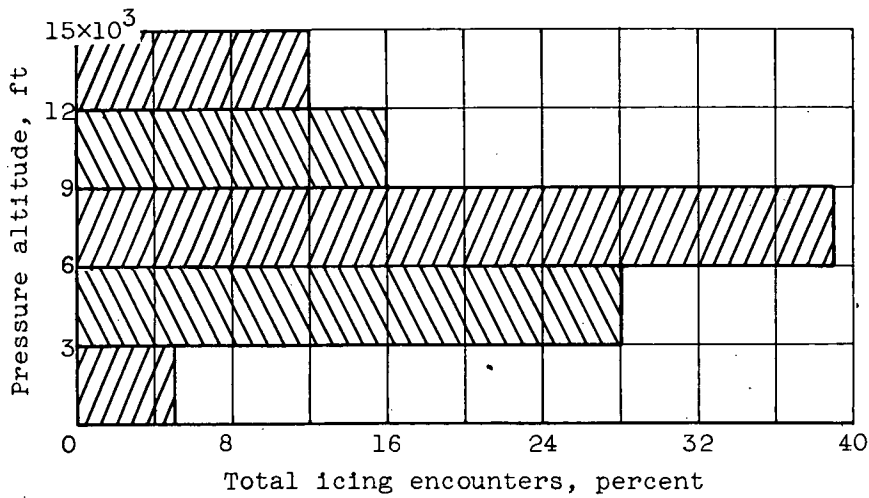

Figure 5. - Frequency of icing encounters with respect to altitudes flown during routine airline operations. - Total icing encounters, 100.

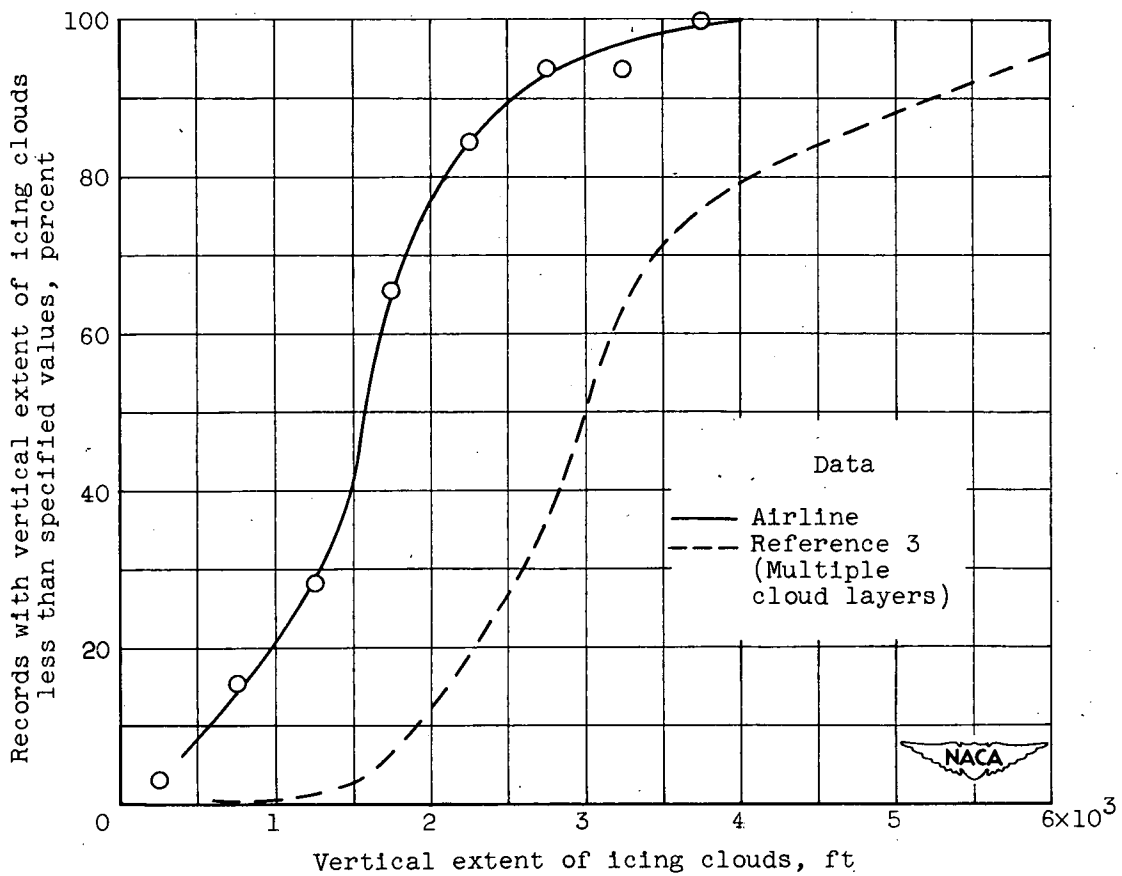

Figure 6. - Cumulative frequency of icing cloud depth obtained from 32 records of climbing and descending during routine airline operations.

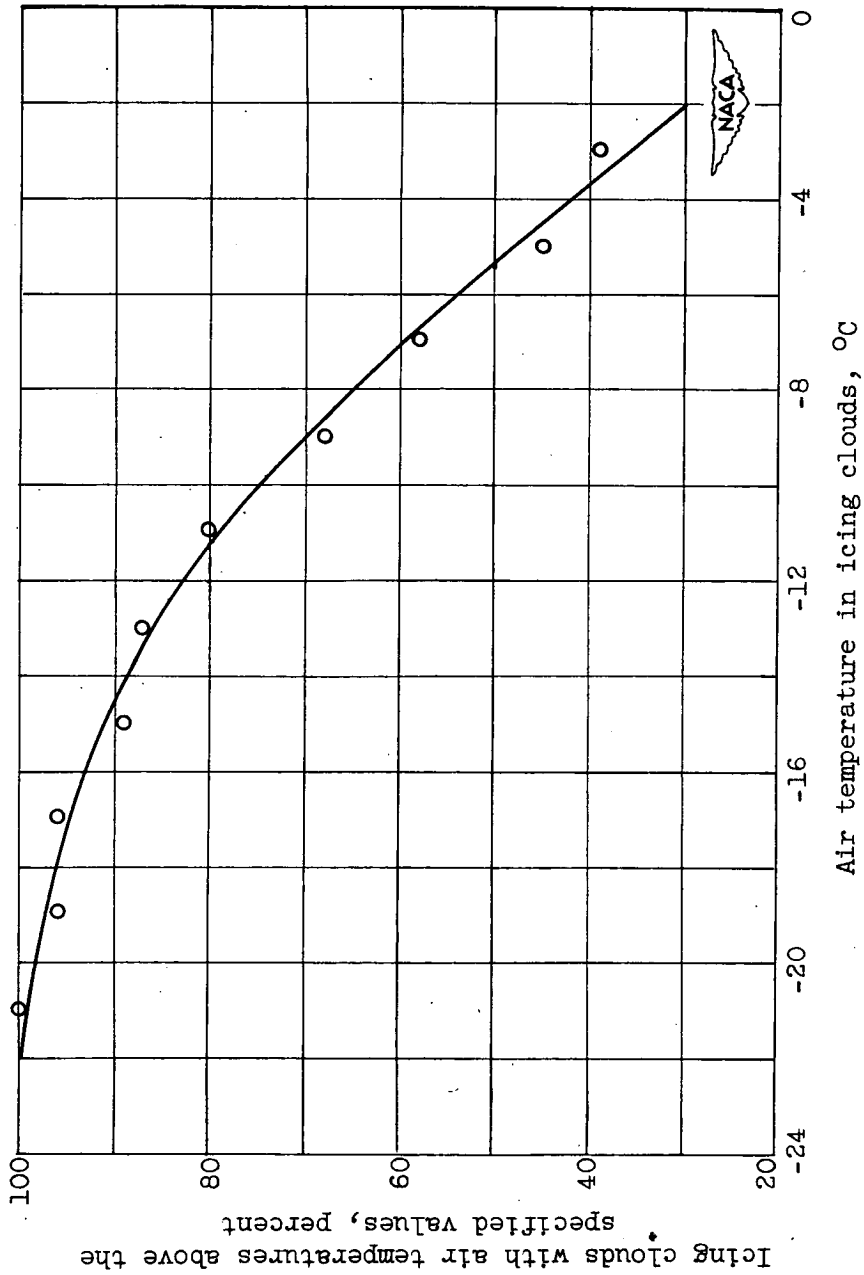

Figure 7. - Cumulative frequency of air temperature in icing clouds obtained from 83 observations during routine airline operations.

2371

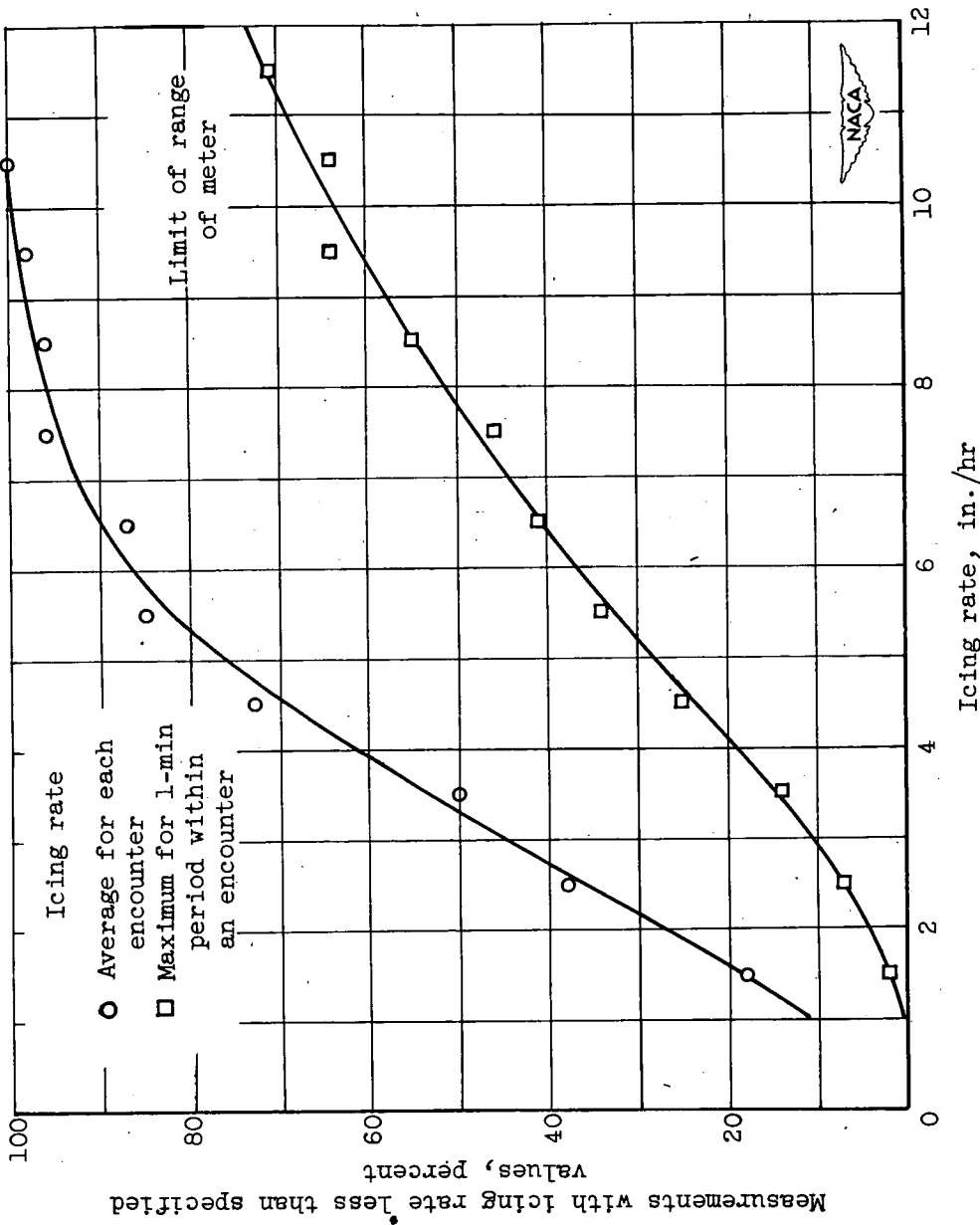

Figure 8. - Cumulative frequency of average and maximum icing rate in 44 icing encounters measured by pressure-type icing-rate meters installed on airline aircraft.

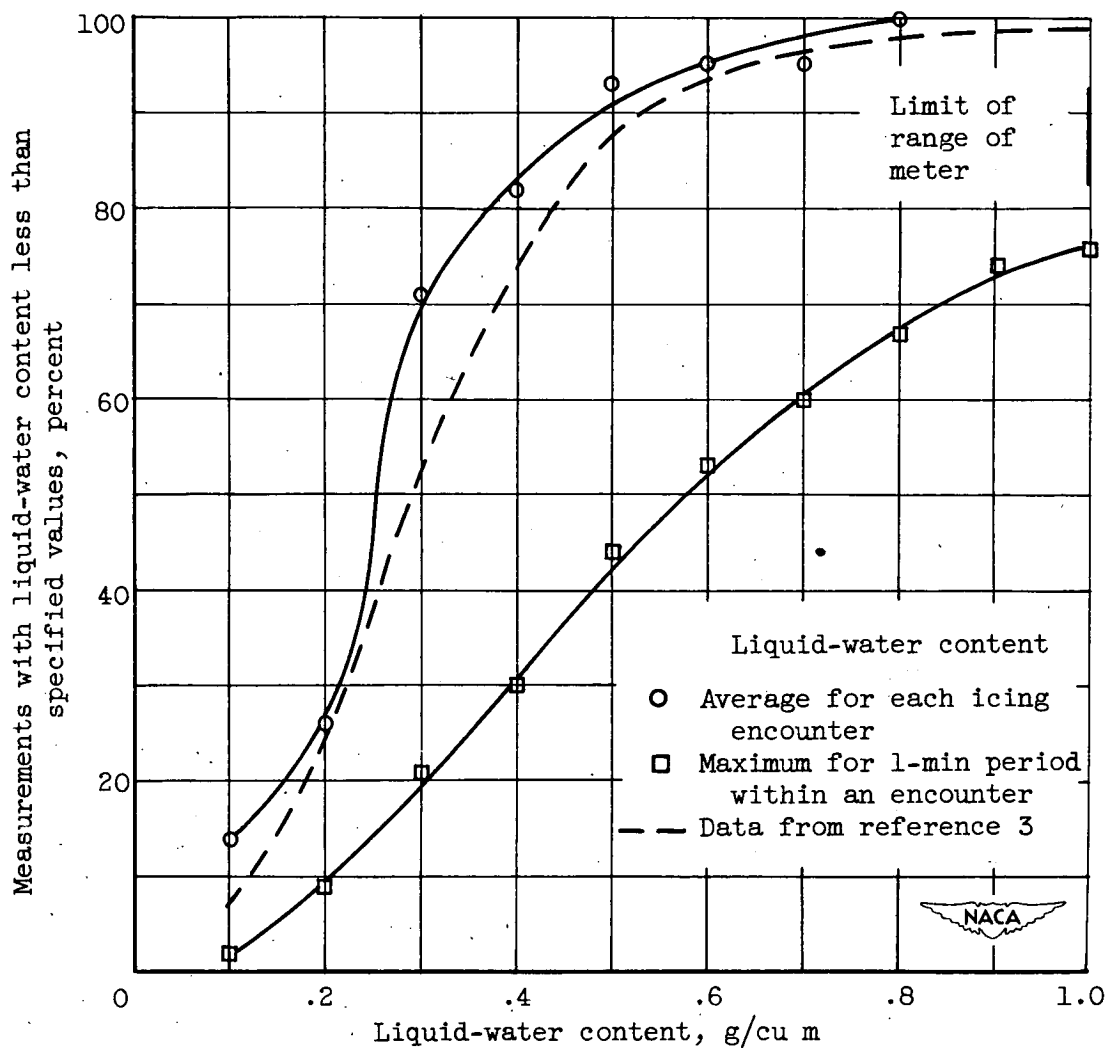

Figure 9. - Cumulative frequency of average and maximum liquid-water content calculated from icing rates in 44 icing encounters measured by icing-rate meters installed on airline aircraft.

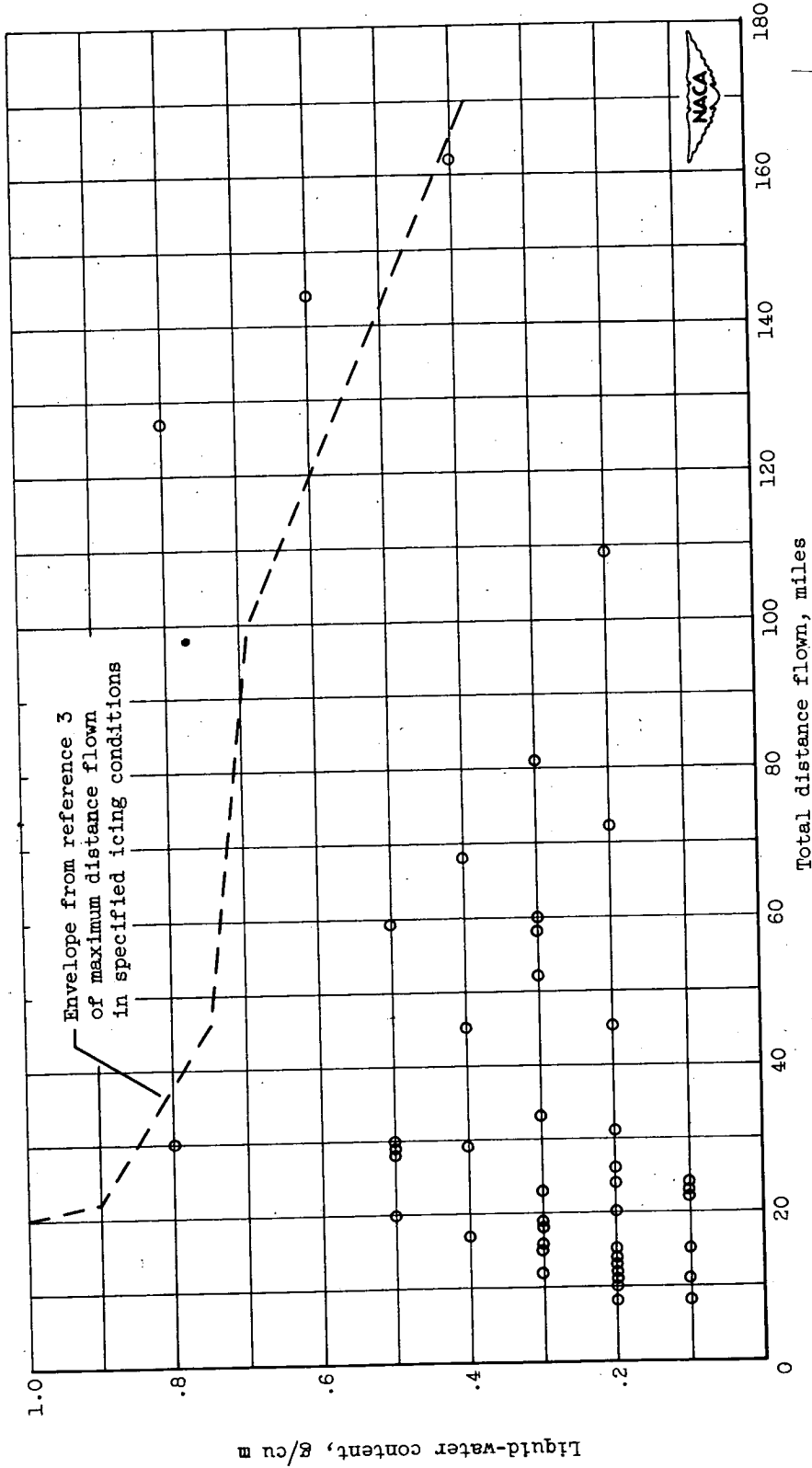
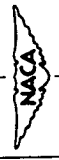

Figure 10. - Maximum distances flown in measurable icing conditions during routine airline operations in relation to average liquid-water content calculated from icing-rate meters.



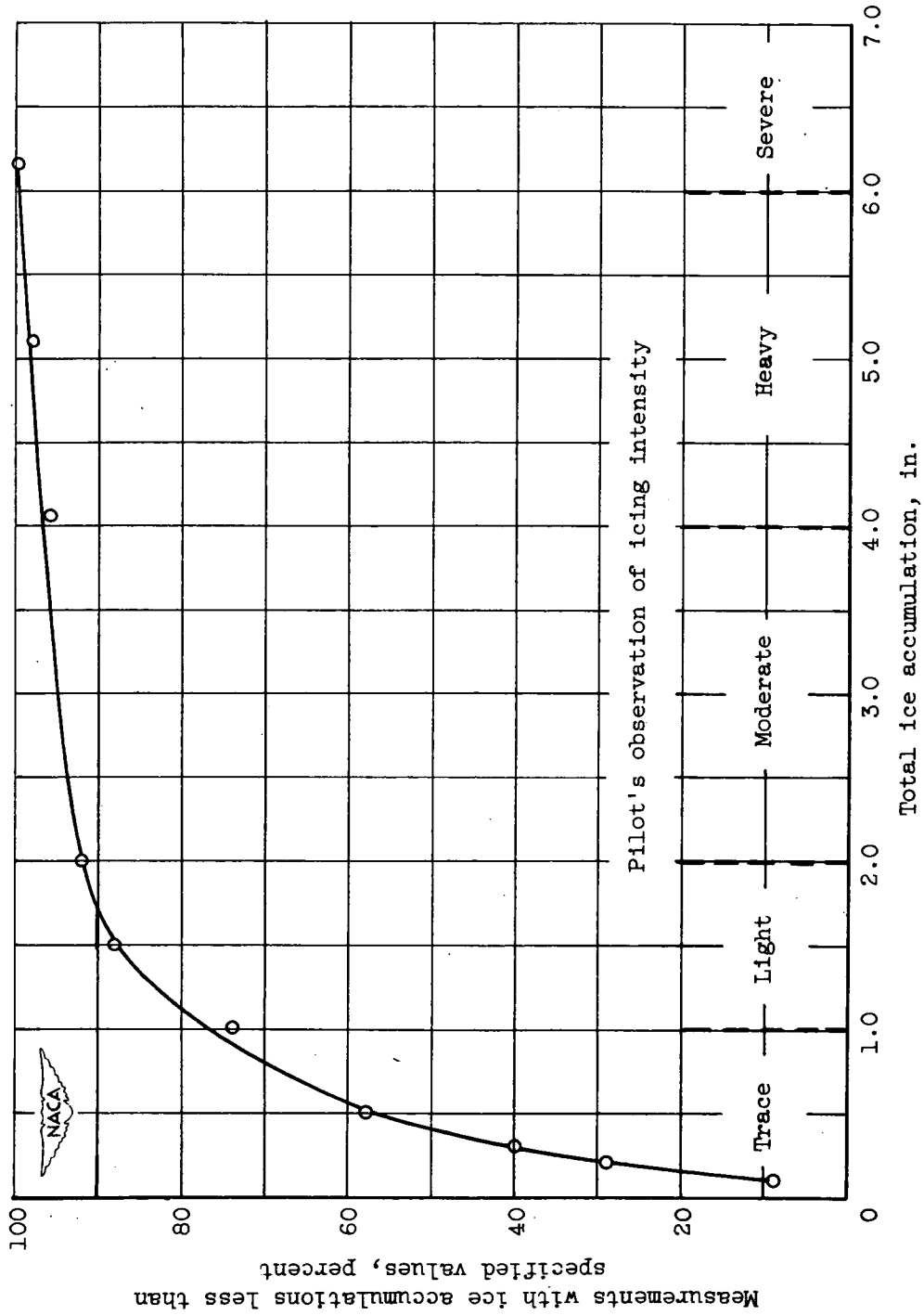

Figure 11. - Cumulative frequency of total ice accumulation measured in 44 icing encounters by icing-rate meters including corresponding icing-intensity categories as observed by flight crews during routine airline operations.