

NATL AERONAUTICS AND SPACE ADM; NASA-CR-165391-Vol-1



NASA CR 165391

**DO NOT DESTROY
RETURN TO LIBRARY
DEPT. 022**

**Experimental Study of Fuel
Heating at Low Temperatures
in a Wing Tank Model**

Final Report – Volume I

Francis J. Stockmer

**Lockheed-California Company
Burbank, California**

**Prepared for
NASA-Lewis Research Center
under contract NAS 3-21977**

NASA
National Aeronautics
and Space Administration

1981

M84-10146

NASA CR 165391

**Experimental Study of Fuel
Heating at Low Temperatures
in a Wing Tank Model**

Final Report – Volume I

Francis J. Stockmer

**Lockheed-California Company
Burbank, California**

**Prepared for
NASA-Lewis Research Center
under contract NAS 3-21977**

NASA

**National Aeronautics
and Space Administration**

1981

TABLE OF CONTENTS

	<u>TITLE</u>	<u>PAGE</u>
	LIST OF FIGURES	iv
	LIST OF TABLES	vi
1.0	SUMMARY	1
2.0	INTRODUCTION	3
3.0	APPARATUS	5
3.1	TEST CELL	5
3.2	TANK CONSTRUCTION	5
3.3	FUEL SYSTEM	5
3.4	COOLING SYSTEM	10
3.5	INSTRUMENTATION AND DATA ACQUISITION	13
3.6	FUEL HEATING SYSTEM	18
4.0	TESTING PROCEDURES	20
4.1	COLD FUEL HOLDUP TESTS	20
4.2	LOW-POWER HEATING TESTS	21
4.3	HIGH-POWER HEATING TESTS	21
4.4	OTHER TEST VARIATIONS	23
5.0	FUELS	24
6.0	RESULTS	27
6.1	COLD FUEL HOLDUP TESTS	27
6.2	LOW-POWER HEATING TESTS	32
6.3	HIGH-POWER HEATING TESTS	37
6.4	FUEL HEATING WITH WITHDRAWAL	42
6.5	OTHER TESTS	42
7.0	DISCUSSION	45
7.1	VISUAL OBSERVATION OF HOLDUP	45
7.2	TANK TEMPERATURE PROFILES	46
7.3	CORRELATION OF HOLDUP	52
7.4	FUEL HEATING PROCEDURES	52
7.5	PRACTICAL APPLICATION OF FUEL HEATING SYSTEMS	53
8.0	CONCLUSIONS	59
9.0	RECOMMENDATIONS	61
	APPENDIX A - CHRONOLOGICAL SUMMARY OF TESTS	62
	REFERENCES	66

FIGURES

<u>NO.</u>	<u>TITLE</u>	<u>PAGE</u>
1.	PLAN VIEW OF FUEL TEST TANK	6
2.	CROSS-SECTION OF FUEL TEST TANK	7
3.	TEST TANK DURING FINAL ASSEMBLY, END PANEL REMOVED	8
4.	TANK INTERIOR VIEWED FROM REMOVABLE END	9
5.	CROSS-SECTION OF BOOST PUMP INSTALLATION	11
6.	FUEL TANK CHILLING AND TEMPERATURE CONTROL SCHEMATIC	12
7.	INSULATED TEST TANK APPARATUS, VAPOR BARRIER COVERING REMOVED	14
8.	ARRANGEMENT OF THERMOCOUPLES IN FUEL TEST TANK	15
9.	EXAMPLE OF COMPUTER-GENERATED TEMPERATURE HISTORY	17
10.	FUEL HEATING AND TRANSPORT FLUID SYSTEM SCHEMATIC	19
11.	TEST TANK SKIN TEMPERATURE SCHEDULES	22
12.	DISTILLATION CHARACTERISTICS OF TEST FUELS, ASTM METHOD D-86 (REF. 8)	25
13.	TANK INTERIOR FOR TEST 103, 6.23% HOLDUP, LFP-11 FUEL	28
14.	TEMPERATURE GRADIENTS FOR COLD FUEL HOLDUP TESTS, LFP-11 FUEL	29
15.	TEMPERATURE GRADIENTS FOR COLD FUEL HOLDUP TESTS, LFP-12 FUEL	30
16.	TEMPERATURE GRADIENTS FOR COLD FUEL HOLDUP TESTS, LFP-13 FUEL	31
17.	TIME HISTORY, NO HEATING, STANDARD DAY, TEST 140, LFP-13 FUEL	33
18.	TIME HISTORY, EXTREME COLD DAY SCHEDULE, NO HEATING TEST 109, LFP-11 FUEL	34
19.	TIME HISTORY, LOW-POWER HEATING, TEST 113, LFP-11 FUEL	35
20.	TIME HISTORIES, BASELINE AND LOW-POWER HEATING, TESTS 133 AND 138, LFP-12 FUEL	36
21.	TIME HISTORIES, BASELINE AND LOW-POWER HEATING, TESTS 127 AND 160, LFP-13 FUEL	38
22.	TIME HISTORY, HIGH-POWER HEATING, TEST 159, LFP-13 FUEL	39
23.	TIME HISTORY, HIGH-POWER HEATING AFTER LONG DURATION COOLING, TEST 118, LFP-11 FUEL	40
24.	TIME HISTORY, HIGH-POWER HEATING, EXTREME HOT DAY, TEST 143, LFP-13 FUEL	41

<u>NO.</u>	<u>TITLE</u>	<u>PAGE</u>
25.	TIME HISTORY, HIGH POWER HEATING, SCHEDULED WITHDRAWAL, TEST 157, LFP-5	43
26.	HOLDUP OF 1.15%, TEST 134, LFP-12 FUEL	47
27.	HOLDUP OF 3.22%, TEST 106, LFP-11 FUEL	48
28.	HOLDUP OF 10.53%, TEST 153, LFP-5 FUEL	49
29.	TEMPERATURE PROFILES BEFORE AND AFTER HEATING, TEST 113, LFP-11 FUEL	50
30.	PERCENT HOLDUP VS. TEMPERATURE AT 0.6 CENTIMETER ABOVE BOTTOM OF TANK	54
31.	TIME HISTORIES, HIGH POWER HEATING, DIFFERENT PROCEDURES, TESTS 151 AND 152, LFP-5 FUEL	55
32.	RECIRCULATION DISTRIBUTOR TUBES	56
33.	TEMPERATURE PROFILE COMPARISON, LOW RE-ENTRY VS. SINGLE ROW DISTRIBUTOR, TESTS 160 AND 164, LFP-13 FUEL	57

LIST OF TABLES

<u>NO.</u>	<u>TITLE</u>	<u>PAGE</u>
1.	THERMOCOUPLE LOCATIONS INSIDE TEST TANK	16
2.	CHARACTERISTICS OF TEST FUELS	26
3.	HORIZONTAL TEMPERATURE DISTRIBUTION PRIOR TO HEATING, TEST 113	51
4.	HORIZONTAL TEMPERATURE DISTRIBUTION AT END OF HEATING, TEST 113	51

1.0 SUMMARY

An experimental investigation was performed under NASA Contract NAS3-21977 to study scale-model fuel heating systems for use with aviation hydrocarbon fuel at low temperatures. The principal objective was to evaluate the effectiveness of the heating systems in providing flowability and pumpability of fuels at extreme low temperatures when some freezing of the fuel would otherwise occur, by performing tests in a facility that simulated the heat transfer and temperature profiles anticipated in wing fuel tanks during flight of long-range commercial aircraft.

A test tank simulating a section of an outer wing integral fuel tank approximately full-scale in height, had been designed, fabricated, and tested during a preceding investigation performed under NASA Contract NAS3-20814 to study the behavior of fuels at low temperatures near the freezing point. Internal tank construction included upper and lower stringers, scavenging ejectors, pump inlet surge box, and other details corresponding to an airplane wing tank construction. The test tank was chilled through heat exchange panels bonded to the upper and lower horizontal surfaces.

Additional equipment was supplied to the test tank to heat MIL-L-23699 lubricating oil externally by a controllable electric heater, then transfer the heat to fuel pumped from the test tank through an oil-to-fuel heat exchanger, and recirculate the heated fuel back to the test tank.

Four fuels were used in this study, with freezing points ranging from -46° to -26° C. Fuels included a commercial Jet A and a paraffinic distillate used during the previous program.

Baseline cold fuel tests to identify partial freezing or "holdup" characteristics were conducted by chilling the tank skins to a nearly constant temperature. After the fuel had reached a desired temperature, it was withdrawn from the tank by gravity flow to the boost pump. The accumulation of solid particles remaining at the bottom of the tank after the liquid was withdrawn, was defined as holdup.

Repeat tests indicated that re-use of fuel reconstituted by melting and blending the frozen holdup did not affect test results.

Heating and recirculating the fuel had a large, predictable result on temperature of the bulk fuel, and had a relatively small effect on temperature of the fuel boundary layer near the bottom of the tank. In this respect, fuel heating had a measurable but small influence in reducing gravity holdup. Methods which increased penetration of heated fuel into the bottom boundary layer increased the capability for reducing holdup. Continuous recirculation during heating, and low re-entry of heated fuel into the test tank were demonstrable improvements. Continuous high-power fuel heating in conjunction with a simulated extreme hot day flight condition did not result in excessive fuel temperature.

Correlation of holdup based on a specific boundary layer temperature was generally applicable for tests with heated fuel, as well as with non-heated fuel.

This investigation has demonstrated the feasibility of the fuel heating concept, has defined a number of problems associated with distribution of the heated fuel, and has provided at least partial solutions to some of the problems. Further research and development should result in additional improvements.

2.0 INTRODUCTION

This report presents the results of a study performed by the Lockheed-California Company under NASA Contract NAS3-21977, titled "Experimental Evaluation of Scale-Model Fuel Heating Systems".

This experimental study was designed to examine the behavior and effectiveness of scale-model fuel heating systems in a test facility representative of a section of a commercial aircraft wing fuel tank subjected to a low temperature environment. Pumpability of present and higher-freezing point fuels were evaluated under heated and non-heated conditions at tank temperatures where some freezing of the fuel would otherwise occur.

Limited and costly crude oil supplies and shifts in competing product demands may make it advantageous to refine jet fuels with broader boiling range and compositional tolerances. These changes very likely may raise the freezing point of the jet fuel (Ref. 1 through 6). The ASTM-D 2386 Freezing Point of Aviation Fuels test determines a temperature at which solids disappear, while the ASTM D-97 Pour Point of Petroleum Oils test determines a temperature at which the fuel does not flow when the test apparatus is positioned horizontally (Ref. 7). In practice, the desired measurement is the lowest temperature at which the fuel will flow by gravity, leaving no solid residue. This temperature is between the temperatures determined by the two tests. Fortunately for aircraft operations, the freeze point test assures some conservatism relative to the temperature at which some of the fuel becomes unavailable due to solidification.

The pumpability and low temperature behavior of jet fuels have been studied in tank environments involving tests where fuel was chilled slowly over a period of many hours to maintain a uniform temperature within the tank (Ref. 8, 9, 10). The fuel was then discharged from the tank to determine the fraction of holdup, or frozen, unpumpable fuel. Repeat tests at several temperatures established a relationship of holdup as a function of temperature.

The Lockheed-California Company, under NASA Contract NAS3-20814, conducted tests of the low temperature behavior of aviation turbine fuels under conditions more directly applicable to commercial airplane wing tank environments. Fuel in a wing tank model was subjected to chilling by heat transfer designed to reproduce the temperature gradients encountered in flight. Results of this study provided considerable insight into the cooldown characteristics, pumpability, and solid formation of a variety of specification and higher-freezing point aviation fuels (Ref. 11 and 12).

The Lockheed-California studies confirm that fuel can be completely discharged from the tank at temperatures at or slightly below the freezing point. If a small fraction of solid fuel, or holdup, can be tolerated, the useful flow temperature can be further decreased. On the other hand, the wing tank temperature gradients, resulting from the very cold skins and low fuel thermal conductivity, can cause small amounts of holdup under some conditions where the bulk fuel temperature is above the freezing point.

Complete flowability of present jet fuels under extreme cold conditions and use of potential higher-freezing-point fuels would be assured if the wing tank fuel were heated in flight. Design and analytical work by Boeing (Ref. 13) identified five potential methods for heating fuel in current aircraft types, as well as a laminar flow wing concept whose structure would furnish thermal insulation. The studies indicated that two methods, heating with engine oil and heating electrically from additional engine-driven generators, were most practical and feasible.

The investigation reported herein continues the studies reported in Ref. 11. The wing tank simulator and chilling system apparatus were retained, but a fuel heating system was incorporated to represent scale-model concepts of anticipated heating power available from engine oil or from electrical heating. Knowledge gained from this investigation is intended to be applicable to the design of airborne fuel heating systems, should such systems be required in order to use higher freezing point fuels at extreme low temperatures. Criteria developed during this study should be applicable to existing jet fuels and for future fuels such as might be produced from raw materials other than crude oil; examples of such potential raw materials are oil shale, tar sands, and coal.

The general scope of this investigation may be summarized as follows:

- o Design the fuel heating systems and other modifications to the existing scale-model fuel tank and related apparatus.
- o Procure Jet A, intermediate freeze point, and high freeze point test fuels, and characterize them in terms of established test methods.
- o Determine the freezing characteristics or "cold fuel holdup" of these fuels as baseline data.
- o Perform tests using low-power fuel heating and high-power fuel heating for simulated extreme cold day and extreme hot day flights.
- o Obtain descriptions and photographic records of important phenomena.
- o Compare holdup characteristics of heated and non-heated fuels. Determine effects of rate-of-heat addition and degree of mixing of recirculated fuel.
- o Determine whether adverse effects can result from operating the high-power heating system under hot day conditions.
- o Recommend future research, standards, or practical applications resulting from this study.

This report includes a description of the test apparatus and procedures, and selected temperature and photographic data. The significance and trends of the results are discussed.

3.0 APPARATUS

3.1 TEST CELL

Experiments with the test tank were performed at the Rye Canyon Research Center of the Lockheed-California Company's Engineering Laboratories. The test cell, located at the east end of Building 209, measures approximately 3.4 meters (11 feet) by 4.6 meters (15 feet). A large window permits observers to view the test cell from the main building.

3.2 TANK CONSTRUCTION

Configuration of the test tank, which was also used in the previous studies (Ref. 11), was designed to simulate a portion of an outer wing fuel tank of a modern commercial jet aircraft. Interior dimensions of the tank are 50.8 centimeters (20 inches) high, 50.8 centimeters (20 inches) wide, and 76.2 centimeters (30 inches) long.

The tank was fabricated from 6061-T6 aluminum alloy sheet, 3.2 mm (0.12 inch) thick for the upper and lower surfaces, and 4.8 mm (0.19 inch) thick for the vertical walls. The lower surface was stiffened by modified I-section aluminum alloy stringers, 57 mm (2.40 inches) high. The upper surface Z-section stringers were 71 mm (2.80 inches) high. An open "surge box", 127 mm (5.0 inches) high, in a corner between a vertical wall and a stringer, surrounded the bottom fuel exit. A small, free-swinging "flapper" check valve installed in one side of the surge box permitted fuel to enter the surge box from the bay between the stringer and the vertical wall. Figure 1 is a plan view sketch of the test tank, showing the bottom stringers, observation windows, and fuel plumbing. The longer dimension, parallel to the stringers, is spanwise with respect to the airplane wing construction. The tank was mounted with this dimension at a 4° angle to the horizontal, with the surge box at the low end, to simulate airplane wing dihedral. Figure 2 is a cross-section of the test tank.

Assembly of the tank was accomplished primarily by riveting, but one end of the tank was removable. The tank was sealed with fuel tank sealant, and the interior was painted with a urethane anti-corrosion coating as used on the L-1011 airplane.

Figure 3 is a photograph of the partially finished test tank, showing the internal construction and the rods used for thermocouple support. The photograph shows the cutouts for the rectangular viewing window at the surge box end, and the circular side windows. Viewing windows had a double pane construction, with the space between the panes evacuated to prevent moisture condensation and improve insulation. Figure 4 is a closeup of the interior of the tank, viewed through a window.

3.3 FUEL SYSTEM

Fuel exited from the tank through a 48.3 millimeter (1.90 inch) diameter opening in the bottom of the tank at the corner of the surge box (Figure 1). Over this opening was an aluminum disc perforated with

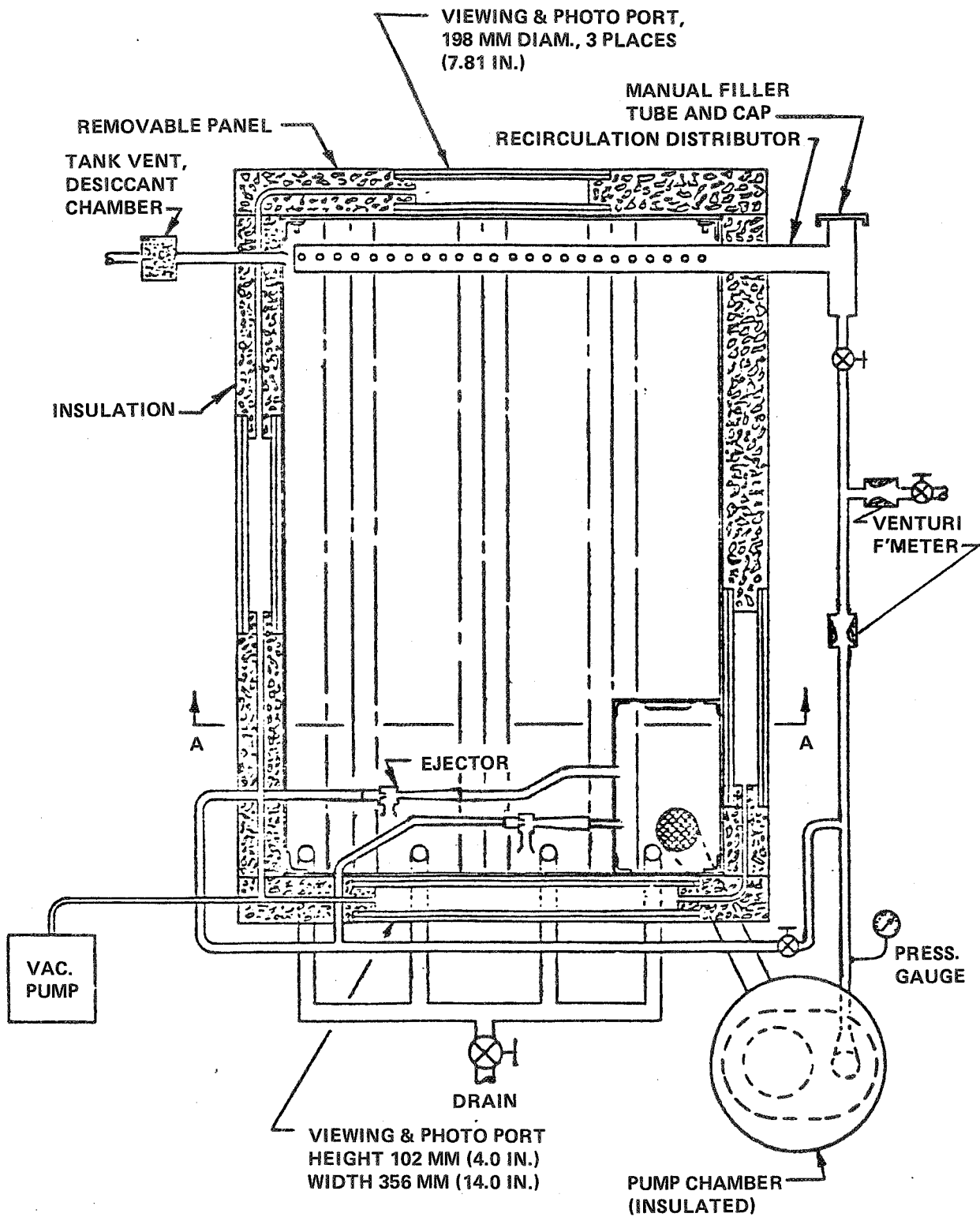
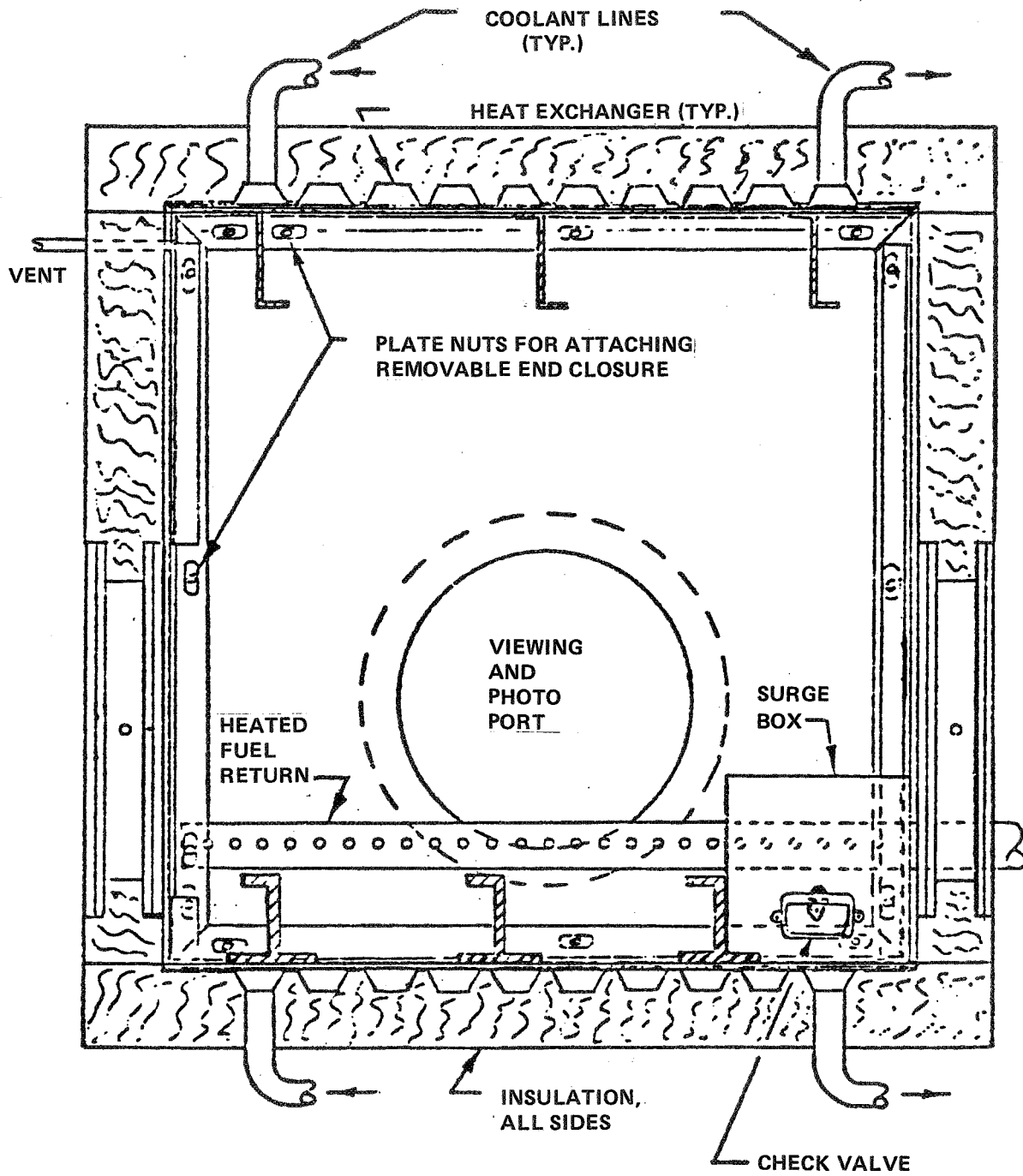

FIGURE 1 - PLAN VIEW OF TEST TANK



(EJECTORS & FUEL OUTLET OMITTED FOR CLARITY)

FIGURE 2 - CROSS-SECTION OF FUEL TEST TANK
(VIEW AA IN FIGURE 1)

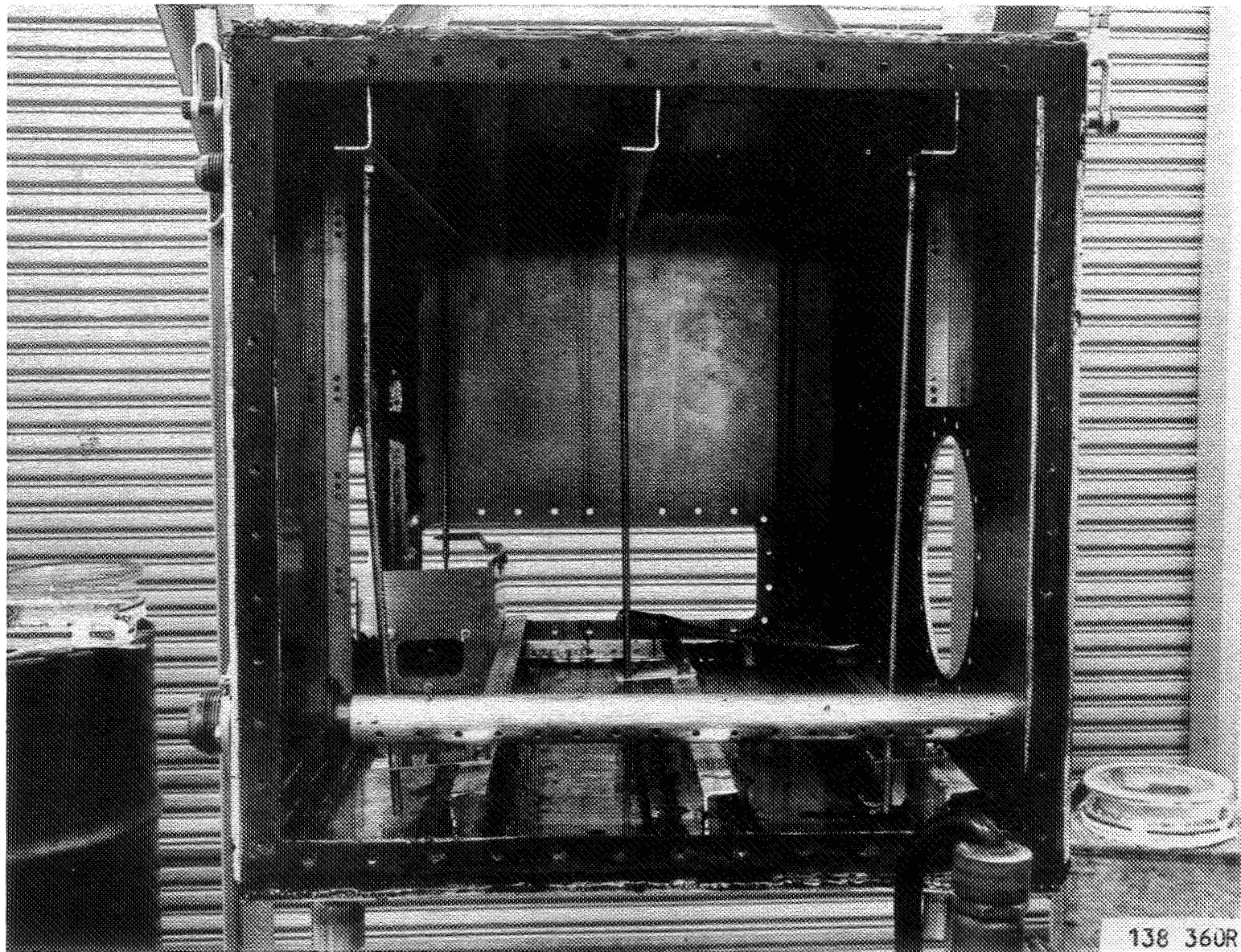

FIGURE 3 - TEST TANK DURING FINAL ASSEMBLY,
END PANEL REMOVED

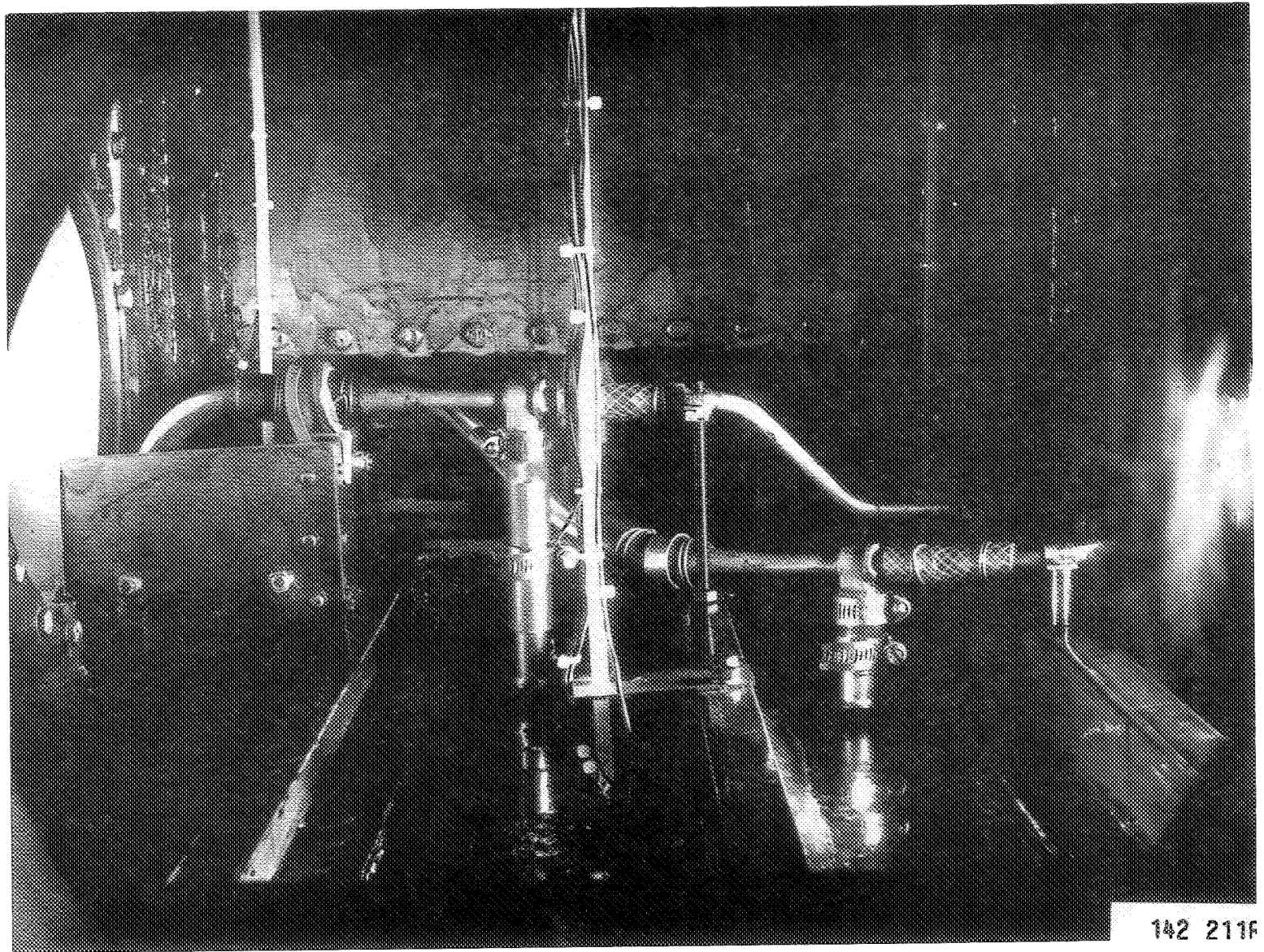

FIGURE 4 - TANK INTERIOR VIEWED FROM REMOVABLE END

6.4 millimeter (0.25 inch) diameter holes. An aluminum tube, tapering from 50.8 millimeters (2.00 inches) outside diameter at the tank to 31.8 millimeters (1.25 inches) diameter, connected the test tank to a small chamber housing an aircraft-type 24 volt direct current boost pump (Figure 5). This is a centrifugal pump used on early jet fighters and was selected for its relatively small power requirements of approximately 360 watts, thereby minimizing heat rejection to the fuel. (By comparison, one L-1011 fuel boost pump is almost 10 times that power.) The pump assembly incorporated a large area 8-mesh screen surrounding the impeller inlet. The dome around the pump motor inhibits fuel circulation and minimizes heat rejection to the fuel. The pump discharged into a line of 12.7 millimeters (0.50 inch) outside diameter. This line branched in one direction to supply motive flow through a control valve to two small ejectors, or jet pumps, which could suck fuel from two of the bays formed by the bottom stringers. These ejectors discharged into the surge box. A branch and shutoff valve in the other direction would permit fuel to be pumped either into or out of the tank. A tee and valve in this branch controlled fuel flow to the heat exchanger. Adjacent to the tank the line size was increased to 31.8 millimeters (1.25 inches) outside diameter. A tee in this line allowed fuel to recirculate into the tank through a perforated tube extending across the tank, and was also connected to a standpipe which served as a dipstick well, or as a manual filler; it was capped during testing. Filling of the test tank usually was accomplished by pumping fuel through the perforated recirculation return tube in the tank.

The tank was vented through a 12.7 millimeter (0.50 inch) tube penetrating the test tank vertical wall as high as possible near the removable end panel. A desiccant chamber prevented the entry of atmospheric moisture during chilldown.

Nearly all liquid fuel could be discharged by means of the boost pump and ejectors. Additional drainage of small quantities of trapped fuel, or total flushing, could be accomplished by small drains installed in each bay between the bottom stringers.

3.4 COOLING SYSTEM

Since the test tank simulated a portion of an aircraft fuel tank, the upper and lower surfaces represented wing skins and were provided with cooling panels to simulate in-flight heat transfer to the atmosphere. Each panel consisted of a flat stainless steel plate 50.8 centimeters (20 inches) by 76.2 centimeters (30 inches) to which was spot-welded another stainless steel plate which had been embossed to provide a serpentine passage for the coolant flow. The panels were bonded to the tank shell with a special thermally-conductive cement.

The coolant system consisted of a reservoir of methanol which was chilled by liquid carbon dioxide. In turn, the methanol was circulated to the heat exchange panels by a centrifugal pump (Figure 6). The flow of refrigerated methanol was divided just outside the test tank to supply the upper and lower cooling panels simultaneously through lines of equal length. Solenoid valves and manual valves were installed to provide throttling of the coolant flow and to alter the distribution as required to achieve approximately equal temperatures on the upper and lower surfaces.

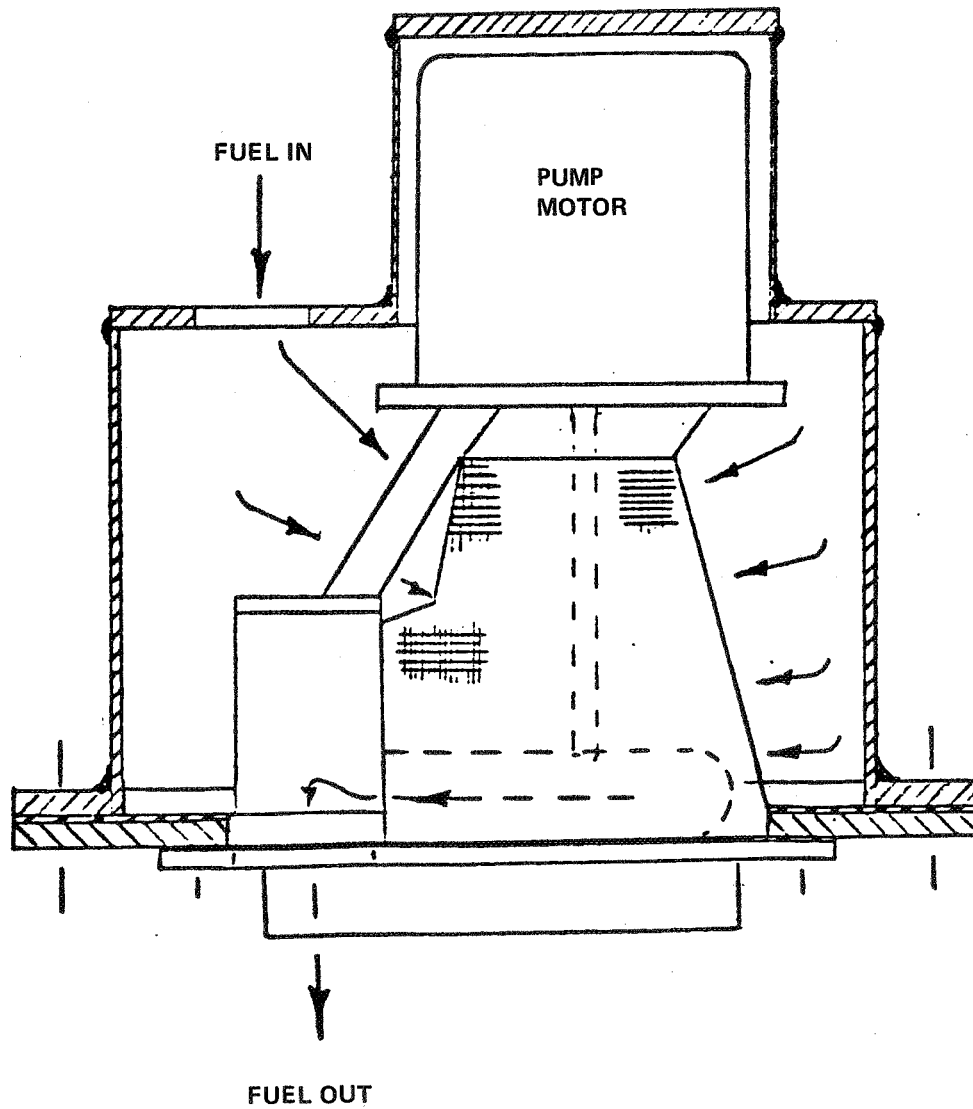

(FITTINGS OMITTED FOR CLARITY)

FIGURE 5 - CROSS-SECTION OF BOOST PUMP INSTALLATION

UPPER COLD PLATE TEMPERATURE
CONTROL SYSTEM. LOWER COLD
PLATE HAS A SIMILAR SYSTEM

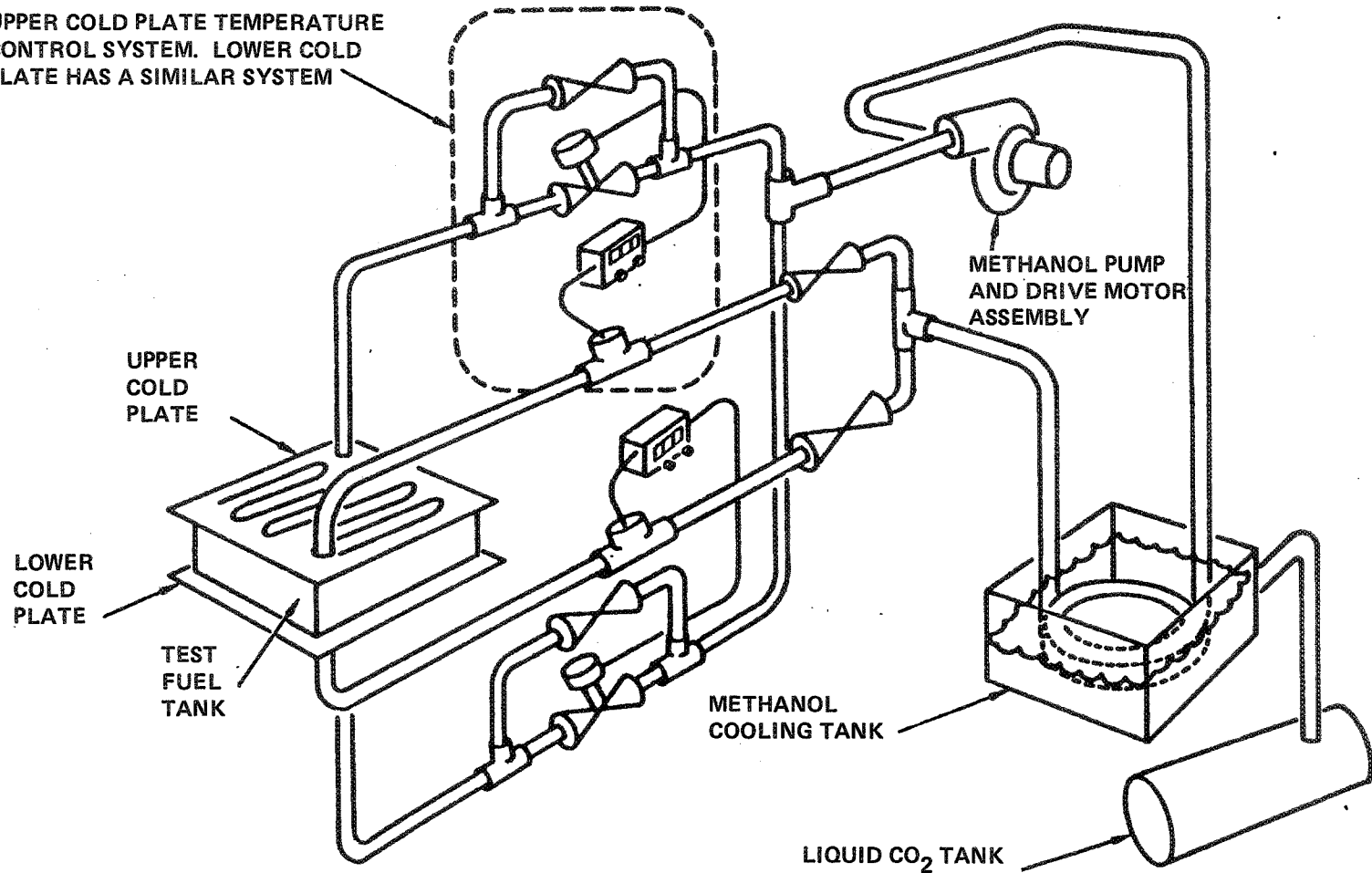

FIGURE 6 - FUEL TANK CHILLING AND TEMPERATURE CONTROL SCHEMATIC

Insulation was provided for the test tank to assure that heat transfer was confined to the top and bottom chilling surfaces. Fiberglass batting was used to fill small voids, and over the entire tank, blocks of solid urethane foam 76 millimeters (3.0 inches) thick were positioned (Figure 7). All external lines, and the boost pump chamber, were insulated by appropriate combinations of fiberglass batting, urethane foam and pre-formed foam rubber tubing jackets. During testing, the tank had an additional covering of a light blanket of insulating paper bonded to flexible aluminum foil which acted as a vapor barrier to inhibit condensation of atmospheric moisture.

3.5 INSTRUMENTATION AND DATA ACQUISITION

An array of 55 thermocouples was used to sense temperatures inside the test tank. Thermocouples were fabricated from copper-constantan wire, and attached to five vertical rod supports inside the test tank. The beads of the thermocouples projected approximately 13 millimeters (0.5 inch) from the rods. Wire bundles from the tops of the rods were gathered to pass through a common penetration near the top of the test tank, after which a sealant was applied at the penetration to prevent fuel leakage.

Figure 8 illustrates the arrangement of these thermocouples inside the test tank. As shown, there were three thermocouple racks with 12 thermocouples each, two with seven thermocouples each, and five additional skin thermocouples. The identification and location of each thermocouple is listed in Table 1. Although only minor relocations of thermocouples from those used for the previous work reported in Ref. 11 are shown, the actual thermocouples were rebuilt and recalibrated for these tests.

Calibrated venturis were used to measure fuel flow rates in the heating system and in the tank outflow line. The venturi differential pressure ports were connected to differential pressure gauges for visual reference, as well as to differential pressure transducers whose output was recorded on the data acquisition system. Oil flow rate was measured with a turbine flowmeter transmitter.

An automatic data recording system was available to acquire temperature and flow rate data. This system was compatible with the central data system at the Rye Canyon Research Center, so that tabulations of test data could be produced by computer. An example of the tabulated computer printout of temperatures is shown in Figure 9, which reproduces a portion of the listing for Test 101. Channels 016, 032, and 048 were reserved as references to monitor equipment temperatures. Hence, starting with channel 16, channel numbers shown as CHOXX on the printout do not correspond to thermocouple numbers, shown as CXX on the printout.

Test data was also acquired by means other than the automatic system. Coolant temperature was monitored on a strip chart whose pens indicated temperatures at the reservoir and at the inlet to the test tank cooling panels. Fuel discharge quantity was measured by weighing fuel on a platform scale of 227 kilograms (500 pounds) capacity. On the scale platform, a clean drum was positioned to contain fuel pumped or drained from the tank. Fuel boost pump pressure was observed visually and recorded

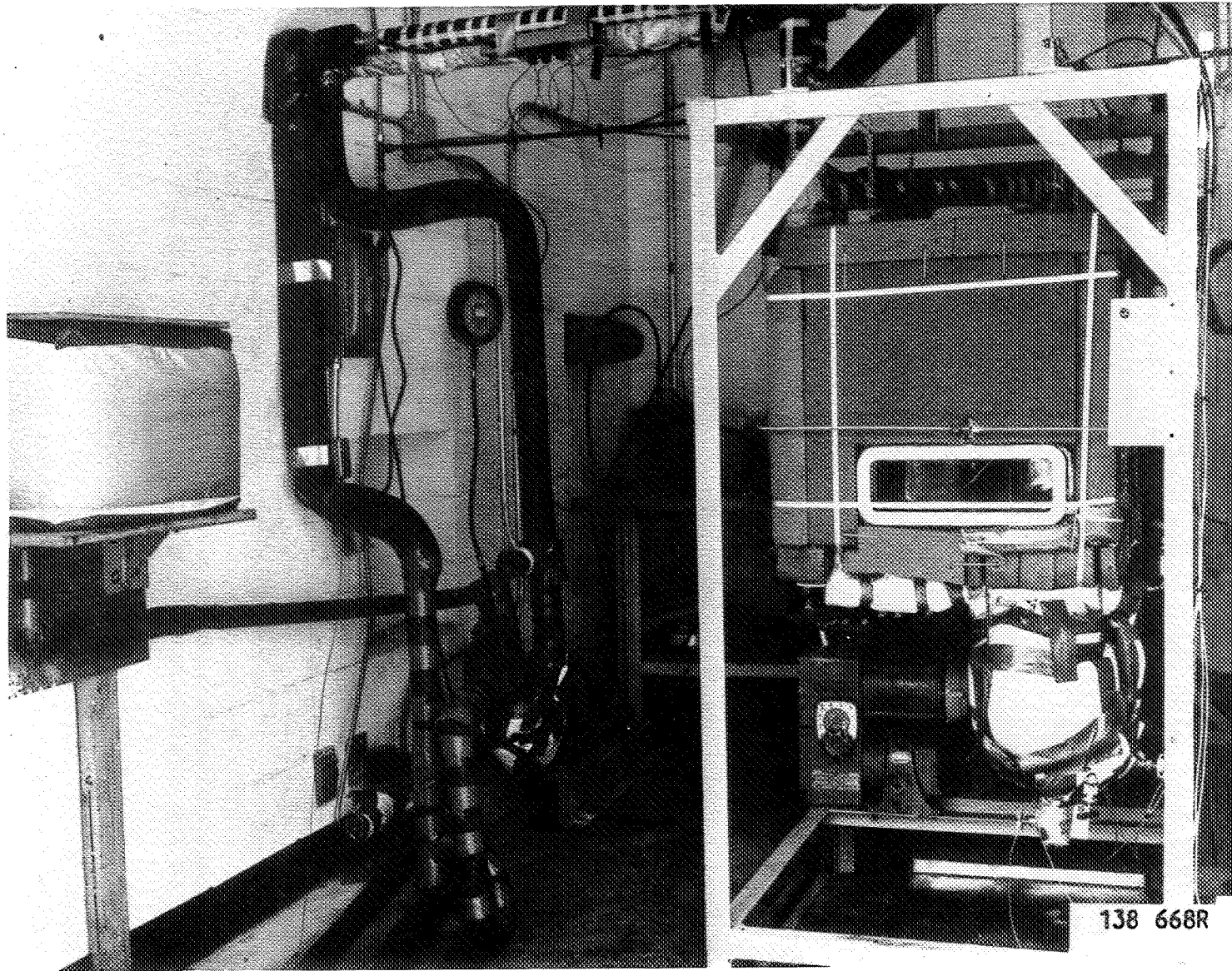
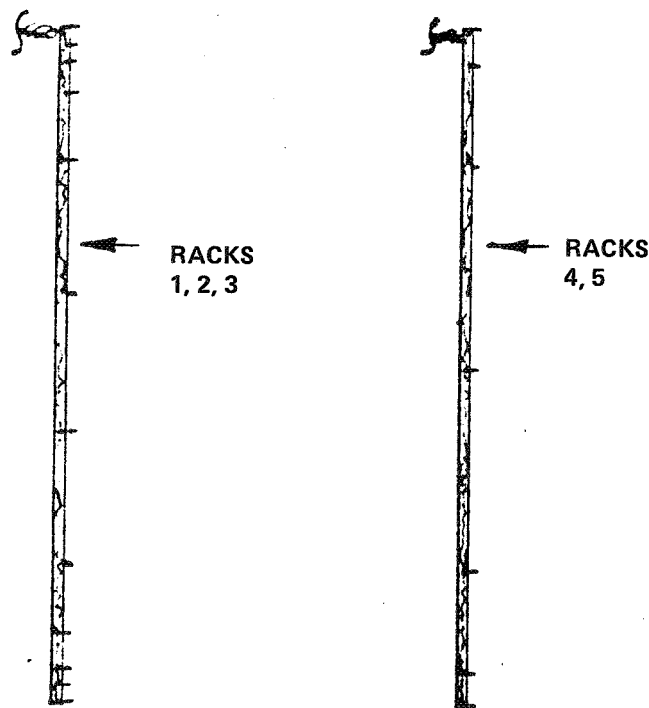
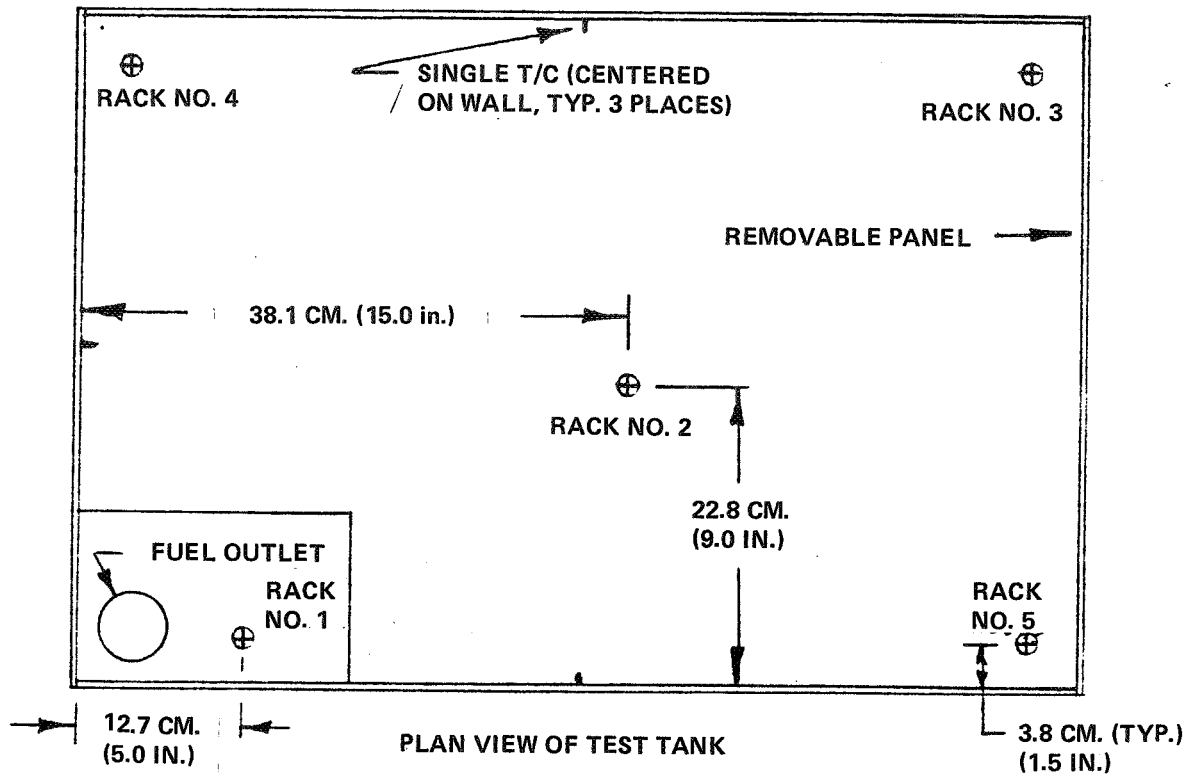

FIGURE 7 - INSULATED TEST TANK APPARATUS, VAPOR BARRIER COVERING REMOVED



DESIGNATION OF THERMOCOUPLE LOCATIONS IS SHOWN IN TABLE 1. T/C WIRE BUNDLES ARE GATHERED TO PASS THROUGH A COMMON TANK PENETRATION.

FIGURE 8 - ARRANGEMENT OF THERMOCOUPLES IN FUEL TEST TANK

TABLE 1
THERMOCOUPLE LOCATIONS INSIDE TEST TANK

Height Above Bottom Cm.	Bottom In.	Thermocouple Designations				
		Rack 1	Rack 2	Rack 3	Rack 4	Rack 5
0	0	1	13	25	37	44
0.6	0.25	2*	14	26	--	--
1.3	0.50	3*	15	27	--	--
2.5	1.00	4*	16*	28*	38	45
5.1	2.00	5*	17*	29*	--	--
10.2	4.00	6*	18*	30*	39	46
25.4	10.00	7*	19*	31*	40	47
40.6	16.00	8	20	32	41	48
45.7	18.00	9	21	33	--	--
48.3	19.00	10	22	34	42	49
50.2	19.75	11*	23	35	--	--
50.8	20.00	12	24	36	43	50

Thermocouples 51, 52, and 53 are centered on vertical panels.

Thermocouples 54 and 55 are located on the upper skin.

Thermocouples 56 and 57, fuel into and out of the heat exchanger.

Thermocouples 58 and 59, oil into and out of the heat exchanger.

Thermocouples 60 and 61, circulating fuel in and out of test tank.

* Relocated from previous test program. (Ref. 11)

NASA FUEL-HEATING/COOLING TEST # 101

TEST: 10594

SPS : 1

DATE: 04-14-80 LFP-11 Jet A - Baseline Static Holdup - 1.86%

OFFSETS			*000	*000	*000	*000	*000	*000	*000	*000	*000
RUN	LOAD	TIME	CH 001	CH 002	CH 003	CH 004	CH 005	CH 006	CH 007	CH 008	CH 009
	In. Above Bot.		RAKE 1	RAKE 1	RAKE 1	RAKE 1	RAKE 1	RAKE 1	RAKE 1	RAKE 1	RAKE 1
			0*00	0*25	0*50	1*00	2*00	4*00	10*00	16*00	18*00
			C 01	C 02	C 03	C 04	C 05	C 06	C 07	C 08	C 09
1	.n	8:32:00	16.9	17.0	17.2	17.2	17.0	17.0	17.2	17.2	17.3
2	.n	8:37:27	12.3	14.7	16.2	16.7	16.8	16.7	16.8	16.6	16.5
3	.n	8:43:33	1.4	6.0	11.8	8.5	14.0	14.1	14.3	14.0	14.0
4	.n	8:49:31	-5.8	-1.3	.6	1.7	4.6	11.3	11.7	11.2	11.7
5	.n	8:55:32	-9.6	-6.1	-4.2	-2.6	.7	8.9	9.0	8.5	9.2
6	.n	9:03:03	-13.5	-10.7	-8.8	-7.3	-5.8	5.6	6.0	5.6	5.8
7	.n	9:20:01	-19.9	-18.4	-16.4	-14.6	-12.9	.7	.2	.3	.1
8	.n	9:33:03	-18.8	-21.4	-19.3	-17.7	-16.4	-6.7	-3.6	-4.1	-3.5
9	.n	10:03:03	-25.4	-28.3	-26.6	-25.4	-24.5	-15.6	-10.5	-11.0	-10.6
10	.n	10:33:03	-28.7	-32.1	-30.3	-29.6	-26.5	-21.6	-16.1	-16.3	-16.3
11	.n	11:03:03	-30.3	-35.5	-34.5	-33.3	-31.4	-26.0	-20.7	-21.4	-20.7
12	.n	11:33:03	-33.5	-38.1	-37.5	-36.5	-33.3	-29.5	-24.5	-25.2	-24.5
13	.n	12:03:03	-34.8	-40.0	-40.2	-38.6	-35.2	-31.9	-27.5	-28.1	-27.7
14	.n	12:33:03	-35.4	-41.2	-41.2	-40.2	-38.7	-33.7	-30.1	-30.4	-30.1
15	.n	13:03:03	-35.6	-41.8	-42.7	-40.8	-36.0	-35.1	-32.0	-32.5	-32.2
16	.n	13:33:03	-36.1	-42.5	-43.2	-41.6	-40.5	-36.5	-33.9	-34.0	-34.0
17	.n	14:03:03	-36.6	-43.1	-43.7	-42.3	-39.1	-37.4	-35.2	-35.1	-35.3
18	.n	14:17:52	-43.3	-43.0	-42.1	-42.3	-41.4	-41.6	-41.0	-41.1	-43.5

OFFSETS			*000	*000	*000	*000	*000	*000	*000	*000	*000
RUN	LOAD	TIME	CH 010	CH 011	CH 012	CH 013	CH 014	CH 015	CH 017	CH 018	CH 019
			RAKE 1	RAKE 1	RAKE 1	RAKE 2	RAKE 2	RAKE 2	RAKE 2	RAKE 2	RAKE 2
			19*00	19*75	20*00	0*00	0*25	0*50	1*00	2*00	4*00
			C 10	C 11	C 12	C 13	C 14	C 15	C 16	C 17	C 18
1	.n	8:32:00	17.3	17.3	17.3	17.2	17.2	17.2	16.7	16.8	16.8
2	.n	8:37:27	16.3	15.4	-2.7	-11.1	8.3	13.9	15.0	16.2	16.3
3	.n	8:43:33	14.1	13.1	-11.3	-28.7	-9.3	-3.7	4.1	12.5	13.9
4	.n	8:49:31	11.2	9.5	-14.4	-34.7	-18.9	-13.9	-7.0	7.0	11.0
5	.n	8:55:32	9.2	7.4	-15.5	-36.9	-24.7	-20.4	-13.9	1.7	8.4
6	.n	9:03:03	5.9	5.3	-17.8	-39.6	-29.4	-25.5	-19.7	-4.2	5.3
7	.n	9:20:01	.0	.1	-22.2	-43.3	-35.2	-32.2	-27.3	-13.0	-1.0
8	.n	9:33:03	-3.7	-3.7	-24.9	-44.9	-37.8	-35.1	-30.7	-17.6	-5.0
9	.n	10:03:03	-10.4	-10.9	-28.9	-46.0	-41.3	-39.0	-35.5	-24.5	-12.4
10	.n	10:33:03	-16.3	-17.0	-32.9	-48.6	-43.7	-41.4	-38.5	-29.0	-18.4
11	.n	11:03:03	-20.6	-22.1	-36.8	-50.3	-46.3	-44.3	-41.4	-32.9	-23.1
12	.n	11:33:03	-24.5	-26.5	-40.2	-51.0	-48.2	-46.5	-43.8	-36.0	-27.0
13	.n	12:03:03	-27.7	-29.9	-43.1	-51.4	-49.0	-47.4	-45.1	-38.0	-29.8
14	.n	12:33:03	-30.2	-32.6	-45.2	-52.0	-49.4	-48.1	-45.9	-39.7	-32.1
15	.n	13:03:03	-32.5	-34.7	-46.6	-52.4	-49.5	-48.6	-46.7	-41.0	-33.9
16	.n	13:33:03	-34.0	-36.1	-46.6	-52.1	-49.7	-48.8	-47.2	-41.8	-35.4
17	.n	14:03:03	-35.3	-37.5	-46.5	-51.7	-50.2	-49.3	-47.8	-42.9	-36.6
18	.n	14:17:52	-44.0	-46.1	-48.7	-52.1	-50.2	-48.5	-46.0	-44.3	-41.5

FIGURE 9 - EXAMPLE OF COMPUTER-GENERATED TEMPERATURE HISTORY

manually as required. Qualitative observations of the nature of the solid fuel buildup in the tank and other remarks were recorded in a permanent notebook for each test. Photography provided black and white prints and color slides.

3.6 FUEL HEATING SYSTEM

Fuel was heated by circulation through the tubes of a shell-and-tube heat exchanger, using MIL-L-23699 synthetic base, aviation turbine engine lubricating oil as the heat transport fluid. Figure 10 is a schematic illustrating the principal features of the system.

Fuel was pumped from the test tank by the boost pump at a controlled flow rate, through the heat exchanger, and was returned to the test tank through the perforated recirculation distributor tube shown in Figures 1 through 3.

The lubricating oil transport fluid was pumped at a controlled rate through an electric immersion heater assembly, through the shell of the heat exchanger, and returned to the pump inlet. A small makeup tank (not shown on the schematic) was teed into the system to accommodate volume changes due to temperature. Heat input to the transport fluid was controlled by varying the voltage applied to the heater until a wattage meter indicated the desired nominal heating rate; maximum capability of the heater was 1500 watts.

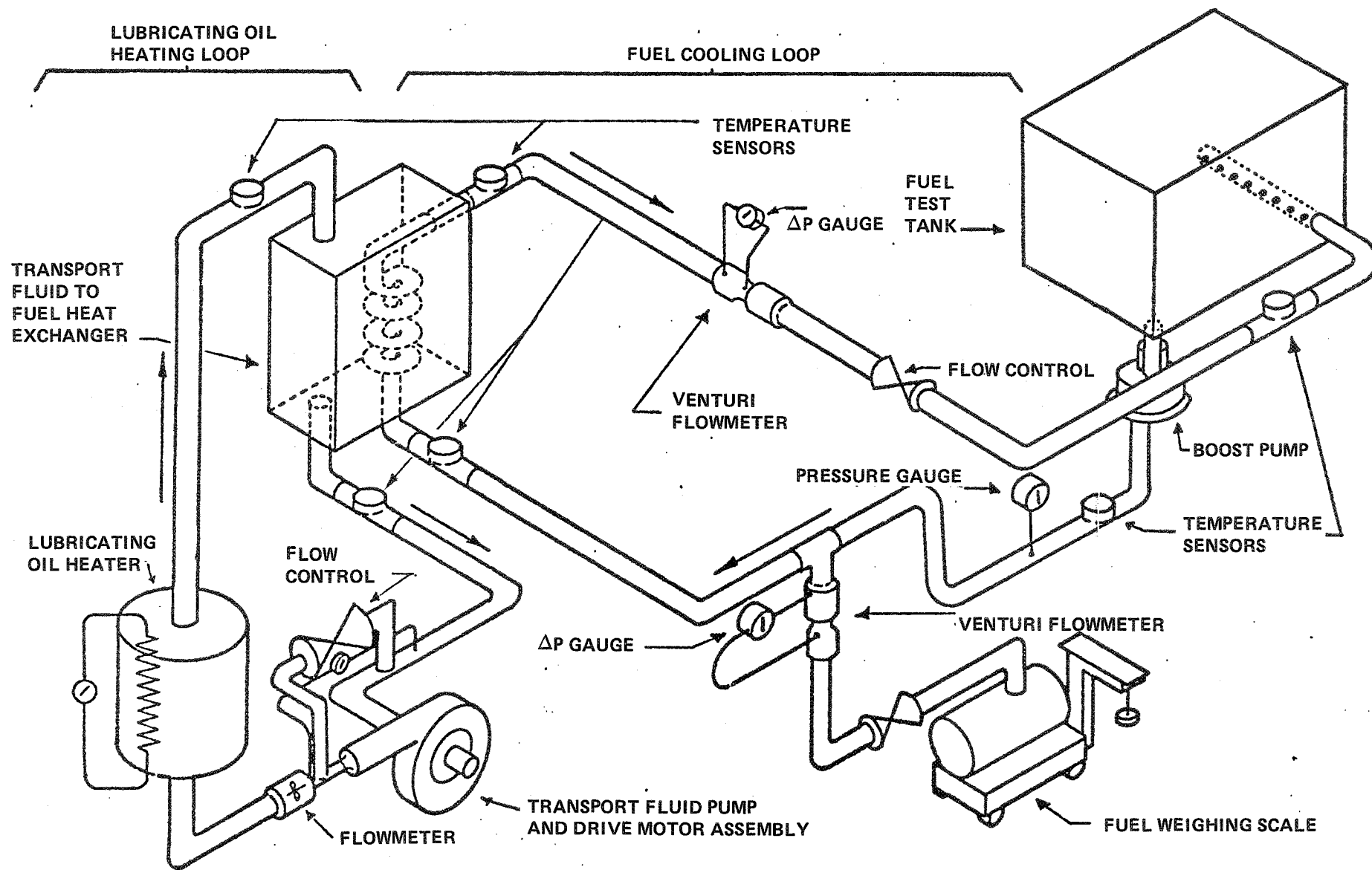

FIGURE 10 - FUEL HEATING AND TRANSPORT FLUID SYSTEM SCHEMATIC

4.0 TESTING PROCEDURES

A generalized procedure for conducting tests is itemized below, followed by details pertinent to the types of tests.

- o Load fuel into the test tank until liquid appears in the vent tube to insure a completely filled tank during chilldown.
- o Check that the coolant in the reservoir has been chilled to the temperature required to perform the test.
- o Start the data acquisition system.
- o Start the coolant circulation system.
- o Control the temperature of the lower and upper panels of the test tank according to the schedule appropriate for the nature of the test.
- o For tests requiring heating, initiate fuel heating at the time or temperature condition selected for the test. (In most cases the heat transfer fluid was heated prior to initiating fuel flow through the heat exchanger.)
- o Record data at nominal six minute intervals for the first 30 minutes, then at nominal 30 minute intervals thereafter, with additional scans at initiation of heating and pumpout.
- o Continue test until a specified fuel temperature is attained for cold fuel holdup tests, or until a scheduled time period is completed.
- o Pump out the fuel in the tank at nine to ten liters per minute (5% of tank capacity per minute). As the fuel level recedes to the top of the lower stringers, energize the ejectors to scavenge fuel from the bays between stringers. Record test data at initiation of pumpout and at one or more points prior to becoming empty.
- o Manually record observations of tank appearance, photograph the tank interior when holdup is evident.
- o Determine the weight percent of holdup.

4.1 COLD FUEL HOLDUP TESTS

These tests were performed with no recirculation or heating of fuel to obtain a range of low temperature holdup measurements analogous to those reported in Ref. 11. At the appropriate time or temperature the fuel was pumped out and weighed. The quantity by weight which did not flow by gravity to the boost pump constituted the gravity holdup. These tests were used to characterize the low temperature behavior of each fuel and also, in the case of the Jet A fuel, to determine reproducibility of results from duplicate tests.

4.2 LOW-POWER HEATING TESTS

During the chilldown test, fuel was recirculated by the boost pump through the fuel heating system heat exchanger, and returned to the test tank through the perforated distributor tube. Heating was regulated at a nominal rate of 300 watts to the lubricating oil transport fluid (2 watts/KG of tank capacity). This simulated the limited-power heating available from an engine lubricating oil heat exchanger used to heat the wing tank (Ref. 13). Heating was initiated when the thermocouple at 10.2 centimeters above the bottom of the tank, representative of bulk fuel temperature, registered 8°C above the freeze point of the fuel. For some tests, heating was initiated one hour after start of the test, at higher fuel temperatures. The heated fuel recirculation rate was approximately 3 liters per minute (1.5% of tank capacity per minute), and the heat transport fluid flow rate was approximately 3.8 liters per minute.

In contrast to the cold fuel holdup tests, which used a constant tank inner surface temperature, heating tests were conducted with variable surface temperatures. Figure 11 shows the time-temperature schedules of surface temperatures used in the various tests. Schedules for the extreme cold day and the extreme hot day were based on a one-day-per-year (0.3%) probability (Ref. 14). Schedule for the standard day was based on a median probability (Ref. 15). Surface temperatures for the three schedules were calculated for 90% ram recovery at 0.80 Mach flight speed at altitudes from 10.7 to 11.9 Km (35,000 to 39,000 ft.). The extreme cold day schedule corresponding to that of Ref. 14 was modified as shown in Figure 11 for better control of bulk temperature chilldown conforming to previous tests on the tank (Ref. 11). Except for long duration and scheduled withdrawal, tests were terminated at about seven hours to eliminate the warming portion of the schedule and achieve maximum holdup.

Low power heating tests were conducted with all four test fuels using the extreme cold day schedule only, except for one scheduled withdrawal test incorporating low-power heating.

Tests were also performed using the applicable temperature schedules, but without heating, prior to each test series involving fuel heating. These tests established baseline information for evaluation of the effects of heating in subsequent tests. Cold scheduled withdrawal tests were also conducted with the higher freezing point fuels. These tests, corresponding to those reported previously (Ref. 11), involved an 11.3 hour duration extreme cold day schedule with fuel withdrawal at 1 l/min. during the last three hours of the test. This simulates a long-range flight with fuel utilization from an outboard reserve tank during the latter portion of cruise.

4.3 HIGH-POWER HEATING TESTS

For these tests, heating was regulated at a nominal rate of 900 watts to the turbine engine oil transport fluid (6 watts/Kg of tank capacity). This simulated the high-power, controllable heating available from an electrical heating system using a heat transport fluid intermediate heat exchanger (Ref. 14). Initiation of heating, and nominal fuel and transport fluid flow rates used the same criteria as those for the low-power heating tests.

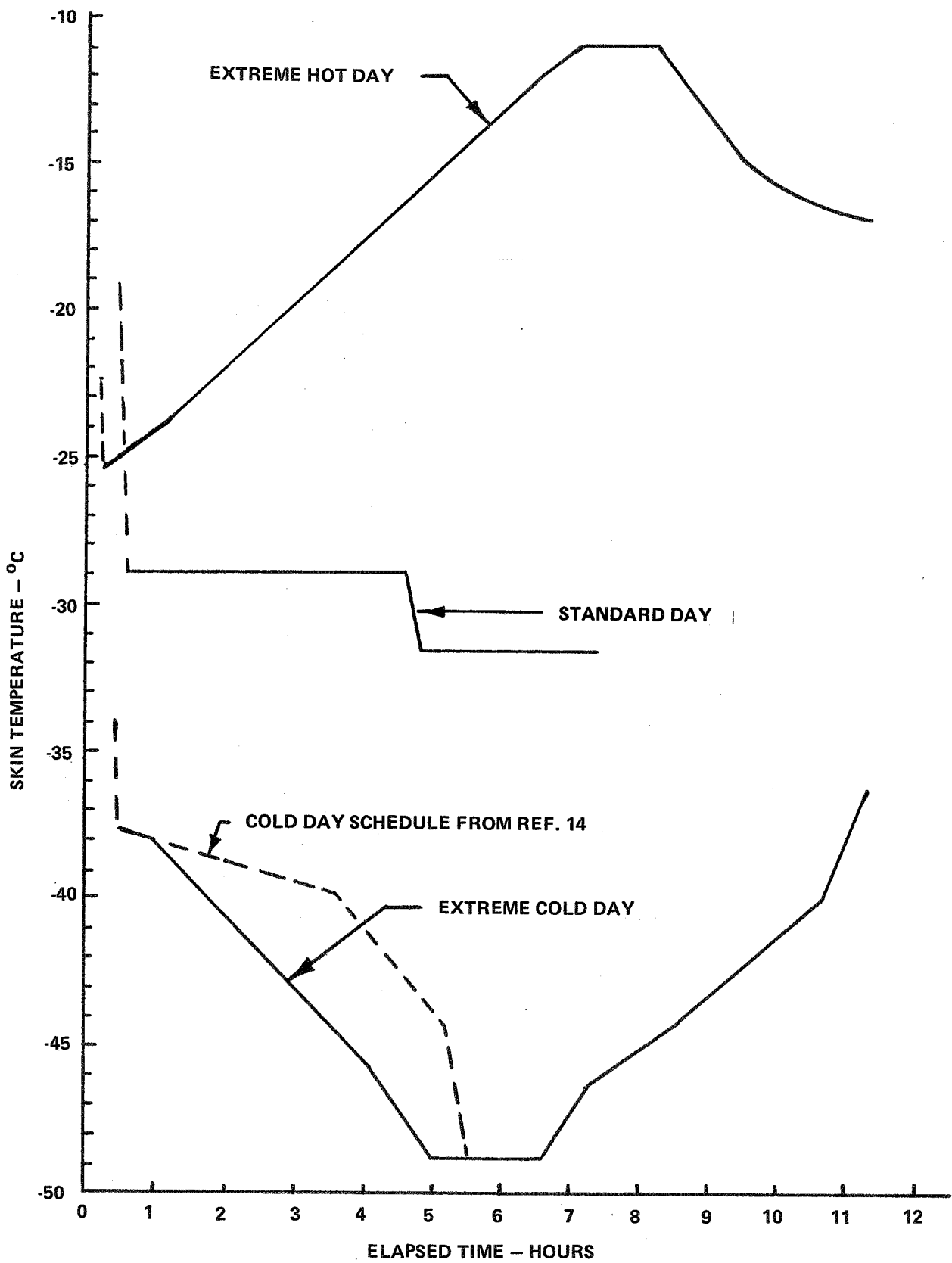

FIGURE 11 - TEST TANK SKIN TEMPERATURE SCHEDULES

High-power heating tests were conducted with all four fuels using the extreme cold day schedule. Tests were also conducted with the Jet A and one higher-freezing point fuel at the extreme hot day schedule to investigate the sensitivity of the fuel heating system to overheating when operated at warm conditions. Fuel heating was initiated at the start of this test and continued for the entire test schedule. Another test with the Jet A fuel at slightly colder than the extreme cold day schedule delayed the initiation of heating until some holdup was evident, in order to investigate the ability of a heating system to improve fuel pumpability by melting partially frozen fuel.

Heated scheduled withdrawal tests were also conducted. These tests used the extreme cold day schedule with gradual fuel withdrawal during the last three hours. Fuel heating was superimposed on these tests, with initiation of fuel heating, fuel recirculation, and heat transport fluid flow corresponding to those of the regular heating tests.

4.4 OTHER TEST VARIATIONS

The fuel recirculation distributor tube shown in Figures 1, 2, and 3, a four-pass fuel heat exchanger, and the recirculation rates defined in the preceding paragraphs were all baseline parameters. Limited testing was conducted with two additional recirculation tube designs, a second heat exchanger, and variations of the heating procedure and recirculation rates. Procedures for the tests with these variations were otherwise the same as those previously described.

5.0 FUELS

Fuels used in the test program were:

- o LFP-5, a paraffinic distillate fuel furnished by a refinery for an earlier test program described in References 11 and 12; freezing point was -28°C .
- o LFP-11, a commercial Jet A, procured from the Lockheed Air Terminal fuel services at Burbank; freezing point was -46°C .
- o LFP-12, a blend of the high freezing point LFP-13 and a straight-run kerosene, formulated by Suntech, Inc. This fuel proved to have a freezing point of -25°C and a pour point of -54°C .
- o LFP-13, an experimental high freezing point fuel formulated by Suntech, Inc., based upon the guidelines for an Experimental Referee Broadened-Specification (ERBS) fuel proposed at the NASA-Lewis "Jet Aircraft Hydrocarbon Fuels Technology" workshop in 1977 (Ref. 16). In these guidelines, freezing point was -20°C maximum, later recommended at -23°C by CRC (Ref. 17).

Figure 12 shows distillation characteristics of the four test fuels. Table 2 is a list of selected characteristics and test methods for the fuels. LFP-12 fuel was intended to have a freezing point intermediate between LFP-11 and LFP-13. However, the blending produced a fuel with a freezing point nearly identical to that of LFP-13, and a difference between freezing point and pour point temperatures considerably greater than those of the other fuels.

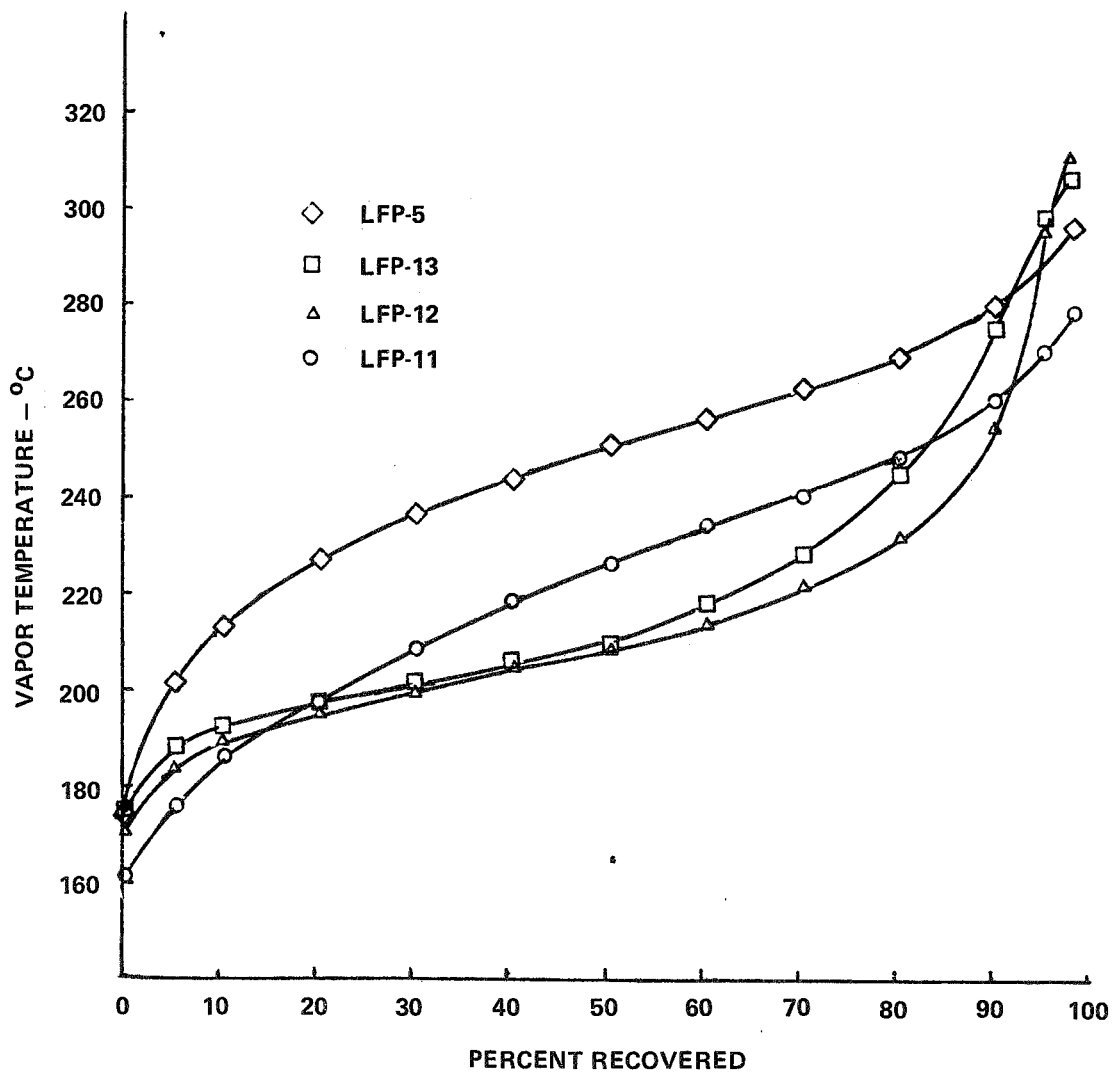

FIGURE 12 - DISTILLATION CHARACTERISTICS OF TEST FUELS,
 ASTM METHOD D-86
 (REF. 7)

TABLE 2
CHARACTERISTICS OF TEST FUELS

	<u>LFP-13</u>		<u>LFP-11</u>		<u>LFP-12</u>		<u>LFP-5</u>	
Specific Gravity	0.8373		0.8324		0.8203		0.8299	
Water KF D1744	117 ppm		67 ppm		79 ppm		-	
	°C	°F	°C	°F	°C	°F	°C	°F
Freeze Point D2386	-26.0	-14.8	-46.0	50.8	-25.0	-13	-28.0	-18.4
Cloud Point, D2500	-23	-9.4	-47.0	52.6	-23.0	-9.4	-31.0	-23.8
Pour Point, D97	-40	-40	-56.7	-70	-53.9	-65	-33.0	-27.4
<u>DISTILLATION</u>								
Initial Boiling Point	175.6	348	162.2	324	171.1	340	173.9	345
5%	188.9	372	176.7	350	184.4	364	202.2	396
10%	193.3	380	186.7	368	190.0	374	213.3	416
20%	198.9	390	198.9	390	195.6	384	227.2	441
30%	202.2	396	208.9	408	200.0	391	236.7	458
40%	206.7	404	218.9	426	205.6	402	243.9	471
50%	210.0	410	226.7	440	208.9	408	251.1	484
60%	218.9	426	234.4	454	214.4	418	256.7	494
70%	228.9	444	241.1	466	222.2	432	263.3	506
80%	245.6	474	248.9	480	232.2	450	270.0	518
90%	275.6	528	261.1	502	255.6	492	280.6	537
95%	298.9	570	271.1	520	295.6	564	-	-
End Point,	306.7	594	278.9	534	311.1	592	296.7	566
Recovery,	97.5%		98.0%		97.5%		-	-
Residue,	1.5%		1.0%		1.5%		-	-
Loss,	1.0%		1.0%		1.0%		-	-

6.0 RESULTS

This section of the report presents a summary of the tests grouped, for the most part, in accordance with the types of tests described in the section on test procedures. A chronological itemization of all test runs may be found in Appendix A, which is a table listing the test number, date, fuel, heating and test variables, holdup results, and remarks. Testing commenced on 14 April 1980.

6.1 COLD FUEL HOLDUP TESTS

Cold fuel holdup tests were used to characterize the low temperature behavior of each fuel in terms of the relationship of holdup (the unpumpable fuel remaining in the tank), and fuel temperature. Tests with LFP-11 Jet A fuel were repeated at the same fuel temperature to evaluate the repeatability of results. The first test used a fresh batch of fuel, the second used the same fuel carefully reconstituted after melting the frozen portion, and the third used reconstituted fuel preheated before testing. The latter procedure was designed to assure complete liquefaction of any dispersed nuclei of solid fuels. All tests gave nearly identical holdups of 3.2 to 3.3 weight percent for a reference fuel temperature of -53°C measured 0.6 cm above the bottom surface.

Figure 13 is a photograph of the interior of the tank after pumpout in Test 103, with 6.23% holdup. Previous testing (Ref. 11) had shown that at least 3% holdup was required to coat the tops of the stringers, after which the solid deposits deepened on the bottom and thickened on the stringers. Texture of the deposits is somewhat rough, but slushy holdup can be seen in the left-hand and right-hand bays.

Figure 14 summarizes the fuel temperature environment for some cold fuel holdup tests with LFP-11, by plotting the temperature gradients in the center of the tank at initiation of pumpout, corresponding to several amounts of holdup. Only the lower portion of the tank is shown. Because of convection currents, readily observable, solid deposits were confined to the lower surfaces. The entire temperature profiles were somewhat symmetrical except that the upper gradients were narrower than those shown for the lower surface.

Note in Figure 14, that in all cases, the bulk of the fuel is above the freezing point, but most of the boundary layer near the lower surface is below the freezing point. The coldest tests had a portion of the boundary layer even below the pour point.

Similar results are plotted in Figure 15 for holdup tests with LFP-12, and in Figure 16 for LFP-13. Although the freezing points of these two fuels are nearly identical, the very low pour point of LFP-12 appears influential in requiring lower fuel temperatures for the same holdup. In this respect, LFP-12 behaves as the formulation intended, namely as an intermediate freezing point fuel between the high LFP-13 and a Jet A.

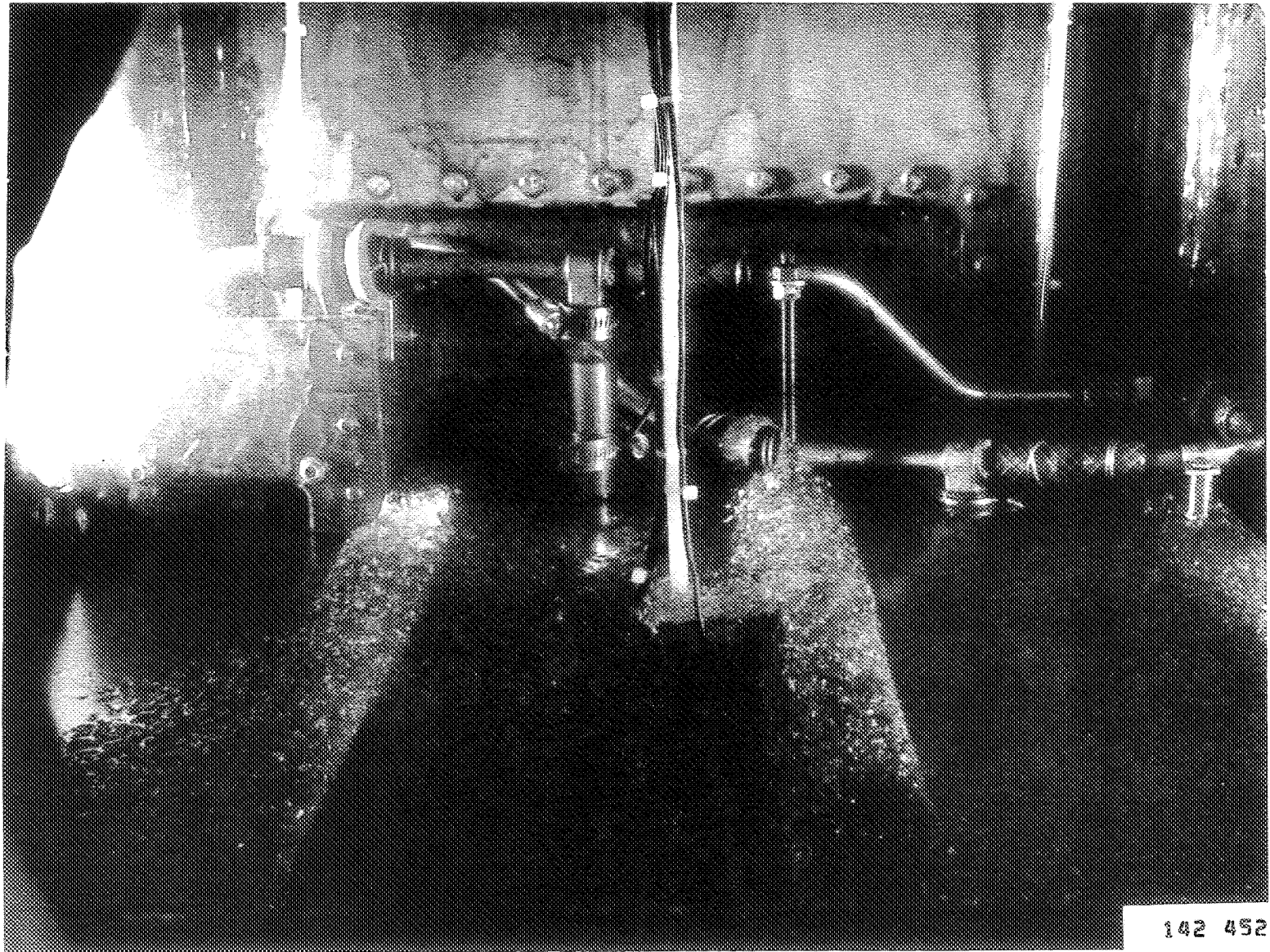

FIGURE 13 - TANK INTERIOR FOR TEST 103, 6.23% HOLDUP, LFP-11 FUEL

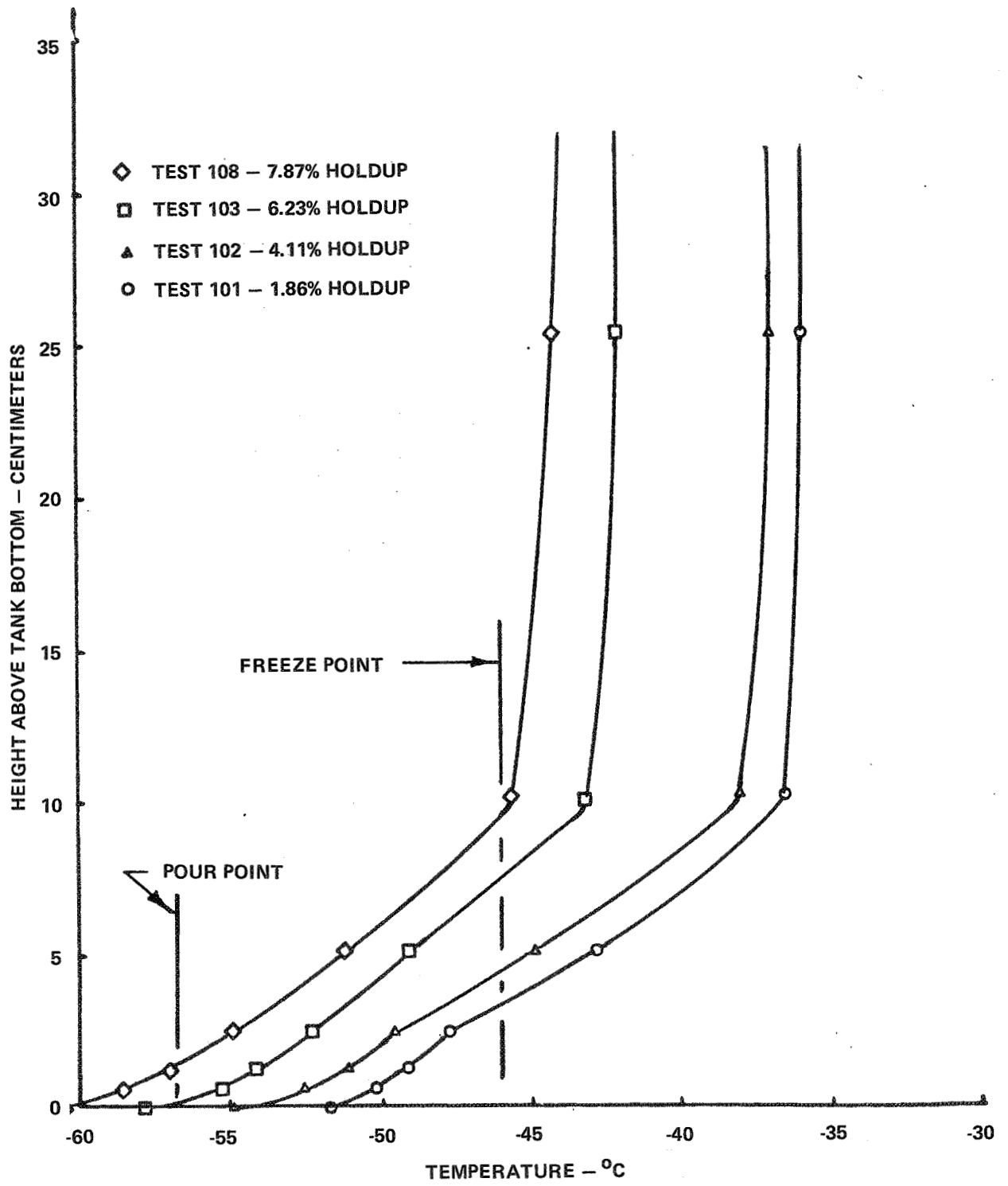

FIGURE 14 - TEMPERATURE GRADIENTS FOR COLD FUEL HOLDUP TESTS, LFP-11 FUEL

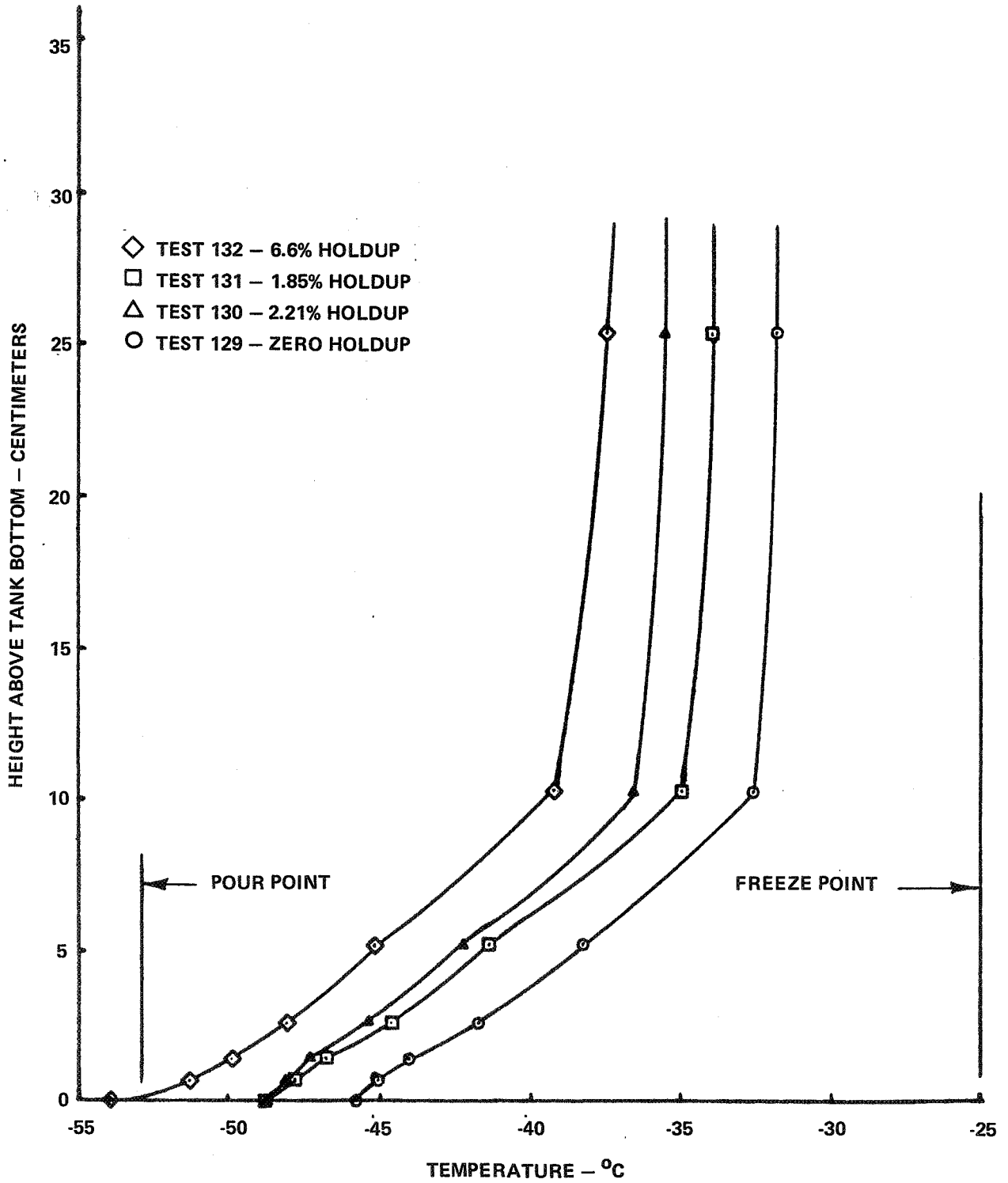

FIGURE 15 - TEMPERATURE GRADIENTS FOR COLD FUEL HOLDUP TESTS, LFP-12 FUEL

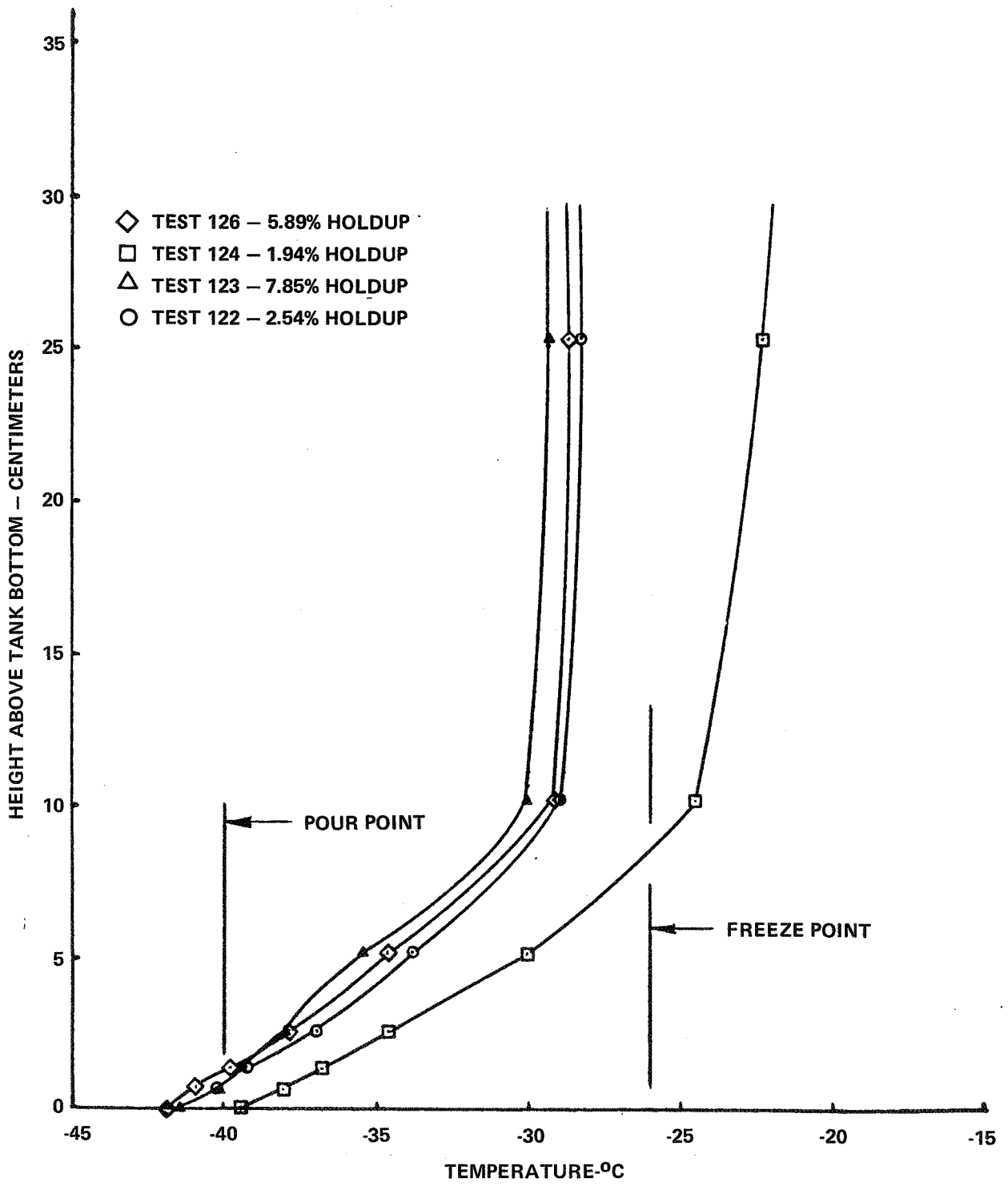

FIGURE 16 - TEMPERATURE GRADIENTS FOR COLD FUEL HOLDUP TESTS, LFP-13 FUEL

Only one test for cold fuel holdup was performed with the LFP-5 fuel, since it had been tested previously for holdup (Ref. 11). The single test served as a repeat point comparison.

6.2 LOW-POWER HEATING TESTS

Prior to performing heating tests, each fuel was tested according to the extreme cold day schedule, shown in Figure 11. Temperature profiles, temperature histories, and holdup were measured for these tests to serve as references for subsequent heating tests. In addition, the high-freezing-point fuel LFP-13 was tested at the standard day schedule. Figure 17 is a time history of temperatures at selected heights above the bottom surfaces at the center of the tank for this test. Although temperatures at the bottom skin and at the 1.3 centimeter level were colder than the -26°C freeze point of the fuel, there was no measurable holdup. Visual observations at the end of the test indicated that a few solid particles had formed but were in such small quantity that they either remained suspended and were pumped out, or were not detectable by the weighing apparatus. These results indicate that this high-freezing-point fuel remains pumpable at standard, non-extreme flight conditions.

Figure 18 is an example of the unheated baseline time history of fuel temperatures at the center of the tank for the extreme cold day schedule. For this test with LFP-11 Jet A fuel, holdup was a slight 0.1%, barely visible at the bottom of the tank. The variations in the lower skin temperature represent less than desired control for that particular test. Temperatures are within 2°C of the schedule, however.

Figure 19 is a time history of temperatures for the center thermocouple rack from the bottom to the center of the tank during a low-power heating test with LFP-11. It can be seen that the heating effect was most pronounced from the 2.5 centimeter (1 inch) level upward. There was no holdup.

A similar pair of tests was performed with LFP-12 intermediate freeze point fuel. Figure 20 is a time history of selected readouts from the center thermocouple rack for the above heating test, with baseline test data superimposed to identify the effects of heating. Holdups were 2.29% for the test without heating, and 1.89% with low-power heating. Although temperature increases above 1.3 centimeters are appreciable, there is only a slight benefit in the holdup zone below 1.3 centimeters.

Results of similar tests with LFP-13 higher freeze point ERBS fuel were more illustrative of the potential benefits of heating. For the baseline test without heating, holdup was 12.9%. This was reduced to 5.44% with low-power nominal 300-watt heating, initiated when the temperature at 10.2 centimeters was reduced to -20°C . Figure 21 is a time history of selected readouts from the center thermocouple rack. The figure illustrates the heating effects and also illustrates the progressive lag in heating response between the center of the tank at 25.4 centimeters and the boundary layer at 1.3 centimeters.

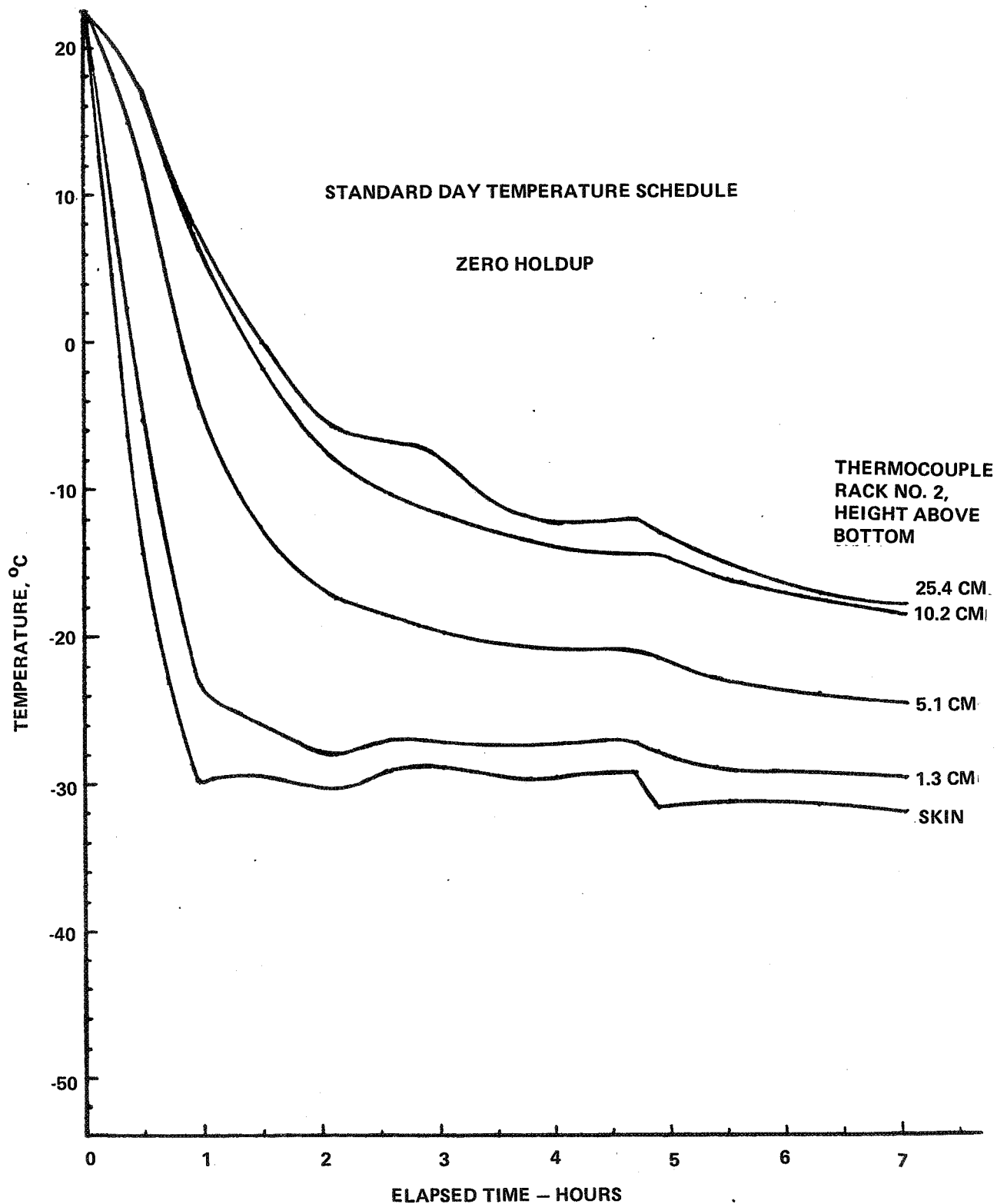

**FIGURE 17 - TIME HISTORY, NO HEATING, STANDARD DAY
TEST 140, LFP-13 FUEL**

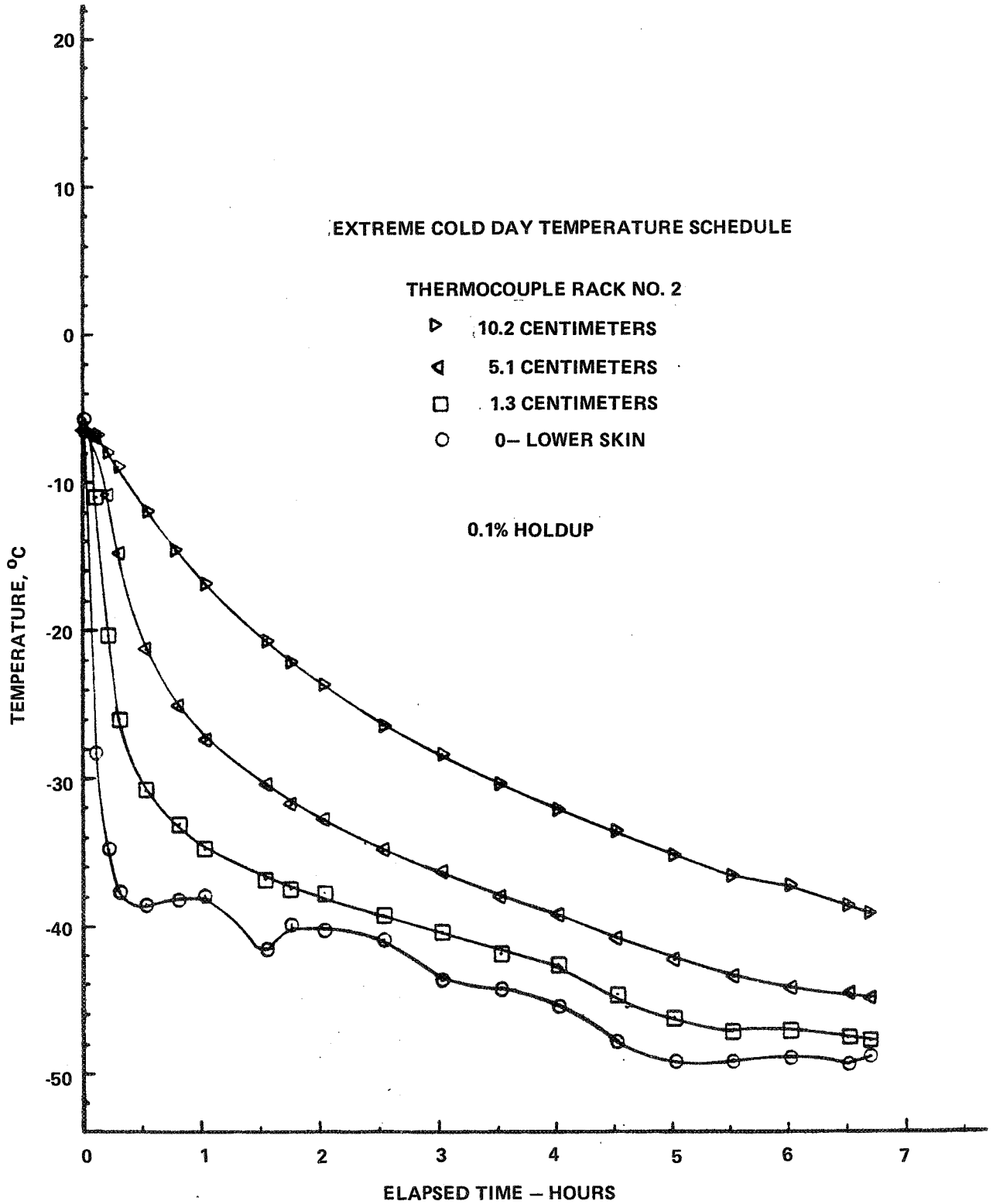

FIGURE 18 - TIME HISTORY, EXTREME COLD DAY SCHEDULE,
NO HEATING, TEST 109, LFP-11 FUEL

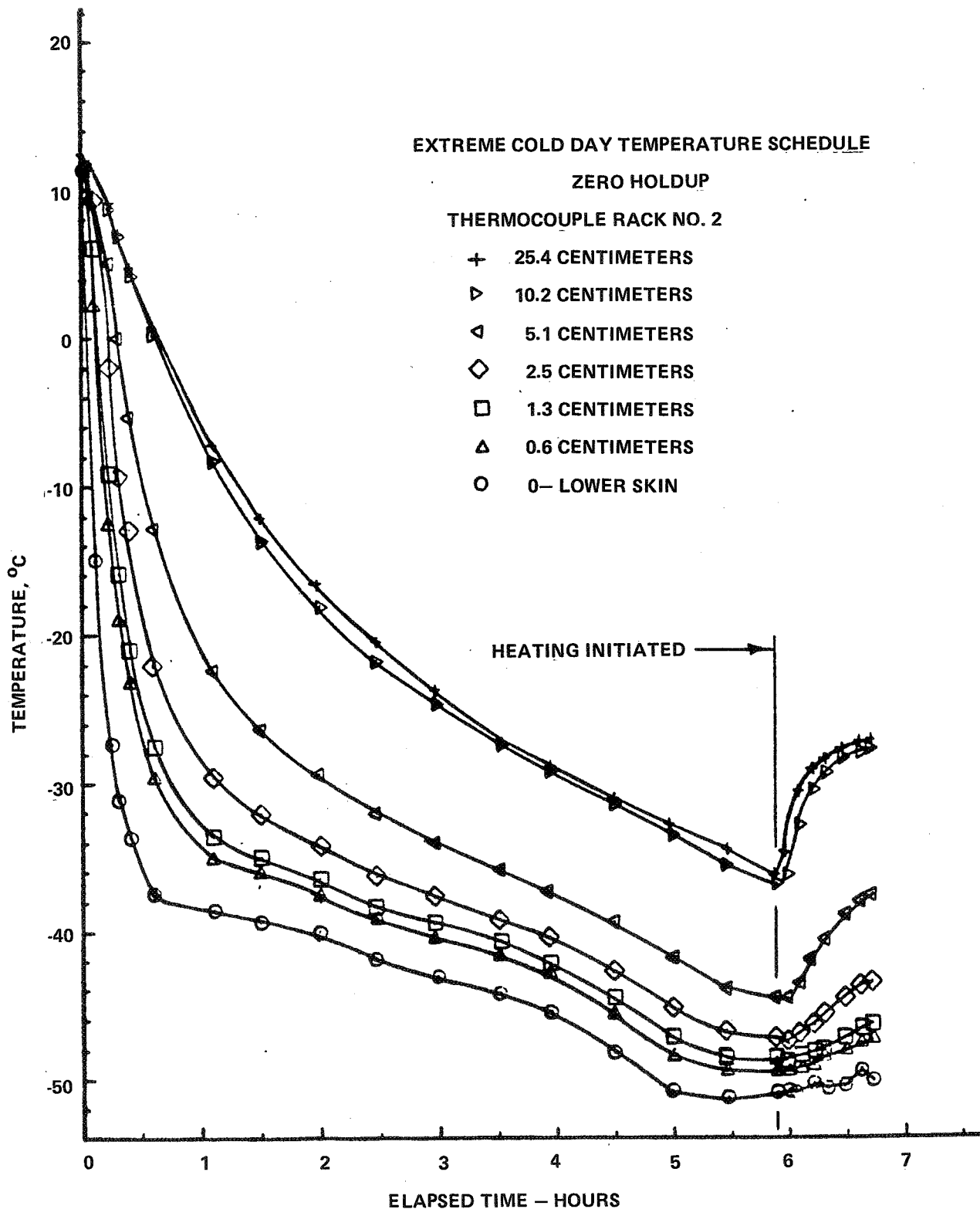

FIGURE 19 - TIME HISTORY, LOW-POWER HEATING,
 TEST 113, LFP-11 FUEL

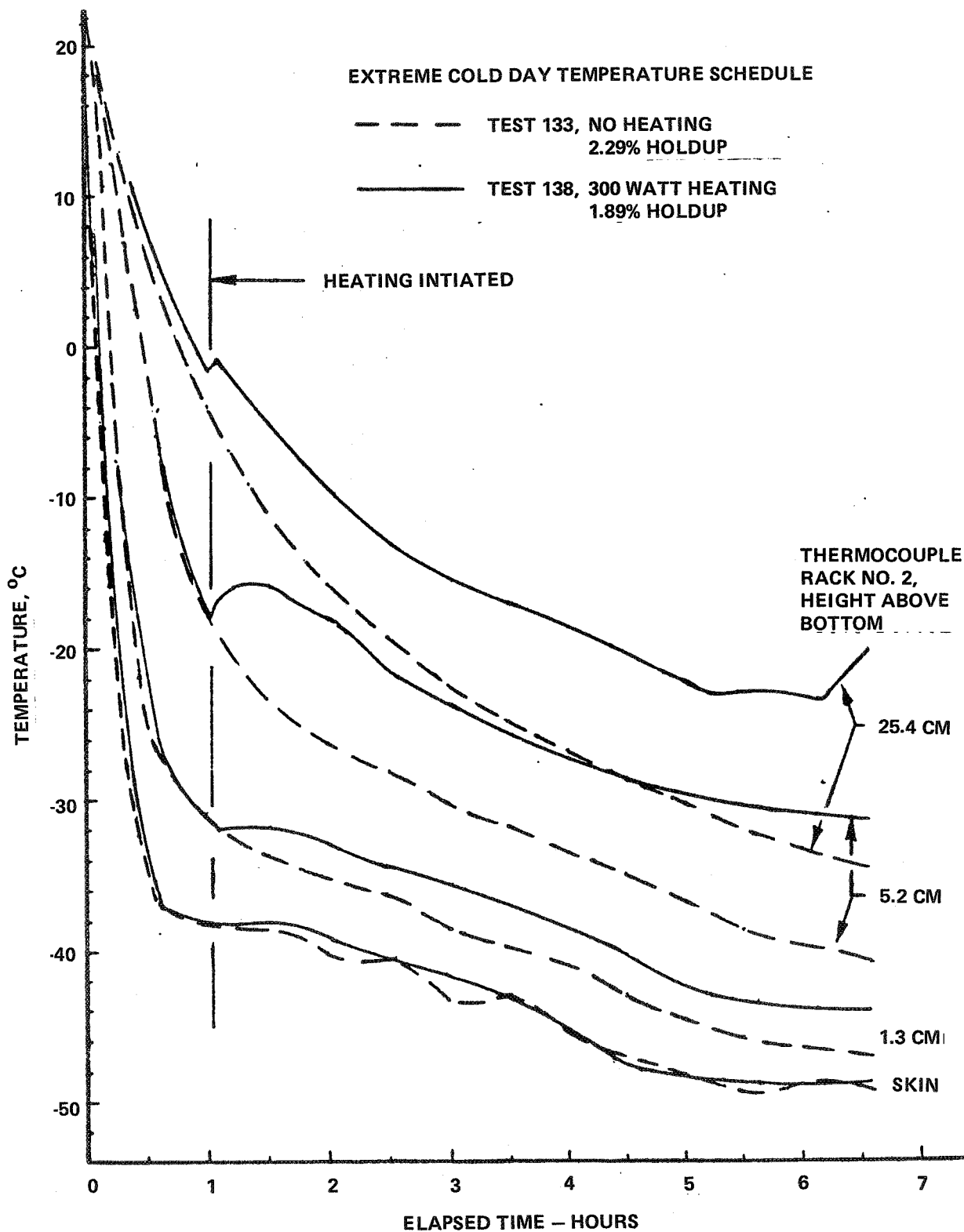

FIGURE 20 - TIME HISTORIES, BASELINE AND LOW POWER HEATING, TESTS 133 AND 138, LFP-12 FUEL

6.3 HIGH-POWER HEATING TESTS

Tests with nominal 900-watt high-power fuel heating commenced with LFP-11 Jet A fuel, using the same procedure as for the low-power fuel heating. For the short period of heating near the end of the test, there was little difference from the temperatures shown in Figure 19 for low-power heating. At the end of the test there was no holdup.

With LFP-12 intermediate freeze point fuel, 900-watt heating was initiated at approximately one hour elapsed test time. At the end of six hours the temperature at 10.2 centimeters was 10.2°C warmer compared with the non-heated reference test, whereas the temperature at the bottom surface was only 1.2°C warmer. Holdup at the end of the test was 1.58%, only slightly different from the 1.89% holdup with 300 watt low-power heating. Test data revealed slightly higher bulk fuel temperature at the end of the test, with boundary layer temperatures similar to those shown in Figure 20.

Results with LFP-13 high freeze point ERBS fuel followed a similar pattern. The bulk fuel temperature became slightly warmer with 900-watt heating compared with 300-watt heating. Holdup was 4.80%, a small improvement over the 5.44% recorded with low-power heating. Figure 22 is a time history of temperatures from the center thermocouple rack for this test.

Although no baseline test was performed with LFP-5 fuel, a 900-watt heating test was performed in which holdup was 5.15%. This was a major reduction from the 25.5% holdup experienced after a scheduled withdrawal test from the previous program described in Reference 11.

For one test with LFP-11 fuel, a long duration test was conducted with the lower surface temperature at a constant -55°C. Heating was delayed until the boundary layer gradient corresponded to that associated with a holdup of approximately 4%, based on data from the cold fuel holdup tests. Figure 23 is a time history of selected temperatures at the center of the tank. When the nominal 900-watt heating was initiated, the effect was readily discernible at and above the 5.1 centimeter level. At the end of the test there was 0.57% holdup. Since fuel temperatures in the boundary layer were continuing to increase at the time, a somewhat longer test probably would have eliminated holdup. The most significant aspect of this test was that heating penetrated into the boundary layer to melt solid deposits which undoubtedly had been formed.

Tests were also performed with LFP-11 and LFP-13 fuels with high-power heating at the extreme warm day schedule to investigate possible fuel overheating with lack of heater regulation. Figure 24 is a time history of the test with LFP-13 (ERBS), showing temperatures from the center thermocouple rack for the lower half of the tank. Fuel temperatures were essentially unchanged at higher levels until the cooling effect of the upper skin was evident at 2.5 centimeters below the upper skin.

The test with LFP-11 Jet A fuel followed a similar pattern. Neither of the tests disclosed any evidence of incipient overtemperature. Reference to the extreme hot day schedule of Figure 11 shows a reduction in skin temperature subsequent to the time at which the tests were terminated; this would tend to decrease the likelihood of achieving undesirably high fuel temperature.

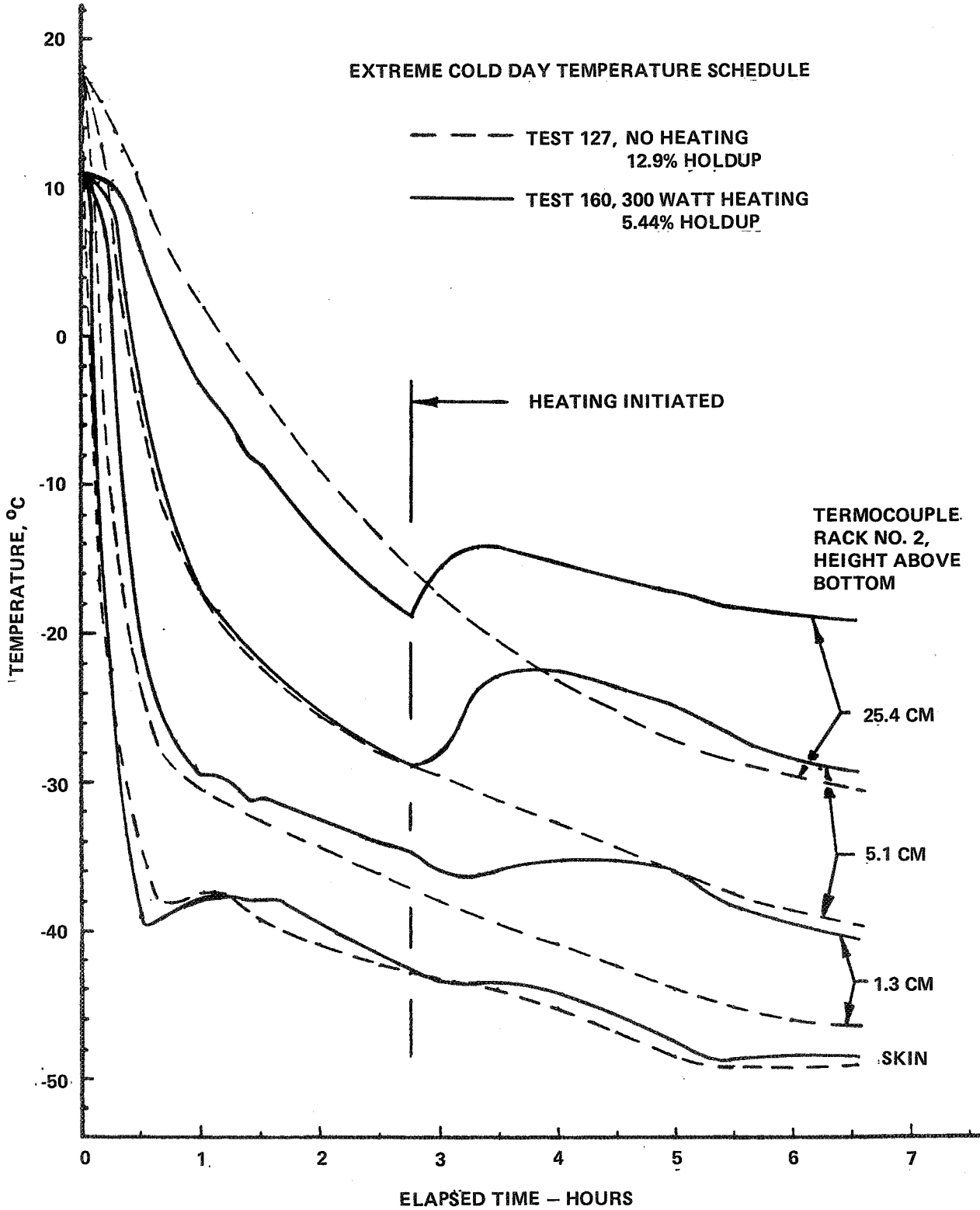

FIGURE 21 - TIME HISTORIES, BASELINE AND LOW-POWER HEATING, TESTS 127 AND 160, LFP-13 FUEL

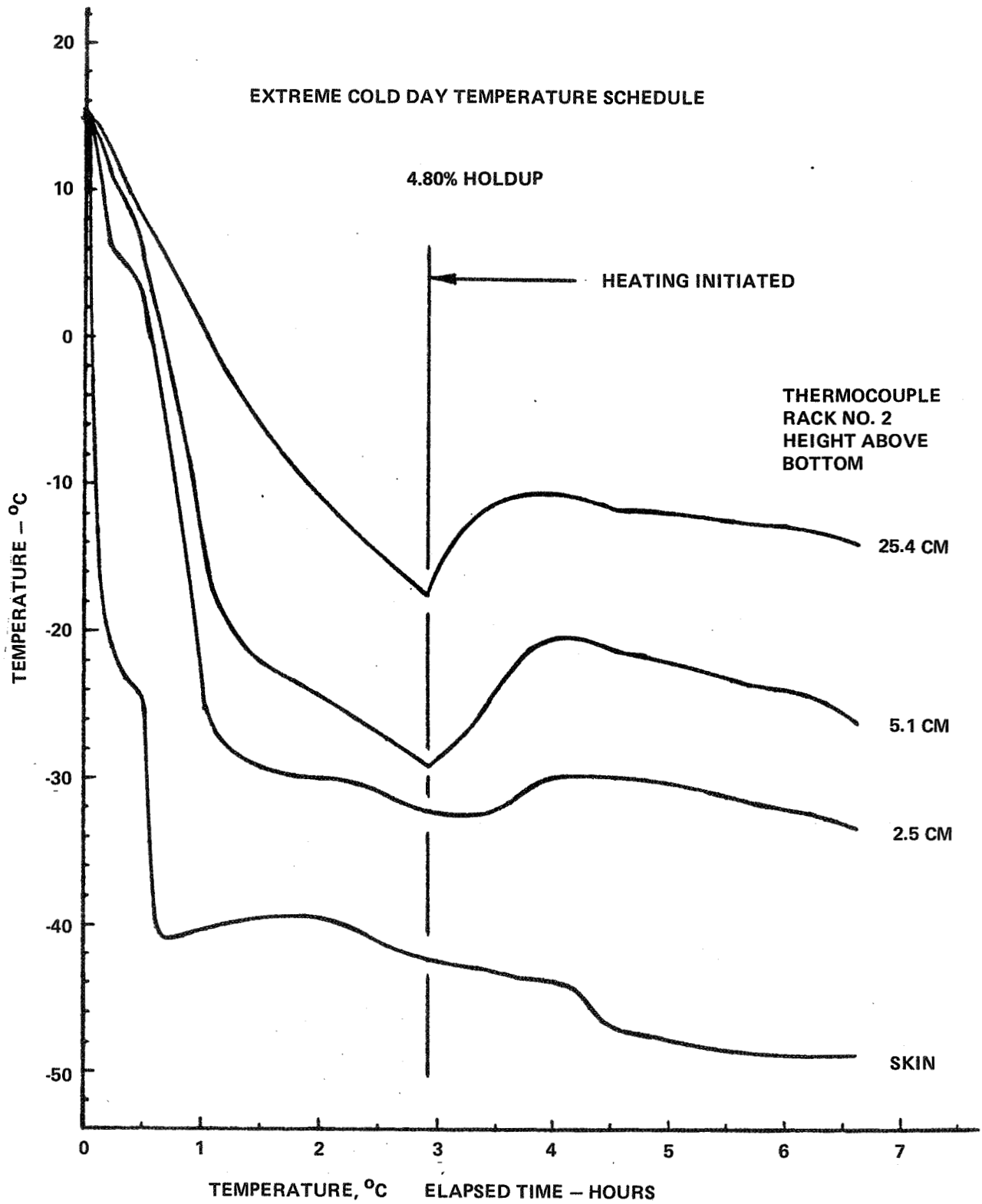

FIGURE 22 - TIME HISTORY, HIGH-POWER
HEATING, TEST 159, LFP-13 FUEL

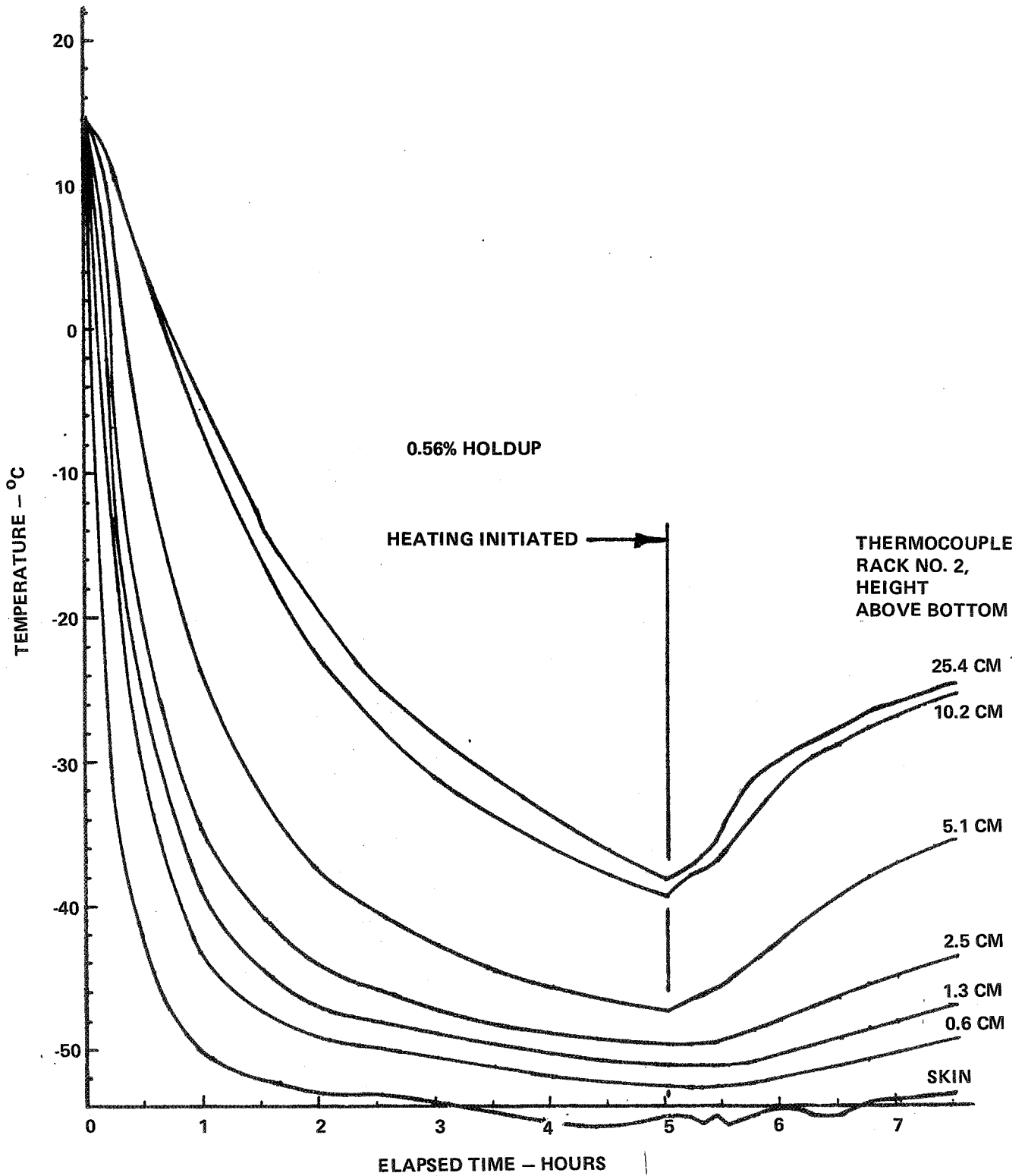

FIGURE 23 - TIME HISTORY, HIGH-POWER HEATING AFTER LONG DURATION COOLING, TEST 118, LFP-11 FUEL

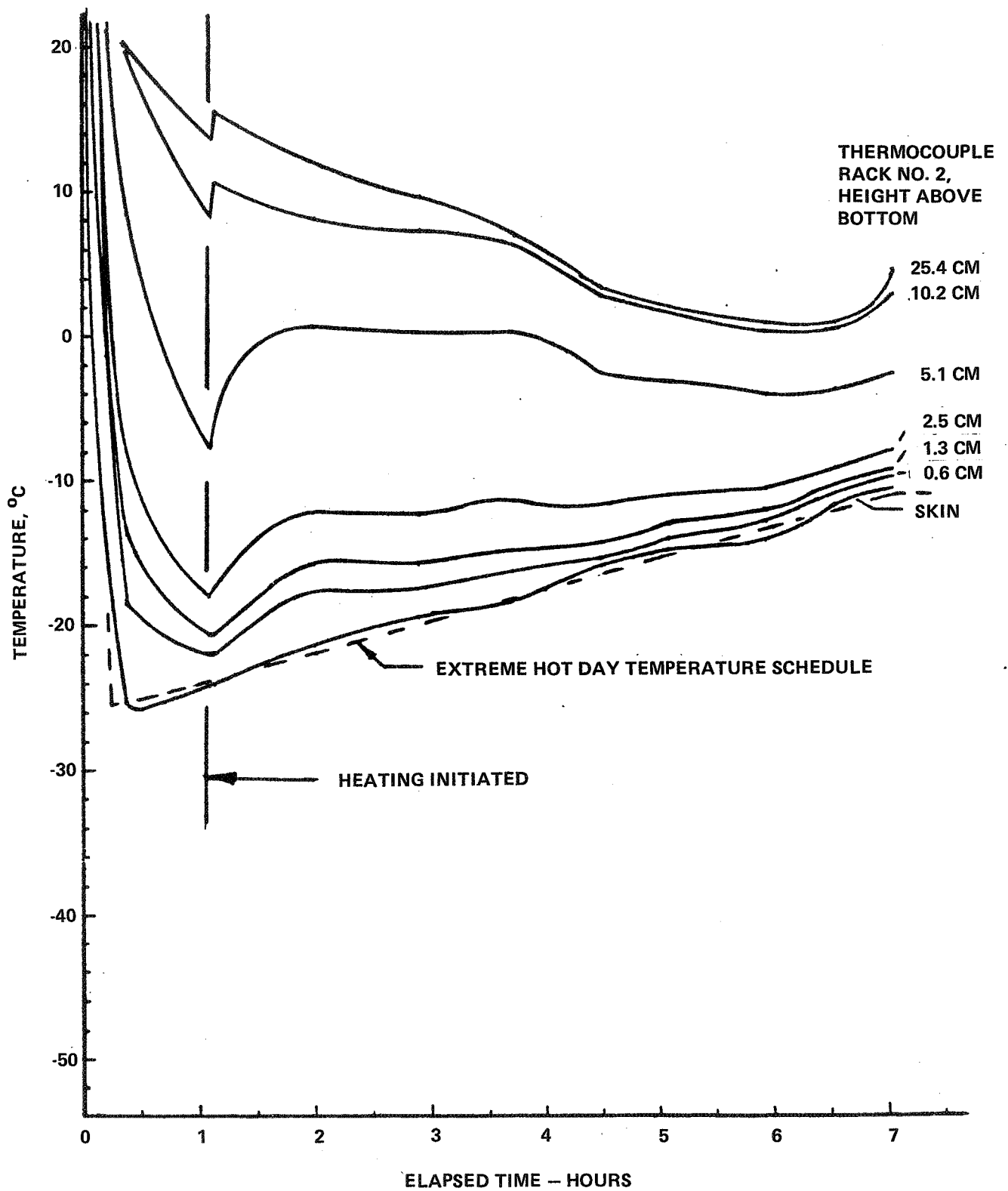

FIGURE 24 - TIME HISTORY, HIGH-POWER HEATING,
EXTREME HOT DAY, TEST 143, LFP-13 FUEL

6.4 FUEL HEATING WITH WITHDRAWAL

Tests were also conducted with the full extreme cold day temperature schedule of Figure 11 and fuel withdrawal at 1 liter per minute during the last three hours of the test. With LFP-11 Jet A fuel, the unheated test produced zero holdup; with LFP-12 intermediate freezing point fuel, the unheated test produced 0.72% holdup, and with LFP-13 high freezing point fuel the unheated test produced 1.15% holdup. It was almost certain that heating during these scheduled withdrawal tests would eliminate these minor holdups. Nevertheless, the behavior of the heated fuel was of interest, and a test was conducted as an example with LFP-11 fuel. For this test, heating was initiated when the (bulk) temperature at 10.2 centimeters on the center rack was reduced to -37°C . High-power nominal 900-watt heating was used for 27 minutes, after which the heating rate was maintained at 300 watts. As expected, there was no holdup. At the time fuel withdrawal was initiated at 8.3 hours, temperature at the 10.2 centimeter level was approximately 14°C warmer than at the same point in the baseline test. During the fuel withdrawal phase, the maximum temperature recorded was 6.5°C , when approximately 85% of the fuel had been withdrawn. (The minimum temperature had been reduced from the -48.8°C shown in Figure 10 to -51°C for the lower freeze point LFP-11 only.)

Since a scheduled withdrawal test without heating had been performed with LFP-5 fuel during the investigation described in Reference 11, it served as a baseline test. The LFP-5 withdrawal test in this program used high-power 900-watt heating, initiated when the temperature at 10.2 centimeters in the center of the tank was reduced to -20°C . At the end of the test, holdup was 1.12%, a dramatic decrease from the 25.5% recorded in the earlier program!

Figure 25 is a time history of fuel temperatures for the lower half of the center of the tank for the above test. A problem with the coolant system allowed skin temperature to increase above the scheduled value between 6.5 and 9 hours; this deviation may have influenced the reduction in holdup. Also, during the earlier test, the bulk fuel was approximately 12°C cooler at the start of the test. Although temperatures up to the 5.1 centimeter level were quite comparable for the two tests until heating was initiated, fuel at the 25.4 centimeter level was approximately 10° colder at that point during the earlier test. The sharp dropoff in temperature at 10.2 and 25.4 centimeters near the end of the test was caused by the receding fuel level, which exposed the thermocouples to the cold temperature in the ullage space.

6.5 OTHER TESTS

This category of testing encompasses variations in equipment and procedures suggested by prior tests, and employed LFP-11, LFP-13, and LFP-5 fuels. For all except two tests, the temperature schedule selected was for the "Extreme Cold Day" situation shown in Figure 10, ending at the minimum temperature phase after approximately seven hours test time.

The effect of longer heating time was investigated with LFP-5 fuel, where two tests were performed according to the "Extreme Cold Day" temperature schedule, with nominal 900-watt high-power heating. For the first test, heating was initiated at 0.5 hour elapsed time, and gravity holdup was 4.32%. For the second test, heating was initiated when the thermocouple at 10.2 centimeters on the center rack registered -20°C ; gravity holdup was 4.40%.

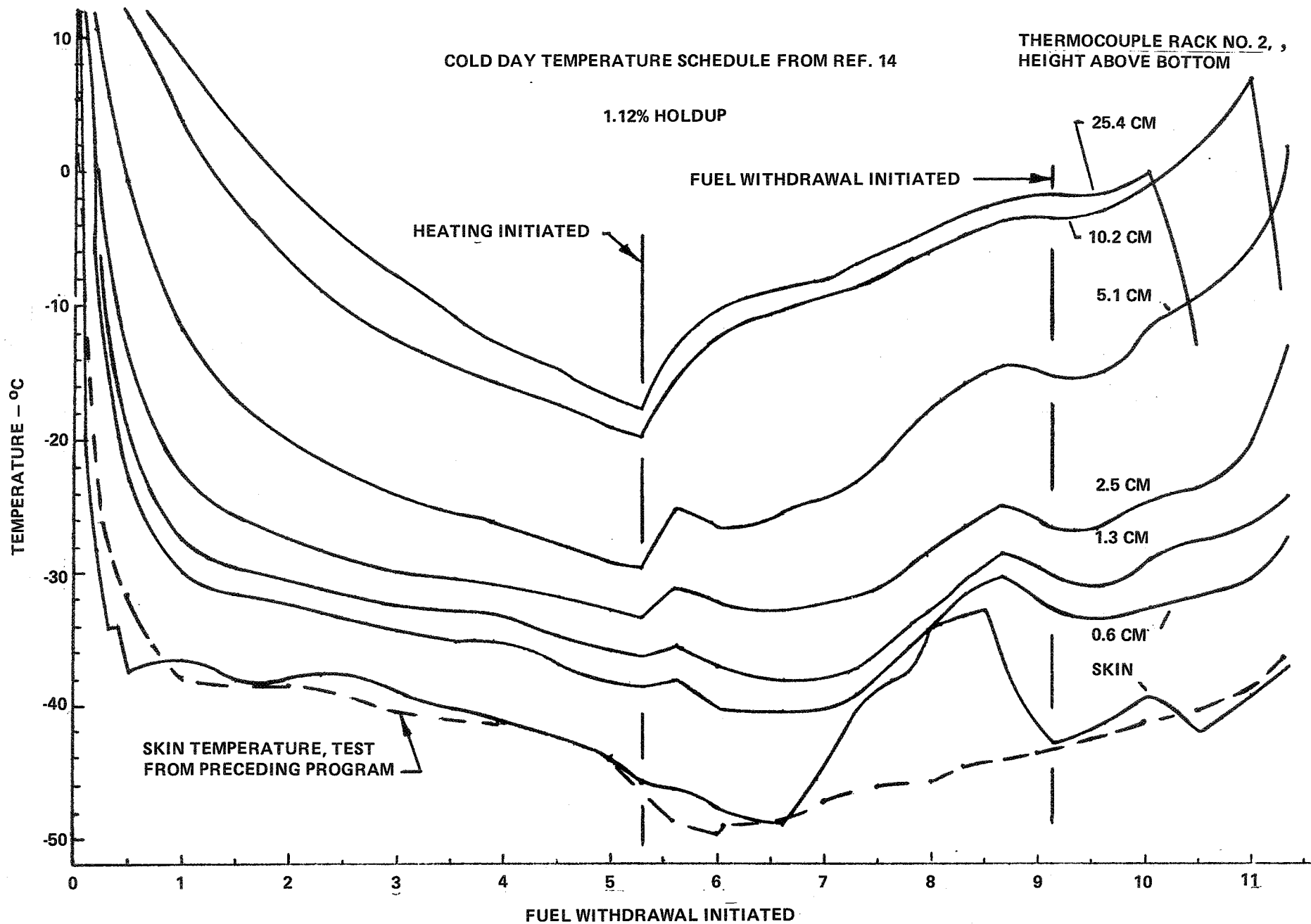

FIGURE 25 - TIME HISTORY, HIGH-POWER HEATING, SCHEDULED WITHDRAWAL, TEST 157, LFP-5 FUEL

One test with LFP-5 fuel, without heating, was interrupted to investigate the correspondence of boundary layer measurements during testing to predicted holdup. After 4 1/2 hours, fuel was withdrawn to measure holdup, after which the cold fuel was reloaded and testing was continued until 6.55 hours elapsed time. Holdup was 8.12% at the first measurement and 10.41% at the end of the test.

One test was conducted with an intermediate power setting between the low and high power values. For LFP-13 ERBS fuel, extreme cold day schedule, nominal 300-watt low-power heating, holdup was 5.44%. With nominal 600-watt intermediate-power heating, gravity holdup was 5.46%; with 900-watt high-power heating, holdup was 4.80%. Most likely, the actual heat transferred to the fuel was much less than the nominal power settings at the transport fluid heater.

Limited combinations of tests were performed with LFP-5, LFP-11, and LFP-13 fuels, using two modified fuel recirculation distributor tubes: one with a single row of holes and one with low re-entry holes aimed at forcing the heated fuel closer to the tank surface. Some tests were performed with a smaller single-pass heat exchanger instead of the baseline 4-pass heat exchanger. One test with LFP-13 investigated the effect of a higher fuel recirculation rate.

In general, those changes which aided the penetration of fuel toward the tank surface, that is, the low re-entry distributor and increased recirculation flow rate, made a small but measurable improvement in the holdup. The replacement heat exchanger had no observable effect.

These distributor variations are discussed in more detail in the following section of the report.

7.0 DISCUSSION

Higher freezing point fuels may have producibility advantages as future aviation fuels. Since the relationship of fuel characteristics to low temperature flow behavior under practical wing tank environments is poorly understood, the previous NASA-Lockheed study (Ref. 11) investigated the low temperature behavior of both Jet A and higher freeze point fuels, particularly the formation of unusable solids. An analytical study by Boeing (Ref. 13) proposed several methods for heating fuel to contend with the freezing problem.

In-flight data from a number of international airlines, compiled by Boeing under NASA Contract NAS3-20815, (Reference 18), demonstrates that long-range commercial aircraft may experience static temperatures as low as -72°C as a one-day-per-year probability. Assuming that 90% of the ram temperature rise is recovered at Mach 0.80, the resulting wing surface is almost -49°C . The Boeing report also relates, however, that the duration of exposure to the extreme cold is usually short, as shown in the resultant "Extreme Cold Day" temperature schedule of Figure 10. By incorporating this information, a significant feature of this testing program was a realistic representation of the aircraft wing tank environment. The chilldown procedure employed was a simulation of conditions to which aircraft are subjected.

7.1 VISUAL OBSERVATION OF HOLDUP

During this test program, as well as during the previous Lockheed program (Reference 11), visual observations proved to be an important means of data acquisition, both for interpreting data gathered through instrumentation and for understanding the process of formation and deposition of solids as described below.

As the upper and lower surfaces are cooled, heat is transferred from the fuel to the coolant. In particular, fuel cooled by the upper surface becomes more dense; the resultant density gradients set up a convective flow of dense, colder fuel toward the bottom of the tank. As profiles are fully developed in the completely filled tank, the center of the tank has a well-mixed uniform temperature, with gradients to the skin temperature over a considerably greater distance at the bottom compared to the top. Precipitation of solid fuel during the chilling is also influenced by the convection currents set up by the density gradients. The first visual evidence of solids is a dulling of the lower surface of the tank. As cooling continues, the dull area spreads along the bottom, then commences to climb the vertical webs of the lower stringers and later to spread across the upper horizontal flanges of the stringers. During this process, the dulling becomes identifiable as solid deposits increasing in depth on the bottom and to a lesser extent on the stringers. Eventually, the deposits form on the upper surfaces and vertical panels.

In most cases, during cold fuel holdup and other unheated tests, solids suspended in the fuel became evident after a coating had begun to form on the lower surfaces. At holdups up to 1%, deposits were on the bottom skin only, between the lower stringers. By 4% holdup, a thin film had covered the vertical webs and upper flanges of the lower stringers. At about 6% holdup, a very slight film was forming on the upper surfaces. Deposits were evident on the vertical panels at about 10% holdup. Although the maximum holdup during this program was 12.9%, during the previous Lockheed program (Ref. 11), the distribution at 20% holdup was approximately 16% on the bottom (covering the

lower stringers), and 4% over the remainder of the tank. Examples of the appearance of a range of holdups are shown in several photographs.

Figure 26 shows a 1.15% holdup with LFP-12 intermediate freeze point fuel. Solids are confined mainly to the bottom surface.

Figure 27 shows a 3.22% holdup with LFP-11 Jet A fuel. Here the lower stringers are covered, as well as the lower surfaces.

A 6.23% holdup with LFP-11 Jet A fuel is shown in Figure 13. Deposits are noticeably thicker on the lower surface and stringers.

Figure 28 shows a 10.53% holdup with LFP-5 fuel. Deposits almost fill the bays between stringers. At the left-hand side of the picture, note the depression in front of the flapper check valve opening, probably caused by gravity flow toward the drain, which connects to the boost pump mounted below the tank. Also visible is the height indicator, installed during the later series of tests, which shows deposits of about 2 1/4 inches, or 5.7 centimeters, between stringers.

7.2 TANK TEMPERATURE PROFILES

The temperature profiles presented in the Results section of this report, Figure 14 for example, have shown only the temperatures measured in the lower portion of the center of the tank. These profiles emphasize the temperature gradients in the bottom boundary layer where the solid accumulation and subsequent holdup occurs.

Two complete vertical temperature profiles are illustrated in Figure 29. These temperatures were measured at the center of the tank for the LFP-11 Jet A fuel. With this fuel and the extreme cold day schedule, 5.9 hours of test time elapsed before the reference thermocouple at 10.2 centimeters indicated 8°C above the freezing point, for initiation of heating. The temperature history for this test is shown in Figure 19. Heating continued for about 0.8 hour before pumpout. Thus, in Figure 29, the two profiles show temperatures prior to heating and at the completion of heating. In both cases, the sharper gradient at the top of the tank is graphic evidence of the effects of convection. Another obvious indication is the small temperature increase over the first two centimeters above the bottom of the tank, which is the most likely zone for gravity holdup.

The complete temperature measurements for the two cases illustrated in Figure 29 are listed in the following two tables. Thermocouple rack locations are defined in Figure 8. Table 3 shows the horizontal temperature distribution throughout the tank prior to heating fuel during the same Test 113. The largest deviation is at the lower skin line of Rack 1, probably caused by its proximity to the tank outlet fitting for fuel boost pump.



142 990R

FIGURE 26 - HOLDUP OF 1.15%, TEST 134, LFP-12 FUEL

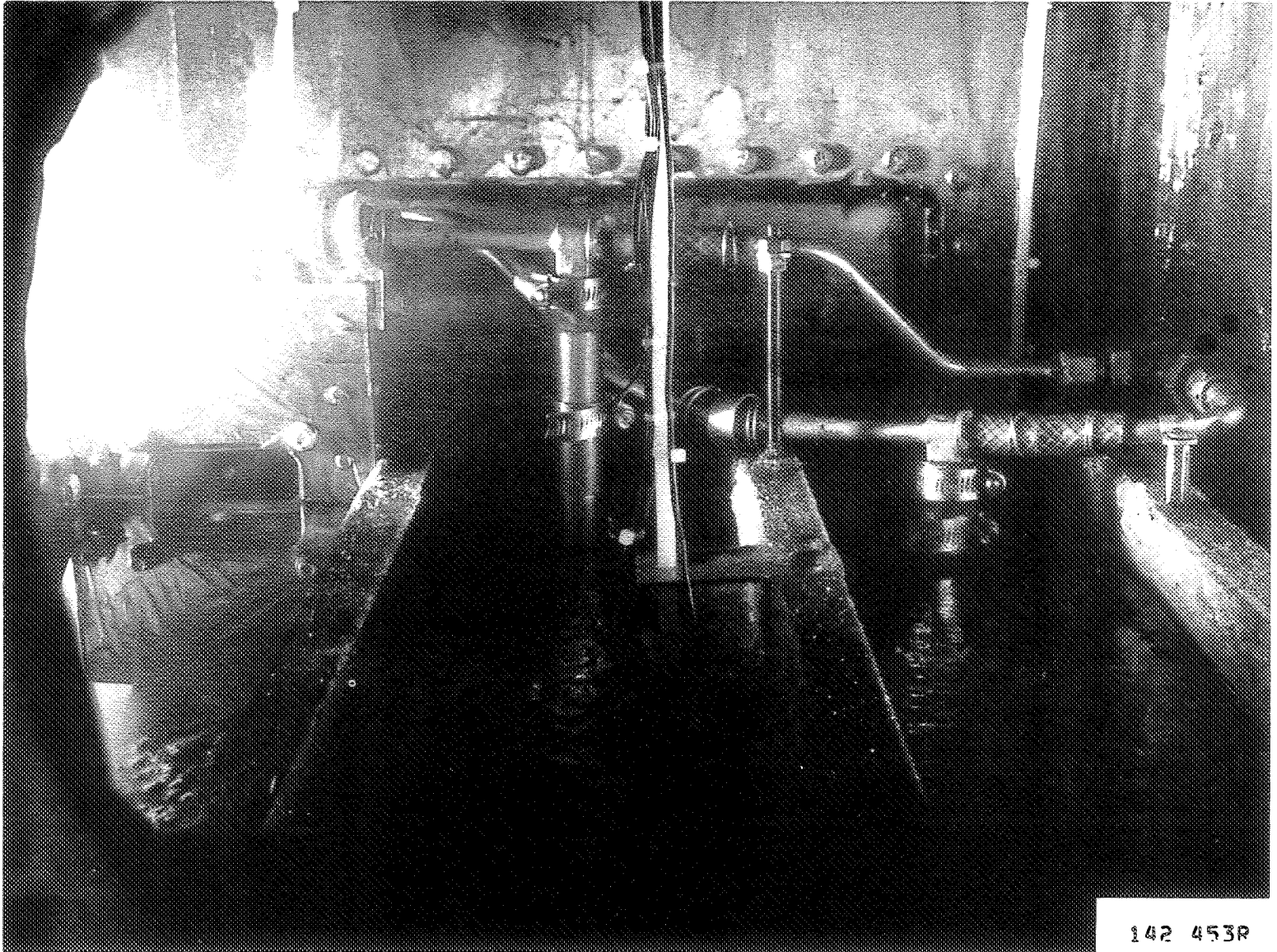
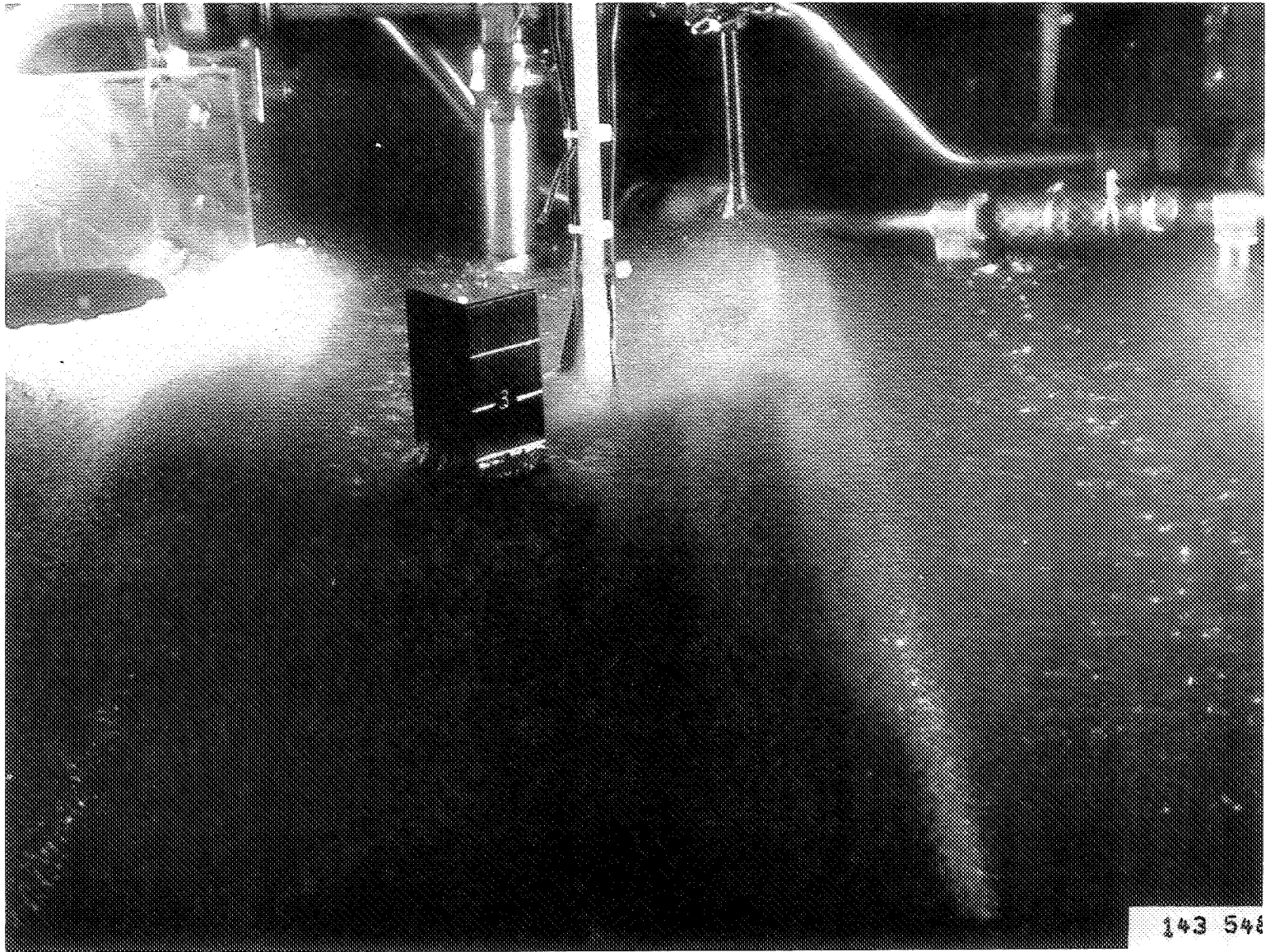

FIGURE 27 - HOLDUP OF 3.22%, TEST 106, LFP-11 FUEL



143 548

FIGURE 28 - HOLDUP OF 10,53%, TEST 153, LFP-5 FUEL

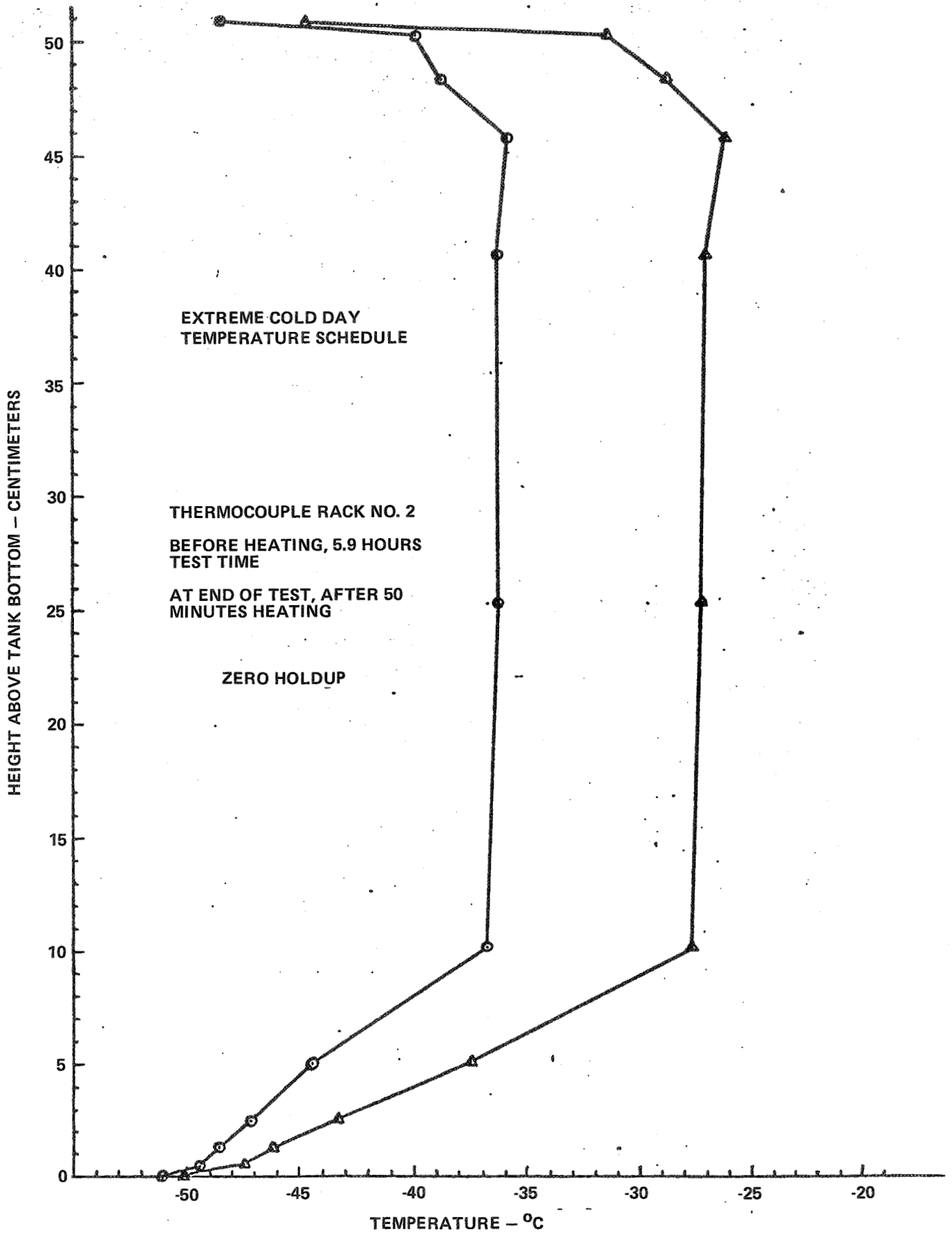

FIGURE 29 - TEMPERATURE PROFILES BEFORE AND AFTER HEATING,
TEST 113, LFP-11 FUEL

Table 4 shows the horizontal temperature distribution throughout the tank at the end of heating, prior to pumpout, for Test 113. The concentration of the circulation path toward the boost pump is apparent from the temperature spectrum of Rack 1. There also appears to be a cold zone through the lower five centimeters of Rack 2, as if the returning heated fuel were initially rising by convection from one end of the tank, then being eventually drawn downward toward the opening for the boost pump.

TABLE 3
HORIZONTAL TEMPERATURE DISTRIBUTION PRIOR TO HEATING, TEST 113

HEIGHT	RACK 1 CM	RACK 2 °C	RACK 3 °C	RACK 4 °C	RACK 5 °C	SIDE 1 °C	SIDE 2 °C	SIDE 3 °C
50.8	-45.9	-48.5	-49.3	-49.0	-46.5			
50.2	-37.4	-39.8	-41.4					
48.3	-35.7	-38.7	-40.9	-35.7	-38.8			
45.7	-35.4	-35.9	-40.9					
40.6	-35.4	-36.5	-36.4	-36.3	-35.6			
25.4	-35.3	-36.3	-36.0	-36.0	-35.4	-36.3	-37.5	-36.7
10.2	-37.4	-36.8	-36.4	-37.7	-36.0			
5.1	-36.9	-44.5	-37.6					
2.5	-42.2	-47.2	-41.5	-48.7	-43.4			
1.3	-42.8	-48.6	-45.8					
0.6	-43.1	-49.5	-47.9					
0	-37.4	-51.1	-50.1	-50.1	-48.7			

TABLE 4
HORIZONTAL TEMPERATURE DISTRIBUTION AT END OF HEATING, TEST 113

HEIGHT CM	RACK 1 °C	RACK 2 °C	RACK 3 °C	RACK 4 °C	RACK 5 °C	SIDE 1 °C	SIDE 2 °C	SIDE 3 °C
50.8	-39.2	-44.7	-46.7	-41.6	-43.3			
50.2	-26.9	-31.4	-32.0					
48.3	-26.2	-28.7	-31.2	-26.1	-30.2			
45.7	-26.1	-26.0	-29.0					
40.6	-27.4	-27.0	-26.9	-27.6	-26.8			
25.4	-26.4	-27.1	-27.2	-26.8	-26.9	-29.5	-29.9	-29.6
10.2	-26.9	-27.6	-27.2	-28.0	-27.0			
5.1	-27.1	-37.5	-28.2					
2.5	-27.1	-43.4	-34.5	-46.9	-36.6			
1.3	-27.3	-46.3	-40.2					
0.6	-29.2	-47.4	-44.2					
0	-35.8	-50.1	-48.4	-49.1	-46.1			

7.3 CORRELATION OF HOLDUP

Figure 30 shows the relationship between percent mass holdup and the fuel temperature measured at 0.6 centimeters above the bottom of the tank. This type of analysis has been useful as a means of estimating holdup at some intermediate point during a test, prior to pumping out the fuel and determining the final holdup by means of the weighing procedure. The figure includes results from the cold fuel tests and from the various heating tests.

The boundary layer temperature 0.6 centimeter above the bottom surface was selected as a correlating parameter indicative of the boundary layer temperatures where solid fuel and wax accumulate. This correlation has been presented and discussed in Reference 12. It is evident that holdup is very sensitive to small temperature variations and considerable data scatter occurs. However, there is no systematic variation between the heated and unheated tests. Hence, heating the fuel reduces holdup by increasing the boundary layer temperature and not by any change in the mechanism of the phase change or solid agglomeration.

Further correlations of holdup based on the previous Lockheed data (Reference 11) and Boeing data is to be reported by a document in preparation by the Coordinating Research Council, Inc. Group on Low Temperature Flow Performance of Aviation Turbine Fuels.

7.4 FUEL HEATING PROCEDURES

Heating rates were defined by the electrical power input to the heat transport fluid heater: 300, 900, and (in one test) 600 watts. The objectives of these tests concentrated on representing the heated fuel temperatures and flow behavior. No attempt was made to analyze the heat transfer of the heating system or to optimize the system for maximum energy transfer. In fact, it was obvious that the heat input to the fuel tank was considerably less than the designated nominal power values. The lubricating oil heat transport fluid was preheated at the start of each test. When fuel heating was initiated (note Figure 21 for example), a temperature increase transient occurred from cooling of the preheated transport fluid. Subsequently, a more uniform heat transfer is maintained. During this time, the fuel cools, but at a lesser rate than if unheated. Changes from 300 to 900 watts nominal heating rates produced small changes in the fuel temperature histories, mainly in the bulk fuel (Figure 22), since for both heating rates only a fraction of the rated power is transferred to the fuel. The fuel-heat transfer fluid heat exchanger was changed during the course of testing to improve the efficiency of heat transfer. Holdup results comparing two sizes of heat exchangers were inconclusive. One obvious advantage of the smaller heat exchanger was the higher operating temperature of the transport fluid, which is beneficial if it becomes necessary to maintain a higher temperature for oil returning to the engine.

Some of the tests were conducted with intermittent rather than continuous fuel heating. This was done to maintain the turbine oil heat transport fluid above 80°C to simulate the requirements of one engine manufacturer and avoid atmospheric moisture condensation. In this mode of operation, the fuel circulation to the heat exchanger was turned off when the lubricating oil was chilled to 80°C. Then the oil temperature was allowed to increase to approximately 120°C before the next heating cycle was initiated.

Figure 31 illustrates the effects of intermittent and continuous heating by comparing two tests performed on consecutive days. For Test 151, intermittent 900-watt heating commenced at approximately 60 minutes elapsed time, while for Test 152 continuous 900 watt heating commenced at approximately 221 minutes elapsed time. (Heating for Test 152 was initiated when the temperature at 10.2 centimeters in the center of the tank was reduced to -20°C .) Despite the longer heating period for Test 151, overall heat input was less and holdup was 7.96%, whereas for Test 152 holdup was 5.15%.

Three configurations for the recirculation distributor tube were tested; Figure 32 presents photographs of these assemblies. During the early phases of testing, the triple row distributor was used, since it had been used in the previous investigation of the behavior of fuels at low temperatures (Reference 11). It contained three rows of 0.63 centimeter (0.25 inch) diameter holes drilled in an aluminum alloy tube with an outside diameter of 3.18 centimeters (1.25 inches), in rows 60° apart radially. When test results showed that the heated fuel was delivered mainly to the bulk fuel zone, another distributor was fabricated of the same tube size, but with a single row of holes spaced at one-half the interval used in the triple row configuration. Whereas the triple row distributor holes had faced downward and to each side, the single row of holes was aimed at the lower edge of the opposite end of the tank in an effort to introduce more heated fuel into the bottom boundary layer. Improvements in temperature distribution and holdup were small.

The low re-entry recirculation distributor used extensions to introduce the heated fuel close to the bottom of the tank. Each of the extended tube assemblies fits in one of the bays formed between the stringers at the bottom of the tank. No modifications to the structure of the tank were required to install this recirculation tube. The total number of holes is the same as on the single row distributor. Figure 33 shows an increase in fuel temperature for the lower nine centimeters of fuel and a concomitant small decrease in bulk fuel temperature, indicating a redistribution of the heated fuel. Holdup was decreased from 5.44% in Test 160 to 4.61% in Test 164 with the low re-entry distributor. While this is a small improvement, it is consistent with the warming of the bottom fuel layer and indicates promise for practical application of distributors that direct heated fuel to the bottom tank surface.

The effect of fuel recirculation rate was small but possibly significant. Using LFP-13 ERBS fuel, extreme cold day temperature schedule, low re-entry distributor, 300 watt heating, and single pass heat exchanger, holdup at 2.1 liters per minute fuel recirculation was 5.14% and at 3.1 liters per minute was 4.67%. For the latter test, fuel temperatures between 0.6 and 5.1 centimeters in the center of the tank averaged 0.7°C higher than for the test with the lower recirculation rate. The change in holdup as a function of temperature difference is in general agreement with the fuel holdup data presented in Figure 30.

7.5 PRACTICAL APPLICATION OF FUEL HEATING SYSTEMS

In formulating the design of a full-scale fuel heating system, one must consider a number of practical restraints:

- o The weight and complexity of the fuel heating system must be minimized. In this respect, the use of engine oil appears to offer the most desirable solution if heating capacity is adequate.

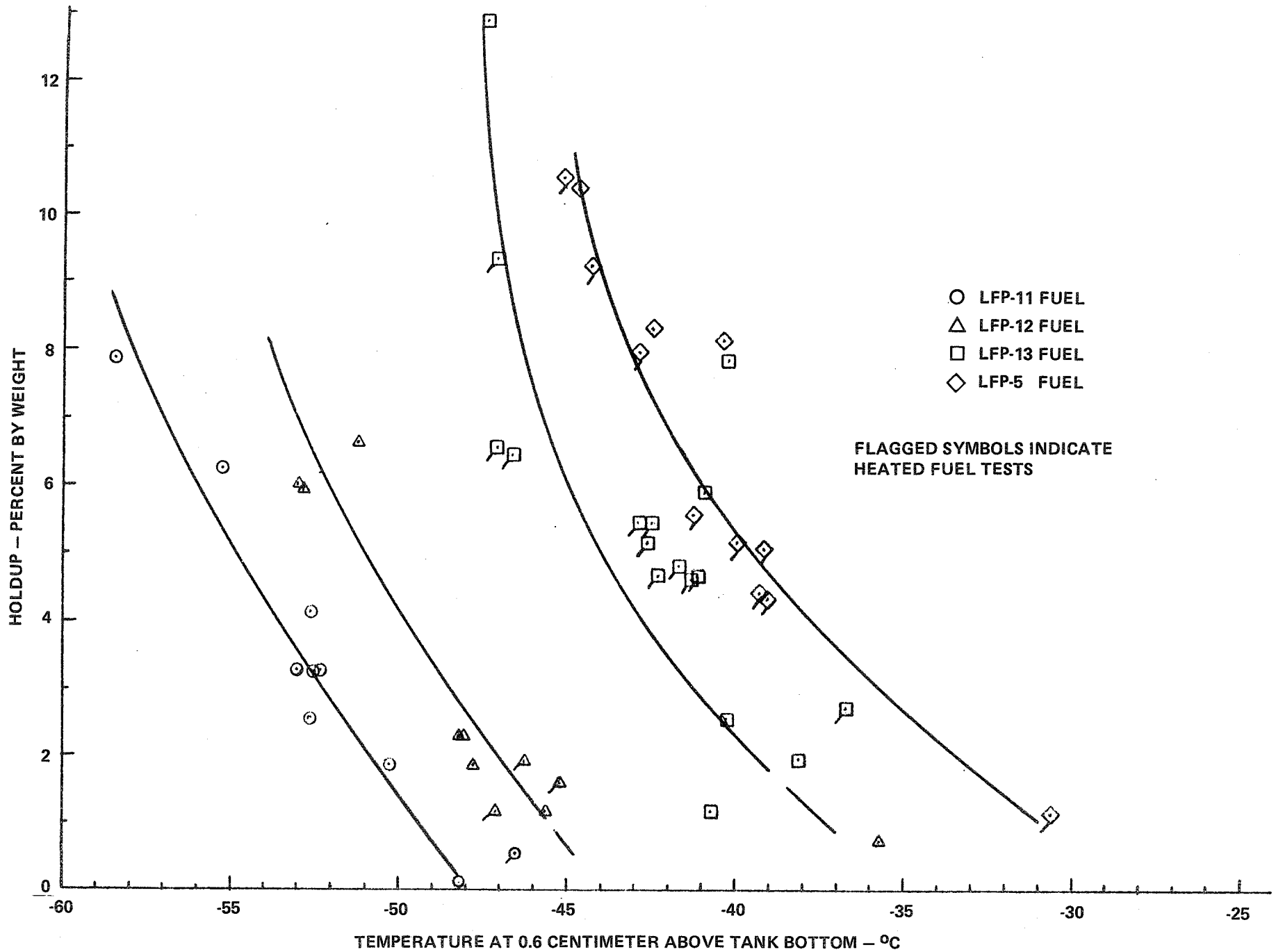

FIGURE 30 - PERCENT HOLDUP VS. TEMPERATURE AT 0.6 CENTIMETER ABOVE BOTTOM OF TANK

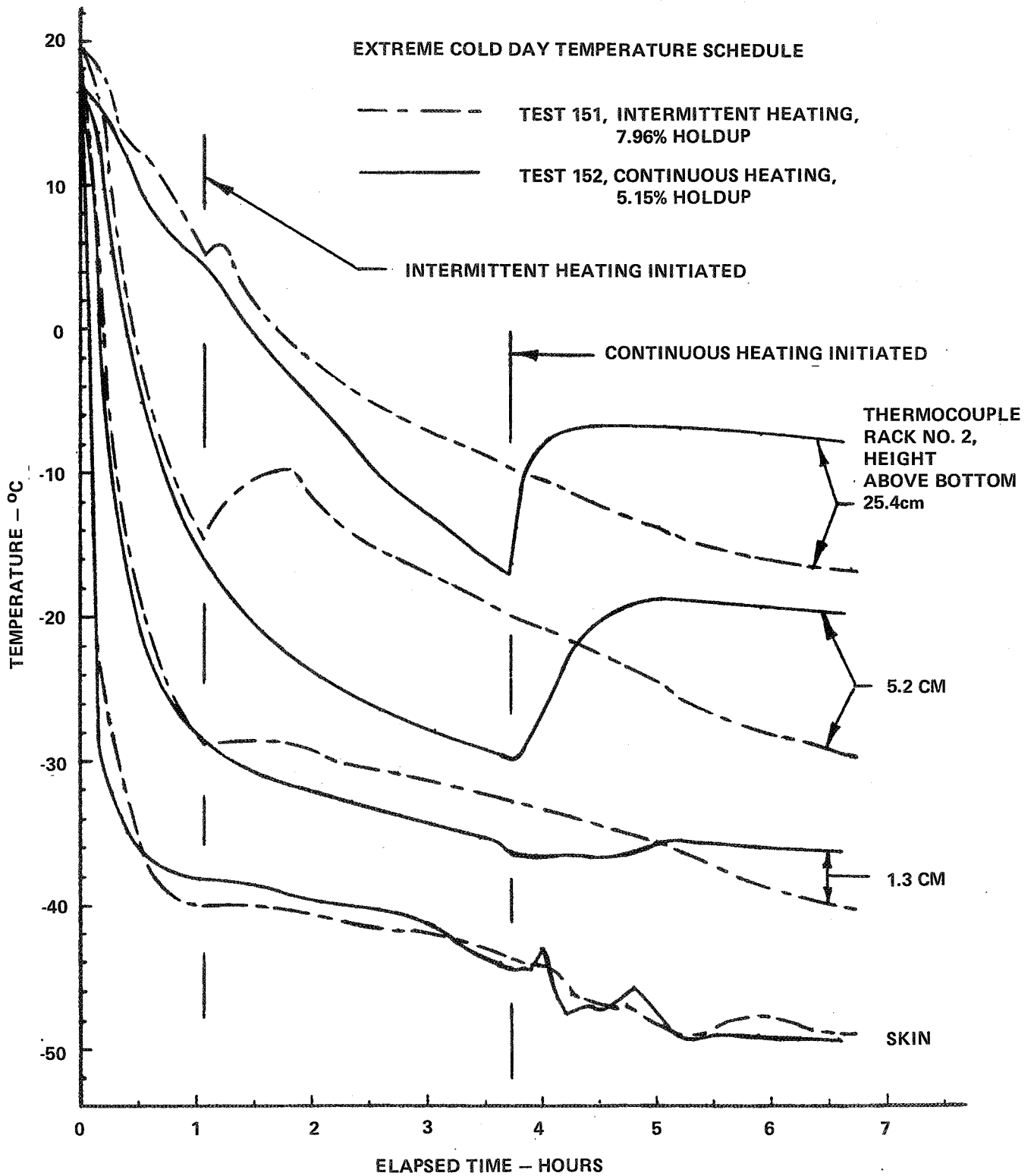

FIGURE 31 - TIME HISTORIES, HIGH-POWER HEATING, DIFFERENT PROCEDURES, TESTS 151 AND 152, LFP-5 FUEL

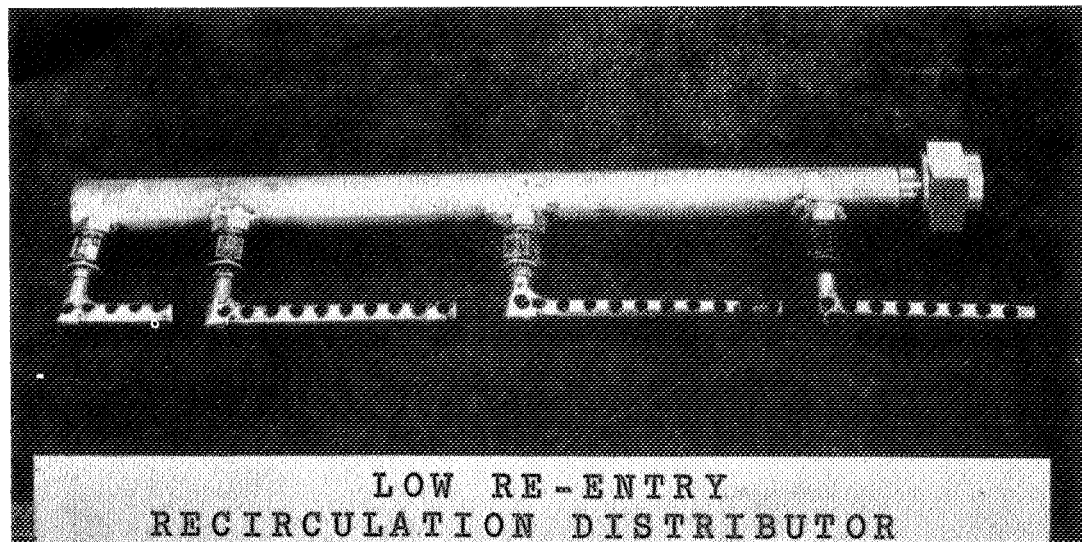
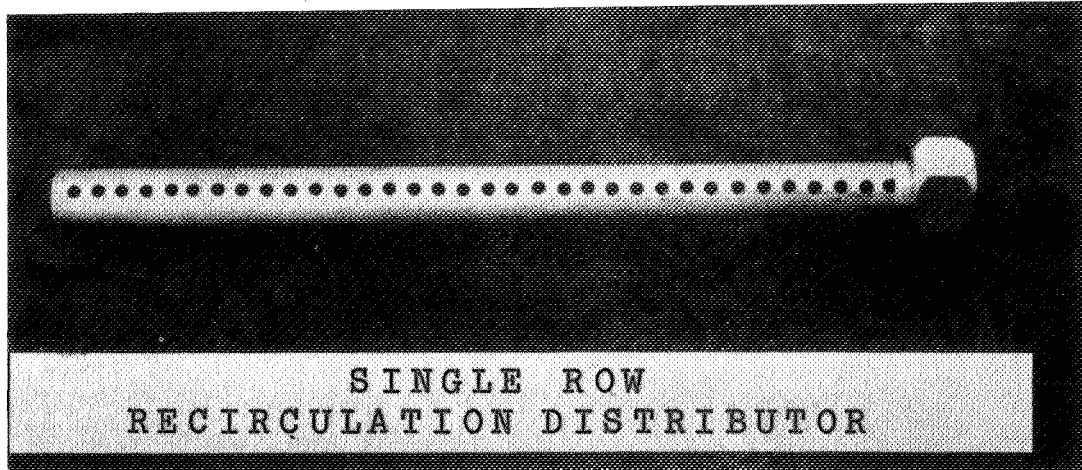
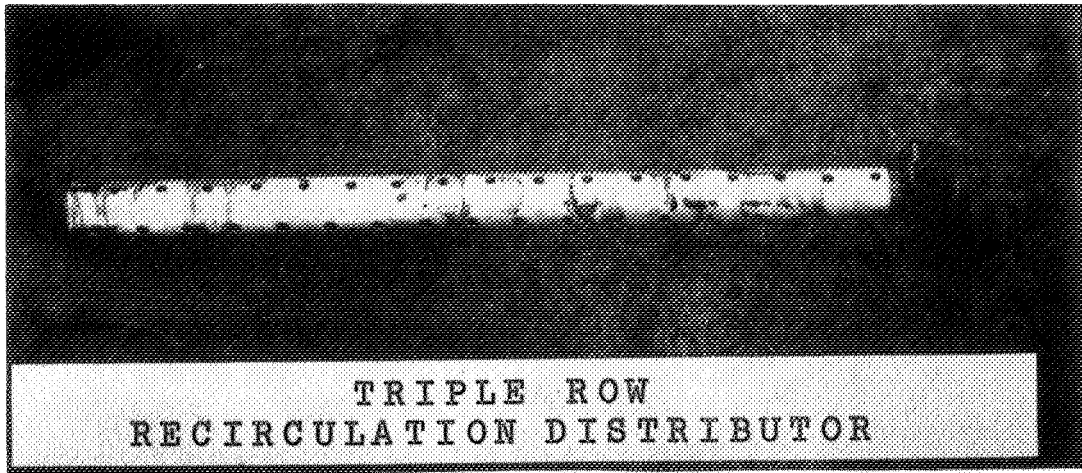

FIGURE 32 - RECIRCULATION DISTRIBUTOR MANIFOLDS

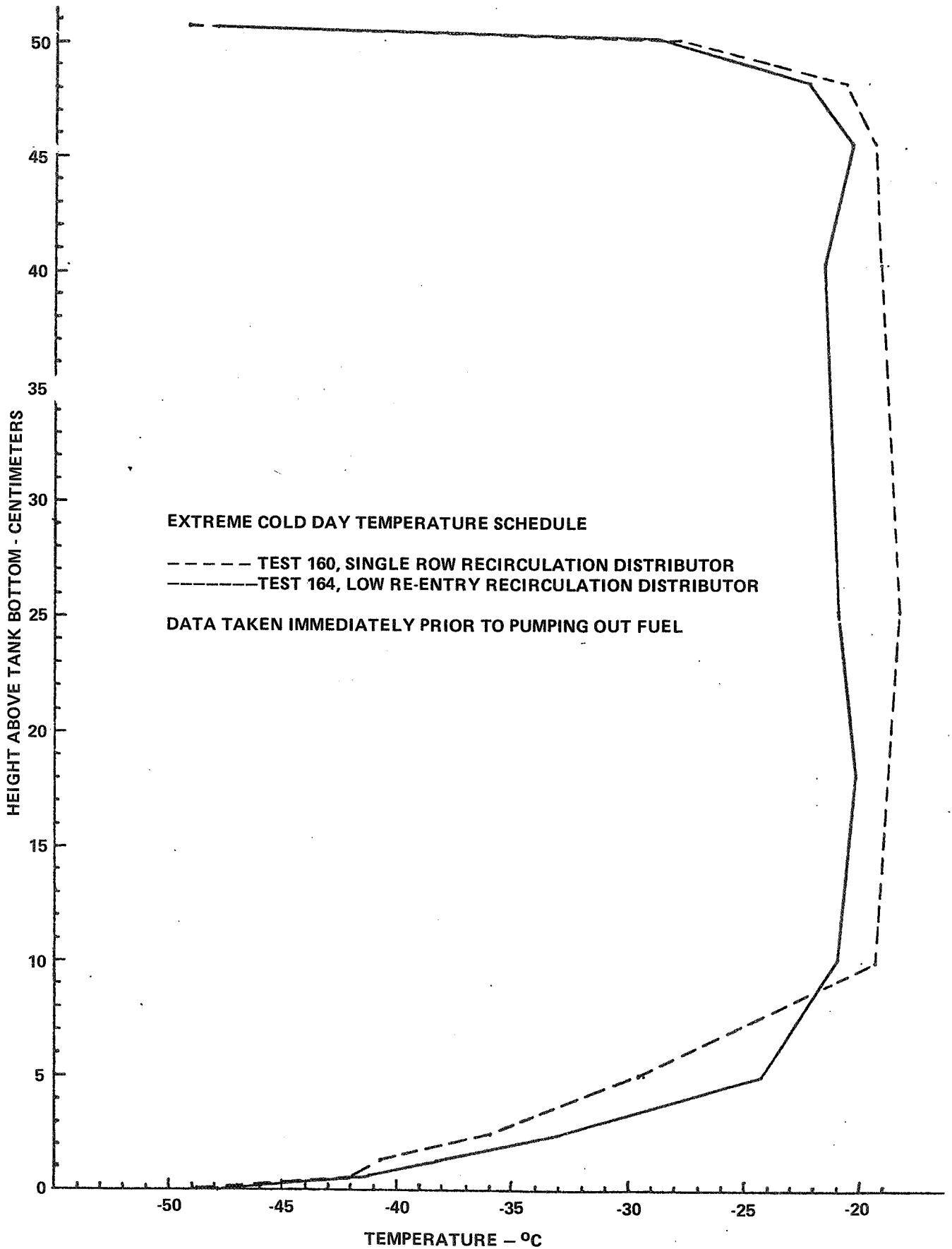

FIGURE 33 - TEMPERATURE PROFILE COMPARISON, LOW RE-ENTRY VS. SINGLE ROW DISTRIBUTOR, TESTS 160 AND 164, LFP-13 FUEL

- o Oil recirculation rate will be limited by the oil pumping capacity of the engine.
- o Imposition of some minimum allowable operating oil temperature could affect oil recirculation rate and heat exchanger design, to be compatible with the net heat available for heating fuel in the tanks.
- o Fuel heating to prevent filter blocking from water ice particles is fairly standard, and in most cases, uses engine oil as the heat source. Since this heating is required throughout the flight after the fuel temperature upstream of the filter approaches the point of ice formation, it has first priority on the available heat.
- o Fuel recirculation rate will be governed by the capacity of the engine fuel pump and fuel control system in excess of engine fuel consumption requirements. It may be feasible to incorporate excess capacity of the fuel tank boost pumps if a higher fuel recirculation rate is required.
- o Although the present tests indicate that fuel overtemperature is ordinarily not a problem if there is no control of high fuel temperature, it could be a problem with low fuel loads, as might occur in diverting to an alternate landing field.

8.0 CONCLUSIONS

Experimental tests were conducted with aviation turbine fuels subjected to low temperatures in a test tank. The test apparatus also contained a system for heating the fuel from heated MIL-L-23699 jet engine lubricating oil. The physical dimensions of the test tank represented a section of an outboard wing tank of a wide-bodied commercial airplane, and chilling was such that internal temperature profiles were comparable to those encountered in flight. Four fuels were tested: a commercial Jet A from stock used in actual service; an intermediate freeze point distillate which proved to have a higher freeze point than expected plus a wide spread between freeze point and pour point; a moderately high freeze point fuel blended along the guidelines for an Experimental Referee Broadened-Specification (ERBS) fuel; and a moderately high freeze point paraffinic distillate used in the preceding test program. Flowability of the fuels was determined by withdrawing the fuel from the test tank and measuring the gravity holdup, or unpumpable fuel remaining in the tank. Various combinations of temperature schedule, fuel recirculation distributor configuration, heat exchanger, rate of heating, recirculation rate, and heating procedure were evaluated for their effectiveness in reducing gravity holdup.

The following conclusions resulted from this investigation:

1. Recirculation of heated fuel has a large, predictable effect on the bulk fuel temperature. The actual penetration of heated fuel into the boundary layers near the tank surfaces is dependent on fuel characteristics, temperatures at which fuel heating is initiated, duration of heating, configuration of the recirculation distributor, and temperature schedule.
2. Recirculation of the heated fuel has a relatively small effect on fuel temperature in the boundary layer near the bottom surface of the tank. This is probably the result of convective flow in which the heated recirculating fuel moves upward in the tank. The colder descending fuel encounters the warm fuel, mixes, and the net result is little or no convective action in the bottom boundary layer. Test results from previous investigation of fuel behavior at low temperatures showed that at holdups of 6% or less, the solid deposits accumulated exclusively on the lower surfaces.
3. Fuel heating has a measurable influence on reducing gravity holdup. For situations which would produce holdups of 1% or 2% without fuel heating, the results of fuel heating are very small. For temperature conditions where greater holdup occurs, the influence of fuel heating becomes more pronounced. Very probably this effect is caused by the closer proximity of accumulating solids to the recirculation path of the heated fuel.
4. Methods which increase penetration of heated fuel into the boundary layer at the bottom of the tank improve fuel pumpability by reducing holdup. The "Low Re-entry" recirculation distributor, for instance, introduces the heated fuel approximately six centimeters lower in the tank than the other two distributors which were positioned above the bottom stringers, and produces a measurable improvement in holdup.

5. Reconstitution and re-use of test fuel does not have a detectable effect on test results. Some earlier concern had been expressed that solid fuel or wax particulates may act as nuclei to accelerate solid precipitation during subsequent re-use of test fuels. While this phenomenon may occur with some heavier fuel oil, a controlled group of tests indicated that aviation turbine fuel did not react in this manner.
6. Correlations of holdup based on boundary layer temperature generally apply to both heated and non-heated cases. Each test fuel has its specific correlation, which is useful in estimating holdup during a test.
7. A limited test of continuous high power fuel heating in conjunction with an extreme hot day temperature schedule did not result in any fuel overtemperature.

9.0 RECOMMENDATIONS

Based on the scale model tank tests performed in this study, which investigated the effects of fuel heating in a low temperature environment, and the conclusions presented in the previous section, the following recommendations are made for future work:

1. Continue the systematic study of recirculation fuel heating. This should include analysis and control of heat transfer to fuel, variations in recirculation rates of fuel and heat transport fluid, and experimental evaluation of recirculation distributor designs for improving penetration of heated fuel into the bottom boundary layer.
2. Conduct a series of tests with an aviation turbine type fuel having a freeze point of approximately -34°C . The series should include non-heating tests to evaluate holdup characteristics, and heating tests similar to those performed in the present investigation but incorporating the objectives of the first recommendation. Such a fuel may represent a more practical example of a future higher-freezing-point fuel than the experimental fuels tested to date.
3. Investigate the use of commercial flow improving additives to reduce holdup of aviation turbine fuels. Tests with the additive-treated fuels should include comparisons with untreated fuel tests and an evaluation of possible tradeoffs in which the use of additives could minimize heating requirements.
4. Tests should investigate whether the small amount of solid fuel holdup affects capacitance type fuel quantity gauging systems by altering the dielectric constant. It may be possible that a significant change in dielectric constant could lead to development of a holdup warning device.

APPENDIX A - CHRONOLOGICAL SUMMARY OF TESTS

Sh. 1 of 4

Test No.	Date	Data Ref. No.	Fuel				Heat Rate			Temp'ture Schedule							Recir. Dist.	Ht. Xch	Heating Method							% Holdup	Photos	Remarks																		
			LFP-11	LFP-12	LFP-13	LFP-5	300 watts	600 watts	900 watts	Cold Fuel Holdup	Extreme Cold Day	Extreme Hot Day	Extreme Cold Day + W'd'l.	Standard Day	Triple Row Manifold	Single Row Manifold			Low Re-entry Manifold	Four-pass Heat Exch'g.	Single-pass Heat Exch'g.	Heat Early in Test	Heat at Spec. Temp.	Intermittent Heating	Continuous Heating																					
101	4-14-80	10594	X						X																											1.86										
102	4-15-80	10608	X						X																												4.11	X								
103	4-16-80	10629	X						X																													6.23	X							
104	4-17-80	10647	X						X																													3.26		FRESH FUEL						
105	4-18-80	10683	X						X																													3.25		TEST FOR REPEATABILITY OF TEST 104						
106	4-22-80	10701	X						X																													3.22	X	FUEL PRE-HEATED TO 44°C ON 4-21 TO ASSURE DE-WAXING						
107	4-23-80	10718	X						X																														2.54							
108	4-24-80	10733	X						X																														7.87	X	COLOR SLIDES, BLACK AND WHITE PHOTOS					
109	4-29-80	10758	X							X					X			X				X																		0.1		NO HEATING. BASELINE FOR COMPARISON WITH HEATING TESTS.				
110	4-30-80	10778	X					X		X					X			X				X																		0		HEATED FOR 42 MINUTES. ABORTED DUE TO POWER OUTAGE.				
111	5-01-80	10788	X					X		X					X			X				X																			0		ABORTED DUE TO SEVERAL EQUIPMENT MALFUNCTIONS			
112	5-05-80	10817	X					X		X					X			X				X																			0		EXTREMELY SHORT HEAT PERIOD. A FEW PARTICLES, NOT MEASUREABLE			
113	5-06-80	10856	X					X		X					X			X				X																			0		STARTED PROCEDURE TO HEAT OIL PRIOR TO HEATING FUEL.			
114	5-07-80	10872	X						X						X			X				X																			0		SMALL INCREASE IN BULK FUEL TEMPERATURE FROM 300 WATTS			
115	5-08-80	10875	X					X		X					X			X				X																				0		REDUCED FUEL CIRCULATION RATE.		
116	5-20-80	11086	X						X						X			X				X																				0		ABORTED TO IMPROVE SKIN TEMPERATURE CONTROL.		
117	5-21-80	11087	X						X						X			X				X																				0		STARTED FUEL HEATING AT 30 MINUTES. NO OVERTEMPERATURE		
118	5-23-80	11088	X						X	X					X			X				X																					0.57		COOLED TO ACHIEVE 3% HOLDUP PRIOR TO START OF HEATING	
119	5-27-80	11100	X												X			X				X																						0		NO HEATING. BASELINE TEST FOR COMPARISON WITH HEATING.

APPENDIX A - CHRONOLOGICAL SUMMARY OF TESTS

Sh. 2 of 4

Test No.	Date	Data Ref. No.	Fuel				Heat Rate			Temp'ture Schedule							Recir. Dist.	Ht. Xch	Heating Method				% Holdup	Photos	Remarks	
			LFP-11	LFP-12	LFP-13	LFP-5	300 watts	600 watts	900 watts	Cold Fuel Holdup	Extreme Cold Day	Extreme Hot Day	Extreme Cold Day + W'd'l. Standard Day	Triple Row Manifold	Single Row Manifold	Low Re-entry Manifold			Four-pass Heat Exch'er.	Single-pass Heat Exch'er.	Heat Early in Test	Heat at Spec. Temp.				Intermittent Heating
120	5-28-80	11099	X				X										X				X		0			
121	6-6-80	11160		X					X														0			Slight evidence of solids, not measurable
122	6-9-80	11167		X					X														2.54			
123	6-10-80	11183		X					X														7.85	X		
124	6-11-80	11211		X					X														1.94			
125	6-12-80	11212		X					X														-			Inadvertent recirculation during pumpout - test invalid
126	6-17-80	11277		X					X														5.89	X		
127	6-18-80	11298		X						X													12.9			No heating. Baseline test prior to heating tests.
128	6-20-80	11341		X			X			X				X					X	X			9.34	X		Tried to maintain oil temperature above 80°C
129	6-24-80	11371		X					X														0			Thermocouple at 10.2CM. 31.7°C; below freeze point
130	6-25-80	11385		X					X														2.27			
131	6-26-80	11402		X					X														1.85			
132	6-30-80	11416		X					X														6.6			
133	7-02-80	11438		X						X													2.29			No heating. Baseline test for heating tests.
134	7-08-80	11484		X			X			X				X					X	X			1.15	X		
135	7-10-80	11521		X						X													-	X		No heating. Test invalid due to equipment malfunction.
136	7-14-80	11561		X						X													5.89			No heating. Skin temperature inadvertently went to -55°C.
137	7-16-80	11607		X				X		X				X			X		X				1.16			Control of heating somewhat erratic
138	7-17-80	11631		X			X			X				X			X		X				1.89			

APPENDIX A - CHRONOLOGICAL SUMMARY OF TESTS

Test No.	Date	Data Ref. No.	Fuel				Heat Rate			Temp'ture Schedule					Recir. Dist.			Ht. Xch.			Heating Method				Photos	Remarks		
			LFP-11	LFP-12	LFP-13	LFP-5	300 watts	600 watts	900 watts	Cold Fuel Holdup	Extreme Cold Day	Extreme Hot Day	Extreme Cold Day + W'd'l.	Standard Day	Triple Row Manifold	Single Row Manifold	Low Re-entry Manifold	Four-pass Heat Exch'er.	Single-pass Heat Exch'er.	Heat Exch'er. in Test	Heat at Spec. Temp.	Intermittent Heating	Continuous Heating	% Holdup				
139	7-18-80	11654		X				X						X				X			X					1.58		Repeat of test 137
140	7-22-80	11686			X							X														0		No heating, standard day, ERBS fuel.
141	7-23-80	11708			X			X						X				X			X					6.57		
142	7-25-80	11746			X		X		X					X				X			X					6.46	X	Similar to test 128, earlier heating
143	7-28-80	11756			X			X		X				X				X			X					0		No fuel overtemperature.
144	7-30-80	11792			X						X															1.15		No heating.
145	8-1-80	11824		X							X															0.72		No heating.
146	8-6-80	11863		X				X		X				X				X		X	X					6.0	X	Skin temperature lower than schedule.
147	8-7-80	12313		X						X																-		Checkout, new test engineer. Test not completed.
148	8-8-80	-		X						X				X												-		No heating. Experimented with new controller. No data.
149	9-15-80	12352			X				X																	8.31	X	Comparison with test 86 of previous program.
150	9-18-80	12406			X	X			X					X		X		X		X	X					9.24	X	First use of single row recirculation manifold.
151	9-23-80	12487			X			X	X					X		X		X		X	X					7.96	X	NASA Project Manager on site witness.
152	9-24-80	12502			X			X	X					X		X		X		X	X					5.15	X	NASA Project Manager on site witness.
153	10-1-80	12589			X			X	X					X		X		X		X	X					10.53	X	Almost static test. Fuel pump power supply failed.
154	10-2-80	12590			X			X	X					X		X		X		X	X					4.32	X	Heating commenced at 0.5 hours elapsed time.
155	10-3-80	12658			X			X	X					X		X		X		X	X					4.40	X	Replaces test 153.
156	10-7-80	12726			X				X																	8.12	X	Intermediate holdup, returned fuel to tank.
156	10-7-80	12726			X				X																	10.41	X	Final holdup.

APPENDIX A - CHRONOLOGICAL SUMMARY OF TESTS

Test No.	Date	Data Ref. No.	Fuel				Heat Rate			Temp'ture Schedule							Recir. Dist.		Ht. Xch		Heating Method				% Holdup	Photos	Remarks
			LFP-11	LFP-12	LFP-13	LFP-5	300 watts	600 watts	900 watts	Cold Fuel Holdup	Extreme Cold Day	Extreme Hot Day	Extreme Cold Day + W'd'l.	Standard Day	Triple Row Manifold	Single Row Manifold	Low Re-entry Manifold	Four-pass Heat Exch'er.	Single-pass Heat Exch'er.	Heat Early In Test	Heat at Spec. Temp.	Intermittent Heating	Continuous Heating				
157	10-8-80	12789				X			X							X			X		X		X	1.12	X		Slightly warmer than scheduled.
158	10-10-80	12788		X			X					X				X			X		X		2.70	-		Warmer than scheduled; cooling system malfunction.	
159	10-14-80	12811			X				X						X				X		X		4.80	X			
160	10-15-80	12840			X		X								X				X		X		5.44	X			
161	10-16-80	12866			X			X							X				X		X		5.46	X		Intermediate power fuel heating.	
162	10-17-80	12882	X				X								X				X		X		0.53	X			
163	10-23-80	13019	X				X								X				X		X		0.48	X		Low re-entry manifold installed.	
164	10-24-80	13021			X		X								X				X		X		4.61	X			
165	10-27-80	13048			X				X						X				X		X		4.65	X			
166	10-29-80	13138				X			X						X				X		X		5.08	X			
167	10-30-80	13162				X	X								X				X		X		5.57	X			
168	11-6-80	13521				X			X						X				X		X		-	-		Aborted - temperature controller malfunction	
169	2-4-81	14432			X		X								X				X		X		5.14	X			
170	2-5-81	14433			X		X								X				X		X		-	-		Aborted - inadvertent withdrawal of fuel	
171	2-6-81	14434			X		X								X				X		X		4.67	X			

REFERENCES

1. Robertson, A. G. and Williams, R. E., "Jet Fuel Specifications: The Need for Change", Shell Aviation News, No. 435, 1976.
2. "Jet Aircraft Hydrocarbon Fuels Technology", NASA Conference Publication 2033, June 7-9, 1977.
3. Dukek, W. G., and Longwell, J. P., "Alternate Hydrocarbon Fuels for Aviation", Exxon Air World, Vol. 29, No. 4, 1977, Pg. 96.
4. Shayeson, M. W., "Jet Fuel Quality Considerations", Shell Aviation News, No. 440, 1977, Pages 26-31.
5. Longwell, J. P. and Grobman, J., "Alternative Aircraft Fuels", Journal of Engineering for Power, Volume 101, 1979, Pages 155-161.
6. Friedman, R., "High-Freezing-Point Fuels Used for Aviation Turbine Engines", ASME Publication 79-GT-141, presented March 1979.
7. "Petroleum Products and Lubricants." Parts 23, 24, and 25, Annual Book of ASTM Standards. American Society for Testing and Materials. Philadelphia, 1980.
8. Smith, Maxwell, "Aviation Fuels", G. T. Foulis and Co. Ltd. (Publishers) 1970.
9. Ford, P. T., "Jet Fuels-Low Temperature Flow Characteristics and Test Methods", Shell Research Ltd., Thornton Research Centre (England), March 1977.
10. Ford, P. T, and Robertson, A. G., "Jet Fuels-Redefining the Low Temperature Requirements", Shell Aviation News, No. 441, 1977.
11. Stockemer, F. J., "Experimental Study of Low Temperature Behavior of Aviation Turbine Fuels in a Wing Tank Model", NASA CR-159615, August 1979.
12. Friedman, R., and Stockemer, F. J., "Temperature and Flow Measurements on Near-Freezing Aviation Fuels in a Wing-Tank Model", ASME Publication 80GT-63, presented March 1980.
13. Pasion, A. J., "Design and Evaluation of Aircraft Heat Source Systems For Use With High-Freezing Point Fuels", NASA CR-159568, May 1979.
14. Pasion, A. J., and Thomas, I., "Preliminary Analysis of Aircraft Fuel Systems For Use With Broadened Specification Jet Fuels", NASA CR-135198, May 1976.
15. "U.S. Standard Atmosphere, 1976", National Oceanic and Atmospheric Administration, Report NOAA-S/T76-1562, 1976.
16. Longwell, J. P., ed: Jet Aircraft Hydrocarbon Fuels Technology. NASA CP-2033, 1977.

17. Prok, G. M., and Seng, G. T., Initial Characterization of an Experimental Referee Broadened-Specification (ERBS) Aviation Turbine Fuel. NASA TM 81440, Jan., 1980.
18. Pasion, A. J., In-Flight Fuel Tank Temperature Survey Data, NASA CR-159569, May 1979.

1. Report No. NASA CR-165391		2. Government Accession No.		3. Recipient's Catalog No.	
4. Title and Subtitle EXPERIMENTAL STUDY OF FUEL HEATING AT LOW TEMPERATURES IN A WING TANK MODEL				5. Report Date August 1981	
				6. Performing Organization Code	
7. Author(s) Francis J. Stockemer				8. Performing Organization Report No. LR 29935	
9. Performing Organization Name and Address Lockheed-California Company P.O. Box 551 Burbank, CA 91520				10. Work Unit No.	
				11. Contract or Grant No. NAS3-21977	
12. Sponsoring Agency Name and Address National Aeronautics and Space Administration Washington, D.C. 20546				13. Type of Report and Period Covered Contractor Report	
				14. Sponsoring Agency Code 505-32-72	
15. Supplementary Notes Final report. Project Manager, Robert Friedman, Aerothermodynamics and Fuels Division, NASA Lewis Research Center, Cleveland, Ohio 44135					
16. Abstract An experimental investigation was performed to study scale-model fuel heating systems for use with aviation hydrocarbon fuel at low temperatures. The principal objective was to evaluate the effectiveness of the heating systems in providing flowability and pumpability at extreme low temperatures when some freezing of the fuel would otherwise occur. The test tank simulated a section of an outer wing tank, and was chilled on the upper and lower surfaces. MIL-L-23699 turbine engine lubricating oil was heated, and transferred the heat to recirculating fuel. Fuels included: a commercial Jet A; an intermediate freeze point distillate; a higher freeze point distillate blended according to Experimental Referee Broadened-Specification (ERBS) guidelines; a higher freeze point paraffinic distillate used in a preceding investigation. Each fuel was chilled to selected temperatures to evaluate umpumpable solid formation (holdup). Tests simulating extreme cold weather flight, without heating, provided baseline fuel holdup data. Heating and recirculating fuel increased bulk temperature significantly; it had a relatively small effect on temperature near the bottom of the tank. Methods which increased penetration of heated fuel into the lower boundary layer improved the capability for reducing holdup. Re-use of fuel reconstituted by melting and blending the frozen holdup did not affect test results. Continuous heating in conjunction with a simulated extreme hot day flight did not result in excessive fuel temperature. Correlation of holdup based on a specific boundary layer temperature was applicable for heated and non-heated fuel.					
17. Key Words (Suggested by Author(s)) Aircraft fuels Jet fuels Fuel temperature Aircraft fuel systems				18. Distribution Statement Unclassified-unlimited STAR Category 28	
19. Security Classif. (of this report) Unclassified		20. Security Classif. (of this page) Unclassified		21. No. of Pages 68	22. Price*

* For sale by the National Technical Information Service, Springfield, Virginia 22161