

(NASA-TM-80097) PRESSURE DISTRIBUTIONS ON N82-13110
THREE DIFFERENT CRUCIFORM AFT-TAIL CONTROL
SURFACES OF A WINGLESS MISSILE AT MACH 1.60,
2.36, AND 3.70. VOLUME 1: TRAPEZOIDAL TAIL
(NASA) 345 p HC A15/MF A01 CACL 01A G3/02 03782 Unclas

NASA Technical Memorandum 80097

**Pressure Distributions on Three
Different Cruciform Aft-Tail Control
Surfaces of a Wingless Missile at
Mach 1.60, 2.36, and 3.70**

Volume I - Trapezoidal Tail

**Milton Lamb, Wallace C. Sawyer,
Donald L. Wassum, and C. Donald Babb**
*Langley Research Center
Hampton, Virginia*

NASA

National Aeronautics
and Space Administration

**Scientific and Technical
Information Branch**

1979

SUMMARY

The results of pressure distribution tests conducted in the Langley Unitary Plan wind tunnel are presented without analysis. The data were obtained for three sets of cruciform aft-tail control surfaces on a wingless missile model at Mach numbers of 1.60, 2.36, and 3.70 for angles of attack from -4° to 20° , model roll angles from 0° to 90° , and tail deflections of 0° and -15° . The test Reynolds number used was 6.6×10^6 per meter.

Volume I presents the pressure distributions for a trapezoidal tail; volume II, for a clipped delta tail; and volume III, for a cranked tail.

INTRODUCTION

Theoretical aerodynamicists are continually seeking consistent and accurate experimental data as an aid in the development and evaluation of computational methods. This study was made to provide a complete set of pressure distribution data on three sets of cruciform aft-tail control surfaces for a wingless missile model.

The investigation was conducted in the Langley Unitary Plan wind tunnel at Mach numbers of 1.60, 2.36, and 3.70 at a Reynolds number per meter of 6.6×10^6 . The angle of attack was varied from -4° to 20° , model roll angle was varied from 0° to 90° in 22.5° increments, and tail deflections were 0° to -15° . The model consisted of a body of revolution with interchangeable aft-tail control surfaces. Three sets of model tails with identical root chords and span lengths were used. The pressures were measured on two adjacent tail surfaces (tails 1 and 2) using 91 pressure orifices per tail surface. The results are presented in plotted and tabular form.

SYMBOLS

b	exposed tail span, cm
C_p	pressure coefficient, $\frac{p_l - p_\infty}{q_\infty}$ (C_p on tables and plots)
c	local chord, cm
M	free-stream Mach number
p_l	local pressure, Pa
p_∞	free-stream static pressure, Pa

q_{∞}	free-stream dynamic pressure, Pa
x	longitudinal distance measured from local chord leading edge, cm
x/c	fraction of local tail chord (see fig. 1)
y	lateral distance measured from root chord, cm
y/b	fraction of exposed tail span (see fig. 1)
α	angle of attack, deg
δ	pitch control deflection (negative with leading edge down; without subscripts, refers to all tails; with subscripts, only to those tails indicated), deg
ϕ	model roll angle, positive clockwise when viewed from rear ($\phi = 0^{\circ}$ when tail no. 1 is in lower vertical position, see fig. 1), deg

Abbreviations:

L.S.	lower surface (see fig. 1)
U.S.	upper surface (see fig. 1)

APPARATUS AND TESTS

Tunnel

The tests were conducted in both the low and high Mach number test sections of the Langley Unitary Plan wind tunnel which is a variable-pressure, continuous-flow facility. The asymmetric sliding-block nozzles lead to the test sections and permit a continuous variation in Mach number from about 1.5 to 2.9 in the low Mach number test section and from about 2.3 to 4.7 in the high Mach number test section.

Model

The configuration consisted of a simple wingless aft-tail cruciform control missile model with three sets of interchangeable tail surfaces. The pressure tubes were integrally cast into the tail surfaces to permit a greater number of more closely spaced pressure orifices (91 per tail surface). Details of the model and pressure orifice locations are given in figures 1 and 2. The upper- and lower-surface orifices were serviced by the same pressure tube, and thus required the taping of one surface while the other surface was being

tested. The missile model was sting mounted from the rear on the main support system of the tunnel.

Test Conditions

Tests were conducted at the following test conditions:

Mach number	Stagnation temperature, K	Stagnation pressure, kPa	Reynolds number, m^{-1}
1.60	339	54.6	6.6×10^6
2.36	339	75.7	6.6
3.70	339	152.7	6.6

The dew-point temperature measured at stagnation pressures was maintained below 239 K to assure negligible condensation effects. In order to assure a turbulent boundary layer, all tests were conducted with a boundary-layer transition strip on the body 3.05 cm aft of the nose. At a Mach number of 1.60, the transition strip consisted of a 0.16-cm-wide strip of sprinkled No. 60 sand. For the other two Mach numbers, the strip was composed of single-spaced No. 40 sand.

Measurements

The angles of attack have been corrected for tunnel-flow misalignment. Pressures were measured by six scanning valves. All pressure coefficients were referenced to free-stream conditions. The accuracy of the scanning-valve system is within 1 percent of the gage range. When expressed as pressure coefficients C_p , 1 percent of the gage range is 0.030 at Mach 1.60, 0.016 at Mach 2.36, and 0.024 at Mach 3.70.

PRESENTATION OF RESULTS

Due to the large volume of data and for the convenience of the reader, the data are presented as three volumes as follows:

- Volume I Trapezoidal tail (planform A)
- Volume II Clipped delta tail (planform B)
- Volume III Cranked tail (planform C)

The pressure coefficients are given in tables I to XXIV, and, to aid the reader, an index of tables follows:

Table	M	ϕ , deg	$\delta_{1,3}$, deg	$\delta_{2,4}$, deg
I	1.60	0	0	0
II	↓	22.5	↓	↓
III		45		
IV		67.5		
V		90		
VI		0		
VII	2.36	22.5		
VIII	↓	45		
IX		67.5		
X		90		
XI		0		
XII		22.5		
XIII	↓	45		
XIV		67.5		
XV		90		
XVI		1.60	0	-15
XVII		2.36	↓	↓
XVIII	3.70	↓		
XIX	1.60	45	-15	
XX	2.36	↓		
XXI	3.70	↓		
XXII	1.60	90	0	
XXIII	↓	2.36	↓	
XXIV		3.70		

Only a limited amount of machine-plotted data are presented to show trends, but all data are presented in tabular form. The plotted data are presented in the following figures:

	Figure
Pressure coefficients, $\phi = 0^\circ$, $\delta = 0^\circ$ -	
M = 1.60	3
M = 2.36	4
M = 3.70	5
Pressure coefficients, $\phi = 22.5^\circ$, $\delta = 0^\circ$ -	
M = 1.60	6
M = 2.36	7
M = 3.70	8

	Figure
Pressure coefficients, $\phi = 45^\circ, \delta = 0^\circ -$	
M = 1.60	9
M = 2.36	10
M = 3.70	11
Pressure coefficients, $\phi = 67.5^\circ, \delta = 0^\circ -$	
M = 1.60	12
M = 2.36	13
M = 3.70	14
Pressure coefficients, $\phi = 90^\circ, \delta = 0^\circ -$	
M = 1.60	15
M = 2.36	16
M = 3.70	17
Pressure coefficients, $\phi = 0^\circ, \delta_{2,4} = -15^\circ -$	
M = 1.60	18
M = 2.36	19
M = 3.70	20
Pressure coefficients, $\phi = 45^\circ, \delta = -15^\circ -$	
M = 1.60	21
M = 2.36	22
M = 3.70	23
Pressure coefficients, $\phi = 90^\circ, \delta_{1,3} = -15^\circ -$	
M = 1.60	24
M = 2.36	25
M = 3.70	26

Langley Research Center
National Aeronautics and Space Administration
Hampton, VA 23665
May 25, 1979

TABLE I. - PRESSURE COEFFICIENTS, $\theta = 0^\circ$, $\delta = 0^\circ$, $M = 1.60$
 (a) $\alpha = -3.49^\circ$

Cp at y/b of														
x/c	0.02		0.22		0.44		0.56		0.67		0.83		0.98	
	U.S.	L.S.	U.S.	L.S.	U.S.	L.S.	U.S.	L.S.	U.S.	L.S.	U.S.	L.S.	U.S.	L.S.
.05	.2497	.2756	.5552	.6159					.5860	.6919	.5601	.6808		
.10	.2348	.2641	.4791	.5278	.5596	.6039	.5709	.6187	.5853	.6360	.5641	.6405	.3576	.4166
.15	.2205	.2504	.4210	.4613	.5149	.5532	.5467	.5819	.5594	.6069	.5443	.5943	.3318	.3751
.20	.1626	.1857	.3627	.4020	.4765	.5104			.5228	.6058	.5175	.5508	.3160	.3418
.25			-.0351	-.0438	.3600	.3722	.4329	.4721	.4713	.5080	.4751	.5009	.2905	.3024
.30	.0423	-.0224	-.0798	-.0759	-.0027	-.0196	.0190	-.0029	.1534	.1089	.4096	.4310	.2850	.2691
.40									-.0201	-.0270	-.0463	-.0503	-.0947	-.0991
.50	.0759	.0522			-.0499	-.0449			-.0364	-.0403	-.0453	-.0470	-.0643	-.0711
.60	.0313	.0251	-.0390	-.0412	-.0604	-.0605	-.0447	-.0486	-.0515	-.0567	-.0837	-.0925	-.0447	-.0732
.70	.0237	.0260	.0628	.0505	-.0759	-.0834	-.0760	-.0801	-.1346	-.1336			-.1955	-.2132
.80	-.2198	-.2241	-.2222	-.2323	-.2673	-.2869	-.2627	-.2991	-.2732	-.3029	-.2724	-.2813	-.1453	-.1475
.90	-.2277	-.2222	-.2523	-.2657	-.2426	-.2604	-.2407	-.2639	-.2504	-.2720	-.2604	-.2713	-.1833	-.1862
.95	-.2276	-.2160	-.2552	-.2688	-.2337	-.2527	-.2397	-.2629	-.2478	-.2639	-.2563	-.2665	-.1754	-.1969

TAIL 1

Cp at y/b of														
x/c	0.02		0.22		0.44		0.56		0.67		0.83		0.98	
	U.S.	L.S.	U.S.	L.S.	U.S.	L.S.	U.S.	L.S.	U.S.	L.S.	U.S.	L.S.	U.S.	L.S.
.05	.4178	.1146	.7988	.2954					.9214	.3413	.9255	.3445		
.10	.4475	.1614	.7019	.2740					.8149	.3337	.8183	.3307	.5350	.2404
.15	.4418	.1568							.7273	.3034	.7427	.3154	.7268	.3196
.20									.6645	.2935	.6805	.2993	.6604	.3047
.25	.1518	-.0206	.0656	-.1109					.6004	.2711	.5920	.2775	.3652	.1965
.30			.0528	-.1352	.0504	-.1124	.0631	-.0806	.2553	.0628				
.40	.2879	-.0312			.0593	-.1274	.0586	-.1134	.0471	-.1045	.0161	-.1154		
.50	.3205	-.0223					.0591	-.1256	.0410	-.1198			-.0694	-.0880
.60					.1252	-.1324	.0802	-.1335	.0345	-.1336	-.0176	-.1540	-.0672	-.0645
.70			.2516	-.0884	.1317	-.1410	.0636	-.1572	-.1484	-.1972	-.2606	-.3258	-.2026	-.2330
.80	-.0910	-.2457	-.1403	-.2950	-.1017	-.2574			-.2270	-.2699	-.2502	-.2868		
.90	-.1533	-.2206			-.1182	-.2596			-.2126	-.2713	-.2192	-.2770		
.95	-.1713	-.1922							-.2077		-.2189	-.2811	-.1739	-.2833

TAIL 2

ORIGINAL PAGE IS
OF POOR QUALITY

TABLE I.- CONTINUED
(b) $\alpha = -1.50^\circ$

Cp at y/b of														
x/c	0.02		0.22		0.44		0.56		0.67		0.83		0.98	
	U.S.	L.S.	U.S.	L.S.	U.S.	L.S.	U.S.	L.S.	U.S.	L.S.	U.S.	L.S.	U.S.	L.S.
.05	.2159	.2314	.5281	.5912					.5538	.6906	.5295	.6808		
.10	.2211	.2388	.4566	.5067	.5489	.5972	.5587	.6250	.5688	.6387	.5605	.6404	.3548	.4134
.15	.2190	.2365	.4112	.4540	.5133	.5600	.5428	.5890	.5635	.6097	.5512	.5930	.3337	.3709
.20	.1538	.1705	.3690	.4057	.4796	.5197			.5361	.6070	.5233	.5480	.3194	.3389
.25			-.0237	-.0372	.3661	.3814	.4400	.4786	.4856	.5145	.4781	.4952	.2909	.2989
.30	.0960	.0708	-.0631	-.0653	.0011	-.0144	.0261	-.0018	.1639	.1105	.4124	.4275	.2812	.2639
.40									-.0357	-.0425	-.0354	-.0388	-.0752	-.0818
.50	.0873	.0923			-.0425	-.0426			-.0562	-.0591	-.0936	-.0982	-.0618	-.0845
.60	.0452	.0496	-.0294	-.0333	-.0526	-.0513	-.0467	-.0507	-.1404	-.1358			-.2060	-.2291
.70	.0585	.0604	.0977	.0775	-.0624	-.0655	-.0777	-.0805	-.2695	-.2939	-.2704	-.2838	-.1694	-.1631
.80	-.2003	-.2019	-.2098	-.2215	-.2655	-.2817	-.2752	-.2950	-.2695	-.2939	-.2704	-.2838	-.2056	-.2041
.90	-.2018	-.1956	-.2287	-.2459	-.2382	-.2487	-.2451	-.2629	-.2512	-.2678	-.2643	-.2765	-.1974	-.2139
.95	-.1893	-.1747	-.2354	-.2478	-.2183	-.2275	-.2397	-.2532	-.2488	-.2610	-.2629	-.2744		

TAIL 1

Cp at y/b of														
x/c	0.02		0.22		0.44		0.56		0.67		0.83		0.98	
	U.S.	L.S.	U.S.	L.S.	U.S.	L.S.	U.S.	L.S.	U.S.	L.S.	U.S.	L.S.	U.S.	L.S.
.05	.3210	.1898	.6695	.4360					.7754	.4756	.7834	.4830		
.10	.3337	.2112	.5832	.3882					.7021	.4502	.7149	.4567	.4513	.3004
.15	.3282	.2011							.6390	.4235	.6550	.4365	.6461	.4360
.20									.5964	.4064	.6119	.4158	.5932	.4064
.25	.1043	.0022	.0245	-.0708					.5482	.3825	.5375	.3722	.3224	.2385
.30			.0026	-.0988	.0243	-.0620	.0427	-.0268	.2324	.1367				
.40	.1954	.0188			.0168	-.0764	.0236	-.0626	.0172	-.0535	-.0060	-.0731	-.0555	-.0634
.50	.2336	.0246					.0133	-.0747	.0025	-.0753			-.0600	-.0516
.60					.0456	-.0905	.0093	-.0871	-.0094	-.0930	-.0510	-.1203	-.1889	-.2125
.70			.2299	-.0427	.0345	-.1019	-.0152	-.1186	-.1832	-.1619	-.2814	-.3213		
.80	-.1181	-.2233	-.1567	-.2477	-.1664	-.2434			-.2609	-.2569	-.2490	-.2782		
.90	-.1751	-.2182			-.1584	-.2397			-.2206	-.2584	-.2328	-.2672	-.1937	-.2571
.95	-.1837	-.1928							-.2155		-.2361	-.2712		

TAIL 2

TABLE I. - CONTINUED
(c) $\alpha = 0.50^\circ$

Cp at γ/b of														
x/c	0.02		0.22		0.44		0.56		0.67		0.83		0.98	
	U.S.	L.S.	U.S.	L.S.	U.S.	L.S.	U.S.	L.S.	U.S.	L.S.	U.S.	L.S.	U.S.	L.S.
.05	.2491	.2630	.5309	.5939					.5324	.6932	.4995	.6605		
.10	.2595	.2730	.4733	.5211	.5310	.5986	.5443	.6240	.5437	.6417	.5290	.6326	.3320	.4080
.15	.2638	.2790	.4299	.4741	.5133	.5691	.5415	.5980	.5489	.6176	.5390	.5910	.3242	.3727
.20	.2112	.2262	.3883	.4294	.4931	.5334			.5336	.6161	.5243	.5465	.3228	.3459
.25			-.0103	-.0238	.3815	.3947	.4501	.4930	.4968	.5232	.4823	.4951	.3027	.3078
.30	.1266	.0696	-.0459	-.0490	.0104	-.0059	.0343	.0058	.1750	.1167	.4186	.4294	.2936	.2720
.40									-.0087	-.0277	-.0405	-.0517	-.0890	-.0992
.50	.1254	.1247			-.0322	-.0385			-.0316	-.0440	-.0304	-.0326	-.0588	-.0696
.60	.0872	.0927	-.0244	-.0265	-.0388	-.0442	-.0428	-.0495	-.0546	-.0606	-.0901	-.0976	-.0310	-.0692
.70	.1022	.1091	.1558	.1310	-.0476	-.0524	-.0769	-.0799	-.1406	-.1369			-.1996	-.2143
.80	-.1733	-.1751	-.1810	-.1901	-.2448	-.2635	-.2405	-.2679	-.2383	-.2673	-.2529	-.2730	-.1826	-.1648
.90	-.1842	-.1797	-.2052	-.2227	-.2290	-.2366	-.2344	-.2473	-.2393	-.2567	-.2530	-.2699	-.2276	-.2171
.95	-.1728	-.1605	-.2075	-.2265	-.2139	-.2147	-.2318	-.2310	-.2366	-.2523	-.2532	-.2681	-.2123	-.2242

TAIL 1

Cp at γ/b of														
x/c	0.02		0.22		0.44		0.56		0.67		0.83		0.98	
	U.S.	L.S.	U.S.	L.S.	U.S.	L.S.	U.S.	L.S.	U.S.	L.S.	U.S.	L.S.	U.S.	L.S.
.05	.2404	.2611	.5325	.5801					.5844	.6499	.5838	.6563		
.10	.2560	.2740	.4694	.5016					.5600	.6072	.5707	.6100	.3522	.3932
.15	.2487	.2623					.5255	.5468	.5417	.5674	.5419	.5623		
.20							.5032	.5129	.5240	.5294	.5139	.5122	.3090	.3122
.25	.0637	.0277	-.0217	-.0297					.4844	.4730	.4730	.4627	.2797	.2876
.30			-.0465	-.0590	-.0107	-.0207	.0142	.0147	.2014	.1865				
.40	.1159	.0895			-.0242	-.0334	-.0110	-.0214	-.0084	-.0193	-.0290	-.0397		
.50	.1408	.0855					-.0233	-.0353	-.0292	-.0404			-.0496	-.0514
.60					-.0242	-.0477	-.0307	-.0501	-.0446	-.0600	-.0778	-.0935	-.0504	-.0619
.70			.1654	.0658	-.0301	-.0573	-.0582	-.0841	-.2104	-.1316	-.2976	-.3042	-.1750	-.2126
.80	-.1487	-.1990	-.1696	-.2109	-.2381	-.2414			-.2749	-.2359	-.2693	-.2591		
.90	-.1917	-.1952			-.2175	-.2305			-.2441	-.2403	-.2513	-.2492		
.95	-.1860	-.1719							-.2401		-.2524	-.2538	-.2237	-.2204

TAIL 2

TABLE I. - CONTINUED
(d) $\alpha = 2.50^\circ$

Cp at y/b of														
x/c	0.02		0.22		0.44		0.56		0.67		0.83		0.98	
	U.S.	L.S.	U.S.	L.S.	U.S.	L.S.	U.S.	L.S.	U.S.	L.S.	U.S.	L.S.	U.S.	L.S.
.05	.2821	.2993	.5223	.5872					.5280	.6726	.4937	.6488	.3253	.4002
.10	.2925	.3090	.4792	.5261	.5267	.5967	.5339	.6246	.5350	.6402	.5128	.6264	.3192	.3717
.15	.2987	.3267	.4390	.4812	.5159	.5718	.5386	.6011	.5428	.6224	.5214	.5859	.3228	.3510
.20	.2699	.2899	.3998	.4409	.4983	.5414			.5357	.6240	.5161	.5407	.3083	.3171
.25			-.0027	-.0167	.3885	.4043	.4573	.4982	.5012	.5286	.4784	.4908	.3041	.2894
.30	-.1379	.0615	-.0367	-.0388	.0150	-.0009	.0403	.0123	.1802	.1275	.4179	.4283	-.0755	-.0890
.40									-.0069	-.0270	-.0376	-.0500	-.0421	-.0553
.50	.1709	.1635			-.0286	-.0337			-.0319	-.0465	-.0307	-.0324	-.0110	-.0506
.60	.1438	.1494	-.0239	-.0255	-.0200	-.0345	-.0401	-.0466	-.0562	-.0635	-.0877	-.0972	-.1870	-.2050
.70	.1531	.1577	.2280	.1866	-.0279	-.0354	-.0754	-.0794	-.1428	-.1369			-.1962	-.1677
.80	-.1474	-.1524	-.1569	-.1703	-.2304	-.2376	-.2149	-.2392	-.2154	-.2443	-.2341	-.2526	-.2412	-.2325
.90	-.1694	-.1673	-.1889	-.2080	-.2044	-.2299	-.2168	-.2395	-.2283	-.2513	-.2388	-.2545	-.2274	-.2362
.95	-.1569	-.1463	-.1744	-.2100	-.1779	-.1893	-.2144	-.2118	-.2260	-.2374	-.2396	-.2545		

TAIL 1

Cp at y/b of														
x/c	0.02		0.22		0.44		0.56		0.67		0.83		0.98	
	U.S.	L.S.	U.S.	L.S.	U.S.	L.S.	U.S.	L.S.	U.S.	L.S.	U.S.	L.S.	U.S.	L.S.
.05	.1721	.3418	.3961	.7132					.4080	.8213	.4073	.8229	.2794	.4872
.10	.1962	.3602	.3569	.6154					.4099	.7345	.4177	.7309		
.15	.1950	.3482					.3925	.6531	.4049	.6712	.4061	.6565	.2476	.3711
.20							.3924	.6012	.3980	.6113	.3949	.5944	.2228	.3311
.25	.0446	.0587	-.0660	.0136					.3816	.5368	.3788	.5300		
.30			-.0888	-.0143	-.0567	.0	-.0300	.0428	.1377	.2181				
.40	.0436	.1615			-.0702	.00	-.0556	.0118	-.0464	.0097	-.0628	-.0129	-.0526	-.0590
.50	.0690	.1593					-.0669	.0017	-.0648	-.0071			-.0428	-.0620
.60					-.0730	.0072	-.0698	-.0109	-.0791	-.0240	-.1047	-.0646	-.1817	-.2072
.70			.0443	.2026	-.0825	.0020	-.0891	-.0440	-.2324	-.0990	-.3117	-.2929		
.80	-.1831	-.1799	-.2010	-.1908	-.2773	-.2200			-.3104	-.2378	-.2960	-.2596		
.90	-.1942	-.1887			-.2374	-.2080			-.2732	-.2300	-.2726	-.2447		
.95	-.1674	-.1846							-.2605		-.2705	-.2489	-.2536	-.2075

TAIL 2

TABLE I. - CONTINGED
(e) $\alpha = 4.50^\circ$

Cp at y/b of														
x/c	0.02		0.22		0.44		0.56		0.67		0.83		0.98	
	U.S.	L.S.	U.S.	L.S.	U.S.	L.S.	U.S.	L.S.	U.S.	L.S.	U.S.	L.S.	U.S.	L.S.
.05	.3108	-.3250	.5252	.5889					.5246	.6741	.4967	.6402		
.10	.3140	-.3305	.4892	.5366	.5291	.6045	.5413	.6304	.5324	.6403	.5079	.6210	.3274	.3948
.15	.3191	-.3513	.4468	.4945	.5284	.5800	.5475	.6066	.5460	.6273	.5182	.5783	.3223	.3744
.20	.3033	-.3250	.4048	.4492	.5101	.5473			.5350	.6444	.5098	.5348	.3226	.3574
.25			-.0012	-.0194	.3970	.4099	.4643	.5021	.5066	.5277	.4708	.4866	.3123	.3277
.30	.1526	.0668	-.0371	-.0376	.0176	.0025	.0470	.0154	.1830	.1343	.4118	.4254	.3107	.2990
.40									-.0076	-.0268	-.0375	-.0485	-.0621	-.0773
.50	.2358	.2217			-.0226	-.0317			-.0337	-.0474	-.0399	-.0398	-.0301	-.0373
.60	.1881	.1858	-.0311	-.0314	.0020	-.0146	-.0425	-.0492	-.0571	-.0648	-.0865	-.0946	.0294	-.0211
.70	.1930	.1923	.2477	.2090	-.0252	-.0211	-.0754	-.0819	-.1430	-.1389			-.1789	-.1918
.80	-.1272	-.1356	-.1437	-.1586	-.2034	-.2272	-.1922	-.2108	-.1966	-.2300	-.2200	-.2306	-.2031	-.1683
.90	-.1515	-.1480	-.1785	-.1930	-.1570	-.1781	-.1965	-.2232	-.2140	-.2356	-.2257	-.2334	-.2512	-.2453
.95	-.1303	-.1186	-.1506	-.1948	-.1370	-.1515	-.1954	-.1986	-.2114	-.2071	-.2256	-.2335	-.2402	-.2465

TAIL 1

Cp at y/b of														
x/c	0.02		0.22		0.44		0.56		0.67		0.83		0.98	
	U.S.	L.S.	U.S.	L.S.	U.S.	L.S.	U.S.	L.S.	U.S.	L.S.	U.S.	L.S.	U.S.	L.S.
.05	.1041	.4396	.2508	.8360					.2563	.9473	.2434	.9479		
.10	.1405	.4747	.2531	.7264					.2830	.8349	.2915	.8309	.2139	.5712
.15	.1565	.4697							.2762	.7388	.2829	.7513	.2879	.7396
.20									.2742	.6708	.2828	.6751	.2798	.6640
.25	.0211	.1114	-.1099	.0469					.2703	.5854	.2707	.5876	.1785	.3721
.30			-.1258	.0253	-.1058	.0391	-.0935	.0648	.0640	.2411				
.40	-.0110	.2293			-.1194	.0451	-.1081	.0456	-.1059	.0375	-.1101	-.0122		
.50	-.0193	.2399					-.1165	.0431	-.1166	.0282			-.0711	-.0716
.60					-.1183	.0341	-.1201	.0394	-.1217	.0150	-.1457	-.0314	-.0591	-.0718
.70			-.0229	.2212	-.1256	.0851	-.1326	.0182	-.2556	-.0588	-.3311	-.2729	-.2112	-.2038
.80	-.2101	-.1600	-.2490	-.1684	-.2895	-.1671			-.3229	-.2612	-.3053	-.2730		
.90	-.2016	-.1886			-.2692	-.1690			-.2880	-.2299	-.2861	-.2373		
.95	-.1682	-.1956							-.2488		-.2827	-.2382	-.2834	-.1864

TAIL 2

TABLE I. - CONTINUED
(1) $\alpha = 6.50^\circ$

Cp at y/b of														
x/c	0.02		0.22		0.44		0.56		0.67		0.83		0.98	
	U.S.	L.S.	U.S.	L.S.	U.S.	L.S.	U.S.	L.S.	U.S.	L.S.	U.S.	L.S.	U.S.	L.S.
.05	.3404	.3519	.5322	.6024					.5302	.6856	.5138	.6391		
.10	.3340	.3583	.5058	.5535	.5560	.6193	.5534	.6334	.5453	.6433	.5289	.6122	.3396	.3949
.15	.3373	.3775	.4681	.5098	.5428	.5829	.5582	.6068	.5592	.6257	.5180	.5683	.3353	.3795
.20	.3280	.3468	.4215	.4589	.5135	.5489			.5457	.6392	.4967	.5255	.3278	.3619
.25			.0038	-.0180	.4008	.4122	.4705	.5034	.5043	.5245	.4553	.4801	.3097	.3331
.30	.1713	-.0776	-.0363	-.0350	.0203	.0030	.0482	.0165	.1807	.1408	.4009	.4236	.3126	.3078
.40									-.0120	-.0258	-.0395	-.0461	-.0517	-.0682
.50	.2693	.2470			-.0192	-.0308			-.0373	-.0476	-.0480	-.0494	-.0190	-.0250
.60	.2210	.2110	-.0366	-.0390	.0042	-.0050	-.0429	-.0531	-.0572	-.0658	-.0832	-.0881	.0226	.0054
.70	.2290	.2274	.2587	.2266	-.0115	-.0211	-.0721	-.0826	-.1402	-.1402			-.1730	-.1814
.80	-.1076	-.1160	-.1325	-.1430	-.1910	-.2288	-.1704	-.1913	-.1819	-.2198	-.2049	-.2160	-.2038	-.1726
.90	-.1269	-.1243	-.1636	-.1748	-.1325	-.1465	-.1744	-.2059	-.2018	-.2112	-.2123	-.2195	-.2568	-.2540
.95	-.0967	-.0847	-.1375	-.1746	-.1170	-.1280	-.1733	-.1817	-.1976	-.1802	-.2098	-.2136	-.2472	-.2581

TAIL 1

Cp at y/b of														
x/c	0.02		0.22		0.44		0.56		0.67		0.83		0.98	
	U.S.	L.S.	U.S.	L.S.	U.S.	L.S.	U.S.	L.S.	U.S.	L.S.	U.S.	L.S.	U.S.	L.S.
.05	.0287	.5336	.1099	.9483					.1164	1.0484	.1057	1.0421		
.10	.0816	.6141	.1363	.8207					.1686	.9189	.1747	.9084	.1517	.6429
.15	.1083	.6111					.1740	.8109	.1743	.8239	.1843	.8066		
.20							.1763	.7289	.1789	.7362	.1802	.7240	.1498	.4786
.25	.0115	.1797	-.1753	.0758					.1748	.6312	.1725	.6378	.1378	.4169
.30			-.1779	.0739	-.1649	.0639	-.1513	.0870	-.0006	.2644				
.40	-.0264	.3257			-.1740	.0933	-.1698	.0870	-.1592	.0729	-.1549	.0376		
.50	-.0196	.3081					-.1729	.1009	-.1754	.0758			-.0767	-.0641
.60					-.1791	.1793	-.1734	.1239	-.1786	.0723	-.1791	.0095	-.0875	-.0662
.70			-.0621	.2652	-.1746	.1807	-.1903	.1026	-.2941	-.0009	-.3436	-.2447	-.2586	-.2093
.80	-.2292	-.1350	-.2782	-.1473	-.3180	-.1092			-.3183	-.2122	-.3159	-.2603		
.90	-.2257	-.1716			-.2916	-.1387			-.2784	-.2096	-.2970	-.2154		
.95	-.1950	-.1903							-.2399		-.2773	-.2116	-.2986	-.1668

TAIL 2

TABLE I. - CONTINUED
(g) $\alpha = 8.50^\circ$

Cp at γ/b of														
x/c	0.02		0.22		0.44		0.56		0.67		0.83		0.98	
	U.S.	L.S.	U.S.	L.S.	U.S.	L.S.	U.S.	L.S.	U.S.	L.S.	U.S.	L.S.	U.S.	L.S.
.05	.3708	.3884	.5591	.6302					.5558	.6811	.5360	.6357		
.10	.3648	.3897	.5292	.5710	.5576	.6208	.5646	.6321	.5544	.6384	.5192	.6023	.3414	.3872
.15	.3674	.4048	.4864	.5238	.5414	.5914	.5596	.6083	.5525	.6246	.4971	.5564	.3309	.3767
.20	.3537	.3782	.4289	.4723	.5176	.5597			.5307	.6404	.4727	.5177	.3220	.3630
.25			.0045	-.0087	.4047	.4230	.4693	.5139	.4921	.5310	.4365	.4791	.3067	.3439
.30	.1968	.0997	-.0298	-.0248	.0220	.0104	.0454	.0221	.1765	.1433	.3885	.4288	.3102	.3217
.40									-.0139	-.0220	-.0420	-.0396	-.0403	-.0535
.50	.3046	.2720			-.0089	-.0251			-.0350	-.0460	-.0549	-.0562	-.0031	-.0092
.60	.2483	.2444	-.0409	-.0440	.0133	.0042	-.0329	-.0502	-.0502	-.0651	-.0721	-.0840	.0305	.0195
.70	.2681	.2685	.2714	.2488	.0091	-.0132	.0643	-.0796	-.1331	-.1400			-.1582	-.1670
.80	-.0367	-.0925	-.1219	-.1237	-.1668	-.2211	-.1521	-.1687	-.1713	-.1936	-.1906	-.2046	-.2099	-.1729
.90	-.1052	-.1005	-.1451	-.1554	-.1224	-.1309	-.1586	-.1817	-.1924	-.1799	-.1987	-.2124	-.2726	-.2589
.95	-.0699	-.0525	-.1265	-.1518	-.1150	-.1109	-.1536	-.1619	-.1862	-.1593	-.1944	-.2108	-.2607	-.2690

TAIL 1

Cp at γ/b of														
x/c	0.02		0.22		0.44		0.56		0.67		0.83		0.98	
	U.S.	L.S.	U.S.	L.S.	U.S.	L.S.	U.S.	L.S.	U.S.	L.S.	U.S.	L.S.	U.S.	L.S.
.05	-.0523	.6273	-.0205	1.0412					-.0081	1.1225	-.0163	1.1093		
.10	.0081	.7584	.0256	.9142					.0506	.9851	.0592	.9725	.0981	.7072
.15	.0565	.7488					.0762	.8696	.0735	.8818	.0881	.8655		
.20							.0792	.7789	.0796	.7844	.0835	.7759	.1178	.5352
.25	-.0110	.2658	-.2469	.1023					.0814	.6716	.0801	.6838	.1142	.4666
.30			-.2446	.1500	-.2222	.0929	-.2020	.1088	-.0678	.2844				
.40	-.0401	.4053			-.2285	.1666	-.2241	.1367	-.2120	.1114	-.1943	.0678		
.50	-.0532	.3733					-.2293	.1802	-.2276	.1324			-.1142	-.0496
.60					-.2321	.2635	-.2298	.2159	-.2327	.1484	-.2066	.0632	-.1319	-.0529
.70			-.0937	.3150	-.2310	.3382	-.2434	.1952	-.3310	.0758	-.3570	-.2074	-.3268	-.2229
.80	-.2537	-.1104	-.3094	-.1302	-.3195	-.0974			-.3344	-.1502	-.3368	-.2260		
.90	-.2611	-.1473			-.2620	-.1290			-.2808	-.1434	-.3058	-.2047		
.95	-.2338	-.1787							-.2588		-.2649	-.2309	-.3192	-.1547

TAIL 2

TABLE I. - CONTINUED
(h) $\alpha = 10.50^\circ$

Cp at y/b of														
x/c	0.02		0.22		0.44		0.56		0.67		0.83		0.98	
	U.S.	L.S.	U.S.	L.S.	U.S.	L.S.	U.S.	L.S.	U.S.	L.S.	U.S.	L.S.	U.S.	L.S.
.05	.3992	.4173	.5741	.6465					.5464	.6734	.5152	.6231		
.10	.3871	.4172	.5324	.5860	.5624	.6370	.5535	.6530	.5339	.6428	.4984	.5981	.3328	.3811
.15	.4056	.4455	.4901	.5395	.5474	.6106	.5562	.6250	.5368	.6335	.4782	.5566	.3261	.3792
.20	.4053	.4187	.4458	.4960	.5253	.5765			.5272	.6446	.4565	.5200	.3190	.3729
.25			.0258	.0093	.4200	.4332	.4831	.5222	.4997	.5352	.4263	.4800	.3072	.3578
.30	.2412	.1127	.0134	-.0042	.0359	.0134	.0581	.0251	.1868	.1440	.3888	.4306	.3165	.3369
.40									-.0019	-.0222	-.0295	-.0394	-.0185	-.0417
.50	.3350	.3024			.0085	-.0168			-.0248	-.0455	-.0565	-.0579	.0389	.0099
.60	.2859	.2820	-.0399	-.0436	.0307	.0121	-.0256	-.0467	-.0429	-.0624	-.0562	-.0773	.0513	.0305
.70	.3104	.3069	.2941	.2722	.0154	.0028	-.0523	-.0724	-.1275	-.1355			-.1474	-.1512
.80	-.0678	-.0730	-.1047	-.1050	-.1575	-.2042	-.1333	-.1514	-.1590	-.1761	-.1769	-.1923	-.2516	-.1731
.90	-.0859	-.0787	-.1229	-.1330	-.0982	-.1240	-.1446	-.1626	-.1776	-.1662	-.1851	-.2026	-.2915	-.2744
.95	-.0429	-.0227	-.1054	-.1261	-.0902	-.0966	-.1358	-.1384	-.1696	-.1473	-.1808	-.1992	-.2709	-.2772

TAIL 1

Cp at y/b of														
x/c	0.02		0.22		0.44		0.56		0.67		0.83		0.98	
	U.S.	L.S.	U.S.	L.S.	U.S.	L.S.	U.S.	L.S.	U.S.	L.S.	U.S.	L.S.	U.S.	L.S.
.05	-.1387	.7330	-.1273	1.1172					-.1228	1.1842	-.1322	1.1705		
.10	-.0641	.8852	-.0682	.9866					-.0433	1.0453	-.0376	1.0340	.0349	.7668
.15	-.0095	.8549							-.0153	.9246	-.0153	.9382	-.0106	.9229
.20									-.0080	.8273	-.0039	.8346	.0005	.8292
.25	-.0332	.3821	-.2946	.1307					-.0057	.7122	.0035	.7305	.0707	.5113
.30			-.2884	.2344	-.2700	.1260	-.2500	.1332	-.1351	.3059				
.40	-.0638	.5048			-.2777	.2611	-.2734	.2071	-.2621	.1639	-.2300	.1027		
.50	-.0727	.4417					-.2789	.2807	-.2737	.2160			-.1580	-.0203
.60					-.2773	.4448	-.2797	.3271	-.2758	.2490	-.2380	.1304	-.1841	-.0314
.70			-.1185	.3682	-.2729	.3732	-.2897	.3510	-.3568	.1655	-.3728	-.1594	-.3681	-.2431
.80	-.2716	-.0788	-.3142	-.1100	-.3022	-.0818			-.3333	-.0761	-.3499	-.1715		
.90	-.3014	-.1181			-.2674	-.1125			-.2919	-.0994	-.3130	-.1556		
.95	-.2695	-.1547							-.2746		-.2865	-.1591	-.3544	-.1896

TAIL 2

TABLE I.-CONTINUED
(i) $\alpha = 12.50^\circ$

Cp at y/b of														
x/c	0.02		0.22		0.44		0.56		0.67		0.83		0.98	
	U.S.	L.S.	U.S.	L.S.	U.S.	L.S.	U.S.	L.S.	U.S.	L.S.	U.S.	L.S.	U.S.	L.S.
.05	.4213	.4545	.5853	.6693					.5444	.6856	.5109	.6332		
.10	.4415	.4617	.5623	.6061	.5931	.6558	.5800	.6597	.5548	.6488	.4983	.5949	.3421	.3863
.15	.4943	.4997	.5395	.5622	.5862	.6219	.5925	.6328	.5706	.6297	.4876	.5447	.3477	.3848
.20	.4815	.4707	.5273	.5332	.5647	.5889			.5547	.6375	.4702	.5075	.3448	.3767
.25			.0754	.0367	.4453	.4434	.5031	.5249	.5156	.5394	.4434	.4715	.3342	.3591
.30	.2774	.1204	.0413	.0171	.0490	.0194	.0629	.0276	.1910	.1399	.4045	.4280	.3437	.3444
.40									-.0014	-.0198	-.0249	-.0365	-.0030	-.0247
.50	.3636	.3304			.0204	-.0057			-.0216	-.0416	-.0573	-.0549	.0616	.0226
.60	.3213	.3187	-.0389	-.0394	.0420	.0166	-.0094	-.0383	-.0351	-.0579	-.0449	-.0655	.0575	.0424
.70	.3468	.3465	.3183	.2966	.0233	.0092	-.0387	-.0650	-.1156	-.1300			-.1453	-.1441
.80	-.0527	-.0544	-.0850	-.0839	-.1340	-.1621	-.1114	-.1246	-.1434	-.1640	-.1670	-.1745	-.2898	-.1930
.90	-.0742	-.0629	-.1030	-.1061	-.1087	-.1121	-.1262	-.1388	-.1652	-.1496	-.1760	-.1865	-.2972	-.2378
.95	-.0224	-.0031	-.0841	-.1039	-.0965	-.0775	-.1182	-.1143	-.1562	-.1315	-.1612	-.1828	-.2780	-.2819

TAIL 1

Cp at y/b of														
x/c	0.02		0.22		0.44		0.56		0.67		0.83		0.98	
	U.S.	L.S.	U.S.	L.S.	U.S.	L.S.	U.S.	L.S.	U.S.	L.S.	U.S.	L.S.	U.S.	L.S.
.05	-.2233	.8205	-.2196	1.1794					-.2197	1.2345	-.2307	1.2202		
.10	-.1445	.9659	-.1517	1.0495					-.1348	1.0975	-.1275	1.0856	-.0349	.8120
.15	-.0589	.9243							-.1056	.9709	-.1070	.9858	-.0922	.9713
.20									-.0944	.8673	-.0893	.8780	-.0812	.8724
.25	-.0625	.5097	-.3367	.1714					-.0857	.7477	-.0781	.7677	.0179	.5473
.30			-.3271	.3042	-.3151	.1901	-.2963	.1562	-.1921	.3248				
.40	-.0887	.6187			-.3236	.3335	-.3159	.3064	-.3048	.2413	-.2727	.1381		
.50	-.0848	.4884					-.3198	.4059	-.3140	.3225			-.1990	.0109
.60					-.3146	.4727	-.3200	.4711	-.3157	.3833	-.2667	.2195	-.2327	.0075
.70			-.1543	.4027	-.3034	.3948	-.3141	.3740	-.3630	.3047	-.3893	-.0851	-.3791	-.2208
.80	-.2890	-.0401	-.3347	-.0887	-.2839	-.0684			-.3185	-.0653	-.3580	-.0900		
.90	-.3192	-.0976			-.2609	-.0945			-.2931	-.0891	-.3097	-.0979		
.95	-.2908	-.1313							-.2797		-.2818	-.1131	-.4052	-.1550

TAIL 2

TABLE I. - CONTINUED
(j) $\alpha = 16.50^\circ$

Cp at y/b of														
x/c	0.02		0.22		0.44		0.56		0.67		0.83		0.98	
	U.S.	L.S.	U.S.	L.S.	U.S.	L.S.	U.S.	L.S.	U.S.	L.S.	U.S.	L.S.	U.S.	L.S.
.05	.5811	.5583	.7155	.7513					.6042	.7182	.5433	.6280		
.10	.6165	.5981	.6921	.7001	.6786	.7048	.6610	.6986	.6152	.6734	.5150	.5840	.3744	.3988
.15	.6169	.6220	.6680	.6640	.6639	.6728	.6531	.6671	.6131	.6497	.4922	.5406	.3739	.4062
.20	.5306	.5323	.6036	.6073	.6329	.6341			.5847	.6766	.4755	.5095	.3656	.4005
.25			.0889	.0536	.4934	.4730	.5413	.5483	.5428	.5484	.4532	.4815	.3532	.3850
.30	.254	.1220	.0470	.0293	.0748	.0354	.0784	.0395	.2059	.1555	.4141	.4414	.3599	.3707
.40									.0118	-.0103	-.0176	-.0259	.0117	.0009
.50	.4054	.3691			.0289	.0059			-.0073	-.0292	-.0148	-.0122	.3580	.3563
.60	.3982	.3862	.0090	.0096	.0276	.0196	-.0010	-.0225	-.0214	-.0431	-.0286	-.0402	.0584	.0517
.70	.4291	.4191	.4216	.3738	.0141	.0190	-.0292	-.0388	-.0852	-.1048			-.2016	-.1362
.80	-.0128	-.0218	-.0386	-.0419	-.0636	-.0559	-.0404	-.0390	-.0781	-.1106	-.1295	-.1234	-.3027	-.2809
.90	-.0284	-.0272	-.0392	-.0705	-.0717	-.0578	-.0678	-.0653	-.1081	-.0942	-.1387	-.1430	-.2918	-.3031
.95	.3502	.3616	.0355	-.0413	-.0575	-.0310	-.0672	-.0539	-.1064	-.0783	-.1201	-.1420	-.2719	-.2802

TAIL 1

Cp at y/b of														
x/c	0.02		0.22		0.44		0.56		0.67		0.83		0.98	
	U.S.	L.S.	U.S.	L.S.	U.S.	L.S.	U.S.	L.S.	U.S.	L.S.	U.S.	L.S.	U.S.	L.S.
.05	-.3533	.7276	-.3455	1.3127					-.3715	1.3049	-.3675	1.2931		
.10	-.2963	.9572	-.2801	1.1793					-.2854	1.1763	-.2886	1.1670	-.1842	.8934
.15	-.1356	.9597							-.2475	1.0523	-.2473	1.0644	-.2412	1.0527
.20									-.2367	.9424	-.2340	.9509	-.2219	.9506
.25	-.1310	.6535	-.4040	.2720					-.2235	.8132	-.2126	.8399	-.3872	.6126
.30			-.3735	.4017	-.3875	.4282	-.3730	.3753	-.2978	.3667				
.40	-.1327	.6942			-.3892	.6668	-.3877	.6442	-.3793	.5078	-.3515	.3257		
.50	-.1034	.5892					-.3908	.5852	-.3857	.5561			-.2697	.1675
.60					-.3649	.5400	-.3892	.5274	-.3862	.5080	-.3284	.4433	-.2856	.2498
.70			-.2431	.4803	-.3330	.4662	-.3605	.4296	-.3490	.3439	-.4115	-.0191	-.4257	-.1163
.80	-.3217	.0055	-.3763	-.0569	-.3278	-.0375			-.2979	-.0280	-.3705	-.0555		
.90	-.3556	-.0467			-.2879	-.0517			-.2916	-.0486	-.3137	-.0623		
.95	-.3317	-.3634							-.2835		-.2932	-.0788	-.4424	-.1545

TAIL 2

TABLE I. - CONCLUDED
(k) $\alpha = 20.50^\circ$

Cp at y/b of														
x/c	0.02		0.22		0.44		0.56		0.67		0.83		0.98	
	U.S.	L.S.	U.S.	L.S.	U.S.	L.S.	U.S.	L.S.	U.S.	L.S.	U.S.	L.S.	U.S.	L.S.
.05	.6539	.6745	.7824	.8480					.6754	.7874	.5685	.6599		
.10	.6595	.6837	.7277	.7638	.7306	.7708	.7067	.7584	.6605	.7240	.5283	.6064	.3848	.4195
.15	.6471	.6747	.6839	.7050	.6859	.7166	.6735	.7074	.6362	.6887	.4990	.5652	.3888	.4357
.20	.5516	.5552	.6113	.6289	.6380	.6631			.5944	.6976	.4865	.5355	.3859	.4342
.25			.0897	.0561	.4891	.4878	.5399	.5695	.5459	.5731	.4669	.5117	.3829	.4259
.30	.2736	.1210	.0458	.0313	.0664	.0402	.0751	.0466	.2058	.1669	.4293	.4695	.3985	.4061
.40									.0115	.0012	-.0046	-.0091	.0423	.0327
.50	.4521	.4056			.3243	.0100			-.0048	-.0151	-.0184	.0220	.0786	.0910
.60	.4677	.4599	.0501	.0498	.0523	.0202	.0040	-.0120	-.0148	-.0203	-.0015	-.0074	.0520	.0734
.70	.5013	.4913	.5065	.4628	.0191	.0172	.0086	-.0208	-.0425	.0195			-.2734	-.1561
.80	.0139	-.0047	-.0008	-.0183	-.0024	-.0238	.0128	-.0035	-.0313	-.0080	-.0896	-.0855	-.3196	-.3190
.90	.0335	.0595	.0187	-.0166	-.0108	.0410	-.0160	-.0102	-.0577	-.0413	-.0896	-.0846	-.3062	-.3084
.95	.1540	.1626	-.0955	-.0811	-.0034	.0862	-.0231	-.0031	-.0567	-.0334	-.0735	-.0703	-.2855	-.2894

TAIL 1

Cp at y/b of														
x/c	0.02		0.22		0.44		0.56		0.67		0.83		0.98	
	U.S.	L.S.	U.S.	L.S.	U.S.	L.S.	U.S.	L.S.	U.S.	L.S.	U.S.	L.S.	U.S.	L.S.
.05	-.4345	.6628	-.4341	1.4160					-.4498	1.3530	-.4378	1.3324		
.10	-.4089	.9295	-.4011	1.2836					-.4124	1.2429	-.4178	1.2275	-.3341	.9381
.15	-.2251	.9676							-.3694	1.1312	-.3713	1.1390	-.3736	1.1225
.20									-.3419	1.0283	-.3478	1.0315	-.3473	1.0257
.25	-.0705	.8289	-.4255	.5396					-.3398	.9001	-.3307	.9166	-.2084	.6761
.30			-.3916	.7912	-.4425	.6685	-.4361	.6091	-.3885	.5154				
.40	-.1533	.7790			-.4315	.7327	-.4448	.7145	-.4427	.6904	-.4164	.5593		
.50	-.1349	.6880					-.4404	.6729	-.4407	.6505			-.4196	.3773
.60					-.3860	.6227	-.4191	.6126	-.4178	.5928	-.3928	.5341	-.3965	.2931
.70			-.3268	.5577	-.3619	.5321	-.3608	.4904	-.3494	.4008	-.4010	.0194	-.4907	-.0858
.80	-.3571	.0494	-.4088	-.0207	-.3479	-.0045			-.3332	.0110	-.3689	-.0127		
.90	-.3797	-.0010			-.3273	-.0163			-.3246	-.0057	-.3050	-.0191		
.95	-.3294	-.0139							-.3121		-.3048	-.0332	-.4463	-.1146

TAIL 2

TABLE II. - PRESSURE COEFFICIENTS, $\theta = 22.5^\circ$, $\delta = 0^\circ$, $M = 1.50$
 (a) $\alpha = -3.35^\circ$

Cp at y/b of														
x/c	0.02		0.22		0.44		0.56		0.67		0.83		0.98	
	U.S.	L.S.	U.S.	L.S.	U.S.	L.S.	U.S.	L.S.	U.S.	L.S.	U.S.	L.S.	U.S.	L.S.
.05	.1752	.2188	.5872	.4301					.7234	.5348	.7042	.5108		
.10	.1853	.2202	.4788	.3725	.6109	.4712	.6495	.5044	.6798	.5132	.6688	.5140	.4297	.3308
.15	.1808	.2103	.4182	.3451	.5599	.4467	.6068	.4741	.6326	.5027	.6228	.5009	.3787	.3053
.20	.1150	.1328	.3689	.3172	.5203	.4251			.5851	.5152	.5786	.4793	.3457	.2903
.25			-.0267	-.0865	.3938	.3180	.4762	.4103	.5253	.4441	.5224	.4444	.3108	.2629
.30	.1196	.0073	-.0689	-.1231	.0186	-.0470	.0417	-.0272	.1785	.0866	.4470	.3877	.2949	.2415
.40									.0047	-.0490	-.0281	-.0689	-.1042	-.1137
.50	.1107	.0164			-.0145	-.0711			-.0092	-.0620	-.0426	-.0441	-.0861	-.0824
.60	.0606	-.0120			-.0210	-.0877	-.0161	-.0704	-.0260	-.0778	-.0687	-.1156	-.0714	-.0793
.70	.0708	.0047	.1072	-.0097	-.0257	-.1009	-.0505	-.0999	-.1146	-.1512			-.2161	-.2056
.80	-.2034	-.2392	-.2057	-.2609	-.2246	-.3102	-.2753	-.3223	-.2860	-.3185	-.2773	-.2959	-.1427	-.1529
.90	-.2027	-.2216	-.2352	-.2817	-.2165	-.2737	-.2416	-.2905	-.2491	-.2883	-.2604	-.2865	-.1732	-.2053
.95	-.1940	-.1886	-.2434	-.2665	-.2102	-.2614	-.2309	-.2706	-.2428	-.2734	-.2570	-.2773	-.1687	-.2078

TAIL 1

Cp at y/b of														
x/c	0.02		0.22		0.44		0.56		0.67		0.83		0.98	
	U.S.	L.S.	U.S.	L.S.	U.S.	L.S.	U.S.	L.S.	U.S.	L.S.	U.S.	L.S.	U.S.	L.S.
.05	.4518	.1022	.7926	.3015					.9141	.3699	.9170	.3781		
.10	.4808	.1596	.7017	.2799					.8090	.3516	.8120	.3543	.5309	.2547
.15	.4754	.1521					.7297	.3251	.7384	.3377	.7210	.3427		
.20							.6680	.3167	.6792	.3240	.6565	.3216	.4239	.2250
.25	.1630	-.0266	.0704	-.1132					.5996	.2978	.5895	.2934	.3728	.2176
.30			.0652	-.1370	.0531	-.1054	.0650	-.0716	.2568	.0809				
.40	.3134	-.0488			.0650	-.1218	.0575	-.1034	.0447	-.0926	.0159	-.1077		
.50	.3396	-.0289					.0604	-.1154	.0372	-.1140			-.0400	-.0665
.60					.1335	-.1303	.0872	-.1286	.0329	-.1296	-.0192	-.1417	-.0408	-.0535
.70			.2634	-.0789	.1576	-.1353	.0680	-.1578	-.1437	.1938	-.2595	-.3183	-.1845	-.2278
.80	-.0638	-.1025	-.1281	-.2822	-.0946	-.2479			-.2229	-.2616	-.2354	-.2776		
.90	-.1444	-.2104			-.1149	-.2451			-.2061	-.2640	-.2118	-.2678		
.95	-.1653	-.1877							-.2097		-.2124	-.2721	-.1768	-.2950

TAIL 2

TABLE 11. - CONTINUED
(b) $\alpha = -1.34^\circ$

Cp at y/b of														
x/c	0.02		0.22		0.44		0.56		0.67		0.83		0.98	
	U.S.	L.S.	U.S.	L.S.	U.S.	L.S.	U.S.	L.S.	U.S.	L.S.	U.S.	L.S.	U.S.	L.S.
.05	.2273	.2126	.5857	.5419					.6144	.6069	.6011	.5856		
.10	.2337	.2192	.4942	.4574	.5664	.5353	.5932	.5614	.6132	.5752	.6095	.5750	.3762	.3690
.15	.2332	.2156	.4338	.4075	.5287	.5095	.5690	.5367	.5958	.5586	.5845	.5528	.3488	.3393
.20	.1670	.1517	.3783	.3665	.4974	.4782			.5646	.5668	.5501	.5184	.3319	.3170
.25			-.0209	-.0539	.3845	.3571	.4641	.4529	.5134	.4881	.5006	.4739	.3038	.2840
.30	.1419	.0428	-.0584	-.0836	.0152	-.0254	.0398	-.0067	.1784	.1040	.4318	.4121	.2951	.2602
.40									-.0005	-.0348	-.0342	-.0585	-.0953	-.1073
.50	.1203	.0699			-.0192	-.0538			-.0181	-.0507	-.0342	-.0365	-.0695	-.0792
.60	.0745	.0385			-.0230	-.0620	-.0262	-.0566	-.0374	-.0672	-.0785	-.1062	-.0603	-.0818
.70	.0869	.0540	.1352	.0544	-.0318	-.0761	-.0589	-.0861	-.1251	-.1417			-.2104	-.2224
.80	-.1882	-.2065	-.1932	-.2259	-.2399	-.2893	-.2780	-.3041	-.2691	-.3006	-.2652	-.2853	-.1603	-.1691
.90	-.1934	-.1992	-.2218	-.2503	-.2181	-.2560	-.2404	-.2717	-.2445	-.2732	-.2576	-.2792	-.1965	-.2169
.95	-.1799	-.1700	-.2296	-.2519	-.1983	-.2377	-.2330	-.2608	-.2402	-.2639	-.2559	-.2764	-.1920	-.2232

TAIL 1

Cp at y/b of														
x/c	0.02		0.22		0.44		0.56		0.67		0.83		0.98	
	U.S.	L.S.	U.S.	L.S.	U.S.	L.S.	U.S.	L.S.	U.S.	L.S.	U.S.	L.S.	U.S.	L.S.
.05	.3334	.1997	.6564	.4309					.7671	.4946	.7798	.5022		
.10	.3490	.2179	.5812	.3884					.7016	.4696	.7131	.4764	.4470	.3120
.15	.3413	.2120					.6376	.4420	.6553	.4512	.6430	.4540		
.20							.5954	.4200	.6115	.4323	.5890	.4237	.3665	.2650
.25	.0974	-.0011	.0274	-.0647					.5485	.3955	.5328	.3874	.3245	.2531
.30			.0057	-.0927	.0258	-.0592	.0435	-.0226	.2339	.1438				
.40	.1984	.0159			.0180	-.0724	.0224	-.0573	.0170	-.0485	-.0069	-.0675		
.50	.2500	.0296					.0114	-.0688	.0016	-.0719			-.0376	-.0515
.60					.0497	-.0819	.0072	-.0824	-.0116	-.0911	-.0516	-.1154	-.0434	-.0406
.70			.2397	-.0259	.0355	-.0923	-.0174	-.1151	-.1846	-.1613	-.2793	-.3122	-.1728	-.2114
.80	-.1043	-.0914	-.1500	-.2301	-.1617	-.2342			-.2395	-.2476	-.2374	-.2671		
.90	-.1724	-.2091			-.1473	-.2304			-.2157	-.2496	-.2249	-.2576		
.95	-.1817	-.1893							-.2130		-.2283	-.2622	-.1957	-.2600

TAIL 2

TABLE II. - CONTINUED
(c) $\alpha = 0.65^\circ$

Cp at y/b of														
x/c	0.02		0.22		0.44		0.56		0.67		0.83		0.98	
	U.S.	L.S.	U.S.	L.S.	U.S.	L.S.	U.S.	L.S.	U.S.	L.S.	U.S.	L.S.	U.S.	L.S.
.05	.2537	.2625	.5437	.5978					.5120	.6743	.4902	.6593		
.10	.2653	.2731	.4824	.5235	.5215	.5879	.5215	.6136	.5231	.6312	.5115	.6277	-.3217	-.4016
.15	.2667	.2792	.4306	.4706	.4892	.5557	.5190	.5867	.5304	.6089	.5226	.5868	.3067	.3678
.20	.2115	.2263	.3781	.4234	.4676	.5236			.5209	.6132	.5102	.5450	.3053	.3426
.25			-.0211	-.0271	.3647	.3902	.4423	.4912	.4875	.5232	.4741	.4958	.2889	.3068
.30	.1218	.0689	-.0586	-.0510	.0062	-.0066	.0341	.0115	.1743	.1192	.4141	.4316	-.2879	-.2803
.40									-.0059	-.0246	-.0382	-.0492	-.0874	-.0987
.50	.1269	.1274			-.0308	-.0333			-.0257	-.0412	-.0274	-.0305	-.0532	-.0705
.60	.0899	.0974			-.0319	-.0359	-.0341	-.0424	-.0475	-.0575	-.0835	-.0956	-.0221	-.0701
.70	.1068	.1158	.1662	.1440	-.0390	-.0451	-.0637	-.0699	-.1347	-.1318			-.1906	-.2159
.80	-.1716	-.1715	-.1794	-.1866	-.2431	-.2623	-.2374	-.2755	-.2333	-.2698	-.2478	-.2714	-.1745	-.1621
.90	-.1817	-.1766	-.2044	-.2186	-.2207	-.2341	-.2323	-.2472	-.2352	-.2550	-.2476	-.2680	-.2221	-.2160
.95	-.1697	-.1583	-.2100	-.2229	-.2033	-.2124	-.2301	-.2297	-.2329	-.2508	-.2477	-.2660	-.2086	-.2218

TAIL 1

Cp at y/b of														
x/c	0.02		0.22		0.44		0.56		0.67		0.83		0.98	
	U.S.	L.S.	U.S.	L.S.	U.S.	L.S.	U.S.	L.S.	U.S.	L.S.	U.S.	L.S.	U.S.	L.S.
.05	.2414	.2649	.5305	.5723					.5845	.6622	.5903	.6695		
.10	.2565	.2745	.4668	.4996					.5638	.6144	.5770	.6190	.3558	.3995
.15	.2487	.2633					.5259	.5519	.5449	.5736	.5474	.5688		
.20							.5052	.5169	.5268	.5343	.5142	.5191	.3097	.3196
.25	.0605	.0268	-.0220	-.0268					.4863	.4777	.4740	.4696	.2814	.2965
.30			-.0461	-.0586	-.0108	-.0204	.0152	.0164	.2038	.1893				
.40	.1120	.0918			-.0247	-.0326	-.0104	-.0194	-.0077	-.0170	-.0287	-.0368		
.50	.1388	.0853					-.0236	-.0324	-.0282	-.0387			-.0413	-.0460
.60					-.0260	-.0444	-.0313	-.0477	-.0443	-.0585	-.0761	-.0905	-.0386	-.0582
.70			.1608	.0993	-.0320	-.0552	-.0591	-.0814	-.2110	-.1312	-.2952	-.3008	-.1710	-.2127
.80	-.1474	-.0730	-.1690	-.2140	-.2413	-.2445			-.2733	-.2343	-.2700	-.2556		
.90	-.1935	-.1913			-.2187	-.2307			-.2444	-.2396	-.2502	-.2456		
.95	-.1877	-.1649							-.2400		-.2505	-.2506	-.2228	-.2202

TAIL 2

TABLE 11. - CONTINUED
(d) $\alpha = 2.65^\circ$

Cp at y/b of														
x/c	0.02		0.22		0.44		0.56		0.67		0.83		0.98	
	U.S.	L.S.	U.S.	L.S.	U.S.	L.S.	U.S.	L.S.	U.S.	L.S.	U.S.	L.S.	U.S.	L.S.
.05	.2477	.3335	.4737	.6414					.4446	.7435	.4257	.7204		
.10	.2669	.3453	.4443	.5737	.4620	.6402	.4505	.6690	.4478	.6887	.4416	.6725	.2914	.4356
.15	.2768	.3676	.4014	.5225	.4413	.6045	.4590	.6341	.4581	.6605	.4494	.5169	.2838	.4001
.20	.2351	.3211	.3555	.4755	.4256	.5685			.4637	.6558	.4475	.5686	.2779	.3713
.25			-.0306	-.0035	.3348	.4235	.4067	.5209	.4422	.5532	.4248	.5154	.2634	.3358
.30	.0717	.0961	-.0691	-.0225	-.0096	.0098	.0194	.0232	.1554	.1359	.3759	.4506	.2675	.3052
.40									-.0199	-.0129	-.0520	-.0393	-.0805	-.0856
.50	.1336	.2084			-.0446	-.0115			-.0407	-.0299	-.0288	-.0312	-.0471	-.0569
.60	.1133	.1734			-.0428	.0045	-.0479	-.0243	-.0626	-.0455	-.0929	-.0843	.0152	-.0560
.70	.1343	.1730	.1896	.2073	-.0490	.0027	-.0839	-.0550	-.1482	-.1195			-.1841	-.2114
.80	-.1570	-.1428	-.1638	-.1669	-.2293	-.2139	-.2143	-.2363	-.2196	-.2347	-.2401	-.2445	-.2010	-.1489
.90	-.1737	-.1604	-.1910	-.2001	-.2150	-.1928	-.2190	-.2284	-.2341	-.2450	-.2427	-.2470	-.2530	-.2044
.95	-.1507	-.1405	-.1846	-.1959	-.2005	-.1742	-.2169	-.2169	-.2317	-.2456	-.2446	-.2469	-.2373	-.2143

TAIL 1

Cp at y/b of														
x/c	0.02		0.22		0.44		0.56		0.67		0.83		0.98	
	U.S.	L.S.	U.S.	L.S.	U.S.	L.S.	U.S.	L.S.	U.S.	L.S.	U.S.	L.S.	U.S.	L.S.
.05	.1724	.3039	.4110	.6873					.4241	.8131	.4188	.8221		
.10	.1904	.3195	.3588	.5943					.4244	.7286	.4341	.7307	.2834	.4890
.15	.1806	.3131							.4099	.6441	.4201	.6672	.4195	.6589
.20									.4053	.5926	.4153	.6068	.4106	.5938
.25	.0477	.0575	-.0708	.0059					.3957	.5328	.3892	.5283	.2293	.3317
.30			-.0963	-.0229	-.0540	.0073	-.0260	.0394	.1460	.2154				
.40	.0517	.1585			-.0639	.0007	-.0534	.0082	-.0427	.0082	-.0574	-.0141		
.50	.0648	.1367					-.0646	-.0016	-.0611	-.0082			-.0524	-.0609
.60					-.0771	-.0012	-.0690	-.0143	-.0757	-.0247	-.0995	-.0665	-.0360	-.0673
.70			.0401	.1837	-.0880	-.0051	-.0913	-.0472	-.2334	-.1006	-.3092	-.2943	-.1843	-.2119
.80	-.1561	-.0729	-.2103	-.2007	-.2886	-.2313			-.3154	-.2366	-.2991	-.2597		
.90	-.1945	-.1945			-.2457	-.2120			-.2788	-.2306	-.2725	-.2453		
.95	-.1668	-.1852							-.2665		-.2680	-.2504	-.2400	-.2061

TAIL 2

TABLE II. - CONTINUED
(e) $\alpha = 4.65^\circ$

Cp at y/b of														
x/c	0.02		0.22		0.44		0.56		0.67		0.83		0.98	
	U.S.	L.S.	U.S.	L.S.	U.S.	L.S.	U.S.	L.S.	U.S.	L.S.	U.S.	L.S.	U.S.	L.S.
.05	.2294	.4141	.4007	.7083					.3959	.8152	.3793	.7851	.2703	.4713
.10	.2374	.4275	.3966	.6381	.4060	.7007	.3956	.7275	.3951	.7451	.3975	.7149	.2685	.4327
.15	.2542	.4626	.3610	.5911	.3890	.6578	.4052	.6856	.4042	.7047	.4008	.6507	.2631	.4037
.20	.2174	.4152	.3172	.5358	.3836	.6138			.4080	.6967	.3940	.5978	.2487	.3664
.25			-.0544	.0205	.3070	.4527	.3683	.5506	.3958	.5803	.3745	.5435	.2544	.3325
.30	.0183	.1343	-.0940	.0082	-.0250	.0251	.0036	.0345			.3349	.4722	-.0732	-.0715
.40									-.0399	-.0015	-.0708	-.0280	-.0433	-.0391
.50	.1482	.2662			-.0659	.0260			-.0587	-.0151	-.0359	-.0384	-.0010	-.0378
.60	.1371	.2145			-.0734	.0617	-.0682	.0010	-.0790	-.0280	-.1027	-.0703	-.1882	-.2019
.70	.1597	.2163	.1956	.2350	-.0818	.0466	-.1050	-.0165	-.1616	-.1027			-.2354	-.1409
.80	-.1483	-.1199	-.1529	-.1507	-.2096	-.1844	-.2035	-.2199	-.2160	-.2160	-.2348	-.2255	-.2875	-.1930
.90	-.1578	-.1359	-.1836	-.1790	-.2102	-.1530	-.2107	-.1952	-.2384	-.2216	-.2333	-.2291	-.2652	-.2037
.95	-.1243	-.1139	-.1910	-.1705	-.2048	-.1543	-.2088	-.1873	-.2357	-.2113	-.2395	-.2290		

TAIL 1

Cp at y/b of														
x/c	0.02		0.22		0.44		0.56		0.67		0.83		0.98	
	U.S.	L.S.	U.S.	L.S.	U.S.	L.S.	U.S.	L.S.	U.S.	L.S.	U.S.	L.S.	U.S.	L.S.
.05	.1109	.3493	.2950	.7917					.2714	.9321	.2598	.9354		
.10	.1288	.3845	.2504	.6872					.3063	.8220	.3125	.8199	.2247	.5689
.15	.1255	.3832							.2956	.7200	.3005	.7412	.2039	.4174
.20									.3021	.6553	.2998	.6671	.1849	.3628
.25	.0254	.0920	-.1193	.0359					.2882	.5778	.2914	.5804		
.30			-.1435	.0123	-.1036	.0318	-.0796	.0596	.0770	.2361				
.40	.0238	.2142			-.1198	.0350	-.1020	.0384	-.0911	.0342	-.0992	.0079	-.0804	-.0838
.50	.0238	.1949					-.1150	.0358	-.1059	.0248			-.0675	-.0875
.60					-.1265	.0642	-.1193	.0299	-.1154	.0119	-.1318	-.0371	-.2029	-.2145
.70			-.0186	.2001	-.1355	.0631	-.1338	.0012	-.2576	-.0650	-.3261	-.2770		
.80	-.2290	-.0838	-.2566	-.1877	-.3126	-.1865			-.3316	-.2692	-.3111	-.2820		
.90	-.2037	-.1993			-.2743	-.1878			-.2939	-.2349	-.2863	-.2432		
.95	-.1731	-.2071							-.2652		-.2787	-.2443	-.2628	-.1842

TAIL 2

TABLE II. - CONTINUED
 (f) $\alpha = 6.65^\circ$

Cp at y/b of														
x/c	0.02		0.22		0.44		0.56		0.67		0.83		0.98	
	U.S.	L.S.	U.S.	L.S.	U.S.	L.S.	U.S.	L.S.	U.S.	L.S.	U.S.	L.S.	U.S.	L.S.
.05	.2124	.5136	.3395	.8004					.3588	.8882	.3438	.8492		
.10	.2105	.5406	.3458	.7256	.3597	.7702	.3490	.7934	.3584	.8004	.3614	.7640	.2561	.5074
.15	.2182	.5824	.3216	.6739	.3506	.7216	.3655	.7403	.3641	.7509	.3563	.6892	.2566	.4698
.20	.1764	.5090	.2793	.6052	.3523	.6664			.3662	.7355	.3504	.6314	.2514	.4392
.25			-.0745	.0450	.2800	.4835	.3316	.5805	.3512	.6075	.3318	.5729	.2404	.4034
.30	-.0223	.1691	-.1132	.0406	-.0422	.0460	-.0178	.0471	.1010	.1666	.2948	.4975	.2474	.3642
.40									-.0629	.0148	-.0895	-.0146	-.0646	-.0546
.50	.1583	.3063			-.0805	.0683			-.0818	.0059	-.0432	-.0456	-.0143	-.0176
.60	.1573	.2586			-.0958	.1027	-.0859	.0369	-.0976	-.0040	-.1126	-.0516	-.0063	-.0125
.70	.1747	.2602	.1903	.2645	-.1111	.0813	-.1215	.0189	-.1739	-.0796			-.1879	-.1858
.80	-.1469	-.0941	-.1481	-.1258	-.2057	-.1450	-.1955	-.2063	-.2254	-.2014	-.2372	-.2070	-.3171	-.1282
.90	-.1394	-.1079	-.1779	-.1519	-.2111	-.1337	-.2085	-.1734	-.2448	-.1972	-.2370	-.2110	-.3201	-.1732
.95	-.1018	-.0890	-.1847	-.1454	-.1968	-.1437	-.2057	-.1638	-.2424	-.1923	-.2303	-.2109	-.3043	-.1846

TAIL 1

Cp at y/b of														
x/c	0.02		0.22		0.44		0.56		0.67		0.83		0.98	
	U.S.	L.S.	U.S.	L.S.	U.S.	L.S.	U.S.	L.S.	U.S.	L.S.	U.S.	L.S.	U.S.	L.S.
.05	.0605	.3821	.1664	.8824					.1300	1.0184	.1177	1.0185		
.10	.0850	.4475	.1492	.7716					.1834	.8948	.2024	.8900	-.1614	-.6275
.15	.0928	.4627							.1876	.7808	.1956	.8002	.2038	.7902
.20									.1876	.7045	.1973	.7151	.1981	.7060
.25	.0258	.1346	-.1694	.0620					.1889	.6153	.1928	.6219	.1344	.3937
.30			-.1820	.0494	-.1545	.0518	-.1341	.0763	.0052	.2537				
.40	.0058	.2759			-.1761	.0732	-.1514	.0715	-.1501	.0643	-.1426	.0286		
.50	-.0177	.2459					-.1656	.0785	-.1576	.0626			-.0986	-.0883
.60					-.1734	.1356	-.1746	.0853	-.1627	.0536	-.1753	-.0040	-.0871	-.0915
.70			-.0596	.2202	-.1704	.1357	-.1910	.0668	-.2858	-.0241	-.3474	-.2551	-.2360	-.2192
.80	-.2353	-.1029	-.2966	-.1715	-.3278	-.1512			-.3380	-.2349	-.3222	-.2712		
.90	-.2389	-.1957			-.2956	-.1636			-.2987	-.2369	-.3004	-.2240		
.95	-.2121	-.2148							-.2523		-.2916	-.2222	-.2838	-.1727

TAIL 2

TABLE II. - CONTINUED
(g) $\alpha = 8.65^\circ$

Cp at y/b of														
x/c	0.02		0.22		0.44		0.56		0.67		0.83		0.98	
	U.S.	L.S.	U.S.	L.S.	U.S.	L.S.	U.S.	L.S.	U.S.	L.S.	U.S.	L.S.	U.S.	L.S.
.05	.1885	.6348	.2936	.9062					.3244	.9622	.3070	.9084		
.10	.1695	.6694	.2979	.8175	.3280	.8433	.3163	.8584	.3322	.8639	.3255	.8110	.2470	.5510
.15	.1851	.6909	.2809	.7500	.3227	.7820	.3325	.7934	.3270	.7998	.3214	.7288	.2500	.5133
.20	.1413	.5793	.2501	.6562	.3216	.7118			.3224	.7696	.3151	.6686	.2469	.4800
.25			-.0850	.0647	.2529	.5087	.2981	.6094	.3111	.6375	.3003	.6068	.2378	.4443
.30	-.0533	.2017	-.1239	.0720	-.0626	.0627	-.0414	.0621	.0740	.1837	.2689	.5255	.2462	.3990
.40									-.0849	.0315	-.1023	.0002	-.0579	-.0380
.50	.1615	.3472			-.1020	.1082			-.1002	.0263	-.0481	-.0495	-.0123	.0027
.60	.1587	.3079			-.1169	.1342	-.1046	.0700	-.1131	.0195	-.1203	-.0320	-.0228	.0136
.70	.1845	.3128	.1639	.3020	-.1349	.1264	-.1362	.0503	-.1873	-.0559			-.2362	-.1676
.80	-.1425	-.0677	-.1462	-.0915	-.2058	-.1072	-.2082	-.1922	-.2351	-.1856	-.2452	-.1918	-.3549	-.1133
.90	-.1246	-.0825	-.1708	-.1204	-.2113	-.1169	-.2047	-.1806	-.2408	-.1782	-.2416	-.1947	-.3369	-.1520
.95	-.0797	-.0753	-.1749	-.1172	-.1945	-.1285	-.1925	-.1460	-.2310	-.1679	-.2306	-.1946	-.3264	-.1687

TAIL 1

Cp at y/b of														
x/c	0.02		0.22		0.44		0.56		0.67		0.83		0.98	
	U.S.	L.S.	U.S.	L.S.	U.S.	L.S.	U.S.	L.S.	U.S.	L.S.	U.S.	L.S.	U.S.	L.S.
.05	.0338	.3896	.0474	.9565					.0076	1.0819	-.0005	1.0748		
.10	.0615	.4933	.0552	.8422					.0753	.9502	.0683	.9429	.1008	.6791
.15	.0698	.5325					.0888	.8347	.0885	.8495	.1070	.8384		
.20							.0894	.7483	.0981	.7551	.1038	.7509	.1078	.5079
.25	.0164	.1825	-.2166	.0843					.0965	.6453	.0968	.6610	.1003	.4387
.30			-.2130	.0894	-.2033	.0718	-.1919	.0930	-.0643	.2672				
.40	-.0155	.3400			-.2243	.1214	-.2059	.1079	-.2056	.9940	-.1904	.0558		
.50	-.0386	.2942					-.2138	.1314	-.2139	.1050			-.1172	-.0714
.60					-.2109	.2049	-.2221	.1560	-.2150	.1087	-.2082	.0460	-.1233	-.0892
.70			-.0908	.2460	-.2069	.2095	-.2388	.1387	-.3199	.0352	-.3642	-.2226	-.2676	-.2309
.80	-.2658	-.0086	-.3082	-.1577	-.3341	-.1203			-.3357	-.1862	-.3358	-.2469		
.90	-.2727	-.1813			-.3090	-.1468			-.2886	-.1848	-.3116	-.2264		
.95	-.2538	-.2092							-.2583		-.2916	-.2226	-.2921	-.1710

TAIL 2

TABLE II. - CONTINUED
(h) $\alpha = 10.65^\circ$

Cp at y/b of														
x/c	0.02		0.22		0.44		0.56		0.67		0.83		0.98	
	U.S.	L.S.	U.S.	L.S.	U.S.	L.S.	U.S.	L.S.	U.S.	L.S.	U.S.	L.S.	U.S.	L.S.
.05	.1420	.7500	.2538	.9993					.2724	.0257	.2706	.9610		
.10	.1323	.7838	.2645	.8893	.3055	.9043	.2857	.9174	.3049	.9144	.2926	.8540	.2462	.5925
.15	.1625	.7778	.2557	.8038	.2914	.8281	.2980	.8388	.2963	.8416	.2904	.7661	.2504	.5563
.20	.1257	.6326	.2171	.6927	.2930	.7471			.2941	.8096	.2849	.7014	.2470	.5196
.25			-.1160	.0792	.2290	.5319	.2704	.6351	.2786	.5632	.2745	.6362	.2397	.4837
.30	-.0857	.2389	-.1454	.1048	-.0826	.0781	-.0637	.0739	.0523	.1980	.2491	.5503	.2394	.4349
.40									-.1021	.0475	-.1118	.0154	-.0634	-.0182
.50	.1461	.4060			-.1210	.1459			-.1153	.0473	-.0515	-.0529	-.0387	.0288
.60	.1546	.3651			-.1371	.1673	-.1225	.1029	-.1266	.0454	-.1278	-.0094	-.0528	.0437
.70	.1924	.3710	.1194	.3499	-.1568	.1834	-.1518	.0794	-.1953	-.0303			-.2887	-.1491
.80	-.1348	-.0404	-.1464	-.0620	-.2152	-.0730	-.2230	-.1682	-.2444	-.1648	-.2494	-.1745	-.3680	-.0952
.90	-.1186	-.0592	-.1638	-.0949	-.1811	-.0904	-.1886	-.1443	-.2216	-.1573	-.2473	-.1757	-.3525	-.1258
.95	-.0580	-.0591	-.1572	-.0855	-.1593	-.0984	-.1683	-.1208	-.1979	-.1497	-.2290	-.1752	-.3440	-.1458

TAIL 1

Cp at y/b of														
x/c	0.02		0.22		0.44		0.56		0.67		0.83		0.98	
	U.S.	L.S.	U.S.	L.S.	U.S.	L.S.	U.S.	L.S.	U.S.	L.S.	U.S.	L.S.	U.S.	L.S.
.05	.0150	.3853	-.0569	1.0205					-.1119	1.1312	-.1111	1.1244		
.10	.0433	.5207	-.0304	.9056					-.0259	.9968	-.0316	.9947	.0261	.7278
.15	.0497	.5835							-.0060	.8761	-.0060	.8920	.0053	.8884
.20									-.0024	.7827	-.0034	.7927	.0165	.7961
.25	.0012	.2228	-.2523	.1087					.0033	.6760	.0127	.7002	.0608	.4730
.30			-.2332	.1415	-.2531	.0941	-.2449	.1098	-.1276	.2823				
.40	-.0333	.4003			-.2680	.1838	-.2585	.1546	-.2548	.1362	-.2357	.0837		
.50	-.0520	.3334					-.2622	.2080	-.2630	.1671			-.1548	-.0482
.60					-.2403	.2895	-.2653	.2453	-.2628	.1889	-.2414	.0983	-.1627	-.0677
.70			-.1232	.2757	-.2410	.2962	-.2728	.2245	-.3503	.1100	-.3749	-.1865	-.3030	-.2615
.80	-.2811	.0664	-.3291	-.1489	-.3534	-.1021			-.3217	-.1304	-.3417	-.2065		
.90	-.3002	-.1699			-.3032	-.1346			-.2707	-.1382	-.3107	-.1974		
.95	-.2961	-.1997							-.2551		-.2922	-.2057	-.3284	-.2175

TAIL 2

TABLE II. - CONTINUED
(1) $\alpha = 12.65^\circ$

Cp at y/b of														
x/c	0.02		0.22		0.44		0.56		0.67		0.83		0.98	
	U.S.	L.S.	U.S.	L.S.	U.S.	L.S.	U.S.	L.S.	U.S.	L.S.	U.S.	L.S.	U.S.	L.S.
.05	.1043	.8552	.2119	1.0660					.2230	1.0757	.2346	1.0066		
.10	.1087	.8840	.2306	.9445	.2758	.9518	.2514	.9641	.2708	.9565	.2599	.8940	.2393	.6327
.15	.1482	.8448	.2236	.8467	.2645	.8664	.2690	.8774	.2749	.8767	.2604	.7999	.2421	.5971
.20	.1127	.6714	.1879	.7258	.2662	.7788			.2694	.8371	.2558	.7321	.2364	.5577
.25			-.1362	.0939	.2128	.5532	.2496	.6582	.2550	.6907	.2469	.6635	.2247	.5228
.30	-.1183	.2738	-.1702	.1468	-.0965	.0940	-.0797	.0867	.0357	.2089	.2255	.5745	.2307	.4667
.40									-.1190	.0659	-.1222	.0305	-.0741	-.0017
.50	.1275	.4854			-.1360	.1832			-.1318	.0702	-.0534	-.0547	-.0619	.0498
.60	.1499	.4347			-.1526	.1933	-.1386	.1361	-.1422	.0724	-.1343	.0134	-.1306	.0684
.70	.1980	.4269	.0583	.4060	-.1742	.3062	-.1642	.1089	-.2058	-.0053			-.3239	-.1304
.80	-.1301	-.0146	-.1616	-.0348	-.1835	-.0384	-.1923	-.1364	-.2178	-.1478	-.2339	-.1546	-.3764	-.0711
.90	-.1223	-.0393	-.1525	-.0683	-.1472	-.0619	-.1565	-.0953	-.1976	-.1376	-.2326	-.1557	-.3632	-.0930
.95	-.0396	-.0427	-.1154	-.0556	-.1341	-.0741	-.1457	-.0590	-.1792	-.1289	-.2191	-.1552	-.3507	-.1127

TAIL 1

Cp at y/b of														
x/c	0.02		0.22		0.44		0.56		0.67		0.83		0.98	
	U.S.	L.S.	U.S.	L.S.	U.S.	L.S.	U.S.	L.S.	U.S.	L.S.	U.S.	L.S.	U.S.	L.S.
.05	-.0042	.3552	-.1438	1.0756					-.2154	1.1694	-.2211	1.1660		
.10	.0226	.5177	-.1102	.9591					-.1262	1.0366	-.1275	1.0366	-.0643	.7633
.15	.0276	.6290							-.0964	.9115	-.0878	.9308	-.0911	.3270
.20									-.0849	.8142	-.0787	.8275	-.0755	.5813
.25	-.0235	.2668	-.2713	.1325					-.0789	.7044	-.0676	.7301	.0023	.5006
.30			-.2585	.1351	-.3002	.1223	-.2917	.1234	-.1859	.2959				
.40	-.0448	.4617			-.3087	.2655	-.3039	.2264	-.2987	.1864	-.2855	.1164		
.50	-.0573	.3646					-.3071	.2988	-.3072	.2513			-.2011	-.0189
.60					-.2727	.3758	-.3043	.3376	-.3078	.2856	-.2761	.1704	-.2010	-.0292
.70			-.1582	.3011	-.2293	.3560	-.2988	.3144	-.3387	.1962	-.3616	-.1330	-.3269	-.2527
.80	-.2856	.0652	-.3343	-.1360	-.3585	-.0927			-.2944	-.0871	-.3395	-.1504		
.90	-.3220	-.1577			-.3310	-.1260			-.2701	-.1087	-.2972	-.1463		
.95	-.3251	-.1855							-.2599		-.2853	-.1580	-.3377	-.2317

TAIL 2

TABLE II. - CONTINUED
(j) $\alpha = 16.65^\circ$

Cp at y/b of														
x/c	0.02		0.22		0.44		0.56		0.67		0.83		0.98	
	U.S.	L.S.	U.S.	L.S.	U.S.	L.S.	U.S.	L.S.	U.S.	L.S.	U.S.	L.S.	U.S.	L.S.
.05	.0580	1.0888	.1178	1.1799					.1357	1.1577	.1548	1.0796		
.10	.0725	1.0563	.1659	1.0443	.2153	1.0368	.1849	1.0424	.1951	1.0323	.1826	.9565	.2107	.7089
.15	.1006	.9595	.1622	.9320	.2106	.9389	.2141	.9441	.2231	.9420	.1891	.8599	.2233	.6715
.20	.0633	.7448	.1442	.7880	.2134	.8383			.2154	.8965	.1942	.7903	.2193	.6294
.25			-.1632	.1279	.1640	.5924	.1964	.7008	.1981	.7356	.1985	.7170	.2064	.5944
.30	-.1937	.3893	-.2033	.2401	-.1313	.1277	-.1107	.1121	-.0119	.2259	.1898	.6179	.2244	.5308
.40									-.1505	.1030	-.1376	.0602	-.0937	.0358
.50	.0678	.6224			-.1694	.2520			-.1575	.1227	-.0147	-.0089	-.1888	.1112
.60	.0942	.5237			-.1873	.4053	-.1686	.2284	-.1646	.1443	-.1409	.0699	-.2848	.1375
.70	.1651	.5257	-.0649	.4856	-.1997	.4618	-.1801	.2327	-.1955	.0625			-.3778	-.0803
.80	-.1276	.0228	-.1702	.0065	-.1097	-.0212	-.1409	-.0019	-.1836	-.1176	-.2377	-.1054	-.3870	-.0254
.90	-.0552	-.0140	-.0527	-.0277	-.0833	-.0285	-.1106	-.0249	-.1641	-.0575	-.2095	-.1051	-.3741	-.0400
.95	-.0782	-.0083	-.0346	-.0187	-.0794	-.0299	-.1044	-.0249	-.1543	-.0173	-.1798	-.1045	-.3573	-.0508

TAIL 1

Cp at y/b of														
x/c	0.02		0.22		0.44		0.56		0.67		0.83		0.98	
	U.S.	L.S.	U.S.	L.S.	U.S.	L.S.	U.S.	L.S.	U.S.	L.S.	U.S.	L.S.	U.S.	L.S.
.05	-.0381	.2713	-.2793	1.1642					-.3684	1.2160	-.3731	1.2085		
.10	-.0207	.4197	-.2366	1.0509					-.2906	1.0932	-.2946	1.0907	-.2394	.8109
.15	-.0131	.5633							-.2525	.9689	-.2509	.9864	-.2517	.9823
.20									-.2379	.8651	-.2354	.8779	-.2302	.8843
.25	-.0740	.3495	-.3247	.1876					-.2262	.7464	-.2193	.7770	-.1213	.5422
.30			-.2857	.3024	-.3792	.2684	-.3742	.1870	-.3031	.3164				
.40	-.0606	.5479			-.3706	.4130	-.3851	.3677	-.3830	.3317	-.3731	.2348		
.50	-.0491	.3866					-.3833	.5079	-.3874	.4777			-.2983	.0821
.60					-.3143	.4656	-.3558	.4624	-.3871	.4490	-.3562	.3860	-.3076	.1055
.70			-.1905	.3316	-.2641	.3900	-.3126	.3743	-.3559	.2996	-.3595	-.0508	-.3811	-.1548
.80	-.2925	.0163	-.3553	-.1165	-.3619	-.0842			-.3189	-.0601	-.3154	-.0911		
.90	-.3360	-.1436			-.3426	-.1126			-.3138	-.0906	-.3021	-.1039		
.95	-.3405	-.1650							-.3051		-.3087	-.1221	-.3697	-.2019

TAIL 2

TABLE II. - CONCLUDED
(k) $\alpha = 20.65^\circ$

Cp at y/b of														
x/c	0.02		0.22		0.44		0.56		0.67		0.83		0.98	
	U.S.	L.S.	U.S.	L.S.	U.S.	L.S.	U.S.	L.S.	U.S.	L.S.	U.S.	L.S.	U.S.	L.S.
.05	.0169	1.3002	.0296	1.2764					.0526	1.2435	.0829	1.1697		
.10	.0280	1.1899	.0969	1.1341	.1367	1.1197	.0964	1.1245	.1258	1.1105	.1374	1.0412	.2227	.8154
.15	.0600	1.0592	.1027	1.0090	.1583	1.0150	.1589	1.0193	.1763	1.0138	.1622	.9382	.2314	.7721
.20	.0291	.8100	.0910	.8503	.1622	.9019			.1869	.9512	.1852	.8635	.2239	.7285
.25			-.1906	.2135	.1253	.6390	.1678	.7491	.1736	.7893	.2059	.7904	.2200	.6805
.30	-.2274	.6624	-.2294	.2846	-.1522	.1775	-.1252	.1434	-.0242	.2525	.2013	.6694	.3033	.6107
.40									-.1497	.1568	-.1312	.1014	-.1253	.0815
.50	-.0556	.6985			-.1826	.4825			-.1543	.2103	.0059	.0103	-.2841	.1893
.60	.0497	.6168			-.1923	.5906	-.1660	.4214	-.1589	.2428	-.1235	.1533	-.3107	.2177
.70	.1632	.6009	-.1175	.5611	-.1952	.5136	-.1806	.3303	-.2007	.2157			-.3973	-.0156
.80	-.1125	.0493	-.0081	.0318	-.0472	.0037	-.0986	.0005	-.1678	.0278	-.2369	-.0359	-.3982	.0410
.90	.0670	.0096	-.0051	.0090	-.0384	.0004	-.0653	.0012	-.1267	.0516	-.2090	-.0318	-.3707	.0284
.95	.1584	.0303	.0040	.0117	-.0380	.0083	-.0644	.0001	-.1047	.0581	-.1609	-.0223	-.3537	.0217

TAIL 1

Cp at y/b of														
x/c	0.02		0.22		0.44		0.56		0.67		0.83		0.98	
	U.S.	L.S.	U.S.	L.S.	U.S.	L.S.	U.S.	L.S.	U.S.	L.S.	U.S.	L.S.	U.S.	L.S.
.05	-.0914	.2144	-.3746	1.2305					-.4558	1.2142	-.4514	1.2031		
.10	-.0632	.3800	-.3201	1.1278					-.4193	1.1088	-.4234	1.1064	-.4009	.8331
.15	-.0478	.4840					-.3705	.9940	-.3786	1.0092	-.3839	1.0075		
.20							-.3476	.8902	-.3576	.9034	-.3605	.9148	-.2661	.6688
.25	-.0928	.3893	-.3240	.2719					-.3489	.7731	-.3458	.8108	-.2685	.5822
.30			-.2842	.4277	-.4363	.3943	-.4380	.3923	-.3922	.3682				
.40	-.0769	.4515			-.4058	.6177	-.4321	.6252	-.4457	.5995	-.4418	.4461		
.50	-.0670	.3481					-.3798	.5483	-.4398	.5349			-.4086	.2969
.60					-.2930	.4844	-.3803	.4889	-.4120	.4851	-.4142	.4390	-.4151	.2154
.70			-.2202	.3501	-.2843	.4149	-.4069	.4023	-.4247	.3237	-.3662	-.0241	-.4374	-.1343
.80	-.2982	.0498	-.3699	-.1115	-.4037	-.0633			-.3810	-.0388	-.3597	-.0626		
.90	-.3323	-.1005			-.3765	-.0967			-.3483	-.0658	-.3398	-.0753		
.95	-.3345	-.1245							-.3204		-.3414	-.0927	-.4047	-.1765

TAIL 2

TABLE III. - PRESSURE COEFFICIENTS, $\phi = 45^\circ$, $\delta = 0^\circ$, $M = 1.60$
(a) $\alpha = -3.31^\circ$

Cp at y/b of														
x/c	0.02		0.22		0.44		0.56		0.67		0.83		0.98	
	U.S.	L.S.	U.S.	L.S.	U.S.	L.S.	U.S.	L.S.	U.S.	L.S.	U.S.	L.S.	U.S.	L.S.
.05	.2207	.1336	.6718	-.3861					.8216	-.4124	.8030	-.3982		
.10	.2381	.1398	.5788	-.3136	-.6903	-.4166	-.7222	-.4395	-.7534	-.4118	-.7412	-.4051	-.4855	-.2757
.15	.2491	.1318	.5264	-.2682	-.6314	-.3869	-.6697	-.4176	-.6924	-.4292	-.6750	-.4023	-.4240	-.2526
.20	.1910	-.0765	.4695	-.2368	-.5819	-.3697			-.6373	-.4615	-.6202	-.4012	-.3914	-.2431
.25			-.0280	-.1257	-.4319	-.2739	-.5164	-.3647	-.5644	-.3936	-.5556	-.3860	-.3392	-.2289
.30	.2203	-.0056	-.0094	-.1510	-.0416	-.0788	-.0596	-.0507	.1941	-.0586	.4726	-.3422	-.3172	-.2121
.40									.0233	-.0754	-.0144	-.0854	-.0985	-.1194
.50	-.1796	-.0075			.0237	-.1156			.0138	-.0913	-.0370	-.0382	-.1000	-.0829
.60	-.1186	-.0137			.0415	-.1261	-.0165	-.1123	.0001	-.1105	-.0499	-.1317	-.0813	-.0878
.70	-.1274	-.0073	-.1666	-.0245	-.0365	-.1352	-.0129	-.1374	-.0898	-.1808			-.2190	-.2371
.80	-.1733	-.2451	-.1802	-.2661	-.1773	-.3232	-.2379	-.3314	-.2714	-.3057	-.2822	-.3002	-.1544	-.1877
.90	-.1813	-.2275	-.2179	-.2905	-.1811	-.2857	-.2246	-.2939	-.2559	-.2898	-.2543	-.2959	-.1613	-.2445
.95	-.1772	-.1754	-.2208	-.2670	-.1833	-.2548	-.2175	-.2674	-.2384	-.2735	-.2487	-.2915	-.1596	-.2472

TAIL 1

Cp at y/b of														
x/c	0.02		0.22		0.44		0.56		0.67		0.83		0.98	
	U.S.	L.S.	U.S.	L.S.	U.S.	L.S.	U.S.	L.S.	U.S.	L.S.	U.S.	L.S.	U.S.	L.S.
.05	.4384	.1510	.7402	-.3443					.8592	-.4400	.8587	-.4481		
.10	.4667	.1987	.6592	-.3182					.7688	-.4109	.7672	-.4222	.4940	-.2845
.15	.4629	.1645							.6970	-.3989	.7095	-.4021	.6856	-.4010
.20									.6428	-.3805	.6546	-.3866	.6247	-.3711
.25	.1530	-.0358	.0607	-.0933					.5815	-.3562	.5636	-.3397	.4090	-.2524
.30			.0526	-.1234	.0453	-.0791	.0587	-.0445	.2499	-.1196				
.40	.2972	-.0215			.0516	-.0985	.0430	-.0797	.0317	-.0695	.0073	-.0848		
.50	.3332	.0223					.0410	-.0934	.0189	-.0944			-.0184	-.0470
.60					.0395	-.1164	.0630	-.1098	.0111	-.1124	-.0342	-.1239	-.0217	-.0269
.70			.2636	-.0382	.0202	-.1279	.0436	-.1426	-.1606	-.1802	-.2673	-.3017	-.1559	-.2054
.80	-.2530		-.1276	-.2126	-.1055	-.2337			-.2363	-.2480	-.2310	-.2622		
.90	-.1325	-.1949			-.1122	-.2360			-.2086	-.2519	-.2149	-.2532		
.95	-.1614	-.1736							-.1957		-.2155	-.2570	-.1853	-.2927

TAIL 2

TABLE III. - CONTINUED
(b) $\alpha = -1.30^\circ$

Cp at y/b of														
x/c	0.02		0.22		0.44		0.56		0.67		0.83		0.98	
	U.S.	L.S.	U.S.	L.S.	U.S.	L.S.	U.S.	L.S.	U.S.	L.S.	U.S.	L.S.	U.S.	L.S.
.05	.2517	.1964	.6122	.5062					.6931	.5423	.6680	.5180		
.10	.2571	.2029	.5274	.4282	.6154	.4943	.6438	.5283	.6619	.5244	.6508	.5187	.4100	.3365
.15	.2652	.1981	.4769	.3786	.5758	.4758	.6074	.5032	.6252	.5215	.6124	.5083	.3725	.3122
.20	.2039	.1409	.4250	.3405	.5364	.4518			.5834	.5356	.5714	.4879	.3480	.2968
.25			.0059	-.0663	.4090	.3371	.4841	.4338	.5306	.4673	.5172	.4518	.3177	.2732
.30	.1915	.0133	-.0293	-.0958	.0279	-.0385	.0474	-.0137	.1847	.0969	.4445	.3955	.3062	.2525
.40									.0070	-.0424	-.0284	-.0640	-.0939	-.1053
.50	.1567	.0550			-.0041	-.0704			-.0080	-.0615	-.0293	-.0277	-.0706	-.0745
.60	.1067	.0313			.0045	-.0796	-.0122	-.0734	-.0256	-.0806	-.0704	-.1125	-.0607	-.0741
.70	.1164	.0515	.1639	.0388	-.0012	-.0916	-.0444	-.1020	-.1141	-.1544			-.2115	-.2139
.80	-.1737	-.2077	-.1827	-.2247	-.2060	-.3028	-.2674	-.3122	-.2813	-.2981	-.2717	-.2890	-.1539	-.1751
.90	-.1846	-.1959	-.2149	-.2478	-.2064	-.2611	-.2356	-.2739	-.2438	-.2773	-.2578	-.2836	-.1903	-.2351
.95	-.1762	-.1626	-.2193	-.2491	-.1930	-.2389	-.2252	-.2567	-.2371	-.2649	-.2548	-.2799	-.1864	-.2354

TAIL 1

Cp at y/b of														
x/c	0.02		0.22		0.44		0.56		0.67		0.83		0.98	
	U.S.	L.S.	U.S.	L.S.	U.S.	L.S.	U.S.	L.S.	U.S.	L.S.	U.S.	L.S.	U.S.	L.S.
.05	.3280	.2317	.6241	.4389					.7237	.5430	.7395	.5479		
.10	.3451	.2433	.5538	.4034					.6720	.5179	.6815	.5208	.4252	.3346
.15	.3384	.2290					.6164	.4818	.6313	.4949	.6190	.4904		
.20							.5784	.4553	.5930	.4668	.5699	.4541	.3586	.2849
.25	.0850	-.0072	.0177	-.0582					.5354	.4223	.5170	.4136	.3207	.2713
.30			-.0035	-.0865	-.0176	-.0461	.0394	-.0086	.2278	.1594				
.40	.1826	.0310			.0095	-.0604	.0152	-.0455	.0095	-.0408	-.0120	-.0567		
.50	.2450	.0579					.0026	-.0610	-.0080	-.0650			-.0297	-.0392
.60					.0387	-.0754	-.0030	-.0767	-.0213	-.0844	-.0588	-.1061	-.0323	-.0221
.70			.2446	.0185	.0236	-.0849	-.0288	-.1108	-.1913	-.1550	-.2792	-.2980	-.1581	-.1983
.80	-.1014		-.1481	-.2089	-.1682	-.2221			-.2247	-.2385	-.2330	-.2554		
.90	-.1869	-.1969			-.1527	-.2234			-.2174	-.2431	-.2225	-.2470		
.95	-.1783	-.1783							-.2175		-.2264	-.2499	-.2058	-.2525

TAIL 2

TABLE III. - CONTINUED
(c) $\alpha = 0.70^\circ$

Cp at y/b of														
x/c	0.02		0.22		0.44		0.56		0.67		0.83		0.98	
	U.S.	L.S.	U.S.	L.S.	U.S.	L.S.	U.S.	L.S.	U.S.	L.S.	U.S.	L.S.	U.S.	L.S.
.05	.2549	.2616	.5243	.5951					.5246	.6714	.4983	.6586		
.10	.2608	.2721	.4682	.5201	.5314	.5854	.5374	.6240	.5356	.6300	.5120	.6309	.3234	.4047
.15	.2619	.2789	.4280	.4698	.5076	.5559	.5328	.5878	.5360	.6118	.5156	.5903	.3080	.3717
.20	.2084	.2272	.3856	.4217	.4827	.5254			.5177	.5186	.5046	.5474	.3053	.3441
.25			-.0133	-.0276	.3729	.3924	.4434	.4931	.4815	.5259	.4696	.4982	.2889	.3091
.30	.1263	.0684	-.0485	-.0519	-.0083	-.0050	.0331	.0126	.1698	.1217	.4119	.4330	.2876	.2834
.40									-.0092	-.0228	-.0389	-.0482	-.0871	-.0958
.50	.1322	.1274			-.0311	-.0336			-.0278	-.0402	-.0237	-.0242	-.0534	-.0675
.60	.0959	.0991			-.0283	-.0395	-.0344	-.0445	-.0481	-.0582	-.0834	-.0959	-.0210	-.0679
.70	.1095	.1192	.1652	.1457	-.0352	-.0473	-.0677	-.0751	-.1343	-.1344			-.1908	-.2154
.80	-.1716	-.1692	-.1801	-.1849	-.2393	-.2580	-.2404	-.2634	-.2319	-.2636	-.2452	-.2703	-.1769	-.1623
.90	-.1815	-.1742	-.2059	-.2153	-.2188	-.2339	-.2308	-.2451	-.2332	-.2545	-.2460	-.2680	-.2238	-.2158
.95	-.1676	-.1555	-.2085	-.2192	-.2012	-.2125	-.2276	-.2281	-.2307	-.2505	-.2464	-.2669	-.2097	-.2230

TAIL 1

Cp at y/b of														
x/c	0.02		0.22		0.44		0.56		0.67		0.83		0.98	
	U.S.	L.S.	U.S.	L.S.	U.S.	L.S.	U.S.	L.S.	U.S.	L.S.	U.S.	L.S.	U.S.	L.S.
.05	.2420	.2706	.5244	.5585					.5797	.6806	.5935	.6828		
.10	.2580	.2759	.4605	.4899					.5618	.6278	.5758	.6293	.3594	.4094
.15	.2498	.2629					.5236	.5646	.5409	.5861	.5430	.5785		
.20							.5026	.5265	.5200	.5427	.5107	.5283	.3113	.3266
.25	.0596	.0214	-.0249	-.0269					.4798	.4827	.4699	.4761	.2817	.3023
.30			-.0491	-.0582	-.0114	-.0183	.0128	.0179	.2003	.1911				
.40	.1076	.0965			-.0242	-.0307	-.0125	-.0190	-.0108	-.0162	-.0304	-.0346		
.50	.1336	.0903					-.0250	-.0323	-.0306	-.0376			-.0412	-.0391
.60					-.0266	-.0460	-.0331	-.0466	-.0462	-.0573	-.0790	-.0886	-.0370	-.0478
.70			.1615	.1201	-.0333	-.0574	-.0603	-.0805	-.2114	-.1303	-.2969	-.2949	-.1674	-.1999
.80	-.1403		-.1692	-.2127	-.2419	-.2364			-.2710	-.2311	-.2683	-.2502		
.90	-.1831	-.1870			-.2182	-.2269			-.2439	-.2379	-.2499	-.2412		
.95	-.1883	-.1617							-.2393		-.2507	-.2467	-.2247	-.2210

TAIL 2

TABLE III. - CONTINUED
(d) $\alpha = 2.70^\circ$

Cp at y/b of														
x/c	0.02		0.22		0.44		0.56		0.67		0.83		0.98	
	U.S.	L.S.	U.S.	L.S.	U.S.	L.S.	U.S.	L.S.	U.S.	L.S.	U.S.	L.S.	U.S.	L.S.
.05	.2207	.3590	.4101	.6876					.4090	.7992	.3947	.7839		
.10	.2361	.3696	.4280	.6139	.4167	.6790	.4094	.7181	.4106	.7315	.4033	.7184	.2703	.4730
.15	.2441	.3885	.3565	.5588	.4126	.6399	.4204	.6692	.4164	.6917	.4050	.6538	.2655	.4276
.20	.1989	.3410	.3270	.5028	.4040	.5364			.4134	.6797	.3964	.6002	.2591	.3931
.25			-.0416	.0083	.3145	.4382	.3727	.5369	.3964	.5737	.3808	.5423	.2454	.3516
.30	.0343	.1222	-.0747	-.0112	-.0251	.0186	.0004	.0310	.1277	.1413	.3403	.4680	.2490	.3200
.40									-.0389	-.0034	-.0682	-.0320	-.0866	-.0827
.50	.1018	.2278			-.0620	.0010			-.0568	-.0181	-.0274	-.0273	-.0586	-.0590
.60	.0852	.1806			-.0654	.0260	-.0658	-.0150	-.0759	-.0334	-.1027	-.0754	.0036	-.0590
.70	.1088	.1764	.1116	.2222	-.0734	.0204	-.0952	-.0428	-.1589	-.1118			-.1921	-.2121
.80	-.1691	-.1370	-.1771	-.1690	-.2367	-.1964	-.2193	-.2438	-.2332	-.2329	-.2499	-.2445	-.2070	-.1446
.90	-.1795	-.1547	-.1983	-.1964	-.2252	-.1744	-.2222	-.2225	-.2388	-.2386	-.2510	-.2457	-.2611	-.1905
.95	-.1529	-.1415	-.2037	-.1891	-.2106	-.1689	-.2200	-.2072	-.2367	-.2374	-.2523	-.2457	-.2454	-.2016

TAIL 1

Cp at y/b of														
x/c	0.02		0.22		0.44		0.56		0.67		0.83		0.98	
	U.S.	L.S.	U.S.	L.S.	U.S.	L.S.	U.S.	L.S.	U.S.	L.S.	U.S.	L.S.	U.S.	L.S.
.05	.1793	.2657	.4239	.6400					.4609	.7980	.4537	.8016		
.10	.1918	.2781	.3627	.5537					.4513	.7147	.4680	.7144	.3018	.4805
.15	.1799	.2678					.4356	.6291	.4458	.6527	.4473	.6466		
.20							.4238	.5784	.4367	.5945	.4356	.5845	.2612	.3621
.25	.0585	.0545	-.0703	-.0047					.4116	.5217	.4126	.5206	.2384	.3237
.30			-.0975	-.0358	-.0477	-.0009	-.0194	.0344	.1567	.2090				
.40	.0554	.1515			-.0640	-.0087	-.0471	.0012	-.0365	.0025	-.0503	-.0175		
.50	.0616	.1155					-.0594	-.0095	-.0552	-.0155			-.0566	-.0536
.60					-.0720	-.0181	-.0652	-.0214	-.0702	-.0334	-.0964	-.0700	-.0388	-.0609
.70			.0437	.1375	-.0823	-.0253	-.0882	-.0544	-.2286	-.1079	-.3079	-.2955	-.1813	-.2073
.80	-.1952		-.2124	-.2106	-.2861	-.2492			-.3128	-.2335	-.2970	-.2558		
.90	-.1893	-.1923			-.2464	-.2237			-.2757	-.2330	-.2703	-.2433		
.95	-.1696	-.1790							-.2639		-.2671	-.2488	-.2283	-.2102

TAIL 2

TABLE III. - CONTINUED
(e) $\alpha = 4.70^\circ$

Cp at y/b of														
x/c	0.02		0.22		0.44		0.56		0.67		0.83		0.98	
	U.S.	L.S.	U.S.	L.S.	U.S.	L.S.	U.S.	L.S.	U.S.	L.S.	U.S.	L.S.	U.S.	L.S.
.05	.1668	.4735	.2869	.8044					.3256	.9152	.3030	.8892		
.10	.1648	.4969	.3032	.7205	.3287	.7770	.3217	.8118	.3245	.8244	.3212	.7954	.2349	.5382
.15	.1944	.5326	.2818	.6615	.3229	.7234	.3315	.7476	.3265	.7667	.3271	.7155	.2387	.4865
.20	.1602	.4704	.2505	.5891	.3158	.6644			.3236	.7418	.3202	.6526	.2350	.4446
.25			-.0881	.0395	.2484	.4775	.2935	.5786	.3097	.6151	.3043	.5871	.2196	.3954
.30	-.0330	.1760	-.1207	.0319	-.0645	.0395	-.0444	.0459	.0711	.1604	.2721	.5038	.2225	.3566
.40									-.0811	.0178	-.1005	-.0137	-.0849	-.0707
.50	.0713	.2898			-.1075	.0728			-.0962	.0101	-.0350	-.0352	-.0448	-.0470
.60	.0740	.2344			-.1143	.1099	-.1046	.0472	-.1084	.0012	-.1261	-.0497	-.0216	-.0442
.70	.1066	.2268	.0498	.2500	-.1174	.1061	-.1344	.0316	-.1845	-.0722			-.2012	-.2057
.80	-.1674	-.1095	-.1756	-.1395	-.2450	-.1365	-.2348	-.2079	-.2538	-.2214	-.2680	-.2243	-.2946	-.1305
.90	-.1728	-.1294	-.1968	-.1699	-.2375	-.1410	-.2365	-.1899	-.2558	-.2011	-.2652	-.2251	-.3128	-.1646
.95	-.1436	-.1326	-.2049	-.1644	-.2284	-.1555	-.2331	-.1819	-.2488	-.1948	-.2613	-.2252	-.2908	-.1762

TAIL 1

Cp at y/b of														
x/c	0.02		0.22		0.44		0.56		0.67		0.83		0.98	
	U.S.	L.S.	U.S.	L.S.	U.S.	L.S.	U.S.	L.S.	U.S.	L.S.	U.S.	L.S.	U.S.	L.S.
.05	.1202	.2320	.2790	.6978					.3274	.8857	.3120	.8949		
.10	.1274	.2568	.2416	.6029					.3564	.7824	.3657	.7869	.2473	.5436
.15	.1152	.2547							.3517	.7073	.3491	.7040		
.20									.3456	.6203	.3541	.6380	.3436	.6314
.25	.0450	.1219	-.1289	.0158					.3383	.5544	.3368	.5597	.1957	.3460
.30			-.1568	-.0165	-.0969	.0140	-.0668	.0470	.1096	.2241				
.40	.0170	.1910			-.1144	.0152	-.0910	.0212	-.0759	.0215	-.0763	-.0008		
.50	.0093	.1445					-.1047	.0167	-.0934	.0094			-.0729	-.0770
.60					-.1245	.0178	-.1105	.0090	-.1043	-.0052	-.1199	-.0473	-.0548	-.0810
.70			-.0197	.1559	-.1312	.0159	-.1274	-.0234	-.2510	-.0809	-.3225	-.2824	-.1912	-.2111
.80	-.2305		-.2640	-.2072	-.3061	-.2155			-.3303	-.2763	-.3117	-.2752		
.90	-.1939	-.1972			-.2844	-.2070			-.2929	-.2372	-.2839	-.2440		
.95	-.1646	-.2051							-.2740		-.2750	-.2467	-.2477	-.1919

TAIL 2

TABLE III. - CONTINUED
 (f) $\alpha = 6.70^\circ$

Cp at y/b of														
x/c	0.02		0.22		0.44		0.56		0.67		0.83		0.98	
	U.S.	L.S.	U.S.	L.S.	U.S.	L.S.	U.S.	L.S.	U.S.	L.S.	U.S.	L.S.	U.S.	L.S.
.05	.0952	.6099	.1959	.9358					.2240	1.0207	.2157	.9793		
.10	.0859	.6527	.2197	.8334	.2525	.8709	.2434	.8982	.2609	.9085	.2403	.8699	.2139	.6057
.15	.1253	.6873	.2124	.7594	.2502	.8018	.2574	.8189	.2558	.8350	.2569	.7781	.2200	.5464
.20	.1053	.5858	.1780	.6629	.2435	.7252			.2549	.7956	.2526	.7069	.2164	.4991
.25			.1305	.0690	.1808	.5138	.2286	.6174	.2362	.6584	.2456	.6342	.1973	.4448
.30	-.0934	.2395	-.1667	.0983	-.1087	.0693	-.0812	.0655	.0215	.1839	.2203	.5414	.2143	.3993
.40									-.1229	.0490	-.1284	.0084	-.0927	-.0526
.50	.0338	.3481			-.1436	.1487			-.1340	.0529	-.0430	-.0434	-.0551	-.0330
.60	.0547	.2930			-.1563	.1713	-.1377	.1161	-.1446	.0536	-.1473	-.0138	-.0526	-.0221
.70	.0951	.2760	-.0046	.2924	-.1708	.2245	-.1606	.0965	-.2112	-.0203			-.2426	-.1968
.80	-.1665	-.0786	-.1970	-.1073	-.2936	-.0987	-.2997	-.1544	-.2917	-.2112	-.2903	-.2012	-.3600	-.1093
.90	-.1768	-.1004	-.1994	-.1395	-.2582	-.1263	-.2734	-.1448	-.2731	-.1841	-.2811	-.1986	-.3378	-.1309
.95	-.1270	-.1100	-.2036	-.1287	-.2242	-.1395	-.2378	-.1445	-.2474	-.1756	-.2648	-.1973	-.3088	-.1464

TAIL 1

Cp at y/b of														
x/c	0.02		0.22		0.44		0.56		0.67		0.83		0.98	
	U.S.	L.S.	U.S.	L.S.	U.S.	L.S.	U.S.	L.S.	U.S.	L.S.	U.S.	L.S.	U.S.	L.S.
.05	.1065	.1913	.1306	.7534					.1970	.9569	.1844	.9619		
.10	.1133	.2239	.1380	.6509					.2455	.8407	.2666	.8441	.1967	.5966
.15	.1025	.2355					.2560	.7263	.2516	.7549	.2562	.7505		
.20							.2600	.6574	.2572	.6779	.2519	.6742	.1743	.4363
.25	.0254	.1740	-.1730	.0393					.2560	.5857	.2478	.5950	.1545	.3753
.30			-.1810	.0078	-.1472	.0285	-.1134	.0584	.0581	.2382				
.40	-.0085	.2263			-.1560	.0424	-.1408	.0442	-.1194	.0439	-.1108	.0166		
.50	-.0172	.1773					-.1493	.0483	-.1337	.0394			-.0986	-.0992
.60					-.1558	.0652	-.1508	.0454	-.1487	.0302	-.1473	-.0211	-.0894	-.1034
.70			-.0673	.1632	-.1495	.0671	-.1644	.0164	-.2731	-.0498	-.3391	-.2688	-.2153	-.2322
.80	-.2409		-.2864	-.2045	-.3057	-.1898			-.3431	-.2604	-.3226	-.2933		
.90	-.2494	-.1975			-.2943	-.1878			-.3057	-.2645	-.2989	-.2494		
.95	-.2291	-.2207							-.2699		-.2905	-.2463	-.2569	-.1804

TAIL 2

TABLE III. - CONTINUED
(g) $\alpha = 8.70^\circ$

Cp at γ/b of														
x/c	0.02		0.22		0.44		0.56		0.67		0.83		0.98	
	U.S.	L.S.	U.S.	L.S.	U.S.	L.S.	U.S.	L.S.	U.S.	L.S.	U.S.	L.S.	U.S.	L.S.
.05	.0143	.7360	.1187	1.0444					.1223	1.1007	.1359	1.0558		
.10	.0196	.8060	.1369	.9297	.1761	.9518	.1643	.9698	.1863	.9789	.1681	.9350	.1969	.6666
.15	.0667	.8145	.1362	.8376	.1845	.8691	.1833	.8824	.1957	.8947	.1922	.8329	.2004	.6038
.20	.0580	.6691	.1103	.7151	.1778	.7790			.1897	.8465	.1884	.7583	.1927	.5495
.25			-.1815	.0939	.1325	.5471	.1682	.6564	.1769	.6978	.1819	.6793	.1787	.4892
.30	-.1515	.3114	-.2136	.1728	-.1492	.0996	-.1238	.0884	-.0222	.2062	.1709	.5754	.1824	.4368
.40									-.1581	.0814	-.1497	.0320	-.1058	-.0375
.50	.0055	.4093			-.1773	.2148			-.1694	.0978	-.0496	-.0504	-.0823	-.0184
.60	.0346	.3482			-.1899	.2423	-.1757	.1864	-.1745	.1116	-.1868	.0235	-.1012	-.0016
.70	.0803	.3314	-.0510	.3384	-.2071	.3511	-.1956	.1646	-.2315	.0356			-.3087	-.1855
.80	-.1690	-.0457	-.2424	-.0786	-.2824	-.0873	-.2997	-.0935	-.2946	-.1706	-.3007	-.1990	-.3689	-.1403
.90	-.1950	-.0760	-.2122	-.1104	-.2371	-.1076	-.2510	-.1116	-.2687	-.1558	-.2882	-.1781	-.3495	-.1021
.95	-.1085	-.0893	-.1892	-.0965	-.2164	-.1185	-.2274	-.1195	-.2489	-.1507	-.2550	-.1739	-.3258	-.1206

TAIL 1

Cp at γ/b of														
x/c	0.02		0.22		0.44		0.56		0.67		0.83		0.98	
	U.S.	L.S.	U.S.	L.S.	U.S.	L.S.	U.S.	L.S.	U.S.	L.S.	U.S.	L.S.	U.S.	L.S.
.05	.1244	.1939	.0338	.7822					.0820	1.0097	.0711	1.0170		
.10	.1228	.2230	.0957	.6898					.1359	.8864	.1500	.8920	.1356	.6344
.15	.1054	.2260					.1463	.7696	.1579	.7946	.1686	.7928		
.20							.1635	.6936	.1571	.7088	.1645	.7091	.1293	.4593
.25	.0039	.1921	-.2117	.0613					.1622	.6080	.1532	.6227	.1063	.3889
.30			-.1989	.0349	-.1853	.0468	-.1609	.0710	-.0057	.2460				
.40	-.0293	.2432			-.1896	.0796	-.1845	.0726	-.1643	.0663	-.1568	.0297		
.50	-.0312	.1934					-.1868	.0957	-.1828	.0703			-.1359	-.1088
.60					-.1753	.1272	-.1857	.1070	-.1878	.0746	-.1798	.0027	-.1279	-.1316
.70			-.0899	.1703	-.1402	.1276	-.1953	.0760	-.2974	-.0027	-.3562	-.2503	-.2443	-.2461
.80	-.2708		-.3074	-.2015	-.3005	-.1713			-.3407	-.2270	-.3284	-.2729		
.90	-.2830	-.1920			-.3117	-.1862			-.3013	-.2410	-.3082	-.2401		
.95	-.2670	-.2184							-.2556		-.2927	-.2327	-.2683	-.1574

TAIL 2

TABLE III. - CONTINUED
(h) $\alpha = 10.70^\circ$

Cp at y/b of														
x/c	0.02		0.22		0.44		0.56		0.67		0.83		0.98	
	U.S.	L.S.	U.S.	L.S.	U.S.	L.S.	U.S.	L.S.	U.S.	L.S.	U.S.	L.S.	U.S.	L.S.
.05	-.0651	.8530	.0200	1.1362					.0396	1.1686	.0573	1.1234		
.10	-.0380	.9536	.0597	1.0082	.1023	1.0180	-.0865	1.0372	.1050	1.0398	.1045	.9958	.1697	.7280
.15	-.0015	.9220	.0666	.9004	.1199	.9261	-.1134	.9402	.1367	.9486	.1304	.8891	.1769	.6577
.20	-.0075	.7356	.0495	.7620	.1150	.8256			.1328	.8909	.1325	.8067	.1687	.5940
.25			-.2179	.1193	.0747	.5795	.1128	.6907	-.1198	.7356	.1292	.7198	.1558	.5326
.30	-.2126	.3896	-.2562	.2333	-.1842	.1292	-.1579	.1102	-.0682	.2273	.1265	.6079	.1616	.4710
.40									-.1932	.1181	-.1701	.0566	-.1258	-.0202
.50	-.0283	.4722			-.2116	.2745			-.2019	.1510	-.0548	-.0528	-.1286	.0014
.60	.0116	.4113			-.2244	.4368	-.2097	.2594	-.2031	.1794	-.1858	.0643	-.2022	.0273
.70	.0631	.3995	-.0984	.3875	-.2401	.3793	-.2266	.2921	-.2562	.0950			-.3477	-.1654
.80	-.1804	-.0140	-.2659	-.0522	-.2297	-.0628	-.2520	-.0608	-.2803	-.1088	-.2986	-.1889	-.3833	-.1454
.90	-.2008	-.0571	-.1984	-.0780	-.2003	-.0890	-.2112	-.0869	-.2505	-.1031	-.2744	-.1595	-.3672	-.0764
.95	-.0958	-.0677	-.1125	-.0677	-.1960	-.0971	-.2030	-.0951	-.2377	-.1068	-.2387	-.1511	-.3501	-.0944

TAIL 1

Cp at y/b of														
x/c	0.02		0.22		0.44		0.56		0.67		0.83		0.98	
	U.S.	L.S.	U.S.	L.S.	U.S.	L.S.	U.S.	L.S.	U.S.	L.S.	U.S.	L.S.	U.S.	L.S.
.05	.1284	.2088	-.0108	.8120					-.0346	1.0519	-.0395	1.0483		
.10	.1281	.2331	.0677	.7325					.0306	.9248	.0318	.9208	.0652	.6571
.15	.1146	.2324					.0465	.8071	.0545	.8263	.0692	.8183		
.20							.0599	.7241	.0618	.7333	.0757	.7330	.0736	.4912
.25	-.0081	.2059	-.2180	.0952					.0623	.6247	.0704	.6442	.0536	.4195
.30			-.2090	.0976	-.2183	.0724	-.2119	.0830	-.0780	.2514				
.40	-.0283	.2388			-.2191	.1391	-.2243	.1171	-.2161	.0940	-.2064	.0521		
.50	-.0382	.1960					-.2205	.1521	-.2283	.1208			-.1645	-.0836
.60					-.1944	.1734	-.2201	.1571	-.2276	.1371	-.2192	.0566	-.1523	-.1073
.70			-.0998	.1666	-.1423	.1639	-.2285	.1243	-.3236	.0539	-.3729	-.2115	-.2701	-.2415
.80	-.2804		-.3168	-.2048	-.3125	-.1673			-.3402	-.1897	-.3383	-.2328		
.90	-.3017	-.1861			-.3167	-.1846			-.2873	-.2031	-.3153	-.2293		
.95	-.3060	-.2153							-.2520		-.3000	-.2391	-.2858	-.2293

TAIL 2

TABLE III. - CONTINUED
(i) $\alpha = 12.70^\circ$

Cp at y/b of														
x/c	0.02		0.22		0.44		0.56		0.67		0.83		0.98	
	U.S.	L.S.	U.S.	L.S.	U.S.	L.S.	U.S.	L.S.	U.S.	L.S.	U.S.	L.S.	U.S.	L.S.
.05	-.1203	.9760	-.0780	1.2079					-.0354	1.2294	-.0162	1.1777		
.10	-.1118	1.0716	-.0170	1.0733	.0311	1.0796	-.0102	1.0902	.0351	1.0958	.0434	1.0461	.1430	.7821
.15	-.0817	1.0095	-.0001	.9562	.0570	.9760	-.0546	.9876	.0748	.9989	.0678	.9352	.1523	.7085
.20	-.0838	.7902	-.0087	.8045	.0555	.8662			.0792	.9358	.0768	.8494	.1417	.6410
.25			-.2504	.1623	.0189	.6064	.0586	.7222	-.0637	.7657	.0766	.7573	.1245	.5746
.30	-.2800	.4997	-.2879	.2753	-.2192	.1658	-.4923	.1335	-.1063	.2457	.0792	.6378	.1329	.5042
.40									-.2263	.1566	-.1950	.0824	-.1488	.0024
.50	-.0801	.5402			-.2457	.4522			-.2357	.2199	-.0621	-.0578	-.2060	.0326
.60	-.0248	.4844			-.2565	.4840	-.2456	.4028	-.2357	.2577	-.2049	.1156	-.2826	.0646
.70	.0434	.4542	-.1512	.4463	-.2683	.4270	-.2571	.3891	-.2772	.2105			-.3777	-.1430
.80	-.2049	.0087	-.2582	-.0244	-.1927	-.0364	-.2129	-.0442	-.2682	-.0463	-.2999	-.1344	-.3848	-.1180
.90	-.2072	-.0389	-.1635	-.0441	-.1746	-.0637	-.1866	-.0628	-.2472	-.0645	-.2605	-.1035	-.3760	-.0514
.95	-.0862	-.0525	-.1074	-.0450	-.1710	-.0714	-.1845	-.0682	-.2308	-.0704	-.2282	-.0942	-.3674	-.0551

TAIL 1

Cp at y/b of														
x/c	0.02		0.22		0.44		0.56		0.67		0.83		0.98	
	U.S.	L.S.	U.S.	L.S.	U.S.	L.S.	U.S.	L.S.	U.S.	L.S.	U.S.	L.S.	U.S.	L.S.
.05	.1204	.2136	-.0617	.8472					-.1497	1.0819	-.1462	1.0818		
.10	.1166	.2387	.0254	.7755					-.0693	.9563	-.0594	.9609	-.0273	.6954
.15	.1002	.2389							-.0531	.8387	-.0443	.8580	-.0182	.8593
.20									-.0377	.7505	-.0314	.7636	-.0061	.7709
.25	-.0217	.2136	-.2215	.1235					-.0317	.6501	-.0086	.6770	.0166	.4457
.30			-.2223	.1297	-.2624	.0981	-.2655	.0972	-.1501	.2622				
.40	-.0454	.2253			-.2573	.1867	-.2698	.1758	-.2707	.1432	-.2551	.0821		
.50	-.0380	.1838					-.2611	.2182	-.2780	.1958			-.1959	-.0561
.60					-.2180	.2286	-.2560	.2198	-.2708	.2065	-.2611	.1241	-.1931	-.0719
.70			-.1361	.1641	-.1603	.2019	-.2537	.1796	-.3492	.1068	-.3545	-.1675	-.3066	-.2545
.80	-.2874		-.3278	-.2042	-.3289	-.1585			-.3437	-.1597	-.3408	-.1966		
.90	-.3097	-.1830			-.3300	-.1852			-.2852	-.1813	-.3116	-.2034		
.95	-.3223	-.2110							-.2624		-.2991	-.2196	-.2680	-.2116

TAIL 2

TABLE III. - CONTINUED
(j) $\alpha = 16.70^\circ$

Cp at y/b of														
x/c	0.02		0.22		0.44		0.56		0.67		0.83		0.98	
	U.S.	L.S.	U.S.	L.S.	U.S.	L.S.	U.S.	L.S.	U.S.	L.S.	U.S.	L.S.	U.S.	L.S.
.05	-.2723	1.1219	-.2480	1.3244					-.1965	1.3199	-.1687	1.2747		
.10	-.2597	1.2176	-.1600	1.1872	-.1141	1.1772	-.1245	1.1832	-.1003	1.1860	-.0833	1.1423	.1063	.8996
.15	-.2107	1.1462	-.1363	1.0579	-.0793	1.0666	.0022	1.0780	-.0583	1.0822	-.0511	1.0276	.1142	.8195
.20	-.2022	.8966	-.1347	.8867	-.0740	.9460			-.0420	1.0084	-.0273	.9364	.1081	.7411
.25			-.3204	.4048	-.1013	.6632	-.0645	.7836	-.0494	.8323	-.0100	.8342	.0795	.6746
.30	-.3736	.8009	-.3485	.5870	-.2909	.3646	-.2660	.2506	-.1820	.2873	.0258	.6984	.1025	.5842
.40									-.2850	.2990	-.2203	.1684	-.2150	.0549
.50	-.2561	.7025			-.3117	.6199			-.2839	.5115	-.0146	-.0125	-.3057	.1212
.60	-.1765	.6001			-.3153	.5815	-.2996	.5461	-.2693	.5228	-.2220	.2827	-.3394	.1753
.70	-.0597	.5743	-.2667	.5406	-.3045	.5071	-.2947	.4534	-.3035	.3347			-.4210	-.0304
.80	-.2613	.0465	-.1533	.0212	-.1780	.0031	-.2073	-.0019	-.2831	-.0060	-.3381	.0071	-.3896	-.0004
.90	-.1141	-.0033	-.1543	-.0000	-.1680	-.0139	-.1848	-.0176	-.2392	-.0207	-.3009	.0035	-.4209	.0587
.95	-.0436	-.0198	-.1500	-.0040	-.1666	-.0176	-.1876	-.0223	-.2233	-.0224	-.2613	.0117	-.4074	.0773

TAIL 1

Cp at y/b of														
x/c	0.02		0.22		0.44		0.56		0.67		0.83		0.98	
	U.S.	L.S.	U.S.	L.S.	U.S.	L.S.	U.S.	L.S.	U.S.	L.S.	U.S.	L.S.	U.S.	L.S.
.05	.1378	.2533	-.0896	.8762					-.3509	1.1076	-.3479	1.1101		
.10	.1254	.2833	.0068	.8398					-.2716	.9930	-.2655	1.0009	-.2094	.7330
.15	.1022	.2771							-.2285	.8750	-.2419	.8963	-.2213	.9005
.20									-.1952	.7809	-.2172	.7954	-.2049	.8098
.25	-.0473	.1680	-.2130	.1571					-.2030	.6717	-.1940	.7096	-.1304	.4833
.30			-.2183	.1903	-.3004	.1476	-.3310	.1288	-.2827	.2664				
.40	-.0661	.1537			-.3080	.2646	-.3211	.2862	-.3613	.2705	-.3596	.1763		
.50	-.0449	.0979					-.3146	.3101	-.3400	.3212			-.3039	.0369
.60					-.2660	.2696	-.2990	.2943	-.3213	.3004	-.3559	.2618	-.3045	.0496
.70			-.1218	.1376	-.2440	.2160	-.2794	.2275	-.3823	.1800	-.3519	-.1142	-.3647	-.2094
.80	-.2860		-.3288	-.2258	-.3699	-.1663			-.3579	-.1354	-.3311	-.1543		
.90	-.3103	-.2117			-.3656	-.1983			-.3111	-.1673	-.2975	-.1692		
.95	-.3201	-.2319							-.2862		-.2928	-.1904	-.3075	-.2578

TAIL 2

TABLE III. - CONCLUDED
 (k) $\alpha = 20.70^\circ$

Cp at y/b of														
x/c	0.02		0.22		0.44		0.56		0.67		0.83		0.98	
	U.S.	L.S.	U.S.	L.S.	U.S.	L.S.	U.S.	L.S.	U.S.	L.S.	U.S.	L.S.	U.S.	L.S.
.05	-.3171	.6173	-.3648	1.4342					-.3151	1.4057	-.2572	1.3713		
.10	-.3317	1.2079	-.2666	1.2996	-.2192	1.2730	-.2263	1.2794	-.2033	1.2793	-.1838	1.2432	.0637	1.0093
.15	-.2892	1.2788	-.2364	1.1691	-.1770	1.1644	-.1220	1.1698	-.1453	1.1733	-.1474	1.1280	.0718	.9233
.20	-.3044	1.0268	-.2251	.9914	-.1576	1.0366			-.1228	1.0897	-.1144	1.0311	.0475	.8399
.25			-.3695	.6309	-.1752	.7441	-.1419	.8625	-.1265	.9094	-.0846	.9215	-.0403	.7674
.30	-.4427	.9419	-.3947	.8424	-.3383	.5879	-.3117	.4951	-.2363	.3536	-.0151	.7709	-.1183	.6656
.40									-.3270	.6071	-.2387	.3479	-.2697	.1392
.50	-.3494	.7997			-.3534	.7243			-.3202	.6659	.0109	.0243	-.3454	.2812
.60	-.2526	.6966			-.3577	.6814	-.3427	.6486	-.2938	.6248	-.2399	.5661	-.3654	.4071
.70	-.1799	.6568	-.2282	.6227	-.3370	.5830	-.3319	.5232	-.3176	.3950			-.4121	.0282
.80	-.2787	.0679	-.1818	.0479	-.2059	.0412	-.2573	.0370	-.3423	.0367	-.3592	.0428	-.4312	.0781
.90	-.1604	.0208	-.1796	.0317	-.1914	.0319	-.2402	.0316	-.2865	.0318	-.3322	.0374	-.4347	.0979
.95	-.1140	.0092	-.1693	.0288	-.1955	.0305	-.2309	.0306	-.2610	.0321	-.3014	.0475	-.4291	.1019

TAIL 1

Cp at y/b of														
x/c	0.02		0.22		0.44		0.56		0.67		0.83		0.98	
	U.S.	L.S.	U.S.	L.S.	U.S.	L.S.	U.S.	L.S.	U.S.	L.S.	U.S.	L.S.	U.S.	L.S.
.05	.0636	.3131	-.0703	.8104					-.4584	1.0395	-.4619	1.0492		
.10	.0816	.3167	-.0022	.7588					-.4385	.9562	-.4398	.9666	-.3997	.7269
.15	.0644	.2982					-.3587	.8648	-.4004	.8738	-.4024	.8780	-.3453	.5733
.20							-.3093	.7797	-.3722	.7828	-.3796	.7912	-.3190	.4897
.25	-.0549	.1366	-.2207	.1018					-.3454	.6646	-.3654	.6922		
.30			-.2325	.1319	-.3446	.1621	-.3678	.1512	-.3780	.2615				
.40	-.0537	.0927			-.3485	.2496	-.3736	.2897	-.3950	.3204	-.4456	.2884	-.4300	.2038
.50	-.0096	.0212					-.3697	.3007	-.3846	.3361			-.4259	.1279
.60					-.3232	.2255	-.3593	.2737	-.3750	.3140	-.4170	.3068	-.4259	-.1865
.70			-.0980	.0597	-.2844	.1679	-.3474	.2027	-.4185	.1898	-.4283	-.0885		
.80	-.2776		-.3216	-.2604	-.3885	-.1938			-.4275	-.1394	-.4017	-.1330		
.90	-.2999	-.2654			-.3948	-.2246			-.3990	-.1749	-.3479	-.1516		
.95	-.2915	-.2806							-.3588		-.3448	-.1752	-.3597	-.2338

TAIL 2

TABLE IV. - PRESSURE COEFFICIENTS, $\phi = 67.5^\circ$, $\delta = 0^\circ$, $M = 1.60$
(a) $\alpha = -3.30^\circ$

Cp at y/b of														
x/c	0.02		0.22		0.44		0.56		0.67		0.83		0.98	
	U.S.	L.S.	U.S.	L.S.	U.S.	L.S.	U.S.	L.S.	U.S.	L.S.	U.S.	L.S.	U.S.	L.S.
.05	.3420	.1390	.7563	.3688					.8830	.3711	.8635	.3359		
.10	.3546	.1426	.6664	.3121	.7478	.3330	.7813	.3664	.8059	.3469	.7859	.3514	.5200	.2447
.15	.3808	.1411	.6120	.2820	.6895	.3403	.7211	.3382	.7359	.3670	.7121	.3498	.4552	.2405
.20	.3309	-.0958	.5433	.2515	.6331	.3369			.6719	.4096	.6502	.3376	.4086	.2316
.25			.0578	-.1180	.4704	.2525	.5503	.3208	.5961	.3299	.5814	.3227	.3668	.2100
.30	.3322	-.0548	.0311	-.1432	.0636	-.0857	-.0770	-.0663	.2081	.0280	.4942	-.2872	.3417	-.1872
.40									.0397	-.0949	-.0017	-.1093	-.0899	-.1290
.50	.2578	.0116			.0646	-.1232			.0329	-.1063			-.0954	-.0935
.60	.1812	-.0087			.1033	-.1322	.0524	-.1203	.0217	-.1208	-.0331	-.1424	-.0788	-.0815
.70	.1708	.0017	.2136	-.0254	.0970	-.1430	.0342	-.1433	-.0687	-.1857			-.2181	-.2355
.80	-.1443	-.2403	-.1616	-.2618	-.1407	-.3338	-.1952	-.3348	-.2472	-.3070	-.2592	-.2935	-.1454	-.2029
.90	-.1685	-.2378	-.1996	-.2840	-.1473	-.2924	-.1850	-.2950	-.2267	-.2910	-.2368	-.2928	-.1493	-.2597
.95	-.1688	-.1792	-.1972	-.2658	-.1613	-.2547	-.1863	-.2666	-.2166	-.2644	-.2331	-.2882	-.1481	-.2631

TAIL 1

Cp at y/b of														
x/c	0.02		0.22		0.44		0.56		0.67		0.83		0.98	
	U.S.	L.S.	U.S.	L.S.	U.S.	L.S.	U.S.	L.S.	U.S.	L.S.	U.S.	L.S.	U.S.	L.S.
.05	.3669	.2322	.6398	.4372					.7254	.5329	.7235	.5436		
.10	.3889	.2707	.5739	.4243					.6749	.5121	.6737	.5224	.4209	.3354
.15	.3846	.2314					.6261	.4737	.6363	.5014	.6172	.4895		
.20							.5882	.4558	.5998	.4770	.5681	.4510	.3686	.2932
.25	.1108	-.0000	.0261	-.0643					.5422	.4312	.5173	.4117	.3371	.2816
.30			.0104	-.1017	.0242	-.0432	.0439	-.0034	.2340	.1635				
.40	.2362	.0188			.0156	-.0576	.0174	-.0410	.0117	-.0390	-.0078	-.0558		
.50	.3070	.0965					.0046	-.0586	-.0068	-.0644			-.0099	-.0266
.60					.0650	-.0777	.0081	-.0760	-.0204	-.0840	-.0537	-.1009	-.0042	-.0123
.70			.2549	.1887	.0466	-.0862	-.0106	-.1115	-.1906	-.1543	-.2720	-.2758	-.1461	-.1923
.80	-.0875		-.1359	-.1871	-.1435	-.2123			-.2270	-.2267	-.2248	-.2419		
.90	-.1500	-.1745			-.1275	-.2201			-.2109	-.2431	-.2139	-.2321		
.95	-.1533	-.1454							-.2041		-.2168	-.2306	-.2143	-.2685

TAIL 2

TABLE IV. - CONTINUED
(b) $\alpha = -1.30^\circ$

Cp at y/b of														
x/c	0.02		0.22		0.44		0.56		0.67		0.83		0.98	
	U.S.	L.S.	U.S.	L.S.	U.S.	L.S.	U.S.	L.S.	U.S.	L.S.	U.S.	L.S.	U.S.	L.S.
.05	.2950	.1986	.6513	.4804					.7395	.5015	.7142	.4705		
.10	.2991	.2018	.5705	.4175	.6488	.4596	.6779	.4925	.6987	.4826	.6809	.4759	.4307	.3108
.15	.3137	.1990	.5200	.3717	.6075	.4537	.6399	.4706	.6571	.4845	.6342	.4705	.3900	.2917
.20	.2568	.1503	.4668	.3377	.5675	.4367			.6104	.5007	.5888	.4563	.3620	.2799
.25			.0262	-.0672	.4318	.3250	.5078	.4112	.5504	.4433	.5312	.4253	.3309	.2606
.30	.2392	-.0114	-.0063	-.0966	.0400	-.0448	.0587	-.0213	.1936	-.0885	.4574	.3763	.3188	.2420
.40									.0143	-.0508	-.0210	-.0704	-.0698	-.1046
.50	.1939	.0529			.0129	-.0796			.0004	-.0691			-.0703	-.0717
.60	.1367	.0303			.0365	-.0881	.0013	-.0799	-.0159	-.0881	-.0613	-.1138	-.0614	-.0670
.70	.1414	.0591	.1925	.0288	.0247	-.0989	-.0276	-.1086	-.1047	-.1595			-.2113	-.2196
.80	-.1569	-.2039	-.1711	-.2255	-.1898	-.3049	-.2465	-.3074	-.2778	-.2905	-.2688	-.2874	-.1517	-.1830
.90	-.1754	-.1961	-.2056	-.2440	-.1800	-.2642	-.2238	-.2730	-.2401	-.2757	-.2536	-.2835	-.1851	-.2463
.95	-.1703	-.1598	-.2057	-.2438	-.1660	-.2379	-.2113	-.2547	-.2317	-.2613	-.2503	-.2793	-.1797	-.2466

TAIL 1

Cp at y/b of														
x/c	0.02		0.22		0.44		0.56		0.67		0.83		0.98	
	U.S.	L.S.	U.S.	L.S.	U.S.	L.S.	U.S.	L.S.	U.S.	L.S.	U.S.	L.S.	U.S.	L.S.
.05	.3004	.2687	.5743	.4967					.6412	.6044	.6464	.6191		
.10	.3193	.2829	.5149	.4668					.6124	.5797	.6199	.5845	.3820	.3716
.15	.3135	.2727					.5664	.5202	.5851	.5526	.5765	.5402		
.20							.5406	.4966	.5571	.5177	.5364	.4949	.3351	.3128
.25	.0688	.0107	-.0007	-.0465					.5105	.4622	.4912	.4485	.3054	.2955
.30			-.0228	-.0787	-.0045	-.0279	.0301	.0092	.2161	.1808				
.40	.1542	.0418			-.0064	-.0402	.0034	-.0276	-.0000	-.0254	-.0199	-.0437		
.50	.2201	.0904					-.0112	-.0429	-.0198	-.0491			-.0273	-.0311
.60					.0164	-.0569	-.0180	-.0576	-.0356	-.0691	-.0672	-.0947	-.0228	-.0254
.70			.2431	.1428	.0060	-.0657	-.0430	-.0923	-.2004	-.1404	-.2716	-.2923	-.1578	-.1943
.80	-.1177		-.1509	-.1965	-.1857	-.2125			-.2169	-.2326	-.2303	-.2485		
.90	-.1733	-.1820			-.1851	-.2151			-.2190	-.2393	-.2205	-.2384		
.95	-.1714	-.1598							-.2207		-.2244	-.2392	-.2227	-.2313

TAIL 2

TABLE IV. - CONTINUED
(c) $\alpha = 0.70^\circ$

Cp at y/b of														
x/c	0.02		0.22		0.44		0.56		0.67		0.83		0.98	
	U.S.	L.S.	U.S.	L.S.	U.S.	L.S.	U.S.	L.S.	U.S.	L.S.	U.S.	L.S.	U.S.	L.S.
.05	.2545	.2605	.5288	.5956					.5250	.6803	.4967	.6632		
.10	.2624	.2725	.4778	.5226	.5345	.5924	.5382	.6252	.5369	.6354	.5147	.6314	.3204	.4027
.15	.2672	.2788	.4380	.4728	.5106	.5623	.5343	.5880	.5370	.6138	.5193	.5891	.3052	.3727
.20	.2144	.2264	.3932	.4263	.4851	.5289			.5211	.6182	.5060	.5465	.3040	.3449
.25			-.0083	-.0266	.3763	.3926	.4482	.4891	.4863	.5255	.4724	.4974	.2896	.3096
.30	-.1372	-.0699	-.0430	-.9506	.0106	-.0066	.0342	.0163	.1714	.1201	.4122	.4331	.2885	.2832
.40									-.0078	-.0239	-.0386	-.0485	-.0864	-.0967
.50	-.1349	-.1295			-.0265	-.0373			-.0267	-.0418			-.0543	-.0700
.60	-.0963	-.1002			-.0249	-.0420	-.0314	-.0475	-.0470	-.0595	-.0821	-.0957	-.0290	-.0700
.70	-.1101	-.1207	.1602	.1463	-.0323	-.0488	-.0654	-.0771	-.1328	-.1354			-.1966	-.2207
.80	-.1699	-.1684	-.1807	-.1858	-.2363	-.2572	-.2448	-.2629	-.2325	-.2626	-.2481	-.2701	-.1765	-.1629
.90	-.1789	-.1732	-.2048	-.2141	-.2172	-.2324	-.2321	-.2453	-.2327	-.2536	-.2482	-.2678	-.2222	-.2149
.95	-.1659	-.1538	-.2072	-.2175	-.1981	-.2092	-.2287	-.2289	-.2293	-.2433	-.2483	-.2666	-.2074	-.2198

TAIL 1

Cp at y/b of														
x/c	0.02		0.22		0.44		0.56		0.67		0.83		0.98	
	U.S.	L.S.	U.S.	L.S.	U.S.	L.S.	U.S.	L.S.	U.S.	L.S.	U.S.	L.S.	U.S.	L.S.
.05	.2393	.2765	.5245	.5664					.5674	.6924	.5734	.7023		
.10	.2553	.2850	.4604	.5025					.5470	.6417	.5656	.6454	.3478	.4186
.15	.2487	.2746					.5171	.5719	.5329	.5972	.5381	.5890		
.20							.4972	.5339	.5154	.5507	.5082	.5349	.3070	.3302
.25	.0611	.0198	-.0269	-.0342					.4769	.4886	.4691	.4801	.2797	.3042
.30			-.0515	-.0663	-.0145	-.0147	.0123	.0205	.1997	.1940				
.40	.1047	.0856			-.0281	-.0260	-.0129	-.0156	-.0106	-.0127	-.0300	-.0324		
.50	.1299	.0954					-.0254	-.0287	-.0309	-.0334			-.0421	-.0406
.60					-.0244	-.0423	-.0316	-.0422	-.0463	-.0522	-.0782	-.0863	-.0401	-.0496
.70			.1517	.1326	-.0321	-.0533	-.0555	-.0766	-.2104	-.1266	-.2961	-.2968	-.1663	-.2010
.80	-.1544		-.1725	-.2111	-.2487	-.2355			-.2768	-.2306	-.2691	-.2512		
.90	-.1884	-.1855			-.2221	-.2253			-.2443	-.2360	-.2495	-.2413		
.95	-.1796	-.1622							-.2388		-.2496	-.2466	-.2235	-.2214

TAIL 2

TABLE IV. - CONTINUED
 (d) $\alpha = 2.70^\circ$

Cp at y/b of														
x/c	0.02		0.22		0.44		0.56		0.67		0.83		0.98	
	U.S.	L.S.	U.S.	L.S.	U.S.	L.S.	U.S.	L.S.	U.S.	L.S.	U.S.	L.S.	U.S.	L.S.
.05	.1998	.3094	.3810	.7160					.3806	.8406	.3642	.8198		
.10	.2207	.3711	.3709	.6322	.3900	.7118	.3800	.7388	.3833	.7650	.3759	.7420	.2549	.4942
.15	.2310	.3904	.3451	.5765	.3877	.6575	.3918	.6833	.3889	.7158	.3814	.6697	.2511	.4495
.20	.1815	.3404	.3211	.5192	.3830	.6091			.3876	.7003	.3753	.6112	.2452	.4072
.25			-.0466	.0136	.2980	.4420	.3514	.5397	.3713	.5798	.3587	.5520	.2310	.3541
.30	.0249	.1422	-.0767	-.0046	-.0328	.0215	-.0110	.0334	.1119	.1380	.3229	.4752	.2363	.3214
.40									-.0482	-.0002	-.0771	-.0292	-.0937	-.0869
.50	.0764	.2325			-.0659	.0054			-.0646	-.0121			-.0683	-.0692
.60	.0572	.1780			-.0706	.0333	-.0684	-.0097	-.0820	-.0266	-.1085	-.0695	-.0095	-.0687
.70	.0797	.1693	.0581	.2195	-.0830	.0279	-.0978	-.0356	-.1628	-.1053			-.2037	-.2178
.80	-.1836	-.1397	-.1930	-.1698	-.2384	-.1928	-.2273	-.2438	-.2470	-.2326	-.2638	-.2465	-.2125	-.1500
.90	-.1838	-.1555	-.2093	-.1976	-.2289	-.1702	-.2292	-.2204	-.2475	-.2333	-.2625	-.2457	-.2645	-.1859
.95	-.1630	-.1494	-.2151	-.1899	-.2199	-.1753	-.2277	-.2078	-.2446	-.2323	-.2606	-.2452	-.2474	-.1914

TAIL 1

Cp at y/b of														
x/c	0.02		0.22		0.44		0.56		0.67		0.83		0.98	
	U.S.	L.S.	U.S.	L.S.	U.S.	L.S.	U.S.	L.S.	U.S.	L.S.	U.S.	L.S.	U.S.	L.S.
.05	.1961	.2460	.4611	.5998					.5089	.7631	.4969	.7729		
.10	.2055	.2553	.3965	.5101					.4987	.6904	.5084	.6950	.3166	.4625
.15	.1922	.2386					.4660	.6021	.4871	.6312	.4847	.6277		
.20							.4488	.5562	.4723	.5781	.4714	.5655	.2800	.3467
.25	.0559	.0281	-.0554	-.0282					.4407	.5077	.4397	.5060	.2575	.3107
.30			-.0826	-.0570	-.0384	-.0104	-.0089	.0263	.1765	.2018				
.40	.0601	.1263			-.0511	-.0195	-.0360	-.0083	-.0239	-.0032	-.0431	-.0241		
.50	.0665	.0963					-.0461	-.0186	-.0422	-.0218			-.0561	-.0548
.60					-.0523	-.0320	-.0477	-.0308	-.0548	-.0399	-.0910	-.0777	-.0556	-.0632
.70			.0585	.1122	-.0685	-.0425	-.0728	-.0643	-.2175	-.1152	-.3049	-.3006	-.1733	-.2103
.80	-.1954		-.2125	-.2233	-.2815	-.2483			-.3040	-.2404	-.2920	-.2614		
.90	-.2006	-.1954			-.2454	-.2278			-.2704	-.2384	-.2649	-.2484		
.95	-.1785	-.1778							-.2583		-.2615	-.2539	-.2165	-.2125

TAIL 2

TABLE IV. - CONTINUED
(e) $\alpha = 4.70^\circ$

Cp at y/b of														
x/c	0.02		0.22		0.44		0.56		0.67		0.83		0.98	
	U.S.	L.S.	U.S.	L.S.	U.S.	L.S.	U.S.	L.S.	U.S.	L.S.	U.S.	L.S.	U.S.	L.S.
.05	.1378	.2724	.2333	.8560					.2614	.9700	.2384	.9433		
.10	.1470	.5015	.2611	.7588	.2749	.8140	.2681	.8463	.2797	.8622	.2628	.8379	.2067	.5693
.15	.1926	.5421	.2383	.6883	.2802	.7520	.2811	.7733	.2811	.7948	.2803	.7503	.2146	.5133
.20	.1529	.4835	.2232	.6045	.2719	.6829			.2783	.7609	.2781	.6810	.2100	.4642
.25			-.0972	.0460	.2094	.4850	.2508	.5878	.2668	.6326	.2627	.6085	.1976	.4060
.30	-.0500	.2044	-.1163	.0449	-.0859	.0482	-.0694	.0510	.0449	.1606	.2370	.5168	.2003	.3641
.40									-.1043	.0307	-.1184	-.0056	-.0995	-.0733
.50	.0206	.3006			-.1168	.0978			-.1182	.0294			-.0700	-.0697
.60	.0180	.2373			-.1140	.1295	-.1227	.0712	-.1276	.0238	-.1432	-.0338	-.0440	-.0552
.70	.0477	.2206	-.0223	.2533	-.1192	.1385	-.1469	.0568	-.1976	-.0509			-.2214	-.2182
.80	-.1941	-.1081	-.2415	-.1393	-.2872	-.1165	-.2881	-.1887	-.2860	-.2284	-.2862	-.2204	-.3035	-.1563
.90	-.2057	-.1308	-.2378	-.1700	-.2674	-.1408	-.2702	-.1763	-.2745	-.1985	-.2842	-.2181	-.3105	-.1454
.95	-.1618	-.1401	-.2336	-.1600	-.2599	-.1552	-.2503	-.1727	-.2504	-.1908	-.2783	-.2175	-.2863	-.1568

TAIL 1

Cp at y/b of														
x/c	0.02		0.22		0.44		0.56		0.67		0.83		0.98	
	U.S.	L.S.	U.S.	L.S.	U.S.	L.S.	U.S.	L.S.	U.S.	L.S.	U.S.	L.S.	U.S.	L.S.
.05	.2359	.1907	.3265	.5816					.4415	.8169	.4211	.8323		
.10	.2248	.2004	.3131	.4882					.4406	.7255	.4513	.7377	.2883	.5019
.15	.2030	.1859					.4076	.6294	.4256	.6584	.4338	.6619		
.20							.3965	.5752	.4129	.5943	.4238	.5953	.2510	.3625
.25	.0267	.0656	-.0866	-.0292					.3858	.5212	.4044	.5286	.2257	.3152
.30			-.1200	-.0700	-.0584	-.0049	-.0343	.0307	.1452	.2071				
.40	.0030	.1327			-.0633	-.0093	-.0534	-.0007	-.0480	.0040	-.0563	-.0150		
.50	.0096	.1001					-.0605	-.0085	-.0588	-.0116			-.0722	-.0732
.60					-.0782	-.0252	-.0631	-.0194	-.0680	-.0280	-.0997	-.0664	-.0686	-.0801
.70			-.0111	.0391	-.0906	-.0312	-.0831	-.0541	-.2231	-.1020	-.3096	-.2952	-.1906	-.2137
.80	-.2255		-.2539	-.2325	-.2870	-.2470			-.3129	-.2532	-.3042	-.2726		
.90	-.2224	-.2038			-.2781	-.2282			-.2869	-.2378	-.2739	-.2524		
.95	-.1841	-.2026							-.2710		-.2663	-.2574	-.2166	-.1984

TAIL 2

TABLE IV. - CONTINUED
(I) $\alpha = 6.70^\circ$

Cp at y/b of														
x/c	0.02		0.22		0.44		0.56		0.67		0.83		0.98	
	U.S.	L.S.	U.S.	L.S.	U.S.	L.S.	U.S.	L.S.	U.S.	L.S.	U.S.	L.S.	U.S.	L.S.
.05	.0342	.1423	.1178	.9837					.1248	1.0726	.1237	1.0374		
.10	.0519	.6034	.1427	.8724	.1709	.9116	.1622	.9357	.1860	.9519	.1600	.9187	.1723	.6489
.15	.1194	.7041	.1446	.7856	.1881	.8315	.1811	.8514	.1900	.8704	.1859	.8213	.1855	.5829
.20	.1026	.6070	.1116	.6789	.1836	.7482			.1857	.8225	.1902	.7438	.1800	.5234
.25			-.1634	.0781	.1307	.5253	.1657	.6340	.1747	.6794	.1813	.6621	.1637	.4557
.30	-.1189	.2831	-.1900	.1314	-.1478	.0814	-.1210	.0767	-.0191	.1828	.1660	.5584	-.1771	.4042
.40									-.1581	.0708	-.1539	.0227	-.1204	-.0590
.50	-.0165	.3667			-.1757	.1908			-.1677	.0872			-.0862	-.0582
.60	-.0146	.3015			-.1879	.2148	-.1718	.1641	-.1762	.0974	-.1754	.0129	-.0803	-.0390
.70	-.0173	.2676	-.0655	.2979	-.1872	.3194	-.1928	.1418	-.2338	.0191			-.2594	-.2155
.80	-.2151	-.0797	-.2659	-.1082	-.3388	-.1010	-.3379	-.1115	-.3083	-.1841	-.3090	-.2130	-.3624	-.2094
.90	-.2365	-.1061	-.2784	-.1409	-.2884	-.1263	-.2338	-.1259	-.2845	-.1721	-.3003	-.1909	-.3301	-.1144
.95	-.1554	-.1172	-.2375	-.1348	-.2367	-.1380	-.2551	-.1375	-.2618	-.1683	-.2791	-.1866	-.3028	-.1308

TAIL 1

Cp at y/b of														
x/c	0.02		0.22		0.44		0.56		0.67		0.83		0.98	
	U.S.	L.S.	U.S.	L.S.	U.S.	L.S.	U.S.	L.S.	U.S.	L.S.	U.S.	L.S.	U.S.	L.S.
.05	.3659	.1386	.2471	.5082					.3402	.8613	.3223	.8764		
.10	.3052	.2322	.2631	.4453					.3743	.7590	.3823	.7718	.2561	.5391
.15	.2482	.1929							.3406	.6527	.3616	.6826	.3715	.6903
.20									.3377	.5935	.3548	.6146	.3670	.6210
.25	-.0052	-.0431	-.1131	-.0644					.3373	.5355	.3579	.5507	.1969	.3268
.30			-.0654	-.0955	-.0858	.0004	-.0612	.0350	-.1172	.2124				
.40	-.0629	.1289			-.0993	.0021	-.0835	.0087	-.0730	.0133	-.0704	-.0050		
.50	-.0209	.0866					-.0937	.0055	-.0880	.0020			-.0875	-.0986
.60					-.0817	-.0116	-.0929	-.0073	-.0951	-.0114	-.1190	-.0533	-.0885	-.1039
.70			-.0563	.1002	-.0664	-.0063	-.0981	-.0480	-.2384	-.0867	-.3244	-.2887	-.2132	-.2213
.80	-.2399		-.2676	-.2367	-.2916	-.2245			-.3206	-.2666	-.3111	-.2816		
.90	-.2606	-.2114			-.2999	-.2276			-.2990	-.2365	-.2838	-.2516		
.95	-.2281	-.2235							-.2780		-.2753	-.2552	-.2273	-.1817

TAIL 2

TABLE IV. - CONTINUED
(g) $\alpha = 8.70^\circ$

Cp at y/b of														
x/c	0.02		0.22		0.44		0.56		0.67		0.83		0.98	
	U.S.	L.S.	U.S.	L.S.	U.S.	L.S.	U.S.	L.S.	U.S.	L.S.	U.S.	L.S.	U.S.	L.S.
.05	-.0709	.0700	.0112	1.0913					.0102	1.1506	-.0154	1.1193		
.10	-.0321	.6891	.0447	.9674	.0787	.9924	.0604	1.0105	.0773	1.0255	.0678	.9927	.1353	.7186
.15	-.0189	.8475	.0498	.8676	.0956	.9008	.0859	.9172	.1072	.9345	.0940	.8853	.1514	.6442
.20	.0242	.7015	.0346	.7375	.0935	.8041			.1077	.8755	.1090	.8003	.1418	.5750
.25			-.2251	.1076	.0522	.5515	.0853	.6741	.0933	.7224	.1043	.7113	.1258	.5003
.30	-.1863	.3799	-.2603	.2192	-.1979	.1194	-.1717	.1024	-.0786	.2048	.0922	.5956	.1285	.4373
.40									-.2071	.1168	-.1896	.0522	-.1391	-.0407
.50	-.0608	.4326			-.2240	.2691			-.2138	.1575			-.1141	-.0452
.60	-.0553	.3550			-.2324	.4236	-.2224	.2624	-.2214	.1895	-.2032	.0663	-.1267	-.0188
.70	-.0112	.3222	-.1140	.3398	-.2466	.3558	-.2400	.2919	-.2700	.0998			-.3235	-.2092
.80	-.2417	-.0486	-.2933	-.0840	-.3250	-.0835	-.3250	-.0755	-.3254	-.1057	-.3331	-.2016	-.3698	-.1835
.90	-.2451	-.0819	-.2880	-.1138	-.2727	-.1125	-.2838	-.1066	-.3020	-.1104	-.3076	-.1824	-.3482	-.1482
.95	-.1600	-.0956	-.1829	-.1126	-.2514	-.1266	-.2630	-.1179	-.2849	-.1199	-.2540	-.1700	-.3311	-.1234

TAIL 1

Cp at y/b of														
x/c	0.02		0.22		0.44		0.56		0.67		0.83		0.98	
	U.S.	L.S.	U.S.	L.S.	U.S.	L.S.	U.S.	L.S.	U.S.	L.S.	U.S.	L.S.	U.S.	L.S.
.05	.4923	-.0403	.2193	.4862					.2340	.9042	.2192	.9140		
.10	.4069	.2672	.2340	.4366					.3018	.7906	.3098	.8039	.2169	.5654
.15	.3163	.2199							.2376	.6767	.2830	.7033	.3184	.7174
.20									.2355	.6126	.2830	.6352	.3061	.6426
.25	-.0062	-.0534	-.1040	-.0749					.2	.5491	.2900	.5668	.1674	.3394
.30			-.0601	-.0576	-.1179	.0122	-.0914	.0402	.2	.2155				
.40	-.0811	.1176			-.1446	-.0009	-.1126	.0233	-.1046	.0245	-.1085	.0026	-.1242	-.1148
.50	-.0568	.0864					-.1311	.0188	-.1132	.0181			-.1269	-.1213
.60					-.0684	.0428	-.1296	.0143	-.1238	.0080	-.1398	-.0376	-.2402	-.2366
.70			-.0879	.0640	-.0619	.0620	-.1032	.0002	-.2592	-.0634	-.3338	-.2781		
.80	-.2573		-.2981	-.2396	-.2982	-.2084			-.3345	-.2667	-.3189	-.2925		
.90	-.2758	-.2344			-.3060	-.2311			-.2978	-.2438	-.2941	-.2494		
.95	-.2533	-.2465							-.2684		-.2802	-.2462	-.2361	-.1705

TAIL 2

TABLE IV. - CONTINUED
(h) $\alpha = 10.70^\circ$

Cp at y/b of														
x/c	0.02		0.22		0.44		0.56		0.67		0.83		0.98	
	U.S.	L.S.	U.S.	L.S.	U.S.	L.S.	U.S.	L.S.	U.S.	L.S.	U.S.	L.S.	U.S.	L.S.
.05	-.1433	.0910	-.1024	1.1754					-.0912	1.2162	-.0841	1.1806		
.10	-.1147	.8110	-.0468	1.0471	-.0157	1.0576	-.0409	1.0758	-.0135	1.0874	-.0179	1.0510	.0847	.7761
.15	-.0730	.9580	-.0334	.9326	.0090	.9604	.0050	.9772	.0235	.9896	.0070	.9461	.1192	.6944
.20	-.0639	.7712	-.0415	.7858	.0160	.8527			.0318	.9212	.0241	.8512	.1128	.6204
.25			-.2678	.1507	-.0216	.5940	.0146	.7101	.0170	.7600	.0248	.7528	.0980	.5416
.30	-.2578	.5061	-.3018	.2783	-.2442	.1704	-.2173	.1327	-.1345	.2259	.0180	.6277	.1075	.4710
.40									-.2523	.1735	-.2143	.0844	-.1618	-.0200
.50	-.1241	.4902			-.2658	.4917			-.2591	.2512			-.1612	-.0144
.60	-.1064	.4155			-.2733	.4575	-.2680	.4416	-.2623	.3016	-.2196	.1327	-.2165	-.0142
.70	-.0464	.3808	-.1739	.3781	-.2855	.3861	-.2824	.3619	-.2997	.2419			-.3570	-.2100
.80	-.2702	-.0223	-.3244	-.0593	-.2773	-.0591	-.2972	-.0676	-.3270	-.0683	-.3415	-.1314	-.3783	-.1530
.90	-.2581	-.0556	-.2510	-.0825	-.2510	-.0939	-.2636	-.0937	-.2951	-.0949	-.3128	-.1142	-.3619	-.1336
.95	-.1700	-.0788	-.1362	-.0877	-.2447	-.1061	-.2564	-.1041	-.2762	-.1059	-.2661	-.1103	-.3525	-.1237

TAIL 1

Cp at y/b of														
x/c	0.02		0.22		0.44		0.56		0.67		0.83		0.98	
	U.S.	L.S.	U.S.	L.S.	U.S.	L.S.	U.S.	L.S.	U.S.	L.S.	U.S.	L.S.	U.S.	L.S.
.05	.5388	.0599	.2263	.3548					.1224	.9426	.1262	.9486		
.10	.4888	.0855	.1964	.3719					.1884	.8246	.2190	.8335	.1658	.5893
.15	.3566	.1867					.1147	.7069	.1801	.7369	.2269	.7441		
.20							.1566	.6384	.1686	.6593	.2236	.6671	.1494	.4279
.25	.0189	-.0619	-.1345	-.0708					.1563	.5684	.2125	.5901	.1240	.3608
.30			-.1012	-.0116	-.1705	.0169	-.1202	.0543	-.0033	.2251				
.40	-.0615	.0647			-.1311	.0568	-.1493	.0583	-.1332	.0529	-.1462	.0188		
.50	-.0641	.0832					-.1680	.0698	-.1418	.0614			-.1531	-.1205
.60					-.0562	.0977	-.1202	.0845	-.1562	.0591	-.1651	-.0033	-.1579	-.1422
.70			-.0956	.0399	-.0724	.1002	-.0756	.0588	-.2823	-.0167	-.3443	-.2544	-.2708	-.2516
.80	-.2795		-.3082	-.2486	-.2922	-.2106			-.3217	-.2359	-.3200	-.2813		
.90	-.2921	-.2561			-.3004	-.2383			-.2874	-.2521	-.2556	-.2559		
.95	-.2725	-.2679							-.2630		-.2726	-.2451	-.2499	-.1543

TAIL 2

TABLE IV. - CONTINUED
(i) $\alpha = 12.71^\circ$

Cp at y/b of														
x/c	0.02		0.22		0.44		0.56		0.67		0.83		0.98	
	U.S.	L.S.	U.S.	L.S.	U.S.	L.S.	U.S.	L.S.	U.S.	L.S.	U.S.	L.S.	U.S.	L.S.
.05	-.2277	.1686	-.2112	1.2450					-.1866	1.2683	-.1725	1.2326		
.10	-.2079	.9180	-.1395	1.1150	-.1083	1.1151	-.1254	1.1314	-.0994	1.1381	-.0970	1.1029	.0420	.8304
.15	-.1616	1.0518	-.1163	.9938	-.0734	1.0145	-.0738	1.0280	-.0593	1.0376	-.0634	.9895	.0809	.7463
.20	-.1432	.8363	-.1152	.8319	-.0616	.8983			-.0468	.9613	-.0455	.8965	.0796	.6669
.25			-.3067	.2883	-.0913	.6254	-.0625	.7439	-.0583	.7966	-.0348	.7935	.0640	.5892
.30	-.3212	.6740	-.3394	.3859	-.2882	.2970	-.2646	.1802	-.1887	.2477	-.0355	.6588	.0775	.5094
.40									-.2885	.2744	-.2373	.1257	-.1851	.0067
.50	-.1844	.5740			-.3058	.5514			-.2943	.3879			-.2188	.0326
.60	-.1640	.4785			-.3132	.4883	-.3051	.4719	-.2945	.4687	-.2394	.2298	-.2938	.0708
.70	-.0904	.4385	-.2348	.4293	-.3203	.4351	-.3100	.3898	-.3234	.2879			-.3877	-.1839
.80	-.2967	.0079	-.3194	-.0293	-.2574	-.0380	-.2823	-.0416	-.3287	-.0504	-.3537	-.0556	-.3843	-.1236
.90	-.2835	-.0341	-.2196	-.0505	-.2405	-.0664	-.2517	-.0672	-.2908	-.0703	-.3228	-.0773	-.3980	-.0688
.95	-.1785	-.0567	-.1650	-.0546	-.2378	-.0762	-.2490	-.0773	-.2719	-.0790	-.2837	-.0793	-.4031	-.0500

TAIL 1

Cp at y/b of														
x/c	0.02		0.22		0.44		0.56		0.67		0.83		0.98	
	U.S.	L.S.	U.S.	L.S.	U.S.	L.S.	U.S.	L.S.	U.S.	L.S.	U.S.	L.S.	U.S.	L.S.
.05	.5023	.0904	.2585	.3345					.0063	.9832	.0272	.9785		
.10	.4893	.1412	.2099	.3893					-.0586	.8617	.1202	.8599	.0981	.5990
.15	.3828	.1445					.0460	.7485	.0692	.7708	.1395	.7641	.1013	.4369
.20							.1342	.6744	.0683	.6859	.1371	.6818	.0713	.3664
.25	.0180	-.0010	-.1359	.0099					.0844	.5855	.1252	.5983		
.30			-.1203	.0235	-.1848	.0570	-.1461	.0651	-.0342	.2274				
.40	-.0587	-.0159			-.1306	.1196	-.1767	.0975	-.1594	.0742	-.1857	.0270	-.1962	-.1081
.50	-.0431	.0473					-.1578	.1249	-.1724	.0986			-.1969	-.1285
.60					-.0809	.1009	-.1016	.1212	-.1756	.1064	-.1808	.0393	-.2945	-.2393
.70			-.0897	.0338	-.1021	.0760	-.0873	.0753	-.2729	.0294	-.3544	-.2202		
.80	-.2842		-.3104	-.2701	-.3086	-.2268			-.3191	-.2137	-.3241	-.2448		
.90	-.3125	-.2820			-.3162	-.2503			-.2901	-.2395	-.2867	-.2439	-.2286	-.2140
.95	-.2982	-.2933							-.2602		-.2582	-.2454		

TAIL 2

TABLE IV. - CONTINUED
 (j) $\alpha = 16.70^\circ$

Cp at y/b of														
x/c	0.02		0.22		0.44		0.56		0.67		0.83		0.98	
	U.S.	L.S.	U.S.	L.S.	U.S.	L.S.	U.S.	L.S.	U.S.	L.S.	U.S.	L.S.	U.S.	L.S.
.05	-.3490	.2689	-.3872	1.3547					-.3508	1.3579	-.3065	1.3256		
.10	-.3478	.9336	-.2988	1.2296	-.2767	1.2172	-.2732	1.2262	-.2541	1.2348	-.2474	1.2011	-.0535	.9385
.15	-.3065	1.1634	-.2637	1.1045	-.2280	1.1078	-.2256	1.1214	-.2028	1.1311	-.2105	1.0878	-.0120	.8501
.20	-.3226	.9517	-.2513	.9326	-.2056	.9864			-.1820	1.0442	-.1770	.9907	-.0201	.7623
.25			-.3851	.5269	-.2224	.7004	-.1946	.8209	-.1860	.8706	-.1617	.8799	-.0479	.6769
.30	-.4386	.8742	-.4105	.7632	-.3646	.5408	-.3458	.4731	-.2784	.3227	-.1572	.7290	-.0416	.5843
.40									-.3573	.5827	-.2919	.3311	-.2577	.0840
.50	-.3150	.7136			-.3758	.6491			-.3626	.6074			-.3270	.1933
.60	-.2759	.6064			-.3768	.6035	-.3710	.5792	-.3580	.5611	-.2839	.4875	-.3618	.3639
.70	-.2027	.5803	-.3220	.5415	-.3751	.5219	-.3646	.4759	-.3737	.3568			-.3904	-.0739
.80	-.3698	.0412	-.2712	.0069	-.2742	.0073	-.3088	.0051	-.3521	.0017	-.3861	-.0101	-.4448	-.0880
.90	-.3250	.0055	-.2493	-.0073	-.2602	-.0132	-.2880	-.0124	-.3237	-.0161	-.3554	-.0269	-.4597	-.0806
.95	-.2155	-.0119	-.2395	-.0112	-.2585	-.0181	-.2865	-.0189	-.2997	-.0235	-.3217	-.0312	-.4495	-.0712

TAIL 1

Cp at y/b of														
x/c	0.02		0.22		0.44		0.56		0.67		0.83		0.98	
	U.S.	L.S.	U.S.	L.S.	U.S.	L.S.	U.S.	L.S.	U.S.	L.S.	U.S.	L.S.	U.S.	L.S.
.05	.2221	.2167	.5855	.3756					-.3080	.9704	-.2796	1.0343		
.10	.2725	.2315	.4938	.3094					-.1587	.8736	-.1979	.9221	-.0997	.6622
.15	.2882	.2041							-.0170	.7148	-.0538	.7921	-.1588	.8231
.20									-.0228	.6464	-.0171	.7027	-.1224	.7363
.25	.0299	-.0337	-.0411	-.0683					-.0196	.5927	-.0687	.6422	-.0825	.4218
.30			-.0729	-.0907	-.2383	.0792	-.2595	.1160	-.1706	.2192				
.40	-.0001	-.1018			-.2132	.1108	-.2343	.1855	-.2303	.2146	-.2401	.1182		
.50	.0058	-.1349					-.2249	.1744	-.2003	.2165			-.2495	-.0280
.60					-.1284	.0677	-.1986	.1345	-.1871	.1783	-.2092	.1687	-.2186	-.0151
.70			-.0207	-.0688	-.0886	.0251	-.1756	.0748	-.2871	.0685	-.3444	-.1673	-.3224	-.2485
.80	-.2856		-.2923	-.3180	-.3040	-.2475			-.3311	-.2059	-.3405	-.2105		
.90	-.3376	-.3366			-.3220	-.2706			-.3314	-.2399	-.2733	-.2216		
.95	-.3456	-.3434							-.3088		-.2247	-.2028	-.2019	-.1933

TAIL 2

TABLE IV. - CONCLUDED
(k) $\alpha = 20.70^\circ$

Cp at γ/b of														
x/c	0.02		0.22		0.44		0.56		0.67		0.83		0.98	
	U.S.	L.S.	U.S.	L.S.	U.S.	L.S.	U.S.	L.S.	U.S.	L.S.	U.S.	L.S.	U.S.	L.S.
.05	-.4230	.5142	-.4599	1.4456					-.3943	1.4313	-.4099	1.4028		
.10	-.4151	.9722	-.4274	1.3389	-.4021	1.3157	-.3874	1.3227	-.3805	1.3261	-.3509	1.2938	-.1563	1.0281
.15	-.4418	1.2964	-.3810	1.2241	-.3436	1.2165	-.3393	1.2233	-.3258	1.2288	-.3162	1.1853	-.1163	.9404
.20	-.4661	1.1116	-.3618	1.0615	-.3192	1.1006			-.2958	1.1381	-.2955	1.0877	-.1047	.8503
.25			-.4440	.7728	-.3252	.8475	-.3054	.9395	-.2908	.9760	-.2759	.9761	-.1260	.7645
.30	-.4901	1.0297	-.4603	.8978	-.4248	.7780	-.4099	.6927	-.3544	.5467	-.2672	.8157	-.1666	.6646
.40									-.4085	.7530	-.3453	.5755	-.3224	.2934
.50	-.4199	.8142			-.4318	.7664			-.4116	.7198			-.3662	.4450
.60	-.3649	.6984			-.4316	.7068	-.4242	.6814	-.4056	.6614	-.3292	.5808	-.4015	.3987
.70	-.3331	.6609	-.3202	.6255	-.4193	.5970	-.4043	.5442	-.4160	.4194			-.4713	-.0459
.80	-.3914	.0651	-.3004	.0382	-.3375	.0425	-.3666	.0426	-.3985	.0433	-.4096	.0342	-.4898	-.0550
.90	-.3044	.0290	-.2967	.0269	-.3090	.0333	-.3497	.0338	-.3705	.0349	-.3944	.0224	-.4792	-.0478
.95	-.2577	.0193	-.2902	.0247	-.3092	.0310	-.3383	.0291	-.3445	.0300	-.3783	.0194	-.4756	-.0419

TAIL 1

Cp at γ/b of														
x/c	0.02		0.22		0.44		0.56		0.67		0.83		0.98	
	U.S.	L.S.	U.S.	L.S.	U.S.	L.S.	U.S.	L.S.	U.S.	L.S.	U.S.	L.S.	U.S.	L.S.
.05	.2184	.1950	.5033	.1663					-.3364	.7699	-.4234	1.0003		
.10	.2969	.2027	.4163	.2039					-.2324	.7005	-.3613	.9214	-.3142	.6948
.15	.3185	.1744					-.0937	.4588	-.1676	.6301	-.2891	.8396		
.20							-.1100	.4140	-.1405	.5624	-.2273	.7636	-.2258	.5503
.25	.0443	-.0278	-.0763	-.1369					-.1411	.4582	-.1869	.6774	-.2031	.4728
.30			-.0951	-.1661	-.2458	-.0581	-.2888	-.0242	-.2528	.1353				
.40	-.0028	-.1202			-.2115	-.0408	-.2582	.0490	-.2754	.1238	-.2982	.1713		
.50	.0198	-.1768					-.2262	.0559	-.2453	.1367			-.3056	.0621
.60					-.1172	-.0582	-.1894	.0179	-.2216	.0837	-.2631	.1711	-.2776	.0321
.70			-.0454	-.1718	-.1232	-.0706	-.1945	-.0392	-.3223	.0269	-.3696	-.1741	-.3724	-.2394
.80	-.2825		-.2970	-.3741	-.3245	-.2930			-.3627	-.2537	-.3684	-.2241		
.90	-.3309	-.3920			-.3422	-.3174			-.3629	-.2827	-.3190	-.2426		
.95	-.3511	-.4021							-.3438		-.2852	-.2527	-.2105	-.2245

TAIL 2

TABLE V. - PRESSURE COEFFICIENTS, $\phi = 90^\circ$, $\delta = 0^\circ$, $M = 1.60$
 (a) $\alpha = -3.43^\circ$

Cp at y/b of														
x/c	0.02		0.22		0.44		0.56		0.67		0.83		0.98	
	U.S.	L.S.	U.S.	L.S.	U.S.	L.S.	U.S.	L.S.	U.S.	L.S.	U.S.	L.S.	U.S.	L.S.
.05	.4287	.2074	.7986	.3257					.9242	.3678	.8920	.3281		
.10	.4372	.2232	.7155	.3015	.7855	.3141	.8130	.3625	.8398	.3311	.8082	.3395	.5441	.2428
.15	.4699	.1684	.6558	.2750	.7131	.3101	.7505	.3286	.7676	.3584	.7314	.3357	.4798	.2445
.20	.4257	.1335	.5783	.2619	.6544	.3232			.6984	.4068	.6676	.3243	.4327	.2323
.25			.0721	-.1044	.4825	.2430	.5686	.3096	.6069	.3161	.5967	.3059	.3798	.2090
.30	.3886	-.0876	-.0518	-.1256	-.0747	-.0831	.0848	-.0710	.2136	.0207	.5082	.2730	.3538	.1869
.40									.0457	-.1039	.0063	-.1158	-.0831	-.1274
.50	.3075	.0087			.1061	-.1170			.0430	-.1154			-.0861	-.0933
.60	.2224	-.0049			.1414	-.1247	.0882	-.1222	.0381	-.1306	-.0221	-.1521	-.0654	-.0708
.70	.2115	.0265	.2419	-.0285	.1369	-.1341	.0697	-.1421	-.0482	-.1918			-.2082	-.2296
.80	-.1213	-.2190	-.1427	-.2660	-.1123	-.3345	-.1698	-.3270	-.2264	-.2937	-.2369	-.2846	-.1282	-.2226
.90	-.1546	-.2353	-.1746	-.2738	-.1326	-.2889	-.1615	-.2869	-.2100	-.2726	-.2202	-.2866	-.1454	-.2835
.95	-.1555	-.1726	-.1723	-.2476	-.1480	-.2477	-.1618	-.2557	-.2019	-.2456	-.2166	-.2844	-.1423	-.2726

TAIL 1

Cp at y/b of														
x/c	0.02		0.22		0.44		0.56		0.67		0.83		0.98	
	U.S.	L.S.	U.S.	L.S.	U.S.	L.S.	U.S.	L.S.	U.S.	L.S.	U.S.	L.S.	U.S.	L.S.
.05	.2779	.3285	.5176	.5592					.5601	.7054	.5662	.6901		
.10	.3010	.3513	.4733	.5171					.5504	.6501	.5512	.6332	.3438	.4036
.15	.2914	.3222							.5291	.5819	.5454	.6053	.5286	.5804
.20									.5194	.5456	.5369	.5610	.5055	.5302
.25	.0596	.0346	-.0151	-.0182					.4964	.5006	.4682	.4794	.3089	.3304
.30			-.0409	-.0489	-.0019	-.0094	.0232	.0269	.2130	.2039				
.40	.1414	.1085			-.0204	-.0259	-.0082	-.0120	-.0092	-.0116	-.0283	-.0302		
.50	.2411	.1875					-.0266	-.0311	-.0348	-.0373			-.0131	-.0098
.60					-.0009	-.0344	-.0361	-.0502	-.0501	-.0587	-.0754	-.0836	.0117	-.0059
.70			.2388	.2170	-.0151	-.0360	-.0637	-.0850	-.2120	-.1363	-.2653	-.2599	-.1536	-.1864
.80	-.1090		-.1416	-.1779	-.2135	-.2103			-.2093	-.2092	-.2279	-.2319		
.90	-.1623	-.1576			-.1763	-.1992			-.2211	-.2371	-.2146	-.2189		
.95	-.1468	-.1168							-.2148		-.2171	-.2156	-.2620	-.2367

TAIL 2

TABLE V. - CONTINUED
(b) $\alpha = -1.45^\circ$

Cp at y/b of														
x/c	0.02		0.22		0.44		0.56		0.67		0.83		0.98	
	U.S.	L.S.	U.S.	L.S.	U.S.	L.S.	U.S.	L.S.	U.S.	L.S.	U.S.	L.S.	U.S.	L.S.
.05	.3370	.2306	.6720	.4682					.7610	.4905	.7324	.4714		
.10	.3381	.2310	.5947	.4149	.6644	.4467	.6945	.4839	.7157	.4687	.6949	.4732	.4420	.3041
.15	.3579	.2109	.5456	.3718	.6233	.4466	.6528	.4626	.6708	.4770	.6466	.4625	.4029	.2946
.20	.3060	.1711	.4901	.3411	.5824	.4343			.6237	.4984	.5979	.4458	.3760	.2820
.25			.0366	-.0657	.4423	.3249	.5191	.4117	.5620	.4420	.5405	.4149	.3422	.2588
.30	.2750	-.0238	.0039	-.0910	.0478	-.0433	.0635	-.0208	.1991	.0901	.4658	.3675	.3270	.2362
.40									.0193	-.0522	-.0163	-.0733	-.0873	-.1073
.50	.2263	.0592			.0284	-.0752			.0069	-.0711			-.0676	-.0733
.60	.1643	.0369			.0589	-.0835	.0115	-.0811	-.0084	-.0908	-.0564	-.1192	-.0564	-.0602
.70	.1659	.0769	.2159	.0355	.0466	-.0961	-.0154	-.1099	-.0973	-.1614			-.2067	-.2160
.80	-.1429	-.1904	-.1613	-.2174	-.1721	-.3062	-.2274	-.3058	-.2708	-.2874	-.2602	-.2842	-.1442	-.1837
.90	-.1679	-.1925	-.1949	-.2339	-.1574	-.2630	-.2098	-.2732	-.2318	-.2742	-.2472	-.2825	-.1803	-.2605
.95	-.1651	-.1596	-.1932	-.2336	-.1558	-.2317	-.1996	-.2500	-.2229	-.2540	-.2440	-.2794	-.1759	-.2565

TAIL 1

Cp at y/b of														
x/c	0.02		0.22		0.44		0.56		0.67		0.83		0.98	
	U.S.	L.S.	U.S.	L.S.	U.S.	L.S.	U.S.	L.S.	U.S.	L.S.	U.S.	L.S.	U.S.	L.S.
.05	.2618	.3066	.5178	.5503					.5598	.7090	.5677	.7009		
.10	.2839	.3164	.4652	.5029					.5524	.6499	.5622	.6406	.3451	.4127
.15	.2797	.3071					.5290	.5776	.5496	.6017	.5422	.5894		
.20							.5156	.5411	.5364	.5603	.5148	.5378	.3248	.3417
.25	.0528	.0244	-.0159	-.0273					.4920	.4970	.4724	.4846	.3003	.3229
.30			-.0389	-.0494	-.0067	-.0104	.0174	.0241	.2053	.2007				
.40	.1127	.0877			-.0223	-.0239	-.0110	-.0146	-.0108	-.0130	-.0296	-.0308		
.50	.1763	.1240					-.0271	-.0320	-.0337	-.0378			-.0280	-.0267
.60					-.0203	-.0443	-.0337	-.0486	-.0476	-.0591	-.0777	-.0869	-.0053	-.0355
.70			.2122	.1831	-.0239	-.0484	-.0612	-.0811	-.2092	-.1306	-.2899	-.2698	-.1646	-.1913
.80	-.1295		-.1509	-.1841	-.2217	-.2143			-.2372	-.2175	-.2501	-.2374		
.90	-.1788	-.1769			-.2095	-.2111			-.2338	-.2327	-.2360	-.2290		
.95	-.1683	-.1515							-.2310		-.2394	-.2332	-.2395	-.2248

TAIL 2

TABLE V. - CONTINUED
(c) $\alpha = 0.55^\circ$

Cp at y/b of														
x/c	0.02		0.22		0.44		0.56		0.67		0.83		0.98	
	U.S.	L.S.	U.S.	L.S.	U.S.	L.S.	U.S.	L.S.	U.S.	L.S.	U.S.	L.S.	U.S.	L.S.
.05	.2596	.2723	.5384	.6029					.5336	.6911	.5066	.6691		
.10	.2684	.2345	.4831	.5248	.5360	.5944	.5372	.6301	.5431	.6449	.5221	.6368	.3290	.4085
.15	.2739	.2670	.4411	.4735	.5093	.5560	.5334	.5925	.5433	.6226	.5251	.5952	.3152	.3804
.20	.2188	.2214	.3968	.4246	.4851	.5242			.5256	.6261	.5113	.5511	.3135	.3526
.25			-.0073	-.0262	.3758	.3897			.4464	.4949	.4903	.5231	.4759	.5007
.30	.1466	.0635	-.0420	-.0493	.0107	-.0077			.0343	.0150	.1736	.1178	.4164	.4342
.40											-.0056	-.0257	-.0364	-.0478
.50	.1364	.1316			-.0243	-.0350					-.0239	-.0435		-.0570
.60	.0969	.0996			-.0218	-.0410	-.0285	-.0456	-.0436	-.0613	-.0806	-.0959	-.0337	-.0761
.70	.1114	.1222	.1628	.1534	-.0293	-.0481	-.0617	-.0760	-.1293	-.1369			-.1956	-.2219
.80	-.1688	-.1684	-.1788	-.1859	-.2340	-.2576	-.2443	-.2681	-.2312	-.2671	-.2458	-.2726	-.1680	-.1618
.90	-.1769	-.1743	-.2029	-.2150	-.2166	-.2310	-.2312	-.2439	-.2308	-.2564	-.2463	-.2639	-.2146	-.2172
.95	-.1645	-.1552	-.2064	-.2185	-.1967	-.2069	-.2270	-.2242	-.2283	-.2516	-.2464	-.2686	-.2031	-.2231

TAIL 1

Cp at y/b of														
x/c	0.02		0.22		0.44		0.56		0.67		0.83		0.98	
	U.S.	L.S.	U.S.	L.S.	U.S.	L.S.	U.S.	L.S.	U.S.	L.S.	U.S.	L.S.	U.S.	L.S.
.05	.2360	.2744	.5245	.5469					.5697	.7147	.5757	.7148		
.10	.2532	.2834	.4608	.4915					.5672	.6556	.5787	.6549	.3576	.4242
.15	.2461	.2749							.5332	.5794	.5571	.6058	.5513	.5982
.20									.5087	.5407	.5351	.5569	.5167	.5460
.25	.0607	.0292	-.0216	-.0275					.4880	.4926	.4712	.4880	.2884	.3121
.30			-.0487	-.0528	-.0134	-.0152	.0123	.0209	.1991	.1965				
.40	.1006	.0888			-.0295	-.0282	-.0148	-.0180	-.0110	-.0146	-.0329	-.0331		
.50	.1238	.0877					-.0257	-.0331	-.0302	-.0369			-.0416	-.0430
.60					-.0313	-.0495	-.0321	-.0474	-.0433	-.0562	-.0784	-.0889	-.0357	-.0537
.70			.1433	.1214	-.0415	-.0587	-.0614	-.0785	-.2141	-.1277	-.2969	-.2996	-.1660	-.2045
.80	-.1570		-.1774	-.2042	-.2563	-.2361			-.2850	-.2363	-.2755	-.2541		
.90	-.1897	-.1853			-.2283	-.2269			-.2506	-.2390	-.2534	-.2436		
.95	-.1785	-.1655							-.2440		-.2530	-.2497	-.2234	-.2202

TAIL 2

TABLE V. - CONTINUED

(d) $\alpha = 2.55^\circ$

Cp at y/b of														
x/c	0.02		0.22		0.44		0.56		0.67		0.83		0.98	
	U.S.	L.S.	U.S.	L.S.	U.S.	L.S.	U.S.	L.S.	U.S.	L.S.	U.S.	L.S.	U.S.	L.S.
.05	.2002	.3181	.3964	.7311					.3696	.8518	.3576	.8419		
.10	.2173	.2197	.3734	.6425	.3834	.7125	.3708	.7498	.3753	.7720	.3725	.7580	.2553	.5006
.15	.2211	.3667	.3494	.5814	.3861	.6660	.3843	.6960	.3822	.7215	.3799	.6840	.2529	.4514
.20	.1644	.3164	.3213	.5210	.3774	.6174			.3817	.7007	.3734	.6254	.2449	.4084
.25			-.0507	.0139	.2947	.4488	.3497	.5476	.3672	.5880	.3592	.5616	.2289	.3570
.30	.0213	.1541	-.0841	-.0030	-.0328	.0237	-.0105	.0342	.1074	.1387	.3234	.4802	.2316	.3208
.40									-.0482	.0036	-.0757	-.0272	-.1030	-.0928
.50	.0644	.2263			-.0673	.0097			-.0627	-.0066			-.0749	-.0817
.60	.0406	.1685			-.0751	.0306	-.0659	-.0060	-.0784	-.0212	-.1094	-.0671	-.0139	-.0807
.70	.0591	.1619	.0396	.2122	-.0892	.0283	-.0974	-.0321	-.1586	-.1012			-.2006	-.2232
.80	-.1980	-.1476	-.2106	-.1738	-.2449	-.1917	-.2390	-.2478	-.2608	-.2375	-.2750	-.2507	-.2022	-.1477
.90	-.1876	-.1600	-.2256	-.2051	-.2354	-.1723	-.2380	-.2221	-.2552	-.2339	-.2695	-.2494	-.2565	-.1825
.95	-.1645	-.1576	-.2284	-.2028	-.2263	-.1788	-.2355	-.2111	-.2526	-.2357	-.2635	-.2487	-.2402	-.1852

TAIL 1

Cp at y/b of														
x/c	0.02		0.22		0.44		0.56		0.67		0.83		0.98	
	U.S.	L.S.	U.S.	L.S.	U.S.	L.S.	U.S.	L.S.	U.S.	L.S.	U.S.	L.S.	U.S.	L.S.
.05	.2149	.2414	.5203	.5295					.6068	.7223	.6179	.7227		
.10	.2244	.2492	.4483	.4729					.5784	.6564	.5946	.6583	.3670	.4375
.15	.2112	.2349					.5295	.5742	.441	.6003	.5503	.6003		
.20							.4980	.528	.5165	.5462	.5150	.5425	.3051	.3306
.25	.0481	.0191	-.0381	-.0346					.4729	.4811	.4726	.4829	.2719	.2955
.30			-.0677	-.0692	-.0217	-.0242	.0063	.0137	.1935	.1875				
.40	.0805	.0840			-.0340	-.0377	-.0175	-.0244	-.0118	-.0186	-.0305	-.0360		
.50	.0912	.0639					-.0282	-.0368	-.0297	-.0371			-.0541	-.0583
.60					-.0394	-.0530	-.0363	-.0451	-.0467	-.0524	-.0799	-.0861	-.0619	-.0681
.70			.0832	.0744	-.0540	-.0681	-.0655	-.0768	-.2135	-.1246	-.3000	-.3045	-.1834	-.2110
.80	-.1852		-.2063	-.2301	-.2728	-.2375			-.2993	-.2523	-.2892	-.2696		
.90	-.2078	-.1995			-.2386	-.2325			-.2620	-.2467	-.2610	-.2547		
.95	-.1943	-.1800							-.2527		-.2589	-.2607	-.2168	-.2149

TAIL 2

TABLE V. CONTINUED
(e) $\alpha = 4.55^\circ$

Cp at y/b of														
x/c	0.02		0.22		0.44		0.56		0.67		0.83		0.98	
	U.S.	L.S.	U.S.	L.S.	U.S.	L.S.	U.S.	L.S.	U.S.	L.S.	U.S.	L.S.	U.S.	L.S.
.05	.1585	.3533	.2419	.8575					.2363	.9804	.2136	.9591		
.10	.1678	.1814	.2631	.7562	.2524	.8176	.2464	.8522	.2608	.8743	.2469	.8522	.1995	.5816
.15	.1881	.4926	.2479	.6849	.2629	.7515	.2632	.7778	.2652	.8026	.2663	.7608	.2064	.5189
.20	.1329	.4422	.2401	.6022	.2642	.6832			.2639	.7638	.2690	.6900	.1971	.4623
.25			-.0886	.0439	.2030	.4839	.2348	.5891	.2536	.6342	.2538	.6145	.1801	.4005
.30	-.0534	.2185	-.1191	.0397	-.0873	.0482	-.0747	.0515	-.0305	.1564	.2303	.5188	.1827	.3514
.40									-.1122	.0334	-.1227	-.0051	-.1160	-.0851
.50	.0166	.2960			-.1102	.0888			-.1178	.0331			-.0911	-.0844
.60	-.0024	.2190			-.1154	.1211	-.1151	.0652	-.1254	.0245	-.1520	-.0333	-.0461	-.0747
.70	.0124	.1935	-.0279	.2407	-.1296	.1246	-.1385	.0516	-.1937	-.0535			-.2218	-.2263
.80	-.2237	-.1222	-.2554	-.1521	-.3052	-.1259	-.3160	-.1319	-.3009	-.2364	-.2909	-.2278	-.2743	-.1561
.90	-.2180	-.1413	-.2640	-.1834	-.2825	-.1475	-.2830	-.1410	-.2802	-.2056	-.2885	-.2236	-.2978	-.1444
.95	-.1657	-.1511	-.2506	-.1796	-.2720	-.1610	-.2605	-.1791	-.2469	-.1986	-.2819	-.2228	-.2739	-.1593

TAIL 1

Cp at y/b of														
x/c	0.02		0.22		0.44		0.56		0.67		0.83		0.98	
	U.S.	L.S.	U.S.	L.S.	U.S.	L.S.	U.S.	L.S.	U.S.	L.S.	U.S.	L.S.	U.S.	L.S.
.05	.2740	.2903	.5557	.5720					.6036	.7233	.6085	.7301		
.10	.2654	.2803	.4801	.4910					.5639	.6513	.5799	.6576	.3637	.4398
.15	.2230	.2360					.5197	.5645	.5375	.5905	.5484	.5966		
.20							.4948	.5183	.5167	.5372	.5205	.5382	.3052	.3194
.25	-.0205	-.0356	-.0403	-.0494					.4781	.4751	.4839	.4825	.2702	.2822
.30			-.0734	-.0870	-.0177	-.0309	.0089	.0085	.1974	.1858				
.40	-.0024	-.0081			-.0318	-.0394	-.0161	-.0241	-.0089	-.0137	-.0309	-.0301		
.50	.0570	.0462					-.0314	-.0312	-.0290	-.0301			-.0712	-.0656
.60					-.0503	-.0537	-.0391	-.0430	-.0444	-.0477	-.0813	-.0835	-.0743	-.0769
.70			.0352	.0581	-.0713	-.0750	-.0682	-.0776	-.2090	-.1219	-.3008	-.3059	-.2028	-.2200
.80	-.2052		-.2176	-.2395	-.2940	-.2553			-.3003	-.2792	-.2944	-.2917		
.90	-.2355	-.2257			-.2537	-.2449			-.2673	-.2563	-.2637	-.2665		
.95	-.2293	-.2151							-.2556		-.2611	-.2709	-.2075	-.2099

TAIL 2

TABLE V. - CONTINUED
(1) $\alpha = 6.55^\circ$

Cp at y/b of														
x/c	0.02		0.22		0.44		0.56		0.67		0.83		0.98	
	U.S.	L.S.	U.S.	L.S.	U.S.	L.S.	U.S.	L.S.	U.S.	L.S.	U.S.	L.S.	U.S.	L.S.
.05	.0771	.3355	.0975	.8774					.0924	1.0742	.0866	1.0476		
.10	.1053	.1085	.1459	.8555	.1419	.9031	.1322	.9342	.1558	.9535	.1327	.9271	.1428	.6503
.15	.1384	.6326	.1332	.7698	.1555	.8224	.1532	.8471	.1648	.8698	.1578	.8258	.1606	.5776
.20	.0974	.5669	.1160	.6639	.1527	.7375			.1641	.8170	.1697	.7462	.1561	.5112
.25			.1539	.0702	.1072	.5156	.1402	.6270	.1514	.6753	.1617	.6621	.1379	.4426
.30	-.1005	.2809	-.1674	.1108	-.1534	.0772	-.1372	.0748	-.0419	.1752	.1416	.5532	.1490	.3821
.40									-.1719	.0708	-.1682	.0201	-.1338	-.0686
.50	-.0173	.3517			-.1793	.1786			-.1801	.0871			-.0837	-.0791
.60	-.0426	.2775			-.1736	.2065	-.1748	.1562	-.1877	.0933	-.1352	.0109	-.0811	-.0561
.70	-.0275	.2412	-.0606	.2794	-.1711	.2842	-.1895	.1371	-.2398	.0154			-.2534	-.2231
.80	-.2611	-.0957	-.2850	-.1230	-.3451	-.1042	-.3418	-.1206	-.3136	-.1886	-.3080	-.2224	-.3503	-.2167
.90	-.2475	-.1204	-.2925	-.1576	-.2927	-.1321	-.2904	-.1315	-.2769	-.1789	-.3034	-.1950	-.3175	-.1308
.95	-.1803	-.1310	-.2327	-.1622	-.2310	-.1452	-.2429	-.1451	-.2500	-.1752	-.2828	-.1936	-.2953	-.1295

TAIL 1

Cp at y/b of														
x/c	0.02		0.22		0.44		0.56		0.67		0.83		0.98	
	U.S.	L.S.	U.S.	L.S.	U.S.	L.S.	U.S.	L.S.	U.S.	L.S.	U.S.	L.S.	U.S.	L.S.
.05	.3983	.3985	.5923	.6066					.6054	.7141	.6174	.7176		
.10	.3535	.3676	.5021	.4900					.5689	.6459	.5904	.6542	.3733	.4467
.15	.2289	.2350					.5329	.5614	.5442	.5344	.5549	.6055		
.20							.5013	.5234	.5161	.5477	.5214	.5511	.2943	.3279
.25	-.0574	-.0703	-.0520	-.0567					.4694	.4845	.4792	.4942	.2553	.2868
.30			-.0905	-.0330	-.0232	-.0241	.0031	-.0155	.1855	.1890				
.40	-.0904	-.0837			-.0396	-.0319	-.0223	-.0195	-.0132	-.0106	-.0322	-.0284		
.50	-.0083	-.0280					-.0360	-.0287	-.0299	-.0275			-.0861	-.0791
.60					-.0600	-.0592	-.0417	-.0398	-.0435	-.0440	-.0808	-.0814	-.0930	-.0886
.70			-.0120	.0124	-.0851	-.0851	-.0704	-.0749	-.2082	-.1175	-.3011	-.3051	-.2165	-.2249
.80	-.2217		-.2155	-.2442	-.3043	-.2883			-.3006	-.2975	-.3020	-.2979		
.90	-.2586	-.2504			-.2640	-.2595			-.2777	-.2613	-.2663	-.2687		
.95	-.2546	-.2371							-.2627		-.2648	-.2728	-.1972	-.1992

TAIL 2

TABLE V. - CONTINUED
(g) $\alpha = 8.56^\circ$

Cp at γ/b of														
x/c	0.02		0.22		0.44		0.56		0.67		0.83		0.98	
	U.S.	L.S.	U.S.	L.S.	U.S.	L.S.	U.S.	L.S.	U.S.	L.S.	U.S.	L.S.	U.S.	L.S.
.05	-.0267	.1585	-.0231	1.0640					-.0288	1.1438	-.0311	1.1146		
.10	-.0210	.1514	-.0227	.9416	.0339	.9751	.0204	1.0010	-.0372	1.0160	-.0287	.9893	.0865	.7145
.15	-.0689	.7697	-.0325	.8416	.0546	.8830	.0484	.9060	-.0676	.9251	.0517	.8836	.1317	.6371
.20	-.0598	.6691	.0124	.7173	-.0612	.7874			.0701	.8625	-.0691	.7982	-.1262	.5656
.25			-.2306	.6994	-.0179	.5476	-.0501	.6606	-.0609	.7099	.0710	.7058	-.1104	.4896
.30	-.1101	.3533	-.2420	.1941	-.2164	.1105	-.1924	.0983	-.1065	.1943	-.0570	.5871	-.1236	.4206
.40									-.2252	.1165	-.2078	.0521	-.1545	-.0495
.50	-.0480	.4097			-.2326	.2586			-.2329	.1582			-.1223	-.0559
.60	-.0759	.3284			-.2400	.3865	-.2332	.2591	-.2401	.1874	-.2126	.9727	-.1263	-.0414
.70	-.0515	.2852	-.0911	.3173	-.2380	.3471	-.2480	.2749	-.2869	.1003			-.3027	-.2447
.80	-.2794	-.0712	-.3031	-.1043	-.3257	-.0865	-.3255	-.0768	-.3266	-.1078	-.3341	-.1995	-.3667	-.1985
.90	-.2796	-.0961	-.2887	-.1323	-.2719	-.1214	-.2736	-.1131	-.2925	-.1130	-.3184	-.1908	-.3442	-.1820
.95	-.2097	-.1113	-.2004	-.1379	-.2440	-.1341	-.2527	-.1235	-.2747	-.1242	-.2755	-.1831	-.3223	-.1692

TAIL 1

Cp at γ/b of														
x/c	0.02		0.22		0.44		0.56		0.67		0.83		0.98	
	U.S.	L.S.	U.S.	L.S.	U.S.	L.S.	U.S.	L.S.	U.S.	L.S.	U.S.	L.S.	U.S.	L.S.
.05	-.3711	.4080	-.5820	.6167					.5774	.7148	.5996	.7290		
.10	-.4081	.4068	-.5409	.4962					.5446	.6478	.5713	.6609	.3678	.4554
.15	-.2931	.2477					.5241	.5728	.5278	.5921	.5423	.6037		
.20							.5042	.5292	.5121	.5421	.5161	.5485	.2879	.3206
.25	-.0625	-.0820	-.0590	-.0588					.4701	.4788	.4803	.4910	.2486	.2771
.30			-.1022	-.0996	-.0134	-.0214	.0070	.0146	.1866	.1842				
.40	-.1154	-.0763			-.0301	-.0265	-.0134	-.0162	-.0086	-.0111	-.0297	-.0273		
.50	-.0546	-.0432					-.0260	-.0219	-.0208	-.0237			-.1036	-.0921
.60					-.0593	-.0525	-.0322	-.0309	-.0324	-.0365	-.0766	-.0768	-.1056	-.1008
.70			-.0482	-.0287	-.0832	-.0711	-.0629	-.0617	-.1997	-.1072	-.2989	-.3013	-.2284	-.2282
.80	-.2269		-.2561	-.2580	-.3019	-.3056			-.2953	-.2905	-.3004	-.2857		
.90	-.2676	-.2628			-.2621	-.2706			-.2832	-.2538	-.2630	-.2623		
.95	-.2648	-.2543							-.2640		-.2600	-.2667	-.1811	-.1855

TAIL 2

TABLE V. - CONTINUED
(h) $\alpha = 10.55^\circ$

Cp at y/b of														
x/c	0.02		0.22		0.44		0.56		0.67		0.83		0.98	
	U.S.	L.S.	U.S.	L.S.	U.S.	L.S.	U.S.	L.S.	U.S.	L.S.	U.S.	L.S.	U.S.	L.S.
.05	-.1218	.0746	-.1352	1.1335					-.1358	1.1993	-.1366	1.1700		
.10	-.0634	.2263	-.0847	1.0094	-.0629	1.0316	-.0807	1.0532	-.0616	1.0701	-.0641	1.0446	.0067	.7739
.15	-.0071	.5179	-.0672	.9034	-.0397	.9376	-.0438	.9540	-.0237	.9736	-.0344	.9349	.0862	.6885
.20	.0208	.7436	-.0644	.7598	-.0270	.8310			-.0153	.9010	-.0170	.8461	-.0798	.6103
.25			-.2768	.1475	-.0609	.5779	-.0270	.6932	-.0263	.7458	-.0050	.7485	.0652	.5304
.30	-.1451	.4500	-.2995	.2630	-.2691	.1597	-.2446	.1233	-.1638	.2155	-.0125	.6191	-.0789	.4531
.40									-.2718	.1820	-.2416	.0886	-.1829	-.0287
.50	-.0680	.4549			-.2853	.4863			-.2791	.2583			-.1655	-.0228
.60	-.0949	.3746			-.2879	.4509	-.2845	.4560	-.2831	.3133	-.2424	.1512	-.1789	-.0081
.70	-.0745	.3328	-.1249	.3465	-.2895	.3744	-.2954	.3566	-.3202	.2666			-.3483	-.2445
.80	-.2958	-.0455	-.3185	-.0848	-.3017	-.0677	-.3001	-.0749	-.3255	-.0718	-.3438	-.1152	-.3739	-.2078
.90	-.3097	-.0779	-.2972	-.1078	-.2692	-.1058	-.2661	-.1040	-.2944	-.1016	-.3220	-.1169	-.3632	-.1737
.95	-.2418	-.0962	-.2032	-.1125	-.2554	-.1208	-.2555	-.1159	-.2799	-.1149	-.2906	-.1223	-.3538	-.1633

TAIL 1

Cp at y/b of														
x/c	0.02		0.22		0.44		0.56		0.67		0.83		0.98	
	U.S.	L.S.	U.S.	L.S.	U.S.	L.S.	U.S.	L.S.	U.S.	L.S.	U.S.	L.S.	U.S.	L.S.
.05	.3015	.4311	.4948	.5776					.5645	.7206	.5754	.7278		
.10	.3427	.4572	.5099	.4511					.5377	.6485	.5530	.6626	.3619	.4597
.15	.3164	.2762					.5339	.5845	.5311	.5940	.5277	.6073		
.20							.5184	.5388	.5139	.5450	.5091	.5550	.2838	.3187
.25	-.0333	-.0853	-.0777	-.0900					.4723	.4823	.4770	.4962	.2403	.2691
.30			-.1179	-.1292	-.0024	-.0119	.0139	.0208	.1818	.1852				
.40	-.1225	-.1040			-.0225	-.0197	-.0030	-.0027	-.0069	-.0026	-.0236	-.0255		
.50	-.0701	-.0483					-.0158	-.0032	-.0137	-.0069			-.1256	-.1047
.60					-.0483	-.0397	-.0219	-.0137	-.0202	-.0135	-.0694	-.0671	-.1205	-.1105
.70			-.0677	-.0582	-.0670	-.0566	-.0475	-.0506	-.1860	-.0870	-.2926	-.2927	-.2351	-.2268
.80	-.2386		-.2822	-.3038	-.2942	-.3022			-.2844	-.2870	-.2945	-.2778		
.90	-.2791	-.2706			-.2724	-.2633			-.2894	-.2499	-.2533	-.2516		
.95	-.2739	-.2713							-.2665		-.2467	-.2545	-.1657	-.1577

TAIL 2

TABLE V. - CONTINUED
(i) $\alpha = 12.56^\circ$

Cp at y/b of														
x/c	0.02		0.22		0.44		0.56		0.67		0.83		0.98	
	U.S.	L.S.	U.S.	L.S.	U.S.	L.S.	U.S.	L.S.	U.S.	L.S.	U.S.	L.S.	U.S.	L.S.
.05	-.2266	.0886	-.2364	1.1941					-.2390	1.2513	-.2253	1.2169		
.10	-.1627	.2001	-.1757	1.0683	-.1572	1.0895	-.1740	1.1046	-.1543	1.1250	-.1505	1.0933	-.0770	.8266
.15	-.0893	.5249	-.1528	.9549	-.1267	.9767	-.1352	1.0014	-.1127	1.0244	-.1210	.9823	-.0233	.7379
.20	-.0377	.7819	-.1463	.8001	-.1122	.8637			-.0974	.9440	-.1001	.8882	.0296	.6541
.25			-.3232	.2590	-.1350	.5983	-.1132	.7236	-.1071	.7721	-.0879	.7841	.0142	.5607
.30	-.1765	.6070	-.3474	.3453	-.3149	.2880	-.2945	.1848	-.2183	.2341	-.0887	.6460	.0236	.4775
.40									-.3127	.2818	-.2829	.1395	-.2133	-.0114
.50	-.0859	.5153			-.3285	.5327			-.3203	.4201			-.2011	.0162
.60	-.1156	.4200			-.3292	.4627	-.3258	.4605	-.3236	.4543	-.2688	.2681	-.2275	.0459
.70	-.0919	.3763	-.1573	.3824	-.3233	.4007	-.3171	.3738	-.3415	.2752			-.3754	-.1906
.80	-.3104	-.0229	-.3338	-.0624	-.2905	-.0569	-.2775	-.0563	-.3061	-.0650	-.3471	-.0758	-.3771	-.1605
.90	-.3240	-.0532	-.3037	-.0834	-.2648	-.0897	-.2642	-.0823	-.2819	-.0878	-.3180	-.0968	-.3933	-.1487
.95	-.2685	-.0789	-.2079	-.0879	-.2501	-.1021	-.2564	-.0949	-.2767	-.0985	-.2923	-.1038	-.3901	-.1496

TAIL 1

Cp at y/b of														
x/c	0.02		0.22		0.44		0.56		0.67		0.83		0.98	
	U.S.	L.S.	U.S.	L.S.	U.S.	L.S.	U.S.	L.S.	U.S.	L.S.	U.S.	L.S.	U.S.	L.S.
.05	.3386	.3149	.4055	.4978					.5618	.7466	.5573	.7309		
.10	.3327	.4266	.4485	.4064					.5260	.6743	.5385	.6662	.3615	.4621
.15	.3013	.2951							.5293	.6217	.5337	.6216	.5210	.6141
.20									.5390	.5767	.5355	.5720	.5107	.5618
.25	-.0184	-.0628	-.0995	-.0997					.5001	.5073	.4876	.5080	.2438	.2772
.30			-.1407	-.1416	.0027	.0016	.0303	.0413	.1976	.1989				
.40	-.1034	-.0957			-.0270	-.0133	.0152	.0222	.0169	.0199	-.0199	-.0146		
.50	-.0842	-.0495					-.0016	.0133	.0134	.0195			-.1370	-.1020
.60					-.0445	-.0329	-.0062	.0008	.0071	.0087	-.0431	-.0399	-.1229	-.1023
.70			-.1039	-.0982	-.0632	-.0559	-.0282	-.0321	-.1707	-.0697	-.2741	-.2753	-.2272	-.2090
.80	-.2572		-.2965	-.3195	-.2979	-.3061			-.2749	-.2808	-.2925	-.2857		
.90	-.2923	-.2816			-.3116	-.2936			-.2872	-.2497	-.2428	-.2445		
.95	-.2846	-.2795							-.2702		-.2355	-.2447	-.1359	-.1212

TAIL 2

TABLE V - CONTINUED
(j) $\alpha = 16.56^\circ$

Cp at y/b of														
x/c	0.02		0.22		0.44		0.56		0.67		0.83		0.98	
	U.S.	L.S.	U.S.	L.S.	U.S.	L.S.	U.S.	L.S.	U.S.	L.S.	U.S.	L.S.	U.S.	L.S.
.05	-.3249	.0693	-.3844	1.2840					-.3831	1.3124	-.3629	1.2893		
.10	-.2992	.1923	-.2992	1.1700	-.3221	1.1681	-.3214	1.1864	-.3068	1.1988	-.3020	1.1727	-.2286	.8995
.15	-.1918	.5075	-.2747	1.0553	-.2723	1.0678	-.2832	1.0841	-.2616	1.1001	-.2723	1.0643	-.1005	.8110
.20	-.1437	.8481	-.2739	.8897	-.2509	.9497			-.2389	1.0090	-.2487	.9682	-.0848	.7231
.25			-.3995	.4589	-.2562	.6730	-.2436	.7933	-.2416	.8463	-.2333	.8584	-.0817	.6354
.30	-.2663	.8193	-.3941	.7267	-.3854	.5324	-.3725	.4810	-.3162	.3323	-.2249	.7059	-.0663	.5413
.40									-.3824	.5965	-.3598	.3617	-.2884	.0963
.50	-.1129	.6435			-.3922	.6076			-.3863	.5833			-.2903	.2239
.60	-.1459	.5082			-.3771	.5547	-.3922	.5394	-.3883	.5323	-.3222	.4602	-.3022	.2909
.70	-.1435	.4874	-.2480	.4562	-.3323	.4759	-.3604	.4419	-.3523	.3363			-.4180	-.1105
.80	-.3477	.0188	-.3863	-.0271	-.3176	-.0201	-.2953	-.0185	-.2966	-.0193	-.3493	-.0343	-.4549	-.1336
.90	-.3594	-.0010	-.3334	-.0515	-.2696	-.0471	-.2898	-.0419	-.2972	-.0411	-.3133	-.0576	-.4367	-.1395
.95	-.3034	-.0144	-.2697	-.0516	-.2432	-.0554	-.2821	-.0534	-.2895	-.0517	-.2973	-.0661	-.4326	-.1390

TAIL 1

Cp at y/b of														
x/c	0.02		0.22		0.44		0.56		0.67		0.83		0.98	
	U.S.	L.S.	U.S.	L.S.	U.S.	L.S.	U.S.	L.S.	U.S.	L.S.	U.S.	L.S.	U.S.	L.S.
.05	.2995	.2779	.4595	.4414					.4382	.8853	.5182	.8498		
.10	.3263	.3258	.4360	.4381					.4567	.7914	.5546	.7766	.3589	.5165
.15	.2990	.3195					.4529	.5963	.5253	.7114	.5648	.7137		
.20							.5110	.5195	.5960	.6371	.5697	.6542	.3200	.3942
.25	.0491	.0199	-.0168	-.0720					.5725	.5533	.5614	.5889	.3002	.3450
.30			-.0493	-.1039	-.0494	-.1484	-.0339	-.0185	.2565	.2299				
.40	-.0173	-.0866			-.1287	-.1735	-.0316	-.0589	.0364	.0268	.0408	.0330		
.50	-.0663	-.1508					-.0960	-.0813	-.0128	.0083			-.0869	-.0453
.60					-.1950	-.1890	-.1286	-.1010	-.0422	-.0109	-.0006	.0007	-.0661	-.0467
.70			-.1331	-.1258	-.2077	-.1975	-.1644	-.1344	-.2153	-.0947	-.2578	-.2547	-.1912	-.1683
.80	-.3171		-.3255	-.3449	-.3581	-.3614			-.3135	-.2992	-.2921	-.2825		
.90	-.3361	-.3212			-.3460	-.3496			-.3190	-.2972	-.2516	-.2485		
.95	-.3255	-.3260							-.2988		-.2420	-.2433	-.1323	-.1029

TAIL 2

TABLE V. - CONCLUDED
(k) $\alpha = 20.53^\circ$

Cp at y/b of														
x/c	0.02		0.22		0.44		0.56		0.67		0.83		0.98	
	U.S.	L.S.	U.S.	L.S.	U.S.	L.S.	U.S.	L.S.	U.S.	L.S.	U.S.	L.S.	U.S.	L.S.
.05	-.4170	.0982	-.4580	1.3353					-.3974	1.3562	-.4416	1.3279		
.10	-.4088	.1710	-.4063	1.2429	-.4367	1.2353	-.4243	1.2539	-.4144	1.2603	-.4117	1.2319	-.3862	.9566
.15	-.3410	.4678	-.3641	1.1336	-.3868	1.1433	-.3680	1.1613	-.3737	1.1707	-.3752	1.1325	-.2430	.8742
.20	-.3254	.8201	-.3562	.9768	-.3647	1.0327			-.3540	1.0790	-.3564	1.0394	-.2371	.7868
.25			-.4428	.6399	-.3577	.7904	-.3575	.8885	-.3444	.9292	-.3463	.9318	-.2259	.7003
.30	-.3578	.8857	-.4275	.8203	-.4410	.7227	-.4291	.6563	-.3952	.5433	-.3389	.7794	-.2044	.6053
.40									-.4341	.7082	-.4218	.5866	-.3845	.3036
.50	-.1287	.6993			-.4329	.6301			-.4301	.6709			-.4140	.3935
.60	-.1822	.5885			-.4005	.6277	-.4201	.6209	-.4009	.6108	-.3781	.5350	-.4047	.3372
.70	-.1999	.5738	-.3327	.5477	-.3701	.5341	-.3452	.4965	-.3345	.3855			-.4777	-.6762
.80	-.3778	.0404	-.4210	.0135	-.3493	.0128	-.3238	.0130	-.3237	.0159	-.3464	.0072	-.4664	-.0949
.90	-.3841	.0439	-.3822	-.0199	-.3173	-.0005	-.3261	-.0018	-.3258	-.0009	-.3245	-.0121	-.4470	-.0989
.95	-.3254	.0462	-.3280	-.0246	-.2987	-.0062	-.3218	-.0096	-.3198	-.0093	-.3269	-.0191	-.4408	-.0983

TAIL 1

Cp at y/b of														
x/c	0.02		0.22		0.44		0.56		0.67		0.83		0.98	
	U.S.	L.S.	U.S.	L.S.	U.S.	L.S.	U.S.	L.S.	U.S.	L.S.	U.S.	L.S.	U.S.	L.S.
.05	.3438	.3802	.4657	.4572					.4275	.7476	.5253	.8956		
.10	.3835	.3951	.4238	.3886					.4592	.6762	.5735	.8082	.4589	.6139
.15	.3460	.3173					.4367	.4259	.5161	.5928	.6029	.7386		
.20							.3913	.3397	.4974	.5043	.5933	.6669	.5017	.5119
.25	.0378	-.0202	-.0942	-.1241					.4356	.4049	.5708	.5887	.4800	.4649
.30			-.1229	-.1530	-.1478	-.2062	-.0855	-.1331	.1455	.1072				
.40	-.0937	-.1191			-.2074	-.2436	-.1508	-.1880	-.0628	-.0957	.0193	.0259		
.50	-.1074	-.1604					-.1930	-.2265	-.1218	-.1457			.0572	.0497
.60					-.2589	-.2874	-.2269	-.2545	-.1537	-.1820	-.0578	-.0542	.0485	.0452
.70			-.1755	-.1836	-.2767	-.3017	-.2583	-.2846	-.2937	-.2528	-.2803	-.2957	-.1162	-.1352
.80	-.3225		-.3554	-.3742	-.4016	-.4166			-.3676	-.3870	-.2970	-.3225		
.90	-.3633	-.3560			-.3979	-.4036			-.3741	-.3858	-.2761	-.3091		
.95	-.3653	-.3665							-.3670		-.2796	-.3068	-.2168	-.2187

TAIL 2

TABLE VI. - PRESSURE COEFFICIENTS, $\theta = 0^\circ$, $\delta = 0^\circ$, $M = 2.36$
 (a) $\alpha = -4.06^\circ$

Cp at y/b of														
x/c	0.02		0.22		0.44		0.56		0.67		0.83		0.98	
	U.S.	L.S.	U.S.	L.S.	U.S.	L.S.	U.S.	L.S.	U.S.	L.S.	U.S.	L.S.	U.S.	L.S.
.05	.1701	.1619	.2599	.3331	.2605	.3189	.2507	.3226	.2536	.3262	.2528	.3134		
.10	.1553	.1743	.2642	.3419	.2622	.3246	.2316	.3349	.2590	.3217	.2486	.3158	.2023	.2437
.15	.1397	.1713	.2679	.3413	.2603	.3236	.2481	.3269	.2584	.3191	.2439	.3122	.1825	.2309
.20	.1209	.1318	.2634	.3314	.2568	.3225			.2529	.3202	.2522	.3107	.1637	.2145
.25			.0357	.0519	.2188	.2760	.2327	.3056	.2473	.3165	.2506	.3091	.1548	.2039
.30	-.0010	-.0046	-.0000	.0191	.0132	.0333	.0266	.0525	.1053	.1273	.2374	.2965	.1482	.1941
.40									.0035	.0306	.0090	.0359	-.0399	-.0184
.50	-.0093	.0176	-.0290	-.0174	.0009	.0323			-.0002	.0250	-.0073	.0184	-.0626	-.0495
.60	.0482	.0440	-.0309	-.0249	.0013	.0285	-.0003	.0250	-.0025	.0210	-.0168	.0072	-.0565	-.0556
.70	.0196	.0283	-.0304	-.0216	-.0074	.0142	-.0152	.0106	-.0449	-.0199			-.1204	-.1227
.80	-.0901	-.0929	-.1254	-.1243	-.1344	-.1330	-.1307	-.1250	-.1255	-.1324	-.1194	-.1296	-.1100	-.1346
.90	-.1141	-.1075	-.1126	-.1125	-.1137	-.1198	-.1107	-.1234	-.1083	-.1129	-.1138	-.1137	-.0912	-.0895
.95	-.1216	-.1125	-.1121	-.1116	-.1107	-.1138	-.1107	-.1105	-.1062	-.1062	-.1127	-.1108	-.0865	-.0853

TAIL 1

Cp at y/b of														
x/c	0.02		0.22		0.44		0.56		0.67		0.83		0.98	
	U.S.	L.S.	U.S.	L.S.	U.S.	L.S.	U.S.	L.S.	U.S.	L.S.	U.S.	L.S.	U.S.	L.S.
.05	.2608	.0623	.4772	.1807			.4488	.1987	.4492	.1995	.4444	.2106	.3997	.2238
.10	.2707	.0687	.4769	.1630			.4454	.1802	.4357	.1855	.4374	.1999	.3581	.1641
.15	.2585	.0665	.4596	.1545			.4379	.1740	.4323	.1777	.4332	.1927	.3120	.1376
.20							.4257	.1644	.4311	.1691		.1869	.2896	.1193
.25	.0961	-.0423	.1249	-.0387			.4076	.1483	.4189	.1573	.4176	.1790	.2643	.1099
.30			.0900	-.0570	.1141	-.0523	.1225	-.0339	.2501	.0522				
.40	.0837	.0063			.1049	-.0637	.1004	-.0599	.1046	-.0510	.1129	-.0387		
.50	.0889	-.0308					.0970	-.0642	.0952	-.0603			.0092	.0196
.60					.0915	-.0703	.0984	-.0657	.0930	-.0631	.0698	-.0646	-.0151	-.0671
.70			.0674	-.0671	.0759	-.0773	.0807	-.0739	-.0115	-.0908	-.0933	-.1192	-.0906	-.1270
.80	-.0295	-.1136	-.0739	-.1129	-.0887	-.1042			-.0612	-.0887	-.1155	-.1132	.0053	-.1173
.90	-.0637	-.1172			-.1009	-.0976			-.0871	-.1038	-.1157	-.1132	-.0627	-.1349
.95	-.0679	-.1102							-.0942	-.1043	-.1184	-.1132	-.0637	-.1273

TAIL 2

TABLE VI. - CONTINUED
(b) $\alpha = -2.06^\circ$

Cp at y/b of														
x/c	0.02		0.22		0.44		0.56		0.67		0.83		0.98	
	U.S.	L.S.	U.S.	L.S.	U.S.	L.S.	U.S.	L.S.	U.S.	L.S.	U.S.	L.S.	U.S.	L.S.
.05	.1373	-.1514	.2629	.3301	.2631	.3206	.2471	.3269	.2551	.3296	.2537	.3170	.1999	.2417
.10	.1314	-.1598	.2709	.3471	.2658	.3258	.2353	.3381	.2605	.3252	.2516	.3197	.1824	.2274
.15	.1258	-.1579	.2791	.3493	.2643	.3229	.2514	.3305	.2628	.3209	.2471	.3153	.1656	.2111
.20	.1091	-.1267	.2672	.3275	.2611	.3197			.2561	.3206	.2550	.3125	.1569	.2001
.25			.0325	.0461	.2237	.2714	.2356	.3077	.2499	.3156	.2530	.3091	.1508	.1919
.30	.0152	-.0125	-.0069	-.0130	.0127	.0305	.0276	.0519	.1080	.1255	.2396	.2959	.1508	.1919
.40									.0037	.0282	.0083	.0335	-.0389	-.0203
.50	.0245	-.0407	-.0347	-.0167	.0023	.0298			-.0003	.0226	-.0086	.0141	-.0514	-.0474
.60	.0708	-.0586	-.0287	-.0198	.0017	.0242	-.0000	.0233	-.0019	.0186	-.0199	.0024	-.0489	-.0465
.70	.0177	-.0337	-.0211	-.0110	-.0088	.0108	-.0146	.0100	-.0438	-.0225			-.1185	-.1175
.80	-.0909	-.0847	-.1187	-.1212	-.1345	-.1325	-.1303	-.1263	-.1257	-.1324	-.1186	-.1289	-.0952	-.1270
.90	-.1004	-.0952	-.1202	-.1117	-.1123	-.1144	-.1116	-.1225	-.1076	-.1109	-.1148	-.1150	-.0958	-.0814
.95	-.1087	-.0985	-.1180	-.1100	-.1101	-.1108	-.1079	-.1116	-.1054	-.1047	-.1141	-.1128	-.0957	-.0925

TAIL 1

Cp at y/b of														
x/c	0.02		0.22		0.44		0.56		0.67		0.83		0.98	
	U.S.	L.S.	U.S.	L.S.	U.S.	L.S.	U.S.	L.S.	U.S.	L.S.	U.S.	L.S.	U.S.	L.S.
.05	.1972	.1092	.3837	.2459			.3670	.2634	.3703	.2626	.3685	.2696	.3330	.2790
.10	.2060	.1105	.3840	.2325			.3634	.2439	.3568	.2485	.3620	.2604	.2944	.2135
.15	.1975	.1040	.3781	.2253			.3558	.2343	.3534	.2392	.3588	.2520	.2582	.1794
.20							.3449	.2255	.3524	.2299		.2397	.2350	.1584
.25	.0566	-.0168	.0789	.0020			.3287	.2067	.3410	.2165	.3448	.2375	.2157	.1473
.30			.0477	-.0251	.0626	-.0180	.0741	.0001	.1903	-.0970				
.40	.0446	.0090			.0548	-.0294	.0520	-.0269	.0581	-.0173	.0683	-.0051		
.50	.0560	-.0180					.0476	-.0310	.0486	-.0279			.0142	.0239
.60					.0493	-.0355	.0491	-.0329	.0460	-.0313	.0306	-.0386	-.0221	-.0462
.70			.0260	-.0447	.0357	-.0426	.0362	-.0441	-.0448	-.0634	-.1141	-.1283	-.0997	-.1223
.80	-.0551	-.1073	-.0983	-.1034	-.1113	-.1032			-.0795	-.0860	-.1341	-.1108	-.0103	-.0996
.90	-.0819	-.1181			-.1211	-.1026			-.1120	-.1007	-.1237	-.1095	-.0784	-.1174
.95	-.0849	-.1122							-.1124	-.1011	-.1156	-.1095	-.0929	-.1240

TAIL 2

TABLE VI. - CONTINUED
(c) $\alpha = -0.06^\circ$

Cp at y/b of														
x/c	0.02		0.22		0.44		0.56		0.67		0.83		0.98	
	U.S.	L.S.	U.S.	L.S.	U.S.	L.S.	U.S.	L.S.	U.S.	L.S.	U.S.	L.S.	U.S.	L.S.
.05	.1487	.1764	.2663	.3283	.2662	.3209	.2414	.3303	.2573	.3329	.2560	.3196		
.10	.1430	.1881	.2704	.3369	.2682	.3286	.2369	.3413	.2616	.3279	.2538	.3220	.1978	.2401
.15	.1352	.1889	.2736	.3375	.2676	.3266	.2541	.3335	.2664	.3220	.2495	.3179	.1821	.2260
.20	.1240	.1541	.2666	.3294	.2638	.3227			.2595	.3208	.2570	.3143	.1679	.2097
.25			.0368	.0526	.2268	.2724	.2382	.3097	.2524	.3163	.2548	.3102	.1599	.1987
.30	.0124	.0139	-.0009	.0206	.0115	.0299	.0293	.0512	.1089	.1281	.2412	.2960	.1545	.1910
.40									.0033	.0270	.0066	.0306	-.0375	-.0218
.50	.0202	.0291	-.0308	-.0106	.0003	.0242			-.0015	.0215	-.0116	.0079	-.0386	-.0413
.60	.0802	.0562	-.0271	-.0155	-.0003	.0229	-.0011	.0200	-.0029	.0177	-.0233	-.0041	-.0407	-.0371
.70	.0279	.0423	-.0190	-.0133	-.0087	.0127	-.0158	.0075	-.0445	-.0231			-.1189	-.1146
.80	-.0848	-.0824	-.1156	-.1219	-.1327	-.1298	-.1295	-.1285	-.1265	-.1328	-.1195	-.1297	-.0952	-.1118
.90	-.0954	-.0919	-.1186	-.1088	-.1105	-.1150	-.1104	-.1209	-.1075	-.1097	-.1167	-.1176	-.1245	-.0887
.95	-.1060	-.0967	-.1172	-.1070	-.1079	-.1099	-.1077	-.1118	-.1050	-.1041	-.1163	-.1156	-.1211	-.1043

TAIL 1

Cp at y/b of														
x/c	0.02		0.22		0.44		0.56		0.67		0.83		0.98	
	U.S.	L.S.	U.S.	L.S.	U.S.	L.S.	U.S.	L.S.	U.S.	L.S.	U.S.	L.S.	U.S.	L.S.
.05	.1442	.1545	.2983	.3263			.2930	.3347	.2975	.3340	.3022	.3361	.2730	.3387
.10	.1518	.1563	.2946	.3158			.2895	.3145	.2840	.3197	.2951	.3262	.2373	.2674
.15	.1442	.1486	.2934	.3124			.2825	.3043	.2804	.3083	.2914	.3168	.2078	.2268
.20							.2722	.2945	.2800	.2982		.2997	.1888	.2043
.25	.0226	.0118	.0351	.0462			.2581	.2731	.2703	.2829	.2788	.3022	.1704	.1904
.30			.0076	.0112	.0179	.0214	.0318	.0380	.1373	.1461				
.40	.0149	.0117			.0089	.0104	.0099	.0108	.0163	.0197	.0284	.0322		
.50	.0292	.0031					.0051	.0068	.0079	.0084			.0142	.0173
.60					.0079	.0057	.0057	.0048	.0054	.0048	-.0044	-.0067	-.0328	-.0310
.70			-.0088	-.0172	-.0024	-.0046	-.0049	-.0062	-.0732	-.0306	-.1319	-.1322	-.1090	-.1150
.80	-.0748	-.0943	-.1133	-.1074	-.1312	-.1184			-.0929	-.0954	-.1271	-.1177	.0104	-.1129
.90	-.0969	-.1095			-.1143	-.1025			-.1048	-.1002	-.1152	-.1118	-.1193	-.0966
.95	-.0985	-.1099							-.1008	-.0992	-.1131	-.1113	-.1282	-.1108

TAIL 2

TABLE VI. - CONTINUED
(d) $\alpha = 1.93^\circ$

Cp at y/b of														
x/c	0.02		0.22		0.44		0.56		0.67		0.83		0.98	
	U.S.	L.S.	U.S.	L.S.	U.S.	L.S.	U.S.	L.S.	U.S.	L.S.	U.S.	L.S.	U.S.	L.S.
.05	.1689	.2088	.2694	.3298	.2697	.3228	.2367	.3332	.2592	.3345	.2564	.3211		
.10	.1617	.2277	.2727	.3376	.2715	.3304	.2393	.3420	.2627	.3306	.2549	.3235	.1975	.2387
.15	.1514	.2396	.2732	.3331	.2702	.3283	.2570	.3368	.2688	.3249	.2504	.3193	.1833	.2259
.20	.1397	.1949	.2647	.3251	.2672	.3248			.2633	.3227	.2584	.3158	.1725	.2110
.25			.0371	.0536	.2295	.2737	.2406	.3124	.2544	.3176	.2558	.3115	.1650	.2006
.30	.0029	.0081	.0014	.0254	.0110	.0314	.0351	.0467	.1100	.1259	.2418	.2971	.1592	.1930
.40									.0037	.0268	.0048	.0273	-.0347	-.0209
.50	-.0034	.0043	-.0260	-.0046	-.0003	.0218			-.0015	.0211	-.0150	.0030	-.0319	-.0308
.60	.0717	.0339	-.0290	-.0118	-.0016	.0201	-.0013	.0185	-.0032	.0169	-.0265	-.0097	-.0375	-.0288
.70	.0352	.0416	-.0224	-.0138	-.0095	.0128	-.0144	.0069	-.0446	-.0232			-.1194	-.1140
.80	-.0769	-.0862	-.1158	-.1262	-.1315	-.1276	-.1278	-.1299	-.1266	-.1330	-.1200	-.1283	-.1168	-.0961
.90	-.0934	-.0884	-.1080	-.1077	-.1101	-.1181	-.1083	-.1182	-.1072	-.1088	-.1180	-.1188	-.1409	-.1094
.95	-.1060	-.0939	-.1090	-.1062	-.1067	-.1102	-.1071	-.1105	-.1048	-.1038	-.1179	-.1167	-.1334	-.1244

TAIL 1

Cp at y/b of														
x/c	0.02		0.22		0.44		0.56		0.67		0.83		0.98	
	U.S.	L.S.	U.S.	L.S.	U.S.	L.S.	U.S.	L.S.	U.S.	L.S.	U.S.	L.S.	U.S.	L.S.
.05	.0948	.2007	.2202	.4138			.2259	.4114	.2321	.4116	.2400	.4086	.2172	.4027
.10	.1033	.2058	.2138	.4101			.2223	.3911	.2193	.3950	.2324	.3985	.1855	.3251
.15	.0985	.1995	.2097	.4059			.2156	.3803	.2151	.3827	.2293	.3884	.1604	.2799
.20							.2060	.3700	.2144	.3714		.3799	.1503	.2548
.25	-.0076	.0446	-.0061	.0899			.1935	.3457	.2057	.3539	.2187	.3718	.1340	.2379
.30			-.0299	.0502	-.0208	.0651	-.0063	.0810	-.0899	.2001				
.40	-.0093	.0439			-.0304	.0558	-.0272	.0539	-.0194	.0610	-.0073	.0726		
.50	.0085	.0287					-.0321	.0501	-.0282	.0493			-.0107	.0170
.60					-.0326	.0466	-.0321	.0488	-.0305	.0457	-.0362	.0278	-.0482	-.0254
.70			-.0367	.0176	-.0396	.0327	-.0410	.0337	-.0982	.0056	-.1329	-.1151	-.1182	-.1016
.80	-.0889	-.0798	-.1186	-.1119	-.1090	-.1211			-.0793	-.0964	-.1153	-.1354	.0069	-.1242
.90	-.1044	-.0950			-.1042	-.1056			-.1022	-.1171	-.1129	-.1162	-.1353	-.0819
.95	-.1023	-.1009							-.1025	-.1058	-.1128	-.1106	-.1294	-.0907

TAIL 2

TABLE VI. - CONTINUED
(e) $\alpha = 3.93^\circ$

x/c	Cp at y/b of													
	0.02		0.22		0.44		0.56		0.67		0.83		0.98	
	U.S.	L.S.	U.S.	L.S.	U.S.	L.S.	U.S.	L.S.	U.S.	L.S.	U.S.	L.S.	U.S.	L.S.
.05	.1885	.2337	.2746	.3366	.2739	.3267	.2338	.3381	.2608	.3369	.2571	.3211	.1961	.2368
.10	.1786	.2611	.2785	.3422	.2754	.3339	.2449	.3426	.2631	.3325	.2547	.3228	.1831	.2254
.15	.1671	.2846	.2786	.3370	.2745	.3315	.2595	.3371	.2699	.3270	.2503	.3189	.1747	.2120
.20	.1507	.2415	.2682	.3275	.2718	.3269	.2417	.3164	.2573	.3186	.2559	.3120	.1690	.2039
.25			.0390	.0548	.2326	.2767	.2471	.3164	.1111	.1282	.2417	.2972	.1638	.1977
.30	-.0028	-.0048	.0036	.0284	.0115	.0329	.0430	.0471	.0040	.0271	.0025	.0246	-.0310	-.0163
.40									-.0014	.0220	-.0188	-.0005	-.0275	-.0183
.50	-.0214	-.0137	-.0221	.0019	.0006	.0234			-.0034	.0175	-.0299	-.0134	-.0361	-.0223
.60	.0492	.0138	-.0277	-.0060	-.0003	.0210	.0003	.0196	-.0448	-.0233			-.1156	-.1117
.70	.0399	.0417	-.0262	-.0109	-.0085	.0131	-.0160	.0063	-.1245	-.1324	-.1183	-.1238	-.1267	-.0884
.80	-.0699	-.0861	-.1142	-.1261	-.1300	-.1255	-.1248	-.1277	-.1063	-.1072	-.1169	-.1175	-.1482	-.1306
.90	-.0883	-.0824	-.1037	-.1049	-.1080	-.1142	-.1045	-.1119	-.1063	-.1072	-.1168	-.1164	-.1414	-.1394
.95	-.1008	-.0850	-.1036	-.1039	-.1048	-.1058	-.1019	-.1049	-.1040	-.1029				

TAIL 1

x/c	Cp at y/b of													
	0.02		0.22		0.44		0.56		0.67		0.83		0.98	
	U.S.	L.S.	U.S.	L.S.	U.S.	L.S.	U.S.	L.S.	U.S.	L.S.	U.S.	L.S.	U.S.	L.S.
.05	.0491	.2624	.1527	.5061			.1642	.4952	.1735	.4973	.1827	.4883	.1693	.4704
.10	.0595	.2700	.1444	.5054			.1609	.4740	.1615	.4775	.1750	.4767	.1405	.3864
.15	.0602	.2602	.1375	.4912			.1550	.4630	.1572	.4635	.1717	.4656	.1196	.3385
.20							.1469	.4518	.1561	.4508		.4566	.1148	.3100
.25	-.0366	.0845	-.0444	.1346			.1361	.4249	.1485	.4318	.1627	.4471	.1050	.2905
.30					-.0550	.1155	-.0403	.1292	.0470	.2600				
.40	-.0332	.0996			-.0648	.1064	-.0601	.1019	-.0517	.1068	-.0396	.1163	.0038	.0171
.50	-.0032	.0613					-.0646	.0987	-.0602	.0954			-.0669	-.0153
.60							-.0651	.0972	-.0620	.0921	-.0647	.0655	-.1160	-.0951
.70					-.0678	.0871	-.0651	.0972	-.0620	.0921	-.0647	.0655	-.1160	-.0951
.80	-.0959	-.0594	-.0600	.0592	-.0743	.0709	-.0717	.0772	-.0777	.0757	-.1096	-.0949	-.0002	-.1175
.90	-.1072	-.0792			-.0988	-.1013			-.0988	-.1002	-.1072	-.1197	-.1360	-.0869
.95	-.0984	-.0872	-.1234	-.0920	-.0992	-.1101			-.0992	-.1057	-.1075	-.1176	-.1288	-.0756

TAIL 2

TABLE VI. - CONTINUED
(f) $\alpha = 5.92^\circ$

Cp at y/b of														
x/c	0.02		0.22		0.44		0.56		0.67		0.83		0.98	
	U.S.	L.S.	U.S.	L.S.	U.S.	L.S.	U.S.	L.S.	U.S.	L.S.	U.S.	L.S.	U.S.	L.S.
.05	.2069	.2541	.2816	.3442	.2760	.3284	.2309	.3427	.2618	.3358	.2554	.3181		
.10	.1947	.2831	.2869	.3504	.2790	.3378	.2483	.3438	.2635	.3327	.2538	.3211	.1944	.2339
.15	.1819	.3143	.2861	.3438	.2786	.3344	.2618	.3381	.2697	.3277	.2498	.3180	.1840	.2248
.20	.1600	.2847	.2748	.3329	.2767	.3290			.2686	.3237	.2574	.3150	.1767	.2135
.25			.0418	.0566	.2345	.2800	.2441	.3187	.2555	.3191	.2542	.3112	.1720	.2066
.30	.0000	-.0072	.0065	.0317	.0137	.0350	.0435	.0511	.1124	.1282	.2392	.2967	.1685	.2013
.40									.0047	.0280	-.0003	.0221	-.0282	-.0120
.50	-.0248	-.0210	-.0171	.0089	.0028	.0265			-.0008	.0234	-.0224	-.0033	-.0283	-.0087
.60	.0320	.0022	-.0236	.0000	.0024	.0239	.0016	.0215	-.0034	.0189	-.0331	-.0157	-.0159	-.0172
.70	.0433	.0387	-.0261	-.0065	-.0059	.0154	-.0146	.0061	-.0455	-.0228			-.1071	-.1070
.80	-.0626	-.0850	-.1130	-.1263	-.1281	-.1236	-.1221	-.1251	-.1229	-.1318	-.1174	-.1219	-.1301	-.0978
.90	-.0808	-.0764	-.1020	-.1030	-.1064	-.1139	-.1028	-.1054	-.1059	-.1063	-.1161	-.1166	-.1594	-.1451
.95	-.0915	-.0745	-.1019	-.1019	-.1034	-.1046	-.1005	-.0997	-.1037	-.1024	-.1160	-.1162	-.1523	-.1517

TAIL 1

Cp at y/b of														
x/c	0.02		0.22		0.44		0.56		0.67		0.83		0.98	
	U.S.	L.S.	U.S.	L.S.	U.S.	L.S.	U.S.	L.S.	U.S.	L.S.	U.S.	L.S.	U.S.	L.S.
.05	.0064	.3181	.0914	.6129			.1089	.5890	.1190	.5934	.1301	.5794	.1238	.5383
.10	.0181	.3314	.0829	.6063			.1044	.5682	.1076	.5682	.1215	.5651	.0962	.4515
.15	.0235	.3242	.0754	.5706			.0993	.5564	.1031	.5544	.1187	.5527	.0827	.4015
.20							.0924	.5455	.1022	.5421		.5432	.0787	.3704
.25	-.0662	.1286	-.0813	.1778			.0830	.5159	.0955	.5192	.1114	.5310	.0733	.3484
.30			-.0896	.1324	-.0852	.1712	-.0707	.1860	.0070	.3269				
.40	-.0535	.1547			-.0950	.1530	-.0836	.1582	-.0812	.1605	-.0687	.1638		
.50	-.0058	.1035					-.0939	.1518	-.0893	.1496			-.0058	.0179
.60					-.0981	.1272	-.0947	.1434	-.0907	.1459	-.0906	.1080	-.0498	.0063
.70			-.0837	.1053	-.1029	.1098	-.0971	.1179	-.1246	.0953	-.1147	-.0707	-.1527	-.0887
.80	-.1049	-.0329	-.1525	-.0655	-.1069	-.0791			-.0847	-.0535	-.1137	-.0962	-.0106	-.0963
.90	-.1123	-.0600			-.1089	-.0967			-.1055	-.0787	-.1147	-.1036	-.1473	-.1030
.95	-.1043	-.0700							-.1060	-.0872	-.1151	-.1080	-.1426	-.1067

TAIL 2

TABLE VI. - CONTINUED
(g) $\alpha = 7.91^\circ$

Cp at y/b of														
x/c	0.02		0.22		0.44		0.56		0.67		0.83		0.98	
	U.S.	L.S.	U.S.	L.S.	U.S.	L.S.	U.S.	L.S.	U.S.	L.S.	U.S.	L.S.	U.S.	L.S.
.05	.2268	.2746	.2897	.3536	.2786	.3303	.2303	.3493	.2589	.3302	.2520	.3129		
.10	.2126	.3136	.2960	.3612	.2826	.3405	.2500	.3444	.2600	.3281	.2491	.3155	.1916	.2323
.15	.1961	.3327	.2942	.3558	.2843	.3387	.2641	.3400	.2660	.3257	.2445	.3124	.1852	.2275
.20	.1699	.3191	.2829	.3449	.2828	.3357			.2671	.3244	.2516	.3115	.1798	.2188
.25			.2455	.0627	.2382	.2883	.2455	.3246	.2607	.3210	.2484	.3089	.1749	.2140
.30	-.0058	-.0027	.0119	.0384	.0172	.0394	.0372	.0513	.1146	.1308	.2331	.2934	.1726	.2076
.40									.0062	.0299	-.0051	.0175	-.0225	-.0085
.50	-.0208	-.0219	-.0102	.0162	-.0067	.0294			-.0002	.0249	-.0270	-.0081	-.0264	-.0056
.60	.0269	-.0007	-.0177	.0070	.0059	.0270	.0035	.0238	-.0034	.0192	-.0366	-.0202	-.0011	-.0141
.70	.0482	.0341	-.0226	-.0006	-.0028	.0191	-.0125	.0079	-.0464	-.0242			-.1062	-.0985
.80	-.0569	-.0838	-.1070	-.1217	-.1241	-.1208	-.1180	-.1225	-.1189	-.1294	-.1155	-.1182	-.1579	-.1012
.90	-.0722	-.0696	-.0976	-.0983	-.1016	-.1097	-.0996	-.1010	-.1045	-.1049	-.1146	-.1148	-.1671	-.1534
.95	-.0797	-.0641	-.0975	-.0973	-.0992	-.1011	-.0977	-.0966	-.1024	-.1018	-.1144	-.1145	-.1562	-.1628

TAIL 1

Cp at y/b of														
x/c	0.02		0.22		0.44		0.56		0.67		0.83		0.98	
	U.S.	L.S.	U.S.	L.S.	U.S.	L.S.	U.S.	L.S.	U.S.	L.S.	U.S.	L.S.	U.S.	L.S.
.05	-.0347	.3611	.0372	.7288			.0611	.6977	.0712	.7005	.0835	.6845	.0828	.6151
.10	-.0195	.3841	.0277	.6888			.0546	.6761	.0600	.6736	.0739	.6645	.0576	.5276
.15	-.0088	.3884	.0207	.6390			.0490	.6664	.0551	.6592	.0713	.6544	.0518	.4749
.20							.0428	.6538	.0538	.6456		.6422	.0493	.4403
.25	-.0896	.1725	-.1122	.2159			.0348	.6170	.0476	.6221	.0651	.6257	.0453	.4151
.30			-.1140	.1696	-.1110	.2160	-.0375	.2462	-.0290	.4049				
.40	-.0756	.2089			-.1212	.1940	-.1154	.2096	-.1069	.2232	-.0943	.2161		
.50	-.0318	.1511					-.1198	.1966	-.1148	.2063			-.0155	.0089
.60					-.1242	.1680	-.1208	.1848	-.1159	.1949	-.1128	.1586	-.0664	.0372
.70			-.1075	.1556	-.1227	.1503	-.1132	.1570	-.1208	.1344	-.1206	-.0416	-.1687	-.0896
.80	-.1135	-.0062	-.1669	-.0332	-.1173	-.0544			-.0905	-.0351	-.1200	-.0699	-.0203	-.0823
.90	-.1233	-.0393			-.1189	-.0666			-.1122	-.0587	-.1217	-.0803	-.1467	-.0854
.95	-.1159	-.0518							-.1125	-.0680	-.1225	-.0871	-.1460	-.0944

TAIL 2

TABLE VI. - CONTINUED
(h) $\alpha = 9.92^\circ$

Cp at y/b of														
x/c	0.02		0.22		0.44		0.56		0.67		0.83		0.98	
	U.S.	L.S.	U.S.	L.S.	U.S.	L.S.	U.S.	L.S.	U.S.	L.S.	U.S.	L.S.	U.S.	L.S.
.05	.2485	.2983	.2992	.3633	.2770	.3317	.2308	.3607	.2654	.3412	.2621	.3293		
.10	.2299	.3402	.3093	.3766	.2811	.3418	.2547	.3536	.2657	.3398	.2593	.3335	.2021	.2481
.15	.2104	.3543	.3102	.3748	.2846	.3413	.2660	.3457	.2710	.3378	.2557	.3317	.1970	.2438
.20	.1814	.3532	.3002	.3663	.2827	.3385			.2725	.3358	.2625	.3295	.1934	.2364
.25			.0572	.0753	.2379	.2913	.2447	.3302	.2669	.3302	.2574	.3239	.1901	.2319
.30	.0143	.0096	.0221	.0498	.0174	.0381	.0322	.0567	.1186	.1350	.2408	.3044	.1889	.2244
.40									.0073	.0311	-.0032	.0198	-.0094	.0013
.50	-.0123	-.0189	-.0011	.0255	.0076	.0303			.0003	.0246	-.0249	-.0065	-.0104	.0026
.60	.032	.0029	-.0106	.0164	.0079	.0306	.0018	.0220	-.0050	.0167	-.0349	-.0188	-.0090	.0083
.70	.0571	.0346	-.0161	.0090	-.0003	.0244	-.0145	.0059	-.0488	-.0279			-.1045	-.0947
.80	-.0532	-.0827	-.1023	-.1175	-.1192	-.1160	-.1120	-.1190	-.1169	-.1273	-.1167	-.1190	-.1672	-.1063
.90	-.0634	-.0628	-.0925	-.0930	-.0979	-.1043	-.0568	-.0969	-.1050	-.1055	-.1144	-.1142	-.1696	-.1645
.95	.0652	-.0537	-.0923	-.0918	-.0955	-.0963	-.0951	-.0937	-.1032	-.1031	-.1141	-.1135	-.1627	-.1657

TAIL 1

Cp at y/b of														
x/c	0.02		0.22		0.44		0.56		0.67		0.83		0.98	
	U.S.	L.S.	U.S.	L.S.	U.S.	L.S.	U.S.	L.S.	U.S.	L.S.	U.S.	L.S.	U.S.	L.S.
.05	-.0691	.3862	-.0107	.8191			.0166	.8457	.0271	.8458	.0415	.8216	.0439	.7155
.10	-.0499	.4227	-.0215	.7575			.0079	.8150	.0150	.8175	.0298	.8030	.0243	.6251
.15	-.0320	.4408	-.0279	.7014			.0016	.7863	.0097	.7943	.0260	.7844	.0259	.5681
.20							-.0038	.7548	.0077	.7680			.0255	.5287
.25	-.1039	.2119	-.1382	.2487			-.0108	.6973	.0021	.7261	.0201	.7380	.0253	.4998
.30			-.1335	.2067	-.1340	.2507	-.1227	.2858	-.0630	.4690				
.40	-.1002	.2753			-.1439	.2337	-.1387	.2510	-.1302	.2716	-.1178	.2664		
.50	-.0621	.1968					-.1430	.2392	-.1383	.2506			-.0185	.0136
.60					-.1434	.2113	-.1429	.2284	-.1384	.2349	-.1325	.1991	-.0944	.0726
.70			-.1297	.2117	-.1320	.1937	-.1217	.1978	-.1249	.1665	-.1291	-.0185	-.1716	-.0883
.80	-.1228	.0216	-.1761	.0053	-.1294	-.0270			-.0984	-.0171	-.1287	-.0484	-.0228	-.0923
.90	-.1354	-.0188			-.1307	-.0394			-.1233	-.0387	-.1304	-.0601	-.1567	-.0966
.95	-.1284	-.0328							-.1237	-.0484	-.1313	-.0677	-.1641	-.1018

TAIL 2

TABLE VI. - CONTINUED
(i) $\alpha = 11.91^\circ$

Cp at y/b of														
x/c	0.02		0.22		0.44		0.56		0.67		0.83		0.98	
	U.S.	L.S.	U.S.	L.S.	U.S.	L.S.	U.S.	L.S.	U.S.	L.S.	U.S.	L.S.	U.S.	L.S.
.05	.2665	.3257	.3177	.3878	.3052	.3644	.2572	.3942	.2908	.3717	.2864	.3588		
.10	.2463	.3701	.3268	.3959	.3098	.3729	.2822	.3812	.2909	.3684	.2832	.3603	.2245	.2717
.15	.2252	.3790	.3265	.3939	.3134	.3689	.2930	.3735	.2955	.3641	.2784	.3561	.2201	.2665
.20	.1946	.3857	.3148	.3835	.3076	.3652			.2968	.3609	.2848	.3526	.2165	.2583
.25			.0654	.0848	.2608	.3164	.2692	.3544	.2910	.3541	.2786	.3445	.2128	.2535
.30	.0224	.0211	.0231	.0587	.0313	.0523	.0469	.0737	.1364	.1514	.2609	.3224	.2114	.2462
.40									.0210	.0442	.0072	.0289	.0065	.0141
.50	-.0048	-.0168	.0046	.0331	.0184	.0426			.0134	.0373	-.0142	.0032	.0059	.0164
.60	.0401	.0067	-.0056	.0242	.0168	.0399	.0155	.0360	.0071	.0278	-.0235	-.0082	.0219	.0339
.70	.0702	.0369	-.0118	.0147	.0075	.0329	-.0015	.0187	-.0391	-.0191			-.1040	-.0868
.80	-.0462	-.0812	-.0952	-.1105	-.1143	-.1132	-.1105	-.1168	-.1170	-.1269	-.1159	-.1184	-.1651	-.1140
.90	-.0541	-.0528	-.0871	-.0871	-.0916	-.1015	-.0913	-.0932	-.1012	-.1017	-.1103	-.1098	-.1713	-.1659
.95	-.0538	-.0437	-.0869	-.0860	-.0900	-.0930	-.0890	-.0893	-.0992	-.0984	-.1093	-.1079	-.1649	-.1613

TAIL 1

Cp at y/b of														
x/c	0.02		0.22		0.44		0.56		0.67		0.83		0.98	
	U.S.	L.S.	U.S.	L.S.	U.S.	L.S.	U.S.	L.S.	U.S.	L.S.	U.S.	L.S.	U.S.	L.S.
.05	-.0945	.3783	-.0477	.8977			-.0160	1.0041	-.0063	1.0244	.0052	1.0133	.0055	.8497
.10	-.0665	.4380	-.0601	.8215			-.0279	.9339	-.0209	.9531	-.0084	.9562	-.0037	.7432
.15	-.0485	.4755	-.0667	.7616			-.0357	.8815	-.0276	.9026	-.0142	.9052	.0026	.6705
.20							-.0417	.8331	-.0303	.8554		.8574	.0026	.6149
.25	-.1115	.2507	-.1583	.2773			-.0476	.7565	-.0359	.7920	-.0203	.8028	.0036	.5712
.30			-.1474	.2429	-.1515	.2814	-.1429	.3104	-.0915	.4975				
.40	-.1177	.3625			-.1602	.2779	-.1565	.2914	-.1480	.3051	-.1368	.2894		
.50	-.0778	.2624					-.1604	.2835	-.1565	.2861			-.0209	.0178
.60					-.1476	.2603	-.1490	.2720	-.1498	.2695	-.1460	.2318	-.1482	.0978
.70			-.1452	.2728	-.1427	.2415	-.1305	.2373	-.1341	.1971	-.1403	.0036	-.1846	-.0713
.80	-.1319	.0496	-.1782	.0489	-.1421	.0016			-.1077	.0029	-.1401	-.0257	-.0255	-.0842
.90	-.1438	.0025			-.1425	-.0102			-.1358	-.0160	-.1423	-.0375	-.1772	-.0885
.95	-.1387	-.0115							-.1364	-.0259	-.1434	-.0456	-.1845	-.0948

TAIL 2

TABLE VI. - CONTINUED
(j) $\alpha = 15.91^\circ$

Cp at y/b of														
x/c	0.02		0.22		0.44		0.56		0.67		0.83		0.98	
	U.S.	L.S.	U.S.	L.S.	U.S.	L.S.	U.S.	L.S.	U.S.	L.S.	U.S.	L.S.	U.S.	L.S.
.05	.3546	.4245	.4095	.4884	.3817	.4452	.3271	.4796	.3601	.4482	.3538	.4309		
.10	.3311	.4762	.4183	.4946	.3877	.4549	.3546	.4604	.3602	.4450	.3507	.4336	.2862	.3330
.15	.3067	.4688	.4169	.4897	.3944	.4505	.3672	.4529	.3663	.4405	.3455	.4289	.2845	.3317
.20	.2724	.4896	.4022	.4763	.3828	.4499			.3671	.4354	.3504	.4238	.2822	.3253
.25			.1169	.1387	.3331	.3942	.3410	.4331	.3612	.4273	.3406	.4073	.2776	.3209
.30	.0772	.0855	.0766	.1091	.0766	.0968	.0914	.1187	.1881	.2020	.3177	.3808	.2760	.3126
.40									.0610	.0855	.0387	.0608	.0412	.0519
.50	.0394	.0193	.0464	.0773	.0630	.0881			.0513	.0761	.0164	.0346	.0586	.0559
.60	.0735	.0421	.0342	.0677	.0609	.0871	.0569	.0791	.0415	.0622	.0076	.0244	.0588	.0758
.70	.0979	.0585	.0266	.0580	.0504	.0817	.0363	.0579	-.0116	.0106			-.1047	-.0601
.80	-.0378	-.0746	-.0766	-.0954	-.0919	-.0896	-.0891	-.0966	-.0979	-.1083	-.0961	-.0969	-.1569	-.1301
.90	-.0300	-.0309	-.0644	-.0664	-.0666	-.0819	-.0677	-.0702	-.0804	-.098	-.0888	-.0867	-.1566	-.1573
.95	-.0248	-.0141	-.0637	-.0646	-.0645	-.0731	-.0655	-.0661	-.0785	-.063	-.0863	-.0828	-.1517	-.1542

TAIL 1

Cp at y/b of														
x/c	0.02		0.22		0.44		0.56		0.67		0.83		0.98	
	U.S.	L.S.	U.S.	L.S.	U.S.	L.S.	U.S.	L.S.	U.S.	L.S.	U.S.	L.S.	U.S.	L.S.
.05	-.0885	.1562	-.1095	1.0214			-.0810	1.2103	-.0728	1.2298	-.0777	1.2228	-.0685	1.0392
.10	-.0755	.2623	-.1204	.9246			-.0832	1.0907	-.0747	1.1094	-.0673	1.1172	-.0511	.9070
.15	-.0753	.3701	-.1255	.8519			-.0922	1.0022	-.0834	1.0238	-.0706	1.0280	-.0388	.8079
.20							-.1007	.9233	-.0894	.9447		.9529	-.0309	.7258
.25	-.1277	.2745	-.1825	.3076			-.1062	.8126	-.0967	.8513	-.0802	.8731	-.0300	.6609
.30			-.1527	.3054	-.1796	.3174	-.1761	.3327	-.1382	.5160				
.40	-.1399	.4514			-.1696	.3512	-.1763	.3589	-.1769	.3630	-.1672	.3372		
.50	-.1083	.4162					-.1658	.3678	-.1641	.3676			-.0390	.0165
.60					-.1653	.3618	-.1642	.3627	-.1588	.3579	-.1595	.3178	-.1577	.1620
.70			-.1592	.4907	-.1657	.3444	-.1516	.3268	-.1568	.2738	-.1598	.0576	-.2081	-.0265
.80	-.1578	.0787	-.1860	.1371	-.1662	.0725			-.1286	.0516	-.1618	.0280	-.0436	-.0392
.90	-.1617	.0681			-.1648	.0837			-.1595	.0387	-.1637	.0154	-.1853	-.0448
.95	-.1546	.0489							-.1596	.0286	-.1643	.0060	-.1899	-.0528

TAIL 2

TABLE VI. - CONCLUDED
(k) $\alpha = 19.91^\circ$

Cp at y/b of														
x/c	0.02		0.22		0.44		0.56		0.67		0.83		0.98	
	U.S.	L.S.	U.S.	L.S.	U.S.	L.S.	U.S.	L.S.	U.S.	L.S.	U.S.	L.S.	U.S.	L.S.
.05	.4592	.5446	.5186	.6128	.4777	.5543	.4123	.5860	.4430	.5451	.4315	.5220		
.10	.4293	.6028	.5261	.6156	.4851	.5622	.4404	.5617	.4435	.5407	.4279	.5248	.3549	.4111
.15	.3983	.5742	.5234	.6077	.4886	.5526	.4546	.5498	.4503	.5344	.4209	.5189	.3559	.4121
.20	.3610	.6111	.5061	.5894	.4743	.5526			.4517	.5280	.4241	.5070	.3543	.4051
.25			.1784	.2003	.4202	.4863	.4262	.5252	.4455	.5176	.4107	.4801	.3496	.3999
.30	.1441	.1677	.1340	.1686	.1323	.1517	.1453	.1711	.2498	.2624	.3847	.4477	.3504	.3837
.40									.1083	.1318	.0775	.0975	.0844	.0933
.50	.0952	.0661	.0959	.1260	.1172	.1395			.0941	.1137	.0547	.0697	.1042	.1101
.60	.1371	.0854	.0822	.1130	.1148	.1357	.1054	.1206	.0803	.0952	.0468	.0594	.0849	.1188
.70	.1576	.0963	.0750	.1023	.1031	.1289	.0795	.0927	.0212	.0380			-.1047	-.0313
.80	-.0036	-.0502	-.0493	-.0705	-.0650	-.0668	-.0639	-.0664	-.0732	-.0742	-.0715	-.0703	-.1489	-.1395
.90	.0185	.0152	-.0356	-.0402	-.0365	-.0522	-.0400	-.0410	-.0545	-.0520	-.0609	-.0600	-.1470	-.1494
.95	.0250	.0419	-.0364	-.0384	-.0334	-.0458	-.0375	-.0382	-.0525	-.0496	-.0558	-.0545	-.1436	-.1415

TAIL 1

Cp at y/b of														
x/c	0.02		0.22		0.44		0.56		0.67		0.83		0.98	
	U.S.	L.S.	U.S.	L.S.	U.S.	L.S.	U.S.	L.S.	U.S.	L.S.	U.S.	L.S.	U.S.	L.S.
.05	-.1811	.2176	-.1742	1.0961			-.1378	1.3171	-.1315	1.3477	-.1267	1.3603	-.1140	1.1717
.10	-.1233	.3713	-.1754	1.0185			-.1265	1.2002	-.1163	1.2306	-.1055	1.2483	-.0741	1.0359
.15	-.1085	.4785	-.1715	.9481			-.1305	1.1071	-.1192	1.1372	-.1041	1.1490	-.0529	.9259
.20							-.1374	1.0158	-.1238	1.0461		1.0641	-.0525	.8321
.25	-.1544	.3384	-.1842	.3664			-.1416	.8870	-.1304	.9359	-.1098	.9720	-.0553	.7557
.30			-.1612	.4306	-.1862	.3892	-.1945	.3859	-.1633	.5648				
.40	-.1617	.6150			-.1797	.4802	-.1841	.4753	-.1865	.4654	-.1834	.4141		
.50	-.1226	.5265					-.1809	.4983	-.1796	.4873			-.0450	.0262
.60					-.1816	.5147	-.1818	.4979	-.1767	.4807	-.1761	.4257	-.1846	.2398
.70			-.1788	.5855	-.1828	.5122	-.1670	.4582	-.1739	.3808	-.1783	.1223	-.2030	.0227
.80	-.1777	.1251	-.1943	.1830	-.1839	.1835			-.1416	.1197	-.1800	.0906	-.0494	.0094
.90	-.1759	.1228			-.1817	.1719			-.1755	.1165	-.1813	.0780	-.1855	.0032
.95	-.1604	.1055							-.1759	.1106	-.1821	.0680	-.1922	-.0062

TAIL 2

TABLE VII. - PRESSURE COEFFICIENTS, $\phi = 22.5^\circ$, $\delta = 0^\circ$, $M = 2.36$
 (a) $\alpha = -4.20^\circ$

Cp at y/b of														
x/c	0.02		0.22		0.44		0.56		0.67		0.83		0.98	
	U.S.	L.S.	U.S.	L.S.	U.S.	L.S.	U.S.	L.S.	U.S.	L.S.	U.S.	L.S.	U.S.	L.S.
.05	.1205	.1880	.3726	.2396	.3267	.2607	.3051	.2678	.3104	.2738	.3062	.2662		
.10	.1179	.1889	.3836	.2617	.3316	.2664	.2931	.2796	.3208	.2708	.3060	.2695	.2489	.2056
.15	.1154	.1791	.3535	.2692	.3323	.2643	.3139	.2731	.3179	.2671	.3021	.2656	.2272	.1930
.20	.0938	.1310	.3107	.2574	.3330	.2614			.3144	.2672	.3114	.2629	.2068	.1770
.25			.0505	.0103	.2904	.2182	.2991	.2524	.3099	.2625	.3102	.2594	.1968	.1662
.30	.0149	-.0057	.0089	-.0182	.0673	-.0042	.0705	.0184	.1527	.0883	.2957	.2469	.1891	.1570
.40									.0422	-.0033	.0448	.0044	-.0156	-.0404
.50	.0513	-.0037	-.0223	-.0361	.0470	-.0087			.0387	-.0099	.0263	-.0133	-.0519	-.0604
.60	.0897	.0092	-.0127	-.0332	.0321	-.0122	.0490	-.0146	.0385	-.0151	.0153	-.0234	-.0490	-.0586
.70	.0137	.0002	-.0020	-.0279	.0148	-.0234	.0289	-.0276	-.0079	-.0524			-.1148	-.1235
.80	-.0758	-.1111	-.1045	-.1329	-.1269	-.1314	-.1171	-.1314	-.1193	-.1180	-.1334	-.1172	-.1212	-.1188
.90	-.0910	-.1127	-.1088	-.1189	-.1265	-.1181	-.1278	-.1179	-.1203	-.1106	-.1246	-.1154	-.0825	-.0974
.95	-.0980	-.1085	-.1128	-.1169	-.1170	-.1171	-.1240	-.1162	-.1190	-.1101	-.1154	-.1150	-.0698	-.1012

TAIL 1

Cp at y/b of														
x/c	0.02		0.22		0.44		0.56		0.67		0.83		0.98	
	U.S.	L.S.	U.S.	L.S.	U.S.	L.S.	U.S.	L.S.	U.S.	L.S.	U.S.	L.S.	U.S.	L.S.
.05	.2876	.0644	.4664	.1902			.4354	.2060	.4376	.2081	.4323	.2165	.3860	.2247
.10	.2933	.0721	.4650	.1732			.4316	.1883	.4220	.1943	.4241	.2068	.3365	.1653
.15	.2798	.0729	.4537	.1634			.4244	.1810	.4178	.1856	.4204	.1984	.3015	.1412
.20							.4129	.1728	.4172	.1769			.2764	.1257
.25	.0972	-.0443	.1237	-.0355			.3955	.1566	.4052	.1648	.4041	.1850	.2554	.1159
.30			.0883	-.0535	.1039	-.0468	.1139	-.0291	.2395	.0581				
.40	.0786	-.0412			.0964	-.0582	.0914	-.0551	.0957	-.0464	.1009	-.0347		
.50	.0728	-.0514					.0875	-.0594	.0860	-.0562			.0084	.0262
.60					.0892	-.0647	.0899	-.0617	.0834	-.0588	.0566	-.0654	-.0092	-.0620
.70			.0633	-.0643	.0741	-.0718	.0753	-.0680	-.0176	-.0859	-.0999	-.1203	-.0894	-.1280
.80	-.0297	-.1219	-.0782	-.1110	-.0896	-.1037			-.0659	-.0866	-.1212	-.1133	.0048	-.1239
.90	-.0602	-.1282			-.1010	-.0992			-.0932	-.1037	-.1190	-.1134	-.0637	-.1444
.95	-.0636	-.1177							-.0995	-.1040	-.1194	-.1134	-.0735	-.1362

TAIL 2

TABLE VII. - CONTINUED
(b) $\alpha = -2.20^\circ$

Cp at y/b of														
x/c	0.02		0.22		0.44		0.56		0.67		0.83		0.98	
	U.S.	L.S.	U.S.	L.S.	U.S.	L.S.	U.S.	L.S.	U.S.	L.S.	U.S.	L.S.	U.S.	L.S.
.05	.1376	.1501	.2999	.2942	.2941	.2934	.2742	.3013	.2836	.3048	.2807	.2951		
.10	.1362	.1572	.3170	.3091	.2982	.3006	.2654	.3129	.2916	.3015	.2803	.2981	.2240	.2243
.15	.1337	.1547	.3231	.3165	.2984	.2994	.2839	.3068	.2936	.2975	.2772	.2942	.2057	.2113
.20	.1154	.1145	.3017	.3007	.2964	.2977			.2887	.2980	.2859	.2912	.1880	.1954
.25			.0503	.0315	.2574	.2508	.2697	.2852	.2836	.2932	.2845	.2874	.1792	.1844
.30	.0267	.0049	.0091	-.0012	.0354	.0153	.0497	.0378	.1335	.1102	.2707	.2737	.1727	.1755
.40									.0246	.0129	.0275	.0186	-.0263	-.0307
.50	.0414	.0184	-.0205	-.0323	.0277	.0108			.0199	.0060	.0090	-.0018	-.0473	-.0525
.60	.0899	.0382	-.0158	-.0331	.0225	.0064	.0226	.0037	.0179	.0013	-.0029	-.0135	-.0419	-.0484
.70	.0256	.0205	-.0069	-.0246	.0088	-.0063	.0073	-.0097	-.0269	-.0382			-.1126	-.1193
.80	-.0759	-.0957	-.1113	-.1257	-.1293	-.1369	-.1223	-.1343	-.1302	-.1216	-.1295	-.1170	-.0987	-.1161
.90	-.0904	-.0982	-.1239	-.1122	-.1215	-.1164	-.1264	-.1175	-.1162	-.1075	-.1164	-.1137	-.0878	-.0862
.95	-.0973	-.1000	-.1230	-.1115	-.1134	-.1152	-.1161	-.1136	-.1074	-.1061	-.1129	-.1134	-.0867	-.0973

TAIL 1

Cp at y/b of														
x/c	0.02		0.22		0.44		0.56		0.67		0.83		0.98	
	U.S.	L.S.	U.S.	L.S.	U.S.	L.S.	U.S.	L.S.	U.S.	L.S.	U.S.	L.S.	U.S.	L.S.
.05	.2116	.1156	.3806	.2554			.3614	.2670	.3651	.2672	.3641	.2716	.3268	.2794
.10	.2170	.1184	.3777	.2404			.3580	.2478	.3509	.2527	.3566	.2622	.2852	.2137
.15	.2062	.1123	.3732	.2311			.3506	.2394	.3468	.2429	.3531	.2540	.2525	.1817
.20							.3400	.2304	.3464	.2331		.2475	.2287	.1598
.25	.0566	-.0154	.0793	.0050			.3245	.2111	.3354	.2190	.3390	.2398	.2098	.1491
.30			.0476	-.0223	.0582	-.0161	.0709	.0024	.1859	.0986				
.40	.0406	-.0011			.0501	-.0274	.0485	-.0248	.3543	-.0160	.0632	-.0041		
.50	.0467	-.0193					.0440	-.0289	.0448	-.0265			.0109	.0232
.60					.0479	-.0336	.0454	-.0311	.0421	-.0297	.0247	-.0389	-.0192	-.0448
.70			.0248	-.0373	.0355	-.0411	.0334	-.0418	-.0453	-.0616	-.1166	-.1265	-.1005	-.1226
.80	-.0543	-.1115	-.0995	-.1076	-.1106	-.1023			-.0812	-.0842	-.1360	-.1098	.0068	-.0988
.90	-.0809	-.1203			-.1194	-.0990			-.1134	-.1001	-.1219	-.1086	-.0857	-.1231
.95	-.0846	-.1169							-.1119	-.1003	-.1148	-.1086	-.1017	-.1287

TAIL 2

TABLE VII. - CONTINUED
(c) $\alpha = -0.22^\circ$

Cp at γ/b of														
x/c	0.02		0.22		0.44		0.56		0.67		0.83		0.98	
	U.S.	L.S.	U.S.	L.S.	U.S.	L.S.	U.S.	L.S.	U.S.	L.S.	U.S.	L.S.	U.S.	L.S.
.05	.1488	.1834	.2666	.3283	.2680	.3219	.2453	.3321	.2604	.3365	.2586	.3229		
.10	.1430	.1974	.2713	.3377	.2715	.3308	.2413	.3442	.2651	.3313	.2576	.3259	.2023	.2425
.15	.1357	.2033	.2758	.3400	.2713	.3303	.2593	.3377	.2710	.3265	.2540	.3223	.1867	.2294
.20	.1249	.1575	.2704	.3330	.2688	.3279			.2653	.3263	.2625	.3186	.1725	.2137
.25			.0399	.0553	.2325	.2782	.2441	.3146	.2599	.3217	.2615	.3143	.1645	.2027
.30	.0152	.0153	.0019	.0224	.0160	.0334	.0338	.0543	.1157	.1314	.2482	.3001	.1591	.1948
.40									.0095	.0286	.0114	.0318	-.0342	-.0210
.50	.0226	.0195	-.0270	-.0119	.0053	.0253			.0038	.0214	-.0067	.0082	-.0360	-.0421
.60	.0826	.0479	-.0236	-.0190	.0045	.0224	.0043	.0189	.0019	.0163	-.0190	-.0051	-.0369	-.0382
.70	.0290	.0368	-.0157	-.0172	-.0041	.0111	-.0107	.0056	-.0408	-.0248			-.1162	-.1158
.80	-.0766	-.0881	-.1142	-.1221	-.1322	-.1314	-.1298	-.1297	-.1290	-.1314	-.1198	-.1266	-.0917	-.1123
.90	-.0909	-.0923	-.1187	-.1082	-.1119	-.1132	-.1113	-.1187	-.1073	-.1080	-.1158	-.1166	-.1225	-.0885
.95	-.1020	-.0966	-.1171	-.1074	-.1084	-.1097	-.1074	-.1106	-.1042	-.1037	-.1151	-.1151	-.1186	-.1037

TAIL 1

Cp at γ/b of														
x/c	0.02		0.22		0.44		0.56		0.67		0.83		0.98	
	U.S.	L.S.	U.S.	L.S.	U.S.	L.S.	U.S.	L.S.	U.S.	L.S.	U.S.	L.S.	U.S.	L.S.
.05	.1450	.1543	.3009	.3271			.2920	.3326	.2984	.3320	.3020	.3334	.2714	.3358
.10	.1536	.1553	.2963	.3156			.2887	.3122	.2847	.3165	.2943	.3231	.2361	.2646
.15	.1454	.1479	.2946	.3120			.2824	.3021	.2804	.3052	.2904	.3141	.2064	.2240
.20							.2723	.2921	.2798	.2953		.3066	.1872	.2014
.25	.0227	.0131	.0357	.0462			.2582	.2708	.2695	.2796	.2770	.2984	.1692	.1876
.30			.0074	.0110	.0179	.0198	.0316	.0368	.1369	.1438				
.40	.0145	.0403			.0093	.0087	.0039	.0098	.0166	.0192	.0274	.0299		
.50	.0289	.0087					.0053	.0057	.0077	.0069			.0087	.0215
.60					.0089	.0044	.0062	.0039	.0053	.0034	-.0050	-.0085	-.0343	-.0316
.70			-.0079	-.0108	-.0011	-.0054	-.0044	-.0091	-.0728	-.0320	-.1319	-.1326	-.1094	-.1153
.80	-.0753	-.0959	-.1125	-.1084	-.1304	-.1146			-.0941	-.0912	-.1253	-.1153	.0046	-.1121
.90	-.0964	-.1085			-.1137	-.0993			-.1046	-.0994	-.1151	-.1109	-.1183	-.0965
.95	-.0934	-.1097							-.1004	-.0986	-.1132	-.1105	-.1273	-.1104

TAIL 2

TABLE VII. - CONTINUED
(d) $\alpha = 1.78^\circ$

Cp at y/b of														
x/c	0.02		0.22		0.44		0.56		0.67		0.83		0.98	
	U.S.	L.S.	U.S.	L.S.	U.S.	L.S.	U.S.	L.S.	U.S.	L.S.	U.S.	L.S.	U.S.	L.S.
.05	.1445	.2459	.2412	.3621	.2440	.3509	.2188	.3625	.2385	.3650	.2373	.3495		
.10	.1399	.2642	.2447	.3726	.2478	.3603	.2199	.3741	.2413	.3611	.2360	.3529	.1846	.2629
.15	.1313	.2879	.2452	.3719	.2482	.3602	.2372	.3682	.2486	.3550	.2329	.3496	.1714	.2500
.20	.1182	.2406	.2377	.3652	.2466	.3572			.2446	.3539	.2412	.3464	.1615	.2338
.25			.0214	.0772	.2108	.3044	.2226	.3447	.2374	.3491	.2399	.3422	.1543	.2221
.30	-.0103	.0242	-.0123	.0462	.0009	.0512	.0236	.0670	.0982	.1485	.2271	.3271	.1488	.2143
.40									-.0044	.0443	-.0030	.0440	-.0390	-.0101
.50	-.0079	.0061	-.0356	.0108	-.0100	.0415			-.0097	.0370	-.0224	.0175	-.0349	-.0290
.60	.0592	.0383	-.0372	.0022	-.0118	.0384	-.0102	.0347	-.0119	.0312	-.0335	.0029	-.0426	-.0263
.70	.0260	.0515	-.0308	-.0024	-.0199	.0287	-.0230	.0219	-.0525	-.0116			-.1212	-.1099
.80	-.0730	-.0824	-.1108	-.1245	-.1211	-.1214	-.1160	-.1225	-.1160	-.1298	-.1117	-.1357	-.1211	-.1062
.90	-.0957	-.0850	-.1058	-.1083	-.1053	-.1195	-.1050	-.1234	-.1052	-.1156	-.1107	.1208	-.1424	-.0936
.95	-.1064	-.0906	-.1072	-.1059	-.1039	-.1086	-.1050	-.1119	-.1038	-.1058	-.1168	-.1170	-.1346	-.1116

TAIL 1

Cp at y/b of														
x/c	0.02		0.22		0.44		0.56		0.67		0.83		0.98	
	U.S.	L.S.	U.S.	L.S.	U.S.	L.S.	U.S.	L.S.	U.S.	L.S.	U.S.	L.S.	U.S.	L.S.
.05	.0991	.1736	.2250	.4116			.2287	.4042	.2354	.4044	.2426	.4007	.2197	.3958
.10	.1055	.1815	.2201	.4143			.2253	.3841	.2227	.3871	.2349	.3897	.1899	.3195
.15	.0991	.1804	.2204	.4035			.2189	.3737	.2189	.3746	.2312	.3796	.1639	.2744
.20							.2096	.3630	.2181	.3638		.3715	.1488	.2491
.25	-.0013	.0387	-.0058	.0830			.1972	.3388	.2092	.3468	.2201	.3630	.1326	.2317
.30			-.0295	.0435	-.0179	.0629	-.0038	.0774	.0922	.1946				
.40	-.0004	.0901			-.0258	.0551	-.0249	.0509	-.0174	.0572	-.0051	.0689		
.50	.0155	.0332					-.0294	.0476	-.0261	.0458			.0059	.0206
.60					-.0275	.0421	-.0291	.0471	-.0281	.0426	-.0327	.0265	-.0476	-.0303
.70			-.0340	.0183	-.0356	.0275	-.0372	.0321	-.0690	.0033	-.1322	-.1154	-.1133	-.1044
.80	-.0910	-.0830	-.1188	-.1025	-.1086	-.1239			-.0803	-.0945	-.1141	-.1355	.0020	-.1282
.90	-.1018	-.0968			-.1037	-.1023			-.1010	-.1168	-.1114	-.1161	-.1275	-.0835
.95	-.0995	-.1008							-.1011	-.1055	-.1113	-.1104	-.1237	-.0885

TAIL 2

TABLE VII. - CONTINUED
(e) $\alpha = 3.77^\circ$

Cp at y/b of														
x/c	0.02		0.22		0.44		0.56		0.67		0.83		0.98	
	U.S.	L.S.	U.S.	L.S.	U.S.	L.S.	U.S.	L.S.	U.S.	L.S.	U.S.	L.S.	U.S.	L.S.
.05	.1297	.3054	.2161	.3996	.2239	.3847	.1930	.3961	.2180	.3945	.2173	.3760		
.10	.1281	.3215	.2203	.4111	.2267	.3939	.2011	.4053	.2191	.3896	.2146	.3793	.1654	.2807
.15	.1213	.3615	.2195	.4092	.2267	.3920	.2157	.3975	.2258	.3836	.2108	.3752	.1548	.2671
.20	.1028	.3365	.2109	.4020	.2248	.3883			.2251	.3826	.2189	.3723	.1486	.2523
.25			.0048	.0998	.1902	.3348	.2006	.3758	.2173	.3779	.2175	.3630	.1443	.2420
.30	-.0327	.0372	-.0269	.0686	-.0131	.0701	.0158	.0799	.0822	.1689	.2051	.3524	.1406	.2346
.40									-.0177	.0603	-.0173	.0552	-.0402	.0017
.50	-.0414	.0044	-.0470	.0325	-.0240	.0596			-.0230	.0537	-.0371	.0258	-.0411	-.0140
.60	.0230	.0387	-.0510	.0229	-.0250	.0566	-.0234	.0517	-.0256	.0474	-.0474	.0114	-.0412	-.0127
.70	.0155	.0713	-.0490	.0162	-.0330	.0471	-.0391	.0383	-.0639	.0020			-.1149	-.1004
.80	-.0798	-.0706	-.1011	-.1187	-.1036	-.1105	-.1030	-.1126	-.1092	-.1234	-.1127	-.1352	-.1291	-.0904
.90	-.0949	-.0737	-.1004	-.1108	-.0993	-.1214	-.1000	-.1195	-.1043	-.1232	-.1134	-.1218	-.1509	-.0984
.95	-.1034	-.0767	-.1011	-.1047	-.0990	-.1101	-.1097	-.1147	-.1035	-.1106	-.1136	-.1166	-.1398	-.1164

TAIL 1

Cp at y/b of														
x/c	0.02		0.22		0.44		0.56		0.67		0.83		0.98	
	U.S.	L.S.	U.S.	L.S.	U.S.	L.S.	U.S.	L.S.	U.S.	L.S.	U.S.	L.S.	U.S.	L.S.
.05	.0618	.1806	.1561	.5064			.1697	.4823	.1773	.4845	.1825	.4738	.1741	.4599
.10	.0654	.1978	.1510	.5090			.1659	.4620	.1657	.4642	.1803	.4617	.1468	.3777
.15	.0590	.2047	.1547	.4724			.1602	.4511	.1620	.4499	.1766	.4507	.1251	.3309
.20							.1521	.4404	.1611	.4375			.1134	.3018
.25	-.0251	.0602	-.0433	.1175			.1410	.4144	.1535	.4193	.1670	.4332	.0996	.2823
.30			-.0630	.0766	-.0506	.1138	-.0368	.1245	.0506	.2500				
.40	-.0088	.1290			-.0599	.0998	-.0567	.0984	-.0484	.1012	-.0357	.1117		
.50	.0078	.0593					-.0610	.0961	-.0567	.0903			.0031	.0217
.60					-.0602	.0747	-.0611	.0902	-.0584	.0885	-.0590	.0659	-.0675	-.0230
.70			-.0573	.0525	-.0663	.0587	-.0666	.0633	-.1147	.0456	-.1120	-.0345	-.1158	-.1004
.80	-.0995	-.0709	-.1341	-.0851	-.1013	-.1075			-.0788	-.0748	-.1079	-.1192	-.0003	-.1218
.90	-.1013	-.0844			-.1010	-.1073			-.1000	-.1024	-.1076	-.1233	-.1262	-.1030
.95	-.0940	-.0902							-.1004	-.1089	-.1079	-.1135	-.1255	-.0821

TAIL 2

TABLE VII. - CONTINUED
(f) $\alpha = 5.77^\circ$

Cp at y/b of														
x/c	0.02		0.22		0.44		0.56		0.67		0.83		0.98	
	U.S.	L.S.	U.S.	L.S.	U.S.	L.S.	U.S.	L.S.	U.S.	L.S.	U.S.	L.S.	U.S.	L.S.
.05	.1118	.3648	.1934	.4410	.2049	.4194	.1695	.4350	.1974	.4227	.1954	.4021		
.10	.1129	.3767	.1994	.4531	.2082	.4290	.1823	.4367	.1983	.4187	.1933	.4057	.1480	.3001
.15	.1078	.4199	.1988	.4511	.2082	.4264	.1955	.4275	.2046	.4131	.1898	.4026	.1413	.2871
.20	.0844	.4287	.1900	.4437	.2069	.4222			.2057	.4117	.1973	.4000	.1366	.2720
.25			-.0087	.1247	.1716	.3675	.1812	.4092	.1990	.4070	.1948	.3951	.1331	.2627
.30	-.0490	-.0660	-.0398	.0929	-.0245	.0893	-.0028	.1024	.0685	.1903	.1824	.3770	.1319	.2552
.40									-.0299	.0775	-.0315	.0656	-.0422	.0144
.50	-.0623	.0130	-.0584	.0548	-.0370	.0797			-.0356	.0707	-.0510	.0359	-.0485	.0006
.60	-.0129	.0457	-.0628	.0445	-.0381	.0757	-.0359	.0696	-.0383	.0639	-.0602	.0205	-.0209	.0017
.70	-.0012	.0907	-.0637	.0367	-.0456	.0667	-.0510	.0562	-.0749	.0151			-.1121	-.0903
.80	-.0804	-.0554	-.0982	-.1093	-.0956	-.0989	-.0973	-.1016	-.1053	-.1172	-.1110	-.1303	-.1719	-.0776
.90	-.0955	-.0569	-.0990	-.1105	-.0948	-.1128	-.0959	-.1104	-.1020	-.1218	-.1119	-.1217	-.1668	-.1035
.95	-.0899	-.0554	-.0999	-.1030	-.0948	-.1113	-.0957	-.1110	-.1012	-.1122	-.1122	-.1164	-.1556	-.1174

TAIL 1

Cp at y/b of														
x/c	0.02		0.22		0.44		0.56		0.67		0.83		0.98	
	U.S.	L.S.	U.S.	L.S.	U.S.	L.S.	U.S.	L.S.	U.S.	L.S.	U.S.	L.S.	U.S.	L.S.
.05	.0380	.1748	.0957	.6134			.1144	.5719	.1235	.5750	.1361	.5570	.1317	.5280
.10	.0445	.1997	.0908	.5804			.1094	.5509	.1125	.5507	.1273	.5432	.1036	.4441
.15	.0389	.2139	.0954	.5278			.1038	.5408	.1085	.5375	.1241	.5326	.0863	.3945
.20							.0966	.5314	.1073	.5257		.5245	.0794	.3630
.25	-.0349	.0770	-.0778	.1520			.0875	.5032	.1095	.5056	.1165	.5142	.0697	.3403
.30			-.0910	.1103	-.0803	.1595	-.0675	.1823	.0109	.5166				
.40	-.0321	.1583			-.0896	.1362	-.0862	.1498	-.0776	.1560	-.0637	.1613		
.50	-.0113	.0973					-.0901	.1360	-.0857	.1457			-.0060	.0178
.60					-.0901	.1086	-.0904	.1264	-.0871	.1389	-.0840	.1120	-.0808	.0007
.70			-.0766	.0896	-.0946	.0922	-.0921	.1011	-.1232	.0861	-.1147	-.0680	-.1231	-.0946
.80	-.1022	-.0508	-.1560	-.0650	-.1063	-.0885			-.0837	-.0532	-.1132	-.0940	-.0093	-.0963
.90	-.1146	-.0686			-.1078	-.1041			-.1041	-.0843	-.1135	-.1025	-.1254	-.1047
.95	-.1080	-.0794							-.1046	-.0921	-.1138	-.1077	-.1232	-.1084

TAIL 2

TABLE VII. - CONTINUED
(g) $\alpha = 7.76^\circ$

Cp at y/b of														
x/c	0.02		0.22		0.44		0.56		0.67		0.83		0.98	
	U.S.	L.S.	U.S.	L.S.	U.S.	L.S.	U.S.	L.S.	U.S.	L.S.	U.S.	L.S.	U.S.	L.S.
.05	.0949	.4249	.1774	.4868	.1836	.4518	.1483	.4700	.1768	.4503	.1726	.4272		
.10	.0982	.4330	.1832	.4989	.1890	.4644	.1642	.4686	.1775	.4467	.1689	.4311	.1313	.3197
.15	.0944	.4674	.1822	.4990	.1900	.4602	.1780	.4598	.1828	.4410	.1656	.4282	.1276	.3076
.20	.0685	.5009	.1729	.4920	.1888	.4562			.1841	.4392	.1729	.4262	.1248	.2928
.25			-.0201	.1521	.1534	.3990	.1625	.4401	.1796	.4344	.1711	.4197	.1214	.2834
.30	-.0603	.1094	-.0503	.1183	-.0348	.1104	-.0152	.1192	.0538	.2086	.1592	.3974	.1205	.2763
.40									-.0424	.0939	-.0446	.0743	-.0446	.0265
.50	-.0748	.0232	-.0678	.0776	-.0473	.1015			-.0481	.0871	-.0629	.0445	-.0485	.0164
.60	-.0394	.0611	-.0723	.0669	-.0493	.0989	-.0475	.0887	-.0507	.0788	-.0705	.0292	-.0304	.0171
.70	-.0127	.1161	-.0759	.0587	-.0568	.0884	-.0614	.0734	-.0851	.0256			-.1371	-.0803
.80	-.0811	-.0371	-.0972	-.0969	-.0925	-.0854	-.0948	-.0893	-.1031	-.1111	-.1081	-.1240	-.1794	-.0606
.90	-.0951	-.0342	-.0926	-.1020	-.0927	-.1006	-.0939	-.1013	-.1004	-.1172	-.1100	-.1180	-.1613	-.1058
.95	-.0688	-.0296	-.0995	-.0983	-.0929	-.1046	-.0939	-.1050	-.0993	-.1133	-.1104	-.1141	-.1556	-.1152

TAIL 1

Cp at y/b of														
x/c	0.02		0.22		0.44		0.56		0.67		0.83		0.98	
	U.S.	L.S.	U.S.	L.S.	U.S.	L.S.	U.S.	L.S.	U.S.	L.S.	U.S.	L.S.	U.S.	L.S.
.05	.0341	.1463	.0461	.6921			.0653	.6808	.0753	.6791	.0890	.6608	.0913	.6062
.10	.0380	.1784	.0433	.6275			.0525	.6601	.0645	.6554	.0796	.6473	.0645	.5245
.15	.0309	.1934	.0470	.5712			.0526	.6503	.0601	.6425	.0763	.6352	.0511	.4705
.20							.0460	.6347	.0587	.6306		.6250	.0472	.4356
.25	-.0398	.0822	-.1034	.1815			.0376	.5927	.0524	.6059	.0704	.6127	.0425	.4107
.30			-.1089	.1424	-.1067	.1905	-.0952	.2274	-.0253	.3892				
.40	-.0553	.1966			-.1153	.1676	-.1126	.1872	-.1035	.2090	-.0892	.2193		
.50	-.0325	.1373					-.1164	.1722	-.1116	.1888			-.0105	.0125
.60					-.1159	.1424	-.1168	.1603	-.1127	.1754	-.1073	.1623	-.0564	.0345
.70			-.0872	.1278	-.1177	.1269	-.1118	.1337	-.1244	.1174	-.1207	-.0419	-.1533	-.1022
.80	-.1135	-.0220	-.1459	-.0412	-.1180	-.0677			-.0903	-.0419	-.1198	-.0719	-.0148	-.0839
.90	-.1299	-.0476			-.1202	-.0820			-.1127	-.0659	-.1206	-.0835	-.1389	-.0939
.95	-.1225	-.0620							-.1132	-.0745	-.1210	-.0907	-.1307	-.1028

TAIL 2

TABLE VII. - CONTINUED
(h) $\alpha = 9.76^\circ$

Cp at y/b of														
x/c	0.02		0.22		0.44		0.56		0.67		0.83		0.98	
	U.S.	L.S.	U.S.	L.S.	U.S.	L.S.	U.S.	L.S.	U.S.	L.S.	U.S.	L.S.	U.S.	L.S.
.05	.0830	.4817	.1652	.5353	.1551	.4887	.1255	.5137	.1580	.4857	.1616	.4645		
.10	.0875	.4856	.1708	.5478	.1668	.5019	.1430	.5040	.1555	.4810	.1562	.4681	.1266	.3479
.15	.0836	.5099	.1685	.5477	.1748	.4981	.1521	.4931	.1583	.4757	.1519	.4650	.1261	.3381
.20	.0560	.5584	.1586	.5379	.1763	.4962			.1588	.4733	.1579	.4618	.1248	.3242
.25			-.0298	.1787	.1409	.4352	.1343	.4733	.1551	.4675	.1548	.4516	.1225	.3148
.30	-.0697	.1378	-.0595	.1422	-.0425	.1313	-.0355	.1363	-.0372	.2313	.1421	.4249	.1211	.3065
.40									-.0566	.1126	-.0554	.0874	-.0433	.0431
.50	-.0850	.0490	-.0759	.1012	-.0561	.1232			-.0627	.1048	-.0734	.0572	-.0421	.0373
.60	-.0588	.0879	-.0817	.0935	-.0580	.1217	-.0560	.1074	-.0655	.0928	-.0804	.0415	-.0371	.0371
.70	-.0263	.1510	-.0853	.0867	-.0651	.1118	-.0690	.0902	-.0971	.0358			-.1587	-.0674
.80	-.0860	-.0151	-.0973	-.0801	-.0918	-.0698	-.0947	-.0793	-.1033	-.1051	-.1068	-.1160	-.1771	-.0471
.90	-.0871	-.0049	-.0991	-.0844	-.0923	-.0866	-.0938	-.0926	-.1012	-.1113	-.1083	-.1118	-.1705	-.0868
.95	-.0573	-.0030	-.0998	-.0823	-.0928	-.0921	-.0934	-.0971	-.1007	-.1114	-.1091	-.1104	-.1684	-.1019

TAIL 1

Cp at y/b of														
x/c	0.02		0.22		0.44		0.56		0.67		0.83		0.98	
	U.S.	L.S.	U.S.	L.S.	U.S.	L.S.	U.S.	L.S.	U.S.	L.S.	U.S.	L.S.	U.S.	L.S.
.05	.0319	.1242	.0039	.7350			.0179	.8145	.0281	.8211	.0442	.8031	.0510	.7113
.10	.0321	.1536	.0030	.6608			.0086	.7753	.0164	.7860	.0325	.7825	.0273	.6315
.15	.0246	.1744	.0019	.6062			.0024	.7386	.0109	.7562	.0284	.7619	.0207	.5704
.20							-.0034	.7038	.0090	.7250		.7412	.0190	.5297
.25	-.0518	.0780	-.1266	.2057			-.0110	.6462	.0035	.6813	.0225	.7140	.0170	.4970
.30			-.1184	.1727	-.1316	.2167	-.1219	.2540	-.0617	.4322				
.40	-.0617	.2238			-.1399	.1994	-.1373	.2191	-.1282	.2433	-.1150	.2533		
.50	-.0316	.1610					-.1410	.2066	-.1364	.2230			-.0151	.0087
.60					-.1349	.1783	-.1400	.1952	-.1366	.2096	-.1300	.1942	-.0794	.0626
.70			-.1175	.1706	-.1311	.1630	-.1223	.1672	-.1247	.1475	-.1280	-.0225	-.1758	-.0959
.80	-.1171	-.0442	-.1477	-.0197	-.1297	-.0473			-.0973	-.0248	-.1277	-.0532	-.0196	-.1058
.90	-.1353	-.0282			-.1304	-.0613			-.1228	-.0469	-.1294	-.0655	-.1489	-.1094
.95	-.1326	-.0417							-.1233	-.0561	-.1305	-.0732	-.1502	-.1161

TAIL 2

TABLE VII. - CONTINUED
(i) $\alpha = 11.76^\circ$

Cp at y/b of														
x/c	0.02		0.22		0.44		0.56		0.67		0.83		0.98	
	U.S.	L.S.	U.S.	L.S.	U.S.	L.S.	U.S.	L.S.	U.S.	L.S.	U.S.	L.S.	U.S.	L.S.
.05	.0605	.5526	.1497	.5970	.1592	.5392	.1300	.5763	.1628	.5395	.1661	.5151		
.10	.0664	.5517	.1530	.6117	.1629	.5503	.1476	.5575	.1603	.5335	.1601	.5196	.1335	.3862
.15	.0649	.5647	.1497	.6149	.1633	.5432	.1559	.5444	.1629	.5269	.1558	.5163	.1337	.3771
.20	.0382	.6187	.1385	.6006	.1615	.5440			.1635	.5243	.1615	.5111	.1329	.3637
.25			-.0422	.2126	.1245	.4733	.1369	.5233	.1602	.5183	.1579	.4948	.1312	.3556
.30	-.0787	.1826	-.0714	.1724	-.0524	.1590	-.0349	.1653	.0415	.2655	.1448	.4640	.1311	.3457
.40									-.0534	.1402	-.0544	.1081	-.0382	.0656
.50	-.0927	.0736	-.0845	.1316	-.0662	.1581			-.0608	.1296	-.0716	.0765	-.0386	.0625
.60	-.0703	.1193	-.0888	.1234	-.0688	.1581	-.0643	.1383	-.0650	.1148	-.0782	.0603	-.0553	.0622
.70	-.0341	.1877	-.0322	.1154	-.0760	.1470	-.0776	.1195	-.0975	.0551			-.1651	-.0517
.80	-.0877	.0088	-.0964	-.0628	-.0898	-.0519	-.0925	-.0626	-.1013	-.0931	-.1053	-.1036	-.1748	-.0320
.90	-.0802	.0261	-.0976	-.0662	-.0505	-.0726	-.0920	-.0774	-.0996	-.0983	-.1072	-.0998	-.1683	-.0588
.95	-.0508	.0248	-.0983	-.0647	-.0906	-.0794	-.0916	-.0833	-.0990	-.1014	-.1078	-.1015	-.1648	-.0836

TAIL 1

Cp at \bar{y}/b of														
x/c	0.02		0.22		0.44		0.56		0.67		0.83		0.98	
	U.S.	L.S.	U.S.	L.S.	U.S.	L.S.	U.S.	L.S.	U.S.	L.S.	U.S.	L.S.	U.S.	L.S.
.05	.0307	.1218	-.0335	.7688			-.0209	.9260	-.0110	.9565	.0036	.9636	.0107	.8429
.10	.0238	.1389	-.0352	.6919			-.0326	.8531	-.0246	.8845	-.0103	.9054	-.0039	.7400
.15	.0159	.1511	-.0386	.6386			-.0397	.8007	-.0317	.8331	-.0160	.8563	-.0020	.6610
.20							-.0456	.7552	-.0344	.7867		.8137	-.0025	.6007
.25	-.0647	.0652	-.1364	.2270			-.0517	.6872	-.0399	.7287	-.0214	.7659	-.0032	.5531
.30			-.1253	.2029	-.1499	.2394	-.1442	.2735	-.0941	.4525				
.40	-.0802	.2312			-.1569	.2310	-.1567	.2514	-.1489	.2726	-.1363	.2784		
.50	-.0448	.1605					-.1596	.2422	-.1570	.2556			-.0136	.0031
.60					-.1469	.2168	-.1494	.2314	-.1494	.2429	-.1453	.2245	-.0320	.0866
.70			-.0995	.2178	-.1419	.1986	-.1317	.2020	-.1347	.1767	-.1360	-.0020	-.1700	-.0784
.80	-.1186	-.0393	-.1611	-.0036	-.1417	-.0280			-.1060	-.0076	-.1361	-.0321	-.0179	-.0917
.90	-.1345	-.0202			-.1419	-.0398			-.1358	-.0269	-.1391	-.0446	-.1676	-.0979
.95	-.1321	-.0254							-.1370	-.0361	-.1406	-.0528	-.1657	-.1050

TAIL 2

TABLE VII. - CONTINUED
(j) $\alpha = 15.76^\circ$

Cp at y/b of														
x/c	0.02		0.22		0.44		0.56		0.67		0.83		0.98	
	U.S.	L.S.	U.S.	L.S.	U.S.	L.S.	U.S.	L.S.	U.S.	L.S.	U.S.	L.S.	U.S.	L.S.
.05	.0931	.7223	.1877	.7764	.1900	.6891	.1570	.7332	.1903	.6771	.1892	.6393		
.10	.0997	.7091	.1918	.7958	.1947	.7010	.1770	.7009	.1872	.6709	.1914	.6425	.1598	.4786
.15	.0953	.7132	.1859	.7952	.1966	.6975	.1853	.6878	.1891	.6641	.1752	.6389	.1614	.4673
.20	.0637	.7615	.1721	.7612	.1928	.7023			.1888	.6621	.1806	.6286	.1604	.4547
.25			-.0244	.2895	.1521	.6225	.1650	.6665	.1847	.6551	.1758	.6024	.1579	.4502
.30	-.0704	.2870	-.0560	.2470	-.0371	.2517	-.0186	.2551	.0588	.3599	.1614	.5648	.1590	.4406
.40									-.0402	.2192	-.0444	.1666	-.0246	.1229
.50	-.0873	.1431	-.0751	.2053	-.0512	.2515			-.0485	.2012	-.0601	.1350	-.0248	.1278
.60	-.0667	.2349	-.0827	.2002	-.0545	.2423	-.0508	.2232	-.0541	.1811	-.0650	.1193	-.1148	.1303
.70	-.0367	.2874	-.0887	.1935	-.0622	.2227	-.0648	.1957	-.0880	.1123			-.1715	-.0073
.80	-.0900	.1016	-.0817	-.0113	-.0779	-.0180	-.0802	-.0226	-.0907	-.0579	-.0963	-.0651	-.1650	.0138
.90	-.0947	.1105	-.0824	-.0112	-.0786	-.0417	-.0795	-.0409	-.0880	-.0617	-.0986	-.0602	-.1572	-.0008
.95	-.0591	.1022	-.0829	-.0069	-.0789	-.0493	-.0792	-.0488	-.0876	-.0661	-.0993	-.0646	-.1519	-.0355

TAIL 1

Cp at y/b of														
x/c	0.02		0.22		0.44		0.56		0.67		0.83		0.98	
	U.S.	L.S.	U.S.	L.S.	U.S.	L.S.	U.S.	L.S.	U.S.	L.S.	U.S.	L.S.	U.S.	L.S.
.05	.0675	.1100	-.0983	.7922			-.0859	1.0480	-.0803	1.0912	-.0758	1.1225	-.0715	.9873
.10	.0329	.1367	-.0952	.7281			-.0939	.9512	-.0870	.9922	-.0752	1.0315	-.0568	.8727
.15	.0074	.1393	-.0837	.6883			-.1032	.8843	-.0964	.9221	-.0817	.9570	-.0519	.7750
.20							-.1107	.8259	-.1013	.8584		.8944	-.0545	.6946
.25	-.0865	.0218	-.1507	.2781			-.1144	.7364	-.1084	.7795	-.0895	.8265	-.0561	.6237
.30			-.1385	.2565	-.1792	.2633	-.1791	.2971	-.1463	.4677				
.40	-.1037	.1746			-.1700	.2854	-.1770	.3000	-.1806	.3242	-.1715	.3206		
.50	-.0703	.1215					-.1694	.3011	-.1708	.3156			-.0253	-.0071
.60					-.1657	.2827	-.1678	.3019	-.1655	.3058	-.1633	.2974	-.1497	.1459
.70			-.1270	.2960	-.1649	.2605	-.1535	.2702	-.1614	.2370	-.1623	.0410	-.1785	-.0352
.80	-.1288	-.0188	-.1743	.0256	-.1729	.0154			-.1287	.0300	-.1638	.0096	-.0293	-.0528
.90	-.1438	-.0188			-.1632	.0157			-.1649	.0140	-.1657	-.0024	-.1616	-.0613
.95	-.1428	-.0229							-.1674	.0032	-.1665	-.0110	-.1673	-.0709

TAIL 2

TABLE VII. - CONCLUDED
(k) $\alpha = 19.76^\circ$

Cp at y/b of														
x/c	0.02		0.22		0.44		0.56		0.67		0.83		0.98	
	U.S.	L.S.	U.S.	L.S.	U.S.	L.S.	U.S.	L.S.	U.S.	L.S.	U.S.	L.S.	U.S.	L.S.
.05	.1489	.9317	.2423	1.0367	.2379	.8938	-.1939	.9365	.2302	.8645	.2262	.8145		
.10	.1456	.8889	.2445	1.0267	.2409	.8954	-.2190	.8903	.2269	.8484	.2177	.8173	.2001	.6065
.15	.1388	.8996	.2363	.9862	.2444	.9125	-.2281	.8748	.2298	.8424	.2110	.8032	.2038	.5970
.20	.1053	.9182	.2205	.9198	.2373	.9189			.2293	.8434	.2160	.7694	.2027	.5828
.25			.0033	.3710	.1948	.8176	.2074	.8521	.2246	.8305	.2097	.7308	.2007	.5775
.30	-.0462	.4077	-.0308	.3311	-.0104	.3716	-.0083	.3666	-.0875	.4720	.1950	.6884	.2057	.5641
.40									-.0179	.3030	-.0229	.2384	.0042	.1937
.50	-.0629	.2308	-.0528	.2938	-.0259	.3463			-.0269	.2821	-.0373	.2064	-.0510	.2076
.60	-.0324	.4617	-.0618	.2932	-.0297	.3235	-.0266	.315	-.0330	.2644	-.0405	.1912	-.1262	.2175
.70	-.0054	.4501	-.0673	.2968	-.0381	.2918	-.0423	.2738	-.0688	.1887			-.1699	.0467
.80	-.0884	.2102	-.0554	.0743	-.0568	.0154	-.0587	.0178	-.0699	-.0078	-.0769	-.0159	-.1695	.0747
.90	-.0734	.1992	-.0558	.0661	-.0570	-.0075	-.0581	-.0036	-.0669	-.0134	-.0795	-.0081	-.1493	.0588
.95	-.0360	.1851	-.0565	.1234	-.0572	-.0158	-.0580	-.0129	-.0668	-.0191	-.0804	-.0132	-.1431	.0204

TAIL 1

Cp at y/b of														
x/c	0.02		0.22		0.44		0.56		0.67		0.83		0.98	
	U.S.	L.S.	U.S.	L.S.	U.S.	L.S.	U.S.	L.S.	U.S.	L.S.	U.S.	L.S.	U.S.	L.S.
.05	.0227	.0877	-.1600	.8427			-.1547	1.0828	-.1565	1.1224	-.1599	1.1529	-.1650	1.0136
.10	-.0171	.1106	-.1495	.7922			-.1477	.9867	-.1448	1.0245	-.1421	1.0621	-.1325	.9121
.15	-.0391	.1054	-.1409	.7585			-.1512	.9096	-.1468	.9442	-.1387	.9793	-.1223	.8131
.20							-.1563	.8343	-.1500	.8654		.9068	-.1197	.7252
.25	-.1124	.0044	-.1759	.3063			-.1567	.7243	-.1547	.7720	-.1366	.8265	-.1172	.6522
.30			-.1597	.2957	-.1906	.2867	-.1982	.2941	-.1794	.4464				
.40	-.1257	.1739			-.1830	.3467	-.1880	.3532	-.1883	.3609	-.1880	.3501		
.50	-.0953	.1615					-.1858	.3772	-.1862	.3851			-.0347	-.0104
.60					-.1836	.3497	-.1861	.3732	-.1842	.3883	-.1797	.3713	-.1805	.2076
.70			-.1511	.3819	-.1840	.3550	-.1697	.3368	-.1804	.3042	-.1813	.3943	-.1343	.0042
.80	-.1468	-.0029	-.1894	.0630	-.1894	.0769			-.1433	.0636	-.1823	.1529	-.0375	-.0101
.90	-.1596	-.0057			-.1795	.0675			-.1836	.0608	-.1827	.0482	-.1766	-.0175
.95	-.1592	-.0069							-.1866	.0544	-.1824	.0376	-.1828	-.0274

TAIL 2

TABLE VIII. - PRESSURE COEFFICIENTS, $\phi = 45^\circ$, $\delta = 0^\circ$, $M = 2.36$
 (a) $\alpha = -4.21^\circ$

Cp at y/b of														
x/c	0.02		0.22		0.44		0.56		0.67		0.83		0.98	
	U.S.	L.S.	U.S.	L.S.	U.S.	L.S.	U.S.	L.S.	U.S.	L.S.	U.S.	L.S.	U.S.	L.S.
.05	.1216	.1012	.4441	.1987	.3883	.2149	.3586	.2259	.3714	.2347	.3625	.2276	.2925	.1707
.10	.1330	.1042	.4441	.2321	.3935	.2199	.3514	.2357	.3819	.2326	.3618	.2304	.2691	.1600
.15	.1377	.0977	.4050	.2262	.3954	.2188	.3754	.2306	.3772	.2282	.3576	.2264	.2477	.1466
.20	.1140	.0606	.3632	.1988	.3973	.2179	.3584	.2121	.3688	.2229	.3653	.2202	.2371	.1374
.25			.0867	-.0288	.3514	.1782	.3584	.2121	.3688	.2229	.3500	.2084	.2291	.1299
.30	.0635	-.0098	.0456	-.0571	.1080	-.0272	.1085	-.0066	.0776	-.0265	.0762	-.0185	.0070	-.0549
.40									.0746	-.0332	.0562	-.0362	-.0345	-.0588
.50	.0743	.0025	.0133	-.0564	.0740	-.0294	.0806	-.0366	.0749	-.0378	.0437	-.0460	-.0362	-.0515
.60	.1206	.0101	.0169	-.0491	.0592	-.0344	.0565	-.0480	.0239	-.0718			-.1076	-.1262
.70	.0363	-.0083	.0294	-.0448	.0422	-.0467								
.80	-.0595	-.1042	-.0881	-.1369	-.1106	-.1088	-.1023	-.1099	-.1018	-.1132	-.1202	-.1175	-.1229	-.1036
.90	-.0739	-.1027	-.0962	-.1299	-.1233	-.1080	-.1136	-.1083	-.1058	-.1095	-.1258	-.1183	-.0855	-.1019
.95	-.0803	-.0986	-.0994	-.1162	-.1196	-.1078	-.1164	-.1083	-.1094	-.1091	-.1239	-.1184	-.0644	-.1124

TAIL 1

Cp at y/b of														
x/c	0.02		0.22		0.44		0.56		0.67		0.83		0.98	
	U.S.	L.S.	U.S.	L.S.	U.S.	L.S.	U.S.	L.S.	U.S.	L.S.	U.S.	L.S.	U.S.	L.S.
.05	.2813	.0977	.4265	.2229			.4010	.2388	.4059	.2409	.4012	.2465	.3579	.2519
.10	.2810	.1028	.4236	.2072			.3980	.2207	.3911	.2262	.3937	.2361	.3078	.1883
.15	.2713	.1003	.4170	.1976			.3914	.2119	.3636	.2170	.3908	.2278	.2740	.1630
.20							.3808	.2030	.3864	.2075		.2208	.2612	.1470
.25	.0806	-.0358	.1079	-.0166			.3647	.1851	.3753	.1944	.3767	.2136	.2379	.1359
.30			.0744	-.0382	.0828	-.0319	.0944	-.0134	.2165	-.0801				
.40	.0590	-.0396			.0743	-.0437	.0722	-.0400	.0772	-.0310	.0822	-.0210	.0141	.0176
.50	.0502	-.0406					.0677	-.0445	.0682	-.0414			.0141	.0176
.60					.0727	-.0502	.0695	-.0472	.0655	-.0448	.0388	-.0560	-.0015	-.0525
.70			.0457	-.0538	.0601	-.0577	.0560	-.0557	-.0309	-.0747	-.1095	-.1225	-.0896	-.1247
.80	-.0381	-.1210	-.0929	-.1036	-.0970	-.1028			-.0732	-.0873	-.1289	-.1128	.0104	-.1232
.90	-.0642	-.1252			-.1073	-.0981			-.1047	-.1029	-.1213	-.1122	-.0830	-.1500
.95	-.0663	-.1165							-.1096	-.1031	-.1185	-.1122	-.0987	-.1418

TAIL 2

TABLE VIII. - CONTINUED
(b) $\alpha = -2.25^\circ$

Cp at y/b of														
x/c	0.02		0.22		0.44		0.56		0.67		0.83		0.98	
	U.S.	L.S.	U.S.	L.S.	U.S.	L.S.	U.S.	L.S.	U.S.	L.S.	U.S.	L.S.	U.S.	L.S.
.05	.1518	.1373	.3378	.2629	.3290	-.2684	-.3043	-.2786	.3181	-.2835	-.3147	-.2746		
.10	.1529	.1444	.3581	-.2745	-.3334	-.2754	-.2980	-.2890	.3271	-.2809	-.3142	-.2780	.2489	.2056
.15	.1527	.1403	.3612	-.2836	-.3336	-.2737	-.3187	-.2832	.3276	-.2772	-.3093	-.2744	.2292	.1934
.20	.1357	.0982	.3344	-.2726	-.3316	-.2723			.3224	-.2775	-.3181	-.2717	.2107	.1791
.25			.0693	-.0169	.2903	-.2277	-.3037	-.2629	.3164	-.2734	-.3162	-.2680	-.2018	-.1688
.30	.0427	-.0085	-.0271	-.0154	-.0553	-.0004	-.0711	-.0239	.1579	.0981	-.3015	-.2552	-.1952	-.1608
.40									.0443	.0014	-.0451	-.0070	-.0136	-.0385
.50	.0530	.0067	-.0037	-.0434	.0472	-.0047			.0396	-.0058	-.0254	-.0137	-.0406	-.0499
.60	.1100	.0222	-.0024	-.0409	.0392	-.0061	-.0433	-.0096	.0373	-.0108	.0124	-.0254	-.0348	-.0479
.70	.0364	.0146	-.0072	-.0329	.0243	-.0167	-.0273	-.0225	-.0102	-.0484			-.1074	-.1222
.80	-.0718	-.0998	-.1027	-.1263	-.1212	-.1278	-.1127	-.1281	-.1207	-.1153	-.1350	-.1178	-.1021	-.1099
.90	-.0833	-.1015	-.1187	-.1116	-.1270	-.1144	-.1225	-.1151	-.1216	-.1083	-.1224	-.1162	-.0838	-.0932
.95	-.0905	-.0977	-.1208	-.1107	-.1146	-.1138	-.1196	-.1125	-.1148	-.1077	-.1147	-.1158	-.0828	-.1063

TAIL 1

Cp at y/b of														
x/c	0.02		0.22		0.44		0.56		0.67		0.83		0.98	
	U.S.	L.S.	U.S.	L.S.	U.S.	L.S.	U.S.	L.S.	U.S.	L.S.	U.S.	L.S.	U.S.	L.S.
.05	.2102	.1351	.3624	.2729			.3464	.2362	.3519	.2868	-.3508	.2902	.3143	.2947
.10	.2137	.1367	.3580	.2583			.3441	.2666	.3382	.2721	-.3448	.2809	.2724	.2269
.15	.2033	.1287	.3537	.2490			.3375	.2573	.3337	.2622	-.3411	.2720	.2417	.1954
.20							.3266	.2480	.3331	.2520		.2643	.2256	.1729
.25	.0484	-.0110	.0723	.0154			.3119	.2276	.3224	.2373	-.3289	.2570	.2031	.1614
.30			.0413	-.0127	.0495	-.0069	.0629	.0114	.1766	.1124				
.40	.0299	.0005			.0407	-.0184	.0408	-.0158	.0471	-.0063	.0568	.0043		
.50	.0328	-.0103					.0359	-.0202	.0382	-.0176			.0144	.0156
.60					.0396	-.0249	.0370	-.0226	.0357	-.0214	.0180	-.0331	-.0152	-.0392
.70			.0155	-.0304	.0286	-.0328	.0250	-.0339	-.0514	-.0545	-.1200	-.1312	-.1006	-.1226
.80	-.0583	-.1097	-.1067	-.1060	-.1140	-.1026			-.0839	-.0861	-.1374	-.1107	.0106	-.0996
.90	-.0832	-.1166			-.1213	-.0986			-.1170	-.0996	-.1192	-.1090	-.0994	-.1265
.95	-.0868	-.1148							-.1099	-.0997	-.1135	-.1091	-.1153	-.1302

TAIL 2

TABLE VIII. - CONTINUED
(c) $\alpha = -0.26^\circ$

Cp at y/b of														
x/c	0.02		0.22		0.44		0.56		0.67		0.83		0.98	
	U.S.	L.S.	U.S.	L.S.	U.S.	L.S.	U.S.	L.S.	U.S.	L.S.	U.S.	L.S.	U.S.	L.S.
.05	.1549	.1884	.2757	.3250	.2785	.3201	.2545	.3306	.2717	.3356	.2709	.3222		
.10	.1488	.2032	.2800	.3351	.2818	.3292	.2507	.3426	.2767	.3313	.2692	.3257	.2096	.2428
.15	.1414	.2122	.2844	.3385	.2817	.3276	.2695	.3366	.2820	.3266	.2646	.3223	.1938	.2293
.20	.1302	.1624	.2783	.3324	.2792	.3252			.2763	.3274	.2732	.3197	.1795	.2134
.25			.0443	.0554	.2422	.2755	.2552	.3143	.2702	.3230	.2714	.3163	.1716	.2021
.30	.0192	.0113	.0058	.0218	.0214	.0314	.0405	.0543	.1230	.1327	.2576	.3021	.1664	.1940
.40									.0151	.0297	.0163	.0327	-.0302	-.0211
.50	.0271	.0064	-.0240	-.0123	.0104	.0248			.0097	.0223	-.0021	.0085	-.0329	-.0413
.60	.0868	.0501	-.0209	-.0196	.0091	.0231	.0091	.0194	.0076	.0171	-.0145	-.0050	-.0337	-.0369
.70	.0325	.0347	-.0131	-.0171	-.0001	.0122	-.0064	.0064	-.0361	-.0243			-.1137	-.1151
.80	-.0779	-.0914	-.1132	-.1209	-.1306	-.1305	-.1285	-.1288	-.1292	-.1179	-.1201	-.1238	-.0884	-.1101
.90	-.0903	-.0927	-.1175	-.1070	-.1116	-.1125	-.1110	-.1167	-.1067	-.1135	-.1149	-.1151	-.1191	-.0877
.95	-.1004	-.0972	-.1160	-.1063	-.1077	-.1087	-.1063	-.1092	-.1030	-.1025	-.1140	-.1135	-.1165	-.1026

TAIL 1

Cp at y/b of														
x/c	0.02		0.22		0.44		0.56		0.67		0.83		0.98	
	U.S.	L.S.	U.S.	L.S.	U.S.	L.S.	U.S.	L.S.	U.S.	L.S.	U.S.	L.S.	U.S.	L.S.
.05	.1460	.1580	.3015	.3280			.2952	.3363	.3006	.3367	.3050	.3391	.2749	.3395
.10	.1535	.1586	.2978	.3174			.2919	.3158	.2870	.3213	.2982	.3284	.2397	.2679
.15	.1456	.1503	.2961	.3133			.2851	.3057	.2833	.3102	.2948	.3186	.2102	.2271
.20							.2748	.2958	.2826	.3001		.3105	.1909	.2045
.25	.0218	.0132	.0367	.0477			.2609	.2741	.2731	.2845	.2825	.3022	.1727	.1904
.30			.0084	.0122	.0190	.0213	.0333	.0386	.1400	.1474				
.40	.0128	.0418			.0102	.0102	.0118	.0115	.0192	.0201	.0306	.0316		
.50	.0257	.0195					.0071	.0072	.0103	.0084			.0101	.0155
.60					.0095	.0054	.0079	.0049	.0078	.0044	-.0026	-.0077	-.0326	-.0310
.70			-.0087	-.0091	-.0005	-.0045	-.0031	-.0082	-.0715	-.0314	-.1309	-.1327	-.1084	-.1152
.80	-.0746	-.0963	-.1136	-.1092	-.1303	-.1151			-.0947	-.0918	-.1288	-.1163	.0062	-.1117
.90	-.0965	-.1075			-.1140	-.0993			-.1061	-.0992	-.1156	-.1109	-.1160	-.0966
.95	-.0984	-.1086							-.1010	-.0984	-.1133	-.1105	-.1277	-.1107

TAIL 2

TABLE VIII. - CONTINUED
 (d) $\alpha = 1.73^\circ$

Cp at y/b of														
x/c	0.02		0.22		0.44		0.56		0.67		0.83		0.98	
	U.S.	L.S.	U.S.	L.S.	U.S.	L.S.	U.S.	L.S.	U.S.	L.S.	U.S.	L.S.	U.S.	L.S.
.05	.1283	.2690	.2242	.3853	.2313	.3745	.2088	.3850	.2286	.3874	.2297	.3712		
.10	.1258	.2824	.2268	.3963	.2349	.3837	.2077	.3974	.2319	.3837	.2277	.3755	.1760	.2813
.15	.1187	.3220	.2259	.3974	.2347	.3829	.2251	.3900	.2390	.3785	.2233	.3720	.1631	.2668
.20	.1051	.2897	.2181	.3919	.2324	.3794			.2345	.3785	.2314	.3693	.1534	.2492
.25			.0096	.0928	.1972	.3253	.2114	.3660	.2269	.3737	.2295	.3660	.1467	.2365
.30	-.0182	.0388	-.0226	.0580	-.0064	.0638	.0157	.0829	.0901	.1672	.2163	.3510	.1420	.2282
.40									-.0112	.0592	-.0092	.0581	-.0421	-.0025
.50	-.0069	.0027	-.0442	.0227	-.0186	.0566			-.0167	.0516	-.0278	.0308	-.0375	-.0265
.60	.0522	.0473	-.0432	.0140	-.0211	.0546	-.0185	.0493	-.0189	.0459	-.0383	.0155	-.0462	-.0254
.70	.0209	.0623	-.0364	.0100	-.0292	.0432	-.0314	.0364	-.0584	.0009			-.1217	-.1065
.80	-.0840	-.0769	-.1068	-.1176	-.1056	-.1146	-.1056	-.1133	-.1107	-.1231	-.1141	-.1357	-.1192	-.1098
.90	-.0996	-.0834	-.1053	-.1097	-.1000	-.1220	-.1010	-.1204	-.1035	-.1225	-.1143	-.1226	-.1409	-.0824
.95	-.1079	-.0902	-.1067	-.1048	-.0997	-.1084	-.1011	-.1152	-.1025	-.1106	-.1145	-.1164	-.1308	-.0976

TAIL 1

Cp at y/b of														
x/c	0.02		0.22		0.44		0.56		0.67		0.83		0.98	
	U.S.	L.S.	U.S.	L.S.	U.S.	L.S.	U.S.	L.S.	U.S.	L.S.	U.S.	L.S.	U.S.	L.S.
.05	.1114	.1530	.2401	.3954			.2439	.3907	.2518	.3905	.2585	.3899	.2357	.3844
.10	.1152	.1606	.2390	.4003			.2402	.3701	.2392	.3748	.2515	.3789	.2075	.3100
.15	.1085	.1603	.2406	.3861			.2344	.3597	.2361	.3626	.2481	.3688	.1779	.2657
.20							.2255	.3487	.2347	.3511		.3605	.1596	.2403
.25	.0066	.0286	.0006	.0710			.2121	.3256	.2257	.3343	.2370	.3512	.1439	.2228
.30			-.0234	.0325	-.0102	.0546	.0053	.0693	.1051	.1846				
.40	.0049	.0824			-.0188	.0474	-.0156	.0429	-.0072	.0493	.0050	.0622		
.50	.0169	.0389					-.0203	.0396	-.0160	.0375			.0068	.0175
.60					-.0189	.0330	-.0199	.0390	-.0183	.0340	-.0225	.0208	-.0463	-.0338
.70			-.0292	.0089	-.0285	.0184	-.0290	.0243	-.0902	-.0044	-.1381	-.1188	-.1171	-.1072
.80	-.0899	-.0867	-.1209	-.1066	-.1178	-.1282			-.0825	-.0990	-.1171	-.1342	.0033	-.1297
.90	-.1044	-.0995			-.1068	-.1019			-.1019	-.1126	-.1129	-.1140	-.1166	-.0844
.95	-.1034	-.1029							-.1019	-.1021	-.1126	-.1096	-.1203	-.0891

TAIL 2

TABLE VIII. - CONTINUED
(e) $\alpha = 3.72^\circ$

Cp at y/b of														
x/c	0.02		0.22		0.44		0.56		0.67		0.83		0.98	
	U.S.	L.S.	U.S.	L.S.	U.S.	L.S.	U.S.	L.S.	U.S.	L.S.	U.S.	L.S.	U.S.	L.S.
.05	.0934	.3624	.1769	.4533	.1896	.4333	.1665	.4439	.1895	.4433	.1910	.4231		
.10	.0969	.3735	.1804	.4672	.1925	.4436	.1702	.4566	.1905	.4384	.1877	.4281	.1432	.3185
.15	.0942	.4200	.1786	.4655	.1922	.4425	.1852	.4469	.1964	.4339	.1835	.4152	.1340	.3031
.20	.0729	.4605	.1703	.4569	.1902	.4373			.1955	.4348	.1907	.4226	.1292	.2852
.25			-.0203	.1316	.1573	.3798	.1710	.4233	.1877	.4293	.1890	.4181	.1256	.2725
.30	-.0545	.0931	-.0500	.0945	-.0309	.0992	-.0053	.1119	.0600	.2038	.1769	.4008	.1223	.2642
.40									-.0350	.0311	-.0324	.0836	-.0478	.0180
.50	-.0496	.0179	-.0672	.0602	-.0441	.0929			-.0405	.0834	-.0505	.0536	-.0519	-.0090
.60	.0040	.0574	-.0679	.0525	-.0457	.0896	-.0413	.0830	-.0430	.0770	-.0597	.0374	-.0358	-.0099
.70	-.0029	.0916	-.0635	.0454	-.0535	.0759	-.0568	.0708	-.0788	.0277			-.1169	-.0962
.80	-.0899	-.0539	-.1012	-.1020	-.0976	-.0970	-.0994	-.0956	-.1053	-.1035	-.1093	-.1259	-.1394	-.1076
.90	-.1065	-.0639	-.1021	-.1037	-.0974	-.1111	-.0983	-.1042	-.1023	-.1145	-.1107	-.1269	-.1496	-.0705
.95	-.1055	-.0687	-.1032	-.1057	-.0977	-.1126	-.0981	-.1075	-.1015	-.1143	-.1108	-.1197	-.1370	-.0826

TAIL 1

Cp at y/b of														
x/c	0.02		0.22		0.44		0.56		0.67		0.83		0.98	
	U.S.	L.S.	U.S.	L.S.	U.S.	L.S.	U.S.	L.S.	U.S.	L.S.	U.S.	L.S.	U.S.	L.S.
.05	.0935	.1234	.1765	.5159			.1932	.4517	.2033	.4542	.2139	.4433	.1985	.4330
.10	.0954	.1382	.1902	.4817			.1893	.4317	.1921	.4343	.2064	.4312	.1745	.3560
.15	.0887	.1428	.1750	.4274			.1835	.4210	.1885	.4203	.2030	.4205	.1456	.3102
.20							.1754	.4105	.1877	.4085		.4124	.1297	.2809
.25	.0068	.0338	-.0382	.0900			.1634	.3864	.1792	.3901	.1929	.4042	.1150	.2613
.30			-.0548	.0521	-.0391	.1020	-.0231	.1091	.0704	.2271				
.40	-.0049	.1095			-.0456	.0818	-.0435	.0858	-.0335	.0840	-.0199	.0954		
.50	.0010	.0540					-.0478	.0809	-.0427	.0745			.0018	.0137
.60					-.0466	.0528	-.0469	.0714	-.0449	.0735	-.0436	.0530	-.0572	-.0340
.70			-.0430	.0303	-.0563	.0369	-.0533	.0490	-.1077	.0317	-.1200	-.1016	-.1166	-.1058
.80	-.1043	-.0712	-.1337	-.0991	-.1045	-.1194			-.0810	-.0849	-.1099	-.1257	-.0026	-.1316
.90	-.1109	-.0871			-.1031	-.1078			-.1017	-.1126	-.1087	-.1245	-.1178	-.1060
.95	-.1045	-.0939							-.1023	-.1141	-.1088	-.1141	-.1183	-.0850

TAIL 2

TABLE VIII. - CONTINUED
 (1) $\alpha = 5.72^\circ$

Cp at y/b of														
x/c	0.02		0.22		0.44		0.56		0.67		0.83		0.98	
	U.S.	L.S.	U.S.	L.S.	U.S.	L.S.	U.S.	L.S.	U.S.	L.S.	U.S.	L.S.	U.S.	L.S.
.05	.0365	.4374	.1297	.5262	.1485	.4964	.1265	.5104	.1512	.5023	.1541	.4788		
.10	.0541	.5048	.1342	.5445	.1518	.5075	.1328	.5168	.1508	.4957	.1494	.4834	.1133	.3582
.15	.0555	.4992	.1324	.5438	.1512	.5056	.1454	.5065	.1558	.4908	.1447	.4798	.1085	.3415
.20	.0318	.6309	.1247	.5242	.1492	.5006			.1565	.4916	.1508	.4768	.1055	.3233
.25			-.0474	.1704	.1188	.4394	.1314	.4839	.1503	.4859	.1489	.4718	.1025	.3104
.30	-.0774	.1408	-.0749	.1313	-.0538	.1380	-.0284	.1443	-.0321	.2448	.1381	.4502	.1023	.3018
.40									-.0582	.1244	-.0549	.1084	-.0544	.0400
.50	-.0901	.0529	-.0913	.1010	-.0680	.1325			-.0638	.1168	-.0720	.0765	-.0578	.0109
.60	-.0561	.0956	-.0944	.0933	-.0698	.1248	-.0653	.1202	-.0663	.1093	-.0798	.0597	-.0451	.0107
.70	-.0318	.1325	-.0936	.0833	-.0766	.1086	-.0790	.1105	-.0977	.0545			-.1267	-.0846
.80	-.0948	-.0234	-.1021	-.0805	-.0982	-.0785	-.1004	-.0762	-.1064	-.0940	-.1132	-.1137	-.1806	-.0978
.90	-.1186	-.0384	-.1039	-.0896	-.0988	-.0932	-.0999	-.0862	-.1041	-.0996	-.1150	-.1198	-.1629	-.0583
.95	-.0925	-.0451	-.1047	-.0875	-.0992	-.0978	-.0999	-.0915	-.1034	-.1038	-.1154	-.1184	-.1576	-.0663

TAIL 1

Cp at y/b of														
x/c	0.02		0.22		0.44		0.56		0.67		0.83		0.98	
	U.S.	L.S.	U.S.	L.S.	U.S.	L.S.	U.S.	L.S.	U.S.	L.S.	U.S.	L.S.	U.S.	L.S.
.05	.1052	.1247	.1234	.5783			.1434	.5240	.1553	.5238	.1696	.5047	.1626	.4819
.10	.1108	.1428	.1164	.5074			.1385	.5043	.1443	.5014	.1621	.4918	.1393	.4078
.15	.1052	.1489	.1027	.4534			.1328	.4972	.1408	.4880	.1588	.4812	.1124	.3585
.20							.1252	.4909	.1397	.4763		.4732	.0987	.3276
.25	.0006	.0472	-.0661	.1149			.1145	.4658	.1320	.4575	.1496	.4634	.0848	.3058
.30			-.0728	.0768	-.0676	.1283	-.0511	.1592	.0347	.2800				
.40	-.0413	.0981			-.0722	.1021	-.0703	.1211	-.0602	.1312	-.0444	.1338		
.50	-.0360	.0635					-.0745	.1056	-.0688	.1175			-.0077	.0067
.60					-.0740	.0748	-.0733	.0920	-.0703	.1073	-.0657	.0941	-.0740	-.0169
.70			-.0491	.0714	-.0806	.0599	-.0766	.0681	-.1223	.0564	-.1190	-.0772	-.1208	-.1002
.80	-.1040	-.0607	-.1320	-.0879	-.1072	-.1069			-.0856	-.0756	-.1144	-.1033	-.0114	-.1061
.90	-.1221	-.0743			-.1073	-.1081			-.1055	-.1021	-.1140	-.1122	-.1220	-.1172
.95	-.1209	-.0836							-.1061	-.1083	-.1142	-.1168	-.1244	-.1192

TAIL 2

TABLE VIII. - CONTINUED
(g) $\alpha = 7.71^\circ$

Cp at y/b of														
x/c	0.02		0.22		0.44		0.56		0.67		0.83		0.98	
	U.S.	L.S.	U.S.	L.S.	U.S.	L.S.	U.S.	L.S.	U.S.	L.S.	U.S.	L.S.	U.S.	L.S.
.05	-.0130	.5281	-.0867	.6153	-.1066	-.5648	-.0869	-.5856	-.1123	-.5654	-.1132	-.5368		
.10	-.0067	-.5589	-.0919	-.6355	-.1103	-.5759	-.0951	-.5825	-.1118	-.5571	-.1068	-.5418	-.0844	-.4003
.15	-.0109	-.5786	-.0898	-.6268	-.1110	-.5716	-.1073	-.5708	-.1154	-.5534	-.1032	-.5390	-.0838	-.3834
.20	-.0124	-.7061	-.0818	-.6040	-.1097	-.5702			-.1161	-.5546	-.1100	-.5349	-.0828	-.3649
.25			-.0738	-.2079	-.0818	-.5062	-.0944	-.5491	-.1122	-.5471	-.1091	-.5263	-.0806	-.3508
.30	-.1090	-.1944	-.0997	-.1682	-.0754	-.1833	-.0554	-.1830	-.0047	-.2882	-.0995	-.4982	-.0802	-.3420
.40									-.0804	-.1602	-.0762	-.1331	-.0619	-.0630
.50	-.1152	-.0881	-.1131	-.1375	-.0897	-.1741			-.0855	-.1520	-.0915	-.1007	-.0665	-.0326
.60	-.0919	-.1378	-.1166	-.1304	-.0916	-.1627	-.0870	-.1623	-.0875	-.1421	-.0973	-.0834	-.0543	-.0334
.70	-.0670	-.1876	-.1162	-.1207	-.0975	-.1423	-.0985	-.1503	-.1130	-.0821			-.1616	-.0730
.80	-.0994	-.0195	-.1087	-.0569	-.1029	-.0580	-.1048	-.0539	-.1108	-.0766	-.1181	-.1004	-.1750	-.0859
.90	-.1166	-.0084	-.1100	-.0620	-.1038	-.0736	-.1046	-.0692	-.1090	-.0826	-.1202	-.1077	-.1680	-.0467
.95	-.0860	-.0123	-.1106	-.0569	-.1041	-.0797	-.1047	-.0763	-.1083	-.0880	-.1207	-.1101	-.1649	-.0508

TAIL 1

Cp at y/b of														
x/c	0.02		0.22		0.44		0.56		0.67		0.83		0.98	
	U.S.	L.S.	U.S.	L.S.	U.S.	L.S.	U.S.	L.S.	U.S.	L.S.	U.S.	L.S.	U.S.	L.S.
.05	.0974	-.1419	.0036	.6037			-.0975	-.6076	-.1122	-.5995	-.1284	-.5739	-.1279	-.5359
.10	-.1069	-.1609	-.0733	-.5417			-.0908	-.5899	-.1010	-.5777	-.1199	-.5613	-.1039	-.4683
.15	-.0983	-.1688	-.0727	-.4915			-.0848	-.5812	-.0965	-.5668	-.1164	-.5506	-.0798	-.4159
.20							-.0781	-.5642	-.0947	-.5568		-.5430	-.0692	-.3832
.25	-.0049	-.0466	-.0793	-.1404			-.0685	-.5246	-.0876	-.5346	-.1087	-.5332	-.0569	-.3671
.30			-.0826	-.1011	-.0938	-.1508	-.0773	-.1853	-.0014	-.3344				
.40	-.0447	-.1062			-.0992	-.1269	-.0956	-.1452	-.0838	-.1661	-.0674	-.1811		
.50	-.0461	-.0637					-.0999	-.1299	-.0927	-.1449			-.0116	-.0043
.60					-.0960	-.1020	-.0990	-.1177	-.0942	-.1321	-.0872	-.1355	-.0882	-.0124
.70			-.0738	-.1104	-.1004	-.0864	-.0991	-.0936	-.1296	-.0787	-.1210	-.0574	-.1245	-.0984
.80	-.1172	-.0579	-.1493	-.0763	-.1127	-.0924			-.0905	-.0633	-.1190	-.0867	-.0156	-.0905
.90	-.1256	-.0681			-.1141	-.1059			-.1112	-.0870	-.1192	-.0977	-.1211	-.0923
.95	-.1225	-.0776							-.1120	-.0942	-.1195	-.1044	-.1228	-.0993

TAIL 2

TABLE VIII. - CONTINUED
(h) $\alpha = 9.71^\circ$

Cp at y/b of														
x/c	0.02		0.22		0.44		0.56		0.67		0.83		0.98	
	U.S.	L.S.	U.S.	L.S.	U.S.	L.S.	U.S.	L.S.	U.S.	L.S.	U.S.	L.S.	U.S.	L.S.
.05	-.0483	-.6074	.0552	.7223	-.0759	-.6511	-.0583	-.6798	.0720	-.6370	-.0759	-.6007		
.10	-.0283	-.6028	.0576	.7300	-.0792	-.6622	-.0676	-.6620	-.0706	-.6277	-.0685	-.6056	-.0635	-.4493
.15	-.0222	-.6600	.0551	.7113	-.0793	-.6582	-.0779	-.6489	-.0753	-.6273	-.0643	-.6015	-.0645	-.4308
.20	-.0430	-.7727	.0468	.6743	-.0775	-.6619			-.0782	-.6297	-.0687	-.5969	-.0635	-.4112
.25			-.0937	.2427	.0513	-.5875	-.0638	-.6269	-.0782	-.6190	-.0670	-.5815	-.0616	-.3963
.30	-.1309	-.2473	-.1179	.2022	-.0919	-.2360	-.0765	-.2282	-.0163	-.3363	-.0576	-.5474	-.0614	-.3874
.40									-.0957	.2036	-.0990	.1610	-.0755	.0890
.50	-.1338	-.1228	-.1306	.1744	-.1071	-.2155			-.1013	-.1950	-.1119	.1291	-.0759	.0579
.60	-.1161	-.1925	-.1332	.1682	-.1092	.1977	-.1049	.2077	-.1040	.1818	-.1142	.1117	-.1108	.0589
.70	-.0905	-.2571	-.1284	.1598	-.1140	-.1764	-.1143	.1902	-.1245	.1159			-.1797	-.0576
.80	-.1008	-.0630	-.1168	-.0284	-.1121	-.0363	-.1142	-.0367	-.1181	-.0560	-.1254	-.0832	-.1688	-.0738
.90	-.1287	-.0210	-.1174	-.0229	-.1127	-.0546	-.1140	-.0549	-.1171	-.0631	-.1271	-.0911	-.1657	-.0306
.95	-.0957	-.0201	-.1179	-.0009	-.1130	-.0625	-.1140	-.0626	-.1166	-.0694	-.1279	-.0942	-.1647	-.0325

TAIL 1

Cp at y/b of														
x/c	0.02		0.22		0.44		0.56		0.67		0.83		0.98	
	U.S.	L.S.	U.S.	L.S.	U.S.	L.S.	U.S.	L.S.	U.S.	L.S.	U.S.	L.S.	U.S.	L.S.
.05	.0879	.1806	.0748	.4019			.0288	.7507	.0528	.7466	-.0757	-.6971	-.0854	.6172
.10	.1111	.1658	.0537	.4081			.0191	.6944	.0403	.7077	-.0658	-.6894	-.0617	.5631
.15	.1105	.1510	.0315	.4106			.0117	.6480	.0344	.6719	-.0620	-.6749	-.0410	.5117
.20							.0043	.6084	.0315	.6363		.6568	.0333	.4787
.25	.0133	.0409	-.1062	.1201			-.0029	.5556	.0247	.5930	-.0553	-.6334	-.0242	.4519
.30			-.1082	.0952	-.1168	.1642	-.1173	.2004	-.0461	.3659				
.40	-.0186	.0805			-.1175	.1423	-.1295	.1660	-.1179	.1892	-.0964	.2220		
.50	-.0206	.0491					-.1253	.1516	-.1265	.1682			-.0139	.0035
.60					-.1118	.1221	-.1207	.1383	-.1268	.1563	-.1152	.1631	-.1068	.0403
.70			-.1187	.1236	-.1085	.1111	-.1179	.1139	-.1401	.1010	-.1397	-.0415	-.1421	-.1074
.80	-.1258	-.0708	-.1772	-.0576	-.1509	-.0775			-.1036	-.0503	-.1381	-.0711	-.0179	-.1008
.90	-.1348	-.0788			-.1445	-.0966			-.1300	-.0721	-.1384	-.0826	-.1296	-.1002
.95	-.1309	-.0859							-.1312	-.0797	-.1387	-.0900	-.1253	-.1077

TAIL 2

TABLE VIII. - CONTINUED
 (ii) $\alpha = 11.71^\circ$

Cp at γ/b of														
x/c	0.02		0.22		0.44		0.56		0.67		0.83		0.98	
	U.S.	L.S.	U.S.	L.S.	U.S.	L.S.	U.S.	L.S.	U.S.	L.S.	U.S.	L.S.	U.S.	L.S.
.05	-.0848	.7018	.0237	.8489	.0460	.7493	.0337	.7716	.0581	.7222	.0668	.5836		
.10	-.0647	.6462	.0248	.8245	.0473	.7606	.0419	.7495	.0537	.7096	.0578	.6883	.0603	.5114
.15	-.0570	.7503	.0222	.7965	.0473	.7660	.0481	.7370	.0541	.7132	.0525	.6831	.0620	.4911
.20	-.0736	.8283	.0145	.7354	.0452	.7693			.0537	.7128	.0567	.6736	.0613	.4691
.25			-.1117	.2765	.0204	.6728	.0327	.7202	.0510	.7016	.0547	.6498	.0600	.529
.30	-.1517	.3022	-.1341	.2417	-.1091	.2852	-.0958	.2812	-.0376	.3922	.0456	.6093	.0614	.4434
.40									-.1122	.2558	-.1056	.1975	-.0796	.1214
.50	-.1419	.1641	-.1464	.2156	-.1235	.2492			-.1179	.2439	-.1174	.1650	-.0835	.0894
.60	-.1389	.3024	-.1461	.2128	-.1248	.2333	-.1215	.2472	-.1206	.2260	-.1206	.1478	-.1546	.0901
.70	-.1166	.3533	-.1342	.2131	-.1250	.2135	-.1253	.2175	-.1305	.1514			-.1893	-.0399
.80	-.1015	.1047	-.1227	.0223	-.1160	-.0144	-.1182	-.0198	-.1232	-.0370	-.1286	-.0611	-.1732	-.0516
.90	-.1307	.0534	-.1233	.0640	-.1163	-.0353	-.1177	-.0390	-.1227	-.0463	-.1297	-.0694	-.1657	-.0109
.95	-.1071	.0528	-.1235	.0767	-.1163	-.0432	-.1177	-.0468	-.1222	-.0536	-.1303	-.0725	-.1651	-.0085

TAIL 1

Cp at γ/b of														
x/c	0.02		0.22		0.44		0.56		0.67		0.83		0.98	
	U.S.	L.S.	U.S.	L.S.	U.S.	L.S.	U.S.	L.S.	U.S.	L.S.	U.S.	L.S.	U.S.	L.S.
.05	.0893	.1352	.0684	.4195			-.0310	.7702	-.0063	.8181	.0206	.8294	.0346	.7362
.10	.1056	.1310	.0794	.4208			-.0418	.7031	-.0209	.7514	.0087	.7818	.0156	.6688
.15	.1027	.1238	.0749	.4112			-.0481	.6562	-.0285	.7028	.0029	.7415	.0026	.5964
.20							-.0526	.6195	-.0319	.6612		.7073	-.0020	.5413
.25	-.0006	.0293	-.0793	.1163			-.0577	.5681	-.0381	.6147	-.0038	.6712	-.0078	.4982
.30			-.0891	.0862	-.1372	.1702	-.1449	.2109	-.0931	.3770				
.40	-.0181	.0691			-.1399	.1575	-.1501	.1845	-.1474	.2109	-.1262	.2381		
.50	-.0342	.0337					-.1454	.1745	-.1526	.1943			-.0168	.0054
.60					-.1423	.1389	-.1421	.1633	-.1491	.1829	-.1427	.1874	-.1190	.0595
.70			-.1016	.1335	-.1447	.1293	-.1344	.1420	-.1529	.1265	-.1591	-.0240	-.1610	-.0961
.80	-.1190	-.0947	-.1722	-.0627	-.1720	-.0687			-.1172	-.0356	-.1578	-.0535	-.0210	-.1079
.90	-.1348	-.0929			-.1644	-.0801			-.1507	-.0572	-.1584	-.0656	-.1345	-.1132
.95	-.1319	-.0963							-.1535	-.0656	-.1589	-.0734	-.1374	-.1191

TAIL 2

TABLE VIII. - CONTINUED
(j) $\alpha = 15.71^\circ$

Cp at y/b of														
x/c	0.02		0.22		0.44		0.56		0.67		0.88		0.98	
	U.S.	L.S.	U.S.	L.S.	U.S.	L.S.	U.S.	L.S.	U.S.	L.S.	U.S.	L.S.	U.S.	L.S.
.05	-.0973	.9335	.0198	1.0921	.0451	1.0515	.0338	1.0674	.0597	.9676	.0681	.9104	.	.
.10	-.0792	.8440	.0155	1.0269	.0434	1.0328	.0412	1.0200	.0542	.9713	.0584	.9140	.0689	.6610
.15	-.0725	.9984	.0080	.9644	.0412	1.0054	.0448	1.0005	.0537	.9728	.0523	.8970	.0718	.6374
.20	-.0903	.9494	-.0036	.8935	.0377	.9680			.0522	.9633	.0559	.8705	.0727	.6122
.25			-.1224	.3545	.0126	.8125	.0276	.9154	.0484	.9323	.0534	.8368	.0706	.5950
.30	-.1657	.4218	-.1447	.3315	-.1139	.3548	-.0983	.3710	-.0402	.5169	.0438	.7838	.0736	.5862
.40									-.1133	.3435	-.1057	.2964	-.0759	.2075
.50	-.1521	.2843	-.1577	.3211	-.1317	.3394			-.1201	.3173	-.1158	.2585	-.1480	.1759
.60	-.1506	.6435	-.1511	.3376	-.1346	.3241	-.1270	.3208	-.1235	.2952	-.1186	.2358	-.1619	.1762
.70	-.1361	.5479	-.1369	.3746	-.1280	.2970	-.1287	.2838	-.1324	.2122			-.1897	.0063
.80	-.1014	.1916	-.1288	.1841	-.1176	.0335	-.1203	.0265	-.1258	.0041	-.1306	-.0147	-.1753	.0081
.90	-.1259	.1257	-.1294	.1493	-.1178	.0265	-.1202	.0070	-.1252	-.0039	-.1317	-.0256	-.1641	.0153
.95	-.1162	.1198	-.1298	.1389	-.1187	.0271	-.1201	-.0011	-.1250	-.0112	-.1321	-.0293	-.1629	.0375

TAIL 1

Cp at y/b of														
x/c	0.02		0.22		0.44		0.56		0.67		0.88		0.98	
	U.S.	L.S.	U.S.	L.S.	U.S.	L.S.	U.S.	L.S.	U.S.	L.S.	U.S.	L.S.	U.S.	L.S.
.05	.0788	.0383	.0583	.2234			-.1238	.7347	-.1157	.8134	-.0943	.3000	-.0702	.8449
.10	.0930	.0454	.0668	.2648			-.1339	.6663	-.1267	.7379	-.0999	.8262	-.0693	.7577
.15	.0927	.0446	.0623	.2772			-.1420	.6224	-.1355	.6870	-.1071	.7685	-.0750	.6714
.20							-.1464	.5902	-.1408	.6457		.7235	-.0794	.6009
.25	-.0082	-.0297	-.0898	.0585			-.1445	.5396	-.1464	.5969	-.1111	.6766	-.0836	.5439
.30			-.0991	.0485	-.1704	.1631	-.1894	.2010	-.1731	.3513				
.40	-.0169	.0124			-.1737	.1568	-.1879	.1910	-.1891	.2239	-.1787	.2545		
.50	-.0363	.0175					-.1866	.1829	-.1858	.2131			-.0307	-.0109
.60					-.1845	.1625	-.1881	.1793	-.1826	.2016	-.1822	.2288	-.1658	.1038
.70			-.1261	.0959	-.1884	.1564	-.1698	.1680	-.1770	.1484	-.1851	.0038	-.1886	-.0639
.80	-.1243	-.1199	-.1845	-.0804	-.1905	-.0580			-.1418	-.0236	-.1847	-.0254	-.0344	-.0777
.90	-.1454	-.1278			-.1866	-.0626			-.1808	-.0405	-.1849	-.0379	-.1769	-.0855
.95	-.1445	-.1282							-.1840	-.0483	-.1851	-.0460	-.1768	-.0942

TAIL 2

TABLE VIII. - CONCLUDED
(k) $\alpha = 19.70^\circ$

Cp at γ/b of														
x/c	0.02		0.22		0.44		0.56		0.67		0.83		0.98	
	U.S.	L.S.	U.S.	L.S.	U.S.	L.S.	U.S.	L.S.	U.S.	L.S.	U.S.	L.S.	U.S.	L.S.
.05	-.0728	1.1737	.0455	1.3658	.0803	1.3973	.0573	1.4088	.0853	1.3820	.0831	1.2868		
.10	-.0612	1.1250	.0359	1.2576	.0726	1.3019	.0638	1.3033	.0753	1.2860	.0708	1.2066		
.15	-.0607	1.2264	.0252	1.1730	.0652	1.2206	.0655	1.2287	.0715	1.2150	.0622	1.1307	.0841	.8752
.20	-.0804	1.0774	.0114	1.0624	.0607	1.1403			.0686	1.1489	.0645	1.0686	.0910	.8088
.25			-.1148	.4266	.0310	.9189	.0446	1.0249	.0642	1.0622	.0602	1.0057	.0886	.7810
.30	-.1593	.5527	-.1368	.4240	-.1045	.4224	-.0866	.4336	-.0292	.5494	.0498	.9192	.0749	.7592
.40									-.1042	.4117	-.0986	.3643	-.0838	.2906
.50	-.1420	.5683	-.1500	.4726	-.1239	.4371			-.1128	.4044	-.1054	.3350	-.1491	.2517
.60	-.1436	.9395	-.1418	.5645	-.1289	.4237	-.1205	.4115	-.1176	.3868	-.1074	.3173	-.1678	.2474
.70	-.1434	.6806	-.1288	.7392	-.1304	.4146	-.1274	.3684	-.1326	.2933			-.1911	.0416
.80	-.1021	.2830	-.1209	.2715	-.1188	.1423	-.1204	.0843	-.1269	.0591	-.1323	.0406	-.1877	.0566
.90	-.1193	.2118	-.1203	.2002	-.1202	.1531	-.1205	.0812	-.1264	.0504	-.1339	.0294	-.1588	.0657
.95	-.1173	.1939	-.1199	.2033	-.1211	.1521	-.1204	.0806	-.1267	.0423	-.1350	.0257	-.1551	.0743

TAIL 1

Cp at γ/b of														
x/c	0.02		0.22		0.44		0.56		0.67		0.83		0.98	
	U.S.	L.S.	U.S.	L.S.	U.S.	L.S.	U.S.	L.S.	U.S.	L.S.	U.S.	L.S.	U.S.	L.S.
.05	.0351	-.0024	-.0130	.2857			-.1581	.7209	-.1573	.7840	-.1601	.8375	-.1654	.8204
.10	.0453	.0054	-.0044	.3338			-.1641	.6582	-.1598	.7154	-.1557	.7780	-.1477	.7545
.15	.0451	.0066	-.0059	.3272			-.1713	.6180	-.1676	.6671	-.1589	.7283	-.1483	.6831
.20							-.1756	.5859	-.1731	.6261		.6874	-.1528	.6177
.25	-.0392	-.0421	-.1287	.0662			-.1762	.5293	-.1785	.5742	-.1587	.6416	-.1558	.5611
.30			-.1307	.0397	-.1906	.1707	-.2050	.1947	-.1964	.3250				
.40	-.0215	.0067			-.1940	.1826	-.2038	.1956	-.2021	.2240	-.2023	.2614		
.50	-.0636	-.0086					-.2030	.1988	-.2015	.2183				
.60					-.2019	.1849	-.2042	.1935	-.1987	.2163	-.1978	.2525	-.0466	-.0180
.70			-.1553	.0769	-.2042	.2041	-.1838	.1833	-.1939	.1673	-.2007	.0211	-.1938	.1528
.80	-.1494	-.1375	-.1982	-.0891	-.2038	-.0289			-.1560	-.0180	-.2008	-.0043	-.2017	-.0340
.90	-.1649	-.1529			-.2008	-.0506			-.1972	-.0286	-.2010	-.0155	-.1936	-.0578
.95	-.1617	-.1549							-.2000	-.0296	-.2019	-.0239	-.1991	-.0671

TAIL 2

TABLE IX.- PRESSURE COEFFICIENTS, $\phi = 67.5^\circ$, $\delta = 0^\circ$, $M = 2.36$
(a) $\alpha = -4.09^\circ$

Cp at y/b of														
x/c	0.02		0.22		0.44		0.56		0.67		0.83		0.98	
	U.S.	L.S.	U.S.	L.S.	U.S.	L.S.	U.S.	L.S.	U.S.	L.S.	U.S.	L.S.	U.S.	L.S.
.05	.1962	.0725	.4435	.1696	.4257	.1826	.3930	.1967	.4078	.2037	.4015	.2011		
.10	.2032	.0720	.4674	.1729	.4302	.1889	.3891	.2049	.4173	.2020	.4015	.2028	.3237	.1483
.15	.2075	.0674	.4580	.1766	.4306	.1876	.4127	.2000	.4138	.1987	.3979	.1993	.2989	.1395
.20	.2028	.0472	.4208	.1750	.4297	.1865			.4108	.1976	.4084	.1966	.2768	.1286
.25			.1222	-.0328	.3804	.1488	.3916	.1827	.4047	.1938	.4067	.1932	.2662	.1208
.30	.0837	-.0364	-.0782	-.0613	.1179	-.0451	.1283	-.0241	.2243	.0441	.3897	.1825	.2581	.1146
.40									.0994	-.0424	.0979	-.0344	.0231	-.0627
.50	.0768	.0036	-.0473	-.0735	.0977	-.0550			.0959	-.0490	.0749	-.0526	-.0186	-.0586
.60	.1616	.0020	.0422	-.0622	.0844	-.0566	.1006	-.0548	.0944	-.0534	.0602	-.0624	-.0194	-.0658
.70	.0676	-.0028	.0512	-.0604	.0675	-.0620	.0785	-.0662	.0388	-.0848			-.0985	-.1280
.80	-.0467	-.1087	-.0772	-.1349	-.0967	-.1058	-.0871	-.1059	-.0913	-.1103	-.1119	-.1152	-.1161	-.1020
.90	-.0675	-.1013	-.0895	-.1263	-.1094	-.1062	-.0987	-.1056	-.0943	-.1082	-.1190	-.1163	-.0838	-.1288
.95	-.0768	-.0907	-.0954	-.1184	-.1121	-.1063	-.1032	-.1057	-.0985	-.1079	-.1202	-.1165	-.0603	-.1228

TAIL 1

Cp at y/b of														
x/c	0.02		0.22		0.44		0.56		0.67		0.83		0.98	
	U.S.	L.S.	U.S.	L.S.	U.S.	L.S.	U.S.	L.S.	U.S.	L.S.	U.S.	L.S.	U.S.	L.S.
.05	.2453	.1515	.3704	.2710			.3501	.2819	.3558	.2828	.3556	.2863	.3164	.2846
.10	.2418	.1505	.3645	.2562			.3441	.2627	.3411	.2687	.3472	.2761	.2685	.2162
.15	.2205	.1429	.3572	.2462			.3383	.2539	.3361	.2594	.3420	.2671	.2378	.1890
.20							.3360	.2457	.3346	.2498		.2596	.2280	.1727
.25	.0453	-.0152	.0781	.0109			.3151	.2264	.3249	.2355	.3292	.2519	.2148	.1607
.30			.0463	-.0141	.0499	-.0087	.0623	-.0102	.1782	.1109				
.40	.1266	-.0145			.0415	-.0205	.0416	-.0169	.0468	-.0084	.0523	-.0004		
.50	.0277	.0114					.0365	-.0215	.0381	-.0193			.0020	.0244
.60					.0397	-.0265	.0374	-.0244	.0355	-.0230	.0112	-.0391	-.0116	-.0433
.70			.0137	-.0287	.0309	-.0343	.0241	-.0351	-.0523	-.0556	-.1232	-.1273	-.0958	-.1196
.80	-.0512	-.1122	-.1109	-.1059	-.1119	-.1005			-.0888	-.0842	-.1358	-.1102	-.0015	-.1121
.90	-.0716	-.1172			-.1193	-.0965			-.1187	-.0993	-.1166	-.1088	-.1212	-.1454
.95	-.0766	-.1132							-.1087	-.0993	-.1123	-.1089	-.1328	-.1463

TAIL 2

TABLE IX. - CONTINUED
(b) $\alpha = -2.11^\circ$

Cp at y/b of														
x/c	0.02		0.22		0.44		0.56		0.67		0.83		0.98	
	U.S.	L.S.	U.S.	L.S.	U.S.	L.S.	U.S.	L.S.	U.S.	L.S.	U.S.	L.S.	U.S.	L.S.
.05	.1799	.1092	.3595	.2400	.3504	.2452	.3241	.2581	.3383	.2636	.3357	.2574		
.10	.1798	.1117	.3742	.2461	.3544	.2532	.3195	.2686	.3462	.2612	.3353	.2608	.2673	.1931
.15	.1786	.1065	.3804	.2493	.3545	.2520	.3399	.2631	.3467	.2568	.3310	.2573	.2471	.1821
.20	.1671	.0886	.3585	.2450	.3521	.2507			.3414	.2563	.3406	.2552		.1689
.25			.0858	.0047	.3096	.2074	.3215	.2439	.3356	.2527	.3391	.2518	.2191	.1594
.30	.0557	-.0154	.0426	-.0257	.0667	-.0100	.0816	.0116	.1719	.0847	.3240	.2393	.2125	.1524
.40									.0554	-.0094	.0575	-.0026	-.0041	-.0435
.50	.0546	.0194	.0104	-.0507	.0579	-.0192			.0508	-.0163	.0360	-.0236	-.0300	-.0475
.60	.1277	.0174	.0086	-.0436	.0508	-.0208	.0531	-.0208	.0489	-.0208	.0219	-.0352	-.0254	-.0488
.70	.0454	.0176	.0175	-.0391	.0357	-.0285	.0370	-.0333	-.0004	-.0570			-.1013	-.1267
.80	-.0663	-.0987	-.0969	-.1201	-.1144	-.1141	-.1061	-.1169	-.1142	-.1150	-.1313	-.1192	-.0932	-.0932
.90	-.0802	-.0992	-.1136	-.1146	-.1251	-.1095	-.1162	-.1113	-.1172	-.1099	-.1268	-.1185	-.0820	-.1099
.95	-.0878	-.0982	-.1180	-.1153	-.1172	-.1088	-.1176	-.1103	-.1156	-.1090	-.1183	-.1183	-.0818	-.1218

TAIL 1

Cp at y/b of														
x/c	0.02		0.22		0.44		0.56		0.67		0.83		0.98	
	U.S.	L.S.	U.S.	L.S.	U.S.	L.S.	U.S.	L.S.	U.S.	L.S.	U.S.	L.S.	U.S.	L.S.
.05	.1942	.1608	.3337	.2983			.3193	.3084	.3263	.3087	.3285	.3112	.2948	.3119
.10	.1950	.1606	.3270	.2839			.3140	.2887	.3121	.2943	.3215	.3015	.2516	.2411
.15	.1775	.1507	.3207	.2743			.3090	.2805	.3075	.2844	.3169	.2921	.2210	.2084
.20							.3060	.2718	.3058	.2741		.2849	.2107	.1852
.25	.0269	-.0013	.0559	.0297			.2859	.2514	.2964	.2591	.3045	.2773	.1906	.1729
.30			.0256	-.0002	.0321	.0654	.0458	.0248	.1569	.1285				
.40	.1114	.0104			.0237	-.0055	.0249	-.0029	.0317	-.0057	.0409	.0154		
.50	.0208	.0117					.0200	-.0077	.0231	-.0054			.0028	.0203
.60					.0220	-.0118	.0206	-.0105	.0204	-.0094	.0032	-.0241	-.0220	-.0322
.70			-.0014	-.0188	.0132	-.0198	.0084	-.0223	-.0633	-.0436	-.1279	-.1357	-.1040	-.1201
.80	-.0652	-.1110	-.159	-.1062	-.1224	-.1036			-.0942	-.0852	-.1331	-.1124	-.0007	-.0965
.90	-.0850	-.1119			-.1109	-.0969			-.1152	-.0981	-.1169	-.1097	-.1242	-.1271
.95	-.0917	-.1122							-.1038	-.0960	-.1134	-.1098	-.1349	-.1338

TAIL 2

TABLE IX. - CONTINUED
(c) $\alpha = -0.12^\circ$

Cp at y/b of														
x/c	0.02		0.22		0.44		0.56		0.67		0.83		0.98	
	U.S.	L.S.	U.S.	L.S.	U.S.	L.S.	U.S.	L.S.	U.S.	L.S.	U.S.	L.S.	U.S.	L.S.
.05	.1585	.1572	.2821	.3161	.2821	.3125	.2593	.3238	.2768	.3279	.2758	.3167		
.10	.1525	.1605	.2869	.3274	.2852	.3210	.2553	.3356	.2811	.3238	.2743	.3205	.2165	.2407
.15	.1452	.1530	.2923	.3269	.2856	.3201	.2735	.3295	.2855	.3196	.2703	.3176	.2004	.2276
.20	.1342	.1407	.2860	.3211	.2830	.3181			.2791	.3201	.2790	.3150	.1859	.2123
.25			.0480	.0470	.2454	.2695	.2581	.3077	.2728	.3157	.2774	.3116	.1782	.2011
.30	.0225	.0072	.0086	.0146	.0239	.0281	.0419	.0501	.1249	.1280	.2636	.2979	.1728	.1931
.40									.0166	.0260	.0203	.0305	-.0267	-.0219
.50	.0286	.0461	-.0218	-.0168	.0125	.0202			.0114	.0190	.0012	-.0365	-.0287	-.0406
.60	.0882	.0454	-.0192	-.0202	.0109	.0175	.0110	.0160	.0098	.0142	-.0116	-.0068	-.0300	-.0363
.70	.0321	.0527	-.0114	-.0153	.0014	.0069	-.0045	.0031	-.0340	-.0265			-.1120	-.1157
.80	-.0730	-.0804	-.1124	-.1203	-.1294	-.1325	-.1272	-.1308	-.1286	-.1301	-.1206	-.1235	-.0888	-.1080
.90	-.0907	-.0985	-.1168	-.1105	-.1120	-.1140	-.1114	-.1168	-.1060	-.1064	-.1146	-.1156	-.1199	-.0913
.95	-.1001	-.1040	-.1154	-.1107	-.1081	-.1103	-.1061	-.1104	-.1020	-.1031	-.1137	-.1141	-.1172	-.1060

TAIL 1

Cp at y/b of														
x/c	0.02		0.22		0.44		0.56		0.67		0.83		0.98	
	U.S.	L.S.	U.S.	L.S.	U.S.	L.S.	U.S.	L.S.	U.S.	L.S.	U.S.	L.S.	U.S.	L.S.
.05	.1432	.1601	.2986	.3271			.2907	.3365	.2964	.3368	.3022	.3375	.2720	.3386
.10	.1479	.1608	.2931	.3150			.2849	.3169	.2827	.3219	.2942	.3273	.2362	.2661
.15	.1372	.1519	.2903	.3106			.2798	.3076	.2789	.3106	.2890	.3172	.2067	.2253
.20							.2775	.2981	.2777	.3001		.3091	.1876	.2025
.25	.0146	.0133	.0338	.0468			.2577	.2764	.2687	.2948	.2773	.3014	.1687	.1888
.30			.0047	.0122	.0157	.0218	.0300	.0396	.1364	.1481				
.40	.1058	.0405			.0073	.0108	.0094	.0120	.0167	.0207	.0271	.0316		
.50	.0227	.0403					.0048	.0074	.0078	.0089			.0009	.0201
.60					.0058	.0060	.0052	.0049	.0052	.0047	-.0057	-.0073	-.0352	-.0302
.70			-.0131	-.0085	-.0037	-.0038	-.0063	-.0077	-.0736	-.0306	-.1324	-.1324	-.1096	-.1151
.80	-.0755	-.0978	-.1122	-.1084	-.1294	-.1146			-.0982	-.0915	-.1270	-.1163	-.0025	-.1104
.90	-.0937	-.1077			-.1049	-.0980			-.1046	-.0989	-.1156	-.1108	-.1196	-.0975
.95	-.0986	-.1090							-.1006	-.0981	-.1136	-.1104	-.1296	-.1122

TAIL 2

TABLE IX. - CONTINUED
(d) $\alpha = 1.88^\circ$

Cp at y/b of														
x/c	0.02		0.22		0.44		0.56		0.67		0.83		0.98	
	U.S.	L.S.	U.S.	L.S.	U.S.	L.S.	U.S.	L.S.	U.S.	L.S.	U.S.	L.S.	U.S.	L.S.
.05	-.1171	-.2251	-.2134	-.3995	-.2293	-.3837	-.2018	-.3930	-.2200	-.3955	-.2218	-.3814		
.10	-.1151	-.2268	-.2164	-.4113	-.2231	-.3932	-.1987	-.4073	-.2221	-.3908	-.2191	-.3858	-.1724	-.2923
.15	-.1086	-.2126	-.2165	-.4111	-.2233	-.3920	-.2152	-.3996	-.2284	-.3863	-.2159	-.3830	-.1595	-.2775
.20	-.0955	-.2118	-.2093	-.3990	-.2210	-.3887			-.2233	-.3878	-.2228	-.3851	-.1503	-.2591
.25			-.0042	-.0910	-.1857	-.3341	-.2006	-.3754	-.2158	-.3831	-.2213	-.3754	-.1435	-.2459
.30	-.0175	-.0407	-.0287	-.0568	-.0125	-.0791	-.0073	-.0938	-.0819	-.1742	-.2091	-.3608	-.1389	-.2370
.40									-.0174	-.0651	-.0125	-.0651	-.0431	-.0324
.50	-.0017	-.0746	-.0502	-.0223	-.0253	-.0628			-.0227	-.0577	-.0345	-.0386	-.0385	-.0253
.60	-.0489	-.0782	-.0456	-.0165	-.0273	-.0579	-.0248	-.0567	-.0246	-.0525	-.0412	-.0235	-.0474	-.0262
.70	-.0156	-.0940	-.0334	-.0168	-.0358	-.0441	-.0379	-.0435	-.0629	-.0384			-.1220	-.1062
.80	-.0888	-.0555	-.1081	-.1118	-.1026	-.1143	-.1033	-.1096	-.1085	-.1192	-.1128	-.1335	-.1187	-.1119
.90	-.1007	-.0894	-.1096	-.1122	-.0994	-.1227	-.1003	-.1189	-.1332	-.1221	-.1134	-.1279	-.1400	-.0793
.95	-.1074	-.0969	-.1115	-.1066	-.0992	-.1091	-.1002	-.1168	-.1023	-.1149	-.1137	-.1193	-.1300	-.0910

TAIL 1

Cp at y/b of														
x/c	0.02		0.22		0.44		0.56		0.67		0.83		0.98	
	U.S.	L.S.	U.S.	L.S.	U.S.	L.S.	U.S.	L.S.	U.S.	L.S.	U.S.	L.S.	U.S.	L.S.
.05	-.1207	-.1478	-.2607	-.3633			-.2605	-.3658	-.2676	-.3663	-.2740	-.3641	-.2495	-.3614
.10	-.1223	-.1517	-.2601	-.3658			-.2553	-.3467	-.2552	-.3508	-.2666	-.3529	-.2218	-.2993
.15	-.1141	-.1486	-.2600	-.3580			-.2502	-.3365	-.2522	-.3394	-.2618	-.3428	-.1885	-.2470
.20							-.2481	-.3263	-.2509	-.3283			-.1693	-.2224
.25	-.0074	-.0198	-.0117	-.0571			-.2295	-.3033	-.2425	-.3118	-.2508	-.3271	-.1523	-.2061
.30			-.0149	-.0197	-.0006	-.0425	-.0141	-.0559	-.1175	-.1676				
.40	-.1020	-.0653			-.0088	-.0324	-.0051	-.0294	-.0023	-.0364	-.0136	-.0493		
.50	-.0134	-.0480					-.0109	-.0254	-.0067	-.0245			-.0001	-.0177
.60					-.0098	-.0216	-.0107	-.0242	-.0095	-.0211	-.0141	-.0111	-.0454	-.0359
.70			-.0251	-.0022	-.0199	-.0078	-.0211	-.0116	-.0850	-.0155	-.1359	-.1235	-.1214	-.1099
.80	-.0876	-.0912	-.1173	-.1095	-.1230	-.1284			-.0882	-.1035	-.1183	-.1263	-.0046	-.1273
.90	-.1037	-.1043			-.1066	-.1003			-.1019	-.1035	-.1120	-.1112	-.1012	-.0862
.95	-.1050	-.1069							-.1013	-.0991	-.1114	-.1094	-.1058	-.0916

TAIL 2

TABLE IX. - CONTINUED
(e) $\alpha = 3.87^\circ$

Cp at y/b of														
x/c	0.02		0.22		0.44		0.56		0.67		0.83		0.98	
	U.S.	L.S.	U.S.	L.S.	U.S.	L.S.	U.S.	L.S.	U.S.	L.S.	U.S.	L.S.	U.S.	L.S.
.05	.0671	-.3440	.1500	-.4886	-.1640	-.4614	-.1599	-.4717	-.1673	-.4706	-.1720	-.4524		
.10	-.0741	-.3433	-.1528	-.5023	-.1672	-.4713	-.1477	-.4856	-.1676	-.4640	-.1686	-.4569	-.1319	-.3471
.15	-.0736	-.3256	-.1508	-.4980	-.1668	-.4705	-.1619	-.4746	-.1737	-.4613	-.1643	-.4538	-.1232	-.3236
.20	-.0539	-.3219	-.1435	-.4766	-.1647	-.4659			-.1723	-.4633		-.4515	-.1181	-.3036
.25			-.0362	-.4356	-.1333	-.4073	-.1472	-.4509	-.1642	-.4575		-.4475	-.1140	-.2954
.30	-.0623	-.0903	-.0647	-.1001	-.0448	-.1179	-.0236	-.1355	-.0433	-.2248		-.4235	-.1106	-.2854
.40														
.50	-.0418	-.1022	-.0798	-.0645	-.0584	-.1100			-.0531	-.1039	-.0587	-.0731	-.0574	-.0625
.60	-.0029	-.1033	-.0736	-.0619	-.0604	-.1005	-.0563	-.1030	-.0551	-.0954	-.0676	-.0563	-.0391	-.0361
.70	-.0065	-.1328	-.0687	-.0609	-.0678	-.0936	-.0687	-.0905	-.0886	-.0443			-.1195	-.0980
.80	-.0973	-.0297	-.1060	-.0911	-.0983	-.0928	-.1070	-.0867	-.1052	-.0973	-.1102	-.1172	-.1368	-.1136
.90	-.1154	-.0674	-.1070	-.0979	-.0988	-.1070	-.0936	-.0985	-.1027	-.1031	-.1110	-.1249	-.1485	-.0865
.95	-.1054	-.0723	-.1063	-.0975	-.0991	-.1100	-.0936	-.1028	-.1022	-.1069	-.1118	-.1221	-.1374	-.0886

TAIL 1

Cp at y/b of														
x/c	0.02		0.22		0.44		0.56		0.67		0.83		0.98	
	U.S.	L.S.	U.S.	L.S.	U.S.	L.S.	U.S.	L.S.	U.S.	L.S.	U.S.	L.S.	U.S.	L.S.
.05	.1649	-.1304	.2052	-.4445			.2238	-.4009	.2381	-.3999	.2461	-.3921	.2270	-.3857
.10	.1572	-.1334	.2088	-.4348			.2249	-.3820	.2266	-.3836	.2391	-.3817	.2042	-.3172
.15	.1330	-.1340	.2130	-.3878			.2205	-.3707	.2242	-.3710	.2346	-.3718	.1679	-.2734
.20							.2173	-.3603	.2225	-.3592		-.3641	.1523	-.2457
.25	-.0830	-.0154	-.0039	-.0617			.1991	-.3371	.2139	-.3416	.2245	-.3570	.1342	-.2273
.30			-.0257	-.0240	-.0204	-.0717	-.0033	-.0788	.0963	-.1902				
.40	-.0779	-.0740			-.0291	-.0593	-.0236	-.0540	-.0142	-.0554	-.0004	-.0691		
.50	-.0125	-.0418					-.0289	-.0532	-.0240	-.0450			-.0063	-.0106
.60					-.0283	-.0316	-.0293	-.0486	-.0267	-.0436	-.0245	-.0320	-.0530	-.0430
.70			-.0328	-.0049	-.0362	-.0160	-.0386	-.0292	-.0360	-.0062	-.1371	-.1122	-.1241	-.1102
.80	-.1070	-.0936	-.1243	-.1122	-.1157	-.1296			-.0868	-.0953	-.1148	-.1347	-.0104	-.1394
.90	-.1214	-.1009			-.1081	-.1021			-.1045	-.1201	-.1113	-.1155	-.0991	-.0960
.95	-.1170	-.1054							-.1051	-.1087	-.1110	-.1080	-.1042	-.0846

TAIL 2

TABLE IX. - CONTINUED
(1) $\alpha = 5.87^\circ$

Cp at y/b of														
x/c	0.02		0.22		0.44		0.56		0.67		0.83		0.98	
	U.S.	L.S.	U.S.	L.S.	U.S.	L.S.	U.S.	L.S.	U.S.	L.S.	U.S.	L.S.	U.S.	L.S.
.05	-.0017	.4304	.0891	.5902	.1113	.5477	.1010	.5593	.1178	.5500	.1236	.5235		
.10	.0171	.4538	.0933	.6115	.1140	.5576	.0989	.5684	.1172	.5408	.1188	.5352	-.0950	.4051
.15	.0238	.4362	.0912	.5952	.1135	.5562	.1111	.5560	.1219	.5425	.1152	.5312	-.0933	.3848
.20	.0065	.4153	.0844	.5551	.1109	.5527			.1223	.5436	.1216	.5287	-.0877	.3628
.25			-.0707	.1785	.0825	.4836	.0971	.5320	.1157	.5360	.1206	.5235	-.0856	.3474
.30	-.0978	.1675	-.0963	.1418	-.0715	.1746	-.0524	.1848	-.0072	.2793	.1109	.4997	-.0853	.3361
.40									-.0759	.1565	-.0685	.1407	-.0609	.0600
.50	-.0863	.1427	-.1099	.1115	-.0879	.1571			-.0809	.1485	-.0842	.1092	-.0673	.0232
.60	-.0439	.1508	-.1056	.1118	-.0896	.1417	-.0838	.1552	-.0831	.1438	-.0910	.0909	-.0527	.0163
.70	-.0321	.1803	-.0998	.1104	-.0953	.1229	-.0959	.1384	-.1097	.0873			-.1349	-.0884
.80	-.1001	-.0014	-.1095	-.0639	-.1018	-.0697	-.1041	-.0636	-.1086	-.0722	-.1156	-.0981	-.1780	-.0986
.90	-.1363	-.0350	-.1108	-.0696	-.1031	-.0840	-.1041	-.0769	-.1069	-.0806	-.1174	-.1091	-.1635	-.0804
.95	-.1146	-.0408	-.1115	-.0681	-.1035	-.0889	-.1042	-.0825	-.1062	-.0870	-.1176	-.1122	-.1578	-.0617

TAIL 1

Cp at y/b of														
x/c	0.02		0.22		0.44		0.56		0.67		0.83		0.98	
	U.S.	L.S.	U.S.	L.S.	U.S.	L.S.	U.S.	L.S.	U.S.	L.S.	U.S.	L.S.	U.S.	L.S.
.05	.2695	.0917	.1306	.4690			.1982	.4443	.2074	.4394	.2188	.4265	.2056	.4136
.10	.2316	.1242	.1569	.4071			.1909	.4245	.1963	.4205	.2118	.4155	.1852	.3510
.15	.1929	.1444	.1728	.3704			.1847	.4151	.1928	.4080	.2080	.4058	.1493	.3037
.20							.1815	.4092	.1909	.3966		.3990	.1352	.2743
.25	.0086	.0082	-.0124	.0702			.1651	.3872	.1824	.3798	.1984	.3914	.1166	.2548
.30			-.0245	.0319	-.0428	.0902	-.0228	.1143	-.0723	.2199				
.40	.0592	.0453			-.0476	.0678	-.0433	.0810	-.0319	.0846	-.0156	.0913		
.50	-.0329	.0449					-.0488	.0688	-.0414	.0753			-.0134	.0034
.60					-.0430	.0435	-.0474	.0586	-.0444	.0681	-.0374	.0570	-.0624	-.0395
.70			-.0412	.0335	-.0495	.0260	-.0550	.0382	-.1088	.0233	-.1344	-.0973	-.1238	-.1084
.80	-.1202	-.0986	-.1347	-.1078	-.1135	-.1281			-.0887	-.0925	-.1151	-.1213	-.0170	-.1326
.90	-.1365	-.1003			-.1096	-.1042			-.1065	-.1188	-.1125	-.1258	-.1027	-.1285
.95	-.1284	-.1036							-.1070	-.1153	-.1123	-.1182	-.1073	-.1070

TAIL 2

TABLE IX. - CONTINUED
(g) $\alpha = 7.86^\circ$

Cp at y/b of														
x/c	0.02		0.22		0.44		0.56		0.67		0.83		0.98	
	U.S.	L.S.	U.S.	L.S.	U.S.	L.S.	U.S.	L.S.	U.S.	L.S.	U.S.	L.S.	U.S.	L.S.
.05	-.0623	.4976	.0348	.7261	.0614	.6502	.0564	.6671	.0753	.6446	.0803	.6186		
.10	-.0423	.5330	.0382	.7113	.0643	.6613	.0557	.6626	.0731	.6338	.0742	.6234	.0630	.4689
.15	-.0324	.5117	.0357	.6693	.0637	.6620	.0656	.6529	.0758	.6391	.0706	.6193	.0637	.4459
.20	-.0455	.4935	.0289	.6220	.0618	.6644			.0763	.6384	.0760	.6158	.0640	.4224
.25			-.1025	.2170	.0360	.5863	.0520	.6294	.0720	.6284	.0752	.6064	.0622	.4050
.30	-.1303	.2298	-.1249	.1825	-.0972	.2314	-.0786	.2469	-.0239	.3406	.0666	.5756	.0615	.3929
.40									-.1004	.2122	-.0923	.1839	-.0703	.0945
.50	-.1284	.1963	-.1358	.1606	-.1138	.1988			-.1053	.2065	-.1058	.1501	-.0771	.0555
.60	-.0921	.2106	-.1339	.1612	-.1154	.1821	-.1091	.1993	-.1074	.1996	-.1103	.1308	-.0625	.0464
.70	-.0716	.2629	-.1243	.1606	-.1188	.1631	-.1176	.1779	-.1252	.1302			-.1643	-.0764
.80	-.1028	.0407	-.1186	-.0284	-.1129	-.0447	-.1145	-.0412	-.1182	-.0512	-.1257	-.0745	-.1698	-.0758
.90	-.1249	.0006	-.1196	-.0246	-.1139	-.0585	-.1145	-.0563	-.1173	-.0620	-.1276	-.0867	-.1609	-.0804
.95	-.1111	-.0060	-.1205	-.0188	-.1142	-.0637	-.1146	-.0632	-.1167	-.0694	-.1282	-.0914	-.1582	-.0798

TAIL 1

Cp at y/b of														
x/c	0.02		0.22		0.44		0.56		0.67		0.83		0.98	
	U.S.	L.S.	U.S.	L.S.	U.S.	L.S.	U.S.	L.S.	U.S.	L.S.	U.S.	L.S.	U.S.	L.S.
.05	.3113	.0565	.0839	.3761			.1576	.4991	.1745	.4875	.1902	.4656	.1858	.4466
.10	.2838	.0643	.1179	.3439			.1518	.4869	.1623	.4674	.1834	.4547	.1660	.3897
.15	.2418	.0811	.1347	.3244			.1461	.4882	.1584	.4593	.1791	.4448	.1332	.3390
.20							.1422	.4776	.1560	.4535		.4379	.1186	.3093
.25	.0209	-.0098	-.0142	.0632			.1270	.4424	.1483	.4397	.1696	.4297	.0994	.2883
.30			-.0203	.0375	-.0702	.1005	-.0461	.1358	.0470	.2661				
.40	.0541	.0555			-.0672	.0791	-.0665	.0941	-.0508	.1151	-.0322	.1207		
.50	-.0409	.0531					-.0710	.0790	-.0612	.0935			-.0184	-.0029
.60					-.0533	.0484	-.0666	.0693	-.0642	.0800	-.0526	.0906	-.0721	-.0237
.70			-.0510	.0372	-.0577	.0334	-.0709	.0475	-.1217	.0321	-.1276	-.0807	-.1225	-.1010
.80	-.1329	-.0982	-.1448	-.0988	-.1169	-.1191			-.0914	-.0888	-.1160	-.1093	-.0219	-.1065
.90	-.1453	-.1084			-.1143	-.1075			-.1089	-.1139	-.1147	-.1192	-.1090	-.1203
.95	-.1357	-.1131							-.1094	-.1173	-.1146	-.1224	-.1124	-.1242

TAIL 2

TABLE IX. - CONTINUED
(h) $\alpha = 9.85^\circ$

Cp at γ/b of														
x/c	0.02		0.22		0.44		0.56		0.67		0.83		0.98	
	U.S.	L.S.	U.S.	L.S.	U.S.	L.S.	U.S.	L.S.	U.S.	L.S.	U.S.	L.S.	U.S.	L.S.
.05	-.1040	.5450	-.0061	.8385	.0208	.7833	-.0189	-.8003	-.0369	.7531	-.0461	.7249		
.10	-.0844	.5994	-.0051	.7869	-.0222	.7991	-.0183	-.7873	-.0342	.7534	-.0375	.7311	.0392	-.5424
.15	-.0735	.5776	-.0076	.7372	-.0219	.7899	-.0262	.7836	-.0357	.7573	-.0328	.7281	.0431	-.5175
.20	-.0834	.5670	-.0144	.6871	-.0199	.7752			-.0359	.7569	-.0376	.7214	.0448	-.4916
.25			-.1267	.2544	-.0032	.6671	-.0140	.7407	-.0331	.7464	-.0371	.7060	.0438	-.4716
.30	-.1543	.2908	-.1472	.2240	-.1190	.2702	-.1025	.3078	-.0510	.4139	-.0297	.6659	.0435	-.4527
.40									-.1213	.2734	-.1124	.2348	-.0830	-.1346
.50	-.1444	.2553	-.1542	.2035	-.1350	.2385			-.1253	.2595	-.1243	.2011	-.0847	-.0944
.60	-.1259	.2777	-.1489	.2107	-.1368	.2242	-.1309	.2398	-.1283	.2402	-.1274	.1759	-.1188	-.0816
.70	-.1122	.3564	-.1403	.2144	-.1357	.2053	-.1349	.2157	-.1384	.1609			-.1819	-.3743
.80	-.1062	.0772	-.1323	.0189	-.1262	-.0177	-.1282	-.0183	-.1311	-.0334	-.1374	-.0504	-.1699	-.0617
.90	-.1458	.0310	-.1329	.0301	-.1272	-.0315	-.1281	-.0354	-.1308	-.0438	-.1385	-.0657	-.1622	-.0610
.95	-.1196	.0235	-.1334	.0413	-.1271	-.0375	-.1280	-.0434	-.1302	-.0517	-.1391	-.0719	-.1609	-.0644

TAIL 1

Cp at γ/b of														
x/c	0.02		0.22		0.44		0.56		0.67		0.83		0.98	
	U.S.	L.S.	U.S.	L.S.	U.S.	L.S.	U.S.	L.S.	U.S.	L.S.	U.S.	L.S.	U.S.	L.S.
.05	.3564	.0141	.0919	.1827			.0913	.6285	.1231	.5752	.1497	.5224	.1538	.4821
.10	.3258	.0210	.1254	.1705			.0838	.6001	.1108	.5656	.1428	.5156	.1349	.4343
.15	.2803	.0209	.1395	.1583			.0773	.5675	.1058	.5555	.1391	.5110	.1058	.3836
.20							.0734	.5322	.1033	.5370		.5094	.0915	.3544
.25	.0484	-.0597	-.0169	-.0209			.0616	.4833	.0962	.5032	.1293	.5637	.0729	.3352
.30			-.0275	-.0292	-.0989	.1156	-.0833	.1563	.0081	.3038				
.40	.0691	-.0051			-.0818	.0830	-.1005	.1152	-.0795	.1359	-.0555	.1622		
.50	-.0315	.0230					-.0919	.0970	-.0893	.1124			-.0260	-.0065
.60					-.0654	.0555	-.0842	.0799	-.0909	.0990	-.0746	.1128	-.0841	.0050
.70			-.0529	-.0021	-.0604	.0390	-.0911	.0561	-.1348	.0481	-.1317	-.0696	-.1295	-.1000
.80	-.1356	-.0979	-.1484	-.1031	-.1500	-.1161			-.0993	-.0829	-.1247	-.0985	-.0291	-.0950
.90	-.1493	-.1082			-.1416	-.1084			-.1177	-.1081	-.1241	-.1090	-.1187	-.1013
.95	-.1389	-.1133							-.1185	-.1151	-.1241	-.1150	-.1222	-.1100

TAIL 2

TABLE IX. - CONTINUED
(1) $\alpha = 11.85^\circ$

Cp at y/b of														
x/c	0.02		0.22		0.44		0.56		0.67		0.83		0.98	
	U.S.	L.S.	U.S.	L.S.	U.S.	L.S.	U.S.	L.S.	U.S.	L.S.	U.S.	L.S.	U.S.	L.S.
.05	-.1419	.0165	-.0468	.9355	-.0100	.9599	-.0079	.9956	.0058	.9434	-.0050	.8828		
.10	-.1286	.6476	-.0501	.8657	-.0123	.9254	-.0099	.9452	.0025	.9272	-.0045	.8928	.0028	.6308
.15	-.1192	.6348	-.0550	.8125	-.0151	.8936	-.0044	.9115	.0029	.9091	-.0097	.8797	.0059	.6089
.20	-.1247	.6369	-.0627	.7547	-.0184	.8570			.0030	.8860	-.0049	.8529	.0073	.5849
.25			-.1519	.2880	-.0392	.7152	-.0177	.8116	.0009	.8480	-.0039	.8130	.0076	.5650
.30	-.1749	.3429	-.1680	.2655	-.1353	.3030	-.1219	.3332	-.0730	.4539	-.0088	.7497	.0111	.5493
.40									-.1371	.3036	-.1292	.2709	-.1111	.1842
.50	-.1577	.3316	-.1688	.2629	-.1542	.2531			-.1430	.2874	-.1377	.2324	-.1478	.1358
.60	-.1514	.3829	-.1604	.2743	-.1558	.2703	-.1499	.2774	-.1459	.2669	-.1385	.2103	-.1655	.1147
.70	-.1296	.4618	-.1526	.2908	-.1453	.2502	-.1485	.2433	-.1509	.1864			-.1929	-.0709
.80	-.1077	.1133	-.1467	.0927	-.1382	.0105	-.1411	.0039	-.1424	-.0118	-.1489	-.0282	-.1789	-.0713
.90	-.1620	.0565	-.1473	.0971	-.1392	-.0036	-.1411	-.0136	-.1436	-.0211	-.1502	-.0442	-.1675	-.0639
.95	-.1354	.0512	-.1477	.0891	-.1398	-.0068	-.1409	-.0217	-.1433	-.0290	-.1509	-.0506	-.1685	-.0509

TAIL 1

Cp at y/b of														
x/c	0.02		0.22		0.44		0.56		0.67		0.83		0.98	
	U.S.	L.S.	U.S.	L.S.	U.S.	L.S.	U.S.	L.S.	U.S.	L.S.	U.S.	L.S.	U.S.	L.S.
.05	.2471	.0688	.2513	-.0365			-.0266	.6952	.0380	.7475	.0931	.6728	.1112	.5521
.10	.2487	.0601	.2349	-.0187			-.0369	.6018	.0247	.6703	.0849	.6561	.0911	.5297
.15	.2349	.0499	.2163	.0095			-.0391	.5409	.0188	.6110	.0800	.6267	.0659	.4872
.20							-.0289	.5006	.0167	.5624		.5951	.0539	.4514
.25	.0522	-.0711	.0084	-.0491			-.0251	.4522	.0119	.5154	.0728	.5627	.0404	.4198
.30			-.0118	-.0353	-.0880	.0686	-.1137	.1379	-.0547	.3070				
.40	.0942	-.0646			-.0866	.0614	-.1024	.1086	-.1218	.1386	-.0859	.1766		
.50	-.0086	-.0626					-.0886	.0987	-.1133	.1143			-.0316	-.0043
.60					-.0906	.0591	-.0807	.0886	-.1069	.1034	-.1055	.1223	-.0992	.0174
.70			-.0449	-.0241	-.0949	.0593	-.0814	.0780	-.1436	.0615	-.1396	-.0631	-.1419	-.1127
.80	-.1314	-.1197	-.1465	-.1157	-.1684	-.0969			-.1183	-.0732	-.1371	-.0914	-.0352	-.0984
.90	-.1509	-.1351			-.1559	-.1072			-.1395	-.0946	-.1381	-.1023	-.1370	-.0995
.95	-.1448	-.1417							-.1351	-.1008	-.1386	-.1087	-.1324	-.1073

TAIL 2

TABLE IX. - CONTINUED
(j) $\alpha = 15.86^\circ$

Cp at y/b of														
x/c	0.02		0.22		0.44		0.56		0.67		0.83		0.98	
	U.S.	L.S.	U.S.	L.S.	U.S.	L.S.	U.S.	L.S.	U.S.	L.S.	U.S.	L.S.	U.S.	L.S.
.05	-.1763	.6882	-.0886	1.1193	-.0448	1.2223	-.0417	1.2595	-.0218	1.2674	-.0132	1.2318		
.10	-.1866	.7571	-.0989	1.0331	-.0521	1.1301	-.0502	1.1547	-.0326	1.1678	-.0244	1.1389	.0021	.8553
.15	-.1580	.7967	-.1087	.9669	-.0620	1.0557	-.0499	1.0820	-.0391	1.0945	-.0343	1.0605	-.0064	.7977
.20	-.1603	.7941	-.1186	.8808	-.0690	.9820			-.0434	1.0265	-.0353	.9933	-.0096	.7438
.25			-.1813	.3462	-.0881	.7814	-.0681	.8889	-.0488	.9408	-.0393	.9231	-.0065	.6993
.30	-.1860	.4611	-.1788	.3540	-.1582	.3550	-.1490	.3586	-.1109	.4719	-.0470	.8236	-.0020	.6629
.40									-.1612	.3688	-.1503	.3218	-.1234	.2305
.50	-.1577	.5630	-.1762	.4069	-.1754	.3810			-.1672	.3678	-.1551	.3021	-.1463	.1913
.60	-.1477	.5761	-.1734	.4369	-.1643	.3728	-.1667	.3679	-.1701	.3515	-.1552	.2874	-.1754	.1749
.70	-.1341	.6334	-.1702	.5189	-.1585	.3568	-.1582	.3286	-.1632	.2621			-.1990	-.0322
.80	-.1087	.1783	-.1673	.1841	-.1547	.0871	-.1565	.0634	-.1578	.0399	-.1635	.0225	-.1910	-.0441
.90	-.1737	.1082	-.1684	.1529	-.1552	.1028	-.1575	.0492	-.1607	.0309	-.1648	.0049	-.1884	-.0410
.95	-.1629	.1100	-.1667	.1443	-.1562	.1027	-.1566	.0450	-.1609	.0227	-.1650	-.0020	-.1830	-.0364

TAIL 1

Cp at y/b of														
x/c	0.02		0.22		0.44		0.56		0.67		0.83		0.98	
	U.S.	L.S.	U.S.	L.S.	U.S.	L.S.	U.S.	L.S.	U.S.	L.S.	U.S.	L.S.	U.S.	L.S.
.05	.2455	.0007	.1812	-.0764			-.1303	.2761	-.1169	.5725	-.0371	.8020	.0235	.7423
.10	.2391	.0001	.1641	-.0676			-.1206	.2457	-.1213	.5171	-.0511	.7214	-.0035	.6679
.15	.2231	-.0073	.1436	-.0510			-.1065	.2391	-.1188	.4793	-.0593	.6615	-.0132	.5844
.20							-.0937	.2459	-.1105	.4429		.6180	-.0215	.5185
.25	.0425	-.1079	-.0325	-.1146			-.0924	.2433	-.1027	.4077	-.0611	.5790	-.0293	.4690
.30			-.0445	-.1070	-.1321	-.0526	-.1476	.0458	-.1323	.2234				
.40	.0755	-.1221			-.1280	-.0499	-.1460	.0436	-.1521	.1089	-.1548	.1926		
.50	-.0266	-.1161					-.1451	.0485	-.1452	.1094			-.0409	-.0186
.60					-.1276	-.0206	-.1453	.0472	-.1402	.1050	-.1516	.1340	-.1463	.0456
.70			-.0608	-.0956	-.1283	-.0085	-.1369	.0473	-.1663	.0683	-.1552	-.0427	-.1545	-.1063
.80	-.1429	-.1741	-.1554	-.1546	-.1837	-.1284			-.1436	-.0644	-.1559	-.0705	-.0443	-.1099
.90	-.1605	-.1812			-.1797	-.1121			-.1679	-.0803	-.1562	-.0625	-.1481	-.1158
.95	-.1640	-.1753							-.1596	-.0861	-.1545	-.0892	-.1426	-.1211

TAIL 2

TABLE IX. - CONCLUDED
(k) $\alpha = 19.86^\circ$

Cp at y/b of														
x/c	0.02		0.22		0.44		0.56		0.67		0.83		0.98	
	U.S.	L.S.	U.S.	L.S.	U.S.	L.S.	U.S.	L.S.	U.S.	L.S.	U.S.	L.S.	U.S.	L.S.
.05	-.1828	.7897	-.0890	1.3315	-.0526	1.4469	-.0557	1.4870	-.0387	1.4973	-.0288	1.4686		
.10	-.1713	.9318	-.0956	1.2260	-.0451	1.3260	-.0491	1.3547	-.0305	1.3687	-.0232	1.3412	.0284	1.0539
.15	-.1733	1.0184	-.1061	1.1382	-.0550	1.2276	-.0450	1.2556	-.0328	1.2695	-.0311	1.2350	.0350	.9625
.20	-.1788	.9783	-.1177	1.0180	-.0635	1.1289			-.0377	1.1780	-.0333	1.1480	.0331	.8953
.25			-.1838	.4161	-.0839	.8877	-.0656	1.0071	-.0457	1.0652	-.0389	1.0572	.0204	.8337
.30	-.1878	.6291	-.1926	.4555	-.1648	.4349	-.1495	.4364	-.1110	.5358	-.0478	.9317	-.0135	.7794
.40									-.1631	.4660	-.1497	.3979	-.1124	.2872
.50	-.1805	.7968	-.1881	.5733	-.1814	.5118			-.1684	.4818	-.1518	.4013	-.1440	.2672
.60	-.1760	.7659	-.1850	.7538	-.1733	.5431	-.1734	.4934	-.1717	.4630	-.1541	.3960	-.1717	.2588
.70	-.1626	.7637	-.1802	.7039	-.1641	.5238	-.1629	.4589	-.1691	.3647			-.2013	.0192
.80	-.1102	.2548	-.1774	.2558	-.1609	.2563	-.1612	.1576	-.1648	.1088	-.1691	.0874	-.2103	.0077
.90	-.1825	.1692	-.1776	.2120	-.1622	.2423	-.1640	.1767	-.1675	.1081	-.1692	.0689	-.2055	.0105
.95	-.1630	.1766	-.1761	.2051	-.1630	.2267	-.1633	.1816	-.1671	.1057	-.1708	.0613	-.1980	.0133

TAIL 1

Cp at y/b of														
x/c	0.02		0.22		0.44		0.56		0.67		0.83		0.98	
	U.S.	L.S.	U.S.	L.S.	U.S.	L.S.	U.S.	L.S.	U.S.	L.S.	U.S.	L.S.	U.S.	L.S.
.05	.2346	-.0726	.0679	-.0689			-.1602	.1516	-.1768	.2950	-.1701	.4248	-.0632	.6952
.10	.2234	-.0635	.0665	-.0673			-.1505	.1399	-.1722	.2666	-.1644	.3881	-.0718	.6149
.15	.2016	-.0633	.0565	-.0586			-.1399	.1408	-.1678	.2503	-.1589	.3636	-.0883	.5323
.20							-.1299	.1470	-.1614	.2377		.3477	-.1013	.4644
.25	.0150	-.1352	-.0752	-.1262			-.1238	.1429	-.1567	.2202	-.1500	.3322	-.1121	.4084
.30			-.0792	-.1184	-.1412	-.0783	-.1668	-.0113	-.1747	.0894				
.40	.0359	-.1397			-.1389	-.0762	-.1659	-.0192	-.1838	.0240	-.1834	.0903		
.50	-.0665	-.1318					-.1618	-.0191	-.1808	.0169			-.0460	-.0149
.60					-.1360	-.0522	-.1576	-.0216	-.1751	.0136	-.1757	.0903	-.1880	.0553
.70			-.0988	-.1023	-.1364	-.0435	-.1485	-.0168	-.1893	-.0096	-.1998	-.0626	-.1970	-.0916
.80	-.1598	-.1876	-.1730	-.1691	-.1878	-.1474			-.1581	-.1000	-.1949	-.0867	-.0501	-.1056
.90	-.1778	-.1926			-.1896	-.1332			-.1915	-.1186	-.1887	-.0957	-.1761	-.1125
.95	-.1811	-.1871							-.1891	-.1243	-.1834	-.1003	-.1725	-.1194

TAIL 2

TABLE X. - PRESSURE COEFFICIENTS, $\phi = 90^\circ$, $\delta = 0^\circ$, $M = 2.36$
 (a) $\alpha = -4.11^\circ$

Cp at y/b of														
x/c	0.02		0.22		0.44		0.56		0.67		0.83		0.98	
	U.S.	L.S.	U.S.	L.S.	U.S.	L.S.	U.S.	L.S.	U.S.	L.S.	U.S.	L.S.	U.S.	L.S.
.05	.2767	.0584	.4585	.1654	.4406	.1780	.3993	-.1901	.4206	-.1983	.4131	-.1972		
.10	.2671	.0676	.4734	-.1681	.4437	.1833	.4003	-.1989	.4305	-.1961	.4136	-.1989	.3300	-.1473
.15	.2563	.0688	.4771	-.1653	.4441	.1826	.4257	-.1951	.4280	-.1925	.4099	-.1957	.3060	-.1389
.20	.2693	.0537	.4484	-.1580	.4433	.1808			.4246	-.1902	.4206	-.1932	.2848	-.1291
.25			.1408	-.0414	.3928	.1424	.4053	-.1774	.4182	-.1867	.4184	-.1899	.2738	-.1226
.30	.1044	-.0535	.0952	-.0646	.1225	-.0469	.1358	-.0275	.2338	-.0378	.4004	-.1791	.2659	-.1171
.40									.1066	-.0461	.1026	-.0368	.0264	-.0597
.50	.0745	-.0067	.0623	-.0773	.1100	-.0590			.1027	-.0523	.0775	-.0564	-.0114	-.0561
.60	.1647	.0033	.0583	-.0666	.0987	-.0622	.1077	-.0587	.1007	-.0568	.0612	-.0667	-.0086	-.0644
.70	.0947	.0026	.0639	-.0645	.0811	-.0687	.0878	-.0695	.0439	-.0878			-.0917	-.1262
.80	-.0392	-.1077	-.0734	-.1196	-.0897	-.1029	-.0797	-.1043	-.0889	-.1098	-.1116	-.1144	-.1025	-.1140
.90	-.0593	-.1095	-.0815	-.1197	-.1032	-.1037	-.0913	-.1040	-.0915	-.1067	-.1180	-.1157	-.0665	-.1324
.95	-.0699	-.0950	-.0890	-.1163	-.1066	-.1041	-.0961	-.1042	-.0955	-.1062	-.1190	-.1159	-.0564	-.1294

TAIL 1

Cp at y/b of														
x/c	0.02		0.22		0.44		0.56		0.67		0.83		0.98	
	U.S.	L.S.	U.S.	L.S.	U.S.	L.S.	U.S.	L.S.	U.S.	L.S.	U.S.	L.S.	U.S.	L.S.
.05	.1908	.2193	.3073	.3408			.2951	.3400	.3028	.3393	.3039	.3386	.2669	.3284
.10	.1882	.2119	.2996	.3267			.2897	.3185	.2882	.3234	.2955	.3274	.2251	.2560
.15	.1719	.1969	.2901	.3145			.2835	.3095	.2825	.3124	.2897	.3170	.1938	.2252
.20							.2805	.3007	.2803	.3013			.3085	.2059
.25	.0115	.0144	.0409	.0498			.2609	.2733	.2704	.2856	.2772	.3001	.1791	.1915
.30			.0138	.0187	.0160	.0224	.0299	.0408	.1378	.1481				
.40	.0983	.0211			.0077	.0109	.0101	.0130	.0153	.0199	.0222	.0258		
.50	-.0030	.0238					.0059	.0082	.0070	.0092			.0014	.0243
.60					.0077	.0040	.0068	.0054	.0053	.0053	-.0144	-.0168	-.0180	-.0217
.70			-.0137	-.0014	.0005	-.0043	-.0046	-.0071	-.0730	-.0301	-.1348	-.1346	-.1046	-.1139
.80	-.0629	-.0932	-.1105	-.1062	-.1232	-.1082			-.0945	-.0889	-.1159	-.1126	-.0023	-.1012
.90	-.0815	-.1093			-.0985	-.0955			-.0997	-.0971	-.1105	-.1092	-.1423	-.1385
.95	-.0856	-.1091							-.0965	-.0961	-.1102	-.1093	-.1414	-.1476

TAIL 2

TABLE X. - CONTINUED
(b) $\alpha = -2.10^\circ$

Cp at y/b of														
x/c	0.02		0.22		0.44		0.56		0.67		0.83		0.98	
	U.S.	L.S.	U.S.	L.S.	U.S.	L.S.	U.S.	L.S.	U.S.	L.S.	U.S.	L.S.	U.S.	L.S.
.05	.2110	.1092	.3700	.2380	.3600	.2431	.3272	.2550	.3452	.2616	.3416	.2561		
.10	.2058	.1142	.3803	.2427	.3633	.2502	.3257	.2658	.3532	.2590	.3419	.2593	.2709	.1938
.15	.1987	.1091	.3879	.2410	.3630	.2497	.3465	.2604	.3546	.2551	.3381	.2565	.2508	.1829
.20	.1955	.0927	.3707	.2348	.3612	.2477			.3496	.2541	.3475	.2538	.2330	.1701
.25			.0952	.0017	.3188	.2042	.3291	.2403	.3433	.2503	.3457	.2506	.2237	.1615
.30	.0645	-.0257	.0516	-.0263	.0699	-.0118	.0869	.0387	.1776	.0823	.3303	.2386	.2167	.1548
.40									.0599	-.0110	.0603	-.0036	-.0023	-.0419
.50	.0440	.0154	.0184	-.0501	.0614	-.0222			.0548	-.0179	.0382	-.0254	-.0235	-.0424
.60	.1311	.0181	.0156	-.0472	.0563	-.0251	.0564	-.0235	.0528	-.0227	.0233	-.0378	-.0206	-.0454
.70	.0575	.0206	.0221	-.0419	.0419	-.0322	.0391	-.0355	.0027	-.0588			-.0995	-.1270
.80	-.0631	-.0371	-.0970	-.1114	-.1109	-.1094	-.1035	-.1114	-.1140	-.1123	-.1309	-.1170	-.0872	-.0896
.90	-.0784	-.0993	-.1092	-.1109	-.1230	-.1064	-.1131	-.1082	-.1167	-.1078	-.1279	-.1172	-.0865	-.1237
.95	-.0853	-.0996	-.1132	-.1117	-.1168	-.1059	-.1152	-.1079	-.1159	-.1072	-.1205	-.1173	-.0868	-.1289

TAIL 1

Cp at y/b of														
x/c	0.02		0.22		0.44		0.56		0.67		0.83		0.98	
	U.S.	L.S.	U.S.	L.S.	U.S.	L.S.	U.S.	L.S.	U.S.	L.S.	U.S.	L.S.	U.S.	L.S.
.05	.1688	.1936	.3012	.3347			.2917	.3370	.3001	.3372	.3018	.3367	.2689	.3345
.10	.1697	.1897	.2933	.3201			.2862	.3163	.2856	.3216	.2936	.3260	.2283	.2615
.15	.1551	.1759	.2856	.3095			.2813	.3078	.2803	.3104	.2885	.3164	.1997	.2265
.20							.2781	.2986	.2774	.2992		.3088	.1922	.2016
.25	.0107	.0126	.0380	.0487			.2584	.2770	.2684	.2831	.2769	.3005	.1768	.1889
.30			.0096	.0166	.0151	.0219	.0293	.0400	.1361	.1463				
.40	.0994	.0259			.0071	.0105	.0089	.0125	.0154	.0197	.0249	.0286		
.50	.0102	.0305					.0048	.0079	.0071	.0089			.0023	.0271
.60					.0067	.0032	.0060	.0053	.0052	.0052	-.0104	-.0127	-.0267	-.0245
.70			-.0108	-.0051	-.0004	-.0049	-.0051	-.0074	-.0735	-.0300	-.1340	-.1342	-.1076	-.1144
.80	-.0677	-.0985	-.1116	-.1066	-.1255	-.1104			-.0957	-.0906	-.1199	-.1146	-.0012	-.0930
.90	-.0868	-.1087			-.1008	-.0971			-.1012	-.0980	-.1128	-.1106	-.1341	-.1211
.95	-.0929	-.1105							-.0977	-.0970	-.1117	-.1105	-.1381	-.1376

TAIL 2

TABLE X. - CONTINUED
(c) $\alpha = -0.12^\circ$

Cp at y/b of														
x/c	0.02		0.22		0.44		0.56		0.67		0.83		0.98	
	U.S.	L.S.	U.S.	L.S.	U.S.	L.S.	U.S.	L.S.	U.S.	L.S.	U.S.	L.S.	U.S.	L.S.
.05	.1608	.1592	.2861	.3183	.2600	.3133	.2603	.3252	.2772	.3303	.2766	.3212		
.10	.1551	.1625	.2903	.3276	.2880	.3220	.2562	.3366	.2820	.3264	.2751	.3247	.2168	.2457
.15	.1477	.1544	.2955	.3285	.2879	.3213	.2750	.3305	.2872	.3219	.2714	.3215	.2008	.2326
.20	.1369	.1420	.2886	.3213	.2852	.3191			.2810	.3224	.2804	.3190	.1864	.2171
.25			.0496	.0476	.2479	.2699	.2596	.3081	.2751	.3180	.2790	.3158	.1785	.2058
.30	.0246	.0064	.0102	.0153	.0246	.0284	.0429	.0501	.1262	.1293	.2649	.3017	.1729	.1980
.40									.0174	.0269	.0210	.0323	-.0267	-.0191
.50	.0198	.0472	-.0208	-.0156	.0133	.0203			.0120	.0198	.0018	.0080	-.0286	-.0377
.60	.0887	.0472	-.0193	-.0189	.0118	.0178	.0111	.0164	.0102	.0146	-.0113	-.0054	-.0298	-.0335
.70	.0359	.0554	-.0122	-.0139	.0021	.0073	-.0046	.0035	-.0337	-.0263			-.1120	-.1143
.80	-.0794	-.0789	-.1130	-.1192	-.1296	-.1315	-.1274	-.1303	-.1289	-.1280	-.1209	-.1227	-.0888	-.1067
.90	-.0922	-.0980	-.1154	-.1092	-.1128	-.1130	-.1118	-.1155	-.1062	-.1054	-.1148	-.1148	-.1209	-.0917
.95	-.0994	-.1034	-.1140	-.1097	-.1084	-.1095	-.1065	-.1098	-.1021	-.1021	-.1138	-.1134	-.1178	-.1067

TAIL 1

Cp at y/b of														
x/c	0.02		0.22		0.44		0.56		0.67		0.83		0.98	
	U.S.	L.S.	U.S.	L.S.	U.S.	L.S.	U.S.	L.S.	U.S.	L.S.	U.S.	L.S.	U.S.	L.S.
.05	.1412	.1639	.2976	.3312			.2911	.3371	.2963	.3359	.2999	.3364	.2701	.3378
.10	.1470	.1631	.2916	.3180			.2852	.3164	.2821	.3198	.2919	.3254	.2337	.2653
.15	.1369	.1535	.2887	.3121			.2794	.3063	.2778	.3081	.2866	.3156	.2044	.2245
.20							.2762	.2971	.2758	.2979		.3076	.1858	.2016
.25	.0133	.0139	.0330	.0467			.2563	.2757	.2664	.2829	.2747	.2995	.1670	.1877
.30			.0040	.0125	.0153	.0223	.0290	.0398	.1345	.1464				
.40	.1128	.0394			.0078	.0105	.0091	.0128	.0154	.0202	.0264	.0308		
.50	.0283	.0399					.0053	.0081	.0071	.0091			.0008	.0241
.60					.0082	.0048	.0065	.0053	.0053	.0056	-.0054	-.0074	-.0334	-.0303
.70			-.0073	-.0082	-.0008	-.0046	-.0046	-.0074	-.0728	-.0295	-.1320	-.1321	-.1087	-.1143
.80	-.0720	-.1000	-.1092	-.1076	-.1272	-.1117			-.0962	-.0909	-.1233	-.1152	-.0029	-.1097
.90	-.0899	-.1072			-.1021	-.0985			-.1017	-.0980	-.1132	-.1097	-.1188	-.0961
.95	-.0947	-.1081							-.0980	-.0972	-.1115	-.1094	-.1278	-.1113

TAIL 2

TABLE X. - CONTINUED
(d) $\alpha = 1.88^\circ$

Cp at y/b of														
x/c	0.02		0.22		0.44		0.56		0.67		0.83		0.98	
	U.S.	L.S.	U.S.	L.S.	U.S.	L.S.	U.S.	L.S.	U.S.	L.S.	U.S.	L.S.	U.S.	L.S.
.05	.1110	.2091	.2096	.4067	.2166	.3908	.2003	.4004	.2155	.4041	.2171	.3919		
.10	.1085	.2138	.2125	.4210	.2196	.4005	.1940	.4148	.2175	.3986	.2146	.3965	.1689	.3025
.15	.1031	.2048	.2134	.4226	.2195	.4000	.2106	.4058	.2237	.3956	.2107	.3933	.1564	.2868
.20	.0900	.1993	.2076	.4042	.2164	.3966			.2182	.3970	.2186	.3906	.1459	.2684
.25			.0032	.0918	.1820	.3416	.1953	.3814	.2114	.3913	.2171	.3868	.1395	.2557
.30	-.0093	.0447	-.0306	.0572	-.0151	.0740	.0035	.0956	.0792	.1791	.2049	.3707	.1346	.2458
.40									-.0197	.0695	-.0142	.0718	-.0460	.0076
.50	-.0012	.0862	-.0527	.0242	-.0277	.0686			-.0253	.0622	-.0316	.0457	-.0419	-.0231
.60	.0484	.0840	-.0457	.0182	-.0300	.0613	-.0277	.0618	-.0271	.0571	-.0422	.0303	-.0493	-.0261
.70	.0163	.0985	-.0402	.0212	-.0378	.0464	-.0411	.0484	-.0653	.0109			-.1228	-.1062
.80	-.0902	-.0548	-.1119	-.1062	-.1040	-.1140	-.1043	-.1070	-.1084	-.1169	-.1131	-.1304	-.1156	-.1200
.90	-.1006	-.0876	-.1126	-.1131	-.1010	-.1225	-.1015	-.1175	-.1041	-.1191	-.1138	-.1229	-.1381	-.0772
.95	-.1064	-.0955	-.1145	-.1081	-.1008	-.1090	-.1014	-.1162	-.1033	-.1148	-.1141	-.1139	-.1280	-.0831

TAIL 1

Cp at y/b of														
x/c	0.02		0.22		0.44		0.56		0.67		0.83		0.98	
	U.S.	L.S.	U.S.	L.S.	U.S.	L.S.	U.S.	L.S.	U.S.	L.S.	U.S.	L.S.	U.S.	L.S.
.05	.1234	.1494	.2974	.3261			.2889	.3353	.2933	.3342	.2963	.3348	.2689	.3363
.10	.1278	.1490	.2988	.3209			.2826	.3157	.2804	.3190	.2888	.3242	.2403	.2683
.15	.1212	.1429	.2934	.3193			.2768	.3058	.2769	.3077	.2838	.3143	.2045	.2263
.20							.2739	.2964	.2750	.2.75		.3072	.1856	.2031
.25	.0124	.0140	.0274	.0420			.2547	.2751	.2659	.2826	.2734	.2999	.1672	.1875
.30			-.0006	.0076	.0164	.0220	.0296	.0398	.1350	.1463				
.40	.1176	.0449			.0104	.0114	.0102	.0129	.0165	.0211	.0283	.0335		
.50	.0300	.0391					.0066	.0081	.0084	.0098			-.0011	.0202
.60					.0091	.0059	.0081	.0060	.0067	.0062	.0001	-.0014	-.0411	-.0381
.70			-.0090	-.0126	-.0025	-.0054	-.0025	-.0058	-.0730	-.0234	-.1294	-.1293	-.1156	-.1124
.80	-.0791	-.1004	-.1115	-.1103	-.1306	-.1156			-.0972	-.0310	-.1252	-.1153	-.0049	-.1199
.90	-.0964	-.1100			-.1060	-.1012			-.1031	-.0982	-.1116	-.1084	-.0959	-.0875
.95	-.1000	-.1098							-.0989	-.0975	-.1092	-.1077	-.1049	-.0946

TAIL 2

TABLE X. - CONTINUED
(e) $\alpha = 3.87^\circ$

Cp at y/b of														
x/c	0.02		0.22		0.44		0.56		0.67		0.83		0.98	
	U.S.	L.S.	U.S.	L.S.	U.S.	L.S.	U.S.	L.S.	U.S.	L.S.	U.S.	L.S.	U.S.	L.S.
.05	.0581	.2714	.1415	.5030	.1540	.4754	.1458	.4849	.1583	.4833	.1617	.4700		
.10	.0625	.2778	.1434	.5228	.1566	.4861	.1372	.4975	.1587	.4758	.1584	.4754	.1252	.3650
.15	.0617	.2645	.1417	.5144	.1564	.4855	.1516	.4860	.1644	.4766	.1545	.4722	.1156	.3456
.20	.0477	.2721	.1357	.4823	.1537	.4821			.1615	.4785	.1617	.4690	.1091	.3236
.25			-.0390	.1361	.1220	.4223	.1382	.4614	.1540	.4716	.1607	.4649	.1043	.3086
.30	-.0429	.0882	-.0684	.1003	-.0496	.1273	-.0311	.1456	.0365	.2310	.1500	.4460	.1006	.2965
.40									-.0528	.1175	-.0456	.1151	-.0600	.0377
.50	-.0072	.1283	-.0789	.0670	-.0635	.1162			-.0582	.1097	-.0618	.0869	-.0614	.0008
.60	.0193	.1268	-.0667	.0606	-.0658	.1031	-.0618	.1132	-.0602	.1057	-.0704	.0691	-.0626	-.0084
.70	.0066	.1481	-.0639	.0632	-.0731	.0852	-.0732	.0967	-.0328	.0546			-.1227	-.1014
.80	-.0946	-.0258	-.1251	-.0826	-.1005	-.0924	-.1017	-.0833	-.1064	-.0902	-.1124	-.1110	-.1290	-.1188
.90	-.1055	-.0694	-.1202	-.0927	-.1014	-.1064	-.1013	-.0970	-.1043	-.0960	-.1136	-.1215	-.1382	-.0881
.95	-.0949	-.0750	-.1149	-.0935	-.1018	-.1089	-.1013	-.1016	-.1037	-.1009	-.1138	-.1217	-.1256	-.0706

TAIL 1

Cp at y/b of														
x/c	0.02		0.22		0.44		0.56		0.67		0.83		0.98	
	U.S.	L.S.	U.S.	L.S.	U.S.	L.S.	U.S.	L.S.	U.S.	L.S.	U.S.	L.S.	U.S.	L.S.
.05	.1368	.1912	.2987	.3241			.2879	.3336	.2915	.3329	.2937	.3324	.2704	.3347
.10	.1380	.1829	.2934	.3133			.2828	.3159	.2793	.3183	.2875	.3223	.2465	.2719
.15	.1250	.1643	.2901	.3096			.2791	.3062	.2769	.3079	.2839	.3137	.2044	.2310
.20							.2767	.2958	.2762	.2981			.3075	.2058
.25	.0017	.0061	.0371	.0522			.2578	.2740	.2674	.2828	.2752	.3006	.1674	.1893
.30			.0066	.0189	.0191	.0212	.0321	.0394	.1362	.1462				
.40	.0912	.0188			.0120	.0102	.0122	.0123	.0182	.0215	.0315	.0364		
.50	.0104	.0264					.0083	.0077	.0098	.0095			-.0064	.0141
.60					-.0127	.0080	.0095	.0053	.0082	.0056	.0068	.0038	-.0464	-.0458
.70			-.0183	-.0125	.0026	-.0003	-.0011	-.0064	-.0712	-.0299	-.1251	-.1264	-.1133	-.1120
.80	-.0902	-.1154	-.1209	-.1136	-.1305	-.1269			-.0987	-.0916	-.1280	-.1149	-.0100	-.1239
.90	-.1098	-.1270			-.1132	-.1044			-.1041	-.0983	-.1099	-.1067	-.0804	-.0963
.95	-.1141	-.1272							-.0993	-.0978	-.1065	-.1058	-.0881	-.0920

TAIL 2

TABLE X. - CONTINUED
(f) $\alpha = 5.87^\circ$

Cp at y/b of														
x/c	0.02		0.22		0.44		0.56		0.67		0.83		0.98	
	U.S.	L.S.	U.S.	L.S.	U.S.	L.S.	U.S.	L.S.	U.S.	L.S.	U.S.	L.S.	U.S.	L.S.
.05	.0061	.3306	.0798	.6187	.0963	.5738	.0953	.5822	.1050	.5760	.1113	.5594	.0863	.4358
.10	.0193	.3410	.0809	.6292	.0993	.5850	.0846	.5913	.1048	.5665	.1066	.5641	.0799	.4122
.15	.0244	.3293	.0781	.5981	.0982	.5838	.0974	.5804	.1091	.5712	.1029	.5600	.0766	.3874
.20	.0114	.3524	.0718	.5551	.0958	.5818			.1082	.5698	.1091	.5565	.0734	.3702
.25			-.0767	.1791	.0680	.5144	.0846	.5541	.1011	.5609	.1083	.5506	.0713	.3551
.30	-.0804	.1296	-.1009	.1434	-.0810	.1879	-.0631	.2058	-.0025	.2935	.0989	.5280	-.0690	.0731
.40									-.0828	.1725	-.0740	.1638	-.0787	.0332
.50	-.0143	.1756	-.0964	.1126	-.0949	.1601			-.0878	.1666	-.0867	.1324	-.0462	.0184
.60	.0005	.1786	-.0884	.1077	-.0967	.1449	-.0928	.1613	-.0900	.1642	-.0958	.1131	-.1434	-.0962
.70	-.0065	.2079	-.0874	.1127	-.1023	.1251	-.1018	.1382	-.1140	.1053			-.1756	-.0925
.80	-.0980	.0077	-.1490	-.0508	-.1080	-.0683	-.1059	-.0591	-.1104	-.0632	-.1167	-.0868	-.1598	-.1002
.90	-.1231	-.0466	-.1398	-.0612	-.1113	-.0826	-.1065	-.0744	-.1086	-.0733	-.1186	-.0966	-.1532	-.1011
.95	-.1061	-.0520	-.1214	-.0606	-.1123	-.0875	-.1065	-.0801	-.1081	-.0804	-.1190	-.1028		

TAIL 1

Cp at y/b of														
x/c	0.02		0.22		0.44		0.56		0.67		0.83		0.98	
	U.S.	L.S.	U.S.	L.S.	U.S.	L.S.	U.S.	L.S.	U.S.	L.S.	U.S.	L.S.	U.S.	L.S.
.05	.1717	.2303	.2976	.3320			.2901	.3339	.2939	.3355	.2956	.3337	.2745	.3344
.10	.1604	.2155	.2917	.3224			.2861	.3163	.2825	.3206	.2907	.3238	.2526	.2792
.15	.1354	.1900	.2844	.3148			.2821	.3060	.2798	.3093	.2869	.3155	.2119	.2366
.20							.2803	.2962	.2786	.2983		.3094	.1942	.2105
.25	-.0212	-.0023	.0438	.0554			.2607	.2742	.2702	.2824	.2775	.3026	.1710	.1926
.30			.0153	.0252	.0213	.0244	.0338	.0411	.1386	.1458				
.40	.0693	-.0075			.0132	.0141	.0134	.0137	.0213	.0218	.0350	.0382	-.0132	.0078
.50	-.0186	.0000					.0095	.0098	.0129	.0106			-.0549	-.0537
.60					.0202	.0114	.0108	.0077	.0105	.0070	.0122	.0070	-.1169	-.1144
.70			-.0296	-.0156	.0101	.0061	.0002	-.0048	-.0703	-.0281	-.1214	-.1242	-.0172	-.1223
.80	-.0933	-.1202	-.1304	-.1223	-.1305	-.1329			-.0999	-.0917	-.1291	-.1142	-.0840	-.0997
.90	-.1148	-.1337			-.1240	-.1098			-.1030	-.0975	-.1079	-.1046	-.0772	-.0968
.95	-.1171	-.1329							-.0992	-.0973	-.1037	-.1035		

TAIL 2

TABLE X. - CONTINUED
(g) $\alpha = 7.86^\circ$

Cp at y/b of														
x/c	0.02		0.22		0.44		0.56		0.67		0.83		0.98	
	U.S.	L.S.	U.S.	L.S.	U.S.	L.S.	U.S.	L.S.	U.S.	L.S.	U.S.	L.S.	U.S.	L.S.
.05	-.0401	.3783	-.0234	.7480	.0433	.6944	.0474	.7051	.0585	.6820	.0664	.6606		
.10	-.0206	.3979	-.0248	.7119	.0463	.7086	.0376	.7048	.0555	.6817	.0593	.6651	.0511	.5120
.15	-.0094	.3959	-.0215	.6656	.0444	.7062	.0479	.6977	.0586	.6844	.0558	.6617	.0501	.4848
.20	-.0201	.4354	-.0160	.6186	.0416	.6930			.0588	.6826	.0608	.6591	.0493	.4577
.25			-.1082	.2165	.0174	.6008	.0358	.6638	.0525	.6723	.0600	.6538	.0468	.4383
.30	-.1022	.1704	-.1293	.1839	-.1077	.2327	-.0914	.2679	-.0373	.3738	.0518	.6248	.0458	.4219
.40									-.1087	.2350	-.0996	.2183	-.0787	.1142
.50	-.0388	.2273	-.1171	.1590	-.1227	.2004			-.1135	.2238	-.1129	.1857	-.0823	.0726
.60	-.0189	.2399	-.1100	.1583	-.1237	.1852	-.1194	.2030	-.1158	.2150	-.1178	.1655	-.0654	.0547
.70	-.0306	.2838	-.1096	.1685	-.1235	.1664	-.1212	.1762	-.1206	.1442			-.1580	-.0954
.80	-.0994	.0388	-.1618	-.0115	-.1176	-.0426	-.1133	-.0339	-.1153	-.0430	-.1217	-.0598	-.1654	-.0840
.90	-.1394	-.0253	-.1398	-.0204	-.1201	-.0562	-.1144	-.0502	-.1149	-.0540	-.1235	-.0750	-.1550	-.0869
.95	-.1208	-.0302	-.1221	-.0166	-.1207	-.0609	-.1146	-.0571	-.1141	-.0613	-.1245	-.0812	-.1516	-.0916

TAIL 1

Cp at y/b of														
x/c	0.02		0.22		0.44		0.56		0.67		0.83		0.98	
	U.S.	L.S.	U.S.	L.S.	U.S.	L.S.	U.S.	L.S.	U.S.	L.S.	U.S.	L.S.	U.S.	L.S.
.05	.1863	.2240	.2650	.3265			.2952	.3333	.3000	.3354	.3019	.3369	.2808	.3381
.10	.1675	.2063	.2660	.3197			.2913	.3168	.2892	.3201	.2969	.3264	.2602	.2880
.15	.1397	.1779	.2640	.3126			.2881	.3075	.2861	.3087	.2936	.3169	.2238	.2437
.20							.2860	.2980	.2848	.2978		.3100	.2042	.2167
.25	-.0288	-.0184	.0232	.0483			.2661	.2772	.2759	.2829	.2838	.3028	.1789	.1978
.30			-.0024	.0165	.0217	.0258	.0372	.0435	.1424	.1468				
.40	-.0588	-.0284			.0140	.0173	.0157	.0151	.0240	.0233	.0385	.0389		
.50	-.0604	-.0248					.0106	.0108	.0146	.0119			-.0199	.0004
.60					.0244	.0207	.0114	.0100	.0111	.0078	.0154	.0095	-.0619	-.0594
.70			-.0635	-.0404	.0222	.0167	.0014	-.0014	-.0708	-.0279	-.1197	-.1221	-.1215	-.1143
.80	-.1110	-.1251	-.1338	-.1356	-.1269	-.1329			-.1010	-.0904	-.1291	-.1121	-.0240	-.1191
.90	-.1202	-.1380			-.1373	-.1201			-.1025	-.0967	-.1065	-.1022	-.0954	-.1017
.95	-.1171	-.1352							-.0992	-.0967	-.1019	-.1009	-.0911	-.1030

TAIL 2

TABLE X. - CONTINUED
(h) $\alpha = 9.86^\circ$

Cp at y/b of														
x/c	0.02		0.22		0.44		0.56		0.67		0.83		0.98	
	U.S.	L.S.	U.S.	L.S.	U.S.	L.S.	U.S.	L.S.	U.S.	L.S.	U.S.	L.S.	U.S.	L.S.
.05	-.0819	.4167	-.0273	.8335	-.0021	.8566	-.0031	-.8841	.0163	-.8486	-.0265	-.8030		
.10	-.0595	.4503	-.0264	.7739	-.0032	.8331	-.0053	-.8533	-.0114	-.8435	-.0176	-.8120	-.0210	-.6098
.15	-.0413	.4576	-.0301	.7246	-.0053	.7981	-.0027	-.8241	-.0122	-.8292	-.0134	-.8111	-.0243	-.5807
.20	-.0483	.5057	-.0355	.6741	-.0077	.7707			.0124	-.8112	-.0175	-.8049	-.0266	-.5531
.25			-.1364	.2503	-.0286	.6520	-.0099	-.7424	-.0077	-.7818	-.0162	-.7831	-.0260	-.5336
.30	-.1209	.2131	-.1541	.2216	-.1316	.2636	-.1175	-.3009	-.0695	-.4226	-.0087	-.7296	-.0253	-.5145
.40									-.1325	-.2769	-.1225	-.2668	-.0899	-.1667
.50	-.0690	.2789	-.1419	.2069	-.1475	.2412			-.1375	-.2673	-.1337	-.2259	-.0922	-.1171
.60	-.0344	.3007	-.1346	.2127	-.1455	.2289	-.1433	-.2459	-.1397	-.2516	-.1364	-.2005	-.1009	-.0917
.70	-.0424	.3644	-.1315	.2265	-.1334	.2114	-.1311	-.2162	-.1287	-.1750			-.1777	-.0875
.80	-.1012	.0680	-.1666	.0340	-.1299	-.0124	-.1265	-.0083	-.1269	-.0227	-.1327	-.0384	-.1622	-.0968
.90	-.1494	-.0037	-.1498	.0230	-.1326	-.0260	-.1279	-.0257	-.1276	-.0328	-.1343	-.0549	-.1649	-.0991
.95	-.1342	-.0072	-.1365	.0244	-.1333	-.0308	-.1277	-.0336	-.1271	-.0404	-.1353	-.0615	-.1666	-.0989

TAIL 1

Cp at y/b of														
x/c	0.02		0.22		0.44		0.56		0.67		0.83		0.98	
	U.S.	L.S.	U.S.	L.S.	U.S.	L.S.	U.S.	L.S.	U.S.	L.S.	U.S.	L.S.	U.S.	L.S.
.05	.1646	.2124	.2132	.2877			.3070	.3376	.3125	.3398	.3108	.3392	.2880	.3371
.10	.1489	.1957	.2109	.2770			.3020	.3189	.3005	.3243	.3051	.3278	.2662	.2916
.15	.1233	.1716	.2049	.2694			.2977	.3091	.2964	.3126	.3007	.3190	.2318	.2468
.20							.2944	.2994	.2937	.3020		.3120	.2112	.2193
.25	-.0324	-.0176	-.0122	.0230			.2753	.2804	.2851	.2865	.2882	.3049	.1843	.2010
.30			-.0349	-.0075	.0235	.0286	.0422	.0444	.1487	.1487				
.40	-.0576	-.0324			.0119	.0178	.0212	.0189	.0287	.0247	.0416	.0402		
.50	-.0661	-.0389					.0149	.0150	.0193	.0142			-.0258	-.0084
.60					.0094	.0151	.0150	.0131	.0158	.0113	.0191	.0110	-.0639	-.0608
.70			-.0812	-.0650	.0170	.0211	.0055	.0021	-.0673	-.0238	-.1172	-.1209	-.1202	-.1117
.80	-.1358	-.1464	-.1523	-.1539	-.1262	-.1253			-.1016	-.0918	-.1266	-.1081	-.0299	-.1153
.90	-.1439	-.1559			-.1392	-.1272			-.1021	-.0952	-.1039	-.0994	-.1077	-.1048
.95	-.1347	-.1489							-.0971	-.0945	-.0991	-.0980	-.1057	-.1042

TAIL 2

TABLE X.- CONTINUED
(1) $\sigma = 11.86^\circ$

Cp at y/b of														
x/c	0.02		0.22		0.44		0.56		0.67		0.83		0.98	
	U.S.	L.S.	U.S.	L.S.	U.S.	L.S.	U.S.	L.S.	U.S.	L.S.	U.S.	L.S.	U.S.	L.S.
.05	-.1181	.3316	-.0738	.9079	-.0464	.9842	-.0391	1.0268	-.0249	1.0329	-.0112	1.0243		
.10	-.0870	.4577	-.0750	.8285	-.0522	.9223	-.0508	.9544	-.0336	.9715	-.0227	.9779	-.0035	.7399
.15	-.0614	.5180	-.0768	.7736	-.0557	.8736	-.0459	.9055	-.0357	.9285	-.0294	.9307	.0012	.6894
.20	-.0689	.5658	-.0791	.7179	-.0583	.8270			-.0363	.8868	-.0281	.8851	.0036	.6411
.25			-.1576	.2712	-.0756	.6748	-.0585	.7789	-.0408	.8298	-.0298	.8321	.0033	.6038
.30	-.1400	.3167	-.1709	.2608	-.1554	.2854	-.1434	.3138	-.1037	.4203	-.0367	.7500	.0064	.5680
.40									-.1557	.3057	-.1460	.2766	-.1150	.1828
.50	-.0920	.3196	-.1553	.2559	-.1618	.2822			-.1606	.2981	-.1546	.2476	-.1196	.1364
.60	-.0532	.3841	-.1506	.2647	-.1499	.2755	-.1500	.2843	-.1560	.2820	-.1547	.2297	-.1547	.1138
.70	-.0516	.4311	-.1487	.2899	-.1464	.2593	-.1433	.2517	-.1424	.2015			-.1922	-.0707
.80	-.1019	.0924	-.1752	.0904	-.1464	.0181	-.1428	.0171	-.1445	-.0007	-.1501	-.0152	-.1813	-.0840
.90	-.1561	.0276	-.1623	.0658	-.1487	.0035	-.1443	-.0002	-.1460	-.0105	-.1510	-.0326	-.1877	-.0875
.95	-.1474	.0214	-.1512	.0556	-.1486	.0012	-.1441	-.0088	-.1460	-.0181	-.1517	-.0398	-.1899	-.0879

TAIL 1

Cp at y/b of														
x/c	0.02		0.22		0.44		0.56		0.67		0.83		0.93	
	U.S.	L.S.	U.S.	L.S.	U.S.	L.S.	U.S.	L.S.	U.S.	L.S.	U.S.	L.S.	U.S.	L.S.
.05	.1207	.2143	.1512	.2275			.3176	.3305	.3233	.3442	.3142	.3463	.2891	.3397
.10	.1082	.1965	.1427	.2175			.3129	.3127	.3124	.3294	.3090	.3357	.2678	.2973
.15	.0885	.1725	.1337	.2101			.3072	.3066	.3098	.3190	.3049	.3263	.2351	.2537
.20							.3062	.3011	.3087	.3102			.3195	.2150
.25	-.0482	-.0162	-.0532	-.0077			.2885	.2846	.2998	.2971	.2950	.3124	.1880	.2082
.30			-.0682	-.0332	.0069	.0061	.0478	.0458	.1611	.1590				
.40	-.0751	-.0301			-.0079	-.0064	.0251	.0192	.0382	.0318	.0480	.0453		
.50	-.0770	-.0374					.0176	.0143	.0281	.0208			-.0352	-.0171
.60					-.0130	-.0228	.0165	.0090	.0244	.0173	.0269	.0172	-.0604	-.0587
.70			-.0954	-.0673	-.0137	-.0258	.0077	-.0030	-.0613	-.0179	-.1128	-.1178	-.1183	-.1136
.80	-.1373	-.1581	-.1654	-.1507	-.1395	-.1446			-.1032	-.1007	-.1291	-.1112	-.0390	-.1200
.90	-.1521	-.1698			-.1513	-.1340			-.1074	-.0977	-.1049	-.0990	-.1078	-.1071
.95	-.1506	-.1647							-.0993	-.0969	-.0985	-.0973	-.1069	-.1050

TAIL 2

TABLE X. - CONTINUED
(j) $\alpha = 15.86^\circ$

Cp at y/b of														
x/c	0.02		0.22		0.44		0.56		0.67		0.83		0.98	
	U.S.	L.S.	U.S.	L.S.	U.S.	L.S.	U.S.	L.S.	U.S.	L.S.	U.S.	L.S.	U.S.	L.S.
.05	-.1083	.2036	-.1179	1.0165	-.0986	1.1587	-.0893	1.2139	-.0832	1.2419	-.0790	1.2351		
.10	-.0894	.3194	-.1217	.9348	-.0998	1.0648	-.0983	1.1063	-.0817	1.1338	-.0755	1.1335	-.0479	.8972
.15	-.0811	.4826	-.1250	.8765	-.1066	.9899	-.0979	1.0287	-.0839	1.0514	-.0812	1.0456	-.0353	.8165
.20	-.0903	.4553	-.1286	.7974	-.1123	.9144			-.0886	.9774	-.0831	.9716	-.0238	.7455
.25			-.1851	.3083	-.1277	.7152	-.1146	.8303	-.0966	.8836	-.0876	.8919	-.0243	.6875
.30	-.1545	.3288	-.1748	.3303	-.1819	.3295	-.1755	.3419	-.1451	.4344	-.0945	.7791	-.0227	.6291
.40									-.1826	.3695	-.1752	.3217	-.1335	.2092
.50	-.1218	.4587	-.1692	.3496	-.1689	.3748			-.1681	.3815	-.1755	.3268	-.1447	.1934
.60	-.0953	.5038	-.1676	.3940	-.1675	.3710	-.1656	.3740	-.1635	.3697	-.1694	.3190	-.1628	.1828
.70	-.0803	.5714	-.1672	.4780	-.1684	.3525	-.1667	.3393	-.1628	.2780			-.2156	-.0240
.80	-.1066	.1453	-.1829	.1358	-.1693	.0826	-.1658	.0713	-.1656	.0524	-.1699	.0408	-.2120	-.0374
.90	-.1720	.0764	-.1790	.1109	-.1704	.1038	-.1672	-.2823	-.1677	.0436	-.1701	.0213	-.2035	-.0419
.95	-.1553	.0711	-.1738	.0970	-.1693	.1085	-.1663	.1339	-.1671	.0352	-.1694	.0129	-.2014	-.0430

TAIL 1

Cp at y/b of														
x/c	0.02		0.22		0.44		0.56		0.67		0.83		0.98	
	U.S.	L.S.	U.S.	L.S.	U.S.	L.S.	U.S.	L.S.	U.S.	L.S.	U.S.	L.S.	U.S.	L.S.
.05	.1083	.1500	.0772	.1275			.1648	.1944	.2761	.3016	.3446	.3633	.3151	.3615
.10	.0883	.1348	.0683	.1157			.1571	.1794	.2582	.2883	.3407	.3556	.2923	.3149
.15	.0635	.1110	.0606	.1075			.1460	.1684	.2503	.2798	.3384	.3472	.2569	.2696
.20							.1365	.1573	.2470	.2708		.3441	.2358	.2432
.25	-.0721	-.0551	-.0890	-.0651			.1190	.1374	.2354	.2556	.3251	.3380	.2096	.2257
.30			-.1004	-.0839	-.1175	-.1151	-.0551	-.0458	.1138	.1264				
.40	-.1008	-.0720			-.1274	-.1287	-.0773	-.0764	-.0099	-.0065	.0612	.0596		
.50	-.1022	-.0748					-.0852	-.0845	-.0281	-.0248			-.0494	-.0168
.60					-.1299	-.1363	-.0878	-.0896	-.0339	-.0323	.0328	.0249	-.0499	-.0461
.70			-.1317	-.1207	-.1343	-.1412	-.0924	-.0930	-.1026	-.0627	-.1122	-.1178	-.1117	-.1109
.80	-.1517	-.1665	-.1863	-.1813	-.1875	-.1892			-.1287	-.1337	-.1356	-.1411	-.0532	-.1440
.90	-.1851	-.1744			-.1806	-.1390			-.1527	-.1401	-.1280	-.1155	-.1079	-.1083
.95	-.1650	-.1747							-.1435	-.1366	-.1157	-.1111	-.0892	-.0832

TAIL 2

TABLE X. - CONCLUDED
(k) $\alpha = 19.86^\circ$

Cp at y/b of														
x/c	0.02		0.22		0.44		0.56		0.67		0.83		0.98	
	U.S.	L.S.	U.S.	L.S.	U.S.	L.S.	U.S.	L.S.	U.S.	L.S.	U.S.	L.S.	U.S.	L.S.
.05	-.1806	.2395	-.1745	1.1058	-.1526	1.2668	-.1425	1.3228	-.1383	1.3583	-.1276	1.3697		
.10	-.1275	.3819	-.1771	1.0313	-.1404	1.1676	-.1362	1.2147	-.1201	1.2475	-.1101	1.2615	-.0762	1.0309
.15	-.1086	.4934	-.1764	.9638	-.1442	1.0805	-.1335	1.1268	-.1165	1.1566	-.1095	1.1640	-.0545	.9374
.20	-.1152	.5203	-.1760	.8572	-.1509	.9892			-.1195	1.0701	-.1102	1.0793	-.0495	.8522
.25			-.1910	.3657	-.1646	.7666	-.1477	.8928	-.1269	.9602	-.1145	.9863	-.0518	.7823
.30	-.1717	.4422	-.1831	.4503	-.1851	.4023	-.1916	.3976	-.1666	.4787	-.1214	.8550	-.0541	.7110
.40									-.1927	.4718	-.1891	.4026	-.1619	.2588
.50	-.1400	.6376	-.1816	.5415	-.1855	.5092			-.1814	.5006	-.1866	.4363	-.1749	.2700
.60	-.1279	.5632	-.1828	.6063	-.1854	.5254	-.1828	.5064	-.1792	.4919	-.1793	.4332	-.1872	.2700
.70	-.1282	.5972	-.1866	.5623	-.1862	.5271	-.1849	.4718	-.1786	.3859			-.2113	.0289
.80	-.1106	.1951	-.1977	.1816	-.1866	.2060	-.1856	.1724	-.1785	.1274	-.1811	.1072	-.2028	.0137
.90	-.1745	.1231	-.1928	.1523	-.1865	.1857	-.1868	-.2825	-.1802	.1275	-.1826	.0867	-.1983	.0085
.95	-.1651	.1262	-.1902	.1348	-.1831	.1724	-.1857	.2340	-.1784	.1250	-.1832	.0779	-.1986	.0067

TAIL 1

Cp at y/b of														
x/c	0.02		0.22		0.44		0.56		0.67		0.83		0.98	
	U.S.	L.S.	U.S.	L.S.	U.S.	L.S.	U.S.	L.S.	U.S.	L.S.	U.S.	L.S.	U.S.	L.S.
.05	.0769	.1305	-.0117	.0381			.0110	.0358	.0409	.0598	.1606	.1761	.2924	.3384
.10	.0518	.1107	-.0024	.0297			-.0058	.0251	.0301	.0480	.1465	.1620	.2507	.2687
.15	.0261	.0786	-.0070	.0206			-.0001	.0185	.0233	.0395	.1376	.1493	.2235	.2353
.20							-.0070	.0110	.0189	.0311		.1352	.2108	.2182
.25	-.0946	-.0827	-.1236	-.1080			-.0198	-.0025	.0102	.0194	.1084	.1215	.1954	.2069
.30			-.1261	-.1050	-.1467	-.1384	-.1287	-.1180	-.0577	-.0532				
.40	-.1252	-.1050			-.1545	-.1490	-.1444	-.1393	-.1268	-.1248	-.0863	-.0859		
.50	-.1232	-.1105					-.1479	-.1435	-.1365	-.1344			-.0442	.0275
.60					-.1547	-.1531	-.1483	-.1459	-.1385	-.1381	-.1198	-.1228	-.0399	-.0368
.70			-.1458	-.1393	-.1566	-.1561	-.1423	-.1414	-.1675	-.1555	-.1838	-.1865	-.1258	-.1303
.80	-.1672	-.1716	-.1925	-.1915	-.1956	-.1970			-.1545	-.1562	-.1907	-.1943	-.0485	-.1379
.90	-.1787	-.1811			-.1883	-.1400			-.1876	-.1878	-.1877	-.1916	-.1683	-.1695
.95	-.1739	-.1779							-.1869	-.1883	-.1870	-.1897	-.1745	-.1770

TAIL 2

TABLE XI. - PRESSURE COEFFICIENTS, $\phi = 0^\circ$, $\delta = 0^\circ$, $M = 3.70$
(a) $\alpha = -3.87^\circ$

Cp at y/b of														
x/c	0.02		0.22		0.44		0.56		0.67		0.83		0.98	
	U.S.	L.S.	U.S.	L.S.	U.S.	L.S.	U.S.	L.S.	U.S.	L.S.	U.S.	L.S.	U.S.	L.S.
.05	-.0802	.0885	-.1689	.2138	-.1781	.2212	-.1857	.2267	-.1780	.2309	-.1791	.2207		
.10	-.0792	.0910	-.1773	.2195	-.1829	.2238	-.1690	.2288	-.1773	.2269	-.1748	.2232	.1601	.1834
.15	-.0749	.0878	-.1791	.2207	-.1836	.2231	-.1750	.2282	-.1801	.2244	-.1720	.2204	.1510	.1791
.20	-.0602	.0743	-.1754	.2167	-.1818	.2226			-.1803	.2225	-.1765	.2183	.1396	.1715
.25			.0425	.0513	.1563	.1935	.1643	.2166	-.1768	.2191	.1757	.2155	.1327	.1649
.30	.0022	.0064	-.0149	.0257	.0257	.0381	-.0363	.0543	.0915	.1019	-.1675	.2061	.1269	.1594
.40									.0134	.0277	.0236	.0363	.0126	.0229
.50	-.0135	-.0035	-.0033	.0070	.0079	.0195			.0083	.0212	.0083	.0190	-.0171	-.0056
.60	-.0088	-.0012	-.0086	.0011	.0062	.0170	-.0063	.0174	.0056	.0169	.0023	.0137	-.0238	-.0153
.70	-.0036	-.0060	-.0115	-.0026	.0022	.0129	-.0035	.0077	-.0108	.0003			-.0469	-.0432
.80	-.0141	-.0326	-.0523	-.0488	-.0444	-.0381	-.0473	-.0428	-.0418	-.0402	-.0477	-.0453	-.0486	-.0472
.90	-.0435	-.0404	-.0454		-.0435	-.0423	-.0440	-.0425	-.0430	-.0418	-.0439	-.0426	-.0422	-.0411
.95	-.0448	-.0418	-.0435	-.0261	-.0425	-.0411	-.0422	.1051	-.0415	-.0395	-.0430	-.0415	-.0411	-.0410

TAIL 1

Cp at y/b of														
x/c	0.02		0.22		0.44		0.56		0.67		0.83		0.98	
	U.S.	L.S.	U.S.	L.S.	U.S.	L.S.	U.S.	L.S.	U.S.	L.S.	U.S.	L.S.	U.S.	L.S.
.05	.1472	.0194	.3285	.1119			.3090	.1287	.3127	.1317	.3100	.1329	.2834	.1416
.10	.1595	.0273	.3228	.0977			.3045	.1166	.3015	.1205	.3058	.1226	.2694	.1185
.15	.1500	.0271	.3174	.0911			.3002	.1102	.2968	.1122	.3019	.1164	.2502	.0958
.20							.2980	.1047	.2949	.1064		.0859	.2299	.0829
.25	.0625	-.0188	.1116	-.0008			.2818	.0947	.2872	.0989	.2905	.1070	.2083	.0743
.30			.0815	-.0021	.0849	-.0071	.0967	.0021	.1852	.0446				
.40	.0488	-.0315			.0698	-.0207	.0703	-.0215	.0761	-.0139	.0839	-.0078		
.50	.0491	-.0168					.0650	-.0256	.0650	-.0244			.0254	.0741
.60					.0663	-.0295	.0645	-.0282	.0638	-.0231	.0596	-.0235	.0059	-.0232
.70			.0546	-.0220	.0599	-.0332	.0636	-.0021	.0118	-.0286	-.0203	-.0496	-.0291	-.0467
.80	-.0053	-.0378	-.0218	-.0361		-.0414			-.0129	-.0111	-.0369	-.0447	.0173	-.0116
.90	-.0256	-.0449			-.0284	-.0332			-.0330	-.0394	-.0384	-.0432	-.0350	-.0440
.95	-.0286	-.0418							-.0362	-.0416	-.0402	-.0429	-.0345	-.0433

TAIL 2

TABLE XI. - CONTINUED
(b) $\alpha = -1.88^\circ$

Cp at y/b of														
x/c	0.02		0.22		0.44		0.56		0.67		0.83		0.98	
	U.S.	L.S.	U.S.	L.S.	U.S.	L.S.	U.S.	L.S.	U.S.	L.S.	U.S.	L.S.	U.S.	L.S.
.05	.0683	.0848	.1767	.2195	.1792	.2213	.1866	.2281	.1801	.2314	.1821	.2221		
.10	.0688	.0898	.1832	.2223	.1842	.2232	.1674	.2302	.1788	.2258	.1774	.2242	.1573	.1804
.15	.0666	.0895	.1825	.2214	.1845	.2221	.1754	.2290	.1813	.2243	.1742	.2213	.1490	.1749
.20	.0558	.0805	.1776	.2176	.1823	.2209			.1813	.2227	.1786	.2190	.1387	.1659
.25			.0424	.0515	.1572	.1910	.1652	.2172	.1780	.2189	.1776	.2160	.1316	.1602
.30	.0076	.0175	.0143	.0257	.0253	.0373	.0367	.0536	.0939	.1059	.1689	.2066	.1257	.1557
.40									.0196	.0263	.0239	.0357	.0120	.0206
.50	-.0015	.0114	-.0055	.0069	.0084	.0185			.0081	.0198	.0082	.0179	-.0157	-.0072
.60	.0103	.0129	-.0108	.0016	.0065	.0165	.0058	.0159	.0052	.0159	.0016	.0122	-.0207	-.0160
.70	.0140	.0166	-.0120	-.0010	.0020	.0119	-.0037	.0071	-.0115	-.0014			-.0454	-.0436
.80	-.0269	-.0307	-.0514	-.0483	-.0447	-.0393	-.0489	-.0453	-.0431	-.0424	-.0493	-.0489	-.0460	-.0491
.90	-.0422	-.0411	-.0458		-.0436	-.0442	-.0446	-.1426	-.0432	-.0432	-.0449	-.0443	-.0408	-.0409
.95	-.0442	-.0420	-.0443	-.0281	-.0425	-.0418	-.0428	.1050	-.0420	-.0412	-.0438	-.0429	-.0413	-.0405

TAIL 1

Cp at y/b of														
x/c	0.02		0.22		0.44		0.56		0.67		0.83		0.98	
	U.S.	L.S.	U.S.	L.S.	U.S.	L.S.	U.S.	L.S.	U.S.	L.S.	U.S.	L.S.	U.S.	L.S.
.05	.1093	.0484	.2676	.1635			.2539	.1745	.2584	.1758	.2559	.1775	.2354	.1863
.10	.1210	.0546	.2602	.1512			.2490	.1620	.2469	.1637	.2515	.1677	.2217	.1609
.15	.1162	.0523	.2549	.1438			.2449	.1549	.2425	.1554	.2479	.1610	.2027	.1352
.20							.2428	.1486	.2407	.1490		.0768	.1903	.1186
.25	.0496	-.0060	.0786	.0214			.2283	.1363	.2339	.1404	.2379	.1485	.1696	.1070
.30			.0534	.0060	.0574	.0073	.0676	.0225	.1457	.0745				
.40	.0266	-.0188			.0429	-.0096	.0423	-.0065	.0489	.0006	.0571	.0078		
.50	.0267	-.0068					.0373	-.0118	.0378	-.0100			.0226	.0474
.60					.0373	-.0161	.0360	-.0138	.0371	-.0089	.0347	-.0130	-.0046	-.0167
.70			.0286	-.0125	.0317	-.0202	.0428	.0043	.0006	-.0227	-.0306	-.0488	-.0325	-.0460
.80	-.0145	-.0395	-.0308	-.0385		-.0423			-.0188	-.0172	-.0445	-.0451	.0151	-.0189
.90	-.0333	-.0488			-.0365	-.0340			-.0416	-.0396	-.0448	-.0430	-.0325	-.0513
.95	-.0360	-.0447							-.0425	-.0410	-.0436	-.0425	-.0351	-.0510

TAIL 2

TABLE XI. - CONTINUED
(c) $\alpha = 0.12^\circ$

Cp at y/b of														
x/c	0.02		0.22		0.44		0.56		0.67		0.83		0.98	
	U.S.	L.S.	U.S.	L.S.	U.S.	L.S.	U.S.	L.S.	U.S.	L.S.	U.S.	L.S.	U.S.	L.S.
.05	.0791	.0912	.1788	.2206	.1810	.2223	.1855	.2283	.1810	.2313	.1793	.2187		
.10	.0794	.0955	.1866	.2242	.1865	.2243	.1649	.2314	.1798	.2266	.1759	.2219	.1556	.1802
.15	.0767	.0951	.1862	.2240	.1866	.2232	.1753	.2300	.1824	.2241	.1735	.2199	.1474	.1735
.20	.0658	.0873	.1800	.2191	.1841	.2217			.1827	.2223	.1780	.2179	.1378	.1637
.25			.0435	.0528	.1595	.1905	.1663	.2188	.1798	.2183	.1770	.2152	.1316	.1554
.30	.0077	.0185	.0147	.0262	.0246	.0384	.0394	.0523	.0952	.1051	.1686	.2063	.1257	.1510
.40									.0144	.0242	.0233	.0355	.0107	.0182
.50	-.0058	.0134	-.0020	.0096	.0071	.0179			.0084	.0179	.0068	.0172	-.0134	-.0076
.60	.0061	.0141	-.0067	.0041	.0057	.0157	.0058	.0151	.0060	.0143	.0001	.0118	-.0172	-.0143
.70	.0143	.0176	-.0099	.0006	.0013	.0114	-.0032	.0072	-.0111	-.0032			-.0447	-.0423
.80	-.0310	-.0298	-.0531	-.0464	-.0485	-.0412	-.0506	-.0461	-.0469	-.0433	-.0531	-.0494	-.0459	-.0471
.90	-.0450	-.0430	-.0460		-.0465	-.0437	-.0460	-.1438	-.0456	-.0442	-.0475	-.0454	-.0563	-.0439
.95	-.0485	-.0445	-.0445	-.0272	-.0442	-.0423	-.0438	.1063	-.0439	-.0422	-.0463	-.0439	-.0566	-.0480

TAIL 1

Cp at y/b of														
x/c	0.02		0.22		0.44		0.56		0.67		0.83		0.98	
	U.S.	L.S.	U.S.	L.S.	U.S.	L.S.	U.S.	L.S.	U.S.	L.S.	U.S.	L.S.	U.S.	L.S.
.05	.0779	.0758	.2076	.2209			.2024	.2237	.2083	.2247	.2070	.2253	.1911	.2331
.10	.0880	.0836	.1991	.2102			.1970	.2107	.1970	.2119	.2014	.2162	.1781	.2050
.15	.0850	.0813	.1940	.2021			.1929	.2029	.1926	.2034	.1982	.2090	.1584	.1764
.20							.1909	.1961	.1909	.1965		.0845	.1521	.1560
.25	.0308	.0155	.0478	.0511			.1788	.1821	.1849	.1865	.1899	.1945	.1365	.1435
.30			.0277	.0257	.0335	.0312	.0420	.0463	.1094	.1084				
.40	.0067	.0049			.0198	.0139	.0182	.0150	.0254	.0221	.0342	.0300		
.50	.0080	.0123					.0137	.0096	.0144	.0106			.0195	.0445
.60					.0130	.0065	.0120	.0070	.0139	.0038	.0136	.0058	-.0100	-.0113
.70			.0069	.0030	.0077	.0014	.0243	.0186	-.0123	-.0082	-.0387	-.0433	-.0367	-.0421
.80	-.0204	-.0346	-.0385	-.0429		-.0487			-.0239	-.0217	-.0484	-.0503	.0126	-.0192
.90	-.0380	-.0463			-.0368	-.0367			-.0405	-.0407	-.0426	-.0443	-.0439	-.0432
.95	-.0395	-.0451							-.0400	-.0413	-.0412	-.0430	-.0455	-.0473

TAIL 2

TABLE XI. - CONTINUED
(d) $\alpha = 2.11^\circ$

Cp at y/b of														
x/c	0.02		0.22		0.44		0.56		0.67		0.83		0.98	
	U.S.	L.S.	U.S.	L.S.	U.S.	L.S.	U.S.	L.S.	U.S.	L.S.	U.S.	L.S.	U.S.	L.S.
.05	.0931	.1075	.1795	.2217	.1807	.2205	.1837	.2273	.1830	.2320	.1825	.2214	.1545	.1804
.10	.0932	.1094	.1868	.2240	.1865	.2225	.1841	.2310	.1811	.2263	.1776	.2233	.1458	.1735
.15	.0894	.1073	.1865	.2234	.1867	.2218	.1746	.2284	.1832	.2233	.1743	.2200	.1376	.1637
.20	.0763	.0977	.1806	.2185	.1842	.2202			.1833	.2211	.1780	.2172	.1334	.1564
.25			.0441	.0513	.1591	.1878	.1660	.2167	.1804	.2170	.1767	.2144	.1291	.1503
.30	.0069	.0148	.0145	.0252	.0251	.0378	.0452	.0492	.0956	.1006	.1682	.2053	.0112	.0195
.40									.0158	.0234	.0225	.0337	.0082	.0053
.50	-.0112	.0057	-.0010	.0105	.0074	.0164			.0091	.0164	.0055	.0149	-.0082	-.0053
.60	-.0048	.0052	-.0048	.0062	.0057	.0145	.0069	.0134	.0068	.0134	-.0001	.0092	-.0132	-.0104
.70	.0029	.0086	-.0080	.0024	.0010	.0107	-.0009	.0066	-.0107	-.0042			-.0439	-.0412
.80	-.0344	-.0354	-.0530	-.0481	-.0458	-.0419	-.0432	-.0476	-.0466	-.0446	-.0519	-.0510	-.0540	-.0420
.90	-.0473	-.0471	-.0479		-.0448	-.0443	-.0447	-.1433	-.0460	-.0451	-.0479	-.0465	-.0575	-.0519
.95	-.0509	-.0466	-.0455	-.0292	-.0437	-.0423	-.0423	.1043	-.0441	-.0429	-.0469	-.0455	-.0557	-.0509

TAIL 1

Cp at y/b of														
x/c	0.02		0.22		0.44		0.56		0.67		0.83		0.98	
	U.S.	L.S.	U.S.	L.S.	U.S.	L.S.	U.S.	L.S.	U.S.	L.S.	U.S.	L.S.	U.S.	L.S.
.05	.0505	.1035	.1520	.2838			.1553	.2785	.1621	.2785	.1620	.2776	.1497	.2841
.10	.0580	.1132	.1419	.2740			.1494	.2648	.1512	.2650	.1554	.2689	.1375	.2526
.15	.0546	.1114	.1367	.2654			.1455	.2563	.1463	.2562	.1520	.2612	.1187	.2201
.20							.1435	.2487	.1447	.2484		.0949	.1148	.1967
.25	.0081	.0332	.0194	.0825			.1329	.2321	.1393	.2369	.1448	.2445	.1041	.1857
.30			.0055	.0494	.0108	.0532	.0138	.0726	.0762	.1457				
.40	-.0125	.0245			-.0023	.0345	-.0028	.0383	.0048	.0454	.0126	.0530		
.50	-.0062	.0250					-.0070	.0323	-.0057	.0337			.0160	.0431
.60					-.0091	.0294	-.0089	.0302	-.0055	.0325	-.0051	.0257	-.0159	-.0063
.70			-.0105	.0223	-.0135	.0234	.0079	.0336	-.0242	.0057	-.0463	-.0352	-.0417	-.0401
.80	-.0252	-.0290	-.0375	-.0390		-.0430			-.0231	-.0202	-.0445	-.0500	.0099	-.0200
.90	-.0408	-.0433			-.0351	-.0403			-.0385	-.0447	-.0409	-.0475	-.0505	-.0392
.95	-.0395	-.0454							-.0390	-.0436	-.0407	-.0446	-.0499	-.0411

TAIL 2

TABLE XI. - CONTINUED
(a) $\alpha = 4.10^\circ$

Cp at y/b of														
x/c	0.02		0.22		0.44		0.56		0.67		0.83		0.98	
	U.S.	L.S.	U.S.	L.S.	U.S.	L.S.	U.S.	L.S.	U.S.	L.S.	U.S.	L.S.	U.S.	L.S.
.05	.1129	.1305	.1830	.2255	.1837	.2228	.1813	.2291	.1840	.2333	.1882	.2270		
.10	.1106	.1290	.1907	.2277	.1894	.2250	.1680	.2341	.1827	.2294	.1832	.2290	.1595	.1866
.15	.1050	.1249	.1902	.2263	.1895	.2243	.1778	.2303	.1849	.2268	.1797	.2258	.1507	.1802
.20	.0896	.1133	.1839	.2207	.1872	.2226			.1850	.2247	.1840	.2235	.1432	.1706
.25			.0465	.0509	.1619	.1902	.1686	.2218	.1821	.2206	.1827	.2206	.1392	.1625
.30	.0075	.0148	.0157	.0254	.0260	.0378	.0509	.0572	.0961	.1051	.1741	.2112	.1362	.1569
.40									.0159	.0245	.0248	.0360	.0118	.0252
.50	-.0117	.0035	-.0002	.0112	.0074	.0173			.0089	.0172	.0069	.0160	-.0022	.0004
.60	-.0072	.0015	-.0033	.0074	.0057	.0147	.0071	.0142	.0065	.0140	.0000	.0095	-.0092	-.0049
.70	-.0052	.0024	-.0061	.0040	.0011	.0099	-.0036	.0054	-.0113	-.0038			-.0423	-.0398
.80	-.0391	-.0395	-.0521	-.0473	-.0455	-.0419	-.0502	-.0468	-.0465	-.0447	-.0522	-.0512	-.0558	-.0463
.90	-.0498	-.0480	-.0496		-.0446	-.0447	-.0457	-.1432	-.0463	-.0452	-.0485	-.0470	-.0560	-.0508
.95	-.0518	-.0461	-.0466	-.0292	-.0440	-.0428	-.0432	.1070	-.0444	-.0430	-.0474	-.0459	-.0538	-.0496

TAIL 1

Cp at y/b of														
x/c	0.02		0.22		0.44		0.56		0.67		0.83		0.98	
	U.S.	L.S.	U.S.	L.S.	U.S.	L.S.	U.S.	L.S.	U.S.	L.S.	U.S.	L.S.	U.S.	L.S.
.05	.0254	.1378	.1044	.3483			.1135	.3381	.1200	.3360	.1200	.3329	.1108	.3382
.10	.0353	.1492	.0931	.3394			.1070	.3228	.1095	.3220	.1123	.3247	.0998	.3020
.15	.0335	.1489	.0897	.3309			.1031	.3139	.1044	.3127	.1089	.3167	.0831	.2647
.20							.1013	.3057	.1025	.3041		.1084	.0790	.2403
.25	-.0050	.0571	-.0007	.1173			.0947	.2876	.0980	.2913	.1042	.2981	.0727	.2297
.30			-.0081	.0793	-.0035	.0830	-.0004	.1026	.0466	.1863				
.40	-.0240	.0526			-.0156	.0649	-.0180	.0675	-.0104	.0742	-.0034	.0818		
.50	-.0146	.0457					-.0217	.0614	-.0209	.0616			.0098	.0449
.60					-.0233	.0595	-.0240	.0590	-.0207	.0596	-.0181	.0521	-.0254	.0049
.70			-.0207	.0488	-.0274	.0528	-.0021	.0566	-.0313	.0276	-.0473	-.0243	-.0463	-.0371
.80	-.0266	-.0201	-.0358	-.0305		-.0333			-.0242	-.0145	-.0438	-.0438	.0043	-.0165
.90	-.0384	-.0376			-.0353	-.0382			-.0395	-.0422	-.0416	-.0469	-.0493	-.0425
.95	-.0370	-.0418							-.0406	-.0441	-.0417	-.0465	-.0487	-.0430

TAIL 2

TABLE XI. - CONTINUED
(1) $\alpha = 6.09^\circ$

Cp at y/b of														
x/c	0.02		0.22		0.44		0.56		0.67		0.83		0.93	
	U.S.	L.S.	U.S.	L.S.	U.S.	L.S.	U.S.	L.S.	U.S.	L.S.	U.S.	L.S.	U.S.	L.S.
.05	.1359	.1577	.1965	.2398	.1964	.2350	.1897	.2411	.1992	.2492	.2026	.2416		
.10	.1313	.1530	.2042	.2414	.2020	.2378	.1808	.2484	.1958	.2423	.1969	.2437	.1720	.2004
.15	.1238	.1467	.2035	.2336	.2020	.2369	.1906	.2433	.1971	.2387	.1933	.2399	.1638	.1947
.20	.1053	.1329	.1966	.2332	.1996	.2349			.1969	.2365	.1976	.2374	.1570	.1859
.25			.0528	.0561	.1734	.2012	.1807	.2342	.1938	.2323	.1962	.2343	.1572	.1781
.30	.0123	.0191	.0201	.0296	.0306	.0414	.0563	.0631	.1037	.1110	.1870	.2247	.1500	.1708
.40									.0207	.0283	.0302	.0413	.0169	.0316
.50	-.0089	.0066	.0040	.0155	.0113	.0206			.0138	.0209	.0111	.0202	.0050	.0103
.60	-.0047	.0039	.0004	.0116	.0093	.0180	.0105	.0176	.0109	.0175	.0026	.0115	-.0029	.0035
.70	-.0059	.0025	-.0024	.0083	.0044	.0134	-.0004	.0076	-.0080	-.0013			-.0417	-.0373
.80	-.0421	-.0412	-.0510	-.0452	-.0459	-.0420	-.0491	-.0470	-.0465	-.0444	-.0525	-.0519	-.0549	-.0470
.90	-.0510	-.0473	-.0503		-.0441	-.0457	-.0430	-.1437	-.0449	-.0434	-.0474	-.0459	-.0578	-.0542
.95	-.0515	-.0448	-.0467	-.0305	-.0427	-.0424	-.0407	.1058	-.0427	-.0412	-.0431	-.0448	-.0556	-.0542

TAIL 1

Cp at y/b of														
x/c	0.02		0.22		0.44		0.56		0.67		0.83		0.98	
	U.S.	L.S.	U.S.	L.S.	U.S.	L.S.	U.S.	L.S.	U.S.	L.S.	U.S.	L.S.	U.S.	L.S.
.05	.0008	.1625	.0614	.4128			.0749	.4019	.0820	.3977	.0799	.3902	.0729	.3943
.10	.0100	.1734	.0490	.4048			.0684	.3851	.0723	.3837	.0713	.3825	.0633	.3519
.15	.0097	.1749	.0455	.3959			.0647	.3760	.0669	.3741	.0680	.3747	.0493	.3102
.20							.0628	.3673	.0648	.3648		.1321	.0444	.2869
.25	-.0190	.0782	-.0195	.1540			.0574	.3475	.0608	.3506	.0652	.3550	.0407	.2727
.30			-.0199	.1146	-.0196	.1188	-.0163	.1368	.0200	.2305				
.40	-.0334	.0823			-.0296	.1017	-.0323	.1015	-.0241	.1077	-.0196	.1153		
.50	-.0210	.0743					-.0356	.0953	-.0344	.0943			.0061	-.0597
.60					-.0382	.0945	-.0379	.0926	-.0337	.0914	-.0298	.0844	-.0276	.0222
.70			-.0281	.0779	-.0403	.0870	-.0109	.0875	-.0362	.0586	-.0462	-.0095	-.0534	-.0361
.80	-.0289	-.0062	-.0392	-.0173		-.0190			-.0259	-.0016	-.0445	-.0331	.0012	-.0091
.90	-.0382	-.0307			-.0364	-.0293			-.0412	-.0317	-.0431	-.0389	-.0459	-.0368
.95	-.0366	-.0354							-.0422	-.0359	-.0436	-.0414	-.0464	-.0408

TAIL 2

TABLE XI. - CONTINUED
(g) $\alpha = 8.09^\circ$

Cp at y/b of														
x/c	0.02		0.22		0.44		0.56		0.67		0.83		0.98	
	U.S.	L.S.	U.S.	L.S.	U.S.	L.S.	U.S.	L.S.	U.S.	L.S.	U.S.	L.S.	U.S.	L.S.
.05	.1657	.1903	.2226	.2677	.2197	.2591	.2068	.2639	.2204	.2736	.2235	.2644		
.10	.1600	.1843	.2309	.2693	.2253	.2623	.2008	.2723	.2177	.2675	.2181	.2666	.1905	.2201
.15	.1504	.1758	.2299	.2670	.2253	.2611	.2119	.2668	.2189	.2634	.2142	.2628	.1828	.2150
.20	.1278	.1585	.2226	.2598	.2228	.2587			.2183	.2602	.2189	.2601	.1762	.2069
.25			.0654	.0680	.1946	.2229	.2013	.2560	.2145	.2553	.2173	.2566	.1722	.1995
.30	.0225	.0289	.0303	.0401	.0368	.0491	.0627	.0675	.1180	.1252	.2077	.2464	.1708	.1928
.40									.0290	.0374	.0389	.0505	.0264	.0411
.50	-.0014	.0162	.0135	.0257	.0195	.0296			.0219	.0297	.0187	.0280	.0141	.0217
.60	.0031	.0128	.0099	.0219	.0175	.0267	.0182	.0261	.0186	.0258	.0087	.0179	.0064	.0133
.70	.0010	.0105	.0067	.0179	.0120	.0217	.0069	.0156	-.0016	.0056			-.0378	-.0327
.80	-.0411	-.0386	-.0474	-.0422	-.0438	-.0395	-.0465	-.0450	-.0443	-.0426	-.0506	-.0498	-.0531	-.0398
.90	-.0495	-.0455	-.0473		-.0418	-.0439	-.0386	-.1431	-.0406	-.0398	-.0440	-.0425	-.0582	-.0547
.95	-.0493	-.0426	-.0438	-.0284	-.0388	-.0392	-.0365	-.1112	-.0382	-.0372	-.0425	-.0412	-.0583	-.0570

TAIL 1

Cp at y/b of														
x/c	0.02		0.22		0.44		0.56		0.67		0.83		0.98	
	U.S.	L.S.	U.S.	L.S.	U.S.	L.S.	U.S.	L.S.	U.S.	L.S.	U.S.	L.S.	U.S.	L.S.
.05	-.0176	.1454	.0237	.4693			.0406	.4652	.0404	.4564	.0467	.4533	.0486	.4587
.10	-.0073	.1644	.0120	.4631			.0333	.4458	.0331	.4430	.0368	.4458	.0405	.4099
.15	-.0064	.1728	.0095	.4549			.0295	.4362	.0295	.4338	.0329	.4376	.0291	.3647
.20							.0274	.4266	.0283	.4237		.1349	.0244	.3412
.25	-.0273	.0870	-.0337	.1885			.0254	.4050	.0256	.4085	.0309	.4157	.0218	.3217
.30			-.0286	.1421	-.0310	.1541	-.0287	.1715	-.0039	.2754				
.40	-.0393	.1063			-.0392	.1370	-.0435	.1370	-.0347	.1440	-.0328	.1516		
.50	-.0312	.0985					-.0462	.1314	-.0449	.1301			.0005	.0463
.60					-.0466	.1301	-.0478	.1290	-.0437	.1268	-.0383	.1186	-.0360	.0425
.70			-.0338	.1041	-.0438	.1219	-.0141	.1193	-.0373	.0898	-.0473	.0069	-.0558	-.0326
.80	-.0335	.0087	-.0421	-.0053		-.0042			-.0289	.0067	-.0462	-.0201	-.0041	-.0108
.90	-.0414	-.0220			-.0395	-.0188			-.0439	-.0179	-.0451	-.0275	-.0472	-.0344
.95	-.0400	-.0270							-.0453	-.0223	-.0456	-.0312	-.0465	-.0392

TAIL 2

TABLE XI. - CONTINUED
(h) $\alpha = 10.09^\circ$

Cp at y/b of														
x/c	0.02		0.22		0.44		0.56		0.67		0.83		0.98	
	U.S.	L.S.	U.S.	L.S.	U.S.	L.S.	U.S.	L.S.	U.S.	L.S.	U.S.	L.S.	U.S.	L.S.
.05	.2037	.2290	.2579	.3053	.2508	.2912	.2307	.2953	.2479	.3035	.2503	.2935		
.10	.1958	.2215	.2671	.3073	.2568	.2952	.2282	.3048	.2452	.2973	.2442	.2953	.2137	.2454
.15	.1837	.2108	.2660	.3043	.2568	.2938	.2406	.2982	.2472	.2935	.2402	.2914	.2067	.2408
.20	.1586	.1902	.2578	.2966	.2541	.2913			.2465	.2900	.2452	.2884	.2005	.2328
.25			.0834	.0854	.2235	.2524	.2290	.2857	.2426	.2853	.2436	.2851	.1964	.2261
.30	.0402	.0440	.0458	.0555	.0536	.0615	.0740	.0778	.1380	.1442	.2333	.2743	.1946	.2194
.40									.0416	.0498	.0508	.0630	.0386	.0519
.50	.0112	.0311	.0283	.0408	.0328	.0425			.0339	.0413	.0292	.0385	.0262	.0341
.60	.0169	.0268	.0247	.0368	.0305	.0400	.0304	.0384	.0305	.0376	.0183	.0277	.0177	.0246
.70	.0147	.0240	.0210	.0317	.0247	.0347	.0185	.0268	.0075	.0145			-.0321	-.0274
.80	-.0364	-.0325	-.0412	-.0380	-.0400	-.0353	-.0421	-.0412	-.0406	-.0395	-.0458	-.0444	-.0530	-.0348
.90	-.0448	-.0412	-.0414		-.0354	-.0383	-.0324	-.1437	-.0344	-.0340	-.0386	-.0369	-.0576	-.0541
.95	-.0451	-.0386	-.0376	-.0241	-.0314	-.0336	-.0301	-.1155	-.0320	-.0313	-.0370	-.0355	-.0596	-.0578

TAIL 1

Cp at y/b of														
x/c	0.02		0.22		0.44		0.56		0.67		0.83		0.98	
	U.S.	L.S.	U.S.	L.S.	U.S.	L.S.	U.S.	L.S.	U.S.	L.S.	U.S.	L.S.	U.S.	L.S.
.05	-.0268	.1237	-.0010	.5199			.0126	.5286	.0233	.5299	.0308	.5293	.0338	.5316
.10	-.0179	.1517	-.0109	.5155			.0044	.5099	.0137	.5153	.0208	.5219	.0273	.4762
.15	-.0163	.1625	-.0132	.5066			-.0001	.5009	.0065	.5040	.0164	.5129	.0183	.4302
.20							-.0029	.4913	.0033	.4927		.1430	.0150	.4014
.25	-.0329	.0937	-.0429	.2156			-.0037	.4678	-.0000	.4762	.0135	.4886	.0139	.3804
.30			-.0345	.1677	-.0411	.1958	-.0409	.2148	-.0224	.3283				
.40	-.0464	.1341			-.0467	.1795	-.0532	.1779	-.0440	.1842	-.0405	.1964		
.50	-.0404	.1299					-.0528	.1720	-.0534	.1699			-.0048	.0383
.60					-.0493	.1688	-.0506	.1693	-.0487	.1662	-.0444	.1592	-.0435	.0686
.70			-.0380	.1304	-.0484	.1563	-.0171	.1579	-.0402	.1269	-.0522	.0268	-.0585	-.0246
.80	-.0413	.0290	-.0451	.0091		.0133			-.0333	.0199	-.0518	-.0023	-.0092	-.0123
.90	-.0471	-.0076			-.0442	-.0031			-.0490	.0023	-.0508	-.0110	-.0517	-.0359
.95	-.0455	-.0135							-.0506	-.0027	-.0513	-.0155	-.0525	-.0396

TAIL 2

TABLE XI. - CONTINUED
(I) $\alpha = 12.09^\circ$

Cp at y/b of														
x/c	0.02		0.22		0.44		0.56		0.67		0.83		0.98	
	U.S.	L.S.	U.S.	L.S.	U.S.	L.S.	U.S.	L.S.	U.S.	L.S.	U.S.	L.S.	U.S.	L.S.
.05	.2474	.2755	.2997	.3504	.2878	.3308	.2597	.3350	.2805	.3403	.2817	.3277		
.10	.2371	.2658	.3098	.3527	.2941	.3358	.2618	.3451	.2777	.3346	.2759	.3303	.2415	.2748
.15	.2220	.2524	.3084	.3493	.2943	.3343	.2745	.3373	.2800	.3308	.2717	.3260	.2351	.2704
.20	.1935	.2279	.2994	.3409	.2917	.3314			.2795	.3275	.2774	.3228	.2294	.2627
.25			.1046	.1070	.2583	.2890	.2613	.3229	.2752	.3218	.2756	.3189	.2249	.2562
.30	.0595	.0638	.0639	.0749	.0698	.0794	.0880	.0964	.1606	.1675	.2640	.3077	.2229	.2491
.40									.0561	.0664	.0646	.0778	.0541	.0636
.50	.0260	.0507	.0459	.0599	.0485	.0599			.0477	.0568	.0410	.0507	.0401	.0472
.60	.0329	.0454	.0424	.0551	.0460	.0569	.0446	.0505	.0440	.0529	.0294	.0393	.0383	.0371
.70	.0316	.0423	.0379	.0497	.0398	.0511	.0319	.0377	.0182	.0270			-.0258	-.0207
.80	-.0291	-.0217	-.0345	-.0310	-.0339	-.0288	-.0364	-.0343	-.0361	-.0343	-.0388	-.0367	-.0517	-.0334
.90	-.0372	-.0325	-.0339		-.0273	-.0295	-.0249	-.1439	-.0277	-.0259	-.0321	-.0299	-.0561	-.0541
.95	-.0392	-.0313	-.0291	-.0165	-.0236	-.0241	-.0226	.1263	-.0251	-.0230	-.0309	-.0286	-.0589	-.0580

TAIL 1

Cp at y/b of														
x/c	0.02		0.22		0.44		0.56		0.67		0.83		0.98	
	U.S.	L.S.	U.S.	L.S.	U.S.	L.S.	U.S.	L.S.	U.S.	L.S.	U.S.	L.S.	U.S.	L.S.
.05	-.0451	.1636	-.0242	.5762			.0058	-.6092	.0150	-.6158	.0223	.6184	.0248	.6121
.10	-.0367	.1747	-.0360	.5775			-.0050	.5896	.0050	.5982	.0116	.6094	.0195	.5529
.15	-.0332	.1810	-.0382	.5648			-.0101	.5792	-.0028	.5849	.0062	.5991	.0127	.5036
.20							-.0134	.5686	-.0060	.5731		.1582	.0108	.4707
.25	-.0451	.1127	-.0528	.2503			-.0170	.5422	-.0097	.5545	.0024	.5719	.0108	.4483
.30			-.0386	.2000	-.0497	.2386	-.0504	.2632	-.0305	.3884				
.40	-.0556	.1704			-.0529	.2218	-.0598	.2225	-.0507	.2312	-.0477	.2472		
.50	-.0507	.1692					-.0591	.2162	-.0593	.2162			-.0027	.0343
.60					-.0551	.2044	-.0570	.2128	-.0550	.2121	-.0512	.2058	-.0509	.0999
.70			-.0448	.1611	-.0551	.1897	-.0222	.1967	-.0466	.1672	-.0597	.0505	-.0635	-.0102
.80	-.0456	.0429	-.0508	.0270		.0295			-.0371	.0355	-.0590	.0188	-.0073	-.0064
.90	-.0536	.0062			.0273	.0129			-.0560	.0235	-.0583	.0091	-.0610	-.0276
.95	-.0517	.0013							-.0578	.0185	-.0589	.0036	-.0611	-.0319

TAIL 2

TABLE XI. - CONTINUED
(j) $\alpha = 25.09^\circ$

Cp at y/b of														
x/c	0.02		0.22		0.44		0.56		0.67		0.83		0.98	
	U.S.	L.S.	U.S.	L.S.	U.S.	L.S.	U.S.	L.S.	U.S.	L.S.	U.S.	L.S.	U.S.	L.S.
.05	.3545	.3885	.4053	.4633	.3811	.4295	.3328	.4274	.3622	.4295	.3563	.4090		
.10	.3381	.3736	.4181	.4669	.3884	.4367	.3458	.4409	.3595	.4236	.3499	.4120	.1936	.2336
.15	.3166	.3537	.4171	.4620	.3891	.4351	.3597	.4305	.3625	.4199	.3450	.4075	.2135	.2541
.20	.2814	.3206	.4064	.4523	.3869	.4316			.3621	.4161	.3515	.4036	.2209	.2607
.25			.1606	.1625	.3478	.3819	.3427	.4145	.3576	.4098	.3476	.3982	.2256	.2631
.30	.1095	.1066	.1134	.1251	.1138	.1162	.1299	.1468	.2183	.2252	.3328	.3847	.2318	.2635
.40									.0951	.1058	.0959	.1097	.0853	.0942
.50	.0698	.0994	.0938	.1084	.0913	.1022			.0858	.0945	.0683	.0780	.0687	.0763
.60	.0771	.0906	.0891	.1018	.0890	.0990	.0850	.0944	.0812	.0898	.0555	.0650	.0600	.0732
.70	.0813	.0866	.0834	.0950	.0814	.0932	.0699	.0801	.0483	.0579			-.0230	-.0124
.80	-.0043	.0031	-.0164	-.0127	-.0162	-.0134	-.0198	-.0210	-.0241	-.0250	-.0185	-.0187	-.0401	-.0321
.90	-.0146	-.0153	-.0102		-.0061	-.0123	-.0047	-.1439	-.0096	-.0100	-.0145	-.0140	-.0452	-.0445
.95	-.0208	-.0178	-.0045	.0034	-.0027	-.0051	-.0018	.1435	-.0067	-.0070	-.0139	-.0129	-.0424	-.0466

TAIL 1

Cp at y/b of														
x/c	0.02		0.22		0.44		0.56		0.67		0.83		0.98	
	U.S.	L.S.	U.S.	L.S.	U.S.	L.S.	U.S.	L.S.	U.S.	L.S.	U.S.	L.S.	U.S.	L.S.
.05	-.0598	.2372	-.0275	.7503			.0049	.8139	.0126	.8295	.0196	.8297	.0247	.8029
.10	-.0473	.2315	-.0394	.7398			-.0071	.7920	.0021	.8043	.0080	.8165	.0191	.7366
.15	-.0456	.2393	-.0429	.7104			-.0129	.7791	-.0062	.7884	.0023	.8042	.0148	.6771
.20							-.0166	.7667	-.0098	.7742		.2190	.0142	.6379
.25	-.0528	.1673	-.0567	.3352			-.0197	.7332	-.0134	.7500	-.0009	.7712	.0143	.6111
.30			-.0398	.2814	-.0516	.3457	-.0520	.3766	-.0330	.5337				
.40	-.0600	.2565			-.0558	.3197	-.0610	.3338	-.0521	.3481	-.0485	.3694		
.50	-.0550	.2555					-.0622	.3230	-.0605	.3302			.0014	.0364
.60					-.0589	.2	-.0604	.3127	-.0572	.3224	-.0514	.3173	-.0510	.1769
.70			-.0482	.2431	-.0585	.2	-.0236	.2865	-.0478	.2651	-.0609	.1093	-.0639	.0287
.80	-.0435	.0740	-.0540	.0744		.07			-.0369	.0804	-.0603	.0735	-.0031	.0172
.90	-.0591	.0455			.0283	.0552			-.0572	.0744	-.0596	.0617	-.0612	.0043
.95	-.0578	.0446							-.0589	.0671	-.0603	.0545	-.0625	-.0032

TAIL 2

TABLE XI. - CONCLUDED
(k) $\alpha = 20.08^\circ$

Cp at y/b of														
x/c	0.02		0.22		0.44		0.56		0.67		0.83		0.98	
	U.S.	L.S.	U.S.	L.S.	U.S.	L.S.	U.S.	L.S.	U.S.	L.S.	U.S.	L.S.	U.S.	L.S.
.05	.4884	.5276	.5343	.6022	.4961	.5517	.4270	.5494	.4588	.5366	.2027	.2374		
.10	.4629	.5054	.5493	.6071	.5044	.5605	.4497	.5591	.4472	.5224	.1955	.2375	.1667	.2021
.15	.4341	.4777	.5486	.6004	.5057	.5584	.4657	.5447	.4493	.5145	.1924	.2348	.1727	.2043
.20	.3907	.4358	.5358	.5892	.5045	.5537			.4494	.5090	.1961	.2335	.1777	.2049
.25			.2305	.2332	.4574	.4951	.4439	.5236	.4468	.5027	.1929	.2311	.1790	.2060
.30	.1696	.1665	.1769	.1911	.1677	.1758	.1835	.2046	.2695	.2793	.1821	.2195	.1849	.2070
.40									.1294	.1419	.0320	.0379	.0352	.0394
.50	.1309	.1671	.1549	.1710	.1452	.1586			.1259	.1354	.0190	.0263	.0078	.0293
.60	.1324	.1526	.1478	.1618	.1420	.1532	.1316	.1404	.1257	.1363	.0194	.0308	-.0162	.0032
.70	.1439	.1511	.1408	.1533	.1317	.1466	.1142	.1232	.0889	.1025			-.0463	-.0445
.80	.0288	.0422	.0081	.0131	.0061	.0093	-.0010	-.0015	-.0188	-.0163	-.0331	-.0325	-.0579	-.0547
.90	.0141	.0171	.0187		.0128	.0090	.0079	-.1445	-.0138	-.0160	-.0292	-.0276	-.0572	-.0566
.95	.0061	.0090	.0256	.0325	.0200	.0194	.0167	.1607	-.0008	-.0016	-.0280	-.0261	-.0557	-.0556

TAIL 1

Cp at y/b of														
x/c	0.02		0.22		0.44		0.56		0.67		0.83		0.98	
	U.S.	L.S.	U.S.	L.S.	U.S.	L.S.	U.S.	L.S.	U.S.	L.S.	U.S.	L.S.	U.S.	L.S.
.05	-.0647	.3028	-.0234	.9690			.0119	1.0840	-.0191	1.1044	.0250	1.1035	.0368	1.0423
.10	-.0542	.2981	-.0378	.9315			-.0028	1.0551	-.0072	1.0738	.0113	1.0853	.0303	.9720
.15	-.0532	.3096	-.0432	.8921			-.0102	1.0389	-.0025	1.0547	.0041	1.0691	.0272	.9014
.20							-.0146	1.0191	-.0065	1.0357		.2741	.0256	.8535
.25	-.0602	.2381	-.0584	.4427			-.0193	.9693	-.0111	1.0014	.0004	1.0225	.0269	.8174
.30			-.0403	.3849	-.0520	.4623	-.0530	.5125	-.0320	.7203				
.40	-.0634	.3623			-.0572	.4328	-.0612	.4613	-.0522	.4908	-.0482	.5225		
.50	-.0592	.3526					-.0631	.4431	-.0608	.4647			.0188	.0734
.60					-.0614	.3992	-.0631	.4278	-.0581	.4493	-.0510	.4574	-.0495	.2775
.70			-.0502	.3511	-.0602	.3775	-.0252	.3926	-.0498	.3750	-.0633	.1838	-.0659	.0822
.80	-.0334	.1163	-.0559	.1384		.1300			-.0340	.1399	-.0623	.1407	.0142	.0604
.90	-.0621	.1083			.0289	.1096			-.0589	.1340	-.0609	.1241	-.0604	.0537
.95	-.0608	.0990							-.0602	.1242	-.0620	.1142	-.0628	.0439

TAIL 2

TABLE XII. - PRESSURE COEFFICIENTS, $\phi = 22.5^\circ$, $\delta = 0^\circ$, $M = 3.70$
 (a) $\alpha = -3.87^\circ$

Cp at y/b of														
x/c	0.02		0.22		0.44		0.56		0.67		0.83		0.98	
	U.S.	L.S.	U.S.	L.S.	U.S.	L.S.	U.S.	L.S.	U.S.	L.S.	U.S.	L.S.	U.S.	L.S.
.05	.0399	.0984	.2344	.1318	.2288	.1692	.2323	.1765	.2220	.1814	.2210	.1789		
.10	.0445	.0983	.2354	.1334	.2352	.1704	.2125	.1784	.2229	.1788	.2185	.1795	.1992	.1470
.15	.0466	.0935	.2323	.1373	.2357	.1691	.2216	.1778	.2265	.1764	.2158	.1764	.1898	.1423
.20	.0368	.0830	.2254	.1400	.2334	.1676			.2267	.1746	.2212	.1740	.1765	.1341
.25			.0654	.0189	.2030	.1423	.2102	.1679	.2221	.1712	.2199	.1714	.1684	.1286
.30	.0070	.0151	.0321	.0018	.0505	.0139	.0619	.0291	.1227	.0723	.2101	.1632	.1619	.1234
.40									.0354	.0038	.0442	.0155	.0303	.0058
.50	.0124	.0051	.0064	-.0079	.0340	-.0059			.0298	-.0009	.0281	-.0010	-.0053	-.0192
.60	.0229	.0024	-.0000	-.0105	.0322	-.0081	.0295	-.0049	.0272	-.0052	.0216	-.0059	-.0140	-.0260
.70	.0198	.0015	-.0015	-.0120	.0276	-.0118	.0187	-.0134	.0060	-.0188			-.0435	-.0489
.80	-.0272	-.0402	-.0479	-.0499	-.0380	-.0474	-.0422	-.0464	-.0407	-.0385	-.0480	-.0477	-.0478	-.0483
.90	-.0377	-.0463	-.0479	-.0439	-.0486	-.0426	-.0481	-.0339	-.0497	-.0419	-.0507	-.0441	-.0470	-.0410
.95	-.0423	-.0428	-.0451	-.0448	-.0475	-.0413	-.0466	-.0410	-.0465	-.0418	-.0479	-.0437	-.0454	-.0437

TAIL 1

Cp at y/b of														
x/c	0.02		0.22		0.44		0.56		0.67		0.83		0.98	
	U.S.	L.S.	U.S.	L.S.	U.S.	L.S.	U.S.	L.S.	U.S.	L.S.	U.S.	L.S.	U.S.	L.S.
.05	.1847	.0191	.3228	.1200			.3009	.1351	.3054	.1388	.3047	.1434	.2798	.1537
.10	.1887	.0279	.3163	.1054			.2965	.1228	.2939	.1273	.2995	.1323	.2615	.1258
.15	.1739	.0281	.3113	.0984			.2926	.1165	.2892	.1193	.2955	.1252	.2355	.1024
.20							.2907	.1108	.2876	.1133		.0680	.2299	.0909
.25	.0691	-.0229	.1078	.0008			.2751	.1004	.2802	.1065	.2846	.1137	.2115	.0836
.30			.0789	-.0037	.0816	-.0063	.0925	.0044	.1797	.0492				
.40	.0467	.0465			.0665	-.0212	.0663	-.0203	.0718	-.0128	.0793	-.0063		
.50	.0461	-.0270					.0611	-.0250	.0606	-.0236			.0206	.0616
.60					.0627	-.0292	.0605	-.0276	.0595	-.0231	.0550	-.0242	.0061	-.0214
.70			.0544	-.0235	.0565	-.0327	.0609	-.0045	.0123	-.0302	-.0238	-.0526	-.0301	-.0486
.80	-.0098	-.0496	-.0221	-.0397	.0585	-.0436			-.0159	-.0167	-.0406	-.0477	.0129	.0363
.90	-.0288	-.0515			-.0297	-.0383			-.0366	-.0426	-.0428	-.0464	-.0239	-.0520
.95	-.0322	-.0475							-.0402	-.0446	-.0448	-.0461	-.0306	-.0530

TAIL 2

TABLE XII. - CONTINUED
(b) $\alpha = -1.89^\circ$

Cp at γ/b of														
x/c	0.02		0.22		0.44		0.56		0.67		0.83		0.98	
	U.S.	L.S.	U.S.	L.S.	U.S.	L.S.	U.S.	L.S.	U.S.	L.S.	U.S.	L.S.	U.S.	L.S.
.05	.0637	.0706	.2072	.1873	.2032	.1947	.2094	.2022	.2027	.2049	.2033	.1995		
.10	.0678	.0741	.2140	.1896	.2091	.1966	.1888	.2046	.2020	.2022	.1991	.2007	.1782	.1612
.15	.0671	.0738	.2130	.1891	.2095	.1957	.1986	.2034	.2049	.1996	.1966	.1976	.1696	.1551
.20	.0551	.0642	.2076	.1861	.2075	.1945			.2052	.1976	.2015	.1953	.1583	.1461
.25			.0594	.0373	.1802	.1665	.1884	.1925	.2018	.1938	.2004	.1923	.1505	.1406
.30	.0123	.0129	.0282	.0123	.0396	.0259	.0501	.0408	.1105	.0902	.1915	.1835	.1440	.1363
.40									.0251	.0134	.0354	.0243	.0214	.0114
.50	.0081	.0104	.0045	-.0064	.0206	.0054			.0199	.0080	.0189	.0070	-.0105	-.0144
.60	.0218	.0118	-.0014	-.0104	.0188	.0032	-.0185	.0043	.0170	.0042	.0132	.0013	-.0170	-.0207
.70	.0235	.0135	-.0035	-.0115	.0141	-.0006	.0079	-.0037	-.0015	-.0112			-.0423	-.0468
.80	-.0268	-.0325	-.0494	-.0512	-.0391	-.0471	-.0445	-.0499	-.0422	-.0435	-.0497	-.0495	-.0474	-.0502
.90	-.0381	-.0433	-.0475	-.0445	-.0478	-.0430	-.0482	-.0418	-.0483	-.0435	-.0493	-.0453	-.0425	-.0399
.95	-.0420	-.0424	-.0450	-.0440	-.0456	-.0425	-.0451	-.0430	-.0451	-.0426	-.0465	-.0447	-.0423	-.0434

TAIL 1

Cp at γ/b of														
x/c	0.02		0.22		0.44		0.56		0.67		0.83		0.98	
	U.S.	L.S.	U.S.	L.S.	U.S.	L.S.	U.S.	L.S.	U.S.	L.S.	U.S.	L.S.	U.S.	L.S.
.05	.1248	.0529	.2637	.1691			.2510	.1797	.2561	.1825	.2563	.1853	.2357	.1937
.10	.1331	.0577	.2558	.1562			.2459	.1671	.2442	.1697	.2504	.1743	.2200	.1652
.15	.1253	.0548	.2508	.1481			.2417	.1598	.2397	.1613	.2465	.1668	.1968	.1394
.20							.2397	.1534	.2381	.1545		.0554	.1914	.1244
.25	.0439	-.0092	.0753	.0221			.2255	.1396	.2313	.1466	.2369	.1528	.1740	.1129
.30			.0496	.0057	.0547	.0064	.0659	.0241	.1437	.0780				
.40	.0230	.0491			.0396	-.0106	.0405	-.0061	.0467	.0015	.0544	.0087		
.50	.0213	-.0141					.0354	-.0116	.0361	-.0090			.0185	.0409
.60					.0353	-.0166	.0345	-.0135	.0355	-.0083	.0315	-.0130	-.0043	-.0157
.70			.0273	-.0121	.0296	-.0205	.0388	.0025	-.0034	-.0233	-.0337	-.0495	-.0347	-.0472
.80	-.0199	-.0450	-.0334	-.0404	-.0319	-.0436			-.0225	-.0203	-.0480	-.0470	.0112	.0199
.90	-.0381	-.0515			-.0406	-.0372			-.0453	-.0414	-.0479	-.0447	-.0364	-.0517
.95	-.0406	-.0469							-.0459	-.0428	-.0463	-.0443	-.0460	-.0542

TAIL 2

TABLE XII. - CONTINUED
(c) $\alpha = 0.12^\circ$

Cp at γ/b of														
x/c	0.02		0.22		0.44		0.56		0.67		0.83		0.98	
	U.S.	L.S.	U.S.	L.S.	U.S.	L.S.	U.S.	L.S.	U.S.	L.S.	U.S.	L.S.	U.S.	L.S.
.05	.0805	.0865	.1834	.2164	.1833	.2174	.1884	.2238	.1841	.2250	.1833	.2152		
.10	.0810	.0915	.1909	.2200	.1889	.2198	.1673	.2269	.1829	.2228	.1797	.2183	.1604	.1769
.15	.0782	.0913	.1902	.2198	.1891	.2189	.1783	.2257	.1856	.2207	.1778	.2159	.1520	.1700
.20	.0669	.0822	.1838	.2149	.1866	.2177			.1859	.2187	.1824	.2135	.1424	.1600
.25			.0459	.0501	.1620	.1869	.1692	.2150	.1830	.2146	.1817	.2110	.1360	.1522
.30	.0108	.0152	.0175	.0227	.0289	.0329	.0415	.0495	.0973	.1030	.1734	.2018	.1299	.1472
.40									.0160	.0220	.0266	.0318	.0135	.0156
.50	-.0019	.0111	.0002	.0061	.0105	.0139			.0101	.0161	.0098	.0137	-.0118	-.0100
.60	.0097	.0120	-.0047	.0014	.0090	.0114	.0086	.0117	.0073	.0123	.0043	.0068	-.0158	-.0163
.70	.0167	.0152	-.0078	-.0026	.0043	.0073	-.0009	.0044	-.0095	-.0052			-.0426	-.0444
.80	-.0291	-.0321	-.0513	-.0506	-.0415	-.0453	-.0477	-.0487	-.0440	-.0446	-.0508	-.0501	-.0441	-.0482
.90	-.0409	-.0449	-.0465	-.0445	-.0461	-.0440	-.0467	-.0448	-.0458	-.0451	-.0476	-.0470	-.0521	-.0466
.95	-.0462	-.0454	-.0442	-.0436	-.0440	-.0433	-.0442	-.0444	-.0436	-.0434	-.0458	-.0455	-.0503	-.0505

TAIL 1

Cp at γ/b of														
x/c	0.02		0.22		0.44		0.56		0.67		0.83		0.98	
	U.S.	L.S.	U.S.	L.S.	U.S.	L.S.	U.S.	L.S.	U.S.	L.S.	U.S.	L.S.	U.S.	L.S.
.05	.0788	.0777	.2081	.2216			.2032	.2259	.2096	.2278	.2097	.2286	.1941	.2370
.10	.0911	.0843	.1996	.2106			.1979	.2128	.1982	.2146	.2040	.2195	.1805	.2082
.15	.0882	.0811	.1948	.2022			.1938	.2049	.1937	.2058	.2007	.2123	.1603	.1792
.20							.1921	.1980	.1919	.1986		.0590	.1543	.1586
.25	.0319	.0114	.0482	.0492			.1811	.1831	.1860	.1894	.1926	.1967	.1387	.1455
.30			.0278	.0231	.0361	.0273	.0429	.0468	.1105	.1096				
.40	.0079	.0525			.0220	.0087	.0195	.0137	.0261	.0211	.0353	.0295		
.50	.0076	.0063					.0151	.0076	.0154	.0098			.0143	.0380
.60					.0150	.0034	.0134	.0056	.0150	.0097	.0142	.0041	-.0110	-.0111
.70			.0071	.0022	.0097	-.0017	.0250	.0152	-.0119	-.0104	-.0398	-.0434	-.0378	-.0419
.80	-.0232	-.0373	-.0397	-.0415	-.0397	-.0467			-.0264	-.0232	-.0512	-.0492	.0078	.0178
.90	-.0406	-.0472			-.0401	-.0366			-.0438	-.0405	-.0458	-.0440	-.0462	-.0423
.95	-.0427	-.0452							-.0430	-.0411	-.0441	-.0428	-.0500	-.0483

TAIL 2

TABLE XII. - CONTINUED
(d) $\alpha = 2.11^\circ$

Cp at γ/b of														
x/c	0.02		0.22		0.44		0.56		0.67		0.83		0.98	
	U.S.	L.S.	U.S.	L.S.	U.S.	L.S.	U.S.	L.S.	U.S.	L.S.	U.S.	L.S.	U.S.	L.S.
.05	.0832	.1191	.1623	.2409	.1642	.2366	.1683	.2445	.1669	.2454	.1695	.2366		
.10	.0829	.1221	.1687	.2437	.1693	.2395	.1494	.2484	.1648	.2431	.1642	.2391	.1433	.1933
.15	.0793	.1200	.1682	.2435	.1696	.2389	.1590	.2459	.1669	.2403	.1605	.2356	.1344	.1863
.20	.0668	.1097	.1623	.2386	.1673	.2373			.1670	.2381	.1642	.2325	.1268	.1751
.25			.0352	.0612	.1436	.2037	.1496	.2338	.1642	.2338	.1630	.2294	.1227	.1678
.30	.0020	.0211	.0001	.0331	.0214	.0426	.0363	.0563	.0840	.1112	.1549	.2197	.1190	.1614
.40									.0086	.0298	.0175	.0397	.0074	.0237
.50	-.0143	.0122	-.0077	.0180	.0021	.0226			.0023	.0239	.0010	.0209	-.0095	-.0038
.60	-.0088	.0111	-.0114	.0137	.0006	.0203	.0008	.0197	.0001	.0202	-.0031	.0138	-.0149	-.0097
.70	-.0015	.0137	-.0139	.0088	-.0037	.0161	-.0075	.0131	-.0156	.0009			-.0438	-.0411
.80	-.0359	-.0352	-.0535	-.0472	-.0437	-.0430	-.0496	-.0469	-.0443	-.0447	-.0502	-.0505	-.0542	-.0416
.90	-.0466	-.0472	-.0470	-.0456	-.0442	-.0459	-.0451	-.0470	-.0453	-.0476	-.0473	-.0488	-.0549	-.0532
.95	-.0494	-.0473	-.0450	-.0436	-.0431	-.0445	-.0436	-.0459	-.0439	-.0447	-.0465	-.0469	-.0516	-.0527

TAIL 1

Cp at γ/b of														
x/c	0.02		0.22		0.44		0.56		0.67		0.83		0.98	
	U.S.	L.S.	U.S.	L.S.	U.S.	L.S.	U.S.	L.S.	U.S.	L.S.	U.S.	L.S.	U.S.	L.S.
.05	.0537	.0859	.1542	.2803			.1591	.2764	.1663	.2778	.1688	.2794	.1556	.2841
.10	.0624	.0972	.1446	.2699			.1535	.2626	.1552	.2642	.1612	.2698	.1437	.2545
.15	.0589	.0974	.1398	.2607			.1497	.2540	.1504	.2554	.1576	.2616	.1264	.2204
.20							.1479	.2463	.1489	.2475		.0661	.1196	.1973
.25	.0148	.0295	.0214	.0802			.1388	.2296	.1436	.2359	.1506	.2435	.1059	.1872
.30			.0072	.0469	.0158	.0510	.0219	.0711	.0796	.1446				
.40	-.0058	.0549			.0024	.0323	.0003	.0367	.0072	.0443	.0156	.0523		
.50	-.0015	.0228					-.0038	.0306	-.0032	.0326			.0113	.0381
.60					-.0049	.0273	-.0058	.0285	-.0030	.0314	-.0033	.0246	-.0176	-.0073
.70			-.0086	.0185	-.0038	.0215	.0105	.0312	-.0226	.0050	-.0467	-.0349	-.0422	-.0389
.80	-.0263	-.0297	-.0396	-.0390	-.0407	-.0423			-.0264	-.0221	-.0475	-.0488	.0052	.0168
.90	-.0414	-.0425			-.0374	-.0402			-.0411	-.0438	-.0435	-.0467	-.0488	-.0388
.95	-.0420	-.0437							-.0413	-.0424	-.0430	-.0437	-.0509	-.0408

TAIL 2

TABLE XII. - CONTINUED
(e) $\alpha = 4.10^\circ$

Cp at γ/b of														
x/c	0.02		0.22		0.44		0.56		0.67		0.83		0.98	
	U.S.	L.S.	U.S.	L.S.	U.S.	L.S.	U.S.	L.S.	U.S.	L.S.	U.S.	L.S.	U.S.	L.S.
.05	.0907	.1977	.1443	.2686	.1478	.2593	.1487	.2669	.1512	.2671	.1588	.2595		
.10	.0889	.1896	.1500	.2720	.1521	.2632	.1353	.2713	.1489	.2656	.1526	.2626	.1328	.2142
.15	.0858	.1871	.1488	.2713	.1524	.2627	.1435	.2671	.1503	.2630	.1489	.2593	.1247	.2073
.20	.0704	.1718	.1428	.2659	.1504	.2612			.1503	.2607	.1523	.2567	.1177	.1958
.25			.0257	.0737	.1277	.2252	.1346	.2580	.1483	.2563	.1505	.2536	.1141	.1879
.30	-.0047	.0357	-.0000	.0452	-.0141	.0517	.0325	.0716	.0727	.1283	.1427	.2435	.1118	.1820
.40									.0016	.0398	.0115	.0501	.0021	.0360
.50	-.0220	.0246	-.0155	.0311	-.0059	.0330			-.0040	.0335	-.0051	.0300	-.0086	.0048
.60	-.0190	.0209	-.0191	.0272	-.0070	.0305	-.0053	.0291	-.0065	.0297	-.0091	.0212	-.0164	-.0006
.70	-.0173	.0213	-.0207	.0221	-.0110	.0251	-.0159	.0204	-.0208	.0083			-.0446	-.0372
.80	-.0431	-.0346	-.0539	-.0420	-.0436	-.0399	-.0477	-.0440	-.0424	-.0431	-.0486	-.0502	-.0561	-.0390
.90	-.0490	-.0464	-.0471	-.0485	-.0408	-.0467	-.0431	-.0473	-.0444	-.0499	-.0464	-.0510	-.0518	-.0529
.95	-.0483	-.0464	-.0457	-.0442	-.0413	-.0452	-.0422	-.0460	-.0437	-.0465	-.0467	-.0486	-.0508	-.0530

TAIL 1

Cp at γ/b of														
x/c	0.02		0.22		0.44		0.56		0.67		0.83		0.98	
	U.S.	L.S.	U.S.	L.S.	U.S.	L.S.	U.S.	L.S.	U.S.	L.S.	U.S.	L.S.	U.S.	L.S.
.05	.0344	.0861	.1065	.3405			.1189	.3316	.1264	.3302	.1294	.3311	.1195	.3326
.10	.0408	.1020	.0960	.3309			.1128	.3163	.1158	.3160	.1214	.3222	.1089	.3011
.15	.0372	.1070	.0925	.3219			.1089	.3073	.1109	.3067	.1177	.3135	.0938	.2613
.20							.1070	.2987	.1091	.2983		.0750	.0869	.2412
.25	.0011	-.0435	-.0001	.1130			.1005	.2807	.1046	.2861	.1126	.2928	.0759	.2260
.30			-.0079	.0732	-.0007	.0806	.0032	.0991	.0514	.1818				
.40	-.0117	.0574			-.0134	.0631	-.0156	.0650	-.0084	.0719	-.0005	.0790		
.50	-.0039	.0406					-.0194	.0587	-.0186	.0596			.0073	.0379
.60					-.0210	.0574	-.0217	.0560	-.0181	.0571	-.0167	.0504	-.0242	.0032
.70			-.0184	.0409	-.0251	.0511	-.0008	.0537	-.0306	.0261	-.0477	-.0239	-.0460	-.0392
.80	-.0285	-.0202	-.0375	-.0331	-.0375	-.0328			-.0257	-.0175	-.0445	-.0428	.0018	.0171
.90	-.0388	-.0375			-.0358	-.0386			-.0402	-.0428	-.0422	-.0466	-.0472	-.0409
.95	-.0387	-.0405							-.0409	-.0439	-.0423	-.0461	-.0483	-.0437

TAIL 2

TABLE XII. - CONTINUED
(f) $\alpha = 6.10^\circ$

Cp at y/b of														
x/c	0.02		0.22		0.44		0.56		0.67		0.83		0.98	
	U.S.	L.S.	U.S.	L.S.	U.S.	L.S.	U.S.	L.S.	U.S.	L.S.	U.S.	L.S.	U.S.	L.S.
.05	.0817	.2668	.1329	.3054	.1405	.2915	.1404	.2981	.1481	.2996	.1563	.2917		
.10	.0796	.2487	.1368	.3091	.1437	.2962	.1298	.3043	.1437	.2971	.1498	.2950	.1323	.2436
.15	.0769	.2439	.1357	.3085	.1436	.2957	.1377	.2995	.1443	.2945	.1459	.2917	.1244	.2369
.20	.0597	.2221	.1295	.3024	.1415	.2940			.1441	.2924	.1490	.2888	.1185	.2249
.25			.0183	.0915	.1191	.2558	.1287	.2918	.1414	.2879	.1472	.2855	.1153	.2160
.30	-.0116	.0578	-.0068	.0621	.0095	.0657	.0269	.0948	.0668	.1479	.1393	.2746	.1138	.2089
.40									-.0030	.0541	.0086	.0646	.0028	.0499
.50	-.0277	.0441	-.0223	.0484	-.0117	.0472			-.0085	.0476	-.0085	.0427	-.0071	.0171
.60	-.0258	.0361	-.0257	.0443	-.0135	.0443	-.0100	.0429	-.0109	.0437	-.0137	.0325	-.0138	.0119
.70	-.0251	.0371	-.0271	.0387	-.0166	.0387	-.0206	.0333	-.0249	.0198			-.0447	-.0316
.80	-.0446	-.0332	-.0483	-.0349	-.0421	-.0358	-.0458	-.0401	-.0413	-.0402	-.0498	-.0492	-.0594	-.0356
.90	-.0469	-.0427	-.0448	-.0488	-.0407	-.0462	-.0425	-.0453	-.0444	-.0493	-.0479	-.0511	-.0546	-.0507
.95	-.0459	-.0438	-.0445	-.0452	-.0415	-.0442	-.0419	-.0449	-.0445	-.0472	-.0468	-.0488	-.0512	-.0523

TAIL 1

Cp at y/b of														
x/c	0.02		0.22		0.44		0.56		0.67		0.83		0.98	
	U.S.	L.S.	U.S.	L.S.	U.S.	L.S.	U.S.	L.S.	U.S.	L.S.	U.S.	L.S.	U.S.	L.S.
.05	.0288	.1100	.0624	.3973			.0798	.3880	.0877	.3838	.0917	.3850	.0851	.3843
.10	.0298	.0983	.0519	.3906			.0732	.3767	.0775	.3695	.0829	.3765	.0760	.3491
.15	.0252	.0903	.0493	.3837			.0691	.3613	.0724	.3599	.0791	.3674	.0626	.3085
.20							.0671	.3523	.0706	.3508			.0563	.2859
.25	-.0108	.0351	-.0191	.1498			.0627	.3333	.0666	.3370	.0754	.3448	.0484	.2683
.30			-.0200	.1046	-.0170	.1124	-.0148	.1283	.0242	.2204				
.40	-.0234	.0595			-.0280	.0958	-.0305	.0948	-.0227	.1009	-.0166	.1091		
.50	-.0168	.0660					-.0338	.0895	-.0325	.0877			.0068	.0345
.60					-.0357	.0892	-.0359	.0868	-.0316	.0849	-.0294	.0802	-.0314	.0193
.70			-.0287	.0630	-.0387	.0826	-.0107	.0817	-.0371	.0525	-.0483	-.0116	-.0498	-.0407
.80	-.0347	-.0046	-.0391	-.0248	-.0394	-.0213			-.0273	-.0104	-.0462	-.0342	.0017	.0131
.90	-.0431	-.0323			-.0378	-.0322			-.0426	-.0348	-.0447	-.0393	-.0451	-.0374
.95	-.0419	-.0390							-.0438	-.0322	-.0450	-.0415	-.0466	-.0419

TAIL 2

TABLE XII.-CONTINUED
(g) $\alpha = 8.09^\circ$

Cp at γ/b of														
x/c	0.02		0.22		0.44		0.56		0.67		0.83		0.98	
	U.S.	L.S.	U.S.	L.S.	U.S.	L.S.	U.S.	L.S.	U.S.	L.S.	U.S.	L.S.	U.S.	L.S.
.05	.0870	.3187	.1407	.3533	.1480	.3348	.1444	.3415	.1553	.3423	.1630	.3330		
.10	.0856	.2987	.1442	.3574	.1506	.3403	.1352	.3487	.1510	.3400	.1550	.3372	.1378	.2793
.15	.0819	.2882	.1428	.3567	.1503	.3396	.1432	.3428	.1511	.3361	.1509	.3336	.1311	.2723
.20	.0611	.2646	.1362	.3501	.1477	.3378			.1495	.3329	.1538	.3308	.1261	.2608
.25			.0205	.1149	.1245	.2957	.1336	.3328	.1465	.3278	.1519	.3273	.1226	.2515
.30	-.0127	.0804	-.0058	.0839	.0104	.0848	.0268	.1111	.0704	.1722	.1439	.3158	.1209	.2434
.40									-.0019	.0711	.0104	.0836	.0076	.0660
.50	-.0282	.0668	-.0217	.0704	-.0104	.0664			-.0073	.0643	-.0074	.0594	-.0029	.0329
.60	-.0268	.0576	-.0254	.0653	-.0123	.0634	-.0098	.0607	-.0107	.0603	-.0148	.0480	-.0112	.0285
.70	-.0266	.0571	-.0267	.0591	-.0165	.0572	-.0202	.0487	-.0246	.0333			-.0429	-.0228
.80	-.0427	-.0270	-.0444	-.0264	-.0397	-.0292	-.0429	-.0346	-.0386	-.0354	-.0481	-.0448	-.0588	-.0283
.90	-.0442	-.0358	-.0424	-.0447	-.0390	-.0413	-.0397	-.0414	-.0416	-.0448	-.0455	-.0481	-.0532	-.0461
.95	-.0434	-.0394	-.0421	-.0439	-.0388	-.0414	-.0393	-.0433	-.0414	-.0449	-.0447	-.0466	-.0487	-.0498

TAIL 1

Cp at γ/b of														
x/c	0.02		0.22		0.44		0.56		0.67		0.83		0.98	
	U.S.	L.S.	U.S.	L.S.	U.S.	L.S.	U.S.	L.S.	U.S.	L.S.	U.S.	L.S.	U.S.	L.S.
.05	.0258	.0186	.0260	.4514			.0436	.4470	.0512	.4436	.0571	.4423	.0533	.4401
.10	.0267	.0359	.0165	.4498			.0363	.4299	.0420	.4292	.0479	.4339	.0463	.4025
.15	.0226	.0430	.0145	.4291			.0321	.4208	.0364	.4189	.0440	.4243	.0348	.3639
.20							.0298	.4115	.0341	.4080		.0935	.0294	.3356
.25	-.0174	.0176	-.0331	.1552			.0283	.3891	.0307	.3931	.0421	.4005	.0247	.3163
.30			-.0281	.1105	-.0303	.1483	-.0306	.1689	-.0010	.2641				
.40	-.0303	.0622			-.0392	.1333	-.0427	.1303	-.0347	.1362	-.0297	.1442		
.50	-.0266	.0584					-.0455	.1257	-.0442	.1226			.0007	.0334
.60					-.0462	.1192	-.0476	.1237	-.0427	.1191	-.0388	.1141	-.0365	.0407
.70			-.0355	.0781	-.0449	.1062	-.0160	.1137	-.0396	.0841	-.0502	.0051	-.0562	-.0359
.80	-.0402	-.0004	-.0429	-.0145	-.0427	-.0129			-.0305	-.0002	-.0493	-.0208	-.0038	.0098
.90	-.0492	-.0275			-.0411	-.0255			-.0462	-.0210	-.0483	-.0273	-.0484	-.0388
.95	-.0466	-.0344							-.0476	-.0252	-.0488	-.0306	-.0484	-.0435

TAIL 2

TABLE XII. - CONTINUED
(h) $\alpha = 10.09^\circ$

Cp at y/b of														
x/c	0.02		0.22		0.44		0.56		0.67		0.83		0.98	
	U.S.	L.S.	U.S.	L.S.	U.S.	L.S.	U.S.	L.S.	U.S.	L.S.	U.S.	L.S.	U.S.	L.S.
.05	.1009	-.3763	.1566	.4112	.1624	.3877	.1562	.3946	.1680	.3929	.1748	.3825		
.10	.0993	-.3588	.1602	.4162	.1651	.3945	.1479	.4025	.1635	.3914	.1661	.3873	.1474	.3222
.15	.0955	-.3411	.1582	.4151	.1648	.3937	.1569	.3961	.1637	.3873	.1611	.3835	.1419	.3152
.20	.0717	-.3135	.1511	.4080	.1622	.3914			.1627	.3838	.1643	.3806	.1378	.3031
.25			.0275	.1440	.1376	.3444	.1462	.3828	.1590	.3779	.1627	.3768	.1344	.2937
.30	-.0093	-.1072	-.0009	-.1114	.0156	-.1083	.0307	-.1305	.0796	-.2046	.1544	-.3640	-.1327	-.2851
.40									.0039	-.0943	.0149	.1067	-.0164	-.0850
.50	-.0252	.0922	-.0174	.0974	-.0055	.0904			-.0021	-.0873	-.0036	.0797	-.0037	.0518
.60	-.0227	.0831	-.0208	.0912	-.0072	.0873	-.0054	.0842	-.0051	-.0832	-.0112	.0666	.0041	.0474
.70	-.0225	.0806	-.0227	.0841	-.0124	.0805	-.0156	.0706	-.0204	.0525			-.0433	-.0125
.80	-.0383	-.0135	-.0396	-.0155	-.0347	-.0192	-.0365	-.0255	-.0341	-.0290	-.0421	-.0382	-.0611	-.0193
.90	-.0401	-.0252	-.0375	-.0366	-.0334	-.0326	-.0339	-.0336	-.0370	-.0385	-.0402	-.0431	-.0601	-.0398
.95	-.0390	-.0303	-.0379	-.0380	-.0335	-.0341	-.0337	-.0364	-.0367	-.0399	-.0405	-.0422	-.0568	-.0466

TAIL 1

Cp at y/b of														
x/c	0.02		0.22		0.44		0.56		0.67		0.83		0.98	
	U.S.	L.S.	U.S.	L.S.	U.S.	L.S.	U.S.	L.S.	U.S.	L.S.	U.S.	L.S.	U.S.	L.S.
.05	.0146	.0118	-.0059	.4949			.0117	.4928	.0161	.4930	.0247	.4951	.0240	.4879
.10	.0203	.0221	-.0131	.4798			.0055	.4772	.0082	.4792	.0153	.4863	.0191	.4500
.15	.0161	.0284	-.0124	.4441			.0032	.4676	.0032	.4683	.0116	.4764	.0096	.4085
.20							.0030	.4578	.0015	.4580		.1010	.0052	.3793
.25	-.0211	.0129	-.0413	.1685			.0036	.4354	.0001	.4418	.0114	.4517	.0039	.3590
.30			-.0322	.1295	-.0392	.1851	-.0391	.1992	-.0210	.3020				
.40	-.0337	.0653			-.0465	.1652	-.0507	.1661	-.0429	.1713	-.0412	.1805		
.50	-.0320	.0446					-.0529	.1614	-.0517	.1585			-.0046	.0289
.60					-.0504	.1392	-.0523	.1562	-.0491	.1558	-.0457	.1490	-.0438	.0640
.70			-.0408	.0996	-.0487	.1243	-.0184	.1423	-.0416	.1194	-.0534	.0245	-.0599	-.0261
.80	-.0449	-.0017	-.0484	.0046	-.0472	-.0021			-.0341	.0136	-.0532	-.0024	-.0088	.0053
.90	-.0530	-.0234			-.0449	-.0153			-.0500	-.0023	-.0525	-.0097	-.0572	-.0380
.95	-.0496	-.0290							-.0516	-.0077	-.0530	-.0137	-.0580	-.0417

TAIL 2

TABLE XII. - CONTINUED
(i) $\alpha = 12.09^\circ$

Cp at y/b of														
x/c	0.02		0.22		0.44		0.56		0.67		0.88		0.98	
	U.S.	L.S.	U.S.	L.S.	U.S.	L.S.	U.S.	L.S.	U.S.	L.S.	U.S.	L.S.	U.S.	L.S.
.05	.1190	.4422	.1791	.4788	.1819	.4494	.1715	.4576	.1840	.4529	.1897	.4394		
.10	.1175	.4264	.1830	.4848	.1846	.4571	.1657	.4649	.1790	.4515	.1807	.4449	.1614	.3705
.15	.1134	.4034	.1808	.4838	.1840	.4560	.1739	.4585	.1793	.4474	.1758	.4410	.1572	.3633
.20	.0875	.3723	.1730	.4762	.1813	.4531			.1782	.4436	.1794	.4379	.1538	.3510
.25			.0377	.1791	.1549	.4009	.1621	.4420	.1744	.4371	.1776	.4339	.1509	.3415
.30	-.0024	.1397	.0068	.1451	.0233	.1404	.0365	.1572	.0899	.2430	.1687	.4201	.1493	.3325
.40									.0097	.1224	.0211	.1338	.0272	.1073
.50	-.0190	.1259	-.0102	.1298	.0010	.1208			.0027	.1152	.0018	.1034	.0116	.0751
.60	-.0160	.1167	-.0136	.1219	-.0010	.1175	-.0002	.1133	-.0003	.1105	-.0064	.0888	.0134	.0699
.70	-.0145	.1137	-.0165	.1141	-.0060	.1103	-.0106	.0984	-.0170	.0757			-.0468	-.0001
.80	-.0334	.0147	-.0312	-.0015	-.0268	-.0036	-.0301	-.0118	-.0286	-.0169	-.0347	-.0292	-.0612	-.0063
.90	-.0345	-.0109	-.0298	-.0241	-.0266	-.0188	-.0282	-.0216	-.0310	-.0267	-.0340	-.0349	-.0576	-.0291
.95	-.0327	-.0155	-.0300	-.0267	-.0266	-.0218	-.0280	-.0250	-.0308	-.0296	-.0340	-.0347	-.0554	-.0393

TAIL 1

Cp at y/b of														
x/c	0.02		0.22		0.44		0.56		0.67		0.88		0.98	
	U.S.	L.S.	U.S.	L.S.	U.S.	L.S.	U.S.	L.S.	U.S.	L.S.	U.S.	L.S.	U.S.	L.S.
.05	.0017	.0048	-.0226	.5285			-.0136	.5386	-.0106	.5404	-.0088	.5440	-.0040	.5343
.10	.0046	.0121	-.0310	.4956			-.0208	.5212	-.0153	.5244	-.0178	.5362	-.0064	.4968
.15	.0001	.0206	-.0318	.4527			-.0247	.5094	-.0224	.5136	-.0215	.5277	-.0139	.4553
.20							-.0265	.4996	-.0244	.5039		.1090	-.0160	.4263
.25	-.0303	.0142	-.0499	.1849			-.0267	.4770	-.0266	.4873	-.0192	.5042	-.0451	.4074
.30			-.0374	.1462	-.0501	.2093	-.0517	.2289	-.0409	.3385				
.40	-.0418	.0679			-.0524	.1806	-.0597	.1985	-.0534	.2083	-.0536	.2210		
.50	-.0407	.0487					-.0566	.1897	-.0581	.1961			-.0059	.0221
.60					-.0552	.1548	-.0559	.1784	-.0521	.1913	-.0519	.1879	-.0529	.0928
.70			-.0464	.1232	-.0551	.1409	-.0227	.1607	-.0463	.1485	-.0556	.0463	-.0619	-.0118
.80	-.0515	.0040	-.0535	.0119	-.0543	.0083			-.0387	.0238	-.0588	.0194	-.0097	-.0000
.90	-.0582	-.0177			-.0510	-.0044			-.0566	.0111	-.0577	.0117	-.0575	-.0273
.95	-.0544	-.0227							-.0585	.0049	-.0584	.0068	-.0585	-.0315

TAIL 2

TABLE XII. - CONTINUED
(j) $\alpha = 16.09^\circ$

Cp at γ/b of														
x/c	0.02		0.22		0.44		0.56		0.67		0.83		0.98	
	U.S.	L.S.	U.S.	L.S.	U.S.	L.S.	U.S.	L.S.	U.S.	L.S.	U.S.	L.S.	U.S.	L.S.
.05	.1667	.6048	.2383	.6464	.2335	.6019	.2125	.6108	.2279	.5967	.2287	.5772		
.10	.1667	.5898	.2427	.6555	.2361	.6124	.2110	.6167	.2220	.5953	.2180	.5830	.1870	.4710
.15	.1621	.5570	.2394	.6541	.2357	.6118	.2199	.6047	.2226	.5910	.2120	.5784	.1881	.4625
.20	.1302	.5172	.2300	.6460	.2329	.6084			.2212	.5866	.2162	.5749	.1865	.4472
.25			.0654	.2680	.2027	.5435	.2060	.5890	.2170	.5788	.2142	.5697	.1842	.4357
.30	.0159	.2214	.0291	.2297	.0429	.2116	.0569	.2308	.1195	.3359	.2042	.5529	.1834	.4255
.40									.0281	.1916	.0367	.1960	.0523	.1476
.50	-.0034	.2079	.0097	.2091	.0206	.1954			.0203	.1838	.0150	.1585	.0362	.1241
.60	.0013	.1914	.0060	.1977	.0184	.1919	.0174	.1844	.0168	.1784	.0060	.1400	.0099	.1178
.70	.0068	.1898	.0015	.1872	.0121	.1837	.0059	.1663	-.0033	.1333			-.0444	.0245
.80	-.0309	.0634	-.0131	.0293	-.0106	.0290	-.0127	.0186	-.0158	.0014	-.0202	-.0105	-.0496	.0242
.90	-.0189	.0239	-.0115	.0056	-.0099	.0107	-.0116	.0051	-.0162	-.0068	-.0206	-.0185	-.0417	.0009
.95	-.0142	.0174	-.0117	.0014	-.0103	.0056	-.0116	.0005	-.0162	-.0118	-.0208	-.0195	-.0395	-.0155

TAIL 1

Cp at γ/b of														
x/c	0.02		0.22		0.44		0.56		0.67		0.83		0.98	
	U.S.	L.S.	U.S.	L.S.	U.S.	L.S.	U.S.	L.S.	U.S.	L.S.	U.S.	L.S.	U.S.	L.S.
.05	-.0310	-.0148	-.0413	.5583			-.0283	.6534	-.0233	.6728	-.0184	.6841	-.0090	.6596
.10	-.0194	.0044	-.0464	.5216			-.0359	.6374	-.0303	.6526	-.0272	.6756	-.0142	.6281
.15	-.0210	.0293	-.0471	.4916			-.0402	.6269	-.0367	.6406	-.0310	.6664	-.0202	.5904
.20							-.0431	.6140	-.0402	.6286		.1519	-.0226	.5602
.25	-.0392	.0198	-.0566	.2259			-.0408	.5800	-.0423	.6063	-.0286	.6364	-.0215	.5374
.30			-.0416	.1922	-.0540	.2555	-.0573	.2970	-.0517	.4270				
.40	-.0505	.0713			-.0548	.2315	-.0616	.2549	-.0577	.2803	-.0580	.3073		
.50	-.0484	.0929					-.0599	.2393	-.0608	.2588			-.0093	.0343
.60					-.0594	.2086	-.0602	.2271	-.0561	.2466	-.0548	.2693	-.0551	.1609
.70			-.0501	.1790	-.0599	.1939	-.0254	.2064	-.0487	.1938	-.0624	.0898	-.0635	.0246
.80	-.0555	.0207	-.0571	.0401	-.0592	.0406			-.0417	.0481	-.0627	.0577	-.0127	.0117
.90	-.0616	.0078			-.0546	.0245			-.0604	.0388	-.0618	.0464	-.0602	.0027
.95	-.0599	.0048							-.0624	.0320	-.0627	.0393	-.0613	-.0039

TAIL 2

TABLE XII. - CONCLUDED
(k) $\alpha = 20.08^\circ$

Cp at γ/b of														
x/c	0.02		0.22		0.44		0.56		0.67		0.83		0.98	
	U.S.	L.S.	U.S.	L.S.	U.S.	L.S.	U.S.	L.S.	U.S.	L.S.	U.S.	L.S.	U.S.	L.S.
.05	.2186	.7794	.3113	.8532	.2972	.7934	.2638	.8109	.2809	.7806	.0820	.4363		
.10	.2199	.7333	.3173	.8664	.3007	.8070	.2672	.8071	.2745	.7779	.0711	.4419	.0631	.3709
.15	.2156	.6986	.3133	.8664	.3011	.8067	.2776	.7922	.2729	.7691	.0713	.4487	.0621	.3736
.20	.1819	.6474	.3017	.8579	.2988	.8016			.2677	.7603	.0830	.4631	.0608	.3712
.25			.1013	.3840	.2643	.7239	.2621	.7720	.2619	.7483	.0851	.4649	.0585	.3708
.30	.0384	.3049	.0594	.3426	.0712	.3139	.0847	.3390	.1486	.4456	.0763	.4357	.0544	.3708
.40									.0454	.2658	-.0045	.1591	-.0197	.1159
.50	.0185	.3187	.0381	.3113	.0475	.2967			.0358	.2581	-.0179	.1305	-.0428	.1040
.60	.0273	.2913	.0329	.2940	.0445	.2925	.0392	.2731	.0314	.2569	-.0169	.1148	-.0475	.1157
.70	.0402	.2917	.0273	.2783	.0369	.2834	.0262	.2491	.0091	.2025			-.0551	.1094
.80	-.0218	.1268	-.0031	.0720	-.0059	.0797	-.0107	.0573	-.0160	.0330	-.0371	-.0049	-.0568	-.0262
.90	-.0171	.0704	-.0000	.0484	-.0032	.0566	-.0070	.0429	-.0165	.0267	-.0326	-.0106	-.0472	-.0333
.95	-.0051	.0649	-.0001	.0442	-.0019	.0494	-.0065	.0364	-.0162	.0194	-.0344	-.0125	-.0453	-.0395

TAIL 1

Cp at γ/b of														
x/c	0.02		0.22		0.44		0.56		0.67		0.83		0.98	
	U.S.	L.S.	U.S.	L.S.	U.S.	L.S.	U.S.	L.S.	U.S.	L.S.	U.S.	L.S.	U.S.	L.S.
.05	-.0489	-.0030	-.0532	.6518			-.0306	.8332	-.0234	.8603	-.0192	.8767	-.0056	.8286
.10	-.0385	.0356	-.0579	.6209			-.0396	.8011	-.0311	.8313	-.0299	.8619	-.0144	.8056
.15	-.0375	.0606	-.0580	.5997			-.0447	.7735	-.0394	.8078	-.0347	.8448	-.0215	.7666
.20							-.0478	.7462	-.0431	.7829		.2152	-.0245	.7307
.25	-.0484	.0600	-.0597	.3000			-.0468	.6979	-.0461	.7463	-.0326	.7967	-.0247	.7005
.30			-.0426	.2668	-.0565	.3236	-.0610	.3663	-.0546	.5190				
.40	-.0582	.0750			-.0567	.3020	-.0641	.3265	-.0599	.3586	-.0604	.4026		
.50	-.0554	.1223					-.0627	.3116	-.0636	.3342			-.0016	.0610
.60					-.0625	.2780	-.0633	.2987	-.0587	.3202	-.0573	.3528	-.0575	.2393
.70			-.0525	.2608	-.0631	.2624	-.0273	.2728	-.0512	.2597	-.0653	.1363	-.0666	.0680
.80	-.0582	.0327	-.0596	.0942	-.0623	.0770			-.0421	.0853	-.0656	.1008	-.0049	.0357
.90	-.0643	.0263			-.0574	.0605			-.0633	.0777	-.0647	.0874	-.0614	.0399
.95	-.0629	.0236							-.0654	.0695	-.0654	.0789	-.0634	.0320

TAIL 2

TABLE XIII. - PRESSURE COEFFICIENTS, $\theta = 45^\circ$, $\delta = 0^\circ$, $M = 3.70$ (a) $\alpha = -3.83^\circ$

Cp at y/b of														
x/c	0.02		0.22		0.44		0.56		0.67		0.83		0.98	
	U.S.	L.S.	U.S.	L.S.	U.S.	L.S.	U.S.	L.S.	U.S.	L.S.	U.S.	L.S.	U.S.	L.S.
.05	.0490	.0490	.2829	.1145	.2672	.1354	.2705	.1452	.2606	.1514	.2568	.1502		
.10	.0483	.0483	.2925	.1125	.2744	.1356	.2477	.1452	.2620	.1484	.2552	.1492	.2299	.1206
.15	.0633	.0471	.2933	.1120	.2751	.1344	.2591	.1447	.2661	.1459	.2530	.1464	.2204	.1154
.20	.0565	.0375	.2816	.1118	.2725	.1328			.2661	.1439	.2591	.1443	.2058	.1078
.25			.0929	.0042	.2387	.1099	.2470	.1365	.2605	.1405	.2583	.1415	.1971	.1026
.30	.0250	-.0051	.0540	-.0153	-.0666	-.0065	.0809	-.0161	.1499	.0566	.2477	.1340	.1899	.0981
.40									.0543	-.0080	.0625	.0032	.0431	-.0049
.50	.0230	.0012	.0279	-.0230	.0526	-.0160			.0476	-.0119	.0456	-.0128	.0042	-.0225
.60	.0378	.0003	.0216	-.0236	.0510	-.0180	.0462	-.0138	.0454	-.0153	.0381	-.0154	-.0046	-.0270
.70	.0307	-.0003	.0165	-.0235	.0451	-.0211	.0354	-.0223	.0199	-.0259			-.0420	-.0489
.80	-.0201	-.0346	-.0427	-.0488	-.0343	-.0403	-.0386	-.0427	-.0393	-.0375	-.0459	-.0474	-.0452	-.0456
.90	-.0331	-.0420	-.0495	-.0453	-.0452	-.0407	-.0438	-.0396	-.0461	-.0420	-.0494	-.0456	-.0487	-.0465
.95	-.0388	-.0408	-.0473	-.0441	-.0460	-.0400	-.0444	-.0399	-.0461	-.0418	-.0492	-.0456	-.0490	-.0500

TAIL 1

Cp at y/b of														
x/c	0.02		0.22		0.44		0.56		0.67		0.83		0.98	
	U.S.	L.S.	U.S.	L.S.	U.S.	L.S.	U.S.	L.S.	U.S.	L.S.	U.S.	L.S.	U.S.	L.S.
.05	.1874	.0438	.2972	.1469			.2808	.1604	.2873	.1644	.2851	.1685	.2620	.1818
.10	.1872	.0516	.2906	.1327			.2759	.1475	.2748	.1515	.2798	.1574	.2424	.1476
.15	.1723	.0512	.2854	.1255			.2716	.1403	.2699	.1432	.2758	.1501	.2146	.1232
.20							.2694	.1341	.2677	.1366		.0628	.2091	.1118
.25	.0534	-.0113	.0936	.0150			.2538	.1233	.2604	.1280	.2651	.1375	.1985	.1053
.30			.0647	.0030	.0693	-.0065	.0799	.0156	.1659	.0656				
.40	.0359	.0409			.0535	-.0089	.0539	-.0101	.0600	-.0025	.0676	.0058		
.50	.0342	-.0203					.0486	-.0146	.0486	-.0138			.0200	.0462
.60					.0495	-.0179	.0477	-.0176	.0473	-.0142	.0427	-.0141	.0076	-.0157
.70			.0439	-.0172	.0436	-.0224	.0463	.0025	.0009	-.0219	-.0317	-.0500	-.0301	-.0473
.80	-.0198	-.0485	-.0299	-.0418	-.0325	-.0446			-.0211	-.0218	-.0478	-.0487	.0124	.0214
.90	-.0355	-.0490			-.0395	-.0381			-.0437	-.0421	-.0480	-.0463	-.0493	-.0493
.95	-.0379	-.0466							-.0457	-.0435	-.0483	-.0460	-.0530	-.0517

TAIL 2

TABLE XIII. - CONTINUED
(b) $\alpha = -1.84^\circ$

Cp at y/b of														
x/c	0.02		0.22		0.44		0.56		0.67		0.83		0.98	
	U.S.	L.S.	U.S.	L.S.	U.S.	L.S.	U.S.	L.S.	U.S.	L.S.	U.S.	L.S.	U.S.	L.S.
.05	.0730	-.0601	.2326	.1674	.2255	.1762	.2295	-.1842	.2242	-.1879	-.2228	-.1845		
.10	.0774	-.0611	.2410	.1688	.2319	.1770	.2074	-.1857	.2240	-.1849	-.2196	-.1847	-.1958	-.1487
.15	.0782	-.0594	.2396	.1674	.2323	.1760	.2188	-.1846	.2268	-.1823	-.2167	-.1816	-.1866	-.1423
.20	.0698	-.0494	.2332	.1631	.2299	.1746			.2270	-.1804	.2220	-.1792	-.1744	-.1330
.25			.0732	-.0242	.2011	-.1477	.2083	-.1747	.2232	-.1767	.2207	-.1763	-.1659	-.1268
.30	.0248	-.0026	-.0405	-.0013	-.0490	-.0163	.0604	-.0311	.1254	-.0793	.2111	-.1679	-.1591	-.1225
.40									-.0354	-.0055	.0441	.0167	.0279	-.0047
.50	.0156	-.0062	-.0150	-.0154	.0303	-.0029			.0288	-.0006	.0271	-.0004	-.0059	-.0169
.60	-.0287	-.0087	-.0086	-.0182	.0286	-.0053	.0281	-.0042	.0259	-.0031	.0205	-.0064	-.0129	-.0217
.70	.0293	-.0097	.0055	-.0182	.0238	-.0089	.0171	-.0116	.0046	-.0167			-.0414	-.0477
.80	-.0233	-.0336	-.0475	-.0487	-.0382	-.0450	-.0422	-.0485	-.0422	-.0410	-.0485	-.0486	-.0475	-.0472
.90	-.0354	-.0437	-.0498	-.0444	-.0477	-.0423	-.0487	-.0432	-.0502	-.0434	-.0516	-.0458	-.0431	-.0450
.95	-.0410	-.0431	-.0463	-.0441	-.0473	-.0422	-.0468	-.0428	-.0475	-.0428	-.0492	-.0456	-.0415	-.0512

TAIL 1

Cp at y/b of														
x/c	0.02		0.22		0.44		0.56		0.67		0.83		0.98	
	U.S.	L.S.	U.S.	L.S.	U.S.	L.S.	U.S.	L.S.	U.S.	L.S.	U.S.	L.S.	U.S.	L.S.
.05	.1261	-.0670	.2508	.1833			.2418	-.1929	.2480	-.1956	.2456	-.1973	-.2254	-.2061
.10	.1322	-.0734	.2423	.1711			.2365	-.1803	.2355	-.1825	.2396	-.1866	-.2085	-.1743
.15	.1238	-.0707	.2372	.1635			.2320	-.1729	.2306	-.1739	.2355	-.1789	-.1834	-.1484
.20							.2295	-.1661	.2285	-.1672		.0653	-.1809	-.1341
.25	.0410	-.0017	.0682	-.0314			.2155	-.1530	.2218	-.1577	.2260	-.1646	-.1685	-.1234
.30			.0430	-.0114	.0492	-.0154	.0600	-.0308	.1367	-.0870				
.40	.0170	-.0447			.0339	-.0022	.0345	-.0007	.0411	-.0081	.0484	-.0152		
.50	.0152	-.0120					.0294	-.0045	.0303	-.0028			.0184	-.0423
.60					.0291	-.0088	.0282	-.0069	.0293	-.0028	.0259	-.0075	-.0030	-.0125
.70			.0228	-.0377	.0235	-.0135	.0331	-.0065	-.0079	-.0183	-.0371	-.0483	-.0367	-.0470
.80	-.0239	-.0455	-.0369	-.0432	-.0388	-.0450			-.0245	-.0222	-.0516	-.0479	-.0109	-.0193
.90	-.0409	-.0503			-.0435	-.0375			-.0478	-.0415	-.0494	-.0449	-.0527	-.0509
.95	-.0425	-.0468							-.0464	-.0426	-.0472	-.0443	-.0562	-.0554

TAIL 2

TABLE XIII. - CONTINUED
(c) $\alpha = 0.15^\circ$

Cp at y/b of														
x/c	0.02		0.22		0.44		0.56		0.67		0.83		0.98	
	U.S.	L.S.	U.S.	L.S.	U.S.	L.S.	U.S.	L.S.	U.S.	L.S.	U.S.	L.S.	U.S.	L.S.
.05	.0837	.0847	.1873	.2134	.1883	.2159	.1922	.2230	.1881	.2240	.1871	.2143		
.10	.0840	.0894	.1953	.2167	.1939	.2180	.1709	.2261	.1867	.2218	.1842	.2176	.1630	.1768
.15	.0811	.0889	.1946	.2164	.1940	.2169	.1818	.2246	.1895	.2193	.1819	.2151	.1545	.1701
.20	.0705	.0792	.1882	.2117	.1917	.2154			.1897	.2176	.1866	.2132	.1452	.1598
.25			.0482	.0481	.1667	.1845	.1726	.2138	.1867	.2137	.1857	.2105	.1390	.1519
.30	.0136	.0111	.0195	.0202	.0311	.0305	.0433	.0484	.0939	.1022	.1771	.2013	.1331	.1470
.40									.0181	.0216	.0281	.0315	.0151	.0151
.50	-.0008	-.0085	-.0022	.0040	.0118	.0123			.0109	.0156	.0118	.0132	-.0106	-.0102
.60	.0105	.0	-.0029	-.0001	.0100	.0099	.0101	.0099	.0086	.0120	.0059	.0058	-.0149	-.0160
.70	.0177	.0	-.0063	-.0045	.0054	.0055	.0000	.0032	-.0100	-.0056			-.0427	-.0449
.80	-.0294	-.0334	-.0520	-.0511	-.0441	-.0452	-.0485	-.0485	-.0453	-.0445	-.0511	-.0508	-.0444	-.0473
.90	-.0418	-.0461	-.0478	-.0451	-.0482	-.0446	-.0483	-.0466	-.0469	-.0451	-.0484	-.0476	-.0538	-.0502
.95	-.0473	-.0461	-.0454	-.0441	-.0462	-.0437	-.0456	-.0446	-.0447	-.0437	-.0467	-.0462	-.0536	-.0547

TAIL 1

Cp at y/b of														
x/c	0.02		0.22		0.44		0.56		0.67		0.83		0.98	
	U.S.	L.S.	U.S.	L.S.	U.S.	L.S.	U.S.	L.S.	U.S.	L.S.	U.S.	L.S.	U.S.	L.S.
.05	.0735	.0801	.2084	.2236			.2050	.2292	.2115	.2301	.2033	.2302	.1940	.2381
.10	.0894	.0869	.1996	.2131			.1993	.2158	.1998	.2170	.2038	.2211	.1801	.2089
.15	.0860	.0846	.1943	.2052			.1950	.2077	.1950	.2086	.2008	.2139	.1593	.1802
.20							.1929	.2006	.1933	.2014		.0710	.1545	.1599
.25	.0278	.0146	.0468	.0518			.1805	.1861	.1871	.1913	.1932	.1988	.1397	.1467
.30			.0255	.0251	.0333	.0309	.0425	.0483	.1111	.1118				
.40	.0057	.0482			.0185	.0126	.0183	.0161	.0252	.0235	.0337	.0315		
.50	.0052	.0041					.0137	.0103	.0148	.0120			.0139	.0394
.60					.0125	.0063	.0121	.0080	.0142	.0116	.0127	.0062	-.0105	-.0099
.70			.0051	.0027	.0073	.0011	.0214	.0167	-.0153	-.0084	-.0422	-.0430	-.0417	-.0424
.80	-.0250	-.0360	-.0429	-.0434	-.0448	-.0477			-.0279	-.0242	-.0535	-.0503	.0069	.0171
.90	-.0417	-.0463			-.0416	-.0374			-.0449	-.0410	-.0468	-.0446	-.0532	-.0432
.95	-.0431	-.0446							-.0433	-.0411	-.0448	-.0432	-.0554	-.0503

TAIL 2

TABLE XIII. - CONTINUED
(d) $\alpha = 2.15^\circ$

Cp at y/b of														
x/c	0.02		0.22		0.44		0.56		0.67		0.83		0.98	
	U.S.	L.S.	U.S.	L.S.	U.S.	L.S.	U.S.	L.S.	U.S.	L.S.	U.S.	L.S.	U.S.	L.S.
.05	.0789	.1375	.1496	.2578	.1528	.2533	.1571	.2607	.1557	.2608	.1597	.2518		
.10	.0778	.1410	.1556	.2611	.1574	.2564	.1389	.2638	.1533	.2589	.1536	.2544	.1332	.2065
.15	.0741	.1392	.1549	.2610	.1576	.2556	.1479	.2618	.1551	.2562	.1499	.2508	.1243	.1996
.20	.0612	.1280	.1494	.2559	.1555	.2540			.1551	.2540	.1538	.2483	.1172	.1879
.25			.0289	.0697	.1325	.2191	.1386	.2500	.1522	.2497	.1522	.2455	.1134	.1799
.30	-.0035	.0266	-.0028	.0397	.0158	.0463	.0298	.0627	.0755	.1219	.1446	.2354	.1096	.1731
.40									-.0031	.0374	.0127	.0466	.0033	.0284
.50	-.0186	.0186	-.0127	.0246	-.0036	.0280			-.0033	.0311	-.0034	.0276	-.0114	-.0009
.60	-.0135	.0172	-.0160	.0208	-.0056	.0257	-.0046	.0250	-.0057	.0273	-.0083	.0197	-.0176	-.0082
.70	-.0064	.0191	-.0184	.0148	-.0099	.0212	-.0131	.0189	-.0210	.0069			-.0466	-.0408
.80	-.0398	-.0340	-.0539	-.0454	-.0489	-.0425	-.0511	-.0460	-.0439	-.0443	-.0504	-.0507	-.0576	-.0449
.90	-.0499	-.0475	-.0464	-.0477	-.0448	-.0471	-.0453	-.0496	-.0452	-.0492	-.0479	-.0505	-.0582	-.0519
.95	-.0502	-.0479	-.0450	-.0442	-.0443	-.0453	-.0444	-.0471	-.0446	-.0457	-.0473	-.0479	-.0564	-.0568

TAIL 1

Cp at y/b of														
x/c	0.02		0.22		0.44		0.56		0.67		0.83		0.98	
	U.S.	L.S.	U.S.	L.S.	U.S.	L.S.	U.S.	L.S.	U.S.	L.S.	U.S.	L.S.	U.S.	L.S.
.05	.0593	.0745	.1655	.2714			.1695	.2678	.1765	.2683	.1785	.2689	.1642	.2738
.10	.0682	.0871	.1549	.2603			.1637	.2540	.1655	.2548	.1715	.2596	.1527	.2461
.15	.0650	.0877	.1496	.2511			.1594	.2456	.1605	.2461	.1679	.2515	.1367	.2118
.20							.1575	.2380	.1588	.2383		.0765	.1266	.1901
.25	.0178	.0269	.0256	.0763			.1478	.2219	.1530	.2270	.1609	.2342	.1107	.1801
.30			.0097	.0437	.0193	.0496	.0263	.0671	.0863	.1382				
.40	-.0002	.0531			.0049	.0317	.0035	.0341	.0103	.0418	.0195	.0498		
.50	.0020	.0170					-.0007	.0285	.0001	.0297			.0098	.0331
.60					-.0019	.0250	-.0026	.0258	.0002	.0282	.0000	.0237	-.0172	-.0096
.70			-.0068	.0130	-.0067	.0192	.0109	.0305	-.0228	.0059	-.0468	-.0355	-.0459	-.0402
.80	-.0267	-.0293	-.0428	-.0419	-.0453	-.0437			-.0278	-.0245	-.0498	-.0507	.0033	.0110
.90	-.0411	-.0420			-.0390	-.0405			-.0422	-.0444	-.0447	-.0469	-.0476	-.0402
.95	-.0410	-.0431							-.0419	-.0428	-.0439	-.0439	-.0508	-.0414

TAIL 2

TABLE XIII. - CONTINUED
(e) $\alpha = 4.14^\circ$

Cp at y/b of														
x/c	0.02		0.22		0.44		0.56		0.67		0.83		0.98	
	U.S.	L.S.	U.S.	L.S.	U.S.	L.S.	U.S.	L.S.	U.S.	L.S.	U.S.	L.S.	U.S.	L.S.
.05	.0480	.2487	.1106	.3050	.1187	.2948	.1218	.3016	.1263	.3011	.1326	.2905	.1100	.2404
.10	.0516	.2254	.1151	.3096	.1220	.2993	.1092	.3060	.1228	.2996	.1254	.2946	.1018	.2328
.15	.0542	.2293	.1146	.3099	.1222	.2987	.1161	.3024	.1236	.2966	.1215	.2913	.0959	.2204
.20	.0419	.2133	.1098	.3043	.1203	.2971			.1233	.2945	.1244	.2887	.0928	.2123
.25			.0091	.0948	.0998	.2582	.1078	.2896	.1204	.2899	.1231	.2856	.0904	.2052
.30	-.0190	-.0565	-.0132	.0645	.0024	.0671	.0169	.0831	.0530	.1480	.1161	.2750	-.0063	.0452
.40									-.0100	.0563	-.0009	.0655	-.0151	.0110
.50	-.0325	.0439	-.0276	.0505	-.0184	.0490			-.0160	.0501	-.0164	.0450	-.0226	.0032
.60	-.0298	.0401	-.0300	.0455	-.0200	.0469	-.0157	.0448	-.0182	.0464	-.0188	.0361	-.0494	-.0359
.70	-.0281	.0414	-.0319	.0395	-.0234	.0419	-.0258	.0383	-.0305	.0219			-.0614	-.0407
.80	-.0460	-.0327	-.0521	-.0360	-.0450	-.0366	-.0469	-.0403	-.0426	-.0406	-.0502	-.0484	-.0577	-.0484
.90	-.0497	-.0438	-.0480	-.0493	-.0431	-.0459	-.0440	-.0467	-.0459	-.0492	-.0490	-.0517	-.0566	-.0559
.95	-.0493	-.0458	-.0470	-.0473	-.0440	-.0462	-.0436	-.0471	-.0458	-.0484	-.0488	-.0508		

TAIL 1

Cp at y/b of														
x/c	0.02		0.22		0.44		0.56		0.67		0.83		0.98	
	U.S.	L.S.	U.S.	L.S.	U.S.	L.S.	U.S.	L.S.	U.S.	L.S.	U.S.	L.S.	U.S.	L.S.
.05	.0452	.0642	.1187	.3232			.1349	.3109	.1431	.3093	.1468	.3089	.1346	.3098
.10	.0521	.0793	.1066	.3109			.1287	.2959	.1320	.2951	.1389	.2998	.1257	.2828
.15	.0495	.0843	.1028	.3006			.1245	.2873	.1269	.2859	.1351	.2916	.1123	.2463
.20							.1224	.2791	.1252	.2777			.1006	.2280
.25	-.0110	-.0338	.0054	.1001			.1141	.2621	.1201	.2656	.1288	.2734	.0869	.2124
.30			-.0060	.0616	.0036	.0729	.0098	.0885	.0626	.1668				
.40	.0005	.0555			-.0101	.0555	-.0109	.0557	-.0034	.0622	.0053	.0702		
.50	-.0011	.0283					-.0150	.0502	-.0135	.0500			.0064	.0333
.60					-.0174	.0481	-.0172	.0475	-.0131	.0480	-.0124	.0437	-.0233	-.0013
.70			-.0152	.0283	-.0214	.0414	.0002	.0483	-.0309	.0221	-.0503	-.0272	-.0491	-.0413
.80	-.0307	-.0246	-.0419	-.0380	-.0414	-.0369			-.0269	-.0209	-.0462	-.0462	.0005	.0111
.90	-.0414	-.0380			-.0375	-.0423			-.0411	-.0454	-.0431	-.0489	-.0440	-.0435
.95	-.0400	-.0405							-.0415	-.0456	-.0430	-.0468	-.0463	-.0454

TAIL 2

TABLE XIII. - CONTINUED
(1) $\alpha = 6.14^\circ$

Cp at y/b of														
x/c	0.02		0.22		0.44		0.56		0.67		0.83		0.98	
	U.S.	L.S.	U.S.	L.S.	U.S.	L.S.	U.S.	L.S.	U.S.	L.S.	U.S.	L.S.	U.S.	L.S.
.05	.0217	.3207	.0792	.3587	.0946	.3426	.0989	.3507	.1066	.3471	.1180	.3387		
.10	.0247	.2943	.0810	.3651	.0959	.3482	.0885	.3551	.1028	.3471	.1094	.3439	.0978	.2838
.15	.0273	.2817	.0796	.3661	.0954	.3478	.0945	.3491	.1029	.3445	.1051	.3402	.0903	.2753
.20	.0162	.2642	.0749	.3599	.0930	.3461			.1023	.3422	.1072	.3373	.0853	.2615
.25			-.0078	.1244	.0741	.3035	.0852	.3389	.0994	.3374	.1056	.3342	.0824	.2525
.30	-.0303	.0848	-.0257	.0932	-.0061	.0895	.0056	.1113	.0387	.1817	.0989	.3223	.0810	.2452
.40									-.0188	.0796	-.0085	.0887	-.0092	.0658
.50	-.0413	.0741	-.0395	.0783	-.0282	.0732			-.0242	.0724	-.0235	.0665	-.0174	.0269
.60	-.0395	.0685	-.0415	.0720	-.0299	.0711	-.0252	.0675	-.0268	.0681	-.0261	.0555	-.0245	.0185
.70	-.0383	.0671	-.0427	.0655	-.0330	.0649	-.0353	.0572	-.0375	.0400			-.0517	-.0288
.80	-.0482	-.0226	-.0498	-.0252	-.0444	-.0272	-.0476	-.0320	-.0427	-.0347	-.0521	-.0430	-.0628	-.0349
.90	-.0499	-.0346	-.0485	-.0434	-.0447	-.0397	-.0460	-.0401	-.0476	-.0438	-.0509	-.0485	-.0566	-.0398
.95	-.0492	-.0397	-.0479	-.0447	-.0453	-.0402	-.0458	-.0421	-.0475	-.0453	-.0511	-.0493	-.0565	-.0505

TAIL 1

Cp at y/b of														
x/c	0.02		0.22		0.44		0.56		0.67		0.83		0.98	
	U.S.	L.S.	U.S.	L.S.	U.S.	L.S.	U.S.	L.S.	U.S.	L.S.	U.S.	L.S.	U.S.	L.S.
.05	.0674	.0314	.0638	.3771			.0989	.3552	.1088	.3526	.1150	.3499	.1087	.3515
.10	.0690	.0501	.0528	.3626			.0924	.3392	.0982	.3382	.1066	.3417	.1003	.3223
.15	.0618	.0572	.0544	.3464			.0881	.3307	.0931	.3288	.1028	.3331	.0872	.2894
.20							.0859	.3224	.0912	.3201		.1099	.0764	.2657
.25	.0099	.0194	-.0131	.1168			.0806	.3042	.0867	.3070	.0978	.3137	.0657	.2489
.30			-.0157	.0777	-.0112	.0980	-.0065	.1148	.0387	.1984				
.40	-.0066	.0578			-.0238	.0820	-.0244	.0803	-.0164	.0857	-.0076	.0934		
.50	-.0089	.0234					-.0282	.0748	-.0262	.0733			.0028	.0344
.60					-.0308	.0723	-.0305	.0725	-.0255	.0708	-.0236	.0659	-.0294	.0128
.70			-.0226	.0397	-.0341	.0637	-.0087	.0688	-.0370	.0409	-.0503	-.0173	-.0500	-.0427
.80	-.0378	-.0210	-.0438	-.0352	-.0405	-.0297			-.0282	-.0151	-.0463	-.0387	-.0027	.0118
.90	-.0460	-.0368			-.0378	-.0388			-.0421	-.0396	-.0443	-.0438	-.0437	-.0398
.95	-.0430	-.0397							-.0427	-.0427	-.0445	-.0451	-.0454	-.0440

TAIL 2

TABLE XIII. - CONTINUED
(g) $\alpha = 8.13^\circ$

Cp at y/b of														
x/c	0.02		0.22		0.44		0.56		0.67		0.83		0.98	
	U.S.	L.S.	U.S.	L.S.	U.S.	L.S.	U.S.	L.S.	U.S.	L.S.	U.S.	L.S.	U.S.	L.S.
.05	.0085	.3853	-.0702	.4204	.0876	.4013	-.0914	.4116	-.1003	.4063	.1126	.3976		
.10	.0106	.3540	-.0706	.4285	.0882	.4085	-.0814	.4166	.0952	.4064	.1030	.4029	.0935	.3354
.15	.0123	.3388	-.0681	.4239	.0874	.4082	-.0869	.4100	.0951	.4040	.0981	.3993	.0870	.3256
.20	-.0000	.3157	-.0627	.4235	.0848	.4064			.0943	.4017	.0997	.3963	.0827	.3101
.25			-.0149	.1584	.0662	.3590	-.0776	.3971	.0914	.3962	.0980	.3927	.0797	.3000
.30	-.0383	.1128	-.0315	.1263	-.0105	.1199	-.0000	.1459	.0328	.2206	.0914	.3795	.0781	.2925
.40									-.0227	.1088	-.0126	.1181	-.0081	.0899
.50	-.0477	.1028	-.0460	.1087	-.0329	.1041			-.0280	.1015	-.0272	.0934	-.0168	.0468
.60	-.0457	.0953	-.0480	.1009	-.0345	.1015	-.0297	.0971	-.0307	.0968	-.0303	.0809	-.0227	.0382
.70	-.0444	.0953	-.0480	.0937	-.0377	.0946	-.0394	.0857	-.0404	.0640			-.0552	-.0193
.80	-.0484	.0003	-.0483	-.0124	-.0434	-.0138	-.0472	-.0197	-.0422	-.0260	-.0522	-.0338	-.0670	-.0275
.90	-.0492	-.0206	-.0477	-.0326	-.0448	-.0273	-.0461	-.0293	-.0472	-.0342	-.0510	-.0417	-.0652	-.0253
.95	-.0484	-.0270	-.0475	-.0360	-.0452	-.0298	-.0460	-.0323	-.0475	-.0371	-.0511	-.0438	-.0627	-.0375

TAIL 1

Cp at y/b of														
x/c	0.02		0.22		0.44		0.56		0.67		0.83		0.98	
	U.S.	L.S.	U.S.	L.S.	U.S.	L.S.	U.S.	L.S.	U.S.	L.S.	U.S.	L.S.	U.S.	L.S.
.05	.0377	-.0178	.0037	.2636			.0546	.4071	.0684	.4011	.0790	.3960	.0782	.3949
.10	.0608	-.0314	.0089	.2615			.0477	.3920	.0586	.3875	.0703	.3882	.0706	.3656
.15	.0638	-.0363	-.0101	.2621			.0430	.3844	.0531	.3779	.0664	.3795	.0582	.3333
.20							.0405	.3764	.0508	.3689		.1299	.0499	.3076
.25	.0140	-.0002	-.0330	.0961			.0391	.3558	.0471	.3550	.0632	.3599	.0417	.2891
.30			-.0267	.0680	-.0297	.1301	-.0264	.1507	.0105	.2347				
.40	.0063	.0601			-.0384	.1058	-.0398	.1154	-.0305	.1172	-.0219	.1227		
.50	.0021	-.0113					-.0429	.1070	-.0400	.1054			.0024	.0302
.60					-.0421	.0861	-.0448	.0992	-.0389	.1030	-.0347	.0953	-.0365	.0318
.70			-.0366	.0398	-.0437	.0748	-.0168	.0899	-.0421	.0702	-.0533	-.0027	-.0519	-.0392
.80	-.0431	-.0273	-.0496	-.0313	-.0454	-.0248			-.0310	-.0068	-.0507	-.0267	-.0023	.0067
.90	-.0544	-.0375			-.0426	-.0343			-.0466	-.0295	-.0490	-.0325	-.0481	-.0382
.95	-.0508	-.0406							-.0478	-.0339	-.0495	-.0353	-.0491	-.0417

TAIL 2

TABLE XIII. - CONTINUED
(h) $\alpha = 10.12^\circ$

Cp at y/b of														
x/c	0.02		0.22		0.44		0.56		0.67		0.83		0.98	
	U.S.	L.S.	U.S.	L.S.	U.S.	L.S.	U.S.	L.S.	U.S.	L.S.	U.S.	L.S.	U.S.	L.S.
.05	.0056	.4518	.0726	.4936	.0888	.4704	.0914	.4820	.1008	.4755	.1130	.4666		
.10	.0083	.4202	.0721	.5032	.0892	.4796	.0819	.4889	.0951	.4759	.1026	.4727	.0941	.3947
.15	.0099	.4023	.0691	.5048	.0882	.4792	.0873	.4814	.0947	.4731	.0972	.4685	.0892	.3836
.20	-.0059	.3756	.0631	.4981	.0855	.4773			.0937	.4703	.0987	.4652	.0858	.3667
.25			-.0162	.1988	.0666	.4247	.0777	.4673	.0907	.4640	.0966	.4612	.0830	.3555
.30	-.0450	.1468	-.0343	.1652	-.0131	.1558	-.0021	.1839	.0325	.2652	.0902	.4467	.0814	.3472
.40									-.0239	.1431	-.0138	.1524	-.0028	.1170
.50	-.0504	.1368	-.0498	.1436	-.0354	.1402			-.0289	.1353	-.0288	.1247	-.0133	.0704
.60	-.0482	.1258	-.0515	.1341	-.0371	.1376	-.0330	.1318	-.0317	.1304	-.0326	.1100	-.0223	.0609
.70	-.0487	.1277	-.0487	.1262	-.0404	.1300	-.0418	.1203	-.0406	.0923			-.0610	-.0078
.80	-.0472	.0184	-.0440	.0026	-.0405	.0023	-.0439	-.0046	-.0396	-.0140	-.0484	-.0219	-.0699	-.0179
.90	-.0458	-.0064	-.0435	-.0186	-.0417	-.0117	-.0431	-.0159	-.0446	-.0220	-.0484	-.0327	-.0655	-.0078
.95	-.0441	-.0127	-.0433	-.0223	-.0421	-.0161	-.0432	-.0193	-.0449	-.0256	-.0488	-.0361	-.0638	-.0157

TAIL 1

Cp at y/b of														
x/c	0.02		0.22		0.44		0.56		0.67		0.83		0.98	
	U.S.	L.S.	U.S.	L.S.	U.S.	L.S.	U.S.	L.S.	U.S.	L.S.	U.S.	L.S.	U.S.	L.S.
.05	.0187	.0302	.0173	.2282			.0146	.4352	.0290	.4416	.0450	.4406	.0485	.4378
.10	.0365	.0360	.0172	.2357			.0076	.4226	.0204	.4281	.0364	.4326	.0423	.4089
.15	.0411	.0317	.0147	.2437			.0025	.4131	.0148	.4173	.0324	.4240	.0309	.3762
.20							-.0005	.4029	.0116	.4077		.1522	.0243	.3495
.25	.0074	-.0152	-.0368	.0990			.0017	.3808	.0085	.3928	.0313	.4037	.0187	.3323
.30			-.0310	.0707	-.0426	.1327	-.0427	.1658	-.0163	.2649				
.40	-.0066	.0699			-.0477	.1111	-.0521	.1294	-.0427	.1442	-.0344	.1538		
.50	-.0095	-.0017					-.0539	.1179	-.0514	.1295			-.0017	.0256
.60					-.0520	.0954	-.0549	.1092	-.0500	.1220	-.0435	.1252	-.0434	.0547
.70			-.0449	.0359	-.0533	.0859	-.0221	.1006	-.0464	.0862	-.0596	.0129	-.0571	-.0303
.80	-.0415	-.0359	-.0559	-.0321	-.0543	-.0164			-.0359	-.0017	-.0576	-.0119	-.0064	.0024
.90	-.0566	-.0442			-.0500	-.0282			-.0531	-.0207	-.0562	-.0189	-.0559	-.0410
.95	-.0553	-.0469							-.0548	-.0259	-.0569	-.0226	-.0558	-.0446

TAIL 2

TABLE XIII. - CONTINUED
(i) $\alpha = 12.13^\circ$

Cp at y/b of														
x/c	0.02		0.22		0.44		0.56		0.67		0.83		0.98	
	U.S.	L.S.	U.S.	L.S.	U.S.	L.S.	U.S.	L.S.	U.S.	L.S.	U.S.	L.S.	U.S.	L.S.
.05	.0087	.5283	-.0804	.5776	.0952	.5521	.0962	.5646	.1063	.5558	.1170	.5460	.0988	.4624
.10	.0123	.4954	-.0792	.5894	.0955	.5627	.0874	.5731	.0999	.5562	.1062	.5525	.0956	.4498
.15	.0147	.4726	-.0757	.5912	.0943	.5627	.0928	.5630	.0994	.5534	.1004	.5481	.0926	.4311
.20	-.0027	.4432	-.0693	.5834	.0915	.5607			.0982	.5503	.1015	.5442	.0903	.4186
.25			-.0137	.2463	.0719	.5015	.0826	.5503	.0950	.5435	.0999	.5397	.0884	.4098
.30	-.0442	.1879	-.0328	.2106	-.0103	.2004	-.0002	.2251	.0356	.3182	.0932	.5235	.0040	.1484
.40									-.0223	.1844	-.0127	.1924	-.0105	.0986
.50	-.0504	.1850	-.0487	.1841	-.0329	.1836			-.0278	.1765	-.0275	.1608	-.0292	.0885
.60	-.0475	.1682	-.0506	.1731	-.0351	.1804	-.0314	.1721	-.0303	.1711	-.0315	.1438	-.0613	.0063
.70	-.0492	.1672	-.0480	.1646	-.0382	.1722	-.0402	.1629	-.0395	.1272			-.0073	-.0047
.80	-.0480	.0456	-.0429	.0209	-.0377	.0231	-.0415	.0148	-.0378	.0027	-.0463	-.0038	-.0466	-.0199
.90	-.0434	.0107	-.0424	-.0010	-.0388	.0084	-.0408	.0026	-.0426	-.0038	-.0466	-.0199	-.0626	.0086
.95	-.0416	.0065	-.0423	-.0050	-.0400	.0028	-.0409	-.0012	-.0429	-.0089	-.0469	-.0243	-.0592	.0103

TAIL 1

Cp at y/b of														
x/c	0.02		0.22		0.44		0.56		0.67		0.83		0.98	
	U.S.	L.S.	U.S.	L.S.	U.S.	L.S.	U.S.	L.S.	U.S.	L.S.	U.S.	L.S.	U.S.	L.S.
.05	.0072	.0172	-.0002	.2093			-.0105	.4415	-.0030	.4612	.0105	.4728	.0182	.4702
.10	.0193	.0223	.0022	.2291			-.0178	.4301	-.0104	.4455	.0021	.4656	.0128	.4436
.15	.0230	.0182	.0043	.2487			-.0229	.4205	-.0169	.4343	-.0019	.4577	.0021	.4142
.20							-.0262	.4102	-.0208	.4246			-.0037	.3906
.25	-.0037	-.0221	-.0397	.1088			-.0247	.3872	-.0238	.4087	-.0015	.4366	-.0067	.3730
.30			-.0335	.0764	-.0505	.1341	-.0521	.1743	-.0388	.2767				
.40	-.0166	.0746			-.0538	.1147	-.0606	.1354	-.0528	.1794	-.0472	.1790		
.50	-.0198	-.0071					-.0611	.1231	-.0605	.1421			-.0048	.0217
.60					-.0600	.0989	-.0612	.1149	-.0576	.1326	-.0513	.1482	-.0506	.0798
.70			-.0485	.0435	-.0610	.0889	-.0264	.1054	-.0499	.0939	-.0642	.0252	-.0627	-.0180
.80	-.0439	-.0395	-.0607	-.0269	-.0608	-.0134			-.0407	.0005	-.0632	-.0007	-.0090	.0004
.90	-.0592	-.0478			-.0554	-.0268			-.0597	-.0162	-.0619	-.0088	-.0603	-.0325
.95	-.0588	-.0510							-.0616	-.0214	-.0627	-.0134	-.0609	-.0367

TAIL 2

TABLE XI.1. - CONTINUED
(j) $\alpha = 16.13^\circ$

Cp at y/b of														
x/c	0.02		0.22		0.44		0.56		0.67		0.83		0.98	
	U.S.	L.S.	U.S.	L.S.	U.S.	L.S.	U.S.	L.S.	U.S.	L.S.	U.S.	L.S.	U.S.	L.S.
.05	.0200	.7115	.1062	.7836	.1198	.7528	.1150	.7665	.1258	.7549	.1344	.7379		
.10	.0280	.6747	.1043	.8016	.1198	.7674	.1079	.7768	.1185	.7553	.1221	.7454	.1166	.6229
.15	.0322	.6423	.1002	.8046	.1186	.7671	.1133	.7648	.1180	.7512	.1157	.7408	.1157	.6067
.20	.0089	.6106	.0923	.7959	.1157	.7637			.1163	.7469	.1169	.7370	.1135	.5841
.25			-.0039	.3665	.0938	.6890	.1018	.7522	.1130	.7393	.1148	.7315	.1112	.5682
.30	-.0410	.2890	-.0264	.3234	-.0043	.3084	.0069	.3273	.0474	.4512	.1077	.7115	.1097	.5571
.40									-.0162	.2892	-.0068	.2890	.0130	.2239
.50	-.0472	.2902	-.0435	.2830	-.0269	.2912			-.0222	.2803	-.0220	.2490	-.0076	.1677
.60	-.0438	.2678	-.0459	.2686	-.0291	.2880	-.0265	.2766	-.0247	.2732	-.0268	.2268	-.0377	.1572
.70	-.0449	.2708	-.0444	.2586	-.0329	.2788	-.0351	.2648	-.0351	.2146			-.0590	.0412
.80	-.0437	.1135	-.0377	.0679	-.0325	.0757	-.0361	.0646	-.0323	.0438	-.0410	.0283	-.0622	.0310
.90	-.0373	.0636	-.0369	.0441	-.0334	.0583	-.0352	.0518	-.0371	.0392	-.0415	.0129	-.0538	.0263
.95	-.0358	.0615	-.0372	.0395	-.0345	.0508	-.0352	.0472	-.0373	.0325	-.0419	.0067	-.0504	.0404

TAIL 1

Cp at y/b of														
x/c	0.02		0.22		0.44		0.56		0.67		0.83		0.98	
	U.S.	L.S.	U.S.	L.S.	U.S.	L.S.	U.S.	L.S.	U.S.	L.S.	U.S.	L.S.	U.S.	L.S.
.05	-.0072	-.0012	-.0350	.3458			-.0300	.4576	-.0279	.4769	-.0259	.4983	-.0229	.4822
.10	.0020	.0056	-.0307	.3467			-.0359	.4421	-.0330	.4592	-.0309	.4915	-.0259	.4715
.15	.0032	.0059	-.0281	.3471			-.0399	.4296	-.0380	.4476	-.0326	.4816	-.0330	.4512
.20							-.0428	.4152	-.0412	.4369		.1868	-.0377	.4325
.25	-.0182	-.0238	-.0495	.1248			-.0406	.3878	-.0431	.4191	-.0273	.4552	-.0357	.4167
.30			-.0386	.0343	-.0552	.1446	-.0582	.1802	-.0524	.2850				
.40	-.0327	.0543			-.0580	.1256	-.0654	.1470	-.0591	.1735	-.0571	.2046		
.50	-.0346	-.0127					-.0649	.1365	-.0651	.1555			-.0074	.0206
.60					-.0643	.1085	-.0648	.1270	-.0605	.1462	-.0565	.1699	-.0597	.1160
.70			-.0526	.0969	-.0650	.1006	-.0289	.1145	-.0523	.1054	-.0666	.0369	-.0641	.0040
.80	-.0510	-.0421	-.0634	-.0088	-.0648	-.0047			-.0430	.0055	-.0665	.0099	-.0109	.0032
.90	-.0649	-.0536			-.0589	-.0204			-.0634	-.0093	-.0653	.0011	-.0625	-.0149
.95	-.0638	-.0563							-.0657	-.0154	-.0660	-.0039	-.0640	-.0209

TAIL 2

TABLE XIII. - CONCLUDED
(k) $\alpha = 20.13^\circ$

Cp at y/b of														
x/c	0.02		0.22		0.44		0.56		0.67		0.83		0.98	
	U.S.	L.S.	U.S.	L.S.	U.S.	L.S.	U.S.	L.S.	U.S.	L.S.	U.S.	L.S.	U.S.	L.S.
.05	.0398	.9299	.1418	1.0435	.1522	1.0052	.1417	1.0234	.1538	1.0097	.1579	.9875		
.10	.0522	.8952	.1391	1.0695	.1519	1.0235	.1363	1.0285	.1452	1.0061	.1432	.9961	.0127	.5635
.15	.0574	.8596	.1338	1.0718	.1503	1.0229	.1420	1.0241	.1441	.9996	.1339	.9912	.0141	.5846
.20	.0292	.8141	.1240	1.0614	.1466	1.0167			.1423	.9940	.1333	.9831	.0128	.5944
.25			.0102	.5160	.1219	.9259	.1295	1.0024	.1386	.9867	.1284	.9591	.0002	.5955
.30	-.0361	.4274	-.0160	.4588	.0077	.4516	.0195	.4691	.0645	.6199	.1200	.9071	-.0006	.5809
.40									-.0059	.4287	-.0037	.3564	-.0286	.2617
.50	-.0421	.4261	-.0350	.4035	-.0161	.4352			-.0124	.4213	-.0201	.3039	-.0342	.2286
.60	-.0392	.3970	-.0386	.3876	-.0185	.4328	-.0165	.4184	-.0156	.4121	-.0248	.2903	-.0362	.2324
.70	-.0424	.4100	-.0372	.3812	-.0229	.4216	-.0251	.4053	-.0266	.3300			-.0393	.0837
.80	-.0380	.1929	-.0292	.1327	-.0234	.1500	-.0257	.1400	-.0242	.1003	-.0318	.0647	-.0368	.0856
.90	-.0278	.1309	-.0284	.1068	-.0248	.1265	-.0251	.1242	-.0275	.0864	-.0312	.0518	-.0373	.0868
.95	-.0272	.1289	-.0284	.1017	-.0252	.1181	-.0255	.1167	-.0277	.0772	-.0312	.0463	-.0372	.0925

TAIL 1

Cp at y/b of														
x/c	0.02		0.22		0.44		0.56		0.67		0.83		0.98	
	U.S.	L.S.	U.S.	L.S.	U.S.	L.S.	U.S.	L.S.	U.S.	L.S.	U.S.	L.S.	U.S.	L.S.
.05	-.0205	-.0090	-.0513	.3988			-.0451	.4947	-.0450	.5249	-.0427	.5623	-.0366	.5497
.10	-.0158	-.0113	-.0493	.3793			-.0505	.4712	-.0489	.5027	-.0484	.5477	-.0395	.5398
.15	-.0157	-.0075	-.0481	.3661			-.0536	.4521	-.0532	.4850	-.0496	.5321	-.0474	.5177
.20							-.0559	.4343	-.0559	.4673		.2125	-.0523	.4966
.25	-.0328	-.0245	-.0572	.1686			-.0527	.4036	-.0573	.4428	-.0422	.4949	-.0484	.4775
.30			-.0424	.1260	-.0586	.1644	-.0635	.2009	-.0618	.2989				
.40	-.0463	.0571			-.0606	.1504	-.0675	.1739	-.0623	.2008	-.0636	.2364		
.50	-.0470	-.0217					-.0667	.1638	-.0664	.1825			-.0040	.0289
.60					-.0666	.1331	-.0671	.1534	-.0619	.1717	-.0592	.1996	-.0619	.1550
.70			-.0554	.1679	-.0674	.1279	-.0303	.1383	-.0545	.1289	-.0686	.0575	-.0664	.0284
.80	-.0572	-.0440	-.0649	.0199	-.0673	.0124			-.0441	.0213	-.0689	.0314	-.0072	.0164
.90	-.0685	-.0516			-.0612	-.0035			-.0660	.0076	-.0678	.0215	-.0641	.0062
.95	-.0667	-.0544							-.0684	.0016	-.0687	.0151	-.0663	-.0004

TAIL 2

TABLE XIV. - PRESSURE COEFFICIENTS, $\phi = 67.5^\circ$, $\delta = 0^\circ$, $M = 3.70$
 (a) $\alpha = -3.80^\circ$

Cp at y/b of														
x/c	0.02		0.22		0.44		0.56		0.67		0.83		0.98	
	U.S.	L.S.	U.S.	L.S.	U.S.	L.S.	U.S.	L.S.	U.S.	L.S.	U.S.	L.S.	U.S.	L.S.
.05	.0918	.0471	.3042	.1039	.2933	.1186	.2928	.1278	.2849	.1327	.2802	.1326		
.10	.1014	.0391	.3139	.1035	.3010	.1174	.2690	.1273	.2869	.1293	.2793	.1304	.2491	.1051
.15	.1054	.0362	.3133	.1020	.3012	.1163	.2840	.1274	.2915	.1267	.2766	.1273	.2393	.0980
.20	.1007	.0372	.3046	.0982	.2983	.1147			.2916	.1246	.2826	.1255	.2240	.0904
.25			.1117	.0012	.2632	.0928	.2718	.1185	.2860	.1214	.2818	.1226	.2139	.0856
.30	.0492	.0034	.0743	-.0106	.0737	.0247	.0930	.0156	.1689	.0449	.2705	.1157	.2060	.0812
.40									.0670	-.0097	.0728	.0019	.0502	-.0077
.50	.0329	.0034	.0481	-.0232	.0617	-.0092			.0597	-.0150	.0560	-.0148	.0086	-.0165
.60	.0452	.0064	.0411	-.0254	.0605	-.0131	.0579	-.0092	.0575	-.0173	.0476	-.0082	-.0001	-.0219
.70	.0500	.0077	.0358	-.0244	.0546	-.0156	.0464	-.0207	.0293	-.0276			-.0406	-.0413
.80	-.0109	-.0212	-.0371	-.0387	-.0315	-.0247	-.0348	-.0321	-.0387	-.0182	-.0430	-.0353	-.0430	-.0433
.90	-.0301	-.0296	-.0476	-.0390	-.0424	-.0283	-.0406	-.0342	-.0433	-.0320	-.0470	-.0392	-.0487	-.0436
.95	-.0388	-.0308	-.0476	-.0374	-.0426	-.0310	-.0419	-.0337	-.0439	-.0316	-.0481	-.0391	-.0482	-.0485

TAIL 1

Cp at y/b of														
x/c	0.02		0.22		0.44		0.56		0.67		0.83		0.98	
	U.S.	L.S.	U.S.	L.S.	U.S.	L.S.	U.S.	L.S.	U.S.	L.S.	U.S.	L.S.	U.S.	L.S.
.05	.1632	.0847	.2585	.1880			.2463	.1947	.2528	.1983	.2550	.2044	.2368	.2193
.10	.1614	.0883	.2512	.1742			.2407	.1815	.2407	.1855	.2487	.1933	.2163	.1778
.15	.1486	.0855	.2454	.1662			.2365	.1740	.2360	.1770	.2446	.1857	.1910	.1520
.20							.2343	.1672	.2342	.1702		.1131	.1804	.1401
.25	.0193	.0039	.0716	.0339			.2181	.1554	.2274	.1608	.2345	.1730	.1706	.1331
.30			.0423	.0133	.0455	.0202	.0605	.0321	.1417	.0897				
.40	.0166	.0624			.0282	.0039	.0348	.0032	.0423	.0111	.0459	.0203		
.50	.0133	-.0056					.0291	-.0015	.0315	-.0005			.0178	.0333
.60					.0276	-.0046	.0290	-.0045	.0305	-.0012	.0225	-.0029	.0050	-.0085
.70			.0239	-.0059	.0231	-.0096	.0234	.0108	-.0197	-.0127	-.0435	-.0456	-.0376	-.0437
.80	-.0371	-.0468	-.0413	-.0439	-.0445	-.0452			-.0283	-.0256	-.0557	-.0480	.0104	.0034
.90	-.0478	-.0478			-.0493	-.0370			-.0524	-.0413	-.0531	-.0446	-.0550	-.0505
.95	-.0483	-.0456							-.0517	-.0423	-.0515	-.0440	-.0582	-.0513

TAIL 2

TABLE XIV. - CONTINUED
(b) $\alpha = -1.81^\circ$

Cp at y/b of														
x/c	0.02		0.22		0.44		0.56		0.67		0.83		0.98	
	U.S.	L.S.	U.S.	L.S.	U.S.	L.S.	U.S.	L.S.	U.S.	L.S.	U.S.	L.S.	U.S.	L.S.
.05	.0943	.0509	.2462	.1549	.2406	.1646	.2417	.1715	.2356	.1762	.2338	.1717		
.10	.0983	.0527	.2552	.1573	.2474	.1648	.2183	.1731	.2362	.1735	.2316	.1716	.2052	.1375
.15	.0983	.0516	.2542	.1554	.2474	.1636	.2320	.1716	.2398	.1711	.2289	.1685	.1965	.1310
.20	.0908	.0411	.2469	.1509	.2446	.1621			.2403	.1692	.2342	.1660	.1842	.1223
.25			.0802	.0180	.2151	.1358	.2217	.1629	.2364	.1655	.2332	.1637	.1757	.1161
.30	.0349	-.0060	.0474	-.0046	.0538	.0103	.0674	.0238	.1347	.0716	.2234	.1557	.1680	.1114
.40									.0413	-.0002	.0500	.0100	.0319	-.0006
.50	.0176	-.0025	.0251	-.0192	.0355	-.0097			.0342	-.0048	.0330	-.0070	-.0033	-.0173
.60	.0294	.0024	.0181	-.0228	.0339	-.0122	.0329	-.0092	.0313	-.0087	.0258	-.0120	-.0100	-.0219
.70	.0349	.0055	.0138	-.0227	.0287	-.0156	.0219	-.0167	.0084	-.0210			-.0402	-.0472
.80	-.0218	-.0316	-.0444	-.0447	-.0371	-.0398	-.0415	-.0444	-.0407	-.0348	-.0470	-.0452	-.0463	-.0446
.90	-.0350	-.0408	-.0511	-.0427	-.0472	-.0395	-.0487	-.0407	-.0497	-.0413	-.0518	-.0446	-.0406	-.0517
.95	-.0420	-.0418	-.0475	-.0421	-.0482	-.0393	-.0479	-.0403	-.0477	-.0408	-.0499	-.0444	-.0390	-.0557

TAIL 1

Cp at y/b of														
x/c	0.02		0.22		0.44		0.56		0.67		0.83		0.98	
	U.S.	L.S.	U.S.	L.S.	U.S.	L.S.	U.S.	L.S.	U.S.	L.S.	U.S.	L.S.	U.S.	L.S.
.05	.1166	.0877	.2301	.2051			.2229	.2101	.2308	.2139	.2308	.2170	.2132	.2277
.10	.1239	.0930	.2227	.1929			.2178	.1975	.2186	.2009	.2241	.2062	.1956	.1918
.15	.1169	.0903	.2178	.1849			.2136	.1901	.2135	.1921	.2202	.1986	.1708	.1652
.20							.2114	.1833	.2115	.1851		.1285	.1656	.1511
.25	.0310	.0083	.0586	.0423			.1986	.1700	.2050	.1755	.2108	.1854	.1567	.1400
.30			.0346	.0195	.0415	.0244	.0509	.0396	.1247	.1002				
.40	.0102	.0649			.0264	.0068	.0262	.0090	.0330	.0166	.0408	.0244		
.50	.0083	-.0017					.0215	.0036	.0223	.0053			.0175	-.0463
.60					.0212	-.0000	.0202	.0017	.0213	.0048	.0184	.0001	-.0035	-.0075
.70			.0151	-.0002	.0159	-.0047	.0251	.0127	-.0129	-.0115	-.0412	-.0450	-.0401	-.0445
.80	-.0314	-.0459	-.0400	-.0442	-.0425	-.0470			-.0268	-.0230	-.0545	-.0480	.0103	.0137
.90	-.0453	-.0502			-.0454	-.0374			-.0484	-.0407	-.0497	-.0442	-.0557	-.0529
.95	-.0455	-.0466							-.0463	-.0415	-.0475	-.0434	-.0584	-.0560

TAIL 2

TABLE XIV. - CONTINUED
(c) $\alpha = 0.19^\circ$

Cp at γ/b of														
x/c	0.02		0.22		0.44		0.56		0.67		0.83		0.98	
	U.S.	L.S.	U.S.	L.S.	U.S.	L.S.	U.S.	L.S.	U.S.	L.S.	U.S.	L.S.	U.S.	L.S.
.05	.0867	.0824	.1904	.2122	.1910	.2138	.1960	.2212	.1908	.2224	.1876	.2118		
.10	.0867	.0875	.1983	.2152	.1967	.2157	.1744	.2242	.1898	.2202	.1845	.2147	.1634	.1741
.15	.0838	.0871	.1976	.2147	.1967	.2147	.1856	.2226	.1927	.2178	.1827	.2127	.1550	.1674
.20	.0733	.0764	.1910	.2097	.1939	.2130			.1930	.2159	.1876	.2109	.1456	.1573
.25			.0495	.0462	.1687	.1821	.1763	.2118	.1901	.2119	.1869	.2083	.1395	.1498
.30	.0138	.0076	.0198	.0179	.0306	.0270	.0454	.0463	.1025	.1005	.1782	.1989	.1335	.1446
.40									.0195	.0198	.0284	.0298	.0147	.0138
.50	-.0016	.0058	.0027	.0023	.0119	.0095			.0126	.0139	.0116	.0114	-.0111	-.0104
.60	.0095	.0076	-.0025	-.0018	.0100	.0075	.0109	.0076	.0037	.0101	.0048	.0041	-.0152	-.0162
.70	.0175	.0114	-.0056	-.0060	.0052	.0033	.0010	.0012	-.0039	-.0070			-.0437	-.0450
.80	-.0309	-.0338	-.0518	-.0501	-.0448	-.0444	-.0483	-.0477	-.0463	-.0419	-.0522	-.0499	-.0449	-.0457
.90	-.0434	-.0462	-.0484	-.0448	-.0483	-.0443	-.0477	-.0460	-.0473	-.0440	-.0494	-.0468	-.0557	-.0526
.95	-.0486	-.0456	-.0463	-.0439	-.0460	-.0430	-.0450	-.0436	-.0449	-.0424	-.0475	-.0454	-.0566	-.0573

TAIL 1

Cp at γ/b of														
x/c	0.02		0.22		0.44		0.56		0.67		0.83		0.98	
	U.S.	L.S.	U.S.	L.S.	U.S.	L.S.	U.S.	L.S.	U.S.	L.S.	U.S.	L.S.	U.S.	L.S.
.05	.0796	.0818	.2070	.2258			.2027	.2300	.2099	.2326	.2099	.2343	.1949	.2438
.10	.0896	.0899	.1981	.2149			.1971	.2169	.1982	.2196	.2039	.2252	.1805	.2139
.15	.0861	.0881	.1928	.2068			.1928	.2092	.1935	.2110	.2006	.2183	.1594	.1849
.20							.1909	.2023	.1916	.2041		.1396	.1549	.1645
.25	.0249	.0182	.0458	.0534			.1787	.1882	.1856	.1940	.1923	.2052	.1404	.1511
.30			.0239	.0267	.0319	.0332	.0416	.0495	.1099	.1141				
.40	.0045	.0672			.0172	.0155	.0175	.0178	.0242	.0256	.0325	.0346		
.50	.0037	.0110					.0128	.0124	.0138	.0140			.0142	.0396
.60					.0119	.0089	.0115	.0100	.0131	.0130	.0112	.0093	-.0099	-.0083
.70			.0039	.0048	.0067	.0038	.0197	.0188	-.0173	-.0054	-.0431	-.0416	-.0422	-.0418
.80	-.0277	-.0365	-.0444	-.0438	-.0455	-.0481			-.0284	-.0256	-.0542	-.0505	.0072	.0090
.90	-.0435	-.0465			-.0422	-.0378			-.0449	-.0409	-.0467	-.0444	-.0548	-.0442
.95	-.0440	-.0450							-.0431	-.0409	-.0447	-.0429	-.0564	-.0514

TAIL 2

TABLE XIV. - CONTINUED
(d) $\alpha = 2.18^\circ$

Cp at y/b of														
x/c	0.02		0.22		0.44		0.56		0.67		0.83		0.98	
	U.S.	L.S.	U.S.	L.S.	U.S.	L.S.	U.S.	L.S.	U.S.	L.S.	U.S.	L.S.	U.S.	L.S.
.05	.0774	.1514	.1405	.2697	.1451	.2638	.1514	.2723	.1487	.2709	.1502	.2603		
.10	.0760	.1544	.1459	.2733	.1493	.2669	.1331	.2749	.1466	.2693	.1436	.2628	.1257	.2135
.15	.0723	.1529	.1454	.2733	.1494	.2661	.1416	.2735	.1481	.2667	.1404	.2597	.1171	.2064
.20	.0598	.1431	.1399	.2680	.1470	.2646			.1483	.2645	.1441	.2575	.1099	.1951
.25			.0235	.0761	.1246	.2292	.1328	.2601	.1456	.2600	.1431	.2548	.1059	.1860
.30	-.0055	.0326	-.0017	.0450	.0135	.0504	.0259	.0688	.0716	.1305	.1357	.2448	.1022	.1804
.40									.0006	.0427	.0088	.0512	.0002	.0312
.50	-.0204	.0244	-.0169	.0300	-.0074	.0332			-.0058	.0360	-.0067	.0325	-.0140	.0011
.60	-.0151	.0220	-.0205	.0254	-.0091	.0312	-.0075	.0292	-.0083	.0322	-.0111	.0242	-.0202	-.0073
.70	-.0084	.0232	-.0220	.0196	-.0131	.0263	-.0161	.0235	-.0234	.0106			-.0482	-.0413
.80	-.0405	-.0321	-.0526	-.0435	-.0463	-.0413	-.0486	-.0441	-.0443	-.0426	-.0508	-.0502	-.0575	-.0466
.90	-.0436	-.0470	-.0468	-.0486	-.0448	-.0461	-.0447	-.0488	-.0459	-.0489	-.0484	-.0509	-.0535	-.0422
.95	-.0502	-.0474	-.0455	-.0445	-.0441	-.0451	-.0440	-.0467	-.0450	-.0460	-.0478	-.0481	-.0585	-.0546

TAIL 1

Cp at y/b of														
x/c	0.02		0.22		0.44		0.56		0.67		0.83		0.98	
	U.S.	L.S.	U.S.	L.S.	U.S.	L.S.	U.S.	L.S.	U.S.	L.S.	U.S.	L.S.	U.S.	L.S.
.05	.0685	.0729	.1813	.2514			.1824	.2514	.1901	.2535	.1929	.2566	.1788	.2631
.10	.0746	.0829	.1716	.2400			.1770	.2381	.1790	.2405	.1855	.2470	.1672	.2361
.15	.0696	.0820	.1660	.2311			.1730	.2303	.1742	.2320	.1818	.2391	.1513	.2026
.20							.1711	.2233	.1724	.2247		.1525	.1382	.1817
.25	.0183	.0212	.0333	.0665			.1599	.2085	.1666	.2141	.1734	.2247	.1208	.1716
.30			.0145	.0361	.0236	.0437	.0327	.0601	.0964	.1286				
.40	.0019	.0693			.0088	.0257	.0091	.0279	.0161	.0356	.0241	.0438		
.50	.0037	.0175					.0046	.0224	.0050	.0238			.0102	.0302
.60					.0031	.0192	.0033	.0199	.0056	.0225	.0042	.0184	-.0161	-.0114
.70			-.0038	.0085	-.0018	.0136	.0136	.0260	-.0218	.0014	-.0458	-.0378	-.0451	-.0408
.80	-.0269	-.0302	-.0450	-.0437	-.0476	-.0460			-.0288	-.0274	-.0510	-.0516	.0036	.0011
.90	-.0421	-.0425			-.0395	-.0395			-.0421	-.0428	-.0444	-.0456	-.0441	-.0415
.95	-.0423	-.0432							-.0414	-.0417	-.0432	-.0433	-.0484	-.0435

TAIL 2

TABLE XIV. - CONTINUED
(e) $\alpha = 4.17^\circ$

Cp at y/b of														
x/c	0.02		0.22		0.44		0.56		0.67		0.83		0.98	
	U.S.	L.S.	U.S.	L.S.	U.S.	L.S.	U.S.	L.S.	U.S.	L.S.	U.S.	L.S.	U.S.	L.S.
.05	.0293	.2396	.0916	.3298	.1015	.3184	.1071	.3264	.1083	.3230	.1141	.3102	.0931	.2568
.10	.0323	.2195	.0951	.3355	.1041	.3232	.0943	.3295	.1048	.3218	.1065	.3143	.0846	.2488
.15	.0343	.2252	.0940	.3362	.1041	.3222	.1013	.3278	.1056	.3188	.1029	.3114	.0846	.2488
.20	.0292	.2157	.0897	.3304	.1021	.3206			.1053	.3167	.1055	.3084	.0789	.2358
.25			.0005	.1099	.0829	.2807	.0923	.3119	.1030	.3120	.1039	.3049	.0760	.2256
.30	-.0236	.0638	-.0194	.0784	.0000	.0779	-.0087	.0930	.0418	.1627	.0975	.2938	.0739	.2194
.40									-.0155	.0684	-.0074	.0757	-.0116	.0510
.50	-.0354	.0539	-.0334	.0620	-.0222	.0607			-.0216	.0616	-.0216	.0556	-.0198	.0165
.60	-.0321	.0502	-.0365	.0556	-.0238	.0586	-.0212	.0561	-.0237	.0575	-.0230	.0465	-.0269	.0063
.70	-.0300	.0503	-.0374	.0492	-.0271	.0533	-.0299	.0499	-.0350	.0318			-.0514	-.0362
.80	-.0490	-.0258	-.0510	-.0327	-.0448	-.0325	-.0471	-.0364	-.0430	-.0379	-.0510	-.0457	-.0629	-.0420
.90	-.0530	-.0410	-.0484	-.0475	-.0440	-.0435	-.0450	-.0438	-.0469	-.0463	-.0500	-.0497	-.0622	-.0358
.95	-.0519	-.0430	-.0475	-.0470	-.0445	-.0436	-.0447	-.0451	-.0466	-.0465	-.0498	-.0496	-.0604	-.0352

TAIL 1

Cp at y/b of														
x/c	0.02		0.22		0.44		0.56		0.67		0.83		0.98	
	U.S.	L.S.	U.S.	L.S.	U.S.	L.S.	U.S.	L.S.	U.S.	L.S.	U.S.	L.S.	U.S.	L.S.
.05	.0774	.0521	.1362	.2848			.1606	.2767	.1688	.2768	.1726	.2778	.1618	.2834
.10	.0824	.0665	.1280	.2716			.1550	.2629	.1577	.2635	.1648	.2689	.1527	.2576
.15	.0769	.0691	.1277	.2620			.1511	.2550	.1531	.2549	.1612	.2608	.1376	.2237
.20							.1494	.2477	.1515	.2474			.1726	.2059
.25	.0194	.0216	.0190	.0778			.1395	.2316	.1462	.2359	.1537	.2460	.1103	.1912
.30			.0055	.0426	.0140	.0556	.0229	.0724	.0819	.1448				
.40	.0039	.0701			-.0006	.0379	.0003	.0402	.0075	.0470	.0158	.0547	.0086	.0294
.50	.0013	.0222					-.0041	.0346	-.0023	.0351				
.60					-.0068	.0320	-.0058	.0322	-.0023	.0336	-.0031	.0288	-.0221	-.0086
.70			-.0074	.0129	-.0113	.0259	.0069	.0351	-.0262	.0091	-.0486	-.0334	-.0478	-.0416
.80	-.0322	-.0281	-.0444	-.0432	-.0454	-.0425			-.0278	-.0262	-.0480	-.0500	.0020	.0073
.90	-.0444	-.0407			-.0382	-.0424			-.0412	-.0455	-.0433	-.0479	-.0415	-.0442
.95	-.0416	-.0424							-.0410	-.0436	-.0427	-.0445	-.0446	-.0446

TAIL 2

TABLE XIV. - CONTINUED
(f) $\alpha = 6.17^\circ$

Cp at γ/b of														
x/c	0.02		0.22		0.44		0.56		0.67		0.83		0.98	
	U.S.	L.S.	U.S.	L.S.	U.S.	L.S.	U.S.	L.S.	U.S.	L.S.	U.S.	L.S.	U.S.	L.S.
.05	-.0096	.3110	-.0512	.3935	-.0630	.3772	-.0680	.3863	.0748	.3799	.0860	.3669		
.10	-.0025	.2774	-.0524	.4013	-.0641	.3839	-.0582	.3894	-.0701	.3790	-.0770	.3721	.0699	.3075
.15	.0018	.2701	-.0514	.4023	-.0641	.3837	-.0627	.3853	-.0698	.3762	-.0725	.3688	.0625	.2977
.20	-.0057	.2571	-.0477	.3958	-.0625	.3822			-.0689	.3737	-.0739	.3661	.0580	.2830
.25			-.0213	.1469	-.0466	.3377	.0549	.3671	-.0664	.3687	-.0719	.3625	.0554	.2718
.30	-.0421	.0932	-.0360	.1155	-.0168	.1098	-.0101	.1204	-.0163	.2000	-.0664	.3501	.0539	.2649
.40									-.0311	.0983	-.0227	.1052	-.0194	.0735
.50	-.0495	.0872	-.0491	.0942	-.0379	.0939			-.0356	.0915	-.0353	.0838	-.0265	.0357
.60	-.0489	.0768	-.0510	.0863	-.0392	.0921	-.0353	.0893	-.0379	.0868	-.0361	.0735	-.0323	.0239
.70	-.0361	.0777	-.0507	.0792	-.0418	.0858	-.0441	.0803	-.0449	.0563			-.0580	-.0324
.80	-.0548	-.0086	-.0510	-.0199	-.0453	-.0186	-.0493	-.0253	-.0448	-.0301	-.0530	-.0361	-.0629	-.0359
.90	-.0556	-.0262	-.0502	-.0389	-.0465	-.0325	-.0485	-.0342	-.0504	-.0381	-.0528	-.0439	-.0562	-.0376
.95	-.0531	-.0304	-.0498	-.0414	-.0473	-.0342	-.0485	-.0368	-.0506	-.0407	-.0531	-.0462	-.0564	-.0377

TAIL 1

Cp at γ/b of														
x/c	0.02		0.22		0.44		0.56		0.67		0.83		0.98	
	U.S.	L.S.	U.S.	L.S.	U.S.	L.S.	U.S.	L.S.	U.S.	L.S.	U.S.	L.S.	U.S.	L.S.
.05	.1487	.0191	.0893	.3204			.1353	.3027	.1454	.3018	.1515	.3009	.1440	.3043
.10	.1395	.0339	.0866	.3021			.1297	.2884	.1350	.2882	.1435	.2920	.1357	.2785
.15	.1239	.0385	.0947	.2850			.1260	.2808	.1301	.2792	.1397	.2836	.1206	.2500
.20							.1243	.2734	.1285	.2713		.1956	.1108	.2285
.25	.0249	-.0038	.0090	.0806			.1162	.2571	.1237	.2593	.1332	.2686	.0998	.2128
.30			.0015	.0472	.0029	.0735	.0112	.0874	.0657	.1625				
.40	.0022	.0717			-.0112	.0572	-.0097	.0553	-.0018	.0605	.0072	.0684		
.50	-.0022	-.0005					-.0139	.0499	-.0117	.0485			.0062	.0331
.60					-.0166	.0480	-.0159	.0474	-.0112	.0467	-.0108	.0430	-.0271	.0000
.70			-.0088	.0150	-.0203	.0406	.0000	.0485	-.0311	.0223	-.0512	-.0269	-.0505	-.0445
.80	-.0392	-.0305	-.0468	-.0442	-.0432	-.0380			-.0275	-.0220	-.0467	-.0458	-.0003	.0025
.90	-.0471	-.0413			-.0385	-.0442			-.0411	-.0455	-.0434	-.0488	-.0420	-.0439
.95	-.0433	-.0440							-.0417	-.0457	-.0433	-.0469	-.0441	-.0460

TAIL 2

TABLE XIV. - CONTINUED
(g) $\alpha = 8.17^\circ$

Cp at γ/b of														
x/c	0.02		0.22		0.44		0.56		0.67		0.83		0.98	
	U.S.	L.S.	U.S.	L.S.	U.S.	L.S.	U.S.	L.S.	U.S.	L.S.	U.S.	L.S.	U.S.	L.S.
.05	-.0261	.3586	.0232	.4558	.0394	.4412	.0494	.4548	.0585	.4480	.0719	.4344		
.10	-.0234	.3082	.0226	.4661	.0387	.4500	.0402	.4594	.0527	.4472	.0616	.4406	.0582	.3675
.15	-.0202	.3030	.0205	.4686	.0379	.4501	.0436	.4535	.0514	.4440	.0568	.4368	.0517	.3563
.20	-.0241	.3002	.0173	.4619	.0357	.4488			.0501	.4413	.0575	.4341	.0481	.3397
.25			-.0350	.1877	.0213	.3994	.0344	.4323	-.0474	.4361	.0553	.4306	.0454	.3267
.30	-.0498	.1205	-.0448	.1549	-.0242	.1473	-.0194	.1565	.0035	.2462	.0501	.4168	.0442	.3211
.40									-.0380	.1338	-.0297	.1417	-.0209	.1017
.50	-.0554	.1166	-.0574	.1268	-.0465	.1315			-.0422	.1267	-.0416	.1185	-.0282	.0604
.60	-.0548	.1075	-.0564	.1169	-.0472	.1294	-.0420	.1243	-.0440	.1215	-.0411	.1061	-.0364	.0465
.70	-.0437	.1123	-.0537	.1101	-.0488	.1223	-.0502	.1148	-.0491	.0857			-.0619	-.0268
.80	-.0579	.0273	-.0526	-.0047	-.0482	-.0011	-.0504	-.0099	-.0458	-.0173	-.0556	-.0227	-.0634	-.0276
.90	-.0569	-.0087	-.0523	-.0245	-.0486	-.0157	-.0502	-.0203	-.0521	-.0245	-.0551	-.0335	-.0653	-.0320
.95	-.0534	-.0150	-.0521	-.0277	-.0496	-.0197	-.0502	-.0235	-.0523	-.0280	-.0555	-.0369	-.0639	-.0357

TAIL 1

Cp at γ/b of														
x/c	0.02		0.22		0.44		0.56		0.67		0.83		0.98	
	U.S.	L.S.	U.S.	L.S.	U.S.	L.S.	U.S.	L.S.	U.S.	L.S.	U.S.	L.S.	U.S.	L.S.
.05	.2203	-.0052	.0260	.1102			.0994	.3411	-.1157	.3313	.1268	.3260	.1229	.3270
.10	.1995	-.0001	.0459	.0997			.0933	.3270	-.1055	.3182	.1186	.3182	.1147	.3010
.15	.1769	-.0001	.0550	.0942			.0893	.3201	-.1005	.3094	.1145	.3098	.1000	.2753
.20							.0879	.3129	-.0987	.3016		.2208	.0932	.2527
.25	.0388	-.0266	.0073	.0086			.0831	.2952	-.0943	.2893	-.1084	.2951	.0834	.2366
.30			.0031	.0044	-.0143	.0977	-.0052	.1147	-.0446	.1851				
.40	.0074	.0472			-.0240	.0737	-.0234	.0790	-.0134	.0799	-.0031	.0839		
.50	.0007	-.0089					-.0272	.0720	-.0230	.0686			.0028	.0333
.60					-.0250	.0525	-.0287	.0661	-.0224	.0666	-.0198	.0584	-.0318	.0105
.70			-.0124	-.0018	-.0288	.0419	-.0080	.0620	-.0369	.0384	-.0537	-.0200	-.0517	-.0446
.80	-.0419	-.0355	-.0499	-.0464	-.0449	-.0392			-.0289	-.0173	-.0485	-.0407	-.0032	.0020
.90	-.0528	-.0440			-.0405	-.0449			-.0428	-.0419	-.0459	-.0454	-.0444	-.0416
.95	-.0481	-.0456							-.0436	-.0452	-.0461	-.0464	-.0461	-.0452

TAIL 2

TABLE XIV. - CONTINUED
(h) $\alpha = 10.16^\circ$

Cp at y/b of														
x/c	0.02		0.22		0.44		0.56		0.67		0.83		0.98	
	U.S.	L.S.	U.S.	L.S.	U.S.	L.S.	U.S.	L.S.	U.S.	L.S.	U.S.	L.S.	U.S.	L.S.
.05	-.0404	.4389	.0085	.5274	.0317	.5178	.0412	.5342	.0510	.5284	.0645	.5131		
.10	-.0418	.3548	.0057	.5410	.0300	.5283	.0320	.5405	.0445	.5274	.0538	.5200	-.0531	.4371
.15	-.0398	.3520	.0027	.5448	.0283	.5283	.0344	.5337	.0431	.5235	.0483	.5161	-.0480	.4241
.20	-.0417	.3376	-.0016	.5383	.0257	.5271			.0415	.5204	.0485	.5133	-.0451	.4046
.25			-.0459	.2328	.0118	.4720	.0258	.5098	.0385	.5156	.0467	.5095	-.0431	.3903
.30	-.0567	.1513	-.0527	.1951	-.0296	.1896	-.0253	.2036	-.0029	.3032	.0415	.4944	-.0416	.3860
.40									-.0427	.1777	-.0342	.1849	-.0187	.1350
.50	-.0588	.1526	-.0602	.1626	-.0523	.1745			-.0468	.1702	-.0459	.1592	-.0298	.0901
.60	-.0567	.1486	-.0590	.1527	-.0535	.1726	-.0479	.1656	-.0488	.1640	-.0454	.1453	-.0390	.0742
.70	-.0514	.1637	-.0569	.1447	-.0529	.1646	-.0550	.1571	-.0521	.1221			-.0655	-.0203
.80	-.0655	.0492	-.0557	.0118	-.0498	.0189	-.0530	.0115	-.0467	-.0004	-.0574	-.0056	-.0716	-.0180
.90	-.0604	.0057	-.0552	-.0076	-.0510	.0036	-.0530	-.0000	-.0545	-.0057	-.0578	-.0189	-.0673	-.0214
.95	-.0560	.0006	-.0545	-.0110	-.0516	-.0015	-.0531	-.0038	-.0548	-.0102	-.0583	-.0236	-.0667	-.0254

TAIL 1

Cp at y/b of														
x/c	0.02		0.22		0.44		0.56		0.67		0.83		0.98	
	U.S.	L.S.	U.S.	L.S.	U.S.	L.S.	U.S.	L.S.	U.S.	L.S.	U.S.	L.S.	U.S.	L.S.
.05	.1884	-.0029	.0195	-.0276			.0441	.3976	.0743	.3732	.0955	.3551	-.0981	.3508
.10	.1739	-.0026	.0272	-.0157			.0373	.3840	.0645	.3618	.0876	.3480	-.0903	.3259
.15	.1627	-.0051	.0364	-.0090			.0323	.3722	.0592	.3540	.0841	.3404	-.0773	.3012
.20							.0299	.3565	.0573	.3467		.2483	-.0721	.2789
.25	.0418	-.0478	-.0069	-.0299			.0317	.3306	.0539	.3339	.0795	.3265	-.0640	.2636
.30			-.0061	-.0168	-.0303	.0764	-.0307	.1291	.0159	.2194				
.40	.0053	.0324			-.0327	.0579	-.0414	.0875	-.0284	.1074	-.0154	.1064		
.50	-.0012	-.0361					-.0391	.0736	-.0380	.0894			-.0000	.0306
.60					-.0326	.0464	-.0388	.0638	-.0366	.0810	-.0298	.0827	-.0370	.0264
.70			-.0176	-.0230	-.0357	.0406	-.0143	.0609	-.0421	.0495	-.0557	-.0072	-.0535	-.0415
.80	-.0445	-.0514	-.0531	-.0532	-.0531	-.0354			-.0314	-.0155	-.0510	-.0298	-.0056	-.0007
.90	-.0578	-.0551			-.0465	-.0416			-.0459	-.0397	-.0491	-.0365	-.0475	-.0371
.95	-.0536	-.0546							-.0471	-.0443	-.0495	-.0396	-.0489	-.0406

TAIL 2

TABLE XIV. - CONTINUED
(i) $\alpha = 12.15^\circ$

Cp at y/b of														
x/c	0.02		0.22		0.44		0.56		0.67		0.83		0.98	
	U.S.	L.S.	U.S.	L.S.	U.S.	L.S.	U.S.	L.S.	U.S.	L.S.	U.S.	L.S.	U.S.	L.S.
.05	-.0418	.4882	.0073	.6116	.0306	.6060	.0394	.6235	.0496	.6198	.0628	.6040		
.10	-.0439	.4031	.0038	.6285	.0286	.6184	.0305	.6323	.0427	.6182	.0514	.6113	.0527	.5159
.15	-.0427	.4271	.0004	.6326	.0266	.6184	.0328	.6242	.0409	.6138	.0456	.6070	.0490	.5000
.20	-.0440	.3998	-.0042	.6257	.0237	.6169			.0390	.6113	.0454	.6043	.0463	.4775
.25			-.0469	.2816	.0098	.5552	.0237	.5972	.0360	.6066	.0436	.6007	.0452	.4635
.30	-.0566	.1904	-.0536	.2379	-.0311	.2397	-.0260	.2578	-.0041	.3670	.0382	.5833	.0440	.4591
.40									-.0425	.2278	-.0355	.2344	-.0167	.1731
.50	-.0591	.2032	-.0599	.2014	-.0533	.2251			-.0472	.2196	-.0468	.2057	-.0292	.1234
.60	-.0581	.1896	-.0588	.1924	-.0543	.2230	-.0484	.2146	-.0486	.2120	-.0457	.1889	-.0434	.1056
.70	-.0565	.2062	-.0576	.1845	-.0535	.2133	-.0546	.2063	-.0517	.1631			-.0655	-.0106
.80	-.0629	.0741	-.0568	.0316	-.0493	.0412	-.0525	.0362	-.0470	.0224	-.0576	.0137	-.0706	-.0097
.90	-.0583	.0220	-.0560	.0115	-.0513	.0242	-.0533	.0240	-.0547	.0185	-.0587	-.0004	-.0667	-.0134
.95	-.0557	.0189	-.0547	.0082	-.0526	.0182	-.0536	.0197	-.0555	.0133	-.0592	-.0062	.0653	-.0178

TAIL 1

Cp at y/b of														
x/c	0.02		0.22		0.44		0.56		0.67		0.83		0.98	
	U.S.	L.S.	U.S.	L.S.	U.S.	L.S.	U.S.	L.S.	U.S.	L.S.	U.S.	L.S.	U.S.	L.S.
.05	.1684	-.0067	.0076	-.0285			-.0012	.3861	.0283	.4130	.0621	.3879	.0728	.3749
.10	.1531	-.0069	.0138	-.0190			-.0078	.3320	.0201	.3990	.0542	.3815	.0654	.3514
.15	.1431	-.0095	.0201	-.0109			-.0129	.2917	.0149	.3872	.0506	.3751	.0537	.3276
.20							-.0152	.2742	.0122	.3733		.2813	.0488	.3080
.25	.0337	-.0504	-.0189	-.0320			-.0105	.2580	.0098	.3478	.0484	.3628	.0424	.2933
.30			-.0146	-.0202	-.0407	.0474	-.0477	.1008	-.0148	.2236				
.40	-.0033	.0114			-.0418	.0387	-.0512	.0756	-.0425	.0982	-.0281	.1325		
.50	-.0091	-.0434					-.0485	.0681	-.0505	.0765			-.0002	.0313
.60					-.0448	.0256	-.0480	.0616	-.0468	.0747	-.0393	.1002	-.0422	.0463
.70			-.0240	-.0304	-.0475	.0253	-.0194	.0630	-.0450	.0473	-.0591	-.0029	-.0569	-.0338
.80	-.0484	-.0560	-.0556	-.0552	-.0588	-.0367			-.0346	-.0144	-.0557	-.0279	-.0055	-.0009
.90	-.0625	-.0619			-.0516	-.0425			-.0509	-.0360	-.0540	-.0357	-.0523	-.0376
.95	-.0602	-.0610							-.0524	-.0402	-.0546	-.0393	-.0527	-.0408

TAIL 2

TABLE XIV. - CONTINUED
(j) $\alpha = 16.16^\circ$

Cp at y/b of														
x/c	0.02		0.22		0.44		0.56		0.67		0.83		0.98	
	U.S.	L.S.	U.S.	L.S.	U.S.	L.S.	U.S.	L.S.	U.S.	L.S.	U.S.	L.S.	U.S.	L.S.
.05	-.0416	.6326	.0124	.8256	.0382	.8264	.0441	.8432	.0541	.8428	.0679	.8256		
.10	-.0431	.5634	.0079	.8505	.0353	.8411	.0351	.8622	.0463	.8391	.0549	.8328	.0612	.7084
.15	-.0424	.5908	.0037	.8529	.0327	.8416	.0369	.8488	.0441	.8332	.0481	.8291	.0596	.6846
.20	-.0451	.5528	-.0018	.8357	.0291	.8398			.0423	.8344	.0476	.8252	.0576	.6542
.25			-.0466	.3922	.0143	.7611	.0275	.8180	.0393	.8306	.0454	.8207	.0561	.6421
.30	-.0565	.2887	-.0537	.3420	-.0308	.3619	-.0256	.3978	-.0028	.5139	.0400	.7986	.0548	.6279
.40									-.0433	.3544	-.0350	.3564	-.0146	.2659
.50	-.0592	.3230	-.0594	.3003	-.0530	.3516			-.0478	.3424	-.0461	.3191	-.0338	.2074
.60	-.0585	.2951	-.0587	.2911	-.0544	.3449	-.0493	.3410	-.0498	.3346	-.0458	.2967	-.0500	.1850
.70	-.0571	.3147	-.0576	.2812	-.0537	.3257	-.0558	.3293	-.0522	.2710			-.0661	.0216
.80	-.0600	.1387	-.0578	.0807	-.0494	.0938	-.0533	.1003	-.0465	.0811	-.0573	.0638	-.0679	.0098
.90	-.0571	.0716	-.0571	.0610	-.0522	.0736	-.0542	.0833	-.0545	.0775	-.0576	.0471	-.0649	.0058
.95	-.0561	.0777	-.0557	.0577	-.0539	.0660	-.0547	.0776	-.0556	.0717	-.0581	.0404	-.0665	-.0077

TAIL 1

Cp at y/b of														
x/c	0.02		0.22		0.44		0.56		0.67		0.83		0.98	
	U.S.	L.S.	U.S.	L.S.	U.S.	L.S.	U.S.	L.S.	U.S.	L.S.	U.S.	L.S.	U.S.	L.S.
.05	.1211	-.0271	-.0125	-.0123			-.0421	.2123	-.0410	.2516	-.0295	.2925	.0266	.4111
.10	.1093	-.0199	-.0083	-.0069			-.0453	.1963	-.0440	.2362	-.0305	.2886	.0212	.4050
.15	.1023	-.0216	-.0038	-.0024			-.0468	.1870	-.0459	.2228	-.0298	.2803	.0113	.3691
.20							-.0481	.1816	-.0489	.2128		.2100	.0053	.3357
.25	.0156	-.0548	-.0334	-.0332			-.0420	.1758	-.0488	.2011	-.0181	.2622	.0026	.3152
.30			-.0239	-.0198	-.0498	.0314	-.0577	.0615	-.0541	.1249				
.40	-.0222	.0150			-.0514	.0234	-.0612	.0397	-.0560	.0605	-.0489	.0979		
.50	-.0245	-.0475					-.0600	.0336	-.0607	.0468			.0127	.0572
.60					-.0556	.0119	-.0603	.0294	-.0571	.0434	-.0495	.0704	-.0522	.0627
.70			-.0349	-.0325	-.0570	.0079	-.0265	.0413	-.0500	.0287	-.0658	-.0101	-.0611	-.0236
.80	-.0535	-.0576	-.0586	-.0566	-.0650	-.0444			-.0374	-.0141	-.0633	-.0295	.0082	-.0171
.90	-.0669	-.0644			-.0567	-.0476			-.0593	-.0411	-.0612	-.0361	-.0577	-.0351
.95	-.0650	-.0639							-.0615	-.0459	-.0621	-.0397	-.0598	-.0405

TAIL 2

TABLE XIV. - CONCLUDED
(k) $\alpha = 20.17^\circ$

Cp at y/b of														
x/c	0.02		0.22		0.44		0.56		0.67		0.83		0.98	
	U.S.	L.S.	U.S.	L.S.	U.S.	L.S.	U.S.	L.S.	U.S.	L.S.	U.S.	L.S.	U.S.	L.S.
.05	-.0383	.7832	.0248	1.1078	-.0526	1.1053	-.0580	1.1262	-.0682	1.1336	.0810	1.1117		
.10	-.0384	.7795	.0194	1.1346	-.0490	1.1236	-.0477	1.1503	-.0595	1.1210	.0666	1.1207	-.0788	.9511
.15	-.0385	.7316	.0143	1.1155	-.0459	1.1237	-.0493	1.1325	-.0569	1.1200	.0590	1.1158	-.0781	.9148
.20	-.0439	.7566	.0072	1.0725	-.0421	1.1195			-.0547	1.1254	.0581	1.1113	-.0770	.8808
.25			-.0435	.5252	-.0257	1.0190	-.0394	1.1008	-.0510	1.1160	.0559	1.1052	-.0749	.8570
.30	-.0586	.4230	-.0524	.4721	-.0284	.5279	-.0211	.5680	-.0046	.6986	-.0498	1.0738	-.0768	.8323
.40									-.0398	.5202	-.0314	.5148	-.0053	.3859
.50	-.0607	.4759	-.0621	.4265	-.0508	.5069			-.0447	.5037	-.0423	.4672	-.0323	.3183
.60	-.0602	.4370	-.0604	.4191	-.0525	.4865	-.0471	.5057	-.0473	.4966	-.0436	.4387	-.0501	.2905
.70	-.0585	.4680	-.0588	.4058	-.0530	.4583	-.0535	.4835	-.0495	.4129			-.0640	.0732
.80	-.0589	.2330	-.0585	.1512	-.0494	.1634	-.0513	.1785	-.0443	.1698	-.0554	.1346	-.0636	.0545
.90	-.0568	.1541	-.0582	.1327	-.0516	.1403	-.0522	.1557	-.0523	.1587	-.0548	.1140	-.0666	.0486
.95	-.0556	.1747	-.0574	.1307	-.0533	.1320	-.0529	.1479	-.0533	.1491	-.0550	.1057	-.0674	.0509

TAIL 1

Cp at y/b of														
x/c	0.02		0.22		0.44		0.56		0.67		0.83		0.98	
	U.S.	L.S.	U.S.	L.S.	U.S.	L.S.	U.S.	L.S.	U.S.	L.S.	U.S.	L.S.	U.S.	L.S.
.05	.0417	-.0376	-.0240	.0059			-.0550	.2267	-.0529	.2549	-.0518	.2812	-.0405	.2835
.10	.0447	-.0293	-.0219	.0057			-.0580	.2092	-.0550	.2391	-.0541	.2750	-.0402	.2839
.15	.0422	-.0303	-.0196	.0054			-.0587	.1985	-.0585	.2252	-.0537	.2646	-.0459	.2725
.20							-.0594	.1921	-.0604	.2143		.2157	-.0502	.2615
.25	-.0103	-.0563	-.0429	-.0316			-.0549	.1848	-.0610	.2014	-.0413	.2443	-.0457	.2514
.30			-.0266	-.0051	-.0555	.0441	-.0632	.0693	-.0637	.1232				
.40	-.0386	.0178			-.0569	.0337	-.0663	.0473	-.0615	.0639	-.0607	.0898		
.50	-.0393	-.0473					-.0655	.0423	-.0654	.0510			.0396	.1261
.60					-.0619	.0259	-.0659	.0414	-.0612	.0482	-.0565	.0630	-.0571	.0582
.70			-.0428	-.0270	-.0626	.0220	-.0300	.0491	-.0539	.0303	-.0685	-.0138	-.0645	-.0226
.80	-.0576	-.0574	-.0615	-.0550	-.0688	-.0417			-.0332	.0009	-.0679	-.0316	-.0356	.0637
.90	-.0693	-.0656			-.0606	-.0475			-.0642	-.0398	-.0661	-.0375	-.0598	-.0338
.95	-.0669	-.0654							-.0671	-.0453	-.0674	-.0408	-.0645	-.0419

TAIL 2

TABLE XV. - PRESSURE COEFFICIENTS, $\theta = 90^\circ$, $\delta = 0^\circ$, $M = 3.70$
(a) $\alpha = -3.95^\circ$

Cp at y/b of														
x/c	0.02		0.22		0.44		0.56		0.67		0.83		0.98	
	U.S.	L.S.	U.S.	L.S.	U.S.	L.S.	U.S.	L.S.	U.S.	L.S.	U.S.	L.S.	U.S.	L.S.
.05	.1588	.0215	.3138	.0983	.3036	.1131	.2972	.1206	.2931	.1249	.2859	.1224	.2522	.0970
.10	.1589	.0244	.3242	.0976	.3116	.1117	.2731	.1202	.2947	.1214	.2846	.1198	.2427	.0908
.15	.1557	.0256	.3239	.0962	.3114	.1108	.2918	.1188	.2993	.1192	.2824	.1168	.2290	.0839
.20	.1446	.0175	.3157	.0926	.3083	.1093			.2999	.1175	.2890	.1154	.2192	.0797
.25			.1185	-.0072	.2748	.0871	.2804	.1111	.2950	.1142	.2879	.1134	.2103	.0756
.30	.0716	-.0278	.0825	-.0248	.0826	-.0050	.1007	.0036	.1756	.0378	.2765	.1067	.2103	.0756
.40									.0708	-.0192	.0772	-.0080	.0516	-.0140
.50	.0407	-.0252	.0606	-.0379	.0677	-.0269			.0637	-.0236	.0594	-.0241	.0099	-.0223
.60	.0470	-.0149	.0529	-.0386	.0662	-.0289	.0639	-.0265	.0610	-.0263	.0503	-.0273	.0024	-.0295
.70	.0576	-.0048	.0475	-.0382	.0602	-.0321	.0515	-.0338	.0327	-.0358			-.0375	-.0520
.80	-.0104	-.0374	-.0326	-.0445	-.0281	-.0404	-.0319	-.0438	-.0372	-.0371	-.0423	-.0476	-.0421	-.0580
.90	-.0305	-.0437	-.0460	-.0446	-.0404	-.0416	-.0394	-.0427	-.0424	-.0441	-.0474	-.0468	-.0464	-.0606
.95	-.0375	-.0448	-.0476	-.0450	-.0411	-.0416	-.0413	-.0425	-.0437	-.0443	-.0490	-.0471	-.0406	-.0603

TAIL 1

Cp at y/b of														
x/c	0.02		0.22		0.44		0.56		0.67		0.83		0.98	
	U.S.	L.S.	U.S.	L.S.	U.S.	L.S.	U.S.	L.S.	U.S.	L.S.	U.S.	L.S.	U.S.	L.S.
.05	.1223	.1361	.2143	.2395			.2073	.2379	.2134	.2384	.2178	.2455	.2038	.2611
.10	.1224	.1356	.2038	.2271			.2013	.2241	.2021	.2258	.2104	.2347	.1841	.2139
.15	.1130	.1305	.1977	.2185			.1969	.2161	.1975	.2174	.2064	.2268	.1623	.1865
.20							.1946	.2087	.1956	.2102			.1517	.1737
.25	.0216	.0227	.0473	.0585			.1818	.1942	.1895	.1997	.1972	.2139	.1416	.1650
.30			.0240	.0296	.0314	.0361	.0416	.0513	.1135	.1182				
.40	.0006	.0273			.0157	.0182	.0173	.0196	.0250	.0275	.0333	.0368		
.50	-.0023	.0129					.0124	.0142	.0141	.0156			.0141	.0374
.60					.0111	.0110	.0112	.0114	.0136	.0144	.0096	.0099	-.0006	.0009
.70			.0064	.0116	.0061	.0056	.0184	.0203	-.0181	-.0036	-.0447	-.0416	-.0399	-.0401
.80	-.0413	-.0438	-.0438	-.0432	-.0466	-.0480			-.0290	-.0274	-.0542	-.0521	.0076	-.0276
.90	-.0484	-.0518			-.0400	-.0387			-.0434	-.0423	-.0467	-.0461	-.0546	-.0545
.95	-.0443	-.0476							-.0420	-.0420	-.0455	-.0448	-.0536	-.0525

TAIL 2

TABLE XV. - CONTINUED
(b) $\alpha = -1.96^\circ$

Cp at y/b of														
x/c	0.02		0.22		0.44		0.56		0.67		0.83		0.98	
	U.S.	L.S.	U.S.	L.S.	U.S.	L.S.	U.S.	L.S.	U.S.	L.S.	U.S.	L.S.	U.S.	L.S.
.05	.1197	.0466	.2517	.1512	.2452	.1607	.2451	.1674	.2402	.1711	.2342	.1640		
.10	.1214	.0516	.2612	.1523	.2525	.1611	.2211	.1691	.2404	.1678	.2327	.1644	.2066	.1340
.15	.1192	.0516	.2609	.1515	.2527	.1602	.2358	.1676	.2436	.1654	.2309	.1620	.1976	.1275
.20	.1109	.0398	.2534	.1471	.2498	.1587			.2442	.1638	.2367	.1603	.1864	.1190
.25			.0834	.0151	.2210	.1319	.2258	.1588	.2405	.1602	.2356	.1581	.1785	.1132
.30	.0444	-.0173	.0508	-.0082	.0590	.0052	.0719	.0208	.1371	.0666	.2256	.1502	.1705	.1081
.40									.0433	-.0030	.0523	.0074	.0332	-.0023
.50	.0193	-.0156	.0316	-.0232	.0399	-.0128			.0361	-.0079	.0345	-.0098	-.0017	-.0174
.60	.0279	-.0088	.0247	-.0256	.0376	-.0150	.0360	-.0140	.0329	-.0113	.0276	-.0163	-.0081	-.0229
.70	.0371	-.0029	.0201	-.0274	.0322	-.0184	.0247	-.0202	.0097	-.0242			-.0391	-.0503
.80	-.0214	-.0378	-.0408	-.0461	-.0343	-.0418	-.0398	-.0457	-.0379	-.0394	-.0462	-.0483	-.0441	-.0541
.90	-.0355	-.0463	-.0509	-.0436	-.0449	-.0414	-.0477	-.0426	-.0481	-.0439	-.0521	-.0469	-.0431	-.0598
.95	-.0423	-.0469	-.0482	-.0438	-.0469	-.0416	-.0479	-.0424	-.0480	-.0438	-.0509	-.0468	-.0468	-.0592

TAIL 1

Cp at y/b of														
x/c	0.02		0.22		0.44		0.56		0.67		0.83		0.98	
	U.S.	L.S.	U.S.	L.S.	U.S.	L.S.	U.S.	L.S.	U.S.	L.S.	U.S.	L.S.	U.S.	L.S.
.05	.0995	.1096	.2070	.2322			.2020	.2329	.2104	.2357	.2110	.2391	.1962	.2503
.10	.1057	.1154	.1971	.2205			.1967	.2200	.1984	.2224	.2039	.2287	.1791	.2110
.15	.0991	.1121	.1922	.2128			.1928	.2123	.1933	.2137	.2000	.2209	.1559	.1840
.20							.1907	.2051	.1913	.2063		.1862	.1481	.1690
.25	.0202	.0201	.0450	.0565			.1782	.1909	.1853	.1960	.1911	.2084	.1402	.1569
.30			.0228	.0288	.0301	.0351	.0406	.0504	.1103	.1152				
.40	-.0011	.0298			.0146	.0174	.0162	.0188	.0233	.0263	.0309	.0352		
.50	-.0037	.0097					.0114	.0133	.0128	.0146			.0160	.0371
.60					.0101	.0101	.0102	.0107	.0125	.0135	.0088	.0094	-.0060	-.0031
.70			.0045	.0092	.0051	.0049	.0177	.0197	-.0192	-.0041	-.0447	-.0415	-.0440	-.0410
.80	-.0380	-.0435	-.0444	-.0434	-.0475	-.0483			-.0291	-.0274	-.0542	-.0519	.0092	-.0239
.90	-.0483	-.0522			-.0403	-.0392			-.0439	-.0426	-.0465	-.0459	-.0549	-.0572
.95	-.0452	-.0481							-.0426	-.0425	-.0450	-.0444	-.0567	-.0565

TAIL 2

TABLE XV. - CONTINUED
(c) $\alpha = 0.03^\circ$

Cp at y/b of														
x/c	0.02		0.22		0.44		0.56		0.67		0.83		0.98	
	U.S.	L.S.	U.S.	L.S.	U.S.	L.S.	U.S.	L.S.	U.S.	L.S.	U.S.	L.S.	U.S.	L.S.
.05	.0904	.0836	.1921	.2118	.1917	.2135	.1956	.2202	.1910	.2212	.1878	.2106		
.10	.0899	.0888	.2001	.2148	.1975	.2157	.1741	.2233	.1897	.2189	.1843	.2132	.1634	.1742
.15	.0867	.0885	.1995	.2144	.1977	.2148	.1854	.2214	.1923	.2165	.1825	.2111	.1549	.1675
.20	.0770	.0777	.1929	.2094	.1952	.2133			.1926	.2148	.1875	.2095	.1456	.1574
.25			.0507	.0454	.1699	.1824	.1762	.2108	.1896	.2108	.1865	.2073	.1396	.1500
.30	.0171	.0051	.0217	.0171	.0341	.0264	.0466	.0451	.1018	.0998	.1779	.1978	.1336	.1448
.40									.0190	.0196	.0293	.0291	.0152	.0134
.50	-.0001	.0023	.0046	.0008	.0143	.0095			.0124	.0135	.0121	.0100	-.0102	-.0107
.60	.0099	.0046	-.0010	-.0021	.0120	.0075	.0120	.0061	.0091	.0102	.0058	.0031	-.0150	-.0168
.70	.0186	.0089	-.0039	-.0078	.0072	.0031	.0017	.0002	-.0092	-.0074			-.0433	-.0465
.80	-.0307	-.0364	-.0505	-.0510	-.0434	-.0446	-.0474	-.0481	-.0446	-.0438	-.0513	-.0509	-.0448	-.0479
.90	-.0430	-.0483	-.0489	-.0451	-.0479	-.0437	-.0483	-.0469	-.0479	-.0452	-.0498	-.0475	-.0547	-.0569
.95	-.0482	-.0476	-.0468	-.0444	-.0466	-.0436	-.0458	-.0445	-.0459	-.0438	-.0481	-.0463	-.0574	-.0596

TAIL 1

Cp at y/b of														
x/c	0.02		0.22		0.44		0.56		0.67		0.83		0.98	
	U.S.	L.S.	U.S.	L.S.	U.S.	L.S.	U.S.	L.S.	U.S.	L.S.	U.S.	L.S.	U.S.	L.S.
.05	.0792	.0842	.2033	.2293			.2013	.2325	.2085	.2348	.2088	.2368	.1947	.2462
.10	.0879	.0939	.1958	.2187			.1957	.2192	.1970	.2216	.2031	.2278	.1802	.2157
.15	.0835	.0929	.1904	.2107			.1916	.2113	.1923	.2132	.1999	.2207	.1587	.1867
.20							.1897	.2042	.1906	.2060		.1868	.1549	.1665
.25	.0199	.0211	.0441	.0554			.1772	.1902	.1846	.1959	.1918	.2090	.1409	.1527
.30			.0220	.0282	.0298	.0349	.0409	.0507	.1094	.1153				
.40	.0019	.0320			.0146	.0173	.0165	.0190	.0237	.0268	.0320	.0361		
.50	.0006	.0122					.0117	.0136	.0134	.0151			.0148	.0373
.60					.0101	.0103	.0105	.0110	.0130	.0139	.0102	.0107	-.0096	-.0077
.70			.0023	.0058	.0050	.0049	.0179	.0198	-.0193	-.0040	-.0438	-.0411	-.0421	-.0405
.80	-.0306	-.0372	-.0454	-.0445	-.0477	-.0484			-.0292	-.0268	-.0537	-.0521	.0080	-.0265
.90	-.0447	-.0474			-.0401	-.0387			-.0431	-.0420	-.0455	-.0456	-.0544	-.0483
.95	-.0441	-.0457							-.0418	-.0418	-.0439	-.0440	-.0554	-.0533

TAIL 2

TABLE XV. - CONTINUED
(d) $\alpha = 2.02^\circ$

Cp at y/b of														
x/c	0.02		0.22		0.44		0.56		0.67		0.83		0.98	
	U.S.	L.S.	U.S.	L.S.	U.S.	L.S.	U.S.	L.S.	U.S.	L.S.	U.S.	L.S.	U.S.	L.S.
.05	.0723	.1381	.1374	.2763	.1427	.2708	.1484	.2780	.1452	.2758	.1461	.2624		
.10	.0715	.1404	.1426	.2805	.1468	.2744	.1305	.2815	.1429	.2741	.1405	.2665	.1234	.2183
.15	.0683	.1377	.1420	.2806	.1471	.2735	.1388	.2805	.1445	.2715	.1377	.2640	.1151	.2114
.20	.0568	.1278	.1365	.2750	.1450	.2719			.1445	.2694	.1416	.2618	.1076	.1993
.25			.0216	.0798	.1230	.2366	.1301	.2669	.1419	.2652	.1405	.2591	.1031	.1907
.30	-.0051	.0324	-.0030	.0491	.0129	.0552	.0231	.0752	.0689	.1358	.1333	.2487	.0989	.1869
.40									-.0021	.0462	.0080	.0539	-.0007	.0334
.50	-.0192	.0231	-.0183	.0326	-.0077	.0374			-.0079	.0398	-.0076	.0350	-.0157	.0024
.60	-.0128	.0216	-.0222	.0269	-.0096	.0352	-.0088	.0342	-.0111	.0361	-.0131	.0273	-.0215	-.0069
.70	-.0058	.0245	-.0230	.0208	-.0138	.0300	-.0179	.0269	-.0251	.0136			-.0487	-.0413
.80	-.0414	-.0313	-.0507	-.0435	-.0463	-.0400	-.0486	-.0425	-.0438	-.0425	-.0508	-.0495	-.0566	-.0481
.90	-.0496	-.0458	-.0461	-.0483	-.0449	-.0461	-.0449	-.0485	-.0456	-.0495	-.0482	-.0515	-.0598	-.0440
.95	-.0499	-.0473	-.0453	-.0440	-.0441	-.0454	-.0444	-.0462	-.0448	-.0471	-.0475	-.0486	-.0602	-.0433

TAIL 1

Cp at y/b of														
x/c	0.02		0.22		0.44		0.56		0.67		0.83		0.98	
	U.S.	L.S.	U.S.	L.S.	U.S.	L.S.	U.S.	L.S.	U.S.	L.S.	U.S.	L.S.	U.S.	L.S.
.05	.0692	.0749	.2028	.2271			.2013	.2322	.2083	.2351	.2110	.2390	.1951	.2459
.10	.0773	.0855	.1345	.2154			.1961	.2193	.1972	.2221	.2041	.2291	.1837	.2197
.15	.0728	.0845	.1888	.2077			.1921	.2116	.1925	.2136	.2003	.2212	.1676	.1876
.20							.1903	.2046	.1908	.2063		.1864	.1523	.1670
.25	.0194	.0220	.0442	.0554			.1777	.1904	.1849	.1959	.1915	.2089	.1341	.1578
.30			.0219	.0279	.0309	.0356	.0420	.0508	.1100	.1152				
.40	.0043	.0352			.0157	.0180	.0175	.0196	.0247	.0273	.0322	.0360		
.50	.0043	.0134					.0127	.0142	.0145	.0157			.0121	.0306
.60					.0110	.0106	.0116	.0115	.0141	.0146	.0110	.0116	-.0147	-.0135
.70			.0005	.0032	.0058	.0053	.0190	.0202	-.0189	-.0038	-.0435	-.0408	-.0429	-.0424
.80	-.0268	-.0330	-.0454	-.0446	-.0473	-.0484			-.0296	-.0278	-.0512	-.0518	.0054	-.0302
.90	-.0413	-.0435			-.0394	-.0384			-.0425	-.0414	-.0448	-.0446	-.0407	-.0433
.95	-.0419	-.0428							-.0412	-.0413	-.0431	-.0430	-.0455	-.0447

TAIL 2

TABLE XV. - CONTINUED
(e) $\alpha = 4.03^\circ$

Cp at y/b of														
x/c	0.02		0.22		0.44		0.56		0.67		0.83		0.98	
	U.S.	L.S.	U.S.	L.S.	U.S.	L.S.	U.S.	L.S.	U.S.	L.S.	U.S.	L.S.	U.S.	L.S.
.05	.0327	.1806	.0858	.3414	.0964	.3308	.1039	.3396	.1032	.3328	.1056	.3165		
.10	.0336	.1806	.0886	.3482	.0987	.3357	.1039	.3415	.1002	.3320	.0976	.3213	.0860	.2654
.15	.0337	.1790	.0881	.3489	.0988	.3347	.0953	.3408	.1011	.3291	.0943	.3187	.0780	.2577
.20	.0248	.1697	.0838	.3424	.0970	.3332			.1010	.3268	.0973	.3157	.0722	.2434
.25			-.0046	.1168	.0785	.2936	.0872	.3236	.0987	.3223	.0963	.3138	.0689	.2350
.30	-.0256	.0614	-.0240	.0847	-.0058	.0850	.0018	.1070	.0389	.1732	.0903	.3022	.0661	.2328
.40									-.0200	.0748	-.0114	.0818	-.0150	.0551
.50	-.0314	.0530	-.0377	.0646	-.0266	.0680			-.0248	.0681	-.0252	.0625	-.0230	.0198
.60	-.0247	.0476	-.0395	.0571	-.0280	.0660	-.0264	.0645	-.0278	.0638	-.0292	.0542	-.0306	.0079
.70	-.0119	.0438	-.0381	.0507	-.0314	.0601	-.0344	.0554	-.0377	.0369			-.0532	-.0391
.80	-.0444	-.0192	-.0454	-.0325	-.0429	-.0302	-.0461	-.0339	-.0418	-.0363	-.0498	-.0423	-.0614	-.0423
.90	-.0507	-.0380	-.0448	-.0473	-.0426	-.0421	-.0443	-.0423	-.0458	-.0448	-.0484	-.0480	-.0617	-.0447
.95	-.0502	-.0411	-.0456	-.0461	-.0430	-.0426	-.0442	-.0439	-.0457	-.0453	-.0484	-.0490	-.0605	-.0463

TAIL 1

Cp at y/b of														
x/c	0.02		0.22		0.44		0.56		0.67		0.83		0.98	
	U.S.	L.S.	U.S.	L.S.	U.S.	L.S.	U.S.	L.S.	U.S.	L.S.	U.S.	L.S.	U.S.	L.S.
.05	.0714	.0891	.2009	.2341			.2012	.2326	.2076	.2349	.2100	.2384	.1970	.2470
.10	.0770	.0923	.1931	.2138			.1961	.2193	.1965	.2216	.2031	.2288	.1884	.2225
.15	.0704	.0855	.1878	.2067			.1919	.2116	.1921	.2133	.1936	.2212	.1704	.1910
.20							.1902	.2047	.1907	.2062		.1878	.1560	.1745
.25	.0136	.0129	.0422	.0530			.1777	.1906	.1848	.1960	.1910	.2088	.1432	.1615
.30			.0208	.0267	.0317	.0365	.0426	.0508	.1106	.1152				
.40	-.0041	.0380			.0162	.0189	.0183	.0202	.0254	.0278	.0330	.0366		
.50	-.0045	.0070					.0135	.0150	.0151	.0163			.0098	.0296
.60					.0115	.0112	.0123	.0123	.0146	.0151	.0123	.0128	-.0187	-.0163
.70			-.0009	.0030	.0063	.0059	.0133	.0206	-.0184	-.0035	-.0428	-.0404	-.0446	-.0451
.80	-.0319	-.0358	-.0468	-.0452	-.0476	-.0486			-.0302	-.0281	-.0529	-.0514	.0028	-.0321
.90	-.0444	-.0462			-.0398	-.0383			-.0420	-.0408	-.0441	-.0437	-.0393	-.0438
.95	-.0432	-.0439							-.0408	-.0406	-.0422	-.0420	-.0411	-.0431

TAIL 2

TABLE XV. - CONTINUED
(f) $\alpha = 6.02^\circ$

Cp at y/b of														
x/c	0.02		0.22		0.44		0.56		0.67		0.83		0.98	
	U.S.	L.S.	U.S.	L.S.	U.S.	L.S.	U.S.	L.S.	U.S.	L.S.	U.S.	L.S.	U.S.	L.S.
.05	.0000	.0926	.0414	.4053	.0548	.3943	.0615	.4034	.0615	.3922	.0685	.3740		
.10	-.0010	.1305	.0427	.4158	.0557	.4007	.0517	.4060	.0573	.3915	.0599	.3796	.0540	.3154
.15	-.0005	.1766	.0417	.4180	.0555	.3937	.0568	.4045	.0579	.3886	.0563	.3772	.0456	.3061
.20	-.0027	.2056	.0389	.4105	.0537	.3982			.0577	.3866	.0581	.3750	.0414	.2893
.25			-.0241	.1568	.0387	.3542	.0488	.3833	.0561	.3824	.0563	.3723	.0390	.2837
.30	-.0350	.0874	-.0373	.1202	-.0172	.1202	-.0138	.1459	.0106	.2119	.0514	.3594	.0376	.2805
.40									-.0337	.1089	-.0268	.1136	-.0250	.0732
.50	-.0292	.0781	-.0468	.0928	-.0387	.1046			-.0381	.1020	-.0387	.0936	-.0314	.0407
.60	-.0201	.0730	-.0459	.0843	-.0401	.1027	-.0375	.1007	-.0401	.0972	-.0385	.0844	-.0343	.0273
.70	-.0099	.0775	-.0439	.0780	-.0414	.0959	-.0447	.0892	-.0449	.0655			-.0593	-.0383
.80	-.0423	-.0080	-.0512	-.0195	-.0420	-.0146	-.0455	-.0179	-.0411	-.0259	-.0494	-.0307	-.0652	-.0378
.90	-.0493	-.0275	-.0496	-.0385	-.0431	-.0299	-.0447	-.0289	-.0464	-.0343	-.0486	-.0395	-.0583	-.0401
.95	-.0485	-.0313	-.0493	-.0408	-.0442	-.0323	-.0449	-.0319	-.0465	-.0368	-.0489	-.0423	-.0558	-.0434

TAIL 1

Cp at y/b of														
x/e	0.02		0.22		0.44		0.56		0.67		0.83		0.98	
	U.S.	L.S.	U.S.	L.S.	U.S.	L.S.	U.S.	L.S.	U.S.	L.S.	U.S.	L.S.	U.S.	L.S.
.05	.1011	.1209	.1968	.2275			.2015	.2326	.2071	.2338	.2078	.2360	.1952	.2436
.10	.0962	.1159	.1893	.2160			.1965	.2138	.1960	.2209	.2013	.2270	.1872	.2195
.15	.0830	.1059	.1856	.2081			.1923	.2124	.1917	.2127	.1977	.2195	.1685	.1938
.20							.1908	.2058	.1903	.2059		.1876	.1608	.1766
.25	.0075	.0111	.0407	.0531			.1786	.1919	.1846	.1958	.1892	.2075	.1464	.1635
.30			.0195	.0260	.0321	.0371	.0426	.0512	.1101	.1152				
.40	-.0159	.0396			.0164	.0196	.0186	.0209	.0257	.0284	.0327	.0370		
.50	-.0177	-.0048					.0136	.0155	.0154	.0168			.0107	.0307
.60					.0105	.0117	.0120	.0125	.0150	.0155	.0126	.0137	-.0205	-.0163
.70			-.0031	.0037	.0059	.0063	.0192	.0209	-.0179	-.0029	-.0427	-.0397	-.0457	-.0463
.80	-.0413	-.0441	-.0493	-.0479	-.0477	-.0490			-.0303	-.0283	-.0534	-.0515	.0034	-.0326
.90	-.0451	-.0471			-.0405	-.0394			-.0424	-.0412	-.0443	-.0438	-.0423	-.0447
.95	-.0429	-.0437							-.0414	-.0410	-.0424	-.0419	-.0421	-.0436

TAIL 2

TABLE XV. - CONTINUED
(g) $\alpha = 8.01^\circ$

Cp at y/b of														
x/c	0.02		0.22		0.44		0.56		0.67		0.83		0.98	
	U.S.	L.S.	U.S.	L.S.	U.S.	L.S.	U.S.	L.S.	U.S.	L.S.	U.S.	L.S.	U.S.	L.S.
.05	-.0176	.1265	.0061	.4600	.0202	.4588	.0288	.4711	.0279	.4570	.0399	.4375		
.10	-.0192	.1854	.0056	.4729	.0194	.4665	.0207	.4752	.0235	.4569	.0298	.4449	.0317	.3740
.15	-.0187	.2248	.0043	.4739	.0185	.4654	.0235	.4721	.0238	.4538	.0255	.4428	.0246	.3629
.20	-.0214	.2168	.0018	.4636	.0164	.4638			.0240	.4524	.0258	.4407	.0214	.3459
.25			-.0421	.1868	.0044	.4155	.0158	.4460	.0228	.4490	.0239	.4379	.0192	.3424
.30	-.0413	.1098	-.0492	.1481	-.0239	.1576	-.0290	.1873	-.0114	.2514	.0199	.4237	.0181	.3330
.40									-.0449	.1483	-.0413	.1515	-.0319	.1072
.50	-.0425	.1065	-.0551	.1203	-.0515	.1434			-.0486	.1405	-.0511	.1310	-.0387	.0671
.60	-.0372	.1012	-.0539	.1124	-.0507	.1409	-.0470	.1388	-.0498	.1349	-.0466	.1208	-.0426	.0512
.70	-.0273	.1039	-.0519	.1058	-.0463	.1320	-.0495	.1249	-.0473	.0970			-.0647	-.0349
.80	-.0477	.0138	-.0543	-.0052	-.0453	.0005	-.0483	.0008	-.0439	-.0106	-.0522	-.0140	-.0637	-.0375
.90	-.0539	-.0123	-.0551	-.0249	-.0470	-.0147	-.0484	-.0121	-.0502	-.0177	-.0521	-.0260	-.0561	-.0399
.95	-.0513	-.0174	-.0541	-.0284	-.0484	-.0188	-.0485	-.0165	-.0506	-.0215	-.0525	-.0300	-.0551	-.0446

TAIL 1

Cp at y/b of														
x/c	0.02		0.22		0.44		0.56		0.67		0.83		0.98	
	U.S.	L.S.	U.S.	L.S.	U.S.	L.S.	U.S.	L.S.	U.S.	L.S.	U.S.	L.S.	U.S.	L.S.
.05	.1126	.1234	.1760	.2051			.2045	.2331	.2080	.2329	.2075	.2352	.1950	.2418
.10	.0986	.1147	.1650	.1941			.1992	.2195	.1976	.2206	.2008	.2261	.1858	.2171
.15	.0847	.1040	.1606	.1881			.1949	.2119	.1937	.2128	.1974	.2186	.1692	.1958
.20							.1931	.2049	.1924	.2064		.1879	.1633	.1783
.25	.0023	.0045	.0284	.0437			.1805	.1907	.1869	.1963	.1891	.2068	.1494	.1650
.30			.0095	.0193	.0320	.0341	.0434	.0500	.1114	.1157				
.40	-.0222	.0417			.0171	.0175	.0187	.0196	.0265	.0282	.0329	.0365		
.50	-.0263	-.0187					.0147	.0146	.0154	.0165			.0062	.0291
.60					.0126	.0118	.0138	.0122	.0152	.0149	.0128	.0136	-.0197	-.0153
.70			-.0166	-.0069	.0076	.0070	.0208	.0212	-.0178	-.0034	-.0427	-.0402	-.0477	-.0486
.80	-.0495	-.0515	-.0533	-.0518	-.0485	-.0497			-.0316	-.0295	-.0537	-.0523	-.0013	-.0350
.90	-.0523	-.0534			-.0444	-.0429			-.0436	-.0424	-.0449	-.0443	-.0439	-.0460
.95	-.0504	-.0511							-.0422	-.0421	-.0430	-.0425	-.0438	-.0448

TAIL 2

TABLE XV. - CONTINUED
(h) $\alpha = 10.01^\circ$

Cp at y/b of														
x/c	0.02		0.22		0.44		0.56		0.67		0.83		0.98	
	U.S.	L.S.	U.S.	L.S.	U.S.	L.S.	U.S.	L.S.	U.S.	L.S.	U.S.	L.S.	U.S.	L.S.
.05	-.0273	.0955	-.0156	.5163	-.0060	.5175	.0050	.5318	.0128	.5291	.0263	.5135		
.10	-.0315	.1653	-.0169	.5326	-.0072	.5270	-.0023	.5406	.0067	.5275	.0172	.5216	.0212	.4418
.15	-.0325	.1910	-.0193	.5295	-.0079	.5270	.0008	.5352	.0049	.5232	.0120	.5190	.0151	.4283
.20	-.0327	.1867	-.0213	.5118	-.0092	.5260			.0031	.5233	.0117	.5165	.0130	.4157
.25			-.0523	.2123	-.0178	.4729	-.0071	.5087	.0010	.5201	.0094	.5134	.0116	.4048
.30	-.0470	.1252	-.0553	.1759	-.0356	.1964	-.0368	.2304	-.0251	.3054	.0053	.4976	.0103	.3909
.40									-.0503	.1896	-.0477	.1952	-.0341	.1402
.50	-.0476	.1330	-.0576	.1523	-.0538	.1865			-.0541	.1804	-.0565	.1727	-.0434	.0984
.60	-.0441	.1272	-.0562	.1433	-.0509	.1811	-.0474	.1806	-.0519	.1753	-.0506	.1616	-.0471	.0804
.70	-.0382	.1349	-.0555	.1342	-.0490	.1678	-.0504	.1643	-.0482	.1330			-.0668	-.0253
.80	-.0517	.0437	-.0588	.0105	-.0478	.0167	-.0501	.0229	-.0466	.0080	-.0550	.0046	-.0622	-.0355
.90	-.0571	.0024	-.0589	-.0089	-.0498	.0012	-.0511	.0082	-.0539	.0030	-.0561	-.0088	-.0578	-.0387
.95	-.0541	-.0043	-.0565	-.0120	-.0521	-.0035	-.0510	.0023	-.0544	-.0017	-.0565	-.0138	-.0581	-.0418

TAIL 1

Cp at y/b of														
x/c	0.02		0.22		0.44		0.56		0.67		0.83		0.98	
	U.S.	L.S.	U.S.	L.S.	U.S.	L.S.	U.S.	L.S.	U.S.	L.S.	U.S.	L.S.	U.S.	L.S.
.05	-.0954	.1238	.1018	.1186			.2055	.2345	.2111	.2386	.2088	.2371	.1956	.2426
.10	-.0771	.1067	.0934	.1078			.1987	.2193	.1999	.2254	.2024	.2285	.1864	.2184
.15	-.0629	.0914	.0884	.1030			.1938	.2108	.1946	.2162	.1989	.2210	.1721	.1993
.20							.1942	.2044	.1925	.2085		.1908	.1663	.1826
.25	-.0088	-.0072	-.0065	.0038			.1826	.1920	.1860	.1982	.1899	.2094	.1522	.1697
.30			-.0129	-.0055	.0295	.0298	.0442	.0509	.1118	.1170				
.40	-.0348	.0430			.0145	.0140	.0214	.0209	.0271	.0290	.0332	.0383		
.50	-.0372	-.0280					.0165	.0166	.0177	.0182			.0060	.0295
.60					.0069	.0057	.0150	.0144	.0177	.0177	.0138	.0156	-.0171	-.0131
.70			-.0325	-.0281	.0013	-.0003	.0220	.0224	-.0165	-.0013	-.0415	-.0389	-.0468	-.0481
.80	-.0534	-.0576	-.0573	-.0561	-.0520	-.0539			-.0320	-.0296	-.0533	-.0520	-.0016	-.0361
.90	-.0579	-.0617			-.0498	-.0491			-.0447	-.0428	-.0446	-.0440	-.0435	-.0456
.95	-.0563	-.0590							-.0427	-.0423	-.0424	-.0421	-.0438	-.0443

TAIL 2

TABLE XV. - CONTINUED
(1) $\alpha = 12.01^\circ$

Cp at y/b of														
x/c	0.02		0.22		0.44		0.56		0.67		0.83		0.98	
	U.S.	L.S.	U.S.	L.S.	U.S.	L.S.	U.S.	L.S.	U.S.	L.S.	U.S.	L.S.	U.S.	L.S.
.05	-.0404	.1510	-.0352	.5724	-.0165	.5924	-.0041	.6082	.0038	.6127	-.0196	.6014		
.10	-.0443	.2005	-.0376	.5923	-.0196	.6029	-.0120	.6215	-.0027	.6093	-.0095	.6090	.0158	.5191
.15	-.0434	.1550	-.0395	.5868	-.0216	.6028	-.0102	.6144	-.0049	.6058	-.0036	.6056	.0115	.5064
.20	-.0408	.2258	-.0401	.5657	-.0236	.6013			-.0069	.6091	-.0027	.6030	.0102	.4910
			-.0605	.2490	-.0312	.5423	-.0190	.5879	-.0091	.6040	-.0007	.5991	.0085	.4733
	-.0534	.1589	-.0578	.2140	-.0403	.2432	-.0434	.2759	-.0327	.3714	-.0035	.5810	.0073	.4577
.40									-.0555	.2351	-.0517	.2446	-.0362	.1797
.50	-.0533	.1790	-.0603	.1832	-.0554	.2302			-.0589	.2283	-.0598	.2208	-.0460	.1346
.60	-.0494	.1734	-.0593	.1744	-.0535	.2200	-.0514	.2272	-.0567	.2236	-.0527	.2091	-.0512	.1145
.70	-.0477	.1807	-.0595	.1668	-.0534	.2031	-.0561	.2071	-.0541	.1741			-.0677	-.0101
.80	-.0604	.0759	-.0611	.0299	-.0514	.0357	-.0554	.0448	-.0504	.0345	-.0589	.0277	-.0673	-.0244
.90	-.0608	.0177	-.0614	.0115	-.0535	.0197	-.0559	.0287	-.0585	.0284	-.0610	.0136	-.0641	-.0294
.95	-.0575	.0151	-.0597	.0083	-.0559	.0140	-.0572	.0223	-.0591	.0240	-.0616	.0080	-.0625	-.0301

TAIL 1

Cp at y/b of														
x/c	0.02		0.22		0.44		0.56		0.67		0.83		0.98	
	U.S.	L.S.	U.S.	L.S.	U.S.	L.S.	U.S.	L.S.	U.S.	L.S.	U.S.	L.S.	U.S.	L.S.
.05	.0831	.1134	.0152	.0282			.1920	.2198	.2089	.2400	.2113	.2428	.1981	.2467
.10	.0633	.0965	.0157	.0288			.1879	.2058	.1968	.2244	.2030	.2320	.1885	.2221
.15	.0485	.0817	.0199	.0323			.1846	.1988	.1937	.2165	.1977	.2230	.1749	.2031
.20							.1843	.1938	.1930	.2106		.1920	.1689	.1861
.25	-.0194	-.0148	-.0298	-.0225			.1756	.1835	.1866	.2021	.1893	.2105	.1544	.1732
.30			-.0255	-.0198	.0053	.0015	.0394	.0447	.1146	.1210				
.40	-.0419	.0443			-.0089	-.0130	.0164	.0151	.0300	.0325	.0339	.0393		
.50	-.0440	-.0358					.0098	.0083	.0201	.0220			.0082	.0227
.60					-.0211	-.0269	.0065	.0024	.0195	.0205	.0166	.0186	-.0158	-.0120
.70			-.0433	-.0393	-.0276	-.0323	.0157	.0134	-.0156	.0009	-.0410	-.0380	-.0471	-.0487
.80	-.0569	-.0609	-.0606	-.0594	-.0607	-.0623			-.0318	-.0322	-.0535	-.0530	.0006	-.0386
.90	-.0662	-.0690			-.0568	-.0562			-.0486	-.0474	-.0452	-.0451	-.0435	-.0460
.95	-.0644	-.0667							-.0466	-.0462	-.0426	-.0426	-.0438	-.0447

TAIL 2

TABLE XV. - CONTINUED
(j) $\alpha = 16.01^\circ$

Cp at y/b of														
x/c	0.02		0.22		0.44		0.56		0.67		0.83		0.98	
	U.S.	L.S.	U.S.	L.S.	U.S.	L.S.	U.S.	L.S.	U.S.	L.S.	U.S.	L.S.	U.S.	L.S.
.05	-.0516	.2877	-.0402	.7528	-.0194	.7833	-.0073	.8031	-.0001	.8132	-.0161	.8055		
.10	-.0594	.2108	-.0444	.7551	-.0234	.7960	-.0162	.8208	-.0073	.8071	-.0045	.8143	-.0150	.7009
.15	-.0590	.2091	-.0481	.7348	-.0261	.7952	-.0150	.8105	-.0101	.8131	-.0014	.8104	-.0123	.6902
.20	-.0530	.3480	-.0506	.7061	-.0293	.7934			-.0122	.8143	-.0030	.8077	-.0115	.6594
.25			-.0663	.3362	-.0366	.7159	-.0240	.7737	-.0145	.8054	-.0052	.8030	-.0098	.6370
.30	-.0592	.2333	-.0589	.2937	-.0428	.3556	-.0467	.3907	-.0367	.5091	-.0097	.7792	-.0085	.6165
.40									-.0585	.3554	-.0544	.3659	-.0399	.2745
.50	-.0617	.2728	-.0644	.2673	-.0590	.3248			-.0614	.3473	-.0619	.3406	-.0466	.2223
.60	-.0596	.2778	-.0642	.2575	-.0570	.3083	-.0543	.3327	-.0597	.3409	-.0551	.3230	-.0511	.1975
.70	-.0591	.2655	-.0641	.2481	-.0566	.2865	-.0589	.3024	-.0560	.2795			-.0697	.0297
.80	-.0650	.1462	-.0649	.0755	-.0544	.0782	-.0583	.0912	-.0524	.0865	-.0615	.0821	-.0713	.0115
.90	-.0641	.0682	-.0647	.0584	-.0563	.0611	-.0591	.0734	-.0609	.0789	-.0632	.0659	-.0680	.0036
.95	-.0622	.0707	-.0627	.0541	-.0585	.0547	-.0591	.0656	-.0610	.0731	-.0636	.0593	-.0663	.0060

TAIL 1

Cp at y/b of														
x/c	0.02		0.22		0.44		0.56		0.67		0.83		0.98	
	U.S.	L.S.	U.S.	L.S.	U.S.	L.S.	U.S.	L.S.	U.S.	L.S.	U.S.	L.S.	U.S.	L.S.
.05	.0502	.0766	.0114	.0272			.0487	.0544	.0985	.1069	.2052	.2277	.1945	.2420
.10	.0348	.0631	.0043	.0221			.0435	.0449	.0865	.0941	.1994	.2193	.1863	.2174
.15	.0229	.0503	.0011	.0185			.0378	.0382	.0773	.0815	.1969	.2132	.1728	.1987
.20							.0327	.0323	.0704	.0708		.1913	.1672	.1815
.25	-.0298	-.0275	-.0402	-.0318			.0362	.0314	.0608	.0593	.1939	.2064	.1525	.1686
.30			-.0287	-.0214	-.0291	-.0297	-.0281	-.0235	.0180	.0139				
.40	-.0502	.0213			-.0373	-.0383	-.0385	-.0398	-.0251	-.0270	.0370	.0367		
.50	-.0510	-.0449					-.0411	-.0424	-.0368	-.0375			.0316	.0481
.60					-.0472	-.0492	-.0444	-.0459	-.0376	-.0392	.0118	.0071	-.0111	-.0072
.70			-.0480	-.0452	-.0512	-.0525	-.0134	-.0151	-.0376	-.0340	-.0457	-.0462	-.0434	-.0450
.80	-.0596	-.0635	-.0620	-.0620	-.0664	-.0671			-.0338	-.0364	-.0585	-.0594	-.0245	-.0367
.90	-.0686	-.0715			-.0593	-.0594			-.0602	-.0611	-.0571	-.0595	-.0454	-.0502
.95	-.0668	-.0697							-.0614	-.0627	-.0565	-.0571	-.0482	-.0507

TAIL 2

TABLE XV. - CONCLUDED
(k) $\alpha = 20.01^\circ$

Cp at y/b of														
x/c	0.02		0.22		0.44		0.56		0.67		0.83		0.98	
	U.S.	L.S.	U.S.	L.S.	U.S.	L.S.	U.S.	L.S.	U.S.	L.S.	U.S.	L.S.	U.S.	L.S.
.05	-.0558	.2527	-.0381	.9771	-.0144	1.0400	-.0009	1.0624	.0065	1.0701	.0226	1.0711		
.10	-.0643	.4703	-.0437	.9434	-.0201	1.0506	-.0125	1.0769	-.0023	1.0775	.0081	1.0805	.0242	.9404
.15	-.0638	.2401	-.0481	.9143	-.0238	1.0426	-.0124	1.0694	-.0060	1.0790	.0007	1.0756	.0235	.9137
.20	-.0572	.4051	-.0515	.8807	-.0276	1.0256			-.0087	1.0746	-.0012	1.0723	.0226	.8727
.25			-.0674	.4431	-.0354	.9155	-.0216	1.0193	-.0117	1.0623	-.0041	1.0670	.0199	.8448
.30	-.0601	.3303	-.0595	.3972	-.0432	.4748	-.0460	.5378	-.0348	.6893	-.0086	1.0333	.0233	.8187
.40									-.0576	.5022	-.0541	.5240	-.0331	.3978
.50	-.0641	.3723	-.0657	.3723	-.0600	.4370			-.0605	.4897	-.0612	.4893	-.0424	.3391
.60	-.0632	.4034	-.0658	.3587	-.0583	.4187	-.0550	.4496	-.0602	.4728	-.0558	.4644	-.0572	.3092
.70	-.0646	.3793	-.0654	.3526	-.0571	.3963	-.0594	.4122	-.0569	.3967			-.0711	.0867
.80	-.0675	.2350	-.0658	.1383	-.0544	.1382	-.0588	.1518	-.0539	.1473	-.0625	.1535	-.0720	.0667
.90	-.0661	.1408	-.0656	.1193	-.0580	.1200	-.0600	.1322	-.0625	.1410	-.0642	.1312	-.0687	.0572
.95	-.0644	.1383	-.0638	.1174	-.0590	.1129	-.0599	.1229	-.0621	.1334	-.0647	.1221	-.0673	.0569

TAIL 1

Cp at y/b of														
x/c	0.02		0.22		0.44		0.56		0.67		0.83		0.96	
	U.S.	L.S.	U.S.	L.S.	U.S.	L.S.	U.S.	L.S.	U.S.	L.S.	U.S.	L.S.	U.S.	L.S.
.05	.0120	.0194	-.0078	.0009			.0139	.0224	.0306	.0387	.0544	.0670	.0779	.1053
.10	.0048	.0174	-.0108	-.0020			.0109	.0165	.0253	.0340	.0484	.0605	.0623	.0758
.15	-.0025	.0103	-.0128	-.0037			.0074	.0119	.0134	.0264	.0439	.0545	.0469	.0572
.20							.0039	.0077	.0164	.0214		.0904	.0370	.0446
.25	-.0394	-.0413	-.0453	-.0395			.0034	.0052	.0124	.0159	.0460	.0501	.0309	.0374
.30			-.0264	.0223	-.0417	-.0395	-.0414	-.0366	-.0128	-.0120				
.40	-.0547	.0250			-.0475	-.0458	-.0487	-.0478	-.0384	-.0372	-.0215	-.0227		
.50	-.0546	-.0501					-.0503	-.0496	-.0464	-.0453			.0572	.2477
.60					-.0545	-.0541	-.0519	-.0515	-.0443	-.0441	-.0305	-.0309	-.0364	-.0233
.70			-.0488	-.0455	-.0566	-.0558	-.0216	-.0206	-.0463	-.0419	-.0594	-.0593	-.0547	-.0545
.80	-.0609	-.0632	-.0630	-.0626	-.0681	-.0684			-.0275	.0160	-.0658	-.0663	.0521	-.0239
.90	-.0702	-.0713			-.0610	-.0613			-.0635	-.0608	-.0634	-.0654	-.0558	-.0613
.95	-.0689	-.0697							-.0659	-.0661	-.0637	-.0644	-.0614	-.0626

TAIL 2

TABLE XVI. - PRESSURE COEFFICIENTS, $\phi = 0^\circ$, $\delta_{2,4} = -15^\circ$, $M = 1.60$
 (a) $\alpha = -3.50^\circ$

Cp at y/b of														
x/c	0.02		0.22		0.44		0.56		0.67		0.83		0.98	
	U.S.	L.S.	U.S.	L.S.	U.S.	L.S.	U.S.	L.S.	U.S.	L.S.	U.S.	L.S.	U.S.	L.S.
.05	.2720	.2808	.6074	.6459			.6359	.7388	.6298	.5566	.6147	.7256		
.10	.2491	.2695	.5005	.5411	.5954	.6198	.6173	.6640	.6193	.6707	.6093	.6720	.3826	.4097
.15	.2229	.2548	.4344	.4689	.5402	.5766	.5718	.6103	.5851	.6374	.5778	.6181	.3579	.3790
.20	.1576	.1874	.3678	.4099	.4957	.5323			.5439	.6432	.5381	.5699	.3389	.3552
.25			-.0365	-.0447	.37	.2459	.4472	.4875	.4900	.5295	.4883	.5163	.3115	.3209
.30	.0126	-.0262	-.0839	-.0774	.6025	-.0128	.0246	.0034	.1602	.1113	.4202	.4402	.2964	.2930
.40									-.0136	-.0203	-.0405	-.0495	-.0889	-.0944
.50	-.0333	.0025			-.0248	-.0131			-.0294	-.0324	-.0660	-.0753	-.0605	-.0611
.60	-.0684	-.0483	-.0736	-.0756	-.0053	-.0136	.0079	-.0047	-.0330	-.0402	-.0755	-.0872	-.0446	-.0670
.70	-.0743	-.0673	-.0282	-.0155	-.0383	-.0433	-.0174	-.0295	-.0522	-.0969			-.1961	-.2084
.80	-.2804	-.2845	-.2710	-.2871	-.2845	-.2971	-.2671	-.2832	-.2595	-.2831	-.2344	-.2558	-.1226	-.1482
.90	-.2980	-.2963	-.3113	-.3215	-.2604	-.3050	-.2505	-.3013	-.2251	-.2595	-.2337	-.2508	-.1607	-.1707
.95	-.2961	-.2946	-.3213	-.3325	-.2470	-.2824	-.2438	-.2762	-.2244	-.2503	-.2303	-.2354	-.1586	-.1844

TAIL 1

Cp at y/b of														
x/c	0.02		0.22		0.44		0.56		0.67		0.83		0.98	
	U.S.	L.S.	U.S.	L.S.	U.S.	L.S.	U.S.	L.S.	U.S.	L.S.	U.S.	L.S.	U.S.	L.S.
.05	.4795	-.2464	1.3701	-.3078					1.3508	-.3596	1.3384	-.3602		
.10	.8027	-.1403	1.2113	-.2575					1.2156	-.2796	1.2124	-.2912	.9129	-.1949
.15	.9847	-.0837					1.0985	-.2438	1.1025	-.2427	1.0916	-.2517		
.20							.9790	-.2303	.9944	-.2292	.9971	-.2345	.7357	-.1011
.25	.8002	-.1712	.3748	-.3895					.8574	-.2307	.8842	-.2300	.6407	-.0976
.30			.4695	-.3831	.4742	-.3823	.4635	-.3737	.4144	-.3138				
.40	.5767	-.2698			.6985	-.3869	.7157	-.3886	.6522	-.3886	.4093	-.3634		
.50	.5553	-.2076					.6546	-.3855	.6230	-.3304			.2534	-.2923
.60					.6219	-.3586	.6101	-.3601	.5758	-.3717	.5061	-.3434	.2852	-.3446
.70			.5824	-.2714	.5448	-.3429	.5042	-.3526	.1652	-.3587	.0231	-.4336	-.0872	-.4628
.80	.0217	-.3937	.0160	-.4052	.0350	-.2986			.0261	-.3401	-.0131	-.4033		
.90	.0520	-.3552			.0335	-.2964			.0263	-.3393	.0031	-.3580		
.95	.0319	-.2804							-.0162	-.3323	-.0045	-.3211	-.0871	-.3811

TAIL 2

TABLE XVI. - CONTINUED
(b) $\alpha = -1.49^\circ$

Cp at y/b of														
x/c	0.02		0.22		0.44		0.56		0.67		0.83		0.98	
	U.S.	L.S.	U.S.	L.S.	U.S.	L.S.	U.S.	L.S.	U.S.	L.S.	U.S.	L.S.	U.S.	L.S.
.05	.2406	.2434	.5646	.6154			.5773	.7290	.5709	.5836	.5581	.7112		
.10	.2426	.2534	.4850	.5298	.5763	.6150	.5891	.6604	.5862	.6642	.5876	.7093	.3590	.3949
.15	.2293	.2458	.4391	.4768	.5417	.5789	.5664	.6116	.5772	.6349	.5752	.6349	.3455	.3692
.20	.1522	.1737	.3906	.4273	.5033	.5384			.5514	.6465	.5402	.5592	.3281	.3435
.25			-.0166	-.0326	.3823	.3029	.4569	.4919	.5050	.5312	.4888	.5052	.3037	.3058
.30	.0733	.0555	-.0605	-.0618	.0089	-.0104	.0351	.0040	.1722	.1138	.4219	.4345	.2868	.2721
.40									-.0082	-.0236	-.0406	-.0526	-.0981	-.1071
.50	.0376	.0148			-.0338	-.0325			-.0290	-.0371	-.0720	-.0816	-.0728	-.0769
.60	-.0645	-.0409	-.0643	-.0666	-.0284	-.0335	-.0340	-.0390	-.0473	-.0534	-.0888	-.0962	.0640	-.0792
.70	-.0572	-.0521	-.0108	-.0188	-.0186	-.0287	-.0464	-.0549	-.1325	-.1287			-.2125	-.2187
.80	-.2675	-.2711	-.2686	-.2775	-.2636	-.2827	-.2582	-.2813	-.2448	-.2825	-.2541	-.2726	-.1484	-.1635
.90	-.2838	-.2800	-.3047	-.3170	-.2572	-.2873	-.2394	-.2802	-.2316	-.2588	-.2540	-.2690	-.1843	-.1988
.95	-.2787	-.2789	-.3191	-.3249	-.2379	-.2743	-.2325	-.2598	-.2281	-.2461	-.2537	-.2650	-.1893	-.2100

TAIL 1

Cp at y/b of															
x/c	0.02		0.22		0.44		0.56		0.67		0.83		0.98		
	U.S.	L.S.	U.S.	L.S.	U.S.	L.S.	U.S.	L.S.	U.S.	L.S.	U.S.	L.S.	U.S.	L.S.	
.05	.4550	-.1806	1.2902	-.2351					1.3153	-.2932	1.3041	-.2989			
.10	.6795	-.0638	1.1293	-.1813					1.1717	-.2108	1.1729	-.2225	.8759	-.1328	
.15	.8169	-.0325							1.0507	-.1800	1.0554	-.1783	1.0498	-.1873	
.20								.9329	-.1686	.9493	-.1685	.9531	-.1753	.6955	-.0527
.25	.6071	-.1277	.2299	-.3622					.8148	-.1731	.8420	-.1741	.6028	-.0509	
.30			.3559	-.3601	.3056	-.3495	.2593	-.3376	.3672	-.2655					
.40	.5219	-.2197			.5309	-.3545	.4131	-.3563	.3669	-.3575	.2786	-.3301			
.50	.4997	-.1759					.6209	-.3597	.5864	-.3626			.0898	-.2886	
.60					.5829	-.3339	.5707	-.3571	.5351	-.3619	.4776	-.3162	.1318	-.3509	
.70			.5244	-.2287	.5127	-.3268	.4764	-.3332	.1439	-.3522	.0036	-.4175	-.1033	-.4160	
.80	-.0114	-.3740	-.0031	-.3832	.0169	-.3045			.0071	-.3470	-.0359	-.3948			
.90	.0190	-.3610			.0041	-.3028			.0026	-.3417	-.0231	-.3490			
.95	-.0012	-.2866							-.0096	-.3290	-.0301	-.3177	-.1009	-.3804	

TAIL 2

TABLE XVI. - CONTINUED
(c) $\alpha = 0.50^\circ$

Cp at y/b of														
x/c	0.02		0.22		0.44		0.56		0.67		0.83		0.98	
	U.S.	L.S.	U.S.	L.S.	U.S.	L.S.	U.S.	L.S.	U.S.	L.S.	U.S.	L.S.	U.S.	L.S.
.05	.2706	.2737	.5564	.6100			.5287	.7241	.5338	.5801	.5105	.6906		
.10	.2808	.2894	.4943	.5419	.5473	.6083	.5618	.6550	.5483	.6647	.5387	.6537	.3328	.3878
.15	.2772	.2923	.4550	.4948	.5282	.5843	.5519	.6155	.5557	.6382	.5551	.6040	.3274	.3727
.20	.2133	.2341	.4106	.4517	.5101	.5500			.5429	.6522	.5333	.5569	.3232	.3483
.25			-.0012	-.0178	.3958	.3463	.4616	.5014	.5073	.5355	.4873	.5002	.3092	.3126
.30	.1000	.0538	-.0374	-.0428	.0180	-.0008	.0420	.0107	.1808	.1182	.4224	.4334	.2936	.2783
.40									-.0035	-.0250	-.0380	-.0513	-.0859	-.0994
.50	.0603	-.0295			-.0247	-.0298			-.0269	-.0404	-.0695	-.0834	-.0550	-.0664
.60	-.0425	-.0188	-.0580	-.0597	-.0329	-.0396	-.0318	-.0386	-.0484	-.0567	-.0873	-.0983	-.0295	-.0629
.70	-.0383	-.0302	-.0004	.0036	-.0242	-.0371	-.0671	-.0710	-.1347	-.1303			-.1949	-.2078
.80	-.2545	-.2599	-.2502	-.2658	-.2555	-.2757	-.2544	-.2934	-.2576	-.2872	-.2623	-.2817	-.1679	-.1644
.90	-.2752	-.2744	-.2890	-.3038	-.2458	-.2813	-.2291	-.2595	-.2426	-.2615	-.2586	-.2727	-.2200	-.2207
.95	-.2716	-.2722	-.2923	-.3109	-.2300	-.2616	-.2246	-.2506	-.2391	-.2523	-.2569	-.2653	-.2228	-.2273

TAIL 1

Cp at y/b of															
x/c	0.02		0.22		0.44		0.56		0.67		0.83		0.98		
	U.S.	L.S.	U.S.	L.S.	U.S.	L.S.	U.S.	L.S.	U.S.	L.S.	U.S.	L.S.	U.S.	L.S.	
.05	.4530	-.0842	1.2141	-.1514					1.2768	-.2194	1.2692	-.2284			
.10	.6103	-.0228	1.0589	-.0969					1.1321	-.1385	1.1321	-.1512	.8371	-.0730	
.15	.7132	-.0055						1.0088	-.1131	1.0179	-.1101	1.0086	-.1204		
.20								.8961	-.1041	.9143	-.1047	.9143	-.1141	.6614	-.0072
.25	.3847	-.0907	.1881	-.3228					.7856	-.1125	.8078	-.1151	.5706	-.0062	
.30			.2427	-.3227	.2061	-.3147	.1748	-.3048	.3513	-.2176					
.40	.3632	-.1775			.3582	-.3193	.3243	-.3222	.2721	-.3227	.1817	-.3000			
.50	.4088	-.1434					.3837	-.3267	.3497	-.3296			.0260	-.2551	
.60					.4688	-.3166	.4163	-.3290	.3669	-.3329	.2672	-.2907	.0535	-.3020	
.70			.4868	-.1823	.5025	-.2938	.4248	-.3270	.0993	-.3472	-.0741	-.4013	-.1895	-.3913	
.80	-.0373	-.3614	-.0221	-.3687	.0106	-.2961			-.0156	-.3386	-.1013	-.3763			
.90	-.0216	-.3692			-.0078	-.2955			-.0089	-.3280	-.0776	-.3291			
.95	-.0446	-.3164							-.0189	-.3149	-.0779	-.3016	-.1503	-.3803	

TAIL 2

TABLE XVI. - CONTINUED
(d) $\alpha = 2.50^\circ$

Cp at y/b of														
x/c	0.02		0.22		0.44		0.56		0.67		0.83		0.98	
	U.S.	L.S.	U.S.	L.S.	U.S.	L.S.	U.S.	L.S.	U.S.	L.S.	U.S.	L.S.	U.S.	L.S.
.05	.2912	.2935	.5231	.5914			.5100	.7213	.5150	.5641	.5060	.6632		
.10	.3023	.3104	.4793	.5342	.5261	.5962	.5367	.6433	.5219	.6505	.5196	.6381	.3204	.3752
.15	.3088	.3284	.4449	.4872	.5142	.5796	.5366	.6179	.5375	.6336	.5242	.5928	.3132	.3689
.20	.2754	.2921	.4064	.4522	.4987	.5500			.5311	.6582	.5147	.5475	.3181	.3501
.25			.0013	-.0130	.3921	.3780	.4590	.5017	.5027	.5343	.4776	.4923	.3076	.3209
.30	.1027	.0403	-.0314	-.0363	.0189	.0011	.0431	.0112	.1824	.1207	.4173	.4306	.3019	.2862
.40									-.0054	-.0281	-.0384	-.0502	-.0731	-.0900
.50	.0828	.0490			-.0215	-.0308			-.0317	-.0469	-.0703	-.0848	-.0395	-.0511
.60	-.0217	-.0073	-.0570	-.0582	-.0317	-.0400	-.0349	-.0460	-.0546	-.0644	-.0882	-.1005	-.0100	-.0444
.70	-.0108	-.0009	-.0157	-.0254	-.0421	-.0537	-.0705	-.0774	-.1412	-.1366			-.1883	-.2025
.80	-.2360	-.2438	-.2380	-.2517	-.2535	-.2775	-.2560	-.2995	-.2668	-.2910	-.2678	-.2855	-.1817	-.1700
.90	-.2616	-.2644	-.2723	-.2884	-.2327	-.2696	-.2325	-.2605	-.2487	-.2668	-.2610	-.2738	-.2492	-.2391
.95	-.2593	-.2614	-.2596	-.2939	-.2233	-.2506	-.2281	-.2493	-.2459	-.2504	-.2573	-.2607	-.2438	-.2444

TAIL 1

Cp at y/b of														
x/c	0.02		0.22		0.44		0.56		0.67		.0.83		0.98	
	U.S.	L.S.	U.S.	L.S.	U.S.	L.S.	U.S.	L.S.	U.S.	L.S.	U.S.	L.S.	U.S.	L.S.
.05	.4742	.0219	1.1345	-.0733					1.2309	-.1346	1.2267	-.1484		
.10	.5942	.0117	.9893	-.0145					1.0860	-.0571	1.0883	-.0737	.7937	-.0054
.15	.6631	.0221					.9676	-.0383	.9746	-.0364	.9677	-.0489		
.20							.8600	-.0327	.8760	-.0372	.8775	-.0485	.6225	.0375
.25	.2231	-.0616	.1633	-.2726					.7528	-.0480	.7749	-.0513	.5348	.0360
.30			.1846	-.2764	.1645	-.2769	.1497	-.2652	.3337	-.1746				
.40	.2495	-.1474			.2725	-.2812	.2487	-.2864	.2094	-.2859	.1417	-.2659		
.50	.2025	-.1078					.2921	-.2911	.2641	-.2949			-.0135	-.2053
.60					.2942	-.2912	.2965	-.2940	.2743	-.2992	.1910	-.2642	.0046	-.2584
.70			.4452	-.1346	.2886	-.2804	.2449	-.2984	.0190	-.3259	-.1230	-.3911	-.2217	-.3842
.80	-.0601	-.3483	-.0279	-.3552	-.0353	-.2819			-.1107	-.3167	-.1506	-.3527		
.90	-.0584	-.3672			-.0131	-.2857			-.1193	-.3234	-.1425	-.3122		
.95	-.0811	-.3293							-.1258	-.3131	-.1541	-.2956	-.1641	-.3812

TAIL 2

TABLE XVI. - CONTINUED
(e) $\alpha = 4.50^\circ$

Cp at y/b of														
x/c	0.02		0.22		0.44		0.56		0.67		0.83		0.98	
	U.S.	L.S.	U.S.	L.S.	U.S.	L.S.	U.S.	L.S.	U.S.	L.S.	U.S.	L.S.	U.S.	L.S.
.05	.3104	.3037	.5203	.5946			.5060	.7253	.5143	.5439	.5066	.6677		
.10	.3096	.3209	.4808	.5411	.5304	.6036	.5382	.6489	.5255	.6537	.5179	.6387	.3243	.3705
.15	.3098	.3415	.4425	.4955	.5205	.5847	.5414	.6228	.5414	.6325	.5176	.5874	.3184	.3730
.20	.2904	.3051	.3998	.4506	.5042	.5512			.5370	.6487	.5078	.5415	.3207	.3566
.25			-.0061	-.0217	.3959	.3976	.4626	.5067	.5052	.5315	.4688	.4878	.3112	.3257
.30	.0854	.0234	-.0422	-.0441	.0167	.0030	.0463	.0159	.1825	.1310	.4110	.4297	.3053	.2923
.40									-.0079	-.0288	-.0383	-.0479	-.0627	-.0809
.50	.1004	.0680			-.0323	-.0369			-.0350	-.0495	-.0693	-.0824	-.0225	-.0362
.60	.0006	.0341	-.0582	-.0583	-.0476	-.0504	-.0434	-.0510	-.0585	-.0669	-.0869	-.0979	.0194	-.0251
.70	.0215	.0342	.0281	.0451	-.0623	-.0680	-.0823	-.0859	-.1450	-.1396			-.1818	-.1909
.80	-.2143	-.2251	-.2199	-.2344	-.2562	-.2938	-.2553	-.3024	-.2735	-.2957	-.2696	-.2844	-.1821	-.1712
.90	-.2442	-.2536	-.2530	-.2699	-.2329	-.2606	-.2395	-.2627	-.2540	-.2639	-.2600	-.2715	-.2618	-.2519
.95	-.2456	-.2518	-.2608	-.2762	-.2281	-.2444	-.2377	-.2523	-.2525	-.2585	-.2544	-.2573	-.2566	-.2573

TAIL 1

Cp at y/b of														
x/c	0.02		0.22		0.44		0.56		0.67		0.83		0.98	
	U.S.	L.S.	U.S.	L.S.	U.S.	L.S.	U.S.	L.S.	U.S.	L.S.	U.S.	L.S.	U.S.	L.S.
.05	.4999	.0853	1.0753	.0199					1.1811	-.0382	1.1774	-.0574		
.10	.5885	.0643	.9353	.0670					1.0357	.0297	1.0399	.0099	.7452	.0556
.15	.6303	.0699					.9212	.0402	.9306	.0424	.9222	.0277		
.20							.8209	.0432	.8378	.0380	.8344	.0227	.5799	.0793
.25	.1548	-.0263	.1332	-.2183					.7227	.0241	.7368	.0188	.4962	.0768
.30			.1393	-.2288	.1329	-.2354	.1275	-.2207	.3170	-.1195				
.40	.1379	-.1222			.2105	-.2415	.1943	-.2455	.1639	-.2455	.1068	-.2292		
.50	.0949	-.0666					.2241	-.2504	.2012	-.2561			-.0447	-.1618
.60					.2130	-.2434	.2268	-.2537	.2071	-.2611	.1313	-.2380	-.0287	-.1898
.70			.2492	-.0882	.1812	-.2412	.1784	-.2701	-.0255	-.2986	-.1622	-.3720	-.2298	-.3590
.80	-.1054	-.3182	-.0703	-.3423	-.1319	-.2962			-.1494	-.3105	-.1888	-.3352		
.90	-.0713	-.3591			-.1307	-.2871			-.1641	-.3098	-.1800	-.3079		
.95	-.0862	-.3260							-.1778	-.3040	-.1901	-.2986	-.1650	-.3723

TAIL 2

TABLE XVI. - CONTINUED
(f) $\alpha = 6.50^\circ$

Cp at y/b of														
x/c	0.02		0.22		0.44		0.56		0.67		0.83		0.98	
	U.S.	L.S.	U.S.	L.S.	U.S.	L.S.	U.S.	L.S.	U.S.	L.S.	U.S.	L.S.	U.S.	L.S.
.05	.3401	.3188	.5338	.6180			.5190	.7347	.5172	.5237	.5164	.6621		
.10	.3303	.3430	.4988	.5615	.5521	.6185	.5558	.6586	.5415	.6572	.5342	.6305	.3337	.3751
.15	.3215	.3563	.4899	.5102	.5391	.5868	.5533	.6262	.5598	.6301	.5202	.5791	.3326	.3741
.20	.2965	.3090	.4218	.4556	.5135	.5524			.5458	.6434	.4943	.5316	.3265	.3564
.25			-.0011	-.0221	.4016	.4103	.4749	.5104	.5053	.5338	.4560	.4816	.3097	.3310
.30	.0586	-.0005	-.0458	-.0474	.0212	.0030	.0509	.0196	.1805	.1371	.4018	.4288	.3076	.3031
.40									-.0122	-.0283	-.0405	-.0449	-.0512	-.0720
.50	.1024	.0718			-.0328	-.0376			-.0384	-.0489	-.0701	-.0769	-.0703	-.0245
.60	.0293	.0574	-.0578	-.0582	-.0503	-.0576	-.0440	-.0542	-.0584	-.0667	-.0846	-.0916	.0238	.0020
.70	.0628	.0706	.0101	.0574	-.0728	-.0808	-.0810	-.0910	-.1419	-.1419			-.1736	-.1782
.80	-.1906	-.2045	-.2003	-.2194	-.2587	-.3055	-.2639	-.3038	-.2802	-.2945	-.2648	-.2802	-.1827	-.1720
.90	-.2259	-.2429	-.2270	-.2518	-.2406	-.2660	-.2431	-.2671	-.2537	-.2668	-.2534	-.2663	-.2665	-.2595
.95	-.2301	-.2537	-.2277	-.2565	-.2375	-.2518	-.2431	-.2617	-.2527	-.2647	-.2458	-.2443	-.2604	-.2700

TAIL 1

Cp at y/b of														
x/c	0.02°		0.22		0.44		0.56		0.67		0.83		0.98	
	U.S.	L.S.	U.S.	L.S.	U.S.	L.S.	U.S.	L.S.	U.S.	L.S.	U.S.	L.S.	U.S.	L.S.
.05	.4872	.1521	.9766	.1395					1.1127	.0814	1.1151	.0536		
.10	.5505	.1390	.8519	.1653					.9741	.1249	.9784	.1090	.6847	.1095
.15	.5697	.1508					.8640	.1317	.8752	.1269	.8646	.1145		
.20							.7736	.1288	.7894	.1200	.7833	.1053	.5291	.1138
.25	.1154	.0324	.1018	-.1677					.6833	.1025	.6929	.0968	.4523	.1125
.30			.0899	-.1734	.1010	-.1873	.1046	-.1733	.2970	-.0617				
.40	.0603	-.0832			.1488	-.1954	.1404	-.1987	.1182	-.2001	.0731	-.1944		
.50	.0332	-.0203					.1564	-.2034	.1385	-.2116			-.0603	-.1192
.60					.1497	-.1778	.1576	-.2059	.1391	-.2168	.0732	-.2096	-.0416	-.1332
.70			.1616	-.0507	.1201	-.1770	.1164	-.2249	-.0772	-.2626	-.1996	-.3454	-.2063	-.3170
.80	-.1283	-.2942	-.1281	-.3295	-.1808	-.3104			-.1871	-.2944	-.2242	-.3133		
.90	-.0910	-.3540			-.1804	-.2787			-.1987	-.2943	-.2084	-.2964		
.95	-.0957	-.3231							-.2104	-.2855	-.2122	-.2903	-.1373	-.3445

TAIL 2

TABLE XVI. - CONTINUED
(g) $\alpha = 8.50^\circ$

Cp at γ/b of														
x/c	0.02		0.22		0.44		0.56		0.67		0.83		0.98	
	U.S.	L.S.	U.S.	L.S.	U.S.	L.S.	U.S.	L.S.	U.S.	L.S.	U.S.	L.S.	U.S.	L.S.
.05	.3722	.3391	.5611	.6425			.5356	.7348	.5430	.5050	.5441	.6408		
.10	.3606	.3701	.5260	.5703	.5629	.6222	.5652	.6545	.5541	.6495	.5271	.6160	.3359	.3658
.15	.3434	.3740	.4827	.5169	.5429	.5912	.5580	.6261	.5554	.6332	.4986	.5657	.3280	.3696
.20	.3079	.3180	.4252	.4650	.5187	.5625			.5352	.6707	.4723	.5214	.3252	.3574
.25			-.0016	-.0149	.4070	.4226	.4700	.5191	.4955	.5348	.4362	.4793	.3120	.3375
.30	.0555	-.0062	-.0468	-.0432	.0244	.0078	.0481	.0234	.1768	.1439	.3889	.4350	.3104	.3143
.40									-.0137	-.0256	-.0427	-.0397	-.0448	-.0585
.50	.1099	.0611			-.0242	-.0358			-.0355	-.0485	-.0681	-.0724	.0144	-.0074
.60	.0550	.0767	-.0586	-.0586	-.0433	-.0579	-.0375	-.0557	-.0501	-.0672	-.0745	-.0875	-.1569	-.1651
.70	.0960	.0950	-.0035	.0380	-.0712	-.0823	-.0767	-.0898	-.1351	-.1416				
.80	-.1731	-.1922	-.1904	-.2054	-.2480	-.3049	-.2592	-.3020	-.2750	-.2853	-.2528	-.2728	-.2008	-.1694
.90	-.2093	-.2066	-.2041	-.2333	-.2363	-.2659	-.2399	-.2677	-.2487	-.2649	-.2401	-.2573	-.2763	-.2660
.95	-.2154	-.2183	-.2128	-.2394	-.2366	-.2537	-.2389	-.2620	-.2473	-.2629	-.2309	-.2369	-.2729	-.2813

TAIL 1

Cp at γ/b of														
x/c	0.02		0.22		0.44		0.56		0.67		0.83		0.98	
	U.S.	L.S.	U.S.	L.S.	U.S.	L.S.	U.S.	L.S.	U.S.	L.S.	U.S.	L.S.	U.S.	L.S.
.05	.4282	.2333	.8530	.2654					1.0191	.2086	1.0285	.1794		
.10	.4825	.2191	.7534	.2680					.8927	.2264	.9006	.2112	.6189	.1627
.15	.4806	.2382							.7919	.2254	.8064	.2201	.7963	.2019
.20									.7164	.2192	.7323	.2118	.7219	.1899
.25	.0896	.0998	.0715	-.1198					.6389	.1902	.6427	.1763	.4144	.1563
.30			.0482	-.1051	.0717	-.1382	.0815	-.1196	.2742	.0032				
.40	.0228	-.0230			.0939	-.1505	.0927	-.1458	.0773	-.1505	.0434	-.1558		
.50	.0172	.0297					.0970	-.1544	.0823	-.1627			-.0585	-.1023
.60					.0901	-.1093	.0949	-.1494	.0783	-.1692	.0259	-.1750	-.0522	-.0896
.70			.1137	-.0136	.0633	-.0785	.0582	-.1690	-.1208	-.2233	-.2313	-.3075	-.1952	-.2639
.80	-.1404	-.2527	-.1449	-.3130	-.2158	-.2665			-.2213	-.2554	-.2500	-.2840		
.90	-.1210	-.3504			-.1919	-.2883			-.2251	-.2606	-.2075	-.2744		
.95	-.1225	-.3238							-.2034	-.2473	-.2008	-.2677	-.1398	-.3154

TAIL 2

TABLE XVI. - CONTINUED
(h) $\alpha = 10.50^\circ$

Cp at γ/b of														
x/c	0.02		0.22		0.44		0.56		0.67		0.83		0.98	
	U.S.	L.S.	U.S.	L.S.	U.S.	L.S.	U.S.	L.S.	U.S.	L.S.	U.S.	L.S.	U.S.	L.S.
.05	.3965	.3533	.5764	.6590			.5329	.7321	.5309	.4884	.5240	.6220		
.10	.3737	.3938	.5257	.5850	.5601	.6369	.5534	.6697	.5290	.6581	.5095	.6071	.3216	.3623
.15	.3486	.3948	.4837	.5358	.5428	.6135	.5511	.6300	.5352	.6454	.4779	.5619	.3207	.3746
.20	.3095	.3389	.4324	.4822	.5238	.5805			.5262	.6735	.4529	.5196	.3195	.3661
.25			.0049	-.0032	.4201	.4330	.4817	.5251	.4975	.5388	.4225	.4801	.3096	.3512
.30	.0494	-.0012	-.0378	-.0374	.0367	.0102	.0582	.0233	.1841	.1418	.3856	.4351	.3173	.3295
.40									-.0027	-.0255	-.0320	-.0398	-.0260	-.0474
.50	.1148	.0555			-.0160	-.0354			-.0253	-.0472	-.0530	-.0702	.0460	.0062
.60	.0805	.1023	-.0538	-.0555	-.0400	-.0547	-.0335	-.0523	-.0442	-.0647	-.0585	-.0798	.0557	.0288
.70	.1257	.1260	-.0019	.0183	-.0715	-.0790	-.0752	-.0877	-.1313	-.1387			-.1461	-.1492
.80	-.1582	-.1800	-.1969	-.1905	-.2349	-.2997	-.2482	-.2963	-.2603	-.2768	-.2420	-.2636	-.2300	-.1634
.90	-.1920	-.1939	-.1853	-.2161	-.2287	-.2629	-.2342	-.2664	-.2402	-.2581	-.2265	-.2487	-.2910	-.2811
.95	-.1971	-.1840	-.1901	-.2217	-.2318	-.2518	-.2341	-.2625	-.2381	-.2613	-.2156	-.2321	-.2814	-.2902

TAIL 1

Cp at γ/b of														
x/c	0.02		0.22		0.44		0.56		0.67		0.83		0.98	
	U.S.	L.S.	U.S.	L.S.	U.S.	L.S.	U.S.	L.S.	U.S.	L.S.	U.S.	L.S.	U.S.	L.S.
.05	.3291	.3051	.6934	.3870					.8947	.3528	.9138	.3209		
.10	.3993	.2912	.6408	.3592					.7909	.3369	.8091	.3243	.5416	.2182
.15	.3834	.3191					.7054	.3394	.7236	.3293	.7231	.3099		
.20							.6499	.3295	.6681	.3159	.6576	.3005	.4222	.2005
.25	.0500	.1738	.0396	-.0731					.5907	.2883	.5890	.2816	.3687	.1952
.30			.0097	-.0292	.0455	-.0930	.0592	-.0636	.2510	.0753				
.40	-.0061	.0275			.0466	-.1011	.0507	-.0396	.0438	-.0932	.0163	-.1060		
.50	.0292	.0712					.0453	-.1019	.0368	-.1064			-.0581	-.0793
.60					.0361	-.0257	.0407	-.0698	.0278	-.1174	-.0179	-.1375	-.0581	-.0483
.70			.0657	.0255	.0117	.0640	.0073	-.0967	-.1566	-.1797	-.2594	-.2919	-.1950	-.2295
.80	-.1614	-.2305	-.1544	-.2953	-.2413	-.2553			-.2137	-.2397	-.2219	-.2660		
.90	-.1438	-.3341			-.1918	-.2747			-.1886	-.2339	-.2085	-.2620		
.95	-.1502	-.3149							-.1880	-.2219	-.2102	-.2546	-.1652	-.2770

TAIL 2

TABLE XVI.- CONTINUED
(i) $\alpha = 12.50^\circ$

Cp at y/b of														
x/c	0.02		0.22		0.44		0.56		0.67		0.83		0.98	
	U.S.	L.S.	U.S.	L.S.	U.S.	L.S.	U.S.	L.S.	U.S.	L.S.	U.S.	L.S.	U.S.	L.S.
.05	.4144	.3666	.5938	.6840			.5330	.7543	.5292	.707	.5247	.6301		
.10	.3918	.4216	.5552	.6048	.5949	.6537	.5824	.6818	.5457	.6609	.5137	.6013	.3483	.3693
.15	.3718	.4121	.5145	.5490	.5833	.6240	.5906	.6369	.5650	.6426	.4503	.5493	.3268	.3776
.20	.3350	.3504	.4595	.4944	.5604	.5901			.5542	.6703	.4719	.5094	.3369	.3703
.25			.0201	.0025	.4417	.4429	.5022	.5307	.5172	.5386	.4428	.4755	.3392	.3531
.30	.0727	.0026	-.0256	-.0328	.0423	.0150	.0617	.0258	.1904	.1426	.4018	.4371	.3501	.3392
.40									-.0017	-.0236	-.0273	-.0368	-.0101	-.0319
.50	.1244	.0688			-.0164	-.0309			-.0236	-.0448	-.0488	-.0647	.0536	.0297
.60	.1077	.1398	-.0322	-.0421	-.0373	-.0519	-.0291	-.0487	-.0383	-.0617	-.0473	-.0685	.0600	.0433
.70	.1596	.1537	.0110	.0173	-.0665	-.0777	-.0686	-.0855	-.1248	-.1352			-.1463	-.1406
.80	-.1381	-.1662	-.1861	-.1763	-.2172	-.2732	-.2365	-.2828	-.2514	-.2730	-.2341	-.2532	-.2733	-.1883
.90	-.1746	-.1757	-.1630	-.1975	-.2208	-.2521	-.2273	-.2554	-.2328	-.2542	-.2178	-.2383	-.3002	-.3057
.95	-.1778	-.1596	-.1640	-.1983	-.2240	-.2391	-.2276	-.2505	-.2308	-.2552	-.2069	-.2191	-.2832	-.2993

TAIL 1

Cp at y/b of														
x/c	0.02		0.22		0.44		0.56		0.67		0.83		0.98	
	U.S.	L.S.	U.S.	L.S.	U.S.	L.S.	U.S.	L.S.	U.S.	L.S.	U.S.	L.S.	U.S.	L.S.
.05	.1911	.3641	.4519	.4920					.6314	.4928	.7459	.4902		
.10	.2877	.3800	.4458	.4458					.6312	.4777	.6847	.4776	.4334	.2887
.15	.2789	.4153					.5642	.4503	.6005	.4664	.6186	.4591		
.20							.5462	.4286	.5722	.4426	.5684	.4317	.3160	.2567
.25	-.0378	.2634	.0005	.0083					.5245	.4024	.5133	.3969	.3035	.2437
.30			-.0322	.0680	.0148	-.0491	.0359	-.0152	.2229	.1494				
.40	-.0399	.0784			.0065	-.0085	.0162	-.0448	.0113	-.0447	-.0138	-.0657		
.50	.0650	.1338					.0053	-.0079	-.0039	-.0595			-.0512	-.0629
.60					-.0087	.0741	-.0024	.0190	-.0161	-.0471	-.0568	-.1151	-.0553	-.0435
.70			.0327	.0641	-.0332	.0969	-.0364	-.0073	-.1883	-.1079	-.2807	-.2604	-.1820	-.2102
.80	-.1667	-.2472	-.1647	-.2800	-.2281	-.2431			-.2202	-.2160	-.2360	-.2433		
.90	-.1636	-.2860			-.2074	-.2623			-.2122	-.2078	-.2267	-.2382		
.95	-.1625	-.3026							-.2152	-.2004	-.2298	-.2381	-.1950	-.2409

TAIL 2

TABLE XVI. - CONTINUED
(j) $\alpha = 16.50^\circ$

Cp at y/b of														
x/c	0.02		0.22		0.44		0.56		0.67		0.83		0.98	
	U.S.	L.S.	U.S.	L.S.	U.S.	L.S.	U.S.	L.S.	U.S.	L.S.	U.S.	L.S.	U.S.	L.S.
.05	.5087	.4100	.6822	.7406			.6171	.7890	.5860	.4575	.5561	.6066		
.10	.4757	.4849	.6207	.6514	.6637	.6923	.6491	.7107	.6041	.6769	.5225	.5889	.3775	.3880
.15	.4412	.4728	.5771	.5904	.6338	.6583	.6355	.6598	.6057	.6554	.4929	.5377	.3639	.3357
.20	.3927	.4010	.5124	.5280	.5988	.6168			.5782	.6675	.4753	.5042	.3591	.3888
.25			.0407	.0096	.4685	.4612	.5248	.5407	.5314	.5487	.4487	.4767	.3481	.3726
.30	.1185	.0280	-.0059	-.0211	.0550	.0221	.0711	.0305	.1979	.1450	.4091	.4439	.3531	.3624
.40									.0041	-.0168	-.0223	-.0298	.0092	-.0013
.50	.1937	.1401			-.0056	-.0247			-.0179	-.0367	-.0431	-.0536	.0557	-.0526
.60	.1710	.1959	-.0106	-.0144	-.0297	-.0441	-.0227	-.0445	-.0346	-.0525	-.0348	-.0471	.0567	-.0478
.70	.2134	.2062	.0065	.0514	-.0615	-.0698	-.0634	-.0792	-.1222	-.1259			-.2078	-.1304
.80	-.1132	-.1418	-.1518	-.1517	-.1604	-.2066	-.1919	-.2274	-.2052	-.2381	-.2067	-.2334	-.3126	-.2836
.90	-.1549	-.1339	-.1246	-.1505	-.1813	-.2082	-.2038	-.2241	-.2018	-.2290	-.1878	-.2144	-.3103	-.3209
.95	-.1434	-.0975	-.1145	-.1456	-.1673	-.1876	-.2018	-.2164	-.1990	-.2345	-.1650	-.1945	-.2867	-.3129

TAIL 1

Cp at y/b of														
x/c	0.02		0.22		0.44		0.56		0.67		0.83		0.98	
	J.S.	L.S.	U.S.	L.S.	U.S.	L.S.	U.S.	L.S.	U.S.	L.S.	U.S.	L.S.	U.S.	L.S.
.05	.0306	.5879	.2002	.7654					.3565	.8742	.3674	.8566		
.10	.0322	.5637	.1819	.7225					.3530	.7755	.3876	.7625	.2494	.5013
.15	-.0350	.5928					.3042	.7008	.3358	.7086	.3697	.6871		
.20							.2937	.6427	.3232	.6410	.3574	.6213	.2278	.3879
.25	-.1645	.4530	-.1327	.0677					.2972	.5576	.3333	.5524	.2077	.3424
.30			-.1560	.1531	-.1165	.0365	-.0820	.0572	.0832	.2274				
.40	.0292	.1955			-.1204	.0876	-.1106	.0507	-.0927	.0336	-.0922	-.0026		
.50	.1082	.2032					-.1188	.0926	-.1090	.0381			-.0817	-.0645
.60					-.1259	.1978	-.1168	.1257	-.1224	.0531	-.1357	-.0338	-.0512	-.0643
.70			.0517	.1102	-.1350	.1334	-.1378	.1055	-.2643	-.0149	-.3290	-.2674	-.2046	-.1984
.80	-.2197	-.2348	-.2315	-.2564	-.3187	-.2103			-.2839	-.2056	-.2962	-.2433		
.90	-.1818	-.2371			-.2813	-.2287			-.2766	-.2163	-.2821	-.2184		
.95	-.1972	-.2589							-.2734	-.2269	-.2767	-.2171	-.2642	-.1747

TAIL 2

TABLE XVI. - CONCLUDED
(k) $\alpha = 20.50^\circ$

Cp at y/b of														
x/c	0.02		0.22		0.44		0.56		0.67		0.83		0.98	
	U.S.	L.S.	U.S.	L.S.	U.S.	L.S.	U.S.	L.S.	U.S.	L.S.	U.S.	L.S.	U.S.	L.S.
.05	.6150	.4951	.7708	.8344			.7191	.8393	.6633	.4426	.5775	.6484	.3772	.4113
.10	.5778	.5813	.6903	.7315	.7236	.7583	.7111	.7677	.6543	.7229	.5341	.6060	.3745	.4233
.15	.5259	.5614	.6343	.6562	.6730	.7046	.6685	.7026	.6316	.6862	.5048	.5590	.3754	.4246
.20	.4551	.4642	.5556	.5775	.4814	.4743	.5342	.5656	.5418	.5689	.4654	.5079	.3732	.4139
.25			.5553	.5265	.4814	.4743	.5342	.5656	.5418	.5689	.4654	.5079	.3732	.4139
.30	.1509	.0513	-.0060	-.0024	.0569	.0322	.0717	.0401	.2015	.1539	.4293	.4713	.3874	.3999
.40									.0083	-.0039	-.0063	-.0110	.0416	.0291
.50	.2099	.1484			-.0027	-.0087			-.0095	-.0213	-.0212	-.0308	.0777	.0871
.60	.2063	.2252	.0334	.0384	-.0203	-.0273	-.0134	-.0255	-.0193	-.0342	.0002	-.0097	.0454	.0717
.70	.2624	.2427	.0163	.0368	-.0433	-.0542	-.0471	-.0581	-.1048	-.1075			-.2629	-.1570
.80	-.0813	-.1251	-.1292	-.1395	-.1182	-.1545	-.1649	-.2002	-.1719	-.2142	-.1681	-.2063	-.3198	-.3235
.90	-.1223	-.0952	-.0397	-.0950	-.1421	-.1799	-.1784	-.1950	-.1680	-.2002	-.1418	-.1837	-.3320	-.3325
.95	-.0740	-.0228	-.0286	-.0888	-.1264	-.1534	-.1730	-.1559	-.1604	-.1824	-.1276	-.1519	-.2826	-.3276

TAIL 1

Cp at y/b of														
x/c	0.02		0.22		0.44		0.56		0.67		0.83		0.98	
	U.S.	L.S.	U.S.	L.S.	U.S.	L.S.	U.S.	L.S.	U.S.	L.S.	U.S.	L.S.	U.S.	L.S.
.05	-.1840	.7481	-.0517	.9767					.0567	1.0548	.0438	1.0427		
.10	-.2014	.7230	-.0221	.8826					.1017	.9281	.1175	.9166	.1330	.6417
.15	-.2147	.7453					.0838	.8224	.1130	.8343	.1329	.8166		
.20							.0841	.7404	.1066	.7433	.1322	.7300	.1185	.4811
.25	-.2620	.5996	-.2400	.1567					.0965	.6348	.1191	.6421	.1089	.4144
.30			-.2560	.2402	-.2310	.0845	-.2019	.0955	-.0585	.2621				
.40	.0660	.2461			-.2312	.2203	-.2277	.1638	-.2089	.1045	-.1878	.0456		
.50	.0410	.2528					-.2361	.2212	-.2253	.1588			-.1101	-.0742
.60					-.2307	.2454	-.2341	.2712	-.2348	.1874	-.2168	.0588	-.1182	-.0786
.70			-.0450	.1442	-.2307	.1833	-.2411	.1988	-.3390	.1154	-.3696	-.1996	-.2718	-.2097
.80	-.2322	-.2125	-.2944	-.2323	-.3466	-.1765			-.3418	-.1570	-.3529	-.2034		
.90	-.1949	-.2332			-.3083	-.2011			-.3212	-.1938	-.3289	-.1872		
.95	-.2177	-.2530							-.2984	-.2100	-.3035	-.1916	-.2980	-.1382

TAIL 2

TABLE XVII. - PRESSURE COEFFICIENTS, $\phi = 0^\circ$, $\delta_{2,4} = -15^\circ$, $M = 2.36$
 (a) $\alpha = -4.06^\circ$

Cp at y/b of														
x/c	0.02		0.22		0.44		0.56		0.67		0.83		0.98	
	U.S.	L.S.	U.S.	L.S.	U.S.	L.S.	U.S.	L.S.	U.S.	L.S.	U.S.	L.S.	U.S.	L.S.
.05	.1657	.1529	.2580	.3300		.3188	.2511	.3054	.2571	.3171	.2472	.3072		
.10	.1541	.1773	.2611	.3260	.3643	.3237	.2411	.3240	.2586	.3231	.2466	.3122	.2013	.2383
.15	.1511	.1531	.2630	.3291	.2610	.3228	.2484	.3185	.2536	.3168	.2419	.3089	.1816	.2230
.20	.1257	.1346	.2601	.3201	.2563	.3217			.2544	.3140	.2487	.3061	.1633	.2078
.25			.0351	.0474	.2185	.2731	.2344	.3007	.2488	.3075	.2465	.3022	.1541	.1961
.30	.0116	.0029	.0005	.0144	.0130	.0302	.0272	.0519	.1072	.1206	.2346	.2895	.1476	.1866
.40									.0038	.0240	.0075	.0316	-.0408	-.0217
.50	-.0145	.0179	-.0200	-.0168	-.0017	.0257			-.0008	.0206	-.0084	.0138	-.0647	-.0515
.60	-.0111	.0232	-.0303	-.0256	-.0009	.0238	-.0021	.0201	-.0029	.0176	-.0182	.0031	-.0586	-.0582
.70	-.0159	-.0034	-.0382	-.0279	-.0075	.0127	-.0178	.0056	-.0445	-.0224			-.1222	-.1233
.80	-.1179	-.1149	-.1445	-.1376	-.1332	-.1330	-.1348	-.1274	-.1341	-.1347	-.1265	-.1421	-.1126	-.1435
.90	-.1330	-.1303	-.1246	-.1382	-.1272	-.1438	-.1154	-.1340	-.1125	-.1319	-.1178	-.1288	-.0909	-.0900
.95	-.1376	-.1342	-.1222	-.1320	-.1191	-.1318	-.1102	-.1240	-.1093	-.1216	-.1162	-.1218	-.0877	-.0920

TAIL 1

Cp at y/b of														
x/c	0.02		0.22		0.44		0.56		0.67		0.83		0.98	
	U.S.	L.S.	U.S.	L.S.	U.S.	L.S.	U.S.	L.S.	U.S.	L.S.	U.S.	L.S.	U.S.	L.S.
.05	.3721	-.0850	1.2167	-.0692			1.3190		1.3495	-.0644	1.3436	-.0595	1.1437	
.10	.4369	-.0909	1.1009	-.0819			1.2045		1.2192	-.0660	1.2190	-.0610	.9758	-.0295
.15	.6351	-.0793					1.1166	-.0713	1.1267	-.0726	1.1196	-.0671	.8615	-.0228
.20							1.0250	-.0857	1.0474	-.0800		-.0034	.7899	-.0212
.25	.3874	-.1304	.3861	-.1696			.8885	-.0948	.9430	-.0894	.9360	-.0805		-.0062
.30			.3941	-.1567	.3972	-.1781	.3877	-.1693	.5626	-.1353				
.40	.4977	-.1301			.4558	-.1848	.4486	-.1838	.4330	-.1789	.3851	-.1735		
.50	.4473	-.1089					.4604	-.1809	.4509	-.1848			.0014	.0018
.60					.4479	-.1669	.4542	-.1693	.4411	-.1768	.3844	-.1761	.2029	-.1919
.70			.4130	-.1636	.4133	-.1656	.4086	-.1620	.2222	-.1694	.1036	-.1760	.0044	-.2190
.80	.1048	-.1869	.1405	-.1789	.1058	-.1658			.0732	-.0852	.0719	-.1750	-.0003	-.0039
.90	.0890	-.1754			.0924	-.1662			.0954	-.1663	.0712	-.1735	-.0010	-.0003
.95	.1097	-.1619							-.0002	-.0068	.0601	-.1753	-.0018	-.0014

TAIL 2

TABLE XVII. - CONTINUED
(b) $\alpha = -2.06^\circ$

Cp at y/b of														
x/c	0.02		0.22		0.44		0.56		0.67		0.83		0.98	
	U.S.	L.S.	U.S.	L.S.	U.S.	L.S.	U.S.	L.S.	U.S.	L.S.	U.S.	L.S.	U.S.	L.S.
.05	.1380	.1413	.2629	.3264		.3189	.2516	.3101	.2575	.3201	.2517	.3117		
.10	.1320	.1637	.2701	.3315	.3623	.3234	.2459	.3268	.2585	.3271	.2520	.3167	.1996	.2380
.15	.1329	.1491	.2767	.3363	.2633	.3236	.2535	.3205	.2621	.3199	.2478	.3129	.1819	.2228
.20	.1093	.1311	.2657	.3165	.2577	.3216			.2568	.3163	.2543	.3095	.1637	.2056
.25			.0318	.0426	.2193	.2721	.2377	.3002	.2503	.3093	.2522	.3052	.1553	.1952
.30	.0215	.0211	-.0075	.0076	.0133	.0293	.0279	.0512	.1075	.1214	.2392	.2907	.1483	.1854
.40									.0027	.0227	.0070	.0300	-.0408	-.0246
.50	.0078	.0311	-.0326	-.0181	.0002	.0231			-.0022	.0176	-.0099	.0093	-.0524	-.0508
.60	-.0037	.0235	-.0327	-.0190	-.0005	.0186	-.0013	.0186	-.0036	.0154	-.0208	-.0022	-.0512	-.0505
.70	-.0154	-.0033	-.0306	-.0170	-.0105	.0063	-.0167	.0047	-.0455	-.0241			-.1206	-.1189
.80	-.1148	-.1094	-.1365	-.1288	-.1374	-.1334	-.1345	-.1279	-.1353	-.1342	-.1267	-.1421	-.1016	-.1286
	-.1274	-.1244	-.1221	-.1365	-.1271	-.1414	-.1200	-.1344	-.1130	-.1292	-.1198	-.1266	-.1000	-.0878
	-.1331	-.1289	-.1188	-.1292	-.1195	-.1283	-.1137	-.1222	-.1094	-.1178	-.1187	-.1219	-.0992	-.0966

TAIL 1

Cp at y/b of														
x/c	0.02		0.22		0.44		0.56		0.67		0.83		0.98	
	U.S.	L.S.	U.S.	L.S.	U.S.	L.S.	U.S.	L.S.	U.S.	L.S.	U.S.	L.S.	U.S.	L.S.
.05	.3562	-.0462	1.1141	-.0348			1.2236		1.2551	-.0321	1.2560	-.0237	1.0598	
.10	.4082	-.0607	1.0091	-.0522			1.1253		1.1411	-.0455	1.1442	-.0376	.9023	-.0157
.15	.5286	-.0492					1.0523	-.0454	1.0655	-.0537	1.0582	-.0464	.7974	-.0150
.20							.9768	-.0636	.9986	-.0607		.0013	.7350	-.0137
.25	.3079	-.1241	.3555	-.1552			.8583	-.0749	.9086	-.0691	.8967	-.0599		-.0042
.30			.3407	-.1477	.3669	-.1690	.3686	-.1573	.5489	-.1198				
.40	.3787	-.1254			.3947	-.1767	.3944	-.1733	.3883	-.1684	.3528	-.1643		
.50	.3593	-.1103					.3958	-.1765	.3914	-.1753			.0052	.0043
.60					.3794	-.1641	.3896	-.1694	.3794	-.1742	.3292	-.1690	.1640	-.1625
.70			.3384	-.1575	.3493	-.1577	.3487	-.1566	.1812	-.1638	.0693	-.1683	-.0225	-.2027
.80	.0383	-.1840	.0937	-.1720	.0676	-.1569			.0512	-.0802	.0386	-.1670	.0027	-.0015
.90	.0330	-.1743			.0512	-.1585			.0614	-.1598	.0371	-.1658	.0027	.0015
.95	.0649	-.1596							.0025	-.0021	.0267	-.1678	-.0016	.0006

TAIL 2

TABLE XVII. - CONTINUED
(c) $\alpha = -0.07^\circ$

Cp at y/b of														
x/c	0.02		0.22		0.44		0.56		0.67		0.83		0.98	
	U.S.	L.S.	U.S.	L.S.	U.S.	L.S.	U.S.	L.S.	U.S.	L.S.	U.S.	L.S.	U.S.	L.S.
.05	.1486	.1619	.2668	.3263		.3194	.2492	.3145	.2592	.3218	.2532	.3123		
.10	.1415	.1912	.2714	.3250	.3622	.3249	.2490	.3290	.2600	.3283	.2546	.3193	.1983	.2372
.15	.1400	.1655	.2705	.3253	.2671	.3247	.2566	.3243	.2652	.3215	.2501	.3153	.1828	.2220
.20	.1164	.1514	.2646	.3168	.2612	.3214			.2601	.3177	.2570	.3119	.1661	.2054
.25			.0355	.0476	.2227	.2710	.2405	.3031	.2533	.3109	.2549	.3070	.1585	.1949
.30	.0170	.0198	-.0022	.0136	.0122	.0284	.0298	.0505	.1091	.1206	.2414	.2918	.1523	.1861
.40									.0035	.0215	.0057	.0275	-.0392	-.0252
.50	.0069	.0283	-.0312	-.0160	-.0017	-.0175			-.0021	.0149	-.0124	.0039	-.0405	-.0456
.60	.0009	.0282	-.0321	-.0184	-.0032	.0156	-.0021	.0152	-.0038	.0122	-.0241	-.0086	-.0424	-.0421
.70	-.0086	.0032	-.0297	-.0165	-.0113	.0066	-.0168	.0020	-.0455	-.0270			-.1210	-.1163
.80	-.1108	-.1058	-.1355	-.1314	-.1363	-.1324	-.1346	-.1303	-.1357	-.1360	-.1278	-.1421	-.0988	-.1110
.90	-.1256	-.1230	-.1183	-.1306	-.1242	-.1405	-.1193	-.1339	-.1130	-.1293	-.1217	-.1268	-.1264	-.0367
.95	-.1320	-.1294	-.1158	-.1237	-.1168	-.1282	-.1135	-.1212	-.1093	-.1186	-.1204	-.1227	-.1250	-.1131

TAIL 1

Cp at y/b of														
x/c	0.02		0.22		0.44		0.56		0.67		0.83		0.98	
	U.S.	L.S.	U.S.	L.S.	U.S.	L.S.	U.S.	L.S.	U.S.	L.S.	U.S.	L.S.	U.S.	L.S.
.05	.3483	-.0056	.9915	-.0030			1.0815		1.1119	-.0097	1.1200	-.0003	.9394	
.10	.3836	-.0342	.9052	-.0205			1.0175		1.0345	-.0244	1.0443	-.0172	.8076	-.0029
.15	.4557	-.0196					.9680	-.0216	.9834	-.0312	.9824	-.0246	.7185	-.0041
.20							.9155	-.0377	.9382	-.0366		.0041	.6693	-.0049
.25	.2333	-.1094	.3152	-.1374			.8230	-.0486	.8708	-.0440	.8540	-.0349		-.0023
.30			.2870	-.1348	.3385	-.1545	.3537	-.1427	.5392	-.1007				
.40	.2791	-.1183			.3410	-.1635	.3494	-.1611	.3517	-.1563	.3255	-.1516		
.50	.2752	-.1065					.3413	-.1653	.3409	-.1640			.0063	.0064
.60					.3214	-.1638	.3338	-.1653	.3257	-.1651	.2818	-.1602	.1296	-.1601
.70			.2662	-.1499	.2931	-.1519	.2973	-.1506	.1454	-.1559	.0377	-.1585	-.0475	-.1918
.80	-.0111	-.1762	.0524	-.1608	.0347	-.1477			.0307	-.0754	.0073	-.1573	.0034	.0010
.90	-.0122	-.1741			.0161	-.1492			.0299	-.1498	.0054	-.1569	.0040	.0040
.95	.0089	-.1599							.0029	.0000	-.0044	-.1586	-.0031	.0027

TAIL 2

TABLE XVII. - CONTINUED
(d) $\alpha = 1.93^\circ$

Cp at γ/b of														
x/c	0.02		0.22		0.44		0.56		0.67		0.83		0.98	
	U.S.	L.S.	U.S.	L.S.	U.S.	L.S.	U.S.	L.S.	U.S.	L.S.	U.S.	L.S.	U.S.	L.S.
.05	.1687	.1929	.2703	.3290		.3204	.2463	.3177	.2599	.3232	.2537	.3133		
.10	.1595	.2281	.2755	.3285	.3617	.3270	.2496	.3280	.2614	.3299	.2550	.3208	.1977	.2362
.15	.1580	.1881	.2726	.3239	.2699	.3273	.2578	.3263	.2667	.3243	.2511	.3171	.1840	.2222
.20	.1337	.1743	.2626	.3143	.2639	.3232			.2631	.3196	.2581	.3128	.1706	.2074
.25			.0345	.0477	.2251	.2713	.2425	.3074	.2552	.3123	.2560	.3077	.1623	.1966
.30	.0057	.0158	-.0002	.0181	.0115	.0291	.0340	.0505	.1104	.1234	.2417	.2928	.1574	.1833
.40									.0035	.0216	.0039	.0242	-.0362	-.0232
.50	-.0046	.0146	-.0269	-.0119	-.0015	.0170			-.0021	.0147	-.0164	-.0009	-.0333	-.0353
.60	.0009	.0237	-.0325	-.0169	-.0035	.0139	-.0025	.0144	-.0041	.0111	-.0277	-.0143	-.0381	-.0339
.70	-.0025	.0057	-.0322	-.0176	-.0118	.0067	-.0154	.0027	-.0455	-.0271			-.1211	-.1160
.80	-.1065	-.1019	-.1356	-.1355	-.1347	-.1301	-.1332	-.1303	-.1352	-.1367	-.1269	-.1398	-.1184	-.0990
.90	-.1233	-.1215	-.1153	-.1270	-.1214	-.1374	-.1159	-.1322	-.1121	-.1251	-.1224	-.1261	-.1438	-.1139
.95	-.1287	-.1266	-.1141	-.1209	-.1145	-.1251	-.1108	-.1198	-.1085	-.1160	-.1217	-.1234	-.1390	-.1296

TAIL 1

Cp at γ/b of														
x/c	0.02		0.22		0.44		0.56		0.67		0.83		0.98	
	U.S.	L.S.	U.S.	L.S.	U.S.	L.S.	U.S.	L.S.	U.S.	L.S.	U.S.	L.S.	U.S.	L.S.
.05	.3476	.0443	.8428	.0309			.8860		.9035	.0168	.8990	.0264	.7698	
.10	.3574	-.0081	.7931	.0146			.8654		.8722	.0049	.8824	.0114	.6856	.0154
.15	.3921	.0124					.8454	.0090	.8550	-.0007	.8646	.0052	.6168	.0110
.20							.8219	-.0056	.8390	-.0054		.0042	.5821	.0100
.25	.1751	-.0889	.2706	-.1182			.7595	-.0170	.8025	-.0128	.7973	-.0042		-.0030
.30			.2335	-.1194	.3018	-.1373	.3297	-.1254	.5204	-.0777				
.40	.1787	-.1155			.2875	-.1476	.3044	-.1464	.3198	-.1421	.3024	-.1366		
.50	.1930	-.0994					.2923	-.1503	.3020	-.1497			.0061	.0062
.60					.2684	-.1510	.2869	-.1514	.2845	-.1513	.2424	-.1496	.0995	-.1390
.70			.1917	-.1359	.2441	-.1486	.2546	-.1465	.1131	-.1503	.0093	-.1519	-.0693	-.1814
.80	-.0468	-.1641	.0045	-.1492	.0069	-.1412			.0128	-.0722	-.0209	-.1507	-.0027	.0006
.90	-.0483	-.1773			-.0096	-.1418			.0025	-.1411	-.0231	-.1505	.0035	.0032
.95	-.0320	-.1625							.0021	-.0003	-.0321	-.1520	-.0048	.0020

TAIL 2

TABLE XVII. - CONTINUED
(e) $\alpha = 3.92^\circ$

Cp at y/b of														
x/c	0.02		0.22		0.44		0.56		0.67		0.83		0.98	
	U.S.	L.S.	U.S.	L.S.	U.S.	L.S.	U.S.	L.S.	U.S.	L.S.	U.S.	L.S.	U.S.	L.S.
.05	.1872	.2171	.2763	.3339		.3244	.2452	.3240	.2615	.3254	.2541	.3125		
.10	.1747	.2567	.2819	.3338	.3616	.3312	.2518	.3293	.2623	.3302	.2553	.3202	.1958	.2336
.15	.1759	.2102	.2791	.3283	.2733	.3302	.2600	.3278	.2674	.3254	.2504	.3162	.1826	.2219
.20	.1504	.1920	.2675	.3179	.2680	.3254			.2659	.3203	.2568	.3121	.1732	.2078
.25			.0360	.0486	.2279	.2733	.2441	.3090	.2571	.3132	.2541	.3075	.1674	.1995
.30	-.0013	-.0162	-.0015	-.0205	-.0123	-.0299	-.0389	-.0500	-.1119	-.1277	-.2402	-.2927	-.1618	-.1921
.40									-.0039	-.0218	-.0009	-.0206	-.0327	-.0194
.50	-.0175	-.0070	-.0230	-.0075	-.0004	-.0183			-.0019	-.0154	-.0201	-.0054	-.0287	-.0236
.60	-.0070	-.0135	-.0295	-.0144	-.0018	-.0157	-.0011	-.0144	-.0042	-.0115	-.0313	-.0182	-.0373	-.0271
.70	-.0042	-.0000	-.0324	-.0162	-.0101	-.0080	-.0169	-.0021	-.0457	-.0270			-.1174	-.1136
.80	-.1063	-.1008	-.1329	-.1349	-.1335	-.1284	-.1313	-.1289	-.1330	-.1370	-.1248	-.1364	-.1285	-.0898
.90	-.1192	-.1180	-.1132	-.1242	-.1187	-.1341	-.1102	-.1294	-.1110	-.1220	-.1217	-.1252	-.1513	-.1339
.95	-.1207	-.1189	-.1116	-.1180	-.1125	-.1214	-.1056	-.1176	-.1078	-.1146	-.1214	-.1233	-.1455	-.1434

TAIL 1

Cp at y/b of														
x/c	0.02		0.22		0.44		0.56		0.67		0.83		0.98	
	U.S.	L.S.	U.S.	L.S.	U.S.	L.S.	U.S.	L.S.	U.S.	L.S.	U.S.	L.S.	U.S.	L.S.
.05	.3201	.0981	.6795	.0701			.7276		.7452	.0523	.7440	.0619	.6485	
.10	.3375	.0172	.6575	.0550			.7148		.7221	.0411	.7318	.0481	.5832	.0426
.15	.3353	.0462					.7042	.0445	.7134	.0354	.7236	.0415	.5244	.0316
.20							.6939	.0310	.7069	.0305		.0000	.4947	.0295
.25	.1367	-.0648	.2227	-.0970			.6516	-.0181	.6854	-.0224	.6895	-.0309		-.0086
.30			.1885	-.1031	.2445	-.1186	.2713	-.1059	.4499	-.0514				
.40	.1001	-.1117			.2281	-.1295	.2450	-.1287	.2600	-.1245	.2581	-.1187		
.50	.1134	-.0875					.2342	-.1323	.2469	-.1321			.0016	.0014
.60					.2146	-.1326	.2300	-.1333	.2367	-.1339	.1979	-.1352	.0649	-.0919
.70			.1324	-.1187	.1962	-.1355	.2034	-.1381	.0815	-.1450	-.0192	-.1463	-.0812	-.1839
.80	-.0726	-.1494	-.0389	-.1403	-.0190	-.1360			-.0049	-.0717	-.0478	-.1447	-.0022	-.0043
.90	-.0797	-.1748			-.0326	-.1360			-.0236	-.1348	-.0499	-.1446	-.0014	-.0018
.95	-.0701	-.1656							-.0033	-.0056	-.0583	-.1459	-.0103	-.0031

TAIL 2

TABLE XVII. - CONTINUED
 (f) $\alpha = 5.92^\circ$

Cp at y/b of														
x/c	0.02		0.22		0.44		0.56		0.67		0.83		0.98	
	U.S.	L.S.	U.S.	L.S.	U.S.	L.S.	U.S.	L.S.	U.S.	L.S.	U.S.	L.S.	U.S.	L.S.
.05	.2050	.2385	.2820	.3389		.3264	.2446	.3290	.2620	.3264	.2529	.3095		
.10	.1893	.2795	.2903	.3427	.3620	.3354	.2554	.3305	.2633	.3292	.2546	.3180	.1940	.2311
.15	.1911	.2281	.2867	.3368	.2773	.3330	.2627	.3271	.2682	.3257	.2506	.3143	.1830	.2205
.20	.1611	.2052	.2747	.3247	.2726	.3266			.2674	.3208	.2568	.3103	.1747	.2085
.25			.0400	.0518	.2304	.2755	.2463	.3104	.2590	.3138	.2533	.3052	.1699	.2019
.30	.0063	.0216	.0043	.0242	.0140	.0315	.0392	.0503	.1131	.1256	.2382	.2900	.1672	.1947
.40									.0045	.0216	-.0018	.0163	-.0290	-.0164
.50	-.0188	.0090	-.0188	-.0016	.0016	.0209			-.0011	.0164	-.0237	-.0088	-.0294	-.0142
.60	-.0100	.0135	-.0250	-.0085	.0013	.0190	.0003	.0166	-.0038	.0125	-.0343	-.0208	-.0179	-.0213
.70	-.0064	-.0038	-.0293	-.0125	-.0070	.0112	-.0155	.0025	-.0459	-.0262			-.1080	-.1087
.80	-.1087	-.1050	-.1312	-.1337	-.1311	-.1262	-.1293	-.1281	-.1310	-.1372	-.1243	-.1334	-.1309	-.1030
.90	-.1145	-.1144	-.1112	-.1214	-.1158	-.1299	-.1076	-.1227	-.1103	-.1170	-.1213	-.1239	-.1606	-.1500
.95	-.1127	-.1114	-.1097	-.1151	-.1098	-.1175	-.1040	-.1113	-.1074	-.1112	-.1200	-.1221	-.1533	-.1550

TAIL 1

Cp at y/b of														
x/c	0.02		0.22		0.44		0.56		0.67		0.83		0.98	
	U.S.	L.S.	U.S.	L.S.	U.S.	L.S.	U.S.	L.S.	U.S.	L.S.	U.S.	L.S.	U.S.	L.S.
.05	.2795	.1463	.5478	.1147			.6035		.6216	.0941	.6236	.1036	.5495	
.10	.2639	.0418	.5340	.1003			.5933		.6033	.0829	.6136	.0905	.4971	.3874
.15	.2772	.0779					.5861	.0846	.5965	.0773	.6081	.0836	.4434	.0573
.20							.5790	.0724	.5920	.0719		.0900	.4182	.0500
.25	.0995	-.0360	.1580	-.0712			.5455	.0589	.5764	.0627	.5837	.0711		-.0094
.30			.1257	-.0224	.1790	-.0953	.2039	-.0327	.3703	-.0211				
.40	-.0409	-.1010			.1649	-.1064	.1789	-.1071	.1948	-.1034	.2051	-.0966		
.50	-.0527	-.0707					.1708	-.1104	.1827	-.1110			.0011	.0010
.60					.1509	-.1099	.1683	-.1114	.1761	-.1130	.1489	-.1170	.0294	-.0701
.70			.0857	-.0984	.1355	-.1142	.1450	-.1200	.0441	-.1316	-.0493	-.1379	-.0769	-.1622
.80	-.0773	-.1376	-.0740	-.1301	-.0516	-.1257			-.0222	-.0672	-.0756	-.1355	-.0031	-.0029
.90	-.0847	-.1626			-.0622	-.1256			-.0514	-.1241	-.0778	-.1354	-.0025	-.0027
.95	-.0764	-.1648							-.0049	-.0063	-.0852	-.1364	-.0114	-.0044

TAIL 2

TABLE XVII. - CONTINUED
 (g) $\alpha = 7.91^\circ$

Cp at y/b of														
x/c	0.02		0.22		0.44		0.56		0.67		0.83		0.98	
	U.S.	L.S.	U.S.	L.S.	U.S.	L.S.	U.S.	L.S.	U.S.	L.S.	U.S.	L.S.	U.S.	L.S.
.05	.2225	.2592	.2874	.3456		.3276	.2437	.3335	.2567	.3217	.2738	.3061		
.10	.2040	.3025	.2984	.3534	.2712	.3388	.2558	.3299	.2580	.3227	.2963	.3122	.2224	.2287
.15	.2045	.2445	.2947	.3475	.2790	.3363	.2637	.3280	.2627	.3204	.3134	.3088	.2303	.2218
.20	.1705	.2172	.2823	.3356	.2772	.3308			.2629	.3175	.2389	.3064	.2281	.2119
.25			.0452	.0588	.2343	.2807	.2473	.3127	.2579	.3118	.2378	.3017	.2003	.2064
.30	.0146	.0276	.0094	.0306	.0167	.0347	.0342	.0516	.1139	.1216	.2310	.2856	.1602	.1998
.40									.0060	.0232	-.0069	-.0124	-.0164	-.0118
.50	-.0153	.0157	-.0125	.0062	.0050	.0257			-.0009	.0189	-.0286	-.0122	-.0142	-.0093
.60	-.0071	.0203	-.0194	-.0030	.0041	.0235	.0027	.0201	-.0052	.0137	-.0389	-.0239	-.0040	-.0178
.70	-.0030	.0005	-.0250	-.0078	-.0042	.0151	-.0133	.0048	-.0480	-.0283			-.1055	-.1003
.80	-.1091	-.1080	-.1293	-.1311	-.1281	-.1229	-.1302	-.1260	-.1362	-.1373	-.1315	-.1304	-.1615	-.1038
.90	-.1103	-.1124	-.1084	-.1182	-.1126	-.1253	-.1097	-.1167	-.1136	-.1146	-.1245	-.1225	-.1737	-.1559
.95	-.1066	-.1061	-.1068	-.1126	-.1064	-.1132	-.1055	-.1078	-.1100	-.1094	-.1226	-.1211	-.1672	-.1651

TAIL 1

Cp at y/b of														
x/c	0.02		0.22		0.44		0.56		0.67		0.83		0.98	
	U.S.	L.S.	U.S.	L.S.	U.S.	L.S.	U.S.	L.S.	U.S.	L.S.	U.S.	L.S.	U.S.	L.S.
.05	.2168	.1798	.4307	.1619			.4962		.5163	.1420	.5238	.1505	.4643	
.10	.2013	.0737	.4204	.1483			.4869		.5008	.1308	.5151	.1385	.4209	.1212
.15	.2117	.1070					.4795	.1275	.4938	.1248	.5103	.1310	.3696	.0892
.20							.4750	.1184	.4891	.1182		-.0053	.3497	.0760
.25	.0562	-.0116	.0965	-.0440			.4463	.1040	.4747	.1076	.4892	.1161		-.0157
.30			.0696	-.0607	.1162	-.0690	.1434	-.0568	.2926	.0124				
.40	-.0171	-.0833			.1046	-.0805	.1188	-.0825	.1353	-.0790	.1528	-.0709		
.50	.0003	-.0519					.1108	-.0855	.1240	-.0867			-.0060	-.0058
.60					.0939	-.0848	.1095	-.0864	.1186	-.0889	.1011	-.0952	-.0004	-.0543
.70			.0360	-.0760	.0788	-.0899	.0907	-.0952	.0042	-.1119	-.0766	-.1298	-.0835	-.1455
.80	-.0647	-.1314	-.1018	-.1220	-.0857	-.1164			-.0426	-.0661	-.1010	-.1259	-.0101	-.0009
.90	-.0789	-.1490			-.0943	-.1159			-.0794	-.1148	-.1024	-.1259	-.0096	-.0093
.95	-.0694	-.1621							-.0124	-.0129	-.1089	-.1267	-.0170	-.0111

TAIL 2

TABLE XVII. - CONTINUED
(h) $\alpha = 9.93^\circ$

Cp at y/b of														
x/c	0.02		0.22		0.44		0.56		0.67		0.83		0.98	
	U.S.	L.S.	U.S.	L.S.	U.S.	L.S.	U.S.	L.S.	U.S.	L.S.	U.S.	L.S.	U.S.	L.S.
.05	.2436	.2810	.2920	.3494		.3264	.2457	.3410	.2664	.3324	.2873	.3183		
.10	.2216	.3250	.3068	.3631	.2712	.3388	.2599	.3359	.2669	.3310	.2918	.3271	.2315	.2417
.15	.2208	.2616	.3090	.3612	.2799	.3370	.2682	.3324	.2710	.3297	.3259	.3254	.2153	.2367
.20	.1844	.2331	.2983	.3522	.2786	.3333			.2713	.3287	.3343	.3234	.2124	.2294
.25			.0562	.0721	.2359	.2855	.2509	.3201	.2667	.3235	.2434	.3183	.2570	.2260
.30	.0255	.0383	.0197	.0424	.0169	.0353	.0330	.0541	.1189	.1290	.2372	.2991	.1761	.2192
.40									.0079	.0270	-.0041	.0161	-.0051	-.0013
.50	-.0070	.0261	-.0030	.0154	.0052	.0263			-.0005	.0201	-.0252	-.0099	-.0063	-.0010
.60	.0007	.0304	-.0118	.0054	.0054	.0250	.0010	.0182	-.0065	.0124	-.0357	-.0223	.0108	.0018
.70	.0058	.0097	-.0176	.0000	-.0022	.0179	-.0157	.0018	-.0501	-.0317			-.1038	-.0965
.80	-.1057	-.1052	-.1323	-.1275	-.1247	-.1189	-.1285	-.1267	-.1363	-.1387	-.1322	-.1329	-.1684	-.1056
.90	-.1079	-.1093	-.1090	-.1152	-.1106	-.1193	-.1070	-.1122	-.1147	-.1156	-.1236	-.1231	-.1746	-.1669
.95	-.1035	-.1014	-.1067	-.1087	-.1047	-.1082	-.1037	-.1055	-.1117	-.1112	-.1213	-.1210	-.1688	-.1687

TAIL 1

Cp at y/b of														
x/c	0.02		0.22		0.44		0.56		0.67		0.83		0.98	
	U.S.	L.S.	U.S.	L.S.	U.S.	L.S.	U.S.	L.S.	U.S.	L.S.	U.S.	L.S.	U.S.	L.S.
.05	-.1212	.2107	.3273	.2110			.3952		.4177	.1950	.4341	.2032	.3874	
.10	.1356	.1074	.3133	.1991			.3876		.4018	.1838	.4254	.1922	.3521	.1672
.15	.1489	.1324					.3800	.1807	.3955	.1770	.4194	.1843	.3021	.1278
.20							.3755	.1698	.3914	.1694		-.0084	.2842	.1096
.25	.0119	-.0063	.0419	-.0162			.3514	.1530	.3786	.1580	.4001	.1670		-.0191
.30			.0166	-.0387	.0600	-.0423	.0860	-.0280	.2186	.0501				
.40	-.0645	-.0676			.0471	-.0539	.0634	-.0549	.0785	-.0514	.0996	-.0428		
.50	-.0349	-.0277					.0553	-.0577	.0683	-.0589			-.0122	-.0103
.60					.0410	-.0579	.0532	-.0586	.0639	-.0612	.0547	-.0700	-.0248	-.0721
.70			-.0071	-.0514	.0277	-.0640	.0367	-.0707	-.0330	-.0896	-.1025	-.1285	-.0977	-.1318
.80	-.0562	-.1246	-.1225	-.1213	-.1151	-.1124			-.0608	-.0658	-.1252	-.1199	-.0162	-.0015
.90	-.0736	-.1348			-.1224	-.1113			-.1075	-.1101	-.1249	-.1189	-.0151	-.0137
.95	-.0712	-.1551							-.0188	-.0172	-.1263	-.1195	-.0210	-.0154

TAIL 2

TABLE XVII. - CONTINUED
(1) $\alpha = 11.91^\circ$

Cp at y/b of														
x/c	0.02		0.22		0.44		0.56		0.67		0.83		0.98	
	U.S.	L.S.	U.S.	L.S.	U.S.	L.S.	U.S.	L.S.	U.S.	L.S.	U.S.	L.S.	U.S.	L.S.
.05	.2636	.3028	-.3160	.3770		.3601	.2712	.3754	.2910	.3662	.3135	.3499		
.10	.2378	.3452	-.3299	.3902	.3006	.3733	.2856	.3717	.2921	.3628	.3113	.3568	.2540	.2684
.15	.2356	.2815	-.3287	.3865	.3094	.3688	.2936	.3659	.2955	.3603	.3268	.3529	.2553	.2622
.20	.1976	.2526	-.3153	.3747	.3056	.3626			.2945	.3566	.3279	.3489	.2569	.2531
.25			-.0658	.0857	.2603	.3126	.2755	.3477	.2896	.3495	.3972	.3399	.2294	.2482
.30	.0347	.0494	-.0283	.0520	.0318	.0494	.0480	.0694	.1359	.1474	.2437	.3179	.2562	.2404
.40									.0209	.0400	.0042	.0248	.0112	.0108
.50	.0002	.0339	-.0029	.0227	.0177	.0385			.0126	.0323	-.0161	-.0009	.0064	.0120
.60	.0074	.0390	-.0065	.0133	.0157	.0354	.0145	.0321	-.0047	.0228	-.0254	-.0123	.0241	.0280
.70	.0140	.0178	-.0135	.0059	.0067	.0267	-.0027	.0148	-.0406	-.0233			-.1061	-.0894
.80	-.1008	-.1018	-.1280	-.1245	-.1200	-.1148	-.1249	-.1210	-.1313	-.1336	-.1268	-.1258	-.1659	-.1162
.90	-.1033	-.1038	-.1045	-.1098	-.1065	-.1134	-.1035	-.1051	-.1091	-.1084	-.1169	-.1156	-.1726	-.1679
.95	-.0979	-.0953	-.1017	-.1045	-.0998	-.1022	-.0990	-.0990	-.1059	-.1044	-.1135	-.1132	-.1667	-.1656

TAIL 1

Cp at y/b of														
x/c	0.02		0.22		0.44		0.56		0.67		0.83		0.98	
	U.S.	L.S.	U.S.	L.S.	U.S.	L.S.	U.S.	L.S.	U.S.	L.S.	U.S.	L.S.	U.S.	L.S.
.05	.0464	.2392	.2469	.2646			.3098		.3282	.2545	.3379	.2593	.3043	
.10	.0766	.1386	.2289	.2537			.3032		.3147	.2432	.3299	.2485	.2754	.2108
.15	.0899	.1536					.2966	.2375	.3098	.2352	.3281	.2399	.2302	.1678
.20							.2924	.2263	.3072	.2268			-.0122	.1456
.25	-.0362	.0066	-.0046	.0107			.2698	.2078	.2962	.2140	.3161	.2206		-.0239
.30			-.0280	-.0164	.0133	-.0108	.0374	.0036	.1563	.0925				
.40	-.0915	-.0657			-.0012	-.0219	.0154	-.0228	.0305	-.0194	.0506	-.0116		
.50	-.0545	.0005					.0085	-.0255	.0197	-.0272			-.0187	-.0154
.60					-.0077	-.0268	.0054	-.0267	.0156	-.0301	.0135	-.0424	-.0394	-.0573
.70			-.0346	-.0261	-.0178	-.0348	-.0094	-.0404	-.0669	-.0613	-.1239	-.1474	-.1115	-.1326
.80	-.0611	-.1136	-.1213	-.1263	-.1386	-.1255			-.0772	-.0713	-.1445	-.1271	-.0230	.0053
.90	-.0726	-.1242			-.1168	-.1161			-.1291	-.1137	-.1304	-.1230	-.0220	-.0190
.95	-.0716	-.1448							-.0258	-.0227	-.1219	-.1231	-.0283	-.0213

TAIL 2

TABLE XVII. - CONTINUED
(j) $\alpha = 15.91^\circ$

Cp at y/b of														
x/c	0.02		0.22		0.44		0.56		0.67		0.83		0.98	
	U.S.	L.S.	U.S.	L.S.	U.S.	L.S.	U.S.	L.S.	U.S.	L.S.	U.S.	L.S.	U.S.	L.S.
.05	.3460	.3977	.4049	.4748		.4438	.3380	.4556	.3574	.4425	.3760	.4200		
.10	.3157	.4379	.4167	.4866	.3759	.4574	.3554	.4469	.3592	.4359	.3753	.4260	.3101	.3265
.15	.3153	.3714	.4160	.4810	.3868	.4478	.3650	.4439	.3628	.4331	.3757	.4213	.2930	.3249
.20	.2724	.3388	.4005	.4676	.3788	.4431			.3629	.4302	.3812	.4160	.2877	.3178
.25			.1156	.1390	.3291	.3874	.3455	.4225	.3577	.4213	.4152	.4001	.2793	.3134
.30	.0913	.1033	.0748	.1006	.0749	.0931	.0921	.1134	.1854	.2038	.3005	.3744	.2885	.3051
.40									.0594	.0809	.0351	.0566	.0395	.0469
.50	.0461	.0824	.0442	.0654	.0605	.0835			.0485	.0704	.0135	.0305	.0575	.0504
.60	.0546	.0887	.0329	.0543	.0583	.0813	.0543	.0737	.0383	.0564	.0043	.0191	.0609	.0710
.70	.0609	.0642	.0256	.0479	.0482	.0731	.0333	.0534	-.0137	.0046			-.1062	-.0641
.80	-.0736	-.0739	-.1106	-.1004	-.0966	-.0905	-.1044	-.1011	-.1161	-.1142	-.1042	-.1034	-.1575	-.1316
.90	-.0795	-.0760	-.0860	-.0838	-.0823	-.0915	-.0787	-.0819	-.0896	-.0858	-.0938	-.0926	-.1653	-.1591
.95	-.0707	-.0679	-.0806	-.0821	-.0756	-.0792	-.0748	-.0758	-.0857	-.0824	-.0887	-.0883	-.1587	-.1533

TAIL 1

Cp at y/b of														
x/c	0.02		0.22		0.44		0.56		0.67		0.83		0.98	
	U.S.	L.S.	U.S.	L.S.	U.S.	L.S.	U.S.	L.S.	U.S.	L.S.	U.S.	L.S.	U.S.	L.S.
.05	-.0755	.2778	.0533	.3729			.1405		.1516	.3887	.1785	.3829	.1676	
.10	-.0449	.1889	.0639	.3593			.1436		.1383	.3755	.1653	.3732	.1427	.3072
.15	-.0266	.1978					.1495	.3662	.1461	.3643	.1581	.3626	.1112	.2626
.20							.1471	.3550	.1562	.3547		-.0352	.0950	.2363
.25	-.0890	.0579	-.0771	.0565			.1295	.3330	.1512	.3389	.1466	.3380		-.0457
.30			-.0326	.0225	-.0642	.0605	-.0447	.0794	.0482	.1847				
.40	-.0733	-.0383			-.0785	.0481	-.0675	.0510	-.0531	.0534	-.0340	.0605		
.50	.0048	.0618					-.0752	.0463	-.0645	.0448			-.0452	-.0432
.60					-.0914	.0313	-.0790	.0424	-.0698	.0413	-.0606	.0231	-.0736	-.0516
.70			-.0825	.0362	-.0998	.0179	-.0865	.0229	-.1230	.0022	-.1318	-.1166	-.1281	-.1162
.80	-.0708	-.1034	-.1502	-.0809	-.1163	-.1263			-.0859	-.0817	-.1226	-.1400	-.0491	.0077
.90	-.0750	-.1032			-.1171	-.1289			-.1142	-.1256	-.1214	-.1337	-.0473	-.0451
.95	-.0844	-.1095							-.0499	-.0495	-.1217	-.1253	-.0522	-.0476

TAIL 2

ORIGINAL PAGE IS
OF POOR QUALITY

TABLE XVII. - CONCLUDED
(k) $\alpha = 19.91^\circ$

Cp at y/b of														
x/c	0.02		0.22		0.44		0.56		0.67		0.83		0.98	
	U.S.	L.S.	U.S.	L.S.	U.S.	L.S.	U.S.	L.S.	U.S.	L.S.	U.S.	L.S.	U.S.	L.S.
.05	.4500	.5079	.5185	.5994			.4245	.5749	.4119	.5405	.4594	.5144		
.10	.4129	.5487	.5288	.6064	.4734	.5653	.4437	.5518	.4440	.5338	.4584	.5199	.3838	.4040
.15	.4108	.4761	.5238	.5995	.4834	.5522	.4539	.5458	.4482	.5320	.4568	.5166	.3669	.4059
.20	.3632	.4395	.5058	.5830	.4726	.5504			.4482	.5274	.4486	.5058	.3671	.4004
.25			.1775	.2019	.4179	.4852	.4325	.5189	.4429	.5161	.4807	.4811	.3566	.3975
.30	.1629	.1707	.1325	.1585	.1309	.1505	.1467	.1698	.2485	.2605	.5741	.4503	.3419	.3890
.40									.1071	.1297	.0781	.0980	.3580	.0928
.50	.1049	.1425	.0947	.1150	.1150	.1373			.0925	.1112	.0517	.0690	.0961	.1065
.60	.1155	.1489	.0811	.1014	.1123	.1325	.1031	.1186	.0767	.0919	.0444	.0578	.0934	.1185
.70	.1220	.1182	.0736	.0935	.1008	.1215	.0770	.0902	.0185	.0350			.1076	.0316
.80	-.0376	-.0397	-.0827	-.0753	-.0693	-.0680	-.0835	-.0790	-.0588	-.0850	-.0810	-.0781	-.1485	-.1374
.90	-.0468	-.0431	-.0558	-.0579	-.0607	-.0623	-.0565	-.0522	-.0674	-.0588	-.0667	-.0664	-.1575	-.1492
.95	-.0338	-.0305	-.0511	-.0513	-.0503	-.0509	-.0514	-.0486	-.0628	-.0569	-.0587	-.0601	-.1508	-.1425

TAIL 1

Cp at y/b of														
x/c	0.02		0.22		0.44		0.56		0.67		0.83		0.98	
	U.S.	L.S.	U.S.	L.S.	U.S.	L.S.	U.S.	L.S.	U.S.	L.S.	U.S.	L.S.	U.S.	L.S.
.05	-.0879	.3702	.0415	.5063			.1142		.1315	.5413	.1553	.5323	.1472	
.10	-.0952	.2710	.0111	.4847			.0984		.1117	.5224	.1403	.5199	.1217	.4254
.15	-.1247	.2842					.0848	.5111	.1016	.5103	.1310	.5072	.0939	.3809
.20							.0732	.5011	.0932	.4995			.0809	.3494
.25	-.1433	.1277	-.1492	.1146			.0528	.4725	.0801	.4812	.1100	.4786		-.0542
.30			-.1551	.1143	-.1150	.1342	-.0921	.1625	-.0086	.2912				
.40	-.1005	.0114			-.1333	.1144	-.1160	.1278	-.0980	.1383	-.0753	.1460		
.50	-.0542	.1512					-.1266	.1182	-.1116	.1255			-.0617	-.0579
.60					-.1488	.0886	-.1333	.1086	-.1182	.1186	-.1032	.1014	-.1013	-.0117
.70			-.1478	.1479	-.1415	.0772	-.1354	.0825	-.1504	.0691	-.1483	-.0757	-.1462	-.0985
.80	-.0958	-.0778	-.1809	-.0353	-.1369	-.0885			-.1050	-.0683	-.1439	-.1015	-.0652	-.0026
.90	-.0921	-.1040			-.1382	-.0853			-.1350	-.0939	-.1433	-.1093	-.0633	-.0583
.95	-.0971	-.1051							-.0659	-.0620	-.1438	-.1148	-.0667	-.0606

TAIL 2

TABLE XVIII. - PRESSURE COEFFICIENTS, $\phi = 0^\circ$, $\delta_{2,4} = -15^\circ$, $M = 3.70$
 (a) $\alpha = -3.87^\circ$

Cp at γ/b of

x/c	0.02		0.22		0.44		0.56		0.67		0.83		0.98	
	U.S.	L.S.	U.S.	L.S.	U.S.	L.S.	U.S.	L.S.	U.S.	L.S.	U.S.	L.S.	U.S.	L.S.
.05	.0775	.0878	.1663	.2131	.1749	.2194	.1836	.2154	.1790	.2242	.1948	.2161	.1800	.1818
.10	.0745	.1006	.1785	.2169	.1756	.2221	.1751	.2200	.1778	.2213	.1939	.2194	.1845	.1774
.15	.0735	.0902	.1863	.2159	.1813	.2205	.1775	.2200	.1799	.2213	.1901	.2172	.1845	.1774
.20	.0577	.0762	.1769	.2112	.1802	.2200			.1797	.2205	.1906	.2154	.1532	.1666
.25			.0416	.0523	.1545	.1911	.1670	.2090	.1767	.2161	.2123	.2127	.1445	.1625
.30	.0032	.0056	.0131	.0240	.0260	.0367	.0388	.0556	.0916	.1023	.2288	.2036	.1385	.1573
.40									.0137	.0239	.0247	.0351	.0775	.0206
.50	-.0102	-.0025	-.0042	.0054	.0065	.0172			.0077	.0169	.0072	.0169	-.0149	-.0087
.60	-.0079	.0005	-.0090	.0006	.0043	.0144	.0047	.0140	.0050	.0133	.0007	.0107	-.0194	-.0177
.70	-.0038	.0002	-.0118	-.0029	-.0000	.0101	-.0052	.0039	-.0127	-.0041			-.0472	-.0490
.80	-.0445	-.0415	-.0563	-.0521	-.0502	-.0456	-.0542	-.0509	-.0507	-.0472	-.0570	-.0541	-.0506	-.0530
.90	-.0533	-.0493	-.0519	-.0545	-.0522	-.0537	-.0515	-.0533	-.0510	-.0528	-.0514	-.0519	-.0479	-.0494
.95	-.0532	-.0515	-.0505	-.0520	-.0486	-.0499	-.0488	-.0498	-.0484	-.0495	-.0493	-.0489	-.0440	-.0490

TAIL 1

Cp at γ/b of

x/c	0.02		0.22		0.44		0.56		0.67		0.83		0.98	
	U.S.	L.S.	U.S.	L.S.	U.S.	L.S.	U.S.	L.S.	U.S.	L.S.	U.S.	L.S.	U.S.	L.S.
.05	.2425	-.0255	.9261	-.0231			.9039		.9088	-.0203	.8873	-.0145	.7970	
.10	.2258	-.0258	.8934	-.0338			.8969		.8884	-.0298	.8832	-.0289	.7576	.0068
.15	.3204	-.0255					.8905	-.0151	.8826		.8779	-.0340	.7023	-.0241
.20							.8835	-.0374	.8733	-.0391		.0099	.6727	-.0300
.25	.2283	-.0399	.4201	-.0588			.8379	-.0361	.8592	-.0417	.8501	-.0329		.0064
.30			.3750	-.0444	.4251	-.0569	.4506	-.0596	.6179	-.0535				
.40	.3160	-.0532			.4018	-.0578	.4166	-.0601	.4263	-.0577	.4320	-.0606		
.50	.3285	-.0517					.4031	-.0590	.4135	-.0590			.0131	.0134
.60					.3802	-.0584	.3964	-.0584	.4052	-.0549	.3757	-.0575	.2108	-.0598
.70			.3111	-.0505	.3585	-.0584	.3663	-.0361	.2514	-.0510	.1439	-.0604	.0533	-.0624
.80	.0920	-.0634	.1241	-.0564	.1365	-.0586			.0999	-.0214	.1112	-.0608	.0134	.0226
.90	.0417	-.0672			.1195	-.0550			.1350	-.0572	.1066	-.0595	.0110	.0121
.95	.0387	-.0636							.0158	-.0077	.0982	-.0612	.0112	.0110

TAIL 2

C-3

TABLE XVIII. - CONTINUED
(b) $\alpha = -1.88^\circ$

Cp at γ/b of														
x/c	0.02		0.22		0.44		0.56		0.67		0.83		0.98	
	U.S.	L.S.	U.S.	L.S.	U.S.	L.S.	U.S.	L.S.	U.S.	L.S.	U.S.	L.S.	U.S.	L.S.
.05	.0685	.0945	.1757	-.2196	.1758	-.2194	.1840	-.2163	.1808	-.2245	.1965	-.2180		
.10	.0671	.0989	.1841	-.2187	.1765	-.2217	.1745	-.2210	.1791	-.2224	.1953	-.2202	.1766	-.1793
.15	.0669	.0925	.1838	-.2145	.1817	-.2197	.1781	-.2203	.1810	-.2219	.1914	-.2181	.1623	-.1733
.20	.0531	.0826	.1785	-.2097	.1803	-.2186			.1807	-.2210	.1922	-.2164	.1508	-.1628
.25			.0411	-.0518	.1550	-.1884	.1675	-.2089	.1780	-.2168	.2153	-.2139	.1414	-.1573
.30	.0066	.0152	.0128	-.0229	.0259	-.0368	.0392	-.0555	.0922	-.1020	.2248	-.2041	.1360	-.1539
.40									.0136	-.0238	.0243	-.0350	.0771	-.0197
.50	.0005	.0092	-.0064	-.0043	.0063	-.0165			.0074	-.0168	.0065	-.0161	-.0130	-.0088
.60	.0053	.0111	-.0109	-.0003	.0046	-.0137	.0047	-.0133	.0047	-.0129	.0003	-.0101	-.0173	-.0126
.70	.0056	.0069	-.0125	-.0031	-.0002	-.0088	-.0051	-.0037	-.0131	-.0052			-.0471	-.0475
.80	-.0400	-.0386	-.0554	-.0517	-.0480	-.0434	-.0534	-.0501	-.0512	-.0477	-.0565	-.0533	-.0491	-.0535
.90	-.0513	-.0483	-.0513	-.0547	-.0512	-.0526	-.0518	-.0536	-.0517	-.0533	-.0517	-.0523	-.0459	-.0490
.95	-.0521	-.0513	-.0503	-.0523	-.0483	-.0499	-.0491	-.0502	-.0490	-.0500	-.0495	-.0495	-.0429	-.0478

TAIL 1

Cp at γ/b of														
x/c	0.02		0.22		0.44		0.56		0.67		0.83		0.98	
	U.S.	L.S.	U.S.	L.S.	U.S.	L.S.	U.S.	L.S.	U.S.	L.S.	U.S.	L.S.	U.S.	L.S.
.05	.2462	-.0112	.8083	-.0119			.7873		.7904	-.0094	.7794	-.0062	.7081	
.10	.2362	-.0220	.7993	-.0263			.7793		.7746	-.0201	.7773	-.0222	.6783	-.0088
.15	.3025	-.0237					.7728	-.0063	.7686		.7742	-.0287	.6243	-.0185
.20							.7686	-.0308	.7665	-.0304		-.0108	.5972	-.0219
.25	.2098	-.0443	.3672	-.0584			.7325	-.0355	.7514	-.0341	.7496	-.0314		.0077
.30			.3188	-.0462	.3638	-.0580	.3736	-.0598	.5368	-.0498				
.40	.2186	-.0540			.3475	-.0584	.3489	-.0623	.3544	-.0606	.3693	-.0623		
.50	.2462	-.0532					.3427	-.0588	.3432	-.0598			.0139	.0141
.60					.3293	-.0584	.3417	-.0582	.3394	-.0551	.3182	-.0584	.1695	-.0610
.70			.2482	-.0504	.3090	-.0585	.3176	-.0365	.2076	-.0514	.1093	-.0614	.0283	-.0637
.80	.0640	-.0644	.0834	-.0565	.1048	-.0585			.0782	-.0209	.0779	-.0616	.0130	-.0195
.90	.0180	-.0686			.0898	-.0554			.1063	-.0579	.0746	-.0601	.0120	-.0125
.95	.0133	-.0647							.0156	-.0083	.0674	-.0613	.0115	-.0116

TAIL 2

TABLE XVIII.- CONTINUED
(c) $\alpha = 0.12^\circ$

Cp at γ/b of														
x/c	0.02		0.22		0.44		0.56		0.67		0.83		0.98	
	U.S.	L.S.	U.S.	L.S.	U.S.	L.S.	U.S.	L.S.	U.S.	L.S.	U.S.	L.S.	U.S.	L.S.
.05	-.0790	-.0914	-.1757	-.2215	-.1769	-.2203	-.1829	-.2170	-.1804	-.2228	-.1930	-.2137		
.10	-.0773	-.1076	-.1848	-.2221	-.1777	-.2227	-.1730	-.2221	-.1786	-.2222	-.1934	-.2167	-.1747	-.1775
.15	-.0773	-.0987	-.1852	-.2188	-.1827	-.2210	-.1776	-.2205	-.1808	-.2221	-.1904	-.2155	-.1620	-.1703
.20	-.0632	-.0893	-.1739	-.2124	-.1809	-.2195			-.808	-.2209	-.1919	-.2144	-.1483	-.1598
.25			-.0426	-.0534	-.1564	-.1882	-.1673	-.2099	-.1782	-.2167	-.2169	-.2121	-.1407	-.1515
.30	-.0068	-.0171	-.0134	-.0239	-.0253	-.0380	-.0404	-.0560	-.0930	-.1028	-.2187	-.2020	-.1331	-.1475
.40									-.0132	-.0237	-.0244	-.0349	-.0758	-.0164
.50	-.0042	-.0097	-.0028	-.0067	-.0060	-.0165			-.0068	-.0164	-.0061	-.0152	-.0095	-.0097
.60	-.0016	-.0119	-.0073	-.0019	-.0042	-.0138	-.0039	-.0130	-.0042	-.0126	-.0006	-.0085	-.0153	-.0173
.70	-.0055	-.0074	-.0107	-.0016	-.0004	-.0091	-.0055	-.0035	-.0136	-.0051			-.0463	-.0459
.80	-.0400	-.0386	-.0559	-.0512	-.0482	-.0440	-.0536	-.0497	-.0514	-.0482	-.0563	-.0538	-.0489	-.0515
.90	-.0525	-.0494	-.0504	-.0546	-.0499	-.0515	-.0524	-.0538	-.0512	-.0540	-.0519	-.0526	-.0526	-.0495
.95	-.0537	-.0536	-.0494	-.0520	-.0480	-.0497	-.0496	-.0504	-.0487	-.0508	-.0498	-.0503	-.0551	-.0555

TAIL 1

Cp at γ/b of														
x/c	0.02		0.22		0.44		0.56		0.67		0.83		0.98	
	U.S.	L.S.	U.S.	L.S.	U.S.	L.S.	U.S.	L.S.	U.S.	L.S.	U.S.	L.S.	U.S.	L.S.
.05	-.2336	-.0069	-.6855	-.0078			-.6799		-.6873	-.0071	-.6825	-.0106	-.6237	
.10	-.2207	-.0082	-.6855	-.0073			-.6725		-.6722	-.0042	-.6803	-.0055	-.6011	-.0302
.15	-.2611	-.0083					-.6667	-.0032	-.6672		-.6774	-.0121	-.5525	-.0051
.20							-.6633	-.0152	-.6649	-.0148		-.0122	-.5294	-.0090
.25	-.1699	-.0412	-.3090	-.0534			-.6333	-.0227	-.6518	-.0190	-.6564	-.0183		-.0083
.30			-.2577	-.0442	-.2945	-.0553	-.3121	-.0550	-.4640	-.0407				
.40	-.1487	-.0534			-.2808	-.0602	-.2818	-.0637	-.2905	-.0598	-.3075	-.0591		
.50	-.1685	-.0525					-.2750	-.0625	-.2783	-.0637			-.0137	-.0149
.60					-.2760	-.0583	-.2759	-.0592	-.2744	-.0569	-.2637	-.0596	-.1321	-.0584
.70			-.1944	-.0490	-.2593	-.0574	-.2586	-.0364	-.1624	-.0513	-.0775	-.0613	-.0069	-.0630
.80	-.0299	-.0640	-.0463	-.0549	-.0746	-.0574			-.0531	-.0200	-.0488	-.0612	-.0116	-.0196
.90	-.0034	-.0689			-.0611	-.0549			-.0700	-.0570	-.0440	-.0596	-.0114	-.0128
.95	-.0071	-.0648							-.0134	-.0089	-.0380	-.0611	-.0104	-.0120

TAIL 2

TABLE XVIII. - CONTINUED
(d) $\alpha = 2.11^\circ$

Cp at γ/b of														
x/c	0.02		0.22		0.44		0.56		0.67		0.83		0.98	
	U.S.	L.S.	U.S.	L.S.	U.S.	L.S.	U.S.	L.S.	U.S.	L.S.	U.S.	L.S.	U.S.	L.S.
.05	.0947	.1086	.1766	.2218	.1768	.2183	.1818	.2173	.1802	.2212	.1962	.2172		
.10	.0914	.1273	.1847	.2209	.1775	.2207	.1718	.2222	.1781	.2217	.1952	.2181	.1744	.1777
.15	.0910	.1110	.1850	.2179	.1825	.2194	.1768	.2192	.1799	.2204	.1914	.2162	.1623	.1710
.20	.0756	.0985	.1797	.2118	.1807	.2178			.1798	.2188	.1917	.2147	.1506	.1605
.25			.0429	.0508	.1554	.1858	.1664	.2089	.1770	.2145	.2153	.2117	.1412	.1534
.30	.0065	.0134	.0133	.0233	.0258	.0374	.0425	.0562	.0928	.1029	.2231	.2020	.1354	.1468
.40									.0126	.0217	.0237	.0328	.0766	.0171
.50	-.0114	.0015	-.0020	.0072	.0053	.0148			.0060	.0146	.0046	.0132	-.0035	-.0076
.60	-.0094	.0026	-.0057	.0027	.0034	.0121	.0033	.0109	.0033	.0107	-.0025	.0063	-.0119	-.0131
.70	-.0033	-.0007	-.0088	-.0010	-.0012	.0080	-.0048	.0026	-.0144	-.0065			-.0452	-.0441
.80	-.0454	-.0444	-.0556	-.0507	-.0482	-.0456	-.0544	-.0514	-.0514	-.0491	-.0563	-.0551	-.0557	-.0451
.90	-.0544	-.0531	-.0520	-.0549	-.0502	-.0524	-.0530	-.0545	-.0519	-.0547	-.0526	-.0530	-.0534	-.0567
.95	-.0548	-.0563	-.0500	-.0518	-.0487	-.0501	-.0503	-.0511	-.0491	-.0514	-.0507	-.0508	-.0594	-.0575

TAIL 1

Cp at γ/b of														
x/c	0.02		0.22		0.44		0.56		0.67		0.83		0.98	
	U.S.	L.S.	U.S.	L.S.	U.S.	L.S.	U.S.	L.S.	U.S.	L.S.	U.S.	L.S.	U.S.	L.S.
.05	.2149	.0276	.5712	.0295			.5801		.5904	.0259	.5911	.0287	.5424	
.10	.2001	.0060	.5667	.0140			.5737		.5759	.0143	.5886	.0127	.5245	.0754
.15	.2217	.0089					.5684	.0290	.5710		.5857	.0060	.4784	.0099
.20							.5653	.0035	.5692	.0037		.0126	.4637	.0047
.25	.1245	-.0352	.2476	-.0460			.5401	-.0060	.5575	-.0010	.5678	-.0017		.0087
.30			.2058	-.0407	.2326	-.0503	.2511	-.0474	.3931	-.0288				
.40	.0903	-.0518			.2167	-.0586	.2220	-.0603	.2320	-.0560	.2495	-.0541		
.50	.1022	-.0514					.2150	-.0620	.2196	-.0620			.0130	.0147
.60					.2136	-.0606	.2148	-.0612	.2162	-.0581	.2124	-.0593	.0986	-.0527
.70			.1472	-.0486	.2031	-.0575	.2002	-.0362	.1197	-.0508	.0502	-.0601	-.0105	-.0633
.80	.0039	-.0623	.0198	-.0531	.0464	-.0561			.0324	-.0198	.0231	-.0596	.0101	.0243
.90	-.0222	-.0686			.0351	-.0537			.0372	-.0555	.0194	-.0579	.0106	.0128
.95	-.0246	-.0648							.0112	.0084	.0140	-.0594	.0096	.0117

TAIL 2

TABLE XVIII. - CONTINUED
(e) $\alpha = 4.11^\circ$

Cp at y/b of														
x/c	0.02		0.22		0.44		0.56		0.67		0.83		0.98	
	U.S.	L.S.	U.S.	L.S.	U.S.	L.S.	U.S.	L.S.	U.S.	L.S.	U.S.	L.S.	U.S.	L.S.
.05	-.1153	-.1335	-.1804	.2260	-.1799	.2214	.1830	-.2207	-.1813	.2221	.2014	-.2238		
.10	-.1094	-.1560	-.1885	.2246	-.1807	.2237	-.1742	-.2255	-.1803	.2251	.2010	-.2241	-.1811	-.1846
.15	-.1072	-.1309	-.1882	.2213	-.1854	.2227	-.1799	-.2221	-.1828	.2237	.1972	-.2222	-.1657	-.1781
.20	-.0936	-.1151	-.1826	.2147	-.1835	.2210			-.1829	.2220	.1995	-.2206	-.1575	-.1677
.25			-.0454	-.0492	-.1579	-.1884	.1693	-.2123	-.1800	-.2176	.2177	-.2177	-.1491	-.1607
.30	-.0978	-.0134	-.0143	-.0237	-.0271	-.0376	.0460	-.0612	-.0947	-.1108	.2311	-.2081	-.1434	-.1545
.40									-.0138	-.0240	.0257	-.0347	-.0803	-.0233
.50	-.0119	-.0004	-.0007	-.0079	.0057	.0150			-.0070	-.0160	.0057	-.0145	-.0020	-.0011
.60	-.0109	-.0009	-.0040	-.0039	.0036	.0123	-.0046	-.0121	-.0040	-.0121	-.0022	.0064	-.0090	-.0065
.70	-.0084	-.0056	-.0069	-.0007	-.0012	-.0075	-.0060	-.0023	-.0139	-.0057			-.0443	-.0425
.80	-.0488	-.0485	-.0544	-.0512	-.0488	-.0464	-.0545	-.0513	-.0517	-.0495	-.0570	-.0561	-.0582	-.0504
.90	-.0546	-.0551	-.0527	-.0546	-.0509	-.0532	-.0522	-.0542	-.0523	-.0554	-.0532	-.0531	-.0619	-.0565
.95	-.0539	-.0561	-.0504	-.0515	-.0488	-.0502	-.0491	-.0505	-.0494	-.0518	-.0513	-.0510	-.0624	-.0554

TAIL 1

Cp at y/b of														
x/c	0.02		0.22		0.44		0.56		0.67		0.83		0.98	
	U.S.	L.S.	U.S.	L.S.	U.S.	L.S.	U.S.	L.S.	U.S.	L.S.	U.S.	L.S.	U.S.	L.S.
.05	.2086	.0531	.4689	.0537			.4869		.5000	-.0481	.5032	-.0500	.4613	
.10	.1558	.0230	.4627	.0388			.4831		.4866	-.0363	.4988	-.0344	.4457	-.0896
.15	.1844	.0268					.4782	.0502	.4819		.4962	-.0274	.4069	-.0237
.20							.4757	.0260	.4798	.0264		.0090	.3920	-.0189
.25	-.0847	-.0258	.1821	-.0359			.4535	.0148	.4698	.0204	.4805	-.0183		-.0044
.30			.1491	-.0361	.1778	-.0433	.1977	-.0365	.3249	-.0133				
.40	-.0531	-.0499			.1617	-.0542	.1690	-.0544	.1793	-.0499	.1949	-.0475		
.50	-.0558	-.0494					.1624	-.0576	.1673	-.0570			.0090	-.0096
.60					.1577	-.0588	.1617	-.0586	.1643	-.0551	.1636	-.0575	.0671	-.0431
.70			.1093	-.0479	.1485	-.0573	.1497	-.0359	.0825	-.0505	.0258	-.0595	-.0237	-.0560
.80	-.0191	-.0601	-.0011	-.0524	.0178	-.0540			.0142	-.0212	.0009	-.0585	.0056	-.0236
.90	-.0373	-.0660			.0082	-.0519			.0038	-.0541	-.0034	-.0568	.0066	-.0080
.95	-.0388	-.0634							.0062	-.0037	-.0077	-.0579	.0055	-.0068

TAIL 2

TABLE XVIII. - CONTINUED
(f) $\alpha = 6.09^\circ$

Cp at y/b of														
x/c	0.02		0.22		0.44		0.56		0.67		0.83		0.98	
	U.S.	L.S.	U.S.	L.S.	U.S.	L.S.	U.S.	L.S.	U.S.	L.S.	U.S.	L.S.	U.S.	L.S.
.05	.1375	.1591	.1941	.2409	.1927	.2350	.1940	.2358	.1978	.2396	.2160	.2408		
.10	.1307	.1872	.2023	.2386	.1936	.2376	.1871	.2403	.1945	.2410	.2162	.2402	.1948	.1996
.15	.1259	.1532	.2018	.2353	.1985	.2366	.1929	.2360	.1958	.2376	.2123	.2385	.1794	.1936
.20	.1048	.1348	.1954	.2281	.1964	.2346			.1954	.2354	.2155	.2365	.1700	.1837
.25			.0519	.0556	.1695	.2007	.1815	.2253	.1921	.2308	.2351	.2334	.1628	.1763
.30	.0129	.0190	.0189	.0282	.0318	.0420	.0511	.0659	.1022	.1155	.2405	.2234	.1586	.1699
.40									.0188	.0289	.0310	.0408	.0921	.0310
.50	-.0089	.0034	.0036	.0128	.0098	.0192			.0118	.0208	.0173	.0196	.0087	.0094
.60	-.0080	.0026	-.0000	.0091	.0074	.0163	.0079	.0162	.0086	.0168	.0013	.0104	-.0034	.0031
.70	-.0074	-.0030	-.0030	.0062	.0024	.0112	-.0021	.0060	-.0102	-.0010			-.0410	-.0387
.80	-.0487	-.0471	-.0529	-.0483	-.0477	-.0446	-.0532	-.0502	-.0508	-.0487	-.0561	.0551	-.0577	-.0497
.90	-.0529	-.0537	-.0517	-.0542	-.0506	-.0520	-.0505	-.0519	-.0516	-.0532	-.0516	-.0512	-.0619	-.0585
.95	-.0527	-.0546	-.0492	-.0504	-.0478	-.0479	-.0474	-.0476	-.0485	-.0496	-.0498	-.0491	-.0623	-.0577

TAIL 1

Cp at y/b of														
x/c	0.02		0.22		0.44		0.56		0.67		0.83		0.98	
	U.S.	L.S.	U.S.	L.S.	U.S.	L.S.	U.S.	L.S.	U.S.	L.S.	U.S.	L.S.	U.S.	L.S.
.05	.1574	.0735	.3686	.0797			.4034		.4101	.0721	.4056	.0730	.3815	
.10	.1110	.0440	.3617	.0655			.3973		.3996	.0606	.4006	.0580	.3652	.1136
.15	.1340	.0414					.3925	.0753	.3970		.4008	.0511	.3335	.0415
.20							.3904	.0505	.3959	.0574			.0084	.3131
.25	.0619	-.0160	.1231	-.0234			.3712	.0381	.3873	.0440	.3894	.0410		.0033
.30			.0946	-.0296	.1284	-.0346	.1485	-.0244	.2511	.0035				
.40	.0167	-.0462			.1121	-.0480	.1200	-.0470	.1312	-.0426	.1441	-.0391		
.50	.0175	-.0460					.1133	-.0513	.1197	-.0505			.0069	.0080
.60					.1065	-.0533	.1122	-.0526	.1170	-.0491	.1177	-.0533	.0354	-.0388
.70			.0667	-.0434	.0984	-.0537	.1052	-.0350	.0522	-.0496	.0055	-.0574	-.0279	-.0648
.80	-.0315	-.0573	-.0181	-.0500	-.0058	-.0515			.0014	-.0212	-.0162	-.0556	.0034	.0319
.90	-.0419	-.0600			-.0124	-.0495			-.0113	-.0520	-.0204	-.0541	.0046	.0068
.95	-.0413	-.0589							.0029	.0018	-.0242	-.0552	.0035	.0049

TAIL 2

TABLE XVIII. - CONTINUED
(g) $\alpha = 8.10^\circ$

Cp at γ/b of														
x/c	0.02		0.22		0.44		0.56		0.67		0.83		0.98	
	U.S.	L.S.	U.S.	L.S.	U.S.	L.S.	U.S.	L.S.	U.S.	L.S.	U.S.	L.S.	U.S.	L.S.
.05	.1683	.1906	.2209	.2691	.2167	.2596	.2141	.2602	.2199	.2626	.2374	.2636	.2141	.2199
.10	.1608	.2254	.2299	.2665	.2176	.2625	.2086	.2649	.2173	.2659	.2382	.2634	.1993	.2144
.15	.1537	.1815	.2293	.2634	.2227	.2617	.2149	.2602	.2190	.2618	.2344	.2616	.1904	.2048
.20	.1290	.1610	.2223	.2554	.2205	.2596			.2184	.2589	.2379	.2595	.1904	.2048
.25			.0657	.0699	.1917	.2236	.2031	.2487	.2145	.2536	.2585	.2564	.1825	.1982
.30	.0245	.0303	.0302	.0393	.0411	.0507	.0582	.0741	.1185	.1250	.2625	.2460	.1784	.1910
.40									.0284	.0377	.0400	.0499	.1098	.0401
.50	.0001	.0134	.0142	.0238	.0190	.0287			.0209	.0293	.0180	.0274	.0176	.0209
.60	.0010	.0126	.0104	.0204	.0167	.0260	.0168	.0254	.0176	.0256	.0082	.0171	.0087	.0127
.70	.0010	.0059	.0070	.0164	.0110	.0204	.0066	.0146	-.0035	.0042			-.0363	-.0339
.80	-.0449	-.0429	-.0487	-.0431	-.0450	-.0414	-.0504	-.0471	-.0489	-.0463	-.0541	-.0531	-.0566	-.0449
.90	-.0494	-.0504	-.0474	-.0531	-.0477	-.0484	-.0468	-.0478	-.0486	-.0489	-.0488	-.0478	-.0622	-.0593
.95	-.0498	-.0517	-.0446	-.0483	-.0437	-.0439	-.0432	-.0435	-.0454	-.0449	-.0468	-.0456	-.0632	-.0611

TAIL 1

Cp at γ/b of														
x/c	0.02		0.22		0.44		0.56		0.67		0.83		0.98	
	U.S.	L.S.	U.S.	L.S.	U.S.	L.S.	U.S.	L.S.	U.S.	L.S.	U.S.	L.S.	U.S.	L.S.
.05	.0840	.0887	.2642	.1060			.3026		.3194	.0993	.3413	.1018	.3298	
.10	.0602	.0667	.2586	.0932			.2933		.3046	.0881	.3325	.0877	.3131	.1356
.15	.0804	.0569					.2925	.1032	.2978		.3292	.0806	.2838	.0655
.20							.2964	.0778	.2943	.0834		.0052	.2625	.0537
.25	.0355	-.0094	.0715	-.0086			.2839	.0653	.2863	.0704	.3100	.0693		-.0001
.30			.0468	-.0215	.0820	-.0228	.1010	-.0104	.1854	.0228				
.40	-.0163	-.0421			.0656	-.0388	.0741	-.0366	.0822	-.0323	.0939	-.0280		
.50	-.0124	-.0409					.0675	-.0416	.0742	-.0408			.0010	.0032
.60					.0578	-.0437	.0655	-.0429	.0722	-.0399	.0665	-.0458	.0101	-.0367
.70			.0270	-.0363	.0508	-.0460	.0638	-.0309	.0234	-.0467	-.0172	-.0560	-.0338	-.0606
.80	-.0336	-.0550	-.0337	-.0473	-.0266	-.0487			-.0112	-.0226	-.0344	-.0530	-.0025	.0633
.90	-.0369	-.0550			-.0308	-.0467			-.0300	-.0493	-.0370	-.0513	-.0014	.0039
.95	-.0322	-.0584							-.0032	-.0024	-.0398	-.0523	-.0025	.0005

TAIL 2

TABLE XVIII. - CONTINUED
(h) $\alpha = 10.09^\circ$

Cp at y/b of														
x/c	0.02		0.22		0.44		0.56		0.67		0.83		0.98	
	U.S.	L.S.	U.S.	L.S.	U.S.	L.S.	U.S.	L.S.	U.S.	L.S.	U.S.	L.S.	U.S.	L.S.
.05	.2057	.2278	.2565	.3064	.2476	.2923	.2400	.2915	.2473	.2918	.2655	.2939		
.10	.1972	.2702	.2665	.3036	.2487	.2961	.2372	.2972	.2446	.2960	.2668	.2928	.2387	.2449
.15	.1880	.2158	.2656	.3004	.2539	.2954	.2442	.2917	.2471	.2920	.2625	.2910	.2240	.2398
.20	.1600	.1926	.2578	.2920	.2516	.2930			.2465	.2891	.2660	.2885	.2145	.2308
.25			.0839	.0894	.2203	.2540	.2315	.2794	.2423	.2836	.2857	.2852	.2069	.2247
.30	.0412	.0469	.0457	.0552	.0555	.0636	.0703	.0869	.1382	.1426	.2844	.2742	.2024	.2174
.40									.0406	.0500	.0519	.0627	.1292	.0513
.50	.0136	.0282	.0288	.0391	.0324	.0417			.0327	.0412	.0289	.0381	.0294	.0337
.60	.0145	.0274	.0247	.0352	.0297	.0391	.0296	.0377	.0293	.0374	.0182	.0268	.0176	.0244
.70	.0148	.0195	.0209	.0302	.0235	.0331	.0179	.0259	.0056	.0144			-.0294	-.0282
.80	-.0373	-.0361	-.0428	-.0381	-.0408	-.0375	-.0457	-.0430	-.0454	-.0429	-.0500	-.0492	-.0549	-.0363
.90	-.0433	-.0446	-.0408	-.0490	-.0410	-.0419	-.0401	-.0414	-.0420	-.0416	-.0433	-.0423	-.0608	-.0581
.95	-.0450	-.0466	-.0375	-.0437	-.0368	-.0369	-.0363	-.0370	-.0387	-.0375	-.0414	-.0401	-.0626	-.0616

TAIL 1

Cp at y/b of														
x/c	0.02		0.22		0.44		0.56		0.67		0.83		0.98	
	U.S.	L.S.	U.S.	L.S.	U.S.	L.S.	U.S.	L.S.	U.S.	L.S.	U.S.	L.S.	U.S.	L.S.
.05	.0507	.1096	.2017	.1340			.2670		.2876	.1319	.3084	.1352	.3004	
.10	.0357	.0875	.1832	.1221			.2561		.2726	.1206	.2983	.1217	.2842	.1573
.15	.0484	.0748					.2469	.1301	.2640		.2938	.1143	.2559	.0945
.20							.2395	.1088	.2579	.1175		.0049	.2355	.0810
.25	.0062	-.0027	.0332	.0065			.2213	.0963	.2470	.1012	.2753	.1022		-.0012
.30			.0157	-.0118	.0415	-.0087	.0627	.0051	.1540	.0451				
.40	-.0338	-.0355			.0247	-.0263	.0351	-.0233	.0517	-.0190	.0730	-.0141		
.50	-.0273	-.0327					.0270	-.0287	.0382	-.0280			-.0007	.0012
.60					.0211	-.0310	.0233	-.0303	.0343	-.0280	.0451	-.0348	-.0013	-.0323
.70			-.0015	-.0272	.0161	-.0347	.0272	-.0238	-.0022	-.0403	-.0281	-.0589	-.0365	-.0566
.80	-.0359	-.0532	-.0459	-.0489	-.0408	-.0494			-.0207	-.0240	-.0447	-.0543	-.0043	.0493
.90	-.0297	-.0491			-.0435	-.0460			-.0449	-.0492	-.0474	-.0517	-.0032	.0014
.95	-.0208	-.0550							-.0060	-.0046	-.0496	-.0526	-.0044	-.0017

TAIL 2

TABLE XVIII. - CONTINUED
($\alpha = 12.0^\circ$)

Cp at y/b of														
x/c	0.02		0.22		0.44		0.56		0.67		0.83		0.98	
	U.S.	L.S.	U.S.	L.S.	U.S.	L.S.	U.S.	L.S.	U.S.	L.S.	U.S.	L.S.	U.S.	L.S.
.05	.2487	.2732	.2983	.3531	.2846	.3328	.2716	.3297	.2808	.3290	.2972	.3289		
.10	.2386	.3242	.3092	.3503	.2859	.3374	.2711	.3365	.2781	.3338	.2995	.3281	.2665	.2744
.15	.2270	.2578	.3081	.3468	.2914	.3368	.2787	.3306	.2810	.3291	.2950	.3259	.2508	.2698
.20	.1952	.2312	.2995	.3370	.2891	.3339			.2804	.3262	.2967	.3232	.2413	.2613
.25			.1058	.1133	.2550	.2915	.2646	.3180	.2759	.3202	.3183	.3194	.2342	.2551
.30	.0612	.0679	.0647	.0755	.0732	.0803	.0863	.1030	.1607	.1681	.3164	.3077	.2299	.2479
.40									.0559	.0656	.0659	.0772	.1503	.0640
.50	.0304	.0475	.0470	.0583	.0486	.0590			.0475	.0570	.0411	.0505	.0430	.0470
.60	.0315	.0463	.0426	.0534	.0460	.0561	.0451	.0536	.0438	.0520	.0296	.0386	.0369	.0376
.70	.0326	.0369	.0384	.0478	.0389	.0496	.0323	.0407	.0174	.0266			-.0230	-.0210
.80	-.0271	-.0265	-.0353	-.0310	-.0345	-.0310	-.0396	-.0372	-.0405	-.0383	-.0432	-.0429	-.0526	-.0332
.90	-.0332	-.0349	-.0306	-.0405	-.0317	-.0328	-.0314	-.0327	-.0337	-.0323	-.0362	-.0357	-.0589	-.0572
.95	-.0370	-.0383	-.0274	-.0333	-.0278	-.0279	-.0276	-.0282	-.0299	-.0281	-.0343	-.0335	-.0616	-.0611

TAIL 1

Cp at y/b of														
x/c	0.02		0.22		0.44		0.56		0.67		0.83		0.98	
	U.S.	L.S.	U.S.	L.S.	U.S.	L.S.	U.S.	L.S.	U.S.	L.S.	U.S.	L.S.	U.S.	L.S.
.05	.0369	.1358	.1927	.1664			.2536		.2740	.1693	.2919	.1735	.2850	
.10	.0203	.1118	.1705	.1547			.3036		.2574	.1575	.2826	.1609	.2688	.1862
.15	.0261	.0969					.2333	.1650	.2477		.2769	.1533	.2405	.1286
.20							.2241	.1436	.2408	.1544		.0115	.2213	.1134
.25	-.0166	.0073	.0109	.0228			.2052	.1307	.2296	.1359	.2573	.1395		.0042
.30			-.0065	.0002	.0313	.0077	.0539	.0224	.1405	.0701				
.40	-.0462	-.0272			.0119	-.0103	.0251	-.0078	.0416	-.0030	.0623	.0031		
.50	-.0401	-.0232					.0164	-.0131	.0279	-.0125			.0026	.0068
.60					-.0001	-.0156	.0115	-.0151	.0236	-.0137	.0346	-.0196	-.0062	-.0223
.70			-.0219	-.0163	-.0080	-.0198	.0125	-.0134	-.0123	-.0296	-.0331	-.0551	-.0364	-.0523
.80	-.0452	-.0507	-.0483	-.0519	-.0522	-.0539			-.0223	-.0222	-.0490	-.0556	-.0015	.0596
.90	-.0389	-.0493			-.0460	-.0466			-.0512	-.0488	-.0512	-.0513	-.0002	.0065
.95	-.0338	-.0498							-.0037	-.0001	-.0526	-.0518	-.0015	.0031

TAIL 2

TABLE XVIII. - CONTINUED
(j) $\alpha = 16.89^\circ$

Cp at y/b of														
x/c	0.02		0.22		0.44		0.56		0.67		0.83		0.98	
	U.S.	L.S.	U.S.	L.S.	U.S.	L.S.	U.S.	L.S.	U.S.	L.S.	U.S.	L.S.	U.S.	L.S.
.05	.3521	.3825	.4026	.4655	.3759	.4303	.3478	.4225	.3617	.4178	.3716	.4104		
.10	.3376	.4521	.4166	.4634	.3777	.4375	.3543	.4307	.3594	.4234	.3762	.4098	.2006	.2136
.15	.3230	.3589	.4152	.4592	.3848	.4374	.3642	.4233	.3634	.4178	.3697	.4069	.2147	.2380
.20	.2832	.3243	.4051	.4481	.3826	.4335			.3629	.4142	.3670	.4025	.2247	.2466
.25			.1615	.1722	.3423	.3833	.3481	.4081	.3580	.4081	.3886	.3967	.2265	.2497
.30	.1102	.1189	.1135	.1263	.1149	.1205	.1310	.1444	.2180	.2210	.4024	.3832	.2280	.2482
.40									.0948	.1049	.0962	.1083	.1820	.0867
.50	.0735	.0971	.0938	.1072	.0900	.1019			.0852	.0945	.0672	.0769	.0654	.0711
.60	.0745	.0957	.0881	.1004	.0873	.0988	.0845	.0933	.0807	.0888	.0543	.0638	.0521	.0685
.70	.0796	.0819	.0822	.0936	.0794	.0918	.0701	.0793	.0476	.0572			-.0246	-.0160
.80	-.0032	-.0048	-.0169	-.0119	-.0178	-.0137	-.0230	-.0211	-.0311	-.0278	-.0286	-.0251	-.0422	-.0342
.90	-.0101	-.0122	-.0106	-.0235	-.0126	-.0141	-.0122	-.0125	-.0167	-.0143	-.0207	-.0183	-.0493	-.0464
.95	-.0181	-.0186	-.0049	-.0148	-.0071	-.0078	-.0076	-.0077	-.0127	-.0103	-.0193	-.0170	-.0467	-.0461

TAIL 1

Cp at y/b of														
x/c	0.02		0.22		0.44		0.56		0.67		0.83		0.98	
	U.S.	L.S.	U.S.	L.S.	U.S.	L.S.	U.S.	L.S.	U.S.	L.S.	U.S.	L.S.	U.S.	L.S.
.05	.0413	.2053	.2009	.2505			.2569		.2736	.2606	.2899	.2699	.2808	
.10	.0203	.1722	.1753	.2385			.4091		.2546	.2473	.2766	.2568	.2619	.2715
.15	.0164	.1546					.2333	.2483	.2434		.2630	.2476	.2322	.2123
.20							.2213	.2289	.2356	.2412		.0149	.2153	.1945
.25	-.0288	.0294	.0073	.0633			.2013	.2117	.2236	.2211	.2475	.2285		.0065
.30			-.0110	.0297	.0290	.0436	.0510	.0639	.1364	.1319				
.40	-.0574	-.0058			.0077	.0235	.0209	.0295	.0370	.0362	.0556	.0421		
.50	-.0517	.0022					.0113	.0234	.0224	.0255			.0036	.0058
.60					-.0063	.0190	.0057	.0215	.0174	.0229	.0273	.0169	-.0073	-.0066
.70			-.0396	.0121	-.0149	.0137	.0065	.0125	-.0170	-.0045	-.0369	-.0420	-.0358	-.0419
.80	-.0490	-.0411	-.0497	-.0448	-.0560	-.0486			-.0226	-.0203	-.0520	-.0549	-.0004	.3148
.90	-.0503	-.0509			-.0478	-.0507			-.0475	-.0486	-.0479	-.0480	.0009	.0175
.95	-.0498	-.0515							-.0022	-.0006	-.0457	-.0462	-.0002	.0028

TAIL 2

TABLE XVIII. - CONCLUDED
(k) $\alpha = 20.08^\circ$

Cp at y/b of														
x/c	0.02		0.22		0.44		0.56		0.67		0.83		0.98	
	U.S.	L.S.	U.S.	L.S.	U.S.	L.S.	U.S.	L.S.	U.S.	L.S.	U.S.	L.S.	U.S.	L.S.
.05	.4827	.5188	.5316	.6044	.4891	.5524	.4458	.5440	.4518	.5160	.2109	.2372		
.10	.4602	.6084	.5476	.6037	.4915	.5631	.4583	.5477	.4423	.5106	.2106	.2366	.1865	.1989
.15	.4432	.4859	.5459	.5979	.5002	.5631	.4695	.5400	.4476	.5057	.2067	.2327	.1817	.2016
.20	.3952	.4449	.5339	.5841	.4985	.5569			.4475	.5025	.2079	.2304	.1874	.2015
.25			.2321	.2463	.4505	.4960	.4505	.5197	.4441	.4965	.2299	.2268	.1865	.2033
.30	.1784	.1875	.1776	.1929	.1744	.1770	.1865	.2014	.2689	.2690	.2353	.2149	.1943	.2041
.40									.1277	.1368	.0276	.0352	.1498	.0372
.50	.1344	.1644	.1547	.1690	.1452	.1575			.1254	.1369	.0132	.0225	.0073	.0266
.60	.1343	.1627	.1465	.1597	.1411	.1528	.1309	.1392	.1245	.1357	.0112	.0203	-.0249	.0020
.70	.1420	.1412	.1393	.1517	.1308	.1431	.1140	.1221	.0874	.1018			-.0546	-.0468
.80	.0329	.0264	.0098	.0134	.0085	.0098	-.0010	-.0001	-.0224	-.0197	-.0351	-.0358	-.0637	-.0575
.90	.0236	.0195	.0138	.0058	.0098	.0088	.0006	-.0003	-.0257	-.0250	-.0316	-.0304	-.0645	-.0593
.95	.0147	.0137	.0238	.0138	.0186	.0180	.0122	.0109	-.0090	-.0116	-.0302	-.0291	-.0631	-.0580

TAIL 1

Cp at y/b of														
x/c	0.02		0.22		0.44		0.56		0.67		0.83		0.98	
	U.S.	L.S.	U.S.	L.S.	U.S.	L.S.	U.S.	L.S.	U.S.	L.S.	U.S.	L.S.	U.S.	L.S.
.05	.0533	.2965	.2269	.3629			.2767		.2924	.3802	.3051	.3936	.2914	
.10	.0319	.2531	.1957	.3489			.3921		.2716	.3655	.2904	.3804	.2727	.3553
.15	.0210	.2350					.2492	.3533	.2594		.2805	.3695	.2431	.3224
.20							.2361	.3414	.2508	.3540		.0186	.2280	.3014
.25	-.0341	.0808	.0107	.1188			.2139	.3228	.2374	.3330	.2577	.3446		.0096
.30			-.0100	.0765	.0339	.1004	.0570	.1212	.1463	.2133				
.40	-.0616	.0282			.0100	.0795	.0250	.0834	.0412	.0917	.0592	.1040		
.50	-.0566	.0495					.0141	.0768	.0256	.0791			.0008	.0036
.60					-.0054	.0716	.0078	.0740	.0200	.0752	.0294	.0758	-.0000	.0199
.70			-.0431	.0563	-.0148	.0646	.0060	.0633	-.0172	.0466	-.0365	-.0146	-.0334	-.0246
.80	-.0506	-.0170	-.0523	-.0262	-.0563	-.0294			-.0220	-.0118	-.0466	-.0390	-.0028	.2399
.90	-.0499	-.0437			-.0479	-.0423			-.0408	-.0412	-.0384	-.0428	-.0018	.0125
.95	-.0498	-.0499							-.0040	-.0018	-.0368	-.0418	-.0026	.0012

TAIL 2

TABLE XIX. - PRESSURE COEFFICIENTS; $\theta = 45^\circ$, $\delta = -15^\circ$, $M = 1.60$
(a) $\alpha = -3.30^\circ$

Cp at y/b of														
x/c	0.02		0.22		0.44		0.56		0.67		0.83		0.98	
	U.S.	L.S.	U.S.	L.S.	U.S.	L.S.	U.S.	L.S.	U.S.	L.S.	U.S.	L.S.	U.S.	L.S.
.05	.2482	-.0696	1.1621	-.2403			1.2855	-.3509	1.2811	-.3349	1.2564	-.3351		
.10	.3478	-.0264	1.0390	-.2212	1.1711	-.1853	1.1664	-.2226	1.1726	-.2288	1.1423	-.2464	.8713	-.1985
.15	.4513	-.0363	.9624	-.1771	1.0482	-.1525	1.0534	-.1566	1.0659	-.1854	1.0315	-.2080	.7758	-.0944
.20	.4839	-.0867	.8539	-.1326	.9351	-.1349			.9575	-.1651	.9338	-.1893	.6871	-.0756
.25			.2228	-.3030	.6757	-.1574	.7521	-.1352	.8211	-.1627	.8250	-.1803	.6040	-.0614
.30	.6299	-.2687	.2976	-.3246	.3046	-.3413	.2611	-.3259	.3316	-.2786	.6890	-.1807	.5293	-.0694
.40									.4124	-.3434	.2950	-.3461	.0206	-.2797
.50	.4977	-.2617			.5144	-.3667			.5192	-.3494	.3799	-.3335	.0988	-.2704
.60	.4002	-.2802	.4368	-.3107	.4955	-.3597	.4920	-.3582	.4919	-.3531	.4298	-.3194	.2114	-.2761
.70		-.2650	.3769	-.3036	.4290	-.3453	.4107	-.3719	.2998	-.3791			-.1233	-.4072
.80	-.1226	-.4165	-.0692	-.4198	-.0298	-.3936	-.0270	-.3772	-.0297	-.3931	-.0498	-.4094	-.1554	-.4094
.90	-.1137	-.3958	-.1040	-.3814	-.0669	-.3675	-.0555	-.3627	-.0483	-.3928	-.0661	-.3824	-.1555	-.4340
.95	-.1174	-.3622	-.1318	-.3462	-.0825	-.3564	-.0689	-.3573	-.0600	-.3852	-.0759	-.3525	-.1473	-.4258

TAIL 1

Cp at y/b of														
x/c	0.02		0.22		0.44		0.56		0.67		0.83		0.98	
	U.S.	L.S.	U.S.	L.S.	U.S.	L.S.	U.S.	L.S.	U.S.	L.S.	U.S.	L.S.	U.S.	L.S.
.05	.4382	-.1654	1.4139	-.2862					1.3727	-.3410	1.3505	-.3315		
.10	.7402	-.0551	1.2458	-.2396					1.2397	-.2518	1.2312	-.2526	.9313	-.1085
.15	.9921	.0595					1.1242	-.2093	1.1266	-.2075	1.1128	-.2071	.8382	-.0577
.20							1.0073	-.1932	1.0212	-.1927	1.0162	-.1909	.7599	-.0433
.25	.8856	.0615	.4060	-.3420					.8838	-.1925	.9032	-.1891	.6660	-.0574
.30			.5096	-.2818	.5286	-.3573	.5308	-.3484	.4565	-.2793				
.40	.8304	.0195			.7524	-.3259	.7322	-.3377	.7002	-.3382	.4539	-.2746		
.50	.7969	.0225					.7096	-.3151	.6701	-.3161			.3176	-.3189
.60					.6904	-.2486	.6663	-.2656	.6240	-.2566	.5477	-.2656	.3237	-.3372
.70			.6767	-.0557	.6165	-.2608	.5446	-.2030	.1822	-.2105	.0457	-.2393	-.0622	-.4354
.80	.0858	-.2863	.0832	-.2963	.0605	-.2702			.0538	-.2048	.0134	-.1856		
.90	.1826	-.2882			.0759	-.1978			.0668	-.1959	.0356	-.1644		
.95	.1898	-.2112							.0637	-.1819	.0311	-.1692	-.0479	-.3923

TAIL 2

TABLE XIX. - CONTINUED
(b) $\alpha = -1.30^\circ$

Cp at y/b of														
x/c	0.02		0.22		0.44		0.56		0.67		0.83		0.98	
	U.S.	L.S.	U.S.	L.S.	U.S.	L.S.	U.S.	L.S.	U.S.	L.S.	U.S.	L.S.	U.S.	L.S.
.05	.3622	-.0428	1.2204	-.1455			1.2581	-.3163	1.2597	-.2721	1.2447	-.2754		
.10	.4720	.0093	1.0610	-.1160	1.1085	-.1508	1.1349	-.1856	1.1414	-.1750	1.1258	-.1887	.8475	-.1252
.15	.5608	-.0001	.9521	-.1288	.9977	-.1117	1.0207	-.1196	1.0324	-.1382	1.0145	-.1562	.7510	-.0190
.20	.5036	-.0314	.8194	-.1364	.8852	-.0892			.9239	-.1268	.9176	-.1419	.6641	-.0147
.25			.1899	-.3117	.6293	-.1080	.7226	-.1041	.8020	-.1307	.8107	-.1368	.5893	-.0203
.30	.6092	-.2018	.2218	-.3036	.2641	-.3072	.2149	-.3068	.3160	-.2599	.6789	-.1382	.5195	-.0383
.40									.3404	-.3295	.2068	-.3217	.0028	-.2523
.50	.4184	-.2444			.4325	-.3304			.4201	-.3340	.2908	-.3125	.0400	-.2424
.60	.3282	-.2586	.4328	-.2729	.4286	-.3388	.4182	-.3277	.4194	-.3349	.3399	-.3016	.0962	-.2558
.70		-.2403	.3626	-.2683	.3836	-.3279	.3623	-.3417	.2495	-.3613			-.1572	-.3844
.80	-.1518	-.4052	-.0824	-.4036	-.0397	-.3631	-.0414	-.3577	-.0501	-.3738	-.0724	-.3945	-.1721	-.4094
.90	-.1386	-.3912	-.1169	-.3825	-.0756	-.3374	-.0618	-.3391	-.0665	-.3731	-.0871	-.3653	-.1637	-.4410
.95	-.1453	-.3615	-.1454	-.3426	-.0920	-.3315	-.0738	-.3326	-.0760	-.3631	-.0962	-.3338	-.1561	-.4293

TAIL 1

Cp at y/b of														
x/c	0.02		0.22		0.44		0.56		0.67		0.83		0.98	
	U.S.	L.S.	U.S.	L.S.	U.S.	L.S.	U.S.	L.S.	U.S.	L.S.	U.S.	L.S.	U.S.	L.S.
.05	.4233	-.0996	1.3488	-.2224					1.3333	-.2865	1.3181	-.2847		
.10	.6441	.0501	1.1732	-.1775					1.1931	-.1910	1.1865	-.1986	.8897	-.0931
.15	.8267	.1518							1.0754	-.1567	1.0767	-.1527	1.0644	-.1576
.20									.9566	-.1422	.9701	-.1424	.9686	-.1452
.25	.7610	.0970	.2694	-.3119					.8534	-.1449	.8574	-.1452	.7137	-.0159
.30			.3785	-.2529	.3714	-.3289	.3550	-.3174	.3823	-.2452			.6206	-.0229
.40	.7446	.0315			.7272	-.3249	.6683	-.3356	.5279	-.3375	.3444	-.2994		
.50	.7201	.0087					.6611	-.3283	.6254	-.3225			.1470	-.2592
.60					.6431	-.2331	.6225	-.2963	.5807	-.2917	.5088	-.2709	.3090	-.3176
.70			.6322	-.0458	.5807	-.2150	.5159	-.2285	.1634	-.2190	.0218	-.2803	-.0791	-.4011
.80	.0561	-.2863	.0619	-.3008	.0451	-.3423			.0335	-.1971	-.0124	-.1903		
.90	.1491	-.2749			.0533	-.2207			.0398	-.1904	.0079	-.1766		
.95	.1704	-.2055							.0339	-.1788	.0025	-.1927	-.0730	-.3911

TAIL 2

TABLE XIX. - CONTINUED
(c) $\alpha = 0.70^\circ$

Cp at y/b of														
x/c	0.02		0.22		0.44		0.56		0.67		0.83		0.98	
	U.S.	L.S.	U.S.	L.S.	U.S.	L.S.	U.S.	L.S.	U.S.	L.S.	U.S.	L.S.	U.S.	L.S.
.05	.4621	.0079	1.1839	-.1084			1.2332	-.2639	1.2396	-.2065	1.2237	-.2088		
.10	.5625	.0394	1.0381	-.0484	1.0794	-.1022	1.1078	-.1205	1.1196	-.1186	1.1017	-.1302	.8252	-.0605
.15	.6451	.0292	.9292	-.0464	.9653	-.0711	.9934	-.0656	1.0096	-.0884	.9891	-.1006	.7313	.0191
.20	.5716	-.0066	.7923	-.0658	.8563	-.0600			.9033	-.0808	.8933	-.0902	.6468	.0263
.25			.1682	-.2800	.6134	-.0882	.7065	-.0631	.7825	-.0831	.7905	-.0866	.5725	.0217
.30	.5458	-.1489	.1906	-.2753	.2119	-.2905	.1884	-.2357	.3020	-.2284	.6644	-.0909	.5061	-.0063
.40									.2571	-.3088	.1554	-.2940	-.0086	-.2334
.50	.3861	-.2200			.3559	-.3006			.3239	-.3162	.2089	-.2890	.0013	-.2254
.60	.2771	-.2330	.4030	-.2275	.3731	-.3080	.3578	-.3044	.3408	-.3196	.2454	-.2840	.0436	-.2519
.70		-.2147	.3368	-.2541	.3405	-.2547	.3094	-.3174	.2015	-.3476			-.2044	-.3837
.80	-.1654	-.3906	-.1011	-.3941	-.0565	-.3443	-.0593	-.3414	-.0754	-.3617	-.1056	-.3822	-.2059	-.3913
.90	-.1529	-.3933	-.1324	-.3723	-.0872	-.3212	-.0807	-.3227	-.0881	-.3587	-.1138	-.3536	-.1792	-.4308
.95	-.1633	-.3656	-.1553	-.3341	-.1031	-.3129	-.0911	-.3152	-.0971	-.3433	-.1214	-.3191	-.1680	-.4094

TAIL 1

Cp at y/b of														
x/c	0.02		0.22		0.44		0.56		0.67		0.83		0.98	
	U.S.	L.S.	U.S.	L.S.	U.S.	L.S.	U.S.	L.S.	U.S.	L.S.	U.S.	L.S.	U.S.	L.S.
.05	.3849	-.0211	1.2563	-.1495					1.2924	-.2255	1.2784	-.2352		
.10	.5277	.1228	1.0856	-.1125					1.1487	-.1339	1.1450	-.1479	.8493	-.0683
.15	.6454	.1742					1.0330	-.1004	1.0348	-.1010	1.0242	-.1094	.7581	.0047
.20							.9176	-.0855	.9299	-.0940	.9293	-.1003	.6733	.0107
.25	.6049	.1088	.2052	-.2491					.7965	-.0982	.8196	-.1012	.5806	.0104
.30			.2755	-.2217	.2461	-.3005	.2163	-.2832	.3541	-.2093				
.40	.6232	.0386			.4160	-.3042	.3977	-.3063	.3299	-.3102	.2203	-.2657		
.50	.6096	.0062					.4994	-.3110	.4490	-.3029			.0519	-.2175
.60					.6442	-.2223	.5932	-.2865	.5230	-.2721	.3536	-.2695	.0912	-.2775
.70			.5605	-.0512	.5542	-.1933	.4988	-.2437	.1573	-.2079	.0026	-.2712	-.1434	-.3710
.80	.0107	-.2762	.0256	-.3060	.0278	-.3164			.0136	-.1794	-.0306	-.2131		
.90	.0965	-.2722			.0135	-.2053			.0146	-.1857	-.0148	-.2086		
.95	.1454	-.2227							.0050	-.1776	-.0217	-.2122	-.0837	-.3836

TAIL 2

TABLE XIX. - CONTINUED
(d) $\alpha = 2.70^\circ$

Cp at y/b of														
x/c	0.02		0.22		0.44		0.56		0.67		0.83		0.98	
	U.S.	L.S.	U.S.	L.S.	U.S.	L.S.	U.S.	L.S.	U.S.	L.S.	U.S.	L.S.	U.S.	L.S.
.05	.5699	.0391	1.1424	-.6795			1.2096	-.2040	1.2189	-.1361	1.1996	-.1386		
.10	.6674	.0567	1.0041	-.0129	1.0527	-.0452	1.0844	-.0485	1.0961	-.0566	1.0759	-.0704	.8008	.0045
.15	.7475	.0444	.8966	-.0036	.9428	.0209	.9708	-.0141	.9866	-.0330	.9642	-.0448	.7096	.0643
.20	.6574	.0501	.7527	-.0074	.8387	.0156			.8817	-.0280	.8705	-.0365	.6276	.0654
.25			.1454	-.2451	.6018	-.0526	.6928	-.0152	.7662	-.0306	.7717	-.0344	.5592	.0571
.30	.4148	-.0878	.1686	-.2526	.1893	-.2636	.1703	-.2588	.2926	-.1958	.6499	-.0404	.4981	.0303
.40									.2107	-.2844	.1269	-.2655	-.0144	-.2170
.50	.2893	-.1938			.2896	-.2801			.2584	-.2931	.1599	-.2652	-.0172	-.2073
.60	.2348	-.1991	.3187	-.2006	.2774	-.2836	.2787	-.2887	.2638	-.2982	.1809	-.2938	.0205	-.2512
.70		-.1820	.2982	-.2279	.2688	-.2676	.2257	-.3004	.1356	-.3296			-.2216	-.3763
.80	-.1730	-.3691	-.1026	-.3758	-.0718	-.3421	-.0980	-.3291	-.1202	-.3534	-.1481	-.3669	-.2044	-.3802
.90	-.1711	-.3933	-.1406	-.3591	-.1021	-.3123	-.1011	-.3123	-.1280	-.3388	-.1553	-.3445	-.1689	-.4130
.95	-.1744	-.3713	-.1643	-.3258	-.1153	-.2946	-.1086	-.3017	-.1308	-.3240	-.1614	-.3168	-.1567	-.3915

TAIL 1

Cp at y/b of														
x/c	0.02		0.22		0.44		0.56		0.67		0.83		0.98	
	U.S.	L.S.	U.S.	L.S.	U.S.	L.S.	U.S.	L.S.	U.S.	L.S.	U.S.	L.S.	U.S.	L.S.
.05	.3044	.0386	1.1266	-.0665					1.2492	-.1593	1.2402	-.1783		
.10	.4018	.1401	.9565	-.0560					1.1071	-.0709	1.1060	-.0912	.8096	-.0356
.15	.4776	.1652					.9943	-.0263	.9961	-.0385	.9851	-.0581	.7197	.0351
.20							.8860	-.0111	.8946	-.0321	.8914	-.0511	.6367	.0382
.25	.4831	.1130	.1513	-.1905					.7661	-.0346	.7854	-.0533	.5450	.0399
.30			.1669	-.1795	.1895	-.2719	.1910	-.2517	.3350	-.1563				
.40	.4946	.0436			.2795	-.2775	.2949	-.2750	.2612	-.2713	.1617	-.2662		
.50	.4846	.0098					.3279	-.2811	.3157	-.2796			.0039	-.1824
.60					.4016	-.2163	.3674	-.2620	.3160	-.2545	.2463	-.2506	.0292	-.2091
.70			.5012	-.0572	.5475	-.0944	.4070	-.2332	.0745	-.2290	-.0944	-.2555	-.2023	-.3567
.80	-.0460	-.2518	.0005	-.3069	.0323	-.2908			-.0089	-.1937	-.1192	-.2283		
.90	.0536	-.2739			.0106	-.2262			.0043	-.1976	-.0839	-.2162		
.95	.1434	-.2503							-.0069	-.1863	-.0805	-.2113	-.1684	-.3821

TAIL 2

TABLE XIX. - CONTINUED
(e) $\alpha = 4.70^\circ$

Cp at γ/b of														
x/c	0.02		0.22		0.44		0.56		0.67		0.83		0.98	
	U.S.	L.S.	U.S.	L.S.	U.S.	L.S.	U.S.	L.S.	U.S.	L.S.	U.S.	L.S.	U.S.	L.S.
.05	.6735	.0621	1.1079	-.0118			1.1796	-.1214	1.1854	-.0626	1.1677	-.0636		
.10	.7512	.0854	.9753	.0384	1.0249	-.0176	1.0563	-.0241	1.0667	-.0097	1.0433	-.0040	.7716	-.0642
.15	.8042	.0607	.8717	.0519	.9163	-.0370	.9449	-.0433	.9600	-.0258	.9348	-.0159	.6843	-.1053
.20	.6843	.0920	.7327	.0492	.8171	.0368			.8591	.0285	.8439	.0211	.6079	-.1003
.25			.1340	-.2117	.5897	-.0027	.6783	-.0383	.7480	-.0259	.7465	.0210	.5437	-.0855
.30	.3151	-.0388	.1519	-.2303	.1678	-.2387	.1550	-.2271	.2828	-.1572	.6332	-.0148	.4879	-.0303
.40									.1748	-.2576	.1024	-.2369	-.0195	-.1937
.50	.2192	-.1605			.2422	-.2566			.2086	-.2668	.1208	-.2425	-.0280	-.1816
.60	.1357	-.1602	.2333	-.1672	.2335	-.2584	.2312	-.2651	.2129	-.2718	.1355	-.2427	-.0159	-.2289
.70		-.1532	.2220	-.1905	.2051	-.2498	.1833	-.2801	.0944	-.3070			-.2183	-.3661
.80	-.1965	-.3317	-.1253	-.3529	-.1284	-.3424	-.1411	-.3310	-.1473	-.3429	-.1738	-.3531	-.1683	-.3748
.90	-.1828	-.3914	-.1598	-.3564	-.1449	-.3111	-.1563	-.3115	-.1625	-.3277	-.1775	-.3349	-.1530	-.3960
.95	-.1876	-.3885	-.1798	-.3243	-.1474	-.2807	-.1629	-.2953	-.1717	-.3184	-.1816	-.3141	-.1478	-.3768

TAIL 1

Cp at γ/b of														
x/c	0.02		0.22		0.44		0.56		0.67		0.83		0.98	
	U.S.	L.S.	U.S.	L.S.	U.S.	L.S.	U.S.	L.S.	U.S.	L.S.	U.S.	L.S.	U.S.	L.S.
.05	.1975	.0933	.9458	.0077					1.2000	-.0675	1.1934	-.1057		
.10	.2481	.1326	.7594	.0041					1.0600	.0171	1.0591	-.0244	.7651	.0067
.15	.2925	.1434					.9451	-.0482	.9534	-.0444	.9408	-.0034	.6785	.0623
.20							.8452	-.0505	.8591	-.0444	.8507	-.0107	.5951	.0647
.25	.3400	.1127	.0617	-.1698					.7394	-.0333	.7492	-.0108	.5056	.0681
.30			.0874	-.1543	.1378	-.2449	.1508	-.2195	.3215	-.1054				
.40	.3893	.0590			.1758	-.2323	.1983	-.2468	.1901	-.2362	.1280	-.2281		
.50	.3940	.0228					.2121	-.2432	.2217	-.2485			-.0343	-.1576
.60					.2557	-.1503	.2289	-.2092	.2165	-.2565	.1682	-.2263	-.0178	-.1634
.70			.4249	-.0582	.3488	-.0085	.2308	-.1883	-.0215	-.2502	-.1465	-.2144	-.2404	-.3162
.80	-.0924	-.2333	-.0338	-.3000	.0257	-.2875			-.1300	-.2241	-.1803	-.2307		
.90	.1549	-.2763			.0011	-.2571			-.0934	-.1987	-.1748	-.2261		
.95	.1176	-.2780							-.0764	-.1859	-.1821	-.2165	-.1899	-.3280

TAIL 2

TABLE XIX. - CONTINUED
(1) $\alpha = 6.70^\circ$

Cp at γ/b of														
x/c	0.02		0.22		0.44		0.56		0.67		0.83		0.98	
	U.S.	L.S.	U.S.	L.S.	U.S.	L.S.	U.S.	L.S.	U.S.	L.S.	U.S.	L.S.	U.S.	L.S.
.05	.7101	.1312	1.0487	.0756			1.1383	-.0263	1.1480	.0200	1.1239	-.0145		
.10	.7527	.1375	.9255	.1020	.0225	-.0861	1.0181	.1020	1.0282	.0833	1.0019	-.0646	-.7326	.1139
.15	.7743	.0937	.8313	-.1091	.3815	-.0994	.9100	-.1056	.9255	.0878	.8966	-.0793	-.8527	.1395
.20	.6456	-.1172	.7041	-.1060	.7885	-.0965			.6286	.0897	.8096	-.0801	-.5825	.1321
.25			.1205	-.1798	.5739	-.0540	.6605	-.0939	.7238	.0848	.7197	-.0784	-.5248	.1222
.30	.2628	-.0037	.1199	-.2059	.1464	-.2051	.1397	-.1976	.2709	-.1208	.6125	-.0686	-.4762	.0832
.40									.1378	-.2286	.0793	-.2108	-.0240	-.1734
.50	.1652	-.1219			.1938	-.2274			.1575	-.2376	.0837	-.2221	-.0291	-.1549
.60	.1039	-.1218	.1857	-.1291	.1851	-.2285	.1796	-.2373	.1590	-.2418	.0900	-.2229	.0104	-.1964
.70		-.1225	.1655	-.1434	.1580	-.2297	.1357	-.2534	.0485	-.2832			-.1878	-.3561
.80	-.2143	-.3082	-.1543	-.3292	-.1561	-.3460	-.1686	-.3294	-.1763	-.3276	-.2003	-.3411	-.1613	-.3800
.90	-.1968	-.3598	-.1829	-.3525	-.1759	-.3073	-.1842	-.3113	-.1899	-.3202	-.1960	-.3246	-.1358	-.3786
.95	-.2011	-.3890	-.1971	-.3177	-.1852	-.2742	-.1894	-.2943	-.1978	-.3123	-.1977	-.3011	-.1129	-.3625

TAIL 1

Cp at γ/b of														
x/c	0.02		0.22		0.44		0.56		0.67		0.83		0.98	
	U.S.	L.S.	U.S.	L.S.	U.S.	L.S.	U.S.	L.S.	U.S.	L.S.	U.S.	L.S.	U.S.	L.S.
.05	.1567	.1218	.8264	.0854					1.1351	-.0270	1.1379	-.0249		
.10	.1932	.1426	.6361	.0904					.9977	-.0967	1.0060	-.0442	.7185	.0517
.15	.2323	.1503					.8755	.1211	.8955	.1160	.8917	-.0668	.6335	.0938
.20							.7847	.1191	.8085	.1123	.8056	-.0737	.5494	.0868
.25	.2997	.1233	.0145	-.1527					.6970	-.0959	.7092	.0734	.4634	.0899
.30			.0784	-.1186	.0976	-.2103	.1202	-.1851	.2982	-.0663				
.40	.3719	.0856			.1270	-.1646	.1457	-.2129	.1405	-.2011	.0944	-.1943		
.50	.3932	.0334					.1552	-.1807	.1593	-.2159			-.0672	-.1329
.60					.2169	-.0524	.1848	-.1362	.1567	-.2085	.1131	-.2059	-.0591	-.1363
.70			.3854	-.0442	.3404	-.0113	.1847	-.1021	-.0567	-.2227	-.1801	-.2044	-.2594	-.2808
.80	-.0391	-.2381	-.0497	-.2867	-.0103	-.2875			-.1521	-.2430	-.2120	-.2275		
.90	.0884	-.2986			-.6231	-.2782			-.1198	-.1958	-.1920	-.2232		
.95	.0574	-.2887							-.1022	-.1765	-.1690	-.2070	-.1795	-.2891

TAIL 2

TABLE XIX.- CONTINUED
(g) $\alpha = 8.70^\circ$

Cp at y/b of														
x/c	0.02		0.22		0.44		0.56		0.67		0.83		0.98	
	U.S.	L.S.	U.S.	L.S.	U.S.	L.S.	U.S.	L.S.	U.S.	L.S.	U.S.	L.S.	U.S.	L.S.
.05	.6741	.1860	.9788	.1623			1.0841	.0872	1.0968	.1105	1.0709	.1013		
.10	.6872	.1831	.8647	.1755	.9354	.1621	.9701	.1762	.9802	.1565	.9527	.1395	.6854	.1561
.15	.6987	.1328	.7830	.1769	.8395	.1662	.8680	.1730	.8820	.1530	.8523	.1469	.6127	.1728
.20	.5890	.1530	.6698	.1712	.7545	.1687			.7935	.1572	.7704	.1428	.5550	.1652
.25			.1065	-.1515	.5559	.1158	.6373	.1545	.6977	.1460	.6879	.1378	.5021	.1537
.30	.2256	.0456	.0911	-.1730	.1210	-.1669	.1226	-.1625	.2593	-.0843	.5890	.1250	.4600	.1124
.40									.1049	-.1955	.0583	-.1856	-.0279	-.1513
.50	.1142	-.0738			.1407	-.1895			.1117	-.2043	.0520	-.2001	-.0178	-.1226
.60	.0565	-.0846	.1360	-.0996	.1303	-.1924	.1274	-.2027	.1071	-.2093	.0507	-.2014	.0116	-.1603
.70		-.0964	.1170	-.0959	.1038	-.1995	.0868	-.2214	.0040	-.2574			-.1748	-.3389
.80	-.2249	-.3112	-.1855	-.3004	-.1869	-.3425	-.1973	-.3206	-.2050	-.3178	-.2226	-.3311	-.1494	-.3848
.90	-.2125	-.3038	-.2131	-.3323	-.2042	-.3030	-.2141	-.3088	-.2173	-.3129	-.2081	-.3116	-.1107	-.3673
.95	-.2104	-.3516	-.2180	-.3119	-.2101	-.2674	-.2196	-.2908	-.2252	-.3103	-.2059	-.2834	-.1126	-.3590

TAIL 1

Cp at y/b of														
x/c	0.02		0.22		0.44		0.56		0.67		0.83		0.98	
	U.S.	L.S.	U.S.	L.S.	U.S.	L.S.	U.S.	L.S.	U.S.	L.S.	U.S.	L.S.	U.S.	L.S.
.05	.1696	.1286	.7248	.1746					1.0516	.1209	1.0703	.0668		
.10	.2205	.1498	.5692	.1641					.9205	.1792	.9427	.1225	.6635	.1009
.15	.2634	.1603					.8026	.2188	.8289	.1989	.8343	.1434	.5793	.1077
.20							.7244	.2061	.7504	.1974	.7538	.1473	.5008	.1003
.25	.3087	.1382	.0238	-.1291					.6485	.1780	.6648	.1462	.4193	.0955
.30			.0949	-.0678	.0700	-.1607	.0939	-.1470	.2695	-.0030				
.40	.3533	.0923			.1152	-.0983	.1081	-.1559	.1058	-.1632	.0623	-.1596		
.50	.3657	.0385					.1260	-.0982	.1193	-.1590			-.0950	-.1366
.60					.2148	-.0217	.1613	-.0484	.1165	-.1110	.0663	-.1937	-.0945	-.1042
.70			.3397	-.0350	.3258	-.0069	.1661	-.0552	-.0840	-.1304	-.2078	-.2201	-.1947	-.2530
.80	.0659	-.2516	-.0930	-.2961	-.0543	-.2822			-.1531	-.3029	-.1590	-.2431		
.90	.0822	-.3118			-.0641	-.2911			-.1113	-.2753	-.1548	-.2185		
.95	.0496	-.2866							-.0874	-.2121	-.1557	-.1879	-.1645	-.2316

TAIL 2

TABLE XIX. - CONTINUED
(h) $\alpha = 10.70^\circ$

Cp at y/b of														
x/c	0.02		0.22		0.44		0.56		0.57		0.83		0.98	
	U.S.	L.S.	U.S.	L.S.	U.S.	L.S.	U.S.	L.S.	U.S.	L.S.	U.S.	L.S.	U.S.	L.S.
.05	.6070	.2320	.9038	.2523			1.0231	-.2008	1.0328	.2079	1.0020	.1891		
.10	.6101	.2335	.7945	.2591	-.8799	.2384	.9182	-.2508	.9253	.2293	.8929	.2147	.6237	-.1906
.15	.6135	.1907	.7225	.2562	-.7903	.2380	.8231	-.2445	.8361	.2232	.8002	.2151	.5651	-.2003
.20	.5384	.1337	.6261	.2446	-.7166	.2428			.7552	.2247	.7252	.2070	.5195	-.1911
.25			.0893	-.1169	.5335	.1762	.6153	-.2261	.6670	-.2121	.6502	.1960	.4772	-.1797
.30	.1830	-.1042	.0613	-.1392	-.0998	-.1263	.1080	-.1249	.2472	-.0453	.5609	.1760	.4451	-.1406
.40									.0762	-.1572	.0389	-.1636	-.0321	-.1244
.50	.0671	-.0266			.0950	-.1493			.0729	-.1685	.0227	-.1806	-.0086	-.0950
.60	.0133	-.0463	.0873	-.0592	.0828	-.1576	.0815	-.1620	.0619	-.1764	.0129	-.1815	.0146	-.1134
.70		-.0606	.0697	-.0465	.0549	-.1715	.0398	-.1866	-.0377	-.2319			-.1685	-.3074
.80	-.2566	-.2958	-.2106	-.2715	-.2205	-.3080	-.2257	-.3005	-.2353	-.3030	-.2362	-.3157	-.0933	-.3812
.90	-.2310	-.2739	-.2382	-.3087	-.2347	-.2934	-.2425	-.2908	-.2478	-.3009	-.2130	-.3004	-.1089	-.3616
.95	-.2264	-.3138	-.2381	-.3045	-.2394	-.2618	-.2488	-.2777	-.2538	-.3033	-.2064	-.2694	-.1123	-.3501

TAIL 1

Cp at y/b of														
x/c	0.02		0.22		0.44		0.56		0.67		0.83		0.98	
	U.S.	L.S.	U.S.	L.S.	U.S.	L.S.	U.S.	L.S.	U.S.	L.S.	U.S.	L.S.	U.S.	L.S.
.05	.1603	.1278	.6210	.2398					.9515	.2571	.9836	.1731		
.10	.2292	.1474	.4918	.2237					.8324	.3051	.8657	.2137	.6026	.1409
.15	.2801	.1584					.7101	.2884	.7499	.3003	.7684	.2328	.5235	.1387
.20							.6474	.2629	.6835	.2731	.6959	.2358	.4486	.1407
.25	.3077	.1438	.0138	-.0329					.5983	.2328	.6173	.2247	.3718	.1420
.30			.0766	-.0321	.0327	-.1255	.0646	-.1122	.2424	.0260				
.40	.3308	.3855			.0966	-.0242	.0629	-.0698	.0623	-.1338	.0334	-.1293		
.50	.3368	.0324					.0892	-.0319	.0685	-.0825			-.1114	-.1122
.60					.1899	.0042	.1208	-.0257	.0687	-.0521	.0196	-.1374	-.1135	-.1284
.70			.2908	-.0328	.2759	-.0150	.1538	-.0499	-.1124	-.1046	-.2298	-.2969	-.1914	-.2543
.80	.0708	-.2599	-.1057	-.3049	-.1095	-.2846			-.1657	-.2837	-.1747	-.2775		
.90	.0749	-.3219			-.1120	-.2484			-.1384	-.2613	-.1692	-.2446		
.95	.0423	-.2882							-.1301	-.2375	-.1687	-.2196	-.1561	-.1596

TAIL 2

TABLE XIX. - CONTINUED
(i) $\alpha = 12.70^\circ$

Cp at y/b of														
x/c	0.02		0.22		0.44		0.56		0.67		0.83		0.98	
	U.S.	L.S.	U.S.	L.S.	U.S.	L.S.	U.S.	L.S.	U.S.	L.S.	U.S.	L.S.	U.S.	L.S.
.05	.5503	.2748	.8223	.3490			.9486	.3381	.9567	.3084	.9173	.2734		
.10	.5435	.2828	.7252	.3420	.8202	.3300	.8562	.3315	.8634	.3030	.8229	.2860	.5562	.2174
.15	.5161	.2466	.6532	.3275	.7403	.3288	.7733	.3278	.7837	.3009	.7387	.2796	.5134	.2253
.20	.4667	.2422	.5668	.3031	.6746	.3292			.7096	.3024	.6726	.2668	.4791	.2130
.25			.0642	-.0847	.5059	.2489	.5851	.3051	.6322	.2892	.6038	.2500	.4397	.2084
.30	.0997	.1816	.0245	-.1096	.0783	-.0866	.0923	-.0810	.2319	.0071	.5235	.2247	.4168	.1824
.40									.0472	-.1174	.0156	-.1369	-.0361	-.1002
.50	.0197	.0321			.0474	-.1195			.0327	-.1350	-.0088	-.1534	.0064	-.0712
.60	-.0151	.0037	.0321	-.0147	.0267	-.1270	.0290	-.1319	.0150	-.1468	-.0203	-.1517	.0378	-.0775
.70		-.0090	.0206	.0189	-.0052	-.1389	-.0143	-.1606	-.0800	-.2081			-.1453	-.2643
.80	-.2801	-.2722	-.2382	-.2436	-.2577	-.2759	-.2605	-.2732	-.2616	-.2894	-.2291	-.2976	-.1003	-.3805
.90	-.2554	-.2682	-.2552	-.2830	-.2383	-.2641	-.2672	-.2659	-.2568	-.2878	-.2134	-.2841	-.1256	-.3633
.95	-.2520	-.2884	-.2333	-.2870	-.2196	-.2439	-.2527	-.2563	-.2516	-.2878	-.2051	-.2568	-.1297	-.3483

TAIL 1

Cp at y/b of														
x/c	0.02		0.22		0.44		0.56		0.67		0.83		0.98	
	U.S.	L.S.	U.S.	L.S.	U.S.	L.S.	U.S.	L.S.	U.S.	L.S.	U.S.	L.S.	U.S.	L.S.
.05	.2255	.1298	.5526	.3018					.8118	.3867	.8780	.3425		
.10	.2794	.1549	.4342	.2719					.7110	.3689	.7773	.3650	.5399	.2365
.15	.3005	.1651					.5890	.3339	.6459	.3403	.6937	.3558	.4665	.2176
.20							.5372	.3627	.5923	.3102	.6313	.3373	.3969	.2019
.25	.2779	.1431	.0180	-.0150					.5244	.2766	.5622	.3120	.3251	.1792
.30			.0333	-.0131	-.0245	-.0211	.0190	-.0701	.2065	.0644				
.40	.3052	.0655			.0453	-.0007	.0018	-.0151	.0138	-.0231	.0057	-.0937		
.50	.3032	.0102					.0462	.0085	.0099	-.0067			-.1163	-.1158
.60					.1771	.0219	.0866	.0156	.0196	-.0014	-.0278	-.0708	-.1186	-.1140
.70			.2259	-.0548	.2190	.0039	.1501	-.0150	-.1406	-.0749	-.2472	-.2858	-.2186	-.2253
.80	.0381	-.2807	-.1031	-.3191	-.1477	-.2678			-.1835	-.2122	-.2043	-.2350		
.90	.0640	-.3207			-.1664	-.2239			-.1570	-.2068	-.2009	-.2310		
.95	.0315	-.2772							-.1576	-.2060	-.2023	-.2341	-.1338	-.1376

TAIL 2

TABLE XIX. - CONTINUED
(j) $\alpha = 16.70^\circ$

Cp at y/b of														
x/c	0.02		0.22		0.44		0.56		0.67		0.83		0.98	
	U.S.	L.S.	U.S.	L.S.	U.S.	L.S.	U.S.	L.S.	U.S.	L.S.	U.S.	L.S.	U.S.	L.S.
.05	.4599	.3638	.6575	.5382			.7132	.5169	.7165	.4709	.6782	.4451		
.10	.4317	.3814	.5789	.5056	.6680	.5158	.6877	.5048	.6830	.4702	.6501	.4482	.4267	.3095
.15	.3885	.3598	.5232	.4701	.6140	.5102	.6410	.5002	.6508	.4703	.6093	.4295	.4206	.3119
.20	.3334	.3604	.4583	.4340	.5694	.4902			.6083	.4711	.5682	.4026	.4155	.3027
.25			.0145	-.0171	.4398	.3773	.5156	.4488	.5568	.4559	.5198	.3770	.3984	.2921
.30	-.0749	.3938	-.0345	-.0351	.0401	-.0140	.0643	-.0007	.2047	.1090	.4625	.3470	.3905	.2622
.40									.0109	-.0461	-.0069	-.0697	-.0078	-.0543
.50	-.1141	.1759			-.0130	-.0436			-.0115	-.0661	-.0349	-.0911	.0386	-.0055
.60	-.1241	.1241	-.0866	.1519	-.0370	-.0265	-.0252	-.0703	-.0302	-.0824	-.0448	-.0900	.0694	-.0025
.70		.0940	-.0975	.1505	-.0700	-.0434	-.0652	-.1000	-.1201	-.1544			-.1334	-.1798
.80	-.2735	-.2189	-.2794	-.1931	-.2909	-.2466	-.2875	-.2342	-.2812	-.2531	-.2367	-.2568	-.1590	-.3137
.90	-.2542	-.2607	-.2515	-.2365	-.2537	-.2374	-.2461	-.2324	-.2463	-.2528	-.2218	-.2446	-.2150	-.3446
.95	-.2491	-.2699	-.2501	-.2448	-.2632	-.2127	-.2366	-.2185	-.2440	-.2511	-.2104	-.2276	-.2416	-.3156

TAIL 1

Cp at y/b of														
x/c	0.02		0.22		0.44		0.56		0.67		0.83		0.98	
	U.S.	L.S.	U.S.	L.S.	U.S.	L.S.	U.S.	L.S.	U.S.	L.S.	U.S.	L.S.	U.S.	L.S.
.05	.3332	.0870	.3836	.3253					.4961	.5668	.5422	.6003		
.10	.3528	.1109	.3113	.2870					.4377	.5001	.5024	.5447	.3663	.3956
.15	.3232	.1315					.3513	.4145	.3937	.4629	.4579	.5148	.3149	.3319
.20							.3117	.4172	.3579	.4575	.4297	.5005	.2528	.2901
.25	.1914	.1011	-.0506	-.0232					.3141	.4460	.3914	.4698	.2007	.2500
.30			.0518	-.0156	-.1308	.0054	-.0942	.0075	.0743	.1645				
.40	.2901	.0055			-.0730	.0440	-.1094	.0278	-.1036	.0097	-.0656	-.0238		
.50	.3193	-.0456					-.0658	.0515	-.1039	.0329			-.1676	-.1317
.60					.1100	.0514	-.0347	.0534	-.0741	.0424	-.1250	-.0346	-.1635	-.1261
.70			.2521	-.0692	.0964	.0123	.0589	.0113	-.1944	-.0387	-.2329	-.2647	-.2493	-.2079
.80	-.0957	-.3012	-.0976	-.3343	-.1837	-.2790			-.2007	-.2466	-.2390	-.2164		
.90	-.0004	-.3202			-.1917	-.2573			-.1981	-.2130	-.2426	-.2083		
.95	-.0283	-.2845							-.1997	-.2067	-.2293	-.2101	-.1874	-.1223

TAIL 2

TABLE XIX. - CONCLUDED
(k) $\alpha = 20.76^\circ$

Cp at y/b of														
x/c	0.02		0.22		0.44		0.56		0.67		0.83		0.98	
	U.S.	L.S.	U.S.	L.S.	U.S.	L.S.	U.S.	L.S.	U.S.	L.S.	U.S.	L.S.	U.S.	L.S.
.05	.4513	.5556	.5521	.8197			.5442	.8608	.5579	.8244	.5192	.7297		
.10	.4320	.7026	.4911	.7894	.5459	.7872	.5609	.7913	.5507	.7674	.5082	.6769	.3433	.4385
.15	.3747	.7686	.4399	.7558	.5228	.7446	.5482	.7425	.5436	.7163	.4864	.6238	.3500	.4444
.20	.2386	.6727	.3831	.6808	.4945	.6951			.5197	.6669	.4603	.5846	.3477	.4373
.25			-.0235	.0852	.3860	.5108	.4585	.5928	.4794	.6044	.4306	.5486	.3403	.4290
.30	-.1593	.5887	-.0718	.1460	.0104	.0605	.0369	.0582		.1656	.1698	.3890	.4951	.3450
.40										-.0249	.0137	-.0368	-.0039	.0058
.50	-.1926	.2814			-.0563	.1034			-.0490	.0043	-.0596	-.0295	.0596	.0640
.60	-.2132	.2174	-.1486	.2381	-.0819	.1203	-.0649	.0563	-.0663	-.0006	-.0578	.0271	.0492	.0787
.70		.1753	-.1698	.2353	-.1117	.1132	-.1045	.0301	-.1504	-.0733			-.1804	-.1161
.80	-.2888	-.1758	-.3058	-.1517	-.2597	-.1525	-.2480	-.2027	-.2626	-.2007	-.2386	-.2069	-.3103	-.1451
.90	-.2872	-.2501	-.2962	-.1952	-.2808	-.1700	-.2513	-.1820	-.2489	-.1882	-.2244	-.1938	-.2948	-.2847
.95	-.2780	-.2658	-.3012	-.2044	-.2922	-.1738	-.2604	-.1838	-.2545	-.1867	-.2068	-.1819	-.3011	-.2707

TAIL 1

Cp at y/b of														
x/c	0.02		0.22		0.44		0.56		0.67		0.83		0.98	
	U.S.	L.S.	U.S.	L.S.	U.S.	L.S.	U.S.	L.S.	U.S.	L.S.	U.S.	L.S.	U.S.	L.S.
.05	.3336	.0758	.3655	.3492					.2148	.6246	.0905	.7153		
.10	.3430	.1160	.3093	.3081					.1983	.5920	.2041	.6466	.1066	.4647
.15	.2972	.1569							.1463	.4991	.1602	.5629	.1950	.5894
.20									.1131	.4885	.1336	.5184	.1806	.5365
.25	.0891	.1050	-.1046	-.0035					.1006	.4395	.1577	.4706	.0671	.2777
.30			-.0244	.0008	-.2016	-.0202	-.2066	-.0112	-.0819	.1360				
.40	.2409	-.0114			-.1606	.0344	-.2069	.0245	-.2214	.0080	-.1778	-.0211		
.50	.2774	-.0819					-.1881	.0526	-.2123	.0369			-.2745	-.1386
.60					-.0202	.0296	-.1470	.0511	-.1787	.0458	-.2206	-.0034	-.2958	-.1459
.70			.1991	-.1124	-.0386	-.0225	-.0694	-.0062	-.2559	-.0319	-.2418	-.2433	-.2895	-.2432
.80	-.1112	-.3344	-.1249	-.3609	-.2652	-.3011			-.2956	-.2558	-.3016	-.2600		
.90	-.0272	-.3547			-.2705	-.3180			-.2933	-.2757	-.2668	-.2175		*
.95	-.0512	-.3234							-.2877	-.2513	-.2477	-.2151	-.2504	-.2197

TAIL 2

TABLE XX. - PRESSURE COEFFICIENTS, $\phi = 45^\circ$, $\delta = -15^\circ$, $M = 2.36$
 (a) $\alpha = -4.25^\circ$

Cp at y/b of														
x/c	0.02		0.22		0.44		0.56		0.67		0.83		0.98	
	U.S.	L.S.	U.S.	L.S.	U.S.	L.S.	U.S.	L.S.	U.S.	L.S.	U.S.	L.S.	U.S.	L.S.
.05	.1763	.0370	1.0486	-.0277	1.1351	-.0550	1.1632	-.0426	1.1905	-.0298	1.1956	-.0391	.8718	-.0296
.10	.2145	.0699	.9300	-.0421	1.0516	-.0545	1.0757	-.0469	1.1104	-.0402	1.0985	-.0420	.7879	-.0234
.15	.2603		.8676	-.0617	.9810	-.0579	1.0139	-.0521	1.0431	-.0474	1.0254	-.0495	.7220	-.0125
.20	.2547	-.0164	.8115	-.0735	.9178	-.0602			.9801	-.0553	.9734	-.0546	.6752	-.0067
.25			.3641	-.1636	.7524	-.0795	.8336	-.0638	.9014	-.0612	.9006	-.0584	.6274	-.0068
.30	.3113	-.0693	.3252	-.1665	.3594	-.1640	.3788	-.1562	.5020	-.1275	.8029	-.0650	.2099	-.1261
.40									.3815	-.1693	.3356	-.1636	.1711	-.1285
.50	.2983	-.1396	.2858	-.1599	.3766	-.1734			.3828	-.1736	.3300	-.1681	.1697	-.1363
.60	.3071	-.1430	.3342	-.1572	.3580	-.1744	.3792	-.1761	.3715	-.1764	.3187	-.1684	-.0267	-.2080
.70	.1359	-.1375	.3520	-.1568	.3263	-.1689	.3394	-.1687	.2726	-.1685			-.0472	-.2110
.80	-.0623	-.1863	.0770	-.1802	.0616	-.1636	.0730	-.1641	.0599	-.1663	.0415	-.1710	-.0471	-.1972
.90	-.0624	-.1768	.0514	-.1762	.0447	-.1649	.0511	-.1639	.0515	-.1676	.0270	-.1714	-.0428	-.1959
.95	-.0562	-.1753	.0403	-.1739	.0416	-.1652	.0412	-.1639	.0419	-.1674	.0193	-.1721		

TAIL 1

Cp at y/b of														
x/c	0.02		0.22		0.44		0.56		0.67		0.83		0.98	
	U.S.	L.S.	U.S.	L.S.	U.S.	L.S.	U.S.	L.S.	U.S.	L.S.	U.S.	L.S.	U.S.	L.S.
.05	.6869	-.0841	1.2210	-.0409				-.0413	1.3219	-.0410	1.3008	-.0352		
.10	.6989	-.0630	1.1074	-.0859				-.0533	1.1951	-.0512	1.1751	-.0461	.9221	-.0250
.15	.8959	-.0683					1.1057	-.0642		-.0537	1.0864	-.0562	.8256	-.0197
.20							1.0168	-.0716	1.0321	-.0688			.7636	-.0213
.25	.4921	-.1427	.3872	-.1685			.8671	-.0813	.9337	-.0774	.9170	-.0694	.0013	-.0204
.30			.3915	-.1505	.3914	-.1714	.3835	-.1620	.5611	-.1253				
.40	.5180	-.0887			.4413	-.1619	.4273	-.1605	.4083	-.1566	.3643	-.1563	-.0019	-.0110
.50	.6732	-.0308					.4354	-.1488	.4175	-.1451			.1849	-.1736
.60					.4521	-.1515	.4338	-.1479	.4082	-.1432	.3472	-.1400	-.0080	-.1927
.70			.6410	-.1508	.4440	-.1523	.3965	-.1448	.2024	-.1439	.0797	-.1396		
.80	.2337	-.1081	.2667	-.1664	.1740	-.1539			.0575	-.0893	-.0146	-.1415	.0004	-.0124
.90	.3381	-.1105			.1876	-.1550			.0871	-.1440	-.0474	-.1446	-.0060	-.1741
.95	.1588	-.0829							-.0040	-.0165	-.0741	-.1467		

TAIL 2

TABLE XX. - CONTINUED
(b) $\alpha = -2.27^\circ$

Cp at y/b of														
x/c	0.02		0.22		0.44		0.56		0.67		0.83		0.98	
	U.S.	L.S.	U.S.	L.S.	U.S.	L.S.	U.S.	L.S.	U.S.	L.S.	U.S.	L.S.	U.S.	L.S.
.05	.2818	.0328	.9949	-.0248	1.0528	-.0347	1.0722	-.0213	1.0964	-.0139	1.0999	-.0190		
.10	.3069	.0758	.8971	-.0263	.9974	-.0342	1.0142	-.0281	1.0453	-.0242	1.0212	-.0256	.8007	-.0196
.15	.3612		.8326	-.0274	.9430	-.0358	.9712	-.0324	.9978	-.0288	.9772	-.0319	.7345	-.0135
.20	.3718	-.0092	.7621	-.0319	.8918	-.0376			.9486	-.0339	.9417	-.0358	.6800	-.0087
.25			.3255	-.1423	.7446	-.0584	.8227	-.0422	.8844	-.0401	.8793	-.0387	.6421	-.0038
.30	.2548	-.0622	.2910	-.1591	.3485	-.1552	.3741	-.1452	.5045	-.1136	.7912	-.0449	.6047	-.0023
.40									.3615	-.1602	.3173	-.1540	.2035	-.1264
.50	.2746	-.1313	.2457	-.1568	.3404	-.1664			.3549	-.1651	.2993	-.1617	.1514	-.1302
.60	.2802	-.1320	.2486	-.1572	.3264	-.1674	.3449	-.1682	.3414	-.1678	.2849	-.1627	.1446	-.1507
.70	.1027	-.1258	.2701	-.1589	.3011	-.1618	.3064	-.1623	.2445	-.1613			-.0443	-.1922
.80	-.0433	-.1818	.0421	-.1650	.0438	-.1555	.0540	-.1563	.0379	-.1594	.0206	-.1639	-.0634	-.1921
.90	-.0529	-.1728	.0335	-.1673	.0187	-.1558	.0336	-.1561	.0299	-.1598	.0067	-.1643	-.0631	-.1948
.95	-.0502	-.1674	.0275	-.1665	.0096	-.1558	.0235	-.1561	.0215	-.1596	-.0008	-.1649	-.0580	-.1961

TAIL 1

Cp at y/b of															
x/c	0.02		0.22		0.44		0.56		0.67		0.83		0.98		
	U.S.	L.S.	U.S.	L.S.	U.S.	L.S.	U.S.	L.S.	U.S.	L.S.	U.S.	L.S.	U.S.	L.S.	
.05	.5047	-.0456	1.1134	-.0169				-.0221	1.2344	-.0223	1.2236	-.0153			
.10	.5254	-.0306	1.0138	-.0455				-.0398	1.1262	-.0384	1.1145	-.0321	.8666	-.0170	
.15	.6539	-.0393							1.0444	-.0497			.7770	-.0134	
.20								.9734	-.0562	.9911	-.0541		.7199	-.0104	
.25	.3724	-.1142	.3618	-.1558				.8683	-.0660	.9055	-.0624	.8847	-.0539	.0020	-.0165
.30			.3427	-.1459	.3664	-.1635		.3697	-.1532	.5493	-.1140				
.40	.4201	-.0374			.3898	-.1688	.3874	-.1680	.3789	-.1635	.3434	-.1586			
.50	.5195	-.0148					.3870	-.1518	.3770	-.1477			-.0003	-.0081	
.60					.3828	-.1473	.3831	-.1455	.3649	-.1415	.3131	-.1379	.1570	-.1727	
.70			.5368	-.1543	.3620	-.1462	.3462	-.1417	.1730	-.1417	.0571	-.1357	-.0281	-.1840	
.80	.2187	-.1152	.2181	-.1574	.0928	-.1474			.0411	-.0869	-.0281	-.1367			
.90	.2633	-.1155			-.1117	-.1488			.0574	-.1407	-.0589	-.1389	.0022	-.0093	
.95	.1333	-.0861							-.0032	-.0137	-.0823	-.1411	-.0046	-.1739	

TAIL 2

TABLE XX. - CONTINUED
(c) $\alpha = -0.26^\circ$

Cp at γ/b of														
x/c	0.02		0.22		0.44		0.56		0.67		0.83		0.98	
	U.S.	L.S.	U.S.	L.S.	U.S.	L.S.	U.S.	L.S.	U.S.	L.S.	U.S.	L.S.	U.S.	L.S.
.05	.3784	-.0588	.9054	-.0043	.9273	-.0125	.9192	-.0015	.9336	.0014	.9306	-.0016		
.10	.3649	-.1022	.8459	-.0065	.9133	-.0118	.9161	-.0066	.9283	-.0047	.8901	-.0062	.6996	-.0086
.15	.4101		.7909	-.0092	.8808	-.0116	.9024	-.0096	.9183	-.0080	.8986	-.0111	.6557	-.0022
.20	.4214	-.0017	.7282	-.0125	.8431	-.0129			.8950	-.0107	.8960	-.0141	.6212	-.0003
.25			.3072	-.1304	.7221	-.0356	.7999	-.0189	.8538	-.0168	.8541	-.0166	.5993	-.0008
.30	.2272	-.0584	.2636	-.1459	.3309	-.1392	.3676	-.1328	.5110	-.0987	.7839	-.0228	.5748	-.0017
.40									.3432	-.1510	.3054	-.1435	.1979	-.1237
.50	.2401	-.1271	.2223	-.1477	.3087	-.1547			.3287	-.1554	.2732	-.1540	.1344	-.1226
.60	.2362	-.1248	.2088	-.1468	.2940	-.1563	.3155	-.1566	.3108	-.1578	.2528	-.1544	.1230	-.1449
.70	.0860	-.1173	.2231	-.1477	.2695	-.1555	.2788	-.1577	.2163	-.1567			-.0614	-.1906
.80	-.0498	-.1713	.0126	-.1551	.0259	-.1494	.0335	-.1510	.0168	-.1513	-.0017	-.1589	-.0790	-.1785
.90	-.0583	-.1698	-.0021	-.1572	.0038	-.1498	.0138	-.1507	.0092	-.1531	-.0153	-.1597	-.0773	-.1825
.95	-.0506	-.1638	-.0066	-.1586	-.0052	-.1500	.0048	-.1507	.0012	-.1526	-.0219	-.1603	-.0733	-.1866

TAIL 1

Cp at γ/b of														
x/c	0.02		0.22		0.44		0.56		0.67		0.83		0.98	
	U.S.	L.S.	U.S.	L.S.	U.S.	L.S.	U.S.	L.S.	U.S.	L.S.	U.S.	L.S.	U.S.	L.S.
.05	.3596	-.0071	1.0113	.0080				-.0065	1.1179	-.0073	1.1174	.0011		
.10	.3954	-.0018	.9245	-.0203				-.0240	1.0399	-.0238	1.0371	-.0176	.7958	-.0077
.15	.4756	-.0195					.9764	-.0320		-.0311	.9801	-.0256	.7222	-.0047
.20							.9223	-.0377	.9440	-.0369			.6728	-.0041
.25	.2376	-.0653	.3273	-.1370			.5631	-.0467	.3736	-.0447	.8535	-.0359	.0077	-.0086
.30			.3006	-.1322	.3428	-.1504	.3526	-.1428	.5385	-.1006				
.40	.3599	-.0135			.3498	-.1586	.3531	-.1599	.3534	-.1552	.3254	-.1486		
.50	.4358	-.0039					.3477	-.1600	.3436	-.1576			.0048	-.0013
.60					.3387	-.1445	.3435	-.1445	.3302	-.1403	.2838	-.1365	.1314	-.1640
.70			.4110	-.0880	.3170	-.1412	.3098	-.1346	.1495	-.1368	.0374	-.1327	-.0466	-.1768
.80	.1766	-.1216	.1662	-.1492	.0576	-.1425			.0311	-.0821	-.0364	-.1336		
.90	.1716	-.1193			.0626	-.1441			.0367	-.1366	-.0678	-.1352	.0066	-.0026
.95	.0857	-.0970							.0017	-.0064	-.0891	-.1377	.0014	-.1726

TAIL 2

TABLE XX. - CONTINUED
(d) $\alpha = 1.73^\circ$

Cp at y/b of														
x/c	0.02		0.22		0.44		0.56		0.67		0.88		0.98	
	U.S.	L.S.	U.S.	L.S.	U.S.	L.S.	U.S.	L.S.	U.S.	L.S.	U.S.	L.S.	U.S.	L.S.
.05	.4754	.0771	.7840	.0194	.7962	-.0137	.7702	-.0224	.7948	.0248	.7990	.0217		
.10	.4172	-.1404	.7725	.0201	.8025	-.0143	.7858	-.0185	.7930	.0201	.7543	-.0186	.6129	-.0087
.15	.4427		.7400	-.0167	.8001	-.0152	.7961	-.0156	.8017	-.0168	.7834	-.0136	.5684	-.0142
.20	.4536	-.0218	.6870	-.0115	.7806	-.0136			.7992	-.0149	.7916	-.0103	.5378	-.0157
.25			.2873	-.1202	.6845	-.0113	.7434	-.0067	.7823	.0091	.7770	-.0075	.5218	-.0134
.30	.2181	-.0425	.2375	-.1377	.3076	-.1331	.3447	-.1201	.4865	-.0820	.7290	.0011	.5084	-.0122
.40									.3196	-.1397	.2807	-.1328	.1701	-.1131
.50	-.1933	-.1223	.2113	-.1369	.2768	-.1442			.3053	-.1441	.2474	-.1447	.1118	-.1097
.60	-.1691	-.1164	.2004	-.1360	.2655	-.1457	.2847	-.1461	.2869	-.1464	.2240	-.1472	.1035	-.1251
.70	-.0557	-.1071	.1945	-.1371	.2445	-.1477	.2516	-.1509	.1940	-.1531			-.0717	-.1881
.80	-.0635	-.1593	-.0161	-.1471	.0121	-.1449	.0172	-.1462	-.0011	-.1484	-.0210	-.1548	-.0819	-.1715
.90	-.0742	-.1721	-.0341	-.1481	-.0048	-.1450	-.0012	-.1458	-.0093	-.1483	-.0343	-.1556	-.0745	-.1726
.95	-.0672	-.1633	-.0381	-.1492	-.0128	-.1451	-.0095	-.1458	-.0167	-.1481	-.0407	-.1562	-.0706	-.1748

TAIL 1

Cb at y/b of															
x/c	0.02		0.22		0.44		0.56		0.67		0.88		0.98		
	U.S.	L.S.	U.S.	L.S.	U.S.	L.S.	U.S.	L.S.	U.S.	L.S.	U.S.	L.S.	U.S.	L.S.	
.05	.2732	-.0034	.9198	.0364				.0123	.9737	-.0108	.9710	-.0182			
.10	.3030	.0000	.8360	-.0136				-.0033	.9340	-.0035	.9369	-.0011	.7215	-.0035	
.15	.3541	-.0080						.8931	-.0099		.9123	-.0054	.6621	-.0045	
.20								.8596	-.0153	.8837	-.0150		.6215	-.0057	
.25	.1693	-.0614	.2776	-.1186				.8018	-.0252	.8320	-.0230	.8231	-.0154	.0044	-.0115
.30			.2441	-.1237	.3131	-.1395	.3383	-.1305	.5271	-.0846					
.40	.3171	-.0289			.3053	-.1494	.3194	-.1499	.3309	-.1458	.3128	-.1403			
.50	.3556	-.0237					.3099	-.1535	.3150	-.1538			.0021	-.0050	
.60					.2935	-.1460	.3063	-.1494	.3005	-.1465	.2596	-.1437	.1092	-.1407	
.70			.3684	-.1186	.2737	-.1387	.2758	-.1325	.1279	-.1325	.0194	-.1334	-.0633	-.1727	
.80	.1323	-.1200	.1082	-.1605	.0286	-.1374			.0179	-.0804	-.0479	-.1333			
.90	.1036	-.1316			.0300	-.1392			.0167	-.1305	-.0787	-.1347	.0029	-.0062	
.95	.0455	-.1093							-.0013	-.0097	-.0962	-.1362	-.0017	-.1713	

TAIL 2

TABLE XX. - CONTINUED
(a) $n = 3.72^a$

Cp at γ/b of														
x/c	0.02		0.22		0.44		0.56		0.67		0.83		0.98	
	U.S.	L.S.	U.S.	L.S.	U.S.	L.S.	U.S.	L.S.	U.S.	L.S.	U.S.	L.S.	U.S.	L.S.
.05	.5344	.1038	.6496	.0487	.7070	.0425	.6699	.0514	.6992	.0522	.7034	.0481		
.10	.4655	.1626	.6901	.0506	.7083	.0435	.6876	.0470	.6399	.0479	.6574	.0455	.5428	.0268
.15	.4788		.6655	.0482	.7112	.0448	.7013	.0439	.7033	.0440	.6904	.0405	.5031	.0306
.20	.4607	.0505	.6265	.0421	.7002	.0431			.7046	.0422	.6981	.0372	.4746	.0317
.25			.2537	-.1050	.6233	.0159	.6667	.0343	.6947	.0362	.6897	.0345	.4597	.0294
.30	.2027	-.0100	.2048	-.1234	.2677	-.1194	.3002	-.1048	.4345	-.0640	.6559	.0273	.4481	.0272
.40									.2733	-.1269	.2368	-.1201	.1342	-.0995
.50	.1483	-.1170	.1753	-.1203	.2397	-.1301			.2651	-.1315	.2051	-.1337	.0808	-.1002
.60	.1346	-.1053	.1766	-.1211	.2285	-.1315	.2500	-.1324	.2515	-.1338	.1846	-.1370	.0781	-.1030
.70	.0233	-.0979	.1775	-.1241	.2085	-.1352	.2184	-.1406	.1642	-.1487			-.0725	-.1875
.80	-.0903	-.1391	-.0279	-.1464	-.0115	-.1419	-.0023	-.1433	-.0207	-.1450	-.0424	-.1514	-.0635	-.1735
.90	-.0970	-.1691	-.0521	-.1464	-.0274	-.1421	-.0212	-.1430	-.0291	-.1451	-.0541	-.1521	-.0645	-.1637
.95	-.0947	-.1621	-.0602	-.1476	-.0337	-.1422	-.0295	-.1430	-.0363	-.1449	-.0598	-.1528	-.0689	-.1621

TAIL 1

Cp at γ/b of															
x/c	0.02		0.22		0.44		0.56		0.67		0.83		0.98		
	U.S.	L.S.	U.S.	L.S.	U.S.	L.S.	U.S.	L.S.	U.S.	L.S.	U.S.	L.S.	U.S.	L.S.	
.05	.1862	.0059	.8298	.0718				.0370	.8225	.0347	.8220	.0401			
.10	.2059	.0021	.7355	.0578				.0228	.8020	.0216	.8039	.0247	.6409	.0203	
.15	.2371	-.0053						.7991	.0172		.7994	.0186	.5901	.0149	
.20								.7817	.0121	.7952	.0100		.5563	.0156	
.25	.1070	-.0623	.1953	-.1044				.7475	.0011	.7626	.0017	.7623	.0077	-.0005	-.0152
.30			.1560	-.1150	.2711	-.1241	.3079	-.1157	.4939	-.0662					
.40	.2776	-.0423			.2464	-.1337	.2757	-.1364	.2980	-.1336	.2989	-.1284			
.50	.2691	-.0390					.2594	-.1395	.2791	-.1415			-.0033	-.0099	
.60					.2186	-.1351	.2507	-.1399	.2665	-.1421	.2394	-.1407	.0891	-.0959	
.70			.3049	-.1103	.1971	-.1350	.2201	-.1288	.1031	-.1290	.0029	-.1303	-.0778	-.1613	
.80	.0673	-.1251	.0535	-.1716	-.0186	-.1307			.0019	-.0798	-.0562	-.1298			
.90	.0808	-.1381			-.0127	-.1333			-.0099	-.1239	-.0854	-.1310	-.0019	-.0113	
.95	.0627	-.1159							-.0065	-.0145	-.0987	-.1325	-.0062	-.1665	

TAIL 2

TABLE XX. - CONTINUED
(1) $\alpha = 5.71^\circ$

Cp at y/b of														
x/c	0.02		0.22		0.44		0.56		0.67		0.83		0.98	
	U.S.	L.S.	U.S.	L.S.	U.S.	L.S.	U.S.	L.S.	U.S.	L.S.	U.S.	L.S.	U.S.	L.S.
.05	.4809	.1087	.6085	-.0811	.6267	.0733	.5884	-.0820	.6162	.0819	.6234	-.0753		
.10	.3770	-.1377	.6139	-.0837	.6257	.0744	.6004	-.0783	.6251	.0784	.5798	-.0743	.4758	-.0462
.15	.4603		.6010	-.0818	.6284	.0763	.6179	-.0744	.6236	.0738	.6090	.0697	.4441	-.0488
.20	.4384	-.0848	.5643	-.0760	.6193	.0746			.6211	.0721	.6166	.0660	.4186	-.0492
.25			.2115	-.0866	.5544	.0450	.5903	.0640	.6130	.0659	.6077	.0627	.4063	-.0464
.30	.1648	.0031	.1641	-.1061	.2232	-.1037	.2593	-.0878	.3781	-.0440	.5801	-.0552	.3971	-.0438
.40									.2242	-.1120	.1928	-.1062	.1023	-.0868
.50	.0997	-.1043	.1346	-.1007	.2041	-.1142			.2166	-.1168	.1612	-.1218	.0564	-.0944
.60	.1026	-.0953	.1309	-.1038	.1931	-.1156	.2123	-.1176	.2067	-.1193	.1426	-.1260	.0625	-.0888
.70	-.0151	-.0875	.1357	-.1061	.1734	-.1196	.1840	-.1271	.1287	-.1388			-.0609	-.1795
.80	-.1128	-.1345	-.0404	-.1444	-.0337	-.1353	-.0223	-.1361	-.0415	-.1387	-.0657	-.1456	-.0636	-.1756
.90	-.1201	-.1643	-.0593	-.1410	-.0506	-.1355	-.0404	-.1360	-.0487	-.1386	-.0756	-.1464	-.0696	-.1638
.95	-.1191	-.1592	-.0693	-.1414	-.0570	-.1356	-.0481	-.1361	-.0550	-.1385	-.0803	-.1469	-.0610	-.1624

TAIL 1

Cp at y/b of															
x/c	0.02		0.22		0.44		0.56		0.67		0.83		0.98		
	U.S.	L.S.	U.S.	L.S.	U.S.	L.S.	U.S.	L.S.	U.S.	L.S.	U.S.	L.S.	U.S.	L.S.	
.05	.1579	.0238	.7070	.0965				.0679	.7051	.0634	.7094	.0668			
.10	.1828	.0160	.6260	-.0804				.0542	.6834	.0509	.6939	.0526	.5714	.0425	
.15	.2070	.0066						.6722	.0486		.0449	.6888	.0464	.5251	.0274
.20								.6754	.0429	.6795	.0387			.4948	.0236
.25	.0766	-.0722	.1055	-.0894				.6685	.0308	.6612	.0298	.6602	.0344	-.0088	-.0215
.30			.0707	-.1030	.2202	-.1067	.2640	-.0992	.4324	-.0453					
.40	.1856	-.0666			.1844	-.1172	.2284	-.1207	.2535	-.1187	.2596	-.1136			
.50	.2144	-.0585					.2066	-.1235	.2357	-.1264			-.0102	-.0163	
.60					.1496	-.1216	.1927	-.1246	.2218	-.1278	.2128	-.1293	.0607	-.0787	
.70			.2345	-.1080	.1297	-.1251	.1634	-.1210	.0724	-.1219	-.0138	-.1208	-.0926	-.1513	
.80	.0608	-.1287	.0281	-.1507	-.0596	-.1192			-.0149	-.0773	-.0620	-.1201			
.90	.1293	-.1419			-.0523	-.1213			-.0345	-.1140	-.0862	-.1215	-.0093	-.0176	
.95	.0565	-.1244							-.0141	-.0208	-.0947	-.1227	-.0137	-.1455	

TAIL 2

TABLE XX. - CONTINUED
(g) $\alpha = 7.71^\circ$

Cp at y/b of														
x/c	0.02		0.22		0.44		0.56		0.67		0.83		0.98	
	U.S.	L.S.	U.S.	L.S.	U.S.	L.S.	U.S.	L.S.	U.S.	L.S.	U.S.	L.S.	U.S.	L.S.
.05	.4131	.1398	.5357	.1180	.5483	.1071	.5101	.1165	.5358	.1145	.5408	.1054		
.10	.3342	.1410	.5360	.1213	.5500	.1086	.5231	.1120	.5471	.1108	.4991	.1049	.4106	.0673
.15	.3938		.5300	.1194	.5507	.1109	.5378		.5499	.1060	.5255	.1003	.3821	.0684
.20	.3672	.1105	.5009	.1131	.5441	.1090			.5451	.1044	.5368	.0964	.3638	.0681
.25			.1731	-.0667	.4854	-.0768	.5172		.5358	.0979	.5304	.0931	.3527	.0651
.30	.1105	.0317	.1262	-.0871	.1761	-.0864	.2212	-.0600	.3209	-.0219	.5034	.0847	.3464	.0619
.40									.1755	-.0952	.1498	-.0917	.0706	-.0775
.50	.0313	-.0857	.0951	-.0807	.1634	-.0966			.1671	-.1002	.1195	-.1088	.0394	-.0867
.60	.0285	-.0722	.0883	-.0844	.1551	-.0979	.1661	-.1007	.1596	-.1030	.1014	-.1143	.0485	-.0809
.70	-.0385	-.0693	.0812	-.0864	.1364	-.1024	.1413	-.1113	.0903	-.1260			-.0596	-.1685
.80	-.1221	-.1349	-.0822	-.1404	-.0550	-.1278	-.0446	-.1271	-.0655	-.1322	-.0881	-.1404	-.0649	-.1863
.90	-.1220	-.1475	-.1001	-.1344	-.0706	-.1277	-.0605	-.1274	-.0718	-.1316	-.0938	-.1423	-.0361	-.1743
.95	-.1196	-.1498	-.1056	-.1339	-.0764	-.1278	-.0675	-.1275	-.0771	-.1314	-.0972	-.1426	-.0310	-.1704

TAIL 1

Cp at y/b of															
x/c	0.02		0.22		0.44		0.56		0.67		0.83		0.98		
	U.S.	L.S.	U.S.	L.S.	U.S.	L.S.	U.S.	L.S.	U.S.	L.S.	U.S.	L.S.	U.S.	L.S.	
.05	.1642	.0531	.5692	.1203				.1009	.6030	.0943	.6163	.0977			
.10	.2065	.0385	.5274	.1047				.0867	.5841	.0824	.6035	.0842	.5117	.0713	
.15	.2366	.0168						.5586	.0806		.5983	.0770	.4689	.0472	
.20								.5544	.0743	.5758	.0695		.4402	.0373	
.25	.0914	-.0694	.0949	-.0714				.5767	.0611	.5537	.0604	.5747	.0644	-.0140	-.0234
.30			.0605	-.0823	.1691	-.0898	.2030	-.0818	.3509	-.0223					
.40	.1275	-.0635			.1403	-.1014	.1755	-.1036	.1921	-.1015	.2134	-.0966			
.50	.1711	-.0530					.1597	-.1064	.1838	-.1092			-.0145	-.0189	
.60					.1083	-.1058	.1489	-.1080	.1757	-.1108	.1704	-.1145	.0318	-.0944	
.70			.1476	-.0948	.0876	-.1108	.1230	-.1125	.0429	-.1186	-.0361	-.1155	-.1053	-.1446	
.80	.0574	-.1332	-.0154	-.1537	-.0846	-.1155			-.0289	-.0755	-.0717	-.1146			
.90	.0818	-.1469			-.0798	-.1162			-.0544	-.1092	-.0858	-.1153	-.0132	-.0202	
.95	.0292	-.1280							-.0185	-.0233	-.0912	-.1162	-.0178	-.1206	

TAIL 2

TABLE XX. - CONTINUED
(h) $\alpha = 9.70^\circ$

Cp at y/b of														
x/c	0.02		0.22		0.44		0.56		0.67		0.83		0.98	
	U.S.	L.S.	U.S.	L.S.	U.S.	L.S.	U.S.	L.S.	U.S.	L.S.	U.S.	L.S.	U.S.	L.S.
.05	.3624	.1535	.4902	.1589	.4879	.1459	.4334	.1546	.4635	.1508	.4717	.1373		
.10	.3095	.1476	.4835	.1626	.4986	.1474	.4544	.1505	.4670	.1462	.4328	.1381	.3667	.0952
.15	.3514		.4784	.1601	.4997	.1500	.4736	.1455	.4739	.1411	.4536	.1341	.3396	.0948
.20	.3194	.1328	.4560	.1531	.4923	.1483			.4695	.1389	.4616	.1303	.3249	.0933
.25			.1431	-.0446	.4362	.1126	.4653	.1322	.4627	.1318	.4536	.1267	.3153	.0899
.30	-.0766	-.0665	.0952	-.0661	.1416	-.0663	.1908	-.0506	.2686	.0006	.4285	.1172	.3051	.0860
.40									.1391	-.0778	.1023	-.0761	.0428	-.0675
.50	-.0056	-.0658	.0622	-.0594	.1279	-.0764			.1332	-.0830	.0742	-.0950	.0279	-.0742
.60	-.0126	-.0480	.0555	-.0636	.1218	-.0778	.1287	-.0822	.1262	-.0861	.0602	-.1015	.0336	-.0687
.70	-.0641	-.0466	.0474	-.0669	.1056	-.0827	.1064	-.0936	.0603	-.1129			-.0677	-.1548
.80	-.1501	-.1225	-.1021	-.1371	-.0726	-.1204	-.0641	-.1203	-.0836	-.1258	-.1036	-.1344	-.0571	-.1899
.90	-.1254	-.1473	-.1198	-.1272	-.0871	-.1202	-.0778	-.1204	-.0900	-.1247	-.1024	-.1359	-.0547	-.1779
.95	-.1185	-.1361	-.1250	-.1259	-.0921	-.1202	-.0840	-.1204	-.0951	-.1245	-.1054	-.1362	-.0513	-.1743

TAIL 1

Cp at y/b of														
x/c	0.02		0.22		0.44		0.56		0.67		0.83		0.98	
	U.S.	L.S.	U.S.	L.S.	U.S.	L.S.	U.S.	L.S.	U.S.	L.S.	U.S.	L.S.	U.S.	L.S.
.05	.2714	.0427	.4803	.1120				.1435	.4719	.1384	.5057	.1390		
.10	.3026	.0212	.4296	.0986				.1304	.4549	.1273	.4934	.1272	.4362	.1085
.15	.2929	.0032					.4252	.1237		.1203	.4882	.1193	.3981	.0802
.20							.4292	.1167	.4497	.1137			.3716	.0624
.25	.0829	-.0745	.0506	-.0719			.4698	.1016	.4320	.1035	.4661	.1059	-.0185	-.0248
.30			.0217	-.0864	.6321	.052	.1383	-.0583	.2619	.0105				
.40	.1132	-.0747			.0458	-.0880	.1042	-.0823	.1312	-.0764	.1508	-.0718		
.50	.1600	-.0584					.0803	-.0874	.1244	-.0851			-.0186	-.0218
.60					.0249	-.0951	.0652	-.0909	.1123	-.0881	.1233	-.0902	-.0021	-.0932
.70			.0735	-.0826	.0288	-.1017	.0415	-.0998	-.0040	-.1106	-.0588	-.1182	-.1043	-.1205
.80	.0861	-.1413	-.0685	-.1515	-.0895	-.1149			-.0519	-.0764	-.0875	-.1154		
.90	.0882	-.1493			-.0823	-.1163			-.0954	-.1083	-.0952	-.1156	-.0168	-.0230
.95	.0216	-.1322							-.0233	-.0261	-.1000	-.1162	-.0216	-.1181

TAIL 2

TABLE XX. - CONTINUED
(i) $\alpha = 11.70^\circ$

Cp at y/b of														
x/c	0.02		0.22		0.44		0.56		0.67		0.83		0.98	
	U.S.	L.S.	U.S.	L.S.	U.S.	L.S.	U.S.	L.S.	U.S.	L.S.	U.S.	L.S.	U.S.	L.S.
.05	.3351	.1769	.4445	.2021	.4470	.1871	.4110	.1985	.4428	.1935	.4507	.1790		
.10	.2763	.1737	.4375	.2070	.4486	.1889	.4279	.1940	.4445	.1886	.4125	.1803	.3504	.1298
.15	.3051		.4270	.2050	.4472	.1914	.4346	.1885	.4487	.1838	.4318	.1759	.3268	.1285
.20	.2696	.1636	.4034	.1982	.4388	.1895			.4411	.1812	.4413	.1718	.3124	.1263
.25			.1133	-.0196	.3845	.1510	.4085	.1743	.4294	.1731	.4331	.1679	.3050	.1227
.30	.0231	.1154	.0650	-.0422	.1075	-.0447	.1435	-.0269	.2398	.0288	.4075	.1573	.2982	.1176
.40									.1045	-.0553	.0876	-.0561	.0377	-.0513
.50	-.0432	-.0421	.0296	-.0366	.0907	-.0541			.0960	-.0608	.0591	-.0766	.0344	-.0570
.60	-.0506	-.0179	.0216	-.0403	.0868	-.0557	.0913	-.0600	.0880	-.0644	.0431	-.0840	.0351	-.0490
.70	-.0960	-.0184	.0113	-.0432	.0757	-.0608	.0705	-.0726	.0294	-.0946				
.80	-.1620	-.1024	-.1216	-.1394	-.0868	-.1159	-.0840	-.1145	-.1034	-.1217	-.1158	-.1295	-.0508	-.1852
.90	-.1352	-.1439	-.1376	-.1229	-.1013	-.1146	-.0954	-.1140	-.1098	-.1199	-.1121	-.1309	-.0783	-.1773
.95	-.1253	-.1431	-.1308	-.1209	-.1063	-.1146	-.1002	-.1139	-.1135	-.1195	-.1149	-.1311	-.0784	-.1739

TAIL 1

Cp at y/b of															
x/c	0.02		0.22		0.44		0.56		0.67		0.83		0.98		
	U.S.	L.S.	U.S.	L.S.	U.S.	L.S.	U.S.	L.S.	U.S.	L.S.	U.S.	L.S.	U.S.	L.S.	
.05	.2786	.0256	.4015	.1371				.1635	.3384	.1712	.3845	.1777			
.10	.3066	.0043	.3590	.1219				.1518	.3253	.1594	.3726	.1674	.3480	.1450	
.15	.3077	-.0095						.3079	.1446		.1515	.3690	.1590	.3117	.1167
.20								.3038	.1369	.3264	.1443			.2895	.0922
.25	.0953	-.0798	.0546	-.0665				.3470	.1201	.3105	.1335	.3531	.1446	-.0342	-.0383
.30			.0505	-.0907	.0297	-.0654	.0622	-.0450	.1686	.0332					
.40	.1159	-.0877			-.0027	-.0775	.0355	-.0687	.0574	-.0585	.0825	-.0487			
.50	.1370	-.0620					.0149	-.0727	.0528	-.0676					
.60					-.0165	-.0878	-.0004	-.0763	.0446	-.0708	.0634	-.0681	-.0303	-.0352	
.70			.0960	-.0752	-.0206	-.1006	-.6203	-.0885	-.0530	-.0975	-.0907	-.1456	-.1149	-.1323	
.80	.0530	-.1503	-.0520	-.1437	-.1241	-.1235			-.0751	-.0875	-.1127	-.1280			
.90	.0789	-.1523			-.1231	-.1241			-.1236	-.1204	-.1161	-.1260	-.0280	-.0370	
.95	.0220	-.1355							-.0362	-.0393	-.1206	-.1261	-.0344	-.1210	

TAIL 2

TABLE XX. - CONTINUED
(j) $\alpha = 15.71^\circ$

Cp at y/b of														
x/c	0.02		0.22		0.44		0.56		0.67		0.83		0.98	
	U.S.	L.S.	U.S.	L.S.	U.S.	L.S.	U.S.	L.S.	U.S.	L.S.	U.S.	L.S.	U.S.	L.S.
.05	.3616	.2566	.4622	.3062	.4523	.2859	.4118	.3002	.4408	.2934	.4476	.2773		
.10	.3079	.2504	.4510	.3137	.4499	.2884	.4293	.2940	.4434	.2874	.4096	.2804	.3470	.2121
.15	.3227		.4346	.3109	.4464	.2912	.4337	.2876	.4484	.2837	.4271	.2754	.3300	.2086
.20	.2751	.2474	.4056	.3041	.4347	.2901			.4411	.2806	.4369	.2714	.3209	.2045
.25			.1100	.0393	.3779	.2448	.4036	.2728	.4278	.2705	.4293	.2660	.3138	.2003
.30	-.0047	.2054	.0569	.0149	.1014	.0102	.1316	.0282	.2375	.0954	.4043	.2517	.3088	.1935
.40									.0994	-.0018	.0832	-.0080	.0457	-.0102
.50	-.0706	.0207	.0065	.0190	.0773	.0031			.0886	-.0078	.0545	-.0317	.0523	-.0130
.60	-.0816	.0549	-.0080	.0171	.0678	.0020	.0796	-.0048	.0786	-.0125	.0396	-.0409	.0594	-.0001
.70	-.1220	.0509	-.0188	.0188	.0522	-.0039	.0565	-.0194	.0185	-.0509			-.0613	-.0998
.80	-.1433	-.0522	-.1389	-.1148	-.1014	-.1131	-.0957	-.1001	-.1102	-.1064	-.1135	-.1116	-.0747	-.1661
.90	-.1268	-.1171	-.1252	-.1202	-.1154	-.0993	-.1087	-.0954	-.1166	-.1012	-.1078	-.1124	-.1192	-.1707
.95	-.1319	-.1282	-.1193	-.1108	-.1155	-.0987	-.1080	-.0949	-.1117	-.1004	-.1074	-.1123	-.1211	-.1633

TAIL 1

Cp at y/b of														
x/c	0.02		0.22		0.44		0.56		0.67		0.83		0.98	
	U.S.	L.S.	U.S.	L.S.	U.S.	L.S.	U.S.	L.S.	U.S.	L.S.	U.S.	L.S.	U.S.	L.S.
.05	.2507	-.0540	.2400	.1240				.2081	.1183	.2274	.1521	.2489		
.10	.2134	-.0639	.2156	.0999				.1984	.1030	.2118	.1379	.2374	.1691	.2156
.15	.2002	-.0697					.1190	.1924		.2040	.1308	.2293	.1364	.1930
.20							.1124	.1866	.1005	.1969			.1230	.1729
.25	.0551	-.1122	.0428	-.0841			.2043	.1667	.0796	.1850	.1156	.2102	-.0562	-.0532
.30			.0425	-.0982	-.0714	-.0518	-.0496	-.0179	-.0045	.0732				
.40	.0865	-.1019			-.0738	-.0687	-.0848	-.0472	-.0705	-.0236	-.0588	-.0042		
.50	.1075	-.0770					-.0956	-.0565	-.0847	-.0387			-.0500	-.0563
.60					-.0929	-.0900	-.0970	-.0667	-.0978	-.0471	-.0676	-.0245	-.1119	-.0823
.70			.0706	-.0130	-.1116	-.0963	-.1024	-.0836	-.1477	-.0788	-.1562	-.1393	-.1590	-.1421
.80	.0430	-.1697	-.0752	-.1469	-.1818	-.1700			-.0999	-.1189	-.1658	-.1604		
.90	.0378	-.1655			-.1700	-.1561			-.1512	-.1575	-.1517	-.1546	-.0466	-.0579
.95	.0079	-.1520							-.0561	-.0615	-.1496	-.1470	-.0541	-.1461

TAIL 2

TABLE XX. - CONCLUDED
(k) $\alpha = 19.71^\circ$

Cp at y/b of														
x/c	0.02		0.22		0.44		0.56		0.67		0.83		0.98	
	U.S.	L.S.	U.S.	L.S.	U.S.	L.S.	U.S.	L.S.	U.S.	L.S.	U.S.	L.S.	U.S.	L.S.
.05	.4197	.3559	.5128	.4370	.4983	.4203	.4467	.4341	.4747	.4260	.4716	.4009		
.10	.3727	.3465	.4990	.4443	.4943	.4238	.4658	.4270	.4777	.4179	.4317	.4052	.3574	.3121
.15	.3679		.4811	.4426	.4913	.4268	.4709	.4214	.4819	.4137	.4486	.4012	.3454	.3052
.20	.3158	.3466	.4474	.4374	.4759	.4260			.4741	.4089	.4566	.3965	.3392	.2989
.25			.1304	.1123	.4156	.3718	.4401	.4044	.4593	.3998	.4459	.3885	.3316	.2934
.30	-.0046	.3115	.0747	.0827	.1243	.0861	.1496	.1049	.2590	.1857	.4179	.3672	.3278	.2843
.40									.1141	.0727	.0879	.0538	.0660	.0406
.50	-.0634	.0954	.6211	.0915	.0959	.0797			.1011	.0666	.0594	.0273	.0673	.0438
.60	-.0734	.1533	.0038	.0941	.0842	.0776	.0950	.0708	.0879	.0584	.0454	.0160	.1015	.0621
.70	-.1138	.1485	-.0079	.0945	.0664	.0699	.0694	.0533	.0244	.0083			-.0435	-.0627
.80	-.1338	.0148	-.1338	-.0745	-.0957	-.0945	-.0914	-.0917	-.1071	-.0905	-.0991	-.0892	-.1040	-.1162
.90	-.1200	-.0751	-.1144	-.0851	-.0963	-.0787	-.0777	-.0666	-.0819	-.0744	-.0864	-.0866	-.1354	-.1530
.95	-.1247	-.0949	-.1179	-.0799	-.0842	-.0735	-.0681	-.0643	-.0736	-.0724	-.0825	-.0862	-.1344	-.1436

TAIL 1

Cp at y/b of														
x/c	0.02		0.22		0.44		0.56		0.67		0.83		0.98	
	U.S.	L.S.	U.S.	L.S.	U.S.	L.S.	U.S.	L.S.	U.S.	L.S.	U.S.	L.S.	U.S.	L.S.
.05	.2221	-.0717	.1611	.1839				.2514	.0443	.2702	.0477	.2849		
.10	.1661	-.0701	.1474	.1357				.2358	.0309	.2526	.0301	.2762	.0612	.2638
.15	.1380	-.0747						.0403	.2273	.2407	.0214	.2667	.0199	.2497
.20								.0207	.2158	.0251	.2302		.0087	.2333
.25	.0048	-.1207	-.0109	-.0650			.0852	.1892	-.0018	.2148	.0028	.2433	-.0686	-.0570
.30			-.0174	-.0836	-.1068	-.0396	-.1023	-.0037	-.0707	.0915				
.40	.0337	-.1114			-.1205	-.0567	-.1268	-.0353	-.1265	-.0103	-.1272	.0205		
.50	.0461	-.0809					-.1384	-.0469	-.1360	-.0282			-.0602	-.0665
.60					-.1349	-.0692	-.1405	-.0550	-.1452	-.0385	-.1455	-.0075	-.1592	-.0460
.70			-.0127	-.0099	-.1454	-.0663	-.1441	-.0688	-.1791	-.0736	-.1765	-.1318	-.1774	-.1520
.80	-.0307	-.1702	-.1261	-.1513	-.1961	-.1274			-.1141	-.1216	-.1726	-.1538		
.90	-.0006	-.1757			-.1857	-.1402			-.1742	-.1680	-.1717	-.1604	-.0553	-.0682
.95	-.0288	-.1618							-.0668	-.0729	-.1725	-.1648	-.0641	-.1416

TAIL 2

TABLE XXI. - PRESSURE COEFFICIENTS, $\theta = 45^\circ$, $\delta = -15^\circ$, $M = 3.70$
(a) $\alpha = -3.83^\circ$

Cp at γ/b of														
x/c	0.02		0.22		0.44		0.56		0.67		0.83		0.98	
	U.S.	L.S.	U.S.	L.S.	U.S.	L.S.	U.S.	L.S.	U.S.	L.S.	U.S.	L.S.	U.S.	L.S.
.05	.1109	.0327	.8043	-.0286	.7610	-.0310	.7443	-.0156	.7534	-.0139	.7448	-.0121		
.10	.1182	.0416	.7464	-.0327	.7744	-.0307	.7382	-.0239	.7549	-.0216	.7062	-.0200	.6559	-.0158
.15	.1448		.7002	-.0349	.7856	-.0335	.7589	-.0262	.7539	-.0257	.7293	-.0245	.6238	-.0174
.20	.1493	-.0044	.6671	-.0363	.7880	-.0359			.7532	-.0277	.7477	-.0277	.5962	-.0187
.25			.3447	-.0615	.7165	-.0437	.7380	-.0326	.7464	-.0296	.7479	-.0308	.5811	-.0206
.30	.1009	-.0315	.2980	-.0582	.3759	-.0482	.4130	-.0526	.5157	-.0486	.7255	-.0334	.5665	-.0222
.40									.3627	-.0625	.3560	-.0642	.2603	-.0561
.50	.1531	-.0565	.2561	-.0634	.3195	-.0576			.3609	-.0583	.3317	-.0693	.2015	-.0602
.60	.1464	-.0582	.2461	-.0640	.3028	-.0563	.3314	-.0543	.3528	-.0557	.3186	-.0602	.1878	-.0637
.70	.0828	-.0575	.2545	-.0628	.2820	-.0545	.2978	-.0584	.2748	-.0531			.0330	-.0692
.80	.0058	-.0678	.0914	-.0632	.0861	-.0548	.0957	-.0587	.0992	-.0540	.0937	-.0637	.0128	-.0668
.90	-.0127	-.0655	.0641	-.0637	.0678	-.0575	.0810	-.0586	.0900	-.0623	.0812	-.0639	.0109	-.0651
.95	-.0145	-.0646	.0554	-.0636	.0618	-.0579	.0748	-.0587	.0834	-.0628	.0753	-.0643	.0125	-.0661

TAIL 1

Cp at γ/b of															
x/c	0.02		0.22		0.44		0.56		0.67		0.83		0.98		
	U.S.	L.S.	U.S.	L.S.	U.S.	L.S.	U.S.	L.S.	U.S.	L.S.	U.S.	L.S.	U.S.	L.S.	
.05	.5819	-.0260	.8818	-.0071				-.0156	.8418	-.0130	.8314	-.0064			
.10	.4635	-.0287	.8705	-.0300				-.0273	.8234	-.0238	.8222	-.0237	.7042	-.0139	
.15	.4980	-.0350						.8315	-.0323		-.0300	.8198	-.0306	.6640	-.0210
.20								.8195	-.0353	.8230	-.0339			.6414	-.0241
.25	.3350	-.0553	.4110	-.0607			.7900	-.0372	.8004	-.0372	.7942	-.0325	.0272	.0019	
.30			.3583	-.0421	.4008	-.0582	.4106	-.0614	.5743	-.0516					
.40	.2889	-.0294			.3849	-.0542	.3817	-.0554	.3839	-.0522	.3856	-.0547			
.50	.2971	-.0259					.3766	-.0536	.3723	-.0517			.0113	.0091	
.60					.3705	-.0554	.3766	-.0540	.3689	-.0487	.3268	-.0504	.1866	-.0507	
.70			.3003	-.0487	.3500	-.0558	.3526	-.0337	.2284	-.0472	.1134	-.0534	.0381	-.0550	
.80	.1178	-.0486	.1091	-.0574	.1297	-.0561			.0820	-.0241	.0596	-.0545			
.90	.1032	-.0540			.1131	-.0533			.1188	-.0523	.0332	-.0545	.0224	.0079	
.95	.1032	-.0474							.0130	.0042	.0127	-.0556	.0088	-.0491	

TAIL 2

TABLE XXI. - CONTINUED
(b) $\alpha = -1.84^\circ$

Cp at γ/b of														
x/c	0.02		0.22		0.44		0.56		0.67		0.83		0.98	
	U.S.	L.S.	U.S.	L.S.	U.S.	L.S.	U.S.	L.S.	U.S.	L.S.	U.S.	L.S.	U.S.	L.S.
.05	.1789	.0405	.6891	-.0175	.6870	-.0215	.6727	-.0071	.6832	-.0048	.6810	-.0028		
.10	.1717	.0492	.7220	-.0217	.6965	-.0211	.6642	-.0154	.6878	-.0132	.6439	-.0104	.6003	-.0088
.15	.1999		.7021	-.0235	.6950	-.0218	.6818	-.0196	.6888	-.0172	.6678	-.0157	.5690	-.0095
.20	.2118	-.0034	.6603	-.0261	.6902	-.0233			.6853	-.0194	.6807	-.0194	.5411	-.0113
.25			.3196	-.0591	.6264	-.0328	.6612	-.0252	.6768	-.0218	.6810	-.0213	.5273	-.0136
.30	.1257	-.0330	.2645	-.0589	.3224	-.0482	.3423	-.0531	.4587	-.0461	.6608	-.0256	.5151	-.0155
.40									.3047	-.0637	.3097	-.0628	.2233	-.0536
.50	.1683	-.0557	.2215	-.0644	.2991	-.0588			.2988	-.0634	.2856	-.0632	.1655	-.0595
.60	.1661	-.0573	.2043	-.0636	.2845	-.0566	.3016	-.0573	.2955	-.0587	.2692	-.0613	.1532	-.0632
.70	.0839	-.0565	.1915	-.0628	.2634	-.0561	.2771	-.0607	.2298	-.0559			.0154	-.0693
.80	.0079	-.0685	.0471	-.0629	.0746	-.0536	.0833	-.0611	.0804	-.0539	.0617	-.0636	-.0034	-.0665
.90	-.0080	-.0655	.0359	-.0637	.0545	-.0579	.0681	-.0610	.0745	-.0621	.0497	-.0641	-.0047	-.0649
.95	-.0093	-.0651	.0313	-.0634	.0480	-.0590	.0627	-.0612	.0695	-.0627	.0450	-.0646	-.0052	-.0655

TAIL 1

Cp at γ/b of															
x/c	0.02		0.22		0.44		0.56		0.67		0.83		0.98		
	U.S.	L.S.	U.S.	L.S.	U.S.	L.S.	U.S.	L.S.	U.S.	L.S.	U.S.	L.S.	U.S.	L.S.	
.05	.3912	-.0121	.7801	.0036				-.0061	.7640	-.0034	.7565	.0020			
.10	.3262	-.0154	.7754	-.0202				-.0186	.7456	-.0151	.7480	-.0158	.6460	-.0082	
.15	.3684	-.0224						.7534	-.0235		-.0219	.7454	-.0231	.6086	-.0151
.20								.7399	-.0269	.7467	-.0255			.5876	-.0173
.25	.2607	-.0543	.3601	-.0591				.7550	-.0323	.7242	-.0295	.7234	-.0277	.0267	-.0027
.30			.3076	-.0439	.3443	-.0585	.3607	-.0602	.5173	-.0474					
.40	.2173	-.0258			.3304	-.0552	.3278	-.0567	.3348	-.0542	.3457	-.0577			
.50	.2385	-.0212					.3221	-.0538	.3221	-.0526			.0128	.0094	
.60					.3217	-.0553	.3238	-.0539	.3186	-.0490	.2937	-.0517	.1584	-.0550	
.70			.2467	-.0486	.3039	-.0554	.3046	-.0345	.1927	-.0474	.0935	-.0542	.0217	-.0560	
.80	.0903	-.0483	.0760	-.0580	.1013	-.0558			.0654	-.0238	.0460	-.0554			
.90	.0603	-.0501			.0867	-.0538			.0946	-.0526	.0222	-.0552	.0232	.0080	
.95	.0595	-.0439							.0134	.0050	.0970	-.0565	.0104	-.0499	

TAIL 2

TABLE XXI. - CONTINUED
(c) $\alpha = 0.15^\circ$

Cp at y/b of														
x/c	0.02		0.22		0.44		0.56		0.67		0.83		0.96	
	U.S.	L.S.	U.S.	L.S.	U.S.	L.S.	U.S.	L.S.	U.S.	L.S.	U.S.	L.S.	U.S.	L.S.
.05	.2835	.0655	.6110	-.0024	.6218	-.0076	.6018	-.0064	.6155	.0088	.6086	.0085		
.10	.2305	.0680	.6272	-.0062	.6296	-.0072	.5988	-.0010	.6201	.0004	.5783	.0019	.5397	-.0006
.15	.2422		.6271	-.0080	.6284	-.0069	.6140	-.0060	.6267	-.0034	.6045	-.0030	.5158	-.0001
.20	.2566	.0032	.6149	-.0111	.6237	-.0083			.6219	-.0056	.6160	-.0065	.4863	-.0013
.25			.3002	-.0537	.5656	-.0194	.5992	-.0116	.6130	-.0083	.6146	-.0084	.4720	-.0035
.30	.1401	-.0320	.2489	-.0570	.2744	-.0463	.2961	-.0492	.4101	-.0384	.5921	-.0129	.4615	-.0056
.40									.2598	-.0614	.2669	-.0588	.1916	-.0481
.50	.1403	-.0571	.2016	-.0652	.2530	-.0607			.2537	-.0623	.2442	-.0667	.1337	-.0561
.60	.1483	-.0582	.1859	-.0639	.2500	-.0580	.2517	-.0583	.2508	-.0594	.2279	-.0610	.1227	-.0609
.70	.0827	-.0564	.1706	-.0624	.2372	-.0560	.2312	-.0604	.1917	-.0552			-.0004	-.0689
.80	.0032	-.0685	.0266	-.0614	.0599	-.0532	.0620	-.0599	.0540	-.0531	.0392	-.0628	-.0176	-.0651
.90	-.0118	-.0657	.0085	-.0623	.0422	-.0562	.0505	-.0597	.0484	-.0611	.0275	-.0633	-.0190	-.0637
.95	-.0114	-.0644	-.0047	-.0624	.0368	-.0580	.0464	-.0600	.0444	-.0618	.0227	-.0638	-.0195	-.0645

TAIL 1

Cp at y/b of															
x/c	0.02		0.22		0.44		0.56		0.67		0.83		0.96		
	U.S.	L.S.	U.S.	L.S.	U.S.	L.S.	U.S.	L.S.	U.S.	L.S.	U.S.	L.S.	U.S.	L.S.	
.05	.2518	.0037	.6864	.0169				.0069	.6910	.0087	.6864	.0135			
.10	.2314	.0064	.6844	-.0053				-.0056	.6739	-.0031	.6808	-.0036	.5867	-.0014	
.15	.2657	.0003						.6901	-.0104		-.0097	.6787	-.0106	.5623	-.0054
.20								.6656	-.0140	.6811	-.0135			.5394	-.0070
.25	.1846	-.0462	.3101	-.0542				.6956	-.0202	.6536	-.0175	.6588	-.0164	.0250	-.0028
.30			.2537	-.0434	.2951	-.0559	.3133	-.0548	.4639	-.0397					
.40	.1502	-.0315			.2806	-.0573	.2814	-.0597	.2912	-.0575	.3082	-.0581			
.50	.1726	-.0184					.2748	-.0538	.2783	-.0533			.0124	-.0086	
.60					.2764	-.0539	.2758	-.0526	.2748	-.0484	.2638	-.0520	.1340	-.0560	
.70			.1983	-.0475	.2604	-.0537	.2595	-.0337	.1622	-.0469	.0764	-.0538	.0076	-.0556	
.80	.0617	-.0482	.0485	-.0576	.0750	-.0541			.0497	-.0238	.0337	-.0547			
.90	.0274	-.0498			.0613	-.0527			.0698	-.0520	.0149	-.0542	.0187	-.0072	
.95	.0296	-.0474							.0120	.0037	.0012	-.0555	.0098	-.0495	

TAIL 2

TABLE XXI. - CONTINUED
(d) $\alpha = 2.15^\circ$

Cp at γ/b of														
x/c	0.02		0.22		0.44		0.56		0.67		0.83		0.98	
	U.S.	L.S.	U.S.	L.S.	U.S.	L.S.	U.S.	L.S.	U.S.	L.S.	U.S.	L.S.	U.S.	L.S.
.05	.3882	.0866	.5473	.0125	.5582	.0072	.5303	.0207	.5513	.0231	.5513	.0228		
.10	.3200	.1044	.5614	.0094	.5643	.0076	.5320	.0138	.5535	.0147	.5184	.0161	.4819	.0109
.15	.2950		.5591	.0075	.5630	.0077	.5478	.0090	.5625	.0107	.5420	.0111	.4654	.0103
.20	.2976	.0143	.5467	.0044	.5587	.0063			.5599	.0086	.5521	.0076	.4402	.0091
.25			.2543	-.0476	.5091	-.0063	.5349	.0027	.5504	.0058	.5518	.0053	.4233	.0067
.30	.1463	-.0261	.2077	-.0543	.2303	-.0437	.2538	-.0447	.3627	-.0303	.5339	.0009	.4129	.0044
.40									.2177	-.0589	.2232	-.0547	.1612	-.0423
.50	.1129	-.0596	.1771	-.0635	.2101	-.0604			.2099	-.0604	.2005	-.0638	.1060	-.0506
.60	.1153	-.0597	.1645	-.0645	.2076	-.0598	.2090	-.0591	.2082	-.0598	.1871	-.0609	.0959	-.0565
.70	.0701	-.0568	.1534	-.0634	.1975	-.0568	.1893	-.0610	.1553	-.0554			-.0122	-.0707
.80	-.0104	-.0679	.0195	-.0616	.0407	-.0538	.0405	-.0537	.0357	-.0527	.0192	-.0627	-.0251	-.0658
.90	-.0211	-.0652	-.0023	-.0618	.0256	-.0561	.0289	-.0592	.0278	-.0605	.0078	-.0628	-.0260	-.0629
.95	-.0216	-.0641	-.0076	-.0619	.0213	-.0572	.0250	-.0595	.0245	-.0610	.0037	-.0633	-.0273	-.0642

TAIL 1

Cp at γ/b of														
x/c	0.02		0.22		0.44		0.56		0.67		0.83		0.98	
	U.S.	L.S.	U.S.	L.S.	U.S.	L.S.	U.S.	L.S.	U.S.	L.S.	U.S.	L.S.	U.S.	L.S.
.05	.1671	.0108	.5906	.0313				.0200	.6182	.0217	.6231	.0260		
.10	.1750	.0148	.5901	.0106				.0073	.6022	.0095	.6165	.0091	.5352	.0118
.15	.1971	.0081					.6174	.0024		.0028	.6139	.0019	.5173	.0033
.20							.5912	-.0012	.6125	-.0010			.4922	.0014
.25	.1261	-.0397	.2529	-.0481			.6261	-.0093	.5841	-.0056	.5950	-.0058	.0204	-.0004
.30			.1985	-.0417	.2476	-.0529	.2686	-.0498	.4114	-.0318				
.40	.1025	-.0345			.2328	-.0587	.2371	-.0609	.2486	-.0571	.2676	-.0556		
.50	.1269	-.0244					.2302	-.0554	.2356	-.0556			.0081	.0041
.60					.2313	-.0533	.2307	-.0521	.2324	-.0482	.2319	-.0522	.1113	-.0547
.70			.1510	-.0462	.2180	-.0524	.2170	-.0330	.1304	-.0456	.0592	-.0530	-.0050	-.0557
.80	.0324	-.0492	.0247	-.0566	.0511	-.0526			.0336	-.0248	.0218	-.0533		
.90	.0252	-.0521			.0379	-.0515			.0455	-.0510	.0049	-.0530	.0133	.0028
.95	.0391	-.0508							.0073	-.0004	-.0031	-.0541	.0057	-.0494

TAIL 2

TABLE XXI. - CONTINUED
(e) $\alpha = 4.14^\circ$

Cp at y/b of														
x/c	0.02		0.22		0.44		0.56		0.67		0.83		0.98	
	U.S.	L.S.	U.S.	L.S.	U.S.	L.S.	U.S.	L.S.	U.S.	L.S.	U.S.	L.S.	U.S.	L.S.
.05	.4309	.1024	.4786	.0305	.4932	.0246	.4638	.0376	.4913	.0398	.4978	.0383		
.10	.3803	.1244	.4917	.0278	.5003	.0251	.4676	.0313	.4917	.0318	.4674	.0324	.4385	.0242
.15	.2949		.4892	.0261	.4988	.0252	.4826	.0271	.4996	.0279	.4892	.0278	.4220	.0228
.20	.3242	.0267	.4780	.0229	.4940	.0237			.4997	.0258	.4977	.0246	.4035	.0215
.25			.2105	-.0397	.4500	.0094	.4706	.0199	.4909	.0228	.4965	.0223	.3879	.0191
.30	.1447	-.0202	.1676	-.0500	.1887	-.0400	.2225	-.0377	.3156	-.0197	.4790	.0174	.3737	.0168
.40									.1789	-.0541	.1868	-.0489	.1357	-.0359
.50	.0892	-.0610	.1416	-.0581	.1678	-.0573			.1705	-.0564	.1636	-.0596	.0836	-.0457
.60	.0844	-.0609	.1301	-.0609	.1657	-.0574	.1685	-.0566	.1677	-.0571	.1502	-.0597	.0747	-.0528
.70	.0432	-.0583	.1210	-.0614	.1575	-.0565	.1523	-.0603	.1228	-.0554			-.0183	-.0715
.80	-.0192	-.0676	.0052	-.0623	.0209	-.0534	.0203	-.0585	.0175	-.0525	.0018	-.0628	-.0200	-.0700
.90	-.0318	-.0640	-.0142	-.0616	.0078	-.0556	.0090	-.0579	.0090	-.0599	-.0091	-.0621	-.0228	-.0637
.95	-.0330	-.0628	-.0189	-.0623	.0045	-.0565	.0060	-.0581	.0055	-.0605	-.0126	-.0624	-.0278	-.0637

TAIL 1

Cp at y/b of														
x/c	0.02		0.22		0.44		0.56		0.67		0.83		0.98	
	U.S.	L.S.	U.S.	L.S.	U.S.	L.S.	U.S.	L.S.	U.S.	L.S.	U.S.	L.S.	U.S.	L.S.
.05	.1479	.0158	.4954	.0481				.0361	.5471	.0373	.5575	.0401		
.10	.1468	.0208	.4918	.0293				.0237	.5317	.0250	.5500	.0238	.4820	.0232
.15	.1514	.0158					.5341	.0190		.0185	.5480	.0165	.4698	.0126
.20							.5163	.0148	.5355	.0146			.4471	.0089
.25	.0757	-.0337	.2072	-.0402			.5502	.0057	.5147	.0096	.5303	.0072	.0154	-.0028
.30			.1560	-.0385	.2017	-.0475	.2247	-.0422	.3567	-.0210				
.40	.0553	-.0373			.1862	-.0568	.1939	-.0577	.2074	-.0533	.2267	-.0516		
.50	.0912	-.0320					.1871	-.0579	.1945	-.0580			.0034	.0001
.60					.1890	-.0535	.1873	-.0534	.1919	-.0511	.1970	-.0545	.0899	-.0465
.70			.0945	-.0453	.1810	-.0502	.1758	-.0317	.1040	-.0453	.0431	-.0534	-.0161	-.0582
.80	.0410	-.0535	.0076	-.0523	.0315	-.0494			.0187	-.0262	.0091	-.0531		
.90	.0553	-.0575			.0174	-.0489			.0230	-.0505	-.0022	-.0523	.0088	-.0010
.95	.0620	-.0538							.0020	-.0036	-.0080	-.0533	.0015	-.0506

TAIL 2

TABLE XXI. - CONTINUED
(f) $\alpha = 6.14^\circ$

Cp at y/b of														
x/c	0.02		0.22		0.44		0.56		0.67		0.83		0.98	
	U.S.	L.S.	U.S.	L.S.	U.S.	L.S.	U.S.	L.S.	U.S.	L.S.	U.S.	L.S.	U.S.	L.S.
.05	.3689	.1046	.4305	.0519	.4527	.0451	.4258	.0576	.4565	.0590	.4712	.0577	.4172	.0414
.10	.3470	.1211	.4390	.0499	.4587	.0456	.4302	.0518	.4565	.0517	.4403	.0525	.4172	.0393
.15	.2666		.4337	.0483	.4545	.0461	.4428	.0477	.4628	.0480	.4605	.0479	.3992	.0378
.20	.2843	.0409	.4205	.0450	.4481	.0445			.4627	.0457	.4677	.0447	.3815	.0352
.25			.1710	-.0299	.4061	.0284	.4250	.0398	.4546	.0424	.4659	.0425	.3704	.0329
.30	.1152	-.0197	.1305	-.0437	.1597	-.0350	.2042	-.0301	.2896	-.0074	.4485	.0370	.3577	.0276
.40									.1545	-.0480	.1656	-.0416	.1231	-.0276
.50	.0526	-.0569	.1047	-.0508	.1344	-.0521			.1445	-.0516	.1416	-.0540	.0712	-.0397
.60	.0486	-.0567	.0963	-.0535	.1304	-.0530	.1382	-.0535	.1399	-.0532	.1277	-.0570	.0641	-.0440
.70	.0244	-.0547	.0885	-.0553	.1215	-.0539	.1201	-.0585	.0989	-.0541			-.0145	-.0697
.80	-.0388	-.0640	-.0115	-.0604	.0042	-.0517	.0040	-.0572	.0032	-.0511	-.0091	-.0611	-.0159	-.0718
.90	-.0462	-.0620	-.0290	-.0595	-.0091	-.0545	-.0075	-.0563	-.0053	-.0575	-.0197	-.0601	-.0204	-.0648
.95	-.0475	-.0607	-.0326	-.0597	-.0124	-.0548	-.0103	-.0564	-.0086	-.0583	-.0233	-.0606	-.0253	-.0637

TAIL 1

Cp at y/b of															
x/c	0.02		0.22		0.44		0.56		0.67		0.83		0.98		
	U.S.	L.S.	U.S.	L.S.	U.S.	L.S.	U.S.	L.S.	U.S.	L.S.	U.S.	L.S.	U.S.	L.S.	
.05	.1285	-.0075	.3779	.0675				.0539	.4714	.0547	.4870	.0557			
.10	.1314	.0026	.3739	.0514				.0421	.4567	.0425	.4800	.0405	.4303	.0384	
.15	.1388	.0005						.4615	.0371		.0361	.4779	.0334	.4192	.0251
.20								.4339	.0330	.4660	.0319			.4008	.0177
.25	.0663	-.0329	.1307	-.0292			.4746	.0226	.4399	.0264	.4611	.0232	.0116	-.0051	
.30			.0880	-.0339	.1500	-.0410	.1770	-.0339	.3011	-.0089					
.40	.0796	-.0361			.1341	-.0528	.1463	-.0527	.1637	-.0483	.1859	-.0460			
.50	.0907	-.0323					.1400	-.0552	.1511	-.0549			.0008	-.0029	
.60					.1345	-.0544	.1393	-.0549	.1485	-.0523	.1594	-.0550	.0696	-.0422	
.70			.0788	-.0451	.1270	-.0512	.1309	-.0328	.0729	-.0462	.0249	-.0539	-.0257	-.0609	
.80	.0529	-.0355	.0029	-.0507	.0050	-.0481			.0055	-.0280	-.0032	-.0531			
.90	.0452	-.0581			-.0054	-.0474			.0008	-.0502	-.0118	-.0522	.0079	-.0040	
.95	.0535	-.0530							-.0011	-.0065	-.0156	-.0529	-.0007	-.0520	

TAIL 2

TABLE XXI. - CONTINUED
(g) $\alpha = 8.13^\circ$

Cp at y/b of														
x/c	0.02		0.22		0.44		0.56		0.67		0.83		0.98	
	U.S.	L.S.	U.S.	L.S.	U.S.	L.S.	U.S.	L.S.	U.S.	L.S.	U.S.	L.S.	U.S.	L.S.
.05	.3649	.1210	.4288	.0772	.4462	.0701	.4186	.0831	.4499	.0843	.4629	.0820		
.10	.3405	.1327	.4367	.0758	.4533	.0706	.4239	.0775	.4478	.0769	.4320	.0773	.4107	.0625
.15	.2685		.4291	.0744	.4490	.0718	.4361	.0728	.4534	.0730	.4517	.0728	.3917	.0601
.20	.2745	.0585	.4133	.0709	.4416	.0703			.4532	.0707	.4584	.0695	.3733	.0581
.25			.1632	-.0182	.3986	.0517	.4165	.0642	.4461	.0670	.4564	.0673	.3624	.0550
.30	.1081	-.0038	.1216	-.0356	.1512	-.0287	.2012	-.0208	.2818	.0077	.4387	.0613	.3531	.0523
.40									.1464	-.0406	.1572	-.0324	.1166	-.0189
.50	.0313	-.0521	.0920	-.0410	.1246	-.0460			.1359	-.0447	.1325	-.0469	.0665	-.0318
.60	.0267	-.0515	.0807	-.0440	.1195	-.0466	.1303	-.0480	.1310	-.0468	.1182	-.0511	.0621	-.0333
.70	.0030	-.0496	.0706	-.0478	.1100	-.0489	.1097	-.0540	.0913	-.0516			-.0076	-.0666
.80	-.0510	-.0604	-.0214	-.0590	-.0031	-.0500	-.0015	-.0548	-.0041	-.0489	-.0143	-.0586	-.0147	-.0721
.90	-.0559	-.0596	-.0384	-.0565	-.0164	-.0516	-.0129	-.0538	-.0124	-.0551	-.0250	-.0577	-.0164	-.0665
.95	-.0550	-.0582	-.0420	-.0571	-.0196	-.0524	-.0165	-.0538	-.0159	-.0556	-.0285	-.0581	-.0123	-.0637

TAIL 1

Cp at y/b of															
x/c	0.02		0.22		0.44		0.56		0.67		0.83		0.98		
	U.S.	L.S.	U.S.	L.S.	U.S.	L.S.	U.S.	L.S.	U.S.	L.S.	U.S.	L.S.	U.S.	L.S.	
.05	.1552	-.0223	.2843	.0711				.0757	.3747	.0751	.4016	.0748			
.10	.1255	-.0150	.2713	.0571				.0649	.3605	.0634	.3946	.0612	.3745	.0569	
.15	.1209	-.0167						.3490	.0597		.0573	.3924	.0545	.3561	.0418
.20								.3259	.0556	.3661	.0530			.3422	.0327
.25	.0636	-.0364	.0571	-.0265				.3982	.0448	.3449	.0469	.3778	.0435	.0047	-.0083
.30			.0457	-.0341	.0879	-.0315	.1164	-.0228	.2299	.0060					
.40	.0559	-.0385			.0796	-.0454	.0888	-.0445	.1111	-.0405	.1382	-.0380			
.50	.0621	-.0351					.0831	-.0482	.0985	-.0479			-.0042	-.0073	
.60					.0685	-.0501	.0847	-.0492	.0964	-.0464	.1134	-.0515	.0458	-.0454	
.70			.0260	-.0451	.0553	-.0507	.0863	-.0332	.0406	-.0483	.0036	-.0568	-.0362	-.0608	
.80	.0239	-.0580	-.0271	-.0531	-.0242	-.0501			-.0078	-.0307	-.0199	-.0549			
.90	.0250	-.0583			-.0249	-.0486			-.0192	-.0513	-.0256	-.0537	.0057	-.0084	
.95	.0365	-.0551							-.0072	-.0108	-.0284	-.0546	-.0056	-.0513	

TAIL 2

TABLE XXI. - CONTINUED
(h) $\alpha = 10.12^\circ$

Cp at y/b of														
x/c	0.02		0.22		0.44		0.56		0.67		0.83		0.98	
	U.S.	L.S.	U.S.	L.S.	U.S.	L.S.	U.S.	L.S.	U.S.	L.S.	U.S.	L.S.	U.S.	L.S.
.05	.3837	.1454	.4488	.1071	.4574	.1002	.4267	.1137	.4570	.1148	.4674	.1111		
.10	.3548	.1516	.4562	.1064	.4646	.1007	.4328	.1082	.4537	.1077	.4358	.1075	.4129	.0883
.15	.2882		.4474	.1052	.4601	.1024	.4449	.1033	.4591	.1035	.4551	.1030	.3933	.0854
.20	.2878	.0813	.4294	.1015	.4529	.1010			.4583	.1009	.4620	.0998	.3744	.0829
.25			.1697	-.0040	.4088	.0797	.4242	.0942	.4512	.0968	.4596	.0972	.3634	.0794
.30	.1099	.0081	.1262	-.0249	.1537	-.0200	.2051	-.0078	.2829	.0271	.4417	.0907	.3553	.0764
.40									.1464	-.0294	.1567	-.0203	.1141	-.0090
.50	.0276	-.0455	.0934	-.0279	.1259	-.0368			.1357	-.0347	.1308	-.0368	.0669	-.0207
.60	.0198	-.0444	.0802	-.0312	.1205	-.0374	.1300	-.0391	.1306	-.0370	.1161	-.0424	.0650	-.0215
.70	-.0100	-.0417	.0684	-.0368	.1105	-.0404	.1095	-.0458	.0899	-.0451			-.0010	-.0605
.80	-.0553	-.0570	-.0236	-.0575	-.0043	-.0462	-.0029	-.0504	-.0064	-.0460	-.0158	-.0540	-.0087	-.0711
.90	-.0580	-.0567	-.0412	-.0527	-.0178	-.0471	-.0140	-.0487	-.0145	-.0510	-.0263	-.0538	-.0032	-.0658
.95	-.0550	-.0551	-.0451	-.0531	-.0214	-.0478	-.0179	-.0490	-.0176	-.0515	-.0299	-.0545	-.0036	-.0629

TAIL 1

Cp at y/b of														
x/c	0.02		0.22		0.44		0.56		0.67		0.83		0.98	
	U.S.	L.S.	U.S.	L.S.	U.S.	L.S.	U.S.	L.S.	U.S.	L.S.	U.S.	L.S.	U.S.	L.S.
.05	.1413	-.0326	.2424	.0761				.0903	.2826	.0927	.3177	.0941		
.10	.1486	-.0251	.2271	.0646				.0797	.2674	.0814	.3099	.0824	.3081	.0767
.15	.1437	-.0273					.2585	.0743		.0755	.3067	.0761	.2905	.0620
.20							.2261	.0698	.2747	.0708			.2809	.0535
.25	.0566	-.0410	.0619	-.0249			.3175	.0603	.2482	.0643	.2931	.0647	.0004	-.0106
.30			.0492	-.0343	.0435	-.0247	.0629	-.0145	.1576	.0189				
.40	.0611	-.0420			.0318	-.0391	.0367	-.0371	.0602	-.0321	.0917	-.0285		
.50	.0594	-.0424					.0304	-.0414	.0476	-.0401			-.0063	-.0107
.60					.0172	-.0451	.0285	-.0430	.0451	-.0394	.0690	-.0443	.0223	-.0429
.70			.0225	-.0442	.0063	-.0482	.0374	-.0312	.0087	-.0473	-.0160	-.0624	-.0425	-.0594
.80	.0054	-.0613	-.0363	-.0589	-.0412	-.0563			-.0187	-.0345	-.0352	-.0591		
.90	.0118	-.0617			-.0406	-.0527			-.0376	-.0548	-.0391	-.0572	.0031	-.0120
.95	.0127	-.0595							-.0102	-.0148	-.0417	-.0582	-.0080	-.0543

TAIL 2

TABLE XXI. - CONTINUED
(1) $\alpha = 12.13^\circ$

Cp at y/b of														
x/c	0.02		0.22		0.44		0.56		0.67		0.83		0.98	
	U.S.	L.S.	U.S.	L.S.	U.S.	L.S.	U.S.	L.S.	U.S.	L.S.	U.S.	L.S.	U.S.	L.S.
.05	.4127	.1757	.4795	.1429	.4804	.1359	.4446	.1513	.4731	.1500	.4799	.1464		
.10	.3793	.1785	.4861	.1427	.4878	.1365	.4515	.1455	.4695	.1433	.4468	.1434	.4223	.1194
.15	.3176		.4761	.1416	.4826	.1390	.4640	.1405	.4749	.1387	.4670	.1394	.4019	.1157
.20	.3124	.1123	.4562	.1376	.4753	.1374			.4740	.1360	.4743	.1360	.3821	.1128
.25			.4821	.1333	.4294	.1128	.4417	.1294	.4668	.1315	.4717	.1329	.3712	.1090
.30	.1276	.0330	.4362	-.0112	.4622	-.0071	.2132	-.0080	.2908	-.0492	.4532	.1259	.3634	.1054
.40									.1520	-.0162	.1609	-.0053	.1158	.0035
.50	.0301	-.0374	.1003	-.0107	.1332	-.0239			.1406	-.0223	.1335	-.0236	.0735	-.0071
.60	.0205	-.0326	.0855	-.0161	.1275	-.0247	.1354	-.0273	.1352	-.0250	.1180	-.0305	.0718	-.0069
.70	-.0086	-.0289	.0728	-.0224	.1168	-.0281	.1153	-.0346	.0919	-.0364			.0054	-.0519
.80	-.0559	-.0511	-.0226	-.0541	-.0027	-.0405	-.0017	-.0444	-.0056	-.0410	-.0158	-.0482	.0041	-.0685
.90	-.0559	-.0541	-.0409	-.0470	-.0168	-.0409	-.0129	-.0429	-.0133	-.0450	-.0253	-.0480	-.0164	-.0639
.95	-.0524	-.0515	-.0451	-.0475	-.0202	-.0411	-.0168	-.0430	-.0168	-.0453	-.0287	-.0484	-.0191	-.0612

TAIL 1

Cp at y/b of															
x/c	0.02		0.22		0.44		0.56		0.67		0.83		0.98		
	U.S.	L.S.	U.S.	L.S.	U.S.	L.S.	U.S.	L.S.	U.S.	L.S.	U.S.	L.S.	U.S.	L.S.	
.05	.1158	-.0382	.1788	.0774				.1006	.2239	.1053	.2445	.1099			
.10	.1262	-.0292	.1770	.0689				.0895	.2057	.0943	.2330	.0996	.2487	.0945	
.15	.1248	-.0319						.2002	.0841		.0883	.2257	.0933	.2249	.0818
.20								.1721	.0792	.2007	.0832			.2151	.0731
.25	.0405	-.0429	.0338	-.0244			.2425	.0692	.1742	.0762	.2075	.0810	-.0084	-.0154	
.30			.0295	-.0345	.0194	-.0209	.0318	-.0092	.0989	.0275					
.40	.0398	-.0446			.0058	-.0353	.0056	-.0323	.0192	-.0261	.0451	-.0214			
.50	.0455	-.0475					-.0023	-.0365	.0055	-.0342			-.0126	-.0163	
.60					-.0086	-.0419	-.0070	-.0382	.0014	-.0341	.0220	-.0380	-.0048	-.0455	
.70			.0138	-.0401	-.0177	-.0460	.0040	-.0285	-.0199	-.0445	-.0368	-.0631	-.0514	-.0617	
.80	-.0070	-.0632	-.0409	-.0625	-.0522	-.0615			-.0300	-.0391	-.0508	-.0638			
.90	-.0052	-.0659			-.0517	-.0562			-.0534	-.0583	-.0532	-.0607	-.0018	-.0178	
.95	-.0020	-.0634							-.0176	-.0205	-.0553	-.0611	-.0147	-.0547	

TAIL 2

TABLE XXI. - CONTINUED
 (f) $\alpha = 16.13^\circ$

Cp at y/b of														
x/c	0.02		0.22		0.44		0.56		0.67		0.83		0.98	
	U.S.	L.S.	U.S.	L.S.	U.S.	L.S.	U.S.	L.S.	U.S.	L.S.	U.S.	L.S.	U.S.	L.S.
.05	.952	.2495	.5672	.2318	.5506	.2247	.5008	.2432	.5270	.2399	.5232	.2327	.4495	.1943
.10	.4502	.2511	.5735	.2334	.5575	.2256	.5106	.2368	.5225	.2343	.4854	.2321	.4281	.1901
.15	.4019		.5605	.2333	.5516	.2293	.5242	.2311	.5281	.2286	.5074	.2281	.4097	.1861
.20	.3720	.1836	.5358	.2287	.5440	.2275			.5269	.2254	.5165	.2246	.3994	.1816
.25			.2215	.0568	.4941	.1951	.4987	.2166	.5191	.2197	.5134	.2209	.3930	.1763
.30	.1533	.0403	.1698	.0245	.1926	.0244	.2394	.0483			.1753	.0202	.1790	.0317
.40									.1629	.0119	.1488	.0097	.1000	.0225
.50	.0430	-.0124	.1261	.0299	.1609	.0096			.1568	.0090	.1315	-.0004	.0971	.0158
.60	.0319	.0075	.1077	.0240	.1539	.0088	.1595	.0053	.1091	-.0096			.0193	-.0274
.70	-.0033	.0114	-.0933	.0168	.1419	.0050	.1386	-.0028	.1006	-.0304	-.0110	-.0330	.0108	-.0614
.80	-.0533	-.0285	-.0151	-.0405	.0064	-.0263	.0073	-.0277	-.0006	-.0304	-.0193	-.0340	-.0169	-.0596
.90	-.0451	-.0488	-.0352	-.0311	-.0084	-.0248	-.0044	-.0261	-.0073	-.0308	-.0222	-.0345	-.0186	-.0553
.95	-.0422	-.0459	-.0388	-.0310	-.0122	-.0251	-.0083	-.0263	-.0110	-.0310				

TAIL 1

Cp at y/b of														
x/c	0.02		0.22		0.44		0.56		0.67		0.83		0.98	
	U.S.	L.S.	U.S.	L.S.	U.S.	L.S.	U.S.	L.S.	U.S.	L.S.	U.S.	L.S.	U.S.	L.S.
.05	.0391	-.0331	.0695	.0955				.1178	.0904	.1240	.1004	.1317		
.10	.0586	-.0338	.0702	.0858				.1079	.0797	.1145	.0919	.1238	.1088	.1208
.15	.0588	-.0331					.0880	.1028		.1086	.0880	.1175	.0859	.1099
.20							.0739	.0980	.0881	.1034			.0803	.1018
.25	.0183	-.0414	-.0119	-.0147			.1700	.0866	.0727	.0959	.0812	.1047	-.0079	-.0050
.30			-.0059	-.0274	-.0088	-.0126	-.0047	.0007	.0300	.0418				
.40	.0061	-.0427			-.0191	-.0271	-.0226	-.0220	-.0160	-.0150	-.0056	-.0085		
.50	.0124	-.0458					-.0279	-.0264	-.0253	-.0232			-.0052	-.0057
.60					-.0306	-.0342	-.0321	-.0284	-.0272	-.0236	-.0182	-.0264	-.0360	-.0368
.70			-.0122	-.0240	-.0373	-.0390	-.0164	-.0228	-.0375	-.0379	-.0531	-.0591	-.0591	-.0630
.80	-.0284	-.0539	-.0499	-.0633	-.0603	-.0651			-.0307	-.0367	-.0615	-.0665		
.90	-.0280	-.0695			-.0562	-.0595			-.0579	-.0624	-.0593	-.0643	.0028	-.0076
.95	-.0251	-.0675							-.0109	-.0112	-.0599	-.0639	-.0079	-.0578

TAIL 2

TABLE XXI. - CONCLUDED
(k) $\alpha = 20.13^\circ$

Cp at y/b of														
x/c	0.02		0.22		0.44		0.56		0.67		0.83		0.98	
	U.S.	L.S.	U.S.	L.S.	U.S.	L.S.	U.S.	L.S.	U.S.	L.S.	U.S.	L.S.	U.S.	L.S.
.05	.6004	.3431	.6755	.3487	.6385	.3432	.5708	.3653	.5949	.3806	.5633	.3429		
.10	.5433	.3500	.6821	.3530	.6454	.3448	.5846	.3588	.5889	.3564	.5067	.3428	.1687	.1855
.15	.5064		.6656	.3539	.6389	.3501	.5990	.3518	.5953	.3488	.5307	.3399	.1764	.1846
.20	.4695	.2891	.6343	.3484	.6234	.3483			.5935	.3456	.5426	.3367	.2071	.1846
.25			.2731	.1159	.5742	.3059	.5708	.3340	.5852	.3379	.5423	.3323	.2237	.1837
.30	.2432	.1330	.2149	.0789	.2342	.0791	.2748	.1082	.3768	.1822	.5235	.3254	.2291	.1832
.40									.2053	.0723	.1854	.0815	.0936	.0264
.50	.0859	.0511	.1609	.0888	.1984	.0639			.1898	.0631	.1568	.0539	.0889	.0200
.60	.0491	.0691	.1377	.0794	.1900	.0623	.1927	.0603	.1800	.0597	.1426	.0438	.1051	.0212
.70	.0104	.0787	.1214	.0707	.1763	.0582	.1695	.0481	.1280	.0323			.0150	.0332
.80	-.0462	.0048	-.0030	-.0142	.0219	-.0201	.0204	-.0108	.0087	-.0132	-.0048	-.0120	.0114	-.0446
.90	-.0492	-.0322	-.0248	-.0123	.0056	-.0080	.0069	-.0053	.0003	-.0079	-.0116	-.0116	.0031	-.0347
.95	-.0235	-.0345	-.0224	-.0095	.0014	-.0064	.0029	-.0056	-.0028	-.0081	-.0111	-.0118	.0142	-.0283

TAIL 1

Cp at y/b of															
x/c	0.02		0.22		0.44		0.56		0.67		0.83		0.98		
	U.S.	L.S.	U.S.	L.S.	U.S.	L.S.	U.S.	L.S.	U.S.	L.S.	U.S.	L.S.	U.S.	L.S.	
.05	-.0169	-.0202	.0154	.1265				.1494	.0398	.1571	.0559	.1653			
.10	.0052	-.0477	.0097	.1204				.1403	.0259	.1477	.0433	.1580	.0741	.1560	
.15	.0081	-.0125						.0192	.1349		.1412	.0360	.1513	.0432	.1460
.20								.0036	.1296	.0118	.1356			.0349	.1372
.25	-.0056	-.0398	-.0417	.0021				.0986	.1173	.0048	.1272	.0262	.1380	-.0033	.0046
.30			-.0284	-.0121	-.0344	.0039	-.0364	.0181	-.0211	.0645					
.40	-.0204	-.0365			-.0417	-.0100	-.0476	-.0044	-.0442	.0026	-.0362	.0106			
.50	-.0149	-.0399					-.0498	-.0088	-.0503	-.0057			.0029	.0027	
.60					-.0484	-.0182	-.0517	-.0113	-.0494	-.0071	-.0456	-.0084	-.0527	-.0195	
.70			-.0349	-.0144	-.0523	-.0237	-.0297	-.0112	-.0496	-.0254	-.0535	-.0519	-.0644	-.0607	
.80	-.0381	-.0613	-.0577	-.0641	-.0643	-.0622			-.0270	-.0301	-.0644	-.0640			
.90	-.0449	-.0684			-.0589	-.0618			-.0609	-.0639	-.0625	-.0649	.0144	.0008	
.95	-.0430	-.0699							-.0036	-.0035	-.0639	-.0667	-.0000	-.0579	

TAIL 2

TABLE XXII. - PRESSURE COEFFICIENTS, $\theta = 90^\circ$, $\delta_{1,3} = -15^\circ$, $M = 1.60$
 (a) $\alpha = -3.45^\circ$

Cp at y/b of														
x/c	0.02		0.22		0.44		0.56		0.67		0.83		0.98	
	U.S.	L.S.	U.S.	L.S.	U.S.	L.S.	U.S.	L.S.	U.S.	L.S.	U.S.	L.S.	U.S.	L.S.
.05	.4777	-.1999	1.3055	-.2850			1.3173	-.3851	1.3157	-.3539	1.2995	-.3510		
.10	.7279	-.0699	1.1678	-.2069	1.1740	-.2461	1.1928	-.2731	1.1993	-.2607	1.1839	-.2729	.8963	-.1883
.15	.6415	-.0673	1.0482	-.1912	1.0490	-.2139	1.0734	-.2139	1.0894	-.2188	1.0718	-.2357	.8074	-.1083
.20	.7801	-.0595	.8886	-.1978	.9309	-.1963	.9762	-.2051	.9734	-.2182	.9734	-.2182	.7201	-.0960
.25			.2853	-.3700	.6665	-.2190	.7667	-.1931	.8521	-.2122	.8632	-.2097	.6427	-.0840
.30	.7923	.129	.4046	-.3817	.4596	-.3692	.4329	-.3574	.3660	-.3212	.7253	-.2116	.5670	-.1156
.40									.5285	-.3754	.3597	-.3558	.0572	-.2941
.50	.7203	-.2114			.6379	-.3710			.6121	-.3791	.5440	-.3477	.1579	-.2835
.60	.5741	-.2183	.6118	-.2774	.5928	-.3765	.5815	-.3790	.5715	-.3791	.5008	-.3319	.3058	-.3164
.70	.3536	-.1740	.5468	-.2589	.5208	-.3645	.4872	-.3660	.3538	-.3694			-.0961	-.4249
.80	.0053	-.3783	-.0002	-.3838	.0269	-.3080	.0248	-.3238	.0138	-.3453	-.0118	-.3988	-.1206	-.4614
.90	.0639	-.3534	-.0373	-.3227	.0097	-.3054	.0099	-.3039	.0054	-.3351	-.0212	-.3680	-.1080	-.4583
.95	.0494	-.2998	-.0198	-.2595	.0052	-.3010	.0032	-.2991	-.0002	-.3272	-.0272	-.3249	-.0923	-.4425

TAIL 1

Cp at y/b of														
x/c	0.02		0.22		0.44		0.56		0.67		0.83		0.98	
	U.S.	L.S.	U.S.	L.S.	U.S.	L.S.	U.S.	L.S.	U.S.	L.S.	U.S.	L.S.	U.S.	L.S.
.05	.4539	.4713	.7145	.7585					.6556	.7526	.6062	.6991		
.10	.4923	.5036	.6572	.6917					.6555	.6975	.6193	.6529	.3598	.4194
.15	.4979	.5141					.6397	.6577	.6399	.6579	.5976	.6099	.3593	.3895
.20							.6064	.6120	.6120	.6053	.5614	.5624	.3634	.3671
.25	.3723	.2954	.0626	.0491				.5263	.5550	.5332	.5162	.5024	.3436	.3467
.30			.1108	.0789	.0410	.0260	.0496	.0460	.2394	.2265				
.40	.4735	.4984			.0987	.0703	.0335	.0184	.0201	.0128	-.0065	-.0155		
.50	.4648	.4790					.0683	.0609	.0059	-.0051			.0181	.0023
.60					.1681	.1353	.0815	.0650	.0131	.0022	-.0454	-.0555	.0271	.0248
.70			.4018	.3900	.2712	.3050	.0704	.0437	-.1213	-.0527	-.0445	-.0171	-.0864	-.0825
.80	-.0330	-.0633	-.0550	-.0809	-.0398	-.0793			-.0915	-.0707	-.0630	-.0376		
.90	.0144	-.0061			-.0557	-.0925			-.0885	-.0847	-.0847	-.0684	-.0564	-.0578
.95	-.0186	-.0268							-.0522	-.0627	-.0728	-.0670	-.1172	-.0788

TAIL 2

TABLE XXII. - CONTINUED
(b) $\alpha = -1.45^\circ$

Cp at y/b of														
x/c	0.02		0.22		0.44		0.56		0.67		0.83		0.98	
	U.S.	L.S.	U.S.	L.S.	U.S.	L.S.	U.S.	L.S.	U.S.	L.S.	U.S.	L.S.	U.S.	L.S.
.05	.4483	-.1177	1.2373	-.1974			1.2762	-.3268	1.2778	-.2807	1.2636	-.2865		
.10	.6160	-.0253	1.0949	-.1312	1.1264	-.1733	1.1496	-.1991	1.1577	-.1869	1.1430	-.2044	.8571	-.1275
.15	.5148	-.0312	.9810	-.1241	1.0051	-.1422	1.0306	-.1464	1.0468	-.1533	1.0311	-.1715	.7666	-.0324
.20	.6499	-.0239	.8321	-.1419	.8904	-.1294			.9366	-.1420	.9330	-.1574	.6819	-.0246
.25			.1946	-.3408	.6378	-.1541	.7328	-.1309	.8152	-.1497	.8250	-.1520	.6079	-.0351
.30	.6591	-.1679	.3109	-.3479	.2726	-.3319	.2220	-.3241	.3250	-.2787	.6924	-.1541	.5363	-.0580
.40									.3488	-.3438	.2171	-.3267	.0134	-.2669
.50	.6558	-.1736			.5976	-.3363			.4376	-.3494	.3019	-.3176	.0531	-.2631
.60	.5143	-.1952	.5696	-.2478	.5662	-.3449	.5539	-.3467	.5288	-.3521	.3598	-.3067	.1083	-.2893
.70	.2437	-.1491	.5022	-.2214	.4951	-.3364	.4671	-.3428	.3394	-.3422			-.1484	-.3988
.80	-.0216	-.3645	-.0146	-.3637	.0091	-.3083	.0059	-.3250	-.0059	-.3437	-.0284	-.3791	-.1458	-.4304
.90	.0326	-.3453	-.0616	-.3245	-.0163	-.2954	-.0119	-.2944	-.0164	-.3305	-.0414	-.3456	-.1238	-.4547
.95	.0202	-.2987	-.0709	-.2441	-.0243	-.2925	-.0213	-.2862	-.0226	-.3189	-.0476	-.3130	-.1062	-.4380

TAIL 1

Cp at y/b of														
x/c	0.02		0.22		0.44		0.56		0.67		0.83		0.98	
	U.S.	L.S.	U.S.	L.S.	U.S.	L.S.	U.S.	L.S.	U.S.	L.S.	U.S.	L.S.	U.S.	L.S.
.05	.3981	.4154	.6629	.7209					.6442	.7340	.6110	.7031		
.10	.4351	.4430	.6128	.6500					.6402	.6854	.6202	.6547	.3658	.4208
.15	.4359	.4531					.6215	.6426	.6250	.6432	.5953	.6088	.3613	.3859
.20							.5886	.5977	.5967	.5929	.5606	.5621	.3550	.3571
.25	.3367	.2852	.0481	.0390				.5329	.5398	.5229	.5109	.4988	.3282	.3334
.30			.0752	.0373	.0311	.0178	.0419	.0401	.2297	.2188				
.40	.4051	.4251			.0734	.0421	.0255	.0106	.0147	.0072	-.0121	-.0203		
.50	.4049	.4155					.0567	.0449	.0003	-.0126			-.0109	-.0163
.60					.1145	.0973	.0687	.0570	.0034	-.0067	-.0521	-.0701	.0105	-.0072
.70			.3412	.3402	.2528	.2565	.0504	.0213	-.1385	-.0620	-.0953	-.0637	-.1118	-.0978
.80	-.0688	-.0900	-.0813	-.0964	-.0762	-.1035			-.1097	-.1018	-.1102	-.0853		
.90	.0036	-.0118			-.0978	-.1114			-.1125	-.1172	-.1238	-.1087	-.0533	-.0544
.95	-.0234	-.0225							-.0849	-.0922	-.1099	-.1035	-.1406	-.1150

TAIL 2

TABLE XXII. - CONTINUED
(c) $\alpha = 0.55^\circ$

Cp at y/b of														
x/c	0.02		0.22		0.44		0.56		0.67		0.83		0.98	
	U.S.	L.S.	U.S.	L.S.	U.S.	L.S.	U.S.	L.S.	U.S.	L.S.	U.S.	L.S.	U.S.	L.S.
.05	.4479	-.0329	1.1645	-.1111			1.2348	-.2579	1.2394	-.1978	1.2212	-.2085		
.10	.5601	-.0056	1.0229	-.0497	1.0786	-.0961	1.1063	-.1190	1.1166	-.1117	1.0999	-.1302	-.8154	-.0701
.15	.4419	-.0006	.9138	-.0477	.9602	-.0684	.9888	-.0653	1.0068	-.0828	.9888	-.1013	.7271	.0142
.20	.5602	-.0067	.7751	-.0723	.8545	-.0596			.8981	-.0782	.8933	-.0909	.6449	.0217
.25			.1650	-.2965	.6129	-.0944	.7050	-.0614	.7822	-.0853	.7897	-.0863	.5703	.0130
.30	.5419	-.1164	.2053	-.2986	.2080	-.2914	.1859	-.2861	.3034	-.2300	.6636	-.0908	.5048	-.0122
.40									.2510	-.3105	.1551	-.2947	-.0091	-.2377
.50	.5650	-.1360			.3603	-.3026			.3109	-.3179	.2047	-.2903	.0001	-.2269
.60	.4481	-.1663	.5365	-.2105	.4120	-.3137	.3607	-.3107	.3263	-.3220	.2341	-.2874	.0401	-.2503
.70	.1409	-.1256	.4674	-.1663	.4707	-.3091	.3536	-.3170	.2036	-.3386			-.2117	-.3789
.80	-.0519	-.3492	-.0236	-.3418	.0074	-.2988	.0029	-.3037	-.0434	-.3320	-.1156	-.3594	-.2162	-.3882
.90	-.0081	-.3440	-.0779	-.3257	-.0237	-.2871	-.0175	-.2821	-.0359	-.3130	-.1141	-.3315	-.1807	-.4338
.95	-.0186	-.3096	-.1028	-.2594	-.0320	-.2803	-.0306	-.2745	-.0386	-.3005	-.1147	-.2995	-.1782	-.4045

TAIL 1

Cp at y/b of														
x/c	0.02		0.22		0.44		0.56		0.67		0.83		0.98	
	U.S.	L.S.	U.S.	L.S.	U.S.	L.S.	U.S.	L.S.	U.S.	L.S.	U.S.	L.S.	U.S.	L.S.
.05	.3333	.3420	.6423	.6923					.6623	.7488	.6445	.7180		
.10	.3612	.3668	.5706	.6029					.6445	.6832	.6387	.6656	.3880	.4356
.15	.3623	.3714					.6062	.6303	.6166	.6396	.5978	.6158	.3703	.3926
.20							.5703	.5835	.5849	.5872	.5581	.5638	.3494	.3561
.25	.3112	.2886	.0301	.0246				.5443	.5270	.5155	.5092	.4991	.3159	.3257
.30			.0340	-.0028	.0187	.0082	.0324	.0326	.2195	.2123				
.40	.3365	.3535			.0404	.0168	.0174	.0020	.0121	.0031	-.0153	-.0240		
.50	.3330	.3468					.0396	.0290	-.0007	-.0160			-.0292	-.0315
.60					.0940	.0741	.0566	.0505	-.0054	-.0149	-.0566	-.0734	-.0177	-.0282
.70			.2894	.2882	.2160	.2257	.0290	.0071	-.1620	-.0734	-.1490	-.1283	-.1307	-.1347
.80	-.0876	-.1109	-.1043	-.1284	-.0885	-.1156			-.1396	-.1361	-.1542	-.1387		
.90	-.0110	-.0197			-.1152	-.1414			-.1386	-.1432	-.1586	-.1505	-.0524	-.0535
.95	-.0181	-.0111							-.1102	-.1149	-.1461	-.1443	-.1546	-.1549

TAIL 2

TABLE XXII. - CONTINUED
(d) $\alpha = 2.55^\circ$

Cp at y/b of														
x/c	0.02		0.22		0.44		0.56		0.67		0.83		0.98	
	U.S.	L.S.	U.S.	L.S.	U.S.	L.S.	U.S.	L.S.	U.S.	L.S.	U.S.	L.S.	U.S.	L.S.
.05	.4720	.0575	1.0947	-.0339			1.1797	-.1685	1.1928	-.1083	1.1747	-.1185		
.10	.5376	.0504	.9593	.0296	1.0296	-.0140	1.0541	-.0343	1.0713	-.0300	1.0531	-.0508	.7710	-.0047
.15	.3977	.0336	.8554	.0364	.9135	-.0101	.9428	.0148	.9638	-.0104	.9443	-.0263	.6854	.0592
.20	.5236	.0486	.7243	.0185	.8131	-.0161			.8611	-.0082	.8542	-.0174	.6061	-.0661
.25			.1362	-.2345	.5848	-.0296	.6766	.0064	.7496	-.0073	.7545	-.0165	.5345	.0557
.30	.4063	-.0500	.1568	-.2481	.1705	-.2472	.1595	-.2467	.2828	-.1849	.6352	-.0231	.4741	.0309
.40									.1935	-.2732	.1167	-.2603	-.0279	-.2138
.50	.3787	-.1034			.2572	-.2651			.2344	-.2816	.1459	-.2619	-.0369	-.1922
.60	.3439	-.1371	.3450	-.1480	.2552	-.2717	.2546	-.2720	.2391	-.2868	.1616	-.2614	-.0048	-.2020
.70	.0740	-.1027	.4132	-.1113	.2471	-.2628	.2099	-.2863	.1187	-.3176			-.2412	-.3527
.80	-.0827	-.3332	-.0382	-.3201	-.0485	-.3067	-.1152	-.2902	-.1357	-.3131	-.1635	-.3346	-.2232	-.3657
.90	-.0482	-.3415	-.0813	-.3320	-.0337	-.2728	-.0921	-.2765	-.1490	-.2944	-.1732	-.3212	-.1909	-.3975
.95	-.0548	-.3234	-.1089	-.2915	-.0435	-.2464	-.0801	-.2640	-.1513	-.2800	-.1805	-.2983	-.1778	-.3689

TAIL 1

Cp at y/b of														
x/c	0.02		0.22		0.44		0.56		0.67		0.83		0.98	
	U.S.	L.S.	U.S.	L.S.	U.S.	L.S.	U.S.	L.S.	U.S.	L.S.	U.S.	L.S.	U.S.	L.S.
.05	.2839	.2920	.5964	.6533					.6868	.7564	.6852	.7304		
.10	.3045	.3090	.5232	.5580					.6453	.6843	.6464	.6722	.3969	.4483
.15	.3027	.3098					.5876	.6171	.6047	.6331	.5961	.6135	.3650	.3963
.20							.5466	.5647	.5681	.5734	.5514	.5606	.3405	.3496
.25	.2601	.2416	.0043	.0013				.5465	.5121	.5026	.5037	.4940	.3013	.3104
.30			-.0046	-.0313	.0053	-.0045	.0223	.0229	.2126	.2041				
.40	.2817	.2979			.0167	-.0022	.0105	-.0064	.0083	-.0002	-.0178	-.0273		
.50	.2770	.2876					.0172	.0119	-.0071	-.0151			-.0452	-.0434
.60					.0841	.0663	.0450	.0428	-.0166	-.0202	-.0630	-.0720	-.0475	-.0440
.70			.2518	.2480	.1147	.1334	.0040	-.0052	-.1784	-.0882	-.1752	-.1657	-.1516	-.1624
.80	-.1161	-.1342	-.1295	-.1505	-.0897	-.1209			-.1637	-.1465	-.1763	-.1715		
.90	-.0290	-.0308			-.1216	-.1505			-.1606	-.1629	-.1791	-.1806	-.0527	-.0532
.95	-.0231	-.0143							-.1408	-.1489	-.1757	-.1781	-.1554	-.1614

TAIL 2

TABLE XXII. - CONTINUED
(e) $\alpha = 4.55^\circ$

Cp at y/b of														
x/c	0.02		0.22		0.44		0.56		0.67		0.83		0.98	
	U.S.	L.S.	U.S.	L.S.	U.S.	L.S.	U.S.	L.S.	U.S.	L.S.	U.S.	L.S.	U.S.	L.S.
.05	.5026	.1212	1.0311	.0674			1.1219	-.0519	1.1363	-.0051	1.1209	-.0209		
.10	.5366	.1093	.9036	-.1143	.9754	.0777	1.0022	.0739	1.0196	-.0616	1.0028	.0403	.7189	.0661
.15	.3766	.0921	.8060	-.1294	.8664	.0929	.8971	.0998	.9173	-.0696	.8975	.0584	.6367	.1064
.20	.5022	.1105	.6841	-.1192	.7735	.0933			.8198	-.0801	.8113	.0622	.5614	.1054
.25			.1129	-.1893	.5605	.0426	.6499	.0861	.7160	-.0725	.7175	.0608	.4939	.0921
.30	.2609	.0199	.1112	-.2072	.1411	-.2028	.1388	-.2035	.2642	-.1349	.6045	.0511	.4401	.0523
.40									.1480	-.2326	.0821	-.2239	-.0460	-.1843
.50	.2452	-.0646			.1939	-.2225			.1745	-.2411	.0953	-.2315	-.0668	-.1605
.60	.2423	-.1034	.2023	-.0855	.1787	-.2268	.1927	-.2325	.1754	-.2473	.1042	-.2339	-.0372	-.1558
.70	.0004	-.0847	.2441	-.0684	.1453	-.2084	.1488	-.2480	.0629	-.2854			-.2370	-.3177
.80	-.1298	-.3027	-.0772	-.3048	-.1538	-.3144	-.1671	-.3103	-.1733	-.3053	-.1990	-.3169	-.1933	-.3583
.90	-.0768	-.3433	-.1004	-.3282	-.1495	-.2938	-.1855	-.2883	-.1904	-.2816	-.2073	-.3199	-.1811	-.3644
.95	-.0726	-.3328	-.1257	-.2910	-.1379	-.2667	-.1891	-.2644	-.2002	-.2682	-.2131	-.3052	-.1636	-.3348

TAIL 1

Cp at y/b of														
x/c	0.02		0.22		0.44		0.56		0.67		0.83		0.98	
	U.S.	L.S.	U.S.	L.S.	U.S.	L.S.	U.S.	L.S.	U.S.	L.S.	U.S.	L.S.	U.S.	L.S.
.05	.3020	.3139	.6173	.6668					.6962	.7607	.6937	.7415		
.10	.2890	.2879	.5171	.5423					.6463	.6800	.6512	.6746	.4051	.4531
.15	.2679	.2625					.5845	.6033	.6027	.6222	.6012	.6167	.3687	.3933
.20							.5448	.5483	.5682	.5641	.5622	.5622	.3427	.3433
.25	.0588	.0090	-.0155	-.0288				.5594	.5116	.4978	.5112	.4983	.2988	.3047
.30			-.0422	-.0607	.0002	-.0133	.0184	.0177	.2083	.2004				
.40	.2344	.2700			-.0038	-.0136	.0019	-.0066	.0022	.0017	-.0211	-.0232		
.50	.2453	.2398					-.0045	-.0041	-.0127	-.0141			-.0644	-.0537
.60					.0481	.0471	.0065	.0071	-.0222	-.0271	-.0655	-.0729	-.0671	-.0606
.70			.2250	.2259	.0262	.0278	-.0181	-.0237	-.1915	-.1005	-.2261	-.1964	-.1845	-.1826
.80	-.1281	-.1503	-.1347	-.1538	-.1274	-.1463			-.1984	-.1660	-.2131	-.1954		
.90	-.1303	-.1259			-.1184	-.1461			-.1887	-.1737	-.2119	-.2041	-.0565	-.0581
.95	-.1111	-.0818							-.1755	-.1741	-.2153	-.2077	-.1578	-.1602

TAIL 2

TABLE XXII. - CONTINUED
(1) $\alpha = 6.55^\circ$

Cp at γ/b of														
x/c	0.02		0.22		0.44		0.56		0.67		0.83		0.98	
	U.S.	L.S.	U.S.	L.S.	U.S.	L.S.	U.S.	L.S.	U.S.	L.S.	U.S.	L.S.	U.S.	L.S.
.05	.4981	.1978	.9313	.1896			1.0388	.1036	1.0576	.1190	1.0488	-.0901		
.10	.5060	.1843	.8194	.2240	.9033	.1784	.9294	.1856	.9474	.1587	.9369	-.1382	.6509	.1321
.15	.3629	.1751	.7373	.2220	.8020	.1898	.8345	.1887	.8542	.1683	.8376	-.1499	.5751	.1518
.20	.4596	.1916	.6296	.1968	.7214	.1896			.7693	.1731	.7580	-.1500	.5091	.1451
.25			.0871	-.1415	.5280	-.1319	.6140	-.1715	.6757	.1598	.6716	-.1424	.4506	.1333
.30	-.1869	-.1112	-.0662	-.1634	-.1079	-.1458	-.1111	-.1539	.2438	-.0770	.5670	-.1243	.4059	.1100
.40									.1033	-.1852	.0475	-.1848	-.0590	-.1552
.50	.1326	-.0176			.1282	-.1756			.1155	-.1928	.0462	-.1999	-.0787	-.1206
.60	.1773	-.0644	.1196	-.0269	.1149	-.1593	.1264	-.1851	.1115	-.1999	.0478	-.2046	-.0493	-.1149
.70	.0033	-.0671	.1559	-.0322	.0849	-.1067	.0875	-.2007	.0074	-.2466			-.2127	-.2713
.80	-.1525	-.2719	-.1292	-.2873	-.2000	-.2777	-.2033	-.2902	-.2092	-.2896	-.2318	-.2940	-.2092	-.3370
.90	-.1017	-.3361	-.1463	-.3199	-.1993	-.2902	-.2217	-.2719	-.2238	-.2702	-.2266	-.2971	-.1515	-.3353
.95	-.0934	-.3431	-.1649	-.2820	-.1812	-.2844	-.2133	-.2465	-.2313	-.2545	-.2243	-.2949	-.1175	-.3151

TAIL 1

Cp at γ/b of														
x/c	0.02		0.22		0.44		0.56		0.67		0.83		0.98	
	U.S.	L.S.	U.S.	L.S.	U.S.	L.S.	U.S.	L.S.	U.S.	L.S.	U.S.	L.S.	U.S.	L.S.
.05	.4504	.4850	.6425	.6793					.6856	.7418	.6856	.7302		
.10	.3580	.3643	.5197	.5285					.6374	.6713	.6420	.6717	.4067	.4595
.15	.2337	.2349					.5748	.5991	.5899	.6215	.5904	.6205	.3614	.3977
.20							.5289	.5489	.5511	.5646	.5491	.5659	.3245	.3439
.25	-.0096	-.0457	-.0363	-.0449				.5512	.4960	.4936	.4995	.5001	.2797	.2995
.30			-.0709	-.0839	-.0109	-.0145	.0088	-.0164	.1903	.1956				
.40	-.0318	.0982			-.0187	-.0212	-.0082	-.0122	-.0040	-.0021	-.0247	-.0245		
.50	.2697	.2950					-.0158	-.0144	-.0162	-.0173			-.0808	-.0699
.60					.0118	.0216	-.0144	-.0165	-.0256	-.0310	-.0680	-.0744	-.0837	-.0794
.70			.2469	.2203	.0118	.0034	-.0330	-.0403	-.1928	-.1067	-.2400	-.2327	-.2113	-.2021
.80	-.1359	-.1607	-.1561	-.1636	-.1480	-.1643			-.2098	-.1929	-.2202	-.2209	-.0613	-.0630
.90	-.1587	-.1741			-.1133	-.1438			-.1981	-.1985	-.2193	-.2277	-.1478	-.1627
.95	-.1712	-.1603							-.1901	-.1987	-.2217	-.2328		

TAIL 2

TABLE XXII. - CONTINUED
(g) $\alpha = 8.55^\circ$

Cp at y/b of														
x/c	0.02		0.22		0.44		0.56		0.67		0.83		0.98	
	U.S.	L.S.	U.S.	L.S.	U.S.	L.S.	U.S.	L.S.	U.S.	L.S.	U.S.	L.S.	U.S.	L.S.
.05	.4643	.2682	.7983	.3282			.9215	.2584	.9464	.2592	.9465	.2192		
.10	.4450	.2581	.7150	.3253	.8000	.2924	.8370	.2977	.8537	.2626	.8496	.2465	.5744	.1911
.15	.3573	.2596	.6480	.3023	.7312	.2941	.7581	.2858	.7736	.2733	.7633	.2480	.5089	.2029
.20	.3973	.2652	.5603	.2742	.6667	.2943			.7018	.2729	.6941	.2412	.4545	.1940
.25			.0604	-.0978	.4957	.2183	.5703	.2664	.6332	.2594	.6171	.2304	.4164	.1810
.30	.1117	.1981	.0283	-.1080	.0807	-.1031	.0857	-.0979	.2249	-.0074	.5246	.2066	.3801	.1498
.40									.0650	-.1312	.0179	-.1414	-.0711	-.1313
.50	.0913	.0371			.0736	-.1042			.0641	-.1400	.0059	-.1607	-.0752	-.1050
.60	.1483	-.0288	.0613	.0254	.0602	-.0783	.0666	-.1287	.0562	-.1510	.0003	-.1668	-.0579	-.0702
.70	.0142	-.0419	.1046	.0074	.0335	-.0207	.0319	-.1304	-.0403	-.2125			-.2119	-.2322
.80	-.1705	-.2682	-.1473	-.2643	-.2323	-.2518	-.2334	-.2580	-.2401	-.2531	-.2604	-.2678	-.1435	-.2750
.90	-.1247	-.3011	-.1746	-.3065	-.2070	-.2741	-.2237	-.2415	-.2485	-.2534	-.2432	-.2700	-.1347	-.3153
.95	-.1261	-.3381	-.1994	-.2720	-.1922	-.2787	-.2007	-.2319	-.2281	-.2430	-.2389	-.2688	-.1388	-.2809

TAIL 1

Cp at y/b of															
x/c	0.02		0.22		0.44		0.56		0.67		0.83		0.98		
	U.S.	L.S.	U.S.	L.S.	U.S.	L.S.	U.S.	L.S.	U.S.	L.S.	U.S.	L.S.	U.S.	L.S.	
.05	.5157	.5537	.6848	.7149					.6384	.7336	.6499	.7278			
.10	.4440	.4482	.5555	.5519					.6046	.6627	.6159	.6685	.3947	.4574	
.15	.2705	.2684						.5846	.6016	.5734	.6109	.5734	.6113	.3504	.3895
.20								.5281	.5491	.5424	.5538	.5397	.5588	.3139	.3296
.25	-.0354	-.0630	-.0457	-.0566				.5664	.4913	.4836	.4970	.4942	.2680	.2837	
.30			-.0837	-.0993	-.0046	-.0100	.0114	.0157	.1872	.1885					
.40	-.0393	-.0278			-.0142	-.0156	-.0021	-.0096	-.0014	-.0035	-.0236	-.0244			
.50	.0944	.1637					-.0091	-.0107	-.0100	-.0154			-.0981	-.0857	
.60					-.0135	-.0118	-.0090	-.0223	-.0171	-.0262	-.0658	-.0716	-.0997	-.0940	
.70			.2437	.2457	.0077	.0003	-.0111	-.0306	-.1836	-.0975	-.2635	-.2602	-.2242	-.2100	
.80	-.1572	-.1834	-.1433	-.1681	-.1829	-.1930			-.2404	-.2027	-.2320	-.2275			
.90	-.1903	-.2007			-.1524	-.1650			-.2080	-.2040	-.2267	-.2255	-.0866	-.0885	
.95	-.1882	-.1748							-.1973	-.2036	-.2280	-.2298	-.1447	-.1547	

TAIL 2

TABLE XXII. - CONTINUED
(h) $\alpha = 10.55^\circ$

Cp at y/b of														
x/c	0.02		0.22		0.44		0.56		0.67		0.83		0.98	
	U.S.	L.S.	U.S.	L.S.	U.S.	L.S.	U.S.	L.S.	U.S.	L.S.	U.S.	L.S.	U.S.	L.S.
.05	.3038	.3164	.5318	.4522			.7278	.4181	.7771	.3854	.7961	.3541		
.10	.3454	.3136	.5135	.4074	.6466	.4203	.6891	.4233	.7234	.3899	.7373	.3664	.4874	.2459
.15	.3684	.3285	.5360	.3714	.6067	.4061	.6462	.4182	.6797	.3938	.6760	.3672	.4376	.2461
.20	.3383	.3631	.5074	.3381	.5806	.3937			.6318	.3916	.6223	.3666	.3979	.2353
.25			.0497	-.0645	.4499	.2947	.5258	.3627	.5685	.3725	.5599	.3538	.3563	.2205
.30	-.0326	.3717	.0140	-.0059	.0554	-.0606	.0689	-.0457	.2014	.0599	.4816	.3188	.3296	.1860
.40									.0273	-.0753	-.0078	-.0881	-.0850	-.1140
.50	.0734	.0741			.0295	-.0222			.0171	-.0888	-.0304	-.1157	-.0802	-.0701
.60	.1245	.0210	.0295	.0665	.0165	.0032	.0237	-.0399	.0058	-.0997	-.0419	-.1304	-.0581	-.0508
.70	.0295	-.0111	.0726	.0410	-.0087	.1038	-.0099	-.0550	-.0836	-.1606			-.2063	-.2139
.80	-.1752	-.2629	-.1608	-.2485	-.2477	-.2300	-.2480	-.2316	-.2404	-.2274	-.2511	-.2362	-.1389	-.1927
.90	-.1408	-.2695	-.1993	-.2938	-.2052	-.2580	-.2065	-.2296	-.2117	-.2266	-.2367	-.2398	-.1569	-.2613
.95	-.1511	-.3248	-.2223	-.2600	-.2029	-.2646	-.2040	-.2354	-.2102	-.2082	-.2335	-.2398	-.1569	-.2473

TAIL 1

Cp at y/b of														
x/c	0.02		0.22		0.44		0.56		0.67		0.83		0.98	
	U.S.	L.S.	U.S.	L.S.	U.S.	L.S.	U.S.	L.S.	U.S.	L.S.	U.S.	L.S.	U.S.	L.S.
.05	.3505	.5185	.5793	.6669					.5877	.7189	.6077	.7075		
.10	.4448	.4893	.5410	.5133					.5677	.6506	.5787	.6521	.3780	.4581
.15	.3557	.3305					.5613	.5947	.5516	.6036	.5502	.5999	.3323	.3879
.20							.5310	.5454	.5335	.5536	.5254	.5524	.2938	.3230
.25	-.0219	-.0654	-.0668	-.0823				.5773	.4868	.4876	.4850	.4905	.2522	.2735
.30			-.1122	-.1244	.0034	-.0078	.0179	.0193	.1860	.1915				
.40	-.0788	-.0571			-.0147	-.0205	.0045	-.0028	.0005	.0037	-.0240	-.0261		
.50	.0275	.0519					-.0066	-.0051	-.0050	-.0052			-.1213	-.0992
.60					-.0125	-.0160			-.0113	-.0163	-.0626	-.0704	-.1152	-.1062
.70			.1156	.1495	.0037	.0062	-.0086	-.0147	-.1688	-.0794	-.2779	-.2679	-.2288	-.2116
.80	-.1655	-.1981	-.1597	-.1695	.2166	-.2270			-.2535	-.2072	-.2399	-.2290		
.90	-.2072	-.2192			-.1819	-.1889			-.2251	-.1993	-.2287	-.2253	-.0698	-.0689
.95	-.2070	-.1928							-.2077	-.1978	-.2245	-.2266	-.1411	-.1436

TAIL 2

TABLE XXII. - CONTINUED
(i) $\alpha = 12.56^\circ$

Cp at γ/b of														
x/c	0.02		0.22		0.44		0.56		0.67		0.83		0.98	
	U.S.	L.S.	U.S.	L.S.	U.S.	L.S.	U.S.	L.S.	U.S.	L.S.	U.S.	L.S.	U.S.	L.S.
.05	.1794	.3753	.3776	.5585			.5056	.6017	.5567	.5719	.5969	.5469		
.10	.1980	.3871	.3381	.4961	.4711	.5466	.5000	.5607	.5424	.5641	.5858	.5549	.3726	.3368
.15	.3361	.4594	.3170	.4677	.4495	.5135	.4883	.5314	.5319	.5484	.5605	.5412	.3426	.3297
.20	.2028	.5251	.3038	.4681	.4252	.4909			.5127	.5253	.5279	.5104	.3247	.3108
.25			-.0240	.0407	.3287	.3778	.4157	.4542	.4806	.4900	.4804	.4681	.3009	.2879
.30	-.1276	.4393	-.0420	.1117	-.0208	.0015	.0207	.0031	.1670	-.1166	.4179	.4065	.2846	.2536
.40									-.0116	-.0255	-.0393	-.0583	-.0939	-.1039
.50	.0897	.1186			-.0217	.0798			-.0331	-.0275	-.0681	-.0921	-.0651	-.0737
.60	.0999	.0645	-.0188	.1012	-.0218	.1017	-.0272	.0481	-.0520	-.0224	-.0844	-.1047	-.0548	-.0674
.70	.0280	.0153	.0470	.0776	-.0440	.1347	-.0548	.0253	-.1332	-.0899			-.2083	-.2096
.80	-.1798	-.2538	-.1840	-.2289	-.2262	-.2219	-.2228	-.2046	-.2231	-.2515	-.2398	-.2397	-.1608	-.1652
.90	-.1539	-.2403	-.2244	-.2779	-.2134	-.2506	-.2148	-.2324	-.2226	-.2255	-.2424	-.2433	-.1970	-.2212
.95	-.1405	-.2939	-.2364	-.2454	-.2108	-.2573	-.2146	-.2500	-.2266	-.2150	-.2426	-.2433	-.1904	-.2162

TABLE I

Cp at γ/b of														
x/c	0.02		0.22		0.44		0.56		0.67		0.83		0.98	
	U.S.	L.S.	U.S.	L.S.	U.S.	L.S.	U.S.	L.S.	U.S.	L.S.	U.S.	L.S.	U.S.	L.S.
.05	.3427	.3925	.3950	.5742					.5520	.7170	.5774	.6981		
.10	.3278	.4419	.4486	.4491					.5369	.6500	.5513	.6387	.3712	.4521
.15	.3077	.3215					.5381	.6115	.5385	.6022	.5275	.5942	.3217	.3831
.20							.5345	.5605	.5272	.5501	.5099	.5473	.2860	.3170
.25	-.0061	-.0560	-.0951	-.1033				.5887	.4900	.4853	.4820	.4882	.2431	.2664
.30			-.1357	-.1450	.0048	-.0050	.0284	.0277	.1908	.1907				
.40	-.0878	-.0796			-.0286	-.0268	.0114	.0032	.0106	.0072	-.0196	-.0226		
.50	-.0637	.0028					-.0084	-.0058	.0047	-.0005			-.1378	-.1078
.60					-.0350	-.0332	-.0134	-.0185	-.0039	-.0137	-.0498	-.0598	-.1245	-.1121
.70			.0088	.0283	-.0201	-.0134	-.0172	-.0245	-.1724	-.0865	-.2804	-.2863	-.2276	-.2121
.80	-.1880	-.2228	-.2185	-.2132	-.2517	-.2542			-.2600	-.2270	-.2518	-.2391		
.90	-.2222	-.2312			-.2190	-.2101			-.2439	-.2100	-.2325	-.2300	-.0793	-.0787
.95	-.2157	-.1991							-.2231	-.2077	-.2308	-.2327	-.1322	-.1309

TABLE 2

TABLE XXII.- CONTINUED
(j) $\alpha = 16.56^\circ$

Cp at y/b of														
x/c	0.02		0.22		0.44		0.56		0.67		0.83		0.98	
	U.S.	L.S.	U.S.	L.S.	U.S.	L.S.	U.S.	L.S.	U.S.	L.S.	U.S.	L.S.	U.S.	L.S.
.05	.3499	.6414	.1052	.8427			.2045	.9474	.2475	.9492	.2537	.9210		
.10	.0484	.6527	.1030	.7835	.2075	.8198	.2418	.8383	.2575	.8431	.2753	.8214	.2218	.5513
.15	.2107	.6680	.1037	.7307	.2052	.7487	.2358	.7629	.2624	.7652	.2811	.7378	.2176	.4921
.20	-.1575	.6194	.1065	.6383	.1991	.6782			.2598	.6957	.2819	.6681	.2062	.4370
.25			-.1565	.0784	.1423	.4749	.2069	.5702	.2368	.6122	.2671	.5963	.1890	.3835
.30	-.2551	.5795	-.1851	.1825	-.1343	.0583	-.1028	.0483	.0184	.1530	.2367	.4998	.1898	.3205
.40									-.1254	.0396	-.1220	-.0106	-.1227	-.0937
.50	.0381	.1792			-.1802	.1741			-.1361	.0676	-.1453	-.0231	-.0891	-.0856
.60	.0147	.1164	-.0996	.1625	-.1576	.2514	-.1556	.1692	-.1483	.0968	-.1593	-.0220	-.0578	-.0784
.70	-.0230	.0589	-.0547	.1379	-.1700	.1587	-.1687	.1651	-.2192	.0217			-.2339	-.2226
.80	-.2337	-.2351	-.2575	-.2063	-.3249	-.1925	-.3236	-.1819	-.2995	-.1789	-.3031	-.2333	-.2460	-.1675
.90	-.1975	-.2292	-.2764	-.2482	-.2997	-.2204	-.2963	-.2120	-.2969	-.2032	-.3000	-.2095	-.2784	-.1376
.95	-.1994	-.2592	-.2761	-.2403	-.2725	-.2305	-.2784	-.2241	-.2913	-.2185	-.2823	-.1984	-.2570	-.1427

TAIL 1

Cp at y/b of														
x/c	0.02		0.22		0.44		0.56		0.67		0.83		0.98	
	U.S.	L.S.	U.S.	L.S.	U.S.	L.S.	U.S.	L.S.	U.S.	L.S.	U.S.	L.S.	U.S.	L.S.
.05	.2992	.2665	.4841	.4197					.4456	.7928	.5311	.7546		
.10	.3028	.2497	.4332	.4196					.4391	.7077	.5208	.6972	.3506	.4700
.15	.2652	.2317					.3767	.5597	.4521	.6498	.5078	.6490	.3101	.4122
.20							.4246	.4870	.4789	.5843	.5140	.6006	.2809	.3532
.25	.0120	-.0119	-.0569	-.1232				.5828	.4950	.5099	.5107	.5381	.2486	.3053
.30			-.0971	-.1531	-.0430	-.1633	.0256	-.0284	.2388	.2125				
.40	-.0324	-.0509			-.1312	-.1948	-.0380	-.0820	.0343	.0048	.0258	.0080		
.50	-.0500	-.0901					-.1018	-.0958	-.0149	-.0174			-.0992	-.0844
.60					-.2157	-.2083	-.1374	-.1123	-.0504	-.0326	-.0224	-.0357	-.0816	-.0871
.70			-.1130	-.0818	-.2325	-.2019	-.1743	-.1373	-.2227	-.1106	-.2720	-.2753	-.2039	-.1904
.80	-.2613	-.2704	-.2807	-.2772	-.3619	-.3486			-.3195	-.3046	-.3016	-.2955		
.90	-.2611	-.2592			-.3314	-.3259			-.3122	-.2874	-.2573	-.2544	-.0561	-.0400
.95	-.2441	-.2466							-.2931	-.2745	-.2509	-.2512	-.1420	-.1291

TAIL 2

TABLE XXII. - CONCLUDED
(k) $\alpha = 20.55^\circ$

Cp at y/b of														
x/c	0.02		0.22		0.44		0.56		0.67		0.83		0.98	
	U.S.	L.S.	U.S.	L.S.	U.S.	L.S.	U.S.	L.S.	U.S.	L.S.	U.S.	L.S.	U.S.	L.S.
.05	.0568	.7842	-.1166	1.0024			-.0532	1.0891	-.0262	1.0911	-.0129	1.0714		
.10	-.0651	.6863	-.0976	.9091	-.0039	.9362	.0211	.9660	.0406	.9714	.0502	.9506	.0840	.6747
.15	-.3492	.7411	-.0783	.8186	-.0081	.8480	.0310	.8701	.0567	.8742	.0676	.8496	.1102	.5946
.20	-.2728	.7315	-.0612	.6923	-.0063	.7542			.0577	.7821	.0732	.7644	.1031	.5193
.25			-.2610	.1983	-.0319	.5206	.0203	.6269	.0426	.6770	.0668	.6746	.0904	.4538
.30	-.3224	.6187	-.2871	.2691	-.2538	.1498	-.2206	.0892	-.1217	.1836	.0457	.5548	.0928	.3662
.40									-.2401	.1290	-.2253	.0405	-.1755	-.0695
.50	-.0205	.2295			-.2719	.3684			-.2546	.2016	-.2352	.0632	-.1365	-.0746
.60	-.0382	.1631	-.1804	.2208	-.2707	.2745	-.2686	.2998	-.2645	.2395	-.2418	.0916	-.1335	-.0617
.70	-.0539	.1138	-.1122	.1923	-.2745	.2174	-.2811	.2179	-.3101	.1529			-.2852	-.2312
.80	-.2512	-.2035	-.3115	-.1859	-.3570	-.1624	-.3565	-.1558	-.3568	-.1520	-.3601	-.1679	-.3545	-.1907
.90	-.2210	-.2224	-.3311	-.2155	-.3276	-.1895	-.3243	-.1866	-.3381	-.1839	-.3513	-.1811	-.3341	-.1639
.95	-.2307	-.2406	-.3075	-.2217	-.3039	-.2019	-.3057	-.2010	-.3291	-.1960	-.3223	-.1907	-.2993	-.1544

TAIL 1

Cp at y/b of														
x/c	0.02		0.22		0.44		0.56		0.67		0.83		0.98	
	U.S.	L.S.	U.S.	L.S.	U.S.	L.S.	U.S.	L.S.	U.S.	L.S.	U.S.	L.S.	U.S.	L.S.
.05	.2647	.3079	.4112	.3465					.3185	.5309	.4660	.7009		
.10	.2625	.2784	.3700	.3449					.2872	.4865	.4563	.6299	.3479	.4804
.15	.2378	.2375					.2111	.3487	.3012	.4703	.4277	.5885	.3325	.4371
.20							.2462	.3287	.3282	.4453	.4286	.5784	.3265	.4017
.25	-.0135	-.0560	-.1238	-.1469				.4113	.3195	.3984	.4168	.5257	.3142	.3787
.30			-.1497	-.1691	-.0988	-.1862	-.0494	-.0946	.1071	.1271				
.40	-.0922	-.0890			-.1747	-.2408	-.0780	-.1595	-.0442	-.0713	.0023	.0208		
.50	-.0987	-.0955					-.1424	-.2039	-.0775	-.1208			.0411	.0102
.60					-.2597	-.3011	-.1940	-.2410	-.1085	-.1603	-.0328	-.0463	.0505	.0191
.70			-.1327	-.1267	-.2904	-.3143	-.2416	-.2785	-.2728	-.2382	-.2694	-.2897	-.1149	-.1377
.80	-.2900	-.3143	-.3266	-.3308	-.4143	-.4220			-.3582	-.3825	-.2918	-.3165		
.90	-.3109	-.3243			-.3997	-.4030			-.3693	-.3812	-.2702	-.3014	-.0270	-.0188
.95	-.3140	-.3173							-.3651	-.3680	-.2721	-.2952	-.1960	-.2037

TAIL 2

TABLE XXIII.- PRESSURE COEFFICIENTS, $\theta = 90^\circ$, $\delta_{1,3} = -15^\circ$, $M = 2.36$
 (a) $\alpha = -4.11^\circ$

Cp at y/b of														
x/c	0.02		0.22		0.44		0.56		0.67		0.83		0.98	
	U.S.	L.S.	U.S.	L.S.	U.S.	L.S.	U.S.	L.S.	U.S.	L.S.	U.S.	L.S.	U.S.	L.S.
.05	.4261	-.0040	1.1800	-.0647	1.1366	-.0658	1.2740	-.0623	1.2948	-.0454	1.2853	-.0543		
.10	.4441	.0714	1.0729	-.0737	1.1461	-.0655	1.1712	-.0564	1.1954	-.0496	1.1860	-.0526	.9332	-.0357
.15	.5795		.9993	-.0801	1.0691	-.0698	1.0933	-.0627	1.1139	-.0570	1.0861	-.0590	.8444	-.0205
.20	.6690	-.0566	.8987	-.0843	.9885	-.0735			1.0357	-.0649	1.0218	-.0648	.7731	-.0067
.25			.3840	-.1675	.7938	-.0927	.8771	-.0755	.9439	-.0717	.9409	-.0698	.7230	-.0133
.30	.4980	-.1254	.3759	-.1783	.3952	-.1716	.4033	-.1632	.5220	-.1361	.6351	-.0763	.6718	-.0189
.40									.4212	-.1754	.3637	-.1687	.2327	-.1397
.50	.1824	-.1098	.3731	-.1733	.4303	-.1803			.4323	-.1785	.3648	-.1714	.1996	-.1526
.60	.2426	-.1133	.3846	-.1671	.4162	-.1675	.4285	-.1699	.4202	-.1755	.3593	-.1716	.2042	-.1851
.70	.1991	-.1001	.3894	-.1664	.3854	-.1626	.3840	-.1630	.3110	-.1639			-.0039	-.2166
.80	.0903	-.1804	.1211	-.1832	.0994	-.1626	.1031	-.1620	.0851	-.1657	.0687	-.1709	-.0225	-.2124
.90	.1161	-.1753	.1050	-.1742	.0804	-.1637	.0823	-.1615	.0779	-.1678	.0540	-.1711	-.0118	-.2041
.95	.1196	-.1626	.0984	-.1644	.0741	-.1632	.0728	-.1607	.0689	-.1682	.0461	-.1717	-.0116	-.2049

TAIL 1

Cp at y/b of														
x/c	0.02		0.22		0.44		0.56		0.67		0.83		0.98	
	U.S.	L.S.	U.S.	L.S.	U.S.	L.S.	U.S.	L.S.	U.S.	L.S.	U.S.	L.S.	U.S.	L.S.
.05	.1910	.2187	.3189	.3315					.3089	.3324	.3041	.3350		
.10	.1895	.2123	.3088	.3200					.2936	.3114	.2965	.3196	.2551	.2606
.15	.1708	.1919					.3010	.3158	.2872	.3022	.2908	.3058	.2107	.2135
.20							.2811	.2894	.2839	.2916			.1977	.1962
.25	.0224	.0159	.0372	.0396			.2596	.2659	.2737	.2746	.2764	.2834		
.30			.0135	.0112	.0161	.0198	.0299	.0342	.1404	.1382				
.40	.1936	.1379			.0074	.0070	.0099	.0061	.0154	.0133	.0170	.0177		
.50	.3086	.2794					.0056	.0019	.0069	.0023			-.0017	-.0029
.60					.0130	.0026	.0067	-.0002	.0049	-.0013	-.0152	-.0231	-.0276	-.0239
.70			.0516	.0395	.0109	-.0013	-.0049	-.0142	-.0745	-.0349	-.1198	-.1328	-.1010	-.1161
.80	.0553	.0217	-.0158	-.0577	-.0969	-.1152			-.0597	-.0516	-.1012	-.1107		
.90	.0523	.0367			-.0932	-.1012			-.1004	-.1019	-.0992	-.1079	.0045	.0034
.95	.0557	.0389							-.0084	-.0077	-.0995	-.1078	-.0041	-.0051

TAIL 2

TABLE XXIII. - CONTINUED
 (b) $\alpha = -2.10^\circ$

Cp at y/b of														
x/c	0.02		0.22		0.44		0.56		0.67		0.83		0.98	
	U.S.	L.S.	U.S.	L.S.	U.S.	L.S.	U.S.	L.S.	U.S.	L.S.	U.S.	L.S.	U.S.	L.S.
.05	.3917	.0280	1.0748	-.0366	1.0482	-.0426	1.1558	-.0285	1.1794	-.0188	1.1752	-.0232		
.10	.4056	.0828	.9761	-.0430	1.0560	-.0422	1.0799	-.0340	1.1069	-.0299	1.1007	-.0303	.8525	-.0204
.15	.4876		.9129	-.0469	.9981	-.0446	1.0241	-.0400	1.0463	-.0358	1.0209	-.0371	.7755	-.0136
.20	.5238	-.0314	.8337	-.0499	.9375	-.0466			.9866	-.0415	.9695	-.0417	.7153	-.0002
.25			.3567	-.1496	.7692	-.0670	.8500	-.0508	.9117	-.0472	.9003	-.0453	.6751	-.0032
.30	.3565	-.1059	.3277	-.1637	.3690	-.1599	.3864	-.1502	.5120	-.1194	.8061	-.0515	.6333	-.0027
.40									.3798	-.1634	.3327	-.1567	.2166	-.1307
.50	.1425	-.1100	.2949	-.1620	.3710	-.1705			.3776	-.1678	.3180	-.1629	.1682	-.1403
.60	.2071	-.1102	.3008	-.1582	.3558	-.1627	.3714	-.1662	.3643	-.1682	.3064	-.1634	.1651	-.1632
.70	.1480	-.0949	.3142	-.1568	.3274	-.1521	.3303	-.1542	.2635	-.1551			-.0304	-.1997
.80	.0282	-.1764	.0801	-.1713	.0623	-.1509	.0684	-.1519	.0522	-.1562	.0356	-.1609	-.0489	-.1918
.90	.0648	-.1727	.0653	-.1629	.0388	-.1529	.0478	-.1521	.0445	-.1566	.0214	-.1614	-.0315	-.1950
.95	.0796	-.1594	.0561	-.1545	.0316	-.1534	.0386	-.1521	.0357	-.1568	.0142	-.1626	-.0395	-.1943

TAIL 1

Cp at y/b of															
x/c	0.02		0.22		0.44		0.56		0.67		0.83		0.98		
	U.S.	L.S.	U.S.	L.S.	U.S.	L.S.	U.S.	L.S.	U.S.	L.S.	U.S.	L.S.	U.S.	L.S.	
.05	.1689	.1959	.3111	.3245					.3048	.3314	.3050	.3371			
.10	.1730	.1904	.3010	.3137					.2892	.3108	.2973	.3187	.2548	.2594	
.15	.1561	.1708						.2984	.3142	.2844	.3012	.2913	.3050	.2106	.2170
.20								.2791	.2864	.2814	.2912			.1950	.1948
.25	.0286	.0177	.0347	.0380				.2612	.2662	.2713	.2745	.2774	.2840		
.30			.0097	.0090	.0168	.0200	.0301	.0340	.1377	.1393					
.40	.1660	.1454			.0087	.0065	.0092	.0057	.0153	.0135	.0247	.0212			
.50	.2556	.2323					.0051	.0019	.0072	-.0023				-.0023	-.0028
.60					.0095	-.0009	.0065	-.0000	.0052	-.0014	-.0106	-.0194	-.0278	-.0320	
.70			.0434	.0343	.0653	-.0073	-.0045	-.0143	-.0738	-.0352	-.1256	-.1352	-.1117	-.1184	
.80	.0378	.0079	-.0278	-.0553	-.1088	-.1207			-.0609	-.0519	-.1044	-.1139			
.90	.0505	.0360			-.0989	-.1040			-.1006	-.1015	-.1023	-.1110	.0040	.0021	
.95	.0521	.0396							-.0073	-.0076	-.1031	-.1105	-.0048	-.0052	

TAIL 2

TABLE XXIII. - CONTINUED
(c) $\alpha = -0.12^\circ$

Cp at y/b of														
x/c	0.02		0.22		0.44		0.56		0.67		0.83		0.98	
	U.S.	L.S.	U.S.	L.S.	U.S.	L.S.	U.S.	L.S.	U.S.	L.S.	U.S.	L.S.	U.S.	L.S.
.05	.3912	.0587	.9509	-.0052	.9312	-.0128	.9759	-.0018	.9970	.0021	.9828	-.0005		
.10	.3857	-.1047	.8756	-.0073	.9388	-.0122	.9538	-.0071	.9747	-.0043	.9690	-.0053	.7627	-.0046
.15	.4340		.8205	-.0096	.9054	-.0120	.9313	-.0104	.9492	-.0079	.9330	-.0098	.6987	.0025
.20	.4424	-.0053	.7552	-.0128	.8654	-.0132			.9172	-.0107	.9095	-.0131	.6526	.0056
.25			.3168	-.1301	.7343	-.0363	.8131	-.0199	.8692	-.0154	.8625	-.0156	.6211	.0054
.30	.2498	-.0800	.2758	-.1468	.3415	-.1447	.3729	-.1337	.5120	-.0985	.7878	-.0218	.5900	.0084
.40									.3482	-.1506	.3124	-.1428	.2028	-.1208
.50	.1008	-.1047	.2346	-.1468	.3183	-.1562			.3356	-.1550	.2818	-.1530	.1414	-.1201
.60	.1607	-.1040	.2201	-.1433	.3037	-.1563	.3239	-.1572	.3199	-.1566	.2634	-.1536	.1317	-.1451
.70	.0979	-.0894	.2427	-.1426	.2772	-.1453	.2862	-.1472	.2246	-.1461			-.0545	-.1829
.80	-.0187	-.1680	.0366	-.1565	.0311	-.1395	.0394	-.1417	.0233	-.1452	.0055	-.1505	-.0722	-.1717
.90	.0067	-.1730	.0274	-.1566	.0077	-.1413	.0195	-.1415	.0158	-.1449	-.0079	-.1511	-.0522	-.1791
.95	.0255	-.1596	.0223	-.1521	-.0008	-.1417	.0106	-.1415	.0075	-.1445	-.0147	-.1516	-.0633	-.1808

TAIL 1

Cp at y/b of														
x/c	0.02		0.22		0.44		0.56		0.67		0.83		0.98	
	U.S.	L.S.	U.S.	L.S.	U.S.	L.S.	U.S.	L.S.	U.S.	L.S.	U.S.	L.S.	U.S.	L.S.
.05	.1414	.1662	.3075	.3210					.3022	.3291	.3036	.3392		
.10	.1500	.1641	.2949	.3082					.2864	.3089	.2964	.3170	.2557	.2605
.15	.1428	.1530					.2976	.3119	.2817	.2992	.2894	.3036	.2125	.2191
.20							.2767	.2850	.2791	.2903			.1906	.1947
.25	.0471	.0306	.0318	.0373			.2598	.2661	.2696	.2741	.2751	.2828		
.30			.0061	.0061	.0173	.0203	.0303	.0340	.1369	.1381				
.40	.1547	.1601			.0092	.0060	.0092	.0060	.0160	.0137	.0266	.0240		
.50	.2059	.1911					.0057	.0028	.0078	.0027			-.0024	-.0036
.60					.0096	-.0009	.0076	.0003	.0058	-.0009	-.0057	-.0143	-.0355	-.0342
.70			.0516	.0413	.0032	-.0075	-.0032	-.0140	-.0725	-.0344	-.1273	-.1347	-.1095	-.1148
.80	.0160	-.0089	-.0364	-.0560	-.1170	-.1239			-.0612	-.0535	-.1061	-.1180		
.90	.0418	-.0292			-.1015	-.1055			-.0994	-.1022	-.1032	-.1138	.0033	.0007
.95	.0393	.0330							-.0080	-.0090	-.1034	-.1116	-.0050	-.0064

TAIL 2

TABLE XXIII. - CONTINUED
(d) $\sigma = 1.88^\circ$

Cp at γ/b of														
x/c	0.02		0.22		0.44		0.56		0.67		0.83		0.98	
	U.S.	L.S.	U.S.	L.S.	U.S.	L.S.	U.S.	L.S.	U.S.	L.S.	U.S.	L.S.	U.S.	L.S.
.05	.3830	.0940	.7973	.0328	.7746	.0239	.7862	.0339	.7918	.0350	.7793	.0333		
.10	.3513	.1263	.7702	.0324	.7821	.0247	.7759	.0290	.7853	.0309	.7819	.0300	.6424	.0182
.15	.3649		.7297	.0304	.7881	.0262	.7833	.0262	.7891	.0272	.7748	.0253	.5881	.0240
.20	.3585	.0296	.6741	.0263	.7702	.0253			.7853	.0244	.7794	.0220	.5521	.0257
.25			.2693	-.1103	.6731	-.0010	.7332	.0160	.7678	.0204	.7624	.0194	.5325	.0235
.30	.1653	-.0368	.2196	-.1285	.3023	-.1266	.3400	-.1155	.4761	-.0747	.7183	-.0126	.5144	.0213
.40									.3130	-.1341	.2847	-.1262	.1675	-.1015
.50	.0660	-.0934	.1877	-.1281	.2655	-.1377			.2988	-.1382	.2497	-.1388	.1092	-.1038
.60	.1168	-.0931	.1647	-.1257	.2504	-.1390	.2755	-.1404	.2824	-.1405	.2278	-.1415	.1003	-.1007
.70	.0622	-.0829	.1673	-.1257	.2315	-.1398	.2426	-.1434	.1919	-.1442			-.0741	-.1799
.80	-.0496	-.1478	-.0112	-.1443	.0010	-.1341	.0118	-.1366	-.0017	-.1396	-.0201	-.1459	-.0863	-.1648
.90	-.0369	-.1783	-.0119	-.1439	-.0185	-.1352	-.0061	-.1362	-.0100	-.1391	-.0339	-.1470	-.0688	-.1703
.95	-.0221	-.1666	-.0146	-.1456	-.0256	-.1352	-.0141	-.1362	-.0181	-.1388	-.0405	-.1476	-.0749	-.1715

TAIL 1

Cp at γ/b of														
x/c	0.02		0.22		0.44		0.56		0.67		0.83		0.98	
	U.S.	L.S.	U.S.	L.S.	U.S.	L.S.	U.S.	L.S.	U.S.	L.S.	U.S.	L.S.	U.S.	L.S.
.05	.1240	.1491	.3014	.3147					.2966	.3265	.2997	.3384		
.10	.1338	.1489	.2990	.3075					.2838	.3077	.2931	.3144	.2555	.2598
.15	.1341	.1447					.2952	.3070	.2808	.2980	.2862	.3014	.2089	.2199
.20							.2749	.2839	.2780	.2898			.1912	.1953
.25	.0436	.0282	.0265	.0326			.2575	.2648	.2688	.2745	.2737	.2809		
.30			.0020	.0017	.0191	.0199	.0312	.0353	.1362	.1383				
.40	.1264	.1281			.0116	.0061	.0114	.0077	.0171	.0147	.0287	.0263		
.50	.1639	.1493					.0084	.0036	.0091	.0036			-.0035	-.0035
.60					.0107	.0003	.0099	.0004	.0073	.0003	.0000	-.0083	-.0415	-.0405
.70			.0472	.0286	.0009	-.0095	-.0019	-.0136	-.0722	-.0339	-.1274	-.1318	-.1123	-.1171
.80	-.0027	-.0253	-.0520	-.0721	-.1221	-.1235			-.0623	-.0551	-.1094	-.1251		
.90	.0159	.0077			-.1000	-.1056			-.1003	-.1036	-.1038	-.1159	-.0021	.0006
.95	.0211	.0169							-.0038	-.0091	-.1033	-.1135	-.0060	-.0065

TAIL 2

TABLE XXIII. - CONTINUED
(e) $\alpha = 3.87^\circ$

Cp at y/b of														
x/c	0.02		0.22		0.44		0.56		0.67		0.83		0.98	
	U.S.	L.S.	U.S.	L.S.	U.S.	L.S.	U.S.	L.S.	U.S.	L.S.	U.S.	L.S.	U.S.	L.S.
.05	.3381	.1115	.6329	.0785	.6398	.0659	.6340	.0756	.6617	.0743	.6554	.0718		
.10	.3161	.1589	.6300	.0786	.6449	.0669	.6398	.0708	.6577	.0713	.6558	.0691	.5490	.0452
.15	.3135		.6057	.0770	.6466	.0692	.6511	.068C	.6587	.0673	.6518	.0644	.5036	.0464
.20	.3147	.0742	.5752	.0718	.6406	.0684			.6563	.0645	.6604	.0612	.4648	.0468
.25			.2226	-.0858	.5691	.0383	.6136	.0566	.6446	.0609	.6515	.0589	.4519	.0432
.30	.1010	.0030	.1705	-.1066	.2418	-.1065	.2684	-.0946	.3981	-.0473	.6193	.0512	.4373	.0408
.40									.2434	-.1139	.2304	-.1064	.1203	-.0854
.50	.0368	-.0799	.1409	-.1062	.2108	-.1162			.2363	-.1183	.1980	-.1206	.0683	-.0951
.60	.0848	-.0767	.1267	-.1060	.1988	-.1177	.2195	-.1201	.2278	-.1208	.1765	-.1255	.0601	-.0843
.70	.0312	-.0718	.1113	-.1067	.1805	-.1211	.1922	-.1273	.1487	-.1348			-.0871	-.1658
.80	-.0717	-.1288	-.0532	-.1314	-.0275	-.1261	-.0176	-.1276	-.0283	-.1309	-.0491	-.1371	-.0806	-.1703
.90	-.0684	-.1724	-.0551	-.1322	-.0442	-.1264	-.0320	-.1275	-.0357	-.1298	-.0609	-.1383	-.0787	-.1602
.95	-.0584	-.1656	-.0525	-.1339	-.0499	-.1266	-.0386	-.1276	-.0426	-.1296	-.0665	-.1388	-.0857	-.1573

TAIL 1

Cp at y/b of														
x/c	0.02		0.22		0.44		0.56		0.67		0.83		0.98	
	U.S.	L.S.	U.S.	L.S.	U.S.	L.S.	U.S.	L.S.	U.S.	L.S.	U.S.	L.S.	U.S.	L.S.
.05	.1364	.1901	.3013	.3141					.2969	.3233	.2959	.3360		
.10	.1432	.1813	.2843	.3002					.2826	.3063	.2906	.3117	.2535	.2570
.15	.1344	.1592							.2903	.3050	.2808	.2971	.2842	.3003
.20									.2761	.2848	.2788	.2898		.2113
.25	.0289	.0153	.0360	.0427					.2808	.2971	.2842	.3003	.2113	.2248
.30			.0107	.0130	.0221	.0190	.0330	.0360	.1374	.1397			.1951	.1994
.40	.0430	.0432			.0107	.0054	.0133	.0078	.0193	.0155	.0315	.0296		
.50	.0849	.0798					.0039	.0031	.0111	.0039			-.0044	-.0037
.60					.0141	.0017	.0096	-.0000	.0094	.0004	.0055	-.0028	-.0507	-.0482
.70			.0332	.0169	.0072	-.0051	-.0021	-.0144	-.0696	-.0335	-.1247	-.1286	-.1145	-.1173
.80	-.0098	-.0362	-.0858	-.1006	-.1231	-.1278			-.0630	-.0566	-.1172	-.1282		
.90	-.0295	.0419			-.1028	-.1050			-.1006	-.1050	-.1058	-.1138	.0004	-.0004
.95	-.0352	-.0384							-.0096	-.0092	-.1036	-.1123	-.0069	-.0068

TAIL 2

TABLE XXIII. - CONTINUED
 (f) $\alpha = 5.87^\circ$

Cp at y/b of														
x/c	0.02		0.22		0.44		0.56		0.67		0.83		0.98	
	U.S.	L.S.	U.S.	L.S.	U.S.	L.S.	U.S.	L.S.	U.S.	L.S.	U.S.	L.S.	U.S.	L.S.
.05	.2783	.1305	.4967	.1285	.5252	.1126	.5251	.1222	.5513	.1189	.5517	.1151		
.10	.2589	.1618	.5083	.1287	.5298	.1137	.5265	.1180	.5531	.1168	.5528	.1129	.4603	.0769
.15	.2588		.4961	.1280	.5342	.1169	.5379	.1151	.5514	.1122	.5476	.1085	.4251	.0729
.20	.2560	.1100	.4662	.1224	.5279	.1159			.5476	.1096	.5564	.1056	.3929	.0703
.25			.1565	-.0582	.4677	.0821	.5111	.1021	.5386	.1064	.5511	.1030	.3796	.0651
.30	.0406	.0492	.1091	-.0817	.1745	-.0821	.2021	-.0696	.3227	-.0163	.5267	.0944	.3675	-.0617
.40									.1787	-.0900	.1754	-.0833	.0798	-.0790
.50	.0160	-.0643	.0892	-.0824	.1486	-.0910			.1723	-.0945	.1461	-.0992	.0303	-.0811
.60	.0575	-.0538	.0845	-.0830	.1373	-.0927	.1606	-.0951	.1661	-.0972	.1267	-.1064	.0259	-.0659
.70	.0039	-.0506	.0701	-.0847	.1210	-.0971	.1351	-.1048	.0982	-.1198			-.0847	-.1347
.80	-.0705	.1204	-.0887	-.1227	-.0608	-.1171	-.0521	-.1176	-.0578	-.1218	-.0780	-.1288	-.0885	-.1714
.90	-.0741	-.1567	-.0919	-.1224	-.0736	-.1171	-.0643	-.1176	-.0642	-.1203	-.0889	-.1299	-.0854	-.1668
.95	-.0681	-.1627	-.0876	-.1236	-.0778	-.1171	-.0693	-.1176	-.0704	-.1200	-.0935	-.1301	-.0904	-.1572

TAIL 1

Cp at y/b of														
x/c	0.02		0.22		0.44		0.56		0.67		0.83		0.98	
	U.S.	L.S.	U.S.	L.S.	U.S.	L.S.	U.S.	L.S.	U.S.	L.S.	U.S.	L.S.	U.S.	L.S.
.05	.1616	.2287	.3079	.3232					.2979	.3255	.2979	.3356		
.10	.1560	.2103	.2997	.3143					.2855	.3102	.2930	.3124	.2572	.2593
.15	.1360	.1821							.2831	.2996	.2878	.3022	.2182	.2285
.20									.2816	.2844	.2813	.2910	.2005	.2069
.25	-.0053	-.0002	.0418	.0405					.2603	.2638	.2724	.2754	.2782	.2836
.30			.0169	.0181	.0261	.0222	.0359	.0369	.1400	.1388				
.40	.0009	-.0115			.0118	.0093	.0162	.0091	.0220	.0158	.0353	.0322		
.50	.0261	.0253					.0130	.0058	.0139	.0046			-.0087	-.0061
.60					.0185	.0026	.0114	.0027	.0122	.0017	.0119	.0006	-.0585	-.0545
.70			.0016	-.0068	.0117	-.0001	-.0015	-.0129	-.0682	-.0322	-.1209	-.1280	-.1185	-.1182
.80	-.0188	-.0491	-.1077	-.1305	-.1233	-.1320			-.0660	-.0602	-.1303	-.1329		
.90	-.0525	-.0601			-.1049	-.1097			-.1039	-.1084	-.1095	-.1162	-.0036	-.0023
.95	-.0618	-.0647							-.0140	-.0123	-.1044	-.1139	-.0119	-.0096

TAIL 2

TABLE XXIII. - CONTINUED
(g) $\alpha = 7.86^\circ$

Cp at y/b of														
x/c	0.02		0.22		0.44		0.56		0.67		0.83		0.98	
	U.S.	L.S.	U.S.	L.S.	U.S.	L.S.	U.S.	L.S.	U.S.	L.S.	U.S.	L.S.	U.S.	L.S.
.05	.1903	.1518	.3822	.1822	.4249	.1650	.4309	.1745	.4550	.1704	.4601	.1639		
.10	.1836	.1509	.3917	.1839	.4289	.1666	.4290	.1706	.4589	.1692	.4618	.1624	.3716	.1135
.15	.1938		.3894	.1837	.4333	.1704	.4389	.1683	.4572	.1636	.4567	.1581	.3523	.1055
.20	.1958	.1382	.3708	.1770	.4288	.1595			.4526	.1614	.4644	.1555	.3290	.1004
.25			.0968	-.0284	.3772	.1316	.4160	.1536	.4440	.1582	.4603	.1528	.3106	.0935
.30	-.0230	-.0968	.0517	-.0555	.1111	-.0528	.1407	-.0400	.2528	-.0186	.4400	.1433	.3074	.0890
.40									.1203	-.0618	.1243	-.0561	.0445	.0700
.50	-.0133	-.0454	.0333	-.0557	.0922	-.0617			.1142	-.0665	.0976	-.0738	-.0020	-.0692
.60	.0397	-.0248	.0304	-.0565	.0829	-.0635	.1010	-.0654	.1095	-.0694	.0801	-.0830	-.0021	-.0791
.70	-.0037	-.0238	.0217	-.0587	.0665	-.0688	.0803	-.0769	.0494	-.0978			-.0911	-.1313
.80	-.0642	-.1135	-.1161	-.1249	-.0946	-.1107	-.0825	-.1109	-.0880	-.1152	-.1035	-.1279	-.1088	-.1360
.90	-.0703	-.1387	-.1174	-.1183	-.1054	-.1105	-.0937	-.1104	-.0928	-.1136	-.1126	-.1227	-.0942	-.1563
.95	-.0675	-.1559	-.1118	-.1199	-.1087	-.1103	-.0983	-.1104	-.0974	-.1131	-.1162	-.1228	-.0735	-.1466

TAIL 1

Cp at y/b of														
x/c	0.02		0.22		0.44		0.56		0.67		0.83		0.98	
	U.S.	L.S.	U.S.	L.S.	U.S.	L.S.	U.S.	L.S.	U.S.	L.S.	U.S.	L.S.	U.S.	L.S.
.05	.1903	.2223	.2745	.3325					.3068	.3241	.3060	.3387		
.10	.1703	.2009	.2768	.3203					.2941	.3090	.3029	.3143	.2648	.2642
.15	.1357	.1645							.3015	.3038	.2921	.2975	.2292	.2344
.20									.2900	.2861	.2911	.2895	.2122	.2118
.25	-.0243	-.0176	.0132	.0346					.2635	.2645	.2822	.2747		
.30			-.0097	.0097	.0268	.0259	.0404	.0386	.1463	.1393				
.40	-.0567	-.0427			.0193	.0131	.0197	.0103	.0272	.0168	.0413	.0324		
.50	-.0492	-.0304					.0153	.0082	.0180	-.0060			-.0096	-.0091
.60					.0248	.0123	.0154	.0053	.0152	-.0027	.0176	.0030	-.0620	-.0598
.70			-.0430	-.0414	.0239	.0102	.0019	-.0088	-.0672	-.0314	-.1177	-.1242	-.1199	-.1221
.80	-.0549	-.0803	-.1235	-.1270	-.1254	-.1331			-.0669	-.0619	-.1335	-.1333		
.90	-.0600	-.0690			-.1113	-.1102			-.1085	-.1083	-.1102	-.1149	-.0048	-.0053
.95	-.0565	-.0614							-.0151	-.0148	-.1042	-.1121	-.0127	-.0122

TAIL 2

TABLE XXIII. - CONTINUED
(h) $\alpha = 9.86^\circ$

Cp at y/b of														
x/c	0.02		0.22		0.44		0.56		0.67		0.83		0.98	
	U.S.	L.S.	U.S.	L.S.	U.S.	L.S.	U.S.	L.S.	U.S.	L.S.	U.S.	L.S.	U.S.	L.S.
.05	.1031	.1289	.2788	.2334	.3336	.2199	.3470	.2301	.3688	.2263	.3781	.2185		
.10	.1098	.1297	.2879	.2373	.3365	.2221	.3419	.2282	.3715	.2266	.3780	.2178	.3111	.1554
.15	.1272		.2829	.2367	.3381	.2271	.3492	.2257	.3709	.2204	.3725	.2140	.2848	.1445
.20	.1297	.1584	.2721	.2281	.3336	.2259			.3651	.2190	.3793	.2115	.2654	.1366
.25			.0389	-.0020	.2631	.1837	.3287	.2092	.3575	.2154	.3759	.2087	.2501	.1268
.30	-.0770	.1607	-.0019	-.0315	.0543	-.0221	.3837	-.0073	.1875	.0569	.3587	.1977	.2448	.1210
.40									.0658	-.0300	.0759	-.0253	.0110	-.0578
.50	-.0513	-.0251	-.0198	-.0285	.0326	-.0302			.0586	-.0349	.0516	-.0448	-.0185	-.0524
.60	.0162	.0058	-.0223	-.0296	.0272	-.0327	.0432	-.0342	.0543	-.0381	.0357	-.0554	-.0249	-.0612
.70	.0202	.0017	-.0249	-.0338	.0142	-.0399	.0244	-.0469	.0021	-.0713			-.1015	-.1359
.80	-.0611	-.1081	-.1371	-.1382	-.1242	-.1175	-.1140	-.1190	-.1164	-.1191	-.1267	-.1239	-.1117	-.1067
.90	-.0697	-.1253	-.1296	-.1242	-.1347	-.1134	-.1229	-.1143	-.1212	-.1154	-.1326	-.1246	-.0832	-.1409
.95	-.0696	-.1450	-.1218	-.1188	-.1329	-.1128	-.1252	-.1140	-.1240	-.1146	-.1322	-.1248	-.0685	-.1395

TAIL 1

Cp at y/b of														
x/c	0.02		0.22		0.44		0.56		0.67		0.83		0.98	
	U.S.	L.S.	U.S.	L.S.	U.S.	L.S.	U.S.	L.S.	U.S.	L.S.	U.S.	L.S.	U.S.	L.S.
.05	.1661	.2127	.2168	.2934					.3186	.3255	.3171	.3385		
.10	.1510	.1948	.2148	.2847					.3066	.3112	.3116	.3148	.2735	.2678
.15	.1231	.1659					.3148	.3086	.3030	.3005	.3055	.3039	.2366	.2359
.20							.2980	.2878	.2935	.2919			.2201	.2138
.25	-.0275	-.0176	-.0091	.0257			.2718	.2667	.2905	.2772	.2935	.2834		
.30			-.0272	-.0054	.0271	.0265	.0446	.0401	.1526	.1407				
.40	-.0564	-.0526			.0163	.0172	.0235	.0134	.0314	.0180	.0447	.0342		
.50	-.0648	-.0527					.0182	.0109	.0219	.0078			-.0160	-.0160
.60					.0082	.0113	.0189	.0102	.0190	.0053	.0214	.0051	-.0629	-.0623
.70			-.0764	-.0670	.0173	.0124	.0064	-.0035	-.0638	-.0282	-.1154	-.1210	-.1201	-.1217
.80	-.0960	-.1230	-.1245	-.1319	-.1241	-.1249			-.0690	-.0653	-.1329	-.1302		
.90	-.1013	-.1041			-.1361	-.1364			-.1105	-.1066	-.1101	-.1132	-.0104	-.0114
.95	-.0864	-.0916							-.0215	-.0214	-.1035	-.1103	-.0190	-.0187

TAIL 2

TABLE XXIII. - CONTINUED
(1) $\alpha = 11.85^\circ$

Cp at y/b of														
x/c	0.02		0.22		0.44		0.56		0.67		0.83		0.98	
	U.S.	L.S.	U.S.	L.S.	U.S.	L.S.	U.S.	L.S.	U.S.	L.S.	U.S.	L.S.	U.S.	L.S.
.05	.0423	.0757	.1752	.2909	.2342	.2767	.2543	.2880	.2765	.2839	.2982	.2764		
.10	.0148	.0434	.1779	.2967	.2363	.2790	.2462	.2890	.2776	.2844	.2962	.2771	.2485	.2031
.15	.0396		.1754	.2954	.2390	.2857	.2533	.2859	.2790	.2782	.2882	.2737	.2184	.1893
.20	.0402	.1682	.1716	.2813	.2341	.2855			.2720	.2781	.2921	.2706	.2016	.1781
.25			-.0131	.0244	.1960	.2392	.2355	.2667	.2637	.2739	.2875	.2672	.1911	.1657
.30	-.1189	.2325	-.0456	-.0045	-.0013	.0125	-.0258	.0288	.1170	.0977	.2713	.2548	-.1818	.1577
.40									.0098	.0035	.0228	.0069	-.0229	-.0395
.50	-.0559	-.0133	-.0651	.0025	-.0215	.0050			.0026	-.0014	.0020	-.0144	-.0472	-.0495
.60	.0379	.0442	-.0601	.0017	-.0256	-.0003	-.0102	.0015	-.0010	-.0047	-.0121	-.0264	-.0418	-.0489
.70	.0365	.0339	-.0517	-.0115	-.0339	-.0108	-.0266	-.0128	-.0450	-.0420			-.1153	-.1239
.80	-.0597	-.0988	-.1351	-.1229	-.1420	-.1408	-.1422	-.1390	-.1415	-.1413	-.1454	-.1325	-.0985	-.1061
.90	-.0631	-.1107	-.1207	-.1162	-.1219	-.1257	-.1281	-.1318	-.1267	-.1203	-.1296	-.1256	-.0947	-.1102
.95	-.0683	-.1337	-.1179	-.1186	-.1203	-.1193	-.1206	-.1220	-.1185	-.1154	-.1253	-.1246	-.1079	-.1234

TAIL 1

Cp at y/b of														
x/c	0.02		0.22		0.44		0.56		0.67		0.83		0.98	
	U.S.	L.S.	U.S.	L.S.	U.S.	L.S.	U.S.	L.S.	U.S.	L.S.	U.S.	L.S.	U.S.	L.S.
.05	.1277	.2055	.1505	.2181					.3304	.3350	.3207	.3474		
.10	.1136	.1882	.1413	.2063					.3178	.3193	.3161	.3236	.2752	.2764
.15	.0901	.1600							.3268	.3135	.3159	.3104	.3104	.3132
.20									.3096	.2937	.3147	.3034	.2390	.2436
.25	-.0462	-.0185	-.0575	-.0158					.2822	.2731	.3052	.2910	.3005	.2926
.30			-.0668	-.0398	.0100	.0066	.0495	.0427	.1646	.1537				
.40	-.0761	-.0486			-.0019	-.0056	.0266	.0154	.0398	.0271	.0513	.0401		
.50	-.0771	-.0567					.0207	.0112	.0295	.0162			-.0236	-.0230
.60					-.0022	-.0192	.0225	.0078	.0261	.0124	.0291	.0127	-.0591	-.0603
.70			-.0992	-.0879	-.0075	-.0199	-.0154	-.0058	-.0594	-.0217	-.1110	-.1177	-.1174	-.1194
.80	-.1090	-.1445	-.1651	-.1597	-.1368	-.1402			-.0715	-.0694	-.1318	-.1297		
.90	-.1206	-.1403			-.1492	-.1476			-.1150	-.1073	-.1198	-.1101	-.0173	-.0176
.95	-.1211	-.1347							-.0287	-.0281	-.1024	-.1072	-.0258	-.0258

TAIL 2

TABLE XXIII. - CONTINUED
(j) $q = 15.86^\circ$

Cp at γ/b of														
x/c	0.02		0.22		0.44		0.56		0.67		0.83		0.98	
	U.S.	L.S.	U.S.	L.S.	U.S.	L.S.	U.S.	L.S.	U.S.	L.S.	U.S.	L.S.	U.S.	L.S.
.05	-.0416	-.0037	.0608	.4062	.1133	.4107	.1376	.4215	.1479	.4178	.1489	.4002		
.10	-.0553	-.0186	.0565	.4120	.1142	.4145	.1236	.4281	.1479	.4164	.1478	.4053	.1127	.3096
.15	-.0428		.0523	.3963	.1154	.4209	.1287	.4226	.1500	.4143	.1448	.4032	.0988	.2908
.20	-.0216	.2292	.0491	.3641	.1097	.4196			.1432	.4138	.1517	.4010	.0858	.2750
.25			-.0855	.0701	.0773	.3623	.1101	.4009	.1340	.4075	.1509	.3976	.0802	.2589
.30	-.1528	.3059	-.1113	.0446	-.0752	.0913	-.0520	.1127	.0192	.1928	.1399	.3807	.0793	.2460
.40									-.0688	.0848	-.0529	.0849	-.0725	.0117
.50	-.0087	.0761	-.1100	.0599	-.0974	.0696			-.0764	.0793	-.0700	.0610	-.0680	-.0230
.60	.0205	.1168	-.1003	.0566	-.1024	.0570	-.0895	.0743	-.0815	.0756	-.0808	.0464	-.0781	-.0357
.70	.0263	.0725	-.0965	.0627	-.1099	.0452	-.1026	.0513	-.1132	.0280			-.1402	-.1184
.80	-.0760	-.0888	-.1602	-.0480	-.1223	-.1104	-.1206	-.1077	-.1242	-.1088	-.1303	-.1208	-.1330	-.1310
.90	-.0807	-.1019	-.1538	-.0808	-.1241	-.1156	-.1208	-.1194	-.1226	-.1141	-.1321	-.1314	-.1490	-.1191
.95	-.0923	-.1054	-.1292	-.0929	-.1248	-.1151	-.1206	-.1227	-.1221	-.1182	-.1323	-.1332	-.1408	-.0995

TAIL 1

Cp at γ/b of														
x/c	0.02		0.22		0.44		0.56		0.67		0.83		0.98	
	U.S.	L.S.	U.S.	L.S.	U.S.	L.S.	U.S.	L.S.	U.S.	L.S.	U.S.	L.S.	U.S.	L.S.
.05	.1104	.1544	.0810	.1163					.2994	.2948	.3549	.3658		
.10	.0875	.1393	.0717	.1072					.2805	.2775	.3521	.3449	.2944	.2918
.15	.0590	.1104					.1683	.1793	.2694	.2702	.3443	.3365	.2630	.2628
.20							.1417	.1550	.2634	.2605			.2468	.2399
.25	-.0685	-.0528	-.0896	-.0645			.2049	.1363	.2549	.2464	.3308	.3177		
.30			-.0959	-.0851	-.1143	-.1170	-.0509	-.0455	.1252	.1188				
.40	-.1034	-.0845			-.1249	-.1309	-.0758	-.0768	.0010	-.0104	.0659	.0534	-.0339	-.0351
.50	-.1025	-.0863					-.0849	-.0844	-.0194	-.0282				
.60					-.1292	-.1383	-.0878	-.0891	-.0269	-.0354	.0370	.0180	-.0480	-.0488
.70			-.1315	-.1294	-.1336	-.1427	-.0905	-.0957	-.0971	-.0653	-.1089	-.1204	-.1104	-.1133
.80	-.1478	-.1635	-.1864	-.1904	-.1862	-.1941			-.0906	-.0865	-.1326	-.1447		
.90	-.1559	-.1634			-.1803	-.1830			-.1514	-.1411	-.1289	-.1202	-.0285	-.0301
.95	-.1564	-.1625							-.0393	-.0405	-.1183	-.1152	-.0355	-.0373

TAIL 2

TABLE XXIII. - CONCLUDED
(k) $\alpha = 19.86^\circ$

Cp at γ/b of														
x/c	0.02		0.22		0.44		0.56		0.67		0.83		0.98	
	U.S.	L.S.	U.S.	L.S.	U.S.	L.S.	U.S.	L.S.	U.S.	L.S.	U.S.	L.S.	U.S.	L.S.
.05	-.0755	-.0312	.0109	.5528	.0570	.5700	.0926	.5792	.1002	.5655	.1178	.5501		
.10	-.1041	-.0290	-.0004	.5380	.0579	.5750	.0717	.5848	.0944	.5722	.1102	.5589	-.0968	.4444
.15	-.1162		-.0207	.4996	.0505	.5774	.0685	.5805	.0924	.5719	.0993	.5578	-.0822	.4203
.20	-.1363	.3044	-.0432	.4627	.0378	.5686			.0823	.5715	.0984	.5556	.0700	.3980
.25			-.1474	.1363	.0058	.4887	.0407	.5502	.0702	.5627	.0921	.5527	.0613	.3771
.30	-.1849	.4112	-.1705	.1067	-.1183	.1635	-.0949	.2003	-.0288	.3001	.0790	.5311	.0566	.3599
.40									-.1082	.1765	-.0895	.1760	-.0848	.0793
.50	-.0407	.1778	-.1575	.1407	-.1475	.1320			-.1179	.1671	-.1055	.1487	-.0923	.0406
.60	-.0180	.1945	-.1537	.1634	-.1545	.1206	-.1378	.1398	-.1249	.1558	-.1149	.1310	-.0782	.0233
.70	-.0121	.1246	-.1539	.1927	-.1472	.1131	-.1474	.1132	-.1471	.0923			-.1512	-.1051
.80	-.1008	-.0616	-.1866	-.0070	-.1423	-.0601	-.1411	-.0719	-.1431	-.0729	-.1496	-.0790	-.1697	-.0928
.90	-.0964	-.0996	-.1716	-.0535	-.1448	-.0494	-.1418	-.0804	-.1434	-.0799	-.1506	-.0942	-.1551	-.0940
.95	-.1058	-.1062	-.1474	-.0694	-.1455	-.0442	-.1419	-.0822	-.1431	-.0857	-.1509	-.0999	-.1498	-.0945

TAIL 1

Cp at γ/b of														
x/c	0.02		0.22		0.44		0.56		0.67		0.83		0.98	
	U.S.	L.S.	U.S.	L.S.	U.S.	L.S.	U.S.	L.S.	U.S.	L.S.	U.S.	L.S.	U.S.	L.S.
.05	.0729	.1297	-.0068	.0013					.0375	.0580	.1901	.1720		
.10	.0528	.1095	-.0081	.0044					.0274	.0466	.1721	.1572	.2925	.2549
.15	.0247	.0738							.0194	.0377	.0241	.0377	.1586	.1452
.20									-.0089	.0111	.0176	.0294		.2356
.25	-.0896	-.0778	-.1220	-.1117					.0935	.0587	.0090	.0181	.1282	.1179
.30			-.1186	-.1174	-.1464	-.1386	-.1275	-.1157	-.0581	-.0534				
.40	-.1239	-.1125			-.1548	-.1500	-.1445	-.1388	-.1272	-.1258	-.0783	-.0828		
.50	-.1222	-.1105					-.1474	-.1434	-.1364	-.1350			-.0165	-.0329
.60					-.1545	-.1555	-.1476	-.1462	-.1386	-.1391	-.1149	-.1175	-.0320	-.0388
.70			-.1473	-.1443	-.1565	-.1591	-.1430	-.1467	-.1656	-.1567	-.1818	-.1841	-.1200	-.1293
.80	-.1685	-.1722	-.1941	-.1946	-.1958	-.2005			-.1008	-.1025	-.1903	-.1937		
.90	-.1755	-.1759			-.1899	-.1911			-.1855	-.1871	-.1873	-.1904	-.0105	-.0270
.95	-.1733	-.1755							-.0251	-.0396	-.1875	-.1904	-.0194	-.0355

TAIL 2

TABLE XXIV. - PRESSURE COEFFICIENTS, $\theta = 90^\circ$, $\delta_{1,3} = -15^\circ$, $M = 3.70$
 (a) $\alpha = -3.95^\circ$

Cp at y/b of														
x/c	0.02		0.22		0.44		0.56		0.67		0.83		0.98	
	U.S.	L.S.	U.S.	L.S.	U.S.	L.S.	U.S.	L.S.	U.S.	L.S.	U.S.	L.S.	U.S.	L.S.
.05	.2987	.0632	.8787	-.0314	.8390	-.0298	.8203	-.0189	.8276	-.0188	.8029	-.0167		
.10	.2511	.0647	.8892	-.0355	.8441	-.0297	.8222	-.0268	.8299	-.0259	.8091	-.0260	.7209	-.0167
.15	.2716		.8531	-.0390	.8529	-.0352	.8377	-.0249	.8309	-.0295	.8066	-.0269	.6831	-.0213
.20	.3376	-.0155	.8071	-.0401	.8498	-.0388			.8286	-.0313	.8166	-.0287	.6374	-.0225
.25			.4024	-.0588	.7838	-.0427	.8064	-.0340	.8185	-.0320	.8121	-.0334	.6263	-.0247
.30	.2321	-.0418	.3593	-.0516	.4276	-.0371	.4526	-.0454	.5665	-.0465	.7834	-.0340	.6202	-.0219
.40									.4054	-.0530	.3943	-.0588	.2702	-.0529
.50	.2485	-.0460	.3240	-.0566	.3844	-.0519			.3996	-.0514	.3638	-.0596	.2158	-.0556
.60	.2376	-.0450	.3000	-.0563	.3661	-.0508	.3914	-.0460	.3969	-.0498	.3452	-.0480	.2045	-.0589
.70	.1903	-.0430	.2844	-.0566	.3450	-.0496	.3575	-.0521	.3153	-.0483			.0451	-.0615
.80	.0679	-.0572	.0975	-.0574	.1260	-.0454	.1336	-.0508	.1303	-.0442	.1066	-.0534	.0250	-.0587
.90	.0349	-.0586	.0817	-.0570	.1052	-.0495	.1166	-.0518	.1221	-.0548	.0940	-.0564	.0298	-.0555
.95	.0389	-.0566	.0784	-.0545	.0985	-.0522	.1100	-.0518	.1144	-.0553	.0881	-.0573	.0276	-.0548

TAIL 1

Cp at y/b of														
x/c	0.02		0.22		0.44		0.56		0.67		0.83		0.98	
	U.S.	L.S.	U.S.	L.S.	U.S.	L.S.	U.S.	L.S.	U.S.	L.S.	U.S.	L.S.	U.S.	L.S.
.05	.1249	.1363	.2204	.2376					.2169	.2368	.2240	.2495		
.10	.1247	.1380	.2101	.2223					.2062	.2224	.2147	.2295	.2042	.2134
.15	.1145	.1295							.2188	.2301	.2000	.2134	.2099	.2217
.20									.1985	.2049	.2001	.2063		.1612
.25	.0302	.0294	.0476	.0558					.2387	.2359	.1937	.1961	.2002	.2042
.30			.0270	.0270	.0332	.0373	.0431	.0500	.1167	.1148				
.40	.0032	.0014			.0181	.0172	.0191	.0184	.0268	.0259	.0360	.0376		
.50	.0126	.0071					.0142	.0126	.0159	.0136			.0089	.0080
.60					.0131	.0091	.0129	.0095	.0147	.0117	.0115	.0083	.0003	.0009
.70			.0171	.0099	.0081	.0038	.0172	.0138	-.0139	-.0032	-.0395	-.0402	-.0346	-.0364
.80	.0618	.0305	-.0271	-.0338	-.0397	-.0413			-.0131	-.0123	-.0376	-.0422		
.90	.0510	.0304			-.0272	-.0295			-.0310	-.0340	-.0340	-.0375	.0248	.0239
.95	.0441	.0236							.0045	.0031	-.0338	-.0378	.0079	.0072

TAIL 2

TABLE XXIV. - CONTINUED
(b) $\alpha = -1.96^\circ$

Cp at γ/b of														
x/c	0.02		0.22		0.44		0.56		0.67		0.83		0.98	
	U.S.	L.S.	U.S.	L.S.	U.S.	L.S.	U.S.	L.S.	U.S.	L.S.	U.S.	L.S.	U.S.	L.S.
.05	.2805	.0641	.7376	-.0221	.7318	-.0226	.7185	-.0093	.7271	-.0078	.7042	-.0078		
.10	.2419	-.0646	.7777	-.0260	.7364	-.0223	.7147	-.0173	.7327	-.0155	.7114	-.0154	.6243	-.0110
.15	.2695		.7735	-.0281	.7460	-.0247	.7288	-.0189	.7345	-.0197	.7095	-.0194	.6126	-.0125
.20	.3026	-.0111	.7413	-.0301	.7410	-.0271			.7305	-.0211	.7184	-.0222	.5715	-.0138
.25			.3561	-.0571	.6757	-.0356	.7066	-.0257	.7204	-.0225	.7151	-.0256	.5502	-.0165
.30	.1749	-.0434	.3029	-.0549	.3519	-.0387	.3761	-.0456	.4953	-.0432	.6321	-.0276	.5533	-.0171
.40									.3328	-.0570	.3327	-.0594	.2237	-.0523
.50	.1929	-.0493	.2697	-.0583	.3322	-.0523			.3274	-.0549	.3047	-.0642	.1702	-.0551
.60	.1860	-.0486	.2497	-.0580	.3172	-.0509	.3320	-.0478	.3242	-.0515	.2877	-.0509	.1654	-.0607
.70	.1415	-.0449	.2267	-.0577	.2958	-.0505	.3076	-.0536	.2551	-.0490			.0237	-.0636
.80	.0400	-.0598	.0628	-.0582	.0931	-.0482	.1042	-.0528	.0980	-.0463	.0723	-.0565	.0054	-.0607
.90	.0087	-.0617	.0451	-.0584	.0744	-.0507	.0880	-.0538	.0908	-.0563	.0608	-.0586	.0202	-.0581
.95	.0104	-.0590	.0431	-.0571	.0693	-.0523	.0819	-.0541	.0859	-.0572	.0556	-.0594	.0049	-.0584

TAIL 1

Cp at γ/b of														
x/c	0.02		0.22		0.44		0.56		0.67		0.83		0.98	
	U.S.	L.S.	U.S.	L.S.	U.S.	L.S.	U.S.	L.S.	U.S.	L.S.	U.S.	L.S.	U.S.	L.S.
.05	.1007	.1112	.2133	.2304					.2143	.2343	.2176	.2425		
.10	.1068	.1178	.2038	.2160					.2027	.2200	.2084	.2236	.1972	.2047
.15	.1000	.1117							.2222	.2334	.1984	.2103	.2036	.2155
.20									.1947	.2015	.1959	.2030		.1571
.25	.0240	.0246	.0457	.0535					.2096	.2134	.1897	.1929	.1943	.1980
.30			.0251	.0249	.0316	.0365	.0424	.0494	.1136	.1130				
.40	.0013	-.0007			.0165	.0158	.0179	.0172	.0250	.0249	.0342	.0359		
.50	.0123	.0064					.0130	.0114	.0145	.0129			.0095	.0077
.60					.0118	.0079	.0117	.0085	.0135	.0108	.0103	.0078	-.0046	-.0044
.70			.0160	.0090	.0067	.0028	.0148	.0118	-.0158	-.0046	-.0408	-.0399	-.0360	-.0379
.80	.0565	.0330	-.0283	-.0345	-.0417	-.0435			-.0140	-.0133	-.0400	-.0459		
.90	.0377	.0256			-.0295	-.0316			-.0332	-.0358	-.0360	-.0401	.0238	.0217
.95	.0324	.0186							.0046	.0028	-.0359	-.0401	.0082	.0067

TAIL 2

TABLE XXIV. - CONTINUED
(c) $\alpha = 0.03^*$

Cp at y/b of														
x/c	0.02		0.22		0.44		0.56		0.67		0.83		0.98	
	U.S.	L.S.	U.S.	L.S.	U.S.	L.S.	U.S.	L.S.	U.S.	L.S.	U.S.	L.S.	U.S.	L.S.
.05	.2974	.0725	.6217	-.0022	.6310	-.0065	.6280	.0076	.6323	.0091	.6145	.0086		
.10	.2461	.0716	.6511	-.0058	.6352	-.0063	.6203	.0000	.6386	.0009	.6221	.0023	.5480	-.0018
.15	.2559		.6540	-.0076	.6449	-.0065	.6332	-.0036	.6441	-.0028	.6205	-.0025	.5322	-.0013
.20	.2717	.0038	.6453	-.0106	.6425	-.0076			.6389	-.0051	.6294	-.0056	.5049	-.0000
.25			.3089	-.0504	.5835	-.0188	.6129	-.0099	.6299	-.0071	.6263	-.0074	.4800	-.0025
.30	.1360	-.0376	.2541	-.0530	.2888	-.0380	.3080	-.0431	.4198	-.0357	.6058	-.0116	.4787	-.0042
.40									.2699	-.0568	.2752	-.0553	.1821	-.0453
.50	.1345	-.0523	.2158	-.0606	.2654	-.0568			.2640	-.0579	.2506	-.0626	.1374	-.0518
.60	.1339	-.0519	.1978	-.0588	.2640	-.0530	.2629	-.0507	.2619	-.0550	.2363	-.0527	.1258	-.0569
.70	.0911	-.0476	.1803	-.0572	.2509	-.0509	.2427	-.0548	.2035	-.0503			.0038	-.0642
.80	.0115	-.0617	.0338	-.0569	.0672	-.0489	.0708	-.0540	.0651	-.0470	.0449	-.0572	-.0117	-.0604
.90	-.0065	-.0631	.0117	-.0577	.0497	-.0514	.0591	-.0543	.0563	-.0562	.0338	-.0585	.0084	-.0581
.95	-.0043	-.0601	.0095	-.0573	.0454	-.0529	.0551	-.0545	.0529	-.0569	.0293	-.0594	-.0130	-.0589

TAIL 1

Cp at y/b of														
x/c	0.02		0.22		0.44		0.56		0.67		0.83		0.98	
	U.S.	L.S.	U.S.	L.S.	U.S.	L.S.	U.S.	L.S.	U.S.	L.S.	U.S.	L.S.	U.S.	L.S.
.05	.0796	.0877	.2104	.2278					.2131	.2330	.2151	.2417		
.10	.0883	.0971	.2021	.2147					.2014	.2192	.2072	.2250	.1989	.2051
.15	.0835	.0335					.2177	.2279	.1971	.2096	.2034	.2165	.1671	.1757
.20							.1936	.2011	.1950	.2024			.1573	.1611
.25	.0220	.0234	.0449	.0517			.1939	.2026	.1889	.1923	.1947	.1992		
.30			.0240	.0236	.0313	.0366	.0428	.0508	.1128	.1131				
.40	.0066	.0055			.0163	.0160	.0180	.0177	.0252	.0253	.0352	.0371		
.50	.0320	.0231					.0131	.0117	.0150	.0135			.0098	.0079
.60					.0117	.0084	.0120	.0088	.0140	.0114	.0120	.0096	-.0098	-.0081
.70			.0171	.0117	.0067	.0034	.0147	.0117	-.0163	-.0043	-.0407	-.0390	-.0381	-.0373
.80	.0402	.0270	-.0278	-.0324	-.0431	-.0451			-.0146	-.0134	-.0428	-.0476		
.90	.0238	.0181			-.0311	-.0331			-.0350	-.0367	-.0376	-.0404	.0243	.0214
.95	.0201	.0144							.0045	.0032	-.0375	-.0402	.0082	.0067

TAIL 2

TABLE XXIV. - CONTINUED
(d) $\alpha = 2.03^{\circ}$

Cp at y/b of														
x/c	0.02		0.22		0.44		0.56		0.67		0.83		0.98	
	U.S.	L.S.	U.S.	L.S.	U.S.	L.S.	U.S.	L.S.	U.S.	L.S.	U.S.	L.S.	U.S.	L.S.
.05	.3022	.0790	.5184	.0217	.5373	.0153	.5396	.0287	.5409	.0304	.5293	.0282		
.10	.2485	.0815	.5420	.0192	.5405	.0157	.5299	.0222	.5460	.0226	.5355	.0224	.4726	.0159
.15	.2529		.5393	.0178	.5505	.0162	.5416	.0168	.5539	.0187	.5333	.0175	.4508	.0142
.20	.2533	.0204	.5313	.0142	.5470	.0152			.5511	.0163	.5421	.0138	.4376	.0131
.25			.2453	-.0411	.4978	.0014	.5235	.0110	.5425	.0137	.5402	.0126	.4151	.0107
.30	.1087	-.0247	.1956	-.0486	.2273	-.0351	.2455	-.0369	.3571	-.0238	.5229	.0069	.4051	-.0088
.40									.2128	-.0522	.2201	-.0497	.1467	-.0368
.50	.0936	-.0510	.1675	-.0578	.2031	-.0542			.2057	-.0543	.1984	-.0591	.1037	-.0466
.60	.0913	-.0504	.1549	-.0582	.2008	-.0534	.2046	-.0505	.2039	-.0542	.1871	-.0527	.0902	-.0474
.70	.0548	-.0462	.1439	-.0569	.1918	-.0503	.1859	-.0539	.1530	-.0494			-.0134	-.0653
.80	-.0100	-.0510	.0161	-.0552	.0379	-.0463	.0368	-.0522	.0355	-.0463	.0202	-.0567	-.0260	-.0598
.90	-.0215	-.0625	-.0080	-.0558	.0222	-.0488	.0263	-.0521	.0268	-.0549	.0100	-.0568	-.0041	-.0565
.95	-.0196	-.0597	-.0119	-.0555	.0185	-.0506	.0231	-.0522	.0235	-.0556	.0059	-.0573	-.0267	-.0576

TAIL 1

Cp at y/b of														
x/c	0.02		0.22		0.44		0.56		0.67		0.83		0.98	
	U.S.	L.S.	U.S.	L.S.	U.S.	L.S.	U.S.	L.S.	U.S.	L.S.	U.S.	L.S.	U.S.	L.S.
.05	.0684	.0780	.2105	.2264					.2128	.2328	.2174	.2434		
.10	.0772	.0872	.2011	.2114					.2010	.2193	.2086	.2274	.1954	.2058
.15	.0725	.0844							.2185	.2293	.1968	.2098	.2041	.2173
.20									.1933	.2019	.1948	.2023		.1555
.25	.0212	.0234	.0444	.0499					.1886	.1972	.1887	.1922	.1945	.1992
.30			.0236	.0223	.0320	.0372	.0436	.0519	.1123	.1130				
.40	.0107	.0086			.0171	.0169	.0187	.0181	.0259	.0261	.0355	.0368		
.50	.0351	.0205					.0138	.0122	.0159	.0144			.0089	.0071
.60					.0125	.0090	.0126	.0094	.0147	.0123	.0130	.0106	-.0148	-.0128
.70			.0150	.0065	.0073	.0037	.0150	.0122	-.0161	-.0042	-.0403	-.0392	-.0389	-.0386
.80	.0249	.0133	-.0296	-.0364	-.0439	-.0459			-.0154	-.0138	-.0455	-.0492		
.90	.0114	.0060			-.0319	-.0338			-.0361	-.0376	-.0384	-.0414	.0193	.0175
.95	.0084	.0035							.0036	.0022	-.0376	-.0406	.0068	.0057

TAIL 2

TABLE XXIV. - CONTINUED
(e) $\alpha = 4.02^\circ$

Cp at y/b of														
x/c	0.02		0.22		0.44		0.56		0.67		0.83		0.98	
	U.S.	L.S.	U.S.	L.S.	U.S.	L.S.	U.S.	L.S.	U.S.	L.S.	U.S.	L.S.	U.S.	L.S.
.05	.2356	.0820	.4160	.0494	.4438	.0425	.4510	.0525	.4510	.0539	.4415	.0497		
.10	.1955	.0783	.4354	.0484	.4461	.0429	.4405	.0477	.4561	.0466	.4459	.0446	.3998	.0324
.15	.1683		.4338	.0470	.4547	.0430	.4500	.0434	.4638	.0429	.4440	.0405	.3762	.0281
.20	.1876	.0394	.4235	.0435	.4516	.0415			.4636	.0409	.4526	.0374	.3649	.0258
.25			.1864	-.0293	.4097	.0251	.4345	-.0357	.4562	-.0381	.4518	.0354	.3506	.0224
.30	.0580	-.0051	.1391	-.0415	.1702	-.0305	.1889	-.0296	.2958	-.0100	.4369	.0301	.3352	.0206
.40									.1604	-.0472	.1681	-.0420	.1145	-.0325
.50	.0516	-.0474	.1146	-.0508	.1474	-.0498			.1525	-.0497	.1485	-.0532	.0704	-.0402
.60	.0511	-.0479	.1048	-.0531	.1446	-.0504	.1502	-.0484	.1503	-.0511	.1393	-.0514	.0601	-.0437
.70	.0230	-.0443	.0967	-.0532	.1365	-.0499	.1331	-.0540	.1100	-.0497			-.0254	-.0638
.80	-.0253	-.0585	-.0038	-.0535	.0128	-.0470	.0100	-.0517	.0121	-.0456	-.0004	-.0558	-.0301	-.0632
.90	-.0329	-.0622	-.0249	-.0534	-.0013	-.0488	-.0002	-.0511	.0023	-.0530	-.0095	-.0549	-.0131	-.0556
.95	-.0318	-.0594	-.0287	-.0535	-.0042	-.0497	-.0027	-.0511	-.0004	-.0536	-.0128	-.0549	-.0349	-.0563

TAIL 1

Cp at y/b of														
x/c	0.02		0.22		0.44		0.56		0.67		0.83		0.98	
	U.S.	L.S.	U.S.	L.S.	U.S.	L.S.	U.S.	L.S.	U.S.	L.S.	U.S.	L.S.	U.S.	L.S.
.05	.0706	.0920	.2072	.2238					.2123	.2325	.2162	.2419		
.10	.0774	.0948	.1995	.2111					.2004	.2183	.2079	.2276	.2064	.2146
.15	.0714	.0854					.2308	.2423	.1959	.2101	.2036	.2171	.1705	.1807
.20							.1932	.2017	.1948	.2029			.1624	.1636
.25	.0151	.0189	.0431	.0485			.1852	.1933	.1886	.1928	.1941	.1987		
.30			.0221	.0214	.0330	.0379	.0441	.0518	.1127	.1119				
.40	-.0039	-.0005			.0179	.0177	.0195	.0181	.0267	.0269	.0365	.0364		
.50	.0023	.0045					.0146	.0125	.0164	.0150			.0083	.0061
.60					.0132	.0095	.0134	.0098	.0153	.0126	.0146	.0111	-.0176	-.0167
.70			.0037	.0011	.0082	.0043	.0155	.0122	-.0157	-.0038	-.0399	-.0393	-.0409	-.0412
.80	.0037	-.0056	-.0390	-.0413	-.0447	-.0464			-.0162	-.0151	-.0476	-.0510		
.90	-.0087	-.0137			-.0328	-.0343			-.0369	-.0390	-.0396	-.0432	.0237	.0187
.95	-.0109	-.0155							.0026	.0007	-.0383	-.0424	.0062	.0042

TAIL 2

TABLE XXIV. - CONTINUED
(f) $n = 6.02^\circ$

Cp at y/b of														
x/c	0.02		0.22		0.44		0.56		0.67		0.83		0.98	
	U.S.	L.S.	U.S.	L.S.	U.S.	L.S.	U.S.	L.S.	U.S.	L.S.	U.S.	L.S.	U.S.	L.S.
.05	.2349	.1017	.3188	.0780	.3496	.0707	.3527	.0792	.3546	.0797	.3559	.0740		
.10	.1485	.0846	.3323	.0781	.3514	.0712	.3448	.0757	.3576	.0733	.3582	.0703	.3207	.0520
.15	.0982		.3325	.0769	.3602	.0722	.3554	.0717	.3638	.06	.3560	.0663	.3046	.0464
.20	.1140	.0505	.3226	.0733	.3578	.0708			.3657	.0611	.3625	.0633	.2900	.0423
.25			.1323	-.0162	.3214	.0515	.3448	.0634	.3615	.0647	.3610	.0614	.2831	.0378
.30	.0096	.0167	.0890	-.0324	.1180	-.0239	.1369	-.0198	.2240	.0056	.3481	.0556	.2706	.0350
.40									.1096	-.0398	.1165	-.0329	.0829	-.0299
.50	.0043	-.0478	.0684	-.0407	.0963	-.0424			.1031	-.0426	.0977	-.0458	.0381	-.0358
.60	.0036	-.0486	.0571	-.0441	.0935	-.0430	.0998	-.0430	.1009	-.0449	.0905	-.0480	.0298	-.0402
.70	-.0114	-.0437	.0482	-.0460	.0867	-.0446	.0850	-.0498	.0675	-.0480			-.0319	-.0610
.80	-.0374	-.0557	-.0257	-.0528	-.0083	-.0451	-.0113	-.0502	-.0083	-.0442	-.0197	-.0548	-.0324	-.0667
.90	-.0390	-.0591	-.0416	-.0517	-.0209	-.0473	-.0205	-.0493	-.0185	-.0512	-.0273	-.0536	-.0181	-.0606
.95	-.0375	-.0568	-.0431	-.0517	-.0238	-.0477	-.0229	-.0497	-.0213	-.0518	-.0301	-.0538	-.0369	-.0569

TAIL 1

Cp at y/b of														
x/c	0.02		0.22		0.44		0.56		0.67		0.83		0.98	
	U.S.	L.S.	U.S.	L.S.	U.S.	L.S.	U.S.	L.S.	U.S.	L.S.	U.S.	L.S.	U.S.	L.S.
.05	.1033	.1214	.2030	.2264					.2120	.2309	.2137	.2390		
.10	.0984	.1189	.1937	.2123					.1998	.2177	.2061	.2264	.2070	.2163
.15	.0849	.1052					.2274	.2387	.1955	.2093	.2018	.2159	.1703	.1805
.20							.1942	.2031	.1945	.2023			.1652	.1672
.25	.0094	.0149	.0424	.0518			.1843	.1919	.1885	.1921	.1923	.1973		
.30			.0232	.0221	.0335	.0385	.0445	.0519	.1130	.1132				
.40	-.0157	-.0100			.0180	.0184	.0201	.0190	.0274	.0274	.0360	.0361		
.50	-.0150	-.0089					.0149	.0132	.0172	.0155			.0081	.0064
.60					.0126	.0100	-.0134	-.0104	-.0161	-.0132	.0150	.0120	-.0183	-.0181
.70			-.0006	.0015	.0080	.0047	-.0160	-.0126	-.0155	-.0036	-.0398	-.0385	-.0432	-.0440
.80	-.0277	-.0313	-.0432	-.0449	-.0454	-.0477			-.0167	-.0156	-.0502	-.0515		
.90	-.0341	-.0364			-.0362	-.0374			-.0397	-.0413	-.0421	-.0445	.0249	.0203
.95	-.0323	-.0355							.0024	.0010	-.0404	-.0431	.0062	.0046

TAIL 2

TABLE XXIV. - CONTINUED
(g) $\alpha = 8.01^\circ$

Cp at y/b of														
x/c	0.02		0.22		0.44		0.56		0.67		0.83		0.98	
	U.S.	L.S.	U.S.	L.S.	U.S.	L.S.	U.S.	L.S.	U.S.	L.S.	U.S.	L.S.	U.S.	L.S.
.05	.1158	.0920	.2386	.1064	.2715	.1019	.2773	.1097	.2829	.1107	.2965	.1032		
.10	.0870	.0803	.2446	.1079	.2726	.1024	.2699	.1079	.2823	.1050	.2959	.1010	.2669	.0771
.15	.0758		.2427	.1070	.2788	.1041	.2785	.1038	.2850	.1012	.2915	.0971	.2588	.0705
.20	.0864	.0655	.2321	.1029	.2753	.1026			.2851	.0995	.2955	.0940	.2421	.0652
.25			.0782	-.0024	.2425	.0804	.2680	.0948	.2819	.0963	.2924	.0921	.2340	.0593
.30	-.0137	.0548	.0405	-.0225	.0731	-.0154	.0931	-.0075	.1660	.0252	.2802	.0859	.2238	.0558
.40									.0685	-.0290	.0780	-.0214	.0589	-.0230
.50	-.0194	-.0399	.0233	-.0326	.0512	-.0328			.0622	-.0324	.0585	-.0362	.0153	-.0298
.60	-.0168	-.0420	.0181	-.0349	.0485	-.0338	.0555	-.0349	.0591	-.0351	.0504	-.0407	.0068	-.0371
.70	-.0219	-.0370	.0142	-.0375	.0425	-.0364	.0430	-.0419	.0318	-.0425			-.0367	-.0575
.80	-.0394	-.0527	-.0404	-.0513	-.0251	-.0447	-.0284	-.0491	-.0255	-.0431	-.0338	-.0528	-.0387	-.0640
.90	-.0368	-.0562	-.0516	-.0492	-.0355	-.0454	-.0369	-.0479	-.0362	-.0494	-.0410	-.0526	-.0245	-.0627
.95	-.0302	-.0565	-.0484	-.0496	-.0399	-.0460	-.0388	-.0480	-.0385	-.0501	-.0437	-.052	-.0414	-.0603

TAIL 1

Cp at y/b of														
x/c	0.02		0.22		0.44		0.56		0.67		0.83		0.98	
	U.S.	L.S.	U.S.	L.S.	U.S.	L.S.	U.S.	L.S.	U.S.	L.S.	U.S.	L.S.	U.S.	L.S.
.05	.1117	.1227	.1780	.2058					.2130	.2307	.2131	.2383		
.10	.1000	.1171	.1683	.1934					.2016	.2179	.2058	.2262	.2006	.2151
.15	.0844	.1034					.2230	.2323	.1984	.2102	.2018	.2157	.1718	.1804
.20							.1967	.2029	.1972	.2038			.1664	.1709
.25	.0055	.0106	.0280	.0425			.1851	.1913	.1914	.1935	.1926	.1972		
.30			.0123	.0176	.0334	.0363	.0454	.0514	.1151	.1140				
.40	-.0217	-.0173			-.0186	-.0171	.0204	.0182	.0286	.0276	.0363	.0358		
.50	-.0233	-.0192					.0159	.0127	.0175	.0154			.0071	.0055
.60					.0144	.0105	.0151	.0105	.0165	.0127	.0154	.0127	-.0175	-.0179
.70			-.0147	-.0078	.0097	.0059	.0174	.0132	-.0150	-.0038	-.0397	-.0395	-.0443	-.0452
.80	-.0401	-.0434	-.0487	-.0492	-.0463	-.0485			-.0175	-.0164	-.0516	-.0524		
.90	-.0445	-.0475			-.0418	-.0438			-.0424	-.0434	-.0440	-.0453	.0207	.0193
.95	-.0428	-.0458							.0012	.0001	-.0420	-.0437	.0047	.0038

TAIL 2

TABLE XXIV. - CONTINUED
(h) $\alpha = 10.01^\circ$

Cp at y/b of														
x/c	0.02		0.22		0.44		0.56		0.67		0.83		0.98	
	U.S.	L.S.	U.S.	L.S.	U.S.	L.S.	U.S.	L.S.	U.S.	L.S.	U.S.	L.S.	U.S.	L.S.
.05	.1045	.1021	.1745	.1360	.2129	.1337	.2404	.1430	.2511	.1456	.2639	.1377		
.10	.0576	.0870	.1764	.1389	.2139	.1344	.2272	.1424	.2489	.1403	.2636	.1372	.2358	.1075
.15	.0520		.1762	.1381	.2146	.1366	.2279	.1383	.2488	.1368	.2590	.1338	.2284	.1007
.20	.0595	.0947	.1698	.1338	.2084	.1353			.2458	.1349	.2615	.1310	.2148	.0945
.25			.0444	.0127	.1793	.1103	.2083	.1281	.2382	.1314	.2578	.1284	.2050	.0874
.30	-.0287	.0731	.0142	-.0107	.0455	-.0046	.0610	.0080	.1322	.0471	.2459	.1217	.1952	.0828
.40									.0398	-.0147	.0588	-.0065	.0441	-.0131
.50	-.0313	-.0353	-.0032	-.0208	.0215	-.0205			.0315	-.0195	.0397	-.0229	.0039	-.0236
.60	-.0299	-.0337	-.0100	-.0225	.0179	-.0215	.0248	-.0236	.0268	-.0224	.0310	-.0286	-.0048	-.0304
.70	-.0299	-.0266	-.0144	-.0264	.0122	-.0248	.0127	-.0305	.0056	-.0331			-.0393	-.0549
.80	-.0432	-.0523	-.0525	-.0557	-.0346	-.0474	-.0382	-.0515	-.0348	-.0449	-.0404	-.0533	-.0435	-.0606
.90	-.0386	-.0545	-.0506	-.0511	-.0438	-.0466	-.0463	-.0494	-.0471	-.0506	-.0491	-.0533	-.0280	-.0636
.95	-.0343	-.0556	-.0491	-.0506	-.0460	-.0475	-.0469	-.0491	-.0482	-.0508	-.0508	-.0535	-.0401	-.0619

TAIL 1

Cp at y/b of														
x/c	0.02		0.22		0.44		0.56		0.67		0.83		0.98	
	U.S.	L.S.	U.S.	L.S.	U.S.	L.S.	U.S.	L.S.	U.S.	L.S.	U.S.	L.S.	U.S.	L.S.
.05	.0954	.1194	.1028	.1170					.2169	.2360	.2143	.2398		
.10	.0807	.1059	.0952	.1065					.2043	.2222	.2074	.2282	.2110	.2200
.15	.0646	.0880					.2225	.2360	.1990	.2131	.2032	.2179	.1752	.1835
.20							.1976	.2018	.1976	.2051			.1692	.1756
.25	-.0037	.0021	-.0066	.0038			.1857	.1905	.1911	.1947	.1933	.1995		
.30			-.0103	-.0064	.0307	.0324	.0462	.0521	.1152	.1154				
.40	-.0354	-.0294			.0158	.0135	.0228	.0191	.0290	.0283	.0357	.0366		
.50	-.0354	-.0307					.0180	.0143	.0195	.0170			.0086	.0058
.60					.0084	.0050	.0166	.0119	.0189	.0154	.0157	.0143	-.0159	-.0162
.70			-.0312	-.0300	.0025	-.0006	.0186	.0143	-.0144	-.0019	-.0399	-.0389	-.0465	-.0465
.80	-.0466	-.0489	-.0539	-.0541	-.0504	-.0524			-.0172	-.0162	-.0521	-.0525		
.90	-.0532	-.0554			-.0478	-.0490			-.0447	-.0455	-.0449	-.0461	.0267	.0218
.95	-.0515	-.0536							.0021	.0002	-.0427	-.0445	.0061	.0044

TAIL 2

TABLE XXIV. - CONTINUED
(i) $\alpha = 12.01^\circ$

Cp at y/b of														
x/c	0.02		0.22		0.44		0.56		0.67		0.83		0.98	
	U.S.	L.S.	U.S.	L.S.	U.S.	L.S.	U.S.	L.S.	U.S.	L.S.	U.S.	L.S.	U.S.	L.S.
.05	.0745	.0945	.1600	.1707	.1985	.1712	.2274	.1813	.2367	.1857	.2515	.1791		
.10	.0347	.0819	.1540	.1746	.1993	.1719	.2133	.1819	.2334	.1809	.2496	.1796	.2207	.1436
.15	.0321		.1419	.1738	.1973	.1748	.2121	.1780	.2322	.1772	.2428	.1756	.2127	.1366
.20	.0352	.1220	.1244	.1688	.1881	.1737			.2279	.1752	.2441	.1722	.1991	.1298
.25			.0159	.0300	.1569	.1457	.1896	.1672	.2198	.1711	.2398	.1695	.1898	.1209
.30	-.0385	.0796	-.0094	.0034	.0301	.0088	.0488	.0271	.1190	.0732	.2279	.1620	.1798	.1157
.40									.0292	.0026	.0489	.0110	.0361	.0009
.50	-.0391	-.0296	-.0247	-.0071	.0027	-.0058			.0203	-.0032	.0299	-.0063	-.0008	-.0178
.60	-.0368	-.0251	-.0285	-.0086	-.0021	-.0070	.0075	-.0090	.0146	-.0059	.0215	-.0127	-.0091	-.0227
.70	-.0370	-.0174	-.0310	-.0131	-.0083	-.0106	-.0047	-.0159	-.0048	-.0203			-.0391	-.0504
.80	-.0468	-.0501	-.0524	-.0535	-.0422	-.0489	-.0459	-.0530	-.0404	-.0478	-.0444	-.0540	-.0447	-.0502
.90	-.0408	-.0525	-.0499	-.0531	-.0463	-.0491	-.0505	-.0522	-.0515	-.0517	-.0518	-.0526	-.0282	-.0599
.95	-.0368	-.0521	-.0491	-.0510	-.0473	-.0497	-.0488	-.0507	-.0501	-.0511	-.0514	-.0519	-.0370	-.0615

TAIL 1

Cp at y/b of														
x/c	0.02		0.22		0.44		0.56		0.67		0.83		0.98	
	U.S.	L.S.	U.S.	L.S.	U.S.	L.S.	U.S.	L.S.	U.S.	L.S.	U.S.	L.S.	U.S.	L.S.
.05	.0817	.1110	.0192	.0287					.2141	.2383	.2169	.2462		
.10	.0669	.0962	.0208	.0307					.2013	.2234	.2077	.2328	.2050	.2225
.15	.0512	.0781							.2037	.2126	.1971	.2150	.2019	.2207
.20									.1884	.1922	.1975	.2088		
.25	-.0121	-.0050	-.0264	-.0189					.1852	.1887	.1933	.2002	.1920	.2011
.30			-.0211	-.0191	.0099	.0057	.0420	.0456	.1175	.1188				
.40	-.0423	-.0379			-.0038	-.0098	.0187	.0146	.0318	.0319	.0365	.0381		
.50	-.0417	-.0393					.0122	.0076	.0222	.0206			.0079	.0033
.60					-.0162	-.0237	.0090	.0014	.0209	.0180	.0183	.0176	-.0146	-.0144
.70			-.0404	-.0395	-.0232	-.0293	.0138	.0069	-.0131	.0003	-.0388	-.0376	-.0462	-.0465
.80	-.0505	-.0523	-.0569	-.0571	-.0581	-.0602			-.0174	-.0175	-.0519	-.0521		
.90	-.0607	-.0618			-.0537	-.0543			-.0479	-.0498	-.0452	-.0468	.0211	.0183
.95	-.0592	-.0601							.0011	-.0027	-.0425	-.0451	.0050	.0012

TAIL 2

TABLE XXIV. - CONTINUED
(j) $\alpha = 16.01^\circ$

Cp at y/b of														
x/c	0.02		0.22		0.44		0.56		0.67		0.83		0.98	
	U.S.	L.S.	U.S.	L.S.	U.S.	L.S.	U.S.	L.S.	U.S.	L.S.	U.S.	L.S.	U.S.	L.S.
.05	.0689	.0899	.1649	.2579	.1991	.2627	.2318	.2755	.2353	.2820	.2479	.2769		
.10	.0250	.0885	.1570	.2648	.2000	.2641	.2153	.2783	.2297	.2782	.2427	.2789	.2142	.2320
.15	.0185		.1419	.2635	.1963	.2687	.2109	.2750	.2277	.2742	.2343	.2750	.2040	.2241
.20	.0144	.1914	.1204	.2566	.1860	.2680			.2225	.2720	.2347	.2712	.1884	.2161
.25			.0112	.0725	.1532	.2316	.1859	.2609	.2134	.2674	.2290	.2676	.1794	.2052
.30	-.0463	.1991	-.0154	.0415	.0248	.0516	.0463	.0760	.1140	.1365	.2165	.2580	.1694	.1986
.40									.0242	.0468	.0429	.0579	.0303	.0403
.50	-.0504	-.0017	-.0380	.0307	-.0030	.0364			.0153	.0399	.0237	.0393	-.0023	.0067
.60	-.0473	.0013	-.0431	.0280	-.0092	.0349	.0013	.0344	.0093	.0363	.0157	.0317	-.0089	-.0030
.70	-.0451	.0123	-.0473	.0233	-.0159	.0308	-.0109	.0249	-.0095	.0139			-.0392	-.0395
.80	-.0517	-.0351	-.0534	-.0414	-.0464	-.0404	-.0492	-.0454	-.0428	-.0438	-.0470	-.0487	-.0427	-.0475
.90	-.0470	-.0514	-.0525	-.0562	-.0468	-.0501	-.0475	-.0517	-.0474	-.0521	-.0459	-.0507	-.0272	-.0441
.95	-.0468	-.0519	-.0519	-.0558	-.0479	-.0520	-.0466	-.0527	-.0461	-.0506	-.0446	-.0474	-.0331	-.0404

TAIL 1

Cp at y/b of														
x/c	0.02		0.22		0.44		0.56		0.67		0.83		0.98	
	U.S.	L.S.	U.S.	L.S.	U.S.	L.S.	U.S.	L.S.	U.S.	L.S.	U.S.	L.S.	U.S.	L.S.
.05	.0478	.0728	.0127	.0286					.1009	.1061	.2117	.2352		
.10	.0344	.0649	.0056	.0221					.0885	.0910	.2038	.2216	.2084	.2192
.15	.0209	.0500							.0571	.0607	.0805	.0812	.2013	.2129
.20									.0306	.0346	.0725	.0700	.1687	.1768
.25	-.0248	-.0137	-.0390	-.0290					.1169	.1404	.0619	.0579	.1986	.2003
.30			-.0259	-.0225	-.0319	-.0229	-.0266	-.0173	.0181	.0146				
.40	-.0531	-.0461			-.0391	-.0326	-.0409	-.0349	-.0256	-.0226	.0411	.0374		
.50	-.0506	-.0458					-.0434	-.0375	-.0374	-.0343			.0284	.0261
.60					-.0489	-.0447	-.0463	-.0415	-.0395	-.0366	.0148	.0089	-.0102	-.0096
.70			-.0473	-.0447	-.0524	-.0487	-.0205	-.0162	-.0389	-.0262	-.0438	-.0436	-.0429	-.0427
.80	-.0555	-.0549	-.0598	-.0588	-.0659	-.0645			-.0149	-.0124	-.0568	-.0567		
.90	-.0655	-.0647			-.0576	-.0565			-.0597	-.0566	-.0563	-.0551	.0424	.0387
.95	-.0636	-.0628							.0192	.0181	-.0566	-.0544	.0242	.0229

TAIL 2

TABLE XXIV. - CONCLUDED
(k) $\alpha = 20.01^\circ$

Cp at y/b of														
x/c	0.02		0.22		0.44		0.56		0.67		0.83		0.98	
	U.S.	L.S.	U.S.	L.S.	U.S.	L.S.	U.S.	L.S.	U.S.	L.S.	U.S.	L.S.	U.S.	L.S.
.05	.0824	.1114	.1852	.3738	.2167	.3828	.2520	.3982	.2514	.4079	.2615	.4044		
.10	.0290	.1176	.1754	.3830	.2178	.3848	.2332	.4029	.2452	.4054	.2545	.4075	.2269	.3488
.15	.0242		.1564	.3800	.2128	.3904	.2264	.4004	.2426	.4010	.2446	.4028	.2151	.3417
.20	.0088	.2838	.1304	.3709	.2003	.3901			.2364	.3991	.2444		.1975	.3320
.25			.0143	.1301	.1652	.3449	.1984	.3821	.2256	.3941	.2381	.3813	.1870	.3183
.30	-.0520	.2383	-.0148	.0957	.0273	.1101	-.0520	.1414	-.1200	.2237	.2247	.3813	.1770	.3073
.40									.0286	.1086	.0454	.1217	.0334	.0957
.50	-.0576	.0272	-.0414	.0821	-.0024	.0947			.0186	.1002	.0256	.0993	.0050	.0535
.60	-.0543	.0504	-.0472	.0791	-.0099	.0923	.0026	.0950	-.0122	.0956	.0169	.0907	.0015	.0387
.70	-.0525	.0637	-.0519	.0728	-.0171	.0866	-.0102	.0822	-.0084	.0637			.0351	-.0255
.80	-.0550	-.0065	-.0579	-.0221	-.0476	-.0208	-.0470	-.0230	-.0390	-.0295	-.0431	-.0275	-.0308	-.0297
.90	-.0521	-.0390	-.0569	-.0451	-.0466	-.0355	-.0434	-.0341	-.0406	-.0380	-.0385	-.0373	-.0242	-.0348
.95	-.0521	-.0459	-.0547	-.0475	-.0481	-.0379	-.0429	-.0372	-.0404	-.0397	-.0375	-.0390	-.0266	-.0348

TAIL 1

Cp at y/b of														
x/c	0.02		0.22		0.44		0.56		0.67		0.83		0.98	
	U.S.	L.S.	U.S.	L.S.	U.S.	L.S.	U.S.	L.S.	U.S.	L.S.	U.S.	L.S.	U.S.	L.S.
.05	.0072	.0196	-.0089	-.0001					.0279	.0374	.0581	.0683		
.10	.0026	.0166	-.0113	-.0040					.0219	.0295	.0474	.0555	.0876	.0904
.15	-.0050	.0075					.0344	.0390	.0188	.0246	.0428	.0501	.0530	.0551
.20							.0042	.0076	.0156	.0199			.0409	.0395
.25	-.0333	-.0269	-.0431	-.0372			.0627	.0748	.0118	.0143	.0401	.0445		
.30			-.0215	-.0201	-.0412	-.0382	-.0379	-.0349	-.0128	-.0127				
.40	-.0574	-.0536			-.0463	-.0441	-.0483	-.0467	-.0370	-.0359	-.0243	-.0229		
.50	-.0541	-.0512					-.0500	-.0485	-.0452	-.0444			.0572	.0571
.60					-.0538	-.0529	-.0516	-.0508	-.0447	-.0444	-.0311	-.0309	-.0357	-.0348
.70			-.0483	-.0468	-.0556	-.0548	-.0272	-.0258	-.0445	-.0395	-.0587	-.0578	-.0547	-.0542
.80	-.0571	-.0569	-.0613	-.0607	-.0674	-.0670			.0014	.0045	-.0643	-.0640		
.90	-.0668	-.0664			-.0592	-.0584			-.0606	-.0596	-.0614	-.0603	.0684	.0660
.95	-.0651	-.0645							.0497	.0470	-.0625	-.0617	.0549	.0525

TAIL 2

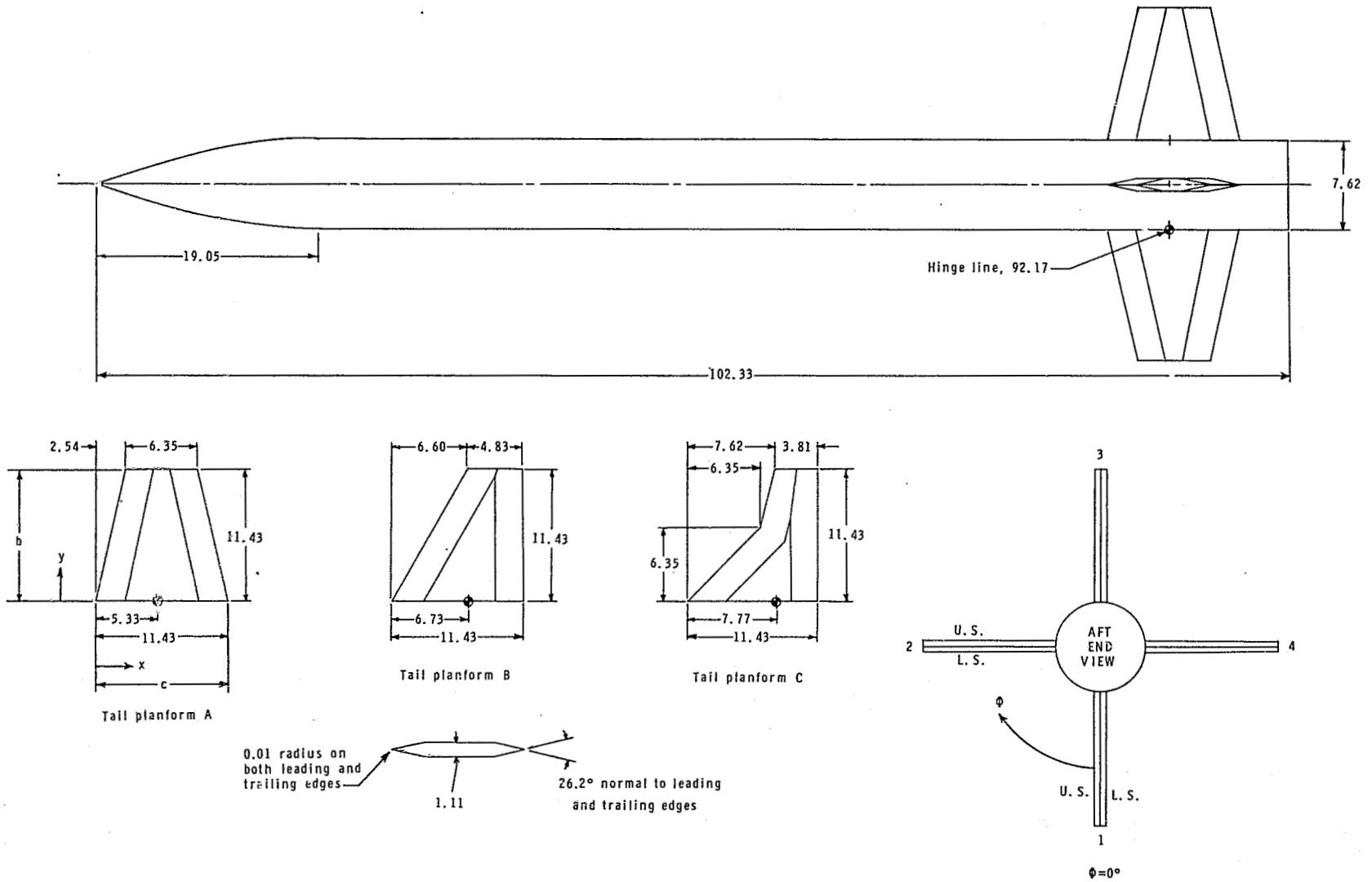
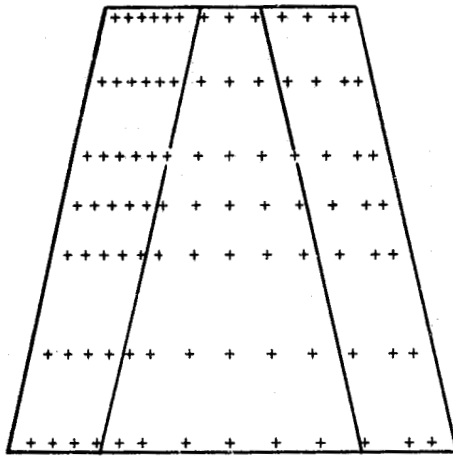
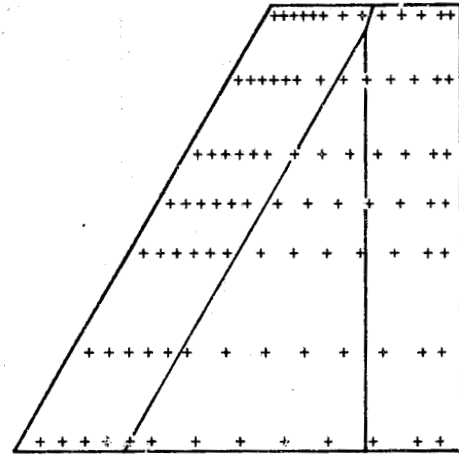


Figure 1.- Details of model. All linear dimensions are in centimeters.

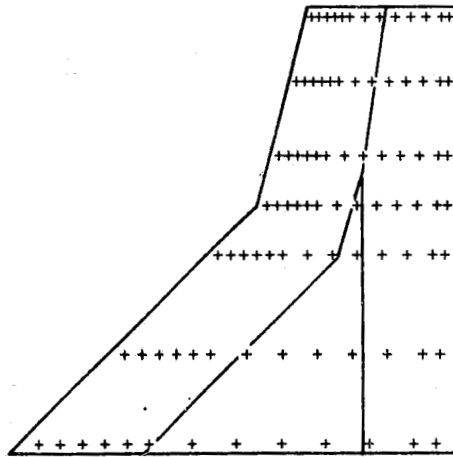


Tail platform A



Tail platform B

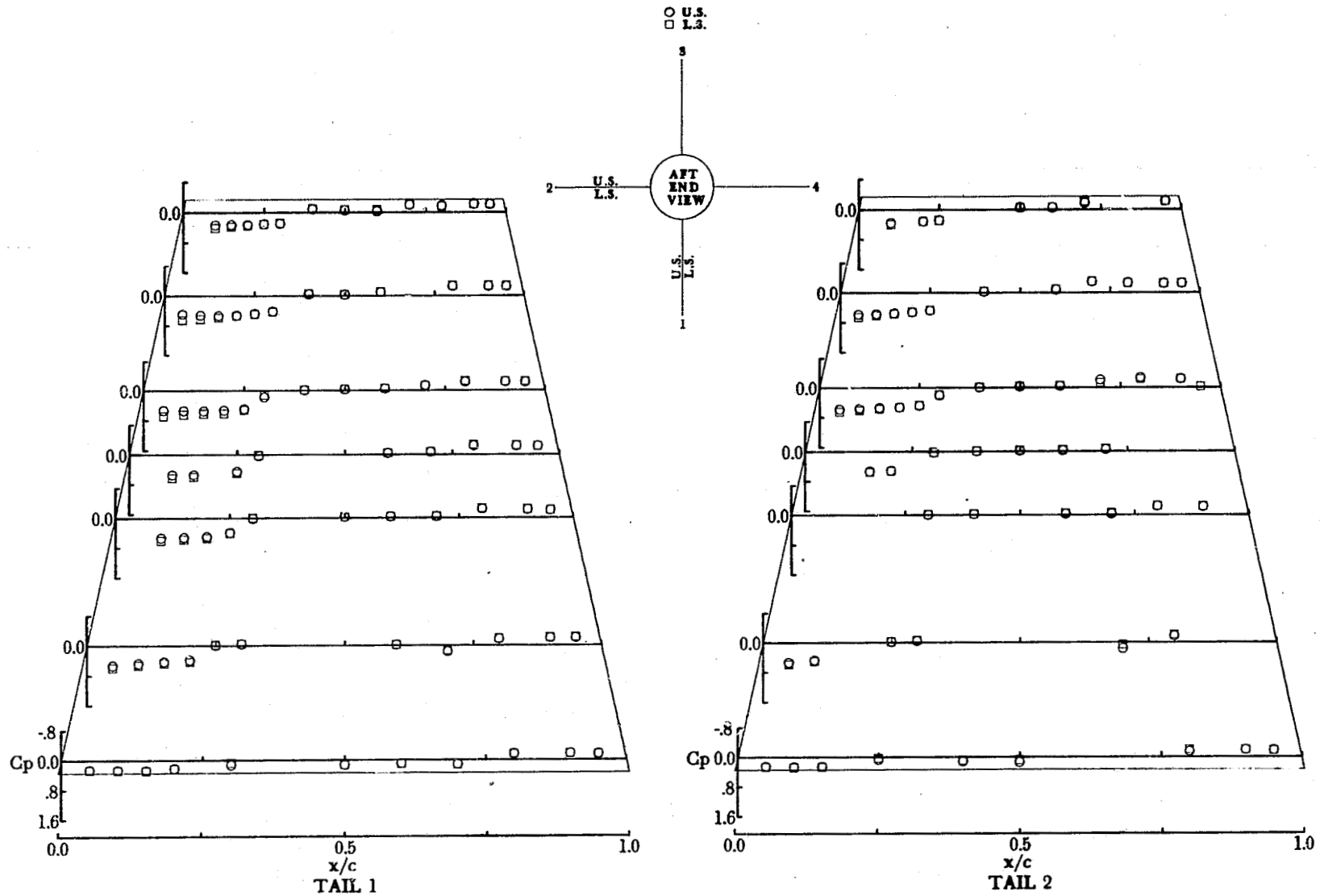
+ pressure orifices

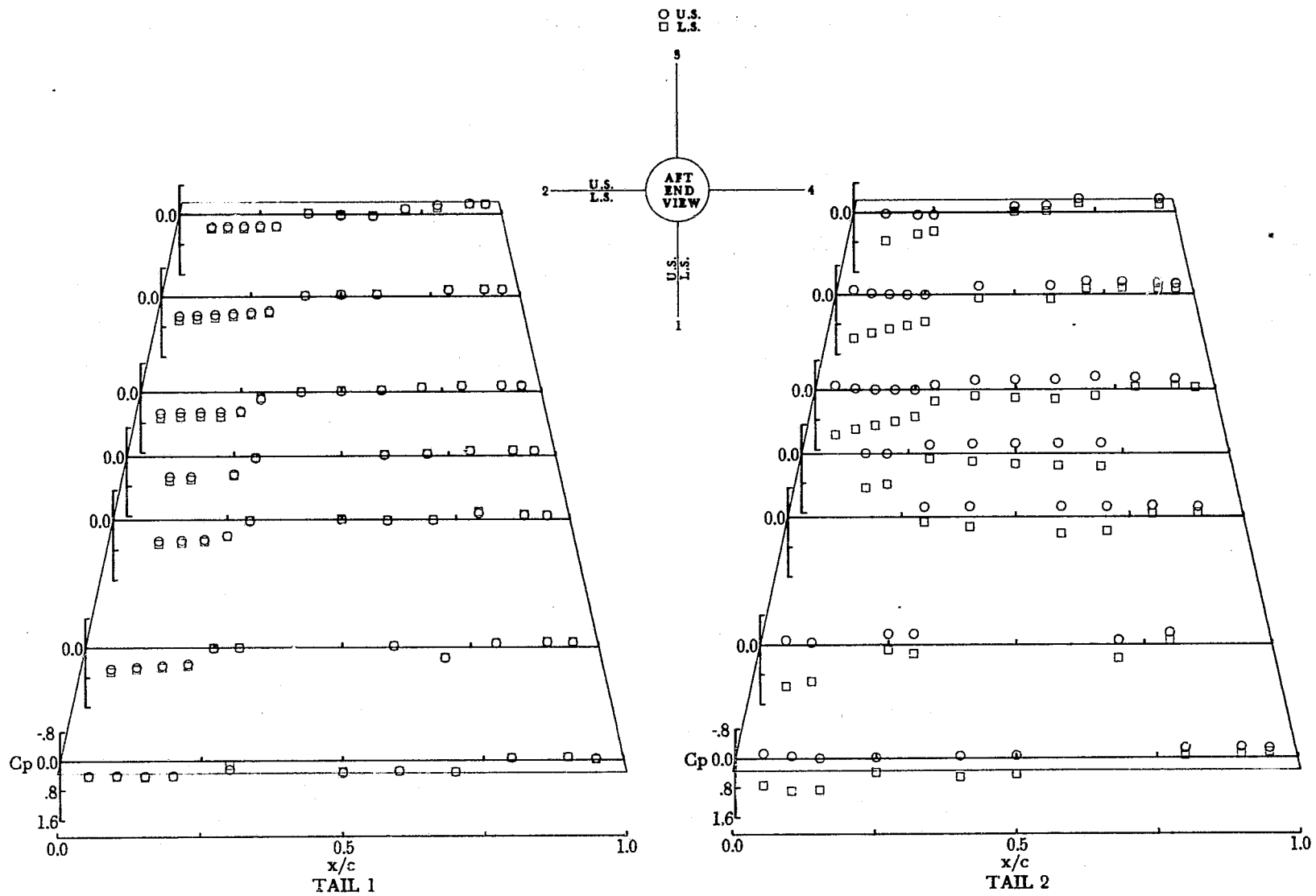


Tail platform C

x/c	y/b						
	0.02	0.22	0.44	0.56	0.67	0.83	0.98
0.05	0.02	0.22	0.44	0.56	0.67	0.83	0.98
.10	.02	.22	.44	.56	.67	.83	.98
.15	.02	.22	.44	.56	.67	.83	.98
.20	.02	.22	.44	.56	.67	.83	.98
.25	.02	.22	.44	.56	.67	.83	.98
.30	.02	.22	.44	.56	.67	.83	.98
.40	.02	.22	.44	.56	.67	.83	.98
.50	.02	.22	.44	.56	.67	.83	.98
.60	.02	.22	.44	.56	.67	.83	.98
.70	.02	.22	.44	.56	.67	.83	.98
.80	.02	.22	.44	.56	.67	.83	.98
.90	.02	.22	.44	.56	.67	.83	.98
.95	.02	.22	.44	.56	.67	.83	.98

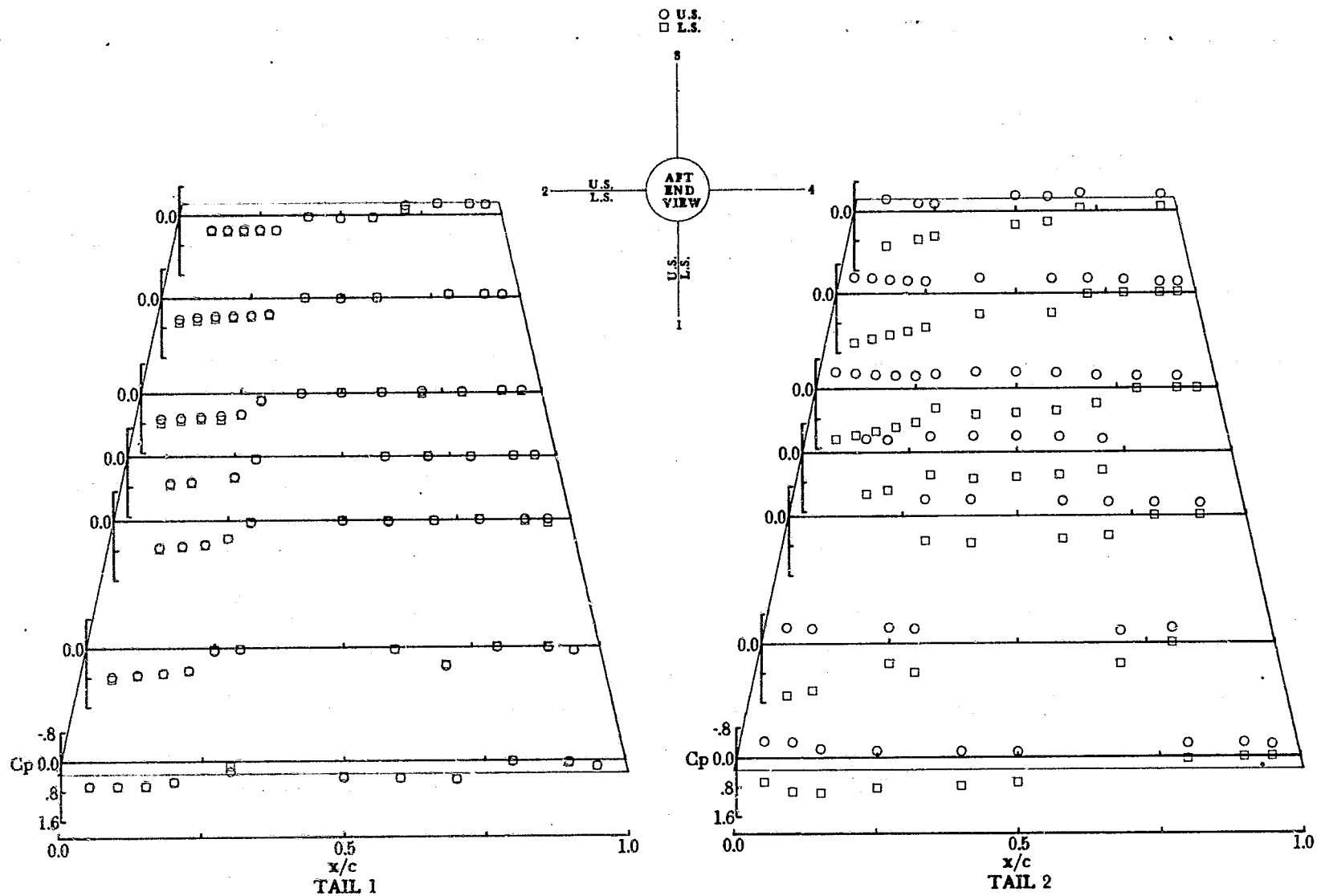
Figure 2.- Details of pressure orifice locations.

(a) $\alpha = 0.50^\circ$.Figure 3.- Pressure coefficients for tail planform A at $M = 1.60$, $\phi = 0^\circ$, and $\delta = 0^\circ$.



(b) $\alpha = 10.50^\circ$.

Figure 3.- Continued.



(c) $\alpha = 20.50^\circ$.

Figure 3.- Concluded.

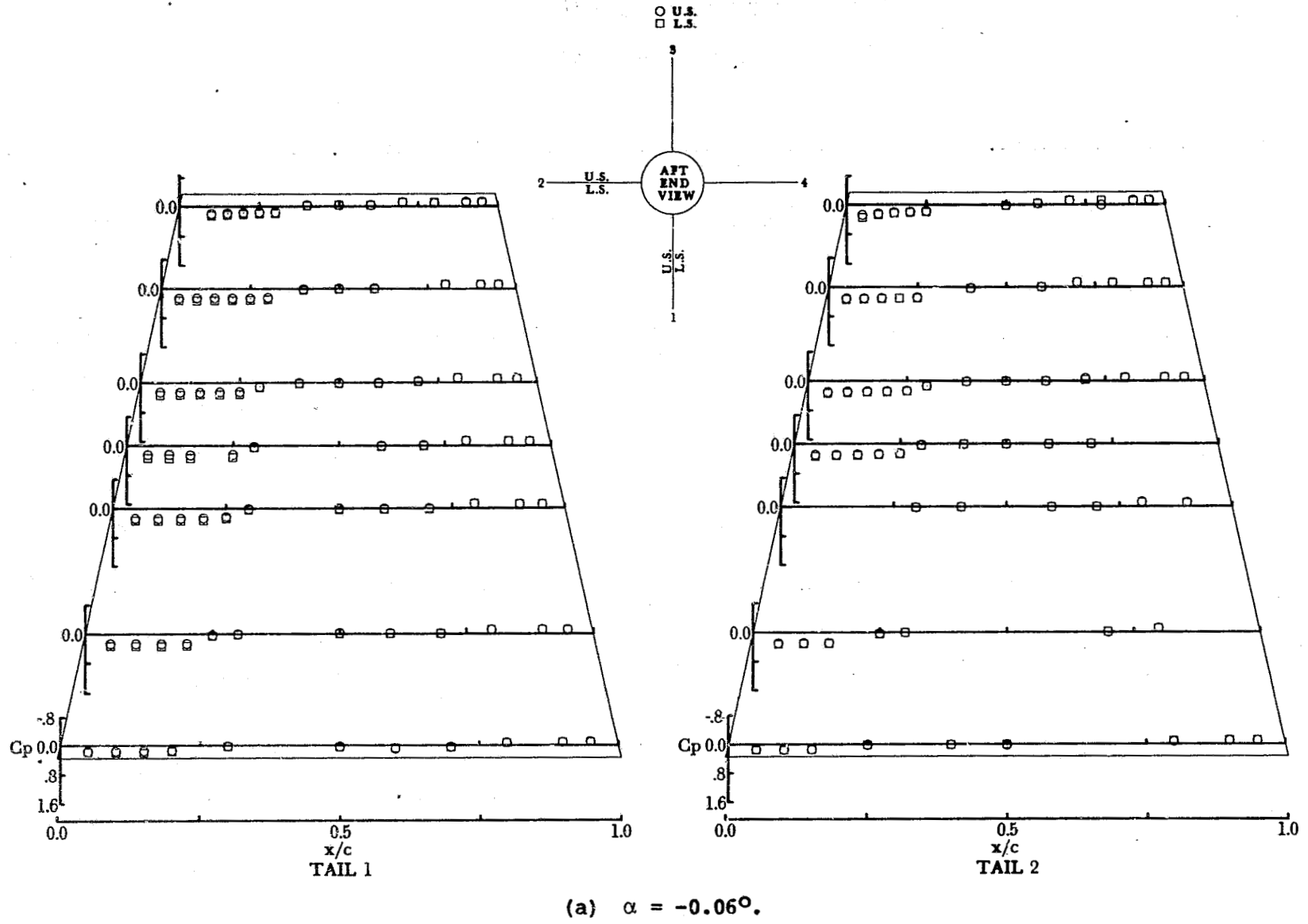


Figure 4.- Pressure coefficients for tail planform A at $M = 2.36$, $\phi = 0^\circ$, and $\delta = 0^\circ$.

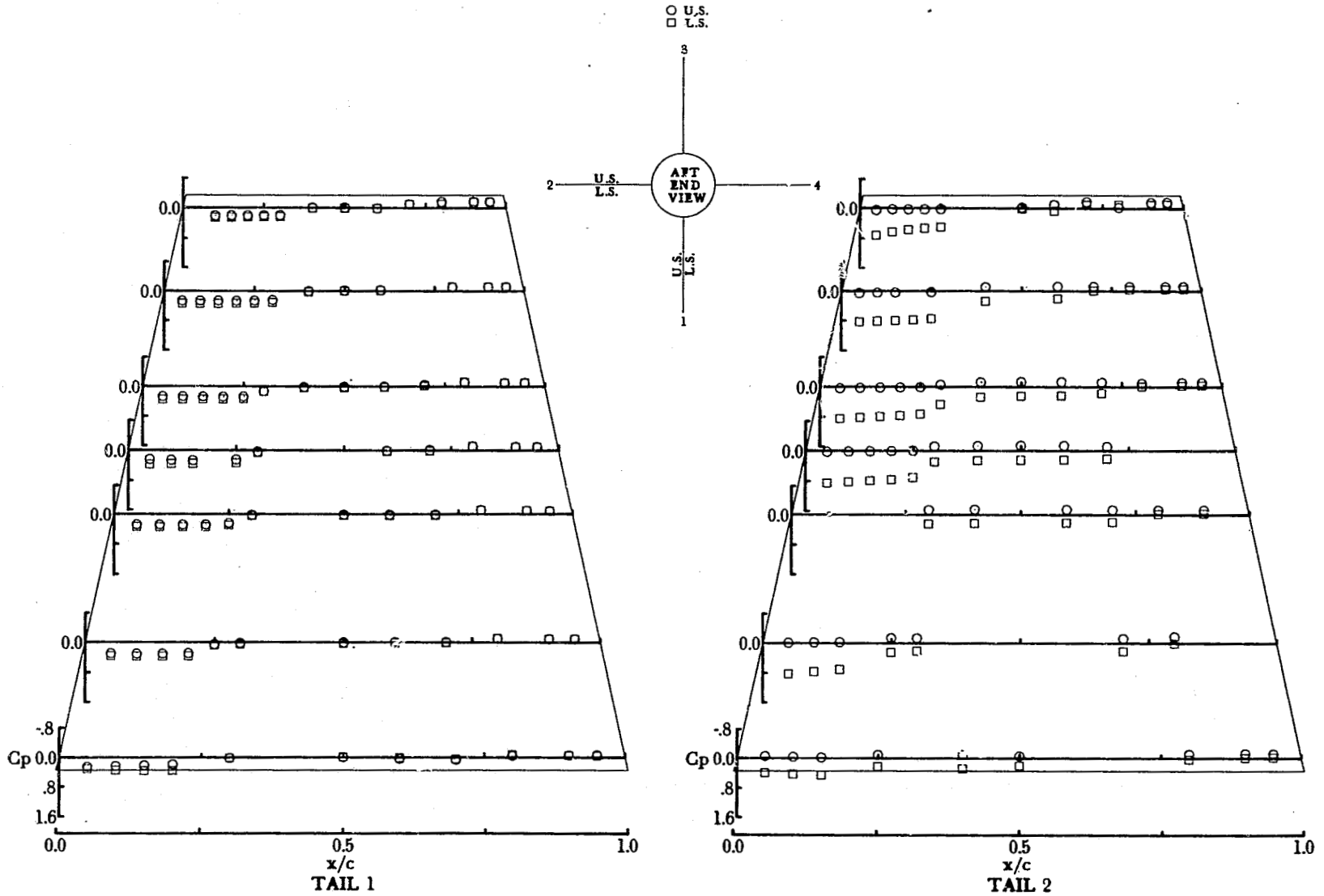
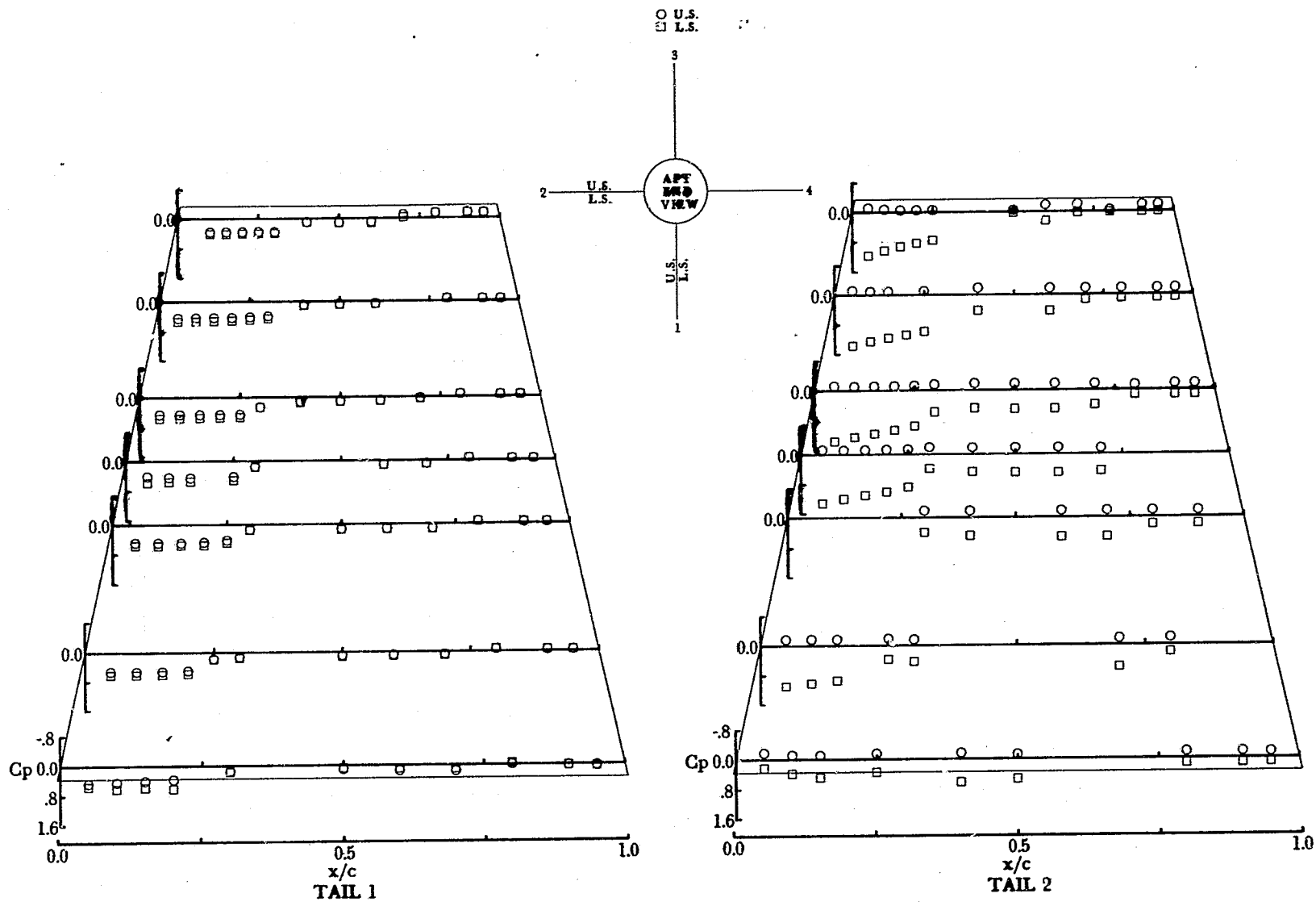
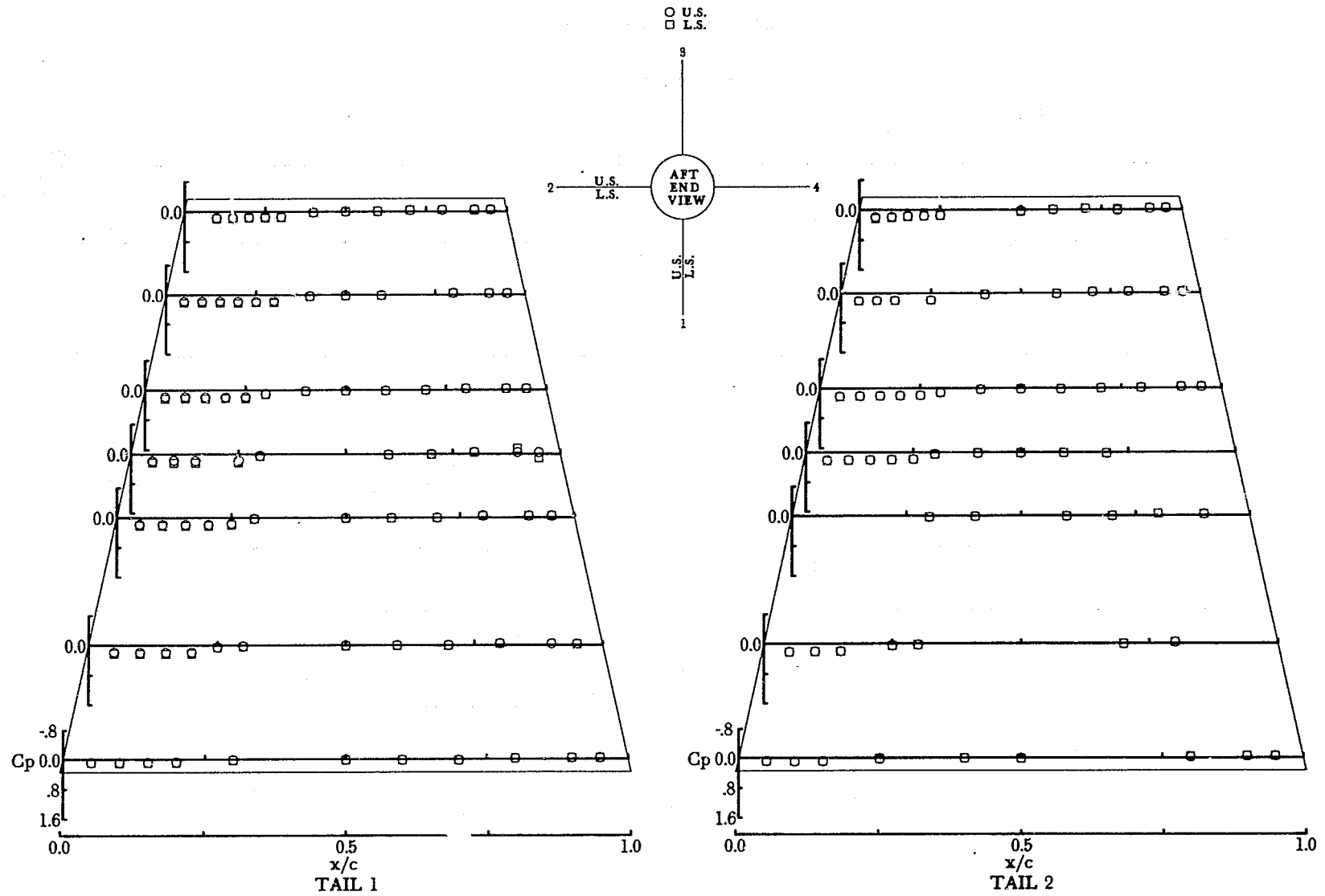
(b) $\alpha = 9.92^\circ$.

Figure 4.- Continued.



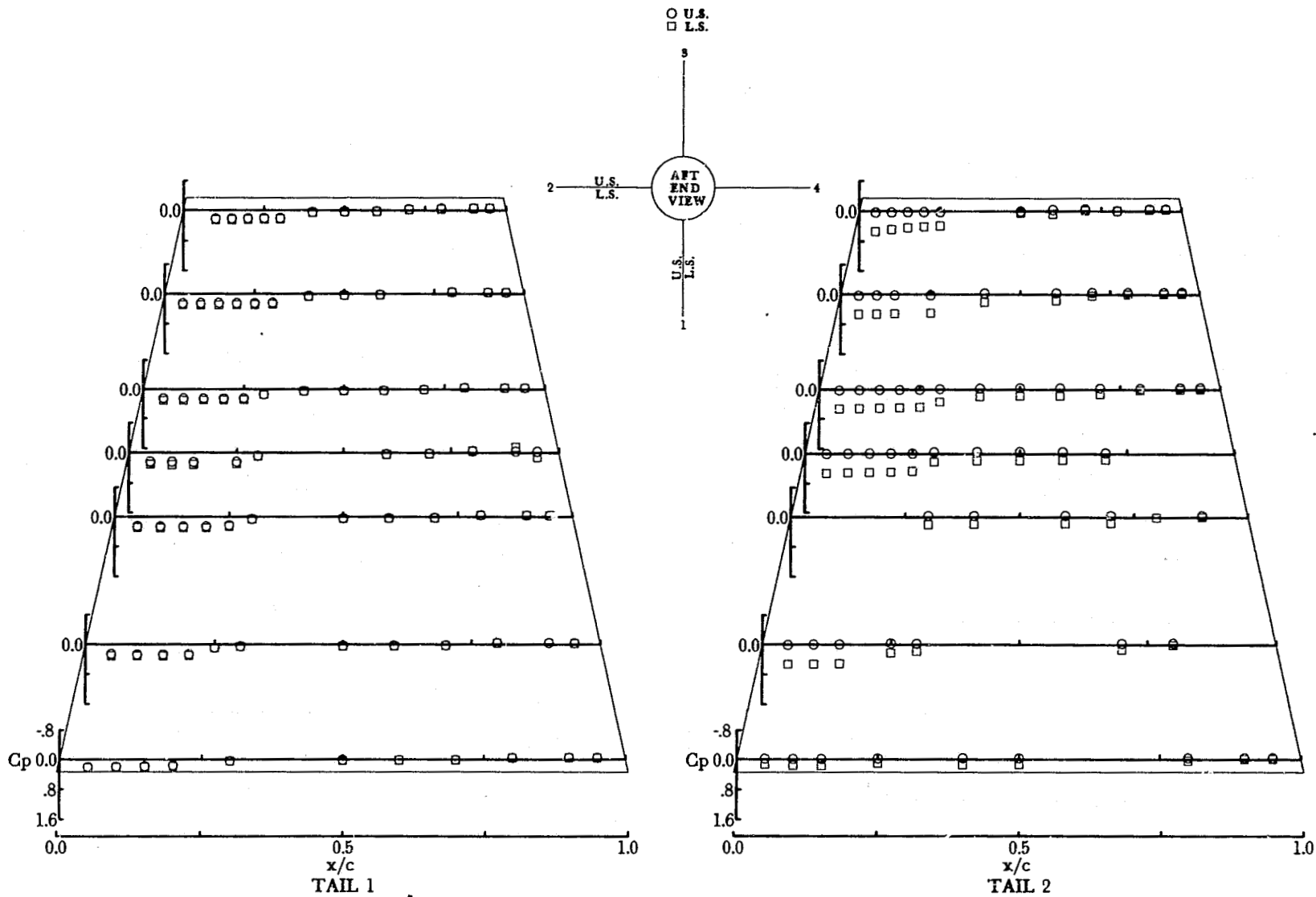
(c) $\alpha = 19.91^\circ$.

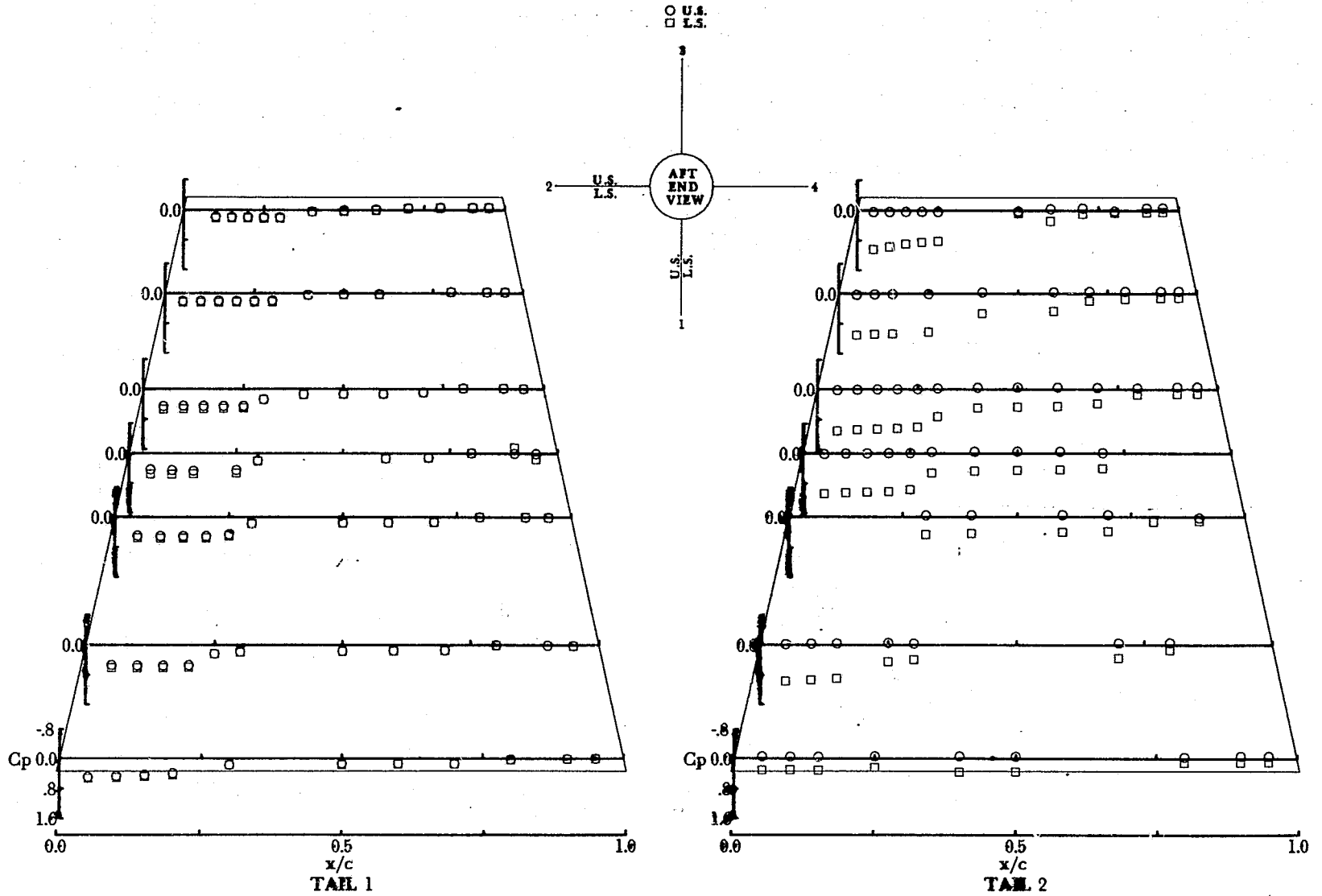
Figure 4.- Concluded.



(a). $\alpha = 0.12^\circ$.

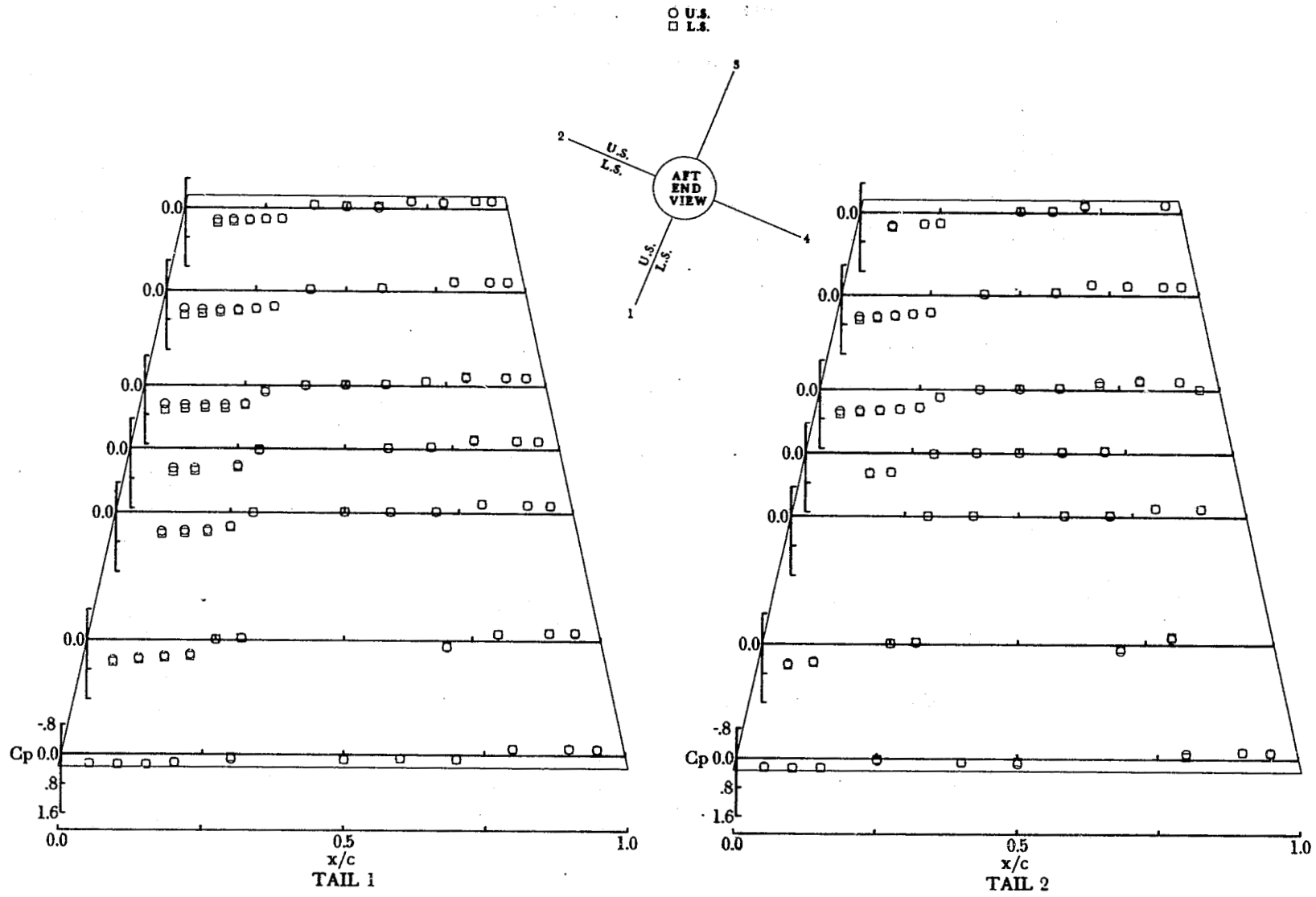
Figure 5.- Pressure coefficients for tail planform A at $M = 3.70$, $\phi = 0^\circ$, and $\delta = 0^\circ$.





(c) $\alpha = 20.00^\circ$.

Figure 5.- Concluded.



(a) $\alpha = 0.65^\circ$.

Figure 6.- Pressure coefficients for tail planform A at $M = 1.60$, $\phi = 22.5^\circ$, and $\delta = 0^\circ$.

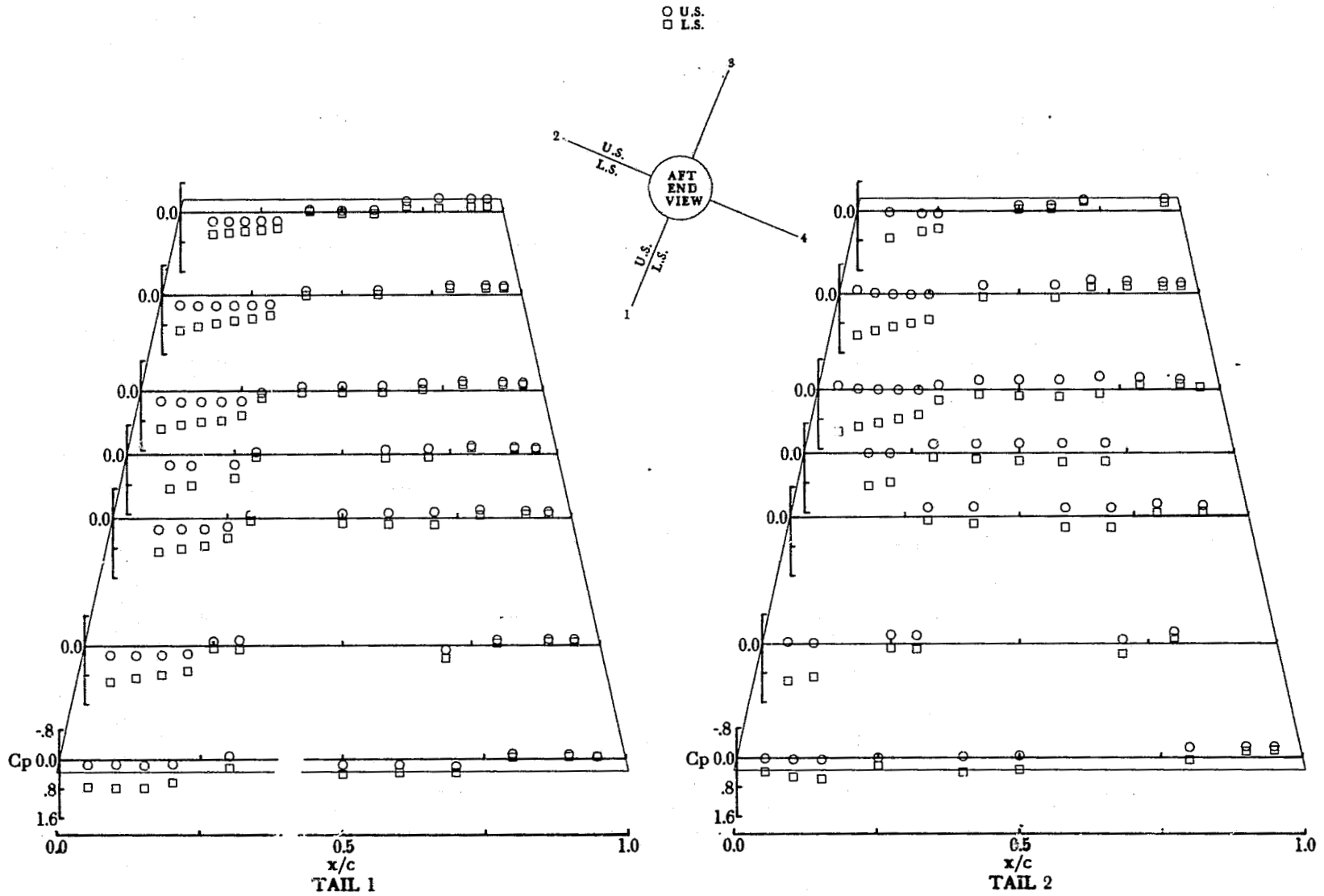
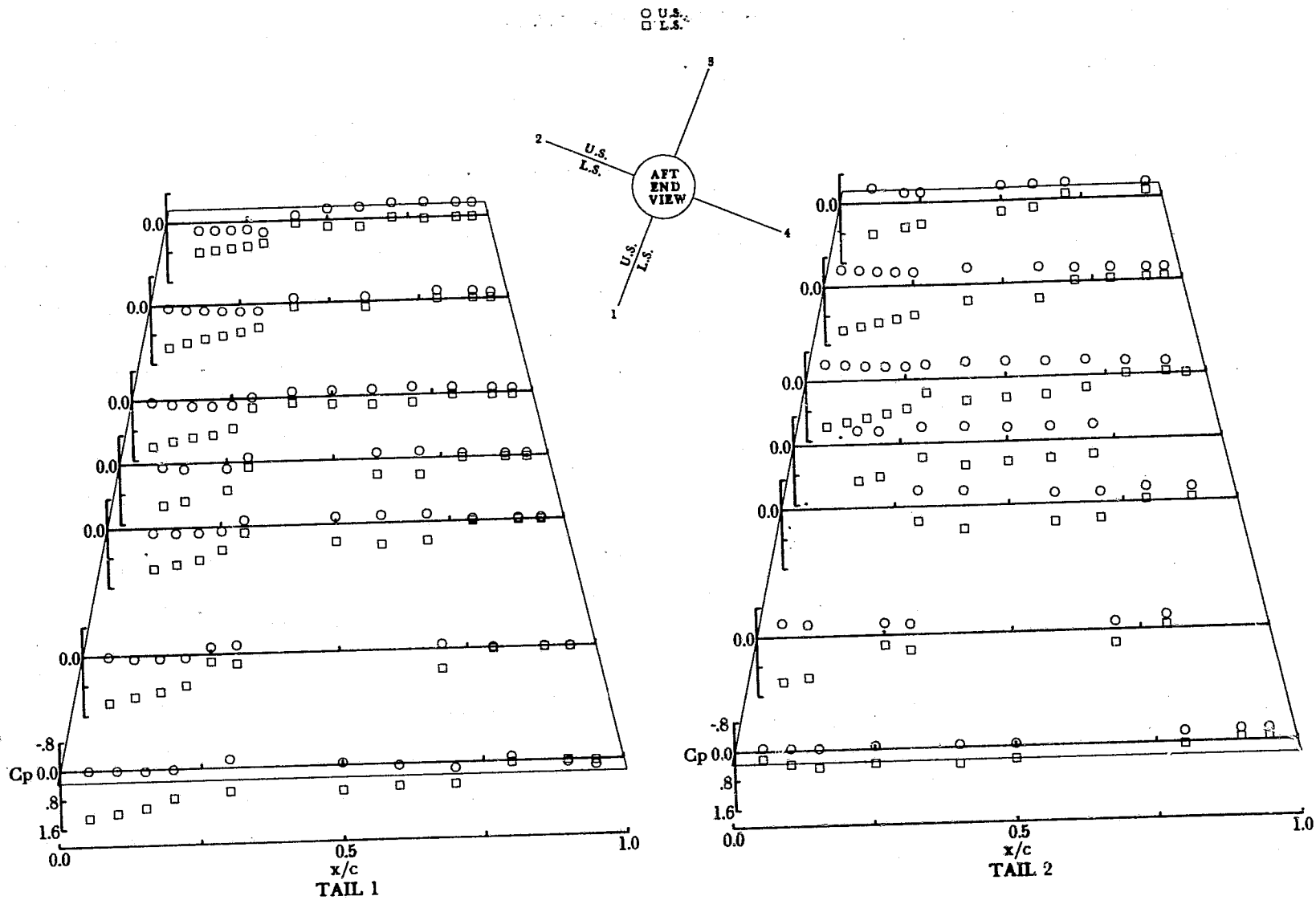


Figure 6.- Continued.



(c) $\alpha = 20.65^\circ$.

Figure 6.- Concluded.

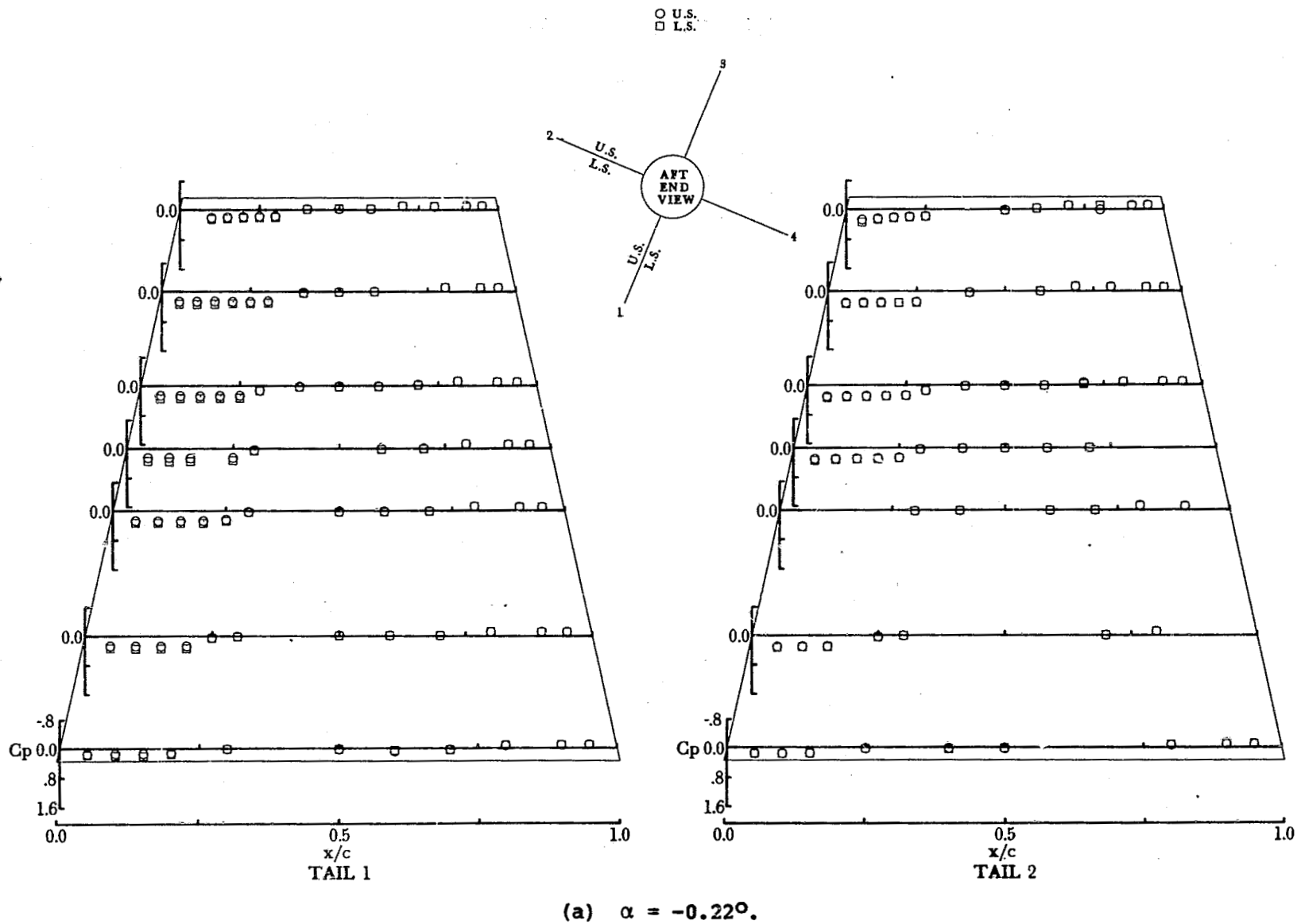


Figure 7.- Pressure coefficients for tail planform A at $M = 2.36$, $\phi = 22.5^\circ$, and $\delta = 0^\circ$.

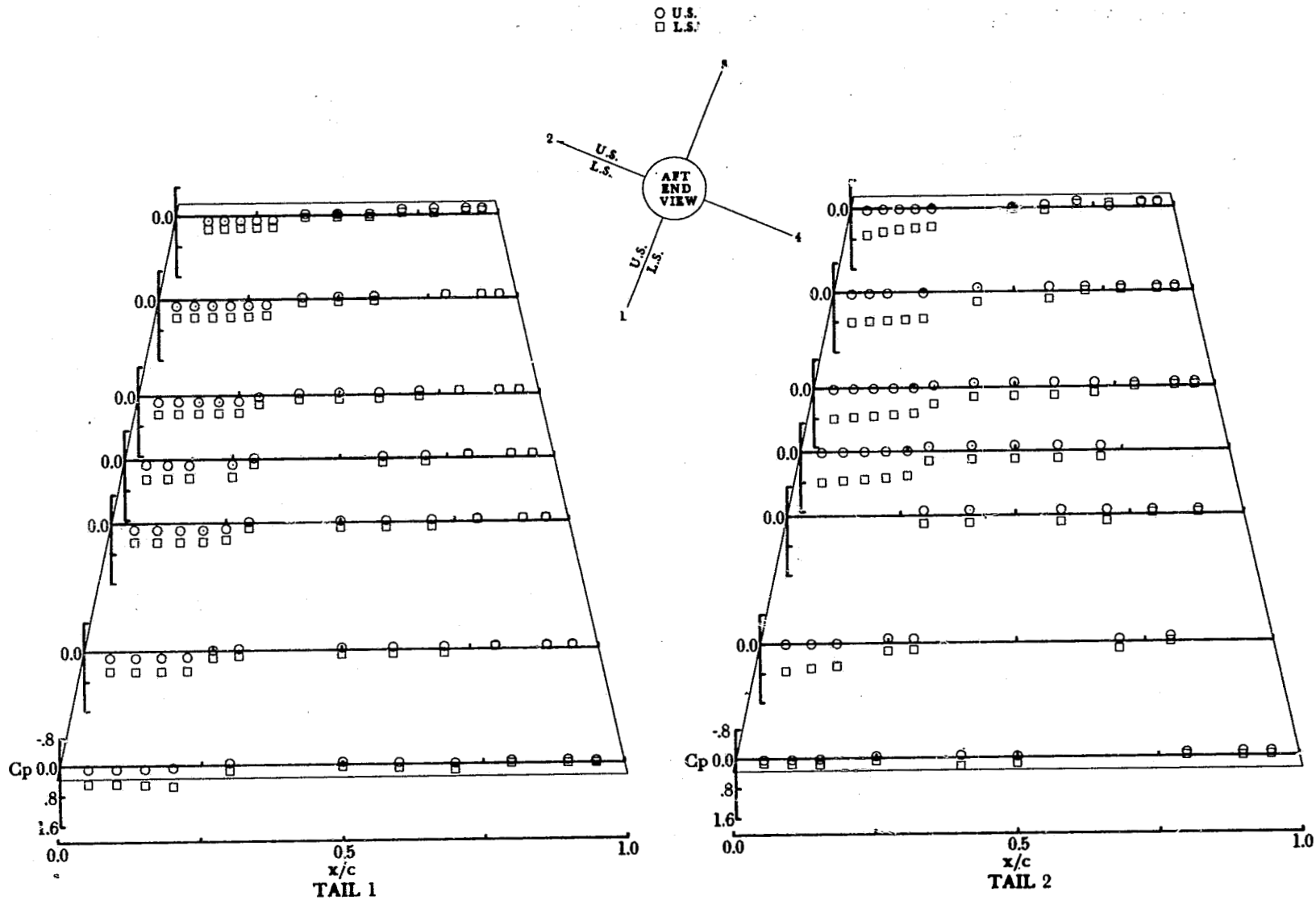


Figure 7.- Continued.

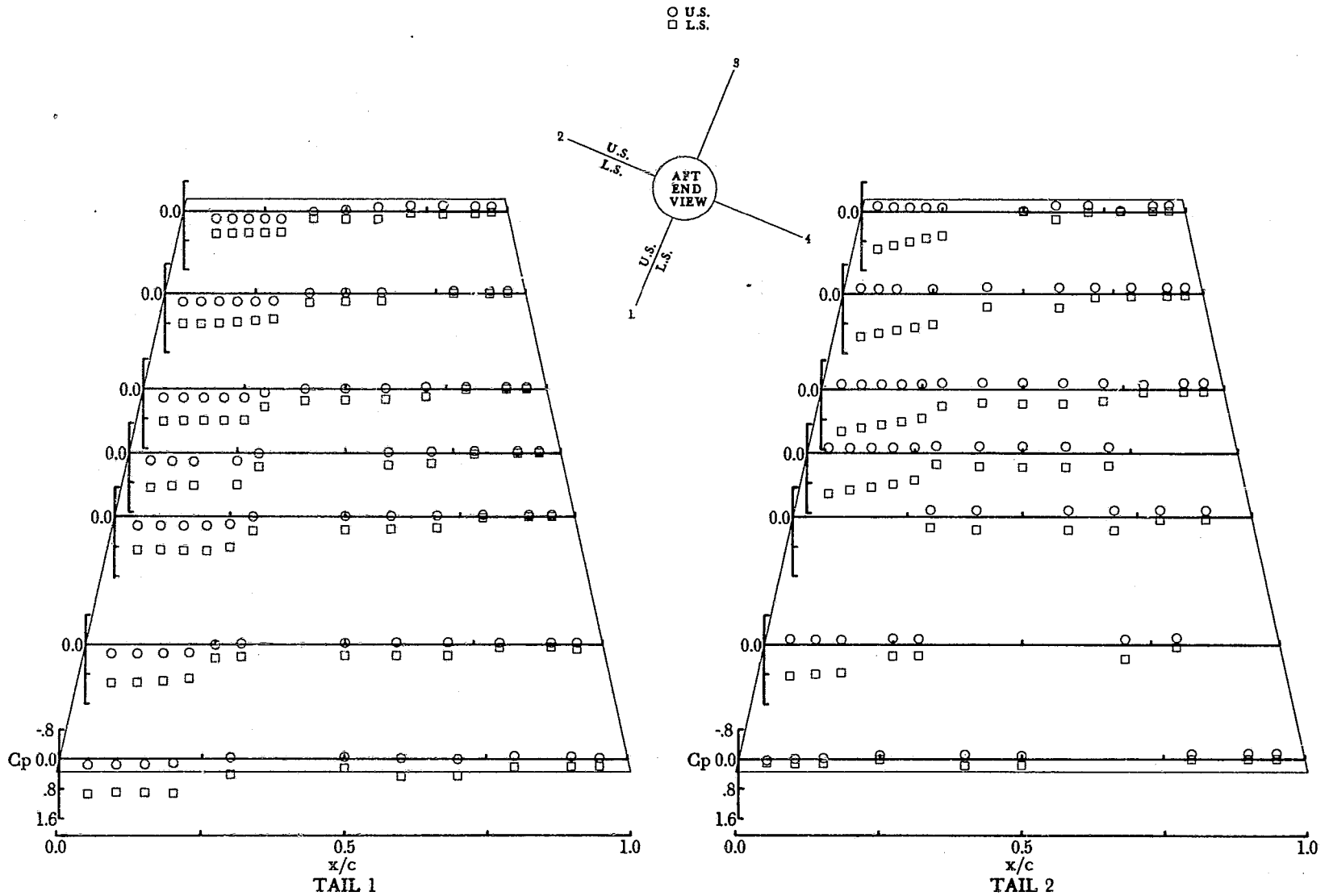
(c) $\alpha = 19.76^\circ$.

Figure 7.- Concluded.

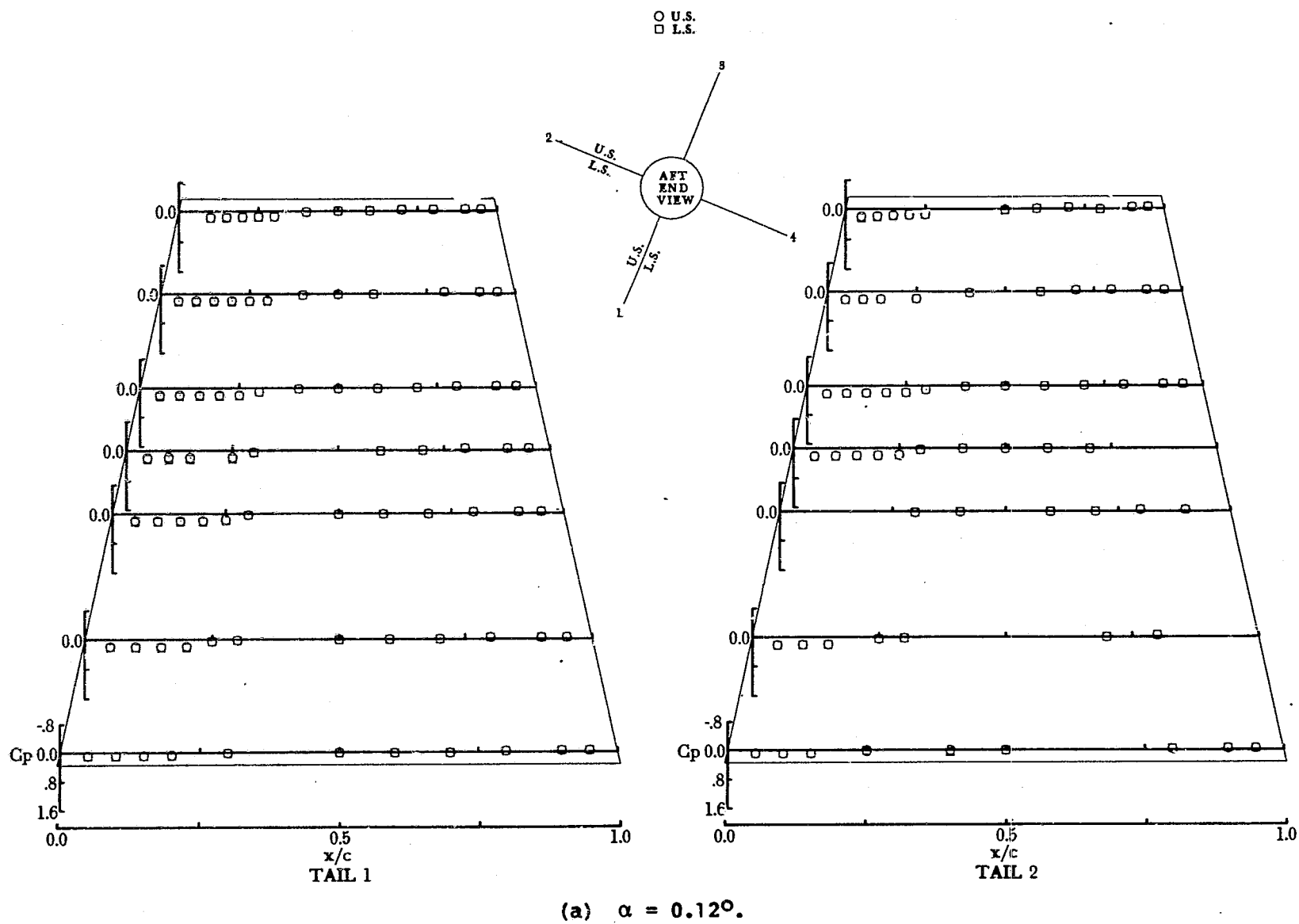
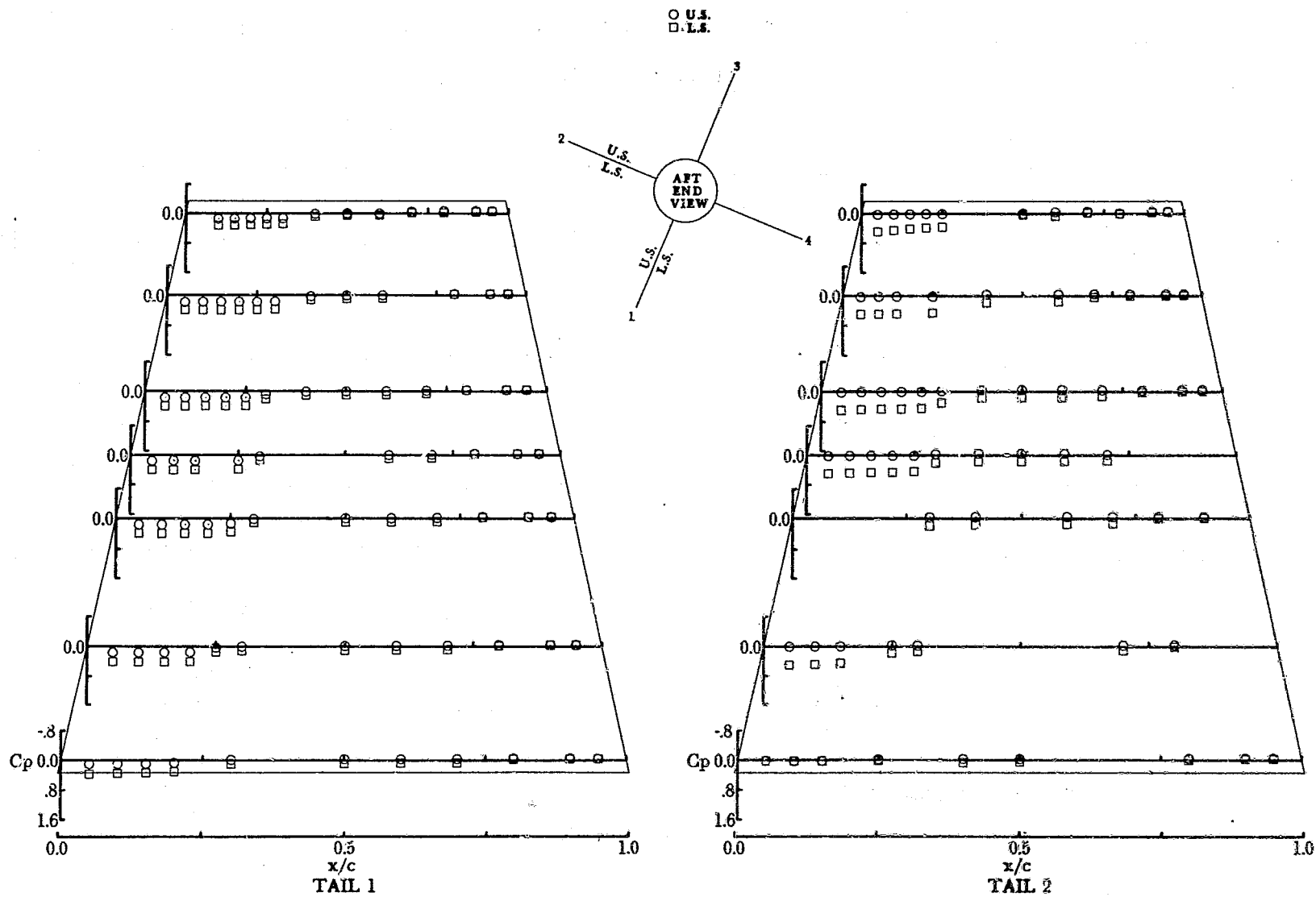


Figure 8.- Pressure coefficients for tail planform A at $M = 3.70$, $\phi = 22.5^\circ$, and $\delta = 0^\circ$.



(b) $\alpha = 10.09^\circ$.

Figure 8.- Continued.

C-3

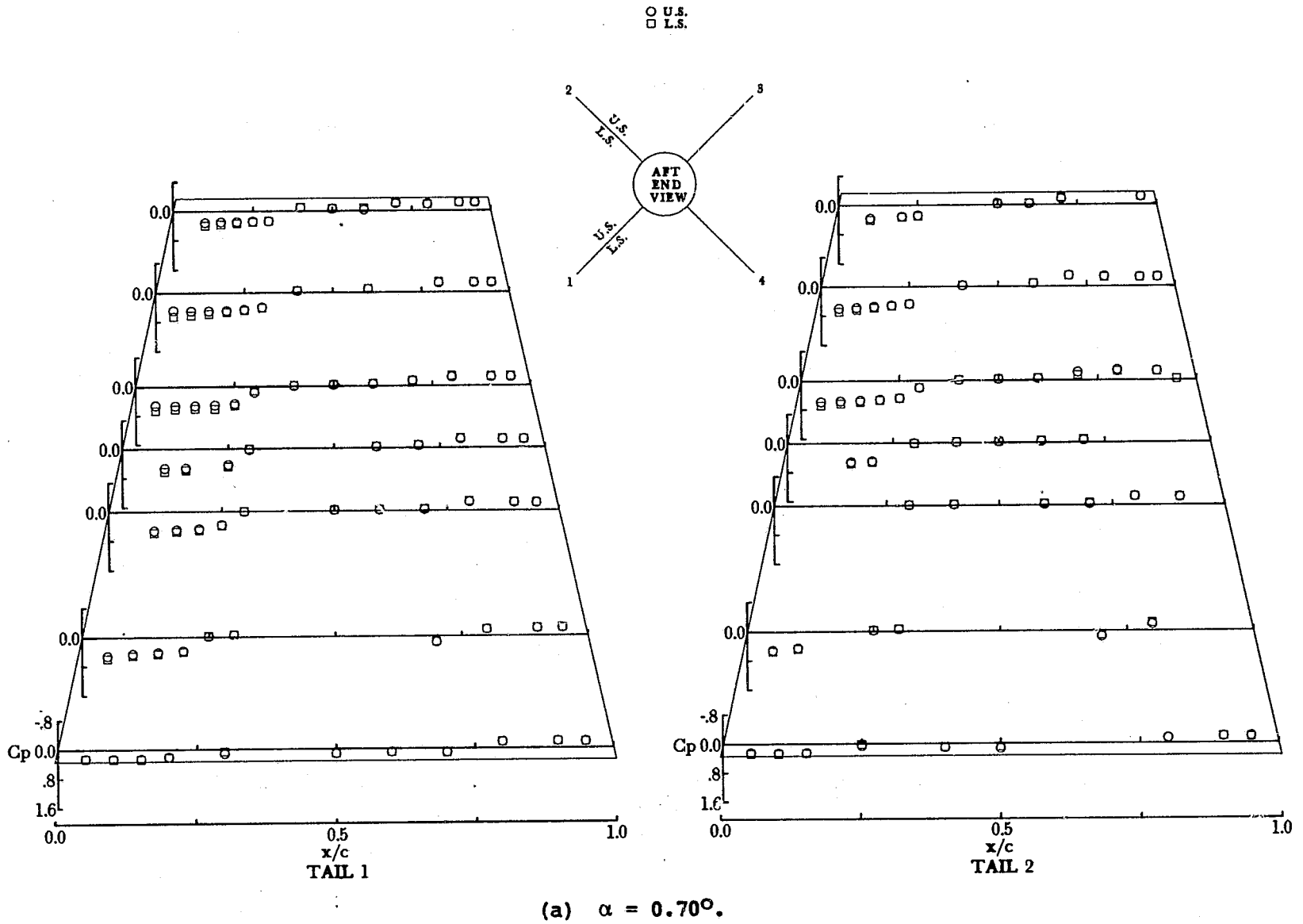
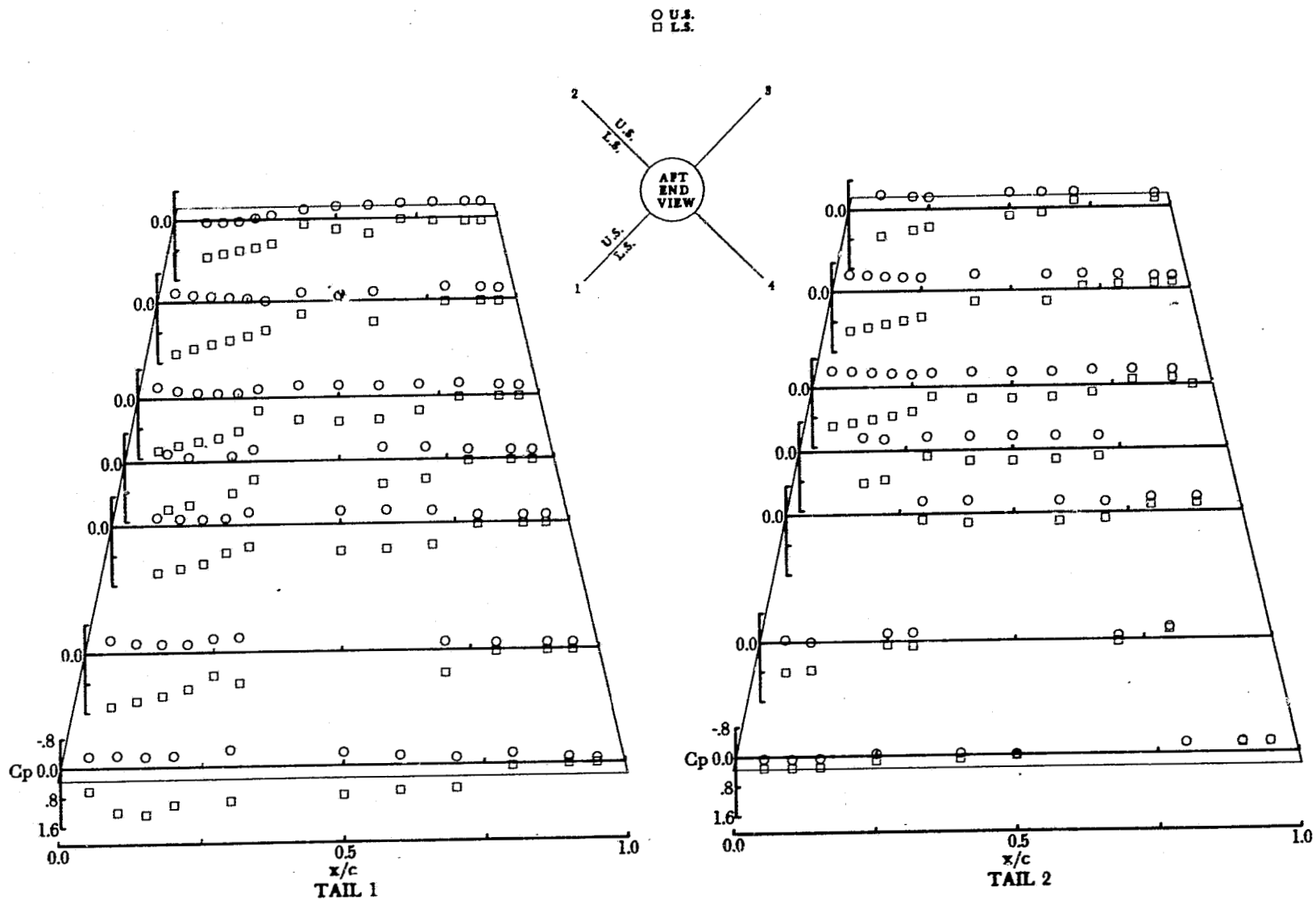
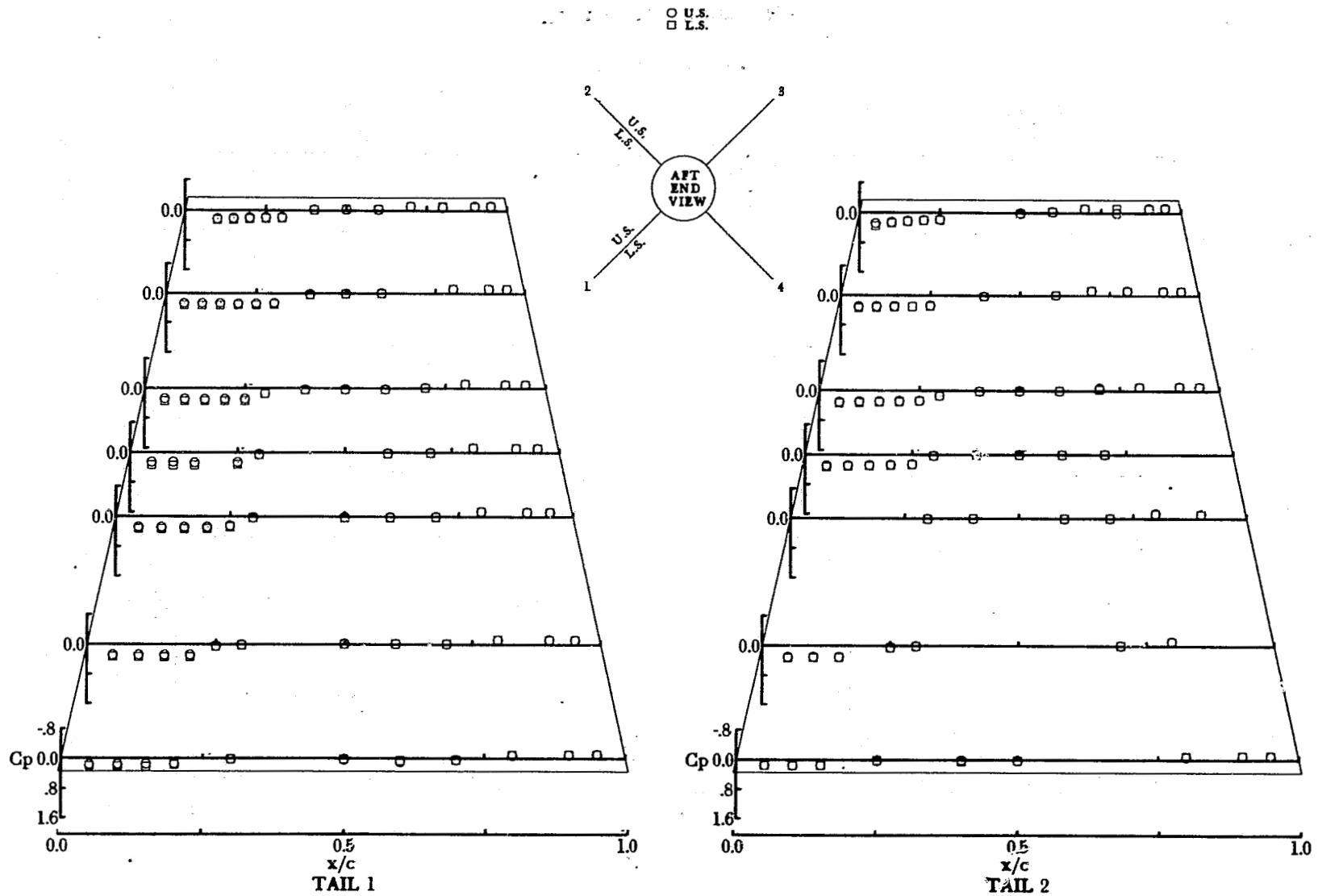


Figure 9.- Pressure coefficients for tail planform A at $M = 1.60$, $\phi = 45^\circ$, and $\delta = 0^\circ$.



(c) $\alpha = 20.70^\circ$.

Figure 9.- Concluded.



(a) $\alpha = -0.26^\circ$.

Figure 10.- Pressure coefficients for tail planform A at $M = 2.36$, $\phi = 45^\circ$, and $\delta = 0^\circ$.

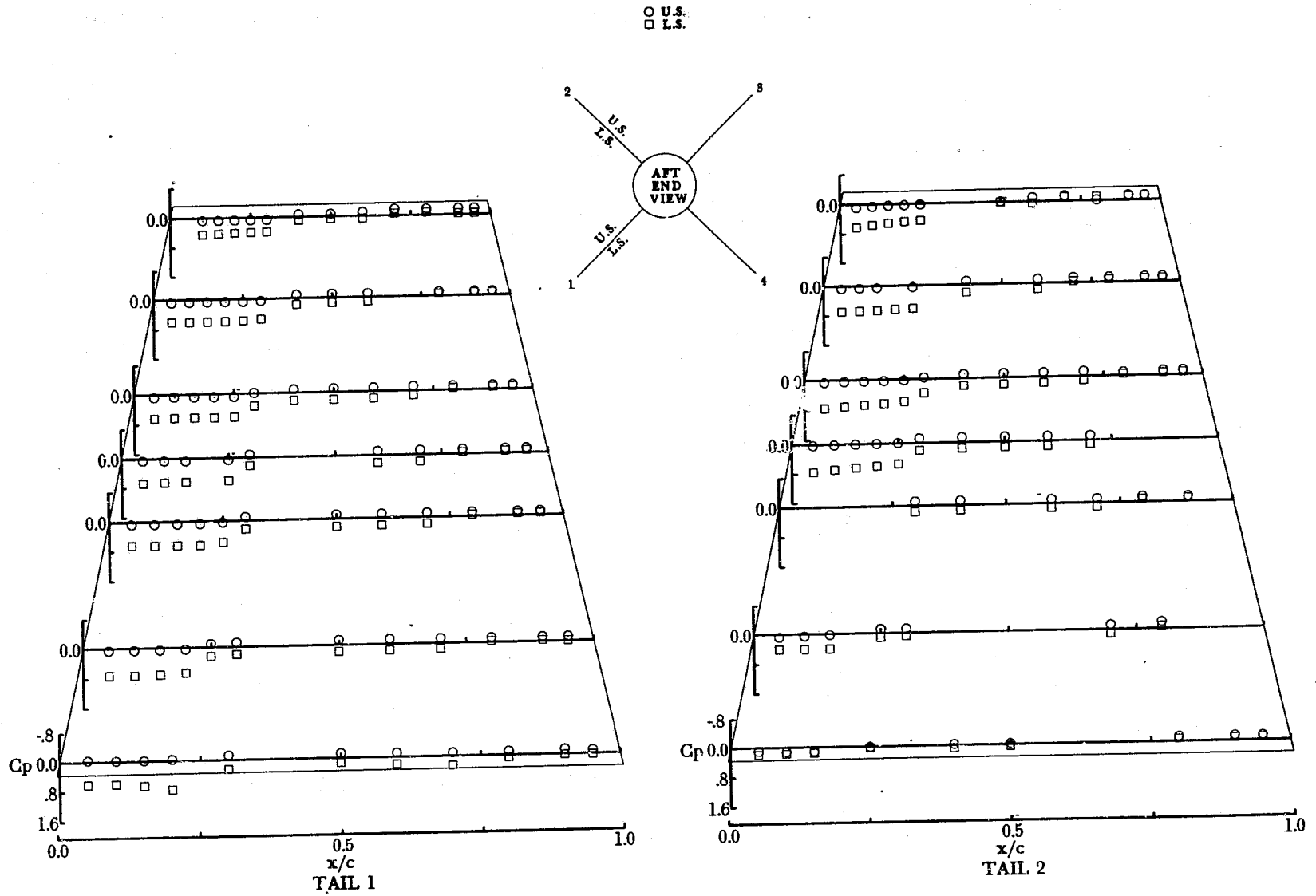
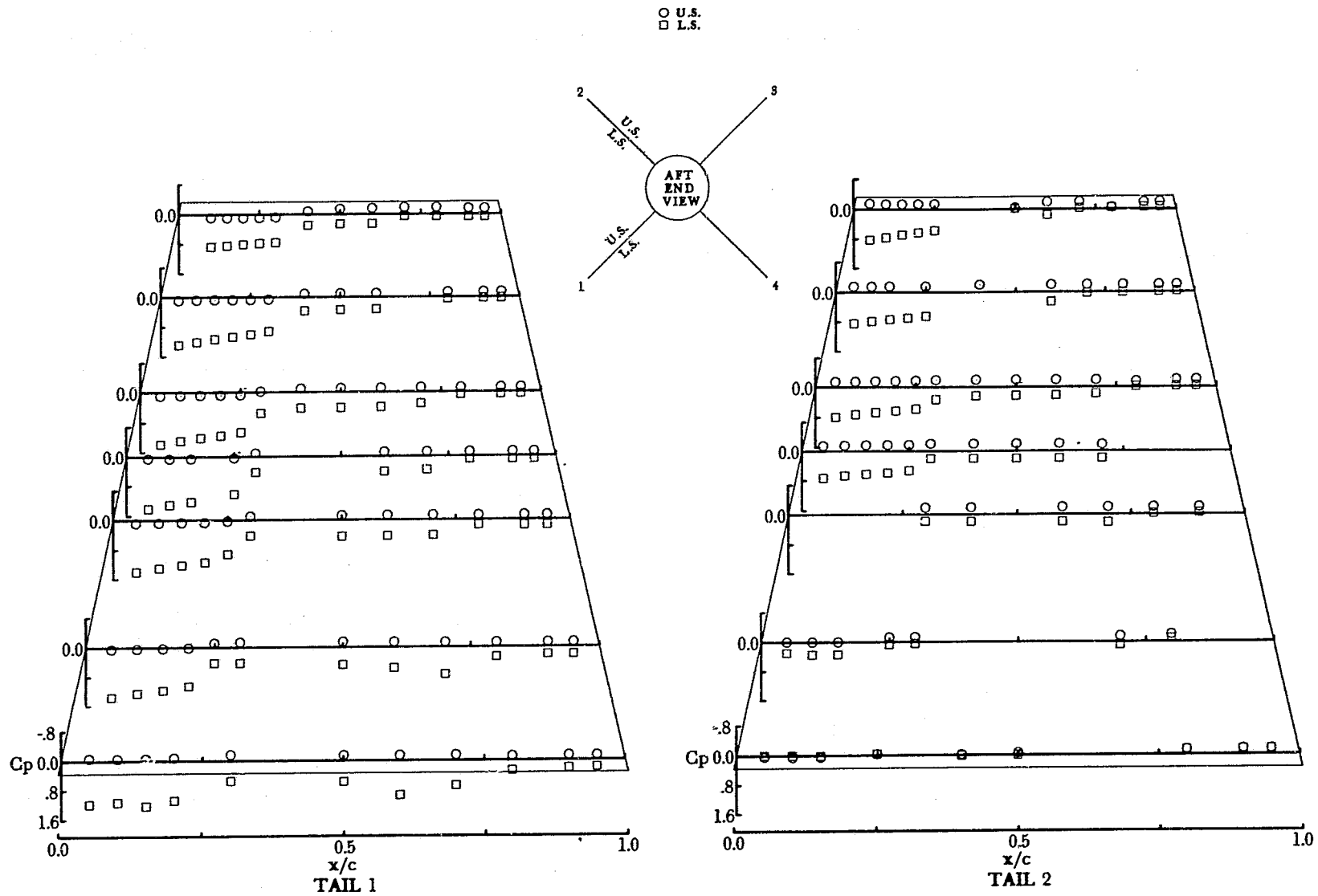


Figure 10.- Continued.



(c) $\alpha = 19.70^\circ$.

Figure 10.- Concluded.

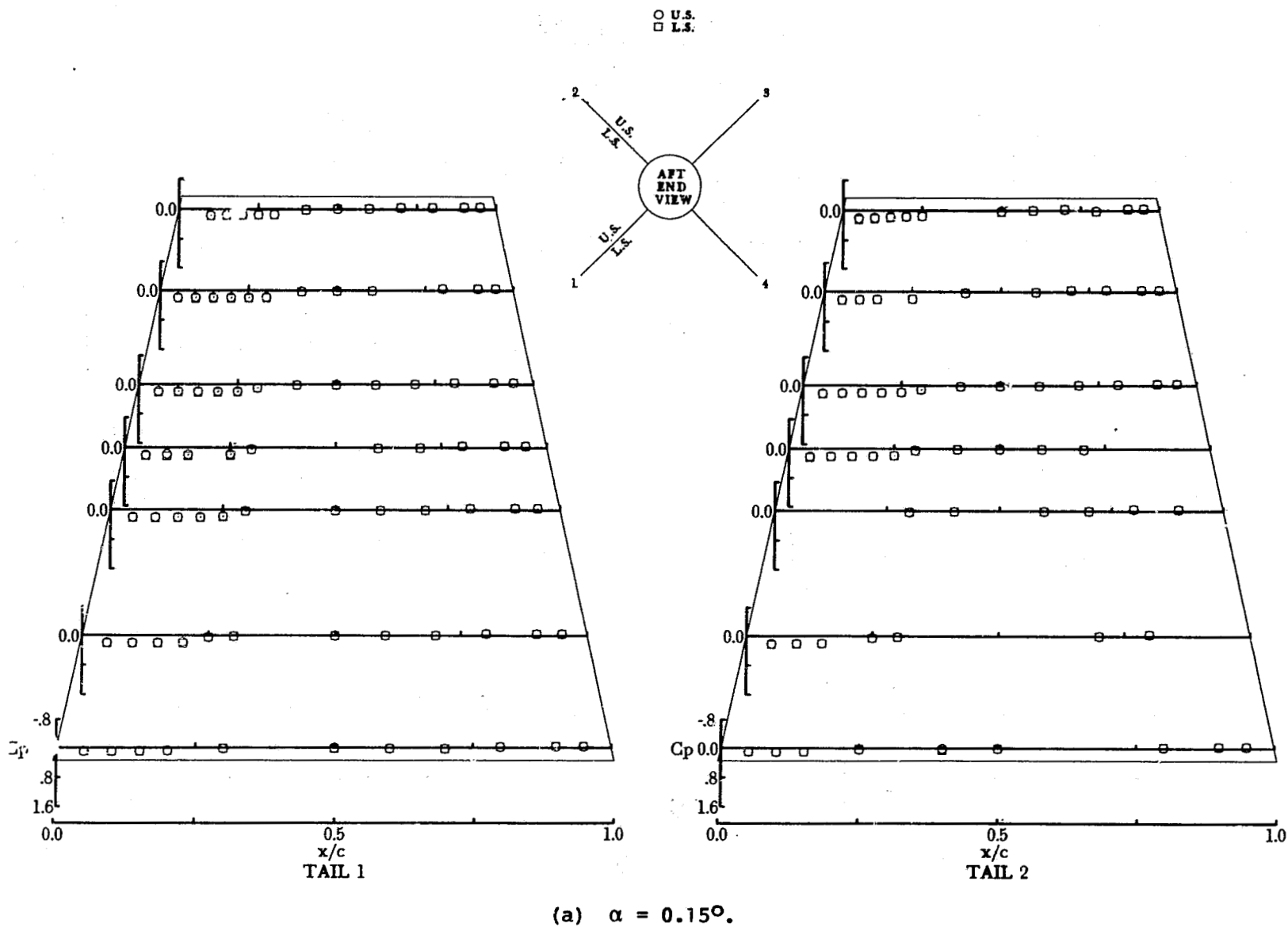


Figure 11.- Pressure coefficients for tail planform A at $M = 3.70$, $\phi = 45^\circ$, and $\delta = 0^\circ$.

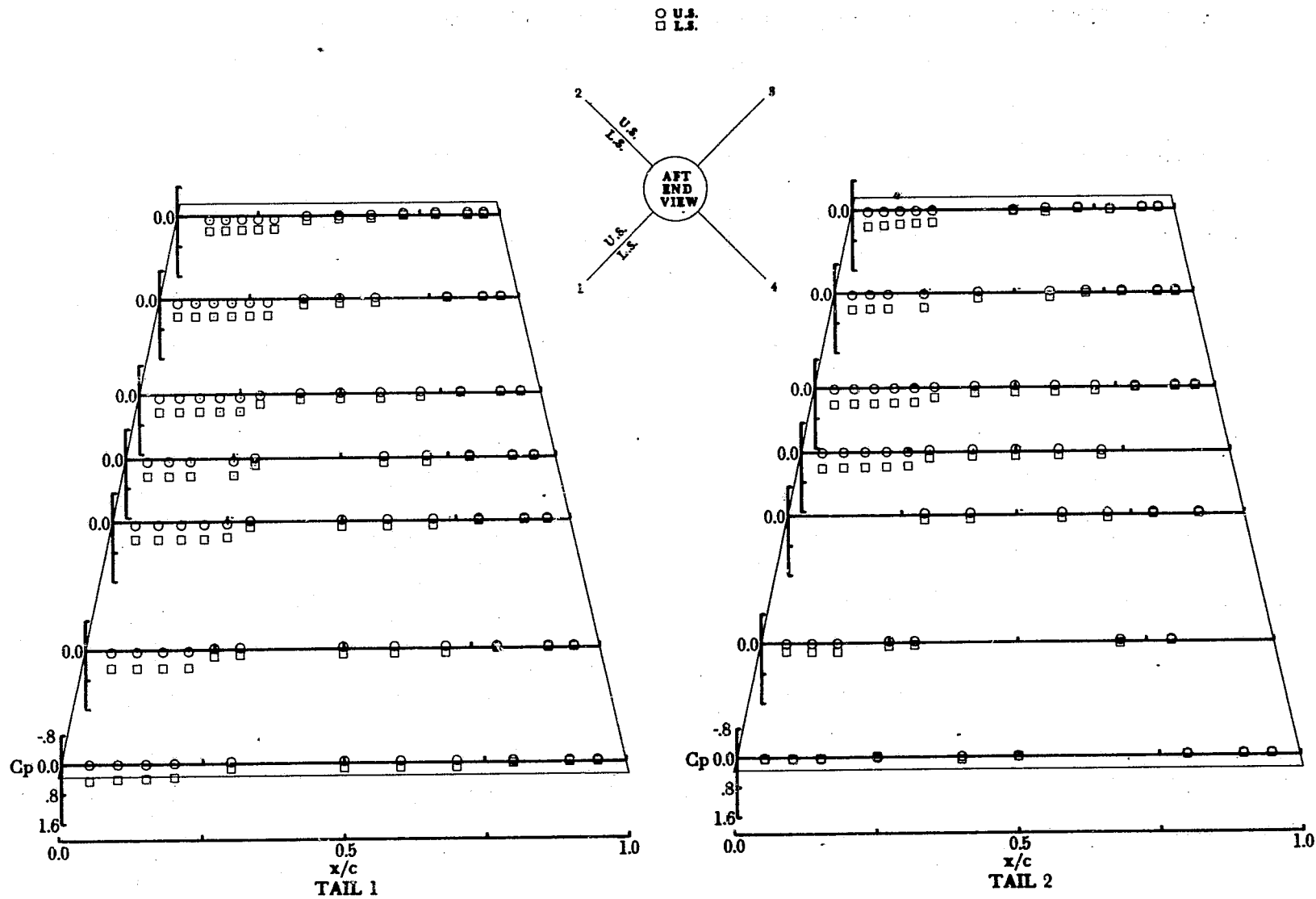
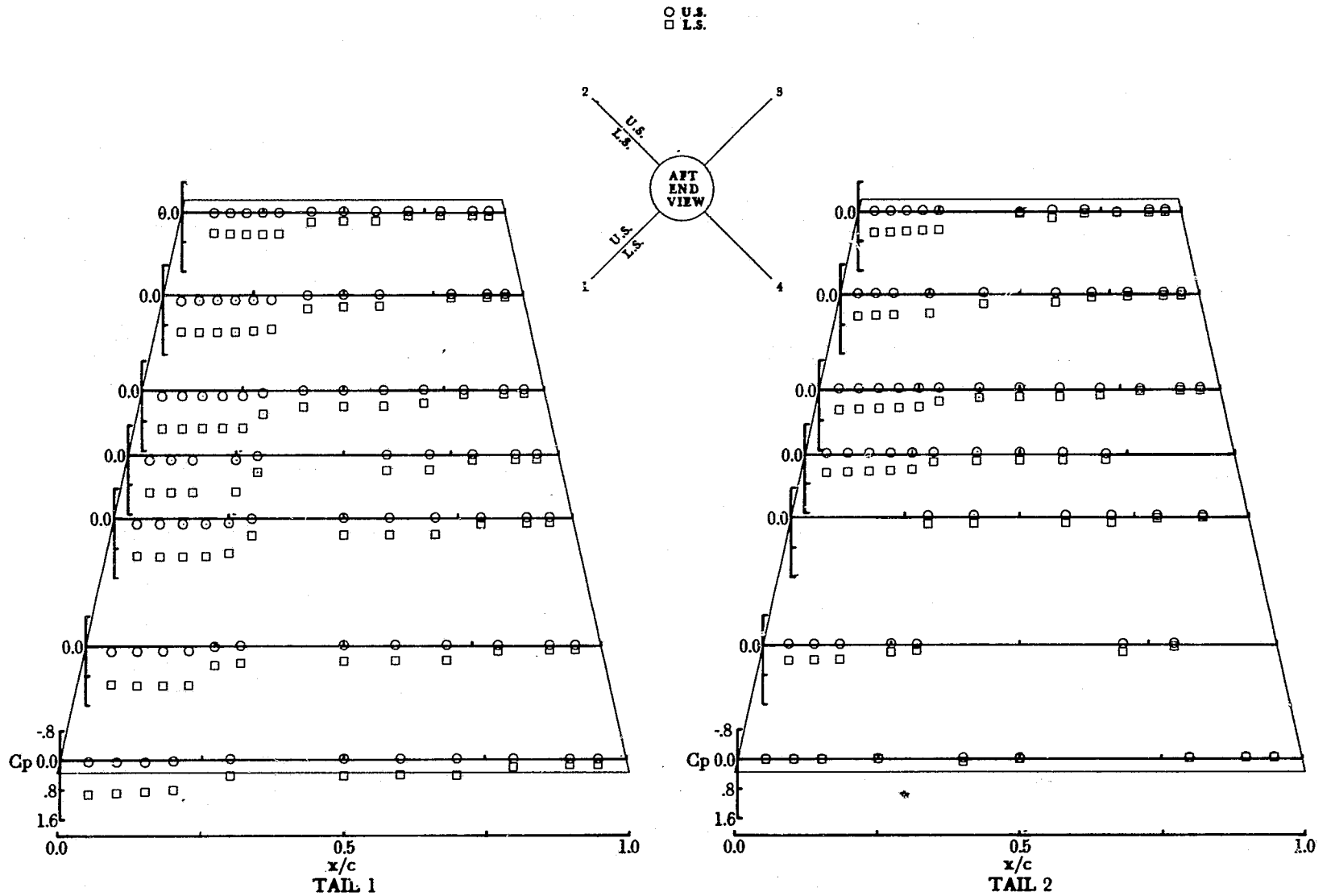


Figure 11.- Continued.



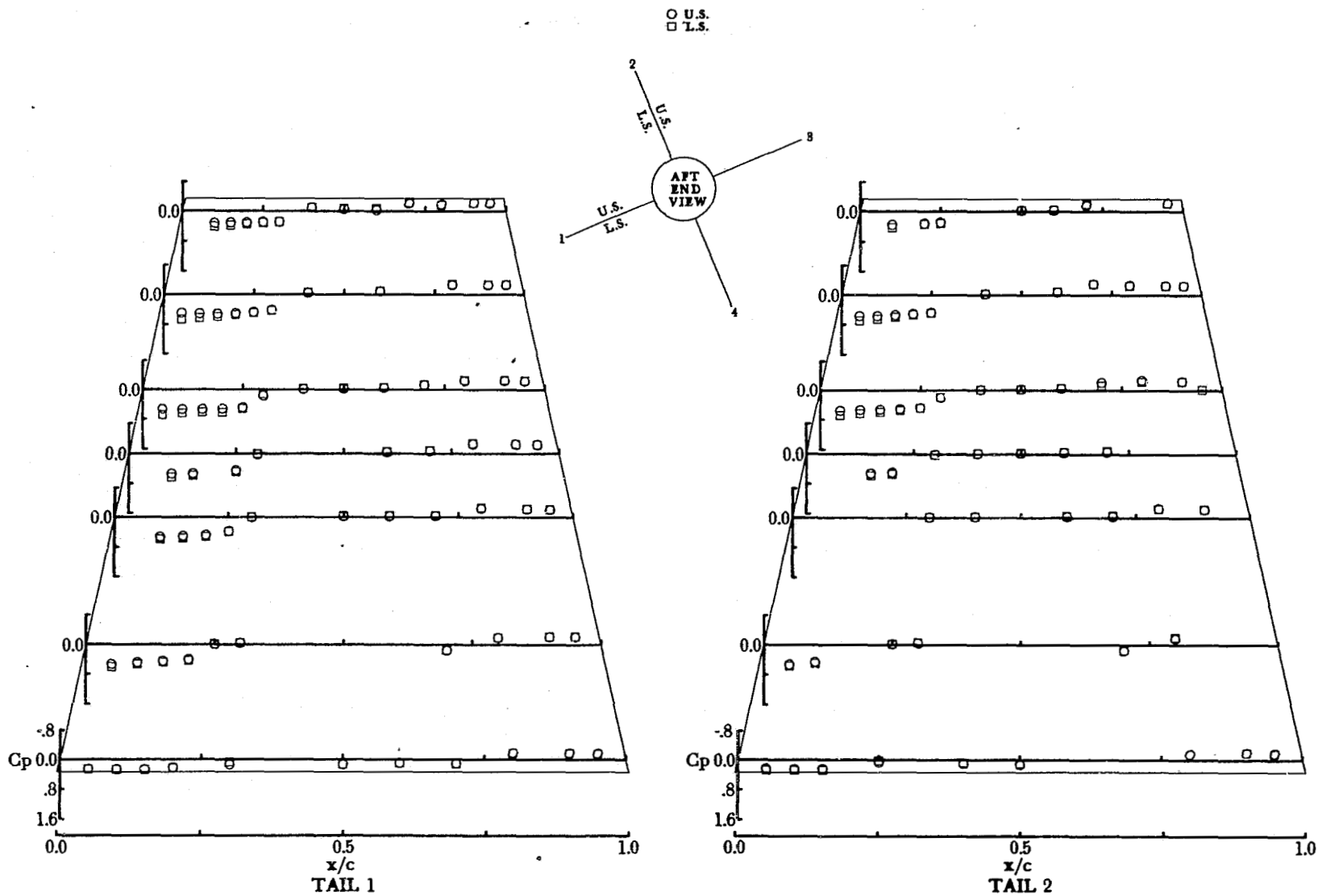
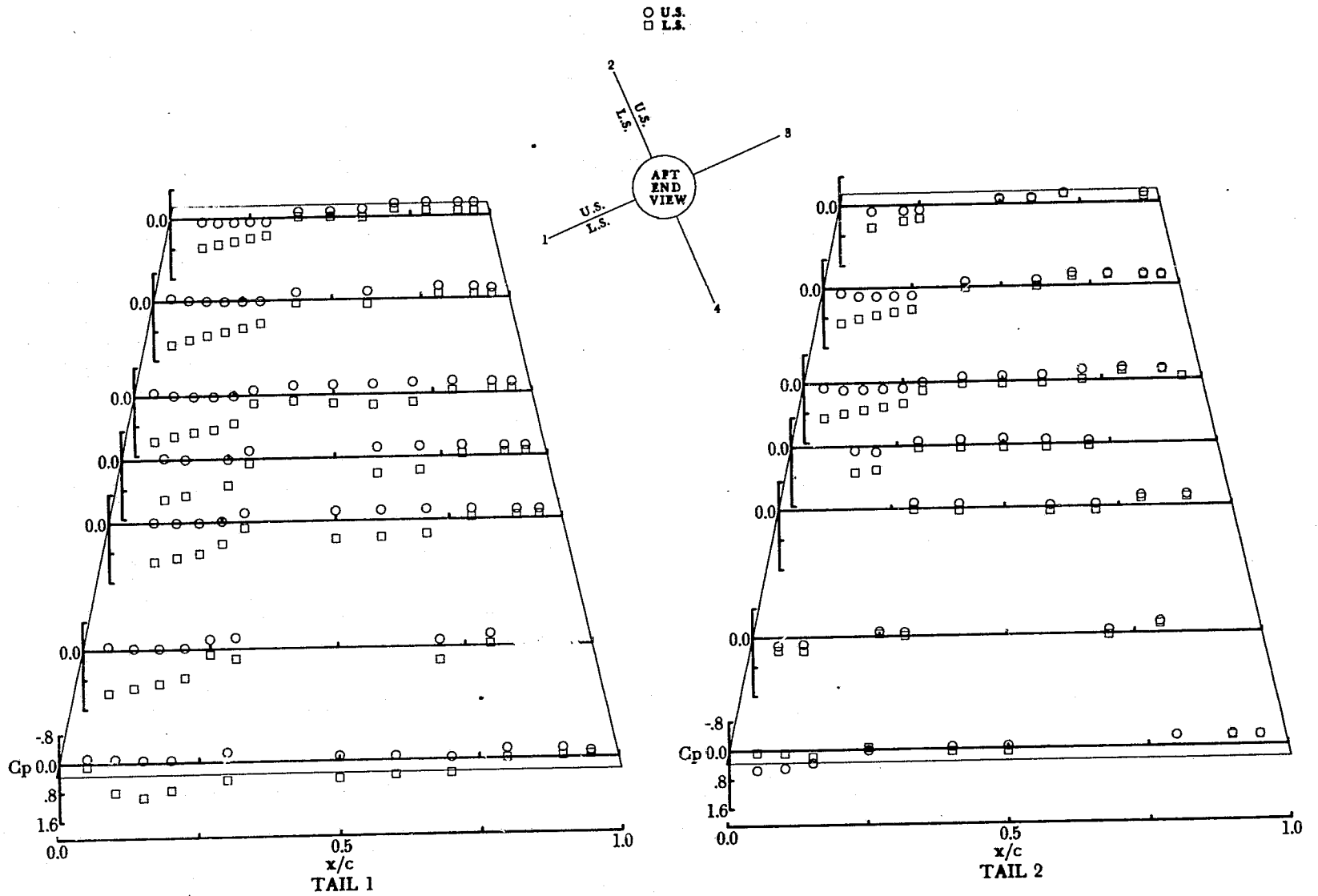
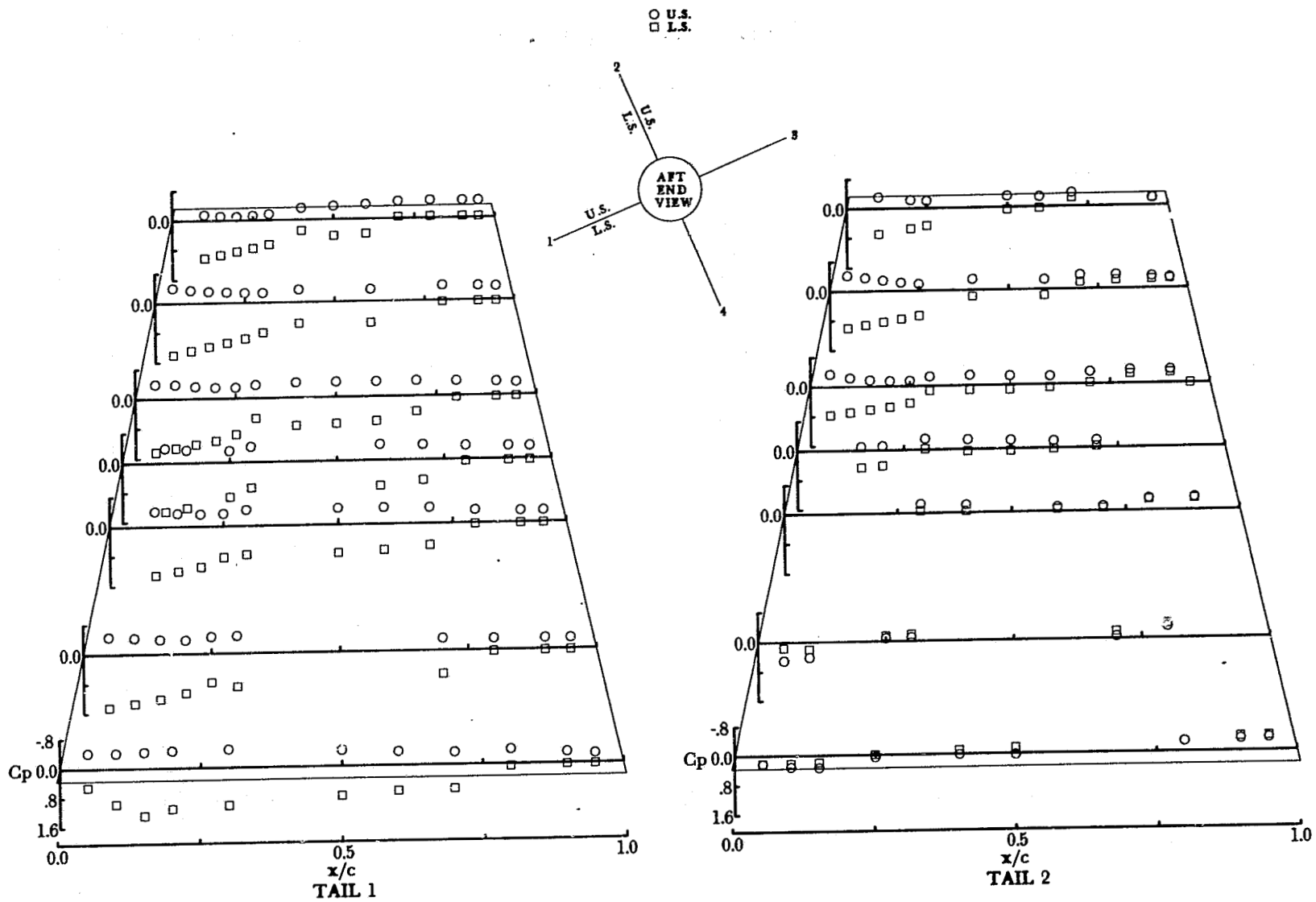


Figure 12.- Pressure coefficients for tail planform A at $M = 1.60$, $\phi = 67.5^\circ$, and $\delta = 0^\circ$.

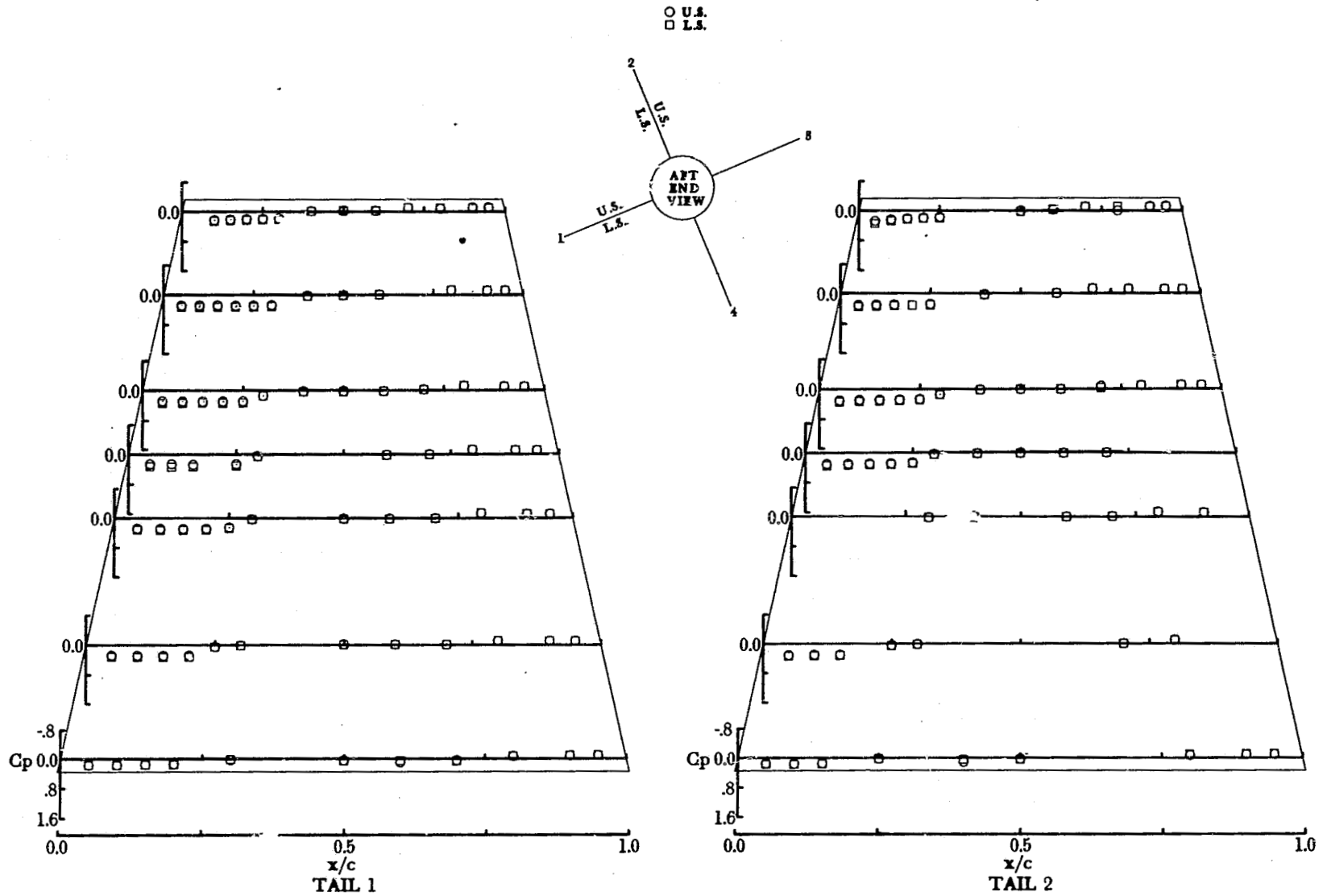


(b) $\alpha = 10.70^\circ$.
 Figure 12.- Continued.



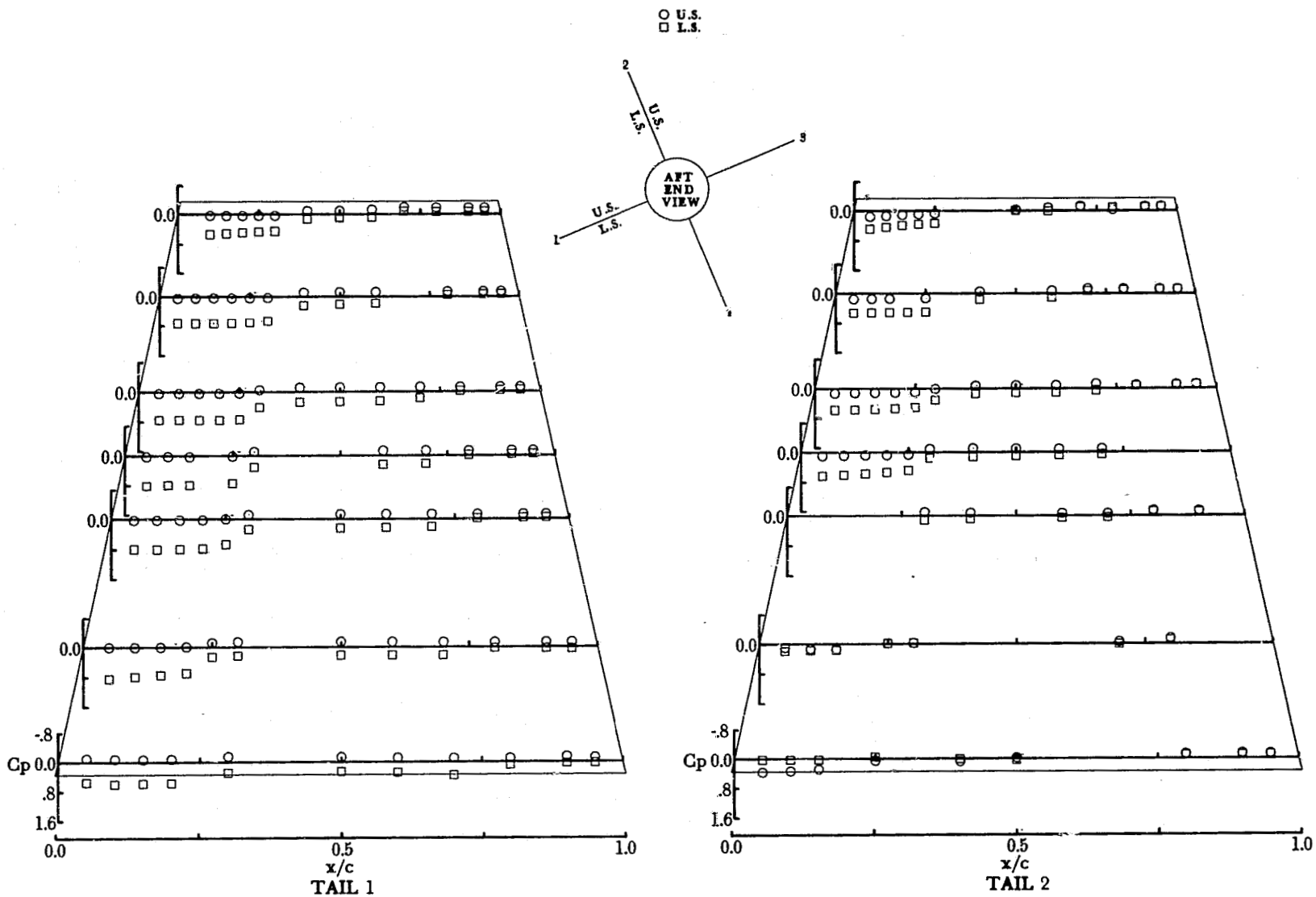
(c) $\alpha = 20.70^\circ$.

Figure 12.- Concluded.



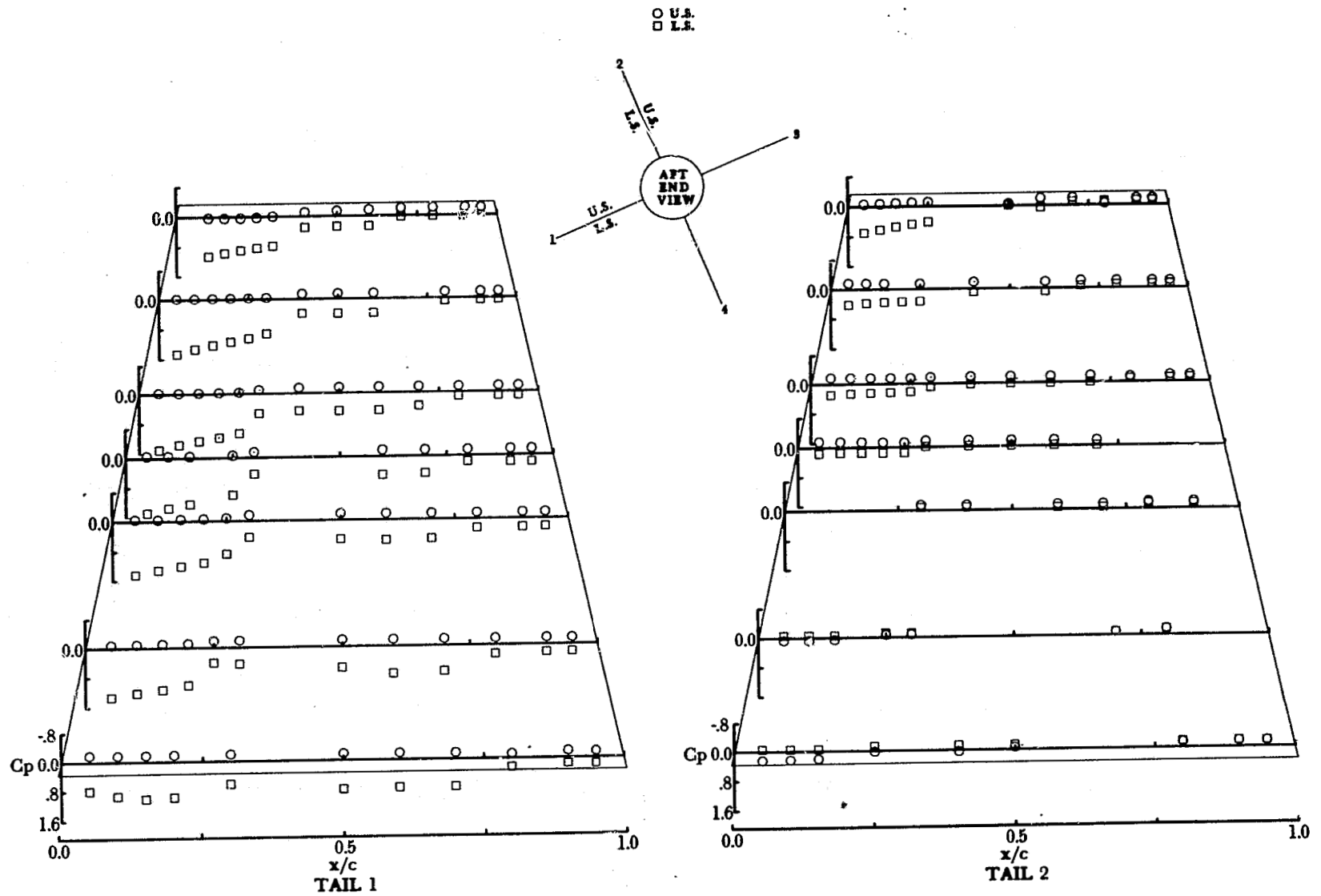
(a) $\alpha = -0.12^\circ$.

Figure 13.- Pressure coefficients for tail planform A at $M = 2.36$, $\phi = 67.5^\circ$, and $\delta = 0^\circ$.



(b) $\alpha = 9.85^\circ$.

Figure 13.- Continued.



(c) $\alpha = 19.86^\circ$.

Figure 13.- Concluded.

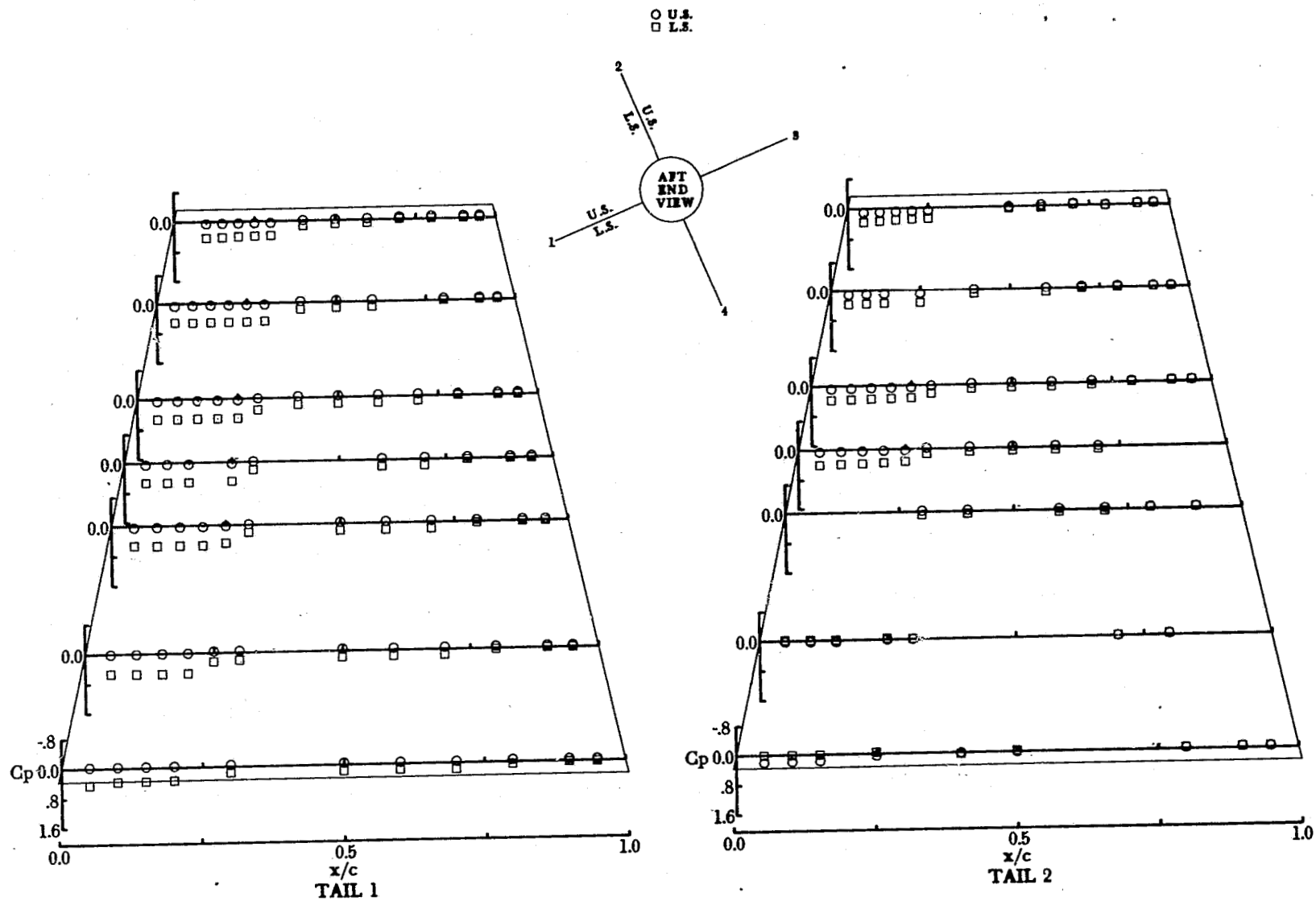
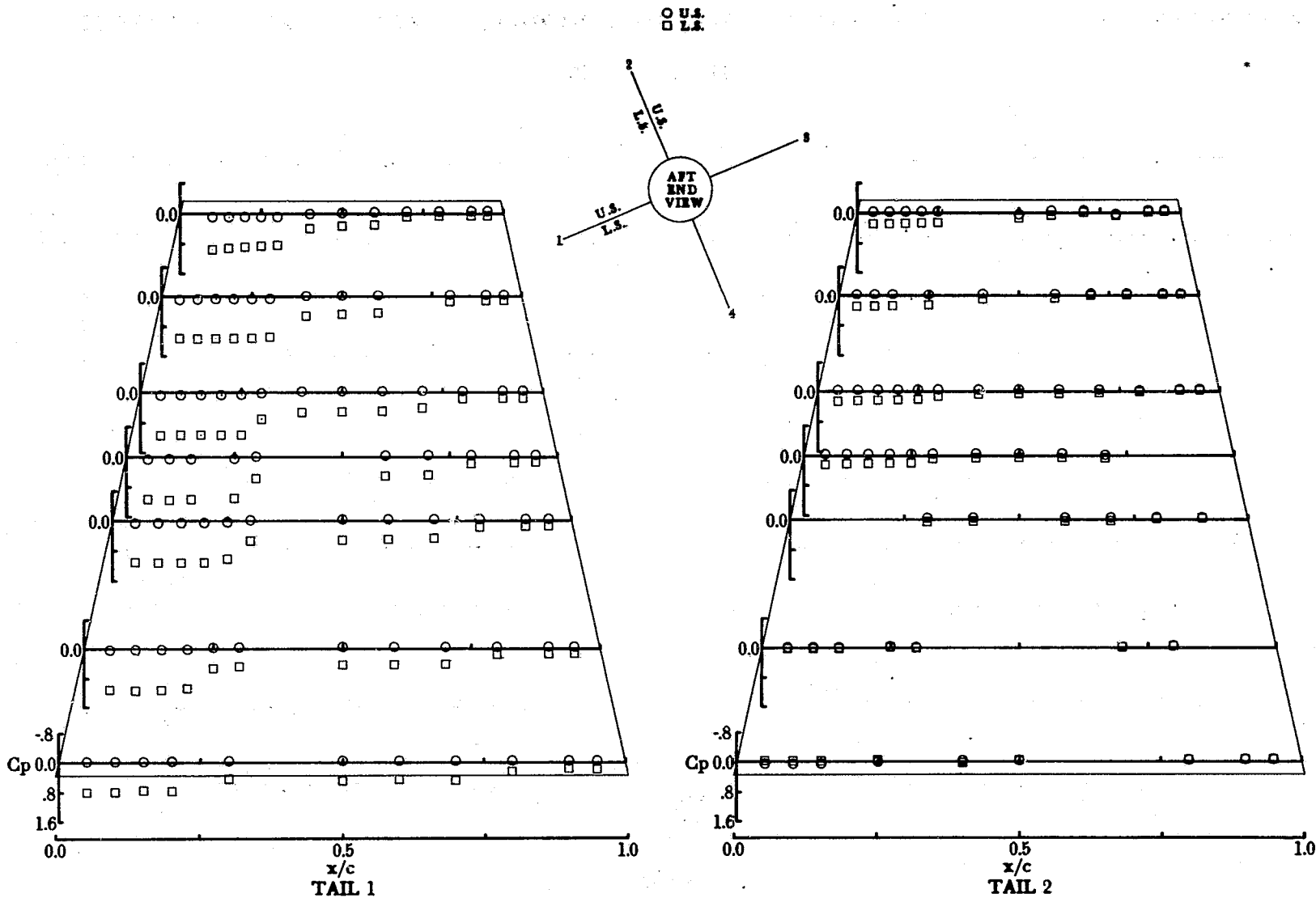
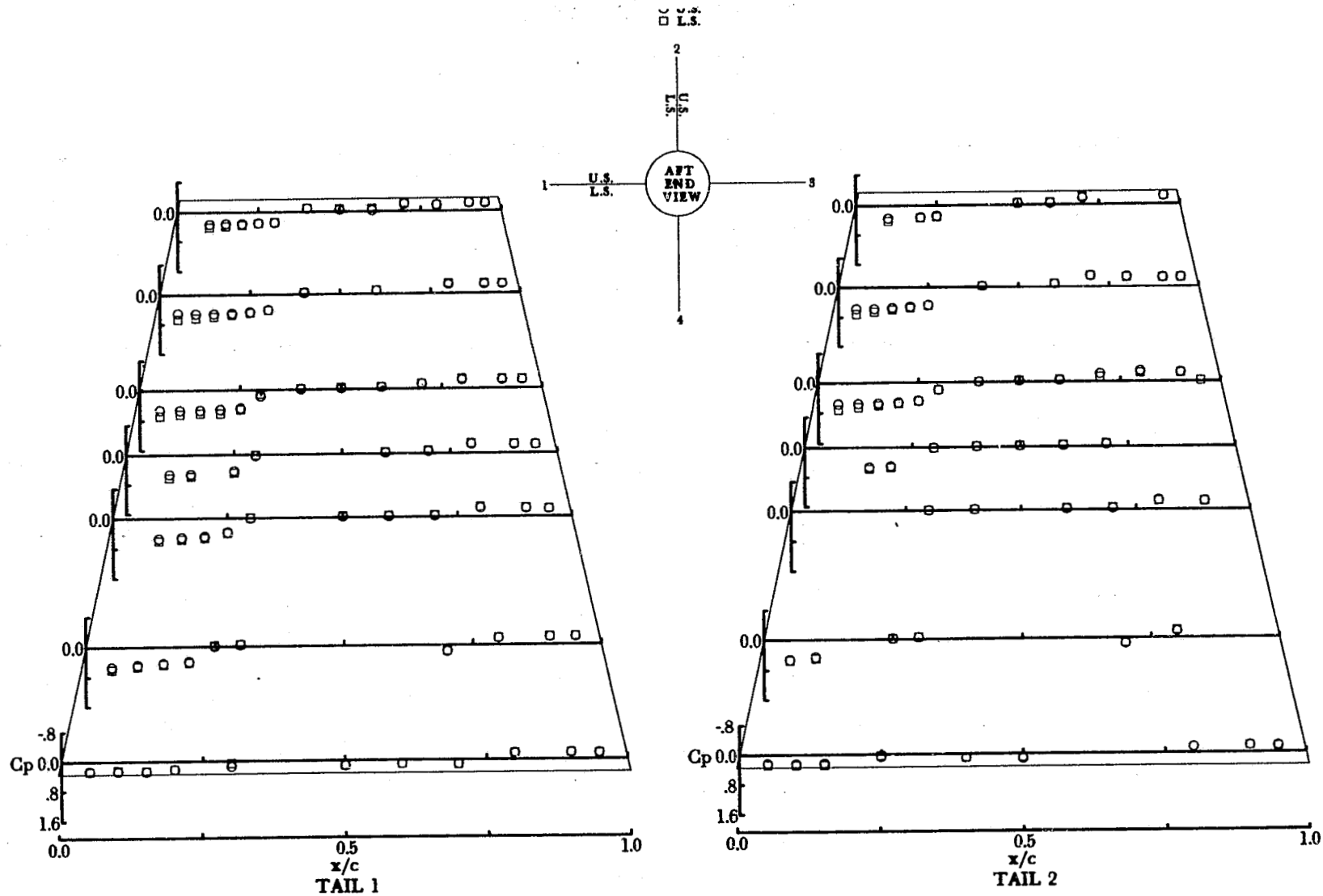


Figure 14.- Continued.



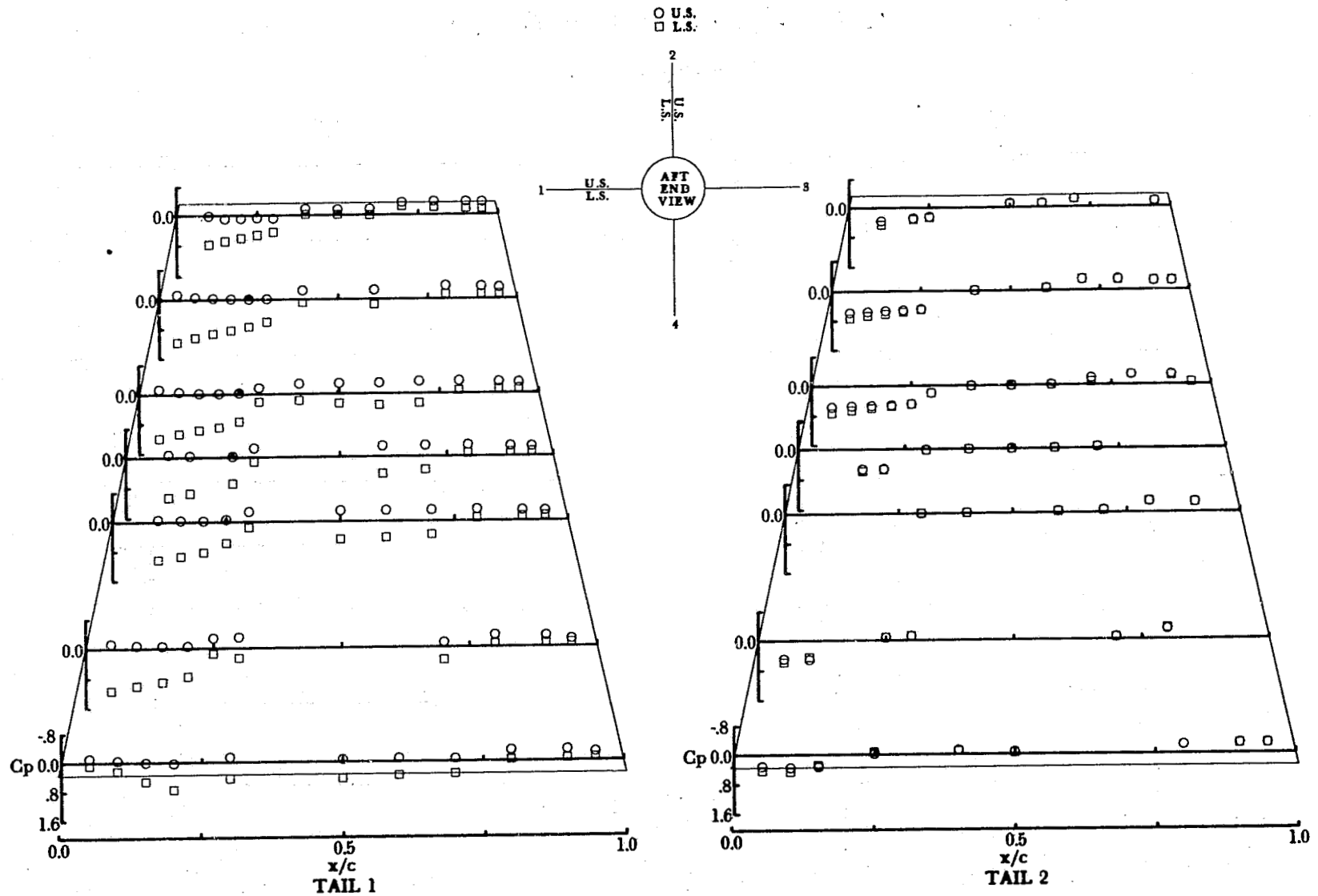
(c) $\alpha = 20.17^\circ$.

Figure 14.- Concluded.



(a) $\alpha = 0.55^\circ$.

Figure 15.- Pressure coefficients for tail planform A at $M = 1.60$, $\phi = 90^\circ$, and $\delta = 0^\circ$.



(b) $\alpha = 10.55^\circ$.

Figure 15.- Continued.

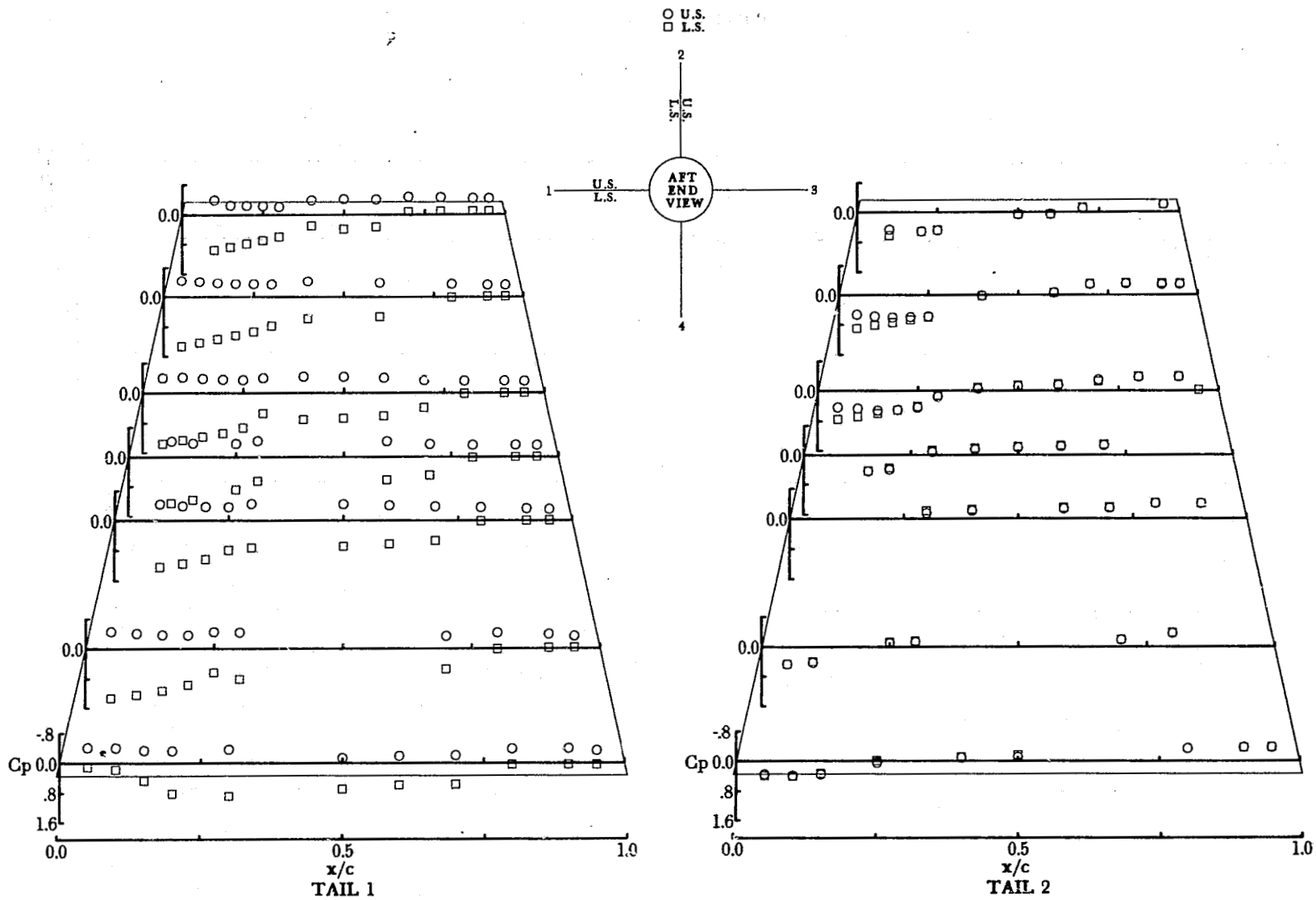
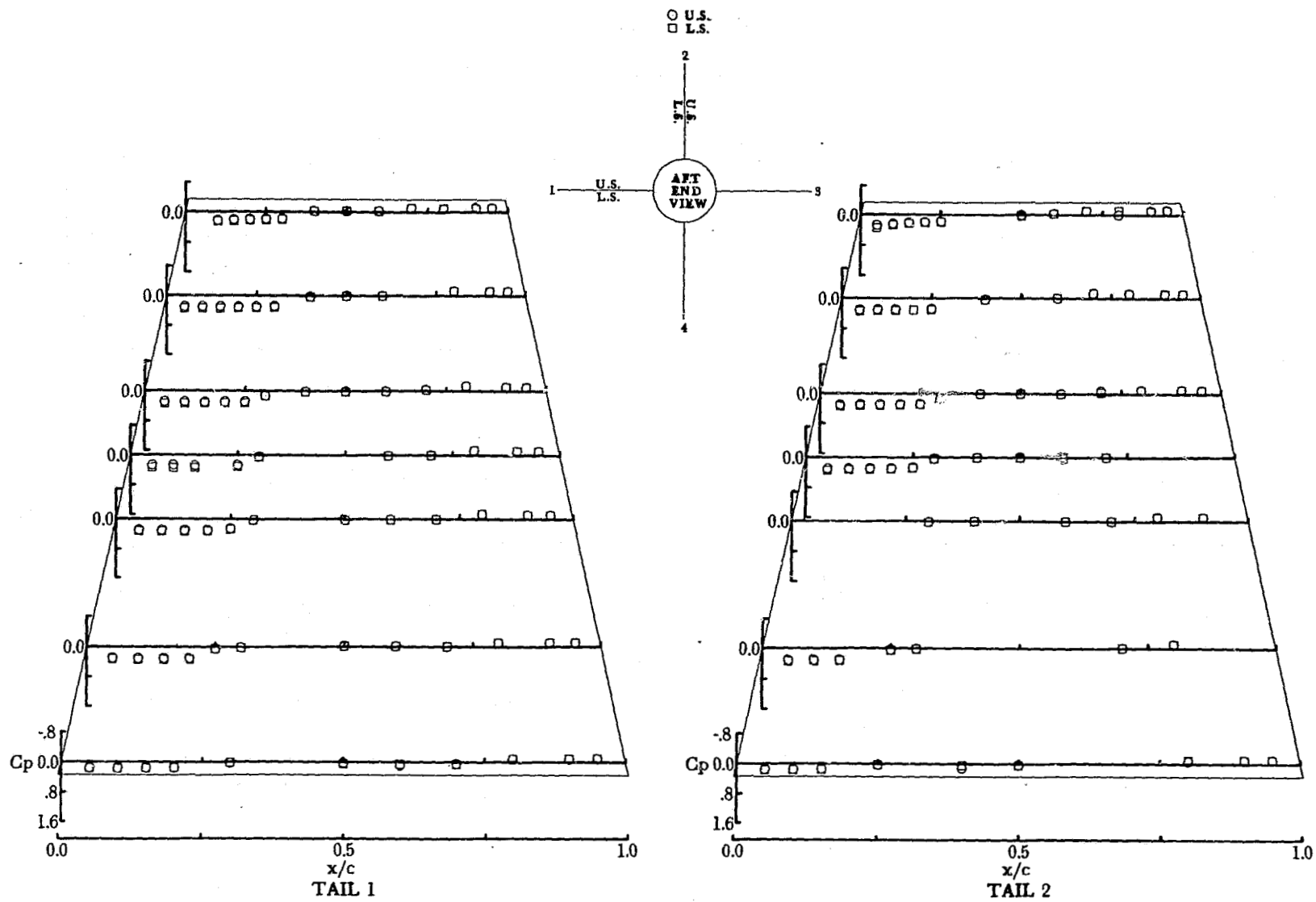
(c) $\alpha = 20.53^\circ$.

Figure 15.- Concluded.



(a) $\alpha = -0.12^\circ$.

Figure 16.- Pressure coefficients for tail planform A at $M = 2.36$, $\phi = 90^\circ$, and $\delta = 0^\circ$.

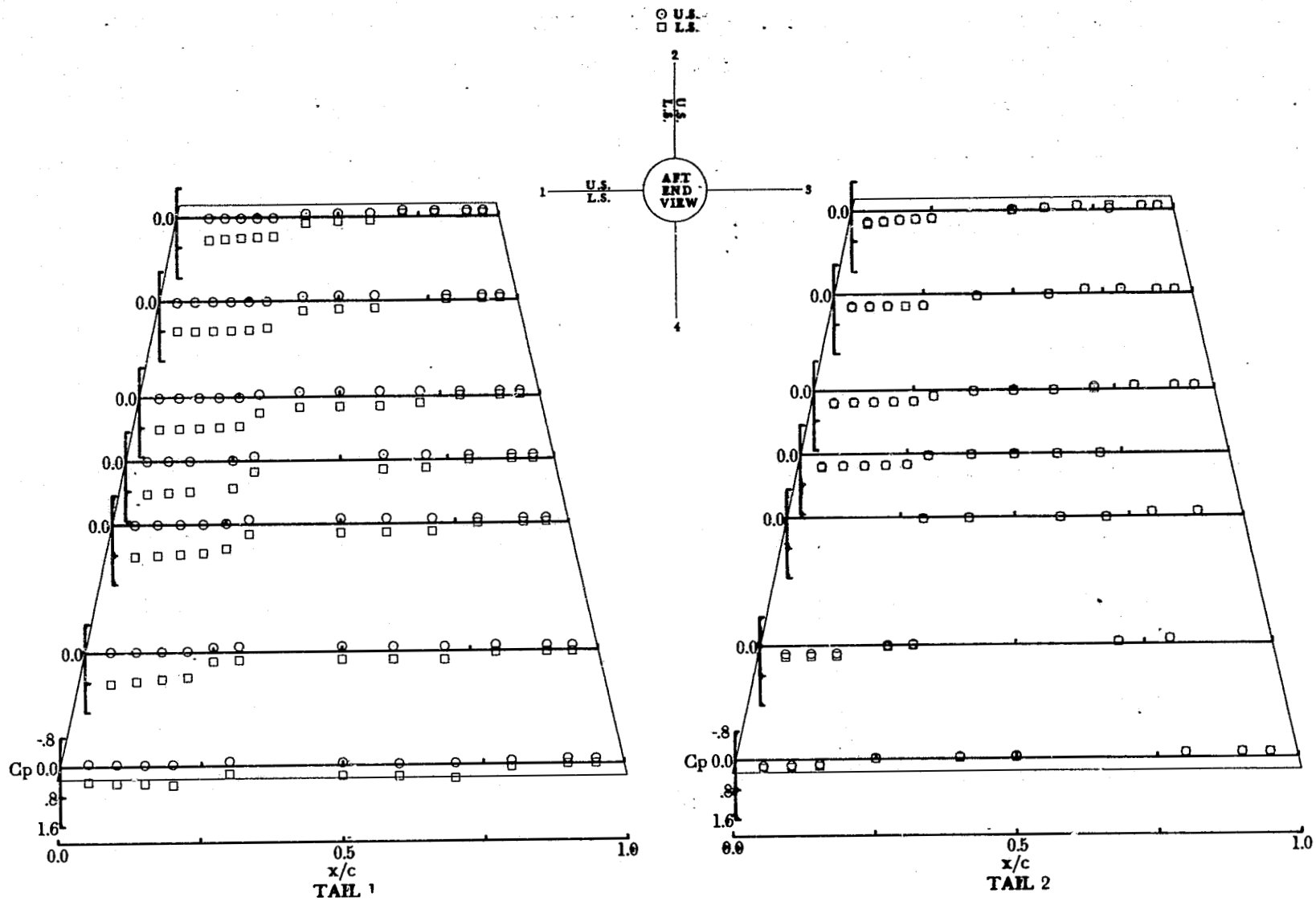
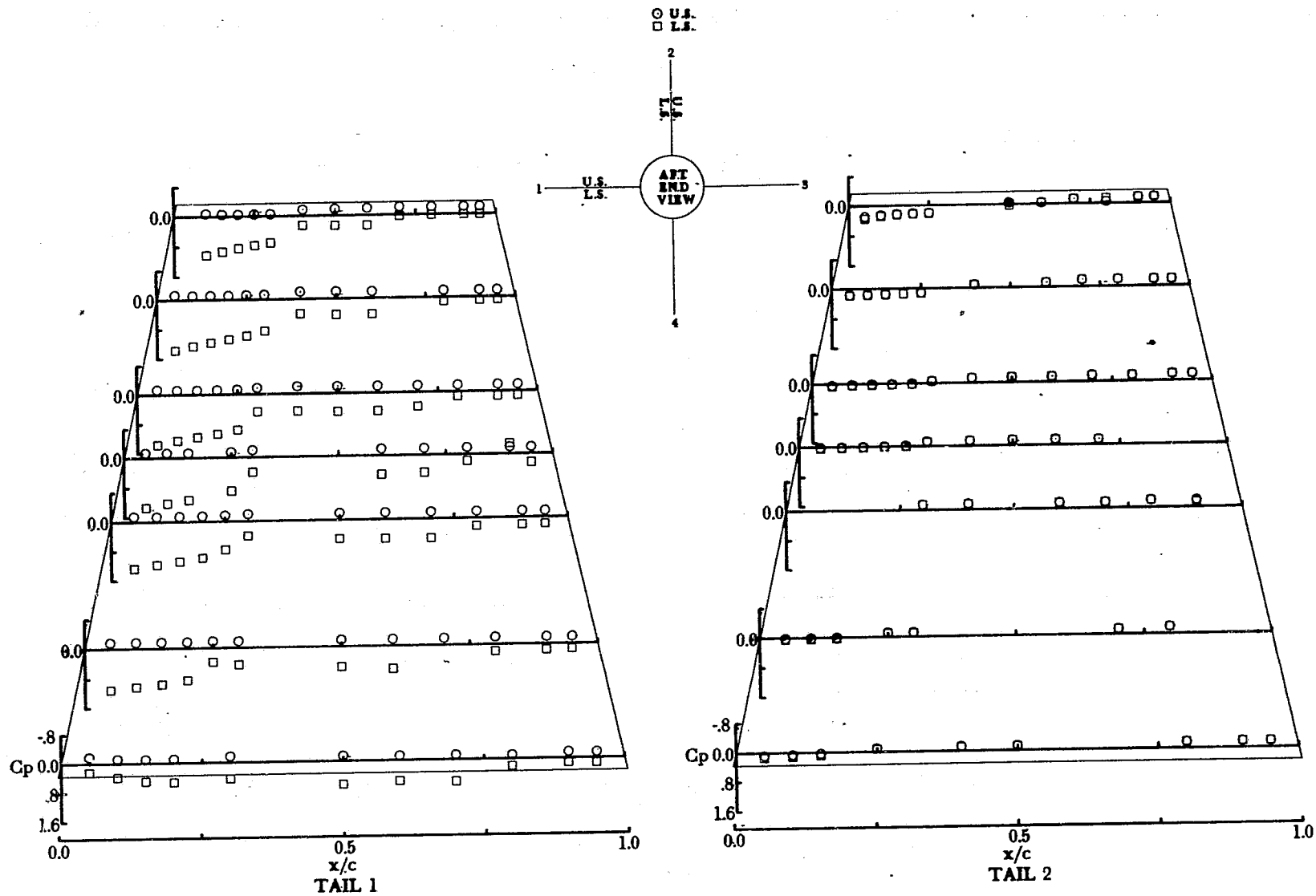
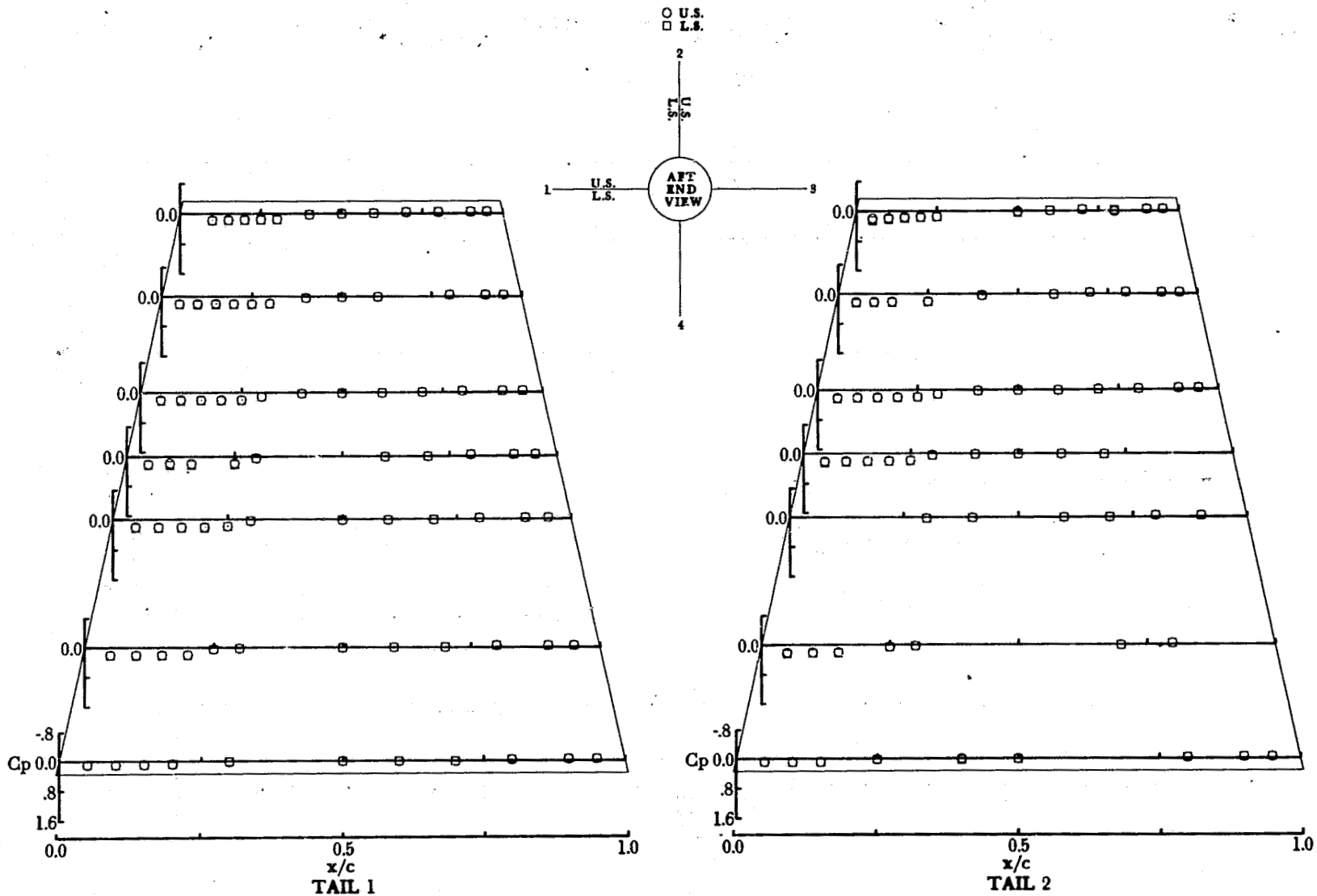
(b) $\alpha = 9.86^\circ$.

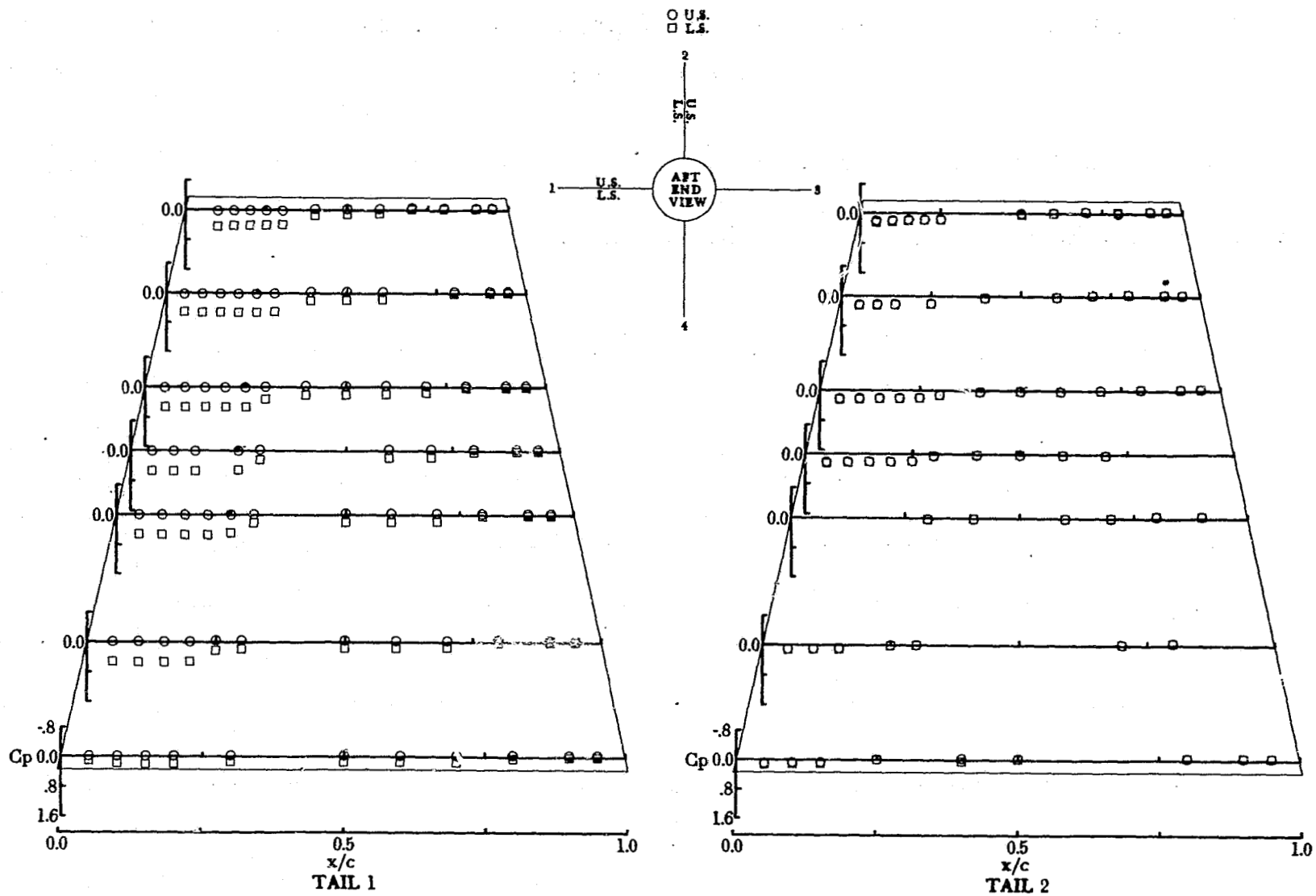
Figure 16.- Continued.



(e) $\alpha = 19.80^\circ$.

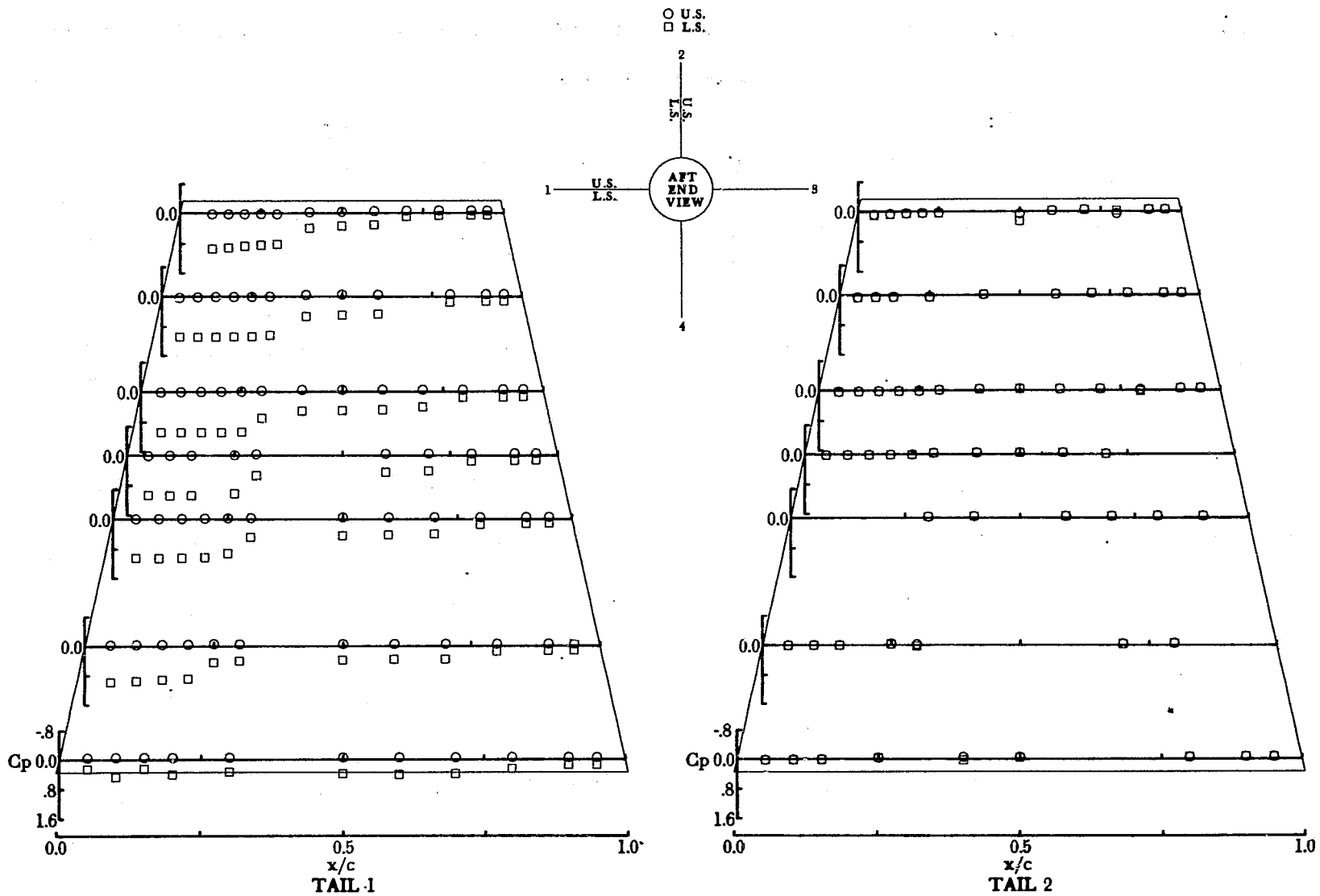
Figure 16.- Concluded.

(a) $\alpha = 0.03^\circ$.Figure 17.- Pressure coefficients for tail planform A at $M = 3.70$, $\phi = 90^\circ$, and $\delta = 0^\circ$.



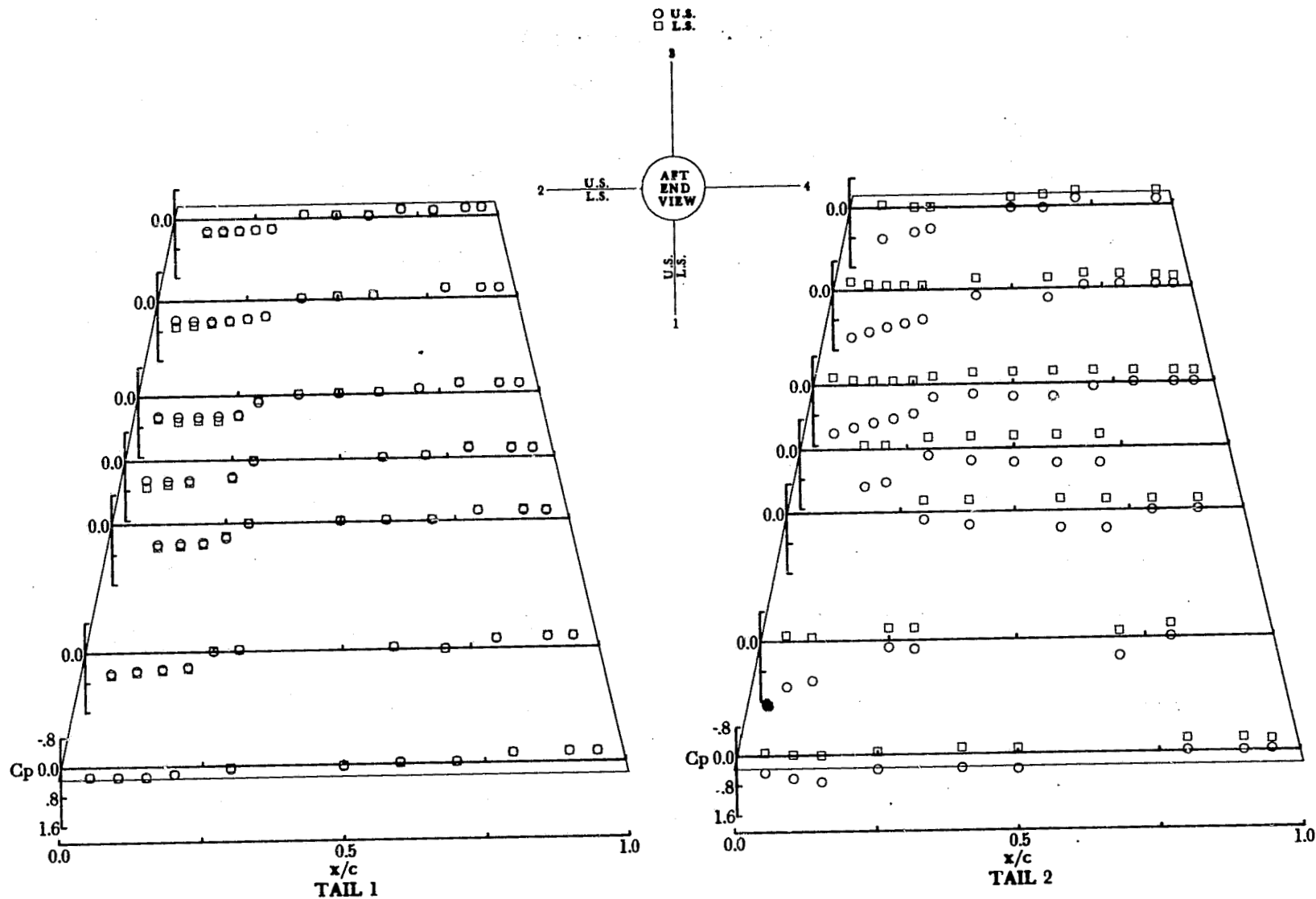
(b) $\alpha = 10.01^\circ$.

Figure 17.- Continued.



(c) $\alpha = 20.01^\circ$.

Figure 17.- Concluded.



(a) $\alpha = 0.50^\circ$.

Figure 18.- Pressure coefficients for tail planform A at $M = 1.60$, $\phi = 0^\circ$, and $\delta_{2,4} = -15^\circ$.

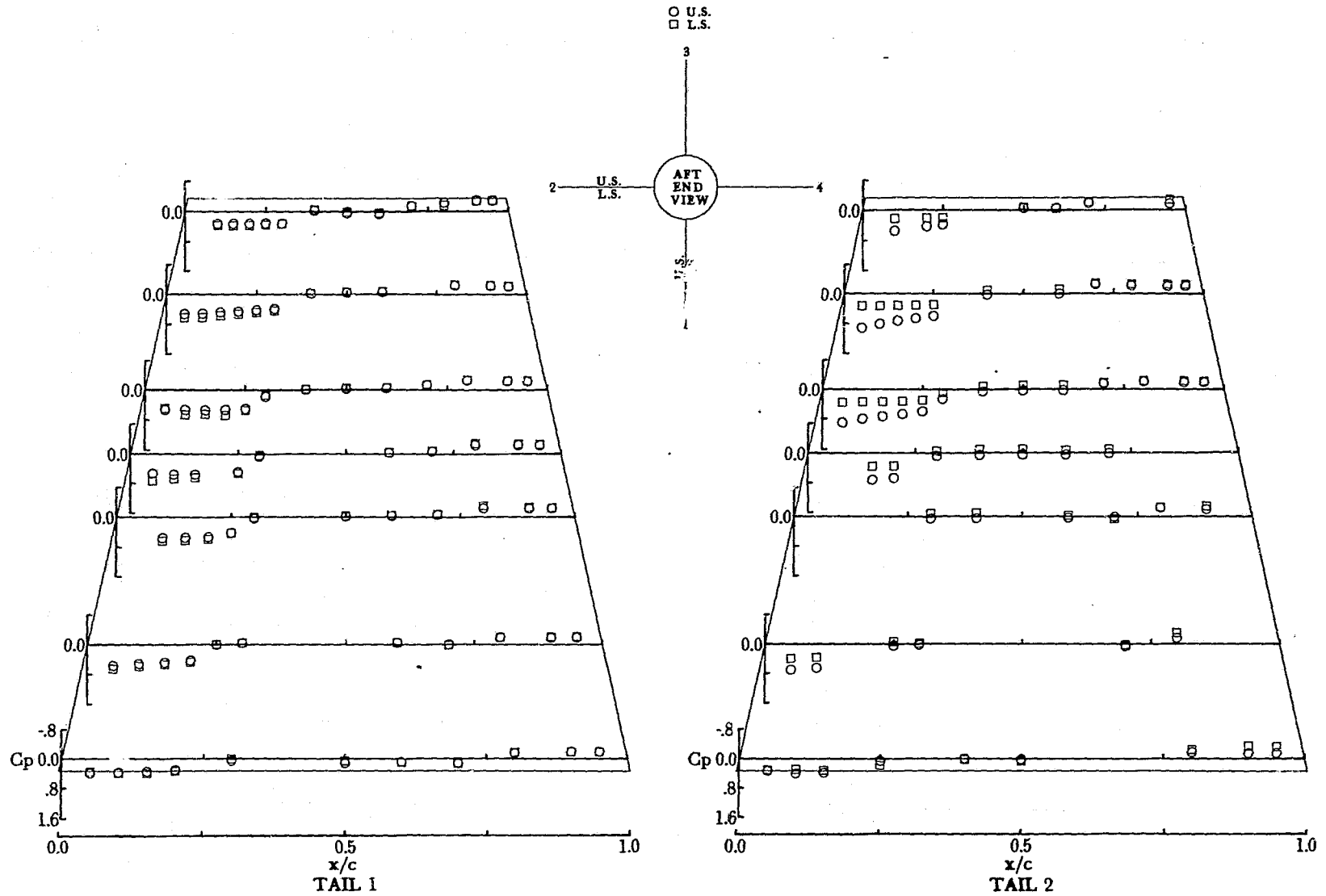
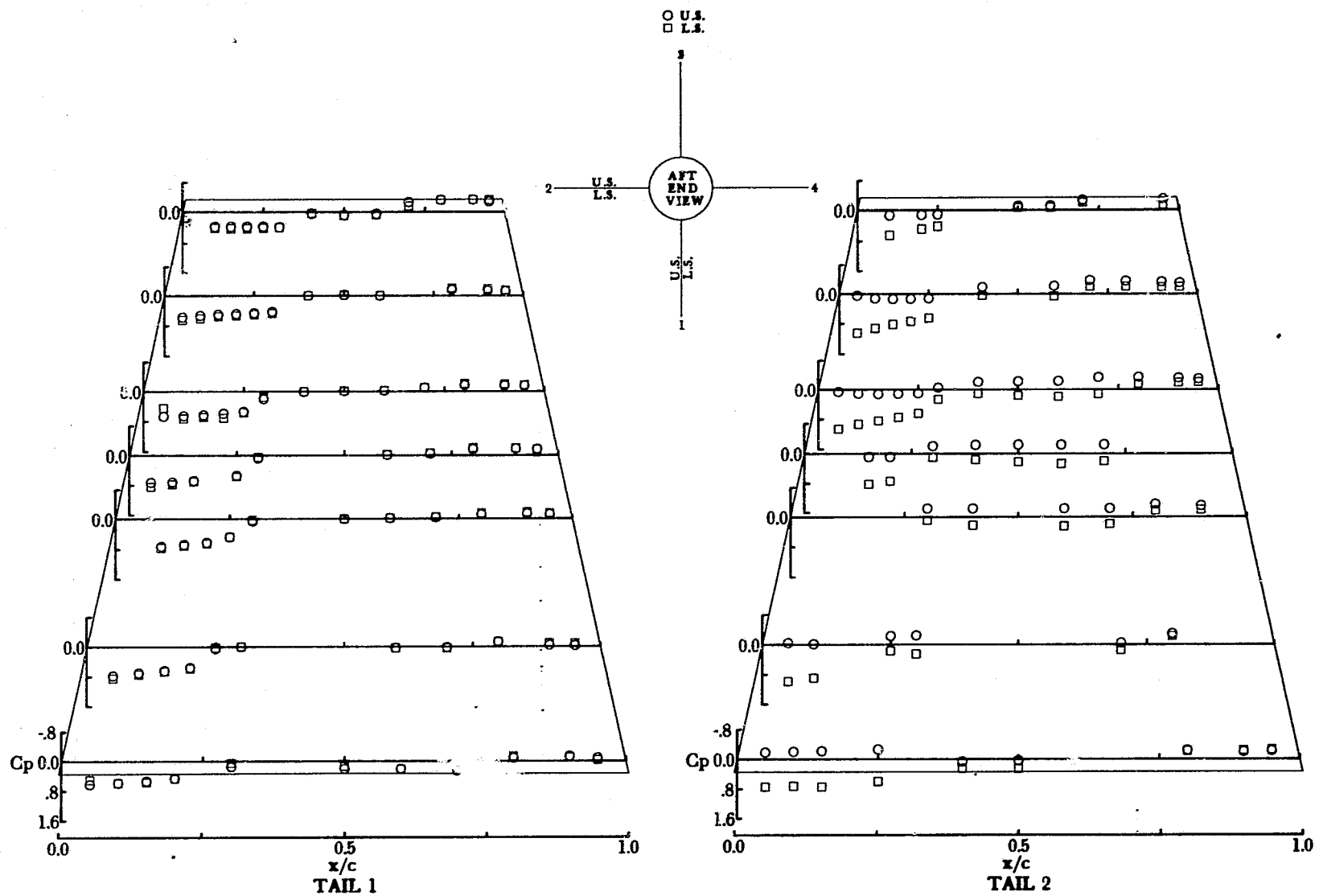
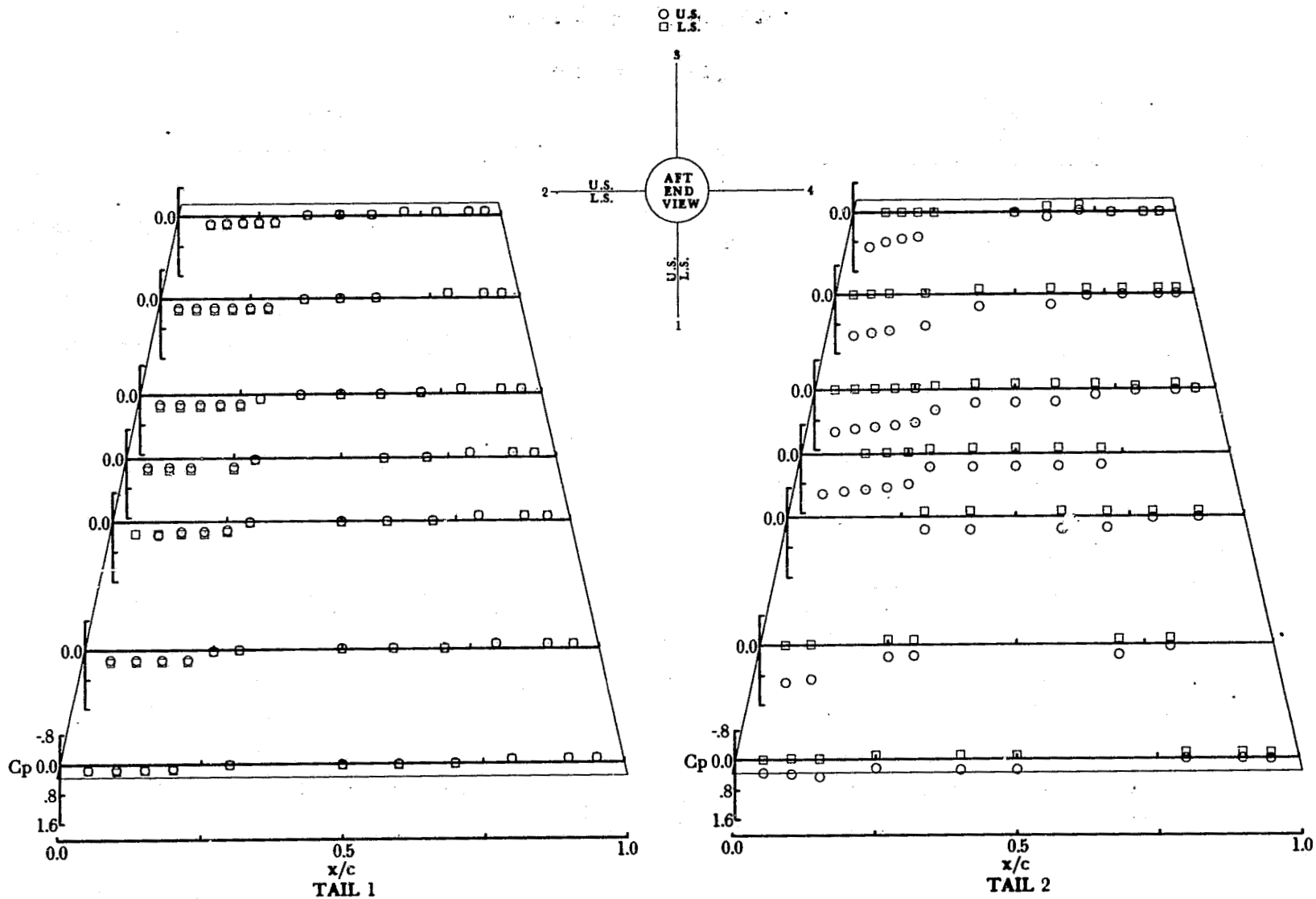
(b) $\alpha = 10.50^\circ$.

Figure 18.- Continued.



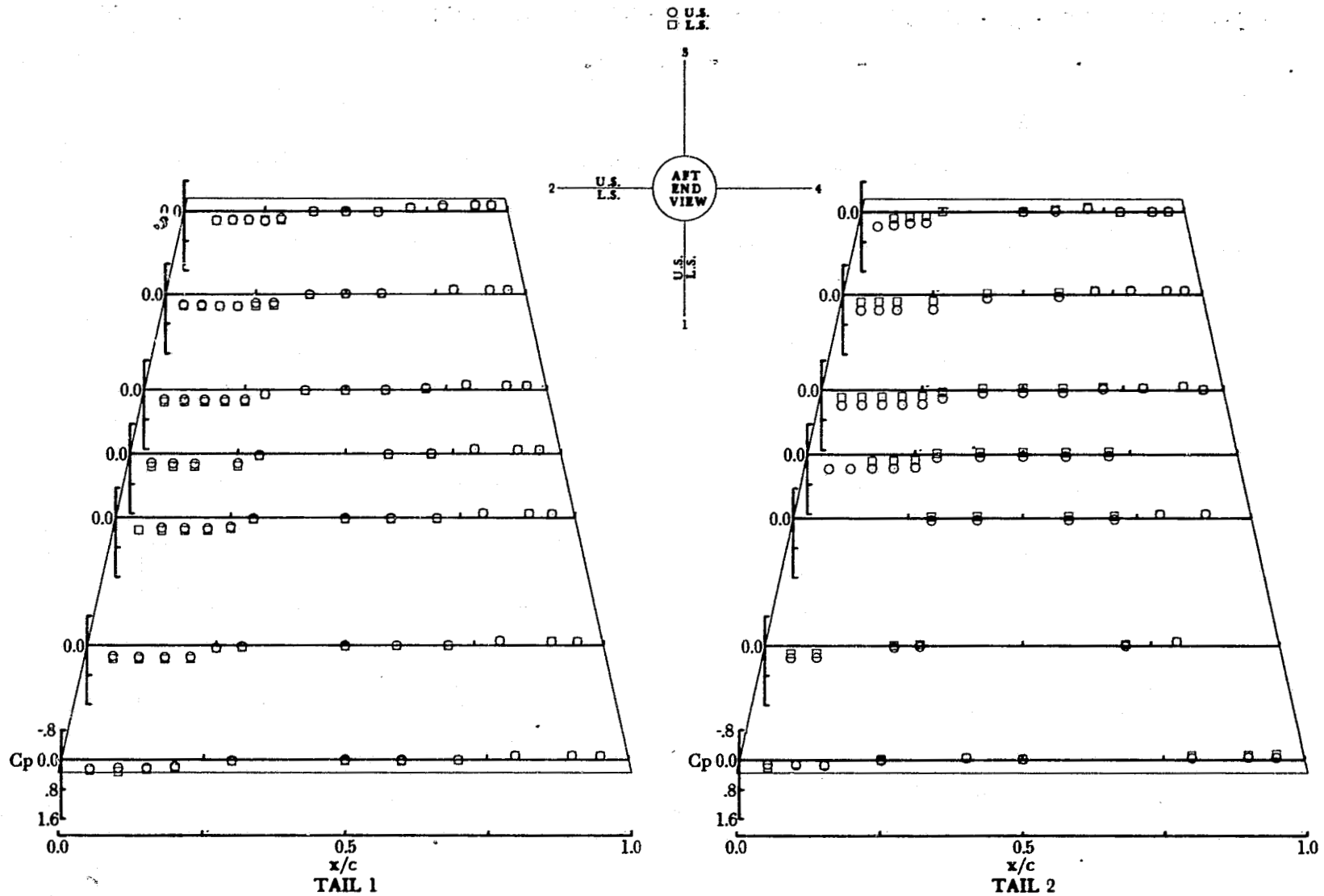
(c) $\alpha = 20.50^\circ$.

Figure 18.- Concluded.



(a) $\alpha = -0.07^\circ$.

Figure 19.- Pressure coefficients for tail planform A at $M = 2.36$, $\phi = 0^\circ$, and $\delta_{2,4} = -15^\circ$.



(b) $\alpha = 9.91^\circ$.

Figure 19.- Continued.

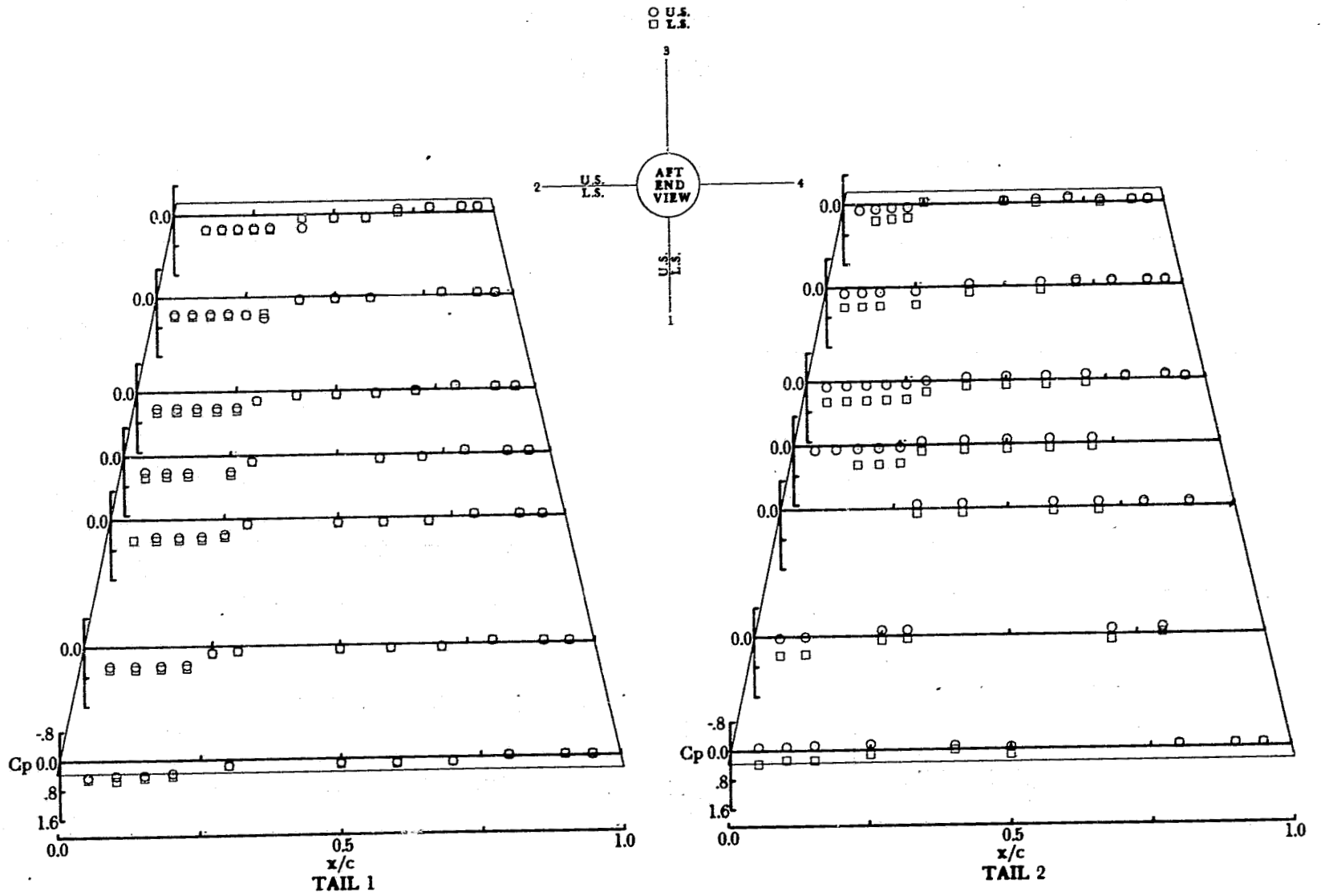
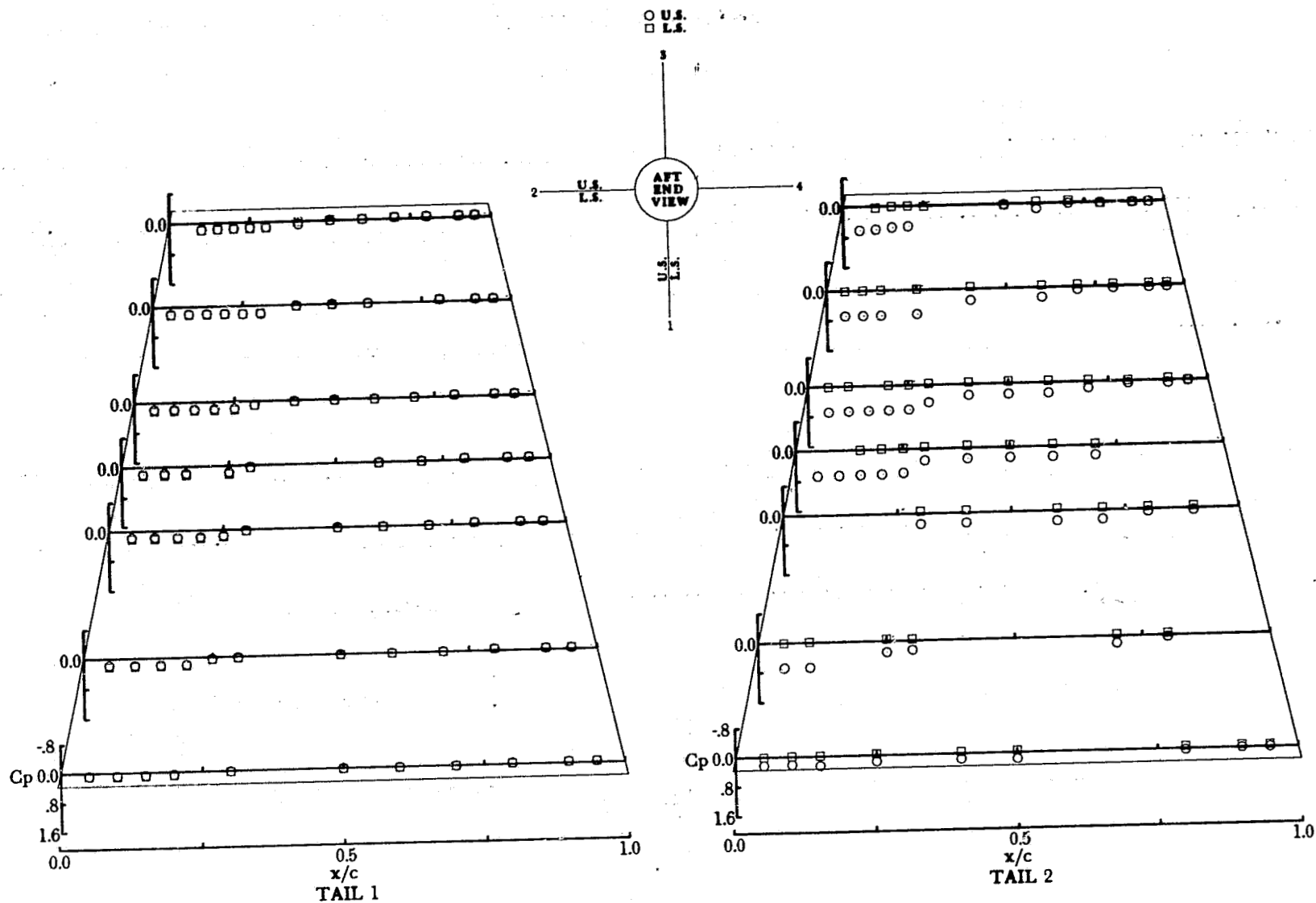
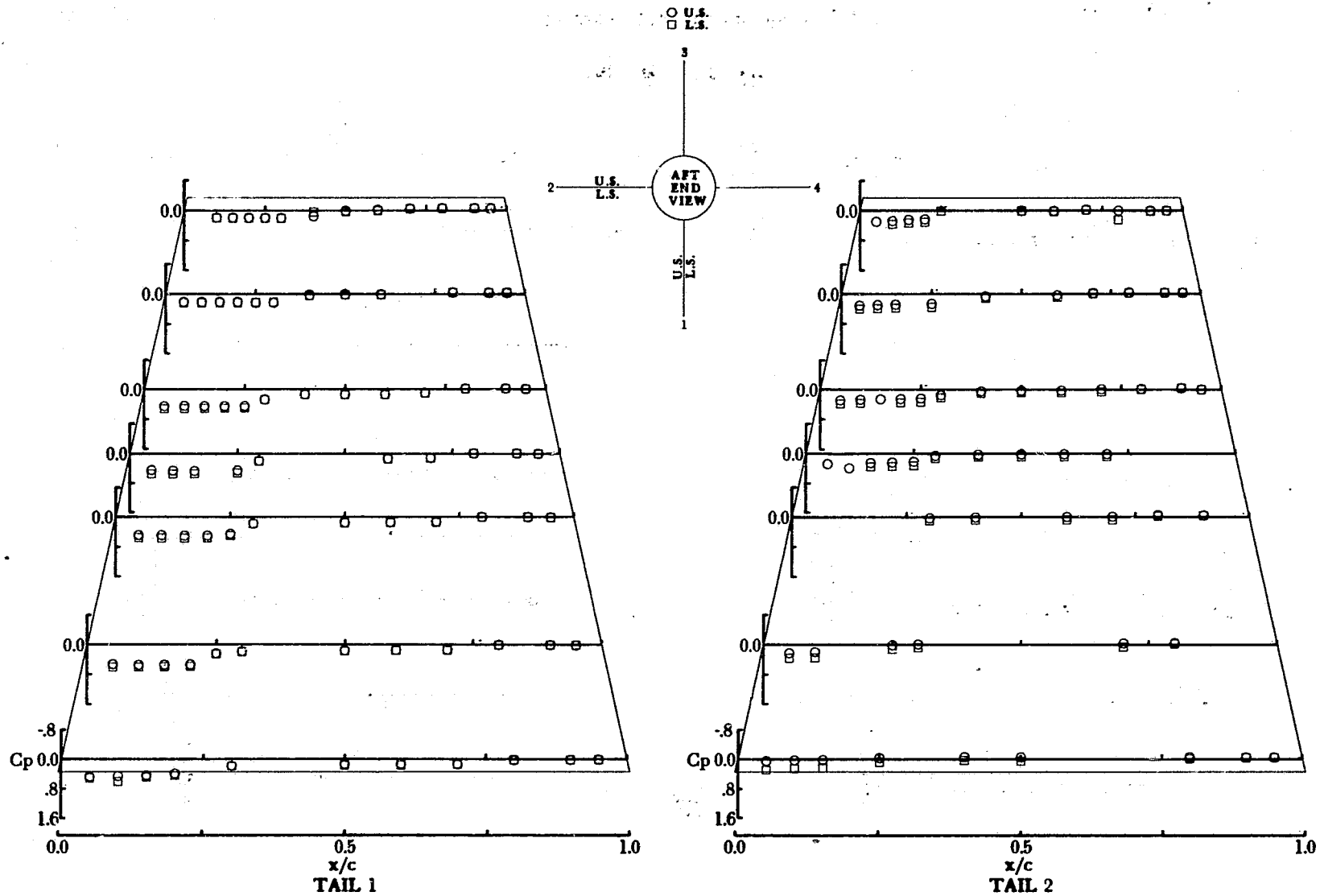
(c) $\alpha = 19.91^\circ$.

Figure 19.- Concluded.



(a) $\alpha = 0.12^\circ$.

Figure 20.- Pressure coefficients for tail planform A at $M = 3.70$, $\phi = 0^\circ$, and $\delta_{2,4} = -15^\circ$.



(c) $\alpha = 20.08^\circ$.

Figure 20.- Concluded.

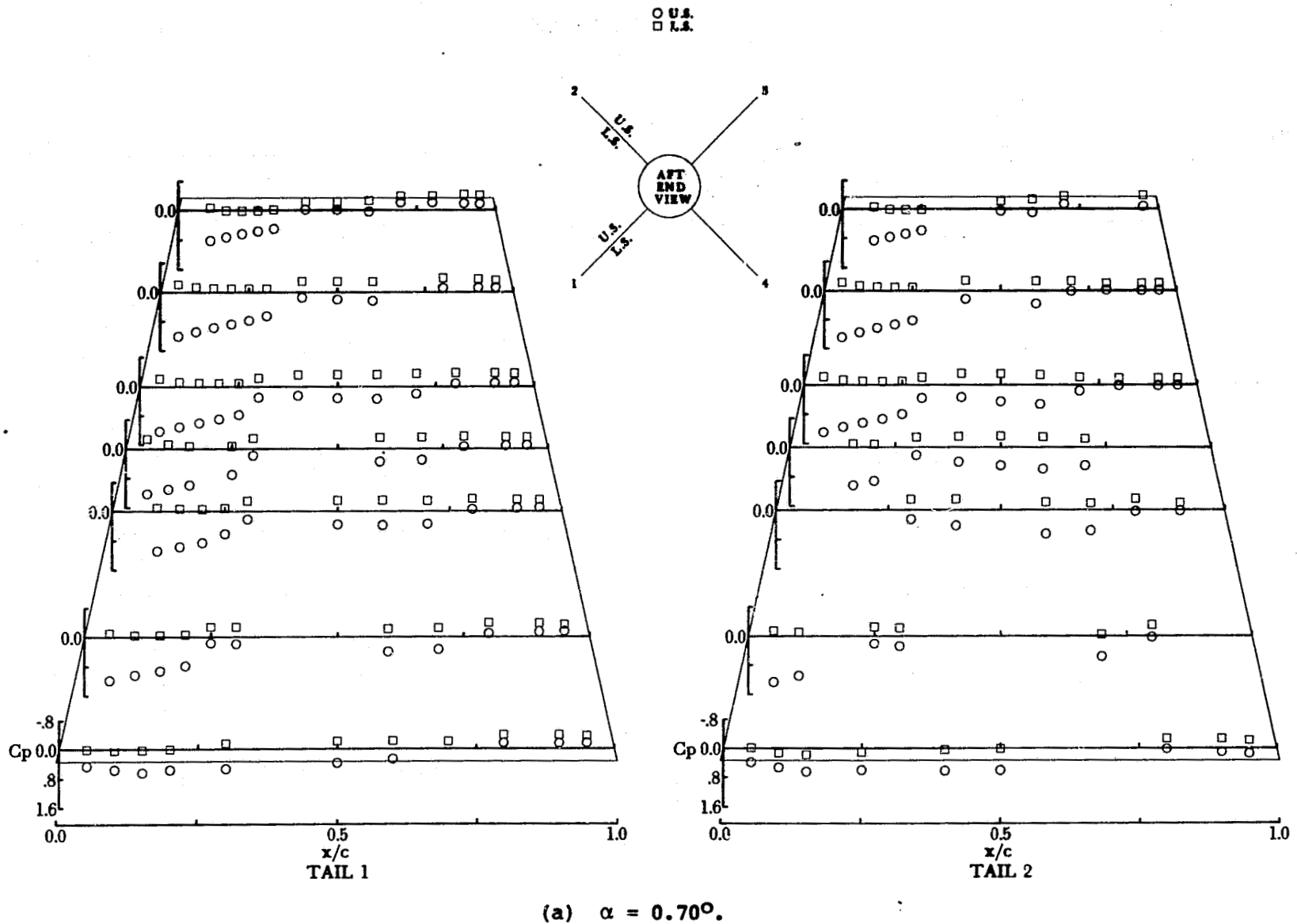
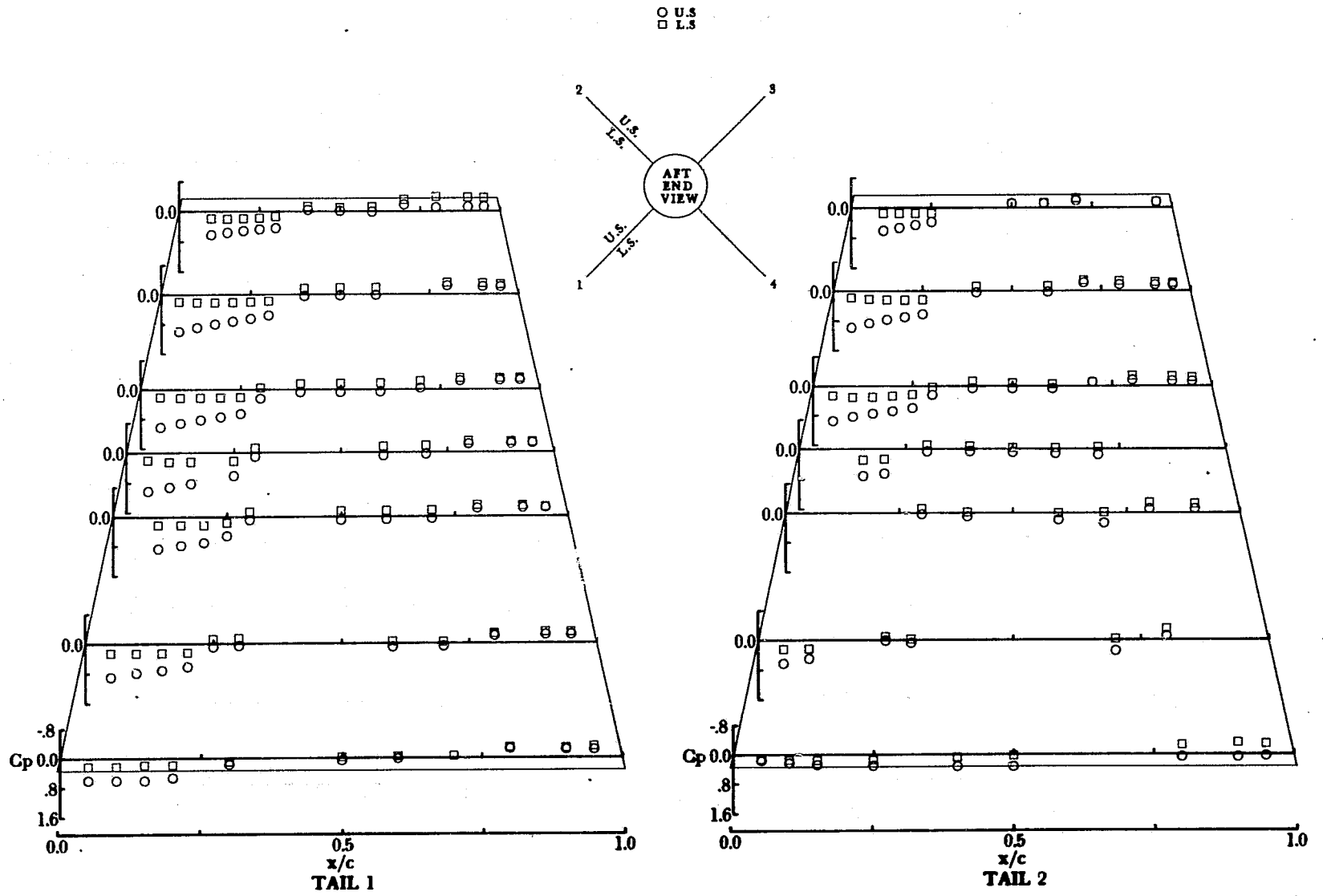


Figure 21.- Pressure coefficients for tail planform A at $M = 1.60$, $\phi = 45^\circ$, and $\delta = -15^\circ$.



(b) $\alpha = 10.70^\circ$.

Figure 21.- Continued.

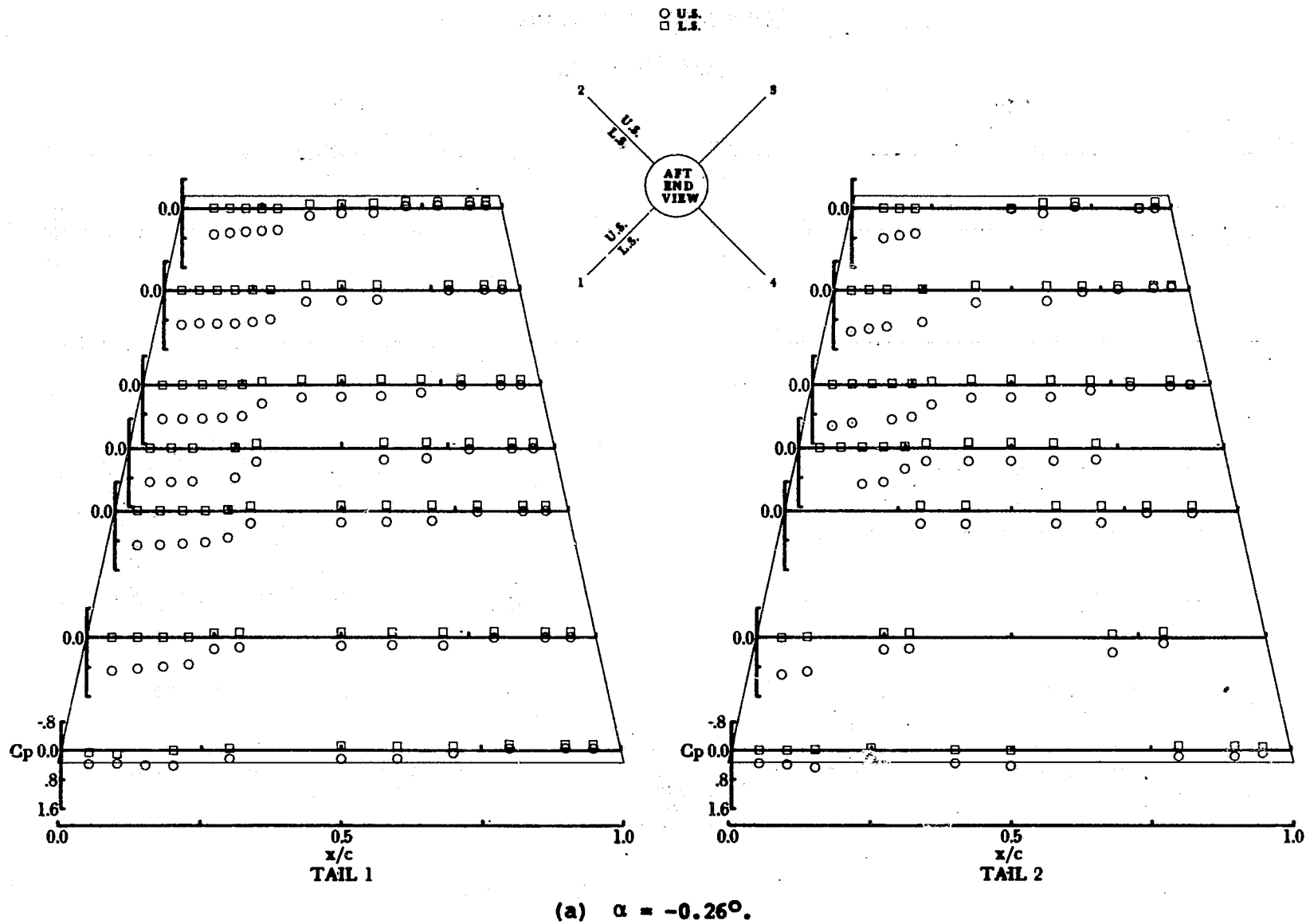
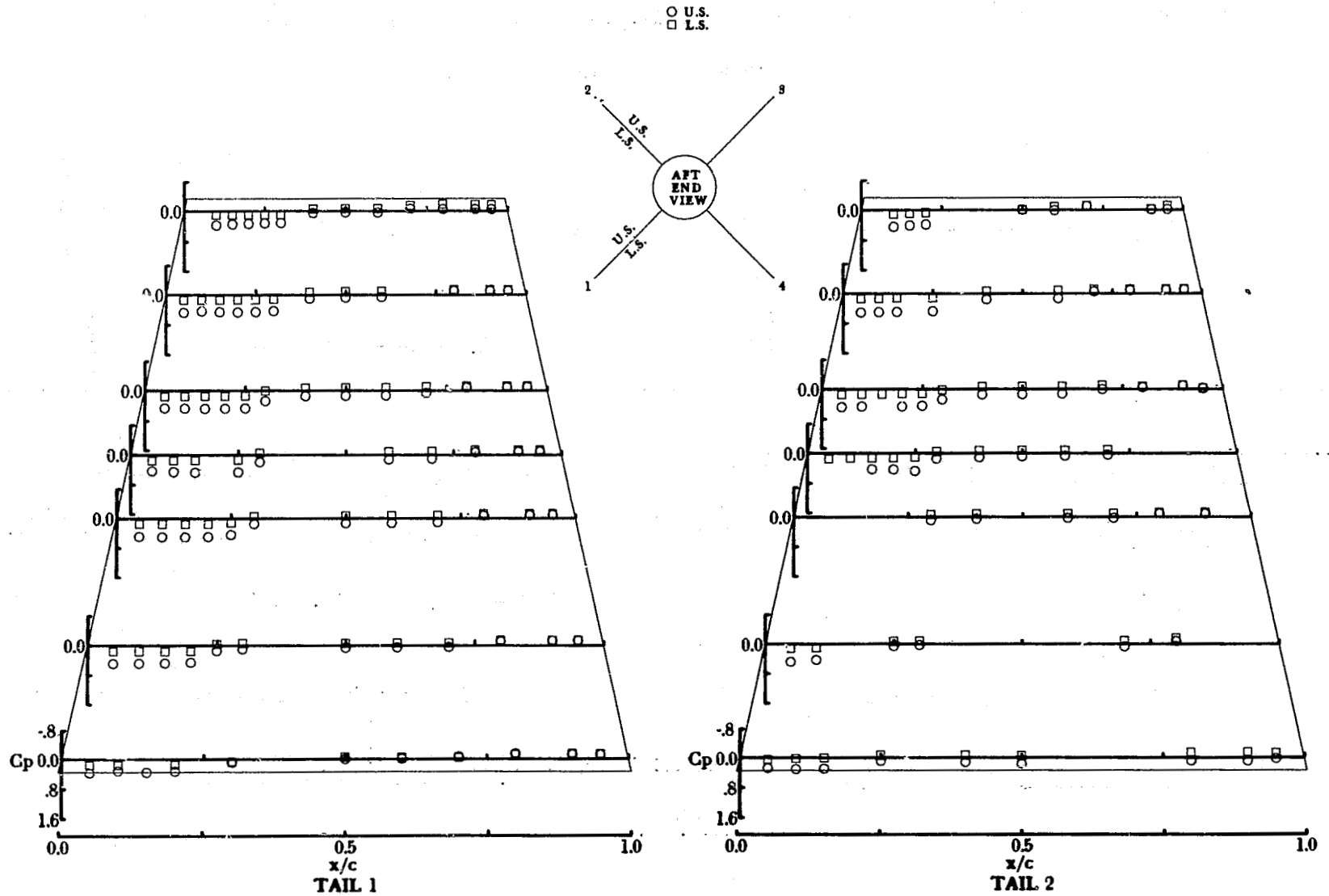
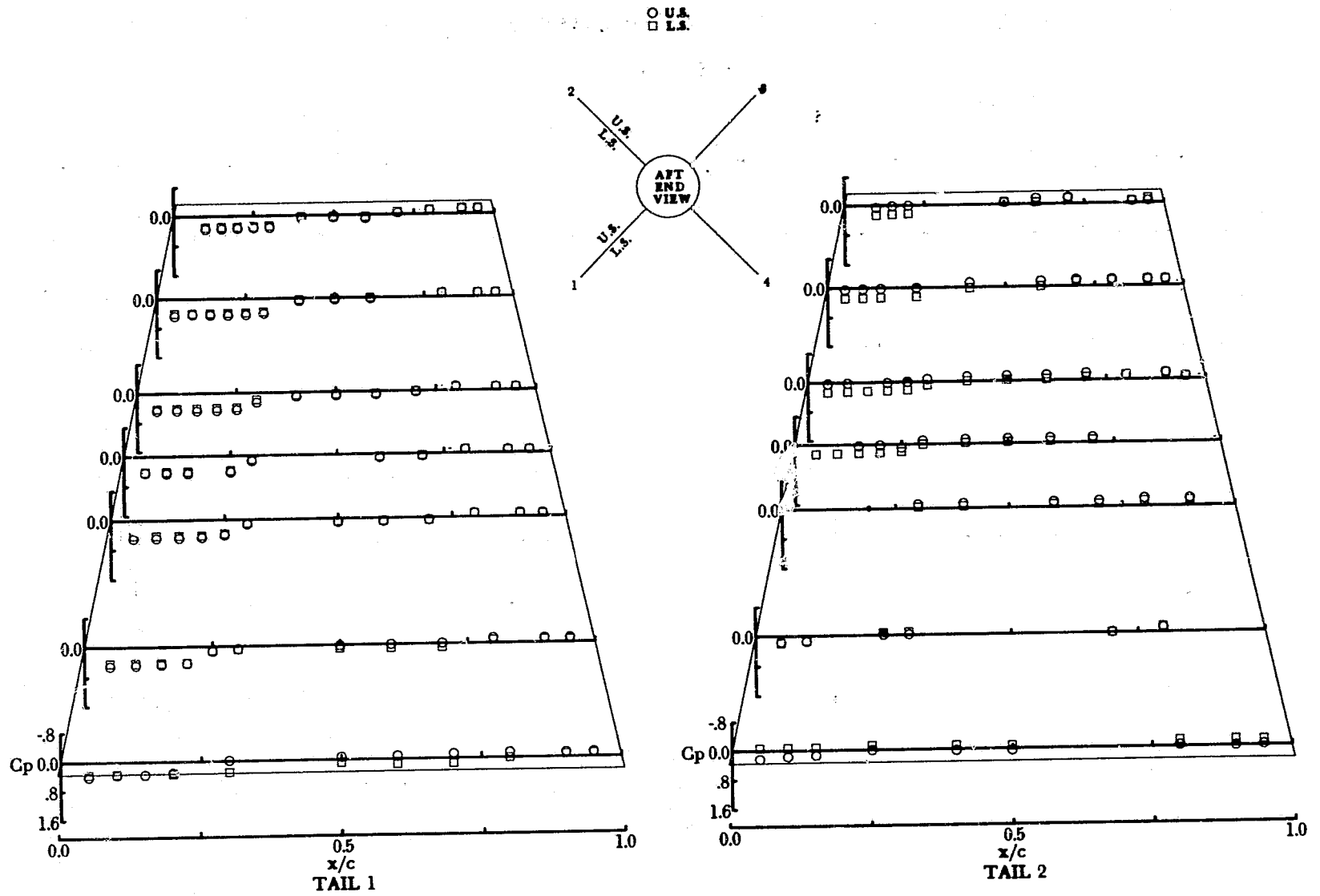


Figure 22.- Pressure coefficients for tail planform A at $M = 2.36$, $\phi = 45^\circ$, and $\delta = -15^\circ$.



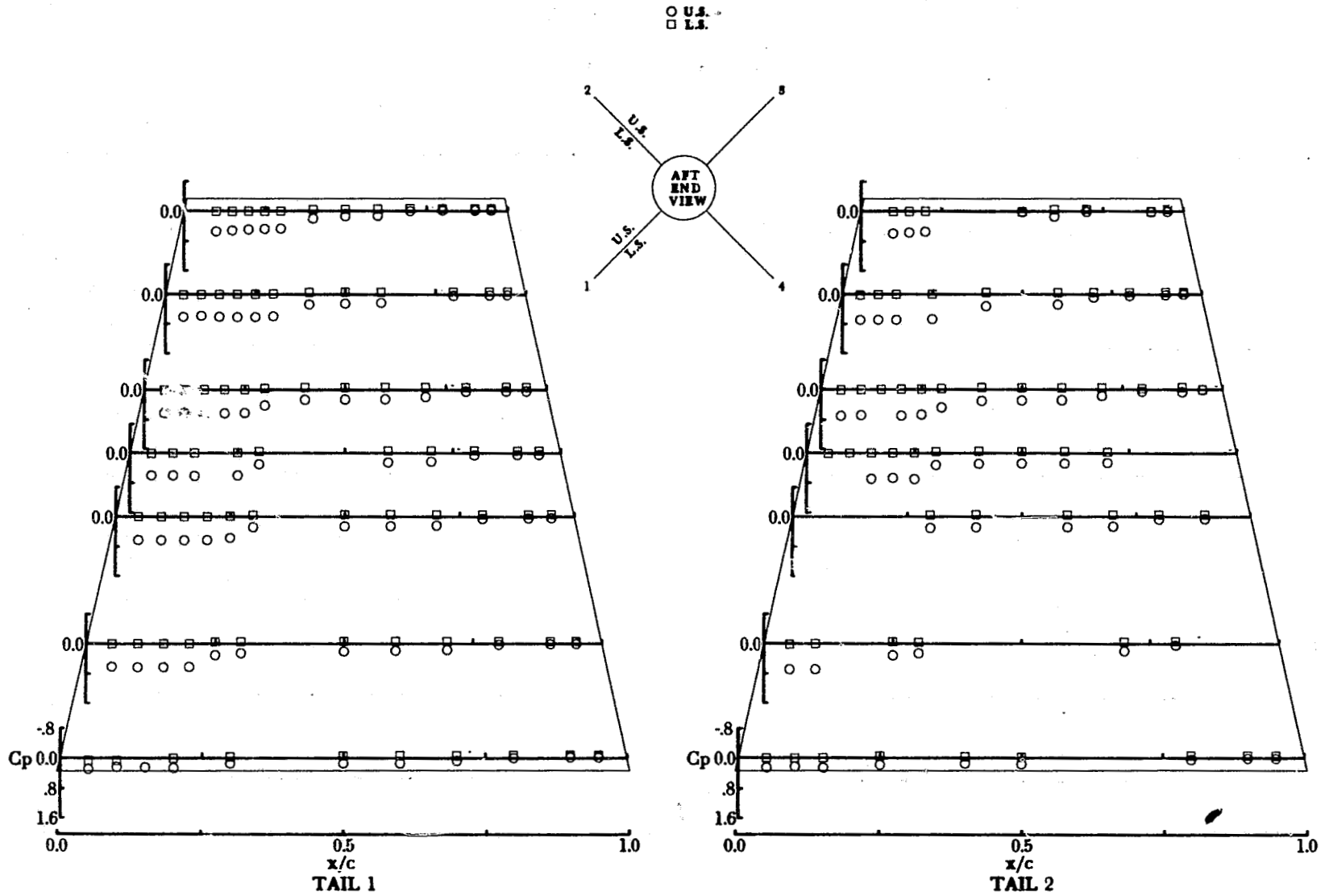
(b) $\alpha = 9.70^\circ$.

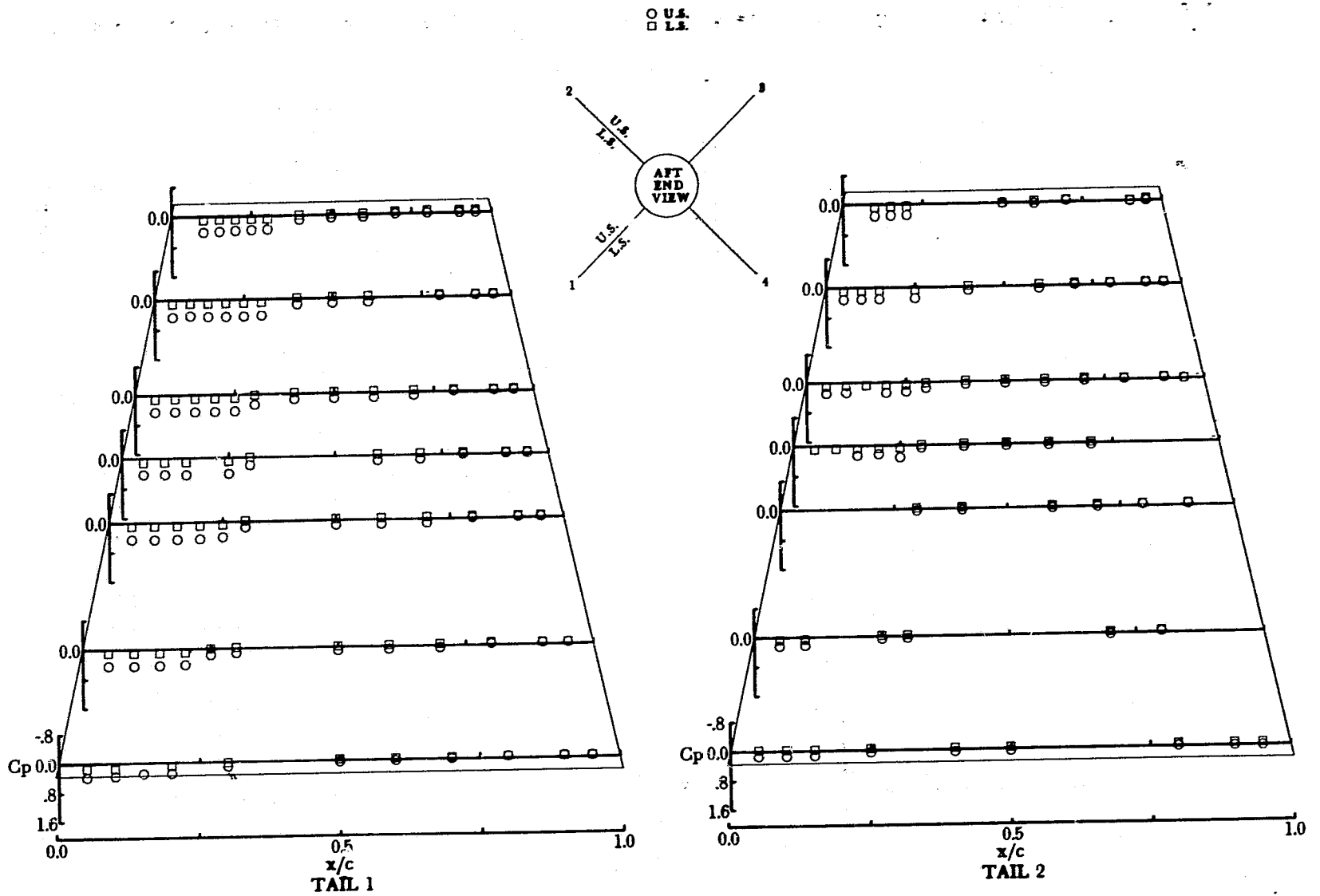
Figure 22.- Continued.



(c) $\alpha = 19.71^\circ$.

Figure 22.- Concluded.

(a) $\alpha = 0.15^\circ$.Figure 23.- Pressure coefficients for tail planform A at, $M = 3.70$, $\phi = 45^\circ$, and $\delta = -15^\circ$.



(b) $\alpha = 10.12^\circ$.

Figure 23.- Continued.

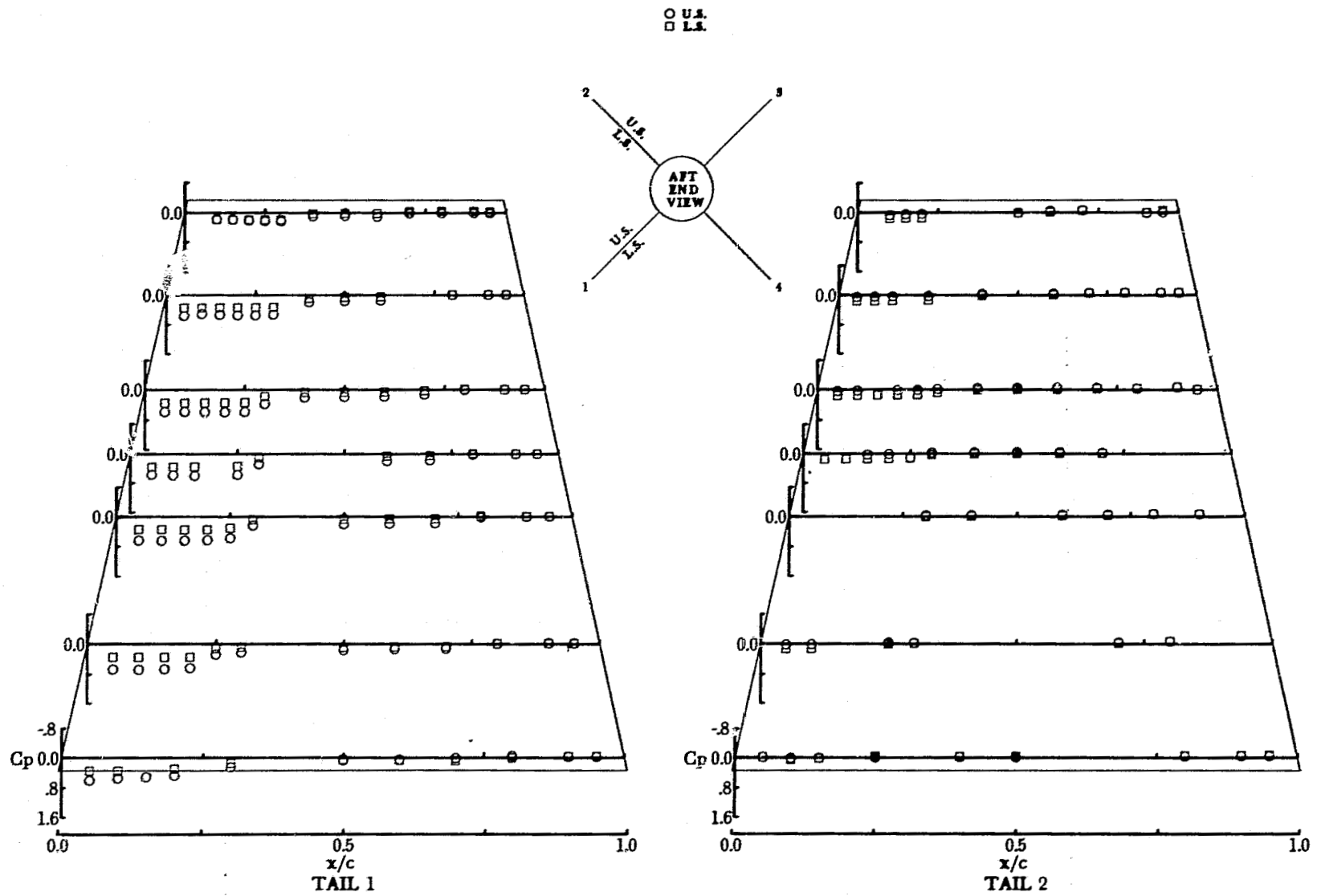
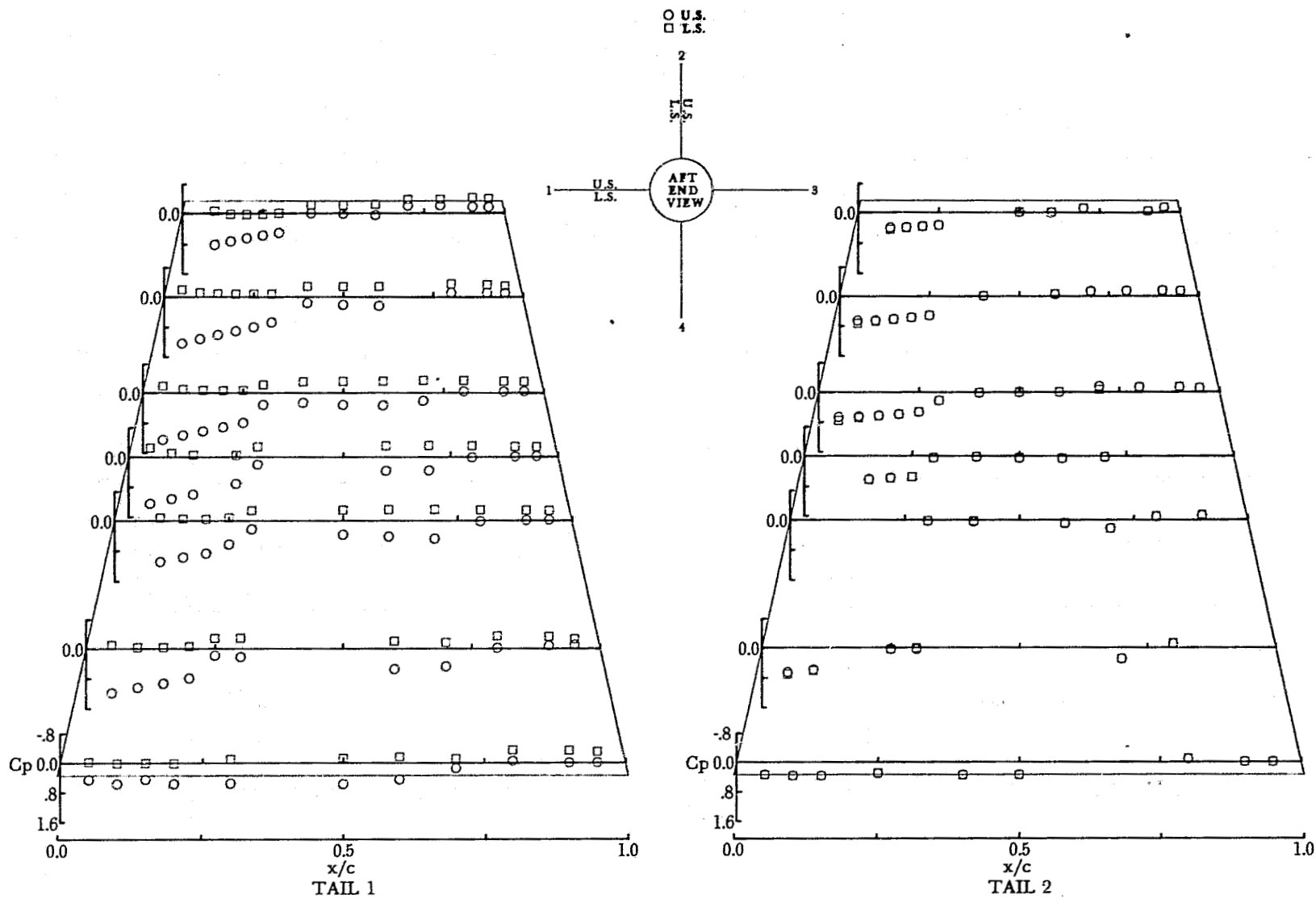


Figure 23.- Concluded.



(a) $\alpha = 0.55^\circ$.

Figure 24.- Pressure coefficients for tail planform A at $M = 1.60$, $\phi = 90^\circ$, and $\delta_{1,3} = -15^\circ$.

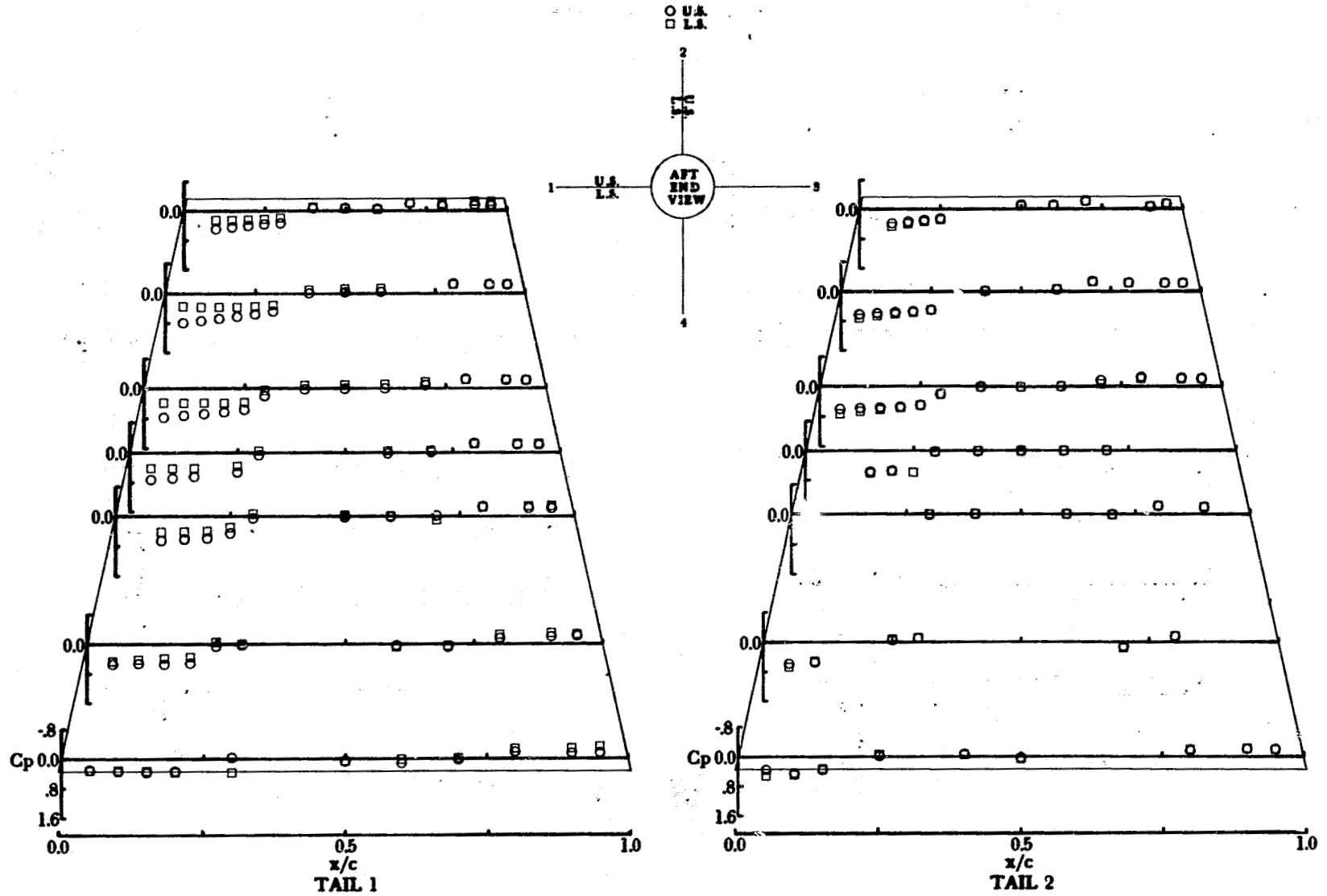
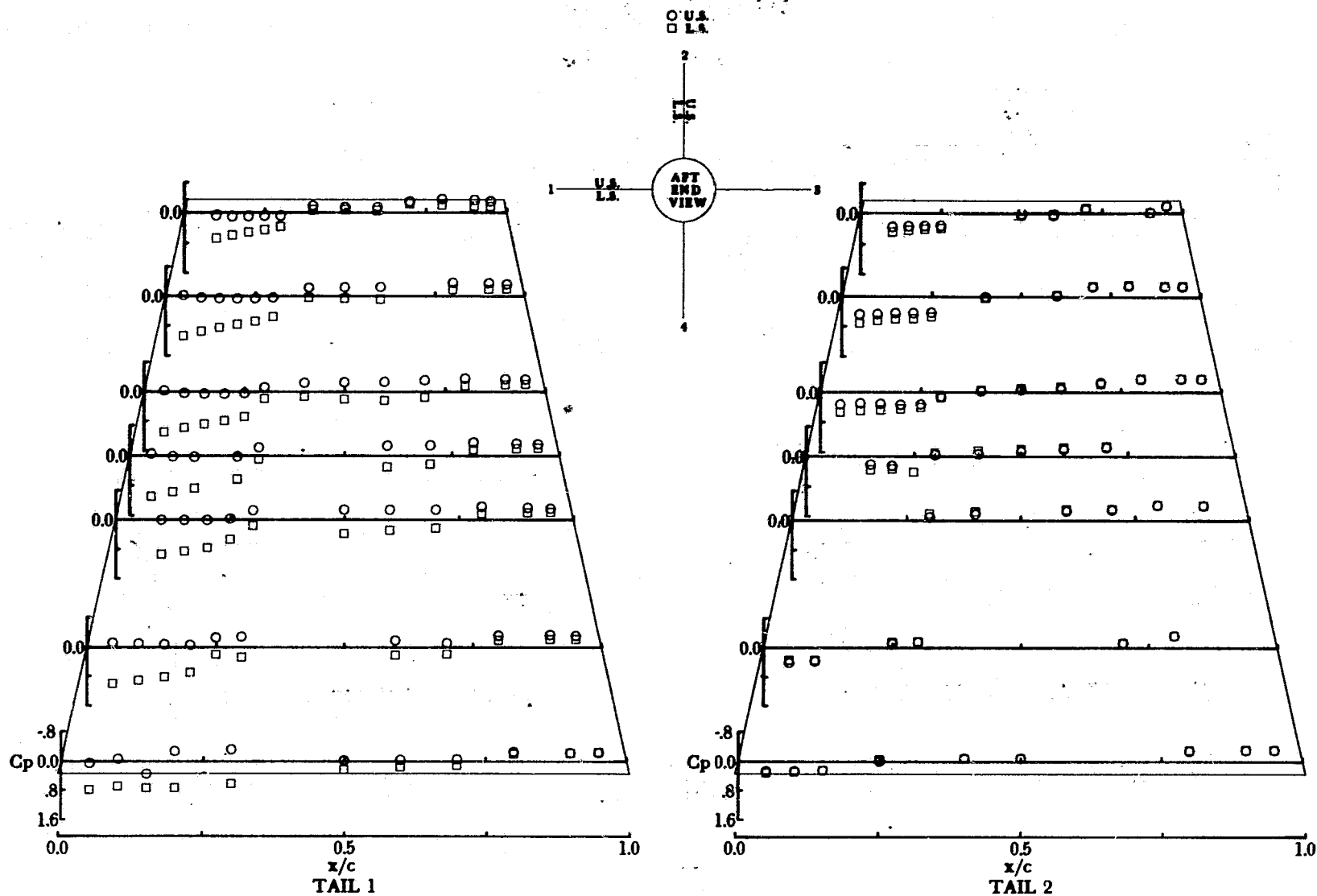
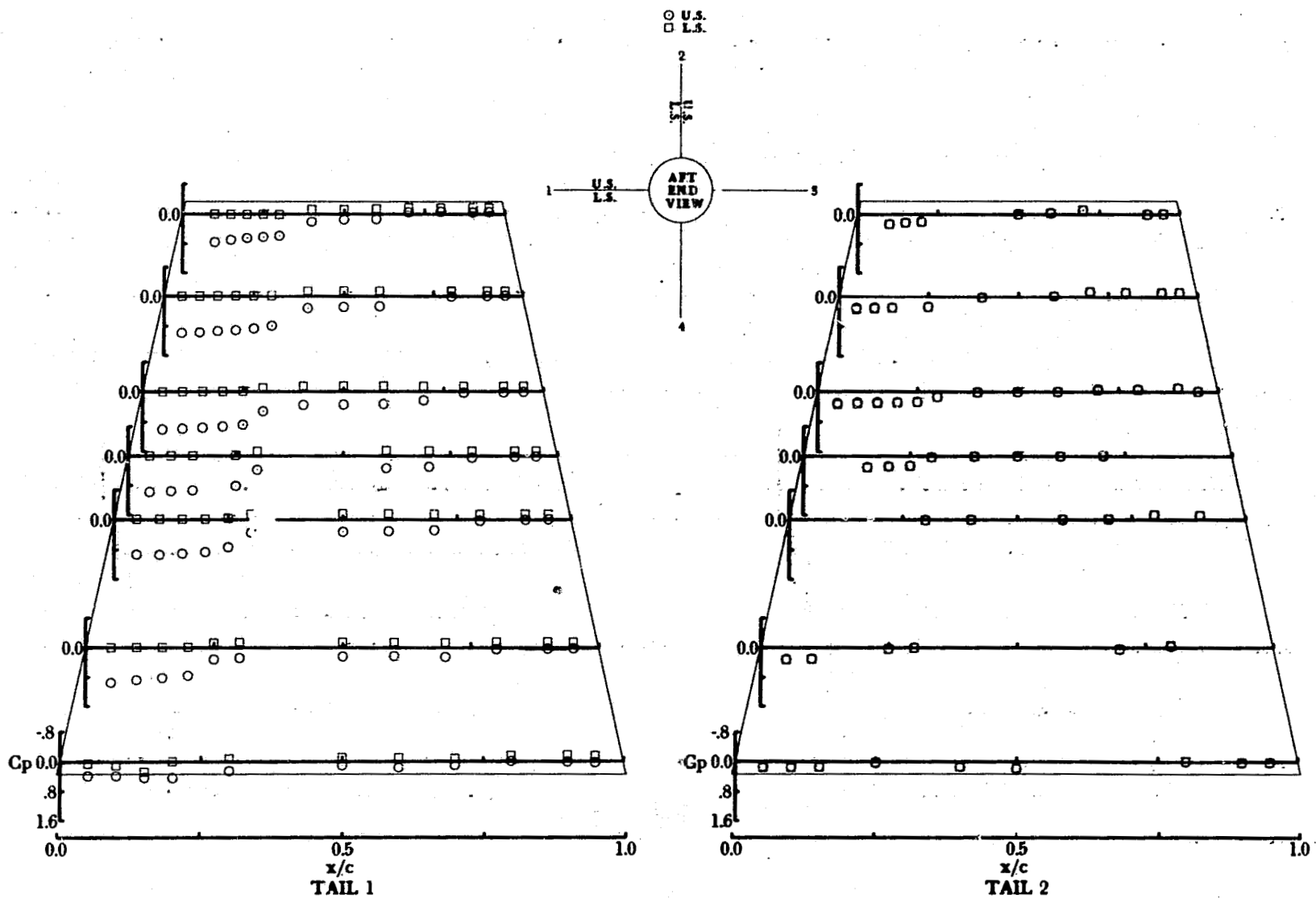
(b) $\alpha = 10.55^\circ$.

Figure 24.- Continued.



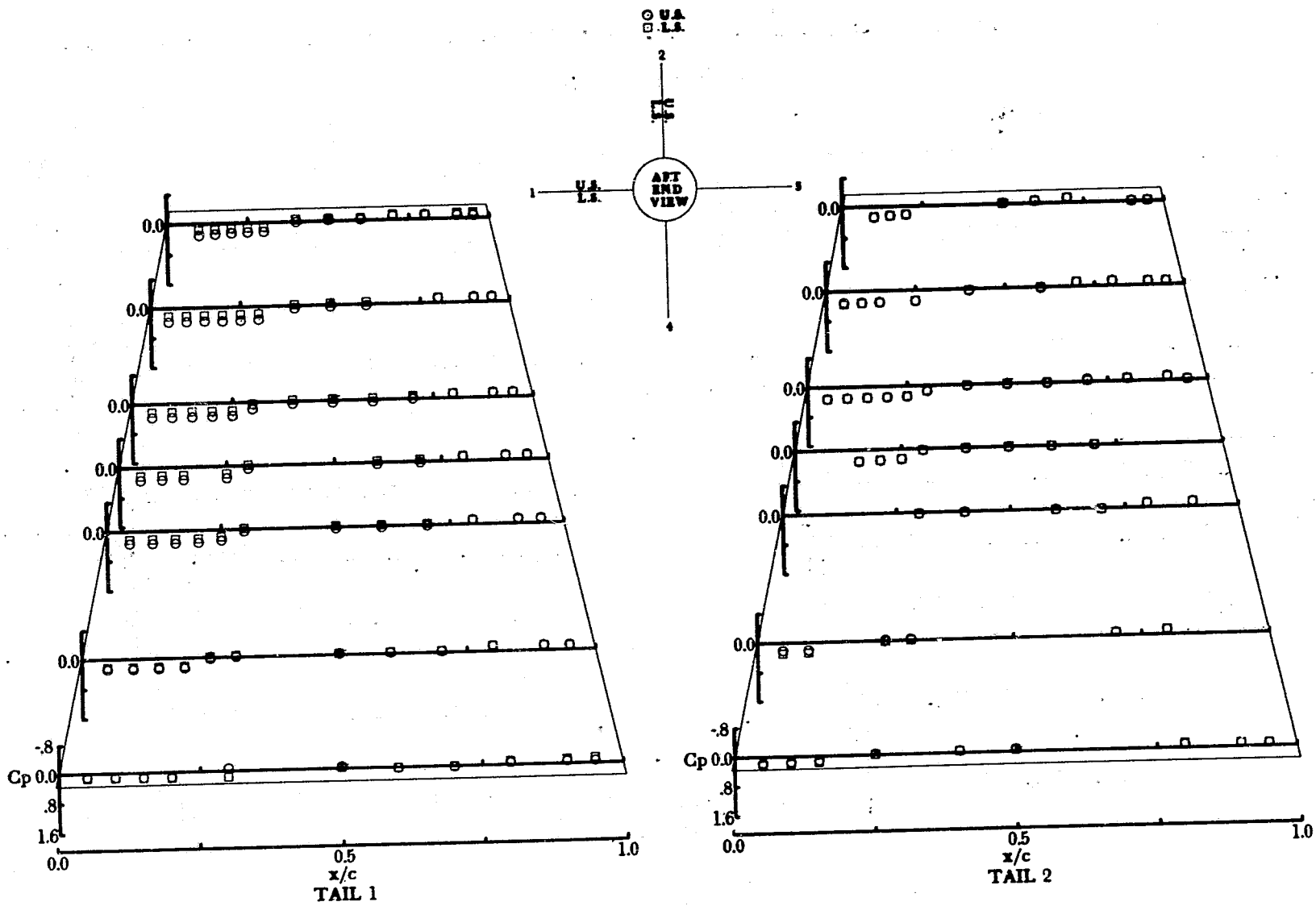
(c) $\alpha = 20.55^\circ$.

Figure 24.- Concluded.



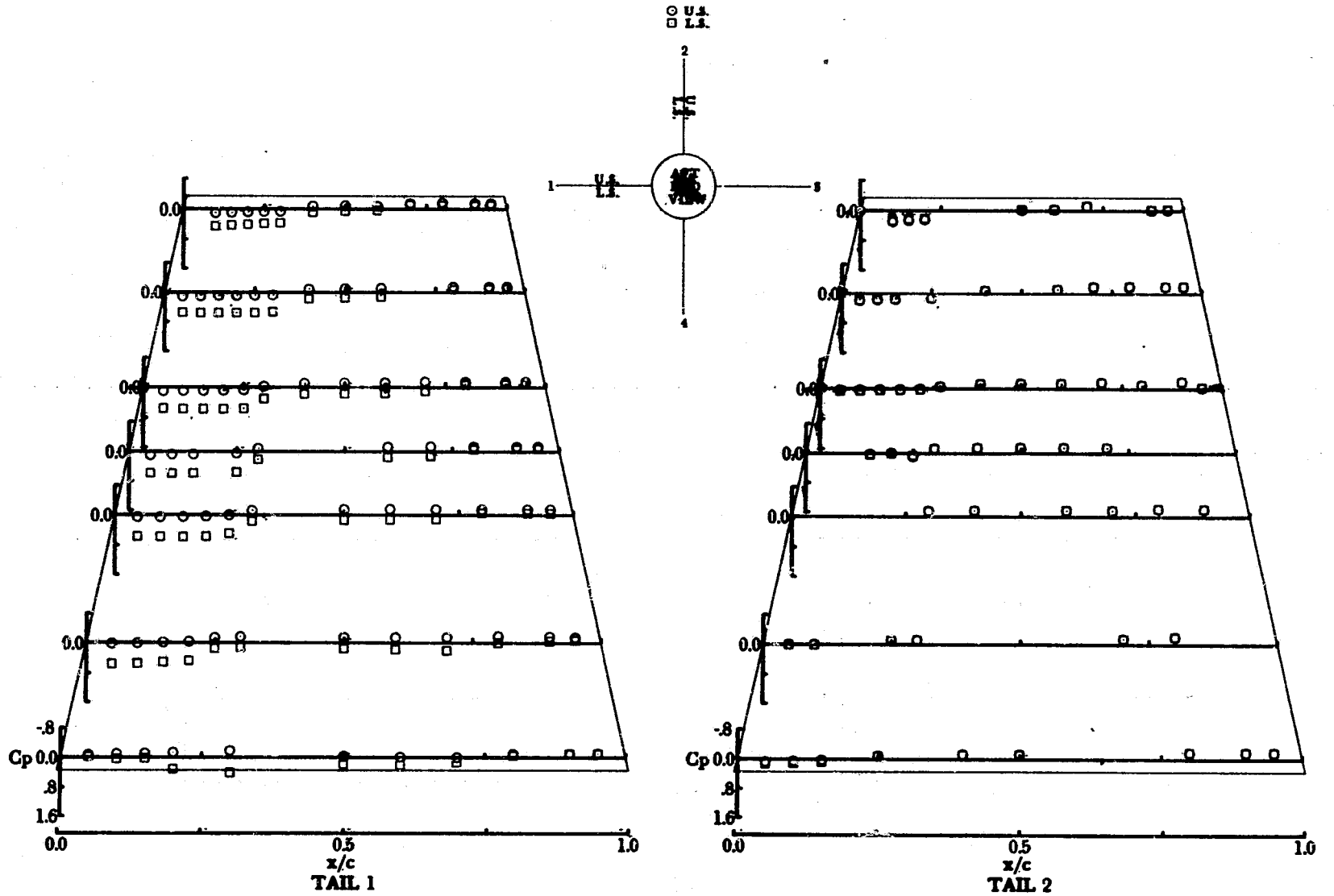
(a) $\alpha = -0.12^\circ$.

Figure 25.- Pressure coefficients for tail planform A at $M = 2.36$, $\phi = 90^\circ$, and $\delta_{1,3} = -15^\circ$.



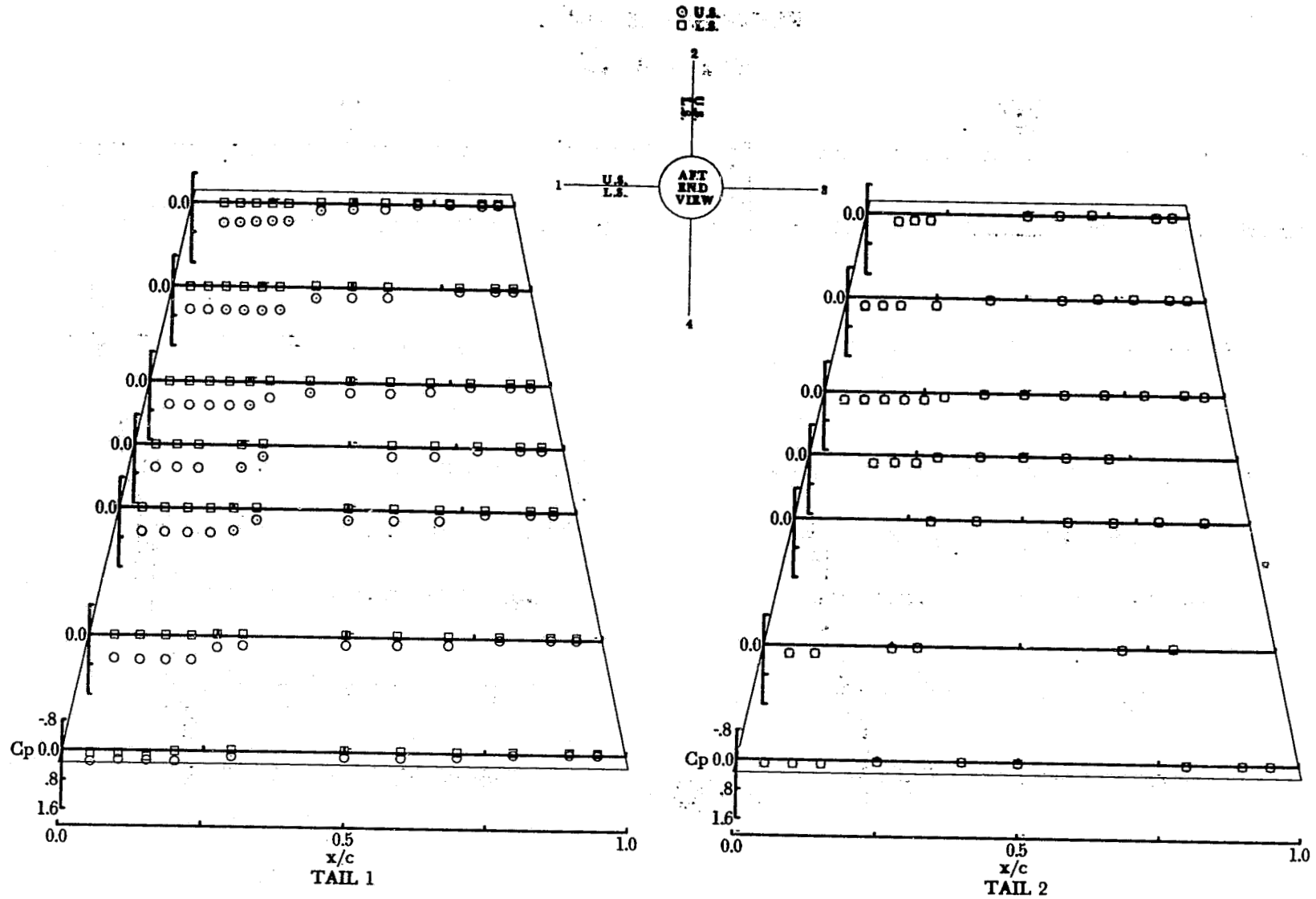
(b) $\alpha = 9.86^\circ$.

Figure 25.- Continued.



(c) $\alpha = 19.86^\circ$.

Figure 25.- Concluded.



(a) $\alpha = 0.03^\circ$.

Figure 26.- Pressure coefficients for tail planform A at $M = 3.70$, $\phi = 90^\circ$, and $\delta_{1,3} = -15^\circ$.

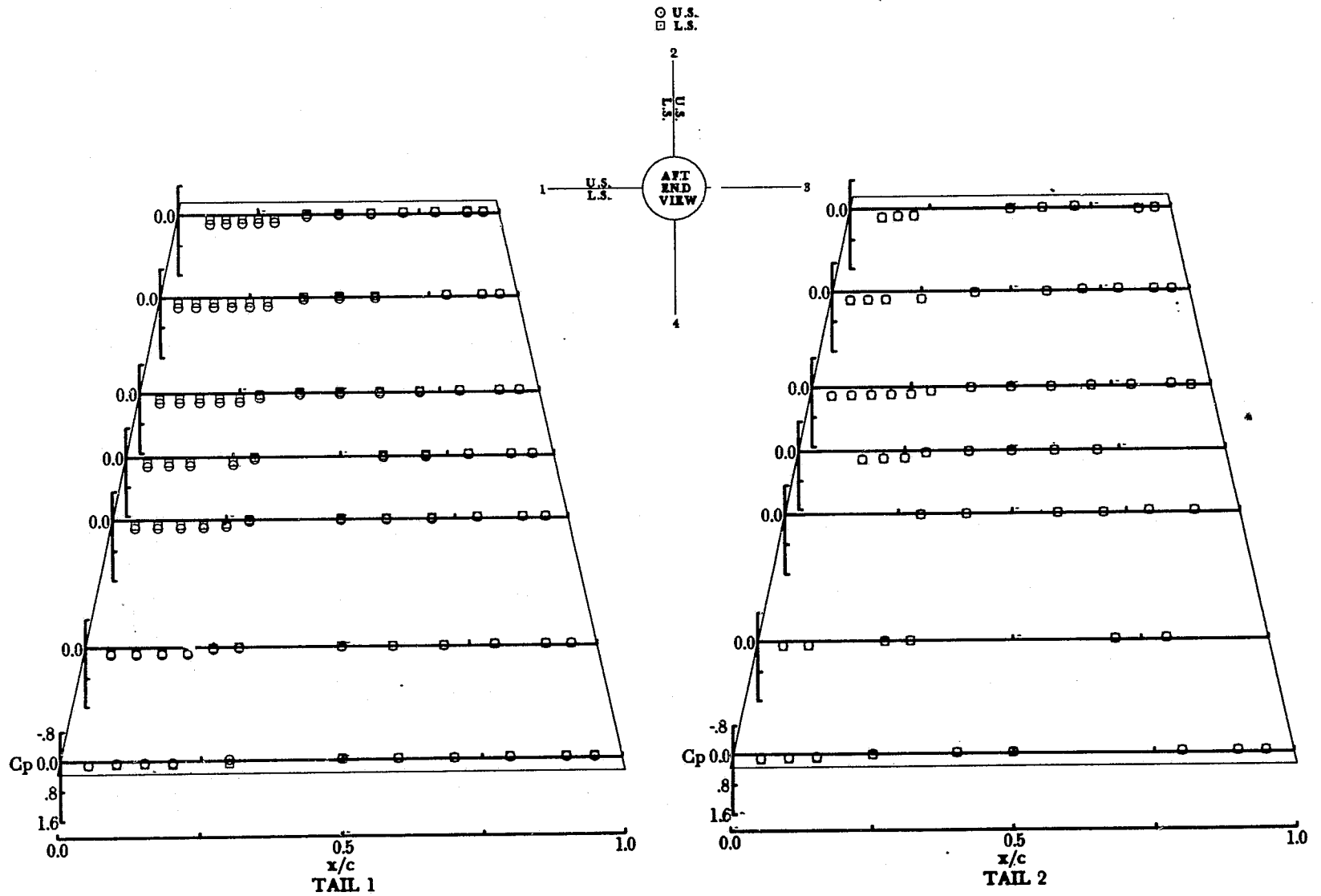
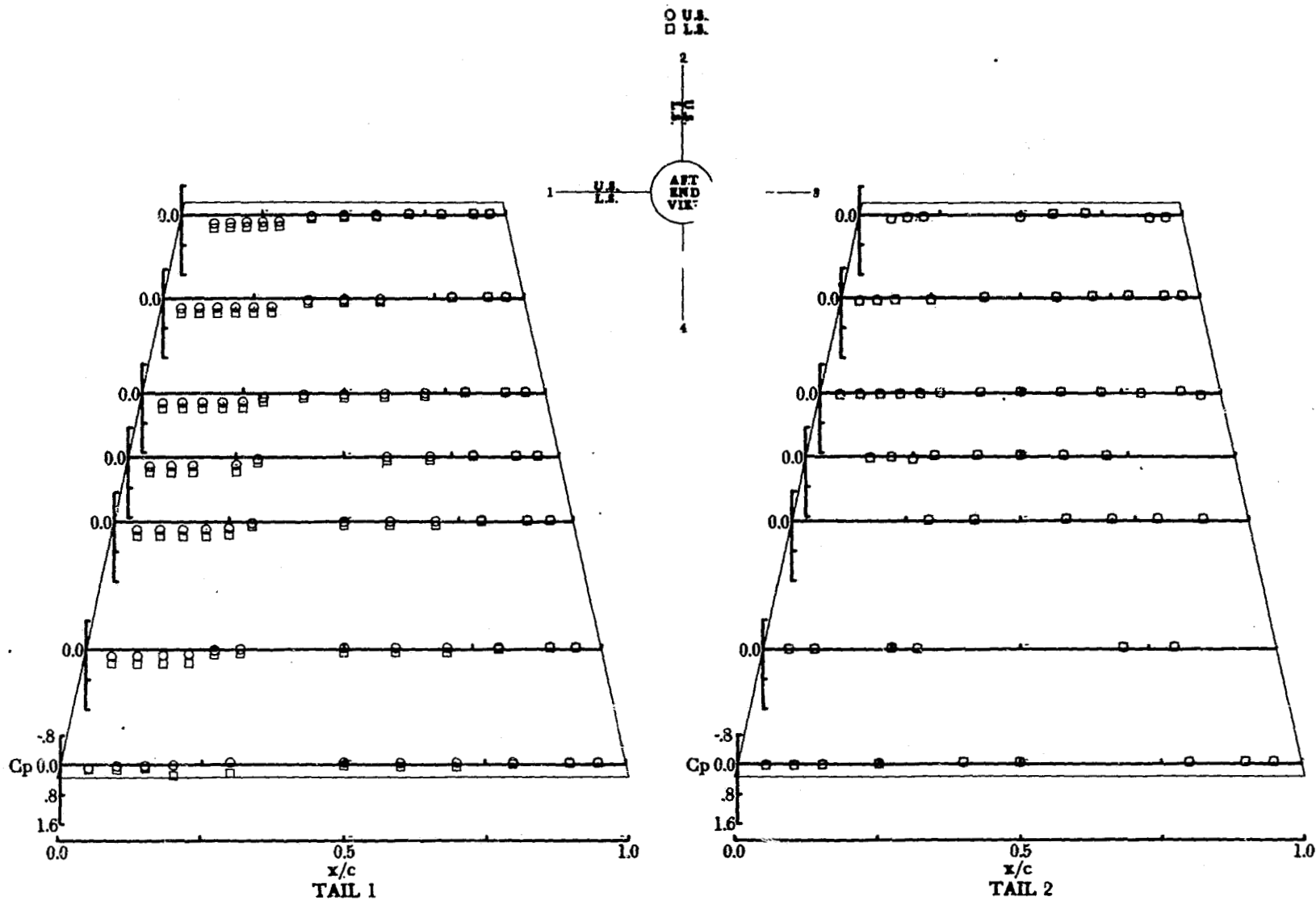
(b) $\alpha = 10.01^\circ$.

Figure 26.- Continued.



(c) $\alpha = 20.01^\circ$.

Figure 26.- Concluded.