

D17

OBSERVING FACILITIES AT THE EUROPEAN SOUTHERN OBSERVATORY (ESO)
IN CHILE FOR COMETARY OBSERVATIONS

Gerhard F. O. Schnur, ESO, La Silla, Chile
Lubos Kohoutek, Hamburger Sternwarte, F.R.G.
Jurgen Rahe, Remeis Sternwarte, Bamberg, F.R.G.

1. Introduction

The European Southern Observatory (ESO) has been operating an observatory in Chile since 1969. This observatory is located on the mountain La Silla (geographical coordinates: $4^h 42^m 55^s 10$ west, $-29^{\circ} 15' 25''.8$ south, 2400 m elevation), about 650 km north of the Chilean capital Santiago. The observatory gives European astronomers easy access to modern observing facilities in the southern hemisphere. A committee of six astronomers reviews every six months applications for observing time and allocates telescope time.

During the past 12 years, more than 10 telescopes have come into operation: they are either fully controlled by ESO or partially operated by individual member countries. The size of the telescopes ranges from a 40 cm Astrograph to the 3.6 m Ritchey-Chretien telescope. Further large telescopes are envisaged: a 2.2 m RC-telescope, which will be identical with the German 2.2 m telescope on Calor Alto in SE-Spain, and a new 3.5 m telescope, the New Technology Telescope (NTT). This latter telescope will incorporate new techniques, that might in the future lead to a telescope of at least 16 meter diameter.

In addition to these telescopes, a great number of auxiliary instrumentation has become operational. Because ESO has to serve all requests of the visiting astronomers these instruments are designed for very different applications. The telescopes and auxiliary instruments that are especially suited for cometary observations will be discussed in the following paragraphs. The discussion will be divided into three parts: photography, photometry-polarimetry and spectroscopy.

2. Photographic Observation of Comets

In Table 1 we have listed the telescopes and their characteristics that can be used for photographic observations. There are only two telescopes available for wide field work ($> 10^{\circ} \times 10^{\circ}$). The limiting magnitude of 16^m in 2 hours of the GPO renders this telescope of little use for distant and faint comets. For any close and bright comet, this telescope will however be a very useful instrument. Due to its frequent availability it is the only telescope on La Silla which can easily be used for unscheduled observations.

The Schmidt telescope, with its heavy burden of the Red Sky Survey, is available only during very few hours for other observations. However, quite a number of comets could be detected or recovered with it. All plates are inspected by H. E. Schuster, immediately after developing, to detect any obvious comet, minor planet, etc. This search is later repeated by R. West at ESO-Garching, and is essentially complete down to 15th magnitude. The many individual discoveries will not be discussed here, and only a few cometary observations shall be mentioned. In 1976 H. E. Schuster detected a comet with the largest perihelion distance of nearly 7 AU. The faintest comet ever observed with this telescope was of 20th magnitude.

Several trials by the author and R. West to detect even fainter known comets with the $16'$ field of the 3.6 m telescope failed during two nights of January 1979. Down to a limiting magnitude of 23^m we could neither detect Comet Halley nor Comet Schuster 1975 II, which had a magnitude of $19^m.5$ one year earlier. Observing time at this telescope is very scarce; it is normally oversubscribed by a factor of 3 to 4.

To observe very distant or faint comets one has the choice of the 3.6 m, 2.2 m, and 1.5 m telescopes. The first with its f-ratio of 3 is ideally suited for very faint objects. The other two telescopes having slightly larger focal lengths, are less suited for faint objects. For

Table 1 : Telescopes for photographic observations

Telescope	Aperture	f-ratio	f- [m]	scale	field- diam[']	calibr. on tel.	offset	variable tracking	Remarks
Schmidt	1 m	3	3	67.5	300	yes	yes	yes	obj. prism
G P O	.4 m	10.4	4.2	51.5	120	no	yes	no	
3.6 m Gas.	3.6 m	3	10.9	18.9	16	yes	yes	yes	Rac. wedge McMullan cam.
3.6 m Trip.	3.6 m	3	11.2	18.3	60	yes	yes	yes	
2.2 m	2.2 m	8	17.6	11.4	60	yes ?	yes	yes	
Dan 1.5 m	1.5 m	8.5	12.8	15.7	60		yes	yes	McMullan cam.

brighter ($<18^m$) comets they are however well suited, especially because their larger f ratio allows the use of interference filters without too many problems of the convergence of the telescopic beam. But interference filters of the necessary size (24 - 30 cm square) are not easily available. Presently there are no special cometary filters on La Silla, but it is hoped that such filters can soon be ordered.

For the Danish 1.5 m and the ESO 3.6 m telescopes, electronographic detectors will be available: i.e., 40 mm and 880 mm McMullan cameras. For a number of cometary studies these cameras will be very important tools due to their linearity and high dynamical range. As can be seen from Table 1, most of the telescopes provide possibilities for calibration during the actual observing. Otherwise appropriate calibration methods are available.

A last comment about photographic observations: the necessary measuring machines for scanning the plates and digitizing the data are available at the ESO-Garching headquarters, as well as a considerable package of software for image handling and processing. The transfer of data will then be via the FITS-format (Wells, et al. 1979), which we recommend to be used for all one or two dimensional data transfers.

3. Photometric - Polarimetric Observations of Comets

Table 2 gives the essential data for the telescopes that are available on La Silla for photometry or polarimetry. In view of future comet Halley-observations, the 2.2 m telescope, which will soon be installed, has already been listed.

In all present ESO telescopes the standard filter size is 24 mm round or square. Filters can be up to 10 mm thick. All photometers are equipped with either dry-ice or peltier cooling boxes, depending on the type of photomultiplier. All normal photomultipliers are available: standard blue sensitive, Ga AS or Si-type ones. All ESO photometers are computer controlled and allow online reduction for the standard colour systems like the Johnson UBV and Stromgren uvby. Similar data acquisition and photometer control is presently being installed at the 0.9 m telescope. We will probably have the same standard photometer at the 2.2 m telescope, shortly after its inauguration.

The largest size of useable diaphragms is given in table 2 as well. These values might be important for surface photometry.

For polarimetry there are presently fewer possibilities. Only at the 1 m and at the 3.6 m telescopes do we have polarimeters. Both of them are not very suited for polarization measurements of extended sources. Since the interest of the astronomical community in surface polarimetry is rather small, we do not have much hope that a special polarimeter for surface polarimetry will become available for cometary observations.

Only one telescope is going to receive a newly designed polarimeter. This is the Dutch 0.9 m telescope, for which A. Tinbergen is presently building a new multichannel polarimeter. Details are presently not known.

Infrared photometry will probably be extended to the 2.2 m telescope by the time it is completed. Both IR systems at the 3.6 m and the 1 m telescopes are to be operated in a very similar way, whereas they differ essentially in technical details. Both systems provide possibilities for scanning and corresponding mapping of extended objects, such as comets.

Sensitivity values and limiting magnitudes are given in the ESO-Manual, which is annually updated. For UBV-photometry, one can reach 17^m within a reasonable time and a statistical error of no more than 10 percent. Polarimetric accuracy depends only on photon statistics, giving a $\sigma < 0.003$ within 10 sec for a star of 8th magnitude in B. In Table 3, we provide more detailed data for the IR, since they are normally not as well known as for the classical photometric bands.

All photometric telescopes, except the 0.9 m telescope, are computer controlled and allow digital offsets and variable tracking rates. Furthermore star catalogues, etc., can be stored and used for fast setting. Reduction programs for the standard UBV, Stromgren, H β , etc., photometric systems are implemented and can be used with slight modifications for other photometric filter systems.

Table 2 : Telescopes for photometric-polarimetric observations

Telescope	f [m]	scale ["/mm]	Diaphr. size ["]	Photom.	Polarim.	Data reduction	Time resolution	IR	Rot.
3.6 m	28.6	7.2	4-30	stand	yes	yes	m sec	yes	yes
2.2 m	17.6	11.4		(stand)		(yes)	(m sec)	(yes)	yes
1.5 m Dan	12.8	15.7		4 col.		(yes)	m sec	no	yes
1 m	15	13.5	4-88	stand	yes	yes	1 sec	yes*	yes
.9 m	12.6	16.4	?4-60	stand	special	(yes)		no	
<.06 m	~8	~25	10-80	stand		yes		no	

Stand : U,B,V ; u,v,b,y, - Strömgren ; any combination of filters possible. Standard diameter 25 mm \emptyset or \square .

* IR : 1 m tel. : J , H , K , L , M , N , Q , P
1.25 1.65 2.2 3.5 4.8 10.2 20 30 [μ m]

either Bolometer : L , M, N, Q, P

InSb : J, H, K, L, M

3.6 m : still in test, probably similar to 1m !however both detectors will be simultaneous at telescope

Table 3 :

Sensitivity and Calibration of the ESO 1 m
InSb and Bolometer Ir-systems

InSb sensitivity

The ESO IR system is based upon the following results for the basic standard, HR 1195 (V = 4.6; B - V = 0.94, spectral type G5 III). Sensitivity values are given for S/N = 1 and IT = 1 second.

BAND	J	H	K	L	M
HR 1195	2.600±.009	2.179±.008	2.079±.008	2.095±.022	2.163±.033
Sensitivity in mag.	11.5	12.0	11.5	8.0	6.0
mJy	40	20	15	180	600

The calibration is derived from stars in common with Thomas, Hyland, and Robinson (1973).

Sensitivity-IR Bolometer

Band	λ eff in μ	Mag α Sco	F_{λ} (M = 0.0) $Wcm^{-2}\mu^{-1}$	F_{ν} (0.0) Jy*	Nominal Sensitivity in Magnitudes for Bolometer 15" ϕ	Log ν
L	3.5	-4.11	5.99×10^{-15}	244	6.00	13.933
M	4.8	-3.81	1.89×10^{-15}	145	3.00	13.796
N	10.2	-4.45	1.30×10^{-16}	43	2.00	13.469
Q	20	-4.84	6.27×10^{-18}	8.3	-1.00	13.176
P	30	-4.98	1.23×10^{-18}	3.7	-2.00	13.000
N ₁	8.1	-4.31	2.32×10^{-16}	51	0.50	13.569
N ₂	9.6	-4.51	1.18×10^{-16}	36	0.50	13.495
N ₃	12.2	-4.64	4.54×10^{-17}	22	-0.50	13.391

* (1) Jy = 1 flux unit = $1 \times 10^{-26} Wm^{-2}Hz^{-1}$

The nominal sensitivity is also given in magnitudes and represents the attainable magnitude with a signal/noise = 1 in a 10 second integration time.

4. Spectroscopic Observing Possibilities for Comets

For spectroscopic and spectrophotometric observations, ESO can offer in La Silla in the future a wide variety of instrumentation. A spectral resolving power from 500 to 300 000 will be possible (Table 4). We only mention the classical coude spectrograph of the 1.52 m telescope, which has widely been used for cometary work; approximate exposure times are given in Table 5.

For the Cassegrain Boller and Chivens spectrographs at least three different detectors are available:

- a) EMI - 2,3 or 4 stage image tubes (IT)
- b) Image Dissector Scanner (IDS)
- c) Reticon Detector (Ret.)
- d) and probably soon a Boksenberg IPCS

For extended objects, where one would like to obtain spatial information only, the image tubes and the IPCS are useful, since IDS and reticon have no spatial resolution. For the Image Tubes, limiting magnitudes cannot yet be given.

For the IDS, integration times, etc., can easily be calculated with the formula:
1 Photon/Angstr./sec at 4800Å for a star of $B = 15^m.6$.

Further information about the performance of the IDS can be found in: ESO Technical Report No. 11, 1979, M. Cullum, "The Image Dissector Scanner." For spectroscopy beyond 800 nm, the Reticon becomes more sensitive than the IDS. Concerning the double line Reticon, which is cooled by liquid N₂, only the following information concerning limiting magnitudes can presently be given: a signal/noise of 10 to 20 for a star of $V = 16^m.0$ is reached at the 3.6 m telescope with 228Å/mm (resolution 10Å) in one hour. The IDS saturates at about 10^m (170 Å/mm) and the Reticon at $V = 6.3$ (230Å/mm). More detailed information about both detectors is published in the ESO Manual. An intensified Reticon is being prepared for the Danish 1.5 m telescope.

Possibly more important are the two new spectrographs that will soon go into operation at the 3.6 m telescope.

5. The ESO Cassegrain Echelle Spectrograph (CASPEC)

It is intended to be an instrument that will provide high spectral resolution (9.5Å/mm to 2.8Å/mm) at the Cassegrain focus of the 3.6 m telescope. A comparable spectral resolution can otherwise only be obtained at the 1.52 m Coude spectrograph. We expect to reach a limiting magnitude as faint as 15^m .

The main optical components are the 15 cm echelle grating and a plane cross dispersion grating, which provides the order selection and thus two-dimensional spectra.

The Caspec will be operated in three different modes, providing resolving powers of 17500, 30300 and 60600, by using different echelle gratings and cameras. The first detector will be a SEC vidicon tube, having a target area of 25 x 25 mm and a pixel size of 25μ. Some data of this instrument are given in Table 6. Figure 1 shows two aspects of this instrument. The user will control this instrument via the Instrument Computer and the standard Cassegrain area peripherals, very similar to the use of all the other Cassegrain instruments. Data reduction will be possible with the ESO-software package IHAP, which is the same for IDS, Reticon and IPCS reductions. A future replacement of the SEC vidicon by a CCD is foreseen.

6. The ESO Coude Echelle Scanner (CES)

The second new instrument that will soon be commissioned is the Coude Echelle Scanner. Providing still more resolving power (>100 000) than the Caspec, it will be mounted in the Coude Laboratory of the 3.6 m building. As it is not planned at the moment to align the Coude-Mirror-System of the 3.6 m telescope, a separate telescope - the Coude Auxiliary Telescope (CAT) - will feed light into this new instrument. The CES can provide virtually scattered-light-free spectra, if a double pass mode is selected.

Table 4 : Telescopes for spectroscopic, spectrophotometric observations.

Telescope	Detector	Scale ["/mm]	Limit. magn. [m]	Slit length [mm]	Spectral Resolut.	phot.	Number of channels	pixel size
3.6 m	BC + IT	7.2	< 18	20	1000-6000	yes		
	+ IDS	"	< 21	< 3	1000-6000	no	2 x 2048	50 10
	+ Retic.	"	<	< 1	800-3000:	no	2 x 1024	35
	+ IPCS	"	< 22	<20	1000-6000	no	variable	
	CASPEC	"	< 15	< 1	17500, 30300, 60600	no	1000	
1.5 m CAT	Digicon	4.4		< 1	70000-120000	no		
	CES Scanner	4.4		< 1	60000-300000	no		
2.2 m	B+C + IT	11.4	< 17	20	1000-6000	yes		
	IDS/Ret. IPCS	"	< 20/ < 21	<3/<1 <20	"	no/no no		
1.52 m	BC+IT	19	< 16	20	1000-6000	yes		
	JDS/Retc.	19	< 19	<3/<1	"	no		
	Coudé	4.2	< 9	<50	10000-100000	yes !		
1.5 m Dan	BC+int.Ret.	15.7	<	<1	1000-6000	no		

Table 5

Approximate Exposure Times 1.52 m Coudé

Magnitude	Camera	Emulsion (B) = baked	Grating range	Exposure Time	Disp A/mm	λ centre
B = 7.5	I	IIa-0 (B)	A 1/1	20 min	20.0	4150
B = 7.5	I	IIIa-J (B)	A 1/2	40 min	20.0	4750
V = 7.5	I	IIa-D	A 2/7	40 min	20.2	5300
R = 7.5	I	098-02 (B)	A 2/8	70 min	20.2	5700
B = 7.5	II	IIa-0 (B)	A 1/3	60 min	12.3	3790
	II	IIIa-J (B)	A 1/4	130 min	12.3	4925
V = 7.5	II	IIa-D	A 2/9	130 min	12.4	5300
R = 7.5	II	098-02 (B)	A 2/10	250 min	12.4	6040
B = 2.5	III	IIa-0 (B)	A 1/5	20 min	3.3	3450
	III	IIIa-J (B)	A 1/6	40 min	3.3	4280
V = 2.5	III	IIa-D	A 2/11	50 min	3.3	5400
R = 2.5	III	098-02 (B)	A 2/12	120 min	3.3	6300

The times given are for a stellar spectrum 230 μ m wide, taken in 1.5 arcsec seeing, and developed in MWP 2. Standard slit widths are assumed, (see Table 4).

Table 6 : Optical Parameters of CASPEC

Resolving power	17 500	30 300	60 600
<i>Dispersion</i> at = 5000 Å	9.5 Å/mm	5.5 Å/mm	2.8 Å/mm
<i>Echelle grating</i> blaze angle line pairs	Jobin Yvon 46°30' 95 mm ⁻¹	Bausch and Lomb 63°26' 79 mm ⁻¹	31.6 mm ⁻¹
<i>Cross disperser</i> blaze angle line pairs		4°18' 300 mm ⁻¹	
<i>White camera</i> focus aperture	F = 279 mm f/1.66	560 mm f/3.3	
<i>Resolution/pixel</i> slit width sky angle	144 μ 1"	173 μ 1"2	86 μ 0"6-
<i>slit length</i> sky angle	192 μ 1"3	277 μ 1"9	138 μ 1"

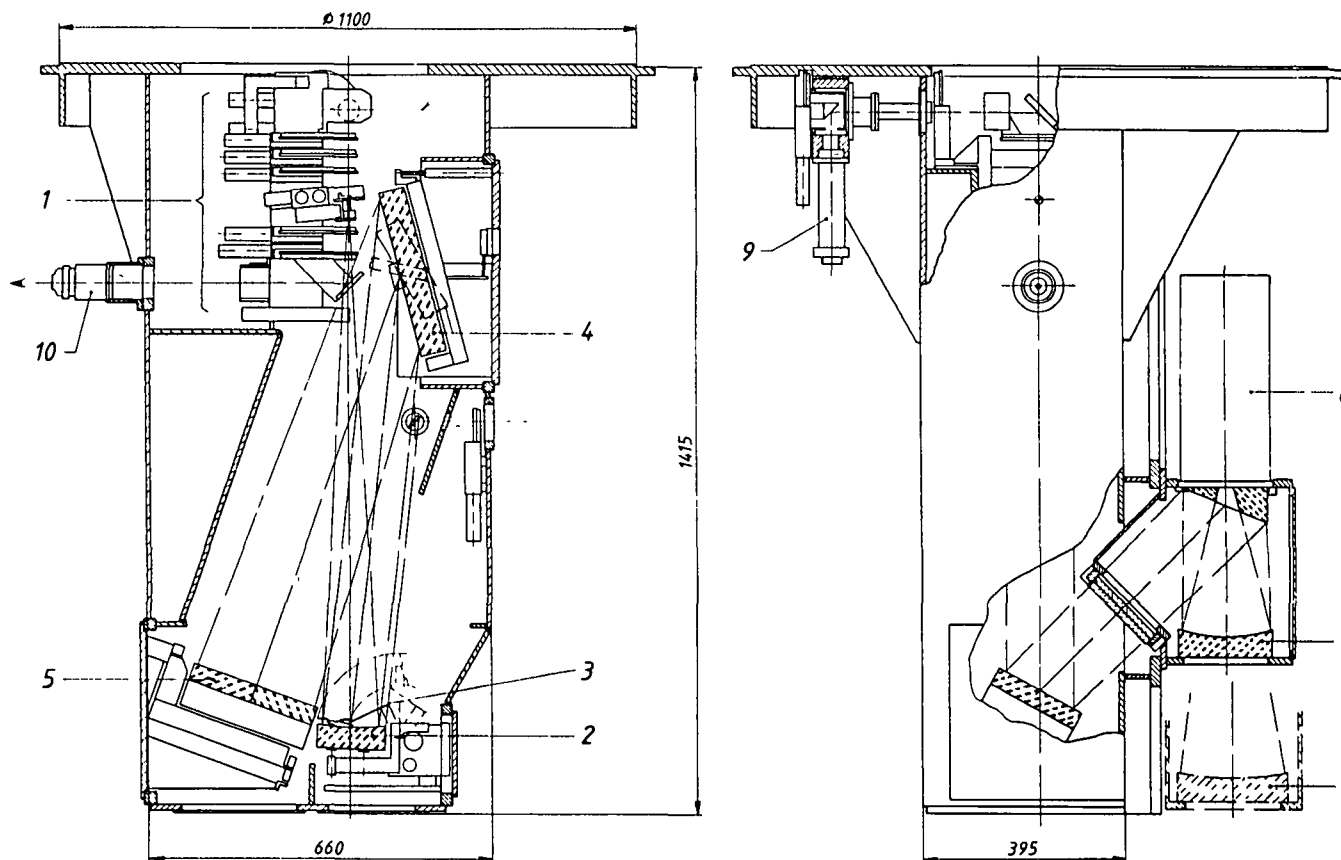

Fig 1 CASPEC Assembly (1) slit area Fig 2, (2) collimator, (3) Hartmann mask, (4) echelle gratings, (5) cross disperser grating, (6) short camera, (7) long camera, (8) detector, (9) comparison lights, (10) slit rear viewer

The optical configuration as seen in Fig. 2, is based on a 200 x 400 mm, 79 gr/mm echelle grating. It combines a single channel, single or double-pass scanner with adjustable entrance and exit slits, and a multichannel mode with fixed array detector geometry. Scanning is done with the echelle grating. The use of photographic plates is not planned, and only photoelectric recording will be available. The highest possible spectral resolution is reached with a slit of 0.5 and the double pass mode, providing a resolving power of 300,000.

With a slit of 1" corresponding to 200μ at the focus of the CAT, the CES reaches a resolving power of 100,000. For the single channel mode a Quantacon photomultiplier is being used, normally with the standard resolving power of 1,000,000. For the multichannel mode, a 1872 channel Digicon detector in the shortward wavelength regions and a cooled Reticon in the near infrared wavelengths regions will be available. Expected performances of the different operational modes of the CES are shown in Figure 3.

The on-line control of the CES and the control of the CAT is very similar to the operation of the other photoelectric spectroscopic detectors (IDS, Reticon, Caspec etc.) and also the reduction of the data will be similar to the reduction of the data obtained with the other detectors. More detailed information about the CES can be found in: Enard, D.: 1979, ESO Technical Report no. 10.

These two new spectrographs, that will soon be operational, will provide new possibilities to obtain cometary spectra for the two reasons: first, the Caspec will allow to observe much fainter objects with the same high spectral resolution as the Coude of the 1.52 m telescope could ever do. Objects that are more than a hundred times fainter will be observable. Secondly, the CES, which is still more sensitive than the old Coude-spectrograph, will provide an even higher spectral resolution up to resolving power of 300,000.

Two recent cometary problems can e.g., easily be attacked: the H_2O^+ detection by Wehinger et al., Ap. J. 190, L43, 1974 and the problem of the $^{12}C/^{13}C$ -ratio determinations (Vanysek, Rahe, Moon + Planets, 18, 441, 1978). With the new spectroscopic instruments we shall be able to detect these features of H_2O^+ either at larger heliocentric distances, or at a fainter level than ever before. Or we will be able to apply the possible new high resolving power to problems such as the ($^{12}C/^{13}C$) ratio that have been extremely difficult to study (Danks et al., Ap. J., 194, 745, 1974). The disturbing contribution of NH_2 to the $^{12}C^{13}C$ band at 4745\AA could be overcome if one would look at other features to determine this ratio, e.g., using the CN (0,0) violet system. Furthermore, the available high spectral resolution and the higher sensitivity should enable us to use the Greenstein effect (Greenstein, J., Ap. J., 128, 106 (1958) to study the internal motions in the coma of comets.

7. Coordination of Cometary Observations at ESO

The coordination of cometary observations at La Silla are extremely important. More and better scheduled observing time could become available when the observing applications for cometary studies are part of a larger research program. To achieve such a coordination, either an astronomer in Europe or a staff astronomer at ESO should coordinate and organize the observations, and carry out the analysis of the observations with any interested astronomers.

In Figure 4, four direct photographs of the head region of comet Bradfield 1979I are shown that were obtained with the ESO 3.6 inch telescope. Exposure times range from 1 to 5 minutes. Some of these images were taken at about the same time when the comet was also observed with the IUE-satellite (Figure 5). UV spectra of comet Bradfield are, e.g., discussed in Feldman et al. (1980) and Rahe (1980).

Technical requirements are special cometary filters, eventual modification of existing instrumentation, and especially simultaneous observations with different telescopes; all this will be possible if a coordinated research program is carried out.

Such a program should be started as soon as possible, long before Comet Halley can be observed. One of the next brighter recurrent comets might be used to apply the different observations described above in a "dry-run."

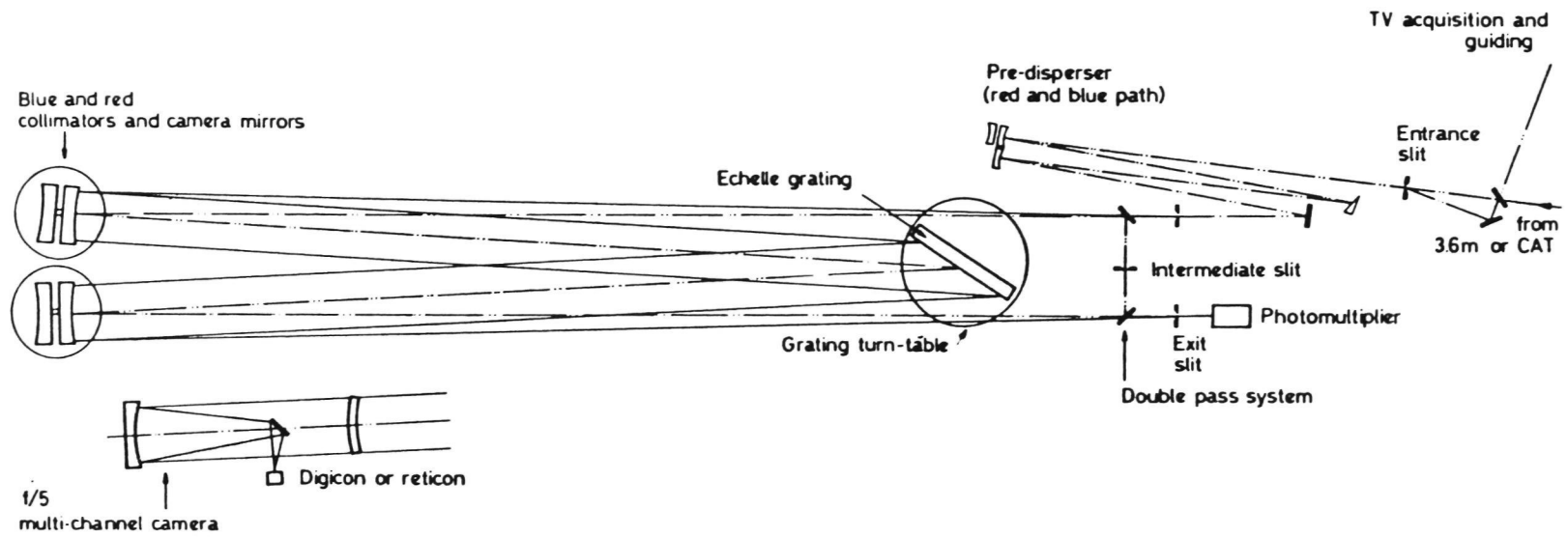

COUDE ECHELLE SPECTROMETER
 SCHEMATIC OF THE OPTICAL ARRANGEMENT

Fig. 2.

125

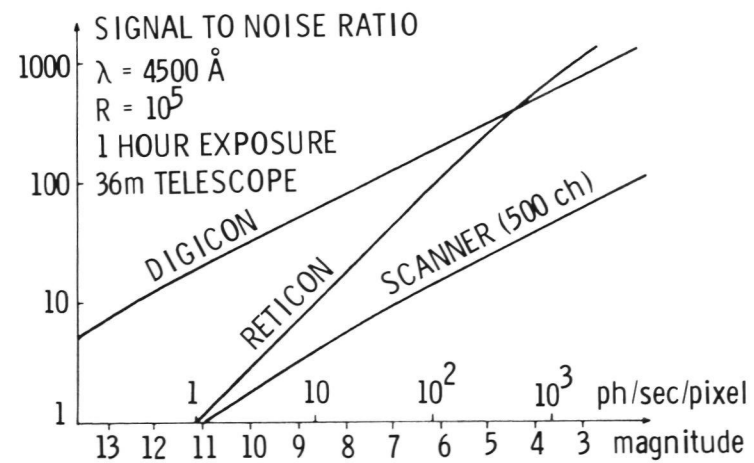

Fig. 3. Computed performance of the CES in different modes.

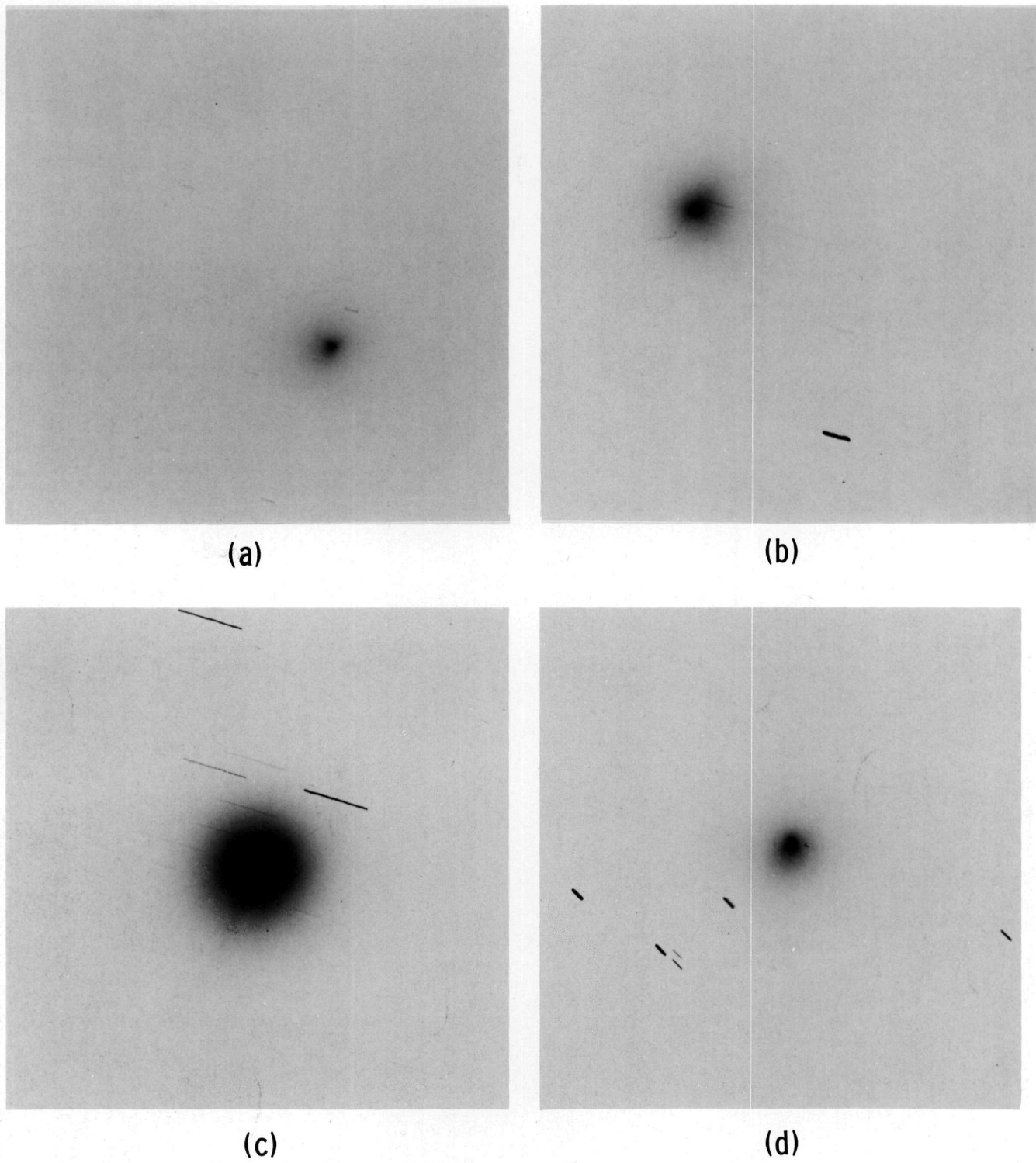

Figure 4. Comet Bradfield 19791, observed on January 22, 1980, with the ESO 3.6 m telescope. (a) Exposure time 1 minute; (b) Exposure time 2 minutes; (c) Exposure time 5 minutes; (d) Comet Bradfield 19791, observed on January 23, 1980, with the ESO 3.6 m telescope. Exposure time 5 minutes.



Figure 5. Comet Bradfield 19791, observed on January 10, 1980, with the IUE satellite.

References

- Cullum, M. 1979, ESO Technical Report No. 11.
- Danks, T. et al. 1974, Ap. J. 149, 745.
- Enard, D. 1979, ESO Technical Report No. 10.
- ESO Manual. 1980, European Southern Observatory, Munich, Germany.
- Feldman, P. D., et al. 1980, Nature 286, 132.
- Greenstein, J. 1958, Ap. J. 128, 106.
- Rahe, J. 1980, Proc. Second European IUE Conf.
- Thomas, Hyland, and Robinson. 1973, Monthly Not. Roy. Astron. Soc. 165, 201.
- Vanysek, V. and Rahe, J. 1978, The Moon and Planets 18, 441.
- Wehinger, P. et al. 1974, Ap. J. 190, L43.