

230

THE ESA MISSION TO COMET HALLEY

R. Reinhard
Space Science Department of ESA
European Space Research and Technology Centre
2200 AG Noordwijk, The Netherlands

Preface

When the "Workshop on Modern Observational Techniques for Comets" was held the Giotto scientific payload had not yet been selected and I presented the model payload. The following paper appears in an updated form to include the actual payload as selected in January and February 1981 by the Selection Committee and the Science Working Team.

Abstract

ESA's Giotto mission to Halley's comet is the "remnant" of a much more ambitious joint NASA/ESA mission involving a Halley fast flyby in 1985 and a Tempel 2 rendezvous in 1988, a mission which could not be carried out because the necessary low thrust propulsion system was not funded by NASA. After briefly reviewing the Giotto mission background various comet selection criteria are given and it is explained why Halley's comet is by far the most outstanding target for a flyby mission.

The mission scientific objectives are given, followed by a somewhat more detailed description of the 10 Giotto scientific instruments. The principles are explained on which the experiments are based, and the experiment key performance data are summarized.

"Mission analysis" focusses on the launch constraints, describes the heliocentric transfer trajectory and, in more detail, the encounter scenario. The Giotto spacecraft major design criteria are explained leading to a brief discussion of the spacecraft subsystem. The ground system design as an integral part of the mission is described. Particular attention, finally, is drawn to the problem of hypervelocity dust particle impacts in the innermost part of the coma and the problem of spacecraft survival, and the adverse effects of impact-generated plasma around the spacecraft.

1. MISSION BACKGROUND

In 1974, the European Space Agency (ESA) performed a mission definition study on a cometary flyby mission of comet Encke in 1980. After review by the ESA scientific advisory bodies no further studies were performed on the mission because it was felt that the scientific return from the short flyby was not consistent with the cost of the mission.

A cometary mission, however, remained in the Long Range Planning report of the Solar System Working Group (1976, 1978) as a possible component of a programme of "planetary" research. An ad hoc Panel, chaired by H. Fechtig, was set up to formulate more precise proposals for a cometary mission. This Panel organized a Workshop on "Cometary Missions" at the European Space Operations Centre (ESOC), Darmstadt on 17-19 April 1978. The purpose of the Workshop was to involve a cross-section of the interested scientific community in Europe in providing suggestions for the orientation of future study and planning work. Subsequently, the Panel asked the Solar System Working Group to recommend a mission definition study covering the following two items:

- (1) A participation of ESA in a NASA rendezvous mission,
- (2) An independent ESA ballistic mission, of the multicomet type, including Halley, Encke, Tempel 2, and possibly C-type asteroids.

If NASA decides to go ahead with the rendezvous mission, the ESA ballistic mission is considered as a complementary rather than as a competing mission. The various payloads are open for US and European Experimenters.

"If NASA would postpone the rendezvous mission, ESA should go ahead with an independent ballistic mission."

After further review and discussion by the scientific advisory bodies, ESA accepted the invitation extended by NASA to study a participation in the cometary mission then under study by NASA. This mission involved a rendezvous with Tempel 2 during its apparition in 1988, and a fast flyby of Halley at 1.53 AU pre-perihelion at the end of 1985. ESA's share of the project was envisaged as the provision of a purely passive probe to be released from the NASA main spacecraft ~ 15 days before Halley encounter and to be targeted at the nucleus. NASA's share of the project was the provision of the main spacecraft and the solar electric propulsion system (SEPS), which is a necessary element for a comet rendezvous mission. With the announcement in January 1980 that the required funding for SEPS was not included in the US president's budget it had to be acknowledged that the basis for a cooperative mission no longer existed.

As an immediate replacement ESA presented the HAPPEN (Halley Post-Perihelion Encounter) mission, proposed earlier by G. Colombo, to its scientific advisory bodies. The idea was that the Geos-3 spacecraft, a derivative of the Geos 1 and 2 spacecraft and instrumented for Earth-magnetotail research, should be retargeted, at the end of its magnetotail mission, to intercept the tail of Halley's comet. This mission, however, was not recommended for further study.

In response to suggestions from the scientific community ESA also examined another option consisting of two spacecrafts based on the Geos concept launched simultaneously by Ariane. One spacecraft (Geos-3) was to perform an Earth-magnetotail mission, the other (Giotto) was to be instrumented for cometary research and to intercept Halley as close to the nucleus as possible.

At its meeting in early March 1980 the Science Programme Committee (SPC) decided:

- (1) that the GEOS-3 part of the combined mission should not be studied further,
- (2) to pursue the study of a mission to Halley's comet, including all possibilities of cooperation with NASA, and
- (3) that the total cost to ESA for the comet Halley mission should not exceed 80 MAU (~ 80M\$).

In view of the limited time remaining before the next apparition of Halley's comet ESA decided not to consider totally new mission or spacecraft concepts. NASA was invited to consider providing a Delta launcher and use of the Deep Space Network (DSN) in return for an appropriate share of the scientific payload.

Consequently the Giotto study proceeded with the following constraints

- o low cost project
- o based on a Geos design
- o launched either by an Ariane rocket in a launch shared with an "applications" satellite or by a Delta rocket.

The study was completed in May 1980 and presented to the scientific community and the ESA science advisory bodies. Giotto was strongly recommended and the SPC at its meeting on 8 and 9 July 1980 decided that Giotto should be included in the ESA programme as the next scientific project.

Since at the time of the SPC decision there was no commitment from NASA to provide the Delta launcher or the DSN in return for an appropriate share of the scientific payload the SPC approval had to be based on an Ariane launcher. Any later offer of NASA to provide the Delta Launch Vehicle and the DSN would require a new decision by the SPC to change the launcher. When this offer finally came in late October 1980 the SPC considering all elements of the offer preferred to maintain the Giotto mission in its originally approved version, i.e., launch by Ariane, but was pleased to see a substantial number of US investigators involved as Co-Is in the candidate European experiment proposals.

Since Giotto formally never reached the status of a cooperative ESA/NASA project, ESA could not, for reasons imposed on ESA by the council, invite US investigators as PIs. A "Call for Experiment Proposals" was sent out in July 1980 to interested European investigators, immediately after project approval with a deadline for submission of proposals by 15 October 1980. The proposals were technically assessed for compatibility with the spacecraft and scientifically reviewed by a Selection Committee. The final payload complement was announced in mid-January 1981. Following instructions by the SPC, the payload was further completed at the first Science Working Team (SWT) meeting in mid-February 1981. The following chapters describe the Giotto project and its scientific payload as of mid-February 1981.

2. COMET SELECTION CRITERIA

2.1 Scientific Criteria

Based on their orbital periods, comets can be categorized as short-periodic (with periods between 3 and 25 years), intermediate-periodic (25-200 years), long-periodic (200- 10^6 years), and "new" comets. The most active and therefore brightest comets are the new ones, comets that have never previously approached the sun. Ideally, then, one would like to rendezvous with a new comet, but this is presently impossible. Firstly, such a rendezvous calls for a continuous low-thrust propulsion system, e.g., solar electric propulsion, and no such system is currently under development. Secondly, to plan a mission to a comet, its orbit must be well known, which means that the comet must have returned at least a few times. This rules out new comets and leaves only the short-periodic and a few intermediate-periodic comets as candidates.

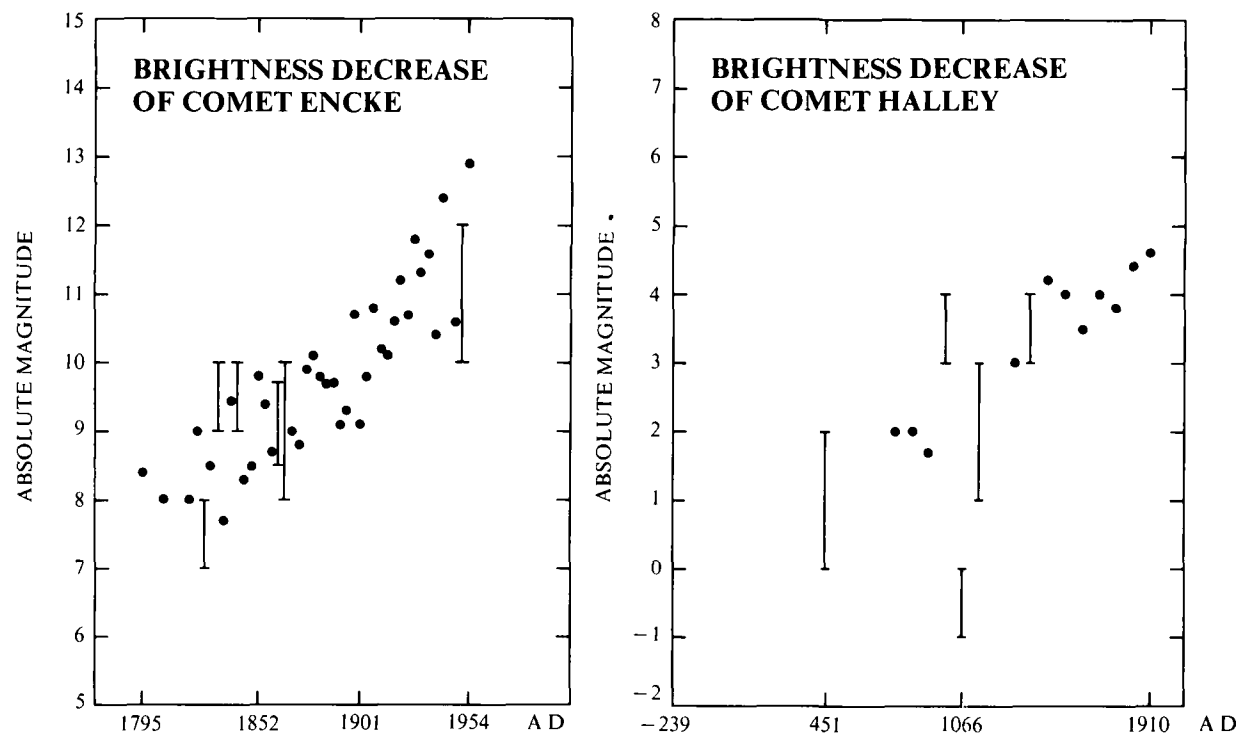

Figure 1. Apparent brightness decrease of periodic comets Encke and Halley. The early observations of Halley are very doubtful but for Encke there appears to be a clear tendency for the brightness to decrease. (Data from Vsekhsyatskii, 1964).

Comets that have returned to the inner solar system several times build up dust layers on their surface because the dust carried away by the gases is pushed back by solar radiation pressure. This simplified mechanism could explain why comets, on the average, tend to decrease in brightness with each return. Figure 1 shows as an example the brightness decrease of comet Encke for which most data exists and also some estimates for comet Halley according to the table by Vsekhsyatskii (1964). All short-periodic comets are considerably less bright than new comets, and they produce two orders of magnitude less gas and dust (see Table 1).

TABLE 1. COMPARISON OF HALLEY WITH OTHER COMETS

group	comet	m_0	\dot{Q}_{H_2O} at 1 AU	
mission can be planned	Encke (1990)	12-13	$3 \cdot 10^{27}$	
	Tempel 2 (1988)	~ 13	$1 \cdot 10^{27}$	
	Tuttle - Giacobini - Kresak (1990)	12	$\sim 1 \cdot 10^{27}$	
	Honda - Mrkos - Pajdusakova (1991)	13-14	$\sim 1 \cdot 10^{27}$	
	Faye (1991)	11-12	$\sim 1 \cdot 10^{27}$	
intermediate periodic	Halley (1986)	5	$1 \cdot 10^{29}$	
mission can not be planned	long periodic	Tago - Sato - Kosaka (1969)	6.4	$2 \cdot 10^{29}$
	or	Bennett (1970)	3.5	$2.5 \cdot 10^{29}$
	"new" comets	Kohoutek (1973)	6.0	$1.5 \cdot 10^{29}$
	West (1976)	5.0	$2.3 \cdot 10^{29}$	

m_0 - absolute total magnitude
 \dot{Q}_{H_2O} - production rate (H_2O molecules per sec)

As Table 1 (reproduced from ESA SCI(80)4, 1980) shows comet Halley's absolute magnitude and gas production are similar to those of long-periodic or "new" comets. A fully developed contact surface, bow shock, dust and ion tails are expected during the planned post-perihelion flyby. Halley is by two orders of magnitude more active than other comets with a predictable orbit.

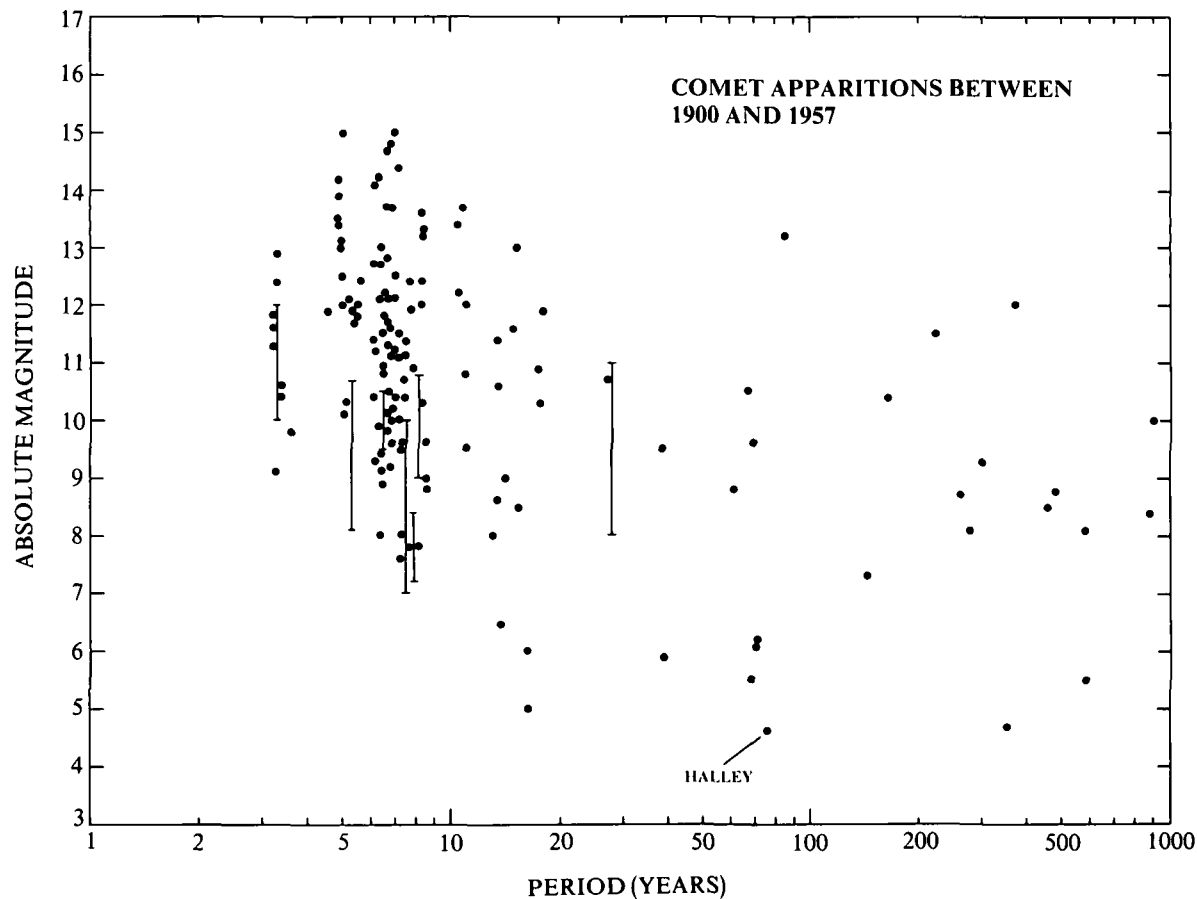

Figure 2. Absolute magnitude of comets with periods up to 1000 years. Of all the comets which have returned at least twice to the inner solar system Halley is the brightest. (Data after Vsekhsyatskii, 1964).

The outstanding nature of Halley is further emphasized in Figure 2 which shows the absolute magnitude of a large number of comets in comparison with their period. With the exception of Halley a long period is identical with a poorly known orbit. Of particular interest is a group of eight with absolute magnitude < 7 and periods < 100 years. The characteristics of the comets in this box are shown in some detail in Table 2.

TABLE 2. Comparison of the 8 brightest short- and intermediate-periodic comets

designation	m_0	P (y)	q (AU)	apparitions		
				last	No. of	next
1901 I	5.9	39.08	0.245	1901	-	did not reappear
Halley	4.6	76.03	0.587	1910	29	1986
1916 III	6.0	16.34	0.471	1916	-	did not reappear
1921 II	6.4	13.85	1.008	1921	-	did not reappear
Schwassmann-Wachmann (1)	2-5	16.3	5.5	1974	4	1990
Pons-Brooks	6.1	70.88	0.774	1954	3	2025
1954 X	6.2	71.95	0.971	1954	-	?
Olbers	5.5	69.47	1.179	1956	3	2025

m_0 - absolute magnitude; p - orbital period; q - perihelion distance to the Sun

Four out of the eight comets either did not reappear or may not reappear, two comets (Pons-Brooks and Olbers) will not reappear before 2025, which only leaves Schwassmann-Wachmann and Halley. Schwassmann-Wachmann's actual brightness is very much smaller than Halley's because its perihelion distance is 5.5 AU (nevertheless, because of its occasional flaring up at the large distance from the Sun Schwassmann-Wachmann is a very exciting target for a cometary mission). In summary, Halley is in fact the most outstanding comet. Considering furthermore that Halley has reappeared at least 29 times and that it might have been even brighter still 2000 years ago than it is today (Figure 1) it is conceivable that Halley is significantly larger than the "average" comet and "worth a visit".

2.2 Technical Criteria

Boissard et al. (1981) have published a few more technically oriented criteria for selection of a target comet. These are:

- o a reliable orbit should be available, in order to predict the ephemerides of the comet with sufficient accuracy;
- o the recovery of the comet should occur well before the encounter (at least 100 d), since the calculated ephemerides should preferably be adjusted with new observations;
- o the comet should be visible from the Earth at encounter in such a way that spacecraft observations can be complemented with ground-based observations;
- o the encounter should occur when the comet is not too far from the Sun (heliocentric distance less than about 1.5 AU) and already shows physical activity;
- o the departure hyperbolic velocity should not exceed about 10 km/s (launch with Ariane), but should preferably be well below this figure (a low departure hyperbolic velocity allows a large payload mass for a given spacecraft);

o the relative encounter velocity between comet and spacecraft should be as low as possible, in order to have a sufficiently long observation time in the proximity of the comet.

Taking into account these criteria and considering the periodic comets that have been observed on more than one apparition and have predicted perihelion passages between 1984 and 2000 Boissard et al. arrive at 10 candidate comets with 19 favorable perihelion passages (Table 3).

TABLE 3. Orbital Characteristics of Candidate Comets (1984 - 2000)

Comet	T	P(y)	q(AU)	i(deg)	Favourable perihelion passage		Departure conditions	
					date	time	v_h (km/s)	δ_A (deg)
Encke	1977 63	3 31	0 341	11 9	1984 Mar	27 0	u	
					1987 Jul	17 0	u	
					1990 Nov	3 6	10	-5*
					1994 Feb	21 3	u	
					1997 Jun	11 0	u	
					2000 Sep	28 7	10	0
Tempel 2	1978 14	5 27	1 369	12 5	1988 Sep	16 7**	4	-5
					1999 Sep	6 6	3	-5
Honda-Mrkos-Pajdusakova	1974 99	5 28	0 579	13 1	1990 Sep	20 0	4	-5
					1996 Jan	17 3	10	-5
Tuttle-Giacobini-Kresak	1978 98	5 58	1 124	9 9	1990 Feb	6 6**	8	-5
D'Arrest	1976 62	6 23	1 164	16 7	1995 Jul	7 0	6 5	-5
Giacobini-Zinner	1979 12	6 52	0 996	31 7	1985 Sep	4 0	3	-5
					1998 Nov	9 7	4	-5
Borelly	1974 36	6 76	1 316	30 2	1987 Dec	18 2	5	-5
					1994 Oct	28 1	9	-5
Arend-Rigaux	1978 09	6 83	1 442	17 9	1984 Dec	1 4	6	-5*
Crommelin	1956 82	27 89	0 743	28 9	1984 Sep	1 0	5	-5
Halley	1910 30	76 09	0 587	162 2	1986 Feb	9 3	3	-5

* Flight time > 500 d

** Close approach to Jupiter before perihelion passage

T - date of last perihelion passage

P - orbital period

q - perihelion distance

i - inclination of orbit plane with respect to the ecliptic

v_h - departure hyperbolic velocity

δ_A - launch asymptote declination

(launch opportunities with unfavorable departure conditions are marked with "u")

As evident from Table 3 comet Halley meets all the criteria in a favorable way apart from its orbit inclination (Halley has a retrograde orbit) which results in a very high flyby velocity. This is indeed a problem as will be discussed later in detail. As Table 3 shows the departure hyperbolic excess velocity required to flyby Halley is one of the lowest.

In principle, minimum departure hyperbolic excess velocities V_h are achieved for comet encounters near the ecliptic plane. This allows two possibilities for an encounter with Halley: a pre-perihelion encounter near the ascending node (9 November 1985) or a

post-perihelion encounter near the descending node (10 March 1986). Depending on the launch dates these encounters can be reached in various ways, even trajectories with one or more full revolutions around the Sun are conceivable. Figure 3 (top) shows the required launch energy $c_3 = V_h^2$ for the case of less than one full revolution around the Sun. Considering only launch energies $c_3 < 20 \text{ km}^2/\text{sec}^2$ we can identify three possibilities

1. launch early 1985; arrival ~ 20 December 1985.
2. launch June/July 1985; arrival ~ 10 December 1985.
3. launch July 1985; arrival ~ 15 March 1986.

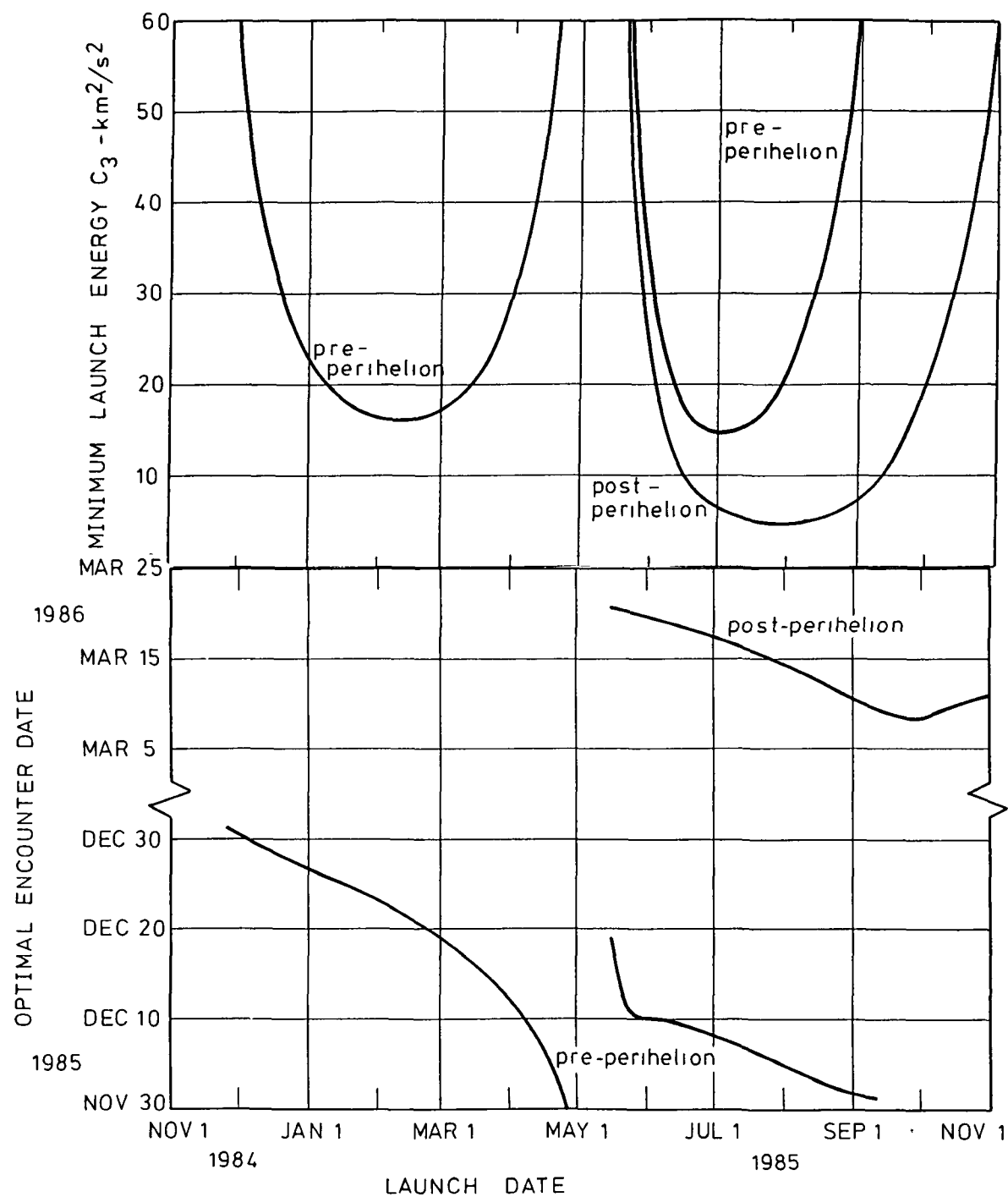

Figure 3. Launch opportunities for Halley encounters with less than one full orbit around the Sun. The upper plot gives the minimum launch energy c_3 required for launch dates between November 1984 and November 1985, the lower plot gives the corresponding optimal arrival dates at the comet. (after Cornelisse, 1980)

The optimal arrival dates are obtained from Figure 3 (bottom). It is interesting to note that the minimum launch energy for a pre-perihelion encounter is reached for an encounter in mid-December 1985 and not around 9 November.

The reason is, of course, that the in-ecliptic V_h required for an encounter around 9 November, when Halley is at 1.8 AU from the sun, is much larger than the combined out-of-ecliptic and in-ecliptic components of V_h for an encounter around 20 December, when Halley is at 1.2 AU from the Sun.

As shown by Cornelisse (1980) the declination of the launch asymptote Δ_A has very unfavorable values for a pre-perihelion encounter: $\Delta_A < -60^\circ$ for a winter 1984/85 launch and $\Delta_A > +20^\circ$ for a summer 1985 launch, if C_3 is required to be reasonably small ($< 20 \text{ km}^2/\text{sec}^2$). This more or less rules out a pre-perihelion encounter of Giotto with Halley, since only $-15^\circ < \Delta_A < +15^\circ$ leads to reasonably small values of C_3 considering an Ariane launch from Kourou. If, in addition, the constraint of a second passenger on Ariane is taken into account then only Δ_A values close to -5° are reasonable, which makes pre-perihelion encounters impossible to achieve with any reasonable payload mass. For the post-perihelion encounter, on the other hand, it turns out that the minimum launch energies coincide with values of Δ_A around 0° .

2.3 Comet Halley's Historical Role

As shown in the previous sections comet Halley's fame was not the prime consideration for its selection. However, it is worth pointing out that Halley is the most prominent of all comets considering the role it played through historical times.

Edmond Halley, an English astronomer, discovered that the comets that appeared in 1531, 1607 and 1682 were actually one and the same comet. He was then able to predict that that comet would reappear in late 1758. Although Halley did not live to see his prediction come true his correct prediction led to his name being given to the most famous comet, and led also to the important discovery of the periodicity of a certain category of comets.

Once the periodicity of Halley's comet was revealed it was also possible to associate several spectacular comet apparitions in historical times with Halley's comet. The earliest "fairly certain" apparition of Halley occurred in 240 BC, although sightings of a comet in the winter of 1057/58 BC, as deduced from ancient Chinese records, have been associated with Halley. Table 4 lists the dates of the last 29 perihelion passages which have been calculated by Yeomans and Kiang (1981). The average period between appearances of the comet is nearly 77 years, but individual orbits vary somewhat in period, due to the gravitational effects of the planets.

TABLE 4. Perihelion Passages of Halley's Comet

	240 BC	May 25 (probably observed)
	164	October 13 (not observed)
	87	August 6
	12	October 11
A.D.	66	January 26
	141	March 22
	218	May 18
	295	April 20
	374	February 16
	451	June 28
	530	September 27
	607	March 15
	684	October 3
	760	May 21
	837	February 28
	912	July 19
	989	September 6
	1066	March 21
	1145	April 19

1222	September 29
1301	October 26
1378	November 11
1456	June 10
1531	August 26
1607	October 27
1682	September 15
1758	March 13
1835	November 16
1910	April 20

The earliest representation of Halley which is still preserved shows its apparition in 1066, the year of the Norman invasion of England. Halley is depicted on the Bayeux Tapestry which was embroidered a few years later showing the history of the conquest. Three apparitions later, in 1301, the Florentine painter Giotto di Bondone saw Halley and incorporated it realistically in a fresco cycle decorating the interior of the Arena chapel in Padua. The "Adoration of the Magi" is the second tier of the cycle and shows Halley as the Star of Bethlehem. Because of this painting, which may be considered as the first scientific description of Halley recorded in history, the European Space Agency (ESA) has given the name "Giotto" to its Halley cometary mission.

Already in 1835, during its second predicted apparition, Halley's comet was the focus of great scientific interest. At that time detailed drawings from visual observations were made which even today serve as a basis for scientific work on Halley.

By 1910, during Halley's third predicted apparition, the scientific interest had grown tremendously, in particular because it was predicted that Halley would come very close to the Earth, and that the Earth would actually go through the tail of the comet. The population was alarmed since it became known that the comet contained cyanide (CN), a poisonous gas. However, the density of molecules in the comet's tail is so thin, that although the Earth actually did go through the comet's tail nothing happened.

The 1985/86 apparition is the fourth predicted apparition and it is the first opportunity for spacecraft to be sent to Halley to observe the comet from close by and to carry out measurements in the cometary atmosphere.

3. MISSION SCIENTIFIC OBJECTIVES

Comets are a substantial component of the solar system with a total mass of planetary magnitude. For unknown reasons, this mass condensed into small bodies for which the internal pressure and temperature were not sufficient to cause differentiation or other physical changes. Thus comets are probably the most pristine, primitive objects available for studies of the evolution of the solar system. Furthermore, the outer skin of a comet is removed during each close passage by the Sun to expose fresh material for analysis. Measurements of the composition and physical constitution of comets will thus yield fundamental information on the chemical and physical conditions that existed near the time of planetary formation and on the processes of condensation, agglomeration, and mixing which were taking place. Comets may contain pre-solar system or interstellar grains, both of which are otherwise unavailable for study. They may have been a major source of organic materials in the atmospheres of the terrestrial planets. Thus a study of their composition should provide clues about the nature of the pre-biological environment on Earth.

Most of the detailed knowledge concerning the state of the formative solar system has come from studies of meteorites. The principal uncertainty is the source of meteorites. A comet mission could establish the relations between comets and meteorites of different classes, as well as between comets and interplanetary dust, meteoroids, and the Apollo asteroids.

Since the composition of comets appears to be similar to that of interstellar clouds, the study of comets may help solve major problems concerning molecule formation and the nature of interstellar clouds and dark nebulae. Some cometary molecules may be the molecular precursors of life.

Whipple's icy conglomerate theory is the most widely accepted theory of the nature of cometary nuclei. Close examination of a comet is needed to test this theory.

The physical mechanisms responsible for the rapid dissociation and ionization of cometary gases and their acceleration into the ion tail are not understood. In situ studies of such cometary phenomena appear essential for the clarification of these processes. Also, such observations can yield new insights into certain geomagnetic and astrophysical phenomena. Comets are unique free probes of the interplanetary medium, but in situ observations are required to establish the link between cometary and solar wind conditions and ground-based observations.

An encounter with a comet is perhaps the last purely exploratory mission left in solar system studies. Very little is presently known about the most active members in our solar system. For example, we can only speculate about the existence and size of a body (the comet nucleus) which around perihelion is able to produce a hydrogen corona which is many times larger than the Sun. The absence of external heating and heating by self-gravitation due to the small mass of the comets led to a composition which is qualitatively different from all other bodies in the solar system.

Observations of comets from near-Earth (ground based or from space) are limited in that they can only provide line of sight integrations. Only molecules with strong emission lines in suitable wavelength ranges can be observed by remote sensing. In particular, the parent molecules from the nucleus can only be detected by in situ measurements which are needed to unravel the complex physical and chemical processes in the cometary atmosphere. The comet nucleus is too small to be resolved by ground based telescopes or even the Space Telescope.

Most of these open questions and problems are addressed by the scientific objectives of the Giotto Scientific Working Group. These are:

- o to provide the elemental and isotopic composition of the volatile components in the cometary coma, in particular to identify the parent molecules,
- o to characterize the physical processes and chemical reactions that occur in the cometary atmosphere and ionosphere,
- o to determine the elemental and isotopic composition of the cometary dust particles,
- o to measure the total gas production rate and the dust flux and size/mass distribution and to derive the dust to gas ratio,
- o to investigate the macroscopic system of plasma flows resulting from the interaction between the cometary and the solar wind plasma,
- o to provide numerous images of the comet nucleus with a resolution down to 50 m. From these the nucleus size and rotation may be deduced and its mass may be estimated.

An intense earth based observation programme is a natural and necessary complement to the Giotto mission.

4. GIOTTO SCIENTIFIC PAYLOAD

To accomplish the objectives as given above the Giotto spacecraft will carry:

- o a camera for imaging the inner coma and the nucleus,
- o neutral, ion and dust mass spectrometers for composition measurements,
- o a dust impact detector for studies of the dust environment,
- o electron and ion plasma analyzers and a magnetometer for plasma studies,
- o an optical probe for in situ measurements of the cometary atmosphere.

This model payload is almost the full complement of instruments needed for a cometary flyby mission distilled from more than a decade of intense study efforts carried out by ESA and NASA for various proposed cometary missions.

The experiments are built by a large number of European and US institutes under the responsibility of more than 80 Principal and Co-Investigators, including 33 US scientists.

Table 5 gives a summary of the Giotto scientific experiments together with their mass/power/data rate allocations as established during the first Science Working Team meeting on 16 and 17 February 1981.

TABLE 5. Summary of Giotto Scientific Experiments

Experiment	Acronym	Mass (kg)	Power (W)	Data Rate (bps)
Camera	HMC	10.2	10.6	20 000
Neutral Mass Spectrometer	NMS	10.0	9	4 184
Ion Mass Spectrometer	IMS	8.2	9	3 200
Dust Mass Spectrometer	PIA	10.0	11.4	6 000
Dust Impact Detector System	DID	2.0	1.8	750
Fast Ion Sensor) JPA	3.6) 6.5	2 900
Implanted Ion Sensor				
Electron Electrostatic Analyzer) RPA	2.6) 6.5	2 900
Positive Ion Cluster Comp. Anal.				
Energetic Particles	EPA	0.4	0.5	96
Magnetometer	MAG	1.2	1.2	1 200
Optical Probe Experiment	OPE	<u>1.0</u>	<u>1.0</u>	<u>618</u>
	Total	49.2	51.0	38 948

Experiment Schedule:

Proposal due	15 October 1980
Announcement of selection	16 January 1981
Review of conceptual experiment design	1 November 1981
Delivery of <u>Structural Model</u>	1 December 1982
Immediate experiment design review	15 January 1983
Delivery of <u>Engineering Model</u>	1 June 1983
Final experiment design review	1 October 1983
Delivery of <u>Flight Model</u>	1 January 1984
Delivery of <u>Flight Spare</u>	1 June 1984
Flight Readiness Review	1 May 1985

A brief description of the experiment principles together with a few key performance data is given below.

4.1 Halley Multicolour Camera

Principal Investigator: H. U. Keller
Max-Planck-Institut fuer Aeronomie
Lindau, W. Germany

Major collaborating institutes (hardware):

Laboratoire de Physique Stellaire et Planetaire, Verrieres, France
Institut d'Astrophysique, Liege, Belgium
Istituto di Astronomia, Padova, Italy
DFVLR, Oberpfaffenhofen, W. Germany
Ball Aerospace Systems Division, Boulder, Colorado

The optical system of the Halley Multicolour Camera (HMC) is a modified Ritchey-Chretien design with correcting field lens. The telescope has a focal length of 96 cm and an aperture of 16 cm, the separation between the primary and the secondary mirror is 25 cm. The telescope is mounted behind the spacecraft bumper shield and therefore protected from direct dust particle impacts. A 45° deflecting mirror is used to look at the comet. A mirror can be tilted ($\pm 1^\circ$) which assures that there is no "blind spot". A baffle of about 40 cm length assures adequate reduction of diffuse sunlight and spacecraft reflected light.

The telescope images onto a focal plane arrangement of 1 linear CCD and 2 area CCDs. A long (1.5°) linear CCD (2048 x 1 pixels with 13 x 13 μ pixel size) is used to detect the nucleus and later for timing and clocking of the two area CCDs. The two area CCDs with two independent segments each (each segment has 385 x 288 pixels with 22 μ x 22 μ pixel size) are masked except for the first four lines which are covered by colour filters, the remaining lines are used as intermediate readout buffers. One of the light sensitive strips is covered by a movable filter plate providing 10 colour bands for coma and nucleus observations.

Since the camera operates in a spin scan mode (Giotto is spinning at 15 rpm) the exposure time is very short. The sensitivity is therefore enhanced by about a factor of 4 using time delay and integration (TDI) during exposure. The HMC can rotate around 180° which allows to follow the nucleus during approach and to image it even after the flyby. Because of data rate limitations only 100 x 100 pixels (each pixel coded with 8 bits) can be transmitted every 4 seconds. The Best Image is stored and continuously updated. It contains the full information (385 x 1152 pixels in 4 colours), requiring a transmission time of 3 minutes at 20 kbps. At 1400 km the HMC is expected to resolve nucleus surface structures down to 30 m.

4.2 Neutral Mass Spectrometer

Principal Investigator: D. Krankowsky
Max-Planck-Institut fuer Kernphysik
Heidelberg, W. Germany

Major collaborating institutes (hardware):

Physikalisches Institut, University of Bonn, W. Germany
Physikalisches Institut, University of Berne, Switzerland
Laboratoire de Geophysique Externe, CNRS, Saint-Maur, France
The University of Texas, Dallas

The neutral mass spectrometer consists of a parallel plate electrostatic analyzer (E-analyzer) and a second parallel plate analyzer coupled with a magnetic analyzer (M-analyzer) in a double focussing geometry (angle and energy). The M-analyzer will provide an identification and a simultaneous measurement of the abundance of all gas species in the 1 - 34 amu mass range with a resolution of < 0.5 amu even if the particles have kinetic energies of up to 20 eV in the comet frame. Some gas molecules may derive significant kinetic energy from dissociation processes of parent species. The E-analyzer will measure the energy distribution function of each gas species in the mass range 1 to 86 amu. Above the range with the M-analyzer (34 amu), the kinetic energy in the comet frame will be small compared to that from the ram velocity of the gas molecule into the instrument. In this range (34 - 86 amu) the E-analyzer will provide mass and abundance information for each gas species. As both the

M- and E- analyzers have focal plane detectors the full mass-energy range is measured simultaneously and no scanning is required. This leads to very high sensitivity and good spatial resolution.

The M- and E-analyzers have separate entrance apertures and ion sources. The detection limit of both analyzers is ~ 10 neutral particles/cm³ and 3×10^{-5} ion/cm³ for $\alpha \sim 1.5$ second integration period each. A spatial resolution of approximately 100 km for each gas species is obtained. Close to the nucleus the instrument will measure both neutrals and ions in a time sharing mode giving a complete set of neutral gas parameters (identity, abundance, energy distribution) every 1.5 seconds and a complete set of ion parameters every 3 seconds. The sensitivity to ambient ions is reduced in this region in order to expand the range of measurable ion densities to 3×10^4 /cm³. At greater distances, both before and after encounter, where the neutral density is too low for detection, only the ion mode will be used.

4.3 Ion Mass Spectrometer

Principal Investigator: H. Balsiger
Physikalisches Institut
University of Berne
Switzerland

Major collaborating institutes (hardware):

Max-Planck-Institut fuer Aeronomie, Lindau, W. Germany
Jet Propulsion Laboratory, Pasadena, California
Lockheed Palo Alto Research Laboratory, California

The ion mass spectrometer measures the ion mass/charge distribution, the energy distribution and the direction of incidence of both solar wind and cometary ions. The main instrument maps the ion distribution on two-dimensional detectors, with one dimension a measure of mass/charge and the other dimension a measure of the elevation angle of the ion's velocity vector. Azimuth angle is scanned by the spacecraft spin and the energy distribution is determined by variation of the voltages applied to the instrument.

Ions incident from the forward hemisphere are deflected into the instrument by an electrostatic mirror which can withstand the expected dust particle impacts. The ions are then accelerated or decelerated by a pair of grids with variable applied voltage before they enter the analysis part of the instrument. The ions are analyzed by a sector magnet (0.35 Tesla) which serves as a momentum/charge filter with a very wide angular acceptance and an electrostatic reflector which spreads the momentum-analyzed ion beam according to their energy/charge. The ions are registered by two microchannel plate detectors with position sensitive readout. The instrument has a mass/charge range of 1-65 amu/q, a mass resolution $m/\Delta m$ of 20 at 20 amu/q and an energy range 0.1-10 keV. The field of view is a fan shaped acceptance cone 100° in elevation (from 5° on one side of the spin axis to 95° on the other side) and 2° in azimuth.

The main instrument is complemented by a smaller second composition analyzer employing two quadrispherical electrostatic analyzers with magnetic deflection (0.15 Tesla) and 12 channeltrons as detectors. This second instrument has a mass/charge range of 8-65 amu/q, a mass resolution $m/\Delta m$ of 20 at 20 amu/q and an energy range of 20-1500 eV. The field of view in elevation is $\pm 6^\circ$ to either side of the spin axis. This forward looking instrument is mainly intended for the inner coma region.

4.4 Particulate Impact Analyzer

Principal Investigator: J. Kissel
Max-Planck-Institut fuer Kernphysik
Heidelberg, W. Germany

Upon impact of a particle onto the sensor's 5 cm² target a plasma is generated from which ions are extracted and accelerated via a 1.5 kV acceleration grid. Once the ions of the impact plasma have passed the grid they fly through a time of flight tube (TOF) of ~ 1 m length when

they separate in time according to their mass. The TOF actually consists of two time of flight tubes which are at an angle of $\sim 15^\circ$ with an ion reflector in-between, used for energy focussing. The time of flight mass spectrum for each individual dust particle impact is then recorded with an electron multiplier at the end of the drift path.

The method of impact ionization mass spectrometry is ideally suited for the fast flyby mission to comet Halley because the amount of positive ions released upon impact increases significantly with the impact velocity. Instruments based on this principle have been successfully flown on Pioneer 8/9, Heos 2, Helios 1/2 or are currently implemented (Galileo, ISPM). The ion reflector, however, will be used for the first time. This together with the high ion yield gives a dramatic improvement of the mass resolution from $m/\Delta m = 5$ (Helios) to $m/\Delta m = 200$ at $m = 100$. This is quite sufficient to separate adjacent mass lines with a dynamic range of 10^3 in the instrument's whole mass range of 1-110 amu and to allow measurements of isotopic ratios such as ${}^7\text{Li}/{}^6\text{Li}$, ${}^{11}\text{B}/{}^{10}\text{B}$ and ${}^{13}\text{C}/{}^{12}\text{C}$.

The specific sensitivity of the method applied and the restrictions due to onboard data processing give ± 15 percent relative accuracy for mass lines, ± 25 percent for mass ratios and a factor 3... 4 for absolute composition data. It is expected that particles can be definitely attached to a mineral type using the composition data. Also the absence of key elements as well as an analysis in terms of minerals known to be abundant in chondrites will further improve the accuracy of the composition data. Variations of particle type or mean composition vs. distance to the comet will yield information on the release mechanism.

Because of the small target area the instrument will predominantly analyze the most frequent dust particles which are expected in the mass range 10^{-16} to 10^{-10} g, corresponding to particle diameters $0.1 - 10\mu$. The target area can be adapted to the actual dust particle flux and varies from $0.5 - 500 \text{ mm}^2$.

4.5 Dust Impact Detector System

Principal Investigator: J. A. M. McDonnell
University of Kent at Canterbury
Canterbury, England

Major collaborating institute (hardware):

Max-Planck-Institut fuer Kernphysik, Heidelberg, W. Germany

Because of its small target area the dust impact mass spectrometer provides predominantly information on the most frequent particles, i.e., particles in the mass range $\sim 10^{-17} - 10^{-10}$ g. However, the bulk of the mass lifted off from the comet nucleus in the form of solids is contained in the larger particles. Measurement of the dust particle number spectrum up to very large masses is necessary to determine the comet dust to gas ratio. This is the main scientific objective of the dust impact detector system.

Because the larger dust particles are relatively infrequent a large area detector is required to reliably determine the dust particle number spectrum. Therefore, the whole shield surface area (2.5 m^2) is used. In order to comply with the enormous dynamic range of particle mass to be covered different types of detectors have to be used:

1. An impact plasma detector array of several hundred cm^2 area will predominantly detect impacts of smaller dust particles ($10^{-11} - 10^{-17}$ g). Principle: The impact plasma is separated by an electric field, the total charge is proportional to the particle mass. The impact plasma detector has two arrays, one without a foil, the other covered by a submicron metallized penetration film, which would observe a somewhat reduced number of impacts depending on the penetrating power or bulk density of the dust particles. This technique, which was successfully used on the Helios 1/2 spacecraft, gives an average of the bulk density in the mass range $10^{-15} - 10^{-11}$ g. Momentum sensing on this acoustically isolated sensor covering the mass range $10^{-13} - 10^{-10}$ g is independent of ionization efficiency, thus allowing the determination of mass at 68 km s^{-1} and hence provide the calibration for the ionization efficiency.

2. The momentum transfer to the front sheet of the shield is measured for non-penetrating particles by 3 microphones mounted 120° apart at the outer end of the front sheet. Principle: The shock wave which is generated by each particle impact propagates through the front sheet and is observed by the microphones. Three sensors are used in coincidence to determine the impact position and to yield the noise immunity necessary for a fast comet flyby. The meteoroid shield momentum measurement uses the whole shield area and would predominantly measure larger particle impacts $> 10^{-10}$ g.

A fourth microphone is placed on the rear sheet of the bumper shield in order to measure the momentum/mass of even larger dust particles which are able to penetrate the front sheet ($m > 10^{-7}$ g).

4.6 Fast Ion Sensor/Implanted Ion Sensor

Principal Investigator: A. Johnstone
Mullard Space Science Laboratory
Holmbury St. Mary, England

Major collaborating institutes (hardware):

Max-Planck-Institut fuer Aeronomie, Lindau, W. Germany
Istituto Plasma Spaziale, Frascati, Italy

This instrument consists of two sensors. A Fast Ion Sensor operating in two modes measures the solar wind distribution with high angular and energy resolution and obtains a 3-dimensional ion distribution with coarse angular and energy resolution. An Implanted Ion Sensor measures the distribution of cometary ions picked up by the solar wind after being ionized at large distances from the nucleus.

The Fast Ion Sensor consists of a hemispherical plate electrostatic energy analyzer with a subsequent quadrispherical sector (80°) to disperse the trajectories according to the input polar angles and a microchannel plate to detect the particles emerging from the analyzer. To find the solar wind distribution the data are accumulated from four polar sectors between 32.5° and 122.5° and from 16 azimuthal sectors centered on the solar direction. In each sector energy resolution is provided by an energy sweep in 32 equal energy bands ($\Delta E/E = 7.5$ percent) in the range 200 - 8000 eV. Data are compressed by only transmitting the energy spectrum of the eight angular bins with the highest fluxes. As the distribution broadens corresponding to an increase in the temperature of the solar wind, adjacent angular bins are combined together.

For the fast 3-d survey, each energy sweep is divided into eight equal energy bands ($\Delta E/E = 30$ percent) from 200 - 8000 eV, with spatial resolution obtained in three polar sectors between 10° and 145° and in four 90° wide azimuthal sectors.

The Implanted Ion Sector (IIS) is an ion spectrometer which combines an electrostatic analyzer with a time-of-flight measurement. The quadrispherical electrostatic analyzer selects positive ions of a given energy per charge E/Q , which are then accelerated by a potential difference, V , before the time T to travel a path length D is determined. By measuring these quantities the mass to charge ratio can be determined.

$$\frac{M}{Q} = 2 \left(V + \frac{E}{Q} \right) \frac{T^2}{D^2}$$

Since cometary particles are ionized by charge-exchange or photons the charge state is predominantly $Q = 1$, allowing the ion mass to be determined.

The instrument uses six time-of-flight tubes with a path length of 4 cm each. The "start" signal is provided by secondary electrons generated by the ion passage through a thin carbon foil, the "stop" signal by secondary electrons generated in the surface layer of a spherically shaped aluminum absorber.

The IIS measures in six polar directions in the range 20° - 160° and in 16 azimuthal sectors over 360° . Both mass and energy spectra are expanded into 32 channels. Within 16 spin periods the instrument generates a complete 3-d distribution of six selected ion groups, while a detailed mass spectrum is accumulated over 32 spin periods. The energy range of the sector is 0.1 - 70 keV with an upper mass limit of 44 amu.

4.7 Electron Electrostatic Analyzer/Positive Ion Cluster Composition Analyzer

Principal Investigator: H. Reme
Centre d'Etudes Spatiale des Rayonnements
CNRS
Toulouse, France

Major collaborating institutes (hardware):

Max-Planck-Institut fuer Aeronomie, Lindau, W. Germany
Space Sciences Laboratory, University of California, Berkeley, California

This instrument consists of two sensors. An Electron Electrostatic Analyzer (EESA) is intended to measure the pitch-angle distributions for suprathermal electrons in the energy range 0.01 - 30 keV, a Positive Ion Cluster Composition Analyzer (PICCA) measures positive ions and positive clathrate hydrates ($R^+ \cdot (H_2O)_m$) up to masses > 200 amu in the innermost part of the coma.

The basic EESA analyzer design is a symmetrical spherical section electrostatic analyzer which has a uniform $360^{\circ} \times 4^{\circ}$ disk-shaped field of view and extremely fine angular resolution capability ($2^{\circ} \times 4^{\circ}$). The symmetric quadrisphere consists of an inner hemisphere which contains a circular opening, and a small circular top cap which defines the entrance aperture. This analyzer is hemispherical in shape but called quadrispherical because the particles are only deflected through 90° . As in the normal quadrispherical analyzer a potential is applied between the inner and outer plates and only charged particles having a limited range of energy and initial azimuth angle are transmitted.

The electrons are registered by a position sensitive detector consisting of a microchannel plate electron multiplier with a position encoding anode and an anti-coincidence scintillator. The position sensitive detector with its anti-coincidence shield form an annulus at the analyzer exit aperture.

The instrument operates in two modes. In the "Full Pitch Angle Mode" a 16 channel energy spectrum in the energy range 0.01 - 30 keV is integrated for 2 sec over all angles. In the "Fast Pitch Angle Energy Scan Mode" the energy range 0.03 - 30 keV is divided into six channels, with spatial information being obtained every 2 sec in 26 viewing directions, each $45^{\circ} \times 45^{\circ}$ wide. In addition, the angular position of the count rate maximum of each of the six energy channels is identified.

The light-weight PICCA subexperiment is intended for operation in the innermost part of the coma only, where the cometary ions are expected to be singly charged and to have negligible thermal velocities. In the spacecraft frame of reference these particles will flow strictly radially towards the spacecraft with a velocity of 68 km/s and their kinetic energy will therefore range from 24 eV (1 amu) to 6.3 keV (256 amu). As the energy E and the charge Q of the particles to be analyzed are known, an E/Q measurement is directly related to their mass m . Thus PICCA is designed to be an electrostatic analyzer with a single channeltron as detecting device with the advantage (i) to be much more lightweight than any magnetic mass spectrometer and (ii) to perform individual measurements of M in less than $10\mu s$.

Even with an $\Delta E/E$ of 10 percent of mass resolution of $\Delta m < 1$ is achieved by using an open deceleration device (DD) into the collimator in front of the electrostatic analyzer. First DD is set to 0V allowing particles with masses 1-8 amu to be analyzed, second DD is set to a discrete positive voltage to reject particles with $m < 8$ amu to allow particles with masses 9-16 to be analyzed, etc. Considering that the energy cycle covering 8 masses at a time in the analyzer itself takes ~ 80 msec a full cycle from 1 to 256 amu takes ~ 2.5 sec.

4.8 Energetic Particles

Principal Investigator: S. McKenna-Lawlor
 St. Patrick's College
 Maynooth, Ireland

Major collaborating institutes (hardware):

Dublin Institute for Advanced Studies, Dublin, Ireland
 Max-Planck-Institut fuer Aeronomie, Lindau, W. Germany

The Energetic Particles Experiment (EPA) is a very lightweight telescope (400 g) with a large geometric factor ($\sim 1 \text{ cm}^2 \text{ sr}$) to measure electrons $> 30 \text{ keV}$, protons $> 100 \text{ keV}$ and particles with $Z > 2$ and $> 2.1 \text{ MeV}$. Three totally depleted silicon surface barrier detectors will be employed:

Detectors	Area	Thickness	Shape
A	1.13 cm^2	50 μm	Circular
B	1.13 cm^2	100 μm	Circular
C	4.0 cm^2	100 μm	Circular

The three detectors have three discriminator thresholds each. Applying various logic combinations from these discriminators, nine energy channels can be derived as listed in Table 6.

TABLE 6. Energy Channels of Energetic Particles Experiment

Particle Type	Channel	Energy Range	Coincidence Condition	Directionality
Electron	1	30-90 keV	A ₁ A ₂ B ₁ C ₁	4 sectors and omnidirectional
Proton	2	0.1-2.1 MeV	A ₂ A ₃ B ₁ C ₁	4 sectors
Alpha	3	2.1-8.0 MeV	A ₃ B ₁ C ₁	omnidirectional
Electron	4	92-185 keV	A ₂ B ₁ B ₂ C ₁	omnidirectional
Electron	5	$> 185 \text{ keV}$	A ₂ B ₁ B ₂ C ₁ C ₂	omnidirectional
Proton	6	2.1-4.0 MeV	A ₂ B ₁ B ₃ C ₁	omnidirectional
Alpha	7	8.0-16.0 MeV	A ₂ B ₁ B ₃ C ₁	omnidirectional
Proton	8	4.0-5.6 MeV	A ₂ B ₁ C ₁ C ₃	omnidirectional
Proton	9	$> 45 \text{ MeV}$	A ₂ A ₃ B ₁ C ₁ C ₂	omnidirectional

As is evident from Table 6 the C detector serves essentially as an active anti-coincidence shield for all channels which use the anti-coincidence of C₁. In addition, the instrument is passively shielded by an aluminum wall of 5 mm thickness which absorbs galactic and solar cosmic rays (e.g., protons < 33 MeV). The aperture of the telescope is a cone with 60° full angle, oriented perpendicular to the spacecraft spin axis. The instrument has coarse spatial resolution provided by accumulating the counting rate in four sectors during one spacecraft spin.

The prime purpose of the EPA is to extend the range of the Giotto plasma analyzers to higher energies and to measure the high energy tail of comet-accelerated particles, the deflection of low energy solar particles at the bow shock and their absorption by cometary dust near the nucleus. In addition, EPA monitors the energetic solar particle fluxes and thus provides useful background information, in particular, during a solar flare to instruments using devices which are sensitive to these particles, such as channeltrons, channel plates and CCD.

4.9 Magnetometer

Principal Investigator: F. M. Neubauer
Institut fuer Geophysik und Meteorologie
T. U. Braunschweig, W. Germany

Major collaborating institutes (hardware):

Laboratory for Extraterrestrial Physics, NASA/GSFC, Greenbelt, Maryland
Istituto Plasma Spaziale, CNR, Frascati, Italy

The magnetic field is measured by a wide range (0.004 – 65536 nT) triaxial ringcore fluxgate magnetometer mounted on the antenna mast. The Giotto magnetometer is identical to the GSFC-fluxgate magnetometers flown on Voyager and intended for flight on ISPM, apart from improved noise characteristics by use of different sensor core alloys.

The principle of the fluxgate magnetometer is as follows: Suppose in the simplest sensor arrangement a ferromagnetic core of soft magnetic material is periodically driven into saturation by a drive coil generating a periodic magnetic field strength of suitable wave shape at the drive frequency f_0 . An additional sense coil around the core will then exhibit a distorted signal composed of frequency components at f_0 and odd harmonics. Addition of an ambient magnetic field component along the core axis will lead to the appearance of even harmonics. Generally, in fluxgate magnetometers the second harmonic is detected because its amplitude turns out to be proportional to the ambient field component parallel to the core or the sense coil axis. In order to obtain good linearity a feedback coil is generally added to compensate the ambient magnetic field in response to the output from the sense coil. In this case, the sense coil is essentially used for zero detection only.

The fluxgate sensor has a ring core which is superior to other geometries in terms of long term zero level stability and drive power requirements. The magnetic material used in these cores is the latest in a series of advanced molybdenum permalloy alloys which have been especially developed for low-noise and high stability.

Since one basic magnetometer reading, i.e., one vector, is described by 40 bits, the allocated data rate of 1200 bps allows a sampling rate of 30 vectors/sec. Measurements before the general science data take which starts only at 3:45 hours before closest approach are obtained by using a small 65 bit-memory. At a sampling rate of two vectors per minute the memory allows to store data for over 13 hours to be transmitted at the begin of the general science data take.

Every magnetic field experiment on a spacecraft has to cope with the problem of contamination by spacecraft fields due to magnetized material and electric currents in the spacecraft. Therefore, a minimum magnetic cleanliness programme which is still compatible with the spacecraft low cost design philosophy was incorporated very early. In addition, measurements during the cruise phase allow the determination of a constant spacecraft magnetic field vector. To a limited extent it is possible to "calibrate" the spacecraft in the

interplanetary medium by controlled changes of experiment and spacecraft modes. Finally, the spin of the spacecraft allows the determination of the B_x and B_y components of the spacecraft magnetic field.

4.10 Optical Probe Experiment

Principal Investigator: A. C. Levasseur-Regourd
Service d'Aeronomie du CNRS
Vernieres-le-Buisson, France

Major collaborating institutes (hardware):

Laboratoire d'Astronomie Spatiale, CNRS, Marseille, France
Space Astronomy Laboratory, University of Florida, Gainesville, Florida

Observations of cosmic dust have traditionally been classified as either "remote" (essentially optical) or "in situ" (mass spectrometers or impact detectors). Optical remote sensing results in a column brightness (integration over the line of sight) whose interpretation (inversion of the integral) is impossible without assumptions about both the spatial distribution of the dust grains and their scattering properties. In a cometary flyby a third type of observation, in-situ photopolarimetric observation and referred to as optical probing, is possible. It is the necessary link between the other in situ observations on Giotto and future, remote only, observations of comets.

For a photopolarimeter aimed tangentially to the spacecraft orbit, inversion of the brightness integral is rigorous and provides, without any assumption, in-situ observation on the local spatial density of dust and gas and on the scattering properties of dust grains. The requirement to observe tangentially offers two possibilities: forward or rearward, corresponding to scattering angles of 73° or 107° from the sun. Because of the less critical engineering demands (smaller baffle, no dust particle impacts) a rearward looking instrument was chosen.

The photopolarimeter utilizes a small refracting photometer composed of an objective lens (F/2.5, 12 mm diameter), eight interference filters located on the flat surface of the plano-convex objective lens, two spectrally matching polaroid foils, a field stop, a field lens, and a microchannel photomultiplier for spectral analysis. No moving parts are used. The rotation of the polaroid analyzers to determine the polarization is provided by the spinning spacecraft. One complete polarization measurement is performed during half a spacecraft spin, i.e., in 2 seconds. Successive line-of-sight measurements can be differenced such that the resulting brightnesses and polarizations only refer to a small volume of space (a "cylinder" of about 140 km in length and 7 km (corresponding to the instrument's 3° cone field of view) in diameter).

The dust will be observed in four spectral bands which are free or almost free of gaseous emissions: 338-362, 438-454, 570-586, 657-698 nm. Simultaneously, four discrete gaseous emissions will be observed: CS (258 nm), OH (309 nm), CN (388 nm), C_2 (516 nm).

The instrument will determine as a function of the spacecraft position:

- o the distribution of gaseous emissions (CS, OH, CN, C_2),
- o the variation of the dust number density,
- o changes in the dust particle size distribution
- o the ratio of gaseous emission/dust scattering.

5. MISSION ANALYSIS

The Giotto mission is a fast flyby of comet Halley near the comet's post-perihelion crossing of the ecliptic plane around 13 March 1986, ~ 1 month after the comet's perihelion passage. The baseline approach is a launch by Ariane in tandem configuration with another spacecraft. Ariane will launch both spacecraft in July 1985 into a Geostationary Transfer Orbit (GTO) (perigee 200 km, apogee 35786 km) where a separation of the two spacecraft will take place. After some resolution of this GTO, the number of which is principally dictated by

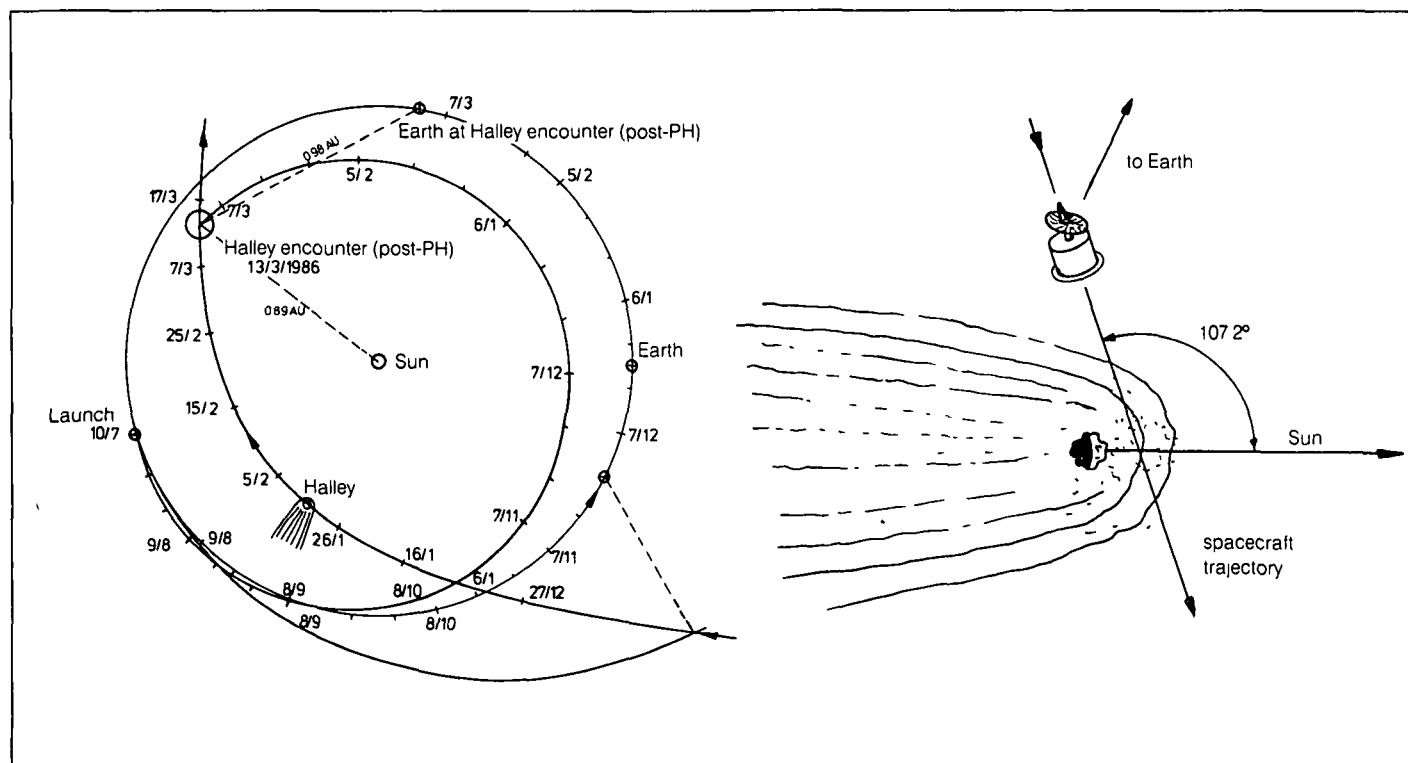

Figure 4. Left: Reference trajectory for Giotto from launch on 10 July 1985 to post-perihelion Halley encounter on 13 March 1986. Right: Geometry at Halley encounter. The spacecraft will be targeted to pass the comet nucleus on the sunward side. The estimated 1σ miss distance is ~ 500 km.

launch data and orbit re-constitution requirements, the solid propellant motor onboard the Giotto spacecraft will be fired close to GTO perigee to inject the spacecraft into the comet transfer trajectory. This heliocentric trajectory (Figure 4, left) has a closest approach to the sun of 0.7 AU and encounters Halley at a distance of 0.89 AU to the sun. The phase angle to the sun is 197.20° (Figure 4, right), i.e., the spacecraft approaches the comet nucleus from "behind", which is very fortunate for spacecraft survival considering that large dust particles are predominantly injected into the sunward hemisphere. The flyby velocity is 68 km s^{-1} .

During the transfer (or cruise) phase, spacecraft communications to earth will be acquired on a daily basis with the prime intent of spacecraft engineering and conditioning. During these intervals it may be possible to operate some experiments within the limits set by engineering constraints.

During cruise a number of mid-course manoeuvres are required to target the spacecraft at the comet nucleus. The spacecraft position is determined by earth-based tracking, while the comet ephemeris will be continuously updated by earth-based observations right up to the last orbit manoeuvre foreseen ~ 2 days before the encounter. The analysis indicates that a 1σ delivery error at the comet of 650×250 km (error ellipse) can be achieved. This error is mostly due to the uncertainty of the nucleus position in the coma (assumed to be $2''$ as seen from earth). It is estimated that a total ΔV of $\sim 150 \text{ m s}^{-1}$ is required which is provided by onboard thrusters using hydrazine.

In principle, it would be possible to use the onboard camera for terminal navigation. This is, however, not feasible for the Giotto mission since the comet must be observed by the camera against the background star field. The camera sensitivity will probably limit star detection at magnitude 6 whereas analysis has shown that there are no suitable guide-stars of sufficient magnitude within the 3° field of view of the camera.

At encounter the spacecraft provides an operational data take period of about 4 hours and in view of the potential hazards to the spacecraft from impacting cometary dust, the data will be transmitted to earth in real-time (no spacecraft on-board memory is provided). During the encounter the strategy in autonomous operation of the spacecraft apart from potential switching of data rates in the case of degradation of receiving conditions due to heavy rain at the site of the ground station.

Table 7 shows the final operation sequence just before the encounter.

TABLE 7. Final Operation Sequence

Start hrs:min	Operation	Transmission in S-band X-band
$t_0 - 32:00$	orientate spacecraft to encounter attitude (1 h)	[Hatched bar in S-band column]
$t_0 - 31:00$	nutaton decay (0.5 h)	
$t_0 - 30:30$	check attitude and correct if necessary (0.5 h)	[Hatched bar in X-band column]
$t_0 - 30:00$	EXPERIMENT OPERATION (2 h) check full calibration including commands (2 h)	
$t_0 - 28:00$	update attitude (0.5 h)	
	(required before final operation : <ul style="list-style-type: none"> • 24 hours for battery charging • 8 hours for phase change material to cool down) 	
$t_0 - 12:00$	check spacecraft status (0.5 h)	[Hatched bar in S-band column]
$t_0 - 4:15$	check spacecraft attitude and housekeeping (0.5 h) check experiment housekeeping (0.5 h)	[Hatched bar in S-band column]
$t_0 - 3:45$	SCIENCE DATA TAKE (4 h)	[Hatched bar in S-band column]
$t_0 + 0:15$	end of nominal mission (because of battery exhaustion and phase change material overload; S/C and experiments will not be switched off and any remaining margins will be exploited).	[Hatched bar in S-band column]

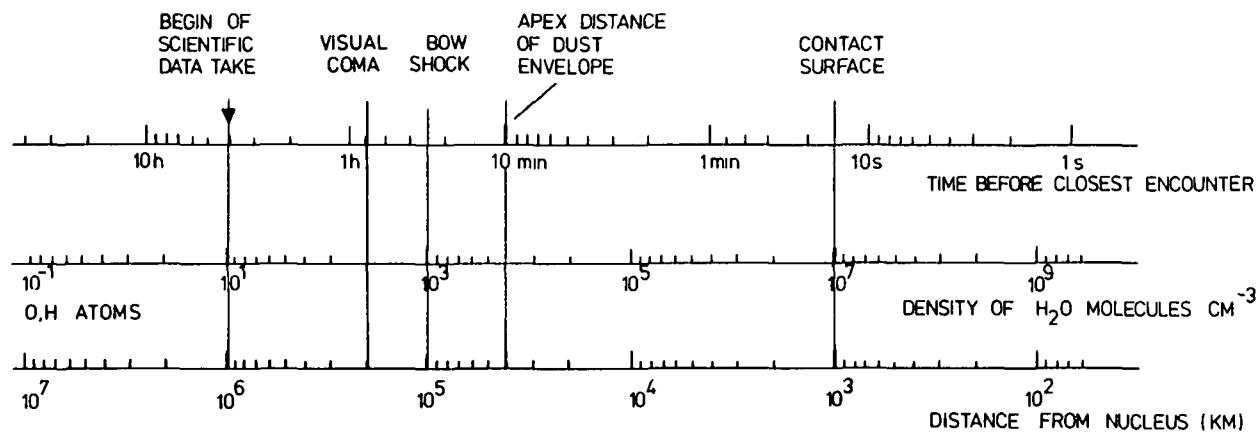

Figure 5. Comet Halley encounter model.

6. SPACECRAFT DESIGN

The cross sectional view of the Giotto spacecraft (Figure 6) shows its main features:

- o a bumper shield consisting of a thin (1.2 mm Al) front sheet and thick (13 mm Kevlar) rear sheet separated by 25 cm to protect the spacecraft against impacting cometary dust particles up to 0.1 g.
- o A solid propellant kick motor centrally mounted along the spin axis with a ΔV capability of ~ 1400 m/s. Four quadrants flap over the kick motor nozzle after firing and complete the front sheet of the bumper shield.
- o An antenna farm consisting of a high gain dish antenna (paraboloid of 1.5 m diameter) and a low gain, large beam-width antenna. The high gain antenna is despun and included at 44° to point at the earth during the encounter.

The spacecraft has essentially three equipment platforms, from top to bottom (Figure 5), the "upper" platform, the "lower" platform and the "experiment" platform which is mounted on top of the rear sheet of the bumper shield (with a small separation). The upper and lower platforms carry spacecraft equipment boxes on both upper and lower faces, whereas all experiment sensors and electronic boxes are mounted on the experiment platform, with the exception of the dust impact detectors (mounted on the front sheet of the bumper shield) and the magnetometer sensor (mounted on the antenna mast). The experiment sensors can protrude from the spacecraft side wall up to 17 cm to allow measurements in the undisturbed flow of cometary particles. The constraint of 17 cm is imposed by the launch dynamic envelope of 218 cm, centered on the spacecraft axis.

Giotto is a spin-stabilized spacecraft, it spins at 15 rpm. At encounter, the velocity vector in the comet frame of reference (relative velocity vector) is aligned with the spin axis, i.e., all cometary particle streaming is from below in Figure 6. The spin axis, however, is not perfectly aligned with the relative velocity vector. Various errors (in-orbit misalignment of the star mapper with respect to the "nominal" spin axis, dynamic imbalance, attitude control error, spin axis nutation) add up to a total error of 0.28° (1σ).

Power is provided by a solar cell array (131 W at 0.9 AU from the sun) and by batteries (584 WH assuming a depth of discharge of 90 percent). Considering on the other hand the energy consumed (X-band transmitter 87.4 W, other subsystems 40.0 W, experiments 61.7W) there is a small positive margin of 90 Wh for the 4-hour Halley encounter. In calculating the energy balance it has been assumed that the solar cell array is lost 2 hours before t_0 due to dust impact which is probably overconservative.

It should be noted that the duration of the science data take period is not only limited by the available power but also by the amount of phase change material used for thermal control and by the availability of ground receiving stations.

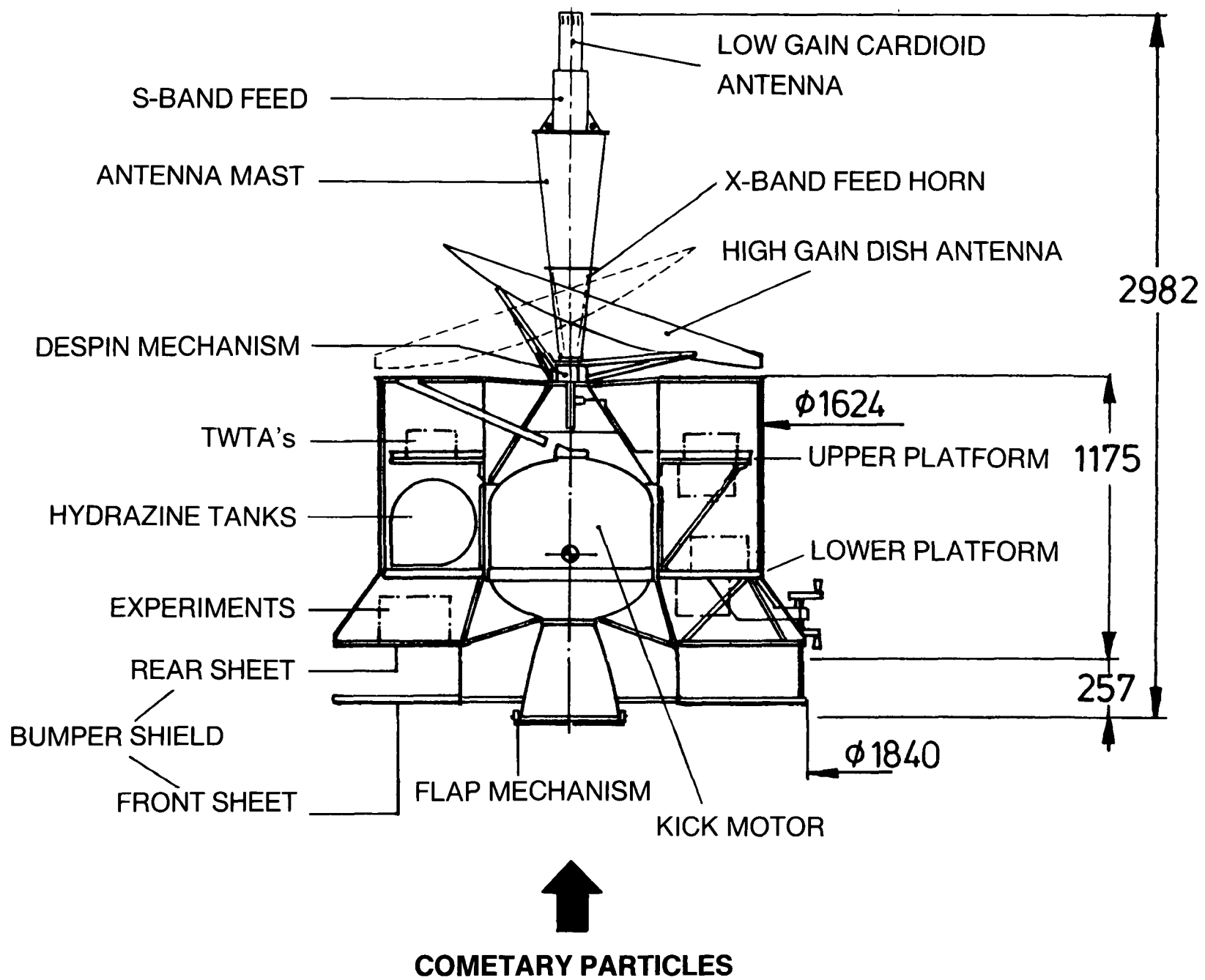

Figure 6. Giotto spacecraft cross-sectional view.

The spacecraft attitude during cruise and encounter is maintained by the Attitude and Orbit Control Subsystem (AOCS) to within 1°. The Attitude Measurement System (AMS) consisting of sun sensors and a star mapper is used throughout the cruise phase to measure solar aspect angle, spin rate and star positions such that the spacecraft attitude can be reconstituted. In the design particular attention has been paid to anomalous conditions should the spacecraft attitude be disturbed and antenna earth pointing be lost. This is particularly important when the spacecraft earth distance is so great that the communication can only be maintained by the HGA. In this anomalous condition the Attitude Recovery Unit (ARU) initiates a recovery sequence in which the Spacecraft is processed at a constant solar aspect angle about the spacecraft-sun line until the appropriate star pattern is recognized. The Reaction Control Equipment has a total ΔV capability of ~ 200 m/s and requires approximately 44 kg of hydrazine. Six thrusters are used: 2 radial, 2 axial, 2 tangential.

The Telemetry Tracking and Command (TT and C) Subsystem consists of a

- o 5 W S-band (2.3 GHz) redundant transmitters operating via a cardioid low gain large beam-width antenna (3° pointing required) or via the high gain antenna (0.5° pointing required),
- o 20 W X-band (8.4 GHz) redundant transmitters (TWT) operating via the high gain antenna,
- o redundant S-band receivers for command reception and ranging.

The X-band link budget shows that 40 kbps can be achieved even if a 5 dB weather margin (rain + feed losses) is included. Statistical analysis of weather data for typical DSN stations indicates that for 99.9 percent of the time the weather would permit data rates in excess of 40 kbps.

The Giotto subsystem mass budget is shown in Table 8.

TABLE 8. Giotto Subsystem Mass Budget

Subsystem	Mass (kg)
Structure	63.4
Thermal	18.2
Attitude Measurement System	10.5
Data Handling	14.8
Attitude and Orbit Control System	11.6
Telemetry, Tracking and Command	40.7
Power	39.7
Harness	33.0
Experiment Payload	54.4
Solid Propellant Motor	305.9 > 33.8
Hydrazine and Helium	44.5 > 0
Bumper Shield	60.0
Balance/Stabilizing Mass	15.3
Margin	<u>38.0</u>
TOTAL	750 kg

At the end of the mission the solid propellant motor will have burnt out and the hydrazine and helium tanks will be empty reducing the total spacecraft mass to 433.4 kg.

7. GROUND SYSTEM DESIGN

As Table 9 shows essentially three mission phases can be distinguished, depending on the required ground station.

TABLE 9. Ground System Mission Phases

	I	II	III
S/C antenna	Launch, GTO, and cruise phase (up to 6 days)	Cruise Phase (up to day 185)	Encounter (after day 185)
S/C Antenna	Cardioid	HGA	HGA
Ground Stations	Carnavon, Kourou Weilheim	Weilheim	Weilheim Parkes
Band	S-band	S-band	X-band X-band

Weilheim (effective radiated power 126.5 dBm) can be used for telecommands throughout the mission. During all mission phases the required ground stations will be connected to the European Space Operations Centre (ESOC) in Darmstadt where the mission control will be exercised. For the 4-hour Halley encounter the Australian CSIRO institute has offered the use of its 64 m antenna at Parkes which is normally used for radio astronomy. This antenna can be linked via satellite to the ESOC allowing transmission of data at a rate of up to 8 kbps. All received encounter data will be stored (at the full data rate) on magnetic tape at Parkes for later dissemination to the experiments. At ESOC data will be separated three ways

- o spacecraft housekeeping data for display on a VDU,
- o experiment science data for display on a VDU (quick-look facility),
- o off-line computer for storage of sampled experiment data.

The quick-look facility will provide VDU sampled data display, data printouts, and first TV images of the comet nucleus. This facility will accommodate for active participation of the experimenters during critical experiment related mission sequences, especially during the encounter.

8. ENVIRONMENTAL EFFECTS

8.1 Dust Particle Impacts

During the Halley flyby, dust particles will impact on the spacecraft's leading surface with a velocity of 68 km s^{-1} and particles with masses $< 10^{-6} \text{ g}$ could easily penetrate the spacecraft structure if it were unshielded. A cloud of debris would be formed inside the spacecraft. This cloud would expand inside and cause catastrophic damage to experiments and subsystems.

Outside $\sim 100,000 \text{ km}$ from the comet nucleus the possibility of dust particle impacts is negligible. Even up to $\sim 50,000 \text{ km}$ the possibility of a dust particle with a mass $> 10^{-6} \text{ g}$ impacting on the spacecraft is only 3 percent (N. Divine, private communication). Close to the nucleus, in particular, if the spacecraft passes the comet on the sunward side the possibility of large dust particle impacts increases dramatically and an unshielded spacecraft would be destroyed many thousands of kilometers before reaching the vicinity of the nucleus. Since the scientific return of the cometary mission is greatly enhanced if the spacecraft reaches the inner part of the coma, it is essential to shield the spacecraft.

Simply increasing the thickness of the leading surface leads to the following dilemma: either the spacecraft cannot be protected within a reasonable shield weight or the shield weight becomes excessive for any meaningful protection. A dual-sheet bumper shield is an ideal and in fact the only solution. This shield consists of a thin front sheet and a thick rear sheet with some space between. The front sheet breaks up the dust particle, the debris cloud expands into the empty space between the two sheets and impacts on the rear sheet. It is desirable to have a large separation between the two sheets in order to distribute the impact energy over a wide area.

The present shield design envisages a 1.3 mm front sheet made out of aluminum and a 13 mm rear sheet made out of Kevlar, with a separation of 25 cm between the sheets. The total shield weight is ~ 60 kg.

It is essential for correct operation of the shield that the 25 cm between the two sheets is kept essentially free. No experiment sensor can be located in this region, particularly none looking through the front sheet to the comet nucleus. Lightweight detectors for dust impacts can however be accommodated on the front sheet, the associated electronics/power units being mounted on the equipment platform.

To calculate the probability of spacecraft survival in the innermost part of Halley, three different mechanisms through which the spacecraft could be destroyed have been considered:

1. Individual large particles, whose debris cloud may not be completely vaporized and impacts on the rear sheet tearing it.
2. Numerous intermediate-sized particles, which produce holes in the front sheet, so that a large fraction of its surface might disappear. A large particle might then impact directly on the rear sheet and its debris cloud would propagate into the spacecraft's interior.
3. A very large number of small particles, which produce craters in the front sheet, leading to its erosion. The front sheet would become thinner and thinner until holes were produced (increasing hazard 2) or until the whole front disappeared.

The hazards due to these three mechanisms have been calculated and all lie in the range of a few percent for a flyby at a distance of a few hundred kilometers. It is concluded that there is a high probability that the spacecraft will survive the Halley encounter. (The details of the shield design, the Halley dust model, and calculations on the survival probability can be found in the Comet Halley Micrometeoroid Hazard Workshop Proceedings, ESA SP-153).

8.3 Spacecraft Plasma Environment

As the spacecraft approaches the comet nucleus cometary neutrals (atoms and molecules), ions and dust particles impact on the front sheet of the bumper shield with a velocity of 68 km s^{-1} . At these high velocities the impacting primary atoms, molecules and ions cause the emission of secondary neutrals and ions. It is estimated that one ion-electron pair is produced by each impacting neutral or ion molecule if the front sheet material is aluminum. The impacting dust particles are broken up into atoms by the impact energy and the atoms are partly ionized depending on the mass of the dust particle. For masses $> 10^{-6} \text{ g}$ the degree of ionization is a few percent.

The impact-generated plasma around the spacecraft gives rise to a space charge cloud in front of the spacecraft, causes a spacecraft potential, and presents a problem to cometary plasma measurements onboard Giotto since the density of the impact-generated plasma may be orders of magnitude higher than that of the cometary ions. These adverse effects have been quantitatively calculated for the case of a fast flyby of Halley at 57 km s^{-1} and a heliocentric distance of 1.5 AU pre-perihelion (details of these calculations can be found in the proceedings of the Halley Probe Plasma Environment Series of Workshops, ESA SP-155).

For the pre-perihelion flyby Figure 7 gives a comparison of total number of ion-electron pairs produced by all dust particle impacts and the number of ions produced by impacting cometary neutrals assuming aluminum as front sheet material. Also shown for comparison is the

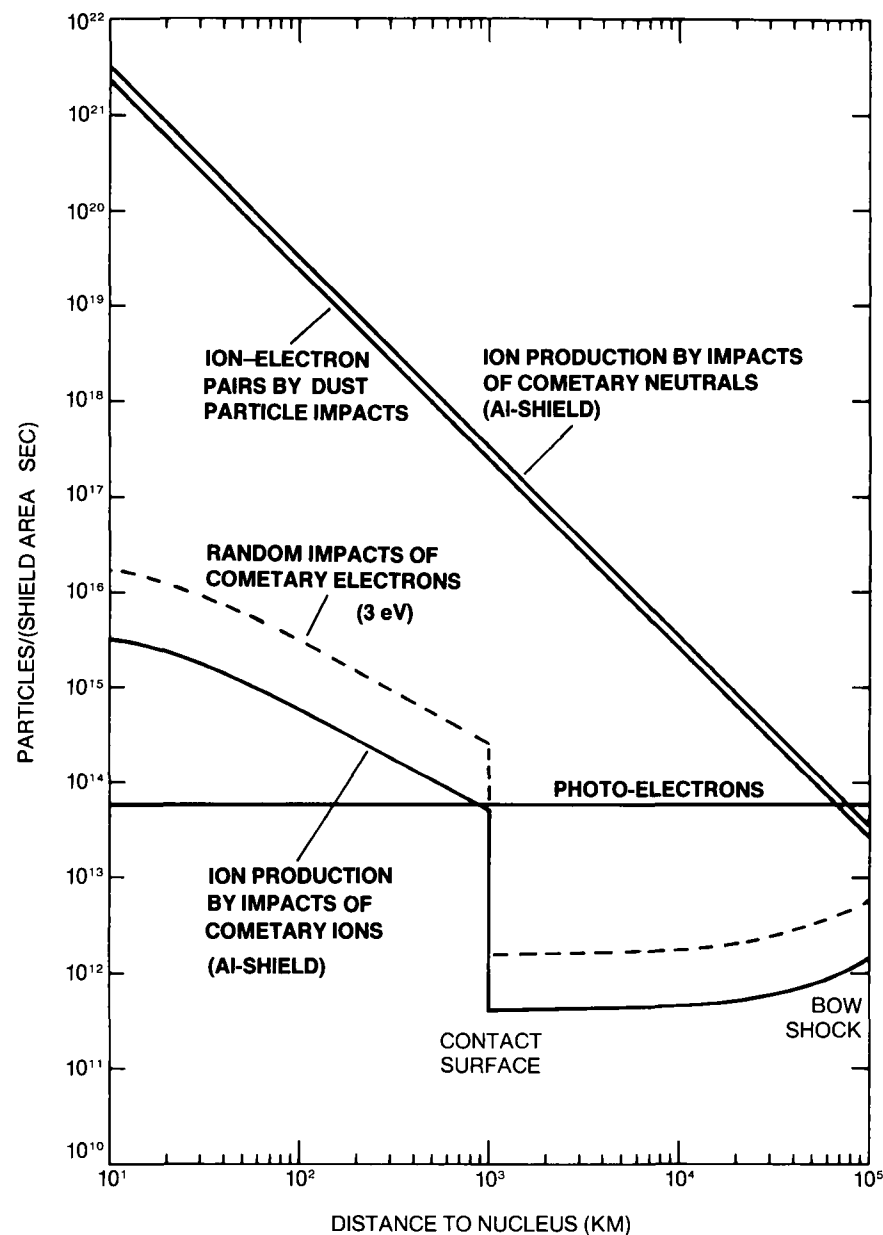

Figure 7. Total production rate of ion-electron pairs by dust particle impacts and of ions by impacts of cometary neutrals. Using gold instead of aluminum as front sheet materials would reduce the ion production by impacts of neutrals by 3 to 4 orders of magnitude. (after Gruen and Reinhard, 1981)

number of ions generated by impacts of cometary ions (identical to the number of impacting cometary ions), the random flux of cometary electrons assuming a mean random kinetic energy of 3 eV and, finally, the flux of photoelectrons. Evidently, the fluxes of the last three species contribute negligibly at distances $< 10^4$ km from the nucleus and the main concern remains about the ion production by cometary neutrals, since the flux of dust impact generated ions is only an upper limit (most of the dust-impact-generated ion-electron pairs recombine before leaving the plasma cloud which is produced upon each dust particle impact).

Since gold has a much lower ion production rate than aluminum for impacting neutrals the front sheet material of the bumper shield is gold. On the other hand, gold has one of the highest ion yields for dust particle impacts. Therefore, only a thin (10μ) gold-coating with negligible interaction and the ion-electron pair production by dust particles is primarily determined by the interaction of the dust particle with the aluminum, whereas the cometary neutrals only interact with the gold-coating.

Other measures to reduce the adverse effect of spacecraft charging include the provision of an equi-potential coating for the Giotto spacecraft in critical areas close to experiment sensors. It is expected that the spacecraft potential is low ($\sim +20$ V).

Finally, although the density of the impact-generated plasma is orders of magnitude higher than that of the cometary ions the adverse effects on detector background might be limited because the highest densities of the impact generated plasma are found above the front sheet away from the plasma sensors and, secondly, the impact-generated ions can be distinguished from the cometary ions by their distinctively different velocity distributions (in the spacecraft frame of reference the distribution of cometary ions is centered at 68 km s^{-1} while the distribution of the impact-generated ions is at rest).

9. SUMMARY

All major bodies of the inner solar system have been explored by spacecraft. Only the most remote planets are as yet beyond our reach. The exploration of the minor bodies, such as comets, is the next natural step. From this we can expect new understanding of a kind that is

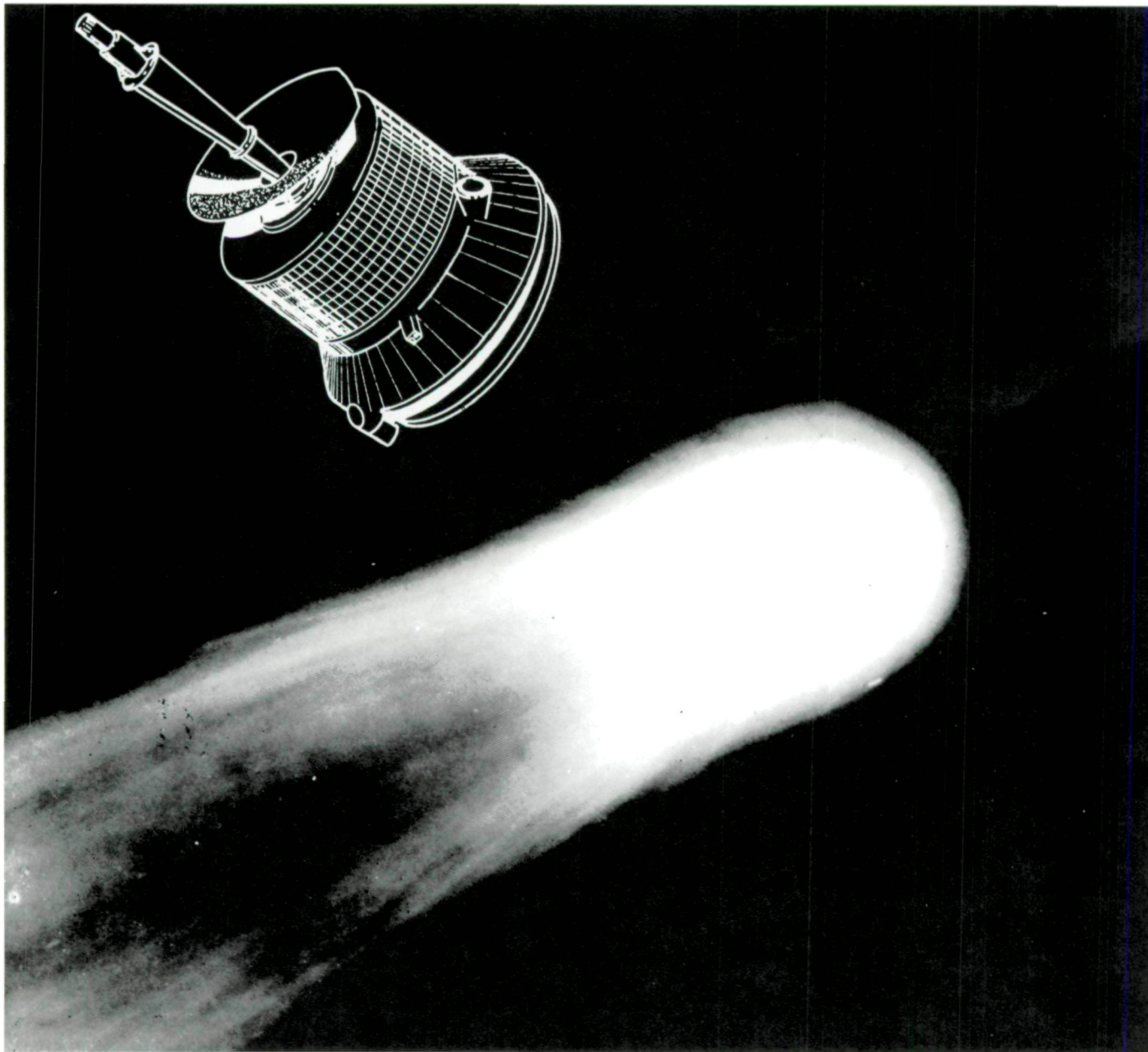

Figure 8. Giotto spacecraft at experiment switch-on, a few hours before closest approach to the comet nucleus.

qualitatively different from that provided by the investigation of the planets. Of the minor bodies, comets are by far the least fractionated and the most active members of the solar system. Stimulated by insolation, the cometary nucleus believed to consist of ice mixed with dust particles (dirty snowball) with a size of only a few kilometers releases its material into a coma, the outer fringes of which extend up to 10^8 km into space. Most of these processes have been at best understood only in their phenomenological aspects. It is the comets' activity that makes them different from all other bodies, but it also prevents us from observing their inner structure. Only in-situ measurements can provide the means to understand the phenomena correctly and to assign the comets their appropriate place in the history of the formation of our solar system.

Halley's comet has been selected for ESA's first cometary mission because of its enormous activity (comparable to "new" comets), its well-known orbit characteristics (29 returns), the low launch energy requirements and its outstanding role in history.

ESA's Giotto mission plans for a launch in July 1985 with a Halley encounter in mid-March 1986, ~ 4 weeks after the comet's perihelion passage. Giotto carries 10 scientific experiments, a camera, neutral, ion and dust mass spectrometers, a dust impact detector system, various plasma analyzers, a magnetometer and an optical probe.

Giotto is a spin-stabilized spacecraft based on a Geos design. It is equipped with a dual-sheet bumper shield to efficiently protect it from dust particle impacts in the innermost part of the coma, and with a high gain despun antenna allowing for a high data rate transmission at 40 kbps. The encounter in the comet environment will last about 4 hours, the flyby velocity is 68 km s^{-1} , the estimated flyby distance is 500 km or less. From this distance the Giotto onboard camera will resolve nucleus surface structures down to less than 30 m. Together with the Russian three-axis stabilized "Venera" spacecraft and the Japanese "Planet A" mission to Halley's comet Giotto will perform the first in-situ measurements at any comet.

REFERENCES

- Boissard, J.-B., S. Flury, G. Janin, and S. Baghi. 1981, Review of Ariane capabilities for interplanetary missions, ESA Journal 5, 1.
- Cornelisse, J. W. 1980, Mission analysis aspects of a comet Halley flyby mission, Internal ESTEC Working Paper No. 1241, May.
- ESA SCI (80) 4. 1980, Giotto - comet Halley flyby, Report on the Phase A Study, European Space Agency, May.
- Gruen, E. and R. Reinhard. 1981, Ion-electron pair production by the impacts of cometary neutrals and dust particles on the Halley probe shield. ESA SP-155, 7.
- Vsekhsvyatskii, S. K. 1964, Physical characteristics of comets (Translated from Russian), Israel Program for Scientific Translations, Jerusalem.
- Yeomans, D. K. and T. Kiang. 1981, The long term motion of comet Halley, accepted for publication in the Monthly Notices of the Royal Astronomical Society, April.