

N O T I C E

THIS DOCUMENT HAS BEEN REPRODUCED FROM
MICROFICHE. ALTHOUGH IT IS RECOGNIZED THAT
CERTAIN PORTIONS ARE ILLEGIBLE, IT IS BEING RELEASED
IN THE INTEREST OF MAKING AVAILABLE AS MUCH
INFORMATION AS POSSIBLE

COMMUTATED AUTOMATIC GAIN CONTROL SYSTEM

A commutated AGC system for the Ohio University prototype Loran-C receiver is described. The circuit design, fabrication, and test results are presented in this paper.

(NASA-CR-164798) COMMUTATED AUTOMATIC GAIN
CONTROL SYSTEM (Ohio Univ.) 25 p
HC A02/MF A01 CSCL 17G

82-14077

Unclas
08525

G3/04

by

Stephen R. Yost

Avionics Engineering Center
Department of Electrical Engineering
Ohio University
Athens, Ohio 45701

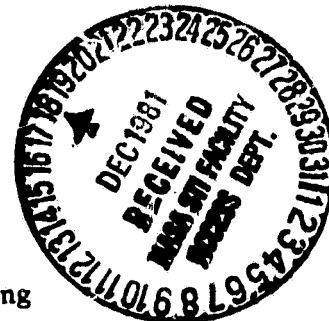

Prepared for

NASA Langley Research Center
Hampton, Virginia 23665

(Contract NGR 36-009-017)

TABLE OF CONTENTS

	PAGE
I. INTRODUCTION	1
II. SAMPLE CIRCUIT	1
III. DC GAIN CIRCUIT	13
IV. AGC AMPLIFIER	13
V. OPERATION	13
VI. TEST RESULTS	16
VII. CONCLUSIONS	21
VIII. SUMMARY	21
IX. ACKNOWLEDGEMENTS	23
X. REFERENCES	23

I. INTRODUCTION

This technical memorandum deals with the commutated automatic gain control (AGC) system that has been designed and built for the Ohio University prototype Loran-C receiver (refer to Figure 1). The current version of the prototype receiver, the Mini L-80, was tested initially in the summer of 1980. The receiver uses a Microcomputer Associates™ Super Jolt microcomputer to control a memory-aided phase-locked loop (MAPLL). The microcomputer also controls the input/output, latitude/longitude conversion, and the recently added AGC system. (For a more detailed description of the receiver operation, refer to TM 80 "A Loran-C Prototype Navigation Receiver for General Aviation." [1])

The Ohio University receiver uses an envelope generator and zero crossing detector to produce a "Loran pulse" which is used by the MAPLL to track the Loran station. It was observed that significant errors in the time differences occurred when very strong or weak stations were included in the Loran chain being tracked [2]. Experiments with a Loran simulator revealed that this error was caused by a phase shift and that this phase shift was due solely to the signal-to-signal ratio of the stations being tracked. For example, a 10 dB signal-to-signal difference produced approximately a ten microsecond error while a 20 dB difference produced approximately a 25 microsecond error. (These results were obtained with an Epsco Loran simulator.)

To reduce or eliminate this error, a commutated AGC was proposed at the December 1980 NASA Joint University Program meeting (refer to Figure 1-A). The AGC samples the peak of the envelope for each station and stores the resulting voltage on a capacitor. This stored voltage is then used to control the gain of the input RF signal. The microcomputer switches the AGC sample from station to station. This paper describes the circuit designed for the AGC and will also present bench and flight test results. The AGC circuit described actually samples starting at a point 40 microseconds after a zero crossing determined by the software lock pulse ultimately generated by a 30 microsecond delay and add network in the receiver front-end envelope detector. Thus this sample point will be at about the peak of the ground wave signal and not necessarily at the peak of the envelope delayed by strong skywave contamination. Throughout this report the reference to "peak of the envelope" has this restricted meaning. The whole idea of AGC control is to adjust the level of each station signal such that the early portion of each envelope rise is about at the same amplitude in the receiver envelope detector.

The final design is an expansion of the original proposed design (refer to block diagram Figure 2, as well as Figures 3, 4, and 5). It consists of three major parts: A) The sample circuit, B) the DC gain circuit and, C) the AGC amplifier circuit.

II. SAMPLE CIRCUIT

The sample circuit is a two-stage sample-and-hold system with three separate channels, the switching of these channels controlled by the

ORIGINAL PAGE IS
OF POOR QUALITY

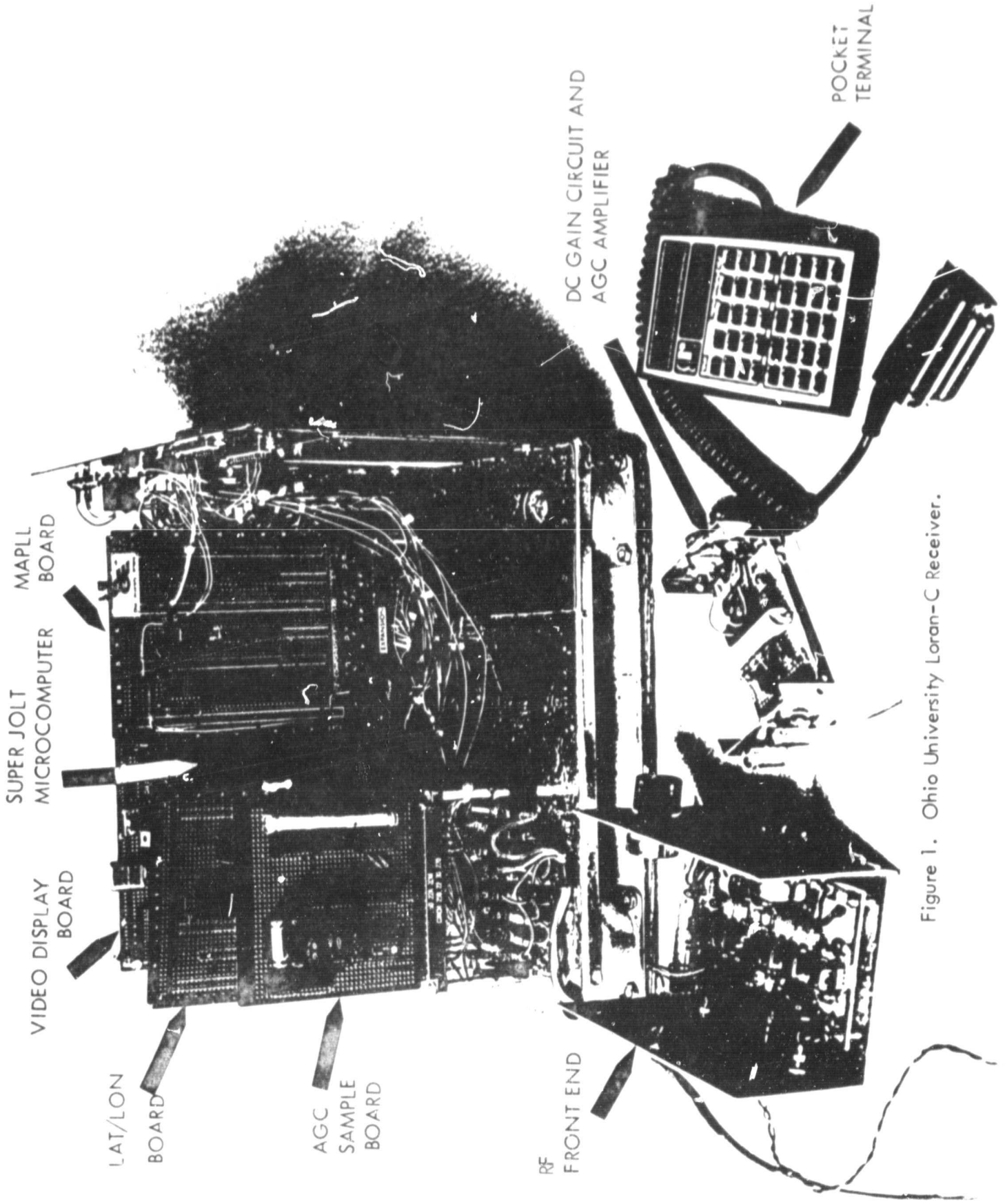
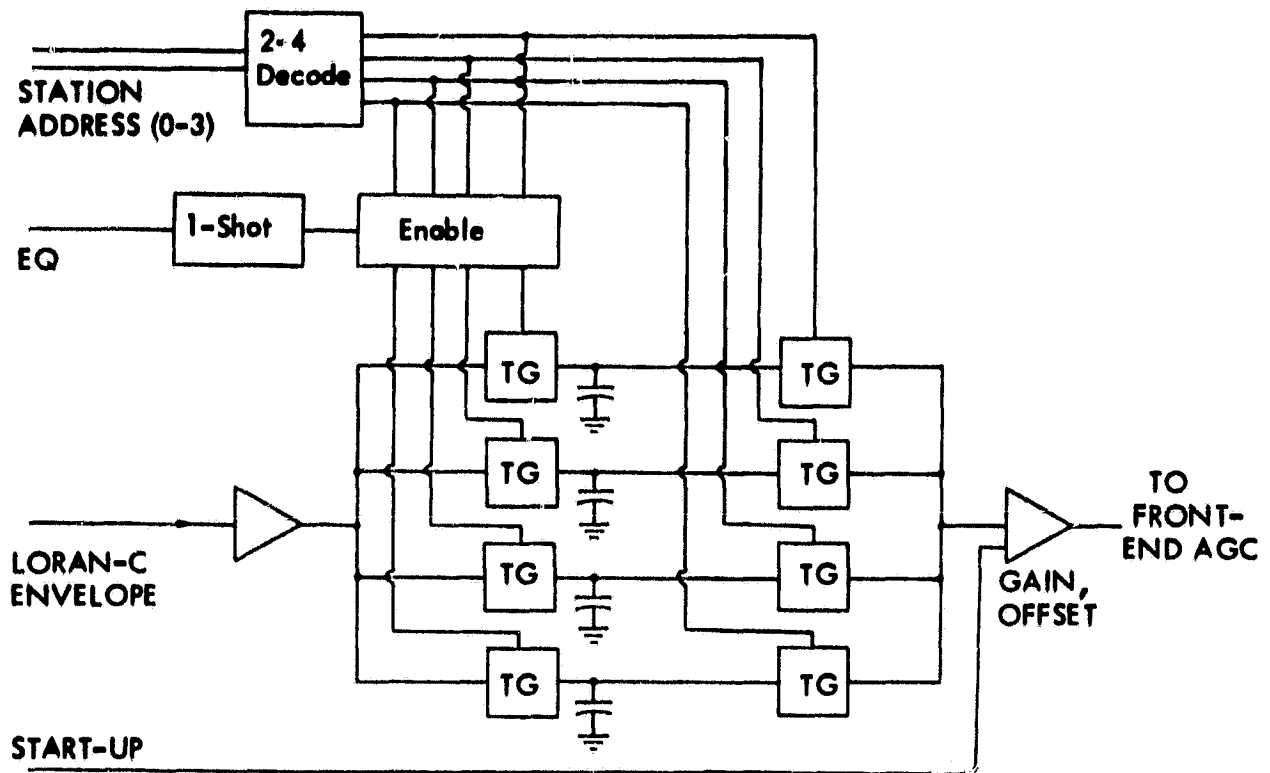

Figure 1. Ohio University Loran-C Receiver.



LORAN-C RECEIVER COMMUTATED AGC

- To be Added to Loran-C Low-Cost Prototype
- Commutated, Sampled AGC
- Avoids Front-End Phase Shift Problem
- Five Chips Required for Breadboard
- Permits Present AGC for Search Mode
- Minimum Load on Computer

Figure 1-A. Proposed Commutated AGC.

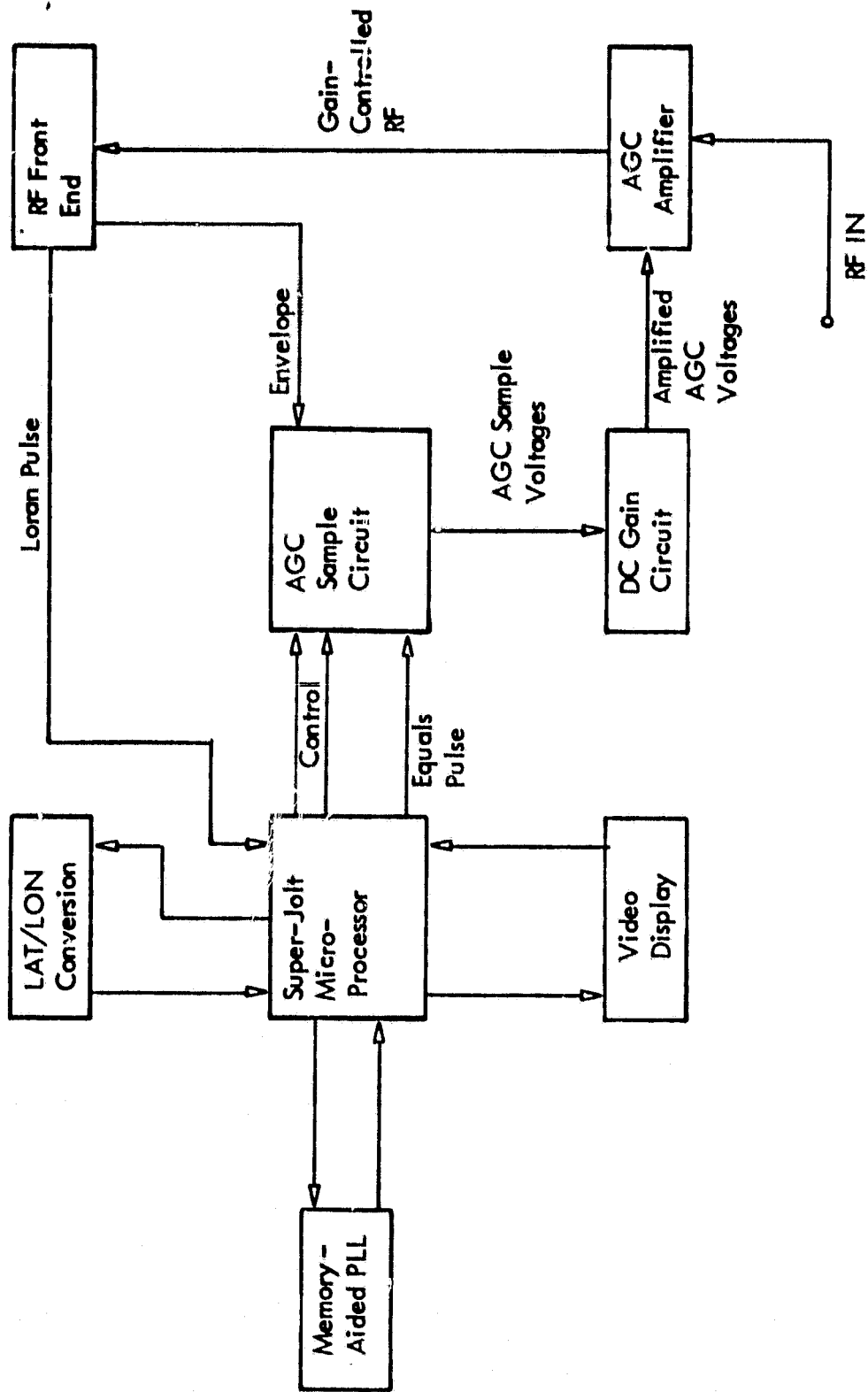
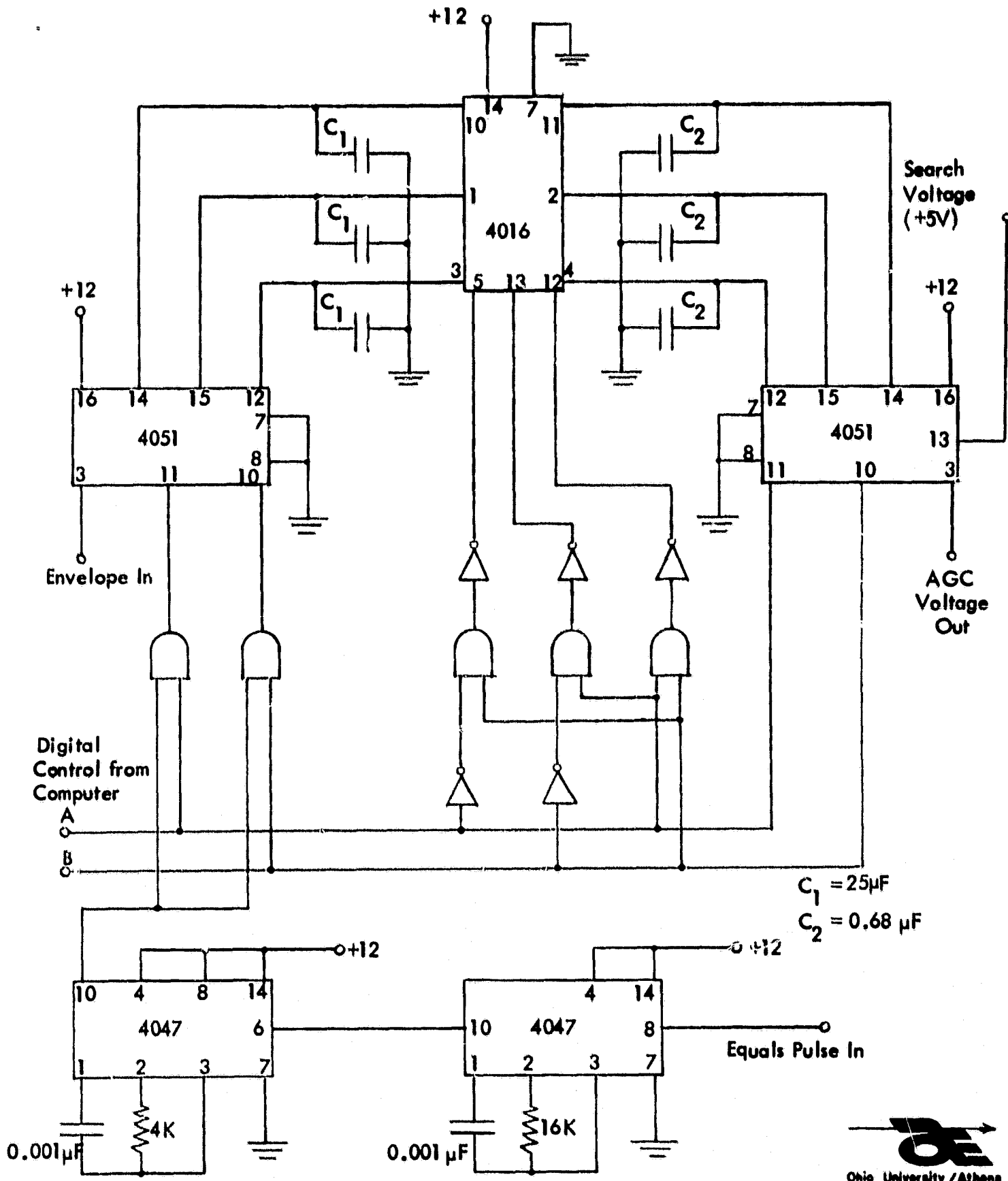

Figure 2. Ohio University Loran-C Receiver Block Diagram with AGC.



The above schematic is of the commutated AGC circuit designed for the Ohio University Loran-C receiver. All of the IC's are CMOS. This circuit is designed to sample the peak of the envelope of a Loran pulse to obtain an AGC voltage.

Figure 3. Sample Circuit.

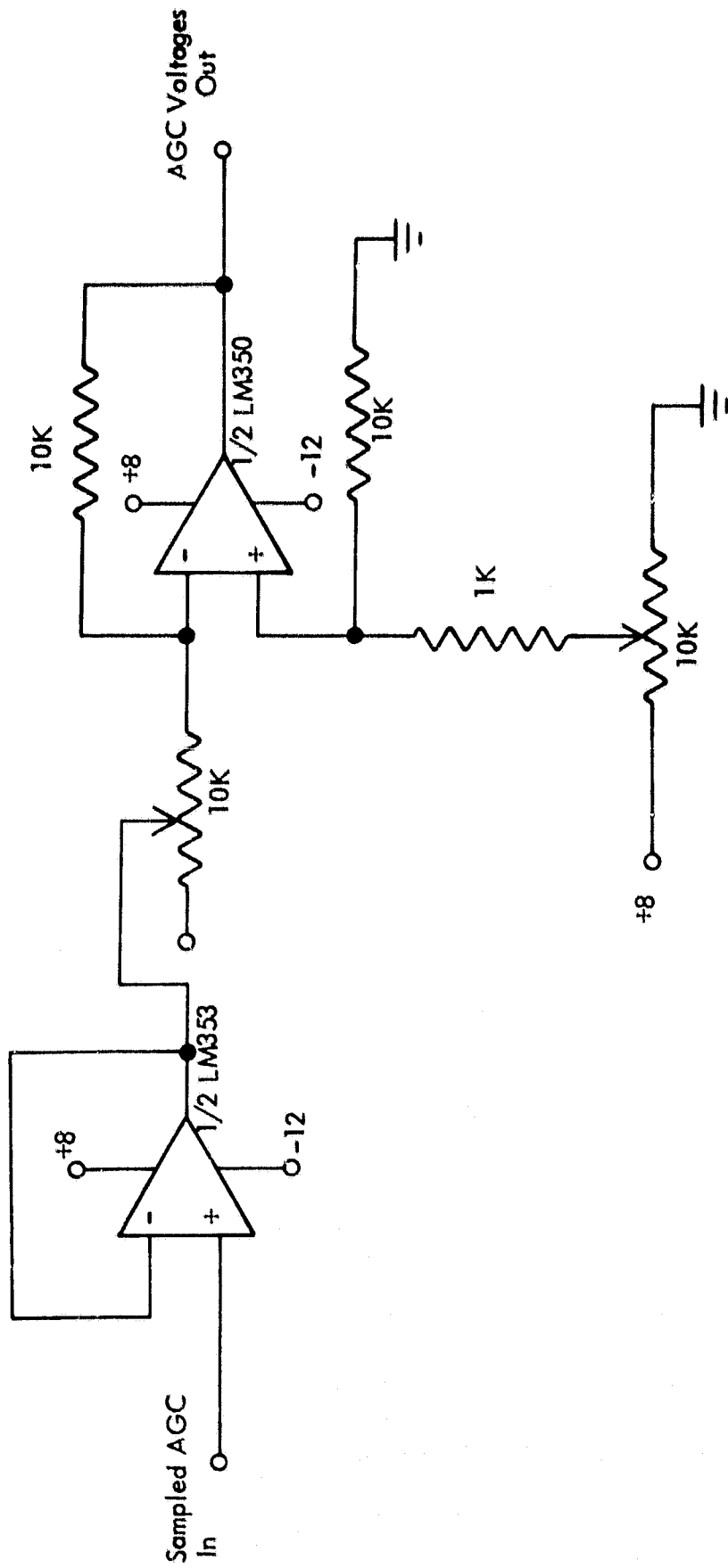

Figure 4. DC Gain Circuit.

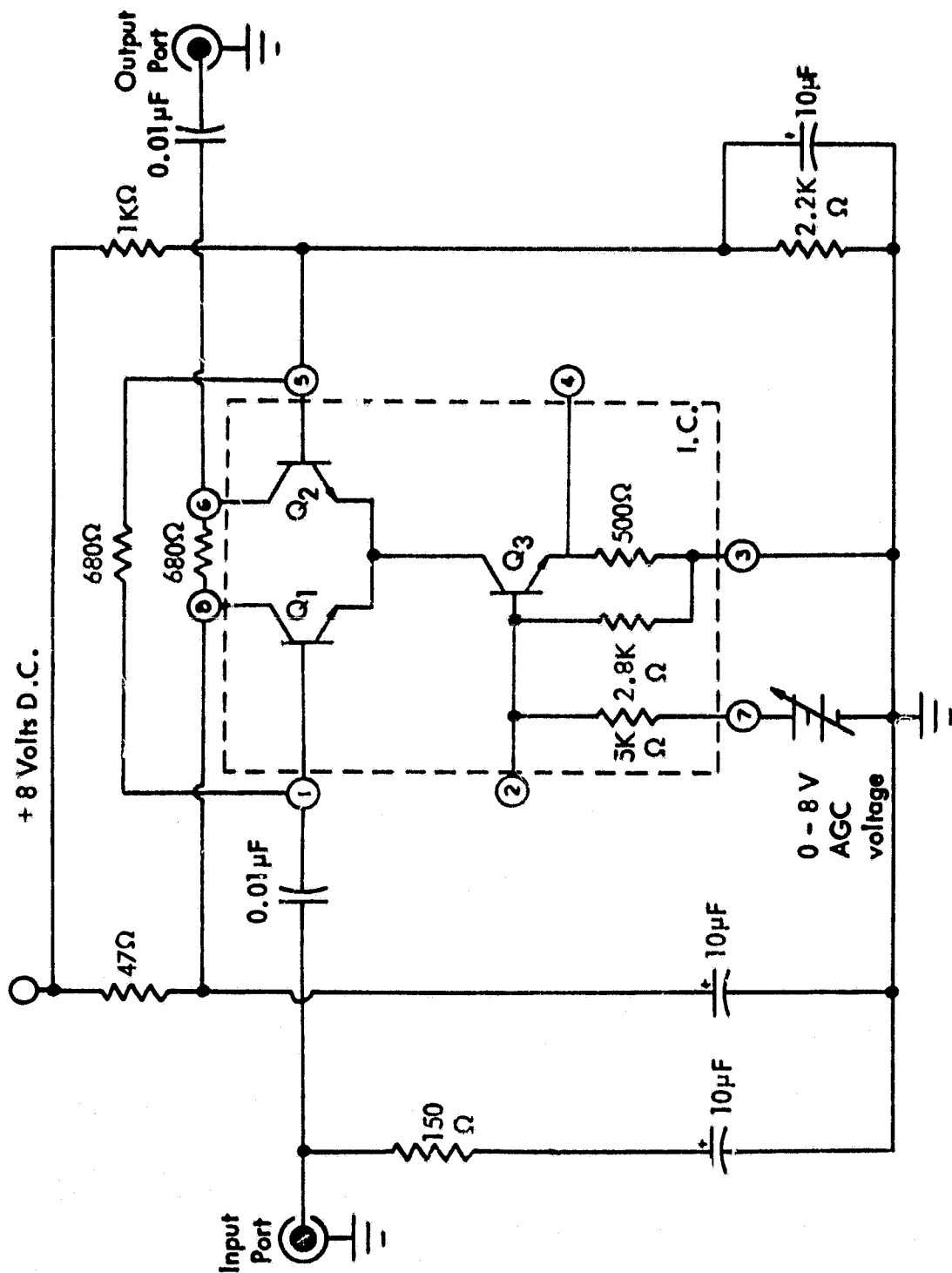

Figure 5. Automatic Gain Control Circuit. (Amplifier only)

microcomputer. All integrated circuits are CMOS, and the supply voltage is +12 volts. This supply voltage is necessary because the sample voltage levels are in the range of 5 to 7 volts. It is important to note that this design has not yet been optimized for minimum chip count.

The amplitude of a station's envelope varies with that station's signal strength (refer to Figures 6 and 7). The two cascaded 4047 monostables create a delayed pulse to sample the peak of the envelope. The first 4047 triggers on the equals pulse (zero crossing; refer to Figure 8), and delays 40 microseconds. The second 4047 triggers on the negative edge of the 40 microsecond delay output and produces a 20 microsecond sample pulse (refer to Figure 9). The delay and duration of the sample pulse is optimized to sample the peak of the envelope for the weak as well as the strong station.

The envelope from the RF front-end is passed through a voltage follower, $1/2$ LM353, and into the 4051 analog demultiplexer. The 4051 has on-chip address decoding; therefore, the two control lines are decoded to:

0	0	search mode
0	1	channel one on
1	0	channel two on
1	1	channel three on

Note that the control lines are ANDed with the sample pulse so that each channel samples the peak of only one station's envelope. Each Loran station consists of eight pulses, and, therefore, the station is actually sampled eight times (refer to Figure 10). These eight 20 microsecond sample pulses are of sufficient duration to charge the 25 microfarad capacitor to the desired final value (the voltage of the peak of the envelope). Each station is sampled on a separate AGC channel every group repetition interval (GRI). The 4016 analog switch is configured for the negative of the logic of the 4051; therefore, the two- to three-line decoder is needed. The 4016 controls the "hold" for each channel. When a receiver channel is on, the corresponding switch for that channel in the 4016 is off. This allows the first stage capacitor to be charged while a constant voltage from the previous GRI charge is outputted from the second stage capacitor to the AGC amplifier. The .68 microfarad capacitor in the second stage of the sample-and-hold is large enough to hold a constant voltage for .1 second, the maximum GRI value. The second 4051 is enabled in the same manner as the first 4051 except that it is not pulsed. In addition, a +5 volt signal is applied to the 00 channel on the second 4051 to serve as a receiver gain setting used during Loran-C station search. The multiplexed output of the AGC sample voltage is represented in Figure 11.

The software changes to implement the procedure outlined above are minimal since the receiver operating software tracks each station individually. When the microcomputer starts its search routine, the 00 channel is activated to output the constant +5 volt search voltage to the AGC amplifier. When all three stations are being tracked, the commutated AGC

ORIGINAL PAGE IS
OF POOR QUALITY

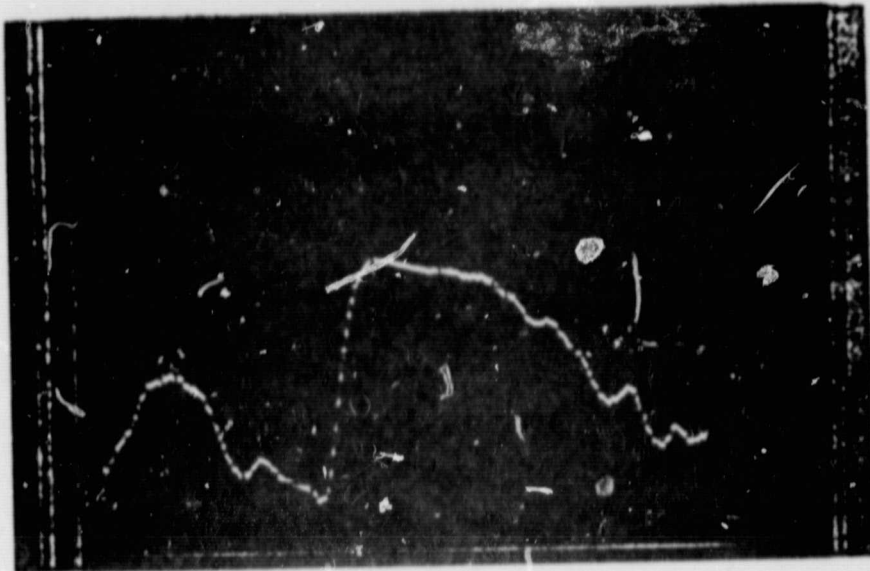

Figure 6. Strong Station Envelope. Live signal,
M station. (Seneca, NY).

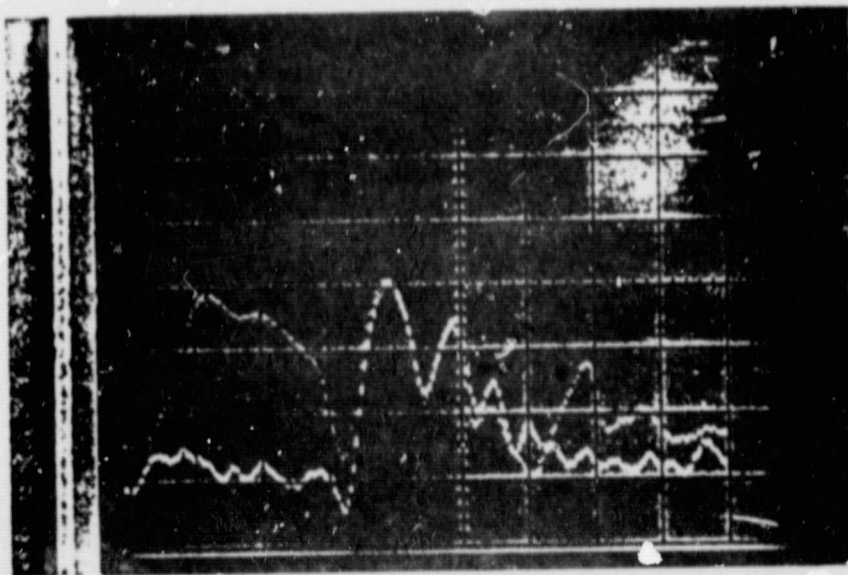

Figure 7. Weak Station Envelope. Live Signal,
Y Station (Carolina Beach).

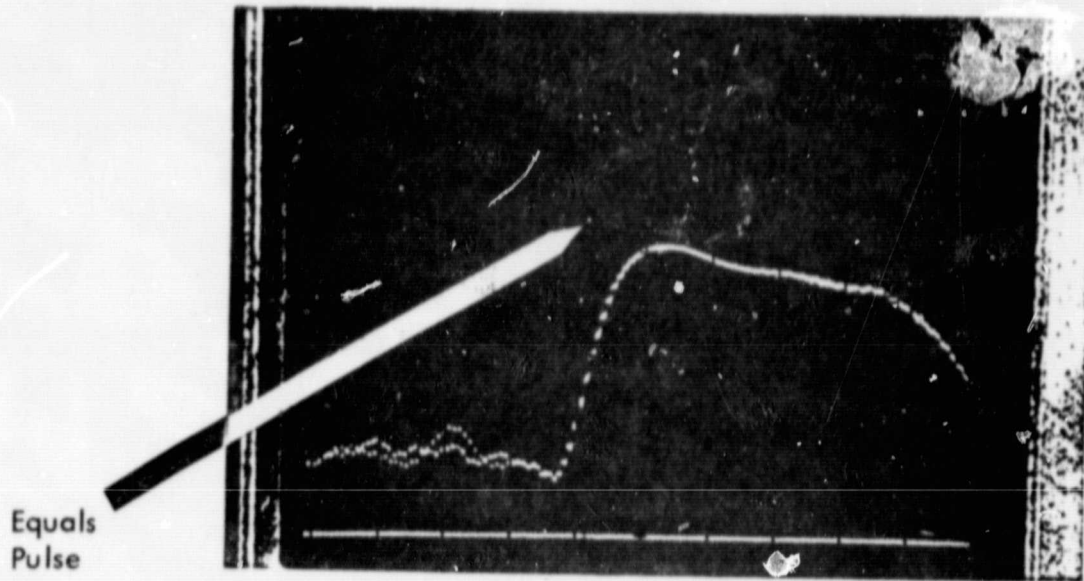

Figure 8. 1 μ s Equals Pulse at Zero Crossing.

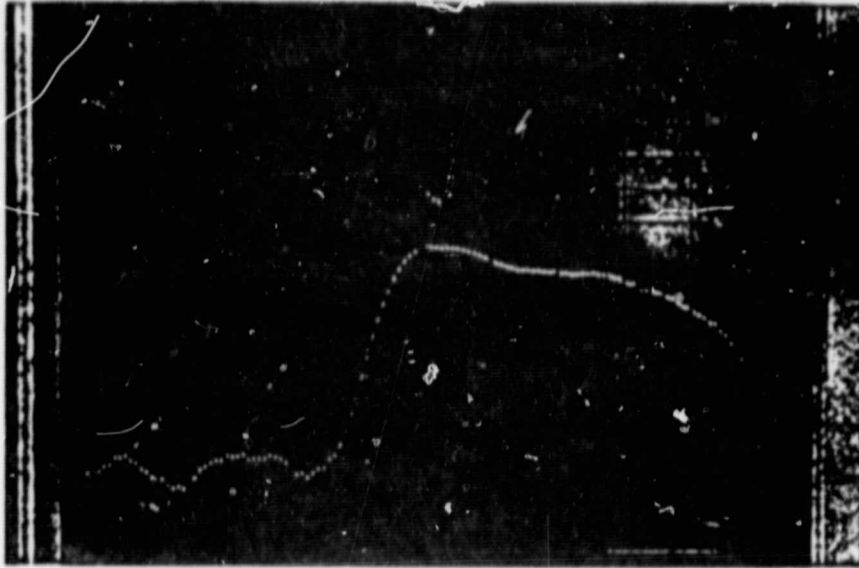

Figure 9. 20 μ s Sample Pulse at Peak of Envelope.

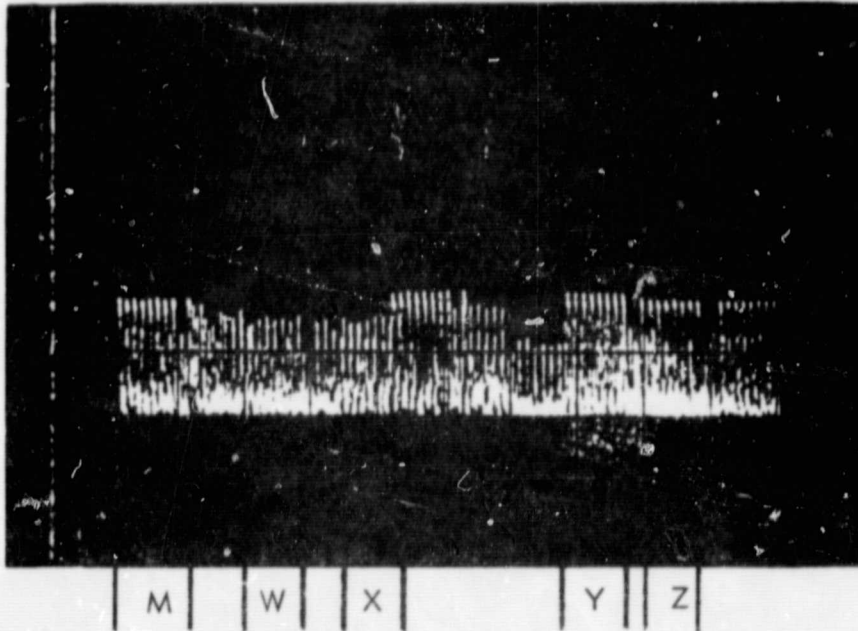
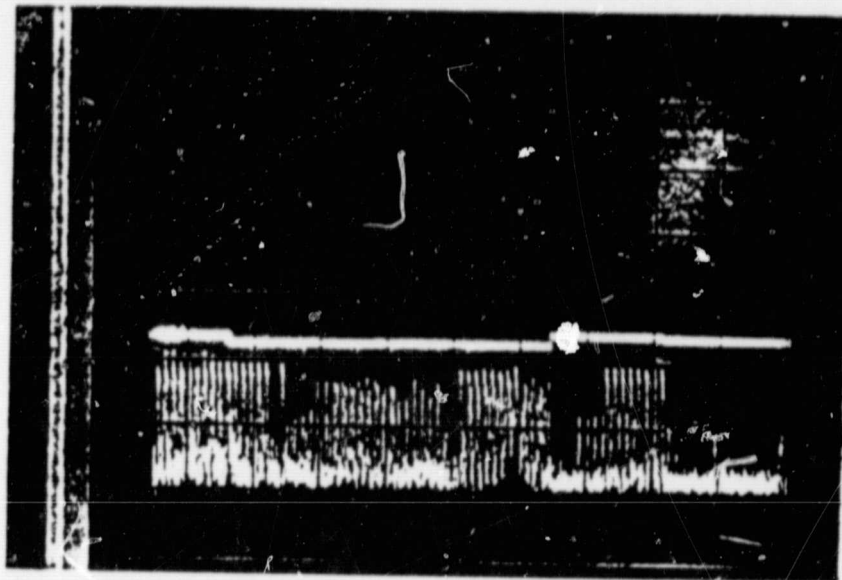

Figure 10. Loran Chain as Received At Clippinger Labs.
GRI = 99600 μ s. Note cross-rate interference.



2 volts/Div.

GND. REF.

Figure 11. AGC Sample Voltages.

is activated and the envelopes for each station are sampled separately. It is not important to identify which Loran-C station is on a certain AGC channel since the microcomputer provides the necessary synchronization as a function of basic receiver operation.

III. DC GAIN CIRCUIT

The three AGC sample voltages are equal to the peak voltages of the envelopes of their respective stations. Therefore, a strong station stores a higher sample voltage than a weak station. The voltage-controlled amplifier designed for this AGC system requires a higher control voltage to amplify the weak stations; therefore, an inverter circuit was designed for this purpose. The circuit actually has a two-fold purpose--inverting and increasing the gain of the sample voltages. An LM 353 dual op-amp was chosen for this circuit. Referring to Figure 4, one can see that one-half of the chip is used for a voltage follower while the other half serves as the gain/inverter. The trimpot on the input to the second op-amp controls the gain of the AGC output voltage while the other trimpot controls the DC level of the output. The adjustment of these trimpots for proper AGC operation will be explained in Section V of this report.

IV. AGC AMPLIFIER

The AGC amplifier utilizes a CA3028A differential cascade amplifier (refer to Figure 5). The accompanying circuit has been optimized for this particular AGC application. (Refer to TM 79 "Automatic Gain Control" for a complete circuit description as well as test results [3].)

V. OPERATION

As stated previously, the gain and DC level trimpots of the DC gain circuit must be adjusted properly for optimum AGC performance (refer to Figure 12). As this graph indicates, the best AGC amplifier performance lies in approximately the three to eight volt range. The adjustment procedure is as follows:

1. Set the gain to unity (adjust the 10K ohm trimpot to its full value),
2. Set the DC level to +8 volts and allow the receiver to track all three stations and,
3. Increase the gain from unity until the lowest AGC voltage is equal to approximately 4 volts.

The properly functioning AGC will be similar to Figure 13. This adjustment procedure outlined above allows for the use of different antenna-preamp combinations which may possess different DC components in the input RF. It is important to note that once the DC gain circuit is properly adjusted to match a certain antenna-preamp combination, it need not be adjusted further.

f = 100 KHz
Input Magnitude 50mV

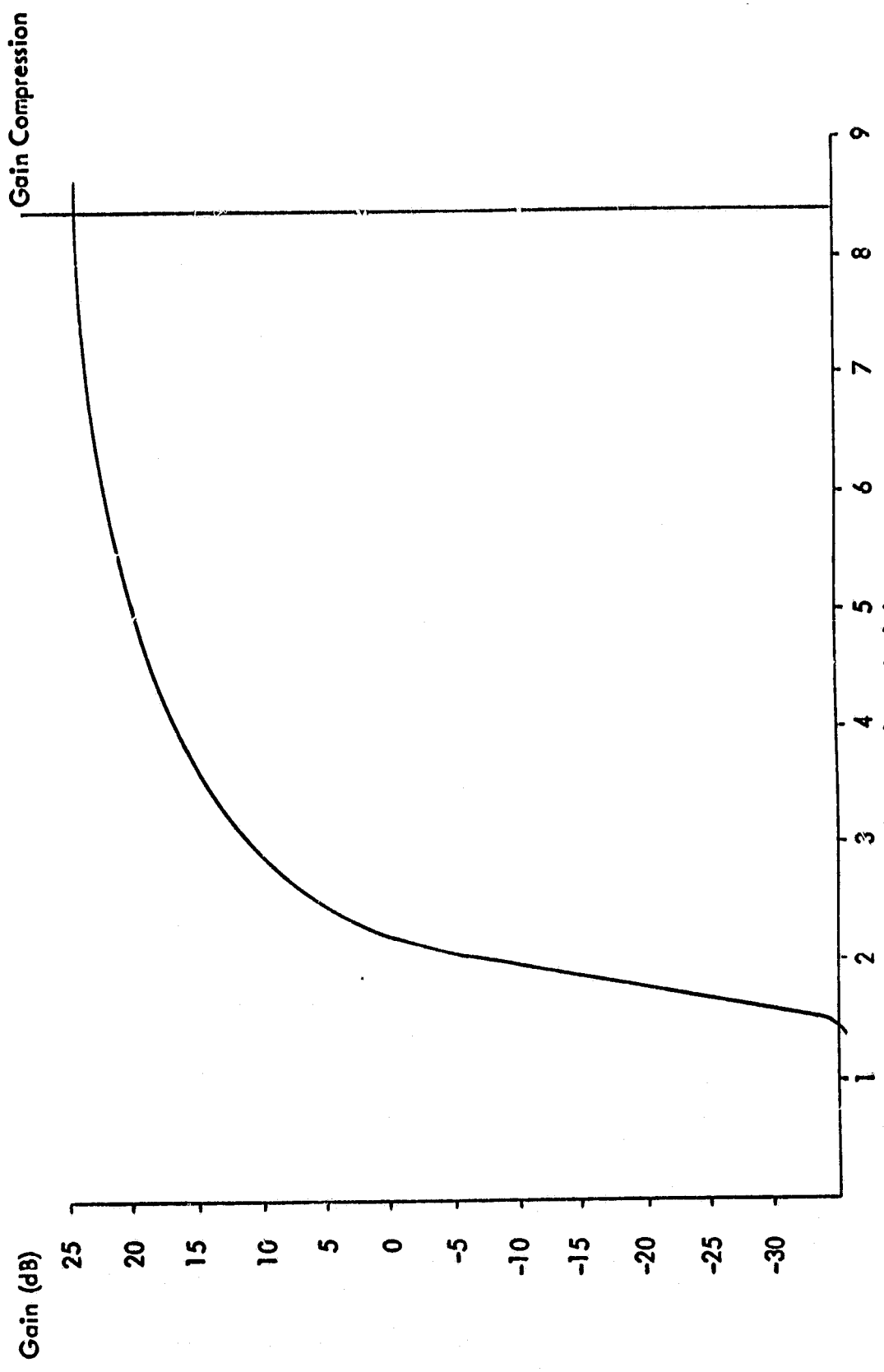
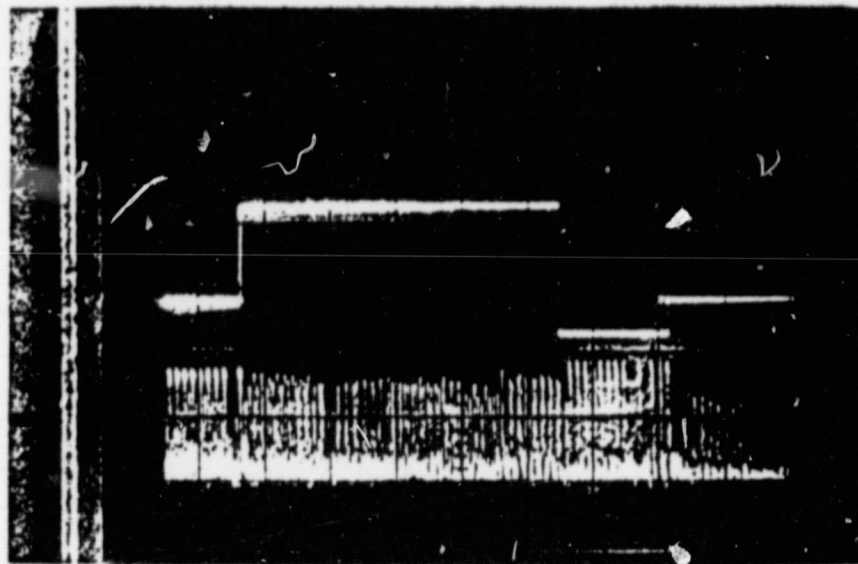

Figure 12. AGC Amplifier Performance Curve.

ORIGINAL PAGE IS
OF POOR QUALITY



2 volts/Div.

GND. REF.

Figure 13. AGC Voltages, Live Signal.

VI. TEST RESULTS

The first test of the AGC system performance was the use of the Epsco Loran simulator to provide different signal-to-signal ratios and record the results. An example of such an experiment appears in Figures 14, 15, and 16. A ten millivolt input signal was used, which is characteristic of the signal strengths encountered with "live" Loran signals. The GRI was set at 99,600 microseconds and the time differences (TD's) were set to resemble those received off the air at Clippinger Labs, Athens, Ohio (TDY=42,594.3 microseconds, TDZ=56,775.9 microseconds). These results are approximated, observed time differences:

<u>Figure #</u>	<u>Attenuation</u>	<u>AGC</u>	<u>TDY</u>	<u>TDZ</u>
14	none	on	42,594.5	56,776.0
16	20dB station Y	on	42,605	56,776
15	20dB station Y	off	42,622	56,776

CONCLUSION: The AGC has little or no effect on "perfect" Loran signals, meaning that there is no degradation of performance with the AGC in operation. Also, twenty dB of signal to signal difference is an extreme case which might be encountered only at the limit of a Loran coverage area.

Following a number of simulator tests, the receiver was tested with a live signal. The first step was to obtain an accurate value for the correct time differences as recorded at Clippinger Labs. The Loran chain used was the U.S. Northeast, GRI=99,600 microseconds. Four receivers were tested and the results are as follows:

<u>Receiver</u>	<u>TDY</u>	<u>TDZ</u>
Texas Instruments 9900	42,594.4	56,776.0
Trimble 10A	42,594.3	56,775.9
TDL 302	42,595	56,776
OU Mini L-80 (no AGC)	42,600	56,775

To obtain enough data points for a good statistical sample, sixty minutes of data was collected with the Ohio U. Loran receiver on October 20, 1981 from 4:00 to 5:00 p.m., thirty minutes without AGC, and thirty minutes with AGC. Each of these thirty-minute segments was broken into ten-minute blocks for a total of six blocks, 550 to 600 data points each. The atmospheric conditions were: light cloud cover with moderate spherics activity observed on an oscilloscope. A statistical analysis package available on Ohio University's IBM 370/158 was used to obtain the results shown in Figures 17 and 18. Most of the accuracy displayed is not significant but the trends are evident.

CONCLUSION: The addition of the AGC improved the value of TDY by approximately four microseconds. The overall accuracy of the receiver is approaching ± 1 microsecond. One point of special interest is the greater variance of TDY with the AGC on. This is due to the occasional sampling of cross-rate interference.

ORIGINAL PAGE IS
OF POOR QUALITY

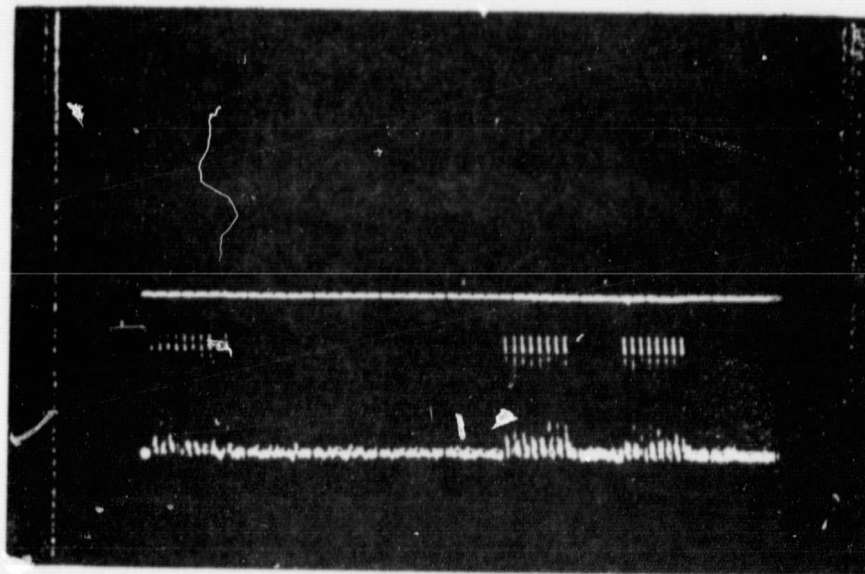

2 volts/Div.

GND REF.

Figure 14. 10 mV Signal on Simulator, No Station Attenuation,
AGC On.

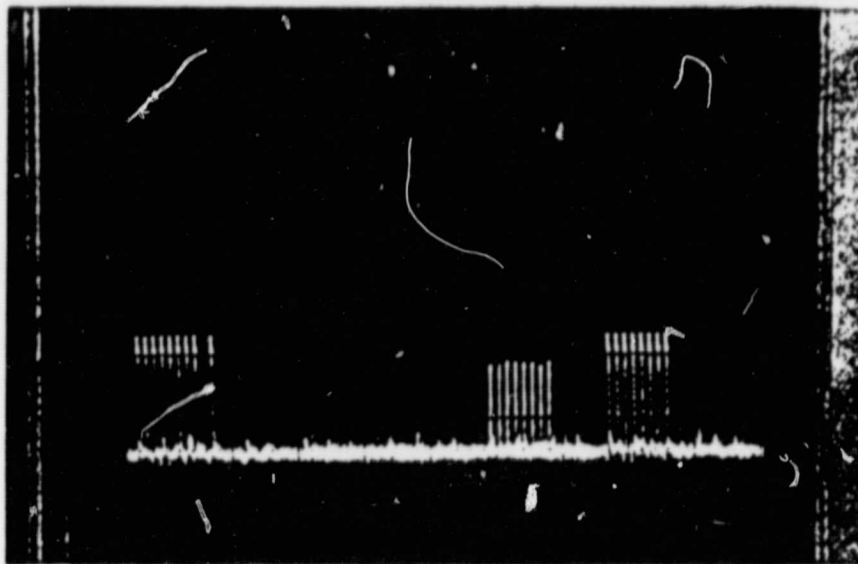

Figure 15. 10 mV Signal, 20 dB Attenuation on Station Y,
AGC Off.

ORIGINAL PAGE IS
OF POOR QUALITY

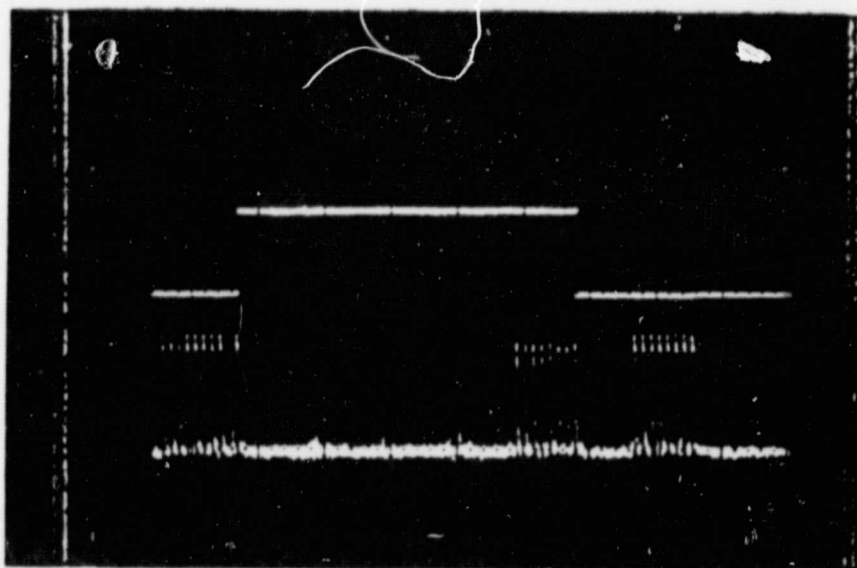

Figure 16. 10 mV Signal, 20 dB of Attenuation On Station Y,
With AGC On. Note improvement from above photo.

AGCTEST1

14:25 FRIDAY, NOVEMBER

MEAN	STANDARD DEVIATION	MINIMUM VALUE	MAXIMUM VALUE	STD ERROR CF MEAN	SUM	VARIANCE
42599.4002347	0.51903853	42597.700000	42601.300000	0.02514750	18147344.500	0.26540059
56775.3119718	0.52392441	56773.600000	56776.700000	0.02538422	24166282.900	0.27449678

AGCTEST1

14:25 FRIDAY, NOVEMBER

MEAN	STANDARD DEVIATION	MINIMUM VALUE	MAXIMUM VALUE	STD ERROR CF MEAN	SUM	VARIANCE
42599.4434109	0.49396906	42597.900000	42600.900000	0.02174578	21981312.800	0.24400543
56775.3350775	0.44001746	56774.100000	56776.600000	0.01937069	29296072.900	0.19361537

AGCTEST1

14:24 FRIDAY, NOVEMBER

MEAN	STANDARD DEVIATION	MINIMUM VALUE	MAXIMUM VALUE	STD ERROR CF MEAN	SUM	VARIANCE
42599.7463659	0.42813454	42598.500000	42601.000000	0.02143654	16997298.800	0.18335057
56775.3644110	0.40127825	56774.200000	56776.500000	0.020008904	22653370.400	0.16102424

Figure 17. Bench Test Results Without AGC.

AGCTEST1

14:15 FRIDAY, NOVEMBER

MEAN	STANDARD DEVIATION	MINIMUM VALUE	MAXIMUM VALUE	STD ERROR CF MEAN	SUM	VARIANCE
42596.2683342	0.61590856	42594.60000	42597.80000	0.02332898	18784354.600	0.37934336
56776.9375283	0.44090375	56775.70000	56776.10000	0.02099570	25038651.500	0.19440141

AGCTEST1

14:14 FRIDAY, NOVEMBER

MEAN	STANDARD DEVIATION	MINIMUM VALUE	MAXIMUM VALUE	STD ERROR CF MEAN	SUM	VARIANCE
42556.6725979	0.59603481	42594.60000	42597.400000	0.02514221	23938992.800	0.35525749
56776.9188612	0.43206040	56775.700000	56777.900000	0.01322537	31908628.400	0.18667619

AGCTEST1

14:13 FRIDAY, NOVEMBER

MEAN	STANDARD DEVIATION	MINIMUM VALUE	MAXIMUM VALUE	STD ERROR CF MEAN	SUM	VARIANCE
42595.5914894	0.87943572	42592.300000	42597.700000	0.03867754	22021920.800	0.77340719
56776.7504836	0.42543371	56775.400000	56777.900000	0.01371055	23353530.000	0.18099394

Figure 18. Bench Test Results With AGC.

The most important test of a prototype navigation receiver is a flight test. Ohio University's DC-3 flying laboratory made two Loran data collection flights on August 29th and 31st, 1981. The flights were centered around south-central Ohio and in areas of light thunderstorm activity. The operational Loran receivers were: TI 9900, Trimble 10A, and O. U. Mini L-80. The results of the August 29th Columbus to Albany via Zanesville leg are presented graphically in Figure 19. (August 31st data is omitted from this report because the results are essentially the same.) The O. U. receiver data was hand-collected and it appears with the flight path plotted by the TI 9900.

CONCLUSION: The plot shows a very close alignment of the two paths. Note the slight (less than .5 nautical miles) north bias of the O. U. receiver path. These plots were obtained with latitude/longitude data and not time difference data. The latitude/longitude conversion employed in the O. U. receiver does not use any overland propagation delay corrections in the calculations. This bias is due mainly to lack of propagation delay correction rather than large time difference errors.

VII. CONCLUSIONS

The addition of AGC to the O. U. Loran-C receiver has improved the accuracy of the time difference calculations to within approximately ± 1.5 microseconds of the observed time differences for a given position. This translates to an improvement of absolute accuracy of approximately 0.5 nautical mile. Tests of Ohio University's receiver with and without the AGC have indicated these results. The majority of error now present in the positional data supplied by the Ohio University receiver is due to the lack of propagation delay corrections.

Two additional refinements could improve the performance of the AGC system further: 1) A filter to reduce the effect of cross-rate interference on the sampling of the envelopes, and 2) An AGC amplifier with more dynamic range for an even greater signal-to-signal gain. Complete software control would eliminate the adjustments outlined in Section V, thus the receiver would require no manual gain adjustments. Other software development could allow for the tracking of all the Loran stations in a particular chain. The three most suitable signals would then be used to obtain positional data.

VIII. SUMMARY

A commutated automatic gain control system has been designed and constructed specifically for the Ohio University prototype Loran-C receiver. The AGC is designed to improve the signal-to-signal ratio of the received Loran signals. The AGC design does not require any analog to digital conversion and it utilizes commonly available components. The AGC system consists of three major parts: 1) the sample circuit, which samples the peak of the envelope of the Loran signal to obtain an AGC voltage for each of three Loran stations, 2) a DC gain circuit to control the overall gain of the AGC system, and 3) an AGC amplifier to amplify

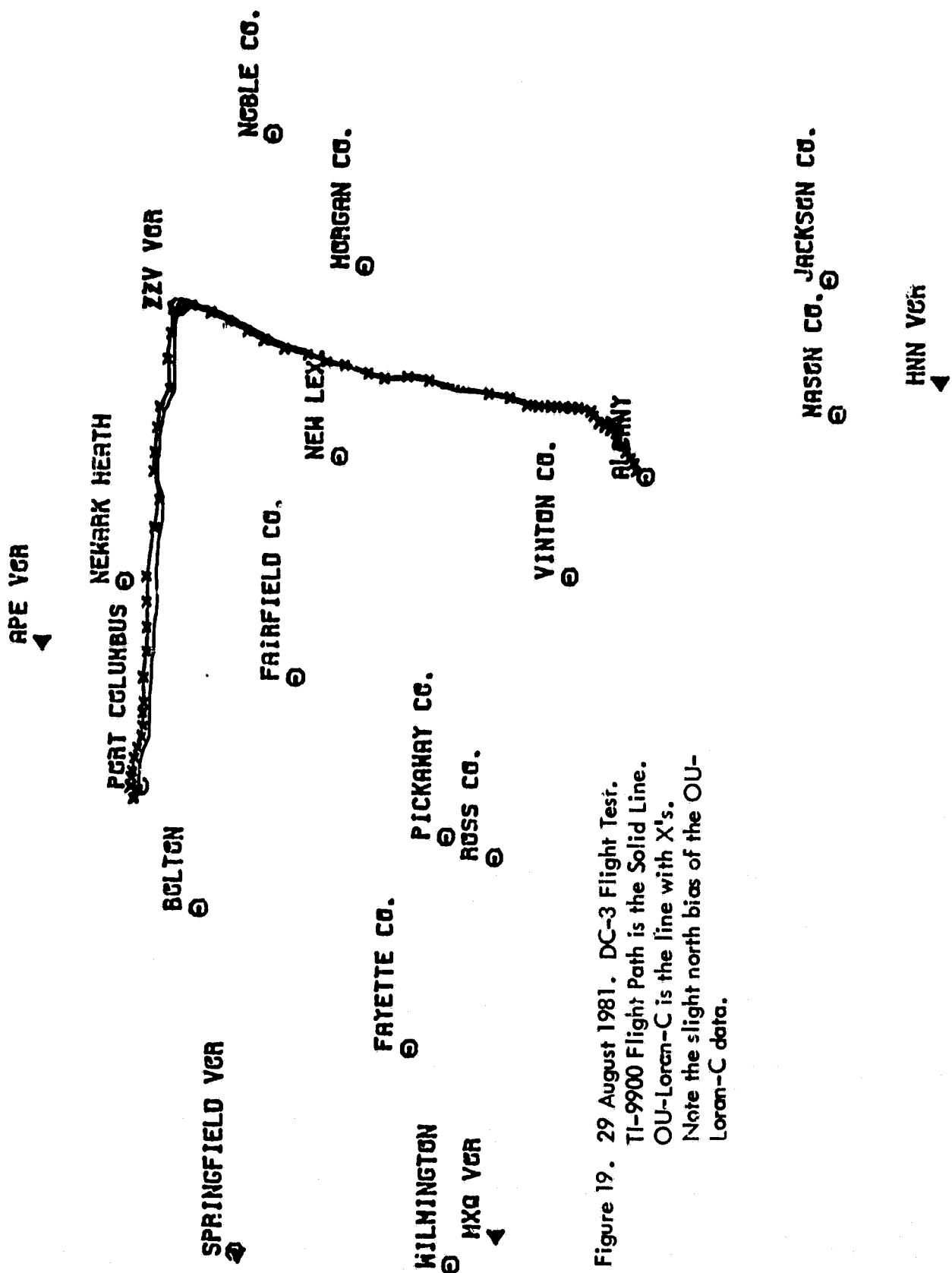

Figure 19. 29 August 1981. DC-3 Flight Test.
 TI-9900 Flight Path is the Solid Line.
 OU-Loran-C is the line with X's.
 Note the slight north bias of the OU-Loran-C data.

the input RF signal. The performance of the AGC system has been observed in bench and flight tests and it has improved the overall accuracy of the Ohio University receiver considerably.

IX. ACKNOWLEDGEMENTS

The design, construction and testing of the commutated AGC system has been funded by the NASA Joint University Program for Air Transportation Research as a part of the continuing development of Ohio University's prototype Loran-C receiver. The author would like to thank Dr. Robert Lilley and Mr. Ralph Burhans, both project engineers, for their help in the design of the AGC. James Nickum, Avionics Engineering Center engineer, helped with the data collection, especially the flight testing. He also took all of the photographs that appear in this paper. Research interns Stan Novacki, James Roman and David Bernard were also of assistance in various phases of this project.

X. REFERENCES

- [1] Lilley, Dr. R.W. and Daryl McCall, "A Loran-C Prototype Navigation Receiver for General Aviation", TM-80, Avionics Engineering Center, Department of Electrical Engineering, Ohio University, Athens, Ohio 45701, August 1981.
- [2] Fischer, Joseph P., "Results of a Loran-C Flight Test Using an Absolute Data Reference", TM-74, Avionics Engineering Center, Department of Electrical Engineering, Ohio University, Athens, Ohio 45701, January 1980.
- [3] Roman, James P., "Automatic Gain Control", TM-79, Avionics Engineering Center, Department of Electrical Engineering, Ohio University, Athens, Ohio 45701, March 1981.
- [4] U.S. Coast Guard, "Loran-C User Handbook", COMDTINST M165623, May 1980.
- [5] "Joint University Program for Air Transportation Research - 1980", NASA Conference Publication 2176, Langley Research Center, December 1980.
- [6] National Semiconductor Corp. CMOS and Linear Data Books.