

DRA

N82-15708

# **USSR Space Life Sciences Digest**

ANNUAL SUMMARY

1980

*Prepared for the*  
**Life Sciences Division**  
**National Aeronautics and Space Administration**  
**Washington, D.C. 20546**

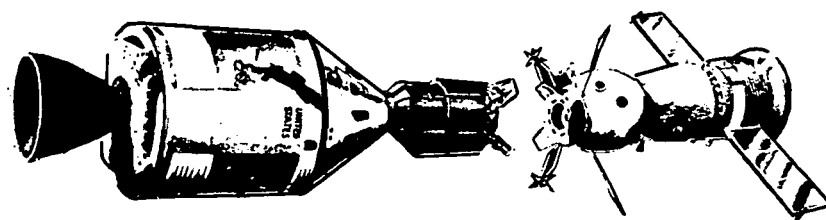

# USSR Space Life Sciences Digest

ANNUAL SUMMARY

1980

*Prepared under the direction of*  
Gerald A. Soffen, Ph.D., Director  
Life Sciences Division  
National Aeronautics and Space Administration  
Washington, D.C. 20546

*Contract NASW-3469*

*Editorial Board*

Arnauld E. Nicogossian, M.D.  
Paul Rambaut, Sc.D.

**Life Sciences Division**  
NASA Headquarters  
Washington, DC.

*Managing Editors*

Courtland S. Lewis  
Kristy L. Donnelly

**BioTechnology, Inc.**  
3027 Rosemary Lane  
Falls Church, VA 22042

## TABLE OF CONTENTS

	<u>Page</u>
INTRODUCTION . . . . .	1
The Soviet Space Program . . . . .	1
Space Medicine and Physiology . . . . .	2
Space Biology . . . . .	3
Life Sciences Technology . . . . .	4
Exobiology . . . . .	4
About the 1980 Summary . . . . .	4
SPACEFLIGHT RESULTS . . . . .	7
Space Medicine and Physiology . . . . .	7
Cardiovascular System . . . . .	7
Musculoskeletal System . . . . .	9
Hematology and Immunology . . . . .	11
Metabolism . . . . .	12
Neurophysiology . . . . .	13
Psychology . . . . .	14
Space Biology . . . . .	15
Pulmonary System . . . . .	15
Musculoskeletal System . . . . .	16
Metabolism . . . . .	17
Neurophysiology . . . . .	18
Radiation Effects and Protection . . . . .	19
Plant Research . . . . .	20
Microbiology . . . . .	21
Life Sciences Technology . . . . .	22
Bioinstrumentation . . . . .	22
Extravehicular Activity . . . . .	23
Exobiology . . . . .	23

## Table of Contents (continued)

	<u>Page</u>
<b>GROUND-BASED RESEARCH</b> .....	<b>25</b>
<b>Space Medicine and Physiology</b> .....	<b>25</b>
Hypokinesia .....	25
Lower Body Negative Pressure .....	28
Exercise .....	28
Acceleration .....	29
Vibration .....	29
Radiation .....	29
Extreme Temperature .....	30
Magnetic Fields .....	30
Space Motion Sickness .....	30
Circadian Rhythms .....	31
Psychology Research .....	32
Pharmacology .....	33
Nutrition .....	33
Crewmember Selection and Training .....	33
Simulation Studies .....	34
<b>Space Biology</b> .....	<b>34</b>
Hypokinesia .....	34
Space Motion Sickness .....	35
Magnetic Fields .....	36
Radiation .....	36
Plant Research .....	37
<b>Life Sciences Technology</b> .....	<b>37</b>
Bioinstrumentation .....	37
Personal Protective Equipment .....	39
Closed Life Support .....	39
Toxicology .....	40
<b>REFERENCES</b> .....	<b>42</b>

## INTRODUCTION

### The Soviet Space Program

Using the Salyut 6 orbital space station as a long-term research base, the Soviets have carried out a highly successful program of space technology and life sciences research. Between September 1977, when it was launched, and the end of 1980, the orbital station was manned by four different two-man prime crews in missions lasting 96, 140, 175, and 185 days. The crew of the 185-day mission included flight engineer V. Ryumin, who had also flown on the 175-day mission just six months earlier. (With nearly a year's total time in space, Cosmonaut Ryumin has logged what is by far the longest flight time of any space traveler.) In addition to the four main crews, by the end of 1980 Salyut 6 had been visited by 10 short-term expeditions, six of which included crewmembers from Soviet bloc countries such as Viet Nam, Cuba, Czechoslovakia, and Hungary.

All crews are transported to the space station aboard Soyuz-series spacecraft, which also serve as return vehicles. Resupply of the orbital complex with expendables such as food, air, water, fuel, and photographic film, as well as delivery of needed scientific equipment, are carried out partly by means of these transport vehicles and partly by expendable "Progress" cargo craft. One vehicle of each type can be docked simultaneously (and automatically) with the space station. This system of enlargement and resupply of the facility is a prototype for planned future orbiting platforms.

With the completion of two more manned missions in the first half of 1981, the current "Interkosmos" research program will have been concluded. The Soyuz 6 orbital station, already far beyond its original design life, will then be docked with a large, unmanned Cosmos spacecraft and boosted into a new orbit where a series of automated systems tests will be performed. The Cosmos craft is the forerunner of a modular expansion unit that the Soviets plan to use in assembling large, permanently operating manned space stations from a Salyut-style core. No further manned missions will be flown until sometime in 1982, when the follow-on Salyut 7 modular station is launched.

Soviet progress in space station development relies on a combination of research in design rooms and laboratories on the ground with actual orbital experience. The same interaction between ground-based research and in-flight tests characterizes the entire Soviet space life sciences program. Therefore, the text of this summary of 1980 Soviet literature is divided into two parts, Ground-Based Research and Spaceflight Results. Within each part, material is organized according to the general breakdown of disciplines observed by the Soviets:

- Space Medicine and Physiology (human)
- Space Biology (animals)
- Life Sciences Technology
- Exobiology.

## Space Medicine and Physiology

The primary focus of research in this area is on the development of methods for predicting, diagnosing, and preventing or ameliorating the effects of spaceflight conditions—particularly weightlessness. Before long-term habitation of space stations can become routine, it is essential that Soviet space program managers and planners have a thorough understanding of factors impacting crew selection (individually and as a group), mission length, activity scheduling, facility design, diet, and the structuring of exercise programs and other deconditioning countermeasures. The current manned flight limit is six months. Thus far, this mission duration appears to be feasible; although there are some individual variations in function, no pathological or irreversible changes are observed in crewmembers. However, more research at this level will be carried out before longer-term missions are flown.

Biomedical data from recent extended-duration missions were still being processed through 1980. The results of studies carried out during the 175-day Salyut 6 mission were published, providing a basis for comparison with the earlier 96- and 140-day flights. These results continue to demonstrate the importance of a well-structured space station microclimate in sustaining the health and performance of the crew.

One important factor in the creation of a good microclimate is the provision of countermeasures against the general deconditioning associated with extended weightlessness. The daily physical exercise prescribed for cosmonauts in the 140- and 175-day missions, along with the regular use of lower body negative pressure (LBNP), the "Penguin" constant loading suit, improved diet, and water-salt additives, prevented or lessened certain changes that had been seen in earlier (and shorter) flights. Cardiovascular adaptations noted on the 175-day flight were generally more moderate, particularly in terms of hemodynamics. Responses to physical load (exercise stress test) were also closer to normal preflight values. These improvements were attributed partly to a greater emphasis in these missions on preflight physical training. Losses of body mass during flight were more moderate—the flight engineer actually *gained* weight. This is explained as being the result of combining regular exercise with a more varied and appealing diet. The exercise program is also credited with reducing the degree and duration of changes found postflight in the motor regulation system.

Another important aspect of the onboard microclimate is the psychological support that is provided. Increasingly elaborate measures are being taken in this area. For example, a special medical group was formed for the 175-day mission to devise ways of alleviating the boredom and sense of isolation experienced by the crew. Frequent two-way audiovisual communications were established between the cosmonauts and their families, and supportive interviews were held with well-known journalists, scientists, athletes, and performers. The visiting crews provide varied interpersonal contact; they also bring with them letters, newspapers, and gifts for the prime crew. Television and music are now provided on board.

A third factor that is important in maintaining a positive onboard environment is the organization of daily routine. All Salyut 6 crews have lived on standard Moscow time, with a normal work week, and with adequate time allotted for sleeping and eating, for recreation, and for being alone. The general goal is to make life aboard the space station as normal as possible.

Soviet ground-based research in the area of space medicine and physiology establishes the basis for inflight tests and programs, as well as for many of the crew-protective and life support measures that are taken in system design (such as cabin atmospheric composition, temperature and vibration control, radiation shielding, water reclamation, and various antideconditioning devices). Many of these laboratory studies involve the simulation of weightlessness, either by mathematical models or through "real" simulation via bedrest or water immersion. Others investigate the effects of acceleration through centrifugation. Since these techniques can reproduce many of the effects of spaceflight on the various systems of the body, they provide the means to anticipate and, ideally, to counteract many of the dangers and difficulties that spaceflight presents. Exercise programs, work-rest schedules, dietary prescriptions, crew selection procedures, and medications to counteract physiological effects are all to a large extent the result of ground-based research.

These studies are vigorously pursued by the Soviets. A recent trend has been toward the increased use of mathematical modeling to predict physiological responses. Nystagmus, the rolling of the eyeballs in response to vestibular disturbance, is being investigated as a possible predictor of susceptibility to space motion sickness. Biorhythms are currently of great interest to Soviet researchers as a basis for planning schedules and assignments. The study of stress and the analysis of inflight tasks and activities are seen as having a large potential for improving the performance effectiveness of cosmonauts. The evolution of the Soviet manned space program depends to a great extent on the interlinking of studies such as these with experience inflight.

### **Space Biology**

Seven Soviet Cosmos biosatellites have been launched since 1966. The three most recent of these (Cosmos 782, 936, and 1129) were collaborative ventures with the U.S. and other countries, and investigated the effects of weightlessness on a variety of organisms. Cosmos 936 and Cosmos 1129 were both equipped with an onboard centrifuge, so that the effects of artificial gravity could be compared with those of unaltered weightlessness. In addition to these flight controls, many experiments also included two sets of ground controls, with some animals confined to a biosatellite mockup and others maintained in a vivarium.

No new biosatellites were launched in 1980; however, the results of many of the previous investigations were released. Most notable were the results of experiments with rats onboard Cosmos 936. Rats exposed to artificial gravity during the 18.5-day flight did not exhibit the disturbances in gas exchange, electrolyte metabolism, postural equilibrium, thyroid calcitonin secretion, or posterior pituitary function that were found in rats exposed to 0 G. The weightless group also exhibited muscular atrophy, deterioration of bone, increased sarcoplasmic protein content, and decreased myocardial myosin ATPase activity; flight control animals experienced these changes as well, but to a lesser extent. In ground-based animal studies, various degrees of confinement and immobilization continued to be used for simulating the stresses of weightlessness.

Plant studies have been conducted onboard the Salyut orbital stations as well as on biosatellites. Attempts to grow higher plants have been unsuccessful, with the plants dying after about 2 weeks. Thus, efforts to include plants in a closed life support system have so far been frustrated. However, various unicellular plant cultures have been grown successfully in space. There is some evidence

from ground-based studies that electrical current might be successfully substituted for gravity. Experiments with plant tissues such as duckweed showed that the early stages of growth are the most sensitive to spaceflight conditions.

### **Life Sciences Technology**

In 1980 a number of new instruments and devices were introduced for use in the space life sciences program. New laboratory bioinstrumentation included a system for detecting gas bubbles in the blood of animals exposed to hypoxic conditions. Several instruments for the study of nystagmus were developed: a portable nystagmograph, a photoelectric nystagmograph, and a device that both induces and measures nystagmus.

Onboard Salyut 6, a massmeter has been installed that allows accurate assessments of changes in weight under weightlessness to be made. The cosmonauts of the 175-day mission donned new semi-rigid, liquid-cooled spacesuits with self-contained life support systems for their one EVA outing. It was reported that the suits provided adequate temperature control under all conditions.

The need to establish parameters for spacesuit and cabin atmospheres prompts investigation of the effects of different gas mixtures and pressure levels on animal physiological functions. Studies of hypoxic and hyperbaric conditions and their effects predominated in 1980.

### **Exobiology**

Data continue to be transmitted from Venus by the Venera 11 and 12 probes. Spectral analysis has revealed detail about the atmospheric composition and cloud layering of the planet. Similar data on the atmospheric composition and structure of Mars were sent back by the Mars 5 orbiter.

### **About the 1980 Summary**

This document summarizes the Soviet life sciences literature, relevant to the space program, that became available in this country during 1980. Due to Soviet publication delays, and to delays in receiving translations, some of the literature refers to studies and results deriving from spaceflights dating back to 1973. Consequently, a large number of missions are discussed. For reference, Table 1 presents information about all the flights mentioned in this summary.



Table 1. Soviet Space Missions Mentioned in  
1980 Annual Summary

Manned Missions\*

<u>Craft Name</u>	<u>Launch</u>	<u>Mission Duration</u>	<u>Crewmembers</u>	<u>Status</u>	<u>Remarks</u>
Salyut 4	26 Dec. 1974			Decayed 2 Feb. 1977	Orbital space station
Soyuz 17	10 Jan. 1975	29.5 days	Gubarev, Grechko	Recovered 9 Feb. 1975	Docked with Salyut 4
Soyuz 18	24 Apr. 1975	63 days	Klimuk, Sevastyanov	Recovered 26 July 1975	Docked with Salyut 4
Salyut 5	22 June 1976			Decayed 8 Aug. 1977	Orbital space station
Soyuz 21	6 July 1976	49 days	Volynov, Zholobov	Recovered 23 Aug. 1976	Docked with and transferred to Salyut 5 on July 7
Soyuz 22	15 Sept. 1976	7.5 days	Bykovskiy, Arksenov	Recovered 23 Sept. 1976	No docking; Earth resources study
Salyut 6	29 Sept. 1977			In orbit	Orbital space station
Soyuz 26	10 Dec. 1977	96 days	Romanenko, Grechko	Recovered 16 Mar. 1978	Docked with and transferred to Salyut 6 on 11 Dec. Returned in Soyuz 27. EVA 1 hr 28 min.
Soyuz 28	2 Mar. 1978	8 days	Gubarev, Remek (Czechoslovakian)	Recovered 10 Mar. 1978	Crew docked with and transferred to Salyut 6
Soyuz 29	15 June 1978	140 days	Kovalenok, Ivanchenko	Recovered 2 Nov. 1978	Crew docked with and transferred to Salyut 6. Returned in Soyuz 31. EVA 29 July 1978, 2 hrs 5 min.
Soyuz 32	25 Feb. 1979	175 days	Lyakhov, Ryumin	Recovered 19 Aug. 1979	Crew docked with and transferred to Salyut 6. Returned in Soyuz 34. EVA 1 hr 23 min.
Soyuz 35	9 Apr. 1980	185 days	Popov, Ryumin	Recovered 11 Oct. 1980 in Soyuz 37 spacecraft	Crew docked with and transferred to Salyut 6-Progress 8 complex. Spacecraft used to return Soyuz 36 crew on 3 June 1980
Progress 9	27 Apr. 1980		Unmanned	Decayed 22 May 1980	Cargo craft docked with Salyut 6-Soyuz 35 on 29 Apr. 1980 to resupply station with fuel and air.

\*Includes unmanned resupply missions.

Table 1. Soviet Space Missions Mentioned in  
1980 Annual Summary (continued)

**Manned Missions (continued)**

<u>Craft Name</u>	<u>Launch</u>	<u>Mission Duration</u>	<u>Crewmembers</u>	<u>Status</u>	<u>Remarks</u>
Soyuz 36	26 May 1980	8 days	Kubasov, Farkas (Hungarian)	Recovered 3 June 1980 in Soyuz 35 spacecraft	Crew docked with Salyut 6 on 27 May 1980. Spacecraft used to return Soyuz 37 prime crew on 31 July 1980
Progress 10	29 June 1980		Unmanned	Decayed 19 July 1980	Docked with Salyut 6 on 1 July 1980; delivered equipment, fuel, and food
Soyuz 37	23 July 1980	8 days	Gorbatko, Tuan (Vietnamese)	Recovered 31 July 1980 in Soyuz 36 spacecraft	Crew docked with Salyut 6 on 24 July 1980. Spacecraft used to return Soyuz 35 prime crew on 11 Oct. 1980
Soyuz 38	18 Sept. 1980	8 days	Romanenko, Mendez (Cuban)	Recovered 26 Sept. 1980	Crew docked with Salyut 6 on 19 Sept. 1980
Progress 11	28 Sept. 1980		Unmanned	Decayed 11 Dec. 1980	Docked with Salyut 6 on 30 Sept. 1980; delivered scientific equipment and radio telemetric system for data transmission to Earth.

**Biosatellites**

<u>Satellite</u>	<u>Launch</u>	<u>Mission Duration</u>	<u>Crewmembers</u>	<u>Status</u>	<u>Remarks</u>
Cosmos 605	31 Oct. 1973	23 days	Rats	Recovered 22 Nov. 1973	
Cosmos 690	22 Oct. 1974	22 days	Rats	Recovered 12 Nov. 1974	
Cosmos 782	25 Nov. 1975	19.5 days	Rats	Recovered 13 Dec. 1975	Joint effort with USA, France, Czechoslovakia, Hungary, Poland, and Rumania
Cosmos 936	3 Aug. 1977	18.5 days	Rats, <i>Drosophila melanogaster</i> , plants	Recovered 22 Aug. 1977	Joint effort with USA, France, and Czechoslovakia
Cosmos 1129	25 Sept. 1979	19 days	Rats	Recovered 14 Oct. 1979	

## SPACEFLIGHT RESULTS

### Space Medicine and Physiology

#### Cardiovascular System

Results of the 175-day two-man flight aboard the Salyut 6 orbital station became available in 1980 (Yegorov, 1980). This was the third prime crew of Salyut 6, complementing earlier 96- and 140-day flights. As in the previous missions, cardiovascular research centered on evaluation of the vascular system's adaptations to prolonged weightlessness—in particular through studies of hemodynamics and cardiac intervals at rest, under physical load, and in response to lower body negative pressure (LBNP). Inflight cardiovascular tests on the 175-day crew are summarized in Table 2.

175-day flight

Table 2. Type and Number of Cardiovascular Tests  
(175-day flight)

Tests	Number of Tests*
Phase analysis of cardiac cycle	16
At rest	
Hemodynamics— (mechanocardiography)	14
At rest	
Rheography	REG 9
	REG of extremities 4/158
	Body REG 9/7
At Rest	
Occlusion plethysmography (calf)	4/3
Jugular vein pressure	7
LBNP tests	7
Exercise stress tests	7

\*Number of tests in the numerator pertains to the commander—the denominator, to the flight engineer.

**hemodynamic adaptations**

Rheographic (REG) and plethysmographic data showed similarities in compensatory mechanisms with those found during the 140-day mission—especially a decreased stroke output and shorter isovolumetric contraction. Arterial pressure decreases found in both cosmonauts were more systematic than those seen in the 140-day mission. In addition, blood outflow was seen to be improved, venous reservoir elasticity increased, and calf vein contractility and venous pressure lowered, so that vessel tone volume was decreased. As in the previous flights, these hemodynamic changes were within expected limits, and can be considered as an adaptation to weightlessness and hypodynamia.

**countermeasures**

An important objective of studies conducted on this mission was to assess the efficacy of preventive measures against the effects of long-duration spaceflight. Consequently, the finding that heart rate and arterial pressure did not show decreased tolerance to LBNP during the mission was significant. Preflight physical training received more emphasis on this flight, as did exercise studies inflight (the cosmonauts exercised 2.5 hr per day for 3 out of every 4 days). In general, the performance of both crewmembers under physical load (as reflected in measures of oxygen sufficiency) did not decrease during the mission. The flight engineer, who had a higher level of preflight physical training, showed a more moderate engagement of compensating mechanisms in response to work (pedaling) than did the commander. He had lower increases in cardiac output, shorter time of acceptance of load, and a faster return to initial heart rate following load. These results suggested that initial conditioning is an important preventive factor. No significant changes in daily EKG readings or in cardiac rhythm were seen in either crewman, indicating good adaptation.

**cardiovascular adaptation**

Adaptation and stabilization of cardiovascular functions noted on the 175-day mission were similar to those found in the previous Salyut 6 crews (Gazenko & Yegorov, 1980). Investigations of the first two prime crews by Degtyarev, Andriyako et al. (1980) indicated that, after an adaptive period of 1-1½ mos, cardiovascular measurements of most cosmonauts approach normal, even in response to such challenges as LBNP. Rheographic measurement of central and peripheral hemodynamic responses at rest in the 96- and 140-day Salyut 6 crews (Turchaninova & Domracheva, 1980) showed that, for three of the four cosmonauts, an initial increase in stroke volume subsided after the first week in space. Cardiac output remained elevated throughout the flights, while cerebral blood filling initially increased and then returned to normal during the last half of the 140-day mission. Leg vessel blood volume decreased, while forearm measurements either did not vary or increased. These data reflect the expected shifts in body fluids during exposure to weightlessness.

**Salyut 4 REG data**

Results of earlier spaceflight studies continue to be received from the USSR. REG data on the functional state of cerebral circulation during adaptation of the Salyut 4 crews to weightlessness were published in 1980 (Kas'yan & colleagues). REGs were used to evaluate cerebral blood flow and redistribution and cardiovascular compensatory reactions at rest and in response to LBNP and bicycle ergometer (VEL) tests pre-, in-, and postflight.

Preflight responses to LBNP included increased return of venous blood from the cranium, altered REG indices, reduced vessel tone, and a decrease in total pulse and systolic blood filling. Cessation of LBNP was followed by a rapid return to baseline. Exercise stress test (VEL) produced an opposite response in the redistribution of blood flow. Especially notable were the increases in pulse and systolic blood filling and venous return from the brain. Inflight, similar though more pronounced responses to LBNP and exercise stress test (VEL) were observed. The more marked reaction of the circulatory system to induced redistribution of blood by LBNP was also observed in the crew of the 96-day expedition aboard Salyut 6 (Degtyarev, Andriyako et al., 1980). Postflight, paradoxical responses to both LBNP and VEL exercise (consisting of a rise in vessel tone and a higher degree of pulse blood filling) were noted in the Salyut 4 crews.

LBNP/VEL response

Reports from Degtyarev and colleagues (Degtyarev, Bednenko et al., 1980; Degtyarev, Doroshev et al., 1980) presented results of cardiovascular measurements taken on the two crews of Salyut 5. The first crew showed high arterial pressure and cardiac output, especially during work. Their EKGs also indicated alterations in the repolarization process, although heart rates remained fairly normal. In contrast, the second crew had a 15-20% increase in heart rate throughout the flight, but no other EKG aberrations. The Soviet scientists attributed the first crew's near-pathological state to fatigue from the large workload required of them, and lack of sleep.

cardiac electrical activity

### Musculoskeletal System

Soviet scientists continued to monitor musculoskeletal system changes associated with spaceflight. The loss of body mass during flight has been of concern; however, weight losses of the three long-term Salyut 6 crews have been moderate and reversible. During the 175-day flight, countermeasures designed to counteract the effects of weightlessness and inactivity were applied. These included intensive physical training applied to the system as a whole, and the use of the Penguin suit, which partly compensated for the absence of gravity by applying load to the skeletal muscles. In addition, continued emphasis was placed on nutritional factors. As on the previous two Salyut 6 missions, the daily caloric allowance was high (3150 kcal, versus the 3900 kcal provided on Salyut 4). Hot dishes were available for every meal, with a wider variety of heated foods being provided. Cargo flights by Progress 5, 6, and 7 delivered fresh fruits, vegetables, and condiments which added to the attractiveness of the cosmonauts' diet. It was reported (Yegorov, 1980) that the overall nutrition and sense of well-being of cosmonauts Lyakhov and Ryumin on the 175-day mission were superior to those of the 96-day and 140-day crews. The additional physical exercise undoubtedly added to well-being, as did the more strict adherence to preventive measures.

nutrition

Measurements taken during the 175-day mission were: body mass, leg (calf) volume, and vestibulomotor function data. As on the two earlier flights, body mass measurements were taken with a unidimensional harmonic oscillator. After an initial variability, from the 28th day of flight Commander Lyakhov experienced a progressive moderate decrease in body mass, with a maximum loss of 5.5 kg (6.6%) on landing.

weight changes

Flight engineer Ryumin showed a slight increase in weight (0.4-0.6 kg) during most of the flight, increasing to a maximum gain of 1.6 kg by day 163. (This is the only inflight weight gain toward the *end* of a mission to be shown by a Soviet cosmonaut.) By the end of the first week postflight, the commander had recovered the weight loss and gained an additional 1.1 kg. The flight engineer exhibited a smaller postflight weight gain. Yegorov believes the progressive weight loss by the commander to be due to an insignificant metabolic deficiency, and the weight gain by the flight engineer to be the result of a diet and water intake sufficient to compensate for energy expenditure. Contrary to expectations, neither crewman had a significant loss of redistributed body fluid after the first several days of flight. Differential effects of exercise could have had some impact on the disparity in weight changes: in measurements taken on the 65th day during treadmill exercise, the commander lost 1050 g, while the flight engineer lost 910 g.

calf volume

Leg volume was estimated by a specially developed device, the IZOG, which treats the calf as a series of seven truncated cones that can be measured and their volumes added. Analysis showed that by the 12th day of flight the commander's leg volume had decreased by 13%, the flight engineer's by 18%. Thereafter, both volumes remained stable throughout the 58th day. The commander's leg volume then decreased to a maximum decrease from preflight values of 19% (on the 143rd day), with about 16.5% decrease at the end of the flight. The flight engineer showed more variability and a larger percentage decrease, with two maximum decreases—one at the 69th-79th day (22.8%) and another at the 156th day (23.7%). On the 170th day his calf volume again began to decline. In crews of both the 140-day and 175-day flights, decrease in leg volume was found to be more pronounced in the first three weeks of flight, with overall patterns of decrease and increase suggesting a wavelike course in the process of loss and recovery.

muscle condition

Changes in muscle condition and muscular functioning associated with spaceflight were also an issue of interest to researchers. Pre- and postflight studies of the motor apparatus and regulatory system conducted with the 175-day flight crew were similar to those carried out in the 140-day mission. Determination of foot support (via the foot's sensitivity threshold), measurement of the Achilles reflex, and stabilographic assessment of postural equilibrium were among the studies performed. The state of motor regulation was determined by both stabilography and perturbation plotting, using incremental shocks to take the body out of equilibrium. Such tests are said to allow accurate evaluations of the state of motor system synergies. Evaluation of the state of calf and thigh muscles during static and dynamic states was carried out by means of the "Miotest." To evaluate the force and speed of muscle groups postflight, the Miotest was supplemented by isokinetic dynamometer, or "Cybex," measurements.

muscle regulation

As in the preceding crew, both members of the 175-day flight crew displayed a degree of proprioceptor hyperactivity. The commander showed a considerable (but reversible) reduction in the threshold of pallesthesia in the support area of the foot. Both crewmembers exhibited a sharp reduction postflight (until the 36th day) in the thresholds of tendon reflex. Additionally, a breakdown occurred in the interextremity synergies; these mechanisms remained impaired through the time of writing (Yegorov, 1980).

Anthropometric and neurologic tests did not reveal any substantial changes in the peripheral muscles, with the exception of a reversible atony in the posterior group of calf muscles and sub-atrophy of the latissimus and trapezius muscles. However, Miotest data indicated a reduction in the functional capability of the posterior group of calf muscles. According to this test, the electromyographic value (cost of exertion) of a standard muscular effort increased more than twofold postflight. Isokinetic dynamometry revealed in both crewmembers a reduction in the force of the gastrocnemius muscle and the frontal tibialis muscle, especially in the commander, whose rate of recovery was slower. From the 3rd through the 11th postflight day, the flight engineer's increase in maximum effort was 30-50%; the commander's, 25-30%.

motor apparatus

Changes in the activity of the motor regulation system in the 175-day crew were similar to those observed in preceding crews, but were considerably less pronounced. Irregularities in the commander's stabilogram persisted past the 11th day postflight, along with a prolonged loss of equilibrium with eyes closed, in the Romberg position. Both crewmembers exhibited slower recovery of equilibrium following external shock and random disturbances, but readaptation was well under way by the 11th day postflight. These changes were not as profound or long-lasting as those found in preceding prime crews, which Yegorov tentatively attributes to the expanded exercise program in this flight. The flight engineer, who exercised more intensively, showed less significant motor regulation changes than the commander.

motor regulation

#### Hematology and Immunology

Hematological studies conducted on crewmembers of the Salyut 6 175-day flight detected elliptical and spherical erythrocytes appearing several days postflight; similarly transformed red blood cell shapes had been found postflight in the commander of the 96-day flight. Such changes in shape are considered to be pathological; however, the number of discocytes in the 175-day crewmembers had returned to normal by postflight day 33. The heterogeneity of erythrocytes may also have contributed to an observed postflight increase in the size of the erythrocyte population of the 175-day crew. Studies of erythrocyte metabolism revealed a reduction in ATP levels in both crewmen, along with an elevated red blood cell metabolic rate.

erythrocyte morphology

Tests have shown no pathological changes in hemoglobin production of individual erythrocyte cells during long-term space missions. Hemoglobin mass decreased postflight (reversibly) in the second and third prime crews of Salyut 6; and during the long adaptation period, erythrocytes are found to enter the bloodstream carrying hemoglobin with some specific functional alterations. Overall, however, the transport of oxygen by hemoglobin is not disrupted during or after spaceflight.

hemoglobin

Yegorov (1980) concludes that long-term spaceflights are accompanied by certain nonpathological hematologic changes which are responses to the adaptation to weightlessness and the readaptation to Earth's gravity.

conclusions

autoantibodies

Since muscle atrophy is associated with long-term exposure to weightlessness, the sera of 15 cosmonauts were analyzed for the presence of autoantibodies after spaceflight (Tashpulatov et al., 1979). Using indirect immunofluorescence, the sera were reacted with group O human or beef heart tissues. Seven cosmonauts possessed positive reactions to one or more of four elements of the human tissue: inserted platelets, sarcolemma, sarcoplasm, and cells of interstitial connective tissue. No differences from preflight tests were observed when bovine tissue was used. Three of the seven positively reacting cosmonauts had especially strong reactions to heart tissue; two of these men were being examined after their third spaceflight. Although the autoimmune reaction was seen in 45% of the cosmonauts studied, it disappeared as the men became readapted to conditions on Earth.

gammaglobulins

The effect of spaceflight on gammaglobulins was also examined (Guseva & Tashpulatov, 1980). The blood of cosmonauts after spaceflights lasting 2, 16, 18 or 49 days was analyzed for protein composition. A 2-day spaceflight was characterized by a decrease in gammaglobulin (especially IgG and IgA) and  $\beta_2$ -glycoprotein fractions. Increases in albumin and most globulins were seen after the 16- and 18-day spaceflights. By contrast, after the 175-day flight a significant reduction in serum levels of the immunoglobulin IgC was observed (Yegorov, 1980).

globulin fractions

Upon completion of the 49-day flight, changes were observed only in globulin fractions:  $C_{3c}$  and  $C_4$  complement factors were monitored at higher-than-normal levels, as were IgG, IgA, and IgM. Two weeks after landing, increased levels of prealbumin and globulin fractions were measured; this change was attributed to readaptation processes.

allergy

On the 175-day Salyut 6 mission, hypersensitivity challenge responses conducted postflight (Yegorov, 1980) detected the appearance, in both crewmen, of a sensitivity to bacterial allergens (streptococcus in the commander, and both streptococcus and staphylococcus in the flight engineer). A distinct sensitivity to formaldehyde was also recorded postflight, although neither crewmember had exhibited such a sensitivity preflight. All of these sensitivity reactions had been seen in previous flights. The sensitivity to formaldehyde observed on the 140-day and 175-day flights confirms the fact that immunological shifts occurring inflight contribute to the development of multivalent allergy, requiring clinical attention. It also points to a need to reduce formaldehyde contamination of the cabin atmosphere.

### Metabolism

electrolyte  
metabolism

The causes, mechanisms, and significance of disturbances in electrolyte metabolism during spaceflight were summarized by Gazenko, Grigor'yev et al. (1980), using results from both USSR and U.S. flights.

fluid shifts

Weightlessness results in a redistribution of blood to the thoracic vessels and the distention of the atria; a reflex increase in renal excretion of fluid follows. Also observed are diminished thirst and fluid intake and a lessened desire for salt. These



persist for some time after landing. Postflight, there is increased fluid intake but decreased diuresis. Since blood osmolarity remains normal, the fluid retention appears to be a response to diminished body fluid volume, an explanation which is corroborated by observed elevation of antidiuretic hormone (ADH) in blood and urine.

Flights in which volumes of body fluids were measured produced contradictory data. Analysis of the information led the authors to note that fluid losses during short-term flights are attributable to extracellular fluid loss; on longer flights, extracellular fluid is probably gradually restored, but there is an overall decrease of intracellular fluid due to muscular atrophy.

**fluid losses**

Among the many chemical imbalances monitored, negative potassium (K) levels have been recorded, even 5 days postflight. This is probably another manifestation of muscular atrophy, since reduction of cell mass results in the concomitant loss of K from cells. Reduced excretion of sodium after flight has also been noted (Yegorov, 1980), indicating a greater loss of this ion during flight. The ratio of sodium/fluid in the urine is restored to normal more rapidly after short flights than after long flights.

**Na/K excretion**

A gradual increase in calcium (Ca) excretion beginning the second week of flight has also been documented. This elevated excretion reaches a maximum after 3-4 wks of flight and remains at that level. The increased Ca excretion is attributable to changes in muscle and, especially, bone tissue anabolism and ongoing catabolism, which is also reflected by negative balances of phosphorus, sulfur, and magnesium. Such alterations are adaptations to weightlessness and do not impair the mechanical strength of the skeleton in space.

**other electrolyte imbalances**

Renal function is not permanently impaired by weightlessness. After long-duration flights, the concentration of osmotically active substances in urine and the reabsorption of osmotically free water have been found to be lower than preflight, even in the presence of high ADH secretion. Therefore, it appears that prolonged exposure to 0 G reversibly affects the concentrating capacity of the kidney and its response to ADH. Such changes in renal function reflect metabolic shifts that develop in 0 G. Changes in the ion regulatory system are apparently secondary to these metabolic shifts, and are directed toward the maintenance of blood homeostasis.

**renal function**

### **Neurophysiology**

Kornilov et al. (1979) compared the effect of prolonged and short-duration spaceflights on otolithic functions of cosmonauts. Pre- and postflight data were obtained from crewmembers of Soyuz 21 and Salyut 5 (49 days), Soyuz 26 and Salyut 6 (96 days), and Soyuz 22 and Salyut 28 (7 days). Intensity of the otolithic reflex was determined by ocular counter-rolling. The degree of expression and the magnitude of asymmetry were greater after prolonged spaceflight than following brief exposures, leading the scientists to hypothesize that a possible interrelationship exists between statokinetic disorders and asymmetry of the otolithic function.

**otolith function**

vestibulometric tests

Yegorov (1980) reported studies of vestibular function and spatial perception in the 175-day Salyut 6 crew. Preflight and postflight measurements were taken of: 1) the intensity of the otolith reflex by ocular counterrotation; 2) semicircular canal threshold response to angular velocity changes; 3) the interaction between the otolith and semicircular canals with incremental angular acceleration; 4) spatial perception; and 5) the level of autonomic stability, through endurance of rotating-chair angular accelerations.

atypical reaction

For the first time in any of the Salyut 6 flights, one crewmember (the commander) experienced pronounced illusory reactions postflight. These took the form of auto-kinetic illusions during fixation on an object, possibly related to more pronounced changes in the sensory systems and in the vestibular analyzer. A decreased otolith reaction in the commander was in marked contrast to all other cosmonauts of Salyut 6, who exhibited hyper-reflection of otolith function postflight. By postflight day 6, the otolith reflex had returned to its preflight value. The flight engineer showed a more typical postflight asymmetry ( $14^{\circ}$ ) due to a significant hyper-reflection on the right side and hypo-reflection on the left side. These shifts in otolith response persisted past the 9th day of testing.

vestibular function

Neither crewman exhibited any change in the threshold response to angular velocity. However, the commander showed more marked disturbances than the flight engineer in other aspects of vestibular function and spatial perception. During rotational vestibulometric tests, he experienced vestibulo-autonomic reactions of the first degree, Achilles type. He also showed a large increase in error in defining vertical lines, both while lying on his side and while sitting. The determination that changes in the sensory system and the vestibular analyzer were more pronounced in the commander than in the flight engineer led to the theory that these shifts were responsible for his expressed statokinetic disorders.

### Psychology

predictive tests

The psychological condition of cosmonauts during flights has been given increasing attention (Beregovoy et al., 1978; Gazenko, 1980; Samsonov, 1979). Potential psychological problems encountered in space include those related to small group isolation, stress, man-machine interaction, and cosmonaut compatibility. Increasing emphasis is being placed by the Soviets on the development of psychological tests to predict responses of people under these conditions. Based on test outcomes, a hypothesis currently being considered is that individuals with very dissimilar personality traits may make the most compatible crew.

adaptive design

Drawing upon the experiences of cosmonauts of previous flights, psychologists (Beregovoy et al., 1978) are also attempting to predict human reactions to unusual and emergency conditions. Based on their results, they are striving to design procedures and machinery accordingly.

A medical group was formed to provide psychological support to the crew of the 175-day Soyuz 32/Salyut 6 mission (Yegorov, 1980). Drawing upon the experiences of the first and second prime crews of Salyut 6 and the schedule of the 175-day flight, they devised a program intended to keep the crew highly motivated, informed, and emotionally stable. Special factors of this flight that were expected to have a psychological impact on the crew were: 1) an increased maintenance and repair workload, 2) a lack of visiting crews, and 3) EVA operations.

175-day flight crew

The psychological support program was based on a series of information exchanges between cosmonauts and the ground, including talks with their families (47 times during the flight), discussions with scientific and technical specialists in different fields, and talk sessions with well-known actors, comedians, and singers. Varied music and news programs were available to the crew, and cargo craft brought letters, newspapers, gifts, etc., aboard. The scientific consultations emphasized upbeat reports of the uses to which the crew's data were being put. These discussions reportedly kept the crew highly motivated toward their research work.

psychological support

The psychological support program was apparently quite effective in maintaining high emotional and working morale throughout the lengthy flight.

conclusion

### Space Biology

The Soviets sent no new biosatellites into orbit in 1980. However, many experimental results from past spaceflight investigations were received from the USSR. Of particular interest were the reports of studies conducted aboard Cosmos 939 (Il'in, Korol'kov et al., 1979; Gzenko, Il'in et al., 1980; Bryanov et al., 1979; Adamovich, Il'in et al., 1980) and Cosmos 1129 (TASS, 1979a; Il'in & Novikov, 1980; Soviet Health Ministry, 1980). Both flights were directed primarily at studying the mechanisms of physiological changes associated with O G.

earlier missions

### Pulmonary System

Pogodin and Mazhbich (1980) studied the shifts in pulmonary hemodynamics caused by changes in body position of anesthetized cats in space. Regional electroplethysmography was used to quantitatively evaluate blood volume and blood flow in individual pulmonary sections (apical, medial, and basal). In the horizontal position (lying on back), dorsal pulmonary sections showed the highest blood filling (14.1 ml/100 cm<sup>3</sup>) and minute volume of blood flow (258 ml/100 cm<sup>3</sup>). The figure below shows the result of the blood filling measure in the vertical (head-up) and reversed vertical positions for apical, medial, and basal pulmonary sections. The volume measurements showed similar trends. The authors concluded that the gradient of blood flow in the lungs is determined primarily by gravity and exists in all body positions; however, the apical regions of the lungs have lower blood filling than the basal regions, regardless of body position.

positional hemodynamics

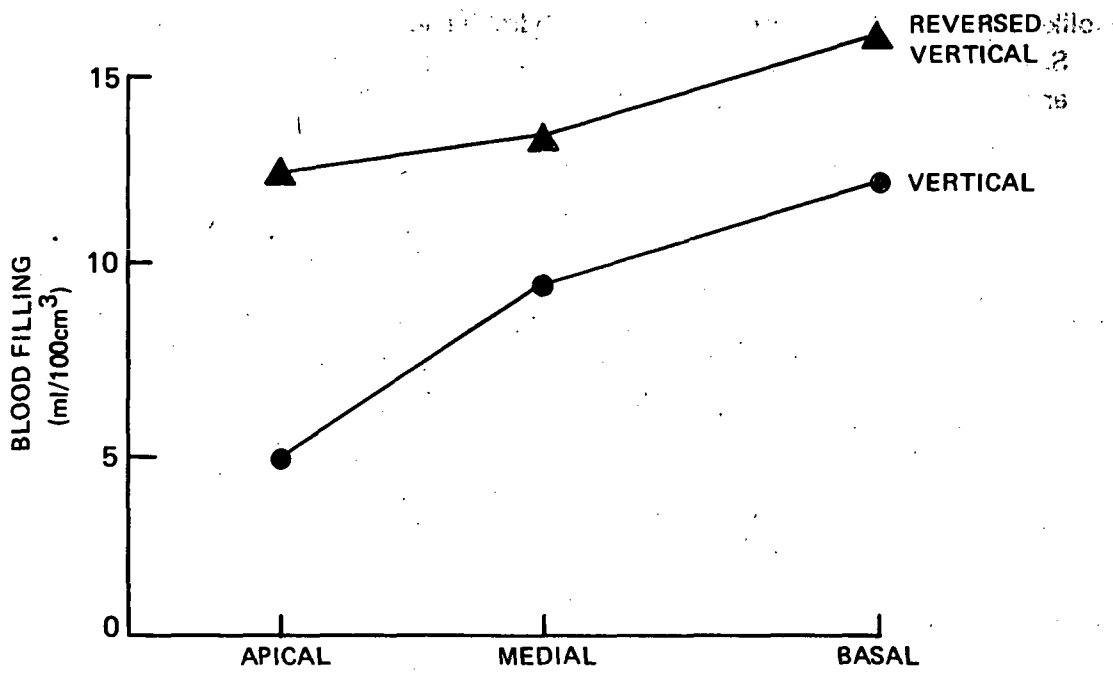

(From Pogodin & Mazhbich, 1980)

### Musculoskeletal System

preventive centrifugation

The effects of spaceflight on the musculoskeletal system of animals received a great deal of attention. Gazenko, Il'in et al. (1980) summarized the results of investigations on rats flown aboard Cosmos 782 and 936 (19.5- and 18.5-day flights, respectively). During the latter flight, 10 of the animals were confined on centrifuges and subjected to artificial gravity (1 G) in order to assess its prophylactic or preventive value, while 20 rats experienced weightlessness. Meanwhile, control subjects on the ground were held in a mock-up of the biosatellite that reproduced all onboard conditions except weightlessness. Vivarium animals also served as controls.

muscular atrophy

Distinct musculoskeletal changes were found in the weightless group. Muscular atrophy was observed, particularly in muscle groups of the hindlimbs. Decreased ATPase activity of myocardial myosin was also evident. The centrifuged rats, however, exhibited less pronounced catabolism.

skeletal changes

Skeletal changes in flight animals included osteoporosis, decreased density and mineralization, and a 30% decrease in mechanical bending strength. The exceptions were the rats exposed to artificial gravity, who showed no alterations in calcium and phosphorus content of the long bones. By contrast, however, in an earlier study of tortoises exposed to flights of 19, 22, 60, or 90 days (Stupakov et al., 1979), no osteoporosis was found in the compact tissue of any of the 10 experimental animals examined. Decreased density and mineralization were noted; and osteoporosis and the resultant decrease in strength were seen in the spongy bone of tortoises exposed to the 60- and 90-day flights.

Histological studies of thyroid calcitonin-secreting cells of rats flown onboard Cosmos 605 (22 days), Cosmos 782 (19.5 days) and Cosmos 936 (18.5 days) permitted the determination of morphological changes produced by spaceflight conditions (Plakhuta-Plakutina, 1980). Thyroids from these rats had fewer and smaller C-cells than the thyroids of control animals, suggesting a decrease in calcitonin secretion. Other physical alterations included decreased follicular epithelial height, consolidation of colloid, and an absence of resorption vacuoles, all of which support the postulate of reduced activity. Renewed thyroid activity postflight was suggested by histological measurements of these parameters in thyroids of rats sacrificed 2 days postflight. No aberrations were noted 25 to 27 days after the flights. Significantly, the thyroids of rats exposed to artificial gravity onboard Cosmos 936 did not differ from vivarium controls, clearly demonstrating that weightlessness is the primary factor associated with these thyroid changes.

**calcitonin secretion**

The Soviet researchers hypothesized that weightlessness causes transiently decreased thyroid calcitonin-cell activity. The result is a lowered level of calcitonin and the release of calcium from bone tissue.

**conclusions**

### **Metabolism**

Soviet researchers have been paying more attention to the molecular mechanisms involved in physiological changes induced by spaceflight conditions. Rats that were flown aboard the three most recent biosatellites, Cosmos 782, 936, and 1129, were analyzed for metabolic, hormonal, and enzymatic responses (Makho et al., 1980; Tigranyan & Vetrova, 1980).

**molecular mechanisms**

Hepatic enzyme activity and related metabolism were investigated in rats flown on Cosmos 782 (19.5 days) and Cosmos 1129 (19 days). Enzyme assays were performed 6-10 hrs or 26 days postflight. Those assays done shortly after landing showed decreased in malate dehydrogenase, isocitrate dehydrogenase, and glucose-6-phosphatase in both flight animals and a control group housed in a ground-based mock-up of Cosmos 1129. Slight increases in fructose diphosphatase and phosphoenolpyruvate activities were measured; large increases of tyrosine aminotransferase and tryptophan pyrolase activities were also found in both sets of animals. The shifts in enzyme levels suggested that spaceflight conditions had induced intensification of gluconeogenesis, with subsequent storage of the glucose in the form of glycogen. These alterations had returned to baseline levels within 26 days after landing. The researchers concluded that stress induced by hypokinesia, rather than exposure to weightlessness, had produced these changes.

**enzyme activity**

The adaptive changes to weightlessness in the hypothalamic-hypophyseal-adrenal system and lymph organs of rats flown aboard Cosmos 782 and Cosmos 936 were investigated by Gzenko, Genin et al. (1980). Increased activity in the neurosecretory processes of the hypothalamus was noted, although there were no changes in catecholamine levels or their regulators. Involution of lymph organs was also observed: mass breakdown of lymphocytes, atrophy of follicles and light centers in the spleen

**hypothalamus and lymph organs**

and lymph nodes, and a drop in thymus and spleen RNA content and DNA synthesis were documented. The degree of atrophy corresponded directly to the degree of a muscle's participation in antigravity support on Earth.

**hypophyseal  
function**

Morphological studies of the posterior pituitary of rats flown onboard the Cosmos 936 biosatellite were also reported (Savina & Alekseyev, 1980). The functional state of the lobe was evaluated on the basis of serial secretions, measurement of neurosecretory corpuscles, determination of the distribution of neurosecretory substance in fibers, and density of neurosecretory substance as related to pituicytes and blood vessels. The authors concluded that neurohormonal secretions diminished in supraoptic and paraventricular hypothalamic nuclei, and there was temporary impairment of vasopressin and oxytocin excretion from neurosecretory fiber endings during the early postflight. Rats exposed to artificial gravity demonstrated less pronounced changes in posterior hypophyseal function.

**electrolyte  
metabolism**

Simulated gravity conditions onboard Cosmos 936 allowed scientists to examine weightlessness as a separate factor influencing animal metabolism (Il'in et al., 1980; Gurovskii et al., 1980). Rat kidneys from animals exposed to 0 G or artificial gravity during the 18.5 day flight were analyzed by microdissection. Water and potassium load tests and electrolytic analyses of various portions of the organ revealed more pronounced changes in the kidneys of rats exposed to weightlessness. The changes included increased sodium excretion during water loading and increased potassium excretion during potassium loading. Electrolytic analyses led to the determination that wet cortical and medullary tissues of both groups possessed decreased potassium levels, apparently due to increased tissue hydration. Neither group exhibited renal structure abnormalities.

**conclusions**

Overall, rats exposed to artificial gravity during the flight did not exhibit the disturbances in gas exchange, electrolyte metabolism, postural equilibrium, muscular atrophy, bone degeneration, increased sarcoplasmic protein content, or decreased myocardial myosin ATPase activity that were seen in animals subjected to the weightless satellite environment.

**Neurophysiology**

**behavioral  
decrements**

Rats that had been flown on Cosmos 782 biosatellite were found to have impaired food-procuring skill compared to their preflight ability (Livshits et al., 1980). Tested 2 to 12 days postflight, the rats demonstrated increased erroneous movements, more failures in negotiating a maze, and greater maze travel time. Diminished muscle strength was poorly correlated with the rats' behavior; reduced hunger stimulation was also discounted. The researchers proposed that changes in the central nervous system resulting from prolonged reduction of sensory impulses inflight were the primary cause for this loss of learned behavior.

The postflight neurochemical characteristics of male Wistar rats flown aboard Cosmos 936 were briefly reported by Gazenko and associates (1979). Results of a biochemical study of samples of the cerebellar tissue, as well as the frontal, temporal, and occipital areas of the cerebral cortex, were presented. It appeared to the scientists that the observed neurochemical changes in a weightless environment were a manifestation of passive inhibition of cerebral cortex activity from lack of stimulation. They discounted stress as a cause. Twenty-five days after the flight, the alterations had disappeared.

neurochemistry

The vestibular system of rats flown aboard Cosmos 936 was also examined (Shipov & Ovechkin, 1980). Nystagmic reactions of the animals were tested in response to a series of increasing angular accelerations 2 wks before launch and again 2, 7, 12, 15, and 23 days after the flight. There were no reliable differences between the nystagmic responses of animals exposed to weightlessness and the responses of vivarium or synchronous control animals (rats exposed to the same habitats and accelerative forces as flight animals) in any of the preflight or postflight tests. However, the flight control animals that had been maintained in an artificial-gravity centrifuge inside the biosatellite showed very different nystagmic reactions after landing. This group demonstrated a temporary postflight increase in latency of onset of nystagmus after rotation, indicating a decrease in sensitivity of the semicircular canals to angular acceleration. The authors pointed out that a similar decrease in sensitivity after prolonged rotation is observed in ground-based experiments.

nystagmus

#### Radiation Effects and Protection

The danger presented by weightlessness and other factors in spaceflight is still unclear. Prokhonchukov and associates (1979) examined the effects of ionizing radiation during spaceflight on the calcium and phosphorus content of bone in rats flown aboard Cosmos 690 in order to define the cause of any observed changes.

ionizing radiation

A group of animals was irradiated for 24 hrs with an 800 rad dose of ionizing radiation using a source within the satellite. Another group of rats onboard the Cosmos spacecraft was not irradiated. Ground-based controls included vivarium animals and synchronous experimental animals with and without radiation treatment.

approach

Bone ash was prepared 2 or 26 days postflight and analyzed for mineral content. A decrease of 3-10% in total ash content of bones of rats subjected to 0 G was observed. Furthermore, a redistribution of calcium and phosphorus was seen in all animals that had flown. However, only those rats subjected to ionizing radiation showed an actual decrease in phosphorus content (up to 29% less than the controls). The phosphorus levels were found to remain significantly depressed in calcified tissue even after 26 days on Earth.

phosphorus

Ionizing radiation during spaceflight did not appear to affect calcium metabolism to any extent. After a readaptation period, calcium levels were equal in experimental and control animals.

calcium

## Plant Research

### purpose

Although it is not as widely publicized as other facets of their space program, the Soviets have been actively studying plant development and growth under spaceflight conditions. Their goal of complete self-sufficiency within a closed life support system in space hinges on plants for oxygen, food, and psychological support (Vasil'yev, 1979).

### research focus

Experiments with higher plants were first conducted aboard Salyut 4. Peas, onions, wheat, carrots, beets, and cabbage were taken on the flights. In all cases, the seeds sprouted, the plants grew for about 2 wks, and then died. Since that time, research has been aimed more at the effect of spaceflight conditions upon plants within definite periods of the life cycles.

### meristem cells

Seeds have been taken into space aboard spacecraft in order to determine the effects, if any, upon subsequent germination and growth on Earth (Nuzhdin & Dozortseva, 1980; Kordium, Mashinskii et al., 1978). These experiments produced mixed results. Barley seeds were taken into space aboard Soyuz 5 and 9. A cytological study of the mitoses in root meristem cells revealed that spaceflight factors induced about 3% aberrant cells, compared to controls. Seeds exposed to radiation in addition to spaceflight factors were found to have 6% aberrant cells in the meristematic tissue.

### gametophyte formation

Gametophyte formation of *Muscari racemosum* and *Anethum graveolens* (dill) was followed after seeds of these two plants were exposed to space conditions aboard Soyuz 20 during its 90-day flight. As the reproductive structures grew, they were compared microscopically with plants that had not been subjected to spaceflight conditions. The male gametophyte of *M. racemosum* seeds exposed to flight grew much faster than the controls; dill plants, however, showed a decrease in both germination rate and percentage of shoot formation after spaceflight. Nevertheless, the actual development of *A. graveolens* appeared unaffected: number of buds and leaves, and characteristics of sporogenesis and gametogenesis, fruiting, embryogenesis, and endosperm development were essentially identical between experimental and control plants.

### tissue changes

The growth of plant cultures in weightlessness has also been studied, without demonstrating any substantial differences (Sidorenko & Mashinskii, 1978; Kordium, Mashinskii, Shepelev et al., 1980). Cultures of *Haplopappus gracilis* were grown on solid agar aboard Soyuz 22 for 9 days. Subsequent growth, reproduction, and structure and function of tissue changes were compared with plants grown on Earth. Optical and electron-microscopic analyses showed that tissue growth was slower than in controls, with some tissue disruption, probably from inflight vibrations. No other differences were noted between experimental and control cultures' growth, formation of reproductive cells, mitotic frequency, nuclear size, or population karyotypes, in plants grown at 18°. Controls grown at 26° did exhibit an increase in biomass over experimental plants.



*Chlorella pyrenoidosa* cultures were analyzed with electron microscopy after 5 days of growth in the dark on semiliquid medium aboard the Soyuz 22-Salyut 6 orbital research station. No discernible ultrastructural reorganization within the cells was seen after the 5-day flight. The liquid culture medium probably afforded the unicellular alga some protection from tissue disruption by inflight vibration, as was seen in the *Haplopappus* cultures.

cellular structure

Other experiments involving subjection of plant tissue to spaceflight conditions included the effects of spaceflight on the emergence of duckweed (*Spirodela polyrhiza*) turions (Kutlakhmedov et al., 1978) and the development of *Polysporus brumalis* (Kasatkina et al., 1980).

test species

Dormant duckweed turions were placed in growth chambers onboard Soyuz 12 and 13 and Cosmos 656; during flight they were activated by kinetin, a growth factor. After landing, growth was monitored by the uptake of tritiated thymidine and by fascicle growth. Inhibition of early meristematic growth was noted, as was an irregular suppression of the function of the first daughter fascicle. Later growth was similar to controls, suggesting that the early stages of duckweed growth are indeed sensitive to spaceflight factors, and provide a useful model.

duckweed growth

The development of fungal cultures in both light and dark was assayed on Salyut 5 (17 days) and Salyut 6 (20 days). Test tube cultures of *Polysporus brumalis* in the fruiting body primordia stage were exposed to 0 G aboard the Salyut 5. Mycelial cultures of the same fungus were exposed on Salyut 6. In the former experiment, fruiting bodies that formed in light had stems and caps that approached those of the control cultures in appearance and anatomical structure, although some structural changes in the hymenophore were seen. Fruiting bodies that developed in the dark had twisted stems and no caps. In the second experiment, the mycelial cultures that were flown onboard Salyut 6 produced fruiting bodies in the light but not in the dark.

light/dark conditions

Onboard the most recent biosatellite, Cosmos 1129, part of one experiment (Soviet Health Ministry, 1980) involved a study of the development of plant tumors. The condition of the tumor, accumulation of dry mass, tissue respiration, and permeability of cell membranes were examined. Another experiment onboard Cosmos 1129 investigated the effects of space radiation on lettuce seeds. Ionizing radiation from space caused a 2- to 2.5-fold increase in chromosomal aberrations in the seeds. The most sensitive region was the rapidly growing root meristem.

recent work

## Microbiology

Another part of the planned closed life support system relies on microorganisms for recycling wastes (Smirnov, 1980). *Proteus vulgaris* has been the bacterium of choice in the past few years for studying the effects of spaceflight on growth and ultrastructure.

waste treatment

After growing under anaerobic conditions in a growth chamber, *P. vulgaris* cells inoculated onto growth medium in space were found to exhibit poor growth relative to ground-based laboratory and transported controls (Kordium, Polivoda et al., 1978). The experimental cultures had fewer and smaller cells that were less responsive to feedback from metabolic products. Electron microscopy revealed cell types I, III, IV, and VI, which are characterized by differing amounts of formazan deposits, fibrillar-granular formations, and membrane structures (Bochagova et al., 1978). Other cell types were also seen, lacking formazan deposits but showing a great deal of internal lysis. Later experiments involved culturing *P. vulgaris* during spaceflight in polyethylene packets in a semisolid medium with Tryptose (Kordium, Mashinskii, Man'ko et al., 1980). Although the packets presented suboptimal growth conditions, growth and morphological characteristics of flight and ground control cultures were nearly identical. Variations were detected in cellular ultrastructure, however.

anaerobic conditions

In an attempt to explain the poor bacterial growth in space, Babskii and colleagues (1978) examined the effects of spaceflight on the culture medium used to support growth. The nutrient agar medium was analyzed for viscosity and sedimentation characteristics after being flown on Soyuz 20 for 3 mos. The researchers found that two factors, the transport of the medium to the launch site and subsequent spaceflight conditions, substantially reduced the mechanical strength of the agar, resulting in a decrease in its ability to support bacterial growth and mobility.

alterations in medium

## Life Sciences Technology

### Bioinstrumentation

Salyut 6

In a continuing effort to monitor physiological changes during spaceflight, the Soviets have developed, installed, and tested new measuring devices onboard Salyut 6.

Fluid shifts in response to weightlessness have been recorded with the Reograf-2, a spacecraft rheographic monitor. Rheograms of the torso, forearm, and shin, as well as rheoencephalograms of the right and left brain hemispheres have been obtained from crews visiting the Salyut 6 orbital space station. These data confirm the redistribution of blood in zero gravity, while making it evident that there are markedly different individual responses (Kas'yan & Turchaninova, 1980). In particular, blood flow and cardiac output during the weightless condition were analyzed. The amount of blood to the brain was found to increase steadily in the first 2 wks of flight. A concomitant 15-20% reduction of blood to the shin was also measured.

rheographic monitor

The phenomena of muscle atrophy and loss of body mass have been of continuing concern to space physiologists. A massmeter has been installed aboard the Salyut 6 station, enabling scientists to obtain regular readings of cosmonauts' mass throughout spaceflights (Sarychev et al., 1980). The continual assessment of cosmonauts' weight allows ground-based not only to analyze weightlessness-induced changes, but to suggest ameliorating steps (e.g., different diets, exercise) to combat potentially hazardous losses during the flight.

massmeter

## Extravehicular Activity

Cosmonauts continue to perform excursions from the orbital space station. The Soviets view as a necessity the ability of crewmembers to leave a spacecraft and function outside. EVA permits the performance of routine inspection and maintenance, the replacement of equipment on the exterior surface of a station, and the technical and operational servicing of nonpiloted satellites (Khrunov, 1980). It could also serve as a method of escape, should there be an accident.

purposes

The Soyuz 32-Salyut 6 crew undertook one EVA during their 175-day spaceflight. New semi-rigid, liquid-cooled spacesuits with integrated, self-contained life support systems were used. During the EVA, physiological parameters including pulse and respiratory rates and body temperature were recorded, and were all deemed satisfactory (Barer et al., 1979). Although Lyakhov and Ryumin reported short-term sensations of local overcooling and overheating, the life support system provided sufficient thermal conditioning during all phases of the EVA.

spacesuits

## Exobiology

The Venera 11 and 12 missions obtained mass spectrometer measurements of the atmospheric composition of Venus. A considerable amount of nitrogen (4.5%) was detected in addition to the main component, carbon dioxide. The isotopic composition of carbon was found to resemble that of Earth (Istomin et al., 1980). Isotopic characterization of argon, however, revealed an abundance of  $Ar^{40}$  nearly equal to the combined fractions of the primary isotopes,  $Ar^{36}$  and  $Ar^{38}$ .

Venutian atmosphere

In an attempt to establish the origin of planetary atmospheres, Izakov (1980) studied the inert gases in general, comparing the relative abundance of their isotopes. He concluded that the process of accretion of gas from the protoplanetary nebulae formed most of the Venutian atmosphere, a large part of Earth's atmosphere, and a part of the Martian atmosphere.

formation process

Another experiment onboard the Venera 11 and 12 probes dealt with the Venus day-sky spectrum (Moroz, Moshkin et al., 1979). Angular distribution of scattered radiation brightness within the 4,500 to 12,000 Å wavelength was recorded during the descent of the probes from 65 km to the surface. The spectra showed absorption bands of carbon dioxide, water, and sulfur. The relative abundance of water to  $CO_2$  was determined to be 20 ppm; sulfur was on the order of 0.01 ppm in the lowest part of the atmosphere. The spectra also revealed the lower cloud boundary to be between 47 and 48 km, with about 6% of the solar flux reaching the planet's surface.

spectral analysis

An ultraviolet photometer on the Mars 5 orbiter sent back data on the atmospheric components of Mars, including water vapor and ozone, temperatures, transport processes, and photochemical processes in the lower and middle atmosphere (Krasnopolsky et al., 1980). An ozone layer 7 km thick and 35-40 km high was found;

Martian atmosphere

it was considerably more dense during the day than at night. Two aerosol layers were also found. The upper layer, 25-40 km high in the morning, rising to 60 km in the evening, apparently consists of ice particles. The lower one has an upper boundary of 20 km.

**possibility of life?**

Based on information sent back from the Viking landers, a number of Soviet scientists believe that their U.S. counterparts are in error in stating that there is no life as we know it on Mars (Imshenetskiy & Murzakov, 1979). Their premise is that there could be hydrated iron oxides of the limonite type and frozen hydrogen peroxide on the planet. Although hydrogen peroxide has strong biocidal effects on microorganisms, it also promotes the extraction of organic nutrients that could be consumed by surviving life. Another possibility, not contradictory, is that microorganisms have evolved with the ability to produce high levels of catalase, an enzyme that splits hydrogen peroxide.

## GROUND-BASED RESEARCH

### Space Medicine and Physiology

#### Hypokinesia

The most convenient and widely used method for reproducing the real effects of weightlessness has been the bedrest regimen at different angles (Genin, 1977). Subjects' reactions to prolonged bedrest closely resemble actual weightlessness effects: there are usually decreases in the volume of circulating blood, decreases in orthostatic stability, decalcification of bone tissue, and muscle atrophy. Bedrest does not, however, simulate the effects of complete blood redistribution, vestibular autonomic disorders, or the subjective feeling of being "weightless."

usefulness of bedrest

Soviet and American scientists have been working cooperatively to standardize experimental procedures and measurements used in ground-based studies on the effects of weightlessness. At the 9th conference of the Joint Soviet-American Committee on Space Biology and Medicine in Leningrad (October 1978), a bedrest protocol was defined. The Soviet component of the protocol was conducted in May and June of 1979. Goals included the comparison of two weightlessness models, horizontal bedrest and antiorthostatic bedrest ( $-6^{\circ}$  head-down tilt). The general conclusion from this study was that physiological alterations accompanying both forms of bedrest are statistically very similar. The head-down position continues to be favored by the Soviets, however, because it more adequately reproduces the clinical symptoms of weightlessness, including the rush of blood and heaviness in the head, nasal congestion and impeded nose breathing, and swelling of the face.

bedrest protocol

Cardiovascular deconditioning in weightlessness continues to be the subject of ground-based experiments. Turbasov (1980) used  $-4^{\circ}$  antiorthostatic hypokinesia for 6 mos to study cardiac bioelectrical activity. He determined that heart rate remains relatively unaltered during the hypodynamic period, although an appreciable increase in heart rate was seen during the recovery period. Observed increases in atrioventricular conductance and QRS complex amplitude and a decrease in the T-wave amplitude were characteristic of the deconditioning.

cardiovascular deconditioning

The Soviets are currently placing greater emphasis upon prophylactic and preventive measures. Assessment of cardiovascular parameters throughout a period of hypokinesia coupled with exposure to rotation on a short-arm centrifuge demonstrated that centrifugation can be an effective countermeasure to deconditioning (Vil'-Vil'yams & Shul'zhenko, 1980b; 1980c). An increasing number of studies show that exercise significantly reduces the effects of hypokinesia on the cardiovascular system (Katkovskiy & Buzulina, 1980; Kakurin et al., 1980). However, Gzenko and his coworkers (Gzenko, Shumakov et al., 1980) found that subjects performing moderate arm exercise after cardiac habituation to a  $-30^{\circ}$  head-down tilt exhibited increased systolic pressure in the left ventricle and femoral artery. Additionally, acidosis with hyperventilation developed in the arterial blood. The researchers concluded that the

preventive measures

head-down position, by displacing blood into the intrathoracic area, imposes increased requirements on the heart, even at low workloads. This observation deserves attention when exercise regimes are being prescribed for spacecrews.

**blood volume** The effects of 6 mos of  $-4^{\circ}$  antiorthostatic hypokinesia with or without exercise on aspects of vascular system function were also investigated (Burkovskaya et al., 1980). Blood volume was found to have declined by the end of the 2nd month—a loss which could be explained by measured decreases in plasma volume and erythrocyte mass. After 4 mos, most subjects did not demonstrate further blood volume decreases.

**erythrocyte changes** Erythrocyte life spans were found to be shortened. Although this effect persisted through the 6th month, no anemia developed. By the end of the 2nd experimental month, when blood volume leveled off, both bone marrow production of erythrocytes and the rate of differentiation of erythroid elements had increased. This appeared to be an adaptive response to the shift of fluids.

**exercise** Some subjects in this study underwent exercise programs during the antiorthostatic period. These people did not exhibit any major differences in vascular reactions from those who did not exercise. By contrast, in a study by Chernuth et al. (1979), physical exercise was found to prevent marked changes in the microcirculation of the hands after 6 mos of strict bedrest. Microcirculation in areas not affected by exercise, such as the sclera and feet, was notably altered.

**vascular tone** Avetikyan and Zingerman (1979) used rheography to follow vascular tone during head-down antiorthostatic positioning. Untrained volunteers subjected to 20 min in a horizontal position, 20 min in a  $-45^{\circ}$  antiorthostatic position, then 20 min more in a horizontal position exhibited increased cerebral artery tone and decreased leg artery tone during the head-down period. When the horizontal position was resumed, vascular tone returned to normal. After the subjects became "trained" with the antiorthostatic position, changes in vascular tone during the test protocol were similar but smaller.

**coagulation** The virtually unaddressed response of blood clotting ability to hypokinesia was examined in a 7-wk study (Drupina et al., 1979). Volunteers were confined to bed with an incline of  $-4^{\circ}$ ; some were involved in a physical exercise program. Hypercoagulation symptoms were evident by the 12th day of hypokinesia and persisted for 2 wks after bedrest was terminated. No significant differences were observed between those who exercised and those who did not, except for a trend toward reduction of fibrinogen content in the former group. The authors proposed that some of the findings were due to the normal decrease in plasma volume and to stress from muscular inertness. Nevertheless, the hypercoagulation that appears to occur with bedrest (and possibly spaceflight) might present a risk of developing cardiovascular disease and/or thrombotic complications.

**immunoglobulins** Immunoglobulin redistribution was detected in subjects undergoing 5-day head-down bedrest (Mukhina et al., 1980). IgA was found in decreased concentrations in blood flowing from the brain and lower extremities; IgG amounts declined in blood

draining from the liver and lower extremities. IgM showed no changes in organic distribution. It was hypothesized that the brain sequesters IgA during immobilization, while the liver and lower limbs accumulate IgG.

The effect of prolonged head-down bedrest (-4<sup>0</sup>) on external respiration and acid-base balance was analyzed in two studies lasting 49 and 182 days (Golikov et al., 1980). Both groups of subjects demonstrated decreased respiration rate, lung ventilation, and oxygen consumption, with relative increases in exhalation time. Decreases in the partial pressures of oxygen and carbon dioxide were observed; increased oxygen and carbon dioxide arterio-alveolar differences were also noted. These changes suggest shifts in the ventilation-perfusion ratio of the lungs and possible disturbances in central respiratory regulation.

**respiration**

The reactions of water-salt metabolism and the kidneys to prolonged hypokinesia were also experimentally tested (Natochin, 1977). Subjects underwent bedrest for 5 to 182 days at various angles. Kidney functioning remained unaltered. However, the antiorthostatic position quickened hemodynamic shifts, causing greater elimination of water and salt. This shift in blood electrolyte composition resulted in slight hypokalemia and hypocalcemia.

**water-salt  
metabolism**

A similar investigation of fluid-electrolyte metabolism was conducted using the water immersion model (Shul'zhenko, Grigor'ev et al., 1980; Shul'zhenko, Tigranian et al., 1980). During a 3-day study, increased fluid and electrolyte excretion was monitored, especially on the first day. This excretory response was attributed to a homeostatic mechanism designed to recover intravascular fluid; i.e., accumulation of blood in the intrathoracic area triggered receptors that respond to excess fluid. The body's reaction is diuresis to reattain "normal" intrathoracic fluid levels.

**water immersion**

Several of the subjects were also exposed to low-magnitude acceleration during immersion. This challenge was found to mitigate the increase in excretion, somewhat normalizing fluid-electrolyte metabolism.

**immersion plus  
acceleration**

Investigation is continuing on ways to prevent or lessen the amount of muscular degeneration that accompanies hypokinesia and spaceflight. Exercise has been found to be the most effective regimen tested for combatting some of the more severe atrophic processes (Tishler et al., 1980). Other methods examined, including lower body negative pressure, salt supplements, and pharmacological preparations (e.g., ephedrine, strychnine), provided no enhancement of neuromuscular activity, even in conjunction with physical exertion.

**muscle atrophy**

The electroencephalograms of people subjected to long-term simulated weightlessness have been examined for resultant alterations or aberrations. The hypokinetic effect on sleep patterns was analyzed by Rotenberg and associates (1980) using not only EEGs but also electrocardiograms, electromyograms, and electrooculograms. No fundamental changes were discerned.

**sleep patterns**

waking EEGs

By contrast, Krupina and coworkers (1980) examined waking EEG activity of volunteers exposed to 6 mo of antiorthostatic hypokinesia ( $-4^{\circ}$ ), some of whom were subjected to countermeasures (e.g., exercise, water-salt additives). Brain wave alterations were noted in all, especially those not undergoing prophylactic regimens. These changes included decreases in alpha amplitude and frequency, and altered EEG activity during flickering lights and hyperventilation. Experimentally induced fatigue and a lack of external stimulation were postulated as the primary causes of the alterations noted.

### Lower Body Negative Pressure

effects of LBNP

The possibility that lower body negative pressure (LBNP) can be used to prevent hemodynamic disorders in weightlessness is a prime reason for the study of the physiological responses it evokes. Humans subjected to LBNP present a decrease in blood volume shift to thoracic organs and, to a lesser extent, the head. This effect has been accurately measured with rheography (Yarullin, Benevolenskaya et al., 1980).

sensory  
improvements

Such fluid redistribution led Bokhov and colleagues (1980) to question whether LBNP could lessen or compensate for the sensory changes that subjects experience when exposed to antiorthostatic positions. Volunteers were evaluated with a visual tracking test and subjective assessment of spatial orientation with eyes closed. When LBNP was applied to people in a horizontal or head-down position, fewer tracking errors were made. Illusions of a head-down position while the subject was horizontal and had eyes closed were common, with or without LBNP, although negative pressure did lessen the frequency of such errors in orientation. The stimulation of mechanoreceptors in the lower body was thought to facilitate more accurate evaluation of spatial orientation.

### Exercise

effects of exercise

Concern about the prevention of hypodynamia in sedentary occupations has led to experiments on the effects of various forms of muscular exertion on the human body (Kovalik, 1979; Vasil'yeva et al., 1979). Isometrics, bicycling, and running produced a general improvement in the physical condition and aerobic potential of the volunteers. Specifically, heart rate and blood pressure decreased while lung capacity increased.

oxygen consumption

Two studies documented oxygen consumption during exercise stress tests. Navakatikyan and colleagues (1979) presented data indicating that females develop more stress reactions than males when tested with equivalent physical loads, leading them to suggest women not be permitted to perform the very heavy work. Glezer and associates (1979) considered the effects of age, body build, and sex on oxygen consumption under a variety of conditions, including physical load. Their results showed that younger people with more muscular development have greater oxygen consumption, regardless of sex.



## Acceleration

The use of acceleration in Soviet research has been to understand the physiological challenge it presents to the human body in a spacecraft. Its effect on psychomotor skills was studied in 1980 by Barer and associates. Subjects were asked to track a moving marker light on a screen while being rotated in a centrifuge. Following exposure to various acceleration levels for 40 sec at angles of 23° or 35° to the body's longitudinal axis, increased errors in tracking were noted and visual disorders were reported. Interestingly, an increase in the angle of tilt of the seat during acceleration resulted in fewer tracking errors and visual dysfunctions, possibly by providing improved circulation to the brain during the challenge.

psychomotor effects

Centrifugation has been used as a countermeasure against cardiovascular deconditioning. Although the cardiovascular changes are not prevented, intermittent centrifugation during simulated weightlessness does appear to lessen the extent of the deconditioning (Vil'-Vil'yams & Shulzhenko, 1980a).

deconditioning countermeasure

## Vibration

Vibrations are sometimes used by Soviet scientists as a diagnostic tool. Gershuni et al. (1980) used ultrasound of frequencies higher than 225 kHz as a probe of the otic labyrinth. When a subject perceived an auditory sensation, the dependence of threshold intensity on the duration of the stimulus could be determined. Data obtained in this manner indicated that ultrasound induces stimulation of spinal ganglion dendrites, not the hair cells of the labyrinth.

ultrasound

The physiological consequences of low-frequency vibrational energies were the subject of a number of investigations. Oceangoing vessels typically produce low-frequency vibrations. Examinations of sailors and fishermen established partial hearing loss in 43.7% of those tested. The extent of loss was directly dependent on the subject's age and length of time of exposure (Menyakin & Poperetskaya, 1980). Another experiment tested human response to low-frequency acoustical energy in the laboratory (Karpova et al., 1979). When first exposed, the subjects reported stress, unpleasant auditory sensations, and mild fatigue; others complained of confusion and mild depression, headaches, and dizziness.

low-frequency vibration

## Radiation

Radiation research in the Soviet Union was directed toward assessment of risks associated with exposure to radiation in different forms and dosages. For example, Totseva and coworkers (1980) examined the incidence of various forms of chromosome damage in the DNA of human lymphocyte cultures. Exposure of the cultures to various doses of proton and X-ray radiation demonstrated that one-break, acentric fragments increased linearly with dosage; double breaks were observed to increase exponentially. Radiations with high linear energy transfer yields increased the incidence of paired fragments while dicentrics and ring chromosomes decreased. The overall yield of chromosomal aberrations was highly correlated with the dose of radiation delivered, suggesting that lymphocyte cultures could be used as a means of estimating the risk of radiation damage from a source.

risk assessment

### Extreme Temperature

thermal regulation

A number of recent studies in the Soviet Union have addressed thermal regulation. One such study dealt with women performing industrial work in microclimates having temperatures of 18-38° and high relative humidity (Machablishvili, 1979). Observations were made of skin temperature, pulse rate, and subjective thermal sensations. It was reported that thermoregulatory stress was evident in women at lower air temperatures and with lighter physical loads than in men (control group). Women were also reported to accumulate more heat than men, who lost it more rapidly.

heat transfer

A review of a book, *Physiological and Hygienic Aspects of High and Low Temperatures*, was received (Azhayev, 1979). Written for space biology and medicine specialists, the book deals with various aspects of heat transfer and the body's ways of regulating temperature and physiological responses.

### Magnetic Fields

electromagnetic fields

Kholodov and Shishlo (1979) discussed the central nervous system's reaction to electromagnetic fields. They surveyed animals ranging from low to high in terms of the nervous-system organization. In man, they considered motor activity, learning, and memory. It was found that people who worked under the influence of strong electromagnetic fields possessed poor memory capacity, an effect which increased with working time. Irritability, impatience, and other indications of stress were observed after exposures over a certain length of time. After 1 to 3 yrs, disruptions in attention and memory were detected, as were depression and fatigue. The researchers suggested that nervous system disorders affecting behavior and personality result from electromagnetic exposure.

### Space Motion Sickness

vestibular studies

Ground-based experiments have been designed to contribute to a fuller understanding of the workings of the vestibular system and its role in the maintenance of balance, the etiology of motion sickness, and methods of treating or preventing this illness. Many studies involve patients with diseases of the inner ear or the brain. It is expected that, by studying pathological conditions and correlating the illness or lesion involved, the normal mode of function might become clear.

equilibrium

The maintenance of upright body position, for example, has been studied by disturbing balance and analyzing electromyograms and motion pictures as the subject restablizes himself (Mamasakhlisov, 1979). The preservation of equilibrium involves many small body oscillations (Semenov & Rebyakova, 1979) that are reactions to proprioceptive, vestibular, and visual cues working in conjunction to maintain the upright position (Gurfinkel', 1980). Equilibrium is thus preserved as a unified sensory complex.

Evaluation of various components of the vestibular system can be made using reflex responses after vestibular disruption resulting from rotation (Yarotskiy, 1979). The reflex response permits assessment of the spinal cord's functional role in the complex. Stimulation of the labyrinth is also frequently used to study the physiological responses such motion invokes (Kapranov, 1979).

reflex

Nystagmus, the rhythmic oscillation of the eyeballs, has been found to be a valuable diagnostic tool. Predictable nystagmic responses to disruption of the vestibular system have been recorded. Rotation, optokinetic stimulation, and electrical stimulation of the vestibular apparatus are just a few of the ways of eliciting nystagmus (Khechinashvili et al., 1978a). It has been found that normal nystagmus reactions measured by frequency are extremely variable; however, the maximum angular velocity of the slow nystagmus component is much less variable, and is recommended as a parameter for assessing vestibular condition (Grigorova et al., 1980; Levashov & Tumakov, 1980).

nystagmus

The results of two experiments suggest that the extinction dynamics of horizontal nystagmus after vestibular challenge might be useful in predicting an individual's susceptibility to motion sickness (Sidel'nikov, 1979; Polyakov et al., 1980). When individuals were rotated at different accelerations or subjected to caloric stimulation of the labyrinth, a delineation of subjects who were highly susceptible to motion sickness compared to those who were least susceptible could be made. The rate of nystagmus attenuation of the stable group was higher than that of the corresponding group. Those less susceptible also exhibited a lower intensity of nystagmus.

extinction dynamics

The corresponding illness of seasickness has also been studied. Almost any form of physical conditioning has been found to reduce vestibular disorders aboard ship (Yefremenko, 1979; Salanin, 1979). Also suggested has been a diet of vegetable purees and lean meat for counteracting inhibited peptic secretory function; diet supplements; and, as a last resort, pharmacological preparations for seasickness prevention. Drugs currently in use include scopolamine, novocain, and dramamine. Khinchikashvili (1979) analyzed the effectiveness of meprobamate, finding that it reduced vestibular dysfunctions after both chair rotation and caloric stimulation. This corresponded to the results he and Maksimovich found in experiments with mice (see Space Motion Sickness, page 31).

preventive drugs

### Circadian Rhythms

Biorhythms of airmen and cosmonauts are receiving a great deal of attention from the Soviets. The difficulties airmen encounter when flying to different time zones were the subject of one discussion. Annenko and Pekshev (1979) suggested either readaptation by the men 3-5 days before flight time, or duty assignments arranged to fit their prevailing biorhythmic schedule. In a similar vein, Alyakrinskiy (1980) and Stepanova (1980) urged that the biorhythms of cosmonauts be taken into account when planning activities in space in order to take advantage of periods of peak efficiency.

biorhythm

circadian rhythm

Sleep-wake patterns are of particular concern to Litsov and coworkers (Litsov, 1979; Litsov & Sarayev, 1980). The sleep parameters, physiological functions, and performance of volunteers deprived of sleep or on altered schedules were recorded. Shifts in circadian rhythm were found to cause sleep disruptions, EEG aberrations, changes in pulse rates, and fatigue for the first week. After the seventh or eighth day, rhythm shifts to the new schedule were seen.

### Psychology Research

pilot stress

The study of stress continues to be a focal point of Soviet psychological research. The response of aircraft pilots to stress was examined by monitoring carbohydrate metabolism; specifically, intracellular glycogen concentration and phosphorylase activity were examined (Pashchenko et al., 1980). These parameters were chosen as indirect measurements of the adenohipophyseal system, which is involved in the stress reaction. Peripheral neutrophils were obtained before and after flight. It was expected that student pilots would experience less stress than experienced pilots. As anticipated, the students exhibited no glycogen accumulation or increased phosphorylase activity, while the advanced pilots did show raised levels.

shipboard stress

Stress in naval personnel was addressed by Solodkov and Lobzin (1980), who were concerned with methods of minimizing such challenges. Three categories were defined: emotional, physiological (from hypodynamia, partial sensory isolation, and perceptual deprivation due to prolonged cruises), and hyperstimulation of higher nervous activity. The authors urged careful selection of crews on the basis of compatibility, thereby facilitating function as a unit.

stress training

Cosmonaut training procedures also emphasize the ability to cope with stressful situations. Training procedures that simulate daily spaceflight tasks as well as emergencies give cosmonauts confidence in dealing with the unexpected (Beregovoi et al., 1979). Familiarity with the equipment and with possible occurrences lowers stress levels and enhances safety.

improving effectiveness

A collection of papers entitled *Psychological Problems of Space Flights* (Samsonov et al., 1979) examined four areas warranting attention by specialists in space psychology. These areas are: the general characterization of psychological problems of spaceflight, psychological analysis of cosmonaut activity, questions concerning cosmonaut training, and man-machine interactions. A dominant theme concerned improving the effectiveness of cosmonaut work activities inflight. Some suggested prerequisites include an investigation of the dynamics of psychological functions at different stages of flight, determination of the characteristics of cosmonaut activity, and discovery of individual psychological differences. Several articles maintained that high effectiveness and reliability of cosmonaut activity can be achieved by: (1) developing and using optimal schedules of daily activity for the crews at all stages of training and execution of the spaceflight; (2) carefully selecting crewmembers for compatibility; (3) ensuring that cosmonauts can adapt to stressful situations; and (4) having the craft designed so that the crew can optimally work and rest.

## Pharmacology

The use of pharmacological preparations to attenuate the physiological effects of spaceflight is a subject of great interest to the Soviet space medicine community. Shaskov and Sabayev (1980) outlined current drug usage in space, citing the changes the body undergoes in the weightless environment and the role the compounds are expected to fulfill.

use of drugs

A nervous system stimulant, securinine, was analyzed for its effect on compensatory reactions of the cardiovascular system to orthostatic stress (Osadchiy, 1980). It was determined that securinine is associated with an increased cardiovascular response to stress, including exaggerated increases in blood pressure and cardiac output. Another facet of the same study confirmed the intermediate role of skeletal muscle activity in the cardiovascular response to stress: when skeletal muscles were paralyzed with the muscle relaxant Lysthenon, compensatory changes in the hemodynamic system were not observed during orthostatic stress.

cardiovascular stress reactions

A review by Bakay and Neschetnaya (1979) surveyed ototoxic drugs. Antibiotics cause the greatest damage and therefore received the most attention. The mode of action (when known) was presented, as were some experimental means of preventing toxicity from occurring.

ototoxicity

## Nutrition

Bychkov and Markaryan (1980) examined long-term ingestion of dehydrated foods, simulating those expected to be used on a prolonged spaceflight. By monitoring biochemical parameters throughout the 120-day experiment, they were able to conclude that a diet of dehydrated foods provided adequate nourishment for extended periods of time. Furthermore, dehydrated food stored for 2 yrs and exposed to proton radiation retained its nutritional value.

dehydrated foods

## Crewmember Selection and Training

The medical selection process used to screen cosmonaut candidates is a 3-step process (Rudnyy et al., 1980). Volunteers between 25 and 45 yrs of age are obtained from among flight personnel and specialists in professions that include engineering and medicine. The physical selection procedure starts with the collection of background information and a cursory examination. The volunteers admitted to stage 2 of the process are then thoroughly examined in a hospital setting. Further screening occurs in stage 3 while the candidates train. The advancement of candidates from one stage to the next is decided by a commission of examining physicians and confirmed by the Chief Medical Commission of the USSR.

medical selection

At present, all members of the cosmonauts corps are male (Shatalov & Vasil'yev, 1980); no females are currently in training. With the prospect of longer missions, the inclusion of women in the crews is viewed as an important morale factor.

female cosmonauts

The training center itself is slated for improvement. A Soviet press report stated that the Center for Cosmonaut Training imeni Gagarin, in Star City, is being upgraded with newer training planes and laboratory facilities. Additions will include a large tank that can hold an entire Salyut orbiting station, a new 18 m arm centrifuge, and a complex of pressure chambers.

improved facilities

### Simulation Studies

The Soviets make use of mathematical modeling to predict many physiological situations during spaceflights. Verigo (1980) defined 3 types of models used. The first uses past flight information in conjunction with ground-based test results. The second type uses forecasting algorithms from time series extrapolations, such as predicting pulse rates from regression equations. The third type of model involves computer simulation of physiological changes in weightlessness.

modeling

Mathematical simulation has been used to analyze, for example, the response of the human cardiovascular system during clinostasis and orthostasis (Palets & Grigoryan, 1980), mechanisms of adaptive control over motor systems in animals and humans (Penev & Tairov, 1979), and bipedal walking under conditions of weightlessness (Beletskii & Konikova, 1979). The advantage of simulation is the ability to predict possible outcomes in the actual situation.

uses of simulation

## Space Biology

### Hypokinesia

As in the research on humans, described earlier, hypokinesia—or immobilization of the body—provides a good model for studying the physiological effects of weightlessness on the mammals in general. Reflecting the Soviets' concern for the less obvious effects of spaceflight-induced stress on the body, many experiments have focused on the stress of immobilization on rats and on its physiological consequences.

immobilization studies

It has been proposed that in space two types of stress come into play: chronic and acute. Chronic stress is simulated through the long-term confinement of rats in small cages, mimicing the stress of the weightless environment. Acute stress is experimentally induced by stringent, short-term immobilization; this simulates the gravitational extremes encountered upon launch and reentry (Kaplanskiy & Durnova, 1980). Simulated weightlessness alone was found to result in decreased thymus weight, increased blood volume—especially to the liver (Kovalev et al., 1980), decreased bodily resistance, increased catecholamine synthesis but decreased epinephrine and norepinephrine synthesis in the adrenals (Matlina et al., 1974), and increased gluconeogenesis (Panin et al., 1979; Ryl'nikov, 1980). When a form of acute stress was added to the chronic stress, it was found that the spleen undergoes a reduction in weight and the lymph organs in general are much more damaged than with chronic stress only.

chronic and acute stress

The reaction to chronic hypokinetic stress was analyzed by Chernov (1980) and Kirichek (1980). A 3-phase stress reaction was observed that included periods of increased motor activity (10 days), adaptation (15-30 days), and loss of adaptive potential (greater than 2 mos). Other responses of rats to hypokinesia include increased thyroid activity for the first 15 days of immobilization (Bekishev, 1978), and phase changes of various enzymes throughout the hypokinetic period (Medkova et al., 1980; Abdusattarov, 1980). It is notable that the results of nystagmic measurements following angular acceleration of immobilized rats were unlike the reactions seen in any animals exposed to weightlessness aboard the biosatellites. It would therefore seem that hypokinesia may not be an appropriate model of weightlessness for studying the vestibular apparatus of rats.

stress reactions

### Space Motion Sickness

To better understand the phenomenon of space motion sickness, the Soviets are investigating the workings of the vestibular apparatus. Cats are the favored organisms for these experiments because of the size of the organs studied and their physiological similarity to those of humans.

use of cats

Panchin (1978) and Gayday (1979) studied aspects of vestibular innervation. The tilting of decerebrate cats in the frontal plane was found to elicit spiking activity in 39 of the 51 vestibulo-spinal neurons examined in the Deiter's nucleus. Maximum activity in response to ipsilateral tilting was shown in 28 of the 39 neurons; the other 11 were mainly stimulated by tilt toward the contralateral side, suggesting differing neuronal responses to vestibular receptors. Activation of motor neurons in the cervical spinal cord was investigated by electrical stimulation of the medial longitudinal fasciculus, Deiter's vestibular nucleus, and the red nucleus. The bioelectrical activity that resulted in the spinal cord following stimulation of the three nerve centers demonstrated that interaction of stimuli occurs before activation of the motor neurons.

vestibular innervation

The effect of unilateral stimulation of the vestibular apparatus on the bioelectrical activity of cat flexor and extensor limb muscles during cold shivering was the focus of Kuz'mina's research (1979; 1980). In the first study, the unilateral destruction of a labyrinth resulted in bilateral facilitation of cold shivering in the flexor extremities, especially on the ipsilateral side; extensor muscle activity was absent, regardless of the labyrinth condition. The destruction of the labyrinth apparently removed efferent inhibition from the vestibular apparatus.

labyrinth destruction

The second study involved stimulation of a labyrinth with caloric or electrical stimuli and its effect on warmed and cooled animals. Warmed animals exhibited no bioelectrical activity, while flexor activity in the muscles of cooled cats was proportional to the reduction in temperature. During caloric stimulation, flexor muscle bioelectrical activity was bilaterally suppressed. Cessation of bioelectrical activity in the ipsi- and contralateral muscles was not simultaneous: usually, the ipsilateral side quenched first, within 2-5 sec after the vestibular stimulus was applied. "Escape" from the stimulation (resumption of bioelectrical pulsation) was sometimes seen in the

labyrinth stimulation

sartorius, but only rarely in the biceps. Electrical stimulation produced the same bioelectrical activity, except that no escape was seen. The experiment demonstrated that the effects of the vestibular apparatus on spinal activity are manifested as tonic stimulation of motoneurons connected to the antigravity musculature.

The response of the primary afferents of the lateral semicircular canal to direct vibration of the labyrinthine wall of frogs was also studied (Orlov, 1980). A glass rod embedded in a resonator enabled frequencies of subsonic and low sonic ranges to be applied to the canal. By obtaining frequency-amplitude characteristics and constructing poststimulus histograms, the responses of the primary afferents were evaluated. The primary afferents of the frog fell into three groups, based on response to frequency characteristics. The first and most numerous group consisted of wide-range units, responding to frequencies from 0.05 Hz to 60-180 Hz. The second group encompassed high-frequency units; vibration responses started only as low as 20-40 Hz, and went to the 100-150 Hz range. The third and smallest group contained the low-frequency units that react to stimulation in the 0.05-20 Hz frequency range.

Maksimovich and Khinchikashvili (1979) tested the effectiveness of tranquilizers for treating the symptoms of motion sickness. Mice were treated with meprobamate, elenium, or nicolite, and exposed to centrifugation. Untreated control animals exhibited vestibular dysfunctions of torsal and eye nystagmus, tail straightening, and tremor of the extremities. Such dysfunctions were weak or absent in mice that had received the drugs. Meprobamate was found to suppress the animals' motor activity the least, as compared with the activity of the controls. This led the researchers to conclude that tranquilizers, especially meprobamate, can effectively ameliorate vestibular reactions caused by centrifugation in mice.

### Magnetic Fields

The physiological effect of high intensity, stationary magnetic fields was the subject of two studies (Vnukova, 1980; Pavlov et al., 1980). The possibility that such a field might provide rodent cell cultures with some protection from radiation-induced damage was disproved. However, stationary magnetic field exposures were found to be associated with increased reticulocyte counts and decreases in erythrocytes, hemoglobin, and hematocrit. Since erythrocyte half-life remained unchanged, it was suggested that magnetic fields may affect erythroid cells of the bone marrow.

### Radiation

Soviet scientists have conducted studies to evaluate the adequacy of *in vitro* systems for determining the extent of damage expected from a given dose of gamma radiation. One such study (Dzhemilev, 1979a) compared *in vivo* and *in vitro* radiation exposures of monkey somatic cells. Analysis of chromosomal aberrations from the two studies revealed no differences, suggesting that *in vitro* radiation exposure can be used as a human model.



The living organism, however, shows variability, as Chernov (1978) demonstrated. Rats were immobilized for 20 days; throughout this period a number of animals were subjected to gamma radiation. Radiosensitivity was found to vary, with the highest values occurring early in the hypokinetic period and decreasing with habituation. This indicated that the degree of stress being experienced at the time is related to the degree of radiation damage sustained.

stress factor

The use of lasers is popular within the Soviet biological community. An example of the applications lasers are being put to was a study by Il'yasova and Popova (1980). X-irradiated gastrocnemius muscle tissue was treated with or without helium-neon laser beams to facilitate recovery from X-ray damage. The entire rat muscle was autografted; after transplantation, the regeneration process was histologically analyzed at 2 wks, 1 mo, and 2 mos postsurgery. The laser therapy produced the best results when applied before, rather than after, grafting the muscle. It was postulated that the laser intensifies ATP formation and, consequently, faster repair of membranes, chromosomes, and organelles damaged by the X-rays.

laser therapy

### Plant Research

Some of the Soviet scientific reports received have dealt with the surveying of plants as possible components of closed life support systems in space. Zhdanova et al. (1978) investigated the resistance of several mushroom species to ultraviolet radiation, finding that the level of damage was inversely correlated with the cellular melanin content. In a similar vein, the capacity of irradiated *Spirodela* (duckweed) meristem cells to grow was studied by Kutlakhmedov and colleagues (1978), who artificially irradiated them with cobalt-60 gamma radiation. *Spirodela* cells grown under simulated weightlessness in a clinostat after radiation exposure were observed to have an increased number of daughter cells, as compared to gravity-grown cultures, indicating a degree of radiation resistance. Increased viability of nonirradiated cells grown in the clinostat was also noted; considering past failures of plant growth aboard spacecraft, this could be an important observation.

closed life support

Gordeyev (1979) discussed this spaceflight growth problem in an article concerned with substituting electrical currents for gravity. Rooted onions in a clinostat exhibited apparently normal growth when a constant current was fed to the plant; removal of the current resulted in erratic growth, followed by death.

electric current

## Life Sciences Technology

### Bioinstrumentation

The development of new bioinstrumentation that can be incorporated into space physiology and biology research was reported in 1980. Kazakova (1980) described a system that uses an ultrasonic instrument, a sensor, and the recorder portion of an electroencephalograph to detect gas bubbles in the venous blood of animals exposed to hypoxic conditions. As a demonstration, the author monitored gas bubble formation in

gas bubble detecto

rabbits and cats exposed to hyperbaric environments, illustrating the species-specific dynamics of formation.

A more accurate method of gas chromatography for tracing distributions of organic compounds was reported by Sopikov and Gorshunova (1980). Direct thermal evaporation of thin sections of organic material allowed relatively fast preparation of tissue samples. Determination of the effects of spaceflight conditions, including hypokinesia, radiation, and hypoxia, on physiological processes should, thus, according to the scientists, become simpler and more rapid.

The study of the small movements of nystagmus requires sensitive equipment. Mironenko and Vilenskiy (1980) reported development of a portable set of instruments capable of recording nystagmus with eyes open or closed. Centered on a 1-channel electrocardiograph, it is able to measure rotational, caloric, positional, or pressure nystagmus. A calibration half-mask makes application of electrodes more convenient.

Photoelectric nystagmography permits the recording of additional data.. Khechinashvili et al. (1978b) reported a modification of the standard apparatus, involving a flexible fiber-optic light guide. This allows the use of a powerful light source and high-voltage photomultipliers while preventing errors from unintentional head movements.

An instrument for the induction of nystagmus was described by Kandaurov et al. (1980). The machine can be operated at two speeds for optokinetic stimulation; the drum itself can be positioned vertically or horizontally. The polygraphic recording (see following) indicates the rhythmic, regularly spaced, triangular oscillations that are obtained.

gas chromatograph

portable  
nystagmograph

photoelectric  
nystagmograph

nystagmus inducer

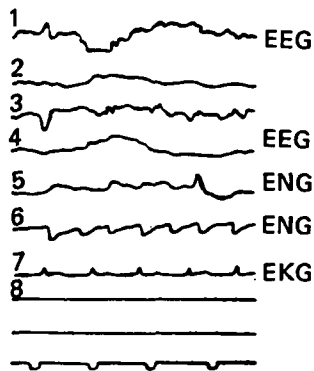

Fragment of polygraphic recording of optokinetic reaction in healthy person (optokinetic stimulation in horizontal plane, rate of drum rotation  $198^{\circ}/s$ ).

## Personal Protective Equipment

One possible variant of a system for emergency rescue of cosmonauts from orbital stations (SERCOS) was described by Belonogov and others (1980). The proposed space capsule holds 3 people and can support life for 24 hrs. Diagrammatic representations of the exterior and interior of the capsule and of stages for return to the Earth's surface are pictured below.

rescue capsule

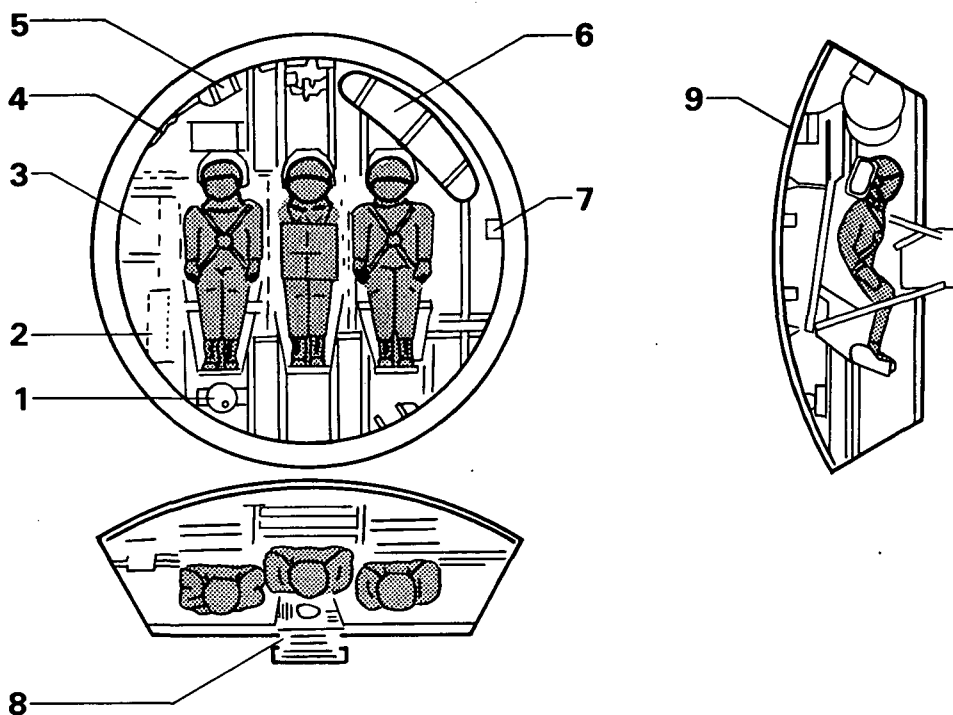

- KEY:
- |  |  |
|--|--|
| 1. Pressure block                      | 6. Parachute                           |
| 2. Commutation block                   | 7. Flotation device                    |
| 3. Power supply block                  | 8. Orientation and stabilization block |
| 4. Radio beacon                        | 9. Soft landing engine                 |
| 5. Unit for inflating flotation device |  |

## Closed Life Support

One of the primary technical problems of life support in space is the provision of water. The ideal procedure would be complete reclamation of water from wastes. The most qualitatively effective methods of recovering water from urine now known involve either evaporation through a semipermeable membrane or osmosis. Such methods are hampered by the clogging of membrane pores from urine solutes. Adamovich, Volgin, and associates (1980) attempted to circumvent this problem by going to a 2-step procedure. The first step recovers 75% of the water by lowering the sample temperature and filtering out the resulting sediment. The filtrate is then passed through a membrane unit such as mentioned above, whereupon "good quality" water, suitable for bathing or for plants, is recovered.

water reclamation

To monitor the purity of reclaimed water, Chizhov and coworkers (1980) evaluated the technique of using ultraviolet fluorescence to detect impurities. Using water reclaimed from condensed atmospheric moisture or from dissociated hydrogen peroxide, they were able to measure alcohol contamination to  $10^{-3}\%$  and acid contamination to  $10^{-4}\%$ . Based on this technique, both methods of reclamation were deemed equivalent in producing clean water.

impurity detection

### Toxicology

Spacesuit atmospheres generally contain contaminants from human waste, such as carbon monoxide, aliphatic and aromatic hydrocarbons, amines, and acetone. Sedov and associates (1980) exposed subjects to simulated altitudes up to 10,000 m, having some perform exercises so as to assess the danger, if any, such wastes present. Although some decompression disorders such as joint pain were reported, the gaseous waste products themselves were apparently not harmful.

spacesuit gaseous wastes

Savina and colleagues considered the possibility of temporary malfunctions of life support equipment in space, resulting in increased temperature, humidity, and atmospheric carbon monoxide (Kalandarov, Bychkov, & Savina, 1980; Zhuravlev et al., 1980). The scientists examined the effects that such chronic carbon monoxide exposure (90 days) had on the adrenal cortex and blood chemistry of human volunteers. At higher dosage exposures ( $15\text{-}20\text{ mg/m}^3$ ) and during simulated emergencies, glucocorticoid function was increased; at lower doses ( $10\text{ mg/m}^3$ ), there were no changes. The blood chemistry responses included adaptation to the lower dose after 41 days; increases in hemoglobin, carboxyhemoglobin, and nonhemoglobin iron at  $20\text{ mg/m}^3$ ; and, surprisingly, more marked effects at  $15\text{ mg/m}^3$ , including increased  $\text{PA}_{\text{CO}_2}$  and  $\text{PA}_{\text{O}_2}$ , lowered pH, and acidosis.

carbon monoxide

The influence of hypoxia in conjunction with the effect of a second stressor on animal physiology captured the interest of a number of Soviet researchers. Mikhalkina (1980) studied the effects of hypoxia and hypercapnia on glycolysis in rat myocardial tissue, and detected large increases in the concentrations of glycolytic products within the heart muscle. The induction of hypoxia at simulated altitudes under varied temperatures and humidities was investigated by Ngi and Keerig (1980), who analyzed the blood chemistry of hypoxic rabbits. They determined that rabbits became hypoxic when exposed to simulated heights of 5,000 m at temperatures of  $20^{\circ}$  or  $44^{\circ}$  and low humidity. Rabbits kept at  $44^{\circ}$  and high humidity exhibited even more severe hypoxia. The authors suggested that the hypoxia was the result of blood redistribution and changes in the activity of respiratory enzymes, not the consequence of a shift in the hemoglobin dissociation curve.

hypoxia

A marked shift of the oxyhemoglobin dissociation curve was also a manifestation (although the shift was to the left) of the effects of hyperoxia on oxygen transport (Ivanov & Chebotarev, 1980). By exposing subjects to a gas mixture of 95% oxygen and 5% nitrogen for 20 min, the scientists were able to detect an increased affinity of hemoglobin for oxygen.

hyperoxia

The reactions of the blood gases to hyperbaric conditions are also the subject of continuing Soviet research. One of the recent reports dealt with the use of gas chromatography to evaluate the physiological response of healthy individuals to increased simulation pressure (Gulyar et al., 1980). Increased pressure was accompanied by increased blood levels of oxygen and calcium dioxide. Additional nitrogen in the external atmosphere limited the  $\text{CaO}_2$  increases. The higher concentrations of this compound were postulated to be the result of more complete oxygenation of hemoglobin and increased plasma diffusion rate. Particularly intriguing was the fact that decompression was not followed by immediate drops in  $\text{CaO}_2$  levels.

**high pressure**

The hyperbaric conditions were not found to greatly alter blood buffer system parameters, although a more acidic pH and increased  $\text{CaCO}_2$  and  $\text{PA}_{\text{CO}_2}$  were detected. From these observations it was proposed that short-term exposure to hyperbaric environments does not affect general physiological functions.

**high pressure**

The consequences of combined hyperbaric and hyperoxic conditions on respiration and blood chemistry were also considered (Gulyar, 1980). In general, the measured oxygen transport rates showed a decrease at the stage of oxygen entry into the lungs and an increase at the stage of incorporation into the blood system.

**hyperbaric  
hyperoxia**

## REFERENCES

- Abdusattarov, A. Effect of hypokinesia on invertase activity of the mucosa of the small intestine. *Aerospace Medicine and Biology*, October 1980. NASA SP-7011(211). Trans. from *Uzb. Biol. Zh.*, 1978, 1:61-62 (abstract).
- Adamovich, B.A., Ye.A. Il'in, A.D. Noskin, V.I. Milyavskiy, G.N. Pliskovskaya, V.K. Golov, V.S. Poleshchuk, V.K. Ovcharov, & A.A. Shipov. Research hardware and habitat of animals used in experiment aboard Cosmos-936 biosatellite. *Space Biology and Aerospace Medicine*, 1980, 14(2):27-32.
- Adamovich, B.A., V.D. Volgin, N.M. Nazarov, Yu.Ye. Sinyak, & S.V. Chizhov. Upgrading efficacy of membrane techniques for regenerating water from urine. *Space Biology and Aerospace Medicine*, 1980, 14(2):130-133.
- Alekseyev, D.A. Method for assessing hemodynamics and detecting latent insufficiency of cerebral circulation in cosmonaut candidates. *Aerospace Medicine and Biology*, October 1980. NASA SP-7011(211). From JPRS, *USSR Report: Space Biology and Aerospace Medicine*, 1980, 14(3):110-116 (abstract).
- Alekseyev, M.A., I.S. Dobronravova, A.V. Naydel', & B.N. Smetanin. Mechanisms for regulating vertical human position during foot movements. NASA TM-76394. Trans. from *Fiziologiya Cheloveka*, 1979, 5(4):579-588.
- Alferova, I.V., A.D. Yegorov, & A.P. Polyakova. Dynamics of diastolic phase structure during a 140-day space flight. From JPRS, *USSR Report: Space Biology and Aerospace Medicine*, 30 October 1980, 14(5):46-50.
- Alyakrinskiy, B.S. Scheduling work and rest periods during long-term space flights. *Space Biology and Aerospace Medicine*, 1980, 14(1):1-8.
- Anichin, V.F. Methods of histological treatment of otic labyrinth. NASA TM-76367. Trans. from *Arkhiv Anatomii, Gistologii i Embriologii*, 1978, 75(8):77-83.
- Annenko, V., & V. Pekshev. Flight safety demands constant attention. Role of biorhythms. From JPRS, *USSR Report: Biomedical and Behavioral Sciences*, 28 March 1980, No. 1, 40. Trans. from *Aviatskiya i Kosmonavtika*, 1979, No. 8, 42-43 (abstract).
- Anonymous. Certain peculiarities of the functioning of the cardiovascular system in bedrest conditions during horizontal and antiorthostatic body positions. NASA TM-75075. Trans. from *Nekotoryye osobennosti funktsionirovaniya serdechno-sosydistoy sistemy v usloviyakh postel'nogo rezima pri gorizontallykh i antiortostaticheskom polozeniyakh tela*. Interkosmos Council, Academy of Sciences USSR Report, 1977, 1-33.

- Anonymous. General requirements and rules for preparing the joint report for the Soviet-American experiment on the effect of hypokinesia (SAEH). NASA TM-76468. Trans. from *Report to the XI Joint Soviet-American Working Group on Space Biology and Medicine*, Moscow, October 1980, 1-12.
- Anonymous. Scientific experiments on the flight of the 1979 biological satellite. NASA TM-76017. Trans. of *Nauchnyye eksperimenty v polete biologicheskogo sputnika 1979 g (plan-prospekt)*, Institut mediko-biologicheskikh problem ministerstva zdravookhraneniya SSSR, Soviet "Interkosmos" Akademii nauk SSSR, Moscow, 1979.
- Arlashchenko, N.I. Effect of sodium bicarbonate on reactivity and trophics of vestibular analyzer. *Space Biology and Aerospace Medicine*, 1980, 14(1):94-100.
- Avetikyan, Sh.T., & A.M. Zingerman. Effect of antiorthostatic factor on human operator (from data of rheography). NASA TM-76111. Trans. from *Fiziologiya Cheloveka*, 1979, 5(6):1052-1059.
- Azhayev, A.N. Physiological and hygienic aspects of high and low temperatures. From JPRS, *Space* (FOUO), 9 January 1980, No. 1, 9-10. Trans. from *Problemy kosmicheskoy biologii*, Tom. 38. Moscow: Izdatel'stvo Nauka Press, 1979.
- Azhayev, A.N., V.I. Zorile, & A.N. Kol'tsov. Effect of high ambient temperature on human performance. *Space Biology and Aerospace Medicine*, 1980, 14(2):53-57.
- Babskii, V.G., V.G. Man'ko, L.V. Polivoda, A.A. S'edin, & V.A. Kordium. The effect of space flight factors on the characteristics of nutrient media for the bacterium *Proteus vulgaris*. *Aerospace Medicine and Biology*, November 1980, NASA SP-7011(212). From *Kosmicheskie Issledovaniia na Ukraine*, 1978, 12:24-30 (abstract).
- Bakay, E.A., & L.B. Neschetnaya. On the mechanisms of harmful effects of certain medicinal preparations on the auditory organ and methods for their prevention. NASA TM-76425. Trans. from *Zhurnal Ushnykh, Nosovykh i Gorlovykh Bolezney*, 1979, 5:78-84.
- Balakhovskiy, I.S., & V.B. Noskov. Renal function and glucocorticoid activity of the adrenal cortex during immersion. From JPRS, *USSR Report: Space Biology and Aerospace Medicine*, 30 October 1980, 14(5):70-74.
- Barer, A.S., T.A. Sokolova, V.M. Tardov, & Yu.P. Yashin. Effect of prolonged +G<sub>z</sub> accelerations on human performance. *Space Biology and Aerospace Medicine*, 1980, 14(3):53-59.
- Barer, A.S., M.I. Vacker, O.G. Gazenko, & L.G. Golovkin. Physiologicohygienic and ergonomic aspects of Salyut 6 cosmonauts extravehicular activity. *Aerospace Medicine and Biology*, January 1980, NASA SP-7011(201), 303. Trans. from paper delivered at the International Astronautical Federation, International Astronautical Congress, 30th, Munich, West Germany, September 17-22, 1979 (abstract).

- Bekishev, K. Effect of sharply lowered muscular activity on the thyroid gland of the white rat. *Aerospace Medicine and Biology*, October 1980, NASA SP-7011(211). Trans. from *Izv. Akad. Kaz. Khim. SSR*, 1978, 2:75-78 (abstract).
- Beletskii, V.V., & N.S. Konikova. Imitation of locomotion under conditions of weightlessness. *Aerospace Medicine and Biology*, October 1980, NASA SP-7011(211). Trans. of *Mechanics of Solids, Akademiia Nauk SSR, Izvestiia*, 1979, 14(5):41-45 (abstract).
- Belonogov, Ye.K., S.A. Ivarovskiy, V.K. Grigorovich, A.Yu. Zatselin, V.V. Ignat'yev, V.A. Sokolov, V.N. Tarasov, & V.Ye. Minenko. System for emergency rescue of cosmonauts for orbital stations (SERCOS). From JPRS, *USSR Report: Space*, 24 June 1980, (6). Trans. from *Problemy Raketnoy i Kosmicheskoy Tekhniki*, 101-108 (abstract).
- Belousova, O.I., P.D. Gorizontov, & M.I. Fedotova. Radiation and the blood system. From JPRS, *USSR Report: Life Sciences—Biomedical and Behavioral Sciences (FOUO 2/80)*, 11 July 1980. Trans from *Radiatsiya i Sistema Krovi*. Moscow: Atomizdat, 1979, 2, 3-5, 126.
- Beregovoi, G.T., I.V. Davydov, N.V. Krylova, & I.B. Solov'eva. Psychological training—one of the most important factors of enhancing the safety of space flights. *Aerospace Medicine and Biology*, January 1980, NASA SP-7011(201), 303. Trans. from paper delivered at the International Astronautical Federation, International Astronautical Congress, 30th, Munich, West Germany, September 17-22, 1979, Paper 79-A-24 (abstract).
- Beregovoy, G.T., N.D. Zavalova, B.F. Lomov, & V.A. Ponomarenko. Experimental and psychological research in aviation and cosmonautics. NASA TM-76288. Trans. of *Eksperimental'no-psichologicheskiye Issledovaniya v Aviatsii i Kosmonavtike*, Nauka Press, Moscow, 1978, 303.
- Blagoveshchenskaya, N.S. Review of book "Vestibular Crises." NASA TM-76354. Trans. from *Vestnik Otorinolaringologii*, 1980, (1):76-77.
- Blagoveshchenckaya, N.S., & V.L. Puchkov. Objective appraisal of tolerance to ventriculography with various radiocontrast media (according to electronystagmography data). NASA TM-76340. Trans. from *Zhurnal Voprosy Neyrokhirurgii*, 1980, 2:47-52.
- Bochagova, O.P., N.I. Kon'shin, E.L. Kordium, & A.F. Popova. The ultrastructure of *Proteus vulgaris* cells grown in orbit on board the Soyuz 22 spacecraft. *Aerospace Medicine and Biology*, November 1980. NASA SP-7011(212). Trans. from *Kosmicheskie Issledovaniia na Ukraine*, 1978, 12:14-20 (abstract).
- Bogomolov, E. Antiprotons detected in primary cosmic radiation. Daily Soviet News Abstracts Publication, 4 March 1980, 1. Trans. from *Sovetskaya Latvija*, 1980, No. 45 (11246), 2 (abstract).



- Bokhov, B.B., B.B. Yegorov, A.A. Savilov, & Yu.N. Taranenko. Study of the combined effect of antiorthostatic position and LBNP on man's tracking accuracy and spatial orientation. From *JPRS, USSR Report: Space Biology and Aerospace Medicine*, 30 October 1980, 14(5):35-40.
- Boloban, V.N., & A.P. Otsupok. Functional asymmetry of posture and body system regulation. NASA TM-76401. Trans. from *Teoriya i Praktika Fizicheskoy Kultury*, 1979, 10:6-10.
- Bondin, V.I. "Cardioleader" use in acyclic types of sports. NASA TM-76085. Trans. from *Teoriya i Praktika Fizicheskoy Kul'tury*, 1979, (6):34-37.
- Boravova, A.I. Interaction between the hippocampus and posterior hypothalamus in performance of orienting reflex. NASA TM-76100. Trans. from *Zhurnal Vysshey Nervnoy Deyatel'nosti*, 1979, 29(3):605-612.
- Boronoyev, A.B. Assessment of oxygen and carbogen therapy effect in Meniere's disease according to clinical and electroencephalographic data. NASA TM-76348. Trans. from *Zhurnal Ushnykh, Nosovykh i Gorlovykh Bolezney*, 1978, 3:72-78.
- Bozhkov, V., Z. Bogdanetski, & T. Radil. Effect of angular orientation on subjective assessment of physical and semantic identity of random forms. NASA TM-76361. Trans. from *Fiziologiya Cheloveka*, 1979, 5(3):441-450.
- Bredov, V.I., & V.S. Baranov. Use of polyurethane foam deformation sensor to record respiratory activity. *Space Biology and Aerospace Medicine*, 1980, 14(2):134-136.
- Bryanov, I.I., A.I. Burnazyan, Ye.I. Vorob'yev, O.G. Gazenko, A.M. Genin, S.A. Gozulov, N.N. Gurovskiy, A.V. Yeremin, L.I. Kakurin, A.G. Kuznetsov, E.F. Panchenkova, & N.M. Rudnyy (Eds.). Biological research on Cosmos biosats. From *JPRS, USSR Report: Space (FOUO 4/80)*, 28 April 1980, 20-23. Trans. from *Biologicheskiye Issledovaniya na Biosputnikakh Kosmos*. Moscow: Izdatel'stvo Nauka, 1979, 237-239 (abstract).
- Bryantseva, L.A., I.S. Breslav, & A.G. Dianov. Respiration and gas exchange under hyperbaric conditions. *Space Biology and Aerospace Medicine*, 1980, 14(2):1-14.
- Burkovskaya, T.Ye., A.V. Ilyukhin, V.I. Lobachik, & V.V. Zhidkov. Erythrocyte balance during 182-day hypokinesia. From *JPRS, USSR Report: Space Biology and Aerospace Medicine*, 30 October 1980, 14(5):75-80.
- Burnazyan, A. Medical support program for 175-day mission outlined. From *JPRS, USSR Report: Space*, 11 February 1980, No. 2, 8-11. Trans. from *Pravda*, 5 September 1979, 3.

- Bychkov, V.P., & M.V. Markaryan. The question of using dehydrated foods during long-term space flights. *Space Biology and Aerospace Medicine*, 1980, 14(2):103-109.
- Chagelishvili, A.D., P.F. Labadze, T.V. Togonidze, A.A. Khavtasi, & T.A. Kakuliya. Dynamics of vibration disease after cessation of contact with vibration. From JPRS, *USSR Report: Life Sciences—Biomedical and Behavioral Sciences*, 7 August 1980, (3). Trans. from *Gigiena Truda i Professional'nyye Zabolevaniya*, 1979, (10):40-41 (abstract).
- Chernov, I.P. The stress reaction of hypokinesia and its effect on general resistance. *Space Biology and Aerospace Medicine*, 1980, 14(3):86-90.
- Chernov, I.P. Change in radiosensitivity of rats during hypokinetic stress. *Aerospace Medicine and Biology*, October 1980. NASA SP-7011(211). Trans. from *Radiobiologiya*, 1978, 4:574-578 (abstract).
- Chernukh, A.M., O.G. Gizenko, B.M. Fedorov, T.N. Krupina, P.N. Aleksandrov, D.I. Shagal, N.Ye. Ranferova, & T.N. Proskurina. Effect of hypokinesia on blood circulation. *Aerospace Medicine and Biology*, December 1980. NASA SP-7011(213). Trans. from *Patol. Fiziol. Eksp. Ter.*, 1979, 3:10-13 (abstract).
- Chizhov, S.V., Yu.Ye. Sinyak, M.I. Shikina, & T.D. Kalinichenko. Use of 'ultraviolet' instrument for monitoring the quality of reclaimed drinking water. From JPRS, *USSR Report: Space Biology and Aerospace Medicine*, 30 October 1980, 14(5):117-120.
- Daniyarov, S.B. Cardiac output at high altitude. *Aerospace Medicine and Biology*, July 1980, NASA SP-7011(208). Trans. from *Rabota Serdtsa v Usloviakh Vysokogor'ia*. Moscow: Izdatel'stvo Meditsina, 1979 (abstract).
- Degtyarev, V.A., L.Ya. Andriyako, V.M. Mikhaylov, V.N. Ragozin, Zh.G. Adamchik, I.V. Alferova, V.A. Andretsov, & A.N. Kozlov. Circulatory reactions of first crew of the Salyut 6 orbital station to functional test with LBNP. From JPRS, *USSR Report: Space Biology and Aerospace Medicine*, 30 October 1980, 14(5):41-45.
- Degtyarev, V.A., V.S. Bednenko, V.K. Gabyshev, V.A. Sapozhnikov, & V.P. Sidorov. Results of inflight: electrocardiographic studies of Salyut 5 crews. From JPRS, *USSR Report: Space Biology and Aerospace Medicine*, 30 October 1980, 14(5):51-55.
- Degtyarev, V.A., V.G. Doroshev, N.A. Lapshina, Z.A. Ragozih, S.I. Ponamerev, & O.B. Kulikov. Hemodynamics and phase structure of the cardiac cycle in members of the first crew of Salyut-5 at rest. *Space Biology and Aerospace Medicine*, 1980, 14(3):18-21.
- Demin, L.S. Work of the cosmonaut. NASA TM-76437. Trans. from *Zemlya i Vselennaya*, 1977, 409.

- Denisov, V.G. The cosmonaut and the spacecraft. NASA TM-76454. Trans. from *Kosmonavt i kosmicheskii korabl'*, Mashinostroyeniye Press, Moscow, 1979, 157.
- Drupina, T.N., L.M. Filatova, & N.I. Tsyganova. Dynamics of hemocoagulation indicators under the influence of certain space flight factors on the body. NASA TM-76481. Trans. from *Aktual'nyye Problemy Hemostaziologii*, ed. B.V. Petrovskiy et al., Nauka Press, Moscow, 1979, 37-45.
- Dzhemilev, Z.A. Comparative study of radiosensitivity of monkey chromosomes under in vivo and in vitro irradiation of cells. From JPRS, *USSR Report: Life Sciences—Biomedical and Behavioral Sciences*, 7 August 1980a, (3). Trans. from *Genetika*, 1979, 15(9):1661-1693 (abstract).
- Dzhemilev, Z.A. Frequency of radiation-induced exchanges in readily identifiable chromosomes in monkeys. From JPRS, *USSR Report: Life Sciences—Biomedical and Behavioral Sciences*, 7 August 1980b, (3). Trans. from *Tsitologiya i Genetika*, 1979, (6):435-437 (abstract).
- Fedorov, I.V. Biochemical bases of pathogenesis of hypokinesia. *Space Biology and Aerospace Medicine*, 1980, 14(3):3-10.
- Fedoruk, A.G., & T.A. Dobrokhotova. Functional asymmetry of operator performance. From JPRS, *USSR Report: Space Biology and Aerospace Medicine*, 30 October 1980, 14(5):56-62.
- Garshin, M.I., & V.Ye. Volyanskiy. Certain features of the cochleovestibular syndrome in the residual stage of traumatic brain disease. NASA TM-76337. Trans. from *Vestnik Otorinolaringologii*, 1980, (2):37-41.
- Gayday, N.I. Sequence of activation of neuronal population in the cat cervical spinal cord by reticulo-, vestibulo-, and rubro-spinal influences. NASA TM-73646. Trans. from *Neyrofiziologiya*, 1979, 11(3):264-267.
- Gazenko, O.G. Psychological compatibility on Earth and in outer space. *Aviation, Space and Environmental Medicine*, 1980, 51(6):622-623.
- Gazenko, O.G., N.N. Demin, A.N. Panov, D.A. Rashevskaya, N.L. Rubinskaia, & R.A. Tigranian. Some neurochemical characteristics of rats after spaceflight in the Cosmos-936 satellite. *Aerospace Medicine and Biology*, January 1980, NASA SP-7011(201), 299. Trans. from *Akademiia Nauk SSSR, Doklady*, 1979, 247(2):510-512(abstract).
- Gazenko, O.G., A.M. Genin, Ye.A. Il'in, L.V. Serova, R.A. Tigranyan, & V.S. Oganov. Adaptation to weightlessness and its physiological mechanisms. From JPRS, *USSR Report: Space*, 2 April 1980, 4:13. Trans. from *Izv. Akad. Nauk SSSR, Ser. Biol.* (Moscow), 1980, 1:5-18 (abstract).

- Gazenko, O.G., & A.I. Grigor'yev. Modeling the physiological effects of weightlessness. Soviet-American experiment. NASA TM-76317. Trans. from *Vestnik Akademii Nauk SSSR*, 1980, (2):71-75.
- Gazenko, O.G., A.I. Grigor'yev, & Yu.V. Natochin. Fluid-electrolyte homeostasis and weightlessness. From JPRS, *USSR Report: Space Biology and Aerospace Medicine*, 30 October 1980, 14(5):1-11.
- Gazenko, O.G., Ye.A. Il'in, A.M. Genin, A.R. Kotovskaya, V.I. Korol'kov, R.A. Tigranyan, & V.V. Portugalov. Principal results of physiological experiments with mammals aboard the Cosmos-936 biosatellite. *Space Biology and Aerospace Medicine*, 1980, 14(2):33-37.
- Gazenko, O.G., V.I. Shumakov, L.I. Kakurin, & V.E. Katkov. Central circulation and metabolism of the healthy man during postural exposures and arm exercises in the head-down position. *Aviation, Space, and Environmental Medicine*, 1980, 51:113-120.
- Gazenko, O.G., & A.D. Yegorov. 175-day space flight: Some results of medical research. NASA TM-76463. Trans. from *Vestnik Akademii Nauk SSSR*, 1980, 9:49-58.
- Genin, A.M. Laboratory simulation of the action of weightlessness on the human organism. NASA TM-75072. Trans. from *Laboratornoye modelirovaniye deystviya nevesomosti na organism cheloveka*. Interkosmos Council, Academy of Sciences USSR Report, 1977, 1-17.
- Genin, A.M. Hazards of high altitude decompression sickness during falls in barometric pressure from 1 atm to a fraction thereof. NASA TM-76015. Trans. from paper delivered at the 10th Conference on Joint Soviet-American Working Group on Space Biology and Medicine, Houston, Texas, October 1979, 1-12.
- Georgiyevskiy, V.S., N.A. Lapshina, L.Ya. Andriyako, L.V. Umnova, V.G. Doroshev, I.V. Alferova, V.N. Ragozih, & Ye.A. Kobzev. Circulation in exercising crew members of the first main expedition aboard Salyut-6. *Space Biology and Aerospace Medicine*, 1980, 14(3):15-18.
- Gershuni, G.V., Ye.M. Tsurul'nikov, L.R. Gavrilov, V.I. Pudov, & A.S. Rozenblyum. Features of the effect of focused megahertz range ultrasound on the otic labyrinth structure during the emergence of auditory sensations. NASA TM-76339. Trans. from *Doklady Akademii nauk SSSR*, 1980, 251(3):763-766.
- Geykhman, K.L., & M.R. Mogendovich. Vegetopostural reactions in antiorthostatic position. *Space Biology and Aerospace Medicine*, 1980, 14(3):82-84.
- Glezer, G.A., M. Charyyev, & N.L. Zil'bert. State of gas exchange in recumbent and orthostatic positions under physical load in healthy persons of varying age, sex and body build. NASA TM-76357. Trans. from *Zdravookhraneniye Turkmenistana*, October 1979, 33(10):24-27.

- Golikov, A.P., V.Ye. Vorob'yev, V.R. Abdrakhmanov, L.L. Stazhadze, V.V. Bogomolov, & S.G. Voronina. External respiration and acid-base balance of human blood during long-term antiorthostatic hypokinesia and in the recovery period. *Space Biology and Aerospace Medicine*, 1980, 14(1):60-66.
- Golovanov, Ya.K. The architecture of weightlessness. NASA TM-75643. Trans. from *Arkhitektura nevesomosti*. Moscow: Mashinostroyeniye Press, 1978.
- Gorbunova, A.V. Effect of restricted mobility on RNA content and nucleotide composition and on protein content in motoneurons of spinal cord anterior horns. *Aerospace Medicine and Biology*, November 1980. NASA SP-7011(212). Trans. from *Dokl. Akad. Nauk SSSR*, 1979, 199(4): 976-979.
- Gordeyev, A. Life of the onion not knowing up from down. NASA TM-76353. Trans. from *Zhanyiye-Sila*, December 1979, 630(12):9-10.
- Goroian, G.P., & I.N. Zakharova. Investigation of the functional state of the CNS under conditions of altitude decompression. *Aerospace Medicine and Biology*, June 1980, NASA SP-7011(207). Trans. from *Fiziologiya Cheloveka*, 1980, 6:115-120 (abstract).
- Gribovskaya, I.V., I.A. Gladchenko, O.I. Novoselova, G.S. Petrov, & L.L. Martynenko. Choice of method for longterm storage of nutrient solutions used to grow vegetables. From JPRS, *USSR Report: Space Biology and Aerospace Medicine*, 30 October 1980, 14(5):121-125.
- Grigorova, V.K., V.K. Popov, & V.S. Todorova. Comparative assessment of prognosis of the diagnostic possibilities of the stop-stimulus and trapezoidal rotation programs. NASA TM-76336. Trans. from *Vestnik Otorinolaringologii*, 1980, 2:30-33.
- Gulyar, S.A. Characteristics of respiration, blood circulation and oxygen regimes in humans during hyperbaric hyperoxia. From JPRS, *USSR Report: Life Sciences—Biomedical and Behavioral Sciences*, 7 August 1980, (3). Trans. from *Fiziologicheskiy Zhurnal*, 1980, (1):45-52 (abstract).
- Gulyar, S.A., A.N. Korol, & Ye.V. Moisenko. Gas chromatographic investigation of blood respiratory function in humans under hyperbaric conditions. From JPRS, *USSR Report: Life Sciences—Biomedical and Behavioral Sciences*, 7 August 1980, (3). Trans. from *Fiziologicheskiy Zhurnal*, 1980, (1):57-82 (abstract).
- Gurfinkel', V.S. Significance of vestibular and proprioceptive afferentation in the regulation of human posture. NASA TM-76470. Trans. from *Report to the XI Joint Soviet-American Working Group on Space Biology and Medicine*, Moscow, October 1980, 1-10.
- Gurovskiy, N. Post-flight recovery of the 175 day mission cosmonauts. From JPRS, *USSR Report: Space*, 28 February 1980, No. 3, 17. Trans. from *Meditinskaya Gazeta*, 1 January 1980, 3 (abstract).

- Gurovskiy, N.N. (Ed.). Joint Soviet-American experiment on hypokinesia: Experimental results. NASA TM-76013. Trans. from *Sovmestnyy Sovetsko-Amerokanskiy Eksperiment po Giopokinezii. Otchet. Rezul'taty Sovmestnogo Eksperiments*, Moscow, Academy of Sciences, USSR and Ministry of Health USSR, October 1979, 1-372.
- Gurovskii, N.N., O.G. Gzenko, B.A. Adamovich, E.A. Il'in, A.M. Genin, V.I. Korolkov, A.A. Shipov, A.R. Kotovskaia, V.A. Kondrat'eva, & L.V. Serova. Study of the physiological effects of weightlessness and artificial gravity in the flight of the biosatellite Cosmos-936. *Aerospace Medicine and Biology*, June 1980. NASA SP-7011(207). Trans. from *Acta Astronautica*, 1980, 7:113-121 (abstract).
- Guseva, Y.V., & R.Yu. Tashpulatov. Effects of flights differing in duration on protein composition of cosmonauts' blood. *Space Biology and Aerospace Medicine*, 1980, 14(1):15-20.
- Hooper, G.R. The cosmonauts-17. *Spaceflight*, 1980, 22(2):64-65.
- Il'in, E.A. Main results of the experiments conducted during the flight of the Cosmos 1129 biosatellite and the status of the preparation of studies on the next biosatellite. NASA TM-76467. Trans. from *Report to the XI Joint Soviet-American Working Group on Space Biology and Medicine*, Moscow, October 1980, 1-22.
- Il'in, Ye.A., V.I. Korol'kov, A.R. Kotovskaya, & A.D. Noskin. Objectives and conditions of physiological experiments on rats conducted aboard the Cosmos-936 biosatellite. *Space Biology and Aerospace Medicine*, January 1980, 14(6):21-26. Trans. from *Kosmicheskaya Biologiya i Aviakosmicheskaya Meditsina*, November-December 1979, 14(6):18-22.
- Il'in, Ye.A., Yu.V. Natochin, N.A. Ilyushko, Yu.I. Kondrat'yev, V.T. Bakteyeva, Ye.M. Gazhala, O.A. Goncharevskaya, Ye.A. Lavrova, & Ye.I. Shakhmatova. Effect of weightlessness and artificial gravity on ion-regulating function of rat kidneys. *Space Biology and Aerospace Medicine*, 1980, 14(3):21-25.
- Il'in, Ye.A., & V.Ye. Novikov. A stand for simulation of weightlessness in laboratory experiments on rats. *Space Biology and Aerospace Medicine*, 1980, 14(3):128-129.
- Il'yasova, Sh.G., & M.F. Popova. Effect of helium-neon laser on the postradiation recovery process in skeletal muscle tissues. From JPRS, *USSR Report: Life Sciences—Biomedical and Behavioral Sciences*, 7 August 1980, (3). Trans. from *Byulleten Eksperimental'noy Biologii i Meditsiny*, 1980, (2):222-224 (abstract).
- Imshenetskiy, A.A., & B.G. Murzakov. New evaluation of possibility of life on Mars. From JPRS, *USSR Report: Space*, 2 April 1980, 4:15. Trans. from *Mikrobiologiya*, 1979, 48(6):1075-1081 (abstract).

- Imshenetskiy, A.A., B.G. Murzakov, M.D. Yevdokimova, & I.K. Dorofeyeva. Effect of hydrogen peroxide and hydrated iron oxides on metabolism of soil microflora. From JPRS, *USSR Report: Space*, 11 February 1980, No. 2, 16-17. Trans. from *Mikrobiologiya*, 1979, No. 5, 919-926 (abstract).
- Imshenetskiy, A.A., B.G. Murzakov, M.D. Evdokimova, I.K. Dorofeyeva, L.A. Kuziurina, & V.M. Iakshina. On the possibility of life on Mars. In *Life sciences and space research: Proceedings of the open meeting of the working group on space biology*, Vol. 18. Oxford and Elmsford, NY: Pergamon Press, 1980 (abstract).
- Ioseliani, K.K. Evaluation and forecasting of mental fitness of flight personnel in the presence of neurosis. *Space Biology and Aerospace Medicine*, 1980, 14(1):101-106.
- Istomin, V.G., K.V. Grechnev, & V.A. Kotchnev. Mass spectrometer measurements of the venous lower atmosphere composition. *Scientific and Technical Aerospace Reports*, 23 February 1980, 18(4):549. From Academy of Sciences (USSR), Moscow, Institute for Space Research (abstract).
- Iurov, S.S., G.A. Leont'eva, I.N. Kniazeva, E.G. Mozgovoi, A.M. Kuzin, I.G. Akoev, & W.S. Belkin. Genetic effects of space hadrons on bacteriophage under alpine conditions. In *Life sciences and space research: Proceedings of the open meeting of the working group on space biology*, Vol. 18. Oxford and Elmsford, NY: Pergamon Press, 1980 (abstract).
- Ivanov, L.A., & N.D. Chebotarev. Effect of hyperoxia on oxygen transport properties of blood. *Space Biology and Aerospace Medicine*, 1980, 14(1):54-59.
- Izakov, M.N. Noble gases in the atmosphere of Venus, Earth, and Mars: The problem of the origin of planetary atmospheres. NTIS HC A03/MF A01. From *Scientific and Technical Aerospace Reports*, 1980, 18(5):686 (abstract).
- Kakurin, L.I., A.I. Gregor'yev, V.M. Mikhailov, & V.A. Tishler. Ground experiments for finding principles and working out methods for preventing adverse effects of weightlessness on the human organism. NASA TM-76465. Trans. from *Report to the XI Joint Soviet-American Working Group on Space Biology and Medicine*, Moscow, October 1980, 1-57.
- Kalandarov, S.K., V.P. Bychkov, & V.P. Savina. Functional changes in the adrenal cortex during simulation of stress situations in the presence of high carbon monoxide levels. *Space Biology and Aerospace Medicine*, 1980, 14(1):120-124.
- Kalandarov, S.S., V.P. Bychkov, A.S. Ushakov, & G.I. Proskurova. Effect of some factors that simulate space flights on blood plasma levels of free and protein-bound 11-hydroxycorticosteroids. From JPRS, *USSR Report: Space Biology and Aerospace Medicine*, 30 October 1980, 14(5):63-69.

- Kandaurov, I.V., L.A. Shestak, & Yu.A. Kuvshinov. Instrument for two-speed optokinetic stimulation. NASA TM-76364. Trans. from *Zhurnal Ushnykh, Nosovykh i Gorlovykh Boleznay*, 1980, 3:78-79.
- Kapelovich, R.L. Therapeutic gymnastics in comprehensive treatment of patients with generalized myasthenia. NASA TM-76312. Trans. from *Voprosy Kurortologii, Fizioterapii i Lechebnoy Fizecheskoy Kul'tury*, 1979, (5):41-45.
- Kaplanskiy, A.S., & G.N. Durnova. Role of dynamic space flight factors in the pathogenesis of involution of lymphatic organs (experimental morphological study). *Space Biology and Aerospace Medicine*, 1980, 14(2):45-52.
- Kapranov, V.Z. Characteristics of vestibulosensory reactions studied by experimental caloric test. NASA TM-76386. Trans. from *Vestnik Otorinolaringologii*, 1979, 1:48-49.
- Karpova, N.I., S.V. Alekseyev, V.N. Yerokhin, Ye.N. Kadyskina, & O.V. Reutov. Early reaction of the organism to low frequency acoustical oscillations. From JPRS, *USSR Report: Life Sciences—Biomedical and Behavioral Sciences*, 7 August 1980, (3). Trans. from *Gigiena Truda i Professional'nyye Zabolevaniya*, October 1979, (10):16-19 (abstract).
- Kasatkina, T.B., G.G. Zharikova, A.B. Rubin, L.R. Palmbakh, E.N. Vaulina, & A.L. Mashinskii. Development of higher fungi under weightlessness. *Aerospace Medicine and Biology*, December 1980. NASA SP-7011(213). In *Life sciences and space research: Proceedings of the open meeting of the working group on space biology*, Vol. 18. Oxford and Elmsford, NY: Pergamon Press, 1980 (abstract).
- Kas'yan, I., & V. Turchaninova. Rheography in weightlessness. NASA TM-76439. Trans. from *Meditinskaya Gazeta*, 23 February 1980, 3.
- Kas'yan, I.I., G.B. Vaynshteyn, V.N. Semernya, K.A. Gorokhov, V.P. Tikhonov, S.I. Ponomarev, & Kh.Kh Asanov. Peculiarities of cerebral circulation at rest and during fulfillment of functional tests in Salyut 4 crews. NASA TM-76301. Trans. from *Izvestiya Akademii Nauk SSSR, Seriya Biologicheskaya*, 1980, 2:165-173.
- Katkovskiy, B.S., & V.P. Buzulina. Evaluation of the functional state of the human cardiovascular system during prolonged antiorthostatic hypokinesia using different levels of physical exercise on a bicycle ergometer. *Space Biology and Aerospace Medicine*, 1980, 14(3):86-87.
- Kazakova, R.T. Ultrasonic method of recording gas bubbles in animal venous blood in a rarefied atmosphere. *Space Biology and Aerospace Medicine*, 1980, 14(3):74-76.
- Khechinashvili, S.N., B.M. Zargaryan, & K.G. Karakozov. Technique of electrical stimulation of the vestibular analyzer under clinical conditions. NASA TM-76347. Trans. from *Vestnik Otorinolaringologii*, 1978a, (5):74-77.



- Khechinashvili, S.N., B.M. Zargaryan, & K.G. Karakozov. Importance of photoelectronystagmography for clinical study of the vestibular function. NASA TM-76404. Trans. from *Zhurnal Ushnykh Nosovykh i Gorlovykh Bolezney*, 1978b, 2:68-72.
- Khenokh, M.A., Ye.A. Kuzicheva, N.V. Tsupkina, N.I. Kon'shin, A.L. Mashinkiy, & G.S. Nechitaylo. Abiogenic synthesis of nucleoside-like compounds tested on Salyut 6. From JPRS, *USSR Report: Space*, 11 February 1980, No. 2, 15. Trans. from *Doklady Akademii Nauk SSSR*, 1979, 249, No. 3, 749-752 (abstract).
- Khinchikashvili, N.V. Effect of meprobamate on the vestibulo-sensory and vestibular somatic reaction. NASA TM-76104. Trans. from *Fiziologicheskii Zhurnal*, 1979, 25(5):507-512.
- Kholodov, Yu.A., & M.A. Shishlo. Electromagnetic fields in neurophysiology. NASA TM-75929. Trans. from *Elektromagnitnyye polya v neyrofiziologii*. Moscow: Nauka Publishing House, 1979.
- Khrunov, Ye.V. Fifteenth anniversary of the first space walk. NASA TM-76435. Trans. from *Zemlya i Vselennaya*, 1980, 2:8-11.
- Khrunov, Ye.V., V.M. Kazachkov, & Ye.N. Khludeyev. Exemplary model of the eye-telescope system in the detection of manned spacecraft on a star background. NASA TM-76434. Trans. of *Kibernetika i Vychislitel'naya Tekhnika*, No. 46. Ergaticheskkiye Sistemy Upravleniya, Kiev, "Naukova Dumka" Press, 1979, 27-30.
- Kirichek, L.Y. Dynamics of stress reaction of rats during experimental hypokinesia varying in duration, and possibility of correction thereof. *Space Biology and Aerospace Medicine*, 1980, 14(1):107-111.
- Klemparskaya, N.N., & G.A. Shal'nova. Normal autoantibodies as radiation resistant factors. From JPRS, *USSR Report: Life Sciences—Biomedical and Behavioral Sciences* (FOUO 2/80), 11 July 1980. Trans. from *Normal'nyye Autoantitela kak Radiozaschitnyye Faktory*. Moscow: Automizdat, 1978, 2, 3-4, 133-135.
- Kolesov, M.A. Influence of specific conditioning on white rat resistance to the combined effect of hypoxia and -G accelerations. *Space Biology and Aerospace Medicine*, 1980, 14(2):137-139.
- Komendantov, G.L., & N.A. Razsolov. Motion sickness. NASA TM-76326. Trans. from *Bolezn' dvizheniya*, 1978, Chap. 5.
- Konstantinov, V.A., N.K. Danilova, & K.P. Ivanov. The effect of the temperatures of different skin layers on the activity of cold thermoreceptors. *Aerospace Medicine and Biology*, November 1980. NASA SP-7011(212). Trans. from *Fiziologicheskii Zhurnal SSSR*, 1980, 66:902-907 (abstract).

- Korbut, V.L. Automatic control of gas exchange in the autotrophic component of a life support system for heterotrophic organisms. From *JPRS, USSR Report: Space Biology and Aerospace Medicine*, 30 October 1980, 14(5):111-116.
- Kordium, E.L., A.L. Mashinskii, A.F. Popova, S.A. Uvarova, & L.A. Khristenko. The effects of orbital flight conditions on the formation of the generative organs in *Muscari racemosum* and *Anethum graveolens*. *Aerospace Medicine and Biology*, November 1980. NASA SP-7011(212). Trans. from *Kosmicheskie Issledovaniia na Ukraine*, 1978, 12:49-49 (abstract).
- Kordium, V.A., L.V. Polivoda, V.G. Man'ko, V.G. Babskii, N.I. Kon'shin, T.G. Gavrish, L.P. Polishchuk, & A.L. Mashinskii. Results of the experiment 'microorganism growth' on the Soyuz 22 spacecraft. *Aerospace Medicine and Biology*, November 1980. NASA SP-7011(212). Trans. from *Kosmicheskie Issledovaniia na Ukraine*, 1978, 12:3-14 (abstract).
- Kordium, V.A., A.L. Mashinskii, E.Ia. Shepelev, G.I. Meleshko, I. Setlik, E.L. Kordium, K.M. Sytnik, A.F. Popova, N.P. Dubinin, & E.N. Vaulina. Biological effects of *Chlorella pyrenoidosa*/strain LARG-1/cultures grown under spaceflight conditions. *Aerospace Medicine and Biology*, December 1980. NASA SP-7011(213). In *Life sciences and space research: Proceedings of the open meeting of the working group on space biology*, Vol. 18. Oxford and Elmsford, NY: Pergamon Press, 1980 (abstract).
- Kordium, V.A., A.L. Mashinskii, V.G. Man'ko, V.G. Babskii, K.M. Sytnik, E.L. Kordium, O.P. Bochagova, Iu.L. Nevedov, V.I. Kozharinov, & G.M. Grechko. Growth and cell structure of *Proteus vulgaris* cultivated in weightlessness in the Cytos apparatus. *Aerospace Medicine and Biology*, December 1980. NASA SP-7011(213). In *Life sciences and space research: Proceedings of the open meeting of the working group on space biology*, Vol. 18. Oxford and Elmsford, NY: Pergamon Press, 1980 (abstract).
- Kornilov, L.N., G.D. Strykh, I.K. Tarasov, & I.Ya. Yakovleva. Results of investigation of otolithic function during manned space flights. From *JPRS, USSR Report: Space*, 11 February 1980, No. 2, 16. Trans. from *Vestnik Otorinolaringologii*, 1979, No. 6, 21-24 (abstract).
- Kovalenko, Ye.A., V.L. Popkov, Yu.I. Kondratev, E.S. Mailyu, Yu.S. Galushko, A.A. Prokhonchukov, V.A. Kazaryan, R.S. Morozova, L.V. Serova, A.N. Potapov et al. Changes of the body functions during longterm hypokinesia. *Aerospace Medicine and Biology*, October 1980. NASA SP-7011(211). Trans. from *Patol. Fiziol. Eksp. Ter.*, 1970, 6:3-9 (abstract).
- Kovalev, O.A., V.F. Lysak, V.I. Severovostokova, & S.K. Sheremeterskaya. Regional redistribution of rat blood after 7 and 30 days of hypokinesia. *Space Biology and Aerospace Medicine*, 1980, 14(3):60-64.
- Kovalik, A.V. Ways of increasing muscular activity by means of isometric muscular exertion. NASA TM-76307. Trans. from *Teoriya i Praktika Fizicheskoy Kultury*, 1979, 12:38-40.

- Krasnopolsky, V.A., V.A. Parshev, A.A. Krysko, & V.N. Rogachev. Structure of the Mars lower and middle atmosphere based on Mars 5 ultraviolet photometry data. NTIS HC A04/MF A01. *Scientific and Technical Abstract Reports*, 1980, 18(5):686 (abstract).
- Krotov, V.P. Water metabolism regulating mechanisms in hypokinesia. NASA TM-7630. Trans. from *Patol. Fiziol. Eksp. Ter.*, 1980, 1:15-18.
- Krupina, T.N., Kh.Kh. Yarullin, & D.A. Alekseyev. Bioelectric activity of the human brain during and after 182-day antiorthostatic hypokinesia. *Space Biology and Aerospace Medicine*, 1980, 14(2):75-83.
- Ksanfomalti, L.V. New studies of Venus. *Aerospace Medicine and Biology*, May 1980. NASA SP-7011(206). Trans. from *Zemlya Vselennaya*, 1979, (4):5-14 (abstract).
- Kutlakhmedov, Iu.A., G.S. Sokirko, D.M. Grodzinskii, A.L. Mashinshii, G.S. Nechitailo, & N.I. Kon'shin. Investigation of the effects of space flight factors on the emergence from the antibiotic state of turions of the great duckweed. *Aerospace Medicine and Biology*, November 1980. NASA SP-7011(212). Trans. from *Kosmicheskie Issledovaniia na Ukraine*, 1978, 12:49-54 (abstract).
- Kutlakhmedov, Iu.A., G.S. Sokirko, & D.M. Grodzinskii. The effects of simulated weightlessness on the reproductive capacity of the great duckweed in the norm and under irradiation. *Aerospace Medicine and Biology*, November 1980. NASA SP-7011(212). Trans. from *Kosmicheskie Issledovaniia na Ukraine*, 1978, 12:55-58 (abstract).
- Kuzmina, G.I. Cold shivering activity after unilateral destruction of the vestibular apparatus. NASA TM-76099. Trans. from *Fiziologicheskii Zhurnal SSSR im. I.M. Sechenova*, 1979, 65(11):1655-1660.
- Kuz'mina, G.I. Bioelectrical activity of limb muscles during cold shivering on stimulation of the vestibular apparatus. NASA TM-76334. Trans. from *Fiziol. Zh.*, 1980, 66(5):702-708.
- Ladyzhenskaya, E.A., & B.Kh. Arifdzhanov. Vestibular reactions in patients during occlusion form of chorioependymitis. NASA TM-76356. Trans. from *Meditsinskiy Zhurnal Uzbekistana*, 1979, (11):16-19.
- Lakshin, A.M., & V.P. Novoselov. Physiological reactions of a passenger to transportation conditions. NASA TM-76350. Trans. from *Gigiyena i Sanitariya*, 1979, 9:84-85.
- Lange, K.A. Physiology of man and animals in the tenth five-year plan. Proceedings of the Thirteenth Congress of the I.P. Pavlov All-Union Physiological Society. NASA TM-76296. Trans. from *Fiziologicheskii Zhurnal SSSR imeni I.M. Sechenova*, 1980, 66(5):757-771.

- Langereux. P. Cosmonaut Klimuk describes 'Soyuz-T' mission plans. From JPRS, *USSR Report: Space* (FOUO 4/80), 28 April 1980, 1-5. Trans. from *Air and Cosmos* (French), 16 February 1980, No. 800, 50-51.
- Letskova, L.I., & K.I. Murakhovskiy. Changes in main parameters of human hemodynamics with lower body compressed in a G suit. From JPRS, *USSR Report: Space Biology and Aerospace Medicine*, 30 October 1980, 14(5):105-110.
- Levashov, M.M., & A.I. Tumakov. Generalized nystagmometric characteristics for diagnostic purposes. *Space Biology and Aerospace Medicine*, 1980, 14(2):123-129.
- Limar, B.Ya., N.S. Mishchancuk, M.V. Kulikova, & V.I. Yermilova. Glycerol test in diagnosing increased intralabyrinth pressure. NASA TM-76110. Trans. from *Zhurnal Ushnykh Nosovykh i Gorlovykh Bolezney*, 1979, No. 6, 55-59.
- Litsov, A.N. Peculiarities of human sleep with double alteration of cycles "sleep waking." NASA TM-76089. Trans. from *Osobennosti sna cheloveka pri dvukratnom cheredovanii tsiklov "sonbodrstvovaniye," Seria Biologicheskaya, Izvestiya Akademii Nauk SSSR*, July-August 1979, No. 4, 505-511.
- Litsov, A.N., & I.F. Sarayev. Effects of unusual schedules of daily activity and sleep deprivation on man's functional state and work fitness. *Space Biology and Aerospace Medicine*, 1980, 14(1): 21-29.
- Livshits, N.N., M.A. Kuznetsova. Z.I. Apanasenko, & Ye.S. Meyzerov. Retention and recovery of food-procuring skill in a maze for rats after space flight in the Cosmos 782 biosatellite. NASA TM-76358. Trans. of *Zhurnal Vyshey Nervnoy Deyatel'nosti*, 1980, 30(1):55-61.
- Lomova, B.F., A.G. Nikolayev, & L.S. Khachatur'yants (Eds.). Peculiarities of cosmonaut's activity in flight. FTD-ID(RS)T-1894-79, 24 January 1980. Trans. from *Osobennosti Deyatel'nosti Kosmonauta i Polete*. Moscow: Publishing House "Mashinostroyeniye," 1976, 1-271.
- Machablishvili, O.G. Effect of production microclimate on female thermal state with increased temperature and air humidity. NASA TM-76082. Trans. from *Vliyaniye proizvodstvennogo mikroklimata na teplovoe sostoyaniye organizma zhenshchin v usloviyakh povyshennykh temperatur i vlazhnosti vozdukha, Vrachebnoye Delo*, June 1979, No. 6, 96-98.
- Machavariani, M.G. Tetraploidy in epithelial kidney cells in monkeys exposed in vivo and in vitro to radiation doses: Part III. From JPRS, *USSR Report: Life Sciences—Biomedical and Behavioral Sciences*, 7 August 1980, (3). Trans. from *Tsitologiya i Genetika*, 1979, (6):446-451 (abstract).
- Makho, I., Sh. Nemet, M. Palkovich, V. Shtrbak, & R.A. Tigranyan. Activity of some hepatic enzymes and lipogenic processes in rat adipose tissue after spaceflight. *Space Biology and Aerospace Medicine*, 1980, 14(3):26-29.

- Maksimovich, Ya.B., & N.V. Khinchikashvili. Effect of tranquilizers on animal resistance to the adequate stimuli of the vestibular apparatus. NASA TM-76109. Trans. from *Farmakologiya i toksikologiya*, 1979, 42(6):606-610.
- Mamasakhlisov, G.V. Investigation of transitional characteristics of the equilibrium system. *Aerospace Medicine and Biology*, July 1980. NASA SP-7011(208). Trans. from *Akademiia Nauk Gruzihskoi SSR, Soobshcheniia*, 1979, 96:433-436 (abstract).
- Markman, V.G. Dynamics of autonomic reactions during voluntary control of the alpha-rhythm. NASA TM-76083. Trans. from *Fiziologiya Cheloveka*, 1979, 5(5):927-930.
- Markov, Yu. "Venera-12" space probe used to study new comet. In Daily Soviet News Abstracts Service, 26 March 1980, 2. Trans. from *Pravda*, 18 March 1980, No. 78 (22508), 6 (abstract).
- Matlina, E.Sh., S.M. Waysman, I.G. Zaydner, B.M. Kogan, & L.V. Nozdracheva. Effect of consecutive cooling and immobilization on catecholamine metabolism in rat tissues. *Aerospace Medicine and Biology*, June 1980. NASA SP-7011(207). Trans. from *Fiziologicheskii Zhurnal SSSR*, 1974, 60(4):540-547 (abstract).
- Matsnev, E.I. Mechanisms for vestibular disorders in space flight. NASA TM-76469. Trans. from *Report to the XI Joint Soviet-American Working Group on Space Biology and Medicine*, Moscow, October 1980, 1-33.
- Matyushichev, V.B., V.R. Taratukhin, & V.G. Shamratova. Estimation of sequelae of external beta-radiation on the organism in conditions of thermal load. NASA TM-76093. Trans. of *Zhurnal Eksperimental'noy i Klinicheskoy Meditsiny (Armenia)*, 1979, 12:12-16.
- Medkova, I.L., N.M. Nikolayeva, & K.V. Smirnov. Secretion, incretion and resecretion of pancreatic lipase during prolonged restriction of motor activity. *Space Biology and Aerospace Medicine*, 1980, 14(3):97-103.
- Melnik, B.E., & E.S. Paladiy. The content of catecholamines in the adrenal glands and sections of the brain under hypokinesia and injections of some neurotropic agents. *Aerospace Medicine and Biology*, October 1980. NASA SP-7011(211). Trans. from *Biol. Nauki*, 1972, 15(11):45-49 (abstract).
- Melik-Aslanova, L.L., & I.D. Frenkel. Effect of sinusoidal modulated currents and acute hypoxia on corticosterone content and activity of certain dehydrogenases in tissues of different rat organs during hypokinesia. *Aerospace Medicine and Biology*, December 1980. NASA SP-7011(213). Trans. from *Vod. Kurortol. Fizioter. Lech. Fiz. Kulit.*, 1978, 1:59-65 (abstract).
- Menyakin, R.P., & V.I. Poperetskaya. Occupational changes in the organ of hearing and equilibrium in sailors and fishermen. NASA TM-76335. Trans. from *Vestnik Otorinolaringologii*, 1980, (1):39-42.

- Mikhalkina, N.I. Effect of hypoxia and hypercapnia on lactate and pyruvate levels in rat blood and myocardium. *Space Biology and Aerospace Medicine*, 1980, 14(1):125-129.
- Milov, M. Greenhouses in space—higher plants in closed ecological systems. From JPRS, *USSR Report: Space*, 12 May 1980, 5:14. Trans. from *Aviatsia i Kosmonovtika*, 1980, 3:36-37 (abstract).
- Minorenko, Yu.T., & A.A. Vilenskiy. Instruments and attachments for electronystagmography. NASA TM-76365. Trans. from *Zhurnal Ushnykh, Nosovykh i Gorlovykh Bolezney*, 1980, 3:79-81.
- Moiseyeva, N.I., G.D. Luchko, R.V. Kremleva, A.V. Morozov, L.I. Nikitina, K.K. Rodionov, A.F. Gurchin, & E.M. Shmatov. Automated system for diagnosing craniocerebral injury. NASA TM-76097. Trans. from *Sovetskaya Meditsina*, 1979, (10):94-98.
- Moroz, B.S., V.G. Bazarov, & S.V. Sachenko. Role of the middle ear muscles apparatus in mechanisms of speech signal and discrimination. NASA TM-76408. Trans. from *Zhurnal Ushnykh, Nosovykh i Gorlovykh Bolezney*, 1979, 5:24-28.
- Moroz, V.I., B.E. Moshkin, A.P. Ekonomov, N.F. Sanko, N.A. Parfentev, & Yu.M. Golovin. The spectrophotometric experiment on board the Venera-11, Venera-12 probes: Some results from the analysis of the Venus day-sky spectrum. In *Scientific and Technical Aerospace Reports*, 23 February 1980, 18(4):549. Trans. from USSR Academy of Sciences, Institute for Space Research, 1979 (abstract).
- Mukhina, N.N., V.V. Chestukhin, V.Ye. Katkov, & A.P. Karpov. Effects of brief antiorthostatic hypokinesia on blood immunoglobulin content. *Space Biology and Aerospace Medicine*, 1980, 14(1):112-115.
- Nasonov, A.S., & V.S. Toroptysov. Development of program for the control of the autotropic component of an ecological system that is closed with regard to exchange of gases. *Space Biology and Aerospace Medicine*, 1980, 14(1):88-93.
- Natochin, Yu.V. Water-salt exchange during bed rest of varying duration. NASA TM-75077. Trans. from *Vodno-solevoy obmen pri postel'nom rezhime razlichnoy prodolzhitel'nosti*. Interkosmos Council, Academy of Sciences USSR Report, 1977, 1-42.
- Navakatikyan, A.O., A.P. Okhrimenko, A.N. Karakashyan, & V.A. Buzunov. Principles for classification of work load for women. NASA TM-76084. Trans. from *Gigiyena truda i professional'nyye zabolovaniya*, July 1979, No. 7, 10-14.
- Ngj, L.V., & Iu.Iu. Keerig. The role of the hypoxic factor at elevated temperatures and possible mechanisms of its development. *Aerospace Medicine and Biology*, November 1980. NASA SP-7011(212). Trans. from *Fiziol. Zh.*, 1980, 66:908-913 (abstract).

- Nikolayev, M.P., & O.N. Mertsalova. Rheoencephalography in Meniere's disease. NASA TM-76387. Trans. from *Vestnik Otorinolaringologii*, 1979, 3:12-15.
- Nuzhdin, N.I., & R.L. Dozortseva. Genetic changes induced by space flight factors in barley seeds on Soyuz 5 and Soyuz 9 craft. *Aerospace Medicine and Biology*, November 1980. NASA SP-7011(212). Trans. from *Zh. Obshch. Biol.*, 1972, 33(2):336-346 (abstract).
- Nvota, J., D. Lamosova, D. Tesarova, V. Cierna, & P. Vyboh. Influence of hypokinesia on physiologic functions in fowl. *Aerospace Medicine and Biology*, April 1980. NASA SP-7011(205). Trans. from *Veterinary Medicine (Prague)*, 1977, 22(7):425-432 (abstract).
- Orlov, I.V. Responses of the frog primary vestibular afferents to direct vibration of the semicircular canal. NASA TM-76332. Trans. from *Fiziol. Zh.*, 1980, 66(1):48-55.
- Osadchiy, L.I. Pharmacological analysis of physiological mechanisms of orthostatic hemodynamic stability. *Space Biology and Aerospace Medicine*, 1980, 14(2):69-74.
- Ovechkin, V.G., & A.A. Shipov. Vestibular nystagmus in rats after hypokinesia and prolonged rotation. From JPRS, *USSR Report: Space Biology and Aerospace Medicine*, 30 October 1980, 14(5):88-93.
- Palets, B.L., & R.D. Grigoryan. Self-regulatory characteristics of the human cardiovascular system in clino- and orthostasis (mathematical modeling). From JPRS, *USSR Report: Life Sciences—Biomedical and Behavioral Sciences*, 7 August 1980, (3). Trans. from *Fiziologicheskiy Zhurnal*, 1980, (1):96-103 (abstract).
- Panchin, Yu.V. Vestibular responses of "fast" and "slow" Dieters' neurons. NASA TM-76345. Trans. from *Neyrofiziologiya*, 1978, 10(3):313-315.
- Panin, L.E., I.E. Kolosov, & Yu.S. Nechayer. Alteration of the activity of glycogenesis key enzymes in the rat liver and kidneys subjected to extreme and subextreme efforts. NASA TM-76098. Trans. from *Byulletin Eksperimental'noy Biologii i Meditsiny*, 1979, 87(6):544-547.
- Pashchenko, P.S., A.V. Pastushenkov, V.V. Grishchenko, & I.V. Lemak. Use of cytochemical parameters of peripheral blood neutrophils to study hormonal and endocrine reactions to flight work loads. *Space Biology and Aerospace Medicine*, 1980, 14(3):138-141.
- Pavlov, A.D., A.I. Solov'yev, Yu.D. Goncharenko, & Ye.N. Pashukov. Studies of the effects of stationary magnetic fields on rat erythron. *Space Biology and Aerospace Medicine*, 1980, 14(1):134-139.
- Pelekhov, P. Commentary on semi-rigid EVA suits. From JPRS, *USSR Reports: Space*, 12 May 1980, 5:13. Trans. from *Komsomol'skaya Pravda*, 19 March 1980, 2 (abstract).

- Penev, G.D., & O.P. Tairov. Mechanisms of adaptive control of complex motor systems (control on position and acceleration). NASA TM-76086. Trans. from *Biofizika*, 1979, 24(4):733-740.
- Plakhuta-Plakutina, G.I. State of rat thyroid C cells following flights on the Cosmos type of biosatellites (according to results of a morphological study). *Space Biology and Aerospace Medicine*, 1980, 14(3):29-33.
- Poddubnyy, A.P. Analog model of interaction in the system human body-temperature sensor-environment. NASA TM-76091. Trans. from *Meditsinskaya Tekhnika*, July-August 1979, No. 4, 17-21.
- Pogodin, A.S., & B.I. Mazhbich. Blood filling and flow in lungs during change in body position in space. NASA TM-76333. Trans. from *Fiziologicheskii Zhurnal SSSR imeni I.M. Sechenova*, 1980, 66(4):555-561.
- Polyakov, V.I., M.I. Serebrennikov, Yu.V. Lysenko, Yu.P. Ozerov, & B.V. Permyakov. Study of the prognostic value of electronystagmograms (ENGs) in vestibular occupational selection. NASA TM-76341. Trans. from *Fiziol. Cheloveka*, 1980, 6(2):366-368.
- Ponomarenko, V.A., & N.D. Zavalova. Some aspects of application of the systemic approach to aviation engineering psychology. *Aerospace Medicine and Biology*, October 1980. NASA SP-7011(211). From JPRS 75956, *USSR Report: Space Biology and Aerospace Medicine*, 1980, 14(3):47-52 (abstract).
- Potapov, P.P. Connective tissue of skeletal muscles and the myocardium under hypokinetic conditions and combination thereof with physical loads. *Space Biology and Aerospace Medicine*, 1980, 14(3):87-90.
- Pravetskiy, V.N. System approach to the problem "man and prolonged space flight." NASA TM-76290. Trans. from *Trudy desyatykh i odinnadtsytkh chteniy, posvyashchennykh razrabotki nauchnogo naskediya i razvitiyu idey K.E. Tsiolkovskogo*, Kaluga, 1975-1976.
- Pravetskiy, N.V., K.G. Bomshteyn, & V.A. Lyapin. Certain aspects of human biomechanics and problems of future space flight. NASA TM-76459. Trans. from *Symposium K.E. Tsiolkovskiy i Nauchnoye Prognozirovaniye*, Inst. of History of Nat. Sciences and Technol., Moscow, 1979, 104-108.
- Prokhonchukov, A.A., N.A. Komissarova, A.G. Kilesnik, & L.L. Novikov. The combined effects of ionizing radiation and weightlessness on calcium and phosphorus content in the mineral fraction of the calcified tissues in the rat skeleton. NASA TM-76342. Trans. from *Radiobiologiya*, 1979, 19(5):760-762.



- Prokhonchukov, A.A., & V.K. Leont'yev. Glycoprotein content of human bone tissue after space flights. *Space Biology and Aerospace Medicine*, 1980, 14(3):81-82.
- Prokhonchukov, A.A., V.K. Leont'yev, N.A. Zhizhina, R.A. Tigranyan, A.G. Kolesnik, & N.A. Komissarova. State of human bone tissue protein fraction after space flights. *Space Biology and Aerospace Medicine*, 1980, 14(2):20-26.
- Pukhova, Ya.I., I.A. Terskov, A.Ya. Anikina, A.V. Shashkin, & L.V. Kirenskiy. On the cellular autoimmune mechanism for eliminating erythrocytes normally and under extreme influences. NASA TM-75735. Trans. from *Patologicheskaya fiziologiya i eksperimental'naya terapiya*, 1979, 2:16-22.
- Radkevich, L.A., & G.S. Ayzikov. Surgical access to separate branches of the cat vestibular nerve. NASA TM-76478. Trans. from *Fiziol. Zh.*, 1977, 63(12):1748-1751.
- Rotenberg, V.S., L.M. Popova, V.I. Kobrin, & L.D. Varrik. Structure of night sleep in long-term akinesia and artificial pulmonary ventilation. NASA TM-76313. Trans. from *Zhurnal Nevropatologii i Psikhatrii imeni S.S. Korsakova*, 1980, 80(4):592-597.
- Rudnyy, N.M., O.G. Gizenko, A.V. Beregovkin, & T.N. Krupina. Program for the medical examination (consultation) of cosmonauts. NASA TM-76471. Trans. from *Report to the XI Joint Soviet-American Working Group on Space Biology and Medicine*, Moscow, October 1980, 1-24.
- Ryl'nikov, Yu.P. Effect of hypokinesia on changes in carbohydrate and lipid metabolism in the heart and liver. *Space Biology and Aerospace Medicine*, 1980, 14(2):90-96.
- Salanin, I.V. Use of physical culture to increase resistance of sailors to motion sickness. NASA TM-76355. Trans. from *Teoriya i Praktika Fizicheskoy Kultury*, 1979, (11):35-37.
- Samsonov, N.D. *Psychological problems of space flights*. Moscow: Nauka, 1979, 1-239.
- Samsonov, N.D., B.F. Lomov, & B.N. Petrov (Eds.). *Psychological problems of space flights*. NASA TM-75659. Trans. from *Psikhologicheskiye problemy kosmicheskikh poletov*. Moscow: Nauka Press, 1979.
- Sapuntsov, Le.Ye., S.I. Mitrofanova, & T.V. Savchenko. Use of elastography for the evaluation of rheologic properties of human soft tissues of the extremities in the norm and in peripheral lymph circulation disorders. NASA TM-76440. Trans. from *Byulleten' Eksperimental'noy Biologii i Meditsiny*, 1979, 88(12):740-741.

- Sarychev, V.A., V.V. Sazonov, A.A. Zlatorunskii, I.A. Samorukov, V.R. Freidel', S.F. Khlopina, A.D. Egorov, & V.I. Somov. Mass measurement under conditions of weightlessness. *Aerospace Medicine and Biology*, December 1980. NASA SP-7011(213). Trans. from *Kosmicheskie Issledovaniia*, 1980, 18:536-549.
- Savina, Ye.A., & Ye.I. Alekseyev. Functional state of the posterior lobe of the neurohypophysis of rats flown aboard the Kosmos-936 biosatellite (Results of morphological study). From JPRS, *USSR Report: Space*, 12 May 1980, 5:13-14. Trans. from *Arkhiv Anatomii, Gistologii i Embriologii*, 1980, 1:62-67 (abstract).
- Sedov, A.V., A.N. Mazin, & N.A. Surovtsev. Probability of altitude decompression disorders when breathing oxygen containing human waste gas. *Space Biology and Aerospace Medicine*, 1980, 14(1):49-53.
- Selivanova, A.T. Disturbances of situational reflexes in experimental neurosis elicited by a change in the spatial factor. NASA TM-73688. Trans. from *Zh. Vysshey Nervnoy Deyatelnosti*, 1979, 29(1):72-79.
- Semenov, L.P., & N.A. Rebyakova. Preservation of equilibrium in orthograde and inverted body positions. NASA TM-76112. Trans. from *Teoriya i Praktika Fizicheskoy Kultura*, 1979, 5: 29-30.
- Serafimov, K. Space research in Bulgaria. NASA TM-76293. Trans. from *Kosmicheskiye Issledovaniya v Bolgarii*, Sofia, 1979, 351-443, Chap. 5.
- Shaskov, V.S., & V.V. Sabayev. Problems and prospects of space pharmacology. From JPRS, *USSR Report: Space Biology and Aerospace Medicine*, 30 October 1980, 14(5):12-28.
- Shatalov, V., & M. Vasil'yev. Shatalov comments on women in cosmonautics. From JPRS, *USSR Report: Space*, 12 May 1980, 5:10-12. Trans. from *Sovetskaya Litva*, 19 March 1980, 4.
- Shaydorov, Yu.I., B.N. Shebalin, & G.I. Meleshko. Study of compatibility of certain higher plants and *Chlorella* as related to a bioregenerative human life support system. *Space Biology and Aerospace Medicine*, 1980, 14(2):116-122.
- Shepelev, Y.Y. Biological systems for human life support: Review of research in the USSR. NASA TM-76018. Trans. from paper delivered at the 10th Conference of the Joint Soviet-American Working Group on Space Biology and Medicine, Houston, Texas, October 1979, 1-24.
- Shipov, A.A., & V.G. Ovechkin. Semicircular canal function in rats after flight aboard the Cosmos-936 biosatellite. *Space Biology and Aerospace Medicine*, 1980, 14(2):38-44.

- Shul'zhenko, E.B., A.I. Grigor'ev, V.B. Noskov, B.R. Dorokhova, & E.A. Aleksandrova. Influence of longitudinal acceleration on fluid-electrolyte metabolism and renal function under conditions of immersion. *Aerospace Medicine and Biology*, July 1980. NASA SP-7011(208). Trans. from *Fiziologija Cheloveka*, 1980, 6:280-285 (abstract).
- Shulzhenko, E.B., R.A. Tigranian, V.E. Panfilov, & I.I. Bzhalava. Physiological reactions during acute adaptation to reduced gravity. *Aerospace Medicine and Biology*, December 1980. NASA SP-7011(213). In *Life sciences and space research: Proceedings of the open meeting of the working group on space biology*, Vol. 18. Oxford and Elmsford, NY: Pergamon Press, 1980 (abstract).
- Sidel'niko, I.A. Vestibular nystagmus under increased ponderability. NASA TM-76101. Trans. from *Izvestiya Akademii nauk SSSR, Seriya Biologicheskaya*, 1979, (4), 498-504.
- Sidorenko, P.G., & A.L. Mashinskii. The effect of space flight conditions on higher plant cells in vitro culture. *Aerospace Medicine and Biology*, November 1980. NASA SP-7011(212). Trans. from *Kosmicheskie Issledovaniia na Ukraine*, 1978, 12:39-42 (abstract).
- Simonov, P.B., & M.N. Rusalova. Electroencephalographic correlates of human emotional stress. From *Aviat. Space Environ. Med.*, 1980, 52(10):1109-1111.
- Slepchuk, N.A., & G.V. Rummyantsev. Role of a decrease in body heat content in the thermoregulatory reaction of the concha auriculae vessels. NASA TM-76370. Trans. from *Fiziol. Zh.*, 1978, 64(6):843-849.
- Smirnov, V.A. Development of microorganisms under conditions of space flight. NASA TM-76302. Trans. from *Visnik Akademii Nauk Ukrain's'koy RSR*, 1980, 44(5):97-99.
- Sokolovskaya, Z.K. *Advances of the Soviet Union in outer space research: Second space decade 1967-1977*. FTD-ID(RS)T-1378-79. Trans. of *Uspekhi Sovetskogo Soyuz v Issledovanii Kosmicheskogo Prostrantva, Vtoroye Kosmicheskoye Desyatiliye 1967-1977*, Moscow Publishing House "Nauka," 1978.
- Soldatov, A.D., & V.I. Finogeyev. Restoration of physical performance capacity of athletes after prolonged restriction of their motor activity. NASA TM-76305. Trans. from *Teoriya i Praktika Fizicheskoy Kultury*, 1979, 5:19-22.
- Soldatov, I. Meniere's disease: A surgeon's tactics. NASA TM-76398. Trans. from *Meditsinskaya Gazeta*, June 20, 1979a, 3.
- Soldatov, I.V. Review of book "Ultrasound in Otorhinolaryngology." NASA TM-76349. Trans. from *Zhurnal Ushnykh, Nosovykh i Gorlovykh Bolezney*, 1979b, (3):86-87.

- Solodkov, A.S., & V.S. Lobzin. Nervous tension and stress in relation to performance of duties by seamen. From JPRS, *USSR Report: Life Sciences—Biomedical and Behavioral Sciences*, 7 August 1980, (3). Trans. from *Voyenno-Meditsinskiy Zhurnal*, 1980, (1):51-54 (abstract).
- Solomin, G.I. System of hygienic inspection of nonmetal materials used in spacecraft equipment. *Space Biology and Aerospace Medicine*, 1980, 14(2):110-115.
- Sopikov, N.F., & A.I. Gorshunova. Isolation and gas chromatographic demonstration of volatile organic substances in thin-layer biological samples. *Space Biology and Aerospace Medicine*, 1980, 14(3):77-79.
- Soviet Health Ministry. Preliminary results of scientific research on biosatellite Cosmos 1129. NASA TM-76287. Moscow, Ministry of Health USSR and the Inst. of Medical and Biol. Problems and the "Intercosmos" Council of the Acad. of Sciences USSR, 1980, 1-37.
- Stepanov, V.N., E.N. Stepanov, & G.S. Shonin. On the question of technical maintenance on board a piloted spacecraft. NASA TM-76441. Trans. of "*K voprosy tekhnicheskogo obsluzhivaniya na bortu pilotiuremogo kosmicheskogo letatel'nogo apparata.*"
- Stepanova, S.I. Biorhythmological status as one of the criteria for cosmonaut status. From JPRS, *USSR Report: Space Biology and Aerospace Medicine*, 30 October 1980, 14(5):29-34.
- Stroganova, Ye.A., Yu.F. Udalov, V.I. But, V.Ye. Potkin, & I.V. Rogacheva. Effect of exercise, vitamin and mineral supplements on reproductive function of albino rats during prolonged hypokinesia. From JPRS, *USSR Report: Space Biology and Aerospace Medicine*, 30 October 1980, 14(5):94-98.
- Stupakov, G.P., A.I. Volozhin, V.A. Korzkhen'yants, V.S. Yagodovskiy, A.N. Pokyakov, V.V. Korolev, & V.A. Elivanov. Effect of factors of prolonged space flight on conditions of tortoise skeleton. NASA TM-76352. Trans. from *Patologicheskaya Fiziologiya i Eksperimental'naya Terapiya*, 1979, (6):9-14.
- Tanchev, K.S. Main principles and techniques of electronystagmography. NASA TM-76366. Trans. from *Zh. Ushnykh, Nosovykh i Gorlovykh Bolezney*, 1980, 3:82-86.
- Tashpulatov, R.Yu., T.A. Danilova, A.T. Lesnyak, V.I. Legen'kov, V.S. Znamenskiy, & Ye.Yu. Dedyuyeva. Antibodies to myofibril antigens in astronauts after spaceflight. NASA TM-76300. Trans. from *Zh. Mikrobiologii, Epidemiologii i Immunobiologii*, 1979, 12:36-39.
- TASS. No pathological changes reported in animals during biosat mission. From JPRS, *USSR Report: Space*, 20 December 1979, No. 1, 21. Trans. from TASS, 23 November 1979a.
- TASS. Soyuz-T modifications. From JPRS, *USSR Report: Space*, 11 February 1980, No. 2, 4. Trans. from TASS, 19 December 1979b (abstract).

- TASS. Cosmonaut training facilities pictured. From JPRS, *USSR Report: Space* (FOUO 7/80), 24 July 1980. Trans. from *Air and Cosmos* (French), 12 April 1980, (808):41.
- Tigranyan, R.A. Unification of some biochemical methods of research in the pre- and postflight periods. NASA TM-76466. Trans. from *Report to the XI Joint Soviet-American Working Group on Space Biology and Medicine*, Moscow, October 1980, 1-7.
- Tigranyan, R.A., & Ye.G. Vetrova. Activity of certain enzymes in subcellular fractions of rat liver after flight on the Cosmos 1129 biosatellite. NASA TM-76472. Trans. from *Report to the XI Joint Soviet-American Working Group on Space Biology and Medicine*, Moscow, October 1980, 1-20.
- Tishler, V.A., V.I. Safonov, & Z.A. Krivitsina. Evaluation of efficacy of the set of preventive measures referable to the human neuromuscular system under hypokinetic conditions. *Space Biology and Aerospace Medicine*, 1980, 14(3):54-57.
- Totseva, A.M., N.I. Ryzhov, V.N. Gerasimenko, & Ye. Demendzhiyev. Effects of 25 and 50 MeV protons on human peripheral blood lymphocyte chromosomes in vitro. *Space Biology and Aerospace Medicine*, 1980, 14(1):80-87.
- Troshin, A.S., N.F. Gamaleya, S.V. Konev, N.F. Krawzova, K.Ye. Kruglyakova, V.L. Levin, & K.A. Samoylova. Photobiology of the animal cell. From JPRS, *USSR Report: Life Sciences—Biomedical and Behavioral Sciences* (FOUO 2/80), 11 July 1980. Trans. from *Fotobiologiya Zhivotnoy Kletki*. Moscow: Izdatel'stvo Nauka, 1979, 2, 3-4, 265-268.
- Tsemakhov, S.G. Vestibular recruitment. NASA TM-76088. Trans. from *Vestnik Otorinolaringologii*, 1979, 4:75-83.
- Turbasov, V.D. Effect of prolonged antiorthostatic position on cardiac bioelectrical activity according to EKG tracings from corrected orthogonal leads. From JPRS, *USSR Report: Space Biology and Aerospace Medicine*, 30 October 1980, 14(5):81-87.
- Turchaninova, V.F., & M.V. Domracheva. Results of studies of pulsed blood flow and regional vascular tonus during flight in the first and second expeditions aboard the Salyut-6-Soyuz orbital complex. *Space Biology and Aerospace Medicine*, 1980, 14(3):11-14.
- Urmancheyeva, T.G., & A.A. Dzhokua. Method for producing clinostatic hypokinesia in monkeys. From JPRS, *USSR Report: Space Biology and Aerospace Medicine*, 30 October 1980, 14(5):126-130.
- Ushakov, A.S. Nutrition during long flight. NASA TM-76436. Trans. from *Zdorov'ye*, 1980, 4 (304):4-5.

- Vasilevskii, N.N. Ecological physiology of the brain. *Aerospace Medicine and Biology*, May 1980. NASA SP-7011(206). Trans. from *Ekologicheskaiia Fiziologiia Mozga*. Moscow: Izdatel'stvo Meditsina, 1979 (abstract).
- Vasil'yev, G. In order to fly infinitely long. From JPRS, *USSR Report: Space*, 11 February 1980, No. 2, 12-14. Trans. from *Aviatsiya i Kosmonavtika*, 1979, No. 10, 38-39 (abstract).
- Vasil'yev, P.V., G.D. Glod, S.I. Sytnik, N.N. Uglova, & Y.P. Mel'nikova. Distinctions in development of pyrogenal fever in animals following prolonged hypokinesia. *Space Biology and Aerospace Medicine*, 1980, 14(1):67-72.
- Vasil'yeva, V.P. Diagnosis of latent forms of labyrinthine affectations. NASA TM-76338. Trans. from *Vestnik Otorinolaringologii*, 1980, 3:22-27.
- Vasil'yeva, V.V., Ye.N. Korableva, & V.V. Trunin. Physical exercises on a bicycle-ergometer and running track to prevent hypodynamia in workers of intellectual labor. NASA TM-76306. Trans. from *Teoriya i Praktika Fizicheskoy Kultury*, 1979, (10):34-36.
- Vavilov, P. Possibilities of forecasting hypercholerinemia in pilots. NASA TM-76087. Trans. from *Kazanskiy Meditsinskiy Zhurnal*, 1979, 60(3):18-20.
- Verigo, V.V. Simulation of physiological systems in order to evaluate and predict the human condition in a space flight. NASA TM-76016. Trans. from paper delivered at the 10th Conference of the Joint Soviet-American Working Group on Space Biology and Medicine, Houston, Texas, October 1979.
- Verigo, V.V. Use of mathematical models for predicting man's condition during space flights. *Space Biology and Aerospace Medicine*, 1980, 14(1):9-14.
- Verigo, V.V., & Yu.G. Korotenskov. Data banks for research in the field of space biology and medicine. *Space Biology and Aerospace Medicine*, 1980, 14(2):146-148.
- Vil'-Vil'yams, I.F., & Ye.V. Shul'zhenko. Functional condition of the cardiovascular system after 3 day immersion and prophylactic rotation on a short radius centrifuge. NASA TM-76299. Trans. from *Fiziol. Cheloveka*, 1980a, 6(2):323-327.
- Vil'-Vil'yams, I.F., & Ye.B. Shul'zhenko. Cardiovascular reaction to periodic head-pelvis accelerations on a short-arm centrifuge. *Space Medicine and Biology*, 1980b, 14(1):36-42.
- Vil'-Vil'yams, I.F., & Ye.B. Shul'zhenko. Functional state of the cardiovascular system under the combined effect of 28-day immersion, rotation on a short-arm centrifuge and exercise on a bicycle ergometer. *Space Biology and Aerospace Medicine*, 1980c, 14(2):63-68.

- Vnukova, Z.Ye. Study of radioprotective effect of high-intensity magnetic fields on mammalian cell cultures. *Space Biology and Aerospace Medicine*, 1980, 14(1):130-133.
- Yablochkin, V.D., G.D. Solomin, V.A. Shchirskaya, N.A. Glazkova, Ye.A. Demchenko, N.Ye. Ostasheva, & E.I. Chukhno. Rapid laboratory method for testing outgassing of thermo-stable plastics and rubber. *Space Biology and Aerospace Medicine*, 1980, 14(1):73-79.
- Yakimenko, M.A., Ye.Ya. Tkachenko, V.E. Divert, & O.A. Fil'ko. Some indices of a system of thermal regulation during adaptation to cold under polar conditions. From JPRS, *USSR Report: Biomedical and Behavioral Sciences*, 28 March 1980, No. 1, 21. Trans. from *Fiziologiya Cheloveka*, 1979, 5(5):931-933 (abstract).
- Yarotskiy, A.I. Effect of cervicolabyrinthine impulsion on the spinal reflex apparatus. NASA TM-76375. Trans. from *Fiziol. Zh.*, 1979, 75(12):1838-1840.
- Yarullin, Kh.Kh., T.V. Benevolenskaya, V.I. Lobachik, T.D. Vasil'yeva, V.A. Gornago, V.V. Degtyarenko, & N.F. Tarasov. Studies of central and regional hemodynamics by isotope and impedance methods during LBNP. From JPRS, *USSR Report: Space Biology and Aerospace Medicine*, 30 October 1980, 14(5):99-104.
- Yarullin, Kh.Kh., V.A. Gornago, T.D. Vasil'yeva, & M.Ye. Gugushvili. Studies of prognostic significance of antiorthostatic position. *Space Biology and Aerospace Medicine*, 1980, 14(3): 48-54.
- Yefremenko, M. Prophylaxis and treatment of seasickness. NASA TM-76083. Trans. from *Morskoy Sbornik*, 1979, (6):40-42.
- Yegorov, A.D. Results of medical research during the 175-day flight of the third prime crew on the Salyut-6-Soyuz orbital complex. Translated into English from *Resultaty meditsinskikh issledovaniy vo vremya 175 sutochnogo poleta tretyego osnovnog ekipazha na orbitalnam komplekse Salyut-6-Soyuz*, Academy of Sciences USSR, Ministry of Health, Moscow, 1980. NASA TM-76450, January 1981.
- Yurov, S.S. Fifth working group conference (space biology) at the XXI plenary session of COSPAR, 28 May-10 June 1978 at Innsbruck. NASA TM-76107. Trans. from *Radiobiologiya*, 1979, 19(5):796.
- Zaitsev, Y. New stage in the development of USSR space research. *Aviation, Space, and Environmental Medicine*, October 1980, 1163-1165.

Zhdanova, N.N., A.N. Liulichev, A.I. Vasilevskaia, & A.L. Antonenko. The survival rate of various species of dark-colored mushrooms under the influence of artificial solar radiation. *Aerospace Medicine and Biology*, November 1980. NASA SP-7011(212). Trans. from *Kosmicheskie Issledovaniia na Ukraine*, 1978, 12:20-24.

Zhuravlev, V.A., Z.M. Karelina, Ye.I. Nikitin, & V.P. Savina. Reaction of human blood to chronic exposure to low doses of carbon monoxide in a confined environment. *Space Biology and Aerospace Medicine*, 1980, 14(1):43-48.