

HIGH SPEED TECHNIQUES FOR
SYNTHETIC APERTURE RADAR IMAGE FORMATION*

Demetri Psaltis
California Institute of Technology
Pasadena, CA 91125

Armand R. Tanguay, Jr.
University of Southern California
Los Angeles, CA 90007

and

Thomas J. Bicknell
Jet Propulsion Laboratory
California Institute of Technology
Pasadena, CA 91109

A synthetic aperture radar system produces data requiring rather complex processing to form the image of the terrain being mapped. The process is essentially a two-dimensional convolution which is usually separated into two one-dimensional convolutions with spatial variance of the reference function in one dimension. The reference functions may be quite large (1000 elements or more) requiring high computation rates for digital systems. Optical systems have a significant advantage due to the parallelism of one- or two-dimensional processing. The linear FM variation of the reference function in both dimensions makes the optical system rather simple. Since the point target phase histories are self-focusing, like Fresnel zone plates, only bandpass filtering is required for moderate resolution systems. The spatial variance of the reference function or phase history in the along-track dimension is linear and can be compensated for by tilting either the input and

* Because this paper was not available at the time of publication, only the abstract is included.

output image planes or a cylindrical lens. An additional complication of higher resolution systems is the requirement to compensate for range migration. This correction is usually performed by lenses used as a phase filter in the transform plane. A conventional radar correlator is shown in figure 1. The range telescope images both the range and the azimuth focal planes. The azimuth telescope affects only the azimuth or along-track dimension, bringing it into coincident focus with range.

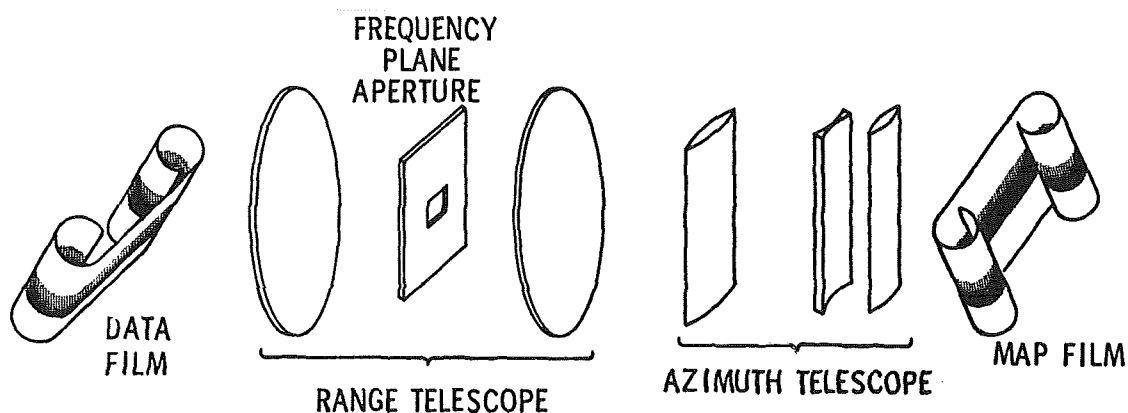

Figure 1.- Film input coherent synthetic aperture radar processor.

The desire to achieve real time throughput, higher reliability, and greater accuracy has led to the development of high speed digital systems for SAR data processing. However, such systems are quite large, costly, and power consumptive, even using recent and expected future developments in digital technology. Many radar applications, such as quick-look or search modes, require or would be better served by onboard processing. These systems require small, lightweight processors, especially for use in conjunction with spacecraft-borne radars. A good example is the upcoming VOIR mission where onboard processing would allow transmission of 10 times as much data as the currently planned ground processing scheme allows.

One possible approach to high speed synthetic aperture radar signal reconstruction involves the utilization of two-dimensional real time spatial light modulators as recyclable replacements for photographic film in the input transducer plane of a modified SAR-coherent optical processor, as shown in figure 2. Leading candidate spatial light modulators include modified Pockels readout optical modulators (PROM), CCD-addressed liquid crystal light valves, and CCD-addressed membrane light modulators. The fundamental physical limitations affecting SAR-processor performance characteristics of such real time devices are under investigation. Current research on the PROM is focused on the effects of device operational mode, device constitutive parameters, electro-optic crystal orientation, writing wavelength, frame rate/data overwrite/presuming, erasure completeness, and image retention on the overall quality of SAR image formation. Both modulated laser scanning and intensified CRT temporal-to-spatial input approaches are being examined.

A spatial light modulator (SLM) that is commonly used in one-dimensional optical processors is the acousto-optic delay line. We are investigating the possibility of using acousto-optic devices (AOD's) as the input SLM in an optical SAR processor. AOD's cannot be used in a conventional SAR processor, however, since they can only introduce one-dimensional spatial modulation in the optical system. In the architecture we are investigating, the two-dimensional processing is accomplished utilizing one spatial dimension and one time dimension. Hence, a one-dimensional spatial modulator can be used. A schematic diagram of the processor is shown in figure 3. The backscattered signal for each transmitted pulse is applied to the AOD. The system is illuminated with a pulse light source in order to "freeze" the traveling acoustic wave in the AOD. The range compression operation is accomplished by

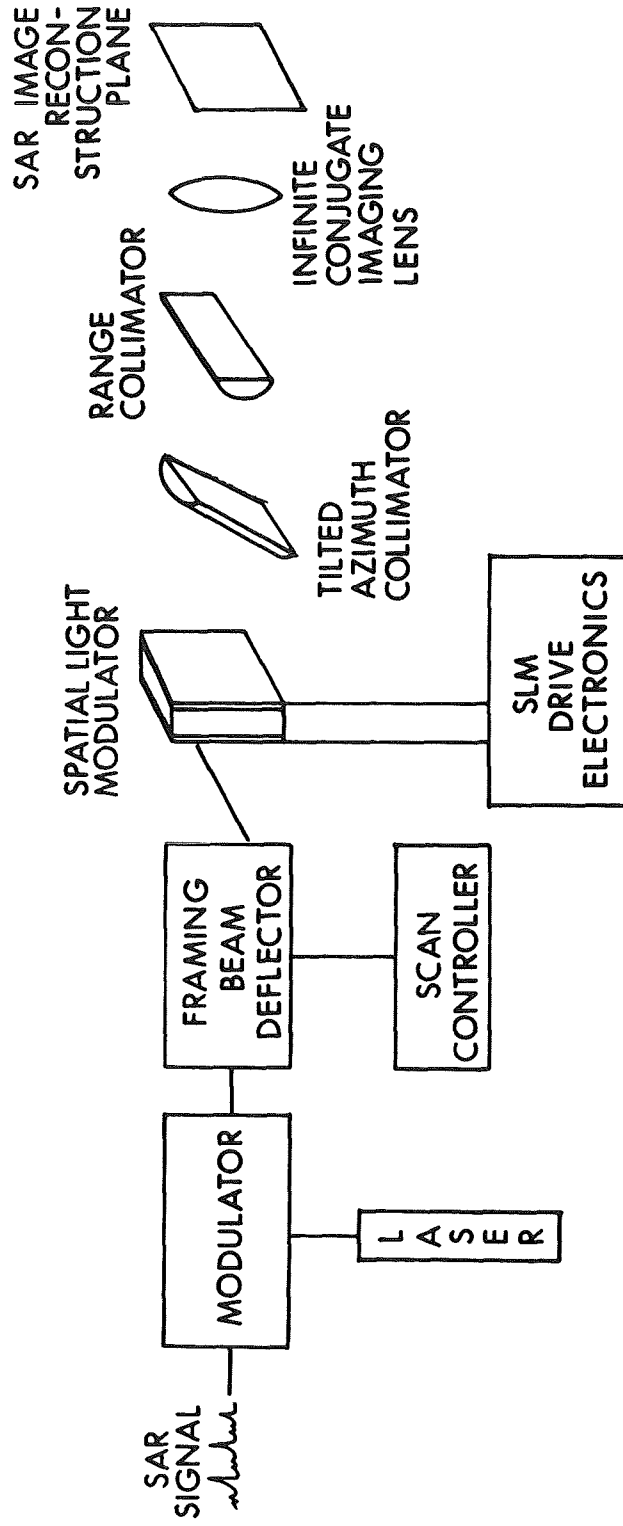

Figure 2.- Real time coherent synthetic aperture radar processor utilizing a two-dimensional spatial light modulator.

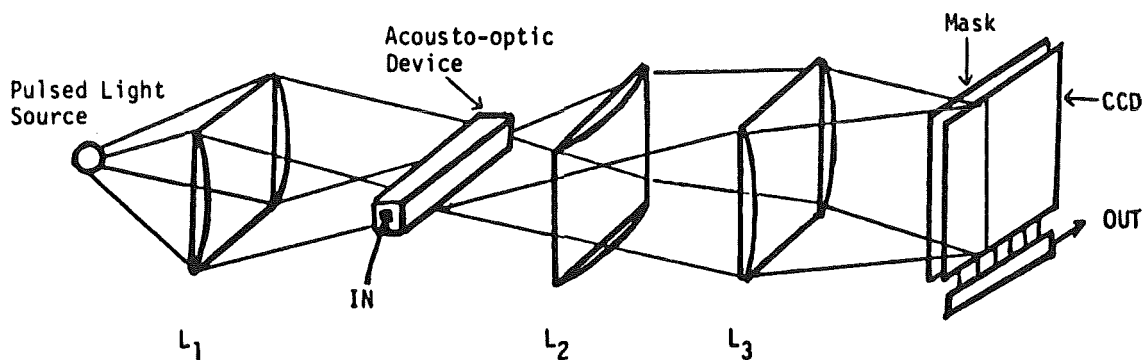

Figure 3.- Real time coherent synthetic aperture radar processor utilizing a one-dimensional acousto-optic modulator and a CCD-array detector.

the focusing action of lens L_2 . The photogenerated charge pattern stored in the CCD is shifted vertically by one pixel after each radar pulse. The signal that reaches the output stage of the CCD at each horizontal (range) location is the correlation of the range compressed signal and the transmittance of the mask placed immediately in front of the CCD detector. Azimuth compression is performed by making the transmittance of the mask a linear FM function in the vertical direction.

Utilization of a two-dimensional spatial light modulator in a real time SAR processor allows for simplicity in image formation, and is, in addition, inherently flexible for handling different radar signal types. A disadvantage in this approach is the relatively recent development status of candidate spatial light modulators. The state-of-the-art of acousto-optic devices is, on the other hand, further advanced and represents a relatively mature technology. The limitations in the AOD/CCD approach are expected to be the dynamic range and number of elements of the CCD detector array. It is hoped that such optical signals in an integrated, compact, and rugged format. Many integrated

real time SAR processors will initiate new mission applications not presently envisioned due to current digital processor limitations.