

NASA CR-166,153

NASA CONTRACTOR REPORT 166153



NASA-CR-166153

1982 000 8169

Predesign Study for a Modern 4-Bladed Rotor
for the NASA Rotor Systems Research Aircraft

H. E. Bishop
J. E. Burkam
R. C. Heminway
C. N. Keys
K. E. Smith
J. H. Smith
J. A. Staley

LIBRARY COPY

1982

LANGLEY RESEARCH CENTER
LIBRARY NASA
HAMPTON, VIRGINIA

CONTRACT NAS2-10689
January 1981



NASA CONTRACTOR REPORT 166153

Predesign Study for a Modern 4-Bladed Rotor
for the NASA Rotor Systems Research Aircraft

H. E. Bishop
J. E. Burkam
R. C. Heminway
C. N. Keys
K. E. Smith
J. H. Smith
J. A. Staley
Boeing Vertol Company
A Division of the Boeing Company
Philadelphia, Pennsylvania

Prepared for
Ames Research Center
under Contract NAS2-10689

NASA

National Aeronautics and
Space Administration

Ames Research Center
Moffett Field California 94035

N82-16042[#]

Abstract

The information presented in this report is the result of engineering studies performed by the Boeing Vertol Company for the National Aeronautics and Space Administration, Ames Research Center under Contract No. NAS 2-10689, Task I -Selection of Rotor System; Task II - Detailed Study; and Task III - Development Plan.

This report includes the trade-off study results and the rationale for the final selection of an existing modern four-bladed rotor system that can be adapted for installation on the Rotor Systems Research Aircraft (RSRA) and the results of the detailed integration studies, parameter change studies, and instrumentation studies; and, the recommended plan for the development and qualification of the rotor system and its parameter variants, its integration on the RSRA, and support of ground and flight test programs.

The rotor system selected is a modern existing rotor system with performance, flying qualities and dynamic characteristics consistent with current rotor technology. The flight envelope of the rotor, installed on the RSRA, is sufficient to conduct evaluation of rotor design lift coefficient vs. gross weight and advance ratio envelopes within engine, transmission, and control limits of the RSRA. In addition, the rotor system is adaptable to systematically vary key rotor parameters for comparative flight testing. The detailed study further evaluates the feasibility of installing the selected rotor system on the RSRA, parameter change capability, and examines the benefits of flight research with the rotor and its parameter variants. The development plan includes a Work Breakdown Structure (WBS), a draft statement of work, data requirements, a program schedule, and a planning price summary.

Table of Contents

	<u>Page</u>
Abstract	i
List of Tables	vi
List of Figures	vi
1.0 Introduction	1
2.0 Summary	4
3.0 Trade-Off Analysis and Rotor System Selection	11
3.1 Technical Merit	11
3.1.1 Technical Level	11
3.1.1.1 Performance	11
3.1.1.1.1 Figure of Merit	11
3.1.1.1.2 Rotor Lift to Effective Drag Ratio	13
3.1.1.2 Vibration/Loads	15
3.1.1.3 Flying Qualities	15
3.1.1.3.1 Flying Quality Boundaries	15
3.1.1.3.1.1 Control Power vs. Roll/Pitch	15
Rate Damping	
3.1.1.3.1.2 Control Sensitivity vs.	16
Forward Speed	
3.1.1.3.2 Control Coupling	17
3.1.1.3.2.1 High G Pullout	17
3.1.1.3.2.2 Pitch/Roll Acceleration	17
3.1.1.3.2.3 Pitch/Roll Velocity	18
3.1.1.3.2.4 Step, Pulse, or Sinusoidal	18
Cyclic Stick Input vs. Forward	
Speed	
3.1.1.3.2.5 Collective Step Input	18
3.1.1.3.2.6 Stick Migration vs. Forward	19
Speed	
3.1.1.3.3 Longitudinal/Lateral Stability (Static and	19
Dynamic)	
3.1.1.3.4 Ground Handling Qualities	20
3.1.1.3.5 Freedom from Coupling Between	20
Lateral/Longitudinal Transient Motions	

	<u>Page</u>
3.1.2 Flight Envelope on RSRA	21
3.1.2.1 Performance Limits	21
3.1.2.1.1 Level Flight	21
3.1.2.1.2 Maneuverability	25
3.1.2.2 Load Limits	26
3.1.2.3 Flying Quality Limits	27
3.1.2.3.1 C.G. Envelope vs. Control Margin	27
3.1.2.3.2 Gust Alleviation Capability	27
3.1.3 Rotor System Adaptability to Parameter Variations	28
3.1.3.1 Aerodynamic Parameters (Airfoils, Planform, Tip Shape and Twist)	28
3.1.3.2 Blade Natural Frequency	30
3.1.3.3 Effective Flap Hinge Location	31
3.1.3.4 Lock Number	31
3.1.3.5 Blade Sweep	31
3.1.3.6 Precone	32
3.1.3.7 Control System Stiffness	32
3.1.3.8 Lag Damping	32
3.1.3.9 Controls Authority	33
3.1.3.10 Coupling (Delta Three)	33
3.2 Cost and Schedule	33
4.0 347/D Rotor System - RSRA Integration	34
4.1 Basic 347 Rotary Wing Head (Modified)	34
4.2 CH-47D Rotor Blade Description	39
4.3 347/D Rotor System Installation/RSRA Modifications	39
4.4 Control System Modifications	40
4.5 Transmission Modification	44
4.6 Blade Severance System Modifications	45
4.7 Aerodynamic Analysis	45
4.7.1 Hover OGE Performance	45
4.7.2 Forward Flight Performance	48
4.8 Structural and Weight Analysis	52
4.9 Dynamics Analysis	52
4.9.1 Introduction	52
4.9.2 Analysis Methodology	54
4.9.2.1 Blade Natural Frequency Analysis	54

	<u>Page</u>
4.9.2.2 Blade, Hub and Control Loads	54
4.9.2.3 Blade Flutter and Divergence	55
4.9.3 Baseline Rotor Loads	55
4.9.3.1 Hub Vibratory Loads	56
4.9.3.2 Blade Alternating Loads	56
4.9.3.3 Control System Loads	65
4.9.4 Stability and Divergence	65
4.9.5 Blade Natural Frequencies	65
4.9.5.1 Effect of Tuning Weights on Blade Frequency	65
4.9.5.2 Effect of 3rd Flap Frequency on Rotor Loads	69
4.10 Stability and Control Analysis	69
4.11 Technical Risks	81
5.0 Parameter Variations	83
5.1 Aerodynamic Parameter Variations	83
5.1.1 Basic Aerodynamic Parameter Variations	83
5.1.2 Expanded Aerodynamic Parameter Variations	99
5.1.3 Tip Shape Variations	104
5.1.4 Rationale for Aerodynamic Parameter Variation Approach	111
5.2 Rotor Dynamic and Flying Quality Parameter Variations	116
5.2.1 Blade Natural Frequency Variations	116
5.2.2 Effective Flap Hinge Location Variation	120
5.2.3 Control Phase Variations	120
5.2.4 Control System Stiffness Variations	120
5.2.5 Lag Damper Variations	122
5.2.6 Flap-Pitch Coupling Variation	122
5.2.7 Mast Height Variation	126
5.2.8 Lock Number Variations	126
5.2.9 Blade Sweep Variations	126
5.2.10 Precone Variations	126
5.2.11 Controls Authority Variations	127
6.0 Instrumentation	127
7.0 Cost Estimates	129

	<u>Page</u>
8.0 Technology Payoff	131
8.1 Flight Envelope	131
8.2 Model Scale Wind Tunnel Tests	137
8.3 Stability and Control Payoffs	140
9.0 Program Development Plan	143
9.1 Preliminary Work Breakdown Structure	143
9.2 Draft Statement of Work	144
9.3 Data Requirements	153
9.4 Planning Price Summary	156
9.5 Program Schedule	156

References

- Appendix A - CH-47 Fiberglass Rotor Blade Design and Fabrication**
- Appendix B - CH-47 Fiberglass Blade Structural and Dynamic Properties**
- Appendix C - Teledyne McCormick Selph Technical and Cost Proposal for 347/D-RSRA Blade Severance System**
- Appendix D - Manhour Estimates for 347/D - RSRA Rotor System Development and Implementation and Parameter Variation Test Program**

LIST OF TABLES

<u>No.</u>	<u>Title</u>	<u>Page</u>
2.0-1	Summary of Trade-Off Scores - RSRA 4-Bladed Rotor System Selection	6
2.0-2	Technical Approach to Aerodynamic Parameter Variations	8
2.0-3	Desired Blade Frequency Variations	10
3.1.3-1	Aerodynamic Parameters	29
4.10-1	RSRA Stability and Control Parameters	80
5.2.1-1	RSRA-347/C Rotor System - Blade Frequency Test Variations Desired	117
6.0-1	Instrumentation	128
8.2-1	Boeing-Vertol Model Rotor Wind Tunnel Tests	138

LIST OF FIGURES

<u>No.</u>	<u>Title</u>	<u>Page</u>
1.0-1	Modern Four-Bladed RSRA Rotor - Trade Study Criteria	2
2.0-1	(SK28732) - RSRA-347/D Rotor System - Installation & Kinematics Layout	7
3.1.1.1-1	Figure of Merit for Candidate Rotors	12
3.1.1.1-2	Lift to Drag Ratio for Candidate Rotors	14
3.1.2.1-1	RSRA Flight Envelope - (4) CH-47D Blades	22

<u>No.</u>	<u>Title</u>	<u>Page</u>
3.1.2.1-2	RSRA Flight Envelope 347 Rotor (4 CH-47C Blades)	23
3.1.2.1-3	RSRA Flight Envelope With YUH-61A Rotor	24
4.1-1	Basic 347 Rotor	35
4.1-2	347 Rotor (Modified)(2 Sheets)	36
4.1-3	Effect of $\Delta 3$ on Forward Speed Flapping	38
4.4-1	RSRA Helicopter Trim (Ref. 11-Figure 50)	42
4.4-2	RSRA Helicopter Trim Longitudinal Trim Conditions	43
4.5-1	RSRA Main Transmission	46
4.7.1-1	RSRA Hover OGE Power Required	47
4.7.1-2	RSRA Hover Ceiling OGE	49
4.7.2-1	RSRA Level Flight Power Required	50
4.7.2-2	RSRA Single Engine Service Ceiling	51
4.8-1	CH-47D Forward Rotor Pitch Link Loads	53
4.9.3-1	4/Rev Vertical Hub Load vs Forward Speed	57
4.9.3-2	4/Rev Hub Side Force vs Forward Speed	58
4.9.3-3	4/Rev Hub Normal Force vs Forward Speed	59
4.9.3-4	4/Rev Hub Pitching Moment vs Forward Speed	60
4.9.3-5	4/Rev Hub Rolling Moment vs Forward Speed	61
4.9.3-6	Alternating Flap Bending Moment vs N.D Blade Radius at Various Speeds	62
4.9.3-7	Alternating Chord Bending Moment vs N.D. Blade Radius at Various Speeds	63
4.9.3-8	Alternating Torsion Bending Moment vs N.D. Blade Radius at Various Speeds	64
4.9.3-9	Steady and Vibratory Pitch Link Load vs Forward Speed	66
4.9.5-1	Blade Natural Frequency Spectrum, CH-47D Composite Rotor Blade	67
4.9.5-2	Effect of Added Weight on Blade Third Flap Model Frequency	68
4.9.5-3	4/Rev Hub Vertical Force vs Third Flap Frequency	70

<u>No.</u>	<u>Title</u>	<u>Page</u>
4.9.5-4	4/Rev Hub Side Force vs Third Flap Frequency	71
4.9.5-5	4/Rev Hub Normal Force vs Third Flap Frequency	72
4.9.5-6	4/Rev Hub Pitching Moment vs Third Flap Frequency	73
4.9.5-7	4/Rev Hub Rolling Moment vs Third Flap Frequency	74
4.9.5-8	Alternating and Steady Pitch Link Load vs Third Flap Frequency	75
4.9.5-9	Alternating Flap Bending Moment vs N.D. Blade Radius at Third Flap Frequency =4.75 Ω , 4.86 Ω , 4.99 Ω , 5.16 Ω , 5.33 Ω and 5.65 Ω	76
4.10-1	RSRA Helicopter Trim	78
5.1.1-1	347/A Rotor System Figure of Merit	85
5.1.1-2	Effect of Camber on Total Aircraft L/D	86
5.1.1-3	Effect of Camber on Figure of Merit	87
5.1.1-4	Effect of Twist on Performance	89
5.1.1-5	Basic Airfoils	91
5.1.1-6	Effect of Airfoil Section on Performance	92
5.1.1-7	Effect of Airfoil Section on Stall Boundaries	93
5.1.1-8	Typical Performance Improvements With Basic Aerodynamic Parameter Variations	95
5.1.1-9	Data for BV 23010-1.58 Airfoil	96
5.1.1-10	Data for VR-7 Airfoil	97
5.1.1-11	Data for VR-8 Airfoil	98
5.1.2-1	Expanded Parameter Variation Blade Section	100
5.1.2-2	Composite Rotor Blade Twist and Untwist Fixture	102
5.1.2-3	Composite Blade-Outboard Test Fixture Assembly (ST 51740)	103
5.1.3-1	Tip/Blade Attachment - RSRA Tip Shape Variation Test Program	105
5.1.3-2	Blade Tip Shape Variations	106

<u>No.</u>	<u>Title</u>	<u>Page</u>
5.1.3-3	Data for Airfoil; BV 13006-0.7	107
5.1.3-4	Effect of Tip Taper on Figure of Merit	110
5.1.3-5	Effect of Tip Taper and Sweep on Forward Flight Power Required	112
5.1.3-6	UH-61A Elliptical Tip Whirl Tower Test Results	113
5.1.3-7	Model Rotor Test Illustrates Elliptical Tip Forward Flight Performance ($.0072 C_T$)	114
5.2.1-1	H-21 Rotor Blade With Internal Tuning Weight Installation	118
5.2.1-2	CH-47C Rotor Blade With External Graphite Stiffening	119
5.2.2-1	Flap Hinge Variation Concept	121
5.2.4-1	Reduced Stiffness Pitch Links (BO-105/BMR)	123
5.2.4-2	Static Stiffness Determination for Standard and Soft Pitch Links (BO-105/BMR)	124
5.2.6-1	Model 347 Pitch Housing With $30^\circ \Delta 3$	125
8.1-1	RSRA Flight Envelope - 347/C Rotor System	132
8.1-2	RSRA Flight Envelope - 347/D Rotor System	133
8.1-3	347/D Rotor System Figure of Merit	135
8.1-4	Effect of Rotor Speed Reduction on 347/D Maximum Test HOGE C_T	136
8.2-1	Correlation of Model Scale Data and Full Scale Estimates	139
8.2-2	Stall Flutter Boundary Effect of Scale	141
8.2-3	Impact on Reynolds Number Variation on Static and Dynamic Stall Characteristics	142
9.4-1	Planning Price Summary	157
9.5-1	Master Schedule for RSRA - 347/D Rotor System Integration and Parameter Variation Test Program	158

1.0 Introduction

The NASA RSRA is presently equipped with a Sikorsky S-61 rotor, a five-bladed rotor that represents twenty-five year old technology. This rotor system will soon enter a flight research program to develop a data base for correlation with analytical predictive computer codes. Replacement of the rotor with a four-bladed state-of-the-art type, to allow utilization of more current technology, is desirable. This pre-design effort will define a modern four-bladed rotor for eventual acquisition and flight research on the RSRA that will:

- (1) quantify the capabilities of a state-of-the-art rotor system,
- (2) quantify the contributions of individual key rotor system parameters to these capabilities, and
- (3) develop the necessary data base for correlation with analytical predictive computer codes.

Brief tradeoff studies were conducted to evaluate candidate rotor systems which satisfy the requirement for an existing modern four-bladed rotor for integration and evaluation on the NASA Rotor Systems Research Aircraft (RSRA). The Boeing Vertol rotor systems evaluated were as follows:

- a. YUH-61A, UTTAS hingeless rotor system
- b. Model 347 articulated rotor system which incorporates the CH-47C rotor blade (347/C rotor system)
- c. Model 347 articulated rotor with CH-47D advanced composite blades (347/D rotor system)

Figure 1.0-1 delineates the rotor system selection criteria (evaluation parameters and weighting factors established for each). The "Best Rotor System" was selected by evaluating each candidate with respect to each parameter, scoring each with a rating factor from 0 to 1 (1 being the best possible) multiplying by the weighting factor and adding up all the scores.

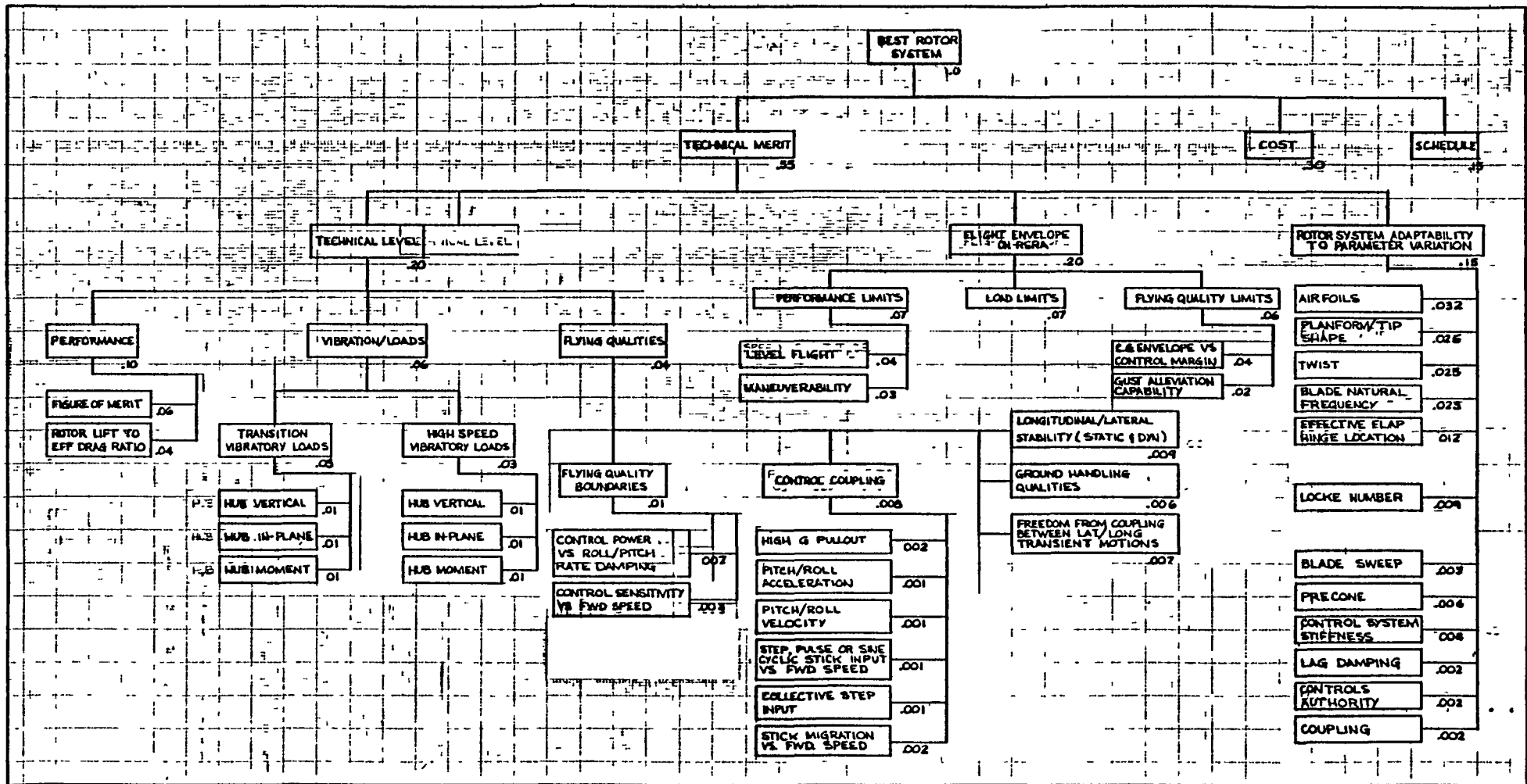

FIGURE 1.0-1 MODERN FOUR-BLADED RSRA ROTOR
TRADE STUDY CRITERIA

The selected rotor system must be a modern existing system with performance, flying qualities and dynamic characteristics consistent with current rotor technology. The flight envelope of the rotor, installed on the RSRA, must be sufficient to conduct evaluation of rotor design lift coefficient vs. gross weight and advance ratio envelopes within engine, transmission, and control limits of the RSRA. In addition, the rotor system must be adaptable to systematically vary key rotor parameters for comparative flight testing.

Cost and schedule preliminary estimates were made considering the following:

- a. Design
- b. Tooling
- c. Fabrication of RSRA/rotor system modification components and blades
- d. Testing (Bench)
- e. Instrumentation
- f. Installation
- g. Assumed Parameter Variation Components (Design, Tooling, fabrication, bench testing, instrumentation and installation)
- h. Support of all ground and flight testing

Pre-design studies were performed to examine the requirements for integration of the 347/D rotor system on the RSRA in sufficient depth to define the modifications required to both the rotor and the RSRA including the blade severance system. Design and technical analyses were performed in sufficient depth to ensure physical, structural, dynamic and system compatibility.

Parameter change studies were conducted to examine the variability of key rotor parameters, to select the parameters to be varied, to determine the techniques for providing the variability and to analyze the modifications required to provide the parameter changes. These studies were of sufficient depth to define both the modifications to the rotor system and the technical risks involved.

Studies were conducted to define rotor blade instrumentation requirements necessary to measure blade airloads and dynamic and structural responses.

Preliminary estimates were made to determine the cost required to implement the 347/D rotor system on the RSRA and to implement proposed parameter variations to be tested in accordance with the following plan:

1. Preliminary design with a government Preliminary Design Review (PDR).
2. Detail design with a government Critical Design Review (CDR), including tool design.
3. Fabrication including all modifications to the 347/D rotor system and the RSRA for the basic rotor installation and parameter variations.
4. Safety of flight qualification of all hardware, based on a contractor-prepared, government-approved plan.
5. Instrumentation
6. Installation and integration on the RSRA under NASA inspection, including ground runs by NASA with Boeing Vertol technical support.
7. Flight Testing by NASA for two (2) years with Boeing-Vertol technical support.

The Development Plan was established using the program outlined under Task II (paragraphs 4 through 6) which includes a Work Breakdown Structure (WBS), a draft Statement of Work, a schedule and a funding plan breaking down costs by WBS task.

2.0 Summary

The selected rotor system (347/D) offers superior performance, flying qualities and dynamic characteristics. This rotor system incorporates the CH-47D fiberglass rotor blade, the most advanced blade utilized on military and commercial production helicopters, combining modern high performance airfoils and composite structures technology. These 347/D features offset the somewhat better match between the 347/C rotor system and the present RSRA flight envelope.

The final total trade-off scores, summarized in table 2.0-1, for each of the rotor system candidates are as follows:

1.	YUH-61A	Rotor System	-	.457
2.	347/C	Rotor System	-	.716
3.	347/D	Rotor System	-	.725

It should be noted here that wherever possible, evaluations and rating factors were established based on calculated parameter values in each trade study category. Otherwise, the evaluation and rating was subjective based on design experience.

Kinematic and installation layouts were prepared to determine the modifications required to the 347/D rotor system and the RSRA. Figure 2.0-1 (SK 28732) presents the final kinematic and installation details. To determine requirements for modification to, and new hardware for, the RSRA emergency escape system for blade severance, Teledyne McCormick Selph (the contractor for the system) was requested to submit a technical proposal and quotation. The proposal is presented in Appendix C. Transmission modifications required to run the 347/D rotor system and parameter variants at 225 rpm were studied and evaluated. This speed would require a gear ratio change in the main bevel mesh from the present 3.40 to 3.05.

Parameter variation studies were conducted and have resulted in the proposed least risk, lowest cost test program.

Except for tip shape variations, a two phase approach is taken to the aerodynamic parameter variations. Phase I utilizes existing CH-47A, CH-47C and CH-47D blades installed on the 347 four bladed hub. For Phase II one set of new blades with the chord of the CH-47D blade and the twist and airfoil of the CH-47C blade will be fabricated. This blade will be retwisted during Phase II to the CH-47D twist to complete the study. As summarized in Table 2.0-2 these combinations of rotor configurations permit the step by step evaluation of the following aerodynamic parameters:

Table 2.0-1 Summary of Trade-Off Scores - RSRA
4-Bladed Rotor System Selection

<u>Trade Study Category (Weight)</u>	<u>Candidate - Scores</u>		
	<u>YUH-61A</u>	<u>347/C</u>	<u>347/D</u>
<u>Primary Categories</u>			
Technical Merit (.55)	.304	.420	.429
Cost and Schedule (.45)	.153	.296	.296
<u>Technical Merit Breakdown</u>			
Technical Level (.20)	.117	.154	.158
Flight Envelope on RSRA (.20)	.129	.168	.170
Rotor System Adaptability to Parameter Variation (.15)	.055	.098	.101
<u>Technical Level Breakdown</u>			
Performance (.10)	.085	.075	.084
Vibration/Loads (.06)	.015	.055	.051
Flying Qualities (.04)	.017	.024	.023
<u>Flight Envelope Breakdown</u>			
Performance Limits (.07)	.040	.061	.057
Load Limits (.07)	.049	.055	.055
Flying Quality Limits (.06)	.043	.052	.058

Fig. 2.0-1 (SK28732)

TABLE 2.0-2 TECHNICAL APPROACH TO AERODYNAMIC PARAMETRIC VARIATIONS

PHASE	-	I	I	II	II	I
ROTOR SYSTEM	S61	347/A	347/C	347/MOD I	347 MOD II	347/D
SOLIDITY (σ)	.0781	.0826	.0893	.1132	.1132	.1132
DIAMETER (M)(FT)	18.899 (62)	18.014(59.1)	18.288 (60)	18.288 (60)	18.288 (60)	18.288 (60)
CHORD (CM) (IN)	46.355(18.25)	58.42 (23)	64.135 (25.25)	81.28 (32)	81.28 (28)	81.28 (32)
BLADE NUMBER	5	4	4	4	4	4
AIRFOIL SECTION	NACA0012 (MOD)	NACA0012 (MOD)	BV 23010-1.58	BV 23010-1.58	BV 23010-1.59	VR7/8
TWIST	-8	-9	-9.14	-9.14	-12	-12
TIP SPEED M/SEC (FT/SEC)	201.17 (660)	215.19(706)	215.19 (706)	215.19 (706)	215.19 (706)	215.19 (706)

BASELINE
DATA &
EFFECT OF
BLADE NO.

EFFECT OF
AIRFOIL
CAMBER
VARIATION

EFFECT OF
SOLIDITY
(CHORD)

EFFECT OF
TWIST

EFFECT OF
LOW DRAG
AIRFOIL

- a. Baseline NACA 0012 data and effect of blade number
- b. Airfoil camber
- c. Planform (solidity or chord)
- d. Blade twist
- e. Low drag airfoils

The following outline presents the proposed parameter variation test program:

- I. Phase I - Basic Aerodynamic Parameter Variation Tests
 - A. CH-47A Blade Tests (347/A Rotor System)

These tests allow for comparative evaluation of a 4-bladed 347/A rotor system against the 5-bladed RSRA S-61 rotor system.
 - B. CH-47C Blade Tests (347/C Rotor System)

These tests allow for evaluation of the effect of airfoil camber.
 - C. CH-47D Blade Tests (Selected Rotor System - 347/D)

These tests allow for evaluation of the effect of variations in solidity, airfoil and twist.
- II. Phase II - Expanded Aerodynamic Parameter Variation Tests
 - A. This phase will require a new set of twistable blades to allow for evaluation of the effects of solidity, airfoil and twist independently, sorting out the parameter variations between the CH-47C and D blades. (347/Mod I and 347/Mod II Rotor Systems)

III. Phase III - Rotor Dynamic and Flying Quality Parameter Variation Tests (Using CH-47C Blades)

A. Blade Natural Frequency Tests

By means of internal tuning weights or by external graphite stiffeners, these tests will allow for evaluation of the effect of frequency variations as follows:

Table 2.0-3 Desired Blade Frequency Variations

<u>Mode</u>	<u>Nominal Frequency @ 230 RPM, ω/Ω</u>	<u>Desired Variation @ 225 RPM, ω/Ω</u>
2 nd Flap	2.57	2.40
3 rd Flap	4.75	5.50
2 nd Chord	5.32	6.00

B. Effective Flap Hinge Location Variation Tests

By means of hub adapters, these tests will allow for evaluation of the effect of shifting the actual flap hinge from the present location (2.22%R) to 5%R.

C. Control Phase Variation Tests

By means of adjustments to the RSRA analogue phase mixer, the best phase setting for the 347/D rotor system can be found with a maximum of three variations.

D. Control System Stiffness Variation Tests

By means of a flexible pitch link assembly, control system stiffness may be lowered, thereby allowing for evaluation of the effects of lowering blade torsional frequency.

E. Lag Damper Variation Tests

By means of simple modification to the hydraulic lag dampers, breakout force and/or damping rate may be modified to obtain the optimum values for the 347/D rotor system on the RSRA.

F. Pitch-Flap Coupling ($\Delta 3$) Variation Tests

By means of varying the pitch link to pitch arm attachment location, 15° positive $\Delta 3$ may be added and tested.

IV. Phase IV - Blade Tip Shape Variation Tests

The CH-47C blades from Phase III will be modified by removing the outboard 10%, 91.44 cm (36 inches) and prepared to adapt the following tip configurations for test:

- A. Set No. 1 - Constant chord with airfoil transition from V23010-1.58 to V13006-0.7.
- B. Set No. 2 - 3:1 chordwise taper with same airfoil transition.
- C. Set No. 3 - Same as Set No. 2 with 15° sweep.
- D. Set No. 4 - Same as Set No. 2 with 25° sweep.

The Development Plan for the 347/D - RSRA Program offers a unique Work Breakdown Structure which has been developed specifically for this type of program. That is, a program where the contractor will design, qualify, fabricate and install a rotor system and parameter variation hardware and support NASA conducted ground and flight testing of that rotor system and its parameter variants.

3.0 Trade-Off Analysis and Rotor System Selection

3.1 Technical Merit (Weighting Factor = .55)

3.1.1 Technical Level (.20)

3.1.1.1 Performance (.10)

3.1.1.1.1 Figure of Merit (.06)

The hover figure of merit (FM) for each candidate rotor system is shown in figure 3.1.1.1.-1. YUH-61A and 347/C rotor system performance is based on flight test data and the 347/D rotor system FM is based on theory. The FM for the 3-bladed CH-47A rotor system is presented for reference purposes and is indicative of the technology level of the 1950's.

**FIGURE OF MERIT FOR
CANDIDATE ROTORS**

FIGURE 3.11.1

ISOLATED ROTOR

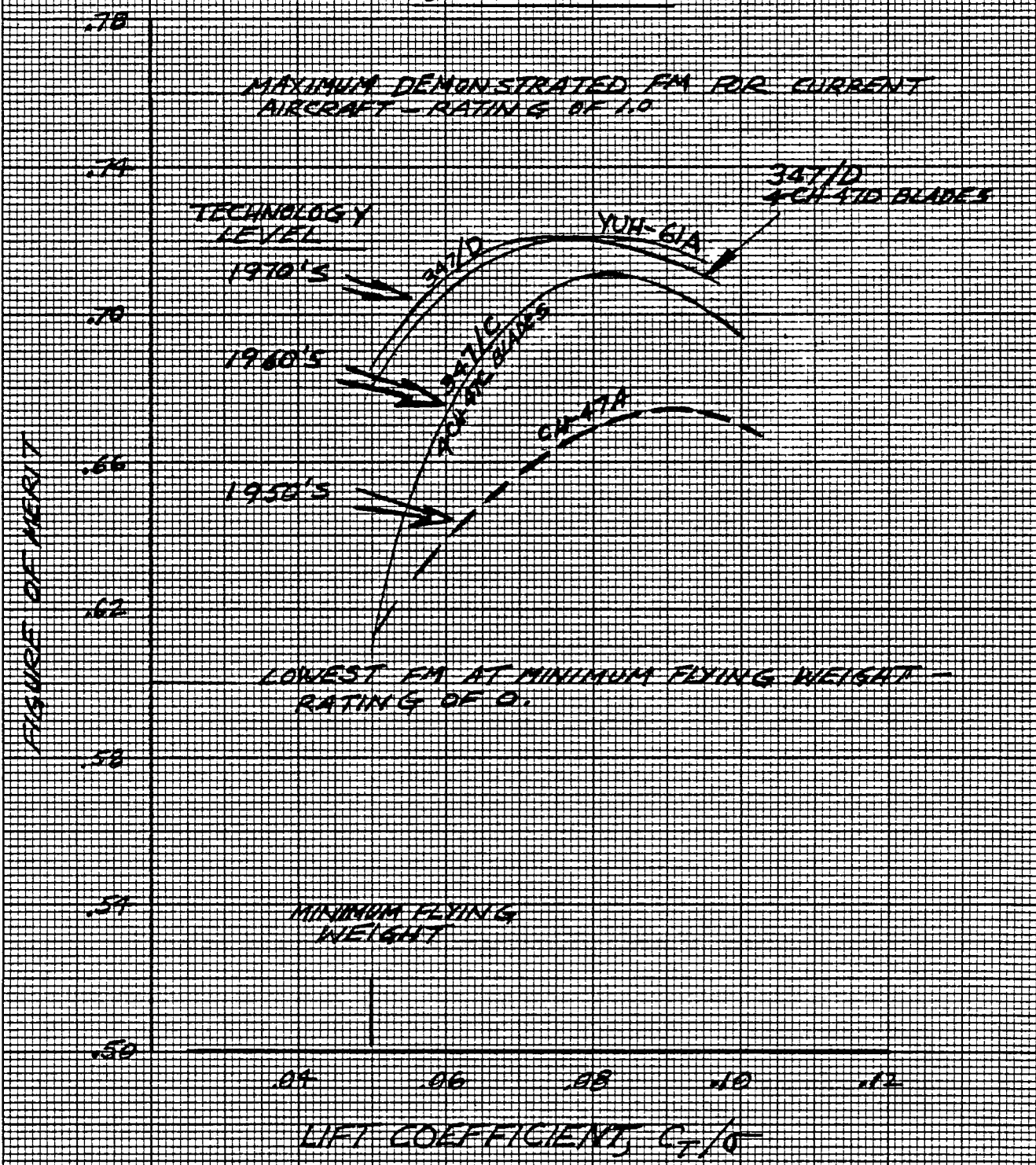

EUGENE DIETZGEN CO.
MADE IN U.S.A.

NO 340R-20 DIETZGEN GRAPH PAPER
20 X 20 PER INCH

The rating factor assigned to each candidate was predicated on the relationship of its maximum FM to a minimum value of 0.6, reflecting the lowest FM at the estimated minimum flying weight; and, a maximum value of 0.76 which reflects the highest FM demonstrated on current production aircraft. The YUH-61A and 347/D rotor systems show FM's of .721 with the 347/C, slightly less, with an FM of .711.

Scores: YUH-61A Rotor System - .045
 347/C Rotor System - .042
 347/D Rotor System - .045

3.1.1.1.2 Rotor Lift to Effective Drag Ratio (L/D_e) (.04)

Rotor L/D_e as a function of advance ratio at a $C_T/\sigma = 0.06$ is presented for each of the candidate rotor systems in figure 3.1.1.1-2. Data was calculated using flight test results with theoretical corrections to the CH-47C and D data to reflect 4-bladed performance. Rating factors were assigned to each rotor system with the minimum rating (0) based on L/D_e 's which reflect minimum power speed performance and the maximum rating (1) based on an $L/D_e = 7.25$, indicative of the highest demonstrated value for a modern 4-bladed rotor system. As shown, the maximum L/D_e for each candidate varied slightly with the highest being the YUH-61A at 7.25 and the lowest, the 347/C at 6.9. The 347/D rotor system shows an L/D_e of 7.15.

Scores: YUH-61A Rotor System - .040
 347/C Rotor System - .034
 347/D Rotor System - .038

**LIFT TO DRAG RATIO
FOR CANDIDATE ROTORS**

FIGURE 3.1.1.1-2

$C_{T/S} = 0.06$

ROTOR LIFT TO DRAG RATIO (L/D_R)

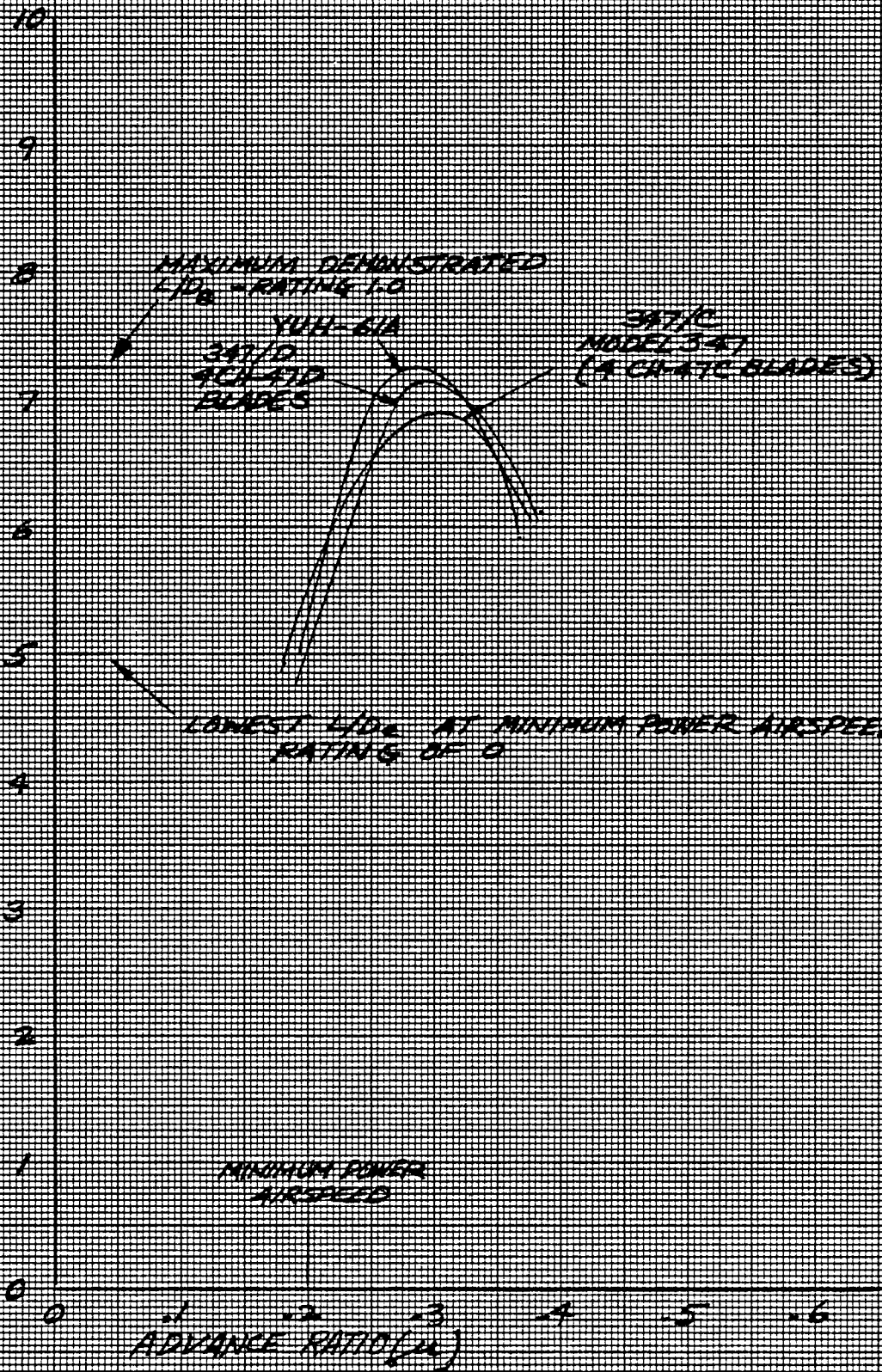

DIETZGEN CORPORATION
MADE IN U.S.A.

NO 340R-MP DIETZGEN GRAPH PAPER
MILLIMETER

3.1.1.2 Vibration/Loads (W.F. = .06)

The three rotor configurations were compared for their fixed system rotor hub vibratory loads in transition 74.08 km/hr (40 knots) and at high speed 277.80 km/hr (150 knots). The thrust was 8391.6 kg (18,500 lbs.) in each case. All results obtained are exclusive of any vibration control devices, i.e. vibratory hub loads have not been reduced through rotating or fixed system vibration control devices. Computer program C-60 was used to compare vibratory hub loads at 4 per rev. in the fixed system. A resultant in-plane hub load was obtained by combining lateral and longitudinal fixed system 4 per rev. loads. A similar combination of fixed system 4 per rev. pitch and roll moments was obtained. The resulting 4 per rev. vertical load, in-plane load, and moments for each configuration were then scored. The YUH-61A rotor system generally produced higher vibratory hub loads because of its larger effective hinge offsets. The 347/C and 347/D rotor systems had very similar vibratory hub load characteristics. The results of this category of the tradeoff study is as follows:

1.	YUH-61A	Rotor System	Score =	.015
2.	347/C	Rotor System	Score =	.055
3.	347/D	Rotor System	Score =	.051

3.1.1.3 Flying Qualities (.04)

3.1.1.3.1 Flying Quality Boundaries (.01)

3.1.1.3.1.1 Control Power vs. Roll/Pitch Rate Damping (.007)

All three candidate rotor systems give sufficient damping in roll to satisfy the requirements of MIL-H-8501A. The YUH-61A hingeless rotor system gives almost twice as much damping as the 347/C or D articulated rotor systems. In pitch, the YUH-61A rotor system gives sufficient damping; however, the 347 rotor systems would depend on the damping from the horizontal stabilizer for satisfactory flying qualities. All three rotor systems meet control power requirements. The YUH-61A rotor system gives almost three times the control power of the 347 rotor systems. The ratio of control power to damping is a

better measure of flying qualities. This ratio is indicative of the maneuverability of the helicopter. The 347 rotor systems, on the RSRA, have about 15% more control power to inertia ratio than the S61 rotor and should be expected to give quite similar flying qualities. The YUH-61A rotor system gives about twice the control power to inertia ratio as the S61 rotor. According to reference (1), the RSRA, with the S61 rotor, "has the 'control feel' of a much heavier helicopter", which was the "unavoidable result of strengthening the airframe." Since more rapid response is considered desirable, the following scores are given:

1.	YUH-61A	Rotor System	-	.0056
2.	347/C	Rotor System	-	.0035
3.	347/D	Rotor System	-	.0028

3.1.1.3.1.2 Control Sensitivity vs. Forward Speed (.003)

Control sensitivity is defined as the increase in rotor roll or pitch moment per inch of control stick motion. Rotors ordinarily increase their control sensitivity with increasing forward speed because of the increase in local air velocity over the blade sections, especially on the advancing side of the disk. The higher the Lock number, the greater the control sensitivity increases. Factors which would slow down the increase in control sensitivity with speed would be swept back blades and C.G.-A.C. offset, both of which were used on the YUH-61A rotor. The Lock numbers of the candidate rotor systems are as follows:

1. YUH-61A Rotor System - 16.05
2. 347/C Rotor System - 11.62
3. 347/D Rotor System - 10.80

It is estimated that the sweepback and C.G.-A.C. offset of the YUH-61A blades will offset the effect of their higher Lock number, giving all candidate rotor systems approximately the same score as follows:

1.	YUH-61A	Rotor System	-	.0015
2.	347/C	Rotor System	-	.0015
3.	347/D	Rotor System	-	.0017

3.1.1.3.2 Control Coupling (.008)

3.1.1.3.2.1 High G Pullout (.002)

In a high G pullout, the high thrust force with rearward thrust vector tilt gives a strong nose up moment to the fuselage. After the initial pitch-up acceleration, the fuselage tends to pitch faster than the rotor unless restrained by a large horizontal stabilizer. Typically, the rotor and the horizontal stabilizer share in restraining the fuselage from pitching up. If the rotor cyclic controls are phased to produce maximum flapping deflection in the direction the stick is pushed, there would be no cross coupling problem. However, if the horizontal stabilizer is taking all the pitching moment from the fuselage and the cyclic pitch is precessing the rotor at constant pitch rate, then the phasing for the hingeless YUH-61A rotor system will be incorrect. In this condition the maximum cyclic pitch must occur 90 degrees before the direction of tilt, whereas the cyclic on the YUH-61A rotor system is set at approximately 70° before the tilt direction.

Scores: YUH-61A Rotor System - .0008
 347/C Rotor System - .0016
 347/D Rotor System - .0016

3.1.1.3.2.2 Pitch/Roll Acceleration (.001)

With control phasing set properly for accelerations, the hingeless YUH-61A rotor or the articulated 347/C or D rotor systems will be free of cross coupling during acceleration in pitch or roll.

Scores: YUH-61A Rotor System - .0008
 347/C Rotor System - .0008
 347/D Rotor System - .0008

3.1.1.3.2.3 Pitch/Roll Velocity (.001)

If rotor controls are phased for acceleration such that there will be no cross coupling, then there will be coupling in the hingeless YUH-61A rotor with pitch or roll velocity.

Scores: YUH-61A Rotor System - .0004
 347/C Rotor System - .0008
 347/D Rotor System - .0008

3.1.1.3.2.4 Step, Pulse or Sinusoidal Cyclic Stick Input vs. Forward Speed (.001)

According to reference (2), pilots report that when hovering, moving the YUH-61A cyclic stick longitudinally at a certain frequency produces almost pure roll motion. In forward flight, where longitudinal control sensitivity increases, this strong cross coupling would be reduced. The articulated rotor exhibits much less cross coupling with this type of excitation.

Scores: YUH-61A Rotor System - .0002
 347/C Rotor System - .0006
 347/D Rotor System - .0006

3.1.1.3.2.5 Collective Step Input (.001)

In hover, a collective step input to any single rotor configuration requires a corresponding step input to tail rotor collective to maintain heading and lateral cyclic to offset increased tail rotor thrust. Since the hingeless YUH-61A rotor tilts the fuselage when lateral cyclic is applied, there may be more delay until rotor tilt is accomplished.

In forward flight, a collective step input increases flapping up in front. An articulated rotor with low flap hinge offset would flap up directly in front, requiring longitudinal cyclic, only, to correct. The hingeless rotor would flap up to maximum before the blades reach 180° (at about 160° azimuth).

This would require lateral cyclic in addition to longitudinal cyclic to correct.

Scores: YUH-61A Rotor System - .0004
 347/C Rotor System - .0008
 347/D Rotor System - .0008

3.1.1.3.2.6 Stick Migration vs. Forward Speed (.002)

Reference (2) states, "Lateral cyclic control migrations during transition from hover occurs on many helicopters. It is particularly noticeable on hingeless rotor aircraft due to the necessity for maintaining rolling moment trim." This problem is due to the inflow velocity distribution change with forward speed. Inflow velocity is minimum at the disk leading edge and maximum at the trailing edge. This velocity change would be compensated by lateral cyclic on an articulated rotor and by lateral plus longitudinal cyclic on a hingeless rotor. Coning angle also causes some difference in local inflow velocity, relative to blade element, which is also compensated by lateral cyclic. At higher forward speeds, the area of reverse flow on the retreating side of the rotor increases in size, requiring longitudinal cyclic compensation. For all these corrections, the hingeless rotor requires a slightly different phase or direction of control stick motion than would be indicated by the resulting fuselage motion.

Scores: YUH-61A Rotor System - .0006
 347/C Rotor System - .0014
 347/D Rotor System - .0014

3.1.1.3.3 Longitudinal/Lateral Stability (Static and Dynamic) (.009)

Static stability in hover, in both lateral and longitudinal directions, is positive for both the YUH-61A and 347 rotors. The hingeless rotor is possibly more speed stable, statically, because as it pitches up in front with forward speed, the pitching moment increase with increase in angle of attack is greater than that of an articulated rotor. This moment increase phenomena is called angle of attack instability.

Dynamic stability is positive if there is enough damping from the rotor and the horizontal stabilizer to make the oscillations due to static stability converge. The hingeless rotor has much higher damping in roll than the articulated rotor; however, the hingeless rotor possesses the undesirable characteristic of gyroscopic coupling between pitch and roll motion. In forward flight, the hingeless rotor possesses more lateral dynamic stability because of higher damping than that of the articulated rotor; however, the increased moment with angle of attack instability requires a larger horizontal stabilizer to provide satisfactory stability (static and dynamic).

Scores: YUH-61A Rotor System - .0045
 347/C Rotor System - .0054
 347/D Rotor System - .0054

3.1.1.3.4 Ground Handling Qualities (.006)

The RSRA landing gear is configured such that when the aircraft is on the ground, the rotor shaft is very nearly vertical. Therefore, when taxiing as a helicopter, the propulsive force must come from the forward component of a tilted rotor thrust vector. At partial thrust, the tilt of the 347 rotor thrust vector is limited to 8 degrees. The YUH-61A rotor is limited to 2 degrees.

Scores: YUH-61A Rotor System - .0012
 347/C Rotor System - .0048
 347/D Rotor System - .0048

3.1.1.3.5 Freedom From Coupling Between Lateral/Longitudinal Transient Motions (.007)

When a helicopter rotor is disturbed in a horizontal direction, the acceleration of the hub causes lead-lag motion of the blades such as to displace the combined C.G. of the blade from the rotor center of rotation. Once displaced, the blades continue to oscillate about the lag hinge at the lag damped natural frequency until the energy is dissipated by lag dampers (in the case of the articulated rotor) or structural hysteresis (in the case of the hingeless rotor)

and aerodynamic damping. The effect of this continuing lead-lag motion is an undesirable shaking of the pylon in a circular path, with fuselage response inversely proportional to fuselage effective mass at the pylon. For most helicopters the effective mass is smallest in the lateral direction because the roll inertia is much less than pitch inertia. The maximum excitation of the blades occurs when they are disturbed at their natural frequency in the rotating system, which is equivalent to rotor speed plus or minus lag natural frequency. Only the difference of the two frequencies is important because it causes blade motion in the sequence which feeds back a force in phase with the exciting force (see references 3 and 4).

The YUH-61A blades have a lag natural frequency approximately 0.7 times rotor speed, therefore, they are most excited by 0.3 rotor speed shaking or about 1.4 Hz. The 347 blades (C or D) with their approximately 0.3 rotor speed natural frequency are most excited by 2.6 Hz shaking. Maneuvers are more likely to contain 1.4 Hz than 2.6 Hz frequency components. This indicates that the YUH-61A rotor is more likely to encounter exciting transients. In addition, the YUH-61A rotor does not incorporate lag dampers; therefore, lag motions will persist longer.

Scores: YUH-61A Rotor System - .0014
 347/C Rotor System - .0028
 347/D Rotor System - .0028

3.1.2 Flight Envelope on RSRA (.20)

3.1.2.1 Performance Limits (.07)

3.1.2.1.1 Level Flight (.04)

The flight envelopes of the candidate rotor systems installed on the RSRA are compared to the CH-47D, CH-47C and YUH-61A flight envelopes in Figures 3.1.2.1-1 to 3.1.2.1-3. The solid lines depict design performance envelopes of the respective aircraft. The CH-47C and CH-47D data reflect three-bladed rotor performance envelopes while the YUH-61A is a four blade configuration.

RSRA FLIGHT ENVELOPE -
(A) CH-47D BLADES
(347/D ROTOR)

FIGURE 3(12)-1

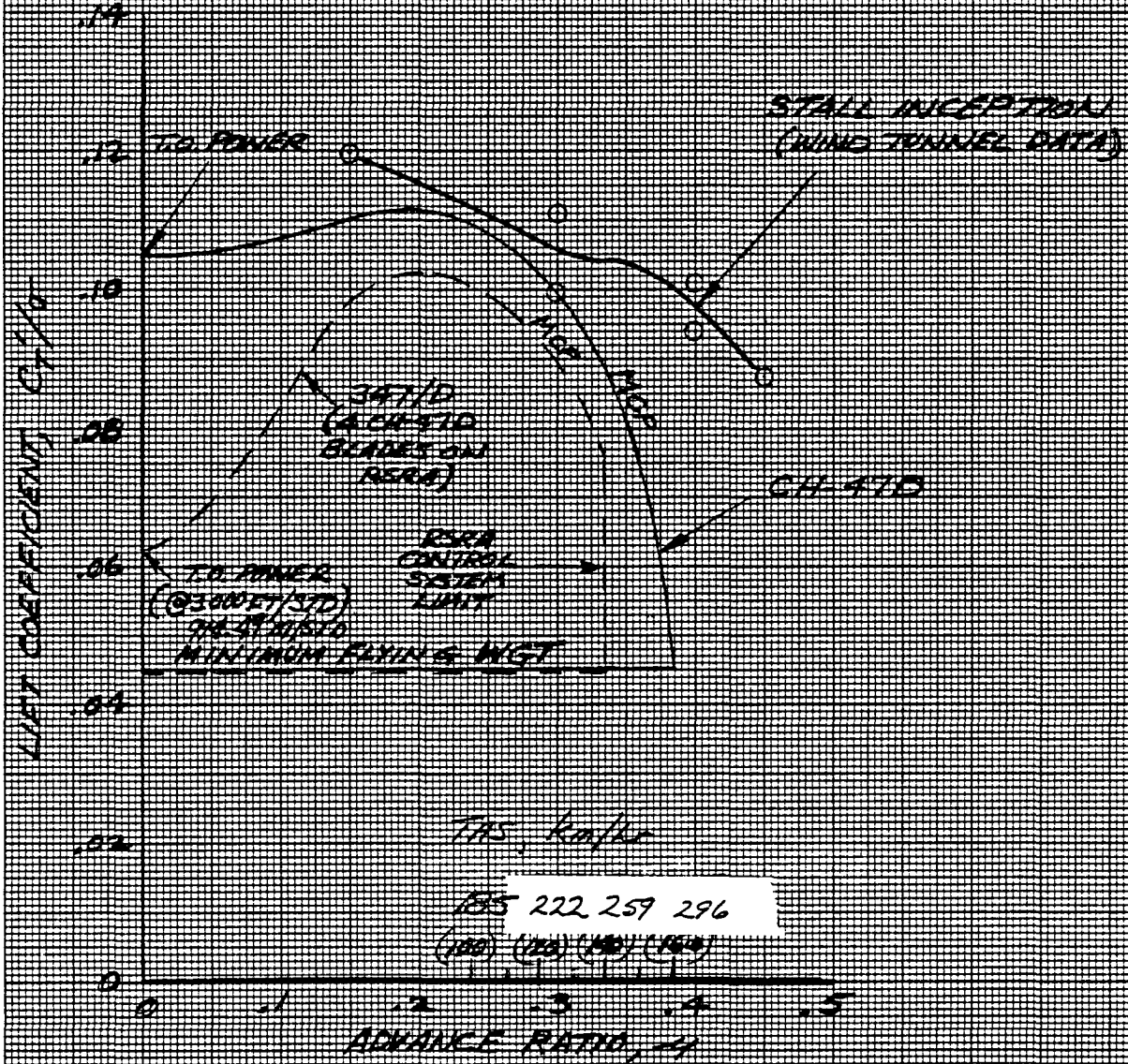

DIETZGEN CORPORATION
MADE IN U.S.A.

NO 340R-MP DIETZGEN GRAPH PAPER
MILLIMETER

RSRA FLIGHT ENVELOPE
347 ROTOR
(4 CH-47C BLADES)
(347/D ROTOR)

FIGURE 3121-2

WIND TUNNEL TEST
 SYMBOL
 □ RWTT075
 ○ NASA/BN TEST

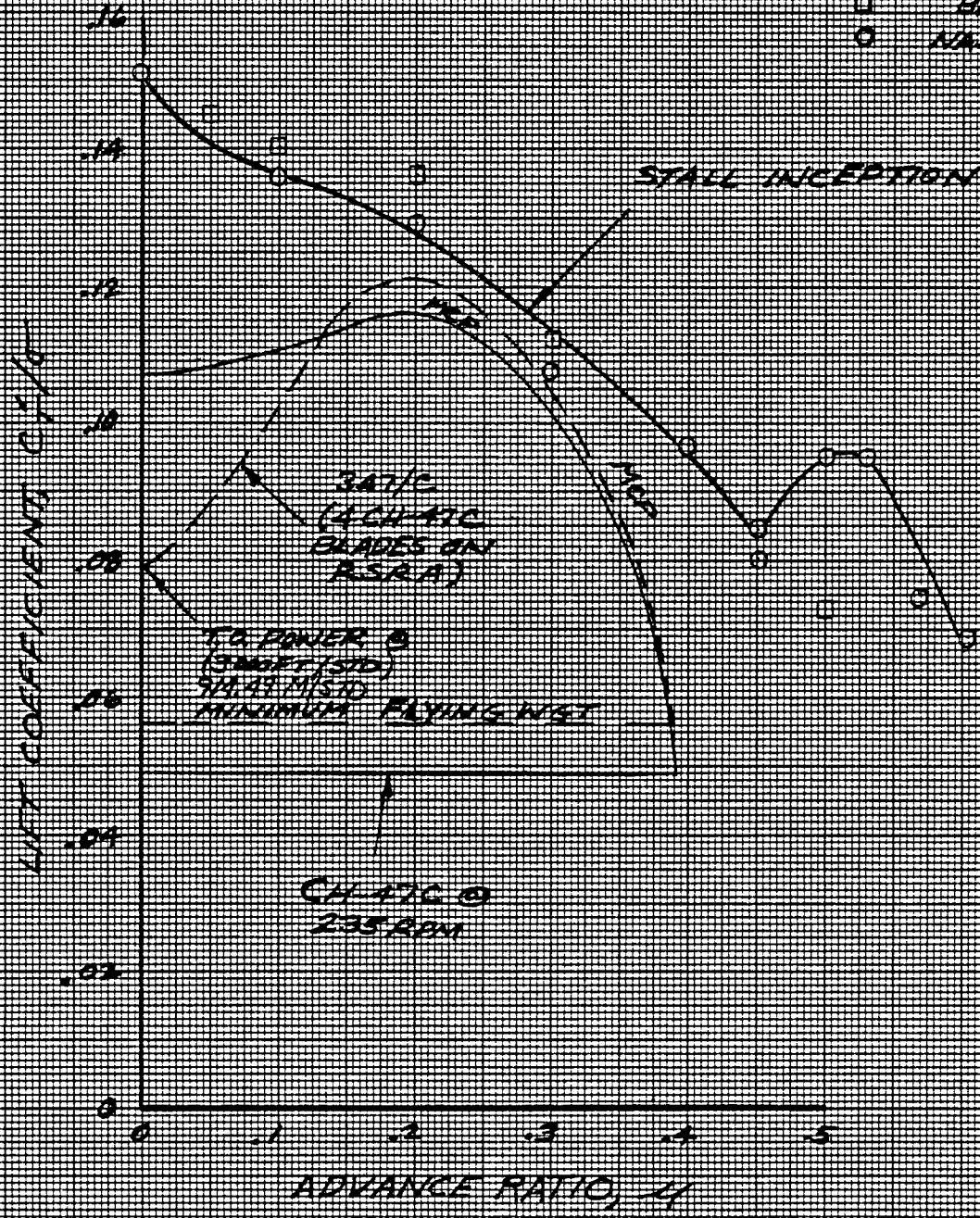

DIETZEN CORPORATION
MADE IN U.S.A.

NO 340R-MP DIETZEN GRAPH PAPER
MILLIMETER

**RSRA FLIGHT ENVELOPE
WITH YUH-61A ROTOR**

FIGURE 3.1.2.1-3

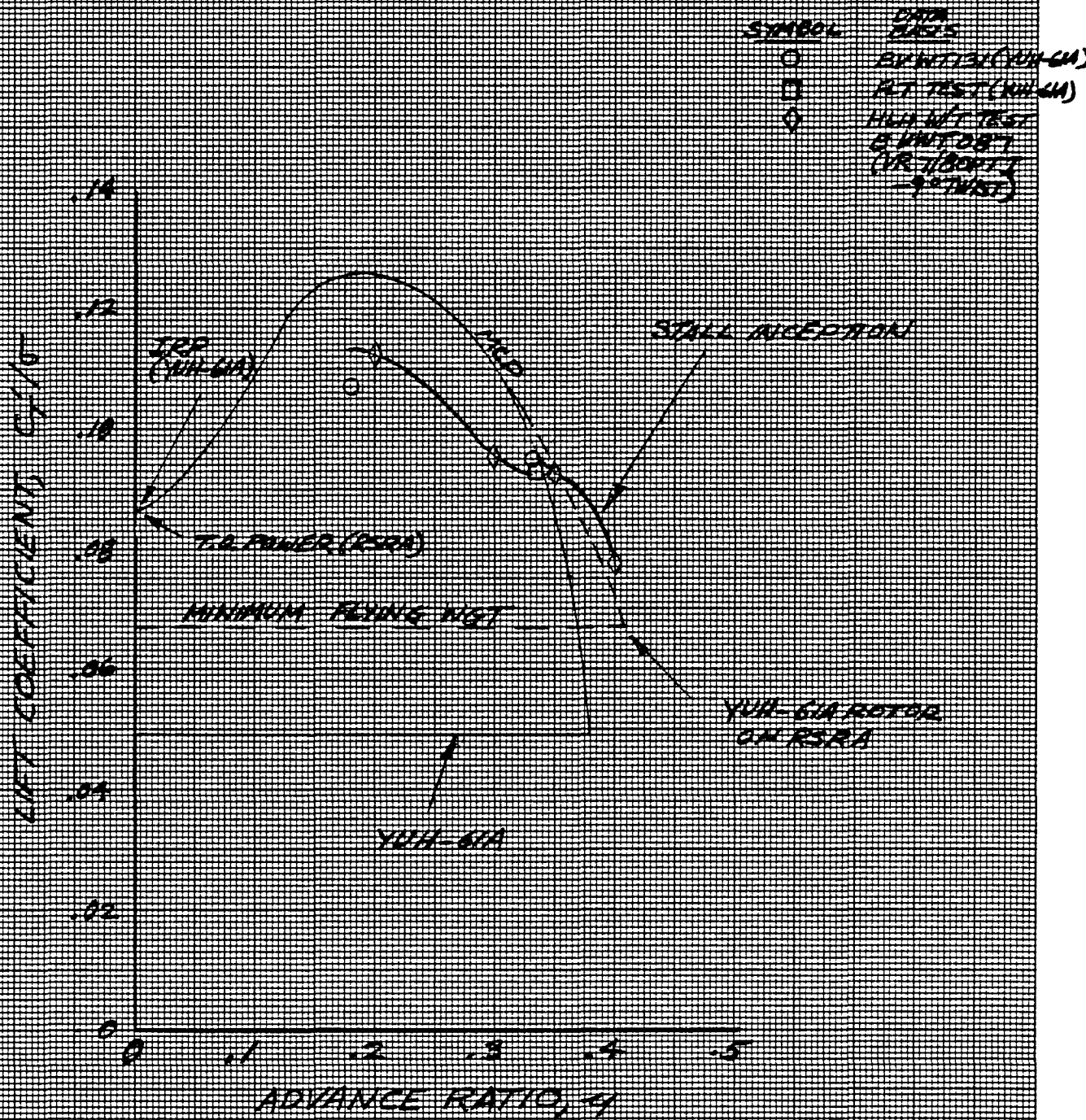

DIETZGEN CORPORATION
MADE IN U.S.A.

NO 340R-MP DIETZGEN GRAPH PAPER
MILLIMETER

Predicted four bladed performance envelopes consistent with the RSRA configuration are shown by the dashed lines. Comparison of the solid and dashed lines indicates the extent to which each rotor system, installed on the RSRA, can be evaluated relative to their design performance.

Rating factors used to rate the level flight envelopes of the candidate blades is predicated on the percentage of the actual performance envelopes which could be evaluated within RSRA gross weight and power available limitations. A rotor system whose design performance could be fully evaluated on the RSRA (in terms of C_T/σ and advance ratio) would be given a rating of 1.0. If RSRA power or other limitations reduce the demonstratable envelope (as defined by the area within the envelope) to one half of the actual rotor system capability, a rating of .5 would be given.

The 347/C system would allow exploration of 77% of the CH-47C envelope while the 347/D rotor system would provide capability of evaluating 67% of the CH-47D envelope. The YUH-61A rotor system, installed on the RSRA, would be capable of evaluating 71% of the UTTAS envelope.

Scores: YUH-61A Rotor System - .028
 347/C Rotor System - .031
 347/D Rotor System - .027

3.1.2.1.2 Maneuverability (.03)

The maneuverability of RSRA with the candidate rotors installed was rated as a function of load factor at the minimum flight gross weight using the stall boundaries defined in Figures 3.1.2.1-1 to 3.1.2.1-3. A maneuver capability equal to or greater than 2g (60° banked turn) at $\mu = .3$, 222 km/hr to 240 km/hr (120 Kt to 130 Kt) is rated 1.0 and 1g capability is defined as 0. The resulting maneuver capability and score for the three rotor systems is presented below.

<u>Rotor System</u>	<u>Load Factor</u>	<u>Score</u>
YUH-61A	1.4	.012
347/C	2.02	.030
347/D	2.37	.030

3.1.2.2 Load Limits (.07)

The 347/D rotor system as installed on the RSRA is limited to an airspeed of 259 km/hr (140 KTS) (TAS) at a C_T/σ of 0.076 due to the load limitations (endurance limits) of the rotor stationary control system components (See Reference 5). Using 333 km/hr (180 KTS) as a desirable maximum speed for performance testing, the 347/D rotor system would have a rating factor of .78. Furthermore, blade flapping will be limited to 8 degrees due to the rotor shaft moment allowable at its critical section. However, the 8 degree flapping limitation is not considered a restriction.

The YUH-61A rotor blade is stress limited so that the maximum steady rotor control moment attainable is only 0.72 times that attainable with the 347/D rotor. The airspeed of this rotor is limited to 328 km/hr (177 KTS). Combining these limitations results in a rating factor of .70.

The maximum steady rotor control moment attainable with the 347/C rotor is .87 times that attainable with the 347/D rotor. The airspeed of this rotor is limited to 302 km/hr (163 KTS). These limitations result in a rating factor of .79.

Scores:	YUH-61A	Rotor System	-	.049
	347/C	Rotor System	-	.055
	347/D	Rotor System	-	.055

3.1.2.3 Flying Quality Limits (.06)

3.1.2.3.1 C. G. Envelope vs. Control Margin (.04)

The maximum steady rolling or pitching moment that could be exerted on the RSRA by the rotor, as installed, was calculated for each candidate. Since C. G. envelope is a direct function of rotor moment capability, the results are as follows:

1. YUH-61A Rotor System - 34998 N-m (25,810 lb-ft) Score = .029
2. 347/C Rotor System - 42126 N-m (31,067 lb-ft) Score = .028
3. 347/D Rotor System - 48432 N-m (35,717 lb-ft) Score = .032

3.1.2.3.2 Gust Alleviation Capability (.02)

In forward flight, an up gust, for example, is encountered initially at the leading edge of the rotor disc. With this initial encounter, the blades respond by flapping up on the retreating side of the disk, causing a roll moment to be exerted on the fuselage. The greater the effective flap hinge offset, the greater the moment, the greater the fuselage response and also, the greater the swashplate tilt if no pilot input or stability augmentation system input. Therefore, the total response of the helicopter will be greater with the hingeless YUH-61A rotor due to the higher flapping stiffness of the rotor. In addition, the gyroscopic effect of the hingeless rotor will introduce further cross coupling in the motions following the gust encounter.

Scores:	YUH-61A	Rotor System	-	.004
	347/C	Rotor System	-	.010
	347/D	Rotor System	-	.010

3.1.3 Rotor System Adaptability to Parameter Variation (.15)

3.1.3.1 Aerodynamic Parameters (Airfoils, Planform, Tip Shape and Twist) (.083)

The optimum rotor system for aerodynamic parameter research is one which will accommodate existing or future blades having basic state-of-the-art or advanced configurations. The 347/D rotor offers a modern system incorporating an existing all-composite blade having advanced aerodynamic parameters. This rotor system offers direct interchangeability with CH-47A and CH-47C blades. Also, it is highly probable that the 347 rotor hub will accommodate future Boeing-Vertol advanced technology blades. Table 3.1.3-1 illustrates the aerodynamic parameter variations of the existing RSRA (S-61) rotor, the 347/D rotor system and the variations obtained with CH-47A and C blades. This basic aerodynamic parameter variation approach allows for the following comparative testing:

1. 347/A vs. RSRA - Compares rotor having approximately the same solidity, the same airfoil, approximately the same twist; but varies the number of blades (4 vs. 5)
2. 347/C vs. 347/A - Allows testing the effect of airfoil camber.
3. 347/D vs. 347/ C - Tests the effect of variations in solidity, airfoil and twist.

This approach has the disadvantage of varying three parameters at one time when CH-47D blades are compared with CH-47C blades. Therefore, an expansion of the test program would require one additional set of twistable blades to vary parameters independently and sort out their effects.

Table 3.1.3-1. Aerodynamic Parameters

Rotor System	<u>RSRA</u> <u>(S-61)</u>	<u>347/D*</u>	<u>347/A</u>	<u>347/C</u>
Diameter, m (Ft.)	18.89 (62)	18.28 (60)	18.01 (59.1)	18.28 (60)
Blade Chord, cm (In.)	46.35 (18.25)	81.28 (32.0)	58.42 (23.0)	64.13 (25.25)
Number of Blades	5	4	4	4
Solidity	.0781	.1132	.0826	.0893
Rotor Speed, RPM	203	225	225	225
Tip Speed, mps FPS	201 (660)	215 (706)	215 (706)	215 (706)
Airfoil	0012	VR7/8	0012	BV23010-1.58
Twist, Deg.	-8	-12	-9	-9

*347 Hub With CH-47D Fiberglass Blades

In order to accomplish the same variation testing with the YUH-61A (UTTAS) rotor system, three additional sets of blades would be required.

Tip shape variation testing would be equally as difficult using either a CH-47 type or UTTAS type blade.

Therefore, the respective scores for the 347/D or C rotor and the UTTAS rotor are;

YUH-61A Rotor System	-	.0166
347/C Rotor System	-	.0664
347/D Rotor System	-	.0664

3.1.3.2 Blade Natural Frequency (.023)

Flapwise and chordwise frequencies may be increased almost independently by bonding unidirectional graphite stiffeners on the external surfaces of the blades. However this technique has the disadvantage of disturbing airfoil contours. Furthermore, the 347/C rotor blade will require additional chordwise stiffening due to blade construction (separated aft fairing boxes). The YUH-61A hingeless blade has an effective flap hinge at approximately 15% span, therefore it is impractical to consider stiffening this blade in the flapwise mode.

Flapwise and chordwise frequencies may be increased or decreased by adding tuning weights at the nodes or antinodes respectively. The 347/D rotor system will be limited with regard to the amount of tuning weight added and spanwise location due to tension-torsion strap assembly CF limitation.

Scores:	YUH-61A Rotor System	-	.0161
	347/C Rotor System	-	.0092
	347/D Rotor System	-	.0115

3.1.3.3 Effective Flap Hinge Location (.012)

To increase the effective flap hinge offset, two techniques may be considered; stiffening the flapwise hinge, or physically changing its location. In the case of the 347/C or D rotor system, it is considered most practical to do the latter. However, this approach would be impossible in the case of the YUH-61A rotor system. The YUH-61A rotor system effective hinge location may be increased by adding flapwise stiffening to the blade "swan-neck" or reduced by adding a tuning weight. This increases or decreases the frequency of the blade as well. It is considered that all candidates should be equally scored at .0072.

3.1.3.4 Lock Number (.009)

No component variations except those resulting from blade aerodynamic variations will be made. Therefore the same relative scoring will be applied as under aerodynamic parameter variations.

Scores: YUH-61A Rotor System - .0018
 347/C Rotor System - .0072
 347/D Rotor System - .0072

3.1.3.5 Blade Sweep (.007)

In the case of the YUH-61A rotor system, drag pin location variation will yield sweep variation. This is considered to represent moderate design and hardware variations. In the case of the 347/C or D rotor systems, blade sweep might be accomplished by adding a stiff spring in parallel with the blade lag damper. This is considered to represent complex design and hardware variations. In addition the spring would effect blade frequency and damping.

Scores: YUH-61A Rotor System - .0049
 347/C Rotor System - .0028
 347/D Rotor System - .0028

3.1.3.6 Precone (.006)

Precone is a built-in upward slope of the blade pitch axis on hingeless rotors. Droop is a bend in the neutral axis of the blade or root fitting just outboard of the pitch change bearings. Precone and droop together give desirable pitch-lag coupling to help suppress air resonance. The combination of precone and droop results in a blade neutral axis slope in the direction of the blade in normal one g cruise flight. To change precone on a hingeless rotor would require a completely new hub. To change droop would require new root fittings between the blade root and the pitch bearing. In an articulated rotor droop variation may be accomplished by installing strong preloaded springs about the flap hinge. Reducing or increasing coning angle in this manner may have some effect on lateral flapping with forward speed, at a cost of high blade root stresses.

Scores: YUH-61A Rotor System - .0030
347/C Rotor System - .0012
347/D Rotor System - .0012

3.1.3.7 Control System Stiffness (.004)

Control system stiffness will be reduced by use of a flexible pitch link. This concept is considered to be equally applicable to each candidate rotor system. The score for each in this category is .0028.

3.1.3.8 Lag Damping (.002)

The YUH-61A rotor system does not employ a lag damper, however the system inherently has adequate damping from structural hysteresis and aerodynamic damping. To add a damping system is considered to represent complex design and hardware variations. The 347/C or D rotor systems incorporate hydraulic lag dampers. It is considered that variations in lag damper break-out and/or damping rate represent readily achievable design and hardware variations.

Scores: YUH-61A Rotor System - .0006
 347/C Rotor System - .0018
 347/D Rotor System - .0018

3.1.3.9 Controls Authority (.002)

Controls authority may be changed by varying the actuator output crank arm length. This concept is considered to represent design and hardware variations of equal complexity for each candidate. Therefore, the score for each is .0014.

3.1.3.10 Coupling (Delta Three) (.002)

In the case of the 347/C or D rotor system, delta three (pitch-flap) coupling variations would be accomplished by changing the angle between the flap hinge axis and the pitch link attachment to the pitch arm. This concept is considered to represent moderately difficult design and hardware variations.

In the case of the YUH-61A hingeless rotor system, delta three coupling variations would be accomplished by changing blade sweep in conjunction with control system stiffness changes. This concept is considered to represent moderate design and hardware variations. However, these changes would also affect torsional frequency.

Scores: YUH-61A Rotor System - .0008
 347/C Rotor System - .0012
 347/D Rotor System - .0012

3.2 Cost and Schedule (.45)

Comparative preliminary estimates of costs were conducted to evaluate the candidate rotor systems based on total program requirements including an assumed parameter variation test program. The resulting relative cost ratios were also applied to schedule considerations. Therefore, cost and schedule are scored together based on the relative cost estimates.

Scores: YUH-61A Rotor System - .153
347/C Rotor System - .296
347/D Rotor System - .296

4.0 347/D Rotor System - RSRA Integration

4.1 Basic 347 Rotary Wing Head (Modified)

The rotary wing head consists of the hub, hinge assemblies, blade retention and pitch varying mechanism, and the blade lead-lag damper. The components of the rotary wing head are essentially those of the Model 347 helicopter forward rotor as presented in figure 4.1-1 except for the changes to the principal parts described below. Government furnished (GFE) CH-47A/B/C parts will be used as is or upgraded for use on the 347/D-RSRA rotor system where feasible.

The basic 347 forward rotary wing head assembly possesses pitch-flap coupling ($\Delta 3$) of 30 degrees. This coupling will be eliminated by removing and replacing the 347 pitch housing assemblies with standard CH-47 pitch change housing assemblies as shown in figure 4.1-2 (sheets 1 and 2).

As illustrated in figure 4.1-3, $\Delta 3$ coupling causes flapping due to cyclic inputs or flapping due to forward speed to be greater and advanced in phase (by about 30 degrees for 30 degrees $\Delta 3$), thus requiring more cyclic input to trim the aircraft. In addition, $\Delta 3$ couples lateral with longitudinal flapping and vice versa. Reference 6 states, "The lateral-longitudinal coupling created is undesirable," especially for single rotor aircraft, which accounts for the little use of simple $\Delta 3$." Therefore the 347/D rotor system as installed on the RSRA will not incorporate $\Delta 3$. However, $\Delta 3$ coupling up to 15 degrees may be investigated during Phase III of the Parameter Variation Test Program to analyze pitch stability improvements obtained through $\Delta 3$ versus those obtained by a horizontal stabilizer variation.

The pitch change housing, fabricated from 7075-T13 aluminum alloy, is designed to permit vertical pin bearing replacement at the organizational

Figure 4.1-1

Figure 4.1-2
Sht. 1

Figure 4.1-2
Sht. 2

EUGENE DIETZEN CO
MADE IN U.S.A.

NO. 340R-5 DIETZEN GRAPH PAPER
5 X 5 PER INCH

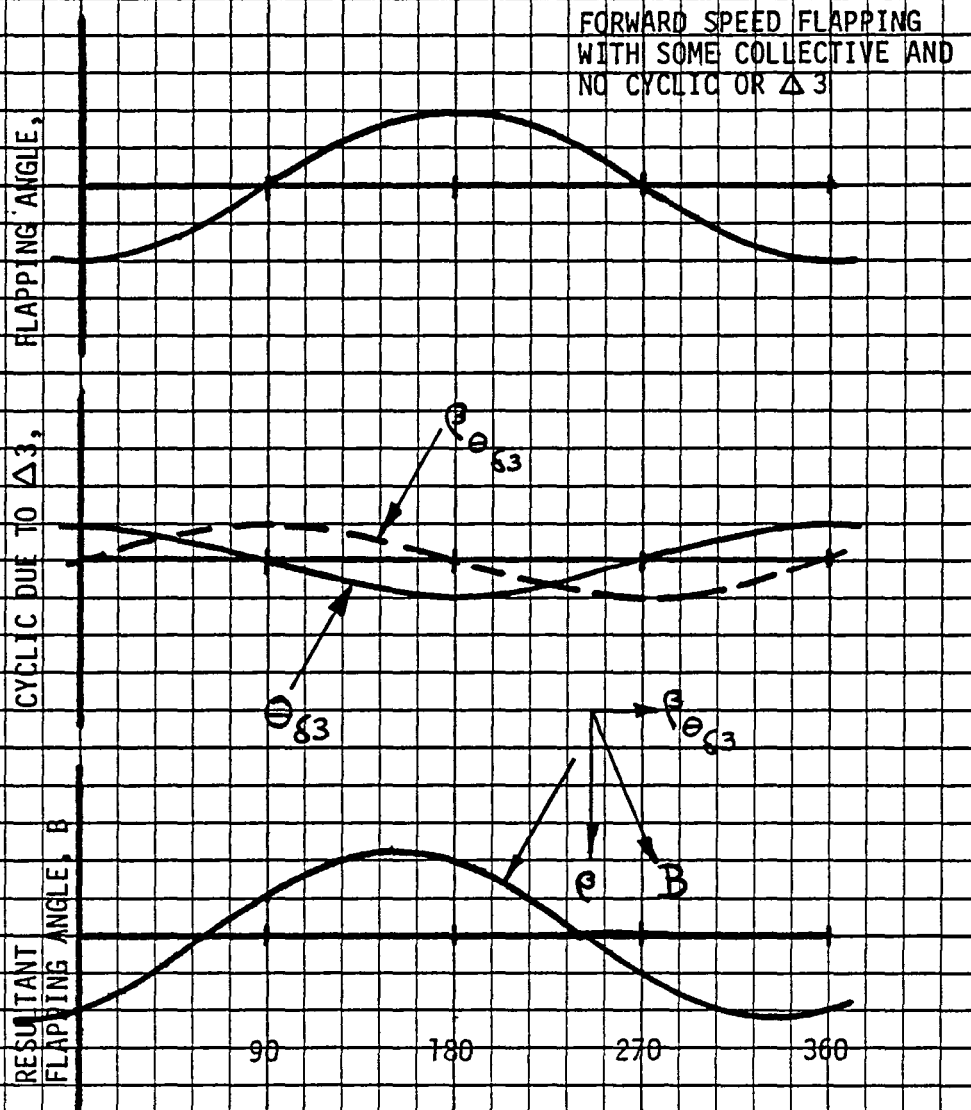

FIGURE 4.1-3 EFFECT OF $\Delta 3$ ON FORWARD SPEED FLAPPING

maintenance level. Vertical hinge oil tanks are molded fiberglass. The blade lead-lag damper is provided with a wider outboard rod end to improve bearing life.

The rotor hub assembly has an overhaul interval of 2400 hours. The pitch change bearings have a minimum B-10 life of 2400 hours and therefore are retired at overhaul. The horizontal hinge pin, the horizontal and vertical hinge pin bearings have a minimum B-10 life of 1200 hours including the effects of pin slope. The hub assembly design provides for horizontal and vertical pin bearing rotation at 1200 hour intervals, AVUM level, thereby establishing 2400 hour overhaul.

4.2 CH-47D Rotor Blade Description

A complete description of the CH-47D fiberglass rotor blade (design and fabrication) is presented in Appendix A. Also presented is a summary of the qualification testing (the verification of structural integrity, dynamic properties, flight safety and performance objectives). Blade structural and dynamic properties are presented in Appendix B.

4.3 347/D Rotor System Installation/RSRA Modifications

As illustrated by figure 2.0-1, the following new components will be needed to adapt the 347/D rotor system to the RSRA rotor shaft:

a. Shaft Adapter

Material - 4340 Steel - Forged Billet Norm. Temp. - MIL-S-5000, Cond. E, 33.02 cm DIA x 30.48 cm (13.0 in. DIA. x 12.0 in.)

Note: This component will be machined with an internal spline to match the RSRA rotor shaft.

b. Support Fitting (provides attachment lugs for connecting the B/V 347 rotating swashplate drive scissors to the shaft adapter)

Material - 4340 Steel Bar, MIL-S-5000, Annealed or Normalized and Tempered 6.35 cm x 12.7 cm x 21.59 cm (2.5 in. x 5.0 in. x 8.5 in.)

- c. Flanged Collar (spacer between shaft adapter and shaft extension)
Material - 4340 Steel - Forged Billet Norm. Temp. - MIL-S-5000,
Cond. E, 33.02 cm DIA x 10.16 cm (13.0 in. DIA. x 4.0
in.)
Note: 4 lugs are provided on this collar for the attachment of
the support links to be used in the flap hinge location
variation test (a proposed Phase III parameter variation
test).
- d. Shaft Extension
Material - 4340 Steel - Forged Billet Norm. Temp. - MIL-S-5000,
Cond. E, 29.21 cm DIA x 33.02 cm (11.5 in. DIA. x
13.0 in.)
Note: This component will be machined with an external spline
to match the B/V 347 rotor hub.
- e. Spacer (provides support for hub)
Material - 4340 Steel - Forged Billet Norm. Temp. - MIL-S-5000,
Cond. E, 29.21 cm DIA x 3.5 cm (11.5 in. DIA. x 3.5 in.)

The shaft adapter is mounted onto the RSRA shaft with the existing RSRA split hub aligning cone (P/N S6110-21059) and pressure plate (P/N S6110-21073); and, the rotary wing head shaft nut (P/N S6110-21082) with shaft key (P/N S6110-21084), shaft key shims (P/N S6110-21086) and shaft nut bolts (P/N S6110-21085). The above hardware should be new. However, old parts may be reused following visual and NDT inspection in accordance with reference 10, page 406.

In addition, the new components needed for the upper control system are delineated in the following paragraph.

4.4 Control System Modifications

Starting with the RSRA upper control actuators, the following components will be retained without modification:

- a. Control Actuators
- b. Control Links (between control actuator output cranks and stationary swashplate member)
- c. Stationary Swashplate Member

- d. Stationary Scissors
- e. Ball Slider
- f. Rotating Swashplate Bearing

The Model 347 rotating swashplate and rotating drive scissors will be used with the following new components:

- a. Swashplate Adapter (Spacer ring between 347 rotating swashplate member and the existing RSRA swashplate bearing)
Material - 4340 Steel Plate, AMS 6359 Annealed 7.62 cm x 45.2 x 45.2 (3.0 in. x 18.0 in. x 18.0 in.)
- b. Retainer (Rotating Swashplate Bearing)
Material - 4340 Steel Plate, AMS 6359 Annealed 3.17 cm x 48.26 cm x 48.26 cm (1.25 in. x 19.0 in. x 19.0 in.)
- c. Pitch Link Assembly (4) Required
The pitch link assemblies are made up from existing CH-47 turn-buckle hardware and new extensions. The pitch link extension material will be;
15-5 PH Stainless Steel Forged Bar Solution Treated per AMS 5659 6.35 cm DIA x 60.96 cm (2.5 in. DIA. x 24.0 in.).
- d. Control Bellcranks (Amplifies Control Actuator Output Stroke) (3) Required
Note: These components will replace the existing bellcranks (P/N 72402-00413-041 & 042) to further amplify the control actuator output stroke.

The control bellcrank change is based upon RSRA trim characteristics presented by figure 4.4-1 (Ref. 11). Figure 4.4-2 is presented to more clearly visualize these characteristics. The aft C.G. condition is considered because it requires more forward cyclic control. In the 259 km/hr (140 knot) case, the angle between the swashplate and the tip path plane ($9\ 1/2^\circ$) is the flapping due to forward velocity. For zero velocity the tip path plane would be parallel to the swashplate. The longitudinal flapping ($-2\ 1/2^\circ$) shown exerts a nose down moment on the fuselage to balance the C.G. offset and the aerodynamic nose up moment on the fuselage. The 347 rotor with CH-47 blades will exert 10% more pitching moment on the fuselage per degree of flapping. This means that flapping can be reduced by 10% to maintain the moment and the same total tip plane tilt as required to achieve the forward speed.

GROSS WEIGHT = 8344 kg (18400 LB)
 SEA LEVEL STANDARD
 NO ROTOR HEAD FAIRING
 DRAG BRAKES CLOSED
 X HT = 20

808.99 cm (318.5") FSCG
 751.84 cm (296") FSCG

LONG FLAPPING,
DEGREES

LONGITUDINAL CYCLIC PITCH,
DEGREES

BODY PITCH ATTITUDE,
DEGREES

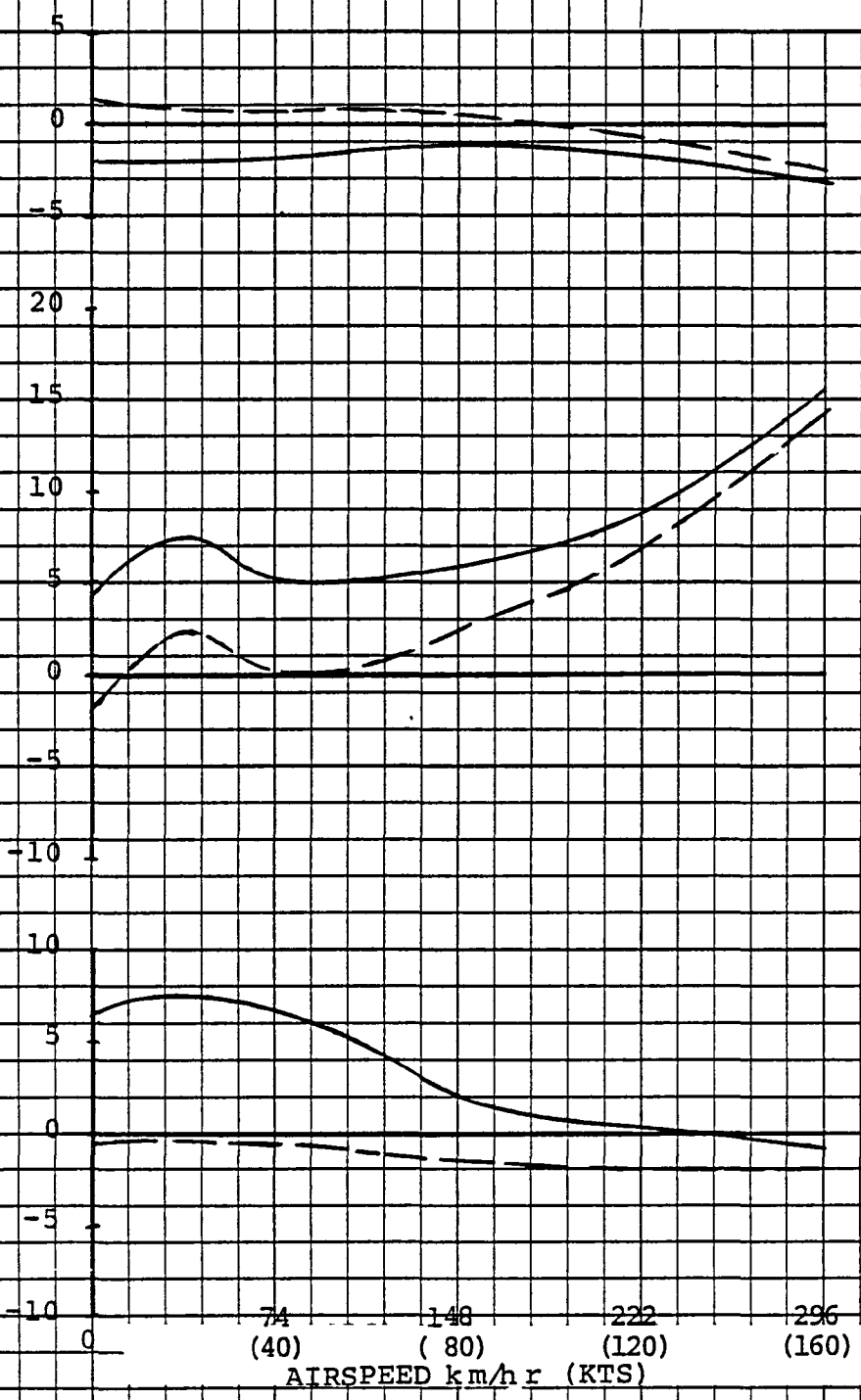

FIGURE 4.4-1 RSHA HELICOPTER TRIM
 (REF. 11 - FIGURE 50)

EUGENE DIETZGEN CO
 MADE IN U.S.A

NO 340R-5 DIETZGEN GRAPH PAPER
 5 X 5 PER INCH

AFT C.G. - 259 kg/hr
(140 KTS) A.S.
GROSS WT. = 8344 kg (18,400 LBS)

HORIZONTAL STABILIZER
INCIDENCE = 2° (LEADING EDGE UP)
(S-61 ROTOR)

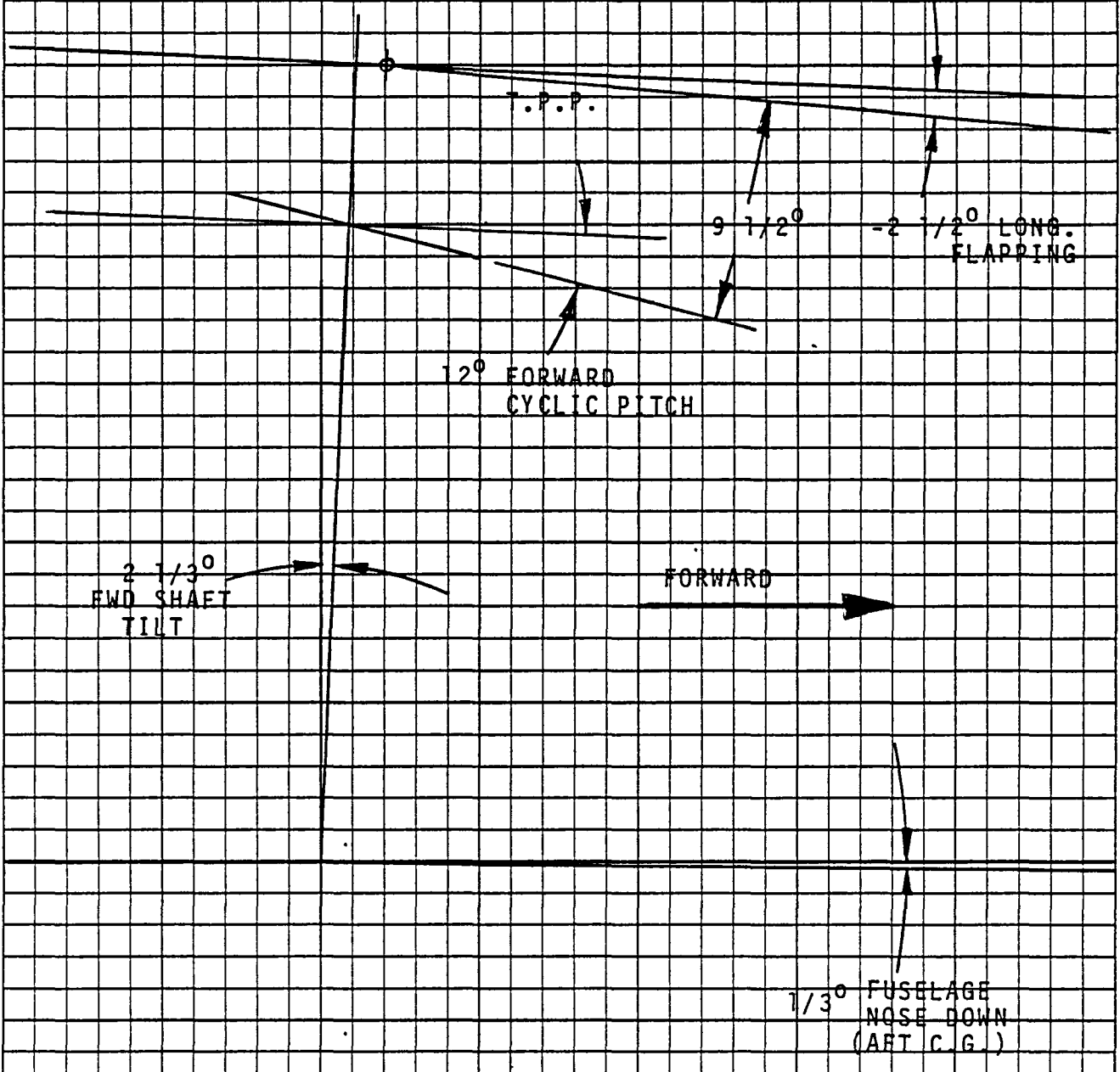

EUGENE DIETZEN CO
MADE IN U.S.A.

NO 340R-5 DIETZEN GRAPH PAPER
5 X 5 PER INCH

FIGURE 4.4-2 RSRA HELICOPTER LONGITUDINAL TRIM CONDITIONS

Further discussion of control requirements are detailed in the Stability and Control Analysis (paragraph 4.10).

Use of the 347/C (CH-47C Blades) rotor system yields similar twist, solidity and pitching moment per degree of flapping as that of the RSRA rotor and therefore similar trim.

Even though the 347/D rotor system results in a reduced cyclic throw that is less than that required for the 347/C or S-61 rotor system, and since it is probable that the parameter variation test program will require airspeeds greater than 259 km/hr (140 knots), and use of the 347/C rotor, the cyclic and collective pitch throws will be kept as near as possible to the original RSRA values by the addition of the new actuator output cranks.

The 347/D rotor system with the new actuator output crank will result in a 5% reduction in the RSRA longitudinal and lateral cyclic. The limiting factor is the amount of swashplate tilt permitted before there is interference with the transmission housing. Therefore, the resulting cyclic control motions are as follows:

$$\begin{array}{l} \text{Fwd. Long.} = .95(15^\circ) = 14.25^\circ \\ \text{Aft Long.} = .95(11^\circ) = 10.45^\circ \\ \text{Lateral} = .95(\pm 8^\circ) = \pm 7.6^\circ \end{array} \quad \text{Tot. Long.} = 24.7^\circ$$

The new actuator output crank changes the effective actuator stroke at the swashplate from the present stroke of 16.25 cm to 19.68 cm (6.4 inches to 7.75 inches). The resulting total collective pitch range is 14.58° compared to the present RSRA collective range of 15.5° . This may limit airspeed with the 347/C rotor due to forward stick control margin requirements. Also, the reduced collective pitch range will only slightly limit high altitude and high rate of climb maneuvers.

4.5 Transmission Modifications

The 347/D rotor system has been designed to operate at a nominal rotor speed of 225 rpm. Based on the RSRA systems handbook (reference 12) the RSRA rotor speed (203 rpm) may be increased by changing the main bevel gear and pinion mesh from the existing reduction ratio of 3.40 to 3.05.

This would require removing and replacing the main bevel gear and its driving pinion cartridge, P/N's S6137-23053-1 and S6137-23054-1, items 10 and 20 illustrated in figure 4.5-1. The tail rotor speed and the speeds of accessory equipment will be maintained by changing the gear ratio at the bevel mesh takeoff for the tail rotor shaft. This mesh change would require a change in the mesh between item 10 and 14 (P/N S6135-20871-1).

4.6 Blade Severance System

Teledyne McCormick Selph, the supplier of the RSRA emergency escape system, has submitted a proposal and quote (Proposal No. B100-80-393), presented in Appendix C, to conduct design and/or design updating to fully define the system and modifications, development testing, hardware procurement and assembly, verification testing and installation on the RSRA.

4.7 Aerodynamic Analysis

The primary aerodynamic effect of installing the 347/D rotor system on the RSRA will be to change the aircraft performance relative to the current test configuration with the S61 rotor installed. A comparison of the RSRA hover and forward flight performance with the 347/CH-47D and S61 rotors installed is presented below.

4.7.1 Hover OGE Performance

The RSRA hover power required at sea level/59°F with the 347/D and S61 rotor systems installed are presented in Figure 4.7.1-1. As shown, the 347/D rotor power required is less than the S61 installation at gross weight higher than 9070 kg (20,000 lbs) due to improved airfoils and increased twist. At weights below 9070 kg (20,000 lbs) the 347/D power required is higher than the S61 rotor due to increased profile power caused by the higher blade area and tip speed of the 347/D rotor.

D210-11723-3

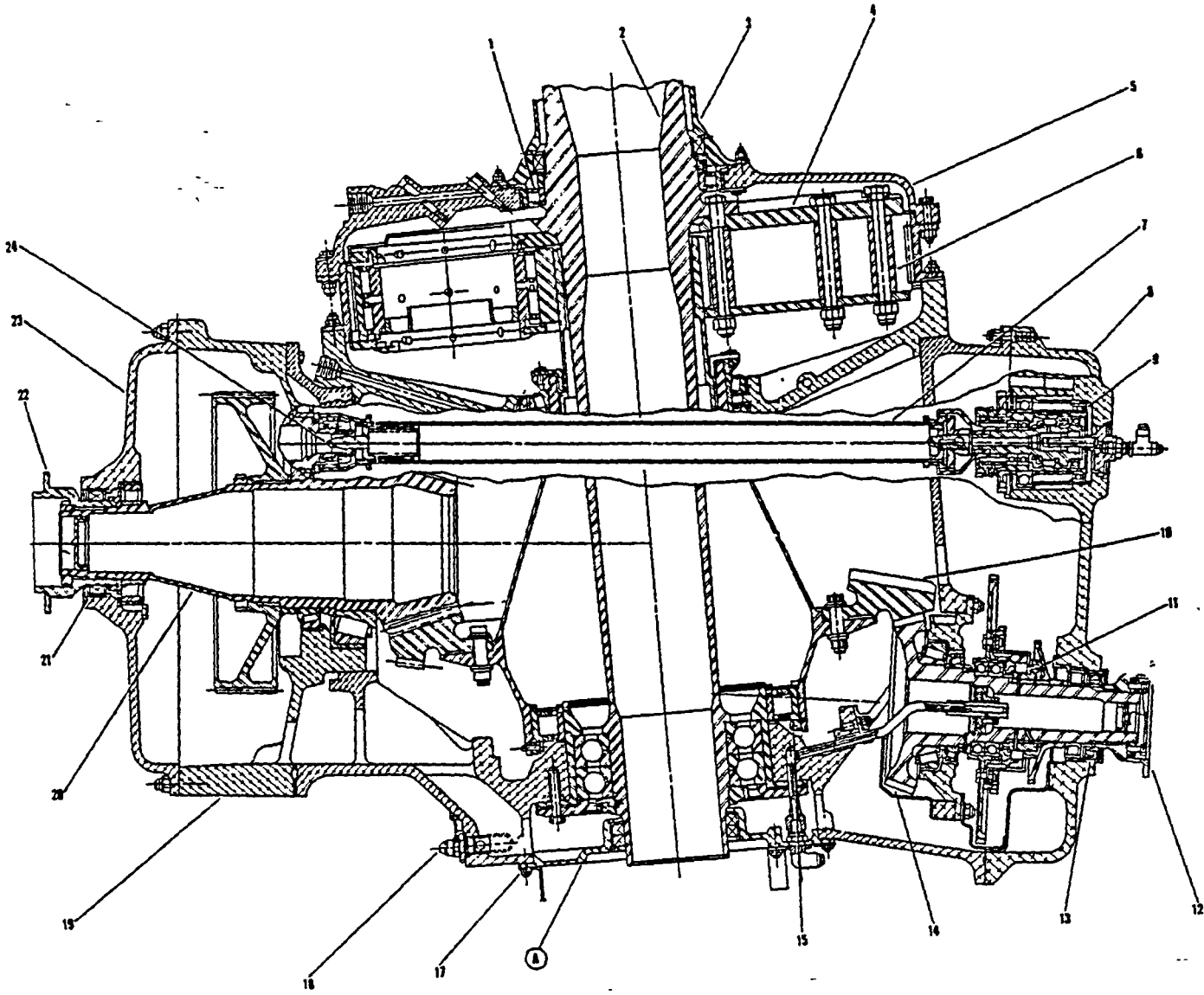
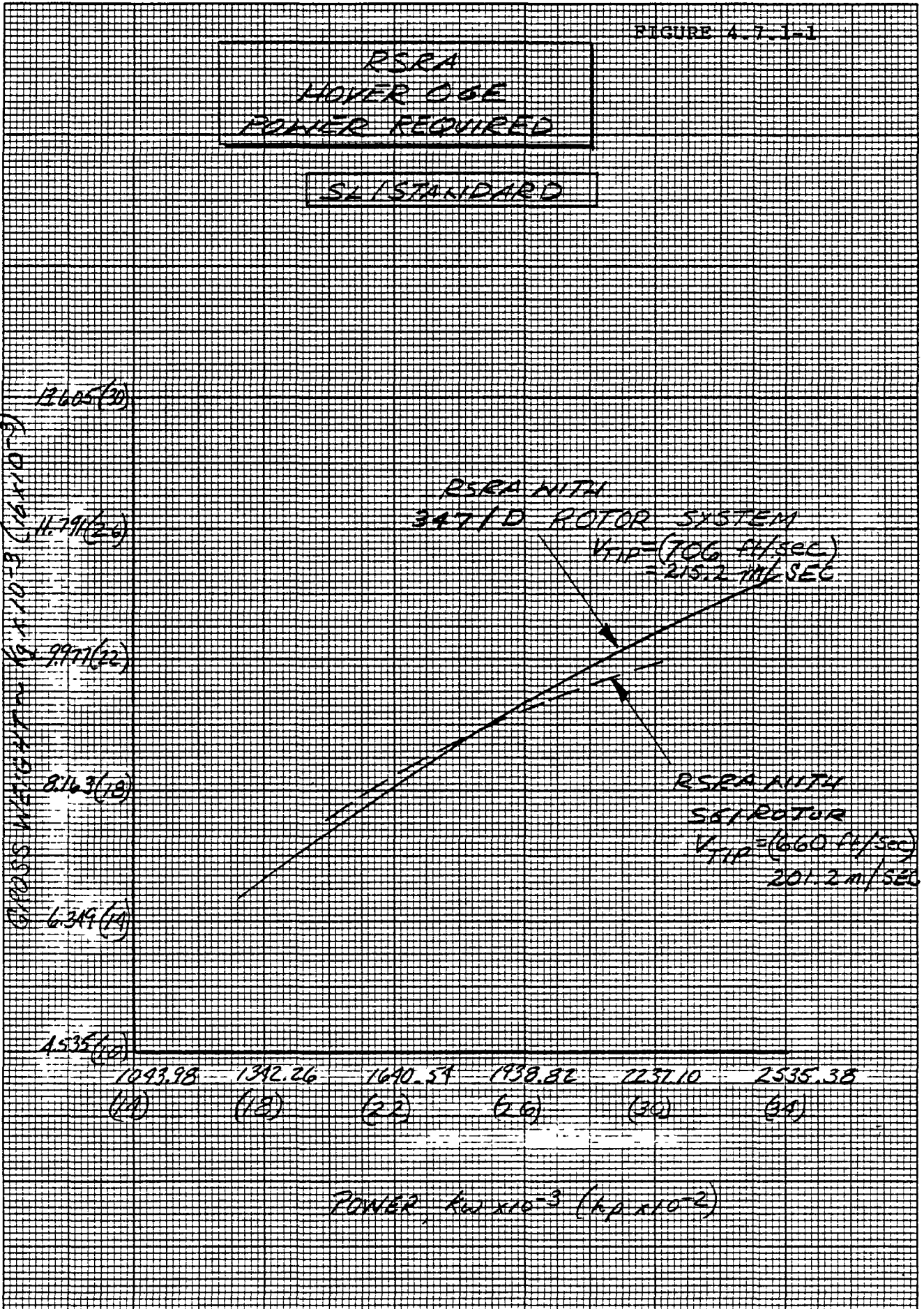

FIGURE 4.5-1 RSRA MAIN TRANSMISSION

FIGURE 4.7.1-1

RSRA
HOVER OGE
POWER REQUIRED

SL STANDARD



EUGENE DIETZGEN CO
MADE IN U.S.A.

NO 34DR-20 DIETZGEN GRAPH PAPER
20 X 20 PER INCH

The RSRA Standard Day hover ceiling with T58-GE-5 engines is presented in Figure 4.7.1-2. At sea level, the RSRA gross weight capability is 725.6 kg (1,600 lb) greater than the S61 rotor due to the lower power required of the 347/D rotor and increased transmission limit power available. The 30 minute transmission limit of 1864.25 kw (2500 hp) with the S61 rotor at 203 RPM increases to 2065.59 kw (2770 hp) for the 347/D rotor operating at 225 RPM. The tail rotor is assumed to operate at the same rotor speed as the S61 installation.

Hover power required for the 347/D rotor is based on the B92 vortex theory analyses. Tail rotor power required, download and transmission and accessory losses are obtained from reference 11.

4.7.2 Forward Flight Performance

The RSRA level flight power required at sea level/59°F is presented in Figure 4.7.2-1 for gross weights of 7250 kg (16,000 lb) and 9070 kg (20,000 lb.) At 7256 kg (16,000 lb) the 347/D rotor power required at 140 Kts is higher than the S61 level due to the increased solidity and tip speed. At 9070 kg (20,000 lb) the S61 cruise power required is considerably higher than the 347/D rotor due to rotor stall associated with the lower solidity and NACA 0012 airfoil configuration of the S61 rotor blade. The RSRA control system imposes a limit for the 347/D rotor system installation of 259 km/hr (140 Kts) noted in this figure and is applicable at all gross weights (see paragraph 4.8).

At minimum power airspeeds the 347/D power required is higher than the S61 power level because of increased solidity and tip speed. Higher minimum power required will reduce the Standard Day one engine inoperative (OEI) service ceiling as shown in Figure 4.7.2-2. At 609 m (2,000 ft) the 347/D-RSRA OEI gross weight capability will be 1496 kg (3,300 lb) less than the current S61 RSRA configuration. Comparison of the Hover OGE and OEI ceiling capability of the two rotors indicates that the S61 maximum takeoff weight will be limited by hover OGE capability unless an IGE takeoff procedure is used. The 347/D rotor maximum takeoff weight will be limited by OEI performance.

RSRA
HOVER CEILING
OGE

FIGURE 4.7.1-2

STANDARD DAY
T.O. POWER (5700 RPM)

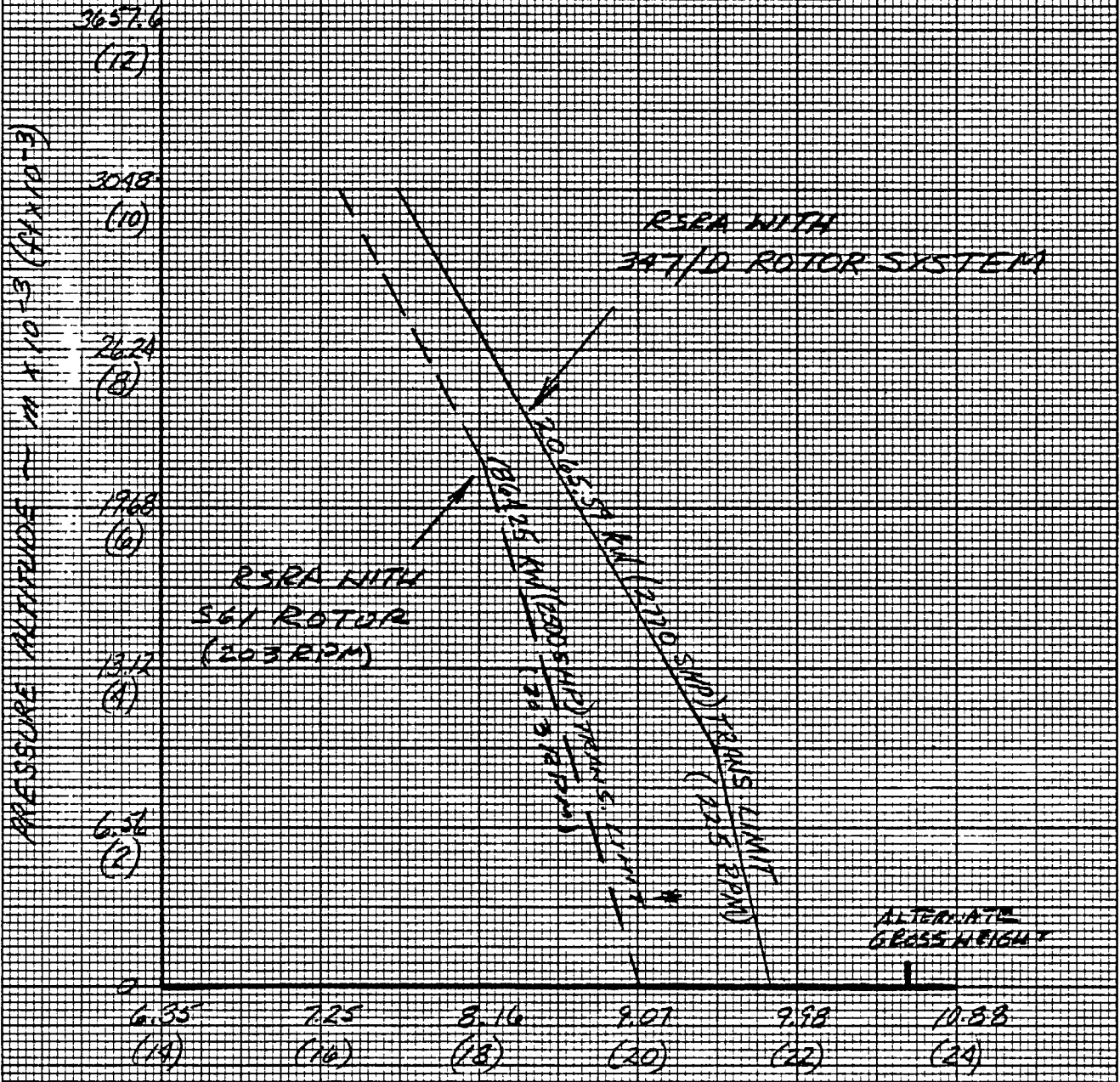

GROSS WEIGHT $\sim kg \times 10^{-3}$ (15×10^{-3})

* 30 MINUTE RATING

EUGENE DIETZGEN CO.
MADE IN U.S.A.

NO 34DR-20 DIETZGEN GRAPH PAPER
20 X 20 PER INCH

**RSRA
LEVEL FLIGHT
POWER REQUIRED
SL STANDARD**

FIGURE 4-1.2-1

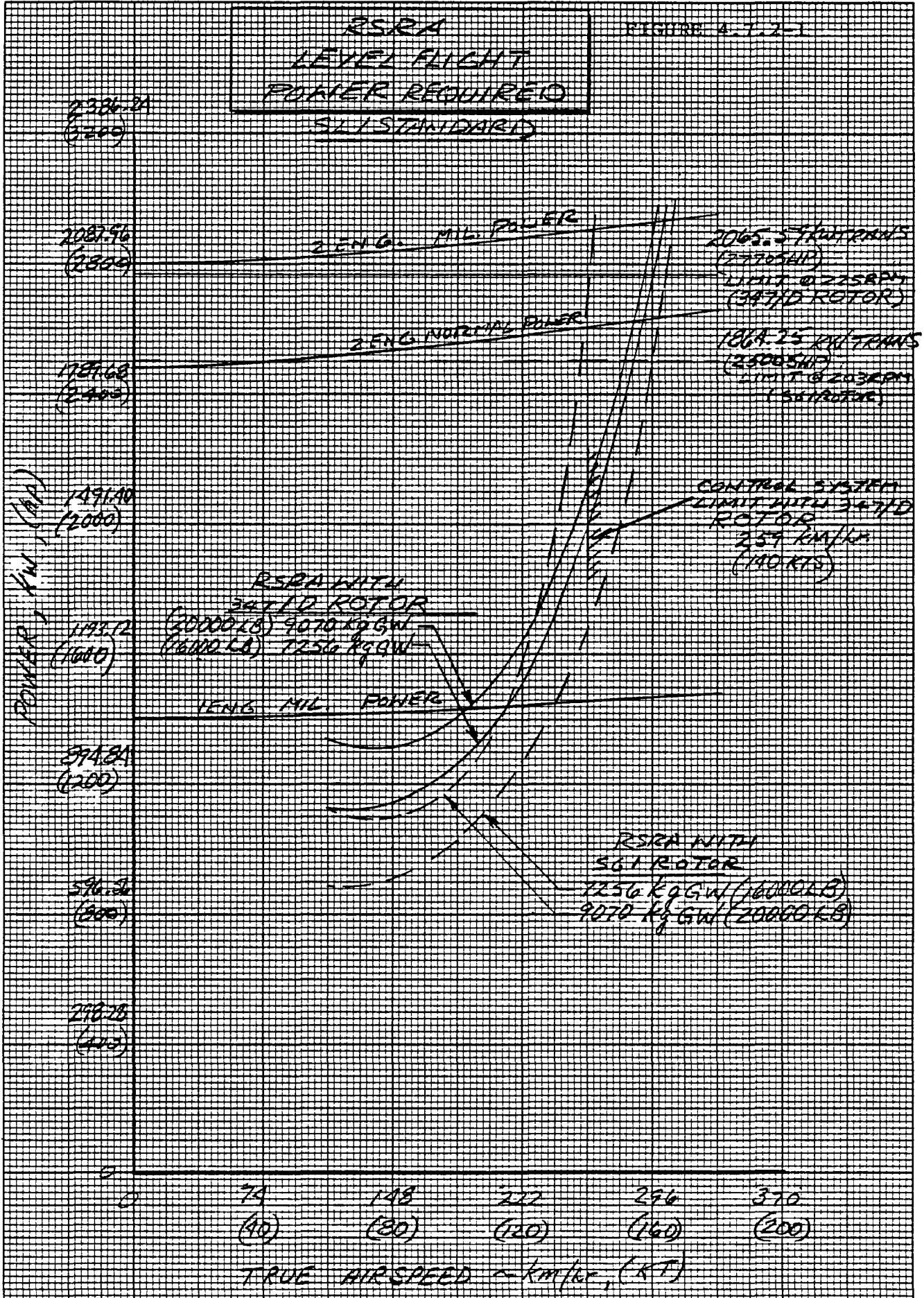

EUBENE DIETZGEN CO.
MADE IN U. S. A.

NO 340R-20 DIETZGEN GRAPH PAPER
20 X 20 PER INCH

**PSRA
SINGLE ENGINE
SERVICE CEILING**

FIGURE 4.7.2-2

STANDARD DAY

MILITARY POWER

PRESSURE ALTITUDE \sim 10^3 (ft $\times 10^{-3}$)

3.657
(12)

3.048
(10)

2.438
(8)

1.828
(6)

1.219
(4)

.609
(2)

6.349
(14)

7.256
(16)

8.163
(18)

9.07
(20)

9.977
(22)

10.884
(24)

PSRA MILITARY POWER
SINGLE ENGINE SYSTEM

PSRA MILITARY POWER

ALTERNATE
PSRA GWT

GROSS WEIGHT \sim $kg \times 10^{-3}$ (lb $\times 10^{-3}$)

EUGENE DIETZGEN CO.
MADE IN U. S. A.

NO 340R-20 DIETZGEN GRAPH PAPER
20 X 20 PER INCH

The 347/D-RSRA power required is derived using the Y92 trim analysis computer program. Y92 is a strip analysis that utilizes two dimensional airfoil section data defined in the Boeing transonic wind tunnel. Nonuniform downwash corrections based on the Vertol B67 forward flight vortex theory are included in the Y92 analyses. A parasite drag of 6.52m^2 (21.4ft^2) or $.45\text{m}^2$ (1.5ft^2) less than the S61 value of 6.97m^2 (22.9ft^2) defined in Reference 11 was used, reflecting a lower hub drag for the four bladed 347/D rotor.

4.8 Structural and Weight Analysis

Based on reference 5, the endurance limits of the RSRA stationary control system components will restrict the 347/D rotor system, as installed on the RSRA, to an airspeed of 259.25 km/hr (140 kts.) at flight conditions similar to those given for the pitch link load data presented by figure 4.8-1. The CH-47 flight conditions presented, resulted in loading on the forward rotor comparable to that to be experienced by the 347/D rotor system on the RSRA at a gross weight of 11337.5 kg ($25,000\text{ lb.}$).

In addition, rotor shaft bending limitations will restrict the 347/D rotor blades to ± 8 degrees of flapping at a 2.2% hinge offset or ± 7 degrees with a 5% hinge offset. This is primarily due to the increase in rotor height of 35.56 cm (14 inches). However, this restriction should not represent an important rotor limitation.

With the installation of the 347/D rotor system, there will be an increase in the total rotor system weight of approximately 267 kg (590 lb.). This estimate is based upon a stated weight for the existing RSRA main rotor system of 1046 kg (2307 lb.) per reference 12. It is assumed that this weight includes the swashplate assembly, Alpha - 1 linkages, pitch links and instrumentation.

4.9 Dynamics Analysis

4.9.1 Introduction

Computer analyses were conducted to determine blade, hub, and control system vibratory loads for a single rotor having a Model 347 hub and 4 CH-47D blades. This study was performed at the following conditions:

CH-47D FORWARD GREEN PITCH LINK LOAD

LEVEL FLIGHT 14965 kg GW, 53.34 cm FWD. (33000 (LBGW, 21) FWD)
 225RPM D-TRIM

- HD 914.4cm(3000 FT)
- ◇ HD 3048cm(10000 FT)
- HD 5486cm(18000 FT)

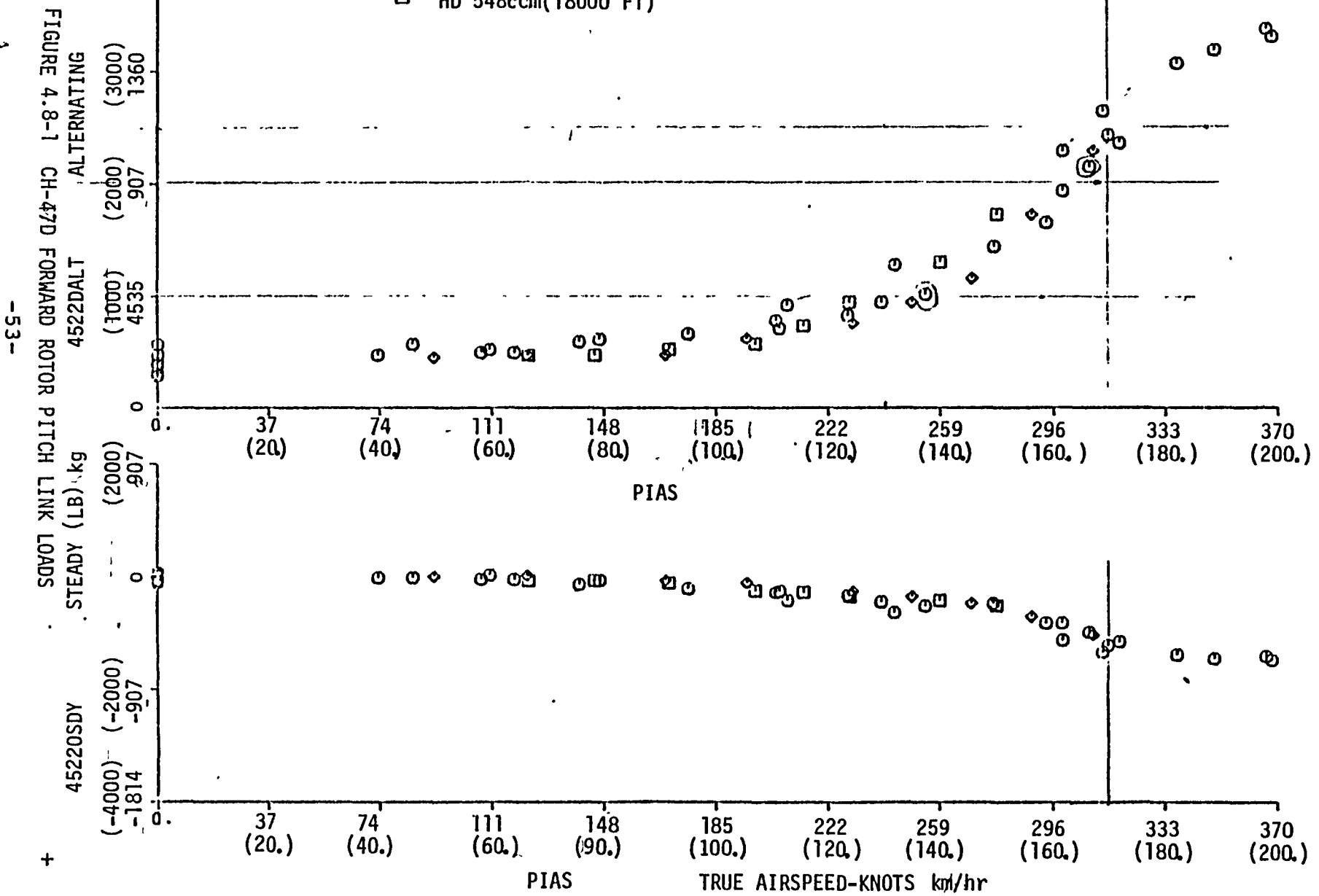

FIGURE 4.8-1 CH-47D FORWARD ROTOR PITCH LINK LOADS

Nominal Rotor Speed	= 225 RPM
Vehicle Gross Weight	= 8389 kg (18500 LB)
Nondimensional Propulsive Force	= .1
Maximum Forward Speed	= 277 km/hr (150 KTS)
Trim to Zero Flapping	

Rotor blade rotating natural frequencies, flutter, and divergence boundaries were calculated. In addition, the effect of increasing the blade third flap frequency on vibratory loads was investigated.

Although dynamic parameter variations such as blade natural frequency are proposed using CH-47C blades, the quantitative effects shown here for variation of third flap frequency are expected to be similar for CH-47C and CH-47D blades in four bladed configurations on the 347 hub at the same flight conditions on the RSRA.

4.9.2 Analysis Methodology

The computer simulations used for this study are programmed on the Boeing Vertol IBM 3033 and have been used extensively for research, production design support, and various correlation studies. Brief descriptions of the applicable programs are given in the following sections.

4.9.2.1 Blade Natural Frequency Analysis

Blade rotating natural frequencies were computed using a Boeing Vertol program called D-01. This lumped mass rotating beam analysis calculates coupled flap/torsion and uncoupled chord modes and frequencies. The effect of control system collective pitch stiffness is included.

4.9.2.2 Blade, Hub and Control Loads

Blade, hub and control system loads were calculated using Boeing computer program C-60. This analysis considers coupled flapwise - torsion deflections and uncoupled chordwise motions of the rotor blades. The blade is represented by 20 lumped masses interconnected in series by elastic elements. Bound-

ary conditions for either articulated or hingeless rotors are applied and the solution obtained by expanding the variables in a 10-harmonic Fourier series.

Airload calculations include the effects of airfoil section geometry, compressibility, stall, three-dimensional flow, unsteady aerodynamics and nonuniform inflow. Static airfoil tables are used to account for compressibility, static stall, and airfoil shape. The unsteady aerodynamic loads are calculated by modifying the static loads resulting from the airfoil tables to include Theodorsen's shed-wake function, dynamic stall effects based on oscillating airfoil data, and yawed flow across the blade.

The nonuniform inflow calculations are based on a tip and root vortex trailed from each blade. Through an iterative technique, each trailed vortex is made compatible with the calculated blade lift distribution, and the lift distribution is compatible with the nonuniform downwash field. The vortex wake is assumed to be rigid and drift relative to the hub with a constant resultant velocity composed of thrust-induced uniform downwash and aircraft airspeed.

4.9.2.3 Blade Flutter and Divergence

Critical flutter and divergence speeds were calculated using a rotating beam analysis with aerodynamics called L-01. The theoretical basis of this program is the lumped parameter method of analysis employing finite difference equations to relate the dynamic aeroelastic quantities of adjacent rotor stations. Rotor natural frequencies are obtained by satisfaction of the root boundary conditions. A classical flutter analysis is made using the coupled flap bending and torsion modes. The analysis employs generalized coordinates and the Theodorsen unsteady aerodynamic theory.

4.9.3 Baseline Rotor Loads

Vibratory loads were calculated for the Model 347 baseline hub with four CH-47D blades at 225 RPM rotor speed, forward speeds of 74 km/hr (40 kt), 148 km/hr (80 kt), 222 km/hr (120 kt), 277 km/hr (150 kt) and .1 nondimensional propulsive force. The rotor was trimmed to zero longitudinal and lateral flapping. A vehicle gross weight of 8389 kg. (18,500 lb) was simulated.

4.9.3.1 Hub Vibratory Loads

4/rev vibratory hub loads versus forward speed are presented in figures 4.9.3-1 through 4.9.3-5. These data show the following trends:

- a. Vertical and side forces increase with increasing values of forward speed.
- b. Normal force and pitching moment increase up to 148 km/hr (80 kts), decrease from 148 km/hr (80 kts) to 222 km/hr (120 kts), and then increase rapidly with increasing forward speed above 222 km/hr (120 kts).
- c. Roll moment increases up to 148 km/hr (80 kts) then decreases up to 277 km/hr (150 kts), the maximum airspeed investigated.

4.9.3.2 Blade Alternating Loads

Alternating blade loads versus nondimensional blade radius at 74 km/hr (40 kts), 148 km/hr (80 kts), 222 km/hr (120 kts), and 277 km/hr (150 kts) forward speed are presented in figures 4.9.3-6 through 4.9.3-8. All blade loads are well below the endurance limit. These data show the following trends:

- a. Alternating flap bending, chord bending, and torsion bending moments increase with increasing forward speed.
- b. Alternating flap bending moments are maximum near $.57R$ and decrease to zero at the blade tip and flap hinge location.
- c. Alternating chord bending moments are also maximum near $.57R$ and decrease to zero at the blade tip.
- d. Alternating torsion bending moments increase inversely with nondimensional blade radius, and are maximum near the pitch arm.

347 HUB/4 CH-47D BLADES

G.W. = 8389 kg (18,500 LBS)

$\bar{X} = .10$

$\beta_{1c} \ \& \ \beta_{1s} = 0$

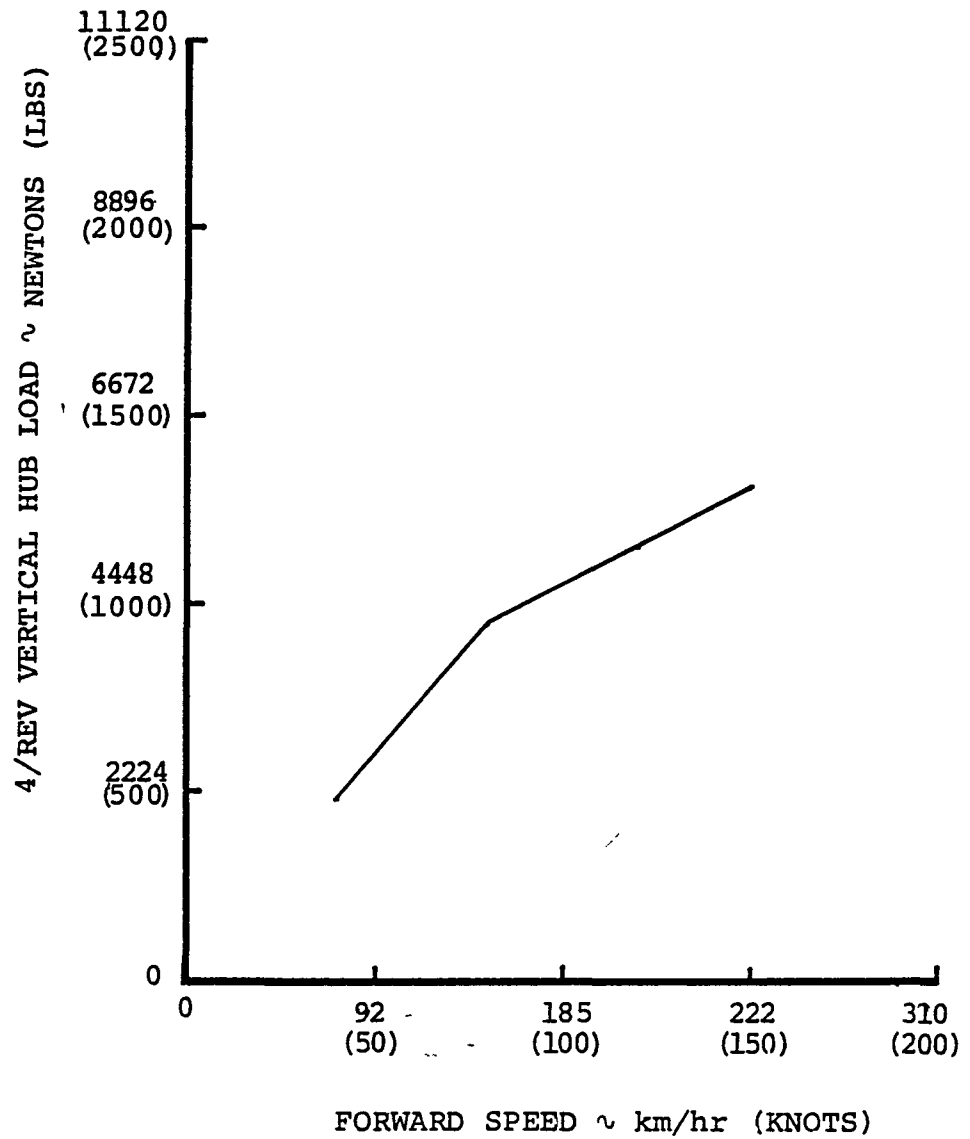

FIGURE 4.9.3-1 4/REV VERTICAL HUB LOAD VS FORWARD SPEED.

347 HUB/4 CH-47D BLADES

$\overline{G.W.} = 8389 \text{ kg (18,500 LBS)}$

$\overline{X} = .10$

$\beta_{ic} \ \& \ \beta_{ls} = 0$

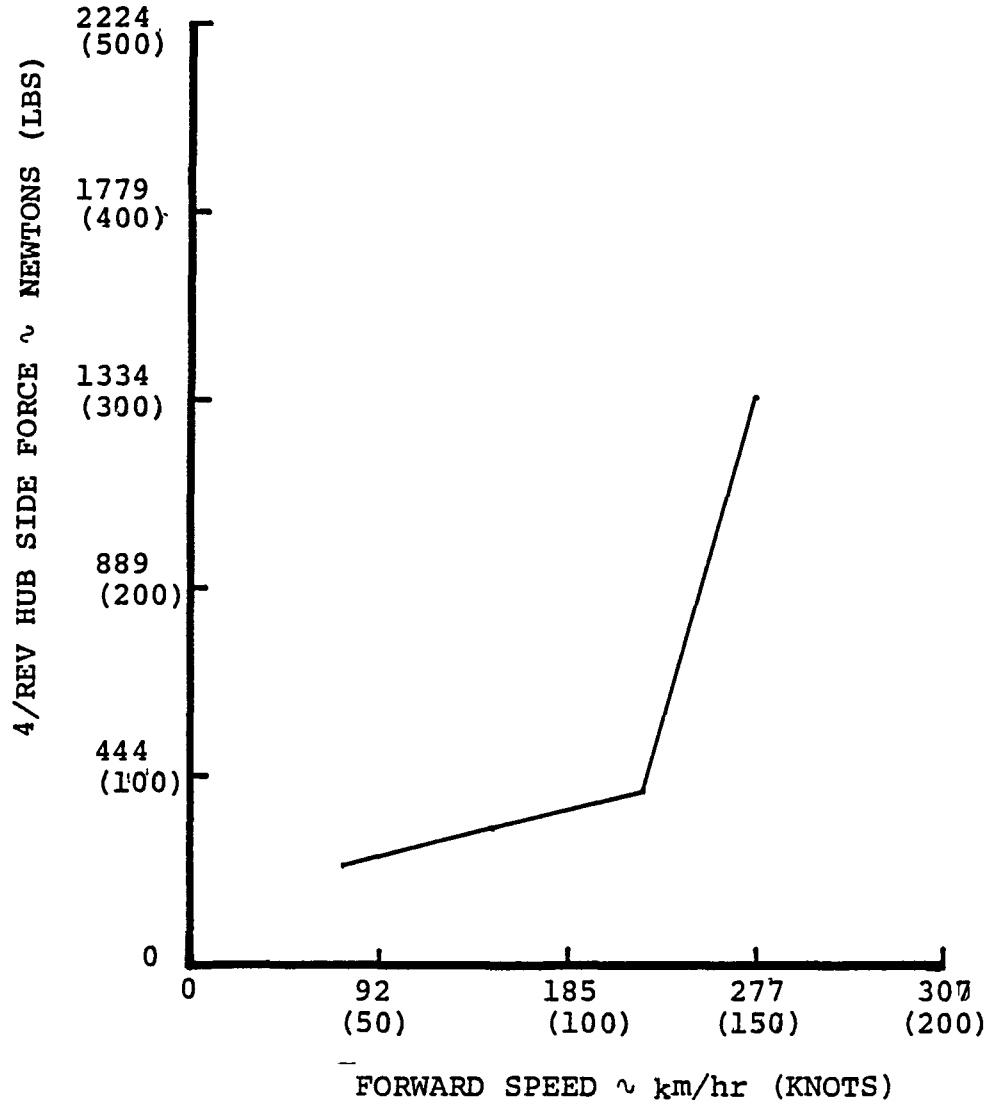

FIGURE 4.9.3-2 4/REV HUB SIDE FORCE VS FORWARD SPEED

347 HUB/4 CH-47D BLADES

G.W. = 8389 kg (18,500 LBS)

$\bar{X} = .10$

$\beta_{1c} \ \& \ \beta_{1s} = 0$

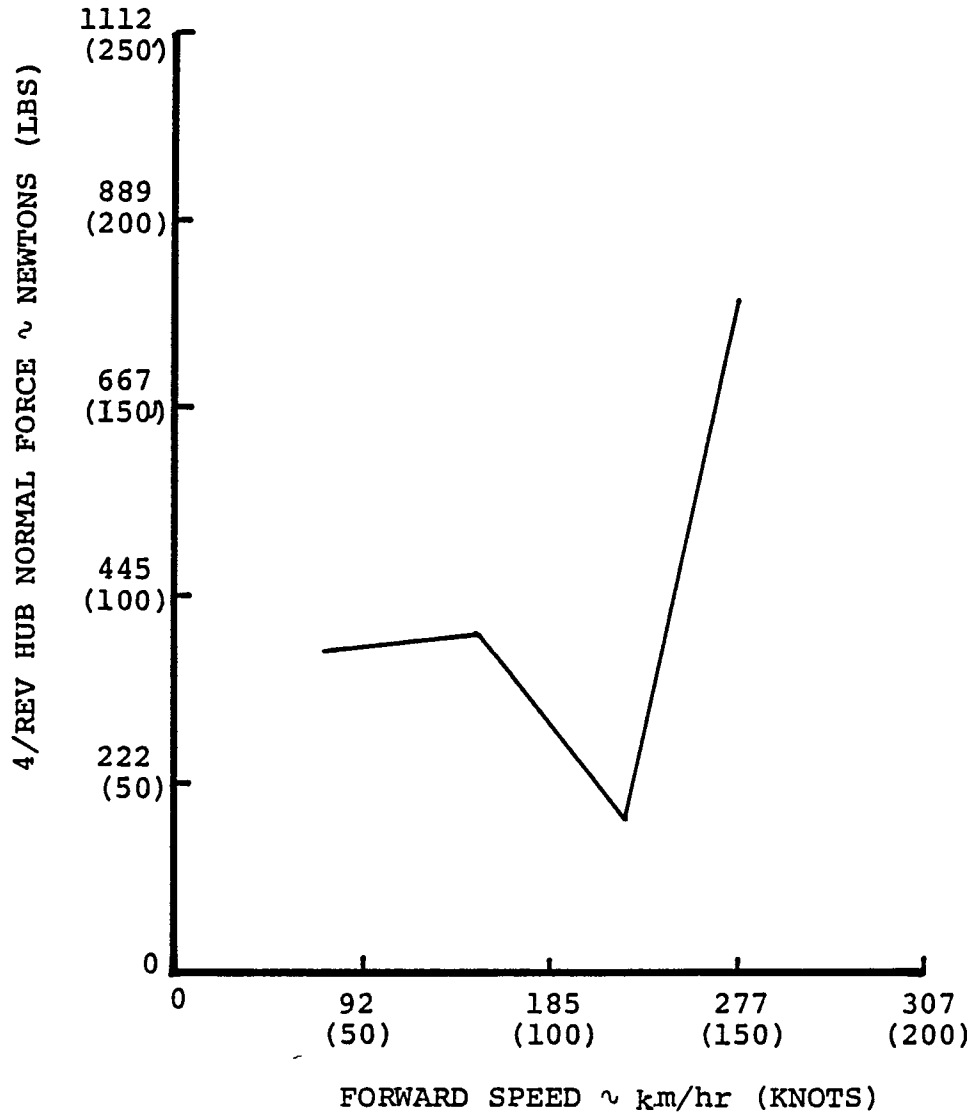

FIGURE 4.9.3-3 4/REV HUB NORMAL FORCE VS FORWARD SPEED

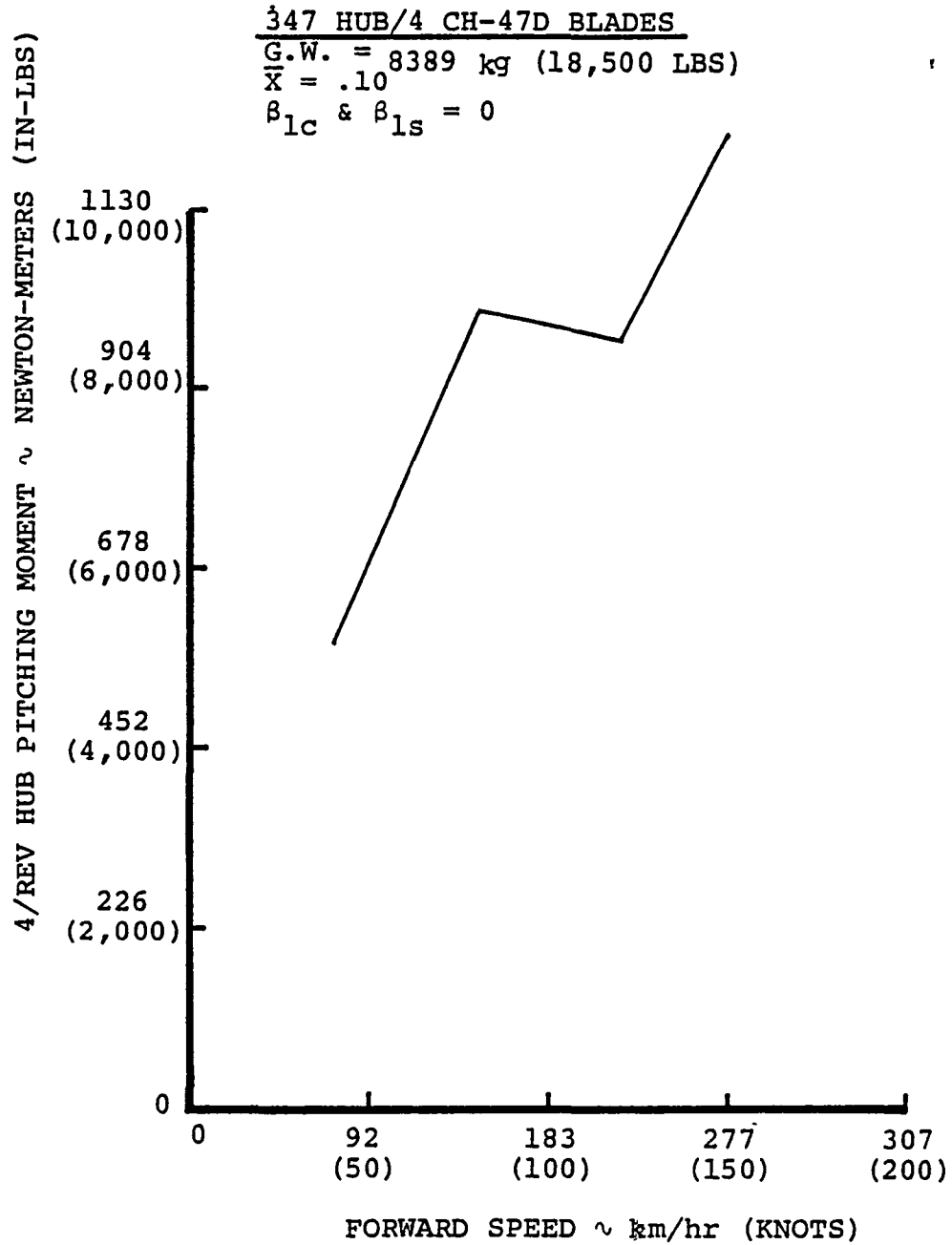

FIGURE 4:9.3-4 4/REV HUB PITCHING MOMENT VS FORWARD SPEED

347 HUB/4 CH-47D BLADES

G.W. = 8389 kg (18,500 LBS)

$\bar{X} = .10$

$\beta_{1c} \ \& \ \beta_{1s} = 0$

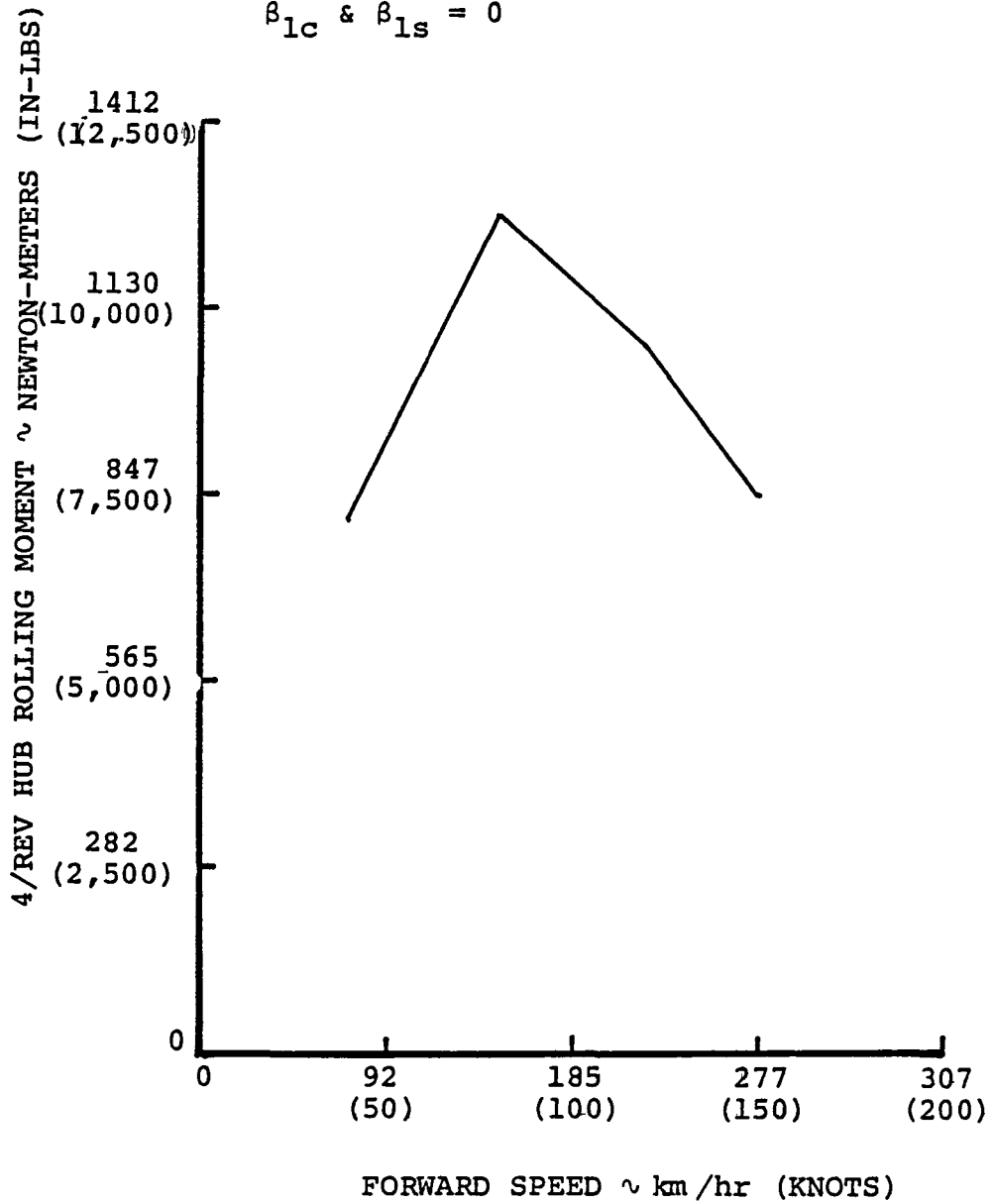

FIGURE 4.9.3-5 4/REV HUB ROLLING MOMENT VS FORWARD SPEED

347 HUB/4 CH-47D BLADES

G. W. = 8389 kg (18,500 LBS)

$\bar{X} = .10$

$\beta_{lc} \text{ \& } \beta_{ls} = 0$

ALTERNATING FLAP BENDING MOMENT ~ NEWTON-METERS (IN-LBS)

ENDURANCE LIMIT
263001 NEWTON-METERS
(59128 IN-LBS) @ .7R

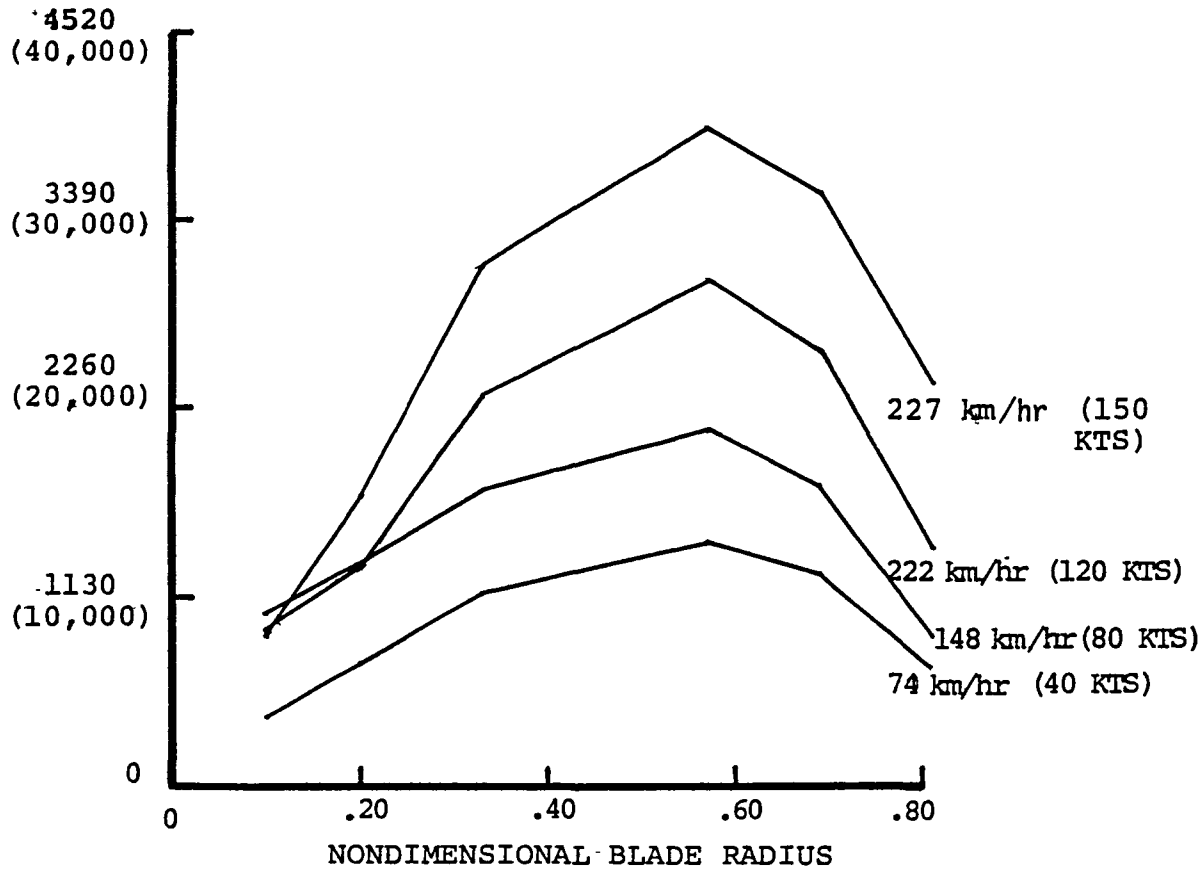

FIGURE 4.9.3-6 ALTERNATING FLAP BENDING MOMENT VS N.D. BLADE RADIUS AT V = 74 (40), 148 (80), 222 (120) 277 km/hr (150 KTS)

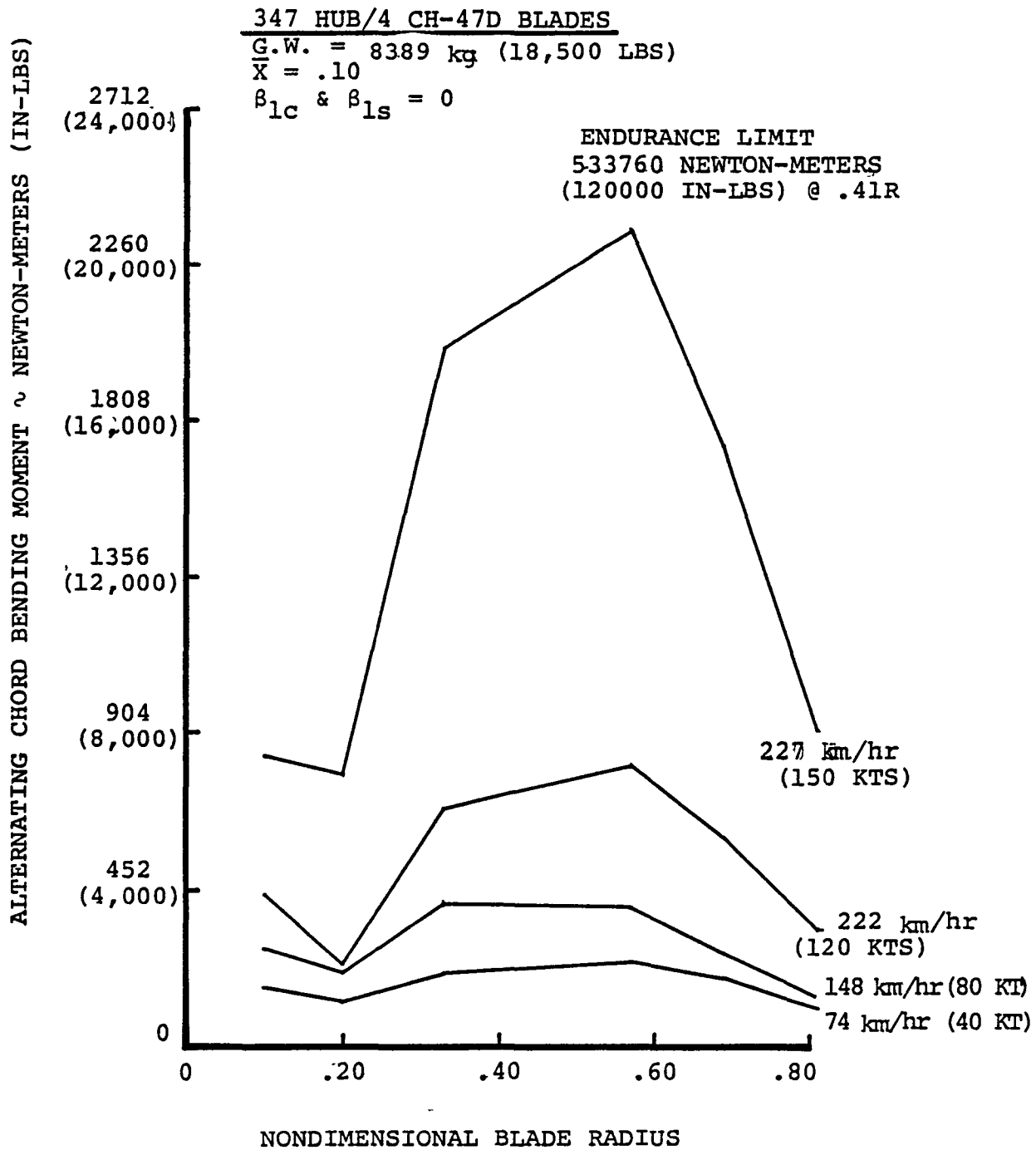

FIGURE 4.9.3-7 ALTERNATING CHORD BENDING MOMENT VS N.D. BLADE RADIUS AT V = 74 (40), 148 (80), 222 (120), and 227 km/hr (150 KTS.)

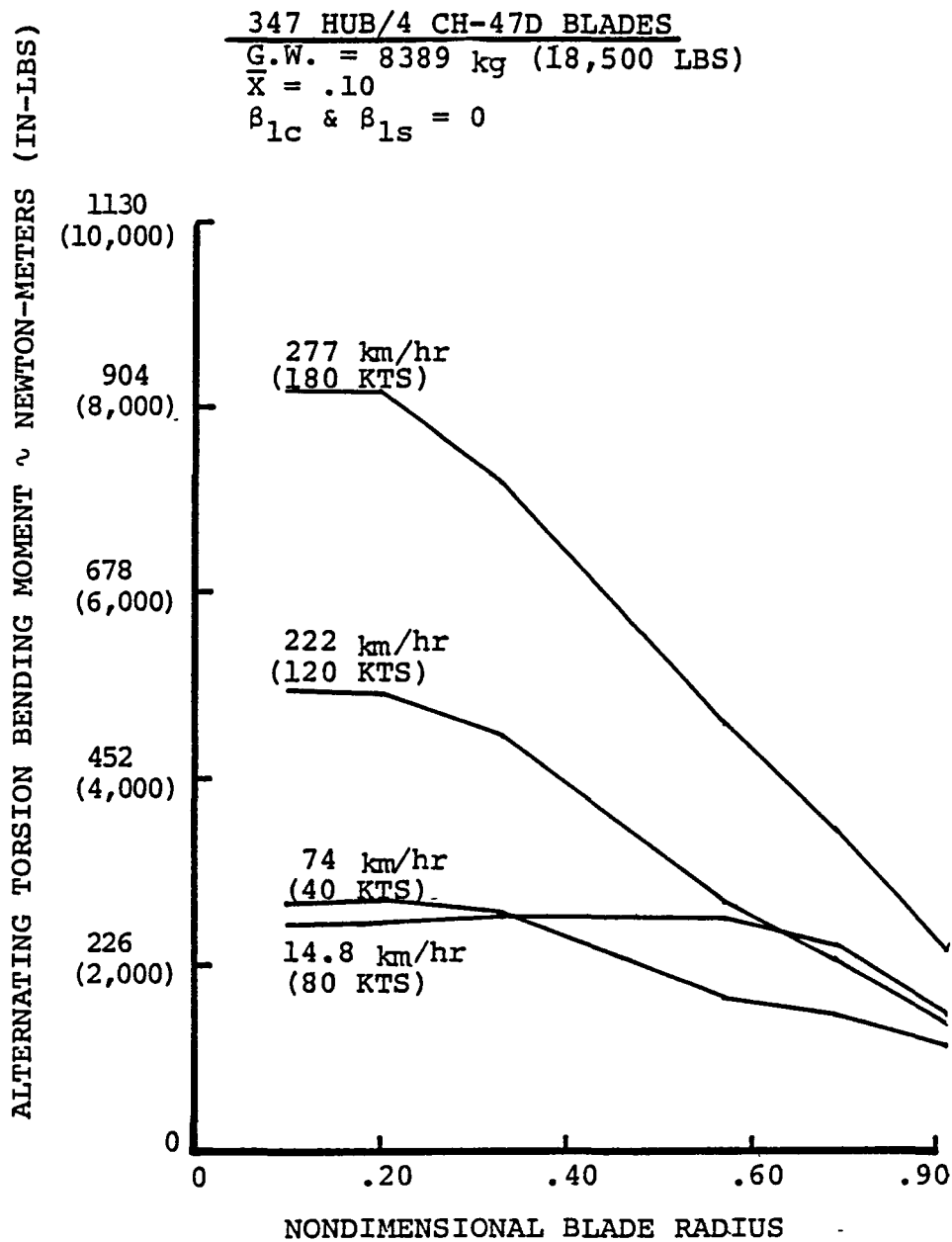

FIGURE 4.9.3-8 ALTERNATING TORSION BENDING MOMENT VS N.D. BLADE RADIUS AT V = 74 (40), 148 (80), 222 (120), AND 277 km/hr (150 KTS.)

4.9.3.3 Control System Loads

Steady and alternating pitch link loads versus forward speed are presented in figure 4.9.3-9. These data show that both the steady and alternating components of the load increase in magnitude with increasing forward speed.

4.9.4 Stability and Divergence

Rotor stability and divergence was investigated for rotor speeds from 150 RPM to 300 RPM, including the nominal speed of 225 RPM. Blade pitch control flexibility was varied by ± 60 percent to determine the sensitivity of this important parameter. For all conditions analyzed the blade was free from flutter and static divergence.

4.9.5 Blade Natural Frequencies

The natural frequency spectrum for the baseline CH-47D composite blade is shown in figure 4.9.5-1. The effect of adding tuning weights on the blade 3rd flap frequency was analytically investigated using the D-01 blade natural frequency computer program. In addition, the effect of this modal frequency placement on hub, control system, and blade loads was determined.

4.9.5.1 Effect of Tuning Weights on Blade Frequency

Blade tuning weights were added at .25R and .90R to determine their effect on the blade 3rd flap frequency. The results of this study are presented in Figure 4.9.5-2. These data show the following:

- a. Adding weight at .25R reduces the 3rd flap frequency. This location is anti-nodal, but does not significantly effect the centrifugal stiffening because of its proximity to the axis of rotation.
- b. Adding weight at .90R increases the 3rd flap frequency. This location is close to a node, but the centrifugal stiffening effect is significant because the weight is positioned at an outboard location.

347 HUB/4 CH-47D BLADES

G.W. = 8389 kg (18,500 LBS)

$\bar{X} = .10$

$\beta_{1c} \ \& \ \beta_{1s} = 0$

ENDURANCE LIMIT
+ 10096 NEWTONS
(+ 2270 LB)

— ALTERNATING

- - - STEADY

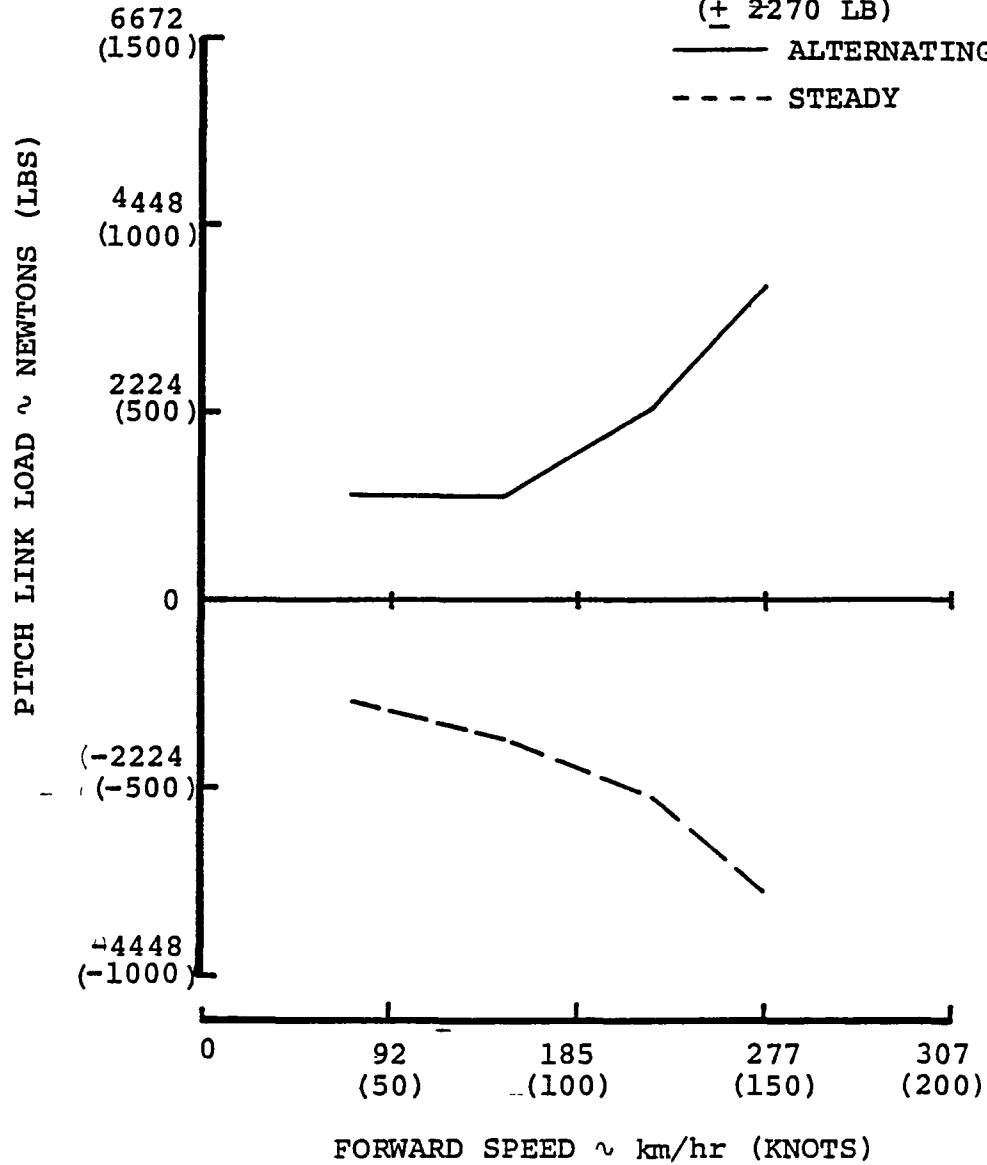

FIGURE 4.9.3-9 STEADY AND VIBRATORY PITCH LINK LOAD VS FORWARD SPEED

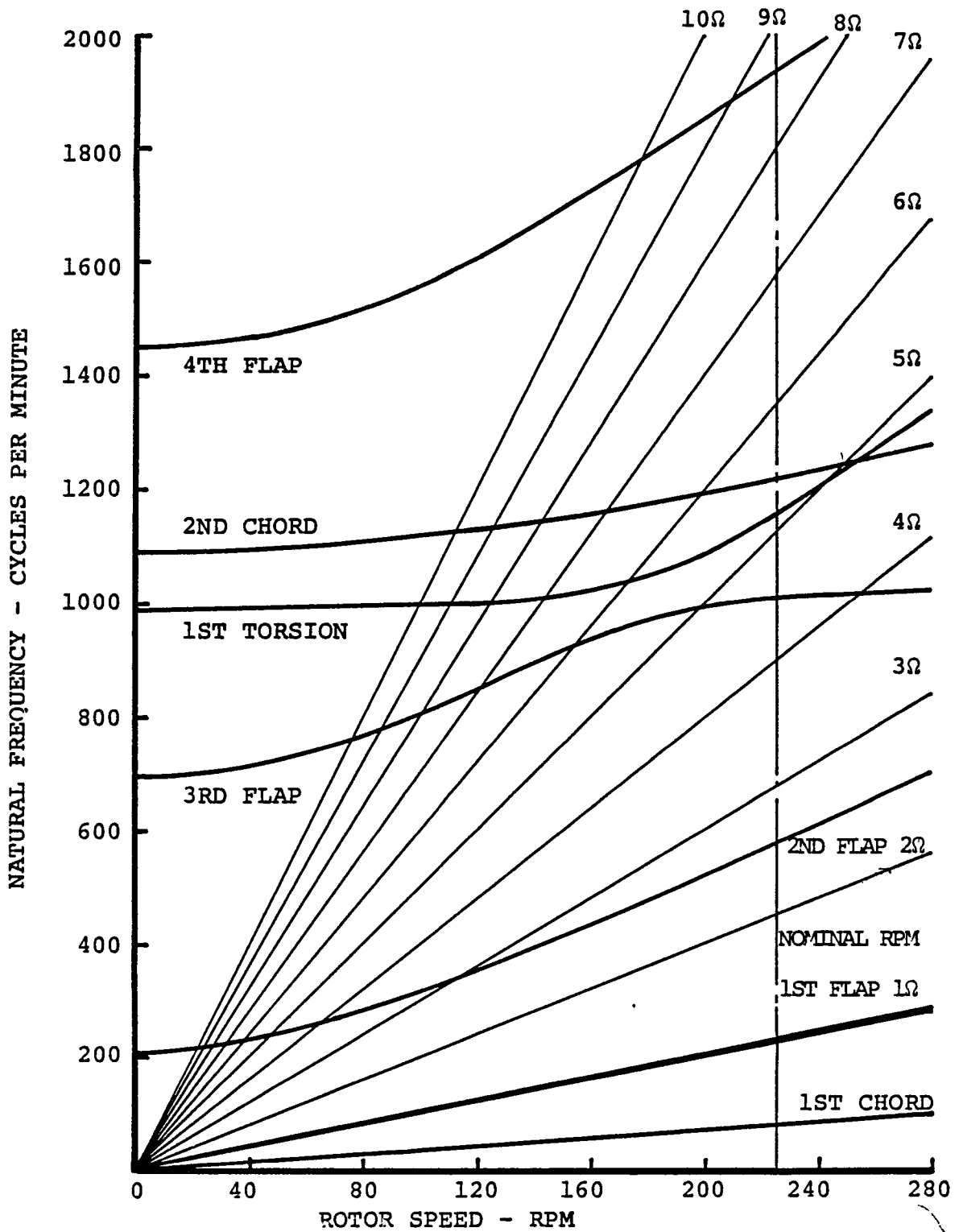

FIGURE 4.9.5-1 BLADE NATURAL FREQUENCY SPECTRUM,
CH-47D COMPOSITE ROTOR BLADE

CH-47D FIBERGLASS ROTOR BLADE

● ROTOR SPEED = 225 RPM

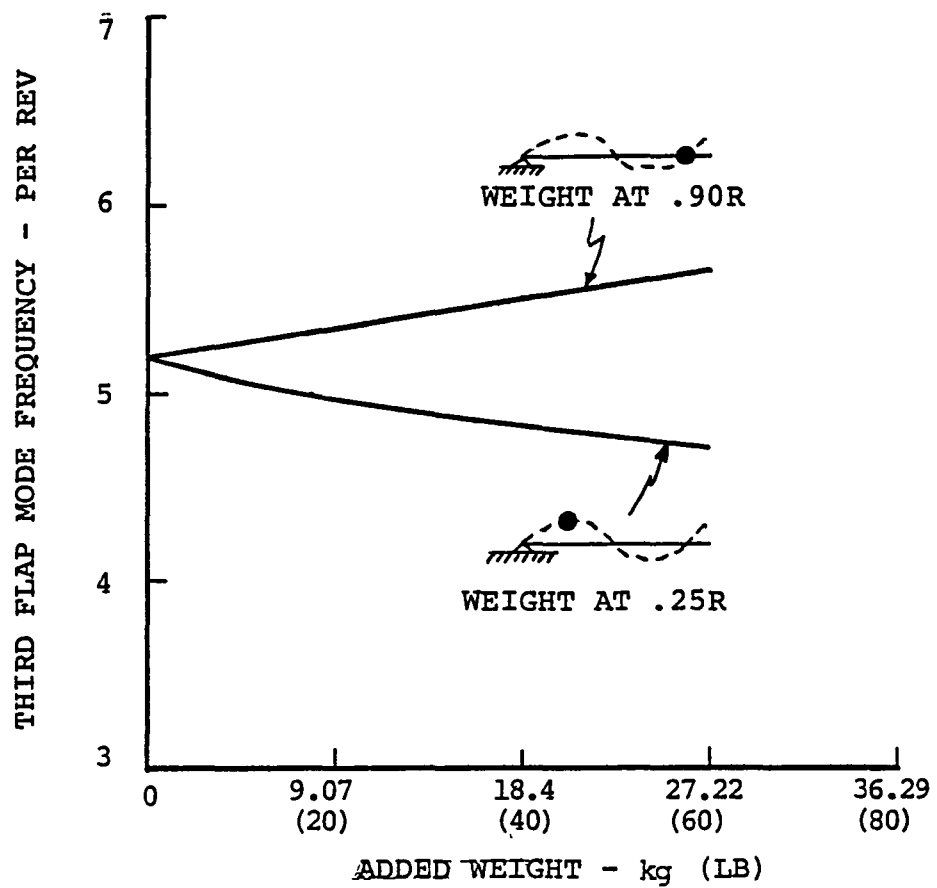

FIGURE 4.9.5-2 EFFECT OF ADDED WEIGHT ON BLADE THIRD FLAP MODE FREQUENCY

4.9.5.2 Effect of 3rd Flap Frequency on Rotor Loads

The effect of the third flap mode natural frequency placement on blade and hub shaking forces was analytically investigated. Calculations were made at 277 km/hr (150 kts) forward speed and 225 RPM, the nominal rotor speed. 4/rev vibratory hub loads versus non-dimensional blade 3rd flap frequency are presented in figures 4.9.5-3 through 4.9.5-7. These data show the following trends:

- a. Vertical and side forces are maximum when the 3rd flap frequency is near 5Ω and minimum when it is shifted up in frequency to approximately 5.6Ω .
- b. Normal force is minimum when the 3rd flap frequency is on 5Ω and increases in magnitude when the mode is raised or lowered in frequency relative to 5Ω .
- c. Pitching and rolling moments are minimum when the 3rd flap frequency is near 5.2Ω and increase with increasing values of frequency.

As shown in Figure 4.9.5-8, steady and alternating pitch link loads are not significantly affected by the frequency placement of this mode.

Figure 4.9.5-9 shows alternating flap bending moment versus non-dimensional blade radius. These data show that flap bending moments are maximum when the blade 3rd flap frequency is tuned near 5Ω and decrease with increasing values of frequency.

4.10 Stability and Control Analysis

This section evaluates the use of the 347/D or 347/C rotor systems on the RSRA and how well they meet the significant flying qualities requirements of specification MIL-H-8501A (Reference 19). This analysis made use of the Boeing Vertol (BV) computer program Y-92 which contains a strip integration analysis of the rotor with airfoil tables complete with mach and stall effects.

347 HUB/4 CH-47D BLADES

G.W. = 8389 kg (18,500 LBS)

V = 277 km/hr (150 KNOTS)

 $\Omega = 225$ RPM $\bar{X} = .10$ $\beta_{1c} \text{ \& } \beta_{1s} = 0$ 

FIGURE 4.9.5-3 4/REV HUB VERTICAL FORCE VS THIRD FLAP FREQUENCY.

347 HUB/4 CH-47D BLADES

G.W. = 8389 kg (18,500 LBS)

V = 277 km/hr (150 KNOTS)

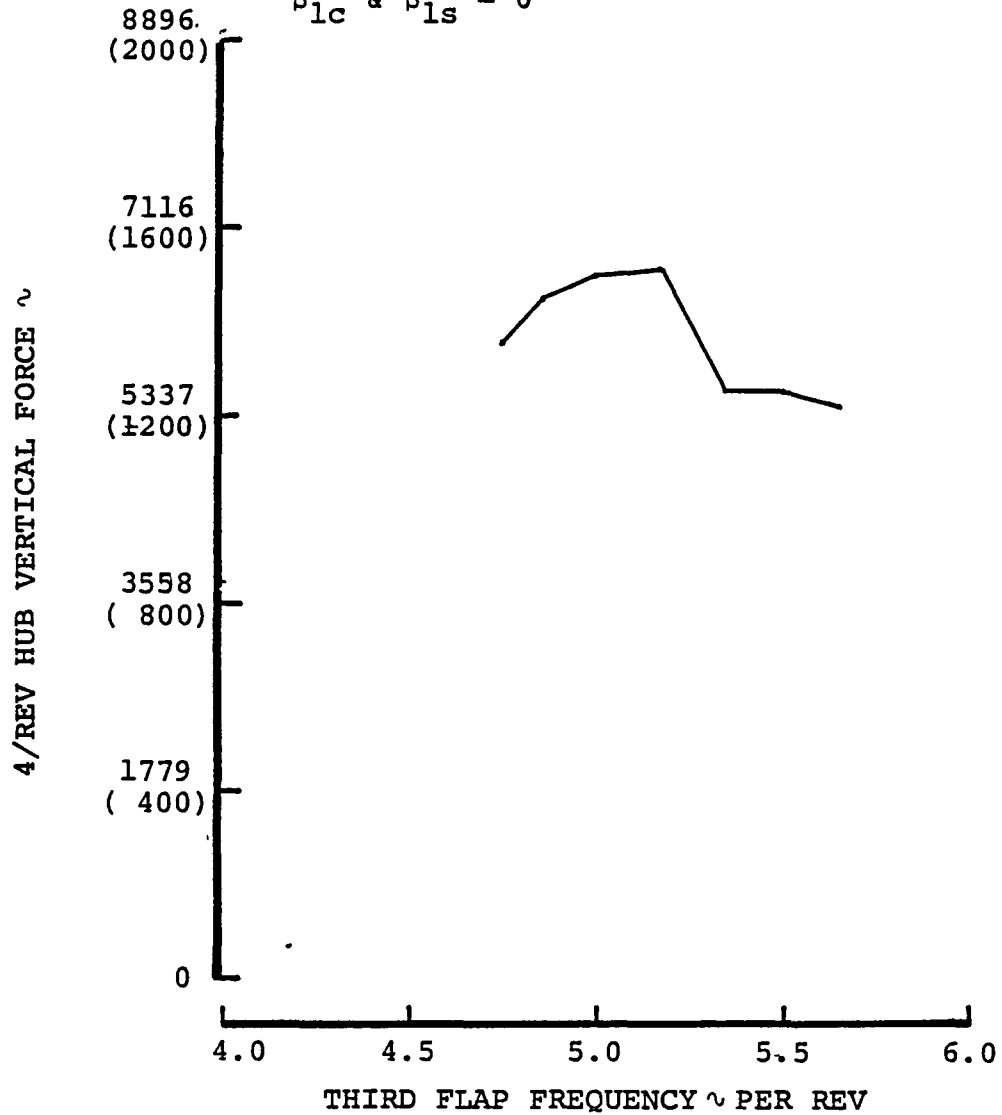
Ω = 225 RPM

\bar{X} = .10

β_{1c} & β_{1s} = 0

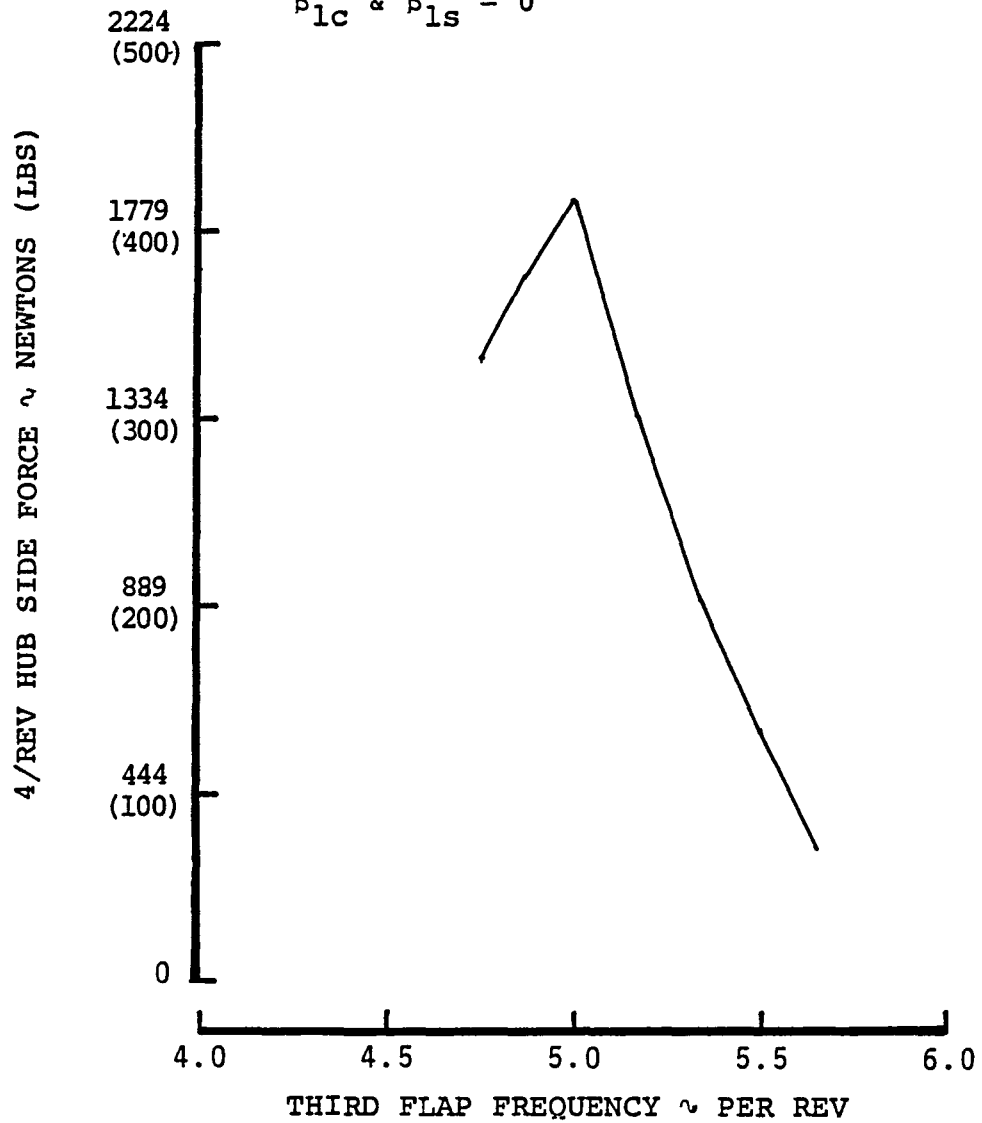

FIGURE 4.9.5-4 4/REV HUB SIDE FORCE VS THIRD FLAP FREQUENCY

347 HUB/4 CH-47D BLADES

G.W. = 8389 kg (18,500 LBS)

V = 227 km/hr (150 KNOTS)

Ω = 225 RPM

\bar{X} = .10

β_{1c} & β_{1s} = 0

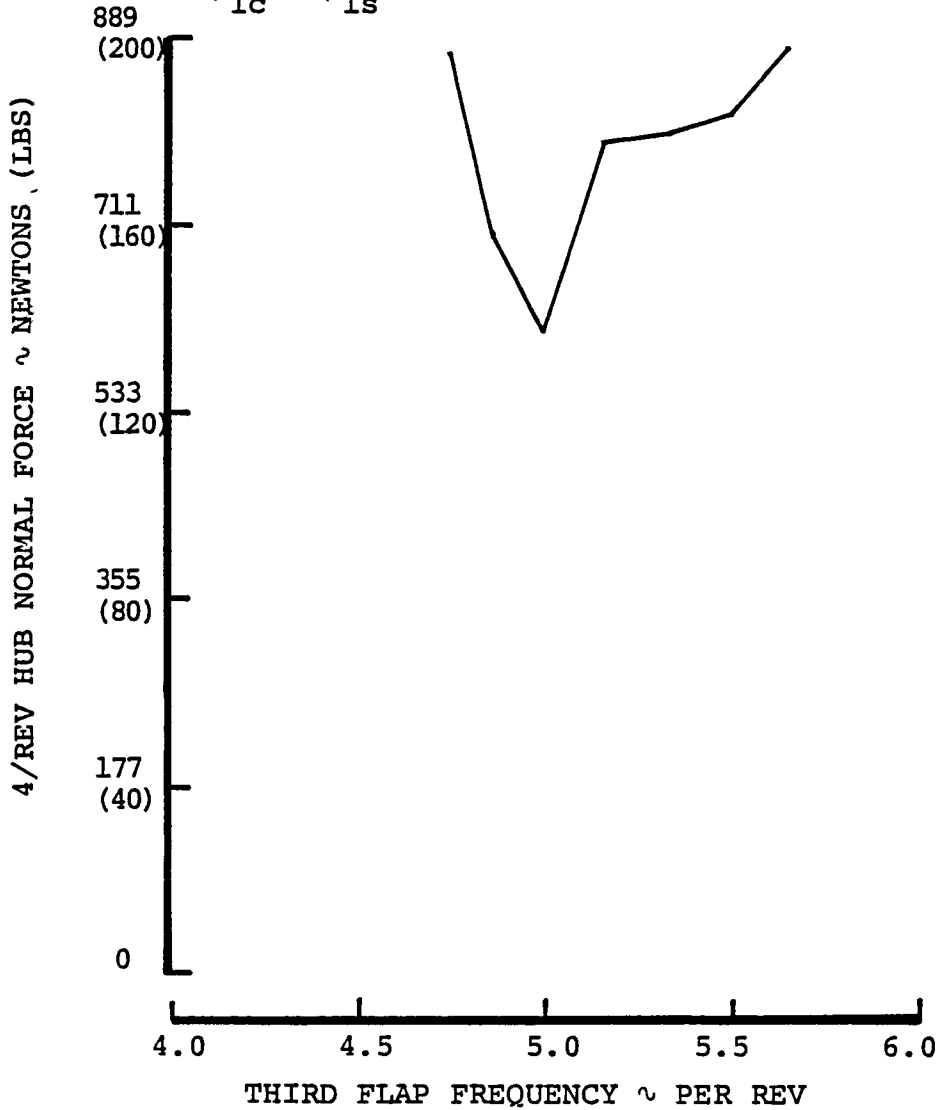

FIGURE 4.9.5-5 4/REV HUB NORMAL FORCE VS THIRD FLAP FREQUENCY

347 HUB/4 CH-47D BLADES

G.W. = 8389 kg (18,500 LBS)

V = 277 km/hr (150 KNOTS)

Ω = 225 RPM

\bar{X} = .10

β_{1c} & β_{1s} = 0

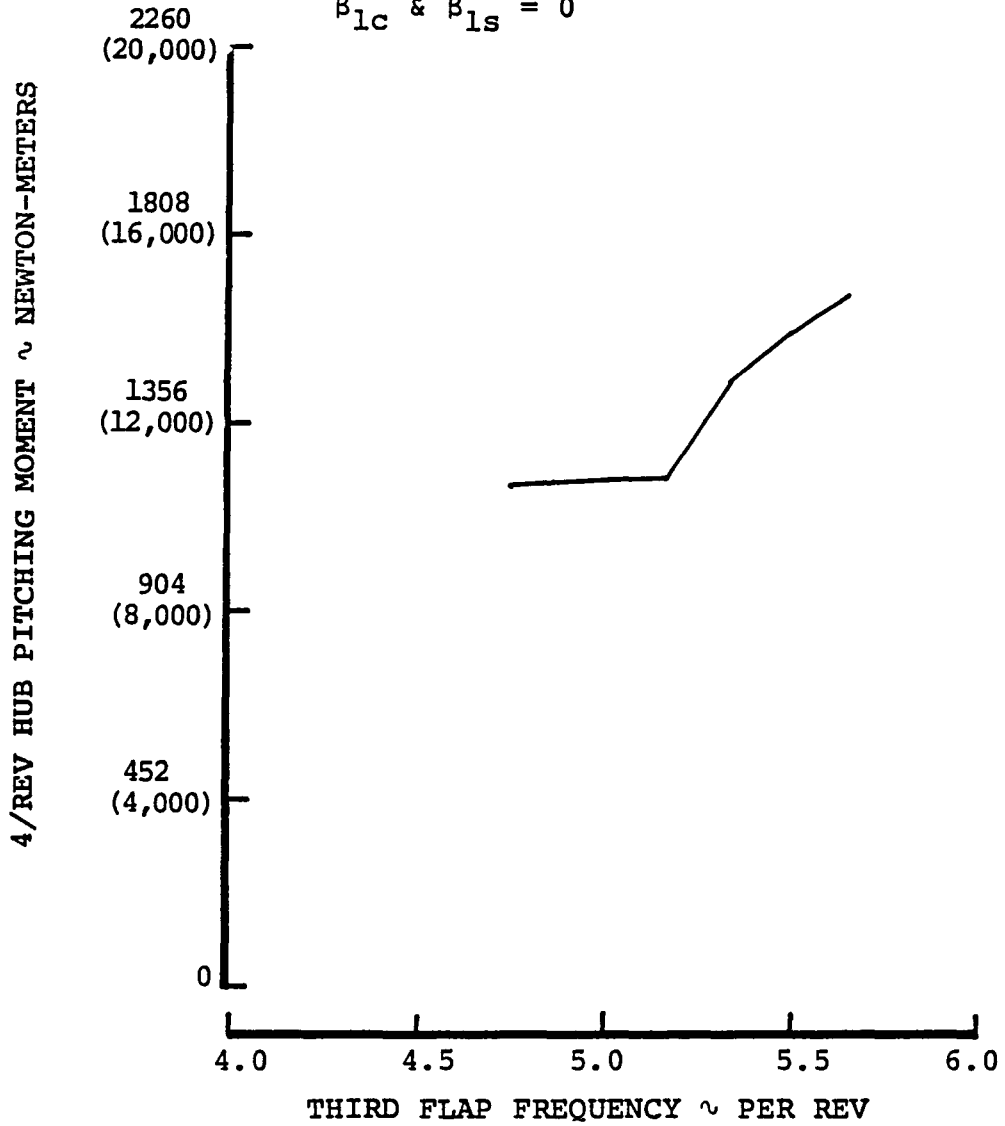

FIGURE 4.9.5-6 4/REV HUB PITCHING MOMENT VS THIRD FLAP FREQUENCY

347 HUB/4 CH-47D BLADES

G.W. = 8389 kg (18,500 LBS)

V = 277 km/hr (150 KNOTS)

Ω = 225 RPM

X = .10

β_{1c} & β_{1s} = 0

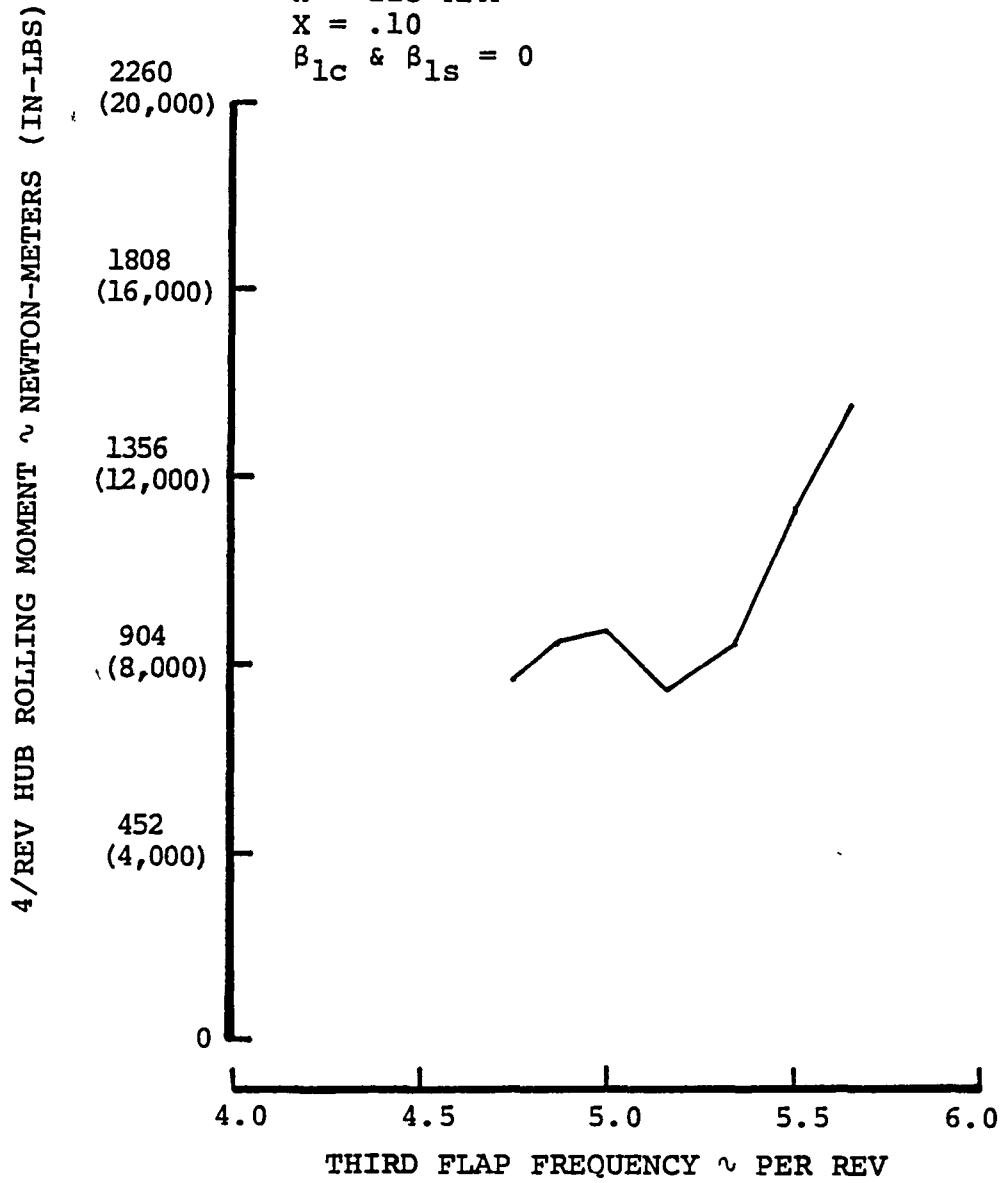

FIGURE 4.9.5-7 4/REV HUB ROLLING MOMENT VS THIRD FLAP FREQUENCY

347 HUB/4 CH-47D BLADES

G.W. = 8389 kg (18,500 LBS)

V = 277 km/hr (150 KNOTS)

Ω = 225 RPM

\bar{X} = .10

β_{lc} & β_{ls} = 0

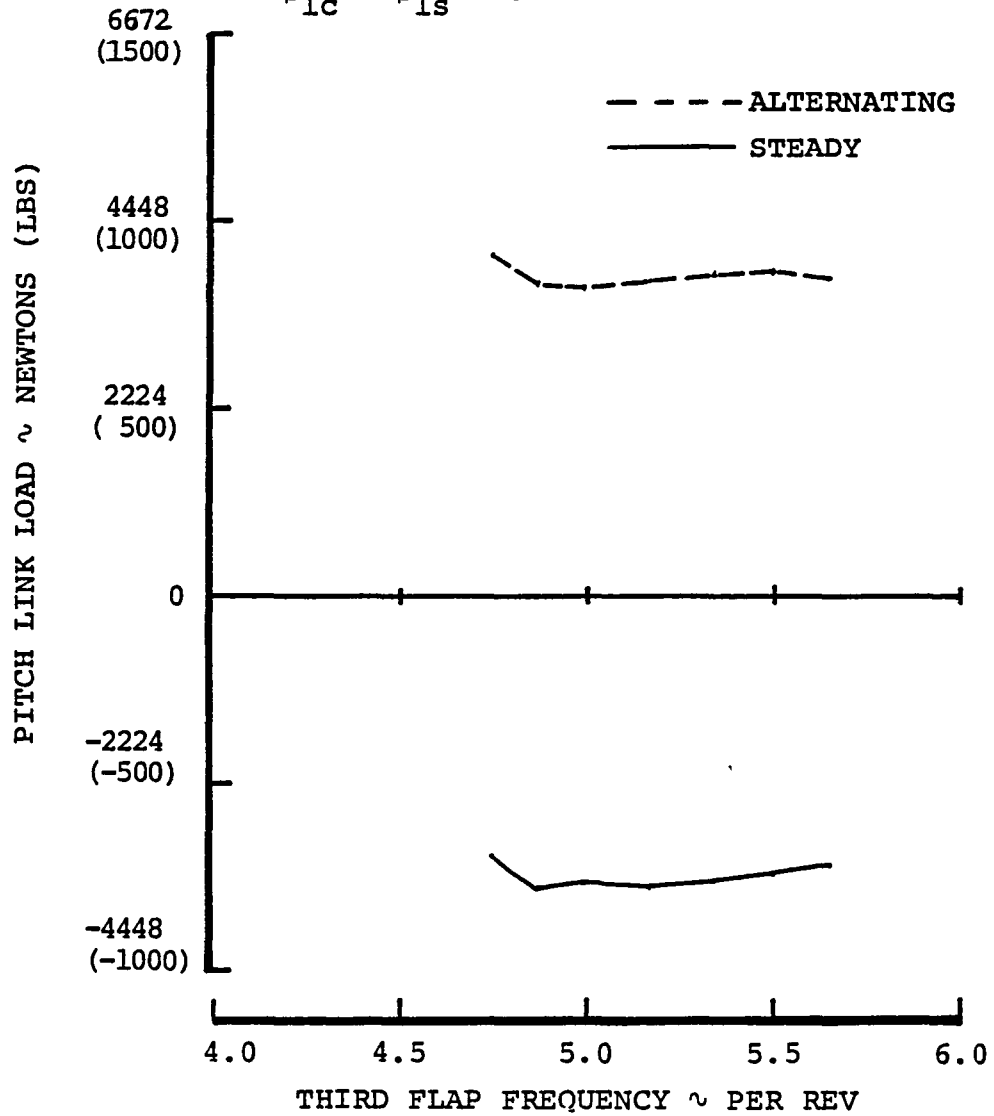

FIGURE 4.9.5-8 ALTERNATING AND STEADY PITCH LINK LOAD VS THIRD FLAP FREQUENCY

347 HUB/4 CH-47D BLADES

G.W. = 8389 kg (18,500 LBS)

V = 277 km/hr (150 KNOTS)

$\Omega = .10$

$\beta_{Ic} \ \& \ \beta_{is} = 0$

ALTERNATING FLAP BENDING MOMENT ~ NEWTON-METERS (IN-LBS)

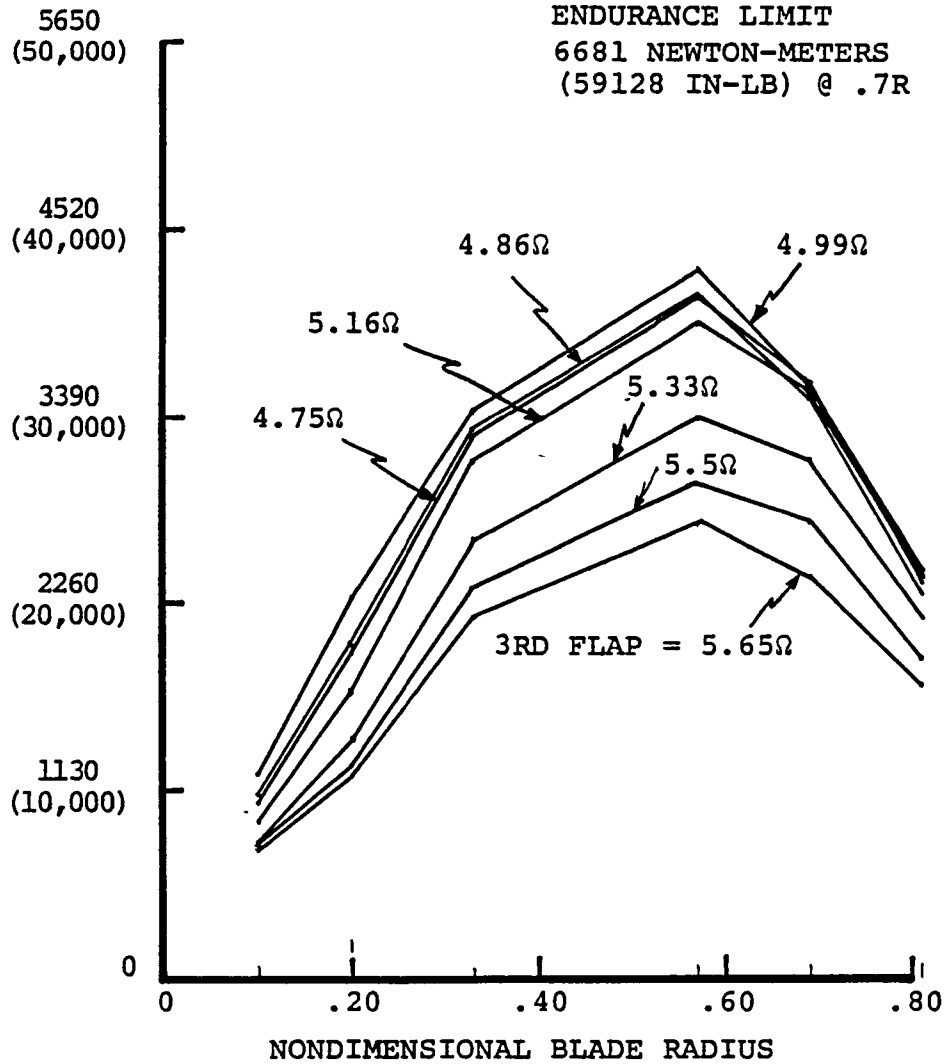

FIGURE 4.9.5-9 ALTERNATING FLAP BENDING MOMENT VS N.D. BLADE RADIUS AT THIRD FLAP FREQUENCY = 4.75Ω, 4.86Ω, 4.99Ω, 5.16Ω, 5.33Ω, AND 5.65Ω.

The program was completely specified for the RSRA configuration including the fuselage aerodynamic forces based on data from References 11 and 12.

The match of the BV analysis to Sikorsky for the same S-61 rotor is presented in figure 4.10-1. In the 74 to 148 km/hr (40 to 80 knot) speed range, the higher attitude and more forward flapping and stick are all related to the difference in predicting moments on the fuselage; possibly due to inaccurate methods of treating rotor downwash effects on the horizontal tail. For consistency, all rotor systems were analyzed and compared using the BV program.

FIGURE 4.10-1 RSRA HELICOPTER TRIM

GW: 8344 kg (18400 LBS)
 CG: 33.75 cm (13.5 IN) AFT
 i_{HT} : 2.5°

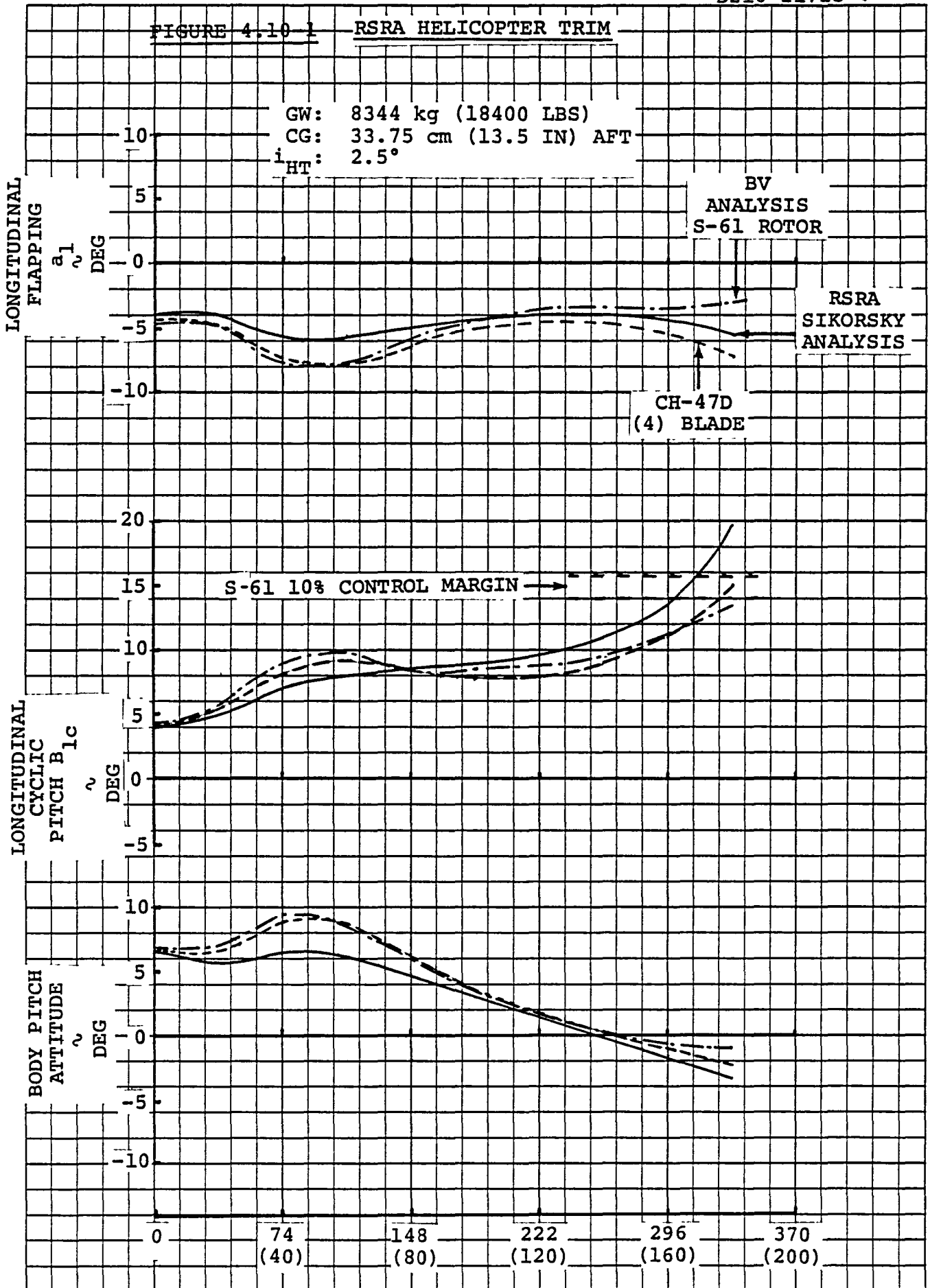

EUGENE DIETZGEN CO
 MADE IN U.S.A.

NO 340R-5 DIETZGEN GRAPH PAPER
 5 X 5 PER INCH

AIRSPEED ~ km/hr (KTS)

The comparison of longitudinal trim for the S-61 and 347/D rotor systems is given in figure 4.10-1. The lesser magnitude of aft flapping, due to higher solidity of the 347/D rotor also results in a slightly larger nose down attitude. The 347/D rotor forward stick margin is as favorable as the basic rotor except for speeds beyond 296 km/hr (160 knots) which are not in the expected flight envelope. The unstable stick position gradient in the 60 to 100 airspeed region indicates poor speed stability. However, neither rotor system is significantly worse.

The lateral trim for zero sideslip was identical for both rotor systems. Sideways flight was not analyzed. However, since rotor flapping is slightly less for the 347/D rotor system, no serious problems are envisioned except that tail rotor margins in a sideslip or sideward flight might be reduced and require a lower lateral flight envelope. Lateral stability in autorotation has had unstable stick gradients. This should be evaluated during the 347/D-RSRA system development program.

Control power, damping and stability parameters were reviewed for several rotor systems and are presented in table 4.10-1. An unexpected result is that even with the lower flap hinge offset, all 347 rotor configurations have nearly the same or better control power than the basic S-61 rotor system. This is largely due to the larger blade, greater tip speed and resulting higher centrifugal force. Pitch damping was the only parameter that did not meet the requirements of MIL-H-8501A (Reference 19) with all rotor systems deficient. This problem has been reported in Reference 11 for the S-61 rotor system. The 347/D rotor system with the 35.5 cm (14 inch) increase in rotor height equals the S-61 characteristics; however, the 347/A rotor system does not.

Table 4.10-1 also notes the longitudinal stability parameters Z_w , M_q and M_w . The higher solidity of the CH-47D blade causes the higher Z_w and less stable M_w which will result in greater gust sensitivity and faster divergence with SAS failures. The SAS off short period roots are noted and some small improvement occurs with the CH-47D blades. The lateral directional dynamics should be close to that with the S-61 rotor system as the only change is rotor lateral flapping with sideslip.

TABLE 4.10-1
RSRA STABILITY & CONTROL PARAMETERS

PARAMETER		S-61 ROTOR	347/D ROTOR NORMAL HT.	347/D ROTOR 35.5 cm (14") INC. HT:	347/A ROTOR 35.5 cm (14") INC. HT:
NO. OF BLADES (b)		5	4	4	4
HINGE OFFSET(e) %		3.39	2.22	2.22	2.22
ROTOR SPEED	rad/sec	21.26	23.56	23.56	23.56
TIP VELOCITY	m/sec (ft/sec)	201. (660.)	213. (706.)	213. (706.)	313. (696.)
LOCK NO.		10.71	10.8	10.8	
ROTOR RESPONSE FACTOR		sec. $\frac{16\gamma}{R}$.07027	.06288	.06288
MOMENT CAPABILITY $\frac{eb}{2} C_F$		123375.	128666.	128666.	97600.
MOMENT/DEG. FLAP $\frac{Nm}{deg.} \frac{ft-lb}{deg.}$		5532. (4080.)	5657. (4172.)	6093. (4494.)	5348. (3944.)
ROTOR SOLIDITY σ		.078	.1132	.1132	.082
LONGITUDINAL (HOVER)		HIL-H-8501A			
CONTROL POWR $1/sec^2/in$.062	.127	.134	.143
DAMPING $1/sec$.26	.170	.1339	.165
Z_w			-.873	-1.160	
M_q			-1.220	-1.215	
M_w			-.00636	-.0021	
} 222 km/hr (120 KTS)					
SHORT PERIOD			-1.049±1.12j	-1.188±1.65j	
LATERAL (HOVER)					
CONTROL PWR.		.20	.725	.700	.760
DAMPING		1.25	1.74	1.34	1.450
					1.275

The capability to autorotate with the 347/D rotor system was reviewed and found sufficient. On the RSRA, the 347/D rotor system full down collective is at $-.2$ degrees at $.75R$. This is lower than the zero setting on the CH-47D helicopter, therefore allowing a higher autorotation rotor speed. The 3-bladed CH-47D rotors have been demonstrated to autorotate at 12698 kg (28,000 lbs.) minimum for the tandem helicopter and, therefore, would be capable at 6349 kg (14,000 lbs) for each 3-bladed rotor or 8435 kg (18,600 lbs) minimum for a 4-bladed rotor. The large change in longitudinal stick from powered flight to autorotation as indicated in figure 21 of reference 11 should be slightly improved with the 347/D rotor system based on classic equations due to its higher solidity and equal control power. When the 347/A or 347/C rotor systems are used some deterioration of this condition can be expected and should be more thoroughly analyzed.

In summary, the stability and control of the RSRA incorporating the 347/D rotor system with the 35.56 cm (14 inch) rotor height extension will closely exhibit the characteristics of the S-61 rotor system in trim, control power and control margins. In flight test, some care should be taken to explore SAS failure effects. Parameter variation of RPM, blade tip shape and solidity must be more thoroughly investigated for their impact on stability and control.

4.11 Technical Risks

The following potential problems are offered to underscore the most important concerns to be addressed and analyzed during the 347/D-RSRA program development phase:

a. Rotor height - aerodynamic instability

Installation of the 347/D rotor system on the RSRA required the hub to be raised 35.56 cm (14 inches) relative to the current S61 installation. Raising the rotor creates a potential aerodynamic problem. Experience on the YUH-61A (UTTAS) aircraft has shown that raising the rotor can cause unstable and intermittent flow separation on the pylon aft of the hub that impinges on the tail rotor in certain flight regimes causing

severe low frequency lateral upsets. For the S-61 rotor, installed close to the pylon, the current hubcap installation alleviates the impingement problem. However, Vertol testing (Reference 18) has shown that the hubcap is ineffective when the rotor is raised.

If a problem is encountered and is severe enough to restrict the flight envelope, then the pylon upper contour must be modified to achieve a more stable pressure gradient aft of the hub to prevent separation. This would require model rotor/fuselage wind tunnel testing to define the modifications. A rotor/fuselage model rather than a static model is necessary since the interaction of the fuselage flow field on the rotor wake has been found to have a significant effect on the separation phenomena as described in Reference 18.

b. Drive System Resonances

Rotor/drive system dynamics analyses will require the following RSRA engine/drive system data:

- (1) Torsional stiffness of main rotor shaft, engine shaft and tail rotor shaft
- (2) Torsional inertia of power turbine, tail rotor and all transmissions.

c. Ground Resonance

Rotor/RSRA system dynamics analyses will require data on the RSRA landing gear stiffness and damping characteristics as a function of landing gear load is needed.

d. Structural Deficiencies

Structural (stress) analyses will require the following data:

- (1) Critical allowable rotor shaft moments

(2) Endurance limits of each component from and including the transmission actuator attachment up to and including the stationary swashplate member.

(3) Allowable swashplate thrust and moment on the swashplate bearing.

e. Hover Performance Test Envelope Reduction

Aerodynamic analyses addressing this potential problem will require data on transmission power or torque limits (30 minute rating) with the gearing changes required to run at 225 RPM.

f. General stability and control problems -

There are no major stability and control problems when flying with the 347/D rotor system when compared to the S-61 rotor system. However, some concerns will require evaluation of SAS failures, tail rotor control and sideslip envelope limitation.

g. Control power reductions

Reduced solidity with the 347/A or 347/C rotor systems along with the small flap hinge offset will result in lower control power. This is especially important in the entry into autorotation maneuver with the large changes of longitudinal stick trim, pitch moments and flapping.

5.0 Parameter Variations

5.1 Aerodynamic Parameter Variations

5.1.1 Basic Aerodynamic Parameter Variations

In addition to testing CH-47D blades, the 347 rotor will permit the testing of CH-47A (347/A rotor system) and CH-47C (347/C rotor system) blades as defined in Table 2.0-2 resulting in the following parameter variations:

a. **Baseline NACA 0012 Data and Effect of Blade Number**

Testing of the 347/A rotor will provide four bladed baseline rotor data for comparison with the more current rotor system designs to be evaluated during the study. Since the 347/A and S61 rotors have similar solidities, twist and the same airfoil section, comparison of existing S61 test data with the CH-47A results will show the effect of reducing the blade number from 5 to 4. As shown in Figure 5.1.1-1, performance estimates indicate that increasing the blade number increases the maximum figure of merit slightly.

b. **Airfoil Camber**

The effect of airfoil camber is obtained by comparing RSRA performance with four CH-47A blades with data obtained with four CH-47C blades. The CH-47C has a BV23010-1.58 cambered airfoil and the CH-47A has a NACA 0012 airfoil. The 23010 airfoil retains the same basic thickness distribution as the 0012 airfoil however its mean line is cambered. Camber was introduced on the CH-47 aircraft primarily to expand the rotor stall limit boundaries that define the structural envelope. The improved stall characteristics of the cambered section also provides an improvement in total aircraft cruise ($\mu = .3$) L/D ratio at lift coefficient values above a C_T/σ of .08 as shown in Figure 5.1.1-2. The increase in section maximum lift coefficient provided by camber also results in improved hover performance at higher thrust coefficients as illustrated in Figure 5.1.1-3.

c. **Planform (Solidity or Chord) Changes**

The effect of changing the blade planform by increasing the chord 27% will be obtained by comparing four CH-47C blades ($\sigma = .0893$) with the new Phase II blades ($\sigma = .1132$) as defined in paragraph 5.1.2. The classical power required analysis indicates that increasing solidity results in a proportional increase in profile power as shown below.

FIGURE 5.1.1-1

**347/A ROTOR SYSTEM
FIGURE OF MERIT**

**MODIFIED NACA 0012
AIRFOIL**

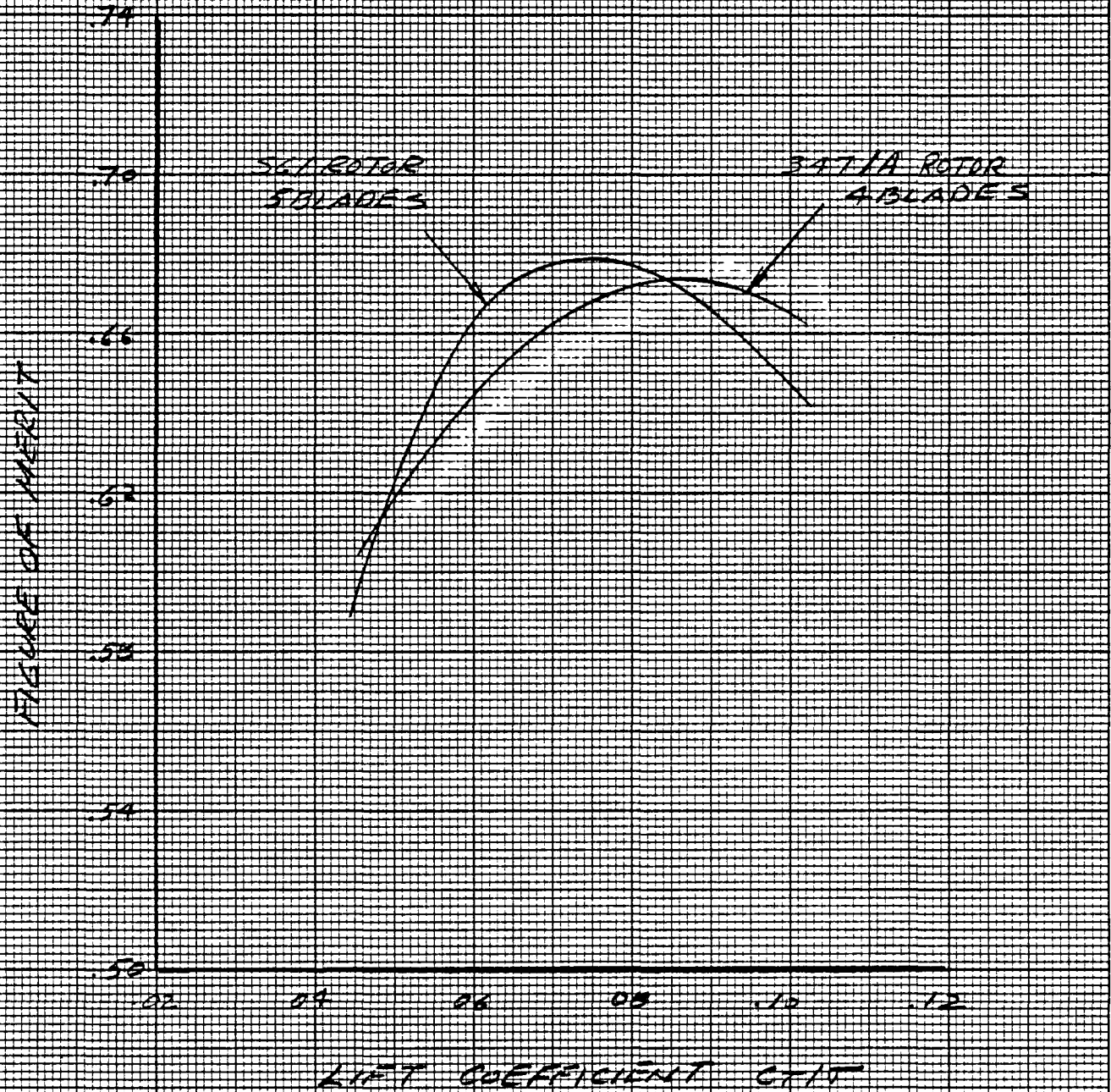

DATA BASIS: 561 - SIKORSKY REPORT SER-72006, 1974
 347/A ROTOR - 3 BLADED FLT TEST CORRECTED
 TO 4 BLADES USING B52 ANALYSIS

EUGENE DIETZGEN CO
MADE IN U S A

NO 340R-20 DIETZGEN GRAPH PAPER
20 X 20 PER INCH

EFFECT OF CHARGER
ON TOTAL AIRCRAFT L/D

FIGURE 5.1.142

$$\mu = .3$$

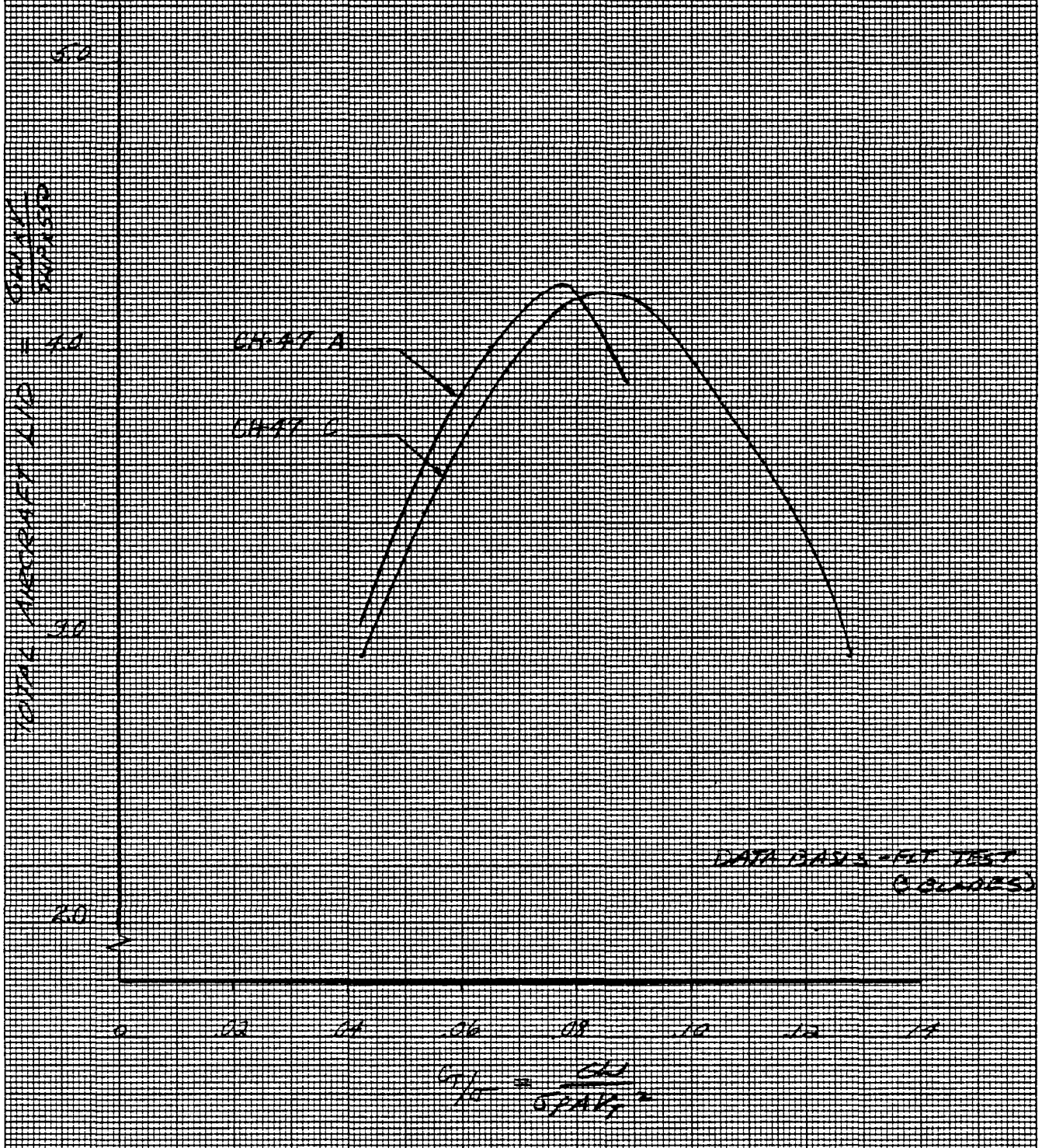

DIETZGEN CORPORATION
MADE IN U.S.A.

NO 34DR-MP DIETZGEN GRAPH PAPER
MILLIMETER

EFFECT OF CAMBER
ON FIGURE OF MERIT

FIGURE 5.1.1-3

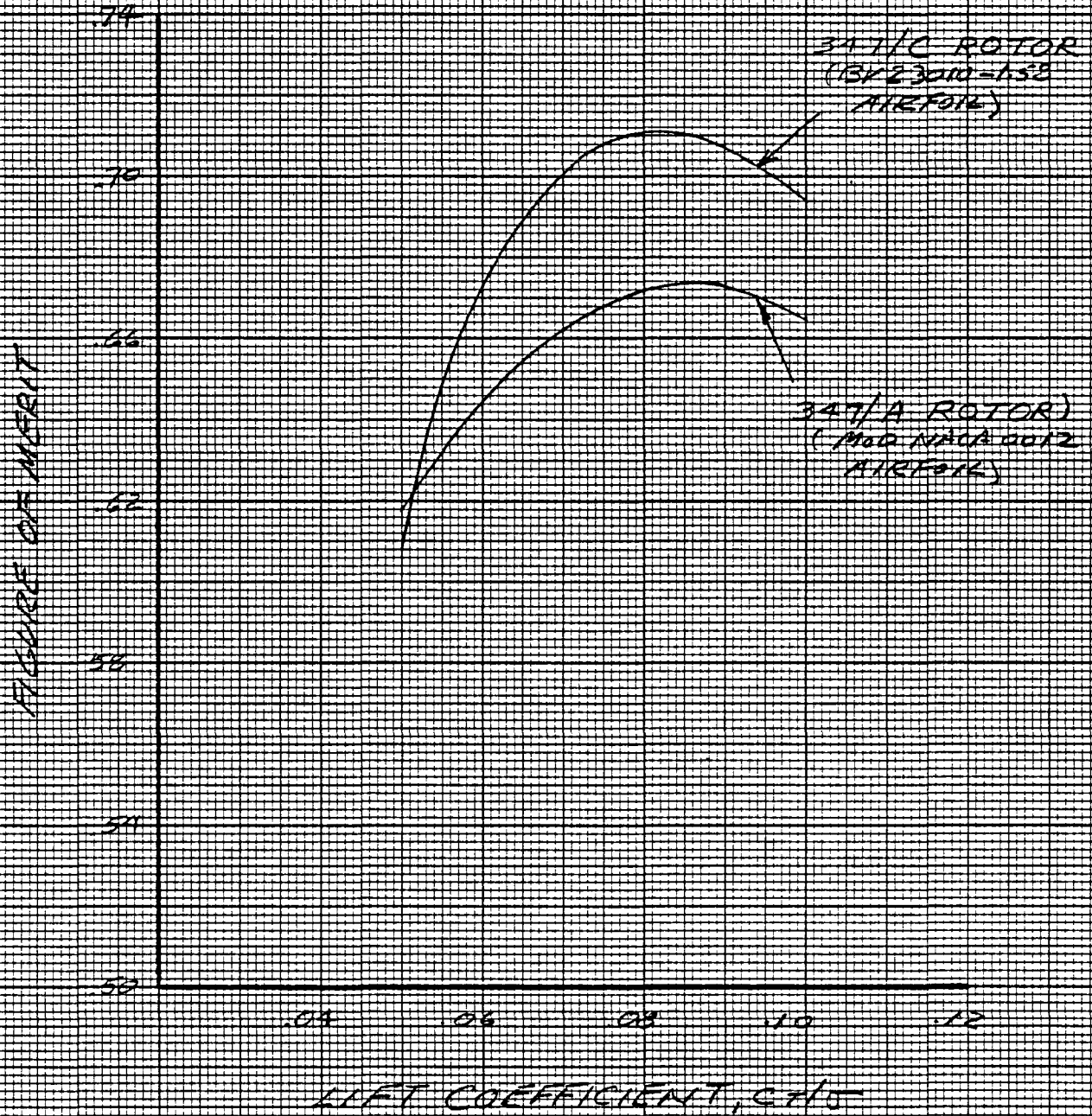

DATA BASIS - 347/C ROTOR - 347 FLIGHT TEST
347/A ROTOR - 3-BLADED FLT TEST CORRECTED
TO 4-BLADES USING 1972 ANALYSIS

<u>FLIGHT CONDITION</u>	<u>PROFILE POWER</u> , % TOTAL POWER	<u>POWER DUE TO SOLIDITY</u> , % TOTAL POWER
Hover OGE	20	5
Minimum Power Airspeed	40	11
Level Flight 259 km/hr (140 Kts)	30	8

A more rigorous analyses would also consider the effect of Reynolds number on profile power and the effect of blade aspect ratio on induced power. However, testing of model rotor blades of various solidities has shown that even relatively sophisticated analyses including the Reynolds number and blade aspect ratio effects do not agree with the test results. Varying the chord on the RSRA will provide valuable additional data for understanding these effects.

d. Blade Twist

The Phase II, 81.28 cm (32 inch) blade will be retwisted from 9° to 12°. The 9 degrees of linear twist corresponds to the 1950 to 1960 generation of helicopters while 12° corresponds to the current designs such as the CH-47D and YUH-61A rotors. The primary purpose of increasing twist is to reduce hover power required. The 3 degrees of additional twist will increase the maximum figure of merit approximately 2.4% based on the model rotor data presented in Figure 5.1.1-4. As shown, increasing the twist from 7° to 14° increased the maximum figure of merit by .04 over a range of tip Mach numbers. The corresponding induced power reduction is approximately 1% per degree of twist.

The effect of twist on forward flight performance is not well defined. Comparisons of rigid and elastic blade analyses show a sizeable elastic effect of twist that increases the compressibility power. Full scale test data is required to confirm these predictions.

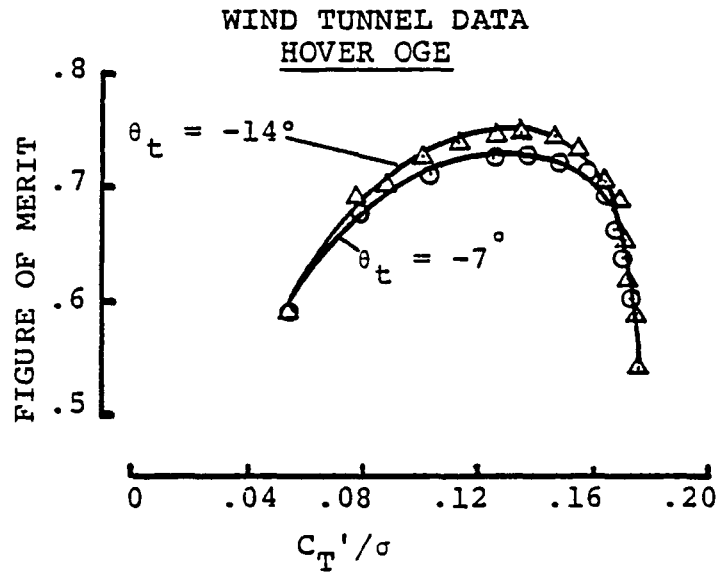

NOTES:

1. BVWT 075, 076
TEST DATA
2. 3 BLADES
3. RADIUS = .914m (3 FT)
4. CHORD = 5.84 cm (2.3 IN)
5. SOLIDITY = .0609
6. TEST DATA AT
MODEL SCALE
REYNOLDS NO.

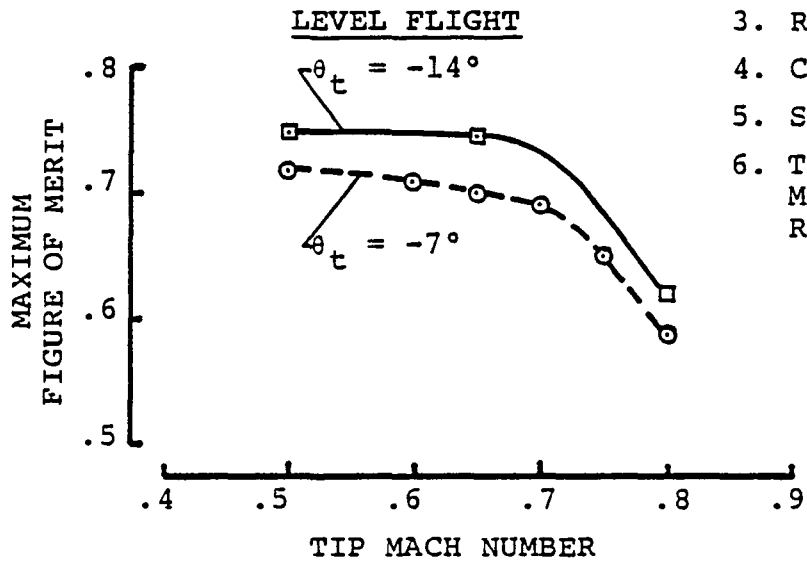

FIGURE 5.1.1-4 EFFECT OF TWIST ON PERFORMANCE

e. Low Drag Airfoil

The effect of replacing the cambered BV 23010-1.58 airfoil with low drag VR7/8 sections will be defined by comparing the retwisted 81.28 cm (32 inch) Phase II blade with the CH-47D blades as defined in Table 2.0-2. The VR7/8 is the third generation of airfoils used on Vertol helicopters as illustrated in Figure 5.1.1-5. The VR7/8 thickness distribution was selected to achieve low drag levels in hover and the mean line was cambered to maintain the 23010 stall boundary improvements in forward flight. Vertol model rotor wind tunnel data presented in Figure 5.1.1-6 shows that the VR7/8 airfoil provides an improvement in both hover and forward flight performance for advance ratios up to .36. As shown in Figure 5.1.1-7 the VR7/8 stall boundaries are slightly improved over the BV 23010 section at advance ratios between .3 and .4. Figures 5.1.1-9 through 5.1.1-11 present data for the basic Boeing Vertol developed airfoils.

ROTOR CONFIGURATION AIRFOIL

347/A

V0011*

1ST GENERATION FOR THE 50s



t/c - 0.11

2ND GENERATION FOR THE MID 60s

347/C

V23010-1.58'



t/c - 0.102

3RD GENERATION FOR THE 70s

347/D

VR-7
.27R-.85R

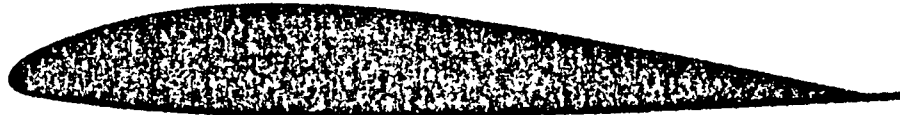

t/c - 0.12

LINEAR TRANSITION .85R-1.0R

VR-8



t/c - 0.08

TIP AIRFOIL (1.0R)

*MODIFIED NACA 0012 - TRAILING EDGE EXTENDED

FIGURE 5.1.1-5 BASIC AIRFOILS

WIND TUNNEL DATA

HOVER OGE

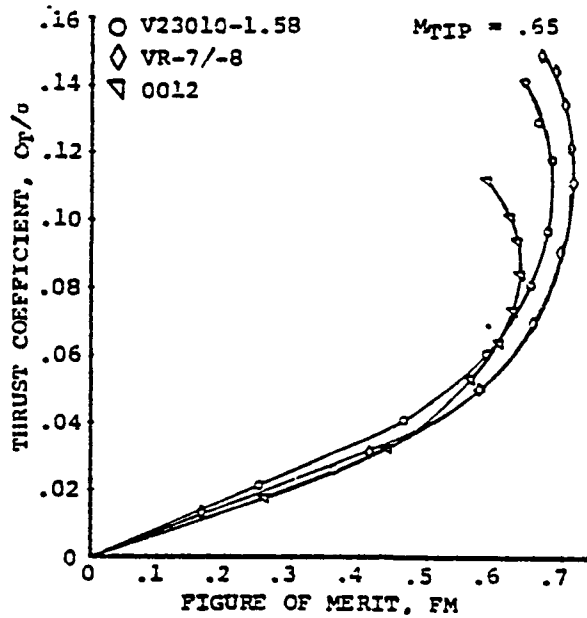

CRUISE

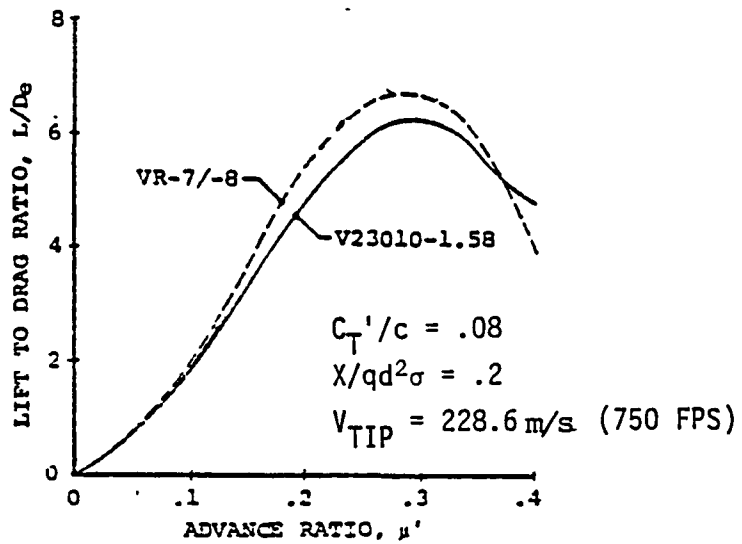

FIGURE 5.1.1.6 PERFORMANCE FOR CURRENT AIRFOIL DESIGNS

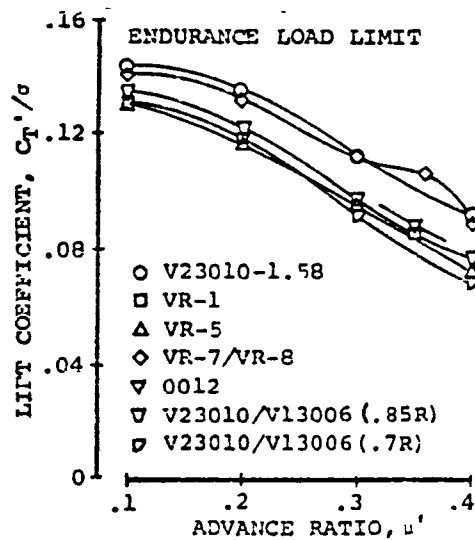
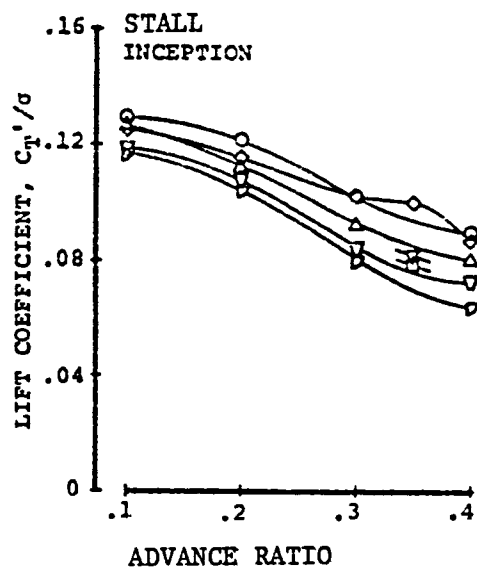

FIGURE 5.1.1-7 EFFECT OF AIRFOIL SECTION ON STALL BOUNDARIES

This page intentionally left blank.

This page intentionally left blank.

FIGURE 5.1.1-9 DATA FOR BV 23010-1.58
AIRFOIL (BV23010-1.58 With 0° T.E. Tab)



(*)
AIRFOIL COORDINATES

x/c	y/c _u	y/c _l
0.0	-0.0225	-0.0225
0.005	-0.0078	-0.0329
0.01	-0.0024	-0.0362
0.015	0.0019	-0.0378
0.025	0.0096	-0.0394
0.035	0.0155	-0.0404
0.047	0.0214	-0.0412
0.06	0.0265	-0.042
0.08	0.0327	-0.0434
0.11	0.0396	-0.0449
0.15	0.0455	-0.0471
0.19	0.0489	-0.0494
0.23	0.0499	-0.0513
0.27	0.0499	-0.0522
0.31	0.0497	-0.05215
0.35	0.049	-0.0517
0.39	0.048	-0.0505
0.43	0.0465	-0.0487
0.47	0.0446	-0.0468
0.51	0.0424	-0.044
0.55	0.0397	-0.0412
0.59	0.0369	-0.038
0.63	0.0336	-0.0346
0.67	0.0301	-0.0308
0.71	0.0263	-0.0269
0.75	0.0223	-0.0226
0.79	0.0181	-0.0182
0.83	0.0137	-0.0136
0.87	0.0093	-0.0093
0.91	0.0056	-0.0057
0.945	0.0028	-0.0031
0.96	0.00235	-0.00235
1.0	0.00235	-0.00235

(*)Coordinates defined in the Vertol reference system, where the reference line approximately bisects the aft 50% of an airfoil.

CHARACTERISTICS

- Thickness, $t/c = 0.102$
- Leading Edge Radius,
 $r/c = 0.0158$
- Center of Leading Edge
Circle at $x/c = 0.0158$
 $y/c = -0.0225$
- Trailing Edge Tab
from $x/c = 0.96$
to $x/c = 1.0$

TYPE OF DATA AND METHOD OF TEST

Two-dimensional tests in the Subsonic Insert of the Boeing Supersonic Wind Tunnel in Seattle, Wash.

Lift and pitching moments were determined with a balance. Drag was determined by a traversing wake probe survey.

Model Chord = 16.2 cm (6.38 in)
Span = 30.5 cm (12.0 in)

SOURCES

- 1) LaPrete, R., Storwick, E.M., Peterson, L.D., Boeing Wind Tunnel Test 927, Boeing Doc. No. D2-24066-1, 1966.
- 2) Eierman, R.L., Nyholm, J.R., Schreiber, R.E., Russell, J.H., Data Report BSWT 412, Boeing Doc. No. D6-20518, Dec. 1967.
- 3) Dadone, L.U., & McMullen, J., HLH/ATC Rotor System Two-Dimensional Airfoil Test, D301-10071-1, Dec. 1971.

FIGURE 5.1.1-10 DATA for VR-7
 AIRFOIL (VR-7 With -5.9° T.E.TAB)

D210-11723-3



AIRFOIL COORDINATES

x/c	y/c _u	y/c _l
0.	0.	0.
.005	.0165	-.00575
.01	.0218	-.0081
.02	.0298	-.0109
.03	.03615	-.0129
.04	.0415	-.01445
.05	.04605	-.01585
.06	.05025	-.01710
.07	.0541	-.01805
.085	.0593	-.01985
.102	.0645	-.02145
.12	.0691	-.02285
.14	.0737	-.0241
.16	.0775	-.0251
.18	.0808	-.0260
.20	.0838	-.0266
.225	.0867	-.0273
.255	.0892	-.0280
.29	.0909	-.0285
.33	.0914	-.0289
.37	.0905	-.0290
.41	.0887	-.0285
.45	.0856	-.0275
.49	.0816	-.0260
.53	.0767	-.0240
.57	.0710	-.0220
.61	.0646	-.0199
.65	.0580	-.0179
.69	.0514	-.0158
.73	.0447	-.0138
.77	.0374	-.01075
.81	.0301	-.00845
.845	.0235	-.0064
.88	.0167	-.00425
.91	.0105	-.00235
.935	.0062	-.0006
.96	.0050	0.0
1.01	.01017	.00517

CHARACTERISTICS

- Thickness, $t/x = 0.12$
 - Leading Edge Circle:
 - $r/c = .0113$
 - Center at $x/c = .01055$
 - $y/c = .004$
 - Trailing edge tab:
 - From $x/c = .96$
 - to $x/c = 1.01$
- T.E. Tab Thickness, $t/c = 0.005$

TYPE OF DATA AND METHOD OF TEST

Two-dimensional test in the subsonic insert of the Boeing supersonic wind tunnel in Seattle, Washington.

Lift and pitching moments were measured with a balance.

Model Chord = 16.2 cm (6.38 in)
 Span = 30.5 cm (12.0 in)

SOURCE

Dadone, L., & McMullen, J.,
 "HLH/ATC Rotor System Two-dimensional Airfoil Test", Boeing Document D301-10071-1, December, 1971

FIGURE 5.1.1-11 DATA FOR VR-8
AIRFOIL (VR-8 With 0° T.E. TAB)

D210-11723-3

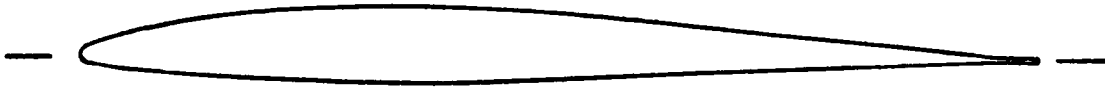

AIRFOIL COORDINATES

x/c	y/c _{upp}	y/c _{low}
0.	0.	0.
.005	.00850	-.00535
.01	.01175	-.0737
.015	.01425	-.00880
.025	.0183	-.01090
.035	.0217	-.01255
.05	.0261	-.01465
.07	.0309	-.01685
.095	.0357	-.0190
.125	.0402	-.0212
.16	.0444	-.0232
.20	.0480	-.0250
.25	.0510	-.0266
.30	.0530	-.0277
.35	.0535	-.0280
.40	.0525	-.0276
.45	.0502	-.0265
.50	.0467	-.0247
.55	.0426	-.0225
.60	.0380	-.0200
.65	.0333	-.0175
.70	.0285	-.0150
.75	.0237	-.0125
.80	.0190	-.0100
.85	.01428	-.0075
.89	.01048	-.0055
.92	.00761	-.0040
.945	.00524	-.00275
.96	.003404	-.001596
1.01	.003404	-.001596

CHARACTERISTICS

- Thickness, $t/x = 0.08$
- Leading Edge Circle:
 $r/c = 0.00585$
Center at $x/c = 0.0058$
 $y/c = 0.00088$
- Trailing Edge Tab:
from $x/c = 0.96$
to $x/c = 1.01$
T.E. Tab Thickness, $t/c = 0.005$

TYPE OF DATA AND METHOD OF TEST

Two-dimensional test in the subsonic insert of the Boeing supersonic wind tunnel in Seattle, Washington.

Lift and Pitching moments were measured with a balance.

Drag was determined by a traversing wake probe survey.

Model Chord = 16.2 cm (6.38 in)
Span = 30.5 cm (12.0 in)

SOURCE

Dadone, L., & McMullen, J., "HLH/ATC Rotor System Two-dimensional Airfoil Test", Boeing Document, D301-10071-1, December, 1971

5.1.2 Expanded Aerodynamic Parameter Variations

To sort out the effects of the three parameter variations between the 347/C and 347/D rotor configurations, a new twistable blade set will be designed, tested and fabricated having the following characteristics:

a. Structural

(1) Root End - Identical to CH-47D Fiberglass Blade

(2) Outboard - Polyurethane Leading Edge Erosion Cap

- Dynamic characteristics to be identical to CH-47D blade

b. Planform - Identical to CH-47D blade (81.28 cm (32 inch) chord - 9.144 m (30 ft.) radius)

c. Airfoil/Twist - BV 23010-1.58/-9 degrees (same as CH-47C blades)

Following flight test of the above MOD I blades, they will be retwisted to -12 degrees (MOD II configuration), reinstrumented and flight tested. The techniques developed by Boeing Vertol for changing the twist of composite model blades will be further developed for use in twisting these full scale blades.

To obtain the physical properties required to match the dynamic characteristics of the CH-47D blade, graphite stiffening will be included in the spar layup to account for the thinner airfoil and the change from titanium and nickel to a polyurethane leading edge erosion cap. Figure 5.1.2-1 presents a first iteration blade section which has been designed to satisfy this requirement.

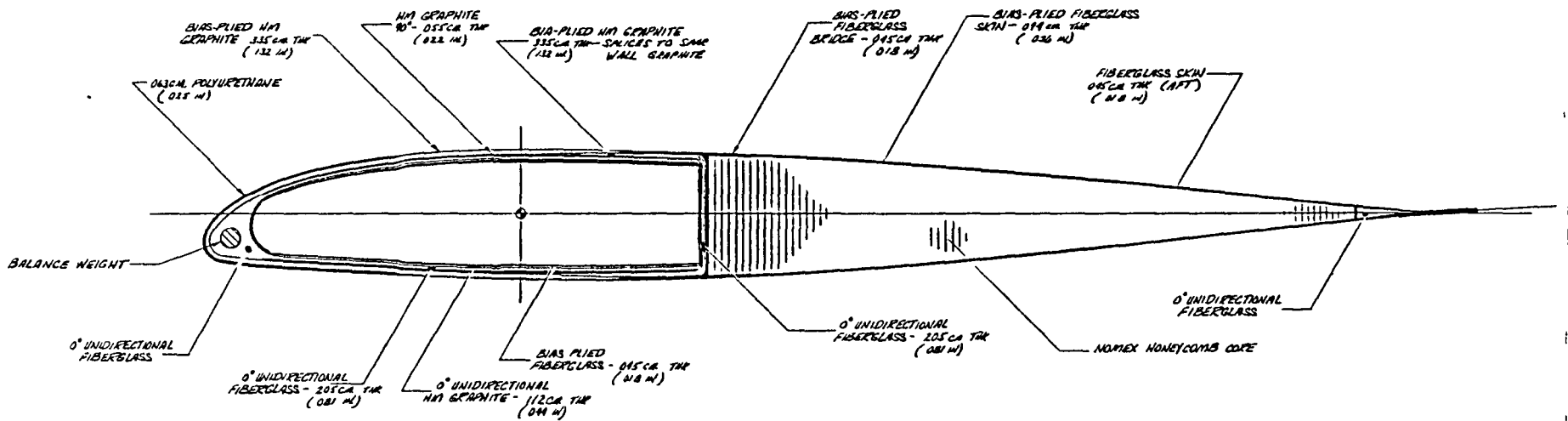

FIGURE 5.1.2-1 EXPANDED PARAMETER VARIATION
BLADE SECTION

Figure 5.1.2-2 presents a conceptual sketch of a racking fixture used to change the twist of composite model blades for wind tunnel testing. The technique which has successfully been employed requires that the blade be over-racked to account for springback and placed in a cold oven. Heat is applied, gradually bringing the temperature of the blade material up to 200 degrees F., holding at temperature for 2 hours and gradually cooling. Approximately 35% springback will result when the blades are released. Additional springback will result when the blades are dynamically loaded.

Qualification of this new blade design will require the fatigue test of one twisted outboard blade section specimen and a static structural properties test of a blade. No root end section or tip section testing will be conducted. These tests will not be required as the blade will be qualified in these areas on the basis of similarity to the CH-47D blade.

The 381 cm (150 inch) long outboard blade fatigue test section will be fabricated, twisted, instrumented and set up for test per figure 5.1.2-3 (ST 51740). The resonance test fixture design is a pin-pin configuration designed to apply axial tension load, simulating centrifugal force, through a compressed rubber spring bank. Combined flap and chord bending moment is applied by a hydraulic actuator operating at the fixture/specimen natural frequency.

The static structural properties test determines nonrotating natural frequencies and stiffnesses (flapwise, chordwise and torsional), mode shapes and shear center. In addition, this test will examine flapwise and chordwise limit loading on the blade.

In addition to the above bench tests, qualification will require a structural endurance whirl test be conducted on the RSRA (tied down).

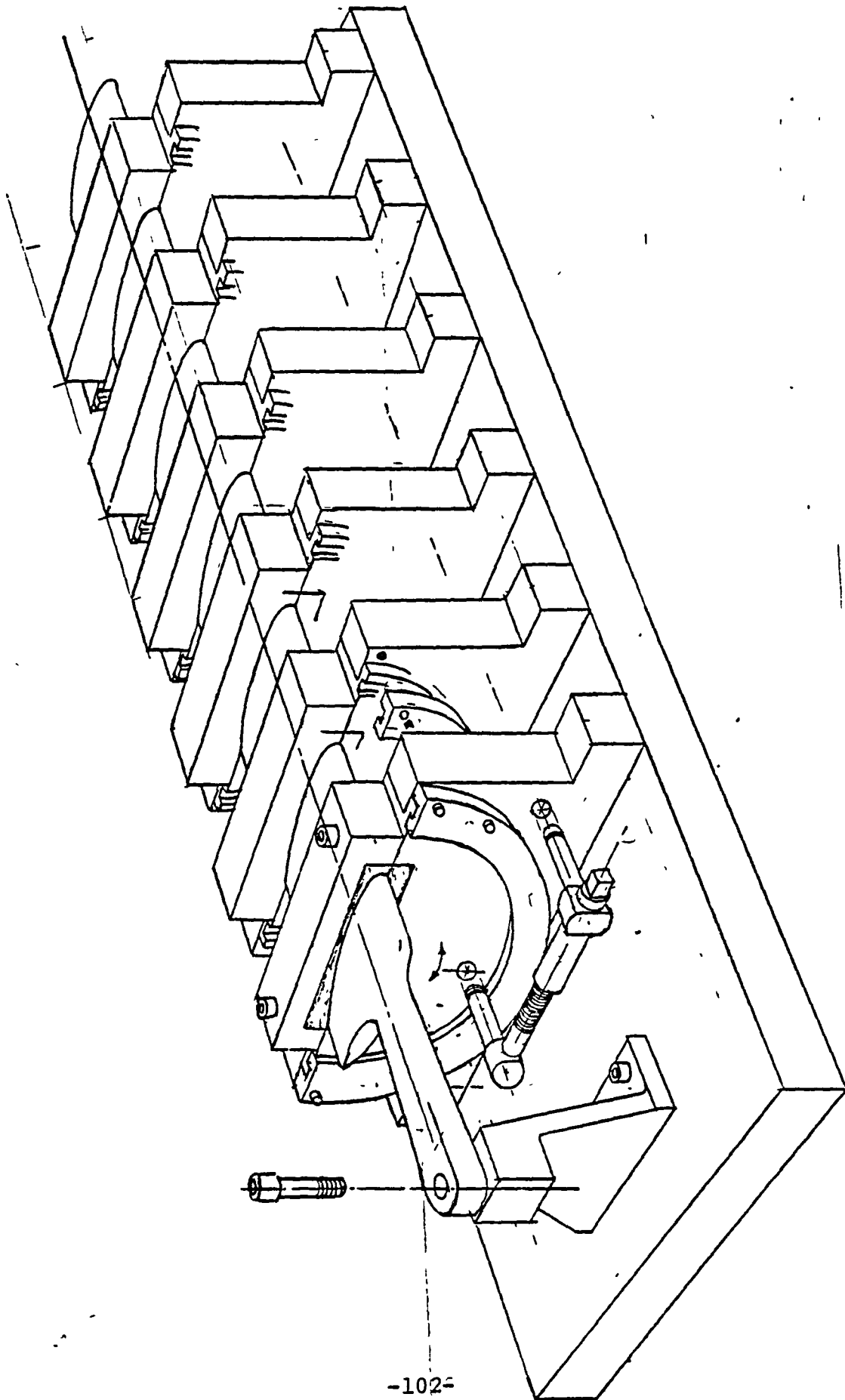

FIGURE 5.1.1.2-2 COMPOSITE ROTOR BLADE TWIST & UNTWIST FIXTURE.

FIGURE 5.1.2-3

FIGURE 5.1.3-1

FIGURE 5.1.3-2 BLADE TIP SHAPE VARIATIONS

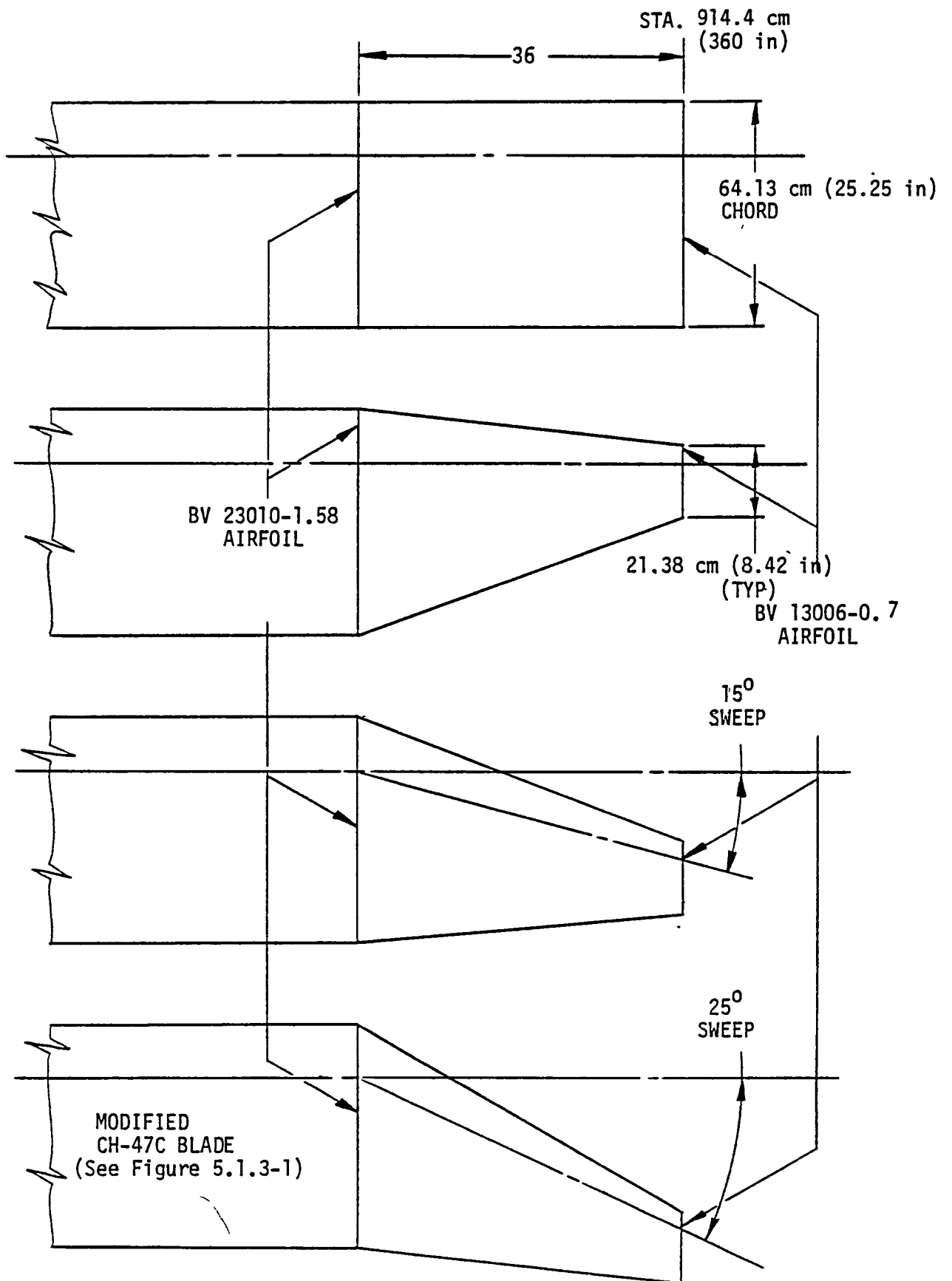

FIGURE 5.1.3-3 DATA FOR
AIRFOIL; BVI3006-0.7



AIRFOIL COORDINATES (*)

x/c	y/c _u	y/c _l
-0.002	-0.0117	-0.0117
0.0	-0.0064	-0.0171
0.0025	-0.004	-0.019
0.0075	-0.0013	-0.0208
0.0125	0.0012	-0.0219
0.025	0.0057	-0.0235
0.05	0.0127	-0.0255
0.075	0.0177	-0.0268
0.1	0.0216	-0.0275
0.15	0.026	-0.0286
0.2	0.0285	-0.0294
0.25	0.0295	-0.0299
0.3	0.0299	-0.03
0.4	0.029	-0.029
0.5	0.0265	-0.0265
0.6	0.0228	-0.0228
0.7	0.0185	-0.0183
0.8	0.0131	-0.0131
0.9	0.0072	-0.0072
0.95	0.004	-0.004
1.0	0.0006	-0.0006

(*)Coordinates defined in the Vertol reference system, where the reference line approximately bisects the aft 50% of an airfoil.

CHARACTERISTICS

- Thickness, $t/c = 0.06$
- Leading Edge Radius:
 $r/c = 0.007$
- Center of Leading Edge
Circle at $x/c = 0.005$
 $y/c = -0.0117$

TYPE OF DATA AND METHOD OF TEST

Two-dimensional tests in the subsonic insert of the Boeing supersonic wind tunnel in Seattle, Washington.

Lift and pitching moments were determined by integration of surface static pressures.

Drag was determined by a traversing wake probe survey.

Model Chord = 17.78 cm (7.0 in)
Span = 30.48 cm (12.0 in)

SOURCE

- 1) Gabriel, E., "Analysis two-dimensional Wind Tunnel Tests of Rotor Blade Airfoils of Varying Camber and Leading Edge Radius", Boeing Document AERO INV.III-288, November, 1965.
- 2) Gray, L., Liiva, J, Davenport, F., "Wind Tunnel Tests of Thin Airfoils Oscillating Near Stall, USAAVLABS TR 68-89A, 1969.

- d. Set No. 4 - Same as set No. 2 with a 25° sweep of the twist axis.

The removeable tips will be composite assemblies basically composed of fiberglass spar and skins with nomex honeycomb core and a polyurethane erosion cap as illustrated in figure 5.1.3-1.

Qualification of this design will require the fatigue and limit load testing of one tip specimen and static structural properties testing of a modified blade. In addition to these bench tests, a structural endurance whirl test will be conducted on the RSRA (tied down).

Structural and dynamic characteristics of the modified blade with the 10% tip sections with respect to the baseline CH-47C metal blade results in the following considerations:

- a. Weight - The weight of each tip section, the attachment hardware and balance weights will be slightly heavier. Extra weight is required to maintain constant lock number and dynamic balance as the center of gravity of the tip hardware is moved inboard and to maintain constant centrifugal force of the tracking weights.
- b. Dynamics - Changes in flapwise natural frequencies caused by moving the weights inboard are negligible.
- c. Loads - The different tip sections will have a definite effect on loads. Vibratory flapwise bending is created by the difference between the aerodynamic and dynamic load components. Moving the tip weights inboard reduces the compensating effect of the dynamic loading and causes the local vibratory flapwise moments to increase. Tapering the airfoil reduces the aerodynamic component and as a result, the flapwise moments are reduced. The corresponding steady flapwise moments are also affected by the balance of aerodynamic and dynamic forces. The tip changes cause a large increase in steady chordwise bending moment due to the combined effect of reduced drag and centrifugal force created by aft sweep of the tip. The centrifugal force is the dominant effect. The amount of lift carried by the tip section is a function of the geometry.

The tapered tip sections will carry less lift than the rectangular sections. Aft sweep of the tip section creates a steady nose down pitching moment. The moment arm from the pitch axis to the center of lift on the aft swept tip section along with the lift force creates the resulting steady pitching moment. Forward speed of the helicopter generates an alternating torsion moment due to the same lift offset effect. The loads on the tip section require that the removable tip must have a substantial structural capability.

Recent studies have shown that tip shape modifications can be an effective means of improving performance. Thin tip, tapered tip and swept/tapered tip configurations will be evaluated on the RSRA. The rationale for the proposed tip shape variations is presented below.

a. Thin Tip

The outboard 10% of radius of the Phase III/CH-47C blades (23010 airfoil) will be modified by transitioning to a 13006 section at the tip. The 13006 section is 4% thinner than the 23010 airfoil and has reduced camber to alleviate compressibility effects at high advancing tip Mach numbers. As shown by the model data presented in Figure 5.1.1-6, the 13006 tip is effective at improving hover and forward flight performance at low lift coefficients and advance ratios. At high lift coefficients the tip effectiveness is reduced due to increased stall power. As shown in Figure 5.1.1-7, the 23010 stall boundaries are reduced to the NACA 0012 level by installing the thin tip.

b. Tapered Tip

The proposed tip taper ratio is 1/3 beginning at 90% radius. This configuration is based on the results of a sensitivity study conducted using the B92 vortex theory analyses and presented in Figure 5.1.3-4. As shown tapering the outboard 10% of the blade is effective at improving hover performance due primarily to reduced induced power. No significant additional improvement is obtained by moving the taper inboard of 90%. The effect of varying the taper ratio is also shown in Figure 5.1.3-4

EFFECT OF TIP TAPER
ON FIGURE OF MERIT

FIGURE 5.1.3-4

$C_{A15} = .09$

DETERMINATION OF RADIAL
LOCATION FOR START OF TAPER

TAPER RATIO = .33

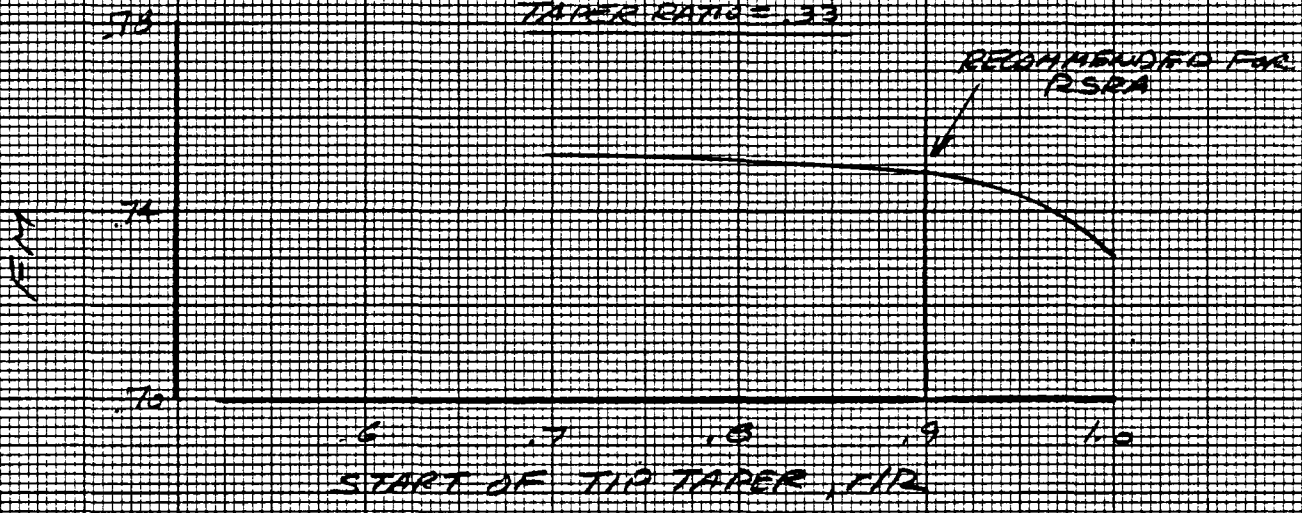

DETERMINATION OF
TAPER RATIO

TAPER STARTS AT .9 r/R

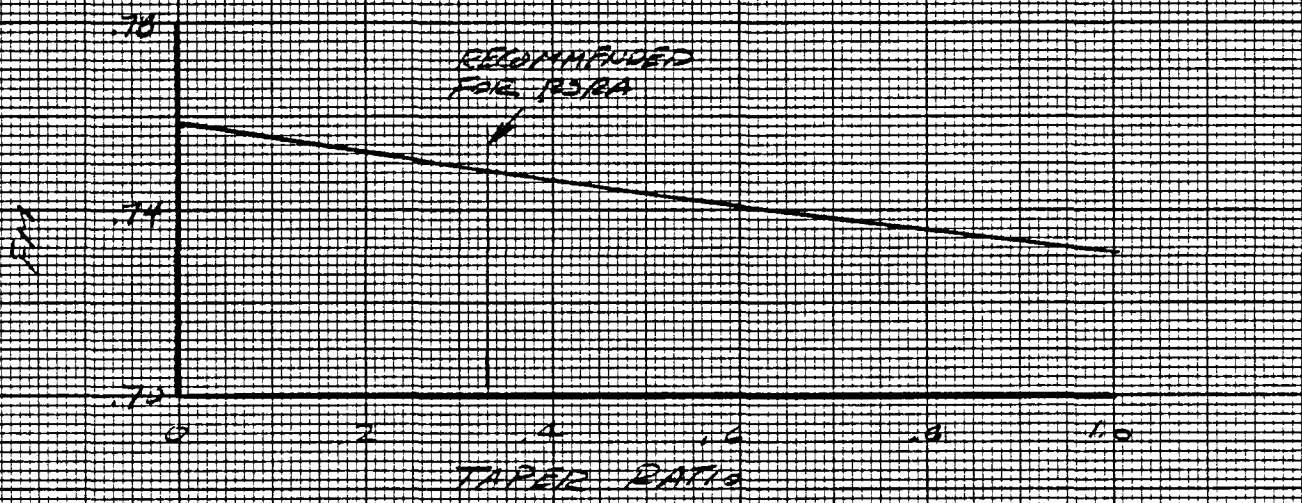

DATA BASIS - 1972 VORTEX THEORY ANALYSIS

EUGENE DIETZGEN CO
MADE IN U. S. A.

NO 340R-20 DIETZGEN GRAPH PAPER
20 X 20 PER INCH

As noted, decreasing the taper ratio results in a proportional reduction in power required. The 1/3 ratio was selected because lower values approaching a pointed tip are difficult to manufacture.

In forward flight the tapered tip also provides an improvement in performance as shown by the full scale 40 x 80 wind tunnel data presented in Figure 5.1.3-5. At an advancing tip Mach number of .86 corresponding to 287 km/hr @ 15°C (155 kt at 59°F), the tapered tip reduced the total power required by 2%. This improvement is due primarily to the effect of reduced blade tip area on the basic profile and compressibility power.

The benefits of tip taper in hover and forward flight were demonstrated by the elliptical tip evaluations conducted on the YUH-61A aircraft. Hover performance improvements were verified by full scale whirl tower tests as shown in Figure 5.1.3-6. The forward flight benefits of taper were verified by model scale testing as shown in Figure 5.1.3-7.

c. Tip Sweep

Tip sweep reduces the compressibility power at high advancing tip Mach numbers as shown in Figure 5.1.3-5. The full scale wind tunnel data indicates that favorable blade dynamic twist effects of moving the center of pressure aft as well as reduced local tip mach numbers contribute to this improvement. As shown in Figure 5.1.3-5 the swept tapered tip configuration is more effective than the rectangular swept tip at reducing compressibility power. The swept/tapered tip with sweep angles of 15° and 25° were selected for the RSRA parameter variation test program.

5.1.4 Rationale for Aerodynamic Parameter Variation Approach

The aerodynamic parameter variation approach described in paragraphs 5.1.1 through 5.1.3 represents the most practical, least risk and lowest cost approach. This approach offers the greatest potential for immediate technology and research payoff.

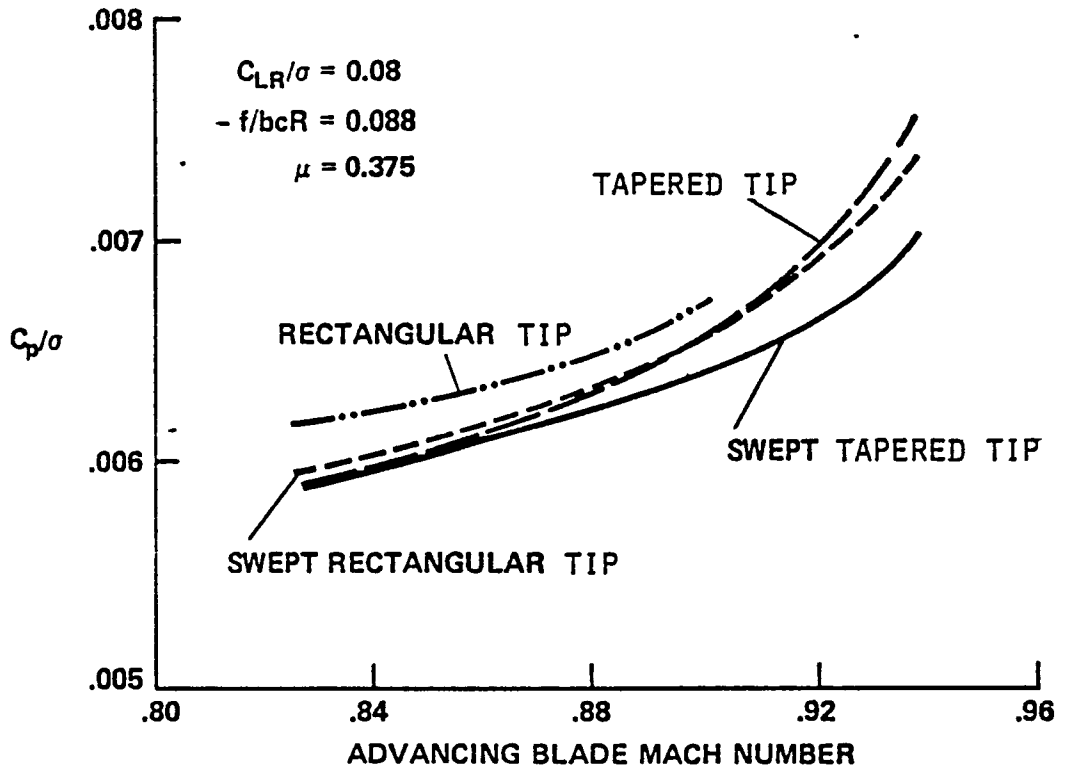

FIGURE 5.1.3-5 EFFECT OF TIP TAPER AND SWEEP ON FORWARD FLIGHT POWER REQUIRED

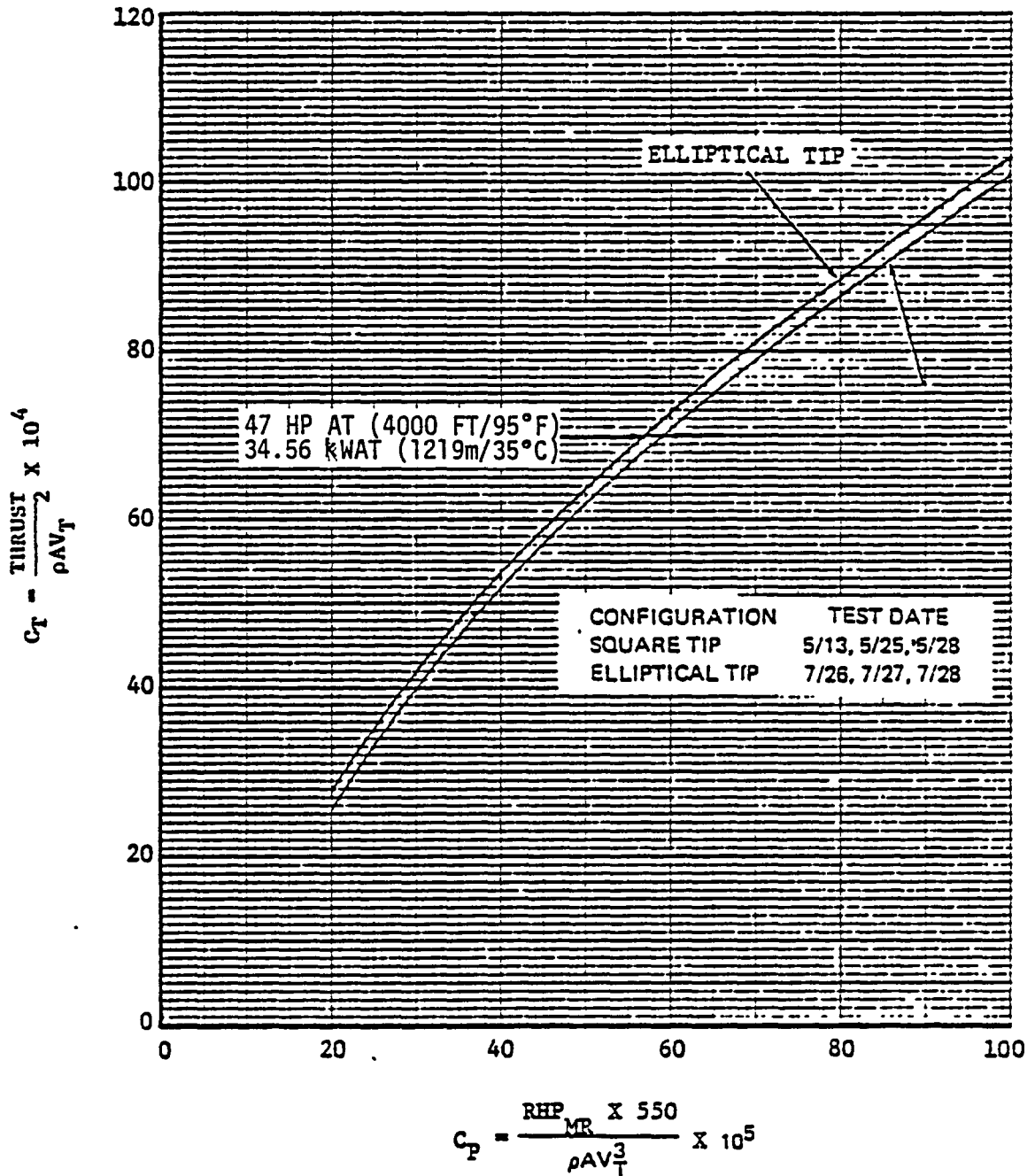

FIGURE 5.1.3-6

UH-61A ELLIPTICAL TIP WHIRL TOWER TEST RESULTS

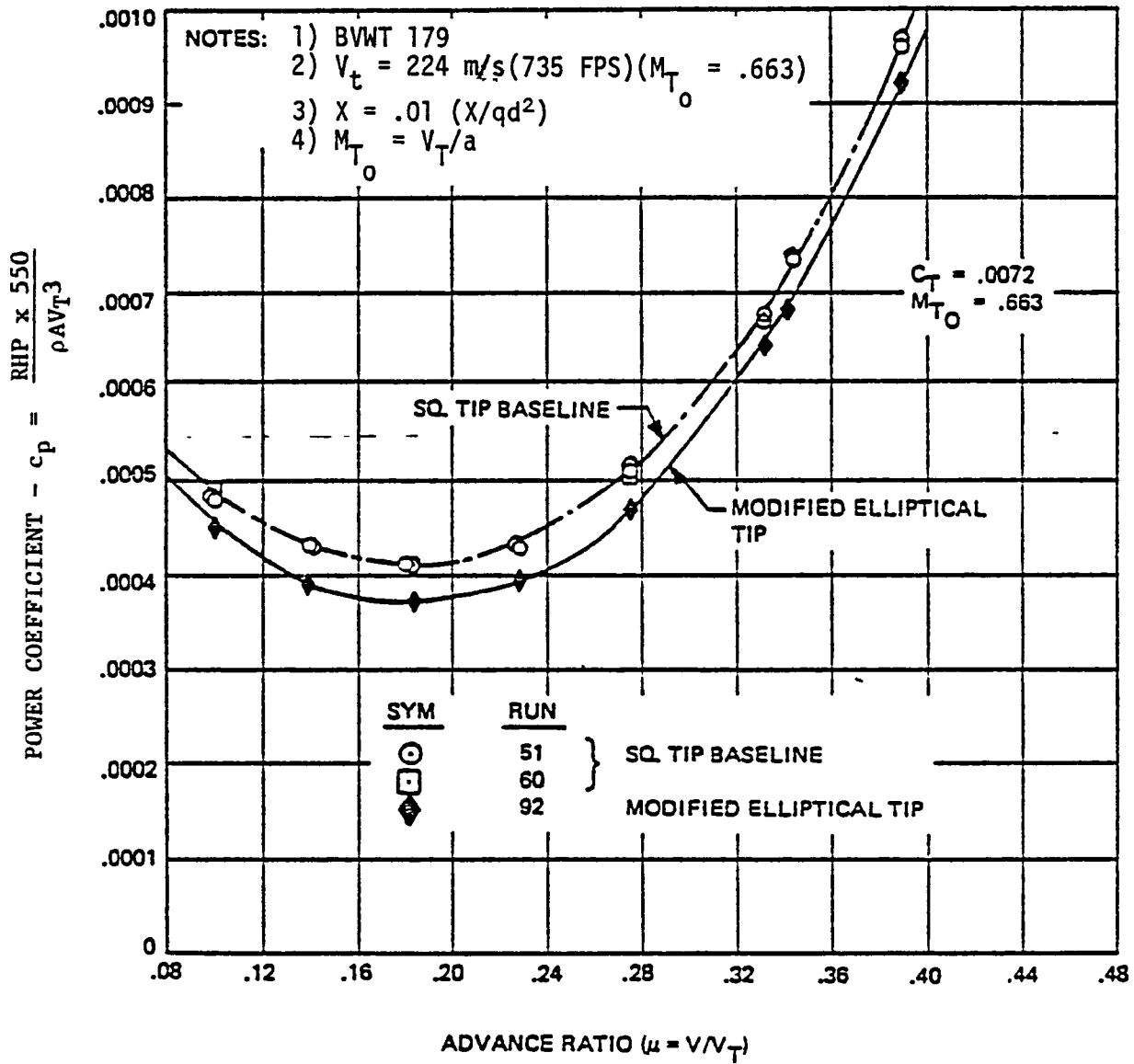

FIGURE 5.1.3-7

MODEL ROTOR TEST ILLUSTRATES ELLIPTICAL TIP FORWARD FLIGHT PERFORMANCE (.0072 C_T)

Other alternate concepts considered for varying aerodynamic parameters are as follows:

- a. Concept A1 - Truncated blades modified with fittings/adapters to accept detachable sections having different geometry over the outboard 30% of the blade.
- b. Concept A2 - Basic blades (new or existing) or substructures with detachable enveloping fairings having different geometry over the entire length of the blade.
- c. Concept A3 - Multiple blade sets each having different geometry with matched structural dynamic properties.

Subjectively considering these alternate approaches, it has been concluded that each one is prohibitive when compared to the proposed approach based on the following reasons:

- a. Cost and schedule resulting from design, tool design and fabrication, fabrication and qualification.
- b. Technical risks associated with structural integrity, and dynamic characteristics.

In considering the alternate approaches, concept A3 (the multiple blade set approach) would be preferred over concepts A1 and A2. With each concept, it would be desirable to maintain dynamic properties between each configuration set as close as possible. The use of independent blade sets minimizes technical risks and offers maximum testing flexibility. By using composite materials, the physical properties of the various blade configurations, such as mass, stiffness and inertia can be most nearly matched to minimize aeroelastic effects while maintaining structural integrity. This is accomplished by proper spar material selection (graphite and/or fiberglass), spar wall and skin thickness variation, and fiber orientation. Composite blades can be molded into any number of airfoil shapes and twist distributions to increase performance. Thickness and planform may vary and nonlinear twist may be employed.

Considering concept A1; the truncated blade/detachable extension approach would limit parameter variations to the outboard 30% span. This would result in airfoil, structural and dynamic constraints as a result of the smaller variable geometric envelope. The original spar strength would be duplicated by adding structural members and doublers to decrease the concentrated strain in the joint area. Therefore, a weight increase would result. Mass distribution and stiffness increase due to the joint in the 70% span region would result in higher CF, inertias and chordwise natural frequency. Flap and torsional natural frequencies could be closely matched to the baseline blade. However, the chordwise frequency change would not have a detrimental effect on rotor dynamic characteristics. The higher inertias will increase rotor vibration loads.

Considering concept A2, analysis of this common blade-substructure/detachable fairing concept has shown that the mass, stiffness and inertia would vary by an appreciable amount between geometry variations. Furthermore, the add-on detachable airfoil fairings would distort under the airloads, thereby altering the aerodynamic properties. In addition, this concept would necessitate a costly root-end fatigue qualification program due to higher loads.

The modified CH-47C metal blade approach was selected for tip geometry variations based on the reduced requirement for span coverage (10% vs. 30% for concept A1). The tip research program is envisioned as one in which planform is the most important shape parameter. Since the attachment joint is moved outboard to a lower bending load region, the structural integrity risk is minimal. Also, since the tip balance hardware and weights are located inboard of the tip section, CF loads on the joint will be minimized.

5.2 Rotor Dynamic and Flying Quality Parameter Variations

5.2.1 Blade Natural Frequency Variations

The purpose of varying blade natural frequencies is to reduce vibrations caused by resonance of the blades with some harmonic airload or to increase the spread between two modes of vibration likely to couple with each other.

The following frequency variation tests will be conducted on CH-47C metal blades:

**Table 5.2.1-1 RSRA-347/C Rotor System
Blade Frequency Test Variations Desired**

<u>Test Case</u>	<u>Frequency Mode</u>	<u>CH-47/C Rotor Blade Nominal Frequency at 230 RPM, ω/Ω</u>	<u>Desired Test Frequency at 225 RPM, ω/Ω</u>
1	2nd Flap	2.57	2.40
2	3rd Flap	4.75	5.50
3	2nd Chord	5.32	6.00

Case 1 - The 2nd flap frequency will be reduced by adding an internal tuning weight assembly of 15.4 kg (34 lb.) distributed between (.38R) and (.52R). The weight assembly will be tightly fitted to the inside surface of the spar with rubber and retained through a CF carrying strap which terminates at the inboard end in a fitting which attaches the assembly to the blade through the incidence pin. The weight assembly will be made up with 50-1.9 cm (3/4 inch) thick steel plates with .635 cm (1/4 inch) thick rubber spacers between the plates. This arrangement will prevent the weight assembly from adding stiffness to the blade. This technique was developed and utilized on production H-21 helicopter blades in the late 50's and during developmental flight testing of CH-47A blades in the early 60's. Figure 5.2.1-1 presents the design concept employed on H-21 blades.

Case 2 - As illustrated by figure 5.2.1-2, the 3rd flap frequency will be increased by bonding (.139 cm thick x 25.4 cm (.055 thick x 10.00 in.) wide) spanwise unidirectional graphite/epoxy doublers to the upper and lower blade surfaces centered on the chordwise C.G. The 15.4 kg (34 lb.) weight assembly installed for test case 1 above, will be retained to maintain the 2nd flap frequency at 2.56 cyc/rev. The leading and trailing edges of the graphite doublers will be faired with an elastomeric fairing compound.

FIGURE 5.2.1-1

FIGURE 5.2.1-2

Case 3 - As illustrated by figure 5.2.1-2, the 2nd chord frequency will be increased by bonding .043 cm thick x 4.44 cm (.017 in. thick x 1.75 in.) wide spanwise unidirectional graphite/epoxy doublers to the upper and lower surfaces of the blade. The trailing edge of the doublers will be located at 5.08 cm (2.00 inches) forward of the trailing edge of the blade. The edges of the doublers will be faired with elastomeric compound. The weight assembly and doublers installed for cases 1 and 2 will be removed for this test case.

5.2.2 Effective Flap Hinge Location Variations

Increasing the effective flap hinge offset increases control power. A secondary effect is to increase flapwise natural frequency, which in turn reduces phase angle between cyclic pitch input and flapping response. The 347/C or D articulated rotor system offers two possible concepts for accomplishing an effective flap hinge offset increase. One method is to add a very stiff hinge about the flap hinge. This method would also increase loads on the pitch change bearings. The method chosen is to physically shift the flap hinge outboard by means of a hub arm adapter fitting as presented in figure 5.2.2-1.

5.2.3 Control Phase Variations

Obviously different rotors require different phasing of swashplate tilt to obtain pure longitudinal response to longitudinal stick motion. Some rotors require different phasing for different flight conditions or maneuvers. Therefore, it would be desired to experiment with control phasing to determine the best compromise. This parameter variation capability is built into the present RSRA controls. It is probable that the best phase setting of the analog mixer can be found with a maximum of two variations.

5.2.4 Control System Stiffness Variations

Varying the control system stiffness can shift blade torsional frequencies if one falls near a harmonic airload or comes near a flap or lag frequency with which it may couple. Varying control system stiffness in conjunction with

FIGURE 5.2.2-1

variations in blade tip geometry and CG-AC relationship may produce a system for attenuating vibrations produced by the blades. The simplest method to vary control system is accomplished by replacing the rigid pitch links with soft pitch links with an adjustable spring rate. For correcting undesirable torsional resonances, two changes in stiffness should suffice. This approach would employ a flexible pitch link similar to the one tested on the BO-105/BMR rotor system in the NASA Ames 40 x 80 Wind Tunnel. Figure 5.2.4-1 presents the BO-105/BMR flexible pitch link assembly. Figure 5.2.4-2 illustrates the difference in stiffness between the BO-105/BMR rigid pitch links and the flexible pitch links. The spring assembly is primarily composed of Belleville spring washers stacked in series. The spring rate is varied by adding or subtracting washers or by stacking washers in parallel.

5.2.5 Lag Damper Variations

The optimum value of lag damping rate should be the minimum which gives a safe margin of modal damping ratio in air or ground resonance even with one failed lag damper. Any higher values of lag damping rate would only produce higher in-plane stresses due to normal lag motion in maneuvers and steady flight. Therefore, once the required lag damping values (rate and/or breakout) are established, no further variations are anticipated. Variations would be accomplished by making minor modifications to the hydraulic dampers, such as changing the control valve breakout spring or changing the rate control slot dimensions within the damper.

5.2.6 Flap-Pitch Coupling Variation

The most common flap-pitch coupling ($\Delta\beta$) direction is flap-up/nose-down or positive $\Delta\beta$. Gust response is somewhat reduced by this type of $\Delta\beta$, as is control sensitivity. Angle of attack instability is also reduced by positive $\Delta\beta$. It is proposed that $15^\circ \Delta\beta$ be tested. This variation will be accomplished using the original Model 347 pitch housing with a new pitch arm installed. Figure 5.2.6-1 presents the present Mod. 347 pitch housing which incorporates $30^\circ \Delta\beta$ as shown in figure 4.1-1. The new pitch arm will be designed and installed to provide $15^\circ \Delta\beta$.

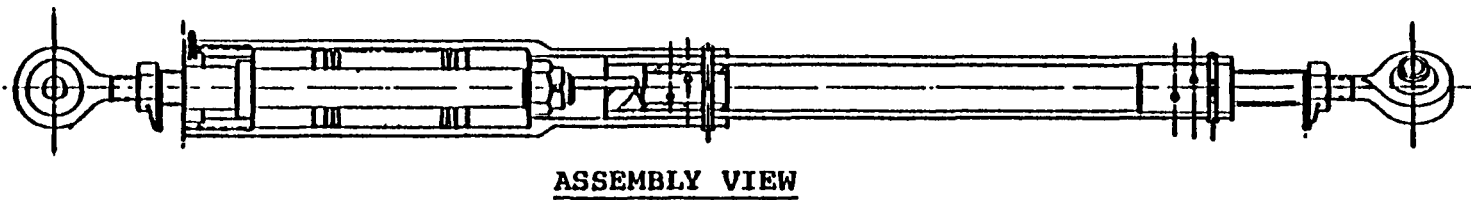

ASSEMBLY VIEW

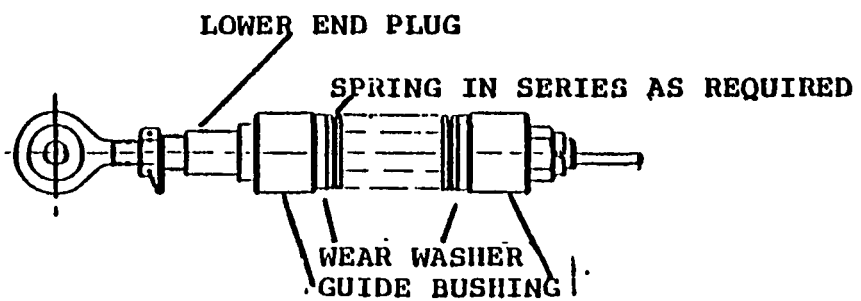

ADJUSTABLE
SPRING ASSEMBLY

FIGURE 5.2.4-1. REDUCED STIFFNESS PITCH LINKS (B0105/BMR)

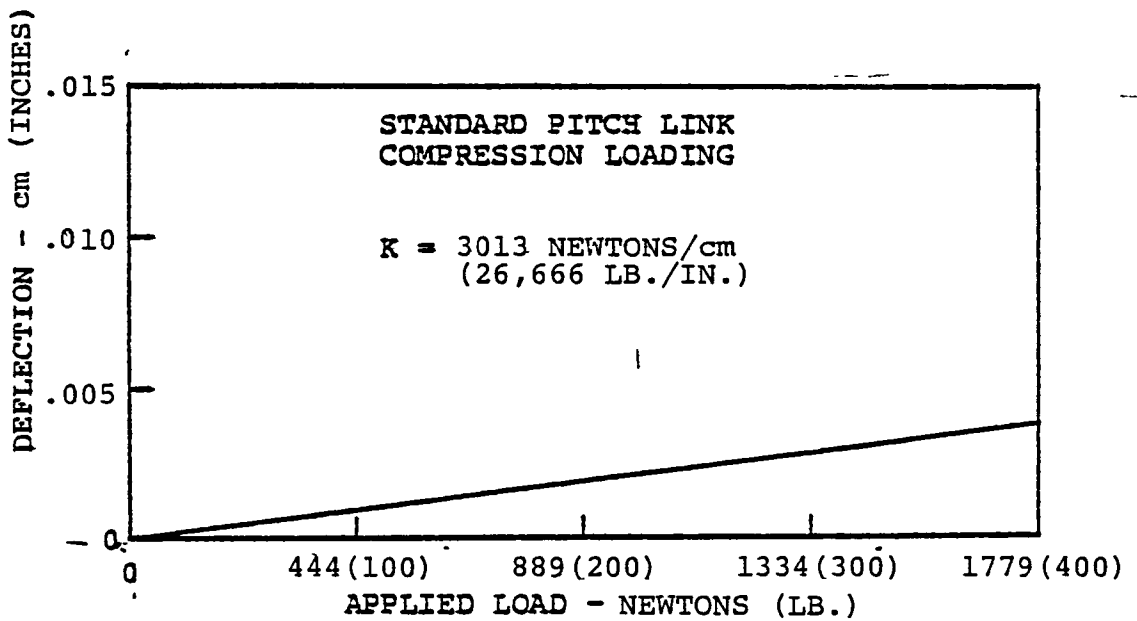
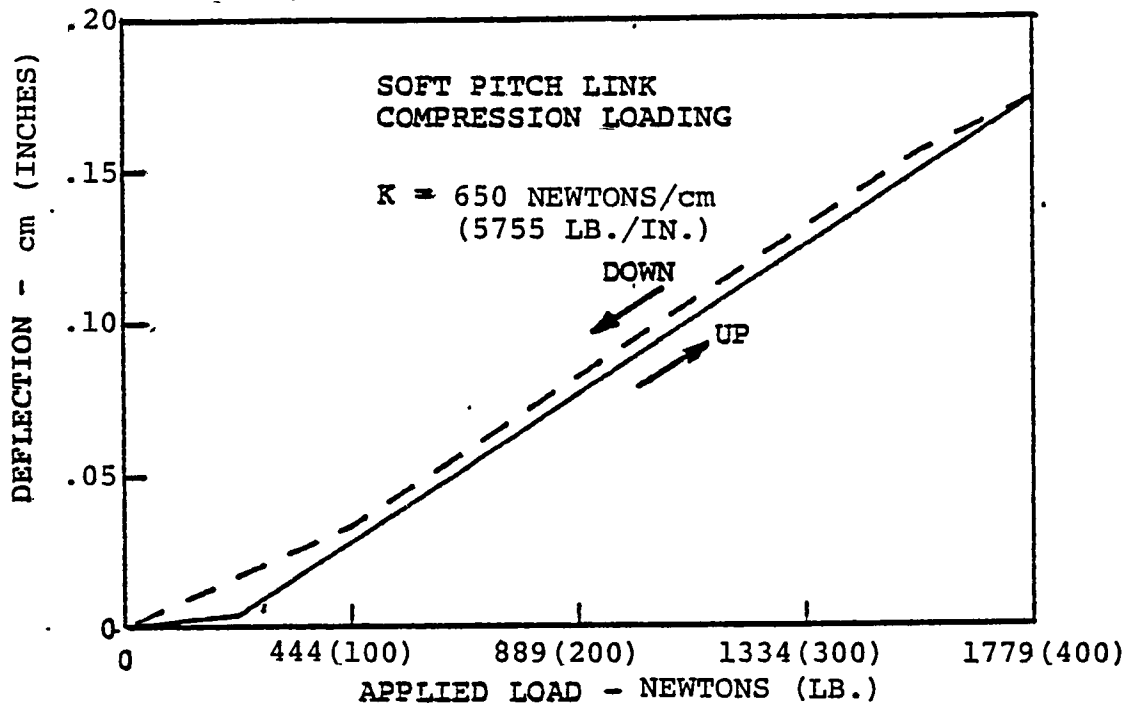

FIGURE 5.2.4-2 STATIC STIFFNESS DETERMINATION FOR STANDARD AND SOFT PITCH LINKS (B0105/BMR)

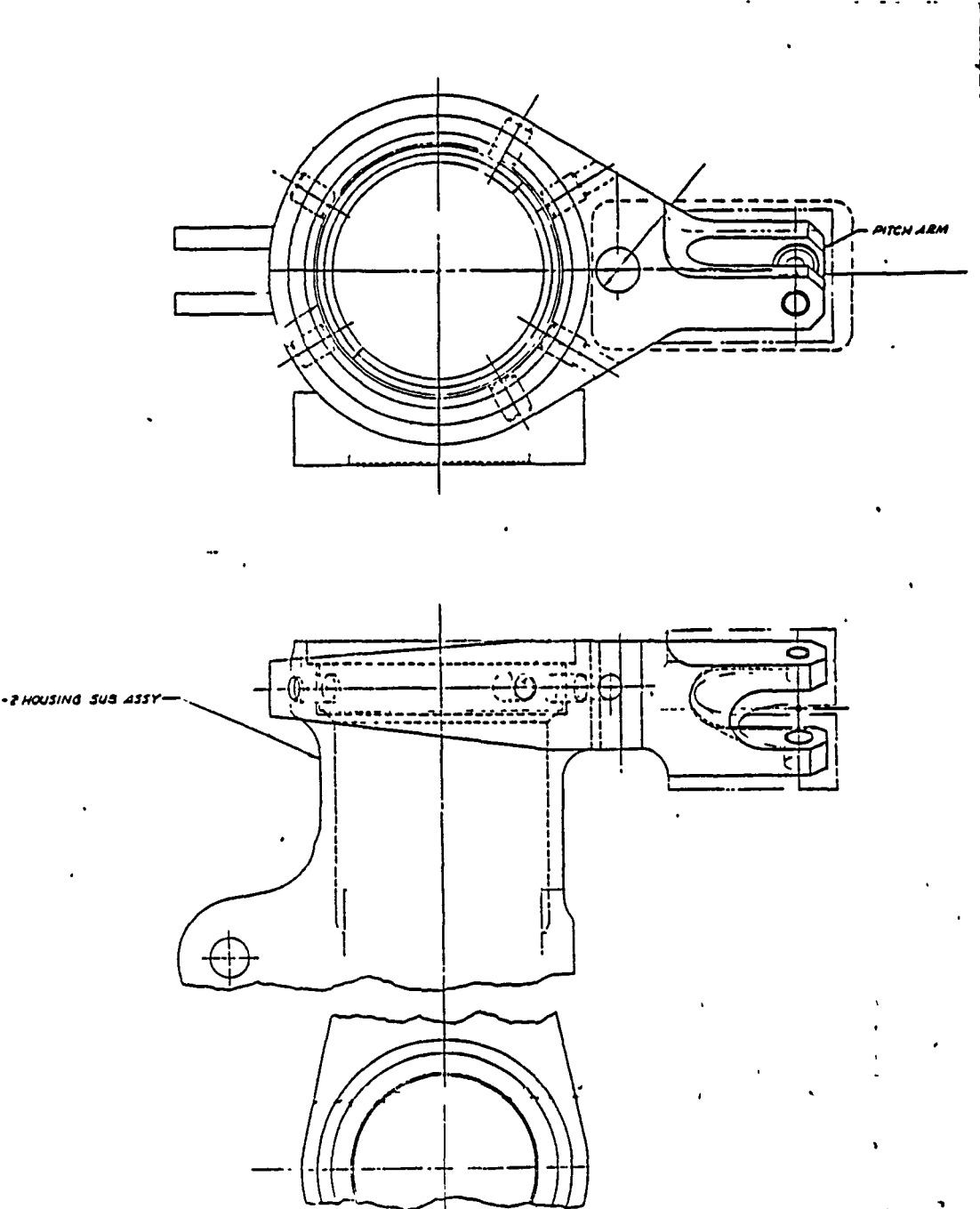

FIGURE 5.2.6-1 MODEL 347 PITCH HOUSING WITH 30° Δ 3

5.2.7 Mast Height Variation

Increasing mast height increases the control power of an articulated rotor system and decreases vibration caused by downwash interference between rotor and fuselage. The adapters required to mount the 347 rotor hub on the RSRA rotor shaft will raise the plane of the rotor by 35.56 cm (14 inches). It is considered that an additional increase in rotor height will not appreciably reduce vibration further. Also, since the rotor shaft is limited in bending, there will be no mast height variation testing.

5.2.8 Lock Number Variations

Lock number is the product of blade chord, air density, lift curve slope, radius to the fourth power, divided by moment of inertia about the flap hinge. The higher the Lock number the quicker the tip path plane tilts in response to swashplate tilt. Increasing blade chord would increase Lock number while increasing inertia would decrease Lock number. It is unlikely that blade chord could be increased while preserving C.G.-A.C. relationship without a corresponding increase in inertia, thus little or no change in Lock number. Therefore, no variations in Lock number will be tested, aside from those resulting as a consequence of substituting different blades.

5.2.9 Blade Sweep Variations

Sweeping blades forward or backward on a hingeless rotor tends to couple flapping with blade pitch change. Aft sweep acts somewhat like $\Delta 3$ in which up-flap produces nose down pitch, a stabilizing influence on blade behavior. Sweep variations on an articulated rotor would be difficult to achieve except by adding a spring in parallel with the lag damper and biasing the blade in one direction. This spring would increase lag frequency and loading on the pitch change bearings. No variations in blade sweep are proposed.

5.2.10 Precone Variations

On a hingeless rotor, precone is a built-in upward slope of the blade pitch axis. Droop is a bend in the neutral axis of the blade outboard of the pitch

change bearings. Precone and droop together give desirable pitch-lag coupling to help suppress air resonance. The combination of precone and droop results in a blade neutral axis slope in the direction the blade takes in normal one g cruise flight. Precone variations on an articulated rotor might be possible by building in droop by installing a strong preloaded spring about the flap hinge. Reducing or increasing coning angle may have some effect on lateral flapping with forward speed, at a cost of high blade root stresses. No variations in droop or precone are proposed.

5.2.11 Controls Authority Variations

Controls authority is interpreted to mean the range of blade pitch due to cyclic or collective control input. Control authority can be changed by varying control bellcrank arm lengths or stops may be changed to restrict control motions. If some change is made to the rotor system which changes control sensitivity, it may be desirable to reduce or increase control authority accordingly in order to maintain the same control response to cyclic stick motion. As stated in paragraph 4.4, the installation of the 347/D rotor system requires a new actuator output crank which will keep the cyclic and collective pitch throws as near as possible to the original RSRA values. However, no variations in controls authority are proposed.

6.0 Instrumentation

A list of instrumentation required to define the blade airloads distribution and dynamic and structural response is presented in Table 6.0-1 in order of priority. As shown, the priority I instrumentation includes a sufficient number of flap bending and blade torsion gages to define the radial thrust and torsion airload distribution for comparison with theoretical predictions as well as model rotor and CH-47D flight test data.

The priority II item is two hot film anemometer rakes located on top of the fuselage ahead of the rotor. The rakes will be positioned to record the tip vortex strength and location in forward flight. These measurements provide an indirect means of verifying the airloads distribution data since the vortex strength and lift distribution must be consistent. The relationship between

the vortex strength, location and the blade lift distribution will be evaluated using the B67 vortex theory analyses.

Table 6.0-1

Instrumentation

Priority I (Blade Instrumentation):

	<u>r/R</u>
<u>Blade Flap Bending:</u>	.09
	.11
	.15
	.20
	.30
	.41
	.55
	.70
	.80
	.90
<u>Blade Chord Bending:</u>	.13
<u>Blade Torsion:</u>	.14
	.27
	.40
	.52
	.67
	.75
	.85
	.95

Priority II (Rotor Wake Survey)

- (2) Hot Film Anemometer rakes with six probes on each rake and positioned on top of the fuselage ahead of the rotor.

In addition to blade gaging defined as priority 1, the following instrumentation will also be required:

- a. Pitch link load gages
- b. Lag damper load gages
- c. Pitch shaft load gages
- d. Blade flap angle transducers
- e. Blade pitch angle transducers
- f. Blade lead-lag angle transducers

It is assumed that rotor thrust and shaft torque and bending measurement transducers presently exist on the RSRA.

7.0 Cost Estimates

Preliminary cost estimates of the tasks required to implement the 347/D rotor system and proposed parameter variants presented herein are based on FY '80 dollars. The following summary is presented for pre-planning purposes only.

A. 347/D - RSRA Rotor System and Integration

- (1) Design and fabrication of new components, acquisition and preparation of 347 rotor hub and swashplate and blade instrumentation \$682,000
(cost assume new GFE pitch housings)
- (2) CH-47D Fiberglass Rotor Blades (4). \$199,000

Note: Cost of CH-47D blades may be eliminated by arranging for Army loan of blades to NASA.

- (3) Spare CH-47D blades (2) \$100,000
 - (4) Structural testing of new rotor components. \$503,000
(Qualification Bench Testing)
 - (5) Modifications to transmission. \$ 89,000
 - (6) Modification to emergency escape system and new blade severance
assemblies. \$343,000
 - (7) Installation of 347/D-RSRA Rotor System \$207,000
 - (8) Support of ground and flight tests. \$417,000
 - (9) Management and Control. \$176,000
- Sub-total. \$2,716,000

B. Parameter Variation Test Program

- (1) Phase I - Basic Aerodynamic Parameter Variation Tests
. \$ 834,000
 - (2) Phase II - Expanded Aerodynamic Parameter Variation Tests
. \$6,152,000
 - (3) Phase III - Rotor Dynamic and Flying Quality Parameter Variation
Tests \$4,871,000
 - (4) Phase IV - Blade Tip Shape Variation Tests. \$1,665,000
 - (5) Management and Control. \$ 520,000
- Sub-total. \$14,042,000
- Total. \$16,747,000

Appendix D presents the Engineering and Manufacturing preliminary manhour estimates for total program requirements upon which the above cost estimate summary is based.

The estimates given are preliminary and are not to be considered as a quotation.

Off-site activities will consist of installation of the 347/D rotor system components, parameter variation components and attendant instrumentation into the RSRA aircraft and support of ground and flight testing.

It is assumed that the NASA RSRA will be available in flight condition, all instrumentation (except that required to be installed for 347 rotor testing) functional, and all systems functional.

8.0 Technology Payoff

8.1 Flight Envelope

In order to fully quantify the full capabilities of the selected state-of-the-art rotor system and the contributions of individual key rotor system parameters, the RSRA test vehicle must be capable of exploring the full design envelope of the test rotor configurations. The selected rotor and parameter variation rotor configurations defined in Table 2.0-2 can be divided into low solidity designs (347/A and 347/C rotors) and high solidity designs (347/MOD 1, 347/MOD II and 347/D rotors). The relationship between the rotor design flight envelope and the RSRA test aircraft envelope for the low solidity rotors will be similar to the 347/C envelope defined in Figure 8.1-1. As shown, the thrust coefficient and advance ratio design envelope of the low solidity rotors can be thoroughly evaluated for C_T values greater than .0050 from hover to 163 kt.

The relationship between the RSRA test aircraft envelope and the rotor design envelope for the high solidity rotors will be similar to the 347/D envelope presented in Figure 8.1-2. As shown, the RSRA flight envelope is less than the

**RSRA FLIGHT ENVELOPE
3471C ROTOR SYSTEM**

FIGURE 8.1-1

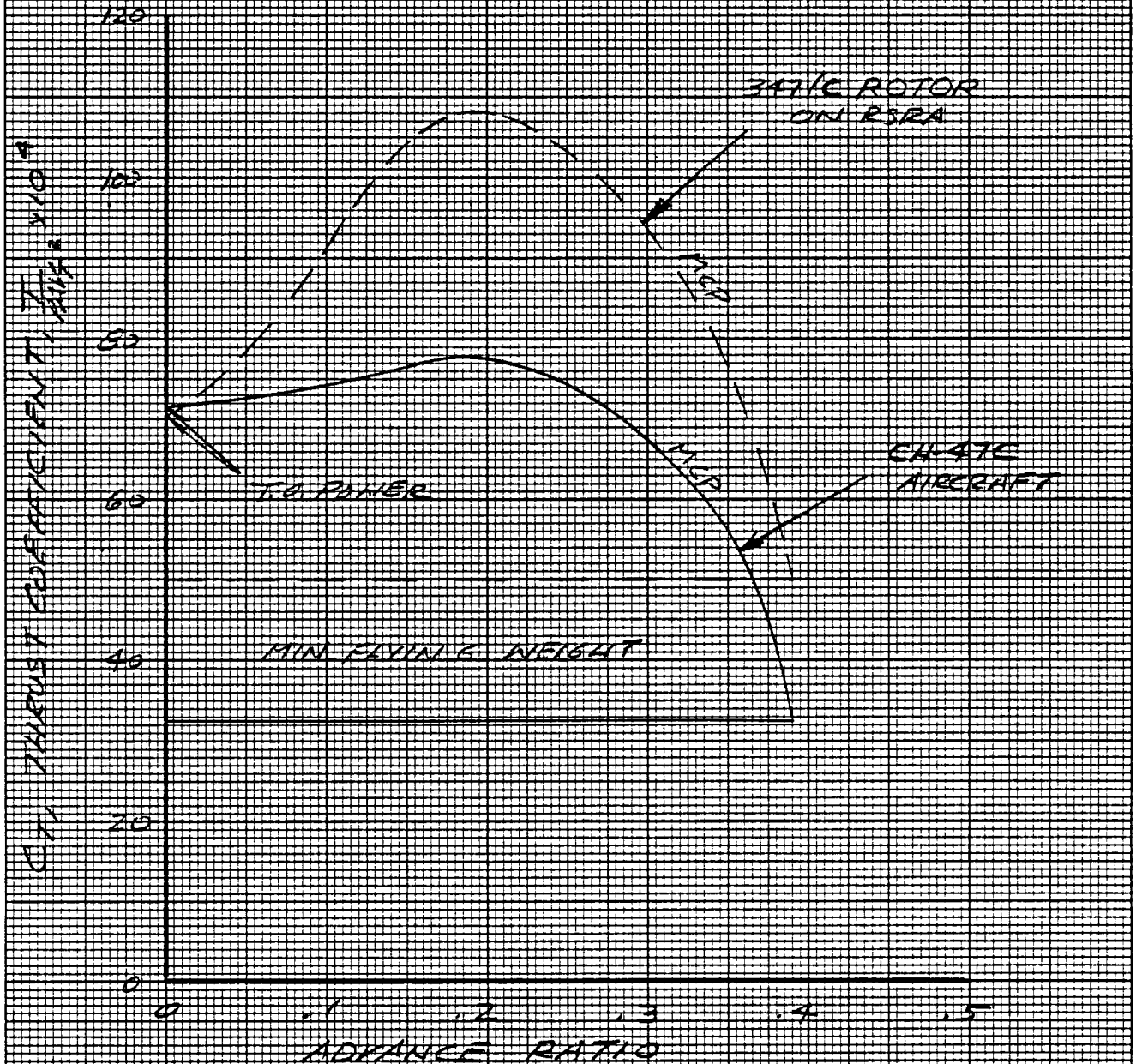

EUGENE DIETZGEN CO
MADE IN U.S.A.

NO 340R-20 DIETZGEN GRAPH PAPER
20 X 20 PER INCH

RSRA FLIGHT ENVELOPE
3A7/D ROTOR SYSTEM

FIGURE 8-1-2

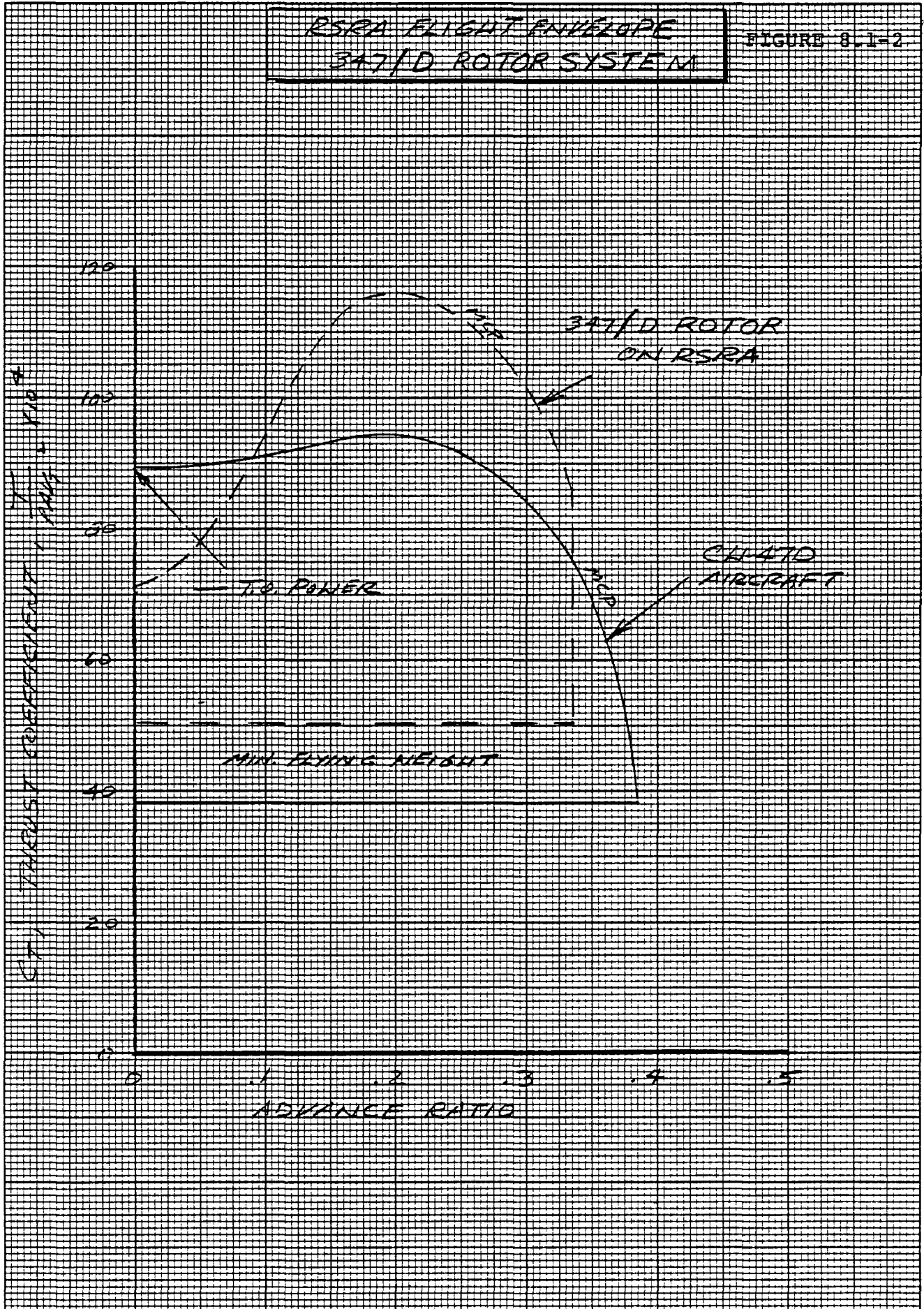

EUGENE DIETZGEN CO
MADE IN U.S.A.

NO 340R-20 DIETZGEN GRAPH PAPER
20 X 20 PER INCH

design envelope at airspeeds below 74 km/hr (40 kt) and above 259 km/hr (140 kt). At low airspeed the RSRA is restricted by the RSRA power available and at high speeds it is limited by the RSRA control system loads generated by the 81.28 cm (32 inch) chord blades. The 259 km/hr (140 kt) limit will permit testing up to the CH-47D best range cruise airspeed of 250 to 259 km/hr (135 to 140 kt).

The forward flight test envelope can be expanded by reducing the tip speed to increase advance ratio and thrust coefficient. The power limited envelope can be further increased by utilizing auxiliary propulsion.

The maximum achievable thrust coefficient of the RSRA in hover with the high solidity rotors can be increased by reducing the rotor speed and over-torquing the transmission. By reducing the main rotor speed during hover and exceeding the 30 minute transmission torque limit for 1 to 2 minutes during a high thrust and low RPM tethered hover test points, the design C_T and figure of merit of the 347/D rotor can be achieved as illustrated in Figure 8.1-3. The relationship between the 30 minute transmission limit, T58-GE-5 engine takeoff power available and the 10 second transmission torque limit are shown in Figure 8.1-4. The torque limits are assumed to be output torque limits and the transmission power limit is proportional to the rotor speed. The increase in main rotor thrust coefficients with decreasing rotor speed are also shown in Figure 8.1-4. At 206 main rotor RPM and takeoff power, the tail rotor begins to stall. The tail rotor tip speed is assumed to be 210 m/sec (690 ft/sec) at a main rotor speed of 225 RPM.

The envelope limitations of the MOD II high solidity rotors could be avoided by building 64 cm (25.25 inch) chord blades with VR7/8 airfoils instead of 81 cm (32 inch) 23010 blades. However, this would increase the program costs considerably since it does not take advantage of commonality with the CH-47D fiberglass blades resulting in additional qualification and manufacturing costs. Another possibility would be to test three-bladed CH-47 rotor systems. This could be accomplished with the same rotor - RSRA adaptation hardware.

**3471D ROTOR SYSTEM
FIGURE OF MERIT**

FIGURE 8.1-3

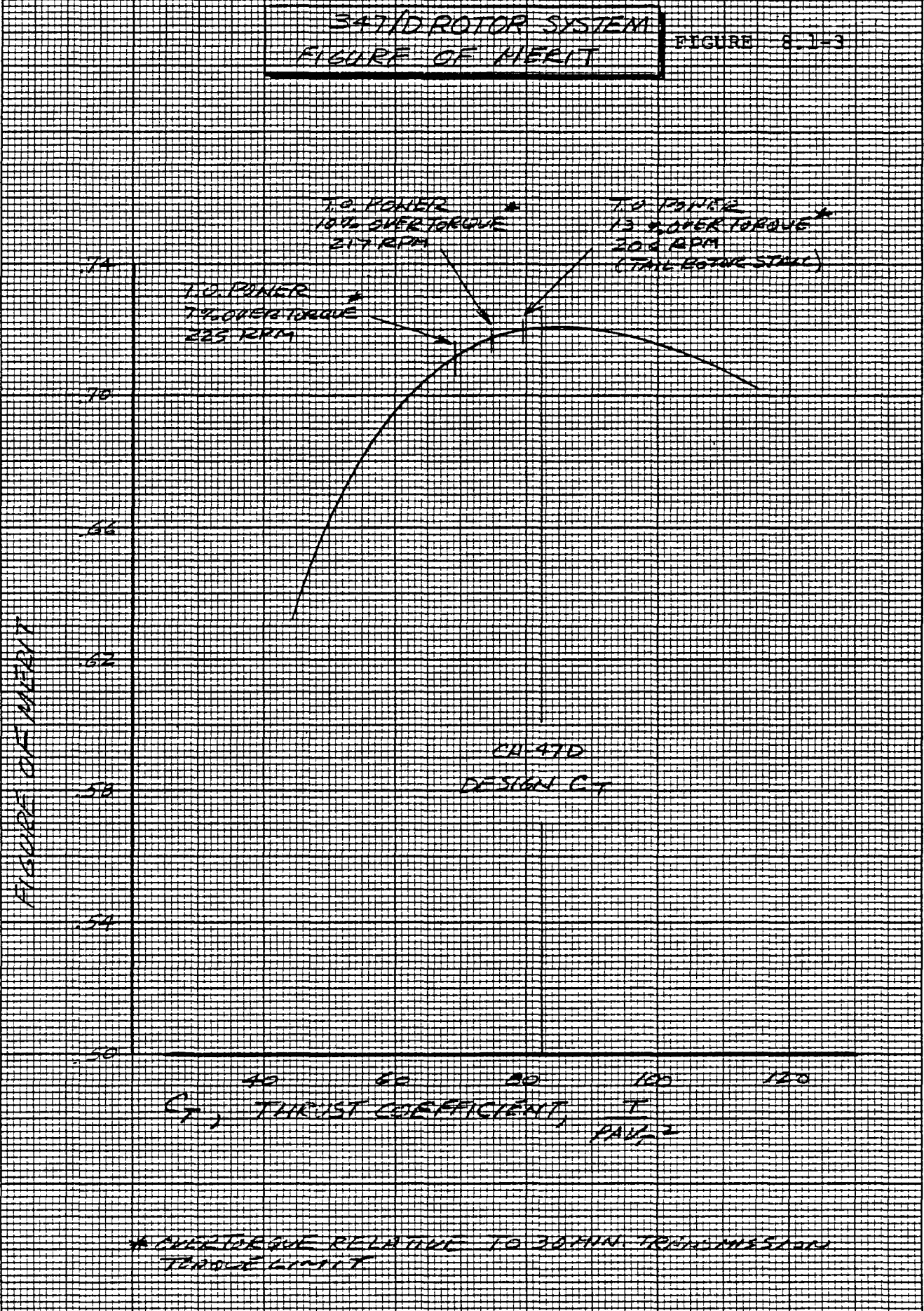

* OVERTORQUE RELATIVE TO 30 MIN. TRANSMISSION TORQUE LIMIT

EUGENE DIETZGEN CO
MADE IN U. S. A

NO 340R-20 DIETZGEN GRAPH PAPER
20 X 20 PER INCH

**EFFECT OF ROTOR SPEED
REDUCTION ON 349/D
MAXIMUM TEST HOGE CT
SUBSTANDARD TEST SITS**

FIGURE 8.1-4

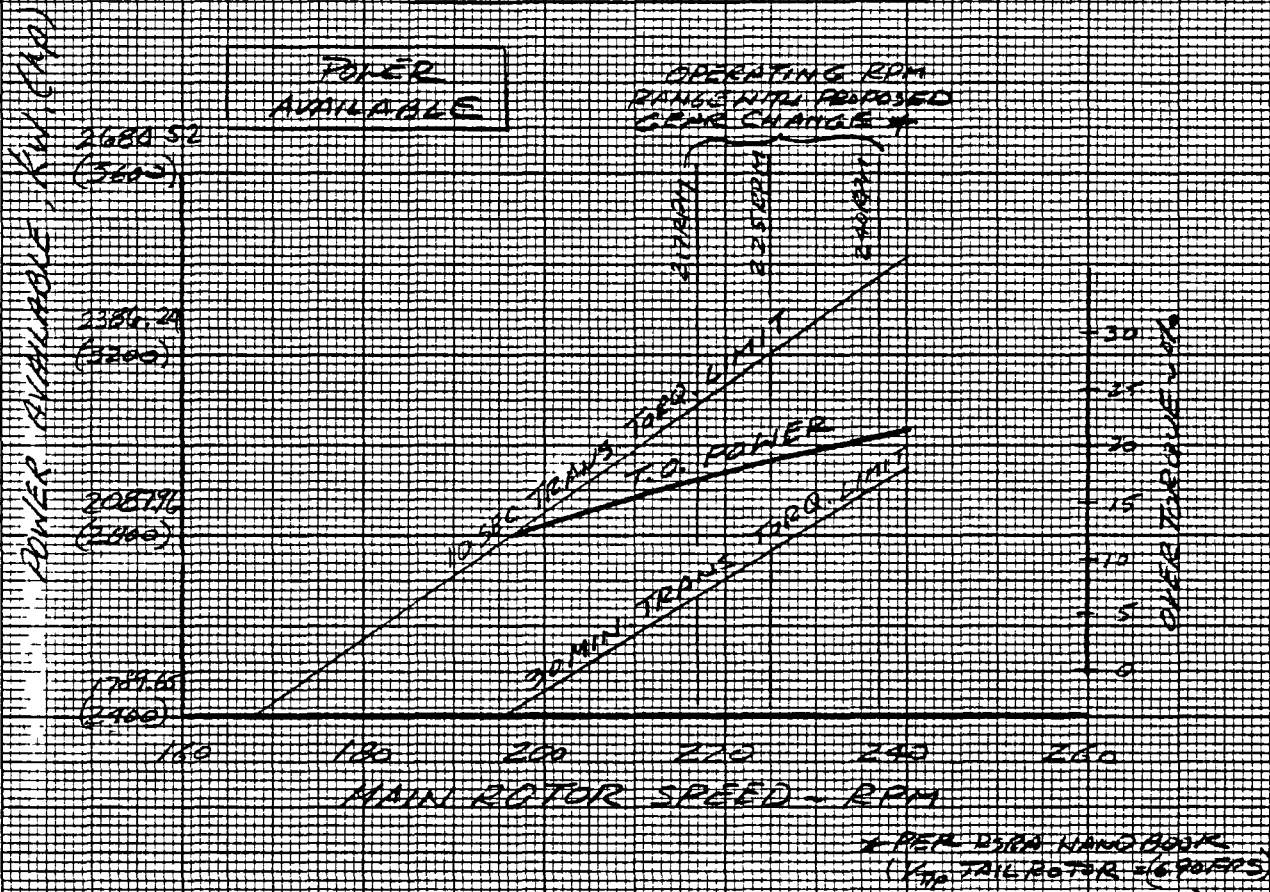

RSRA CT LIMITATIONS

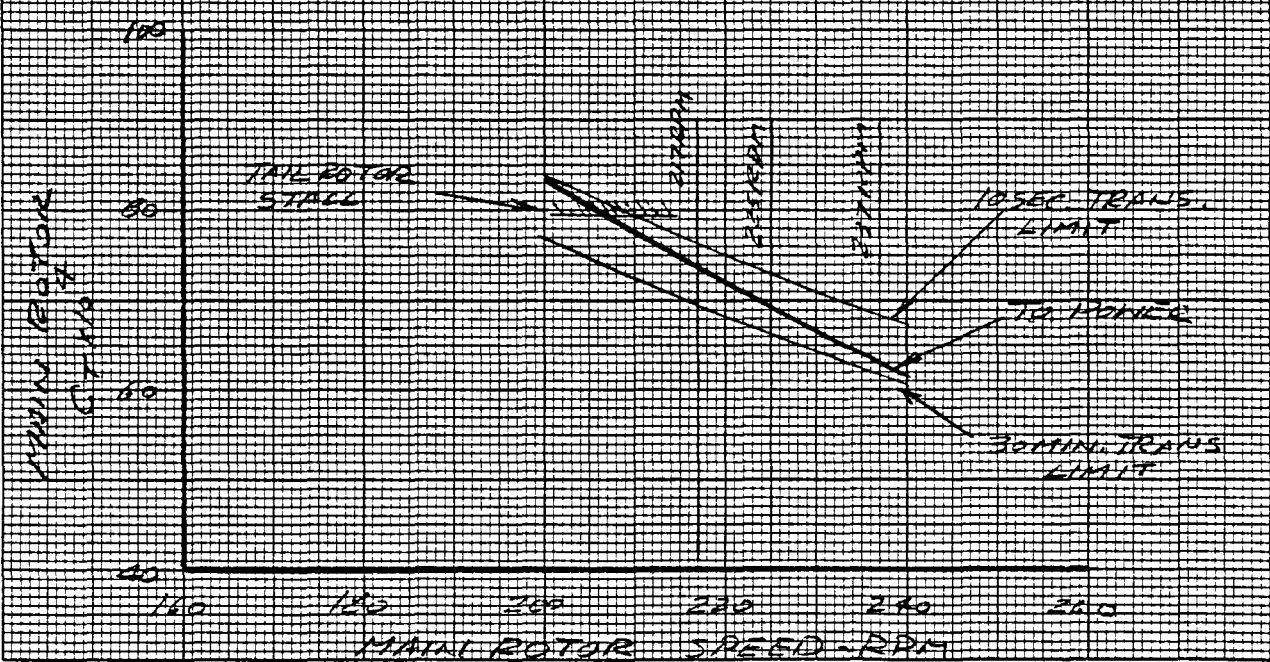

PER RSRA HANDBOOK
 (V_{TA} TAIL ROTOR = 690 KTS)
 AT 225 MR RPM 210 m/SEC

EUGENE DIETZGEN CO
 MADE IN U.S.A.

NO 340R-20 DIETZGEN GRAPH PAPER
 20 X 20 PER INCH

8.2 Model Scale Wind Tunnel Tests

One additional technical benefit of testing the 347/D and 347/C rotor systems on the RSRA is that it will result in a full scale rotor data base for correlation with existing Boeing Vertol model scale rotor wind tunnel data. Comparisons of model and full scale test results will show the effect of Reynolds number and other scaling parameters on performance, loads and flying qualities. Model testing is a relatively inexpensive method used by industry to develop advanced rotor designs. Boeing Vertol has used model rotor testing extensively to develop the latest generation of rotor designs and is currently in the process of testing and developing advanced designs. A summary of the testing conducted on the 347/C and 347/D model rotor systems is presented in Table 8.2-1.

In order to use model testing to its full potential, the effects of scaling must be fully understood. As shown in Figure 8.2.1, the 347/D model rotor system hover and forward flight power required is lower than full scale estimates derived from theory. The differences between model and full scale performance is attributed to Reynolds number effects on profile power. Simplified incremental airfoil section drag corrections are typically applied to the model profile power. These corrections have been verified in hover, however, in forward flight, where there are considerable unsteady aerodynamic effects, these corrections have not been confirmed. The RSRA test program will afford the opportunity to investigate forward flight scale effects.

Table 8.2-1

BOEING VERTOL MODEL ROTOR

WIND TUNNEL TESTS

<u>ROTOR SYSTEM</u>	<u>TEST</u>	<u>ROTOR DIA. (FT)</u>	<u>TYPE OF TEST</u>	<u>TEST CONDITIONS</u>
347/C	BVWT 033	16.0	PERFORMANCE AND BLADE LOADS	FORWARD FLIGHT
	BVWT 040	5.5	PERFORMANCE	$\mu=0, .1, .2, .3, .4$
	BVWT 048	16.	BLADE & HUB LOADS	$\mu=.2, .3, .35$
	BVWT 049	5.5	PERFORMANCE	$\mu=.05, .1, .2, .2, .4, .5, .6$
	BVWT 056	5.5	PERFORMANCE	$\mu=.1, .2, .3, .4$
	BVWT 065	5.5	PERFORMANCE AND BLADE LOADS	$\mu=.05, .1, .2, .3, .35$
	BVWT 068	5.5	PERFORMANCE AND BLADE LOADS	$\mu=.0, .5, .1, .2, .25, .3, .35$
347/D	BVWT 256	10.1	PERFORMANCE, LOADS AND VIBRATION	$\mu=0, .15, .3, .4, .45, .5$

NO. 340R-MP DIETZGEN GRAPH PAPER
MILLIMETER

DIETZGEN CORPORATION
MADE IN U.S.A.

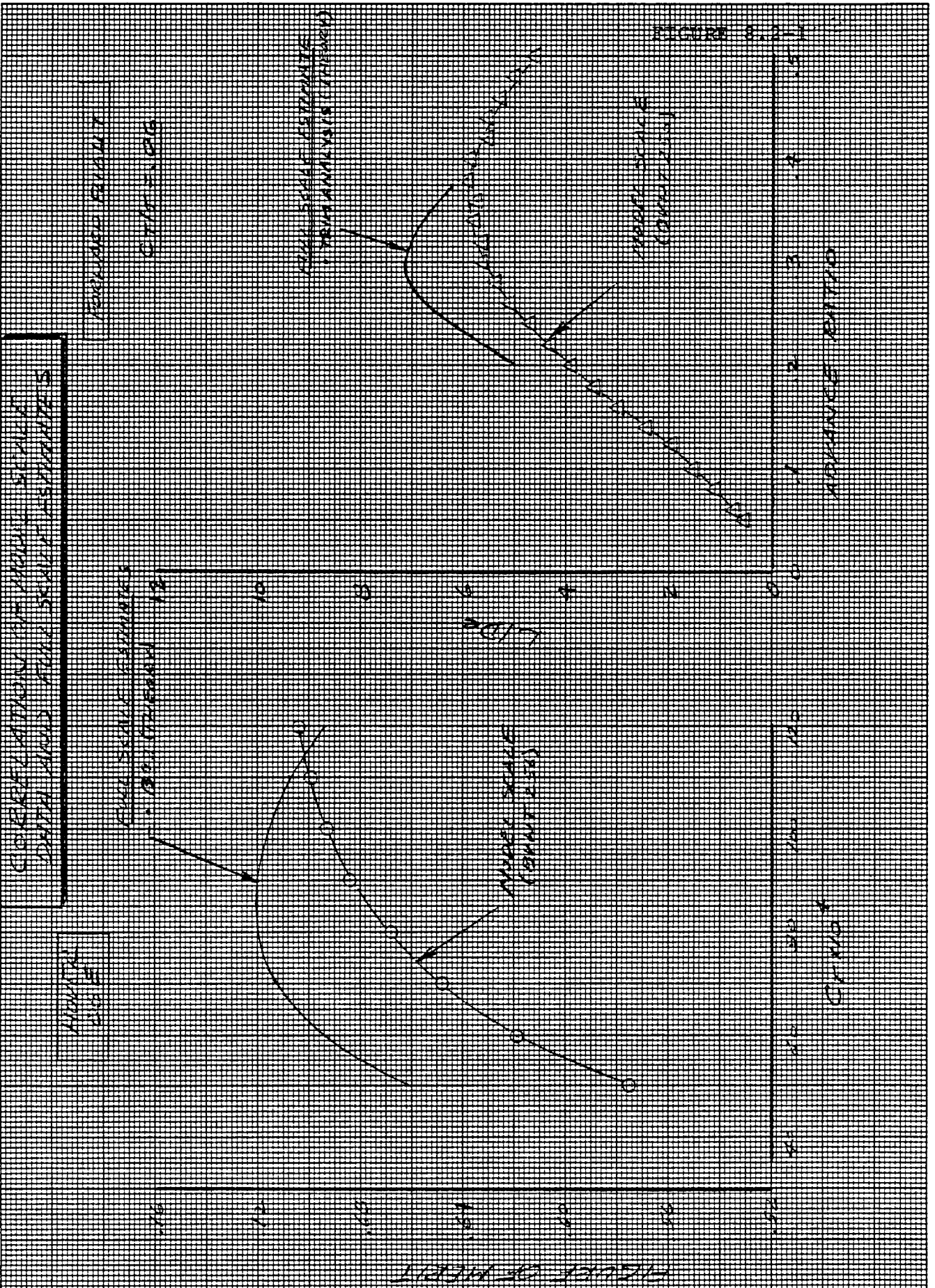

Another key area where scaling effects are not understood is rotor stall limits. Airfoil section maximum lift coefficient versus Reynolds number trends indicate that model rotors should have stall boundaries considerably lower than full scale; however, the limited amount of full scale/model scale comparisons available show no significant difference as illustrated in Figure 8.2-2. One possible explanation is that the oscillating airfoil stall delay effects are larger at the lower Reynolds number as indicated by the section data presented in Figure 8.2-3. Measurements of model and full scale performance and airloads data during the RSRA program could contribute significantly to understanding this phenomena.

8.3 Stability and Control Payoffs

Changes in flap hinge offset and solidity separately or in combinations would provide an ideal opportunity to explore their influence on pitch and roll control during high rate maneuvering flight. This is especially important with military helicopter missions stressing nap-of-the-earth type flight.

The possibility of gaining insight into improved gust alleviation and pitch stability can be obtained by varying tip sweep and blade aerodynamic center - center of gravity offset.

V23010-1.58 ROTOR SYSTEMS

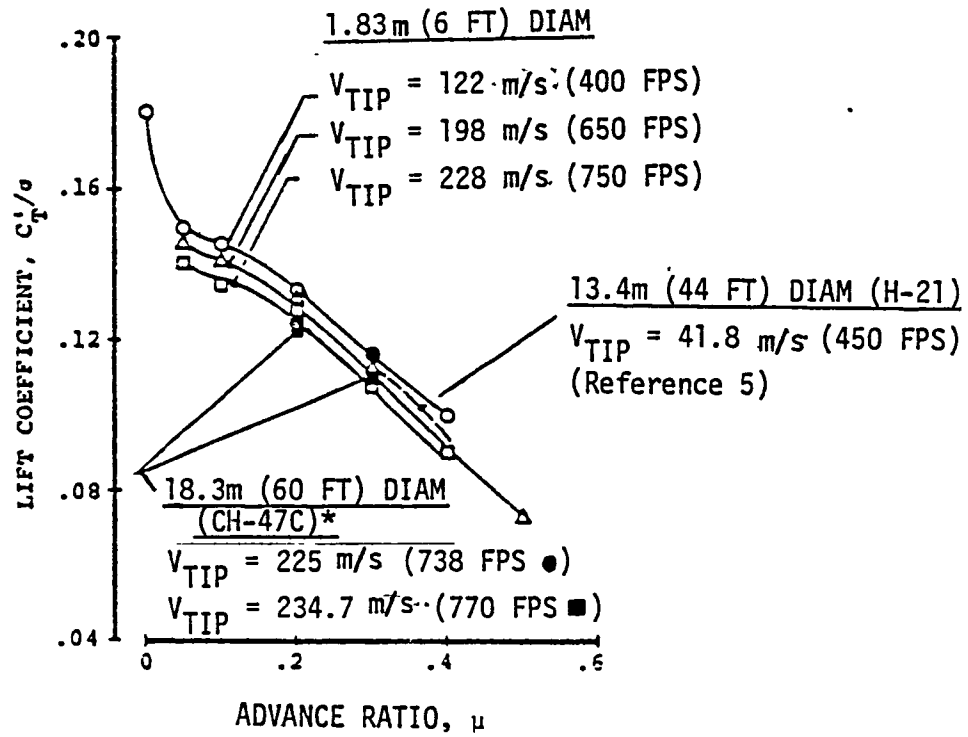

*AVE. AFT ROTOR DATA CORR. TO ISOLATED CONDITION

FIGURE 8.2-2 STALL FLUTTER BOUNDARY EFFECT OF SCALE

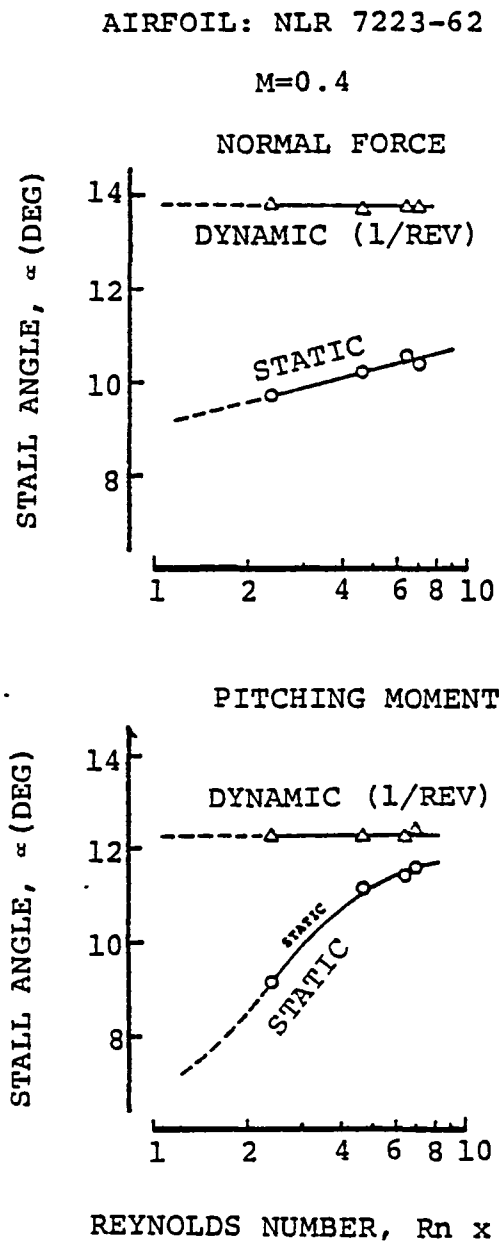

FIGURE 8.2-3 IMPACT OF REYNOLDS NUMBER VARIATION ON STATIC AND DYNAMIC STALL CHARACTERISTICS

9.0 Program Development Plan

9.1 Preliminary Work Breakdown Structure

The plan for the development and qualification of the 347/D Rotor System, its integration with the NASA RSRA, development and qualification of parameter variation hardware and support of all ground and flight testing is based upon the following preliminary RSRA Program Work Breakdown Structure (WBS):

**RSRA PROGRAM
PRELIMINARY WORK BREAKDOWN STRUCTURE
WBS ELEMENT TITLE**

WBS LEVEL

1 2 3 4

RSRA Program

RSRA - 347/D Rotor System

Design, Fab and Install Rotor System

Ground and Flight Test Rotor System

Management and Control

Parameter Variation Test Program

Phase I - Basic Aerodynamic Par. Var. Tests

Phase II - Expanded Aero. Par. Var. Tests

Phase III - Rotor Dyn. and Fly. Qual. Par. Var. Tests

Nat. Freq. Var Tests (Flap & Chord)

Eff. Flap Hinge Loc. Var. Tests

Contral Phase Var. Tests

Control Sys. Stiffness Var. Tests (Tors. Freq.)

Lag Damper Var. Tests

Delta 3 Coupling Var. Tests

Phase IV - Blade Tip Shape Var. Tests

Management and Control

The RSRA Program WBS is based upon the program defined under Task II, Detailed Study, (paragraphs 4 through 6) and has been developed specifically for this type of program. That is, a program where the contractor will design, qualify, fabricate and install a rotor system and parameter variation hardware and support NASA conducted ground and flight testing of that rotor system and its parameter variants.

9.2 Draft Statement of Work

Recital

The objective of this program is to develop the 347/D Rotor System and its parameter variants for the NASA Rotor Systems Research Aircraft (RSRA), implementation and support of all ground and flight testing. The 347/D Rotor System will be used to perform rotor system studies and comparative testing which will quantify the capabilities of state-of-the-art and advanced technology rotor systems, quantify the contributions of individual key rotor system parameters to rotor capabilities, and develop the necessary data base for correlation with analytical predictive computer codes. The foregoing pre-design study indicates that the selection of the 347/D Rotor System ensures the acquisition of a least cost, lowest risk, versatile rotor system that provides the capability to evaluate the contributions of key rotor system parameters to improvements in speed, payload, efficiency, vibration, agility, noise, aeroelastic stability and aerodynamic stability and control.

Statement of Work

The Boeing Vertol Company, as an independent contractor and not as an agent of the Government, shall furnish the personnel, equipment, material and facilities necessary to perform the design, fabrication and qualification of the 347/D Rotor System and its parameter variants for the NASA RSRA, installation of the rotor system and parameter variation hardware, and support of all ground and flight testing in accordance with the following tasks:

1. Task I - Rotor System Design

- a. Conduct a Preliminary Design Study of the 347/D Rotor System, parameter variation concepts, and Emergency Escape System as follows:
- (1) Establish design criteria and specifications appropriate for a flightworthy rotor system, parameter variation components and the Emergency Escape System for subsequent flight testing on the NASA RSRA.
 - (2) Obtain and analyze RSRA data on drive system torsional characteristics, lower controls and mixing, and control system hydraulic actuators.
 - (3) Analytically determine static and dynamic loading conditions for component structural design. Flight maneuver, gust, landing, autorotating, ground handling, static, and miscellaneous loading conditions shall be investigated. Critical design conditions for structural and aerodynamic capability and operational use of the rotor and airframe will be identified.
 - (4) Develop the preliminary design 347/D Rotor System in accordance with the criteria and requirements established in (1) above. Conduct analyses as required to generate preliminary design information on the 347/D Rotor System integrated with the RSRA.
 - (5) Perform structural analyses to size components and substantiate the design, including fatigue, limit and ultimate loading and coupled drive system-rotor system dynamic stability.
 - (6) Perform an analysis to identify and assess major risk areas associated with the rotor system design including parameter variants and the Emergency Escape System.

- (7) Review the rotor system design including parameter variants and the Emergency Escape System and define all qualification bench test requirements including number of specimens, type and magnitude of loading, methods of applying loads, instrumentation required and duration of fatigue testing. In addition, RSRA tie-down endurance whirl testing shall be considered and defined.
 - (8) Review the rotor system design including parameter variants and establish flight test instrumentation requirements.
 - (9) Present an oral briefing to government personnel at NASA Ames to summarize the results of the Preliminary Design.
- b. Upon approval of the Preliminary Design, the contractor will develop the Detail Design of all 347/D Rotor System components, including control system components, all parameter variation components, all tooling required to fabricate components, all test fixtures, and all bench, ground and flight test instrumentation installations.

2. Task II - Fabrication and Instrumentation

- a. Upon completion and release of detail design documentations, the contractor shall manufacture and/or procure the following:
- (1) Tooling required to manufacture the 347/D Rotor System components and parameter variation hardware.
 - (2) 347/D Rotor System components including RSRA interface components, parameter variation hardware and Emergency Escape System for subsequent qualification and ground and flight testing.
 - (3) Bench test fixtures for qualification testing of critical components.

- b. Instrument components as required for qualification bench testing and subsequent ground and flight testing of the 347/D Rotor System and its parameter variants.
3. Task III - Qualification Bench Testing and Ground and Flight Tests

- a. The contractor shall prepare and/or support preparation of test plans for qualification bench testing of critical components, ground testing including RSRA tie-down endurance whirl testing and flight testing of the 347/D Rotor System and its parameter variants. The test plans for the Emergency Escape System modifications and Blade Severance Assemblies will be subcontracted.

- b. Component Qualification Bench Tests:

Upon approval of the component test plan, a component test program shall be conducted in accordance with the approved plan to assure flight worthiness of the 347/D Rotor System and its parameter variants. The testing shall include the verification of structural properties, structural substantiation (fatigue, limit and ultimate loading), data reduction and analyses of test data.

- c. Ground Tests (347/D Rotor System):

Upon approval of the ground test plan, the contractor shall install the 347/D Rotor System on the RSRA (in ground tie-down configuration) and support system tests and a whirl test in accordance with the approved plan.

As a minimum, the following systems tests will be conducted:

- (1) Rotor System and Control Tests - Control system interference checks and blade static clearance checks shall be completed prior to rotating checks.

- (2) Aircraft systems tests (rotor rotating) shall be conducted to provide final checkout of the complete aircraft prior to whirl and flight testing. These tests shall functionally check the entire system and shall include track and balance of the rotor system, cyclic control input at down collective pitch control settings and instrumentation calibration. Rotor and drive system stability, structural loads and vibration characteristics shall be monitored.
- (3) The blade severance system will be functionally tested to insure proper operation using both the basic and the redundant energy transfer lines.

The whirl test of the 347/D Rotor System shall be conducted to define stability, performance and stress characteristics of the system over a range of power, collective and cyclic pitch, and rotor speed. The whirl test shall consist of tracking, a strain and motion survey, an overspeed run, and an endurance test.

d. **Safety of Flight Review:**

Prior to flight test, the contractor shall substantiate the flightworthiness of the 347/D Rotor System on the RSRA during a flight verification review meeting at the contractor's facility.

e. **Flight Tests (347/D Rotor System):**

Upon approval of the flight test plan and satisfactory completion of the safety of flight review, the contractor shall support the flight test of the 347/D Rotor System in accordance with the approved plan using the RSRA to obtain structural, dynamic and performance data at various flight speeds, rotor speeds, maneuvers, load factors to 80% of design-limit loads, center of gravity locations and gross weights. Testing shall cover a sufficient range of variables to provide a comparison of both the characteristics of the basic RSRA (S-61) rotor system and the characteristics and limitations of the 347/D

Rotor System on the RSRA. The contractor shall provide technical and maintenance support for the flight program (at the NASA-Ames facility), including materials, spare parts, and services and perform data reduction of all significant flight-test data.

4. Task IV - Parameter Variation Flight Test Program

a. Phase I - Basic Aerodynamic Parameter Variation Tests

(1) 347/A Rotor System

Following the testing of the 347/D Rotor System, the contractor shall install CH-47/A blades onto the 347 rotor hub and provide technical and maintenance support of systems ground checkout tests and flight testing of this configuration.

(2) 347/C Rotor System

Following the testing of the 347/A Rotor System, the contractor shall install CH-47/C blades onto the 347 rotor hub and provide technical and maintenance support of systems ground checkout tests and flight testing of this configuration.

b. Phase II - Expanded Aerodynamic Parameter Variation Tests

(1) 347/MOD I Rotor System

Following the testing of the 347/C Rotor System, the contractor shall install the MOD I blades onto the 347 rotor hub and provide technical and maintenance support of systems ground checkout tests, endurance whirl testing and flight testing of this configuration.

(2) 347/MOD II Rotor System

Following the testing of the 347/MOD I Rotor System, the contractor shall rework (retwist the blades), reinstrument as required, install the MOD II blades onto the 347 hub and provide technical and maintenance support of systems ground checkout tests, endurance whirl testing and flight testing of this configuration.

c. Phase III Rotor Dynamics and Flying Qualities Parameter Variation Tests

(1) Natural Frequency Variation Tests

(a) Reduced Second Flap Frequency Tests

Following the Phase I tests, the contractor shall rework the CH-47C blades to install tuning weights to reduce the 2nd flap frequency of the blades, install the blades onto the 347 hub and provide technical and maintenance support of systems ground checkout tests, endurance whirl testing and flight testing.

(b) Increased Third Flap Frequency

Following the reduced 2nd flap frequency tests, the contractor shall rework the blades to install (bond) graphite stiffeners to increase the 3rd flap frequency of the blades, install the blades onto the 347 hub and provide technical and maintenance support of systems ground checkout tests, endurance whirl testing and flight testing.

(c) **Increased Second Chord Frequency**

Following the increased 3rd flap frequency tests, the contractor shall rework the blades (removing previously installed tuning weights and stiffness and installing graphite stiffness to increase the 2nd chord frequency of the blades), install the blades onto the 347 hub and provide technical and maintenance support of systems ground checkout tests, endurance whirl testing and flight testing.

(2) **Effective Flap Hinge Location Variation Tests**

The contractor shall install the flap hinge offset adapters and CH-47 C or D blades and provide technical and maintenance support of systems ground checkout tests, endurance whirl testing and flight testing.

(3) **Control Phase Variation Tests**

The contractor shall adjust the rotor controls (analogue phase mixer) to test several phase settings and provide technical and maintenance support of systems ground checkout tests and flight testing.

Note: These tests may be conducted during the initial ground checkout and/or flight testing of the 347/D Rotor System under Task III to determine and set the optimum phase positions in the analogue phase mixer.

(4) **Control System Stiffness Variation Tests**

The contractor shall install the flexible pitch link assemblies onto the 347/C or D rotor system and provide technical and maintenance support of systems ground checkout tests and flight testing.

(5) Lag Damper Variation Tests

The contractor shall install modified lag dampers to test variations in breakout force and/or damping rate and provide technical and maintenance support of systems ground checkout tests and flight tests.

Note: These tests may be conducted during the initial ground checkout and/or flight testing of the 347/D Rotor System under Task III to determine and set the optimum damping parameters.

(6) Pitch-Flap Coupling ($\Delta 3$) Variation Tests

The contractor shall install modified pitch housings having positive $\Delta 3$ and provide technical and maintenance support of systems ground checkout and flight tests.

d. Phase IV - Blade Tip Shape Variation Tests

Following the Phase III natural frequency tests, the contractor shall rework the CH-47C blades to accept the various tip sets to be tested, install the tip shape variations, install the reworked blades, and provide technical and maintenance support of systems ground checkout tests, endurance whirl testing and flight testing.

Note: All parameter variation testing defined for Phase I, II, III and IV shall cover a sufficient range of variables to provide a comparison of both the characteristics of the basic rotor system and the characteristics of the rotor system incorporating the variation. Technical and maintenance support of the flight test program shall include materials, spare parts and services; assistance in monitoring all critical parameters of flying qualities performance, structural loads, and vibrations; and, data reduction and analysis of all flight test data as required.

4. Reports and Documentation

The contractor shall submit the following reports and documentation:

A. Data and Reports

- (1) Performance**
- (2) Stability and Control**
- (3) Structural Criteria**
- (4) Weights**
- (5) Specifications**
- (6) Structural Analysis**
- (7) Detail, Assembly and Installation Drawings**
- (8) Maintenance and Inspection Document**

B. Plans

- (1) Qualification Bench Test Plan**
- (2) Ground Test Plan**
- (3) Flight Test Plan**
- (4) Parameter Variation Flight Test Plan**

C. Program Status Reports

- (1) Monthly Technical Progress Reports**
- (2) Quarterly Financial Management Reports**

9.3 Data Requirements

The following data of the latest issue in effect is required to accomplish the development and testing of the 347/D Rotor System and its parameter variants on the NASA RSRA:

A. Drawings

<u>Drawing No.</u>	<u>Description</u>
S6110 -21059	Cone, Hub Aligning, Split
-21073	Plate, Pressure
-21082	Nut, Shaft
-21084	Key
-21085	Bolt Assy, Shaft Nut
-21086	Shim
-21377-8	Cover Assembly
-21377-18	Fairing Subassembly
-23001	Main Rotor, Upper Plate
-23009	Main Rotor, Steel, Lower Plate
-23040	Main Rotor Shaft
-23351	Rotor Shaft
-24000	Swashplate Assembly
-24001	Swashplate Subassembly
-24002	Swashplate, Rotating
-24003	Liner, Shrink Fit
-24007	Shim, Laminated
-24009	Spacers, Matched Set
-24012	Swashplate Subassembly
-24013	Swashplate, Stationary
-24015	Liner, Press Fit
-24017	Ring Bearing
-24018	Spacer, Outer
-24019	Spacer, Inner
-24025	Ring, Bearing
-24035	Scissors Assy, Stationary Swashplate
-24050	Scissors Assy, Rotating Swashplate

<u>Drawing No.</u>	<u>Description</u>
S6135 -20011-5	Housing, Assy, Upper
-20060-5	Cover, Rear
-20602-3	Housing and Gear Assy, Take-Off
-20625-4	Gear
-20629-5	Housing, Lower
-20638-6	Cover, Input
-20639-9	Housing, Input
-20663-2	Guide, Swashplate
-20871-1	Gear and Plug Assy, Bevel
-22048-1	Housing, Upper
S6137 -23040-1	Shaft, Main Rotor
-23053-1	Gear, Bevel
-23054-1	Gear, Bevel
72100 -08100	Head Installation
-08512	Scissors Assembly
72400 -00010	Flight Controls Mechanical Schematic Diagram
-00100	General Arrangement, Flight Controls
-00400	Servo Actuator Installation
-02200	Analogue Mixer Installation
SB1555-1	Bearing, Annular Ball

Note:The drawings listed above were identified from illustrated parts breakdowns of the Navy SH-3D/G helicopter. In the case where different part numbers are used on the RSRA, then the drawing of the applicable part is required.

B. Documents

<u>Document No.</u>	<u>Title</u>
SER-72039	Systems Requirements Handbook for the Rotor System Research Aircraft

<u>Document No.</u>	<u>Title</u>
SER-720042	Unknown (Stress Analysis Report)
SER-72005	Unknown (Structural Report)
SER-72006	Performance, Stability and Control Report

C. Additional Data

- (1) Torsional stiffness of main rotor shaft, engine shaft and tail rotor shaft.
- (2) Torsional inertia of power turbine, tail rotor, and all transmissions.
- (3) RSRA landing gear stiffness and damping characteristics (this data is needed as a function of landing gear load for ground resonance analysis).
- (4) RSRA Airframe modal model with isolation system and with load cell system.
- (5) RSRA airframe vibration limits vs. airspeed.
- (6) Transmission torque limitations

9.4 Planning Price Summary

The Planning Price Summary for the subject program is given in Figure 9.4-1.

9.5 Program Schedule

The Master Schedule for the performance of the subject program is given in Figure 9.5-1.

PLANNING PRICE DATA (CAL. YEAR 1980 DOLLARS)
(THOUSANDS)

RFE B059 - 347/D ROTOR SYSTEM FOR THE RSRA AIRCRAFT						TOTAL PROGRAM	DESIGN (1)	BENCH TESTING (2)	TOOL DESIGN (3)	TOOL FAB. (4)	MSN FAB. (5)	BLADE FAB. (6)	ROT. SYS. FAB. (7)	INSTRUMENT-A/C (8)	GRD. & FLT. TESTING (9)	MANAGEMENT & CONTROL (10)
WBS LEVEL	1	2	3	4	5											
	RSRA	PROGRAM														
						16,747	11,482	1,788	469	3,189	89	2,471	1,092	390	5,082	696
		RSRA - 347/D ROTOR SYSTEM				2,705	278	503	8	4	77	299	624	111	624	178
		DESIGN, FAB. AND INSTALL ROT. SYS.				1,852	278	503	8	4	58	299	624	78	-	-
		GROUND & FLIGHT TEST - ROT. SYS.				677	-	-	-	-	19	-	-	34	624	-
		MANAGEMENT AND CONTROL				176	-	-	-	-	-	-	-	-	-	176
		PARAMETER VARIATION TEST PROGRAM				14,042	1,204	1,285	461	3,185	11	2,172	467	278	4,457	520
		BASIC AERODYNAMIC PARAMETER VARIATION TEST				834	-	-	-	-	-	145	-	111	578	-
		EXPANDED AERODYNAMIC PARAMETER VARIATION TEST				6,152	317	392	404	2,794	-	1,226	-	167	852	-
		ROTOR DYNAMIC & FLY QUAL PARAMETER VARIATION TEST				4,871	531	631	13	84	-	553	467	-	2,591	-
		NATURAL FREQUENCY VARIATION TESTS (FLAP & CHORD)				1,997	223	78	13	84	-	553	-	-	1,047	-
		EFFECTIVE FLAP HINGE VARIATION TESTS				1,047	114	218	-	-	-	-	362	-	953	-
		CONTROL PHASE VARIATION TESTS				265	8	-	-	-	-	-	-	-	257	-
		CONTROL SYS. STIFFNESS VARIATION TESTS (TORS. FREQ.)				546	83	75	-	-	-	-	72	-	815	-
		LAG DAMPER VARIATION TEST				357	49	-	-	-	-	-	20	-	288	-
		DELTA 3 COUPLING VARIATION TEST				658	55	261	-	-	-	-	13	-	530	-
		BLADE TIP SHAPE VARIATION TESTS				1,665	356	262	44	307	11	248	-	-	837	-
		MANAGEMENT AND CONTROL				520	-	-	-	-	-	-	-	-	-	520

FIGURE 9.4-1 PLANNING PRICE SUMMARY

<p>FORM 22900 (4/73)</p> <p style="text-align: center;">LEGEND</p> <p>PDR - Preliminary Design Review CDR - Critical Design Review SFR - Safety of Flight Review</p>	<p>BOEING VERTOL COMPANY <small>A DIVISION OF THE BOEING COMPANY</small> PHILADELPHIA PENNSYLVANIA 19142</p> <p>MASTER SCHEDULE</p> <p>TITLE <u>RSRA-347/D ROTOR SYSTEM INTEGRATION AND PARAMETER</u> <u>VARIATION TEST PROGRAM</u></p> <p>AUTHORIZATION _____</p>	<p>ATTACHMENT _____ OF _____ PAGE _____ OF _____</p> <p>REFERENCE NO: _____</p> <p>DATE ISSUED: _____ REV: _____</p> <p>ISSUED BY: _____</p> <p>PREPARED BY: <u>K.E. Smith</u></p> <p>APPROVED: _____</p> <p>APPROVED: _____</p>
---	---	--

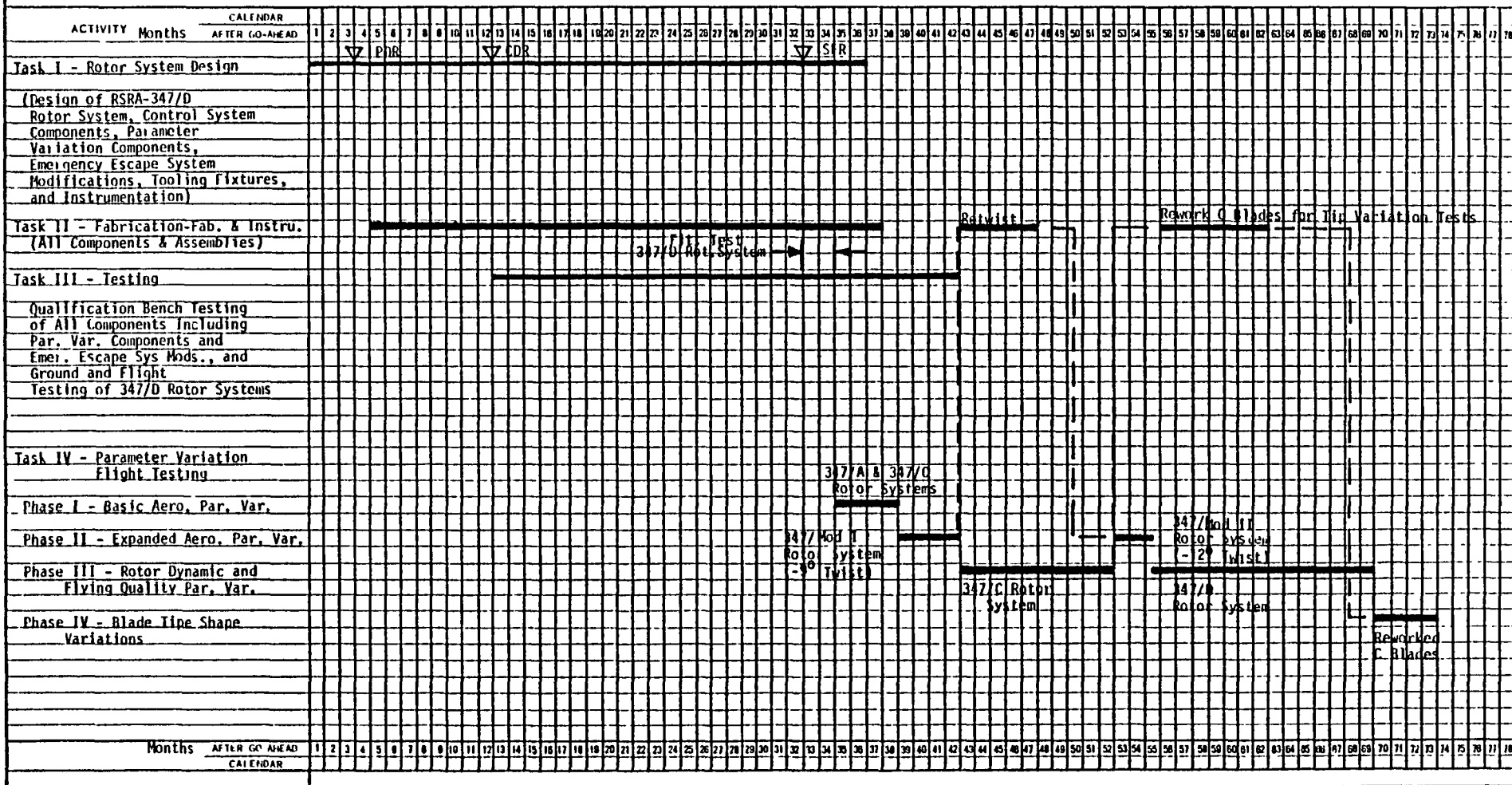

-158-

FIGURE 9.5-1

D210-11723-3

References:

1. Arcidiacono, P.J., deSimone, G. and Occhiato, J., "Preliminary Evaluation of RSRA Data Comparing Pure Helicopter, Auxiliary Propulsion and Compound Helicopter Flight Characteristics", AHS Paper No. 80-10, Presented at the 36th Annual Forum of the American Helicopter Society, Washington, D.C., May 1980.
2. White, F. and Blake, B.B., "Improved Method of Predicting Helicopter Control Response and Gust Sensitivity", AHS Paper No. 79-25, Presented at the 35th Annual Forum of the American Helicopter Society, Washington, D.C., May 1979.
3. Miao, W., "Visualization of the Mechanism of the Mechanical Instability", Boeing Vertol Interoffice Memorandum No. 8-7453-1-1708, dated 18 December 1968.
4. Burkam, J., "Criteria for Mechanical Instability or Ground Resonance", Boeing Vertol Interoffice Memorandum No. 8-7458-1-114, dated 1 May 1968.
5. Altman, B., et. al., "Substantiation of the Structural Adequacy of the Fatigue Loaded Dynamic Components of the Air Force Model H-3 Helicopter", Sikorsky Report No. SER-611501, dated 1 February 1971.
6. Seckel, E., Stability and Control of Airplanes and Helicopters, Academic Press, 1964.
7. Sandford, R. W. and Belko, R. P., "CH-47 Fiberglass Rotor Blade Design and Fabrication", AHS Paper No. 11-2, Presented at the National Specialists Meeting of the American Helicopter Society (Midwest Region), Philadelphia, PA, October 1980.
8. Sandford, R., "YCH-47D Fiberglass Rotor Blade Loads and Structural Analysis", Boeing Vertol Report No. 145-SS-607.1.1, dated 24 April 1978.

References: (continued)

9. McCracken, C., "CH-47D Rotary Wing Head and Upper Controls System Specification", Boeing Vertol Document No. D145-10066-1, dated 1 May 1980.
10. S-61N Maintenance Manual, Sikorsky Document Number SA4045-80.
11. Rorke, J., "Performance, Stability and Control Report", Sikorsky Report No. SER-72006, dated 21 June 1974.
12. Monteleone, R., Systems Requirements Handbook for the Rotor Systems Research Aircraft, Sikorsky Document No. SER-72039, dated 15 May 1977.
13. Sacks, F., "Fatigue and Ultimate Load Test of the 114R1702 Rotor Blade", Boeing Vertol Report No. D145-10014-3, dated 5 October 1979.
14. W. Woolman, "CH-47 Fiberglass Rotor Blade Qualification - Full Scale Physical Properties, Natural Frequency and Limit Load Tests - Final Report", Boeing Vertol Report No. D145-10014-4, dated 22 Aug. 1979.
15. "Predesign Study for an Aero/Acoustic Research Rotor System", Boeing Vertol Report No. D210-11042-1, dated September 1976 (NASA Report No. NASA CR-145017).
16. "Proposal for a High Performance Rotor Blade System", Boeing Vertol Document No. D210-11298-1, dated September 1977.
17. Sheffler, M., et al, "Full Scale Wind Tunnel Investigation of a Bearingless Main Helicopter Rotor - Final Report", Boeing Vertol Report No. D210-11659-1, dated October 1980 (NASA Report No. NASA CR152373).
18. Sheridan, P. and Smith, P., "Interactional Aerodynamics - A New Challenge to Helicopter Technology", AHS Paper No. 79-59, Presented at 35th Annual Forum of the American Helicopter Society, Washington, D.C., May 1979.

References: (continued)

19. Helicopter Flying and Ground Handling Qualities, Requirements for, Military Specification No. MIL-H-8501A

Appendix A
CH-47 Fiberglass Rotor Blade
Design and Fabrication

**CH-47 Fiberglass Rotor Blade
Design and Fabrication**

Robin W. Sandford

Raymond P. Belko

Boeing Vertol Company

**PRESENTED AT THE
AMERICAN HELICOPTER SOCIETY
MIDEAST REGION**

**NATIONAL SPECIALISTS' MEETING
"ROTOR SYSTEM DESIGN"**

**Holiday Inn
22, 23, 24 October 1980
PHILADELPHIA, PENNSYLVANIA 19105**

**ALL PUBLISHING RIGHTS RESERVED BY THE
AMERICAN HELICOPTER SOCIETY
1325 18th STREET NW
WASHINGTON, DC 20036**



PREPRINT NO. II-2



CH-47 Fiberglass Rotor Blade Design and Fabrication

Robin W Sandford

Structures Technology Engineer
and

Raymond P. Belko

Rotor Blade Design Engineer Specialist

Boeing Vertol Company
Philadelphia, Pennsylvania

Abstract

Production deliveries of the fiberglass rotor blade for the CH-47 Chinook helicopter will start early in 1981. The blades will be installed on both military and commercial aircraft.

This paper describes the design, fabrication, and quality control techniques required to produce flightworthy blades. It discusses the coordination required between Engineering, Manufacturing, and Quality Control and the technological and operational advancements learned from previous programs that are instrumental in fabricating a high-quality production rotor blade of advanced composite materials at low cost.

The paper also summarizes the qualification bench, whirl, and flight tests. Achievement of design objectives such as improvements in performance, safety, damage tolerance, reliability, and maintainability was verified during qualification testing.

Introduction

In June 1972 the Boeing Vertol Company initiated the design, manufacturing technology, and developmental effort for a CH-47 composite rotor blade under contract to the United States Army. This blade was later incorporated into the CH-47D modernization program. The prototype program consisted of fabrication and test of 40 blades: 8 bench-test blades and 32 flight-test blades. The flight-test blades are now mounted on three CH-47D and one CH-47C aircraft which are currently being evaluated by the Army. Production of these blades with minor fabrication improvements was initiated early in 1980 for retrofit on the CH-47C helicopter. The objective of this paper is to follow this program from concept to production, touching briefly on all phases, i.e., design, tooling, fabrication, quality control, bench test, and flight test.

Program Description

The primary objective of the CH-47 composite blade program was to provide a significant improvement in the safety, reliability, and maintainability of rotor blades for the CH-47 aircraft. Specific design requirements and objectives were established at the start of the program.

The program is in two phases, development and production.

Development

Development has been completed and consisted of preliminary and production blade design plus tool design and tool fabrication, fabrication of tool-proving and test blades; reliability development, qualification, bench, and whirl tests; and a flight-test qualification program.

Production

The initial stages of this phase are practically completed and blades are now in production. This phase consisted of design and tooling update; qualification of a third source for fiberglass; trackmaster program to assure interchangeability; blade repairability program; and development of ground support equipment.

Design Requirements and Objectives

- **Interchangeability** – The root end was configured for installation on existing CH-47C rotor hubs. The centrifugal force (CF) of the fiberglass rotor blade operating at 225 rpm does not exceed the CF load imposed by the CH-47C metal rotor blade when operated at 245 rpm.
- **Performance** – Improved rotor performance is achieved by replacing the 23010 airfoil of the CH-47C blade with the improved VR-7 and VR-8 airfoils and by tailoring the twist at each spanwise radial section. Moment stall boundary is increased by increasing the blade chord from 25.25 inches on the metal blade to 32 inches on the composite blade.
- **Safety** – The use of fiberglass-reinforced epoxy with its inherently slow crack propagation characteristics and its high damage tolerance results in a rotor blade of failsafe construction.
- **Maintainability** – Reduced maintenance is achieved by a rotor blade that will require only simple field inspections, minimum requirements for maintenance at all levels, and maximum field reparability.
- **Reliability** – The design objective for MTBR to depot level is 3,600 hours. This is achieved through the use of materials that are insensitive to the service environment and the elimination of complex safety inspections.

Presented at the American Helicopter Society National Specialists' Meeting on Rotor System Design, October 1980.

Rotor Blade Geometry

The use of fiberglass as the primary structural material in the CH-47 composite rotor blade permits the optimization of blade geometry to an extent not possible with the extruded CH-47B/C metal spar blades. Blade airfoil section, thickness, and twist are tailored along the span to provide an optimized dynamic and structural blade configuration. Thus tailoring of geometry was first accomplished in the U.S. Army/Boeing Advanced Geometry Blade (AGB) program. In the AGB, existing airfoil sections were employed along the span to provide an optimum aerodynamic configuration. Figure 1 shows the AGB compared to CH-47 rotors of the time. Planform taper and a low twist oriented to high-speed flight were used in the AGB. In the CH-47 fiberglass blade program, Boeing-developed advanced airfoils are used along the span to provide improved performance. The fiberglass blade shown in Figure 1 has a 12-degree twist which increases the hover figure of merit over the 9-degree twist of the CH-47B and C blade.

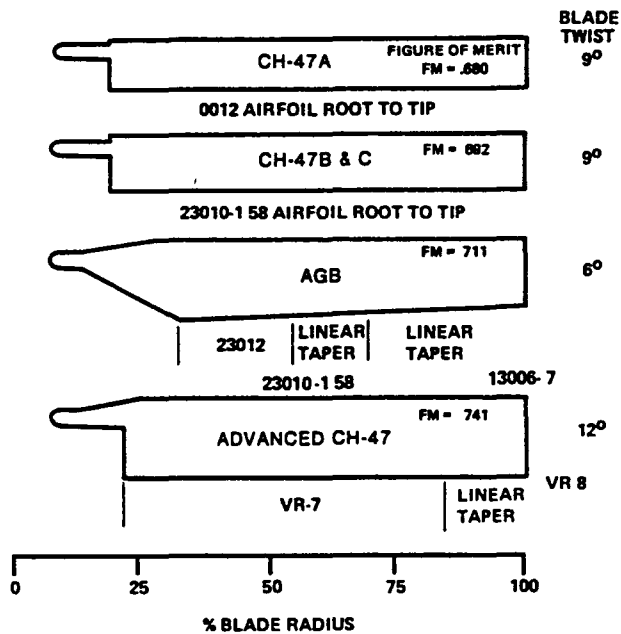

Figure 1. Glass Composite Blades Allow Utilization of Advanced Aerodynamics

The fiberglass blade radius is the same as that of the CH-47B and C, 30 feet. The chord has been increased from the current 25.25 inches to 32 inches and the normal operating rotor rpm has been reduced to 225. The D-shaped spar terminates at the root end in a fittingless, single-pin wraparound joint which mates with the current CH-47C pitch bearing housing. The blade planform, shown in Figure 2, is rectangular from approximately 27-percent radius (station 97) to the tip and incorporates a 30-degree taper inboard from 27-percent radius to interception with the root end.

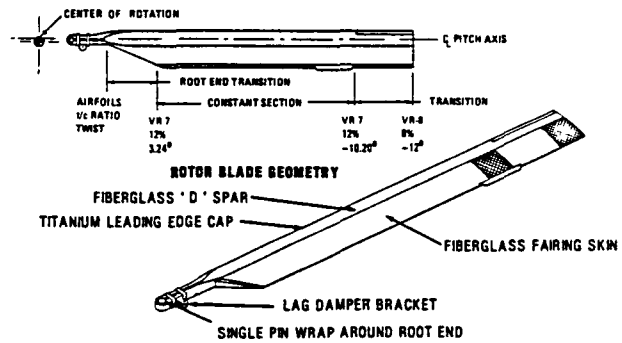

Figure 2. The CH-47 Fiberglass Rotor Blade

The geometric parameters are summarized below

Blade Attachment	Sized for installation on CH-47C rotor hub
No. Blades per Rotor	3
Blade Radius	30 feet
Blade Chord	32 inches
Disk Loading at 30,000 lb	5.9 lb/ft ²
Solidity	0.085
Tip Speed	707 ft/sec
Rotor Speed (normal operating speed)	225 rpm
Hub Configuration	CH-47C/YCH-47D
Airfoil	
Root Cutout to 85%R	VR-7
85%R to Tip	Linear transition
Tip	VR-8
Root Cutout	30°
First Full Airfoil Inboard	Approximately 27%R
Twist (linear)	11° geometric 12° aerodynamic
Root End Configuration	Single-pin wrap

Rotor Blade Structural Concept

Figures 3 and 4 present the structural concept which was initially developed during the Heavy-Lift Helicopter program and applied to the CH-47, the main difference being one-pin versus two-pin root attachments. The CH-47 blade consists of a unidirectional and crossplied fiberglass D-spar terminating in a single pin as the primary structural element. The unidirectional material is laid in an increasingly thick strap from tip to root and symmetrically back to the tip. The leading edge of the spar is covered with a titanium nose cap; the nose cap provides erosion protection as well as bending and torsional stiffness. A nickel cap is bonded to the blade in the high-wear area at the tip. The tip

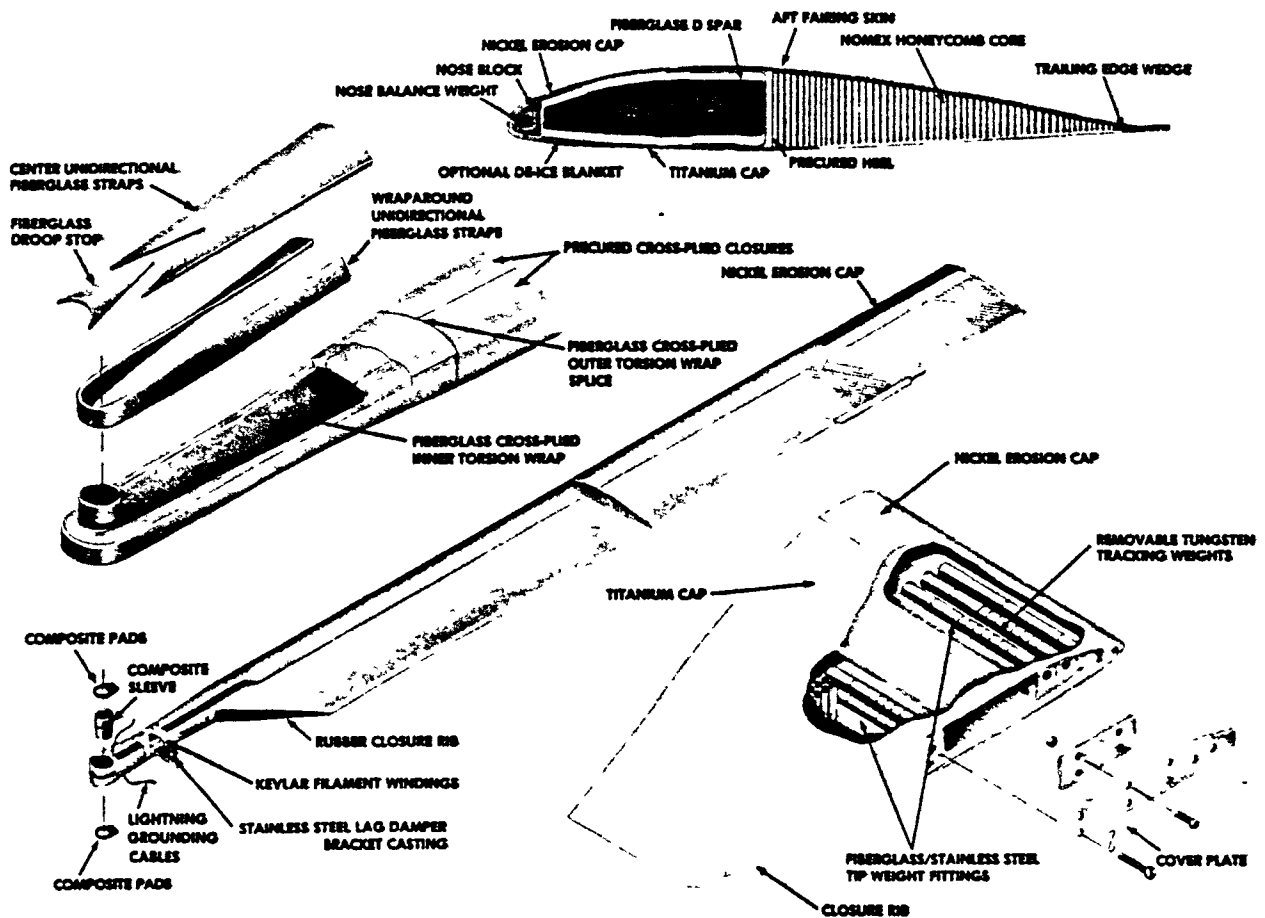

Figure 3. Construction Details of the CH-47 Fiberglass Rotor Blade

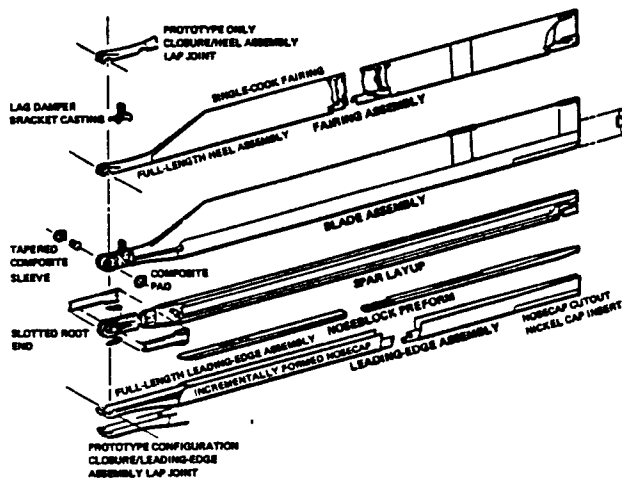

Figure 4. Blade Major Assemblies

weight fittings, consisting of stainless-steel tubes surrounded by fiberglass, are integrally cured in place during the spar and spar heel cures. Also cured in place with the spar is the noseblock which houses the chordwise balance weights.

The single-box aft fairing consists of a fiberglass trailing-edge wedge and crossplied fiberglass skins over a nonmetallic NOMEX

honeycomb core. The fairing is fabricated as a unit with the fiberglass heel portion of the D-spar and aft tip weight fitting. The aft fairing skins extend forward under the titanium noscap, providing a failsafe attachment and eliminating any possibility of moisture entry at this joint.

The stainless-steel lag damper bracket is bonded to the cured blade. This assembly is then overwound with prestressed KEVLAR fibers. The preload is designed so that the bond will never be in tension.

Design support testing was held to a minimum due to the applicability of HLH and UTTAS data^{1,2,3}. This experience provided data for the following:

- Lightning conductivity
- Sand erosion
- Moisture entry and migration
- Impact resistance
- Ballistic damage
- Fatigue failure characteristics
- Failsafety
- Material properties

Design Development

Root End Attachments

The CH-47 composite root end, as shown in Figures 3 and 4, consists of unidirectional and bias-ply fiberglass terminating in a single-pin connection. This pin joint contains a replaceable filament-wound sleeve which is cold-bonded in position. The lag damper attachment consists of a stainless-steel casting which is bonded and filament-wound with KEVLAR onto the fiberglass root end shank. This design is unique to the CH-47 blade as there was no previous experience with fiberglass single-pin root attachment, fiberglass-wound sleeves, or filament-wound steel fitting attachments. Development structural tests were performed subjecting this area (Figure 5) to combined flight loads of CF, bending, and torsion. The tests proved the feasibility of this concept.

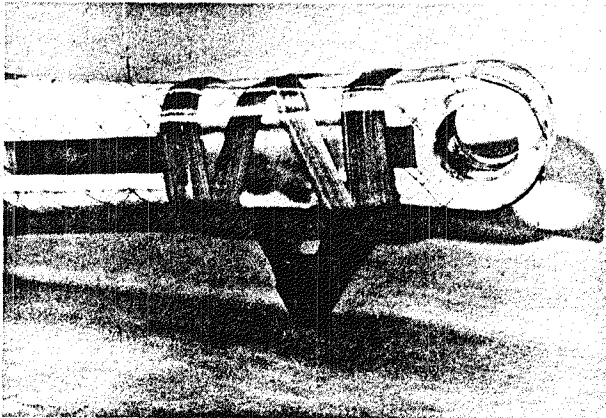

Figure 5. Filament-Wound Lag Damper Bracket

The lag damper bracket was redesigned from a forging to a casting (Figure 6). The forging required extensive machining all over to remove decarb and to match the blade contour. The casting required machining in the lug area only, thus reducing costs considerably. The coupon fatigue tests shown in Figure 7 were conducted to establish design allowables for the casting. Quality control inspections of the casting showed a high-quality structure free of voids or flaws.

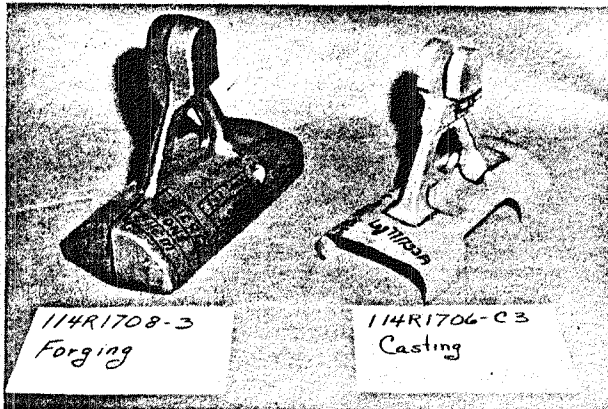

Figure 6. Lag Damper Bracket

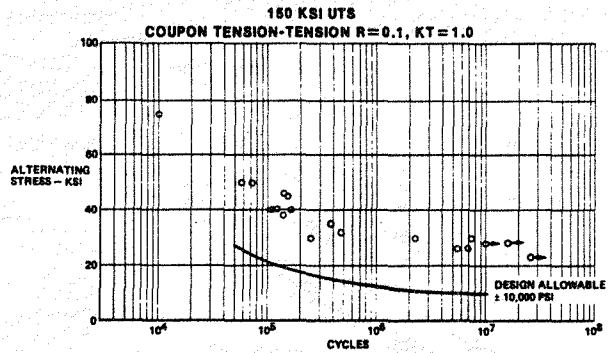

Figure 7. Fatigue Strength of 15-5PH Stainless-Steel Casting

Fiberglass Material Selection

Earlier Boeing Vertol fiberglass rotor blades for the HLH and UTTAS used S-glass with a 250°F cure system. As a result of a design-to-cost study which showed considerable cost savings, a change from S-glass to E-glass was made. The cure cycle remained the same.

A comparison of the strength properties in Table I and Figure 8 shows a strength reduction in E-glass of approximately 15 percent. However, the resulting strength margins were satisfactory.

TABLE I. COMPARISON OF TENSILE PROPERTIES OF S-GLASS AND E-GLASS

Prepreg System	Fiber Orientation (deg)	E (ksi x 10 ⁻³)	F _{tu} (ksi)
SP250S	0	6.3	153
SP250E	0	5.5	130
SP250S	±45	1.8	23
SP250E	±45	1.8	20

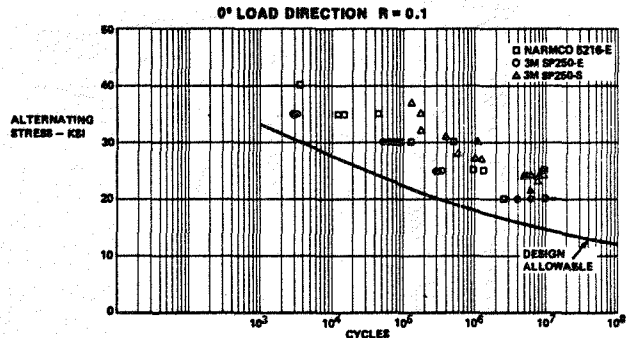

Figure 8. Tension Fatigue Strength of Unidirectional E-Type Fiberglass

Aft Fairing Assembly

The aft fairing is a single-box, fiberglass skin and trailing edge, NOMEX core honeycomb structure. The fairing assembly is

shown in Figure 4. Included in the assembly is the precured spar heel and the aft tip weight housing. The fairing root end is tapered at 30 degrees to reduce the stress concentration at the spar interface.

Fiberglass was selected as the skin material because of the damage tolerance and durability demonstrated in years of service on the CH-47A, B, and C helicopters. Fatigue testing of fiberglass blade skins returned from service² demonstrated that when properly protected by paint there is no strength degradation.

The selection of NOMEX as the core eliminates the corrosion experienced with metal. NOMEX also provides a substantial benefit during fabrication. When enclosed between two molds to a fixed dimension, NOMEX deflects and provides a back pressure against the skin. As the temperature increases during the cure cycle, the back pressure decreases to zero and the NOMEX sets in this deflected position with little or no springback. Fatigue, static, moisture penetration, and migration testing of fiberglass/NOMEX specimens was conducted during the HLH program. To reduce costs, as emphasized by the Army, fabrication studies were performed that permitted reduction in core machining from two-side machining of contour to one-side machining. This is accomplished by machining all contour variation for both upper and lower surfaces on one side. The core is then seated in a contoured fixture and bonded in position during the fairing cure.

Leading Edge

An effort was made to form the CH-47 leading edge of titanium with the same procedure used on the HLH program. This required male and female ceramic molds, between which the titanium sheet was placed and then heated in an oven to creep-form the part. Due to the smaller leading-edge radius, twist, and airfoil differences, contour control and repeatability were inconsistent. A new process was required to assure a contour which was precise and repeatable at production rates. A development program was initiated and the incremental hot-sizing technique was selected. This process feeds the titanium sheet between heated male and female metal-forming dies in increments of approximately 30 inches until the entire leading edge of about 300 inches is formed. The formed part is then chemically milled to remove scale and cleaned to prepare the part for bonding. This new process gives contour repeatability, reduces chem-milling time (due to less heat exposure time), and increases production rates. The CH-47 blade leading edge is now being formed with this process at costs and rates compatible with the CH-47 modernization program requirements.

Tip Weight Fittings

Tip weight fittings presented a problem in providing an adequate structural attachment in the fiberglass blade. Attachment of the fittings to the spar with metal blade techniques such as rivets, bolts, or hard-to-hard bonding did not appear feasible without unacceptable buildup or internal contour control of the fiberglass spar. Drilling holes at the tip through the titanium leading edge for riveting or bolting created holes which could not be deburred at the titanium/fiberglass interface. Hard-to-hard bonding, which was tried on the HLH fiberglass rotor blade, re-

quired difficult internal control of the fiberglass spar contour. The CH-47 design evolved as stainless-steel tubes which carry the tip weights embedded in unidirectional fiberglass. The tubes are placed in the uncured fiberglass which is shaped to the required contour. This subassembly of tubes and uncured fiberglass is then assembled with the uncured spar for the forward fitting and the uncured heel for the aft fitting. The spar/forward fitting and heel/aft fitting assembly are then cocured, creating assemblies that are homogeneous structures.

Bonded Assembly

The HLH fiberglass rotor blade bonded assembly consisted of a subassembly of a cured spar and cured aft fairing. This type of assembly required a spar cure, fairing cure, and bonded-assembly cure; it also created a cured surface-to-cured surface interface at the critical spar heel/fairing bondline. This type of bondline is subject to voiding due to mismatch or irregularities. The CH-47 fiberglass rotor blade bonded assembly consists of a subassembly of an uncured spar and cured aft fairing; this requires a fairing cure and bonded-assembly cure only. The spar is cured during the bonded-assembly cure, thereby eliminating a separate spar cure cycle. The critical spar heel/fairing bondline is now a hard surface-to-soft surface bond due to the spar being cocured and bonded in one operation; this eliminates mismatch and irregularities between interfaces, creating good bondlines. This type of assembly also permits the aft fairing skins to be extended forward under the titanium nose cap, providing a failsafe attachment (see Figure 9) and eliminating any possibility of moisture entry at this interface.

Lightning Protection

The rotor blade has been designed for all-weather flight capability. The design criterion for lightning is that the blade will be capable of withstanding a 200,000-ampere strike with get-home capability and multiple 50,000-ampere strikes with only minor repair required. The main lightning protection member is the titanium nose cap; this component protects the spar, graphite and internal balance and tracking weights. The aft fairing is protected in the critical areas of tip and trim tab by aluminum mesh screens. The screens carry any strike over the fairing into the nose cap. The nose cap is grounded to the hub through a titanium strip connecting the nose cap and the hub lightning ground cable. Full-scale blade tests have shown that lightning strikes up to 200,000 amperes will be carried on the surface of these components and grounded into the aircraft without major damage to the blade.

Integral Spar Inspection System

Due to the slow crack propagation inherent to fiberglass, the active spar inspection system required for metal blades is unnecessary. Testing of both HLH and UTTAS specimens has shown that spar damage will become clearly visible before any significant structural degradation. This damage will become apparent through chordwise cracking of the titanium nose cap, a nonflight-critical part, in the airfoil area, or delamination of the outer torsion wrap in the root end area. Deletion of the Integral

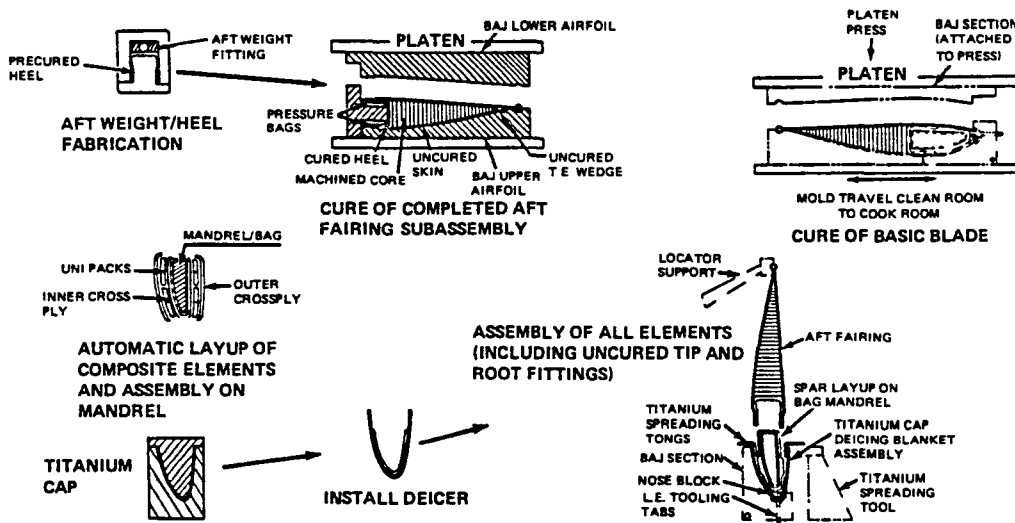

Figure 9. Production Composite Rotor Blade Manufacturing Concept

Spar Inspection System eliminates one of the major causes of unnecessary blade removal, malfunction of the ISIS indicator.

Tooling and Manufacturing Development

In order to meet goals and objectives established by design criteria and requirements of the CH-47 rotor blade, a coordinated effort between Design, Tooling, and Manufacturing was required. Key representatives from each functional department participated in development of the tooling and manufacturing concept. The basic blade design concept, detail parts, and components were analyzed to identify tool requirements, processes to be used, and inherent risks. Charts of sequential operations for each part of the blade from detail through final assembly were developed; these charts identified every element of work and process involved in the fabrication of a part or assembly. Tools, shop aids, and facility requirements were also identified. In many cases problems were eliminated or risks minimized during sequence development prior to fabrication. Significant design and tooling changes were identified and incorporated before hardware fabrication, resulting in cost avoidances in the blade fabrication. The major production tooling and manufacturing concepts are identified in Figure 9.

Major tooling or fabrication changes incorporated between prototype and production design include the following

- Aft weight/heel assembly female solid rubber mandrel replaced with an inflatable mandrel to improve contour and quality of laminate. The solid rubber mandrel provided unequal laminate pressure and poor corner definition.
- Prototype core was machined on both sides, this required two temporary skin bonding operations for chucking purposes. A contoured bonding fixture and machine fixture were required. The core is now machined on one

side only by bonding one temporary skin on a flat bonding fixture and machining with a flat machine fixture. All the contours, both upper and lower, are combined and machined on one side. During the fairing cure the core is displaced to form upper and lower airfoil contours. This process eliminates the following.

- one side machining
- one temporary bonding operation
- a contoured bonding fixture
- a contoured machining fixture.
- The prototype blade required a heel and root shank closure. These parts were combined for production by extending the heel inboard to include the root shank closure. This eliminates one part and one cure cycle (see Figure 4).
- The production leading edge and root shank closure were modified into one part the same as the heel and root shank closure.

Quality Control

During the prototype program, extensive inspections were performed on incoming materials and throughout all stages of fabrication. Based on the prototype inspections and testing of prototype hardware, inspections and acceptance criteria were developed.

Incoming materials receive the normal inspections for strength and physical properties. As each component is fabricated only visual inspection is performed. Major subassemblies such as the leading edge and aft fairings are visually and ultrasonically inspected. The final blade assembly is inspected visually, ultrasonically, and by X-ray. All inspections are nondestructive and within the existing state of the art; no exotic inspection developments were required. Figures 10 and 11 show some of the major areas of concern for required inspections.

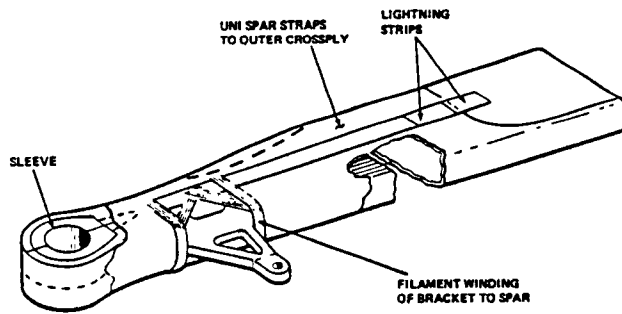

Figure 10. Root End Section Inspection Areas of CH-47 Composite Rotor Blade

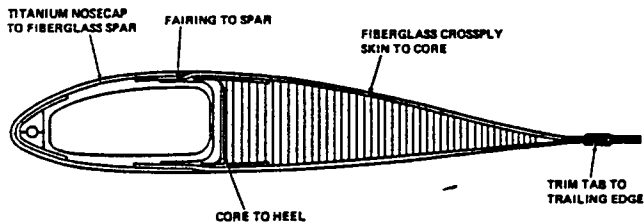

Figure 11. Outboard Section Inspection Areas of CH-47 Composite Rotor Blade

Contour inspections show that the closed-metal-mold concept of fabrication produces blades with repeatable consistency and within the required tolerances. Contour inspection of each blade will not be required in production.

Test Results

Bench Tests

Figure 12 shows the bench qualification tests that were conducted on six blades. The structural concept of this blade is very similar to those of the HLH and UTTAS and the structural performance demonstrated with those blades can also be applied to the CH-47. Therefore, no additional tests such as ballistic impact or falsafety were considered necessary.

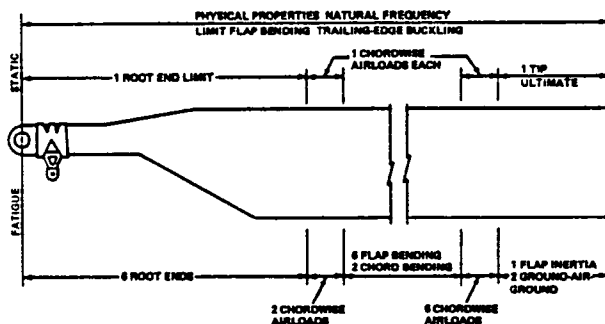

Figure 12. CH-47 Fiberglass Blade Bench Qualification Tests

The static tests of a complete blade confirmed the blade physical properties and natural frequencies. Special limit-load tests were conducted to ensure that buckling of the spar wall and

trailing edge would not occur.

The most significant test section is the one including root end retention. In the fatigue testing of the root ends, loading includes a combination of flap, chord bending and torsion, plus a steady axial load for centrifugal force. The tests were run considerably above flight loads in order to induce failures and to verify the required life in a minimum of test time.

The results of the tests are shown in Figure 13. The strength in terms of flap bending is the most important since it is this loading that produces the highest stresses in the fiberglass loop. The chord bending moment was applied to produce the lag damper load across the lag hinge or vertical pin.

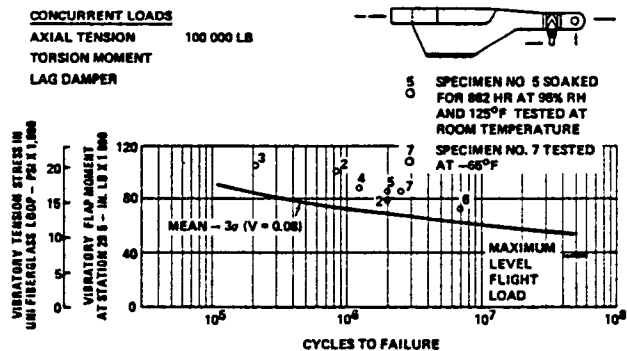

Figure 13. CH-47 Fiberglass Blade Root End Fatigue Test

The concurrent torsional loads were also considerably above flight loads. The loadings were selected to give an L-N shape between 10^5 to 10^7 cycles. The strength levels obtained and the endurance limit determined agreed with those anticipated from the earlier developmental test and analysis. The margin between the endurance limit and the maximum level-flight load indicated that the fatigue life objective would be met. Specimen No. 5 was subjected to 862 hours of soaking at 95-percent relative humidity and 125°F in order to show the resistance of the design to a possible environmental condition. Specimen No. 7 was tested at -65°F primarily to evaluate the effect of low temperature on the KEVLAR filament winding, which has a negative thermal coefficient of expansion. Both specimens fell within the scatter of the other four; these conditions apparently have no effect on the strength. The endurance limit was determined by considering all six specimens as belonging to the same family. The testing on each specimen was terminated when clearly visible damage had occurred, although structural integrity still existed. The damage consisted of cracking of a fiberglass pad on the blade surface around the vertical pin bore, by cracking and delamination of the outer fiberglass ± 45 -degree crossply, and by separation of the crossply from the unidirectional loop. These conditions are illustrated in Figure 14.

There were no failures of the damper bracket KEVLAR filament windings. Specimen No. 2 was subjected to limit and ultimate loads to show adequate remaining strength at this point of damage. The loads consisted of 100-percent design ultimate flap bending moment, 100-percent design ultimate torsional moment,

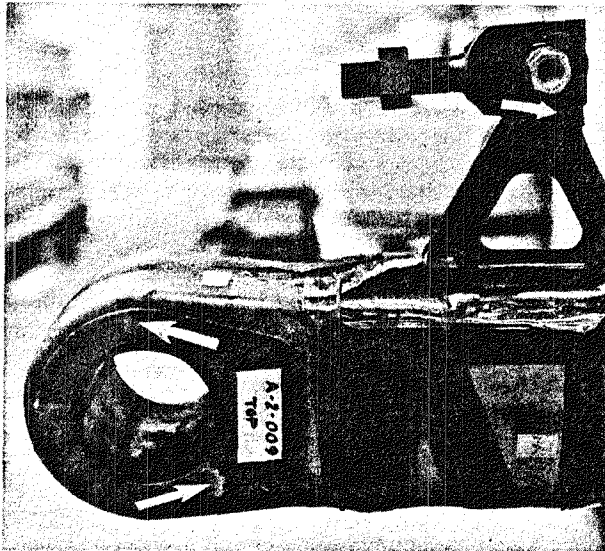

Figure 14. Typical Failures of Root End Test

104-percent design ultimate damper load, and 108-percent design ultimate centrifugal force load. Failure occurred at the latter load condition in the loop area during a subsequent load application.

The outboard spar sections were tested with a steady axial load and alternating flap bending in a resonant beam fixture. The flap bending moments produce practically all of the alternating tension stresses at the critical locations of the spar structure. The results of tests are shown in the S-N diagram of Figure 15.

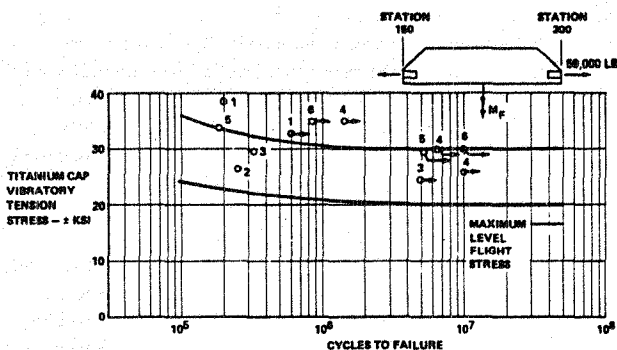

Figure 15. CH-47 Fiberglass Blade Outboard Fatigue Test

Fatigue testing of the outboard spar sections generated no failures in any fiberglass structure. This was fully expected based on the HLH and UTTAS testing and the design and manufacturing improvements incorporated into the CH-47 blade.

Fatigue testing of the outboard spar sections did generate failures in the titanium nose cap. Previous failures of titanium nose caps were attributed to processing defects similar to those which always showed up in metal fatigue tests. For the CH-47 production blade, changes were made to eliminate the previously identified defects. The failures of the full-size titanium nose cap

occurred somewhat lower than coupon tests and showed the same wide scatter typical of metal blade tests. However, the safety of the blade is not at issue since, after a titanium failure, the fiberglass at every spar station is capable of carrying the flight loads for hundreds of hours.

The remaining chordwise airload and blade tip testing all met or exceeded the design objectives.

Whirl Test

The rotor whirl test provides a simulated flight environment before actual flight testing. A 123-hour test was conducted including blade tracking, load measurement, natural frequency determination, and blade performance evaluation.

The three fiberglass rotor blades were flat-tracked within 1/16 inch and collective-tracked within 1/4 inch by adjusting pitch links, trim tabs, and tracking weights. Tracking was accomplished by the fourteenth run, which is excellent for a set of new blades.

Rotor blade natural frequency was determined by using spectral analysis of blade bending and pitch link gages as a function of rpm. Harmonic content increases in the loads point to natural frequency responses. The data shows good correlation with predicted frequencies.

The stress and motion survey produced no surprises as loads fell within predicted values. Stress data was collected on blade bending at several stations and on all three pitch links, in addition to gages monitoring tower components and test conditions. A 275-rpm overspeed condition was successfully demonstrated.

Performance test data substantiates the power required of 2,523 horsepower at 42,500 pounds gross weight when referred to 4,000 feet/95°F. The most likely fairing of the data indicates a figure of merit of 0.738 at the design condition. Figures 16, 17, and 18 show these results.

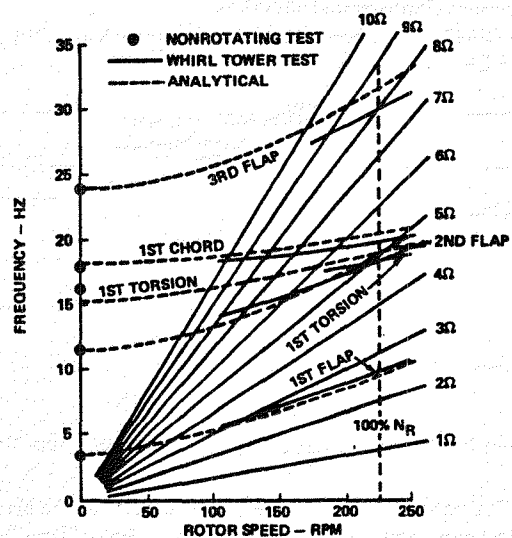

Figure 16. Fiberglass Rotor Blade Frequency Spectrum

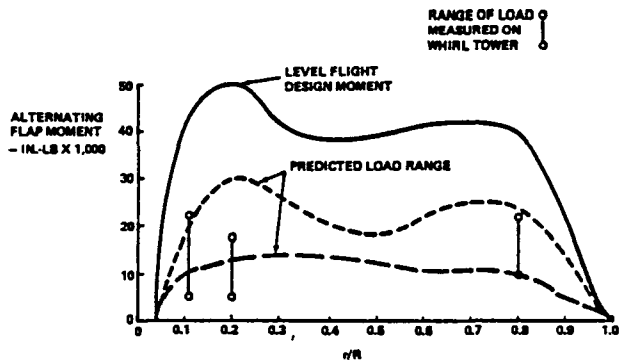

Figure 17. Blade Flap Bending Moments Fall Within Predicted Range in Whirl Test

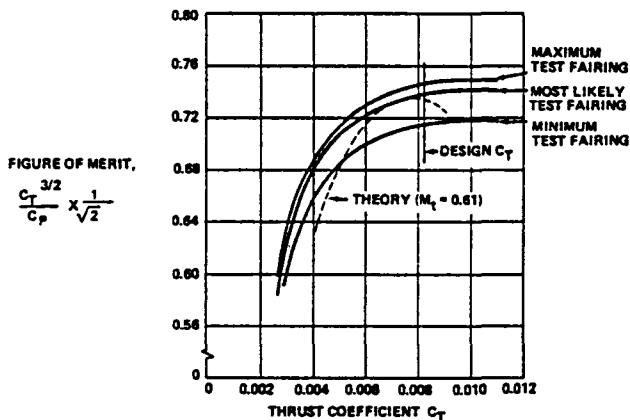

Figure 18. Figure of Merit From CH-47 Fiberglass Blade Whirl Tower Tests

The postwhirl-test inspection of the rotor blades revealed no primary structural problems and provided the basis for releasing the YCH-47D fiberglass rotor blades for flight testing.

Flight Test

The flight testing of the CH-47C and YCH-47D with fiberglass blades has covered performance, flying qualities, vibration, and loads evaluation. As a direct result of the new rotor blade with its increased chord and improved airfoils, the CH-47 performance and flying qualities at high gross weight have been greatly improved. The main benefit of the fiberglass blade, however, is its structural performance and safety. The success of the blade is largely dependent on the accuracy of load predictions and the comparison of measured flight loads with the fatigue endurance limits established during the bench tests. A complete account of flight load survey data for the rotor blade is beyond the scope of this paper. Eighty-two flights were conducted for load survey measurements and structural demonstration at gross weights between 33,000 and 50,000 pounds.

In summary, the blade design bending moment predictions correlate extremely well with the measured loads for what appears to be the most critical level-flight condition. The comparison of predicted and measured flap and chord bending moments is contained in Figures 19 and 20.

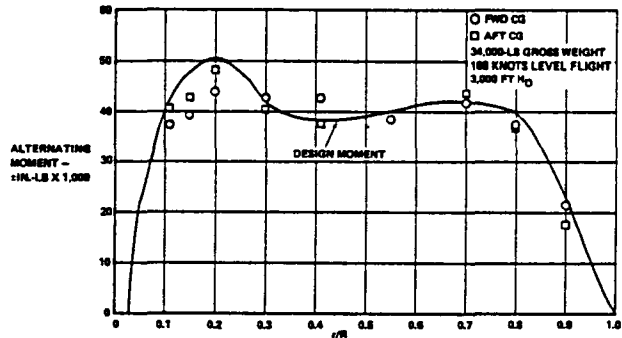

Figure 19. Correlation of Predicted Design Flap Bending Moment With Measured Flight Test Data

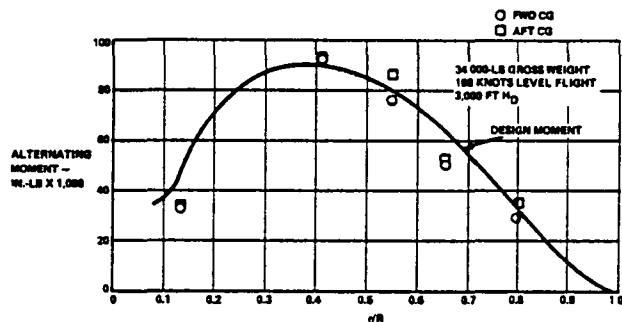

Figure 20. Correlation of Predicted Design Chord Bending Moment With Measured Flight Test Data

The structural flight envelopes for the metal-blade CH-47C and for the CH-47 with the fiberglass blades are shown in Figure 21. A considerable increase in speed is obtained at the high gross weight and at 33,000 pounds at high altitude due to the increased stall boundary and acceptable blade loads.

CH-47 FLIGHT ENVELOPES

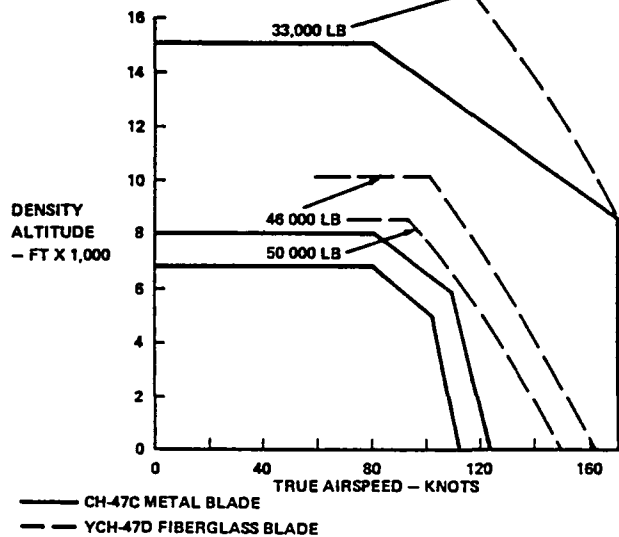

Figure 21. Improved Structural Flight Envelope With Fiberglass Rotor Blade

Combining the measured flight loads, bench test endurance limits, and helicopter mission profile to perform a fatigue life calculation shows that the blade fiberglass components, the damper bracket, and KEVLAR windings will have essentially unlimited fatigue life. The fatigue life of the titanium nose-cap for the aft rotor blades is calculated to be just over 10,000 hours, which exceeds the original design objective of 3,600 hours. Because of the previously mentioned failsafety, the blade fatigue life will be on condition when a nose-cap failure occurs. The methodology used to calculate the titanium nose-cap life is the same as that used for components critical to flight safety and is therefore very conservative for this application.

Conclusions

The fiberglass rotor blade represents a major advance in rotor system failsafety and reliability.

A fabrication sequence has been defined for a truly production-oriented composite rotor blade with a cost equivalent to that of current metal blades. The rotor blade is now in production for retrofit on the CH-47C helicopter.

The qualification tests have been completed verifying the strength and failure characteristics and that failsafety can be achieved simply by visual inspection.

The U.S. Army has completed its development and operational test program, accumulating 467 flight hours on two helicopters. No major problems were encountered and initial results indicate that the reliability predictions will be met. The Army is presently conducting a reliability and maintainability program.

References

1. Scarpati, Thomas, Sandford, Robin, and Powell, Robert, THE HEAVY LIFT HELICOPTER ROTOR BLADE, Paper No. 710, 29th Annual National Forum of the American Helicopter Society, Washington, DC, May 1973.
2. Scarpati, T.S., Feenan, R.J., and Stratton, W.K., THE RESULTS OF FABRICATION AND TESTING OF THE PROTOTYPE COMPOSITE ROTOR BLADES FOR HLH AND UTTAS, Paper No. 75-1010, AIAA 1975 Aircraft Systems and Technology Meeting, American Institute of Aeronautics and Astronautics, New York, NY, August 1975.
3. Stratton, W.K. and Belko, R.P., STATUS OF CH-46 COMPOSITE ROTOR BLADE, The Navy Helicopter Association Symposium, May 1976.

Appendix B
CH-47 Fiberglass Blade
Structural and Dynamic Properties
(Excerpt from Boeing-Vertol
Document No. 145-SS-607.1.1)
(Reference 8)

7.0 PHYSICAL PROPERTIES

7.1 Structural Properties

The blade structural section properties versus blade span are shown in Figures 31 through 38. The physical constants of materials used are given in Figure 39. The properties included are:

Weight Distribution

Chord Center of Gravity

Flap Stiffness

Chord Stiffness

Torsion Stiffness

Axial Stiffness

Chord Neutral Axis

Pitch Inertia

Difference Pitch Inertia

Shear Center

The distribution of physical properties for the CH-47C rotor head used for natural frequency and load analysis are given on Page 65.1.

DISTRIBUTION OF PHYSICAL PROPERTIES
FOR CH-47C ROTOR HEAD

WEIGHT		FLAP STIFFNESS		CHORD STIFFNESS		PITCH INERTIA		DIFFERENCE PITCH INERTIA	
$\frac{M}{R}$	LB/IN	$\frac{M}{R}$	LB-IN ² x10 ⁻⁶	$\frac{M}{R}$	LB-IN ² x10 ⁻⁶	$\frac{M}{R}$	LB-IN ² /IN	$\frac{M}{R}$	LB-IN ² /IN
.082	4.83	.082	11.59	.082	650	.082	61.3	.082	0.0
.075	4.83	0.0	11.59	0.0	650	.042	61.3	0.0	0.0
.075	8.92					.042	72.9		
.025	6.30					0.0	72.9		
.025	8.01								
0.0	3.01								

ABOVE PROPERTIES ARE USED FOR NATURAL FREQUENCY
 AND LOAD ANALYSES

EUGENE PIETZGEN CO.
MADE IN U.S.A.

NO. 34007-20 DIE-CUTTEN GRAPH PAPER
20 X 20 PER INCH

10

1

1

1

1

1

1

QUANTITY
WEIGHT DISTRIBUTION
FIGURE 13

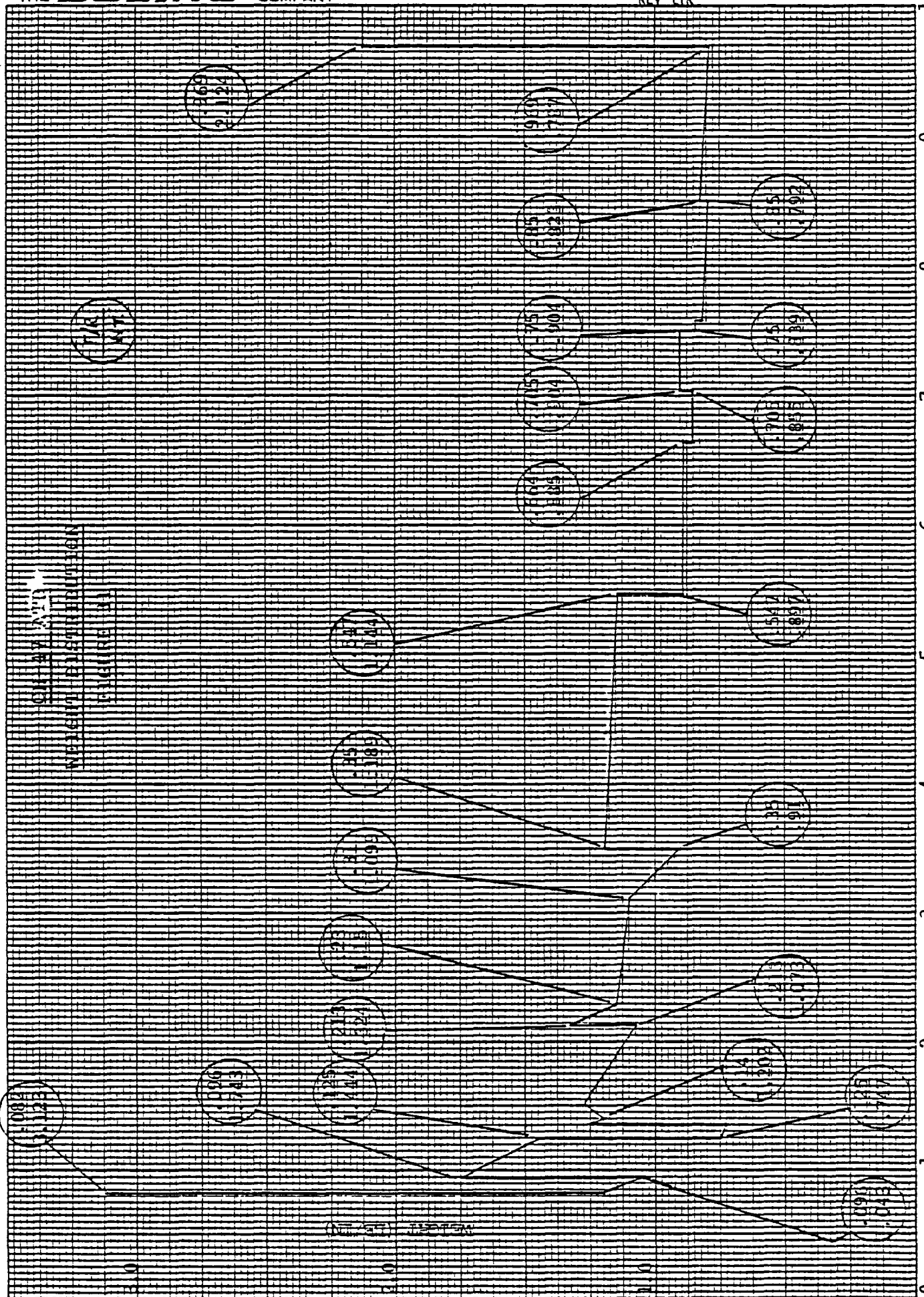

EUGENE DIETZGEN CO.
MADE IN U.S.A.

NO. 3414K-10 DIETZGEN GRAPH PAPER
10 X 10 PER INCH

YCN-47D FIBERGLASS ROTOR BLADE
COORDINATE CENTER OF GRAVITY POSITION

FIGURE 811

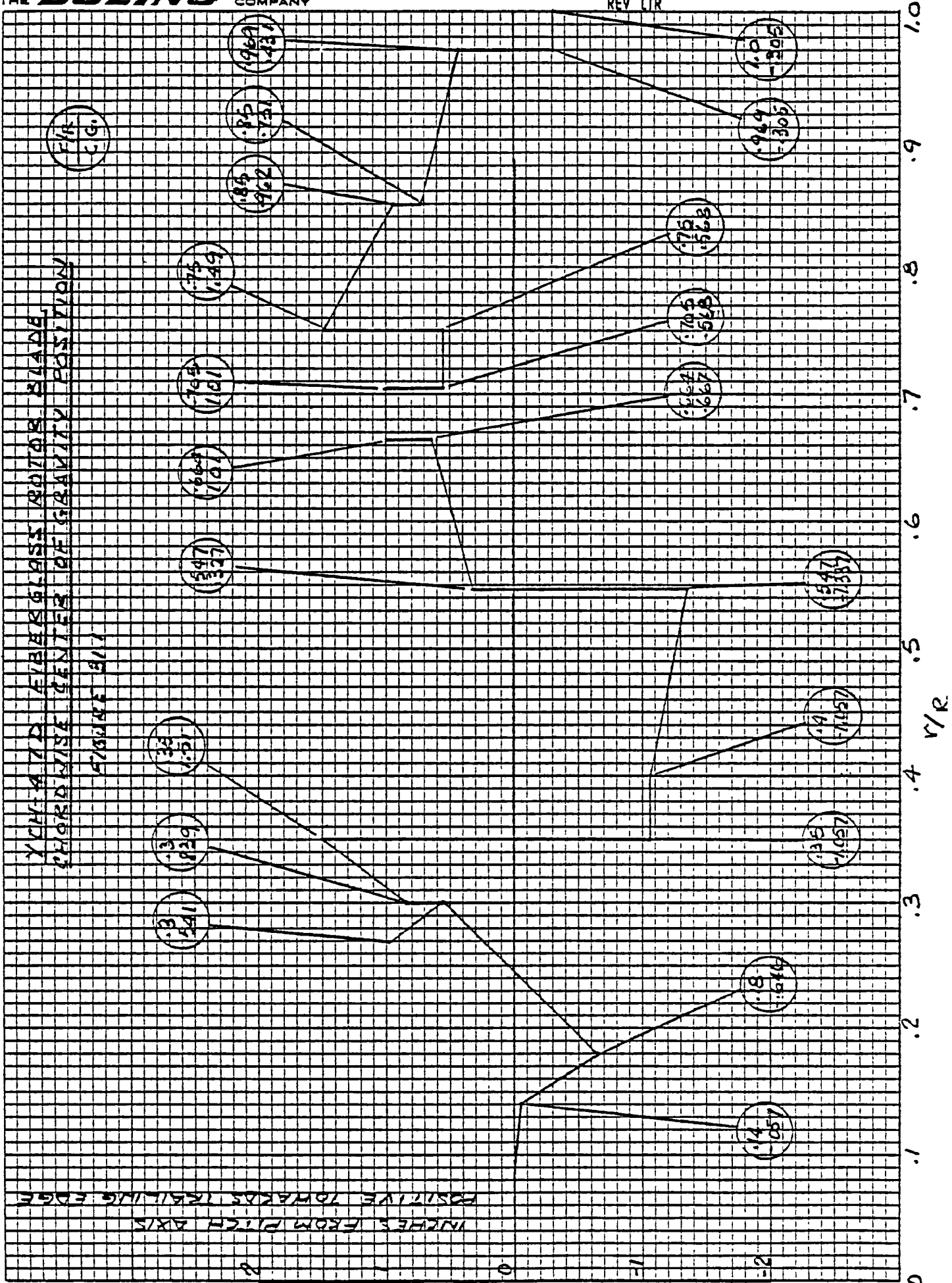

EUGENE DIETZGEN CO.
MADE IN U.S.A.

NO. 240K-14 DIETZGEN GRAPH PAPER
10 X 10 PER INCH

YEM #10 FIBERGLASS ROTOR BLADE

FLAP ATTACHMENTS

FIGURE 32

FIBERGLASS

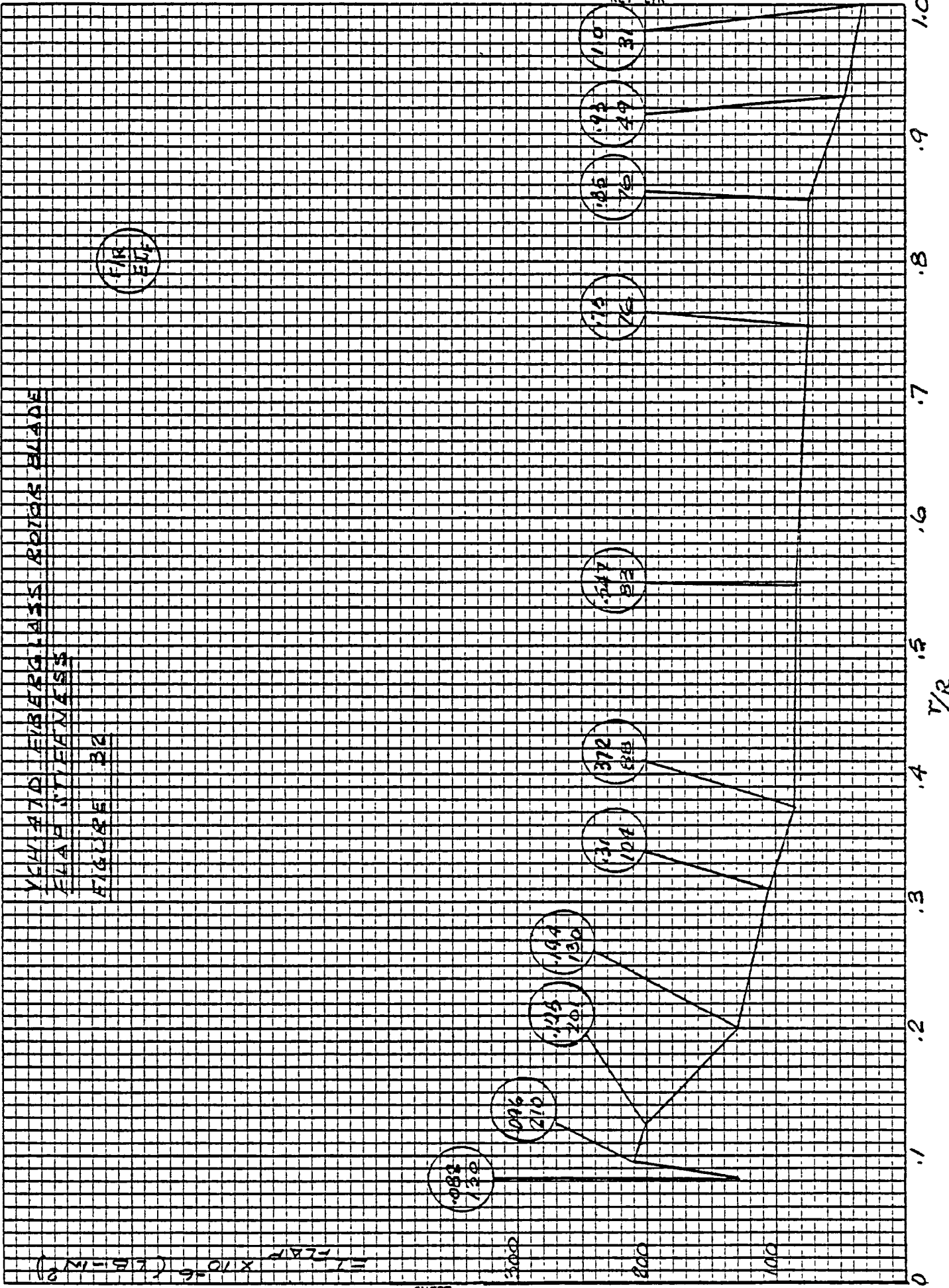

1/2 FLAP X 10⁻⁶ (R.B.-IN²)

MINIMUM DIMENSIONS MM
MADE IN U.S.A.

10 X .10 PER INCH

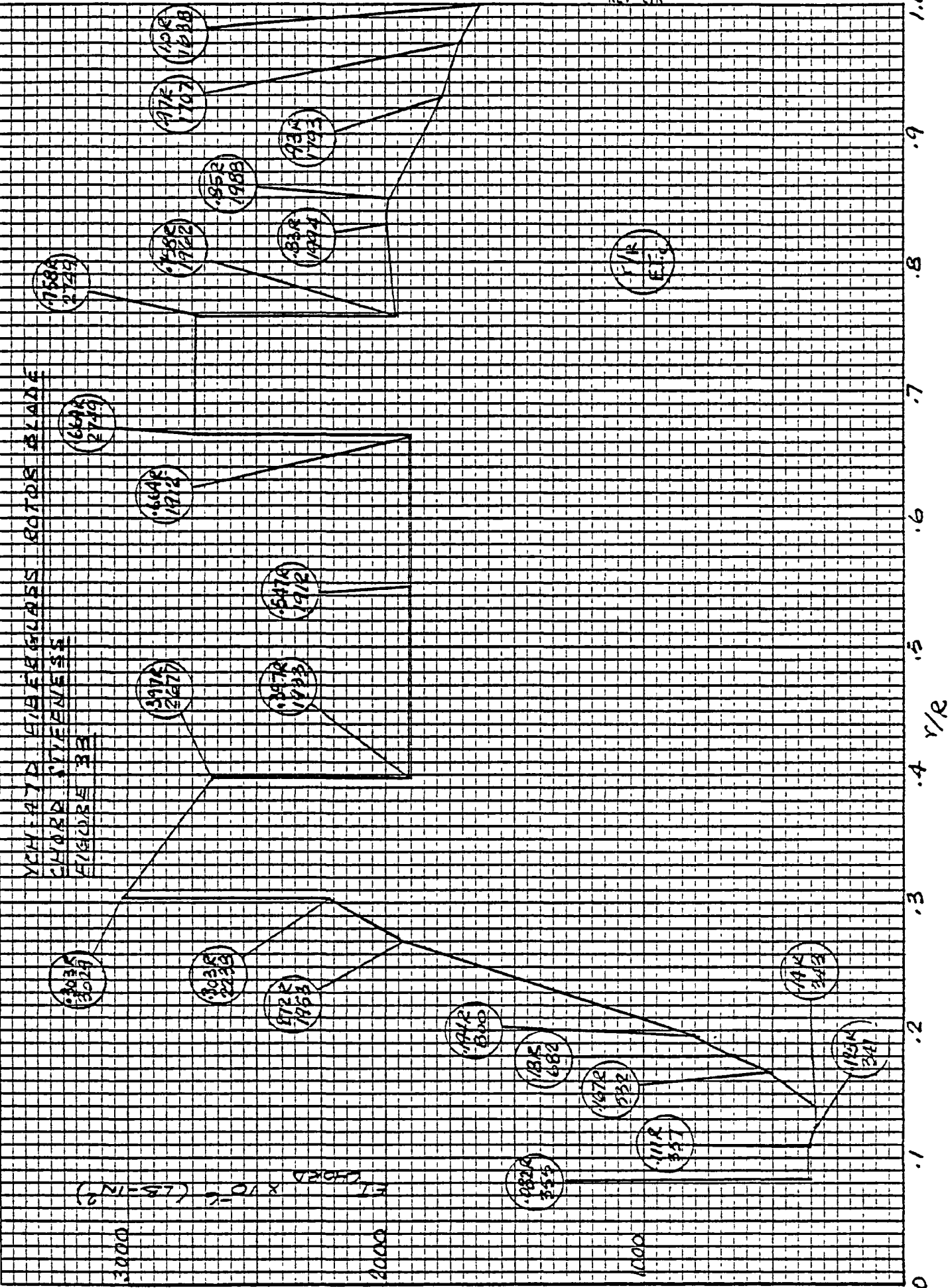

EUGENE DIETZGEN CO.
MADE IN U.S.A.

DIETZGEN GRAPH PAPER
10 X 10 PER INCH

YGM-47D FIBERGLASS ROTORS BLADE
SECTION STIFFNESS
TABLE 3A

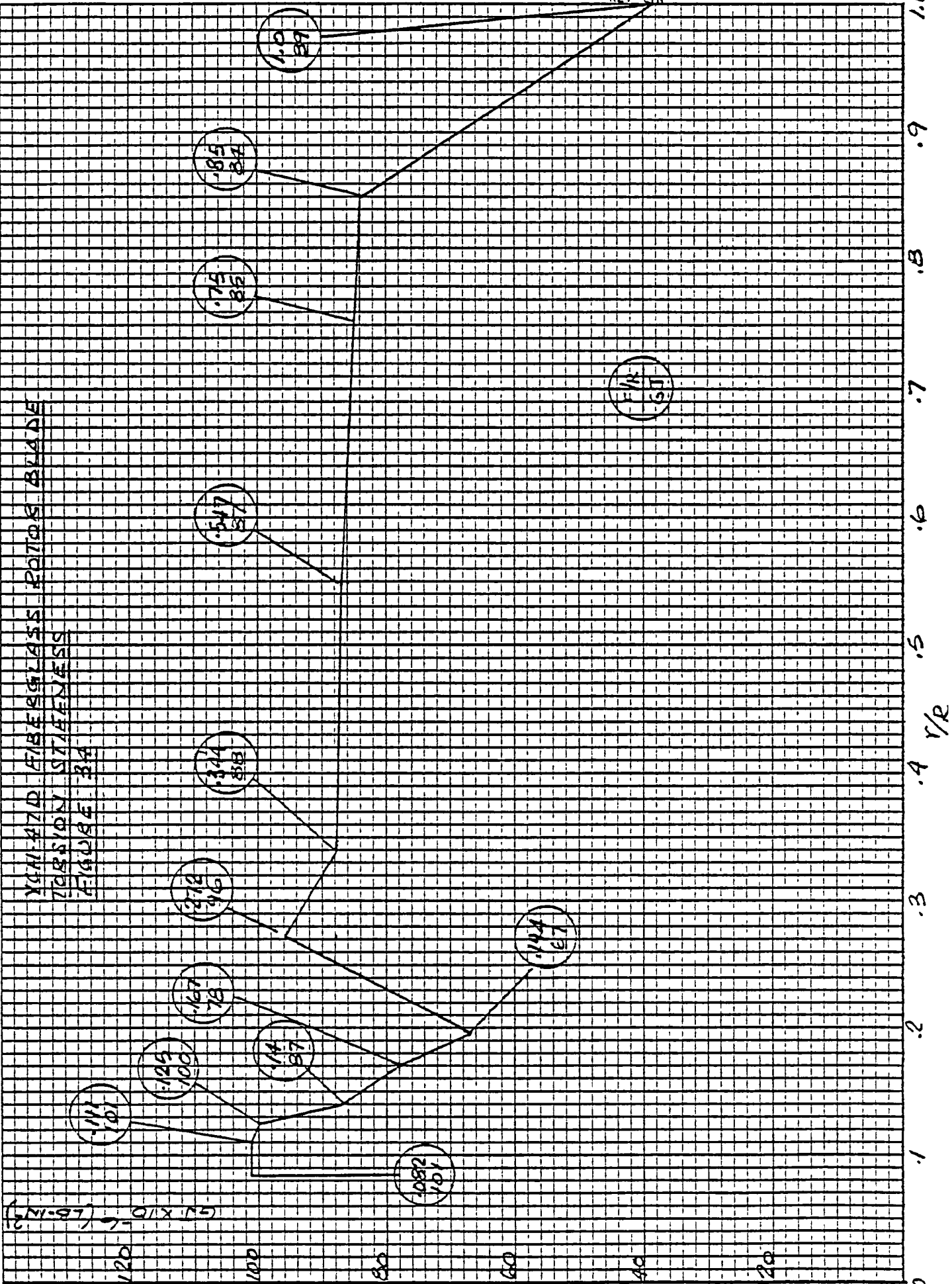

(145-SS-607.1.1) (LB-IN²)

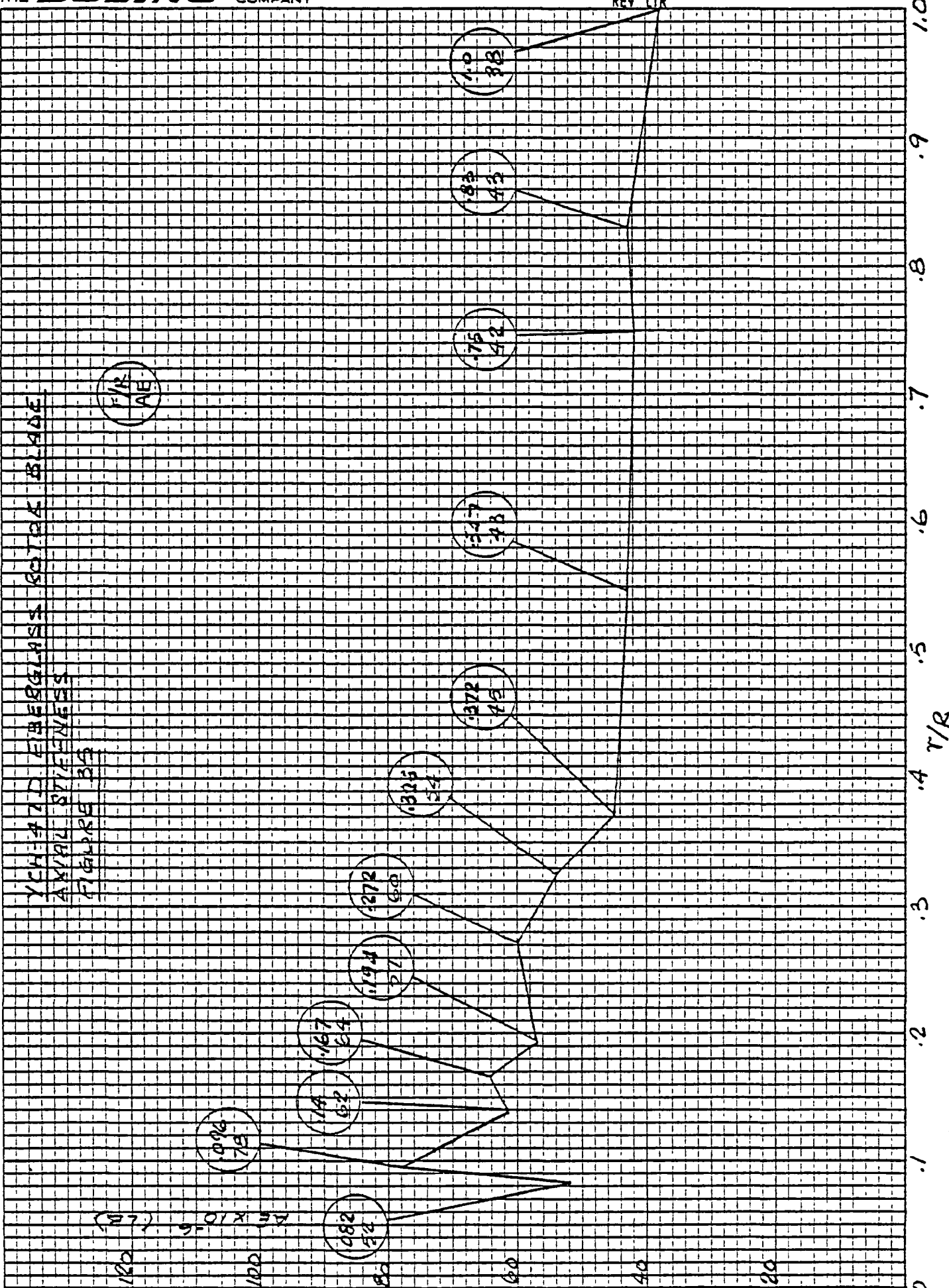

MADE IN U. S. A.

10 X 10 PER INCH

EUGENE DIETZGEN CO.
MADE IN U. S. A.

3000 IN. DIETZGEN GRAPH PAPER
10 X 10 PER INCH

WHEEL FIFTEENTH ROTOR BLADE
SIX STATION POINTS
FIGURE 32

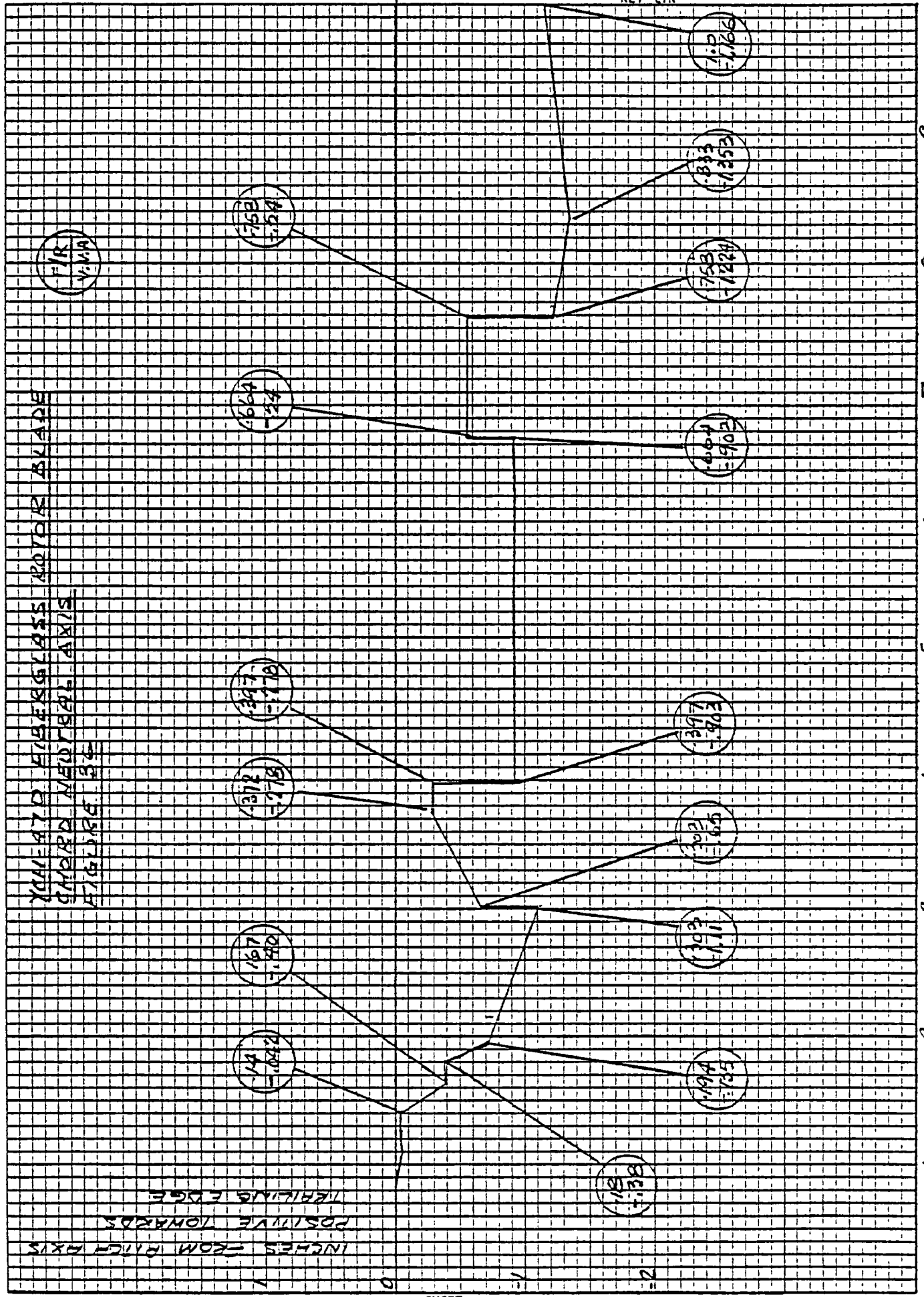

MADE IN U S A

10 X 10 PER INCH

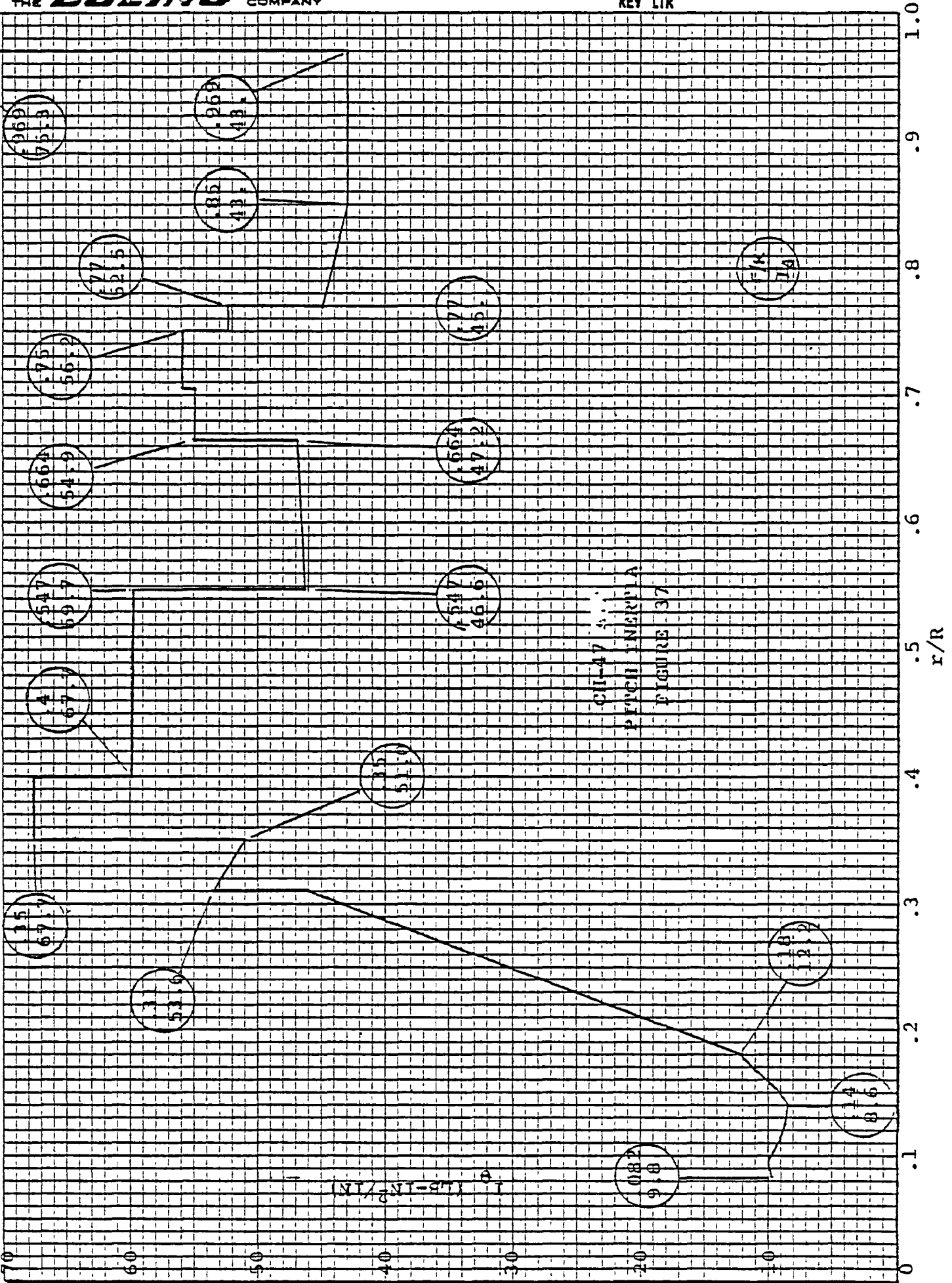

CI-47
PITCH INERTIA
FIGURE 37

REPRODUCED FROM ORIGINAL DRAWING
MADE IN U.S.A.

10 X 10 PER INCH

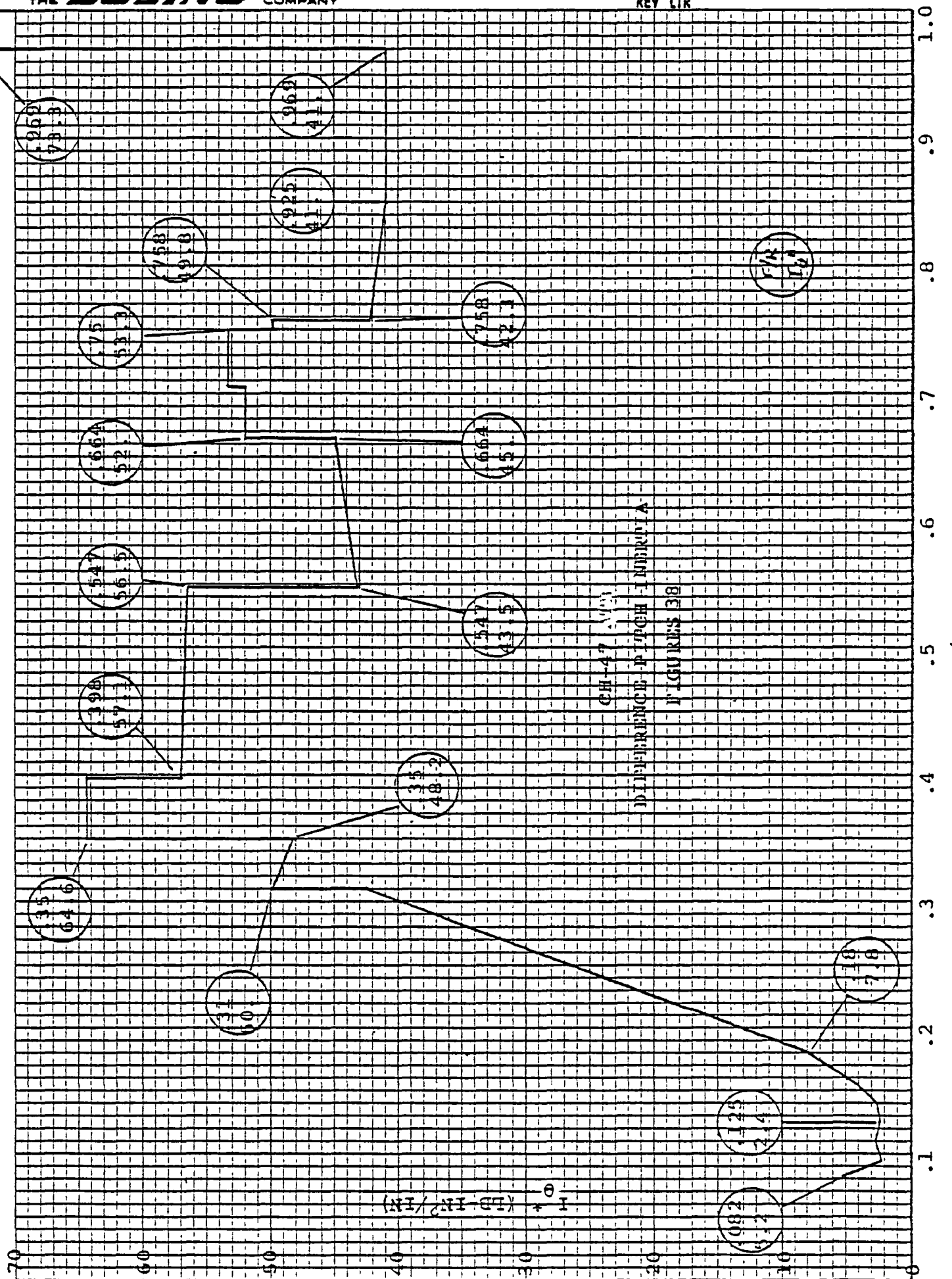

LUBENE DITZGEN CO.
MADE IN U.S.A.

14 MILIGRAM GRAPH PAPER
10 X 10 PER INCH

YCH-4700 AIRCRAFT ROTOR BLADE

SHAFT CENTER LOCATION

FIGURE 2811

INCHES FROM PITCH AXIS
POSITIVE TOWARDS
TRAILING EDGE

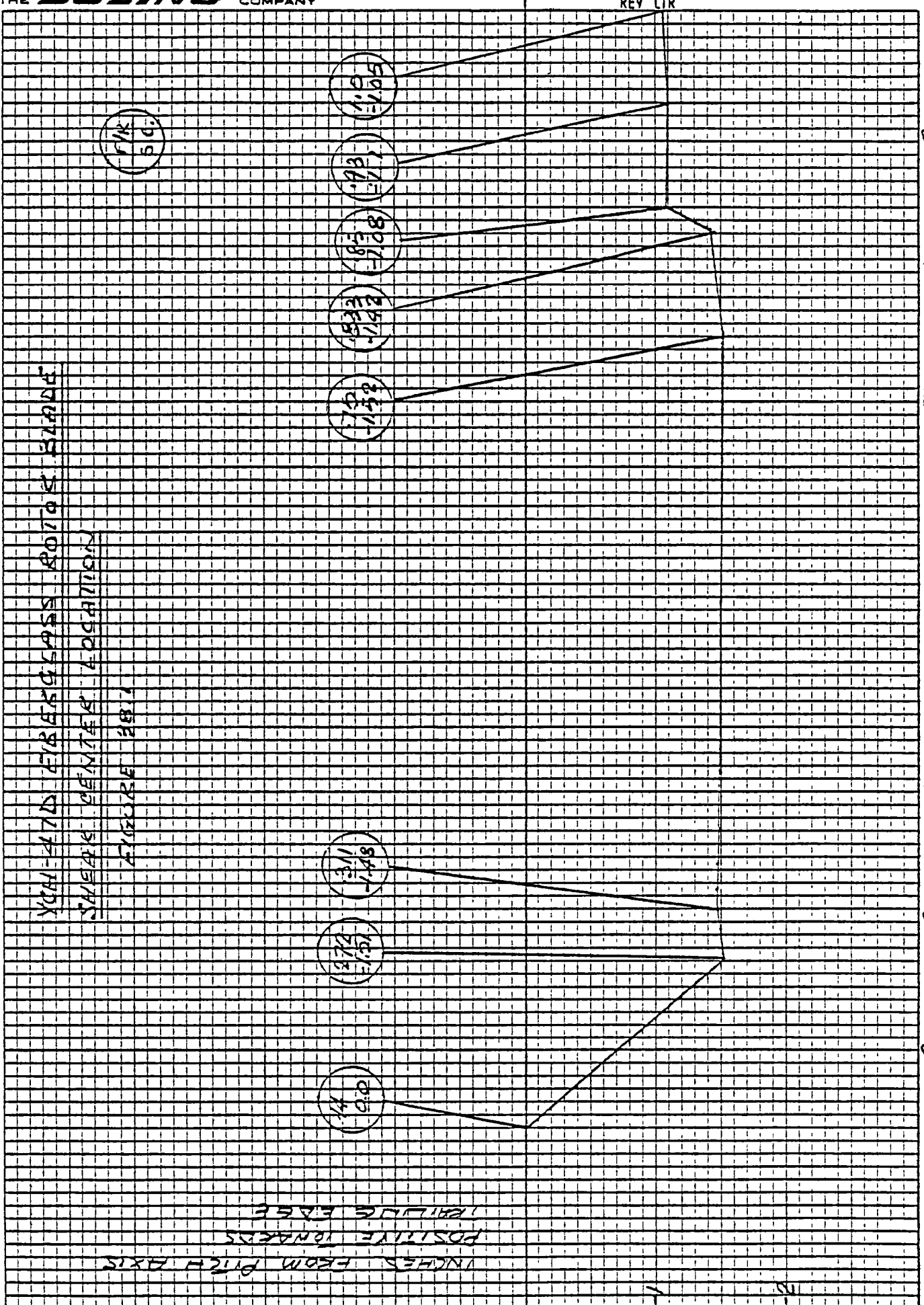

THE **BOEING** COMPANY

PREPARED BY: R.W. Sandford

NUMBER

CHECKED BY:

REV LTR

DATE: 12-13-77

MODEL NO. YCH-47D

FIGURE 39

PHYSICAL CONSTANTS OF MATERIALS USED IN THE
COMPUTATION OF CH-47 ATB PHYSICAL PROPERTIES

MATERIAL	MODULUS OF ELASTICITY PSIX10 ⁻⁶	DENSITY #/IN ³	MODULUS OF RIGIDITY PSIX10 ⁻⁶
SP-250 0° Uni	6.3	0.067	0.52
+45° Xply	1.78	0.067	1.67
90° Uni	1.74	0.067	0.52
Graphite 0°	18.0	0.055	0.70
90°	2.0	0.055	0.70
Simulated De-Ice Blanket			
+ 45°	1.78	0.67	1.67
Titanium Nose Cap	15.0	0.16	6.20
Nickel Erosion Strip	25.0	0.322	9.5
Steel Balance Weights	29.0	0.288	12.50
Tungsten Balance Weights	60.0	0.609	21.40
Nomex Core 2#/FT ³	0.0105	0.00116	0.0042
Nomex Core 3#/FT ³	0.0175	0.00174	0.007
Buna 'N' Rubber Cap	0.0	0.062	0.0
EA 9628 Adhesive	0.0	0.062	0.0
FM-37 Foam Adhesive	0.0	0.043	0.0
FM-123-2 Adhesive	0.0	0.042	0.0
EA 2216 Adhesive	0.0	0.0382	0.0
Titanium Primer AF-30	0.0	0.042	0.0
Paint, Magna Coat	0.0	0.108	0.0

8.0 DYNAMIC CHARACTERISTICS

8.1 Natural Frequencies

The flapwise, chordwise and torsional blade natural frequency spectrums are established using the L-01 computer program.

The program is based on the Leone-Myklestad method of rotor blade free vibration analysis which employs transfer equations to calculate the free vibratory response of the rotor blade. The analysis involves the representation of the structure by a number (up to 50) of elastic beam segments whose mass is concentrated at the centers. The quantities; shear, moment, slope and deflection, are calculated at the centers of each of these segments in terms of the quantities at the blade tip by means of transfer equations derived for a finite beam segment. Equations involving relationships between these quantities at the blade tip and the blade root are obtained by sequential application of the transfer equations from the tip to the root. After applying the boundary condition equations to the equations governing the tip and root quantities, a characteristic equation evolves of a very high order. The roots of which are the system natural frequencies. The characteristic equation is solved for its roots using a trial and error scheme. By substituting each root into the boundary condition equations, the tip and root unknown quantities are solved for each natural mode, which in conjunction with original finite difference equation, defines the total response of each beam section for that mode.

The spectrums are plotted over a range of rotor speeds in Figure 40 and the non-dimensional frequencies are tabulated in Figure 41.

The frequencies over the 225 to 250 rpm rotor speed range are comparable with the CH-47C blade frequencies for its operating rotor speed range. The frequencies are sufficiently displaced from blade integer harmonics so as to alleviate aircraft vibrations. At 250 rpm the second mode flap frequency is close to 5/rev. Helicopter flight and wind tunnel loads surveys have experienced no excessive load amplification attributable to this type of condition.

10.2 Classical Flutter

The results of the classical flutter analysis using L-01 computer program indicate that the rotor blade is free from flutter up to at least 1.25 times the limit rotor speed (281 rpm) for forward speeds up to 233 knots. This favorable characteristic is attributed to the blade shear center location and the mass center both lying forward of the aerodynamic center.

$$233 \text{ Knots} = 1.15 \times V_D \quad (V_D = 1.15 \times 176)$$

1CH-47D FIBERGLASS ROTOR BLADE
NATURAL FREQUENCY SPECTRUM

FIGURE 70

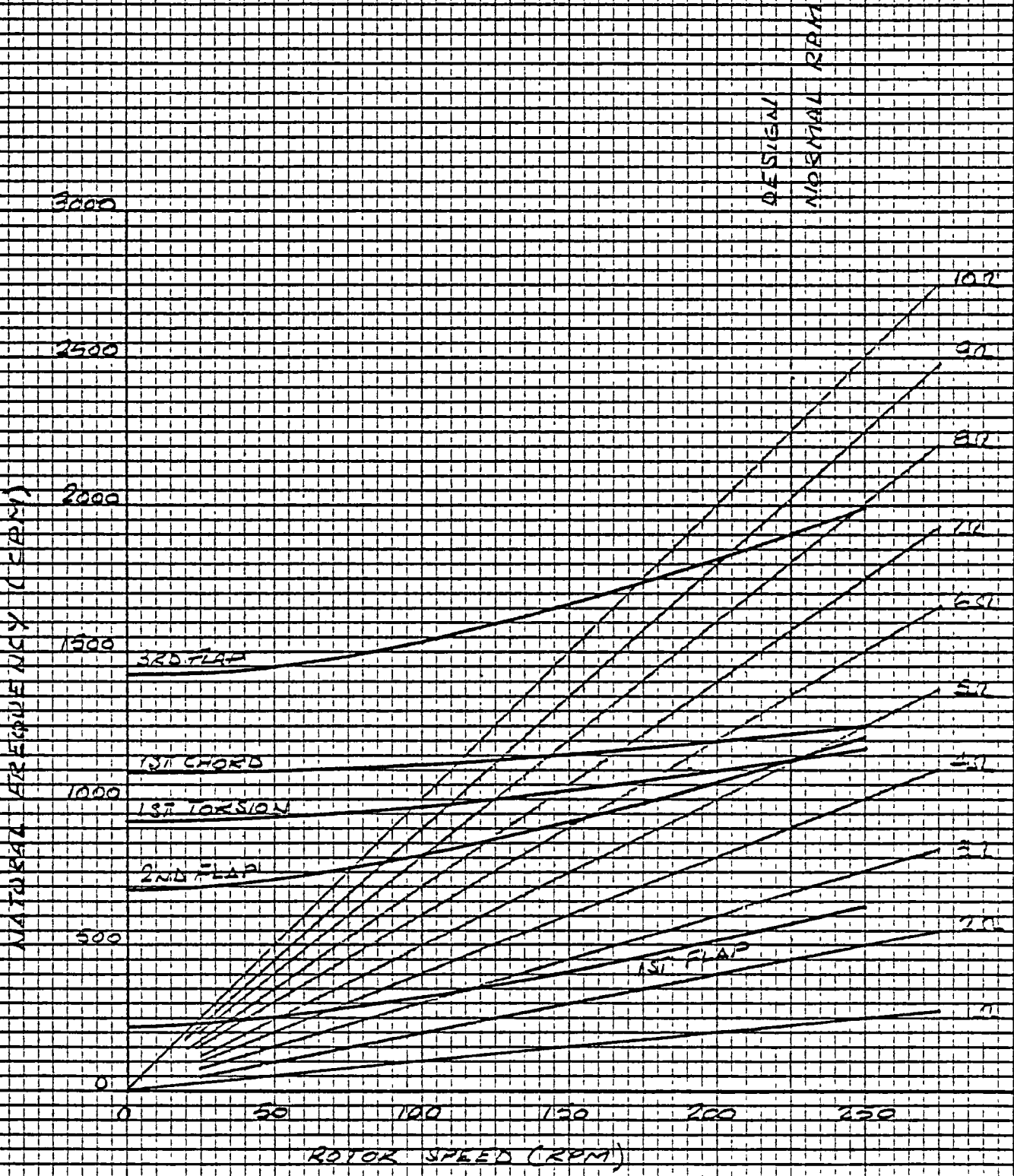

EUGENE DIETZEN CO.
MADE IN U. S. A.

DU 3400-10 DILITZEN GRAPH PAPER
10 X 10 PER INCH

BLADE NATURAL FREQUENCIES
FIGURE 40.1

	ROTOR SPEED (RPM)	
	0	225
	CPM	PER REV.
FIRST FLAP	207	2.56
SECOND FLAP	693	5.06
THIRD FLAP	1429	8.44
FIRST CHORD	1094	5.41
FIRST TORSION*	932	5.04

* $K_{\theta} = 1.85 \times 10^6$ IN. LB/IN

MATERIAL PROPERTIES SUMMARY FIGURE 41

THE BOEING COMPANY

ITEM	E x 10 ⁶ PSI	FTU PSI	FCU PSI	$\frac{f_{cu}}{R=1.0}$ PSI	G x 10 ⁶ PSI	F _{su} PSI	f _{se} PSI
SP250-Z							
0°	5.5	130000	87000	13600	.52	6940	1600
90°	1.74	2980	20000	560	.52	6940	1600
± 45°	1.78	20000	20000	2680	1.67	46300	5000
HT-GRAPHITE							
0°	18.0	140000	-	39400	.70	7450	-
90°	2.0	5460	-		.70	7450	
TITANIUM 6AL-4V ANNEALED SHEET	15.0 L 18.0 T	132000	132000	27500	6.2	79000	14150
17-4PH 150-170KSI	28.5	150000	150000	20800	11.2	-	-
AISI 301 SS 1/2 HARD	26.0	141000	141000	23000	11.5	77000	13280
4340 STL. 125-145KSI	29.	125000	125000	20000	11.0	75000	-
AISI 304 SS	29.	95000	95000		12.5	42000	-
15-5 PH SS INVESTMENT CASTING	-	150000	150000	10000	-	-	-
ELECTRO FORMED NICKEL	25.	114000	114000	28500	-	-	-
EA9628 ADHESIVE	See Paragraph 9.5						
NOMEX HONEYCOMB	See Paragraph 9.5						
<p>* at 10⁷ cycles for ferrous materials at 5 x 10⁷ cycles for non-ferrous materials</p> <p>REF. IOM 8-7451-5-156</p> <p>REF. FIGURE 48</p> <p>REF. PARAGRAPH 9.3, 9.4</p> <p>D210-11326-1</p> <p>BMS 8-189 TYPE II p. 5,6,7</p> <p>BOEING VERTOL UNPUBLISHED DATA</p> <p>REF. FIGURE 60</p> <p>REF. 12</p> <p>REF. 8 PAGE 2-103, 2-104</p> <p>DIVIDING THE RESPECTIVE TENSION VALUE BY $\sqrt{3}$</p> <p>REF. FIGURE 43</p> <p>REF. 8 PAGE 2-121</p> <p>REF. IOM 8-7451-5-75</p> <p>REF. 14 PAGE 2-10.3.2-1</p> <p>REF. 8 PAGE 2-11</p> <p>MIL-T-6845 AND BOEING DESIGN MANUAL, FIG. 21.342-1</p> <p>FIGURE 62</p>							

NUMBER 145-SS-607.1.1
REV LTR

Appendix C
Teledyne McCormick Selph
Technical and Cost Proposal
for 347/D-RSRA Blade Severance System

TABLE OF CONTENTS

<u>PARAGRAPH</u>	<u>TITLE</u>	<u>PAGE</u>
1.0	INTRODUCTION	1
2.0	PROGRAM PLAN	2
3.0	TECHNICAL APPROACH	8
3.1	BLADE SEVERANCE ASSEMBLY (BSA)	8
3.2	ROTATING TRANSFER UNIT (RTU)	11
3.3	ROTOR HEAD ATTACHMENT.	12
3.4	QUALIFICATION.	12
4.0	QUALITY ASSURANCE.	13
5.0	PRICING.	14

TABLE

2-I	PRODUCTION PLAN.	7
-----	--------------------------	---

FIGURES

3-1	BLADE SEVERANCE ANGLES	9
3-2	BLADE SEVERANCE ANGLES	10

APPENDIX A - QUALITY CONTROL PLAN

1.0

INTRODUCTION

This proposal is prepared and submitted in response to Boeing Vertol letter 8-4435-5-0145, dated 5 September 1980 for a blade removal subsystem compatible with the RSRA and a modern four-bladed rotor system manufactured by Boeing.

The program proposed herein involves the design, development test and integration of a new Rotary Transfer Unit (RTU) and blade severance device for this four (4) blade rotor system.

Since the proposed system is essentially the same as the current system, with adaptation of the RTU plates and reshaping of the Blade Severance Assembly (BSA), no formal qualification of the system is proposed. Two (2) half system tests of the TRU will be conducted and sufficient BSA tests to verify the charge size and cutting capability.

This proposal is based entirely on the scope-of-work defined herein in lieu of a detailed Request for Quotation from Boeing. Pricing contained herein is based on September 1980 dollars.

2.0

PROGRAM PLAN

This proposed program is presented in schedule format under Figure 2-1. As noted, it is expected to require a total of 45 weeks plus holidays to complete the planned effort from receipt of contract to installation of the hardware on the RSRA vehicle.

Schedule Items I and II will involve the necessary release of procedural direction at Teledyne McCormick Selph (Tmc/S) plus a meeting at Boeing to resolve all the details associated with the system concept, installation and mounting of the final system. Subsequent to full base line agreement, Tmc/S will proceed with design/design updating to fully define the system and modifications. New design details will be created for the Shaft Cam, Rotating Plate, Stationary Plate and Blade Severance Assembly. The Shielded Mild Detonating Cord (SMDC) and Flexible Confined Detonating Cord (FCDC) will be simple configuration additions to existing drawings upon completion of Item IV mock-up. Item IV will require a Tmc/S employee to make physical mock-ups of the SMDC and FCDC lines on the rotor head plus the RTU section when available. This phase will extend well into the program and cannot be completed until about the twenty-eighth week, since the TRU components will be required to finalize the SMDC configurations.

Developmental testing under Task V will be directed at charge sizing for the FLSC used in the BSA. For planning purposes Tmc/S proposes to conduct up to 16 tests against Boeing-Vertol supplied flat plate samples representative of the blade cross section at approximately Station 46.78. Three (3) FLSC sizes will be considered in the range of 125 to 200 grain per foot. These will be incremental tests subject to charge size modification at each step. The data resulting from these tests will be analyzed and an optimized charge selected. This selected charge size will be tested against full blade cross sections.

2.0 PROGRAM PLAN (Cont'd)

Item V includes hardware procurement and assembly for all end item components needed to conduct the design verification testing, lot acceptance testing and provide the air vehicle deliverable hardware. Two (2) BSA's will be fabricated to final configuration before the main lot is committed to fabrication assembly. These two (2) units will be tested at temperature extremes under Task VII against Rotor Blade Sections provided by Boeing-Vertol. Upon successful completion of these tests, the balance of the BSA lot will be assembled and acceptance tested on additional rotor blade sections. Under Tasks VII and VIII a test stand will be fabricated with the stationary, rotating and cam sections of the RTU. Two (2) half system tests will be conducted of the sequencer, cam thruster and firing pin assembly components to verify the entire RTU design and blade severance positional sequence.

TMc/S proposes to supply one engineering technician for a period of two weeks to install all TMc/S supplied hardware on the air vehicle under Task IX.

A Critical Design Review (CDR) is proposed in the twelfth week of the program to review the design concept and details. This meeting is scheduled for two days at Teledyne in Hollister, California.

Minimum data is proposed for this program pending further definition by Boeing-Vertol. These data will include:

- a. Development Report with RTU test addendum.
- b. Lot Acceptance Test report.
- c. Letter progress reports on a monthly basis.
- d. Top assembly drawings of the production hardware.
- e. A system reliability report addressing the modified portions of the system, proposed with an unbiased confidence.

2.0 PROGRAM PLAN (Concl'd)

Task XII will cover all elements of Program Management plus those nonrecurring elements of Planning, Test Engineering and Quality Engineering.

The only other apparent element not considered in this proposal relative to hardware is the RTU enclosures installed on the bottom of the RTU/transmission. Teledyne does not possess details of the enclosure(s) which may require rework/redesign to accommodate the repositioned Sequencers/Cam Thrusters.

The proposed hardware for this program is shown in Table 2-II. A total of sixteen (16) Boeing-Vertol supplied flat plate rotor specimens will be required plus ten (10) actual rotor sections. One extra rotor section will be required for use as a master jig or from which a master tool can be fabricated for BSA production.

	SYS QTY	P/N	DVT	DEL	LAT	LOSS	TOTAL	NO. OF CONFIGS.
Stationary Plate	1	72750-08324 (MOD)	1	1	0	0	2	1
Sequencer	2	815971	2	2	5	1	10	1
Cam Thrusters	4	815643	4	4	5	2	15	1
CDF Lines	2	815581-1 to -6	2	2	5	4	13	2
Manifold 3-Part	2	816008	4	2	0	2	8	1
Manifold 4-Part	1	816000	2	1	0	2	5	1
Cam Plate	1	72750-08323 (MOD)	1	1	0	0	2	1
Rotating Plate	1	72750-08322 (MOD)	1	1	0	0	2	1
Firing Pin Assembly	8	815630	8	8	5	2	23	1
SMDC - Lower Manifold	8	815612	8	8	5	6	27	3
Lower Shaft Manifold	1	816005 (MOD)	0	1	0	1	2	1
Rotor Shaft SMDC	8	815612	0	8	5	4	17	1
Upper Shaft Manifold	1	816004 (MOD)	0	1	0	1	2	1
FCDC Rotor Head	8	815581-7	0	8	5	4	17	1
Double Unions	4	815989	0	4	0	1	5	1
SMDC - BSA	8	815612	0	8	5	4	17	2
BSA	4		2	--	5	1	10	1
Boeing Supplied Blade Flat Plate Samples			16				16	
Boeing Supplied Blade Sections			6		5		11	

PRODUCTION PLAN

Table 2-II

3.0

TECHNICAL APPROACH

The proposed task requires the modification of the existing Rotor Systems Research Aircraft (RSRA) escape system to convert the current five (5) blade rotor system to a four (4) blade configuration.

Blade severance angle will be dictated by the necessity to ensure that the aft blade clears the tail assembly of the aircraft. Figure 3-1 defines the angular severance position for the aft rotor blade as currently established for the 5-blade RSRA configuration. This configuration presents a problem in that the proposed severance charge may contain slightly more explosive than the current RSRA Blade Severance Assembly. It is therefore important to sever the forward blade with the maximum possible rotational clearance with respect to the flight crew. Figure 3-2 shows an alternate plan for blade severance. Figure 3-2 presents a shortcoming in that the aft blade is severed with a trajectory generally corresponding with the aircraft flight path. Therefore the overall philosophy of blade severance angles must be studied in depth to achieve the optimum severance angles for this proposed system.

3.1

BLADE SEVERANCE ASSEMBLY (BSA)

The major effort anticipated for this proposed program will be the establishment of an optimum FLSC charge for severing the Boeing-Vertol blade. It is important for air crew safety to use the smallest possible explosive charge while ensuring maximum or total severance of the target. TMC/S proposes to approach this by first testing various sizes of FLSC against flat plate specimens followed by partial to full functional tests of the BSA against actual blade cross sections.

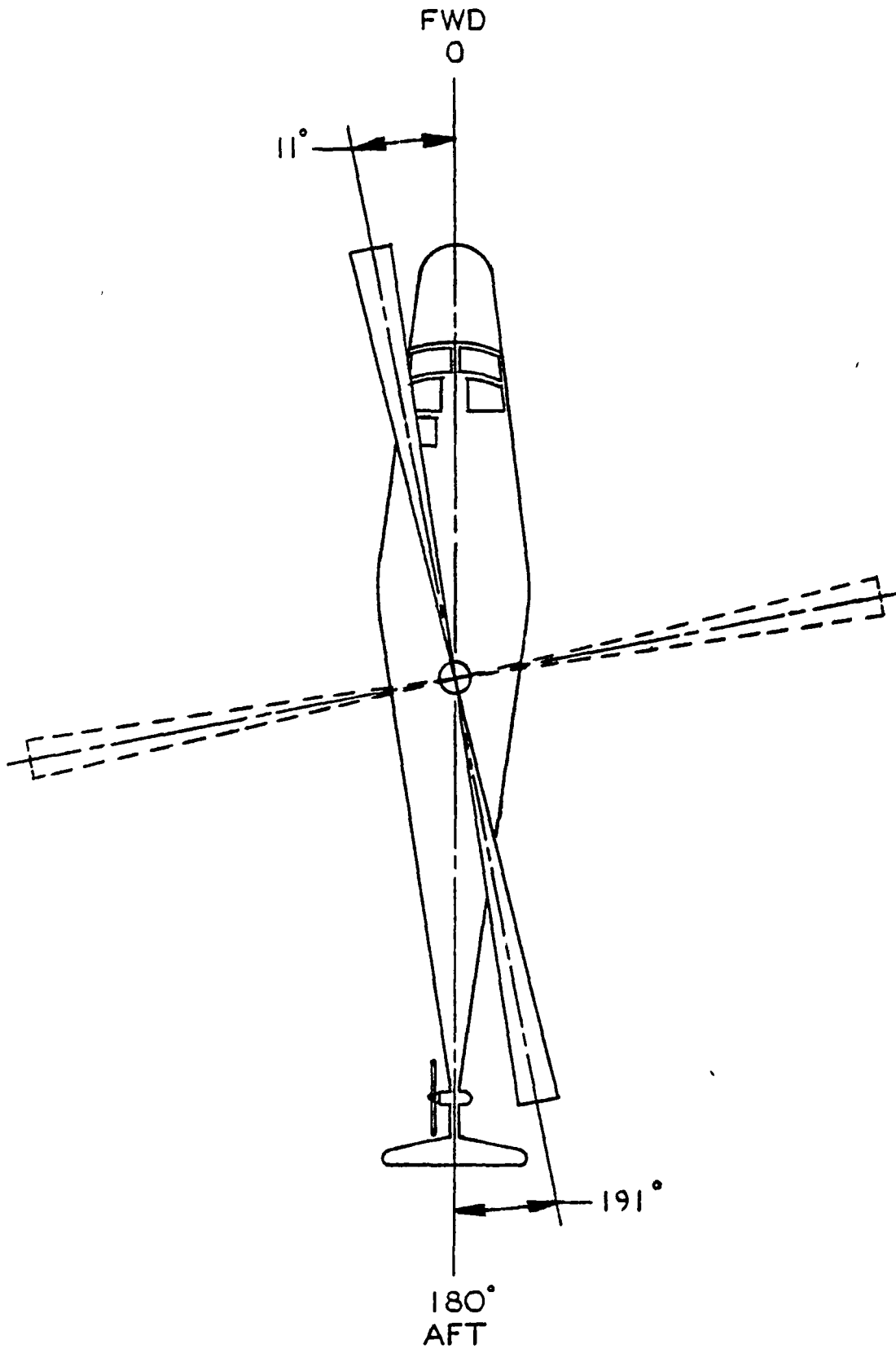

Fig. 3-1

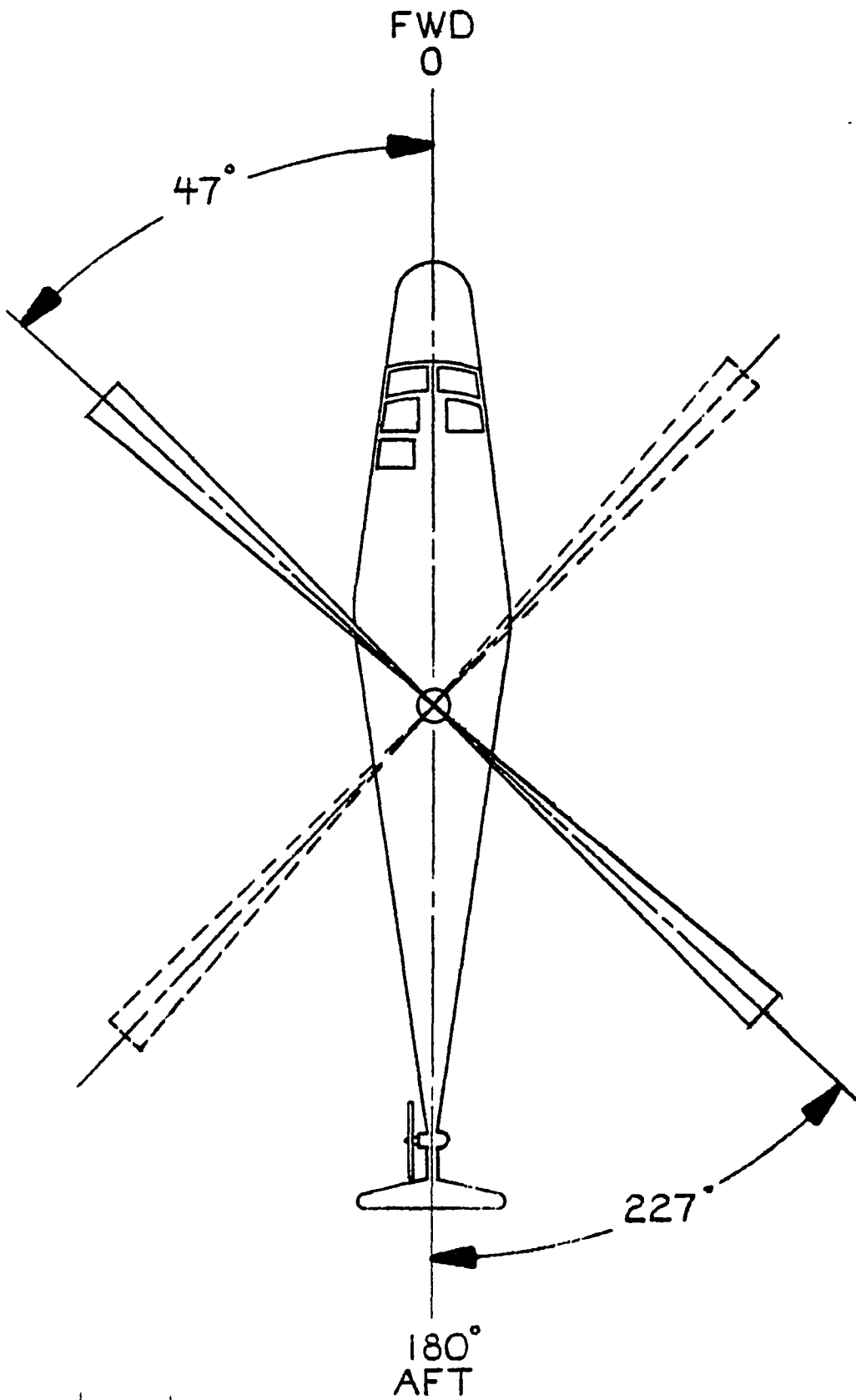

Fig. 3-2
-10-

3.1 BLADE SEVERANCE ASSEMBLY (BSA) (Concl'd)

An analysis of Boeing drawings 114R1702 and 114R1710 indicates that the severance point will be immediately adjacent to Station 46.280. Adjusting for the centerline of the BSA, the actual severance point will be at Station 46.780. The current RSRA severance point is at Station 45.50 which means that the proposed design will protrude an additional 1.28 inches into the air crew ejection path. At this time there does not appear to be an acceptable alternate severance point inboard of this station; however, the added intrusion into the aircrew ejection envelope does not appear to be significant.

The target at the proposed severance point appears to be approximately 1.00 in thick. Based on past experience with fiberglass, kevlar or graphite composites, a charge size of approximately 180 grains of CH-6 per foot is expected to sever the blade.

3.2 ROTATING TRANSFER UNIT (RTU)

When revised for this application this unit will consist of:

- a. New cam shaft extension.
- b. New rotating plate.
- c. New stationary plate.
- d. Two (2) sequencers.
- e. Four (4) cam thrusters
- f. Eight (8) firing pin assemblies.
- g. Necessary interconnect lines from the stationary side of the aircraft to the BSA's.

Page Missing

4.0

QUALITY ASSURANCE

Quality Assurance for this proposed program has been established in conformance with MIL-Q-9858A and is documented by the Quality Control Plan contained in Appendix A of this proposal. Further, this proposal is based on Teledyne Material Review Board authority for all nonconformities associated with the hardware designed by TMC/S, except for interface controls, as may be defined at a later date by Boeing-Vertol in the form of interface control drawings or specification.

5.0

PRICING

The following prices are presented for the proposed program. These prices are in September 1980 dollars and are based strictly on the scope-of-work presented herein.

Nonrecurring:	\$ 71,824
Production Hardware:	132,636
Data and Meetings:	<u>43,935</u>
Total Program:	\$248,395

APPENDIX A
QUALITY CONTROL PLAN

DID NO. _____
CDRI. NO. _____
P.O. NO. _____
CONTRACT NO. _____

DATA MGR. FILE NO. _____
DEPT FILE NO. 660299
ISSUE DATE 26 September 1980
REVISION N/C
SUPERSEDING _____
DATE _____

QUALITY CONTROL PLAN
FOR
ROTOR SYSTEMS RESEARCH AIRCRAFT (RSRA)
BLADE REMOVAL SYSTEM

PREPARED FOR

BOEING VERTOL COMPANY
PHILADELPHIA, PENNSYLVANIA

TMc/S PROPOSAL NO. B100-80-393

Teledyne McCormick Selph

3601 UNION ROAD, HOLLISTER, CALIFORNIA 95023



CODE IDENT. NO 06331

INTRODUCTION

The Teledyne McCormick Selph (TMC/S) Quality, Safety, Environmental Assurance Program (Q-SEA), has been structured to satisfy the requirements as defined in Military Specification MIL-Q-9858A, "Quality Program Requirements". These requirements and Teledyne McCormick Selph's ability to satisfy the Quality Assurance requirements of Boeing Vertol Company, are delineated in detailed instructions which are part of the TMC/S Quality Assurance Manual. For purposes of this proposal, the following brief is submitted to familiarize Boeing Vertol Company with the quality system adhered to by TMC/S.

TABLE OF CONTENTS

<u>PARAGRAPH</u>	<u>TITLE</u>	<u>PAGE</u>
1.0	SCOPE	1
2.0	ORGANIZATION	1
3.0	RELIABILITY	1
4.0	QUALITY CONTROL	2
4.1	Program Review	2
4.2	Procurement Control	3
4.3	Receiving Inspection	4
4.4	In-Process and Final Inspection	5
4.5	Testing	5
4.6	X-Ray and Neutron Radiographic Inspection	6
4.7	Handling, Packaging and Shipping	6
4.8	Control of Nonconforming Materials	6
4.9	Material Review	7
4.10	Corrective Action	7
4.11	Records	8
4.12	Drawing and Change Control	9
4.13	Configuration Control	9
4.14	Inspection Status Identification	10
4.15	Limited Life Item Control	10
4.16	Handling of Government/Customer Furnished Equipment and Materials	11
4.17	Training and Certification of Personnel	11
4.18	Quality Audit	12
4.19	Sampling Inspection	12
4.20	Costs Related to Quality	12
5.0	TEST	13
5.1	Test Engineering	13
5.2	Non-Destructive and Functional Tests	13
5.3	Metrology	14
6.0	SYSTEM SAFETY	14
7.0	ENVIRONMENTAL CONTROL	15

TABLE OF CONTENTS

<u>EXHIBIT</u>	<u>TITLE</u>	<u>PAGE</u>
A	Quality Organization Chart.....	A-2
B	Procurement Quality Assurance Provisions	B-2 & B-3
C	Vendor History Card	C-2
D	Inspection Plan and Report	D-2
E	Operation Sheet	E-2 & E-3
F	Discrepancy Report	F-2
G	Stamp Control Listing	G-2 & G-3

1.0 SCOPE

The purpose of this Quality Program Plan is to familiarize customers with the quality program as adhered to by Teledyne McCormick Selph.

2.0 ORGANIZATION

The Quality Assurance Department is divided into five (5) divisions. These divisions report to the Executive Vice President, thereby assuring that Quality Assurance management has full and unimpeded access to executive levels. (See Exhibit A)

These five (5) divisions are:

Reliability
Quality Control
Test
System Safety
Environmental Control

3.0 RELIABILITY

The Reliability Division is responsible for implementation of a Reliability program which assures that contractual Reliability goals at the specified confidence levels are inherent in the product design and are not degraded during subsequent manufacture inspection or test. The Reliability program shall include the following elements to the extent necessary to economically attain the specified Reliability goals:

- (A) Preparation of contractually required Reliability Program Plans.

3.0 RELIABILITY (Continued)

- (B) Reliability Indoctrination and Training.
- (C) Reliability Prediction and Estimation.
- (D) Failure Mode Analysis.
- (E) Human Factor Evaluation of the Manufacturing, Inspection and Testing Operations.
- (F) Design Reviews.
- (G) Failure Reporting and Analysis.
- (H) Design and Experiments for Reliability Evaluation.
- (I) Systematic and Periodic Assessment of Demonstrated Product Reliability.

4.0 QUALITY CONTROL

Quality Control Division (Quality Engineering and Inspection) is responsible for developing and maintaining a continuous Quality Program which encompasses all quality requirements from review of customer contracts to the shipment of the end product. The sections that follow define the various elements of control employed by TMc/S in producing quality products in accordance with contractual requirements. The system employed satisfies the requirements specified in MIL-Q-9858A.

4.1 PROGRAM REVIEW

Early Quality planning is an important aspect of the quality program due to the diversity of programs, products, and customer requirements. Quality Engineering and Test Engineering shall conduct an early and complete review of the requirements of the Contract/Purchase Order to identify and make timely provision for planning, special controls, processes tooling, skills, etc., necessary to insure compliance with the imposed quality requirements.

All Purchase Requisitions and/or Purchase Order changes are reviewed and approved by Quality Engineering. Quality Engineering assures all specifications, quality system requirements, drawings, processes, preservation and packaging requirements, test reports, source and/or government inspection, inspection records, certifications, which are applicable, are specified on the Requisition and/or Purchase Order. See Exhibit B, Form 842 "Procurement Quality Assurance Provisions". In addition Quality Control maintains an active program for the formal evaluation and approval of procurement sources. The Quality Control division exercises review and approval authority on the adequacy of all procurement sources. All approved sources are listed in the TMc/S "Approved Vendor List" (AVL) which is issued on a quarterly basis. Only suppliers listed in the AVL shall be acceptable for procurement activity. Each supplier shall satisfy one of the following conditions prior to being added to the AVL:

- a. Have a previous record of supplying high quality/reliable articles of the type being procured.
- b. Be listed in current issue of CASE Manual (Coordinated Aerospace Supplier Evaluation).
- c. Have been added to AVL on basis of an acceptable TMc/S on site survey conducted jointly by Quality Engineering and Purchasing Division.
- d. Have been approved as an acceptable supplier by a TMc/S customer.

The quality capabilities of TMc/S supplier's are objectively evaluated on a quarterly basis and these evaluation results are made available to all operating departments. On a quarterly basis, a Vendor Defect Report is prepared and issued by Quality

4.2 PROCUREMENT CONTROL (Continued)

Control, which summarizes vendor cumulative performance for the reporting period. Vendors are rated on the basis of unit percent defective of the total number of units received (See Exhibit C). Suppliers ratings are made available to them and assistance provided by Quality Control to effect improvement in unsatisfactory performance rating when required. Suppliers with unsatisfactory ratings are removed from the AVL.

TMc/S performs source inspection at a supplier's facility in cases where the quality of a product cannot be adequately ascertained by TMc/S Receiving Inspection due to the nature and complexity of the procured material. When required, TMc/S source inspection requirements will be imposed and so indicated on the applicable procurement document.

4.3 RECEIVING INSPECTION

Quality Inspection shall perform receiving inspection of procured materials; and review vendor supplied inspection records, test reports, certification, etc., to the extent necessary for adequate assurance of vendor quality performance. The amount and type of inspection is as specified on the "Inspection Plan and Report" (IP&R) which is prepared by Quality Engineering and approved by the Product Engineer. This document is used by inspection to record all of the inspection observations (See Exhibit D). In addition, TMc/S has chemical and physical test analysis performed, by an independent test lab, on every tenth (10th) item of raw material received at TMc/S to verify the validity of the test reports received from suppliers. All receiving inspection records are maintained by Quality Control and provide data as to the number of parts accepted and rejected. Complete documentation traceability is available and on file for review.

4.4

IN-PROCESS AND FINAL INSPECTION

Manufacturing process instructions and detailed quality control inspection criteria are integrated into production planning (Operation Sheets) Exhibit E. Operation Sheets are prepared by Process Engineering and reviewed and approved by Quality and Product Engineering prior to release. Operation Sheets delineate inspection points where inspection (e.g. dimensional, visual, functional, physical, etc.) shall be performed to verify that the product is manufactured according to the requirement as specified by drawing, specification or design disclosure. The Operation Sheet shall be used by inspection to record the "as built" condition of the product and will reflect quality acceptance of each manufacturing and inspection function completed. Inspection points are established at those points which will minimize potential delays resulting from deficiencies, and are at or before the last point at which the acceptability of an operation may be completely verified. Final inspection shall be performed on completed items before submission to the Government/Customer for acceptance. The extent and quantity of final inspection shall be sufficient to provide assurance that the required quality is present.

4.5

TESTING

Quality Control conducts in-process and final testing (non-destructive and acceptance) on all products as required by the drawing and/or specifications. Performance testing, in nearly every case, is destructive in nature and, therefore, performed on a sample basis. Performance testing shall be in accordance with the customer requirements and shall normally be performed to test procedures developed by Test Engineering which is part of the Q.A. organization. As required by contract test procedures are normally customer approved and all testing is usually witnessed by the customer representative. Results of tests are documented in formal test reports which are prepared by Test Engineering and are maintained in file for customer review.

4.6

X-RAY AND NEUTRON RADIOGRAPHIC INSPECTION

All products requiring x-ray, are processed in accordance with the requirements specified in MIL-STD-453. Interpretation of x-rays by inspection is in accordance with the accept/reject criteria incorporated in the Operation Sheets. Personnel performing x-ray interpretation are certified in accordance with the specification requirements. Neutron Radiography is performed for TMc/S by an independent testing agency. Only certified TMc/S personnel who have received special training on neutron principles and practices perform neutron interpretation.

4.7

HANDLING, PACKAGING AND SHIPPING

Quality Control shall provide for adequate inspection instructions for handling, packaging and shipping, to protect the quality of products and prevent damage, loss, deterioration, degradation, or substitution of products. Detailed inspection instructions are incorporated in The TMc/S Operation Sheets and are subject to Quality Engineering approval. In addition, inspection shall witness the final packaging and shipping operation to assure that products are packaged in accordance with contractual requirements and that data items (certifications, test reports, etc.) required by contract accompany each shipment from TMc/S.

4.8

CONTROL OF NONCONFORMING MATERIALS

The TMc/S quality program provides an effective and positive system for controlling nonconforming material, including procedures for its identification, segregation and disposition. All nonconforming supplies are positively identified, segregated as appropriate, and controlled to prevent unauthorized use, shipment and intermingling with conforming supplies. When materials are found to be defective, the condition is documented on TMc/S Form 82 "Discrepancy Form" (See Exhibit F) and the defective material is routed to an "inspection bond" where it is held pending Material Review Board (MRB) action.

TMc/S maintains a Material Review Board (MRB) which is composed of one (1) representative whose primary responsibility is product quality and one (1) representative whose primary responsibility is product design. When Government Source Inspection (GSI) is contractually imposed, the resident Government representative functions as the third member of MRB. The MRB representative shall be responsible for the internal disposition of nonconforming material. TMc/S assumes full MRB authority on all products over which TMc/S has design cognizance. In all cases, the acceptance of material which deviates from customer specifications and/or interface dimensions is the prerogative of and shall be prescribed by the customer.

The Quality Control organization effects a program which detects, at the earliest possible point, conditions adverse to product quality. Design, purchasing, manufacturing, testing and other operations which could result in, or have resulted in, defective supplies, services, facilities, technical data, standards, etc.; and, which could create excessive losses or costs, are identified and changed as appropriate by actions which are a part of the quality program. The TMc/S system provides for rapid feedback to suppliers, information concerning nonconformances which are detected during receiving inspection, fabrication or assembly operations, or during test or use. The supplier shall insure that prompt remedial and preventive action is taken to preclude recurrence of nonconformances. Failure of suppliers to provide effective corrective action shall be cause for removing the supplier from the "Approved Vendor List" (AVL). Quality Engineering shall be responsible for obtaining and coordinating all Corrective Action responses for nonconformities attributable to TMc/S. The TMc/S corrective action system includes the following activities:

4.10 CORRECTIVE ACTION (Continued)

- (1) Analysis of defects or failures to determine the extent and cause of the defects or failures.
- (2) Analysis of the quality trends in processes or performance of work to correct unacceptable quality performance.
- (3) Introduction of required improvements and corrections, including the initial review of the adequacy of such measures and the monitoring of the effectiveness of the corrective measures once they have been instituted.

All Quality Assurance Division Managers are responsible for providing management with visibility into problem areas. This visibility is provided in reports which are issued to TMc/S Executive Management on a bi-weekly basis.

4.11 RECORDS

TMc/S maintains records of inspections and tests performed through the entire manufacturing and acceptance process. These records provide evidence that the required inspections and tests have been performed and indicate the number of rejections in each lot, the reason or cause for rejection, and the responsibility for corrective action. The records are suitable in format, accuracy and detail to permit analysis, as required, for initiation of specific corrective actions. Control of records and component traceability is a function of Quality Control and records will be maintained for the period of time specified in the procurement document.

4.12 DRAWING AND CHANGE CONTROL

TMc/S provides for control of specifications, drawings and drawing changes to insure that specifications, drawings and drawing changes required by applicable controlling documents are, in fact, used for production of hardware per contract requirements and that obsolete drawings are not available for use.

Drawing initiation, release, distribution and control are accomplished in accordance with the TMc/S Drafting Room Manual. Quality Control as part of the quality audit program, performs continuous audits to assure that obsolete drawings are removed from the established Master Control Stations.

All changes to engineering drawings and/or specifications are reviewed and approved by Quality Engineering prior to release. Quality Engineering assures that the change notice (E.O.) is properly prepared and that effectivity points (lot number, job, date, etc.) are clearly established. The E.O. is also used by TMc/S as a vehicle to disposition material affected by the proposed change.

4.13 CONFIGURATION CONTROL

TMc/S shall exercise configuration management techniques in accordance with TMc/S Interdepartment Procedures. The basic document for Configuration Control is the Indentured Data List (IDL). Additions, deletions or changes to the IDL are reviewed and approved by Quality Engineering prior to incorporation. Manufacturing and inspection operations shall be performed to the drawing, procedure, specification, revision as specified on the IDL. Inspection shall verify the "as built" condition in the manufacturing/inspection work instructions.

4.13 CONFIGURATION CONTROL (Continued)

As materials flow into the production cycle, configuration checks are performed by Inspection to assure that only materials identified with the proper revision letter enter the production cycle. The results of these configuration checks are recorded in the body of the manufacturing work instruction document by Inspection, thereby assuring closed-loop traceability to the original inspection acceptance records.

Configuration controls as exercised over suppliers are as defined on the TMc/S Purchase Order. Quality Engineering is responsible for reviewing and approving all Purchase Orders prior to release. During this review Quality Engineering is responsible for assuring that products, services and supplies are procured to the baseline established configuration. Configuration verification is performed by TMc/S at receiving inspection when materials are received from the supplier.

4.14 INSPECTION STATUS IDENTIFICATION

TMc/S maintains a system for identifying the status of material (i.e., accept, reject, provisional, scrap) throughout the manufacturing and inspection cycles. The indication of the status is maintained through the use of inspection tags, stamps, and labels. In-process inspection acceptance status is indicated on the accompanying documentation. Status indications are the responsibility of the Quality Assurance department (See Exhibit G).

4.15 LIMITED LIFE ITEM CONTROL

TMc/S maintains a system for the identification, use and control of limited life items. All items having limited life are identified as such as part of Receiving Inspection. Expiration dates of limited life items are specific as to month, day and year.

4.16 HANDLING OF GOVERNMENT/CUSTOMER FURNISHED
EQUIPMENT AND MATERIALS

TMc/S maintains a program for positive, identification, segregation and control of Government/Customer furnished equipment and materials. The controls are established when equipment and materials are received and processed through Receiving Inspection. Information relative to materials or equipment found damaged, malfunctioning or unsuitable for use during Receiving Inspection shall be reported to the Government/Customer through the TMc/S Contracts department. Inspection tags and/or labels are identified so as to note that material is Government/Customer property.

4.17 TRAINING AND CERTIFICATION OF PERSONNEL

TMc/S maintains a training program for product quality, calibration, manufacturing, and other personnel who have an effect upon or who are responsible for the determination of product quality. This program includes a method of measuring the proficiency of personnel completing the course. Training needs are continually assessed to determine requirements for additional training. Where special skills are required in the manufacture, inspection, and processing of products, TMc/S maintains an active certification program. Certification consists of a training program followed by a formal testing procedure to assure the proficiency of each individual. Personnel satisfactorily completing a certification program are given a "Certification Card" as objective evidence of achieving certification. In accordance with company procedure, an IBM report is issued on a monthly basis listing all certified personnel, a description of operation certified, and dates of certification and recertification.

4.18 QUALITY AUDIT

Quality Audits are performed to provide an impartial evaluation of the Quality program and include an assessment of the adequacy of quality program procedures, inspections, tests, process controls, certifications and calibrations. Audits are performed on a continuous established frequency by Quality Assurance personnel. Results of each audit are maintained by the Quality Assurance organization along with the corrective action taken to eliminate the documented deficiencies. Summaries of detailed product quality audits and corrective actions taken are prepared and distributed as required to contractors and/or top management.

4.19 SAMPLING INSPECTION

TMc/S employs the use of sampling plans to determine the quality of articles. TMc/S standard sampling plans and procedures conform to the requirements as specified in MIL-STD-105. The establishment of "Classification of Characteristics" by Project and Quality Engineering, determines appropriate AQL levels of acceptance in accordance with MIL-STD-105. If alternate sampling plans are developed, they shall be prepared in detail to show the lot size, sample size, acceptance criteria and operating characteristics. These plans are subject to customer approval.

4.20 COSTS RELATED TO QUALITY

TMc/S maintains a system which provides for the collection and analysis of quality cost data. Cost data is used as a management element to assess the efficiency and effectiveness of the quality program. Quality cost data is used to serve the purpose of identifying the costs of rework and reinspection. The TMc/S Finance Department issue monthly reports which summarize the rework/inspection costs for the previous month.

5.0 TEST

The Test Division is responsible for nondestructive testing, functional testing, Test Engineering and Metrology.

5.1 TEST ENGINEERING

Test Engineering is responsible for the following activities as a minimum:

1. Reviews customer contractual requirements as related to testing of TMc/S products and prepares test procedures to implement these requirements.
2. Monitors the testing activity within TMc/S and at independent testing agencies.
3. Designs functional and environmental test fixtures.
4. Reviews requests for testing.
5. Participates in failure analyses as required.
6. Participates in Design Reviews as required.
7. Assists in proposal preparation.
8. Performs data reduction and prepares test reports of the testing performed by the Test Division.
9. Provides data of testing to the Reliability Division for analysis.

5.2 NON-DESTRUCTIVE AND FUNCTIONAL TESTS

Non-Destructive and Functional tests are performed within the Test Division in accordance with approved test procedures and standard practices. In order to perform these functions the Test Division maintains test equipment and qualified test personnel capable of ensuring data collection with sufficient accuracy and reliability to meet contract requirements.

5.3

METROLOGY

The Metrology Department is responsible for the calibration of measuring and testing equipment and production tooling which are used to verify product conformance to technical requirements. The laboratory has capability of calibrating tools, gages, electronic test equipment, pressure, torque and force equipment used in the manufacture and testing of the product. The TMc/S Calibration System satisfies the requirement of MIL-C-45662 Calibration System Requirements. All equipment is calibrated in accordance with established approved procedures using standards traceable to NBS. These standards are subject to periodic calibration at approved independent laboratories. A recall system is maintained to ensure periodic calibration of inspection and test equipment. Each item is labeled to clearly indicate when the next calibration is due. Records are maintained to record each individual calibration and is periodically analyzed to determine trends of deterioration and to provide realistic revision of calibration intervals.

6.0

SYSTEM SAFETY

The System Safety Division has the responsibility of implementing an effective system safety program. The System Safety division has been commissioned by TMc/S Executive Management with the authority and responsibility for the accomplishment of the following tasks:

1. Establishing safety design criteria, safety objectives, and preliminary engineering designs which identify hazards, methods of detection, and any required safety changes.

6.0 SYSTEM SAFETY (Continued)

2. Participating in the design review program.
3. Participating with the Reliability Division in failure analyses and accident investigations including the establishment of corrective action.
4. Determining, evaluating, and providing safety considerations in tradeoff studies.
5. Approving engineering test procedures to assure safety verification of design.

7.0 ENVIRONMENTAL CONTROL

The Environmental Control Division has the responsibility of identifying both Federal and State environmental regulations applicable to TMc/S and the establishment of the necessary programs and controls required to satisfy these regulations. As a minimum the following areas shall be attended to:

- (A) Air Pollution Control
- (B) Water Quality Control
- (C) Hazardous Waste Disposal
- (D) Toxic Substance Control
- (E) Explosive Classification

EXHIBIT A

Quality Organization Chart

EXECUTIVE
VICE
PRESIDENT

QUALITY, SAFETY, ENVIRONMENTAL ASSURANCE
(Q-SEA)

RELIABILITY

ENVIRONMENTAL
CONTROL

QUALITY
CONTROL

TEST

INDUSTRIAL
SAFETY

SYSTEM
SAFETY

A-2

EXHIBIT B

Procurement Quality Assurance Provisions



Teledyne McCormick Selph

3601 UNION ROAD, HOLLISTER, CA 95023

Procurement Quality Assurance Provisions

(CLAUSES ARE APPLICABLE ONLY AS NOTED BY CODE ON PURCHASE ORDER)

SECTION 1 - QUALITY PROGRAM/SYSTEM REQUIREMENT

The seller's Quality Program/inspection system shall conform to the applicable specification, as imposed by contract and is subject to inspection and approval by TMc/S Quality Assurance.

- 1.1 MIL-Q-9858A
- 1.2 MIL-I-45208
- 1.3 MIL-Q-21549
- 1.4 NHB 5300.4 (1B)
- 1.5 NPC 200-3
- 1.6 MIL-C-45662

SECTION 2 - SOURCE INSPECTION

2.1 TMc/S Inspection

TMc/S shall perform inspection/test of products/services at the supplier's facility, prior to each shipment. The earliest notice possible shall be furnished to TMc/S regarding the seller's plans for in-coming, in-process, Final Assembly Inspection/Test of products or services to permit mutual seller and TMc/S schedule and understanding of such inspection points and magnitude. The seller shall furnish reasonable access to relative contract, design and specification data; and necessary equipment and space to perform such inspection/tests. Each contract shipment must bear evidence of TMc/S inspection/test, unless otherwise waived by TMc/S.

2.2 Government Source Inspection

Government inspection is required prior to shipment from your plant. Upon receipt of this order, promptly furnish a copy to the Government Representative who normally services your plant or, if none, to the nearest Army, Navy, Air Force or Defense Supply Agency inspection office so that appropriate planning for Government inspection can be accomplished. In the event the representative or office cannot be located, our Purchasing Agent should be notified immediately.

2.3 Government Source Inspection (NASA) NHB 5300.4 (1B) (Formerly NPC 200-2)

All work on this order is subject to inspection and test by the Government at any time and place. The Government Quality Representative who has been delegated NASA Quality Assurance functions on this procurement shall be notified immediately upon receipt of this order and must be notified forty-eight (48) hours in advance of the time articles or materials are ready for inspection or test.

2.4 Government (NASA) Inspection Reservation NHB 5300.4 (1B) (Formerly NPC 200-2)

The Government has the right to inspect any or all of the work included in this order at the supplier's plant.

SECTION 3 - CERTIFICATION

3.1 Certificate of Compliance

Each shipment shall be accompanied by two (2) legible copies of a signed Supplier Certificate of Conformance (Form 836) which certifies that all requirements of the Purchase Order have been complied with. The certificate shall identify the parts/materials certified, all serial numbers for serialized parts or lot numbers for items identified by lot number, and shall show the Purchase Order number.

3.2 Certificate of Material Conformance

Each shipment shall be accompanied by two (2) signed legible copies of a Supplier Certificate of Conformance (Form 836) which certifies that the Purchase Order items were produced from material for which the seller has objective evidence, available for examination (specific data or other objective evidence) to the effect that the material conforms to all drawing and/or specification requirements. In addition certification will reflect the material type and specification numbers.

3.3 Certificate of Material Conformance - TMc/S Furnished

Each shipment shall be accompanied by two (2) signed legible copies of a Supplier Certificate of Conformance (Form 836) which certifies that the Purchase Order items were produced from materials furnished by Teledyne McCormick Selph and the certificate shall list the part number, purchase order/work order number and IR/DR number as found on the Inspection Card accompanying the material shipped to the seller.

3.4 Certificate of Age Sensitive Material

Each shipment shall be accompanied by two (2) signed legible copies of a Supplier Certificate of Conformance (Form 836) which identifies the material and includes information required for control of age sensitive material including the cure date/dates of manufacture, identification of material by lot number, expiration date or length of shelf life (state if indefinite) and special storage and handling requirements if any.

3.5 Certificate of Qualified Products

Each shipment shall be accompanied by two (2) signed legible copies of a Supplier Certificate of Conformance (Form 836) which identifies the materials as qualified to the required specification and listed on an official Qualified Products List (QPL). Where material is qualified but not included in the QPL, the certification shall reflect the qualifying test report number, the approving agency and the specification/drawing number of the material qualified.

3.6 Certificate of Special Processes

Each shipment shall be accompanied by two (2) signed legible copies of a Supplier Certificate of Conformance (Form 836) which identifies all special processes performed to specification, such as, but not limited to: heat treating, welding, soldering, glass to metal sealing, anodizing, chemical films, non-destructive testing etc., and a statement that the processing was performed to specification requirements. Certificate shall identify each process by name, specification number (type and class), identification of certified operator and the name and address of the agency that performed the processes if other than the seller.

SECTION 4 - RECORDS AND REPORTS

4.1 Inspection Reports

Each shipment shall be accompanied by two (2) legible copies of an inspection report reflecting results of all inspection performed as required by this Purchase Order. The reports shall as a minimum identify the item(s) inspected by part name, part number, revision letter and serial number if applicable; the specification and tolerance applicable to the given characteristic(s); actual dimensional measurements where the characteristic checked is out of tolerance; and identification of the inspector who performed the inspection. (NOTE - Compliance to TMc/S Q.A. Form 211 when part of the Purchase Order shall satisfy this requirement.)

4.2 Test Reports

Each shipment shall be accompanied by two (2) legible copies of a test report reflecting results of all tests performed (electrical, functional, environmental, mechanical, operational, proof, pressure leak or other tests) as required by this Purchase Order. The report shall as a minimum identify the item(s) tested, the characteristics tested, the method of testing, the specification and tolerance applicable to the given characteristics, actual test results, assurance that the test results are within specification limits and the signature of a responsible representative of the seller.

4.3 Nondestructive Test Reports

Each shipment shall be accompanied by two (2) legible copies of actual nondestructive test results identifiable with acceptance requirements and material submitted. These reports must contain the signature of a responsible representative of the agency performing the inspection and must assure conformance to specified requirements. X-Ray/N-Ray films or other supporting evidence shall become the property of TMc/S and shall accompany the test report.

(CLAUSES ARE APPLICABLE ONLY AS NOTED BY CODE ON PURCHASE ORDER)



Teledyne McCormick Selph

Procurement Quality Assurance Provisions (continued)

(CLAUSES ARE APPLICABLE ONLY AS NOTED BY CODE ON PURCHASE ORDER)

4.4 Chemical/Physical Test Reports

Each shipment shall be accompanied by two (2) legible copies of actual results of chemical/physical tests conducted on materials submitted. Reports shall identify material specification and revision, tests conducted and results and identify the material lot utilized.

4.5 Calibration Test Report

Each shipment shall be accompanied by two (2) legible copies of a test report reflecting results of all calibrations performed as required by this Purchase Order. The report shall as a minimum include results of calibration(s) performed, date(s) of calibration, specification(s) to which calibrated, evidence of traceability of calibration(s) to the National Bureau of Standards, the name of the agency performing the calibration(s) if other than the seller, and the signature of a responsible representative of that agency.

SECTION 5 - PLANS/PROCEDURES

5.1 Factory Inspection and Test Plan

The seller shall prepare and maintain an Inspection and Test Plan including a product flow chart of operational sequence of inspection, test, and process control points for the items to be fabricated on this purchase order. Type of inspection or test at each point must be sufficiently described and identified. One (1) legible and reproducible copy of the plan shall be submitted to TMc/S Quality Control a minimum of two weeks prior to start of fabrication. The plan is subject to the disapproval of TMc/S representatives whenever it does not accomplish its objectives.

5.2 Welding and Brazing Schedules

The seller shall forward to TMc/S one (1) legible copy of the prepared welding and/or brazing schedule for approval, on the forms supplied by TMc/S Quality Control, prior to production.

SECTION 6 - IDENTIFICATION

6.1 Traceability

Materials used must be identifiable by lot number, material type, specification and applicable change letter or number, heat or melt number, etc., and traceable to records of acceptance. Parts fabricated by the Seller shall be identified with the lot of material used. When two (2) or more parts are joined in an assembly, Seller shall prepare an assembly parts list identifying each part in the assembly: by part number and serial number and the lot of material from which fabricated when fabricated by the Seller or lot control number when the part is a standard purchased part. Traceability records shall be available for review by TMc/S.

6.2 Serialization

Seller shall identify each component, sub system, and assembly by serial number in accordance with purchase order, drawing and/or specification requirements. Seller's serialization system shall preclude the possibility of duplication of serial numbers. Seller's Quality Control system shall provide for traceability of all serialized supplies to the source. When two or more serialized parts are joined in an assembly, a list for each assembly serial number, containing part numbers, change letters and serial numbers of components, must accompany each shipment.

6.3 Manufacturing Lot or Batch Number

All parts and/or material, and applicable documents, must be identified by a manufacturing lot or batch number by the Seller. Where stamping of individual parts is not practical due to size or shape, the manufacturing lot or batch number shall be stamped on the smallest unit packaged by the supplier. NOTE: In the absence of a Lot Control Specification required by this purchase order, a lot or batch number shall be defined as parts and/or material produced by one manufacturer in one unchanged process, in accordance with the same drawing and/or specification revision.

6.4 Heat and/or Melt Identification

All parts and/or material, and applicable documents, must be identified by a heat number, heat code, heat lot number or melt by the Seller. Where

stamping of individual parts is not practical due to size or shape, the heat number, heat code, heat lot number, or melt number shall be stamped on the smallest unit package by the Seller.

6.5 Age Sensitive Material

Seller shall identify all age sensitive parts and/or materials (items having characteristics susceptible to quality degradation with age, such as but not limited to rubber, synthetic rubber, adhesives, resins, plastic-base paints, elastomers, etc.). Age sensitive items must be marked in such a manner as to indicate the date at which the critical life was initiated and when the useful life will be expended (i.e., shelf life expiration).

SECTION 7 - SAMPLES

7.1 First Article

The first article(s) produced must be submitted to, and inspected and accepted by, TMc/S Quality Control prior to further production. Compliance with requirements will be determined by inspection of one part to applicable drawings and specifications, unless more than one part is specified on the purchase order. When submitted to TMc/S, first article items shall be accompanied by the Seller's first article inspection report. First articles shall be tagged or otherwise identified to show the tool number, tool serial number, and when applicable, the individual cavity number used. (When more than one cavity is used, first articles from each cavity must be submitted.)

7.2 Test Bars - Castings

The seller shall furnish to TMc/S with each shipment of castings, two (2) test bars representative of each heat treat lot and made from the same melt as the castings supplied and one (1) spectrographic disc representative of the entire heat or melt. The test bars and spectrographic disc must be permanently identified with the material heat number, heat treat lot number, alloy identification, and the TMc/S purchase order number. The test bars shall conform to Federal Test Standard No. 151.

7.3 Test Bars - Forgings

The seller shall furnish to TMc/S with each shipment of forgings, two (2) test bars produced from the same heat of material as the forgings supplied. The test bars must be permanently identified with the material heat number, heat treat lot number, alloy identification, and the TMc/S purchase order number. Test bars must have the same percentage of reduction as the parts supplied. Test bars shall conform to Federal Test Standard No. 151.

7.4 Weld Joint Specimens

The seller shall prepare three (3) typical joints of each weld required by the purchase order, using the same material required for the finished part. Fabrication of weld specimens shall be in accordance with applicable weldment specification and shall be witnessed by a TMc/S Quality Control representative.

SECTION 8 - SPECIAL PROVISIONS

8.1 Homogeneous Requirements

All parts supplied under this purchase order shall be from one lot, homogeneous and identical, that is, there shall be no change in material, process, design, or method of manufacture by the seller unless such change is approved by TMc/S, and such change is indicated by a change in lot number(s).

8.2 Process Approvals

Special processes such as, but not limited to: welding, heat treating, anodizing, chemical films, nondestructive testing and any subcontracting thereof, require approval or certification of process, equipment, procedures, and personnel, as indicated in applicable specifications and standards. This approval must be established with TMc/S prior to fabrication under this contract. The seller is responsible for special process specification compliance by all of his subcontractors, and must maintain objective evidence of such compliance.

(CLAUSES ARE APPLICABLE ONLY AS NOTED BY CODE ON PURCHASE ORDER)

EXHIBIT C

Vendor History Card

DATE	P.O. NO.	DWG. NO.	JOB NO.	DR/IR NO.	LOT SIZE	NO. REJECT	% DEFECT	INSP TIME	CL	ACC	RTV	REWORK	SCRAP	ACCUMULATIVE TOTALS				
														LOTS RECD	UNITS RECD	UNITS REJECT	% DEFECT	

VENDOR HISTORY CARD



MATERIAL RATING

- S = SIMPLE
- C = COMPLEX
- D = DIFFICULT

VENDOR NAME/ADDRESS _____

CATEGORY NO. _____

EXHIBIT D

Inspection Plan and Report

EXHIBIT E

Operation Sheet



TELEDYNE McCORMICK SELPH

OPERATION SHEET

REV.

PAGE OF

TITLE

Mc/S P/N

PRODUCT ENGR

DATE

CUSTOMER P/N

PROCESS ENGR

DATE

TOTAL QTY

PRELOAD

TEST

LOSS

SHIP

LOT NO.

DIV NO.

JOB NO.

TASK NO.

SHOP ORD NO.

QUALITY ENGR

DATE

STEP NO.

MANUFACTURING INSTRUCTIONS

QTY STAMP & DATE

INSPECTION INSTRUCTIONS

STAMP & DATE

QTY ACCD RE-DR NO. REMARKS

B-2



TELEDYNE MCCORMICK SELPH

OPERATION SHEET CHANGE RECORD

PAGE OF

TITLE

PART NO.

REV LTR	BPL REV	REF PAGE	REF STEP	DESCRIPTION OF CHANGE	EFFECT. DATE, LOT, S/N	APPROVAL		
						PROD. ENGR	PROC ENGR	QUALITY E

B-3

EXHIBIT F

Discrepancy Report

VENDOR OR WORK AREA _____ DWG. NO. _____ REV. _____

DATE _____ P O ' W O N O _____ JOB NO. _____ REFER TO _____

A _____ LOT SIZE _____ SAMPLE SIZE _____

DESCRIPTION OF DEFECTS		INSPECTION TIME	SAMPLE	100%	
ITEM	DWG N/OR SPEC.	ACTUAL	A Q L	QTY	100%

PLANNER
 PURCHASING
 INSPECTOR _____

M.R.B.
DISPOSITION
 P.R.B.

ITEM	REWORK AND USE AS IS	UAI	RTV	SCRAP

QUALITY ASSURANCE
 ENGINEER
 CUSTOMER
 GOVERNMENT

CORRECTIVE ACTION TAKEN TO PREVENT RECURRENCE OF THE ABOVE DISCREPANCIES (TO BE COMPLETED BY THE VENDOR OR PRODUCTION SUPERVISOR)

EFFECTIVITY (DATE OR SERIAL NO.) _____

(USE OTHER SIDE IF REQUIRED) **SIGNATURE** _____

F-2

_____ **TITLE**

_____ **ORIGINATOR**

Exhibit G

Stamp Control Listing

STAMP

USE

ACCEPTANCE



applied when the specific characteristic or parameter is in complete conformance with acceptance criteria (drawings, specification, etc.)

WITH HELD



applied when specific characteristics or parameters for material or process varies from inspection requirements and is being released to PRB or MRB for disposition.

REJECT



applied when material is not to be used for its originally intended purpose and will be referred to salvage for disposal.

X-RAY



applied to denote acceptance of product after X-Ray per operation sheet and/or procedure requirement.

STORES RELEASE



applied to materials released from stores to denote that released materials conform to the drawing or specification requirements.

CALIBRATION



applied to Test or Measuring Equipment to denote proper calibration.

QUALITY/TEST
ENGINEERING



applied to documentation to indicate approval or acceptability by Quality/Test Engineering.

CHIEF CHEMIST



applied to documentation to indicate approval or acceptability by the Chief Chemist or personnel assigned to the Chief Chemist.

TEST
ACCEPTANCE



applied to documentation to indicate acceptability of Test results.

PENETRANT
INSPECTION



applied to materials or documentation to indicate Penetrant Inspection compliance with MIL-I-6866

WELDING



applied to materials and/or documentation to indicate welding in accordance with applicable specification.

STAMP

USE

CHEM LAB
TECHNICIAN



applied to Chem Lab documentation for purposes of identifying personnel performing in process work and/or testing.

NOTE: This stamp is not intended to denote material or process acceptability.

LFE
TECHNICIAN



applied to LFE documentation for purposes of identifying personnel performing in process work and/or testing.

NOTE: This stamp is not intended to denote material or process acceptability.

POWDER BLENDING
TECHNICIAN



applied to material/documentation to identify personnel performing powder blending work. In addition stamp applied to various tags which are attached to TMc/S explosive powder products. Stamp applied to explosives being transferred from storage to manufacturing area.

MASS SPEC



applied to materials and/or documentation to indicate compliance with Mass Spec testing.

MRB



applied to materials and/or documentation to indicate material acceptance through Material Review Board (MRB) action.

NEUTRON
RADIOGRAPHY



applied to materials and/or documentation to indicate that materials have been inspected and accepted through the Neutron Radiography method of nondestructive testing.

TEST
TECHNICIANS



applied to documentation to indicate performance of required test. (Does not denote acceptability of results.)

Appendix D
Manhour Estimates for
347/D-RSRA Rotor System Development
and Implementation and
Parameter Variation Test Program

347/D ROTOR SYSTEM FOR THE ROTOR
SYSTEM RESEARCH AIRCRAFT (RSRA)

ENGINEERING MANHOUR ESTIMATE

I BASIC PROGRAM ESTIMATE

A. ITEMS 1. THRU 7 AND ITEM 10 (SEE REFERENCE b. IOM 8-7545-ARS-014)

ITEM 1. REMOVE 347 HUB, ROTATING SWASHPLATE
AND DRIVE SCISSORS (FT. RUCKER MUSEUM).
RETURN THESE TO BOEING VERTOL FACILITIES.

a. ENGINEERING:

ROTOR SYSTEM/PROJECT ENG'R
(1/2 MAN FOR ONE WEEK) 20 M/H

ITEM 2. DESIGN AND FABRICATE "DUMMY" HUB (WELDMENT)
FOR 347 DISPLAY AT FT. RUCKER MUSEUM.

a. ENGINEERING:

ROTOR SYSTEM DESIGN ENG'R -
ONE SKETCH @ 60 M/H 60 M/H
TECHNOLOGY SUPPORT @ 60 M/H 36
PROJECT ENGINEERING 24

SUB-TOTAL ENGINEERING (ITEM 2.) 120 M/H

ITEM 3. ASSEMBLE MOCKUP DISPLAY ROTOR FOR 347
ASSUMPTION: ALL COMPONENTS WILL BE GOV'T
FURNISHED CH-47C COMPONENTS.

a. ENGINEERING:

ROTOR SYSTEM DESIGN ENGR
1/4 MAN FOR TWO WEEKS 20 M/H
PROJECT ENGINEERING
1/4 MAN FOR TWO WEEKS 20

SUB-TOTAL ENGINEERING (ITEM 3.) 40 M/H

ITEM 4. INSTALL MOCKUP DISPLAY ROTOR (LESS THE
ROTATING SWASHPLATE) ON 347 (FT. RUCKER MUSEUM)

a. ENGINEERING:

ROTOR SYSTEM DESIGN ENGR
1/4 MAN FOR ONE WEEK 10 M/H
PROJECT ENGINEERING
1/4 MAN FOR ONE WEEK 10

SUB-TOTAL ENGINEERING (ITEM 4.) 20 M/H

I BASIC PROGRAM ESTIMATE (Cont'd)

A. ITEM 5. PERFORM COMPLETE TEARDOWN INSPECTION OF ALL 347 ROTOR AND SWASHPLATE COMPONENTS

a. ENGINEERING:

ROTOR SYSTEM DESIGN ENGR	
1/2 MAN FOR 1 WEEK	20 M/H
PROJECT ENGINEERING	
1/2 MAN FOR 1 WEEK	<u>20</u>

SUB-TOTAL ENGINEERING (ITEM 5)

40 M/H

ITEM 6. REFURBISH AND REASSEMBLE 347 ROTOR (SEE IOM 8-7545-ARS-014) PROGRAM REQMTS

a. ENGINEERING:

ROTOR SYSTEM DESIGN ENGR	
1/2 MAN FOR 1 WEEK	20 M/H
PROJECT ENGINEERING	
1/2 MAN FOR 1 WEEK	<u>20</u>

SUB-TOTAL ENGINEERING (ITEM 6)

40 M/H

ITEM 7. DESIGN - INTEGRATION - INSTALLATION OF THE REFURBISHED 347 ROTOR SYSTEM ON RSRA.

a. ENGINEERING:

1. ROTOR SYSTEM DESIGN	
14 DWGS @ 200 M/H EA.	2,800 M/H
2. TECHNOLOGY SUPPORT @ 60%	1,680
3. PROJECT ENGINEERING	
1 MAN FOR 6 MOS.	<u>960</u>

SUB-TOTAL DESIGN & SUPPORT

5,440 M/H

4. INTEGRATION/LIAISON	
ROTOR SYSTEM DESIGN ENGR	
1/2 MAN FOR 6 MOS	480 M/H
TECHNOLOGY	
1/4 MAN FOR 6 MOS	240
PROJECT ENGINEERING	
1/4 MAN FOR 6 MOS	<u>240</u>

SUB-TOTAL ENGINEERING (ITEM 7)

6,400 M/H

ITEM 10. DESIGN, FABRICATE, INSTALL AND CALIBRATE INSTRUMENTATION (ONE CH-47D FIBERGLASS BLADE FROM ITEM 8)

a. ENGINEERING:

INSTR. ENGR 12 GAGES @ 40 M/H EA.	480 M/H
TECHNOLOGY/DESIGN SUPPORT	60
PROJECT ENGINEERING 1/4 MAN FOR 3 MOS	<u>120</u>

SUB-TOTAL ENGINEERING (ITEM 10.)

660 M/H

TOTAL ENGINEERING I.A.

7,340 M/H

I	B.	<u>ITEM 8.</u>	FABRICATION OF FOUR CH-47D FIBERGLASS BLADES (NOTE: BLADES MAY BE USED ON LOAN BASIS AS GOVERNMENT-FURNISHED).	
	a.	<u>ENGINEERING:</u>	ANY ENGINEERING REQUIRED IS COVERED BY LIAISON UNDER ITEM 7.	<u>-0- M/H</u>
	C.	<u>ITEM 9.</u>	FABRICATION OF TWO CH-47D FIBERGLASS BLADES (THESE ARE REQUIRED AS SPARES)	
	a.	<u>ENGINEERING:</u>	ANY ENGINEERING REQUIRED IS COVERED BY LIAISON UNDER ITEM 7.	<u>-0- M/H</u>
	D.	<u>ITEM 11.</u>	STRUCTURAL TESTING OF NEW ROTOR COMPONENTS INCL. DESIGN AND FAB. OF TEST FIXTURES	
	a.	<u>ENGINEERING:</u>		
		1.	<u>PITCH ARM ATTACHMENT FATIGUE TEST</u>	
		(a)	<u>ENGR'G LABS ENGR'G</u>	
			FIXTURE DESIGN (4 WKS)	160 M/H
			TEST PREPARATION (6 WKS)	240
			TESTING (16 WKS)	640
			TEST REPORT (2 WKS)	80
		(b)	<u>TECHN/DESIGN SUPPORT @ 25%</u>	280
		(c)	<u>PROJECT ENGR'G 1/4 MAN 28 WKS</u>	280
			SUB-TOTAL ENGR'G 11.a.1	<u>1,680 M/H</u>
		2.	<u>ADAPTERS/LINKS/SHAFT FATIGUE TEST</u>	
		(a)	<u>ENGR'G LABS ENGR'G</u>	
			FIXTURE DESIGN (8 WKS)	320 M/H
			TEST PREPARATION (8 WKS)	320
			TESTING (16 WKS)	640
			TEST REPORT (4 WKS)	160
		(b)	<u>TECHN/DESIGN SUPPORT @ 25%</u>	360
		(c)	<u>PROJECT ENGR'G 1/4 MAN 36 WKS</u>	<u>360</u>
			SUB-TOTAL ENGR'G 11.a.2	<u>2,160 M/H</u>
			TOTAL ENGINEERING I.D.	<u><u>3,840 M/H</u></u>

I E. ITEM 12. MODIFICATIONS TO EXISTING EMERGENCY ESCAPE SYSTEM
INCL. NEW BLADE SEVERENCE ASSEMBLIES. THIS ITEM WILL
BE SUB-CONTRACTED (TELEDYNE MC CORMICK SELPH)

a. ENGINEERING:

1.	ROTOR DESIGN ENGR		
	PREPARE SPEC.		320 M/H
	VENDOR LIAISON/WITNESS TESTS/ TRAVEL, ETC.		320
2.	PROJECT ENGR'G	1/8 MAN FOR 6 MOS	<u>120</u>

TOTAL ENGINEERING I.E.

760 M/H

F. ITEM 13. INSTALLATION OF THE ROTOR ON THE ROTOR SYSTEM
RESEARCH AIRCRAFT (RSRA)

a. ENGINEERING:

	TEST ENGR	1 MAN FOR 2 WKS	80 M/H
	ROTOR DES./PROJ. ENGR	1 MAN FOR 2 WKS	80
	TRANSMISSION EFFORT		<u>760</u>
	TOTAL ENGINEERING I.F.		

920 M/H

G. ITEM 14. SUPPORT OF GROUND TESTS AND FLIGHT TESTS (INCL.
GROUND TIEDOWN TEST TO PERFORM STRUCTURAL
CHECKOUT OF THE ROTOR SYSTEM AND INSTRUMENTA-
TION CALIBRATION AND CHECKOUT

a. ENGINEERING:

1. GROUND & FLIGHT TEST PLAN (NASA WRITTEN)

B/V SUPPORT TO PLAN 1 MAN FOR 1 MO. 160 M/H

2. TEST PREPARATION

	TEST ENGR	- 1/4 MAN FOR 2 MOS	80 M/H
	INSTR. ENGR	- 1/4 MAN FOR 2 MOS	80
	DES./TECHN. ENGR	- 1/4 MAN FOR 2 MOS	80
	PROJECT ENGR	- 1/4 MAN FOR 2 MOS	<u>80</u>

SUB-TOTAL TEST PREP. 320 M/H

3. GROUND TEST (INCL. 50 HR. TIEDOWN RUN)

	TEST ENGR	- 1 MAN FOR 8 WKS	320 M/H
	INSTR. ENGR	- 1 MAN FOR 8 WKS	320
	PROJECT ENGR	- 1/2 MAN FOR 8 WKS	160
	DES./TECHN. ENGR	- 1/2 MAN FOR 8 WKS	<u>160</u>

SUB-TOTAL GROUND TEST 960 M/H

4. FLIGHT TEST (ASSUMED 30 FLT. HRS)

	TEST ENGR	- 1 MAN FOR 6 WKS	240 M/H
	INSTR. ENGR	- 1 MAN FOR 6 WKS	240
	PROJECT ENGR	- 1 MAN FOR 6 WKS	240
	DES/TECHN. ENGR	- 1 MAN FOR 6 WKS	<u>240</u>

SUB-TOTAL FLIGHT TEST 960 M/H

I G. ITEM 14. a. 5. TEST REPORT (NASA WRITTEN)
B/V SUPPORT TO REPORT 1 MAN FOR 1 MO. 160 M/H

TOTAL ENGINEERING I.G. 2,560 M/H

II PARAMETER VARIATION TEST PROGRAM COSTS

A. PHASE I - BASIC AERO - ITEM 15.a.

ITEM 15. PARAMETER VARIATION TEST PROGRAM

1. PHASE I - BASIC AERODYNAMIC PARAMETER VARIATION TESTS

a. CH-47A BLADES

(FOR WORK REQUIREMENTS SEE IOM 8-7545-ARS-014)

(1) <u>NO ENGINEERING</u>	-0-	M/H
(2) <u>INSTRUMENTATION</u>	320	
(3) <u>GROUND AND FLIGHT TESTING</u>		
TEST PLAN (B/V SUPPORT OF NASA)	40	M/H
TEST PREP - 1 MAN FOR 2 WKS	80	
GROUND TESTING - 3 MEN FOR 2 WKS	240	
FLIGHT TESTING - 4 MEN FOR 6 WKS	960	

SUB-TOTAL GROUND & FLIGHT TEST 1,320 M/H

SUB-TOTAL CH-47A BLADES 1,640 M/H

2. CH-47C BLADES (SAME AS CH-47A) 1,640 M/H

TOTAL ENGINEERING II A.1. 3,280 M/H

B. PHASE II - EXPANDED AERO - ITEM 15.b.

2. PHASE II - EXPANDED AERODYNAMIC PARAMETER VARIATION TESTS

a. DESIGN AND FABRICATE FOUR NEW BLADES

(FOR WORK REQUIREMENTS SEE IOM 8-7545-ARS-014)

(1) ENGINEERING

(a) BLADE DESIGN

15 DRWGS @ 140 M/H EA.	2,100	M/H
- SUPV. ADMIN. @ 15%	300	
TECHN. SUPPORT @ 100%	2,400	
PROJECT ENGR'G (1 MAN - 9 MOS)	1,440	
TOOLING/MFG LIAISON (1/2 MAN - 12 MOS)	960	

SUB-TOTAL BLADE DESIGN/LIAISON 7,200 M/H

B. PHASE II - (Cont'd)

2. b. QUALIFICATION TESTING

GROUND RULE: NO FATIGUE OR STATIC
LOAD TESTING. QUAL
BY SIMILARITY

(1) NATURAL FREQUENCY TEST

TEST PREP	40 M/H
TESTING (4 WKS)	160
TEST REPORT	40
DES./TECH. SUPPORT	60
PROJECT ENGR'G	<u>60</u>

SUB-TOTAL NATURAL FREQUENCY TEST 360 M/H

c. INSTRUMENT ONE BLADE (NO ENGINEERING) -0- M/H

d. INSTALLATION, CHECKOUT & CALIBRATION 320 M/H

e. SUPPORT GROUND AND FLIGHT TESTING

TEST PLAN (B/V SUPT OF NASA)	80 M/H
TEST PREP - 1 MAN FOR 4 WKS	160
GROUND TESTING (INCL. GROUND WHIRL) 3 MEN FOR 8 WKS	960
FLIGHT TESTING - 4 MEN FOR 6 WKS	960
TEST REPORT (B/V SUPT OF NASA)	<u>80</u>

SUB-TOTAL GROUND & FLIGHT TEST 2,240 M/H

f. RETWIST BLADES TO -12° BY HEATING AND RACKING

(1) MFG/TOOLING LIAISON	960 M/H
(2) OUTBOARD INTERM. FATIGUE TEST	
FIXTURE DESIGN	320 M/H
TEST PREP	120
TESTING (6 WKS)	240
REPORT	120
DES/TECH. SUPT	200
PROJECT ENGR'G	<u>200</u>

SUB-TOTAL O/B INTERM. 1,200 M/H

SUB-TOTAL RETWIST TO -12° 2,160 M/H

g. STRUCTURAL PROPERTIES TESTING

NATURAL FREQUENCY TEST	
TEST PREP	40 M/H
TESTING (4 WKS)	160
TEST REPORT	40
DES./TECH. SUPT	60
PROJECT ENGR'G	<u>60</u>

SUB-TOTAL STRUCT. PROP. TESTS 360 M/H

h. RE-INSTRUMENT ONE BLADE (NO ENGINEERING) -0-

i. INSTALLATION, CHECKOUT AND CALIBRATION 320

B. PHASE II - (Cont'd)

2. j. SUPPORT GROUND AND FLIGHT TESTING

TEST PLAN (B/V SUPT OF NASA)	40 M/H
TEST PREP - 1 MAN FOR 2 WKS	80
GROUND TEST - 3 MEN FOR 3 WKS	360
FLIGHT TEST - 4 MEN FOR 6 WKS	960
TEST REPORT (B/V SUPT OF NASA)	<u>80</u>

SUB-TOTAL GROUND & FLIGHT TEST 1,520 M/H

TOTAL ENGINEERING II B.2 14,480 M/H

C. PHASE III - ROTOR DYNAMICS AND FLYING QUALITIES

1. ITEM 1. NATURAL FREQUENCY VARIATION TEST (FLAP AND CHORD)

a. DESIGN, FABRICATE AND INSTALL MID SPAN TUNING WEIGHTS TO REDUCE FLAP AND CHORD FREQUENCIES

(1) DESIGN - 4 DRWGS @ 140 M/H EA.	560 M/H
(2) DES/TECH SUPT @ 100%	560
(3) MFG LIAISON 1/2 MAN FOR 3 MOS	240
(4) PROJECT ENGR'G 1/4 MAN FOR 6 MOS	240
(5) TEETER BALANCE	<u>120</u>

SUB-TOTAL DESIGN, FAB., ETC. 1,720 M/H

b. DESIGN, FABRICATE AND TEST ONE FATIGUE TEST SPEC.

FIXTURE DESIGN	320 M/H
TEST PREP	160
TESTING (8 WKS)	320
REPORT	120
DES/TECH. SUPT	240
PROJECT ENGR'G	<u>240</u>

SUB-TOTAL FIXTURE DESIGN, TEST, ETC. 1,400 M/H

c. INSTALL ON AIRCRAFT AND PERFORM 20 HOUR GROUND TIEDOWN TEST AND INSPECT.
MANHOURS - SEE NEXT ITEM -0-

d. SUPPORT GROUND AND FLIGHT TEST

(1) TEST PLAN (B/V SUPT OF NASA)	160 M/H
(2) TEST PREP (1 MAN FOR 4 WKS)	160
(3) GROUND TEST INCL. 20 HR. TIEDOWN 3 MEN FOR 6 WKS	720
(4) FLIGHT TEST - 4 MEN FOR 6 WKS	960
(5) TEST REPORT (B/V SUPT OF NASA)	<u>160</u>

SUB-TOTAL GROUND & FLIGHT TEST 2,160 M/H

e. REMOVE TUNING WEIGHTS
MFG LIAISON

C. PHASE III - Cont'd)

1. f. DESIGN, FABRICATE AND INSTALL GRAPHITE STIFFENERS TO INCREASE FLAP FREQUENCY

GROUND RULE - NO TESTING REQ'D

(1)	DESIGN - 4 DRWGS @ 140 M/H EA.	560 M/H
(2)	DES./TECH SUPT @ 100%	560
(3)	MFG LIAISON 1/2 MAN FOR 3 MOS	240
(4)	PROJECT ENGR 1/4 MAN FOR 6 MOS	240
(5)	TEETER BALANCE	<u>120</u>

SUB-TOTAL DESIGN, FAB, ETC. . 1,720 M/H

- g. INSTALL ON AIRCRAFT AND PERFORM 15 HOUR GROUND TIEDOWN TEST AND INSPECT -
MANHOURS - SEE NEXT ITEM -0-

- h. SUPPORT GROUND AND FLIGHT TESTS

(1)	TEST PLAN (B/V SUPT OF NASA)	120 M/H
(2)	TEST PREP (1 MAN FOR 3 WKS)	120
(3)	GROUND TEST INCL. 15 HR. TIEDOWN 3 MEN FOR 4 WKS	480
(4)	FLIGHT TEST - 4 MEN FOR 6 WKS	960
(5)	TEST REPORT (B/V SUPT OF NASA)	<u>120</u>

SUB-TOTAL GROUND & FLIGHT TEST 1,800 M/H

- i. REMOVE STIFFENERS
MFG. LIAISON 40

- j. DESIGN, FABRICATE AND INSTALL GRAPHITE STIFFENERS TO INCREASE CHORD FREQUENCY

GROUND RULE - NO TESTING REQ'D

(1)	DESIGN - 4 DRWGS @ 140 M/H EA.	560 M/H
(2)	DES./TECH SUPT @ 100%	560
(3)	MFG/LIAISON - 1/2 MAN FOR 3 MOS	240
(4)	PROJECT ENGR'G - 1/4 MAN FOR 6 MOS	240
(5)	TEETER BALANCE	<u>120</u>

SUB-TOTAL DESIGN, FAB, ETC. 1,720 M/H

- k. INSTALL ON AIRCRAFT AND PERFORM 15 HOUR GROUND TIEDOWN TEST AND INSPECT. MANHOURS - SEE NEXT ITEM -0-

C. PHASE III - Cont'd)

1. SUPPORT GROUND AND FLIGHT TESTS

(1) TEST PLAN (B/V SUPT OF NASA)	120 M/H
(2) TEST PREP (1 MAN FOR 3 WKS)	120
(3) GROUND TEST INCL. 15 HR TIEDOWN 3 MEN FOR 4 WKS	480
(4) FLIGHT TEST - 4 MEN FOR 6 WKS	960
(5) TEST REPORT (B/V SUPT OF NASA)	<u>120</u>

SUB-TOTAL GROUND & FLIGHT TESTS 1,800 M/H

m. REMOVE STIFFENERS
MFG. LIAISON 40

TOTAL ENGINEERING II C.1.

12,440 M/H

II C. PHASE III

2. ITEM 2. EFFECTIVE FLAP HINGE VARIATION TESTS

a. DESIGN AND FABRICATE HUB ADAPTERS AND PITCH
ARM ADAPTERS (ONE SHIP SET AND ONE SET FOR
THE FATIGUE TEST)

(1) DESIGN - 6 DRWGS @ 200 M/H EA.	1,200 M/H
(2) DES./TECH SUPT @ 60%	720
(3) MFG. LIAISON 1/2 MAN FOR 4 MOS.	320
(4) PROJECT ENGR'G 1/4 MAN FOR 8 MOS	<u>320</u>

SUB-TOTAL DESIGN & FAB ADAPTERS 2,560 M/H

b. DESIGN FIXTURES AND FABRICATE AND PERFORM
FATIGUE TEST

(1) TEST PLAN	160 M/H
(2) FIXTURE DESIGN	240
(3) TEST PREP.	240
(4) TESTING (16 WKS)	640
(5) TECH/DESIGN SUPT @ 25%	320
(6) TEST REPORT	160
(7) PROJECT ENGR'G 1/4 MAN FOR 32 WKS	<u>320</u>

SUB-TOTAL FATIGUE TEST 2,080 M/H

c. INSTALL ON AIRCRAFT AND PERFORM 15 HOUR GROUND
TIEDOWN TEST AND INSPECT. MANHOURS - SEE NEXT ITEM -0-

d. SUPPORT GROUND AND FLIGHT TESTS

(1) TEST PLAN (B/V SUPT OF NASA)	160 M/H
(2) TEST PREP (1 MAN FOR 4 WKS)	160
(3) GROUND TEST INCL. 15 HR. TIEDOWN 3 MEN FOR 4 WKS	480
(4) FLIGHT TEST - 4 MEN FOR 6 WKS	960
(5) TEST REPORT (B/V SUPT OF NASA)	<u>160</u>

SUB-TOTAL GROUND & FLIGHT TEST 1,920 M/H

TOTAL ENGINEERING II C.2.

6,560 M/H

II C. PHASE III

3. ITEM 3. CONTROL PHASE VARIATION TESTS

GROUND RULE - NO HARDWARE REQUIRED

a. ADJUST AIRCRAFT ANALOGUE PHASE MIXER
(4 MEN FOR 1 WK) 160 M/H

b. SUPPORT GROUND AND FLIGHT TESTS

(1) TEST PLAN (B/V SUPT OF NASA) 80 M/H
(2) TEST PREP (1 MAN FOR 2 WKS) 80
(3) GROUND TEST - 3 MEN FOR 1 WK 120
(4) FLIGHT TEST - 4 MEN FOR 6 WKS 960
(5) TEST REPORT - (B/V SUPT OF NASA) 80

SUB-TOTAL GROUND & FLIGHT TEST 1,320 M/H

TOTAL ENGINEERING II C.3.

1,480 M/H

4. ITEM 4. CONTROL SYSTEM STIFFNESS VARIATION TESTS
(TORSIONAL FREQUENCY)

a. DESIGN, FABRICATE AND TEST (TWO FATIGUE)
FLEXIBLE PITCH LINK ASSEMBLIES SIMILAR TO
SK28296.

(1) DESIGN - 5 DRWGS @ 140 M/H EA. 700 M/H
(2) DES./TECH SUPT @ 100% 700
(3) MFG LIAISON 1/2 MAN FOR 3 MOS 240
(4) PROJECT ENGR'G 1/4 MAN FOR 6 MOS 240
(5) TEST PLAN 120
(6) FIXTURE DESIGN 160
(7) TEST PREP - 1 MAN FOR 3 WKS 120
(8) FATIGUE TEST (12 WKS) 480
(9) TECH./DES/SUPT @ 25% 220
(10) TEST REPORT 120
(11) PROJECT ENGR'G - 1/4 MAN FOR 22 WKS 220

SUB-TOTAL DES./FAB/FATIGUE TEST 3,320 M/H

b. INSTALL ON AIRCRAFT AND PERFORM GROUND CHECKOUT
(PROOF LOAD) TEST - SEE NEXT ITEM -0-

c. SUPPORT GROUND AND FLIGHT TESTS

(1) TEST PLAN (B/V SUPT OF NASA) 160 M/H
(2) TEST PREP (1 MAN FOR 4 WKS) 160
(3) GROUND TEST INCL. PROOFLOAD
3 MEN FOR 4 WKS 480
(4) FLIGHT TEST - 4 MEN FOR 6 WKS 960
(5) TEST REPORT (B/V SUPT OF NASA) 160

SUB-TOTAL GROUND AND FLIGHT TEST 1,920 M/H

TOTAL ENGINEERING II C.4.

5,240 M/H

II C. PHASE III

5. ITEM 5. LAG DAMPER VARIATION TESTS

- a. DESIGN, FABRICATE/PROCURE, INSTALL AND TEST DAMPER MODS TO VARY BREAKOUT AND/OR DAMPING RATIO

NOTE: VENDOR TO ACCOMPLISH

(1) SPEC. MODS	320 M/H
(2) VEND. LIAISON/WITNESS TESTS/ TRAVEL, ETC.	320
(3) PROJECT ENGR'G	<u>320</u>

SUB-TOTAL DES./FAB/ETC. 960 M/H

- b. INSTALL AND CHECKOUT (SEE NEXT ITEM) -0-

- c. SUPPORT GROUND AND FLIGHT TEST

(1) TEST PLAN (B/V SUPT OF NASA)	160 M/H
(2) TEST PREP (1 MAN FOR 4 WKS)	160
(3) GROUND TEST INCL. CHECKOUT 3 MEN FOR 4 WKS	480
(4) FLIGHT TEST - 4 MEN FOR 6 WKS	960
(5) TEST REPORT (B/V SUPT OF NASA)	<u>160</u>

SUB-TOTAL GROUND & FLIGHT TESTS 1,920 M/H

TOTAL ENGINEERING II C.5.

2,880 M/H

6. ITEM 6. Δ 3 COUPLING VARIATION TEST

- a. DESIGN, FABRICATE AND TEST (ONE FATIGUE) PITCH ARM ADAPTER TO CHANGE Δ3

(1) DESIGN - 3 DRWGS @ 140 M/H	420 M/H
(2) TECH. SUPT @ 100%	420
(3) MFG. LIAISON 1/2 MAN FOR 3 MOS	240
(4) PROJECT ENGR'G 1/4 MAN FOR 6 MOS	240
(5) TEST PLAN	120
(6) FIXTURE DESIGN	120
(7) TEST PREP 1 MAN FOR 3 WKS	120
(8) FATIGUE TEST (6 WKS)	240
(9) TECH/DES. SUPT @ 25%	160
(10) TEST REPORT	120
(11) PROJECT ENGR'G 1/4 MAN FOR 18 WKS	<u>180</u>

SUB-TOTAL DES./FAB/FATIGUE TEST 2,380 M/H

II C. PHASE III

6. ITEM 6. (Cont'd)

b. INSTALL AND CHECKOUT (SEE NEXT ITEM) -0- M/H

c. SUPPORT GROUND AND FLIGHT TESTS

(1) TEST PLAN (B/V SUPT OF NASA)	120 M/H
(2) TEST PREP (1 MAN FOR 3 WKS)	120
(3) GROUND TEST INCL. CHECKOUT	
3 MEN FOR 3 WKS	360
(4) FLIGHT TEST - 4 MEN FOR 6 WKS	960
(5) TEST REPORT (B/V SUPT OF NASA)	<u>120</u>

SUB-TOTAL GROUND AND FLIGHT TESTS 1,680 M/H

TOTAL ENGINEERING II C.6. 4,060 M/H

D. PHASE IV - BLADE TIP SHAPE VARIATION TESTS

1. DESIGN AND MODIFY FOUR CH-47C BLADES.

ASSUMPTION - BLADES OBTAINED FROM ARMY - NO COST.

a. BLADE DESIGN MOD

14 DRWGS @ 80 M/H EA.	1,120 M/H
MFG. LIAISON	240
SUPV./ADMIN. @ 10%	<u>140</u>

SUB-TOTAL DESIGN ENGINEERING 1,500 M/H

b. TECHNOLOGY SUPPORT ENGINEERING @100% 1,500

c. PROJECT ENGINEERING 1 MAN FOR 6 MOS 960

d. NATURAL FREQUENCY TEST (7 WKS)

(1) ENGR'G LABS	240 M/H
(2) SUPPORT ENGR'G	<u>80</u>

SUB-TOTAL NATURAL FREQUENCY TEST 320

SUB-TOTAL ENGINEERING D.1 4,280 M/H

D. PHASE IV - Cont'd)

2. DESIGN, FABRICATE AND TEST (ONE FATIGUE)
FOUR SETS (4 EACH) OF TIP COVERS - 36" LONG

a. TIP COVER DESIGN

12 DRWGS @ 80 M/H EA.	960 M/H
MFG. LIAISON	160
SUPV./ADMIN. @ 10%	<u>120</u>

SUB-TOTAL DESIGN ENGR'G 1,240 M/H

b. TECHNOLOGY SUPT ENGR'G @ 100% 1,240

c. PROJECT ENGINEERING 1 MAN FOR 6 MOS 960

d. BLADE TIP FATIGUE (8 WKS)

(1) ENGR'G LAB	560 M/H
(2) SUPPORT ENGR'G	<u>140</u>

SUB-TOTAL TIP FATIGUE 800

e. SUPPORT GROUND AND FLIGHT TESTS

(1) TEST PLAN (B/V SUPPORT OF NASA)	120 M/H
(2) TEST PREP - 1 MAN FOR 4 WKS	160
(3) GROUND TESTING - 3 MEN FOR 4 WKS	480
(4) FLIGHT TEST - 4 MEN FOR 8 WKS	1280
(5) TEST REPORT (B/V SUPT OF NASA)	<u>120</u>

SUB-TOTAL GROUND & FLIGHT TEST 2,160 M/H

SUB-TOTAL ENGINEERING D.2 6,400 M/H

TOTAL ENGINEERING II D. 10,680 M/H

347/D ROTOR SYSTEM FOR THE ROTOR
SYSTEM RESEARCH AIRCRAFT (RSRA)

TRAVEL REQUIREMENTS

I. BASIC PROGRAM

A. ITEM 1 THRU 7 AND ITEM 10

1. ONE ONE MAN/TWO DAY TRIP TO FT. RUCKER (HUB REMOVAL)
2. ONE TWO MAN/ONE DAY TRIP TO FT. RUCKER (DISPLAY INST'L)
3. TWO TWO MAN/THREE DAY TRIPS TO NASA AMES, CALIF. (PROGRAM COORD)
4. TWO TWO MAN/THREE DAY TRIPS TO NASA AMES, CALIF. (RSRA INST'L)
5. ONE ONE MAN/ONE WEEK TRIP TO NASA AMES, CALIF. (INSTRUMENTATION)

B. ITEM 8

NONE

C. ITEM 9

NONE

D. ITEM 11

1. TWO TWO MAN/TWO DAY TRIPS TO NASA AMES, CALIF. (PROGRAM COORD)

E. ITEM 12

1. FOUR TWO MAN/TWO DAY TRIPS TO TELEDYNE

F. ITEM 13

1. ONE TWO MAN/TWO WEEKS TRIP TO NASA AMES, CALIF. (ROTOR INSTALLATION
IN THE RSRA)

G. ITEM 14

1. TWO TWO MAN/THREE DAY TRIPS TO NASA AMES, CALIF. (PROGRAM COORD)
2. ONE TWO MAN/EIGHT WEEKS TRIP TO NASA AMES, CALIF. (GROUND TEST PROGRAM)
3. ONE TWO MAN/FOUR WEEKS TRIP TO NASA AMES, CALIF. (GROUND TEST PROGRAM)
4. ONE FOUR MAN/SIX WEEKS TRIP TO NASA AMES, CALIF. (FLIGHT TEST PROGRAM)

II. PARAMETER VARIATION TEST PROGRAM

A. PHASE I - BASIC AERO

1. ONE THREE MAN/TWO WEEKS TRIP TO NASA AMES, CALIF. (GROUND TEST)
2. ONE FOUR MAN/SIX WEEKS TRIP TO NASA AMES, CALIF. (FLIGHT TEST)

TRAVEL REQUIREMENTS

II. B. PHASE II - EXPANDED AERO

1. SIX TWO MAN/THREE DAY TRIPS TO NASA AMES, CALIF. (PROGRAM COORD)
2. ONE THREE MAN/EIGHT WEEKS TRIP TO NASA AMES, CALIF. (GROUND TEST)
3. ONE FOUR MAN/SIX WEEKS TRIP TO NASA AMES, CALIF. (FLIGHT TEST)
4. ONE THREE MAN/THREE WEEKS TRIP TO NASA AMES, CALIF. (GROUND TEST)
5. ONE FOUR MAN/SIX WEEKS TRIP TO NASA AMES, CALIF. (FLIGHT TEST)

C. PHASE III - ROTOR DYN. AND FLY. QUAL.

1. NATURAL FREQUENCY VARIATION

- a. SIX TWO MAN/THREE DAY TRIPS TO NASA AMES, CALIF. (PROGRAM COORD)
- b. ONE THREE MAN/SIX WEEKS TRIP TO NASA AMES, CALIF. (GROUND TEST)
- c. ONE FOUR MAN/SIX WEEKS TRIP TO NASA AMES, CALIF. (FLIGHT TEST)
- d. ONE THREE MAN/FOUR WEEKS TRIP TO NASA AMES, CALIF. (GROUND TEST)
- e. ONE FOUR MAN/SIX WEEKS TRIP TO NASA AMES, CALIF. (FLIGHT TEST)
- f. ONE THREE MAN/FOUR WEEKS TRIP TO NASA AMES, CALIF. (GROUND TEST)
- g. ONE FOUR MAN/SIX WEEKS TRIP TO NASA AMES, CALIF. (FLIGHT TEST)

2. EFFECTIVE FLAP HINGE VARIATION

- a. FOUR TWO MAN/THREE DAY TRIPS TO NASA AMES, CALIF. (PROGRAM COORD)
- b. ONE THREE MAN/FOUR WEEKS TRIPS TO NASA AMES, CALIF. (GROUND TEST)
- c. ONE FOUR MAN/SIX WEEKS TRIPS TO NASA AMES, CALIF. (FLIGHT TEST)

3. CONTROL PHASE VARIATION

- a. ONE THREE MAN/ONE WEEK TRIP TO NASA AMES, CALIF. (GROUND TEST)
- b. ONE FOUR MAN/SIX WEEK TRIP TO NASA AMES, CALIF. (FLIGHT TEST)

4. CONTROL SYSTEM STIFFNESS VARIATION

- a. FOUR TWO MAN/THREE DAY TRIPS TO NASA AMES, CALIF. (PROGRAM COORD)
- b. ONE THREE MAN/FOUR WEEKS TRIPS TO NASA AMES, CALIF. (GROUND TEST)
- c. ONE FOUR MAN/SIX WEEK TRIPS TO NASA AMES, CALIF. (FLIGHT TEST)

5. LAG DAMPER VARIATION

- a. ONE TWO MAN/THREE DAY TRIP TO NASA AMES, CALIF. (PROGRAM COORD)
- b. ONE THREE MAN/FOUR WEEKS TRIP TO NASA AMES, CALIF. (GROUND TEST)
- c. ONE FOUR MAN/SIX WEEKS TRIP TO NASA AMES, CALIF. (FLIGHT TEST)

6. $\Delta 3$ COUPLING VARIATION

- a. TWO TWO MAN/THREE DAY TRIP TO NASA AMES, CALIF. (PROGRAM COORD)
- b. ONE THREE MAN/FOUR WEEKS TRIP TO NASA AMES, CALIF. (GROUND TEST)
- c. ONE FOUR MAN/SIX WEEKS TRIP TO NASA AMES, CALIF. (FLIGHT TEST)

D. PHASE IV - BLADE TIP SHAPE VARIATION

1. FOUR TWO MAN/THREE DAY TRIPS TO NASA AMES, CALIF. (PROGRAM COORD)
2. ONE THREE MAN/FOUR WEEKS TRIPS TO NASA AMES, CALIF. (GROUND TEST)
3. ONE FOUR MAN/EIGHT WEEKS TRIP TO NASA AMES, CALIF. (FLIGHT TEST)

8-1650-510-510
ATTACHMENT (1)
NUMBER 10-17-83
REV LTR PAGE 1 OF 5

THE BOEING COMPANY RFE 8059 - PLANNING COST ESTIMATE FOR 347/D ROTOR SYSTEM FOR THE RSRA RESEARCH AIRCRAFT

FACILITY	ACTIVITY	MFG TECH	TOOL DESIGN	TOOL FAB	MATERIAL MARKS	GROUND FREIGHT TEST (MONTHS)	PLANNING PERMITS	QUALITY CONTROL	QUALITY ASSURANCE	DAYS PER DIEM	ALIGNMENT TO PPL
1.	BASIC PROGRAM COSTS					77				9	
2.	REMOVE 347 HUB				700			105	46		
3.	FABRICATE "DUMMY" HUB				120			10	8		
4.	ASSEMBLE MOCKUP ROTOR FOR 347					48				6	
5.	INSTALL MOCKUP ROTOR ASSEMBLY ON 347				80		8	48	7		
6.	PERFORM COMPLETE TEST-DOWN 347 ROTOR & SUBASSEMBLY				160		16	54	9		
7.	REFURBISH & REASSEMBLE ROTOR								40		
8.	DESIGN-INTEGRATION/INSTALLATION ON RSRA				859		94	113	61		
SUB-TOTAL	INSTRUMENTATION OF ONE BLADE				1999	120	200	330	177	15	3,204
9.	FABRICATION OF FOUR CH-47D FIBERGLASS BLADES	68			2285		228	352	149		
SUB-TOTAL		68			2385		228	352	149		3,022
10.	FABRICATION OF TWO CH-47D FIBERGLASS BLADES (SPARES)	34			1143		114	177	74		
SUB-TOTAL		34			1143		114	177	74		1,542
11.	STRUCTURAL TESTING OF NEW ROTOR COMPONENTS				3486		349	305	210		
SUB-TOTAL					3486		349	305	210		4,450

SHEET

FORM 1000 (1/78)

THE **BOEING** COMPANY

PROGRAM	ACTIVITY	MFG TECH	TOOL DESIGN	TOOL FAB	MANUF MILES	GROUND FLIGHT TEST (99-010)	PLANNING	QUALITY CONTROL	QUALITY ASSURANCE	DAYS - Per Dev.	MAN-HOURS TO THE
12.	MODIFICATION TO EXISTING EMERGENCY ESCAPE SYSTEM	—	—	—	VENDOR	—	—	—	—	—	—
SUB-TOTAL		—	—	—	249	520	39	185	16	14	70
13.	INSTALLATION OF RATOR ON RSRA.	—	—	—	1748	—	175	149	174	14	70
SUB-TOTAL		—	—	—	1748	520	199	334	170	14	70
14.	SUPPORT OF GROUND TESTS & FLIGHT TESTS	—	—	—	—	5600	—	1437	—	196	990
SUB-TOTAL		—	—	—	—	5600	—	1437	—	196	990
PHASE I	BASIC AERODYNAMIC PARAMETER VARIATION TEST	—	—	—	—	—	—	—	—	—	—
(a)	CH-47A BLADES	—	—	—	461	—	46	71	30	—	—
(b)	INSPECT & REFURISH INSTRUMENT ONE BLADE	—	—	—	939	—	94	113	61	—	—
(c)	INSTALLATION, CHECK-OUT & CALIBRATION	—	—	—	160	—	16	25	10	—	—
(d)	SUPPORT GROUND & FLIGHT TEST	—	—	—	—	3200	—	704	—	112	560
(a)	CH-47C BLADES	—	—	—	1560	3200	156	913	101	112	560
SUB-TOTAL		—	—	—	3120	6400	312	1837	302	224	1120
PHASE II	EXPANDED AERODYNAMIC PARAMETER VARIATION TESTS	—	—	—	—	—	—	—	—	—	—

SHEET

THE BOEING COMPANY

PARAGRAPH	ACTIVITY	NFG TECH 1786	TOOL DESIGN 7846	TOOL FAB 39133	MANUF. M/HRS 10,282	GROUND & FLIGHT TEST (M/HRS)	PLANNING & TRAINING (M/HRS)	QUALITY CONTROL (M/HRS)	QUALITY ASSURANCE (M/HRS)	DAYS - Avn. Dwn. Qtd.	MANHOURS TOTAL
(1)	DESIGN OF FAB (S) AND BLADES	—	—	—	1102	—	110	171	88	—	—
(2)	QUALIFICATION TESTING	—	—	—	939	—	84	113	61	6	30
(3)	INSTRUMENT AND BLADE	—	—	—	—	240	—	48	—	—	—
(4)	INSTALLATION, CHECKOUT & CALIBRATION	—	—	—	—	5600	—	1231	—	196	980
(5)	SUPPORT GROUND & FLIGHT TESTING	—	—	—	—	—	—	—	—	—	—
(6)	RETAIN BLADES TO -120	403	1000	5000	1440	—	644	648	254	—	—
(6a)	BENCH TEST (FATIGUE)	—	—	—	2252	—	225	202	346	—	—
(7)	CONDUCT STRUCTURAL PROPERTIES TESTS	—	—	—	670	—	67	67	60	—	—
(8)	REINSTRUMENT ONE BLADE	—	—	—	939	—	94	113	61	4	20
(9)	INSTALLATION, CHECKOUT & CALIBRATION	—	—	—	—	160	—	32	—	—	—
(10)	SUPPORT GROUND & FLIGHT TESTING	—	—	—	—	3600	—	792	—	126	630
SUB-TOTAL		2,182	8826	44,483	17,624	9600	5,930	5,338	4,890	332	1660
PHASE III	ROTOR DYNAMIC FLYING QUALITY PARAMETER VARIATION TESTS	—	—	—	—	—	—	—	—	—	—
(1)	NATURAL FREQUENCY VARIATION TEST	54	300	1500	—	—	—	128	48	—	—
(2)	DESIGN, FABRICATE & INSTALL MIDSPAN	85	—	—	2830	—	283	338	324	—	—
(3)	TUNING WEIGHTS FITTING TEST SPECIMEN	78	—	—	2614	—	261	237	230	—	—
(4)	INSTALL ON H/C & PERFORM 20 H/C GROUND TIEDOWN TEST & INSPECT	—	—	—	—	2560	—	560	—	90	450
(5)	SUPPORT GROUND & FLIGHT TESTING	—	—	—	—	2400	—	528	—	84	420

PARAGRAPH	ACTIVITY	MFG TECH	TOOL DESIGN	TOOL FAB	MANUF M/MS.	GROUND FLIGHT TEST (HRS)	PLANNING STAFFS	QUALITY CONTROL	QUALITY ASSURANCE	DAYS - GEN DAY	DAYS - PEN DAY	MINIMUMS TOTAL
(e)	REMOVE TURNING WEIGHTS	8	—	—	272	—	27	23	18	44	220	—
(f)	INSTALL GRAPHITE STIFFENERS	11	—	—	380	—	38	59	85	—	—	—
(g)	INSTALL ON A/C & PERFORM 15 HOUR GROUND TIEDOWN TEST & INSPECT	—	—	—	—	1280	—	256	—	84	420	—
(h)	SUPPORT GROUND & FLIGHT TESTS	—	—	—	—	2440	—	480	—	—	—	—
(i)	REMOVE STIFFENERS	5	—	—	80	80	8	28	5	2	10	—
(j)	FABRICATE & INSTALL GRAPHITE STIFFENERS	11	—	—	380	—	38	59	85	—	—	—
(k)	CORD FREQUENCY	—	—	—	—	1280	—	256	—	44	220	—
(l)	INSTALL ON A/C & PERFORM 15 HOUR GROUND TIEDOWN TEST & INSPECT	—	—	—	—	2440	—	480	—	84	420	—
(m)	SUPPORT GROUND & FLIGHT TESTS	5	—	—	80	80	8	28	5	2	10	—
(n)	REMOVE STIFFENERS	—	—	—	—	—	—	—	—	—	—	—
(2)	EFFECTIVE FLAG MIDGE VARIATION TESTS	—	—	—	4820	—	484	410	353	—	—	—
(a)	FABRICATE HUB MOUNTERS & PITCH ARM ADAPTERS	—	—	—	—	—	—	—	—	—	—	—
(b)	PERFORM FATIGUE TEST	—	—	—	1442	—	1444	130	94	48	240	—
(c)	INSTALL ON A/C & PERFORM 15 HOUR GROUND TIEDOWN TEST & INSPECT	—	—	—	—	1360	—	272	—	—	—	—
(d)	SUPPORT GROUND & FLIGHT TESTS	—	—	—	—	2440	—	480	—	84	420	—
(3)	CONTROL PHASE VARIATION TESTS	—	—	—	—	400	—	80	—	14	70	—
(a)	ADJUST A/C HANDLE	—	—	—	—	—	—	—	—	—	—	—
(b)	PHASE MIXER SUPPORT GROUND & FLIGHT TEST	—	—	—	—	2440	—	480	—	84	420	—

THE BOEING COMPANY

PROGRAM	ACTIVITY	MFG TECH	TOOL DESIGN	TOOL FWA	MANUF M/HRS	GROUND FLIGHT TEST (M/HRS)	PLANNING (M/HRS)	QUALITY CONTROL	QUALITY ASSURANCE	DAYS		MATERIALS TOTAL
										Qual	Avn Dign	
(4)	CONTROL SYSTEM STAFFERS VARIATION TESTS	—	—	—	772	—	77	64	110	28	140	
(b)	FABRICATE & TEST FLEXIBLE PIVOT ARM ASSEMBLIES	—	—	—	—	800	—	160	—	84	420	
(c)	INSTALL & PERFORM GROUND CHECKOUT TEST SUPPORT GROUND & FLIGHT TESTS	—	—	—	—	2400	—	480	—	—	—	
(5)	LAG DAMPER VARIATION TESTS	—	—	—	VENDORS	—	—	—	60	14	70	
(b)	DAMPEN MOD INSTALL & CHECKOUT	—	—	—	—	400	—	80	—	84	420	
(c)	SUPPORT GROUND & FLIGHT TEST	—	—	—	—	2400	—	480	—	—	—	
(6)	A3 COUPLING VARIATION TEST	—	—	—	2822	—	282	254	250	—	—	
(4)	FABRICATE & TEST PITCH ARM ADAPTER TO CHANGE A3 TO D0	—	—	—	—	400	—	80	—	14	70	
(b)	INSTALL & CHECKOUT SUPPORT GROUND & FLIGHT TEST	—	—	—	—	3200	—	640	—	112	560	
SUB-TOTAL		357	300	7500	16,592	28,600	2,658	7,552	1,667	1,000	5,000	58,166
PHASE IV	BLADE TIP SHAPE VARIATION TESTS	—	—	—	—	—	—	—	—	—	—	—
(1)	MANY FOUR CH-47C BLADES	364	1000	5000	8,120	—	1312	1184	867	164	820	
(2)	FABRICATE & TEST GROUND & FLIGHT TEST	—	—	—	2,630	4800	463	263	611	—	—	
SUB-TOTAL		364	1000	5000	10,750	4800	1,575	2,407	1,478	164	820	27,374
GRAND TOTAL		2973	10,136	50,634	58,987	55,680	10,565	22,873	9,111	1,930	9,665	270,856

RFE 8059
 OPERATIONS PER DIEM, TRAVEL, AND LODGING REQUIREMENTS

ACTIVITY	AIRFARE	CAR RENTAL	PER DIEM	LODGING
1. DEV MECH. 3 MEN X 3 DAYS	3	3	9	9
4. DEV MECH. 3 MEN X 2 DAYS	-	2	6	6
13. DEV MECH. 10 MEN X 1 WEEK	10	28	70	70
QUALITY 2 MEN X 1 WEEK	2	-	14	14
14. DEV MECH 10 MEN X 14 WEEKS	-	392	980	980
QUALITY 2 MEN X 14 WEEKS	-	-	196	196
PHASE I BASIC AERODYNAMIC PARAMETER VARIATION TEST				
1. (d) DEV MECH 10 MEN X 8 WEEKS	-	224	560	560
QUALITY 2 MEN X 8 WEEKS	-	-	112	112
2. DEV MECH. 10 MEN X 8 WEEKS	-	224	560	560
QUALITY 2 MEN X 8 WEEKS	-	-	112	112
PHASE II EXPANDED AERODYNAMIC PARAMETER VARIATION TEST				
4. DEV MECH. 10 MEN X 3 DAYS	-	12	30	30
QUALITY 2 MEN X 3 DAYS	-	-	6	6
5. DEV MECH. 10 MEN X 14 WEEKS	-	392	980	980
QUALITY 2 MEN X 14 WEEKS	-	-	196	196

OPERATIONS PER DIEM, TRAVEL, AND LODGING REQUIREMENTS (CONTINUED)

PHASE II EXPANDED AERODYNAMIC PARAMETER VARIATION TEST (CONTINUED)

ACTIVITY		AIRFRAME	CAR RENTAL	PER DIEM	LODGING	
9.	DEV MECH.	10 MEN X 2 DAYS	-	8	20	20
	QUALITY	2 MEN X 2 DAYS	-	-	4	4
10	DEV MECH.	10 MEN X 9 WEEKS	-	252	630	630
	QUALITY	2 MEN X 9 WEEKS	-	-	126	126
PHASE III ROTOR DYNAMIC AND FLYING QUALITY PARAMETER						
1.c	DEV MECH.	10 MEN X 6 WEEKS + 3 DAYS	-	180	450	450
	QUALITY	2 MEN X 6 WEEKS + 3 DAYS	-	-	90	90
1.d	DEV MECH.	10 MEN X 6 WEEKS	-	168	420	420
	QUALITY	2 MEN X 6 WEEKS	-	-	84	84
1.g	DEV MECH.	10 MEN X 3 WEEKS + 1 DAY	-	88	220	220
	QUALITY	2 MEN X 3 WEEKS + 1 DAY	-	-	44	44
1.h	DEV MECH.	10 MEN X 6 WEEKS	-	168	420	420
	QUALITY	2 MEN X 6 WEEKS	-	-	84	84
1.i	DEV MECH.	10 MEN X 1 DAY	-	4	10	10
	QUALITY	2 MEN X 1 DAY	-	-	2	2
1.k	DEV MECH.	10 MEN X 3 WEEKS + 1 DAY	-	88	220	220
	QUALITY	2 MEN X 3 WEEKS + 1 DAY	-	-	44	44

RFE 8059
OPERATIONS PER DIEM, TRAVEL, AND LODGING REQUIREMENTS (CONTINUED)

ACTIVITY		AIRFARE	CAR RENTAL	PER DIEM	LODGING	
PHASE III ROTOR DYNAMIC AND FLYING QUALITY PARAMETER (CONTINUED)						
1.l	DEV MECH.	10 MEN X 6 WEEKS	-	168	420	420
	QUALITY	2 MEN X 6 WEEKS	-	-	84	84
1.m	DEV MECH	10 MEN X 1 DAY	-	4	10	10
	QUALITY	2 MEN X 1 DAY	-	-	2	2
2.c	DEV MECH	10 MEN X 3 WEEKS + 3 DAYS	-	96	240	240
	QUALITY	2 MEN X 3 WEEKS + 3 DAYS	-	-	48	48
2.d	DEV MECH.	10 MEN X 6 WEEKS	-	168	420	420
	QUALITY	2 MEN X 6 WEEKS	-	-	84	84
3.a	DEV MECH.	10 MEN X 1 WEEK	-	28	70	70
	QUALITY	2 MEN X 1 WEEK	-	-	14	14
3.b	DEV MECH.	10 MEN X 6 WEEKS	-	168	420	420
	QUALITY	2 MEN X 6 WEEKS	-	-	84	84
4.b	DEV MECH.	10 MEN X 8 WEEKS	-	224	560	560
	QUALITY	2 MEN X 8 WEEKS	-	-	112	112
5.b	DEV MECH	10 MEN X 1 WEEK	-	28	70	70
	QUALITY	2 MEN X 1 WEEK	-	-	14	14

RFL 8059

OPERATIONS PER DIEM, TRAVEL, AND LODGING REQUIREMENTS (CONTINUED)

ACTIVITY		AIRFARE	CAR RENTAL	PER DIEM	LODGING	
PHASE III ROTOR DYNAMIC AND FLYING QUALITY PARAMETER (CONTINUED)						
5.c	DEV MECH.	10 MEN X 6 WEEKS	-	168	420	420
	QUALITY	2 MEN X 6 WEEKS	-	-	84	84
6.b	DEV MECH.	10 MEN X 1 WEEK	-	28	70	70
	QUALITY	2 MEN X 1 WEEK	-	-	14	14
6.c	DEV MECH.	10 MEN X 8 WEEKS	-	224	560	560
	QUALITY	2 MEN X 8 WEEKS	-	-	112	112
PHASE IV BLADE TIP SHAPE VARIATION TESTS						
2.	DEV MECH.	10 MEN X 12 WEEKS*	-	328	820	820
	QUALITY	2 MEN X 12 WEEKS*	-	-	164	164
*Last Week is 5 Days - Return on Friday						
	TOTAL		15	3,865	11,595	11,595

- NOTE; o OFF-SITE SUPPORT FOR ALL ACTIVITY IS BASED ON DEV. MECH. 10 MEN (5 M X 2 Shifts) & QUALITY 2 MEN (1 M X 2 SHIFTS) FOR ALL BUT INITIAL OFF-SITE ACTIVITY, 1/N 1.84.
- o AIRFARE REPRESENTS NUMBER OF REQ'D ROUND TRIP FARES. 3 FARES FOR 1/N 1.84. INITIAL ACTIVITY; 12 FARES FOR REMAINING ACTIVITY. NO PROVISION IS MADE FOR CREW REPLACEMENT OR ROTATION.

MAIN TRANSMISSION MODIFICATION

MANUFACTURING MANHOUR ESTIMATE

	MANHOURS
1. Familiarization Course 3 men x 1 week x 1 shift 1 supervisor 1 crew chief 1 transmission mechanic	120
2. Remove Rotor Blades, Hub Assembly and Main Transmission from RSRA Aircraft 5 men x 3 days x 1 shift	120
3. Disassemble Transmission, Remove and Replace Input Pinion and Bevel Gears Pattern New Gear Assembly 2 men x 12 days x 1 shift	192
4. Install Main Transmission in Aircraft 5 men x 3 days x 1 shift	120
5. Ground Run Aircraft - Run Transmission Torque Tests as Required 5 men x 2 days x 1 shift	80
6. Remove Rotor Blades, Hub and Transmission 5 men x 3 days x 1 shift	120
7. Disassemble Transmission - Check Gear Pattern - Reassemble 2 men x 3 days x 1 shift	48
8. Install Transmission, Hub Assy & Blades in Aircraft 5 men x 3 days x 1 shift	120
9. Ground Run Aircraft - Xmsn Tests 5 men x 2 days x 1 shift	80
10. Secure Aircraft 5 men x 2 days x 1 shift	80
	<hr/>
SUB-TOTAL MANHOURS	1,080
Quality Control	<u>304</u>
TOTAL MANHOURS	1,384

Estimate is based on the following planning factors:

- o Operations manhours estimate to be used as pre-planning information only.
 - o All work to be performed off-site at NASA-Ames facility utilizing Boeing/Vertol personnel.
 - o This program to be accomplished in conjunction with the proposed 347/D Rotor System program on the RSRA.
 - o NASA to provide work area, work stands, special transmission tools, lubricants, gages etc. as required for disassembly and assembly of the main transmission.
 - o The estimate assumes that aircraft and/or transmission related Engineering data or assistance will be provided by NASA.
 - o In lieu of a transmission test stand, the NASA-RSRA will be ground run at various transmission torque loads.
 - o NASA (aircraft) to be available and in ground run mode prior to removal of transmission.
-
- o A one (1) week aircraft familiarization course is to be provided to Boeing/Vertol personnel.
 - o The transmission modification is limited to the replacement of the main input bevel pinion and bevel ring gear.
 - o Transmission parts are all considered as buy.
 - o No provision is made for returning the main transmission to an original configuration after tests are completed. Any estimate for accomplishing a refurbishment of the transmission would be the result of separate negotiations.
 - o No manhours for instrumentation included.
 - o No planning manhours included due to the fact that all work is to be accomplished off-site.
 - o All work will be directed by Engineering.
 - o Recommendation is made that this program be performed by the aircraft manufacturer.

RSRA TRANSMISSION MOD

TRAVEL & PER DIEM

o FAMILIARIZATION

TRAVEL

(1)	Supervisor	x	2 days
(1)	Crew Chief	x	2 days
(1)	Transmission Mech	x	2 days
	Inspector	x	2 days

PER DIEM

(1)	Supervisor	x	7 days
(1)	Crew Chief	x	7 days
(1)	Xmsn Mech	x	7 days
	Inspector	x	7 days

o REMOVE XMSN FROM A/C

PER DIEM

(5)	A/C Crew	x	5 days
(1)	A/C Inspector	x	5 days

o MODIFY XMSN

TRAVEL

(2)	Xmsn Men	x	2 days
(1)	Xmsn Inspector	x	2 days

PER DIEM

(2)	Xmsn Men	x	37 days	(Include run A/C)
(1)	Inspector	x	37 days	

o GROUND RUN A/C

TRAVEL

(5)	A/C Crew	x	2 days
(1)	Inspector	x	2 days

PER DIEM

(5)	A/C Crew	x	28 days
(1)	Inspector	x	28 days

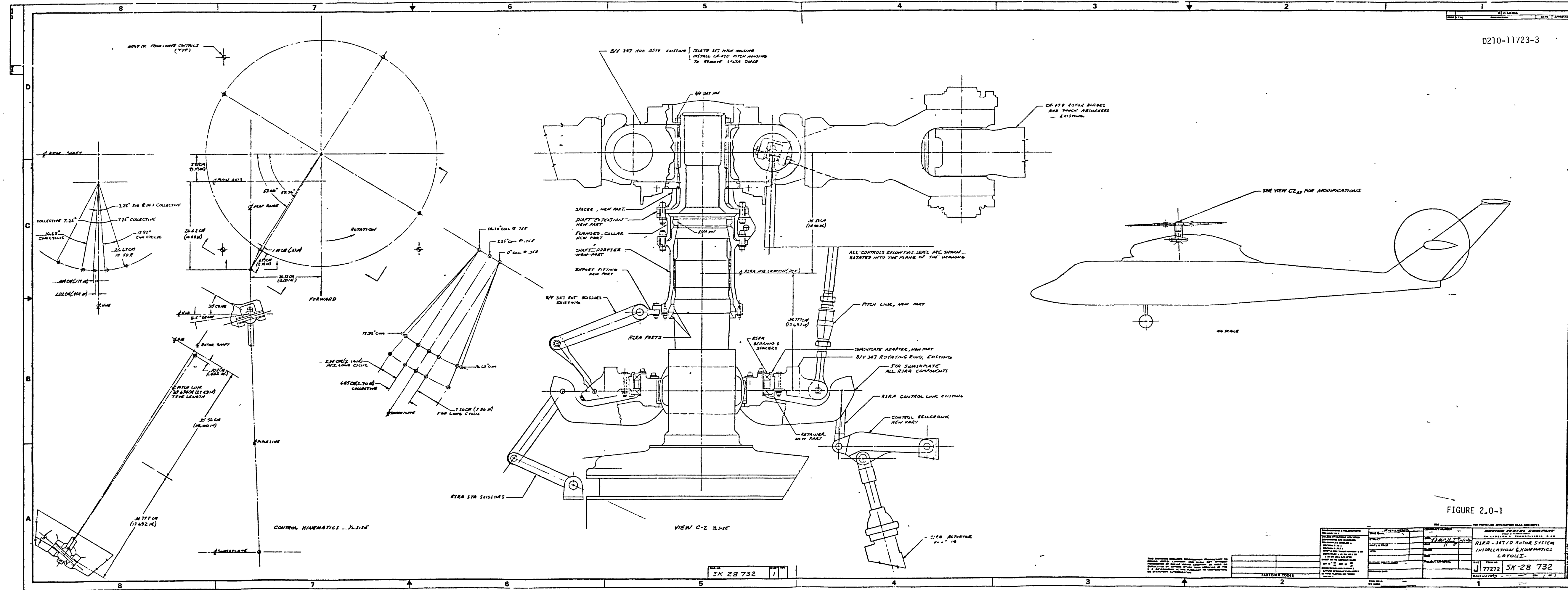

FIGURE 2.0-1

TITLE: RIRA-347/D ROTOR SYSTEM INSTALLATION & KINEMATICS LAYOUT PROJECT: 71722 DRAWING NO: SK 28 732 SHEET NO: 1 OF 2		DATE: 11/72 BY: [Signature] CHECKED: [Signature]
APPROVED: [Signature] TITLE: [Title]	APPROVED: [Signature] TITLE: [Title]	APPROVED: [Signature] TITLE: [Title]

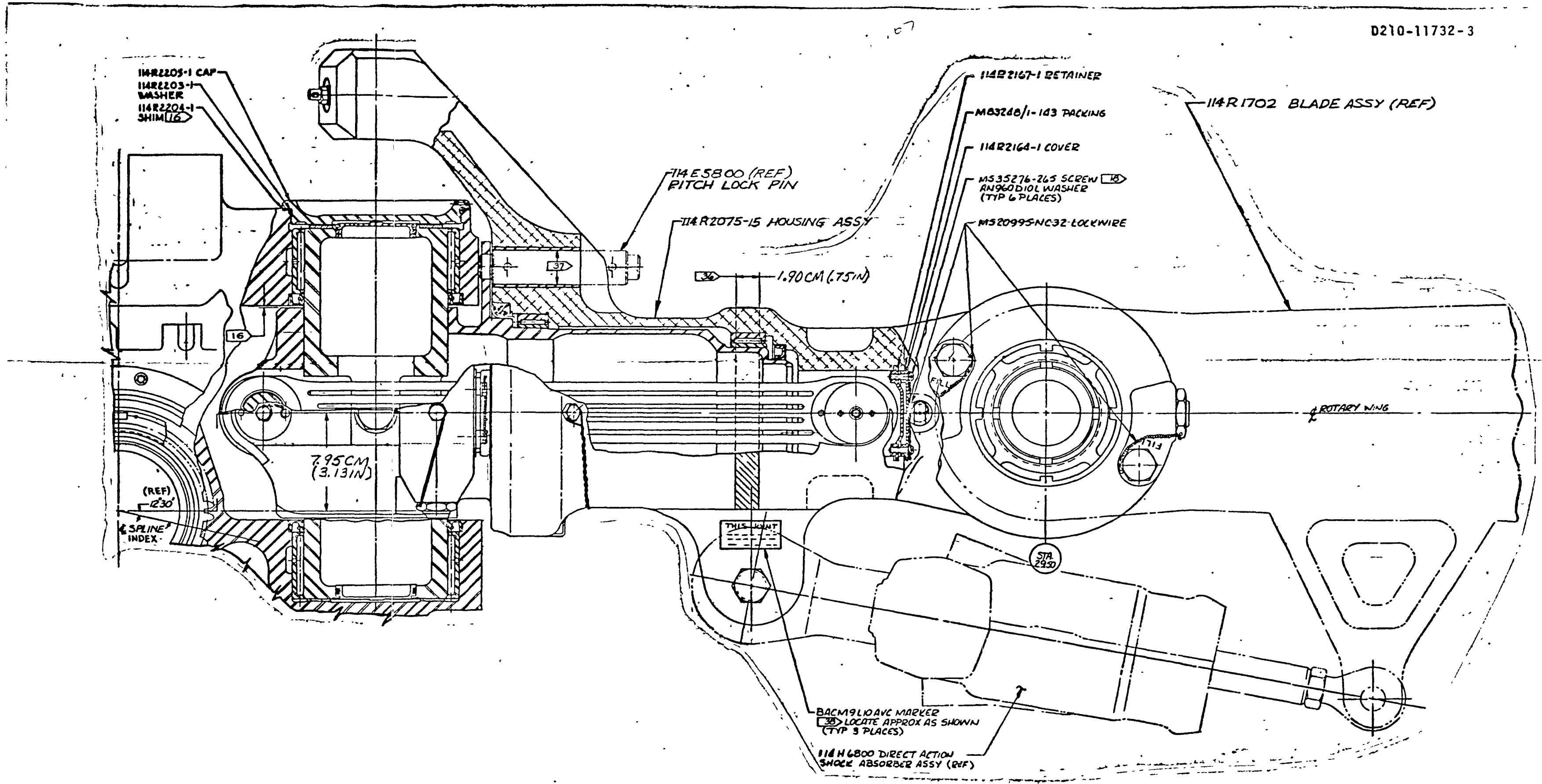
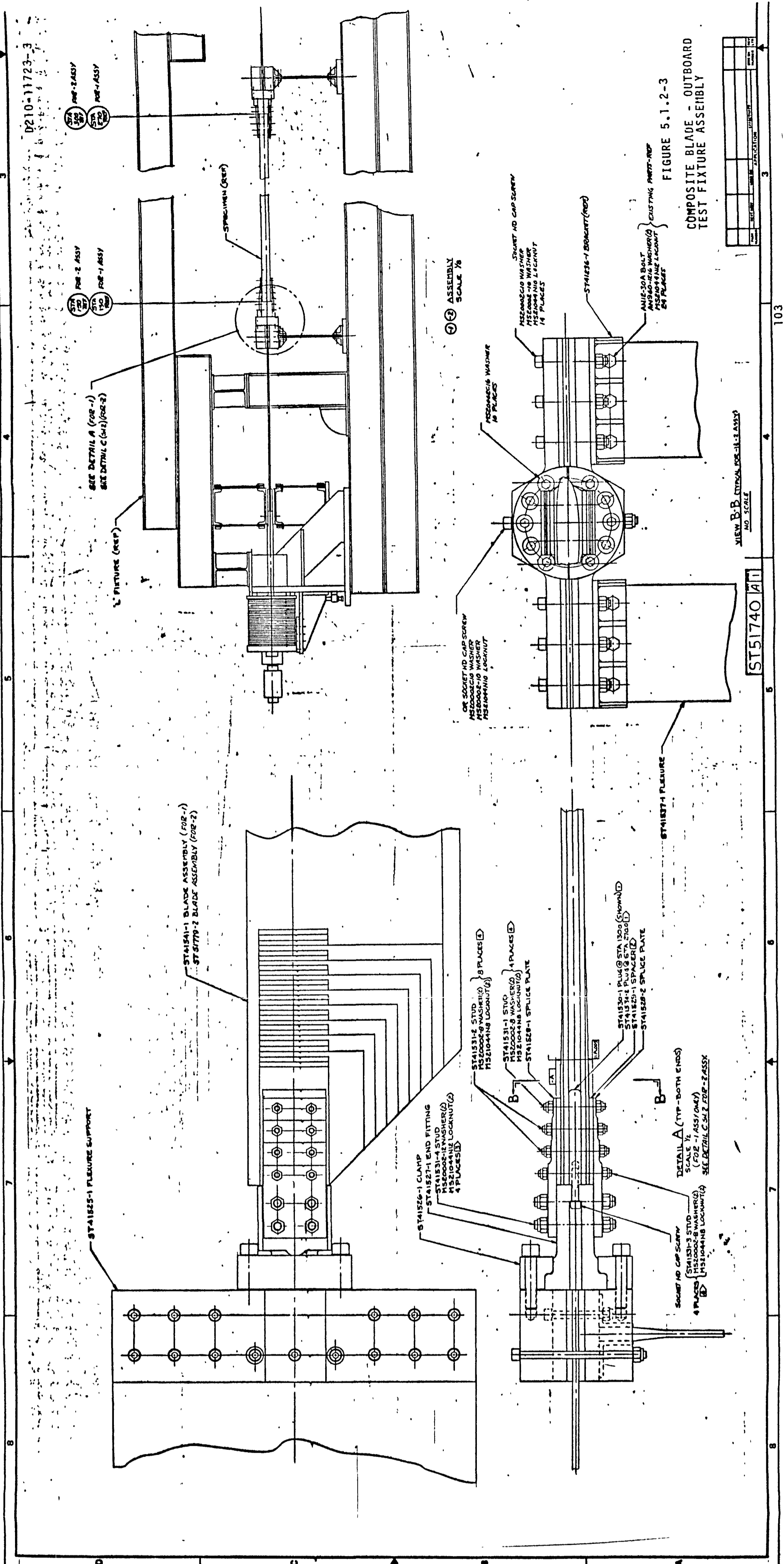

FIGURE 4.1-2 347 ROTOR (MODIFIED) (SH 1 OF 2)

110471212



D210-11723-3

103

COMPOSITE BLADE - OUTBOARD TEST FIXTURE ASSEMBLY

FIGURE 5.1.2-3

ST51740 A1

VIEW B-B

NO SCALE

NO SCALE

ASSEMBLY SCALE 1/8

ASSEMBLY SCALE 1/8

DETAIL A (FOR-1) SCALE 1/2

DETAIL A (FOR-1) SCALE 1/2

DETAIL C (FOR-2) SCALE 1/2

DETAIL C (FOR-2) SCALE 1/2

DETAIL A (TYP - BOTH ENDS) SCALE 1/2

DETAIL A (TYP - BOTH ENDS) SCALE 1/2

VIEW B-B (TYP - FOR-1 & 2) SCALE 1/2

VIEW B-B (TYP - FOR-1 & 2) SCALE 1/2

NO SCALE

NO SCALE

2/2/80

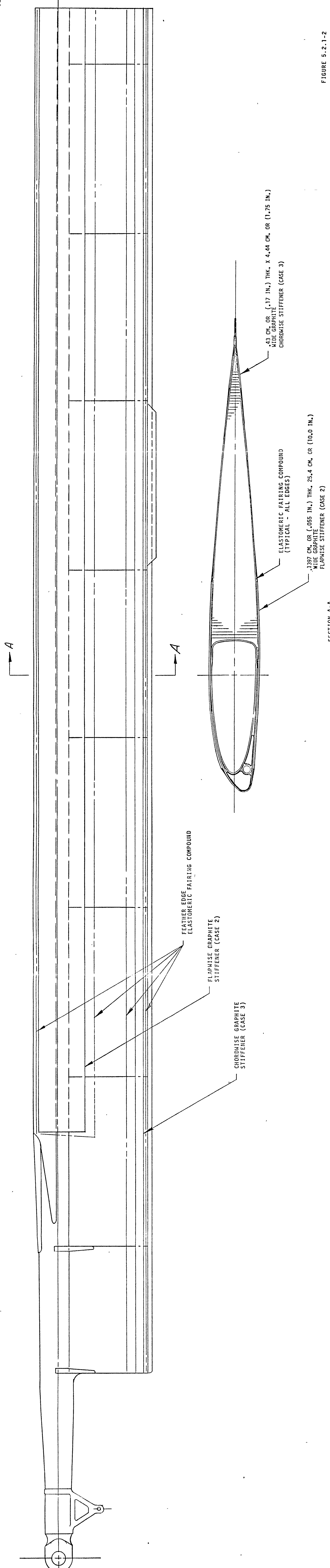

FIGURE 5.2.1-2

CH-47C ROTOR BLADE WITH EXTERNAL GRAPHITE STIFFENING

HUB ADAPTER

BEARING
(2 positions)

SUPPORT LINK

HUB SPACER

FIGURE 5.2.2-1

FLAP HINGE VARIATION CONCEPT
DRAWN BY K-SHITH 9/10/80 SCALE: 1/1

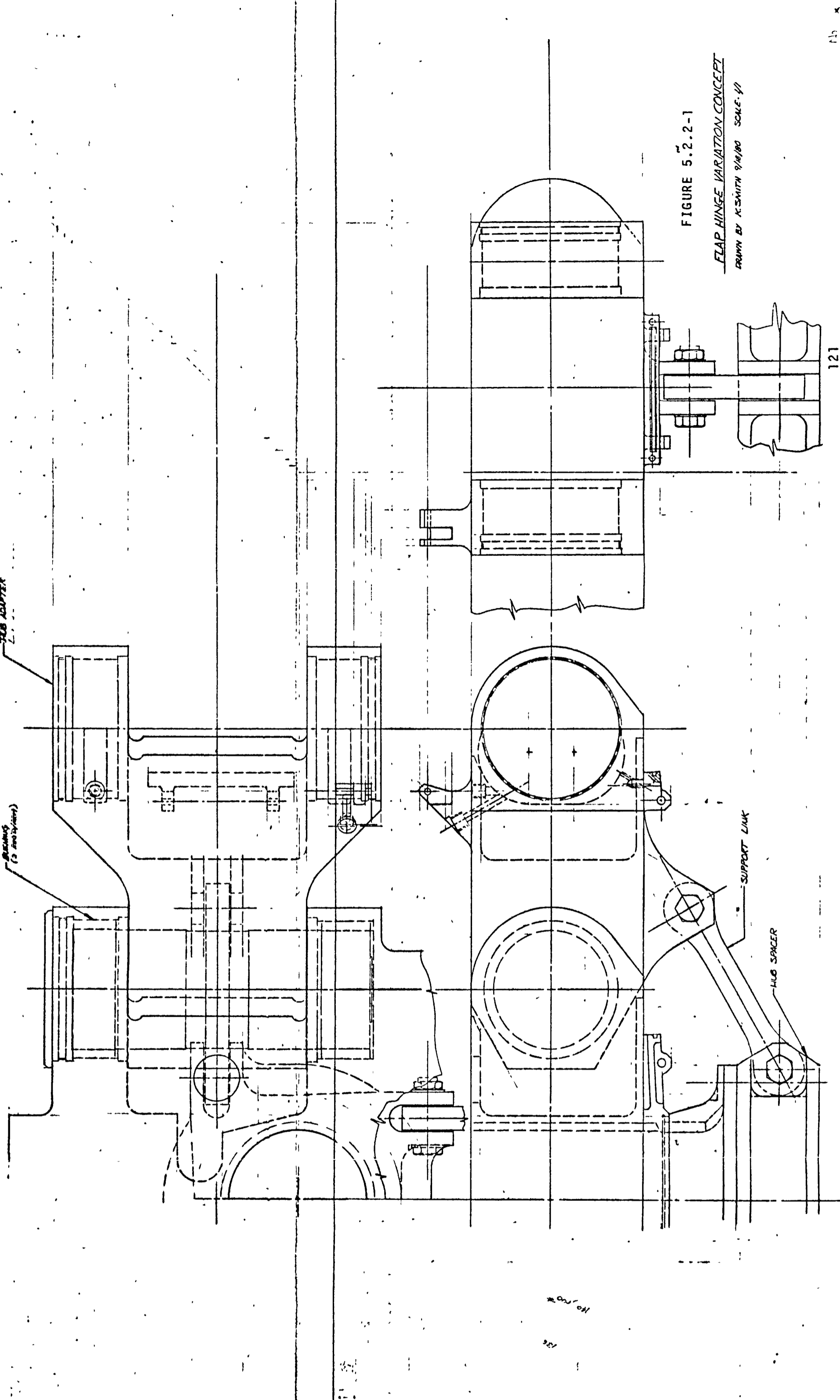

1 Report No NASA CR 166153	2. Government Accession No	3. Recipient's Catalog No.	
4 Title and Subtitle Predesign Study for a Modern 4-Bladed Rotor for the NASA Rotor Systems Research Aircraft		5. Report Date January 1981	6. Performing Organization Code
		8. Performing Organization Report No D210-11723-3	10. Work Unit No
7 Author(s) K. E. Smith, etal		11 Contract or Grant No. NAS2-10689	
9. Performing Organization Name and Address Boeing Vertol Company Philadelphia, PA		13. Type of Report and Period Covered Contractor Report	
		14 Sponsoring Agency Code	
12. Sponsoring Agency Name and Address National Aeronautics and Space Administration Ames Research Center Moffett Field, CA			
15. Supplementary Notes Point of Contact: Gerald Shockey MS237-3, NASA Ames Research Center FINAL REPORT FTS#448-6571 COM.# 415-965-6571 Moffett Field, CA 94035			
16. Abstract This report includes the trade-off study results and the rationale for the final selection of an existing modern four-bladed rotor system that can be adapted for installation on the Rotor Systems Research Aircraft (RSRA) and the results of the detailed integration studies, parameter change studies, and instrumentation studies; and, the recommended plan for the development and qualification of the rotor system and its parameter variants, its integration on the RSRA, and support of ground and flight test programs.			
17 Key Words (Suggested by Author(s)) 4-Bladed Helicopter Rotor RSRA		18 Distribution Statement Star Category 01	
19 Security Classif (of this report) UNCLASSIFIED	20 Security Classif (of this page) UNCLASSIFIED	21 No of Pages 225	22. Price*

End of Document