

NASA CR 166154

NASACR-166,154



NASA-CR-166154
19820008170

PRE-DESIGN STUDY FOR A MODERN FOUR-BLADED ROTOR
FOR THE
ROTOR SYSTEMS RESEARCH AIRCRAFT (RSRA)

By Charles W. Hughes and Andrew H. Logan

March 1981

LIBRARY COPY

FEB 2 1981

LANGLEY RESEARCH CENTER
LIBRARY, NASA
HAMPTON, VIRGINIA

Prepared under Contract No. NAS2-10690 by
HUGHES HELICOPTERS, INC.
Culver City, California

for

AMES RESEARCH CENTER

NATIONAL AERONAUTICS AND SPACE ADMINISTRATION



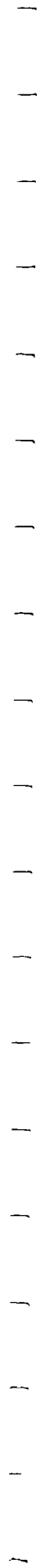

PRE-DESIGN STUDY FOR A MODERN FOUR-BLADED ROTOR
FOR THE
ROTOR SYSTEMS RESEARCH AIRCRAFT (RSRA)

By Charles W. Hughes and Andrew H. Logan

March 1981

Distribution of this report is provided in the interest
of information exchange. Responsibility for the con-
tents resides in the author or organization that pre-
pared it.

Prepared under Contract No. NAS2-10690 by
HUGHES HELICOPTERS, INC.
Culver City, California

for

AMES RESEARCH CENTER
NATIONAL AERONAUTICS AND SPACE ADMINISTRATION

1
2
3
4
5
6
7
8
9
10
11
12
13
14
15
16
17
18
19
20
21
22
23
24
25
26
27
28
29
30
31
32
33
34
35
36
37
38
39
40
41
42
43
44
45
46
47
48
49
50
51
52
53
54
55
56
57
58
59
60
61
62
63
64
65
66
67
68
69
70
71
72
73
74
75
76
77
78
79
80
81
82
83
84
85
86
87
88
89
90
91
92
93
94
95
96
97
98
99
100

PREFACE

This report was prepared by Hughes Helicopters, Inc., under NASA Contract NAS2-10690 funded by National Aeronautics and Space Administration. The Hughes Helicopter project manager was Mr. Andrew H. Logan and Mr. Charles W. Hughes was project engineer. The authors acknowledge the contribution of Mr. Bennet Arnstein who was the principal designer.

Technical program direction was provided by Mr. G. Shockey of NASA Ames Research Center.



CONTENTS

	<u>Page</u>
PREFACE	iii
LIST OF TABLES	vi
LIST OF ILLUSTRATIONS	viii
SUMMARY	1
INTRODUCTION	2
ROTOR SYSTEM SELECTION	4
Candidate Rotor Systems	4
Selection of Modern Four-Bladed Rotor	6
Selected Rotor System	11
DETAILED STUDY	12
Integration and Pre-design Studies	12
Parameter Change and Technology Payoff Studies	17
Instrumentation Plan	22
DEVELOPMENT PLAN	24
Work Statement and Program Plan	24
Cost and Schedule Estimates	31
CONCLUSIONS	33
RECOMMENDATIONS	34
REFERENCES	35

LIST OF TABLES

<u>Table</u>		<u>Page</u>
1	Rotor Comparison	38
2	Candidate Rotor RPMS with RSRA Gears	39
3	Thrust Coefficient Comparison	39
4	Rotor Selection Tradeoff Chart	40
5	Rating of Candidate Rotor Systems	41
6	Hovering Power Required at 8346 kg. Gross Weight	42
7	Rotor Attachment Modifications	43
8	Transmission Gear Changes	44
9	Comparison of RSRA and YAH-64 Rotor System Ground Resonance Parameters	44
10	Damping Product Data	45
11	YAH-64 and RSRA Rotor Control System Comparison Before Modifications	46
12	RSRA Stationary Control System Modifications	47
13	Control System Modifications	48
14	Basic Strain Gage/Position Instrumentation Items for the YAH-64 Main Rotor Installed on the RSRA	49
15	Rotating Accelerometers, YAH-64 Main Rotor Installed on the RSRA	53
16	Pressure Transducers, YAH-64 Main Rotor Installed on the RSRA	55
17	YAH-64 Main Rotor for the RSRA - Work Breakdown Structure	59

LIST OF TABLES (CONT)

<u>Table</u>		<u>Page</u>
18	Development Plan for YAH-64 Main Rotor on RSRA, Labor Cost, Wind Tunnel Test, Start January 1982	63
19	Total Costs for YAH-64 on RSRA - Alternate A, Wind Tunnel Test, Start January 1982	64
20	Development Plan for YAH-64 Main Rotor on RSRA , Labor Cost, Whirl Tower Test, Start January 1982	65
21	Total Costs for YAH-64 on RSRA - Alternate B, Whirl Tower Test, Start January 1982	66
22	Development Plan for YAH-64 Main Rotor on RSRA, Labor Cost, Wind Tunnel Test, Start January 1983	67
23	Quarterly Labor Cost Report, Wind Tunnel Test, Start January 1982 ,	68
24	Total Costs, Quarterly Report, Wind Tunnel Test, Start January 1982	69
25	Blade Option Study, 2 Blade Sets, Labor Costs	70
26	Blade Option Study, 5 Blade Sets, Labor Costs	71
27	Blade Option Study, 6 Blade Sets, Labor Costs	72
28	Blade Option Study, Total Cost Comparison	73

LIST OF ILLUSTRATIONS

<u>Figure</u>		<u>Page</u>
1	Hughes YAH-64 Hub Assembly	74
2	Straps for YAH-64 Hub Assembly	74
3	YAH-64 Composite Main Rotor Blade	75
4	YAH-64 Blade Geometry	75
5	Sikorsky UH-60A Hub	76
6	UH-60A Blade	76
7	Boeing Vertol YUH-61A Hub	77
8	YUH-61A Blade	77
9	Kaman K-747 Blade for AH-1S	78
10	Boeing Vertol YCH-47D Blade	79
11	Airfoil Comparison	80
12	Hub-to-Fuselage Height Variations Simplified by Static Mast Design	81
13	YAH-64 Rotor System on the RSRA	82
14	YAH-64 Main Rotor Installed on RSRA with Recommended Controls and Support Structure	83
15	Rotor Support Structure Design	85
16	Schematic Detail of Interface Between RSRA Transmission and AAH Fixed Mast Mounting Platform	87
17	YAH-64 Rotor on RSRA-Fixed Mast Mounted on Main Gear Box Housing (Concept)	89
18	YAH-64 Fixed Mast Mounting Platform for RSRA - Replaces RSRA Transmission Cover	91

LIST OF ILLUSTRATIONS (CONT)

<u>Figure</u>		<u>Page</u>
19	Critical Main Rotor Mast Bending Moments	93
20	RSRA Flight Controls Modified to Match YAH-64 Rotor Head	95
21	Blade Severance Installation YAH-64 Blade on RSRA	97
22	Modified YAH-64 Masts for the RSRA Installation	99
23	Barrels for New Pitch Links to Accommodate Different Mast Heights	101
24	Pitch Link Assemblies for Various Mast Heights	103
25	Tool for Adjusting Pitch Links	105
26	Variation of δ_3 as a Design Parameter with YAH-64 Rotor on RSRA	107
27	Plan Form YAH-64 Composite Blade for the Rotor System Research Aircraft (RSRA) Hub	109
28	Modern 4-Bladed Tip Shapes Swept Tip-Standard, YAH-64 M/R for the RSRA	111
29	Modern 4-Bladed Tip Shapes Square Tip-Baseline, YAH-64 M/R for the RSRA	113
30	Modern 4-Bladed Tip Shapes Swept-Tapered, YAH-64 M/R for the RSRA	115
31	Modern 4-Bladed Tip Shapes OGEE Tip, YAH-64 M/R for the RSRA	117
32	Effect of Twist on YAH-64 Rotor Performance on the RSRA	119
33	Effect of Planform Variation on YAH-64 Rotor Performance on the RSRA	120

LIST OF ILLUSTRATIONS (CONT)

<u>Figure</u>		<u>Page</u>
34	Effect of Tip Speed on YAH-64 Rotor Performance on the RSRA	121
35	Wet Filament Winding Machines	122
36	Internal Tooling Concept	123
37	External Mold Concept	124
38	Tubular Winding Machine	125
39	Ring Winder Schematic	126
40	HH-02 Representative Pressure Distributions and Proposed Chordwise Location of Pressure Transducers	127
41	Development Plan for YAH-64 Main Rotor on RSRA, Wind Tunnel Test, Start January 1982	128
42	Development Plan for YAH-64 Main Rotor on RSRA, Whirl Tower Test, Start January 1982	129
43	Development Plan for YAH-64 Main Rotor on RSRA, Wind Tunnel Test, Start January 1983	130

SUMMARY

This report presents the results of studies conducted by Hughes Helicopters, Inc. (HH, Inc.), for NASA Contract NAS2-10690, "Pre-Design Study for a Modern Four-Bladed Rotor for the Rotor Systems Research Aircraft (RSRA)." The report presents the process used to select the rotor system, studies conducted to mate the rotor with the RSRA and provide parametric variability, and the development plan which would be used to implement these studies.

Various candidate rotor systems are described and compared in this report to aid in the selection of a modern four-bladed rotor for the RSRA. The YAH-64 rotor system was selected as the candidate rotor system for further development for the RSRA. The YAH-64 rotor was selected primarily for the following reasons:

- 1.0 The YAH-64 rotor system incorporates advanced aerodynamic and structural features in blade profile, blade planform, blade construction, and hub design.
- 2.0 The rotor system design incorporates a redundantly supported static mast which eliminates any potential load problems with the transmission, simplifies hub attachment to the fuselage, and also simplifies variations in hub-to fuselage spacing (mast height).
- 3.0 Blade parameter testing is facilitated by the existence of both composite and metal blades with similar geometry but differing in stiffness. Composite blades will be used as the baseline when this rotor is tested on the RSRA.

This report then presents the studies which were conducted to integrate the YAH-64 main rotor with the RSRA. These studies show that the YAH-64 main rotor would be easily integrated with the RSRA with low technical risk. The YAH-64 rotor system also lends itself to parametric changes with relative simplicity.

A development plan is presented in this report for implementing the program based on the predesign studies. The plan includes a work breakdown structure (WBS) with a draft statement of work, schedule estimates, and cost estimates. Program options are investigated based on wind tunnel versus whirl tower testing and a number of different blade sets to be fabricated. Total contractor program costs with wind tunnel testing, eight blade sets, and contractor support of two years of flight testing is estimated to cost six million dollars (with 11 percent inflation).

INTRODUCTION

The National Aeronautics and Space Administration is engaged in a program to provide and validate the rotor system technology that is required to substantially improve the performance, dynamics, noise levels, cost and other features of both civil and military rotorcraft. One of the major research tools available for developing improved rotor system technology is the RSRA developed by NASA. The RSRA is truly a flying wind tunnel which was developed solely for rotor research and not for a particular mission. The RSRA is uniquely qualified for flight validation/demonstration of advanced technology and expanding the technology flight data base.

The RSRA presently uses the Sikorsky S-61 five bladed rotor system which represents a 25 year-old technology with a symmetrical blade profile, rectangular planform, and aluminum structure. This rotor system is now entering a flight test phase which will provide data for correlation with model tests, large scale wind tunnel tests, and computer analysis predictions.

The next step in the rotor research program is to update the RSRA rotor system to incorporate the latest rotor technology. The present effort is a predesign study to select a modern four bladed main rotor for testing on the RSRA, integrate the main rotor system with the RSRA while providing rotor parametric change capability, and develop program plans, schedules and cost estimates to implement these studies.

The first step in this rotor predesign study was the selection of a modern four-bladed main rotor that will serve as the baseline rotor for the integration and development studies. To ensure availability and minimize development risks and costs, only rotors developed in the United States were considered for this study. This study considered all the four-bladed rotors developed recently that have the thrust capability to be tested on the RSRA in its helicopter mode. In addition, advanced technology blades not presently on a four-bladed rotor were considered during this selection study. It was recognized these blades would incur a development penalty in order to adapt them to a four-bladed hub, but in the interest of thoroughness, they were included. The candidate rotor systems were evaluated and ranked as to their technical merit, integration requirements, and development requirements. Technical merit considered any unique aerodynamic or structural features while integration requirements considered how well the rotor systems adapt to the RSRA. The development requirements judged the rotor systems as to how well blade design parameter changes (such as blade stiffness,

airfoil contour, or blade planform) could be incorporated. On the basis of this review, the YAH-64 main rotor system was selected. The rationale for this selection is presented and discussed.

Integration and installation studies were then conducted to develop rotor attachment and control system modifications necessary to mate the YAH-64 main rotor with the RSRA. Several different approaches were investigated and the lowest risk approaches were recommended for implementation. The analysis showed that the YAH-64 static mast/truss network concept is an ideal method of rotor attachment.

Parametric change and technology payoff studies were also conducted. Parameters were varied and potential payoffs were determined. Parameters to be changed and the techniques for implementation are presented. Among the parameters varied are twist, planform, and rotor blade tips.

Instrumentation requirements were defined and are included in this report. The instrumentation provides basic research data such as pressure distributions as well as insuring safety-of-flight. The required instrumentation details locations both spanwise and chordwise as well as defining the types of instrumentation.

A development plan is presented for design, fabrication, and testing of the YAH-64 main rotor on the RSRA. A work breakdown structure of the program along with a draft statement of work are also presented. Schedule and cost estimates were developed to integrate the YAH-64 main rotor with the RSRA. The costs presented include basic program elements such as design, fabrication with parametric changes, safety-of-flight qualification, installation and ground run, and flight test support. In addition, two alternative cost estimates were developed to compare the benefits of substituting whirl tower testing for testing in the 40 x 80 wind tunnel. The cost impact of number of blade sets is also evaluated. The cost estimates were developed using a network analysis, ARTEMIS, which provided a flexible and effective scheduling/cost estimate tool.

ROTOR SYSTEM SELECTION

CANDIDATE ROTOR SYSTEMS

The modern four-bladed rotors that are prime candidates for testing on the RSRA are as follows: the rotor system for the YAH-64 attack helicopter developed by Hughes Helicopters, the rotor system for the UH-60A utility helicopter developed by Sikorsky Aircraft, and the rotor system for the YUH-61 utility helicopter developed by Boeing Vertol. In addition to these, the four-bladed Bell 412 and Boeing Vertol 347 rotor systems were considered but rejected for further study. The 412 rotor system developed by Bell Helicopter has many advanced features but at the RSRA helicopter design gross weight, the 412 rotor system would be too heavily loaded ($C_T/\sigma = .116$) to provide meaningful data. The rotor used for the Boeing Vertol Model 347 program was also a four-bladed rotor. Since this rotor used standard metal CH-47 blades and a standard fully articulated hub (Reference 1), it was not considered a "modern" four-bladed rotor and thus was eliminated from further study.

To make the selection process comprehensive, combination rotor systems were considered that used modern four-bladed hubs with advanced rotor blades not now used on a four-bladed rotor. The other advanced rotor blades considered in this selection study were Kaman blades developed for the AH-1S attack helicopter and the Boeing Vertol blades developed for the YCH-47D improved utility helicopter. Both of these systems would require additional development work for adaptation to a four-bladed hub.

The candidate rotors system are described as follows:

A. The YAH-64 main rotor system consists of hub with blades that are advanced both structurally and aerodynamically. References 2 and 3 describe this rotor. The soft inplane rotor hub is virtually bearingless using stainless steel straps to replace both flapping and feathering bearings and react the centrifugal force. Lead-lag damping is accomplished by elastomeric dampers. Figure 1 shows the hub assembly and Figure 2 shows the strap assembly. The composite blades being developed under an Army Manufacturing Method and Technology Program will be used with this hub. Reference 4 describes this blade which is shown in Figure 3. The composite blades are made with Kevlar 49 as the primary material with graphite used for tailoring the blade's stiffness. Also available for testing on the hub are metal blades initially developed for the YAH-64 which are geometrically similar to the composite blades, (the composite blade tip airfoil is a NACA 64A009 while the metal blade tip airfoil is a NACA 64A006). Thus two blades differing structurally but geometrically similar, would be available for testing on the YAH-64 rotor system to determine the impact of stiffness variations. The YAH-64 blades incorporate aerodynamic improvements such as swept tips and advanced airfoils as shown in Figure 5. The HH-02 and the NACA 64A009 (used at the blade tip) airfoils were specially chosen for the rotor systems to optimize advancing and retreating blade characteristics.

B. The UH-60A main rotor system consists of an articulated hub with elastomeric bearings and blades whose main structural member is a welded titanium spar. References 5 and 6 describe the hub and blades. Figure 5 shows the hub for the UH-60A rotor. This hub is machined from a titanium forging and the elastomeric bearings are enclosed within the arms of the hub. The bearing sets (two per blade) react the blade centrifugal loads as well as providing freedom for blade pitch, flap, and lead/lag motion. Hydraulic dampers are used to prevent rotor instabilities due to the soft inplane design.

The blade is shown in Figure 6. The titanium spar is encased within a fiberglass skin which forms the aerodynamic contour. The fiberglass is stabilized by a lightweight nonmetallic honeycomb core and the blade is bolted to the rotor head through a fiberglass laminate cuff. Advanced aerodynamic features of this blade include the swept tip, SC1095 airfoil, and a high nonlinear twist distribution.

C. The YUH-61A developed by Boeing Vertol has a hingless, soft-inplane main rotor system (References 7 and 8). The titanium rotor hub uses standard pitch change bearings with the hub design similar to that used on the Bolkow 105 helicopter. Flapping and lead-lag motions are accommodated by deflections of the blade shank. The blades are constructed of fiberglass with Nomex honeycomb core. Fiberglass unidirectional fibers form the blade spar and extend inboard from the blade tip around the root loop and back to the blade tip. Figures 7 and 8 show the rotor hub and blade respectively. The blade incorporates conventional rectangular planform and advanced cambered airfoils (VR-7 and 8), distributed spanwise.

D. Other four-bladed rotors were considered which combined four-bladed hubs with advanced technology blades from existing rotors other than four-bladers. The blades from these systems were included but with a hub development penalty. Blades considered were those on the Bell 214, Bell AH-1T, and the Bell AH-1S. The rotor systems for the AH-1T and 214 with maximum gross weights of 6350 kg. (14,000 lbs) and 6260 kg. (13,800 lbs) respectively were considered to be too large as four bladers for testing on the RSRA. The blades chosen for further study were the Kaman K-747 blades used on the AH-1S (Reference 9). These composite blades have a multi-cell spar of fiberglass (S glass), fiberglass skins which enclose a Nomex honeycomb core, and a Kevlar-epoxy trailing edge. The blade construction features and aerodynamic features are shown in Figure 9. These blades incorporate a tapered tip with advanced cambered airfoils (VR-7 and 8) distributed spanwise.

Other advanced blades included for consideration were the advanced blades developed for the YCH-47D (Model 234) improved Chinook to be produced by Boeing Vertol. These fiberglass blades are described in References 10 and

11. The blades have fiberglass D spars, Nomex honeycomb core, and fiberglass skins. Figure 10 shows the blade's construction details. Advanced airfoils used for this blade are the VR-7 and VR-8. Swept tips or planform changes are not incorporated in this design.

The rotor systems/blades chosen then as candidates for the modern four-bladed rotor for the RSRA are: YAH-64, UH-60, YUH-61, Kaman K-747 blades, and the YCH-47D blades. One prime advantage all these systems possess, is that they all use advanced airfoils which were designed for helicopter use. The airfoils include the Hughes HH-02, Sikorsky SC-1095, and the Boeing Vertol VR-7 and -8 series: References 3, 12, 13, and 14 present data on these advanced airfoils while Figure 11 compares the aerodynamic performance of the different airfoils. Table 1 presents the geometric characteristics of the candidate rotor systems and for comparison, the RSRA existing rotor system is also included.

SELECTION OF MODERN FOUR-BLADED ROTOR

The candidate rotor systems/blades discussed in the previous section were evaluated on the basis of technical merit, integration requirements, and development requirements. Technical merit considers the rotor system's advanced features such as unique structural details and aerodynamic advancements. Integration requirements consider how well the rotor systems adapt to the RSRA. Candidates that have minimal integration requirements rate high in the evaluation process. Development requirements judge the candidates on the ease with which they can accommodate parametric variations. Hub systems and blades that can easily accept parametric variations are rated highly. The development requirements also evaluate subjectively the candidates on other features such as ease of instrumentation, spare part availability, and wind tunnel requirements.

The initial step in evaluating the candidate rotor system/blades is to determine a rpm which was potentially available on the RSRA. In addition, the candidate blades were considered as if they were mounted on an existing hub.

Table 2 presents the candidates and their existing operating rpm. Also presented in Table 2 are the available RSRA rpms closest to the candidates' operating rpm. The potential gear ranges for the RSRA are obtained from Reference 15. By using different gears and the large governed range (92% to 107%) of the engines, the candidate rotors can all be tested at their design rpm.

Next, one of the four-bladed hubs was chosen for the YCH-47D and K-747 blades. The Boeing YUH-61A hub needs specially designed blades which can accommodate flapping and lead-lag motion, in order to function. The Hughes YAH-64 and Sikorsky UH-60A have articulated hubs which could accommodate other blades with specially fabricated fittings. The YAH-64 hub is designed for a centrifugal force (C. F.) of approximately 266.7×10^3 newtons (60,000 lbs) whereas the UH-60A hub is designed for a C. F. of 311.4×10^3 newtons (70,000 lbs)(Reference 5). Thus the UH-60 hub was chosen to mate with the K-747 and YCH-47D blades. The C. F. of the K-747 blades at 324 rpm is approximately 444.8×10^3 newtons (100,000 lbs)(Reference 9) and the YCH-47D blade C. F. at 225 rpm is estimated at 400.3×10^3 newtons (90,000 lbs) (unpublished sources).

These operating speeds would have to be reduced or the hubs redesigned to accommodate the large centrifugal forces. Reducing the operating speeds could cause blade frequency problems which would then necessitate redesigning the blades. It was decided to evaluate the K-747 and YCH-47D blades at their design rpms on the UH-60A hub which would then require additional design, development and testing.

In addition to strengthening the hub, a fitting would have to be designed in order to adapt the K-747 and YCH-47D blades to the UH-60A hub. It was estimated the new fitting would place the blade bolt holes at Station 45. The new radii for comparison purposes were then 9.27 meters (365 inches) for the YCH-47D blades and 6.81 meters (268 inches) for the K-747 blades. Table 3 presents the candidate rotors, their operating rpm, radii, and solidity weighted thrust coefficients. The gross weights for this comparison study are the RSRA's design and maximum helicopter gross weights. Tables 1, 2 and 3 along with the candidate rotors' descriptive summaries were used for the selection study.

A rotor selection tradeoff chart was developed to quantify the selection process. The three major evaluation items (technical merit, integration requirements, and development requirements) are given equal weighting for the tradeoff chart. Each of these three items were subdivided further. Table 4 presents the chart and the detailed weighing factors.

Technical Merit evaluates the hubs, blades, and construction features. A measure of thrust capability is determined by using the steady state thrust coefficients presented in Table 3. Hub designs are evaluated by considering their advanced structural features while blade designs are considered from both an aerodynamic and structural standpoint. Blades are weighted quite heavily in this section since their performance will primarily determine the rotor's performance on the RSRA.

In this section, thrust capability was not rated as high as hub and blade design due to the RSRA's unique capabilities. Since the RSRA was designed as a flying wind tunnel it can use its wings or auxiliary propulsion to select the rotor thrust and propulsive conditions independent of aircraft flight condition. Consequently, a rotor with advanced aerodynamic or structural characteristics would have higher Technical Merit than a rotor which matches the present S-61 rotor performance but without advanced features.

Integration requirement features are straightforward. This evaluation item considers ease of attachment to the RSRA, difficulty of transmission modifications, and control system modification difficulty.

The third major evaluation area is development requirements. As stated previously, this area primarily evaluates the candidates on degree of difficulty in accepting parametric variations and development features not covered under integration requirements (such as availability of spare parts). Mast height variability is evaluated primarily to investigate hub/fuselage interference. Hub and blade variability is also evaluated in this technical area. The ability of the blade to accept both aerodynamic and structural changes is considered. The final evaluation item is an attempt to consider and weigh various development features not adequately covered in the rest of the tradeoff chart.

The individual candidates are ranked from 1 to 5 (for each feature) with 3 being considered average. The maximum any candidate can score is 150 points. The tradeoff selection chart comparing the candidates is shown in Table 5. The rationale for the ratings for each factor follows.

TECHNICAL MERIT

All of the candidate rotor systems were judged to have approximately equal Technical Merit with the exception of the combination rotor system using the Kaman K-747 blades which was ranked lower. The details of this evaluation are presented below.

Thrust Capability

The thrust capability of the five candidate rotors were compared in two conditions: hover and maneuvering flight, out-of-ground effect (OGE) hover power required was estimated for each rotor using a generalized procedure presented in Reference 16 ($C_T = 1.93 C_p^{.774}$)

The predicted main rotor power was then corrected to total power by including tail rotor, accessories, and gearbox losses. The resulting total power was then corrected for both OGE and IGE conditions. The advanced rotor systems' power required were further adjusted using results from YAH-64 hover tests. These factors were judged necessary to fairly compare the RSRA and the advanced rotors since the formula from Reference 16 was based on older technology helicopters. Table 6 presents the OGE and IGE power required (sea level, standard day) for the candidate systems with the RSRA included as a baseline. The UH-60A and YCH-47D system rated the highest in this comparison. In OGE hover, all rotor systems with the exception of the YCH-47D system would exceed the gearbox 186.4×10^4 watt (2500 HP) 30 minute rating. In IGE hover, all candidates except the K-747 blades can hover within the 30 minute rating. The K-747 rotor system has the following options: rolling takeoffs, or using the gearbox transient limit of 216.2×10^4 watts (2900 HP).

Maneuvering flight thrust capability is indicated by the candidates solidity weighted thrust coefficient (C_T/σ) which was presented in Table 3. The YCH-47D (four-blader) has the lowest C_T/σ of the systems and hence the highest load factor potential and thus was top rated under this feature. The UH-60A, YUH-61A, and K-747 were very close in C_T/σ capability and given an equal rating. The YAH-64 would be the most heavily loaded rotor and thus was given a No. 2 (below average) rating.

Hub Designs

Since the K-747 and YCH-47D blades need to be adapted to an existing hub, they were rated below average (No. 1) for this feature. The hubs for the YAH-64, UH-60, and YUH-61A all have various advanced features. The YAH-64 was rated above average (No. 4) due to its existing "strap pack" hub which eliminates flapping and feathering bearings. In addition, the YAH-64 uses elastomeric dampers to eliminate lead-lag instabilities. The advantages of the elastomeric/titanium hub of the UH-60 was recognized but the lead-lag dampers are hydraulic which kept its hub rating at No. 3 (average). The advanced hub/blade design of the YUH-61A which eliminates flapping and lead-lag bearings was rated a No. 3 (average) since the hub uses standard pitch change bearings.

Blade Design

All the candidates use advanced helicopter airfoils listed in Table 1 and whose characteristics are shown in Figure 11. Thus each candidate was rated above average (No. 4) in blade aerodynamics.

The rotor systems use composite blades or hybrid blades (metal/composite construction), and these blades with their advanced structures were all rated above average (No. 4).

INTEGRATION REQUIREMENTS

In all three features, the candidates were rated equally except for attachment to the research vehicle and transmission modifications. The YAH-64 was rated higher because it uses a static mast to transfer hub loads to the fuselage which simplifies the attachment hardware. The static mast feature eliminates the hub forces from the transmission which means the existing transmission case, bearings, and internal transmission parts will not have to be replaced or redesigned due to potentially higher stresses. In fact, the static mast feature will reduce the transmission loads (other than torque) below the loads generated by the existing RSRA rotor. In addition, the YAH-64 transmission modification will only involve gear train changes and mast adaptors.

DEVELOPMENT REQUIREMENTS

This section evaluates the ease in which the candidates can accommodate parametric variations as well as access any special development advantages or disadvantages of the candidates. The YAH-64 rated higher than the other candidates in this section primarily due to its static mast design and two types of blades available for testing.

Rotor Mast Height Variability

The candidates were all judged fairly equal in this category except for the YAH-64 which because of its static mast design was rated slightly higher than the other systems. Figure 12 shows how the static mast design aids in hub/fuselage variations.

Hub Variations

The YAH-64, UH-60, and YUH-61A were judged equal in this category. Since the K-747 and YCH-47D require new hubs or significant blade root end changes to adapt to existing hubs they were downgraded in this category.

Blade Variations

The all composite or composite/metal construction of these candidate blades would accommodate airfoil or tip shape modifications. The all composite blades would be better able to accommodate structural changes while maintaining geometric shapes than the hybrid blades. Different materials could be used to fabricate the all composite blades and achieve structural changes such as stiffness while maintaining the same airfoil and geometric dimensions. Blades with metal spars cannot be structurally modified as easily as the composite spar blades. With metal spar blades, the spar geometry has to be changed to vary the structural properties of the spar. This requires new tooling. With composite blades, the geometry of the spar can be kept the same while changing the spar material and/or fiber orientation to achieve structural changes. The YAH-64 will use all composite blades (see above) and in addition, hybrid metal/composite blades that were first developed for the YAH-64. These blades (hybrid) which are similar geometrically to the all composite blades (while differing in weight and stiffness) would be available for testing on the RSRA. Thus the YAH-64 candidate had the highest rating (No. 5); the all composite blades were rated 4 and the hybrid blades were rated 3.

Other Development Features

The standard four-bladed rotor system candidates were judged fairly equal in development features except for the YUH-61A. Since the YUH-61A is not in production nor in development it was given a No. 2 rating (slightly below average). Both the K-747 and YCH-47D blades would require a large amount of development work to fabricate a four-bladed system. Due to this fact, the K-747 and YCH-47 candidates were rated below average (No. 1) for this feature.

SELECTED ROTOR SYSTEM

The YAH-64 rotor system obtained the highest rating in the rotor selection chart and thus was chosen as the rotor system to develop further for testing on the RSRA. Essentially this system won the tradeoff study due to its advanced "strap-pack" hub design, composite blades with metal blades also available for testing, and the YAH-64 static mast design which greatly simplifies the rotor to fuselage attachment. In addition, the aerodynamic features of the blade incorporate technology equivalent to advanced rotors under development. Figure 13 shows this rotor installed on the RSRA.

DETAILED STUDY

This section of the report details the studies and predesign work conducted to integrate the YAH-64 main rotor with the RSRA. Also presented are parametric variability studies and technology payoff analyses. The section concludes with the instrumentation plan.

INTEGRATION AND PRE-DESIGN STUDIES

The YAH-64 rotor installation chosen for the RSRA consisted of a static mast with a truss support network and a modified RSRA stationary control system. The YAH-64 static mast system used to mate the rotor with the RSRA. A truss and structure was chosen to transmit the rotor loads to the balance/isolation platform. Major changes in the transmission case were avoided by using the truss. The YAH-64 rotating control system was mated by bell-crank changes in the RSRA stationary system. Figure 14 (Drawing 464-0002) presents the configuration chosen to mate the YAH-64 with the RSRA. The rotor centerline and swashplate are shown for the minimum mast height configuration. The tradeoff studies which support the selected design are described in the following sections. The two major integration items were rotor attachment to the RSRA including transmission modifications, and control system modifications.

YAH-64 Rotor Attachment to the RSRA

The static mast design of the YAH-64 as discussed in the previous section was chosen for integration into the RSRA. Figure 15 shows the static mast concept as installed on the YAH-64.

In the YAH-64 installation, the main rotor moments and shears are carried by a mast rigidly bolted to a mast platform, which also supports the main transmission. This platform is then attached to the fuselage deck by a truss network. The transmission reacts only drive torque. A similar approach was used to integrate the YAH-64 rotor system onto the RSRA.

Two static mast mounting approaches were available with the RSRA. One approach involved mounting the static mast directly to the existing transmission top and the second involved mounting the static mast to a platform and truss structure which carries loads directly to the rotor isolation system. The basic RSRA structure and the truss structure are shown schematically in Figure 16 (Drawing 464-5000). Figure 17 (Drawing 464-0000) shows the mast mounted directly to the transmission and installed on the RSRA while

Figure 18 (Drawing 464-0001) shows the mast to platform and truss concept on the RSRA. The primary difference between the two approaches is the load paths. In the first approach, the loads are carried through the transmission while in the second approach, the loads are transferred directly to the rotor balance platform. In both approaches, the mast support platform forms the top of the RSRA transmission. The two mounting approaches were evaluated on the number of new parts needed and the technical risk. Based on the comparison, the platform/truss mounting concept (the second approach) was selected. A parts comparison for the two rotor attachment concepts is shown in Table 7. Although the total number of parts to be added and modified is approximately the same for both concepts the platform/truss parts are judged to be less expensive than the parts to be fabricated/modified using the existing transmission.

Before conducting a stress analysis, the location of the YAH-64 rotor was determined relative to the RSRA. The location of the YAH-64 rotor hub centerline was determined by the clearance required by the blade droop at full pitch. In order to prevent fuselage/blade interference, the YAH-64 rotor will be installed at RSRA WL 310.5 which is .25 meters (9.8 in.) higher than the existing RSRA rotor. Figure 18 shows the location of the YAH-64 rotor hub centerline for minimum clearance.

The YAH-64 mast loads were reviewed to determine the feasibility of the two static mast concepts. The combined hub and swashplate loads for the YAH-64 M/R mast based on the AAH loads are shown in Figure 19. The three mast critical cases are shown: 1. Entry pull-up, power on, 4. Entry pull-up, power off, and 5. Maximum G pull-up, power off. The YAH-64 modified mast attaches to the airframe at approximately the same waterline location for both the static mast design under consideration (WL 282). Thus the mast moments for both design approaches for the minimum rotor clearance and maximum rotor height (based on existing YAH-64 mast) are shown in Figure 19. The comparison shows that either mounting approach will sustain the loads and that the critical component are the bolts mounting the mast to the gearbox or platform. The difference in loads caused by swashplate location is negligible and Figure 19 shows the margin of safety of a modified mast will be adequate.

The platform/truss structure is similar in design to the YAH-64 (Figure 15 and Figure 18) except it has six fittings for twelve truss legs in lieu of four fittings for eight truss legs. This highly redundant structure will enable the new design to carry the static mast loads. The final detail design and stress analysis will size the platform and truss legs.

It was decided the mast to transmission housing approach was much riskier than the platform/truss approach due to the complex and difficult task of stress analysis with a transmission housing. In addition, mast height changes (see parameter change studies) would require additional analysis with potential transmission housing changes. The platform/truss structure can be analyzed much more forthrightly than the transmission case and changes can be accomplished much less expensively. In addition, two slightly different designs will be considered during the preliminary design for the new platform which will also function as the transmission cover. One, a flexible boot may be used between the platform/cover and the housing. Two, the platform will fit loosely into the transmission housing (with seals) with sufficient clearance so that loads are not transmitted through the transmission housing.

In addition to attachment changes, the YAH-64 main rotor will require transmission gear changes as discussed in the previous section to obtain the 289 operating rpm. Gear changes which are presented in the RSRA handbook (Reference 15) will be used to obtain 285 M/R rpm and the beep range available on the RSRA will then be used to obtain the 289 operating rpm. The new gears (input spur and bevel mesh) that will be required and a comparison with the existing gears on the RSRA are given in Table 8. Again, these gear changes should entail low risk since the RSRA was designed to accept these new gears.

Ground Resonance

The YAH-64 rotor which is smaller than the standard RSRA rotor will require less system damping to avoid ground resonance. Simple calculations using the Coleman required damping product (Reference 17) show that approximately one-third the pylon (hub) damping required for the large S61 rotor (RSRA) will be required with the YAH-64 rotor using the $\pm 4^\circ$ blade damper amplitude damping of the rotors. This is confirmed by more exact calculations which include the effect of the slight increase in fuselage frequencies caused by the lower effective hub mass with the YAH-64 rotor.

The following analyses show a large damping margin with the RSRA rotor system and an even larger margin will exist with the YAH-64 rotor system.

Analysis

Reference 17 shows the anisotropic Coleman product of damping required as:

$$\bar{\lambda}_y \bar{\lambda}_f = \frac{1}{2} \Lambda_3 \left(\frac{1}{\sqrt{\Lambda_1}} - 1 \right)$$

This readily reduces to:

$$C_y (C_f \omega_f) = \frac{\eta}{4} \sigma_f^2 \omega_y^3$$

where:

$$C_y = \text{hub damping, } 172.7 \times 10^3 \frac{\text{N-sec}}{\text{m}} \left(985.9 \frac{\text{lb-sec}}{\text{in.}} \right) \text{Pitch;} \\ 401.7 \times 10^3 \frac{\text{N-sec}}{\text{m}} \left(2294 \frac{\text{lb-sec}}{\text{in.}} \right) \text{Roll}$$

$$(C_f \omega_f) = \text{blade damping stiffness } \frac{\text{N-m}}{\text{rad}} \left(\frac{\text{in-lb}}{\text{rad}} \right)$$

η = number of blades (5 for RSRA; 4 for AAH)

σ_f = first mass moment of blade about lag hinge, N-sec^2 (lb-sec^2)

ω_y = hub natural frequency (rad/sec)

Table 9 is a comparison of the two different rotor system properties which shows nearly 3 times more hub damping required for the RSRA rotor. Reference 18 was used for the RSRA properties.

Table 10 shows the product of damping, the equivalent hub masses, hub frequencies, and the product of damping margins for the pitch (brakes off) and roll modes with each of the rotor systems. Since the large amplitude ($\pm 4^\circ$ lag) damper motion of the RSRA blade damper results in damping that approaches coulomb damping, the damping stiffness, $C_f \omega_f$, at 203 rpm and .25/rev lag natural frequency calculated from Figure II-4 of Reference 18 was used for both the 110 rpm (pitch) and the 340 rpm (roll) critical rotor speeds. This is a conservative assumption for the 340 rpm rotor speed, which shows the smallest though much more than adequate margin.

Control Modifications

Two different approaches were considered to mating the control system of the YAH-64 and the RSRA. The objective was to obtain the same blade motions with the YAH-64 rotor on the RSRA as on the attack helicopter. Table 11 compares the existing RSRA and YAH-64 control system. The RSRA control motions were obtained from RSRA Drawing No. 72400-00010.

One approach to mating the YAH-64 rotor and RSRA control system was to use the existing fixed control system of the RSRA and change the rotating swashplate and pitch horn arms of the YAH-64. Figure 17 (Drawing 464-0000) shows a control motion schematic/layout of the effects of changing the pitch horn arms and the rotating swashplate. The pitch link loads would increase approximately 28% (9.5/7.43) with this design for flight conditions comparable to the AAH.

Next, changes in the fixed system were considered. The fixed system collective travel was modified in order to match the YAH-64 rotor. Three bellcranks will be modified as shown in Table 12 to change the swashplate collective travel from .03 to .04 meters (± 1.03 to ± 1.647 inches). This necessitates that the amplification factor of the three bellcranks be changed from 1.357 to 2.17

The YAH-64 cyclic blade motions were then changed by modifying the fixed system swashplate arm. Again using Drawing No. 72400-00010, the new bellcranks will produce lateral and longitudinal inputs of .11 and .18 meters (4.35 and 6.92 inches) at the stationary swashplate. (For reference, the existing bellcranks produce travels of .07 and .11 meters (2.718 and 4.346 inches) for lateral and longitudinal inputs.) Thus to reproduce the YAH-64 total swashplate motion, the new stationary swashplate arm must be .51 meters (20.2 inches)(see Table 12). Figure 20 (Drawing 464-8000) shows the new stationary swashplate and bellcranks installed on the RSRA. In addition, Figure 18 (Drawing 464-0001) shows the location of the new swashplate along the mast. This vertical position of the swashplate assures clearance between the swashplate and the new platform at full down collective and maximum cyclic pitch.

The recommended approach is to change the stationary control system and not change the loads in the rotating system due to geometry changes. Other items that will be considered during a follow-on program include bellcrank loads, cowling changes, and swashplate phasing and potential changes to the RSRA built-in control couplings. The analog mixer capability of the RSRA should ensure that swashplate phasing problems will be minimized.

Other Modifications

Blade severance assembly will be straightforward. Figure 21 (Drawing 464-1002) shows the blade severance assembly installed on the YAH-64 blade. The existing YAH-64 deicing receptacles are used to mate the severance assembly with the blade. Both the composite and metal blades will accept the severance assembly. Secondary bonding operations will also be used to attach the assembly to the blade. Qualification testing which is to be

conducted in the follow-on program will include testing of the shaped charges on scrap/unuseable blades to determine their cutting ability. The uncomplcated installation of the severance assembly coupled with qualification testing will assure a low risk design.

PARAMETER CHANGE AND TECHNOLOGY PAYOFF STUDIES

This section details the parameter to varied, concepts for parametric variation, and technical risks involved. Changes were considered in the hub/mast and blades.

Hub/Mast

Mast height changes are shown in Figure 17. The rotor hub center-line for minimum rotor/fuselage clearance is .25 meters (9.8 inches) above the RSRA rotor centerline. The proposed maximum mast height change is .37 meters (14.7 inches) above the minimum clearance height. Longer mast heights (up to an additional .51 meters (20 in.) can be accommodated before the bolt limit is exceeded but this would require a new mast rather than modification of the existing mast. Mast height changes would require modified static masts, new drive shafts, and new/modified pitch links. The basic support structure (platform/truss) will be designed to accommodate the highest mast height. The mast height changes are considered low risk and will allow the study of rotor/fuselage interactions. The new masts can be machined from existing forgings and Figure 22 (Drawing 464-5001) presents the basic dimensions on the new masts. Due to the swashplate location when the YAH-64 main rotor is installed on the RSRA additional machining will be required. The wall thickness of the masts shown in Figure 22 was adjusted to account for the loss in structural inertia from the basic mast. New pitch links will be required for this installation. Figure 23 (Drawing 464-3000) shows the new barrels required for their installation and Figure 24 (Drawing 464-3001) presents the new pitch link assemblies. The barrels keep the same length/diameter as for the standard YAH-64 rotor system so that long column buckling problems are minimized. A special tool was drawn (Figure 25) to keep the pitch link rod ends centered when the pitch links are changed for track adjustments.

During the follow on program, a new approach will be considered. Rather than change the pitch link and drive scissor assemblies with mast height, it might be more advantageous to raise the stationary swashplate. The preliminary design study will consider weight, cost, and hub drag.

Delta-three changes are also proposed for the hub. The basic YAH-64 pitch housing forgings (7-211411177) will be machined to accept different pitch horn arms. Figure 26 (Drawing 464-2000) shows this design concept. Two different pitch horn arms are shown with Δ_3 of $\pm 20^\circ$. Twenty degree Δ_3 angles are the maximum allowed due to hub clearances. The control motion is the same for all configurations since the distance from the pitch change axis to the pitch link is kept at .24 meters (9.5 in.) Δ_3 changes are effected by modifying the pitch housings and machining new pitch horn arms. This is considered a low risk approach since the same basic load carrying structure, the pitch housing, is the same and the control travels are kept the same.

Blades

Two basic YAH-64 blade sets will be tested during the follow-on program. The first set will be the composite blades shown in Figure 27 (Drawing 464-1001). Next, the metal blades tested on the YAH-64 during the prototype testing will be investigated on the RSRA. The planform of the composite and metal blades are identical with the tip airfoil being the only geometric difference between the two sets. The Composite blade tip has a NACA 64A009 while the Metal blade has a NACA 64A006 at the tip. The torsional properties differ between the blade sets with the composite blades $GJ = .046 \times 10^6$ Newton-M² (16×10^6 lb-in²) and the metal blades $GJ = .055$ Newton-M² (19×10^6 lb-in²). This phase of the testing should allow a determination of a blade's structural properties upon performance and other characteristics. This approach is very low risk as both sets will have been flight tested when the RSRA 4-bladed program is ready to be flown.

Next changes in blade tips were considered. Figures 28 through 31 (Drawings 464-1003 through -1006) show the blade tips to be investigated. All blade tip changes have kept the airfoils the same to facilitate comparisons. A square tip, Figure 29, is proposed as the baseline rotor. The swept tip shown in Figure 28 is the standard rotor of the YAH-64. The swept-tapered tip design shown in Figure 30 is based on References 19 through 21. The OGEE tip (Drawing 464-1006) is based on References 20 and 22 through 25.

The impact of other parameter variations was evaluated in both hover and forward flight. The hover performance was calculated using a strip momentum approach with a variable downwash. The forward flight performance was calculated using a rigid, flapping blade divided into discrete segments. The blade motion and forces are integrated azimuthally to give the rotor performance. The rotor was trimmed to the proper thrust and propulsive force. Both of these analyses have been used on the YAH-64 rotor development effort.

The YAH-64 rotor twist was varied over a wide range. The twist of the YAH-64 rotor was varied from -6° to -15° , with -9° being the design value. This range was considered the practical limit considering actual helicopter operation. The analysis showed that at the RSRA helicopter design gross weight of 8346 Kg (18,400 lb), twist has a small effect on hover power required (Figure 32). In forward flight, the effect of twist becomes more pronounced. At 77 m/s (150 knots), and 8346 Kg. (18,400 lb) gross weight, an increase of twist of three degrees results in a two percent reduction in power. Conversely, a three degree decrease results in a three to four percent increase in power. The twist-induced reduction in power required is a significant savings in operational costs. The disadvantage to the increased twist is the increase in blade loads and airframe vibration. Due to the complexity of modelling the main rotor hub mounting and the rotor/body interference, an estimate of blade loads has not been made at this time. However, due to the large design fatigue life and design load factor of the YAH-64 rotor system, the strength of the blades should be sufficient to accommodate any increased loads. Therefore, tests with variations in twist are considered to have good potential payoff but low risk. Blades with -12° twist should be tested in addition to the standard -9° twisted blades.

Planform change was also evaluated as to its impact on rotor performance. Two basic planform shapes were considered. The first was a linear two-to-one taper from root to tip. The second was a two step taper which maintained a constant chord out to 80 percent radius then tapered to the tip. Both planform variations maintained the same thrust weighted solidity of the basic YAH-64 rotor blade. The results indicate that at 8346 Kg (18,400 lb) gross weight planform is more influential in hover than at forward speed. In hover, the planform changes result in almost a two percent reduction in power required (Figure 33). At 77 m/s (150 knots) forward flight, the planform tapers result in an approximate one percent reduction in power required (Figure 33). This level of power reduction has a high potential payoff for planform taper. Consequently, the two-to-one tapered planform is suggested for flight test.

Tip speed is the parameter which has the highest potential payoff with the lowest risk. Figure 34 shows the effect of rotor tip speed variation on the YAH-64 rotor performance as installed on the RSRA. Performance improvements on the order of three percent can be gained in hover by a three percent reduction in tip speed. In forward flight, tip speed changes are undesirable primarily because the YAH-64 rotor is heavily loaded at the RSRA design gross weight. Any change in tip speed results in either retreating blade stall for at tip speed reduction or drag divergence for a tip speed increase. The tip speed reduction also has the additional noise reduction benefit. The tip speed reduction also has the lowest risk. Consequently, it should be evaluated from both a performance and acoustic viewpoint.

In addition to these parametric changes, a blade incorporating several performance improvement features should be investigated during the preliminary design phase of the program. The advanced blade should also be considered for fabrication. Thus the total blade sets proposed for the follow on program are as follows:

- Four standard metal blades
- Four standard composite blades
- Twelve blades with new tips
 - Four square tip blades
 - Four swept-tapered tip blades
 - Four OGEE tip blades
- Four blades with new twist
- Four blades with new planform
- Four blades with new planform, twist, and possibly airfoils

Blade fabrication techniques will be used that will ensure high quality flight-worthy blades while minimizing cost where possible. Wet filament winding and cocure fabrication accompanied by broad goods layup, and premolding select items, are techniques that will be used to produce the subject blades. These are proven methods which have been demonstrated to produce high quality, flightworthy blades at minimal cost. The wet filament winding process has been successfully used by Hughes Helicopters on many major past, as well as current blade and fuselage programs.

Wet filament winding consists of passing dry filaments through a resin impregnator, wetting the filaments with resin and then passing the filaments through an eye or loom onto the rotating drum or mandrel mounted on a winding machine (Figure 35). Considerations of profile or shape are made in the initial selection of mandrel tooling.

Inflatable bladders mounted over shaped styrofoam mandrels will be used as tooling for the spar tubes. The inflatable bladder approach, which is dictated by the internal blade geometry, assures desired configurations, and maintains intimate contact with adjoining spar tubes, leading edge weights, trailing edge longo, and other internal members, as well as outer skins as shown in Figure 36.

New blade molds would be fabricated. A new mold is dictated, inasmuch as any alteration to the existing YAH-64 composite blade mold would destroy its use on that program. The closed cavity molds will be pressure balanced, low mass concept of monolithic construction. The profiles will be configured for the various parametric changes.

The contours will be machined by a numerically controlled, 3 axis milling machine, or 3D profiler. The mold halves will have positive indexing to maintain alignment and internal features to accurately position various pre-machined or premolded items, such as root retention fittings, tip weights, and cores. In order to minimize cost, mold inserts for the various tip configurations will be adapted to the basic blade mold.

The mold will be placed in a mold press. The bladders inside the spar tubes will be pressurized to assure full peripheral contact to adjacent members. The tubes in the mold press will be pressurized to balance the spar tube bladder pressure and prevent the mold from distortion. Figure 37 presents a schematic drawing of the tooling with a mold insert for tip fabrication. The integrally heated mold will be heated per a time/temperature schedule to cure the resin. During the cure cycle, the contoured styrofoam spar tube mandrels effectively shrink, minimizing removal difficulties of the internal tooling.

For complex tip shapes, templates will be generated, which will be used to form plaster shapes for cast back soft tooling. Generally, this type of tooling is used in making tip caps, fairings, closures, foam cores, as well as bonding fixtures for secondary bonding operations.

Skins, spar caps, and chordwise stiffeners will be wound on appropriate mandrels. The skin mandrel is generally of a fiberglass/wood construction for economy on a minimal run quantity.

Accommodation within the mold will be provided for the varied locations of accelerometers and pressure transducers, as may relate to test considerations and requirements. Localized "pockets" and/or gloves will enable the instrumentation to be placed below the airfoil surfaces.

Hughes Helicopter, Inc. winding equipment consists of a programmable computer controlled, servo drive, helical machine; 24 foot length by 48 inch diameter capacity; a gear-chain change ratio machine; 25 foot length by 24 inch diameter capacity; a longitudinal winder, and a programmable computer controlled servo drive ring winder. Secondary support equipment for composite structure fabrication includes, but is not limited to, a water jet cutter, a large cure oven, metal working and composite working machinery, and NDI

ultrasonic testing equipment. Figure 38 shows the tubular winding machine and Figure 39 shows a schematic of the ring winder.

All part fabrication will be accomplished in the newly enlarged Advanced Composites Laboratory.

INSTRUMENTATION PLAN

Instrumentation shall be provided to measure blade airloads and blade dynamic and structural response. In addition, the instrumentation will ensure safety-of-flight. This section of the report details the rotating instrumentation and other special instrumentation requirements. The basic instrumentation of the RSRA (fixed system and tail rotor) such as control positions, vibration measurements, balance loads, attitude and rate measurements shall remain the same as for the basic RSRA test flights and these instrumentation items are not listed.

The basic instrumentation of the YAH-64 main rotor blade which includes strain gages and position potentiometers shall be included when the YAH-64 rotor is installed on the RSRA. This basic instrumentation was obtained from Reference 26 and is presented in Table 14. One blade shall be designated the number one blade and the other blades will be numbered sequentially in a counterclockwise direction. Items added to the basic AAH instrumentation will be used to detect any differences, if any, among the blades in flight. Outboard torsion gages were used on previous flight test programs (Reference 27) and were very helpful in determining differences among blades in flight. The location of the strain gage instrumentation is shown in Figure 27 (Drawing 464-1001). The location of the gages parallels the locations presently used on the YAH-64 flight test program. Retention of the same locations will provide a one-to-one comparison which will assist in determining installation effects.

Instrumentation techniques and test results from References 28 and 29 were used to determine additional research instrumentation. Miniature, temperature-compensated accelerometers will be used to determine rotor mode shapes by measuring blade/hub motions directly. Table 15 presents the accelerometers and their locations. Adjacent blades will be instrumented in order to identify rotor modes (e. g. , scissors modes). Figure 27 also shows the location of the accelerometers.

Blade airloads and aerodynamic environment will be determined by absolute pressure transducers. Differential pressure transducers were eliminated

from consideration since Reference 28 concluded differential pressure measurements mask details of the aero-environment such as local shocks. Reference 29 was also used as a guide for the spanwise location and number of the pressure transducers. The station location for the pressure transducers will be Station 115. ($r/R = 0.4$), Station 173. ($r/R = 0.6$), Station 216. ($r/R = 0.75$), Station 245. ($r/R = 0.85$), Station 258.5. ($r/R = 0.9$) and Station 278. ($r/R = 0.965$). Station 278 is approximately the middle of the YAH-64 swept tip. Table 16 presents the pressure transducer instrumentation. The pressure transducer locations were selected to provide an accurate measurement of the pressure distribution as predicted from two dimensional wind tunnel data. Figure 40 shows the transducer chordwise locations as compared to HH-02 pressure distributions at two representative Mach number/angle of attack combinations. The comparison shows that the locations will provide an accurate measurement of the maximum pressure peak ($MACH No. = 0.46\alpha = 7.8^\circ$) and the location of any shock ($MACH No. = 0.79\alpha = 1.72^\circ$). The blade spanwise locations of the pressure transducers are shown in Figure 27.

Gloved instrumentation (Reference 29) will be used for the pressure transducers. The composite blade construction lends itself well to mold inserts which will form blade indentations for the gloves.

The total number of rotating instrumentation items will be 232. These items listed will provide a complete description of the rotor's dynamic and aerodynamic environment as well as providing safety-of-flight monitoring.

In addition, the following instrumentation in the fixed system is recommended for use during a special acoustic evaluation of the YAH-64. The instrumentation includes: 1) Cockpit microphones - Two microphones having a frequency range to 10,000 Hz are to be mounted in the cockpit for measurement of noise entering through the windshield, 2) Fuselage external microphones - Two microphones are to be mounted on the fuselage adjacent to the cockpit. They should be located such as to determine cockpit excitation by blade overpressure and/or acoustic pressure. These microphones should have aerodynamic fairings and be self aligning with the airstream to prevent excessive turbulence noise.

DEVELOPMENT PLAN

This section of the report presents the plans and documentation required to implement the predesign studies. Cost and schedule estimates are then shown which are based on the development plans.

WORK STATEMENT AND PROGRAM PLAN

To accomplish a program which includes design, fabrication, and testing of the four-bladed rotor on the RSRA, a full understanding of the RSRA is necessary. The RSRA documentation necessary is presented in following paragraphs. Essentially, all drawings, analyses, and reports generated during the design, fabrication, and testing of the vehicle should be transmitted to the contractor. The following items are required:

- All Drawings of the RSRA

- Principal Areas and Dimensions Report

- Mass Properties Reports

 - Weight and Balance

 - Mass Moments

- Aerodynamic Performance and Stability and Control Reports

 - Analytical Report

 - Wind Tunnel Test

 - Flight Dynamic Model

- Structural Reports

 - Structural Criteria

 - Loads

 - Stress Analysis (including items such as the transmission)

- Dynamic Analysis Report

- System Requirements Handbook

- Flight Control System Design Report

Subsystem, Systems, and Ground Test Reports

- Control System Proofload
- Electrical System Checks
- Hydraulic System Checkout
- Shake Tests
- Stability Augmentation System
- Others

Flight Test Reports

The above reports and drawings should reflect the latest revisions and any RSRA configuration changes. As additional flight tests are conducted with the RSRA, the data should be made available in a timely manner.

Based on the availability of the RSRA data, a work breakdown structure (WBS) has been prepared for the whole program. Table 17 presents the WBS for this program detailed to the fourth level. This WBS presents an option to the development program to include either wind tunnel or whirl tower testing. The recommended option is for wind tunnel testing but cost and schedule information is also presented later for the whirl tower testing. The wind tunnel option is recommended to give more depth to this research program and generate data which can be combined with the RSRA flight test. Comparisons between RSRA and full scale wind tunnel tests would be very beneficial and could provide insight into wind tunnel interference effects.

Using the WBS as a guide the following draft statement of work was prepared.

DESIGN, FABRICATION, AND TESTING OF A MODERN FOUR-BLADED ROTOR FOR THE ROTOR SYSTEMS RESEARCH AIRCRAFT (RSRA)

1.0 GENERAL SCOPE OF WORK

This contract is intended to result in flight qualified hardware which will be tested on the RSRA. The work shall include detail design, design analyses, fabrication, and qualification testing for a modern four-bladed rotor with parameter change capability. Modifications to the RSRA and ground run and flight test support shall also be provided by the contractor. This work shall be based on previously conducted pre-design studies.

2.0 DESCRIPTION OF TASKS

The contractor shall furnish the personnel, equipment, material, and facilities necessary to perform the following tasks keyed to the WBS.

2.1 Preliminary Design (WBS 1100)

NASA shall provide to the contractor the data, drawings, and reports that define the latest RSRA configuration (WBS 1110). Pre-design studies already conducted shall form the basis of this preliminary design.

The most cost effective means of adapting the chosen four-bladed rotor to the RSRA shall be finalized during this task. Technical risk assessment as well as actual costs should be used to determine the best approach for mating the rotor system and the RSRA. The contractor may use approaches different from those proposed during the pre-design studies.

Items to be considered for integration shall include: control system, mast/pylon support, cowlings and fairings, drive system (transmission changes plus rotor drive shaft), and the active balance/isolation system. In addition, the emergency escape system with the blade severance system shall be designed.

During this preliminary design, blade instrumentation requirements shall be reviewed and any additions/changes from the pre-design studies will be determined. Blade concepts shall be investigated and designed that accept the required instrumentation.

Design parameter changes shall be finalized during this task. Parametric variations to be considered shall include but not be limited to control couplings, mast heights, and blade changes. Blade designs shall investigate new twists, planforms, tips, and airfoil sections. Work conducted during the pre-design studies shall be used to guide this task.

Design analyses shall be conducted to determine both the desired parametric variations and the optimum methods of adapting the four-bladed rotor system to the RSRA. Some of the disciplines which shall be considered are performance, dynamics, stability and control, stress, and weights.

This task shall culminate in a Preliminary Design Report and a Preliminary Design Review.

2.2 Detail Design (WBS 1200)

After the Preliminary Design Review, the contractor shall conduct a detail design of the configuration. The detail design effort shall include all necessary drawings, weights analysis, dynamic analysis, and stress analysis. Assembly drawings, installation drawings, and motion layouts (where applicable) shall be prepared as well as detail part drawings.

The detail design shall be comprehensive and will include all parts and assemblies necessary to mate the RSRA with the 4-bladed rotor system. In addition, all parametric change capability shall be detail designed. The detail design will include any special features needed for the instrumentation requirements.

Design criteria shall be established with the concurrence of NASA's technical monitor. Established design criteria for the four-bladed rotor system will be used when applicable. A stress analysis report shall be prepared in contractor's format. The parts that are critical in the design will be identified and load monitoring curves shall be established.

A design review will be conducted four and a half months after the start of the detail design work at the contractors place of business. This design review will monitor the work accomplished to date. Approval will also be given at this design review for long lead time procurement. This approval cycle will facilitate the fabrication work.

A Critical Design Review will be held at the completion of this task. NASA approval must be obtained at the Critical Design Review in order to proceed to fabrication.

2.3 Fabrication (WBS 1300)

During this phase of the program all basic rotor components should be procured. These parts shall include rotor hub, basic blades, forgings to be modified, and the necessary hardware for assembly.

All parts necessary to mate the RSRA and the four-bladed rotor shall be fabricated. These parts shall include the control system, mast/pylon support structure, cowlings and fairings, drive shafts, and the emergency escape system. NASA will provide the transmission gear changes.

In addition, all blades and components that provide parametric variability shall be fabricated. Tool proof blades and qualification test blades shall also be fabricated during this task.

During this phase of the program, the contractor shall present an instrumentation plan which defines the instrumentation items and their locations. Items to be considered include strain gages, position potentiometers, accelerometers, and pressure transducers.

Upon NASA approval of the instrumentation plan, the rotor system shall be instrumented.

2.4 Safety-of-Flight Qualification (WBS 1400)

The contractor shall submit a qualification plan defining the procedures to be followed and the required testing to ensure safety-of-flight for all rotor components. The contractor shall implement a quality assurance program in accordance with the applicable requirements of MIL-Q-9858A. The contractor shall maintain and use any data records essential to the effective operation of the quality assurance system.

Upon NASA's approval of the qualification plan, the contractor shall conduct any special testing needed for the experimental hardware. This work shall include, if required, fabrication of test fixtures and machines. Both static and fatigue tests will be performed. Blade severance assembly tests shall be conducted.

2.5 Wind Tunnel Test (WBS 1500)

The contractor shall submit a wind tunnel test plan for NASA approval. The plan shall address instrumentation requirements, test module integration, tunnel installation, wind tunnel test conditions, and test objectives.

The contractor shall obtain a data system for the tunnel testing and assure that any special data requirements caused by the tunnel installation will be met.

Design and analyses shall be conducted to integrate the rotor system with the tunnel. Dynamic analyses will ensure that the system is free from any instabilities and/or load amplification problems. Stress analyses will also be performed to ensure that the support structure and control system have adequate static and fatigue strength. Any special components necessary to mate the rotor system with the tunnel shall also be fabricated during this task.

The rotor shall be installed in the tunnel and the systems checked out. System checkout shall include rotor interference checks, instrumentation checks, and control system proofload. Then, the rotor system with parameter changes shall be tested, data reduced and analysed, and a wind tunnel report prepared. An interim wind tunnel data report shall also be submitted.

2.6 Rotor Installation/Integration on the RSRA (WBS 1600)

The contractor shall prepare an installation plan for the rotor system on the RSRA. Rotor system maintenance manuals shall be provided by the contractor and any special maintenance procedures caused by the RSRA installation shall be detailed.

The contractor shall install the rotor system with modifications on the RSRA. Items such as new cowlings and fairings shall have been fabricated by the contractor and will be installed on the RSRA by contractor personnel under NASA guidance. Installation shall include control system mast/pylon support, drive system, rotor hub, and blades with their severance assemblies. NASA will modify the basic transmission to obtain new rotor rpms if necessary.

Upon installation all systems shall be checked. The control system will be proofloaded and interference checks conducted. Instrumentation system checks will include positive identification and sign convention checks.

The contractor shall submit a Ground Run Test Plan for NASA approval. The plan shall address general test procedures, critical test conditions, special instrumentation requirements, and on-line data reduction requirements. The test plan will define all test conditions.

NASA shall conduct the ground run with contractor support. Ground run tests based on the test plan shall be conducted. The ground runs will verify the frequency plots and freedom from ground resonance. Rotor and fuselage damping characteristics will be determined from the ground runs. These ground runs will also serve as rotor system and instrumentation checks.

Data reduction and analyses shall be performed by NASA with contractor support. The data and analyses shall be included in a contractor supplied Safety-of-Flight Report for the safety-of-flight review.

2.7 NASA Flight Test (WBS 1700)

NASA will conduct a two year flight test program with the four bladed rotor system on the RSRA. The contractor shall submit a flight test and instrumentation plan. The flight test plan will define the best conditions and parametric variations to be investigated with the four bladed rotor on the RSRA. The instrumentation plan shall list all instrumentation added to the total helicopter by the contractor. All calibrations shall be listed in the plan.

Full contractor support shall be required for the first three months of flight test. Contractor personnel will be on site at NASA Ames for the first quarter year of flight testing to assist in the program. The required contractor

personnel are as follows: project engineer/manager, stress analyst, dynamicist, performance analyst, data reduction technician, instrumentation technician, and mechanics. Contractor personnel shall be available to assist NASA during the remainder (1-3/4 years) of the flight test program.

2.8 Program Reporting (WBS 1800)

The contractor shall deliver the following reports to NASA at the time indicated:

<u>Document</u>	<u>Delivery Months After Contract Award</u>
Plan of Performance	1
Project Status Reports	15th day of each month
Performance and Cost Report	15th day of each month
Meeting Reports	10 days after contractor/ NASA meeting
Preliminary Drawings	6
Preliminary Design Report	6
Detail Drawings	15
Stress and Dynamics Report	15
Qualification Plan	15
Instrumentation Plan	16
Wind Tunnel Test Plan	26
Wind Tunnel Test Data Report	32
Wind Tunnel Test Final Report	35
Rotor/RSRA Installation Plan	27
Ground Run Test Plan	35
Safety-of-Flight Report	38
Flight Test Plan	38
Instrumentation Report	38

COST AND SCHEDULE ESTIMATES

Cost estimates and development plans have been based on these predesign studies and previous development experience at Hughes Helicopters, Inc.

In order to obtain flexibility and easily investigate the impact of changes on cost, the development plan was programmed using the ARTEMIS system at Hughes Helicopters, inc. ARTEMIS is a processing system for project management which was developed by Metier Management Systems, Inc. The basic hardware of the system consists of a central processor, printer, CRT with keyboard, and disc drive. Some of the uses of the system include:

- Cost Engineering
- Progress Measurement and Reporting
- Job Lists
- Estimating
- Financial Modeling

ARTEMIS is only as good as the estimates (schedule, manhours, inflation rates, others) used to program the system but since ARTEMIS can be easily changed, sensitivity analyses can be conducted to obtain the effects of schedule, inflation rates, and other factors upon the cost of the program. In order to develop cost estimates, four major inputs were made to the ARTEMIS system: schedule, manhours, labor categories, and distributed labor rates. Any of these variables may be changed independently and the effects upon costs determined. The Modern 4-Bladed Program was input on the ARTEMIS System. At the start of the development program new and better estimates (rates, hours, schedule) can be obtained. The system will then obtain the latest cost estimates. In addition, ARTEMIS will be used to monitor the program's progress, both schedule and costs.

Figure 41 presents the development plan schedule which includes wind tunnel testing (preferred option). An accounting calendar is used to generate this schedule. The duration of each task is listed in manufacturing days (5 days per week) but actual calendar time is used to determine the length of the program. The effects of accelerating the program (for example a six day work week) can also be studied with ARTEMIS but the costs presented in this report are for a standard week. In Figure 41, if any portion of an activity lies within a calendar month a "+" sign is shown in that month but the activity duration which is being computed internally will be handled correctly. Table 18 shows the total manhours per activity and labor costs for the program with the wind tunnel testing included. The inflation rate was estimated to be 11 percent a year and the start date was assumed to be January, 1982. Table 19 presents

the estimated material costs, travel/per diem costs, and total dollar costs associated with the program. Fabrication costs are the major expense for this program. The following items were included in the fabrication/procurement cost of this program.

Four standard metal blades

Four standard composite blades

One completed hub assembly

RSRA modifications - drive shaft, static mast, new mast platform/truss, pitch links, delta₃ variations, cowling, and control system.

Twenty four (24) new blades

New tips

Four square tip blades

Four swept-tapered tip blades

Four ogee tip blades

Four blades with different twist

Four blades with different planform

Four blades with the best combination of the above with new airfoils

The largest fabrication cost is the new blades. Savings can be attained by eliminating some of the blade parametric changes and these estimates will be presented later.

The alternative plan which substituted whirl tower testing in place of the wind tunnel tests was also evaluated. Figure 42 presents the schedule and costs are shown in Tables 20 and 21.

The effect of a delay in the contract start was also evaluated. The ARTEMIS program was then used to estimate schedule and labor costs for a start date of January 1983. Figure 43 shows the new program schedule with wind tunnel testing included. Table 22 presents the new labor costs with a one year delay. The year delay causes a labor growth of approximately 11 percent which is the inflation factor being used for these studies.

More detailed cost estimates were then made with the wind tunnel test option starting in January 1982. First cost estimates were prepared for three-month periods over the length of the program. Quarterly labor cost reports are shown in Table 23. Table 24 presents the total costs on a quarterly basis.

As mentioned previously, the blade fabrication costs are one of the major expenses of the program. Thus, a study was made to determine the effects of number of blade sets upon cost. These studies included the effects of limiting the number of blades tested upon detail design and fabrication but other cost activities (such as preliminary design or testing) were not re-estimated. Qualification testing was re-estimated for the first option only.

First a two blade set (8 blades) was considered. This program would use blades already available from previous YAH-64 testing and no new blades would have to be fabricated. The metal and composite blades would be tested. Table 25 presents the total labor costs of this option.

Next a program option was considered which included the basic blade sets (metal and composite blade) but added an additional three blade sets with new tips. This option was chosen since only one new basic blade mold with different tip inserts would be needed. The labor costs for this option are shown in Table 26.

A final option was the two basic blade sets, new tips and one new blade. This program would still be a savings over the original program since only two new basic blade molds would be required. Total labor costs for this option are shown in Table 27.

Table 28 includes material and subcontract costs and provides a total cost comparison between the options and the original program.

CONCLUSIONS

A study has been conducted to select a modern four-bladed main rotor for the Rotor System Research Aircraft. In addition to selection of a rotor system, the study included definition of vehicle integration requirements, instrumentation, parameter variation capability, and a program plan. The program plan included costs and schedules to flight test the selected rotor system on the RSRA. Based on the study, the following conclusions can be drawn:

- The YAH-64 main rotor system is the optimum modern, four-bladed rotor system for the RSRA. The RSRA can hover in-ground-effect with the YAH-64 rotor system and perform the RSRA mission.

- The integration of the YAH-64 main rotor into the RSRA is a low risk effort. The YAH-64 stationary mast allows the rotor system to be mounted onto the RSRA without imposing any additional loads on the RSRA drive train and transmission.
- The RSRA stationary control system can be readily modified to provide the required YAH-64 blade motion. This requires the fabrication of three additional bellcranks and a stationary swash-plate adapter.
- The YAH-64/RSRA vehicle has good ground resonance stability.
- The YAH-64 rotor system has a wide range of parametric change capability, including mast height, pitch-flat coupling, blade stiffness, airfoil, planform, tip shape and twist. Changes in blade design can be accomplished by fabricating additional blade sets using composite materials and the wet-filament-winding fabrication technique.
- Total program costs are estimated to be six million dollars to design, fabricate, install, wind tunnel test, and flight test a YAH-64 rotor system on the RSRA. Total program costs can be reduced by procuring fewer blade sets or by substituting whirl tower testing for testing in the Ames large scale 40 x 80 tunnel.

RECOMMENDATIONS

Based on the results of this study, it is recommended that:

- The YAH-64 rotor system be flight tested on the RSRA.
- As a part of the RSRA flight test program, the YAH-64 rotor system be tested in the Ames 40 x 80 large scale tunnel to provide data for flight safety but also to provide data for additional correlation between analyses, wind tunnel test, and RSRA flight test.

REFERENCES

1. Duke, F. H. and Hooper, W. C., THE BOEING MODEL 347 ADVANCED TECHNOLOGY HELICOPTER PROGRAM, Journal of the American Helicopter Society, Vol. 17, No. 2, April 1972.
2. Dendy, J. C., and Landers, C. L., YAH-64 ADVANCED ATTACK HELICOPTER DESIGN, 31st Annual National Forum of the American Helicopter Society, Preprint No. 911, May 1975.
3. Amer, K., La Forge, S., Neff, J. and Prouty, R., AERODYNAMIC AND DYNAMIC DESIGN AND DEVELOPMENT OF THE MAIN ROTOR OF THE YAH-64 ADVANCED ATTACK HELICOPTER, 32nd Annual National Forum of the American Helicopter Society, Preprint No. 1013, May 1976.
4. Lund, H. T., Yao, S. S. and Kiraly, R. L., YAH-64A COMPOSITE MAIN ROTOR BLADE, American Helicopter Society National Specialists Meeting, Philadelphia, Pennsylvania, October 1980.
5. Rybicki, R. C., THE SIKORSKY ELASTOMERIC ROTOR, 35th Annual National Forum of the American Helicopter Society, Preprint No. 79-48, May 1979.
6. Arcidiacono, P., and Zincone, R., TITANIUM UTTAS MAIN ROTOR BLADE, Journal of the American Helicopter Society, Vol 21, No. 2, April 1976.
7. Hoffrichter, J. S., and McCracken, C. M., DAMAGE-TOLERANT DESIGN OF THE YUH-61A MAIN ROTOR SYSTEM, Journal of the American Helicopter Society, Vol 24, No. 3, July 1978.
8. Feenan, R. J., Scarpati, T. S., and Stratton, W. K., UTTAS/HLH ROTOR BLADE FABRICATION AND TESTING, Journal of the American Helicopter Society, Vol. 22, No. 4, October 1977.
9. Maloney, P. F., Dite, L. G., and Powell, R. D., THE ARMY'S IMPROVED MAIN ROTOR BLADE FOR THE AH-1 HELICOPTER, 33rd Annual National Forum of the American Helicopter Society, Preprint No. 77. 33. 12, May 1977.
10. "Vertol Extending Chinook Service Live", Aviation Week and Space Technology, October 3, 1977.

11. Sandform, R. W., and Belko, R. P., CH-47 FIBERGLASS ROTOR BLADE DESIGN AND FABRICATION, American Helicopter Society National Specialists Meeting, Philadelphia, Pennsylvania, October 1980.
12. Dadone, L., ROTOR AIRFOIL OPTIMIZATION: AN UNDERSTANDING OF THE PHYSICAL LIMITS, 34th Annual National Forum of the American Helicopter Society, Preprint No. 78-4, May 1978.
13. Prouty, R. W., A STATE-OF-THE-ART OF TWO-DIMENSIONAL AIRFOIL DATA, Journal of the American Helicopter Society, Vol. 20, No. 4, October 1975.
14. Dadone, L., U.S. ARMY HELICOPTER DESIGN DATCOM, VOLUME I AIRFOILS, U.S. Army Air Mobility Research and Development Laboratory, CR 76-2, May 1976.
15. SYSTEMS REQUIREMENTS HANDBOOK FOR THE ROTOR SYSTEMS RESEARCH AIRCRAFT, Sikorsky Report SER 72039 (Draft of NASA CR - Unnumbered).
16. Lewis, II R. B., ARMY HELICOPTER PERFORMANCE TRENDS, Journal of the American Helicopter Society, Vol. 17, No. 2, April 1972.
17. Coleman, R.P., THEORY OF SELF-EXCITED MECHANICAL OSCILLATIONS OF HINGED ROTOR BLADES, NACA A. R. R. 3G29, July 1943.
18. Ham, E. and Klusman, S., AEROELASTIC AND MECHANICAL STABILITY ANALYSIS REPORT, Report SER-72024 Prepared by Sikorsky Aircraft for NASA under Contract NAS 1-13000, April 1975.
19. Hoad, D. R., HELICOPTER MODEL SCALE RESULTS OF BLADE-VORTEX INTERACTION IMPULSIVE NOISE AS AFFECTED BY TIP MODIFICATION, Presented at the 36th Annual Forum of the American Helicopter Society, May 1980 (Preprint No. 80-62).
20. Stroub, R. H., Rabbott, J. P., and Niebanck, C. F., ROTOR BLADE TIP SHAPE EFFECTS ON PERFORMANCE AND CONTROL LOADS FROM FULL SCALE WIND TUNNEL TESTING, Journal of the American Helicopter Society, October 1979.

21. Lee, A. and Mosher, M., A STUDY OF THE NOISE RADIATION FROM FOUR HELICOPTER ROTOR BLADES, NASA CP 2052, May 1978.
22. Mantay, W.R., Campbell, R.L., and Shidler, P.A., FULL-SCALE TESTING OF AN OGEE TIP ROTOR, Presented at Specialists Meeting on Helicopter Acoustics, Va., May 1978 (Part of NASA CP 2052).
23. JanakiRam, D.S., EXPERIMENTAL EVALUATION OF ACTIVE AND PASSIVE MEANS OF ALLEVIATING ROTOR IMPULSIVE NOISE IN DESCENT FLIGHT, NASA CR-159188, November 1979.
24. Balcerak, J.C. and Feller, R., EFFECT OF SWEEP ANGLE ON THE PRESSURE DISTRIBUTIONS AND EFFECTIVENESS OF THE OGEE TIP IN DIFFUSING A LINE VORTEX, NASA CR-132355, September 1973.
25. Landgrebe, A.J. and Bellinger, E.D., EXPERIMENTAL INVESTIGATION OF MODEL VARIABLE GEOMETRY AND OGEE TIP ROTORS, NASA CR-2275, 1974.
26. Kiraly, R.L., VOLUME I, SAFETY OF FLIGHT REVIEW AIR-WORTHINESS SUBSTANTIATION DOCUMENT COMPOSITE MAIN ROTOR BLADE FOR THE YAH-64/AAH, prepared under Contract DAAK50-78-G-0004, Hughes Helicopters Report No. CMRB 79-041, May 1980.
27. Hughes, C.W. and Sernicke, R.K., FLIGHT TEST OF A HINGELESS FLEXBEAM ROTOR SYSTEM, USAAMRDL TR 74-38, U.S. Army Air Mobility R&D Laboratory, Fort Eustis, Virginia, June 1974.
28. Bowden, T.H. and Shockey, G.A., A WIND-TUNNEL INVESTIGATION OF THE AERODYNAMIC ENVIRONMENT OF A FULL-SCALE HELICOPTER ROTOR IN FORWARD FLIGHT, USAAVLABS Technical Report 70-35, U.S. Army Aviation Material Laboratories, Fort Eustis, Virginia, July 1970. AD875744.
29. Shockey, G.A., Cox, C.R., and Williamson, J.W., AR-1G HELICOPTER AERODYNAMIC AND STRUCTURAL LOADS SURVEY, USAAMRDL TR-76-39, U.S. Army Air Mobility R&D Laboratory, Fort Eustis, Virginia, February 1977.

TABLE 1. - ROTOR COMPARISON

Helicopter Rotor	Hub Type	Gross Weight kg (lb)	No. of Blades	Chord m (in.)	Radius m (ft)	Solidity	Twist Deg.	Airfoil	RPM.	PARAMETER	
										ΩR m/sec ft/sec	$C_{T/\sigma}$
RSRA Sikorsky S-61	Articulated (Bearings)	Des. 8346. (18,400.) Max. 10,614. (23,400.)	5	0.46 (18.25)	9.45 (31)	0.078	-8	NACA 0012	203	201 (660)	0.075 0.096
YAH-64 Hughes AAH	Articulated (Stainless Steel Flexure)	Des. 6276. (13,837.) Max. 8006. (17,650.)	4	0.53 (21.0)	7.32 (24.0)	0.092	-9	HH-02 NACA 64A009	289	221 (726)	0.066 0.085
UH-60A Sikorsky UTTAS	Articulated (Elastomeric)	Des. 7462. (16,450.) Max. 9185. (20,250.)	4	0.53 (20.75)	8.18 (26.83)	0.082	-16.4° (Equivalent)	SC1095	258	221 (725)	0.071 0.087
YUH-61A Boeing UTTAS	Flexure/Pitch Bearings	Des. 7223. (15,925.) Max. 8845. (19,500.)	4	0.59 (23.23)	7.47 (24.5)	0.100	-12°	VR-7,8,9	286	224 (734)	0.066 0.081
YCH-47D Improved Boeing	Articulated	Des. 21,319. (47,000.) Max. 23,133. (51,000.)	3 x 2	0.81 (32.0)	9.14 (30.0)	0.085	-12°	VR-7,8	225	215 (707)	0.082 0.089
Kaman K-747 Blades AH-1S	Teetering	4536. (10,000.)	2	0.76 (30.0) (Taper Tip)	6.71 (22.0)	0.0625	-10°	VR-7,8	324	227 (746)	0.080

TABLE 2. - CANDIDATE ROTOR RPMS WITH RSRA GEARS

Candidate	Existing rpm	Closest Available RSRA rpm
Baseline - RSRA	203	203
YCH-47D	225	225
UH-60A	258	256
YUH-61A	286	285
YAH-64	289	285
K747	324	320

TABLE 3. - THRUST COEFFICIENT COMPARISON

PARAMETER						
Rotor System	G. W. kg	Solidity 4 Blades	RPM	R m (ft)	ΩR (ft/sec)	$C_{T/\sigma}$
RSRA	8346	0.078	203	9.45	201	0.075
	10614	(5 blades)		(31)	(660)	0.096
YAH-64	8346	0.092	289	7.32	221	0.088
	10614			(24)	(726)	0.112
UH-60A	8346	0.082	258	8.18	221	0.079
	10614			(26.83)	(724.9)	0.101
YUH-61A	8346	0.100	286	7.47	224	0.076
	10614			(24.5)	(733.8)	0.097
YCH-47D with new hub	8346	0.110	225	9.27	218	0.047
	10614			(20.4)	(716.3)	0.060
K-747 blades with new hub	8346	0.122	324	6.81	231	0.071
	10614			(22.3)	(756.5)	0.090

TABLE 4. - ROTOR SELECTION TRADEOFF CHART

Feature	Weighting Factor
Technical Merit (10)	
<ul style="list-style-type: none"> ● Thrust Capability ● Hub Design ● Blade Design (5) <ul style="list-style-type: none"> Aerodynamic Features - Planform, Tipshape, Airfoil (S), Twist Structural Features 	<p style="text-align: right;">2</p> <p style="text-align: right;">3</p> <p style="text-align: right;">3</p>
Integration Requirements (10)	
<ul style="list-style-type: none"> ● Attachment to RSRA ● Transmission Modification ● Control Modifications 	<p style="text-align: right;">4</p> <p style="text-align: right;">3</p> <p style="text-align: right;">3</p>
Development Requirements (10)	
<ul style="list-style-type: none"> ● Rotor Mast Height Variability ● Hub Variability - Delta 3, Other Couplings ● Blade Variability (4) <ul style="list-style-type: none"> Aerodynamically - Planform, Tip Shapes, Airfoils, Twist Structurally - Stiffness, Weight ● Other Development Features <ul style="list-style-type: none"> Wind Tunnel Requirements - Instrumentation Requirements, Spare Part Availability 	<p style="text-align: right;">2</p> <p style="text-align: right;">2</p> <p style="text-align: right;">2</p> <p style="text-align: right;">2</p> <p style="text-align: right;">2</p>
Rating 5 - Excellent 4 - 3 - Average 2 - 1 - Poor	

TABLE 5. - RATING OF CANDIDATE ROTOR SYSTEMS

ROTORS											
Feature	Weighting Factor	YAH-64		UH-60		YUH-61A		K-747		YCH-47D	
		Rating	Score	Rating	Score	Rating	Score	Rating	Score	Rating	Score
TECHNICAL MERIT											
Thrust Capability	2	2	4	4	8	3	6	2	4	5	10
Hub Design	3	4	12	3	9	3	9	1	3	1	3
Blade Design											
Aerodynamic	3	4	12	4	12	4	12	4	12	4	12
Structural	2	4	8	4	8	4	8	4	8	4	8
SUBTOTAL SCORE			36		37		35		27		33
INTEGRATION REQUIREMENTS											
Attachment to RSRA	4	4	16	3	12	3	12	3	12	3	12
Transmission Modifications	3	4	12	3	9	3	9	3	9	3	9
Control Modifications	3	3	9	3	9	3	9	3	9	3	9
SUBTOTAL SCORE			37		30		30		30		30
DEVELOPMENT REQUIREMENTS											
Rotor Mast Height Variability	2	4	8	3	6	3	6	3	6	3	6
Hub Variability	2	3	6	3	6	3	6	1	2	1	2
Blade Variability											
Aerodynamically	2	4	8	3	6	4	8	4	8	4	8
Structurally	2	5	10	3	5	4	8	4	8	4	8
Other Development Features	2	3	6	3	6	2	4	1	2	1	2
SUBTOTAL SCORE			38		30		32		26		26
TOTAL SCORE			111		97		97		83		89
NORMALIZED TO 150			0.74		0.65		0.65		0.55		0.59

TABLE 6. - HOVERING POWER REQUIRED AT 8346 kg
(18,400 LB) GROSS WEIGHT

Rotor System	Transmission Watt (hp)	
	OGE	IGE*
RSRA	179.3 x 10 ⁴ (2404)	161.3 x 10 ⁴ (2163)
YAH-64	207.2 x 10 ⁴ (2779)	186.4 x 10 ⁴ (2500)
UH-60A	193.3 x 10 ⁴ (2592)	174.0 x 10 ⁴ (2333)
YUH-61A	205.5 x 10 ⁴ (2756)	184.9 x 10 ⁴ (2333)
YCH-47D	179.0 x 10 ⁴ (2400)	161.0 x 10 ⁴ (2159)
K747	221.0 x 10 ⁴ (2964)	198.9 x 10 ⁴ (2667)

*Height/diameter = 0.5

TABLE 7. - ROTOR ATTACHMENT MODIFICATION

<u>Approach A</u>	<u>Approach B</u>
Mast Attachment to Existing RSRA Transmission	Mast Attachment to New Platform/Truss Structural
<u>EXISTING PARTS</u>	
RSRA Active Balance/Isolation Platform 72090-00501	RSRA Main Transmission Assembly 72350-08500
<u>MODIFIED PARTS</u>	
RSRA Main Transmission Assembly 72350-08500	RSRA Active Balance/Isolation Platform 72090-00501
YAH-64 Static Mast 7-211160020	YAH-64 Static Mast 7-211160020
<u>NEW PARTS</u>	
Drive Shaft	Drive Shaft
	Mast Support Platform/ Transmission Cover 464-0001
	Truss Structure 464-0001

TABLE 8. - TRANSMISSION GEAR CHANGES

Gears	Reduction Ratio	
	YAH-64 on the RSRA	Existing RSRA Rotor
Input Spur	1.85	2.34
Freewheel Unit Mesh	2.54	2.54
Bevel Mesh	3.05	3.40
Planetary Set	4.63	4.63

TABLE 9. - COMPARISON OF RSRA AND YAH-64 ROTOR SYSTEM
GROUND RESONANCE PARAMETERS

PARAMETER

Rotor System	Mass Moment About Lag Hinge, σ_f N-sec ² (lb-sec ²)	Damping Stiffness $C_f \omega_f$ N-m/rad (in. -lb./rad)	Required Hub Damping $\sigma_f^2 n / C_f \omega_f$ N/m sec ⁴ rad $\frac{\text{lb}}{\text{in}} \text{-sec}^4 \text{rad}$
RSRA	427.0 (96.0)	43.3 x 10 ³ (383 x 10 ³)	21.07 (.1203)
YAH-64	226.0 (50.8)	28.0 x 10 ³ (248 x 10 ³)	7.29 (0.0416)

TABLE 10. - DAMPING PRODUCT DATA

Rotor System	Effective Hob Mass N/m sec ² (lb/in sec ²)		Hub Frequency W _y rad/sec		Product of Damping Required - $n/4 \sigma_f^2 W_y^3$ N ² -sec (lb ² -sec)		Product of Damping Available - C _y C _f W _f N ² -sec (lb ² -sec)		Product of Damping Ratio Margin = $\frac{\text{Avail}}{\text{Req.}} - 1$	
	Pitch	Roll	Pitch	Roll	Pitch	Roll	Pitch	Roll	Pitch	Roll
RSRA	3.71 x 10 ³ (211.8)	4.76 x 10 ³ (271.7)	8.68	26.5	1.49 x 10 ⁸ (7.53 x 10 ⁶)	42.3 x 10 ⁸ (214.0 x 10 ⁶)	74.8 x 10 ⁸ (378 x 10 ⁶)	173.9 x 10 ⁸ (879 x 10 ⁶)	49.1	3.1
YAH-64	3.68 x 10 ³ (210.0)	4.73 x 10 ³ (269.9)	8.72	26.6	0.34 x 10 ⁸ (1.71 x 10 ⁶)	9.6 x 10 ⁸ (48.6 x 10 ⁶)	48.3 x 10 ⁸ (244 x 10 ⁶)	112.6 x 10 ⁸ (569 x 10 ⁶)	141.7	10.7

TABLE 11.- YAH-64 AND RSRA ROTOR CONTROL SYSTEM
COMPARISON BEFORE MODIFICATIONS

	Pitch Horn Arm	Blade Motion			Swashplate Motion		
		Collective	Longi- tudinal	Lateral	Collective	Longi- tudinal	Lateral
YAH-64	L. E. .24m (9.5 in.)	20° Total	+12.09° -21.27°	+8° -11.68°	.04m (± 1.647 in.)	+7.32° -12.74°	+4.85° -7.0°
RSRA with Present M/R	L. E. .20m (8.0 in.)	14° Total	+11.0° -15.0°	+8° -8°	.03m (± 1.03 in.)	+8.15° -11.15°	+6.05° -6.05°

TABLE 12. -RSRA STATIONARY CONTROL SYSTEM
MODIFICATIONS

Reference Drawing No. 72400-00010

BELLCRANKS		
Location Number	Ratio	
	Present 1.357	New Bellcranks 2.17
535 - 536	10/7.373	12/5.525
525 - 526	10/7.373	12/5.525
515 - 516	10/7.373	12/5.525
STATIONARY SWASHPLATE		
Present Arm = .33m (12.88 in.)		
New Arm = .51m (20.2 in.)		

TABLE 13.- CONTROL SYSTEM MODIFICATIONS

<u>Approach A</u>	<u>Approach B</u>
Rotating System Changes	Stationary System Changes
<u>EXISTING PARTS</u>	
RSRA Fixed System (Including Stationary Swashplate) 72400-00100	YAH-64 Rotor Hub Installation 7-211410003
<u>MODIFIED PARTS</u>	
Pitch Housing 7-211411176	Pitch Links 7-211511135
Pitch Links 7-211511135	
<u>NEW PARTS</u>	
Pitch Horn Arm 464-0000	Three (3) Bellcranks (Associated Links)
Rotating Swashplate 464-0000	Stationary Swashplate

TABLE 14.- BASIC STRAIN GAGE/POSITION INSTRUMENTATION
ITEMS FOR THE YAH-64 MAIN ROTOR INSTALLED
ON THE RSRA

	<u>Location/Item</u>		<u>Units</u>
Flapwise Bending	Sta. 46.0,	Blade 1	IN-LB
Flapwise Bending	Sta. 51.5,	Blade 1	IN-LB
Flapwise Bending	Sta. 69.0,	Blade 1	IN-LB
Flapwise Bending	Sta. 103.0,	Blade 1	IN-LB
Flapwise Bending	Sta. 174.0,	Blade 1	IN-LB
Flapwise Bending	Sta. 222.0,	Blade 1	IN-LB
Flapwise Bending	Sta. 246.0,	Blade 1	IN-LB
Flapwise Bending	Sta. 260.0,	Blade 1	IN-LB
Flapwise Bending	Sta. 274.0,	Blade 1	IN-LB
Chordwise Bending	Sta. 46.0,	Blade 1	IN-LB
Chordwise Bending	Sta. 53.0,	Blade 1	IN-LB
Chordwise Bending	Sta. 69.0,	Blade 1	IN-LB
Chordwise Bending	Sta. 103.0,	Blade 1	IN-LB
Chordwise Bending	Sta. 174.0,	Blade 1	IN-LB
Chordwise Bending	Sta. 246.0,	Blade 1	IN-LB
Chordwise Bending	Sta. 260.0,	Blade 1	IN-LB*
Torsion Bending	Sta. 104.5,	Blade 1	IN-LB
Torsion Bending	Sta. 224.0,	Blade 1	IN-LB

*Added to the Basic YAH-64 Composite M/R Blade Instrumentation

TABLE 14. - BASIC STRAIN GAGE/POSITION INSTRUMENTATION
ITEMS FOR THE YAH-64 MAIN ROTOR INSTALLED
ON THE RSRA (CONT)

	<u>Location/Item</u>		<u>Units</u>
Torsion Bending	Sta. 260.5,	Blade 1	IN-LB
Torsion Bending	Sta. 260.5,	Blade 2	IN-LB*
Torsion Bending	Sta. 260.5,	Blade 3	IN-LB*
Torsion Bending	Sta. 260.5,	Blade 4	IN-LB*
Flapwise Bending	Sta. 26.0, Pitch Change Housing	Blade 1	IN-LB
Flapwise Bending	Sta. 28.75, Pitch Change Housing	Blade 1	IN-LB
Chordwise Bending	Sta. 26.0, Pitch Change Housing	Blade 1	IN-LB
Flapwise Bending	Sta. 34.5, Lead-Lag Link	Blade 1	IN-LB
Flapwise Bending	Sta. 39.0, Lead-Lag Link	Blade 1	IN-LB
Chordwise Bending	Sta. 34.5, Lead-Lag Link	Blade 1	IN-LB
Chordwise Bending	Sta. 39.0, Lead-Lag Link	Blade 1	IN-LB
Leading Edge	Lead-Lag Damper Load	Blade 1	LB
Trailing Edge	Lead-Lag Damper Load	Blade 1	LB

*Added to the Basic YAH-64 Composite M/R Blade Instrumentation

TABLE 14.- BASIC STRAIN GAGE/POSITION INSTRUMENTATION
 ITEMS FOR THE YAH-64 MAIN ROTOR INSTALLED
 ON THE RSRA (CONT)

	<u>Location/Item</u>		<u>Units</u>
Flapping Angle	Sta. 11, Feathering Bearing	Blade 1	DEG
Feathering Angle	Sta. 11, Feathering Bearing	Blade 1	DEG
Flapping Angle	Sta. 11, Feathering Bearing	Blade 2	DEG*
Feathering Angle	Sta. 11, Feathering Bearing	Blade 2	DEG*
Lead-Lag Angle	Sta. 34.5, Lead-Lag Pin	Blade 1	DEG
Lead-Lag Angle	Sta. 34.5, Lead-Lag Pin	Blade 2	DEG*
Pitch Link Load		Blade 1	LB
Pitch Link Load		Blade 2	LB
Pitch Link Load		Blade 3	LB*
Pitch Link Load		Blade 4	LB*
Main Rotor Torque			IN-LB
Main Rotor RPM			

*Added to the Basic YAH-64 Composite M/R Blade Instrumentation.

TABLE 14.- BASIC STRAIN GAGE/POSITION INSTRUMENTATION
 ITEMS FOR THE YAH-64 MAIN ROTOR INSTALLED
 ON THE RSRA (CONT)

	<u>Location/Item</u>	<u>Units</u>
<u>Stationary Instrumentation</u>		
M/R	Stationary Mast Longitudinal Bending	IN-LB
M/R	Stationary Mast Lateral Bending	IN-LB
Hub	Accelerations	G
	Vertical	
	Longitudinal	
	Lateral	

TABLE 15.- ROTATING ACCELEROMETERS, YAH-64 MAIN ROTOR
 INSTALLED ON THE RSRA

	<u>Location</u>		<u>Units</u>
Flapwise Acceleration	Sta. 26.0, Pitch Change Housing	Blade 1	G
Flapwise Acceleration	Sta. 46.0,	Blade 1	
Flapwise Acceleration	Sta. 51.5,	Blade 1	
Flapwise Acceleration	Sta. 69.0,	Blade 1	
Flapwise Acceleration	Sta. 103.0,	Blade 1	
Flapwise Acceleration	Sta. 174.0,	Blade 1	
Flapwise Acceleration	Sta. 222.0	Blade 1	
Flapwise Acceleration	Sta. 246.0	Blade 1	
Flapwise Acceleration	Sta. 260.0	Blade 1	
Flapwise Acceleration	Sta. 274.0	Blade 1	
Chordwise Acceleration	Sta. 26.0, Pitch Change Housing	Blade 1	
Chordwise Acceleration	Sta. 46.0,	Blade 1	
Chordwise Acceleration	Sta. 53.0,	Blade 1	
Chordwise Acceleration	Sta. 69.0,	Blade 1	
Chordwise Acceleration	Sta. 103.0,	Blade 1	
Chordwise Acceleration	Sta. 174.0,	Blade 1	
Chordwise Acceleration	Sta. 246.0,	Blade 1	

TABLE 15.- ROTATING ACCELEROMETERS, YAH-64 MAIN ROTOR
 INSTALLED ON THE RSRA (CONT)

	<u>Location</u>		<u>Units</u>
Chordwise Acceleration	Sta. 260. 0,	Blade 1	G
Flapwise Acceleration	Sta. 26. 0, Pitch Change Housing	Blade 2	
Flapwise Acceleration	Sta. 51. 5	Blade 2	
Flapwise Acceleration	Sta. 103. 0,	Blade 2	
Flapwise Acceleration	Sta. 222. 0,	Blade 2	
Flapwise Acceleration	Sta. 260. 0,	Blade 2	
Flapwise Acceleration	Sta. 274. 0,	Blade 2	
Chordwise Acceleration	Sta. 26. 0, Pitch Change Housing	Blade 2	
Chordwise Acceleration	Sta. 53. 0,	Blade 2	
Chordwise Acceleration	Sta. 103. 0,	Blade 2	
Chordwise Acceleration	Sta. 174. 0,	Blade 2	
Chordwise Acceleration	Sta. 222. 0,	Blade 2	
Chordwise Acceleration	Sta. 260. 0,	Blade 2	

TABLE 16.- PRESSURE TRANSDUCERS, YAH-64 MAIN
 ROTOR INSTALLED ON THE RSRA

<u>Location</u>			<u>Units</u>
Abs. Pressure, Station 115.0 (Total of 14)			PSIA
1%	Chord	Upper Surface (US) and Lower Surface (LS)	
3%	Chord	US and LS	
8%	Chord	US and LS	
25%	Chord	US and LS	
45%	Chord	US and LS	
70%	Chord	US and LS	
92%	Chord	US and LS	
Abs. Pressure, Station 173.0 (Total of 20)			
1%	Chord	US and LS	
3%	Chord	US and LS	
8%	Chord	US and LS	
15%	Chord	US and LS	
25%	Chord	US and LS	
35%	Chord	US and LS	
45%	Chord	US and LS	
55%	Chord	US and LS	
70%	Chord	US and LS	
92%	Chord	US and LS	
Abs. Pressure, Station 216.0 (Total of 30)			
1%	Chord	US and LS	
3%	Chord	US and LS	
8%	Chord	US and LS	
15%	Chord	US and LS	
20%	Chord	US and LS	

TABLE 16.- PRESSURE TRANSDUCERS, YAH-64 MAIN ROTOR INSTALLED ON THE RSRA (CONT)

	<u>Location</u>	<u>Units</u>
Abs. Pressure, Station 216.0 (Total of 30) (Cont)		
25%	Chord	US and LS
30%	Chord	US and LS
35%	Chord	US and LS
40%	Chord	US and LS
45%	Chord	US and LS
50%	Chord	US and LS
55%	Chord	US and LS
70%	Chord	US and LS
80%	Chord	US and LS
92%	Chord	US and LS
Abs. Pressure, Station 245.0 (Total of 32)		
1%	Chord	US and LS
3%	Chord	US and LS
8%	Chord	US and LS
15%	Chord	US and LS
20%	Chord	US and LS
25%	Chord	US and LS
30%	Chord	US and LS
35%	Chord	US and LS
40%	Chord	US and LS
45%	Chord	US and LS
50%	Chord	US and LS
55%	Chord	US and LS
60%	Chord	US and LS
70%	Chord	US and LS
80%	Chord	US and LS
92%	Chord	US and LS

TABLE 16. - PRESSURE TRANSDUCERS, YAH-64 MAIN ROTOR INSTALLED ON THE RSRA (CONT)

	<u>Location</u>	<u>Units</u>
Abs. Pressure, Station 258.5 (Total of 32)		
1%	Chord	US and LS
3%	Chord	US and LS
8%	Chord	US and LS
15%	Chord	US and LS
20%	Chord	US and LS
25%	Chord	US and LS
30%	Chord	US and LS
35%	Chord	US and LS
40%	Chord	US and LS
45%	Chord	US and LS
50%	Chord	US and LS
55%	Chord	US and LS
60%	Chord	US and LS
70%	Chord	US and LS
80%	Chord	US and LS
92%	Chord	US and LS
Abs. Pressure, Station 278.0 (Total of 32)		
1%	Chord	US and LS
3%	Chord	US and LS
8%	Chord	US and LS
15%	Chord	US and LS
20%	Chord	US and LS
25%	Chord	US and LS
30%	Chord	US and LS
35%	Chord	US and LS

TABLE 16.- PRESSURE TRANSDUCERS, YAH-64 MAIN ROTOR INSTALLED ON THE RSRA (CONT)

<u>Location</u>			<u>Units</u>
Abs. Pressure, Station 278.0 (Total of 32) (Cont)			PSIA
40%	Chord	US and LS	
45%	Chord	US and LS	
50%	Chord	US and LS	
55%	Chord	US and LS	
60%	Chord	US and LS	
70%	Chord	US and LS	
80%	Chord	US and LS	
92%	Chord	US and LS	

TABLE 17.- YAH-64 MAIN ROTOR FOR THE RSRA -
WORK BREAKDOWN STRUCTURE

LEVEL	1	2	3	4
	1000	RSRA Flight Test of YAH-64 Main Rotor		
		1100	Preliminary Design	
			1110	Required Data Definition
			1120	Aircraft System Modifications
				1121 Control System
				1122 Mast/Pylon Support
				1123 Cowling
				1124 Drive System
				1125 Balance System Interface
			1130	Emergency Escape
				1131 Integration
				1132 Blade Severance System
			1140	Blade Instrumentation
				1141 Requirements
				1142 Installation
			1150	Rotor System Parametric Variations
				1151 Blade Tips/Twist/Airfoil/Planform
				1152 Mast Height
				1153 Control Coupling (δ_3)
			1160	Design Analyses
				1161 Performance
				1162 Dynamics
				1163 Stress
				1164 Weights
				1165 Stability and Control
				1166 Technology Payoff Studies
			1170	Preliminary Design Report
			1180	Preliminary Design Review
		1200	Detail Design	
			1210	Aircraft System Modifications
				1211 Control System
				1212 Mast/Pylon Support
				1213 Cowling
				1214 Drive System
			1220	Emergency Escape System
			1230	Blade Instrumentation
			1240	Rotor System Parametric Variations
				1241 Blade Tips/Twist/Airfoil/Planform
				1242 Fabrication/Tooling Concept
				1243 Mast Height
				1244 Control Coupling (δ_3)

TABLE 17. - YAH-64 MAIN ROTOR FOR THE RSRA -
 WORK BREAKDOWN STRUCTURE (CONT)

LEVEL 1	2	3	4
		1250	Design Analyses
			1251 Dynamics
			1252 Stress
			1253 Weights
		1260	Detail Design Stress Report
		1270	Design Reviews
			1271 Design Review - Procurement Approval
			1272 Critical Design Review
	1300		Fabrication
		1310	Basic Rotor System
			1311 Procure Hub
			1312 Procure Basic Blades
		1320	Aircraft System Modifications
			1321 Control System
			1322 Mast/Pylon Support
			1323 Cowling
			1324 Drive System
			1325 Emergency Escape System
		1330	Rotor System Parametric Variations
			1331 Detail Tooling Design
			1332 Tool Proof Blade Specimen
			1333 Qualification Test Blades
			1334 Test Blades
			1335 Mast Height
			1336 Control Couplings
		1340	Instrumentation
			1341 Instrumentation Plan
			1342 Blades
			1343 Hub/Drive System
			1344 Control System
	1400		Safety-of-Flight Qualification
		1410	Qualification Plan
		1420	Blade Parametric Variation
			1421 Design/Fabricate Test Hardware
			1422 Static Test
			1423 Fatigue Test
		1430	Blade Severance Assembly Test

TABLE 17. - YAH-64 MAIN ROTOR FOR THE RSRA -
 WORK BREAKDOWN STRUCTURE (CONT)

LEVEL	1	2	3	4
	(Option A)	1500	Wind Tunnel Test	
		1510	Wind Tunnel Test Plan	
		1520	Instrumentation	
			1521 Data System	
			1522 Installation	
		1530	Test Module Integration	
			1531 Design/Analyses	
			1532 Fabrication	
		1540	Tunnel Installation	
			1541 Hardware	
			1542 Systems Checkout	
		1550	Wind Tunnel Testing	
		1560	Data Reduction/Analyses	
		1570	Wind Tunnel Report	
	(Option B)	1500	Whirl Tower Test	
		1510	Whirl Tower Test Plan	
		1520	Whirl Tower Integration	
			1521 Procure Instrumentation System	
			1522 Procure Hardware	
		1530	Whirl Tower Installation	
			1531 Instrumentation	
			1532 Hardware	
			1533 Systems Checkout	
		1540	Whirl Tower Testing	
		1550	Data Reduction/Analyses	
		1560	Whirl Tower Report	
		1600	Rotor Installation/Integration on the RSRA	
		1610	Installation Plan	
		1620	Install Rotor/Associated Hardware	
		1630	Systems Checkout	
			1631 Control System Motion/Interference Checks	
			1632 Instrumentation	
		1640	Control System Proofload	
		1650	Ground Run Test Plan	
		1660	Ground Run	
			1661 Freedom from Ground Resonance	
			1662 Verification of Frequency Plots	
			1663 Instrumentation Checks	

TABLE 17.- YAH-64 MAIN ROTOR FOR THE RSRA -
 WORK BREAKDOWN STRUCTURE (CONT)

LEVEL 1	2	3	4
		1670	Data Reduction/Analyses
		1680	Safety-of-Flight Review
			1681 Safety-of-Flight Review Data
			1682 Safety-of-Flight Review Board
			1683 Flight Safety Approval
	1700	NASA	Flight Test
		1710	Flight Test Plan
		1720	Instrumentation Plan
		1730	Test Support
	1800		Program Reporting
		1810	Program Plan of Performance
		1820	Monthly Progress Reports
			1821 Technical
			1822 Cost/Performance

TABLE 18. - DEVELOPMENT PLAN FOR YAH-64 MAIN ROTOR ON RSRA,
LABOR COST, WIND TUNNEL TEST, START JANUARY 1982

DEVELOPMENT PLAN FOR YAH-64 MAIN ROTOR ON ROTOR SYSTEM RESEARCH AIRCRAFT (RSRA)

LABOR COST REPORT - ALTERNATE A' - WIND TUNNEL TEST

START DATE 4-JAN-82		FINISH DATE 27-MAR-87						
* COST GROUP	ACTIVITY NUMBER	ACTIVITY DESCRIPTION	WBS CODE	DURATION WORK DAYS	MAN HOURS	ACTIVITY COST	SUB TOTAL	* COST GROUP
1	20	PLAN OF PERFORMANCE REPORT DEVELOPMENT	1010	21	225	\$ 9642	\..... \$ 239727	(1)
	30	PRELIMINARY DESIGN	1100	121	6051	\$ 230085		
2	60	DETAIL DESIGN DEVELOPMENT	1200	165	17490	\$ 688615	\..... \$ 688615	(2)
3	110	FABRICATION	1310	247	66789	\$2349000	\..... \$2488240	(3)
	120	INSTRUMENTATION	1340	206	3543	\$ 139240		
4	170	QUAL. HARDWARE DESIGN & FABRICATION	1421	62	942	\$ 39810	\..... \$ 161618	(4)
	180	QUALIFICATION TESTING	1422	124	3174	\$ 121808		
5	210	WIND TUNNEL HARDWARE DESIGN & FAB.	1530	51	1795	\$ 78618	\..... \$ 382750	(5)
	220	WIND TUNNEL HARDWARE INSTALLATION	1540	31	1488	\$ 49563		
	225	WIND TUNNEL TEST	1550	41	3641	\$ 126514		
	230	WIND TUNNEL TEST DATA REDUCTION & ANA.	1560	103	2884	\$ 128056		
6	330	INSTALL ROTOR & SYSTEM CHECKOUT	1620	82	5314	\$ 192721	\..... \$ 289559	(6)
	360	GROUND RUN TEST	1660	21	1982	\$ 63816		
	370	SOF DATA PREPARATION & REVIEW	1680	21	697	\$ 33022		
7	420	FLIGHT TEST (FULL SUPPORT)	1730	62	4613	\$ 187177	\..... \$ 435725	(7)
	430	FLIGHT TEST	1730	432	3802	\$ 248548		

ARTEMIS PROJECT RSR REPORT SPEC RSRAC BY KMF

* COST GROUPS RELATE TO NASA CONTRACT # NAS2-10690 STATEMENT OF WORK 3.2.4 COST ESTIMATES.

TOTAL PROJECT LABOR COST = \$ 4686233

TABLE 19. - TOTAL COSTS FOR YAH-64 ON RSRA - ALTERNATE A,
WIND TUNNEL TEST, START JAN. 1982

<u>Cost Group(WBS)</u>	<u>Material/Subcontract</u>	<u>Travel/Per Diem</u>	<u>Labor</u>	<u>Subtotal</u>
(1) Preliminary Design (1100)	—	\$ 500.	\$ 239,727.	\$ 240,227
(2) Detail Design (1200)	—	\$ 1,100.	\$ 688,615.	\$ 689,715.
(3) Fabrication (1300)	\$1,430,000.	—	\$2,488,240.	\$3,918,240.
(4) Qualification of Hardware (1400)	\$ 25,000.	—	\$ 161,618.	\$ 186,618.
(5) Wind Tunnel Test (1500)	\$ 20,000.	\$ 34,700.	\$ 382,750.	\$ 437,450.
(6) Installation on RSRA Ground Run (1600)	—	\$ 46,800.	\$ 289,559.	\$ 336,359.
(7) Flight Test (1700)	—	\$ 34,700.	\$ 435,725.	\$ 470,425.
SUBTOTAL	\$1,475,000.	\$117,800.	\$4,686,233.	
			TOTAL COST	\$6,279,033.

TABLE 20. - DEVELOPMENT PLAN FOR YAH-64 MAIN ROTOR ON RSRA,
LABOR COST, WHIRL TOWER TEST, START JANUARY 1982

DEVELOPMENT PLAN FOR YAH-64 MAIN ROTOR ON ROTOR SYSTEM RESEARCH AIRCRAFT (RSRA)

LABOR COST REPORT - ALTERNATE 'B' - WHIRL TOWER TEST

START DATE 4-JAN-82									FINISH DATE 14-JAN-87
* COST GROUP	ACTIVITY NUMBER	ACTIVITY DESCRIPTION	UBS CODE	DURATION WORK DAYS	MAN HOURS	ACTIVITY COST	SUB TOTAL	* COST GROUP	
1	20	PLAN OF PERFORMANCE REPORT DEVELOPMENT	1010	21	225	\$ 9642			
	30	PRELIMINARY DESIGN	1100	124	6051	\$ 230085			
						 \$ 239727	(1)	
2	60	DETAIL DESIGN DEVELOPMENT	1200	165	17490	\$ 688615			
						 \$ 688615	(2)	
3	110	FABRICATION	1310	247	66789	\$2349000			
	120	INSTRUMENTATION	1340	206	3543	\$ 139240			
						 \$2488240	(3)	
4	170	QUAL. HARDWARE DESIGN & FABRICATION	1421	62	942	\$ 39810			
	180	QUALIFICATION TESTING	1422	124	3174	\$ 121808			
						 \$ 161618	(4)	
5	270	WHIRL TOWER PROCURE PARTS INSTALLATION	1520	41	1443	\$ 60271			
	280	WHIRL TOWER TEST	1540	21	1697	\$ 70695			
	290	WHIRL TOWER TEST DATA REDUCTION & ANA.	1550	51	1020	\$ 46175			
						 \$ 177141	(5)	
6	330	INSTALL ROTOR & SYSTEM CHECKOUT	1620	82	5314	\$ 190643			
	360	GROUND RUN TEST	1660	21	1982	\$ 61583			
	370	SOF DATA PREPARATION & REVIEW	1680	21	697	\$ 31813			
						 \$ 284038	(6)	
7	420	FLIGHT TEST (FULL SUPPORT)	1730	62	4613	\$ 187177			
	430	FLIGHT TEST	1730	432	3802	\$ 242585			
						 \$ 429761	(7)	

ARTEMIS PROJECT RSR REPORT SPEC RSRAC BY KMF

* COST GROUPS RELATE TO NASA CONTRACT # NAS2-10690 STATEMENT OF WORK 3.2.4 COST ESTIMATES.

TOTAL PROJECT LABOR COST = \$ 4469141

TABLE 21. - TOTAL COSTS FOR YAH-64 ON RSRA - ALTERNATE B,
WHIRL TOWER TEST, START JANUARY 1982

<u>Cost Group (WBS)</u>	<u>Material/Subcontract</u>	<u>Travel/Per Diem</u>	<u>Labor</u>	<u>Subtotal</u>
(1) Preliminary Design (1100)	—	\$ 500.	\$ 239,727.	\$ 240,227.
(2) Detail Design (1200)	—	\$ 1,100.	\$ 688,615.	\$ 689,715.
(3) Fabrication (1300)	\$1,430,000.	—	\$2,488,240.	\$3,918,240.
(4) Qualification of Hardware (1400)	\$ 25,000.	—	\$ 161,618.	\$ 186,618.
(5) Whirl Tower Test (1500)	\$ 75,000.	\$ 3,000. (mileage)	\$ 177,141.	\$ 255,141.
(6) Installation of RSRA Ground Run (1600)	—	\$46,800	\$ 284,038.	\$ 330,838.
(7) Flight Test (1700)	—	\$34,700.	\$ 429,761.	\$ 464,461
SUBTOTAL	\$1,530,000.	\$86,100.	\$4,469,141.	
			TOTAL COST	\$6,085,241.

TABLE 22. - DEVELOPMENT PLAN FOR YAH-64 MAIN ROTOR ON RSRA,
WIND TUNNEL TEST. START JANUARY 1983

DEVELOPMENT PLAN FOR YAH-64 MAIN ROTOR ON ROTOR SYSTEM RESEARCH AIRCRAFT (RSRA)

LABOR COST REPORT - ALTERNATE 'A' - WIND TUNNEL TEST

START DATE 3-JAN-83									FINISH DATE 21-MAR-88	
* COST GROUP	ACTIVITY NUMBER	ACTIVITY DESCRIPTION	WBS CODE	DURATION WORK DAYS	MAN HOURS	ACTIVITY COST	SUB TOTAL	* COST GROUP		
1	20	PLAN OF PERFORMANCE REPORT DEVELOPMENT	1810	21	225	\$ 10788				
	30	PRELIMINARY DESIGN	1100	124	6051	\$ 257361				
							\..... \$ 268148	(1)		
2	60	DETAIL DESIGN DEVELOPMENT	1200	165	17490	\$ 751124				
							\..... \$ 751124	(2)		
3	110	FABRICATION	1310	247	66789	\$2602131				
	120	INSTRUMENTATION	1340	206	3543	\$ 154248				
							\..... \$2756380	(3)		
4	170	QUAL. HARDWARE DESIGN & FABRICATION	1421	62	942	\$ 43957				
	180	QUALIFICATION TESTING	1422	124	3174	\$ 134724				
							\..... \$ 178682	(4)		
5	210	WIND TUNNEL HARDWARE DESIGN & FAB.	1530	51	1795	\$ 86718				
	220	WIND TUNNEL HARDWARE INSTALLATION	1540	31	1488	\$ 54674				
	225	WIND TUNNEL TEST	1550	41	3641	\$ 144714				
	230	WIND TUNNEL TEST DATA REDUCTION & ANA.	1560	103	2884	\$ 146213				
							\..... \$ 432319	(5)		
6	330	INSTALL ROTOR & SYSTEM CHECKOUT	1620	82	5314	\$ 219825				
	360	GROUND RUN TEST	1660	21	1982	\$ 71930				
	370	SOF DATA PREPARATION & REVIEW	1680	21	697	\$ 37157				
							\..... \$ 328913	(6)		
7	420	FLIGHT TEST (FULL SUPPORT)	1730	62	4613	\$ 210587				
	430	FLIGHT TEST	1730	432	3802	\$ 269237				
							\..... \$ 479824	(7)		

ARTEMIS PROJECT RSR REPORT SPEC RSRAC BY KNF

* COST GROUPS RELATE TO NASA CONTRACT # NAS2-10690 STATEMENT OF WORK 3.2.4 COST ESTIMATES.

TOTAL PROJECT LABOR COST = \$ 5195390

TABLE 23. - QUARTERLY LABOR COST REPORT, WIND TUNNEL TEST,
START JANUARY 1982

QUARTERLY LABOR COST REPORT

DEVELOPMENT PLAN FOR YAH-64 MAIN ROTOR BLADE ON ROTOR SYSTEM RESEARCH AIRCRAFT (RSRA)

ALTERNATE 'A' - WIND TUNNEL TEST

START DATE 4-JAN-82

FINISH DATE 27-MAR-87

PERIOD FROM DATE	PERIOD TO DATE	PERIOD LABOR COSTS	CUMULATIVE LABOR COSTS	COST IN MILLIONS						
				0	1	2	3	4	5	6
1-JAN-82	31-MAR-82	124685	124685	I*	I	I	I	I	I	I
1-APR-82	30-JUN-82	115043	239727	I**	I	I	I	I	I	I
1-JUL-82	30-SEP-82	257602	497329	I*****	I	I	I	I	I	I
1-OCT-82	31-DEC-82	240982	738311	I*****	I	I	I	I	I	I
1-JAN-83	31-MAR-83	316365	1054677	I*****I*	I	I	I	I	I	I
1-APR-83	30-JUN-83	586036	1640712	I*****I*****	I	I	I	I	I	I
1-JUL-83	30-SEP-83	673691	2314404	I*****I*****I***	I	I	I	I	I	I
1-OCT-83	31-DEC-83	647181	2961585	I*****I*****I*****I	I	I	I	I	I	I
1-JAN-84	31-MAR-84	640317	3601902	I*****I*****I*****I*****	I	I	I	I	I	I
1-APR-84	30-JUN-84	114054	3715956	I*****I*****I*****I*****	I	I	I	I	I	I
1-JUL-84	30-SEP-84	250300	3966255	I*****I*****I*****I*****I	I	I	I	I	I	I
1-OCT-84	31-DEC-84	179934	4146190	I*****I*****I*****I*****I*	I	I	I	I	I	I
1-JAN-85	31-MAR-85	104319	4250509	I*****I*****I*****I*****I***	I	I	I	I	I	I
1-APR-85	30-JUN-85	187678	4438187	I*****I*****I*****I*****I****	I	I	I	I	I	I
1-JUL-85	30-SEP-85	34178	4472365	I*****I*****I*****I*****I*****	I	I	I	I	I	I
1-OCT-85	31-DEC-85	32524	4504889	I*****I*****I*****I*****I*****	I	I	I	I	I	I
1-JAN-86	31-MAR-86	34998	4539887	I*****I*****I*****I*****I*****	I	I	I	I	I	I
1-APR-86	30-JUN-86	36127	4576013	I*****I*****I*****I*****I*****	I	I	I	I	I	I
1-JUL-86	30-SEP-86	37787	4613800	I*****I*****I*****I*****I*****	I	I	I	I	I	I
1-OCT-86	31-DEC-86	34835	4648635	I*****I*****I*****I*****I*****	I	I	I	I	I	I
1-JAN-87	31-MAR-87	37598	4686233	I*****I*****I*****I*****I*****	I	I	I	I	I	I

ARTEMIS PROJECT RSR REPORT SPEC RSR3H BY KMF

TABLE 24. - TOTAL COSTS, QUARTERLY REPORT, WIND TUNNEL TEST,
START JANUARY 1982

Period From Date	Period To Date	Period Labor Costs	Period Material/ Subcontract Travel Costs	Cumulative TOTAL Costs
1 JAN 82	31 MAR 82	124,685	250	124,935
1 APR 82	30 JUN 82	115,043	250	115,293
1 JUL 82	30 SEP 82	257,602	370	257,972
1 OCT 82	31 DEC 82	240,982	370	241,352
1 JAN 83	31 MAR 83	316,365	360	316,725
1 APR 83	30 JUN 83	586,036	311,790	897,826
1 JUL 83	30 SEP 83	673,691	311,790	985,481
1 OCT 83	31 DEC 83	647,181	311,790	958,971
1 JAN 84	31 MAR 84	640,317	327,418	967,735
1 APR 84	30 JUN 84	114,054	231,284	345,338
1 JUL 84	30 SEP 84	250,300	28,998	279,298
1 OCT 84	31 DEC 84	179,934	20,060	199,994
1 JAN 85	31 MAR 85	104,319	20,838	125,157
1 APR 85	30 JUN 85	187,678	22,402	210,080
1 JUL 85	30 SEP 85	34,178	690	34,868
1 OCT 85	31 DEC 85	32,524	690	33,214
1 JAN 86	31 MAR 86	34,998	690	35,688
1 APR 86	30 JUN 86	36,127	690	36,817
1 JUL 86	30 SEP 86	37,787	690	38,477
1 OCT 86	31 DEC 86	34,835	690	35,525
1 JAN 87	31 MAR 87	37,598	690	38,288
SUBTOTAL		\$4,686,233	1,592,800	
TOTAL COSTS				\$6,279,033

TABLE 25. - BLADE OPTION STUDY, 2 BLADE SETS, LABOR COSTS

DEVELOPMENT PLAN FOR YAH-64 MAIN ROTOR ON ROTOR SYSTEM RESEARCH AIRCRAFT (RSRA)

LABOR COST REPORT - ALT 'A - WIND TUNNEL TEST - 2 BLADE SETS

TIMENOW 4-JAN-82									FINISH DATE 27-MAR-87	
* COST GROUP	ACTIVITY NUMBER	ACTIVITY DESCRIPTION	WBS CODE	DURATION WORK DAYS	MAN HOURS	ACTIVITY COST		SUB TOTAL	* COST GROUP	
1	20	PLAN OF PERFORMANCE REPORT DEVELOPMENT	1810	21	225	\$ 9642				
	30	PRELIMINARY DESIGN	1100	124	6051	\$ 230085	\.....	\$ 239727	(1)	
2	60	DETAIL DESIGN DEVELOPMENT	1200	165	10890	\$ 449095	\.....	\$ 449095	(2)	
3	110	FABRICATION	1310	247	19365	\$ 732258				
	120	INSTRUMENTATION	1340	206	3543	\$ 139240	\.....	\$ 871498	(3)	
4	170	QUAL. HARDWARE DESIGN & FABRICATION	1421	62	397	\$ 16325				
	180	QUALIFICATION TESTING	1422	124	397	\$ 17822	\.....	\$ 34147	(4)	
5	210	WIND TUNNEL HARDWARE DESIGN & FAB.	1530	51	1795	\$ 78618				
	220	WIND TUNNEL HARDWARE INSTALLATION	1540	31	1488	\$ 49563				
	225	WIND TUNNEL TEST	1550	41	3641	\$ 126514				
	230	WIND TUNNEL TEST DATA REDUCTION & ANA.	1560	103	2884	\$ 128056	\. . . .	\$ 382750	(5)	
6	330	INSTALL ROTOR & SYSTEM CHECKOUT	1620	82	5314	\$ 192721				
	360	GROUND RUN TEST	1660	21	1747	\$ 63816				
	370	SOF DATA PREPARATION & REVIEW	1680	21	697	\$ 33022	\.....	\$ 289559	(6)	
7	420	FLIGHT TEST (FULL SUPPORT)	1730	62	4613	\$ 187177				
	430	FLIGHT TEST	1730	432	3802	\$ 248548	\.....	\$ 435725	(7)	

ARTENIS PROJECT RSR REPORT SPEC RSRAC BY KMF

* COST GROUPS RELATE TO NASA CONTRACT # NAS2-10690 STATEMENT OF WORK 3.2.4 COST ESTIMATES.

TOTAL PROJECT LABOR COST = \$ 2702500

TABLE 26. - BLADE OPTION STUDY, 5 BLADE SETS, LABOR COSTS

DEVELOPMENT PLAN FOR YAH-64 MAIN ROTOR ON ROTOR SYSTEM RESEARCH AIRCRAFT (RSRA)

LABOR COST REPORT - ALT. 'A' - WIND TUNNEL TEST - 5 BLADE SETS

TIMENDU 4-JAN-82									FINISH DATE 27-MAR-87	
* COST GROUP	ACTIVITY NUMBER	ACTIVITY DESCRIPTION	WBS CODE	DURATION WORK DAYS	MAN HOURS	ACTIVITY COST	SUB TOTAL	* COST GROUP		
1	20	PLAN OF PERFORMANCE REPORT DEVELOPMENT	1810	21	225	\$ 9642				
	30	PRELIMINARY DESIGN	1100	124	6051	\$ 230085				
							\$ 239727	(1)		
2	60	DETAIL DESIGN DEVELOPMENT	1200	165	12870	\$ 528951				
							\$ 528951	(2)		
3	110	FABRICATION	1310	247	37939	\$1361664				
	120	INSTRUMENTATION	1340	206	3543	\$ 139240				
							\$1500904	(3)		
4	170	QUAL. HARDWARE DESIGN & FABRICATION	1421	62	942	\$ 39810				
	180	QUALIFICATION TESTING	1422	124	3174	\$ 121808				
							\$ 161618	(4)		
5	210	WIND TUNNEL HARDWARE DESIGN & FAB.	1530	51	1795	\$ 78610				
	220	WIND TUNNEL HARDWARE INSTALLATION	1540	31	1480	\$ 49563				
	225	WIND TUNNEL TEST	1550	41	3641	\$ 126514				
	230	WIND TUNNEL TEST DATA REDUCTION & ANA.	1560	103	2884	\$ 128056				
							\$ 382750	(5)		
6	330	INSTALL ROTOR & SYSTEM CHECKOUT	1620	82	5314	\$ 192721				
	360	GROUND RUN TEST	1660	21	1747	\$ 63816				
	370	SOF DATA PREPARATION & REVIEW	1680	21	697	\$ 33022				
							\$ 289559	(6)		
7	420	FLIGHT TEST (FULL SUPPORT)	1730	62	4613	\$ 187177				
	430	FLIGHT TEST	1730	432	3802	\$ 248548				
							\$ 435725	(7)		

ARTEMIS PROJECT RSR REPORT SPEC RSRAC BY KMF

* COST GROUPS RELATE TO NASA CONTRACT # NAS2-10690 STATEMENT OF WORK 3.2.4 COST ESTIMATES.

TOTAL PROJECT LABOR COST = \$ 3531233

TABLE 27. - BLADE OPTION STUDY, 6 BLADE SETS, LABOR COSTS

DEVELOPMENT PLAN FOR YAH-64 MAIN ROTOR ON ROTOR SYSTEM RESEARCH AIRCRAFT (RSRA)

LABOR COST REPORT - ALT 'A' - WIND TUNNEL TEST - 6 BLADE SETS

TIMEHOW 4-JAN-82		FINISH DATE 27-MAR-87						
* COST GROUP	ACTIVITY NUMBER	ACTIVITY DESCRIPTION	WBS CODE	DURATION WORK DAYS	MAN HOURS	ACTIVITY COST	SUB TOTAL	* COST GROUP
1	20	PLAN OF PERFORMANCE REPORT DEVELOPMENT	1810	21	225	\$ 9642		
	30	PRELIMINARY DESIGN	1100	124	6051	\$ 230085		
						\.....	\$ 239727	(1)
2	60	DETAIL DESIGN DEVELOPMENT	1200	165	15310	\$ 616759		
						\.....	\$ 616759	(2)
3	110	FABRICATION	1310	247	49993	\$1773499		
	120	INSTRUMENTATION	1340	206	3543	\$ 139240		
						\.....	\$1912738	(3)
4	170	QUAL. HARDWARE DESIGN & FABRICATION	1421	62	942	\$ 39810		
	180	QUALIFICATION TESTING	1422	124	3174	\$ 121808		
						\.....	\$ 161618	(4)
5	210	WIND TUNNEL HARDWARE DESIGN & FAB.	1530	51	1795	\$ 78618		
	220	WIND TUNNEL HARDWARE INSTALLATION	1540	31	1488	\$ 49563		
	225	WIND TUNNEL TEST	1550	41	3641	\$ 126314		
	230	WIND TUNNEL TEST DATA REDUCTION & ANA.	1560	103	2884	\$ 128056		
						\.....	\$ 382750	(5)
6	330	INSTALL ROTOR & SYSTEM CHECKOUT	1620	82	5314	\$ 192721		
	360	GROUND RUN TEST	1660	21	1747	\$ 63816		
	370	SOF DATA PREPARATION & REVIEW	1680	21	697	\$ 33022		
						\.....	\$ 289559	(6)
7	420	FLIGHT TEST (FULL SUPPORT)	1730	62	4613	\$ 187177		
	430	FLIGHT TEST	1730	432	3802	\$ 248548		
						\.....	\$ 435725	(7)

ARTEMIS PROJECT RSR REPORT SPEC RSRAC BY KNF

* COST GROUPS RELATE TO NASA CONTRACT # NAS2-10690 STATEMENT OF WORK 3.2 4 COST ESTIMATES.

TOTAL PROJECT LABOR COST = \$ 4038876

TABLE 28 - BLADE OPTIONS, TOTAL COST COMPARISON

COST

Cost Group	Original Program (8 Blade Sets)	Basic Blades (2 Blade Sets)	New Blade Tips (5 Blade Sets)	New Blade And Tips (6 Blade Sets)
(2) Detail Design	\$ 689,715	\$ 449,095	\$ 520,951	\$ 616,759
(3) Fabrication	\$3,918,240	\$1,380,498	\$2,369,904	\$2,962,238
(4) Qualification	\$ 186,618	\$ 39,147	\$ 186,618	\$ 186,618
Subtotal	\$4,794,573	\$1,868,740	\$3,077,473	\$3,765,615
TOTAL PROGRAM COST (Other cost groups same as original)	\$6,279,033	\$3,353,200	\$4,561,933	\$5,250,075

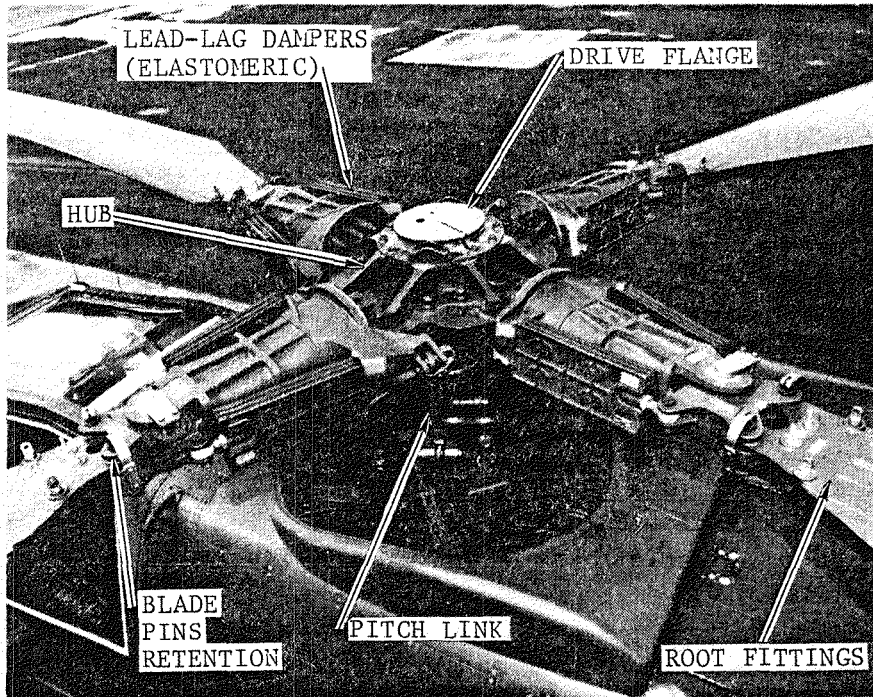

Figure 1.- Hughes YAH-64 Hub Assembly

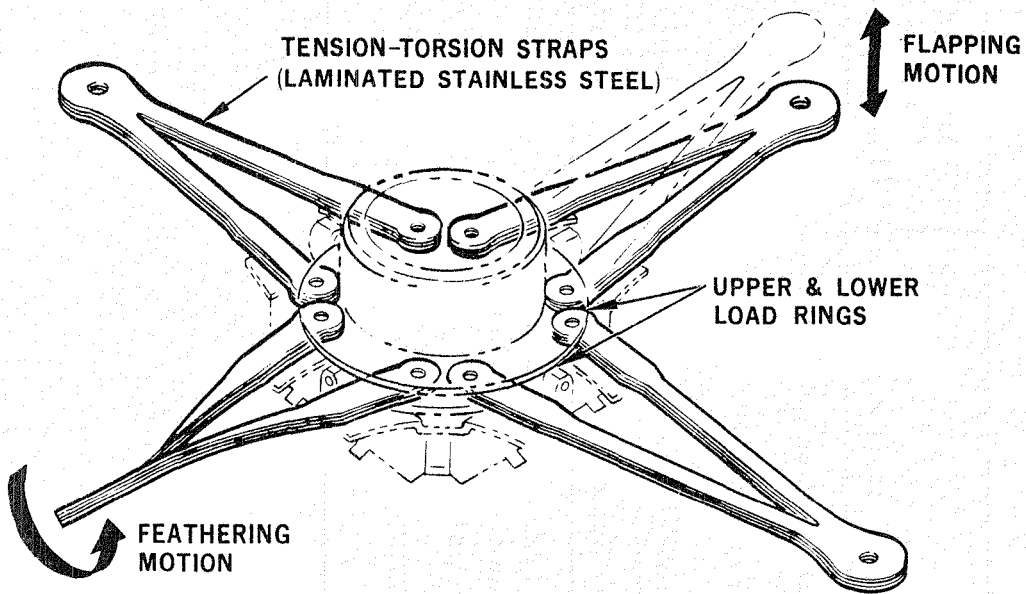

Figure 2.- Straps for YAH-64 Hub Assembly

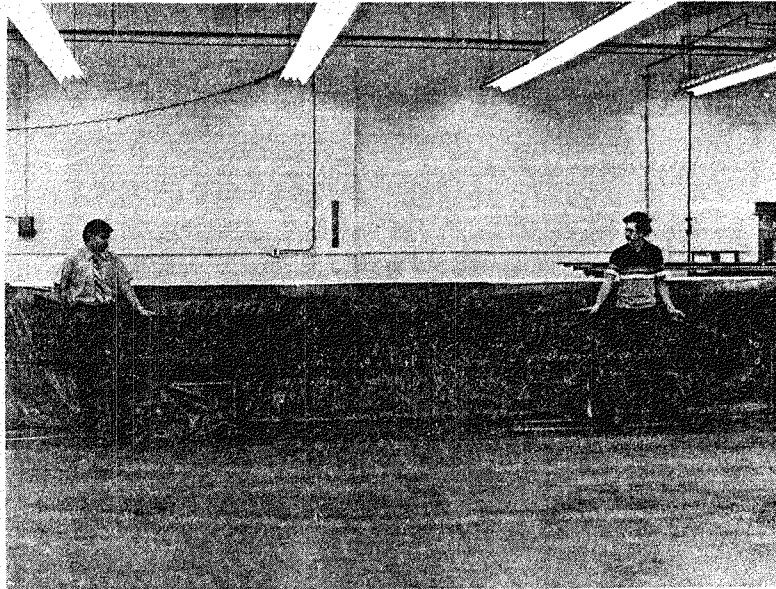

Figure 3.- YAH-64 Composite Main Rotor Blade

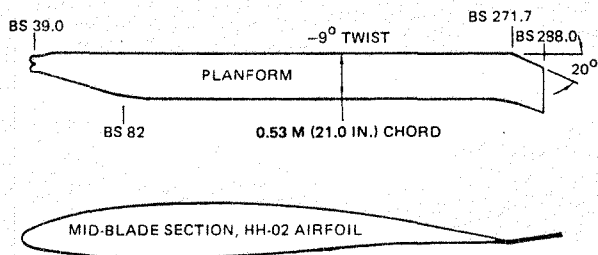

Figure 4.- YAH-64 Blade Geometry

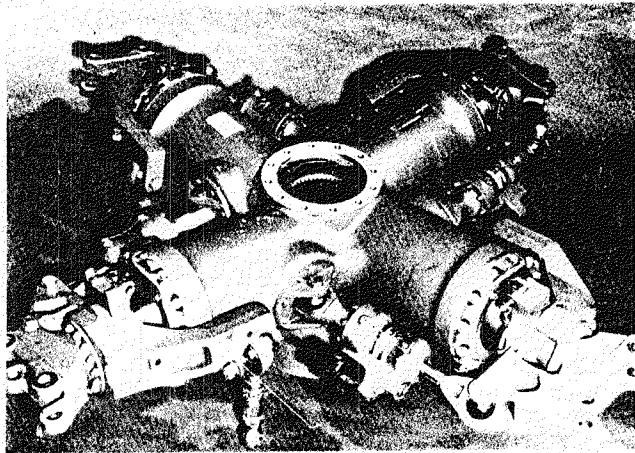

Figure 5.- Sikorsky UH-60A Hub

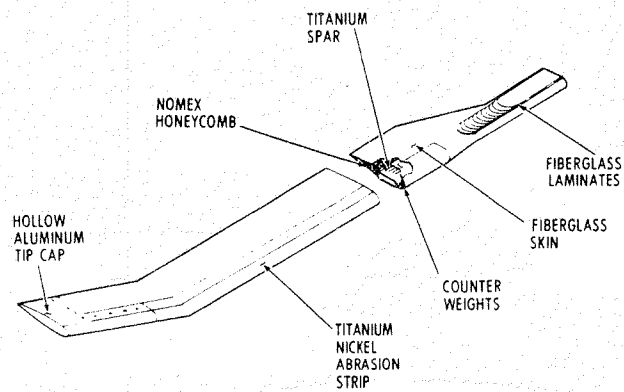

Figure 6.- UH-60A Blade

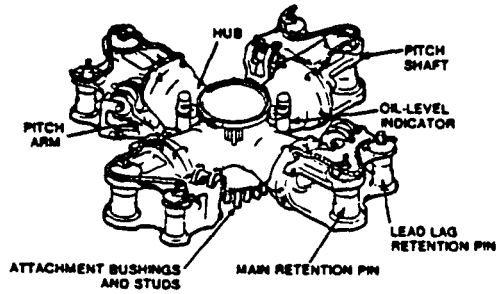

Figure 7.- Boeing Vertol YUH-61A Hub

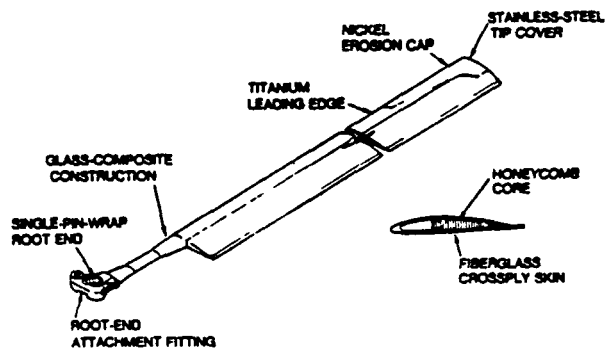

Figure 8.- YUH-61A Blade

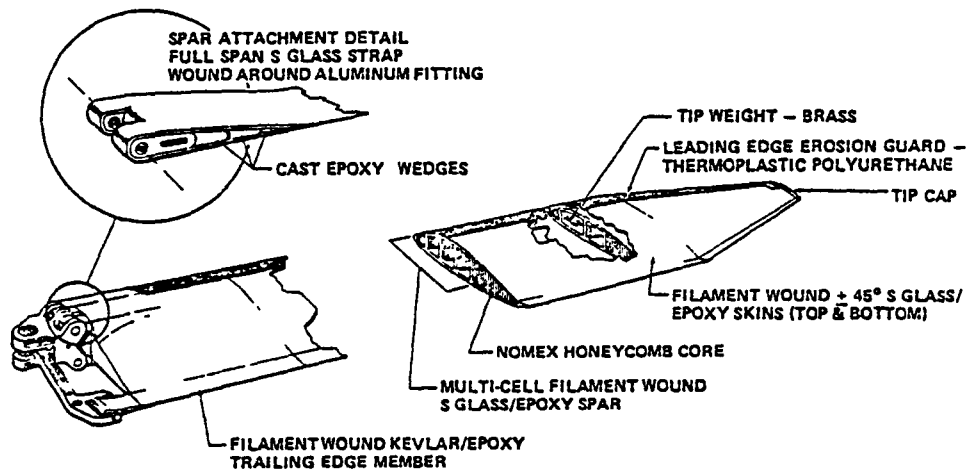
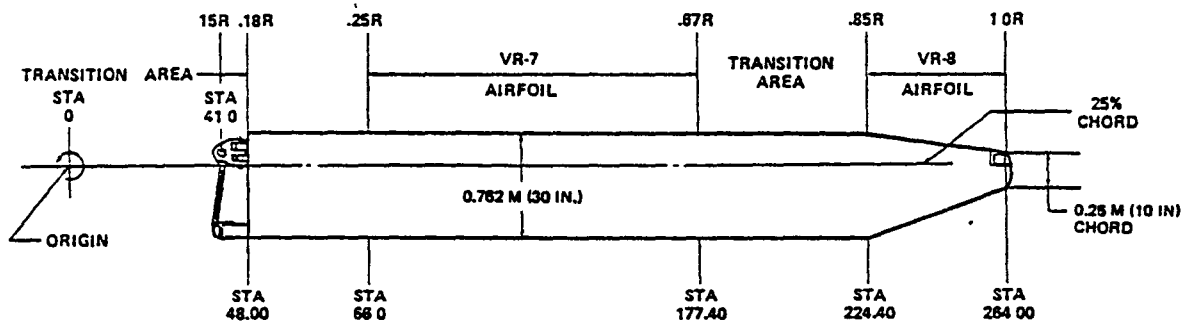

Figure 9.- Kaman K-747 Blade for AH-1S

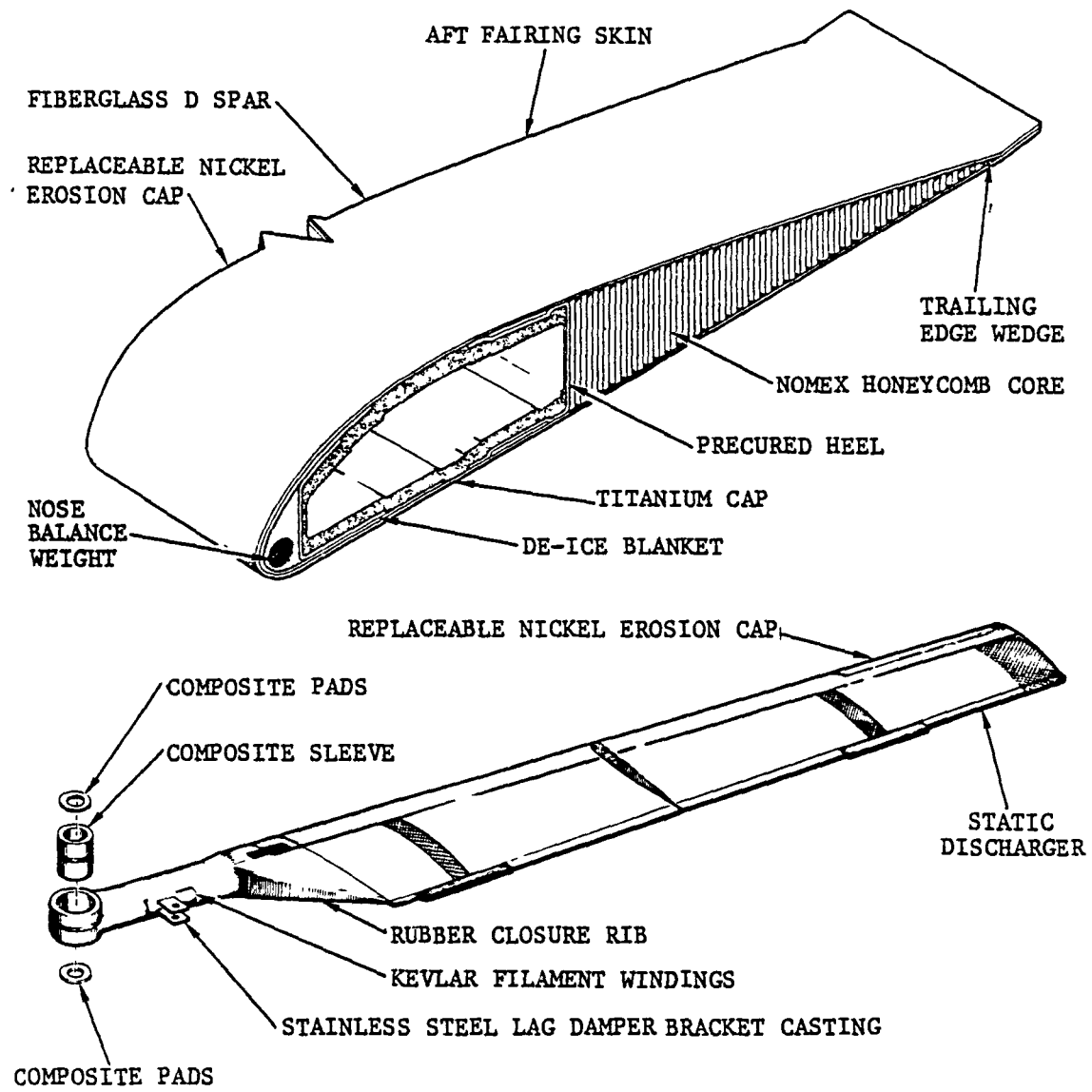

Figure 10.- Boeing Vertol YCH-47D Blade

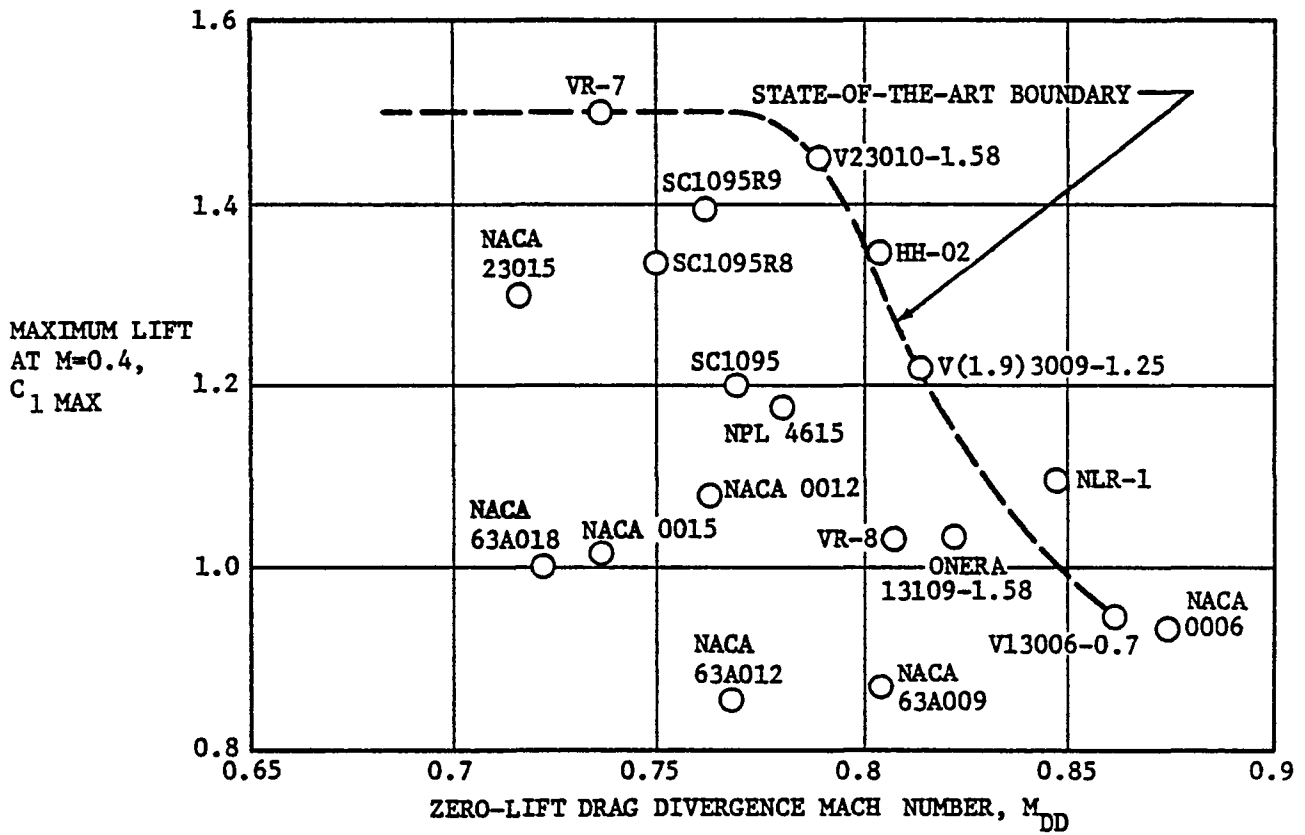

Figure 11.- Airfoil Comparison

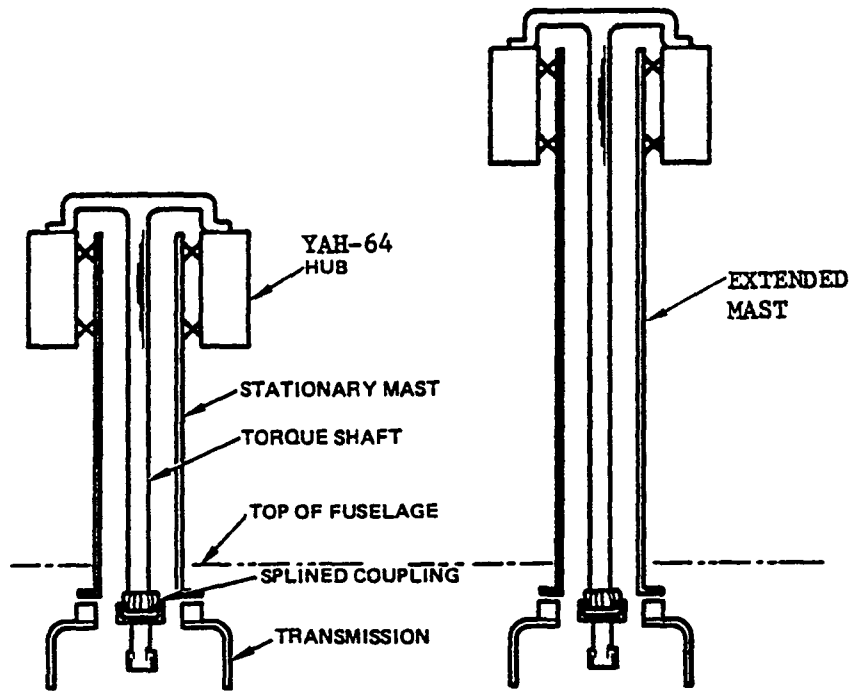

Figure 12. - Hub-to-Fuselage Height Variations Simplified by Static Mast Design

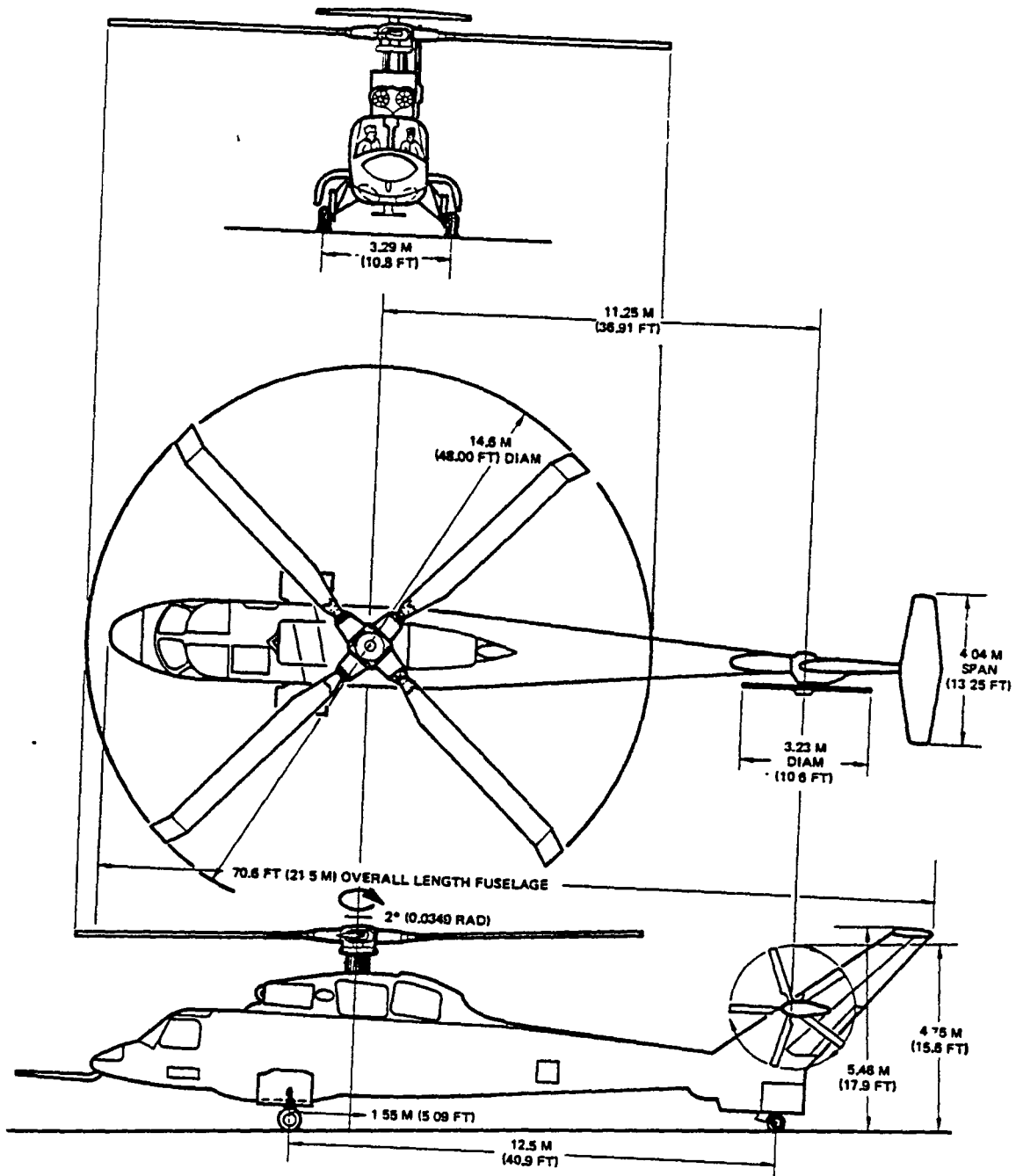

Figure 13.- YAH-64 Rotor System on the RSRA

**THIS PAGE LEFT BLANK
INTENTIONALLY**

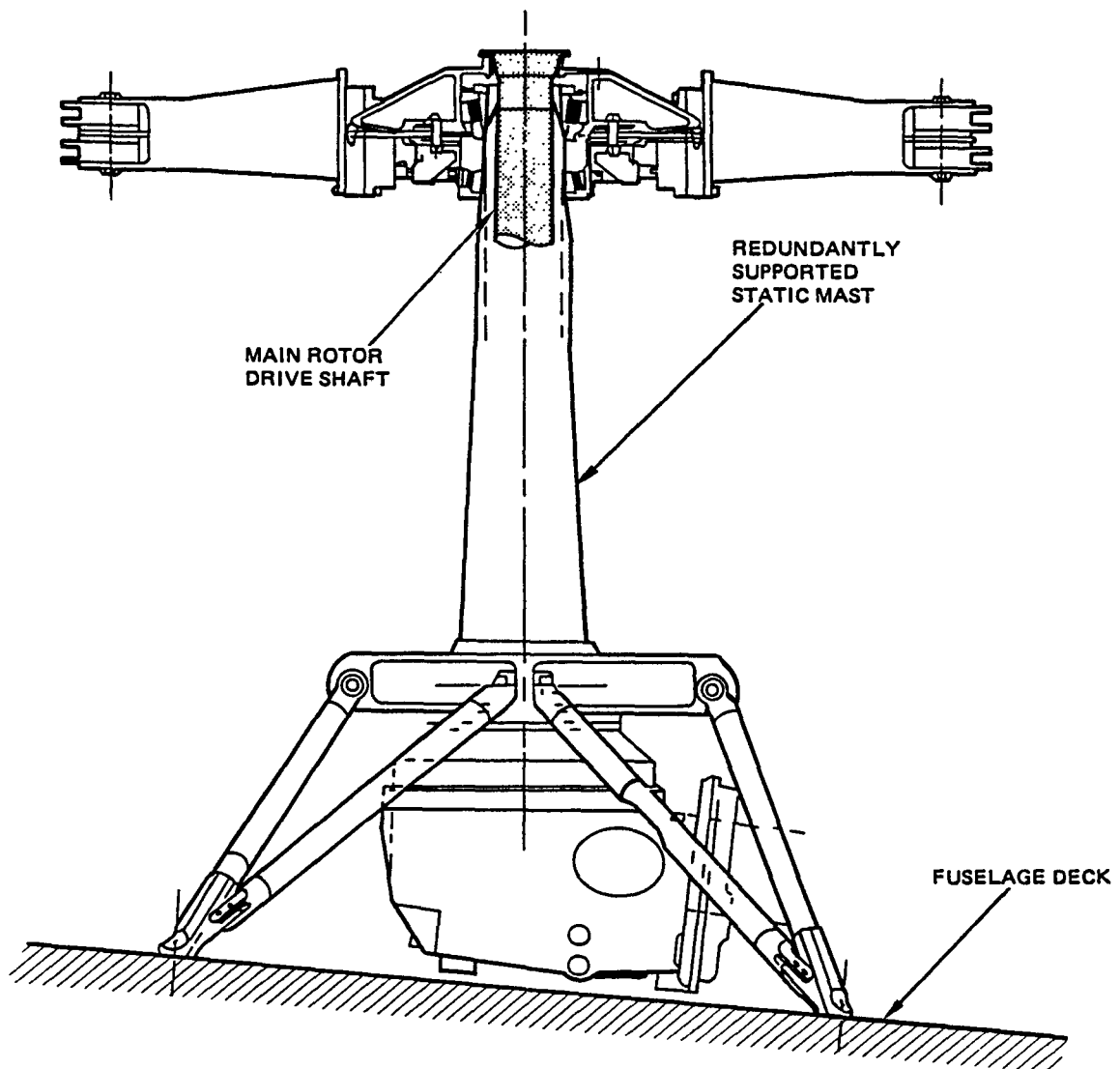

Figure 15. - Rotor Support Structure Design

**THIS PAGE LEFT BLANK
INTENTIONALLY**

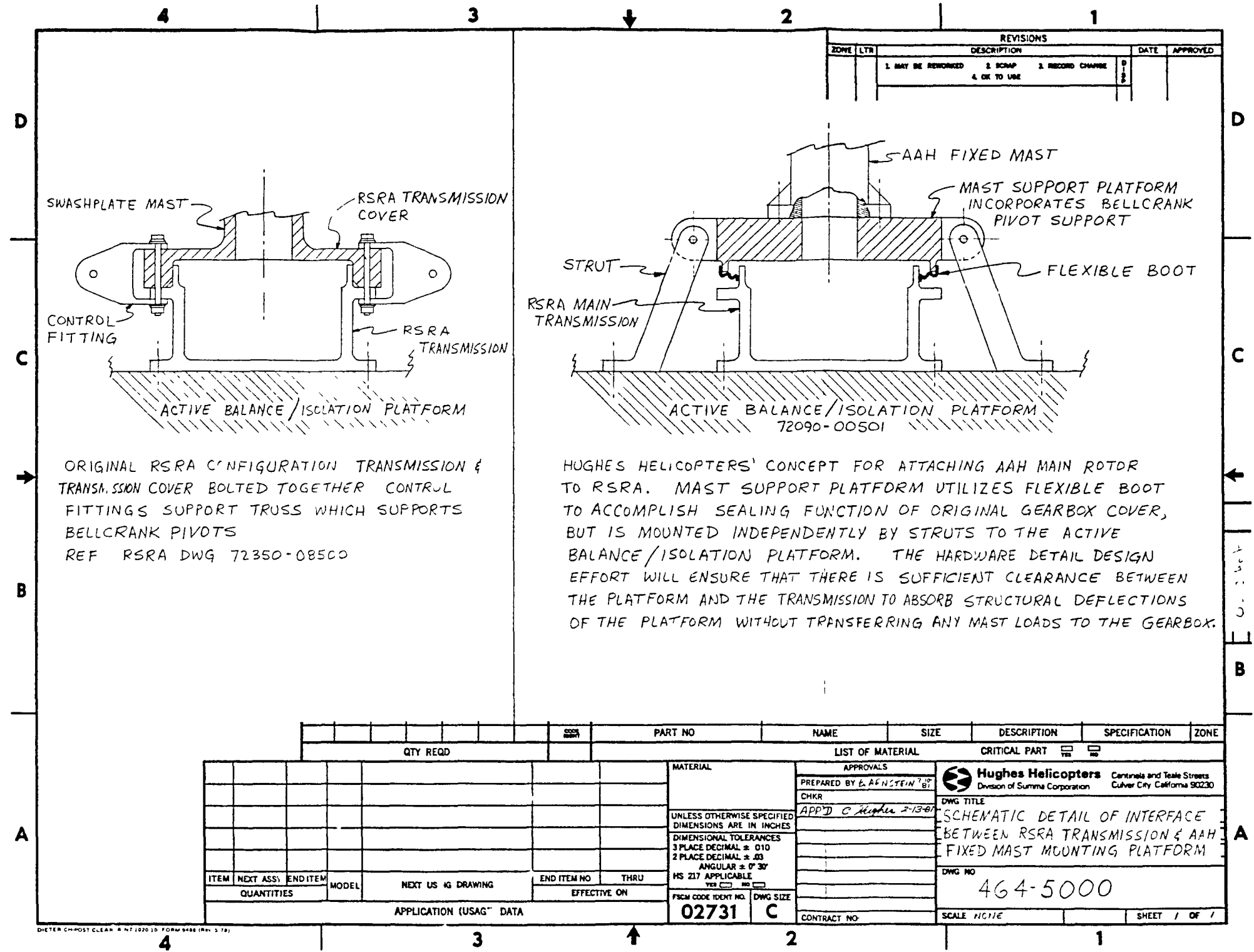
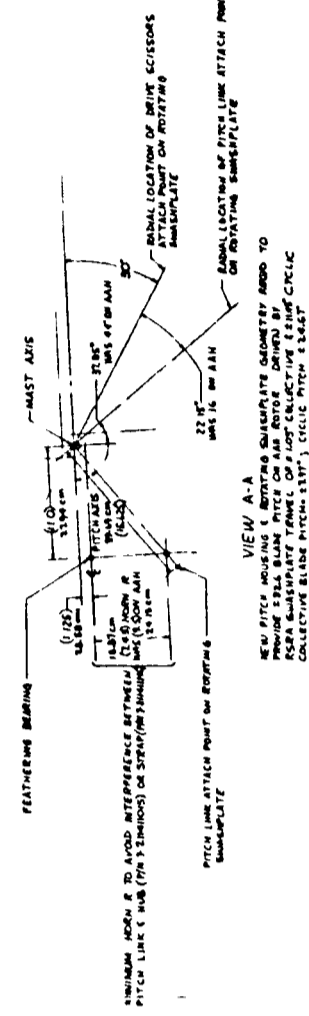
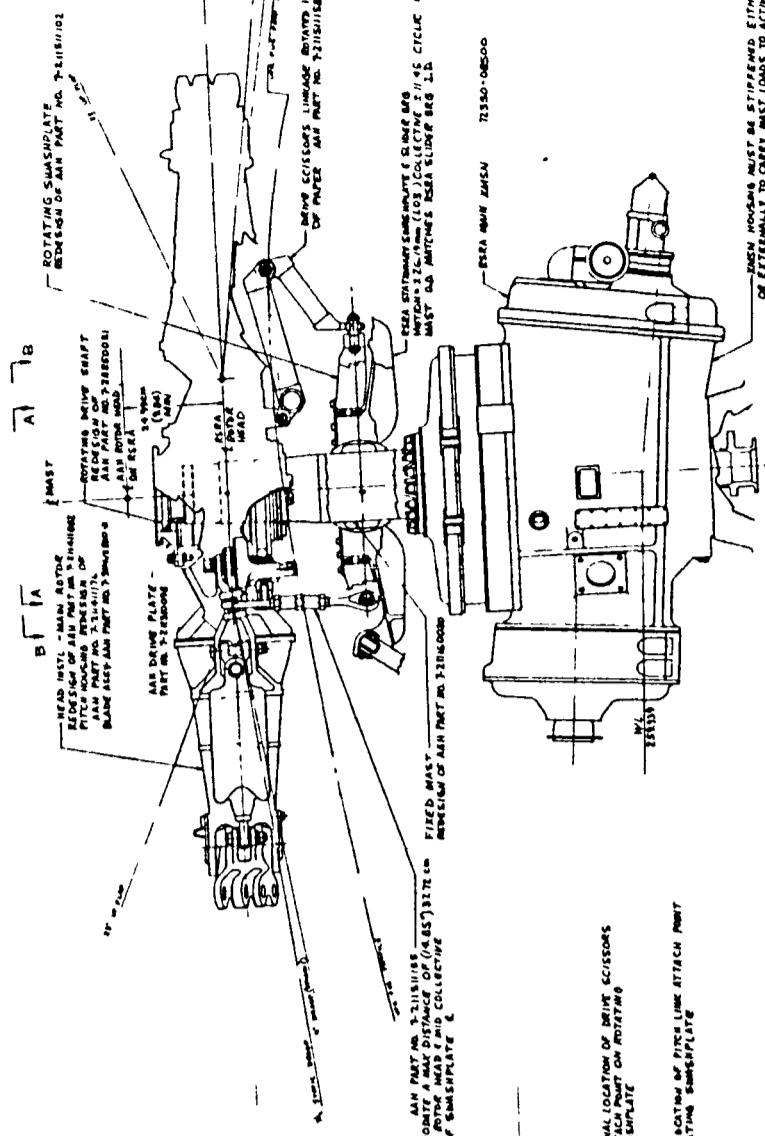
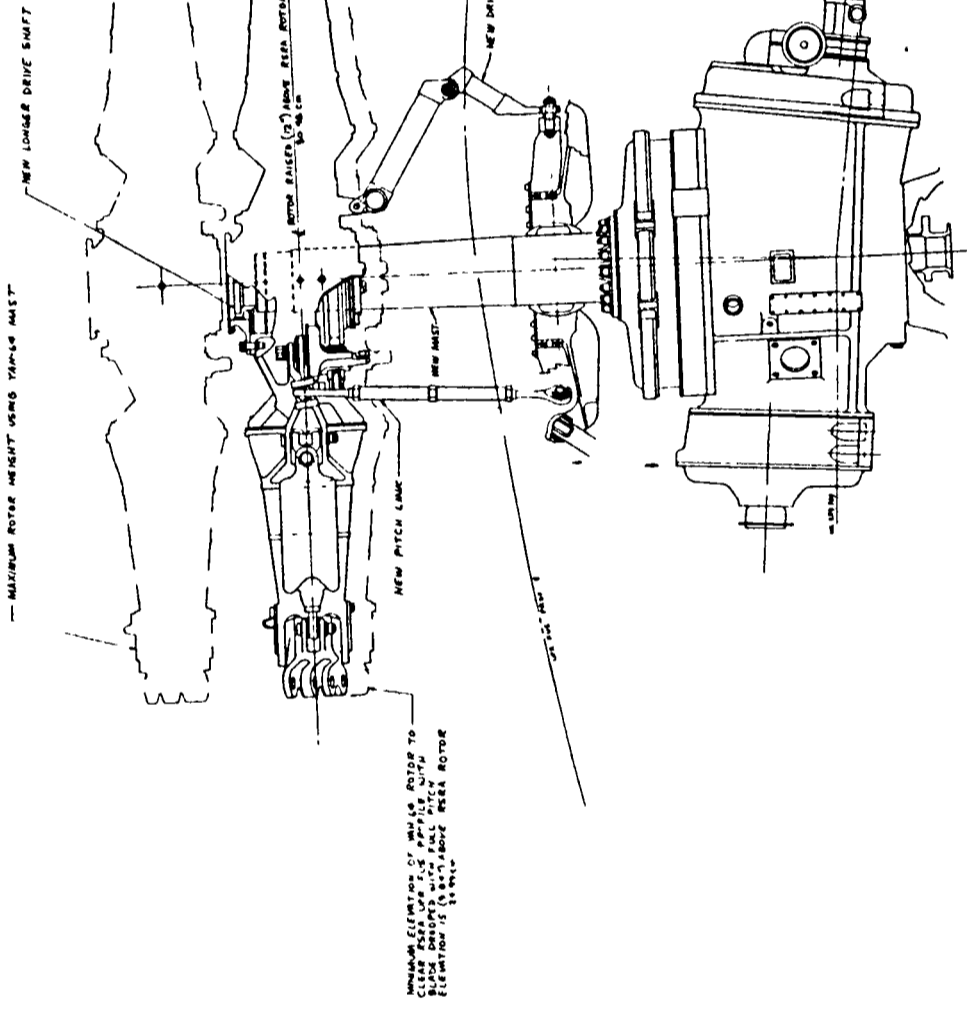
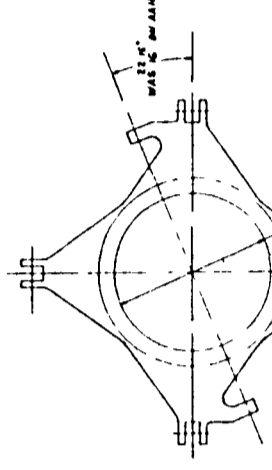

Figure 16. - Schematic Detail of Interface Between RSRA Transmission and AAH Fixed Mast Mounting Platform

**THIS PAGE LEFT BLANK
INTENTIONALLY**



DESIGNED BY	DATE
CHECKED BY	DATE
APPROVED BY	DATE
PROJECT NO.	434000
REV.	1

Figure 17. - YAH-64 Rotor on RSRA-Fixed Mast Mounted on Main Gear Box Housing (Concept)

**THIS PAGE LEFT BLANK
INTENTIONALLY**

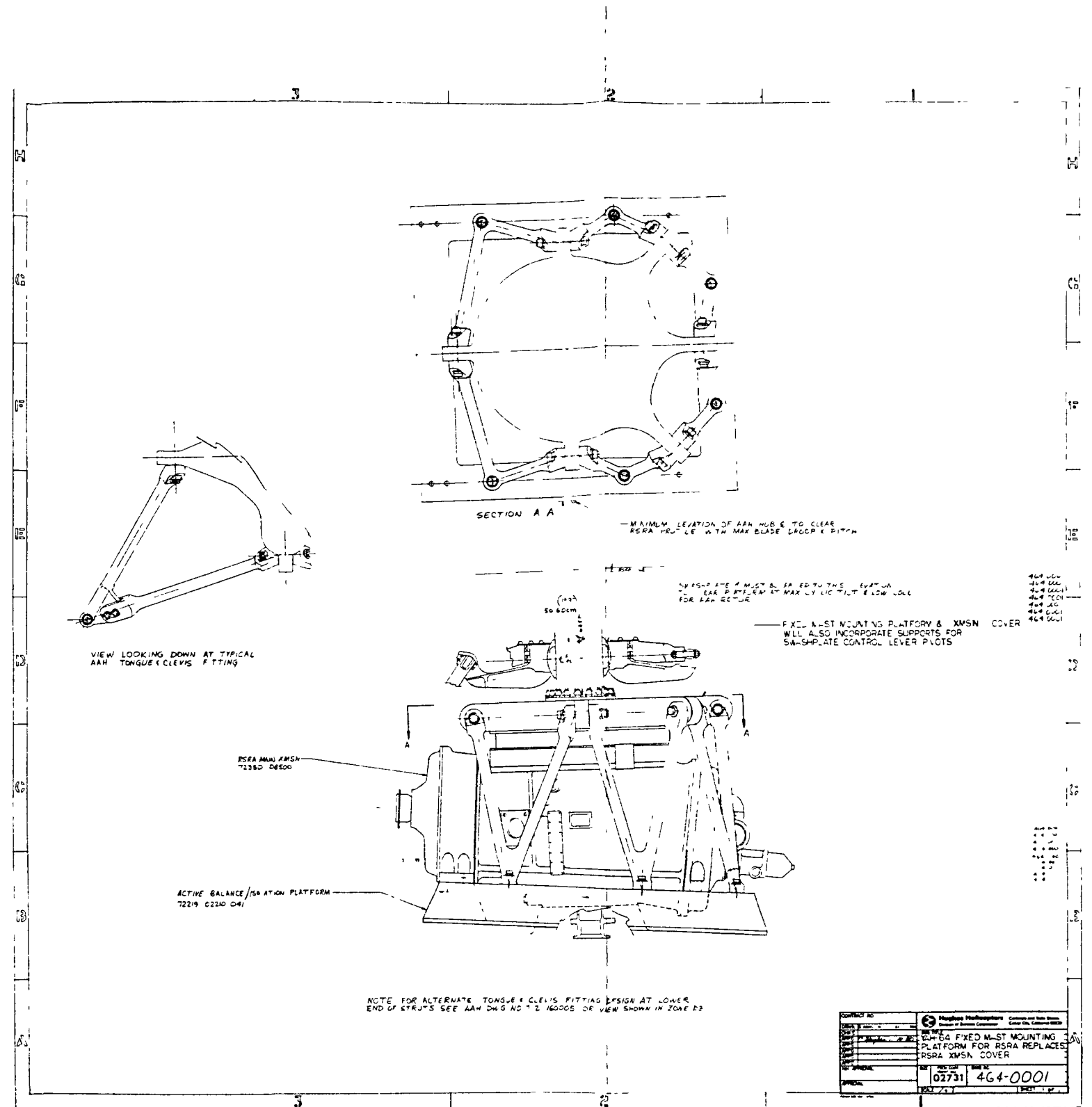

Figure 18. - YAH-64 Fixed Mast Mounting Platform for RSRA - Replaces RSRA Transmission Cover

**THIS PAGE LEFT BLANK
INTENTIONALLY**

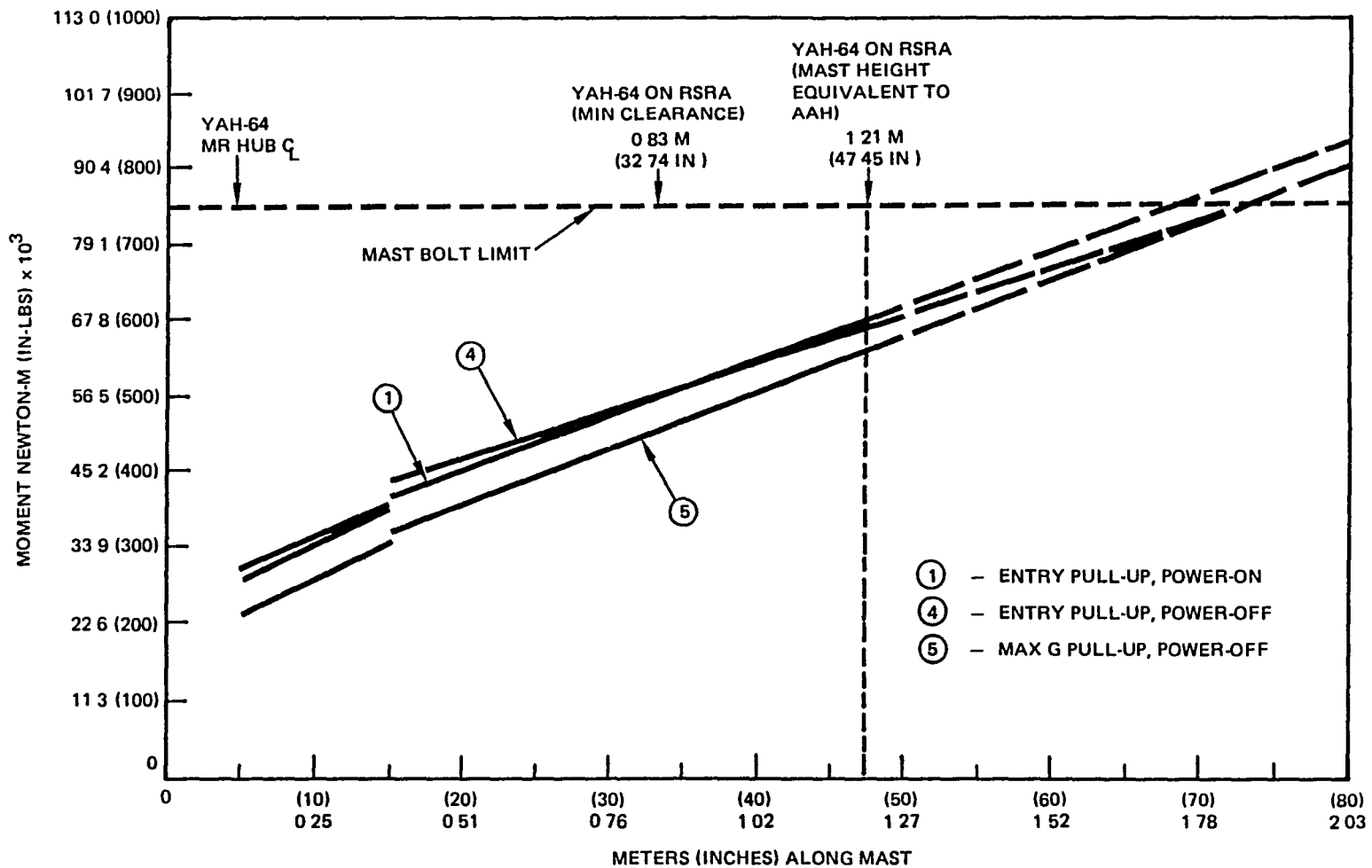
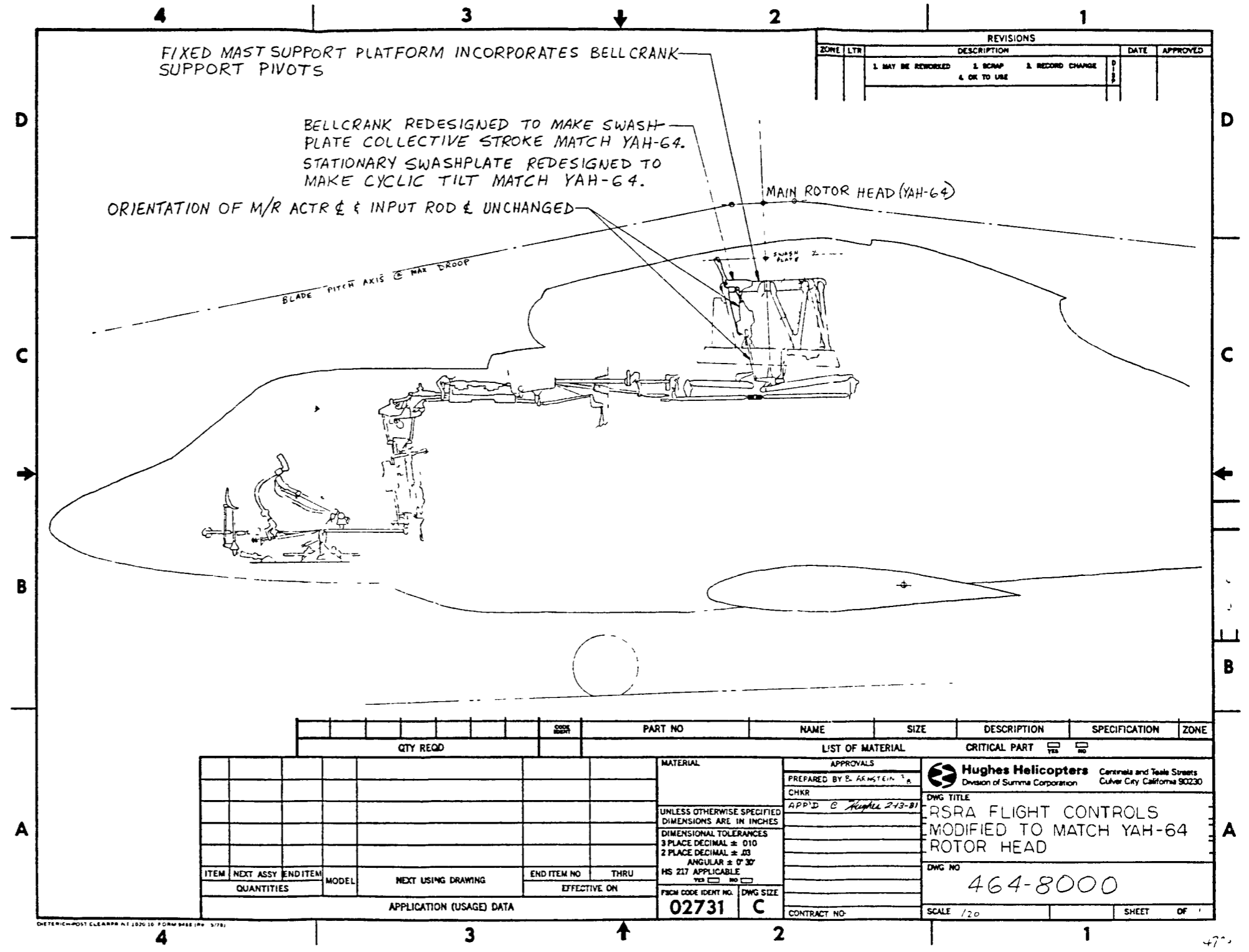

Figure 19. - Critical Main Rotor Mast Bending Moments

**THIS PAGE LEFT BLANK
INTENTIONALLY**



REVISIONS			
ZONE	LTR	DESCRIPTION	DATE
1		MAY BE REWORKED	
2		SCRAP	
3		RECORD CHANGE	
4		OK TO USE	

QTY REQD		PART NO		NAME		SIZE		DESCRIPTION		SPECIFICATION		ZONE	

ITEM		NEXT ASSY		END ITEM		MODEL		NEXT USING DRAWING		END ITEM NO		THRU	
QUANTITIES										EFFECTIVE ON			

MATERIAL		APPROVALS	
UNLESS OTHERWISE SPECIFIED DIMENSIONS ARE IN INCHES		PREPARED BY E. ARNSTEIN	
DIMENSIONAL TOLERANCES		CHKR	
3 PLACE DECIMAL ± 0.10		APP'D C Hughes 243-B1	
2 PLACE DECIMAL ± .03			
ANGULAR ± 0° 30'			
MS 217 APPLICABLE			
YES <input type="checkbox"/> NO <input type="checkbox"/>			
FORM CODE IDENT NO.		DWG SIZE	
02731		C	

APPLICATION (USAGE) DATA		CONTRACT NO	
		464-8000	

Figure 20. - RSRA Flight Controls Modified to Match YAH-64 Rotor Head

**THIS PAGE LEFT BLANK
INTENTIONALLY**

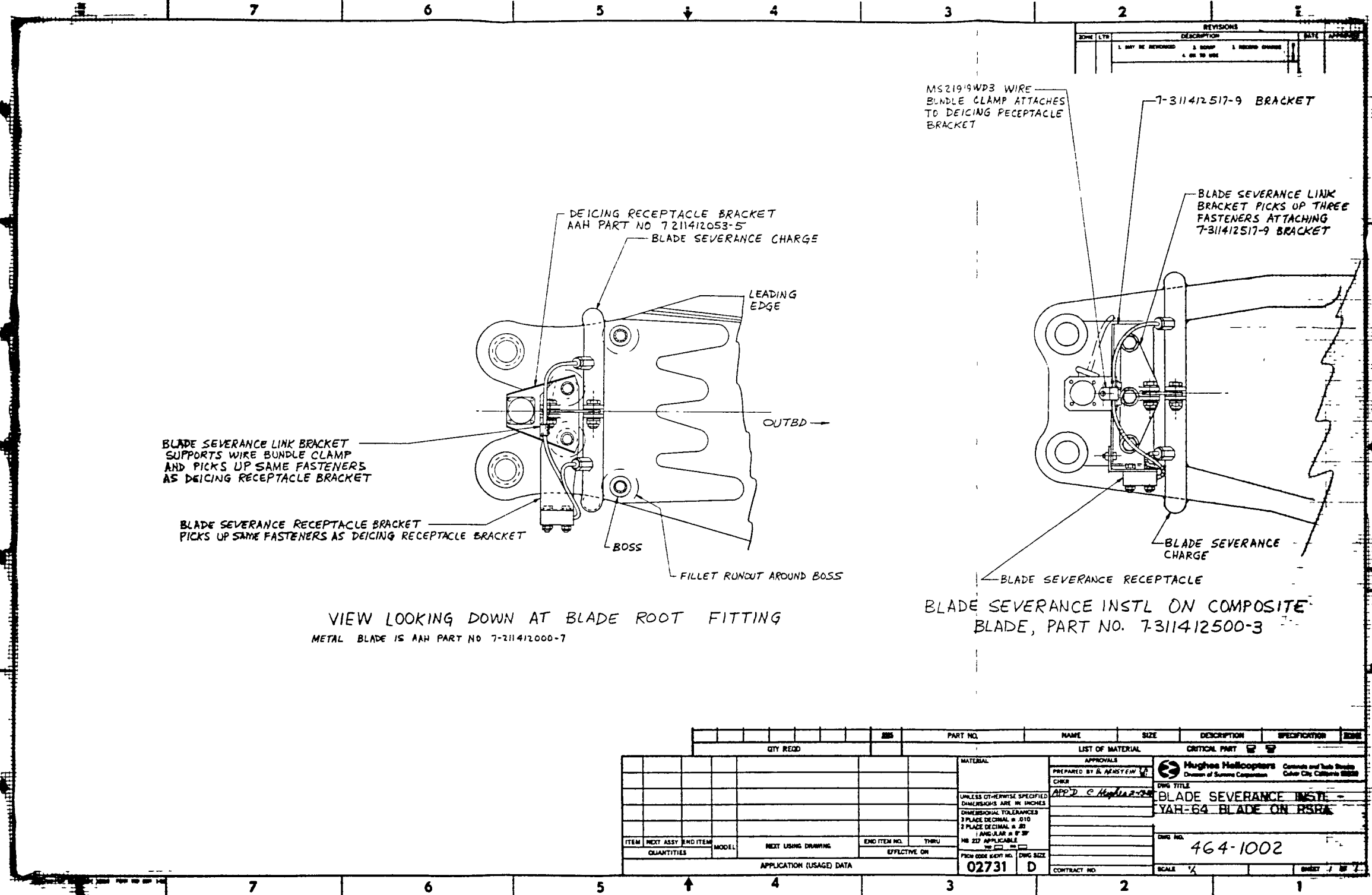

Figure 21. - Blade Severance Installation
YAH-64 Blade on RSRA

**THIS PAGE LEFT BLANK
INTENTIONALLY**

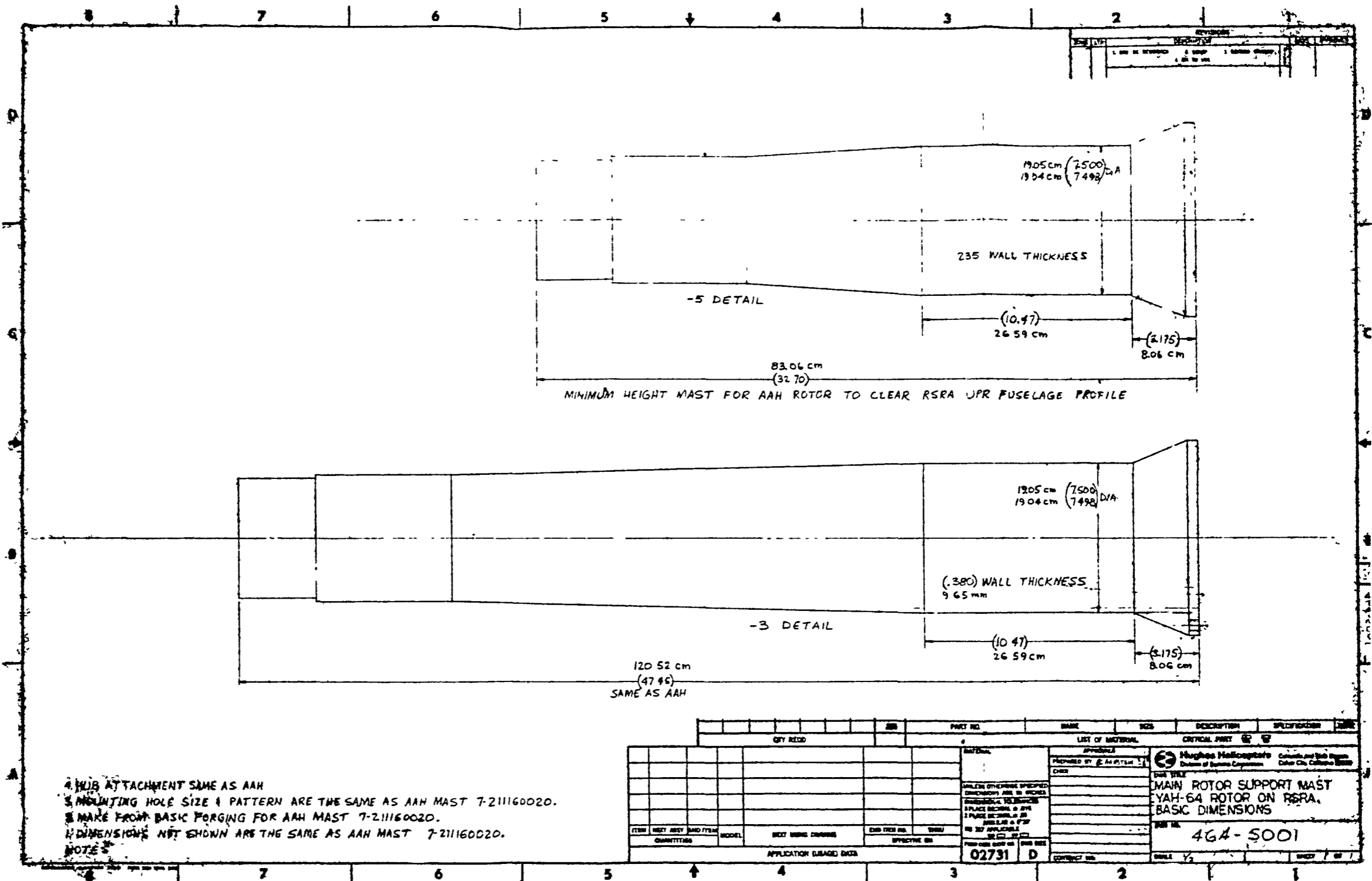

Figure 22. - Modified YAH-64 Masts for the RSRA Installation

**THIS PAGE LEFT BLANK
INTENTIONALLY**

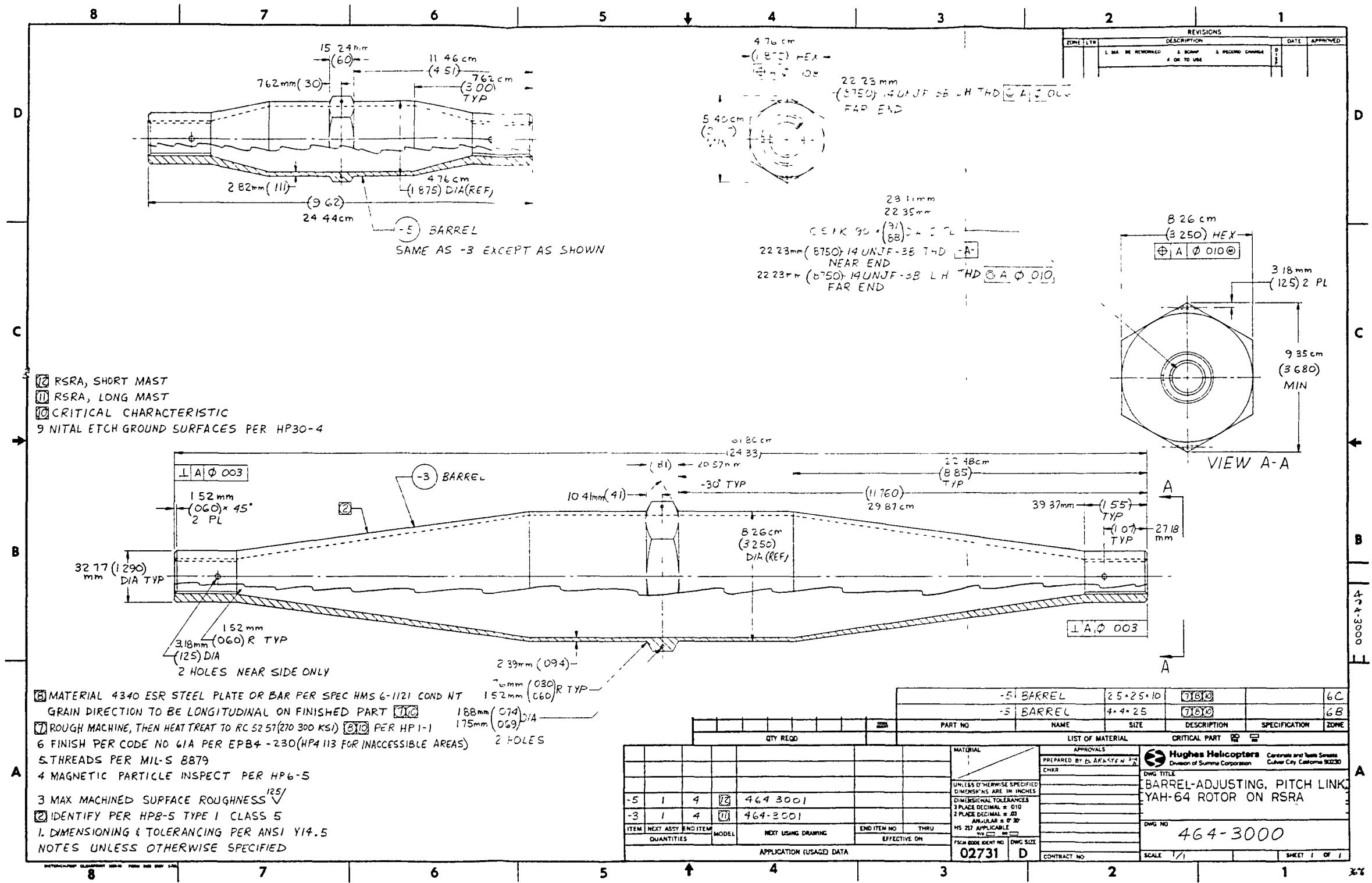
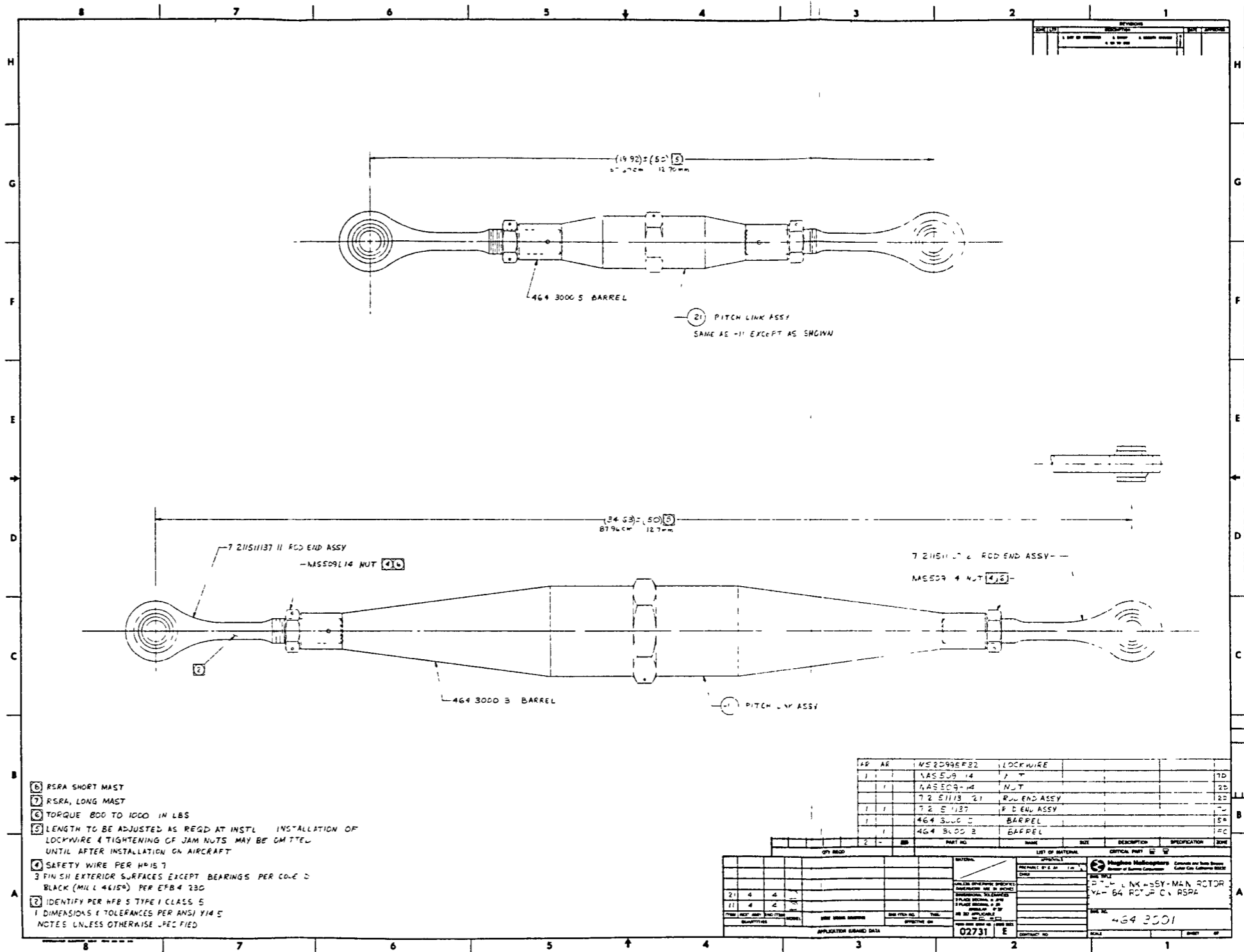

Figure 23. - Barrels for New Pitch Links to Accommodate Different Mast Heights

**THIS PAGE LEFT BLANK
INTENTIONALLY**



- ⑤ RSRA SHORT MAST
 - ⑥ RSRA LONG MAST
 - ⑦ TORQUE 800 TO 1000 IN LBS
 - ⑧ LENGTH TO BE ADJUSTED AS REQD AT INSTL. INSTALLATION OF LOCKWIRE & TIGHTENING OF JAM NUTS MAY BE OMITTED UNTIL AFTER INSTALLATION ON AIRCRAFT
 - ⑨ SAFETY WIRE PER HPS 7
 - ⑩ FINISH EXTERIOR SURFACES EXCEPT BEARINGS PER CO-C 2 BLACK (MIL 46150) PER EFB 4 230
 - ⑪ IDENTIFY PER HPS TYPE I CLASS 5
- 1 DIMENSIONS & TOLERANCES PER ANSI Y14.5
 NOTES UNLESS OTHERWISE SPECIFIED

QTY REQD	UNIT	PART NO	NAME	SIZE	DESCRIPTION	SPECIFICATION	ZONE
1		MS2099EFB2	LOCKWIRE				TD
1		NASS09-14	NUT				2D
1		7 2 51113 21	ROD END ASSY				2D
1		7 2 51127	ROD END ASSY				2D
1		464 3000 5	BARREL				5A
1		464 3000 3	BARREL				2C

QTY REQD	UNIT	PART NO	NAME	SIZE	DESCRIPTION	SPECIFICATION	ZONE
21	4	4					
11	4	4					

APPLICATOR GRADED DATA

02731 E

464 3001

Figure 24. - Pitch Link Assemblies for Various Mast Heights

**THIS PAGE LEFT BLANK
INTENTIONALLY**

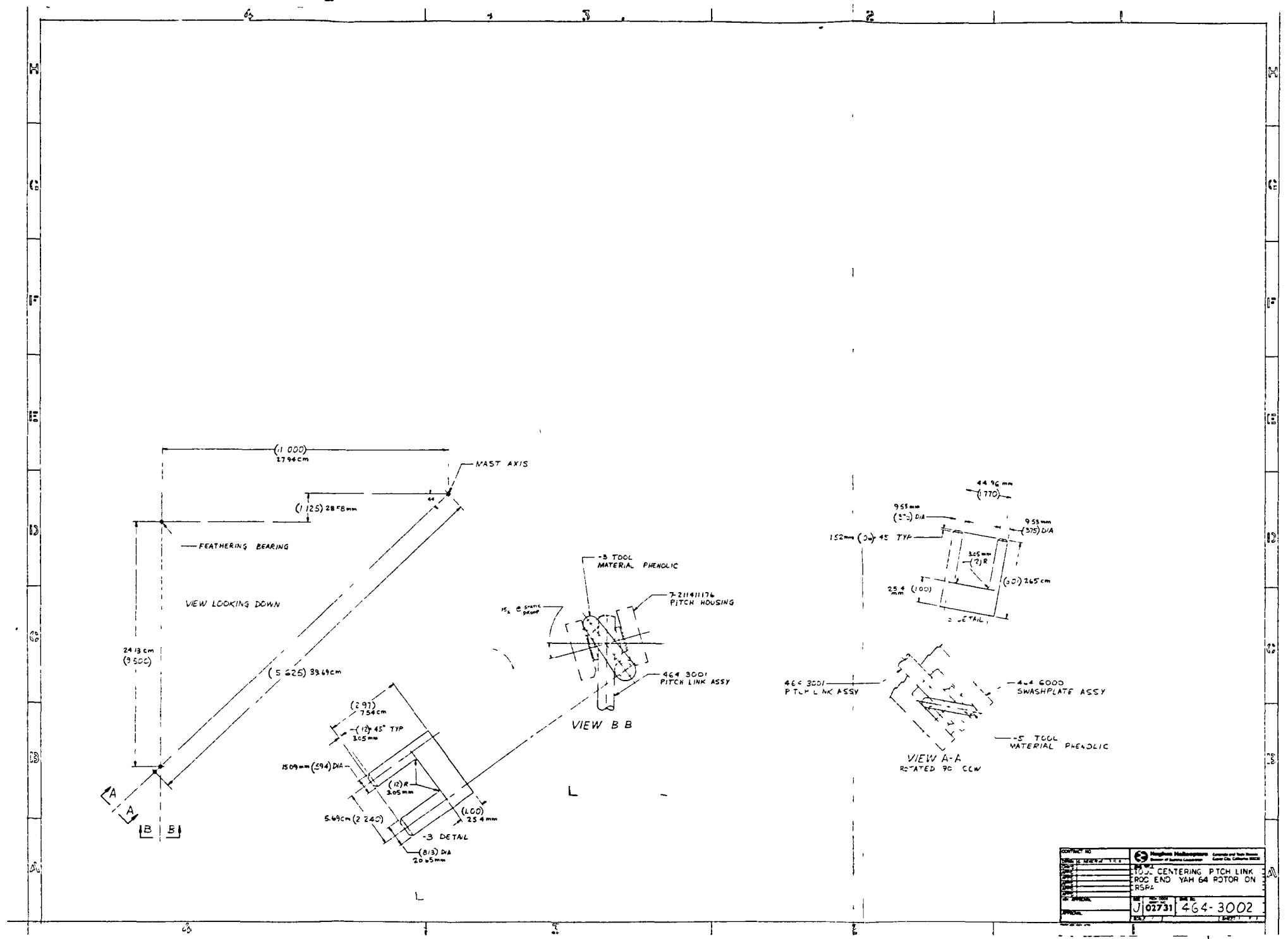

CONTRACT NO.	
PROJECT NO.	
ISSUE NO.	
DATE	
BY	
CHECKED BY	
APPROVED BY	
REVISIONS	
TITLE: CENTERING PITCH LINK ROD END YAW 64 ROTOR ON RSPA	
J 02731 464-3002	

Figure 25.- Tool for Adjusting Pitch Links

**THIS PAGE LEFT BLANK
INTENTIONALLY**

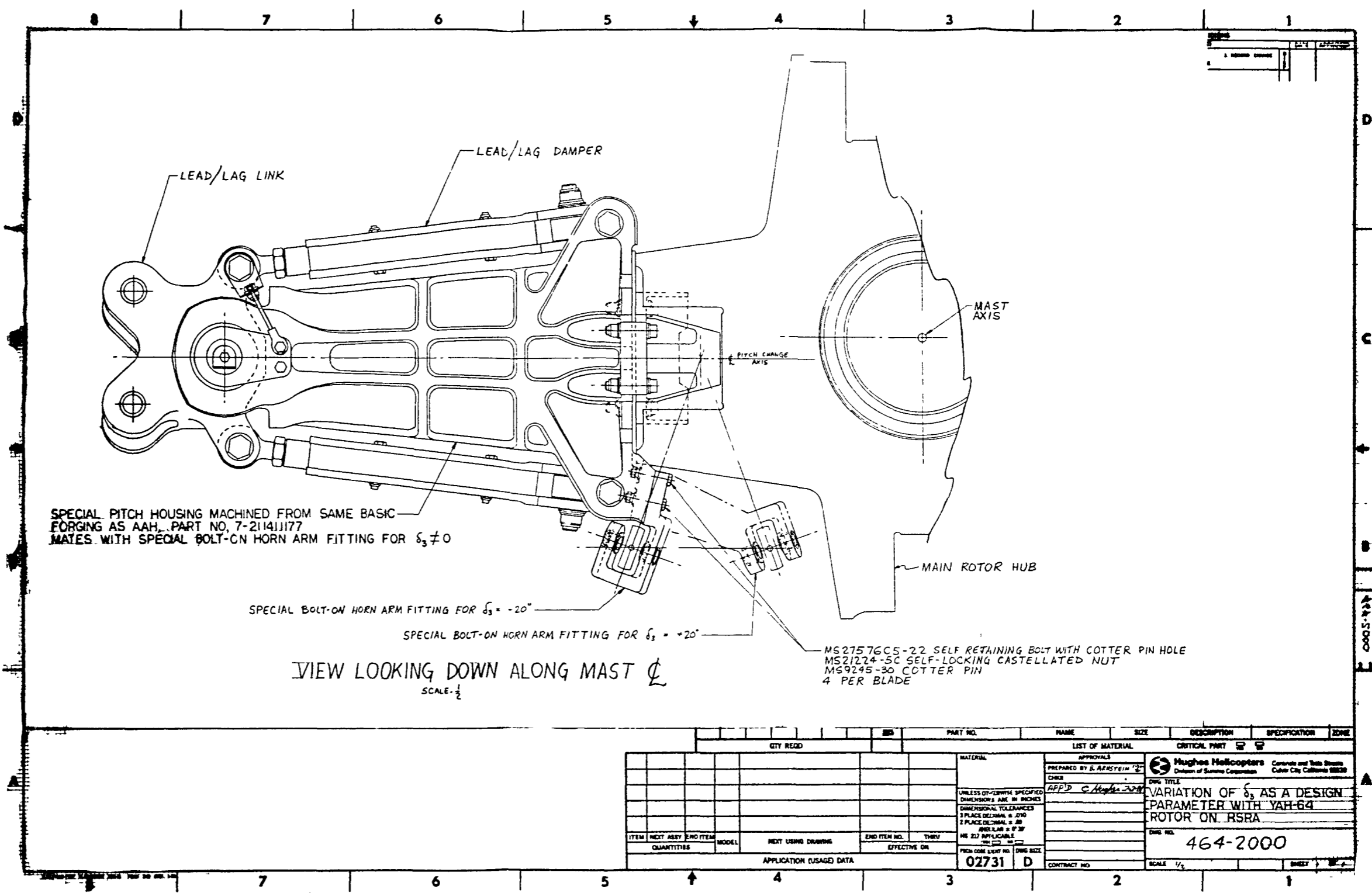

QTY REQD		PART NO.		NAME		SIZE	DESCRIPTION	SPECIFICATION	ZONE
LIST OF MATERIAL									
APPROVALS									
PREPARED BY B. ARSTEIN									
CHKD APP'D C. Hughes									
UNLESS OTHERWISE SPECIFIED DIMENSIONS ARE IN INCHES									
DIMENSIONAL TOLERANCES									
3 PLACE DECIMAL ± .010									
2 PLACE DECIMAL ± .005									
1 PLACE DECIMAL ± .030									
MS 217 APPLICABLE									
FINISH CODE LIST NO. (DWG SIZE)									
02731 D									
CONTRACT NO.									
HUGHES HELICOPTERS									
Division of Boeing Corporation									
464-2000									
SCALE $\frac{1}{2}$									
SHEET									

Figure 26.- Variation of δ_3 as a Design Parameter with YAH-64 Rotor on RSRA

**THIS PAGE LEFT BLANK
INTENTIONALLY**

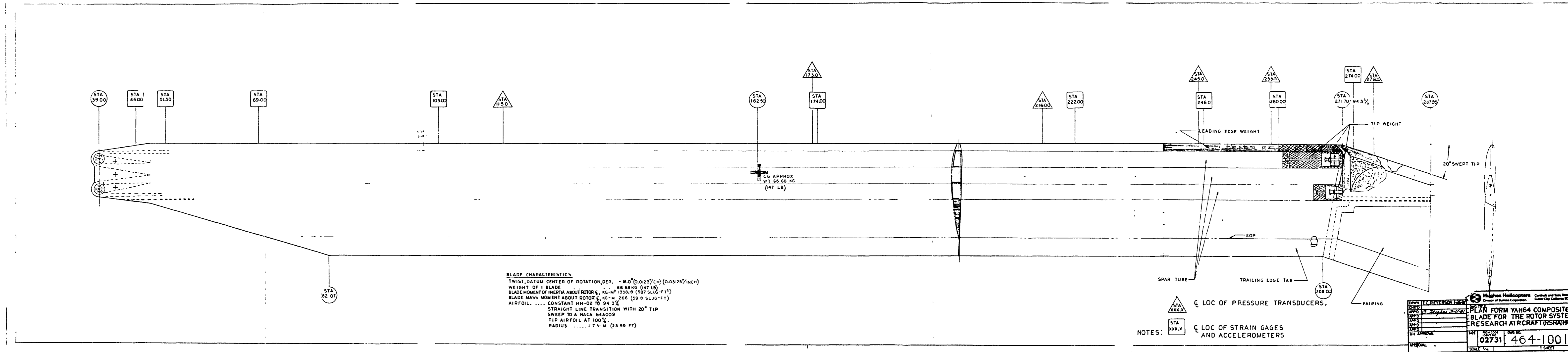

DRAWN: T.C. RAYSON CHECKED: C. Hughes APP'D: APP'D: APP'D: APP'D: IN APPROVAL: APPROVAL:	DATE: 1/27/71 SIZE: 11x17 SCALE: 1/2" = 1'-0" SHEET: 1	Hughes Helicopters Division of Boeing Corporation Torrance and Santa Monica Culver City, California 90230
---	---	--

Figure 27. - Plan Form YAH-64 Composite Blade for the Rotor System Research Aircraft (RSRA) Hub

**THIS PAGE LEFT BLANK
INTENTIONALLY**

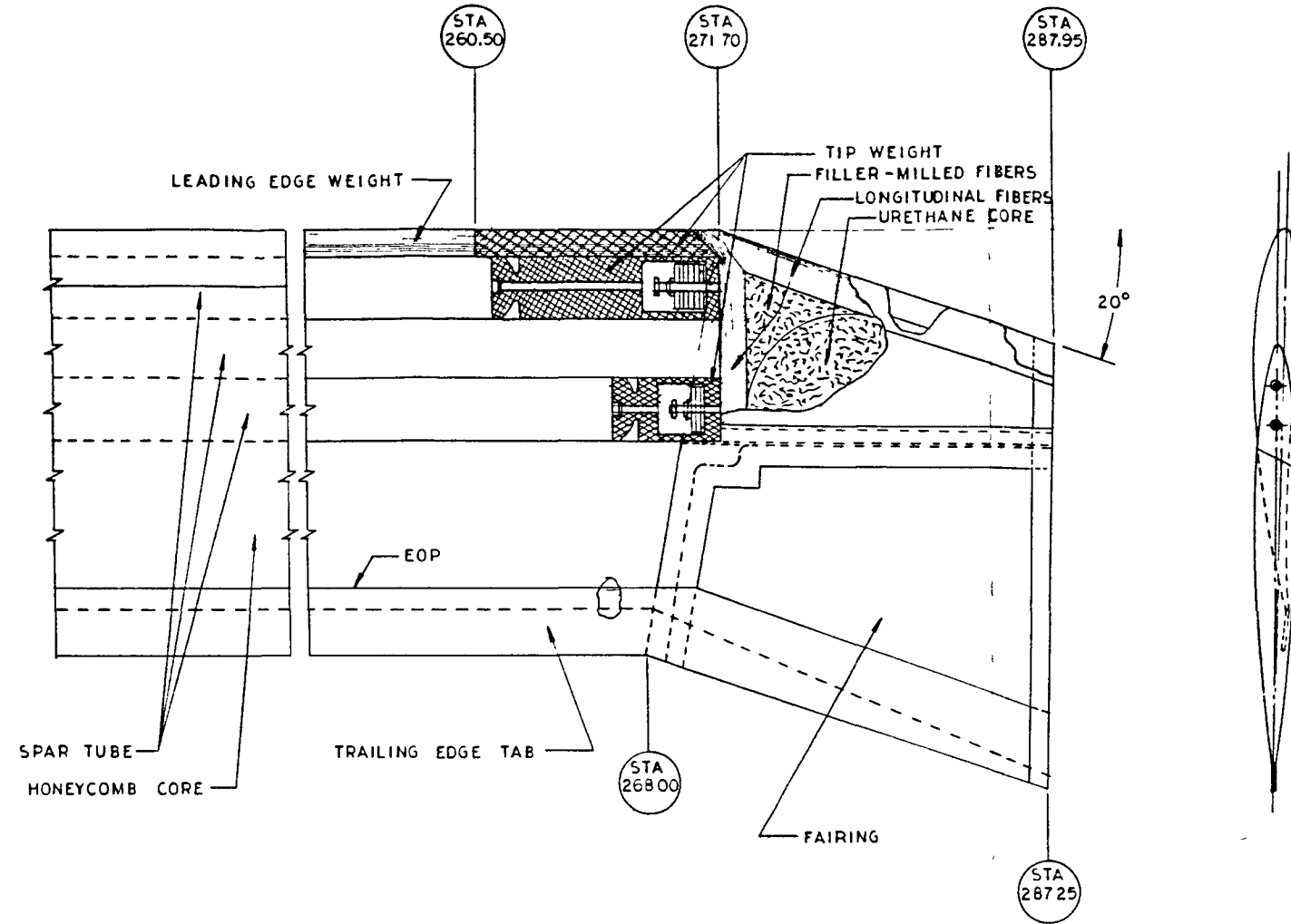

CONSTANT HH-02 AIRFOIL TO CANTED STA 271.70
 STRAIGHT LINE TRANSITION TO A
 NACA 64A009 AIRFOIL AT THE TIP.

NOTES

CONTRACT NO		Hughes Helicopters Division of Summa Corporation		Centrate and Testa Streets Culver City, California 90230
DRWN	T.C. REYERSON 29-81	DWG TITLE		
CHK'D		MODERN 4-BLADED TIP SHAPES		
APP'D	<i>C. Hughes 2/11/81</i>	SWEPT TIP-STANDARD,		
APP'D		YAH-64 M/R FOR THE RSRA		
APP'D		SIZE	FSCM CODE IDENT NO	DWG NO
HH APPROVAL		C	02731	464-1003
APPROVAL		SCALE	1/2"	SHEET

Figure 28. - Modern 4-Bladed Tip Shapes
 Swept Tip-Standard, YAH-64 M/R
 for the RSRA

**THIS PAGE LEFT BLANK
INTENTIONALLY**

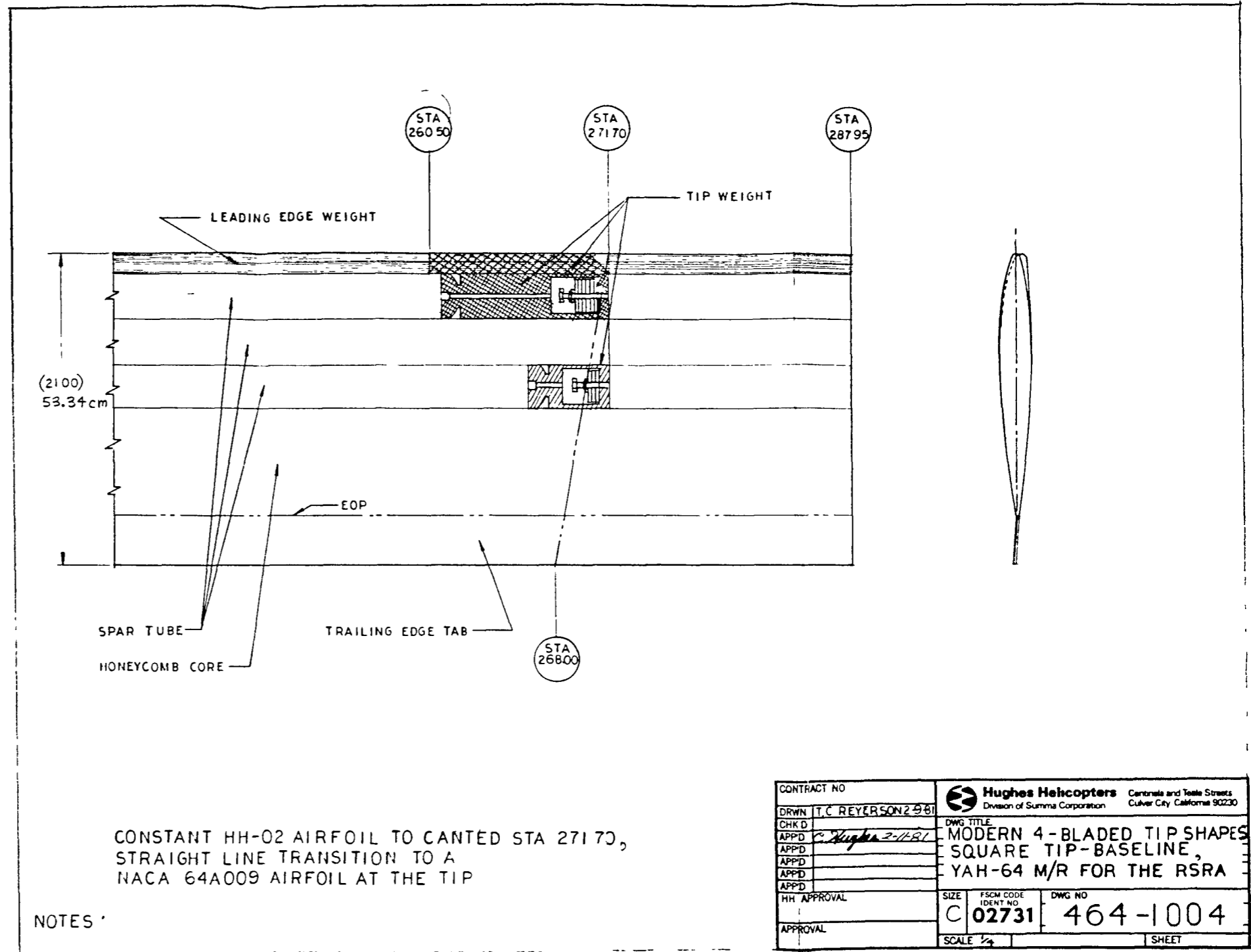
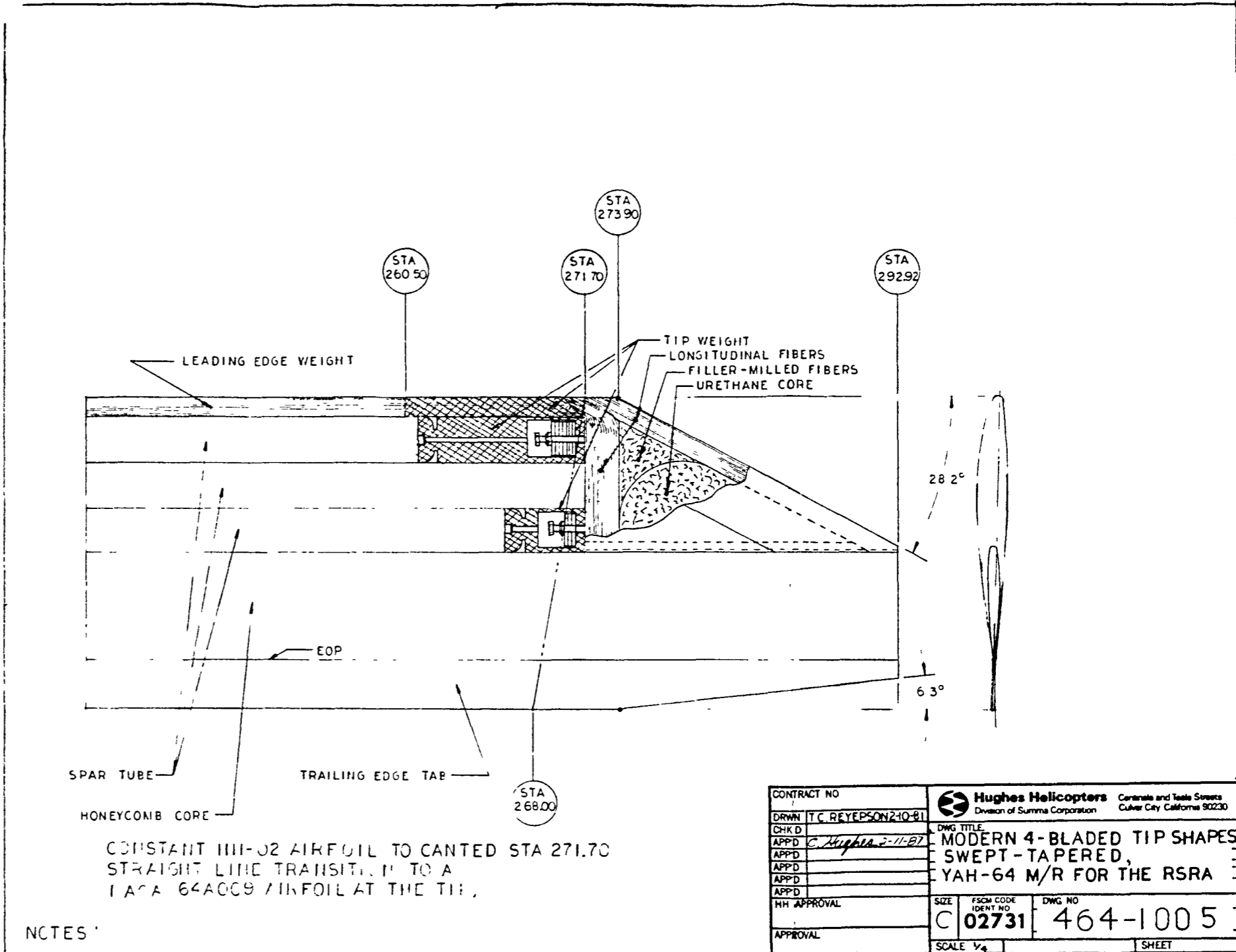

Figure 29. - Modern 4-Bladed Tip Shapes
 Square Tip-Baseline, YAH-64 M/R
 for the RSRA

**THIS PAGE LEFT BLANK
INTENTIONALLY**



CONSTANT IIII-02 AIRFOIL TO CANTED STA 271.70
 STRAIGHT LINE TRANSITION TO A
 IACA 64A009 AIRFOIL AT THE TIP.

NOTES

CONTRACT NO		 Hughes Helicopters <small>Division of Summa Corporation</small>		<small>Centrale and Teale Streets Culver City California 90230</small>
DRWN	T.C. REYEPSON 2-10-81	DWG TITLE		
CHK D		MODERN 4-BLADED TIP SHAPES		
APPD	<i>C. Hughes 2-11-81</i>	SWEPT-TAPERED,		
APPD		YAH-64 M/R FOR THE RSRA		
APPD		SIZE	FSM CODE IDENT NO	DWG NO
HH APPROVAL		C	02731	464-1005
APPROVAL		SCALE	1/4	SHEET

Figure 30. - Modern 4-Bladed Tip Shapes
 Swept-Tapered, YAH-64 M/R
 for the RSRA

**THIS PAGE LEFT BLANK
INTENTIONALLY**

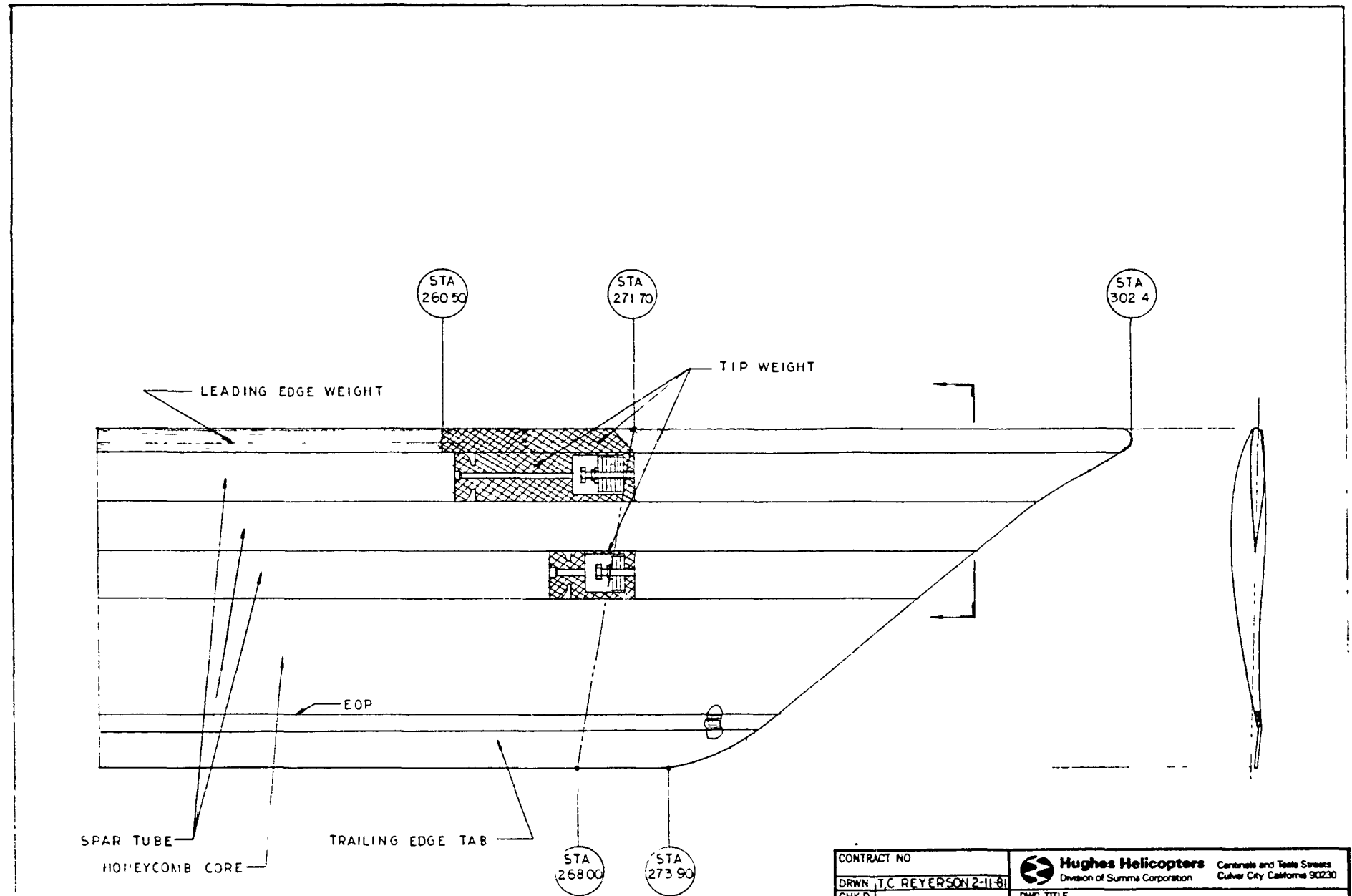

CONSTANT HH-02 AIRFOIL TO CANTED STA 271.70,
 STRAIGHT LINE TRANSITION TO A
 IIACA 64A009 AIRFOIL AT THE TIP

NOTES

CONTRACT NO		Hughes Helicopters <small>Division of Summa Corporation</small>	
DRWN T.C. REYERSON 2-11-81		<small>Centrale and Teale Streets Culver City California 90230</small>	
CHK D	DWS TITLE		
APPD <i>T.C. Reyer</i>	MODERN 4-BLADED TIP SHAPES		
APPD	OGEE TIP		
APPD	YAH-64 M/R FOR THE RSRA		
APPD	SIZE	FSCM CODE IDENT NO	DWG NO
HH APPROVAL	C	02731	464-1006
APPROVAL	SCALE 1/4"	SHEET	

Figure 31. - Modern 4-Bladed Tip Shapes
 OGEE Tip, YAH-64 M/R for the RSRA

**THIS PAGE LEFT BLANK
INTENTIONALLY**

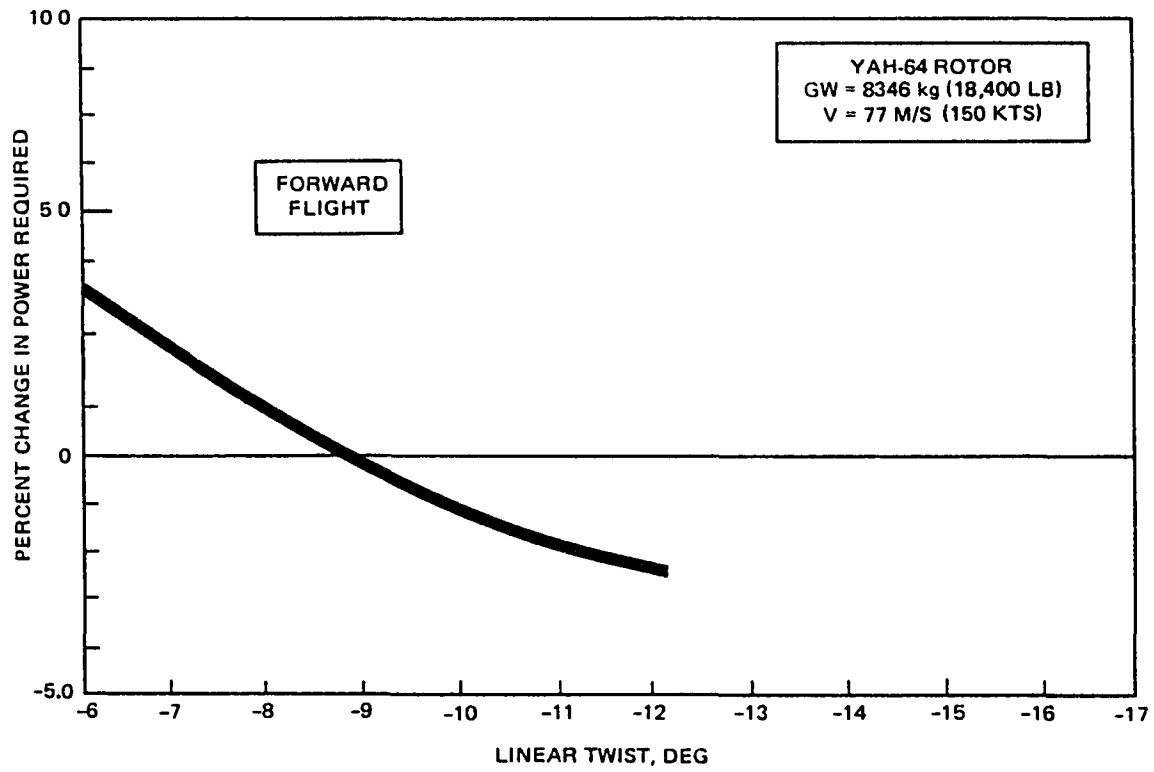
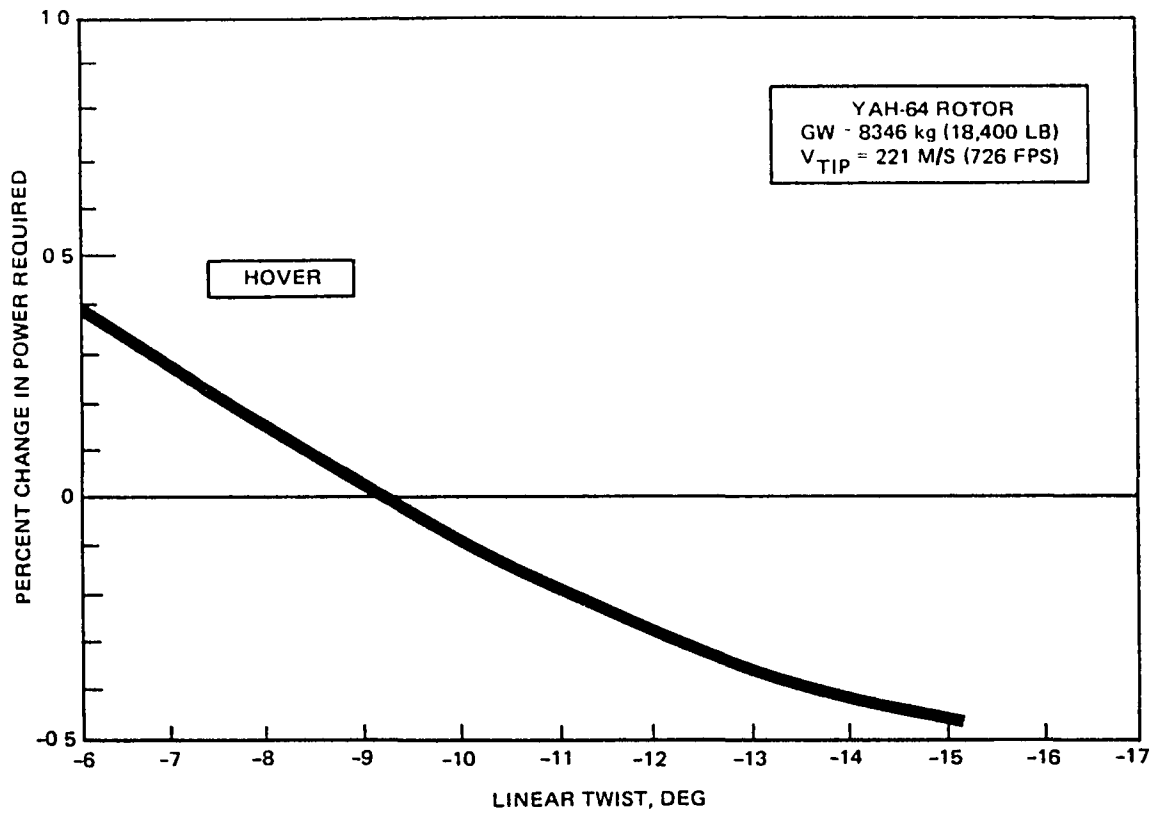

Figure 32. - Effect of Twist on YAH-64 Rotor Performance on the RSRA

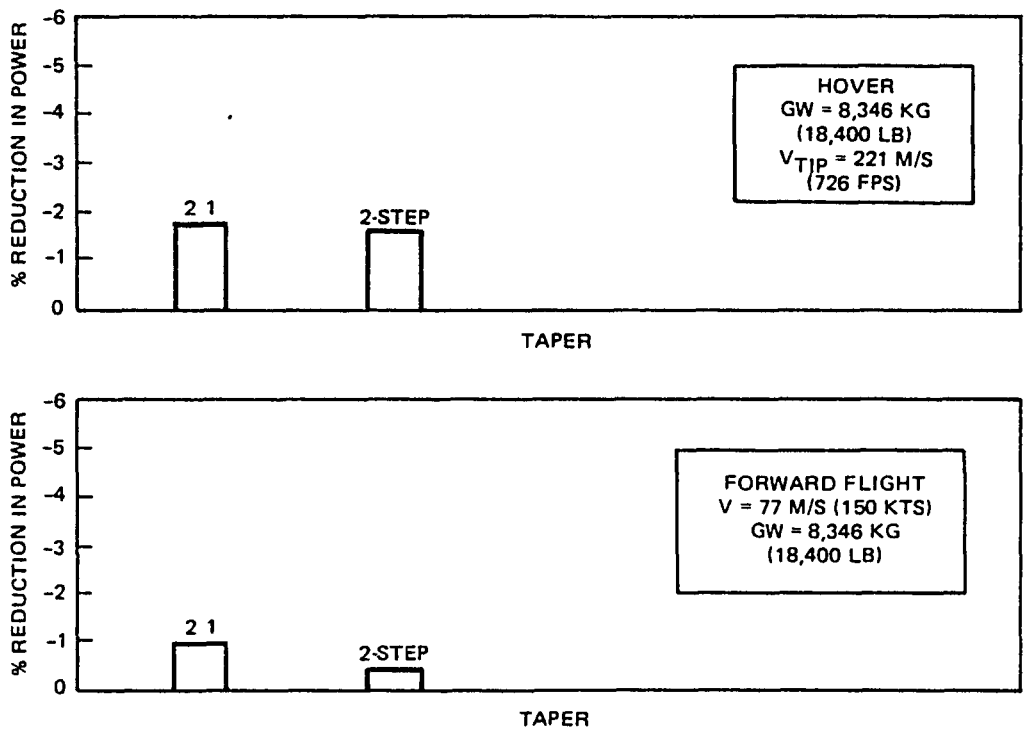

Figure 33. - Effect of Planform Variation on YAH-64 Rotor Performance on the RSRA

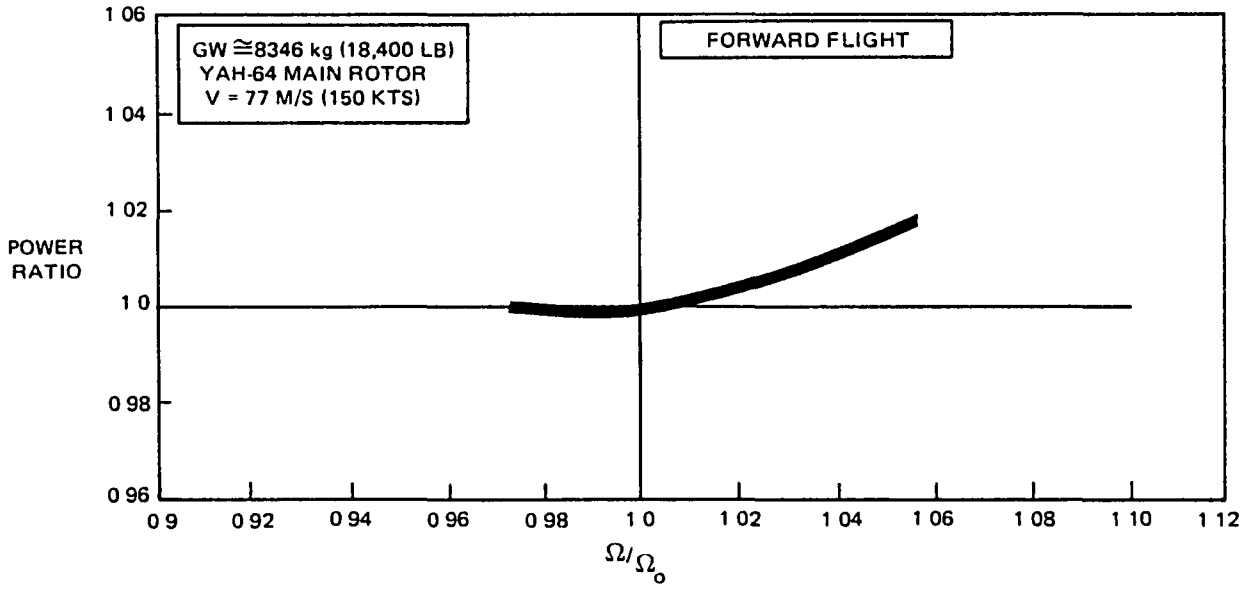
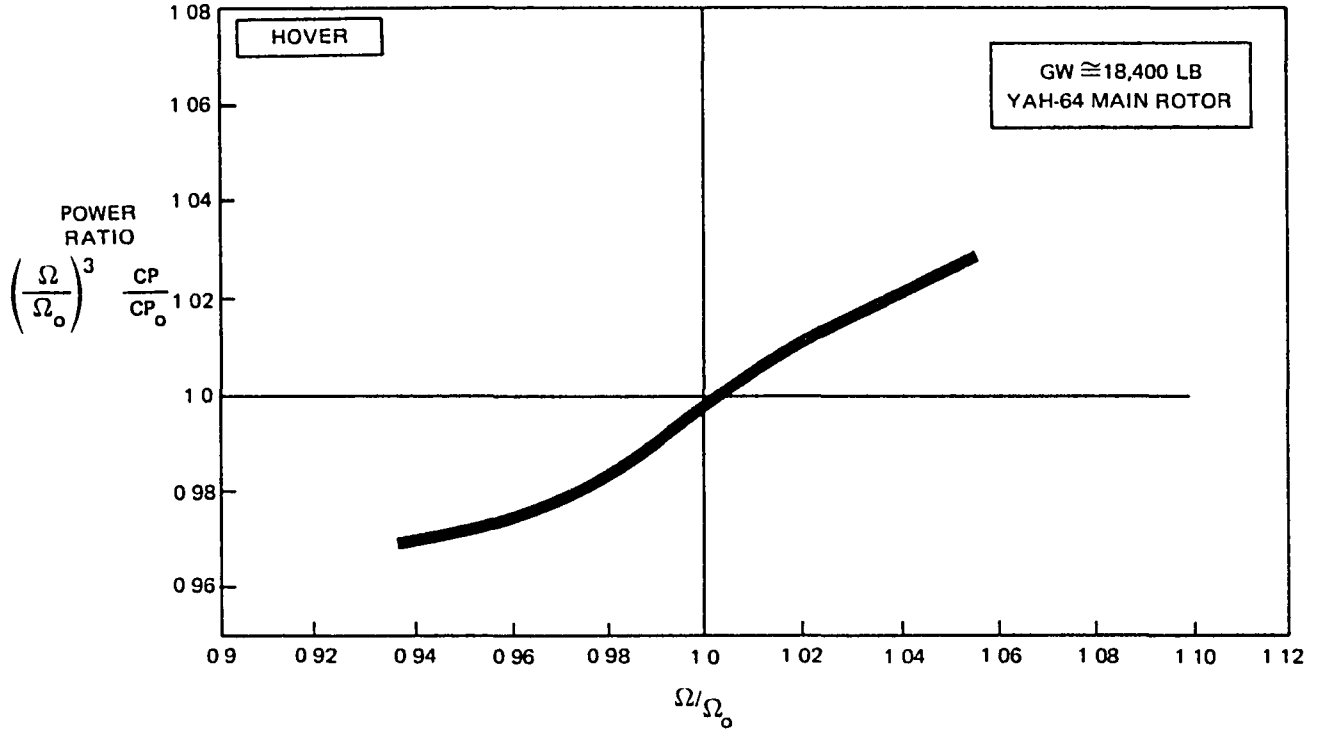

Figure 34. - Effect of Tip Speed on YAH-64 Rotor Performance on the RSRA

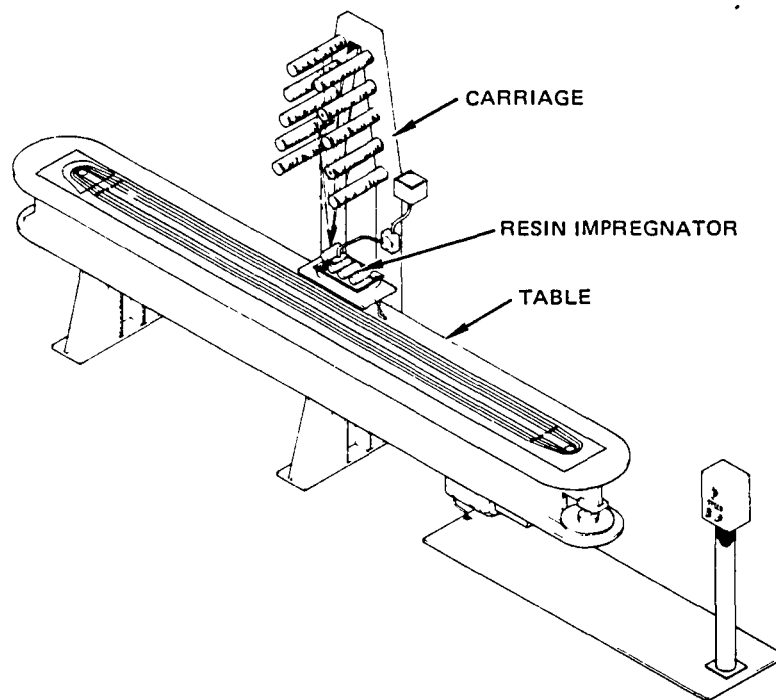

Figure 35. - Wet Filament Winding Machines

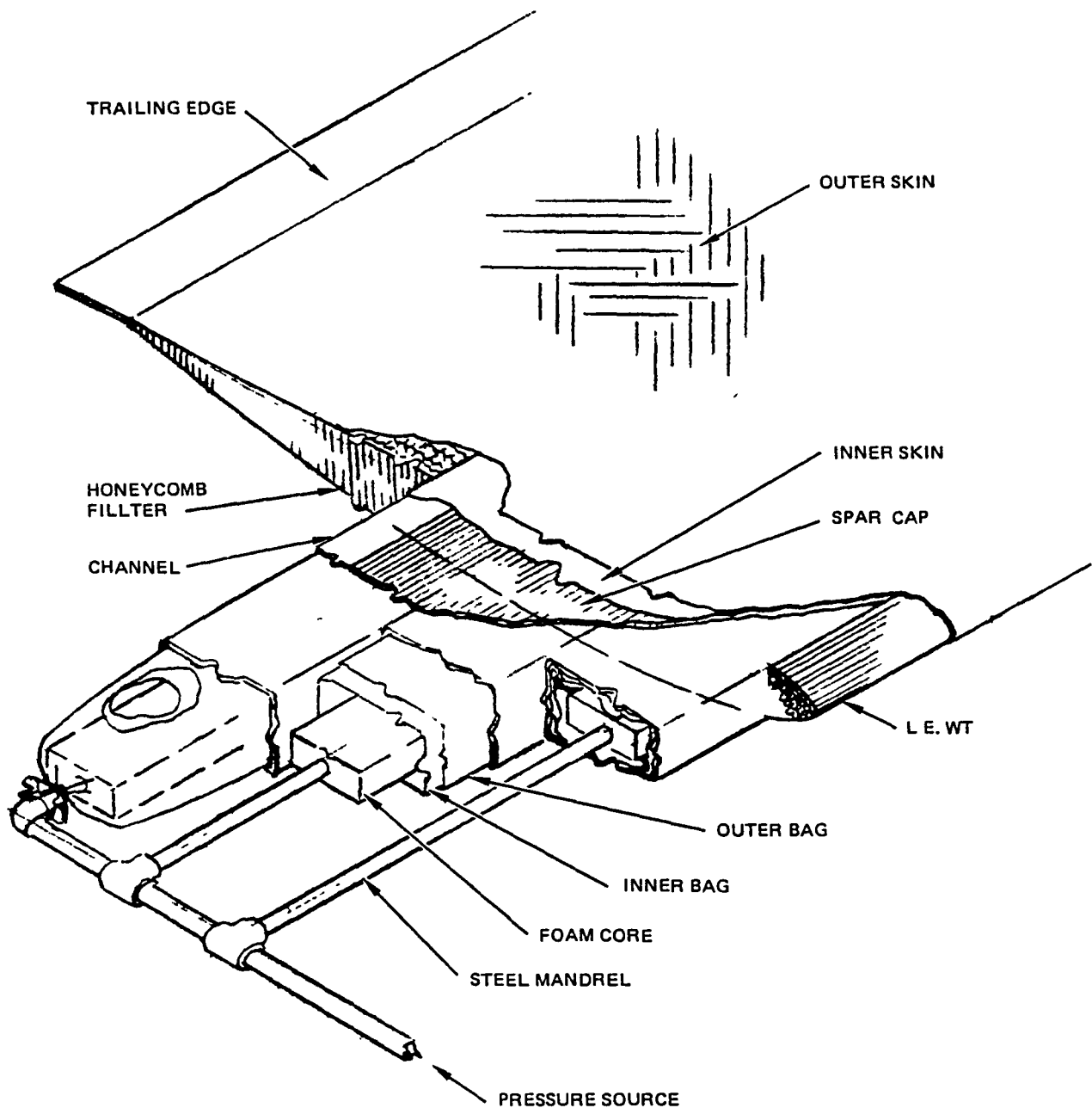

Figure 36. - Internal Tooling Concept

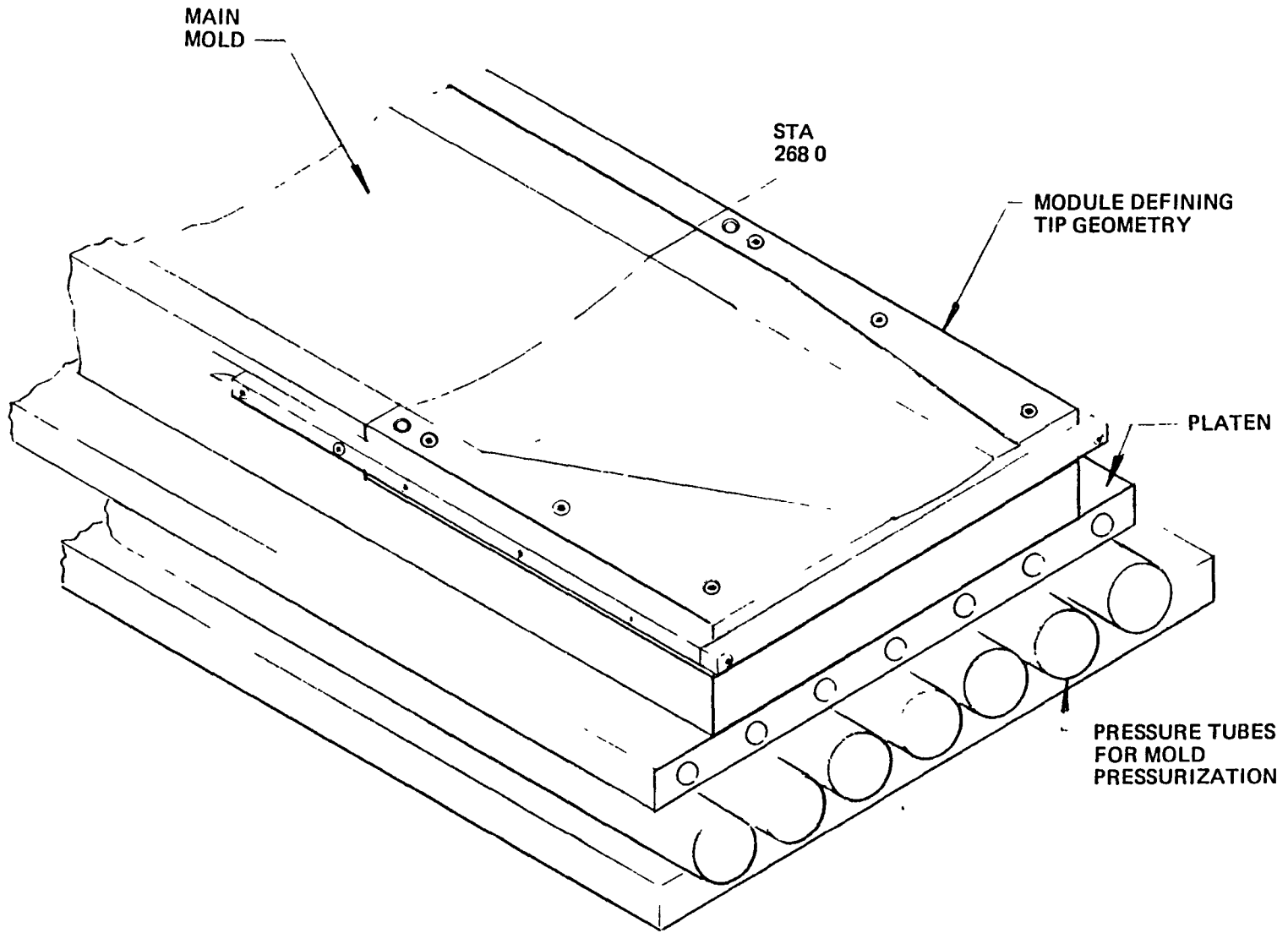

Figure 37.- External Mold Concept

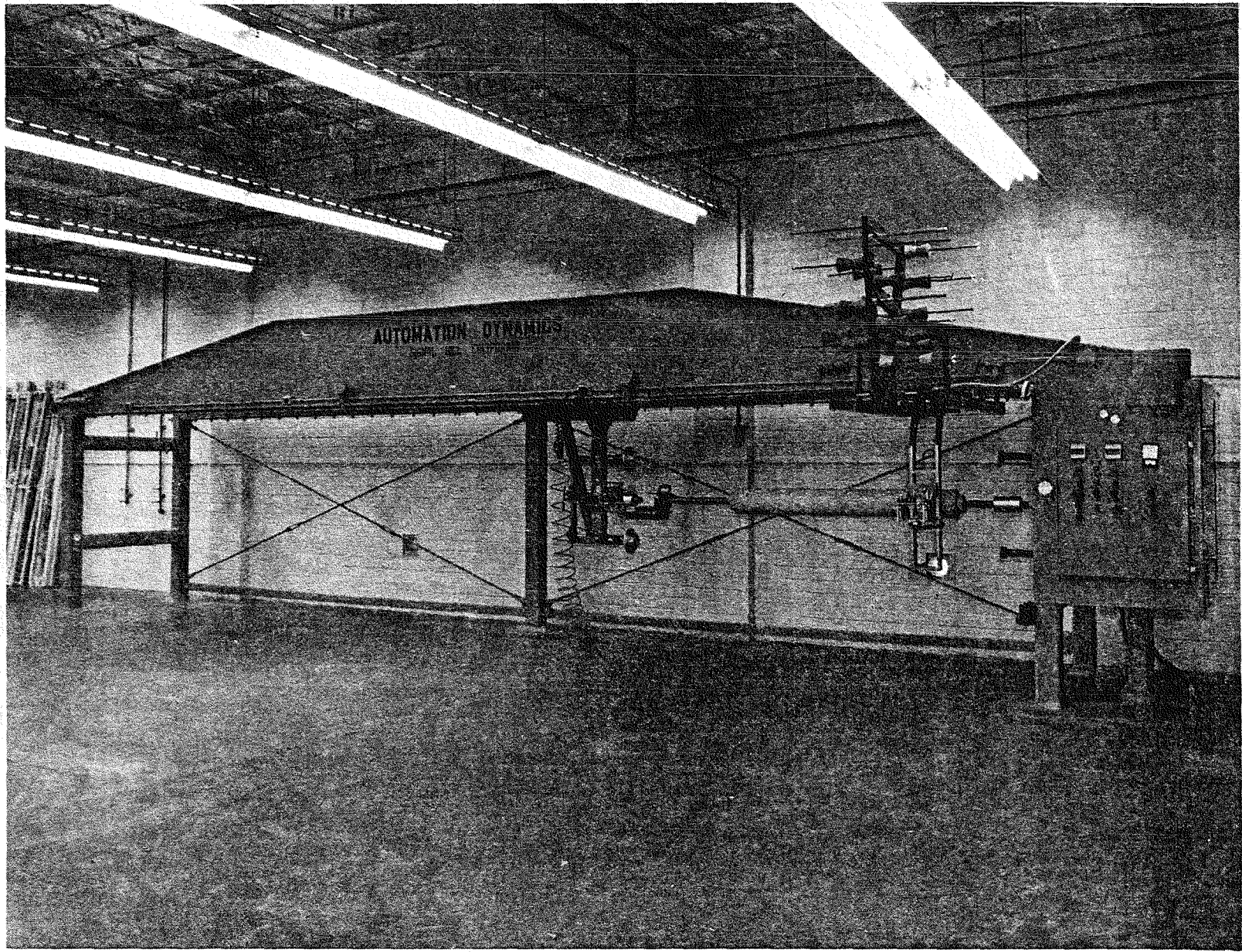

Figure 38. - Tubular Winding Machine

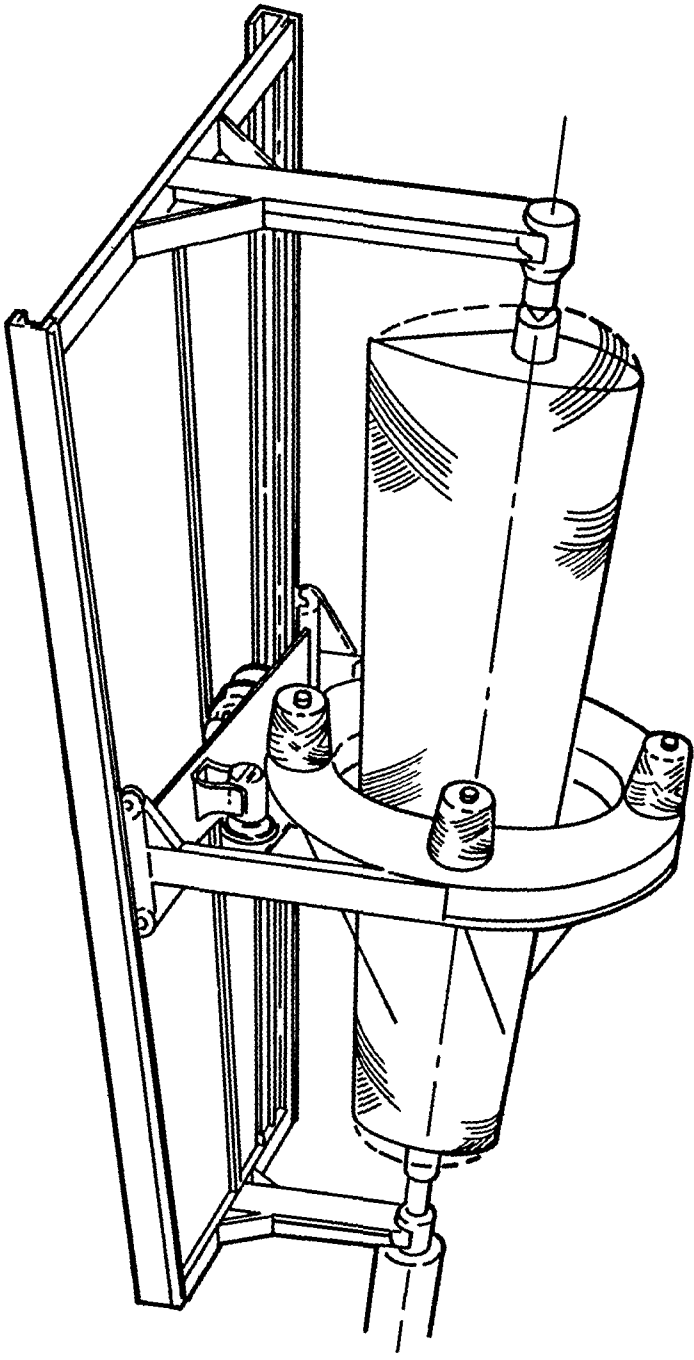

Figure 39. - Ring Winder Schematic

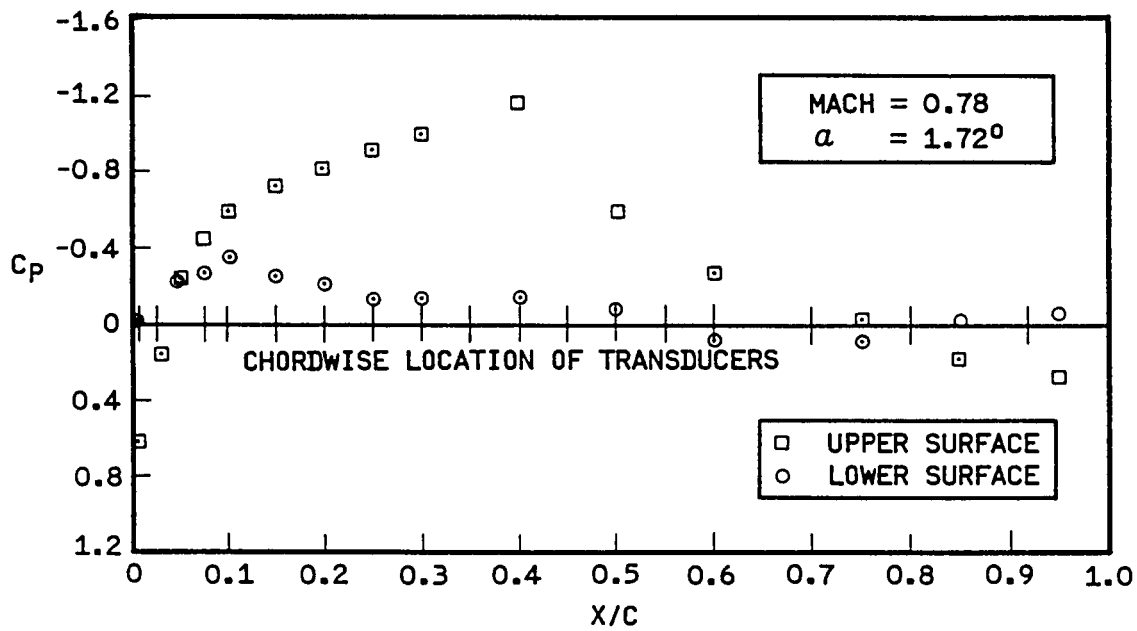
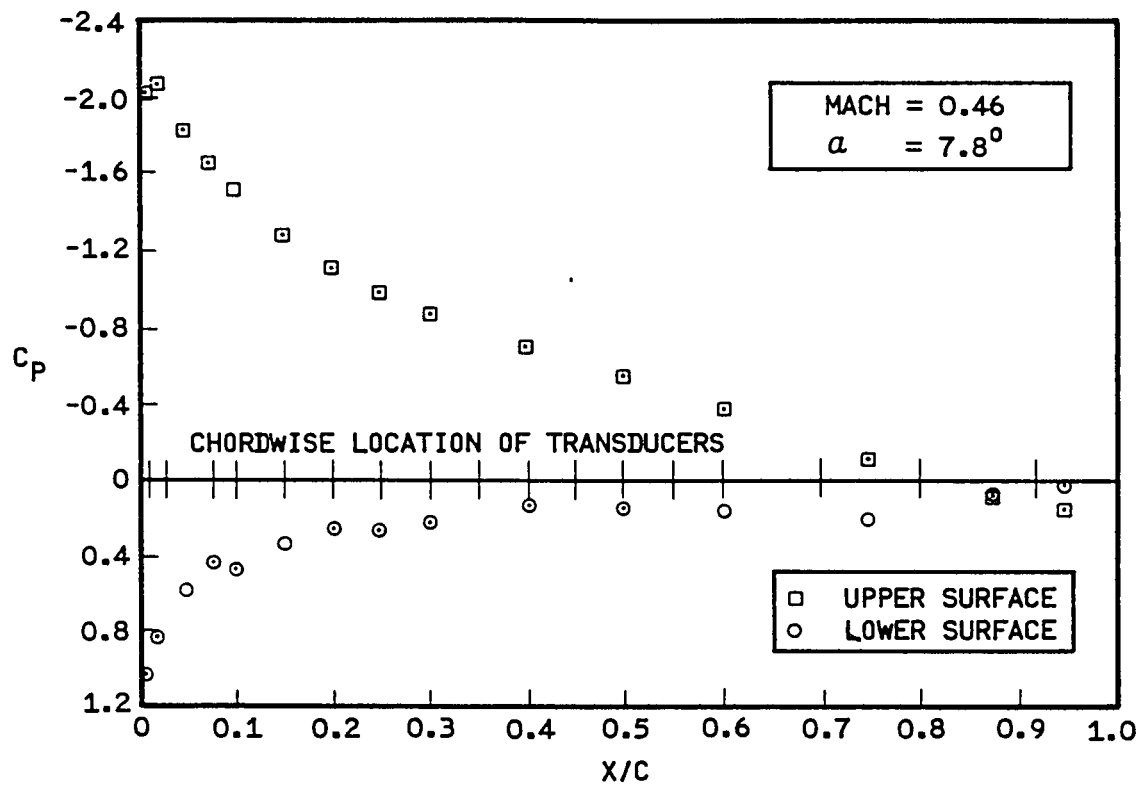

Figure 40. - HH-02 Representative Pressure Distributions and Proposed Chordwise Location of Pressure Transducers

DEVELOPMENT PLAN FOR YAH-64 MAIN ROTOR ON ROTOR SYSTEM RESEARCH AIRCRAFT (RSRA)

ALTEPHATE 'A - WIND TUNNEL TEST
 =====

TIMENOW 4-JAN-82

PROJECTED FINISH DATE 27-MAR-87

ACT #	ACTIVITY DESCRIPTION	WBS CODE	ORIG DUR	82	82	82	83	83	84	84	85	85	86	86	87
				JAN 4	JUN 4	DEC 4	JUN 4	DEC 4	JUN 4	DEC 4	JUN 4	DEC 4	JUN 4	DEC 4	JUN 4
10	CONTRACT AWARD		1	+
20	PLAN OF PERFORMANCE REPORT DEVELOPMENT	1810	21	+
30	PRELIMINARY DESIGN	1100	124	+++++
40	SUBMIT PRELIMINARY DESIGN REPORT	1170	1	.	+
50	PRELIM. DESIGN REVIEW & APPROVAL	1180	2	.	+
60	DETAIL DESIGN DEVELOPMENT	1200	165	.	+++++
70	DETAIL DESIGN REVIEW & APPR MAT. PURCH.	1271	2	.	.	+
80	PREPARE PURCHASE REQUISITIONS		5	.	.	+
90	SUBMIT DETAIL DESIGN STRESS RPT & DWGS	1260	1	.	.	.	+
100	CRITICAL DESIGN REVIEW & APPROVAL	1272	2	.	.	.	+
150	SUBMIT SOF QUALIFICATION PLAN	1410	1	.	.	.	+
160	SOF QUALIFICATION PLAN APPROVAL		10	.	.	.	+
110	FABRICATION	1310	247	.	.	.	+++++
130	SUBMIT INSTRUMENTATION PLAN	1341	1	.	.	.	+
140	INSTRUMENTATION PLAN APPROVAL		10	.	.	.	+
120	INSTRUMENTATION	1340	206	.	.	.	+++++
170	QUAL. HARDWARE DESIGN & FABRICATION	1421	62	.	.	.	++++
180	QUALIFICATION TESTING	1422	124	+++++
190	SUBMIT WIND TUNNEL TEST PLAN	1510	1	+
200	WIND TUNNEL TEST PLAN APPROVAL		10	+
210	WIND TUNNEL HARDWARE DESIGN & FAB.	1530	51	+++
220	WIND TUNNEL HARDWARE INSTALLATION	1540	31	++
225	WIND TUNNEL TEST	1550	41	+++
230	WIND TUNNEL TEST DATA REDUCTION & ANA	1560	103	+++++
240	WIND TUNNEL TEST DATA REPORT		1	+
250	WIND TUNNEL TEST FINAL REPORT	1570	1	+
310	SUBMIT ROTOR INSTALLATION PLAN	1610	1	+
320	ROTOR INSTALLATION PLAN APPROVAL		10	++
330	INSTALL ROTOR & SYSTEM CHECKOUT	1620	82	++++
340	SUBMIT GROUND RUN TEST PLAN	1650	1	+
350	GROUND RUN TEST PLAN APPROVAL		10	++
360	GROUND RUN TEST	1660	21	++
370	SOF DATA PREPARATION & REVIEW	1680	21	+++
380	SUBMIT SOF REPORT		1	+
400	SUBMIT FLIGHT TEST PLAN	1710	1	+
410	SUBMIT INSTRUMENTATION PLAN	1720	1	+
390	SOF APPROVAL RELEASE		21	++
420	FLIGHT TEST (FULL SUPPORT)	1730	62	+++
430	FLIGHT TEST	1730	432	+++++

ARTEMIS PROJECT RSR REPORT RSRBC VERSION 117/32/5 BY KMF

ORDERED BY ES WITHIN PHASE

+ = < ONE MONTH

Figure 41. - Development Plan for YAH-64 Main Rotor on RSRA,
 Wind Tunnel Test, Start January 1982

DEVELOPMENT PLAN FOR YAH-64 MAIN ROTOR ON ROTOR SYSTEM RESEARCH AIRCRAFT (RSRA)

ALTERNATE 'B' - WHIRL TOWER TEST

TIMENOW 4-JAN-82

PROJECTED FINISH DATE 14-JAN-87

ACT #	ACTIVITY DESCRIPTION	WBS CODE	PROJECTED FINISH DATE														
			82 JAN 4	82 JUN 4	82 DEC 4	83 JUN 4	83 DEC 4	84 JUN 4	84 DEC 4	85 JUN 4	85 DEC 4	86 JUN 4	86 DEC 4	87 JUN 4			
10	CONTRACT AWARD		1	+	.	:	:	:	:	:	:	:	:	:	:	:	:
20	PLAN OF PERFORMANCE REPORT DEVELOPMENT	1810	21	+	:	:	:	:	:	:	:	:	:	:	:	:	:
30	PRELIMINARY DESIGN	1100	124	+++++	:	:	:	:	:	:	:	:	:	:	:	:	:
40	SUBMIT PRELIMINARY DESIGN REPORT	1170	1	:	+	:	:	:	:	:	:	:	:	:	:	:	:
50	PRELIM DESIGN REVIEW & APPROVAL	1180	2	:	+	:	:	:	:	:	:	:	:	:	:	:	:
60	DETAIL DESIGN DEVELOPMENT	1200	165	:	+++++	:	:	:	:	:	:	:	:	:	:	:	:
70	DETAIL DESIGN REVIEW & APPR MAT. PURCH	1271	2	:	:	+	:	:	:	:	:	:	:	:	:	:	:
80	PREPARE PURCHASE REQUISITIONS		5	:	:	+	:	:	:	:	:	:	:	:	:	:	:
90	SUBMIT DETAIL DESIGN STRESS RPT. & DWGS.	1260	1	:	:	:	+	:	:	:	:	:	:	:	:	:	:
100	CRITICAL DESIGN REVIEW & APPROVAL	1272	2	:	:	:	+	:	:	:	:	:	:	:	:	:	:
150	SUBMIT SOF QUALIFICATION PLAN	1410	1	:	:	:	+	:	:	:	:	:	:	:	:	:	:
160	SOF QUALIFICATION PLAN APPROVAL		10	:	:	:	+	:	:	:	:	:	:	:	:	:	:
110	FABRICATION	1310	247	:	:	:	+++++	:	:	:	:	:	:	:	:	:	:
130	SUBMIT INSTRUMENTATION PLAN	1341	1	:	:	:	+	:	:	:	:	:	:	:	:	:	:
140	INSTRUMENTATION PLAN APPROVAL		10	:	:	:	+	:	:	:	:	:	:	:	:	:	:
120	INSTRUMENTATION	1340	206	:	:	:	+++++	:	:	:	:	:	:	:	:	:	:
170	QUAL. HARDWARE DESIGN & FABRICATION	1421	62	:	:	:	++++	:	:	:	:	:	:	:	:	:	:
180	QUALIFICATION TESTING	1422	124	:	:	:	:	+++++	:	:	:	:	:	:	:	:	:
260	SUBMIT WHIRL TOWER TEST PLAN	1510	1	:	:	:	:	+	:	:	:	:	:	:	:	:	:
265	WHIRL TOWER TEST PLAN APPROVAL		10	:	:	:	:	+	:	:	:	:	:	:	:	:	:
270	WHIRL TOWER PROCURE PARTS INSTALLATION	1520	41	:	:	:	:	+++	:	:	:	:	:	:	:	:	:
280	WHIRL TOWER TEST	1540	21	:	:	:	:	++	:	:	:	:	:	:	:	:	:
290	WHIRL TOWER TEST DATA REDUCTION & ANA.	1550	51	:	:	:	:	+++	:	:	:	:	:	:	:	:	:
300	WHIRL TOWER TEST FINAL REPORT	1560	1	:	:	:	:	+	:	:	:	:	:	:	:	:	:
310	SUBMIT ROTOR INSTALLATION PLAN	1610	1	:	:	:	:	+	:	:	:	:	:	:	:	:	:
320	ROTOR INSTALLATION PLAN APPROVAL		10	:	:	:	:	+	:	:	:	:	:	:	:	:	:
330	INSTALL ROTOR & SYSTEM CHECKOUT	1620	82	:	:	:	:	++++	:	:	:	:	:	:	:	:	:
340	SUBMIT GROUND RUN TEST PLAN	1650	1	:	:	:	:	+	:	:	:	:	:	:	:	:	:
350	GROUND RUN TEST PLAN APPROVAL		10	:	:	:	:	+	:	:	:	:	:	:	:	:	:
360	GROUND RUN TEST	1660	21	:	:	:	:	++	:	:	:	:	:	:	:	:	:
370	SOF DATA PREPARATION & REVIEW	1680	21	:	:	:	:	++	:	:	:	:	:	:	:	:	:
380	SUBMIT SOF REPORT		1	:	:	:	:	+	:	:	:	:	:	:	:	:	:
400	SUBMIT FLIGHT TEST PLAN	1710	1	:	:	:	:	+	:	:	:	:	:	:	:	:	:
410	SUBMIT INSTRUMENTATION PLAN	1720	1	:	:	:	:	+	:	:	:	:	:	:	:	:	:
390	SOF APPROVAL RELEASE		21	:	:	:	:	++	:	:	:	:	:	:	:	:	:
420	FLIGHT TEST (FULL SUPPORT)	1730	62	:	:	:	:	++++	:	:	:	:	:	:	:	:	:
430	FLIGHT TEST	1730	432	:	:	:	:	:	:	+++++	:	:	:	:	:	:	:

ARTEMIS PROJECT RSR REPORT RSRBC VERSION 117/32/5 BY KMF

ORDERED BY ES WITHIN PHASE

'+' =< ONE MONTH

Figure 42. - Development Plan for YAH-64 Main Rotor on RSRA,
 Whirl Tower Test, Start January, 1982

DEVELOPMENT PLAN FOR YAH-64 MAIN ROTOR ON ROTOR SYSTEM RESEARCH AIRCRAFT (RSRA)

ALTERNATE A - WIND TUNNEL TEST

TIMENDW 3-JAN-83

PROJECTED FINISH DATE 21-MAR-88

ACT #	ACTIVITY DESCRIPTION	WBS CODE	ORIG DUR	83 JAN 3	83 JUN 3	83 DEC 3	84 JUN 3	84 DEC 3	85 JUN 3	85 DEC 3	86 JUN 3	86 DEC 3	87 JUN 3	87 DEC 3	88 JUN 3
10	CONTRACT AWARD		1	+											
20	PLAN OF PERFORMANCE REPORT DEVELOPMENT	1810	21	+											
30	PRELIMINARY DESIGN	1100	124	+++++											
40	SUBMIT PRELIMINARY DESIGN REPORT	1170	1		+										
50	PRELIM DESIGN REVIEW & APPROVAL	1180	2		+										
60	DETAIL DESIGN DEVELOPMENT	1200	165			+++++++									
70	DETAIL DESIGN REVIEW & APPR. MAT. PURCH.	1271	2			+									
80	PREPARE PURCHASE REQUISITIONS		5			+									
90	SUBMIT DETAIL DESIGN STRESS RPT. & DWGS.	1260	1				+								
100	CRITICAL DESIGN REVIEW & APPROVAL	1272	2				+								
150	SUBMIT SOF QUALIFICATION PLAN	1410	1				+								
110	FABRICATION	1310	247				+++++++								
160	SOF QUALIFICATION PLAN APPROVAL		10				+								
130	SUBMIT INSTRUMENTATION PLAN	1341	1				+								
140	INSTRUMENTATION PLAN APPROVAL		10				+								
120	INSTRUMENTATION	1340	206				+++++++								
170	QUAL HARDWARE DESIGN & FABRICATION	1421	62				+++								
180	QUALIFICATION TESTING	1422	124				+++++								
190	SUBMIT WIND TUNNEL TEST PLAN	1510	1					+							
200	WIND TUNNEL TEST PLAN APPROVAL		10					+							
210	WIND TUNNEL HARDWARE DESIGN & FAB.	1530	51					+++							
220	WIND TUNNEL HARDWARE INSTALLATION	1540	31						++						
225	WIND TUNNEL TEST	1550	41						+++						
230	WIND TUNNEL TEST DATA REDUCTION & ANA.	1560	103						+++++						
240	WIND TUNNEL TEST DATA REPORT		1						+						
250	WIND TUNNEL TEST FINAL REPORT	1570	1							+					
310	SUBMIT ROTOR INSTALLATION PLAN	1610	1						+						
320	ROTOR INSTALLATION PLAN APPROVAL		10						++						
330	INSTALL ROTOR & SYSTEM CHECKOUT	1620	82						+++++						
340	SUBMIT GROUND RUN TEST PLAN	1650	1							+					
350	GROUND RUN TEST PLAN APPROVAL		10							++					
360	GROUND RUN TEST	1660	21							++					
370	SOF DATA PREPARATION & REVIEW	1680	21							+++					
380	SUBMIT SOF REPORT		1								+				
400	SUBMIT FLIGHT TEST PLAN	1710	1								+				
410	SUBMIT INSTRUMENTATION PLAN	1720	1								+				
390	SOF APPROVAL RELEASE		21								+				
420	FLIGHT TEST (FULL SUPPORT)	1730	62								+++				
430	FLIGHT TEST	1730	432								+++++++				

ARTEMIS PROJECT RSR REPORT RSRBC VERSION 117/32/5 BY KMF ORDERED BY ES WITHIN PHASE '+' =< ONE MONTH

Figure 43. - Development Plan for YAH-64 Main Rotor on RSRA, Wind Tunnel Test, Start January 1983

1 Report No NASA CR 166154	2 Government Accession No	3 Recipient's Catalog No	
4 Title and Subtitle Predesign Study for a Modern Four-Bladed Rotor for the Rotor Systems Research Aircraft (RSRA)		5 Report Date March 1981	6 Performing Organization Code
		8 Performing Organization Report No	
7 Author(s) C. W. Hughes and A. H. Logan		10 Work Unit No	
9 Performing Organization Name and Address Hughes Helicopter, Inc., Division of Summa Corp. Culver City, CA.		11 Contract or Grant No NAS2-10690	
		13 Type of Report and Period Covered Contractor Report	
12 Sponsoring Agency Name and Address National Aeronautics and Space Administration Ames Research Center Moffett Field, CA. 94035		14 Sponsoring Agency Code	
		15 Supplementary Notes Point of Contact: Gerald Shockey MS-237-3, NASA/Ames Research Center Moffett Field, CA. 94035 FINAL REPORT FTS #448-6571 COM. #415-965-6571	
16 Abstract <p>The report presents the process used to select the rotor system, studies conducted to mate the rotor with the RSRA and provide parametric variability, and the development plan which would be used to implement these studies.</p> <p>Various candidate rotor systems are described and compared in this report to aid in the selection of a modern four-bladed rotor for the RSRA. The YAH-64 rotor system was selected as the candidate rotor system for further development for the RSRA.</p>			
17 Key Words (Suggested by Author(s)) 4-Bladed Helicopter Rotor RSRA		18 Distribution Statement Star Category 01	
19 Security Classif (of this report) UNCLASSIFIED	20 Security Classif (of this page) UNCLASSIFIED	21 No of Pages 130	22 Price*

End of Document