

NF

# NASA Technical Memorandum 83268

(NASA-TM-83268) BOLT CLAMPUP RELAXATION IN  
A GRAPHITE/EPOXY LAMINATE (NASA) 32 p  
HC A03/M1 A01 CSCL 11D

N82-19320

Unclas  
G3/24 09200

## BOLT CLAMPUP RELAXATION IN A GRAPHITE/EPOXY LAMINATE

K. N. Shivakumar and John H. Crews, Jr.

January 1982



National Aeronautics and  
Space Administration

Langley Research Center  
Hampton, Virginia 23665



## BOLT CLAMPUP RELAXATION IN A GRAPHITE/EPOXY LAMINATE

K. N. Shivakumar\* and John H. Crews, Jr.\*\*  
NASA Langley Research Center  
Hampton, Virginia 23665

### SUMMARY

A simple bolted joint was analyzed to calculate bolt clampup relaxation for a graphite/epoxy (T300/5208) laminate. This study was based on a viscoelastic finite-element analysis of a double-lap joint with a steel bolt. Clampup forces were calculated for various steady-state temperature-moisture conditions using a 20-year exposure duration.

The finite-element analysis predicted that clampup forces relax even for the room-temperature-dry condition. The relaxations were 8, 13, 20, and 30 percent for exposure durations of 1 day, 1 month, 1 year, and 20 years, respectively. As expected, higher temperatures and moisture levels each increased the relaxation rate. The combined viscoelastic effects of steady-state temperature and moisture appeared to be additive.

From the finite-element analysis, a simple equation was developed for clampup force relaxation. First, the equation was postulated to have the same functional form as the inverse of the material compliance in the thickness direction. Second, the two constants in the equation were fitted, by a least-square regression analysis, to the room-temperature-dry results. Finally, the equation was generalized to include temperature and moisture viscoelastic effects by using material hygrothermal shift factors from the literature. This generalized equation was used to calculate clampup forces

---

\* National Research Council Resident Research Associate.

\*\* Senior Engineer.

for the same temperature-moisture conditions as used in the finite-element analysis. The two sets of calculated results agreed well.

The clampup equation was further evaluated by comparing calculated and measured clampup forces. Instrumented (strain-gaged) bolts were monitored throughout a 100-day test period. Three steady-state test environments were used: room-temperature dry, room temperature with a laboratory ambient moisture level (0.46 percent), and an elevated-temperature (66°C) dry case. The equation agreed reasonably well with the test data.

## INTRODUCTION

Recent studies have shown that bolt clampup improves the strength of composite joints [1,2]. This improvement, however, may decrease somewhat if the bolt clampup forces relax under long-term exposure. Resin-based composites are viscoelastic at room temperature [3], and this behavior is even more pronounced at high temperatures and moisture levels [4]. The clampup forces should be especially susceptible to this viscoelasticity because they act in the resin-dominated thickness direction. This concern raises several questions:

(1) Will the initial clampup force remain unchanged? (2) If not, how much relaxation occurs during the life of the joint? (3) What are the effects of high temperature and moisture on relaxation? This paper examines these questions.

A double-lap bolted joint in a graphite/epoxy (Gr/Ep) laminate was analyzed. The joint consisted of T300/5208 Gr/Ep laminates with a 32-ply quasi-isotropic layup. The joint clampup force was calculated for different exposure durations using a linear viscoelastic finite-element analysis. The analysis was carried out for a total exposure duration of 20 years using several steady-state temperature and moisture conditions.

In addition to the finite-element analysis, an equation was developed for clampup force as a function of time, material properties, and initial clampup force. Constants in this equation were obtained by fitting it to finite-element results using a least-square regression analysis. The equation was then generalized to calculate the viscoelastic effects of temperature and moisture by using hygrothermal shift factors.

To evaluate the equation, clampup relaxation tests were conducted for three steady-state environments. They were room-temperature dry, room-temperature ambient (0.46 percent moisture), and elevated-temperature (66°C) dry. In each case, the test duration was 100 days.

SYMBOLS

- $a_{TH}$       hygrothermal shift factor
- $D_0$         elastic compliance,  $m^2/N$
- $D_t$         time-dependent compliance,  $m^2/N$
- $D_1$         viscoelastic compliance constant, see Eq. (1)
- $d$           bolt hole diameter, mm
- $E$           modulus,  $N/m^2$
- $F_0$         elastic clampup force, N
- $F_t$         time-dependent clampup force, N
- $F_1$         viscoelastic clampup force constant
- $G$           shear modulus,  $N/m^2$
- $M$           moisture content, percentage of laminate weight
- $m, N$        constant parameters
- $n$           viscoelastic power law constant
- $t$           exposure time, minutes
- $\nu$          Poisson's ratio

Subscripts

- 1          longitudinal (fiber) direction
- 2          transverse (across the fibers) direction

## DESCRIPTION OF THE PROBLEM

Fig. 1(a) shows the double-lap bolted joint in a graphite/epoxy laminate. The joining was by a steel bolt with 6.35-mm (0.25-in) diameter ( $d$ ). The joint had an edge distance of  $4d$  and width of  $8d$ . The steel washers had 12.5-mm (0.5-in) diameter and 1.3-mm (0.052-in) thick. The same joint configuration and materials were used in both the analyses and tests.

Because the laminate was quasi-isotropic and the bolt clampup loading was axisymmetric about the bolt axis, the joint was idealized as an axisymmetric problem. The hatched region in Fig. 1(b) was modeled in the finite-element analysis.

The finite-element analysis was carried out for three temperatures: 23°C (73°F room temperature), 66°C (150°F), and 121°C (250°F). Four moisture conditions ( $M$ ) were used: 0.0 percent (dry), 0.5 percent, 1.0 percent, and 1.5 percent (saturated). This analysis assumed steady-state conditions, that is, the laminate temperature and moisture remained unchanged throughout the analysis. The clampup relaxation tests were conducted for an initial torque of 5.65 N·m (50 in·lb).

## VISCOELASTIC ANALYSIS

The analysis consisted of three parts. First, the linear viscoelastic properties were generated for the T300/5208 Gr/Ep composites. Next, these properties were used in the finite-element (F-E) analysis to calculate bolt clampup forces for different temperature and moisture conditions. Finally, a simple equation for bolt clampup force was developed using the F-E results and a least-square regression analysis.

## Material Characterization

The laminate properties needed for the present analysis were calculated starting with the fiber and matrix properties. The micromechanics procedure from Ref. 5 was used first to generate the lamina elastic properties from the fiber and matrix behavior, and then to generate the lamina viscoelastic properties. These lamina properties were used in the lamination theory to calculate the needed laminate properties. These calculations were based on the following usual assumptions [4]:

1. The fibers are elastic.
2. The matrix is linear viscoelastic.
3. The composite obeys hygrothermal shift factor rules.
4. Viscoelastic response depends only on the time elapsed since load application.

Since all fiber properties were not available, an inverse technique was followed to calculate them. Lamina properties from Ref. 6 and elastic resin properties from Ref. 7 were used in micromechanics equations [5] to calculate the fiber properties by iteration. These results are presented in Table 1 together with the elastic properties of the resin and those computed for the lamina and laminate.

As reported in Ref. 7, the effective time-dependent compliance  $D_t$  for the 5208 epoxy resin can be represented by a power-law equation. For the room-temperature-dry (RTD) case

$$D_t = D_0 + D_1 t^n \quad (1)$$

where

$D_0$  = elastic compliance

$D_1$  = viscoelastic compliance constant for the RTD case ( $D_1 = 0.10$ ,  
Ref. 7)

$n$  = viscoelastic power-law exponent ( $n = 0.2 \pm 0.04$ , Ref. 7)

$t$  = elapsed time after loading, minutes

Eq. (1) was generalized to account for the effects of temperature and moisture by using hygrothermal shift factors,  $a_{TH}$  (see, for example, Ref. 8), and assumption 3. The time-dependent compliance for a given temperature and moisture condition was then expressed as

$$D_t = D_0 + D_1(t/a_{TH})^n \quad (2)$$

As previously mentioned,  $D_0$  depends on temperature and moisture, but  $D_1$  is a constant, determined from the RTD reference case. The  $D_0$  and  $D_1/(a_{TH})^n$  values for different temperatures were taken from Ref. 7. For the different moisture conditions, the shift factors  $a_{TH}$  were taken from Ref. 9. The viscoelastic parameters used are given in Table 2. The desired time-dependent modulus was calculated as the inverse of  $D_t$  from Eq. (2).

As mentioned already, viscoelastic properties of the lamina were calculated using elastic fiber properties (see Table 1) and viscoelastic resin properties through micromechanics equations [6]. The laminate properties were obtained using lamination theory [10]. These properties were then used in a viscoelastic F-E analysis to calculate clampup force and its relaxation.



### Finite-Element Analysis

The general purpose viscoelastic finite-element program VISCEL [11] was used in the analysis. The analysis was checked by solving the two examples given in Ref. 12.

Finite-Element Procedure--An idealization of the joint is shown in Fig. 2(a). The line OZ represents the bolt axis, which is also the axis of rotation for the present assumption of axial symmetry. The joint midplane is represented by OX. The  $x$  displacements were restrained along OZ and  $z$  displacements were restrained along OX. For simplicity, the washer was considered as a part of the bolt head. The interface BC between bolt head and the laminate was assumed to be smooth, so it carried only normal stresses. The hole surface AB was treated as stress free because a preliminary analysis showed that  $x$  displacements along this surface were less than one-half the clearance for a Class I fit (about 0.19 mm for the present case). The outer boundary DE was restrained against  $x$  displacements.

The F-E model is shown in Fig. 2(b) as four-noded axisymmetric elements. The steel bolt is represented by elastic elements and the laminate was modeled by viscoelastic elements. The clampup force was introduced by applying an initial displacement  $V_0$  in the negative  $z$  direction, as shown. This displacement was constant during this time-dependent analysis.

A preliminary elastic analysis was made to study two different F-E meshes. Clampup forces were calculated from the Fig. 2(b) mesh having 150 elements with 193 nodes and from another mesh having 254 elements with 308 nodes. The two forces differed by only about 0.3 percent; hence, the Fig. 2(b) mesh was adopted for the present analysis.

To select a proper time-interval scheme for the viscoelastic analysis, a convergence study was made with three different time-interval schemes. The first scheme was based on doubling the previous time interval. The time intervals were doubled starting from  $t = 0.60$  minutes, to yield 0.60, 1.2, 2.4, 4.8 . . . minutes. This scheme was considered because the 5208 resin compliance follows a power law in the time domain. Hence, accurate results would be expected using this scheme [11]. The other two schemes had the same starting time but smaller time intervals. A very close agreement was found for the three schemes. As a result, the doubling scheme was used in all subsequent analyses. These calculations were terminated when the doubling time scheme reached about 20 years.

Finite-Element Results--As previously mentioned, clampup force relaxation was calculated for different steady-state combinations of temperature and moisture. The clampup force was obtained by summing the bolt nodal forces needed to maintain the displacement  $V_0$  shown in Fig. 2(b). The results are presented as normalized clampup force versus exposure time, expressed in hours for convenience. The normalized clampup force is the ratio of clampup force  $F_t$  at time  $t$  and the elastic (initial) clampup force  $F_0$ . The curves of clampup force versus exposure time are referred to as clampup relaxation curves.

Fig. 3 shows clampup relaxation curves for three temperatures, namely 23°C (room temperature), 66°C, and 121°C. The laminate is dry in all three cases. Selected finite-element results are represented by symbols. (The curves represent results from an equation, which will be explained in the next section.) The results in Fig. 3 indicate that clampup force relaxes even at room temperature. Relaxations of 8 percent, 13 percent, 20 percent, and

30 percent are shown for exposure times of 1 day, 1 month, 1 year, and 20 years, respectively. The rate of clampup relaxation increases with temperatures, as expected, and clampup relaxation for 66°C and 121°C are 36 percent and 54 percent, respectively, at 20 years of exposure. The 66°C (150°F) temperature was selected because it was considered to be an extreme skin temperature for commercial transport aircraft. Similarly, the 121°C (250°F) was considered to be the maximum temperature for T300/5208 Gr/Ep applications.

Fig. 4 shows clampup relaxation curves for room temperature with four moisture conditions: 0.0 percent, 0.5 percent, 1.0 percent, and 1.5 percent. The outer curves represent the two extreme moisture conditions, namely, dry and saturated (1.5 percent). As expected, the clampup relaxation increases with laminate moisture. After 20 years of exposure, the relaxation is 30 percent for the dry condition and 63 percent for the saturated condition. In typical applications, however, laminates rarely reach saturation. Depending on the ambient relative humidity and temperature, laminates typically attain a moisture content of about 0.4 percent to 0.8 percent [13] of their total weight.

Fig. 5 shows clampup relaxation for 66°C, again with four moisture conditions: 0.0, 0.5, 1.0, and 1.5 percent. Clampup relaxations for the four conditions are about 36, 49, 60, and 71 percent, respectively, for 20 years of exposure. Comparing the results in this figure with those in Figs. 3 and 4 shows that the combined effects of temperature and moisture are additive. That is, using the room-temperature-dry case as a reference, the temperature effects in Fig. 3 can be added to the moisture effects in Fig. 4 to obtain the predicted combined effects shown in Fig. 5. This result follows directly from the shift-factor approach used in the present viscoelastic analysis.

### Equation for Clampup Force

The proposed equation for time-dependent clampup force was inspired by Eq. (1), discussed earlier for resin matrix compliance  $D_t$ .

$$D_t = D_0 + D_1 t^N$$

For the bolted joint, the viscoelastic resin acts together with the elastic fibers and steel bolt to govern the clampup relaxation. The transverse flexibility (compliance) of the joint can also be expressed by a power law as

$$\bar{D}_t = \bar{D}_0 + \bar{D}_1 t^N \quad (3)$$

Because the flexibility and the clampup force are inversely related, we can express the clampup force  $F_t$  as

$$F_t \propto \frac{1}{\bar{D}_t} = \frac{1}{\bar{D}_0 \left\{ 1 + \frac{\bar{D}_1}{\bar{D}_0} t^N \right\}}$$

or

$$F_t = \frac{F_0}{1 + F_1 t^N}$$

where

$F_0$  = elastic clampup force

$F_1$  = viscoelastic clampup constant

$N$  = exponent constant

The constants  $F_1$  and  $N$  were evaluated using a least-square regression analysis with F-E results for the RTD case shown earlier in Fig. 3.  $F_1$  was 0.0178 (based on  $t$  in minutes) and  $N$  was 0.20. This  $N$  value is the same as the  $n$  used in Eq. (1), as might be expected. Hence,  $N$  in the previous equation is replaced by  $n$ .

$$F_t = \frac{F_0}{1 + F_1 t^n} \quad (4)$$

Normalizing this equation yields

$$F_t/F_0 = \frac{1}{1 + F_1 t^n} \quad (5)$$

Eq. (5) is shown in Fig. 3 fitted to the RTD F-E results. This equation passes through each F-E point and therefore appears to adequately describe the clampup relaxation for this reference RTD case.

Eq. (5) was fitted to other F-E results for different temperatures and moistures. An analysis of these fits suggested that Eq. (4) could be generalized by using the shift-factor approach. Accordingly,  $F_t$  for a given temperature-moisture condition was expressed as

$$F_t = \frac{F_0}{1 + (F_1/a_{TH})^n t^n}$$

or

$$F_t/F_0 = \frac{1}{1 + (F_1/a_{TH})^n t^n} \quad (6)$$

The  $a_{TH}$  values used in this equation were the same as those used in Eq. (2) for  $D_t$  and are given in Table 2.

The solid curves in Fig. 3 represent the results obtained from Eq. (6) for 66°C and 121°C. The symbols represent the F-E results discussed earlier. For the 121°C condition, the equation slightly underestimates the force compared to F-E analysis. But, in general, the equation agrees very closely with the F-E results.

Fig. 4 shows results for room temperature with the four moisture conditions. Again the dashed curve represents Eq. (5) fitted to the RTD F-E results. The solid curves come from Eq. (6) and agree quite well with the F-E results. Fig. 5 shows the close agreement also found for the 66°C condition.

To examine the variation of  $F_1$  with joint thickness, two other joint thicknesses were analyzed. These joints had 64 and 128 plies, one being thinner than the 96-ply joint already discussed and the other being thicker. They were all analyzed by the same procedure. Values of  $F_1$  were calculated to be 0.0183 for 64-ply and 0.0174 for 128-ply joint thicknesses. These differ from the 96-ply value of  $F_1 = 0.0178$  by only 2.8 percent and -2.2 percent, respectively. Hence,  $F_1 = 0.0178$  was assumed valid over a range of joint thicknesses.

This study shows that if the material compliance can be defined by  $D_t = D_0 + D_1 t^n$  and the material obeys the shift-factor rules, then the corresponding clampup relaxation can be calculated from

$$F_t = \frac{F_0}{1 + (F_1 / (a_{TH})^n) t^n}$$

for any steady-state temperature and moisture condition.

## CLAMPUP RELAXATION TESTS

### Test Procedure

The tests were conducted to evaluate the viscoelastic analysis. Three test conditions were selected: room-temperature dry (RTD), room-temperature-ambient moisture content (RTA), and elevated-temperature dry (ETD). The test specimen configuration was the same as the one used in the F-E analysis (see Fig. 1). Three replicate tests were conducted in each condition.

Before testing, some of the specimens were preconditioned. Specimens for the RTA condition were taken from a material stock that had been stored in the laboratory for about 2 years. Desorption tests showed that this stock had about 0.46-percent moisture based on laminate weight. Specimens for the dry test condition were taken from the same laboratory stock and were carefully dried for about 100 days. These dry specimens were then stored in a desiccator cabinet until tested.

Bolt clampup forces were measured by commercially available instrumented bolts. These bolts had an axial hole containing a strain gage bridge, calibrated to measure axial bolt load. A chamfered washer was used under the bolt head to accommodate the small fillet between the bolt head and shank. This washer and the one under the nut were polished to get good surface contact. Each bolt assembly was "preaged" [14] by repeated torquing using dummy specimens.

The bolts were initially torqued to about 5.65 N·m (50 in·lb). This torquing operation required only about 10 seconds, and the first clampup measurement was made immediately after bolt torquing. The clampup force was then measured periodically throughout the 100-day test period.

The three test conditions required slightly different test procedures. In RTA tests, specimens were simply torqued and placed on a laboratory work bench. However, in the RTD tests, the specimens were torqued and then returned to the desiccator cabinet. In each ETD test, a dry specimen was slowly heated to thermal equilibrium at 66°C using a small laboratory oven. Then, the bolt was torqued from outside the oven using a long socket extension, inserted through a small access hole in the oven. The ETD specimens remained in the oven at 66°C throughout the 100-day test period.

Ref. 14 showed that the bolt clampup forces relax slightly even in the absence of material viscoelasticity. To account for the presence of this "embedment" relaxation, several additional tests were conducted. In these tests, a steel plate was used in place of the laminates. These tests were conducted at room temperature using the procedure just described.

#### Test Results

Because the 6.35-mm instrumented bolts had hollow shanks (3.90-mm internal diameter), their axial stiffness was somewhat smaller than the solid-shank bolts in the F-E analysis. To account for this, the F-E program was rerun using a hollow bolt for the RTD reference case. Again, Eq. (4) was fitted to these RTD results to determine  $F_1$ . This new value of  $F_1 = 0.0147$  (time in minutes) was used when the clampup equation was compared with test results.



Fig. 6 shows results for the RTD condition. The symbols represent averages from three replicate tests conducted for 100 days. The three curves represent Eq. (6) for  $n = 0.16, 0.20, \text{ and } 0.24$ . Ref. 7 reported that  $n$  varies over this range for 5208 epoxy. Because  $n$  was not measured for the test material, this range of values was used in the calculations. The calculated relaxation for  $n = 0.20$  agrees well with the measured results in Fig. 6. For 100 days of exposure, the calculated force had relaxed to about 86 percent of its initial value, compared to a measured value of about 88 percent. Throughout the 100-day period, the three replicate tests agreed closely with one another. The maximum scatter was less than  $\pm 1$  percent of the average values. Also, the average instrument drift at the end of the 100-day test was found to be less than 1 percent when the joints were unclamped. The drift correction was applied only to the 100-day test result. These scatter and drift values were also typical of those found in the RTA and ETD tests.

Fig. 7 shows the RTA results. The solid curves represent Eq. (6) for three  $n$  values with the RTA test conditions--room temperature with 0.46-percent moisture ( $a_{TH} = 0.12$ ). The upper and lower curves bracket the test results. Except for the last two data points, the  $n = 0.20$  curve closely predicts the test results. After 100 days, the computed clampup had relaxed to 81 percent, but the corresponding measured value was 86 percent. The discrepancy between the calculated and measured forces may have been caused by moisture absorption during the RTA tests. Because neither temperature nor humidity was controlled, "traveler" coupons accompanied the RTA test specimens to monitor their moisture level. The traveler coupon weights increased by about 0.2 percent during the 100-day test period. Although the compressed

material under the clamped bolt probably did not absorb 0.2-percent moisture [15], even a smaller moisture increase could produce enough swelling to account for the clampup discrepancy shown in Fig. 7.

The embedment relaxation tests at room temperature showed that clampup relaxed only to about 97 percent, and this stabilized value was reached in about 10 days. Although these embedment tests with a steel block may not be directly applicable to a composite joint, they do suggest that embedment relaxation was small compared to the viscoelastic relaxation.

The computed and measured results for the ETD case are presented in Fig. 8. The computed curves bracket the test data, but again the correlation deteriorated toward the end of the test. Some of the discrepancy between the calculated and measured results may be caused by the shift factor used for the ETD case. All shift factors used in this study were taken from the literature and therefore may not apply precisely to the test material. However, a more likely source of the discrepancy is moisture absorption during the ETD tests. As previously described, dry specimens were placed in an oven which was maintained at 66°C during the 100-day ETD test. The relative humidity inside the oven, however, was not controlled. Furthermore, the oven had several small access holes that allowed moisture to enter. The relative humidity inside the oven was estimated to be about 9 percent (using average values for laboratory temperature and humidity during the test period) and the corresponding equilibrium moisture level was 0.13 percent. As a result, the clamped specimens could have absorbed moisture during the test. The associated swelling would tend to counteract the viscoelastic clampup relaxation.

## CONCLUDING REMARKS

A double-lap bolted joint in a laminate (T300/5208 graphite/epoxy) was analyzed to calculate the relaxation of bolt clampup force. A viscoelastic finite-element program was used in this analysis to calculate the clampup force relaxation at different steady-state temperatures (23°C, 66°C, and 121°C) and moisture conditions (dry, 0.5 percent, 1.0 percent, and 1.5 percent). The analysis was carried out for a total exposure duration of about 20 years.

Results showed that the clampup force relaxes even at the room-temperature-dry condition. The relaxations were about 8 percent, 13 percent, 20 percent, and 30 percent for exposure durations of 1 day, 1 month, 1 year, and 20 years, respectively. Results for high temperatures and moistures showed, as expected, increased rates of relaxation. The combined viscoelastic effects of temperature and moisture predicted by the analysis were additive.

A simple analytical expression for clampup force relaxation was developed and fitted to room-temperature-dry finite-element results using a least-square regression analysis. This equation was then generalized to include temperature and moisture viscoelastic effects by using material hygrothermal shift factors.

The clampup relaxation equation was evaluated by comparing its calculated clamping forces with measured values. Tests were conducted with different steady-state temperatures and moistures for a 100-day duration. In general, the calculated and measured clampup forces were in good agreement.

## ACKNOWLEDGMENT

The first author acknowledges the National Academy of Sciences, National Research Council, Washington, DC, for their financial support during this research.

## REFERENCES

- [1] Crews, J. H., Jr., "Bolt-Bearing Fatigue of a Graphite/Epoxy Laminate," Joining of Composite Materials, ASTM STP 749, American Society for Testing and Materials, 1981, pp. 131-144.
- [2] Hart-Smith, L. J., "Mechanically-Fastened Joints for Advanced Composites-- Phenomenological Considerations and Simple Analysis," Douglas Aircraft Co., Douglas Paper 6748, Fourth Conference on Fibrous Composites in Structural Design, San Diego, CA, Nov. 1978.
- [3] Halpin, J. C., "Introduction to Viscoelasticity," Progress in Materials Science Series, Vol. 1, Technomic Publishing Co., 1968, p. 87.
- [4] Schapery, R. A., "Viscoelastic Behavior and Analysis of Composite Materials," Composite Materials, Vol. 2, Academic Press, 1974, p. 85.
- [5] Kriz, R. D. and Stinchcomb, W. W., "Elastic Moduli of Transversely Isotropic Fibers and Their Composites," Experimental Mechanics, 1969, p. 46.
- [6] Advanced Composites Design Guide, Vol. 4: Materials, 3rd ed. (3rd rev.), Air Force Flight Dynamics Laboratory, Contract No. F33615-74-C-5075, Jan. 1977.
- [7] Kibler, K. G. and Carter, H. G., "Viscoelastic Parameters of Epoxy Resin from Thermomechanical and Electrical Conductivity Measurements," Composite Materials: Testing and Design (Fifth Conf.), ASTM STP 674, American Society for Testing and Materials, 1979, pp. 282-288.
- [8] Schapery, R. A., "Deformation and Failure Analysis of Viscoelastic Composite Materials," Inelastic Behavior of Composite Materials, C. T. Herakovich, Ed., ASME Applied Mechanics Symposia Series, Vol. 13, 1975.

- [9] Kibler, K. G., "Effects of Temperature and Moisture on Creep Compliance of Graphite/Epoxy Composites," 50th Meeting of AGARD Structures and Materials Panel, Athens, Greece, Apr. 1980.
- [10] Ashton, J. E. and Whitney, J. M., "Theory of Laminated Plates," Progress in Materials Science Series, Vol. IV, Technomic Publishing Co., 1970.
- [11] Gupta, K. K., Akyuz, F. A., and Heer, E., "VISCEL--A General Purpose Computer Program for Analysis of Linear Viscoelastic Structures--User's Manual," TM 33-466, Vols. I and II, Jet Propulsion Laboratory, Oct. 1972. (COSMIC Program No. NOP-13197, Vols. I and II.)
- [12] White, J. L., "Finite Elements in Linear Viscoelasticity," Proc. of 2nd Conference on Matrix Methods in Structural Mechanics, AFFDL-TR-68-150, Air Force Flight Dynamics Laboratory, 1968, pp. 489-516.
- [13] Hammond, C. L. and Carroll, J. R., "Environmental Effects on Composites," AIAA Paper 78-498, AIAA/ASME 19th Structures, Structural Dynamics, and Materials Conference, Bethesda, MD, Apr. 1978.
- [14] Bickford, J. H., "Preventing Failures in Bolted Joints, Part I--Avoiding Assembly Errors," Machine Design, Aug. 1978.
- [15] Whitney, J. M. and Browning, C. E., "Some Anomalies Associated with Moisture Diffusion in Epoxy Matrix Composite Materials," Advanced Composite Materials--Environmental Effects, ASTM STP 658, American Society for Testing and Materials, 1978, pp. 43-60.

TABLE 1--Elastic properties.

Material	Modulus, GPa			Poisson's Ratio	
	$E_1$	$E_2$	$G_{12}$	12	23
Fiber	205.5	37.0	101.7	0.34	0.45
Resin <sup>a</sup>	4.1	4.1	1.54	.33	.33
Lamina <sup>b</sup>	131.0 <sup>c</sup>	13.0 <sup>c</sup>	6.4 <sup>c</sup>	.34 <sup>c</sup>	.35
Laminate	53.3	14.3	20.7	.28	.31
Steel	206.8	206.8	79.54	.30	.30

<sup>a</sup>Isotropic material (Ref. 7).

<sup>b</sup>Fiber volume is 0.63.

<sup>c</sup>Data from Ref. 6.

TABLE 2--Viscoelastic parameters of 5208 resin.

Temperature, °C (°F)	Moisture, M, %	<sup>a</sup> a <sub>TH</sub> (Ref. 9)	D <sub>0</sub> (10 <sup>-10</sup> m <sup>2</sup> /N)	$\frac{D_1}{(a_{TH})^n}$
23 (73)	0.0	1.00	2.45 <sup>a</sup>	0.10 <sup>a</sup>
	0.5	1.00 x 10 <sup>-1</sup>	2.55	.16
	1.0	1.00 x 10 <sup>-2</sup>	2.61	.25
	1.5	1.00 x 10 <sup>-3</sup>	2.70	.39
66 (150)	0.0	2.69 x 10 <sup>-1</sup>	2.73 <sup>a</sup>	0.13 <sup>a</sup>
	0.5	2.69 x 10 <sup>-2</sup>	2.86	.21
	1.0	2.69 x 10 <sup>-3</sup>	2.93	.33
	1.5	2.69 x 10 <sup>-4</sup>	3.06	.52
121 (250)	0.0	5.00 x 10 <sup>-3</sup>	3.02 <sup>a</sup>	0.29 <sup>a</sup>

<sup>a</sup>Ref. 7.

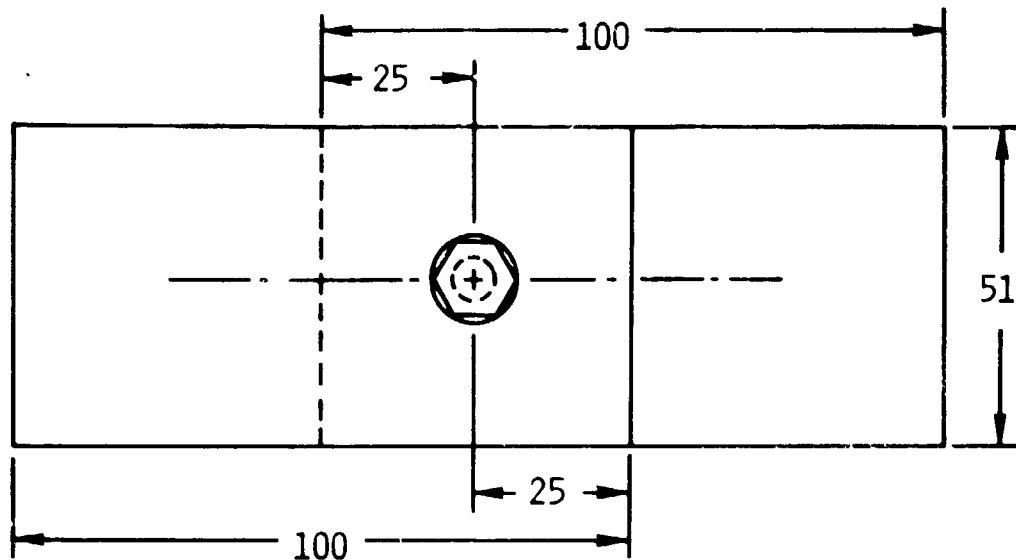

(a) Plan view of specimen.

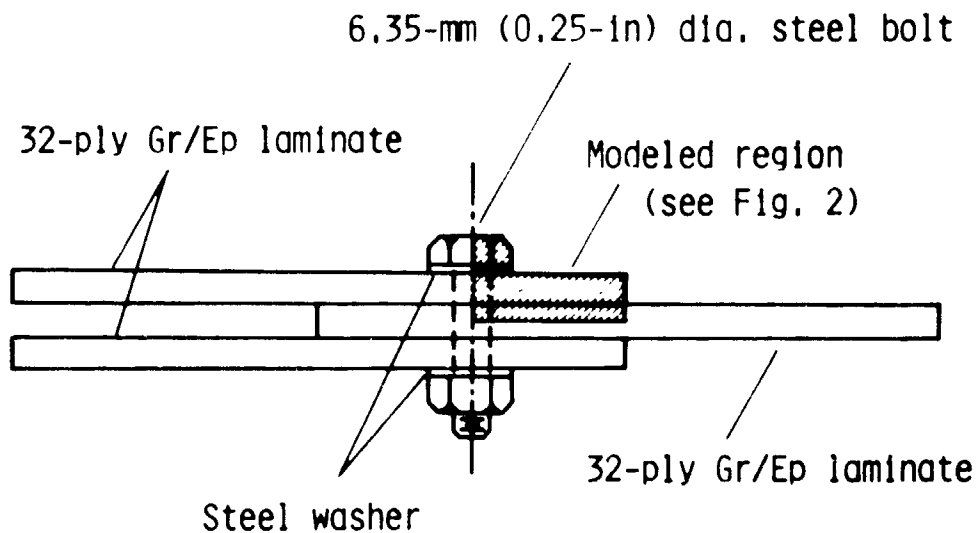

(b) Side view of specimen.

Fig. 1.- Specimen configuration and dimensions.



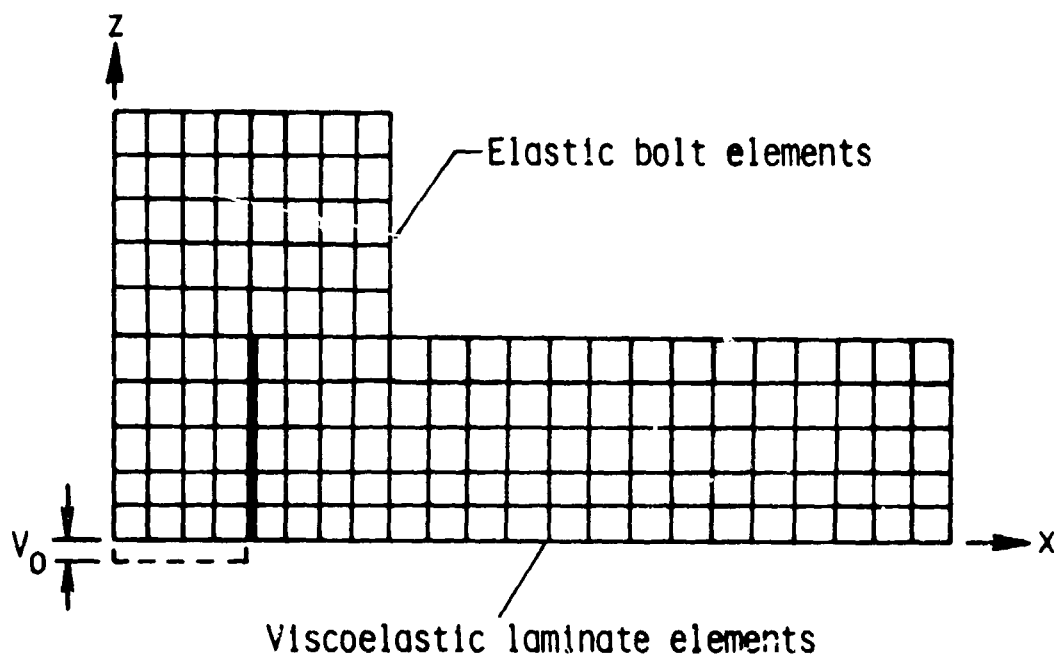
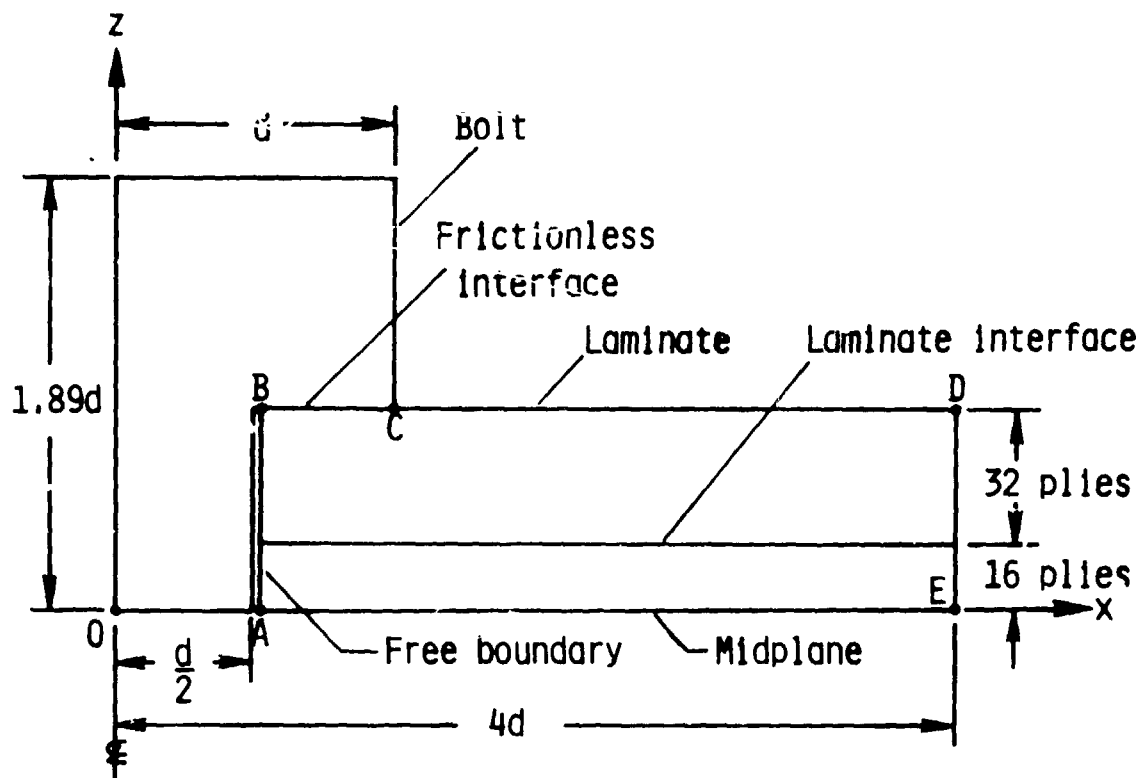

Fig. 2.- Joint idealization and finite-element model.

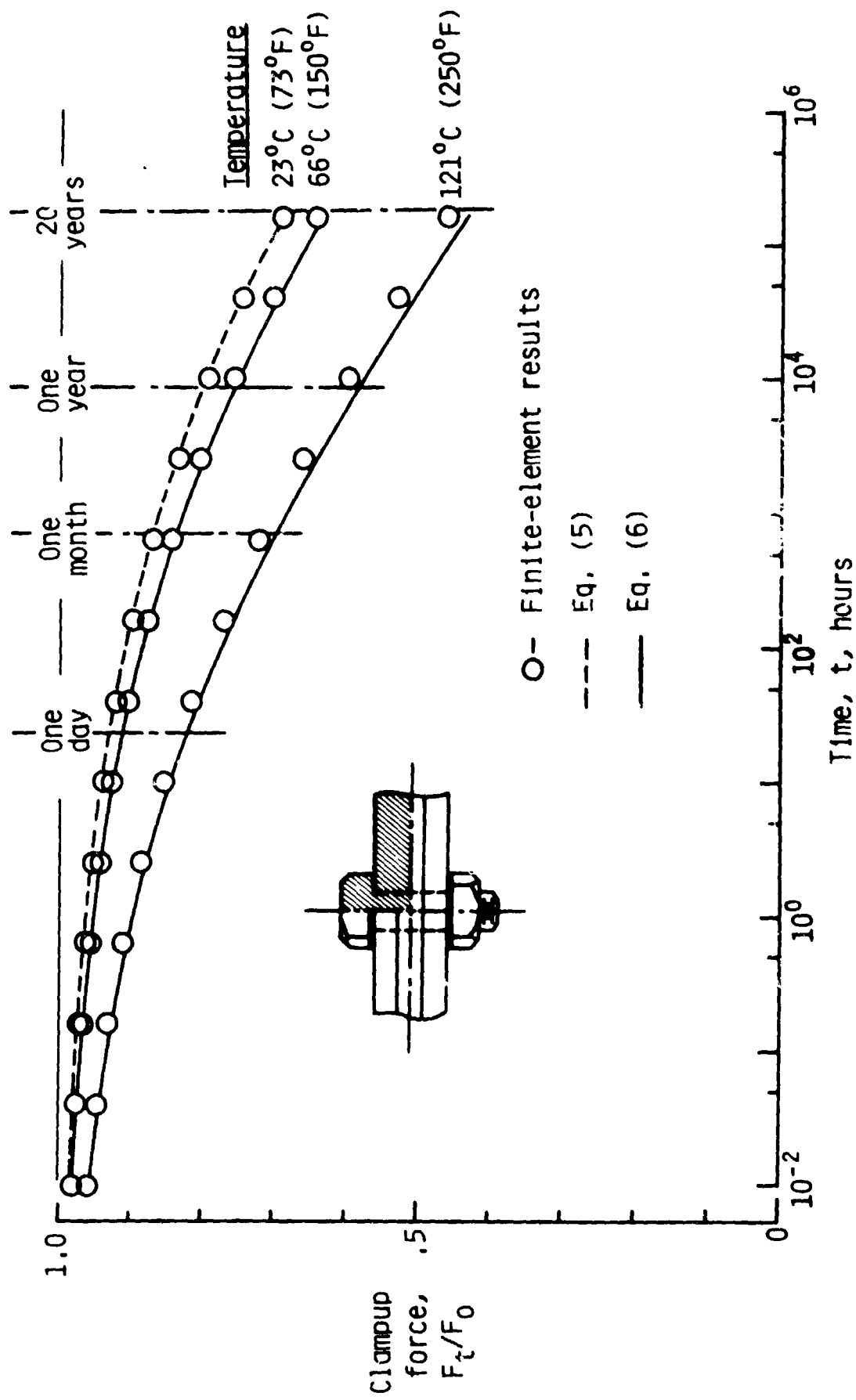

Fig. 3.- Clampup relaxation at several temperatures for the dry condition.

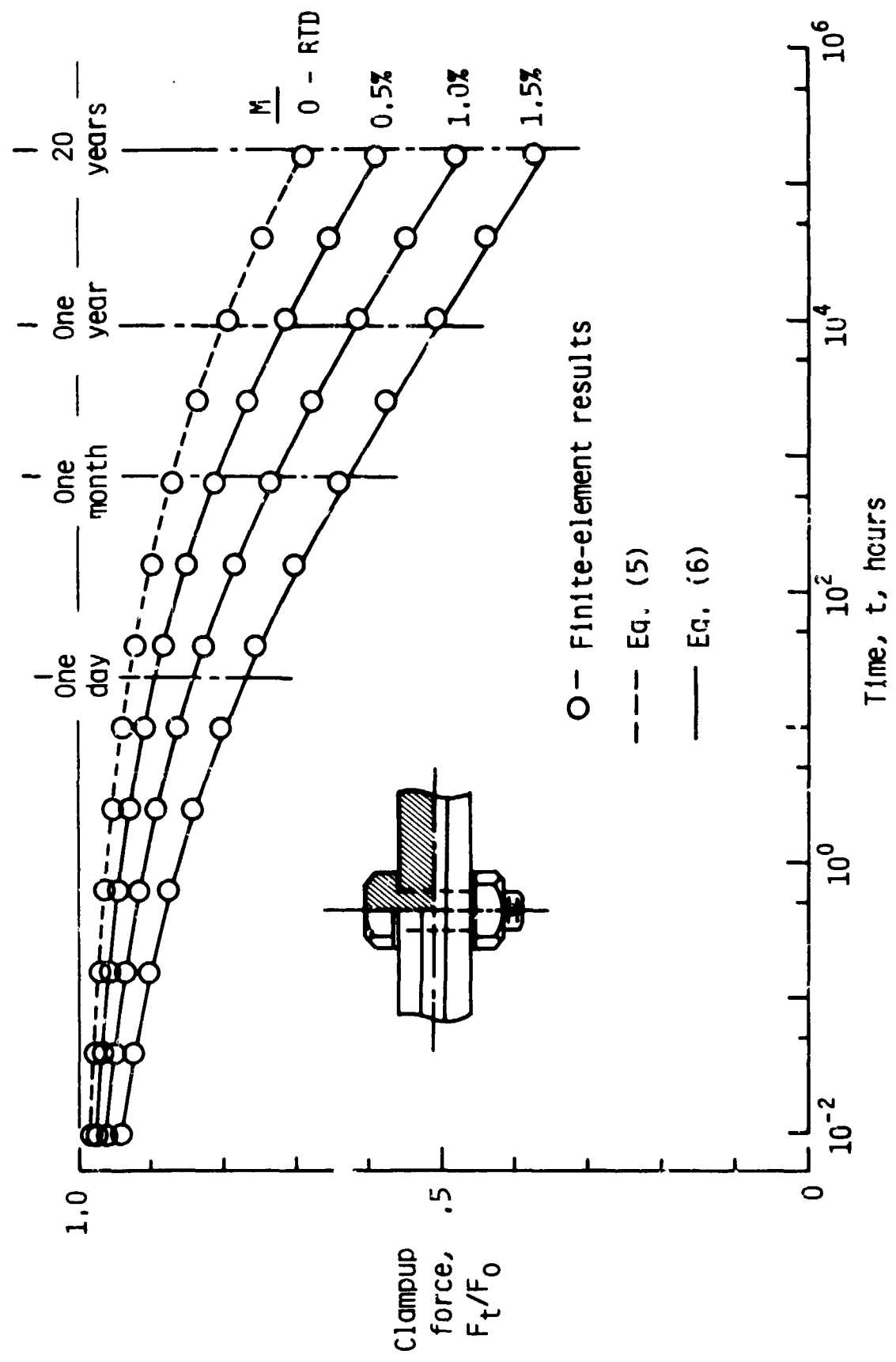

Fig. 4.- Clampup relaxation for several moisture levels at room temperature (23°C).

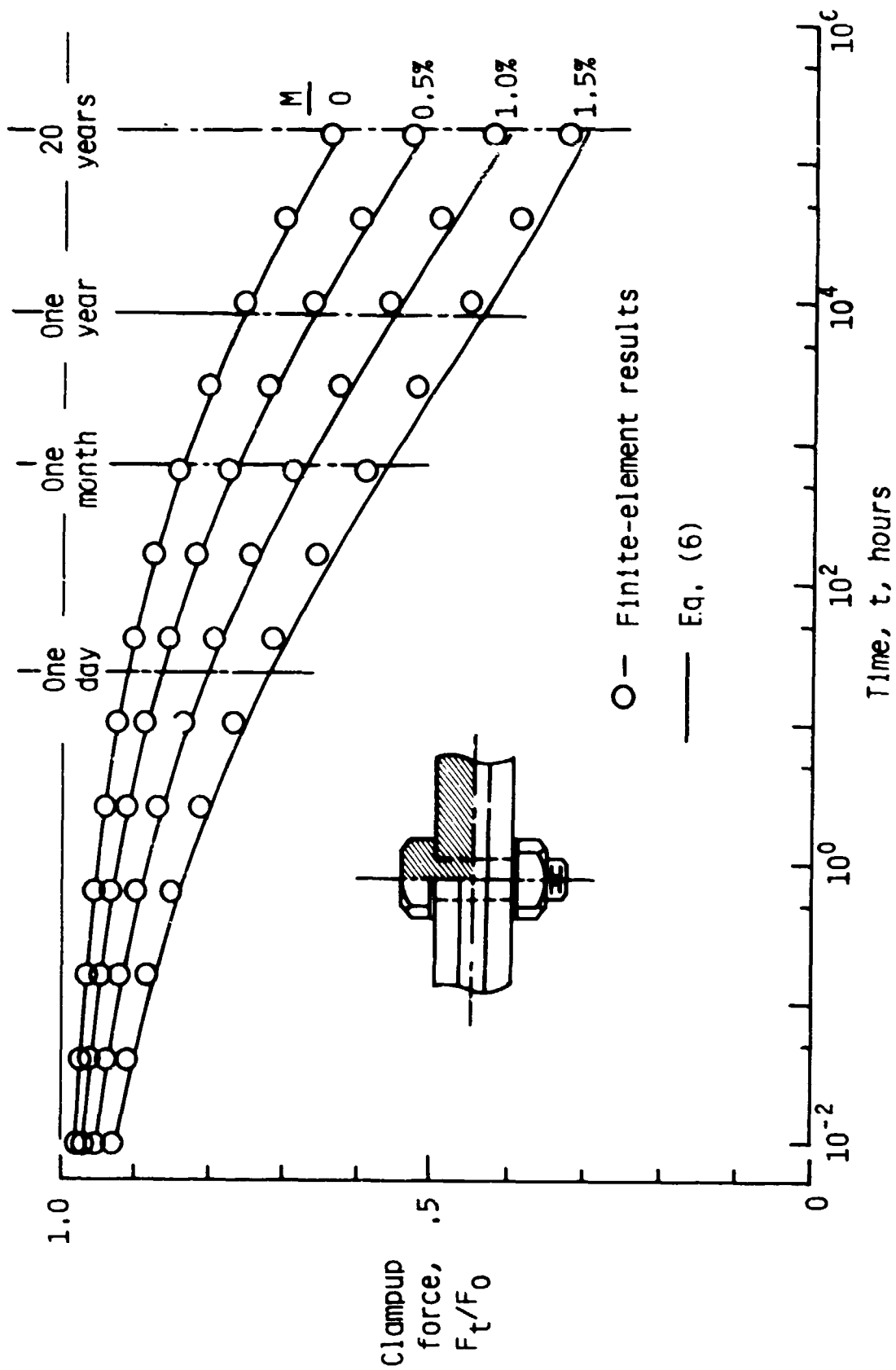

Fig. 5.- Clampup relaxation for several moisture levels at 66°C.

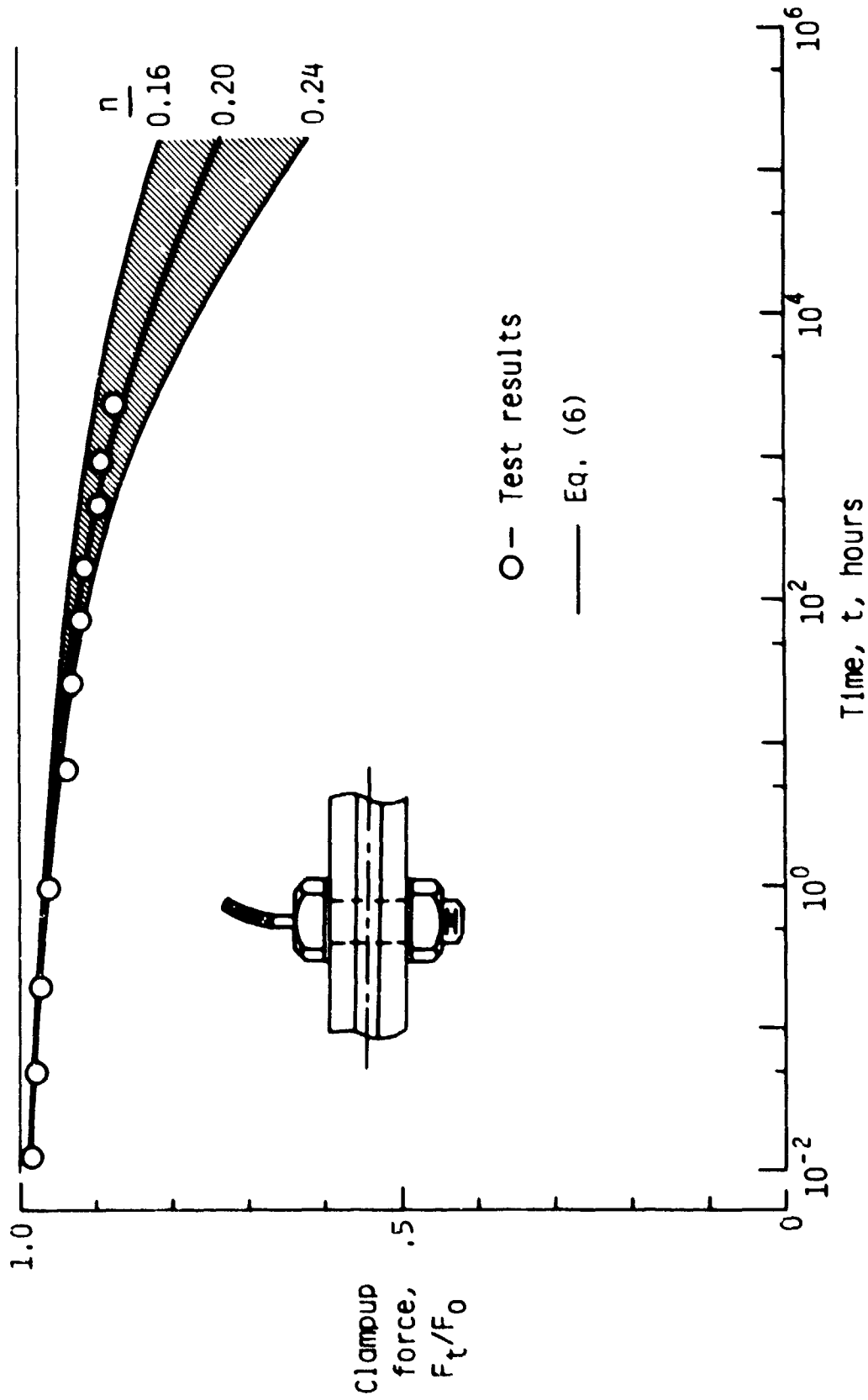

Fig. 6.- Room-temperature-dry (RTD) test results.

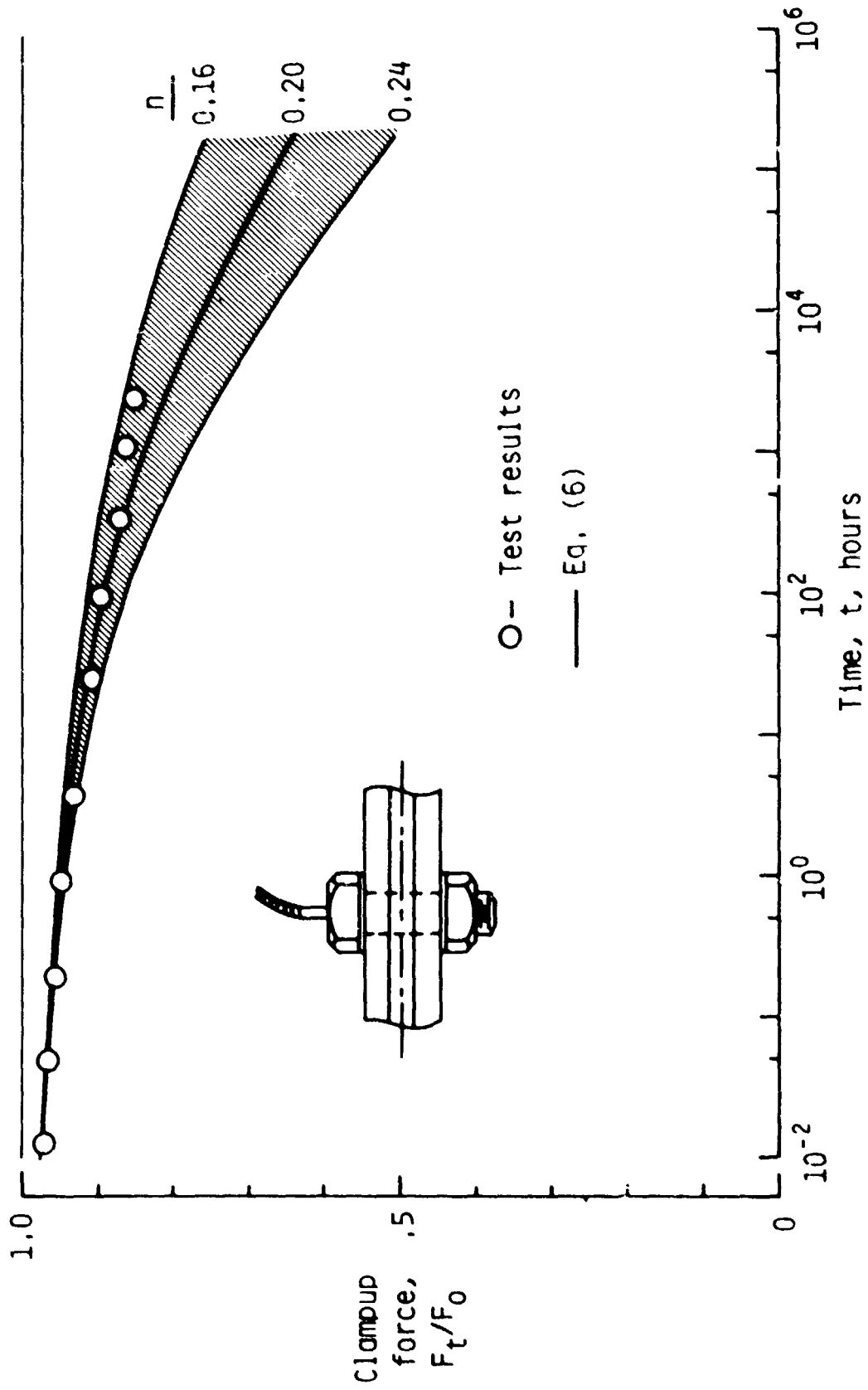

Fig. 7.- Room-temperature-ambient (RTA) test results.

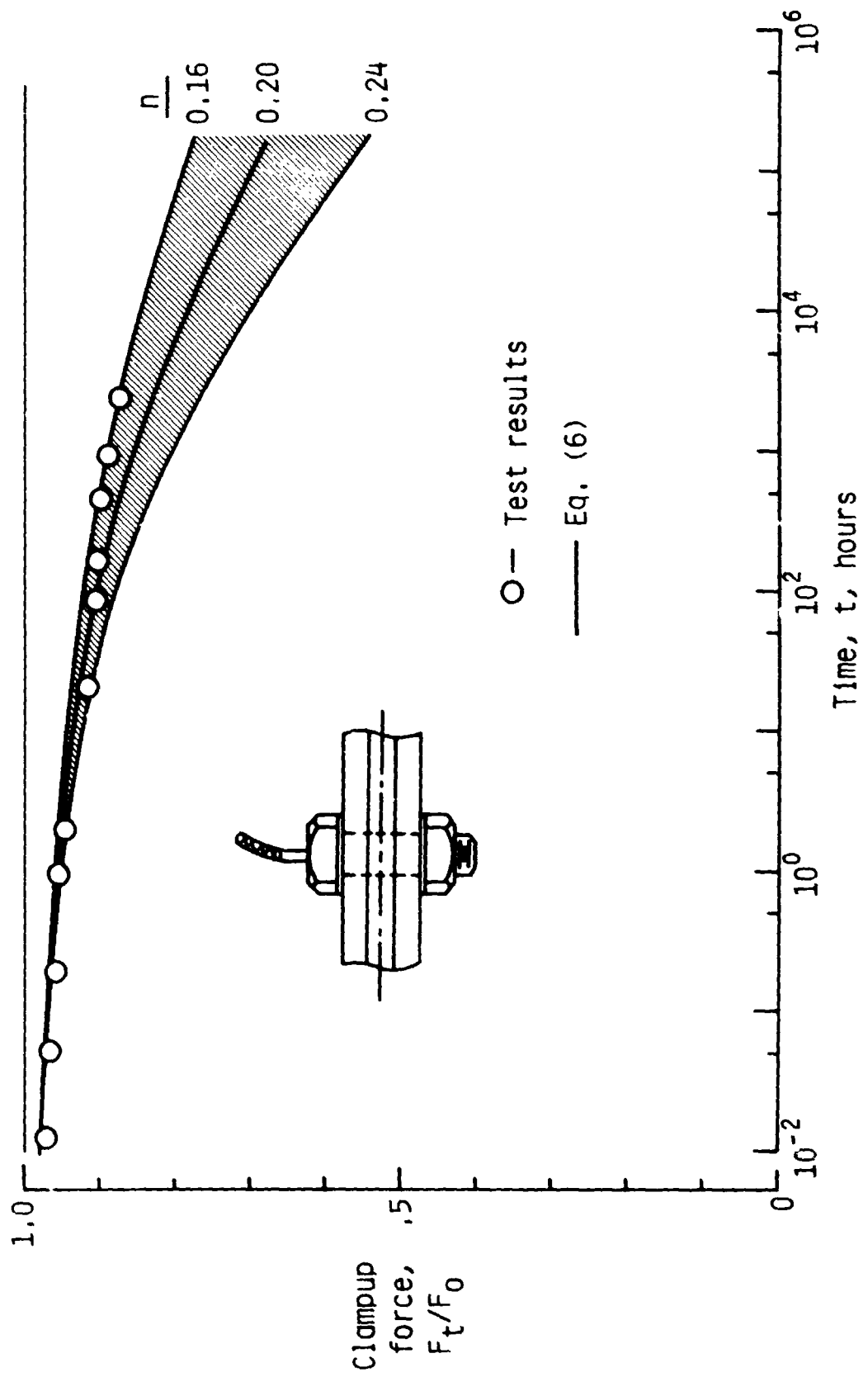

Fig. 8.- Elevated-temperature-dry (ETD) test results.