

**NASA
Technical
Paper
1944**

February 1982

Tribological Properties at 25° C of Seven Polyimide Films Bonded to 440C High-Temperature Stainless Steel

Robert L. Fusaro

TP
1944
c. 1



**LOAN COPY: RETURN TO
FWL TECHNICAL LIBRARY
KIRTLAND AFB, N. M.**

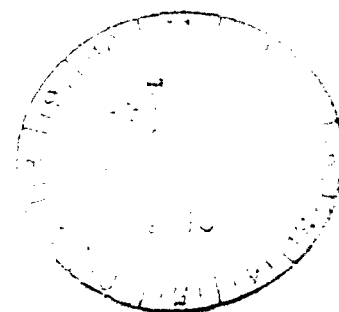

NASA

**NASA
Technical
Paper
1944**

1982

TECH LIBRARY KAFB, NM



0067701

Tribological Properties at 25° C of Seven Polyimide Films Bonded to 440C High-Temperature Stainless Steel

Robert L. Fusaro
*Lewis Research Center
Cleveland, Ohio*

NASA

National Aeronautics
and Space Administration

Scientific and Technical
Information Branch

Trade names or manufacturers' names are used in this report for identification only. This usage does not constitute an official endorsement, either expressed or implied, by the National Aeronautics and Space Administration.

Summary

The tribological properties of seven polyimide films applied to 440C high-temperature stainless steel substrates were studied at 25° C (room temperature) on a pin-on-disk friction and wear apparatus. The polyimides fell into two groups according to friction and wear properties. The polyimides in group I had slightly lower friction but much higher wear than those in group II. The wear rate for group II polyimides was about an order of magnitude lower than that for group I polyimides.

The wear mechanism for most of the polyimides was adhesion, but the wear particles for group I polyimides were larger than those for group II polyimides. Also, group I polyimides spalled from the wear track, an indication that they were more brittle than group II polyimides.

One group II polyimide composition (PIC-2) produced a wear track that was different in appearance from the others. The wear track was very smooth, glossy, and transparent. Some loose wear particles were "plate-like," an indication that the wear process may have been caused by spalling of a very thin surface layer or have resulted from a fatigue-like wear process. Even though the appearance and wear process may have been different, the film wear rate was about the same as that for the other group II polyimides.

The transfer films found on most of the riders that slid on the polyimides consisted of "clumps" of compacted polyimide wear particles. These clumps tended to slide across the contact area, and they wore the metallic rider after long sliding durations. One group II polyimide composition (PIC-2) did not demonstrate this type of transfer. Instead, a thin, plastically flowing transfer film was found.

All polyimide films gave lower friction coefficients for a hemispherical rider (105-MPa contact stress) than for riders with flat areas (8.7- and 13.8-MPa contact stress) sliding on the film under the same total load.

Introduction

It has been shown in previous investigations (refs. 1 and 2) that polyimide and polyimide-bonded graphite fluoride films have potential for solid-

lubricant applications (such as in foil bearings) where long thermal soaks are encountered. Low weight loss rates, good adhesion, and good friction and wear properties were obtained for films thermally aged at temperatures to 315° C.

The word polyimide is a generic designation and refers to a class of long-chain polymers that have recurring imide groups as an integral part of the main chain. By varying the monomeric starting materials, polyimides of different chemical composition and structure can be obtained. The polyimide chains consist of aromatic rings alternated with heterocyclic groups, and because of the multiple bonds between these groups the polyimides are characterized by a high thermal stability (400° C in air, 500° C in inert atmospheres) (refs. 3 to 5). They also have a high radiation stability, being able to withstand high exposure to neutrons, electrons, ultraviolet light, and gamma radiation (refs. 5 to 7). They are resistant to most common chemicals and solvents but are attacked by alkaline materials (refs. 6 and 7). At the decomposition point they crumble to a fine powder without melting. For a more detailed discussion of the physical properties of polyimides, see references 5 to 10.

In previous tribological studies conducted by this author (refs. 1 to 4 and 11 to 14), a commercially available polyimide from Dupont designated PI-4701 was used. Several other polyimides are now commercially available. The objective of this investigation was to determine if any of these polyimides had better tribological properties than the others.

Seven commercially available polyimides were evaluated. They were designated PIC-1 through PIC-7. PIC-1 (PI-4701) was the polyimide used in previous investigations. The films were applied to 440C high-temperature (HT) stainless steel disks and evaluated on a pin-on-disk friction and wear apparatus. The pin material was also 440C HT stainless steel and was slid against the film under a 1-kilogram load at a speed of 1000 rpm (2.6 m/sec). In addition to sliding a hemispherically tipped pin (as is normally done), riders with 0.95-millimeter-diameter and 1.20-millimeter-diameter flats on them were also slid against the film. This was done to investigate the effect of a controlled, lower, constant contact stress on the tribological properties of the films.

Materials

The polyimides used were obtained as precursor solutions. In most instances a thinner consisting of N-methyl-pyrrolidone and xylene was added to the polyimides to make them sprayable. Seven types of polyimides were evaluated. The chemical composition and structure of four of the polyimides were proprietary. They are designated in table I as polyimide types PIC-1 to PIC-4. The structures of the other three polyimides are known and are shown in figure 1. They are designated in table I as polyimide types PIC-5 to PIC-7 in this investigation. The manufacturer and manufacturer's designation are also shown in table I. The polyimide used in previous work by this investigator (refs. 1 to 4 and 11 to 14) is designated as PIC-1 (PI-4701). The films were applied to AISI 440C HT stainless steel disks (1.2 cm thick by 6.3 cm diam) that had a Rockwell

TABLE I. - DESIGNATION OF POLYIMIDE TYPES USED

IN THIS INVESTIGATION

Polyimide designation	Molecular structure	Manufacturer	Manufacturer's designation
PIC-1	Proprietary ↓	DuPont	Pyralin 4701
PIC-2			Pyralin 5081
PIC-3			Pyralin 5077
PIC-4			Pyralin 3301
PIC-5	Figure 1(a)	Upjohn	Polyimide 2080
PIC-6	Figure 1(b)	Gulf Oil Chemical Co.	Thermid 600
PIC-7	Figure 1(c)	DuPont	NR 150B

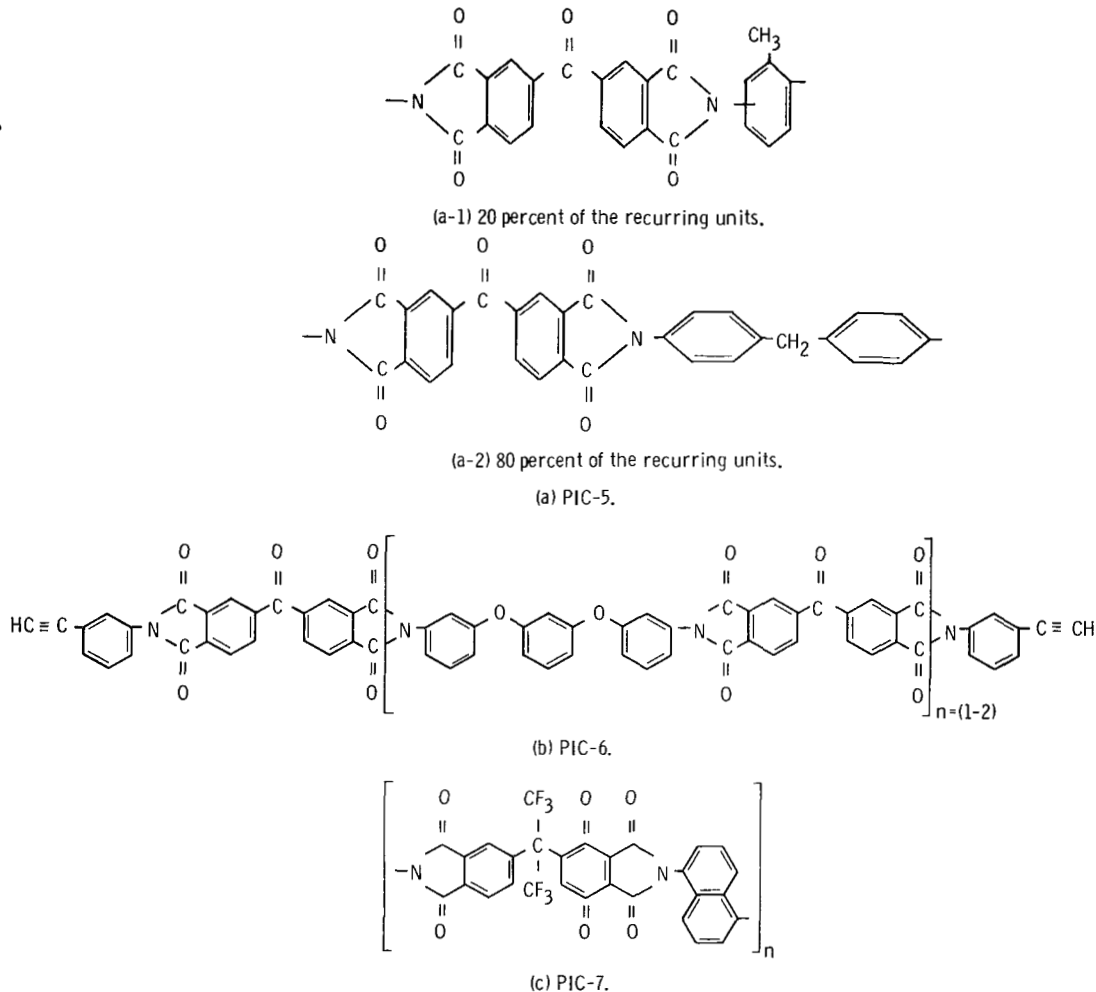

Figure 1. - Structure of polyimide types PIC-5, PIC-6, and PIC-7.

hardness of C-60. The riders used were made of AISI 440C HT stainless steel of Rockwell hardness C-58.

Friction Apparatus

A conventional type of pin-on-disk friction and wear apparatus was used in this study (fig. 2). The riders were either hemispherically tipped pins with a radius of 0.475 centimeter or the same hemispherically tipped pins with 0.95-millimeter- or 1.20-millimeter-diameter flats worn on the hemisphere (see insert fig. 2). They were loaded with a 1-kilogram deadweight against the film, which was applied to a flat, 6.3-centimeter-diameter disk. The disk was rotated at 1000 rpm, and the rider slid on the disk at a radius of 2.5 centimeters, giving it a linear sliding speed of 2.6 millimeters per second. The friction specimens were enclosed in a chamber for atmosphere control. To obtain an air atmosphere of 10 000 ppm H_2O (approx. 50 percent relative humidity), dry air and dry air bubbled through water were mixed. Humidity was monitored continuously.

Procedure

Surface Preparation and Cleaning

The metallic disk surfaces were roughened by sandblasting to a centerline average (cla) roughness of 0.9 to 1.2 micrometers. After surface roughening the disks were scrubbed with a brush under running tap water. The disks were rinsed in distilled water and then clean, dry compressed air was used to quickly dry the surfaces. The disks were stored in a dessicator until they were ready for coating with the polyimides.

The rider was lightly scrubbed with ethyl alcohol and with levigated alumina. It was next rinsed in distilled water and dried with compressed air. Polyimide films were not applied to the riders.

Film Application and Cure

An artists airbrush was used to apply the polyimide films to the disks. The films did not dry rapidly; thus only a thin layer was applied at one time to prevent "running." Each layer was completely cured before

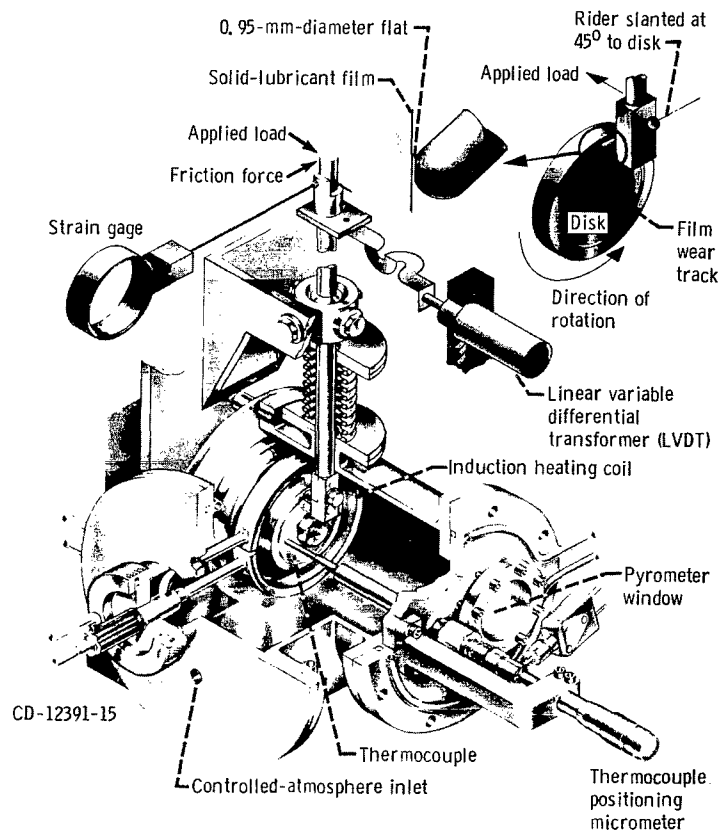

Figure 2. - Friction and wear apparatus.

the next layer was applied. The cure was to slowly raise the temperature from ambient (25° C) to 320° C at a rate of approximately 1½ degrees centigrade per minute. The temperature was then held at 320° C for 1 hour. Minor variations of this cure did not appear to affect the friction and wear results. The film thicknesses evaluated in this study were from 20 to 25 micrometers. Since each layer applied was from 8 to 13 micrometers thick, as many as three applications were needed to achieve the desired thickness.

Friction and Wear Tests

The procedure for conducting the friction and wear tests was as follows: A rider and disk (with applied polyimide film) were inserted into the friction apparatus, and the test chamber was sealed. Moist air (10 000 ppm H₂O) was purged through the chamber for 15 minutes. Moist air was used as a controlled atmosphere. The flow rate was 1500 cubic centimeters per minute, and the volume of the chamber was 2000 cubic centimeters. After 15 minutes of purging, the disk was set into rotation at 1000 rpm and a 1-kilogram load was gradually applied. The 1-kilogram load applied to the 0.95-millimeter-diameter flat (0.0071-cm² area) gave a projected contact stress of 13.8 MPa (2000 psi); the 1-kilogram load applied to the 1.20-millimeter-diameter flat (0.011-cm² area) gave a projected contact stress of 8.7 MPa (1250 psi). Initial measurements of the transfer area film on the hemispheres indicated that the maximum contact stresses involved were greater than 105 MPa (15 000 psi). The test temperature was 25° C.

Each test was stopped after 1 kilocycle of sliding. After the rider and disk were removed from the friction apparatus, the contact areas were examined by optical microscopy and photographed. Surface profiles of the disk wear tracks were also taken. Rider and disk were placed back into the apparatus and the previous test procedure was repeated. The rider was not removed from the holder, and locating pins in the apparatus insured that it was returned to its original position.

Each test was stopped and the test procedure repeated after selected sliding times. Film wear was calculated by measuring the cross-sectional area of the polyimide film wear track (from the surface profiles) after each sliding interval.

Analysis of Sliding Surfaces

Optical microscopy techniques were used to study the lubricating films, the transfer films, and the wear particles in this investigation. The surfaces were viewed at magnifications to 2000. At these high magnifications the depth of field was very small

(~1 μm); thus the focusing distance was used in measuring various features on the sliding surfaces, such as film thickness and wear track depth.

The thin (1 μm or less) polyimide films were transparent. Since illumination and observation of the surfaces were normal to the surfaces, interference fringes could be seen in the films both on the disk wear track and on the rider. Interference fringes indicated that very smooth and continuous solid lubricant films were present.

Results and Discussion

Friction Coefficient

The friction traces for the three contact areas during the initial stages of sliding on a PIC-2 polyimide film are compared in figure 3. The results are typical of all seven polyimide films. The friction coefficient for the hemisphere sliding against the film was lower than for either flat area; and the friction coefficient, in general, was lower for the 0.0071-square-centimeter-area flat than for the 0.011-square-centimeter-area flat. According to Amontons's law the friction force should be independent of the apparent area of contact for constant load. Bowden and Tabor (ref. 15) have shown that Amontons's law does not apply when hard surfaces slide on thin metallic films. A similar effect appears to have occurred for thin polyimide films applied to a hard substrate.

The friction coefficients for the seven polyimide films are plotted in figure 4 as a function of sliding

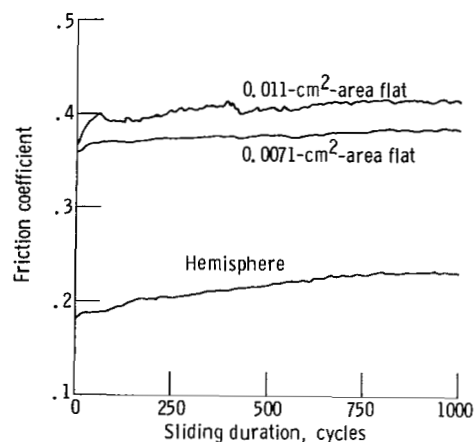

Figure 3. - Friction traces during initial stages of sliding on PIC-2 polyimide film, showing effect of contact area (or contact stress) on friction coefficient. Experimental conditions: ambient temperature, 25° C; sliding speed, 1000 rpm (2.6 m/sec); load, 1 kg (9.8 N); moist air atmosphere (50 percent relative humidity).

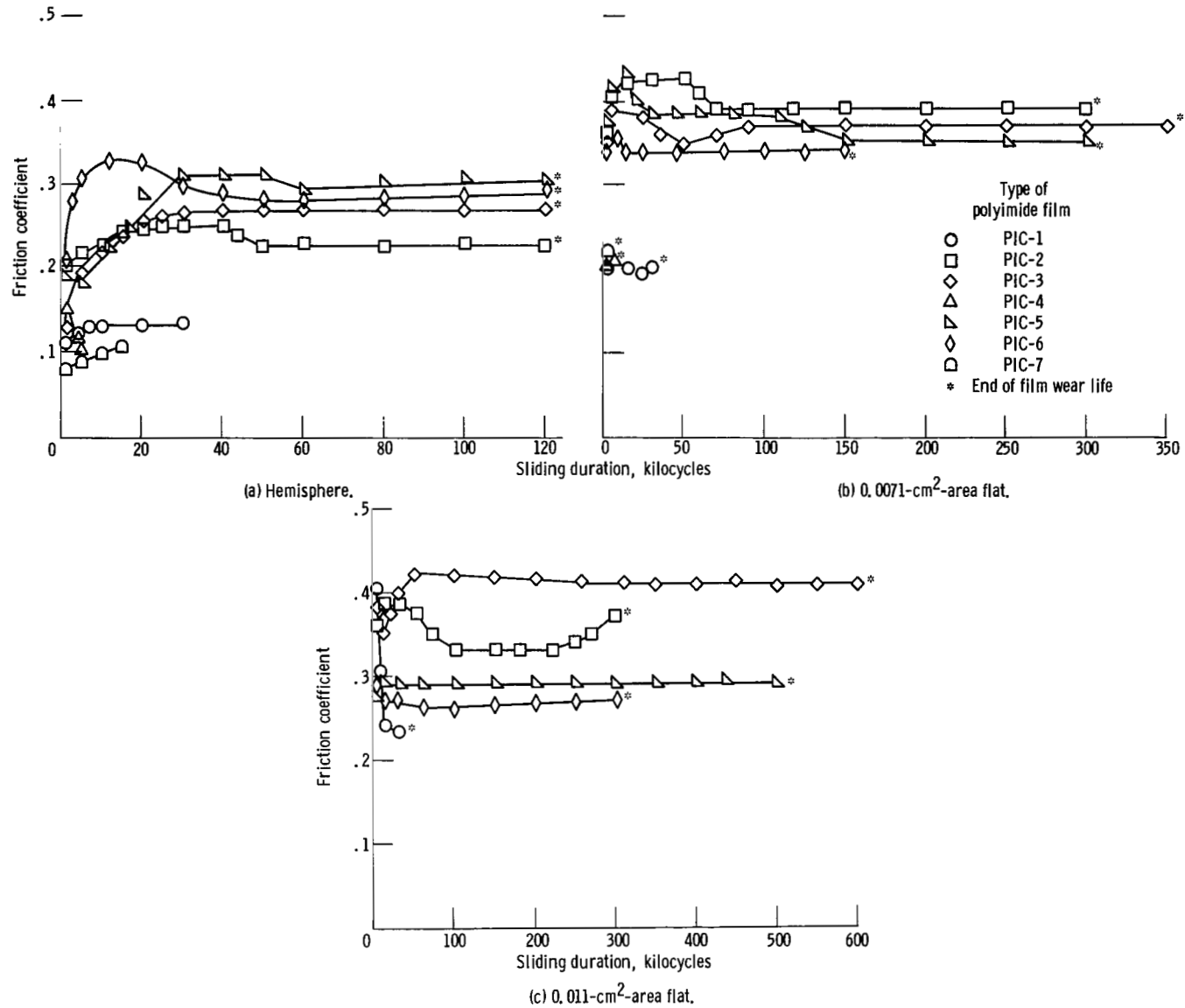

Figure 4. - Average friction coefficient as a function of sliding duration for a hemisphere, a 0.0071-cm²-area flat, and a 0.011-cm²-area flat sliding on films applied to 440C HT stainless steel substrates. Experimental conditions: ambient temperature, 25^o C; sliding speed, 1000 rpm (2.6 m/sec); load, 1 kg (9.8 N); moist air atmosphere (50 percent relative humidity).

duration. The results for the hemisphere sliding on the film are plotted in figure 4(a). The lowest friction coefficients were obtained with polyimide films PIC-1, PIC-4, and PIC-7; however, as the figure indicates, the wear lives (time to wear through the film or time until spalling occurred) were very short. The low friction coefficients and short wear lives of these three films were also found for the other two contact areas (figs. 4(b) and (c)).

It is not clear which of the other polyimides gave the lowest friction coefficient. The values obtained depended on the sliding duration and the type of rider contact. Table II gives values for the average friction coefficient obtained for each film and the variation that occurred with sliding duration for a

particular individual experiment. The test duration is also given.

Film Wear

Film wear was determined by taking surface profiles of the film wear track after each sliding interval and measuring the cross-sectional area of the material worn away. At least four traces were taken at each interval and averaged. Figure 5 plots the average cross-sectional areas for each polyimide as a function of sliding duration for the hemisphere, the 0.0071-square-centimeter-area flat, and the 0.011-square-centimeter-area flat, respectively.

TABLE II. - SUMMARY OF FRICTION AND WEAR RESULTS FOR POLYIMIDE FILMS
BONDED TO 440C HT STAINLESS STEEL SUBSTRATES

[Experimental conditions: 440C HT stainless steel riders; 1-kg load; 1000-rpm sliding speed (2.6 M/sec); 50-percent-relative-humidity atmosphere.]

Type of polyimide	Area of contact, cm ²	Variation of friction coefficient	Average friction coefficient	Test duration, kilocycles	Thickness of film worn through, μm	Average film wear rate	
						cm ² /kc	m ³ /N-m
PIC-1	Hemisphere	0.10 - 0.14	0.13	30	20	(40±8)×10 ⁻⁷	(40±8)×10 ⁻¹⁵
	0.0071	.14 - .25	.20	30	16	(60±10)	(60±10)
	.011	.19 - .29	.24	30	25	(130±25)	(130±25)
PIC-2	Helisphere	0.18 - 0.25	0.23	120	16	(10±2)×10 ⁻⁷	(10±2)×10 ⁻¹⁵
	0.0071	.36 - .43	.39	300	11	(3±1.5)	(3±1.5)
	.011	.36 - .42	.33	280	12	(4±1)	(4±1)
PIC-3	Hemisphere	0.12 - 0.29	0.27	120	12	(6±2)×10 ⁻⁷	(6±2)×10 ⁻¹⁵
	0.0071	.22 - .41	.37	350	9	(2±1)	(2±1)
	.011	.32 - .42	.41	600	13	(3±0.5)	(3±0.5)
PIC-4	Hemisphere	0.10 - 0.18	0.18	5	8	(80±20)×10 ⁻⁷	(80±20)×10 ⁻¹⁵
	0.0071	.18 - .25	.21	1	5	(350±150)	(350±150)
PIC-5	Hemisphere	0.19 - 0.37	0.30	120	14	(6±1)×10 ⁻⁷	(6±1)×10 ⁻¹⁵
	0.0071	.16 - .42	.35	300	12	(3.5±0.5)	(3.5±0.5)
	.011	.21 - .30	.29	500	16	(4±0.5)	(4±0.5)
PIC-6	Hemisphere	0.21 - 0.37	0.28	120	18	(12±0.5)×10 ⁻⁷	(12±0.5)×10 ⁻¹⁵
	0.0071	.20 - .36	.34	150	18	(12±2)	(12±2)
	.011	.22 - .29	.27	300	15	(7±2)	(7±2)
PIC-7	Hemisphere	0.07 - 0.15	0.10	15	13	(40±11)×10 ⁻⁷	(40±11)×10 ⁻¹⁵
	0.0071	.18 - .25	.22	1	6	(50±30)	(50±30)

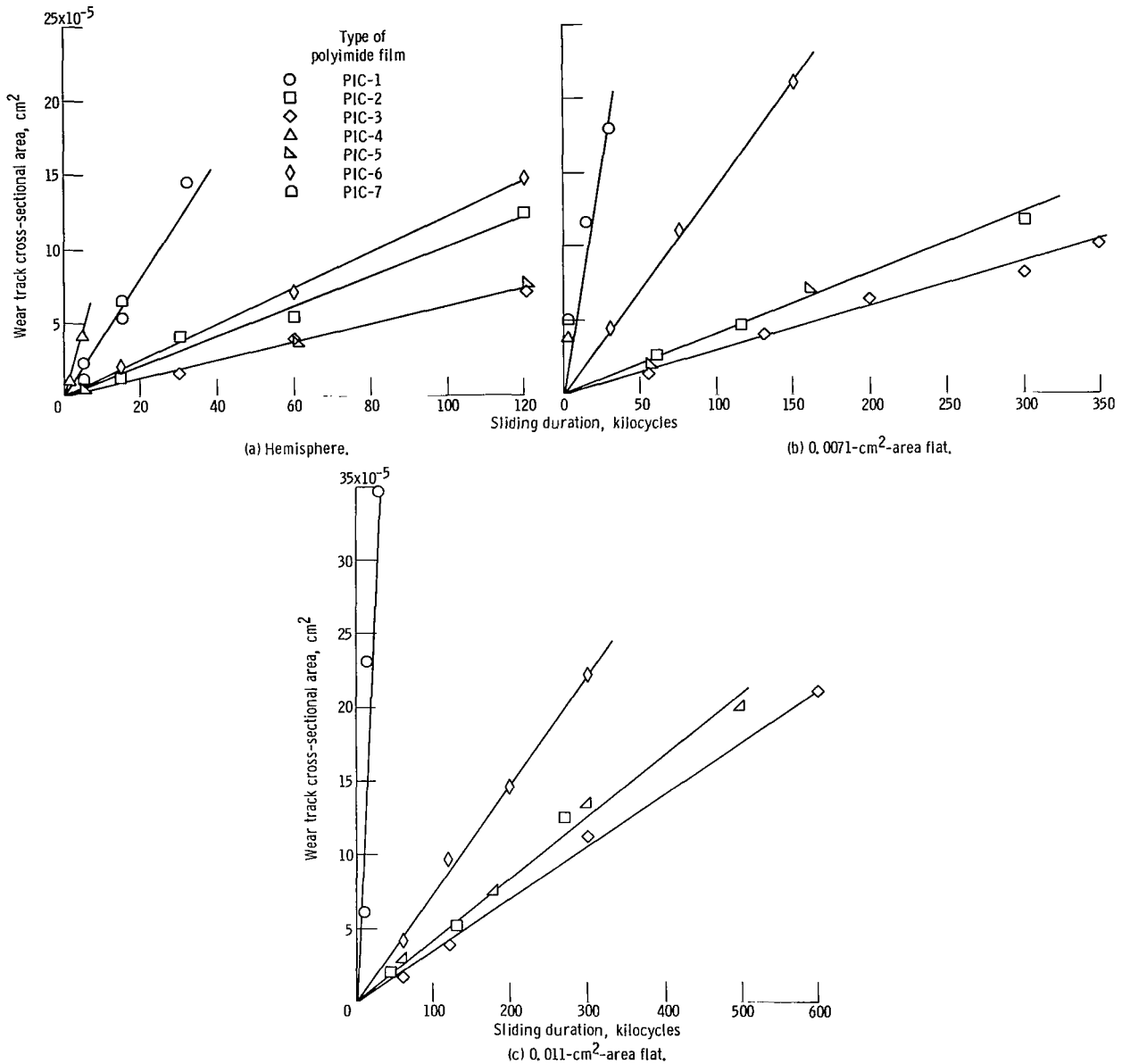

Figure 5. - Wear of seven polyimide films as a function of sliding duration for a hemisphere, a 0.0071- cm^2 -area flat, and a 0.011- cm^2 -area flat sliding on films applied to 440C HT stainless steel substrates. Experimental conditions: ambient temperature, 25 $^{\circ}$ C; sliding speed, 1000 rpm (2.6 m/sec); load, 1 kg (9.8 N); moist air atmosphere (50 percent relative humidity).

The general trend was that the wear for each individual film increased linearly (from zero) as a function of sliding duration. A linear regression fit (least squares) of the data (from each test) was made and an average film wear rate determined. Table II gives the average wear rates (and the variation obtained) for each film and for each type of rider

contact in square centimeters per kilocycle and cubic meters per newton-meter.

The table indicates that the films that gave the lowest friction coefficients (PIC-1, PIC-4, and PIC-7) also gave the highest wear rates. It is also seen for these three films that as the area of contact increased (or contact stress decreased) the wear rates

increased. The wear rates obtained for these three films varied from $(350 \pm 150) \times 10^{-15}$ to $(40 \pm 8) \times 10^{-15} \text{ m}^3/\text{N m}$.

The other four films (PIC-2, PIC-3, PIC-5, and PIC-6) gave much lower wear rates; and as the stress was reduced from that of the hemisphere to that of the flat, the film wear rate decreased. The film wear rates obtained for the 0.0071- and 0.011-square-centimeter-area flats were nearly equal.

The lowest overall wear rates were obtained with the PIC-3 film. The next best film wear rates were obtained with the PIC-5 film. The wear rates for the PIC-2 film were very similar to those for the PIC-5 film for the two flat areas; however, the wear rates for the hemisphere sliding on the film were a little higher. The PIC-6 film was the fourth best.

Film Wear Mechanisms

The wear mechanisms of the polyimide films were studied by using an optical microscope to magnifications of 2000. It was observed that the type of rider contact (whether it be a hemisphere or flat) did not alter the film wear track appearance on any one particular type of polyimide. The wear tracks on some polyimides, however, looked very different from those on other polyimides.

Photomicrographs of the film wear tracks on PIC-2 and PIC-3 films are shown in figure 6. The appearance of the PIC-3 film wear track is also typical of the wear tracks on PIC-5 and PIC-6 polyimide films. As figure 6(a) illustrates, the surface of the wear track on the PIC-2 film was very smooth and glossy, and striations occurred in the sliding direction. In localized areas, however, defects (wedge-shaped areas) are visible. Figure 7(a) shows an example of these areas under higher magnification. The material in these areas appears to be in the process of spalling.

High-magnification photomicrographs of the PIC-3 film wear track (fig. 7(b)), the PIC-5 film wear track (fig. 7(c)), and the PIC-6 film wear track (fig. 7(d)) are also presented. At low magnification the wear tracks for these three films look identical, but at high magnification differences are apparent. The flow properties of the films and the general surface topography are different.

Very fine wear particles of PIC-3 (also typical of PIC-5 and PIC-6) are visible at the sides of the track (fig. 6(b)), but the PIC-2 film produced larger plate-like wear particles (fig. 6(a)). This implies that the wear process of the PIC-2 film may be related to surface fatigue, while the wear process of PIC-3 is related to adhesive wear. The texture of the PIC-3 wear track surface is also indicative of what would happen during adhesive wear; that is, the wear

particles appear to have been pulled out of the surface.

Representative photomicrographs of the wear track surfaces on PIC-4 (also typical of PIC-1 and PIC-7) are shown in figure 8. Bright areas are evident on the wear track, but the wear track, in general, is very dark colored (fig. 8(a)). High-magnification photomicrographs of these bright areas suggest that they are agglomerated wear particles that are still adhering to the wear track. The wear process again appears to be adhesion, but the wear particles are produced at a faster rate and are larger than those produced on the PIC-2, PIC-5, and PIC-6 films.

In addition to adhesive wear, two of the films (PIC-4 and PIC-7) tended to spall in localized areas around the film wear track. These spalls occurred regardless of the type of contact (hemisphere or flat area). Figure 9 is a photomicrograph of a spall that occurred on the PIC-7 film wear track after 15 kilocycles of sliding. Because the material that spalled did not make a clean break with the substrate, the spall was probably due to the brittleness of the polyimide and not to poor adherence of the film to the substrate.

A few small spalls also occurred after long sliding durations in the PIC-2 polyimide films. The tests were stopped when the spalls were observed. Thus the test duration times, given in table II, specify the time when spalling was observed.

Rider Wear and Transfer

Two types of polymer transfer to the rider were observed for the different polyimides. The first type was a very adherent, plastically flowing thin film transfer. The second type was more powdery, and, although it adhered to itself to form clumps, it did not adhere well to the rider.

The first type of transfer could be found for all the polyimides after short sliding intervals. However, as sliding distance increased, all the polyimides except PIC-2 tended to produce transfer films of the second type.

The thin, flowing type of transfer (from PIC-2 films) did not seem to be affected by contact geometry. Transfers to the hemisphere and the flat areas looked very similar. Figures 10(a) and (b) are photomicrographs of the transfer to the hemispherically tipped riders after 1 and 60 kilocycles of sliding; and figures 11(a) and (b) are photomicrographs of the transfer to the 0.0071-square-centimeter-area flat after 1 and 300 kilocycles of sliding. The polyimide (PIC-2) tended to build up in the entrance region of the

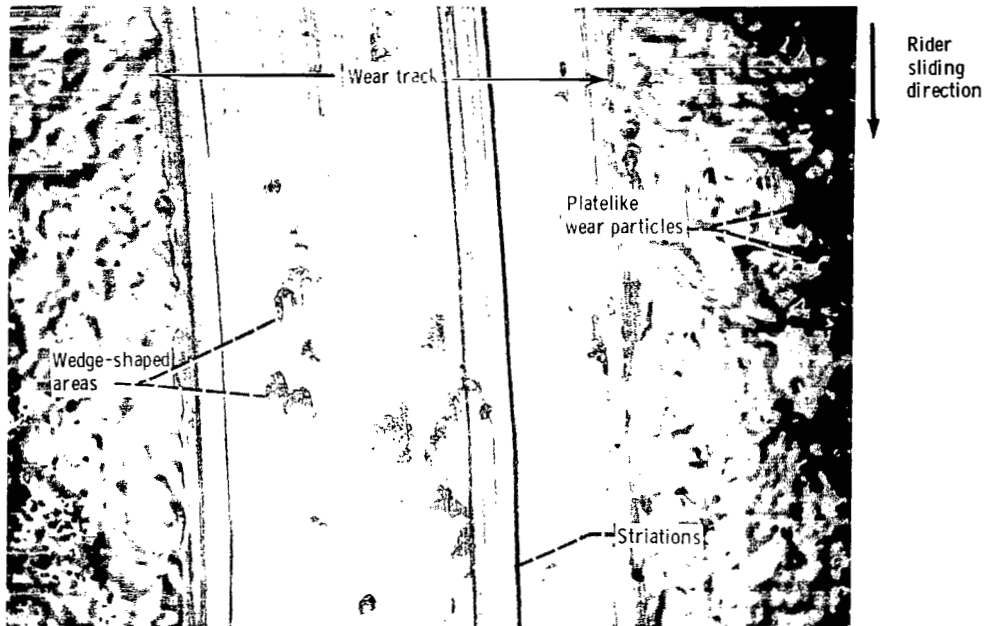

(a) PIC-2 film (sliding duration, 125 kilocycles).

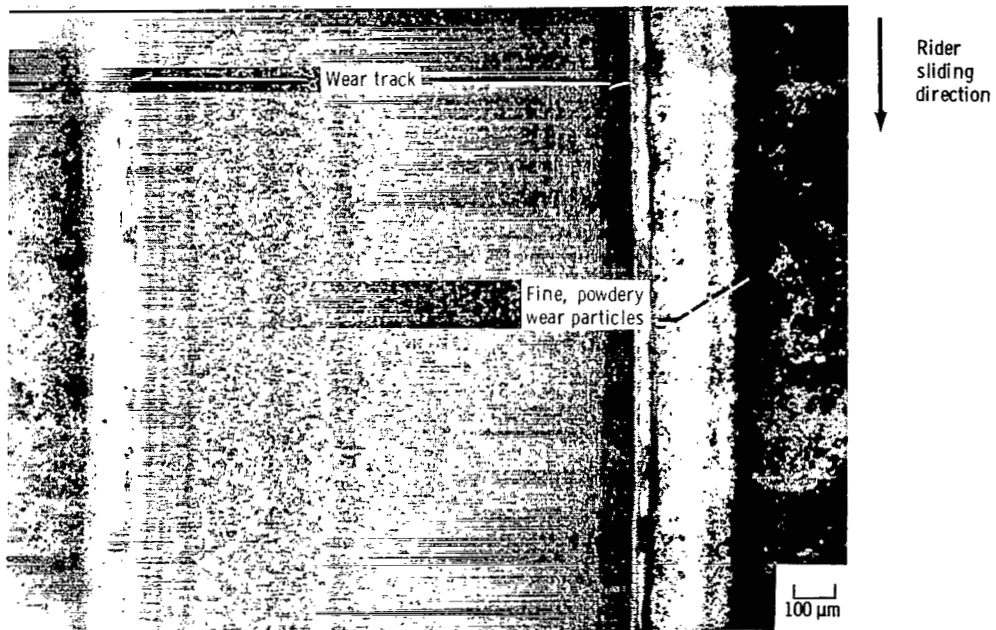

(b) PIC-3 film (sliding duration, 600 kilocycles).

Figure 6. - Photomicrographs of PIC-2 and PIC-3 film wear tracks. (The appearance of PIC-3 films is also typical of PIC-5 and PIC-6 polyimide films.

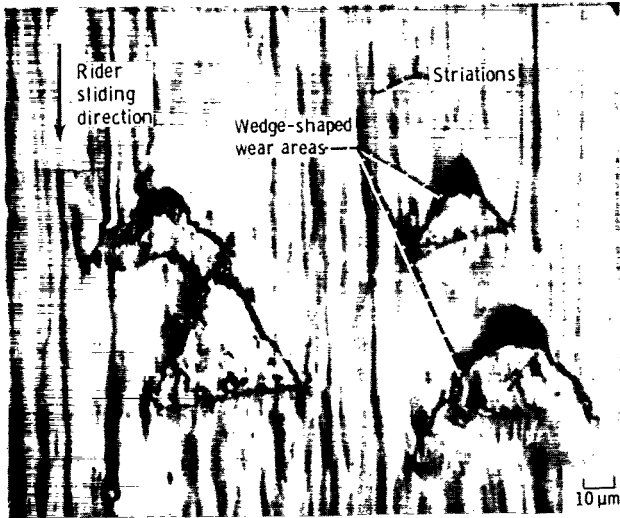

(a) PIC-2 film.

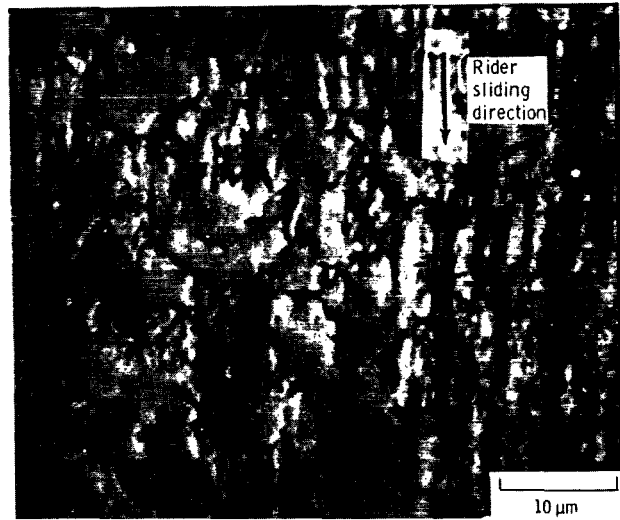

(b) PIC-3 film.

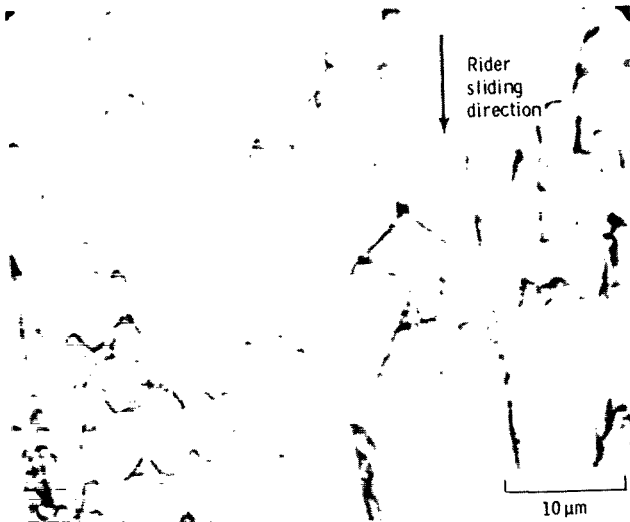

(c) PIC-5 film.

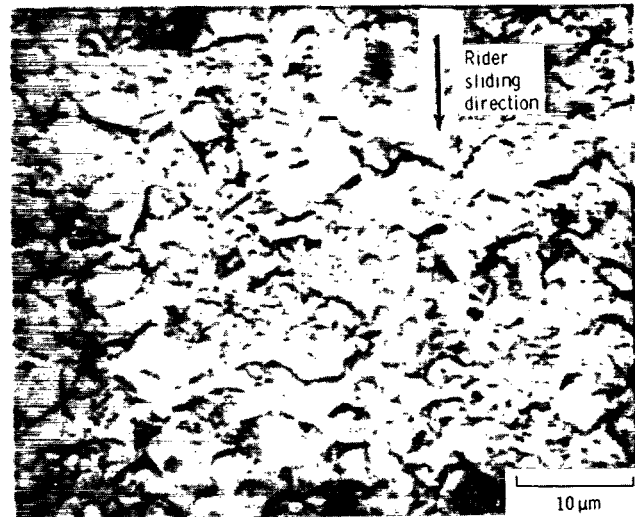

(d) PIC-6 film.

Figure 7. - High-magnification photographs of middle of wear tracks on four types of polyimide film.

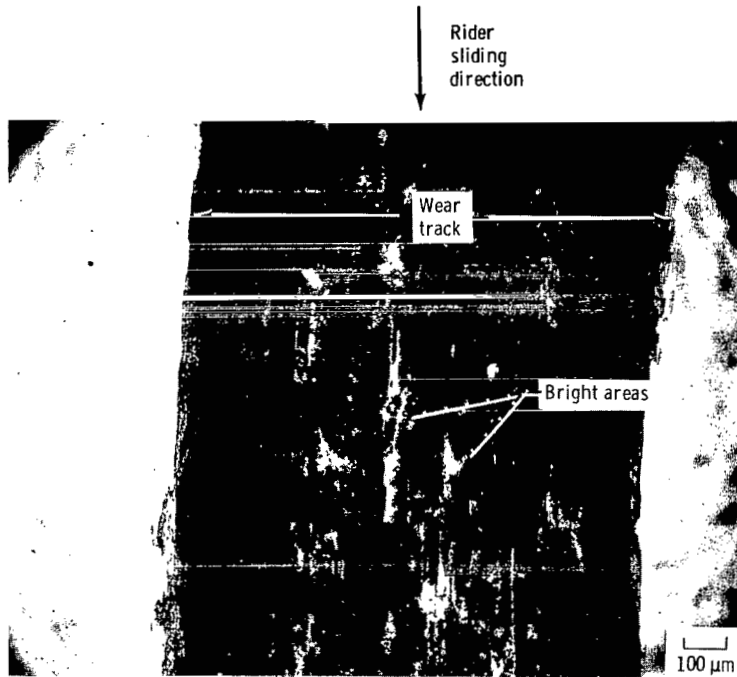

(a) Overview of film wear track.

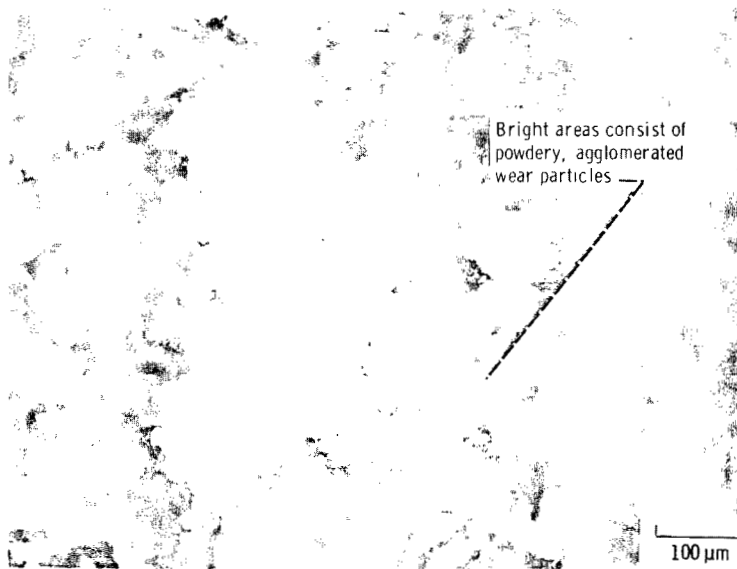

(b) High magnification view of center of film wear track.

Figure 8. - Photomicrographs of PIC-4 film wear track after 10 kilocycles of sliding. (These photomicrographs also typify the wear surfaces found on PIC-1 and PIC-7 films.)

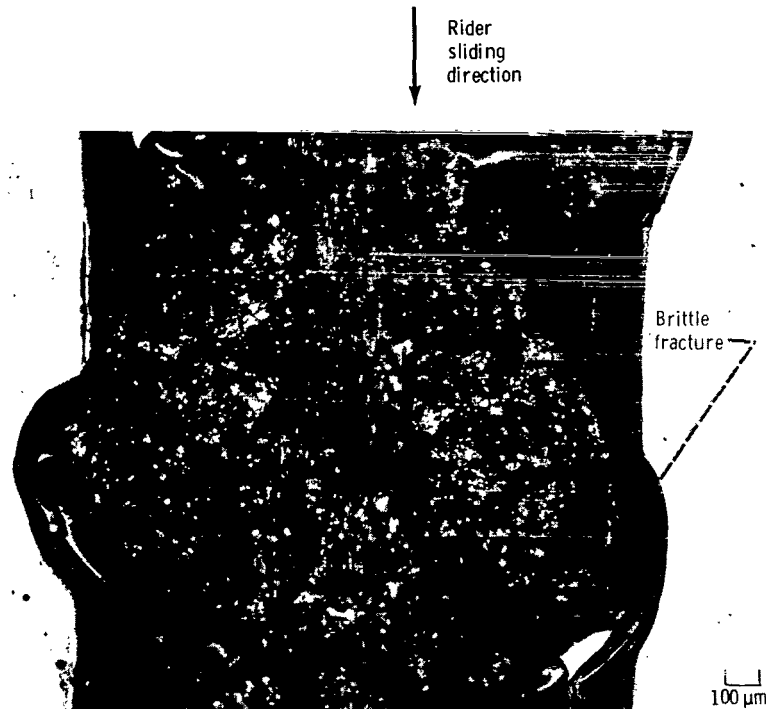

Figure 9. - Photomicrograph of PIC-7 film wear track after 15 kilocycles of a sliding hemisphere on the film. (This photomicrograph also typifies what happened when the flat areas slid against the film and also what happened to the PIC-4 films for all three contact areas.)

contact zone, but in the contact zone the films were very thin.

Figures 12(a) and (b) are high-magnification photomicrographs of the transfer to the 0.0071-square-centimeter-area flat after it slid on a PIC-2 film for 1 and 300 kilocycles. In the initial stages of sliding the transfer was plate-like (fig. 12(a)); but as sliding continued, the polyimide coalesced into a fairly continuous thin film (fig. 12(b)). The brighter-looking areas in figure 12(b) are carbide particles. The black-and-white photograph does not indicate it, but there were thin transfer films on the carbide particles and these films showed broad, colorful interference bands. The transfer between the carbide particles was not as smooth and thus appears darker. In either case the film transfer was less than 1 micrometer thick.

The second type of transfer appeared on the remaining polyimides. The transfer was powdery and, although it adhered to itself to form clumps, good adherence to the rider did not occur. In general, either clumps (compacted powdery material) or loose powdery polyimide was found in the contact area. Figure 13, which gives photomicrographs of the transfer to a hemispherically tipped rider after it slid on a PIC-5 film for 1 and 60 kilocycles, illustrates

this type of transfer. Large amounts of powdery polyimide material were found in the entrance region (fig. 13(a)) or at the sides of the contact area (fig. 13(b)).

When the first type of transfer occurred, no measurable wear was observed on the metallic rider. When the second type occurred, some rider wear was observed, especially for the PIC-3 film. Figure 14 gives photomicrographs of the transfer and wear to the 0.011-square-centimeter-area flat, which slid on the PIC-3 film for 1, 300, and 600 kilocycles. The wear is most noticeable at the sides of the contact area (fig. 14(b)). A clump of polyimide material is visible in figure 14(b) in the exit area of the contact. The clump appears to have slid across an area that has a groove in it. It also appears that the clump of polyimide material has worn this groove in the metal rider. Apparently the polyimide clumps are forced through the contact area; and instead of shearing, they slide at the metal interface and cause the metal to wear.

Figure 15 gives high-magnification photomicrographs of the transfer (clump-like material) to the 0.0011-square-centimeter-area flat, which slid on the PIC-3 film for 60 and 600 kilocycles. Initially the clumps are small (fig. 15(a)); but as the film wears,

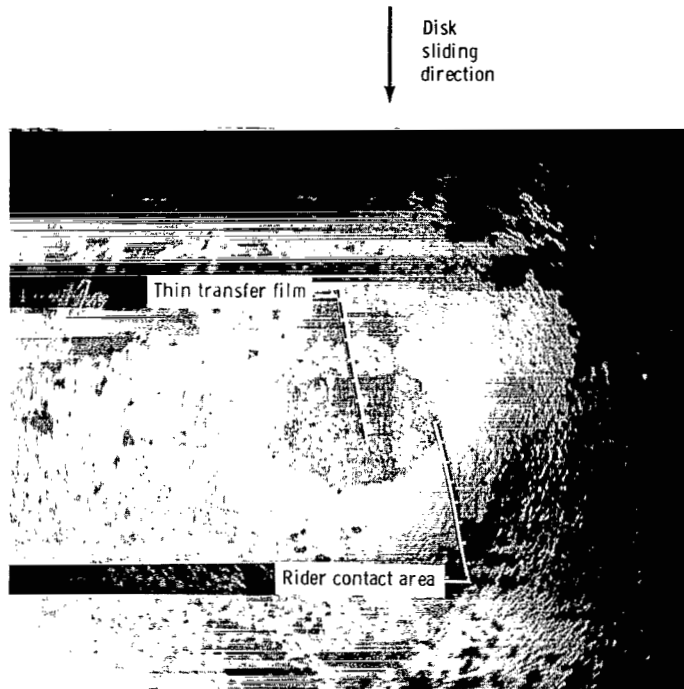

(a) Sliding duration, 1 kilocycle.

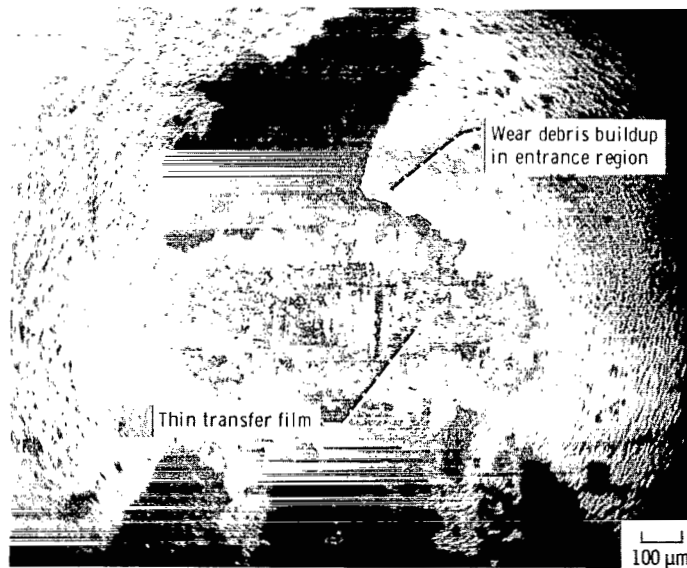

(b) Sliding duration, 60 kilocycles.

Figure 10. - Photomicrographs of transfer to hemispherically tipped riders after sliding on PIC-2 film for 1 and 60 kilocycles.

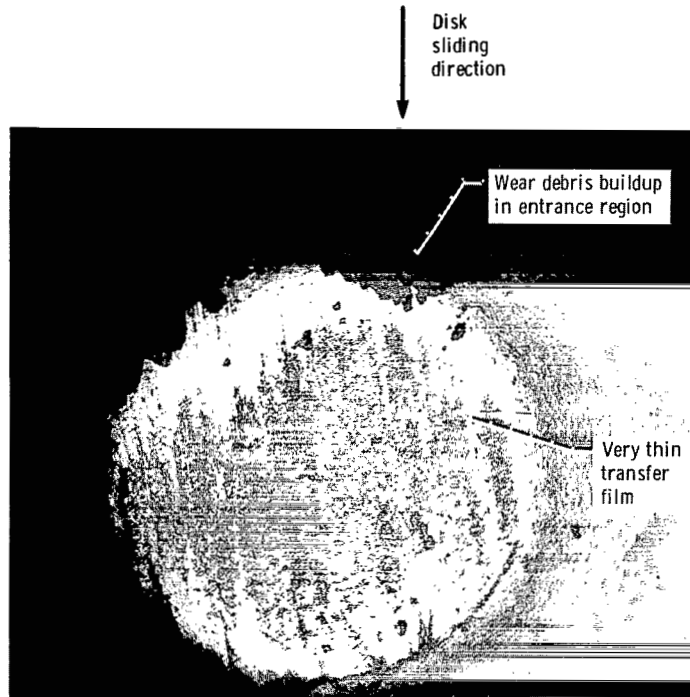

(a) Sliding duration, 1 kilocycle.

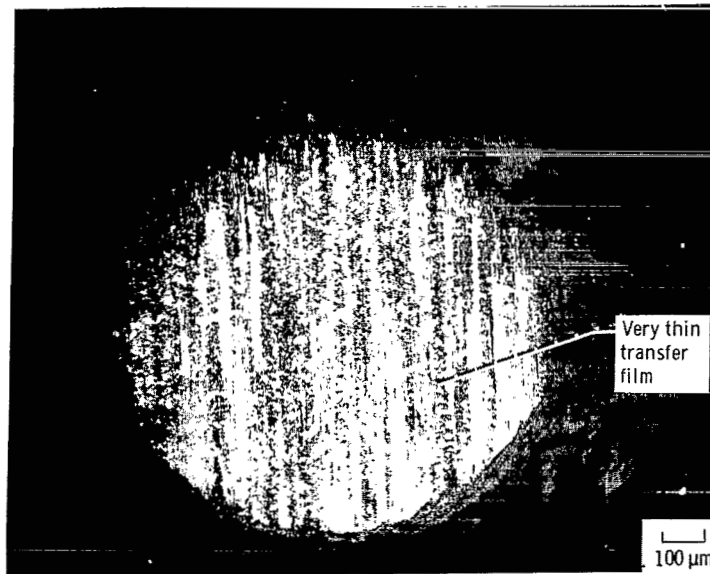

(b) Sliding duration, 300 kilocycles.

Figure 11. - Photomicrographs of transfer film to 0.0071-cm^2 -area flat after sliding on PIC-2 film for 1 and 300 kilocycles.

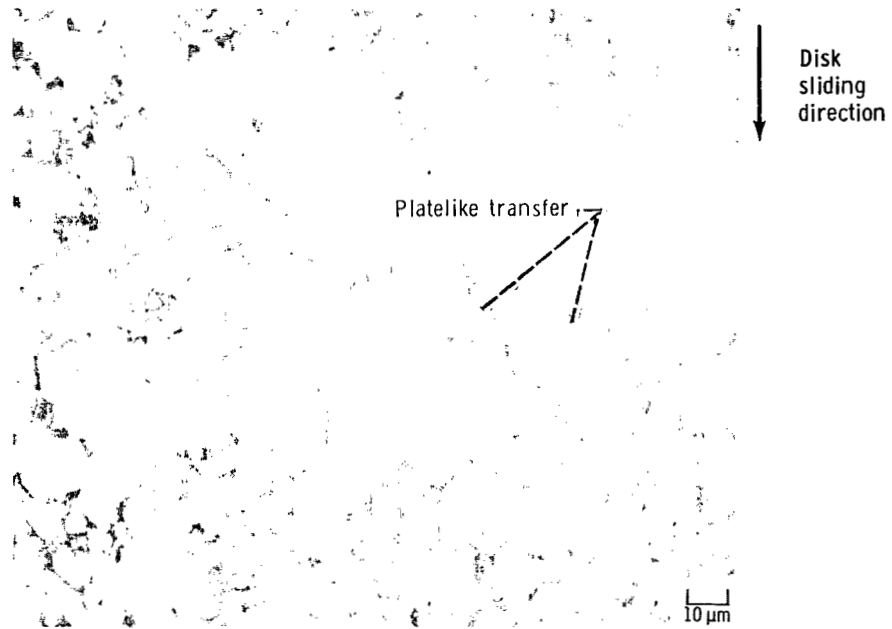

(a) Sliding duration, 1 kilocycle.

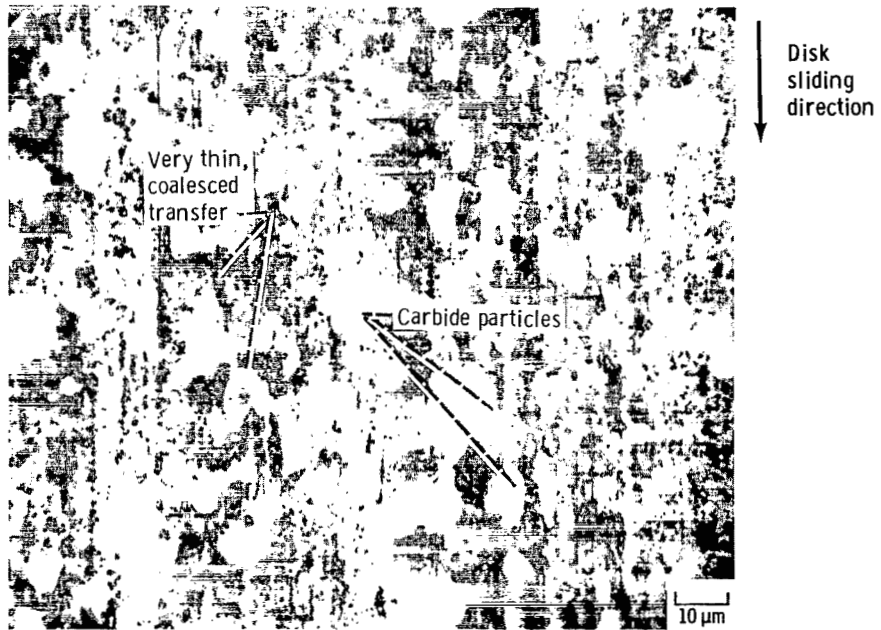

(b) Sliding duration, 300 kilocycles.

Figure 12. - High-magnification photomicrographs of contact areas shown in figure 11 of transfer to 0.0071-cm²-area flat after sliding on PIC-2 film for 1 and 300 kilocycles.

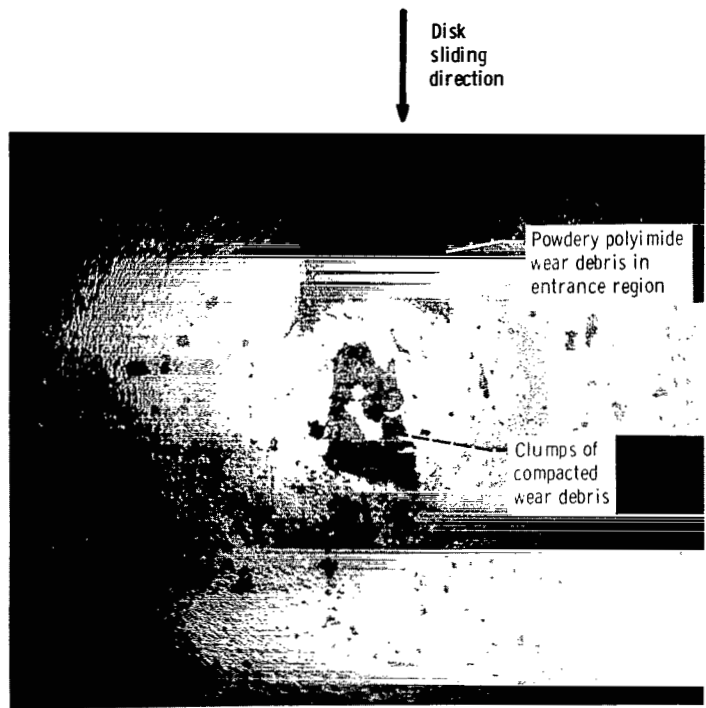

(a) Sliding duration, 1 kilocycle.

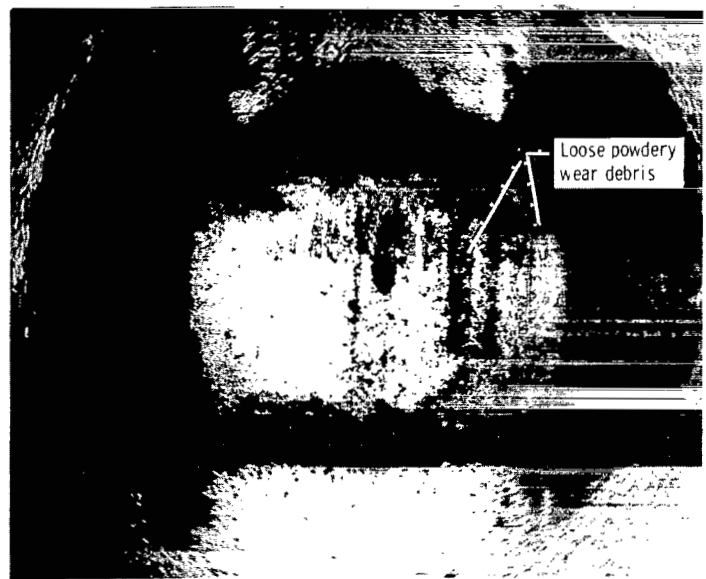

(b) Sliding duration, 60 kilocycles.

Figure 13. - Photomicrographs of transfer to hemispherically tipped riders after sliding on PIC-5 film for 1 and 60 kilocycles.

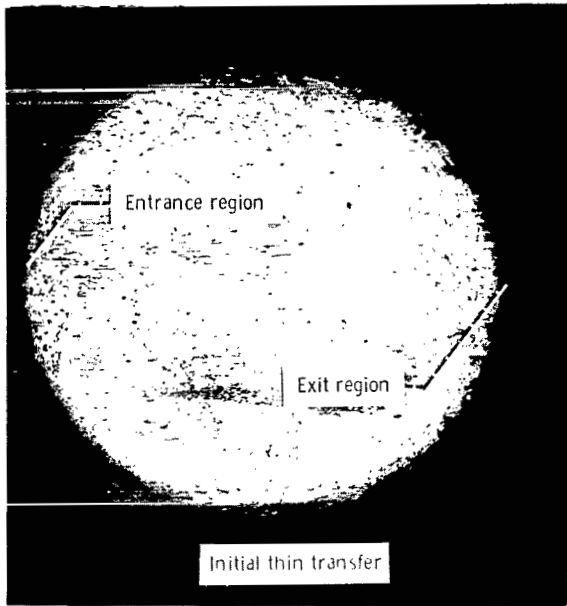

(a) Sliding duration, 1 kilocycle.

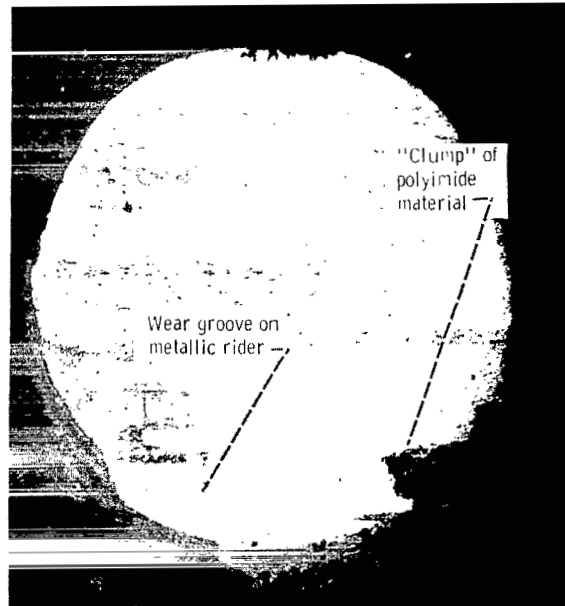

(b) Sliding duration, 300 kilocycles.



(c) Sliding duration, 600 kilocycles.

Figure 14. - Photomicrographs of transfer and wear to 0.011-cm²-area flat after sliding on PIC-3 film for 1, 300, and 600 kilocycles.

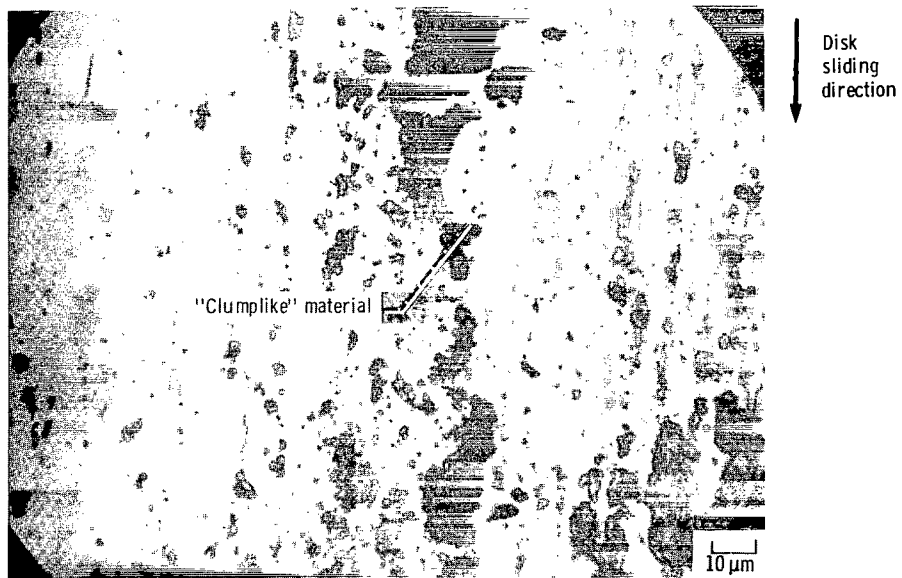

(a) Sliding duration, 60 kilocycles.



(b) Sliding duration, 600 kilocycles.

Figure 15. - High-magnification photomicrographs of transfer to 0.011-cm²-area flat after sliding on PIC-3 film for

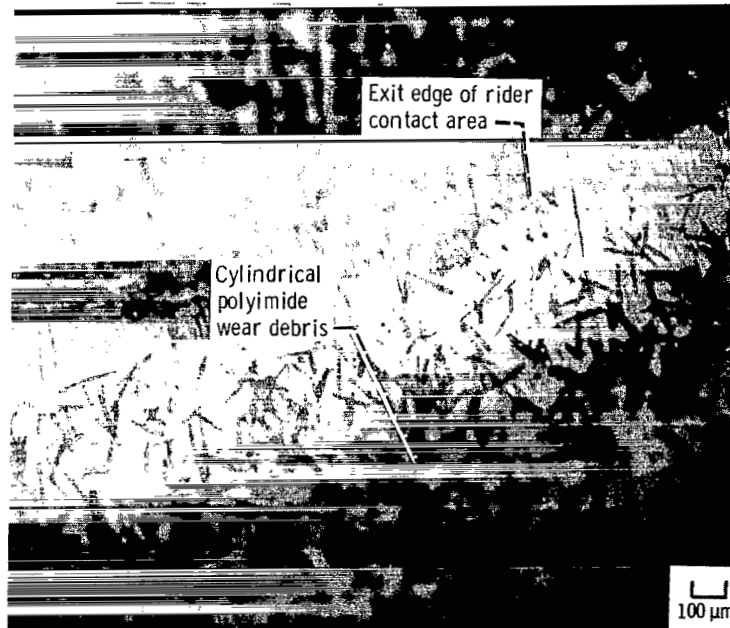

(a) Exit region of rider contact area.

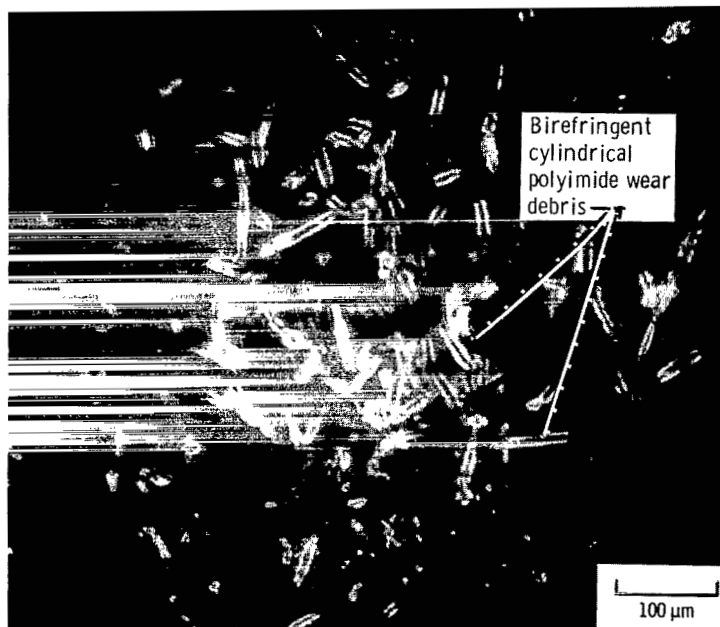

(b) Region outside film wear track.

Figure 16. - High-magnification photomicrographs of exit region of rider contact area and region outside of film wear track, showing cylindrically shaped wear particles produced during initial stages of sliding on most of the polyimide films.

they grow thicker and larger. The thickness of the clumps in figure 15(b) after 600 kilocycles is 3 to 4 micrometers.

Cylinder or Roll Formation

Aharoni (ref. 16) has proposed that some rigid polymers can wear by a process termed "roll formation." This type of wear particle was also observed for most of the polyimides in this study; however, they only occurred during the initial stages of sliding (<1 kilocycle). Figure 16(a) shows cylindrical polyimide wear particles in the exit region of the rider, and figure 16(b) shows them in a region outside the wear track. Figure 16(b), which was taken between crossed polaroid filters, shows that the cylinders are birefringent and thus anisotropic.

Figure 16(a) suggests that one source of cylinder production is the transfer film on the rider. As the transfer film leaves the contact area, it tends to break off and roll up to form a cylinder. Another possible source of cylinders is the surface of the cured polyimide film. Initial passes over this film may cause the production of cylinders as Aharoni (ref. 16) proposes. However, after very short sliding distances the surface changes (transfer films are produced, the film surface loses its smooth character, etc.) and the conditions are not suitable for cylinder production.

Summary of Results

Tribological studies at 25° C of seven polyimide films applied to 440C high-temperature stainless steel substrates had the following results:

1. The polyimides fell into two groups according to friction and wear properties.

a. Group I: Lower friction, higher wear polyimide types PIC-1, PIC-4, and PIC-7

b. Group II: Higher friction, lower wear polyimide types PIC-2, PIC-3, PIC-5, and PIC-6

2. The wear mechanism for most of the polyimides was adhesion, but the adhesive wear particles of group I polyimides were larger than those of group II polyimides.

3. Group I polyimides tended to spall from the wear track, an indication that they were more brittle than group II polyimides.

4. In general, the film wear rates for group I polyimides tended to increase with decreasing contact stress, but those for group II polyimides tended to decrease with decreasing contact stress.

5. Most of the polyimides produced thick transfer films that consisted of compacted polyimide wear

particles. These wear particles tended to slide across the rider contact area rather than to flow plastically, and after long sliding durations they tended to wear the metallic rider. One exception, however, was the polyimide PIC-2; this polyimide produced thin plastically flowing transfer films.

6. During the initial stages (1 kilocycle) of sliding, birefringent cylindrical wear particles were observed. These may have been produced by the "rolling up" of a thin surface layer of the polyimide film or from the polyimide transfer film rolling up as it flowed across and out of the rider contact area.

Lewis Research Center
National Aeronautics and Space Administration
Cleveland, Ohio, April 16, 1981

References

1. Fusaro, Robert L.: Effect of Thermal Exposure on Lubricating Properties of Polyimide Films and Polyimide-Bonded Graphite Fluoride Films. NASA TP-1125, 1978.
2. Fusaro, Robert L.: Effect of Thermal Aging on the Tribological Properties of Polyimide Films and Polyimide-Bonded Graphite Fluoride Films. NASA TM-79045, 1979.
3. Fusaro, Robert L.; and Sliney, Harold E.: Lubricating Characteristics of Polyimide Bonded Graphite Fluoride and Polyimide Thin Films. ASLE Trans., vol. 16, no. 3, July 1973, pp. 189-196.
4. Fusaro, Robert L.; and Sliney, Harold E.: Graphite Fluoride as a Solid Lubricant in a Polyimide Binder. NASA TN D-6714, 1972.
5. Todd, N. W.; and Wolff, F. A.: Polyimide Plastics Withstand High Temperature: Mater. Des. Eng., vol. 60, no. 2, Aug. 1964, pp. 86-91.
6. Sroog, C. E.; et al.: Aromatic Polypyromellitimides from Aromatic Polyamic Acids. J. Polymer Sci., Pt. A., vol. 3, no. 4, 1965, pp. 1373-1390.
7. Heacock, J. F.; and Berr, C. E.: Polyimides—New High Temperature Polymers: H-Film, A Polypyromellitimide Film. SPE Trans., vol. 5, no. 2, Apr. 1965, pp. 105-110.
8. Adrova, N. A.; et al.: Polyimides: A New Class of Thermally Stable Polymers. Progress in Materials Science Series, Vol. 7, Technomic Publishing Co., Inc., 1970.
9. Devine, M. J.; and Kroll, A. E.: Aromatic Polyimide Compositions for Solid Lubrication. Lubr. Eng., vol. 20, no. 6, June 1964, pp. 225-230.
10. Freeman, James H.; et al.: Resins and Reinforced Plastic Laminates for Continuous Use at 650° F. SPE Trans., vol. 5, no. 2, 1965, pp. 75-83.
11. Fusaro, Robert L.: Polyimide Film Wear—Effect of Temperature and Atmosphere. NASA TN D-8231, 1976.
12. Fusaro, Robert L.: Effect of Atmosphere and Temperature on Wear, Friction and Transfer of Polyimide Films. ASLE Trans., vol. 21, no. 2, Apr. 1978, pp. 125-133.
13. Fusaro, Robert L.: Lubrication and Wear Mechanisms of Polyimide-Bonded Graphite Fluoride Film Subjected to Low Contact Stress. NASA TP-1584, 1980.
14. Fusaro, Robert L.: Lubrication and Wear Mechanisms for a Hemisphere Sliding on Polyimide-Bonded Graphite Fluoride Film. NASA TP-1524, 1979.
15. Bowden, F. P.; and Tabor, D.: The Friction and Lubrication of Solids. Oxford University Press (London), 1950.
16. Aharoni, S. M.: Wear of Polymers by Roll-Formation. Wear, vol. 25, 1973, pp. 309-327.

1. Report No. NASA TP-1944	2. Government Accession No.	3. Recipient's Catalog No.
4. Title and Subtitle TRIBOLOGICAL PROPERTIES AT 25⁰ C OF SEVEN POLYIMIDE FILMS BONDED TO 440C HIGH-TEMPERATURE STAINLESS STEEL	5. Report Date February 1982	6. Performing Organization Code 505-32-42
7. Author(s) Robert L. Fusaro	8. Performing Organization Report No. E-758	10. Work Unit No.
9. Performing Organization Name and Address National Aeronautics and Space Administration Lewis Research Center Cleveland, Ohio 44135	11. Contract or Grant No.	13. Type of Report and Period Covered Technical Paper
12. Sponsoring Agency Name and Address National Aeronautics and Space Administration Washington, D. C. 20546	14. Sponsoring Agency Code	
15. Supplementary Notes		
16. Abstract The tribological properties of seven polyimide films applied to 440C high-temperature stainless steel substrates were studied at 25 ⁰ C with a pin-on-disk type of friction and wear apparatus. The polyimides fell into two groups according to friction and wear properties. Group I polyimides had slightly lower friction but much higher wear than group II polyimides. The wear mechanism was predominately adhesion, but the wear particles were larger for group I polyimides. For most of the polyimides the transfer films consisted of "clumps" of compacted wear particles. One polyimide composition produced a very thin transfer film that sheared plastically in the contact area.		
17. Key Words (Suggested by Author(s)) Polyimides; Solid lubricants; Wear mechanisms; Polymer friction; Transfer films; Bond film lubricant	18. Distribution Statement Unclassified - unlimited STAR Category 27	
19. Security Classif. (of this report) Unclassified	20. Security Classif. (of this page) Unclassified	21. No. of Pages 21
		22. Price* A02

* For sale by the National Technical Information Service, Springfield, Virginia 22161

National Aeronautics and
Space Administration

Washington, D.C.
20546

Official Business

Penalty for Private Use, \$300

THIRD-CLASS BULK RATE

Postage and Fees Paid
National Aeronautics and
Space Administration
NASA-451



4 1 15,0, 020482 80090305
DEPT OF THE AIR FORCE
AF WEAPONS LABORATORY
ATTN: TECHNICAL LIBRARY (SUL)
KIRTLAND AFB TX 77117

NASA

POSTMASTER:

If Undeliverable (Section 158
Postal Manual) Do Not Return