

3 1176 01351 8734

*ISM*  
NASA TM-82805

NASA Technical Memorandum 82805

NASA-TM-82805 19820014124

# A Preliminary Comparison Between the SR-3 Propeller Noise in Flight and in a Wind Tunnel

James H. Dittmar  
*Lewis Research Center  
Cleveland, Ohio*

and

Paul L. Lasagna  
*Hugh L. Dryden Flight Research Center  
Edwards, California*

Prepared for the  
One hundred third Meeting of the Acoustical Society of America  
Chicago, Illinois, April 27-30, 1982



LIBRARY COPY  
DEC 18 1986  
LANGLEY RESEARCH CENTER  
LIBRARY, NASA  
HAMPTON, VIRGINIA



A PRELIMINARY COMPARISON BETWEEN THE SR-3  
PROPELLER NOISE IN FLIGHT AND IN A WIND TUNNEL

James H. Dittmar  
Lewis Research Center  
Cleveland, Ohio

and

Paul L. Lasagna  
Hugh L. Dryden Flight Research Center  
Edwards, California

SUMMARY

The noise generated by supersonic-tip-speed propellers is a possible cabin environment problem for future airplanes powered by these propellers. Models of such propellers were previously tested for acoustics in the Lewis 8-by-6-foot wind tunnel. One of these propeller models, SR-3, has now been tested in flight on the Dryden Jetstar airplane and noise data have been obtained.

Preliminary comparisons of the maximum blade passing tone variation with helical tip Mach number taken in flight with those taken in the tunnel showed good agreement when corrected to the same test conditions. This indicates that the wind tunnel is a viable location for measuring the noise of these propeller models. Comparisons of the directivities at 0.6 and 0.7 axial Mach number showed reasonable agreement. At 0.75 and 0.8 axial Mach number the tunnel directivity data fell off more towards the front than did the airplane data. A possible explanation for this difference is boundary layer refraction which could be different in the wind tunnel from that in flight. This may imply that some corrections should be applied to both the airplane and wind tunnel data at the forward angles. At and aft of the peak noise angle the boundary layer refraction does not appear to be significant and no corrections appear necessary.

INTRODUCTION

One of the possible propulsive systems for a future energy-efficient airplane is a high-tip-speed turboprop. When the turboprop airplane is at cruise, the combination of airplane forward speed and the propeller rotational speed results in supersonic velocities over the outer portions of the propeller blades that may create a cabin noise environment problem for the airplane at cruise. Three models of this type of propeller have been previously tested for noise in the NASA Lewis 8-by-6-foot wide tunnel (refs. 1 to 3). This wind tunnel does not have acoustic damping material on its walls and there has been a concern that this lack of acoustic material may have compromised the noise data.

As part of the program to evaluate the noise of these propellers the NASA Dryden Jetstar airplane was modified to test these propellers in flight. The SR-3 propeller was the first one tested on this airplane and preliminary noise data have been obtained. The intent of this paper is to make a preliminary comparison between the noise measured on the Jetstar

E-1144

N82-21998 #



airplane and that previously obtained in the 8-by-6-foot wind tunnel to assess the validity of the tunnel for conducting such acoustic experiments.

#### APPARATUS AND PROCEDURE

The eight-bladed propeller model used in these noise comparisons was the SR-3 propeller. This propeller model is nominally 0.622 meter (24.5 in.) in diameter. Table I shows some of its design characteristics and more information is available in references 4 and 5. A picture of the propeller in the 8-by-6-foot wind tunnel can be seen in figure 1(a) and on the Jetstar airplane in figure 1(b).

To measure the propeller noise, pressure transducers were installed in the wind tunnel bleed holes visible in figure 1(a). The locations of these transducers are shown in figure 2(a). The positions are identified as A thru E, as in reference 3, and are located on the top wall of the wind tunnel which is approximately one and one-half propeller diameters above the propeller tip. On the Jetstar airplane microphones were installed flush in the airplane fuselage which is approximately eight-tenths of a propeller diameter from the propeller tip. The propeller axis is tipped three degrees downward on the airplane to align it with the flow. The microphones on the airplane were installed along a line directly underneath the propeller centerline. The locations of the microphones reported herein are numbered 1 thru 9 as can be seen in figure 2(b).

In the wind tunnel the propeller was operated at its design blade setting angle of 61.3 degrees. The propeller was tested at nominal tunnel axial Mach numbers,  $M$ , of 0.85, 0.80, 0.75, 0.70, and 0.6. (A list of symbols is in the Appendix.) These tests were all performed at a nominally constant advance ratio,  $J$ , of 3.06. The results are reported in reference 3.

A large amount of data at different conditions were taken on the Jetstar airplane. The intent of this paper was to compare the same test points on the airplane as in the wind tunnel but drive system limitations on the airplane forced some different test points. At a 61.5 degree blade setting angle,  $\beta$ , the propeller was tested on the airplane at nominal Mach numbers,  $M$ , of 0.80, 0.75, 0.70, and 0.60. At Mach 0.60 the propeller advance ratio was 3.00 and at Mach 0.70 the advance ratio was 3.05. However, at the Mach 0.75 and 0.80 conditions, a power limitation prevented the tests from being performed near the desired advance ratio of 3.06. At  $M = 0.75$  the advance ratio tested was 3.31 and at  $M = 0.80$  it was 3.39. These higher advance ratios mean that the propeller rotational speed was not as high as desired and resulted in helical tip Mach numbers,  $M_H$ , lower than those tested in the tunnel. Propeller tests were also performed on the airplane at a 59.3 degree blade setting angle. This setting angle produced less loading on the blades and allowed the drive system to rotate the propeller nearer to the design advance ratio. With the 59.3 degree blade setting angle the propeller was tested at an advance ratio of 3.13 at a nominal  $M = 0.75$ , 3.02 at  $M = 0.70$  and 3.12 at  $M = 0.60$ . The noise data from both of these blade setting angles is used in the comparisons. The airplane was flown at a nominal altitude of 9.1 km (30 000 ft.) for the test points reported.

The signals from the pressure transducers and microphones were recorded on magnetic tape and narrowband spectra from 0 to 10 000 Hz, with a bandwidth of approximately 26 Hz, were taken for each of the test points. For the purposes of this preliminary report only the blade passing tone levels



have been taken from these spectra and all of the figures in this report show blade passing tone levels only. The blade passing tone levels for the tunnel tests previously reported in reference 3, are repeated in Table II. The blade passage tone levels measured on the Jetstar airplane are compiled in Table III.

## RESULTS AND DISCUSSIONS

### Variation with Helical Tip Mach Number

The maximum measured blade passing tone levels on the top wall of the wind tunnel are plotted as a function of helical tip Mach number,  $M_H$ , (vector sum of axial and rotational Mach numbers) in figure 3(a). This plot is taken from reference 3 and the propeller advance ratio for all of these data points was at a nominal value of 3.06. A curve has been fit to the data points and is seen to rise sharply between the helical tip Mach numbers of 0.8 and 1.0 and then to level off at helical tip Mach numbers over 1.1.

The same plot for the maximum measured blade passing tone levels on the airplane fuselage as a function of helical tip Mach number is shown in figure 3(b). Here two data sets are plotted, one for the propeller at 61.5 degree setting angle and the other at 59.3 degree setting angle. The two airplane curves show generally the same shape as that measured in the wind tunnel with a sharp rise and then a levelling off at higher helical tip Mach numbers.

The noise of these types of propellers is generally viewed as being produced by two mechanisms referred to as thickness and loading. The thickness (or volume) noise results from the displacement of the air by the blade and the loading noise results from the action of the blade forces upon the air. At the lower end of the curves in figure 3(b) the loading noise seems to dominate with the more highly loaded 61.5 degree setting angle exceeding that at the more lightly loaded 59.3 degree angle. At the higher end of the curve, where thickness noise may dominate, the two curves are very close together as would be expected since the thickness noise at the two setting angles would be similar.

The magnitudes of the noise measured in the wind tunnel and in flight, shown in figure 3, are not the same since the experimental conditions were different. There are two primary differences; atmospheric conditions and geometry. The airplane tests were performed at 9.1 km (30 000 ft.) where the air is less dense than in the wind tunnel tests. As shown in reference 6, to correct for this, the wind tunnel data should be changed by twenty times the log of the ratio of the atmospheric pressure in flight to that in the tunnel. Since at each axial Mach number in the tunnel the pressure is different, this correction results in reductions in the tunnel noise of 9.51 decibels at an axial Mach number of 0.6, 9.02 at 0.7, 8.56 at 0.75, 7.97 at 0.8, and 7.45 at 0.85. The geometric conditions are also different between the tunnel and flight tests. In the tunnel the propeller tips are 1.5 propeller diameters from the wall of the wind tunnel while in flight they are 0.8 diameter from the fuselage. Because, in both cases, the measurement locations are so close to the source, the noise does not necessarily meet farfield conditions. Therefore the proper correction for distance is somewhat uncertain. Reference 7 has suggested that a distance correction of 15 times the log of the distance ratio be used instead of the normal farfields correction of 20 times the log. The 15 log correction is



used here and as will be seen brings the two sets of data into close agreement. It should be noted, however, that the standard 20 log correction gives a value only one decibel different. The difference between the two, 15 log and 20 log, is too small to determine which is the correct one to apply to the data. Taking the distance from the measurement location to the tangent point on the propeller tip circle gives a distance correction of 3.1 decibels. (No correction was made for the slightly different distances to each microphone location that result from the three degree tilt of the propeller.) The combination of altitude and distance corrections reduces the wind tunnel data by 6.4 decibels at an axial Mach number of 0.6, 5.9 at 0.70, 5.5 at 0.75, 4.9 at 0.80, and 4.4 at 0.85.

These corrections are applied to the curve that was fit to the tunnel data and placed on the same plot as the Jetstar data, in figure 4. The comparison of the curve of maximum blade passage tone levels measured in the wind tunnel (corrected to flight conditions) with the flight curves, shown in figure 4, is very good. At the higher helical tip Mach numbers tested the corrected wind tunnel and flight values are almost identical. At the lower helical tip Mach numbers the corrected wind tunnel data is slightly lower, less than 1 dB, than the 61.5° blade setting angle data taken on the airplane. The slight difference is probably well within the expected data error of the two experiments. This preliminary comparison between the corrected wind tunnel and flight data indicates that the wind tunnel is a viable location for determining the maximum blade passage noise of these types of propellers at high speed flight conditions.

#### Directivity

To further compare the data taken in the wind tunnel with that taken in flight, directivities along the wall have been plotted in figure 5. A straight line was used to connect the data points and no attempt was made to fit the data points with a curve. These directivity comparisons in figure 5 are taken at four different axial Mach numbers, 0.6, 0.7, 0.75, and 0.80 and the wind tunnel data are corrected to flight conditions as before. Since the conditions were not exactly the same for the propeller tested in flight as they were in the tunnel, having different loadings or different advance ratios, the directivities are not expected to be identical but should be relatively close and have similar shapes.

Figure 5(a) is a comparison of the directivities at an axial Mach number of 0.6. As can be seen, the general shape comparison of the directivities is good. The two sets of data show the noise dip around 100° which may be an indication of a lobed pattern as mentioned previously in reference 3 and they generally have the same fall off toward the front. The tunnel curve is a little higher than the 61.5° airplane curve because the propeller was operated at a higher helical tip Mach number in the tunnel and the tunnel is higher than the 59.3° airplane data because of the higher propeller loading. (See figs. 3 and 4 and Tables II and III).

Figure 5(b) is a comparison at the axial Mach number of 0.70. Here again the tunnel and flight directivities appear to be in good agreement. The dip around 100° is present in all of the data and the rate of fall off to the front and to the rear is similar. The airplane data at 59.3° shows the same general shape as the tunnel data but is slightly higher in level, probably because it was taken at a higher helical tip Mach number.

The tunnel and airplane directivities at axial Mach numbers of 0.75 and 0.80 show some differences. On each of these figures, 5(c) and (d), the directivities near the peak noise, 110°, are similar and the fall off



for angles greater than  $110^\circ$  is similar. (The one data point which is different in this region,  $M = 0.75$ ,  $61.5^\circ$  at the  $107^\circ$  angle is possibly 5 dB low because of a gain setting error but this cannot be confirmed.)

Significant differences in the directivity between the wind tunnel and flight curves exist at forward angles. At  $M = 0.75$  and  $0.80$ , the data taken in the wind tunnel falls off considerably faster toward the front than the airplane data. An explanation of the fall off has been suggested by Hanson, reference 8. Hanson has suggested that significant reductions in the forward radiated noise measured at the wall are caused by the wall boundary layer. The amount of reduction increases with increasing Mach number, with increasing boundary layer thickness, and as the measuring point moves forward. This phenomena would apply to both the Jetstar and wind tunnel data. The observations relative to the data at  $0.75$  and  $0.80$  axial Mach number (figs. 5(c) and (d)) suggest that the wind tunnel boundary layer is thicker than the Jetstar fuselage boundary layer and would thus account for the more rapid fall off of the tunnel data.

It should be noted here that this possible boundary layer refraction does not affect the data at and aft of the peak angle (around  $110^\circ$ ) since the two sets of data, with apparently different amounts of refraction, show the same peak values (see fig. 4). This would indicate that even though some corrections for boundary layer refraction may be needed on both the airplane and tunnel data at the forward angles, the peak blade passage tones values, at and aft of the peak angle (around  $110^\circ$ ), do not require corrections. This conclusion can also be drawn from the theoretical refraction results of reference 8.

#### CONCLUDING REMARKS

Preliminary noise data taken with the SR-3 propeller model flown on the NASA Dryden Jetstar airplane were compared with data taken previously in the NASA Lewis 8-by-6-foot wind tunnel. Comparisons of the maximum blade passing tone variations with helical tip Mach number showed good agreement when the tunnel data were corrected to the flight test conditions. This indicated that the wind tunnel is a viable location for obtaining peak noise data on these propellers.

Comparisons of the directivities taken in the tunnel and in flight showed fairly good agreement at axial Mach numbers of  $0.6$  and  $0.7$ . However at axial Mach numbers of  $0.75$  and  $0.80$  the tunnel data fell off more rapidly toward the front than did the airplane data. A possible explanation for this is that boundary layer refraction causes the noise to be lower at these forward locations. This boundary layer refraction could be present on both the airplane and in the tunnel and different boundary layer thicknesses could result in different directivities. This would point to a possible need for a correction to both the flight data, as suggested by Hanson, and to the wind tunnel data at the forward angles. This boundary layer refraction does not appear to affect the noise data at and aft of the peak angle since both the wind tunnel and flight tests show that same values. Therefore it does not appear that the corrections to the values are necessary for data at and aft of the peak. The directivity comparison suggests that the wind tunnel can yield meaningful directivity data as well as peak noise data and that it is an appropriate facility for the determination of near-field noise of supersonic propellers operating at high subsonic cruise Mach numbers.



## APPENDIX

- D propeller diameter
- J advance ratio,  $J = V/ND$
- M axial Mach number
- $M_H$  helical tip Mach number (vector sum of tip rotational and axial Mach numbers)
- N propeller rotational speed (revolutions/time)
- V axial velocity
- Z axial distance from propeller plane (positive downstream)
- $\beta$  blade setting angle at 0.75 radius with respect to plane of rotation
- $e$  angle with respect to propeller axis

## REFERENCES

1. J. H. Dittmar, B. J. Blaha, and R. J. Jeracki, "Tone Noise of Three Supersonic Helical Tip Speed Propellers in a Wind Tunnel at 0.8 Mach number," NASA TM-79046 (1978).
2. J. H. Dittmar, R. J. Jeracki, and B. J. Blaha, "Tone Noise of Three Supersonic Helical Tip Speed Propellers in a Wind Tunnel," NASA M-79167 (1979).
3. J. H. Dittmar, R. J. Jeracki, "Additional Noise Data on the SR-3 Propeller," NASA TM-81736 (1981).
4. J. F. Dugan, B. A. Miller, and D. A. Sagerser, "Status of Advanced Turboprop Technology," CTOL Transport Technology, 1978 (NASA CP-2036, Pt.1), pp. 139-166 (1978).
5. R. J. Jeracki, D. C. Mikkelson, and B. J. Blaha, "Wind Tunnel Performance of Four Energy Efficient Propellers Designed for Mach 0.8 Cruise," NASA TM-79124 (1979).
6. J. D. Revell and R. H. Tullis, "Fuel Conservation Merits of Advanced Turboprop Transport Aircraft," LR-28283, Lockheed-California Company, Burbank, Calif. (August 1977). (NASA CR-152096).
7. "Energy Consumption Characteristics of Transports Using the Prop-Fan Concept," D6-75780, Boeing Commercial Airplane Co. Seattle, Wash. (1976). (NASA CR-137937).
8. D. B. Hanson, "Shielding of Prop-Fan Noise by the Fuselage Boundary Layer," HSER-8165, Hamilton Standard, Windsor Locks, Conn. (August 1981).

TABLE I. - SR-3 PROPELLER CHARACTERISTICS

Design cruise tip speed, m/sec (ft/sec) . . . . .	244 (800)
Design cruise power loading, kW/m <sup>2</sup> (shp/ft <sup>2</sup> ) . . . . .	301 (37.5)
Number of blades . . . . .	8
Geometric tip sweep, deg . . . . .	45
Predicted design efficiency, percent . . . . .	81
Nominal diameter, D, cm (in.) . . . . .	62.2 (24.5)



TABLE II. - PROPELLER BLADE PASSING TONE MEASURED IN 8-BY-6-FOOT WIND TUNNEL

Test conditions				Transducer position				
Blade setting angle	Tunnel Mach number	Propeller advanced ratio	Propeller helical tip Mach no.	A	B	C	D	E
61.3°	0.60	3.06	0.86	126.0	129.0	126.0	128.0	(a)
	.70	3.06	1.0	131.5	139.0	133.5	139.0	129.0
	.75	3.06	1.08	129.0	140.0	138.5	146.0	128.5
	.80	3.06	1.14	128.0	138.0	136.0	143.0	130.0
	.85	3.05	1.21	(a)	139.0	(a)	145.5	(a)

aNo data available.

TABLE III. - PROPELLER BLADE PASSING TONE MEASURED ON JETSTAR AIRPLANE

Test conditions				Microphone position								
Blade setting angle	Airplane Mach number	Propeller advance ratio	Propeller helical tip Mach no.	1	2	3	4	5	6	7	8	9
61.5°	0.584	3.00	0.83	Not operating	104.0	113.5	118.0	121.5	120.5	121.5	112.5	110.0
	.684	3.05	.97	"	117.0	124.0	127.5	132.0	131.0	132.0	122.0	118.0
	.750	3.32	1.03	"	121.0	129.0	131.5	136.0	132.5	132.5	128.5	123.0
	.800	3.39	1.09	"	120.0	131.0	132.5	135.5	134.5	138.0	132.5	126.5
59.3°	.610	3.12	.87	"	104.0	112.0	116.5	120.0	117.5	120.5	111.5	109.5
	.716	3.02	1.03	"	120.5	128.5	132.0	136.0	133.5	134.0	129.5	121.0
	.755	3.06	1.08	"	124.0	130.5	132.5	135.0	134.0	137.5	129.0	124.5
	.805	3.13	1.14	"	116.5	131.5	134.0	137.0	136.0	139.0	135.0	126.0



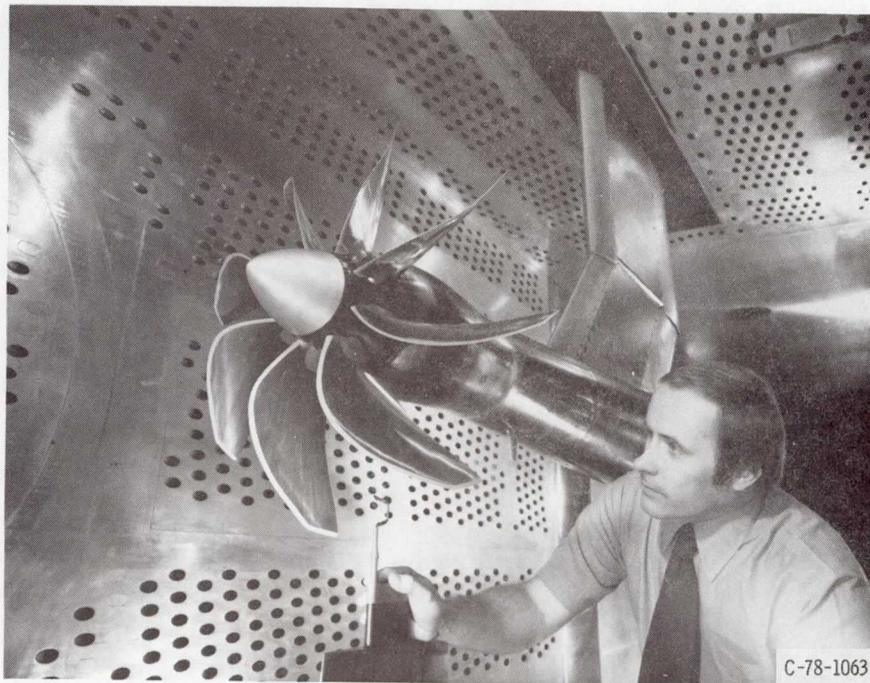

(a) PROPELLER IN 8- BY 6-FOOT WIND TUNNEL.



(b) PROPELLER ON JETSTAR AIRPLANE.

Figure 1. - SR-3 propeller installation.



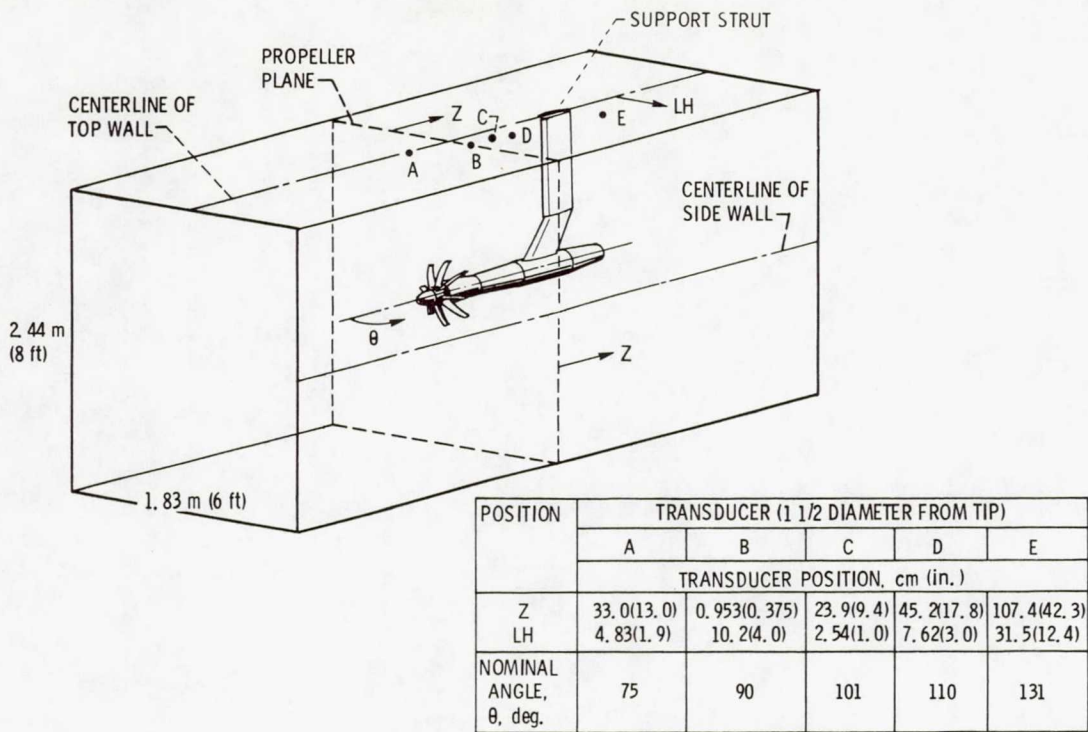

(a) Pressure transducers in 8-by-6 foot wind tunnel.

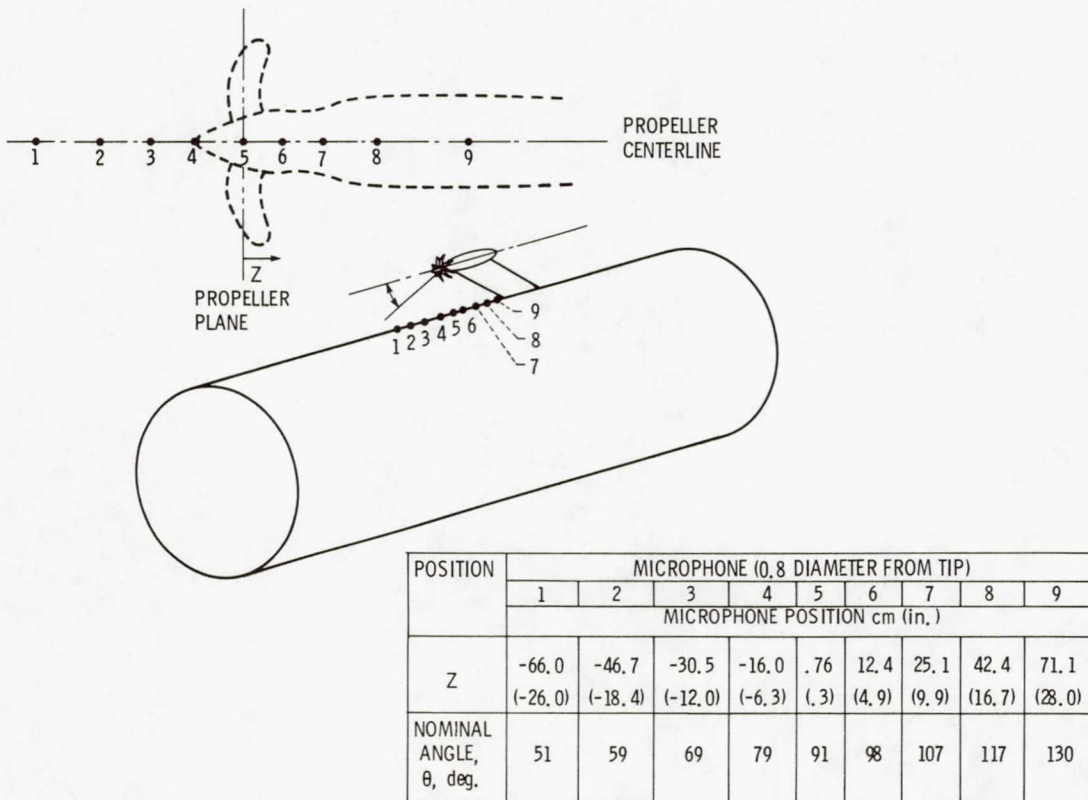

(b) Microphones on airplane.

Figure 2. - Measurement locations.



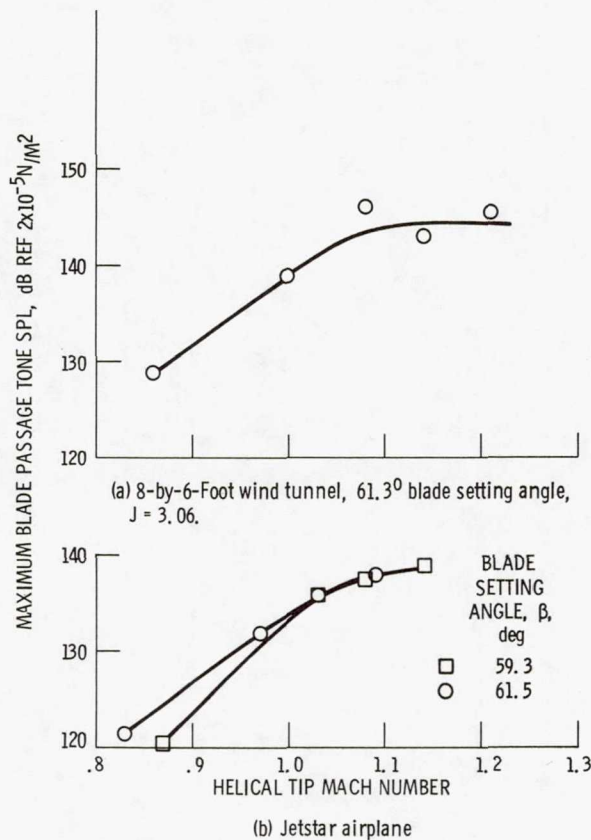

Figure 3. - Maximum blade passage tone variation with helical tip mach number.

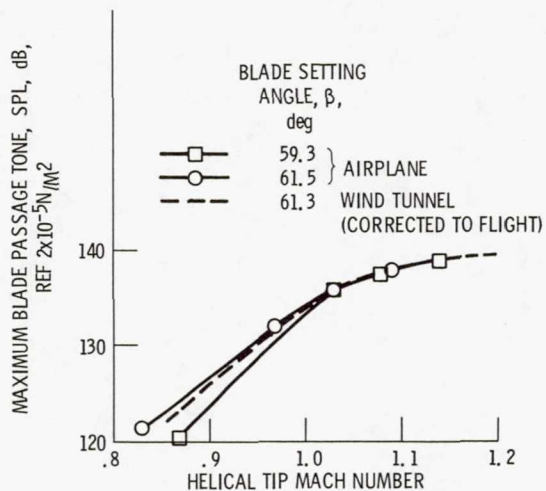

Figure 4. - Comparison of maximum blade passage tones from the wind tunnel and flight tests.



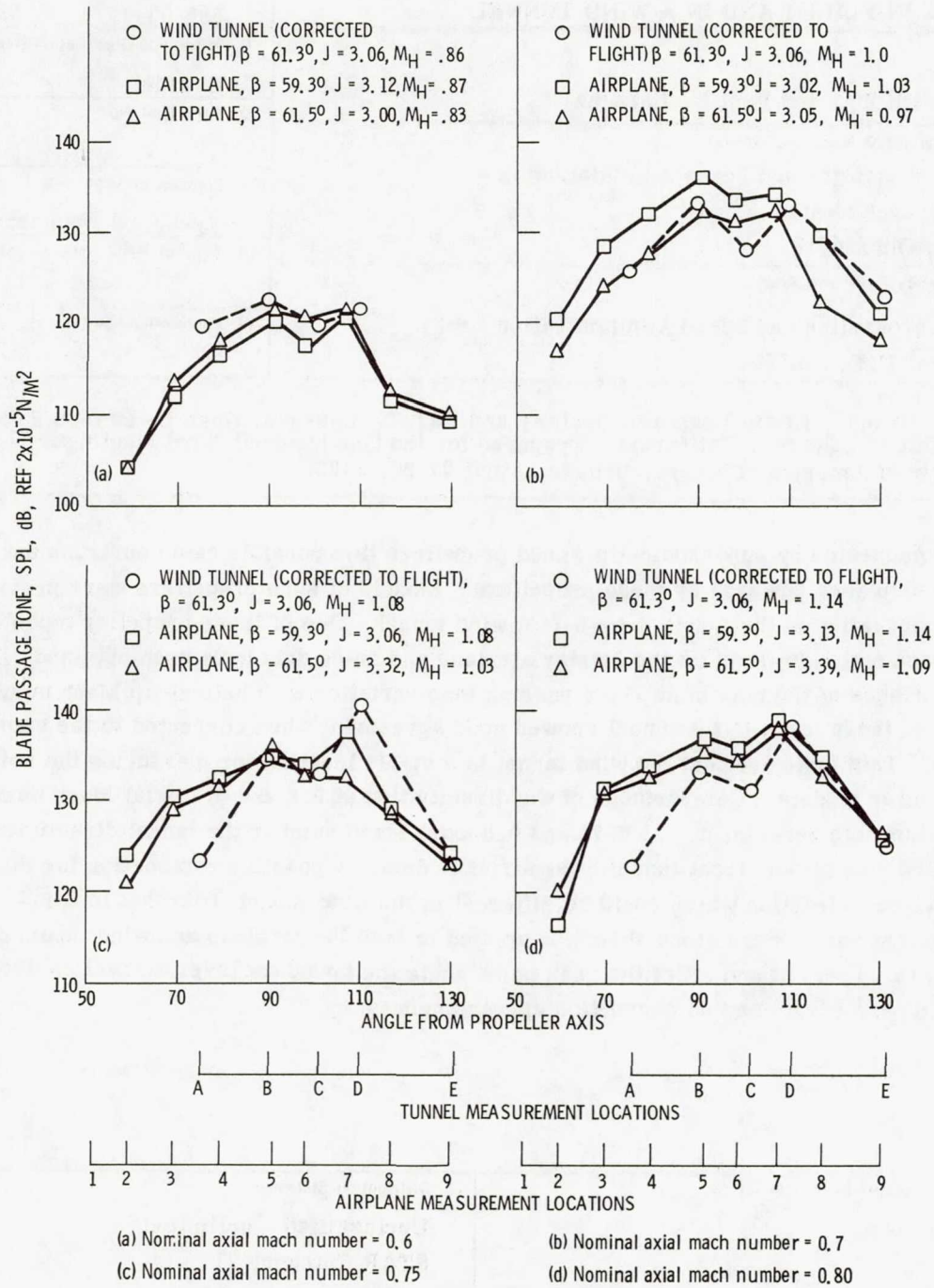

Figure 5. - Blade passing tone directivity



1. Report No. NASA TM-82805	2. Government Accession No.	3. Recipient's Catalog No.	
4. Title and Subtitle  A PRELIMINARY COMPARISON BETWEEN THE SR-3 PROPELLER NOISE IN FLIGHT AND IN A WIND TUNNEL		5. Report Date	
		6. Performing Organization Code 535-03-12	
7. Author(s)  James H. Dittmar and Paul L. Lasagna		8. Performing Organization Report No. E-1144	
		10. Work Unit No.	
9. Performing Organization Name and Address National Aeronautics and Space Administration Lewis Research Center Cleveland, Ohio 44135		11. Contract or Grant No. Technical Memorandum	
		13. Type of Report and Period Covered	
12. Sponsoring Agency Name and Address National Aeronautics and Space Administration Washington, D.C. 20546		14. Sponsoring Agency Code	
15. Supplementary Notes James H. Dittmar, Lewis Research Center; and Paul L. Lasagna, Hugh L. Dryden Flight Research Center, Edwards, California. Prepared for the One hundred third Meeting of the Acoustical Society of America, Chicago, Illinois, April 27-30, 1982.			
16. Abstract  The noise generated by supersonic-tip-speed propellers is a possible cabin environment problem for future airplanes powered by these propellers. Models of such propellers were previously tested for acoustics in the Lewis 8-by-6-foot wind tunnel. One of these propeller models, SR-3, has now been tested in flight on the Jetstar airplane and noise data have been obtained. Preliminary comparisons of the maximum blade passing tone variation with helical tip Mach number taken in flight with those taken in the tunnel showed good agreement when corrected to the same test conditions. This indicated that the wind tunnel is a viable location for measuring the noise of these propeller models. Comparisons of the directivities at 0.6 and 0.7 axial Mach number showed reasonable agreement. At 0.75 and 0.8 axial Mach number the tunnel directivity data fell off more towards the front than did the airplane data. A possible explanation for this is boundary layer refraction which could be different in the wind tunnel from that in flight. This may imply that some corrections should be applied to both the airplane and wind tunnel data at the forward angles. At and aft of the peak noise angle the boundary layer refraction does not appear to be significant and no correction appears necessary.			
17. Key Words (Suggested by Author(s)) Propeller noise Noise Supersonic tip speed		18. Distribution Statement Unclassified - unlimited STAR Category 71	
19. Security Classif. (of this report) Unclassified	20. Security Classif. (of this page) Unclassified	21. No. of Pages	22. Price*

\* For sale by the National Technical Information Service, Springfield, Virginia 22161



