

DOE/NASA/20320-39  
NASA TM-82804

DO NOT DESTROY  
RETURN TO LIBRARY

# Effect of Rotor Configuration on Guyed Tower and Foundation Designs and Estimated Costs for Intermediate Size Horizontal Axis Wind Turbines

G. R. Frederick  
University of Toledo

and

J. R. Winemiller and J. M. Savino  
National Aeronautics and Space Administration  
Lewis Research Center

25 JUN 1982  
MCDONNELL DOUGLAS  
RESEARCH & ENGINEERING LIBRARY  
ST. LOUIS

March 1982

Prepared for  
**U.S. DEPARTMENT OF ENERGY**  
**Conservation and Renewable Energy**  
**Division of Wind Energy Systems**

M82-13940

NATL AERONAUTICS AND SPACE ADM ; NASA-1M-0007

NOTICE

This report was prepared to document work sponsored by the United States Government. Neither the United States nor its agent, the United States Department of Energy, nor any Federal employees, nor any of their contractors, subcontractors or their employees, makes any warranty, express or implied, or assumes any legal liability or responsibility for the accuracy, completeness, or usefulness of any information, apparatus, product or process disclosed, or represents that its use would not infringe privately owned rights.

# **Effect of Rotor Configuration on Guyed Tower and Foundation Designs and Estimated Costs for Intermediate Size Horizontal Axis Wind Turbine**

G. R. Frederick  
University of Toledo  
Toledo, Ohio

and

J. R. Winemiller and J. M. Savino  
National Aeronautics and Space Administration  
Lewis Research Center  
Cleveland, Ohio 44135

March 1982

Work performed for  
U.S. DEPARTMENT OF ENERGY  
Conservation and Renewable Energy  
Division of Wind Energy Systems  
Washington, D.C. 20545  
Under Interagency Agreement DE-AI01-76ET20320

**Page intentionally left blank**

**Page intentionally left blank**

# CONTENTS

	<u>Page</u>
SUMMARY . . . . .	1
INTRODUCTION . . . . .	1
CONCEPT SELECTION . . . . .	2
DESIGN LOADS AND REQUIREMENTS . . . . .	4
DESIGN APPROACH . . . . .	5
DESIGN RESULTS . . . . .	8
COST METHODOLOGY . . . . .	9
DISCUSSION . . . . .	10
CONCLUSION . . . . .	11
APPENDIX A: Variation of guy tension with direction of wind -- no preload in guys . . . . .	13
APPENDIX B: Variation of guy tension with direction of wind -- preload in guys . . . . .	15
REFERENCES . . . . .	19

1

EFFECT OF ROTOR CONFIGURATION ON GUYED TOWER AND FOUNDATION  
DESIGNS AND ESTIMATED COSTS FOR INTERMEDIATE SIZE  
HORIZONTAL AXIS WIND TURBINES

G. R. Frederick\*, J. R. Winemiller\*\*,  
and J. M. Savino\*\*

SUMMARY

Three designs of a guyed cylindrical tower and its foundation for an intermediate size horizontal axis wind turbine generator are discussed. The primary difference in the three designs is the configuration of the rotor. Two configurations are two-blade rotors with teetering hubs - one with full span pitchable blades, the other with fixed pitch blades. The third configuration is a three-bladed rotor with a rigid hub and fixed pitch blades. In all configurations the diameter of the rotor is 38 meters and the axis of rotation is 30.4 meters above grade, and the power output is 200 kW and 400 kW. For each configuration the design is based upon for the most severe loading condition - either operating wind or hurricane conditions.

The diameter of the tower is selected to be 1.5 meters (since it was determined that this would provide sufficient space for access ladders within the tower) with guy rods attached at 10.7 meters above grade. Completing a design requires selecting the required thicknesses of the various cylindrical segments, the number and diameter of the guy rods, the number and size of soil anchors, and the size of the central foundation. The lower natural frequencies of vibration are determined for each design to ensure that operation near resonance does not occur. Finally, a cost estimate is prepared for each design.

A preliminary design and cost estimate of a cantilever tower (cylindrical and not guyed) and its foundation is also presented for each of the three configurations. The estimated costs of the guyed towers and the cantilever towers are compared with the installed costs of truss type towers and foundations of the 200 kW Mod-OA wind turbines at Block Island and Culebra.

INTRODUCTION

Eight DOE/NASA horizontal axis wind turbine generators have been installed to date in utility networks at various locations throughout the country: four intermediate size wind turbines, the 38 meter diameter 200 kW Mod-OA's; one large wind turbine, the 61 meter diameter 2000 kW Mod-1; and three other large wind turbines, the 91 meter diameter 2500 kW Mod-2's. The four Mod-OA's and the Mod-1 each have a steel truss type tower and a large concrete spread foundation. These are first generation experimental wind turbines that were designed with a stiff supporting structure and, therefore, were quite expensive. They were built and installed in utility networks primarily to gain early operating experience. The Mod-2, on the other hand, was conceived and developed from the outset to be a cost effective source of electricity when mass produced. The Mod-2 has a steel tubular cantilever tower (a flexible supporting structure) with an anchored concrete

\*University of Toledo, Department of Civil Engineering, Toledo, Ohio 43606

\*\*NASA-Lewis Research Center, Cleveland, Ohio 44135

foundation which utilizes grouted rock anchors to assist in resisting overturning moments. The use of grouted anchors resulted in a foundation that is significantly smaller and less expensive than a conventional spread foundation.

The foundations for these eight wind turbines were constructed with ready-mix concrete. The tower, nacelle, and rotor of each Mod-0A and the Mod-1 were assembled with the aid of large mobile cranes. A large gin pole-type hoist was used for assembly of the Mod-2's.

Three of the Mod-0A's were installed in somewhat remote locations: two on the off-shore islands of Block Island, Rhode Island and Culebra, Puerto Rico; and one at Clayton, New Mexico which is about 150 miles from Amarillo, Texas, the closest large city. The fourth Mod-0A is on Hawaii where ready-mix concrete and large cranes are readily available. Therefore, it can be seen that wind turbine generators have usually been sited where it is expensive to have ready-mix concrete and large cranes.

It is anticipated that many intermediate size wind turbines will be used at remote sites in small utility networks or in stand-alone applications, such as in villages. The NASA experience with installation of the Mod-0A's at Block Island, Clayton, and Culebra suggests that the installed costs of intermediate size wind turbines (and, perhaps, large ones) could be significantly reduced if the costs of the tower, foundation, and field assembly can be reduced by employing more cost effective concepts.

In an effort to reduce costs of intermediate size wind turbines, NASA has undertaken a conceptual design study of a wind turbine having a 38 meter (125 ft.) diameter rotor, and a hub height of 30.4 meters (100 ft.). Three rotor configurations and two generator sizes were studied:

- Configuration No. 1 - 2-blade rotor with full span pitchable blades in a teetered hub and a 200 kW generator
- Configuration No. 2 - 2-blade rotor with fixed pitch blades in a teetered hub and a 400 kW generator
- Configuration No. 3 - 3-blade rotor with fixed pitch blades in a rigid hub and a 400 kW generator

Included in this study were evaluations of several different tower concepts, foundation designs, and erection methods. In this report, a guyed tower and foundation design for each of the above three configurations is presented as well as its estimated cost. For reference, a preliminary design of a cylindrical cantilever tower on a spread foundation has been completed for each configuration. A cost estimate for each of these is also included.

## CONCEPT SELECTION

The first step taken in the development of low cost towers and foundations was to review the fabrication and erection costs of the Mod-0A towers and foundations. The tower fabrication costs were \$79,000 each, F.O.B. the manufacturer's plant. The crane rental costs were approximately \$30,000 at Culebra to erect the tower and to lift the nacelle and rotor atop the tower; these include barge charges and costs of an erection crew. At Block Island the tower was erected using small cranes which were on the island. However, it was necessary to barge a large crane to the island to lift the nacelle and rotor. The associated crane costs were approximately \$71,000. The foundation costs, including excavation, backfill and other site preparations

were \$35,000. These costs (in 1980 dollars) for the foundation, tower and installation were judged to be high and, therefore, these items were selected as candidates for replacement with lower cost concepts. Shipping costs for the tower are not included in this study because they varied so widely.

A number of tower, foundation and assembly concepts were investigated. The tower and foundation concept selected for detailed evaluation is shown schematically in figure 1. This concept utilizes a guyed cylindrical steel tower on a precast spread foundation; the guy rods are attached to grouted soil anchors.

A cylindrical tower was chosen because it reduces the number of pieces that must be assembled at the site compared to a truss-type tower. All welding required to fabricate the tower sections is done in the fabricator's shop. Then, the fabricated tower sections are joined at the site by bolting. No field welding is required.

The tower diameter was selected to accommodate an access ladder, platforms, and the electrical cables associated with a wind turbine generator. The wall thicknesses were chosen to provide the required flexural strength and stiffness, and to place the tower natural frequencies within acceptable ranges.

A precast spread foundation was chosen to eliminate the need for ready-mix concrete. The resulting foundation design proved to be too large to ship economically as a single unit. Therefore, the foundation was designed utilizing three smaller precast components with provisions for joining at the site. Two components are inter-connected to form the footing and the pedestal is then bolted to the footing (fig. 2). This foundation is assembled in a carefully formed excavation to insure uniform bearing between the soil and foundation. It may be desirable to use granular bedding to achieve this uniform bearing.

Both steel cables and solid steel rods were considered for use as guys. A preliminary cost comparison, based on informal discussions with vendors, suggested that rods would be more cost effective than cables. For this study, rods were chosen. However, if a guyed tower is to be built, it is recommended that the question of whether to use cables or rods be evaluated in greater detail.

By using guy rods to stabilize the tower, the required tower foundation can be made smaller than would be required if a spread foundation alone were designed to resist the overturning moments. Also, the use of guy rods reduces the required tower wall thicknesses below the guy attachment ring. To avoid tilting the rotor axis and to minimize the rotor to tower overhang distance, the attachment ring for the guy rods was located a short distance below the tips of the blades, but as high as possible above the base of the tower to reduce the guy rod tension needed to resist the horizontal loads. A distance of 10.7 meters (35 ft) above the tower base was selected.

Three groups of guy rods, with the groups spaced at  $120^{\circ}$ , were selected to allow easy access to the tower base for trucks delivering the rotor and drive train components. Within a group of guy rods there are three rods. This arrangement was selected to keep the diameter of the rods from becoming very large. Groups of rods also offer an advantage with respect to safety; if one rod fails, collapse of the tower is not imminent. The location of the guy anchors at ground level was chosen at a radius of 9.1 meters (30 ft) from the tower centerline.

A number of methods were evaluated for anchoring the guy rods. Two of the most cost effective were grouted anchors and screw anchors. A grouted



anchor is constructed by boring a hole (4 in. or larger in diameter) into the ground. The depth of the hole is a function of the desired load capacity, properties of the soil, and the hole diameter. After the hole has been bored, a guy rod tie-down and tendons are inserted and the hole is pressure grouted with Portland cement grout. A grouted anchor is shown schematically in figure 3. An advantage of grouted anchors is that they are suited to a wide variety of soils, rocks, and soils with rock fragments. It is also possible to prestress these anchors so that they are not subject to fatigue loading associated with variable winds.

A screw anchor is shown schematically in figure 4. It consists of helical flights welded to a shaft with a guy rod tie-down. A screw anchor is installed by "screwing" it into the ground. The required length of a screw anchor is a function of the desired load capacity, properties of the soil, and the diameter of the flights. By their very nature, screw anchors are limited to rock-free soils. Their advantage is that they do not use grout or concrete. For this study, however, grouted anchors were chosen because of their applicability to a wider range of soil conditions.

The installation procedure selected for this study utilizes a 45,000 kg (50 ton) mobile crane to lift the two tower segments into position. (An analysis by an experienced NASA erection contractor showed that this was the most economical method for the Mod-0 site at Plum Brook, Sandusky, Ohio.) After the site has been cleared and rough-graded, and the excavation formed, a mobile crane would remove the foundation components from the shipping trucks and place them in the excavation. Then, the components would be grouted and bolted together to form the spread foundation. The tower, soil anchors and guy rods would then be installed.

#### DESIGN LOADS AND REQUIREMENTS

For this conceptual design study the loads imposed on the structure were dead loads, wind loads, operating thrust loads and/or hurricane thrust loads as shown in figures 5(a), (b), and (c). The larger value of the operating or hurricane load was used for each of the following rotor configurations:

<u>Configuration No.</u>	<u>No. of Blades</u>	<u>Pitch Capability</u>	<u>Max. Rotor Thrust</u>	<u>Wind Speed</u>	<u>Dead Loads</u>
1	2	Full span pitchable	7,700 kg (17,000 lb)	17.9 mps (40 mph)	20,000 kg (44,000 lb)
2	2	Fixed pitch	12,250 kg (27,000 lb)	53.6 mps (120 mph)	20,000 kg (44,000 lb)
3	3	Fixed pitch	18,400 kg (40,500 lb)	53.6 mps (120 mph)	20,000 kg (44,000 lb)

The operating thrust load for Configuration No. 1 was obtained using the MOSTAB computer code at cutout wind speed of 40 mph and 40 rpm rotor speed. The 120 mph wind speed is a hurricane loading case used on a stationary rotor for Configurations No. 2 and No. 3. Hurricane design loads applied to the nacelle are assumed to occur with the yaw drive disengaged and the blades unrestrained against rotation. In this configuration the bedplate is free to rotate about the tower centerline (yaw) and the blades are free to rotate about the axis of the rotor. The estimated combined weight of the rotor,

generator, gearbox, bedplate, and miscellaneous equipment is 20,000 kg (44,000 lb).

The soil conditions for this study were chosen to be those of the Mod-0 site in Sandusky, Ohio. This site has a stratum of medium silty clay, about 7 meters (22 ft) thick, underlain by shale rock. An allowable soil bearing pressure of 2500 pounds per square foot on the silty clay was used for the tower foundation design.

An analysis for three groups of guys spaced at  $120^{\circ}$ , presented in appendix A, indicates that the maximum guy rod tension due to wind occurs when the wind direction is at an angle of  $30^{\circ}$  with one of the rods. (In this analysis, the guy rods are not pretensioned and some of the guy rods may become slack.) For this present system of three equally spaced groups of guy rods as shown in figures 6(a) to (c), the maximum horizontal component of guy rod tension due to the wind is 1.155 times the resultant wind force at the elevation of the guy ring. The analysis also indicates that the maximum compressive force exerted on the tower due to the wind occurs when the wind direction coincides with one group of guy rods. At this time, two of the groups have the same tensile force and the rods of the third group have zero force. The horizontal component of the guy rod tension for each group is equal to the resultant wind force at the elevation of the guy ring. Accordingly, the vertical component is associated with a horizontal component that is twice the resultant wind force. This analysis is used for the hurricane loading case when the calculated rod tension exceeds the preload in the rod.

Another analysis, presented in appendix B, is similar to that in appendix A except that the guy rods are pretensioned so that none of the guy rods become slack as the wind direction changes. In this analysis, the required guy rod preload is calculated as well as the maximum guy rod force. This analysis is used for the operating load cases.

Using the appropriate analysis, it was determined that a rod preloaded to 13,600 kg (30,000 lb), 40,800 kg (90,000 lb) per group of guy rods, would be sufficient to prevent any guy rod from becoming slack during operating conditions. This value of preload is 140 percent of the calculated value and provides an allowance for possible creep in the soil anchors as well as possible errors in initial tensioning. The analysis also indicates that the rods of one or two groups may become slack for Configuration No. 2 and Configuration No. 3 during hurricane loading conditions.

## DESIGN APPROACH

The tower and foundation systems were designed for the critical wind load condition plus dead load and guy rod preload. The first step in the design process was to determine the applicable loads for the configuration under investigation. Then, the bending moment diagram was constructed for the tower and the wall thicknesses selected to provide the required section moduli. Next, the guy rod diameter was selected based upon the calculated preload so that a rod would not become slack during the application of design operating loads and the associated variation in tension due to changing wind direction. Finally, the central foundation was designed and the number of soil anchors selected. Following these steps, the tower structural stability was investigated, a fatigue analysis (of the tower, guy rods and soil anchors) was performed and a dynamic analysis was undertaken. These studies are described briefly.

The tower shell was investigated for structural stability (buckling). In this investigation two considerations are important; overall structural

stability of the tower and local buckling. The design procedure in the eighth edition (1980) of the AISC Manual of Steel Construction was followed. The overall structural stability was investigated by determining the effective slenderness ratio and computing the allowable compressive stress. Whenever the ratio of the outside diameter to the wall thickness exceeds  $3300/F_y$ , local buckling must be investigated. When the ratio of outside diameter to wall thickness is between the limits of  $3300/F_y$  and  $13,000/F_y$ , the allowable compressive stress is given by

$$F_a = \frac{662}{D/t} + 0.4 F_y$$

The design allowable compressive stress is the smaller of the values given by the preceding equation and that associated with the effective slenderness ratio. The allowable bending stress is  $0.66 F_y$  when  $D/t \leq 3300/F_y$  and is  $0.6 F_y$  when  $D/t > 3300/F_y$ .

The AISC interaction equations are then used to determine if the proposed cross section is adequate. In these equations, the right hand side was increased from 1.0 to 1.33 to reflect that wind loading is included:

$$\frac{f_a}{F_a} + \frac{f_b}{F_b} \leq 1.33, \text{ when } \frac{f_a}{F_a} \leq 0.15$$

or

$$\frac{f_a}{0.6 F_y} + \frac{f_b}{F_b} \leq 1.33 \text{ and } \frac{f_a}{F_a} + \frac{C_m f_b}{(1 - f_a/F_e) F_b} \leq 1.33, \text{ when } \frac{f_a}{F_a} > 0.15$$

The notation used here is the standard AISC notation.

A fatigue analysis was performed on the tower for the 2-blade rotor with variable pitch blades. The procedure in the 1980 edition of the AISC Manual of Steel Construction was followed for two conditions:

- a) start-up to rated power and rated power to shut-down
- b) operation at rated power

The critical design condition for the towers of the 2-blade rotor with fixed pitch blades and the 3-blade rotor with fixed pitch blades was hurricane loading. Since the number of load applications of hurricane loading is low, a fatigue analysis was not required. Fatigue analyses of these two configurations were also performed for the above two conditions to verify that they are not critical when fatigue is considered.

The AISC procedure is described in appendix B of the specifications. It involves selecting the appropriate stress category based upon the type of member and weld detail. In this analysis stress category C was selected for the groove welds and adjacent base metal at changes in wall thickness. The procedure further involves selecting a loading condition based upon the number of expected load cycles. For start-up or shut-down cycles, loading condition 1 (20,000 to 100,000 cycles) was selected. For cycles at rated power, loading condition 4 (over 2,000,000 cycles) was selected. Since it is anticipated

that a wind turbine will experience fewer than 20,000 hurricane loadings during its lifetime, fatigue need not be considered for this loading case.

After selecting the stress category and loading condition, the allowable range of stress is read from table B3. The actual range of stress cannot exceed this value; also, the maximum stress cannot exceed the applicable allowable stress.

A fatigue analysis of the guy rods and soil anchors was also undertaken. To eliminate fatigue considerations in the soil anchors, pre-tensioned soil anchors were selected. The value of the pretension was selected to be 36,400 kg (80,000 lb) for each soil anchor. This value is sufficient to prevent a soil anchor from experiencing fluctuating forces for all loading conditions in all three concepts.

A fatigue analysis for the guy rods of Configuration No. 1 was performed for the operating load case since this case is associated with higher loads than the hurricane loading case as a consequence of the full span pitchable blades. This fatigue analysis was carried out using the residual stress method as outlined in Engineering Considerations of Stress, Strain and Strength by R. C. Juvinal. This analysis indicated that three 5.1 cm (2 in.) diameter guy rods (of AISI 4140 heat treated alloy steel with an ultimate tensile strength of 10,760 kg/cm<sup>2</sup> (153,000 psi)) in each of the three groups and pretensioned to 13,600 kg (30,000 lb) each would be associated with a factor of safety of 3.4 based upon the ultimate strength.

For Configuration No. 2 and Configuration No. 3 the loads associated with the hurricane loading case are considerably greater than those associated with the operating load case. Since the anticipated number of repetitions of hurricane loading during the life of a wind turbine will be small, these loads are treated as static. The operating loads for these concepts are not expected to be significantly greater than those for Configuration No. 1. Hence, guy rods as outlined for Configuration No. 1 are judged to be satisfactory. The analysis indicates that during hurricane winds one or two groups of guy rods will become slack. There are no detrimental effects that are anticipated to be associated with this. The factors of safety for Configuration No. 2 and Configuration No. 3 are 6.0 and 4.3, respectively, based upon ultimate strength (during hurricane loading conditions).

The design of the grouted soil anchors was developed by DRC Consultants, Inc. of New York City. Their recommendation was to use 3.5 cm (1-3/8 in.) diameter Dywidag threadbars with an ultimate tensile strength of 10,550 kg/cm (150,000 psi) that are prestressed to 36,400 kg (80,000 lb), and to use one threadbar per each guy rod. By prestressing the threadbars to 80,000 lb, there will be no fluctuation of force in the threadbars and fatigue need not be considered. For this design, the grout bulb is 10 cm (4 in.) in diameter by 7.3 meter (20 ft) long and is located in rock. The stressing length of the threadbar is 15.6 meter (43 ft). Each threadbar is prestressed by using a 1.8 meter (5 ft) square concrete pad. A soil anchor is shown in figure 7.

The dynamic analysis was performed by R. Christie \*, using the procedure in an Oregon State University report "Modeling the Response of Wind Turbines

---

\* "Vibration Analysis of Three Guyed Tower Designs for Intermediate Size Wind Turbines," W. L. Tanksley and Associates, September, 1981, (Technical Memorandum Report for Task Orders 228-1 and 346-1, NASA Contract NAS 3-21900).

to Atmospheric Turbulence" by R. W. Thresher et al, reference 1. This method is a finite element technique based upon an energy method. Here the tower is treated as a single finite element and four natural frequencies are determined. Two of the modes are for motion in the plane of the tower and axis of rotation, and two of the modes are in a vertical plane normal to the first plane. The results of this analysis are approximate since changes in wall thickness cannot be incorporated directly using a single finite element.

## DESIGN RESULTS

The recommended designs of the tower and foundation systems for the three configurations investigated are summarized in figure 6 (a) to (f). The central foundation for Configuration No. 3, which is also typical for Configuration No. 1 and Configuration No. 2, is detailed in figure 2.

In figures 6 (a) to (c) the indicated locations of changes in wall thickness are essentially the theoretical locations for these changes. No terminal distance has been used in this conceptual design study. Also, the wall thickness in the vicinity of the guy ring is greater than indicated on these figures. After the upper tower section is lifted into position, the sections are bolted together with sixteen (16) ASTM A-325 bolts. The steel in the tower conforms to ASTM A-572.

The guy rod attachments to the tower are located beneath the guy ring of the lower tower section. Attachment plates are welded to the lower flange of the guy ring as indicated in figure 6(d) for Configuration No. 2. A clevis connects each guy rod to the attachment plate. The guy rod material is AISI 4140 alloy steel that has been heat treated to achieve an ultimate tensile strength of 10,760 kg/cm<sup>2</sup> (153,000 psi). The guy rods are 5.1 cm (2 in.) in diameter and contain a turnbuckle to facilitate pretensioning. The design utilized here provides one soil anchor connected directly to each guy rod.

The base of the tower was designed to simulate a hinged condition yet provide torsional restraint. The vertical loads are transmitted to the foundation through a "Fabreeka" pad (Fabreeka is the tradename of a fiber and rubber composite material that possesses a relatively low modulus). The torsional restraint is provided by twelve (12) 1-1/2 inch diameter dowels. The design of the tower base for Configuration No. 3 is shown in figure 6(e). The use of a "Fabreeka" pad ensures that the distribution of vertical stresses is essentially uniform even though the strain distribution throughout the "Fabreeka" is non-uniform. The dowels serve to transmit the yaw moments through the central foundation into the soil. Here the torsional restraint provided by the horizontal components of the tension in the guy rods as the tower rotates (slightly) has been neglected.

The design of the central foundation for Configuration No. 3 is summarized in figure 2. As mentioned earlier, this foundation is constructed from three precast sections, two rectangular slab sections and a cylindrical pedestal. The two slab sections are bolted together to form the footing. A seam of grout is placed between them, prior to bolting, to insure uniform contact between them. Anchor bolts for the pedestal have been cast in the slab sections. The central foundation was designed to withstand a concentric load due to dead loads and the vertical components of the guy rod tension as well as a horizontal shear force due to eccentricity of dead loads with respect to the tower centerline and due to wind loading. After the footing size was determined so that the induced soil bearing pressure did not exceed the allowable soil bearing capacity, the foundation was checked for resistance to sliding due to horizontal shear. Finally, the size of the foundation was checked to ensure that the surrounding soil could resist the yaw moments.

The grouted soil anchors are prestressed to a load of 36,400 kg (80,000 lb). After installation, each anchor is proof-tested to at least 125 percent of its design load. Within a group of soil anchors, it will be necessary to space the anchors such that their individual load capacities are not adversely affected. For this conceptual design study, a soil anchor spacing of four to five feet was considered acceptable.

Personnel access to the nacelle is through ladders inside the tower. A possible ladder arrangement is shown in figure 6(f).

For the tower designs summarized earlier and a soil anchor stiffness of  $2.23 \times 10^5$  kg/cm ( $15 \times 10^6$  lb/ft), the results of the dynamic analysis indicated that operation at 40 rpm does not coincide with resonance. For Configuration No. 1 a natural frequency occurs at approximately 3.4 P, for Configuration No. 2 at 3.6 P, and for Configuration No. 3 at 3.7 P. The stiffness of a guy rod-soil anchor system is obtained by combining the stiffness of a guy rod in series with the stiffness of a soil anchor. For Configuration No. 1, the effective horizontal stiffness of a guy rod-soil anchor system is approximately  $4.52 \times 10^4$  kg/cm ( $3.04 \times 10^6$  lb/ft) \*. This stiffness is rather high and leads to a stiff tower design. The stiffness is high primarily due to two features

- (a) the grout bulb is located in rock
- (b) the soil anchor is prestressed

For comparison, a conceptual design of a cylindrical cantilever (nonguyed) was developed for each of the three rotor configurations. These are shown in figure 8. These designs were completed for the same loads as the guyed towers. The steps in the design procedure are the same as for the guyed towers except the guys and soil anchors are eliminated, and the spread foundations must resist the overturning moments. The natural frequencies of vibration are somewhat lower than for the guyed towers and are in the range of 0.91 P for Configuration No. 1 to 1.23 P for Configuration No. 3.

#### COST METHODOLOGY

Costs were developed for the following items only: the tower fabrication, the precast concrete foundation, the guy rods and fittings, the grouted soil anchors, and field assembly. In all cases, the cost estimates were made by vendors who specialize in that particular item. Whenever possible, layout drawings of each tower concept and specifications were sent out to more than one vendor to obtain fabrication costs. The costs for the guy rods and fittings were quotations obtained from suppliers of these components. A fabricator of precast concrete products quoted the cost of the precast tower foundation sections. These costs did not include the costs of the forms required to cast the sections. To obtain a design and the installed costs of the grouted soil anchors, a small contract was awarded to a major vendor and installer of grouted anchors. The tower installation costs were made by a NASA contractor who has been providing erection services for the Mod-0 test site at Sandusky, Ohio.

The itemized estimated costs are shown in tables 1 to 3. The cost of the tower includes the tower shell, flanges, guy ring, base and manway. The costs reflect the costs of materials and fabrication, and of installation at the site. The cost of the guys includes the guy rods, their fittings and installation. The cost of the soil anchors includes their installation and proof-

---

\* Ibid.

testing. The cost of the foundations is the F.O.B. cost, and therefore, does not include shipping charges. The above prices do not include the costs associated with providing access to the top of the tower, nor do they include the costs for any of the equipment (such as the yaw bearing, nacelle, drive train, rotor etc.) that is later installed on the tower. Access could be provided by ladders and platforms inside the tower. Corten steel was selected for the tower material to eliminate the cost of painting.

## DISCUSSION

In this conceptual design study the effect of the critical rotor thrust load on the cost of the tower and foundations was investigated. From the summary of estimated costs presented in tables 1 to 3, it can be seen that the minimum cost is for a tower and foundation that is associated with the two blade rotor with full span pitchable blades and that the maximum cost is for the three blade rotor with fixed pitch blades. The rotor with full span pitchable blades is designed to have the blades feathered in high winds which significantly reduces the wind thrust on the rotor. Accordingly, the thrust at operating conditions for this rotor exceeds the wind thrust on the rotor in high winds. For rotors with fixed pitch blades the wind thrust in high winds exceeds the wind thrust on the rotor during operating conditions. As a result, the loads transmitted to the tower for a rotor with fixed pitch blades exceed those for a rotor with full span pitchable blades. Obviously, the loads transmitted to the tower from the three blade rotor exceed those for the two blade rotor.

When higher loads are transmitted to a tower of fixed diameter and height, the wall thickness of the various tower segments must be increased; thereby increasing the tower weight and cost. Increased tension in the guy rods does not necessarily require that larger guy rods be used. For rotors with full span pitchable blades, the critical design case is associated with operating loads, for rotors with fixed pitch blades, the critical design case is associated with hurricane winds. Since the number of load repetitions associated with operating loads is high, fatigue must be considered. The number of load repetitions associated with hurricane winds is low enough that these loads can be considered as static. Accordingly, for the configurations investigated here, the same arrangement of guy rods can be used for rotors with full span pitchable blades and fixed pitch blades.

In selecting the optimum tower and foundation configuration, it is obviously necessary to consider factors other than the cost of the tower and foundation. These factors include the number of blades, the need for a pitch control mechanism, the need for teetering, etc. For example, the two blade rotor with full span pitchable blades is associated with the minimum tower and foundation costs. However, this configuration requires that a pitch change mechanism be included in the rotor. This mechanism increases the first cost as well as maintenance costs which offsets some, if not all, of the savings achieved in the tower and foundation. On the other hand, a two blade rotor with fixed pitch blades is less expensive to fabricate and maintain, but results in a more costly tower and foundation. A three blade rotor with fixed pitch blades eliminates both the teetered hub and the pitch change mechanism, but it requires a more expensive tower and foundation. These items are not addressed in this study. The importance of these factors is pointed out here so that the reader becomes aware of their existence and the need to consider the wind turbine as a complete system.

The major cost item for each configuration investigated was the tower shell. It is associated with more than 60 percent of the total estimated cost for the tower and foundation. Hence, to obtain a significant reduction in the cost of the tower and foundation, the cost of the tower shell would need to be reduced.

In this study, readily available components were utilized wherever possible rather than components designed specifically for a wind turbine system. An attempt was made to use "low cost" items as well; for example, steel plate was used for the tower, guy rods were used rather than struts, and soil anchors were used rather than massive foundations. Further, an attempt was made to reduce the number of operations required in the fabrication shop and to reduce the number of pieces requiring assembly in the field. An example of this is the use of a cylindrical tower rather than a lattice tower.

The estimated cost for the three configurations are now compared to the actual costs for the Mod-OA steel truss type towers and to estimated costs for cantilever towers on spread foundations (without soil anchors). The costs for the Mod-OA towers at Culebra and Block Island were \$144,000 and \$185,000 respectively. The estimated costs for three cantilever tower designs are:

<u>Configuration</u>	<u>Estimated Costs</u>
No. 1: 2 blades, full span pitchable	\$ 89,100
No. 2: 2 blades, fixed pitch	\$107,600
No. 3: 3 blades, fixed pitch	\$123,400

It is seen, from a comparison of these costs with those of tables 1 to 3, that the guyed towers are considerably less expensive than the Mod-OA truss type towers. However, the guyed tower has a modest cost advantage over only the cantilever tower for Configuration No. 3 and is slightly more expensive than the cantilever tower for Configurations No. 1 and No. 2. The reason the cantilever tower for Configuration No. 3 is more expensive than the guyed tower is that the tower and foundation must be heavy to withstand the high hurricane force on the 3-blade rotor.

### CONCLUSION

In this study the effects of three different rotor configurations on the costs of the tower and its foundation for a horizontal axis wind turbine have been investigated and are compared with those of the Mod-OA's. The axis of the rotor was placed 30.5 meters (100 ft) above grade and was supported on a 1.45 meter (4 ft-9 in.) diameter cylindrical tower. The tower is guyed 10.7 meters (35 ft) above grade. The rotor configurations and rated power output were

- (a) two blade rotor with full span pitchable blades in a teetered hub and a 200 kW generator
- (b) two blade rotor with fixed pitch blades in a teetered hub and a 400 kW generator
- (c) three blade rotor with fixed pitch blades in a rigid hub and a 400 kW generator



The concept of guying the tower was also investigated in this study. The use of guy rods reduces the size of the spread foundation base for the tower and also reduces the tower weight. Grouted soil anchors and screw anchors were considered for anchoring the guy rods. Unless the underlying soil contains rock fragments or unless rock is close to the ground surface, either type of anchor appears to be acceptable. When there are rock fragments, or when rock is close to the surface, grouted anchors are recommended. The third concept investigated was the effect of using fixed pitch blades rather than variable pitch blades on the requirements of the tower and foundation. It was then possible to obtain incremental costs for the tower and foundation when fixed pitch blades were used, and when three blades were used instead of two.

The estimated costs of the guyed cylindrical tower and prefabricated foundation for each of the three cases are

<u>Rotor Configuration</u>	<u>Estimated Cost</u>
2 blades, full span pitchable	\$ 92,800
2 blades, fixed pitch	102,800
3 blades, fixed pitch	108,800

Hence, the cost of the tower and foundation is increased by \$10,000 if the pitch change mechanism is not used in the rotor. This cost is increased by an additional \$6,000 if three blades are utilized rather than two and if the teeter mechanism is eliminated.

Designs and costs were also developed for cantilever (non-guyed) cylindrical steel towers with poured spread foundations (no soil anchors). The estimated costs for these cantilever tower designs are

<u>Rotor Configuration</u>	<u>Estimated Cost</u>
2 blades, full span pitchable	\$ 89,100
2 blades, fixed pitch	107,600
3 blades, fixed pitch	123,400

When the guyed tower costs are compared with the cantilever tower costs, it is seen that the guyed towers are 4 percent more, 5 percent less, and 13.4 percent less for Rotor Configurations No. 1, 2, and 3 respectively. The higher cost of the cantilever tower for Configuration No. 3 is due to the heavy tower and large foundation necessary to withstand the high hurricane wind force on the 3-blade rotor.

The costs for the 38 meter diameter, 200 kW Mod-OA truss type towers at Culebra and at Block Island were \$144,000 and \$185,000 respectively. These Mod-OA wind turbines had fully pitchable blades.

Therefore, this conceptual design study has shown that a guyed cylindrical tower for Rotor Configuration No. 1 is approximately 36 percent and 50 percent less expensive than the steel truss tower for the Mod-OA at Culebra and Block Island respectively.

## APPENDIX A

### VARIATION OF GUY TENSION WITH DIRECTION OF WIND--NO PRELOAD IN GUYS

For the case without preload in the guys one or two groups of the guys may become slack; that is, the force in these guys may go to zero. Initially, there is no force in the guys; the guys are installed in a snug condition to prevent wobble of the tower.

In this derivation, the groups of guys are represented by OA, OB, and OC, the equivalent wind force at the attachment of the guys is represented by W, and the wind direction is represented by  $\phi$  (as indicated fig. A-1). By observation, the following can be written

- a) for  $0^\circ < \phi < 120^\circ$  guys OA and OB resist the wind force and the force in guy OC is zero.
- b) for  $120^\circ < \phi < 240^\circ$  guys OB and OC resist the wind force and the force in guy OA is zero.
- c) for  $240^\circ < \phi < 360^\circ$  guys OC and OA resist the wind force and the force in guy OB is zero.

For  $0^\circ < \phi < 120^\circ$ , the force diagram (using horizontal components) shown in figure A-2 may be drawn. In this diagram  $H_A$  is the horizontal component of the tension in guy OA and  $H_B$  is that in guy OB.

To maintain equilibrium, the following must be satisfied.

$$\Sigma F_y = 0$$

$$H_B = W \sin \phi / \cos 30^\circ \quad (A-1)$$

$$\Sigma F_x = 0$$

$$H_A = W(\cos \phi + \sin \phi \tan 30^\circ) \quad (A-2)$$

For  $120^\circ < \phi < 240^\circ$  the equilibrium equations can be written as follows, where  $\alpha = \phi - 120^\circ$  (referring to fig. A-3).

$$H_C = W \sin \alpha / \cos 30^\circ \quad (A-3)$$

$$H_B = W(\cos \alpha + \sin \alpha \tan 30^\circ) \quad (A-4)$$

Similarly for  $240^\circ < \phi < 360^\circ$  the equilibrium equations can be written as follows, where  $\gamma = \phi - 240^\circ$ .

$$H_A = W \sin \gamma / \cos 30^\circ \quad (A-5)$$

$$H_C = W(\cos \gamma + \sin \gamma \tan 30^\circ) \quad (A-6)$$

The results of the above six equations are plotted in figure A-4. From this figure it can be seen that the maximum horizontal component of the tension in a group of guys is  $1.155 W$ . It occurs when the wind direction forms an angle of  $30^\circ$  with a group of guys.

The compressive force in the tower due to the tension in the guys is denoted by  $C_T$ . An expression for  $C_T$  can be obtained by using summation of vertical forces; the result is

$$C_T = V_A + V_B + V_C$$

where the  $V$ 's are the vertical components of the tension in the guys. Relating the  $V$ 's to the  $H$ 's, the expression becomes

$$C_T = H_A \tan \beta + H_B \tan \beta + H_C \tan \beta \quad (A-7)$$

Using the values from figure A-4, equation (A-7) can be evaluated and the results are plotted in figure A-5. From this figure the maximum value of the compressive force in the tower due to the tension in the guys is  $2W/\tan \beta$ . It occurs when the wind direction coincides with the guy that is slack.

## APPENDIX B

### VARIATION OF GUY TENSION WITH DIRECTION OF WIND--PRELOAD IN GUYS

For the case with preload in the guys the preload is calculated so that no guy will become slack. In this analysis it is acceptable for the force in a guy to approach zero as the design value of the wind force is reached.

In this derivation, the groups of guy rods are represented by OA, OB, and OC, the equivalent wind force at the attachment of the guys is represented by W, and the wind direction is represented by  $\phi$  (as indicated in fig. B-1).

The forces in the guys at any time are represented by  $G_A$ ,  $G_B$  and  $G_C$ . The initial forces (preload) in the guys are represented by  $G_{A,i}$ ,  $G_{B,i}$  and  $G_{C,i}$  and the changes in tension due to horizontal motion at the guy ring are represented by  $\Delta G_A$ ,  $\Delta G_B$  and  $\Delta G_C$ .

Also,  $\Delta$  is the horizontal displacement of the guy ring in the direction of the wind. It can be shown that, for a tower with three equally spaced guys of equal stiffness, the resultant stiffness is the same in all directions. Therefore, the displacement will be in the direction of the applied force as if none of the guys become slack.

The changes in length of the guys are represented by  $\Delta_A$ ,  $\Delta_B$  and  $\Delta_C$ ; the horizontal components of these are represented by  $\Delta_{HA}$ ,  $\Delta_{HB}$  and  $\Delta_{HC}$ . The cross-sectional area of a guy, its length and Young's modulus of the guy material are represented by A, L and E respectively. Here, all guys have the same values for A, L and E.

Referring to figure B-2, the displacements can be related by

$$\Delta_{HA} = \Delta \cos \phi$$

$$\Delta_{HB} = \Delta \cos(120^\circ - \phi) \tag{B-1}$$

$$\Delta_{HC} = \Delta \cos(240^\circ - \phi)$$

and

$$\Delta_A = \Delta_{HA} \cos \beta$$

$$\Delta_B = \Delta_{HB} \cos \beta \tag{B-2}$$

$$\Delta_C = \Delta_{HC} \cos \beta$$

Relating the change in force in a guy to its elongation, the following expressions can be written

$$\Delta G_A = \Delta \frac{AE}{L} \cos \beta \cos \phi$$

$$\Delta G_B = \Delta \frac{AE}{L} \cos \beta \cos(120^\circ - \phi) \quad (B-3)$$

$$\Delta G_C = \Delta \frac{AE}{L} \cos \beta \cos(240^\circ - \phi)$$

Now the total forces in the guys can be written as

$$G_A = G_{A,i} + \Delta G_A$$

$$G_B = G_{B,i} + \Delta G_B \quad (B-4)$$

$$G_C = G_{C,i} + \Delta G_C$$

Writing the equilibrium equations,

$$\Sigma F_x = 0$$

$$[G_A - G_B \cos 60^\circ - G_C \cos 60^\circ] \cos \beta = W \cos \phi \quad (B-5)$$

$$\Sigma F_y = 0$$

$$[G_B \sin 60^\circ - G_C \sin 60^\circ] \cos \beta = W \sin \phi \quad (B-6)$$

Since all guys will be preloaded with the same tension,

$$G_{A,i} = G_{B,i} = G_{C,i} = G_i$$

Using this in equation (B-6), the result is

$$\Delta G_B - \Delta G_C = W \frac{\sin \phi}{\cos \beta \sin 60^\circ}$$

or

$$\Delta = \frac{WL}{AE} \sqrt{3} \cos^2 \beta \sin 60^\circ \quad (B-7)$$

Substituting into equation (B-5), the result is

$$\begin{aligned} G_i + \Delta \frac{AE}{L} \cos \beta \cos \phi - G_i + \Delta \frac{AE}{L} \cos \beta \cos(120 - \phi) \cos 60^\circ \\ - G_i + \Delta \frac{AE}{L} \cos \beta \cos(240 - \phi) \cos 60^\circ = W \cos \phi / \cos \beta \end{aligned} \quad (B-8)$$

Using the conditions for Configuration No. 1 in equation (B-7) and equation (B-8), the results are summarized in figure B-3. The values used were

$$P = 58,880 \text{ lb}$$

$$E = 29 \times 10^6 \text{ psi}$$

$$L = 540 \text{ in.}$$

$$A = 3\pi \text{ in}^2 \text{ (3-2 in. diameter rods)}$$

$$\beta = 52.4^\circ$$

Increasing the maximum value of the calculated pretension by 40 percent, the design preload at each group of guy rods is 90,000 lbs. This then leads to a maximum tension of 154,300 lbs in a group of guy rods and a displacement  $\Delta = 0.21$  inches.

TABLE 1. - TOWER AND FOUNDATION ESTIMATED QUANTITIES AND COSTS

[Rotor Configuration No. 1: Two-blade rotor, full span pitchable ]

Quantity	Unit	Description	Unit	Cost
37,400	lb	Structural steel	\$ 1.30	\$47,000
9	ea	Guy rod and fitting assembly	600.00	5,400
9	ea	Soil anchor assembly	2100.00	18,900
1	ea	Central foundation	6000.00	6,000
	lump	Foundation installation and tower erection		15,500
				\$92,800

Not included: shipping costs

TABLE 2. - TOWER AND FOUNDATION ESTIMATED QUANTITIES AND COSTS

[Rotor Configuration No. 2 Two-blade rotor, fixed pitch blades]

Quantity	Unit	Description	Unit	Cost
44,000	lb	Structural steel	\$ 1.30	\$55,000
9	ea	Guy rod and fitting assembly	600.00	5,400
9	ea	Soil anchor assembly	2100.00	18,900
1	ea	Central foundation	8000.00	8,000
	lump	Foundation installation and tower erection		15,500
				\$102,800

Not included: shipping costs

TABLE 3. - TOWER AND FOUNDATION ESTIMATED QUANTITIES AND COSTS

[Rotor Configuration No. 3 Three-blade rotor, fixed pitch blades]

Quantity	Unit	Description	Unit	Cost
47,200	lb	Structural steel	\$ 1.30	\$60,000
9	ea	Guy rod and fitting assembly	600.00	5,400
9	ea	Soil anchor assembly	2,100.00	18,900
1	ea	Central foundation	9,000.00	9,000
	lump	Foundation installation and tower erection		15,500
				\$108,800

Not included: shipping costs

## REFERENCES

1. Thresher, R. W.; et al.: Modeling the Response of Wind Turbines to Atmospheric Turbulence. Rep. No. RL0/2227-81/2, Oregon State Univ., 1981.



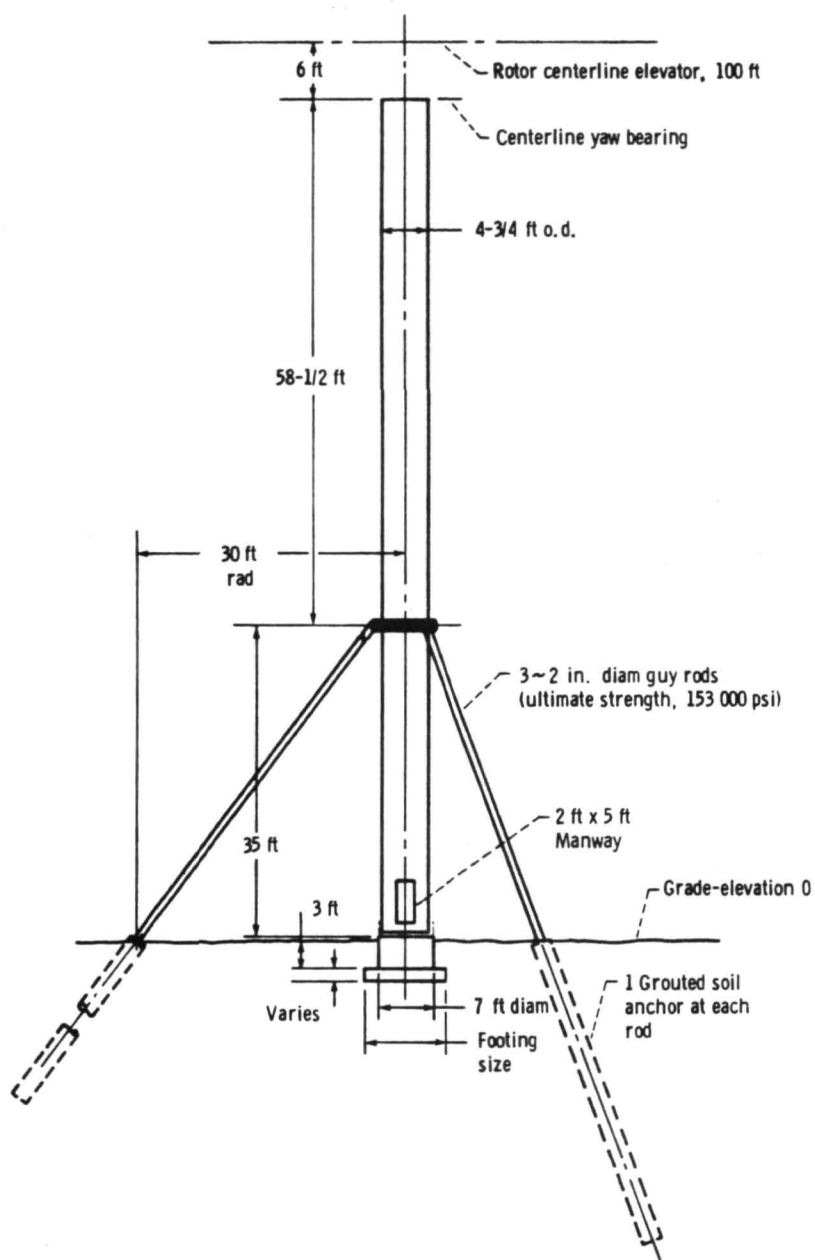

Figure 1. - Tower and foundation concept for an intermediate size (200 to 400 kw) wind turbine.

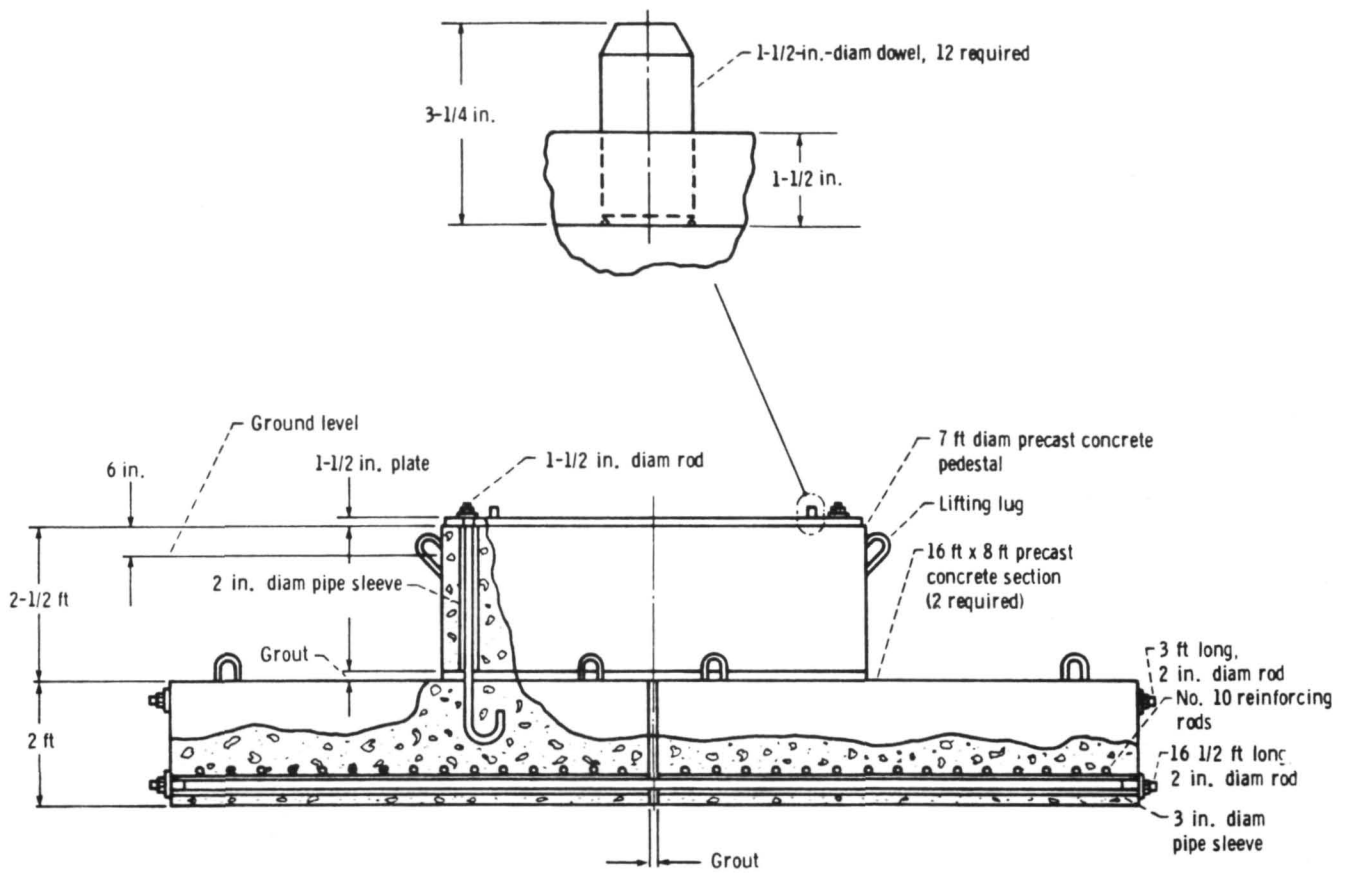

Figure 2. - Central foundation - Configuration 3.

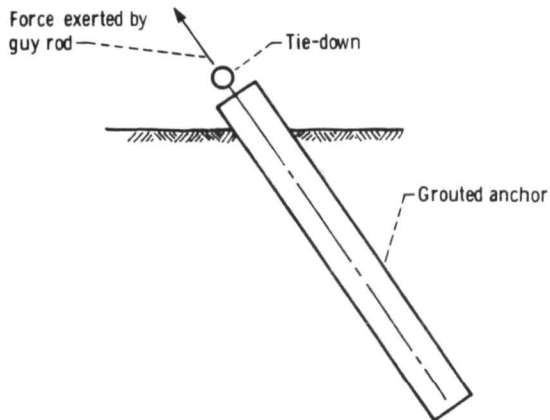

Figure 3. - Schematic of grouted soil anchor.

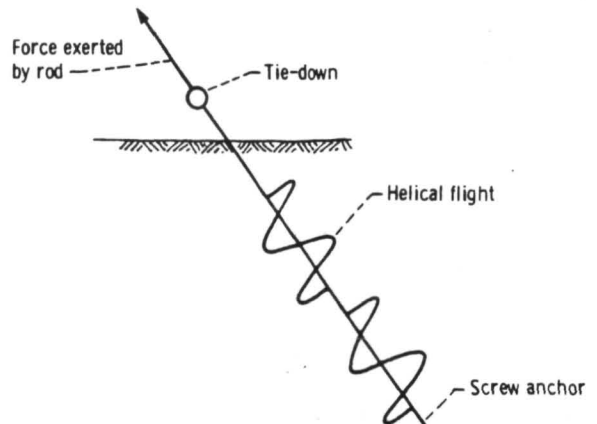
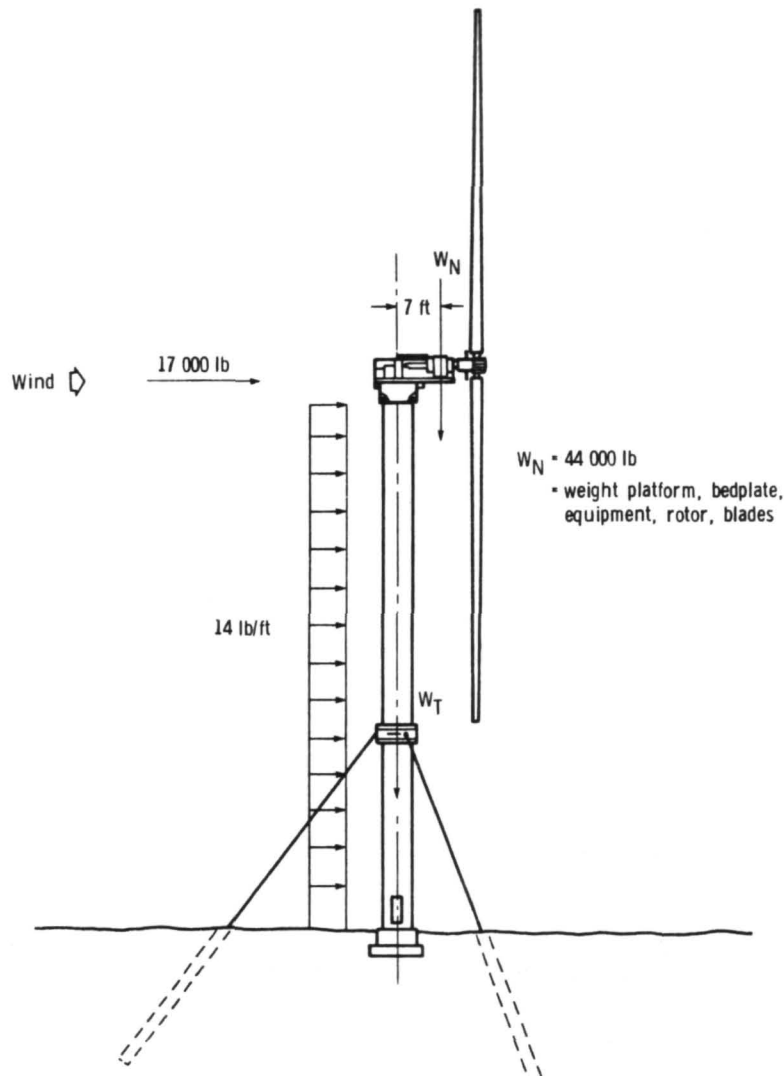
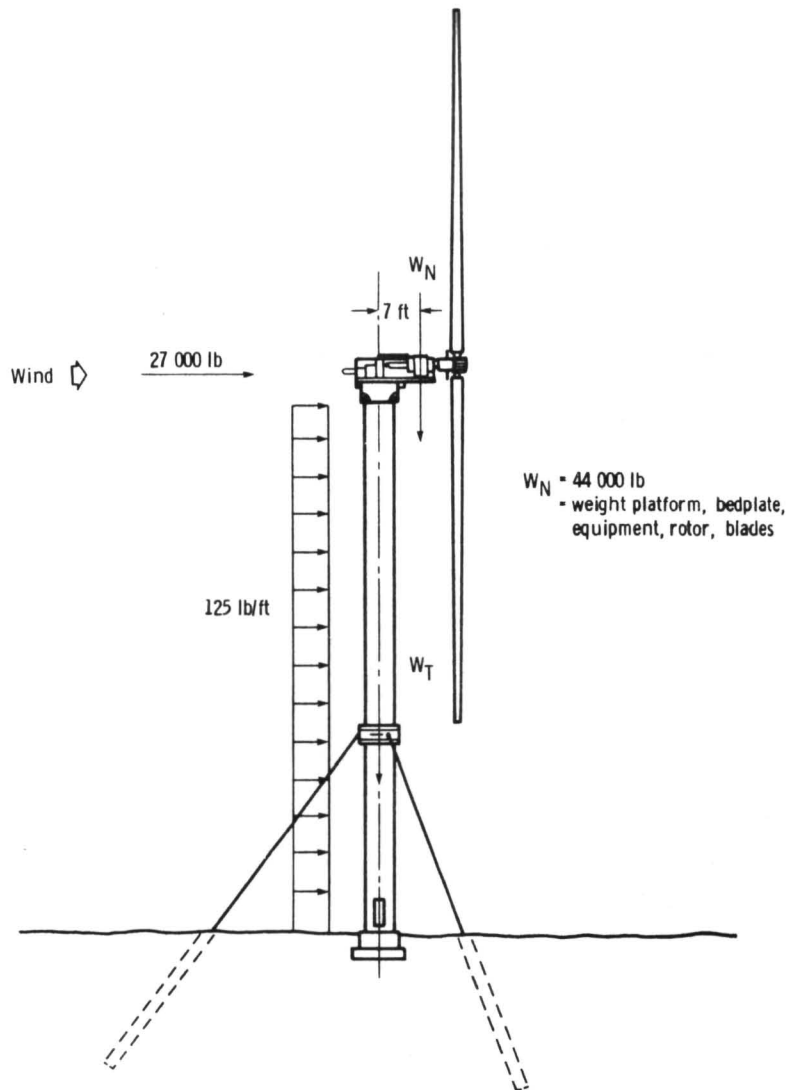

Figure 4. - Schematic of screw anchor.



(a) Operating load case for Configuration 1.

Figure 5. - Design loads.



(b) Hurricane load case for Configuration 2.

Figure 5. - Continued.

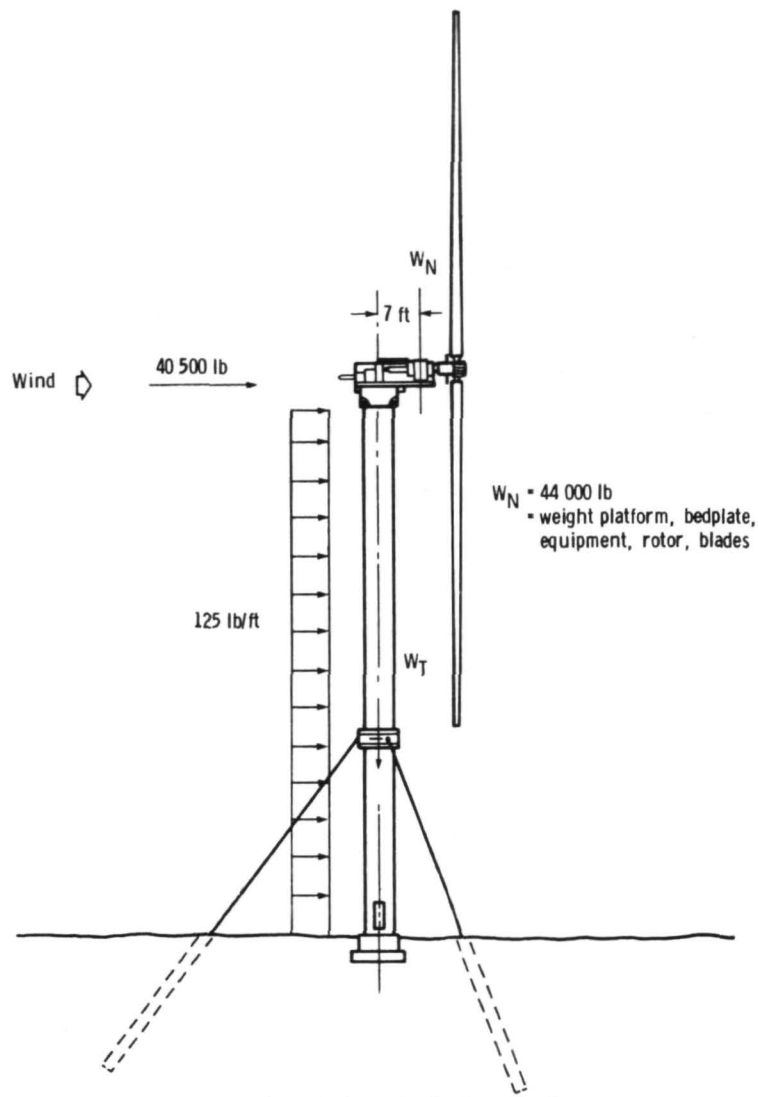

(c) Hurricane load case for Configuration 3.

Figure 5. - Concluded.

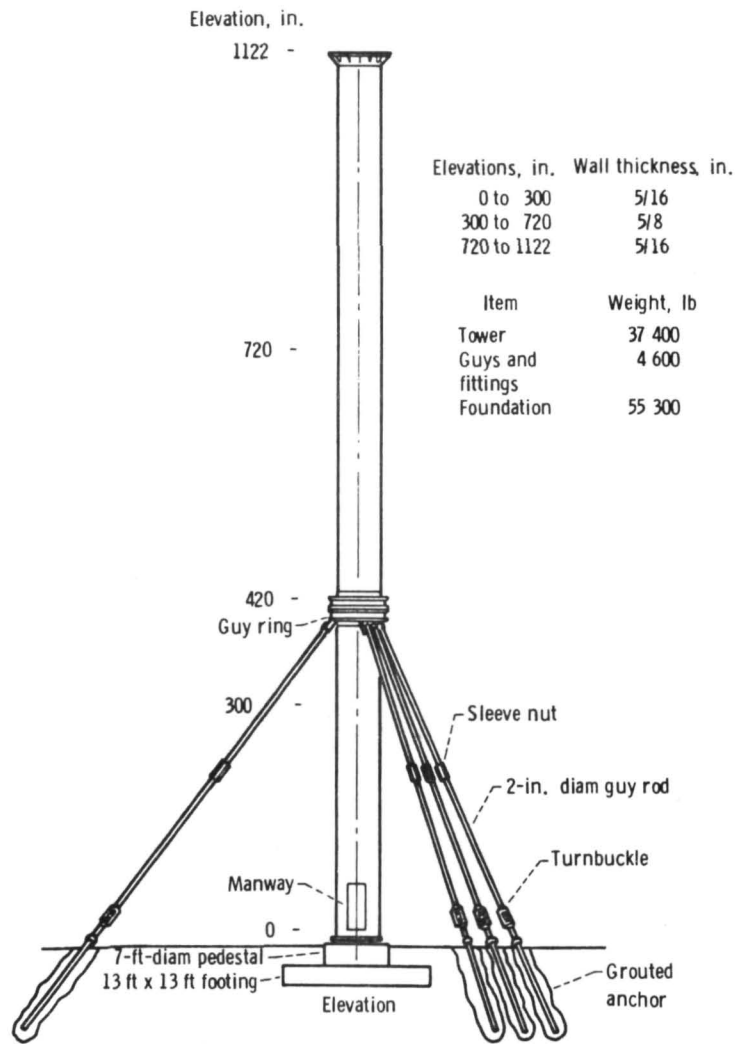

(a) Tower and foundation design - Configuration 1.

Figure 6. - Details of tower design.

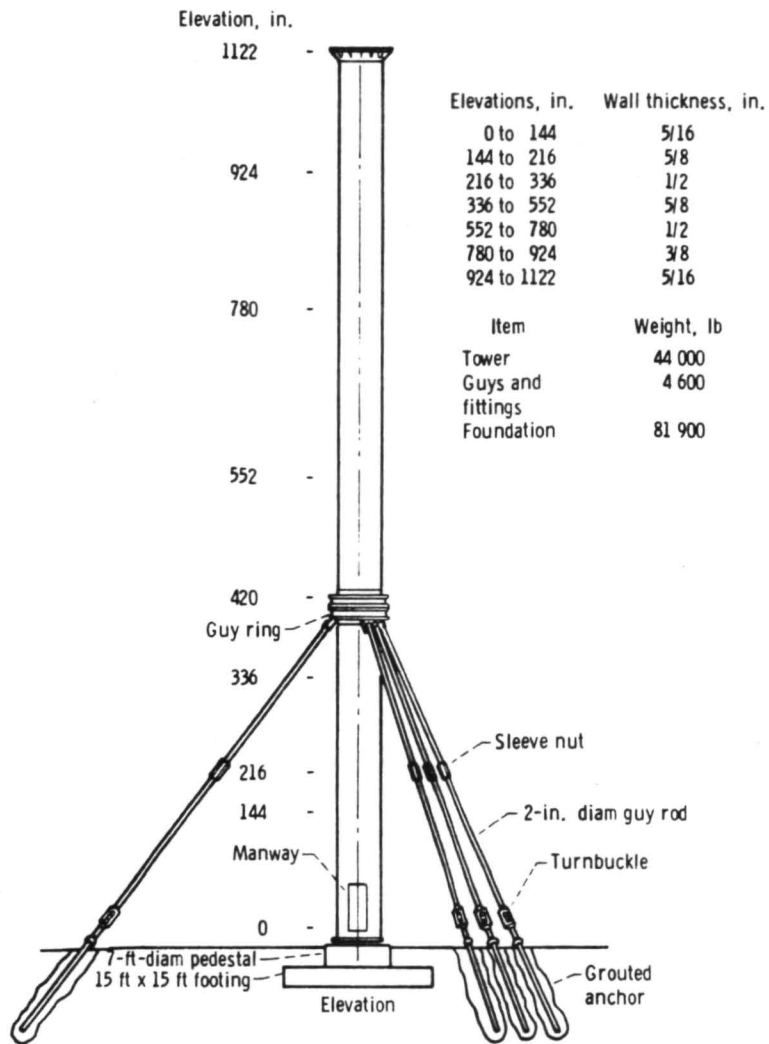

(b) Tower and foundation design - Configuration 2.

Figure 6. - Continued.

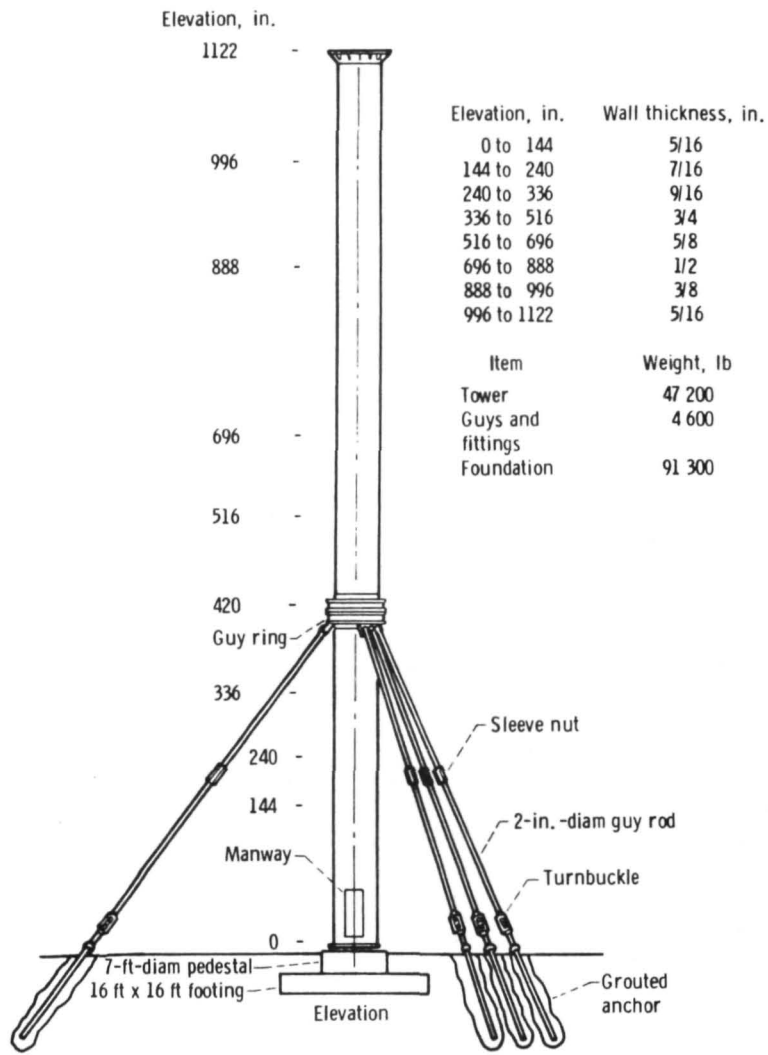

(c) Tower and foundation design - Configuration 3.

Figure 6. - Continued.



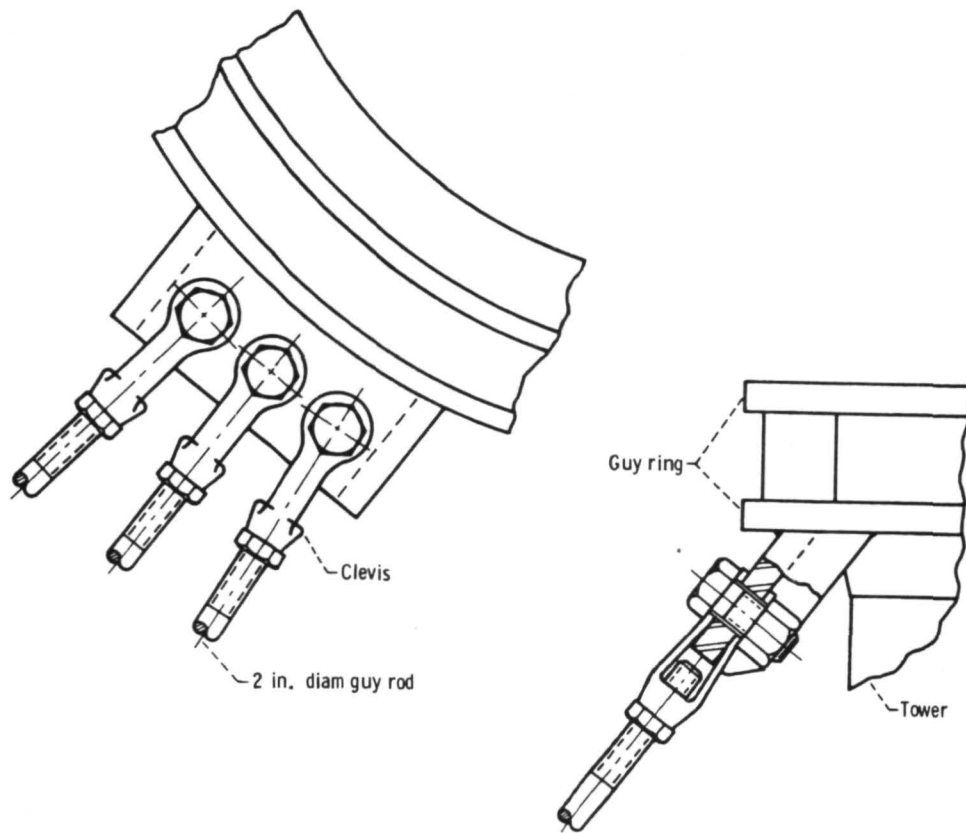

(d) Guy rod attachment detail.

Figure 6. - Continued.

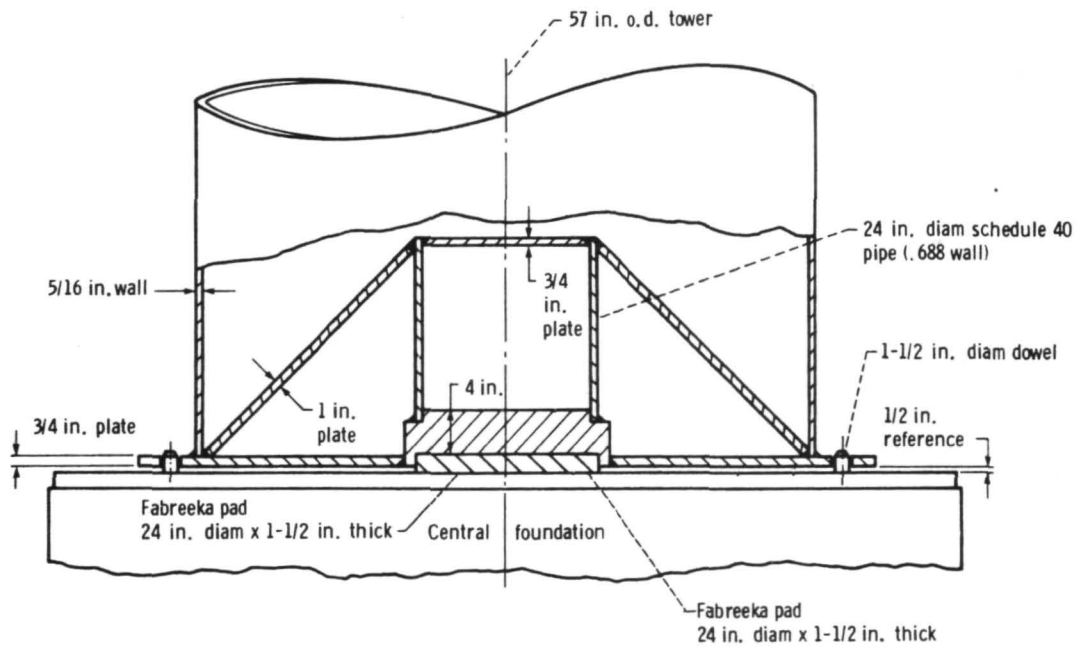

(e) Tower base detail - Configuration 3.

Figure 6. - Continued.

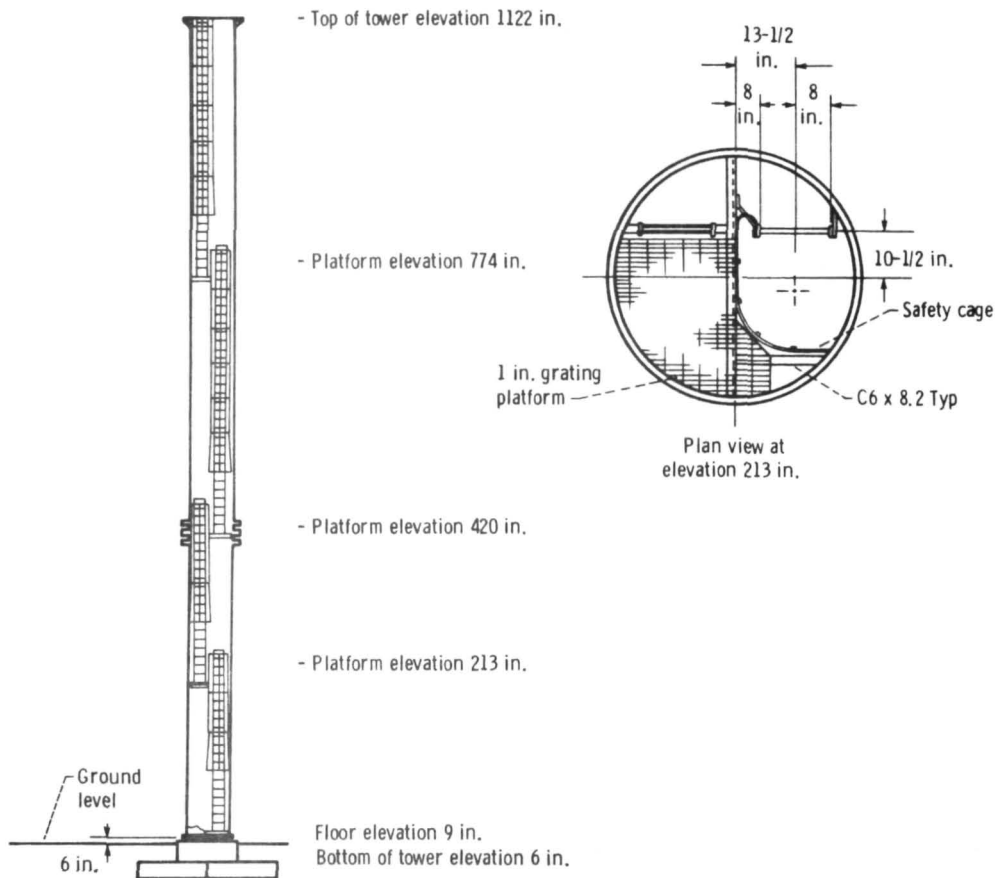

(f) Ladder and platform detail.

Figure 6. - Concluded.

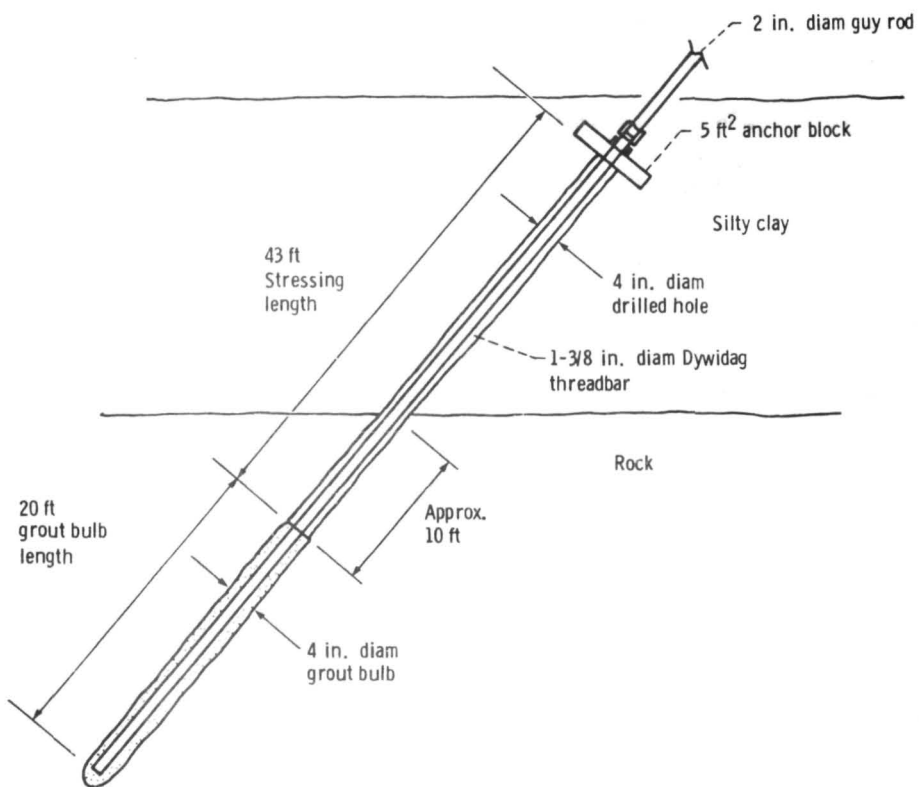

Figure 7. - Grouted soil anchor.

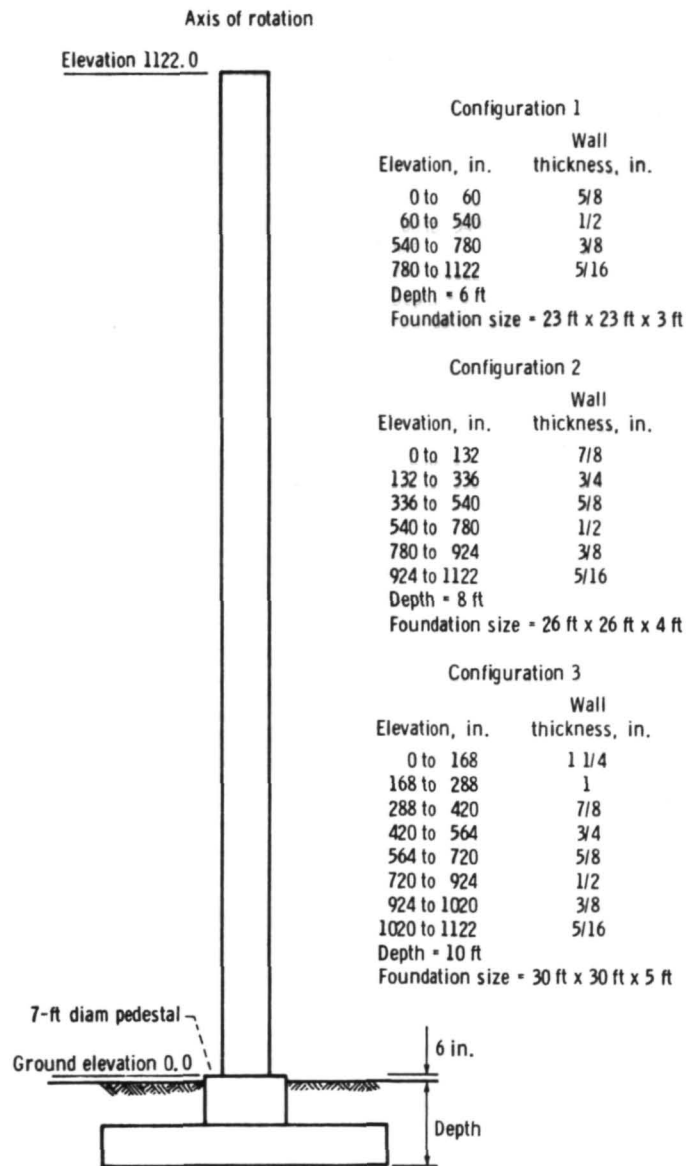

Figure 8. - Details of designs - cantilever towers and foundations.

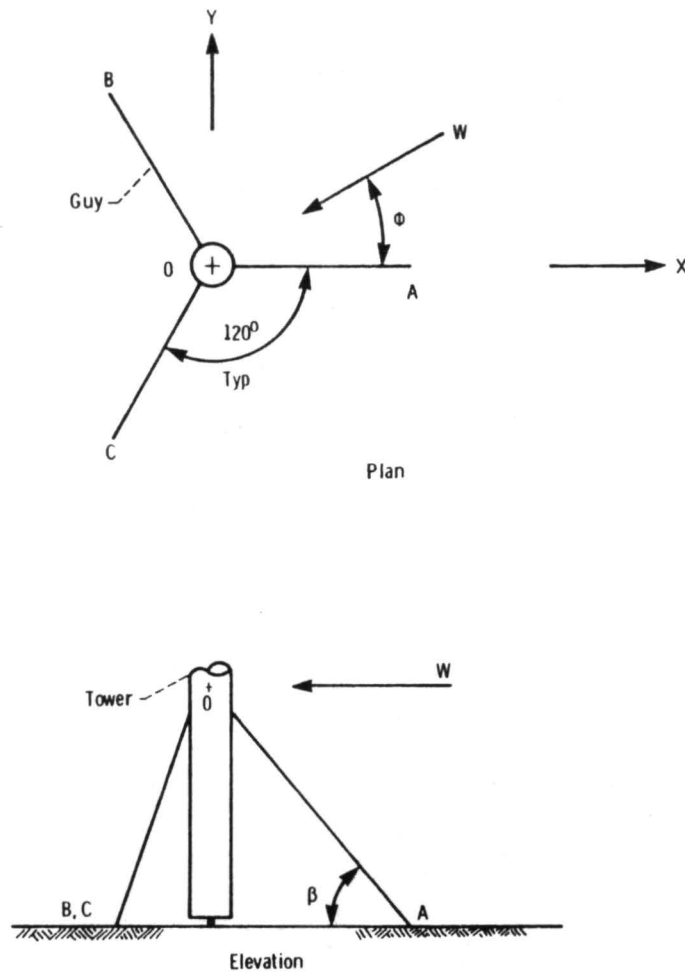

Figure A-1. - Coordinate system for guy rod force analysis.

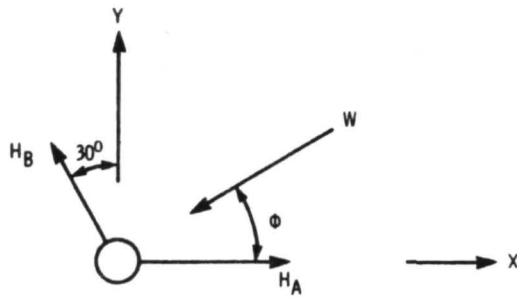

Figure A-2. - Force system for guy rod force analysis -  $0^\circ < \phi < 120^\circ$ .

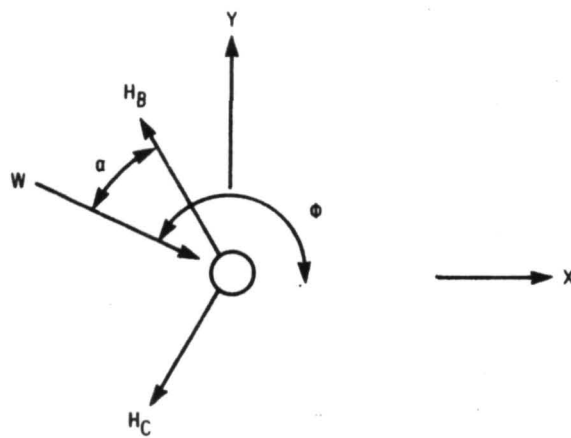

Figure A-3. - Force system for guy rod force analysis -  $120^\circ < \phi < 240^\circ$ .

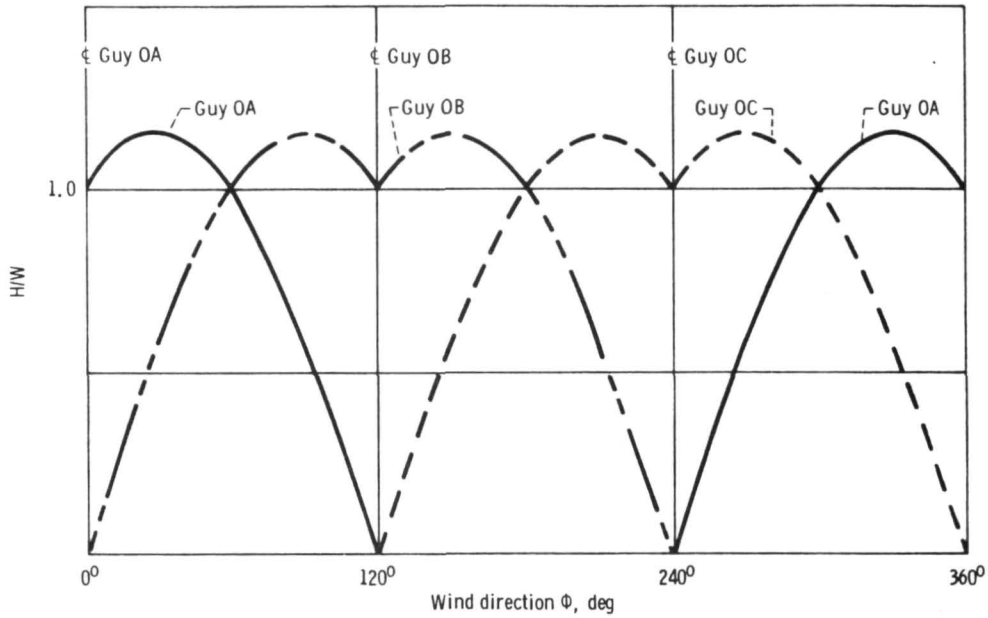

Figure A-4. - Variation of guy rod tension with direction of wind.

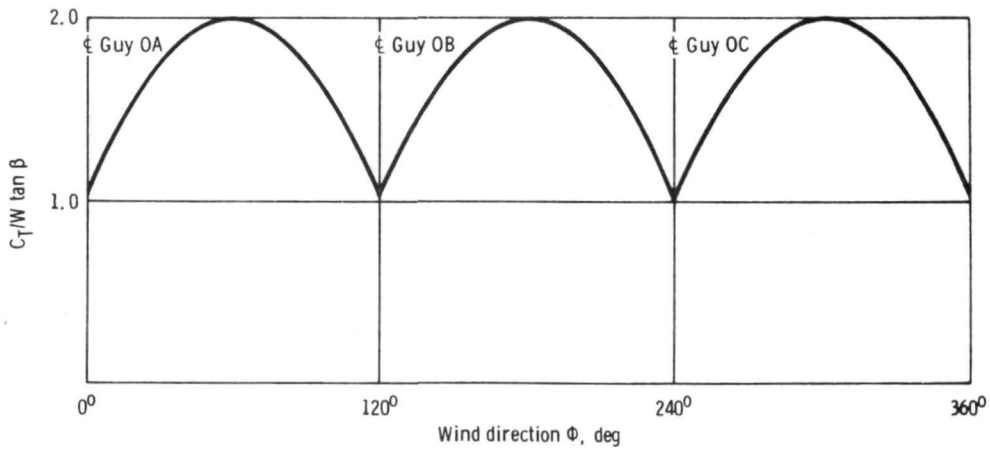

Figure A-5. - Compressive force in tower due to tension in guy rods.

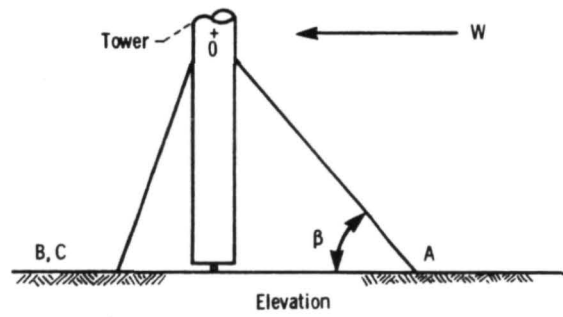
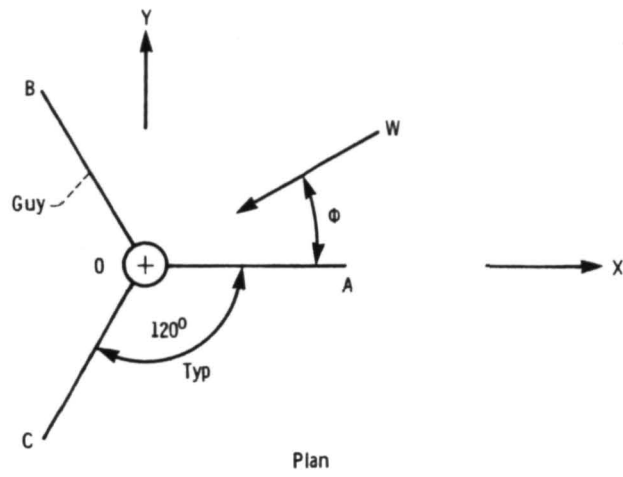

Figure B-1. - Coordinate system for guy rod force analysis.

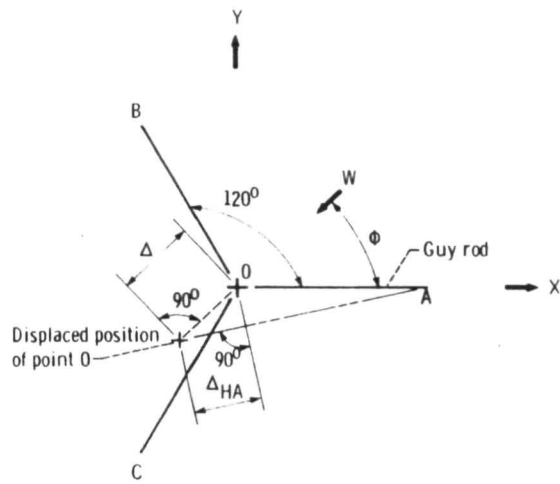

Figure B-2. - Displacement geometry for guy rod force analysis.

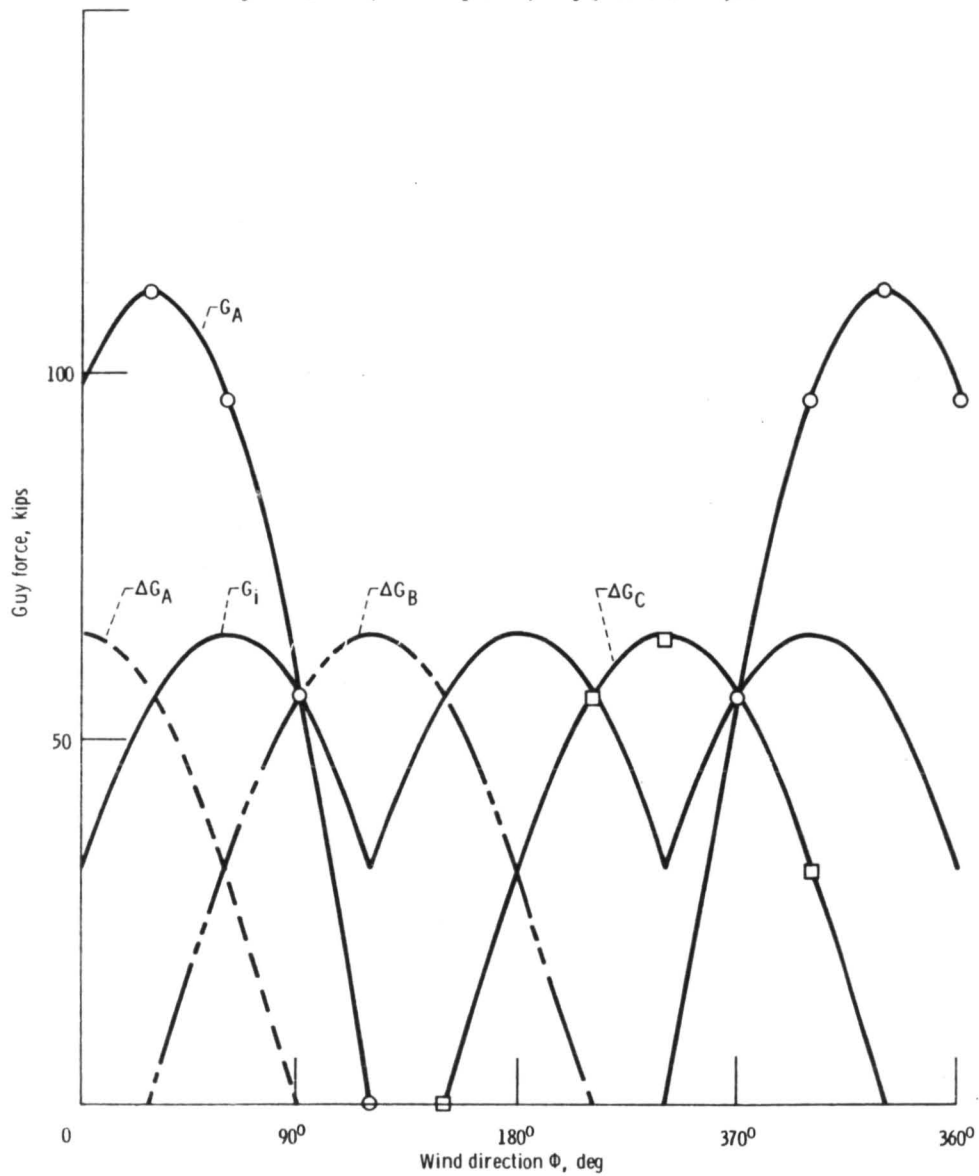

Figure B-3. - Variation of guy rod tension with direction of wind.



1. Report No NASA TM-82804	2. Government Accession No.	3. Recipient's Catalog No.	
4. Title and Subtitle <b>EFFECT OF ROTOR CONFIGURATION ON GUYED TOWER AND FOUNDATION DESIGNS AND ESTIMATED COSTS FOR INTERMEDIATE SIZE HORIZONTAL AXIS WIND TURBINES</b>		5. Report Date March 1982	6. Performing Organization Code 776-33-41
		8. Performing Organization Report No. E-1136	10. Work Unit No.
7. Author(s) G. R. Frederick, University of Toledo, and J. R. Winemiller and J. M. Savino, Lewis Research Center		11. Contract or Grant No.	
		13. Type of Report and Period Covered Technical Memorandum	
9. Performing Organization Name and Address National Aeronautics and Space Administration Lewis Research Center Cleveland, Ohio 44135		14. Sponsoring Agency Code DOE/NASA/20320-39	
		12. Sponsoring Agency Name and Address U. S. Department of Energy Division of Wind Energy Systems Washington, D. C. 20545	
15. Supplementary Notes Final report. Prepared under Interagency Agreement DE-AI01-76ET20320.			
16. Abstract Three designs of a guyed cylindrical tower and its foundation for an intermediate size horizontal axis wind turbine generator are discussed. The primary difference in the three designs is the configuration of the rotor. Two configurations are two-blade rotors with teetering hubs - one with full span pitchable blades, the other with fixed pitch blades. The third configuration is a three-bladed rotor with a rigid hub and fixed pitch blades. In all configurations the diameter of the rotor is 38 meters and the axis of rotation is 30.4 meters above grade, and the power output is 200 kW and 400 kW. For each configuration the design is based upon for the most severe loading condition - either operating wind or hurricane conditions. The diameter of the tower is selected to be 1.5 meters (since it was determined that this would provide sufficient space for access ladders within the tower) with guy rods attached at 10.7 meters above grade. Completing a design requires selecting the required thicknesses of the various cylindrical segments, the number and diameter of the guy rods, the number and size of soil anchors, and the size of the central foundation. The lower natural frequencies of vibration are determined for each design to ensure that operation near resonance does not occur. Finally, a cost estimate is prepared for each design. A preliminary design and cost estimate of a cantilever tower (cylindrical and not guyed) and its foundation is also presented for each of the three configurations. The estimated costs of the guyed towers and the cantilever towers are compared with the installed costs of truss type towers and foundations of the 200 kW Mod-0A wind turbines at Block Island and Culebra.			
17. Key Words (Suggested by Author(s)) Wind turbine towers Guyed towers		18. Distribution Statement Unclassified - unlimited STAR Category 44 DOE Category UC-60	
19. Security Classif. (of this report) Unclassified	20. Security Classif. (of this page) Unclassified	21. No. of Pages	22. Price*