

## **General Disclaimer**

### **One or more of the Following Statements may affect this Document**

- This document has been reproduced from the best copy furnished by the organizational source. It is being released in the interest of making available as much information as possible.
- This document may contain data, which exceeds the sheet parameters. It was furnished in this condition by the organizational source and is the best copy available.
- This document may contain tone-on-tone or color graphs, charts and/or pictures, which have been reproduced in black and white.
- This document is paginated as submitted by the original source.
- Portions of this document are not fully legible due to the historical nature of some of the material. However, it is the best reproduction available from the original submission.

51074  
Solar Pond Project

(NASA-CR-160619) SOLAR POND POWER PLANT  
FEASIBILITY STUDY FOR DAVIS, CALIFORNIA (Jet  
Propulsion Lab.) 73-1-10-304/M-A01

882-12613

CR-10A

88-112

11/84

00004

# Solar Pond Power Plant Feasibility Study for Davis, California

February 15, 1973

Prepared for

The City of Davis

under a Memorandum of Understanding

between the City of Davis and the Jet Propulsion Laboratory

Jet Propulsion Laboratory

California Institute of Technology

Pasadena, California

JPL PUBLICATION 82-104

5107-4  
Solar Ponds Project

# Solar Pond Power Plant Feasibility Study for Davis, California

Y.C. Wu  
M.J. Singer  
H.E. Marsh  
J. Harris  
A.L. Walton

February 15, 1982

Prepared for  
The City of Davis  
Through an Agreement with  
National Aeronautics and Space Administration  
by  
Jet Propulsion Laboratory  
California Institute of Technology  
Pasadena, California

(JPL PUBLICATION 82-16)

Reference to any Specific Commercial Product,  
Process, or Service by Trade Name or Manufacturer  
Does Not Necessarily Constitute an Endorsement by  
the U.S. Government or Jet Propulsion Laboratory,  
California Institute of Technology.

## ABSTRACT

The city of Davis, California, sponsored this study to determine the feasibility of constructing a solar pond power plant at Davis. The work was commissioned by Davis under an agreement with the National Aeronautics and Space Administration. Conducted by the Jet Propulsion Laboratory, Pasadena, California, the study included site visits, weather data compilation, soil and water analyses, conceptual system design and analyses, a material and equipment market survey, conceptual site layout, and a preliminary cost estimate.

Results of the study indicate that a solar pond power plant at Davis is technically feasible but economically unattractive. The relatively small scale of the proposed plant and the high cost of importing salt resulted in a disproportionately high capital investment with respect to the annual energy production capacity of the plant.

In the future, if low-cost hardware is developed and an economical source of salt becomes available, a reassessment of the concept would be warranted. Cycle optimization and increased plant size would also increase the economical attractiveness of the proposed concept.

## ACKNOWLEDGEMENTS

This study was conducted by the Jet Propulsion Laboratory through NASA Task RD-152, Amendment No. 313, and was sponsored by the city of Davis, California, (P.O. No. 01276) and the Pacific Gas and Electric Company.

The results presented in this report reflect the contribution of members of the Jet Propulsion Laboratory staff. Dr. Y. C. Wu was the principal investigator and provided overall task coordination. Major contributors to the study included Mr. M. J. Singer, System Analysis; Dr. H. E. Marsh, Soil and Water Chemistry; Mr. J. Harris, Construction and Cost Estimates; and Dr. A. L. Walton, Economic Analysis. In addition, the Pacific Gas and Electric Company, the city of Davis, and the University of California at Davis participated in the study by providing data, soil samples and independent analyses.

## CONTENTS

PART ONE: EXECUTIVE SUMMARY.....	1
PART TWO: SOLAR POND POWER PLANT FEASIBILITY STUDY FOR THE CITY OF DAVIS, CALIFORNIA.....	1-1
1. INTRODUCTION	
1.1 GENERAL BACKGROUND.....	1-3
1.2 STUDY GUIDELINES AND OBJECTIVES.....	1-3
2. SOLAR POND CONCEPT.....	2-1
3. DESIGN, ENVIRONMENTAL AND OTHER CONSTRAINTS	
3.1 DESIGN PARAMETERS AND CONSTRAINTS..	3-1
3.2 SITE ENVIRONMENTAL CHARACTERISTICS..	3-1
3.2.1 Climatic Characteristics.....	3-1
3.2.2 Soil Properties.....	3-1
3.2.3 Water Quality.....	3-3
4. SYSTEM CHARACTERISTICS	
4.1 THE BASELINE SYSTEM.....	4-1
4.1.1 The Solar Pond Complex.....	4-1
4.1.2 The Power Conversion Subsystem.....	4-1
4.1.3 Transport and Auxiliary Subsystems.....	4-1
4.2 GENERAL SYSTEM OPERATION.....	4-1
4.3 SYSTEM PERFORMANCE.....	4-3

5.	PLANT DESCRIPTIONS	
5.1	SOLAR POND COMPLEX.....	5-1
5.2	POWER CONVERSION SUBSYSTEM.....	5-1
5.2.1	The Turbogenerator Unit.....	5-1
5.2.2	Heat Exchangers.....	5-5
5.2.3	Feed Pump.....	5-5
5.2.4	Organic Fluid.....	5-5
5.3	TRANSPORT AND AUXILIARY SUBSYSTEMS.....	5-5
5.3.1	Hot Brine Loop.....	5-5
5.3.2	Cooling Water Loop.....	5-5
5.3.3	Surface Flushing, Brine & Fresh Water Make-Up.....	5-8
5.3.4	Wave Suppression Subsystem.....	5-8
5.3.5	Water Treatment Facilities.....	5-8
5.3.6	Miscellaneous Service Equipments.....	5-9
5.4	INSTRUMENTATION AND CONTROL.....	5-9
5.4.1	Climatological Data.....	5-9
5.4.2	Solar Pond Characteristics.....	5-10
5.4.3	Flow Stream Characteristics.....	5-10
5.4.4	Equipment Status.....	5-10
6.	START-UP AND OPERATION OF THE POND	
6.1	START-UP.....	6-1
6.2	OPERATION AND MAINTENANCE.....	6-1
7.	COST ESTIMATE	
7.1	CAPITAL COSTS.....	7-1
7.2	OPERATION AND MAINTENANCE COSTS.....	7-1
7.3	ENERGY COSTS.....	7-1



7.3.1	Busbar Electric Energy Costs.....	7-1
7.3.2	Thermal Energy Costs.....	7-3
8.	PROJECT MILESTONES AND CONSTRUCTION SCHEDULE	
8.1	PROJECT MANAGEMENT.....	8-1
8.2	SITE STUDY AND ENVIRONMENTAL EVALUATION.....	8-1
8.3	DESIGNS, SPECIFICATIONS AND GENERAL ENGINEERING.....	8-1
8.4	MATERIAL, EQUIPMENT AND SUPPLY ORDERS.....	8-1
8.5	POND CONSTRUCTION.....	8-1
8.6	INSTALLATION OF POWER CONVERSION, TRANSPORT AND AUXILIARY SUBSYSTEMS.....	8-1
8.7	FILLING OF THE SOLAR POND AND THE ESTABLISHMENT OF THE NECESSARY SALT GRADIENT.....	8-2
8.8	POND WARM-UP.....	8-2
8.9	PRELIMINARY OPERATIONS.....	8-2
9.	MISCELLANEOUS ISSUES	
9.1	CONTINUED SITE SPECIFIC EVALUATION.....	9-1
9.2	SUPPLYING THERMAL ENERGY FOR PROCESS USE.....	9-1
10.	CONCLUSIONS AND RECOMMENDATIONS.....	10-1
	REFERENCES.....	11-1
	APPENDIXES	
A.	PRELIMINARY LABORATORY ANALYSIS OF SOIL AND WATER SAMPLES.....	A-1
B.	NOTES AND DISCUSSIONS OF POND CONSTRUCTION AND POND LINING.....	B-1
C.	SOLAR POND POWER PLANT COST BREAKDOWN.....	C-1

FIGURES

1. Site Layout for a 300 kW<sub>e</sub> Solar Pond Power Plant at Davis.....2

2-1. The Solar Pond Electric Power Generation Concept.....2-3

3-1. Comparison of the Spectral Absorption.....3-1

4-1. The Proposed Davis Solar Pond Power Plant Flow Schematic.....4-2

4-2. Solar Pond Temperature and Power Output Profiles.....4-4

4-3. Daily Operating Hours of Solar Pond at 300 kW<sub>e</sub> Gross Output....4-5

5-1. Solar Pond Dike Reinforcement Schematic.....5-2

5-2. Maintenance Pond and Power Station Platform.....5-3

5-3. Proposed Power Cycle and Essential Components.....5-4

5-4. Wave Suppression Network, Inlet and Outlet Pipe Arrangement  
Schematic.....5-7

7-1. Solar Pond Power Plant Economy of Scale.....7-4

8-1. Tentative Project Milestones for the Davis 300 kW<sub>e</sub> Summer  
Peaking Solar Pond Power Plant Construction.....8-3

8-2. Solar Pond Construction Schedule.....8-4

A-1. Apparatus for Test of Soil Permeability.....A-2

A-2. Permeation of Water and Brine in Davis Pond Soil Sample.....A-3

A-3. Comparison of the Spectral Absorption.....A-7

B-1. Site Layout for a 300 kW<sub>e</sub> Solar Pond Power Plant at Davis.....B-2

B-2. Solar Pond Dike Reinforcement Schematic.....B-3

B-3. Maintenance Pond and Power Station Platform.....B-4

TABLES

1. Cost Summary of Davis Solar Pond Power Plant.....3

2. Cost Summary of an Alternate Davis Solar Pond Power Plant.....4

3-1. Climatic Data for the City of Davis.....3-2

5-1. Characteristics of Heat Exchangers.....5-6

7-1. 300 kW<sub>e</sub> Summer Peaking Solar Pond Power Plant Cost Summary.....7-2

C-1. Preliminary Solar Pond Construction Cost Estimate  
(1) Without Liner.....C-2

C-2. Preliminary Solar Pond Construction Cost Estimate  
(1) With Liner.....C-3

C-3. Cost Information for Various Subsystems, Miscellaneous Items,  
and Annual Operation and Maintenance.....C-5

C-4. Financial Parameters.....C-6

C-5. Typical Output of JPL Solar Pond Power Plant Economic  
Analysis Computer Program.....C-7

PART ONE  
EXECUTIVE SUMMARY

## EXECUTIVE SUMMARY

This report presents the results of a solar pond power plant feasibility study conducted for the city of Davis, California, and the Pacific Gas and Electric Company (PG&E). Davis has a land resource site that contains abandoned sewage evaporation ponds and experiences a daily summer electric demand peak. The concept of constructing salt gradient solar ponds in the abandoned sewage ponds and installing electric power conversion equipment to supply peaking electricity offers benefits to both the city and to PG&E. Approximately 170 acres of dry pond structures are available for conversion to solar ponds.

For study purposes, the following power plant requirements and configuration design guidelines were established:

- (1) Power plant gross output - 300 kW.
- (2) Operate plant 6 h/day from June through September.
- (3) Maximum use of existing dike structures.
- (4) Develop a new water well for the water supply.
- (5) Import salt.
- (6) Investigate the suitability of using existing ground clays for the pond liner.

Under the Department of Energy sponsorship, JPL has been involved in other similar feasibility studies; therefore, a significant data base and analytical capability were available to support this study. As a result, the study included site visits, weather data compilation, soil and water analyses, a material and equipment market survey, conceptual system design, generation of a conceptual site layout, and a preliminary cost estimate. In addition to this contracted effort, PG&E conducted site soil testings. Results will be available in a separate document. While conducting this study, a possible secondary application of supplying seasonal thermal energy to a nearby Hunt-Wesson tomato-processing plant was suggested; however, time and funding limitations prevented a detailed analysis of this application.

The baseline power plant configuration consists of a 17,100 m<sup>2</sup> (4.22 acres) solar pond, a 4,050 m<sup>2</sup> (1 acre) evaporation maintenance pond, a power station pad and water well (Figure 1-1). The solar pond is 2.55 m (8.4 ft) deep, and the plant is entirely self-contained.

The plant can operate at capacity from April to September (exceeding the design goal of June to September). Gross output will be 300 kW and net output will be 230 kW. Over a full year the plant will deliver  $0.3576 \times 10^6$  kWh of electrical energy to the grid. Alternatively, the solar pond can supply  $4.943 \times 10^6$  kWh of thermal energy at 85°C (185°F) or  $7.34 \times 10^6$  kWh at 60°C (140°F) to a thermal load.

The estimated total plant capital cost is \$2,142,000 (a summary breakdown is presented in Table 1). Power plant equipment includes the Rankine-cycle turbine generator, heat exchangers, and control subsystem. The transport and auxiliary subsystem includes the pipes and pumps to move hot brine and cooling water to the heat exchangers, in-pond pipes and diffusers, pond maintenance equipment and control, and monitoring equipment.

4  
Z

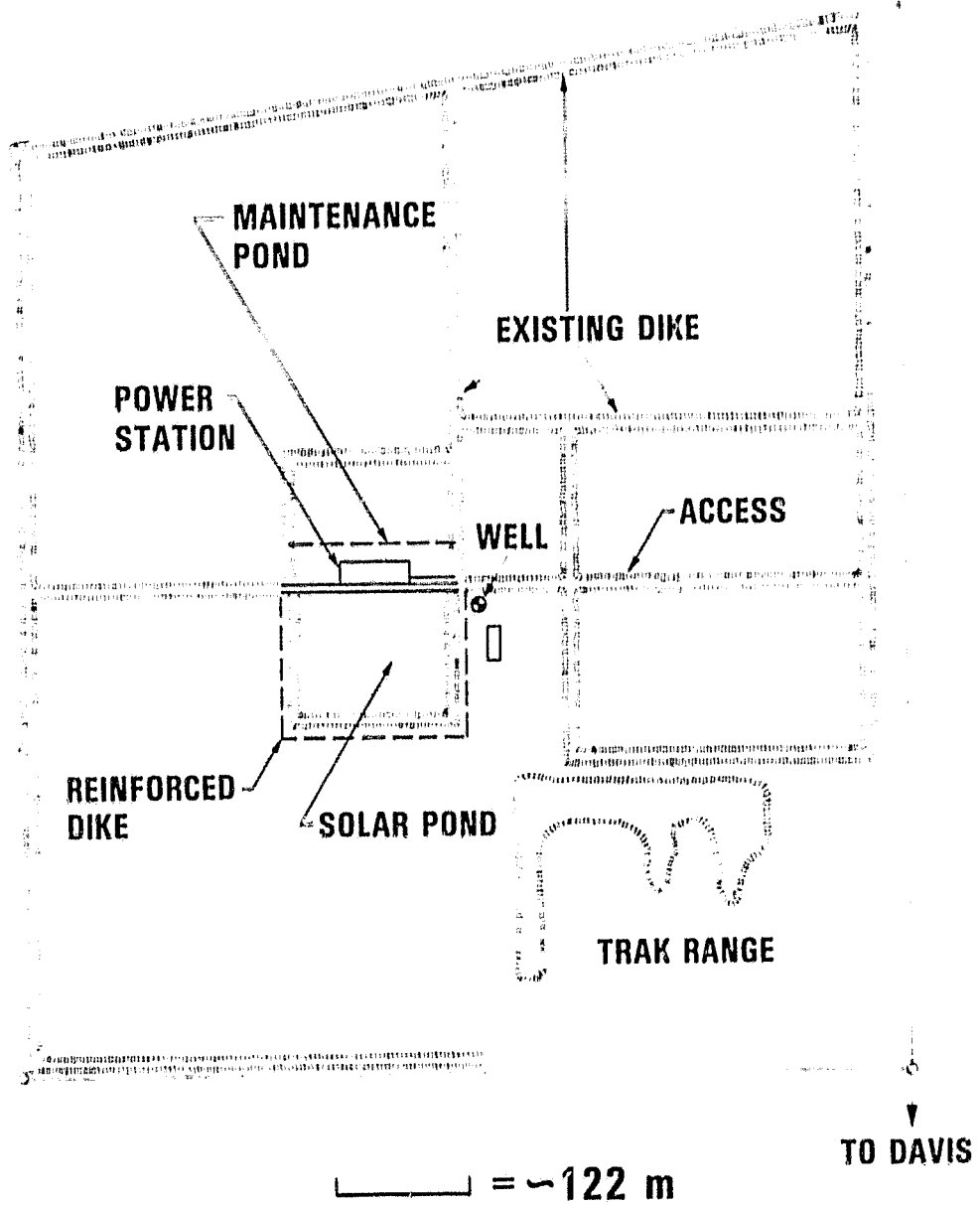

Figure 1. Site Layout for a 300 kW<sub>e</sub> Solar Pond Power Plant at Davis

From the outset of the study, salt for the solar pond was recognized as being a significant cost driver. PG&E and JPL independently researched

Table 1. Cost Summary of Davis Solar Pond Power Plant  
(4.2-Acre Pond, 300 kWe Installed Capacity)

Cost Items	Cost (1981\$)
Project Management	100,000
Designs and Specifications	100,000
Power Plant Equipment	536,000
Transport and Auxiliary Subsystems	604,000
Pond Construction	236,000
Salt	385,000
Liner	181,000
Total Capital Costs	2,142,000
Annual Operation and Maintenance Costs	73,000

the market and found that forty dollars per delivered ton was the best available price. This single element amounts to \$385,000.

The need for a synthetic liner in the solar pond is uncertain. PG&E conducted soil tests and found clay type soils at the surface and below grade. JPL conducted laboratory tests on a single-surface sample. The results of the tests showed that the surface clay was not sufficiently impermeable. Therefore, for purposes of this study, a liner has been included. The question, however, remains open concerning the suitability of below-grade materials.

The optical quality of the underground water at Davis is extremely good. A high-performance pond will result from its use.

A 300-kW peaking plant and a 4.22-acre solar pond at Davis is clearly not cost effective. The projected busbar electric energy cost is 1,451 mills/kWh. If the pond is used to supply thermal energy for industrial process use, the estimated thermal energy costs are \$22.37/million Btu and \$15.05/million Btu for temperatures of 85°C (185°F) and 60°C (140°F), respectively. System optimization to achieve better performance and clay substitution for the proposed synthetic liner might produce a 30% reduction in busbar energy costs but cannot

make the plant cost effective. Several factors combine to produce these results:

- (1) The plant is small and achieves no economy of scale. The large cost elements related to the power plant and transport equipment are strongly size-dependent. At the 300-kW level these costs normalize to \$3800/kW installed. From studies related to the Salton Sea experiment, power plant and transport system costs are \$2240/kW installed for a 5-MW plant and \$1230/kW for a 600-MW plant.
- (2) The plant has been designed as a peaking unit, and the load factor is low: 18%. The same power conversion unit could run at a baseload level with a 20- to 25-acre solar pond and produce 5 times more energy per year.
- (3) The cost of salt and the synthetic liner account for 26% of the total installed cost. This is an expense that a more favorable site, e.g., the Salton Sea or south San Francisco Bay, would not incur.

Lower busbar electric energy cost could be realized by developing the full potential of the site with a baseload power plant. To illustrate this potential, an extrapolated estimate of the costs for a 100 acre solar pond power plant at the site was made, and the results are summarized in Table 2. The results indicate a busbar electric energy cost of 433 mills/kWh. In the future, a lower-cost power conversion system might be developed that could also significantly change the results of this study.

Table 2. Cost Summary of an Alternate Davis Solar Pond Power Plant (100-acre Pond, 1.20 MW<sub>e</sub> Installed Capacity)

Cost Items	Cost (1981\$)
Project Management	500,000
Design and Specification	500,000
Power Conversion, Transport and Auxiliary Subsystem	3,240,000
Pond Construction	1,337,000
Salt	7,485,000
Liner	3,793,000
Total Capital Costs	16,855,000
Annual Operation and Maintenance Costs	400,000
Annual Power Output:	$8.76 \times 10^6$ kWh <sub>e</sub>
Busbar Energy Cost:	433 mills/kWh <sub>e</sub>



PART TWO

SOLAR POND POWER PLANT FEASIBILITY STUDY  
FOR THE CITY OF DAVIS, CALIFORNIA

PRECEDING PAGE BLANK NOT FILMED

## SECTION 1

### INTRODUCTION

#### 1.1 GENERAL BACKGROUND

The city of Davis, California, is a leader in energy conservation and energy management. Davis was the first city in California to institute building energy standards and continues to provide innovative solutions to energy consumption problems. The Pacific Gas and Electric Company (PG&E) is very supportive of the efforts of Davis, and the utility and the city at times undertake cooperative projects.

The climate of Davis is characterized by high summer afternoon temperatures. As a result, air conditioning loads and electric energy demands are high from June to September. Electric power production using solar energy appears to have merit because solar energy availability will closely match the load demand.

One of the solar options that is being examined for electric power production is the salt gradient solar pond (solar pond). Davis owns approximately 170 acres of land along the city's northern boundary. A hope exists for developing a portion of this area into an energy park. The site consists of predominantly dry evaporation ponds, which were formerly part of a sewage treatment plant. The ponds are about 1.52 m in depth and have a clay soil base.

The city of Davis, in partnership with PG&E, commissioned the Jet Propulsion Laboratory (JPL) to conduct a small plant feasibility study. The study was constrained in time and budget and therefore was limited in scope.

#### 1.2 STUDY GUIDELINES AND OBJECTIVES

The study focuses on the cost and technical feasibility of constructing a solar pond power plant on the Davis site. The conceptual design is based upon "off the shelf" hardware, imported salt and maximum utilization of an existing pond structure. For study purposes the plant is designed to:

- (1) Develop 300 kW gross power output.
- (2) Operate for a minimum of 6 h/day from June to September.
- (3) Prevent saline contamination of the underground water system.
- (4) Include a water well for the fresh water supply.

The specific objectives of the study are to:

- (1) Size the solar pond.
- (2) Develop a conceptual power plant design.
- (3) Predict system performance.
- (4) Estimate total plant cost.
- (5) Estimate a construction schedule.

A secondary objective was added to the study to evaluate the possibility of providing seasonal solar pond thermal energy for a nearby Hunt-Wesson tomato-processing plant.

## SECTION 2

### THE SOLAR POND CONCEPT

A solar pond is a body of water that converts solar energy into thermal energy. Currently, research is being conducted to develop several classifications of ponds typically labeled "salt gradient," "saturated," "shallow" and "membrane." Among these classifications the salt gradient pond is receiving the most attention because of its inherently large thermal storage capacity, potentially lowest cost and capability of coupling with electric power generation equipment. For these reasons, a salt gradient pond (hereafter referred to simply as pond or solar pond) is proposed for the Davis application.

In a normal body of water a portion of the solar radiant energy penetrates into the sub-layers. As the radiant energy passes through successive layers, it is gradually absorbed and causes the water to warm. The warming decreases the density and the water rises, carrying with it the absorbed solar energy. At the surface the energy is lost to the atmosphere by radiation, evaporation, and convection. Thus, the body of water remains cool.

In a salt gradient solar pond density is made to increase with depth. This condition is achieved with a high salt concentration at the bottom and a low concentration at the surface. With a sufficiently high salt concentration or density, lower zone waters can absorb solar energy and yet remain denser than the waters immediately above. Convective currents are eliminated; therefore, the lower zone waters remain in place and continue to absorb solar energy. Temperatures approaching 100°C (212°F) have been observed in the bottom zone of working solar ponds.

Salt gradient ponds are typically large bodies of salt water, 2.5 to 5-m deep. The specific gravity of the bottom layer is 1.2 or greater while the surface is maintained near 1.0. The ponds, depending on size and depth, are capable of storing tremendous amounts of thermal energy and, therefore, can supply energy on a continuous 24-h/day basis. In electric power generation applications solar pond power plants can deliver base-load power with load factors of 0.8 to 0.9, or they can be operated at high output levels to meet peak demands.

In practice a solar pond will have three distinct layers or zones: an upper convective layer, a middle non-convective layer, and a bottom storage layer. The upper convective layer, which has a very low uniform salt concentration, is 0.15- to 0.3-m thick; it exists because of wind-induced mixing and diurnal effects of heating and cooling. The energy absorbed by the upper layer is lost; therefore, efforts must be taken to minimize its thickness.

The non-convective layer, also known as the gradient zone, is 1.0 to 1.3-m deep with salt concentration increasing with the depth (from less than 4% at the top to as high as 25% at the bottom). This zone is the key to the successful operation of a solar pond. It allows radiant energy to penetrate to the lower zone and acts as an insulator between the bottom and upper layers, a function similar to the glazing layer of a flat plate collector.

The bottom, or storage, zone is convective with a uniform high salt concentration. This zone may be 1- to 4-m deep, depending on the storage needs of a specific application.

The types of salt that can be used in a solar pond include sodium chloride, magnesium chloride, sodium carbonate, sodium sulfate and others. The basic requirement is high solubility and transparency. The amount of salt required for initial start-up is large, ranging from 550 to 900 kg/m<sup>2</sup> of pond area.

During the normal operation of the pond, salt will gradually diffuse from the bottom to the surface layer. This action tends to degrade the salt gradient. In order to maintain the necessary salt gradient, the surface layer must be flushed with fresh or low salinity water from time to time. Meanwhile, high salinity brine must be injected into the bottom layer to make up the salt loss.

Figure 2-1 is a schematic diagram of a solar pond power plant. The solar pond transforms solar energy into thermal energy, and a Rankine-cycle heat engine converts the thermal energy into shaft power that in turn produces an electric output. Cold water for condensing the organic fluid may be taken from the upper convective zone of the pond or from any other convenient source.

A solar pond in a high insolation zone can achieve a working storage zone temperature of 80 to 85°C (176 to 185°F) and a thermal energy collection efficiency of 15 to 20%. The conversion of the thermal energy to electric energy will be 8 to 9% efficient and produce an overall solar to electric efficiency of 1.0 to 1.5%. Although the efficiency appears to be low, a salt gradient solar pond electric power system can be economically viable because it can be built from low cost materials and components.

Salt gradient solar ponds have been built and put into service in various countries of the world since the 1960s. The most notable ponds are located at Ein Bokek on the Dead Sea in Israel, at Miamisburg, Ohio, and at Albuquerque, New Mexico. A large solar pond power plant experiment is also being planned at the Salton Sea in Southern California. The technology is ready for applications.

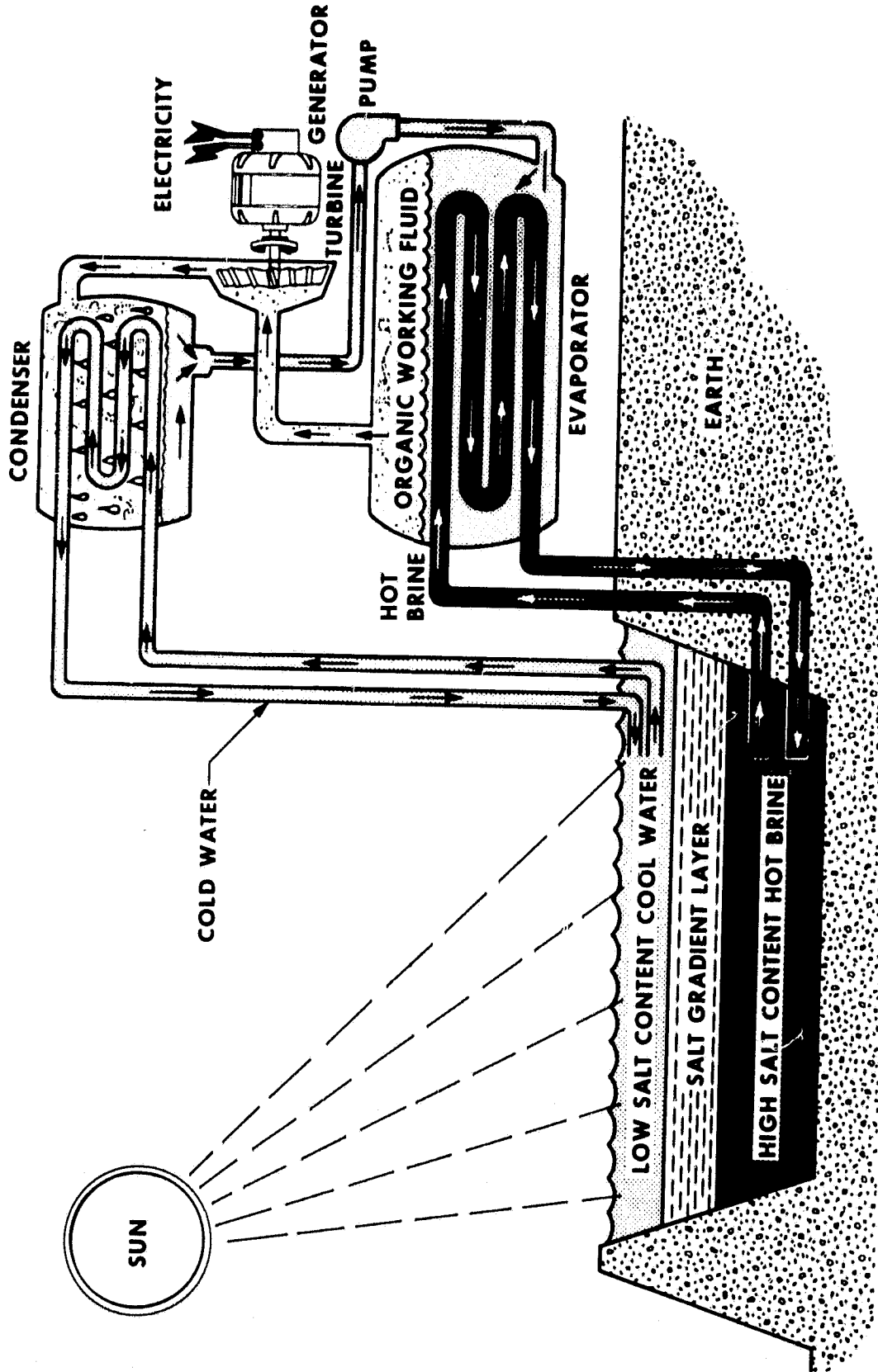

Figure 2-1. The Solar Pond Electric Power Generation Concept

## SECTION 3

### DESIGN, ENVIRONMENTAL AND OTHER CONSTRAINTS

#### 3.1 DESIGN PARAMETERS AND CONSTRAINTS

The following design parameters and constraints were established for this investigation:

- (1) The solar pond and the evaporation pond are to make maximum use of the existing abandoned sewage treatment ponds.
- (2) If possible, locally available clay materials shall be used as the pond lining material.
- (3) All required salt is to be imported.
- (4) Local ground water is to be developed for filling and maintaining the pond.
- (5) The plant will be designed to produce as a minimum, 300 kW gross output for 6 h/day from June to September.
- (6) The mechanical components will be off-the-shelf where they are available, similar to those used by Ormat Turbines, Ltd. of Israel (Reference 1).
- (7) Mechanical subsystem cost estimates will be based upon Ormat equipment.

#### 3.2 SITE ENVIRONMENTAL CHARACTERISTICS

##### 3.2.1 Climatic Characteristics

Pertinent climatic information is compiled and summarized in Table 3-1. The data are mostly compiled from the recorded data for the city of Davis. Sacramento data is used to fill data gaps.

##### 3.2.2 Soil Properties

Use of on-site materials is desirable in the construction of the ponds. The material must have the qualities of (1) forming an impermeable pond liner to prevent seepage of brine and (2) not reacting with the hot brine to generate H<sub>2</sub>S gas, which could adversely affect the salinity gradient.

Preliminary soil characteristics were determined from a laboratory analysis of a soil sample taken from the bottom surface at one location of one of the abandoned ponds. The results are reported in Appendix A. The results indicate that (1) the surface soil does not have adequate sealing properties; it is more silt-like than clay-like; and (2) there is no evidence that potential heat-stimulated, gas-producing biological activity exists.

Table 3-1. Climatic Data for the City of Davis

MONTH	EVAPORATION <sup>a</sup> m/s x 10 <sup>-9</sup>	PRECIPITATION <sup>a</sup> m/s x 10 <sup>-9</sup>	WIND <sup>b</sup> AVE. m/s	WIND <sup>b</sup> MAX m/s	AVE. MIN. <sup>b</sup> TEMP °C	AVE. MAX. <sup>b</sup> TEMP °C	AVE. TEMP <sup>a</sup> °C	AVE. REL. HUMIDITY <sup>a</sup> MORNING %	HUMIDITY <sup>a</sup> AFTERNOON %	INSOLC W/m <sup>2</sup>
JAN.	12.69	35.4	3.44	26.82	2.8	11.7	7.3	85	70	84
FEB.	22.12	27.9	3.49	22.80	4.7	15.1	9.9	79	61	118
MAR.	39.20	20.6	4.02	29.50	5.4	17.8	11.7	68	51	187
APR.	62.11	15.1	4.02	20.12	7.4	21.8	14.6	58	43	254
MAY	88.35	5.0	4.20	15.65	9.9	26.0	18.0	51	36	305
JUN.	05.32	1.0	4.47	21.01	12.6	30.2	21.4	47	31	332
JUL.	10.89	0.1	4.11	16.09	14.2	33.8	24.0	47	28	333
AUG.	98.19	0.5	3.89	16.99	13.8	32.9	23.3	49	29	298
SEPT.	81.40	1.9	3.49	18.78	12.9	30.9	21.9	51	31	243
OCT.	52.27	9.4	3.00	30.40	9.7	25.1	17.4	57	39	168
NOV.	25.08	20.9	2.82	31.29	5.8	17.6	11.7	75	59	107
DEC.	12.32	29.6	3.13	31.29	3.5	11.8	7.6	84	70	75
AVERAGE	59.10	13.9	3.67	8.6	22.9	15.7	63	46	209	

a DAVIS (5/26-11/79)

b SACRAMENTO (1959-->1978)

c DAVIS (1/57-12/76) - averaged over entire day



The Davis soil sample failed, in the permeation tests, to form an expanded gel with water, which is characteristic of good sealing clays. Both water and brine permeated the material at a rate approximately 200 times as fast as the acceptable seepage rate recommended by Ormat, Ltd. (Reference 1). Not one of three tests of the Davis soil sample for pond-degrading microbial activity showed any signs of gassing. This is promising, and some optimism can be attached to the results since one of the tests was designed as worst case with maximum potential for hydrogen sulfide generation.

Because the Davis soil sample was obtained from the surface layer, the permeation test results cannot be considered conclusive. The clay from lower layers should be further tested to provide more complete information on the applicability of the soil as lining material.

### 3.2.3 Water Quality

The transmission of light through the upper convective and gradient zone directly affects the performance of a solar pond; therefore, concerns over the quality of water in solar pond application are mainly related to the quality of optical transmissivity. For this reason, a water sample from a water well at the proposed site was studied. The results are reported and discussed in Appendix A. In summary, (1), because the well water is excellent, no decolorization is considered necessary although usual settling and filtration may be desirable; and (2) because the study does not contain the effects of salt, study of candidate salt effects on light transmission should be conducted in the future.

Figure 3-1 shows the water light absorptivity of Davis water, distilled water, and Salton sea water within the light wavelength of interest to solar pond application. In general, clear water absorbs very little light in the 400 to 700 nm range. If the water is turbid, significant absorption will show up in this range. Whether or not dissolved absorbers are present, water absorbs considerable light in the range above 700 nm. Effects of dissolved substances are in the blue end, 500-nm or lower, of the spectrum. These effects are clearly shown in Figure 3-1 between Salton Sea water and distilled water. The optical quality of the Davis water, as can be seen, is better than the treated Salton sea water and is almost as good as the distilled water.

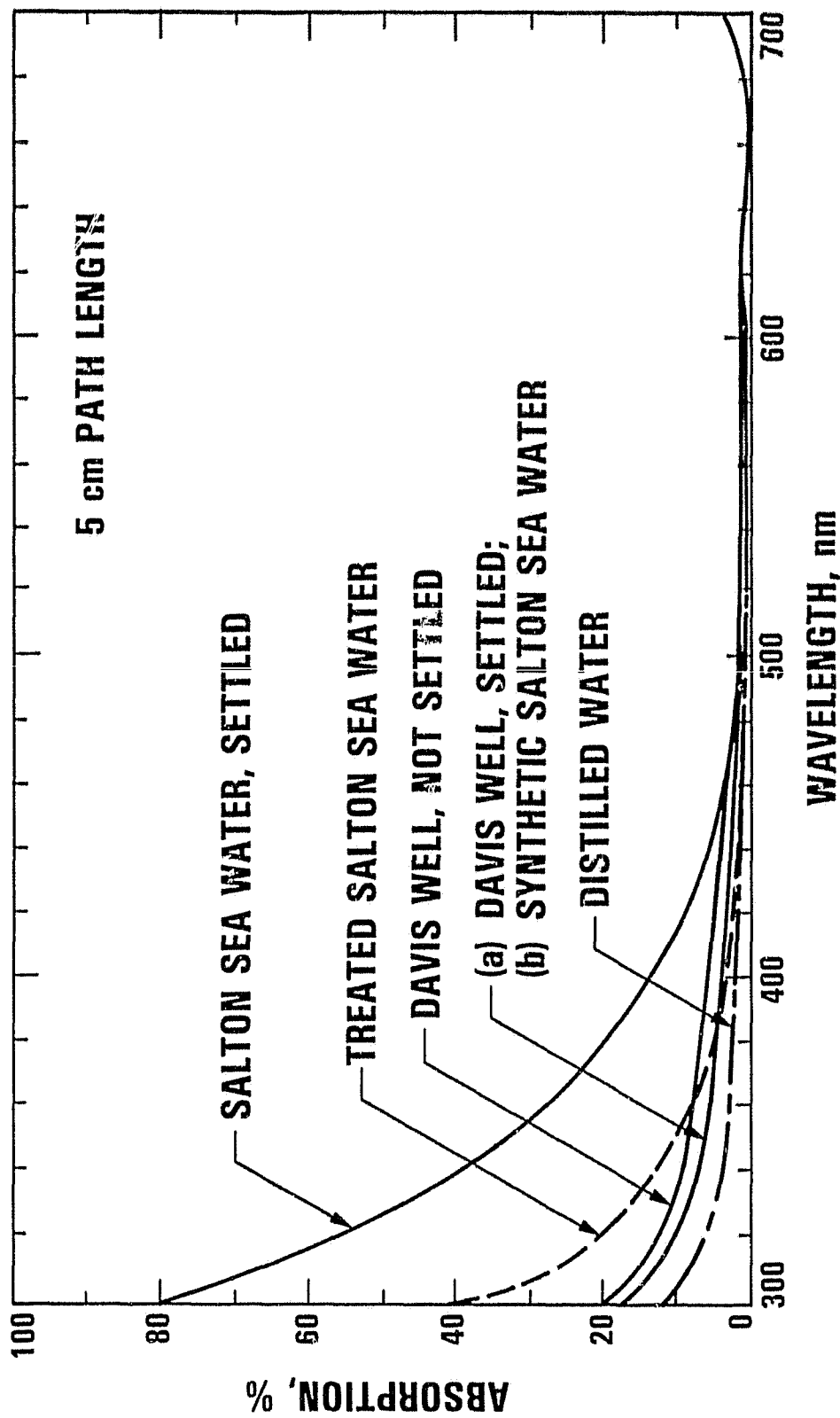

Figure 3-1. Comparison of the Spectral Absorption

## SECTION 4

### SYSTEM CHARACTERISTICS

#### 4.1 THE BASELINE SYSTEM

The selected baseline power plant will deliver 300 kW<sub>e</sub> gross output for at least 6 h/day to meet the peak demands experienced by the city of Davis during the summer months. The system has no redundant components because non-operating time is sufficient for repair and regular maintenance.

Figure 4-1 shows a flow diagram of the baseline system. Its main subsystems are briefly described below. The physical plant and its essential components will be described in more details in Section 5.

##### 4.1.1 The Solar Pond Complex

The solar pond complex consists of a solar pond 17,100 m<sup>2</sup> (4.22 acres) in area and 2.55 m deep, an evaporation pond of 4,050 m<sup>2</sup> (1 acre) in size, and a power plant site. Pond area is measured at the gradient zone-storage zone interface.

##### 4.1.2 The Power Conversion Subsystem

The power conversion subsystem is a 300-kW organic Rankine turbine system that contains the following essential components: an organic Rankine turbine, a generator, a vaporizer (or boiler) including a separator, a preheater, a regenerator, a feed pump, a condenser and the connecting pipe lines.

##### 4.1.3 Transport and Auxiliary Subsystems

Elements in this category include a hot brine loop, cooling water loop, fresh water make-up line, brine make-up line, solar pond blow down line, water treatment facilities, and wave suppression system.

#### 4.2 GENERAL SYSTEM OPERATION

The general operation of the power system is best explained by following the flows shown in Figure 4-1. In steady state operation, hot brine from the solar pond is pumped through the vaporizer and the preheater to transfer the thermal energy to the organic working fluid; it is then returned to the storage layer.

In the vaporizer, the working fluid of the power cycle is vaporized at a modest pressure and directed to the turbine. Expansion through the turbine produces shaft rotation to drive the generator. After expansion to a lower pressure, the vapor passes through the regenerator, rejects part of its thermal energy, and then condenses into liquid in the condenser. The feed pump sends the liquid to the regenerator for preheating before returning it to the vaporizer to complete the cycle.

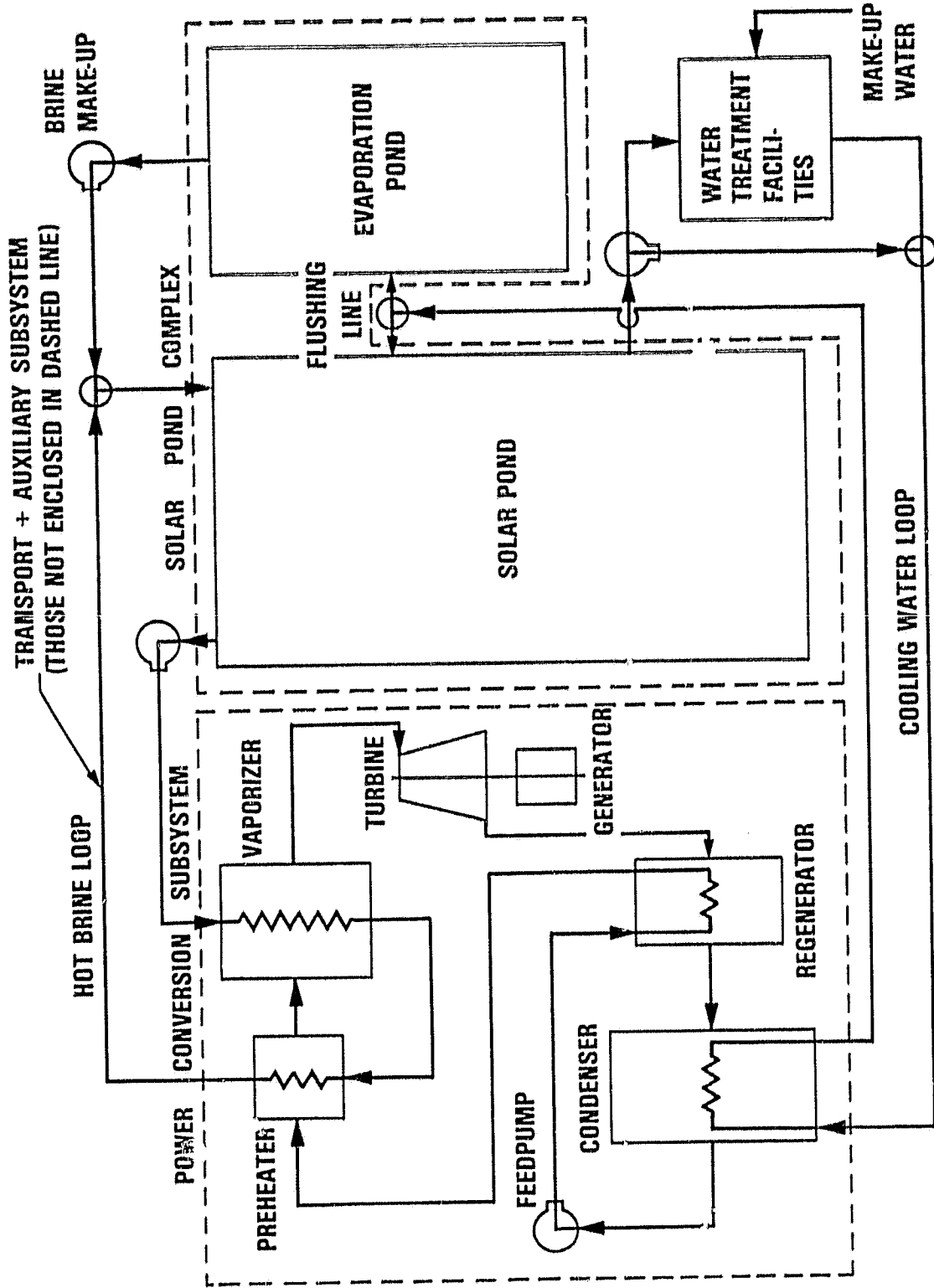

Figure 4-1. The Proposed Davis Solar Pond Power Plant Flow Schematic

Under normal operating conditions, the cooling water loop circulates water from the surface layer of the solar pond through the condenser and back to the surface layer. Intermittently, when the salt concentration of the surface layer reaches a critical level, the returned cooling water is flushed into the evaporation pond through the flushing line. In order to make up the water loss by flushing and evaporation, fresh make-up water is supplied from time to time through the cooling water loop. The fresh water is normally treated in a water treatment facility before it enters the system. When necessary, the cooling water from the surface layer can also be pumped through the water treatment facility before it goes to the condenser.

The brine make-up line runs from the evaporation pond to the hot brine line for regular brine make-up to the storage layer of the solar pond.

### 4.3 SYSTEM PERFORMANCE

Solar pond performance varies as a function of both design and operating specifications. In general, a pond with a shallow thermal storage layer (lower convecting zone) will provide peak output during summer and no output during winter months. A pond with a larger thermal storage layer (>2 m) can provide a more constant level of power generation throughout the year.

A performance analysis was made for the baseline system. The pond supplies thermal energy to the power conversion subsystem at a constant temperature of 85°C (185°F) from April to September. The annual-average pond thermal and power plant net electrical outputs during the fourth year of operation are 33.00  $W_t/m^2$  and 2.39  $W_e/m^2$ , respectively. For a 17,100- $m^2$  (4.22-acre) solar pond, this represents an annual-average net electrical output rate of 40.82  $kW_e$  ( $0.3576 \times 10^6/kWh_e/yr$ , or  $4.9433 \times 10^6 kWh_t/yr$ ). The electrical output and storage zone temperature profiles are shown in Figure 4-2, while the number of hours the plant operates per day is shown in Figure 4-3. Analysis of these profiles indicates that the solar pond power plant will produce a nominal 300  $kW_e$  (gross) output for at least 6 h/day from approximately April 21 to September 10.

If thermal energy is extracted at 60°C (140°F), the annual averaged thermal energy output will be 48.77  $W_t/m^2$  which amounts to an annual total output of  $7.34 \times 10^6 kWh_t$ .

Warm-up times for a 2.55-m deep solar pond at Davis will be from 105 to 120 days if heating begins at the spring equinox (March 21).

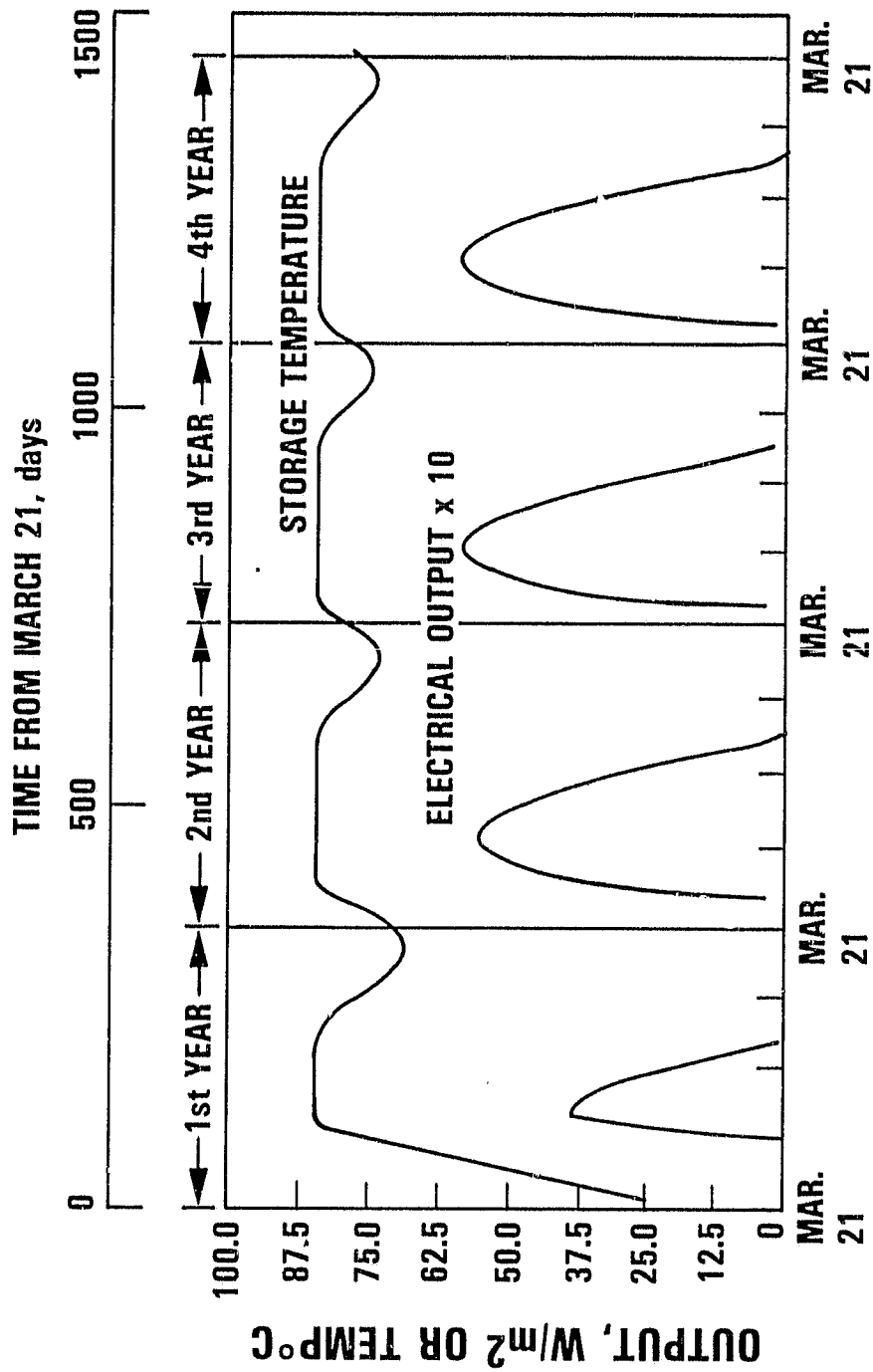

Figure 4-2. Solar Pond Temperature and Power Output Profiles

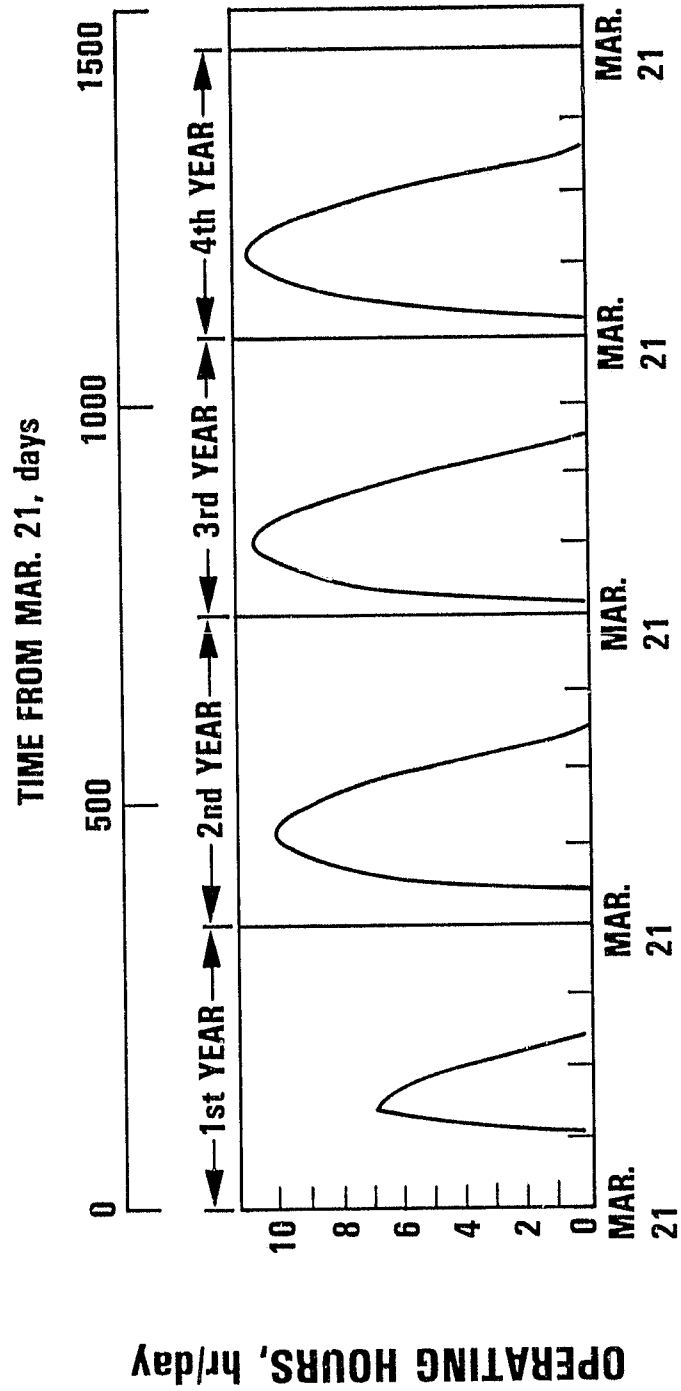

Figure 4-3. Daily Operating Hours of Solar Pond at 300 kW<sub>e</sub> Gross Output

## SECTION 5

### PLANT DESCRIPTIONS

#### 5.1 SOLAR POND COMPLEX

The solar pond complex consists of the solar pond, evaporation pond for maintenance purposes, power plant site, and a water well. A layout of the entire complex is shown in Figure 1-1 (adapted from Reference 2). The complex is sited on an abandoned surface sewage treatment farm situated about two miles north of the city of Davis, California.

The solar pond will be constructed within an existing pond by excavating 0.61 m from the present pond floor. It will have a total surface area, measured at the upper level of the storage zone, of 17,100 m<sup>2</sup> (4.22 acres). The pond will have a total depth of 2.55 m, which consists of 0.25 m of surface layer, 1.30 m of nonconvecting zone, and 1.00 m of storage zone.

The dike is raised by 1.52 m with a 2:1 slope (Figure 5-1) by using all the excavated earth for this purpose.

The evaporation or maintenance pond is 4,050 m<sup>2</sup> (1 acre) in area and is created by a strip of the existing pond on the north side of the solar pond. Extra excavation of 0.91 m from the original floor will be made.

A power plant platform is built on the dike, separating the solar pond from the evaporation pond. Figure 5-2 shows the construction of the evaporation pond and the platform.

The original plan was to use the local clay for the sealing of the ponds; however, analysis of one soil sample indicated that local clay may not be adequate for sealing purpose. An artificial liner may be required.

More pond construction details and discussions on the lining of the ponds and salt supply are given in Appendix B.

#### 5.2 POWER CONVERSION SUBSYSTEM

The power conversion subsystem can be purchased from Ormat as a single supplier, however, components can also be supplied by other U.S. suppliers. The main components of the subsystem are shown in Figure 5-3 (see also Figure 4-1) and are further explained below:

##### 5.2.1 The Turbogenerator Unit

This unit consists of an organic Rankine turbine, a generator, and the necessary gear box and controls. The unit selected will have 300 kW gross output capacity and can be obtained from Ormat. Because of its low-temperature operation condition, the turbine has an exceptionally long life and requires minimal maintenance.



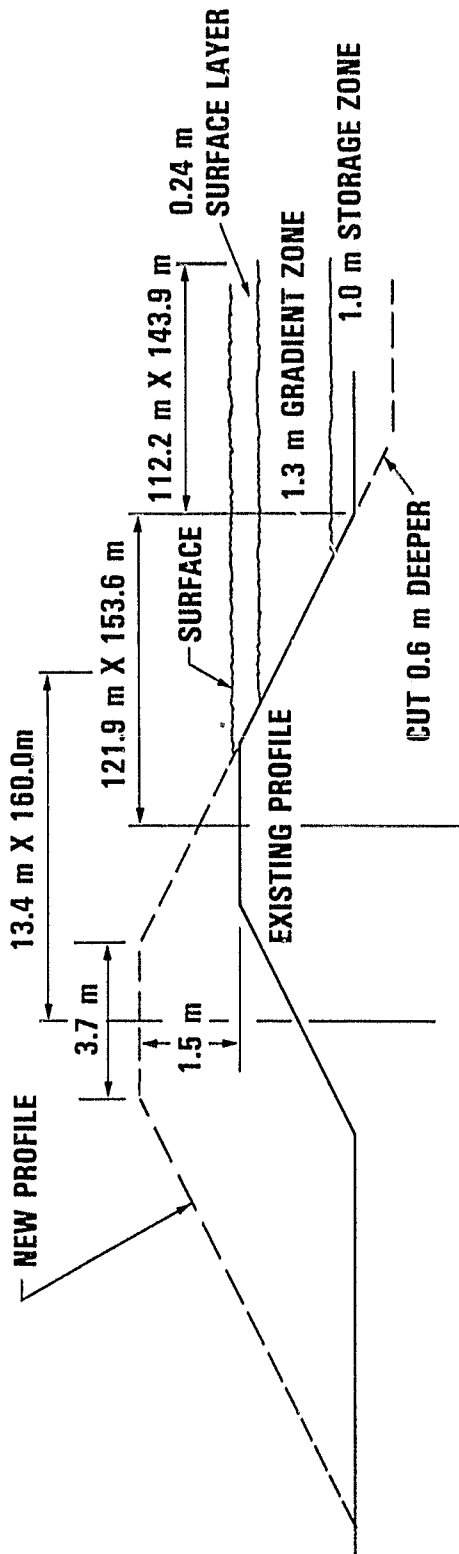

Figure 5-1. Solar Pond Dike Reinforcement Schematic

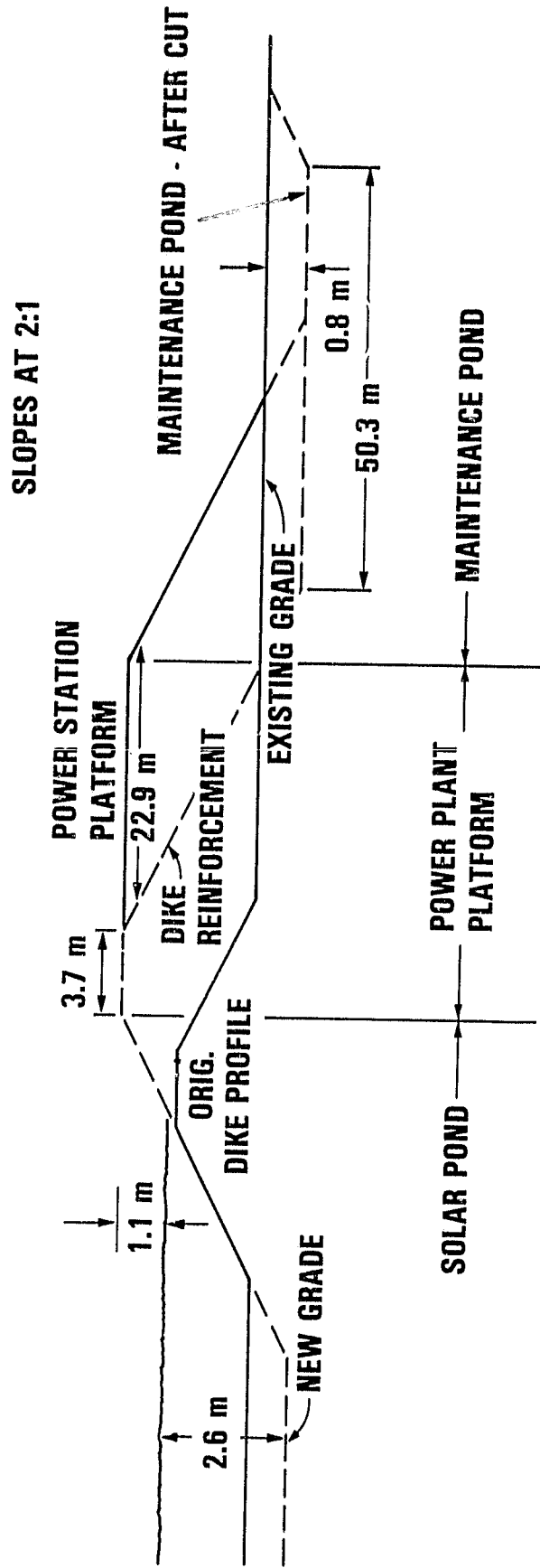

Figure 5-2. Maintenance Pond and Power Station Platform

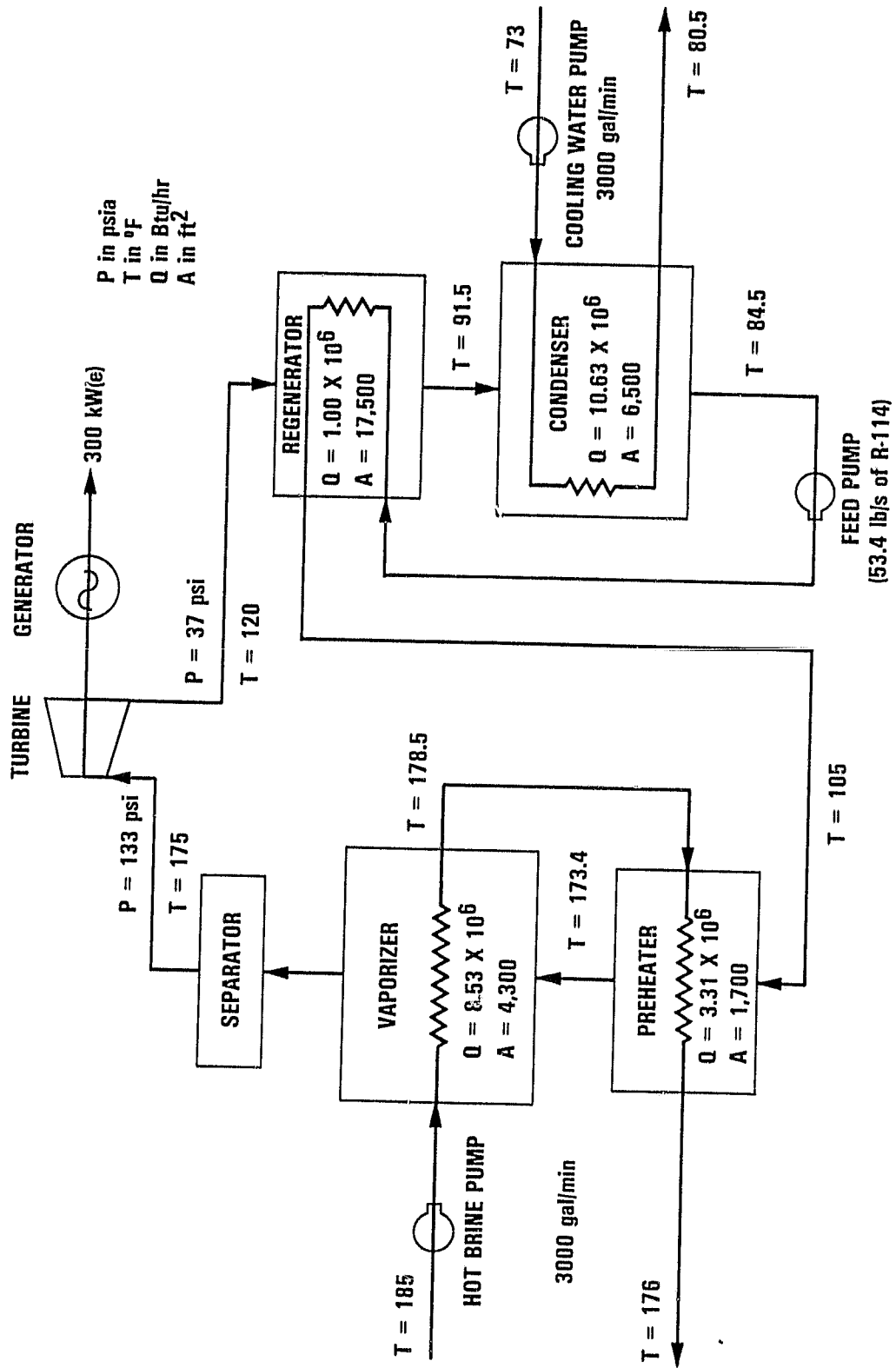

Figure 5-3. Proposed Power Cycle and Essential Components

### 5.2.2 Heat Exchangers

Heat exchangers include a vaporizer, condenser, regenerator and preheater. These are heat exchangers of the shell-and-tube type. Due to the low operating temperature, this equipment is relatively corrosion-free. The brine in the storage zone, in particular, has high salt content and is oxygen free; therefore, it causes very little biofouling to the vaporizer and preheater. The surface water, on the other hand, has lower salt content and is more prone to algal growth that must be controlled to eliminate biofouling of the condenser. Table 5-1 shows the essential characteristics of this equipment.

### 5.2.3 Feed Pump

This component is an off-the-shelf item. The plant requires a feed pump with a capacity of 400 gal/min and 250 ft of head.

### 5.2.4 Organic Fluid

A large number of organic fluids are available. The selection is based on many factors, such as thermophysical properties and chemical stability in the operational temperature range, corrosive properties with respect to turbine and heat exchanger materials, toxicity and cost. R-114, R-11 and R-113 are potential candidates. R-114 is selected for this power plant.

## 5.3 TRANSPORT AND AUXILIARY SUBSYSTEMS

The transport and the auxiliary subsystems are those subsystems that are required for the efficient operation and proper service and maintenance of the solar pond power plant. The important ones are briefly described below:

### 5.3.1 Hot Brine Loop

This loop is required for the circulation of hot brine between the storage zone of the solar pond and the vaporizer and preheater of the power conversion subsystem. The pipe diameters are determined by the tradeoff between the flow velocity and pressure drop. Outlet and inlet flow velocities from the pipe ends to the storage zone are reduced by the use of diffusers to avoid excessive mixing that will upset the stability of the pond. An arrangement of the pipes and diffusers is shown in Figure 5-4.

The flow rate for the loop is estimated to be 3000 gal/min. The main pipe line is 18 in. in diameter, and the two branch lines in the pond are 12 in. in diameter. A pump with a 3000 gal/min and 100-ft head capacity is required in addition to the necessary valves and fittings.

### 5.3.2 Cooling Water Loop

This loop is required for the circulation of cooling water through the condenser of the power conversion subsystem for the dissipation of the reject heat. In the baseline design the surface of the solar pond serves as the heat sink for the power plant, thus saving the expenses of a cooling tower or a spray pond. As in the hot brine loop, the inflow and the outflow must be smoothly distributed over the pond surface to ensure that the local flow

Table 5-1. Characteristics of Heat Exchangers

Types of Heat Exchangers	Thermal Load (Btu/h)	Heat Transfer Area (ft <sup>2</sup> )	<sup>a</sup> LMTD (°F)	Pressure Drop (psi)
Vaporizer	8.53 x 10 <sup>6</sup>	4,300	6.5	4.0
Preheater	3.31 x 10 <sup>6</sup>	1,700	23.0	4.5
Condenser	10.63 x 10 <sup>6</sup>	6,500	6.5	4.5
Regenerator	1.00 x 10 <sup>6</sup>	17,500	7.5	5.0
<sup>a</sup> Logarithmic mean temperature difference				

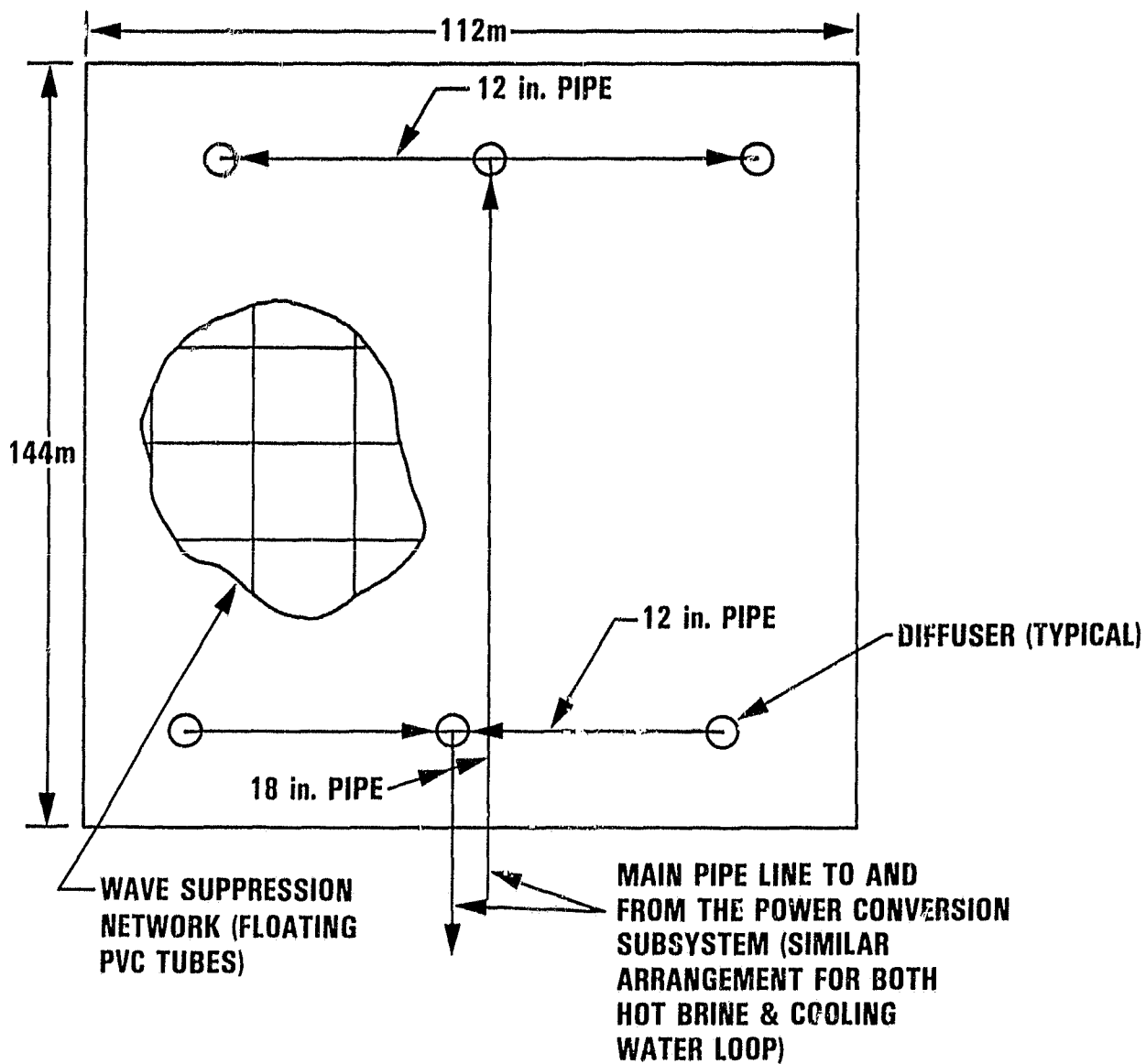

Figure 5-4. Wave Suppression Network, Inlet and Outlet Pipe Arrangement Schematic

velocities are sufficiently low. Diffusers are thus necessary; a design such as the one shown in Figure 5-4 for the hot brine loop will be used.

The cooling water loop flow rate is estimated to be 3000 gal/min. The main pipe line is 18 in. in diameter, and the branch lines are 12 in. in diameter. A pump with a 3000 gal/min capacity (100-ft head), along with the necessary valves and fittings, is necessary.

### 5.3.3 Surface Flushing, Brine and Fresh Water Make-Ups

Maintenance can be accomplished on a continuous basis or intermittently. Because of the small size of the pond, maintenance on a continuous basis will result in extremely low flow rates for these subsystems, so an intermittent maintenance approach has been selected. Therefore, these subsystems will be operated at a predetermined interval for a short duration.

The flushing line (Fig. 4-1) is connected to the return segment of the cooling water loop. This line will be opened only during the flushing period, which will direct the cooling water return into the evaporation pond instead of the solar pond.

The fresh water make-up line is connected to the outgoing segment of the cooling water loop and is opened only during the maintenance period. Make-up water replaces water loss due to flushing and evaporation.

The brine make-up line is connected to the return segment of the hot brine loop. Like the fresh water make-up, this line is opened only during the maintenance period. A pump with a 65 gal/min (50-ft head) capacity has been selected for pumping the brine from the storage section of the evaporation pond into the hot brine loop return line.

### 5.3.4 Wave Suppression Subsystem

To prevent wind-induced waves or disturbance of the solar pond surface layer, a means of preventing wave formation and propagation is necessary. Effective methods for wave suppression in small ponds are either panels of floating nets or tubes over the pond surface. Experiments (Reference 3) have shown that effective wave suppression can be achieved by 2.5-m panels spaced approximately every 15 m or by polyvinylchloride (PVC) pipes forming 3 x 3-m floating squares. The use of net panels is generally more expensive; therefore, the use of the PVC tubes is proposed for the present pond. The tubes will be capped and floated on the surface and anchored to hold their position.

### 5.3.5 Water Treatment Facilities

Water treatment requirements depend on the quality of the water supply. As indicated earlier, the Davis well water is expected to be of very good quality; therefore, no sophisticated treatment facilities are anticipated. A settling tank, and a filtration facility (for the removal of dirt and addition of chemicals for the control of the growth of algae) are considered necessary.

### 5.3.6 Miscellaneous Service Equipments

This category includes equipment for pond initial fill, control of salt gradient, power plant start-up, and cleaning of equipment such as heat exchangers. These components are all off-the-shelf equipment that can be ordered from suppliers in the United States.

## 5.4 INSTRUMENTATION AND CONTROL

The object of system instrumentation and control is to ensure efficient operation and to maintain integrity and reliability of the solar pond power plant. Additional instrumentation is included to assist in plant performance analysis.

System instrumentation will include requisite sensors (as enumerated in Section 5.4.1), data collection, recording and reporting subsystems. Data recording and reporting will be performed by a real-time, automatic, preprogrammed computing system (microprocessor or minicomputer). A system status display board will show the status of all flow streams, pumps and valves, critical temperatures and pressures, critical parameters of turbine, generator and switch gear operation. In addition, the computing system will perform trend prediction and report this information to the plant operator. Trends requiring operator action, as well as "alarm" conditions will be automatically displayed with a warning light and audible signal. The computing system will display graphic and tabular summaries of monthly performance.

This real-time computing system will also perform analysis and logic for control functions that are frequent or periodic, particularly for those functions that are measurement-dependent and require fast response. Operations that are infrequent or that do not require fast response will be manually controlled. Valve operation for frequently used or large valves will be by electric or pneumatic drive. Occasionally used or small valves will be manually operated. The control system will feature a manual override for all operations. Control system design assumes that the solar pond power plant is connected to a relatively large grid. Therefore, there is no requirement for an immediate response at site to change in demand.

Sensor measurements include climatological data, solar pond characteristics, flow stream characteristics and equipment status. Conceptual design specifies approximately 200 sensors. The computing system will report, record, and use for purposes of plant control, the following information:

### 5.4.1 Climatological Data

A weather monitoring station installed at the site will measure:

- (1) Total horizontal insolation (daily average).
- (2) Ambient temperature (two-hour average).
- (3) Relative humidity (six-hour average).
- (4) Wind speed maximum, average and direction (daily values).
- (5) Precipitation (daily total).
- (6) Evaporation (daily total).



#### 5.4.2 Solar Pond Characteristics

A mast containing the following sensors will be erected at the center of pond. In addition, a floating raft with a duplicate sensor set will be furnished to measure parameters at other locations within the solar pond.

- (1) Brine density profile will be measured at 10 vertical positions within the middle nonconvecting layer.
- (2) Brine temperature profile will be measured at 10 vertical positions within the middle convecting layer.
- (3) Total horizontal insolation will be measured at the interface of the middle nonconvecting zone and the lower convecting zone.

A group of five buried masts will measure the following ground characteristics beneath the solar pond to a depth of 10 m (under the solar pond center and four corners):

- (1) Temperature profile at five depths (daily average).
- (2) Ground water flow rate at five depths (daily average).
- (3) Thermal conductivity at five depths (daily average).

#### 5.4.3 Flow Stream Characteristics

Measurements to be made are:

- (1) Optical clarity, salinity, density and flow rate of surface flushing and evaporation makeup water (daily values).
- (2) Optical clarity, salinity, density and flow rate of brine makeup stream (daily values).
- (3) Pressure, temperature and flow rate of hot brine at heat exchanger inlets and outlets (continuous monitoring).
- (4) Pressure, temperature and flow rate of cooling water at heat exchanger inlets and outlets (continuous monitoring).
- (5) Air pressure for pneumatic controls (continuous monitoring).
- (6) Liquid levels in all heat exchangers (continuous monitoring).

#### 5.4.4 Equipment Status

Measurements to be made are:

- (1) pump power consumption for all pumps (continuous monitoring).
- (2) valve position for all valves (continuous monitoring).

- (3) turbine speed, level of vibration (continuous monitoring).
- (4) Generator output frequency, voltage, gross and net electrical power output (continuous monitoring).

Emergency control will respond appropriately to turbine overspeed, high level of vibration, overvoltage, overload, and main power failure. Additional alarms in the instrumentation system will report conditions of high pressure, low or high water or brine levels in the heat exchangers, loss of working fluid, low air pressure, and generator undervoltage/underfrequency.

## SECTION 6

### START-UP AND OPERATION OF THE POND

#### 6.1 START-UP

The pond can be filled and the salt gradient established in three ways (Reference 3 and 4): by natural diffusion, stacking, or redistribution. Redistribution is the most convenient method. It consists of partially filling the solar pond with high salinity brine. Fresh water or low salinity brine is then pumped through a horizontal diffuser that is immersed in the upper portion of the existing solution. The diffuser is subsequently raised to the surface either in a continuous motion or in discrete steps of no more than 5 cm. The brine above the diffuser will be progressively diluted while the diffuser and the water level rise. Timing must be coordinated so that the diffuser reaches the surface at the predetermined final level of the pond. Application of this method in experimental solar ponds has shown that the redistribution rate appears to be quite flexible, depending mainly on the capacity of the pumps used. It has also been shown that this procedure is effective when it is performed intermittently instead of continuously.

#### 6.2 OPERATION AND MAINTENANCE

Under normal operation conditions, hot brine is constantly circulating between the storage layer of the solar pond and the vaporizer and preheater of the power conversion subsystem, while cooling water is similarly circulating between the surface layer of the pond and the condenser of the power conversion subsystem. With time, the solar pond will lose water due to evaporation, and the storage layer will lose salt to the upper layers by salt diffusion. The surface layer may then reach a critical salt concentration level at which the pond salt gradient stability can no longer be maintained. For these reasons, the pond needs to be properly maintained by regular replenishing of the loss of water and salt.

In general, three tasks are important in maintaining the solar pond:

- (1) Addition of concentrated brine into the storage layer to replace the loss of salt due to diffusion.
- (2) Flushing of the surface layer with fresh or low saline water to remove excess salt.
- (3) Addition of fresh or low salinity water to the surface layer to make up for evaporation and flushing water losses.

In principle, these maintenance tasks can be done either on a continuous basis or at regular intervals. Maintenance based on regular interval is recommended.

A preliminary estimate indicates that to keep the surface layer salt concentration below 80,000 part/10<sup>6</sup> maintenance will be required on 40-day

intervals. The procedure will require a couple of days of continuous operation. The sequence of operations are:

- (1) Flushing of the surface layer.
- (2) Addition of high concentration brine to the storage layer.
- (3) Addition of fresh water to the surface.

The brine flushed from the surface layer will be concentrated in the evaporation pond and saved for recycling to the storage layer. Estimates indicate that maintenance requires  $3.84 \times 10^5$  gal/yr of brine with a minimum concentration of 250,000 part/ $10^6$  and  $1.13 \times 10^7$  gal/yr of fresh water.

## SECTION 7

### COST ESTIMATE

#### 7.1 CAPITAL COSTS

Capital cost estimates are based on the latest standard labor, material and equipment price guides, and on quotes from component vendors. Table 7-1 presents a summary. More details of the cost estimate are presented in Appendix C.

The plant installed capital cost is \$7,140/kW. On a unit pond area basis, the pond construction cost is equivalent to \$47/m<sup>2</sup>. If the total plant costs are considered, the per unit pond area costs will be \$125/m<sup>2</sup>. The significance of these cost numbers are discussed in Section 7.3 along with the discussion of energy costs.

#### 7.2 OPERATION AND MAINTENANCE COSTS

The annual operation and maintenance costs are estimated to be \$73,000 (also shown in Table 7-1), which consists of \$60,000 for labor, \$3,000 for materials and \$10,000 for general maintenance.

#### 7.3 ENERGY COSTS

The capital costs and the annual operation and maintenance costs given in Sections 7.1 and 7.2, along with the annual electric power output of  $0.3576 \times 10^6$  kWh<sub>e</sub>/yr (equivalent to an annual average of 41 kW<sub>e</sub>) as given in Section 4.3, are used in an economic analysis computer model to calculate the energy costs of the baseline system. The main assumptions and the method of computations are described in Appendix C. The results are summarized in Table 7-1.

##### 7.3.1 Busbar Electric Energy Costs

For a system life of 20 years the busbar energy cost is 1,451 mills/kWh if the year of commercial operation is 1985.

These costs are extremely high. One reason for the high cost is the small output capacity (41 kW<sub>e</sub> averaged over the year). The other reason is the rather high installed power plant capacity with respect to the solar pond size (300 kW<sub>e</sub> capacity for a 4.22-acre pond). This inevitably results in a very low load factor (about 18% of the installed capacity) as compared with a normal baseload plant (70 to 90% load factor).

A larger plant with a well balanced design of installed capacity to pond size will reduce the energy cost. Additional assessment for an installed power plant capacity of 150 kW<sub>e</sub> with the same amount of annual power output indicates an energy cost of 1,260 mills/kWh<sub>e</sub>, assuming 1985 commercial operation. This is almost 200 mills/kWh<sub>e</sub> less than that of the baseline

Table 7-1. 300 kW<sub>e</sub> Summer Peaking Solar Pond Power Plant Cost Summary

Description	Costs (1981\$)
Project Management	100,000
Design and Specifications	100,000
Pond Complex - Without Liner (With Liner)	621,000 (802,000)
Including construction costs of the solar pond, evaporation pond, power plant platform, water well and salt cost	
Power Conversion Subsystem	536,000
Including all the components of the power cycle	
Transport and Auxiliary Subsystems	604,000
Including all transport and auxiliary subsystems, instrumen- tation and controls	
TOTAL CAPITAL COST	Without Liner \$1,961,000 (With Liner) (2,142,000)
Annual Operation and Maintenance Costs	\$ 73,000

design, result of changing the design from 18% load factor to 36% load factor. However, as the solar pond capacity is relatively small, further improvement in energy cost by reduced installed power plant capacity is limited because the unit installed power plant cost tends to increase steeply as its size decreases. Figure 7-1 shows this tendency from estimates of unit plant costs of various size. Based on this trend, a large solar pond power plant is expected to be much more cost effective than a smaller plant.

### 7.3.2 Thermal Energy Costs

Because a solar pond can also be used to supply thermal energy for industrial or other uses, a cost analysis was also made for the thermal energy costs delivered at the pond site. For such a system, the total capital cost is estimated to be \$1,389,000 with an annual operation and maintenance cost of \$48,000. These cost numbers and the annual thermal energy outputs calculated in Section 4-3 ( $4.9433 \times 10^6$  kWh<sub>t</sub>/yr at 85°C and  $7.34 \times 10^6$  kWh<sub>t</sub>/yr at 60°C) are used in the cost analysis. The thermal energy costs are \$22.37/million Btu for extraction temperature of 85°C and \$15.05/million Btu for extraction temperature of 60°C.

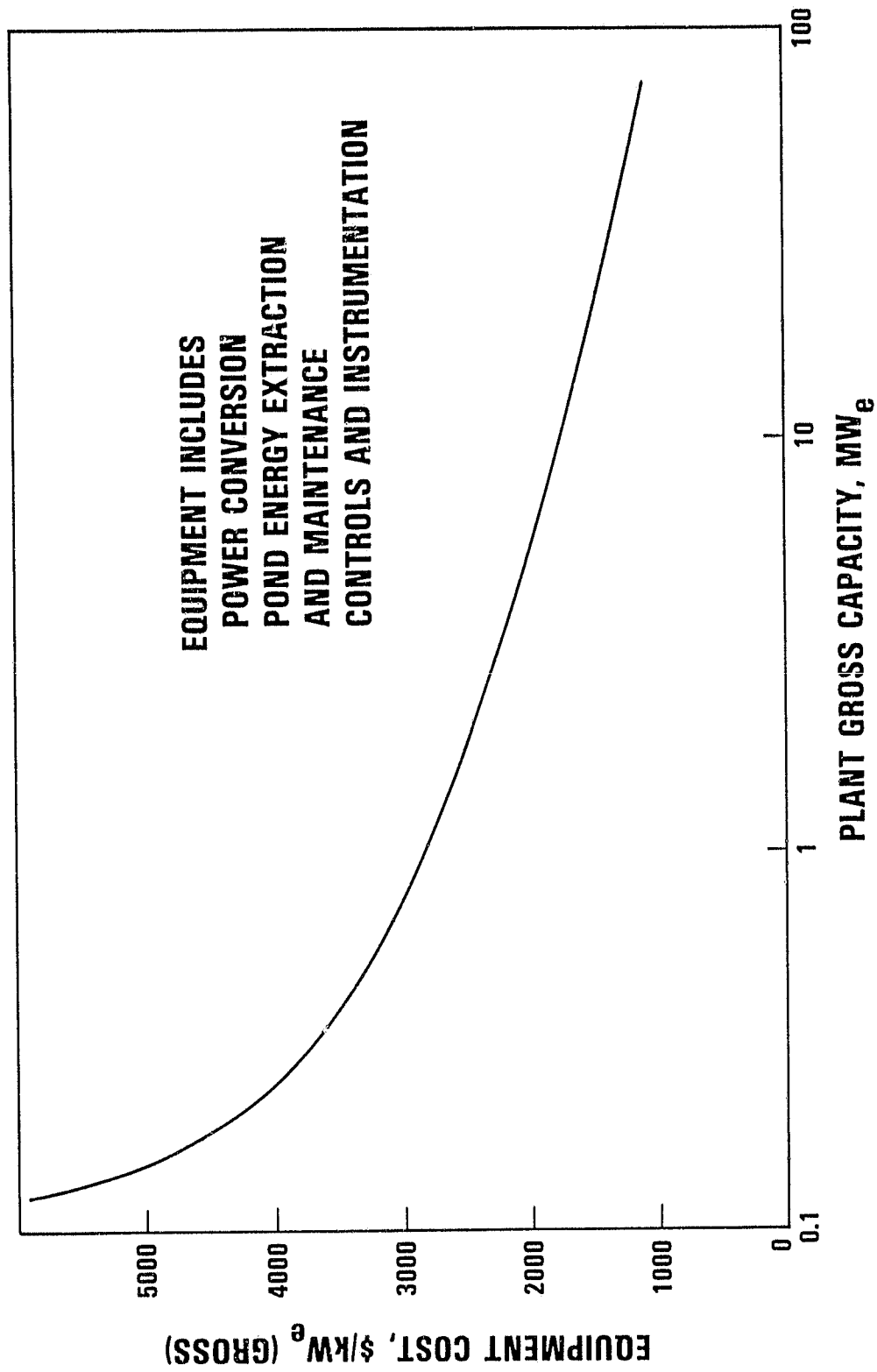

Figure 7-1. Solar Pond Power Plant Economy of Scale



## SECTION 8

### PROJECT MILESTONES AND CONSTRUCTION SCHEDULE

The 300-kW plant can be constructed in 18 months. A tentative milestones chart for the project is shown in Figure 8-1. The principal tasks of the project are:

#### 8.1 PROJECT MANAGEMENT

In addition to the general management of the entire project, this task also takes care of regulatory matters and permits, as well as oversees the timely ordering of material and equipment from the beginning to the end of the project.

#### 8.2 SITE STUDY AND ENVIRONMENTAL EVALUATION

In this task, the site will be thoroughly examined for the needs of the construction. Thorough soil and water analyses will be made, and environmental impact will be carefully assessed. This phase will take about three months.

#### 8.3 DESIGNS, SPECIFICATIONS AND GENERAL ENGINEERING

This task, which will take about four months, includes the detailed design and formulation of specifications for all the necessary equipment and material.

#### 8.4 MATERIAL, EQUIPMENT AND SUPPLY ORDERS

This is the placement of purchase or rental orders and receipt of deliveries of material, equipment and miscellaneous supplies. Six months will be required.

#### 8.5 POND CONSTRUCTION

Construction of the solar pond complex, which includes construction of the solar pond and the evaporation pond, power plant platform, as well as the drilling of a water well and other related work, will require three months. A proposed schedule for this portion of project is shown in Figure 8-2.

#### 8.6 INSTALLATION OF POWER CONVERSION, TRANSPORT, AND AUXILIARY SUBSYSTEMS

The power conversion, transport, and auxiliary subsystems are installed at different times during the project period; therefore, this task covers a rather long period. Six months are estimated for the completion of all installation work.

#### 8.7 FILLING OF THE SOLAR POND AND THE ESTABLISHMENT OF THE NECESSARY SALT GRADIENT

This task, which is based on the capacity of the water well and the time required for the salt gradient to establish itself, will take about one month.

#### 8.8 POND WARM-UP

If the pond is ready for warm-up in spring, it should not take more than four months to warm up to the operational level. Warm-up time will vary according to the characteristics of the season.

#### 8.9 PRELIMINARY OPERATIONS

Because of the experimental nature of the pond, in the initial operation at least, two months are allocated for the first test run and for the training of operating personnel.

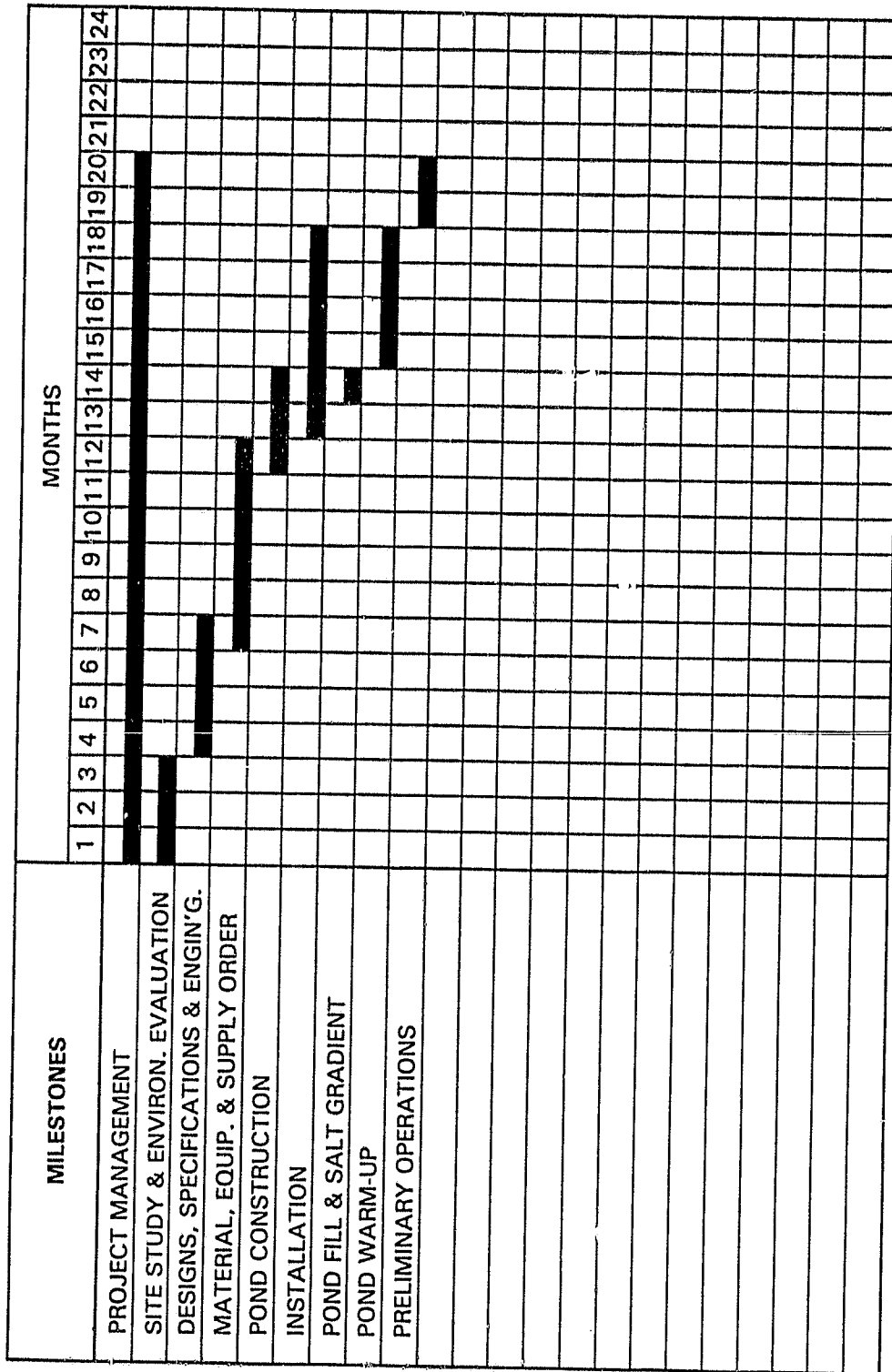

Figure 8-1. Tentative Project Milestones for the Davis 300 kWe Summer Peaking Solar Pond Power Plant Construction

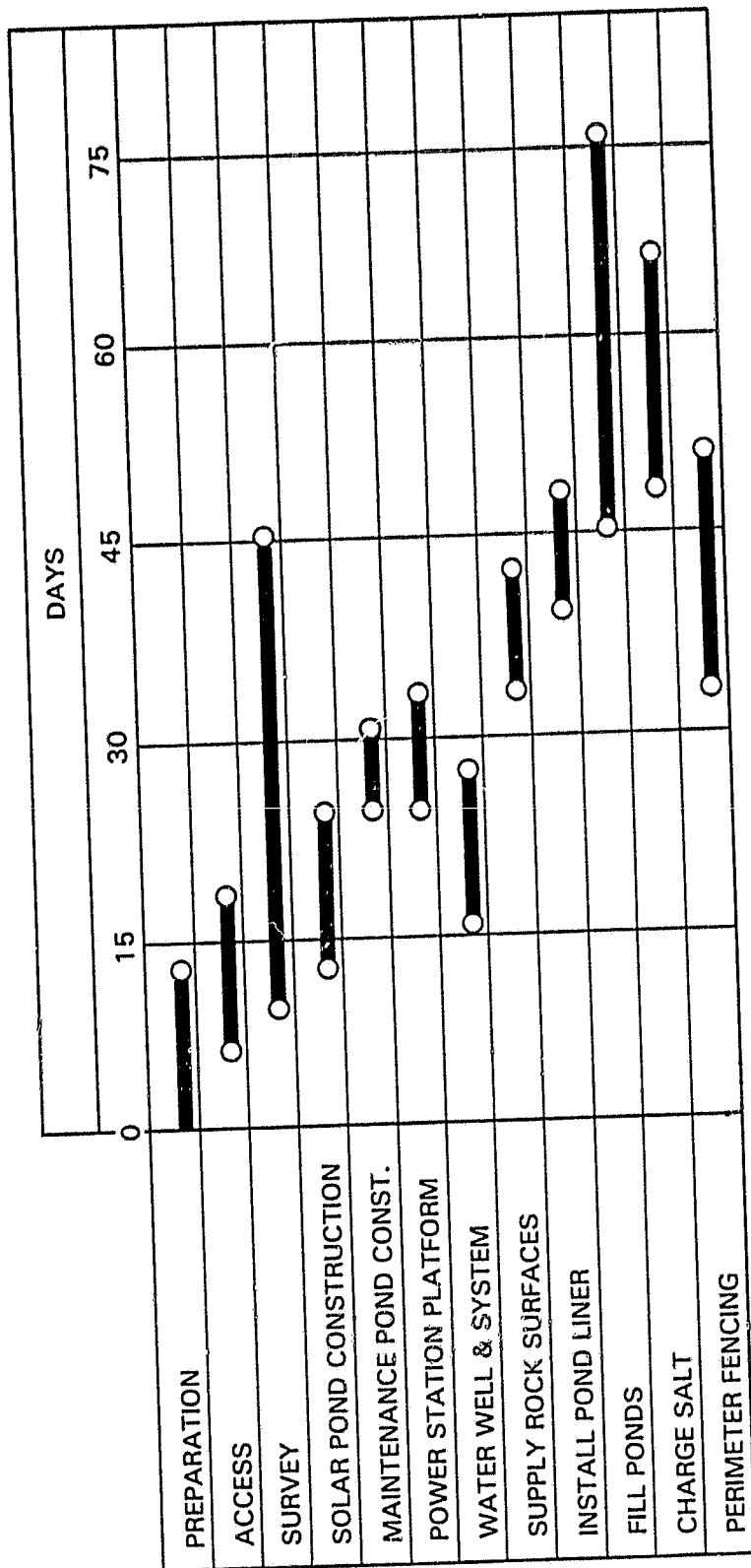

Figure 2-2. Solar Pond Construction Schedule

## SECTION 9

### MISCELLANEOUS ISSUES

#### 9.1 CONTINUED SITE SPECIFIC EVALUATION

The soil and water sample analyses made for this study were preliminary. Additional testing will be required. Although the preliminary results indicate the need for an artificial pond lining, soil samples from different locations or strata may indicate otherwise. Further testing is important, especially in the following areas:

- (1) Soil analysis from different locations and strata to obtain conclusive information about sealing properties and soil brine interaction chemistry.
- (2) Investigation of the effects of various salts on the optical properties of the water. These effects will directly affect the selection of water clarification equipment.

#### 9.2 SUPPLYING THERMAL ENERGY FOR PROCESS USE

In principle, the thermal energy collected and stored in a solar pond can be used to serve various purposes with the installation of the appropriate equipment. The proposed solar pond is no exception; however, the baseline system design is intended for the generation of electric power for summer peak demands, and the equipment is selected and sized for this purpose. To use thermal energy for industrial process heat, either partially or fully, different equipment installations are necessary; consequently, the cost of the system would be affected.

The baseline system as discussed in Section 4.3 will have the capability of delivering  $4.9433 \times 10^6$  kWh<sub>t</sub>/yr. of thermal energy or  $0.3567 \times 10^6$  kWh<sub>e</sub>/yr. of net electric power if thermal energy is extracted at a constant temperature of 85°C. If the extraction temperature is 60°C its thermal energy delivery capacity will be  $7.34 \times 10^6$  kWh<sub>t</sub>/yr. In principle, the proportion of thermal and electric outputs can be shifted to meet the requirements of each application; however, two factors should be carefully considered:

- (1) The cost of the power conversion subsystem is rather high, and economy dictates the maximum use of the conversion facilities.
- (2) as the system is intended for meeting summer peak demands, the pond is rather shallow and the available thermal energy concentrates in the summer and the early fall months.

For uniform year-around thermal energy supply, this type of shallow pond may not be appropriate. A deeper pond may be required. In addition, the temperature level of the required thermal energy is also an important factor in the solar pond application as the preliminary cost analysis in Section 7-3 indicates.

In fact, if the need for thermal energy is one of the important considerations, a larger and deeper pond may be a better design. The best system, which will result in the most economic use of the solar pond system for both process heat and electric power, should be separately evaluated.

## SECTION 10

### CONCLUSIONS AND RECOMMENDATIONS

The following conclusions can be made from this study:

- (1) The preliminary laboratory analysis of soil and water samples from the Davis solar pond site indicates:
  - (a) That water optical quality is excellent.
  - (b) That local surface soil and clay are inadequate for the sealing of the solar pond against leakage. An artificial liner appears to be necessary.
- (2) The electric energy costs of the proposed baseline system are very high; therefore, a system of this type (large installed power plant capacity for peaking purpose) and size is not economically viable at the current stage of development although the concept is technically feasible.
- (3) Energy cost reduction is possible by the consideration of the following:
  - (a) Larger plant to take advantage of the economy of scale.
  - (b) System that has an optimized match of solar pond size and installed power plant capacity to take advantage of higher load factor.
  - (c) Plant concept that can cogenerate electric power and thermal energy for process use.
  - (d) Low-cost salt supply.

From these conclusions it is clear that the proposed concept is not economically viable. Although cost reduction is possible, it is not likely that, given the existing state of technology development, the cost can be sufficiently reduced. For this reason, it is recommended that, at the present time, the concept should not be further pursued. Further study can only be justified for experimental purposes and for the development of technology for future applications. Such a study should be aimed at system optimization and the exploration of the potential benefit of the economy of scale.

## REFERENCES

- 3-1. A Study of the Feasibility of a Solar Salt Pond Generating Facility in the State of California, U.S.A., 2nd Interim Report, Ormat Turbines, Yavne, Israel, November, 1980.
- 5-1. "Abandoned Sewer Plant and Landfill," Map, Sheet 4 of 7, Warenski-Garcia (Marysville, California), Job 77-408, 1977.
- 5-8. Conceptual Design of the Truscott Brine Lake Solar Pond System, Vol. 1, SERI/TR-731-1202, SERI, June, 1981.
- 6-1. Zangrando, F., "A Simple Method To Establish Salt Gradient Solar Ponds," Technical Note, Solar Energy, Vol. 25, 1980, pp. 467-477.
- C-1. Lin, E.I., et al, Regional Applicability and Potential of Salt-Gradient Solar Ponds in the United States, to be published, Report prepared by JPL for DOE.



## APPENDIX A

### PRELIMINARY LABORATORY ANALYSIS OF SOIL AND WATER SAMPLES

#### A-1. SOIL SAMPLE STUDY

Soil investigations were conducted by the Pacific Gas & Electric Company (PG&E) and the Jet Propulsion Laboratory (JPL). PG&E results are discussed in detail in Appendix B. The soil sample analysis conducted by JPL is reported below.

There are two environmental questions concerning the anticipated use of the existing, abandoned ponds for containing salt gradient solar ponds and brine maintenance ponds:

- (1) Can the present soil liner be expected to provide a seal against seepage, minimize the loss of brine and adequately control the contamination of ground water?
- (2) Will such use of the soil adversely affect essential solar pond characteristics?

A limited laboratory study addressing these two questions was made, using one small sample of soil taken from one location in the bottom surface of one pond. To the extent that this sample can be taken as representative, the general conclusions are as follows:

- (1) The surface soil does not have adequate sealing properties; it is more silt-like than clay-like.
- (2) No evidence was found of potential heat-stimulated, gas-producing biological activity, a phenomenon that can be a hazard to gradient stability. Details of this investigation follow.

##### A.1.1 Sealing Properties

A series of permeation measurements were made at room temperature to test the capacity of the Davis pond soil sample for its sealing capacity. Four 1-in. diameter glass tubes were set up for the test as illustrated in Figure A-1. An 8-in. bed of soil was compacted into each tube on a 1-in. layer of sand (the bottom of each tube was open to allow free drainage). The test liquid (100 ml of water or brine) was carefully placed on top of the soil bed. Over a period of days, the following positions were monitored: liquid surface level, soilwater interface, and water penetration into the soil. Two soil samples were tested against two fluids. The soils were Davis pond soil and Volclay 100, a specially-prepared bentonite supplied by American Colloid Corporation. The two fluids were distilled water and a brine of about 24% concentration prepared by concentrating Salton Sea water. (Salton Sea water was selected for convenience because Davis water was not available early in the study period).

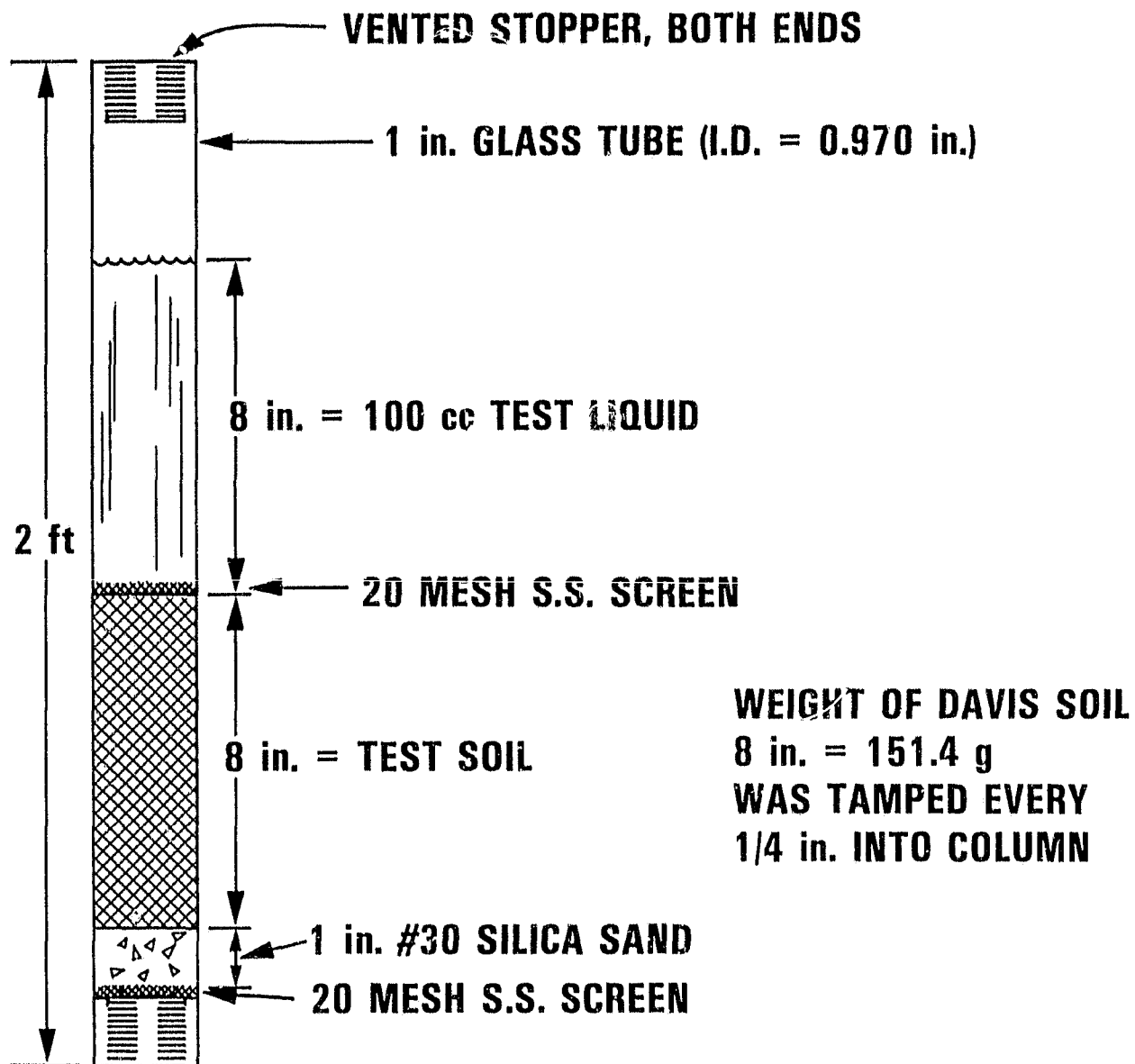

Figure A-1. Apparatus for Test of Soil Permeability

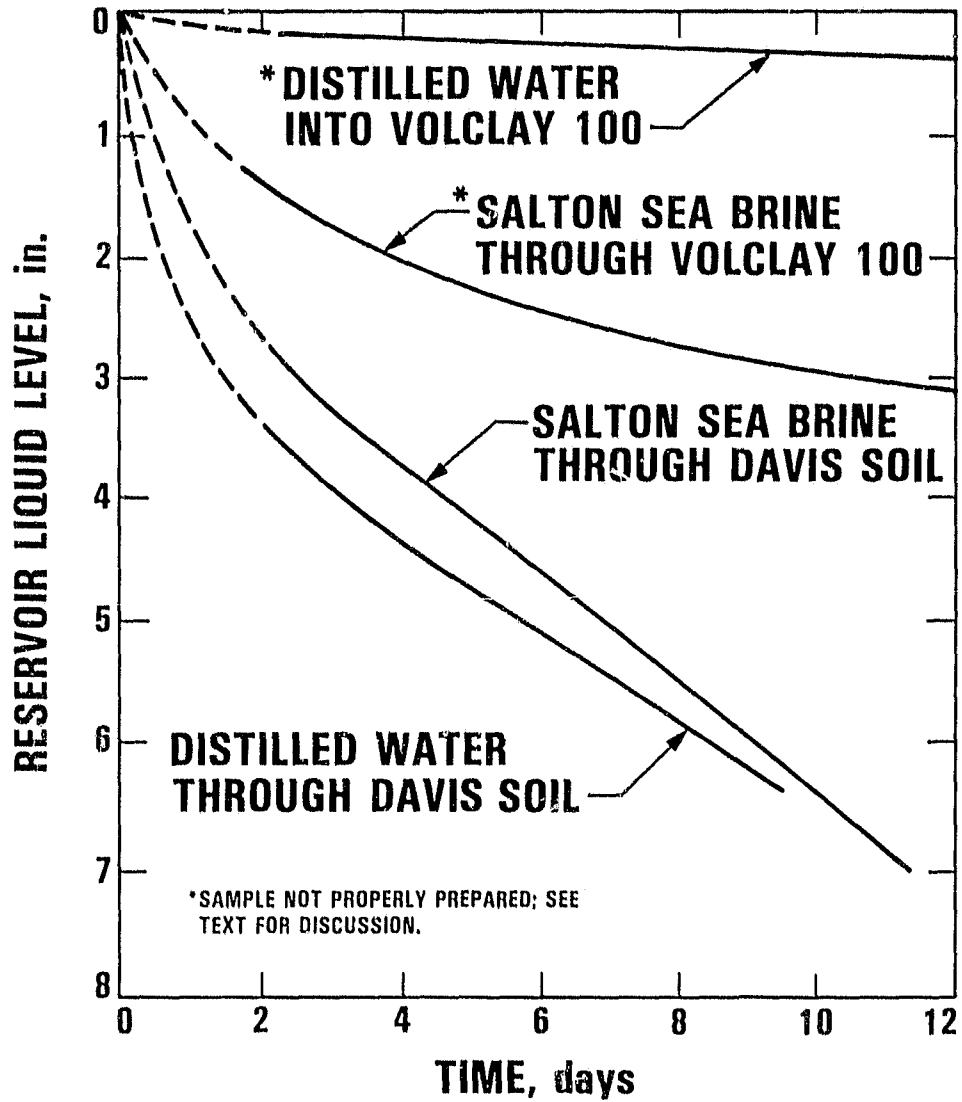

Figure A-2. Permeation of Water and Brine in Davis Pond Soil Sample

The nearly linear rate of liquid flow through the beds is presented graphically in Figure A-2, which shows the rapid flow of both brine and water through the Davis soil. On the other hand, water does not flow through Volclay. Instead, the special clay absorbs water and forms an impermeable gel. In this instance, the surface of the soil swelled to a level 0.9 in. above its original position. After twelve days, the water penetration was only 0.4 inches. By contrast, the Davis soil swelled 0.125 in., in brine and 0.2 in. in water, and the penetration was total. Volclay's response to brine was entirely different from that of water because the high ionic concentration inhibits the water-clay association that is necessary for gel formation. Swelling was only 0.375 in., and penetration was total although the rate was slower than that of Davis soil. After these experiments were completed, JPL learned that the manufacturers recommend the following procedure for the preparation of Volclay for testing (and use) with brine:

- (1) Volclay should be admixed with native soil.
- (2) Gelation should be obtained with low-salinity water prior to the introduction of brine.

Variations such as these will be included in future investigations aimed at the development of solar pond technology.

In their report on Phase 1 for the Salton Sea Experiment (Reference 1), Ormat Turbines, Ltd., set  $10^{-8}$  sec<sup>-1</sup> as the upper practical limit of the subsoil property: permeability/stratum thickness. Put in those terms, the data from these tests indicate that permeation through Davis soil is two hundred times too fast whether the fluid is water or brine. Volclay's sealing of water is excellent, but it passes brine thirty times too fast under the inappropriate test conditions described above.

These tests were made at room temperature. At elevated temperatures, the rates may be higher. Data from recent holes bored by PG&E indicate the likelihood of much better sealing properties a few feet below the pond bottom. Adequate sub-soil sampling and further testing, including the effects of brine, temperature, and material preparation must be done to determine with confidence the feasibility of relying on the native structure for seepage control.

#### A.1.2 Soil Biological Activity

The salt gradient layer is the keystone of a solar pond. Its chief characteristic is a complete lack of convective heat transfer. Its stability must be assured. One type of disturbance, which can disrupt a gradient, is important to look for and guard against. If appropriate anaerobic microorganisms and nutrients are present in the soil at or near the bottom of the pond, their metabolism can be accelerated by the elevated temperature of the pond. Some of the metabolic products are gaseous. Gas evolution vigorous enough to mix the pond contents has been experienced in past research.

JPL is developing a method and procedures for investigating the possibility of gas evolution for specific sites. The results of the Salton Sea study are worth stating as a background for judging the results of the tests of the Davis materials described below.

One soil sample from the near-shore floor of the Salton Sea produced gas when heated in the presence of Salton Sea water. The gas evolution was never vigorous enough to mix the supernatant liquid. Instead, the gas was absorbed in the water, diffused through it, and vaporized from the surface.

Furthermore, when Salton Sea brine was used instead of water, the activity was suppressed to an undetectable degree. No gas evolution was measured. The tentative conclusion is that biological reactions are not likely to occur. Development of the methodology is continuing. Further testing of Salton Sea materials is planned.

The Davis soil sample was tested in a similar way in three test runs. In each test, a 1-lb sample of the soil as submerged in deoxygenated water or brine (500 to 600 ml) and held at 75°C (167°F) for several weeks. To provide adequate time for evidence of activity to be observed, the first two tests were started before the sample of Davis well water arrived. The waters used were as follows:

Test 1 - Salton Sea water (3.8% Total Dissolved Solids)

Test 2 - Owens Valley water with 3.8% NaCl added

Test 3 - Davis well water with 24% NaCl added

Test 1 duplicates the conditions of the Salton Sea test, which showed activity. Periodically, the tests were sampled and analysed for H<sub>2</sub>S, a gaseous produce of the metabolism being investigated. During the six-week (five-week for Test 3) testing period, no H<sub>2</sub>S was detected in any of the three tests. The tentative conclusion is that gassing bio-activity is not likely to be a problem at Davis. More testing is needed to confirm this conclusion.

## A-2. WATER SAMPLE STUDY

Only that solar radiation that is transmitted through the two upper layers of a solar pond to the storage zone at the bottom (a distance of from 1 to 1.5-m) is recoverable for useful purposes. Therefore, the clarity of the water and brines is an important factor affecting the performance of a solar pond system. Part of the overall methodology for site-specific evaluation under development at JPL is an approach for investigating light transmission, the factors that affect it, and treatments to improve it.

A small-scale study was made of a water sample taken from an on-site well in order to estimate the magnitude of potential light transmission problems. The general conclusions are:

- (1) The Davis well water is excellent; no decolorization will be necessary. Settling or filtration might be advisable.

- (2) Potential salt candidates must be investigated for their effects on light transmission.
- (3) Other factors that might affect light transmission should be investigated. In particular, a study should be made to determine whether or not treatment for control of algal growth in the upper convecting layer will be necessary.

The optical quality of the Davis well water sample was determined by comparison with waters that have been previously tested. The basic measurement is the absorption of light with respect to wavelength in a spectrophotometer. The comparison of spectral absorptions is shown in Figure A-3. In general, clear waters absorb very little light in the 400 to 700 nm range. If any of the samples in Figure A-3 were turbid, significant absorption would show up in this range. Whether or not dissolved absorbers are present, water absorbs considerable light in the region above 700 nm. Effects of dissolved substances are in the blue end, 500 nm and lower, of the spectrum.

According to previous calculations made at JPL, the variations in absorption illustrated in Figure A-3 represent a wide range of predicted solar pond performance. (These predictions are computerized and account for both water and solar spectral properties). If the two upper layers of a pond were as clear as distilled water, a transmission to the storage zone of 45% is predicted. In the Salton Sea case, sea water will be used to flush the upper layer. The gradient would be composed of progressively stronger brine made by evaporating Salton Sea water. Because the colored matter also concentrates, absorption increases with depth. Only 8% transmission is predicted. A factor to note is that a major fraction of the color can be removed from Salton Sea water by activated carbon. With this treatment during testing, measurements yielded a prediction of 24%, a very acceptable figure.

Davis water, by itself, is significantly better than carbon-treated Salton Sea water. A more comprehensive study of the contributions of candidate salts is recommended. Also, further study, using representative candidate materials, should be made to determine any tendency for solar pond surface water to sustain algal growth and whether or not treatment to prevent growth will be necessary. In a test with Davis soil and well water the two materials exposed together to sunlight for many days and protected from outside contamination showed no growth. No indigenous organisms were evident.

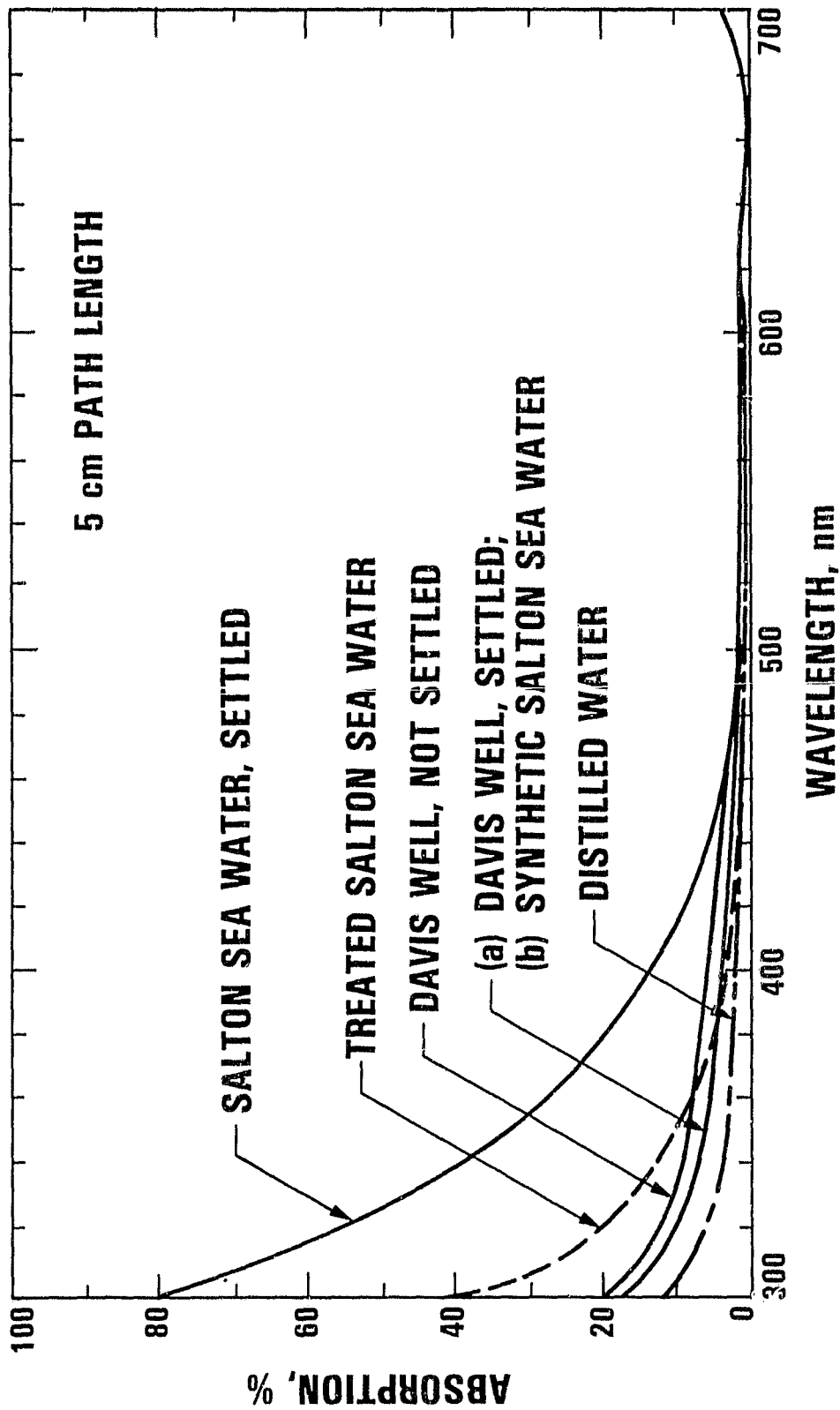

Figure A-3. Comparison of the Spectral Absorption

## APPENDIX B

### NOTES AND DISCUSSIONS OF POND CONSTRUCTION AND POND LINING

#### B-1. GENERAL POND CONSTRUCTION NOTES

The proposed solar pond complex is sited on an abandoned surface sewage treatment farm situated about two miles north of the city of Davis, California. The rectilinear land plot occupies approximately 170 acres in a farming neighborhood. Its surface is segmented into shallow, rectangular impoundments formed by low earthworks dikes. The dike construction is intact, providing structure for surfaced roads and having armored slopes established at about 2:1 above the 1.83-m deep pans.

A reinforced concrete pumping and control station with a circular thick ener tank is located in the center of the development. Its southeasternmost corner accommodates an active target shooting range, a kart track and an earth storage embankment. Davis permits use of the northwesternmost pond area by a model aircraft activity.

The area designated for solar pond conversion is shown in Figure B-1. It requires 0.61 m of excavation from the existing bottom, and it contains an area of 17,100 m<sup>2</sup> (4.22 acres) measured at the upper layer of the storage zone. The evaporation pond is located immediately north of the solar pond, and the power station is positioned between the solar and the evaporation ponds. Access to the site for construction and operation will be established from the northsouth county road along the existing dike structure.

A well site is suggested as shown in Figure B-1.

An improvement is required at the county road entry so that construction and equipment loads may conveniently enter and depart. In lieu of detailed planning, a round sum is budgeted in the preliminary cost estimate(s) for this part of the proposed project.

The east-west dike that extends from the county road to the proposed solar pond site should be widened.

The existing pond is 1.83 m deep with dikes, therefore, 0.61 m will be cut from the existing bottom. The excavated earth will be used to raise the existing dike perimeter by 1.52-m, and the balance will be used to fill the outside dike perimeter at a slope of 2:1 (Figure B-2).

The evaporation pond will be established by cutting 0.91 m from the bottom of one side of the adjacent pond. Only one acre is required for this facility, so a narrow strip along the southern edge of the pond will be employed. An earthworks platform for the power station will be created on the solar pond centerline adjoining the dike that separates the solar pond from the evaporation pond (Figure B-3). The nature of the soil dictates that earth moving in this project should be done in dry weather.



ORIGINAL PAGE IS  
OF POOR QUALITY

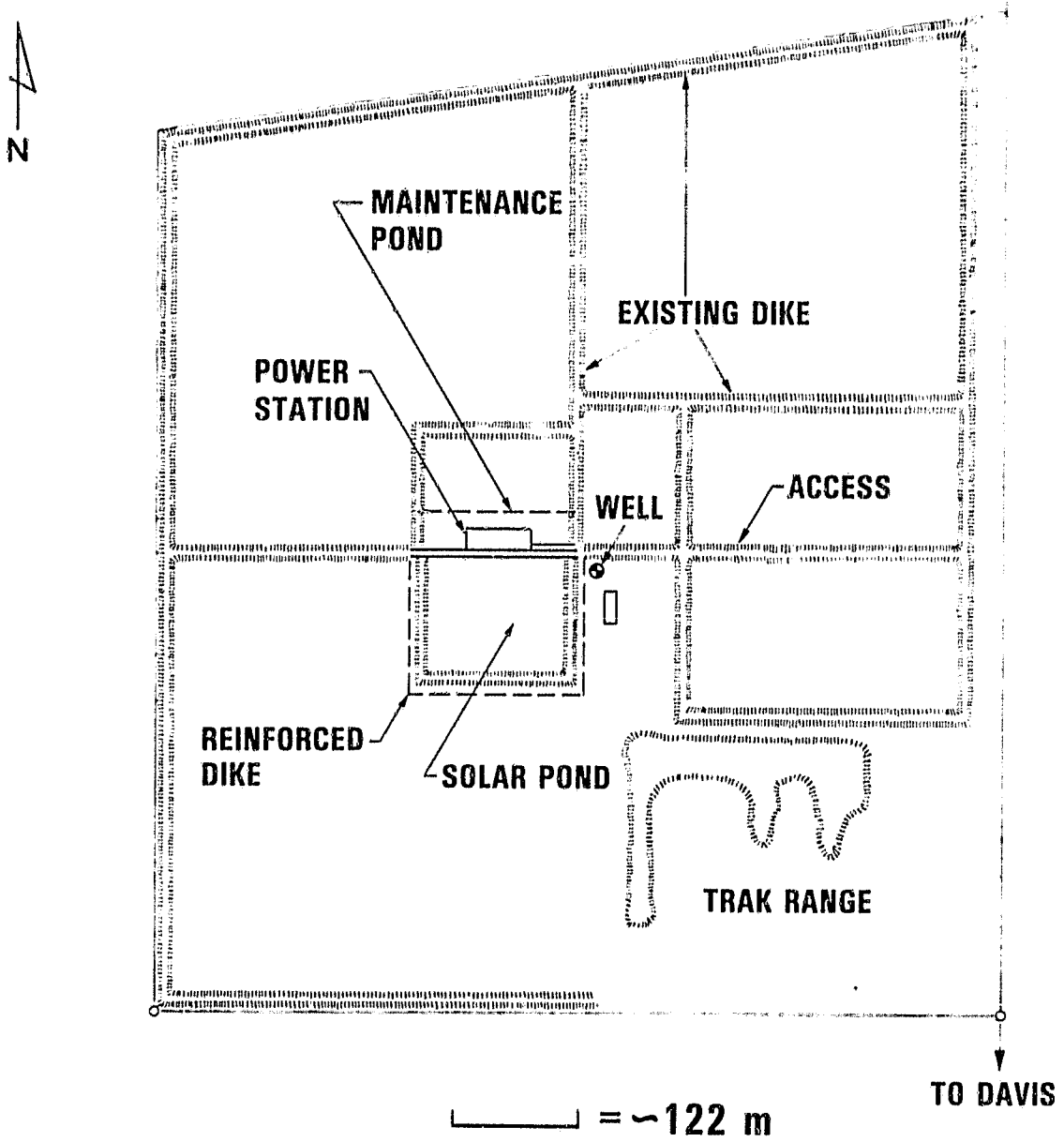

Figure B-1. Site Layout for a 300 kW<sub>e</sub> Pond Power Plant at Davis

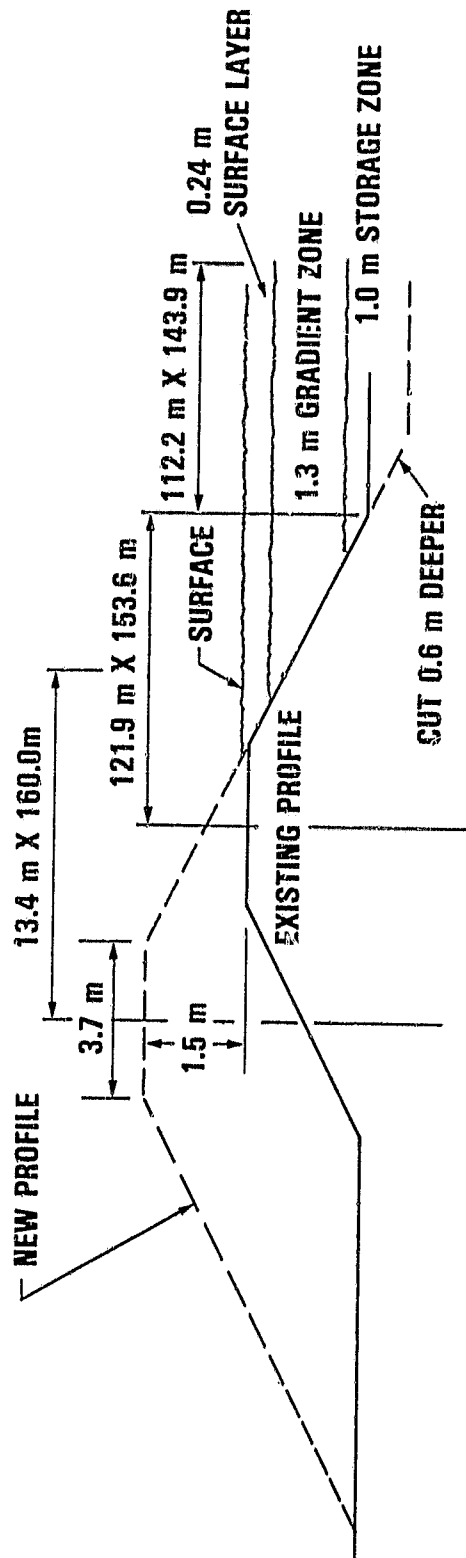

Figure B-2. Solar Pond Dike Reinforcement Schematic

SLOPES AT 2:1

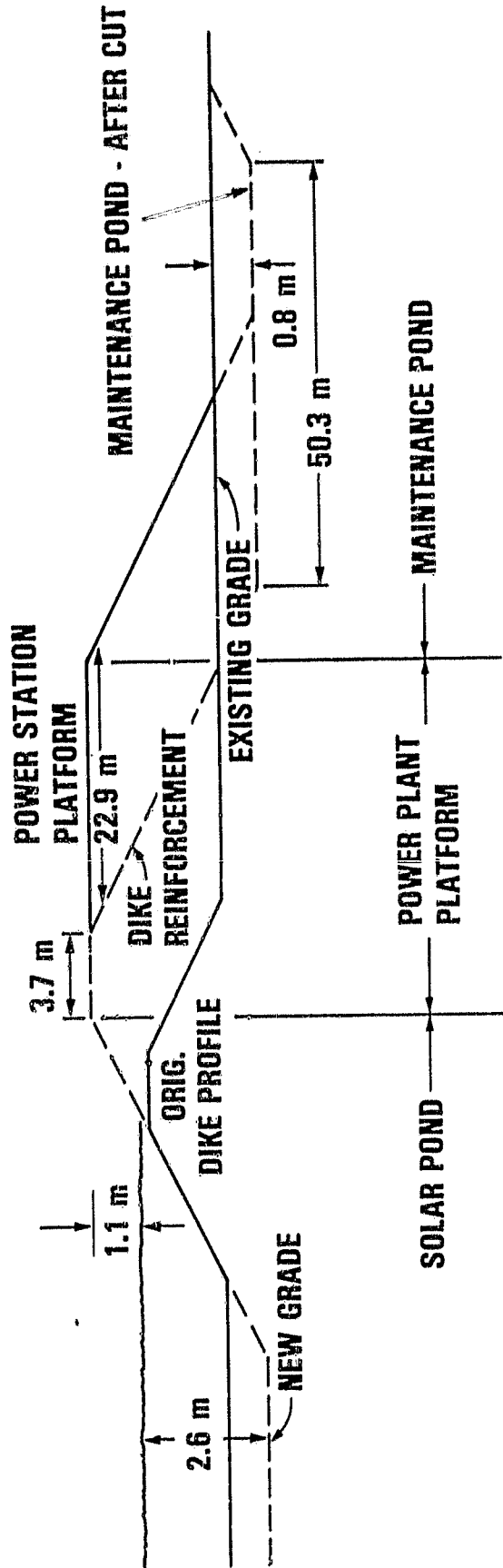

Figure B-3. Maintenance Pond and Power Station Platform

## B-2. POND LINING

The solar pond must be made impermeable so that:

- (1) The integrity of the aquifer that supplies water to the farming community and to the city can be protected.
- (2) The expensive salt can be prevented from leaking into the ground.

To minimize construction costs, it is desirable to use local soil or clay to line the ponds. This possibility is still being explored. A preliminary soil sample analysis, however, is reported in Appendix A. Additional sub-soil investigation was conducted by PG&E, and a further report is planned.

The PG&E investigation indicates that the first 5.49 m of the sample contains silty clay interbedded with consistent clays. After a thin sandy aquifer, more silty clay and stiff clay follow to below a depth of 9.15 m. Preliminary results indicate that the local surface soil and clay appear to be unsuitable for the sealing of the pond. Further effort will be required to evaluate subsurface materials. For this study, the use of an artificial pond lining material has been assumed.

## B-3. SALT SUPPLY

The following salt supply alternatives were considered:

- (1) Sodium chloride and other evaporates from Great Salt Lake, Utah (transportation costs are forbidding).
- (2) Mixed salts from the surface of Searles Lake, California (transportation costs are forbidding).
- (3) Delivery of a salt cargo by ocean carrier from Baja California production to some delta discharge (e.g. Stockton, California).
- (4) Bitterns (ocean salt brines from which sodium chloride has been precipitated) available at Newark/Hayward, California.

None of these alternatives are really attractive; however, the alternative of using bay salt from Newark/Hayward is by far the best. According to Leslie Salt quotes, a delivered cost of about \$40/ton is expected for this salt supply.

## APPENDIX C

### SOLAR POND POWER PLANT COST BREAKDOWN

#### C-1. PRELIMINARY SOLAR POND CONSTRUCTION COST ESTIMATE

The detailed cost breakdown for the construction of the pond complex is given in Table C-1 for ponds without artificial liner and in Table C-2 for ponds using an artificial liner. Note that results in Table C-1 are adjusted by the difference in liner costs to obtain results in Table C-2. Following Table C-2 are additional notes supporting both Tables.

#### C-2. ADDITIONAL COST INFORMATION FOR VARIOUS SUBSYSTEMS AND MISCELLANEOUS ITEMS

Table C-3 shows additional costs for the power conversion, transport and auxiliary subsystems and other miscellaneous items as well as the estimate of annual operation and maintenance costs. Note that the cost of the power conversion, transport and auxiliary subsystems amounts to \$1,140,000 while Ormat's latest estimate for such a system is \$1,150,000 (the cost of the water treatment facilities of \$50,000 is not included in the Ormat's estimate).

#### C-3. ASSUMPTIONS AND CALCULATIONS OF ENERGY COSTS

An economic analysis computer program was used to calculate the energy costs of the solar pond power plant. Basically, delivered energy cost ( $\overline{\text{BBEC}}$ ) was calculated from the formula.

$$\overline{\text{BBEC}} = \frac{\text{LCC} \cdot \text{CRF}}{\text{CAP} \cdot \text{CF} \cdot 8760}$$

where

$\overline{\text{BBEC}}$  = Busbar Energy Cost

LCC = Solar Pond Life Cycle Costs

CRF = Capital Recovery Factor

CAP = System Capacity

CF = Capacity Factor

These factors are related to basic financial parameters as described in Reference 5.

In the present case, the capital costs and annual operation and maintenance cost given in Sections 7.1 and 7.2 and the annual energy output of  $0.3576 \times 10^6$  kWh<sub>e</sub>/yr. (equivalent to an annual average of 41 kW<sub>e</sub>) as given in Section 4.3 were used to compute the energy costs.

The basic assumptions on the financial parameters are listed in Table C-4,

Table C-1. Preliminary Solar Pond Construction Cost Estimate (1)  
 ... Without Liner

	Note	Quantity	Rate \$	\$K Activity Sub-Total	\$K Group Sub-Total
<b>PREPARATION</b>					
Clear and Spoil	2	5 acre	500.00	2.5	
Break, Load, haul Surfacing		1,900 ft	5.00	13.5	
Remove, Store Slope Protection	3	3,800 ft	6.00	22.8	
Install (temporary) Water Tank	4	1	Lump	2.0	40.8
<b>ACCESS</b>					
Correct County Road Entrance		Allow	Lump	5.0	
Break, Load, haul Surfacing		1,300 ft	5.00	6.5	
Regrade Access Dike (15'width)	5	1,300 ft	2.00	2.6	
Provide Base-course surface (12")		500 yd <sup>3</sup>	12.00	6.0	20.1
<b>SURVEY</b>					
	6	Allow	Lump	5.0	5.0
<b>SOLAR POND CONSTRUCTION</b>					
Cut and Grade		14,800 yd <sup>3</sup>	0.70	10.4	
Fill, Control Moisture, Compact		14,800 yd <sup>3</sup>	0.70	10.4	
Fine Grade		230,000 ft <sup>2</sup>	0.10	23.0	
Surface Dike Roadways - Base Course		530 yd <sup>3</sup>	12.00	6.4	
Wave Protection Layer - (3/4" x 2")	7	650 yd <sup>3</sup>	15.00	9.8	60.0
<b>POWER STATION PLATFORM</b>					
Borrow and comcompact	8	6,200 yd <sup>3</sup>	0.70	4.3	
Road Access Fill		700 yd <sup>3</sup>	0.90	0.7	
Rock Surfaces		667 yd <sup>3</sup>	12.00	8.0	
Foundation and Structure			(Not provided)		13.0
<b>EVAPORATION POND CONSTRUCTION</b>					
Cut and Grade		4,840 yd <sup>3</sup>	0.70	3.4	
Finish Grade		43,650 ft <sup>2</sup>	0.10	4.4	7.8
<b>WATERWELL, PUMP AND SYSTEM</b>					
250' x 8 inch casing (250 GPM)	9	1	Estimate	17.5	
250" x 3 inch casing (50 GPM)	10	1	Estimate	6.0	23.5
<b>SALT SUPPLY</b>					
NaCl Delivered	11	9,500 ton	40.00	380.0	
Apparatus for Charge	12	Allow	Lump	5.0	385.0
<b>POWER COST, POND FILL</b>					
					3.2
<b>PERIMETER FENCE AND GATES</b>					
		2,800 ft	6.00	16.8	16.8
					-----
	13			SUB-TOTAL DIRECT COST	575.2
				ADD, ENGINEERING (8%)	45.8
					-----
				TOTAL CONSTRUCTION COST	621.0

Table C-2. Preliminary Solar Pond Construction Cost Estimate (1)  
With Liner

	Note	Quantity	Rate \$	\$K Activity Sub-Total	\$K Group Sub-Total
PRELIMINARY CONSTRUCTION COST ESTIMATE... <u>WITHOUT</u> LINER					621.0
DEDUCT VARIATIONS:					
Wave Protection Layer, Solar Pond Engineering	14			9.8 <u>45.8</u>	<u>55.6</u> 565.4
		SUB-TOTAL			
ADD VARIATIONS:					
Solar Pond Linr Evaporation Pond Liner	15			136.7 <u>40.3</u>	<u>177.0</u> 742.4
		SUB-TOTAL			
ADD ENGINEERING (8%)					<u>59.6</u>
Solar Pond with Linings, Total (Preliminary) Construction Cost					802.0

## NOTES TO PRELIMINARY CONSTRUCTION COST ESTIMATES

1. The estimate is preliminary because a conceptual rather than a formal design is being treated. Accordingly, volumes and formations in the estimate are tentative.
2. CLEAR AND SPOIL. The existing pan is overgrown with weeds and brush that must be removed thoroughly.
3. SLOPE PROTECTION. The concrete slabs placed loosely on dike slopes in the earlier construction must be removed. Because they have the potential for some other use, their careful salvage is suggested.
4. WATER TANK. A water supply is required in the procedure of earth fill in the interests of moisture control.
5. ACCESS DIKE. The width available on dike tops is about eight crowned feet, which is inadequate. A 12-ft width can be struck off.
6. SURVEY. Assuming that property lines are soundly established and dike alignments are fixed, a survey must establish level control.
7. WAVE PROTECTION. The unlined pond estimate provides a wear course of rock placed at pond surface level to protect the earth formation.
8. POWER STATION PLATFORM. This estimate establishes a foundation, 75 ft x 200 ft to accommodate the station, its facilities and accessories.
9. 250-gpm PUMP. Arbitrarily, this deep-well turbine unit was selected as one that would complete the pond fillings in 30 days of constant duty.
10. 50-gpm PUMP. This replacement unit (to be positioned after ponds are filled) is one selected to provide wash water for pond operation.
11. SALT SUPPLY. Provision is made for 9,500 tons delivered in 25-ton truck-load lots.
12. CHARGE APPARATUS. A procedure should be established for transferring bulk salt from truckload to the pond; the "charge apparatus" estimate allows a sum for this budget item.
13. ENGINEERING. This estimate includes the hiring of independent geotechnical engineering design and construction control.
14. WAVE PROTECTION. The lined pond alternative will rely upon the liner sheet that extends up and over the dike slope to protect the embankment.
15. LINER. This estimate is based on application of Dupont's Hypalon in an improved product that provides heat resistance, as might be provided and has been suggested by the supplier, Watersaver, Inc.



Table C-3. Cost Information for Various Subsystems, Miscellaneous Items and Annual Operation and Maintenance

Description	Cost (US\$)	
Project Management		\$100,000
Design and Specifications		\$100,000
Power Conversion Subsystem		
Preheater	\$ 17,000	
Vaporizer (Boiler)	43,000	
Regenerator	175,000	
Condenser	65,000	
Feed Pump	6,000	
Turbine	55,000	
Generator	15,000	
Controls	70,000	
<sup>a</sup> Miscellaneous	90,000	
Sub-Total		\$536,000
Transport and Auxiliary Subsystems		
Hot Brine Loop	\$167,000	
Cooling Water Loop	162,000	
Flushing & Make-up Water Loop	26,000	
Brine Make-up Loop	4,000	
Instrumentations	15,000	
Controls and Monitoring	70,000	
Water Treatment Facilities	50,000	
Pond Fill Equipments	10,000	
Wave Suppression System	10,000	
Plant Start-up Equipment	20,000	
Miscellaneous Service Equipment	25,000	
<sup>a</sup> Miscellaneous	45,000	
Sub-Total		\$604,000
Grand Total		\$1,340,000
Annual Operation and Maintenance		
Personnel	60,000	
Materials	3,000	
General Maintenance	10,000	
TOTAL		\$ 73,000

<sup>a</sup>Miscellaneous include shipping, extra support structure, and equipments or parts such as valves, etc.

Table C-4. Financial Parameters

		RATES
System Lifetime	20 years	
Year of Dollar Estimate	1981	
Depreciation Method	Sum-of-years-digits	
Construction Time	2 years	
Miscellaneous Expense Rate		2.25%
Investment Tax Credit Rate		10%
Tax Rate California		51%
Discount Rate Investor Owned Utility (PG&E)		11.0% (nominal)
Capital Recovery Factor Electric Power Applications		12.6%
Inflation Rate		7.2%
O&M Escalation Rate		9.3% (nominal)
Capital Escalation Rate		7.2% (nominal)

Table C-5. Typical Output of JPL Solar Pond Power Plant  
Economic Analysis Computer Program

DAVIS SOLAR POND ELECTRIC APPLICATION WITH LINER

CAPITAL EXPENDITURES TABLE (1981 DOLLARS)

YEAR 1983	CONSTRUCTION WITH LINER 2142000.	0.	0.	
ESCALATION RATES	.0720	.0000	.0000	.0000

SYSTEM VARIABLES (1985 DOLLARS)

Base Year	:	1981
Year of Commercial Operation	:	1985
System Life	:	20
System Capacity (MW)	:	.4200-01
Plant Capacity Factor	:	1.0000
Discount Rate	:	.1100
General Escalation Rate	:	.0720
Capital Recovery Factor (CRF)	:	.12558
Accounting CRF	:	.16980
Accounting Lifetime	:	10.
Initial Annual Operations Cost	:\$	.10418+06
Operations Escalation Rate	:	.0930
Depreciation Method	:	Sum-of-the-years digits
Depreciation Factor	:	.67947
Income Tax Rate	:	.5100
Investment Tax Credit	:	.1000
Insurance, Other Taxes, Etc. Rate	:	.0225
Fixed Charge Rate	:	.1643

PRESENT VALUE AMOUNTS (1985 DOLLARS)

CAPITAL EXPENDITURES

Total	.29291+07
Tax Reduction (Depreciation)	.10150+07
Tax Reduction (Investment Credit)	.29290+06
Amortized Investment	.16211+07
OTHER CAPITAL RELATED CHARGES (Insurance, Property taxes, etc)	.52481+06
INCOME TAX PAYMENTS	.16873+07
OPERATIONS COST	.17790+07
MAINTENANCE COST	.00000
FUEL COST	.00000
SYSTEM LIFE-CYCLE COST	.56123+07
BUSBAR ENERGY COST (MILLS PER KWH - YCO DOLLARS)	.19155+04
BUSBAR ENERGY COST (MILLS PER KWH - BYR DOLLARS)	.14505+04