

FINAL REPORT  
PIONEER VENUS LARGE PROBE NEUTRAL MASS SPECTROMETER  
Submitted to  
NATIONAL AERONAUTICS AND SPACE ADMINISTRATION  
WASHINGTON, D. C. 20546

by

THE UNIVERSITY OF TEXAS AT DALLAS  
P. O. BOX 688  
RICHARDSON, TEXAS 75080

GRANT: NAGW-64

E0506-01

(NASA-CR-168963) PIONEER VENUS LARGE PROBE  
NEUTRAL MASS SPECTROMETER Final Report  
(Texas Univ. at Dallas, Richardson.) 83 p  
HC A05/MF A01 CSCL 14B

N82-24284  
Unclas  
G3/19 27858



Dr. John Hoffman  
Principal Investigator

May 24, 1982

A neutral gas mass spectrometer was flown to Venus as part of the Pioneer Venus Multiprobe to measure the composition of its lower atmosphere. On December 9, 1979, the probe entered the Venus atmosphere and descended slowly to its surface (part way on a parachute) producing data for nearly one hour below an altitude of 62 km. The instrument measured the composition of the gases relative to  $\text{CO}_2$ , the dominant gas, that it sampled from the atmosphere through a special leak. Mass range extended from 1 to 208 amu with a sensitivity of the order of 1 ppm relative to  $\text{CO}_2$ . The interest in studying the atmospheric composition of Venus stems largely from the fact that there are marked differences in pressure, temperature and composition between the atmospheres of Venus and earth, yet these two planets are so similar in size, mass, and distance from the sun. The Venus surface pressure and temperature are 90 bars and 750K, respectively, compared to 1 bar and 285K (average) on earth. It has been known for some time that  $\text{CO}_2$  is the dominant atmospheric constituent and that nitrogen is present to a relatively small percentage ( 10 percent). It was also thought that sulfuric acid is a major contributor to the composition of the clouds but was unclear just how the sulfur cycle, the transport of sulfur between the lower atmosphere and the cloud levels, operated. The contents of the noble gases had been estimated to be similar to that on earth.

Analysis of the flight data has shown that the abundance of nitrogen in the lower atmosphere is approximately 3.5 percent,  $^{40}\text{Ar}$  is a factor of 4 less abundant than on earth, and the isotopic ratio of argon is significantly altered. On earth primordial argon ( $^{36}\text{Ar}$ )

is only 0.34 percent (1 part in 300) of  $^{40}\text{Ar}$ , the radiogenic component, whereas on Venus it is 85 percent of the  $^{40}\text{Ar}$ . Even though the  $^{40}\text{Ar}$  is less abundant on Venus, the  $^{36}\text{Ar}$  is more than 75 times as large as on earth. This was quite an unexpected result. The ratio of the primordial argon isotopes,  $^{36}\text{Ar}/^{38}\text{Ar}$ , is about the same as on earth. Isotopic composition of carbon, nitrogen, and oxygen are, within the limit of errors, also the same as on earth.

It appears that sulfur does not exist in the cloud regions in the form COS, as was thought pre-Pioneer Venus, but most likely is found in the oxidized state,  $\text{SO}_2$ . There exists a change in the sulfur form below 24 km where COS does appear, but may be the result of the leak blockage that is described below.

One of the major problems that the mass spectrometer had to address was the sampling of the atmosphere over a pressure range of 0.1-100 bars while measuring concentrations of the order of 1 ppm of the dominant gas ( $\text{CO}_2$ ).

Sampling of the Venus atmosphere occurred through two small microleaks, each consisting of a 3.2 mm diameter passivated tantalum tube whose outer end was forged to a flat plate configuration having a conductance of the order of  $10^{-7} \text{ cm}^3/\text{s}$  for the primary leak and  $10^{-6} \text{ cm}^3/\text{s}$  for the secondary leak (Hoffman et al., 1980). These leaks protruded from the sounder probe into the atmosphere. Analysis of the inflow through the leaks was performed by a miniature magnetic sector field mass spectrometer. Removal of the atmospheric samples was accomplished by a combination of chemical getters and sputtering ion pumping. To preserve the wide dynamic range of the instrument, that is, to enable measurement of substances in the Venus atmosphere at the 1 ppm

level of  $\text{CO}_2$ , as the atmospheric pressure varied over the 3 decade range while the probe descended to the surface, the larger conductance leak was closed at 47 km. A variable conductance valve, installed between the instrument ion source and the primary getter pump, was opened pneumatically by the increasing atmospheric pressure, causing the conductance from the ion source to the getter pump to be increased at a rate that approximated the increased throughput of the atmospheric sampling leak, thereby maintaining a nearly constant pressure in the ion source of the instrument. Preflight laboratory simulation of a descent, with pressure varying from 0.5 to 100 bar and temperature from 300 to 750 K, showed the  $\text{CO}_2$  signal to vary by only a factor of 5 (Hoffman et al., 1979c). Data were taken from 62 km down to the surface of Venus.

From approximately 50 to 28 km altitude the leaks were blocked by an overcoating of cloud particle materials, presumably by droplets of sulfuric acid. During this time the in-flow of atmospheric gases was stopped and mainly background or residual gases in the mass spectrometer were seen, except for  $\text{SO}_2$  and  $\text{H}_2\text{O}$  which appeared to originate from the blocking materials. Below 30 km the primary leak reopened (the secondary leak had been valved off by this time), and the atmospheric gas flow returned to normal.

Data obtained during the period of blockage was long regarded as useless. However, recently it was realized that while the leaks were coated the instrument was sampling Venus water in the form of the sulfuric acid solution. During the rest of the mission the water entering the spectrometer consisted of a mixture of water from the Venus atmosphere and terrestrial water outgassing from the walls of

the inlet tubing. The strong signals associated with the sulphuric acid incident allowed disentanglement of the contributions of Venus and Earth water to the observations and the determination of the ratio of deuterium to hydrogen in the Venus component. The result was  $1.6 \times 10^{-2}$  compared to a terrestrial value of  $1.6 \times 10^{-4}$ .

The planet Venus may have possessed the equivalent of a terrestrial ocean and enjoyed a benign climate several billion years ago. At present the surface of Venus is very hot and dry. The atmosphere consists mostly of carbon dioxide gas with a little nitrogen and contains very little water vapor. There has been speculation that Venus might once have had an ocean since most theories for the origin of the planet call for Venus and Earth to have been almost identical twins. According to these models the sun would have been cooler and less luminous four and half billion years ago just after the planets were formed and the temperature on Venus low enough for liquid water to exist on its surface. Sometime later as the sun grew brighter the rising temperature drove water into the atmosphere as steam and released carbon dioxide from limestone on the surface. The water and carbon dioxide would have prevented the escape of infrared radiation from the lower layers of the atmosphere and caused it to grow still warmer. The result would have been the evaporation of even more water and production of more carbon dioxide in a paroxysm called a "runaway greenhouse." Finally the oceans would have evaporated completely and the surface temperature may have become as high as 1300 K.

At this point the outermost portions of the planet's atmosphere would have consisted mostly of hydrogen gas evolved from the water by reactions with hot surface rocks or resulting from dissociation of the hydrogen and oxygen in water by solar ultra violet radiation. Hydrogen is so light that it would readily have escaped from the gravitational field of Venus leaving the oxygen behind to oxidize iron and other substances on the planet.

A small fraction ( $3.2 \times 10^{-4}$ ) of the water on Earth is heavy water (HDO) containing deuterium. It is reasonable to assume that originally the ratio of HDO to  $H_2O$  was the same on both Venus and Earth. During the early phases of the escape process the flow of hydrogen would have been so strong that it would have swept deuterium along with it. Later, when the flow rate dropped sufficiently low, much of the deuterium would have been retained by the planet. The result would have been an enrichment of deuterium in the residual water left on the planet. The discovery that the ratio of heavy water to normal water on Venus is one hundred times greater than it is in sea water on Earth is clear evidence that Venus once had at least one hundred times as much water as it does today. If that water were liquid it would have covered the planet to an average depth of 9 meters. But because escape of most of the hydrogen associated with an ocean would not have resulted in deuterium enrichment this value is only a lower limit. The result is quite consistent with the possible existence of the equivalent of a full terrestrial ocean, or a major fraction of one.

As stated above, the abundances of primordial Ne and Ar on Venus are two orders of magnitude greater than on earth. Kr and Xe abundances are also greater.

The significance of these results emerges from a comparison of Cytherean and terrestrial abundances of Kr and Xe with those of Ne and Ar. In the atmosphere of Venus the latter two gases exceed terrestrial abundances by factors of 40 and 75 respectively. In contrast, abundances of the heavier inert gases in the Cytherean atmospheres exceed terrestrial values by factors of only 3.5 to less than 30. Thus, models for the formation of the terrestrial planets in which the inert gases are accumulated by the accretion of planetary material with characteristic "planetary" ratios similar to those found in meteorites are difficult to defend. In particular, these results present a serious problem for the proposal that a large pressure gradient existed in the solar nebula so that grains that condensed to form Venus absorbed about two orders of magnitude more inert gases than did those that formed the earth. In such a model there is no reason to expect less enhancement of krypton and xenon in the Venus atmosphere than neon and argon. Indeed, in view of the large amount of xenon perhaps sequestered in terrestrial shales the opposite might be true in the case of that gas. The large excess in Ne and <sup>36</sup>Ar in the atmosphere of Venus also creates problems for models of terrestrial planet genesis in which volatiles are outgassed from late accreting veneers of similar material. In fact, with the conspicuous exception of neon the inert gases seem to become more and more "solar" in character the closer the planet sampled is to the sun.

Thus, it appears that the noble gases on Venus have a large solar component compared to Earth and Mars.

The Venus exosphere has a peculiar distribution of atomic hydrogen that has provoked considerable discussion since 1967 when the ultraviolet photometer on Mariner 5 detected anomalous Lyman  $\alpha$  emissions several thousand km above the planet's surface. Subsequent analysis of the Mariner 5 bright limb data revealed an increase in the scale height of Lyman  $\alpha$  scatterers at about  $10^4$  km from the center of the planet, suggesting a two component exosphere that could be fitted by exospheric distributions of  $H_2$  and H at  $650 \pm 50$  K, with  $H_2$  being the dominant constituent. The possibility of an atomic hydrogen-deuterium exosphere was also considered.

The Monte Carlo calculation of the global distribution of hydrogen in the exosphere of Venus, with hot hydrogen produced by charge exchange of  $H^+$  ions with both atomic hydrogen and oxygen, has yielded a result that is in reasonable agreement with altitude distributions of H based on Lyman  $\alpha$  measurements. This confirms the hypothesis that exospheric charge exchange reactions are sources of sufficient hot hydrogen to explain the two-temperature exosphere of Venus. Uncertainties in model parameters and in data on the Venus exosphere presently allow a source of similar magnitude of nonthermal hydrogen due to exothermic chemical reactions involving  $H_2$ . Present model results indicate that  $H_2$  chemistry could be the dominant cause of hydrogen escape while being a secondary source of the nonescaping hot hydrogen on Venus.



It has also been shown from the Monte Carlo calculations that it is necessary to include a thermospheric wind system in global models of the hydrogen exosphere of Venus to account for the large diurnal variation of H near the exobase that was deduced from charge exchange equilibrium calculations from the Pioneer Venus data. A wind system consisting of a solar diurnal tide with a cross-terminator day to night speed of 200 m/s superimposed on a retrograde global rotation with equatorial speed of 100 m/s provides a good fit to the phase and amplitude of the exobase diurnal variation.

Attached is a set of reprints of papers referred to in the Bibliography.

## BIBLIOGRAPHY

### Journal Papers:

Donahue, T. M., J. H. Hoffman and R. R. Hodges, Jr., Krypton and Xenon in the atmosphere of Venus, Geo. Res. Lett., 8, 513, 1981.

Donahue, T. M., J. H. Hoffman, R. R. Hodges, Jr., and A. J. Watson, Venus was wet: A measurement of the ratio of D to H, Science, 630, 1982.

Hodges, R. Richard, Jr., and B. A. Tinsley, Charge exchange in the Venus ionosphere as the source of the hot exospheric hydrogen, J. Geophys. Res., 86, 7649, 1981.

Hodges, R. Richard, Jr., and B. A. Tinsley, The influence of thermospheric winds on exospheric hydrogen on Venus, Icarus, in press, 1982.

Hoffman, J. H., R. R. Hodges, Jr., M. B. McElroy, and T. M. Donahue, Venus lower atmospheric composition: Preliminary results from Pioneer Venus, Science, 203, 800, 1979a.

Hoffman, J. H., R. R. Hodges, M. B. McElroy, T. M. Donahue, and M. Kolpin, Composition and structure of the Venus atmosphere: Results from Pioneer Venus, Science, 205, 49, 1979b.

Hoffman, J. H., R. R. Hodges, Jr., and K. D. Duerksen, Pioneer Venus large probe neutral mass spectrometer, J. Vac. Sci. Technol., 16(2), 692, 1979c.

Hoffman, J. H., R. R. Hodges, Jr., W. W. Wright, V. A. Blevins, K. D. Duerksen, and L. D. Brooks, Sounder probe neutral gas mass spectrometer, IEEE Geosci. Rem. Sensing, GE-18(1) 80-84, 1980.

Hoffman, J. H., V. I. Oyama, and U. von Zahn, Measurements of the Venus lower atmosphere composition: A comparison of results, J. Geophys. Res., 85, 7871, 1980.

Hoffman, J. H., R. R. Hodges, Jr., T. M. Donahue, and M. B. McElroy, Composition of the Venus lower atmosphere from the Pioneer Venus mass spectrometer, J. Geophys. Res., 85, 7882, 1980.

### Papers at Conferences:

American Geophysical Union-Spring Meeting, 1980.

Planetary Atmospheres Principal Investigators Conference, GSFC, Feb., 1981

Venus Conference, Palo Alto, California, Nov., 1981.

## KRYPTON AND XENON IN THE ATMOSPHERE OF VENUS

T. M. Donahue

Department of Atmospheric and Oceanic Science, University of Michigan,

Ann Arbor, Michigan 48109

J. H. Hoffman and R. R. Hodges, Jr.

Department of Physics, University of Texas at Dallas, Richardson, Texas 75080

ORIGINAL PAGE IS  
OF POOR QUALITY

**Abstract.** Probable values of the mixing ratios of krypton and its isotopes on Venus by the Pioneer Venus large probe neutral mass spectrometer are reported. An upper limit to most of the xenon isotope mixing ratios is also set. Based on a  $^{36}\text{Ar}$  mixing ratio of 30 ppm the krypton mixing ratio is probably 47 ppb and its upper limit 69 ppb. The upper limit for Xe is 120 ppb but there is probably considerably less than 40 ppb. Atmospheric krypton and xenon on Venus exceed terrestrial values by factors of 3.5 and no more than 30, much less than the ratios for neon and argon. It appears that the noble gases on Venus have a large solar component compared to Earth and Mars.

The purpose of this letter is to report a determination by the Pioneer Venus Sounder Probe Neutral Mass Spectrometer (LNMS) of upper limits to the concentration of krypton and xenon along with most of their isotopes in the atmosphere of Venus. In the case of the krypton isotopes  $^{80}\text{Kr}$ ,  $^{82}\text{Kr}$ ,  $^{83}\text{Kr}$ ,  $^{84}\text{Kr}$  and  $^{86}\text{Kr}$  possible measurements of their concentrations will be reported as well. The upper limit to the krypton mixing ratio is probably 47 ppb (v/v) with a quite conservative value 50% larger, or 69 ppb. In fact, it is likely that 47 ppb represents a measured concentration, with the corresponding values for separate isotopes being 3.6, 12, 7, 25 and 4.2 ppb. The probable upper limit to the sum of the mixing ratios of the isotopes  $^{128}\text{Xe}$ ,  $^{129}\text{Xe}$ ,  $^{130}\text{Xe}$ ,  $^{131}\text{Xe}$  and  $^{132}\text{Xe}$  is 40 ppb by volume. A very conservative upper limit is a value three times this large. The upper limits for the individual isotopes are 1.5, 9.5, 4, 14 and 10 ppb respectively, or, conservatively, larger values by a factor of about 3. Actually measured were the ratios of counting rates for the Kr and Xe isotopes relative to  $^{36}\text{Ar}$ . The mixing ratios and upper limits quoted are based on use of the most probable value for the  $^{36}\text{Ar}$  concentration of 30 ppm v/v as determined from the LNMS measurements (Hoffman, *et al.*, 1980).

The significance of these results emerges from a comparison of Cytherean and terrestrial abundances of Kr and Xe with those of Ne and Ar. In the atmosphere of Venus the latter two gases exceed terrestrial abundances by factors of 40 and 75 respectively. In contrast, abundances of the heavier inert gases in the Cytherean atmospheres exceed terrestrial values by factors of only 3.5 to less than 30. Thus, models for the formation of the terrestrial planets in which the inert gases are accumulated by the accretion of planetary material with characteristic "planetary" ratios similar to those found in meteorites (Signer and Suess, 1963) will be difficult to defend. In particular, these results present a serious problem for the proposal (Pollack and Black, 1979) that a large pressure gradient existed in the solar nebula so that grains that condensed to form Venus absorbed about two orders of magnitude more inert gases than did those that formed the earth. In such a model there is no reason to expect less enhancement of krypton and xenon in the Venus atmosphere than neon and argon. Indeed, in view of the large amount of xenon perhaps sequestered in terrestrial shales the opposite might be true in the case of these gases. The large excess in Ne and  $^{36}\text{Ar}$  in the atmosphere of Venus also creates problems for models of terrestrial planet genesis in which volatiles are outgassed from late accreting veneer of similar material (Anders and Owen, 1977). In fact, with the conspicuous exception of neon the

inert gases seem to become more and more "solar" in character the closer the planet sampled is to the sun.

The Pioneer Venus LNMS has been described previously (Hoffman, *et al.*, 1979a) and results obtained by it reported (Hoffman, *et al.*, 1979b, c and 1980). The instrument was a miniature magnetic sector-field mass spectrometer that covered the mass range  $^{1208}$  amu in 232 steps at selected mass numbers. A table showing the masses sampled has been published (Hoffman, *et al.*, 1980). Gases were admitted to the ionization chamber through microleaks and the pressure in the chamber regulated by two pairs of chemical getter and ion sputter pumps, one pumping the chamber through a variable conductance valve, the other pumping the region of the mass analyzer. The purpose of the variable conductance valve was to maintain a relatively constant pressure of  $\text{CO}_2$  in the ion source. The result was a slow increase in the counting rate for  $\text{CO}_2$  at low altitudes as was shown in Fig. 1 of Hoffman, *et al.* (1980). Inert gases were pumped during periods of data collection only by the sputter pump attached to the mass analyzer. Because the pumping speed for inert gases was essentially constant, the counting rate at the  $^{36}\text{Ar}$  mass setting increased with decreasing altitude more rapidly than that at  $^{44}\text{CO}_2$ . The ratio of the counting rate for  $^{36}\text{Ar}$  and  $\text{CO}_2$  corrected for the differences in gas pumping speeds was referred to preflight calibration data to obtain the  $^{36}\text{Ar}$  and  $\text{CO}_2$  mixing ratios. The mixing ratio for  $^{36}\text{Ar}$  is  $30 \pm 3$  ppm by volume (Hoffman, *et al.*, 1980). With the help of laboratory calibration data the mixing ratios for any noble gas can be obtained by comparing the counting rate at the appropriate mass setting to that for  $^{36}\text{Ar}$ .

Ion acceleration voltages during each mass sweep were set by reference to the values appropriate for  $136$  ( $^{136}\text{Xe}^+$ ),  $68$  ( $^{136}\text{Xe}^{++}$ ) and  $15$  ( $\text{CH}_5^+$ ) amu. Methane and xenon containing mainly  $^{136}\text{Xe}$ , about 5%  $^{134}\text{Xe}$  and traces of other isotopes were used as marker gases. Mass resolution varied from 1 part in 440 near 40 amu to 1 part in 200 near 136 amu.

Atmospheric composition data began after opening the microleaks when the probe was at 62 km. At about 51 km the leaks were blocked by cloud droplets. At 30 km they reopened. During and after the time of leak blockage various substances were produced within the mass spectrometer, probably by interactions of  $\text{CO}_2$ ,  $\text{H}_2\text{SO}_4$  products and a vacuum sealant substance. Most prominent among these was a hydrogenic compound (perhaps a form of  $\text{C}_2\text{H}_2$ ) at 78.052 amu. The counting rate at analyzer settings corresponding to these contaminants increased between 30 km and 13 km (31,000 cts at 78 amu) and then decreased toward the surface (10,000 cts at 78 amu). A useful criterion for distinguishing a contaminant from a potential atmospheric species is whether the signal at a given mass setting increases with decreasing altitude like  $\text{CO}_2$  or argon or passes through a maximum like the substance at 78 amu.

Because xenon was used as a marker gas an appreciable background counting rate in the channels belonging to all Xe isotopes, but particularly those for  $^{134}\text{Xe}$  and  $^{136}\text{Xe}$  was observed at high altitude both before and after entry. For this reason little attention was paid to those data until G. Wetherill (1980) suggested to the authors that a useful upper limit to the Xe mixing ratio might be determined from them. Inspection of the data showed in fact that the counting rates for all Xe isotopes except  $^{134}\text{Xe}$  and  $^{136}\text{Xe}$  were

Copyright 1981 by the American Geophysical Union.

appreciably higher at low altitudes than near 60 km, or before entry. There should be at least three contributions to the counting rate: a background, roughly equal to the average pre-entry or high altitude counting rate, and a "residual" component in part of contributions from atmospheric xenon and in part from impurities. The impurities could be either xenon liberated from the ion pumps by some of the exotic compounds formed after leak blockage or these same compounds with masses close to those of xenon isotopes. The background counting rate for each isotope was determined by averaging 6 readings taken before leak blockage and multiplying this average by the ratio of the counting rate at 136 amu to the high altitude average at 136 amu. The correction was necessary because the counting rates at 136 amu and 134 amu increased on the order of 30% below 16 km, probably due to decreasing efficiency in the ion pump with increasing CO<sub>2</sub> load. There were variations in the counting rates at 136 amu and 134 amu below 16 km probably because of changes in the pumping speed for xenon. Some ten closely spaced mass numbers were sampled near 134 and 136 amu. Comparison of mass channels above and below 16 km support the interpretation that the changes below 16 km involve xenon and not some impurity. Presumably the background of all xenon isotopes should be varying in the same way because of these effects.

The background thus obtained was subtracted from the total counting rate at each altitude to obtain a residual. Residuals tended to increase fairly rapidly below 20 km to a maximum near 13 km and then decrease by a factor of about 3 to the last data point taken 0.6 km above the surface of Venus. In Fig. 1 are shown the total, background and residual counting rates for the sum of the data at 128, 129, 130, 131, 132 amu. One way to obtain an upper limit to the xenon mixing ratio (excluding <sup>134</sup>Xe and <sup>136</sup>Xe) would be to compare the counting rate at the lowest altitude or 24 per frame with 20480, the counting rate at 35.981 amu (<sup>36</sup>Ar). This ratio multiplied by 2.7 would give the concentration relative to <sup>36</sup>Ar. The factor of 2.7 is the experimentally determined ratio of spectrometer sensitivity for Ar relative to Xe. The difference in sensitivity for the two gases is caused mainly by a difference in ionization cross sections, and also by broadening of the higher mass peak, difference in the branching ratio for single and double ionization by 70 eV electrons and difference in pumping speeds. The result, 95 ppb where the <sup>36</sup>Ar mixing ratio is taken as 30 ppm, is of dubious usefulness because it weighs one measurement too heavily. If instead of the counting rates at the lowest altitude the means of the last 5 samples are compared, the ratio of Xe to Ar count rates is  $1.5 \times 10^{-3}$  giving an upper limit of 120 ppm to the Xe mixing ratio. This procedure leads, however, to an altitude dependent Xe mixing ratio with a maximum above 13 km.

If it is assumed that the residual counting rate can be separated into a component that varies with altitude in the same way as does <sup>36</sup>Ar and another that varies as does the archetypical artifact at 78 amu, a better evaluation of the atmospheric xenon contribution can be obtained. This procedure is suggested because the Xe count rates maximize near 13 km where the 78 amu rate also peaks. In Fig. 1 smooth curves are shown roughly fitted to the data. One of these represents  $24 \times 10^{-4}$  [78 amu], another  $20 \times 10^{-4}$  [78 amu] +  $5 \times 10^{-4}$  [<sup>36</sup>Ar], and a third  $21 \times 10^{-4}$  [78 amu] +  $9.1 \times 10^{-4}$  [<sup>36</sup>Ar] where the values of [78 amu] and [Ar] near the surface are approximately  $10^4$  and  $2 \times 10^4$  respectively. The data can best be represented by assuming that there is no detectable Xe contribution whatever (curve a). Owing to the scatter in the data it is possible that as many as 10 of the counts at the surface out of 30 are attributable to an atmospheric constituent that varies like <sup>36</sup>Ar, i.e., to Xe (curve b). Curve c clearly overestimates the <sup>36</sup>Ar like component. Hence, the most probable value of the mixing ratio of the Xe isotopes from this kind of analysis is 0, but a reasonable upper limit relative to <sup>36</sup>Ar is  $1.35 \times 10^{-3}$ . This is 40 ppb v/v based on a value of 30 ppm for the Ar mixing ratio. The uncertainty in the ratio to <sup>36</sup>Ar is almost entirely in the Xe measurement. For this reason we give a range of values of mixing ratios based on a specific <sup>36</sup>Ar value. If the <sup>36</sup>Ar concentration is taken to be its upper limit, 30 ppm, the Xe upper limit changes accordingly by a factor of 5/3 to 67 ppb. This is the

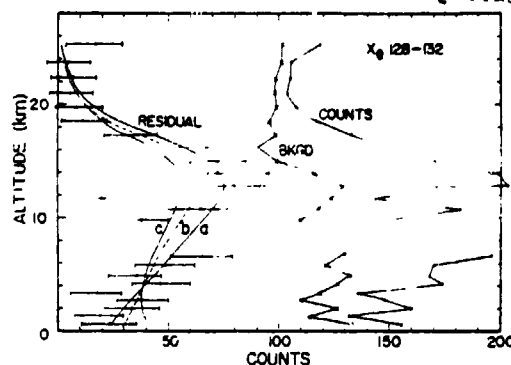

Fig. 1. Counting rates as functions of altitude for five Xe isotopes, 128-132.

upper limit, however, only if the Ar mixing ratio is 50 ppm. All values and limits for Kr and Xe quoted henceforth will assume that <sup>36</sup>Ar mixing ratio is 30 ppm. To summarize: the most probable mixing ratio of the sum of the 5 Xe isotopes is 0 ppb, the largest value allowed by curve b is 40 ppb and the extreme upper limit where the residual count rate in the lowest 3.5 km is assumed to be entirely due to atmospheric Xe is 120 ppb v/v.

Similar analysis applied to isotopes individually yields the following results for the most probable value and the two upper limits ("curve b" and extreme)

<sup>128</sup> Xe, 0 ppb, < 1.5 ppb, < 4.7 ppb
<sup>129</sup> Xe, 0 ppb, < 9.5 ppb, < 35 ppb
<sup>130</sup> Xe, 0 ppb, < 4 ppb, < 10 ppb
<sup>131</sup> Xe, 0 ppb, < 14 ppb, < 40 ppb
<sup>132</sup> Xe, 0 ppb, < 10 ppb, < 47 ppb

If the isotope mixing ratios are given by the second column their relative abundances are 0.038, 0.24, 0.10, 0.36 and 0.25 to be compared with terrestrial values of 0.03, 0.33, 0.05, 0.26, and 0.33.

Obviously this apportionment of the residual counting rates is not unique. If it is correct we do not know whether the constituents that vary with altitude like the impurity at 78 amu are other impurities or Xe isotopes liberated from the pumps by a mechanism involving impurities. However, it is difficult to imagine a collection of compounds that would produce elevated counting rates at the accelerating voltages appropriate to the 5 Xe isotopes and not at any of the 31 voltages sampled between <sup>86</sup>Kr and <sup>128</sup>Xe, nor at the 22 higher mass positions.

Even more significant than the results obtained for xenon were those for krypton. In the range of accelerating potentials for masses near 80 amu there were steps appropriate for <sup>80</sup>Kr, SO<sub>2</sub>, HSO<sub>3</sub>, <sup>82</sup>Kr, <sup>84</sup>Kr and <sup>86</sup>Kr. Unfortunately, the apparatus had been exposed to <sup>86</sup>Kr before flight, and a background of about 35 <sup>86</sup>Kr counts was recorded before and after entry at high altitude. There was no background at the locations of the other isotopes. On the other hand, there were low but significant counting rates in all of the channels just listed below 30 km. The sum of the counting rates in the <sup>80</sup>Kr, <sup>82</sup>Kr, <sup>83</sup>Kr and <sup>84</sup>Kr channels is shown in Fig. 2. Unlike the Xe data in Fig. 1 the variation with altitude is relatively small up to 16 km where an abrupt decrease occurs. This behavior is characteristic of the sum of two constituents, one decreasing with altitude like <sup>36</sup>Ar the other increasing to a maximum near 13 km like 78 amu. The data are fitted best by curve b giving 13 cts from the opposed Kr contribution and 6.5 cts from an internal contaminant. The instrumental factor relating Ar to Kr sensitivities is 2.4. Therefore, the abundance ratio of Kr to <sup>36</sup>Ar is  $15.5 \times 10^{-4}$  and the Kr mixing ratio 47 ppb. From Fig. 2 it can be determined that the range in uncertainty is 12 to 69 ppb for curves a and c respectively. Unlike the results for xenon there seems to be a strong indication of the presence of atmospheric constituents in these data. Hence, these observations may well represent measurements rather than upper limits. On the other hand, if the artifact contribution is not subtracted the data place an upper limit of 69 ppb on the combined

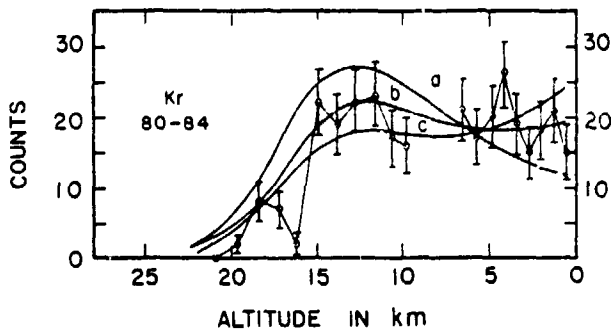

Fig. 2. Counting rates as function of altitude for 4 Kr isotopes 80-84; a)  $1.63 \times 10^{-4} [^{36}\text{Ar}] + 8.7 \times 10^{-4} [78 \text{ amu}]$ ; b)  $6.5 \times 10^{-4} [^{36}\text{Ar}] + [78 \text{ amu}]$ ; c)  $9.6 \times 10^{-4} [^{36}\text{Ar}] + 4.3 \times 10^{-4} [78 \text{ amu}]$ .

abundance of Kr isotopes 80 through 84 in the atmosphere of Venus. Thus from an analysis parallel to that for Xe the most probable mixing ratio for these Kr isotopes is 47 ppb. The largest value allowed by curve c is 69 ppb and the extreme upper limit where all 19.5 counts allowed by curve b near the surface are ascribed to Kr is also, fortuitously, 69 ppb.

The data for individual species show much scatter but are fitted best by various linear combinations of " $^{36}\text{Ar}$  like" and " $78 \text{ amu}$  like" components:

$$\begin{aligned} ^{80}\text{Kr} & 0.5 \times 10^{-4} [^{36}\text{Ar}] + 2 \times 10^{-4} [78 \text{ amu}] \\ ^{82}\text{Kr} & 1.7 \times 10^{-4} [^{36}\text{Ar}] + 1.8 \times 10^{-4} [78 \text{ amu}] \\ ^{83}\text{Kr} & 1.0 \times 10^{-4} [^{36}\text{Ar}] + 2.4 \times 10^{-4} [78 \text{ amu}] \\ ^{84}\text{Kr} & 3.5 \times 10^{-4} [^{36}\text{Ar}] + 1.1 \times 10^{-4} [78 \text{ amu}] \end{aligned}$$

The most probable mixing ratio implied by this analysis together with the limits set by fitting curves like a and c of Fig. 2 to the data are as follows

$$\begin{aligned} ^{80}\text{Kr} & 0 < 3.6 < 10.2 \text{ ppb} & 10.8 \text{ ppb} \\ ^{82}\text{Kr} & 6 < 12.2 < 17 \text{ ppb} & 15 \text{ ppb} \\ ^{83}\text{Kr} & 0 < 7.2 < 19 \text{ ppb} & 15.5 \text{ ppb} \\ ^{84}\text{Kr} & 7 < 25 < 28 \text{ ppb} & 28 \text{ ppb} \end{aligned}$$

Upper limits obtained by attributing all counts near the surface to Kr are on the right.

In the case of  $^{86}\text{Kr}$  as for the xenon isotopes it is necessary to subtract a background. The result is a small residual at low altitudes which varies as

$$0.6 \times 10^{-4} [\text{Ar}] + 1.4 \times 10^{-4} [\text{amu}]$$

The "measured" mixing ratio of  $^{86}\text{Kr}$  is thus 4.3 ppb and the upper limit 9 ppb.

If these results do indeed represent observations of atmospheric krypton the relative abundances of Kr isotopes on Venus are 0.07, 0.23, 0.14, 0.48 and 0.08 corresponding to terrestrial relative abundances of 0.023, 0.116, 0.115, 0.57 and 0.173.

Istomin, et al. (1980) have reported that the mixing ratio of  $^{84}\text{Kr}$  in the atmosphere of Venus is  $600 \pm 200$  ppb by volume. The isotope ratios appear to be terrestrial. It is not possible to reconcile such a result with ours. Count rates of the order of 200 per frame rather than 10 per frame would be needed. Nor is there any evidence that the LNMS became insensitive to heavy gases by the time it reached Venus. The absence of variation in its response to the xenon marker gas during cruise and entry is evidence to the contrary. It is possible that the krypton detected by the Venera NMS was terrestrial, since the spectrometer had been exposed to krypton and utilized ion sputter pumps. The absence of a high altitude check in the Venera measurements leaves this possibility open and inviting.

Fig. 3 shows the concentration of inert gases in the atmospheres of the terrestrial planets and a C3V chondritic meteorite in units of

cc at STP per gram of planetary matter. The small excesses in abundance of Kr and Xe in the atmosphere of Venus compared with that of Earth are in striking contrast with the large increases in Ne and Ar. The ratios are 3.5 and less than 30 for  $^{84}\text{Kr}$  and  $^{132}\text{Xe}$ , 43 and 74 for  $^{20}\text{Ne}$  and  $^{36}\text{Ar}$ . Careful study has further reinforced our conviction (Hoffman, et al., 1979b) that the constituent detected at 36 amu is argon and not some compound such as HCl. As we pointed out in the introduction these results appear to be fatal for simple models of the acquisition of volatiles by the terrestrial planets. The ratio of  $^{36}\text{Ar}$  to  $^{84}\text{Kr}$  is 1000 on Venus. Compared to a solar ratio of 3710 (Cameron, 1973), a terrestrial ratio of 48, a Martian ratio of 32 (Owen, et al., 1977) and a meteorite ratio of about 75, this could be taken to suggest a much larger "solar" component of inert gases in the Cytherean atmosphere than on the other planetary bodies of the inner solar system. We might assume that Venus is a planet with the Earth's endowment of volatiles to which some process contributed an extra dose of volatiles with abundances in solar proportions and containing 75 times as much  $^{36}\text{Ar}$  per gram as does the earth's atmosphere. The  $^{36}\text{Ar}$  ratios would perforce be correct if the added inert gases were atmophile. The extra component of any other inert gas on Venus would be equal to 75 times the solar abundance ratio of that gas relative to  $^{36}\text{Ar}$  divided by the terrestrial abundance ratio to  $^{36}\text{Ar}$ . This is about 1 for  $^{84}\text{Kr}$  and 1.5 for  $^{132}\text{Xe}$ . Thus, there could be about twice as much atmophile  $^{84}\text{Kr}$  on Venus as on earth. There may be 5 to 10 times as much xenon in terrestrial shales as there is in the atmosphere (Canalas, et al., 1968; Fanale and Cannon, 1971), although evidence to the contrary has been published by Podosek, et al. (1980). Since the corresponding "planetary" xenon would presumably be atmophile on

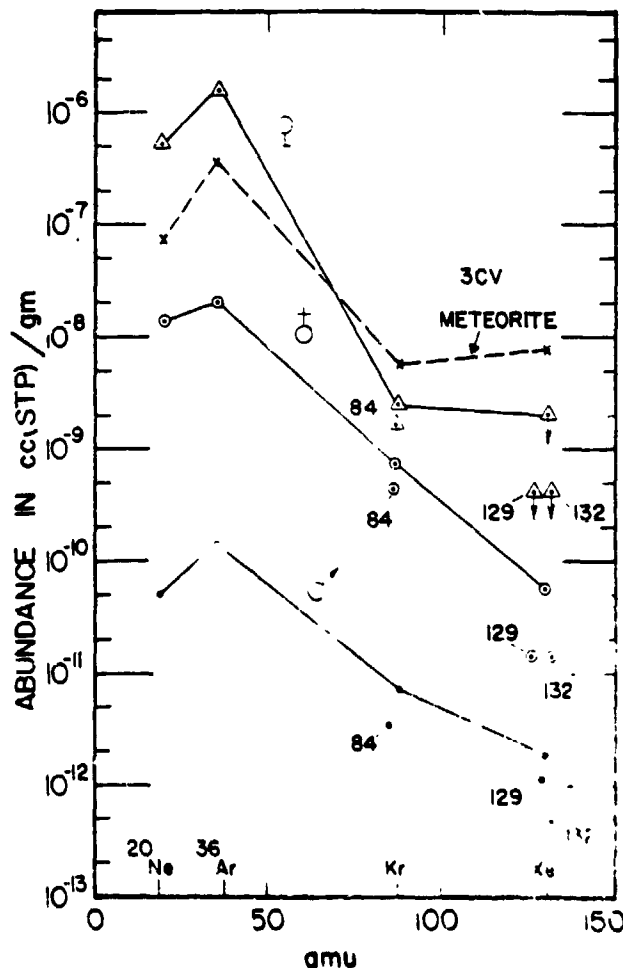

Fig. 3. Abundances of rare gas isotopes on three terrestrial planets and C3V meteorites.

Venus where the surface temperature is 700K we might expect the atmosphere of Venus to contain 6.5 to 11.5 times as much  $^{132}\text{Xe}$  as that of the earth.

There is a conspicuous problem in accounting for the behavior of neon. Since the solar ratio of  $^{20}\text{Ne}$  to  $^{36}\text{Ar}$  is about 30 and the terrestrial ratio is 0.57, there should be not 43 but almost 1900 times as much neon on Venus as on the earth. Explaining the depletion of neon relative to argon on Mars, the Earth, the Moon and in meteorites was a problem before the results from Venus became available. We can only remark that it still continues to be difficult. The other volatiles accompanying the rare gases would present no problem. The solar ratios of O, C, and N to  $^{36}\text{Ar}$  are about 240, 140 and 35 while the terrestrial ratios are about  $2.7 \times 10^6$ ,  $1.3 \times 10^6$  and  $3.6 \times 10^4$  where the oxygen is only that associated with outgassed  $\text{CO}_2$ . Hence, the extra source of volatiles would bring to Venus only a tiny increment of oxygen, carbon and nitrogen.

Wetherill (1980a, 1980b) has invoked enhanced solar wind implantation of gases in material forming planetesimals during the first  $10^7$  years of planetary formation to explain the excess neon and argon on Venus. A solar wind enhancement of about 100, preferential irradiation of the innermost edge of an opaque planetesimal disk and accumulation of this enriched material principally by Venus is involved. Relatively serious loss of solar wind implanted neon would account for the neon anomaly. As Wetherill points out a large abundance of argon relative to heavier noble gases is a natural consequence. On the other hand, there is a problem in explaining quantitatively the necessary preference of enriched material for Venus. Recently McElroy and Prather (1981) have also proposed a mechanism for planetary formation that involves significant contribution of a solar wind component in the volatiles accumulated by Venus. Whatever the final explanation it seems clear that the results presented here constitute a fresh challenge to our understanding of the processes that were involved in the formation and evolution of the terrestrial planets and their atmospheres.

**Acknowledgments** We wish to thank G. Carignan, and G. Wetherill for valuable discussions and insights. This research was supported in part by NASA under grants NAGW-64 and NAS2-9126.

## References

- Anders, E. and T. Owen. Mars and Earth: origin and abundances of volatiles. *Science*, **198**, 453, 1977.
- Cameron, A. W. G., Abundances of elements in the solar system. *Space Sci. Rev.* **15**, 121, 1973.
- Canals, R. A., E. C. Alexander, Jr. and O. K. Manuel, Terrestrial abundances of noble gases. *J. Geophys. Res.*, **73**, 3331-3334, 1968.
- Fanale, F. P. and W. A. Cannon, Physical absorption of rare gas on terrigenous sediments. *Earth Planet. Sci. Lett.*, **11**, 362, 1971.
- Hoffman, J. H., R. R. Hodges, Jr., T. M. Donahue and M. B. McElroy, Composition of the Venus lower atmosphere from the Pioneer Venus mass spectrometer. *J. Geophys. Res.*, **85**, 7882, 1980.
- Hoffman, J. H., R. R. Hodges, Jr. and K. D. Dverksen, Pioneer Venus large probe neutral mass spectrometer. *J. Vac. Soc. Technol.*, **16**(2), 692, 1979a.
- Hoffman, J. H., R. R. Hodges, Jr., M. B. McElroy, T. M. Donahue and M. Kolpin, Venus lower atmospheric composition: preliminary results from Pioneer Venus. *Science*, **203**, 800, 1979b.
- Hoffman, J. H., R. R. Hodges, Jr., M. B. McElroy, T. M. Donahue and M. Kolpin, Composition and structure of the Venus atmosphere: results from Pioneer Venus. *Science*, **205**, 49, 1979c.
- Istomin, V. G., K. V. Grecknev and V. A. Kocknev, Mass spectrometry of the Venus lower atmosphere: krypton isotopes and other recent results of processing the data of measurements on-board the Venera 11-12 spacecraft. *J. Geophys. Res.*, 1980.
- McElroy, M. B. and M. Prather, Noble gases in the terrestrial planets: clues to evolution. *Nature*, 1981, to be published.
- Owen, T., K. Biemann, D. R. Ruckneck, J. E. Biller, D. W. Howarth and A. L. Lafleur, The composition of the atmosphere at the surface of Mars. *J. Geophys. Res.*, **82**, 4635, 1977.
- Pollack, J. B. and D. C. Black, Implications of the gas compositional measurements of Pioneer Venus for the origin of planetary atmospheres. *Science*, **205**, 56, 1979.
- Signer, P. and H. E. Suess, Rare Gases in the sun, in the atmosphere and in meteorites. in *Earth Science and Meteoritics*, Chapter 13 (eds., J. Geiss and E. D. Goldberg) Interscience: New York, 1963.
- Wetherill, G. W.,  $^{36}\text{Ar}$  on Venus. *Lunar Science*, **XI**, 1239-1241, 1980a.
- Wetherill, G. W., Solar wind origin of  $^{36}\text{Ar}$  on Venus, preprint, submitted to *Icarus*, 1980b.

(Received December 2, 1980;  
revised February 27, 1981;  
accepted April 2, 1981.)

ORIGINAL PAGE IS  
OF POOR QUALITY

ORIGINAL PAGE IS  
OF POOR QUALITY

*Journal: In Press*

VENUS WAS WET: A MEASUREMENT OF THE RATIO OF D TO H

T. M. Donahue  
Department of Atmospheric & Oceanic Science  
The University of Michigan  
Ann Arbor, Michigan 48109

J. H. Hoffman and R. R. Hodges, Jr.  
Department of Physics  
University of Texas at Dallas  
Richardson, Texas 75080

and

A. J. Watson  
Marine Biological Association of the U.K.  
The Laboratory  
Citadel Hill  
Plymouth, Devon, England

ORIGINAL PAGE IS  
OF POOR QUALITY

ABSTRACT

The deuterium-hydrogen abundance ratio in the Venus atmosphere was measured while the inlets to the Pioneer Venus Large Probe mass spectrometer were coated with sulfuric acid from Venus' clouds. The ratio is  $(1.6 \pm 0.2) \times 10^{-2}$ . The hundred fold enrichment of deuterium means that Venus outgassed at least 0.3% of a terrestrial ocean and possibly more.



One of the most significant problems relating to the origin and evolution of the planet Venus is that of its "missing" water. There certainly is no liquid water on the surface of Venus today and there is probably not more than 200 ppm by volume of water vapor in the atmosphere (1). Either Venus was formed of material very poor in water (2) or whatever water was originally present has since disappeared, the hydrogen into space and the oxygen into the interior (3). It has long been recognized that measurement of the ratio of deuterium to hydrogen in the atmosphere of Venus today would discriminate between these alternatives. There are various ways that gases escape from a planet's atmosphere, ranging from classical Jeans escape to hydrodynamic outflow at a supersonic velocity. Most mechanisms that have been identified as potentially important for escape of hydrogen from Venus discriminate strongly against loss of deuterium and heavier gases with one conspicuous exception. Hydrodynamic flow would have carried HD away along with  $H_2$ . This mode of escape would have prevailed in an atmosphere in which hydrogen was a dominant constituent. The velocity of the flowing  $H_2$  would have become too low to sweep HD along when the mixing ratio of  $H_2$  dropped below about 2% by volume (4). Subsequent escape of hydrogen should have resulted in an enrichment of deuterium in the hydrogen compounds residing in the atmosphere. The atmosphere of Venus now contains two orders of magnitude less hydrogen (in the form of  $H_2O$ ) than that corresponding to the critical mixing ratio of 2%. Thus a one hundred fold enrichment of deuterium is the most that can be expected even if Venus outgassed an appreciable fraction of the equivalent of a terrestrial ocean of water. If the initial ratio of D to H on Venus was about  $1.5 \times 10^{-4}$ , as it is on Earth, the present ratio could be at most about  $1.5 \times 10^{-2}$ . In this paper evidence will be presented that the ratio of D to H on Venus is  $(1.6 \pm 0.2) \times 10^{-2}$ .

Data obtained by the Pioneer Venus Sounder Probe neutral mass spectrometer (LNMS) have been scrutinized in the hope of using them to deduce the ratio of D to H on Venus. This mass spectrometer and its mode of operation during its descent to the surface of Venus has been described fully elsewhere (5). The instrument was a magnetic sector device that scanned the mass spectrum in 236 discrete steps from 1 to 208 amu once every 64 seconds. Gas from the atmosphere was admitted to the ionization chamber of the LNMS through two microleaks and pumped internally by chemical getter and ion sputter pumps. The leaks were opened at about 63 km in the upper cloud layer of Venus and data obtained in 51 mass spectra between this altitude and the surface. Just as the probe entered the lower cloud layer at about 50 km the inlet leaks became clogged with a substance that was almost surely sulfuric acid from cloud droplets. Evidence for this event was the dramatic drop in  $\text{CO}_2$  and noble gas counting rates and a similarly striking increase in counting rates in channels appropriate to  $\text{H}_2\text{O}$  and  $\text{SO}_2$ . One inlet leak was valved off at 47 km; the other was cleared between 29 km and 26 km.

Attempts to measure the Cytherean D/H ratio from the mass spectrometer data have been hampered by the problem of distinguishing Venus hydrogen from terrestrial hydrogen transported to that planet in the spectrometer. A mass peak found at 18.010 amu was surely caused by  $\text{H}_2\text{O}$  and there was also a channel at 19.010 amu appropriate for the detection of HDO (6). The inlet tubes were heated to inhibit condensation and this led to the production of some degassed water vapor during the time the probe was descending. While the probe was in the middle cloud layer between 62 km and 50 km above the surface of Venus (and before the leaks were blocked) the mass 18 signal increased rapidly (Fig. 1A). There were very few counts in the mass 19 channel. After the leaks were clogged the amount of water detected increased noticeably (Fig. 1). When they reopened the counting rate

remained high. although not as high initially as it had been when the leaks were stopped. The mass 18 and mass 19 count rates increased between 25 km and about 7 km and thereafter decreased again although they continued to remain large. The ratio of mass 19 to 18 counts in the lowest 10 km was between  $3 \times 10^{-3}$  and  $5 \times 10^{-3}$  (Fig. 2). This result suggests that there are two components in the data, one ascribable to outgassed terrestrial water with an  $\text{HDO}/\text{H}_2\text{O}$  ratio of about  $3 \times 10^{-4}$  (7) and the other to Cytherean water, either outgassed or collected directly from the atmosphere but with a D to H ratio higher than terrestrial. Clearly the low altitude data, which do not maintain anything like a constant counting rate ratio to those of  $\text{CO}_2$  or the noble gases, result partly from outgassed water. A guide to decomposing them into a terrestrial and a Venus component is needed.

There was a time when the hydrogen being sampled by the mass spectrometer surely contained a very large contribution from Venus. This was while the leaks were clogged with cloud droplets of  $\text{H}_2\text{SO}_4$  and large signals at 18 and 19 amu were detected. In effect the entire mass spectrometer was behaving like a large hydrogen enrichment chamber during this time. Figs. 1A and 1B clearly show a great increase in count rates at 18 and 19 amu between frames 51 and 80 -- from 50.3 km to 26 km. Although the  $\text{CO}_2$  count rate decreased abruptly between frames 49 and 51 little of the water vapor detected in frame 51 seems to be from the  $\text{H}_2\text{SO}_4$  sealing the inlets. The ratio of 19 to 18 amu count rates was  $1 \times 10^{-3}$ . After frame 51 the mass 19 signal rapidly increased so that the 19/18 ratio rose quickly to values above  $10^{-2}$ . The 19/18 ratios are plotted in Fig. 2 with 1  $\sigma$  error bars. The contrast between conditions when the leaks were plugged and when they were open is great. The average ratio when the signals were greatest -- frames 63 through 73 -- was  $(2.68 \pm 0.20) \times 10^{-2}$ . This result is a clear

indication that the water detected during the time the leaks were coated has quite a different composition than at other times. Since the largest ratio measured -- in frame 63 -- was  $(3.2 \pm 0.4) \times 10^{-2}$  the ratio of HDO to  $H_2O$  abundance on Venus is at least  $2.8 \times 10^{-2}$ . It could be larger if not all the water detected in frame 63 was Venus water.

Further refinement of this analysis is possible. While the leaks were blocked, and in fact at all times, the mass 18 peak, which will be called  $S_{18}$ , has two components  $E_{18}$  and  $V_{18}$ , from terrestrial and Cytherean sources respectively. Whether these are caused by outgassed or freshly sampled water does not matter. Similarly at mass 19,  $S_{19}$  is composed of  $E_{19}$  and  $V_{19}$ . For the terrestrial component (8)

$$E_{19}/E_{18} = 3.2 \times 10^{-4}$$

For the Cytherean component

$$V_{19}/V_{18} = R$$

where R must be constant. The problem is to find R. Obviously there is no unique solution. On the other hand, R cannot be less than  $2.8 \times 10^{-2}$ . Larger values of R are implied if in fact  $E_{18}$ , the outgassed terrestrial contribution to the counting rate during leak blockage, was not negligible even at frame 63.  $V_{18}$  is thereby reduced and R increased. The small ratio of  $E_{19}$  to  $E_{18}$  means that  $E_{19}$  is a very small part of  $S_{19}$  even if R is as large as  $10 \times 10^{-2}$  (1.6 counts out of 165). Larger R comes about by decreasing  $V_{18}$  rather than increasing  $V_{19}$ .

The four simultaneous equations for  $V_{18}$ ,  $V_{19}$ ,  $E_{18}$  and  $E_{19}$  have been solved for various values of R. Fig. 1A and 1B show  $S_{18}$ ,  $V_{18}$  and  $E_{18}$ ,  $S_{19}$ ,  $V_{19}$  and  $E_{19}$  for  $R = 3.2 \times 10^{-2}$  (8). In principle  $E_{18}$  could have any value less than  $S_{18}$  and R could be very large. For  $R = 2.8 \times 10^{-2}$  positive values of  $E_{18}$  for frames 63 through 69 are

ORIGINAL PAGE IS  
OF POOR QUALITY

obtained only if the extreme limits allowed by the  $1 \sigma$  error bars on  $S_{18}$  and  $S_{19}$  are assumed. On the other hand if  $R$  is  $3.6 \times 10^{-2}$   $E_{18}$  at frame 71 is 2000 and at frame 80 it is 1850. It is difficult to imagine how the outgassed terrestrial component could have been much larger at frame 71 than it was at frames 80 and 82 just after the leak opened. For this reason  $R$  appears to be constrained to lie within the range  $2.8$  to  $3.6 \times 10^{-2}$ .

In fact, there is reason to believe that  $E_{18}$  and  $E_{19}$  should have been considerably smaller at frames 69 and 71 than at frame 80. The reason is that one microleak was closed off from the ion source by a valve just after frame 55 at 47 km. Thus the source of outgassed water (the heated inlet tube walls) was cut approximately in half at that time. The fact that  $S_{18}$  and  $S_{19}$  extrapolate backward from their values at frame 63 to levels far below those at frames 49 and 51 shows the effect of this reduction. A cap can be placed on  $E_{18}$  and  $E_{19}$  during the time the leaks were blocked by connecting the points after frame 80 with about half the value measured at frame 49. This procedure would exclude values of  $E_{18}$  and  $E_{19}$  that would allow  $R$  to be greater than  $3.2 \times 10^{-2}$  -- allowing for  $1 \sigma$  deviations in  $E_{18}$  and  $E_{19}$ . Connecting the actual count rates before and after closure would permit  $R$  to be  $3.4 \times 10^{-2}$ . Imposition of the condition that no value of  $E_{18}$  while the leak was blocked could be larger than those attained just after it cleared would allow  $R$  to be as large as  $3.6 \times 10^{-2}$ . If confidence limits are relaxed to three standard deviations the same procedure expands the range of  $R$  from  $2.2$  to  $4.0 \times 10^{-2}$  (9).

In Fig. 1 it can be seen that the outgassed terrestrial components  $E_{18}$  and  $E_{19}$  increase rapidly after frame 63 in response to heating of the leak tubing and evaporation of the overcoat of sulfuric acid. The steady decrease in  $R$  (Fig. 2) clearly shows that the amount of terrestrial water relative to Venus water was increasing during this time. The Venus components maximize at frame 69 and then decrease until the leak opens between frames 77 and 80. Just after the entrance

ORIGINAL PAGE IS  
OF POOR QUALITY

to the leak cleared, as signalled by a great increase in  $\text{CO}_2$  count rate,  $V_{18}$  and  $V_{19}$  drop sharply while  $E_{18}$  and  $E_{19}$  increase.  $R$  drops from .0236 to .0136. Immediately  $V_{18}$  and  $V_{19}$  begin to rise again, very probably because water from the Venus atmosphere was being sampled. The outgassing terrestrial components remain relatively constant down to frame 90 at 19 km where they begin to increase rapidly with decreasing altitude. This behavior is almost surely ascribable to an increase in temperature of the walls of the mass spectrometer. It is interesting that after the leak cleared  $V_{18}$  maintains a constant ratio of about 1.15 to the  $^{36}\text{Ar}$  count rate between 25 km and 10 km. This may mean that Venus water was being directly sampled and that the chemical getter was not pumping water. If so the mixing ratio below 10 km decreased toward the surface by about 30%. This behavior is similar to that reported by Moroz, *et al.* (1) Further study of this effect is being undertaken.

The hydrogen associated with the equivalent of a terrestrial ocean could have escaped from Venus in the form of  $\text{H}_2$  if it had left at an average rate of  $7 \times 10^{10} \text{ cm}^{-2} \text{ s}^{-1}$  for 4.6 billion years. This flux is less than the largest flux that diffusion could have supported if the water vapor or  $\text{H}_2$  mixing ratios were greater than about 0.35% (4). However, it does not seem likely that escape of the hydrogen associated with the equivalent of a terrestrial ocean or even a large fraction of that much hydrogen would have occurred at such a slow pace over billions of years. Instead, it is very likely that after a large amount of water had outgassed from Venus, a runaway greenhouse ensued (10) and that a copious amount of hydrogen produced from this water appeared in the atmosphere.  $\text{H}_2$  would then have been the dominant gas in the upper atmosphere if, for example, the surface of Venus acted as an efficient sink for oxygen because of reactions such as



Escape would have been powered by solar EUV heating and a supersonic hydrodynamic outflow of  $\text{H}_2$  would have resulted. There is a limit of about  $10^{12} \text{ cm}^{-2} \text{ s}^{-1}$

to the rate at which  $H_2$  would have escaped in this way (4).

Still this flux is large enough to have exhausted the equivalent of an ocean in 280 Myr. The  $H_2$  flowing outward would have swept heavier gases along unless their mass was large enough for them to diffuse downward so fast that they would have remained in the atmosphere. On the other hand, there is a maximum flux of  $H_2$  that could have been supported by diffusion if the background gas was  $CO_2$ . When the mixing ratio is small enough the diffusion limited flow will no longer be rapid enough to allow a hydrodynamic flow of  $H_2$  to sweep HD away. This occurs when the mixing ratio of  $H_2$  becomes about  $2 \times 10^{-2}$  by volume (4). Thus, enrichment of deuterium begins only after the mixing ratio of  $H_2$  drops below about 2% no matter how much water was originally present on the planet. The subsequent enrichment is then just the ratio of  $2 \times 10^{-2}$  to the present equivalent  $H_2$  mixing ratio. The enrichment given by the present HD to  $H_2$  ratio of  $(3.2 \pm 0.2) \times 10^{-2}$  is  $100 \pm 12$  referred to an initial ratio of  $3.2 \times 10^{-4}$ . It implies that the mixing ratio of  $H_2O$  is now  $200 \pm 25$  ppm. This value is in good agreement with the 100 - 200 ppm measured by the Venera Spectrophotometer (1).

The possibility that there is a large abundance of deuterium in the upper atmosphere of Venus was suggested by the Mariner 5 Lyman  $\alpha$  observation (11). It has recently been asserted again by McElroy, et al. (12). They argue that a mass 2 ion detected by the ion mass spectrometer on the Pioneer Venus orbiter is  $D^+$ . The D/H ratio of about  $1 \times 10^{-2}$  for the bulk atmosphere implied by this interpretation is one that could have resulted from nonthermal loss of hydrogen resulting from collision of fast oxygen atoms produced in dissociative recombination of  $O_2^+$  with hydrogen atoms. The ratio of  $(1.6 \pm 0.2) \times 10^{-2}$  obtained by the LIMS clearly agrees with the value required by McElroy, et al. The lifetime of  $9 \times 10^8$  years for hydrogen deduced from their mechanism would allow the water vapor mixing ratio to grow from 200 ppm to 2 percent in about  $4.2 \times 10^9$  years. There is time enough left for hydrodynamic escape to have exhausted the equivalent of a terrestrial ocean. Although the measurement reported here cannot reveal how much additional water may have been outgassed from the planet before the critical mixing ratio of  $2 \times 10^{-2}$ .

was reached it would be astonishing if the quantity were not considerably larger than this lower limit (0.3 percent of a terrestrial ocean) (13).

**ORIGINAL PAGE IS  
OF POOR QUALITY**



- REFERENCES AND NOTES
- (1) V. I. Moroz, B. E. Moshkin, A. P. Ekonomov, N. F. San'ko, N. A. Parfent'ev and Y. U. Golovin, Publ. 117, Space Res. Inst., USSR Acad. of Sci., Moscow (1979); J. H. Hoffman, V. I. Oyama, and U. von Zahn, J. Geophys. Res. 85, 7871 (1980).
  - (2) J. S. Lewis, Earth Planet. Sci. Lett. 10, 73 (1970).
  - (3) J. C. G. Walker, K. K. Turekian and D. M. Hunten, J. Geophys. Res. 75, 3558 (1970).
  - (4) A. Watson, T. M. Donahue, and J. C. G. Walker, Icarus, 48, 150(1981); See also D. Hunten, Icarus, 37, 113 (1979), and M. Sekiya, K. Nakazawa and C. Hayashi, Earth Planet. Sci. Lett. 50, 197 (1980). The transition from a flow in which HD is fully entrained in escaping H<sub>2</sub> to one in which it is essentially retained by the atmosphere is not abrupt. For Venus it probably would have begun when the mixing ratio of H<sub>2</sub> was considerably larger than 2%. Careful study of this transition is needed as is a firm value for the present total hydrogen mixing ratio in the atmosphere of Venus. Until these are achieved the close agreement between model predictions and observations reported here must be regarded as perhaps fortuitous.
  - (5) J. H. Hoffman, R. R. Hodges, T. M. Donahue and M. B. McElroy, J. Geophys. Res. 85, 7882 (1980).
  - (6) Correction was made for contributions from <sup>18</sup>O<sup>+</sup>, <sup>36</sup>Ar<sup>++</sup>, <sup>18</sup>OH<sup>+</sup> and <sup>38</sup>Ar<sup>++</sup>. Interferences from other species such as HCl, F and H<sub>2</sub>O were found to be negligible.
  - (7) The HDO to H<sub>2</sub>O and HD to H<sub>2</sub> ratios are twice the H to D ratios. The D/H ratio of seawater is 1.56x10<sup>-4</sup> (R. Hagemann, G. Nief, and E. Roth, Tellus 22, 712 (1970)).
  - (8) The data for frames 75 and 77 have been corrected to allow for deliberate reduction of the ionization voltage from 70 volts to 30 and 22 volts respectively in these frames, as in frames 44 and 46, 108 and 111.
  - (9) If a 3 σ error is allowed for in evaluating E<sub>18</sub> and E<sub>19</sub> a ratio of 2.2 x 10<sup>-2</sup> permits nonnegative values for all frames 63 through 77. However, such a value of R calls for negative E<sub>18</sub> and E<sub>19</sub> for central values of S<sub>18</sub> and S<sub>19</sub> at all frames and for all 1 σ extremes except at frames 73 and 77.

- (10) C. Sagan, Technical Report 2234, Jet Propulsion Laboratory (1960);  
A. P. Ingersoll, J. Atmos. Sci. 26, 1191 (1969). C. Sagan in  
International Dictionary of Geophysics, S. Ramstein ed. London,  
Pergamon Press, 2049 (1968) discussed the possibility that Venus lost  
the hydrogen associated with a terrestrial ocean.
- (11) C. A. Barth, J. Atmos. Sci. 25, 564 (1968); T. M. Donahue, J. Atmos. Sci.  
25, (1968); M. B. McElroy and D. M. Hunten, J. Geophys. Res. 74, 1720 (1969).
- (12) M. B. McElroy, M. J. Frather and J. M. Rodriguez, (Science in press) show that  
the present escape modes on Venus would imply a lower limit of  $800 \text{ g cm}^{-2}$   
of  $\text{H}_2\text{O}$  on Venus 4.5 billion years ago. Escape of deuterium is negligible  
and it is taken to be so in this paper as well.
- (13) We thank G. Carignan and K. C. Lohmann for useful comments. Supported by  
NASA grants NAS2-9126 and NAGW-64.

ORIGINAL PAGE IS  
OF POOR QUALITY

ORIGINAL PAGE IS  
OF POOR QUALITY

Fig. 1 (A) Counts per data frame in  $H_2O$  channel,  $E_{18}$  and  $V_{18}$ , the terrestrial outgassed and Venus components for  $R = 3.2 \times 10^{-2}$ . Error bars are  $1 \sigma$ . During the period between frames 55 and 63 an isotope ratio measurement (IRM sequence) was being made. (B) Similar plots for the  $HDO$  channel. Time of leak opening is indicated by the broken vertical line.

Fig. 2 Ratio of counting rates for  $HDO$  and  $H_2O$  as function of data frame (time). The period of leak blockage is set off by the vertical lines at frames 50 and 79.

ORIGINAL PAGE IS  
OF POOR QUALITY

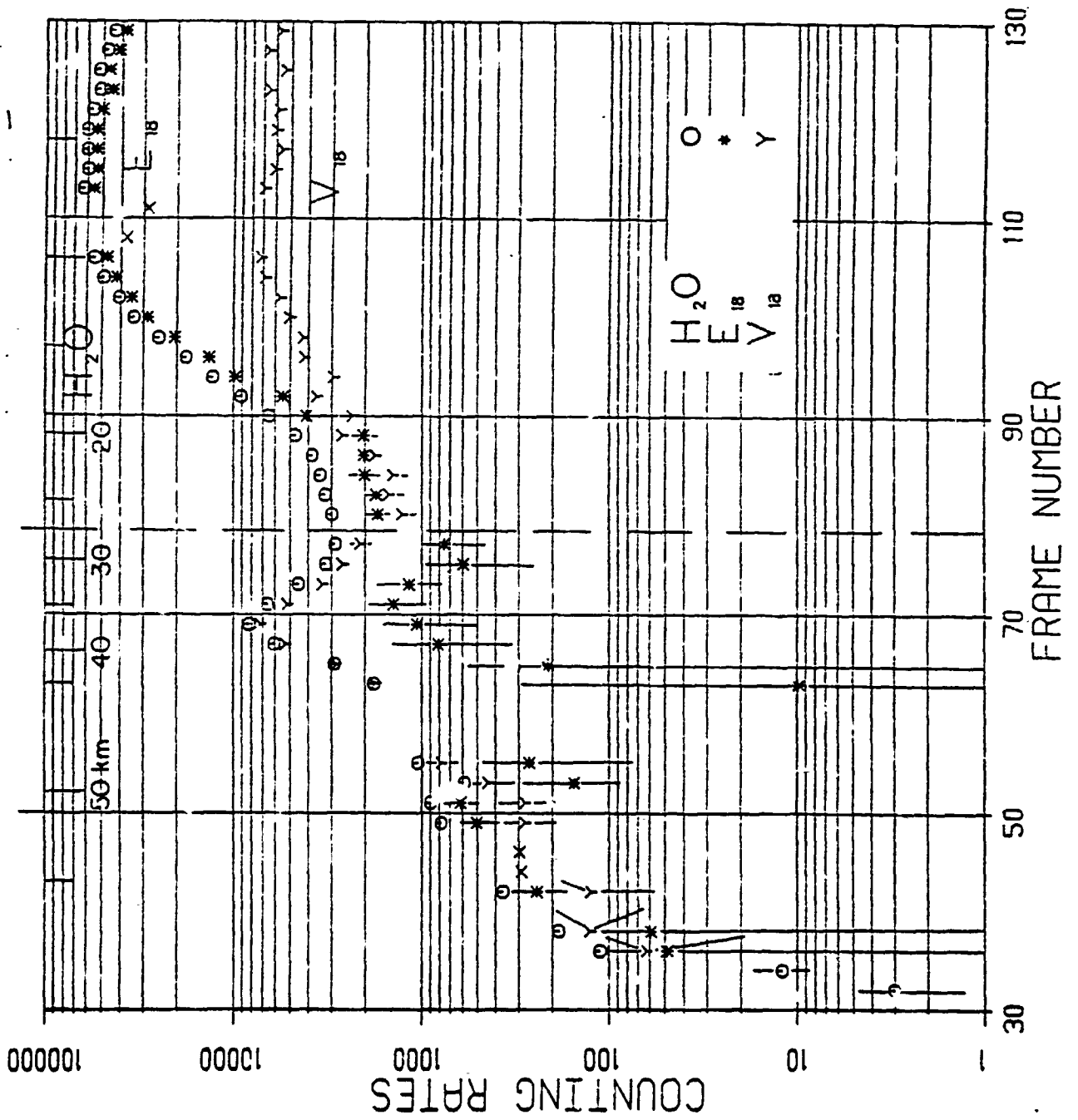

ORIGINAL PAGE IS  
OF POOR QUALITY

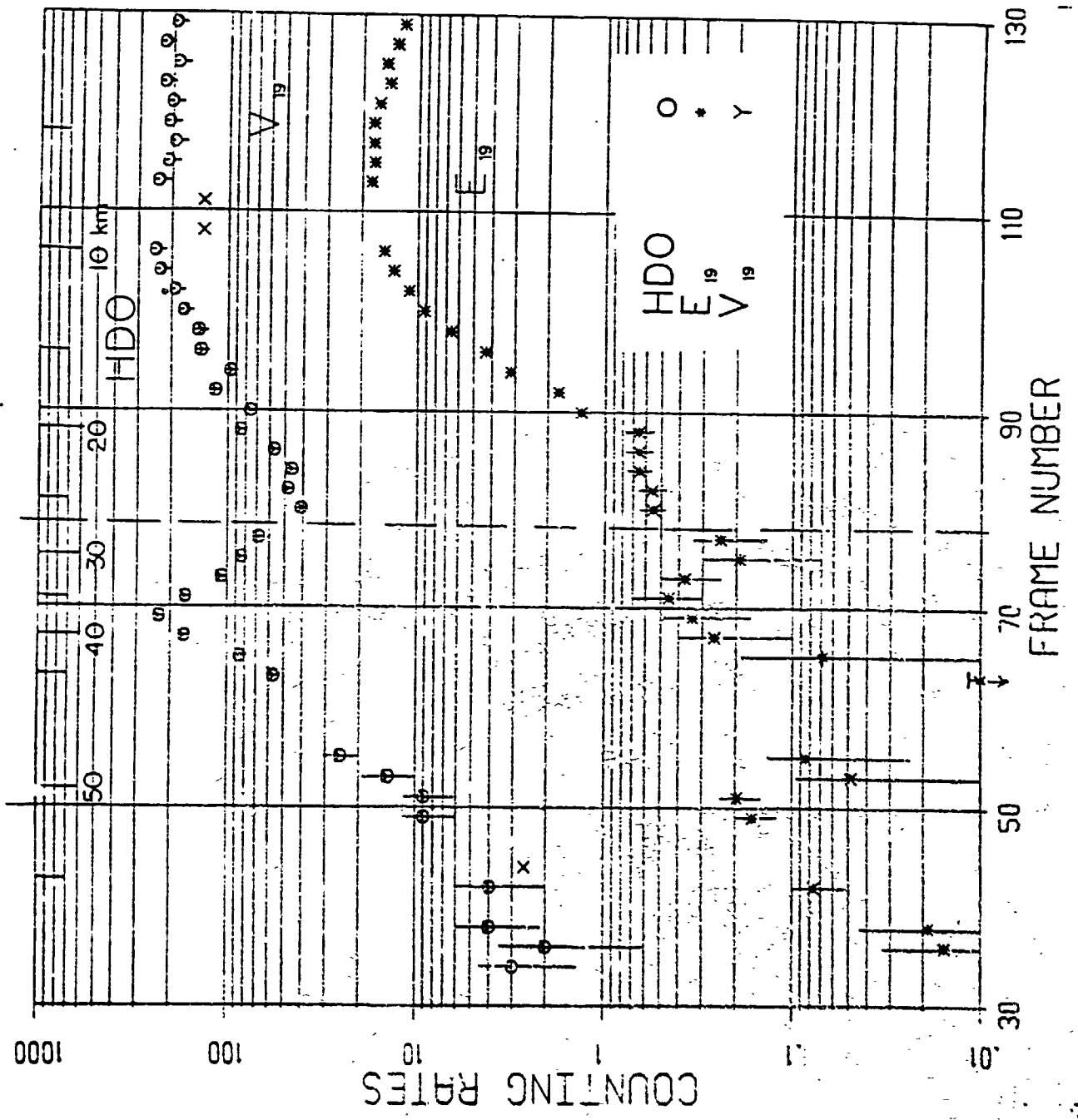
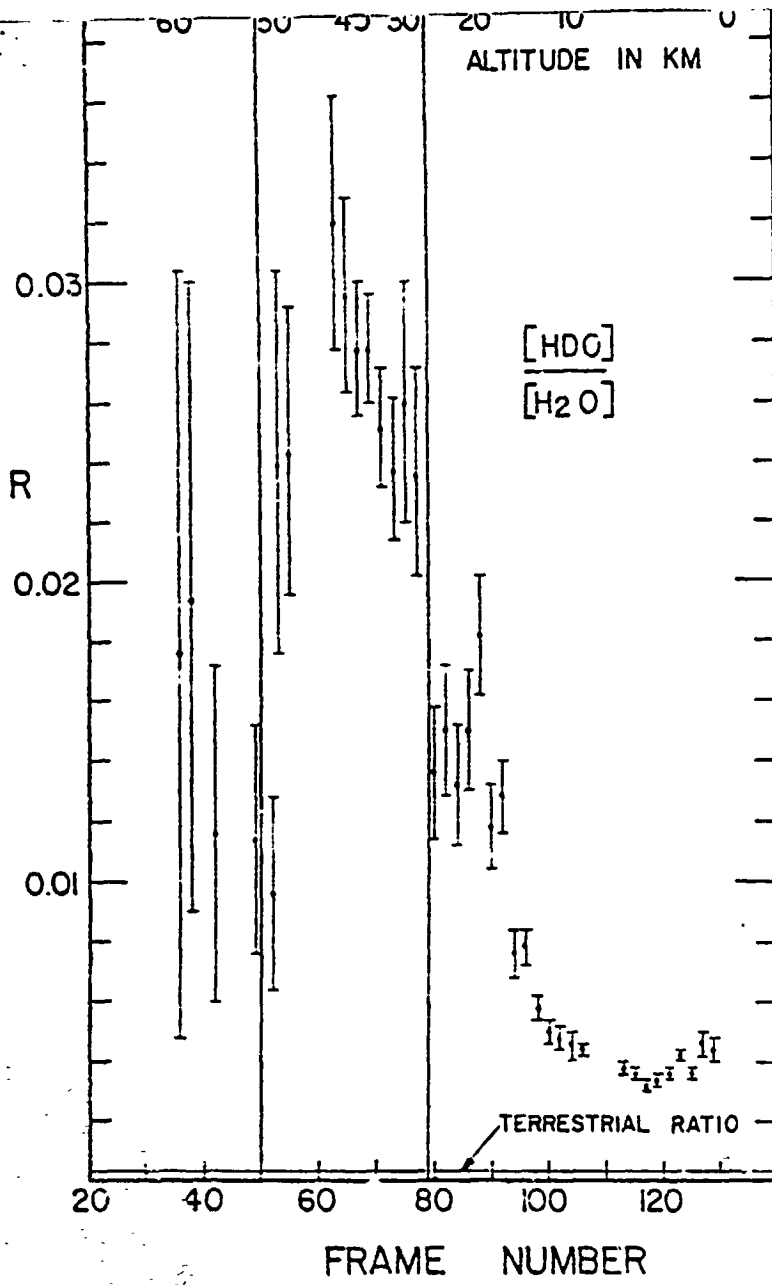

Fig. 2



ORIGINAL PAGE IS  
OF POOR QUALITY

ORIGINAL PAGE IS  
OF POOR QUALITY

CHARGE EXCHANGE IN THE VENUS IONOSPHERE AS THE SOURCE OF THE HOT EXOSPHERIC HYDROGEN

R. Richard Hodges, Jr. and Brian A. Tinsley

University of Texas at Dallas, Richardson, Texas 75080

**Abstract.** A global Monte Carlo model of the exosphere of Venus, simulating the normal exospheric processes, as well as the production of a 'hot' hydrogen component by charge exchange of  $H^+$  with H and O, has been computed. The resulting altitude profiles of atomic hydrogen concentration over both the day and night hemispheres are in reasonable agreement with Mariner 5 and Mariner 10 observations of Lyman  $\alpha$ , showing that the ionospheric charge exchange reactions are a significant source of 'hot' hydrogen, possibly the dominant source. However, the uncertainties in the available atomic hydrogen data allow for production of a similar amount of nonthermal H by chemical processes involving  $H_2$  as suggested by Kumar and Hunten (1974).

Introduction

When Mariner 5 flew past Venus in 1967, an ultraviolet photometer detected strong emissions in the 1050-1250 Å range that were assumed to be Lyman  $\alpha$  photons, resonantly scattered by atomic hydrogen [Barth et al., 1967]. Further analysis of the data by Barth et al. [1968] revealed a peculiar altitude distribution of the radiation over the bright limb that indicated a sudden increase in the scale height of the scatterers at about  $10^4$  km from the center of the planet, suggesting a two component exosphere. Barth et al. [1968] also noted that the bright limb data could be fitted to an exosphere of  $H_2$  and H: at  $650 \pm 50$  K, with  $H_2$  being the dominant constituent. The possibility of an atomic hydrogen-deuterium exosphere was considered by Barth [1968], McElroy and Hunten [1969], and Wallace [1969]. A two-temperature atomic hydrogen exosphere was also discussed by Wallace [1969], while the possibility that the 'hot' H could result from an ionospheric charge exchange reaction was mentioned by Sze and McElroy [1975] and discussed by Chamberlain [1977].

Subsequent work by Anderson [1976] verified that the Mariner 5 ultraviolet photometer data from both the bright limb and the dark disk were compatible with a bimodal velocity distribution of atomic hydrogen. Takacs et al. [1980] have shown that the ultraviolet spectrometer data from Mariner 10 are consistent with Anderson's analysis of the Mariner 5 measurements. The salient features of the Venus hydrogen exosphere are a cold component with temperature varying from  $275 \pm 50$  K in daytime to  $150 \pm 50$  K at night, a nearly constant concentration of about  $2 \times 10^5 \text{ cm}^{-3}$  at a reference radius of 6305 km, and a hot component with apparent temperature in the range 800-1500 K and a reference level concentration of about  $10^3 \text{ cm}^{-3}$ .

Kumar and Hunten [1974] showed that several ion-neutral chemical reactions involving

molecular hydrogen in the Venus ionosphere could act as sources of nonthermal hydrogen atoms, making a two-temperature atomic hydrogen exosphere plausible. The energy distributions of the hot atomic hydrogen produced by ionospheric chemical reactions were studied further by Ferrin [1976] and by Cravens et al. [1980] using theoretical models for the  $H_2$  abundance in the Venus atmosphere. Cravens et al. [1980] concluded that the major source of dayside nonthermal H is the recombination of  $OH^+$ . Kumar et al. [1981] have utilized the Pioneer Venus orbiter measurements of  $H_2^+$  and other constituents to derive a self consistent, vertical distribution of  $H_2$  with abundance of about 10 ppm. From the altitude dependence of the rate of production of H in their model calculations, Kumar et al. [1981] concluded that the reaction of  $H_2^+$  with O provides adequate nonthermal hydrogen to explain the nonthermal Lyman  $\alpha$  measurements, while recombination of  $OH^+$  is the dominant cause of hydrogen escape, producing an escape flux of about  $10^8 \text{ cm}^{-2} \text{ s}^{-1}$ .

While considerable effort has been devoted to the role of molecular ion chemistry as the cause of the Venus exosphere hot hydrogen, much less attention has been given to alternative processes. In an exosphere there is a natural excess of ion temperature over that of neutrals, allowing the charge exchange reactions



to increase the superthermal hydrogen population, while



acts as a sink for both thermal and suprathreshold hydrogen atoms [Tinsley et al., 1975; Mahler and Tinsley, 1977; Chamberlain, 1977; Cravens et al., 1980; Hodges et al., 1981]. On Venus the initial protons and the resultant neutral hydrogen atoms in reaction (1) or (2) have temperatures of several thousand degrees Kelvin [Miller et al., 1980]. Owing to a general increase in ion temperature from day to night in the Venus exosphere (from about 2000 K to 5000 K according to Miller et al.), the hot hydrogen arising from these reactions is likely to have a higher temperature at night than in daytime, in qualitative agreement with the empirical model of Anderson [1976]. Cravens et al. [1980] conclude on the basis of vertical column equilibrium calculations that these reactions are probably just as important as the  $H_2$  reaction with  $O^+$  in producing 'hot' H at night, but not in the daytime.

It should be noted that vertical column, chemical-ballistic equilibrium models neglect global scale transport, a phenomenon that is likely to be quite important for hot hydrogen because thermal speeds are similar in magnitude to orbit velocity. Thus the hydrogen that is produced at night by charge exchange, as well as by other chemical processes, must influence the daytime distribution. As an initial step toward understanding the role of lateral transport we have addressed one element of the problem: What three-dimensional exospheric hydrogen distribution would be produced on Venus if molecular ion chemistry were nonexistent and all hot hydrogen were produced by reactions (1) and (2)? Subsequent calculations and discussion show that the resultant self consistent hydrogen distribution fits the Mariner 5 and 10 Lyman  $\alpha$  measurements, both in daytime and at night. This does not preclude the existence of the ion molecular reactions, but it does challenge their significance because the influence of the charge exchange reactions is unchanged by the addition of other processes.

The two sources of exospheric hydrogen that we consider are the flux of thermal atoms upward through the exobase and reaction (2) within the exosphere. Neutral atoms from either source may undergo effective velocity conversion by reaction (1). Most atoms emerge from the exobase, travel through the exosphere in ballistic trajectories, and reenter the thermosphere, where collisions, primarily with atomic oxygen, produce a distribution of upgoing velocities that includes thermalized as well as reflected components. The exobase source flux differs only slightly from the downcoming flux, the difference being equal to the net upward flux needed to supply losses due to ionization and escape. The contribution of reaction (2) to the exosphere can be determined absolutely from direct measurements of  $H^+$  and O, but the magnitude of the exobase source cannot be predetermined. Because the total source is proportional to the global atom abundance it produces, the source magnitude can be determined by fitting the computed model distribution of relative concentration to the Mariner 5 ultraviolet photometer data.

A model of the Venus exosphere has been obtained by Monte Carlo simulation, a method that has been used extensively in studies of exospheric processes on the moon and Mercury [cf. Hodges, 1973b, 1978, 1980; Curtis and Martle, 1978; Smith et al., 1978]. Two separate global distributions of hydrogen were computed, one corresponding to the exobase source and the other to reaction (2). In each case the atoms were followed in trajectory, randomly experiencing reactions (1) and (2), as well as photoionization and momentum transfer due to Lyman  $\alpha$  scatter as determined by appropriate probability distributions. The amplitude of the exobase source distribution was determined from a logarithmic fit of the sum of the two distributions in daytime to the Anderson [1976] bright limb model between radii of 6500 km and 7600 km. Subsequent discussion will show that the charge exchange reactions provide sufficient hot hydrogen to explain the bimodal distribution indicated by the Mariner 5 ultraviolet photometer data.

#### Exosphere Simulation Method

In any exosphere the most important physical process is collisionless ballistic transport, in which atoms emerge from the top of the thermosphere with thermal speeds, travel in essentially elliptic orbits with periapses below the base of the exosphere, and reenter the thermosphere. These ballistic atoms tend to travel lateral distances that are proportional to their temperature, so that warm atoms are more mobile than cold ones, making migration from day to night more rapid than the reverse. As a result, exospheric equilibrium (i.e., the condition of no lateral flow) requires highest concentrations in nighttime. Hodges and Johnson [1968] showed that for gases with thermal speeds much less than the escape velocity, the exospheric equilibrium condition corresponds to exobase concentration being proportional to the  $-5/2$  power of temperature.

Thermal escape, the production of satellite particles, and nonthermal processes such as charge exchange and photoionization tend to make analytical methods of study of planetary exospheres impractical. On the other hand, by using Monte Carlo exosphere simulation methods [Smith et al., 1978; Hodges, 1973b, 1980], the accuracy of the resulting model is limited only by the accuracy of mathematical descriptions of the physical processes. The specific methods used in this investigation are discussed below, and the assumed exosphere environment is presented in the next section.

It is convenient to approximate the velocity distribution of atoms entering the exosphere from the thermosphere as Maxwellian. For the earth the higher exobase temperature results in significant thermal escape, which causes a depletion of the high energy tail of the downcoming velocity distribution. This depletion is partially balanced by the downward flux of hot hydrogen atoms from charge exchange, approximately restoring a Maxwellian character to the velocity distribution [Hodges et al., 1981]. With lower exosphere temperatures on Venus, the downcoming hot atoms should more than compensate any thermal loss, and the uncertainty is in the amount of the surplus in the tail due to the albedo flux of 'hot' atoms. Following a suggestion of Chamberlain [1977] it has been assumed that the nonthermalization of downcoming hot hydrogen can be approximately accounted for by assuming that 30% of the reentering hydrogen atoms are reflected back into the exosphere in random direction, but with no change in kinetic energy.

In the Monte Carlo simulation of a Maxwellian exosphere, the velocities of thermal upgoing atoms at the exobase are chosen at random from the Maxwell-Boltzmann flux distribution

$$f(v) = \frac{1}{2\pi} (m/kT)^2 v e^{-(mv^2/2kT)} \cos v \quad (4)$$

where  $k$  is Boltzmann's constant,  $T$  is temperature,  $m$  is the hydrogen atomic mass,  $v$  is speed, and  $\nu$  is the angle between the velocity vector and local vertical [Smith et al., 1978]. Owing to the azimuthal symmetry of (4) about



local vertical, both the vertical and the horizontal components of velocity are specified by the same probability function

$$f' = \frac{mv'}{kT} e^{-(mv')^2/2kT} \quad (5)$$

where  $v'$  represents either the vertical or the horizontal component of  $v$ . This expression is readily integrated to provide a cumulative distribution function  $U$ , which has as its inverse

$$v' = \left( -\frac{2kT}{m} \ln(U) \right)^{1/2} \quad (6)$$

If a random variable with uniform distribution between 0 and 1 is substituted for  $U$ , the resulting  $v'$  is a random deviate of function (5). Two such deviates are used to give vertical and horizontal components of velocity, and a random azimuth chosen from a uniform distribution from 0 to  $2\pi$  specifies the direction of the horizontal component.

Atom trajectories are calculated by one of two methods, depending on the initial random deviates for velocity and minimum possible lifetimes for each ionization process. If the time of flight of the atom in an elliptic trajectory is shorter than the shortest of the lifetimes and if the speed is suborbital, the trajectory is approximated as elliptical. Otherwise the trajectory is computed by numerical integration of the equation of motion of a particle in a central gravitational field.

Above the exobase the only collisions considered in the model are those associated with the charge exchange reactions (1) and (3). Collision cross sections for these reactions are larger than those for momentum transfer and also slowly varying functions of relative velocity [cf. Banks and Kockarts, 1973]. Assuming ions to be Maxwellian with temperature  $T_1$  and concentration  $n_1$ , their flux through a sphere of cross section  $\sigma$  surrounding a hydrogen atom with velocity  $v$  is the collision frequency

$$v_c = 2\pi n_1 \left(\frac{M}{\pi}\right)^{3/2} \int_0^\pi \sin\theta \int_0^\infty dv_1 v_1^3 \sigma e^{-w|v_1-v|^2} \quad (7)$$

where

$$w = \frac{M_1}{2kT_1} \quad (8)$$

and the subscript 1 denotes properties of the ions. If  $\sigma$  is approximated as a constant, then integration of (7) gives

$$v_c = \sigma n_1 v \left[ \left(1 + \frac{1}{2wv^2}\right) \operatorname{erf}(wv^{1/2}) + \frac{e^{-wv^2}}{v(\pi w)^{1/2}} \right] \quad (9)$$

where  $\operatorname{erf}$  is the error function. The cross section assumed for reaction (1) is  $7 \times 10^{-15} \text{ cm}^2$ , and for reaction (3) a cross section of  $1.3 \times 10^{-15} \text{ cm}^2$  was used.

To account for the possibility that a hydrogen

atom above the ionopause may charge exchange with solar wind protons, the solar wind interaction with Venus has been approximated as a uniform flow around the sunward side, but leaving an antisunward cylindrical void with diameter equal to the terminator size of the ionopause. Data from the plasma analyzer on the Pioneer Venus orbiter suggest such a flow pattern with an average solar wind speed jump of about 0.8 in crossing the bow shock, accompanied by an erratic concentration jump that is generally in excess of unity [Mihalov et al., 1980]. Lacking better knowledge, it has been assumed that the average flow is compressed minimally in passing Venus, so that the flux near the ionopause is approximately that in the undisturbed solar wind. The charge exchange cross section appropriate for the 1-keV protons of the solar wind is  $2 \times 10^{-15} \text{ cm}^2$  [Pite et al., 1962]. Assuming an average solar wind proton flux of  $3 \times 10^8 \text{ cm}^{-2} \text{ s}^{-1}$  at 1 AU, the value of  $v_c$  appropriate for reaction (1) in the solar wind near Venus is estimated to be  $1.1 \times 10^{-6} \text{ s}^{-1}$ . The velocity of the energetic neutral hydrogen produced by charge exchange in the solar wind has been assumed to be antisunward, so that it returns to the thermosphere if the reaction occurs nearer the Venus-sun axis than the exobase radius; otherwise it escapes.

Probabilities of occurrence of reactions (1) and (3) are assumed to be represented by the extinction formula

$$u = \exp\left(-\int_0^t v_c(t') dt'\right) \quad (10)$$

If  $u$  is a uniform deviate with range 0 to 1, then  $t$  is the lifetime of the hydrogen atom for the reaction in question. Because  $v_c$  varies along the trajectory of the atom, numerical integration is used to determine if (and when) ballistic flight time exceeds the reaction lifetime.

When a hydrogen atom is in sunlight, its trajectory is continually perturbed by resonant scatter of solar Lyman  $\alpha$  photons, a mechanism that is mainly important in modifying the population of atoms in satellite orbits. Assuming the exosphere to be optically thin at altitudes where orbiting hydrogen exists, the data of Meier and Mange [1970] suggest a Lyman  $\alpha$  scatter frequency of  $2.24 \times 10^{-3} \text{ s}^{-1}$  at 1 AU, which corresponds to  $4.18 \times 10^{-3} \text{ s}^{-1}$  at Venus. The trajectory calculation uses a time deviate equal to

$$-\frac{\ln(u)}{4.18 \times 10^{-3}} \quad (11)$$

where  $u$  is a uniform random number between 0 and 1. When this time has elapsed, the velocity of the atom is impulsively perturbed antisunward by the momentum of the absorbed photon, followed immediately by an equal perturbation in a random direction to account for uniform reradiation. Then another time deviate is computed to determine the next occurrence of this phenomenon. Because the mechanism is mainly important near trajectory apoapses, the attenuation of solar Lyman  $\alpha$  is ignored.

Photoions formed within the ionosphere are

treated as part of the ion-neutral-ion cycle, but photoions formed outside the ionopause are counted as hydrogen escape events because it is assumed that these ions are swept away from Venus by the solar wind. To determine the photoionization frequency for atomic hydrogen, the cross section given by Banks and Kockarts [1973] of

$$6.31 \times 10^{-18} \left( \frac{\lambda}{911.75} \right)^3 \quad \lambda < 911.75 \text{ \AA} \quad (12)$$

was used, where  $\lambda$  is wavelength in Angstroms. Integration of the product of this cross section and the photon flux data of Torr et al. [1979] gives ionization frequencies at 1 AU that range from  $5.4 \times 10^{-8} \text{ s}^{-1}$  in 1974 to  $1.7 \times 10^{-7} \text{ s}^{-1}$  in 1979, the later value being appropriate to both the Mariner 5 and the Pioneer Venus data collection periods when corrected for the distance of Venus from the sun. A logarithmic deviate similar to that used above for resonant scatter was also used in the calculation to determine the photoionization lifetime for each trajectory.

#### Venus Exosphere Environment

An essential element in this simulation of the Venus exosphere is a morphologic model of ion and neutral atomic oxygen and hydrogen ion concentrations and temperatures. In the model adopted for this study, simple but physically reasonable global distributions have been fitted to recent in situ measurements made by instruments on the Pioneer Venus orbiter.

The neutral mass spectrometer data of Niemann et al. [1980] show atomic oxygen to be the major constituent of the upper thermosphere, with concentration that is empirically approximated at daytime maximum and nighttime minimum by

$$n[O]_{\text{day}} = 5.9 \times 10^9 e^{-0.0665(z-140)} \quad (13)$$

and

$$n[O]_{\text{night}} = 3.1 \times 10^9 e^{-0.157(z-140)} \quad (14)$$

where  $z$  is altitude in kilometers above a mean planet radius of 6052 km. The global variation of  $n[O]$  adopted for this study is a logarithmic interpolation, linear in the cosine of the solar zenith angle, given by the approximation

$$n[O] = \exp\{a \ln(n[O]_{\text{day}}) + (1-a) \ln(n[O]_{\text{night}})\} \quad (15)$$

where

$$a = \frac{1}{2}(1 + \cos \chi) \quad (16)$$

and  $\chi$  is solar zenith angle.

Niemann et al. [1980] also show that the neutral temperature in the thermosphere varies from about 100 K in nighttime to near 240 K in

daytime, with uncertainties of the order of  $\pm 20$  K. The segmented-linear function

$$T = \begin{cases} 240 & \chi \leq 60^\circ \\ 170 + 140 \cos \chi & 60^\circ < \chi < 120^\circ \\ 100 & \chi \geq 120^\circ \end{cases} \quad (17)$$

has been adopted to approximate the global temperature distribution.

The base of the exosphere is approximated by a surface at the level where the mean free path length of atomic hydrogen equals the scale height of atomic oxygen [McAfee, 1967], i.e.,

$$\frac{r_p^2 kT}{GMm} = \frac{1}{\sigma_m n[O]} \quad (18)$$

where  $r_p$  is the exobase radius,  $k$  is Boltzmann's constant,  $GM$  is the gravitational parameter,  $m$  is the atomic mass of oxygen, and  $\sigma_m$  is the cross section for atomic oxygen-hydrogen momentum transfer collisions (about  $5 \times 10^{-15} \text{ cm}^2$ ). Using the foregoing temperature and atomic oxygen concentration approximations, the exobase altitude in daytime is 196.9 km, and at night it is 154.4 km. To accommodate the day-night difference in exobase altitude, the exobase has been assumed to approximate a sphere of radius 6227.7 km with center offset 21.3 km sunward of the planet's geometric center. (The geometric center is assumed to coincide with the center of mass of the planet in ballistic trajectory calculations.)

The ionosphere of Venus shows great variability in response to temporal changes in the solar wind. The ionopause altitude has been noted to move hundreds of kilometers in a period the order of 24 hours [Brace et al., 1980], and ion temperature excursions are similarly dramatic [Miller et al., 1980]. For purposes of this study it is assumed that neutral hydrogen responds sufficiently slowly to ionospheric changes that its distribution corresponds to average ionospheric conditions.

Data from the Pioneer Venus orbiter retarding potential analyzer reported by Miller et al. [1980] have been used to construct an average global ion temperature model. At altitudes above 310 km an isothermal ion temperature of 1800 K has been assumed for solar zenith angles less than  $120^\circ$ , increasing linearly with  $\cos \chi$  to 5000 K at the nadir. At night the ion temperature is assumed to be 200 K at 150 km and to increase linearly with altitude to 1800 K at 310 km. Over the subsolar point the model ion temperature is 550 K below 228 km and increases linearly with altitude to 1800 K between 228 km and 310 km. At intermediate locations in daytime the ion temperature is found by interpolation between the subsolar and terminator profiles. An average electron temperature of 5000 K, independent of location, has been assumed as an approximation to the nearly isothermal temperature measured by Miller et al.

The morphology of the assumed ionosphere model is illustrated in Figures 1 and 2 in graphs of altitude (above an assumed mean planet radius of 6052 km) versus solar zenith angle for constant concentrations of  $O^+$  and  $H^+$ , respectively. In each figure the lower boundary is the exobase,

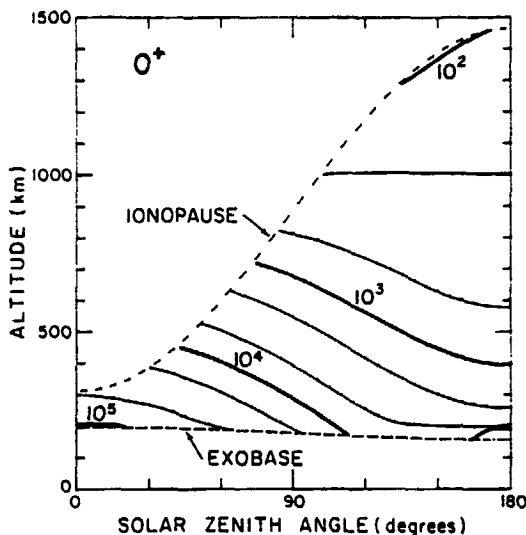

Fig. 1. Contours of constant  $O^+$  concentration (ions per cubic centimeter) in the Venus exosphere.

while the upper boundary is the ionopause. The latter curve represents an analytic approximation of the average ionopause altitude data of Brace et al. [1980]. The altitude profiles of  $O^+$  and  $H^+$  for daytime and night reported by Taylor et al. [1980] were used to establish subsolar and antisolar conditions. Ion and electron temperatures discussed above were used to make hydrostatic extensions of the ion concentration profiles to 1500 km. Concentrations at intermediate zenith angles were approximated by logarithmic interpolations similar to equation (15).

### Results

Exospheric hydrogen data were accumulated in a three-dimensional grid of audit zones arranged on spheres concentric with the exobase. The radii of these spheres varied from  $r_b$  ( $= 6227.7$  km) to  $2r_b$  in 14 equal decrements of gravitational potential ( $GM/r$ ), so that deviations of concentrations from barometric equilibrium would be apparent. Global morphology was obtained by subdividing each sphere into 32 zones of equal area, the zone boundaries being formed by eight meridians spaced  $45^\circ$  apart and by latitudes of  $0^\circ$  and  $\pm 30^\circ$ . Intended to provide flexibility in future calculations, this scheme is not ideally suited to the present problem, where all globally varying parameters depend only on solar zenith angle. Spatial data presented in the following discussion represent only the events accumulated in the low-latitude audit zones, i.e.  $\pm 30^\circ$ .

Figure 3 summarizes the results of the present model calculations. The pluses denote the contribution of the hot hydrogen produced by charge exchange of ionospheric protons with atomic oxygen in the exosphere (reaction (2)), while the squares represent total hydrogen concentration. Daytime data were averaged over longitudes of  $\pm 67.5^\circ$  from local noon, and the night data were averaged over a similar zone about local midnight. Superimposed on the day and night plots, respectively, are graphs of the

bright limb and dark disk atomic hydrogen exosphere profiles derived from Mariner 5 ultraviolet photometer data by Wallace [1969] and Anderson [1976], and from the Mariner 10 ultraviolet spectrometer data by Takacs et al. [1980].

What is immediately apparent in Figure 3 is the fact that the present exosphere simulation calculation reproduces the two component nature of the Lyman  $\alpha$  observations, including the proper night-to-day concentration and scale height ratios at high altitudes. The only apparent discrepancy is at low altitude at night, where a fairly high concentration may have been masked by the assumption of constant concentration at the arbitrary critical level of 6305 km in the Mariner 5 and 10 data reduction. Anderson [1976] acknowledges that the data 'do not exclude an increase [in concentration at 6305 km] toward the dark limb.' The range of uncertainties arising from analyses of Mariner data below 7000 km radius is about an order of magnitude, easily accommodating the present model.

The lowest computed points in Figure 3 correspond to the exobase, where the hydrogen concentration varies from about  $4.4 \times 10^6$   $cm^{-3}$  at night to  $3.9 \times 10^5$   $cm^{-3}$  in daytime, for a night-to-day concentration ratio of 11.3. This is remarkably close to the exospheric equilibrium ratio of 11.0 given by equation (17) of Hodges [1973a].

Global rates for various events in the Venus exosphere are tabulated in Table 1 in units of  $10^{26}$  events/s. The specific contribution of the ionospheric  $O + H^+$  source and the total rates for all exospheric atoms (i.e., ballistic atoms entering the exosphere through the exobase as well as those of ionospheric origin within the exosphere) are listed. It can be noted that although hot hydrogen is produced by charge exchange of  $H^+$  with O at about 11% of the rate of its production due to charge exchange of H with  $H^+$ , the former source does not contribute proportionately to the escape rate. This is because the small scale height of atomic oxygen

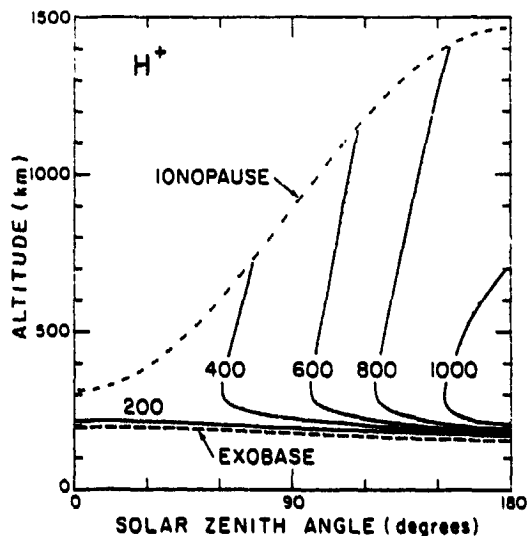

Fig. 2. Contours of constant  $H^+$  concentration (ions per cubic centimeter) in the Venus exosphere.

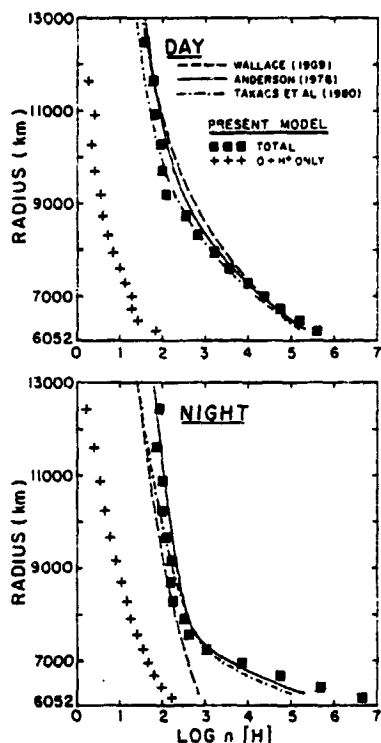

Fig. 3. Daytime and nighttime atomic hydrogen concentration profiles. Discrete symbols denote present results, squares giving the total concentration and pluses the contribution due to the ionospheric  $O + H^+$  charge exchange reaction. Line graphs are published models derived from Lyman  $\alpha$  measurements.

forces the reaction of  $H^+$  with  $O$  to occur mainly near the exobase, where the  $H^+$  temperature is minimum, resulting in cooler hot hydrogen than that from reaction (1). In addition, the table shows that the net ionospheric production of  $H$  by the  $H^+ + O$  reaction ( $3.5 \times 10^{25}$  atoms  $s^{-1}$ ) is much less than the ionization rate due to the reverse reaction ( $2.9 \times 10^{26}$  atoms  $s^{-1}$ ), indicating that these reactions are not in equilibrium in the Venus exosphere and hence that there must be a large downward flow of protons across the exobase.

Most of the  $H$  escaping from Venus is outward flowing hot hydrogen with sufficient energy to overcome the gravitational potential. However, 14% of the escape flux is due to ion formation outside the ionopause, where acceleration in the solar wind may preclude return to the exosphere.

The ratio of any of the rates tabulated in Table 1 to the escape rate can be interpreted as the average number of such events in the lifetime of an exospheric atom, which in turn is  $1.9 \times 10^6$  s. Thus each atom experiences about seven charge exchange reactions, four of which result in a hot, or energetic, atom being formed. The average number of ionizations per atom is about 3.4. Only about 8% are injected into satellite orbits, which have a mean duration of  $2.4 \times 10^5$  s, making the average orbit time per escaping atom  $1.9 \times 10^4$  s. The fraction of exospheric atoms in orbit is found to be 0.01 by dividing average orbit time by lifetime. This contrasts sharply with the conditions in the exosphere of earth, where roughly 45% of the hydrogen is in

satellite orbits [Hodges et al., 1981].

The total Venus hydrogen escape rate of  $9.1 \times 10^{25}$  atoms  $s^{-1}$ , corresponding to an average flux of  $2 \times 10^7$  atoms  $cm^{-2} s^{-1}$ , greatly exceeds the classical Jeans thermal evaporation rate for the cold Venus exobase, which is of the order of  $10^2$  atoms  $cm^{-2} s^{-1}$ . By comparison, the total terrestrial escape flux is about  $2 \times 10^8$  atoms  $cm^{-2} s^{-1}$ , with the Jeans escape flux varying from perhaps 15% to 50% of the total [Tinsley, 1978].

#### Discussion

The present exosphere model is preliminary and approximate in nature, intended mainly to provide a first-order answer to the question of the importance of charge exchange relative to  $H_2$  chemical processes as the source of the hot hydrogen on Venus. From the agreement shown in Figure 3 between the calculated altitude profiles and those derived from the Mariner 5 and 10 Lyman  $\alpha$  observations, it is evident that ionospheric charge exchange is a significant, and possibly dominant, source of the hot hydrogen. This source is mainly due to the  $H + H^+$  reaction and hence is fixed by the thermal part of the atomic hydrogen distribution. The apparent factor of 2 variability of the hot  $H$  on Venus implied by differences in the Mariner 5 and 10 data allows an indeterminate, and perhaps equal, addition of nonthermal  $H$  from  $H_2$  chemistry as proposed by Kumar and Hunten [1974]. Pioneer Venus orbiter Lyman  $\alpha$  measurements may eventually help resolve this question. The 'pure speculation' of Chamberlain [1977] 'that the solar wind would produce a distended low-density hot plasmasphere on the downwind side of the planet which could be effective in producing a hot coronal component' seems to have been borne out by the Pioneer Venus measurements and the present calculations.

TABLE 1. Venus Exosphere Global Event Rates

Type of Event	Rate (Unit = $10^{26} s^{-1}$ )	
	Ionospheric Source $O+H^+ + O^+H$	Total
Production of hot $H$		
$H + H^+ \rightarrow H^+ + H$	0.001	3.27
$O + H^+ \rightarrow O^+ + H$	0.35	0.35
Conversion to energetic $H$		
$H + H^+(\text{solar wind}) \rightarrow H^+ + H$	0.001	0.19
Loss by ionization		
$H + hv \rightarrow H^+ + e$	$3 \times 10^{-4}$	0.21
$H + O^+ \rightarrow H^+ + O$	$4 \times 10^{-4}$	2.87
Escape of $H$		
$H + H^+(\text{solar wind}) \rightarrow H^+ + H$	0.001	0.07
$H + hv \rightarrow H^+ + e$	$3 \times 10^{-4}$	0.04
Gravitational escape	0.005	0.80
Total escape rate	0.006	0.91
Satellite orbit insertion	0.001	0.07

The significance of the magnitude of the hydrogen escape rate from Venus as obtained in Table 1 is not clear. That rate does not include the direct escape of  $H^+$  ions, which could be at least as important as the escape of hot neutral hydrogen. Furthermore, the origin of the escaping hydrogen is uncertain. Its escape rate is similar to the expected average influx of hydrogen from impacting cometary bodies. The escaping H could also be provided by capture of 11% of the solar wind proton flux incident on the planet. Thus the budget of accretion or loss of hydrogen on Venus remains an open question.

Results presented in Table 1 imply that the global rate of loss of exospheric hydrogen due to charge exchange with  $O^+$  is 8 times as large as the rate of the reverse reaction that converts  $H^+$  to H. This imbalance suggests a net excess of production of  $H^+$  in the exosphere, requiring a substantial escape of  $H^+$  or a downward flow of protons that recombine in the thermosphere. The small scale heights of O and  $CO_2$  and their reactions with  $H^+$  produce a virtual sink for downward flowing protons at the exobase, encouraging the flow implied by the present model calculations.

Bertaux et al. [1978] have analyzed Lyman  $\alpha$  measurements made with a photometer and absorption cell on the Venera 9 and Venera 10 orbiters. The line width was found to increase sharply between 1.5 and 1.75 Venus radii, which they interpreted as due to a population of hot hydrogen atoms in satellite orbits, created by charge exchange of exospheric hydrogen with solar wind protons that had become turbulent after bow shock crossing. However, an extreme deceleration of the neutralized solar wind ions, from typical velocities of the order of 400 km/s to subspace speeds ( $< 8$  km/s at the bow shock) would be required to achieve orbit status. In the course of the present calculation it has become apparent that charge exchange with solar wind protons is the dominant means of deorbiting satellite hydrogen, and thus it is unlikely to be a net source of orbiters.

Bertaux [1978] postulated a similarly localized population of satellite particles in orbit around earth at  $5 R_E$  based on OGO 5 data using a similar absorption cell. This interpretation has been questioned by Prisco and Chamberlain [1979], who show that the data can be explained by a source of satellite particles below  $4.6 R_E$  with 'temperature' decreasing from 1.2 times the neutral temperature at  $3 R_E$  to the neutral temperature beyond  $6 R_E$ . By analogy, the Bertaux et al. [1978] proposal that a high altitude source of satellite particles is required for Venus would also seem questionable.

Thermospheric rotation and winds bias the exobase velocity distribution, causing a shift and change in amplitude of the exobase concentration maximum and minimum [Hodges, 1973a; Tinsley et al., 1975]. In a separate calculation in which a rotating exobase was assumed, with speed matched to the cloud top rotation, there was a shift of the nightside maximum similar to that in the data of Brinton et al. [1980] but no substantial change in amplitude of the exobase diurnal variation from the data presented in Figure 3. A convergence of the neutral winds toward the nightside would enhance this amplitude. The cross-terminator wind of 200 m/s

derived from thermosphere temperature data by Mayr et al. [1980] has been invoked by Brinton et al. [1980] to explain their large night-to-day concentration ratio. Because these winds are poorly defined, their effects are not addressed in the present calculation. It is to be expected that their inclusion would increase the nighttime concentration. A future set of exosphere models for a range of solar activity will include the effects of winds of various magnitudes as well as the recently discovered day-to-night ion flow in the exosphere [Knudsen et al., 1980] which biases the velocities of hot H produced by charge exchange in the terminator region. While an enhancement of the nighttime thermal H seems realistic, it would increase the discrepancy with the nighttime Mariner 5 and 10 data. We suggest that the latter concentrations are less reliably determined than those for daytime and that the use of more realistic, nonisothermal, nonisotropic models similar to those now being developed for earth [Hodges et al., 1981] in radiative transfer calculations would increase the nightside H concentrations inferred from Venus Lyman  $\alpha$  measurements.

#### Conclusions

The Monte Carlo calculation of the global distribution of hydrogen in the exosphere of Venus, with hot hydrogen produced by charge exchange of  $H^+$  ions with both atomic hydrogen and oxygen, has yielded a result that is in reasonable agreement with altitude distributions of H based on Lyman  $\alpha$  measurements. This confirms the hypothesis that exospheric charge exchange reactions are sources of sufficient hot hydrogen to explain the two-temperature exosphere of Venus. Uncertainties in model parameters and in data on the Venus exosphere presently allow a source of similar magnitude of nonthermal hydrogen due to exothermic chemical reactions involving  $H_2$  as suggested by Kumar and Hunten [1974]. A comparison of present model results with the calculations of Kumar et al. [1981] indicates that  $H_2$  chemistry could be the dominant cause of hydrogen escape while being a secondary source of the nonescaping hot hydrogen on Venus.

**Acknowledgments.** It is a pleasure to acknowledge the helpful suggestions of D. M. Hunten and of an unidentified referee. This research was supported by the National Aeronautics and Space Administration under grants NAGW-64 and NGL 44-004-026.

The Editor thanks D. E. Shemasky, R. E. Hartle, and H. C. Brinton for their assistance in evaluating this paper.

#### References

- Anderson, D. E., Jr., The Mariner 5 ultraviolet photometer experiment: Analysis of hydrogen Lyman alpha data, *J. Geophys. Res.*, **81**, 1213, 1976.
- Banks, P. M., and G. Kockarts, *Aeronomy Part A*, Academic Press, New York, 1973.
- Barth, C. A., Interpretation of the Mariner 5 Lyman- $\alpha$  measurements, *J. Atmos. Sci.*, **25**, 564, 1968.
- Barth, C. A., J. B. Pearce, K. K. Kelly, L. Wallace, and W. G. Fastie, Ultraviolet

- emissions observed near Venus from Mariner 5, Science, 158, 1675, 1967.
- Barth, C. A., L. Wallace, and J. B. Pearce, Mariner 5 measurements of Lyman alpha radiation near Venus, J. Geophys. Res., 73, 2541, 1968.
- Bertaux, J. L., Interpretation of OGO-5 line shape measurements on Lyman  $\alpha$  from terrestrial exospheric hydrogen, Planet. Space Sci., 26, 431, 1978.
- Bertaux, J. L., J. Blamont, M. Marcelin, V. G. Kurt, N. N. Romonova, and A. S. Smirnov, Lyman-alpha observations of Venera-9 and 10, I, The non-thermal hydrogen population in the exosphere of Venus, Planet. Space Sci., 26, 817, 1978.
- Brace, L. H., R. F. Theis, W. R. Hoegy, J. H. Wolfe, J. D. Mihalov, C. T. Russell, R. C. Elphic, and A. F. Nagy, The dynamic behavior of the Venus ionosphere in response to solar wind interactions, J. Geophys. Res., 85, 7663, 1980.
- Brinton, H. C., H. A. Taylor, Jr., H. B. Niemann, H. G. Mayr, A. F. Nagy, T. E. Cravens, and D. F. Strobel, Venus nighttime hydrogen bulge, Geophys. Res. Lett., 7, 865, 1980.
- Chamberlain, J. W., Charge exchange in a planetary corona: Its effect on the distribution and escape of hydrogen, J. Geophys. Res., 82, 1, 1977.
- Cravens, T. E., T. I. Gambosi, and A. F. Nagy, Hot hydrogen in the exosphere of Venus, Nature, 283, 178, 1980.
- Curtis, S. A., and R. E. Hartle, Mercury's helium exosphere after Mariner 10's third encounter, J. Geophys. Res., 83, 1551, 1978.
- Ferrin, I. R., The distribution of hot hydrogen atoms in the upper atmosphere of Venus, Ph.D. thesis, Univ. of Colo., Boulder, 1976.
- Fite, W. L., A. C. H. Smith, and R. F. Stebbings, Charge transfer in collisions involving symmetric and asymmetric resonance. Proc. Roy. Soc., London, Ser. A, 268, 527, 1962.
- Hodges, R. R., Jr., Differential equation of exospheric lateral transport and its application to terrestrial hydrogen, J. Geophys. Res., 78, 7340, 1973a.
- Hodges, R. R., Jr., Helium and hydrogen in the lunar atmosphere, J. Geophys. Res., 78, 8055, 1973b.
- Hodges, R. R., Jr., Gravitational and radiative effects on the escape of helium from the moon, Proc. Lunar Planet. Sci. Conf., 9th, 1749, 1978.
- Hodges, R. R., Jr., Methods for Monte Carlo simulation of the exospheres of the moon and Mercury, J. Geophys. Res., 85, 164, 1980.
- Hodges, R. R., Jr., and F. S. Johnson, Lateral transport in planetary exospheres, J. Geophys. Res., 73, 7307, 1968.
- Hodges, R. R., Jr., R. Rohrbaugh, and B. A. Tinsley, The effect of the charge exchange source on the velocity and 'temperature' distributions and their anisotropies in the earth's exosphere, J. Geophys. Res., 86, in press, 1981.
- Knudsen, W. C., K. Spenner, R. C. Whitten, and K. L. Miller, Ion energetics in the Venus nighttime ionosphere, Geophys. Res. Lett., 7, 1045, 1980.
- Kumar, S., and D. M. Hunten, Venus, an ionospheric model with an exospheric temperature of 350° K, J. Geophys. Res., 79, 2529, 1974.
- Kumar, S., D. M. Hunten, and H. A. Taylor, Jr., H<sub>2</sub> abundance in the atmosphere of Venus, Geophys. Res. Lett., 8, 237, 1981.
- Maher, L. J., and B. A. Tinsley, Atomic hydrogen escape rate due to charge exchange with hot plasmaspheric ions. J. Geophys. Res., 82, 689, 1977.
- Mayr, H. G., I. Harris, H. B. Niemann, H. C. Brinton, N. W. Spencer, H. A. Taylor, Jr., R. E. Hartle, W. R. Hoegy, and D. M. Hunten, Dynamic properties of the thermosphere inferred from Pioneer Venus mass spectrometer measurements, J. Geophys. Res., 85, 7841, 1980.
- McAfee, J. R., Lateral flow in the exosphere, Planet. Space Sci., 15, 599, 1967.
- McElroy, M. B., and D. M. Hunten, The ratio of deuterium to hydrogen in the Venus atmosphere. J. Geophys. Res., 74, 1720, 1969.
- Meier, R. R., and P. Mange, Geocoronal hydrogen: An analysis of the Lyman-alpha airglow observed from OGO-4, Planet. Space Sci., 18, 803, 1970.
- Mihalov, J. D., J. H. Wolfe, and D. S. Intriligator, Observations of the solar wind-Venus interaction, J. Geophys. Res., 85, 7613, 1980.
- Miller, K. L., W. C. Knudsen, K. Spenner, R. C. Whitten, and V. Novak, Solar zenith angle dependence of ionospheric ion and electron temperatures and density on Venus., J. Geophys. Res., 85, 7759, 1980.
- Neimann, H. B., W. T. Zaspzrak, A. E. Hedin, D. M. Hunten, and N. W. Spencer, Mass spectrometric measurements of the neutral gas composition of the thermosphere and exosphere of Venus, J. Geophys. Res., 85, 7817, 1980.
- Prisco, R. A., and J. W. Chamberlain, Doppler line profiles in a planetary corona: An extended approach, J. Geophys. Res., 84, 4363, 1979.
- Smith, G. R., D. E. Shemansky, A. L. Broadfoot, and L. Wallace, Monte Carlo modeling of exospheric bodies: Mercury, J. Geophys. Res., 83, 3783, 1978.
- Sze, N. D., and M. B. McElroy, Some problems in Venus aeronomy, Planet. Space Sci., 23, 763, 1975.
- Takacs, P. Z., A. L. Broadfoot, G. R. Smith, and S. Kumar, Mariner 10 observations of hydrogen Lyman alpha emission from the Venus exosphere: Evidence of a complex structure, Planet. Space Sci., 28, 687, 1980.
- Taylor, H. A., Jr., H. C. Brinton, S. J. Bauer, R. E. Hartle, P. A. Cloutier, and R. E. Daniell, Jr., Global observations of the composition and dynamics of the ionosphere of Venus: Implications for the solar wind interaction, J. Geophys. Res., 85, 7765, 1980.
- Tinsley, B. A., Effects of charge exchange involving H and H<sup>+</sup> in the upper atmosphere, Planet. Space Sci., 26, 847, 1978.
- Tinsley, B. A., R. R. Hodges, Jr., and D. F. Strobel, Diurnal variations of atomic hydrogen: Observations and calculations, J. Geophys. Res., 80, 626, 1975.
- Torr, M. R., D. G. Torr, R. A. Ong, and H. E. Hinteregger, Ionization frequencies for major thermospheric constituents as a function of solar cycle 21, Geophys. Res. Lett., 6, 771, 1979.
- Wallace, L., Analysis of the Lyman alpha observations of Venus made from Mariner 5, J. Geophys. Res., 74, 115, 1969.

(Received November 24, 1980;  
revised June 3, 1981;  
accepted June 4, 1981.)

THE INFLUENCE OF THERMOSPHERIC WINDS ON EXOSPHERIC HYDROGEN ON VENUS

R. Richard Hodges, Jr. and Brian A. Tinsley  
University of Texas at Dallas  
P. O. Box 688, Richardson, Texas 75080

Submitted to Icarus  
November 2, 1981

Abstract. Monte Carlo models of the distribution of atomic hydrogen in the exosphere of Venus have been computed which simulate the effects of thermospheric winds, the production of a 'hot' hydrogen component by charge exchange of  $H^+$  with H and O in the exosphere, as well as classic exospheric processes. A thermosphere wind system that is approximated by a retrograde rotating component with equatorial speed of 100 m/s superimposed on a diurnal solar tide with cross-terminator day to night winds of 200 m/s is shown to be compatible with the thermospheric hydrogen distribution deduced from Pioneer Venus orbiter measurements by Brinton et al. (1980).

Introduction

The Venus exosphere has a peculiar distribution of atomic hydrogen that has provoked considerable discussion since 1967 when the ultraviolet photometer on Mariner 5 detected anomalous Lyman  $\alpha$  emissions several thousand km above the planet's surface [Barth et al., 1967]. Subsequent analysis of the Mariner 5 bright limb data by Barth et al. [1968] revealed an increase in the scale height of Lyman  $\alpha$  scatterers at about  $10^4$  km from the center of the planet, suggesting a two component exosphere that could be fitted by exospheric distributions of  $H_2$  and H at  $650 \pm 50$  K, with  $H_2$  being the dominant constituent. The possibility of an atomic hydrogen-deuterium exosphere was considered by Barth [1968], McElroy and Hunten [1969], and Wallace [1969]. A two-temperature atomic hydrogen exosphere was also discussed by Wallace [1969].

Anderson [1976] and Takacs et al. [1980] have shown that data from the Mariner 5 ultraviolet photometer and the Mariner 10 ultraviolet spectrometer, respectively, are compatible with a bimodal velocity distribution of atomic hydrogen in the Venus exosphere. The salient features of the models resulting from these analyses are a cold component with temperature varying from  $275 \pm 50$  K in daytime to  $150 \pm 50$  K at night, a nearly constant concentration of about  $2 \times 10^5$   $cm^{-3}$  at a reference radius of 6305 km, and a hot component with apparent temperature in the range 800-1500 K and a reference level concentration of about  $10^3$   $cm^{-3}$ .

The relative importance of possible alternative sources of the hot hydrogen component for the two-temperature Venus exosphere remain less certain. Kumar and Hunten [1974] showed that several ion-neutral chemical reactions involving molecular hydrogen in the Venus ionosphere could act as sources of nonthermal hydrogen atoms, making a two-temperature atomic hydrogen exosphere plausible. The energy

distributions of the hot atomic hydrogen produced by ionospheric chemical reactions were studied further by Ferrin [1976] and by Cravens et al. [1980] using theoretical models for the  $H_2$  abundance in the Venus atmosphere. Cravens et al. [1980] concluded that the major source of dayside nonthermal H is the recombination of  $OH^+$ . Kumar et al. [1981] have utilized the Pioneer Venus orbiter measurements of  $H_2^+$  and other constituents to derive a self consistent, vertical distribution of  $H_2$  with abundance of about 10 ppm. From the altitude dependence of the rate of production of H in their model calculations, Kumar et al. [1981] concluded that the reaction of  $H_2^+$  with O provides adequate nonthermal hydrogen to explain the nonthermal Lyman  $\alpha$  measurements, while recombination of  $OH^+$  was postulated to be the dominant cause of hydrogen escape, producing an escape flux of about  $10^8 \text{ cm}^{-2} \text{ s}^{-1}$ .

An alternative origin of hot hydrogen in any exosphere is through the charge exchange reactions



that convert high temperature ionospheric protons to suprathermal neutral hydrogen atoms [Tinsley et al., 1975; Maher and Tinsley, 1977; Chamberlain, 1977; Cravens et al., 1980; Hodges et al., 1981; Hodges and Tinsley, 1981]. On Venus the velocity distribution of initial protons and the resultant neutral hydrogen atoms in reaction (1) or (2) correspond to temperatures of several thousand degrees Kelvin [Miller et al., 1980]. Owing to a general increase in ion temperature from day to night in the Venus exosphere (from about 2000 K to 5000 K according to Miller et al.), the hot hydrogen arising from these reactions is likely to have a higher temperature at night than in daytime, in qualitative agreement with the empirical model of Anderson [1976].

On the basis of a vertical column equilibrium calculation, Cravens et al. [1980] suggest that the charge exchange reactions and the  $H_2$  reaction with  $O^+$  are probably of similar significance in producing hot H at night, but not in the daytime. However, global scale transport, a phenomenon that is neglected in vertical column, chemical-ballistic equilibrium models, is actually quite important for hot hydrogen. Owing to the similar magnitudes of thermal proton speed and orbit velocity, the hot hydrogen that is produced at night by charge exchange neutralization of protons must travel ballistically into the daytime hemisphere.

As an initial step toward understanding the roles of both charge exchange and lateral transport in the Venus exosphere, Hodges and Tinsley [1981] addressed one element of the global hot hydrogen problem: What three-dimensional exospheric hydrogen distribution would



be produced on Venus if molecular ion chemistry were nonexistent and all hot hydrogen were produced by reactions (1) and (2)? The resulting self consistent hydrogen distribution fits the Mariner 5 and 10 Lyman  $\alpha$  measurements, both in daytime and at night, suggesting that charge exchange is a major source of the hot hydrogen.

An important deficiency of the Hodges and Tinsley [1981] model is that at the exobase the thermal hydrogen night to day concentration ratio of 11:1 is much less than the 400:1 ratio determined by Brinton et al. [1980] on the basis of charge exchange equilibrium of H with Pioneer Venus orbiter measurements of O, CO<sub>2</sub>, O<sup>+</sup> and H<sup>+</sup> in the upper thermosphere. Mayr et al. [1980] have shown that thermospheric wind induced diffusion should cause a night to day hydrogen ratio of about 100:1. Hodges and Tinsley [1981] noted that the effect of thermospheric winds on the distribution of velocities of thermal atoms leaving the thermosphere and entering the exosphere is important to the distribution of hydrogen on earth [Hodges, 1973a; Tinsley et al., 1975] and probably on Venus as well. We have now incorporated a thermospheric wind system into the Venus exosphere simulator. Subsequent discussion will show that the diurnal hydrogen variation in the upper thermosphere determined by Brinton et al. may be produced by the action of thermospheric winds on the exobasic hydrogen velocity distribution.

#### Venus Exosphere Simulation

Collisionless ballistic transport, in which atoms emerge from the top of the thermosphere with thermal speeds, travel in essentially elliptic orbits with periapses below the base of the exosphere, and hence reenter the thermosphere, is the characteristic process of any exosphere. Ballistic atoms tend to travel lateral distances that are proportional to their temperature, so that warm atoms are more mobile than cold ones, making migration from day to night more rapid than the reverse. As a result, exospheric equilibrium (i.e., the condition of no lateral flow) requires highest concentrations in nighttime. For gases with thermal speeds much less than the escape velocity, exospheric equilibrium produces exobase concentrations that are proportional to the  $-5/2$  power of temperature, but this condition is modified by a bias of the velocity distribution due to lateral motion of the exobase and the resulting ballistic advection [Hodges and Johnson, 1968; Hodges, 1973a].

Thermal escape, the production of satellite particles, and nonthermal processes such as charge exchange and photoionization tend to make analytical methods of study of planetary exospheres impractical. On the other hand, by using Monte Carlo exosphere simulation methods [Hodges, 1973b, 1980; Hodges et al., 1981; Hodges and Tinsley, 1981; Smith et al., 1978] the accuracy of the resulting model is limited only by the accuracy of mathematical descriptions of the physical processes and the computer time resource devoted to the accumulation of statistical data.

The results presented here were obtained with the Venus exosphere Monte Carlo simulator described in Hodges and Tinsley [1981]. The only modification of the simulator was that needed to make the exobase temperature distribution agree with the revised temperature data published by Neimann et al. [1980]. In daytime the temperature was

ORIGINAL PAGE IS  
OF POOR QUALITY

increased from 240 K to 285 K and at night from 100 K to 110 K.

In Monte Carlo exosphere simulators the random velocities of atoms entering the exosphere from the thermosphere are chosen from a flux distribution [Smith et al., 1978]. On Venus we have approximated this distribution by a Maxwellian with temperature and mean flow velocity corresponding to that of exobase atomic oxygen. The lateral thermospheric wind velocity is added to random deviate velocity vectors derived from a flux distribution that is predominantly Maxwellian, but modified by reflection of 30% of the downcoming hydrogen atoms with unchanged speeds, in accordance with a suggestion of Chamberlain [1977].

The Venus thermospheric wind system is approximated by the superposition of two parts: a divergenceless rotational component

$$v_R = \hat{\theta} W_R \sin \theta \quad (3)$$

and a solar diurnal tide component with horizontal velocity

$$v_T = W_T \{ \hat{\theta} \sin \theta - \hat{\phi} \cos \theta \cos \phi \} \quad (4)$$

where  $W_R$  is the equatorial speed of the rotational component,  $W_T$  is the cross terminator wind speed associated with the diurnal tide,  $\theta$  is colatitude, and  $\phi$  is longitude measured from the subsolar meridian. Unit vectors in the directions of increasing colatitude and longitude are denoted  $\hat{\theta}$  and  $\hat{\phi}$ , respectively.

On Venus there are two distinct sources of exospheric hydrogen: the flux of thermal atoms upward through the exobase (the 'exobase source'); and reaction (2) within the exosphere (the 'ionospheric source'). Neutral atoms from either source may undergo effective velocity conversion by reaction (1). Most atoms emerge from the exobase, travel through the exosphere in ballistic trajectories, and reenter the thermosphere, where collisions, primarily with atomic oxygen, produce a distribution of upgoing velocities that includes thermalized as well as reflected components. The exobase source flux differs only slightly from the downcoming flux, the difference being equal to the net upward flux needed to supply losses due to ionization and escape. The contribution of reaction (2) to the exosphere can be determined absolutely from direct measurements of  $H^+$  and  $O$ , but the magnitude of the exobase source must be determined by normalization of model results to measured atomic hydrogen concentrations.

We have chosen the hydrogen concentration profile of Anderson [1976] derived from dayside Mariner 5 Lyman  $\alpha$  results for normalization of the model, which we have done using separate calculations for the ionospheric source (i.e. hydrogen produced by reaction (2)) without the exobasic source, and for the exobasic source without the ionospheric source. The results for the exobasic source alone above 9000 km radius have been fitted to the Anderson [1976] daytime profile reduced by the small contribution of the ionospheric

source (cf. Hodges and Tinsley [1981]). This dayside high altitude region was chosen for the normalization to avoid problems with the question of multiple scattering that may have affected the Mariner 5 Lyman  $\alpha$  data at lower altitudes.

In the computer simulation of the Venus exosphere, hydrogen concentration data are accumulated in a three-dimensional grid of audit zones arranged on spheres concentric with the exobase. The radii of these spheres ranges from the exobase at  $r_b (= 6227.7 \text{ km})$  to  $2r_b$  in 14 equal decrements of gravitational potential ( $GM/r$ ), so that deviations of concentrations from barometric equilibrium are readily apparent. Global morphology is obtained by subdividing each sphere into 32 zones of equal area, the zone boundaries being formed by eight meridians spaced  $45^\circ$  apart and by latitudes of  $0^\circ$  and  $\pm 30^\circ$ . Only data from the low latitude zones are considered in this work.

#### Effects of Thermospheric Winds on H at the Exobase

Diurnal variations of the exobase concentration of hydrogen from three exosphere simulations are superimposed in Figure 1. Squares denote the Hodges and Tinsley [1981] model that neglected thermospheric winds. These data have been raised by an order of magnitude in the graph to avoid overlap with other results. The diamonds denote results from a simulation with a simple retrograde rotating exobase with  $W_R = -100 \text{ m/s}$  and no tidal component. Visual comparison of the static and rotating exobase models reveals a distinct downwind shift of the daytime minimum and of nighttime maximum but no significant effect on the ratio of the night and day extremes.

The current thermosphere wind system deduced from Pioneer Venus orbiter data by Mayr et al. [1980] is approximated by an exobase rotation speed of  $W_R = -100 \text{ m/s}$  and a tidal wind component having cross terminator speed of  $W_T = 200 \text{ m/s}$ . The exosphere simulation for rotation superimposed on tidal winds, designated 'RT' in subsequent discussion, is indicated by the triangles in Figure 1. As in the rotation only model there are rotation-induced shifts of the daytime minimum and of the nighttime maximum. However the night to day ratio of H concentration is greatly increased by the cross terminator wind component.

The histogram in Figure 2 shows the diurnal variation of the RT model extrapolated to 165 km. Overlaid by the histogram are the experimental data points for 165 km determined by Brinton et al. [1980] from Pioneer Venus orbiter measurements. The initial normalization of the model to the Mariner 5 Lyman  $\alpha$  high altitude results by the method described in the previous section has been augmented by an additional adjustment of the model by a multiplicative factor of 1.8 to produce the apparent fit of the histogram with the Brinton et al. data. What is important in Figure 2 is that the salient features of the diurnal hydrogen oscillation, which include a broad daytime minimum, a peaked nighttime maximum that is noticeably shifted toward sunrise, and a large night to day concentration ratio, are faithfully reproduced by the model.

The exobase boundary condition used in the model calculations is commonly referred to as the zero-net-ballistic-flux approximation. This implies a detailed balance of the downward and the nonescaping

ORIGINAL PAGE IS  
OF POOR QUALITY

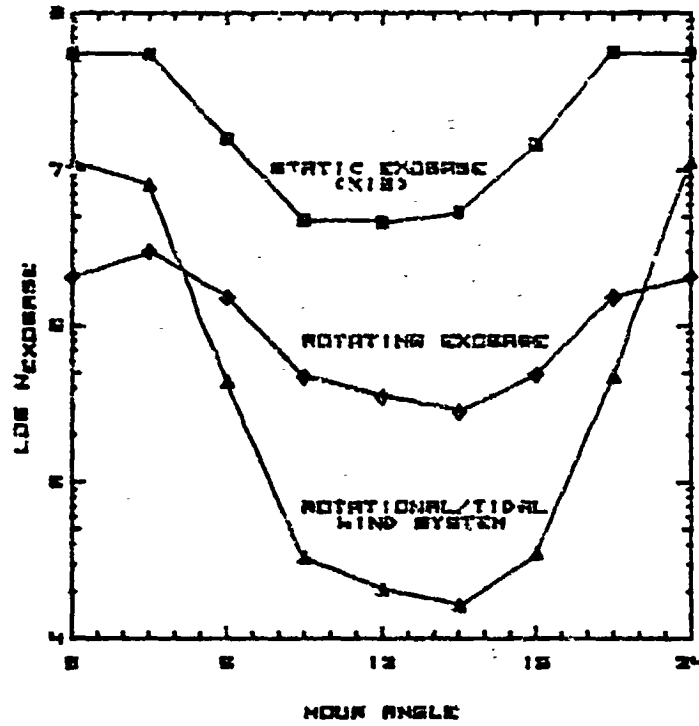

Figure 1. Three models of the diurnal distribution of atomic hydrogen at the exobase.

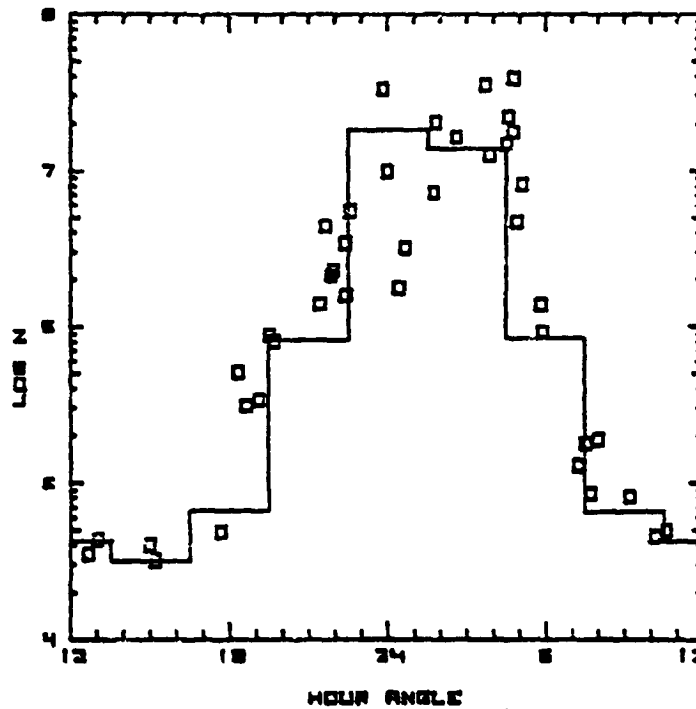

Figure 2. The RT model extrapolated to 165 km altitude is plotted as a histogram overlaying the atomic hydrogen data points of Brinton et al. [1980] for 165 km.

upward atomic fluxes at the exobase, with negligible excess thermospheric advection of hydrogen. Tinsley et al. [1975] included thermospheric advection for the earth in an ad hoc manner but found the effect to be small. A more complicated hydrogen flow pattern that includes a net downward ballistic flux of H in daytime, an upward flux at night, and day to night advection in the thermosphere could be devised to produce the measured diurnal pattern, but this pattern would probably be unrealistic in view of the small time constant for chemical equilibrium of H with  $H^+$ , O, and  $O^+$  near the exobase and the need to consider day to night advection of  $H^+$  as well. Owing to the closeness of the reproduction of the Brinton et al. [1980] diurnal variation by the present model and to the relatively small increase in the night to day concentration ratio found when thermospheric advection of hydrogen in the relatively thick thermosphere of earth was considered by Tinsley et al. [1975], the zero-net-ballistic-flux approximation is probably justified.

#### Radial Morphology of the Venus Exosphere

The radial distribution of hydrogen for the static exobase model of Hodges and Tinsley [1981] is shown in Figure 3 and that for the RT model (i.e. exobase winds approximated by  $W_R = -100$  m/s and  $W_T = 200$  m/s) is shown in Figure 4. Curves give the day and night profiles derived by Wallace [1969] and by Anderson [1976] from Mariner 5 Lyman  $\alpha$  measurements and by Takacs et al. [1980] from Mariner 10 data. Diamond symbols represent noon model concentrations on the day plots and midnight on the night plots. Left pointing arrowheads denote model concentrations  $45^\circ$  prior to noon or midnight while those pointing right correspond to  $45^\circ$  after noon or midnight.

At high altitudes the models produce hot hydrogen distributions that are in satisfactory agreement with the Mariner Lyman  $\alpha$  measurements. Except for the pre-midnight data in the RT model, the nighttime thermal hydrogen concentrations at low altitudes have a smaller scale height than the Mariner profiles, suggesting much larger exobase concentrations, in agreement with Brinton et al. [1980]. We have previously suggested in Hodges and Tinsley [1981] that the velocity distribution of H on Venus is probably nonisotropic and nonisothermal, as it is on earth [Meriwether et al., 1980; Hodges et al., 1981], and that this should have a noticeable effect on the flux of scattered Lyman  $\alpha$  at night, decreasing confidence in the interpretations of the Mariner measurements near the dark limb.

Some significance must be attached to the fact that it is possible to reproduce the low altitude portion of the Mariner Lyman  $\alpha$  results by an exospheric model with no thermospheric winds, but that to fit the Brinton et al. [1980] diurnal variation near the exobase both a wind system and an increase in overall normalization of the model by a factor of 1.8 is required, leaving a discrepancy of about a factor of 5 between the model and the Mariner results in daytime between 7500 and 8500 km radius where radiative transfer calculations should be fairly reliable. One possibility that should be considered is that the simple wind system described by equations (3) and (4) could be augmented by higher order spherical harmonic components that would preferentially affect exospheric hydrogen near the exobase. Perhaps more important is the possibility that in the current Pioneer Venus

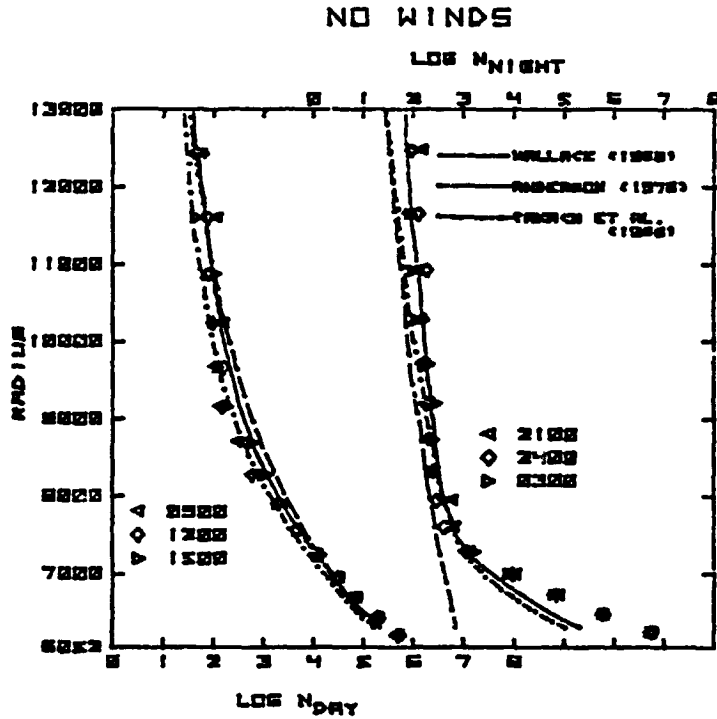

Figure 3. Static exobase model radial distributions of H for day and night. Each diamond symbol denotes a noon or midnight audit zone while the left and right pointing arrowheads, respectively, refer to adjacent audit zones  $45^\circ$  before and after that represented by the diamond. Line graphs are profiles of H derived from Lyman  $\alpha$  measurements.

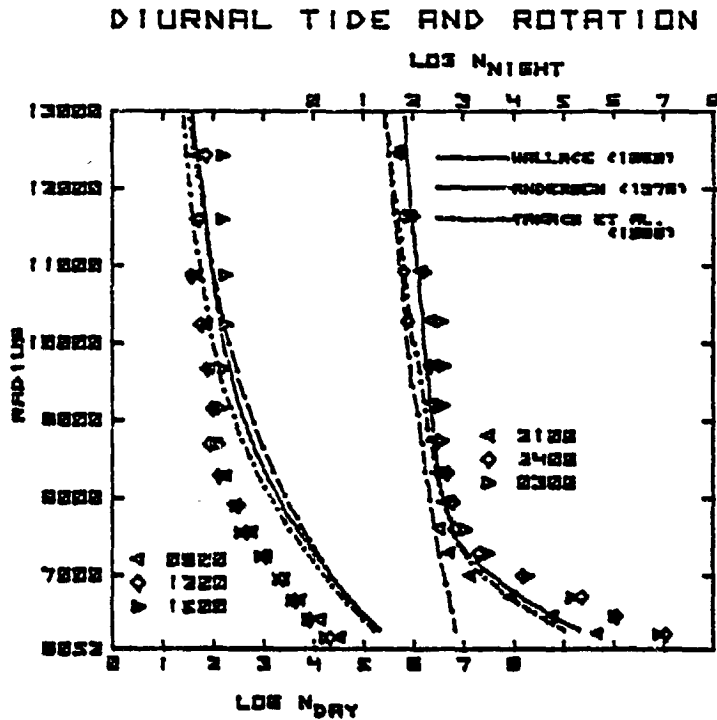

Figure 4. RT model radial distributions of H for day and night.

ORIGINAL PAGE IS  
OF POOR QUALITY

orbiter epoch the wind system and  $H^+$  concentrations differ appreciably from conditions during the 1967 and 1974 Mariner measurements.

Lyman  $\alpha$  data are now been obtained by the Pioneer Venus orbiter. It will be of interest to see how consistent the results of radiative transfer analyses of these data are with the present model and with the H concentrations determined from in situ measurements. It may not be possible to deduce a complex model from the Lyman  $\alpha$  data but it should be possible to simulate Lyman  $\alpha$  scattering on a nonuniform, nonthermal exospheric model such the present one, and test for consistency with the Lyman  $\alpha$  data.

### Conclusions

It has been shown that it is necessary to include a thermospheric wind system in global models of the hydrogen exosphere of Venus to account for the large diurnal variation of H near the exobase that was deduced from charge exchange equilibrium calculations from the Pioneer Venus data. A wind system consisting of a solar diurnal tide with a cross-terminator day to night speed of 200 m/s superimposed on a retrograde global rotation with equatorial speed of 100 m/s provides a good fit to the phase and amplitude of the exobase diurnal variation found by Brinton et al. [1980].

The inclusion of processes producing hot hydrogen in the Monte Carlo exosphere simulation allow the 'two-temperature' vertical profile of the Mariner 5 and 10 Lyman  $\alpha$  measurements to be fitted, but it has not been possible to reconcile the Pioneer Venus exobase data and the Mariner results to better than a factor of 5. Changes in the dynamics of the Venus thermosphere between the Mariner and Pioneer Venus missions could account for this discrepancy. It should be possible to test the consistency of exobase and altitude variations when radiative transfer calculations are made for a model such as the one given here and compared with the Pioneer Venus Lyman  $\alpha$  data.

Acknowledgments. It is a pleasure to acknowledge the support of this research by the National Aeronautics and Space Administration under grant NGL 44-004-026.

### References

- Anderson, D. E., Jr.(1976). The Mariner 5 ultraviolet photometer experiment: Analysis of hydrogen Lyman alpha data, J. Geophys. Res., **81**, 1213-1216.
- Barth, C. A. (1968). Interpretation of the Mariner 5 Lyman- $\alpha$  measurements, J. Atmos. Sci., **25**, 564.
- Barth, C. A., J. B. Pearce, K. K. Kelly, L. Wallace, and W. G. Fastie (1967). Ultraviolet emissions observed near Venus from Mariner 5, Science, **158**, 1675.
- Barth, C. A., L. Wallace, and J. B. Pearce (1968). Mariner 5 measurements of Lyman alpha radiation near Venus, J. Geophys. Res., **73**, 2541-2545.

ORIGINAL PAGE IS  
OF POOR QUALITY

- Brinton, H. C., H. A. Taylor, Jr., H. B. Niemann, H. G. Mayr, A. F. Nagy, T. E. Cravens, and D. F. Strobel (1980). Venus nighttime hydrogen bulge, Geophys. Res. Lett., 7, 865-868.
- Chamberlain, J. W. (1977). Charge exchange in a planetary corona: Its effect on the distribution and escape of hydrogen, J. Geophys. Res., 82, 1-9.
- Cravens, T. E., T. I. Gambosi, and A. F. Nagy (1980). Hot hydrogen in the exosphere of Venus, Nature, 283, 178-180.
- Ferrin, I. R. (1976). The distribution of hot hydrogen atoms in the upper atmosphere of Venus, Ph.D. thesis, Univ. of Colo., Boulder.
- Hodges, R. R., Jr. (1973a). Differential equation of exospheric lateral transport and its application to terrestrial hydrogen, J. Geophys. Res., 78, 7340-7346.
- Hodges, R. R., Jr. (1973b). Helium and hydrogen in the lunar atmosphere, J. Geophys. Res., 78, 8055-8064.
- Hodges, R. R., Jr. (1980). Methods for Monte Carlo simulation of the exospheres of the moon and Mercury, J. Geophys. Res., 85, 164-170.
- Hodges, R. R., Jr., and F. S. Johnson (1968). Lateral transport in planetary exospheres, J. Geophys. Res., 73, 7307-7317.
- Hodges, R. R., Jr. and B. A. Tinsley (1981). Charge exchange in the Venus ionosphere as the source of the hot exospheric hydrogen, J. Geophys. Res., 86, 7649-7656.
- Hodges, R. R., Jr., R. Rohrbaugh, and B. A. Tinsley (1981). The effect of the charge exchange source on the velocity and 'temperature' distributions and their anisotropies in the earth's exosphere, J. Geophys. Res., 86, 6917-6925.
- Kumar, S., and D. M. Hunten (1974). Venus, an ionospheric model with an exospheric temperature of 350° K, J. Geophys. Res., 79, 2529-2532.
- Kumar, S., D. M. Hunten, and H. A. Taylor, Jr. (1981). H<sub>2</sub> abundance in the atmosphere of Venus, Geophys. Res. Lett., 8, 237-240.
- Maher, L. J., and B. A. Tinsley (1977). Atomic hydrogen escape rate due to charge exchange with hot plasmaspheric ions. J. Geophys. Res., 82, 689-695.
- Mayr, H. G., I. Harris, H. B. Niemann, H. C. Brinton, N. W. Spencer, H. A. Taylor, Jr., R. E. Hartle, W. R. Hoegy, and D. M. Hunten (1980). Dynamic properties of the thermosphere inferred from Pioneer Venus mass spectrometer measurements, J. Geophys. Res., 85, 7841-7847.
- McElroy, M. B., and D. M. Hunten (1969). The ratio of deuterium to hydrogen in the Venus atmosphere. J. Geophys. Res., 74, 1720-1739.
- Meriwether, J. W., S. K. Atreya, T. M. Donahue, and R. G. Burnside (1980). Measurements of the spectral profile of Balmer alpha emissions from the hydrogen geocorona, Geophys. Res. Lett., 7, 967-970.
- Miller, K. L., W. C. Knudsen, K. Spenner, R. C. Whitten, and V. Novak (1980). Solar zenith angle dependence of ionospheric ion and electron temperatures and density on Venus., J. Geophys. Res., 85, 7759-7764.
- Neimann, H. B., W. T. Kasprzak, A. E. Hedin, D. M. Hunten, and N. W. Spencer (1980). Mass spectrometric measurements of the neutral gas composition of the thermosphere and exosphere of Venus, J. Geophys. Res., 85, 7817-7827.



ORIGINAL PAGE IS  
OF POOR QUALITY

- Smith, G. R., D. E. Shemansky, A. L. Broadfoot, and L. Wallace (1978). Monte Carlo modeling of exospheric bodies: Mercury, J. Geophys. Res., 83, 3783-3790.
- Takacs, P. Z., A. L. Broadfoot, G. R. Smith, and S. Kumar (1980). Mariner 10 observations of hydrogen Lyman alpha emission from the Venus exosphere: Evidence of a complex structure, Planet. Space Sci., 28, 687-701.
- Tinsley, B. A., R. R. Hodges, Jr., and D. F. Strobel (1975). Diurnal variations of atomic hydrogen: Observations and calculations, J. Geophys. Res., 80, 626-634.
- Wallace, L. (1969). Analysis of the Lyman alpha observations of Venus made from Mariner 5, J. Geophys. Res., 74, 115-132.

ORIGINAL PAGE IS  
OF POOR QUALITY

## Venus Lower Atmospheric Composition: Preliminary Results from Pioneer Venus

**Abstract.** Initial examination of data from the neutral mass spectrometer on the Pioneer Venus sounder probe indicates that the abundances of argon-36, argon-38, and neon-20 in the Venus atmosphere are much higher than those of the corresponding gases in Earth's atmosphere, although the abundance of radiogenic argon-40 is apparently similar for both planets. The lower atmosphere of Venus includes significant concentrations of various gaseous sulfur compounds. The inlet leak to the mass spectrometer was temporarily blocked by an apparently liquid component of the Venus clouds during passage through the dense cloud layer. Analysis of gases released during the evaporation of the droplets shows the presence of water vapor to some compound or compounds of sulfur.

The sounder probe, or large probe, of the Pioneer Venus multiprobe spacecraft (1) entered the atmosphere of Venus on 9 December 1978. It carried seven instruments, including a neutral mass spectrometer, designed to measure the composition of the lower atmosphere of Venus.

The mass spectrometer, a single focusing magnetic sector device (2), was intended to measure atomic masses ranging from hydrogen to lead. Gases were admitted to the instrument through a set of two microleaks. The leaks were hermetically sealed prior to launch by means of a ceramic cap attached to a flange in the shell of the probe behind the heat shield. The cap was broken with a pyrotechnic device, exposing the leaks to the Venus atmosphere a few seconds after the parachute was deployed and the heat shield jettisoned. Gas molecules entering the leaks passed through an ion source where they could be ionized by electrons with an impact energy of 70 eV. The electron impact energy was reduced to 30 and 22 eV on successive mass scans on three occasions during descent, providing additional aids for the identification of parent molecules, whose cracking patterns change significantly as the ambient energy is reduced from 70 to 22 eV. Additional simplification of the spectrum occurs since the production of doubly charged ions is negligible at lower impact energies.

Ambient gases were removed from the ion source by a chemical getter. The pumping speed was controlled by a valve connecting the ion source and getter. The valve was allowed to open during descent in response to increasing atmospheric pressure, maintaining in this fashion a relatively constant pressure at the ion source (3). Preliminary flight data indicate that the pressure in the

ion source responded as expected to changes in external pressure, increasing by less than a factor of 10 while the external pressure increased by a factor of  $10^3$ . An anomaly occurred near 50 km in a region of the atmosphere where Knollenberg and Hunten (4) and Ragent and Blamont (5) detected the presence of significant concentrations of particulate material. The conductance of the leak to the ion source decreased as though the inlet had been blocked by some foreign material. The leak remained closed for approximately 10 minutes and then gradually opened over a period of about 5 minutes, at which time the flow of atmospheric gases to the ion source was fully restored (about 30-km altitude). Operation of the spectrometer then remained normal until the signal was lost, presumably at impact.

The operation of the mass spectrometer was controlled by a microprocessor (6). Two calibration gases, methane and  $^{136}\text{Xe}$ , were introduced into the mass analyzer immediately prior to the initiation of the measurement sequence. Mass peaks associated with the calibration gases were used to provide reference points which the microprocessor could utilize to control the mass scan sweep voltage. A lookup table of nouns stored in the microprocessor defined positions in the mass spectrum of a preselected set of mass peaks. The microprocessor, scanning this table, directed the instrument to measure the amplitudes only of the preselected mass peaks. This pro-

cedure served to eliminate the time associated with the normal method of sweeping between adjacent mass numbers. Thus, the spectrum from 1 to 208 atomic mass units (amu) was scanned in 64 seconds, providing an average spatial resolution for the measurement of individual gases equivalent to approximately 1 km of altitude in the Venus atmosphere. Complete processing of data from the sounder probe should eventually provide as many as 55 mass spectra, extending from an altitude of about 68 km down to the planetary surface.

Preliminary examination of the data indicates the presence of surprisingly large concentrations of  $^{36}\text{Ar}$ ,  $^{38}\text{Ar}$ , and  $^{20}\text{Ne}$ . The mixing ratio (volume to volume) of  $^{36}\text{Ar}$  in the Venus atmosphere is approximately  $10^{-4}$ , compared to a value of  $3.2 \times 10^{-5}$  observed for Earth's atmosphere. The atmosphere of Venus, however, is approximately 90 times more massive than that of Earth. It follows that the absolute abundance of  $^{36}\text{Ar}$  in the Venus atmosphere must be approximately 200 to 300 times larger than that of Earth. The abundance of  $^{20}\text{Ne}$  is apparently also high in the atmosphere of Venus, comparable to that for  $^{36}\text{Ar}$ . The abundance ratio  $^{36}\text{Ar}/^{38}\text{Ar}$  in the Venus atmosphere is, however, similar to values observed for Earth, meteorites, and the moon.

Table 1 gives a comparison of the abundances of  $^{36}\text{Ar}$  reported for the sun (7), Venus, Earth, and Mars (8). Results are quoted in terms of mass mixing ratios (gram per gram), that is, ratios of the mass of atmospheric  $^{36}\text{Ar}$  referenced with respect to the total mass of the parent body. The relative abundance of  $^{36}\text{Ar}$  appears to decrease with increasing heliocentric distance, at least for the inner solar system. The pattern is not altered significantly if we consider the concentration ratio  $^{36}\text{Ar}/^{12}\text{C}$  (Table 1). The ratio quoted for Venus assumes that most of that planet's  $^{36}\text{Ar}$  and  $^{12}\text{C}$  resides in its atmosphere. The ratio quoted for Earth assumes that most of the terrestrial  $^{36}\text{Ar}$  occurs in the atmosphere but that the bulk of the terrestrial  $^{12}\text{C}$  is found in

Table 1. Abundances of  $^{36}\text{Ar}$  and values of the concentration ratio  $^{36}\text{Ar}/^{12}\text{C}$  for the sun, Venus, Earth, and Mars.

Abundance	Sun	Venus	Earth	Mars
$^{36}\text{Ar}$	$1 \times 10^{-4}$	$\sim 10^{-6}$	$3.5 \times 10^{-11}$	$1.9 \times 10^{-13}$
$^{36}\text{Ar}/^{12}\text{C}$	$3 \times 10^{-2}$	$\sim 10^{-4}$	$2 \times 10^{-6}$	$1.7 \times 10^{-8}$ to $6.6 \times 10^{-9}$

carbonate minerals (9). A range of values is given for Mars, reflecting various assumptions regarding the abundance of condensed carbon on that planet (8). If most of the martian  $^{36}\text{Ar}$  and  $^{12}\text{C}$  were to reside in its atmosphere, the ratio would be  $1.7 \times 10^{-3}$  g per gram.

The relative abundances of  $^{12}\text{C}$  and  $^{14}\text{N}$  are apparently similar on Venus and Earth (9), although the absolute abundance for  $^{12}\text{C}$  (gram per gram) may be higher for Venus by about a factor of 1.5. The situation is less clear for Mars since significant quantities of  $^{14}\text{N}$  appear to have been lost as a result of escape (10) and since major uncertainty is attached to present estimates for the surface-sub-surface reservoirs of  $^{12}\text{C}$ . Anders and Owen (11) have argued that the low abundance of  $^{36}\text{Ar}$  and the relatively high value for the concentration ratio  $[^{40}\text{Ar}]/[^{36}\text{Ar}]$  in the martian atmosphere might be taken to indicate that Mars formed with approximately 1/35 as much carbon and nitrogen as Earth, and that Mars had degassed less efficiently than Earth (by about a factor of 4). The abundance of  $^{40}\text{Ar}$  on Venus appears similar to that for Earth. Our data suggest that the mixing ratio of  $^{40}\text{Ar}$  to  $^{36}\text{Ar}$  is about 1. The presence in the Venus atmosphere of high concentrations of  $^{36}\text{Ar}$ ,  $^{38}\text{Ar}$ , and  $^{20}\text{Ne}$ , together with normal, by terrestrial standards, concentrations of  $^{40}\text{Ar}$ ,  $^{12}\text{C}$ , and  $^{14}\text{N}$ , suggests that the use of scaling procedures based on measurements of primordial noble gases to estimate abundances of other volatiles in a planetary atmosphere may be subject to error. The new data for Venus, in combination with earlier information from Mars and Earth, suggest that the concentration of primordial noble gases may vary appreciably from planet to planet, even though variations in the abundance of other more reactive volatiles such as carbon and nitrogen may be quite small.

The blockage of the inlet leaks of the mass spectrometer which occurred in a region of dense clouds may have provided an unscheduled, although fortunate, opportunity for direct measurement of at least one component of the Venus clouds. The decrease in conductance observed was quite marked. The amplitude of the primary  $\text{CO}_2^+$  mass peak (44 amu) decreased by four orders of magnitude to a small residual background level. At the same time, the amplitudes of other peaks also declined to levels consistent with residuals to be ex-

pected if the flow were interrupted after the ion source had been exposed to a large sample of atmospheric gas. Two microleaks were used in parallel during the early phase of the descent of the probe, in order to increase gas throughput to the ion source in low-density regions of the atmosphere. The secondary leak, which had a fivefold larger conductance, was closed at 47 km by an electronically operated valve. Gases admitted to the instrument passed only through the primary leak for the balance of the descent. The blockage occurred approximately 3 minutes before the second microleak was closed, an indication that both leaks must have been blocked, presumably by material from the clouds. It seems probable that the blocking material should have been present in liquid form in order to account for the relatively complete degree to which gases were excluded during the subsequent 10 minutes.

The primary inlet leak had an external heater attached to its inlet tube to ensure that the temperature of the leak would always remain above that of the ambient atmosphere. Preflight tests in a simulated Venus atmosphere showed that the leak temperature would vary from about  $20^\circ\text{C}$  above ambient temperature at higher altitudes to about  $5^\circ\text{C}$  above ambient at lower altitudes. The heater was designed to vaporize any droplets that might lodge on the inlet leak and to preclude condensation. About 10 minutes after the probe passed out of the cloud layer the overcoating of the primary leak evaporated, aided no doubt by the heater, thus permitting a resumption of the flow of external gases through the leak. At this time marked increases were observed in signals measured by the spectrometer at mass numbers 18, 48, and 64 amu, with somewhat smaller peaks at 17, 19, 32, 50, and 66 amu. There can be little doubt that the condensed material which blocked the inlet tube contained a compound or compounds of sulfur together with  $\text{H}_2\text{O}$ . Further work will be required in order to categorically identify the condensed material. There is no reason to reject, however, at this stage, the notion that the clouds of Venus may contain significant concentrations of hydrated  $\text{H}_2\text{SO}_4$  (12).

Additional evidence for the importance of sulfur may be derived from data obtained in an essentially cloud-free region at lower altitudes. Peaks were ob-

served in the mass spectrum at 64 and 48 amu and at other mass numbers that may be associated with radicals or compounds containing sulfur. Further analysis will be required to provide categorical identification of the more abundant sulfur compounds. It is apparent, however, that the lower atmosphere of Venus must include a significant supply of sulfur and that the relative concentrations of more abundant sulfur compounds must change appreciably with altitude. Continuing analysis of these data should provide invaluable insights into the complex chemical and photochemical processes which combine to form and maintain the planet-wide clouds of Venus.

J. H. HOFFMAN

R. R. HODGES, JR.

Center for Space Sciences, University of Texas at Dallas, Richardson 75080

M. B. McELROY

Center for Earth and Planetary Physics, Harvard University, Cambridge, Massachusetts 02138

T. M. DONAHUE

Department of Atmospheric and Oceanic Sciences, University of Michigan, Ann Arbor 48105

M. KOLPIN

Physics International, San Leandro, California 94577

#### References and Notes

1. L. Colin and C. F. Hall, *Space Sci. Rev.* **20**, 283 (1977).
2. J. H. Hoffman, *ibid.*, p. 461.
3. ———, R. R. Hodges, K. D. Duerksen, *J. Vacuum Sci. Technol.*, in press.
4. R. G. Knollenberg and D. Hunten, *Science* **203**, 792 (1979).
5. B. Ragent and J. Blamont, *ibid.*, p. 790.
6. R. R. Hodges, J. Saxton, J. H. Hoffman, in preparation.
7. A. G. W. Cameron, *Space Sci. Rev.* **15**, 121 (1973).
8. T. Owen, K. Biemann, D. R. Rushneck, J. E. Biller, D. W. Howarth, A. L. Lafeur, *J. Geophys. Res.* **82**, 4635 (1977); M. B. McElroy, T. Y. Kong, Y. L. Yung, *ibid.*, p. 4379.
9. M. B. McElroy, *Int. Rev. Sci.* **11-9**, 127 (1976); H. D. Holland, *The Chemistry of Atmospheres and Oceans* (Wiley, New York, 1978).
10. M. B. McElroy, Y. L. Yung, A. O. Nier, *Science* **194**, 70 (1976).
11. E. Anders and T. Owen, *ibid.* **198**, 453 (1977).
12. L. D. G. Young and A. T. Young, *Astrophys. J.* **179**, L39 (1973).
13. We are indebted to R. Bass, R. Bickel, J. Blair, A. Blevins, L. Brooks, M. Brumit, K. Duerksen, P. Francis, H. Hammack, F. Harris, C. Hearne, J. Jackson, P. Johnson, W. Lane, E. Lee, W. Lord, B. Milam, N. Miller, C. Portis, S. Randazzo, J. Rhodes, R. Ricamore, S. Rogillio, J. Saxton, C. Shippy, T. Stepoway, J. Stevens, D. Tipton, W. Wright, and D. York of the University of Texas at Dallas for development of the hardware. W. Dodson wrote the data reduction software. Special thanks are due L. Polaski of Ames Research Center for his support throughout the program. Work at the University of Texas at Dallas was supported by NASA contracts NAS2-8802 and NAS2-9485.

16 January 1979

ORIGINAL PAGE IS  
OF POOR QUALITY.

Reprint Series  
6 July 1979, Volume 205, pp. 49-52

## Composition and Structure of the Venus Atmosphere: Results from Pioneer Venus

*Abstract. Results from the Pioneer Venus sounder probe neutral mass spectrometer indicate that there is no difference in the isotopic ratios of carbon and oxygen between Venus and Earth to within  $\pm 5$  percent. The mixing ratio of nitrogen is  $3.5 \pm \frac{1}{2}$  percent with an isotopic ratio within 20 percent of that of Earth. The ratio of argon-36 to argon-40 is 85 percent, and the ratio of argon-38 to argon-36 is 20 percent. The mixing ratios of argon-36 and argon-40 are approximately 40 and 50 parts per million, respectively, with an error of about a factor of 2 (mainly toward a lesser amount) resulting from uncertainty in the response of the ion pump to rare gases. Hydrogen chloride cannot account for more than a few percent of the 36 mass peak, and therefore the large excess of primordial argon is a reasonable conclusion. The ratio of neon-20 to argon-36 of  $0.5 \pm 0.3$  is definitely terrestrial in character rather than solar. These results indicate that there is a large excess of all primordial noble gases on Venus relative to Earth. There appears to be a considerably higher abundance of sulfur compounds below 20 kilometers than in or above the main cloud layer. The 32 and 60 mass peaks show a sharp increase below 22 kilometers, indicating the possible production of sulfur and carbon oxysulfide (COS) at the expense of sulfur dioxide.*

The mass spectrometer on the Pioneer Venus sounder probe, which entered the Venus atmosphere on 9 December 1978 (1), measured the atmospheric composition relative to  $\text{CO}_2$ , the dominant constituent, from an altitude of 61 km to the surface. The instrument, a single-focusing, magnetic-sector spectrometer (2), scanned the mass range from hydrogen through mercury with a dynamic range of six decades. Because the instrument was designed to measure atmospheric composition rather than density, a gate valve (3), operated by the increasing atmospheric pressure encountered during descent, was installed to control the ion source pressure to a relatively constant value as the inlet leak throughput continually increased. The result was as follows: (i) a sensitivity of 1 part per million (ppm) was attained throughout most of the descent while the atmospheric pressure changed by four orders of magnitude and (ii) the instrument output sig-

nals are not related directly to atmospheric density but are relative to  $\text{CO}_2$ . Figure 1 is the altitude profile of  $\text{CO}_2$  in terms of instrument output signal (related to counting rate). Since this is not a density profile but a measure of the partial pressure of  $\text{CO}_2$  in the ion source, all other data will be presented as mixing ratios relative to this  $\text{CO}_2$  profile.

The decrease in signal starting at 51 km is caused by a blockage of the inlet leak, which occurred after the probe passed through most of the cloud layer designated region C of the nephelometer data (4). This blockage occurred presumably as a result of an overcoating of cloud materials (hydrated  $\text{H}_2\text{SO}_4$  droplets) which lasted until the probe emerged from the lower haze layer at 31 km (5), at which time the flow of atmospheric gases resumed.

The isotopic ratios of C and O,  $^{13}\text{C}$  to  $^{12}\text{C}$ , and  $^{18}\text{O}$  to  $^{16}\text{O}$  have been found to be close to Earth values. The C ratio from

the  $\text{CO}_2^{2+}$  peaks at mass 22 and 22.5 is about 0.012, approximately 5 percent higher on Venus than on Earth, with a standard deviation of  $\pm 5$  percent. The 45/44 mass peak ratio ( $\text{CO}_2^+$ ) yields, on the average, a similar number. The  $^{18}\text{O}/^{16}\text{O}$  ratio was within 1 percent of the Earth value (0.00204), also with a standard deviation of  $\pm 5$  percent.

In order to determine the  $\text{N}_2$  abundance on Venus from the mass spectrometer data, several methods were used. Because of the rather large production of CO from  $\text{CO}_2$  in the ion source, the 28 mass peak is comprised of both  $\text{CO}^+$  and  $\text{N}_2^+$  (the majority being  $\text{CO}^+$ ). The  $\text{CO}^+$  peak amplitude is a function of the degree to which the gate valve to the ion source pump (a chemical getter pump) was open, and its ratio to  $\text{CO}_2^+$  varied from 0.4 when the valve was closed to 0.12 when the valve was wide open. On the basis of data from the lowest part of the descent profile and corrections for the CO contribution, the  $\text{N}_2$  mixing ratio was found to be approximately 2.5 percent. However, the uncertainty in the result is fairly large, at least 50 percent.

A second method is to derive the  $\text{N}_2$  content from the 29/28 mass peak ratio. If the nitrogen isotopic ratio is equivalent to that in Earth's atmosphere and if the 29 mass peak consists entirely of the  $^{13}\text{C}$  and  $^{15}\text{N}$  isotopic peaks (which does not appear to be true between 20 and 5 km), the  $\text{N}_2$  mixing ratio was found to be 3 percent below 5 km and approximately 4 percent above the dense cloud layer. The uncertainty is of the order of 50 percent. Because of the magnitude of the uncertainties, there is no implication in these numbers that the atmosphere is anything but well mixed. If the nitrogen isotopic ratio were increased by 20 percent, the  $\text{N}_2$  mixing ratio would increase by 1.5 percent. For a 70 percent increase in the  $^{15}\text{N}/^{14}\text{N}$  ratio, as was found on Mars (6), the 29/28 mass ratios for both C and N would become equal and it would be impossible to determine the  $\text{N}_2$  abundance by this method. However, since the 29/28 mass peak ratio is 0.103, the maximum allowed enhancement in the  $^{15}\text{N}/^{14}\text{N}$  ratio would be 35 percent. This value would require the entire 28 mass peak to be  $\text{N}_2$ , which it clearly cannot be. It therefore appears that the most probable value of the nitrogen isotopic ratio is close to that on Earth.

The third method for determining the  $\text{N}_2$  abundance is based on the peak at 14 atomic mass units (amu), which consists of a mixture of  $^{14}\text{N}$ ,  $\text{CH}_2$  from methane, and  $\text{CO}_2^{2+}$  and  $\text{N}_2^{2+}$ . If corrections are made for methane and doubly charged

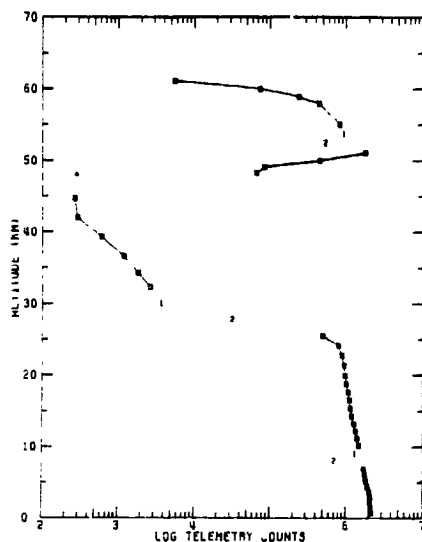

Fig. 1. The  $\text{CO}_2$  counting rate as a function of altitude: 1 and 2 indicate times when the ion source electron energy, normally 70 eV, was reduced to 30 or 22 eV, respectively.

ions, the  $\text{N}_2$  mixing ratio from the 14 mass peak is 4 percent above the clouds and 6 percent near the surface. At the low altitude the methane correction becomes very large, which increases the uncertainty in the measurement.

From all of these data, the best estimate of the  $\text{N}_2$  mixing ratio in the Venus atmosphere is  $3.5 \pm 3$  percent. This value compares favorably with the values from the gas chromatograph on the sounder probe (7) of 4.6, 3.5, and 3.4 percent at 54, 44, and 24 km, respectively, and with the value for the Venera 9 and 10 mass spectrometers was 1.8 percent (9).

extrapolated to the lower atmosphere. The value for the Venera 9 and Venera 10 mass spectrometers was 1.8 per-

One of the discoveries from the mass spectrometer data reported earlier (1) is the surprisingly large concentration on Venus of primordial  $^{36}\text{Ar}$  and  $^{38}\text{Ar}$ , in a ratio of 5 to 1, which seems to be a constant among the bodies in the inner part of the solar system. The isotopic ratio of  $^{36}\text{Ar}$  to  $^{40}\text{Ar}$  is 0.85, with an error of  $\pm 10$  percent. The mixing ratio of  $^{36}\text{Ar}$  is 40 ppm with an error of a factor of 2, mainly toward a lower value. This yields a  $^{40}\text{Ar}$  mixing ratio of approximately 50 ppm with a similar uncertainty. The error in the measurement stems from the use of a sputter-ion pump as the sink for rare gases that enter through the inlet leak. The ion pump is attached to the mass analyzer section of the instrument, separated from the ion source by the very small object slit. The ion source pump is a chemical getter which does not pump rare gases. Because the pumping speed of an ion pump for rare gases is somewhat lower than for  $\text{CO}_2$  and since such pumps tend to regurgitate rare gases

when pumping a heavy load of active gases (such as  $\text{CO}_2$ ), there is some uncertainty about the absolute concentration of rare gases in the instrument. The measured values thus tend to be upper limits. Moreover, these values increase with time throughout the descent, as seen in Fig. 2.

Therefore, we found that the best course was to determine the mixing ratio of  $^{36}\text{Ar}$  near the beginning of the descent, above 50 km, before the pump had time to accumulate much Ar. The decrease in  $^{36}\text{Ar}$  counts relative to the 44 mass peak counts as seen in the top four points (Fig. 2) is caused by a slower rise in the 44 peak amplitude than in the 36 peak, presumably due to pumping by the walls of the ion source cavity. When equilibrium was reached, the ratio measurement was obtained. Appropriate correction factors for ionization efficiency have been applied. The 40 mass peak had a preentry background amplitude which increased during entry as a result of the vibration of the pump (a well-known phenomenon); thus it was not possible to obtain an absolute determination of the  $^{40}\text{Ar}$  mixing ratio. Therefore, the isotopic ratio of Ar was determined from the portion of the flight below 25 km, after the pump had been exposed to a considerable quantity of Venus atmospheric Ar. Of course, suitable corrections were made for background peak amplitudes. The  $^{40}\text{Ar}$  mixing ratio was then determined from that for  $^{36}\text{Ar}$  and the Ar isotopic ratio. The  $^{36}\text{Ar}/^{38}\text{Ar}$  mixing ratio was the same above 50 km as below 25 km; this result demonstrates the validity of using the low-altitude portion of the descent for isotopic ratio measurements.

The gas chromatograph has measured an increasing Ar mixing ratio with altitude (from 18 to 30 ppm), but the higher value has an uncertainty that includes the lower value (7). The reverse is not true. It seems, at this time, however, that the Ar concentrations determined by the mass spectrometer are somewhat larger than the gas chromatograph values (18 ppm at 24 km), even if allowance is made for the problems caused by the ion pump. The Venera 11 and Venera 12 mass spectrometers measured a value of 150 ppm for all isotopes with the radiogenic content ( $^{40}\text{Ar}$ ) equal to the sum of the  $^{36}\text{Ar}$  and  $^{38}\text{Ar}$ , which agrees closely with the present value (10). However, the Venera 11 and Venera 12 gas chromatograph value was  $40 \pm 20$  ppm (11). Thus it appears that the mass spectrometer results from both Venera and Pioneer Venus tend to be higher than the gas chromatograph data. These results suggest that perhaps the ion pump enhance-

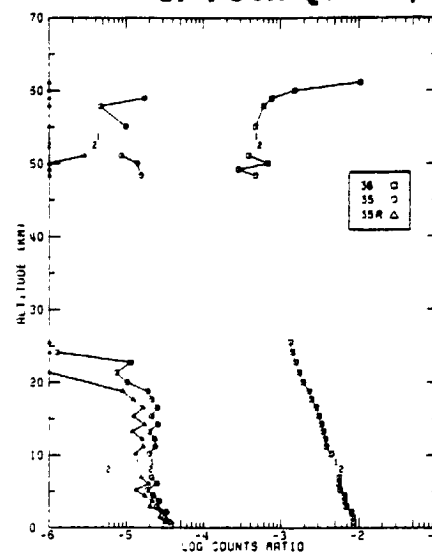

Fig. 2. Counting rate for the 36 and 35 mass peaks relative to the counting rate for the 44 mass peak as a function of altitude. The curve labeled "35R" is the 35 mass peak less a background counting rate.

ments are not properly accounted for or that there is some systematic error in the gas chromatograph data.

The question of whether the 36 mass peak might not be due to HCl instead of  $^{36}\text{Ar}$  can be answered on the basis of a consideration of the mixing ratio of the 35 mass peak (Fig. 2), which is seen to increase with decreasing altitude but less steeply than Ar. There is a background of scattered ions in the mass spectrometer on the low mass side of a very large ion peak (in this case  $\text{CO}_2^-$ ), which increases with increasing pressure in the mass spectrometer. This amounts to the order of 10 to 15 counts at the 35 mass peak position.

The cracking pattern for HCl as determined by the flight spare instrument based on the use of 70-eV electrons yields a 36/35 mass peak ratio of 7.0. Therefore, if the 35R mass peak (background subtracted) is entirely Cl from HCl, the HCl contribution to the peak at 36 amu is everywhere less than 2 percent. Even without subtracting the background and assuming that the entire 35 mass peak is due to Cl (which it most probably is not), one finds that the HCl contribution to the 36 mass peak is less than 8 percent at the beginning of the descent and drops to less than 3 percent at the end of the flight. The isotopic ratio of Cl on Earth ( $^{37}\text{Cl}/^{35}\text{Cl}$ ) is 0.326. On Venus the 37/35 mass peak ratio varies from 0.5 to 3, an indication that some substance besides Cl is a major contributor to at least the 37 mass peak. The fact that the primordial Ar isotopic ratio (found to be independent of altitude) is very close to that observed for Earth, Mars, the moon, and meteorites also argues against

any appreciable HCl contribution to the 36 and 38 mass peaks. From these arguments we conclude that the large excess of primordial Ar is a valid result and that the mixing ratio of HCl in the lower atmosphere of Venus is less than a few parts per million.

The principal Ne isotopes at 20 and 22 amu are primordial. It is unlikely that the isotope at 22 amu will yield a value of the Ne mixing ratio because of the large  $\text{CO}_2^{2+}$  peak of 20,000 to 60,000 counts. Even at an electron energy of 30 eV, the  $\text{CO}_2^{2+}$  account for the entire 22 mass peak. When 22-eV electrons are used, essentially no Ne is ionized. A value of the Ne content of the Venus atmosphere was determined from the ratio of the 20 mass peak, after correction for  $^{40}\text{Ar}^{2+}$  and the difference in ionization efficiencies of Ne and Ar, to the  $^{36}\text{Ar}$  mass peak. This ratio is  $0.5 \pm 0.3$ . This result was also taken from the lower part of the flight data because of the rare gas peak enhancement right after entry, referred to above. Here also the uncertainty is quite large because of the unknown action of the ion pump on rare gases. It is clear, however, that the  $^{20}\text{Ne}/^{36}\text{Ar}$  ratio is less than unity and is nearly the Earth value of 0.57. This result would tend to preclude a large accumulation of primordial gases from the sun since the solar wind  $^{20}\text{Ne}/^{36}\text{Ar}$  ratio is of the order of 50 (12). An additional argument against the sun as a source for the excess primordial gases on Venus is that the present-day solar wind flux fails to account for the abundance by some seven orders of magnitude. Of course, there might have been a considerably larger flux sometime in the past, but it would have had a very different Ne/Ar ratio than at present.

The  $^{20}\text{Ne}/^{36}\text{Ar}$  ratio of 0.5 compares favorably with that ratio obtained by the gas chromatograph (7), based on the assumption that  $^{36}\text{Ar}$  is approximately 45 percent of the total Ar measured by the gas chromatograph. Thus, whatever is causing the discrepancy in mixing ratio determined by each instrument appears to be affecting both Ne and Ar in a similar manner. The Venera 11 and Venera 12 mass spectrometers obtained a value for  $^{20}\text{Ne}$  of 10 ppm (10), which is at the lower end of the present range of values but within the error range.

In order to determine the Kr abundance in the Venus atmosphere, we compared the total number of counts of the 84 mass peak in the first 12 spectra (to the point of leak blockage) to the total of the 44 mass peak counts. There were only four counts at mass 84, which gives a mixing ratio of less than 1 ppm for  $^{84}\text{Kr}$ . It is not clear whether any of the 84 mass peak counts are spurious, although the

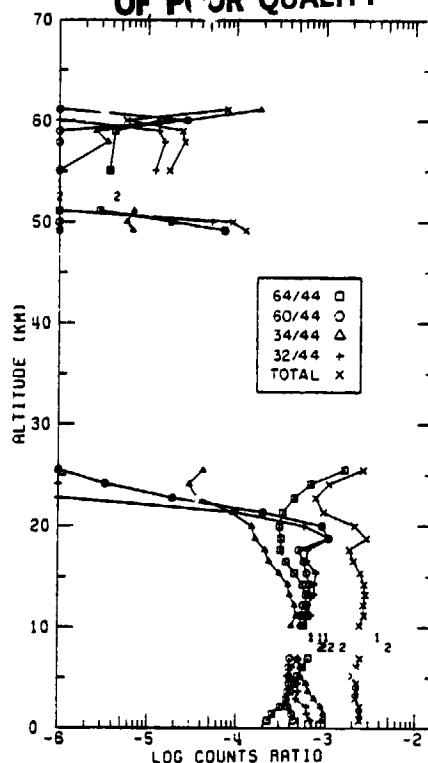

Fig. 3. Counting rates of several S compounds (identified by mass number) relative to the counting rate for the 44 mass peak as a function of altitude. The curve labeled "TOTAL" is the sum of the counting rates for the four curves shown plus the counting rates for the 48 and 96 mass peaks.

$^{84}\text{Kr}$  and  $^{82}\text{Kr}$  mass peaks have no counts in any of the first 12 spectra. Therefore, an upper limit of 1 ppm for Kr appears reasonable. The Venera 11 and Venera 12 mass spectrometers obtained a value of 0.5 ppm for the  $^{84}\text{Kr}$  mixing ratio (10). These numbers do not rule out a large excess of Kr on Venus, which would be consistent with the excess of the other primordial gases.

It was not possible to determine the He content of the Venus atmosphere because of the very high residual He peak (20,000 counts) which resulted from backfilling the sounder probe with a mixture of 1 percent He in  $\text{N}_2$  before launch. A slow leakage through glass feed-through insulators and other possible microscopic leaks ( $10^{-12}$  cm<sup>3</sup>/sec at standard temperature and pressure or less) during the 5 months the He was in the probe before encounter produced the accumulation.

There is considerable evidence for the existence of S compounds in the lower atmosphere of Venus (Fig. 3). The several curves are ratios of counting rates relative to the 44 mass peak (Fig. 1). The curve labeled "64/44" is most likely due to  $\text{SO}_2$  with possibly some addition of  $\text{S}_2$  in the lower portion. The 64/44 curve turns up above 25 km because there appears to have been a source of  $\text{SO}_2$  in the

droplet that blocked the leak. The curve labeled 60/44 has had 1 percent of the 78 mass peak (an artifact) subtracted from it. The residual (plotted) is most likely COS. The 34/44 curve has been corrected for  $^{18}\text{O}$  and  $^{34}\text{S}$  by subtraction of 0.4 percent of the  $^{16}\text{O}_2$  and 4.4 percent of the  $^{32}\text{S}$  measurements. This mass peak is at the  $\text{H}_2\text{S}$  mass defect position but is not well resolved from the  $^{34}\text{S}$  mass peak position. It is assumed, at present, that this peak is from  $\text{H}_2\text{S}$ . The 32/44 mass peak is either  $\text{O}_2$  or  $\text{S}$ ; 10 percent of the 64 mass peak and 0.01 percent of the 44 mass peak have been subtracted from it. The position of the peak in the spectrum favors the S mass defect, although the mass difference is only 1 part in 1800. The curve labeled "TOTAL" is a sum of the 64/44, 60/44, 34/44, and 32/44 curves plus the 48 and 96 mass peak counts. The 48 mass peak profile closely follows that of the 64 mass peak, and the 96 mass peak does not exceed 13 counts with an average of seven counts.

The most interesting feature of these data is the sudden appearance of the 32 and 60 mass peaks below 22 km. It appears as though there might be a substantial production of S and COS, possibly at the expense of  $\text{SO}_2$ . Moreover, there seems to be considerably more S below the main cloud layer (~50 km) than in or above it. The dip in total S centered at 22 km is not presently accounted for but could result from a mismatch in ionization efficiencies between the various S compounds or a slow pumpout of  $\text{SO}_2$  from the large excess acquired from the droplet on the leak.

Unfortunately, the gas chromatograph's lowest sample was taken at 24 km, at the point where the 60 mass peak reached its minimum value. The negative result reported from that instrument (7) is consistent with the present data.

A warning needs to be heeded at this point in the data analysis. Although the mass peaks measured in the spectrum are real, it is not clear that all of the chemical reactions (for example, COS production) are occurring in the atmosphere. Until further laboratory work has been completed, it is uncertain how the inlet system, which is at atmospheric temperature, is affecting the results.

In addition, there are significant peaks in the mass spectrum indicating the presence in the ion source of  $\text{H}_2\text{O}$  vapor (more than one would expect to be of atmospheric origin), mass 75 (an artifact peak), and methane (higher than the calibration gas amount). The effects of these substances on possible chemical reactions occurring in the ion source remain to be evaluated. In addition to these laboratory studies, we are also investigating

the mass defect information contained in the descent data in the hope that we might be able to better identify the atmospheric constituents.

J. H. HOFFMAN  
R. R. HODGES, JR.

*Center for Space Sciences,  
University of Texas at Dallas,  
Richardson 75080*

M. B. McELROY

*Center for Earth and Planetary  
Physics, Harvard University,  
Cambridge, Massachusetts 02138*

T. M. DONAHUE

*Department of Atmospheric and  
Oceanic Sciences, University  
of Michigan, Ann Arbor 48105*

M. KOLPIN

*Physics International,  
San Leandro, California 94577*

#### References and Notes

1. J. H. Hoffman, R. R. Hodges, Jr., M. B. McElroy, T. M. Donahue, M. Kolpin, *Science* **203**, 800 (1979).
2. J. H. Hoffman, *Spac. Sci. Rev.* **20**, 461 (1977).
3. ———, R. R. Hodges, K. D. Duerksen, *J. Vacuum Sci. Technol.*, in press.
4. B. Ragent and J. Blarront, *Science* **203**, 790 (1979).
5. R. G. Knollenberg and D. M. Hunten, *ibid.*, p. 792.
6. T. Owen *et al.*, *J. Geophys. Res.* **82**, 4635 (1977).
7. U. I. Oyama, G. C. Carle, F. Woeller, J. B. Pollack, *Science* **203**, 802 (1979).
8. V. von Zahn, K. H. Fricke, H. J. Hoffman, K. Pelka, *Geophys. Res. Lett.*, in press.
9. Yu. A. Surkov, N. N. Bagrov, A. P. Pulinpenko, B. I. Verkin, V. F. Ivanova, A. N. Pudov, *Geokhimiya No. 4* (1978), p. 506.
10. V. G. Istomin, K. V. Grechnev, V. A. Kochnev, V. A. Pavlenko, L. N. Ozerov, V. G. Klimovitskiy, *Astron. Zh.* **5**, 4 (1979).
11. B. G. Gel'man *et al.*, *ibid.*, p. 4.
12. A. W. G. Cameron, *Space Sci. Rev.* **15**, 121 (1973).
13. Work at the University of Texas at Dallas was supported by NASA contracts NAS2-8802 and NAS2-9485.

15 May 1979

ORIGINAL PAGE IS  
OF POOR QUALITY

# Pioneer Venus large probe neutral mass spectrometer

J. H. Hoffman, R. R. Hodges, and K. D. Duerksen

Center for Space Sciences, The University of Texas at Dallas, P. O. Box 688, Richardson, Texas 75080

(Received 29 September 1978; accepted 18 December 1978)

A neutral particle mass spectrometer has been constructed to measure the composition and abundance of the atmospheric gases of the planet Venus. This instrument is being flown on the Pioneer Venus Multiprobe and will sample the planet's atmosphere from an altitude of 67 km to its surface. The mass spectrometer is a single focusing magnetic sector field instrument capable of scanning the mass range from 1–208 amu with a sensitivity of better than 1 ppm relative to the dominant gas, CO<sub>2</sub>. It possesses a unique inlet system which is capable of sampling gases from an environment of 770 K and 100 atm. Operation of the instrument is under the control of a microprocessor. Through this powerful device, a highly efficient peak stepping and data compression program is effected permitting transmission to earth of the entire mass spectral output in only 64 seconds at a data rate of 40 bits/s resulting in an excellent altitude resolution of variations of atmospheric composition. An isotope ratio measurement cell purges an atmospheric sample of active gases yielding an enriched rare gas sample for isotopic ratio analysis. To maintain an ultraclean vacuum in the mass analyzer tube, a combination of ion pumping and chemical gettering is employed. Instrument weight is 11 kg, volume is 10650 cm<sup>3</sup>, and power is 14 W

PACS numbers: 07.5 + .h , 06.70.Td, 07.30.Cy, 07.30.Hd

## I. INTRODUCTION

The composition of the atmosphere of the planet Venus is of interest both because of the similarities between the planets Venus and Earth, but more importantly because of their marked differences.<sup>1</sup> The National Aeronautics and Space Administration has recently launched a spacecraft mission to Venus to explore the atmosphere, clouds, winds, circulation patterns, solar wind interactions solar flux input, and its resultant effect on the planet. This mission, called Pioneer Venus, consists of two spacecrafts, the Orbiter, and a Multiprobe.<sup>2</sup> The latter includes four probes and a carrier vehicle, the bus. The largest probe carries the mass spectrometer designed to measure the relative composition of the neutral atmosphere from 67-km altitude to the surface. The current knowledge of the atmosphere<sup>3</sup> dictates an instrument of considerable complexity in that the gases being measured vary in temperature from approximately 240–770 K and in pressure from 0.1–95 atm. Wide dynamic and mass ranges are required to survey the atmospheric gases and determine the cloud composition. Samples are continuously introduced into the instrument through a chemically passive inlet leak that insures no significant modification of the sample composition. A variable speed pumping system consisting of both ion pumps and chemical getters is used to maintain a nearly constant ion source pressure, thereby utilizing the instrument's full dynamic range over the entire descent time. An Isotopic Ratio Measurement Cell (IRMC) utilizes a molecular sieve and chemical getter to enrich the nonreactive gas content of a high-altitude atmospheric sample, enabling subsequent determination of the inert gas isotopic ratios. The movement of gases from one part of the system to another is determined by a series of electrically operated valves which are controlled

by a microprocessor, the "brain" of the instrument. The entire instrument, as viewed in Fig. 1, has a volume of 10650 cm<sup>3</sup> with the base being 31 × 36 cm and weighs approximately 11 kg. The instrument is packaged in two units on a single baseplate, one being the mass analyzer and the other being the electronics unit.

## II. INSTRUMENT DESCRIPTION

The large probe neutral mass spectrometer (LNMS) uses a single focussing magnetic sector field mass analyzer whose mass range extends from 1–208 amu, with resolution sufficient to separate the mercury isotopes, and a sensitivity sufficient to detect minor constituents in the 1 ppm range relative to the CO<sub>2</sub> in the Venus atmosphere. Figure 2 is a functional block diagram of the instrument showing the mass spectrometer, power supply and control circuits.

After the Large Probe encounters the top of the atmosphere its protective heat shield is ejected and a parachute deployed. Pyrotechnic devices are activated, which break a hermetic cover over the inlet leaks. The inlet leaks are passivated tantalum tubes 1/8 in. in diameter which have been forged into a flat plate configured leak with a leak rate on the order of  $1 \times 10^{-7}$  cm<sup>3</sup>/s. Ambient gases passing through these chemically passive inlet leaks enter the ion source in a partially collimated molecular beam. Ionization occurs by electron bombardment and mass analysis by a sector field magnetic analyzer. Ions following one of the two allowed trajectories through the magnet enter counting systems. The counting rate vs time, relative to a reference time (this determines mass number) is telemetered back to earth as a compressed data word at a rate of 40 bits/s. At this data rate the entire mass spectrum is scanned in only 64 s by a highly efficient peak



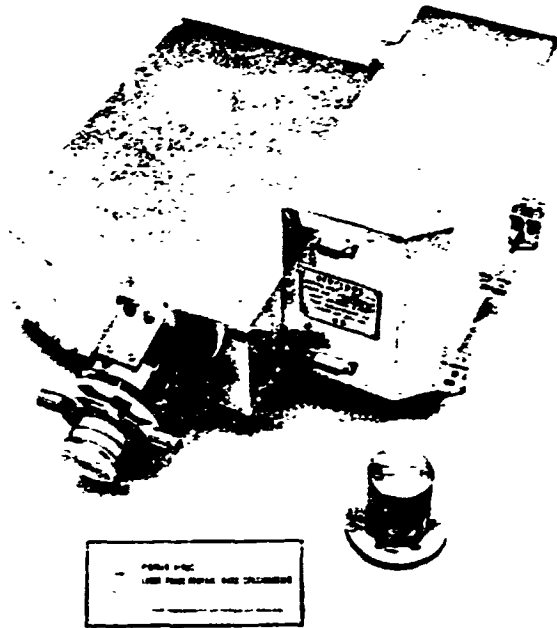

FIG. 1 UTD mass spectrometer for the Pioneer Venus Mission. The tall section on the right houses the electronics. The low section on the left houses the mass analyzer. The white object in the foreground is a hermetic cover which protrudes through the spacecraft wall. Pyrotechnic devices break this cover after the instrument enters the top of the atmosphere exposing the inlet leaks.

stepping routine controlled by a microprocessor. Ionizing electron energy is stepped through three levels to provide spectral data on the energy dependent cracking patterns of gas samples to aid in the identification of unknown substances and the separation of parent peaks and fragmentary ions. At high altitude the leaks are open, but at about 48 km the secondary leak is eliminated by closing valve 1, reducing the inflow of atmospheric gas as pressure increases.

### A. Pumping system

An extremely good vacuum is maintained in the mass spectrometer ion source and mass analyzer by a set of three chemical getters (G in Fig. 2) and two ion pumps. One getter and pump is attached to the ion source region, another pair to the mass analyzer. The third getter in the IRMC is used for removal of reactive gases for the high-altitude sample.

In order to maintain a constant pressure in the ion source cavity throughout descent, getter 1 is located behind a variable conductance valve (VCV in Fig. 2) directly in line with the inlet tube on the opposite side of the ion source cavity. The VCV, initially closed with a conductance of  $1 \text{ cm}^3/\text{s}$ , is pneumatically opened by increasing atmospheric pressure, thus increasing the conductance to the getter pump, as the atmospheric pressure increases during descent. This increased gas flow rate is balanced by the increased throughput to the pump resulting in a relatively constant ion source pressure. With the VCV fully opened the getter has a pumping speed of nearly 2 liter/s and a capacity of several times that required to maintain pressure of  $<10^{-5}$  Torr in the ion source cavity.

Should the spacecraft survive impact on the Venus surface the getter has the capacity for one-half hour additional instrument operation. In addition to the getter, a 2 l/s ion pump (ion pump 2) is attached to the ion cavity. This pump is controlled by the microprocessor, but it is also activated whenever the analyzer pump current exceeds a fixed threshold.

The ion source cavity and mass analyzer section are separated by a very narrow ion focussing aperture. A pressure differential ratio of up to 700 can be maintained across the aperture by ion pump 2 (2 l/s) and getter 2. The small size and weight constraints of spacecraft operations required that special ion pumps be developed at UTD for the mass spectrometer.

Initial evacuation of the mass spectrometer vacuum envelope and associated pumps was done by attaching the instrument to a set of three vacuum manifolds, each connected to an ion pump having an 8- or 60-l/s pumping rate. The instrument was attached to the manifold system through a set of five manual valves. An automatically temperature controlled oven was placed over the instrument and manifolds for bakeout. Chemical getters and the molecular sieve were activated by heating them to a temperature of  $250^\circ\text{C}$  for several hours.

### B. IRMC system

The Isotope Ratio Measurement Cell (IRMC) is a device for collecting a sample of the atmosphere at high altitude in order to concentrate its rare gas content for the purpose of determining the isotopic ratios of the rare gases. A combina-

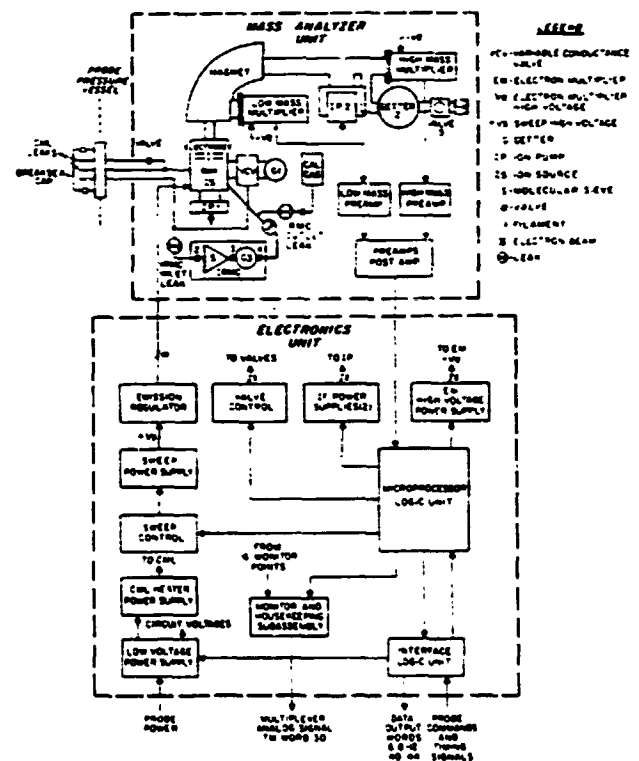

FIG. 2 Block diagram of the UTD mass spectrometer showing mass analyzer, ion pumps, getters, valves, and electronics. G1 is a zirconium-aluminum alloy getter. G2 and G3 are zirconium-graphite getters. Ion pumps are UTD design. The VCV is pneumatically operated by the atmospheric gases which enter through the lower tube in the breakseal cap.

tion of molecular sieve (S—Fig. 2) and getter (getter 3, Fig. 2) removes a very high percentage of the active gases leaving essentially the pure rare gas content along with some nitrogen. Leak 1 with a conductance of approximately  $0.5 \text{ cm}^3/\text{s}$  allows gas to flow into S which has a volume of  $30 \text{ cm}^3$  and is filled with 20 g of molecular sieve material Linde 5A. At the initiation of the mission, gas flows through the IRMC Inlet Leak into S.

After 80 s valve 2 is closed by a pyrotechnic device, when about 2000 Torr  $\text{cm}^3$  of gas has passed through the leak. Valve 3 is opened for the last 10 s before valve 2 is closed transferring the partially purified gas into the getter (volume  $\sim 30 \text{ cm}^3$ ) where final purging occurs. Assuming the mixing ratios of rare gases to be a few hundred ppm, 2 Torr  $\text{cm}^3$  of rare gases with about half as much nitrogen will be in the getter volume at a pressure of approximately 0.08 Torr. At about 4 min before parachute jettison, (48 km) valve 1 is closed decreasing the atmosphere inflow rate, the ion source cavity pump is turned on to evacuate the ion source of atmospheric gases for 64 s. Then valve 4 is opened and the rare gases are leaked into the ion source cavity. The conductance of this leak is  $0.025 \text{ cm}^3/\text{s}$ , maintaining a nearly constant rare gas pressure in the ion source throughout the rare gas measurement period of 96 s. Subsequent to the measurement period, valve 4 is closed while pump 1 purges the source cavity of rare gases for 32 s. Then operation reverts to the measurement of atmospheric samples.

### C. Calibration system

Calibration of the mass spectrometer is performed by using a Venus Atmosphere Simulator (VAS). This consists of the vacuum manifold, pumps, and oven described above and a high-pressure high-temperature chamber capable of simulating the entire descent including Venus surface atmospheric conditions (770 K and 100 atm). A  $100\text{-l/s}$  ion pump is attached to the VAS chamber along with an appropriate gas filling manifold and pressure and temperature gages. The mass analyzer inlet leaks protrude into the VAS chamber as though they were sampling the Venus atmosphere.

The VAS is operated as follows. Carbon dioxide is admitted to the VAS chamber following a pressure-temperature-time profile which simulates the descent of the Pioneer Venus large probe into the Venus atmosphere while the mass spectrometer monitors the  $\text{CO}_2$  spectrum. Figure 3 is a typical plot of the  $\text{CO}_2$  peaks versus VAS chamber pressure and temperature. Mixtures of  $\text{CO}_2$  with other gases expected to exist in the Venus atmosphere have also been run on the VAS.

### IV. SUMMARY

The hostile environment of the planet Venus coupled with the weight, power, and size constraints of space flight have

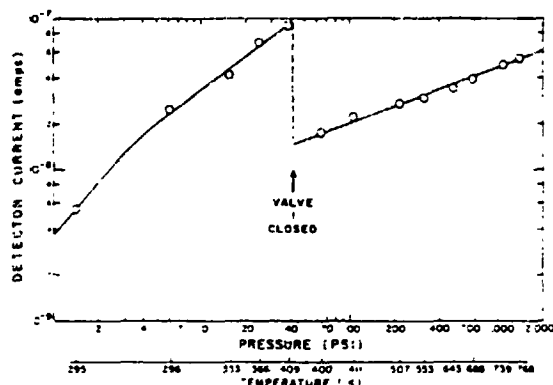

FIG. 3 Detector current for mass 44( $\text{CO}_2$ ) vs VAS chamber pressure and temperature. The dashed line indicates the valving off of the second inlet leak. The detector current pulses are converted to digital counts by the multiplier preamps and postamps. Small (1 order of magnitude) change in  $\text{CO}_2$  peak amplitude (proportional to ion source pressure) for greater than three orders of magnitude change in VAS chamber pressure results from pneumatic operation of VCV. This preserves the ability of the instrument to measure trace constituents from entry into the atmosphere down to the surface of Venus.

required the design and construction of a new and different mass spectrometer. A combination of ion and chemical pumping is used to maintain a vacuum in the mass analyzer and remove the atmosphere gases which enter the ion source chamber through a small leak. The near constant  $\text{CO}_2$  pressure maintained in the analyzer by the VCV permits a sensitivity sufficient to detect minor constituents in the 1-ppm range on Venus over a mass range from 1–208 amu over most of the descent. The microprocessor which controls the operation of the instrument through a highly efficient peak stepping and data compression program, permits acquisition of a complete mass spectrum roughly once each minute, resulting in excellent height resolution of variations of atmosphere composition caused by winds, waves, and the physical and chemical processes active in the production of the acids which form the clouds of Venus.

### ACKNOWLEDGMENT

It is a pleasure to acknowledge the support of this work by the NASA/Ames Research Center Pioneer Project Office, Contract NAS2-8802.

<sup>1</sup>T. M. Donahue, *Space Sci. Rev.* 20(3), 259 (1977).

<sup>2</sup>L. Colin, *Space Sci. Rev.* 20(3), 249 (1977).

<sup>3</sup>D. M. Hunten, G. E. McGill, and A. F. Nagy, *Space Sci. Rev.* 20(3), 265 (1977).

<sup>4</sup>L. E. Bergquist, NASA CR-114594 (1973).

ORIGINAL PAGE IS  
OF POOR QUALITY

# Pioneer Venus Sounder Probe Neutral Gas Mass Spectrometer

J. H. HOFFMAN, R. R. HODGES, JR., W. W. WRIGHT, V. A. BLEVINS, K. D. DUEKSEN, AND L. D. BROOKS

**Abstract**—A neutral gas mass spectrometer was flown to Venus as part of the Pioneer Venus Multiprobe to measure the composition of its lower atmosphere. Encounter occurred on December 9, 1978. The instrument, mounted in the Sounder Probe, was activated after the probe entered the top of the atmosphere, and it obtained data during the descent from 62 km to the surface. Atmospheric gases were sampled through a pair of microleaks, the effluent from which was pumped by a combination of ion and getter pumping. A pneumatically operated valve, controlled by the ambient atmospheric pressure, maintained the ion source pressure at a nearly constant value during descent while the atmospheric pressure varied by 3 orders of magnitude. This action preserved the more than 6-decade dynamic range of the instrument throughout the descent. A single focusing magnetic sector field mass spectrometer with mass resolution sufficient to reasonably separate argon from  $C_3H_4$  at 40 amu provided the mass analysis and relative abundance measurements. A microprocessor controlled the operation of the mass spectrometer through a highly efficient peak-top stepping routine and data compression algorithm that effected a scan of the mass spectrum from 1 to 208 amu in 64 s while requiring an information rate of only 40 b/s to return the data to earth. A subscale height altitude resolution was thus obtained. Weight, size, and power requirements were minimized to be consistent with interplanetary flight constraints.

Manuscript received September 1, 1979. This work was supported by NASA under Contracts NAS2-8802 and NAS2-9485.

The authors are with the University of Texas at Dallas, P.O. Box 688, Richardson, TX 75080.

## INTRODUCTION

THE PIONEER VENUS Sounder Probe [1] carried to Venus, among other experiments, a neutral gas mass spectrometer experiment, the purpose of which was to study the composition of the lower atmosphere of the planet. On December 9, 1979, the probe entered the Venus atmosphere and descended slowly to its surface (part way on a parachute) producing data for nearly one hour below an altitude of 62 km. The instrument measured the composition of the gases relative to  $CO_2$ , the dominant gas, that it sampled from the atmosphere through a special leak. Mass range extended from 1 to 208 amu with a sensitivity of the order of 1 ppm relative to  $CO_2$ . The interest in studying the atmospheric composition of Venus stems largely from the fact that there are marked differences in pressure, temperature and composition between the atmospheres of Venus and earth, yet these two planets are so similar in size, mass, and distance from the sun. The Venus surface pressure and temperature are 90 bars and 730 K, respectively, [2] compared to 1 bar and 285 K (average) on earth. It has been known for some time that  $CO_2$  is the dominant atmospheric constituent and that nitrogen is present to a relatively small percentage (<10 percent) [3]. It was also thought that sulfuric acid is a major contributor to

the composition of the clouds [4] but was unclear just how the sulfur cycle, the transport of sulfur between the lower atmosphere and the cloud levels, operated. The contents of the noble gases had been estimated to be similar to that on earth [5].

A preliminary analysis of the flight data has shown that the abundance of nitrogen in the lower atmosphere is approximately 3.5 percent,  $^{40}\text{Ar}$  may be as much as a factor of 10 to 15 less abundant than on earth, and the isotopic ratio of argon is significantly altered. On earth primordial argon ( $^{36}\text{Ar}$ ) is only 0.34 percent (1 part in 300) of  $^{40}\text{Ar}$ , the radiogenic component, whereas on Venus it is 85 percent of the  $^{40}\text{Ar}$ . Even though the  $^{40}\text{Ar}$  is less abundant on Venus, the  $^{36}\text{Ar}$  is more than 15 times as large as on earth. This was quite an unexpected result. The ratio of the primordial argon isotopes,  $^{36}\text{Ar}/^{38}\text{Ar}$ , is about the same as on earth. Isotopic composition of carbon, nitrogen, and oxygen are, within the limit of errors, also the same as on earth.

It appears that sulfur does not exist in the cloud regions in the form COS, as was thought pre-Pioneer Venus [6], but most likely is found in the oxidized state,  $\text{SO}_2$ . There exists a change in the sulfur form below 24 km where COS does appear. Further details on scientific results from the mass spectrometer experiment can be found in [7] and [8].

The purpose of this paper is to describe some of the unique features of the mass spectrometer instrumentation that was used for the Pioneer Venus mission. After a general discussion of the instrument, packaging and mounting in the probe, the atmosphere sampling system and pumping system will be described, followed by the mass analyzer and its operating characteristics and finally the microprocessor that controls the operation of the entire instrument, and is thought to be the first such item to have been flown on a deep space probe.

#### GENERAL INSTRUMENT DESCRIPTION

The large probe neutral mass spectrometer (LNMS) consisted of a miniature magnetic sector-field mass analyzer, a gas inlet and pumping system, and an electronics package, all mounted on a common baseplate, 31 X 36 cm. Fig. 1 is a picture of the instrument. The taller section houses the electronics while the lower section contains the mass spectrometer and pumping system. Volume of the package is 10.6 l and weight is 11 kg. The mechanism in the foreground is the breakseal device, a hermetic cap, which covers the inlet leaks. The package was mounted so that the inlet and breakseal protruded through the wall of the spherical probe just below its equator. The gas leaks, which were thin metal tubes, 6 cm long, protruded from the flange past the aeroshell beyond the probe's boundary layer into the free-streaming atmospheric gases. In this way sampling of the atmosphere should be free from contamination by vapors emitted from the probe's surface.

Shortly after the Sounder Probe encountered the top of the Venus atmosphere and its heat shield ejected by deployment of the parachute, the breakseal cap was activated by a pair of pyrotechnic devices exposing the inlet leaks to the atmosphere. Data were gathered from this point, at an altitude of

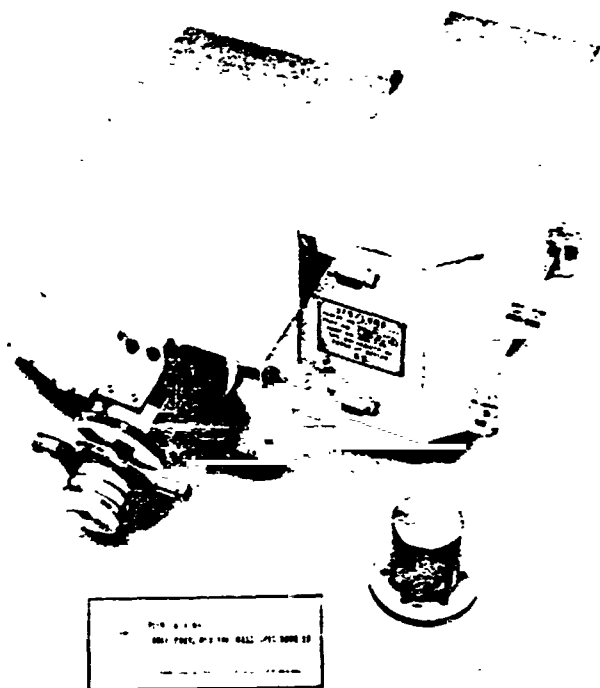
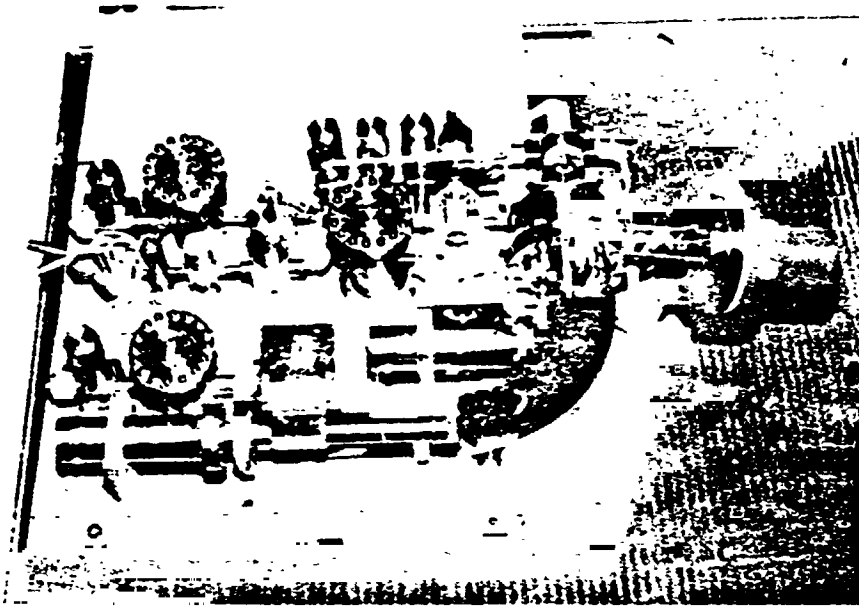

Fig. 1. Mass spectrometer instrument package. Low section to left houses mass analyzer and pumps. High section on right contains electronics. White cylinder in foreground of analyzer section is the breakseal which protrudes through probe wall and contains atmospheric sampling leaks. Pyrotechnic devices (small cylinders on each side of cap) break open cap after probe enters atmosphere.

62 km, to loss of signal at the surface. For the first 17 min the probe floated down on a parachute. After parachute jettison an additional 37 min elapsed before the probe reached the surface. Each scan of the mass spectrum (described below) required 64 s giving a total of 51 spectra from the flight. The average altitude decrement per spectral scan was 1.2 km, somewhat less than the  $\text{CO}_2$  scale height.

#### ATMOSPHERE SAMPLING AND PUMPING SYSTEM

Atmospheric gases were sampled through a pair of micro-leaks [9], each consisting of a  $\frac{1}{8}$ -in diameter passivated tantalum tube whose outer end was forged to a flat plate configuration having a conductance of the order of  $10^{-7}$   $\text{cm}^3/\text{s}$  for the primary leak and  $10^{-6}$   $\text{cm}^3/\text{s}$  for the secondary leak. The secondary leak was operative from breakseal activation to shortly before parachute jettison at 46 km, a period of over 12 min, during which time the atmospheric pressure was relatively low. Gases entering the leaks were passed into the instrument ion source for analysis and on to a chemical getter (a zirconium-aluminum alloy). The gas pumping system has been described in [9]. In order to maintain a relatively constant ion source pressure during descent, a variable conductance gate valve, between the ion source and the getter, was opened gradually by the increasing atmospheric pressure. As the leak's throughput increased, so too did the throughput to the getter. The purpose of maintaining a constant ion source pressure was to preserve the dynamic range (>6 decades) of



ORIGINAL PAGE IS  
OF POOR QUALITY

Fig. 2. Mass analyzer and pumps. Magnet is in lower right foreground. Inlet leaks attach to flange at far right. Three cylindrical cans contain the getters. Analyzer ion pump is the rectangle in center foreground.

the instrument while the atmosphere pressure changed by 3 orders of magnitude.

The mass analyzer was pumped by an ion getter pump and another chemical getter. The conductance to this pumping system from the ion source region was limited by the mass spectrometer object slit to about  $5 \text{ cm}^3/\text{s}$ . This ion pump was the only sink for noble gases; its speed was conductance limited and hence constant through most of the descent to the Venus surface. Since the throughput of the leaks increased with increasing atmospheric pressure and the variable conductance valve throughput also increased, the ratio of noble gases to  $\text{CO}_2$  would be expected to increase as the probe descended, which indeed it did. The effect of the different gas flow paths and pumping speeds for the noble gases versus  $\text{CO}_2$  was then to artificially enhance the signal amplitudes of the noble gas peaks in the mass spectra. Through calibration of the gas flow rates the mixing ratios of the noble gases were determined.

From approximately 50 to 28 km the leaks were blocked [8] by an overcoating of cloud particle materials, presumably by droplets of sulfuric acid. During this time the in-flow of atmospheric gases was stopped and mainly background or residual gases in the mass spectrometer were seen, except for  $\text{SO}_2$  and  $\text{H}_2\text{O}$  which appeared to originate from the blocking material. Below 30 km the primary leak reopened (the secondary leak had been valved off by this time), and the atmospheric gas flow returned to normal.

#### MASS SPECTROMETER

For analysis of the gases sampled from the Venusian atmosphere, a single focusing magnetic sector-field mass spectrometer was chosen. This instrument consisted of an electron bombardment ion source, a magnetic momentum analyzer and a detector system. Fig. 2 is a picture of the mass spectrometer and pumping systems. Normally, the ionization source was an electron beam having an impact energy of 70 eV. However, three times during descent the electron energy

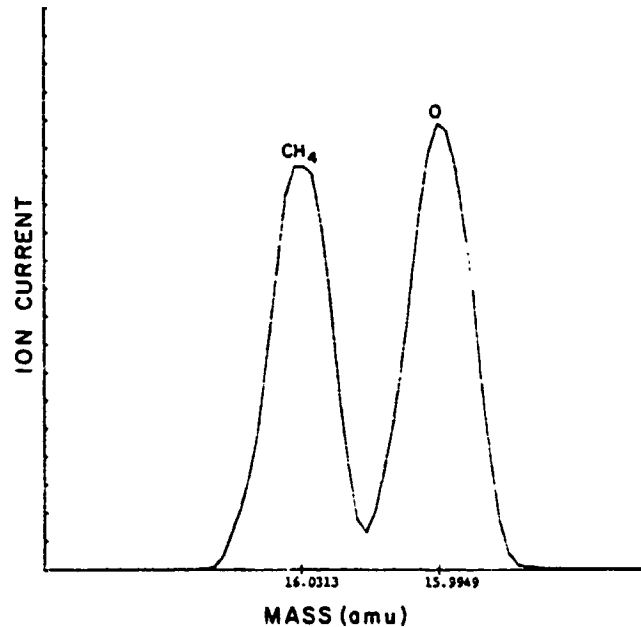

Fig. 3. Mass doublet at 16 amu. Peak right due to oxygen ions at 15.9949 amu; peak at left is from  $\text{CH}_4$  ions at 16.0313 amu. Mass difference is 1 part in 440. Valley between peaks is 9 percent of 0 peak.

was reduced to 30 and 22 eV for successive mass spectrum scans. Owing to the modification of cracking patterns produced by electrons of reduced energy, additional information on the identification of parent molecules and the separation of doubly charged species was provided by these low energy spectra. Dual tungsten filaments were provided as a redundant ionization source.

The ion beam emitted from the ion source was mass analyzed by the magnetic momentum analyzer and detected by a pair of electron multiplier-counter channels which had band passes of 40 MHz. The two detector channels simultaneously accepted ions in the mass ranges 1-16 amu (low mass range)

TABLE I  
PORTION OF A FLIGHT DATA RECORD SHOWING MASS NUMBER TABLE  
STORED IN MICROPROCESSOR AND INSTRUMENT OUTPUT (RELATED  
TO COUNTING RATE) CALLED "DATA"

amu	data	amu	data	amu	data	amu	data
15.013	7680	39.972	1696	109.886	0	152.576	0
15.018	16896	40.029	80	111.873	1	152.890	0
15.023	22528	43.991	1769472	112.933	0	153.894	0
15.028	22016	44.991	21504	113.934	1	154.911	1
15.033	12800	45.102	108	114.904	1	155.887	0
15.995	335872	45.995	7936	115.921	1	157.876	0
16.018	40960	47.000	94	116.436	0	158.890	0
16.031	39936	47.966	10	116.925	0	159.859	0
1.008	3520	2.950	23	117.449	1	160.899	0
17.002	296	3.000	26	117.978	0	3.050	70
17.026	244	3.050	29	118.449	0	10.000	66
17.985	336	48.974	2	118.892	0	10.050	70
18.010	1088	49.968	3	119.466	0	161.893	0
18.034	66	50.969	2	119.981	0	162.424	0
18.987	34	51.980	0	120.925	0	162.959	0
18.998	18	54.004	0	121.985	0	163.438	1
19.007	5	59.966	1	122.894	0	163.939	0
19.981	480	60.988	0	123.920	1	164.342	0
19.992	184	61.977	0	124.893	0	164.464	0
20.006	112	62.994	1	126.922	2	165.441	0
20.015	30	63.962	5	127.906	0	165.524	0
20.993	10	3.800	12	128.905	29	166.430	0
21.991	45056	1.950	13312	129.921	5	166.929	0
21.995	47104	4.000	34816	130.914	23	167.180	0
22.496	560	4.050	12256	131.922	48	167.432	0
26.002	112	64.960	3	133.905	440	167.937	0
26.014	122	55.961	23	134.471	14	168.892	0
27.010	102	66.963	280	134.960	26	170.901	0
27.023	124	67.964	6272	135.453	102	171.934	0
27.997	507904	69.971	1	135.742	3456	20.950	76
27.995	606208	71.973	1	135.824	7808	11.000	96
28.000	655360	74.927	0	135.907	9728	11.050	78
28.005	671744	77.040	2	135.990	8192	178.934	1
28.012	499712	77.916	1	136.073	5248	179.367	0
28.032	122880	78.053	16	136.448	140	179.874	0
28.997	6656	78.924	1	136.952	17	180.384	0
29.003	7040	79.915	1	137.970	5	180.823	0
29.039	992	79.958	0	138.442	2	181.311	0
29.997	1024	80.947	1	138.960	0	182.903	0
30.046	208	81.914	1	139.395	1	183.430	0
30.973	11	81.975	0	139.921	1	183.884	0
31.006	26	82.936	0	140.406	2	187.366	0
31.972	128	83.937	0	140.939	0	188.396	0
31.990	120	85.911	29	141.432	3	190.817	0
2.016	22016	90.910	1	141.882	2	192.883	0
32.985	18	93.920	0	142.381	0	194.824	0
33.966	15	95.943	0	142.929	1	197.941	0
33.992	19	96.967	0	143.436	0	199.003	0
34.005	21	97.948	0	143.946	0	199.596	0
34.972	15	98.971	0	144.459	0	200.378	0
35.005	12	99.479	0	144.882	2	201.889	0
35.966	656	99.970	0	146.841	0	203.923	0
36.981	704	100.489	0	148.853	0	205.998	0
36.966	9	100.990	0	150.615	0	206.955	0
37.948	152	101.985	0	150.921	0	208.019	0
39.950	1376	102.975	0	151.280	0	15.000	20992
39.958	1504	103.478	0	151.589	0	14.000	19456
39.965	1664	103.985	0	151.951	1	12.000	344064

and 15-203 amu (high mass range). Mass resolution in the high mass channel was  $M/\Delta M \geq 440$  (10 percent valley) as evidenced by the doublet at mass 16 shown in Fig. 3. The peaks shown are from  $^{16}\text{O}$  and  $\text{CH}_4$ , which have a mass difference of 1 part in 440. Resolution of the low mass channel is adequate to produce a valley of less than 1 percent between peaks at 15 and 16 amu.

The high bandwidth of the counter system, utilizing Be-Cu 16 stage discrete dynode electron multipliers, produced a dynamic range of over 6 decades. The  $\text{CO}_2$  peak reached a counting rate of 9 MHz in flight. The background count accumulation was typically zero per integration period of 235 ms.

Scanning of the mass spectrum occurred by stepping the ion acceleration high voltage to successive peak tops under the control of a microprocessor. The complete spectrum, consisting of 236 mass peak positions, was scanned at the rate of 4 samples per second in 59 s. Five seconds were then required for background samples and for returning the peak stepping program. The latter was accomplished by the introduction of two calibration gases, methane and  $^{136}\text{Xe}$ , into the mass spectrometer just prior to the measurement sequence. Mass peaks produced by the calibration gases at 15 ( $\text{CH}_3^+$ ), 68 ( $^{136}\text{Xe}^+$ ), and 136 ( $^{136}\text{Xe}^+$ ) amu provided reference points that the

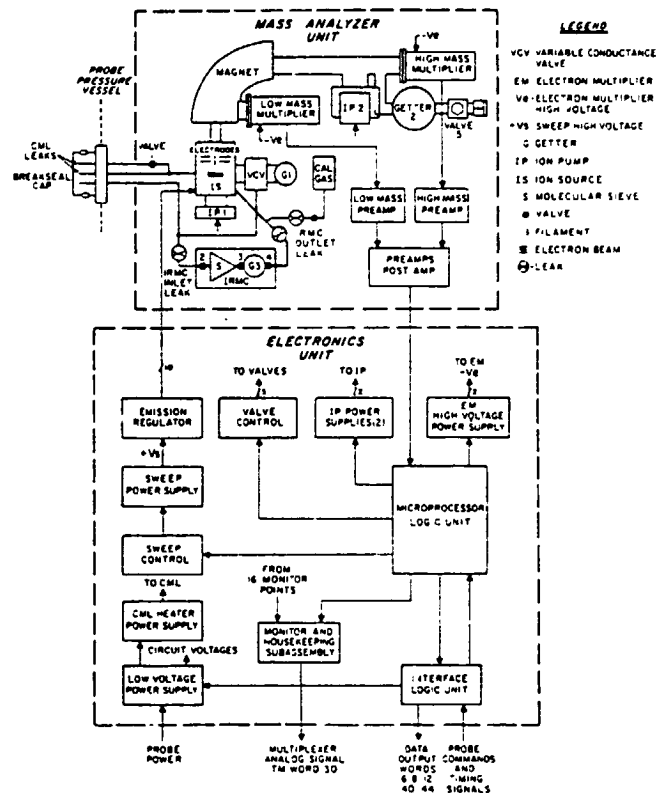

Fig. 4. Block diagram showing mass analyzer, ion pumps, getter, valves and electronics units. G1 is a zirconium-aluminum getter. G2 and G3 are zirconium-graphite getters. Ion pumps are UTD design. VCV is operated by ambient atmospheric pressure.

microprocessor could utilize to control the ion acceleration voltage. A lookup table of nouns stored in the microprocessor defined positions in the mass spectrum of a preselected set of mass peaks, which included several sequential positions around key mass numbers, such as 15, 28, 40, and 136 amu and mass defect positions for all known gas species to be measured. At several mass numbers two or more peak positions were set, e.g., at 16 ( $\text{O}$  and  $\text{CH}_4$ ), 32 ( $\text{O}_2$  and  $\text{S}$ ) and 34 ( $^{34}\text{S}$  and  $\text{H}_2\text{S}$ ).

The microprocessor scanning this table directed the instrument to measure the amplitudes only of the preselected mass peaks. Table I is a sample of the noun table and corresponding count record from the flight data just prior to the leak blockage. This procedure served to eliminate the time associated with the normal method of analog scan, sweeping from one mass number to the next. At an accumulation rate of 4 samples per second, the entire spectrum from 1 to 208 amu was stepped through in 59 s which required a data transmission bit-rate of only 40 b/s plus housekeeping and a status word. Ten bit words in the base 2 floating point format were used. This method gave 2-percent accuracy over the entire dynamic range of the counting system.

Control of the instrument during checkout and cruise phases of the mission was through a 16-bit quantitative command, which controlled primarily the sweep mode, electron energy, electron multiplier gain and selected the prime filament. However, during descent, major events concerning the instrument, such as breakseal cap eject and Isotope Ratio Measurement Cell (IRMC) sequence (see below) were commanded by the probe event sequencer, while the operation of the instrument

itself was controlled entirely by the microprocessor. Had the prime filament failed during flight, the redundant filament would have automatically been activated.

Fig. 4 is a block diagram of the electronics and mass analyzer showing the major components of each subsection. The pre-amplifiers and first 4 stages of the pulse counter are packaged adjacent to the electron multipliers to minimize cable lengths and capacitance.

#### IRMC SEQUENCE

A noble gas enrichment cell, the IRMC, was included in the instrument package to collect an atmospheric sample just after initiation of the instrument operation, purge the sample of CO<sub>2</sub> and later (just before parachute jettison) introduce the sample into the mass spectrometer for measurement of the isotopic ratios of the enriched inert gases remaining in the cell.

#### CALIBRATION

Calibration of the flight instrument was performed using a high pressure, high temperature chamber, called the Venus Atmosphere Simulator (VAS) capable of reproducing the Venus descent profile of temperature and pressure down to the surface conditions (730 K and 90 Atm). The VAS chamber is attached to a 100 l/s ion pump and an appropriate gas filling manifold with pressure and temperature gauges. The instrument inlet leaks protrude into the VAS chamber to sample its gases, simulating the sampling of the Venus atmosphere.

Operation of the VAS involves admitting mixtures of gases, usually in CO<sub>2</sub>, into the high pressure chamber in a stepwise manner following a model atmosphere profile while recording the mass spectrometer output signals as a function of input conditions. A minicomputer reads the output signals through the ground support equipment which simulates the Probe systems, expands the compressed data words and displays the results either as a line printer output, or graphically.

A typical CO<sub>2</sub> response curve can be found in [9] where the CO<sub>2</sub> signal strength is plotted as a function of VAS chamber pressure and temperature. The descent CO<sub>2</sub> profile from Venus rather closely (within a factor of 2) follows this profile, except of course where the leak blockage occurred.

#### CONCLUSION

Studies of the atmosphere of Venus with its rather hostile environmental conditions of very high pressure and temperature and clouds comprised of acids and perhaps free sulfur particles coupled with the weight, power, size, and data transmission constraints of interplanetary flight have required the design and development of a unique mass spectrometer experiment.

Sampling of the atmosphere occurred through a pair of micro-leaks; pumping of the effluent gases was accomplished by a combination of ion and chemical pumps and a special pneumatically operated valve which maintained a nearly constant ion source pressure during descent. The mass spectrometer operation was controlled by a microprocessor which scanned the mass spectrum from 1 to 208 amu in approximately 1 min by a highly efficient peak-top stepping routine resulting in subscale height resolution of the variations in atmospheric composition. The instrument operated from 62 km to impact on the surface of Venus producing 51 mass spectra of the Venus atmosphere from which information on the abundance of noble gases, sulfur compounds, and isotopic ratios of several gases are being obtained. Scientific results may be found in the referenced papers [1]-[9].

#### ACKNOWLEDGMENT

We are indebted to R. Bass, R. Bickel, J. Blair, M. Brumit, P. Francis, H. Hammack, F. Harris, C. Hearn, J. Jackson, W. Lane, W. Lord, C. Portis, J. Rhodes, R. Ricamore, J. Saxton, C. Shippy, T. Stepoway and D. Tipton of The University of Texas at Dallas for their roles in the development and testing of the instrument, and to C. Hall and L. Polaski of NASA Ames Research Center for their support of the program.

#### REFERENCES

- [1] L. Colin, "Encounter with Venus," *Science*, vol. 203, pp. 743-744, 1979.
- [2] A. Seiff, D. Kirk, S. Sommer, R. Young, R. Blanchard, D. Juergens, J. Lepetich, P. Intriari, J. Findlay, and J. Derr, "Structure of the atmosphere of Venus up to 110 kilometers: Preliminary results from the four Pioneer Venus entry Probes," *Science*, vol. 203, pp. 787-790, 1979.
- [3] A. P. Vinogradov, Yu. A. Surkov, B. M. Andreichikov, O. M. Kalinkina, and I. M. Grechischeva, in C. Sagan, T. C. Owen, and H. J. Smith, Eds., *Planetary Atmospheres*. Dordrecht, The Netherlands: Reidel, 1971, p. 3.
- [4] A. T. Young, "The clouds of Venus," *J. Atmos. Sci.*, vol. 32, pp. 1125-1132, 1975.
- [5] W. C. Knudsen and A. D. Anderson, "Estimate of the radiogenic <sup>4</sup>He and <sup>40</sup>Ar concentration in the Cytherian atmosphere," *J. Atmos. Sci.*, vol. 74, pp. 5629-5632, 1969.
- [6] R. G. Prinn, "Venus: Chemical and dynamical processes in the stratosphere and mesosphere," *J. Atmos. Sci.*, vol. 32, pp. 1237-1247, 1975.
- [7] J. H. Hoffman, R. R. Hodges, Jr., M. B. McElroy, T. M. Donahue, and M. Kolpin, "Venus lower atmospheric composition: Preliminary results from Pioneer Venus," *Science*, vol. 203, pp. 800-802, 1979.
- [8] —, "The composition and structure of the Venus atmosphere: Results from Pioneer Venus," *Science*, vol. 205, pp. 49-52, 1979.
- [9] J. H. Hoffman, R. R. Hodges, and K. D. Duerksen, "Pioneer Venus Large Probe neutral mass spectrometer," *J. Vac. Soc. Technol.*, vol. 16, pp. 692-694, 1979.

ORIGINAL PAGE IS  
OF POOR QUALITY

## Measurements of the Venus Lower Atmosphere Composition: A Comparison of Results

J. H. HOFFMAN

*Physics Department, University of Texas at Dallas, Richardson, Texas 75080*

V. I. OYAMA

*NASA Ames Research Center, Moffett Field, California 94035*

U. VON ZAHN

*Physikalisches Institut, Universität Bonn, Bonn, West Germany*

ORIGINAL PAGE IS  
OF POOR QUALITY

From the Pioneer Venus, as well as the Venera 11 and 12 spacecrafts, data on the chemical composition of the Venus atmosphere from about 700 km to the surface were obtained. In general, reasonable consistency can be found among the results from the seven gas analyzers that encountered Venus in December 1978. One of the more significant findings is the large excess abundance of primordial gases on Venus. The O<sub>2</sub> abundances below 30 km must be very small, since none of the instruments detected O<sub>2</sub> there. In and near the clouds the O<sub>2</sub> mixing ratio may be as much as a few tens of parts per million. The CO mixing ratio is 20-30 ppm. The existence of COS, originally reported to be a major sulfur compound in the lowest part of the atmosphere, is doubtful there, and its mixing ratio at higher altitudes does not exceed a few parts per million. On the other hand, SO<sub>2</sub> may exist below the clouds at a mixing ratio of the order of 100 ppm. In the clouds it is less than 10 ppm. A serious discrepancy in the data still exists for the case of the water vapor abundance. As a result of the cross-checks provided by the number and types of instruments flown to Venus, confidence in the validity of these results on its atmospheric composition has progressed to a reasonable degree of certitude.

### INTRODUCTION

In December 1978 no less than seven gas analyzers made in situ measurements of the Venus atmospheric chemical composition. Three mass spectrometers and two gas chromatographs sampled the lower atmosphere (here defined as the altitude range from 0- to 65-km altitude), and two mass spectrometers sampled the upper atmosphere above 130 km. Table 1 lists the experiments and their associated missions and gives a major reference for each.

As described in much more detail in the referenced publications of Table 1, this unique complement of highly sophisticated instrumentation has provided us with a great wealth of information concerning the composition of the atmosphere of Venus. In this paper we present a critical assessment of the general constraints for measurements of the Venus atmospheric composition imposed by the atmosphere itself and by the Pioneer Venus mission, the approaches taken to improve the confidence in the data obtained, a critical examination of the current results, and finally some recommendations for future planetary atmosphere or cometary missions.

### GENERAL CONSTRAINTS ON MEASUREMENTS OF THE VENUS ATMOSPHERE

The study of the composition of a planetary atmosphere a quarter of an astronomical unit away from earth necessarily imposes constraints on the system employed for the measurements, and when the atmosphere itself is as hostile as that of Venus, the task becomes a double challenge. The constraints imposed upon this mission may be considered to be of two

general types: those associated with the severe environment of the Venus atmosphere and those imposed by the practicality of sending a mission to another planet in the solar system to obtain measurements of its atmospheric composition.

The Venus experiments succeeded in producing data on the composition of the atmosphere from the order of 700 km above its surface down to the surface itself. Over this altitude range a pressure increase of over 17 decades was encountered. The bus and the orbiter mass spectrometers (BNMS and ONMS) covered the upper range down to approximately 130 km. The sounder probe mass spectrometer (LNMS) and gas chromatograph (LGC) and the Venera instruments (VNMS and VGC) covered the range from 65 km to the surface. The intermediate range from 130 to 65 km has not been measured to date.

In the lower atmosphere the pressure range which the instruments sampled varied from 0.1 bar to nearly 100 bars, while in the upper atmosphere the pressure range encountered was some 10 decades. Sampling of the upper atmosphere was direct in that the atmospheric gases were allowed direct entry into the mass spectrometer ion source, whereas for the mass spectrometers in the lower atmosphere a pressure-reducing device (a leak) had to be employed to lower the atmospheric pressure some 8-10 orders of magnitude to the range of pressures at which mass spectrometers operate ( $10^{-5}$ - $10^{-6}$  mbar). At the same time, alteration of the chemical composition of the sampled gas stream as it passed through the leak had to be kept to an absolute minimum. The gas chromatographs, however, were able to sample the atmosphere directly. In the case of the LGC the atmospheric gases continuously flowed through a sample loop assembly except during the time (10 s) when the atmosphere was sampled by diverting the flow of the



TABLE 1. Pioneer Venus and Venera 11 and 12 Gas Analyzers

	LNMS	LGC	VNMS	VGC	BNMS	ONMS
Instrument type	mass spectrometer	gas chromatograph	mass spectrometers†	gas chromatograph	mass spectrometer	mass spectrometer
Mission/ spacecraft	NASA Pioneer Venus/ sounding probe	NASA Pioneer Venus/ sounding probe	USSR Venera 11 and 12/landers	USSR Venera 12/ lander	NASA Pioneer Venus/ multiprobe bus	NASA Pioneer Venus/ orbiter
Sampling* Altitude range, km	LA 0-60	LA 2.2-52	LA 2-23	LA 0-42	UA > 130	UA > 145
Reference	<i>Hoffman et al.</i> [this issue]	<i>Oyama et al.</i> [this issue]	<i>Istomin et al.</i> [1979]	<i>Gel'man et al.</i> [1979]	<i>von Zahn et al.</i> [this issue]	<i>Niemann et al.</i> [this issue]

\*LA is lower atmosphere, and UA is upper atmosphere.

†Each of the two landers carried one mass spectrometer. The results of the two instruments are identical [*Istomin et al.*, 1979].

carrier gas, helium, to empty the contents of the sample loop into the chromatographic column. During acquisition of samples 1 and 2 the sample flow path was heated a few degrees above the ambient atmospheric temperature. This procedure reduced wall absorption effects to a minimum. All of the lower atmosphere instruments also encountered a temperature range of approximately 250-740 K. The upper atmosphere temperatures were about a factor of 2 lower, down to 120 K.

To accomplish the sampling of the lower atmosphere, the LNMS employed a pair of small passivated microleaks [*Hoffman et al.*, 1979a]. The effluent from the leaks had to be removed from the mass spectrometer as rapidly as it entered in order to minimize contamination from previously measured samples and to prevent a pressure buildup in the instrument. A chemical getter pump was chosen as the main pump of the ion source of the mass spectrometer, and a combination of a chemical getter pump and sputter ion pump maintained a vacuum in the mass analyzer section of the instrument. The main chemical getter pump was isolated from the ion source by a variable conductance valve which was opened by the increasing atmospheric pressure, thus increasing the effective pumping speed of the getter as the leak throughput increased. This valve action proved to maintain a nearly constant ion source pressure of gettered gases, like CO<sub>2</sub>, while the atmospheric pressure varied over 3 decades.

Besides being able to remove efficiently the effluent from the microleaks, these pumps were required to maintain a very clean vacuum in the mass spectrometer from the time that it was assembled in the laboratory and calibrated to the time that it arrived at the Venus atmosphere and actually performed the measurements for which it was designed. One of the major problems encountered was that because all of the gases which entered the vacuum envelope of the instrument had to be pumped out by the internal pumps, leakage of earth's atmospheric gases, particularly argon, into the system proved to be troublesome. The getter pumps do not pump argon, and ion pumps are fairly inefficient in pumping all of the noble gases. The time from final pumping of the instrument in the laboratory on a specially constructed vacuum manifold system until the instrument encountered Venus was approximately 9 months. Even leaks of the order of 10<sup>-12</sup> STP cc/s, which are very difficult to detect, proved to be large enough to permit a small accumulation of argon in the instrument prior to its encounter with Venus. When an ion pump which has previously pumped noble gases is exposed to active gases, such as CO<sub>2</sub>, during the descent into the Venus atmosphere, the pump may regurgitate some of the noble gases back into the vacuum system to which it is attached. Thus a small back-

ground of <sup>40</sup>Ar remained in the instrument when it began its measurements in the Venus atmosphere.

Another problem with the accumulation of noble gases occurred because the sounding probe was backfilled with a mixture of nitrogen and 1% helium at the time it was finally assembled at Cape Canaveral prior to the launch. The purpose of the helium was to aid in detecting leaks in the spacecraft through which the probe atmosphere could be lost to space during the cruise phase of the mission. However, sub-microscopic leaks in the mass spectrometer analyzer and the permeation of helium through the glass feedthroughs caused an accumulation of helium in the instrument during the 5-month period in which it was bathed in the probe atmosphere. The background of helium has caused some uncertainty in the measurement of Venusian <sup>4</sup>He.

Although the gas chromatograph did not suffer the background problems of the mass spectrometer, because it does not have a self-contained vacuum system, it did require a pre-entry treatment to saturate some active sites in its columns for O<sub>2</sub> and SO<sub>2</sub> before parts per million amounts of these gases could be detected. To satisfy this condition, a mixture of these gases at 1% in helium was injected through these columns prior to entry, and the excesses were thoroughly flushed out with pure helium.

The gas chromatograph was designed to be operated in the probe environment at a pressure of approximately 1 bar. As a safety precaution, to provide a minimum of 1-bar pressure inside the probe to insure safe high-voltage power supply operation in the LNMS in case the original gases sealed in the probe prior to launch had leaked out during the cruise phase, a small high-pressure nitrogen bottle was installed in the probe. Its gas was released into the probe's interior just prior to entry into the Venus atmosphere. During flight there was no perceptible leakage from the probe resulting in its interior pressure becoming nearly 1.3 bars at entry and increasing slowly during descent to 1.8 bars. Because the regulator controlling the head pressure of the LGC was referenced to the probe internal pressure, a larger mass flow occurred than was planned, resulting in shortened retention times for all gases. The consequences of this will be discussed later.

In addition to the extreme ranges of temperature and pressure encountered during descent, a multitude of highly reactive chemical species exist in the Venus atmosphere. In the upper atmosphere, considerable amounts of O and N gave rise to general background, interference, and memory effects in the mass spectrometers. These were difficult to control because of the very limited time and power available to bring the instrument surfaces to chemical and thermal equilibrium

with the gas sampled. In the lower atmosphere the cloud region is composed of droplets of sulfuric acid, and a number of sulfur-bearing compounds were detected, as has been reported earlier [Hoffman *et al.*, 1979b]. As the sounder probe passed through the middle cloud region, the inlet leaks of the LNMS were overcoated with a substance which blocked the flow of ambient gases into the instrument. It is believed that this substance consisted of droplets of sulfuric acid from the clouds. The leaks remained closed until the probe descended some 20 km below the cloud level, at which time the flow of atmospheric gases was restored to normal [Hoffman *et al.*, 1979b, 1980, this issue]. The gas chromatograph, on the other hand, had no problems with sample flows, primarily because all flow paths had a minimum diameter of 1 mm, which was probably an order of magnitude or more larger than the diameter of the largest cloud droplet.

The major constraint imposed on the measurement sequences in the Venus atmosphere by the mission profile itself was the quite limited time available in which to actually make the measurements. Because of the unknowns and complexities of the mass spectra encountered it would have been desirable to apply all technically available means to uniquely determine the chemical identity and abundance of the atmospheric constituents. Mass scanning with different energies of the ionizing electrons, full range scans of the mass spectra, enrichment of noble gases for increased sensitivity, and application of the flythrough mode in the upper atmosphere are all examples of techniques which enhance the detection capabilities of the gas analyzers. The limited time of descent through the Venus atmosphere, however, made it unfeasible to use the full range of options available, as this would have introduced shortcomings in the altitude resolution and raised questions about stability of the instrument performance in all its operational modes. This time constraint was most severe in the case of the BNMS instrument, which traversed in only 44 s the altitude region between the exobase, at 200 km, down to 130 km, a range that contains eight pressure scale heights. Therefore the BNMS did not use variable electron energies in the ion source, nor did it sample continuous mass spectra in this altitude region. Of course, for the ONMS, because of the extended length of the orbital mission, many analyses of the upper atmosphere were possible, and the mission did not impose constraints on the time of analysis.

In the lower atmosphere the instruments could not operate until after parachute deployment and heat shield ejection, which occurred at approximately 65-km altitude. From there the time it took the probe to reach the surface was approximately 54 min. During this time the mass spectrometer accomplished 46 scans of the mass spectrum, and the gas chromatograph collected three atmospheric samples at 52-, 42-, and 22-km altitude and made a complete analysis of each. Since the time of descent of the sounder probe was less than 1 hour and the round trip communication time from earth to Venus occupied 10% of this time, no real-time commands to the instruments were planned during the descent phase of the mission. Therefore each instrument had to be controlled by the sequencer of the probe and by logic systems, such as microprocessors. In general, the operation of the various instruments was not limited by data rate considerations, but more by the constraints of time for each analysis and integration times necessary to obtain the measurements of the composition of the atmosphere at the desired sensitivity and altitude resolution.

The LGC was constrained by the high temperatures that were encountered in the lower atmosphere, because the elastomeric seals in the miniature solenoid valves were limited to sealing at temperatures below 180°C. Thus only three samples could safely be acquired during the descent phase, since the last valve movement was constrained to the above temperature. The time required for each analysis was approximately 10 min, and the power limitation to heat columns further reduced the suite of molecules that could be measured.

The LGC relied on retention time data for identification of the gases of interest. This procedure was deemed valid because of the limited number of stable gases in the low-mass range, thus providing confidence in the retention data. Added assurance was provided by the use of reference gases (internal standards) that were released to the third sample. These were Freon 14 and 22, which provided discrete markers in the chromatograms from which relative retention times could be calculated from the absolute retention times measured for these peaks.

The high entry speed of the BNMS (11.6 km/s) into the upper atmosphere poses the problem of potential dissociation of molecules upon impact with the open ion source of the instrument because a CO<sub>2</sub> molecule for example, encounters the BNMS with 31 eV of kinetic energy. Therefore below 200-km altitude this instrument spent 25% of its scarce measurement time in the flythrough mode of the ion source which permitted measurement of only those atmospheric constituents that reach the ion detector without prior wall collisions.

Naturally, there were weight and power limitations imposed by the mission. Typically, 10 kg and 10 W are required for each instrument of this type, except that in some cases additional power was available for heaters. Since the probes were required to enter the atmosphere and therefore pass through a high-g entry deceleration, the trajectory profiles required that the instrument be designed to survive a 450-g acceleration test.

While the constraints discussed above imposed by the atmosphere of Venus and those necessarily associated with a mission of this kind proved in some cases to be design drivers of the instruments, none were so severe that they precluded the measurements of the Venus atmosphere itself. As will be seen below, interesting and unexpected data have been obtained on the composition of the Venus atmosphere, and the agreements between the data obtained from the several instruments that have been flown to the Venus atmosphere are reasonably good.

#### CONFIDENCE BUILDERS FOR THE VALIDITY OF THE ATMOSPHERIC COMPOSITION DATA

In order to increase the confidence in the validity of the results obtained on the composition of the atmosphere of Venus a number of different instruments were designed into the payloads that flew to Venus in December 1978. In both the Pioneer Venus and the Venera missions the primary composition instruments were mass spectrometers and gas chromatographs. In addition, the Pioneer Venus UV spectrometer and Venera spectrophotometer have also provided certain composition results.

For the upper atmosphere composition measurements, redundancy was realized by including both the multiprobe bus and the orbiter mass spectrometers (BNMS and ONMS) in the Pioneer Venus mission. Inclusion of the BNMS in-

strument on the multiprobe bus permitted extension of the range of density measurements with respect to the orbiter capabilities toward higher densities by 3–4 scale heights into the important region of the homopause. In contrast to the lower atmosphere mass spectrometers, which measured mixing ratios, the two upper atmosphere mass spectrometers yielded absolute number densities of the atmospheric constituents. By the summation of all partial mass densities, absolute total mass densities were calculated. These total density figures in turn were compared with the density results obtained from the observation of drag effects experienced by the Pioneer Venus orbiter in the upper atmosphere [Keating *et al.*, this issue]. At the time of this writing, it can be concluded that the BNMS- and drag-derived total densities are in excellent agreement, whereas the densities measured by the ONMS are approximately a factor of 1.5 lower [Niemann *et al.*, this issue]. Possible sources for this slight disagreement could be uncertainties in the effective drag coefficient of the orbiter, minor errors in the trajectories used (note that in the dayside thermosphere of Venus a change of CO<sub>2</sub> density by a factor of 1.5 occurs over an altitude interval of only 2 km), uncertainties in the reduction of densities measured in the spectrometer ion sources to ambient densities, temporal and spatial variations in the state of the upper atmosphere, some unaccounted for changes of absolute instrument sensitivities with respect to their laboratory calibrations, or a combination of these potential error sources.

The densities in the lower atmosphere were determined from the LGC data by summing all the components measured within its fixed sample volume at known temperature, and these compare very favorably with the results obtained from the atmospheric structure experiment (LAS) by Seiff *et al.* [1979].

Important as confidence builders for upper atmospheric composition measurements are tests for thermal equilibrium between the various constituents. In their simplest form, these tests start with the assumption of (1) a molecular diffusion coefficient  $D$  much larger than the eddy coefficient  $K$  and (2) zero vertical bulk motions. Under these circumstances the measured scale height of any one constituent ought to be inversely proportional to its molecular mass  $M$ . In the Venus atmosphere one would expect that these scale heights would be constant above 180-km altitude at any given location, because the exospheric temperature reaches a plateau at that altitude.

For the composition measurements of the lower atmosphere both a mass spectrometer and a gas chromatograph were used to obtain some redundancy in the data for those chemical species which both instruments could measure directly, such as the noble gases and some sulfur compounds, and also to extend the range of measurements beyond the capabilities of each instrument. For example, because the dominant gas of the Venus atmosphere is CO<sub>2</sub>, the mass spectrometer produces by dissociative ionization of CO<sub>2</sub> a very large peak in the mass spectrum due to CO ions. This precludes a measurement of trace amounts of ambient CO by the mass spectrometer and makes the measurement of nitrogen difficult. On the other hand, the mass spectrometer is ideally suited for the measurement of isotopic ratios of different elements such as carbon, oxygen, nitrogen, argon, neon, and helium. The LGC had the capability of measuring Ne, Ar, Kr, N<sub>2</sub>, O<sub>2</sub>, CO, CH<sub>4</sub>, SO<sub>2</sub>, H<sub>2</sub>S, H<sub>2</sub>O, COS, and CO<sub>2</sub> directly without fragmentation. However, at the lower altitude, where the large amount of nitrogen in the atmosphere interfered with the measurement of

oxygen, trace amounts of oxygen were not measurable. Although theoretically capable, the LGC was not designed to measure isotopic ratios. Specifically, it was designed to produce results on chemically distinct species, whereas the mass spectrometer has the capability of observing a broad range of masses, in this particular case, from hydrogen through lead. Thus these two instruments were complementary in the data they produced on the composition of the Venus atmosphere.

Certain redundancies in the data from the mass spectrometer have been used to help identify different constituents of the atmosphere and to increase confidence in the abundance ratios that have been determined for these substances. Altitude profiles in the region of the atmosphere below where the leaks reopened, that is, below 28 km, of gettered and non-gettered gases, because of the different pumping paths in the mass spectrometer for these substances, place limits on the determination of which gases are ambient in the Venus atmosphere. The altitude profiles of ambient Venus gases must lie between these limits [see Hoffman *et al.*, this issue, Figure 1]. CO<sub>2</sub> is a gettered gas, and it has a rather steep profile; <sup>36</sup>Ar is a nongettered gas, and its profile is somewhat flatter. Any substance with a steeper profile than CO<sub>2</sub> that has a constant mixing ratio in the Venus atmosphere must originate at least in part within the instrument. The COS profile below 20 km is an example of this.

The mass spectrometer ion source has the capability of forming ions by impacting neutral gas molecules with electrons of three different energies. The normal electron energy is 70 eV, which produces a significant number of multicharged ion species, as well as dissociatively ionized substances. Use of the other two energies, 30 and 22 eV, tend to eliminate the doubly charged ion species from the spectrum and minimizes or at least alters the fractionation patterns produced from a given parent substance. From the data taken at the low electron energies the confidence level in the chemical identification of parent molecules is improved. An example of this is the mass 3 peak, which consists of ions of the HD molecule, the <sup>3</sup>He atom, and the H<sub>3</sub> molecule, the last being formed in the ion source. Through the use of the low-energy spectra and the subtraction of the other substances that form peaks at mass 3, it was determined that there is no evidence for the existence of <sup>3</sup>He, at least to a limit of  $3 \times 10^{-4}$  of <sup>4</sup>He in the Venus atmosphere. Fractionation patterns were also useful in identifying SO<sub>2</sub> and H<sub>2</sub>S molecules. In the case of SO<sub>2</sub> the fragment SO at mass 48 tracked the 64 parent SO<sub>2</sub> peak very closely and aided in its identification over that of S<sub>2</sub>, which is also mass 64 but would not produce a 48 peak. The HS peak at mass 33 also followed very closely the profile of the mass 34 peak, indicating that 34 indeed was due to H<sub>2</sub>S and not the <sup>34</sup>S isotope, since <sup>34</sup>S would not produce a peak at mass 33 amu.

Doubly charged peaks in the mass spectrum were also useful in determining isotopic ratios. For instance, from the mass 22 and 22.5 peaks, as well as from the mass 44 and 45 peaks, the <sup>12</sup>C/<sup>13</sup>C isotopic ratio was determined. A mass 19 peak was produced by <sup>38</sup>Ar<sup>++</sup>, and the ratio of this to <sup>38</sup>Ar<sup>+</sup> aided in determining the correction required for <sup>40</sup>Ar<sup>++</sup> to the peak at mass 20. The residual mass 20 peak was due to <sup>20</sup>Ne after a small correction for H<sub>2</sub><sup>18</sup>O.

From these examples it is quite clear that through the use of fractionation pattern peaks and doubly charged peaks the redundancy exhibited in the mass spectrum is useful in giving confidence to the proper identification of parent molecules existing in the Venus atmosphere.

TABLE 2. Venus Lower Atmosphere Mixing Ratios

	LNMS	LGC†	VNMS	VGC	BNMS
<sup>4</sup> He					12±2 <sup>a</sup>
<sup>3</sup> He/ <sup>4</sup> He	<3.10 <sup>-4</sup>				
<sup>20</sup> Ne	9±20 <sup>a</sup>	4.3 ± 0.7	12 ± 3		
<sup>22</sup> Ne/ <sup>20</sup> Ne	0.07 ± 0.02				
Total Ar	70±30 <sup>a</sup>	67.2 ± 2.3	115 ± 20	50 ± 10	<30
<sup>36</sup> Ar	30±10 <sup>a</sup>		(42 ± 2)%		<9
<sup>40</sup> Ar	33±22 <sup>a</sup>		(50 ± 2)%		<20
<sup>40</sup> Ar/ <sup>36</sup> Ar	1.03 ± 0.04		(1.19)‡		
<sup>38</sup> Ar/ <sup>36</sup> Ar	0.18 ± 0.02		(0.19)‡		
<sup>84</sup> Kr	<0.2	<2	0.4 ± 0.2		
N <sub>2</sub> (in %)	4 ± 2		4.5 ± 0.5	2.5 ± 0.3	
52 km		4.60 ± 0.14			
42 km		3.54 ± 0.01			
22 km		3.41 ± 0.01			
O <sub>2</sub>				<20	
52 km	<30	43 ± 25			
42 km		16 ± 8			
22 km	<30				
CO				28 ± 7	
22 km		20 ± 0.4			
12 km				7 ± (4)	
COS					
22 km	<3	<2			
	LNMS	LGC	VSP§	VGC	OUVS¶
SO <sub>2</sub>					0.1
70 km					
52 km	<10	<600			
22 km	<300	185 ± 43		130 ± 35	
H <sub>2</sub> O				≥50±100%	
52 km	<1000	<600	200		
42 km		5200 ± 80	150		
22 km		1350 ± 20	60		
0 km			20		

Mixing ratios are given as parts per million, except those for N<sub>2</sub>, which are given as percent. Where altitude is unspecified, it is not given in the original paper; for LNMS it is the average value from 25 km to the surface.

<sup>a</sup>Deduced from ratio to <sup>36</sup>Ar.

†LGC data at 22 km unless otherwise specified. For intercomparison the error bars are 1σ, except those for O<sub>2</sub>, which are 3σ.

‡Result derived in this paper; not in referenced work.

§Venera spectrophotometer [Moroz et al., 1979].

¶Orbiter ultraviolet spectrometer [Stewart et al., 1979].

The mass spectrometer flown on the sounder probe had the mass resolution capability of separating some doublet mass peaks at various mass numbers. For example, at mass 16, CH<sub>4</sub> and O have a mass difference of 1 part in 440. The instrument had sufficient resolution capability to separate these two peaks with a valley of 10% between the peaks if they had equivalent amplitudes. This high-resolution capability was a powerful tool in separating overlapping mass peaks at a given mass number. Besides the example given at mass 16 for methane and atomic oxygen, at mass 19 the <sup>38</sup>Ar doubly charged peak was separated from the <sup>18</sup>OH peak. At mass 30 the C<sub>2</sub>H<sub>6</sub> peak was clearly identified from the C<sup>18</sup>O and NO peaks. At mass 32, while the sulfur and O<sub>2</sub> peaks were not completely separated, the peak position gave a weighting to one or the other of these constituents and helped in the determination that molecular oxygen does not seem to exist to a measurable degree in the Venus atmosphere.

To increase the confidence in the data returned from the BNMS, this instrument contained a system for an in-flight calibration of the absolute instrument sensitivity for helium, which is measured by the low-mass channel (1-8 amu). This calibration was successfully performed 2 days before the in-

strument encounter with Venus [von Zahn et al., this issue]. The gain of the high-mass electron multiplier, which counted ions with masses at or above 12 amu, was measured in flight by its comparison with simultaneous readings of an independently functioning electrometer amplifier. The overlap in the two detector systems extended from 10<sup>-13</sup> to 10<sup>-12</sup> A of electrometer current, in which range the electrometer was operating quite stably.

#### EXAMINATION OF COMPOSITION RESULTS

In Table 2 a compilation of Venus lower atmospheric composition data as they were obtained from the gas analyzers aboard the Pioneer Venus as well as the Venera 11 and 12 spacecrafts is presented. Also listed are the respective results of two additional optical experiments, the Venera spectrophotometer (VSP) and Pioneer Venus orbiter ultraviolet spectrometer (OUVS). References for these data are given as footnotes to Table 2. Other references are listed in Table 1. The data values and error bars are quoted as they appear in the referenced works. Values which are put in parentheses derived in this paper by combining results from the cited papers. In case of the BNMS results it should be emphasized

that the actual measurements were taken at or above 130-km altitude. Hence their extrapolations into the lower atmosphere are dependent on certain model assumptions, as will be discussed below. With respect to the Venera results, no in-depth discussion of their confidence levels and error bars is attempted, but nevertheless, they are listed here for their obvious interest. Note also that all mixing ratios are given in parts per million, except for  $N_2$ , whose abundance is given in percent.

#### Helium

As was mentioned above, the LNMS results on helium suffered from the fact that the internal sounder probe atmosphere contained 1% helium. The result is that a rather large helium background has to be subtracted from the data, precluding the determination of a mixing ratio at this time.

On the other hand, the mass 3 peak can be entirely accounted for by contributions from the HD peak, assuming an isotopic ratio for hydrogen the same as that on earth, and a manufacturing in the mass spectrometer ion source of  $H_3^+$  from mainly the hydrogen mass 1 peak. Also the  $^3He$  residual was negligible. This left a residual of essentially zero counts at mass 3 that could be attributed to  $^3He$ . Therefore even though the  $^4He$  peak amplitude from ambient gas is uncertain, the  $^3He/^4He$  ratio is probably less than  $3 \times 10^{-4}$ . This value allows for a factor of 3 less  $^4He$  than the mass 4 corrected counting rate would indicate and assumes an upper limit of 5 counts for  $^3He$ . Thus the true helium isotopic ratio may be much less and could be as small as that on earth ( $1.4 \times 10^{-6}$ ) or even lower.

The LGC did not measure helium, because it was advantageous to use helium as the carrier gas to improve instrument sensitivity. Results from the Venera probes have not yet produced data on helium.

The BNMS result on the lower atmosphere helium abundance was derived by *von Zahn et al.* [this issue] by extrapolation from the actual measurements performed at and above 130-km altitude. This extrapolation was based on an eddy coefficient profile derived from the BNMS composition measurement, assumptions on the temperature profile between 100 and 130 km, and the change of mean molecular mass in the latter altitude region. Although the lowest altitude measurements of the BNMS were in fact obtained below the homopause, the small atomic mass of He and the eddy coefficient, having been found to decrease with altitude, cause a significant decrease in the helium mixing ratio in going from the 130-km level down to the 100-km altitude. The estimated uncertainty of the derived He mixing ratio in the lower atmosphere is given by *von Zahn et al.* [this issue] (Table 2). Here it may be noted that a similar connection of upper and lower atmosphere argon data can be done with much more confidence, because the atomic masses of the argon isotopes are very similar to the mean molecular mass of the atmosphere throughout the whole altitude range under consideration.

#### Neon

The neon content of the Venus atmosphere was determined by the LNMS instrument by taking the ratio of the corrected (as discussed above)  $^{20}Ne$  peak height to that of  $^{36}Ar$ . The measured value is  $0.3 \pm 0.2$ . The rather large error stems from the fact that the correction for doubly charged argon is a fairly sizable one, although the correction for the heavy water is very small. On the basis of the value for the  $^{36}Ar$  mixing ratio in the Venus atmosphere the mixing ratio of  $^{20}Ne$  was de-

termined to be 10 ppm. No direct measurement is available of the neon isotope at mass 22 from the LNMS instrument, because the doubly charged  $CO_2$  peak at mass 22 is overwhelmingly large and it was impossible to make a correction for it that would be meaningful. However, results from the inert gas enrichment cell (IRMC) [*Hoffman et al.*, this issue], which concentrated a sample of inert gases by removing the  $CO_2$ , indicate that the  $^{22}Ne/^{20}Ne$  value was  $0.07 \pm 0.02$ , a value that agrees well with the solar wind value [*Geiss et al.*, 1970].

The LGC value for neon is somewhat lower but within the error bar of the LNMS value. The VNMS value is also consistent with the other measurements. The VGC cannot measure neon, because it uses neon as a carrier gas, just as the LGC used helium as the carrier gas. So the determination of  $^{20}Ne$  in the Venus atmosphere appears to show fairly good agreement between three of the instruments which did make the measurement.

For the BNMS a meaningful measurement of  $^{20}Ne$  could not be obtained because of the appearance of a large  $H_2O$  peak upon entry into the Venus upper atmosphere. This peak is caused by water released from the ion source surfaces when they are exposed for the first time to a large flux of atomic oxygen. At 150-km altitude, for example, the ratio of ion currents of mass 18<sup>+</sup> to mass 44<sup>+</sup> was 1/40. Therefore the contribution from  $H_2^{18}O$  totally dominated the mass 20 peak. In addition, the cross section for ionization by electron impact is much smaller for Ne than for  $H_2O$ , further compounding the problem of measuring the thermospheric Ne content by the BNMS.

#### Argon

For the LNMS the basic measurement of all of the noble gas abundances in the Venus atmosphere was done through the  $^{36}Ar$  peak, because it had a negligible residual before encounter with Venus and no interference from other gases. It is therefore the most reliable peak upon which to base the measurement. Since argon is a noble gas, it is not gettered, and its ratio to  $CO_2$  in the mass spectrometer increases with time, as was discussed above. The ratio of ion-counting rates of the mass 36-44 ion peaks actually goes from  $10^{-1}$  to nearly  $10^{-2}$  between 25 km and the surface, but because of the large and increasing pumping speed for  $CO_2$  versus that for argon the mixing ratio of argon is very much less than the counting rate ratio. By knowing the conductances of the different pumping paths of these two gases within the instrument and the ratio of their ionization efficiencies the mixing ratio of  $^{36}Ar$  was determined to be  $30 \pm 20$  ppm [*Hoffman et al.*, this issue]. The isotopic ratios  $^{40}Ar/^{36}Ar$  and  $^{38}Ar/^{36}Ar$  were found to be  $1.03 \pm 0.04$  and  $0.18 \pm 0.02$ , respectively, after appropriate corrections were made for the residual argon in the mass spectrometer. These values are average values of the data in the lower 25 km of the atmosphere. There were no significant trends in the mixing ratio in this region. From the isotopic ratios of argon and the mixing ratio of  $^{36}Ar$  the mixing ratios of the other argon isotopes were calculated. The total argon mixing ratio then is the sum of that of the three isotopes and is determined to be  $70 \pm 50$  ppm.

The LGC argon mixing ratio value is  $67.2 \pm 2.3$  ppm. This is also for the sum of the three isotopes, since the LGC treats all isotopes of a given substance identically. This value differs from that reported earlier [*Oyama et al.*, 1979]. The earlier report was based upon a misidentification of certain peaks following the  $N_2$  peak. Ar was identified as  $O_2$ , and CO was

identified as Ar. These identifications were based on the best fit retention times of these peaks compared to the pre-launch calibration retention times. It was assumed that the temperature of the column would rise during the later stages of the third analysis, but subsequently, that was not found to be the case. In fact, the shorter retention times for all gases resulted from a higher absolute column head pressure generated by a carrier gas pressure regulator referenced to the higher than expected pressure in the probe. The higher mass flow rates resulted in retention times of all gases being moved forward. When this fact was discovered, the Freon internal standards were used to determine relative retention times, and a quantitative value for each of the gases that was measured was obtained [Oyama *et al.*, 1980].

The VNMS obtained an argon mixing ratio of  $115 \pm 20$  ppm with isotopic ratios of  $^{40}\text{Ar}/^{36}\text{Ar}$  of 1.19 and  $^{38}\text{Ar}/^{36}\text{Ar}$  of 0.19. These isotopic ratio values are considered to be in excellent agreement with those determined by the LNMS, and the mixing ratio lies within the LNMS error limits.

The result obtained for the mixing ratio of argon by the VGC instrument is  $50 \pm 10$  ppm, which is in reasonable agreement with the value obtained by the Pioneer Venus instruments but a little more than a factor of 2 lower than that obtained by the VNMS. The source of this difference is being considered by the Venera experimenters. Assuming that some systematic error will be found in the VNMS result, there seems to be general agreement between the various lower atmospheric composition instruments on the mixing ratio of argon, which is of the order of 60–70 ppm. The isotopic ratio  $^{40}\text{Ar}/^{36}\text{Ar}$ , being about 1, is quite different from the value of 300 in the earth's atmosphere. This implies that there is a large excess of primordial argon, as well as neon, in the Venus atmosphere as compared to the earth's atmosphere [Hoffman *et al.*, this issue], since the Venus atmosphere is nearly 100 times more massive than the earth's. The very large abundance of  $^{36}\text{Ar}$  relative to that of the earth raised the question as to whether the mass 36 peak in the LNMS might not be due to HCl instead of  $^{36}\text{Ar}$ . This can be answered on the basis of a consideration of the amplitude of the mass 35 peak, which could possibly be due to chlorine ions. In the LNMS there is a background of scattered ions in the mass spectrum on the low-mass side of a very large ion peak, in this case  $\text{CO}_2^+$ , which increases with increasing pressure in the mass spectrometer. The background from this source in the region of the mass 35 peak is of the order of 20–30% of the peak amplitude. Another correction from the  $\text{H}^{34}\text{S}$  peak removes an additional 30–40% of the peak amplitude. The residual peak may be attributable to chlorine. The fractionation pattern for HCl yields a mass 36 to 35 ratio, that is HCl to Cl, of 7.0. Therefore assuming that the residual peak is entirely due to chlorine, the contribution of HCl to the mass 36 peak would be less than 2% of the peak amplitude at every altitude, and therefore HCl would not contribute significantly to the argon determination. On earth the isotopic ratio of  $^{37}\text{Cl}/^{35}\text{Cl}$  is 0.326. On Venus the 37/35 mass peak ratio varies from 0.5 to 3, the variation being due in large part to the statistical fluctuations of the very low counting rates, indicating that some substance other than chlorine is a major contributor in the LNMS to at least the mass 37 peak. It is therefore concluded that the large excess of primordial argon is a valid result and that the mixing ratio of chlorine in the atmosphere of Venus is less than a few parts per million.

In the case of the BNMS experiment, only upper limits on the argon abundances in the Venus atmosphere were derived for the following reasons [Mauersberger *et al.*, 1979]: above

150 km the altitude gradients of both the mass 36 and the mass 40 ion currents exhibit a much too shallow gradient to be identified as signals from ambient argon. Judging from their scale heights, these signals are caused by background gases released from the high-speed impact of ambient atomic oxygen on the ion source surfaces. Below 130 km the gradients of masses 36 and 40 became too steep to be argon. In this altitude region the mass spectrum was dominated by scattered ions within the instrument analyzer due to the rapidly rising ambient  $\text{CO}_2$  pressure. As a result, Mauersberger *et al.* [1979] concluded that at no altitude was  $^{36}\text{Ar}$  or  $^{40}\text{Ar}$  positively identifiable in the BNMS data. The authors also calculated upper limits on the  $^{36}\text{Ar}$  and  $^{40}\text{Ar}$  number densities at 135-km altitude and derived, by using appropriate model assumptions, upper limits on the mixing ratios of these Ar isotopes in the lower atmosphere (see Table 2).

The limits on argon isotope abundances derived from the BNMS are not in satisfactory agreement with the results from composition measurements performed directly in the lower atmosphere (see Table 2). If the LNMS and LGC values as given in Table 2 are considered to be correct, then an explanation of the low BNMS value is necessary. If a different altitude profile for the background gas on masses 36 and 40 is assumed (see discussion by Mauersberger *et al.* [1979]), the BNMS value could be raised by 20%. The extrapolation of the abundances of  $^{36}\text{Ar}$  and  $^{40}\text{Ar}$  relative to  $\text{CO}_2$  from the altitude of measurement (135 km) to the lower atmosphere is, of course, model dependent. By using half or twice the value of the eddy coefficient  $K$  in the model the extrapolated value of  $^{36}\text{Ar}/\text{CO}_2$  changed by only  $-15\%$  and  $+4\%$ , respectively. For  $^{40}\text{Ar}/\text{CO}_2$  the change was even smaller. This insensitivity to  $K$  is due to the atomic masses of the argon isotopes being close to the mean molecular mass of the Venus lower and middle atmosphere.

Since the two effects discussed above are unable to account for the disagreement between the BNMS and LNMS-LGC data, one may speculate whether the BNMS result is affected by an unknown loss of multiplier gain in the last 15 s of the mission, which were crucial for the determination of the argon abundance limits. This potential gain loss could possibly be attributed to the rather large count rates produced by the multiplier from the  $\text{CO}_2$ , CO, O, and  $\text{N}_2$  ion currents below 150 km. However, this condition had occurred many times before during laboratory calibrations at high  $\text{CO}_2$  pressures and had not resulted in any notable damage to the multiplier. A posteriori there is no self-consistent means from only the BNMS science and housekeeping data to firmly establish and to quantify such a potential loss of multiplier gain in the BNMS. Therefore there appears to be no valid reason to change the limits as published by Mauersberger *et al.* [1979].

The expectedly rather small argon abundance at 150-km altitude has not yet been positively identified by the ONMS mass spectrometer. As Niemann *et al.* [1979] reported, the  $^{40}\text{Ar}$  peak of the ONMS was obscured by an anomalously high background peak probably caused by  $^{40}\text{K}^+$  and  $\text{NaOH}^+$  ions sputtered off the ion source grids by the 10-km/s impact of  $\text{CO}_2$ . This situation has not been resolved at the time of this writing.

#### Krypton

Neither of the Pioneer Venus lower atmospheric composition instruments was actually able to detect krypton. The upper limits are of the order of 0.2–2 ppm, the LNMS value being lower. From the VNMS data, indications are that the

mixing ratio is of the order of 0.4 ppm. None of these values disallows an excess in the absolute abundance of krypton in the Venus atmosphere.

#### Nitrogen

The mixing ratio of nitrogen has been determined in the lower atmosphere of Venus by four of the five atmospheric composition instruments. The values, while exhibiting fair agreement, do not have overlapping error bars. The biggest discrepancy seems to be between the two Venera instruments, where the values are 4.5 and 2.5% with errors of 0.5% that do not overlap. The LNMS and LGC values are fairly consistent with each other and with the VNMS value, leaving the VGC value to be somewhat lower than the other three. The uncertainty of the LNMS measurement is fairly large because of the fact that at the mass 28 parent peak for  $N_2$  a very high signal from CO is found, leaving the  $N_2$  peak amplitude somewhat uncertain. The latter was determined from the LNMS data by an examination of the mass 30 to 28 peak ratios. At mass 30 the  $^{12}C^{16}O$  peak is separated from the  $C_2H_4$  peak by the high mass resolution of the instrument. By knowing the  $^{12}C^{16}O$  counting rate and the oxygen isotopic ratio (measured) the CO contribution to the mass 28 peak was calculated. The remainder was  $N_2$ , from which its mixing ratio was determined.

Another way of determining the nitrogen mixing ratio is through the mass 14 peak, which results from N ions which are fragmented from the  $N_2$  molecules by the ion source of the instrument. This method was used to determine the  $N_2$  abundance from the VNMS data. In the LNMS case a correction had to be made at the mass 14 peak ( $CH_2^+$ ) from methane, which was introduced into the mass spectrometer as a calibration gas. Since the correction was fairly large, the value of nitrogen as determined by this method is somewhat uncertain. However, consistency was obtained between the actual value by this method and the mass 30/28 isotopic ratio method.

The LGC quoted error bars [Oyama *et al.*, 1979] indicate that the mixing ratio of nitrogen does indeed vary with altitude from 4.6% at 52 km to 3.5% at 42-km altitude and 3.4% at 22-km altitude. The error bars quoted in the referenced work are confidence intervals calculated from the calibration data acquired during tests and are determined to 3  $\sigma$ . No simulation tests have revealed any altitude dependent errors, such as sampling errors or errors due to increasing temperature of the instrument as the probe descended toward the surface. Therefore Oyama *et al.* [this issue] suggest that the mixing ratio of nitrogen does vary from a higher value to a lower value with decreasing altitude in the atmosphere of Venus.

Because of diffusive separation of  $N_2$  and  $CO_2$  at altitudes above 100 km the  $N_2$  abundances measured by the BNMS above 130 km cannot be compared directly with the values measured in situ in the lower atmosphere. As has been mentioned already, von Zahn *et al.* [1979] have used the comparison of the measured ratio  $N_2/CO_2$  in the upper and lower atmosphere to derive an estimate of the strength of turbulent mixing in the 100- to 140-km region.

#### Molecular Oxygen

In the LNMS data there is a mass peak at 32 amu both in the high-altitude region around 50-55 km before the leak plugged and in the lower region of the atmosphere below 25 km. In the upper region the peak can be reasonably well accounted for by  $O_2$  formed in the mass spectrometer ion source by the dissociative ionization of  $CO_2$ . In the lower part of the

atmosphere there is considerably more mass 32 than can be attributed to this source, and the peak position is shifted toward that of sulfur. However, by additional subtractions of contributions to the mass 32 peak of S from  $H_2S$ , of S and  $O_2$  from  $SO_2$ , and of S from COS the amplitude of the peak can be accounted for. Therefore from the LNMS data, only an upper limit of 30 ppm can be placed on the mixing ratio of  $O_2$  in the Venus lower atmosphere. This is consistent with the upper limit of 20 ppm obtained by the VGC. To date, the VNMS has not yet reported a value for  $O_2$ .

The abundance of oxygen found by the LGC at 52-km altitude is 43 ppm, whereas at 42 km it is substantially less at 16 ppm. At 22 km it is undetectable because of the huge nitrogen peak tail. The error bar on the high-altitude determination includes the LNMS limit value at that altitude. At 42 km the LGC value lies within the upper limit determined by the VGC. The VGC does not directly measure  $O_2$  but must determine it by subtraction of the argon from the chromatogram peak. Thus the  $O_2$  limit of the VGC may be high. At 22 km there appears to be concurrence that the  $O_2$  mixing ratio is below the detection limit of all the instruments.

#### Carbon Monoxide

The mixing ratios of carbon monoxide as determined by the two gas chromatographs agree very well at a value of the order of 20-28 ppm. The error bars of the VGC measurement overlap those of the LGC, although the reverse is not true. The fact that mass spectrometers cannot determine the mixing ratio of carbon monoxide in a highly rich carbon dioxide atmosphere is one reason why a multiplicity of instruments was flown to study the Venus atmosphere.

#### Carbon Dioxide

It was well known before the Pioneer Venus flight that  $CO_2$  is the dominant gas in the Venus atmosphere. This was reconfirmed by the LGC, which made a direct measurement of the  $CO_2$  abundance. The mass spectrometers used  $CO_2$  as the reference gas for relative abundance measurements and also confirmed the dominance of  $CO_2$ . Abundances of all constituents found in the Venus atmosphere have been reported as mixing ratios.

#### Carbonyl Sulphide

In earlier results reported from the LNMS data [Hoffman *et al.*, 1979b] it was shown that between 23 and 20 km there was a large increase in the COS mixing ratio from essentially zero to a peak value of approximately  $10^{-3}$ , followed by a small decrease and then a rather constant mixing ratio from that altitude down to the surface. This profile is not consistent with that of an ambient atmospheric gas. Laboratory results from studies with the flight spare instrument, conducted by applying a coating of an 85% solution of  $H_2SO_4$  in  $H_2O$  to the inlet leak and heating it in a  $CO_2$  atmosphere in a chamber in which the Venus atmosphere pressure and temperature can be simulated, have shown that it is possible to produce the same profile that was observed in the Venus atmosphere. It is therefore concluded that at least the rapid rise in COS at the 20-km level is an artifact of the measuring system and not a real phenomenon existing in the Venus atmosphere. Also, the rather constant mixing ratio of COS below that altitude may be an artifact, because the origin of COS could be a residual remaining in the instrument after the initial production. Therefore only an upper limit of 500 ppm can be set at this time. It



is clear that at 22 km and above, the mixing ratio of COS in the Venus atmosphere must be less than 3 ppm, which is consistent with the value obtained from the LGC at this same altitude. Unfortunately, 22 km was the lowest altitude at which the LGC sampled the Venus atmosphere. Therefore it is not certain that COS exists at all above the few parts per million level in the Venus atmosphere.

#### Sulfur Dioxide

The Pioneer Venus orbiter ultraviolet spectrometer (OUVS) can detect trace gases in the atmosphere at and above the cloud tops by observing their absorption spectra in scattered sunlight. Early in the mission, sulfur dioxide was detected by this means [Stewart *et al.*, 1979]. Since the scattered sunlight probes the atmosphere to a depth that depends on wavelength, it was possible to deduce from the spectrum the mixing ratio of SO<sub>2</sub> near 40 mbar and near 20 mbar by modeling the scattering near 280 nm and near 210 nm, respectively. The results show that the mixing ratio of SO<sub>2</sub> is about 0.1 ppm at 40 mbar and that the scale height of SO<sub>2</sub> is approximately one fifth of the scale height of the ambient atmosphere [Esposito *et al.*, 1979].

A one-dimensional model of the photochemistry of sulfur compounds above 58 km (the base of the upper cloud), including vertical eddy mixing, shows that the small SO<sub>2</sub> scale height is due to a combination of the efficient oxidation of SO<sub>2</sub> and inefficient vertical mixing. The upward flux of SO<sub>2</sub> predicted by the model is sufficient to replace the H<sub>2</sub>SO<sub>4</sub> settling downward from the upper cloud, and the model also predicts an SO<sub>2</sub> mixing ratio of 5 ppm at 58 km [Esposito *et al.*, 1979; Winick and Stewart, 1980] that is consistent with the result from the LNMS at 55 km. The SO<sub>2</sub> signal in the LGC high-altitude sample is very small; hence the large upper limit placed on this value from the LGC data.

In the altitude region below 25 km, several values of the mixing ratio of sulfur dioxide were obtained. The LGC and VGC results at 185 and 130 ppm, respectively, agree very well in that their error bars do overlap. On the other hand, the LNMS had considerable difficulty in determining the mixing ratio of SO<sub>2</sub> in this region of the atmosphere. This results from the overcoating of the inlet leaks by presumably sulfuric acid cloud droplets as the sounder probe passed through the middle cloud region at an altitude around 52 km. Below this altitude there is evidence that a considerable amount of SO<sub>2</sub> has resulted from the material that blocked the leaks, giving rise to a large mass 64 peak, the residual from which, even after the leak had reopened at approximately 30-km altitude, remained in the spectrum from there to the surface. Therefore it is unclear whether SO<sub>2</sub> is being observed from the ambient atmosphere or if the entire mass 64 peak is due to the residual SO<sub>2</sub> from the leak blockage material. Hence all that can be determined at this time is an upper limit to the mixing ratio of SO<sub>2</sub>, which is 300 ppm and is consistent with the values determined by the gas chromatographs.

#### Water Vapor

The only major discrepancy in the measurements from the several different instruments of the composition of the Venus atmosphere exists in the determination of the water vapor content. The differences occur basically between the LGC values at 42- and 22-km altitude and the VGC value, which is for an altitude range below 42 km but is not given at any specific altitude and may well be an average value, as is the case for

all VGC measurements. In addition to the composition measurements, which have already been discussed, the Venera probes contained a spectrophotometer (VSP), which determine the altitude profile of water vapor from the depth of H<sub>2</sub>O absorption bands (800–1200 nm) in the spectrum of scattered daylight [Moroz *et al.*, 1979]. The mixing ratios determined by this instrument show a decrease from 200 ppm at 54 km to 20 ppm at the surface of Venus (see Table 2). These results are fairly consistent with the VGC results but are markedly at variance with those obtained by the LGC. The source of this discrepancy has not yet been determined.

The data obtained by the LGC at the 52-, 42-, and 22-km altitudes are consistent with the vapor pressure of water over sulfuric acid solutions of  $\geq 85$ –86% at 54°C, 88–89% at 132°C, and  $\gg 95$ % at 283°C, respectively. They agree with a model of sulfuric acid concentrations which predicts the vapor pressure of water, as a function of altitude, and provides for a sink for water in the clouds. Laboratory simulation studies have shown that for this range of concentrations of sulfuric acid added to the top of chromatographic columns the water of solution is not added to the water vapor level detected and that the water vapor is not removed from subsequent samples. However, the peaks obtained from flight data for water vapor show characteristic similarities to peaks emerging from columns pretreated with sulfuric acid solutions and differ from columns that have not been so treated. This can be construed as additional evidence for the sulfuric acid nature of the cloud particles.

The water vapor peak in the LNMS spectra is very large even at an altitude above that where the leak was blocked by the droplet of sulfuric acid. Hence the large upper limit value determined at 52 km of 1000 ppm. It is possible that the water peak in this region is indeed ambient, but all other sources of possible water vapor have not yet been excluded. However, below the point where the leak was blocked by the sulfuric acid droplet, a large increase in the water vapor peak was observed, indicating that the droplet was producing water vapor as well as SO<sub>2</sub> during the time that it was overcoating the leak and blocking the flow of ambient gases into the instrument. Below the region where the droplet had evaporated and the return flow of atmospheric gases began, the water vapor peak increases markedly again but does not follow a profile of that of an ambient atmospheric gas. Hence it is not clear what percentage, if any, of the water peak is due to ambient water vapor or whether it is all due to residual water which has now been accumulated in the instrument.

#### CONCLUSIONS

As can be seen from an examination of the composition results presented in Table 2, there is fairly good agreement between the mixing ratios of all constituents determined by the several instruments from the Pioneer Venus program and the Venera 11 and 12 flights. An important exception is water vapor, where a serious discrepancy still exists. However, Oyama *et al.* [1980] show a correlation between the water vapor concentrations as measured by the LGC and those that would exist in equilibrium with certain concentrations of H<sub>2</sub>SO<sub>4</sub> as evidence for the validity of their values. However, this must be contrasted with the agreement between the VGC and spectrophotometric values, which were obtained by two entirely independent techniques, one by an in situ measurement and one by remote sensing.

When initial results were first reported, there was more than



an order of magnitude difference in the mixing ratio obtained for argon by the various instruments. To date, after a much more careful analysis of the data the range of differences in these measurements is about a factor of 2. The original fairly large differences were not basically a problem of errors in laboratory calibrations of the sensitivity of the different instruments but one of properly accounting for backgrounds in the spectra, identification of peaks, pumping speed considerations of rare gases versus active gases, and time constants of electrometer amplifiers. All of these situations have now been analyzed, and corrections have been made for them, which was not possible in the short time between the arrival of the spacecraft at Venus and the first preliminary reporting of results in the literature. However, even in the first results reported, the impact of the large excess of the primordial gases in the Venus atmosphere was noted, and this very important result has not been affected by the more detailed and careful analysis which has occurred since the original publications. Even the uncertainty in the argon mixing ratio of a factor of 2, which still exists if all of the measurements reported in Table 2 are considered, does not negate the fact of the large excess of primordial argon. If the lower mixing ratio values are considered to be more likely, then the actual abundance or mass mixing ratio of  $^{40}\text{Ar}$  in the Venus atmosphere is a factor of 2 less than that in the earth's atmosphere. This implies that the radiogenic source of argon in Venus or the rate at which this substance was accumulated in the Venus atmosphere has been somewhat less than that for the earth. However, if the VNMS value of the  $^{40}\text{Ar}$  mixing ratio is taken at face value, then this indicates a fair similarity between the  $^{40}\text{Ar}$  content of the two planets.

The chlorine mixing ratio upper limit in the atmosphere as determined from the LNMS data is a few parts per million. The sulfur (as  $\text{SO}_2$ ) abundance was found to be of the order of 100–200 ppm below the clouds. The ratio of these seems to contradict the Venera 11 and 12 spectrophotometer results [Surkov *et al.*, 1979] found in aerosols collected in the cloud region wherein the Cl:S ratio was 10. The chlorine content of the aerosols translates into a gaseous mixing ratio of less than 1 ppm (Yu. A. Surkov, private communication, 1980), which does not contradict the mass spectrometer result. The sulfur content below the clouds is much higher in relation to the chlorine than it is in the aerosols, but the relationship between these sulfur forms is unclear. In the clouds, sulfur, as  $\text{SO}_2$ , has an upper limit of the order of 10 ppm as determined by the LNMS. The UV spectrometer result of 0.1 ppm at 70 km translates through a model to 5 ppm at 55 km. If the model is valid, this could represent a conflict between the aerosol values and the gaseous values, although it is unknown what gaseous abundance for sulfur relates to the aerosol value.

From the experiences gained in the measurement of a planetary atmosphere remote from the earth, several recommendations for any future such experiments in either the Venus atmosphere or that of other planets or comets can be made.

In general, the level of contaminant gases observed in the Venus upper atmosphere by both the BNMS and the ONMS spectrometers was higher than was expected from the experience gained in previous experiments performed in the terrestrial thermosphere. This situation is probably caused by the high entry velocities (11.6 and 10 km/s for BNMS and ONMS, respectively) and the high molecular mass of  $\text{CO}_2$ . This combination provided for 31-eV impact energy of  $\text{CO}_2$  at the BNMS instrument versus the typical 9-eV energy of  $\text{N}_2$  in

a terrestrial satellite experiment and 4.6-eV impact energy of  $\text{CO}_2$  in the case of the Viking upper atmosphere spectrometers [Nier and McElroy, 1977]. With this lowering of the encounter velocities one also notes a definite lowering in the level of the contaminant problem. Therefore for future planetary or cometary missions we recommend application of even more stringent bake-out procedures for the parts and full spectrometer sensors than we have employed already. In the case of the BNMS the bake-out temperature of the fully assembled spectrometer was limited to 200°C because of the electron multipliers used. A 450°C bake-out procedure for the spectrometer would have probably resulted in a lower level of Venus entry background gas but would have necessitated the use of a different multiplier. A second measure for countering the background problem is to take at least a few continuous mass scans in the time period where science-critical data are collected. Such spectra would be of great help in unraveling the relative contributions of ambient gases and contaminant peaks.

The use of several different operating modes of the instrument for short-term measurements, such as in the case of the bus approach into the Venus atmosphere or a high-speed approach to a comet, would be undesirable, because it seems important to obtain redundancy and consistency of measurements rather than to introduce other types of data, such as those obtained by low electron energies for flythrough modes or the like. While these may add confidence to the identification of parent molecule species in some cases, they may also detract from the basic composition measurements which are being sought in an unknown atmosphere.

Because of the experience of the accumulation of helium in the LNMS instrument as a background gas, due to the fact that the internal probe atmosphere did contain 1% helium, it would be highly desirable not to backfill pressurized vehicles with a gas that is likely to be a minor constituent of the atmosphere which is to be studied. However, this may not always be possible, as in the present case. Helium was the only gas which could be used for leak detecting, because other more complex molecules would have affected the results of the infrared measurements and therefore could not be used as trace gases in the probe for leak detection.

From a consideration of the results produced by the LNMS instruments the high-resolution capability of looking at mass doublets proved to be an extremely valuable feature of the instrument and would be very desirable in the measurement of any unknown atmosphere.

The results from the composition measurements of the Venus atmosphere provided by the Pioneer Venus and Venera 11 and 12 spacecrafts might have turned out quite differently had only one instrument or type of instrument been flown. Venus simply has too complex an environment to be attacked with a single instrument. But as a result of the cross-checks provided by the several instruments the knowledge of the atmospheric composition and the confidence in the validity of the measurements has progressed to a reasonable degree of certitude. It appears that the results presented here now may form the basis of the models which must be developed or updated to understand the chemistry and physics of the atmosphere as well as its origin.

*Acknowledgments.* One of us (J. H. H.) wishes to express his gratitude to the Max-Planck-Institut für Kernphysik in Heidelberg for support while he was a visiting scientist there (June to December 1979). We especially acknowledge the contributions and helpful discussions of R. R. Hodges, Jr., D. Krankowsky, K. Mauersberger, and

A. I. F. Stewart on this project. Work at the University of Texas at Dallas was supported by NASA contracts NAS2-8802 and NAS2-9485. Work at the University of Bonn was supported by grant WRK 275 of the Bundesministerium für Forschung und Technologie, Bonn.

## REFERENCES

- Esposito, L. W., J. R. Winick, and A. I. Stewart, Sulfur dioxide in the Venus atmosphere: Distribution and implications. *Geophys. Res. Lett.*, **6**, 601-604, 1979.
- Geiss, J. P., Eberhardt, F., Bühler, J., Meister, and P. Signer, Apollo 11 and 12 solar wind composition experiments: Fluxes of He and Ne isotopes. *J. Geophys. Res.*, **75**, 5972-5978, 1970.
- Gel'man, B. G., V. G. Zolotukhin, N. I. Lamonov, B. V. Levchuk, L. M. Mukhin, D. F. Nenarokov, B. P. Okhotnikov, V. A. Rotin, and A. N. Lipatov, An analysis of the chemical composition of the atmosphere of Venus on an AMS of the Venera-12 using a gas chromatograph. *NASA Transl. Rep.*, TM-7476, 1979.
- Hoffman, J. H., R. R. Hodges, Jr., and K. D. Duerksen, Pioneer Venus large probe neutral mass spectrometer. *J. Vac. Sci. Technol.*, **16**(2), 692-694, 1979a.
- Hoffman, J. H., R. R. Hodges, Jr., M. B. McElroy, and T. M. Donahue, Composition and structure of the Venus atmosphere: Results from Pioneer Venus. *Science*, **205**, 49-52, 1979b.
- Hoffman, J. H., R. R. Hodges, Jr., W. W. Wright, V. A. Blevins, K. D. Duerksen, and L. D. Brooks, Pioneer Venus sounder probe neutral gas mass spectrometer. *IEEE Trans. Geosci. Electron.*, GE-18, 80-84, 1980.
- Hoffman, J. H., R. R. Hodges, Jr., T. M. Donahue, and M. B. McElroy, Composition of the Venus lower atmosphere from the Pioneer Venus mass spectrometer. *J. Geophys. Res.*, this issue.
- Istomin, V. G., K. V. Grechnev, V. A. Kochnev, Mass spectrometry measurements of the composition of the lower atmosphere of Venus. *NASA Transl. Rep.*, TM-75477, 1979.
- Keating, G. M., J. Y. Nicholson III, and L. R. Lake, Venus upper atmosphere structure. *J. Geophys. Res.*, this issue.
- Mauersberger, K., U. von Zahn, and D. Krankowsky, Upper limits on argon isotope abundances in the Venus atmosphere. *Geophys. Res. Lett.*, **6**, 671-674, 1979.
- Moroz, V. I., B. E. Moshkin, A. P. Ekonomov, N. F. San'ko, N. A. Parfent'ev, and Yu. M. Golovin, Spectrometric experiment onboard the Venera -11. 12 descenders: Some results of the analysis of the Venus day-side spectrum (in Russian). *Publ. 117*, Space Res. Inst., USSR Acad. of Sci., Moscow, 1979.
- Niemann, H. B., R. E. Hartle, W. T. Kasprzak, N. W. Spencer, D. M. Hunten, and G. R. Carignan, Venus upper atmosphere neutral composition: Preliminary results from the Pioneer Venus orbiter. *Science*, **203**, 770-772, 1979.
- Niemann, H. B., W. T. Kasprzak, A. E. Hedin, D. M. Hunten, and N. W. Spencer, Mass spectrometric measurements of the neutral gas composition of the thermosphere and exosphere of Venus. *J. Geophys. Res.*, this issue.
- Nier, A. O., and M. B. McElroy, Composition and structure of Mars' upper atmosphere: Results from the neutral mass spectrometer on Viking 1 and 2. *J. Geophys. Res.*, **82**, 4341-4349, 1977.
- Oyama, V. I., G. C. Carle, F. Woeller, and J. B. Pollack, Venus lower atmospheric composition: Analysis by gas chromatography. *Science*, **203**, 802-805, 1979.
- Oyama, V. I., G. C. Carle, and F. Woeller, Corrections on the Pioneer Venus sounder probe gas chromatographic analysis of the lower Venus atmosphere. *Science*, **203**, 399, 1980.
- Oyama, V. I., G. C. Carle, F. Woeller, J. B. Pollack, R. T. Reynolds and R. A. Craig, Composition of the Venus lower atmosphere from the Pioneer Venus gas chromatograph. *J. Geophys. Res.*, this issue.
- Seiff, A., D. B. Kirk, R. E. Young, S. C. Sommers, R. C. Blanchard, J. T. Findlay, and G. M. Kelly, Thermal contrast in the atmosphere of Venus: Initial appraisal from Pioneer Venus probe data. *Science*, **205**, 46-49, 1979.
- Stewart, A. I., D. E. Anderson, Jr., L. W. Esposito, and C. A. Barth, Ultraviolet spectroscopy of Venus: Initial results from the Pioneer Venus orbiter. *Science*, **203**, 777-779, 1979.
- Surkov, Yu. A., F. F. Kurnozov, V. K. Khristianov, V. N. Gur'yanov, V. N. Glazov, B. N. Korchnyanov, and A. G. Dupchenko, Study of the aerosol cloud layer of Venus. *Sov. Astron. AJ*, Engl. Transl., **5**(1), 1979.
- von Zahn, U., K. H. Fricke, H.-J. Hoffmann, and K. Pelka, Venus: Eddy coefficient in the thermosphere and the inferred helium content of the lower atmosphere. *Geophys. Res. Lett.*, **6**, 337-340, 1979.
- von Zahn, U., K. H. Fricke, D. M. Hunten, D. Krankowsky, K. Mauersberger, and A. O. Nier, The upper atmosphere of Venus during morning conditions. *J. Geophys. Res.*, this issue.
- Winick, J. R., and A. I. F. Stewart, Photochemistry of SO<sub>2</sub> in Venus' upper cloud layer. *J. Geophys. Res.*, this issue.

(Received January 7, 1980;  
revised May 8, 1980;  
accepted May 9, 1980.)

ORIGINAL PAGE IS  
OF POOR QUALITYComposition of the Venus Lower Atmosphere From  
the Pioneer Venus Mass Spectrometer

J. H. HOFFMAN AND R. R. HODGES

*Physics Department, The University of Texas at Dallas, Richardson, Texas 75080*

T. M. DONAHUE

*Department of Atmospheric and Oceanic Sciences, The University of Michigan, Ann Arbor, Michigan 48105*

M. B. MCELROY

*Center for Earth and Planetary Physics, Harvard University, Cambridge, Massachusetts 02138*

Data from the Pioneer Venus sounder probe neutral mass spectrometer confirm that the major constituents of the lower atmosphere of Venus are  $\text{CO}_2$  and  $\text{N}_2$ , with the latter having a mass abundance of about 3%. The data allow the order of up to 1000 ppm of water vapor and 500 ppm of  $\text{SO}_2$  and COS below the clouds, but lower bounds for the abundances of these compounds cannot be established because they appeared in large amounts as lingering products of the reaction of cloud droplets deposited on the gas inlet leak to the mass spectrometer. The presence of several minor constituents on Venus is more certain. Of particular significance is the discovery that there is a hundred-fold excess of nonradiogenic argon and neon on Venus over terrestrial abundances in addition to a small deficit of radiogenic  $^{40}\text{Ar}$ . The isotopic ratios of carbon, oxygen, and nonradiogenic argon are similar to those on earth. Other minor constituents detected on Venus include helium and ethane, and there is strong, but presently inconclusive, evidence for  $\text{H}_2\text{S}$ . Through laboratory simulation it has been shown that the measured pattern of volatile release during the evaporation of cloud materials blocking the inlet leak correspond to the volatiles produced when a leak is coated with an 85% concentration solution of  $\text{H}_2\text{SO}_4$  and immersed in a Venus atmosphere simulator.

## INTRODUCTION

Interest in studying the composition of the atmosphere of our sister planet, Venus, stems from the fact that Venus and earth are similar in many aspects (i.e. mass, size, and orbit), but more importantly because of the marked differences that occur between these two seemingly similar planets. The Venus atmosphere is nearly 100 times more massive than that of earth, the surface temperature of the planet is more than 2½ times higher, and the dominant gas surrounding Venus is carbon dioxide. The sulfuric acid clouds of Venus encompass the entire planet, whereas the water clouds on earth only partially cover the planet. To study the composition of the lower atmosphere of this interesting planet, a miniature mass spectrometer [Hoffman *et al.*, 1980] was designed and flown to Venus in 1978 as one of the instruments of the Pioneer Venus mission [Colin, 1979].

One of the major problems that the mass spectrometer had to address was the sampling of the atmosphere over a pressure range of 0.1–100 bars while measuring concentrations of the order of 1 ppm of the dominant gas ( $\text{CO}_2$ ). In addition, because the instrument was operated in a pressurized spacecraft, a gas removal or pumping system had to be included with the instrument to maintain the mass spectrometer at its operating pressure ( $<10^{-5}$  torr) and to remove the gases that had been previously sampled from the atmosphere to avoid contamination of new samples. To get the true picture of the composition of this unknown atmosphere, the sampling system had to be designed to minimize alteration of the chemical forms of the gas species sampled from the atmosphere. The in-

strument which addressed these problems of measuring the rather hostile environment of the Venus atmosphere was designed and built at The University of Texas at Dallas.

Sampling of the Venus atmosphere occurred through two small microleaks, each consisting of a 3.2 mm diameter passivated tantalum tube whose outer end was forged to a flat plate configuration having a conductance of the order of  $10^{-7}$   $\text{cm}^3/\text{s}$  for the primary leak and  $10^{-9}$   $\text{cm}^3/\text{s}$  for the secondary leak [Hoffman *et al.*, 1980]. These leaks protruded from the sounder probe into the atmosphere. Analysis of the inflow through the leaks was performed by a miniature magnetic sector field mass spectrometer that covered the mass range from 1 through 208 amu with a dynamic range of over 6 orders of magnitude. Removal of the atmospheric samples was accomplished by a combination of chemical getters and sputtering ion pumping. To preserve the wide dynamic range of the instrument, that is, to enable measurement of substances in the Venus atmosphere at the 1 ppm level of  $\text{CO}_2$ , as the atmospheric pressure varied over the 3 decade range while the probe descended to the surface, the larger conductance leak was closed at about 47 km. A variable conductance valve, installed between the instrument ion source and the primary getter pump, was opened pneumatically by the increasing atmospheric pressure, causing the conductance from the ion source to the getter pump to be increased at a rate that approximated the increased throughput of the atmospheric sampling leak, thereby maintaining a nearly constant pressure in the ion source of the instrument. Preflight laboratory simulation of a descent, with pressure varying from 0.5 to 100 bar and temperature from 300 to 750 K, showed the  $\text{CO}_2$  signal to vary by only a factor of 5 [Hoffman *et al.*, 1979c]. The variation in flight was larger due to temporary plugging of the leaks

(to be discussed below) as the spacecraft descended through the clouds [Hoffman *et al.*, 1979b].

Preliminary results of the composition of the Venus atmosphere have been reported [Hoffman *et al.*, 1979a, b]. This paper contains an update of the preliminary results based upon a more detailed analysis of the flight data and various laboratory studies on simulation of flight results.

#### INSTRUMENTATION AND CALIBRATION

Detailed descriptions of the mass spectrometer instrumentation can be found in Hoffman *et al.*, [1979c, 1980]. Some important aspects of the instrument pertinent to a discussion of the results are its very high mass resolution capability, sufficient to separate many mass doublets, such as  $^{40}\text{Ar}$  and  $\text{C}_2\text{H}_4$  at mass 40 that has a mass difference of 1 part in 580. One of the problems of the operation of a mass spectrometer for the analysis of complex spectra of gases is the overlapping of ion peaks either as parent ions or as fragment ions formed in the instrument by the dissociative ionization of complex molecules. This high-resolution capability proved useful in separating many nearly overlapping peaks, such as doubly charged  $^{38}\text{Ar}$  ions from  $^{18}\text{OH}$  ions at the mass 19 position in the spectrum,  $\text{C}^{16}\text{O}$  and  $\text{C}_2\text{H}_6$  at mass 30, and the mass 40 doublet mentioned above. Besides the high-resolution property, another feature which aided in this identification process was the use of three different electron energies in the ionization process. The normal electron energy was 70 eV, but 3 times during the flight through the Venus atmosphere the ionization energy was cycled on successive scans of the mass spectrum to 30 and 22 eV. All doubly charged ion species are removed from the spectrum when low energy electrons are used and the fractionation patterns of complex molecules are significantly altered, thus aiding in their identification.

An on-board microprocessor controlling the operation of the mass spectrometer provided a high degree of efficiency in obtaining data through a peak top stepping routine and data compressing algorithm that effected a reading of the mass spectrum from 1 to 208 amu obtaining a set of 232 measurements in 64 s (including a 5 s period for reading backgrounds and retuning the peak stepping routine) while requiring an information rate of only 40 bits per second to return the data to earth. A subscale height altitude resolution was thus attained. There was no scan or sweep of the mass spectrum as is done in conventional mass spectrometer operation. Instead, use of the microprocessor in the peak stepping routine eliminated the time that is usually spent sweeping the valley between spectral peaks that occurs when an analog spectral scan system is employed. A lookup table of nouns stored in the microprocessor defined positions in the mass spectrum of a preselected set of mass peaks, which included several sequential positions around key mass numbers, such as 15, 28, 40, and 136 amu and mass defect positions for all known gas species to be measured. At several mass numbers, two or more peak positions were set (e.g., at 16 (O and  $\text{CH}_4$ ), 32 ( $\text{O}_2$  and S), and 34 ( $^{34}\text{S}$  and  $\text{H}_2\text{S}$ )). The microprocessor scanning this table directed the instrument to measure the amplitudes only of the preselected mass peaks. Table 1 is a sample of the noun table and corresponding count record from the flight data just prior to the leak blockage. Listed here are all of the mass numbers that were monitored. Forty five scans of the noun table were completed after entry into the Venus atmosphere. Surface impact occurred during the 46th scan. Just prior to entry, the instrument was operated through four scans to give background

peak amplitude information. Owing to the very high mass resolution of the mass analyzer, it was necessary that each of these measurements be made with an ion acceleration potential tolerance of the order of 0.02%. This, in turn, required periodic fine tuning of program parameters by tracking the positions of spectral peaks from two calibration gases that produced peaks at 136 ( $^{136}\text{Xe}^+$ ), 68 ( $^{136}\text{Xe}^{++}$ ), and 15 ( $\text{CH}_3^+$ ) amu.

A noble gas enrichment mechanism, called the isotope ratio measurement cell (IRMC), collected an atmospheric sample at approximately 62 km above the Venus surface, and through a combination of sorption and getter pumping, purified this sample of chemically active gases for later measurement of the isotopic ratios of the concentrated noble gases. This sample was introduced into the mass spectrometer just before parachute jettison and immediately after the secondary microleak was valved off (this was during the time of leak blockage). A special peak stepping routine was employed to measure the noble gases in this sample. Because the peak amplitudes were lower than expected, it was only possible to determine the neon isotopic ratio from these data. The reason for the low peak amplitudes is unknown.

Preflight calibration of the flight instrument was performed by using a high-pressure-high-temperature chamber, called the Venus atmosphere simulator (VAS), capable of reproducing the Venus descent profile temperature and pressure conditions down to the surface values of 740 K and 90 atm. The instrument inlet leak protruded into the VAS chamber to sample its gases, simulating the sampling of the Venus atmosphere. Operation of the VAS involved admitting mixtures of gases (e.g.,  $\text{N}_2$ ,  $\text{SO}_2$ ,  $\text{COS}$ ,  $\text{Ar}$ ,  $\text{Xe}$ ,  $\text{Hg}$ ,  $\text{C}_2\text{H}_6$ ,  $\text{HCl}$ ) usually with  $\text{CO}_2$  as the dominant gas, into the high-pressure chamber in a stepwise manner following a model Venus atmosphere profile while recording the mass spectrometer output signals.

#### ANALYSIS METHODS

One of the consequences of the gas pumping system of the mass spectrometer was the fact that because chemically active and chemically inert gases were pumped by different mechanisms, the gases flowed through different paths having different conductances within the instrument's vacuum envelope. The active gases principally flowed through the variable conductance valve to the main chemical getter which maintained a vacuum in the ion source. The throughput of this pneumatically operated valve continually increased due to the opening of the valve by the increasing atmospheric pressure at a rate that nearly matched the increased throughput of the inlet leak. Chemically inert gases were not pumped by the getter, and therefore their only path of evacuation was through the very narrow ion optics slits connecting the instrument ion source with the mass analyzer. The pump on the analyzer consisted of another chemical getter and a miniature sputter ion pump that was the only sink for chemically inert gases. Because the conductance of the instrument ion optics slits was very low, the pumping in this direction was conductance limited and remained essentially constant throughout the flight through the Venus atmosphere. The result of the two different gas flow paths and pumping mechanisms was that the partial pressures of the inert gases increased faster than those of the active gases, producing an artificially larger signal for the inert gases. Thus, for example, the ratio of the argon peaks to carbon dioxide continually increased with time and always was much greater than the atmospheric mixing ratio.

TABLE 1. Portion of Flight Data Record Showing Mass Number Table Stored in Microprocessor and Instrument Output (Related to Counting Rate) called 'Data'

amu	data	amu	data	amu	data	amu	data
15.013	7680	39.972	1696	109.886	0	152.576	0
15.018	16896	40.029	80	111.873	1	152.890	0
15.023	22528	43.991	1769472	112.923	0	153.894	0
15.028	22016	44.991	21504	113.934	1	154.911	1
15.033	12800	45.302	108	114.904	1	155.887	0
15.995	335872	45.995	7936	115.921	1	157.876	0
16.018	40960	47.000	94	116.436	0	158.890	0
16.031	39936	47.966	10	116.925	0	159.859	0
1.008	3520	2.950	23	117.449	1	160.899	0
17.002	296	3.000	26	117.978	0	9.050	70
17.026	244	3.050	29	118.449	0	10.000	66
17.985	336	48.974	2	118.892	0	10.050	70
18.010	1088	49.968	3	119.466	0	161.893	0
18.034	66	50.969	2	119.981	0	162.424	0
18.987	34	51.980	0	120.925	0	162.959	0
18.998	18	54.004	0	121.985	0	163.438	1
19.007	5	59.966	1	122.894	0	163.919	0
19.981	480	60.968	0	123.920	1	164.342	0
19.992	384	61.977	0	124.893	0	164.464	0
20.006	112	62.994	1	126.922	2	165.441	0
20.015	30	63.962	5	127.906	0	165.934	0
20.993	10	3.800	12	128.905	29	166.430	0
21.991	45056	3.950	13312	129.921	5	166.929	0
21.995	47104	4.000	34816	130.914	23	167.180	0
22.496	560	4.050	32256	131.922	48	167.432	0
26.002	112	64.960	3	133.905	440	167.937	0
26.014	122	65.961	23	134.471	14	168.892	0
27.010	102	66.963	280	134.960	26	170.901	0
27.023	124	67.964	6272	135.453	102	177.934	0
27.988	507904	69.971	1	135.742	3456	10.950	76
27.995	606208	71.973	1	135.824	7808	11.000	96
28.000	655360	74.927	0	135.907	9728	11.050	78
28.005	671744	77.040	2	135.990	8192	178.934	1
28.012	499712	77.916	1	136.073	5248	179.367	0
28.032	122880	78.053	16	136.448	140	179.874	0
28.997	6656	78.924	1	136.952	17	180.384	0
29.003	7040	79.915	1	137.970	5	180.823	0
29.039	992	79.958	0	138.442	2	181.931	0
29.997	1024	80.947	1	138.960	0	182.903	0
30.046	208	81.914	0	139.395	1	183.430	0
30.973	11	81.975	0	139.921	1	183.884	0
31.006	26	82.936	0	140.406	2	187.366	0
31.972	128	83.937	0	140.939	0	188.396	0
31.990	320	85.912	29	141.432	3	190.817	0
2.016	22016	90.910	1	141.882	2	192.883	0
32.985	18	93.920	0	142.381	0	194.824	0
33.966	15	95.943	0	142.929	1	197.941	0
33.992	19	96.967	0	143.436	0	199.003	0
34.005	21	97.948	0	143.946	0	199.896	0
34.972	15	98.971	0	144.459	0	200.978	0
35.005	12	99.479	0	144.882	2	201.889	0
35.966	656	99.970	0	146.841	0	203.923	0
35.981	704	100.489	0	148.853	0	205.998	0
36.966	9	100.990	0	150.615	0	206.955	0
37.968	152	101.985	0	150.921	0	208.019	0
39.950	1376	102.975	0	151.280	0	15.000	20992
39.958	1504	103.478	0	151.589	0	14.000	19456
39.965	1664	103.985	0	151.951	1	12.000	344064

Figure 1 shows a flight profile of carbon dioxide and  $^{36}\text{Ar}$  from the altitude at which the probe was configured to begin making measurements, that is at 62 km after the heat shield had been ejected and a parachute deployed, down to the surface of the planet. When the gases first entered the mass spectrometer,  $\text{CO}_2$  was pumped by the clean walls of the vacuum envelope and instrument electrodes faster than was Ar. Therefore, the ratio of  $^{36}\text{Ar}$  to  $\text{CO}_2$  decreases until the surfaces

come to equilibrium with the gas mixture inside the instrument. This occurs at about 60 km altitude. The rather sudden decrease in the gas densities at approximately 50 km altitude was caused by a blockage of both inlet leaks of the instrument, presumably by sulfuric acid droplets from the middle or lower cloud region of the atmosphere. The secondary leak was programmed to be valved off at approximately 3 km lower altitude than where the blockage occurred. The in-

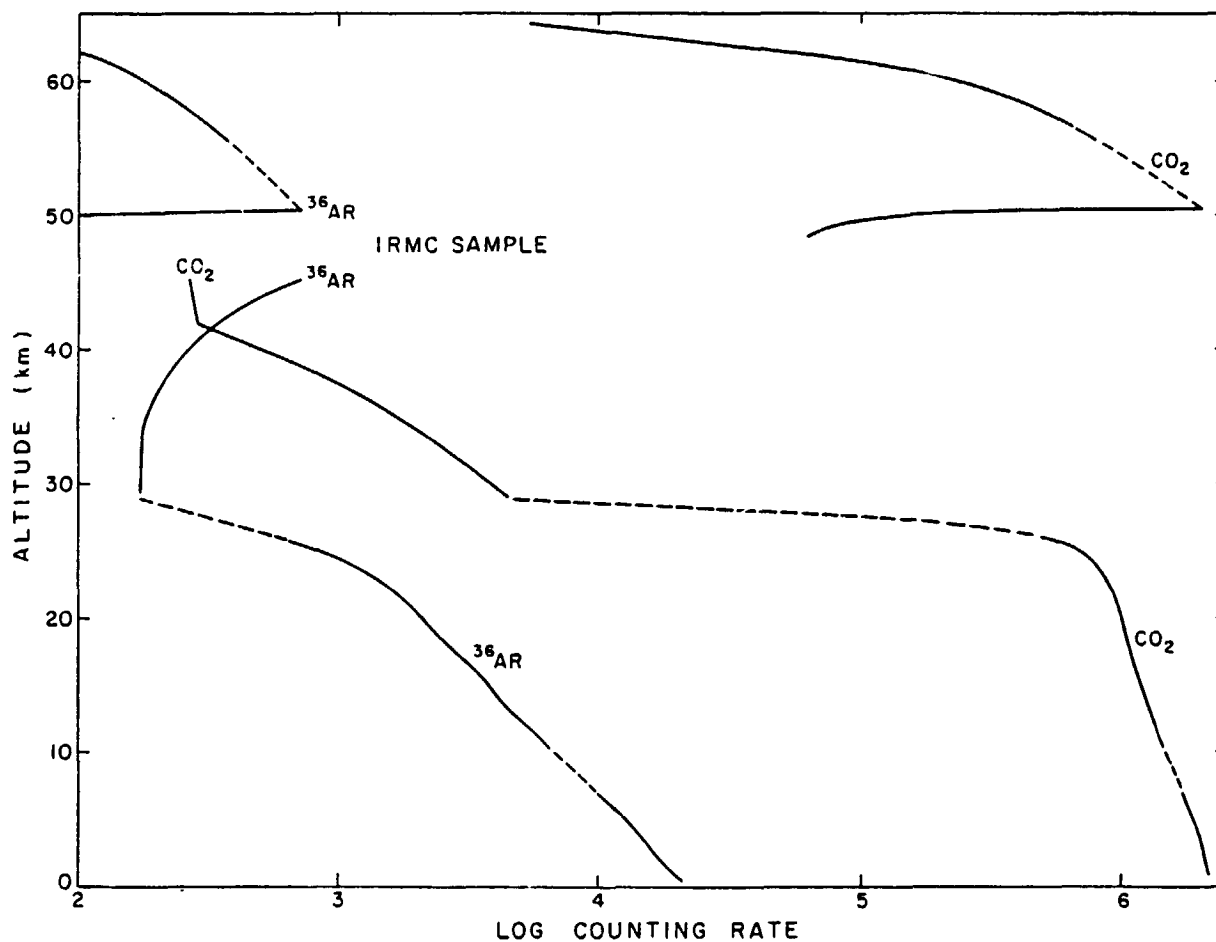

Fig. 1. Altitude profile of  $^{36}\text{Ar}$ , a nongettered gas, and  $\text{CO}_2$ , a gettered gas (see text). The decrease in counting rate at 50 km is due to the leak blockage by  $\text{H}_2\text{SO}_4$  droplets. The leaks reopened near 28 km. The argon increase at 45 km comes from the enriched gas cell (IRMC) sample which was measured between 48 and 45 km. Dashed portions of the curves indicate times when low electron energy data were taken (not plotted).

flow of ambient gases was effectively stopped until the probe descended to just below 30 km, at which point it is presumed that the overcoating of the primary leak had evaporated and the flow of ambient gases returned. From there to the surface of the planet, the altitude profiles of both  $^{36}\text{Ar}$  and  $\text{CO}_2$  are characteristic of those of nongettered and gettered gases, respectively. The difference in slopes is due to the pumping phenomena which were discussed above. Any gas having a constant mixing ratio in the Venus atmosphere over this altitude range will have a profile with altitude that must lie between these two curves as limits. Any substance that increases less rapidly than  $\text{CO}_2$  or more rapidly than argon must have at least a partial source within the instrument. Rates of change of some volatiles (i.e.,  $\text{SO}_2$  and  $\text{H}_2\text{O}$ ) resulting from reactions involving remnant cloud materials in the gas inlet did lie outside these bounds.

To determine the mixing ratio of an inert gas relative to that of  $\text{CO}_2$ , the conductance paths for each type of gas in the instrument must be known. The mixing ratio of the inert gas is given by

$$M_x = \frac{R_x}{R_{\text{CO}_2}} \cdot \rho \cdot \frac{C_A}{C_V + C_A} \cdot \frac{[\text{CO}_2]}{[\text{CO}_2 + \text{N}_2]}$$

where

$M_x$  volume mixing ratio of gas  $x$ ;

$R_x$  counting rate for gas  $x$ ;

$\rho$  instrument sensitivity ratio of  $\text{CO}_2$  to gas  $x$ ;

$C_A$  conductance from ion source through instrument ion optics slits to analyzer ion pump;

$C_V$  conductance of variable conductance valve, a function of atmospheric pressure;

$[\text{CO}_2]/[\text{CO}_2 + \text{N}_2]$  factor that converts  $M_x$  to a mixing ratio since  $\text{N}_2$  is a nonnegligible part of the Venus atmosphere.

Because  $C_A/C_V$  is quite small (or the order of  $10^{-2}$ ) the counting rate ratio of argon to  $\text{CO}_2$  (Figure 1) is much larger than the mixing ratio.

In principle, the measurement of  $C_A$  and  $C_V$  are straightforward and have been done in the laboratory. However, some uncertainty in these values is introduced because of the unknown pumping speeds of the getters and pumps themselves. Pumping speed of the getter is a function of the amount of gas which it has previously pumped. Its pumping speed will decrease gradually as its capacity begins to be filled. An ion pump speed is determined by the type of gas it is pumping and the mixture of gases which is being fed into it. For example, the speed of the ion pump will change if it is

pumping a mixture of CO<sub>2</sub> and a noble gas over that which it has for the noble gas alone. This is because the noble gas is buried in the ion pump and overcoated by chemically stable sputtered material involving the active gas. As a result the pumping speed for argon is a function of how much CO<sub>2</sub> is mixed with the argon. When a large amount of an active gas is introduced into an ion pump, the pump may regurgitate some of the noble gases which it has previously pumped. Hence, it is unclear whether there is a sufficient pressure buildup of any noble gas in the analyzer section to affect the effective value of C<sub>r</sub> for such gas. The consequence is that there is some uncertainty in the total pumping speed in the instrument for both noble and active gases. Hence, the error bars given for the mixing ratios of noble gases are fairly large. On the other hand, the isotopic ratio measurement of any gas is very straightforward, because the isotopes of a given gas are pumped at essentially the same speeds, since they are very close in mass number and chemically identical. Thus isotopic ratios are determined quite precisely.

The blockage of the inlet leaks by the overcoating of the sulfuric acid droplets caused a loss of data from approximately 50 to 30 km. During this time, peaks in the mass spectrum at 64, 48, and 18 amu exhibited marked increases indicating that the leak droplet material was forming sulfur dioxide and water vapor, which are presumably dissociation products of sulfuric acid. No parent molecules of sulfuric acid were observed, nor was any SO<sub>2</sub> (80 amu) observed. Laboratory tests have shown that SO<sub>2</sub> will not pass through the inlet leaks without dissociation. To determine how sulfuric acid decomposes under the flight conditions, a laboratory simulation test of the leak blockage was performed. The inlet leaks were coated with a solution of 85% sulfuric acid and water until the flow of ambient gases into the instrument was stopped. The leaks were then inserted into the Venus atmospheric simulator (VAS), the chamber filled with carbon dioxide, and the temperature of the chamber raised following the profile incurred during Venus atmosphere descent. The leak reopened, and the

TABLE 2. Volume Mixing Ratios of Gases Found in the Venus Atmosphere

Gas*	Venus Atmosphere Mixing Ratio, ppm	Earth Atmosphere Mixing Ratio, ppm
<sup>20</sup> Ne	9†	16
<sup>22</sup> Ne	1†	2
Total Ne	10†	18
<sup>36</sup> Ar	30-10 <sup>+20</sup>	31
<sup>38</sup> Ar	6†	6
<sup>40</sup> Ar	31†	0.93%
Total Ar	40-120†	0.93%
<sup>36</sup> Kr	<0.2	0.5
N <sub>2</sub>	4 ± 2%	78%
O <sub>2</sub>	<30	21%
SO <sub>2</sub> 55 km	<10	
Below 24 km	<300	
COS Above 24 km	<3	
Below 20 km	<500	
H <sub>2</sub> S	3†	
C <sub>2</sub> H <sub>4</sub>	2†	
H <sub>2</sub> O	<1000	
Cl	<10	
Hg	<5	

\*In those rows where altitude is unspecified, result is average value from 24 km to surface.

†Deduced from ratio to <sup>36</sup>Ar.

TABLE 3. Isotopic Ratios of Some Substances Found in the Venus Atmosphere

Gas	Venus Atmosphere Isotopic Ratio	Earth Atmosphere Isotopic Ratio
<sup>3</sup> He/ <sup>4</sup> He	<3 × 10 <sup>-4</sup>	1.4 × 10 <sup>-6</sup>
<sup>22</sup> Ne/ <sup>20</sup> Ne	0.07 ± 0.02	0.097
<sup>20</sup> Ne/ <sup>36</sup> Ar	0.3 ± 0.2	0.58
<sup>38</sup> Ar/ <sup>36</sup> Ar	0.18 ± 0.02	0.187
<sup>40</sup> Ar/ <sup>36</sup> Ar	1.03 ± 0.04	296
<sup>13</sup> C/ <sup>12</sup> C	≤ 1.19 × 10 <sup>-2</sup>	1.11 × 10 <sup>-2</sup>
<sup>18</sup> O/ <sup>16</sup> O	2.0 ± 0.1 × 10 <sup>-3</sup>	2.04 × 10 <sup>-3</sup>

flow of carbon dioxide resumed at about the same temperature (250°C) as in flight. During the blockage time, water vapor, SO, SO<sub>2</sub>, and several reaction products of sulfuric acid and vacuum sealant (e.g., 77 and 78 amu) were observed in the mass spectrum in approximately the same ratios as seen in the Venus data. From these tests it is fairly clear that the blockage material in flight was sulfuric acid that came from the clouds.

From this same test, after the leaks reopened and the temperature of the chamber was raised through the range of approximately 300°-325°C equivalent to an altitude of 20-25 km in the Venus atmosphere, a sudden increase in the mass 60 peak, which is attributable to COS, was observed. The peak amplitude passed through a maximum and then decreased with further increase in temperature of the VAS chamber. This profile of the 60 amu peak matches very closely that of the mass 60 peak in the flight data, indicating that the maximum in the mass 60 altitude profile observed at 19 km altitude that was reported earlier [Hoffman et al., 1979b] is not a real feature of the Venus atmosphere, but probably results from the reaction of sulfuric acid and CO<sub>2</sub> in the leak. From this it is clear that the only atmospheric COS and SO<sub>2</sub> measurements were obtained in the clouds. At lower altitudes this data allows, but does not require, substantial amounts of COS and SO<sub>2</sub>.

#### ATMOSPHERIC COMPOSITION RESULTS

A summary of Venus atmospheric composition results derived from the mass spectrometer data are given in Tables 2 and 3. Table 2 lists volume abundances of gases relative to carbon dioxide. It can be noted that in many cases the uncertainties of measurements relative to CO<sub>2</sub> are quite large. This is because of the pump speed problem discussed above; it is expected that on-going laboratory synthesis will reduce these uncertainties substantially. Relative isotopic abundances of some elements are given in Table 3. A discussion of the measurements of each substance listed in these tables follows.

#### Argon

Because of the higher residual <sup>40</sup>Ar peak in the instrument (approximately 1100 cts/s) compared to that of <sup>36</sup>Ar (3 cts/s), the 36 peak was used to determine the argon mixing ratio. First the mixing ratio of <sup>36</sup>Ar was determined by the method described above. Then the ratios of the argon isotopes were calculated from the data obtained below 28 km (where the leak reopened) where the residuals had become small, (a few percent) compared to the peak amplitudes. From knowledge of the abundance of one of the isotopes and the isotopic ratios, the total argon mixing ratio was obtained. The <sup>36</sup>Ar mixing ratio is 30-10<sup>+20</sup> ppm. Further laboratory tests of the con-

ductances of the valves and the slits, and the pumping speeds of getters and ion pumps in the presence of other gases, all of which are needed to determine the argon mixing ratio, should result in a reduction in the magnitude of this uncertainty. The isotopic ratio measurements of argon however are much more straightforward, and the results indicate that the  $^{38}\text{Ar}$  to  $^{36}\text{Ar}$  ratio is  $0.18 \pm 0.02$  which agrees very well with the accepted value for the earth's atmosphere of 0.187. The mixing ratios of  $^{36}\text{Ar}$  and  $^{38}\text{Ar}$  are approximately equal to those in the earth's atmosphere (30 and 6 ppm, respectively), but since the mass of the Venus atmosphere is 90 times that of earth, the total amounts of these nonradiogenic rare gases on Venus are nearly 2 orders of magnitude greater than on earth. The  $^{40}\text{Ar}$  to  $^{36}\text{Ar}$  ratio in the Venus atmosphere is  $1.03 \pm 0.04$ , in comparison with 296 on earth, implying that the total amount of Venus radiogenic argon is about one third of that on earth. The total argon mixing ratio is calculated to be 70 ppm (assuming the 30 ppm value for  $^{36}\text{Ar}$ ). The large enhancement in the nonradiogenic argon isotopes relative to  $^{40}\text{Ar}$  was noted in the preliminary analysis of the data, and further examination of the data analysis methods has supported this finding.

#### Neon

The mixing ratio of  $^{20}\text{Ne}$  in the Venus atmosphere was determined by measuring the ratio of the  $^{20}\text{Ne}$  peak, after appropriate corrections were made for doubly charged  $^{40}\text{Ar}$  (~30%) and for  $\text{H}_2^{18}\text{O}$  (a few percent), to the  $^{36}\text{Ar}$  peak. The resulting  $^{20}\text{Ne}$  to  $^{36}\text{Ar}$  ratio is 0.3 with an uncertainty of  $\pm 0.2$ . Because the mixing ratio of  $^{20}\text{Ne}$  is determined from its ratio to  $^{36}\text{Ar}$ , the actual value of the neon mixing ratio is a function of the  $^{36}\text{Ar}$  mixing ratio, and of course, its uncertainty includes that determined for argon. Even with the sizeable uncertainty associated with the neon abundance, it is quite clear that its ratio to  $^{36}\text{Ar}$  is less than unity, like earth (which is 0.58), and markedly different from the solar abundance ratio of the order of 30, determined from solar wind measurements [Cameron, 1973].

The isotopic ratio,  $^{22}\text{Ne}/^{20}\text{Ne}$ , could not be determined directly from the data because the doubly charged  $\text{CO}_2$  peak at mass 22 is overwhelmingly larger than any peak that could be attributable to neon. Even at the reduced electron energy of 30 eV, the  $\text{CO}_2^{++}$  peak accounts for the entire mass 22 peak, while 22 eV electrons produce essentially no neon ions. However, the neon isotopic ratio was measured at 30 eV in the enriched noble gas sample (from the IRMC), giving the value of  $0.07 \pm 0.02$ . The error bar (1 sigma) is large owing to the low amplitudes of the peaks obtained during this measurement. The Venus ratio appears to be some 25% lower than the accepted value for earth (0.097), but it is very close to that of the solar wind [Geiss et al., 1972].

#### Helium

A problem occurred with the measurement of helium because the sounder probe was filled with a mixture of He and  $\text{N}_2$  before flight to aid in detecting leaks in the hermetically sealed probe. Submicroscopic leaks in the mass spectrometer vacuum envelope and the permeation of helium through glass electrical feedthrough terminals ( $10^{-12}$  cm<sup>3</sup>/s) caused a significant accumulation of helium in the instrument during the 5 month period in which it was bathed in the probe's internal atmosphere. The result was that a rather large background had to be subtracted from the flight data. This, coupled with

the uncertainty in the pumping speed for noble gases (as discussed above), has complicated the determination of the mixing ratio of  $^4\text{He}$  to the extent that it is not reasonable to give a helium mixing ratio at this time.

The peak at mass 3 is due to the HD molecule and to  $\text{H}_3^+$  ions formed in the ion source of the mass spectrometer. These substances account for the entire mass 3 peak over the whole altitude range of the measurements, leaving essentially no residual that could be attributable to  $^3\text{He}$ . It should be noted that a terrestrial H/D ratio (6700) was needed to fit these data, implying that Venus and earth hydrogen are similar. Assuming that because of statistical fluctuations a maximum of five counts could be assigned to  $^3\text{He}$ , the  $^3\text{He}/^4\text{He}$  ratio would have an upper limit of  $3 \times 10^{-4}$ . This value allows for a factor of 3 less  $^4\text{He}$  than the mass 4 corrected data would indicate. Through further analysis of the behavior of helium in the instrument, the limit of the helium isotopic ratio may be reduced eventually by 1 order of magnitude or more. In the earth's atmosphere this ratio is  $1.4 \times 10^{-6}$ , but since the  $^3\text{He}$  abundance in the Venus atmosphere is masked by the HD peak (most likely from the large amount of water vapor and methane in the instrument), it is uncertain how the  $^3\text{He}$  mixing ratio on Venus is related to that of earth. Even so, a large excess of  $^3\text{He}$  cannot be excluded by the results.

#### Krypton

The data indicate that the abundance of krypton on Venus is very small and that only an upper bound can be obtained. There are low, but nonnegligible, ion counts at each of the isotopes of krypton, but statistical fluctuations preclude determining whether these counts track the argon data. When compared to the largest expected krypton peak, at 84 amu, each mass corresponding to a krypton isotope is too large to indicate an earth-like isotope abundance pattern. Large peak amplitudes occur at 78 and 86 amu from vacuum sealant residual and  $^{86}\text{Kr}$  that had been introduced into the instrument during preflight calibration, while presently unknown substances may contribute to the other krypton masses. Therefore, the 84 amu data is the best source for an estimate of the upper bound for krypton on Venus. The total 84 amu peak implies a  $^{84}\text{Kr}$  to  $^{36}\text{Ar}$  ratio of  $4 \times 10^{-3}$  with a 1 sigma uncertainty of  $2 \times 10^{-3}$ . With a value of 30 ppm for the  $^{36}\text{Ar}$  abundance the  $^{84}\text{Kr}$  mixing ratio would have an upper limit of 0.2 ppm.

#### Carbon

The isotopic ratio of carbon,  $^{13}\text{C}/^{12}\text{C}$ , was determined from the ratio of the peaks at mass 22.5 and 22 as well as from 45 to 44. The first pair results from doubly charged  $\text{CO}_2$  and the second set from singly charged  $\text{CO}_2$ . The average ratio was found to be  $1.19 \pm 0.06 \times 10^{-3}$ , a value that is approximately 7% higher than the accepted value for terrestrial carbon, and lies just outside the 1 sigma error bar. However, the Venus value is probably an upper limit. In fact, the average value from the 45/44 ratio is higher than that from the 22.5/22 ratio. The ratios are not constant with altitude but tend to peak at 10-12 km. There is a distinct possibility that  $\text{HCO}_2^+$  may be contributing in different proportions to the 45 and 22.5 peaks, more to the former because this molecule would tend to ionize dissociatively rather than form a doubly charged ion of mass 45 amu. The origin of the  $\text{HCO}_2^+$  is not known but may be formed in the instrument from  $\text{CO}_2$  and hydrogen.



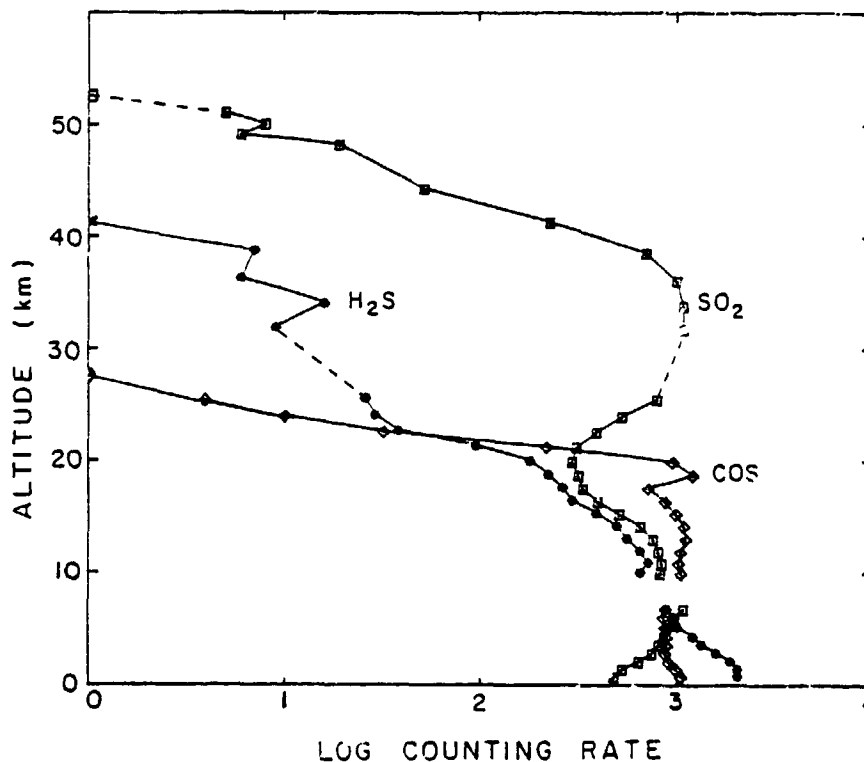

Fig. 2. Altitude profiles of COS, SO<sub>2</sub>, and H<sub>2</sub>S. Maximum in the SO<sub>2</sub> profile at 33 km is from evaporation from the H<sub>2</sub>SO<sub>4</sub> droplet on the leak. The peak in COS at 20 km is an artifact. Dashed portions of curves indicate times when low electron energy data were taken (not plotted).

#### Nitrogen

The abundance of nitrogen in the Venus atmosphere was determined from the 30/28 mass peak ratio. The 30 mass peak consists of <sup>12</sup>C<sup>18</sup>O, whereas the 28 peak is the sum of <sup>12</sup>C<sup>16</sup>O and <sup>14</sup>N<sub>2</sub>. By knowing the oxygen isotopic ratio (see below), the percentage of the 28 peak owing to CO was determined. The mixing ratio of the nitrogen was then calculated to be  $4 \pm 2\%$ . Thus the total abundance of nitrogen on Venus is equivalent to 1.5–4.5 times of that in the earth's atmosphere.

The <sup>14</sup>N peak can in principle be used to determine the N<sub>2</sub> mixing ratio. However, the mass 14 peak in the present case consists of, besides <sup>14</sup>N, CH<sub>2</sub> from methane, CO<sup>++</sup>, and N<sub>2</sub><sup>++</sup>. When corrections were made for all these contributions, the nitrogen mixing ratio was found to be in the range stated above but had a larger uncertainty and therefore contributed no new information to the N<sub>2</sub> mixing ratio.

#### Oxygen

The <sup>18</sup>O to <sup>16</sup>O isotopic ratio from the 44 and 46 peaks was found to be  $2.0 \pm 0.1 \times 10^{-3}$ , a value that agrees very closely with that of the earth's atmosphere and lies well within the error of 1 standard deviation. The peak in the mass spectrum at 32 amu can be attributed to O<sub>2</sub> and to sulfur ions. From the dissociative ionization of CO<sub>2</sub>, approximately  $2 \times 10^{-4}$  O<sub>2</sub> ions are produced relative to CO<sub>2</sub> ions. By making this correction to the 32 peak, all of its amplitude can be accounted for in the region of the clouds above where the leak blocked. This leaves an upper limit to the ambient O<sub>2</sub> concentration in this region of the Venus atmosphere of 30 ppm. In the lower part of the atmosphere, after the leak had reopened, a much larger peak at mass 32 was observed, and its position was shifted toward

that of sulfur. Contributions to this peak consist of ions formed by dissociative ionization of SO<sub>2</sub> (both S<sup>+</sup> and O<sub>2</sub><sup>+</sup>) and S<sup>+</sup> from H<sub>2</sub>S and COS. By making appropriate corrections for all of these sources of the mass 32 peak again, all of the peak amplitude can be accounted for. Therefore, the upper limit for the O<sub>2</sub> mixing ratio in this part of the atmosphere is also 30 ppm.

#### Sulfur Dioxide

The variation with altitude of several sulfur compounds is shown in Figure 2. From the closeness with which the peaks at 48 and 64 amu track each other, it is fairly certain that the ions which formed the 64 peak in the mass spectrum are due to SO<sub>2</sub> and those at mass 48 are due to SO which result from dissociative ionization of SO<sub>2</sub> in the ion source. This would preclude the possibility of a significant amount of S<sub>2</sub> ions at 64 amu because these would not produce the 48 peak. In the region above the altitude of leak blockage, there is an average of only one to two counts per mass spectrum at the mass 64 peak. (These are not shown in the figure.) Because of uncertainties in the wall adsorption of SO<sub>2</sub>, the actual SO<sub>2</sub> mixing ratio may be larger than this peak amplitude would indicate. This argues for an upper limit of 10 ppm. After the leak was blocked, the magnitude of the 64 peak grew rapidly (see Figure 2) as was discussed above, indicating that SO<sub>2</sub> was coming from a vaporization of the leak blockage material. When the leak reopened, a large SO<sub>2</sub> peak remained which did not follow the CO<sub>2</sub> altitude profile but exhibited a rather large maximum at an altitude of approximately 6 km above the surface and decreased a factor of 3 from there to the surface. Similar variations of SO<sub>2</sub> and SO have been noted in laboratory tests of

leaks that have been blocked with sulfuric acid and subsequently reopened by heating in the VAS chamber. Because of this large contaminant, only an upper limit of 300 ppm can be placed on the SO<sub>2</sub> mixing ratio for the lower atmosphere. It is quite possible that the actual mixing ratio is much lower and that the mass 64 peak almost entirely is due to cloud materials which earlier had blocked the leak.

#### Carbonyl Sulfide

Previously reported mass spectrometer results [Hoffman *et al.*, 1979b] showed a very rapid 3 order of magnitude increase in the peak at 60 amu from 24 to 20 km followed by a factor of 2 decrease between 19 and 18 km and then a rather constant amplitude to the surface, as is shown in Figure 2. This profile is not typical of an ambient atmospheric gas, particularly the maximum at 19–20 km. The laboratory tests of leak blockage with sulfuric acid in the VAS chamber, as described above, and the closeness of the 62/60 amu peak ratio to that of the sulfur isotopes in both the flight and laboratory data, indicate that the 60 amu peak is due to COS and that COS probably was formed in the leak in some reaction involving the H<sub>2</sub>SO<sub>4</sub> droplets and CO<sub>2</sub>. Therefore, it is concluded that the rapid rise in the COS is an artifact of the measurement system and that the presence of COS in the Venus atmosphere is questionable. If the entire 60 amu peak were considered ambient, the mixing ratio would be less than 500 ppm, but from the considerations given above it is quite probable that this is a very high upper limit. Above 24 km there is no 60 amu peak in the spectrum, which implies an upper limit for COS of 3 ppm, again a conservative value.

#### Hydrogen Sulfide

The peak in the mass spectrum at 34 amu has an altitude profile (slope) (Figure 2) below 24 km similar to that of <sup>36</sup>Ar except for a small enhancement near 10 km. A correction has been made to the peak amplitude for the <sup>34</sup>S contribution from the sulfur dissociatively ionized from SO<sub>2</sub> and COS. The remaining 34 peak probably was due to H<sub>2</sub>S. This contention is supported by the fact that the 33 peak, HS ions produced in the ion source, tracks it very well. The similarity in slopes between H<sub>2</sub>S and Ar arises because the getter does not pump H<sub>2</sub>S significantly, and therefore it has the same flow path as argon in the instrument. It also is possible that the 34 amu peak is H<sub>2</sub>O<sub>2</sub>, with the 33 peak being HO<sub>2</sub>. Laboratory studies involving these gases will be necessary to resolve this question. For now it is assumed that this peak is H<sub>2</sub>S, in which case the ratio of H<sub>2</sub>S to <sup>36</sup>Ar would be 0.09 ± 0.01, if the <sup>36</sup>Ar mixing ratio is 30 ppm, then the H<sub>2</sub>S mixing ratio is 3 ± 2 ppm. In the region of the clouds it appears that relative to <sup>36</sup>Ar the H<sub>2</sub>S mixing ratio is a factor of 3 less than in the lower part of the atmosphere. It does not appear that the bulk of the 34 amu peak is produced in the instrument in a reaction involving hydrogen or water vapor or any other sulfur compound because its altitude profile follows that of argon.

#### Ethane

The nongettered gas, C<sub>2</sub>H<sub>6</sub>, forms the only other peak in the mass spectrum that has an altitude profile similar to that of <sup>36</sup>Ar and is a candidate for an ambient Venus gas. The ratio of ethane to <sup>36</sup>Ar is 0.07 ± 0.03, making its mixing ratio of the order of 2 ppm. Ethane was measurable at 30 amu by virtue of the fact that the mass spectrometer's mass resolution was suf-

ficiently high to separate the C<sub>2</sub>H<sub>6</sub> peak from an almost equal amplitude <sup>12</sup>C<sup>18</sup>O peak.

#### Water Vapor

The peak in the mass spectrum at 18 amu owing to water vapor in the cloud region of the atmosphere has a rather constant ratio to CO<sub>2</sub> of approximately 500 ppm. However, it is not clear if it is all due to ambient water vapor or partly to some instrumental source, although the residual before entry into the atmosphere was very low. Therefore, only a conservative upper limit of 1000 ppm will be reported at this time. In the region where the leak was blocked, the mass 18 peak grew rapidly (along with the SO<sub>2</sub> peak), indicating that the droplet on the leak was emitting water, a phenomenon that has been observed in laboratory studies of leaks coated with sulfuric acid. Below the altitude at which the leak reopened, the water peak again passed through a maximum, probably caused by heating of the inlet leak and a more rapid release of residual vapor into the mass spectrometer. Hence, it is not clear how much of the water vapor measured below the clouds is ambient.

#### Chlorine

For a discussion of the improbability that the large mass 36 and 38 peaks may include a significant amount of chlorine or HCl, the reader is referred to Hoffman *et al.* [1979b, this issue]. The conclusion drawn there is that the mixing ratio of chlorine in the lower atmosphere is not more than 10 ppm.

#### Mercury

At the high mass end of the spectrum there were only a few scattered counts, and no consistent pattern was found in the data in the range of the mercury isotopes (masses 198–204) near the surface of Venus. From laboratory calibrations on mercury it is concluded that the upper limit on this mixing ratio is 5 ppm.

#### CONCLUSION

In the foregoing discussion, all results quoted are based on data from the sounder probe neutral mass spectrometer. These results are in general agreement with reported data from six other atmosphere analyzers which sampled the Venus atmosphere in December 1978 as part of the Pioneer Venus and Venera 11 and 12 missions (cf. the companion paper Hoffman *et al.* [this issue] for a detailed comparison of these measurements).

It is clear that the major constituents of the Venus atmosphere are CO<sub>2</sub> and N<sub>2</sub>, with the latter being of the order of 3% by mass. Owing to the excessive amount of Venus atmosphere in comparison with that of earth, the amount of atmospheric N<sub>2</sub> on Venus is about 3 times that in the earth's atmosphere. However, since there are 2 or 3 atm of nitrogen fixed in the earth's crust, the total mass mixing ratio of nitrogen is similar for the two planets. For Mars the nitrogen abundance is 1–2 orders of magnitude less [Owen *et al.*, 1977]. All other constituents of the Venus atmosphere have volumetric mixing ratios less than 100 ppm with the exception of water vapor, COS, and SO<sub>2</sub> for which higher upper limits have been quoted.

For oxygen the mass spectrometer determined only an upper limit of 30 ppm, but the actual abundance may be lower. A low value would be necessary if the amount of reduced sulfur compounds in the atmosphere were very high.

Earlier reports indicated evidence of a large abundance of COS below 20 km with a sharp decrease between there and 24 km, a feature which laboratory tests described above now suggest to be an artifact of the passage of CO<sub>2</sub> and H<sub>2</sub>SO<sub>4</sub> into the heated inlet leak. Because there is no COS above 24 km, it is not clear that there is evidence for any COS in the Venus atmosphere above the few parts per million level.

It is interesting to note that the ratio of SO<sub>2</sub> to H<sub>2</sub>O being evaporated from cloud droplets was equivalent to that from H<sub>2</sub>SO<sub>4</sub> at a concentration of 85%. This is consistent with leak blockage by mode 2, and possibly mode 3, droplets that were observed by the Pioneer Venus cloud particle spectrometer [Knollenberg and Hunten, 1979] in the middle and lower cloud regions.

Because of the SO<sub>2</sub> produced from the cloud droplet on the leak, it is not possible to specify the amount of ambient SO<sub>2</sub> in the lower atmosphere, and only an upper limit has been set. However, the H<sub>2</sub>S measurement of a few parts per million is probably valid, although H<sub>2</sub>O<sub>2</sub> may fit the data equally well. The total sulfur mixing ratio in the lower atmosphere (below 20 km) may be of the order of 10<sup>-3</sup> to 10<sup>-4</sup>, allowing for undetected amounts of SO<sub>2</sub> and COS, but not as great as 10<sup>-3</sup> as reported earlier [Hoffman et al., 1979b]. In the clouds the sulfur mixing ratio is probably in the range of 10<sup>-5</sup>.

The large excess of the nonradiogenic rare gases in the Venus atmosphere over that in the earth's atmosphere is a result that was noted earlier [Hoffman et al., 1979a, b] and has withstood more careful data analysis tests since then. If these gases are assumed to be primordial, this finding implies a defect in generally accepted theories of the origin of the solar system. Pollack and Black [1979] described the problem in some detail, concluding that the grain accretion hypothesis, with a rather flat temperature gradient but a steep pressure gradient in the solar nebula in the region where the terrestrial planets formed, best accounts for the conditions found on these planets. Older ideas imply that volatile incorporation occurred during a cooling down phase in the evolution of the solar nebula which would have resulted in a depletion of primordial gases in the vicinity of Venus rather than an excess.

Also of significance is the fact that the total abundance of radiogenic <sup>40</sup>Ar is only about one third of that on earth. This is truly curious because on earth about 10% of the argon that has been produced by radioactive decay of potassium has been released to the atmosphere, presumably because of the weathering of rocks. On the moon, where no weathering occurs, the present rate of emission of <sup>40</sup>Ar is about 6% of the total production rate, implying that other mechanisms of release of trapped gases are as important as weathering [Hodges and Hoffman, 1975]. Therefore, it was expected that the amount of <sup>40</sup>Ar on Venus might be quite large; it is possible that the low amount found there indicates that Venus has much less potassium than earth. However, the Venera 8, 9, and 10 data suggest a similarity [Surkov et al., 1976], at least near the surface, and hence the lower Venus <sup>40</sup>Ar may result from a less efficient release mechanism on that planet than from earth [Pollack and Black, 1976].

The <sup>20</sup>Ne/<sup>36</sup>Ar ratio being of the order of 0.3, more like the earth rather than the sun, indicates that the origin of these gases is not accumulation from the solar wind unless the solar ratio was markedly different in early geologic time than that

found today. In addition, the isotopic ratios of carbon, oxygen, and nonradiogenic argon were found to be similar to those on earth. The ratio of the neon isotopes seem to be more like that of the solar wind.

The Pioneer Venus and Venera experiments flown to our sister planet to study its atmospheric chemical composition have shown that there are marked differences in the atmospheres of the two planets besides the very high surface temperature and pressure of Venus and the dominant gas on Venus being CO<sub>2</sub>. The presence on Venus of excess nonradiogenic, possibly primordial, rare gases, the almost total absence of O<sub>2</sub>, and the possible presence of reducing compounds like C<sub>2</sub>H<sub>6</sub> and H<sub>2</sub>S are significant.

*Acknowledgments.* One of us (J. H. H.) wishes to acknowledge the support he received from the Max Planck Institut für Kernphysik in Heidelberg while in residence as a Visiting Scientist from June–December 1979. We appreciate the interest and support of C. Hall and the Pioneer Project Office at NASA Ames Research Center throughout this program and especially that of L. Polaski, C. Leidich, and J. Terhune in helping make this experiment a success. Also, L. Colin, Project Scientist, deserves recognition for his guidance and interest. We acknowledge the fine work and dedication of the technical staff at The University of Texas at Dallas who unselfishly gave of their time and talents in design, fabrication, testing, and calibration of the instrument.

#### REFERENCES

- Campanon, A. W. G., Abundance of elements in the solar system, *Space Sci. Rev.*, **15**, 123, 1975.
- Colin, L., Encounter with Venus, *Science*, **203**, 743, 1979.
- Geiss, J., F. Buehler, H. Bockelée-Bruehaert, and C. Filleux, Solar wind composition experiment, Apollo 16 Preliminary Science Report, NASA SP-315, no. 14, 1974.
- Hodges, R. R., Jr., and J. Hoffman, Implications of atmospheric <sup>40</sup>Ar escape on the interior structure of the moon, *Proc. Lunar Sci. Conf.*, **6**, 3039, 1975.
- Hoffman, J. H., R. R. Hodges, Jr., M. B. McElroy, and T. M. Donahue, Venus lower atmospheric composition: Preliminary results from Pioneer Venus, *Science*, **203**, 800, 1979a.
- Hoffman, J. H., R. R. Hodges, M. B. McElroy, T. M. Donahue, and M. Kolpin, Composition and structure of the Venus atmosphere: Results from Pioneer Venus, *Science*, **205**, 49, 1979b.
- Hoffman, J. H., R. R. Hodges, Jr., and K. D. Duerksen, Pioneer Venus large probe neutral mass spectrometer, *J. Vac. Sci. Technol.*, **16**(2), 692, 1979c.
- Hoffman, J. H., R. R. Hodges, Jr., W. W. Wright, V. A. Blevins, K. D. Duerksen, and L. D. Brooks, Sounder probe neutral gas mass spectrometer, *IEEE Geosci. Rem. Sensing*, **GE-18**(1) 30–34, 1980.
- Hoffman, J. H., V. I. Cyamco, and U. von Zahn, Measurements of the Venus lower atmosphere composition: A comparison of results, *J. Geophys. Res.*, this issue.
- Knollenberg, R. G., and D. M. Hunten, Clouds of Venus: A preliminary assessment of microstructure, *Science*, **205**, 70, 1979.
- Owen, T., K. Biemann, D. R. Rushneck, J. E. Biller, D. W. Howarth, and A. L. Lafleur, The composition of the atmosphere at the surface of Mars, *J. Geophys. Res.*, **82**, 4635, 1977.
- Pollack, J. B., and D. C. Black, Implications of the gas compositional measurements of Pioneer Venus for the origin of planetary atmospheres, *Science*, **205**, 56, 1979.
- Surkov, Y. A., F. F. Kirnozov, V. N. Glazov, and G. A. Fedoseyev, Investigations of Venusian gamma-radiation by Venera 9 and Venera 10, paper presented at 19th meeting of COSPAR, Philadelphia, Pennsylvania, 1975.

(Received December 12, 1979  
revised May 8, 1980,  
accepted May 13, 1980.)