

WASH LK-100,010



3 1176 00504 3139

DOE/NASA/0124-7
NASA CR-165510
ERC TR-8191

NASA-CR-165510
19820016620

Small Passenger Car Transmission Test- Mercury Lynx ATX Transmission

M. P. Bujold
Eaton Corporation
Engineering & Research Center

September 1981

LIBRARY COPY

JUN 21 1982

LANGLEY RESEARCH CENTER
11100 COLLETTA
HAMPSHIRE, VIRGINIA

Prepared for
NATIONAL AERONAUTICS AND SPACE ADMINISTRATION
Lewis Research Center
Under Contract DEN 3-124

for
U.S. DEPARTMENT OF ENERGY
Conservation and Renewable Energy
Office of Vehicle and Engine R&D

NOTICE

This report was prepared to document work sponsored by the United States Government. Neither the United States nor its agent, the United States Department of Energy, nor any Federal employees, nor any of their contractors, subcontractors or their employees, makes any warranty, express or implied, or assumes any legal liability or responsibility for the accuracy, completeness, or usefulness of any information, apparatus, product or process disclosed, or represents that its use would not infringe privately owned rights.

DOE/NASA/0124-7
NASA CR-165510
ERC TR-8191

Small Passenger Car Transmission Test- Mercury Lynx ATX Transmission

M. P. Bujold
Eaton Corporation
Engineering & Research Center
Southfield, Michigan 48037

September 1981

Prepared for
National Aeronautics and Space Administration
Lewis Research Center
Cleveland, Ohio 44135
Under Contract DEN 3-124

for
U.S. DEPARTMENT OF ENERGY
Conservation and Renewable Energy
Office of Vehicle and Engine R&D
Washington, D.C. 20585
Under Interagency Agreement DE-AI01-77CS51044

1182-24496#

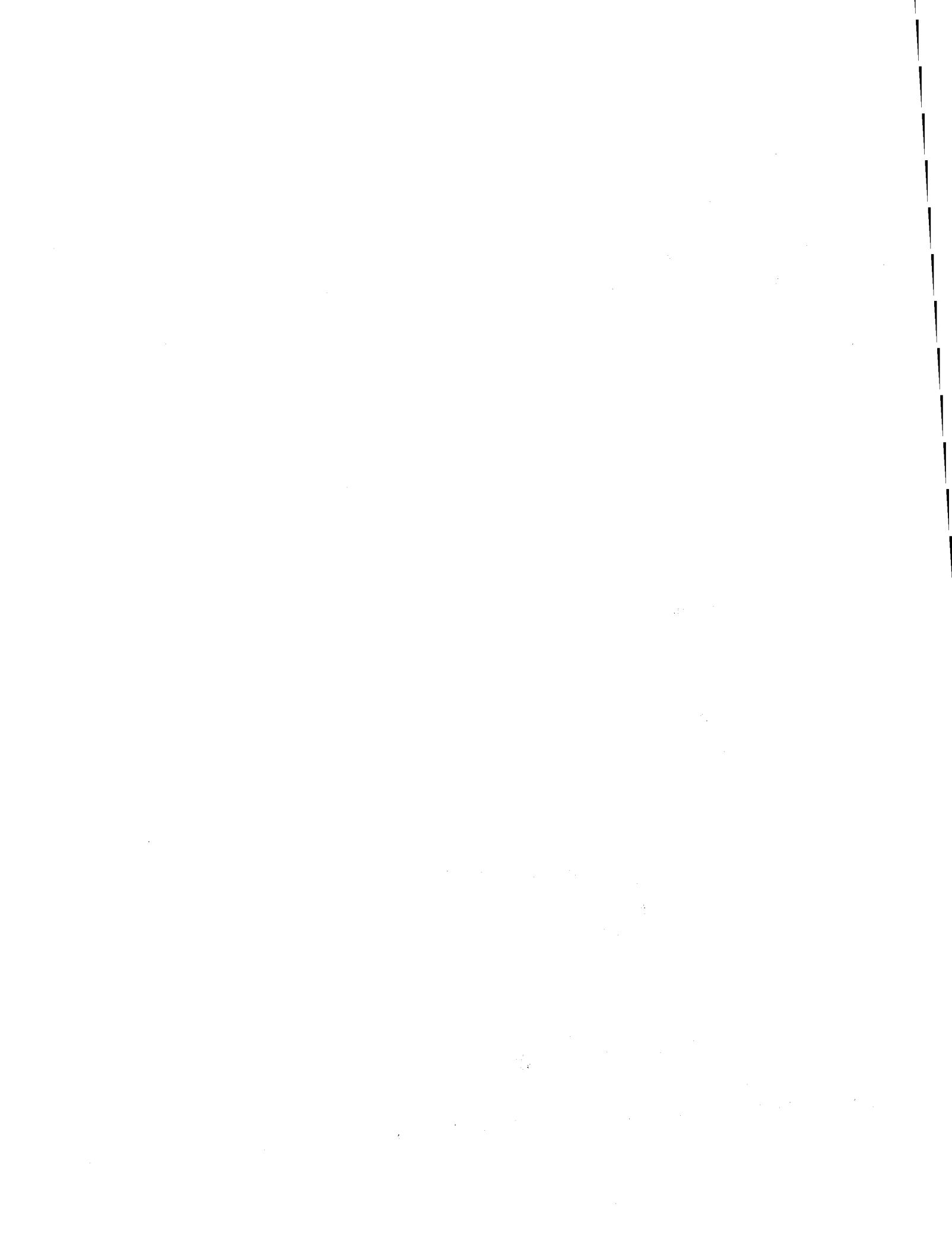

PREFACE

The Electric and Hybrid Vehicle Research, Development, and Demonstration Act of 1976 (Public Law 94-413) authorized a Federal program of research and development designed to promote electric and hybrid vehicle technologies. The Energy Research and Development Administration, now the Department of Energy (DOE), which was given the responsibility for implementing the Act, established the Electric and Hybrid Vehicle Research, Development, and Demonstration Project to manage the activities required by Public Law 94-413.

The National Aeronautics and Space Administration under an Interagency Agreement was requested by ERDA (DOE) to undertake research and development of propulsion systems for electric and hybrid vehicles. The Lewis Research Center was made the responsible NASA Center for this project. The work presented in this report is a part of that program.

The work described in this report was conducted under Contract DEN3-124 with the National Aeronautics and Space Administration (NASA) and sponsored by the Department of Energy through an agreement with NASA.

TABLE OF CONTENTS

	<u>PAGE</u>
SUMMARY.....	1
INTRODUCTION.....	2
EQUIPMENT TESTED.....	3
TEST APPARATUS.....	4
TEST PROCEDURE.....	16
TEST RESULTS.....	26
DRIVE PERFORMANCE COVER SHEET.....	27
Drive Performance 1st Gear Input Torque = 10 lb-ft	29
" " " " " 20 lb-ft	34
" " " " " 30 lb-ft	39
" " " " " 40 lb-ft	44
" " " " " 50 lb-ft	49
" " " " " 60 lb-ft	54
" " " " " 70 lb-ft	59
" " " " " 80 lb-ft	64
DRIVE PERFORMANCE COVER SHEET.....	69
Drive Performance 2nd Gear Input Torque = 10 lb-ft	71
" " " " " 20 lb-ft	76
" " " " " 30 lb-ft	81
" " " " " 40 lb-ft	86
" " " " " 50 lb-ft	91
" " " " " 60 lb-ft	96
" " " " " 70 lb-ft	101
" " " " " 80 lb-ft	106
DRIVE PERFORMANCE COVER SHEET.....	111
Drive Performance 3rd Gear Input Torque = 10 lb-ft	113
" " " " " 20 lb-ft	118
" " " " " 30 lb-ft	123
" " " " " 40 lb-ft	128
" " " " " 50 lb-ft	133
" " " " " 60 lb-ft	138
" " " " " 70 lb-ft	143
" " " " " 80 lb-ft	148

TABLE OF CONTENTS (cont.)

	<u>PAGE</u>
CROSS SECTIONAL ROAD LOAD PERFORMANCE COVER SHEET	153
Cross Sectional Road Load Performance 3rd Gear	
Output Torque = 25 lb-ft	155
" " 47 lb-ft	160
" " 79 lb-ft	165
" " 110 lb-ft	170
" " 145 lb-ft	175
" " 177 lb-ft	180
" " 208 lb-ft	185
" " 243 lb-ft	190
COAST PERFORMANCE COVER SHEET.....	195
Coast Performance 1st Gear Engine Torque = 10 lb-ft	200
" " " " 20 lb-ft	202
" " " " 30 lb-ft	207
" " " " 40 lb-ft	212
" " " " 50 lb-ft	217
COAST PERFORMANCE COVER SHEET.....	222
Coast Performance 2nd Gear Engine Torque = 10 lb-ft	224
" " " " 20 lb-ft	229
" " " " 30 lb-ft	234
" " " " 40 lb-ft	239
" " " " 50 lb-ft	244
" " " " 60 lb-ft	249
" " " " 70 lb-ft	254
" " " " 80 lb-ft	259
COAST PERFORMANCE COVER SHEET.....	264
Coast Performance 3rd Gear Engine Torque = 10 lb-ft	266
" " " " 20 lb-ft	271
" " " " 30 lb-ft	276
" " " " 40 lb-ft	281
" " " " 50 lb-ft	286
" " " " 60 lb-ft	291
" " " " 70 lb-ft	296
" " " " 80 lb-ft	301
NO LOAD LOSSES COVER SHEET.....	306
No Load Losses 1st Gear Closed Throttle.....	307
" 1st Gear Open Throttle.....	309
" 2nd Gear Closed Throttle.....	311
" 2nd Gear Open Throttle.....	313
" 3rd Gear Closed Throttle.....	315
" 3rd Gear Open Throttle.....	317
APPENDIX.....	319

SUMMARY

The small passenger car transmission test was initiated to supply electric vehicle manufacturers with technical information regarding the performance of commercially available transmissions. This information would enable EV manufacturers to design a more energy efficient vehicle. With this information the manufacturers would be able to estimate vehicle driving range as well as speed and torque requirements for specific road load performance characteristics.

This report covers the 1981 Mercury Lynx ATX transaxle. This transmission was tested per a passenger car automatic transmission test code (SAE J651b) which required drive performance, coast performance, and no load test conditions. Under these test conditions the transmission attained maximum efficiencies in the 93% range for drive performance tests. The major results of this test are the torque, speed and efficiency curves which are located in the data section of this report. These graphs map performance characteristics for the Mercury Lynx ATX transmission.

INTRODUCTION

The Mercury Lynx ATX is a commercially available automatic transmission which is suited for a small passenger car installation. The transmission is equipped with three forward driving ranges: a neutral, reverse and park. Very little technical information in the area of torque, speed and efficiency data is currently available on this transmission. This lack of available information was the principal reason for the initiation of this test.

The principal object of this test was to map torque, speed, and efficiency curves of the test transmission in each gear range and in both drive performance and coast performance conditions. The test was performed per the specifications of the Passenger Car Automatic Transmission Test Code - SAE J651b. The torque and speed limits of this test were governed by the torque and speed limits of an engine which would typically be supplied with this transmission. The test code specified that three basic tests were to be conducted which involved holding the torque constant and varying the transmission speed. The three specific tests were drive performance, coast performance, and no load losses which were conducted in first, second and third gear.

The test code required that the transmission should be held in gear over the complete range of the test. In order to accomplish this, it was necessary to block the valves. This kept the transmission locked in gear. The test code also specified an oil temperature requirement to ensure that a set viscosity level be attained throughout the tests. This temperature requirement was accomplished through the use of an immersion heater and oil cooler.

There were two main factors which determined the amount of load which could be applied to the system. These factors were the temperature of the transmission oil and the torque-speed characteristics of the absorber and dynamometer. The torque-speed characteristics of the absorber and dynamometer are contained in the Appendix.

The data that were obtained from the torque and speed sensors were placed directly onto tape. The tape was then fed into a computer which reduced the data and generated the necessary graphs and technical information. The main advantage to this method of data reduction is that any fluctuation that may occur due to system resonance is averaged by the computer. This method minimizes the operator error and allows the data to be viewed soon after the tests are completed.

EQUIPMENT TESTED

This report involves the test conducted on a 1981 Mercury Lynx ATX (C1712PMA A2, 149228 ELEP AE). The automatic transaxle (ATX) combines an automatic transmission and differential into a single powertrain component designed for front wheel drive applications.

The ATX uses three friction clutches, one band and a single one way clutch. These components are applied as necessary to transmit engine torque through a compound planetary gear set. The planetary provides three forward gear ratios and one reverse. The ATX uses a standard torque converter with an internal splitter gear which provides mechanical connection between the engine and the transaxle. The splitter gear minimizes the converter slippage in second and third gear range. In first and reverse the engine torque is 100% hydraulically transmitted. In second and third gears the engine torque is split between the converter turbine and the splitter gear. This reduces torque converter losses and improves the efficiency of the transmission.

The transmission hydraulic system is pressurized by a gear type pump which provides the working pressure to operate the friction elements and automatic controls.

TEST APPARATUS

The test apparatus used in testing the Mercury Lynx ATX transmission consisted of the following basic items which are described and listed below. The set-up was basically the same for drive and coast performance tests except that the transmission was indexed 180° for coast performance tests.

The driving dynamometer was used to power the transmission. A torque sensor was placed on the dynamometer shaft to accurately monitor the torque into the transmission. A speed pickup was placed on the dyno shaft to measure the speed into the transmission.

The output shaft of the transmission was coupled to a torque sensor which accurately measured its torque. The torque sensor shaft was then coupled to a HY-VO chain drive (4:1 ratio) which was coupled to the absorber shaft. The purpose of the chain drive was to increase the slower output shaft speed into a range which would be acceptable to the absorber power requirements. The absorbing dynamometer was used to apply the system load. A speed pickup was mounted to the absorber shaft to measure output speed.

The transmission oil temperature was controlled through the use of a heat exchanger and circulation heater. When the transmission was operating at light load, the oil cooler was shut down and the circulation heater was engaged so that the oil could be kept up to temperature specification. When the transmission was operating under heavy load, the oil cooler was operating and the circulation heater was disengaged so that the temperature specification was not exceeded.

The transmission was held in first gear by placing the gear selector lever in its appropriate setting. The transmission was held in second gear by blocking the 1 to 2 shift valve in the second position. The transmission was held in third gear by placing stops in the 1 to 2 shift valve and the 2 to 3 shift valve so the valves were kept in the 2 and 3 position, respectively.

The transmission differential was locked for the entire test program. This was accomplished by welding the pinion gears to the differential carriers. This allowed the power to flow through one output shaft. This means that the output torques (drive performance) and input torques (coast performance) shown in the graphs are twice the values that each wheel would feel. However, the output speeds (drive performance) and input speeds (coast performance) are the actual speeds at each wheel.

The instrumentation for the setup consisted of the following basic items. The Lebow torque sensor was used in conjunction with a Daytronic signal conditioner (878). The Himmelstein torque sensor was matched with a Daytronic signal conditioner (878A). The magnetic speed pickup was used with an Airpax speed readout. These signals were then fed into a Sangamo 3500 tape recorder. The tape recorded data were then fed into a Hewlett Packard Analyzer which reduced the data.

<u>DESCRIPTION</u>	<u>PART NO.</u>	<u>MANUFACTURER</u>
Driving Dynamometer	Model 26G308	General Electric
Flexible Coupling	226 SN	Thomas-Rexnord
Torque Sensor	MCRT6-02T(2-3)	Himmelstein
Pilot Bearing	SFT-15	Sealmaster
Transmission	Lynx ATX	Mercury
Rear Bearing	209-SFF	MRC
Flexible Coupling	226 SN	Thomas-Rexnord
Torque Sensor	1648-5K	Lebow
Torque Sensor	1248-20K	Lebow
Absorber	1014DG	Dynamatic
Heat Exchanger	F-301-ER-2P	Young
Circulation Heater	NWHO-2	Chromalox
Pressure Gage	D-0252	Marsh
HY VO Chain Drive (4:1)	1.25 WIDE	Morse

INSTRUMENTATION

Torque Signal Conditioner	878A	Daytronic
Torque Signal Conditioner	878	Daytronic
Speed Readout	761400110	Airpax
Temperature Conditioner	810	Daytronic
Thermocouples	6610WBA2	Applied Instruments
FM Tape Recorder	3500	Sangamo
Speed Pickup	3030 AN	Electro
Speed Conditioner	840	Daytronic
Analyzer	5451B	Hewlett Packard

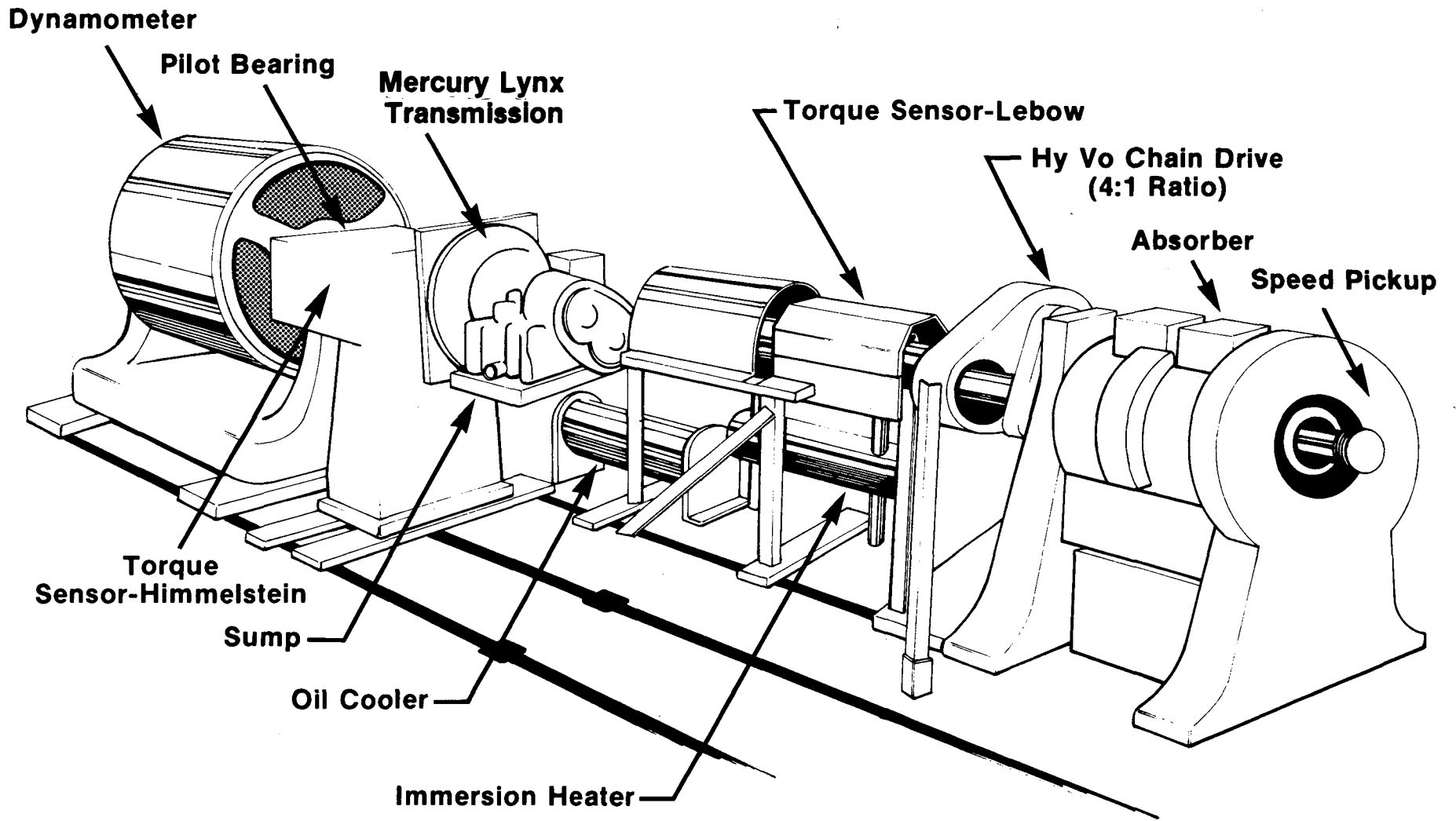

Drive Performance Test Setup

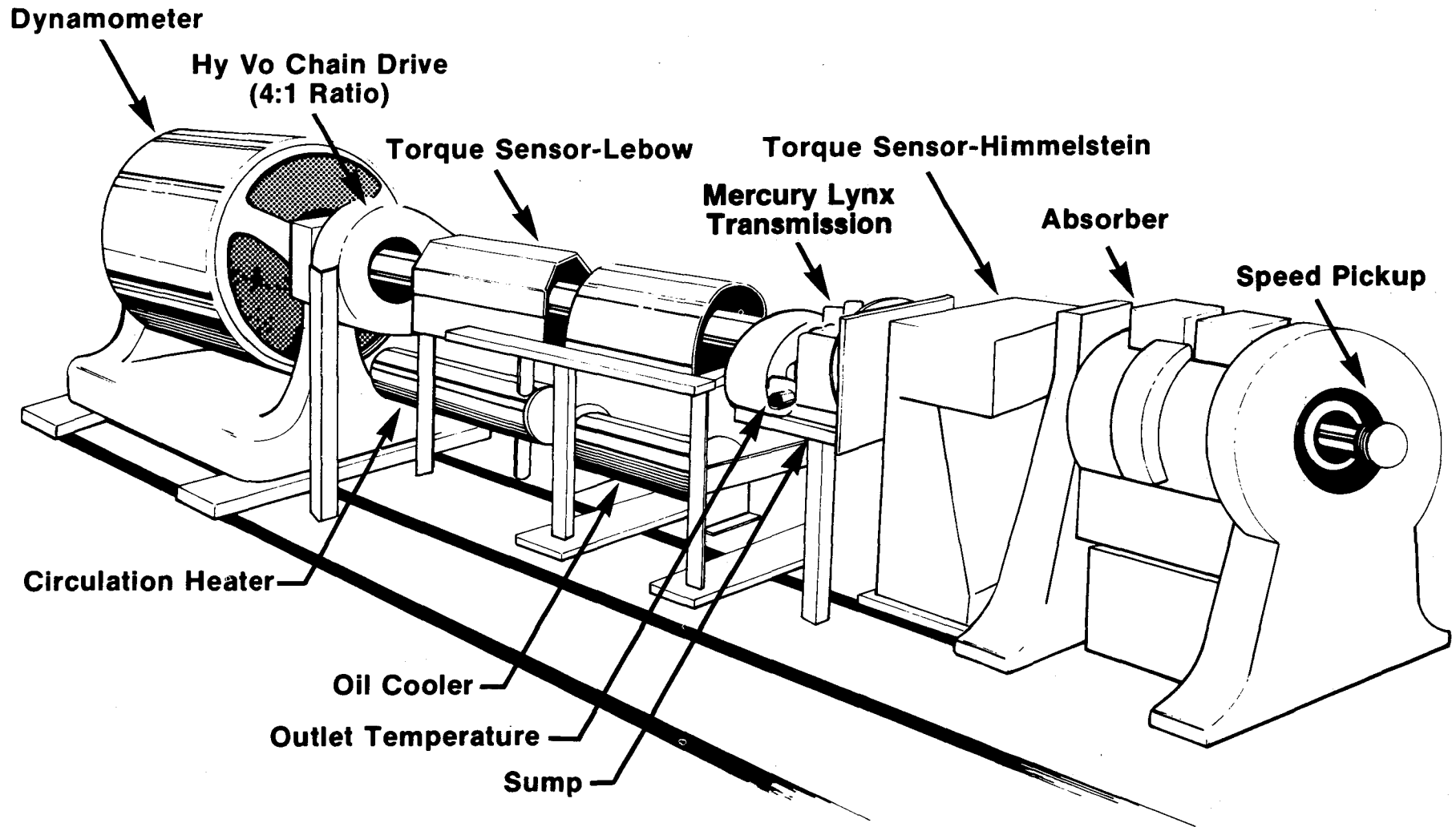

Coast Performance Test Setup

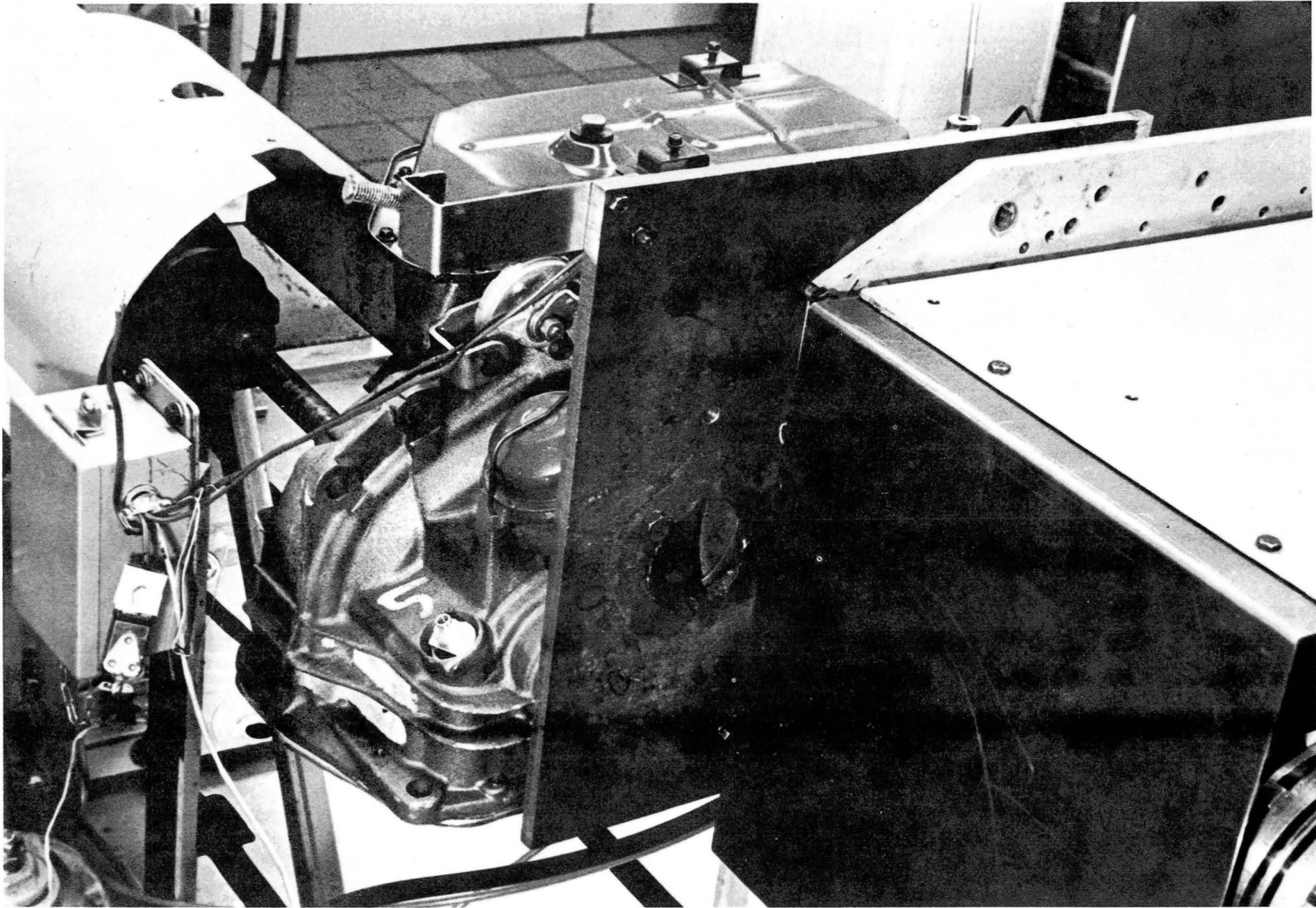

**1981 Mercury Lynx Drive Performance Test Setup
Front View**

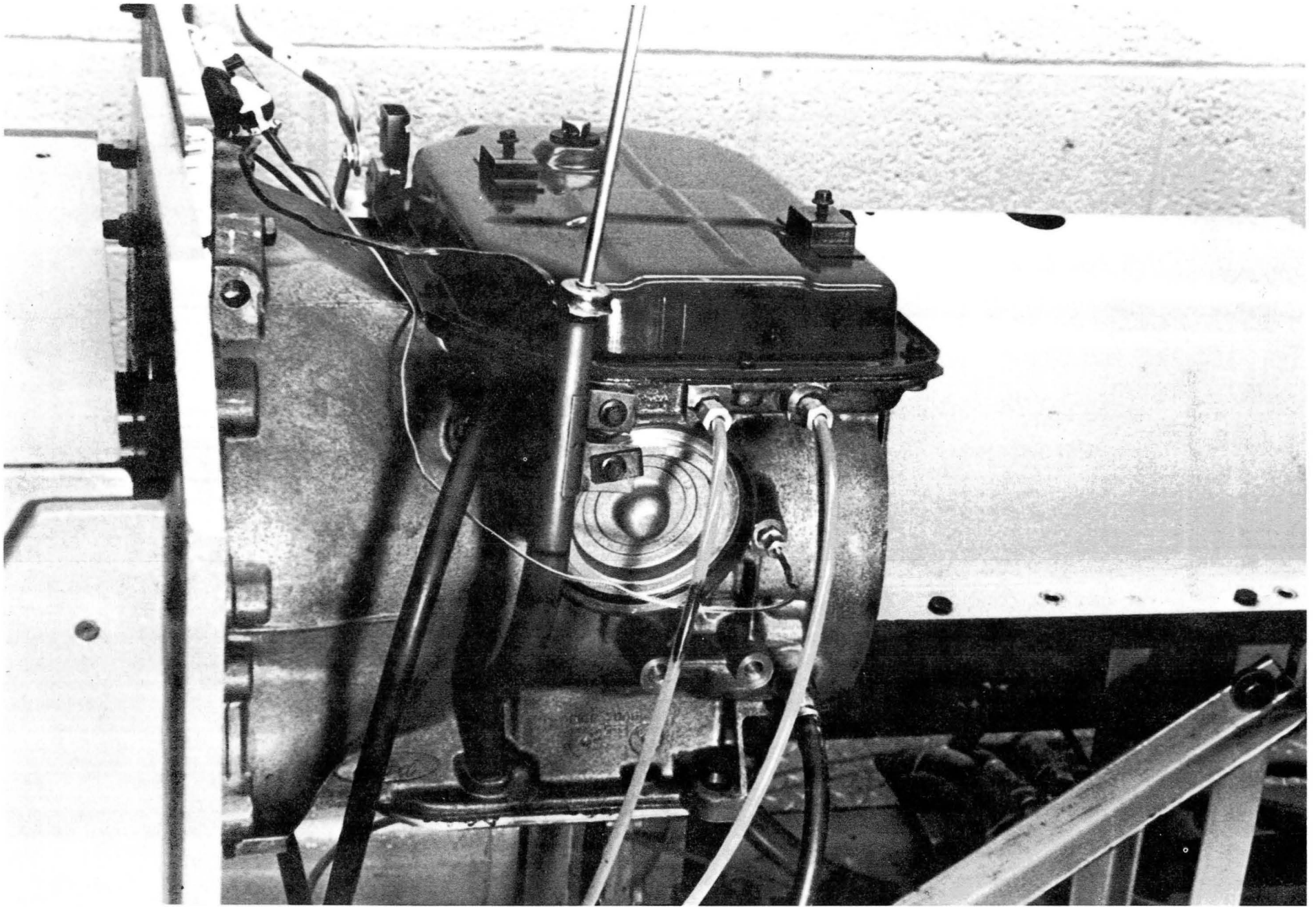

**1981 Mercury Lynx Drive Performance Test Setup
Side View**

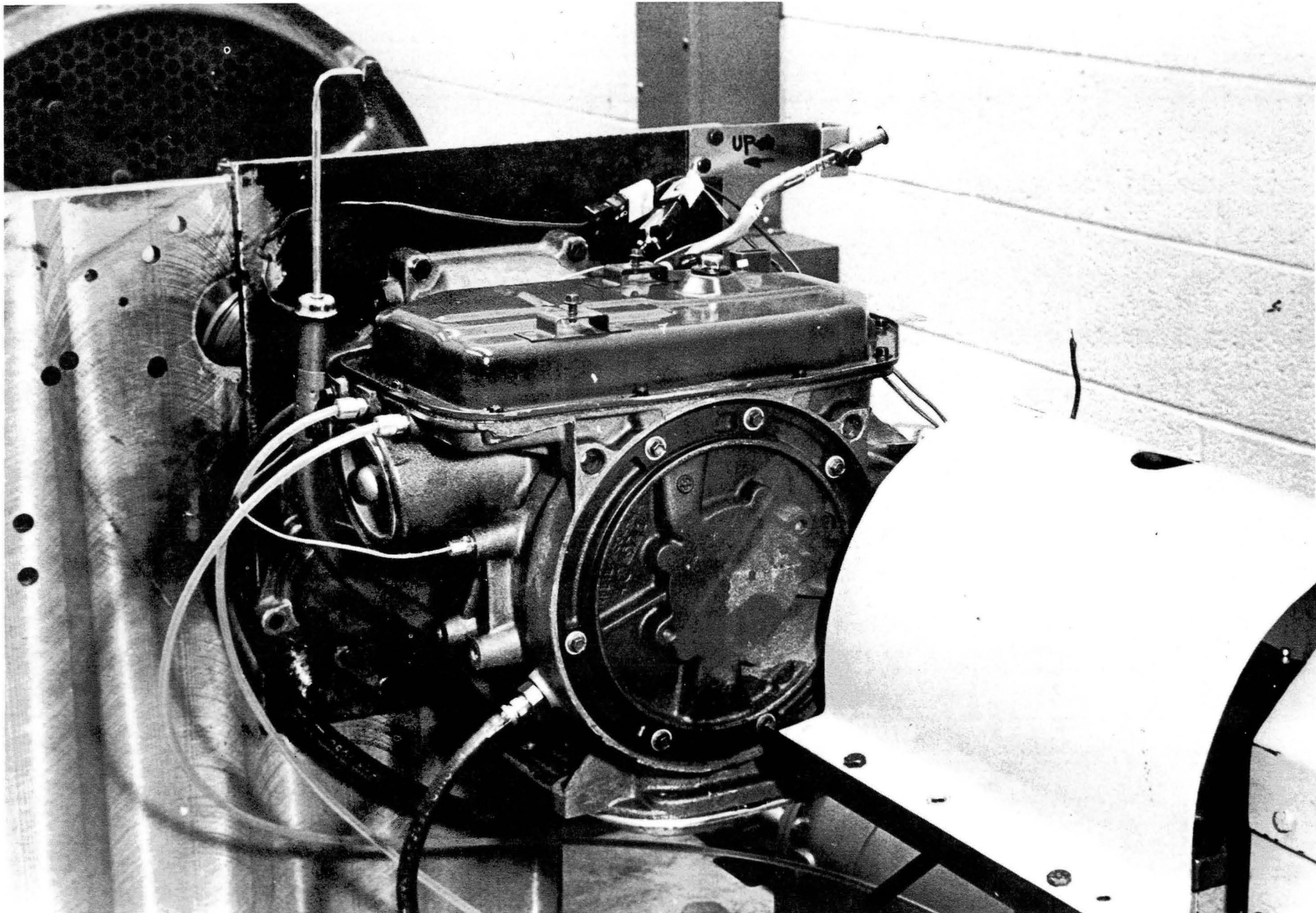

1981 Mercury Lynx Drive Performance Test Setup
Back View

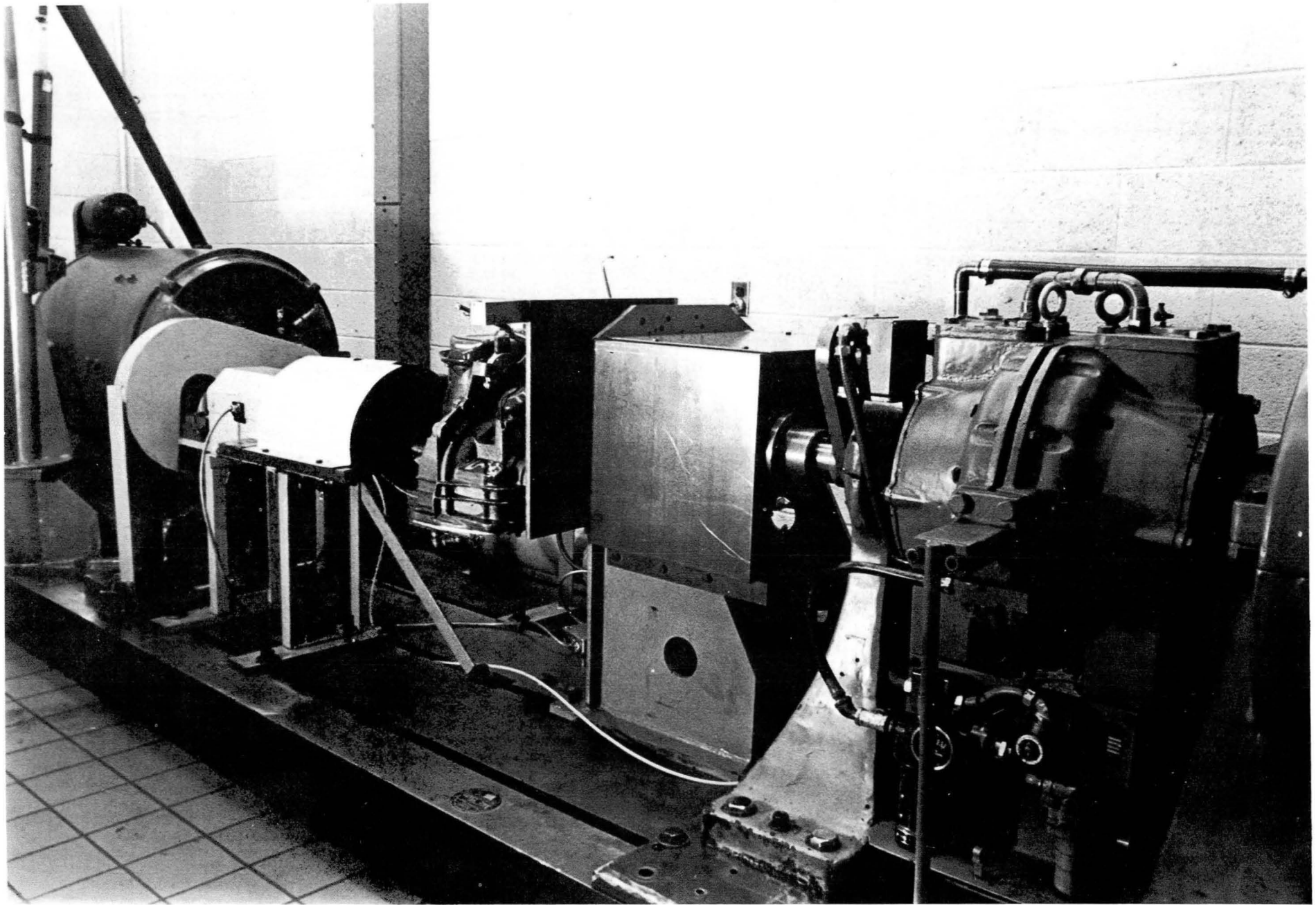

**1981 Mercury Lynx Coast Performance Test Setup
Front View**

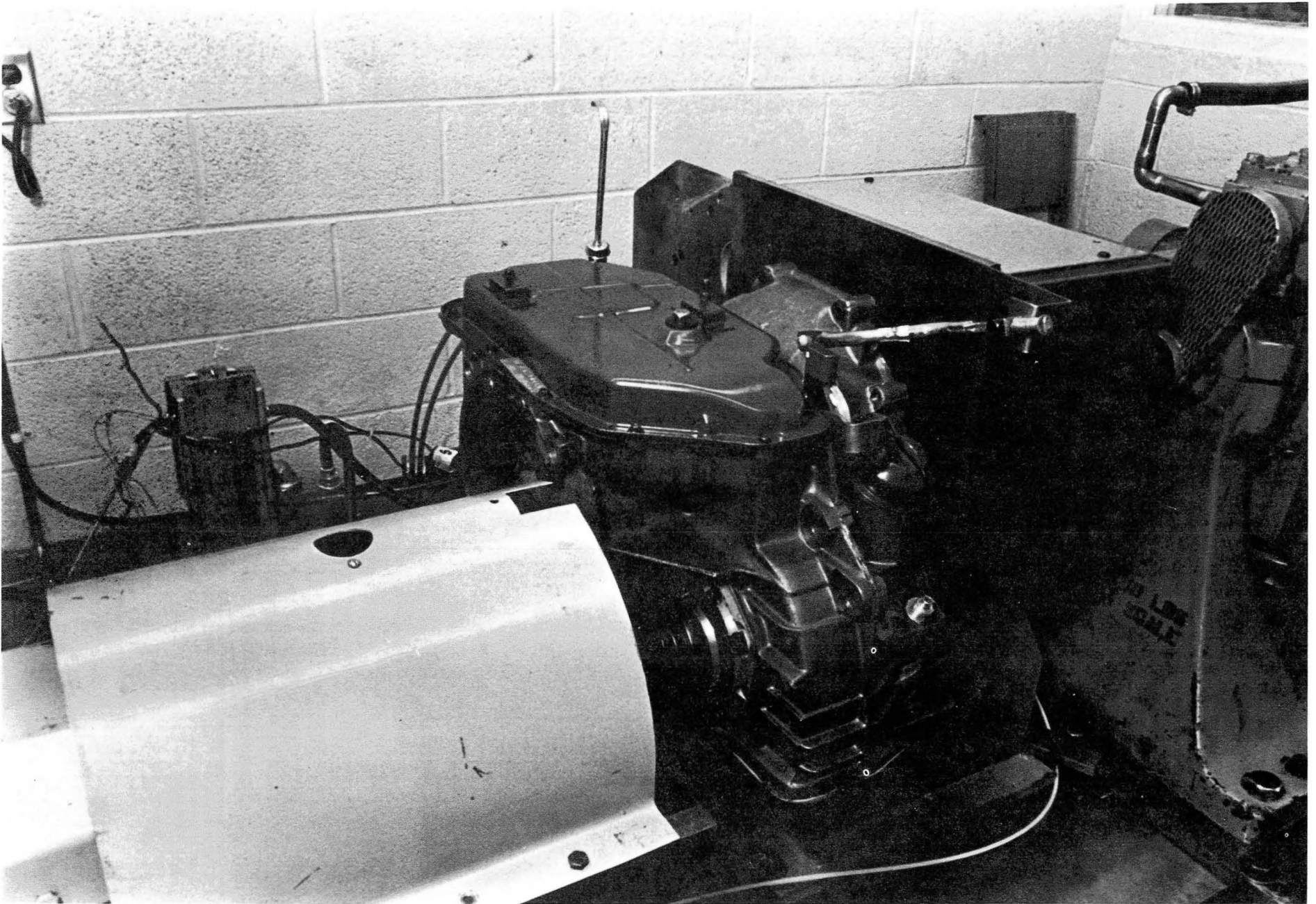

**1981 Mercury Lynx Coast Performance Test Setup
Side View**

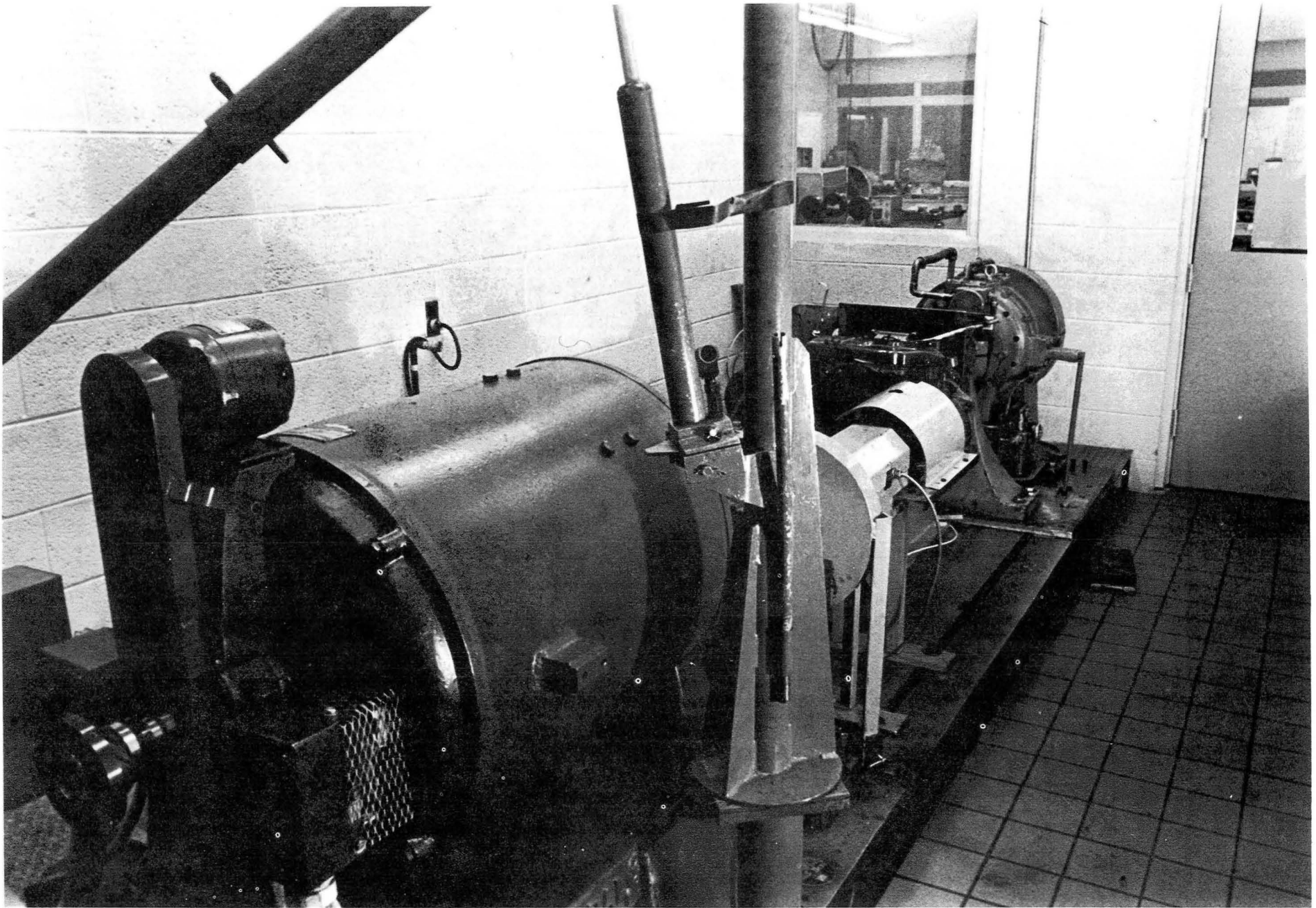

**1981 Mercury Lynx Coast Performance Test Setup
Back View**

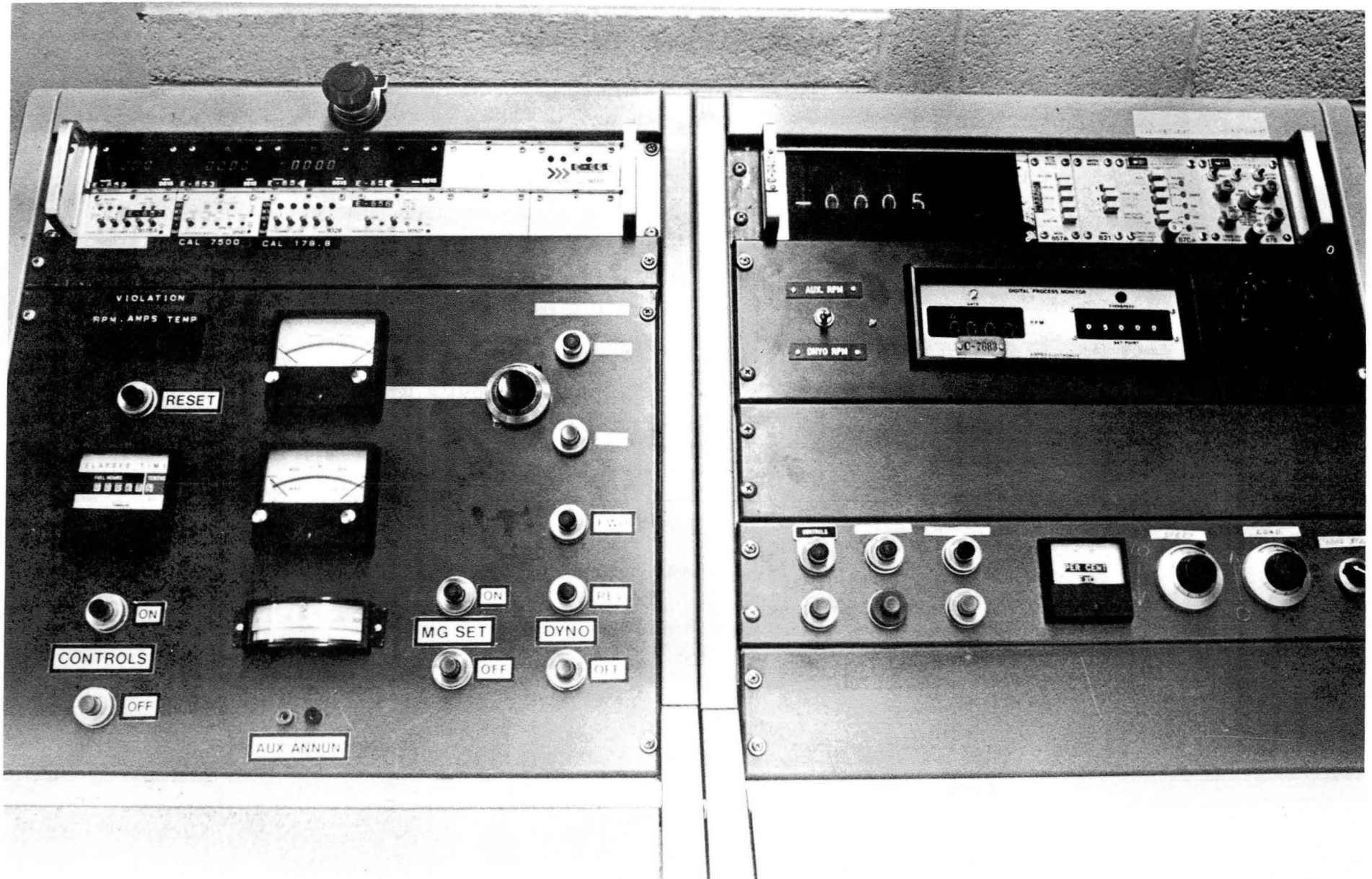

Control Console



**Control Console
with Data Reduction Equipment**

TEST PROCEDURE

The test was conducted per the Passenger Car Automatic Transmission Test Code-SAE J651b. The code states that three basic tests should be performed on the transmission. These tests are Drive Performance, Coast Performance and No Load Losses. Each test was performed to the accuracies stated in the code. The throttle valve was modulated throughout the test to its normal operating positions. The table on page 18 indicates the engine torque and its related throttle valve setting.

The limits of the test were determined by the normal operating conditions of an engine typically supplied with this transmission. The transmission was tested at a torque which ranged from 10-80 lb-ft on the input shaft of the transmission. The torque was incremented by 10 lb-ft for each test. The speed limits of the test ranged from 700 to 3800 rpm on the input shaft of the transmission.

The first test conducted was the Drive Performance - Constant Input Torque test. The input torque was held at 10 lb-ft, and the speed was incremented from 750-3800 rpm. The torque was then set to 20 lb-ft, and the transmission was run through the same speed range. This procedure was followed for input torques of 10, 20, 30, 40, 50, 60, 70, and 80 lb-ft. The throttle valve was modulated to match the appropriate input torque for these test ranges. The starting speed was dependent on when the torque could be attained, which was characteristic of the torque converter. The data recorded in this test were input and output speed, input and output torque, line pressure, sump temperature, outlet temperature, case hotspot temperature and ambient temperature.

This procedure was performed on the transmission in first, second and third gear range. The transmission was held in each gear through the entire torque and speed range per the explanation given in the Test Apparatus section of this report.

The next portion of the Drive Performance test to be conducted was the Cross Sectional Road Load Performance test. This test was conducted in third gear and involved holding the transmission output shaft at a constant torque while varying the input speed. The output torques selected were 25, 47, 79, 110, 145, 177, 208, and 243 lb-ft. The speed range was from 750 to 3800 rpm on this input shaft. The starting speed was dependent on when the torque could be attained. The throttle valve was modulated throughout this test to match the appropriate engine torque. The data recorded in this test was input and output torques, input and output speeds, line pressure, sump temperatures, outlet temperatures, case hotspot temperature and ambient temperatures.

The No Load Losses portion of the test was performed next. This test was run with the output shaft turning freely. The input torque and speed were recorded for an entire speed range which ran from 700 rpm to 3700 rpm. This test was performed in each gear range by disconnecting the output shaft and allowing it to turn freely.

The parameters recorded in this test were input torque and speed, line pressure, sump temperature, outlet temperature, case hotspot temperature, and ambient temperature.

The final test performed was the Coast Performance test. For this test the transmission was oriented in the reverse direction so that the dynamometer drove through the output shaft of the transmission and the power was taken up in the absorber. The test was conducted by setting the converter impeller torque at a constant level and varying its speed in the range set by the previous tests. In order to run this test, it was necessary to spin the torque converter shaft at approximately 400 rpm so that the charge pump would generate the line pressure necessary to operate the transmission. The torque and speed ranges of this test were different from the previous tests due to torque converter characteristics. The speed was limited by two conditions. These conditions were the lowest speed necessary to maintain line pressure and the lowest speed at which the required torque could be attained. The amount of torque which could be applied to the system was limited by the current limits of the dynamometer controller. The first gear Coast Performance test reached the current limit at the 50 lb-ft run. This was due to the slow output speed in first gear which was beyond the dynamometer torque-speed characteristics. The data recorded during this portion of the test were input and output torque, input and output speed, line pressure, sump temperature, outlet temperature, case hotspot temperature, and ambient temperature. The throttle valve was set to the idle position during the entire test.

The transmission was filled with Dexron II automatic transmission fluid through the entire test schedule. The physical and chemical properties of the transmission fluid were monitored throughout the test. The fluid did not appreciably change colors or properties throughout the tests. However, it should be noted that when operating in the coast performance mode this pump is turning at a slower speed which means less flow for cooling purposes. This could become a factor in the amount of power which could be transmitted under coast performance.

Following is a table of engine torque vs. throttle cable position. The transmission throttle cable was modulated for each engine torque level throughout the tests.

<u>ENGINE TORQUE (lb-ft)</u>	<u>THROTTLE CABLE POSITION (in.)</u>
closed	0.00
10	0.125
20	0.25
30	0.38
40	0.50
50	0.62
60	0.75
70	0.88
80	1.0
open	

CALIBRATION

The test apparatus was calibrated before and after a major test was completed. The major components calibrated were the torque sensors and the speed readouts. The torque sensors were calibrated with their respective readouts and attaching cables so that a total system accuracy was obtained. The calibration was performed by placing a set of known weights at a known distance to produce the resultant torque. The weights were weighed on a Toledo Digital Scale Model No. 1070, which is calibrated to a set of weights traceable to the National Bureau of Standards. A second calibration method was used as a check against the dead weights. This involved a hydraulic calibration stand which compared a calibrated torque cell (traceable to the National Bureau of Standards) to the test torque transducers. The calibration sheets contained in this section show the calculated torque and the actual torque which appeared on the readout (measured torque). The torque sensors were calibrated to the limits of the range over which they were to operate.

The speed readout was an AIRPAX counter (Model No. 761400110) which was calibrated in an operating range from 0 to 4500 rpm. The counter was calibrated with a Hewlett Packard electric counter (Model No. 5245L) used in conjunction with a WWVB frequency comparator (True Time, Inc. Model No. 60-TR). The accuracy of the digital readout was ± 1 count.

4/24/81
DEN3-124

CALIBRATION SHEET
HIMMELSTEIN TORQUE SENSOR #MCRT 6-02T (2-3)
CAL VALUE = 58.5 lb-ft
(Drive performance torque was positive. Direction of torque was clockwise.)

CALCULATED TORQUE (lb-ft)	MEASURED TORQUE (lb-ft)
0.0	0.0
16.6	16.5
33.3	33.0
50.0	50.0
66.6	66.5
83.3	83.5
100.0	100.0
116.6	116.5
133.3	133.5
150.0	150.0
166.6	166.5
150.0	150.0
133.0	133.5
116.6	116.5
100.0	100.0
83.3	83.5
66.5	66.5
50.0	50.0
33.3	33.0
16.6	16.5
0.0	0.0

4/23/81
DEN3-124

CALIBRATION SHEET
LEBOW TORQUE SENSOR #1648-5K
CAL VALUE = 271

(Coast performance torque was negative. Direction of torque is labeled above each column.)

CALCULATED TORQUE (lb-ft)	MEASURED TORQUE (lb-ft)	
	Clockwise	Counter Clockwise
0.0	0.0	0.0
41.6	42.0	41.5
83.3	84.0	83.5
125.0	125.5	125.0
166.6	167.0	166.5
208.3	209.0	208.0
250.0	251.0	250.0
291.6	293.0	291.5
333.3	335.0	333.5
375.0	377.0	375.0
416.6	419.0	416.6
375.0	377.5	374.5
333.0	335.0	333.0
291.6	293.0	291.0
250.0	251.5	249.5
208.3	210.0	207.5
166.6	168.0	166.0
125.0	126.5	124.5
83.3	84.0	83.0
41.6	42.0	41.0
0.0	0.0	0.0

4/23/81
DEN3-124

CALIBRATION SHEET

LEBOW TORQUE SENSOR #1248-20K

CAL VALUE = 271

(Coast performance torque was negative. Direction of torque was counterclockwise.)

CALCULATED TORQUE (lb-ft)	MEASURED TORQUE (lb-ft)	
	Clockwise	Counter Clockwise
0.0	0.0	0.0
166.6	163.7	164.1
333.3	334.0	332.6
500.0	498.0	498.5
666.6	663.8	667.0
833.3	829.3	836.3
1000.0	999.6	1000.4
1166.6	1163.7	1164.9
1333.3	1329.7	1335.0
1500.0	1497.7	1505.2
1666.6	1666.0	1668.9
1500.0	1498.5	1506.9
1333.3	1329.2	1351.0
1166.6	1165.7	1165.1
1000.0	996.4	1002.9
833.3	830.7	835.0
666.6	662.0	665.9
500.0	498.9	504.9
333.3	332.6	333.0
166.6	167.0	163.1
0.0	0.0	1.9

SYSTEM ACCURACY

The instruments used in the test setup have been calibrated to insure the accuracy of the test data. The individual components utilized in the tests have manufacturers' specifications which guarantee the accuracy of the instrumentation. These accuracies are listed and combined in the Appendix section to determine the total system accuracy. The three major factors involved in the system accuracy are the torque signals, speed signals, and data reduction equipment. Worst case system accuracies for the torque sensors, cabling and readout were determined from the calibration charts and are shown below.

TAPE RECORDER: Sangamo Model #3500
ACCURACY: $\pm 0.05\%$ of Full Scale

TORQUE SENSOR: Lebow (1648-5K) + Daytronic (878A)
ACCURACY: $((\text{Calculated Torque} - \text{Measured}) / \text{Full Scale Torque}) \times (100) =$
 $((210.0 - 208.3) / 416.66) \times (100) = \pm 0.408\%$ of Full Scale

TORQUE SENSOR: Himmelstein (MCRT 6-62T(2-3)) + Daytronic (878)
ACCURACY: $((\text{Calculated Torque} - \text{Measured}) / \text{Full Scale Torque}) \times (100) =$
 $((33.3 - 33.0) / (166.66)) \times (100) = \pm 0.18\%$ of Full Scale

SPEED SENSOR: Speed Pickup + Airpax Counter
ACCURACY: Calibration was ± 1 Count $(1/4000) \times (100) = \pm 0.025\%$ of
Full Scale

SPEED CONDITIONER (Frequency to Voltage Converter-Daytronic 840)
ACCURACY: 0.05% of Average DC Voltage = $\pm 0.10\%$ of Full Scale

HEWLETT PACKARD ANALYZER (HP 5451B Fourier Analyzer)
ACCURACY: 12 Bits = $2^{11} = 2048$ Bits = 1 Volt
 $(1/2048) \times (100) = \pm 0.048\%$ of Full Scale

COMPUTER INTER NUMBER CALCULATION (Method of Program Calculation)
= 0.5% of Full Scale

The inter number calculation error resulted from the method that the computer used to average the acquired data. This method is explained in the Appendix.

From the instrument accuracy determined above, a system accuracy may be determined. There are two generally accepted methods for calculating a system error. These methods are the root mean square and the sum of the errors. Both methods are tabulated in the Appendix and charted below for torque, speed, power and efficiency readings.

	<u>ROOT MEAN SQUARE METHOD % OF FULL SCALE</u>	<u>SUM OF ERRORS METHOD % OF FULL SCALE</u>	<u>FULL SCALE</u>
Torque Error (Lebow)	0.416%	0.508%	416 lb-ft
Torque Error (Himm.)	0.193%	0.278%	166 lb-ft
Speed Error	0.124%	0.223%	4000 RPM
Power Out Error	0.662%	1.132%	137 HP
Efficiency Error	0.701%	1.732%	100%

DATA REDUCTION

The signals obtained from the torque and speed transducers of the test stand were placed directly into a Sangamo Tape Recorder Model No. 3500. The information on the tape was then fed into a computer which was used to compile the data. While in the computer, the data were reviewed to ensure their accuracy, and then a hard copy was printed out on a line printer.

The following procedure was used to record the input and output torque. The torque signals were placed in the tape recorder as voltage. A calibration value was determined in engineering units (lb-ft) for each torque sensor. The torques were recorded on channels one and two in the following manner:

CHANNEL 1: PRECALIBRATION ZERO CALIBRATION VOLTAGE PRERUN
ZERO DATA

CHANNEL 2: PRECALIBRATION ZERO CALIBRATION VOLTAGE PRERUN
ZERO DATA

This information was then fed into the computer which integrated and compiled a 2.5-second sample of data to obtain an average value in engineering units.

The frequency signals from the speed pickups were placed directly into the tape recorder. The data on the tape were then fed into a frequency-to-voltage unit which turned the frequency into a DC voltage which in turn was fed into the computer. The method for recording speeds is shown below.

CHANNEL 3: ZERO FREQUENCY CALIBRATION FREQUENCY PRERUN ZERO
FREQUENCY DATA

CHANNEL 4: ZERO FREQUENCY CALIBRATION FREQUENCY PRERUN ZERO
FREQUENCY DATA

The data on these channels were then fed into the computer which integrated and compiled a 2.5-second sample of data to obtain an average speed value in engineering units.

The computer was programmed to take the values of torques and speeds and calculate efficiency and power from them. From the data it has generated, the computer would print out the required graphs and data per the contract specification. The main advantage of taking data in this manner was that the computer would calculate an integrated average which would minimize the error in a fluctuating signal. Any fluctuation due to system resonance or gear teeth meshing would be integrated and averaged.

TEST RESULTS

The data contained in this segment of the report have been divided into three major sections. These sections are Drive Performance, Coast Performance, and No Load Losses. There are five data sheets for each test condition in the Drive Performance and Coast Performance tests. The organization of this data is described and listed in the Table of Contents. Cover sheets for Drive Performance, Coast Performance and No Load Losses have been placed at the beginning of each section to describe the enclosed sheets.

DRIVE PERFORMANCE

1st Gear

Graphs Contained in This Section

Torque Ratio -vs- Output Speed

Output Torque -vs- Output Speed

Input Speed -vs- Output Speed

Efficiency -vs- Output Speed

Efficiency -vs- Power Out

28

Torque In

Speed In

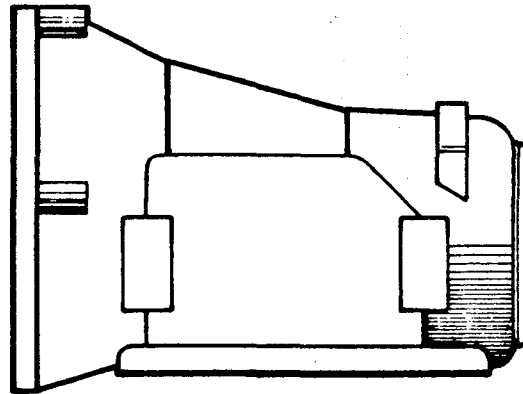

Torque Out

Speed Out

Drive Performance Tests

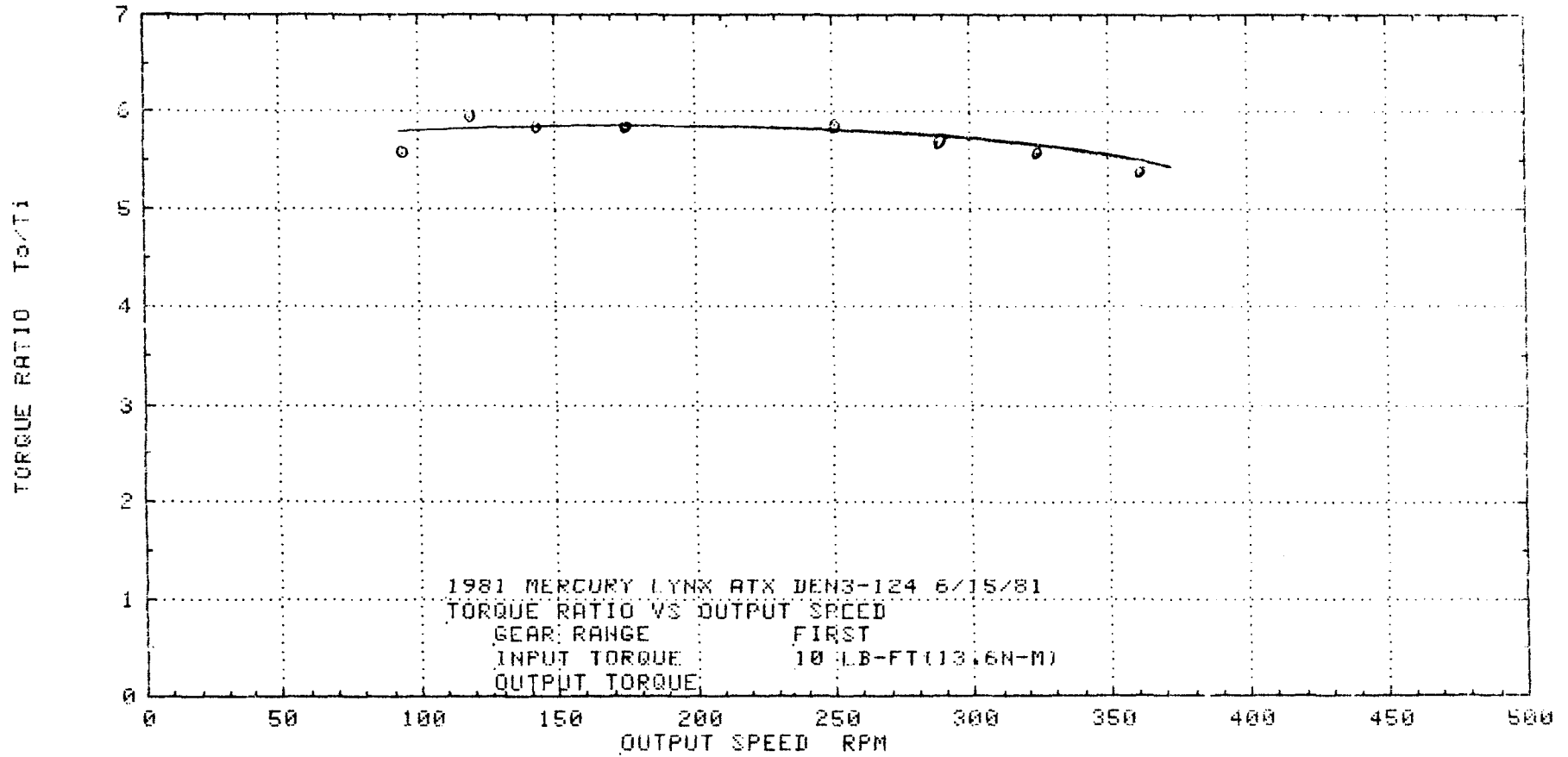

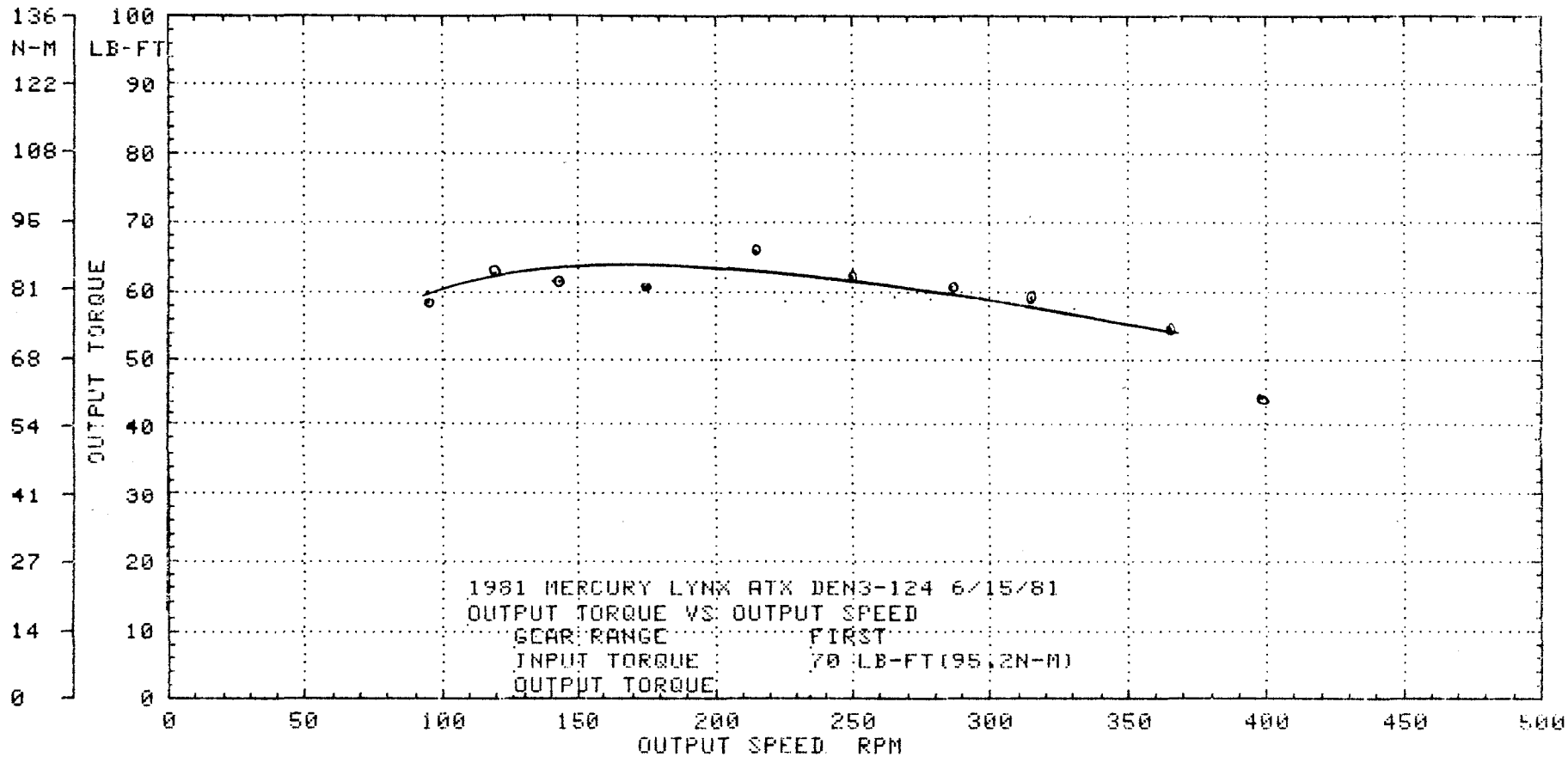

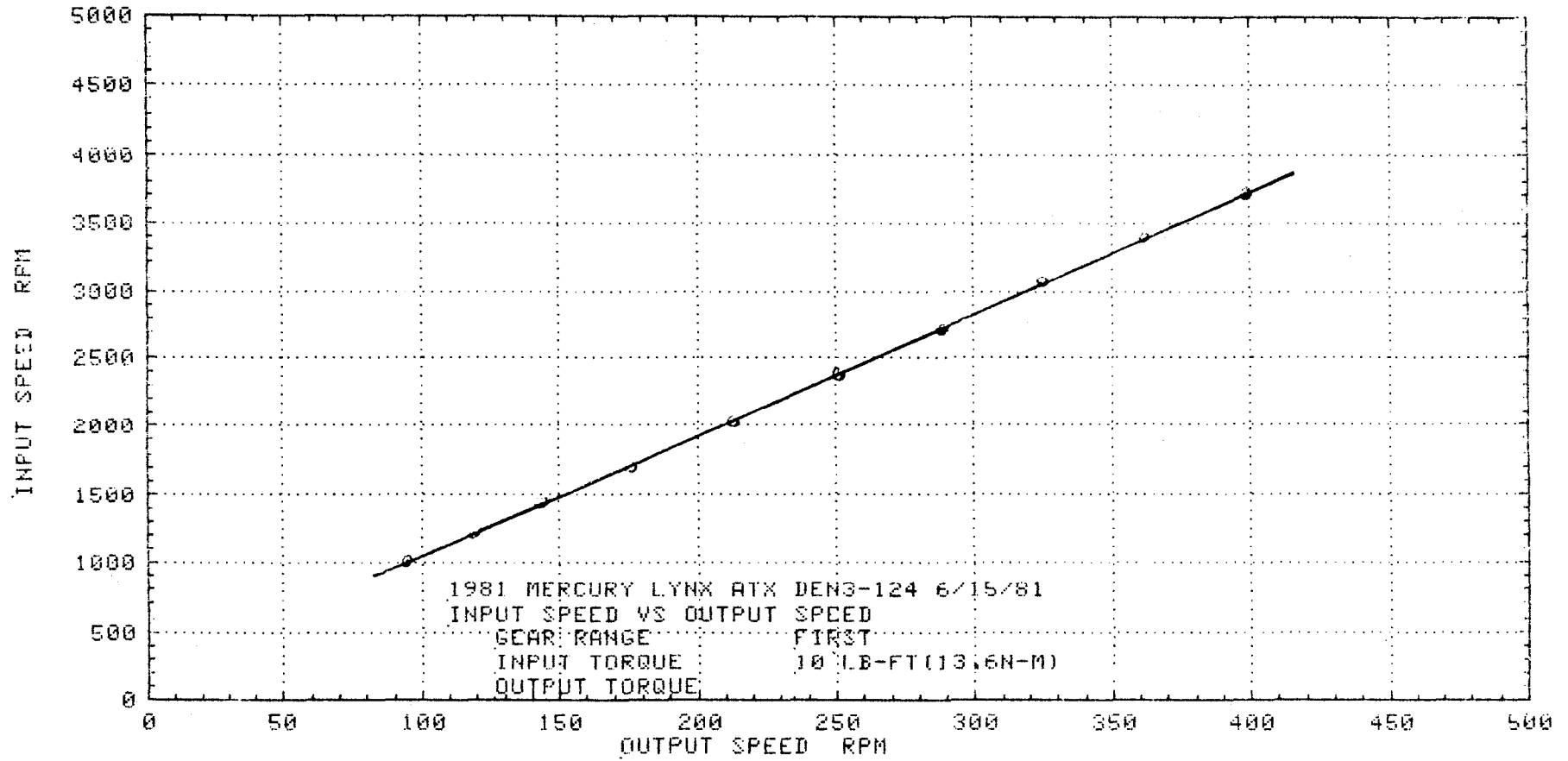

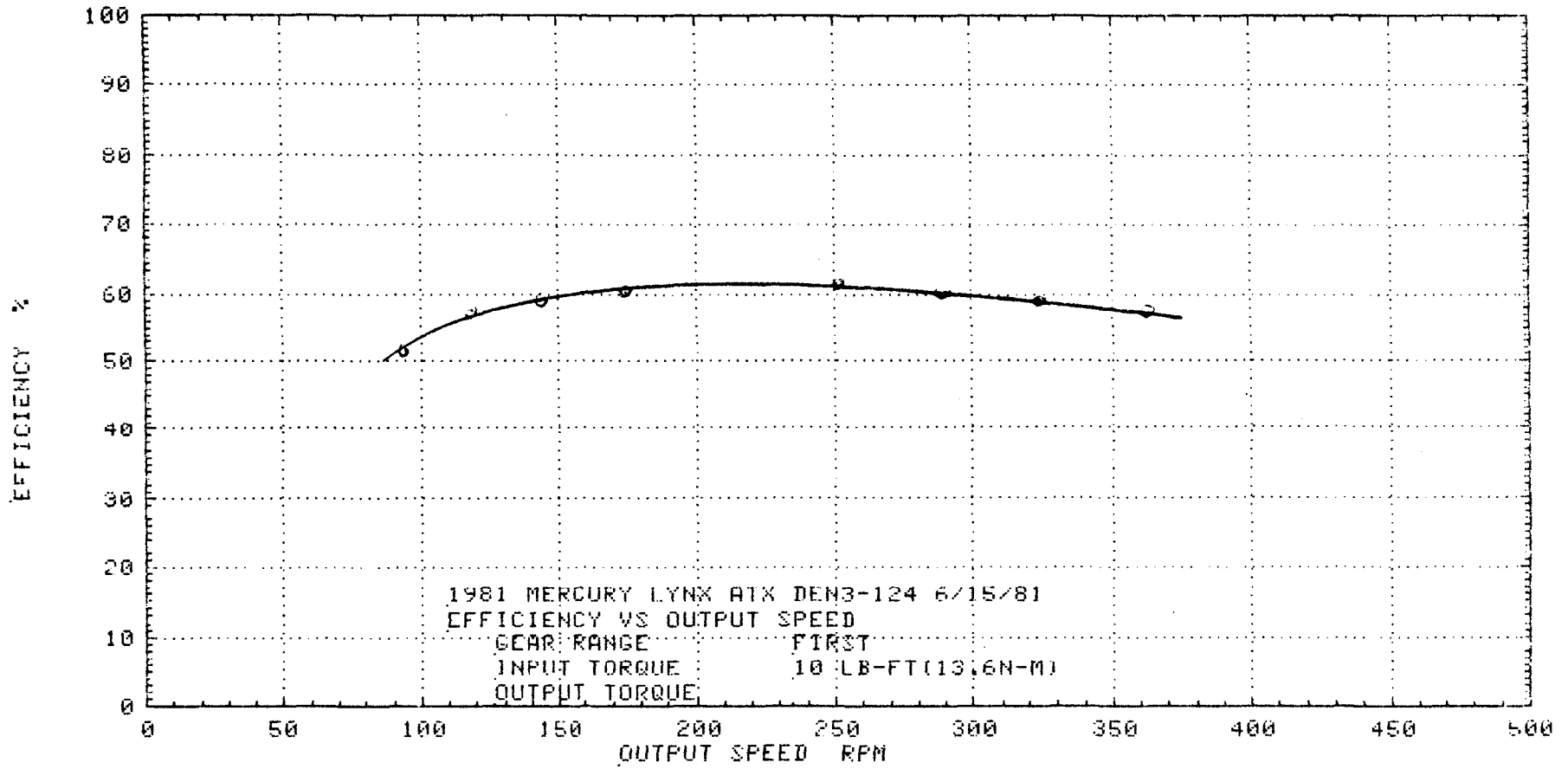

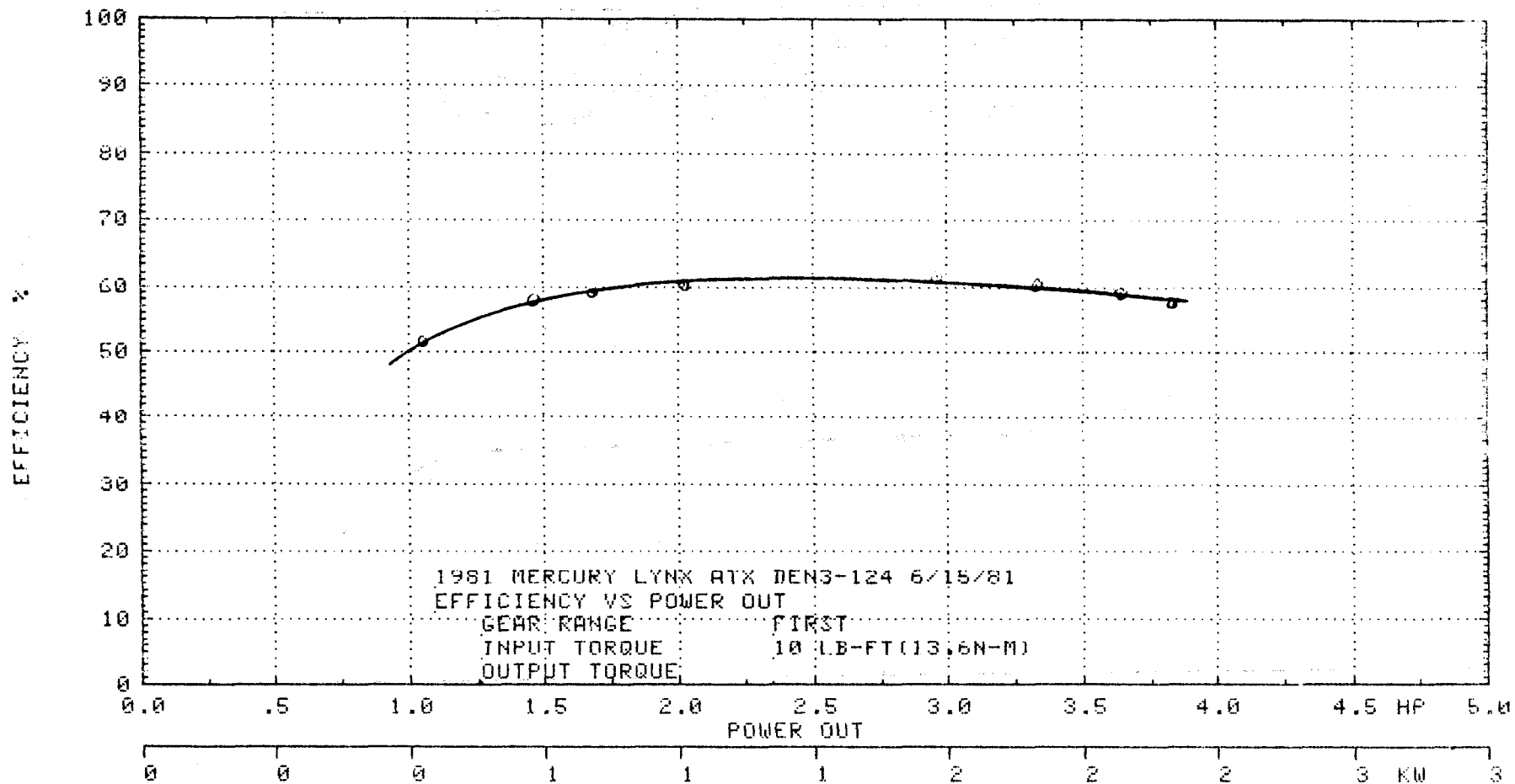

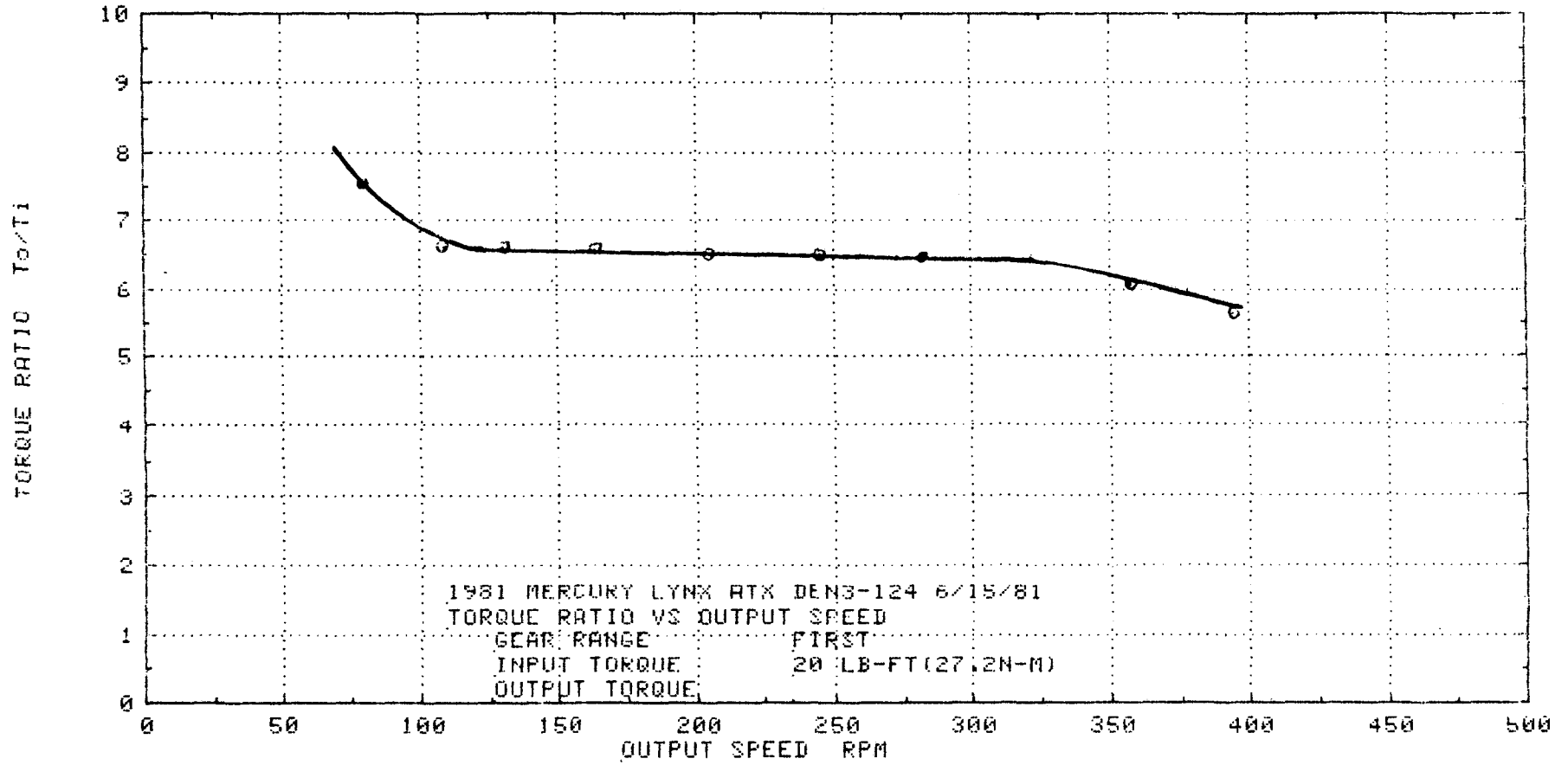

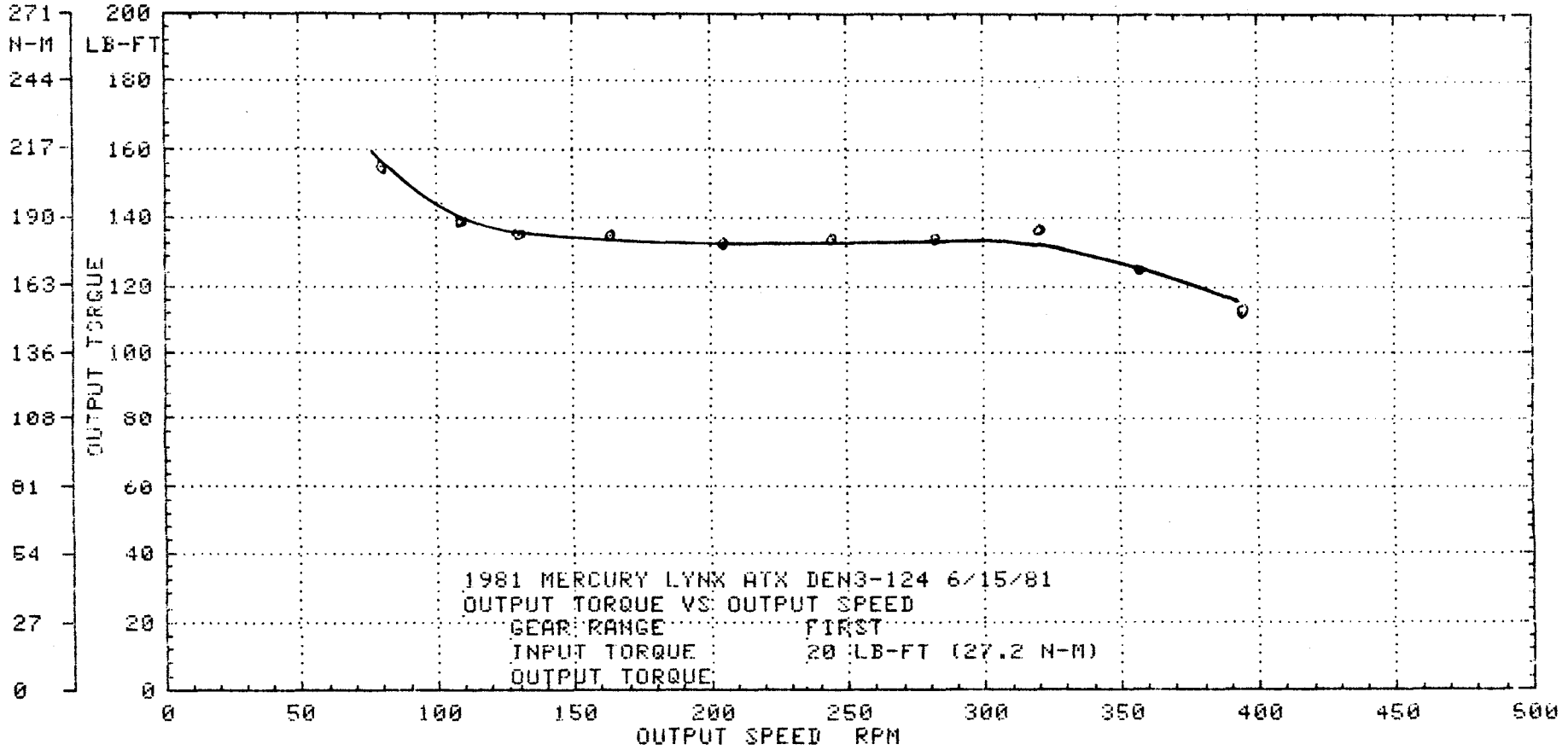

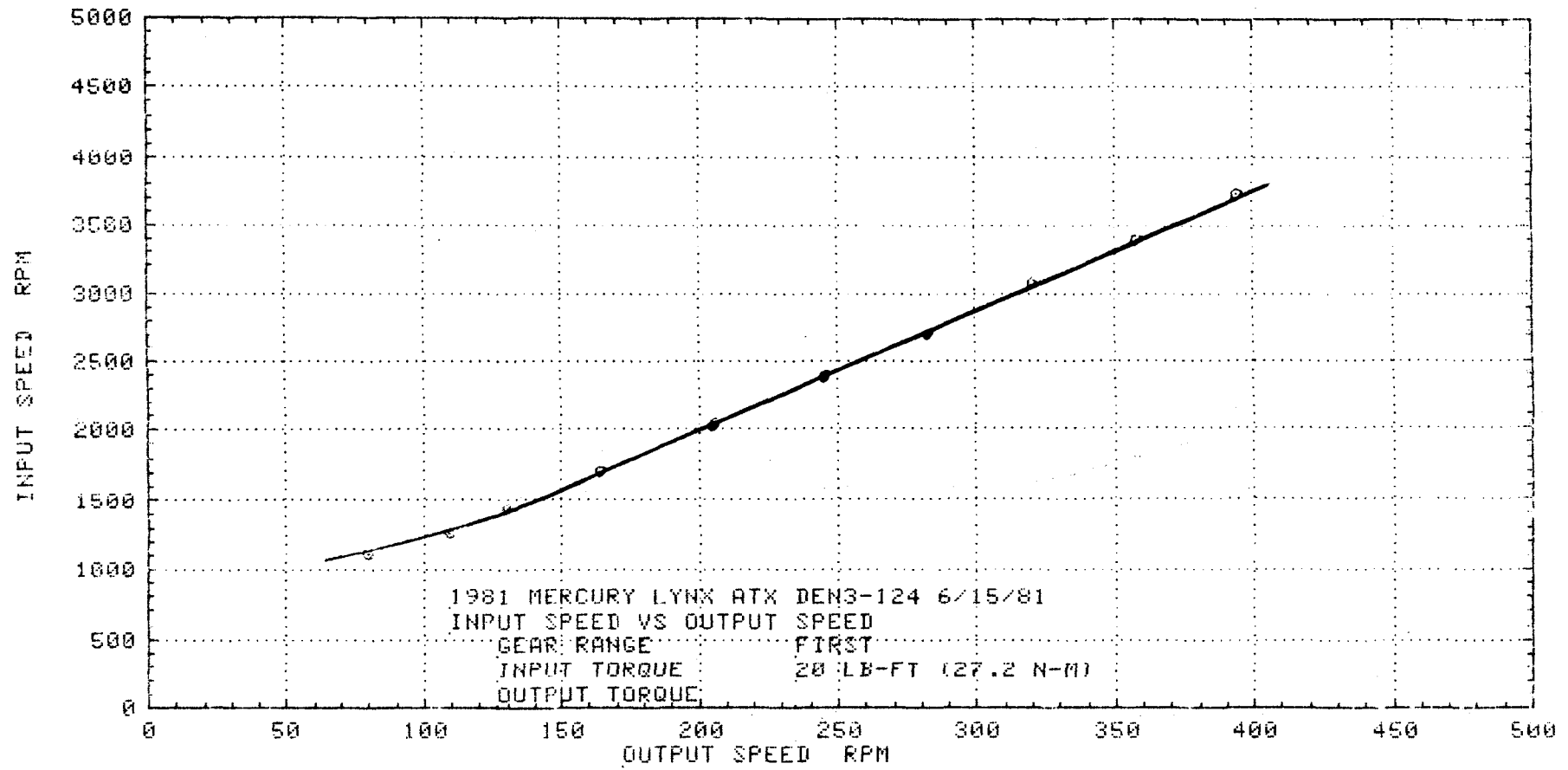

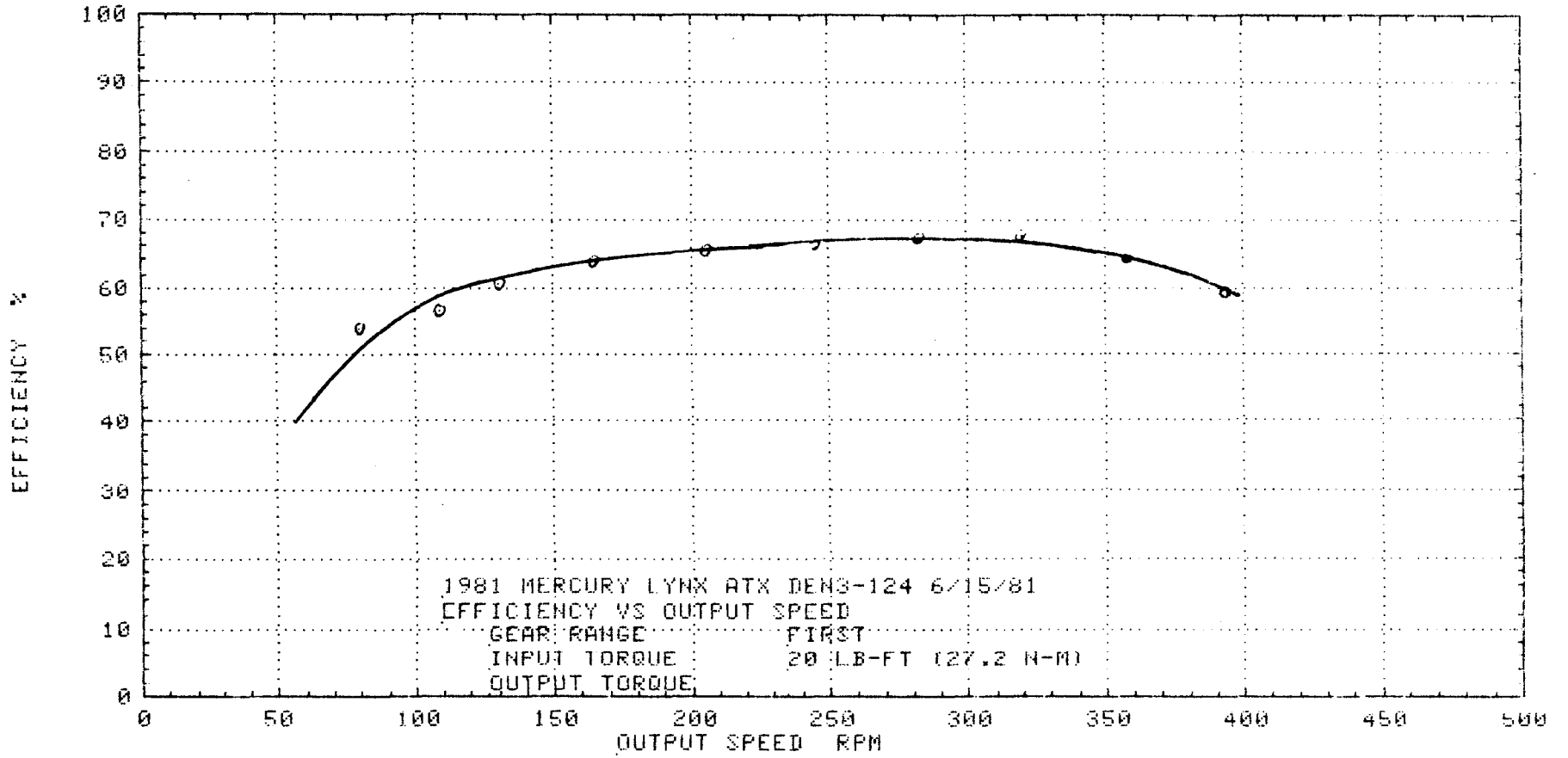

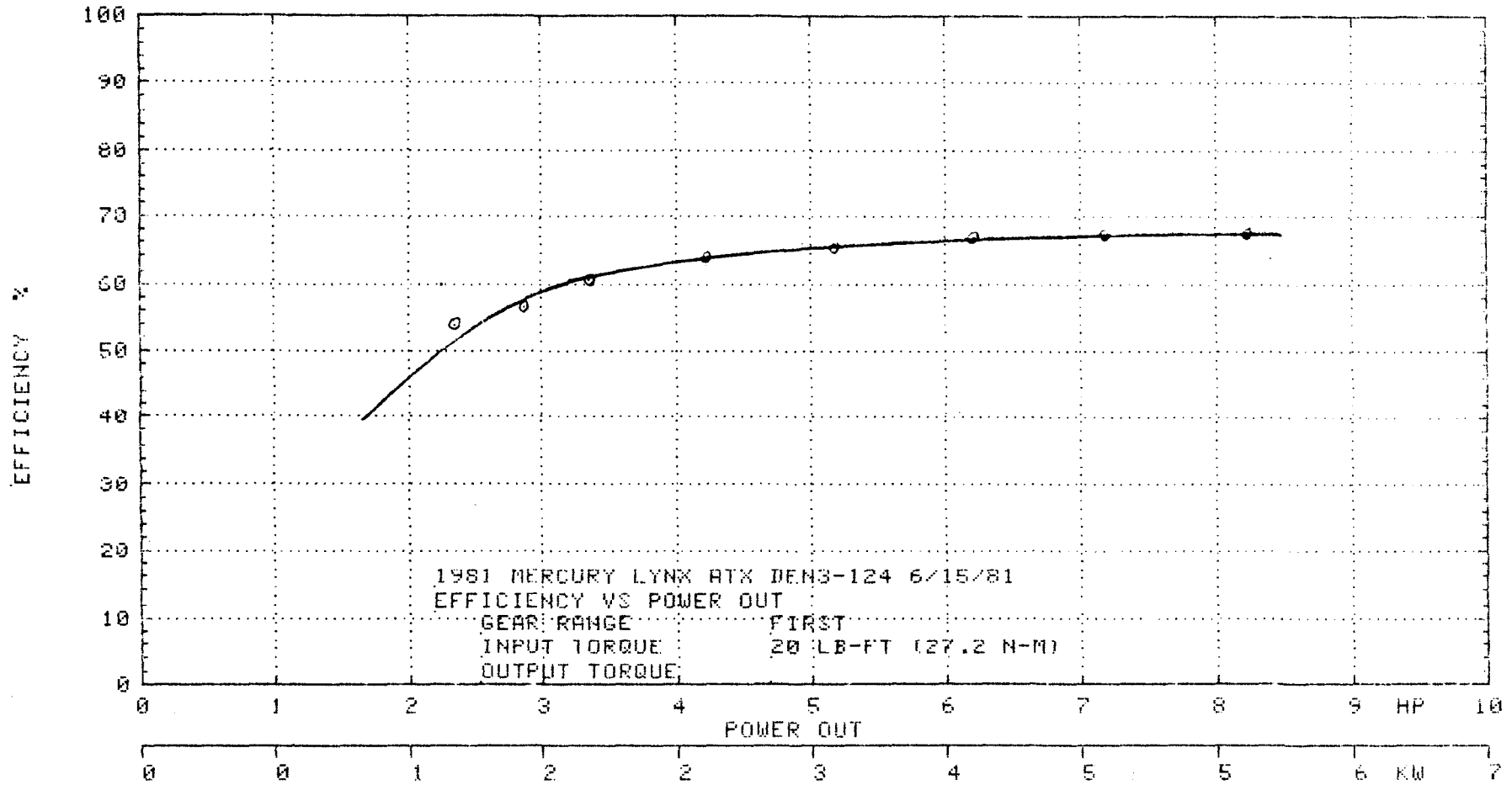

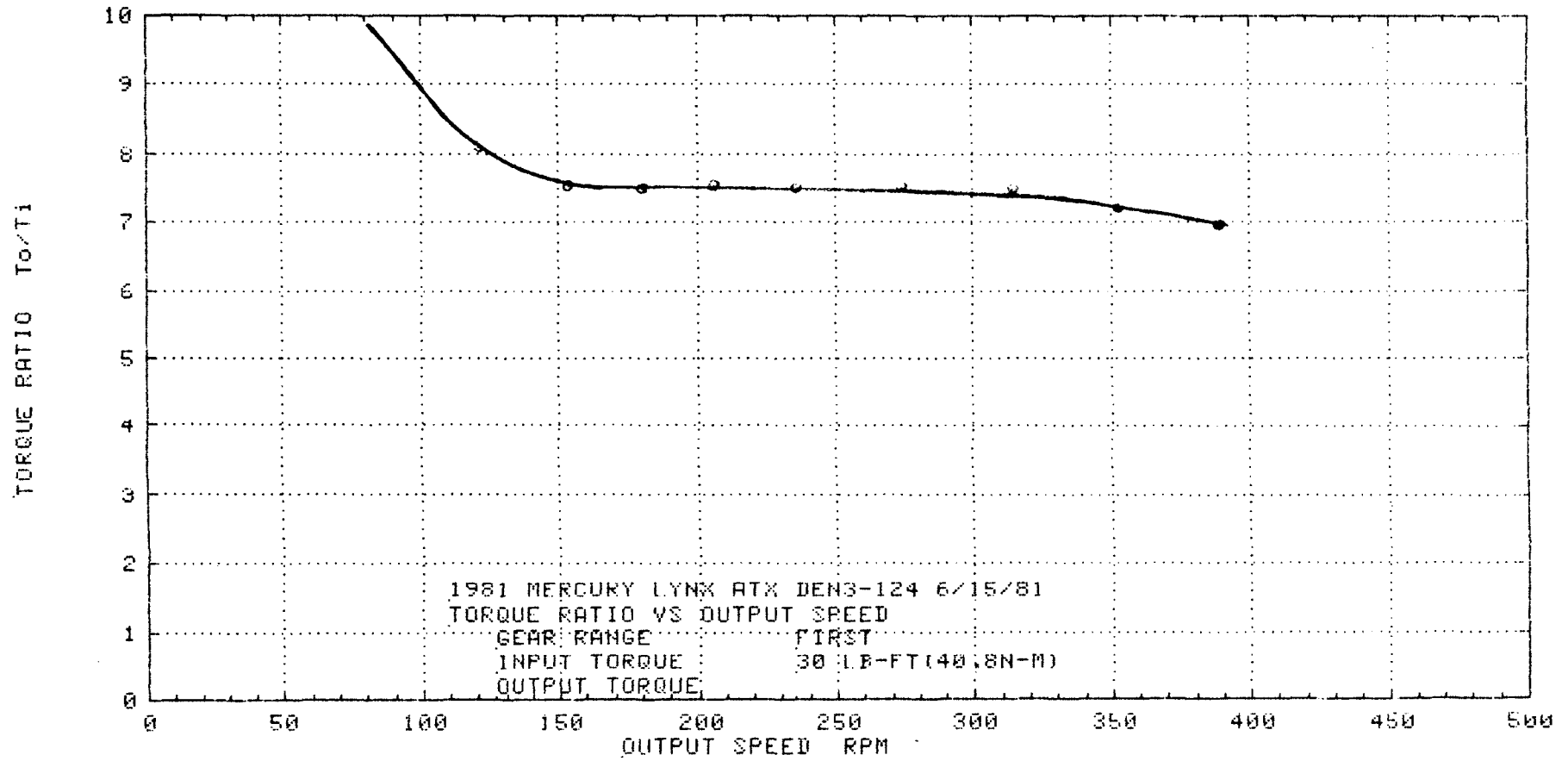

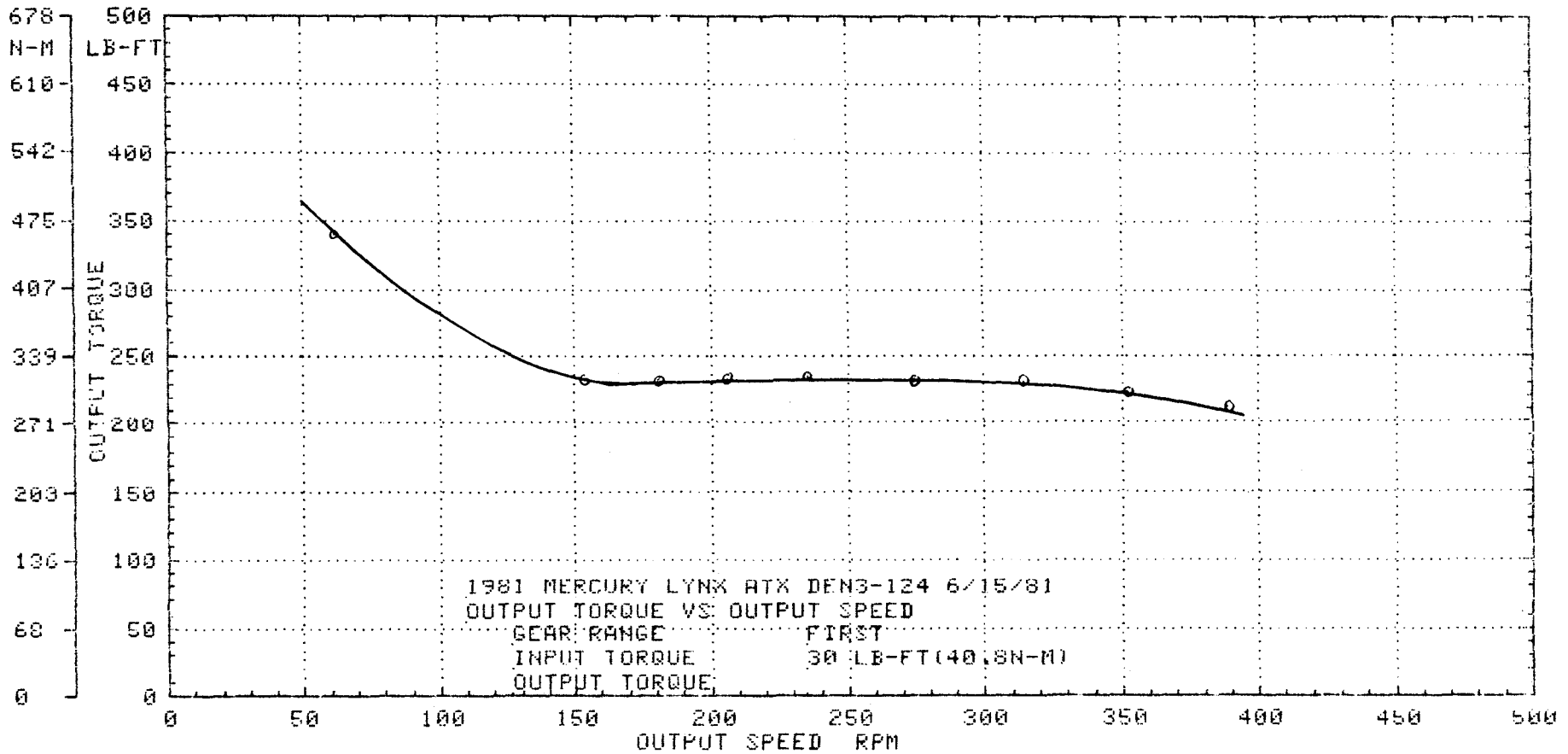

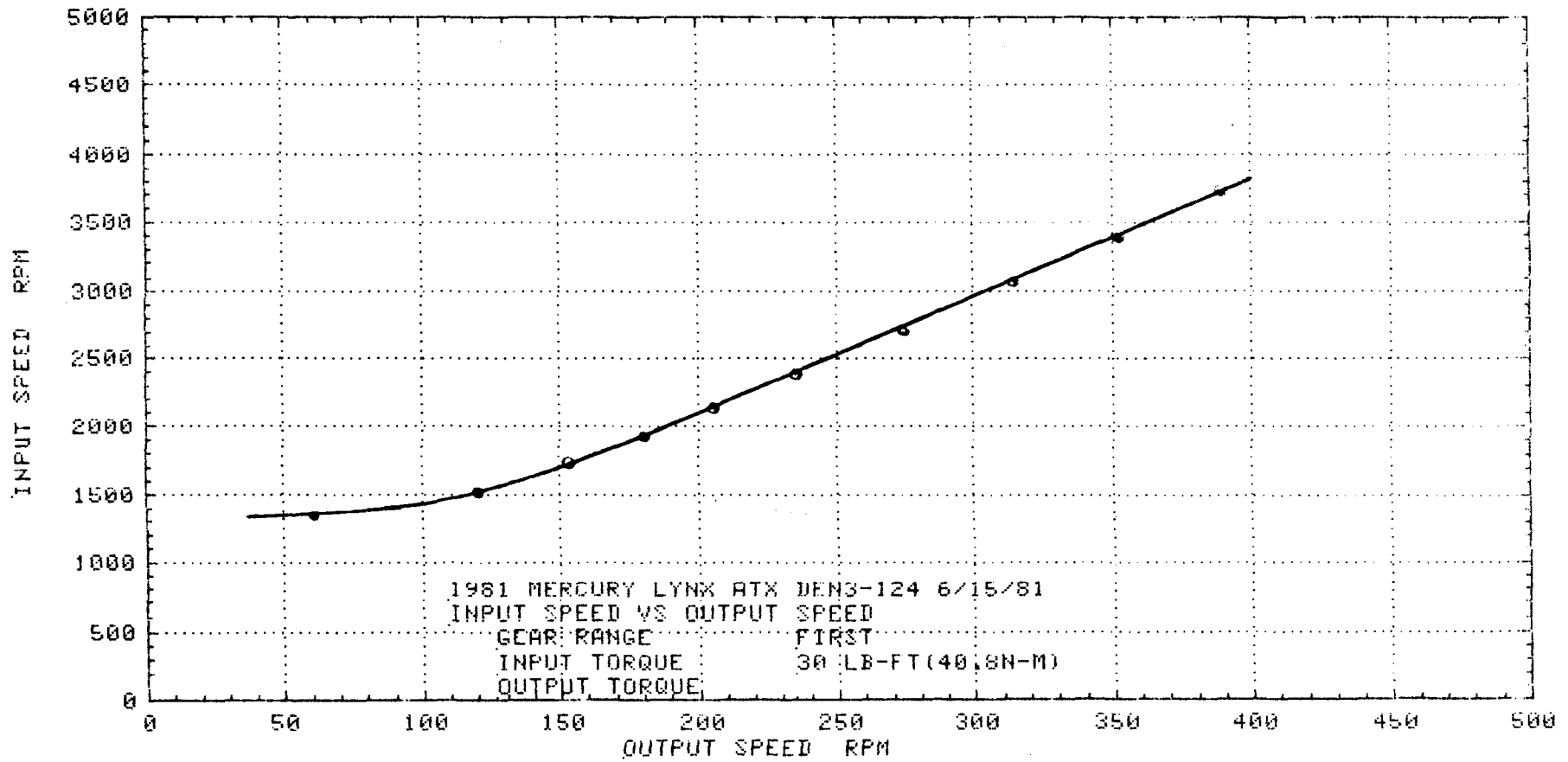

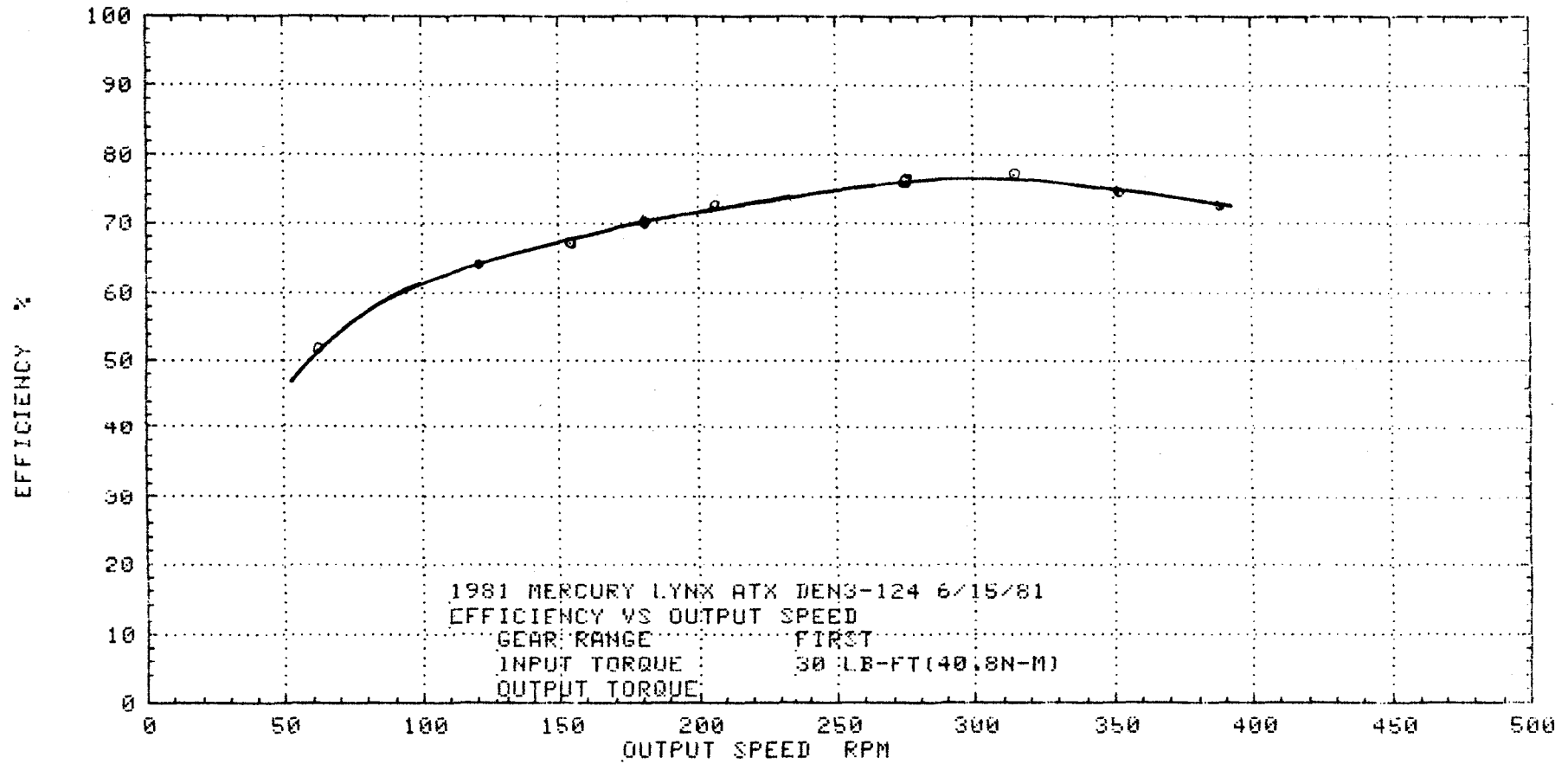

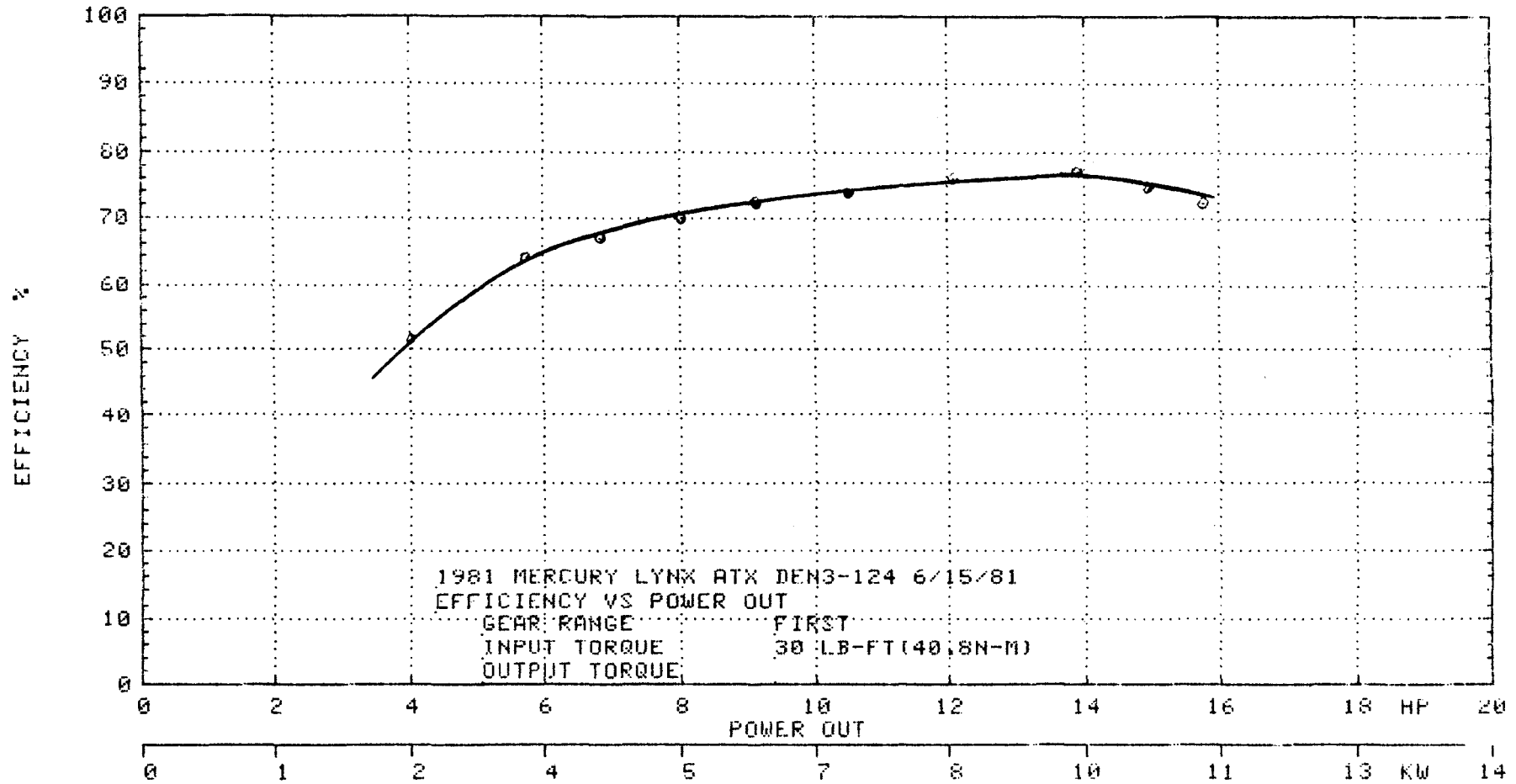

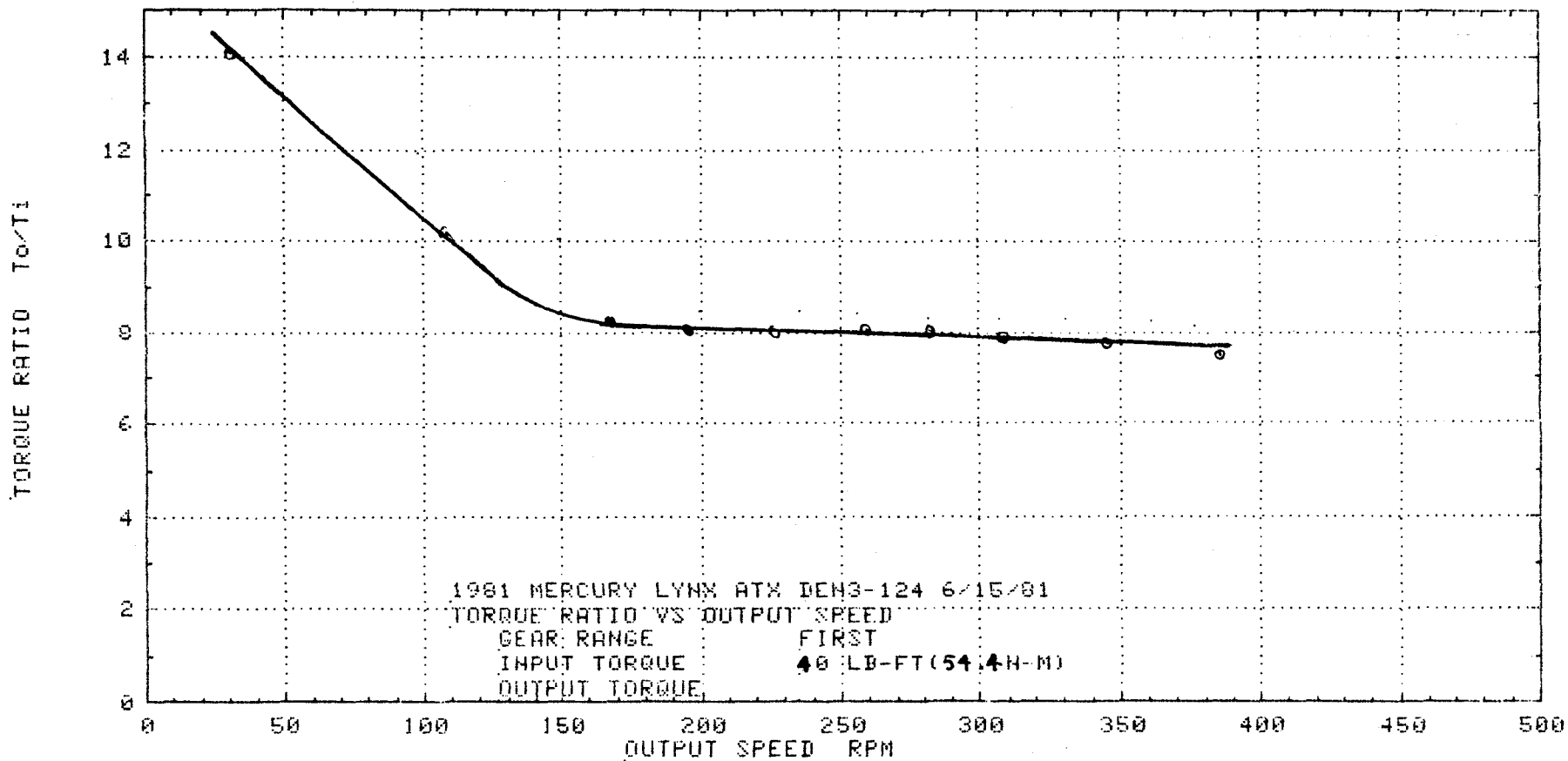

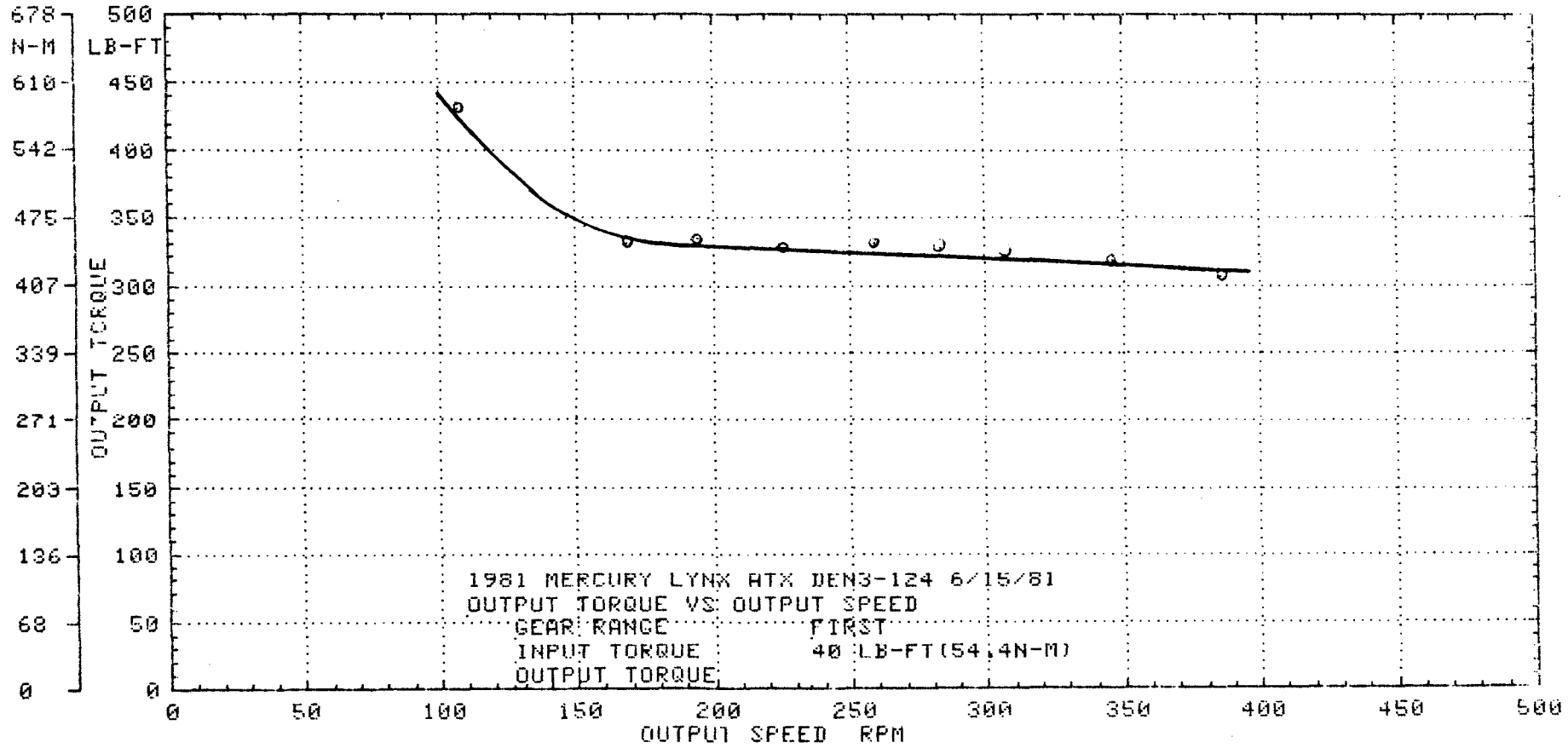

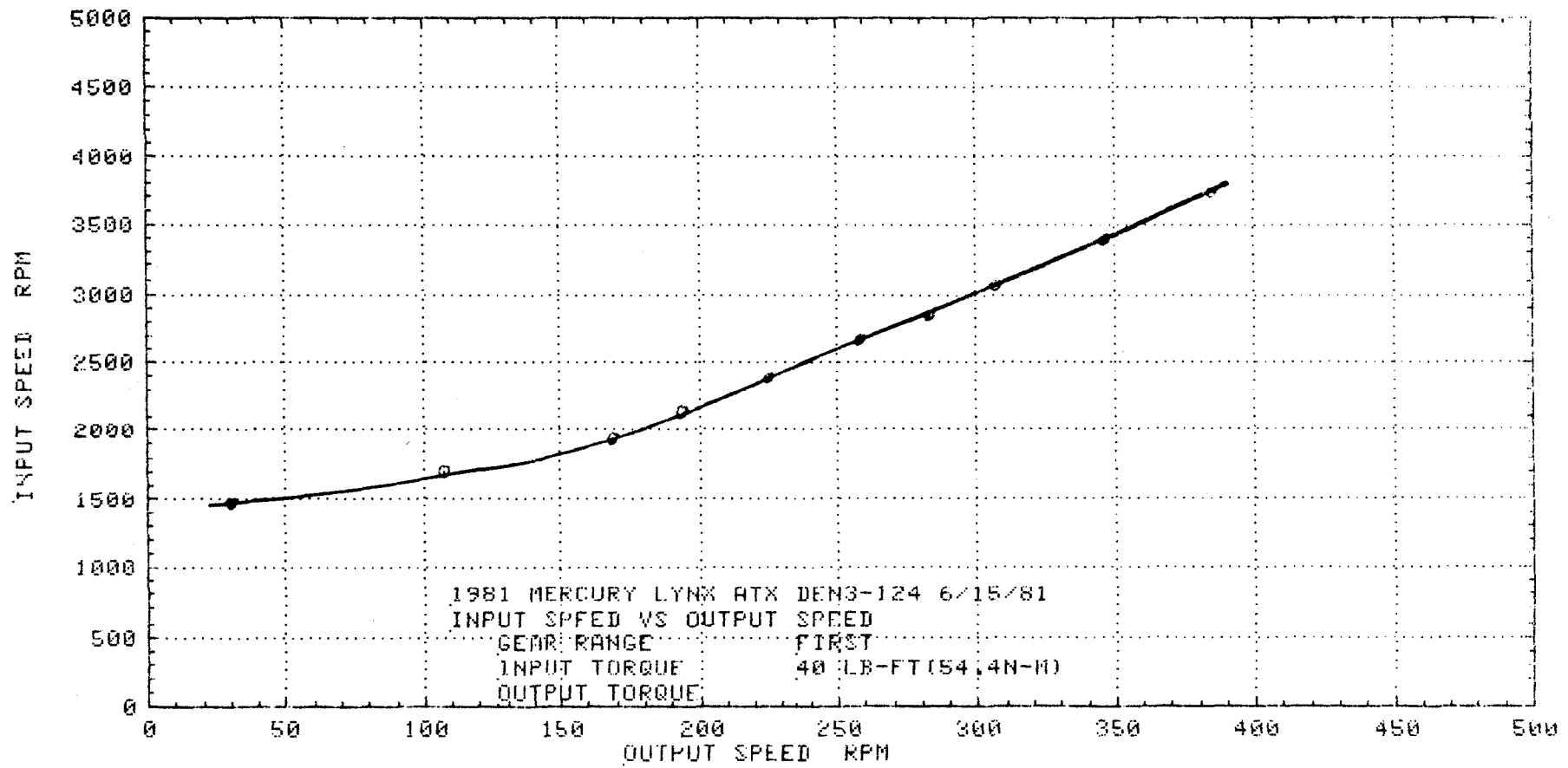

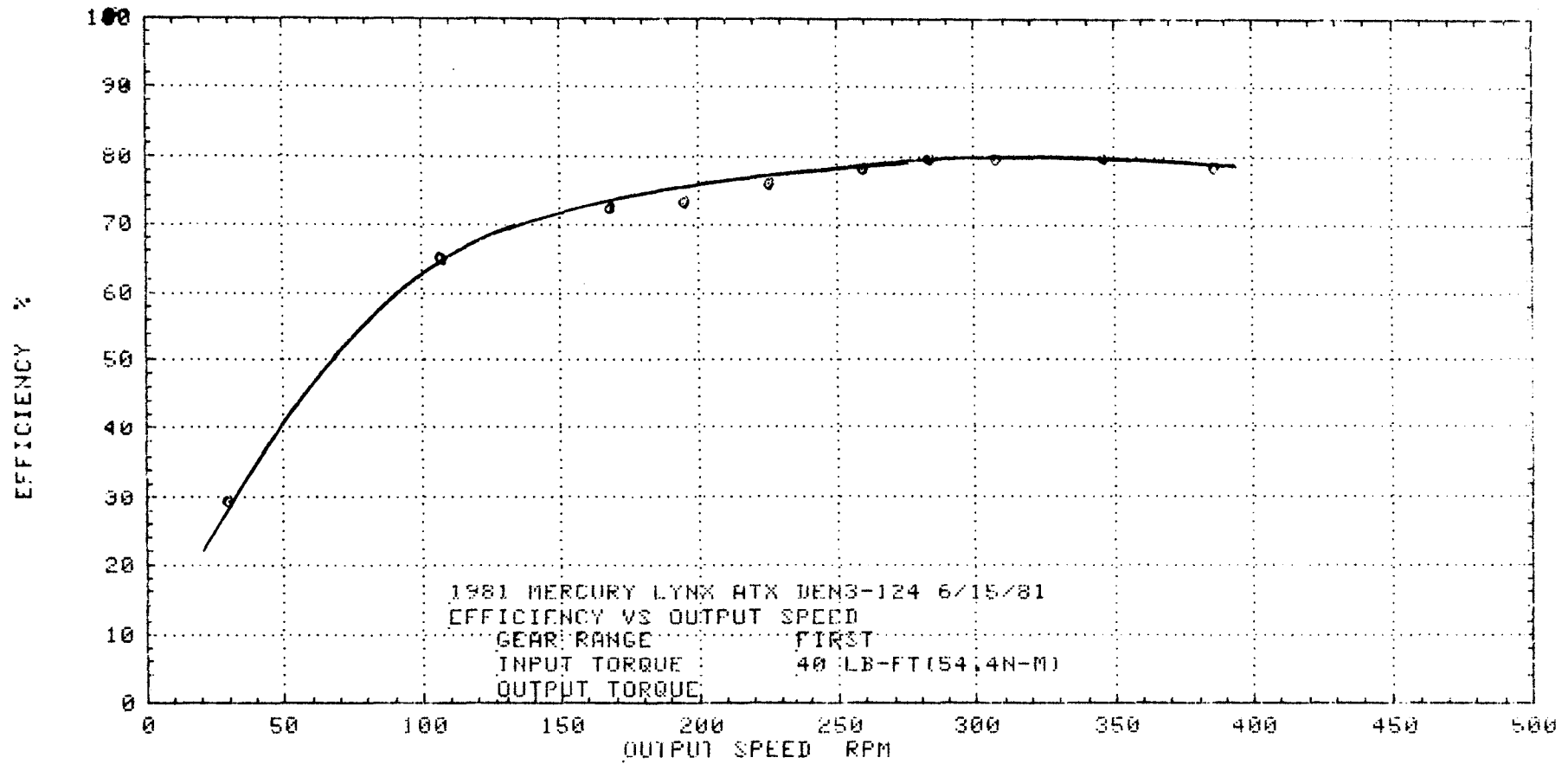

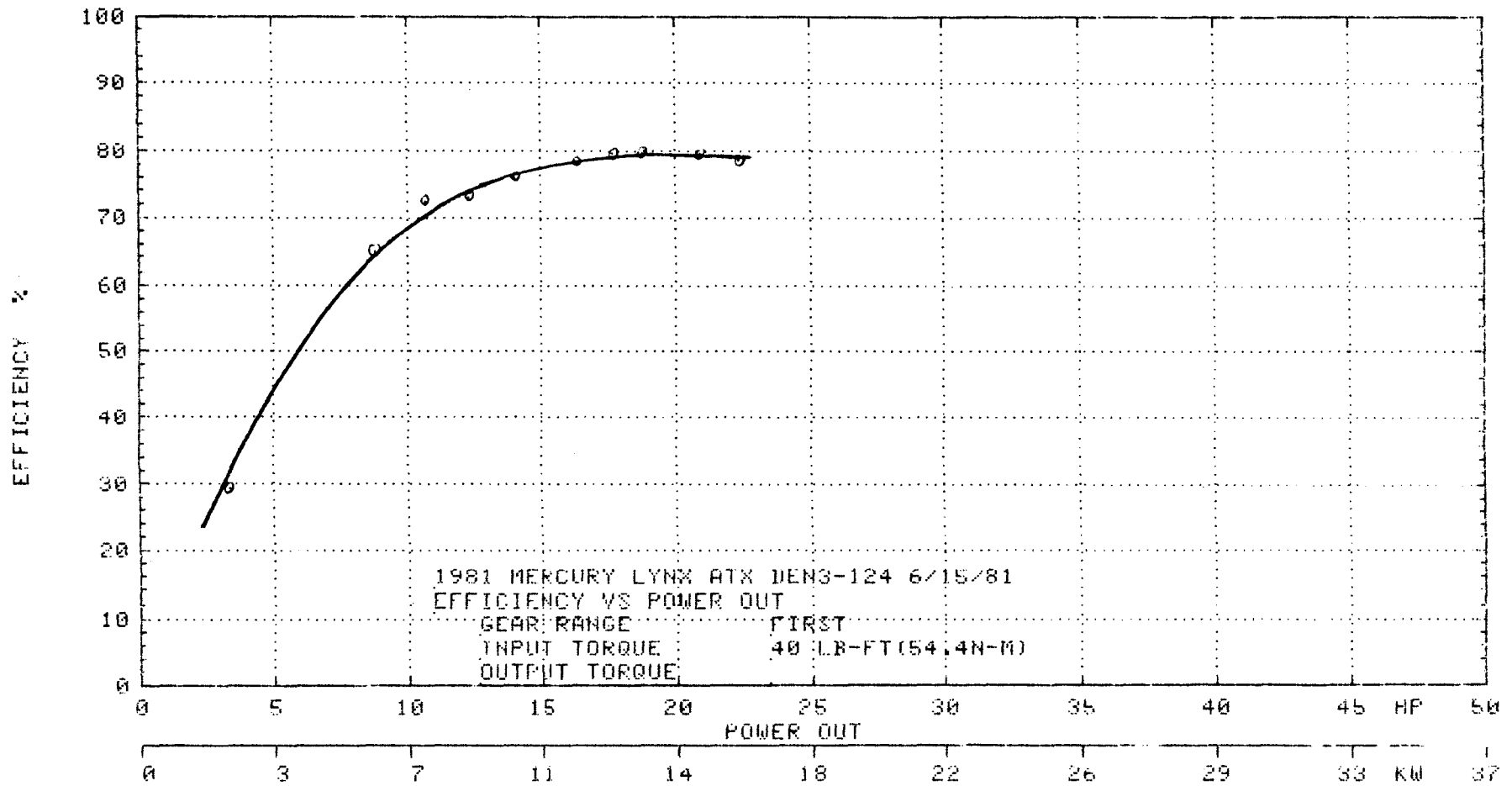

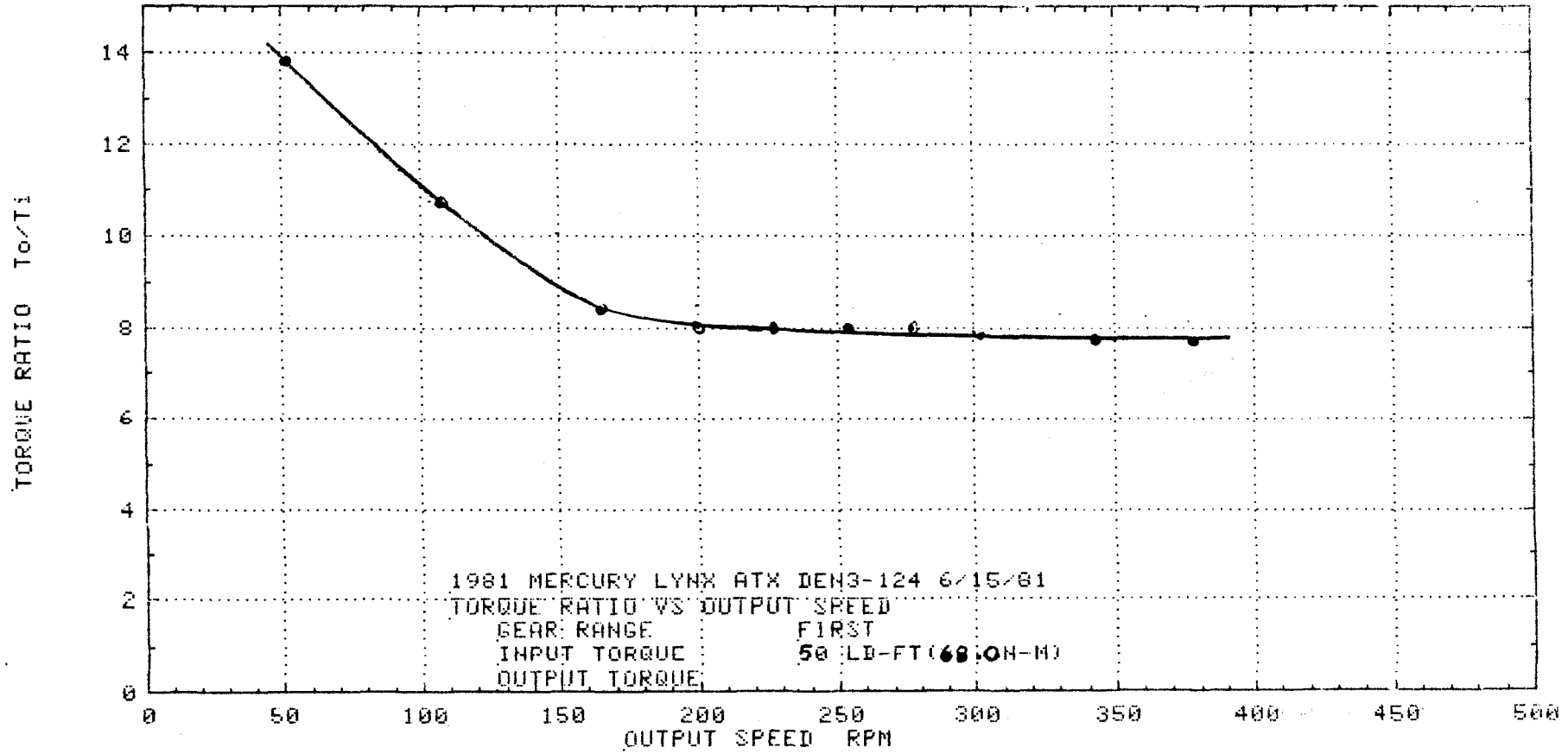

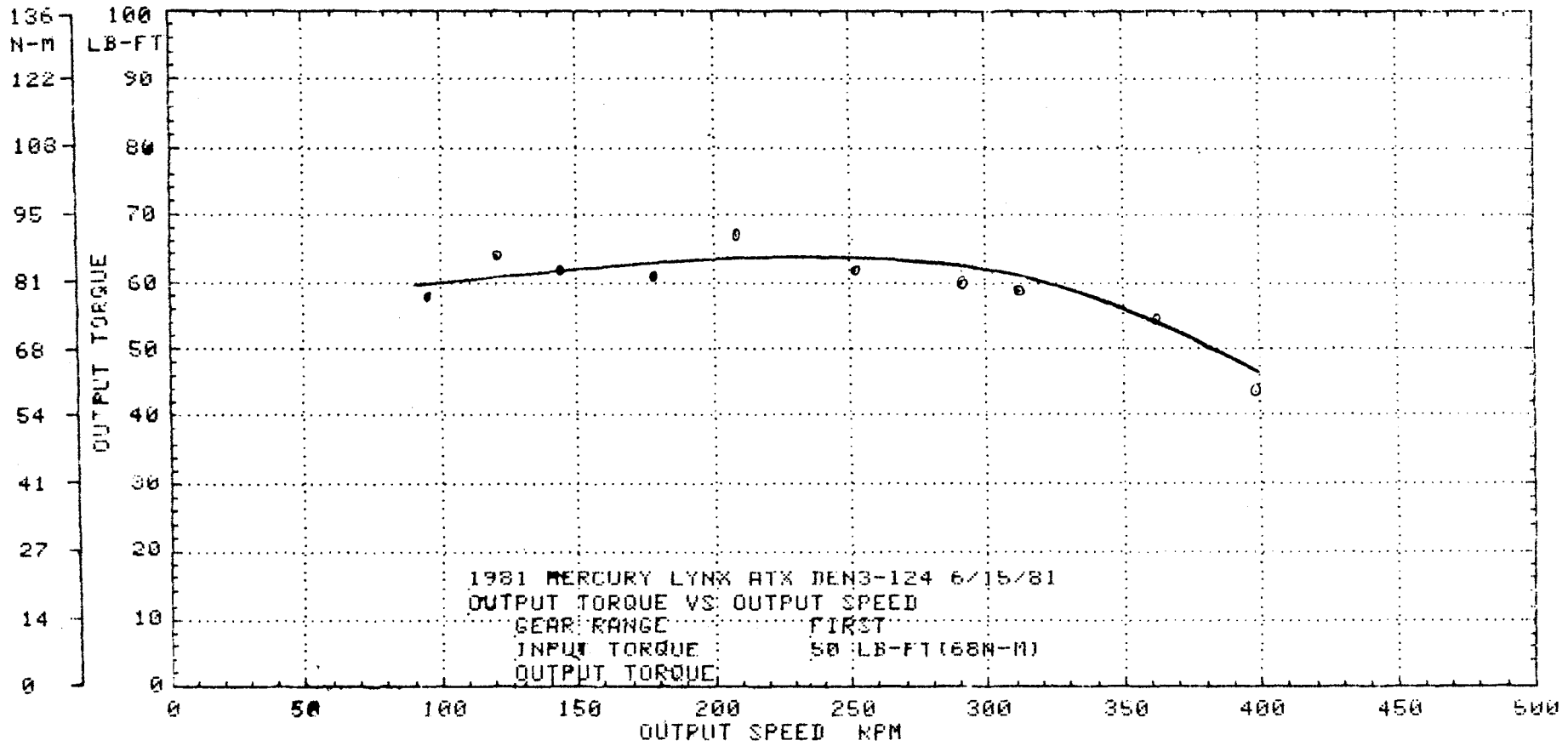

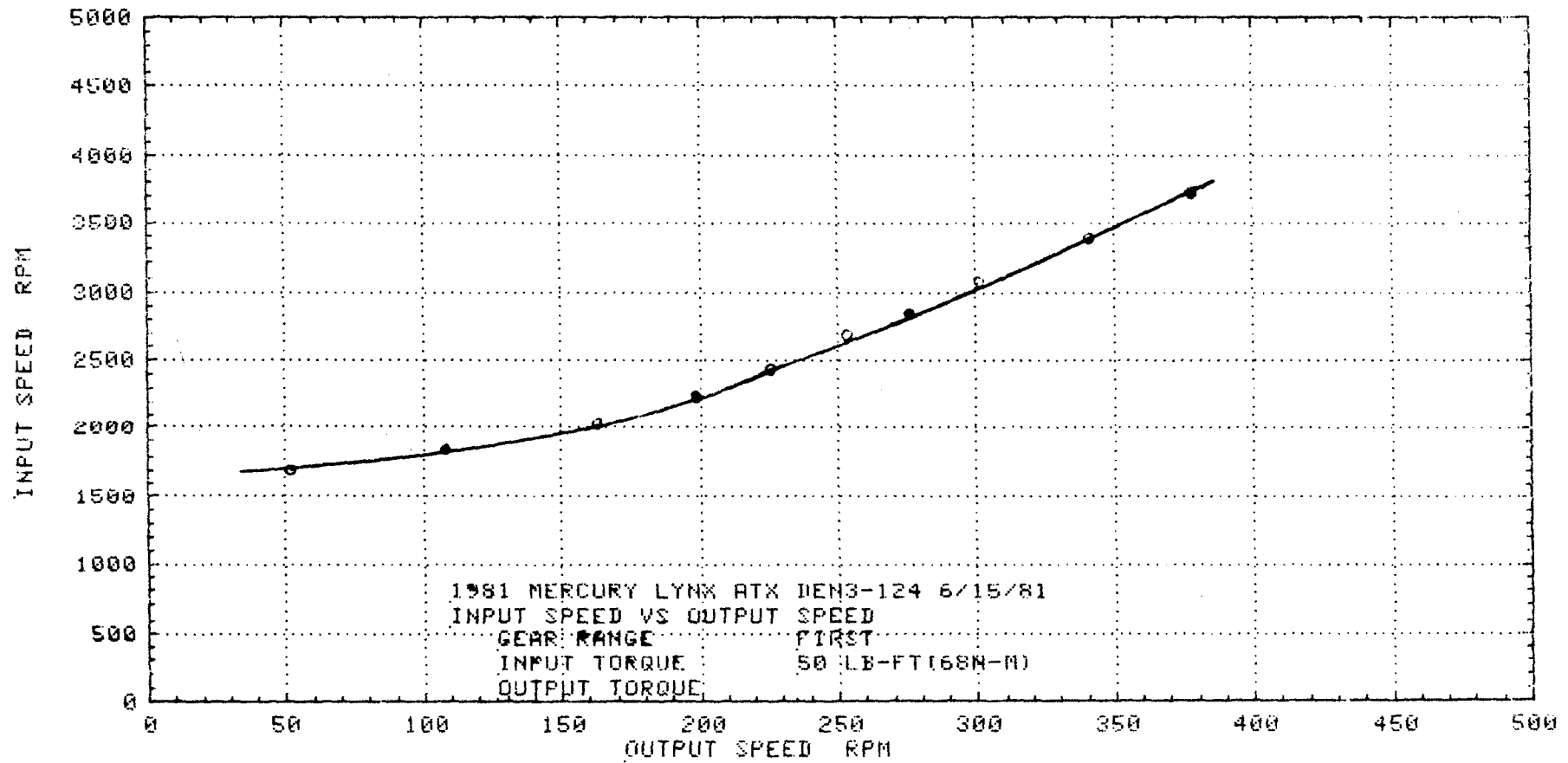

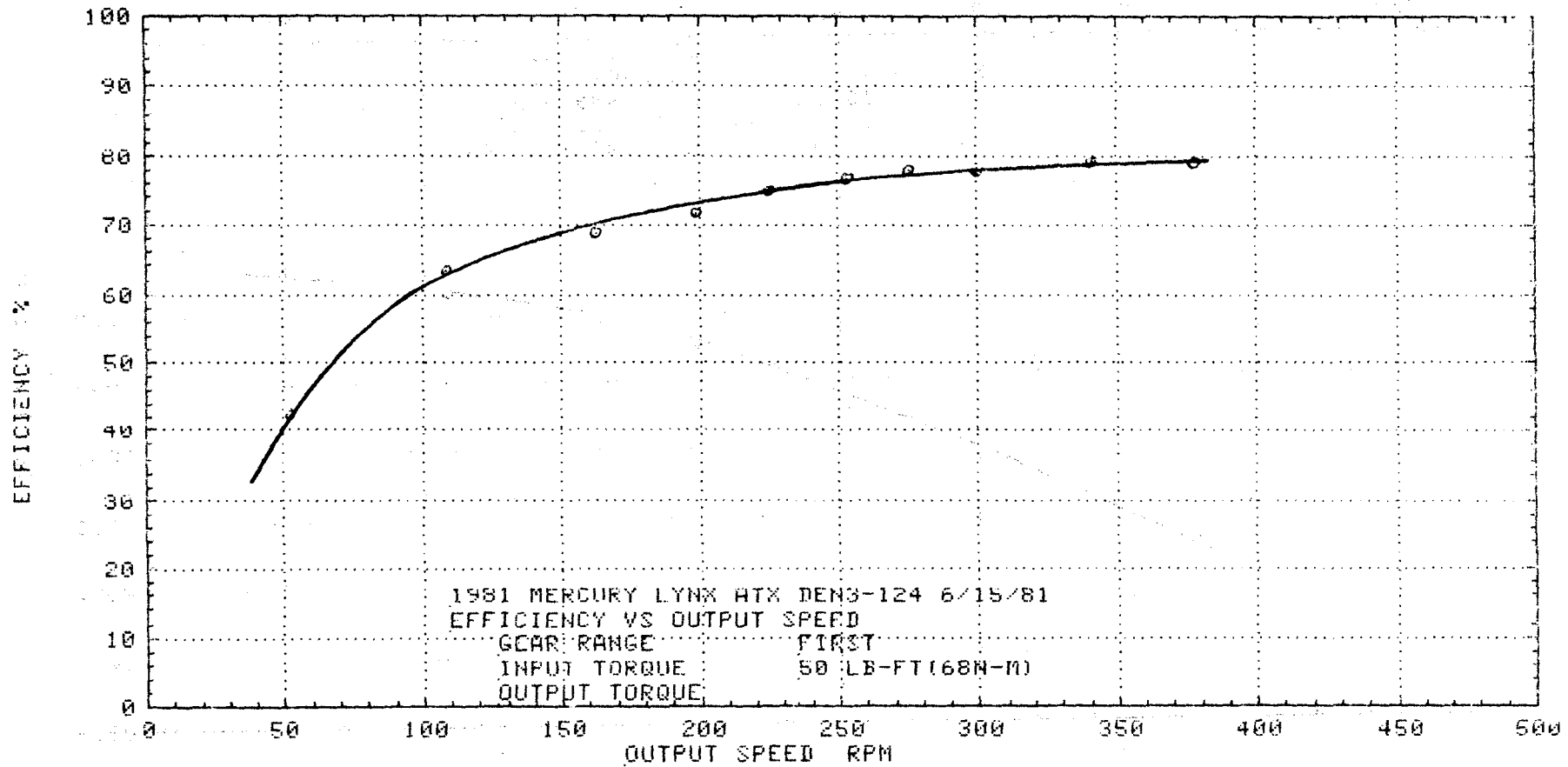

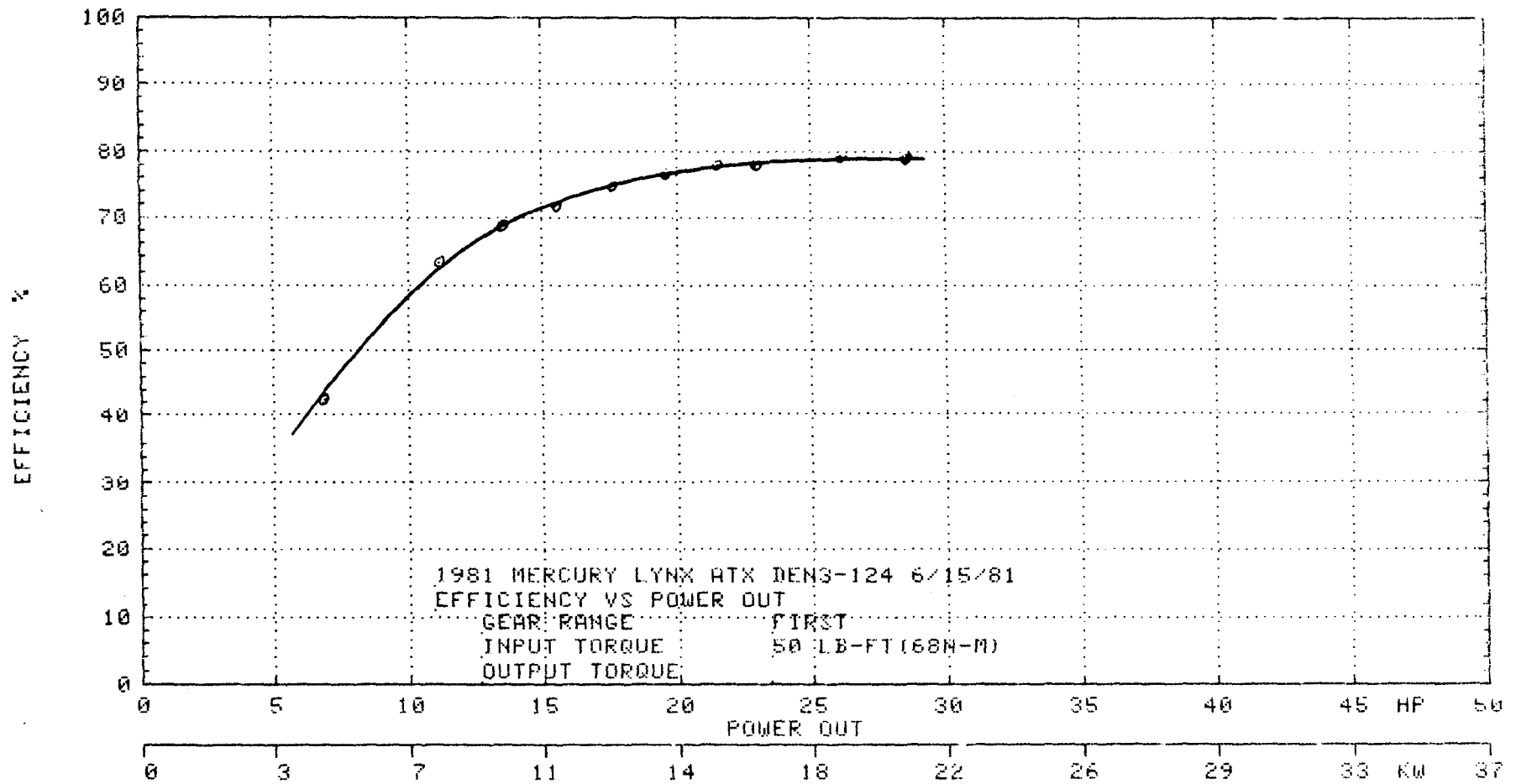

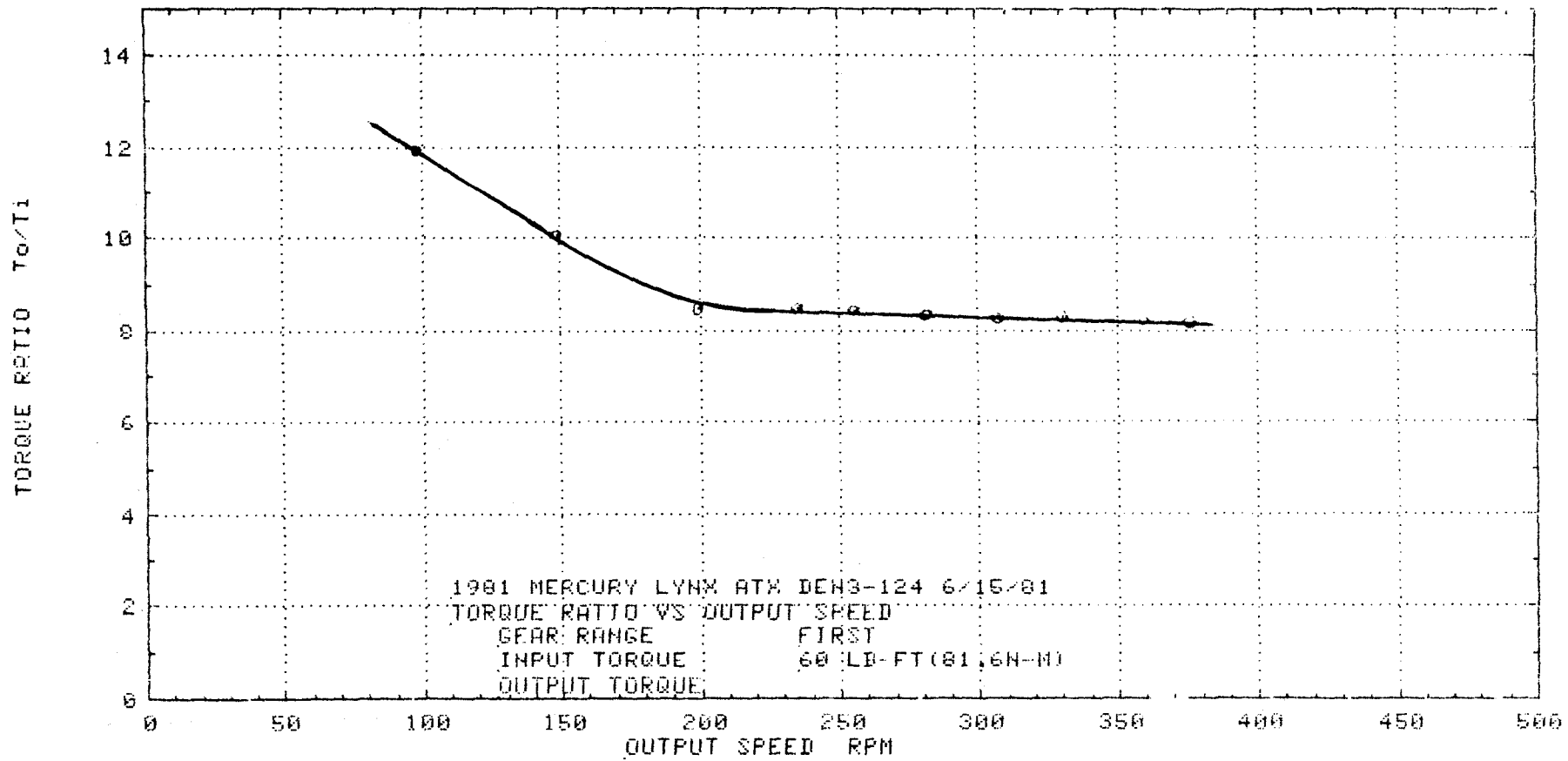

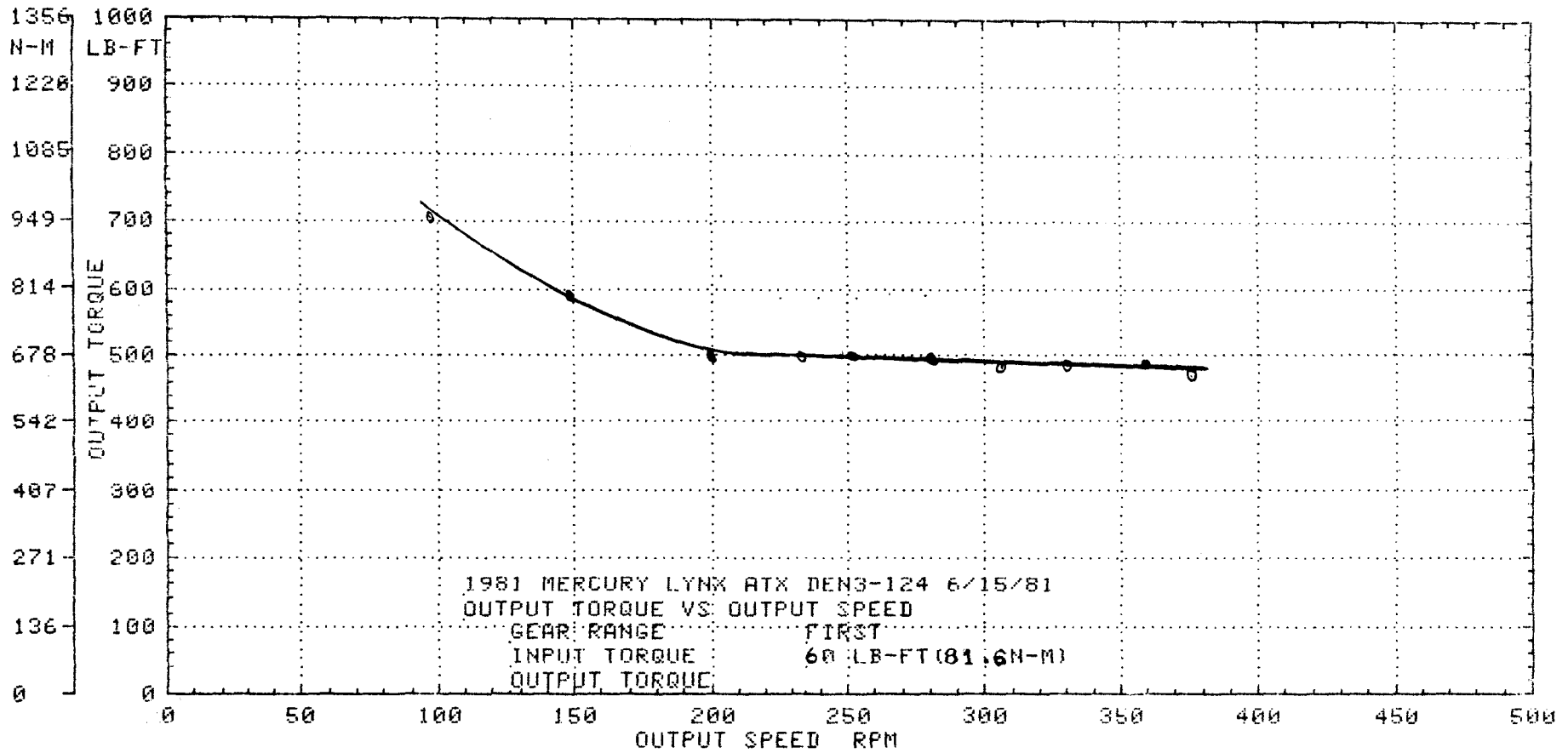

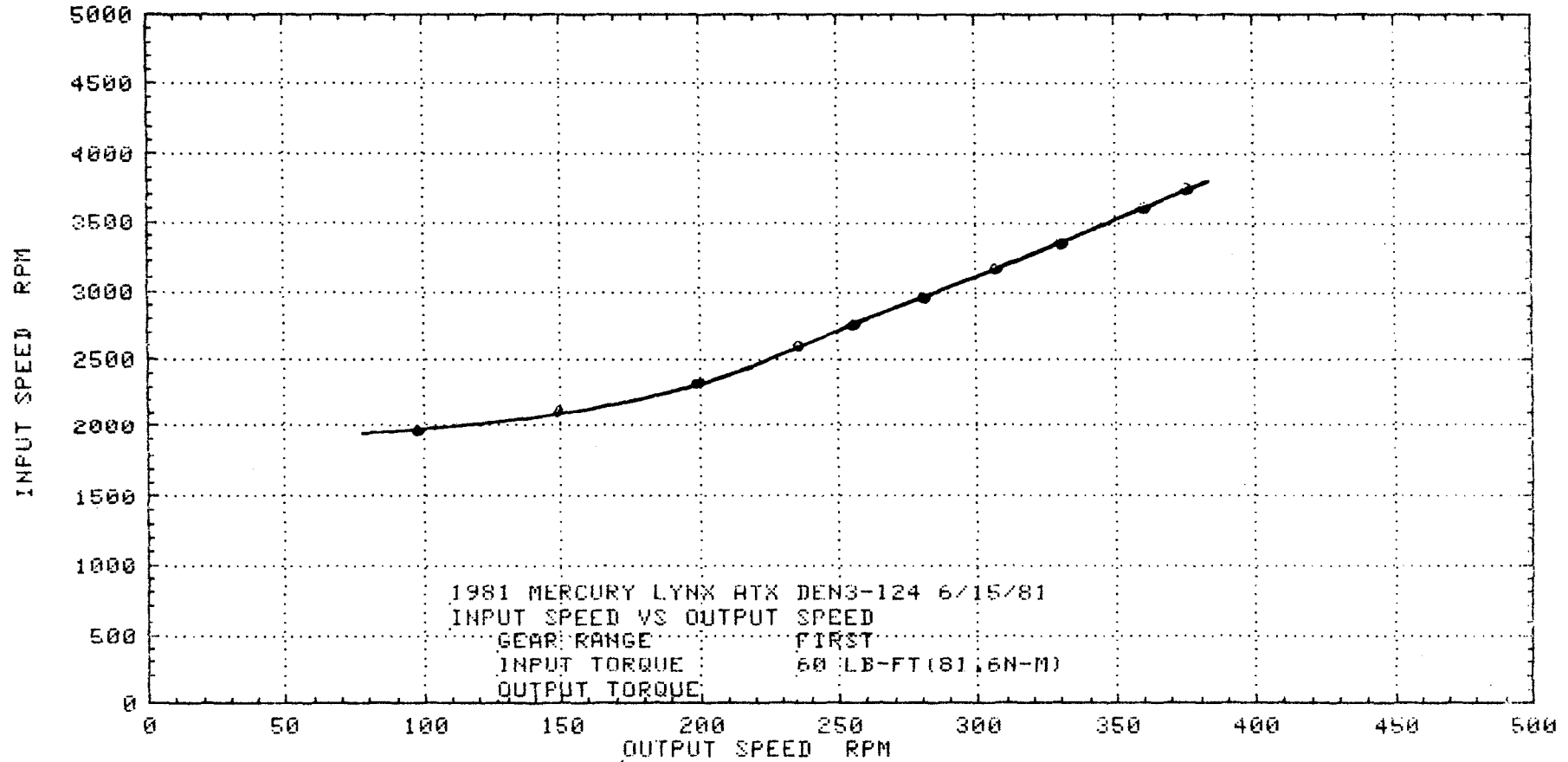

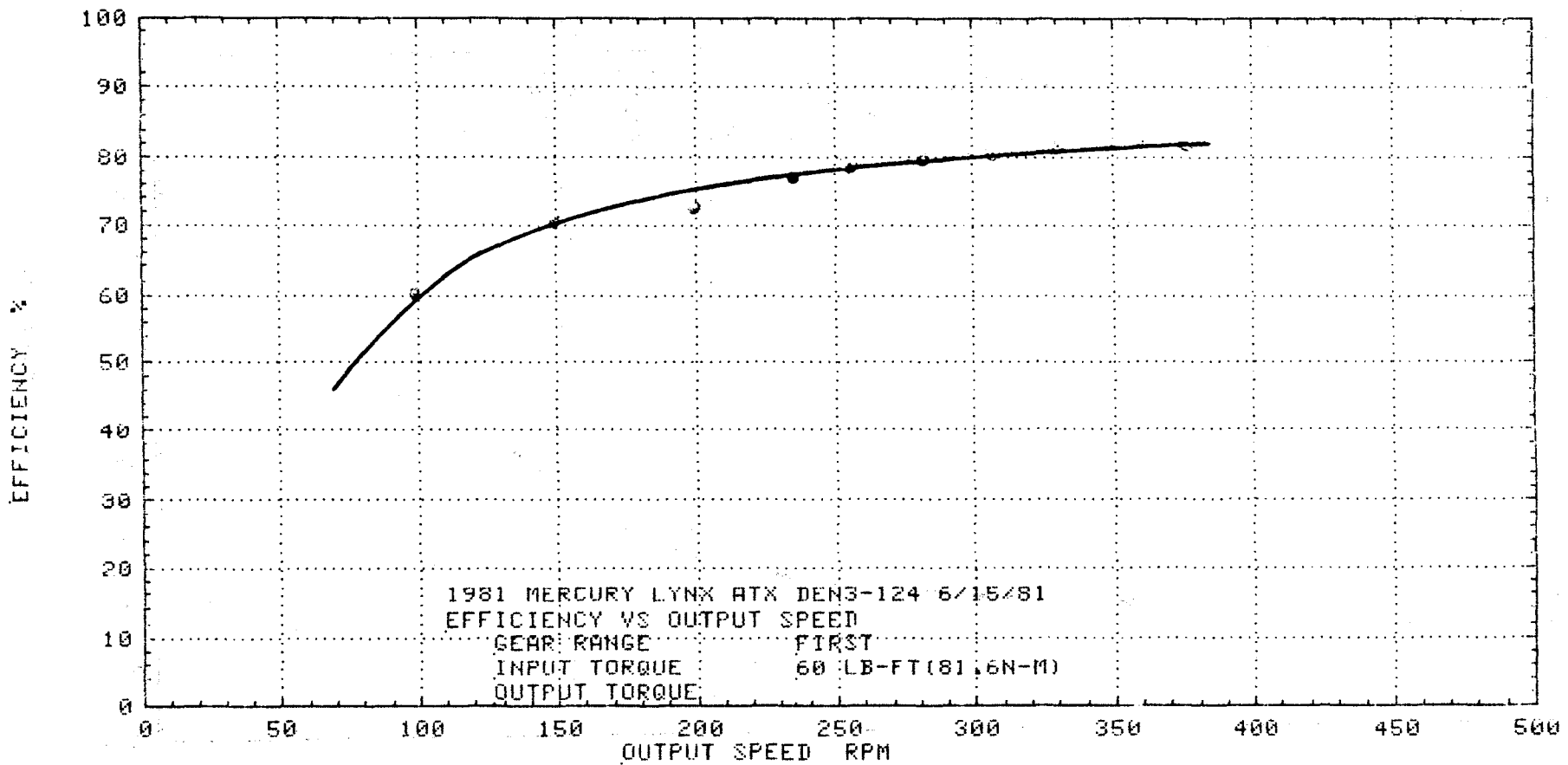

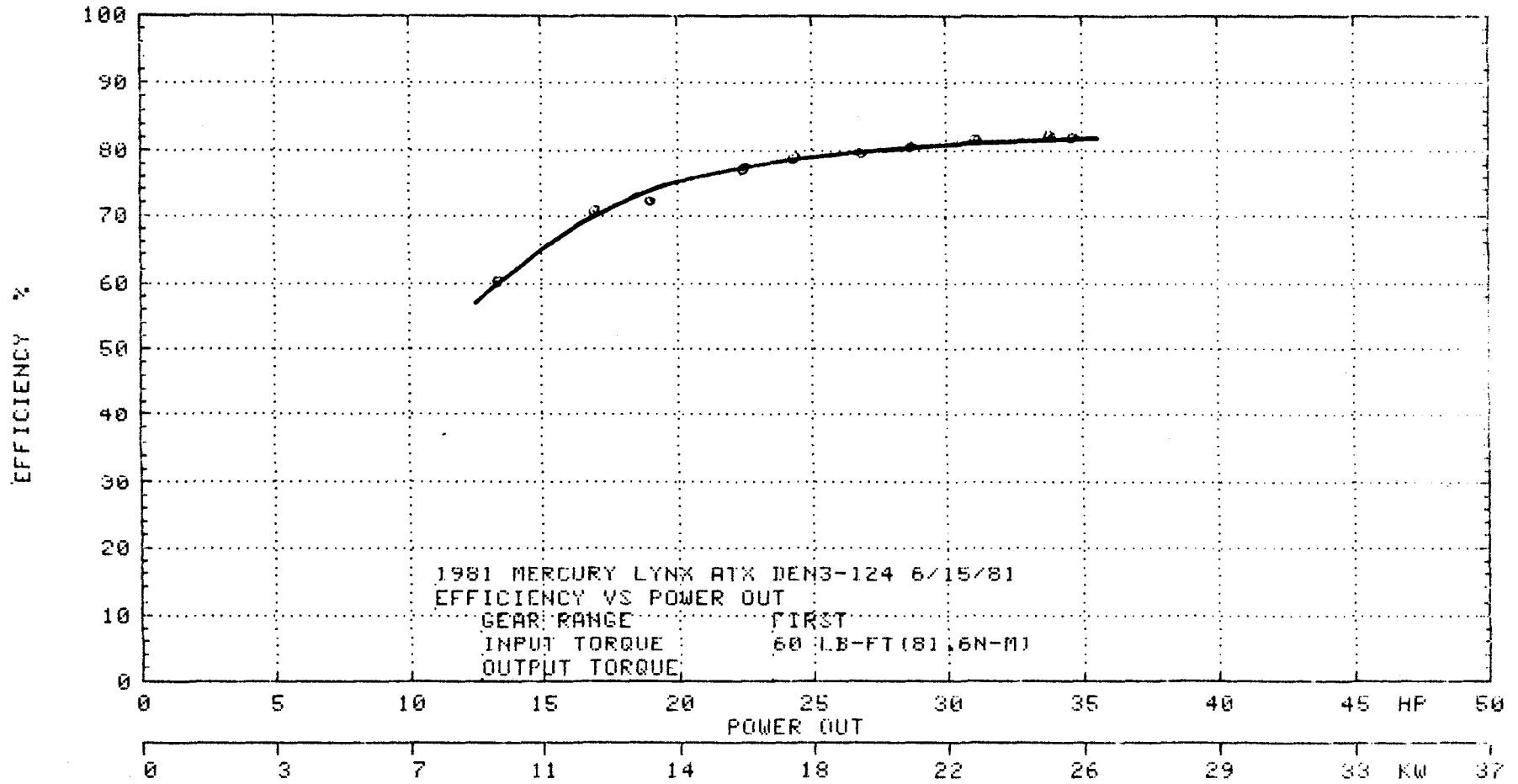

TORQUE RATIO T_o/T_i

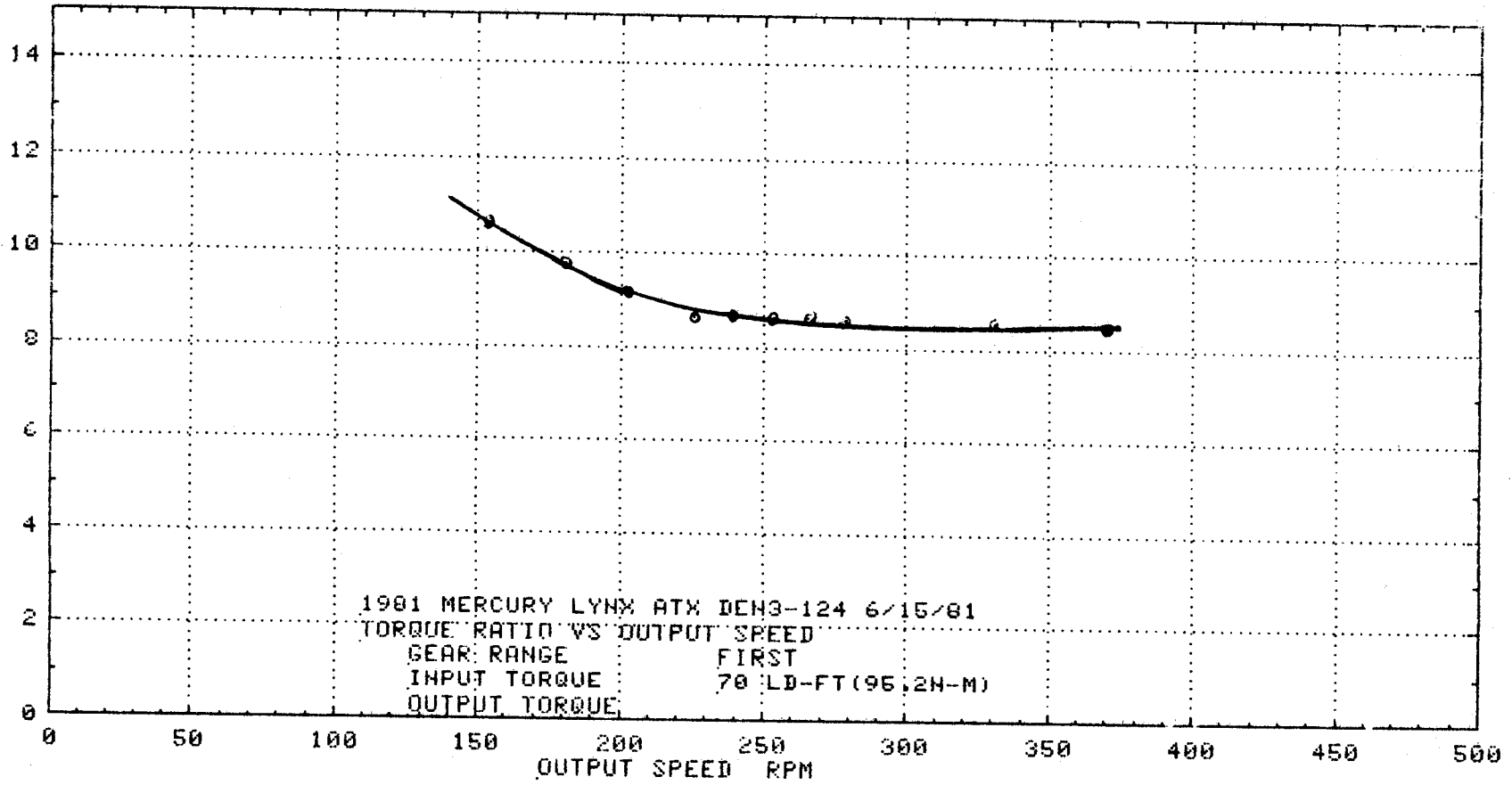

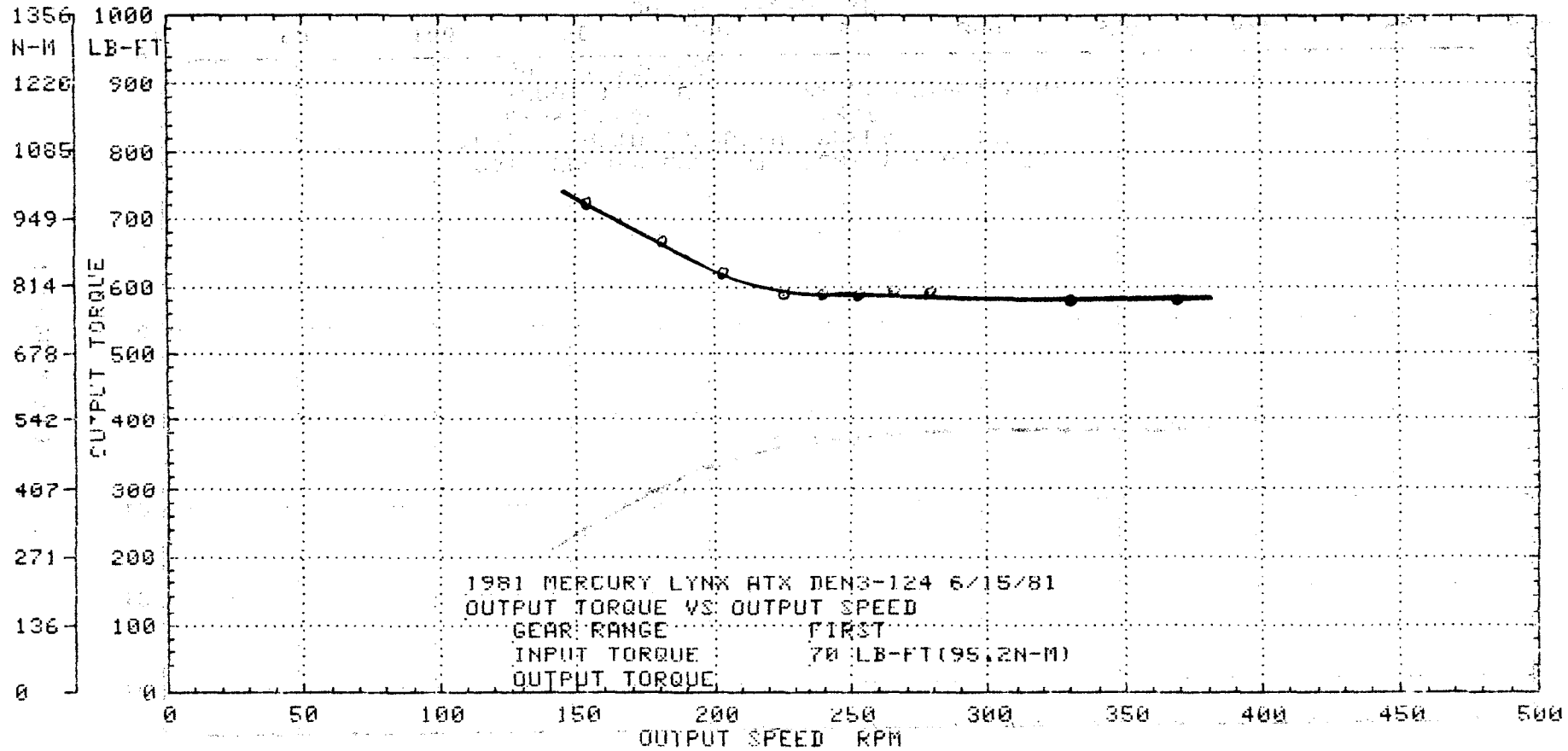

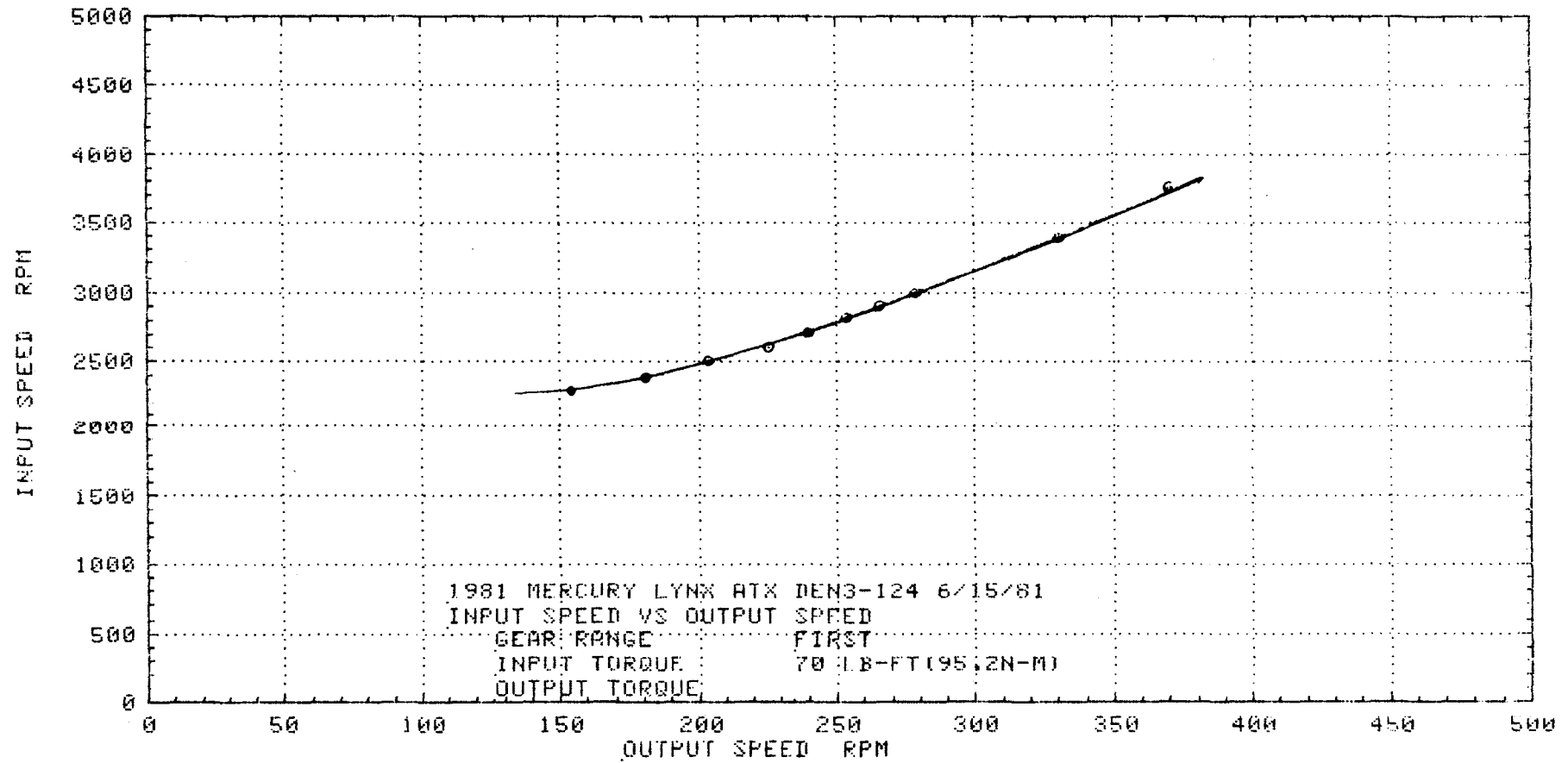

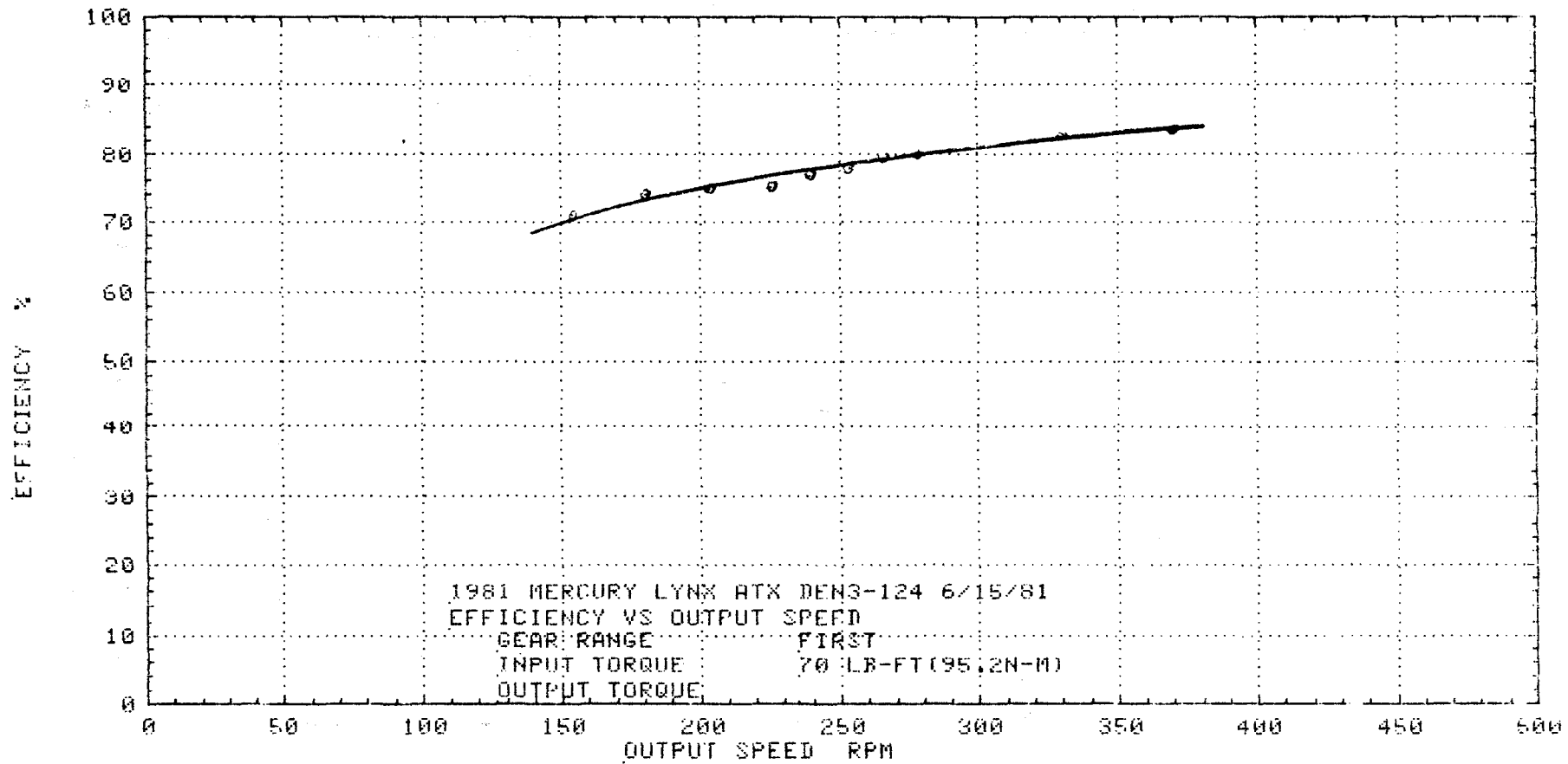

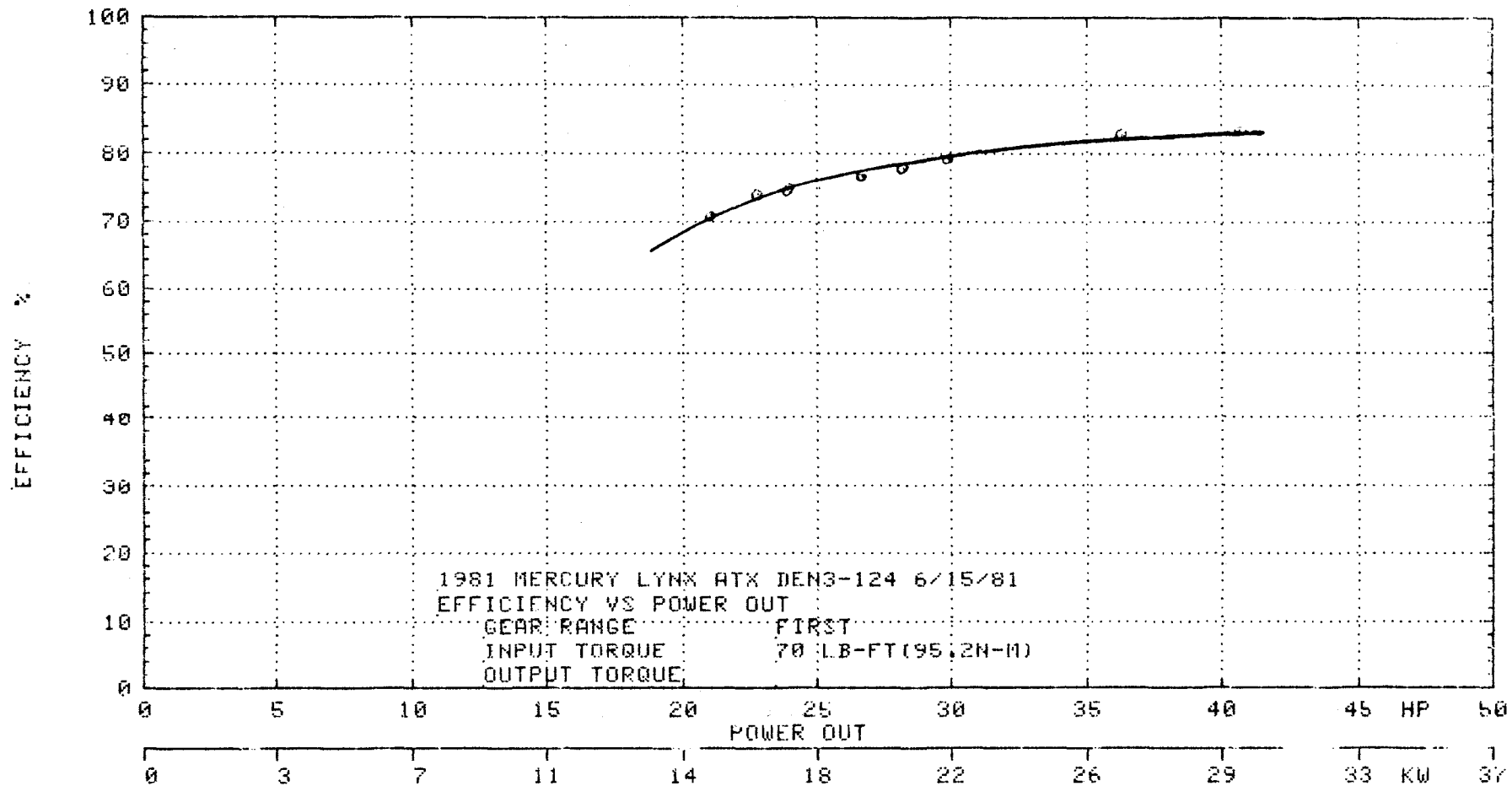

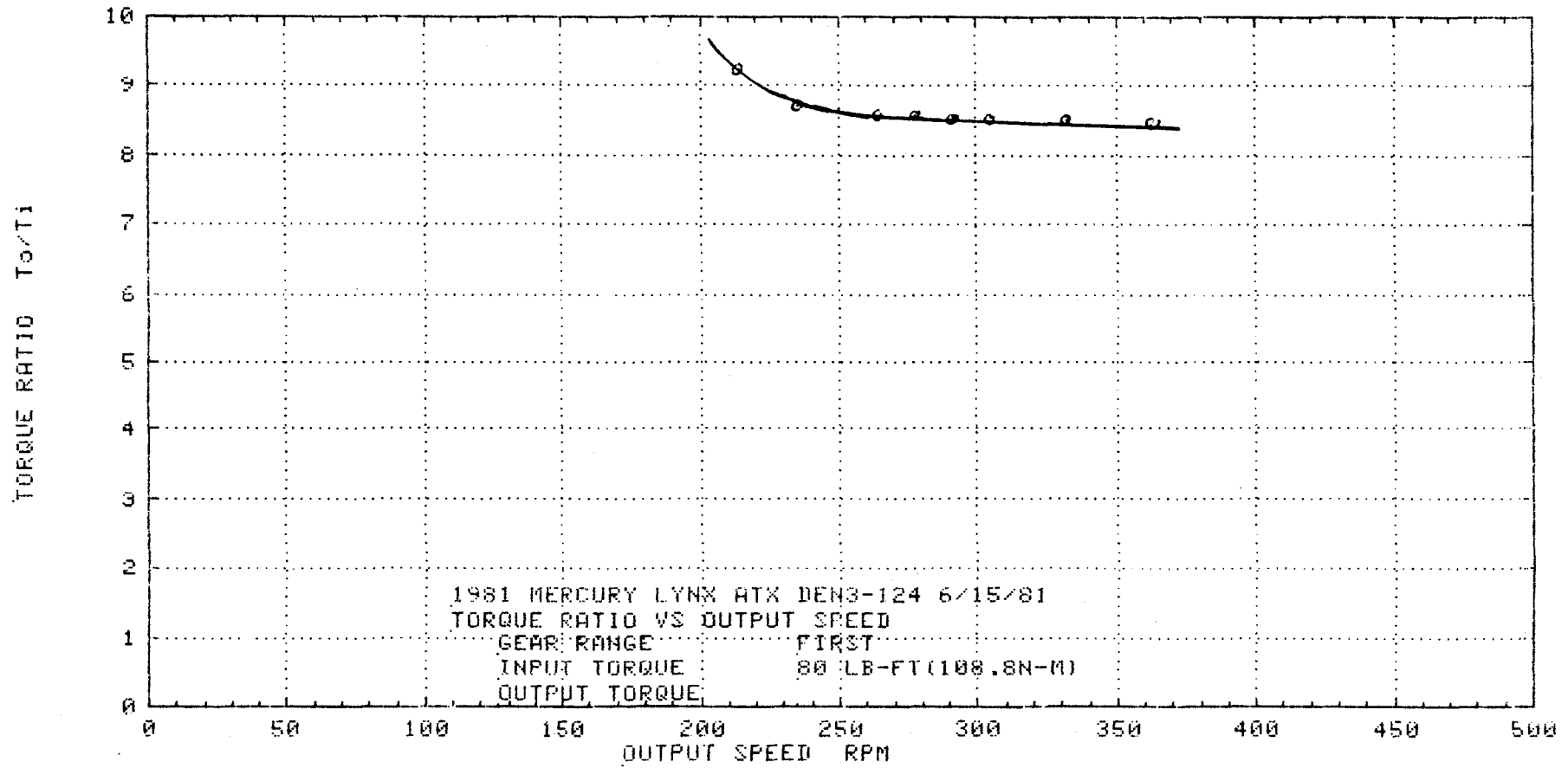

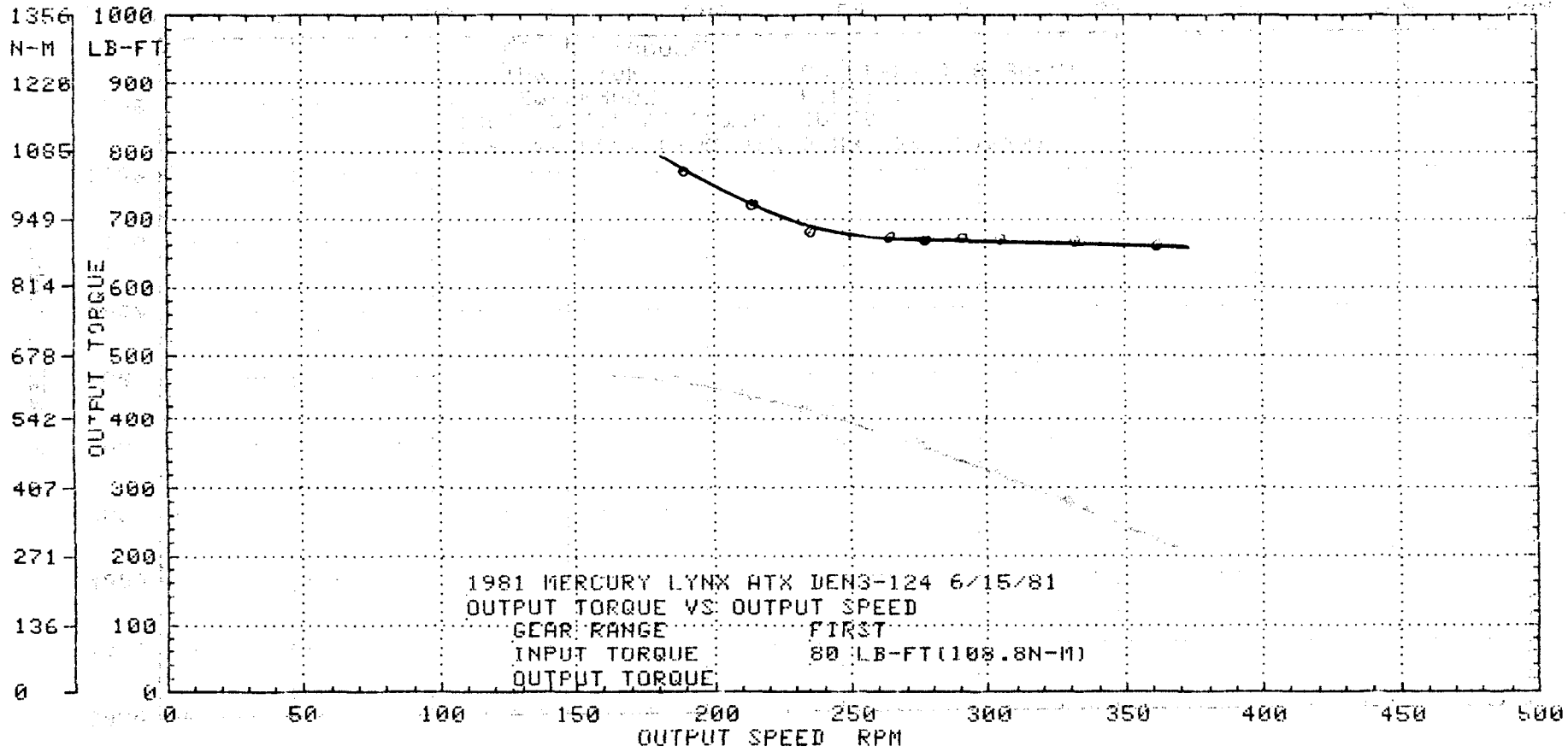

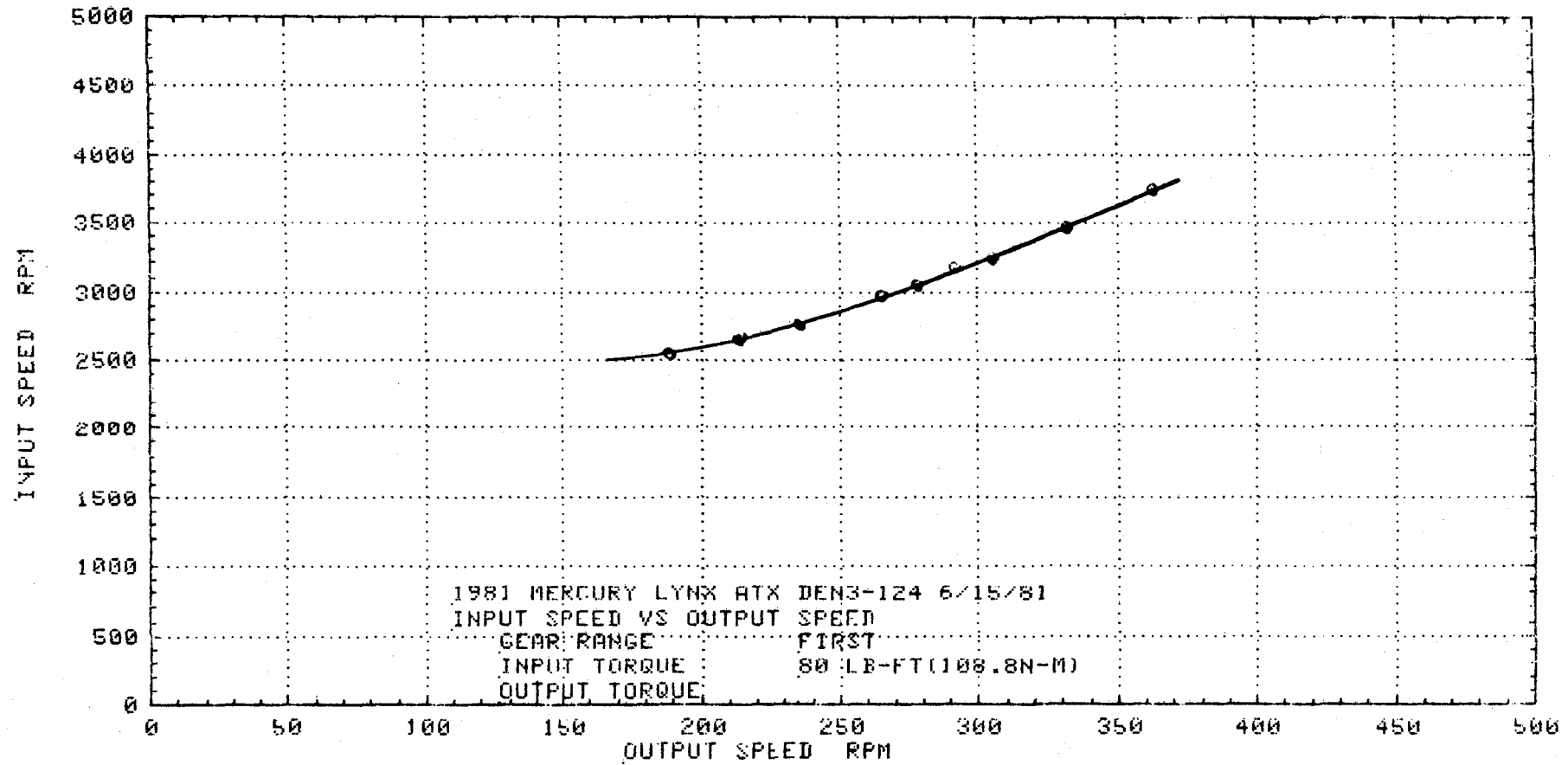

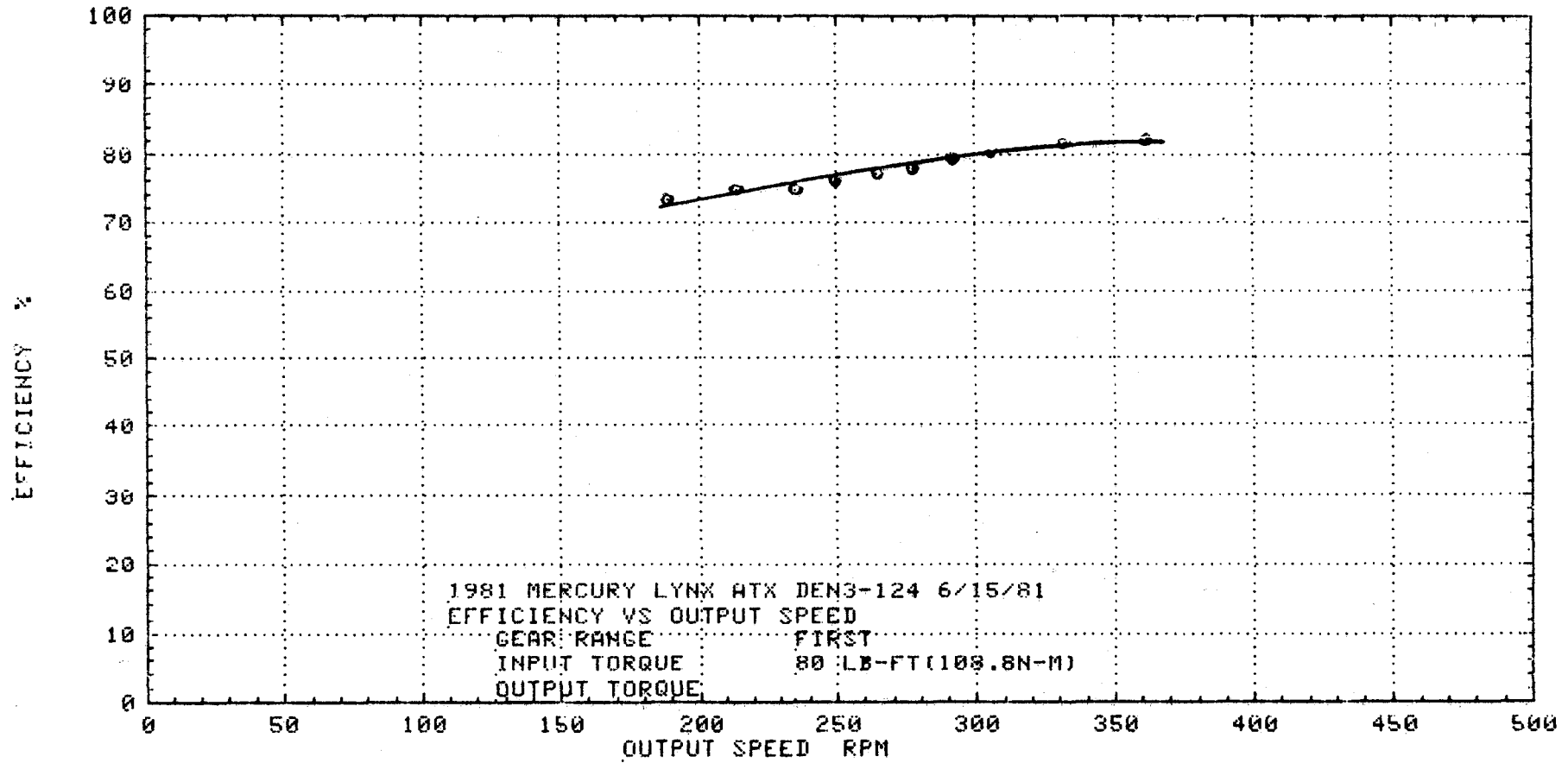

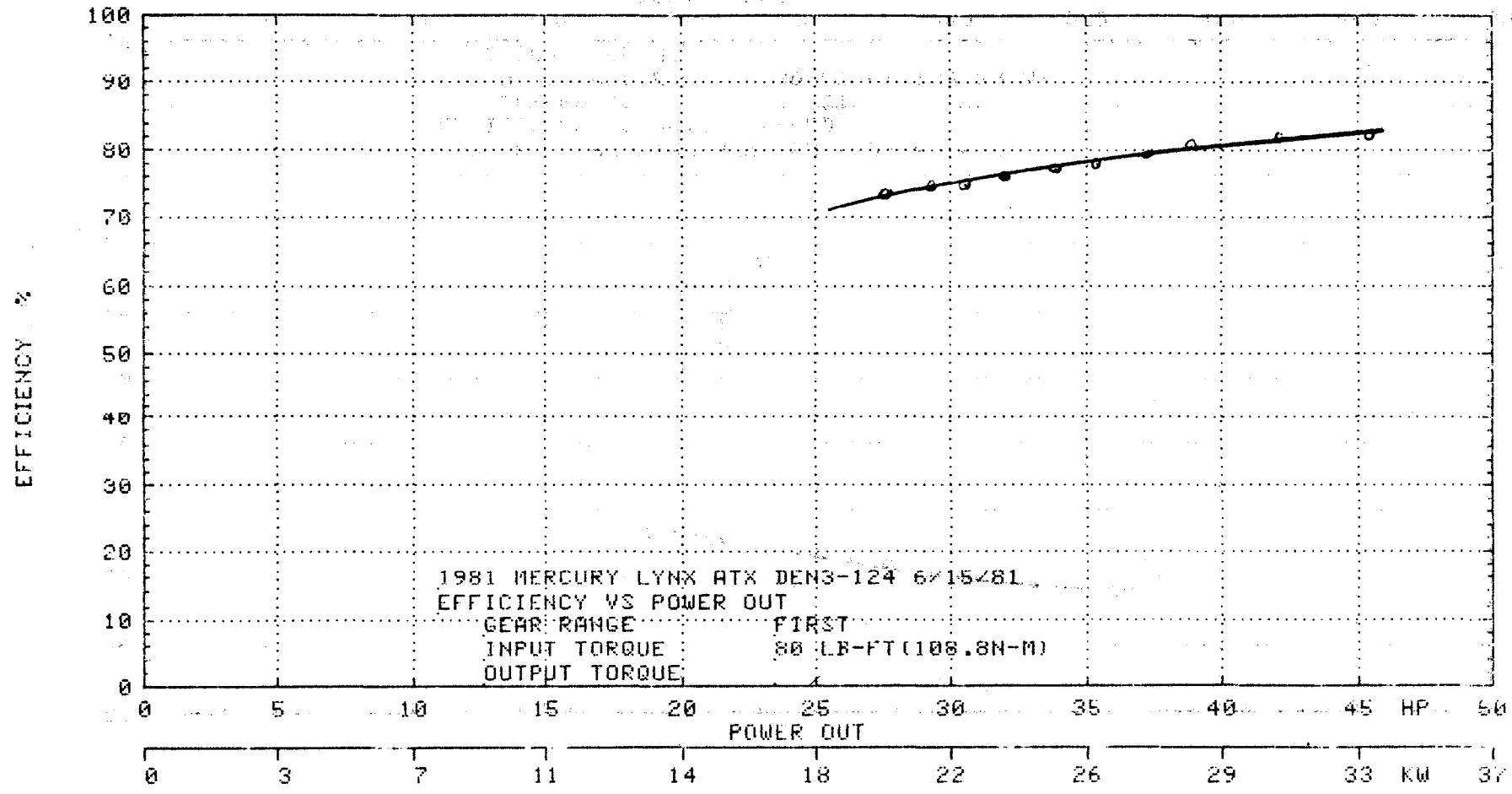

DRIVE PERFORMANCE

2nd Gear

Graphs Contained in This Section

Torque Ratio -vs- Output Speed

Output Torque -vs- Output Speed

Input Speed -vs- Output Speed

Efficiency -vs- Output Speed

Efficiency -vs- Power Out

70

Torque In

Speed In

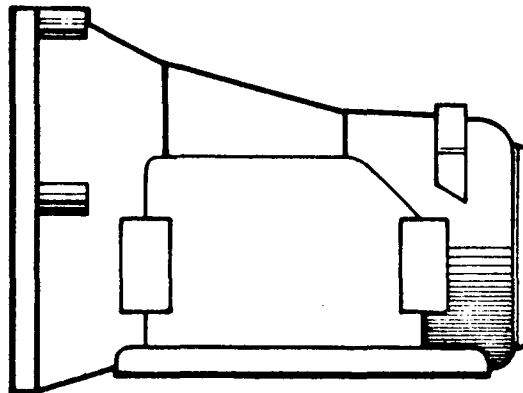

Torque Out

Speed Out

Drive Performance Tests

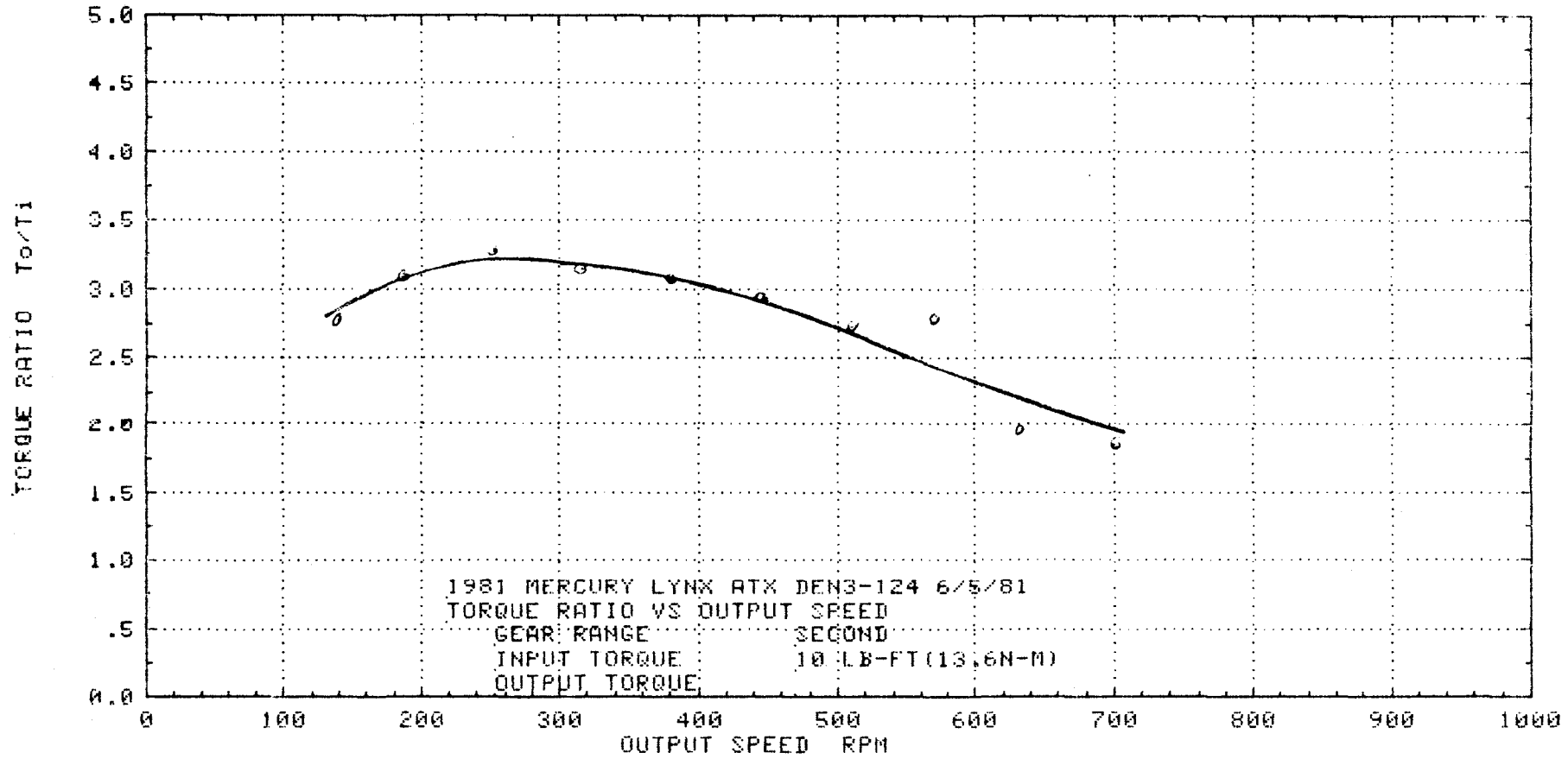

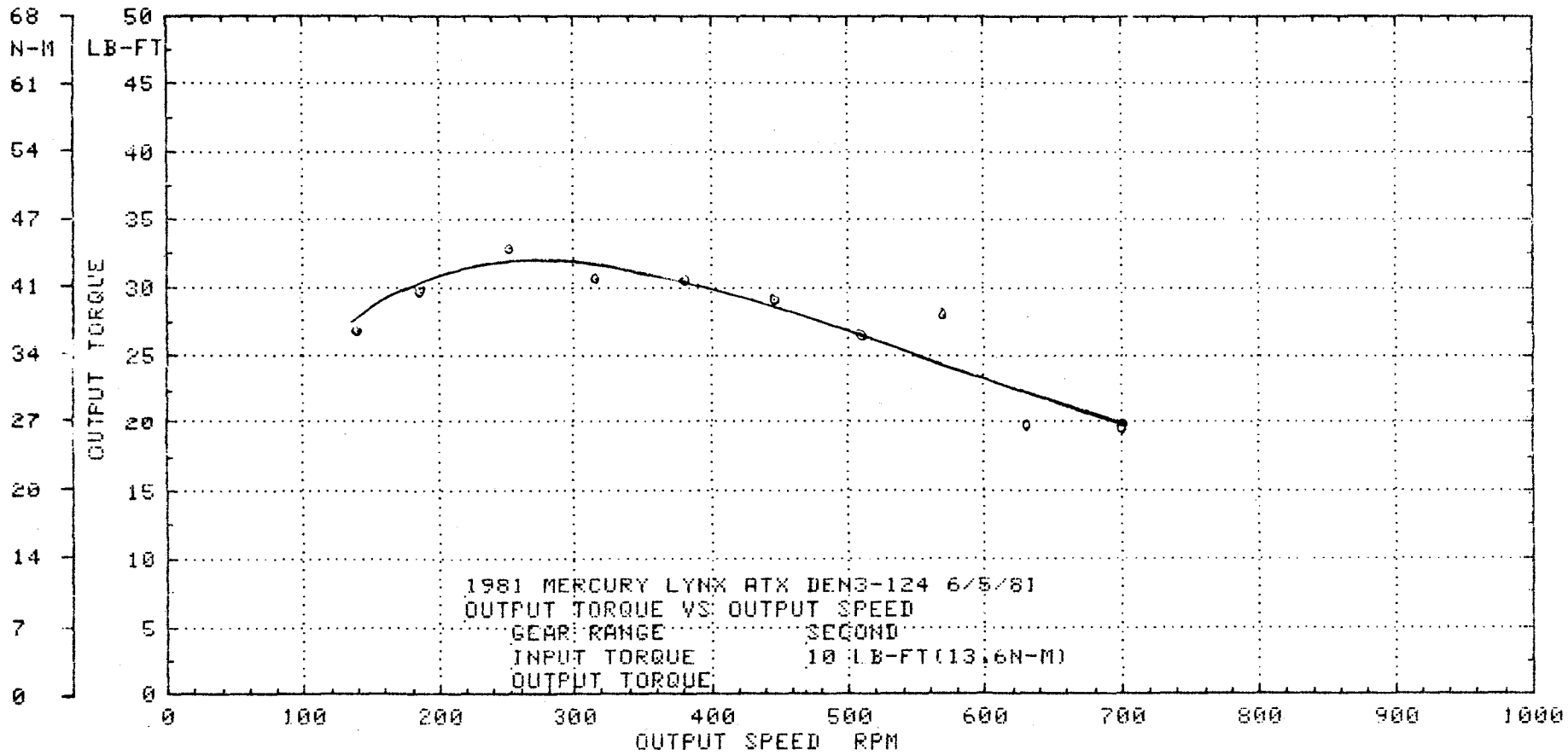

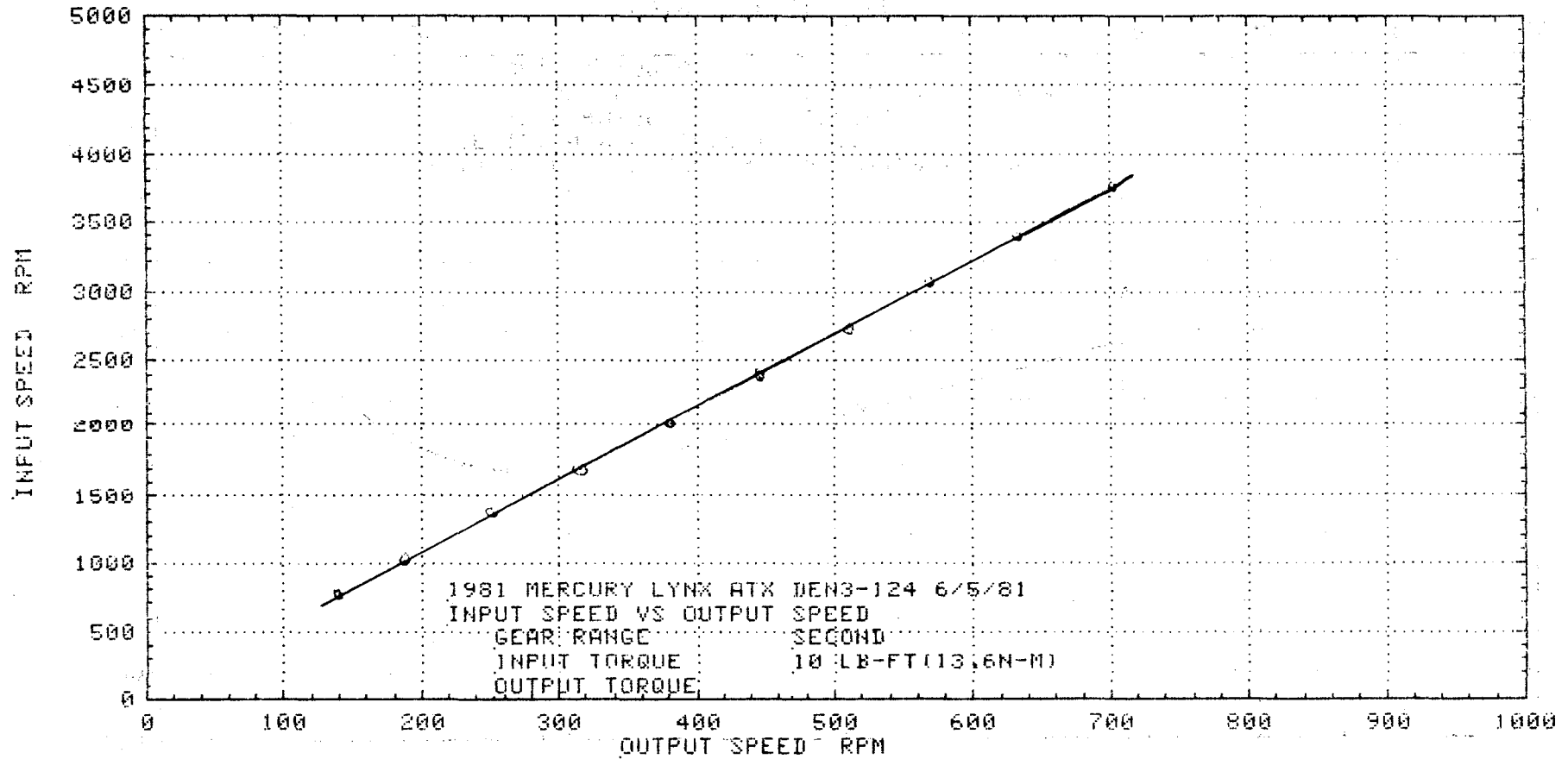

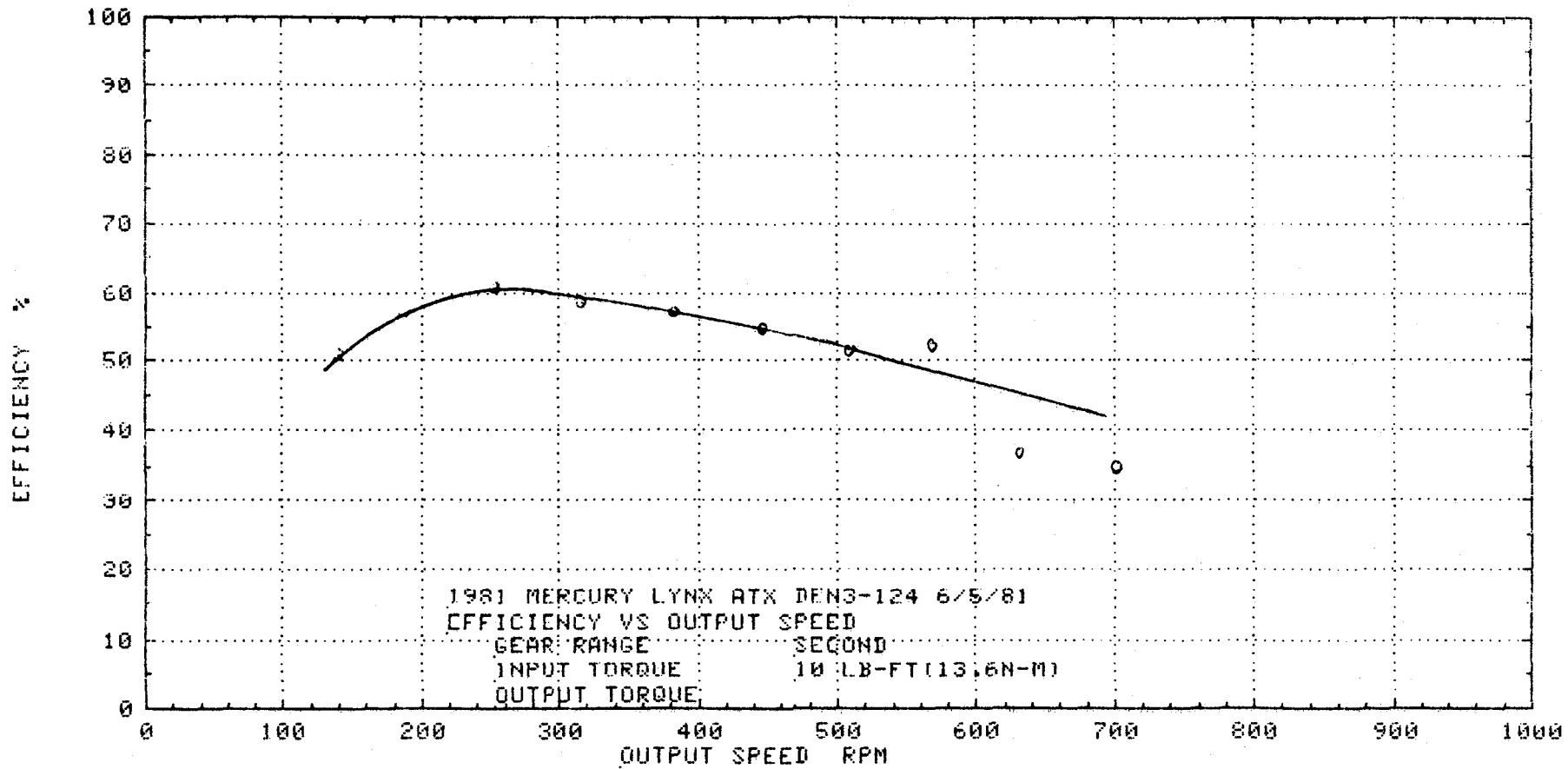

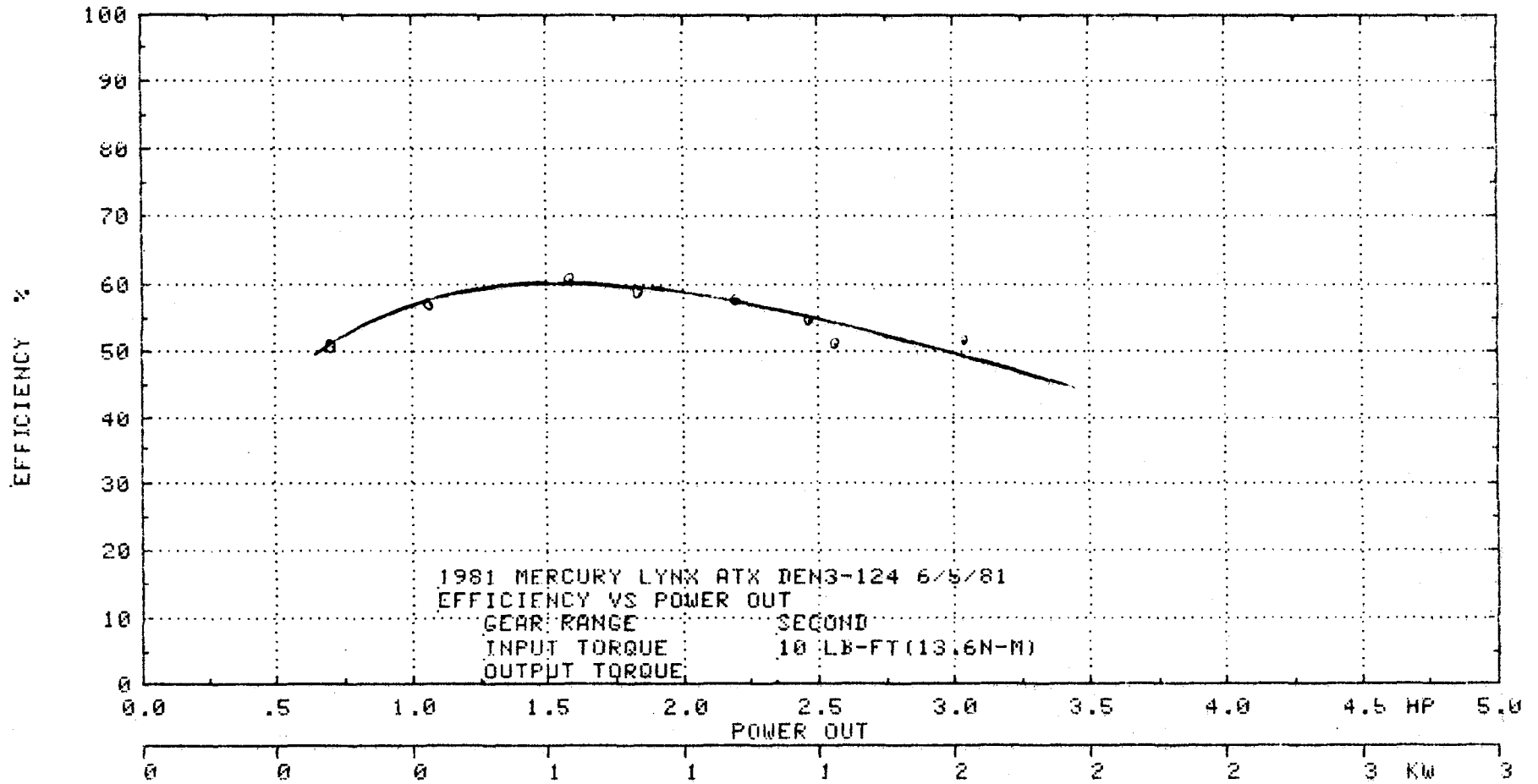

TORQUE RATIO T_o/T_i

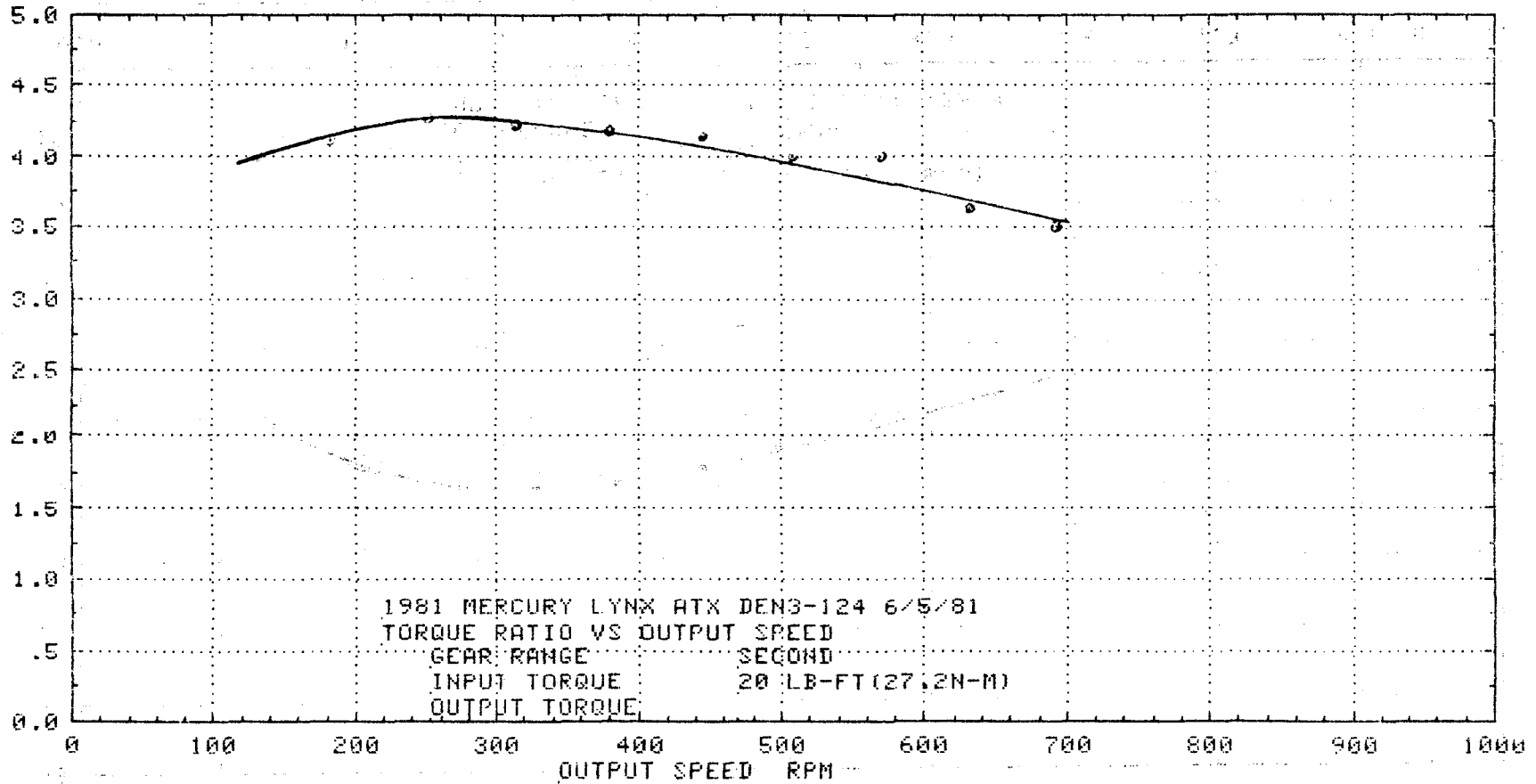

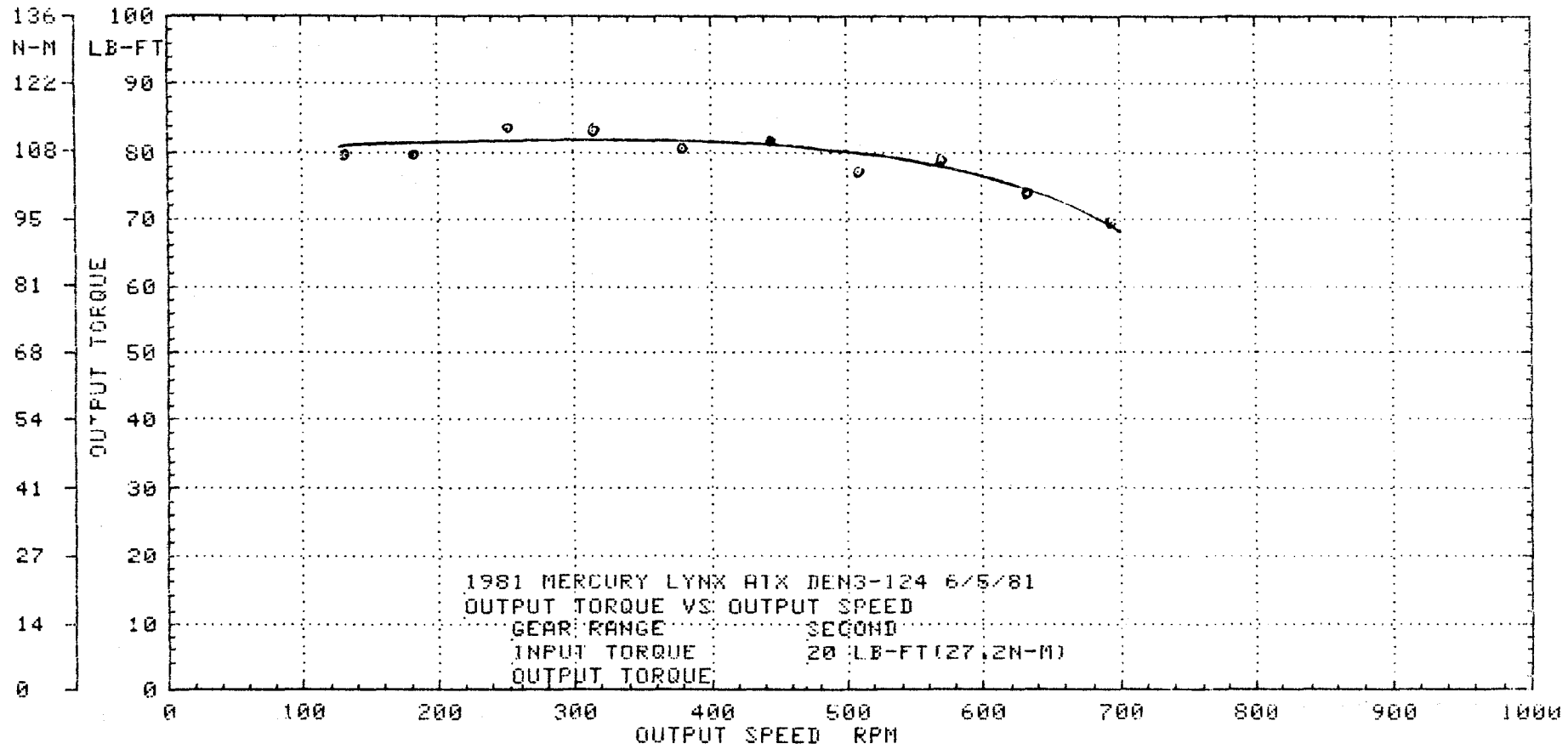

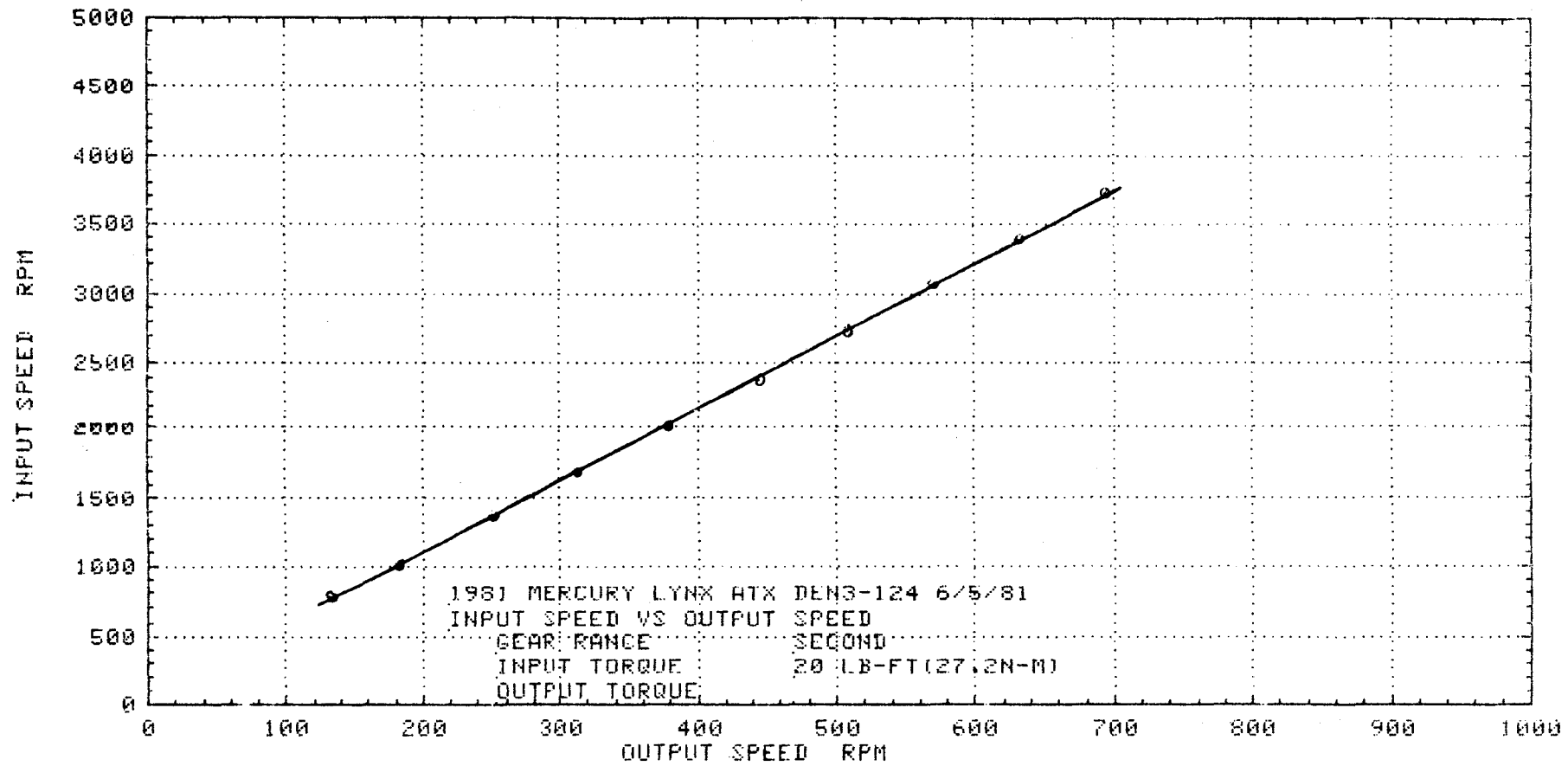

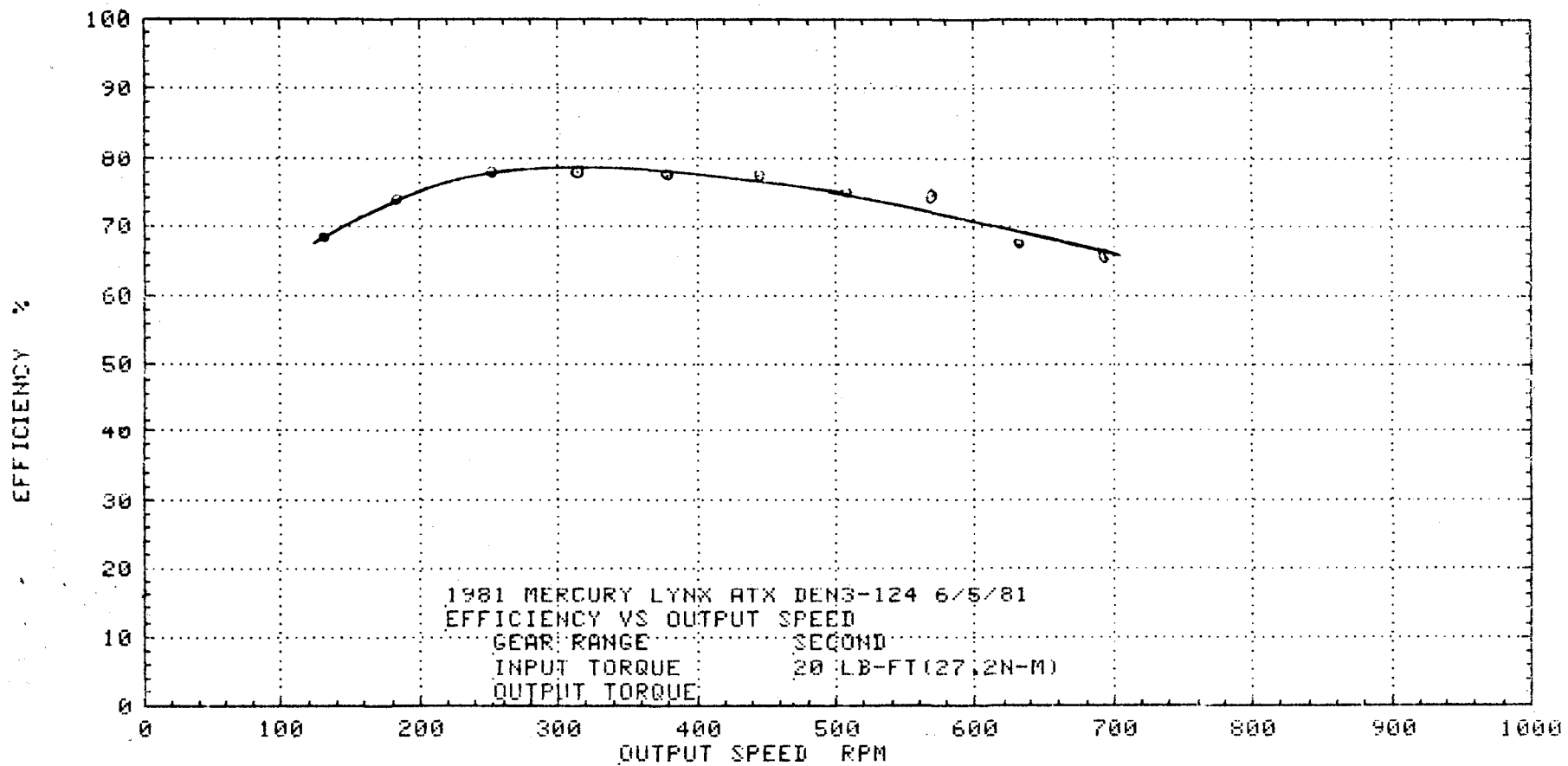

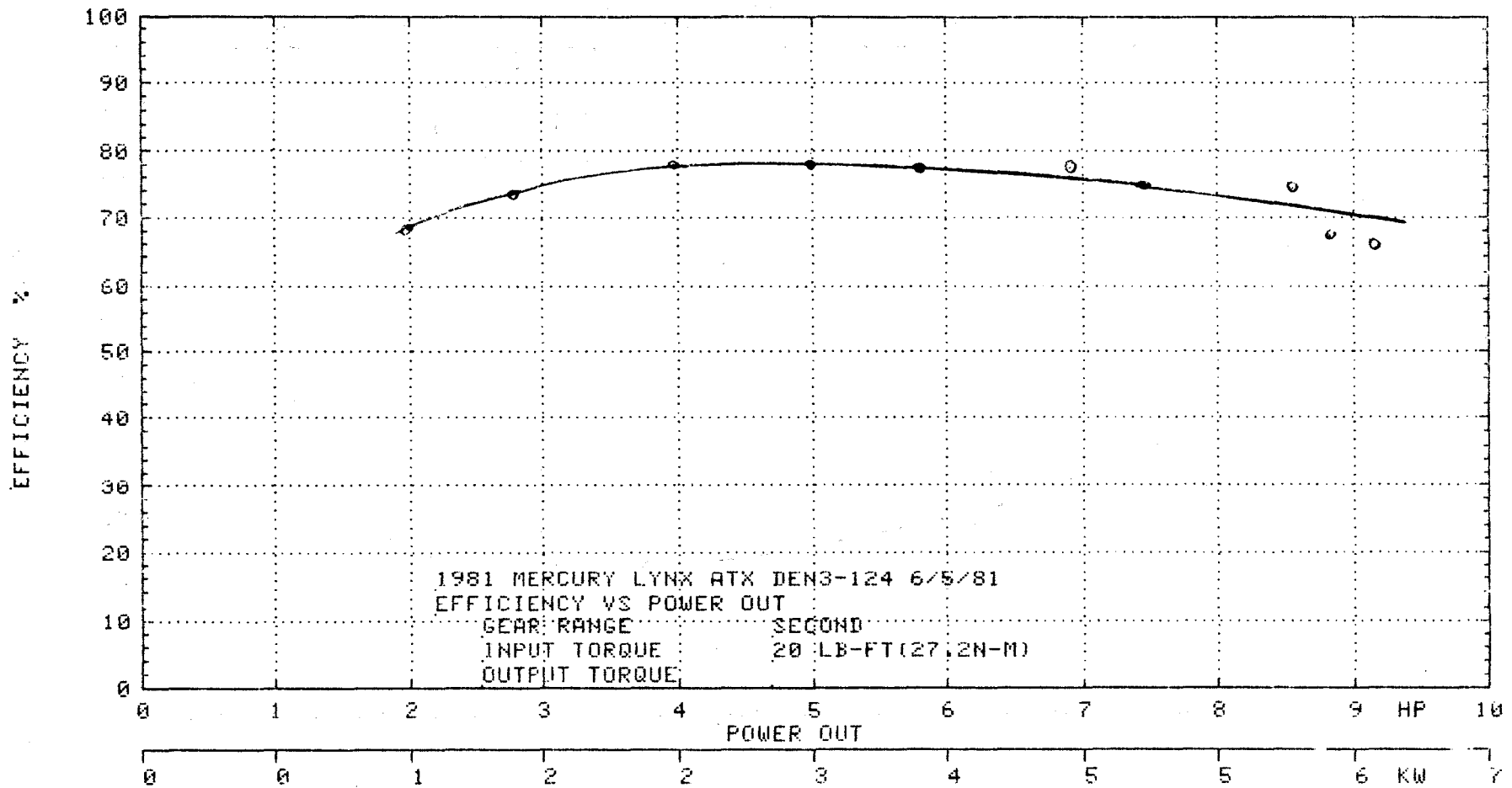

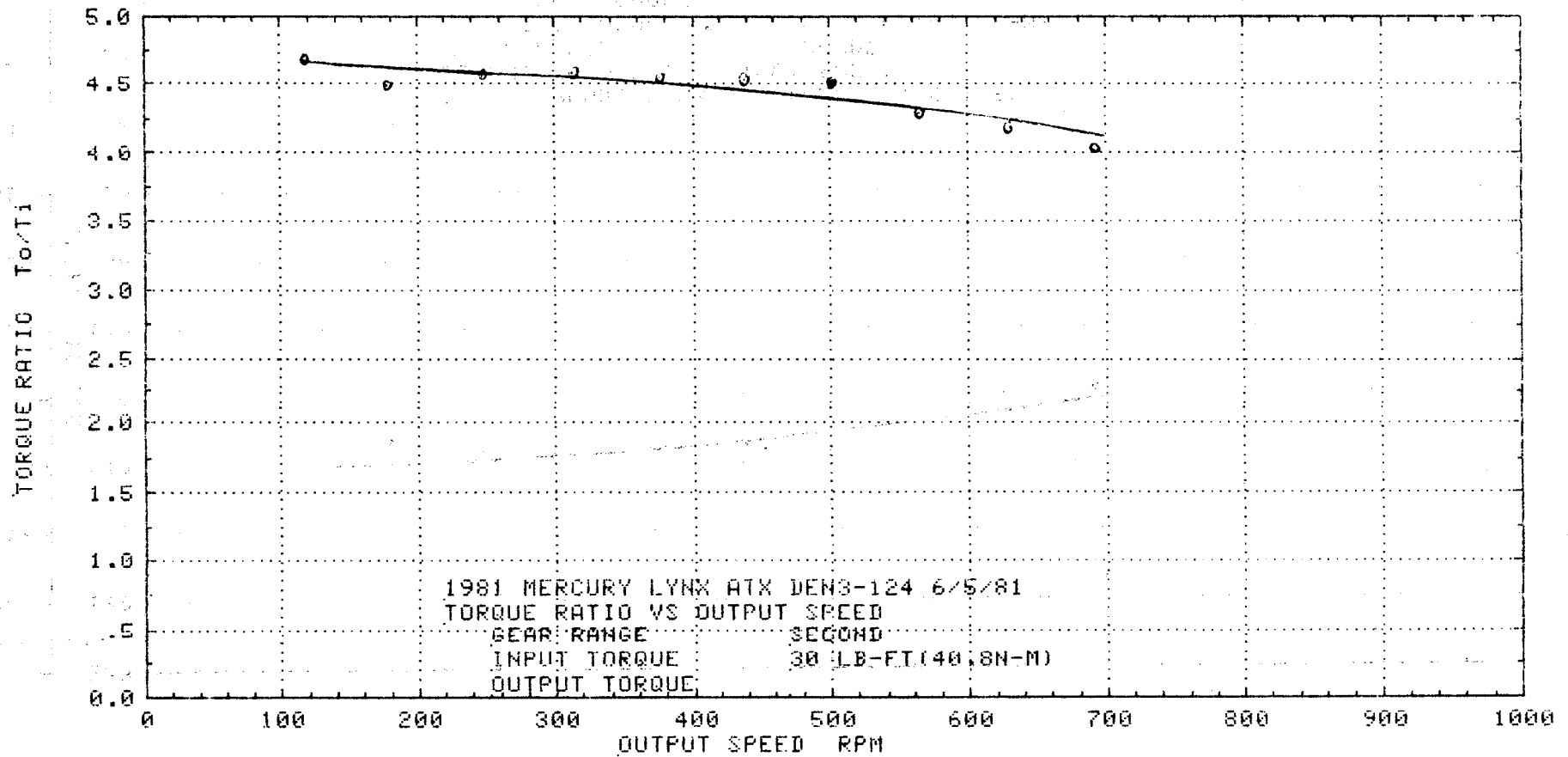

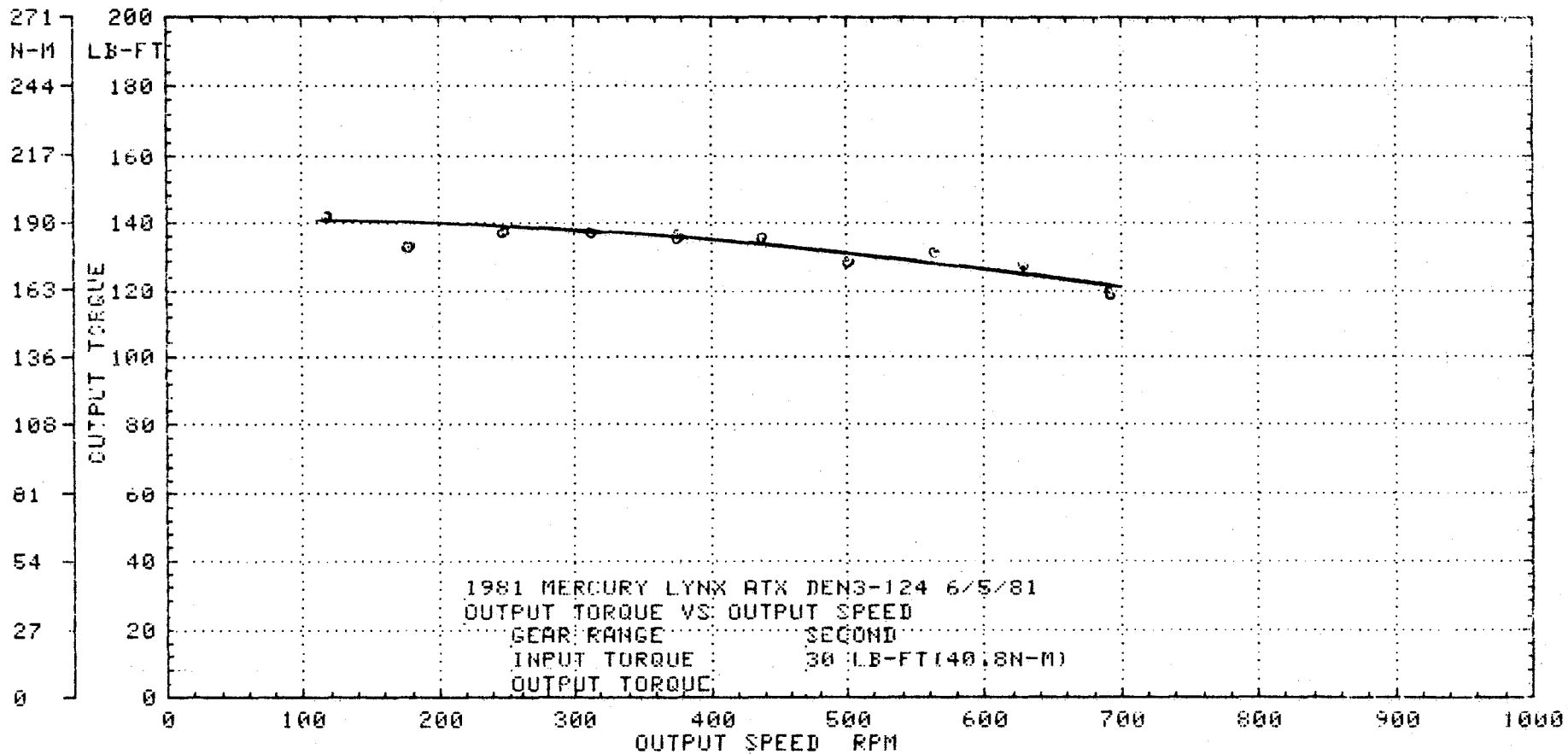

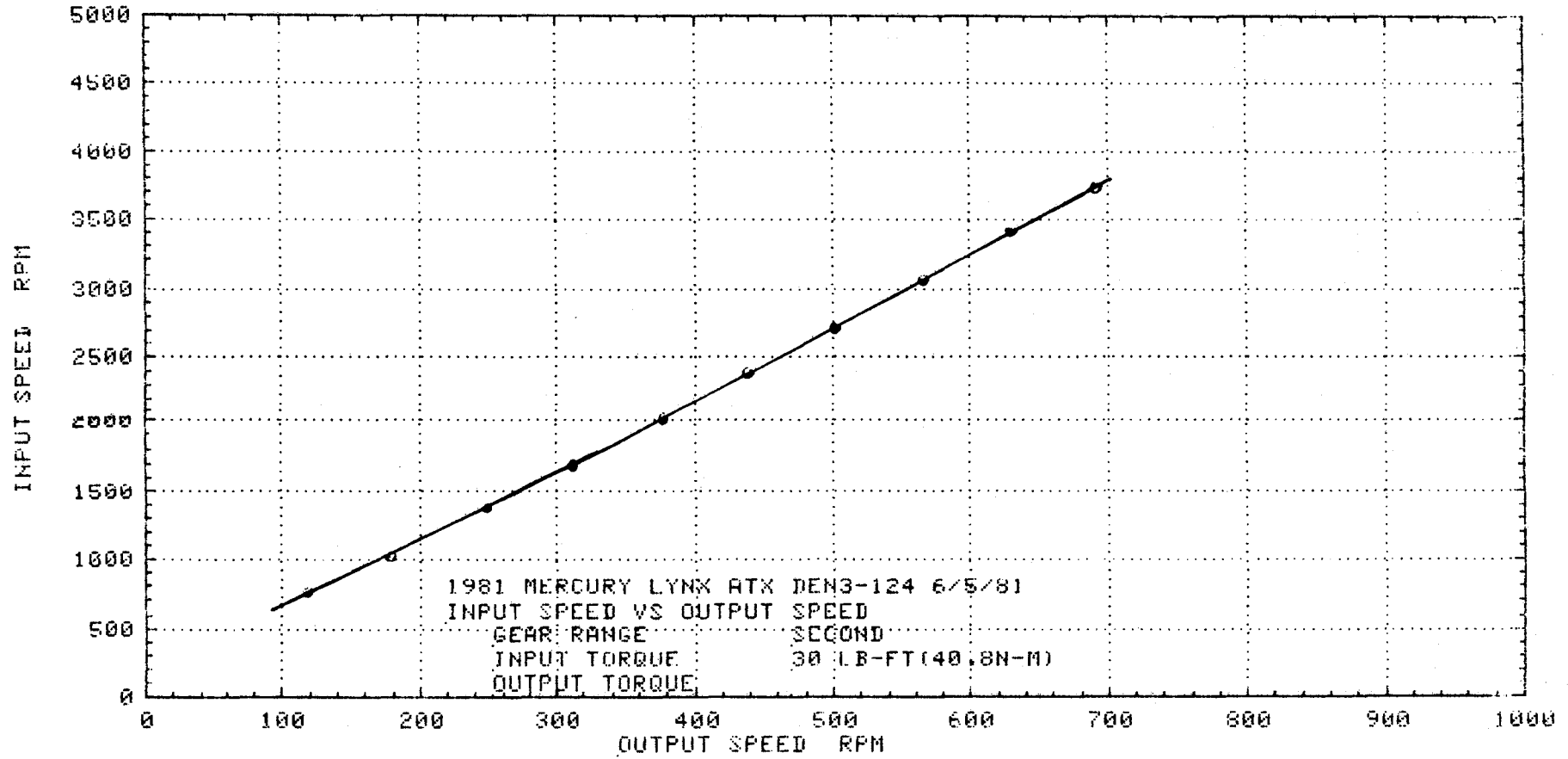

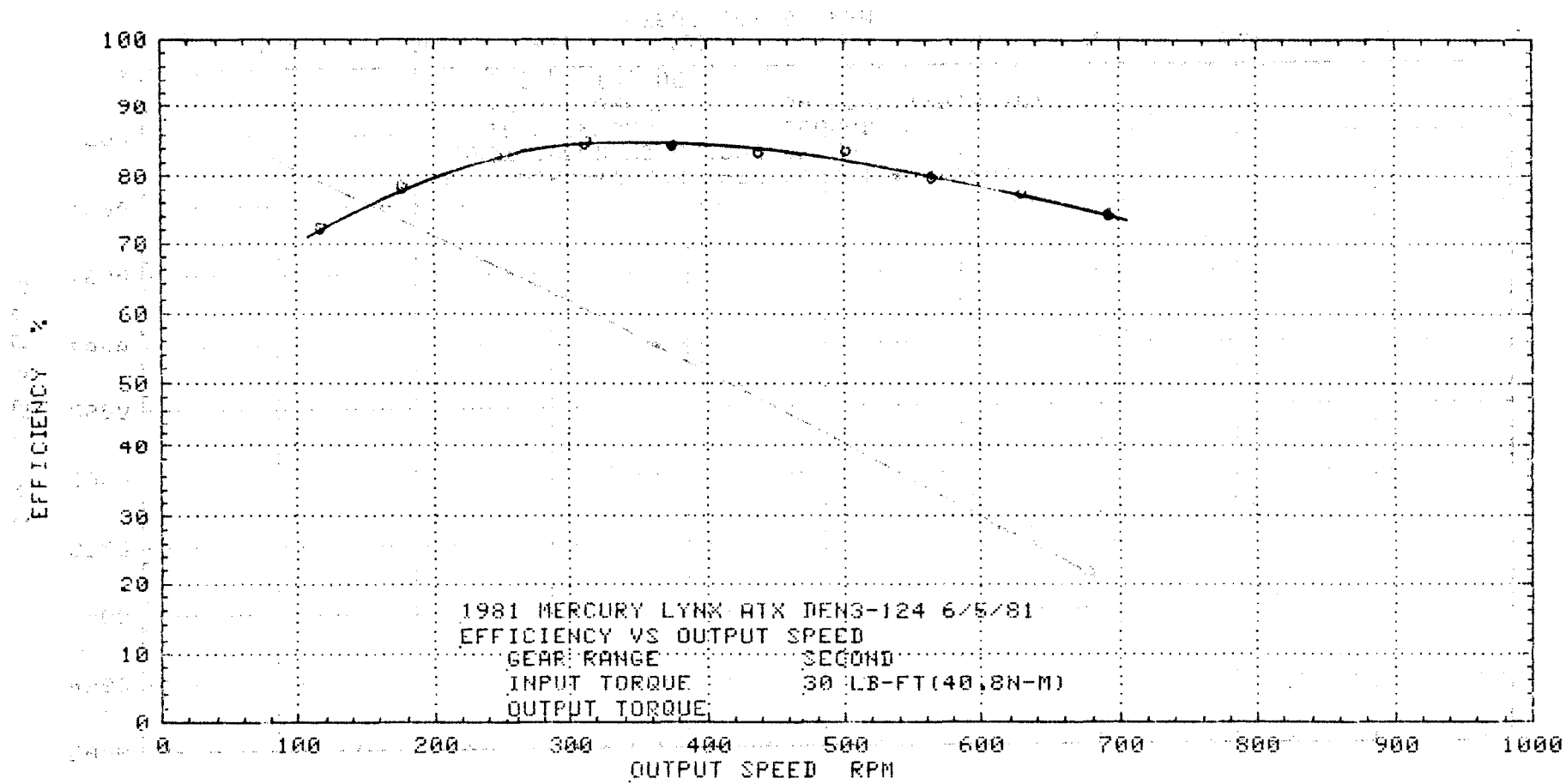

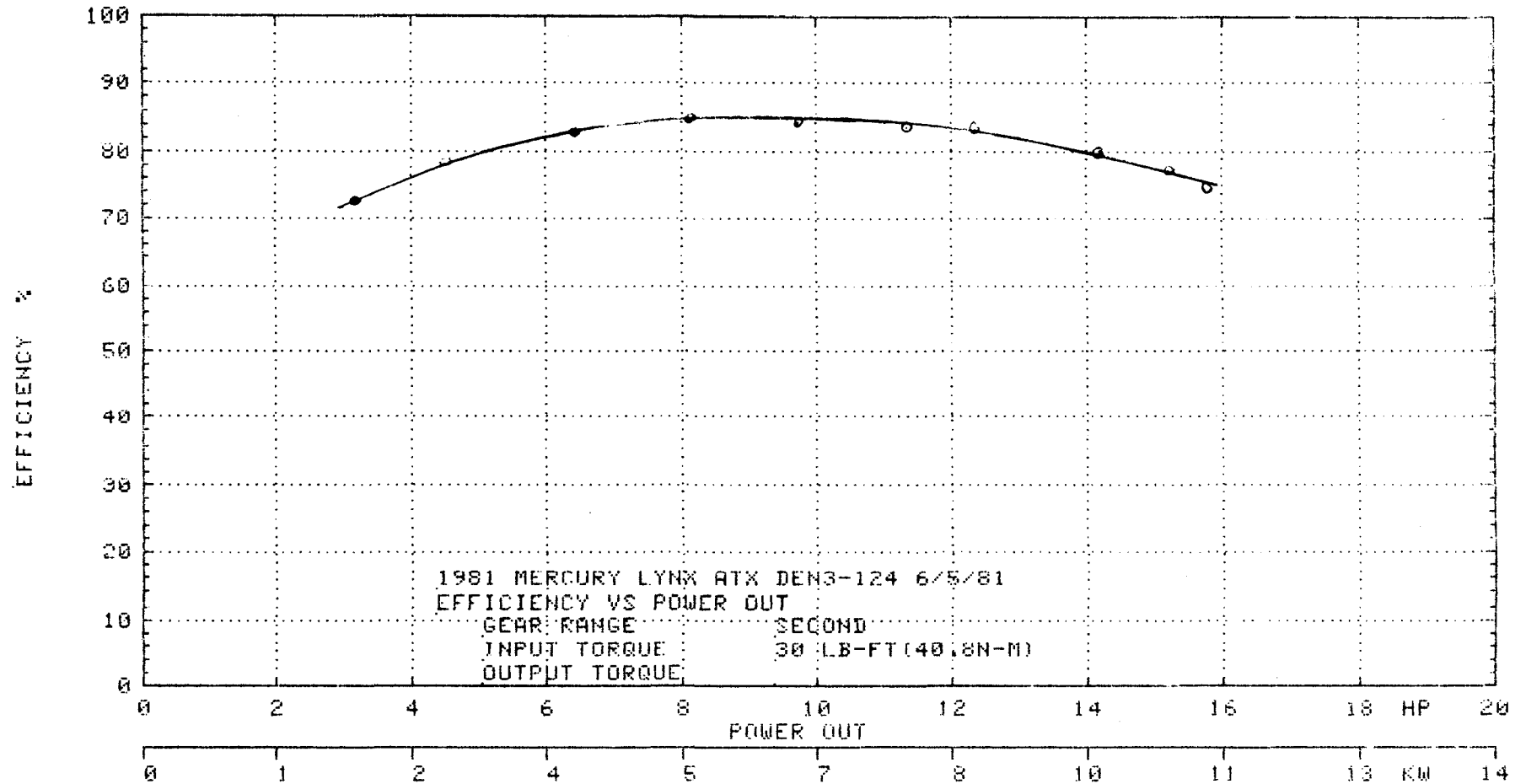

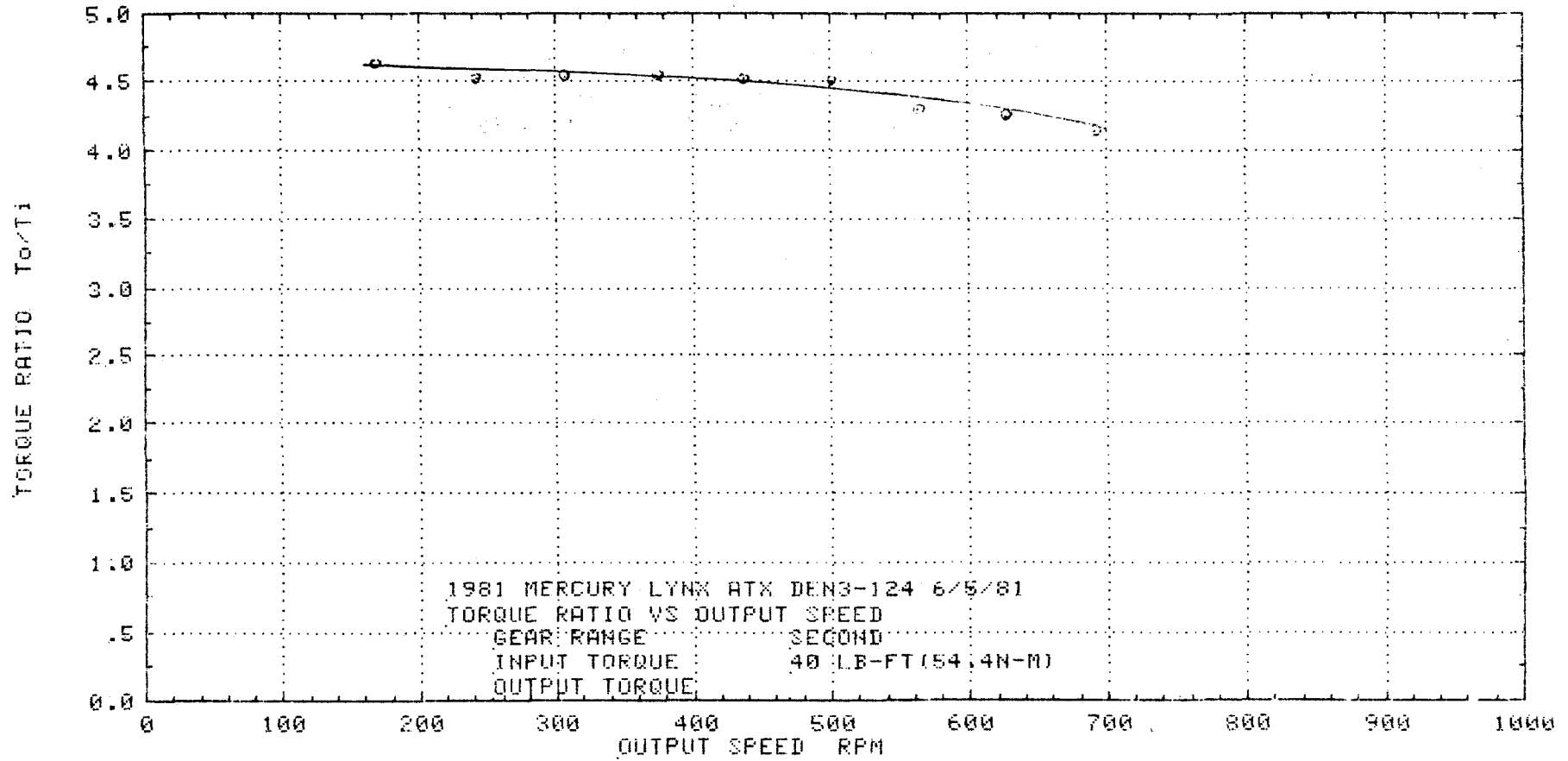

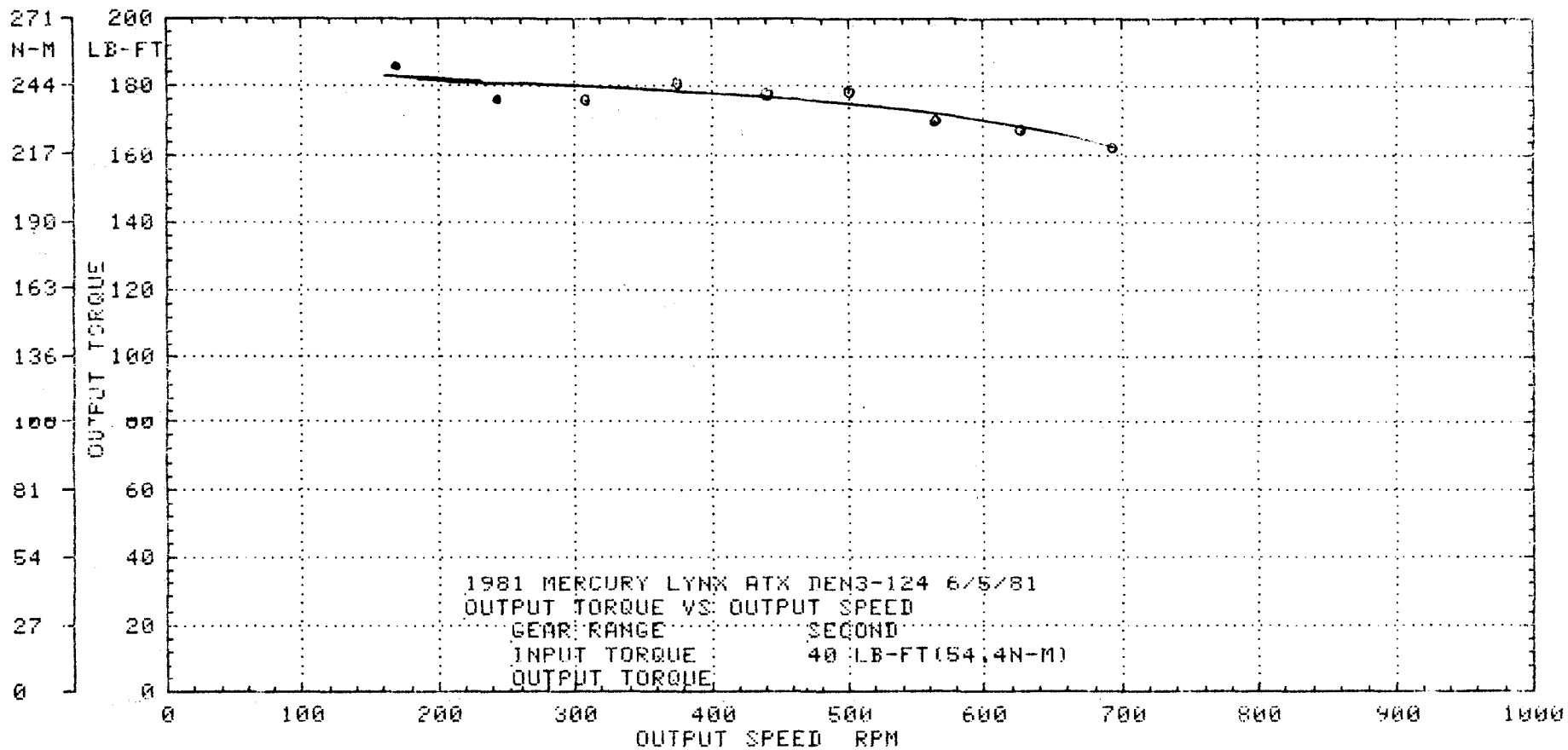

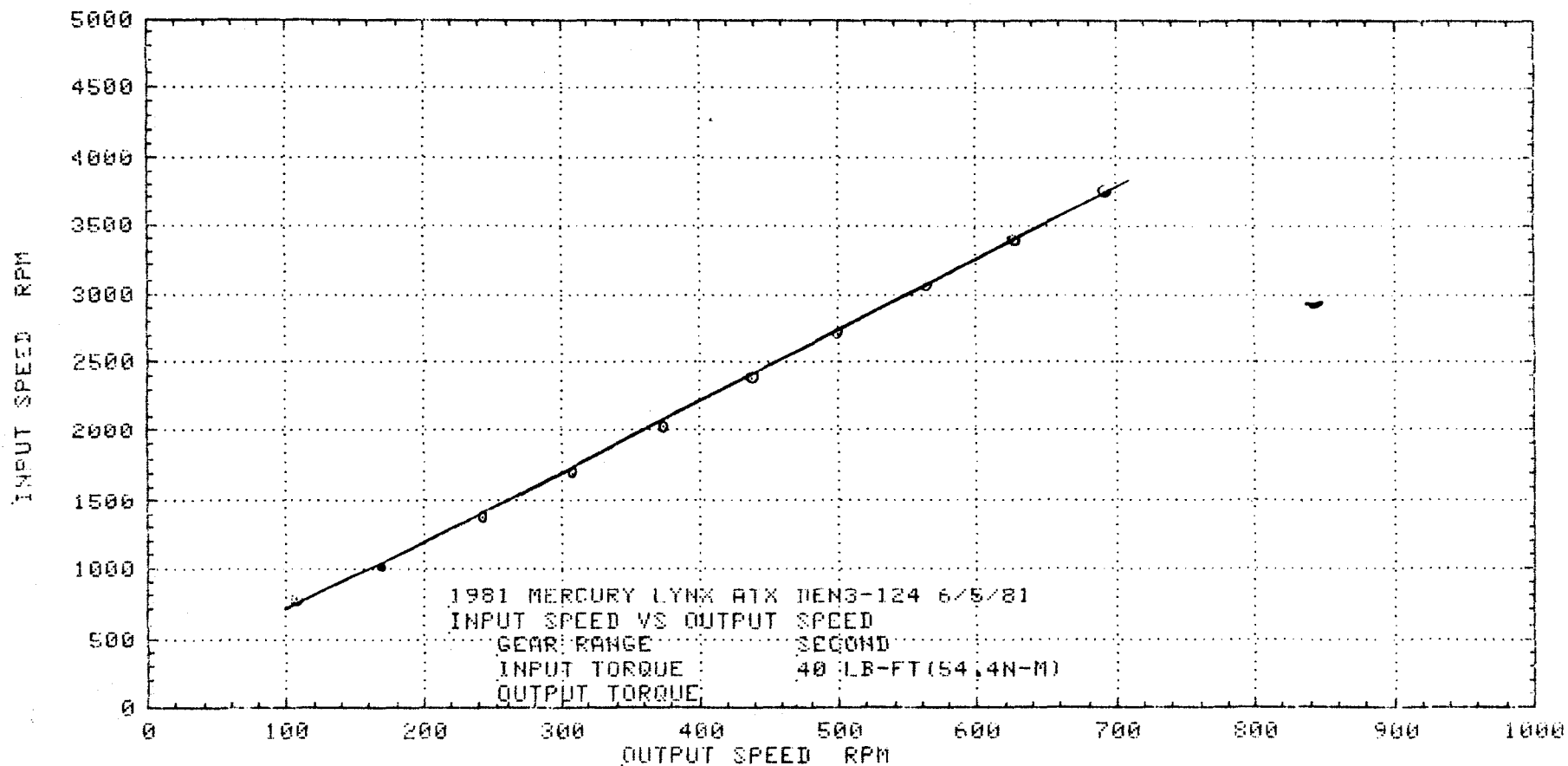

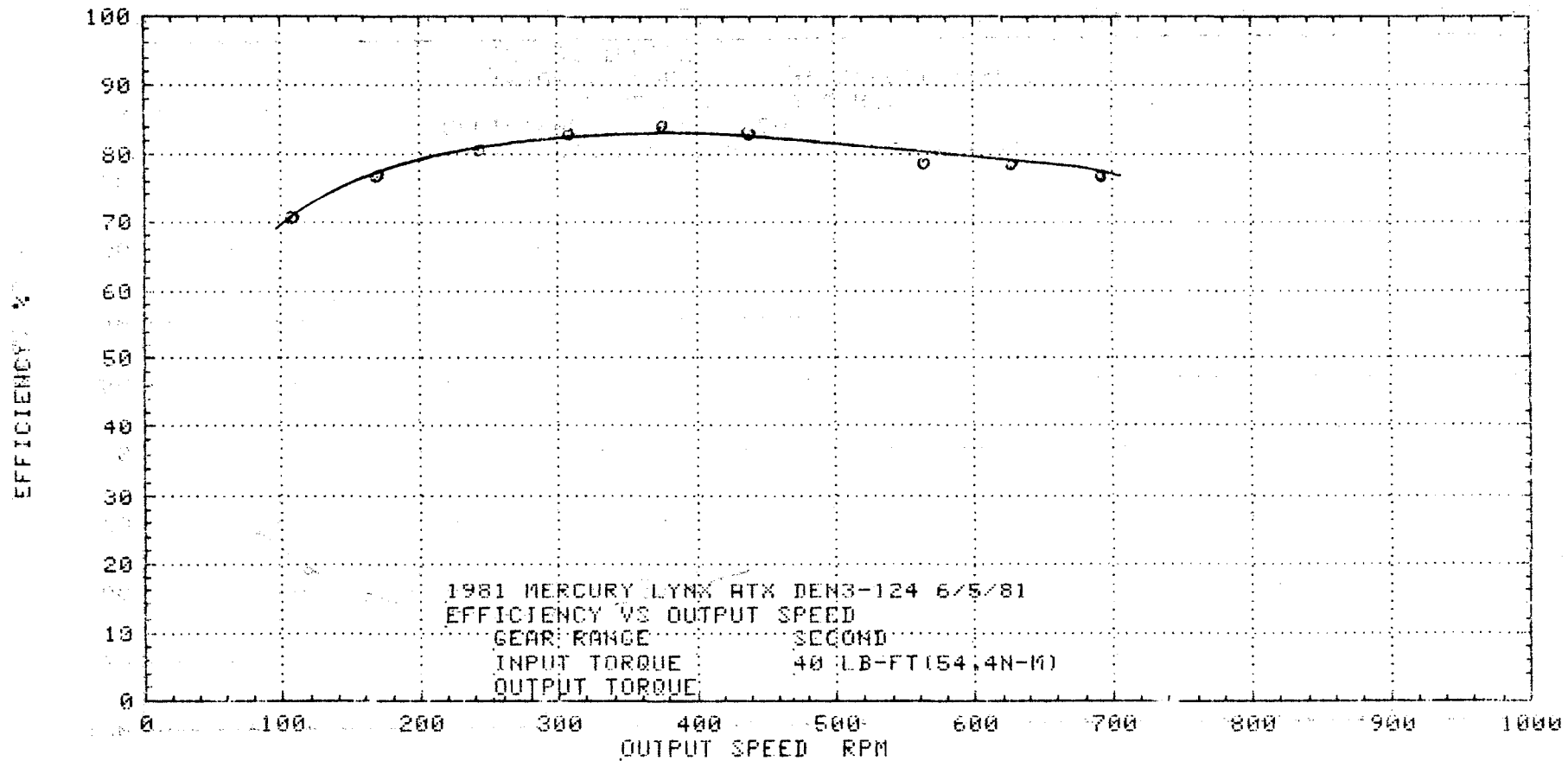

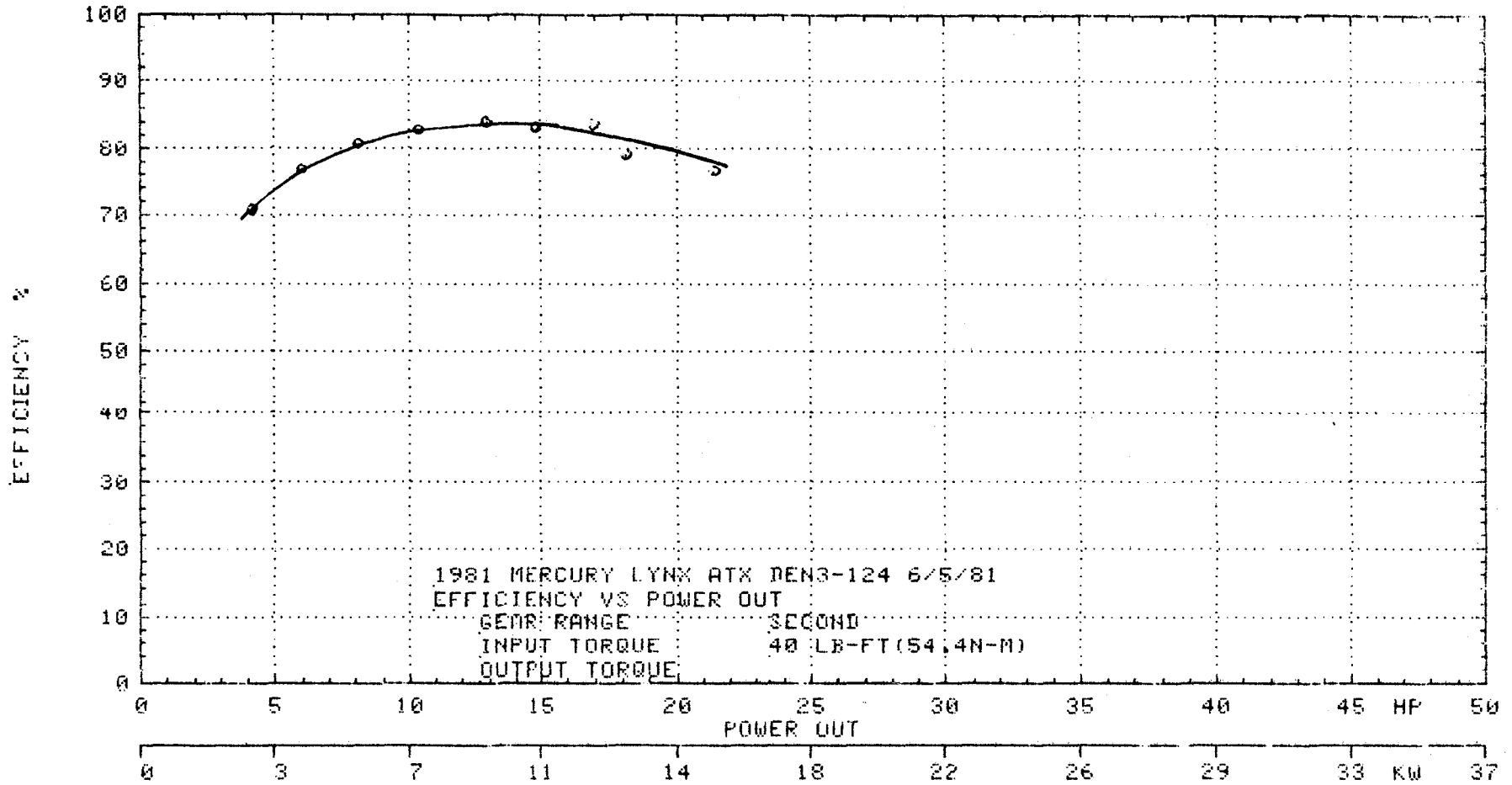

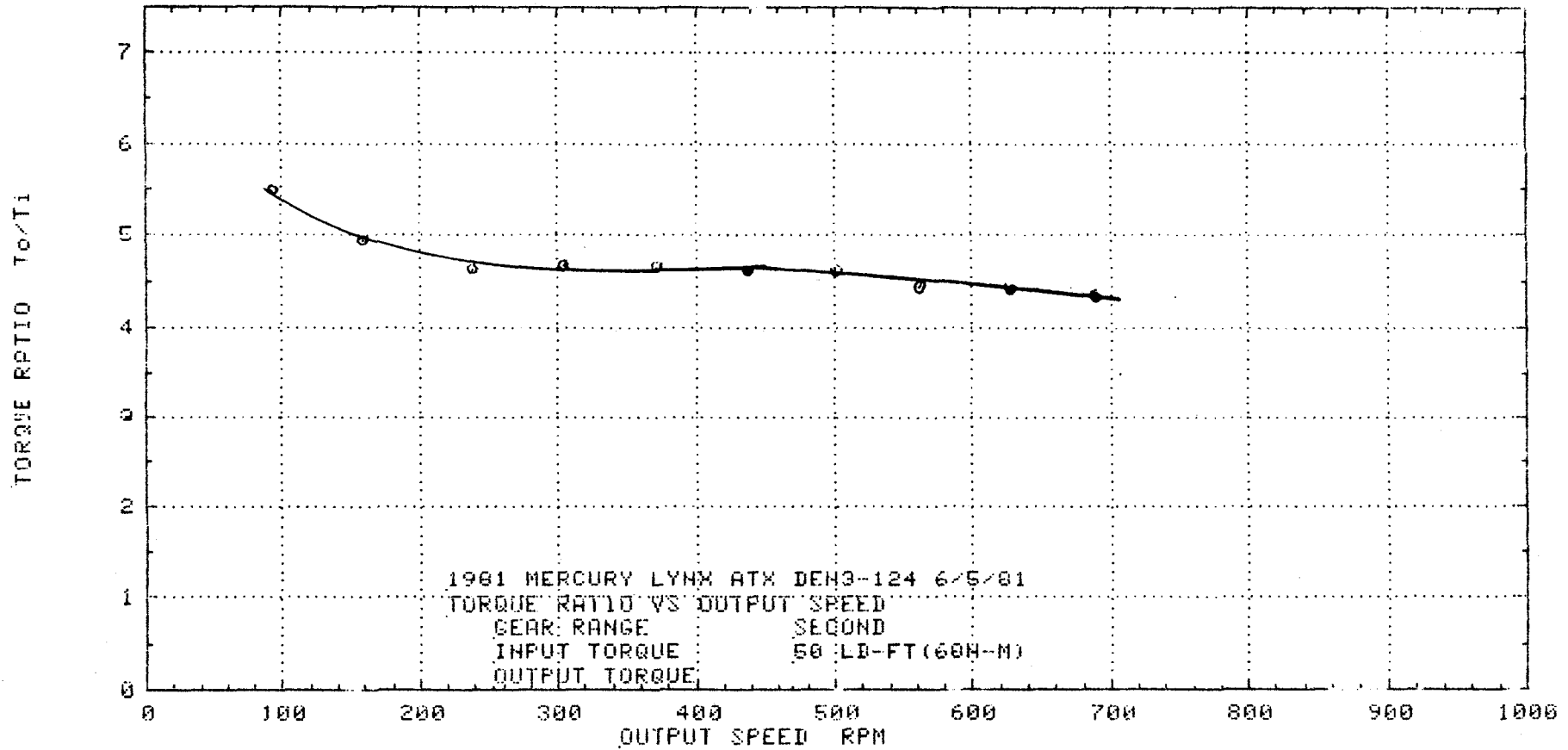

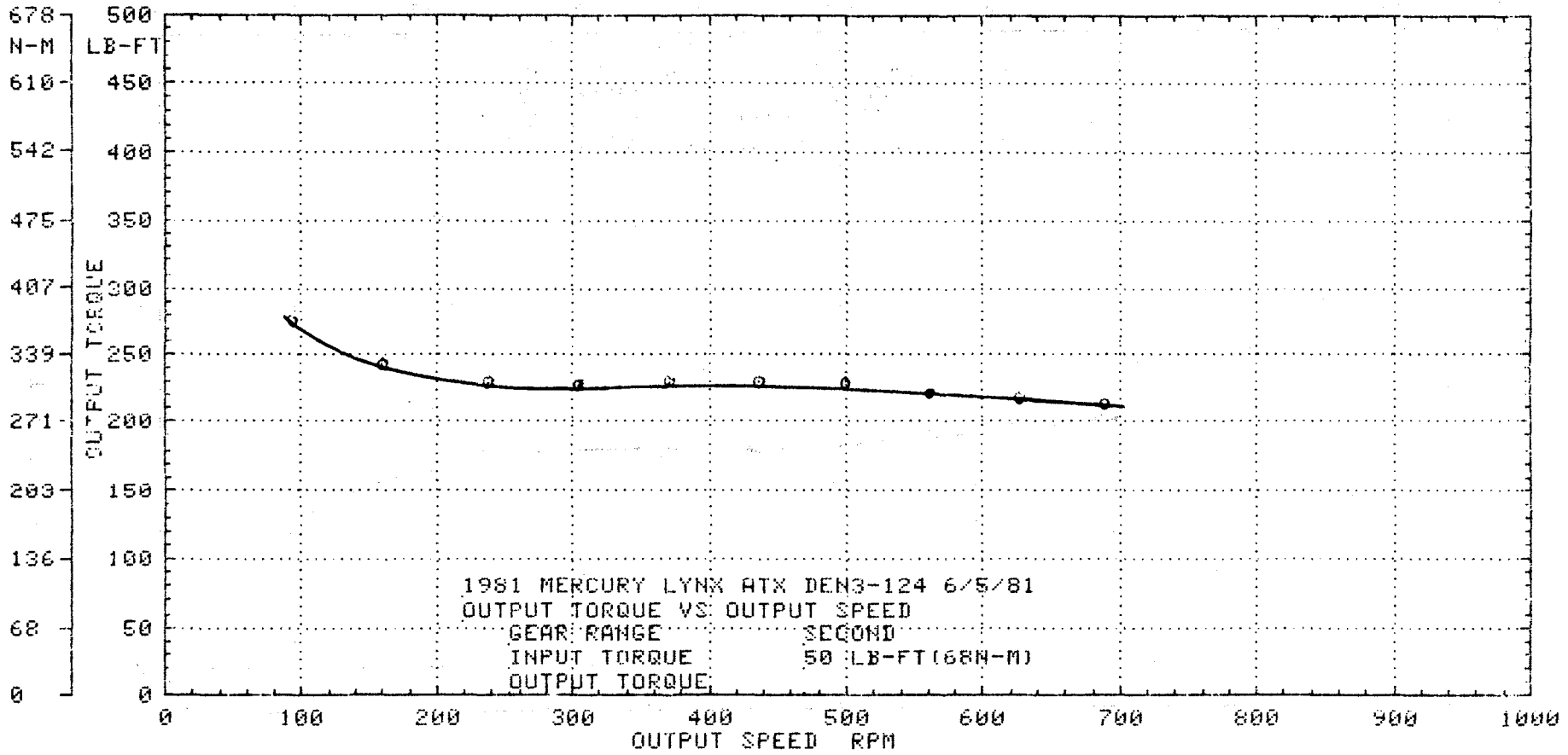

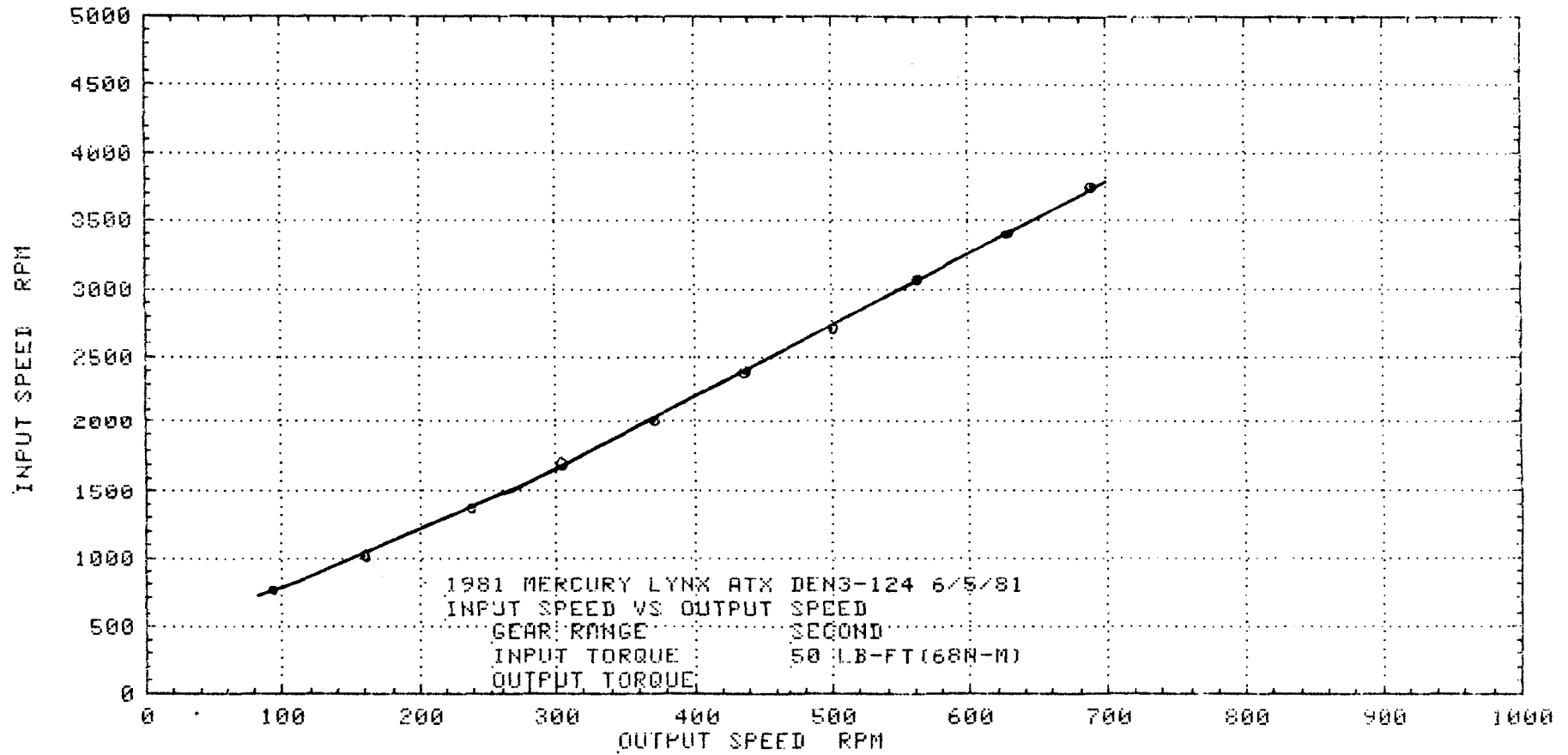

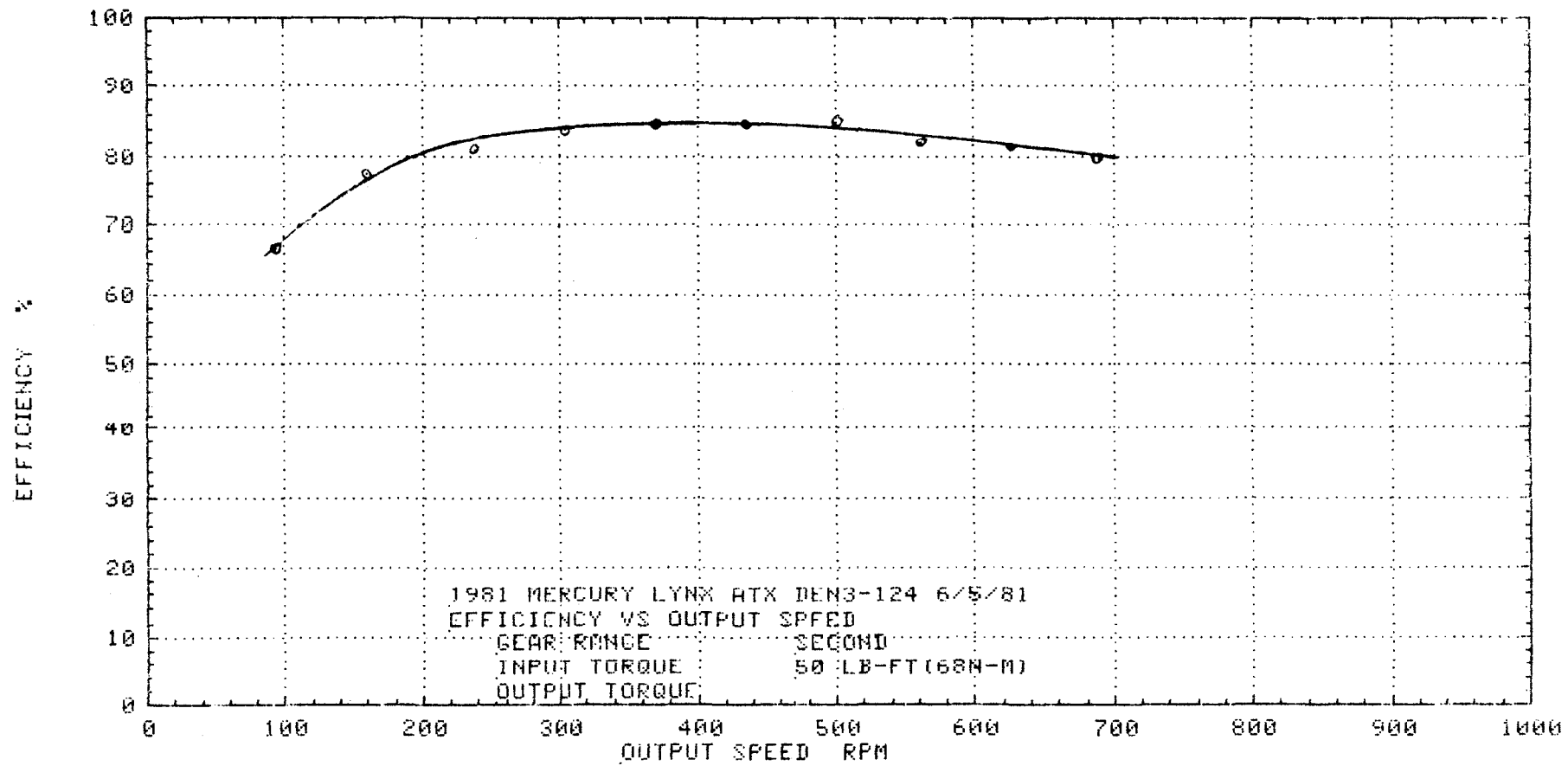

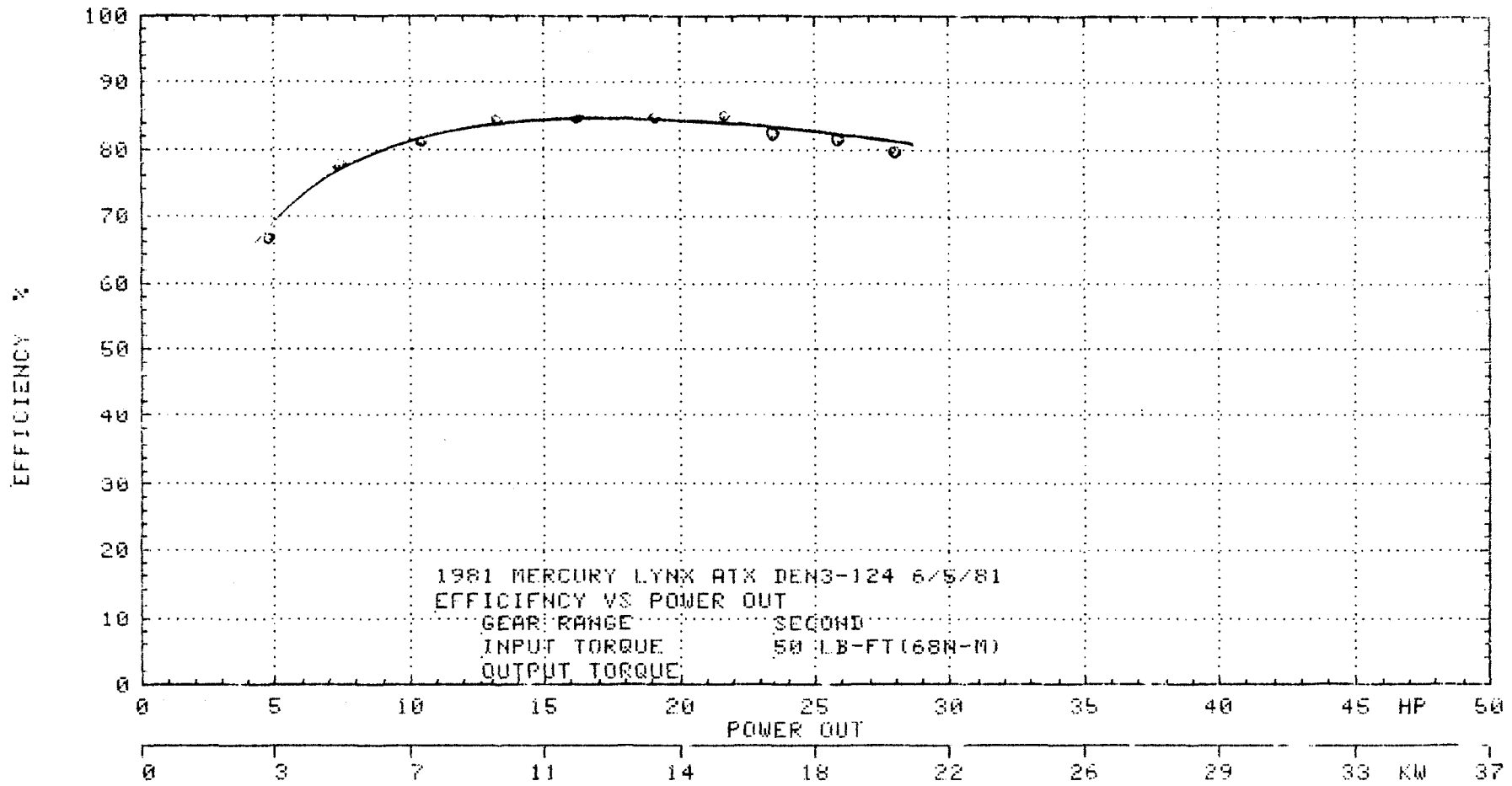

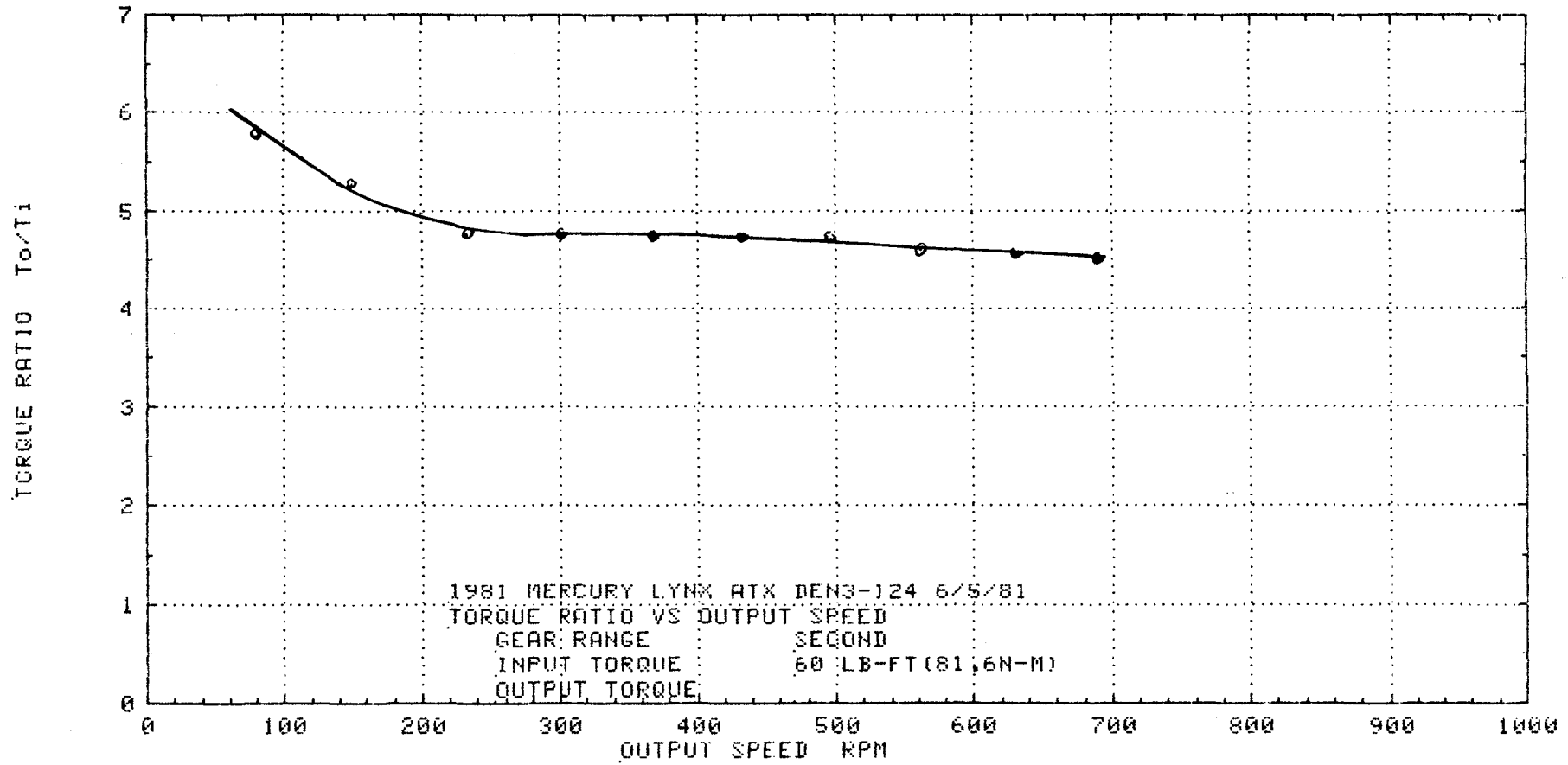

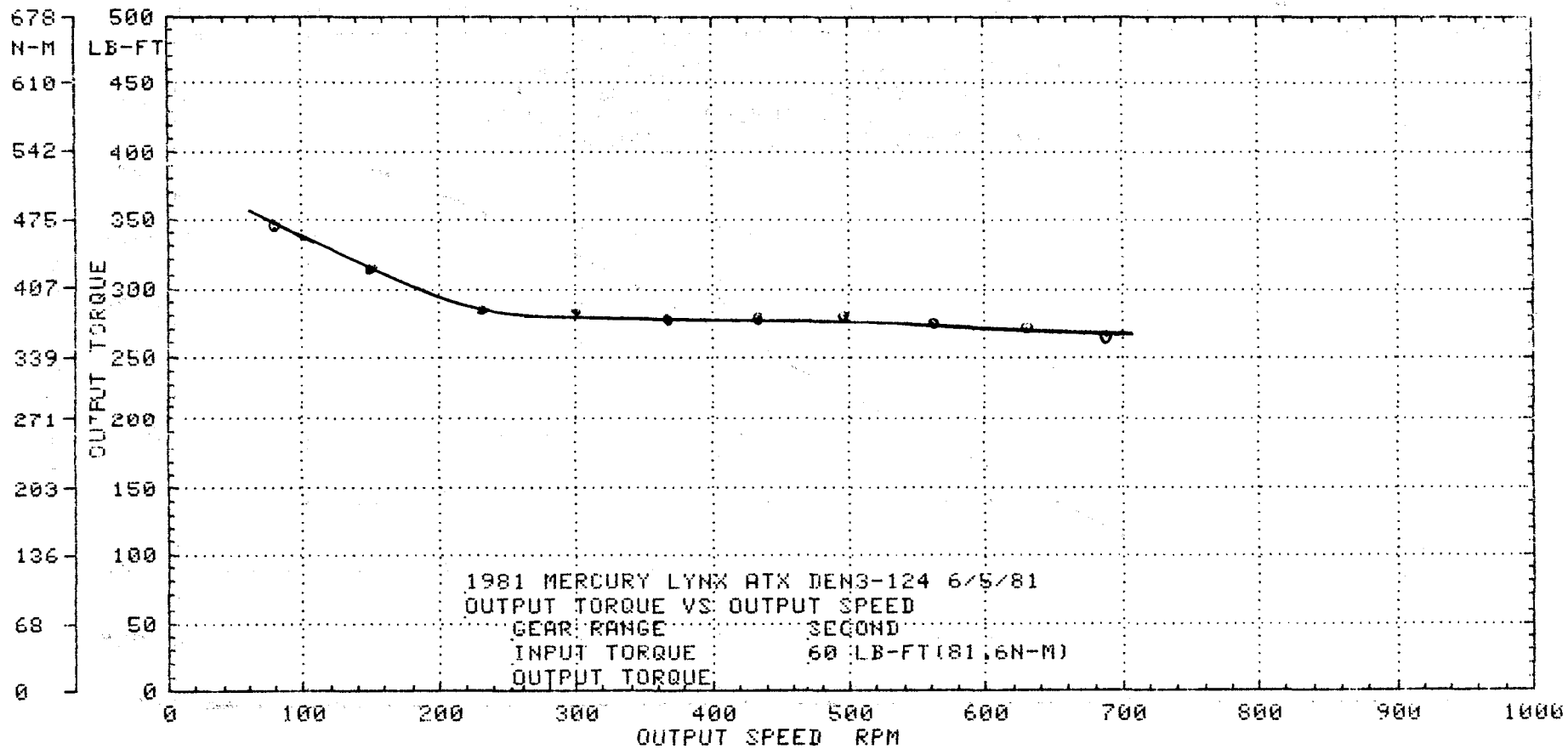

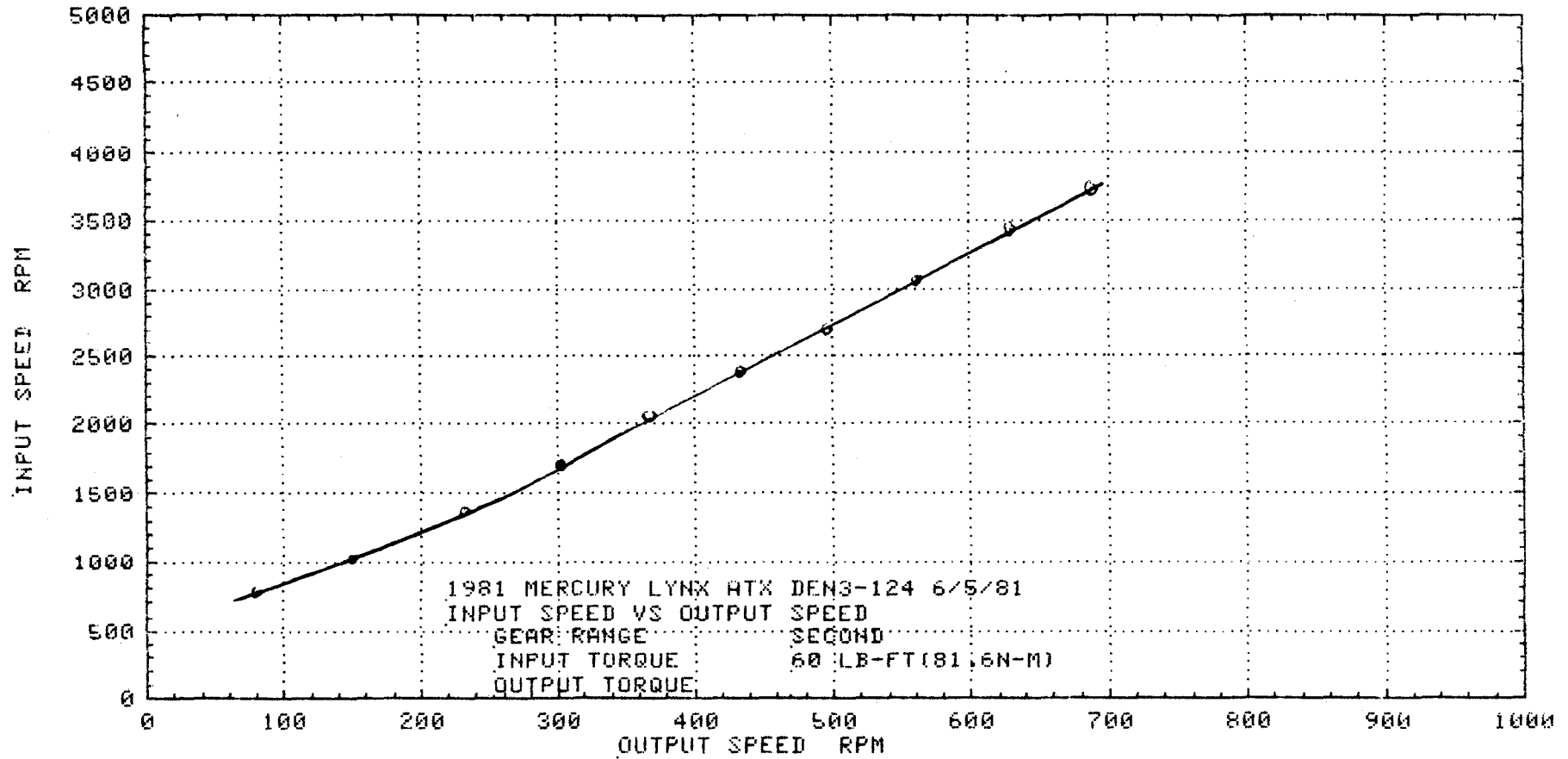

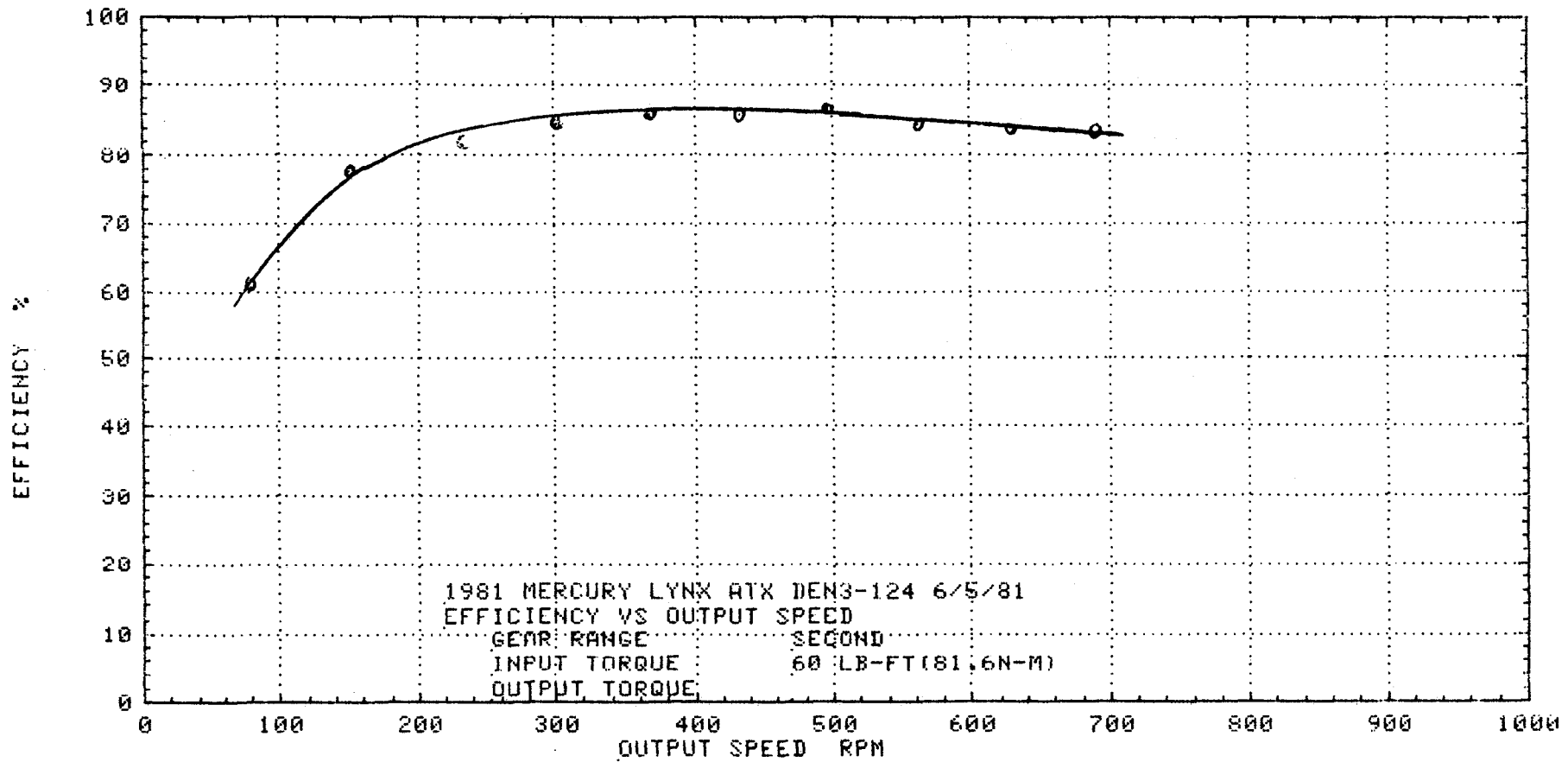

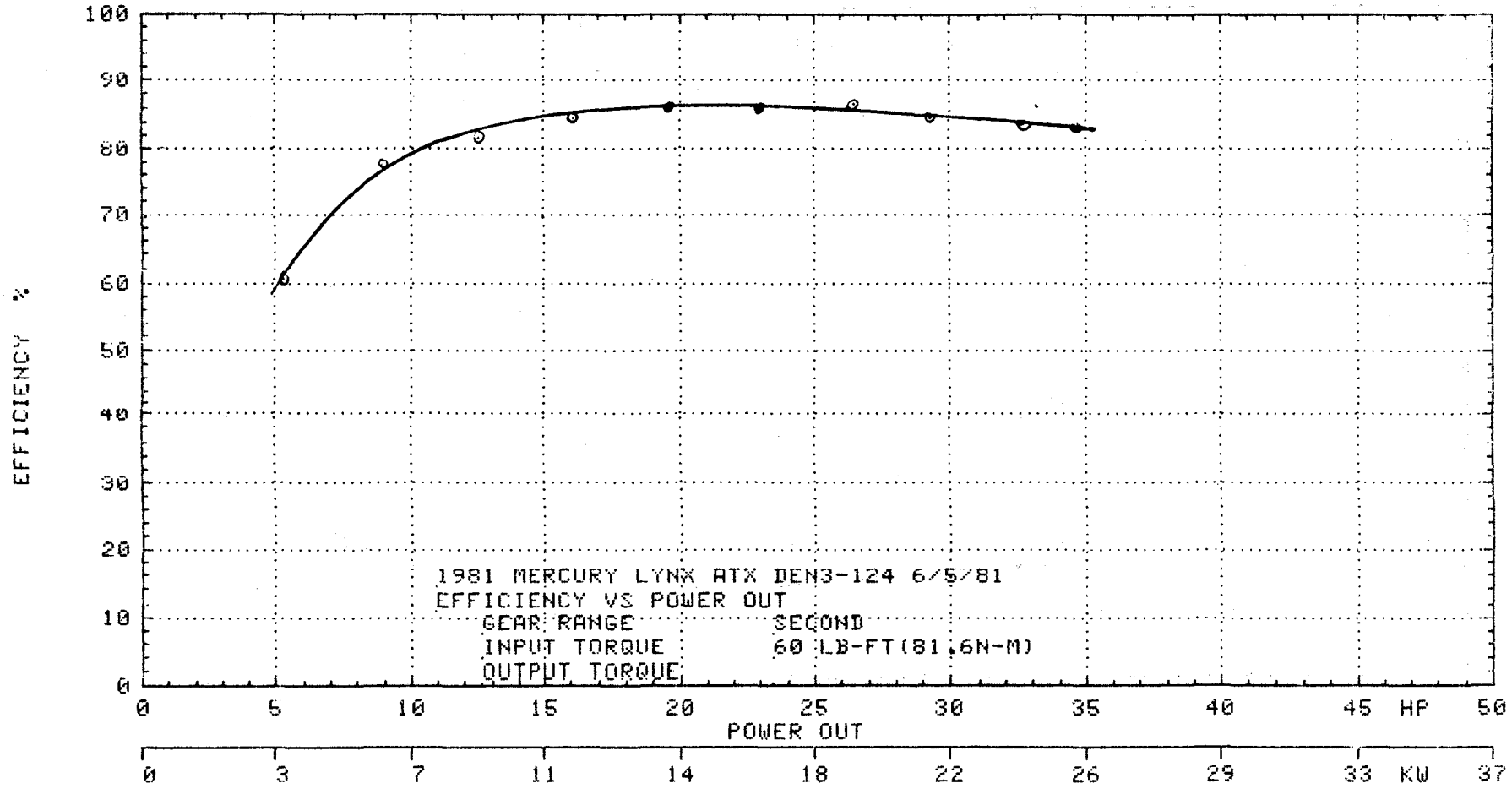

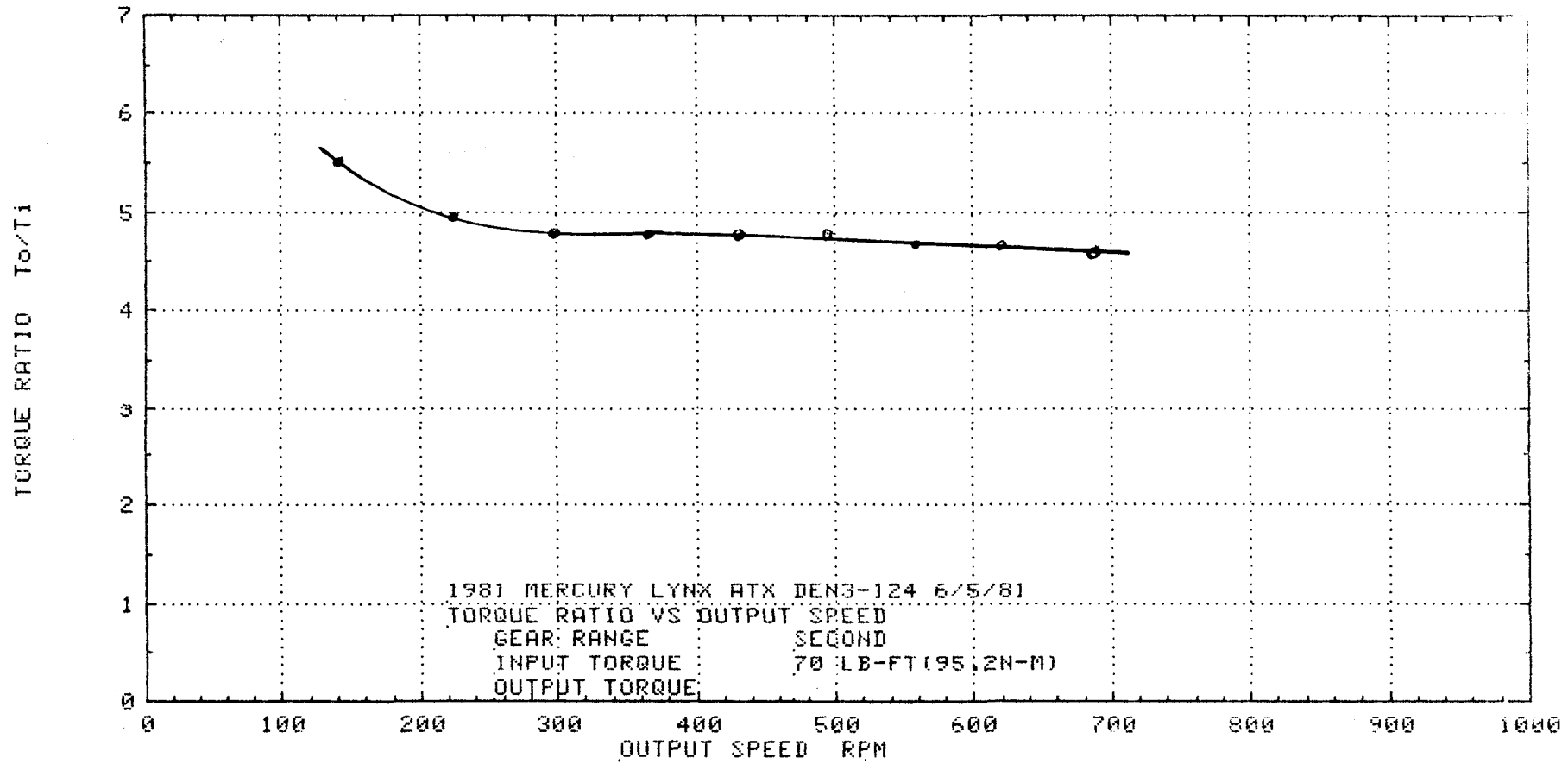

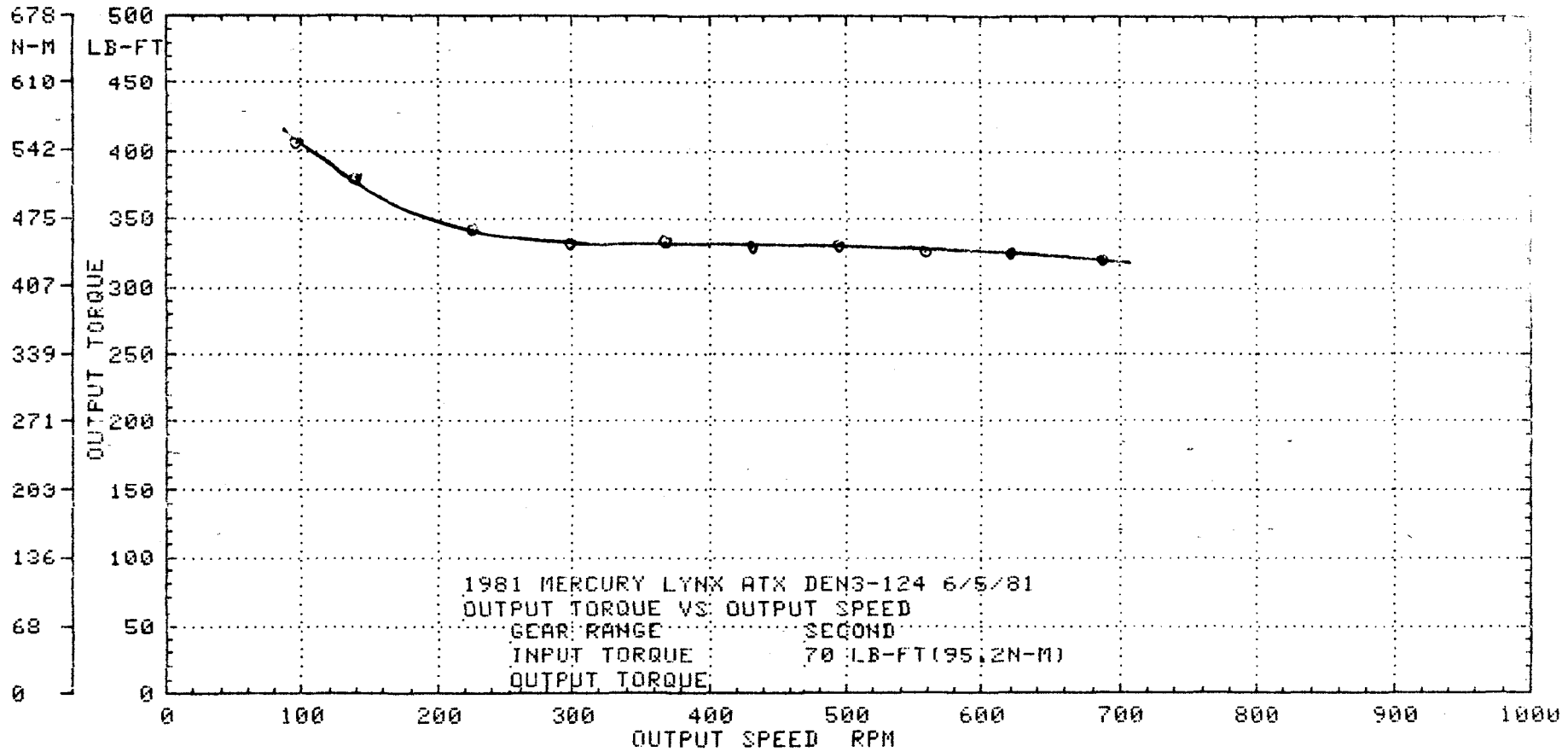

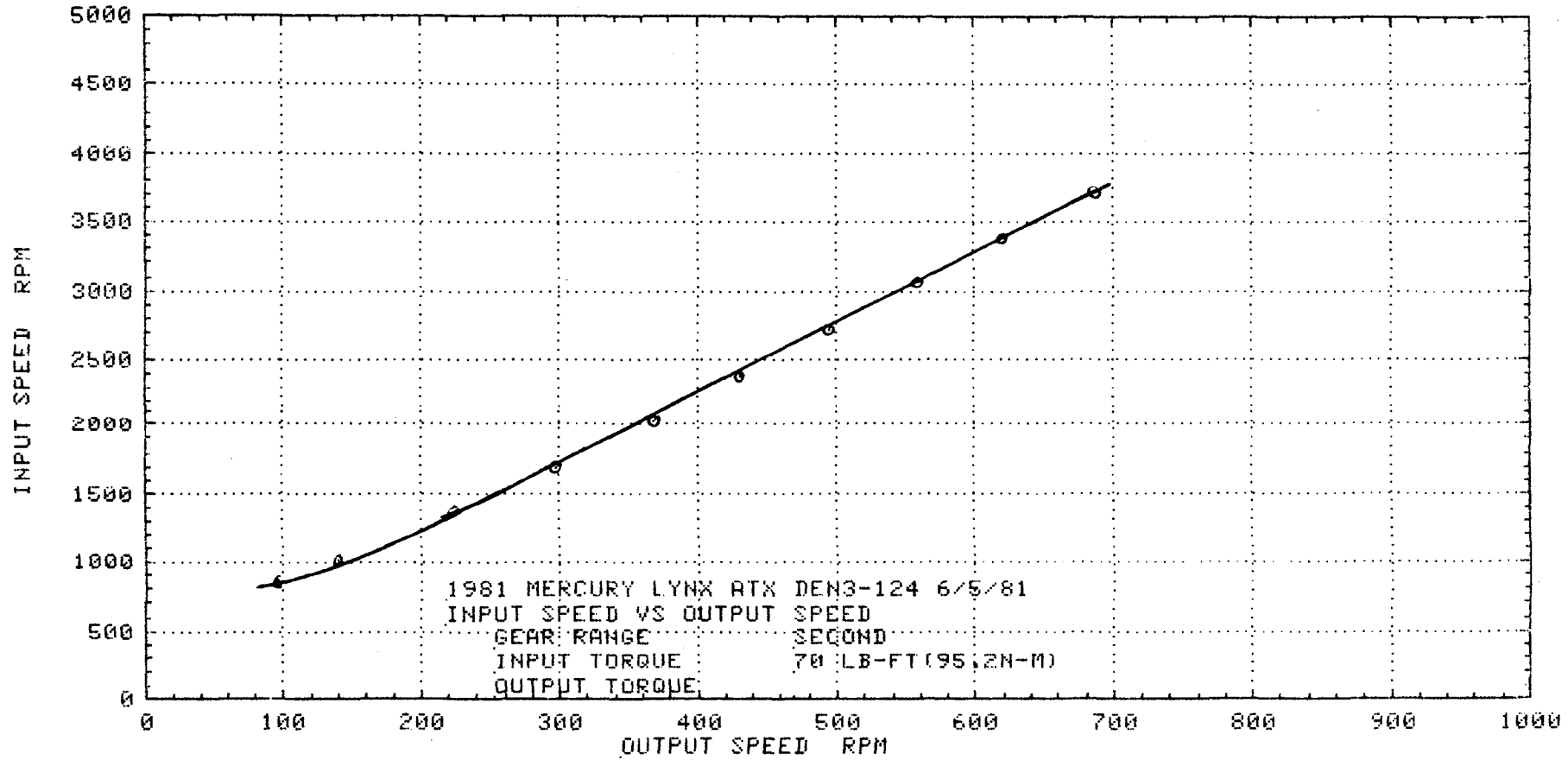

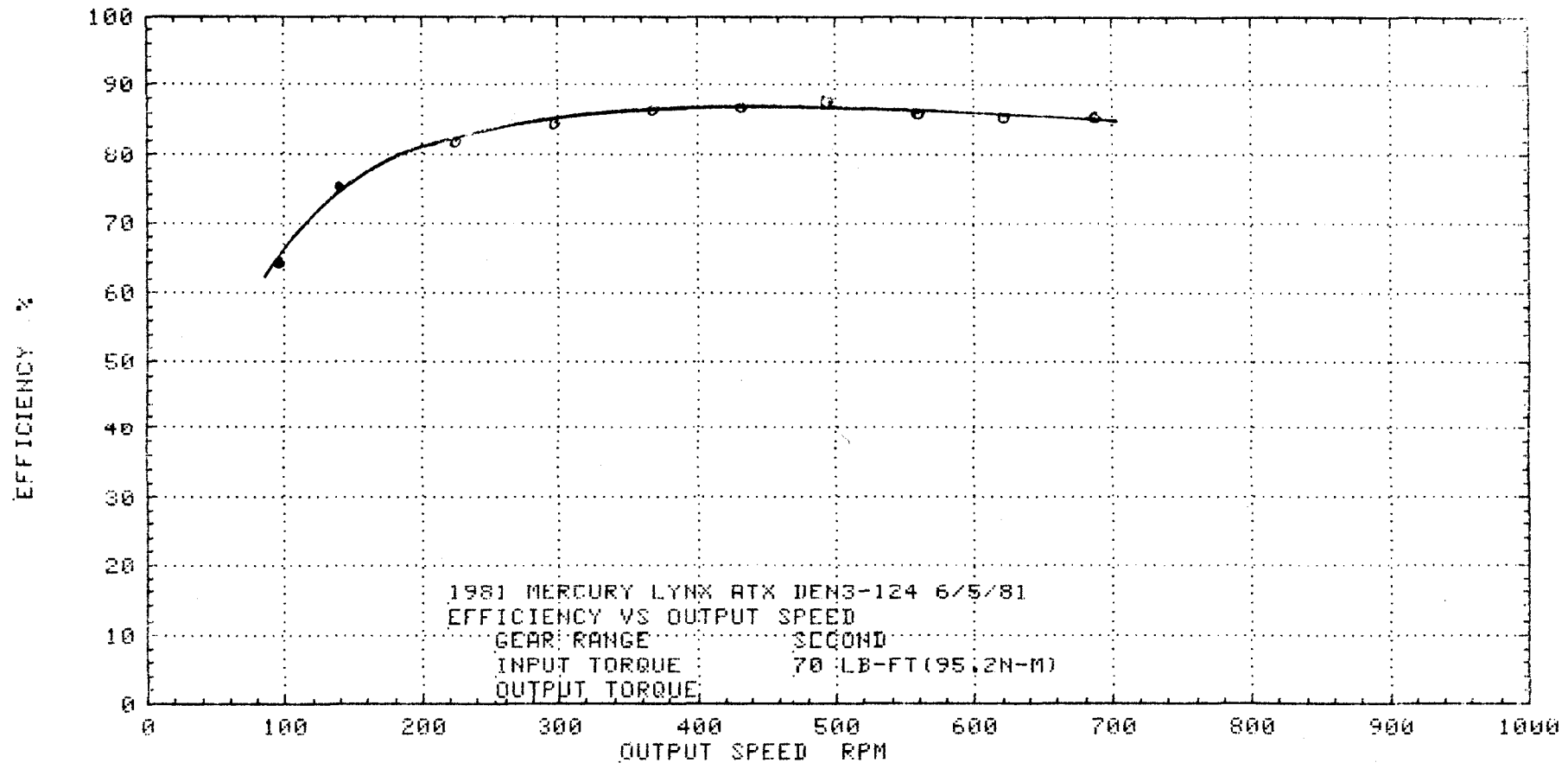

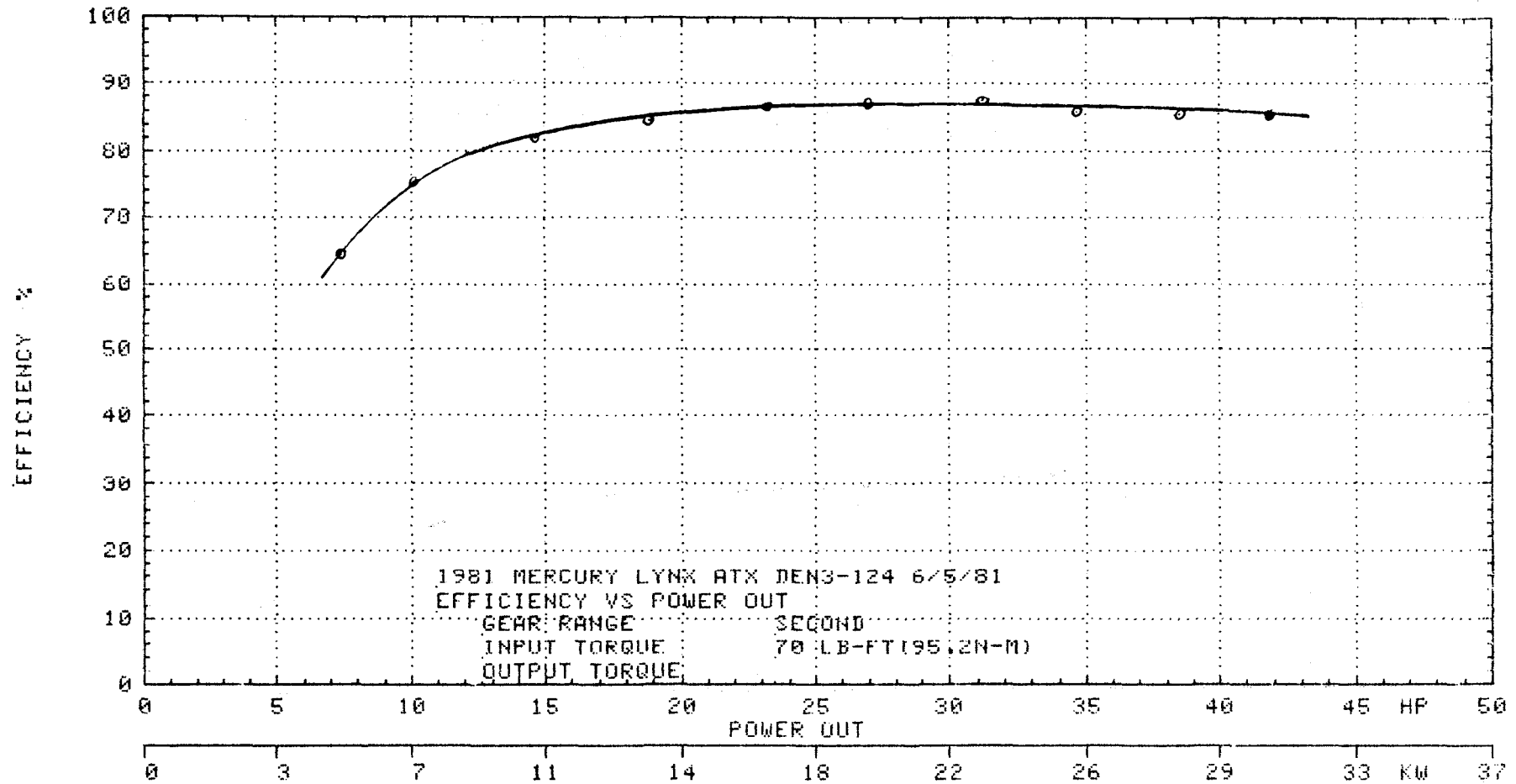

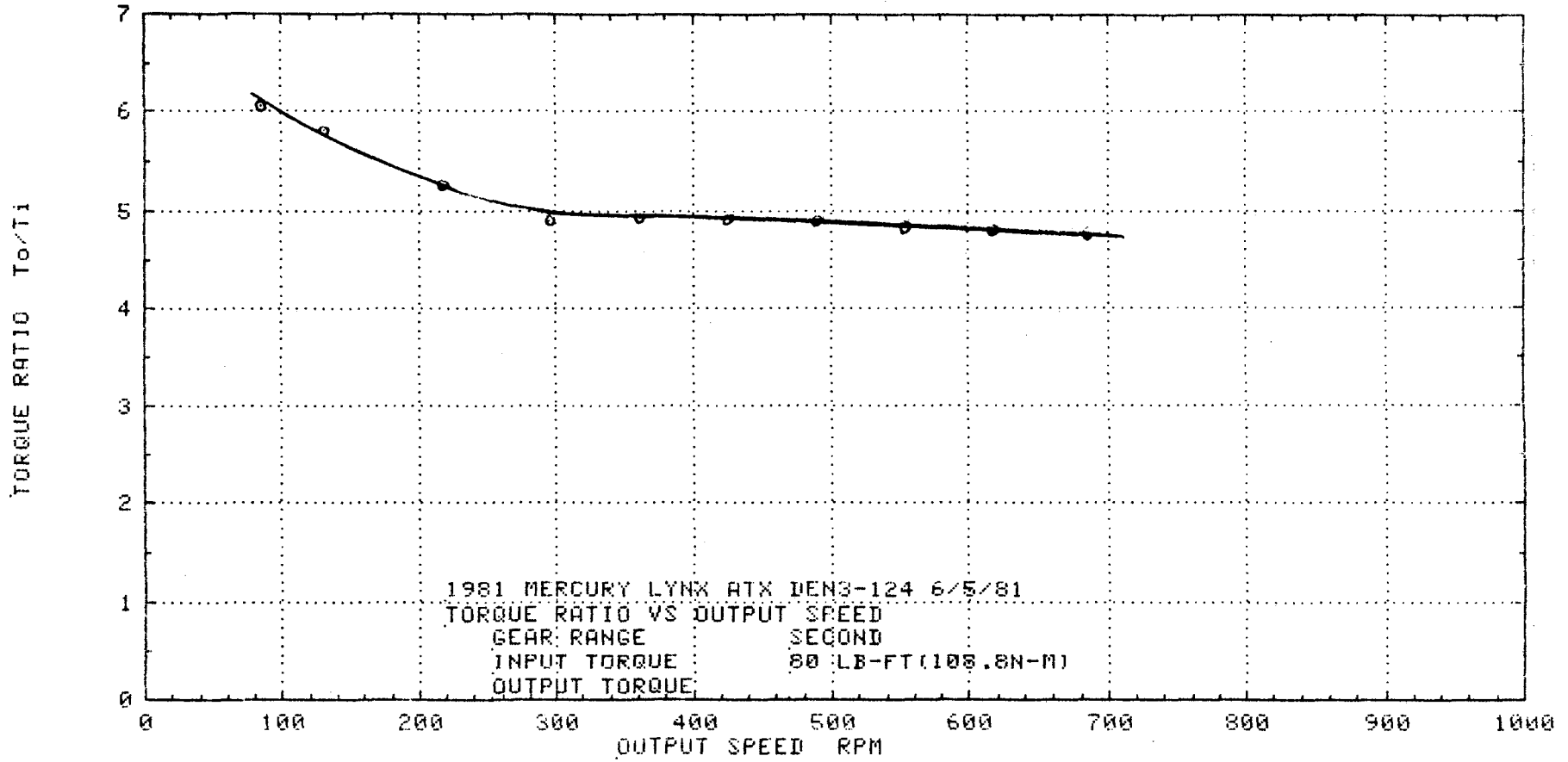

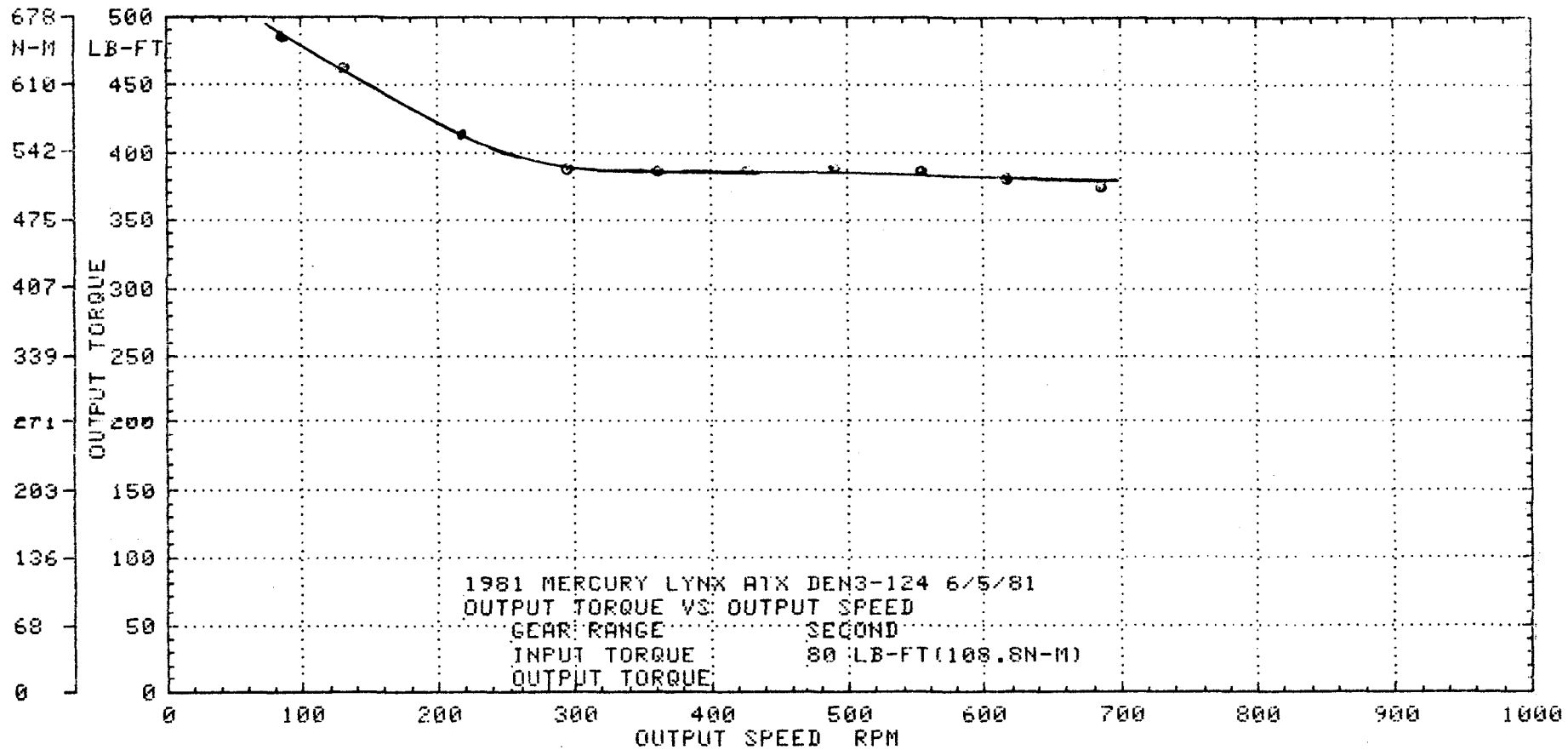

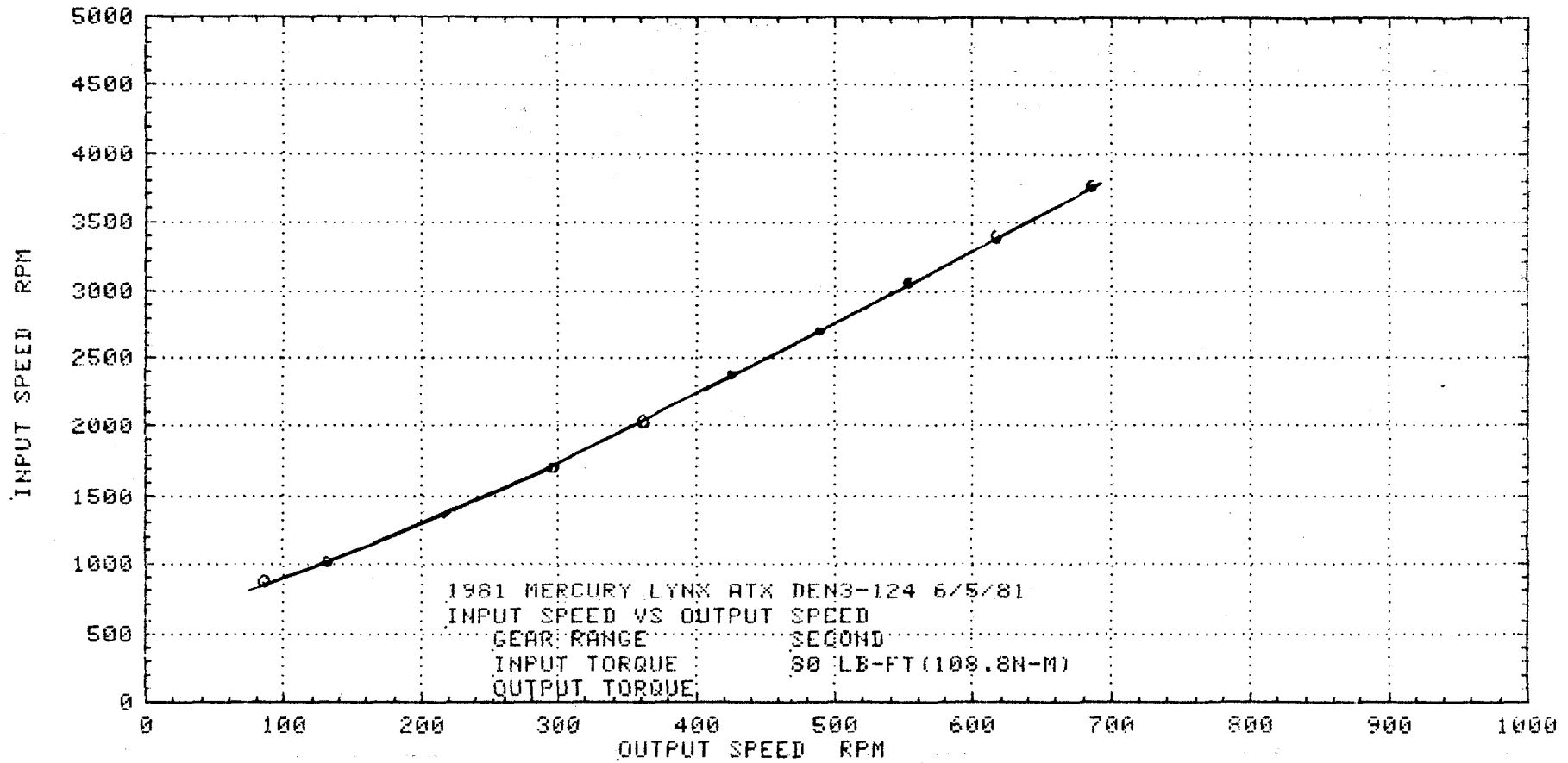

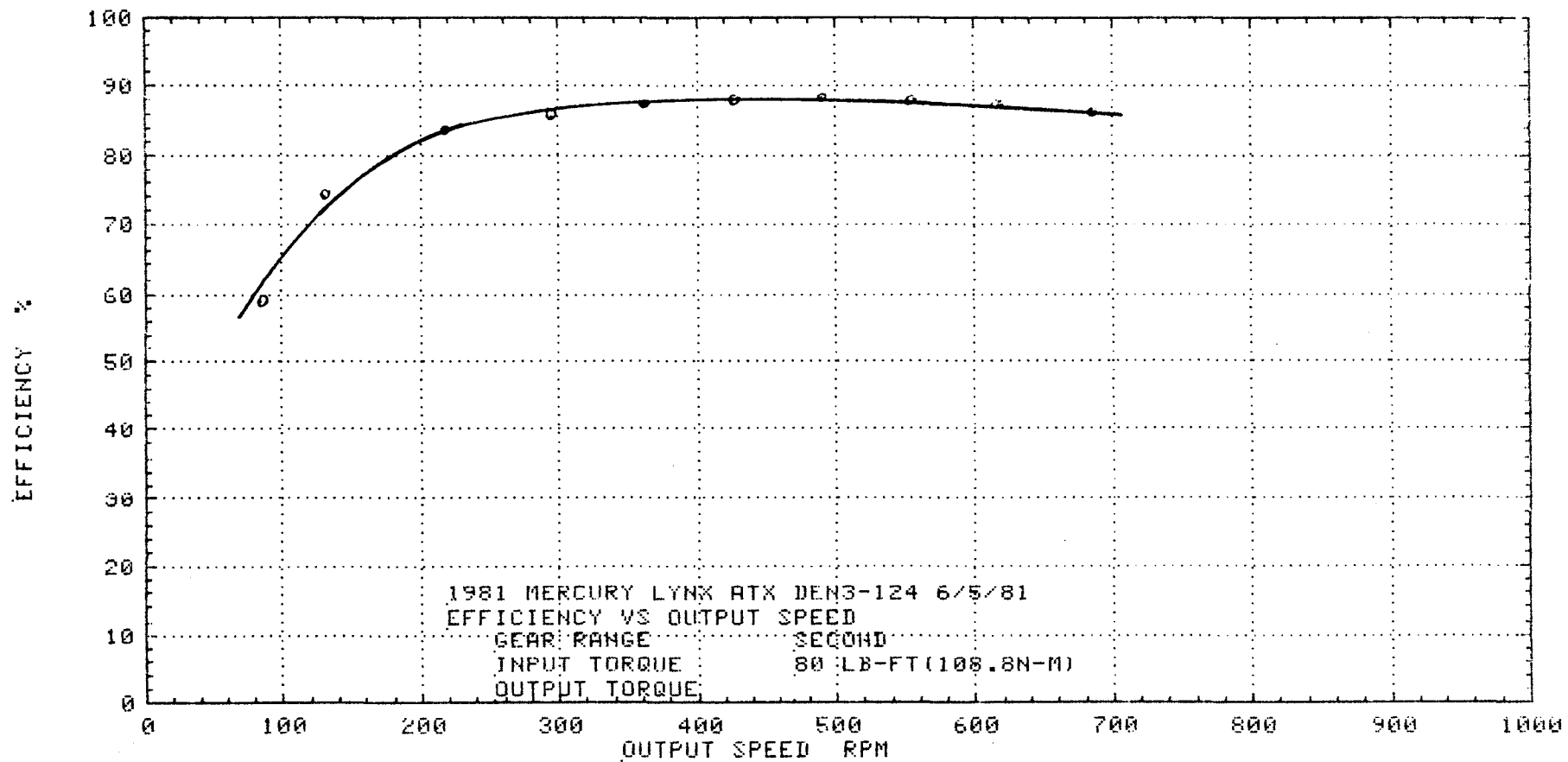

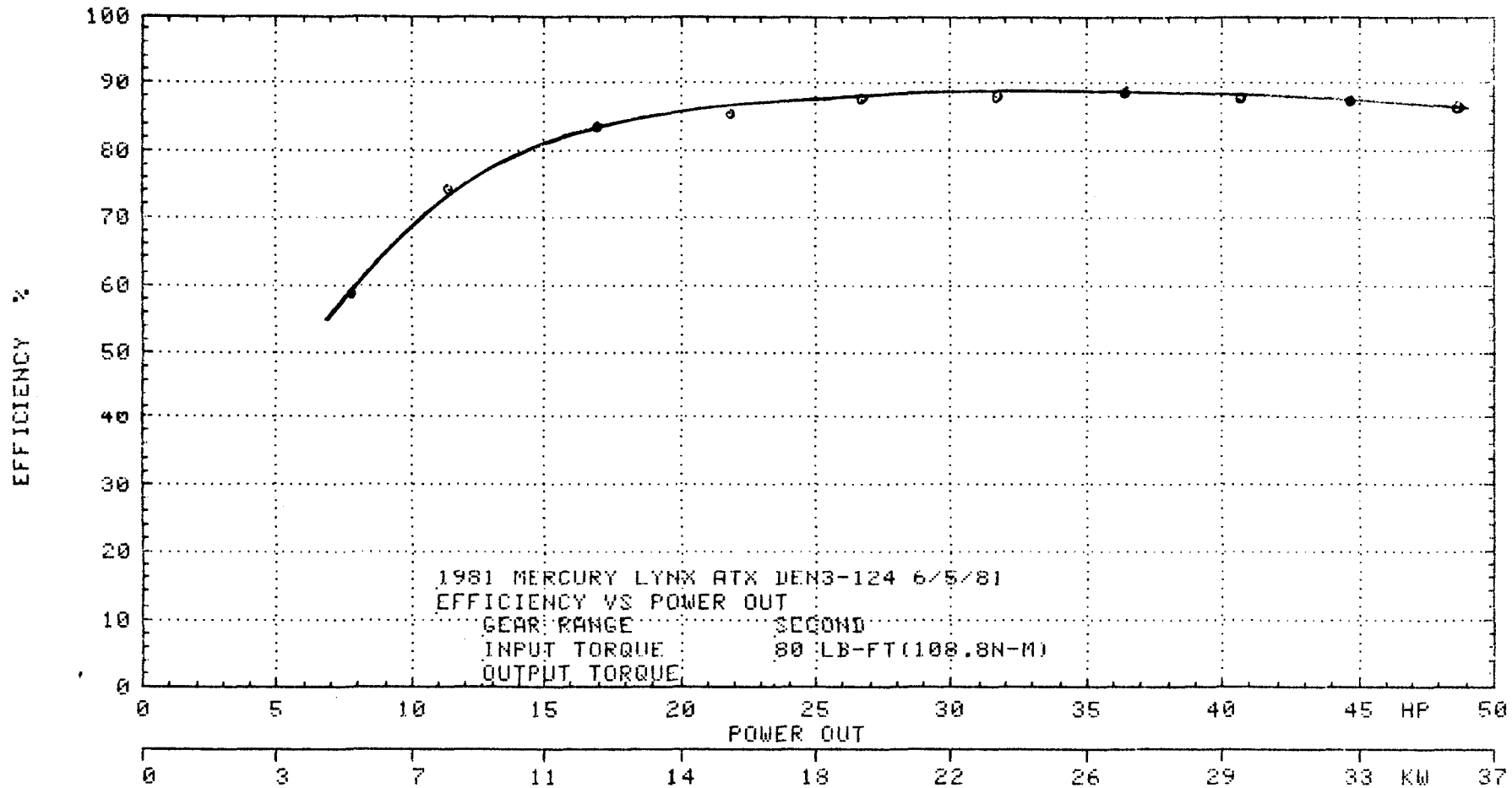

DRIVE PERFORMANCE

3rd Gear

Graphs Contained in This Section

Torque Ratio -vs- Output Speed

Output Torque -vs- Output Speed

Input Speed -vs- Output Speed

Efficiency -vs- Output Speed

Efficiency -vs- Power Out

112

Torque In

Speed In

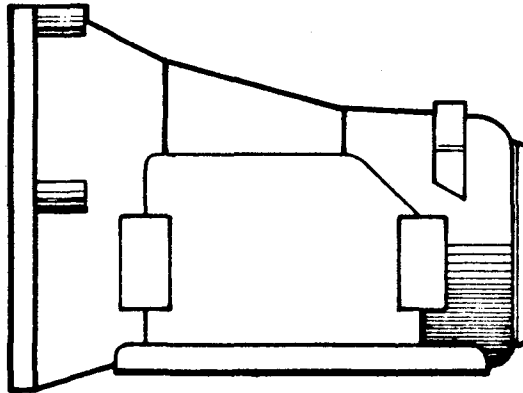

Torque Out

Speed Out

Drive Performance Tests

TORQUE RATIO T_o/T_i

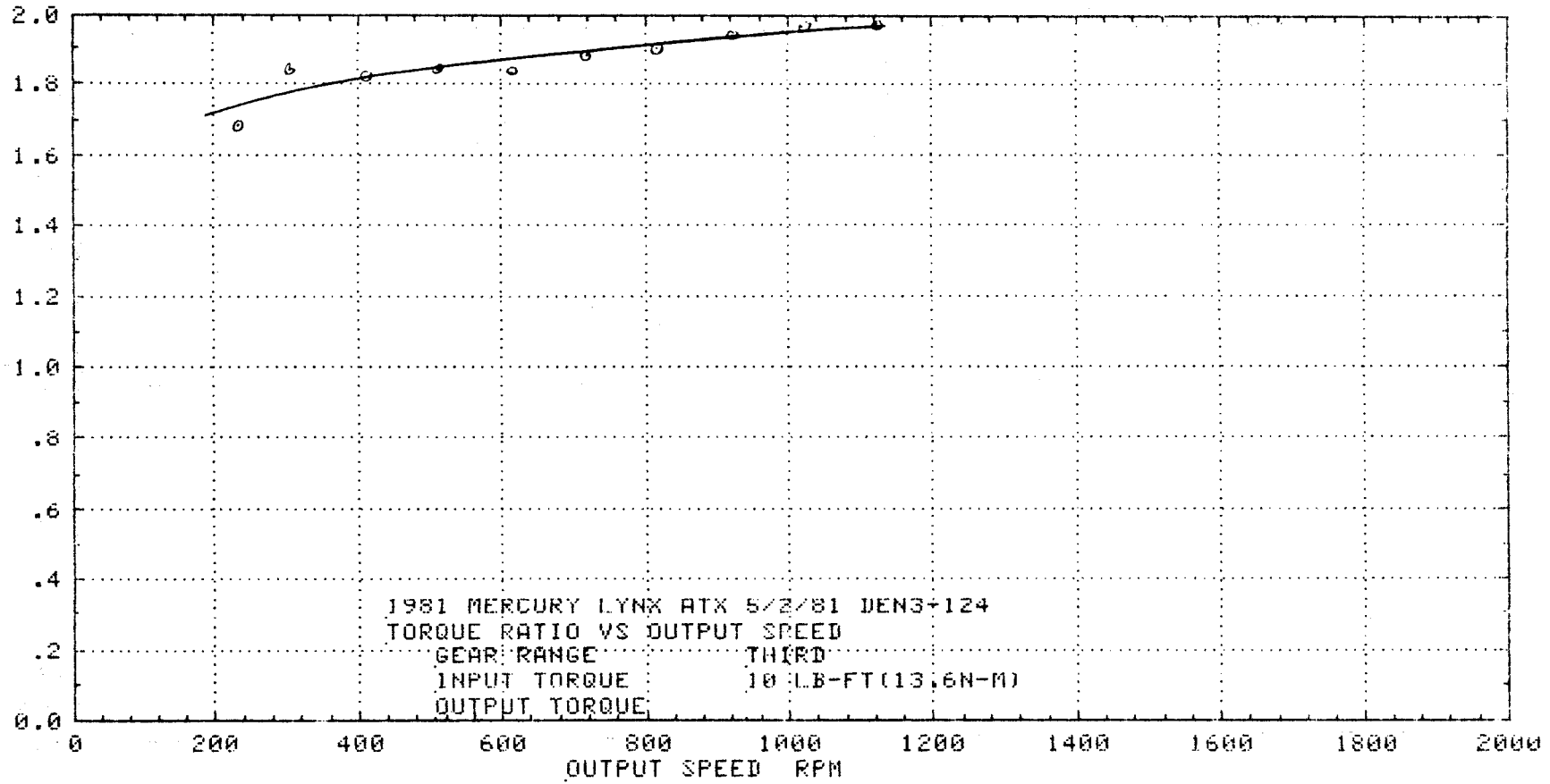

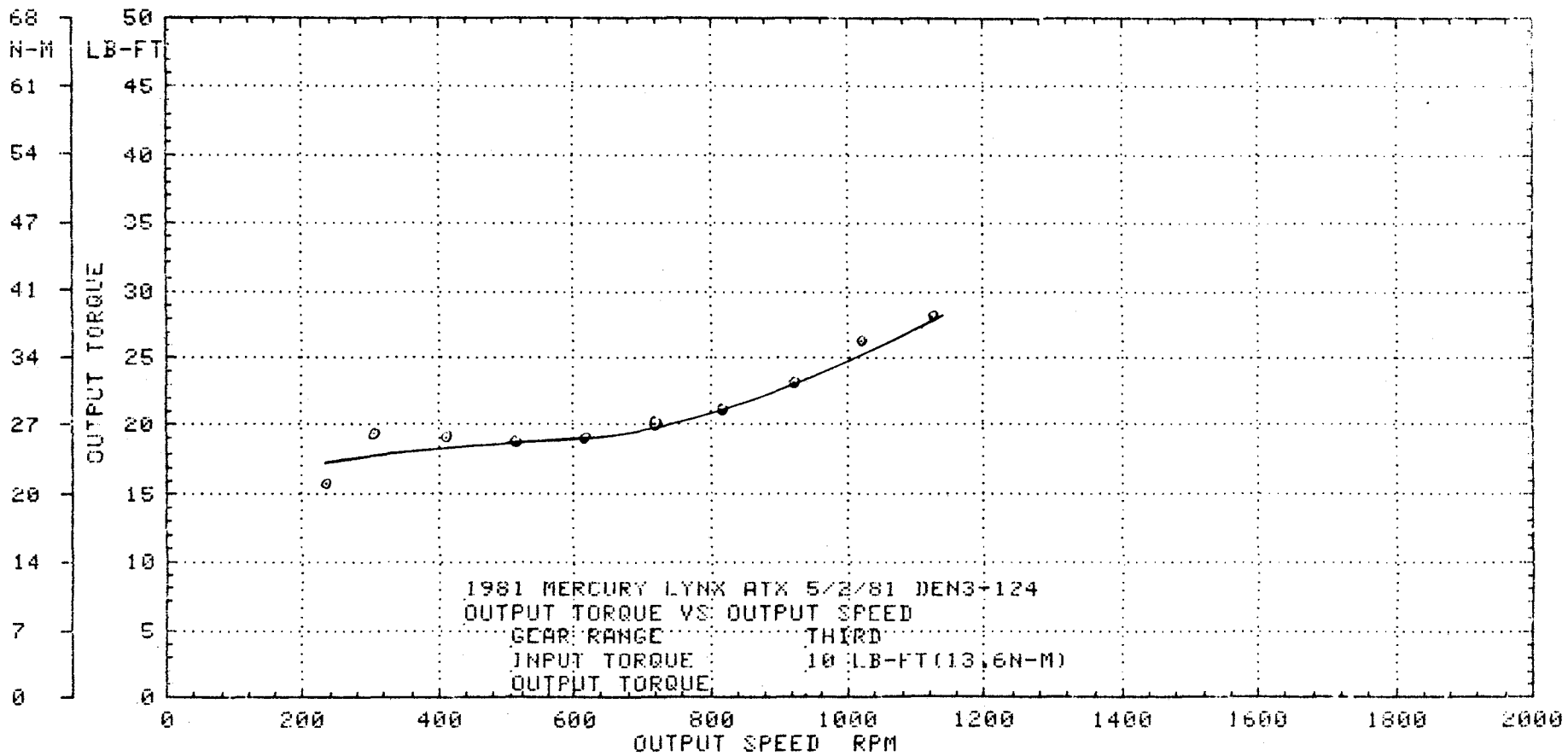

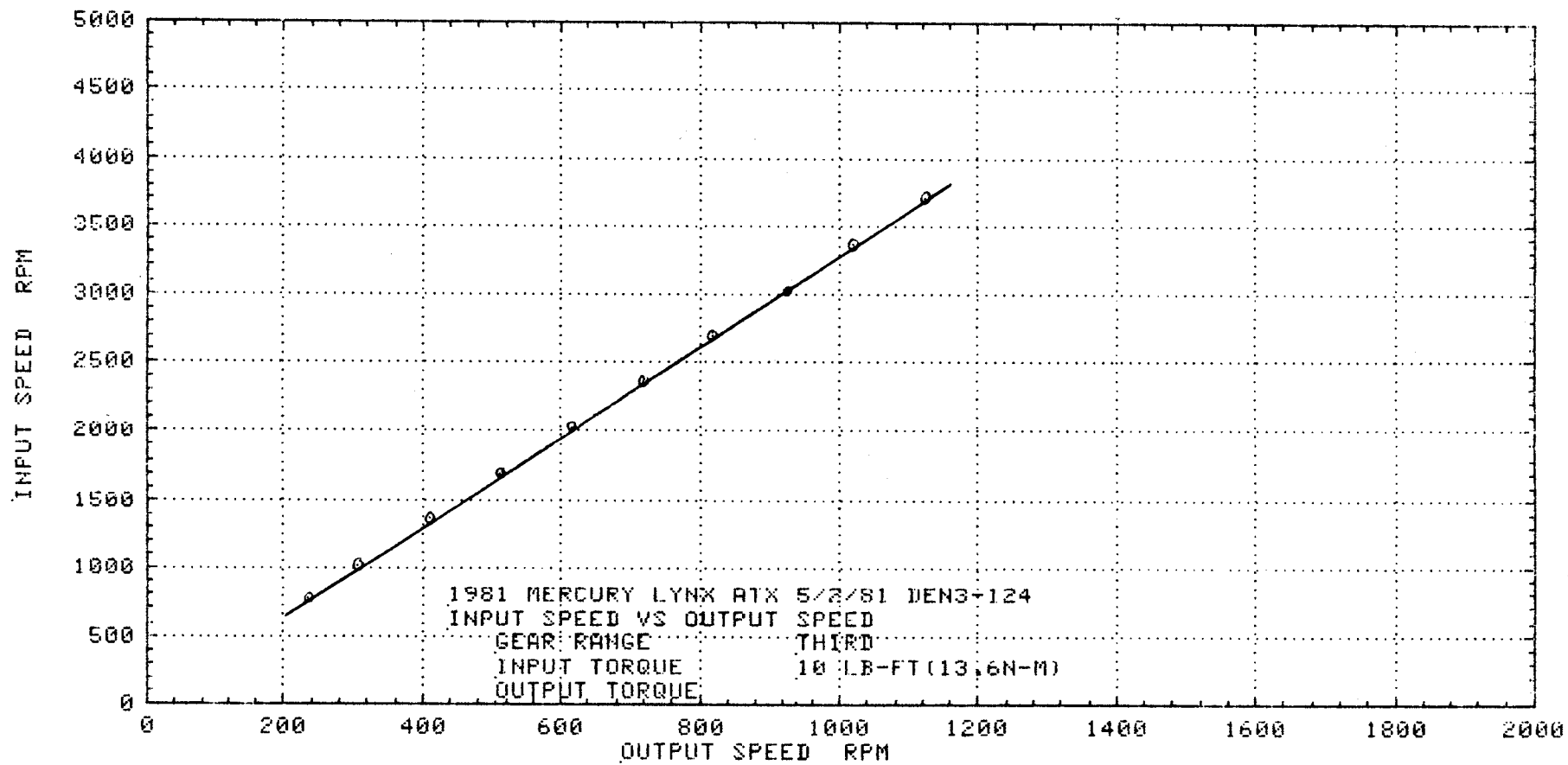

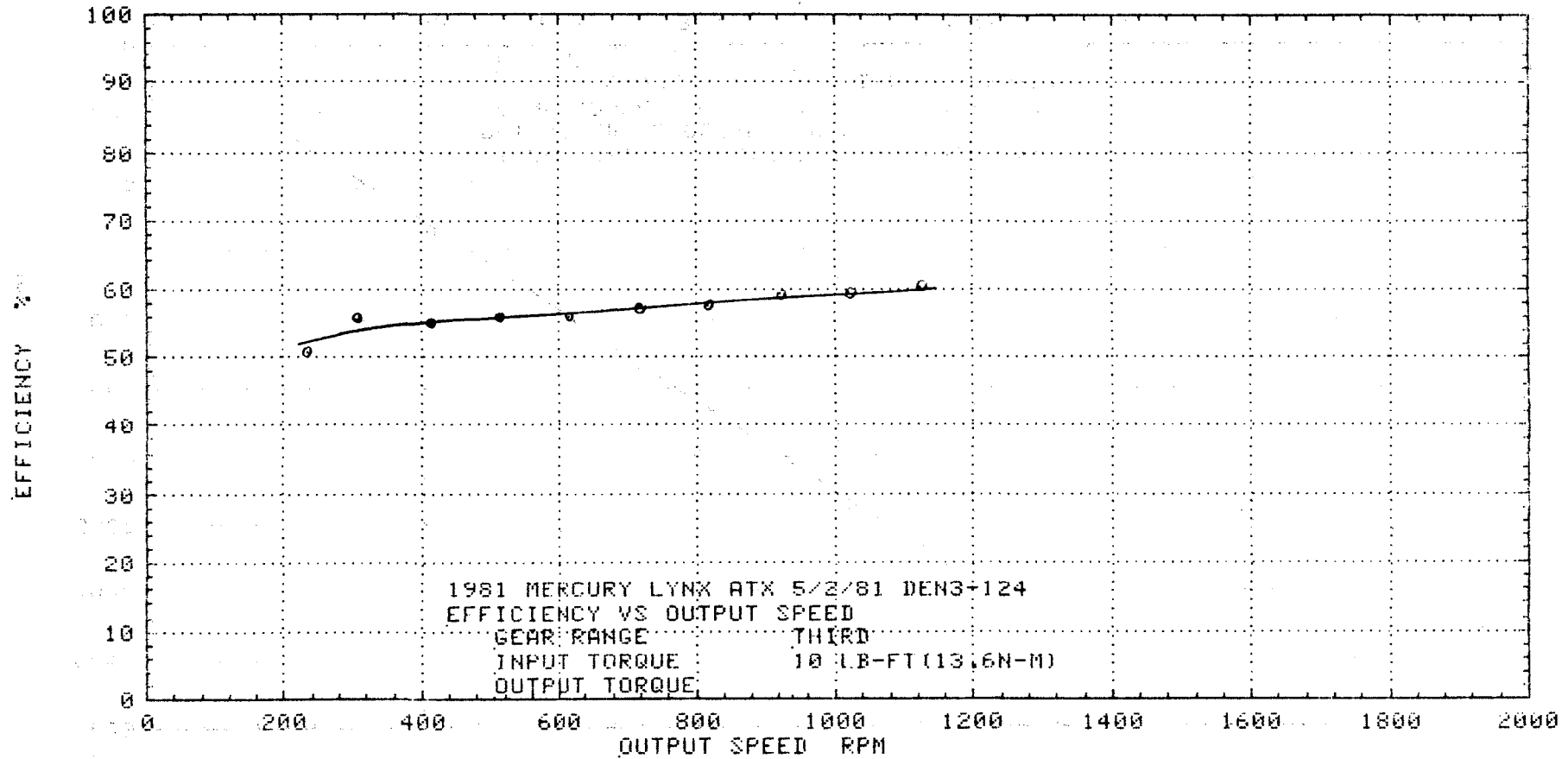

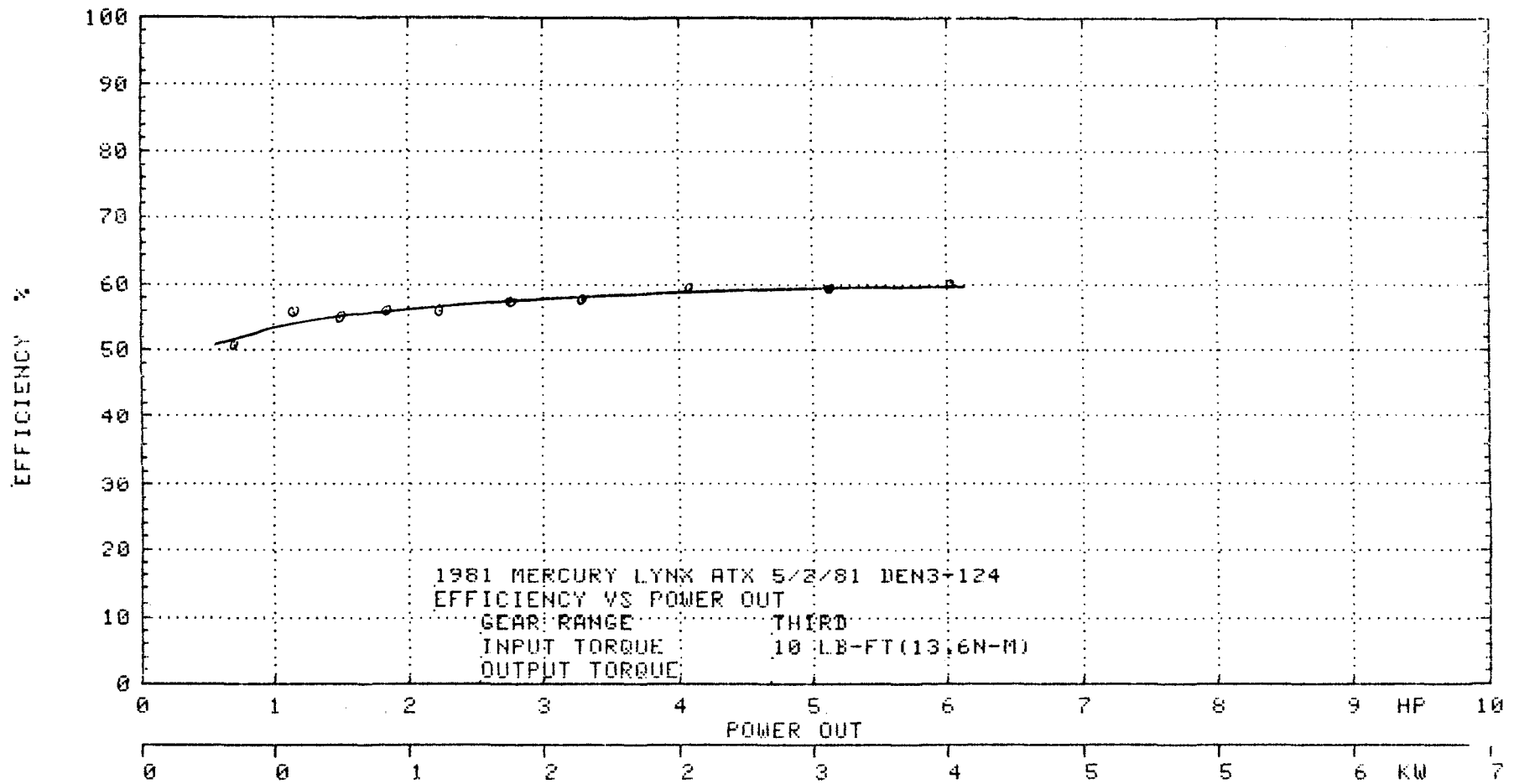

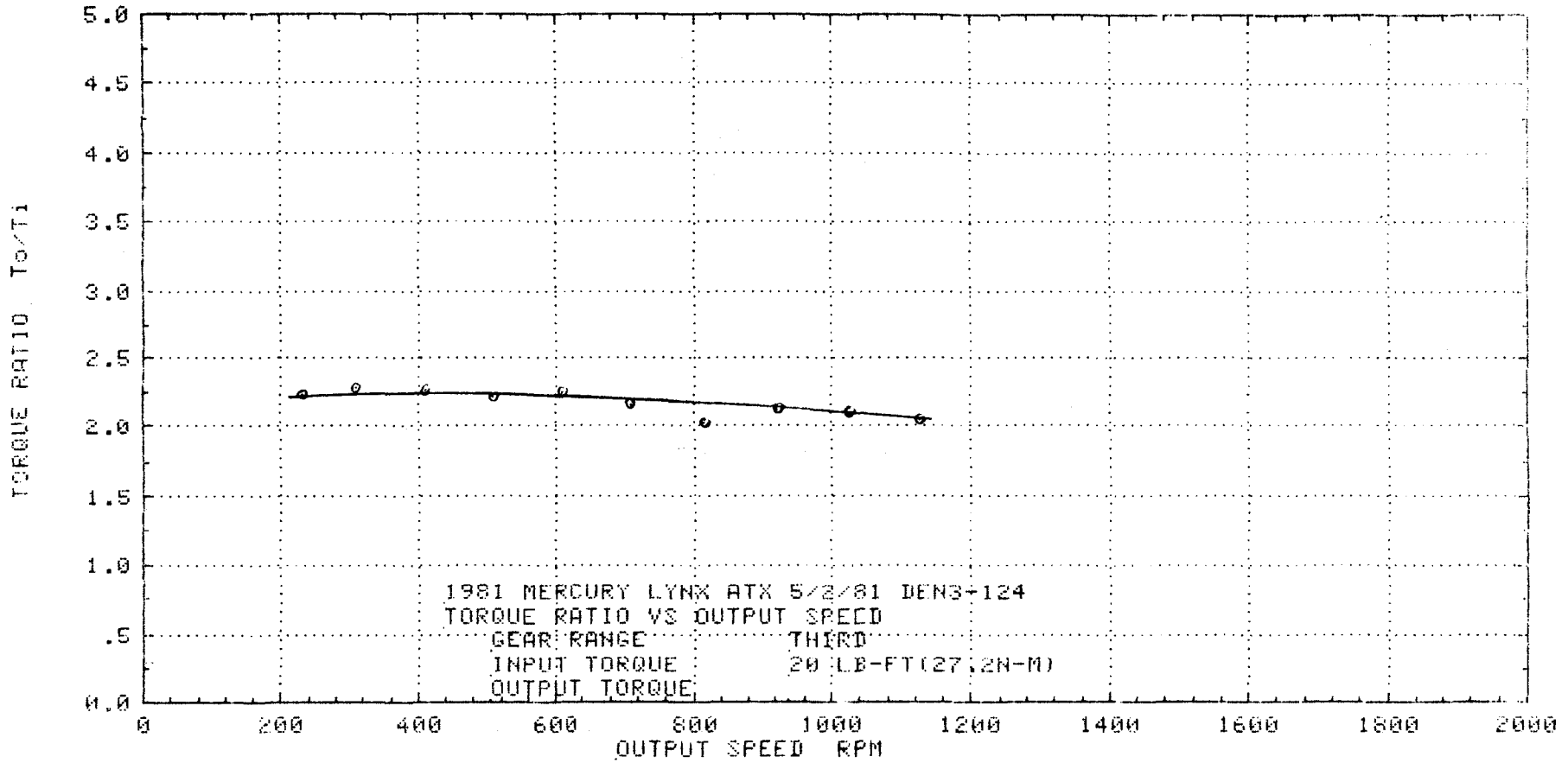

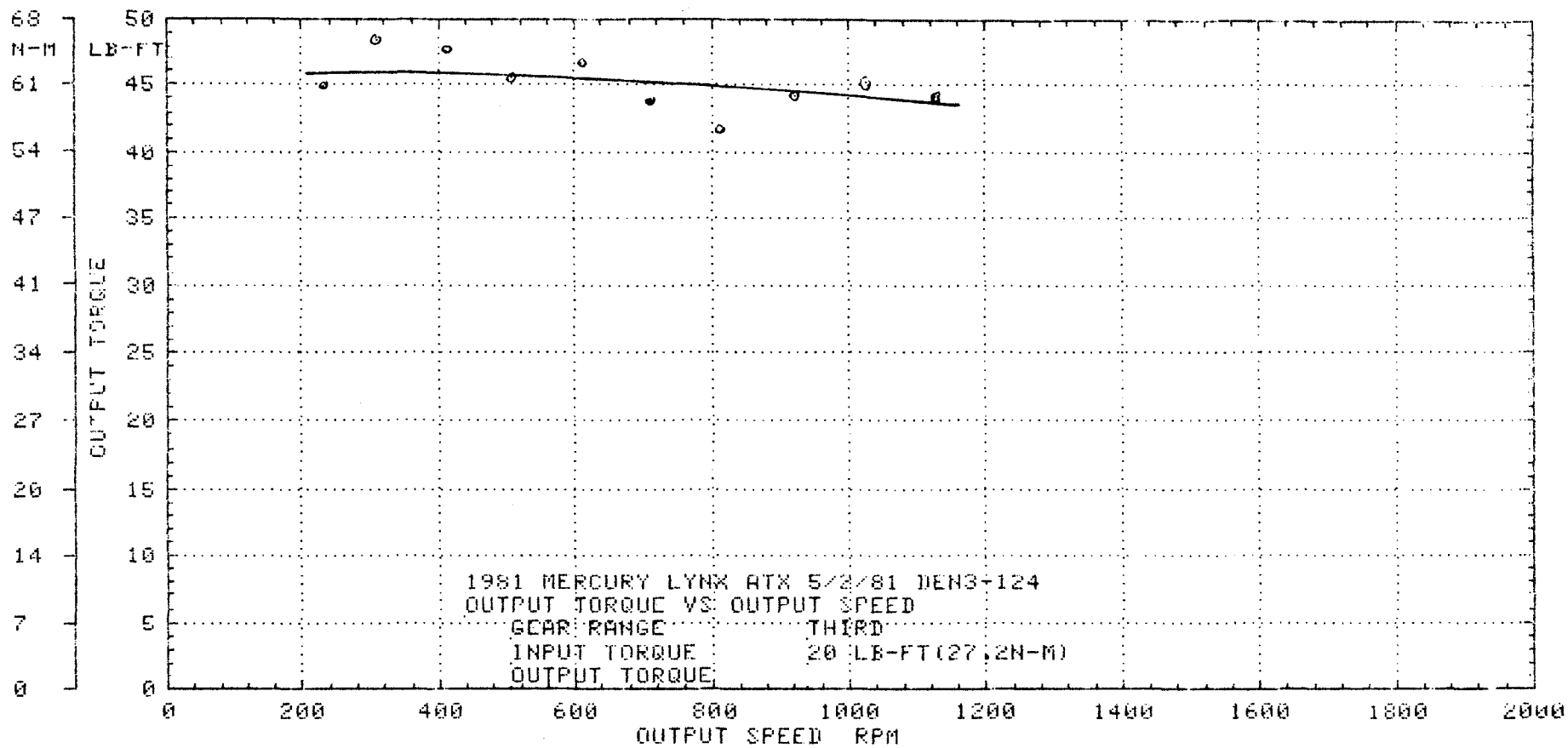

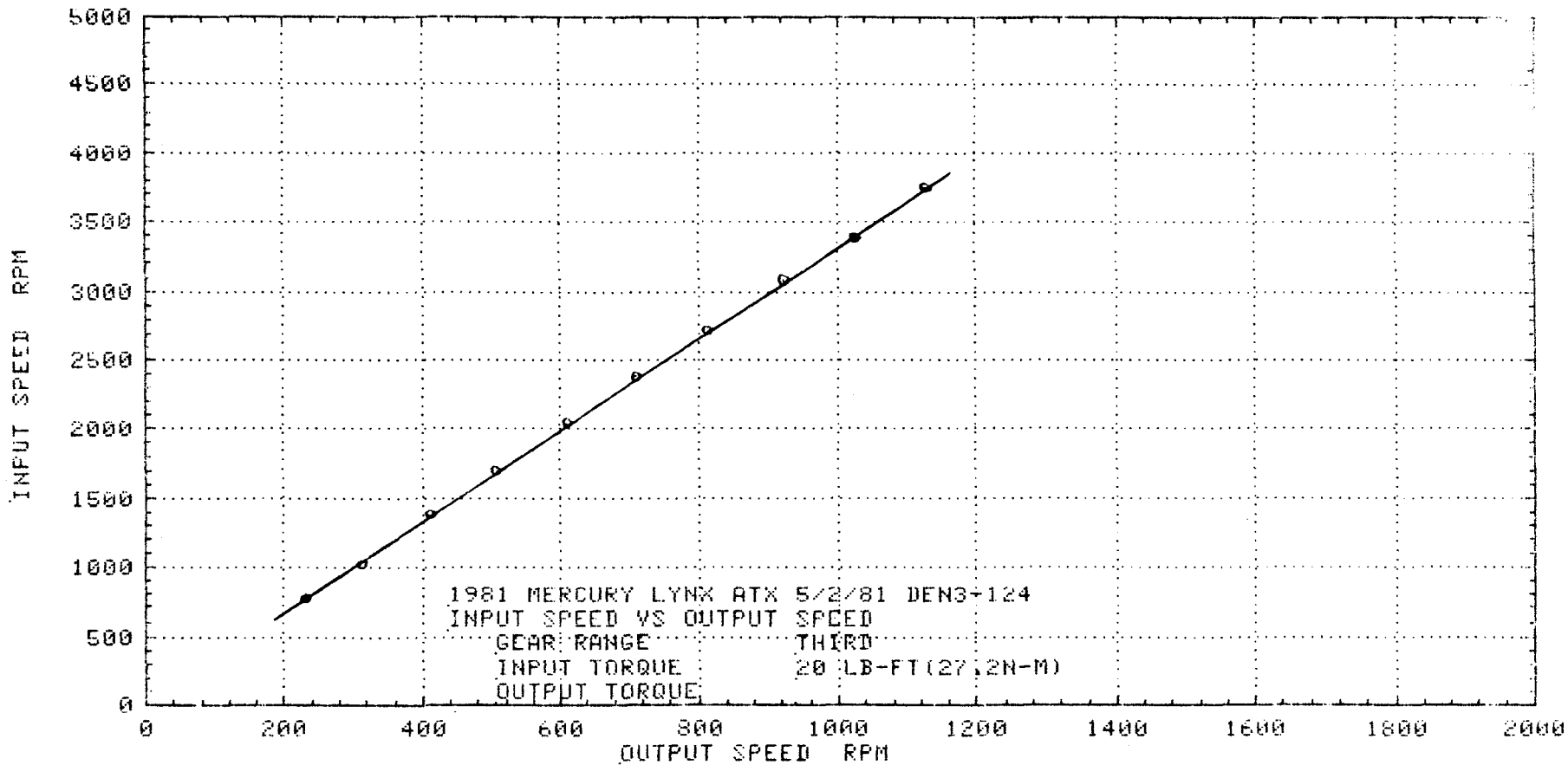

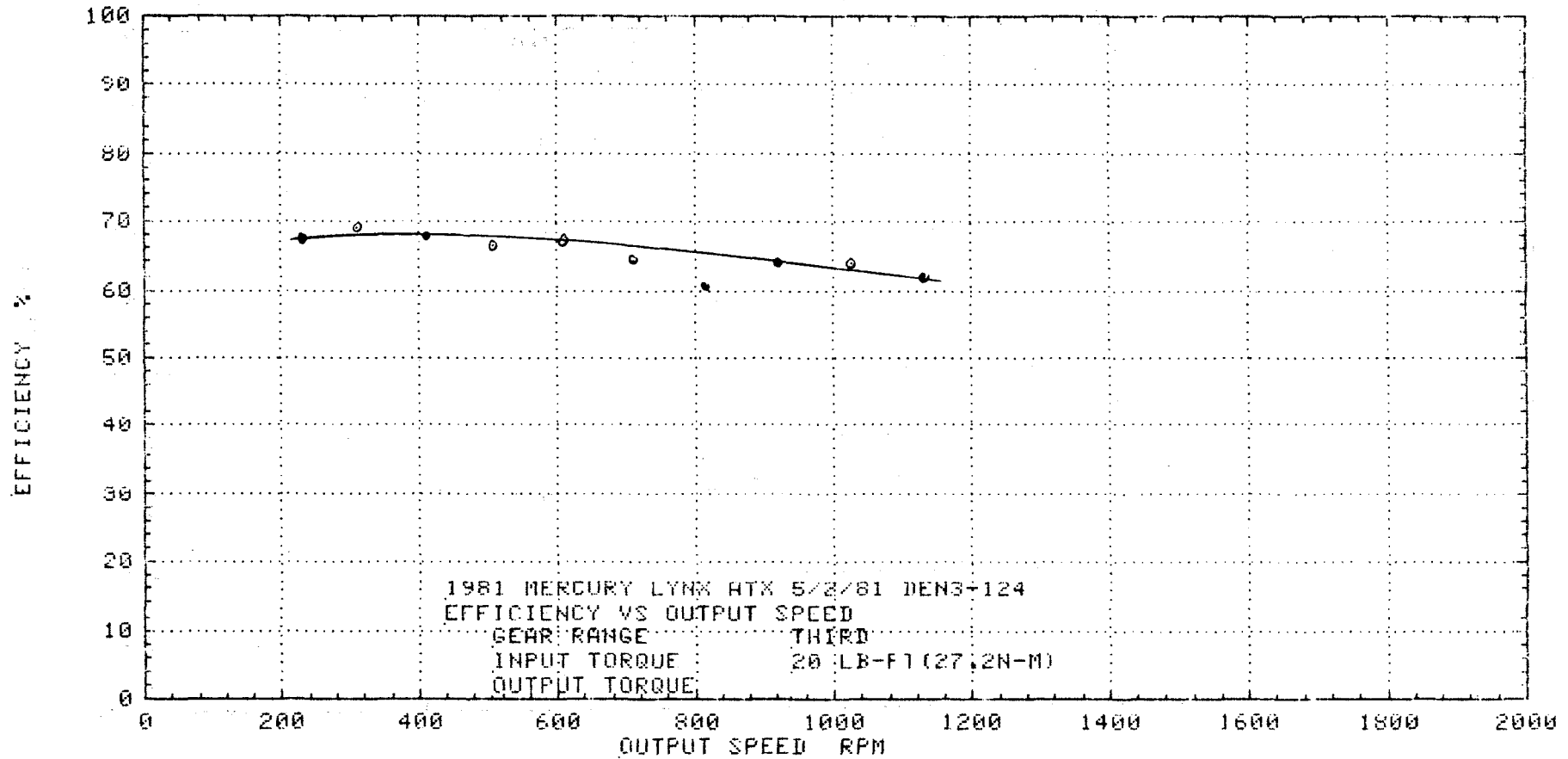

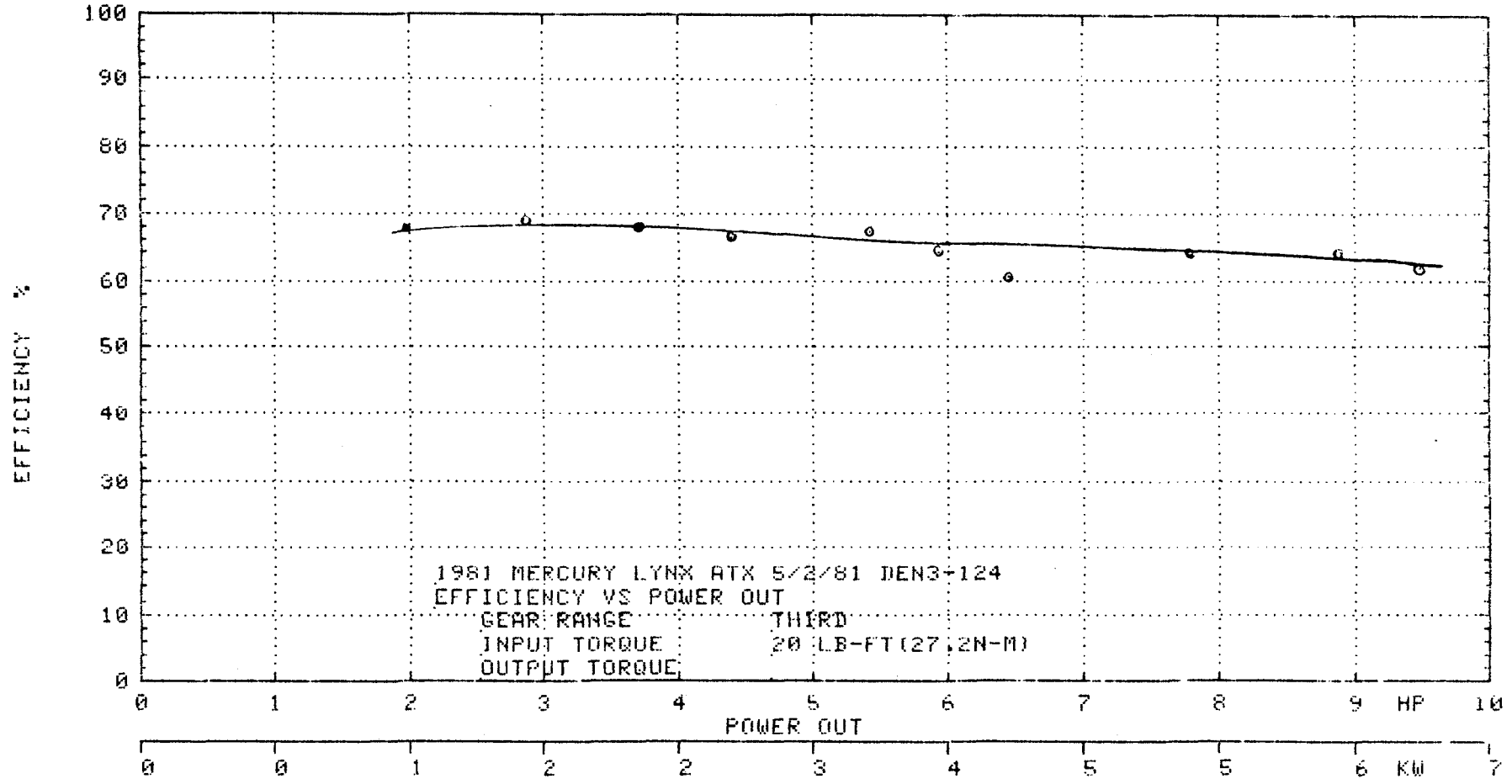

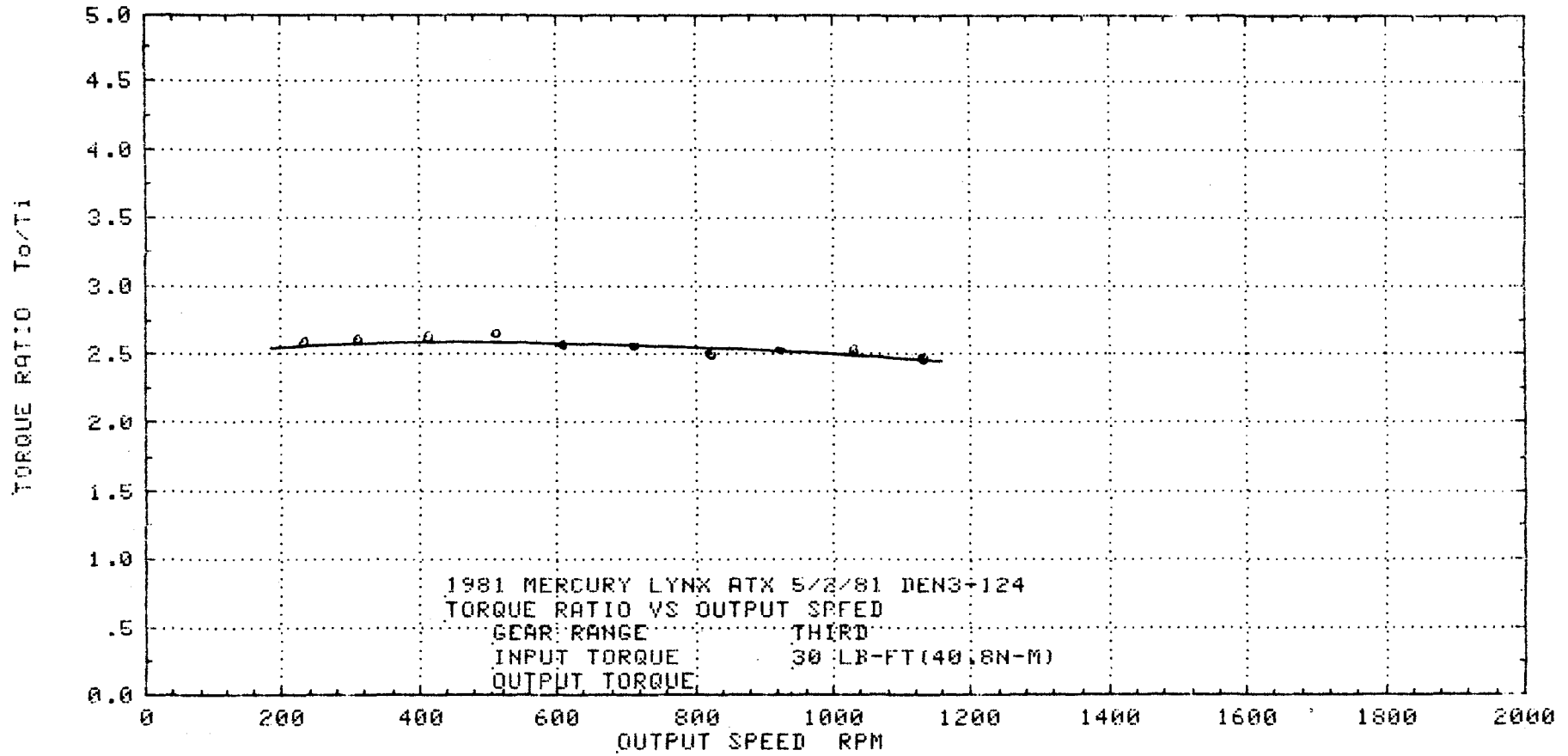

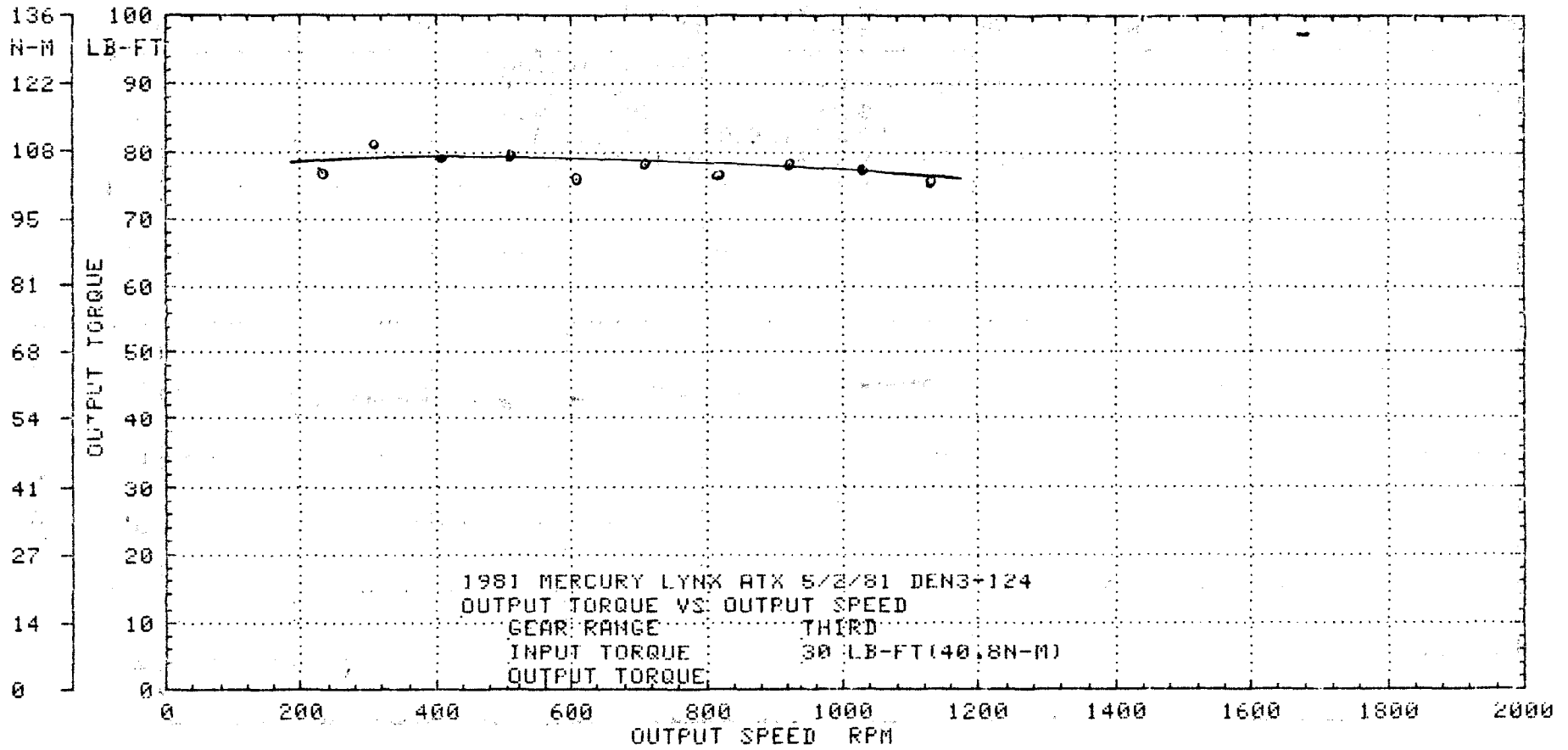

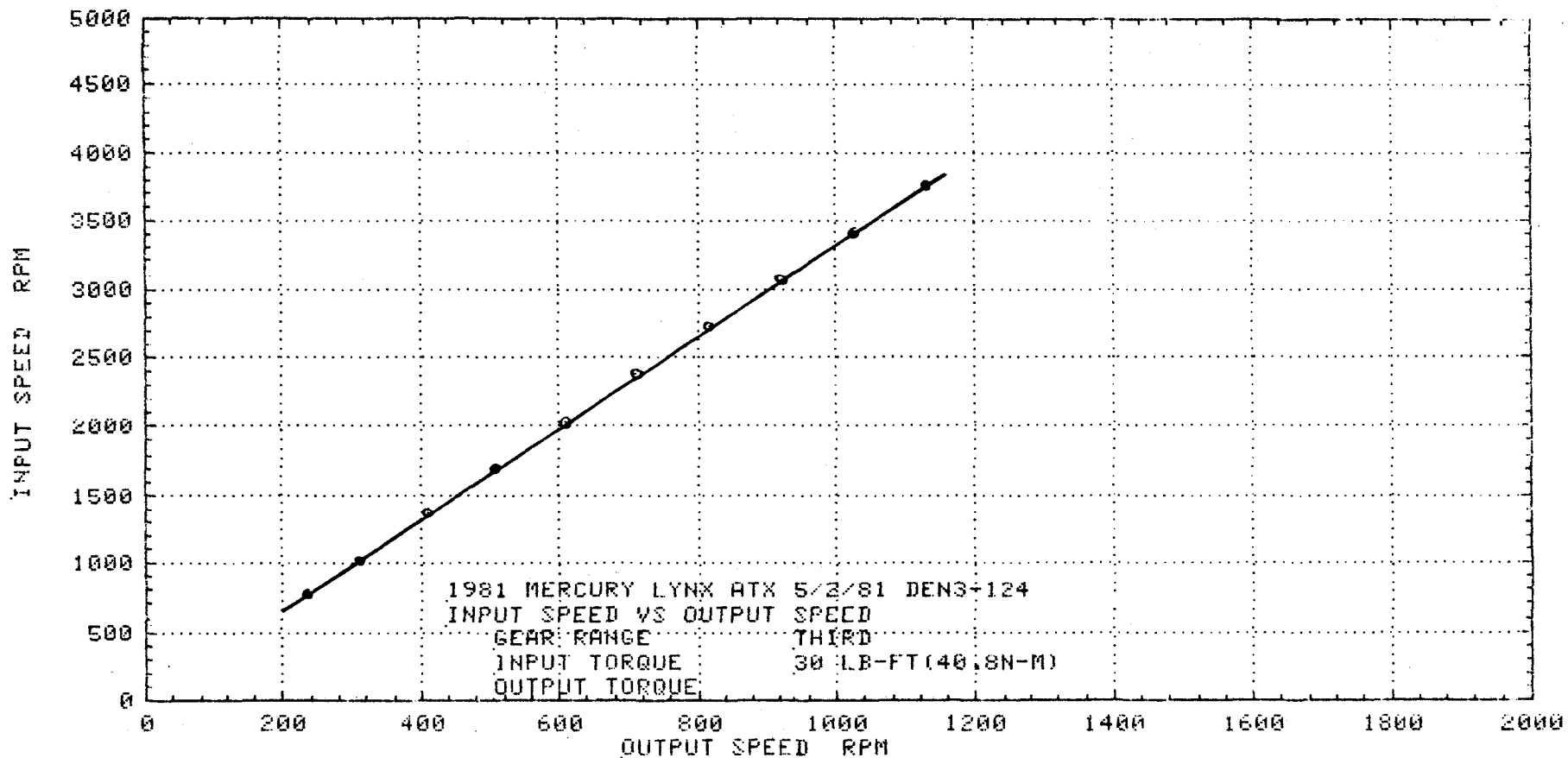

% EFFICIENCY

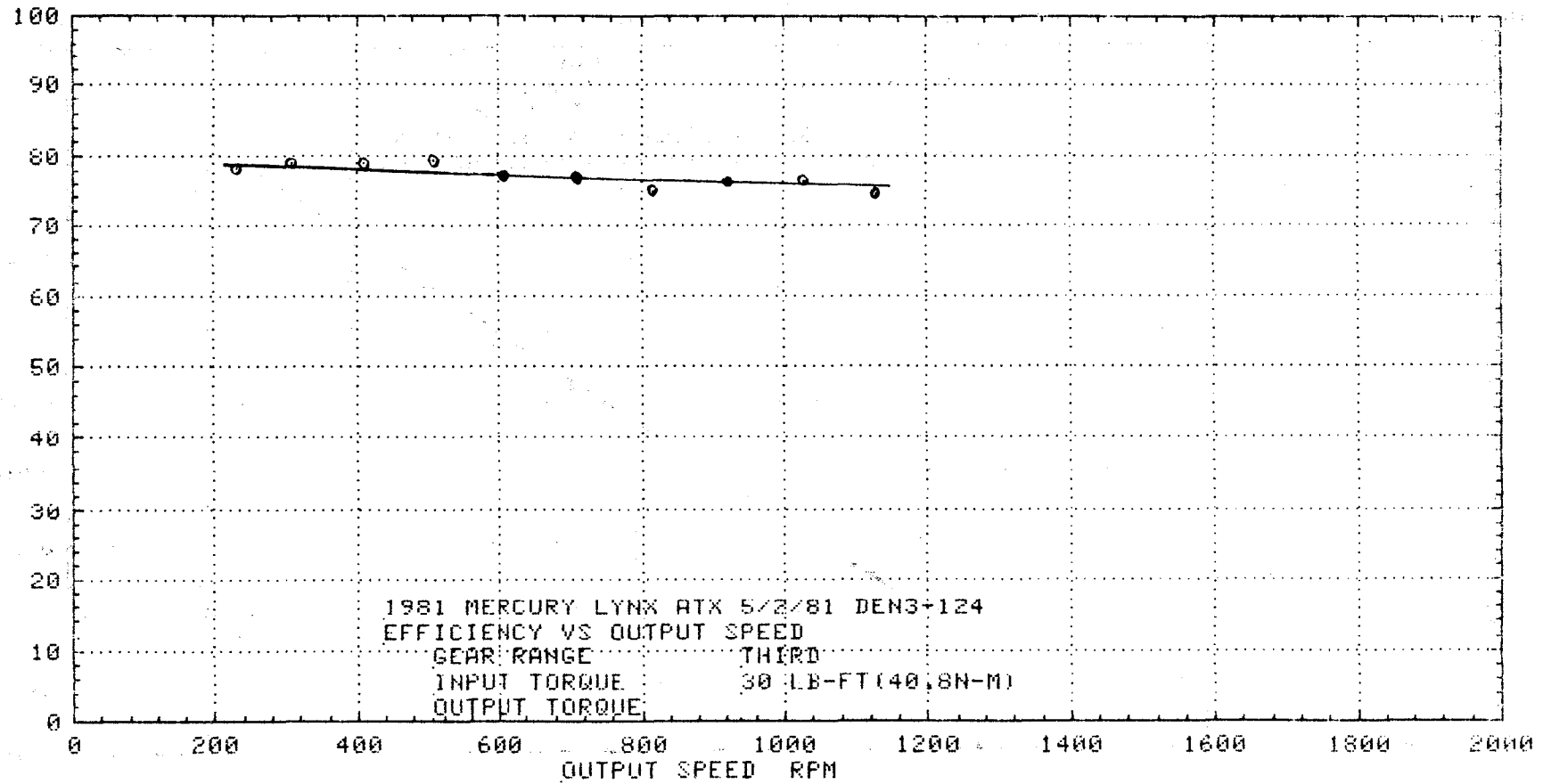

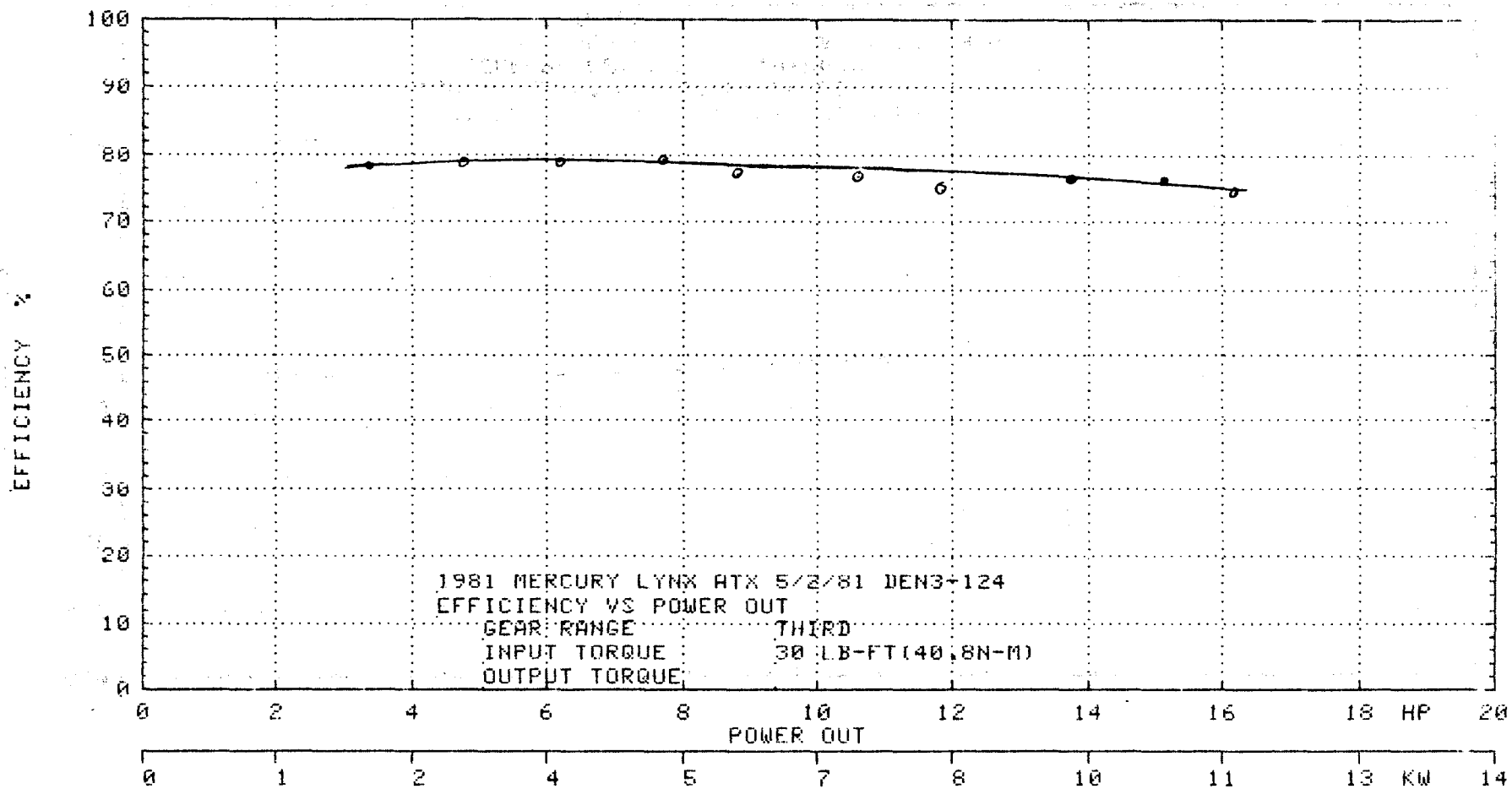

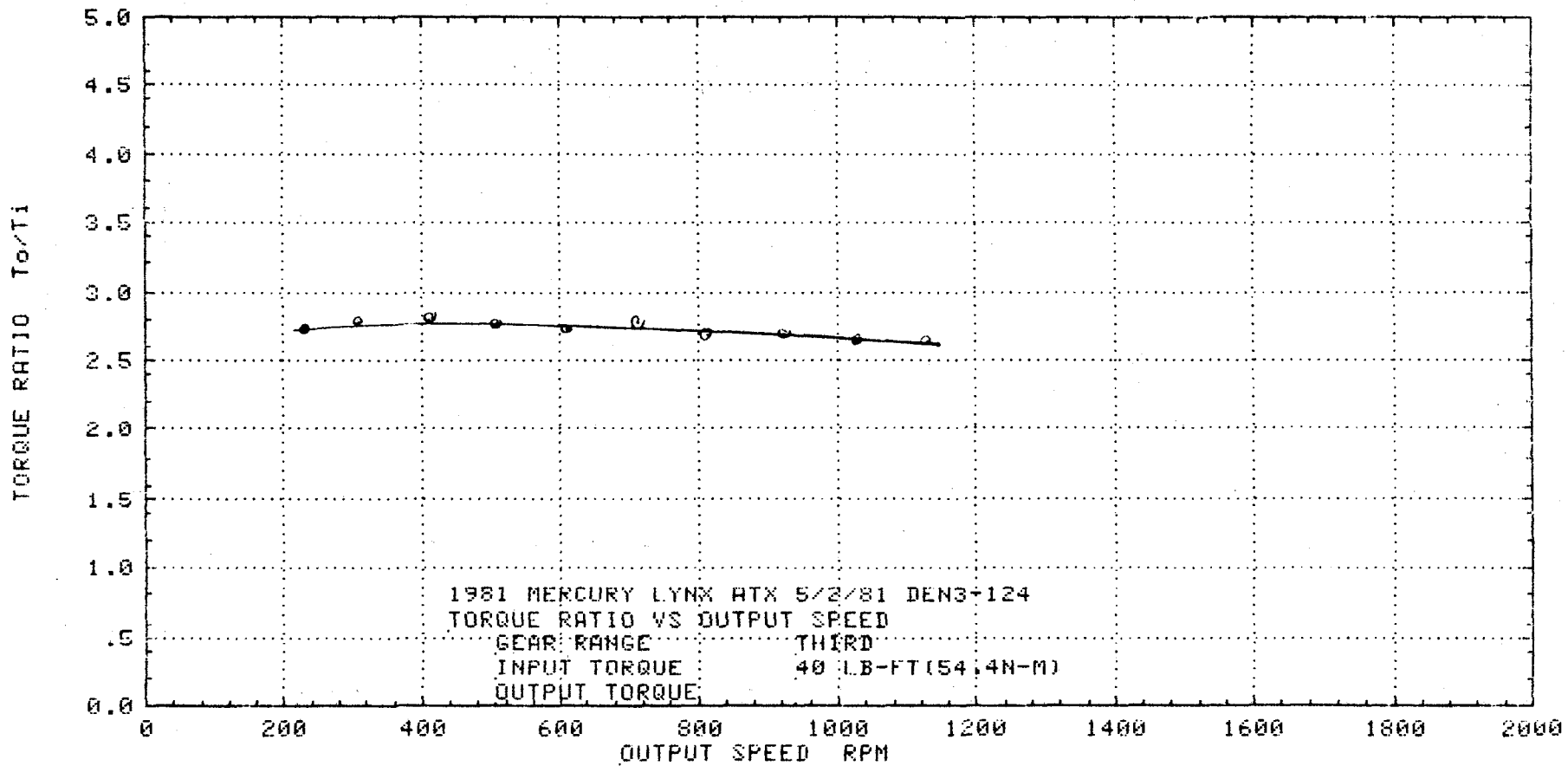

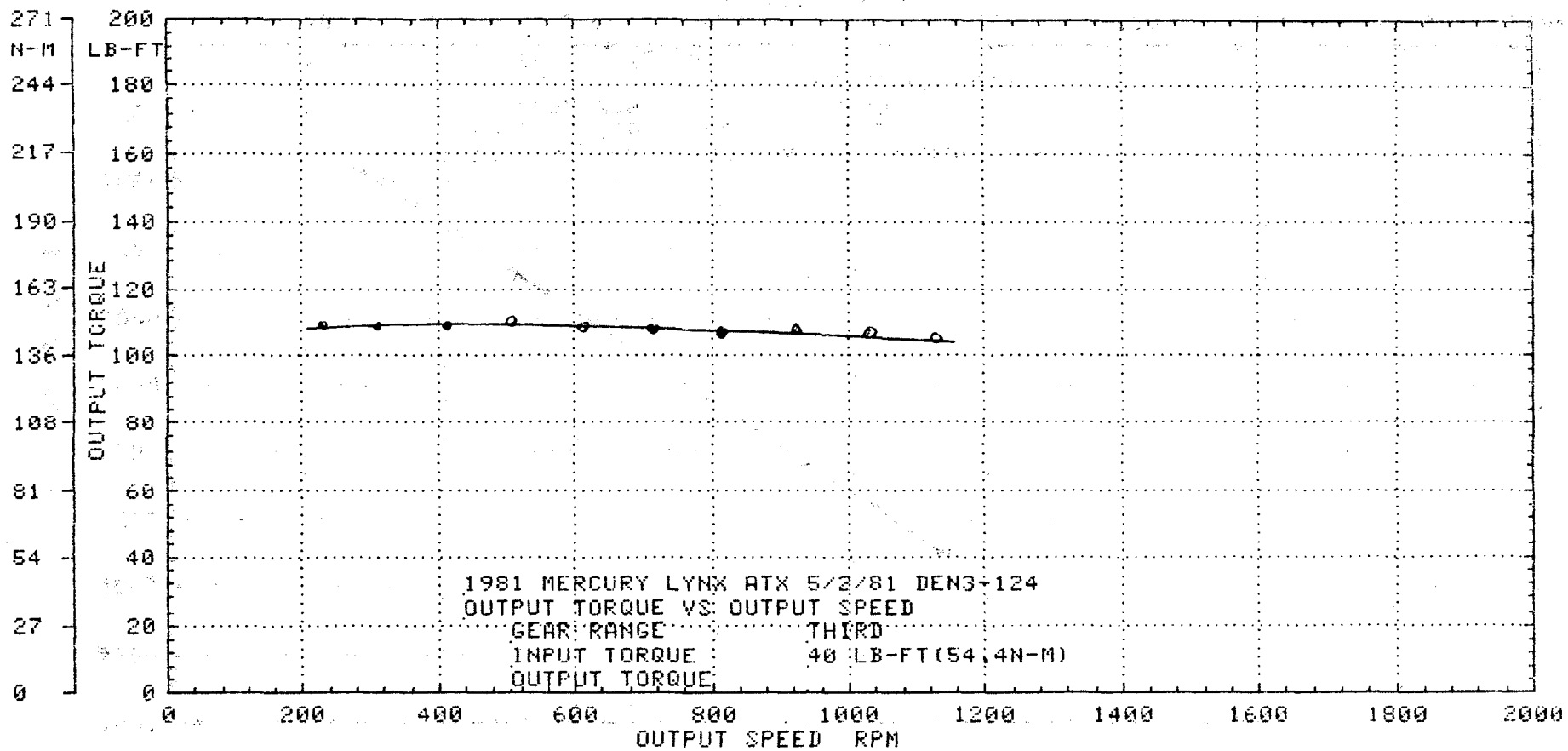

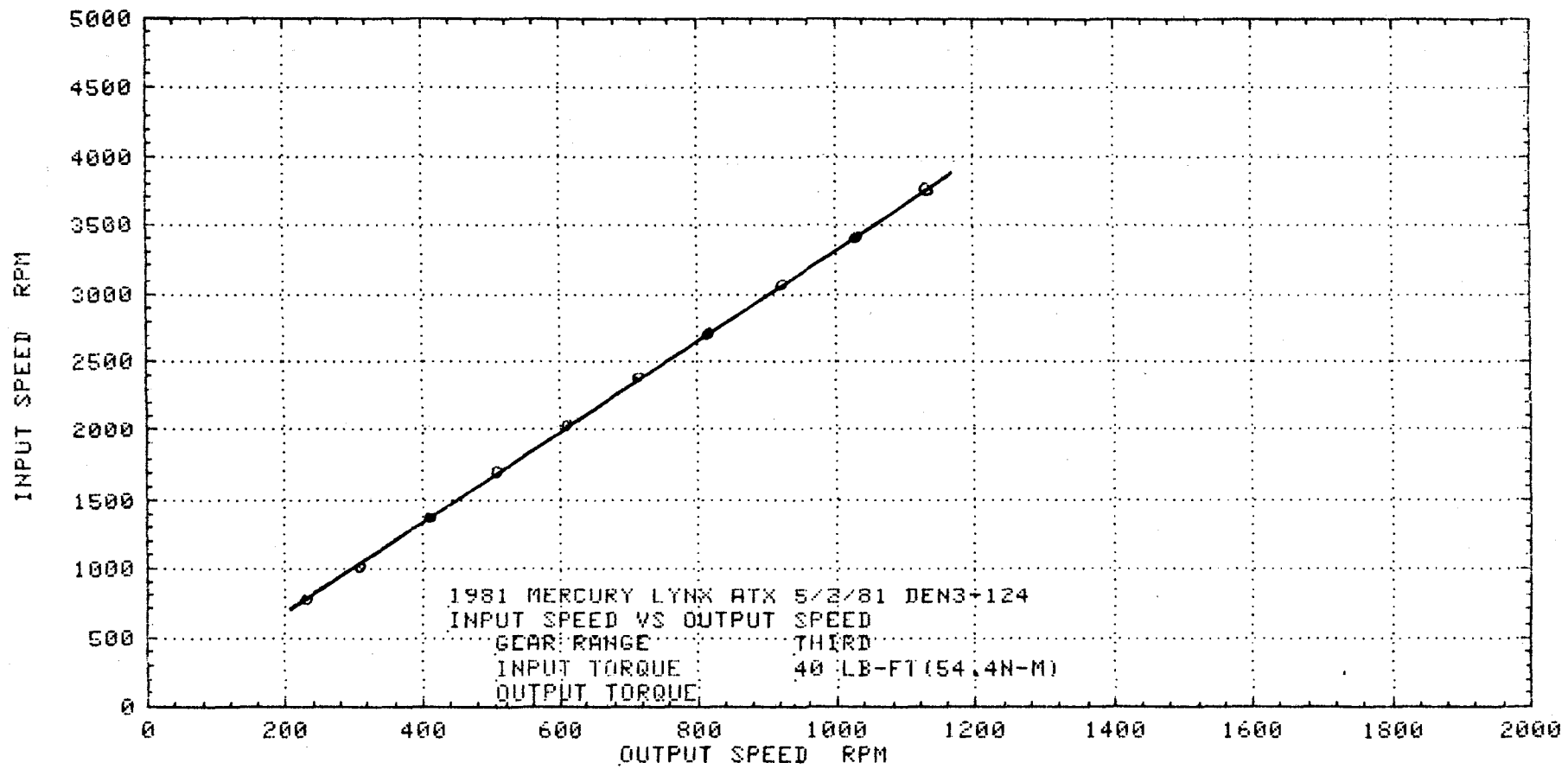

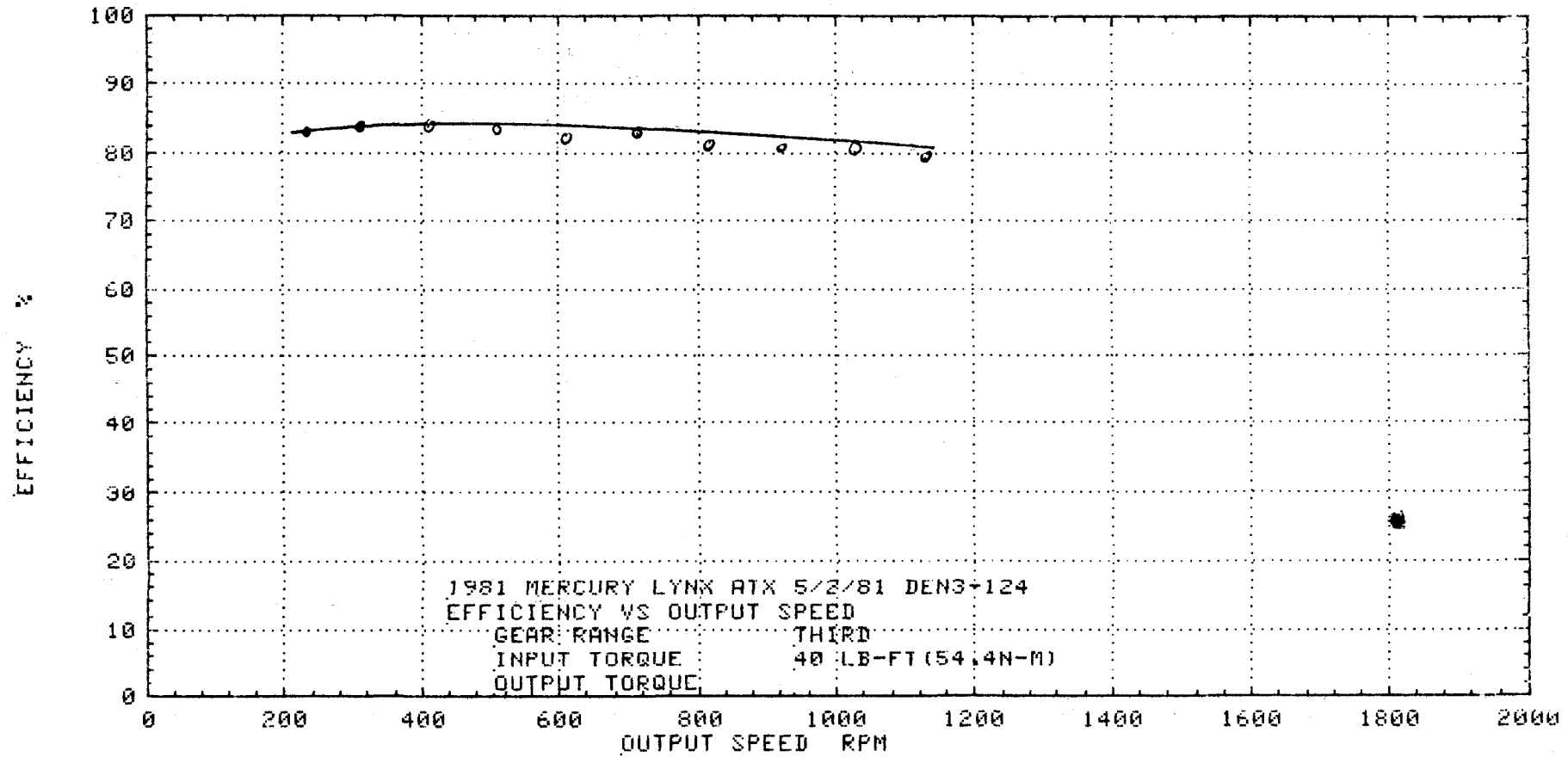

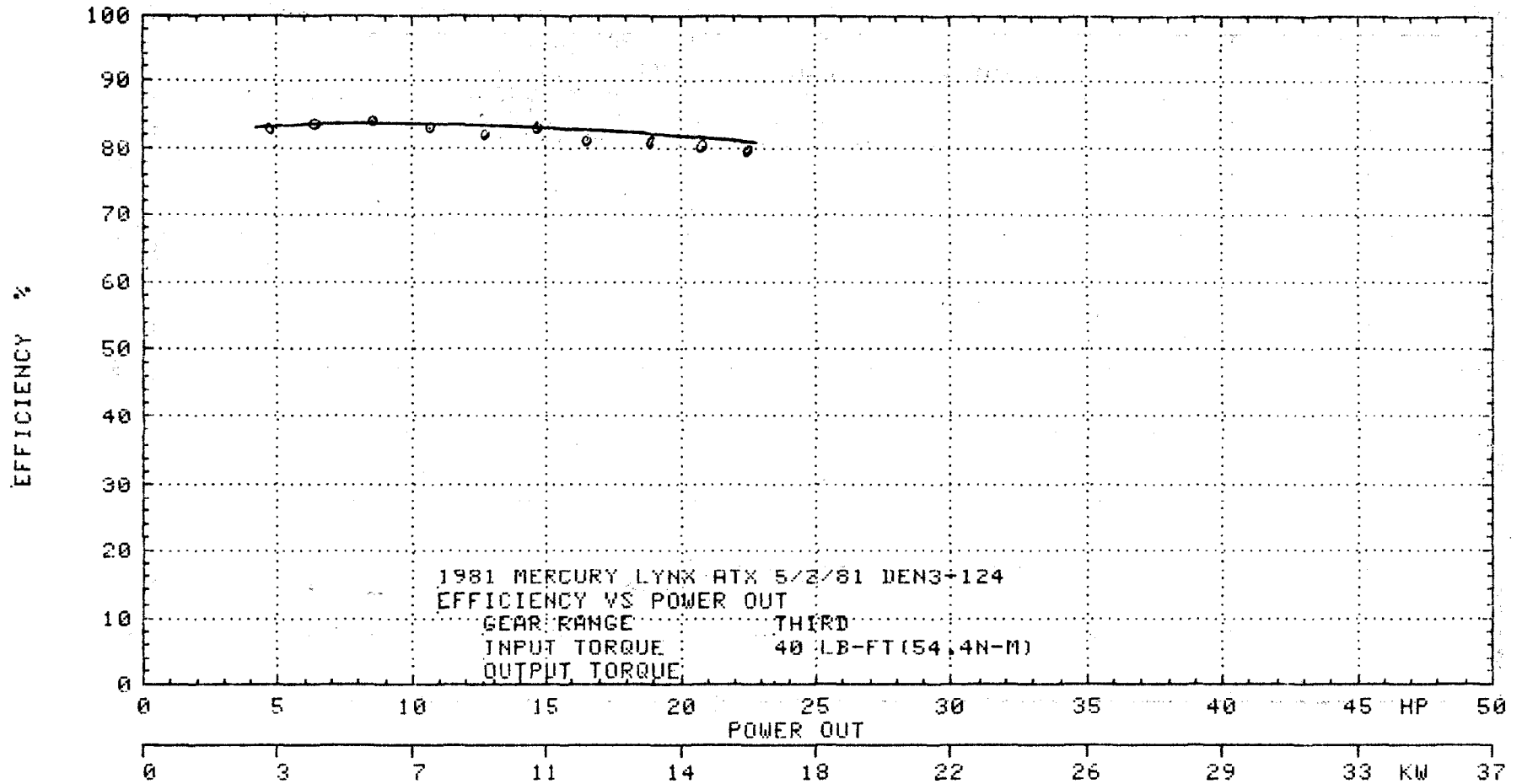

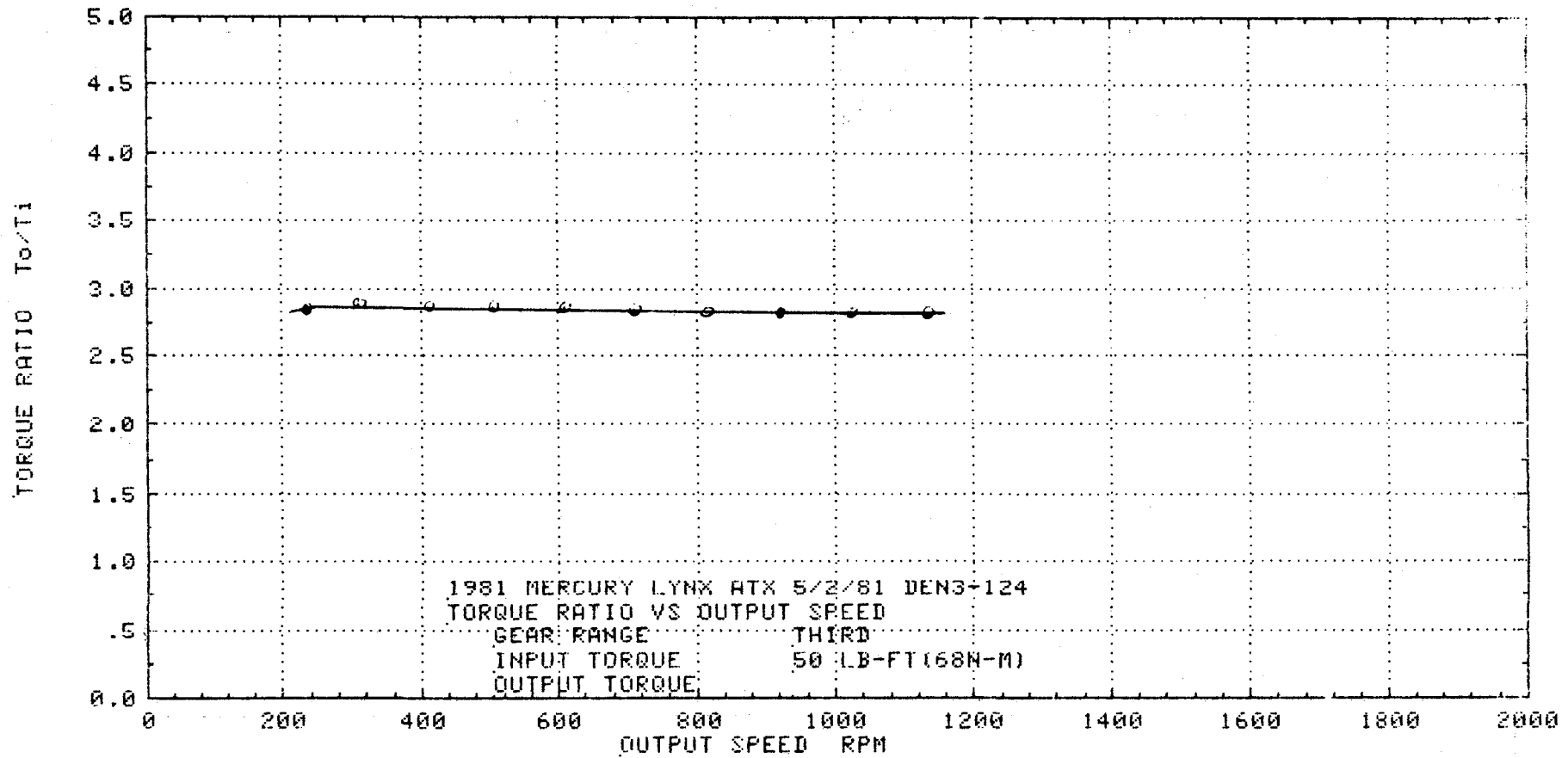

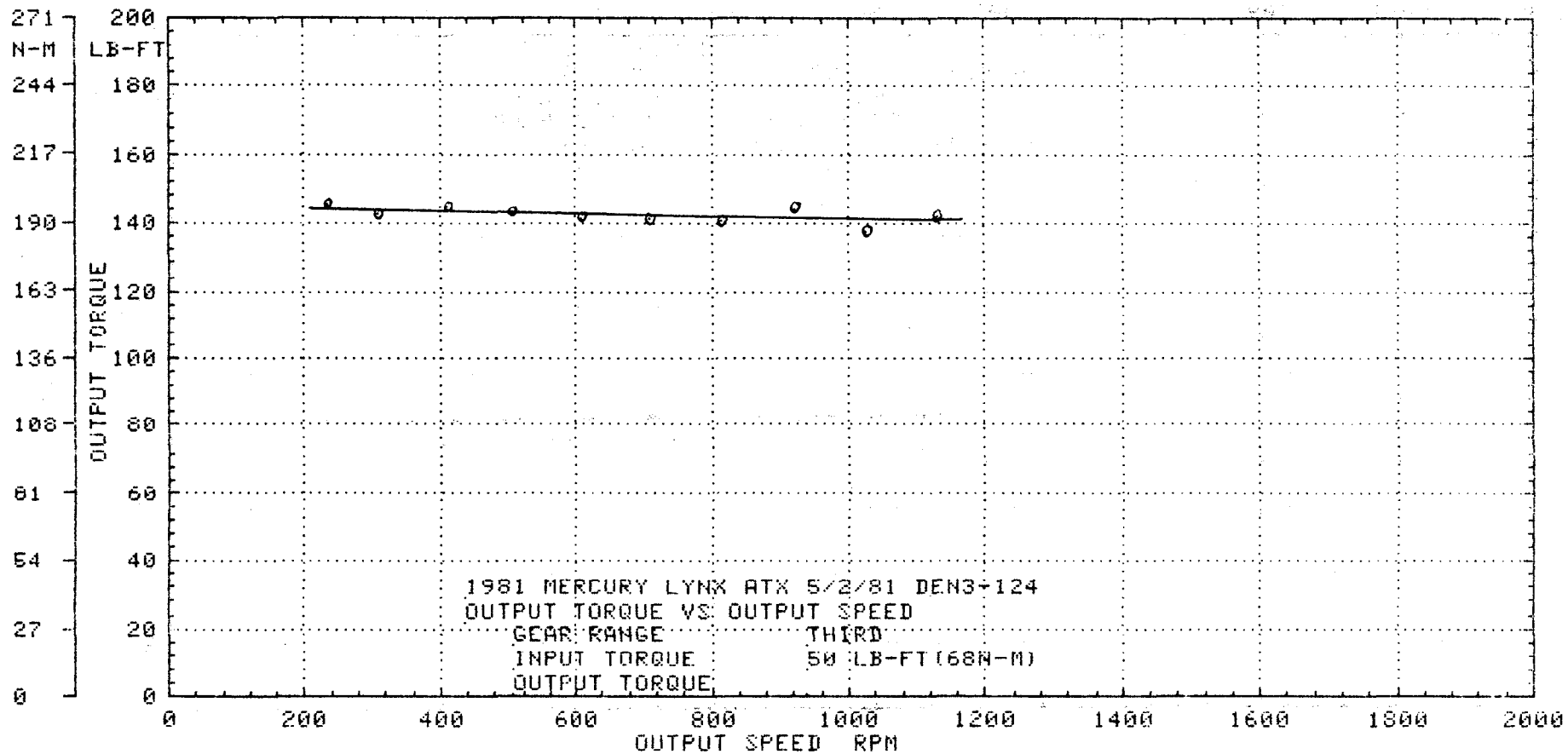

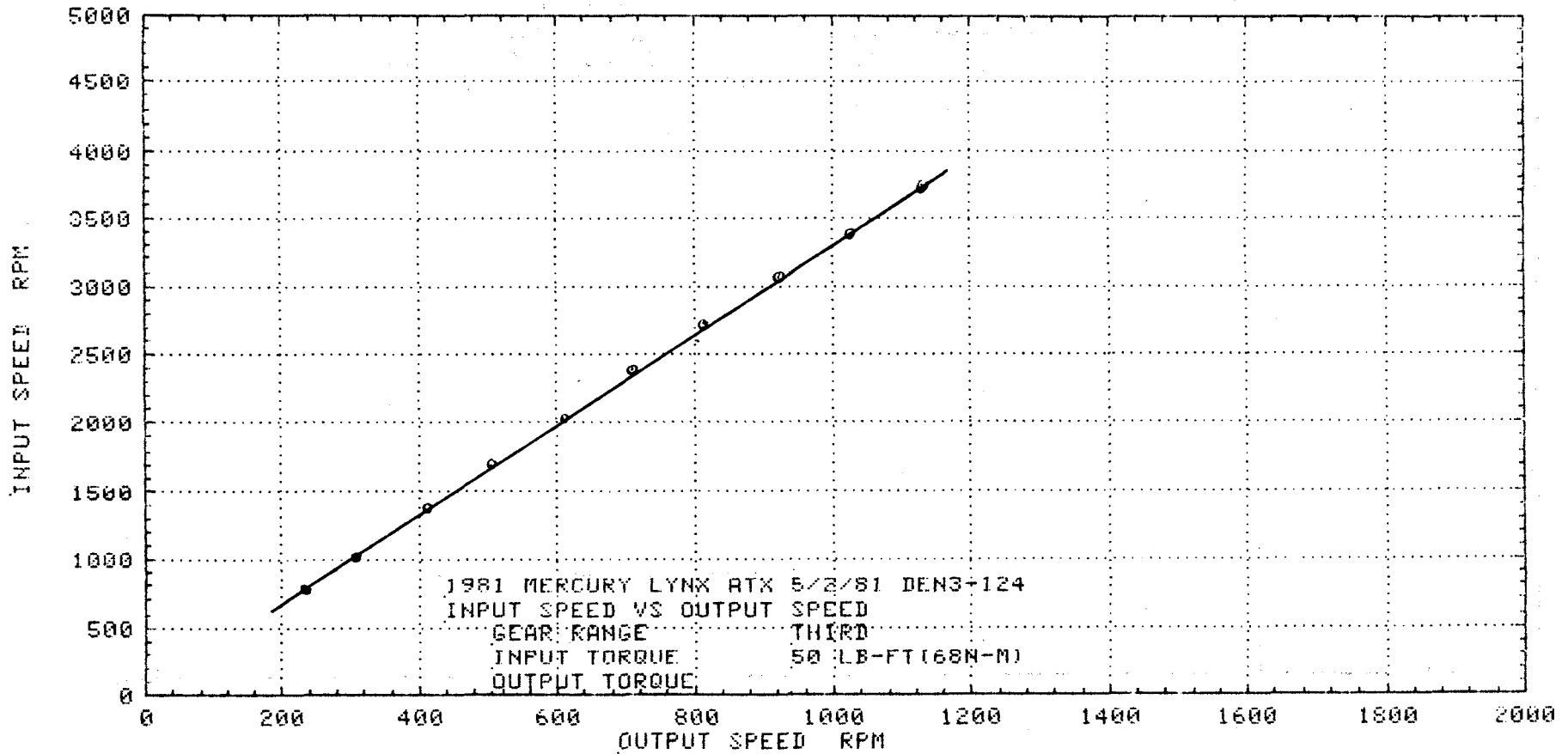

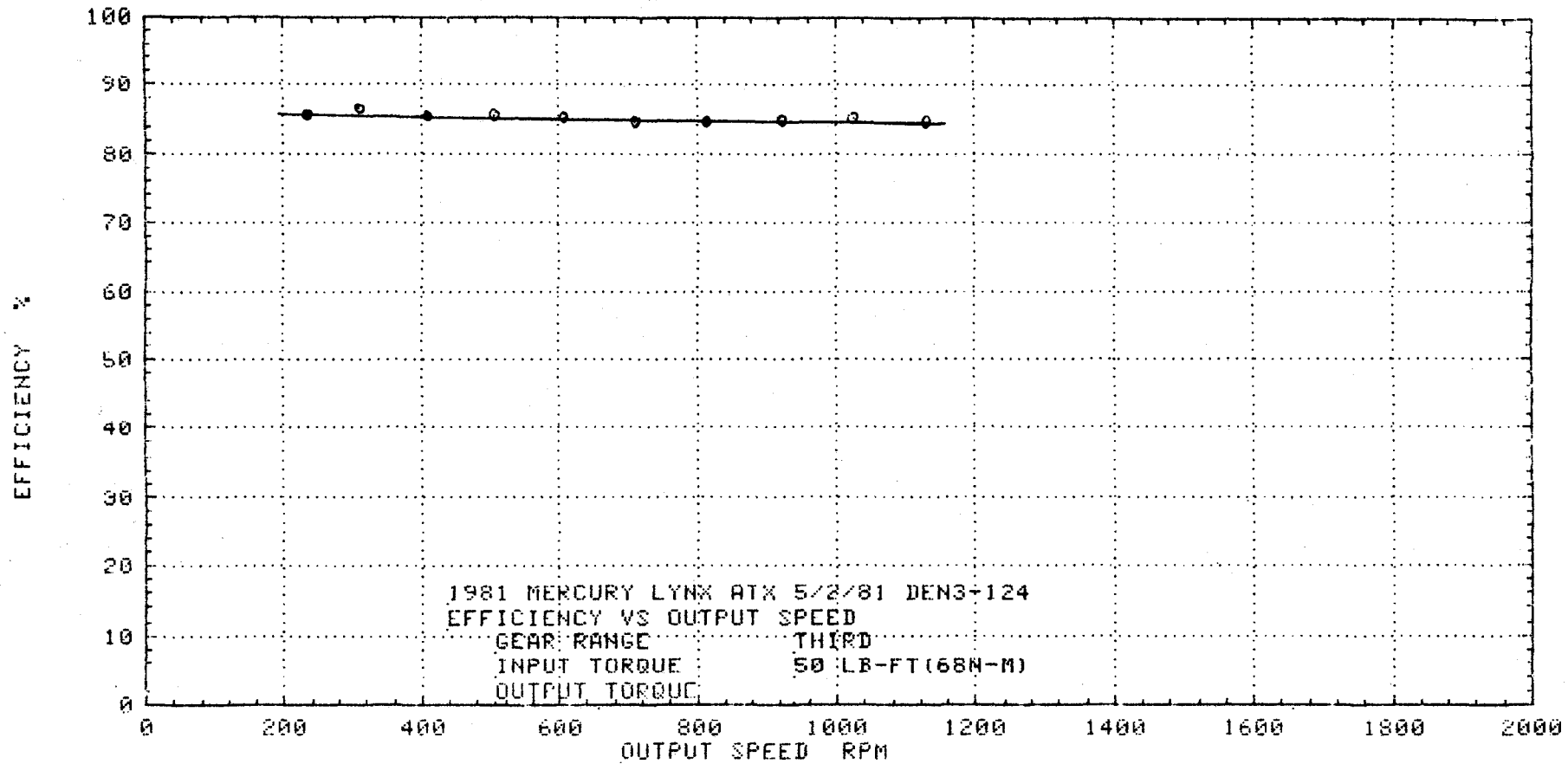

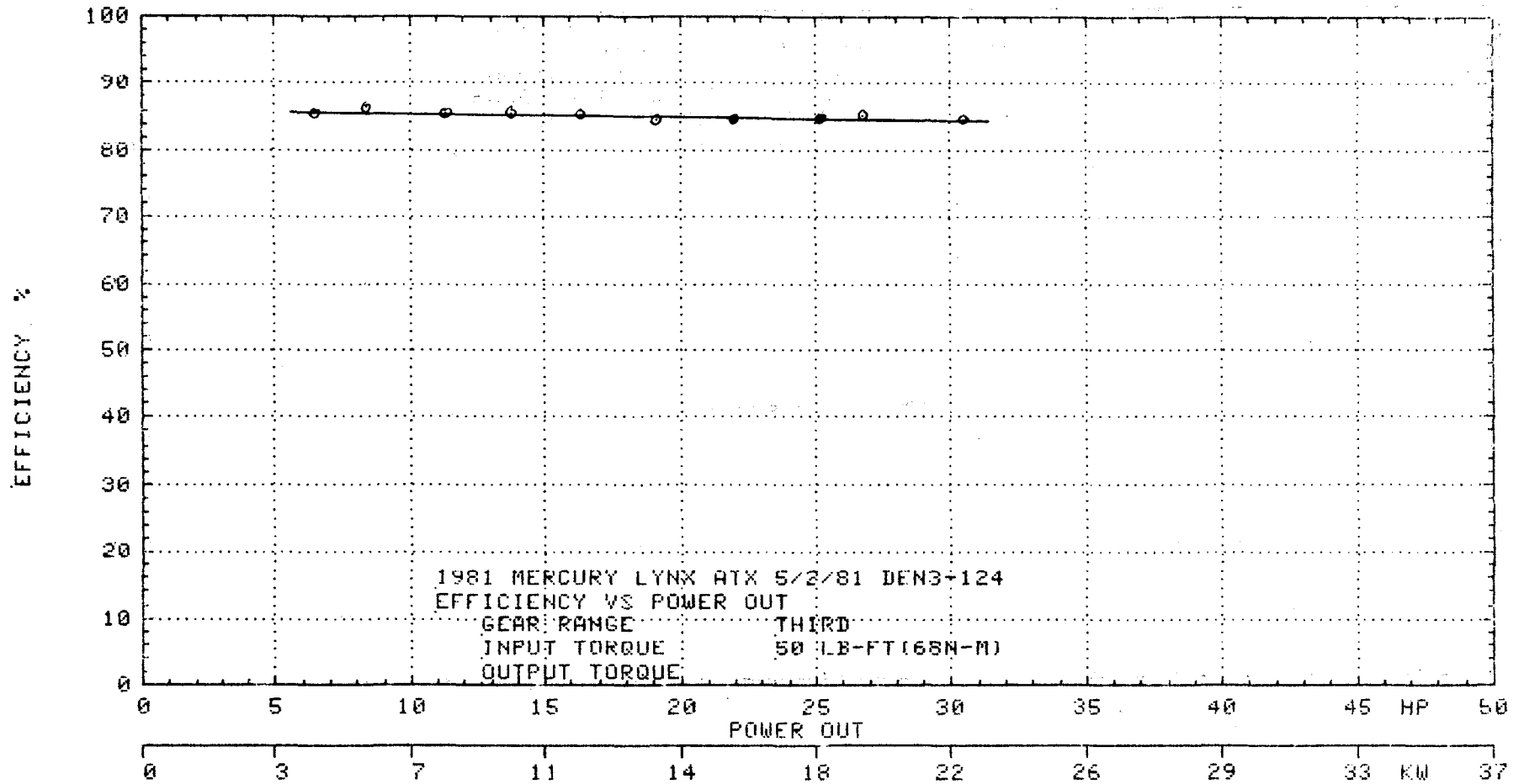

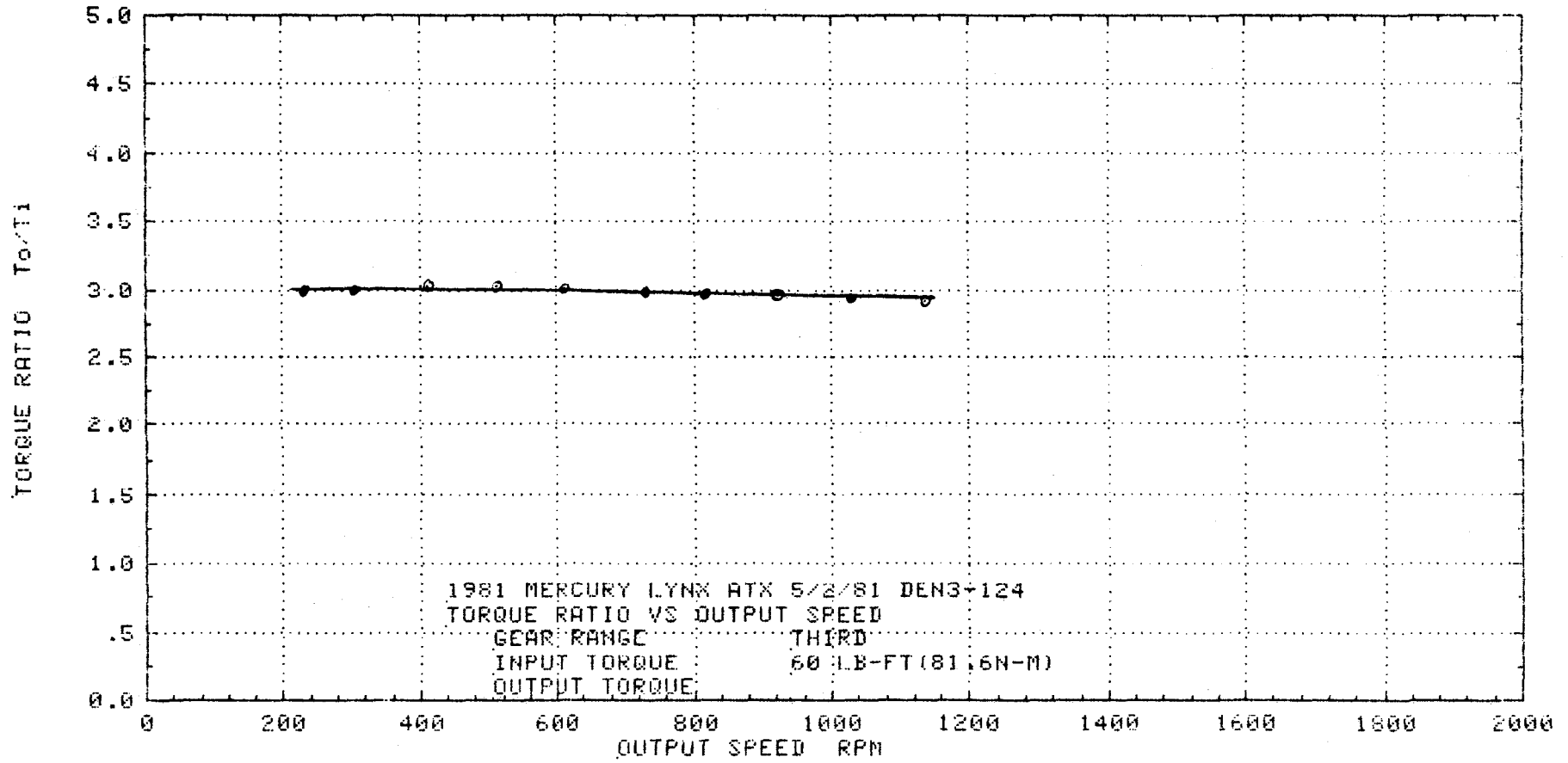

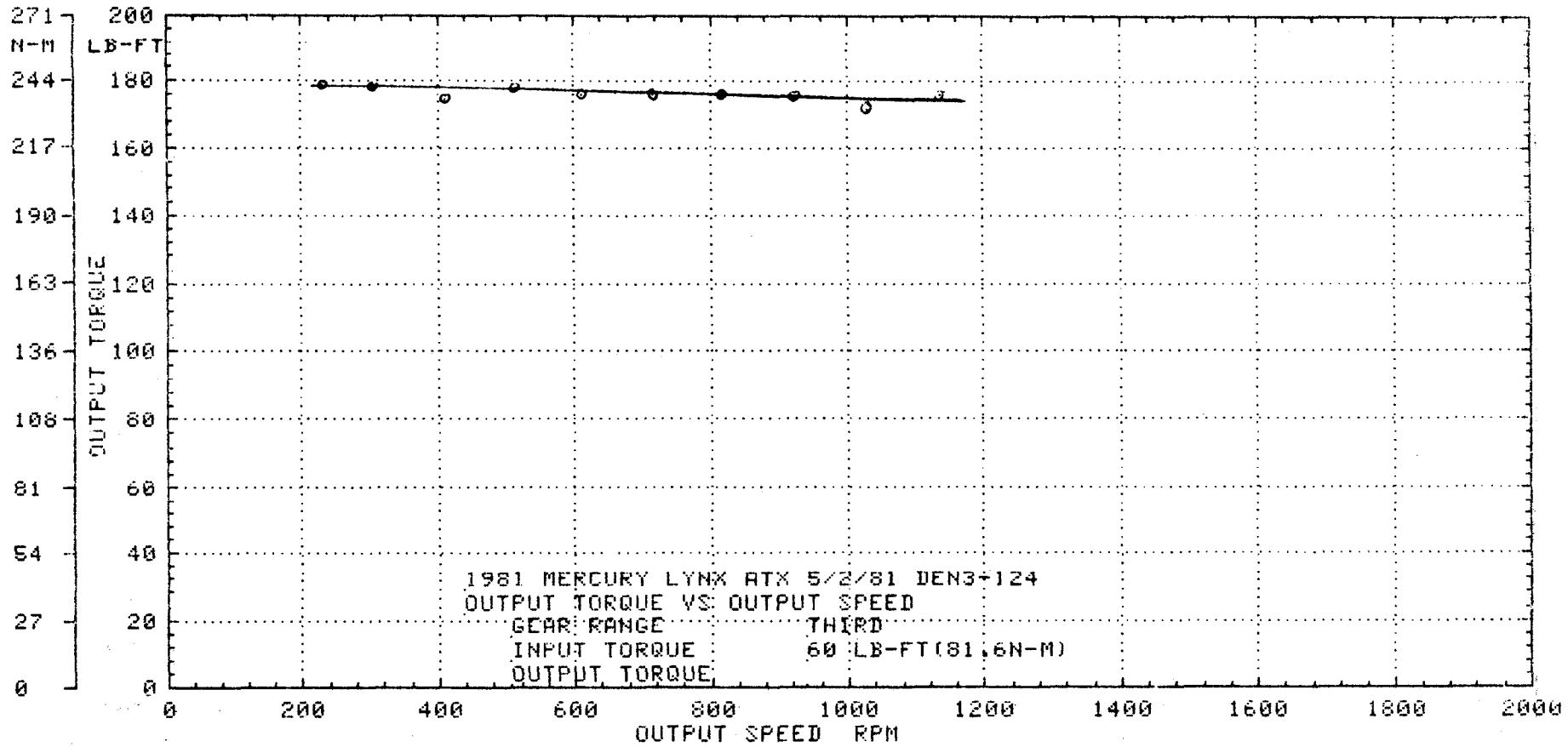

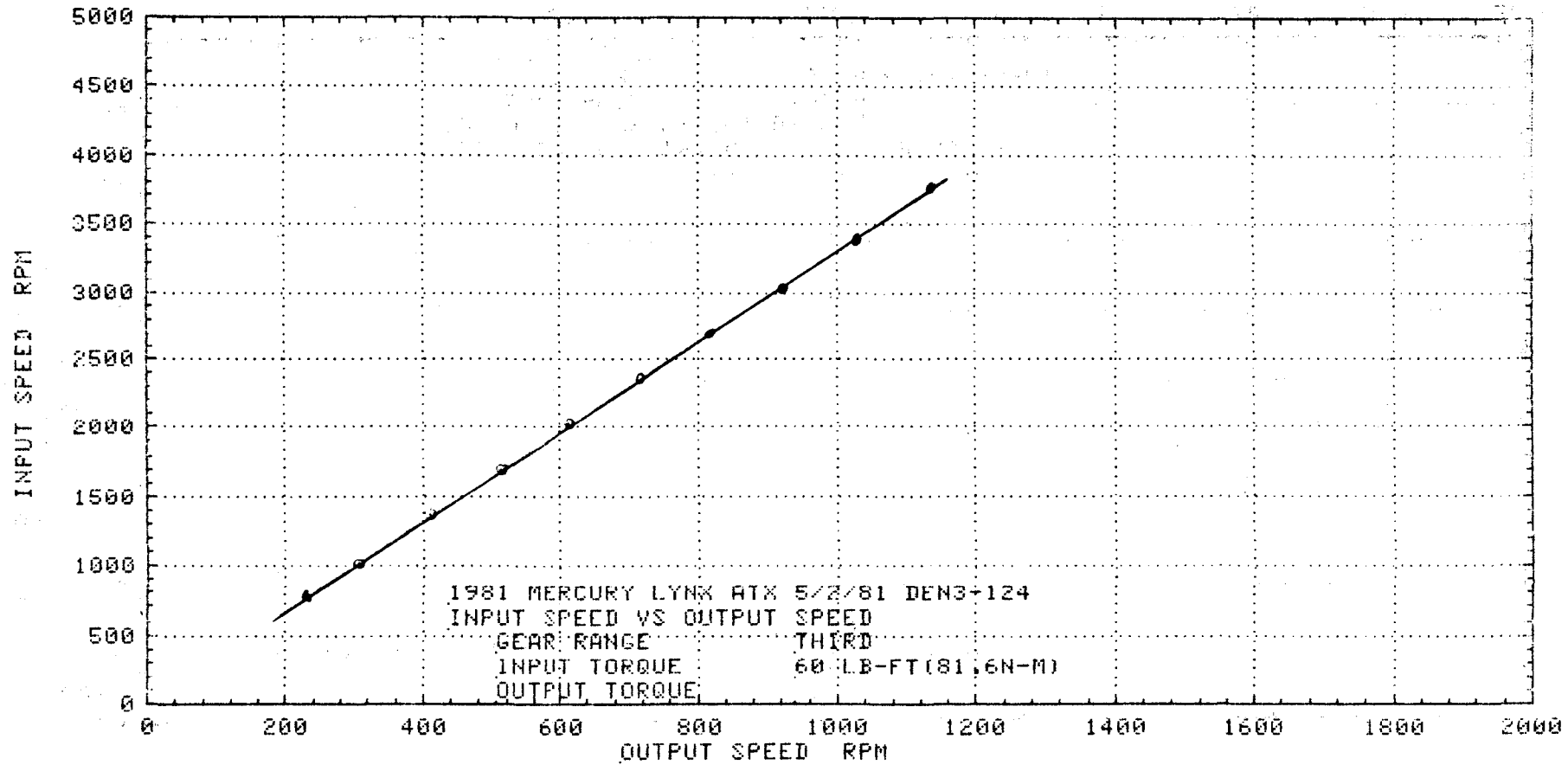

% EFFICIENCY

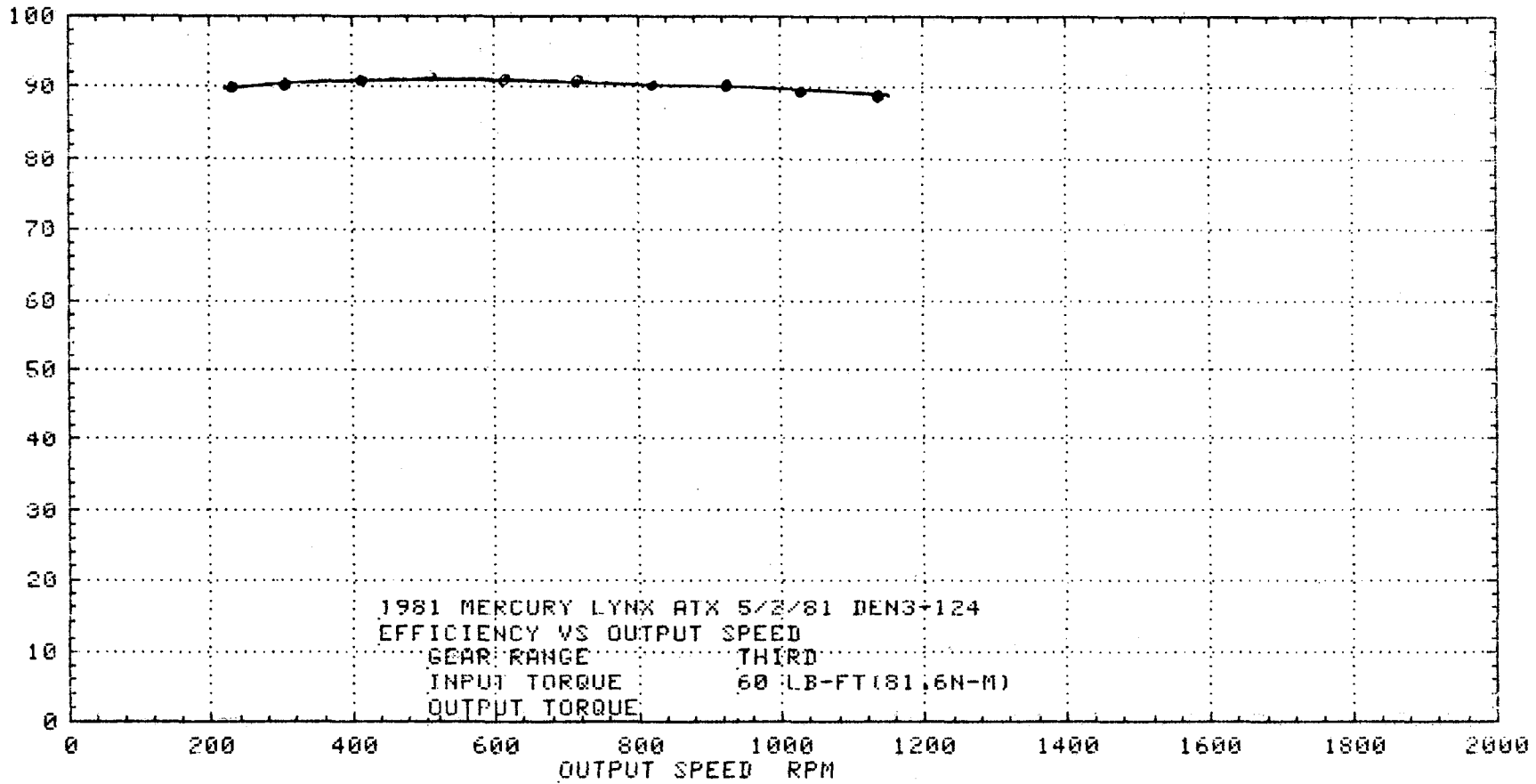

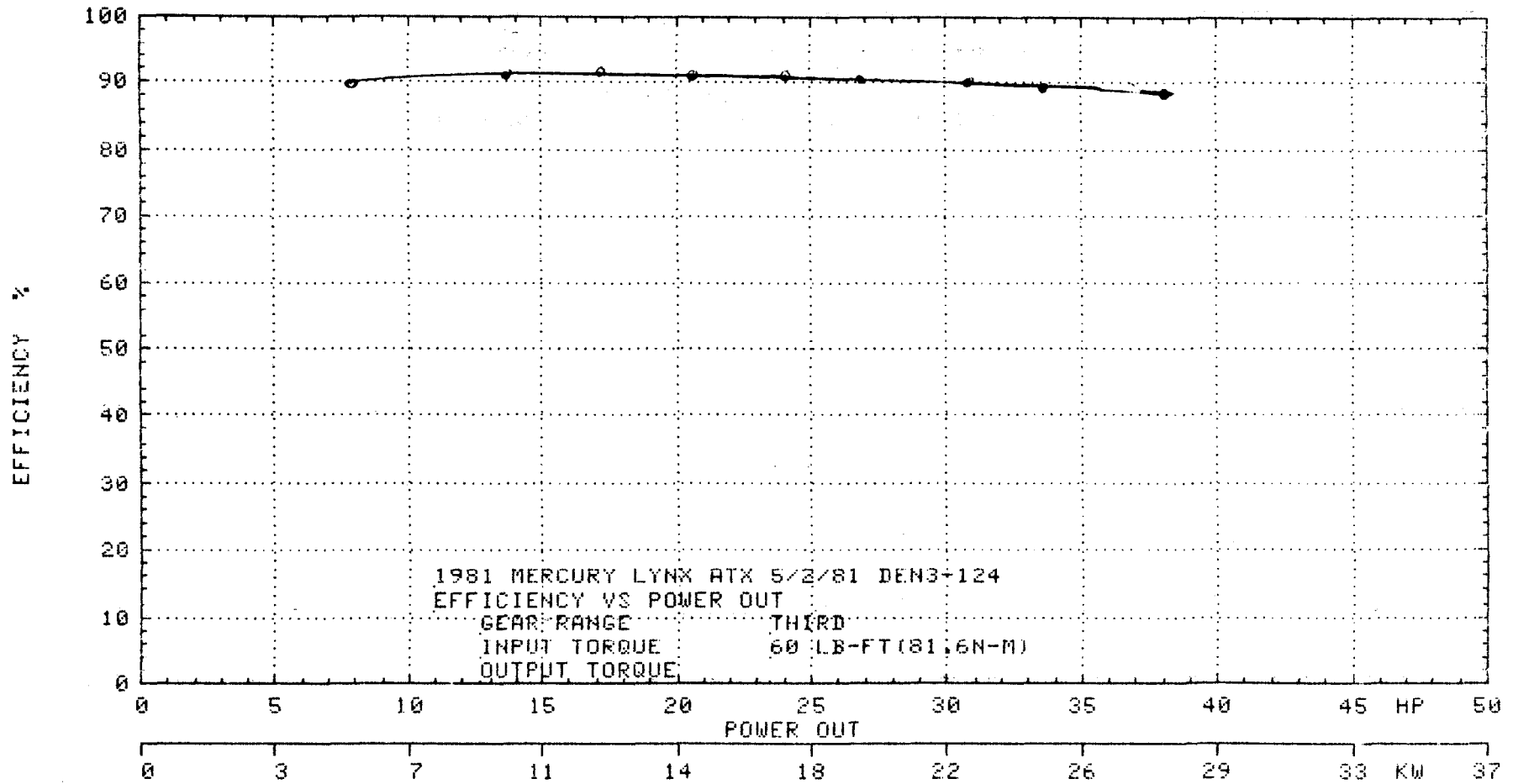

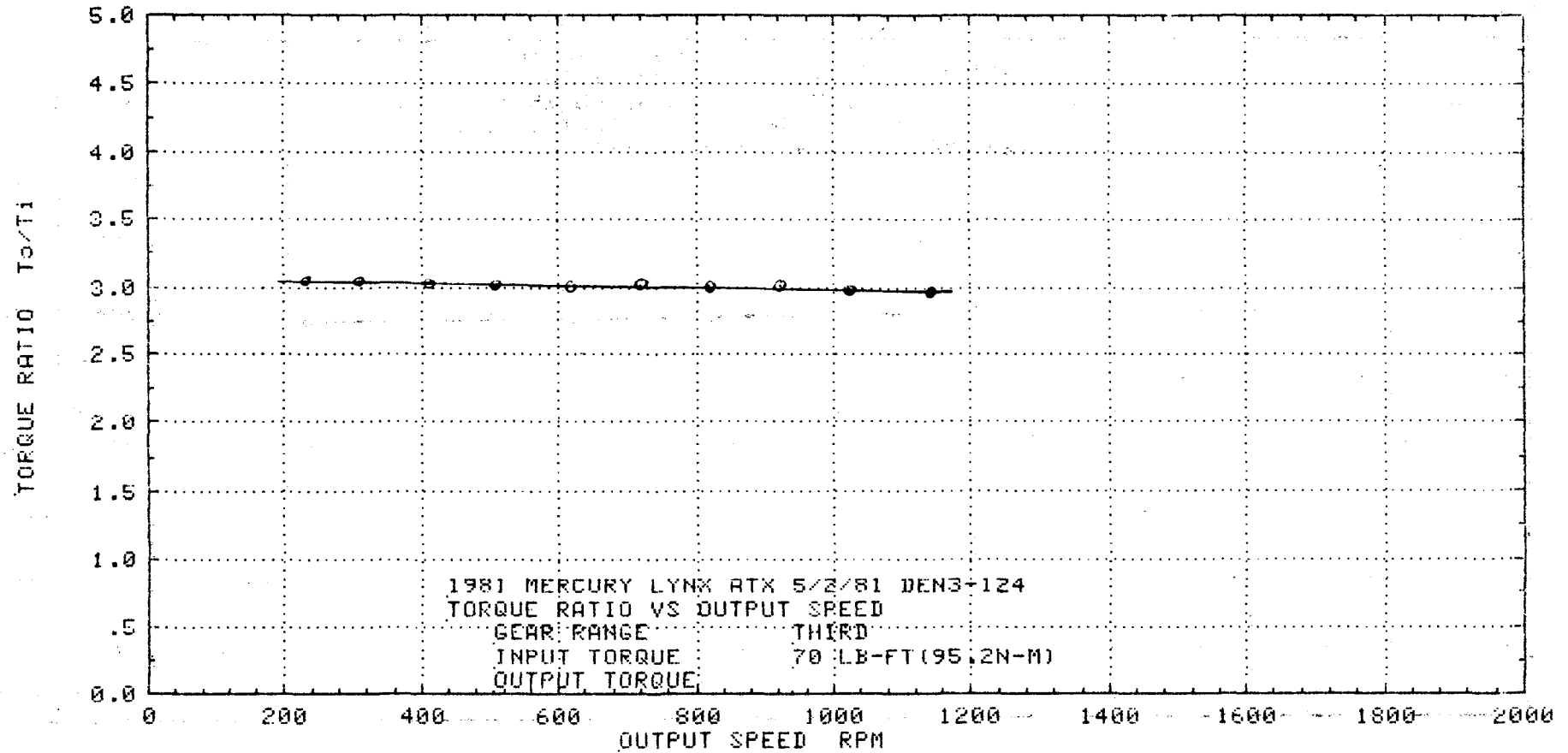

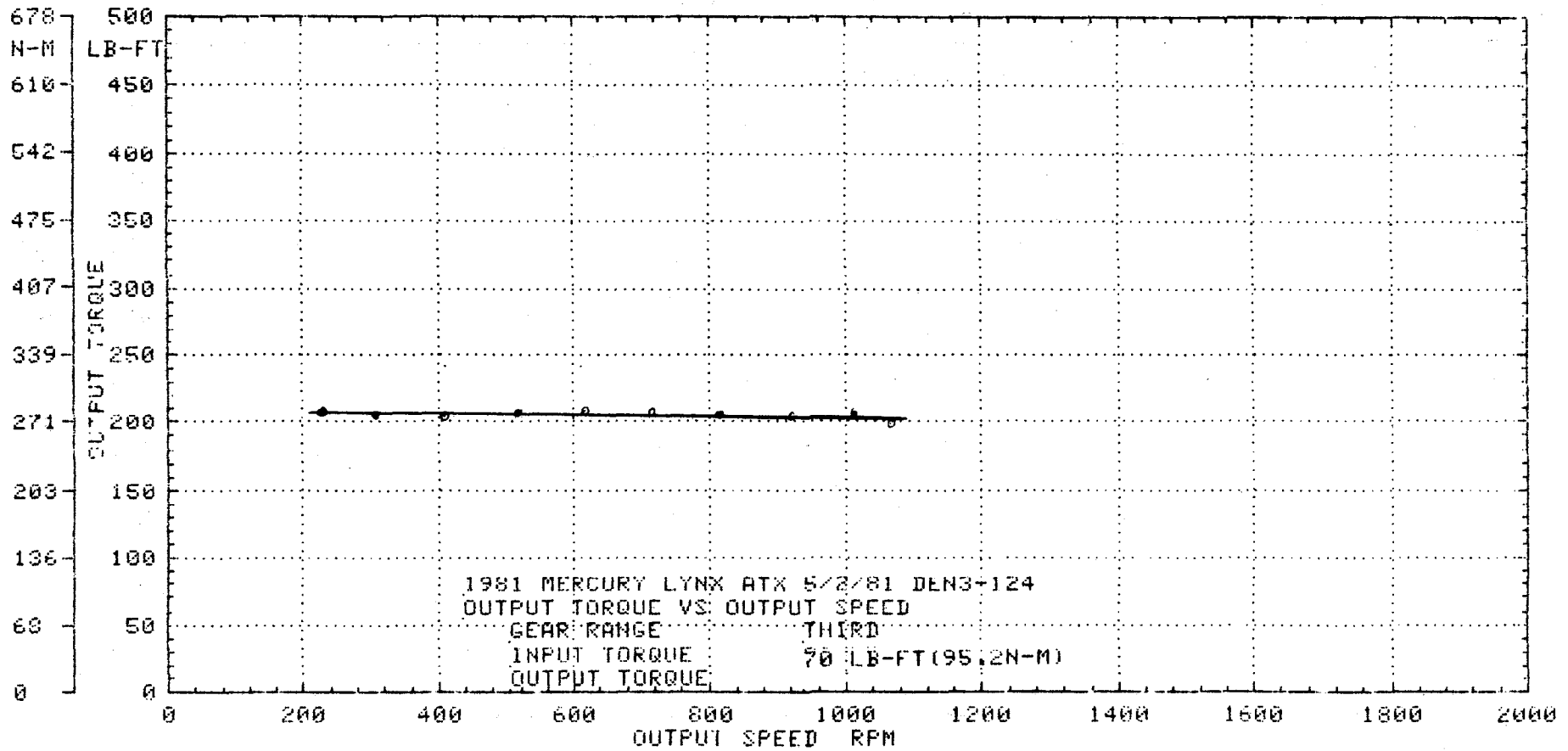

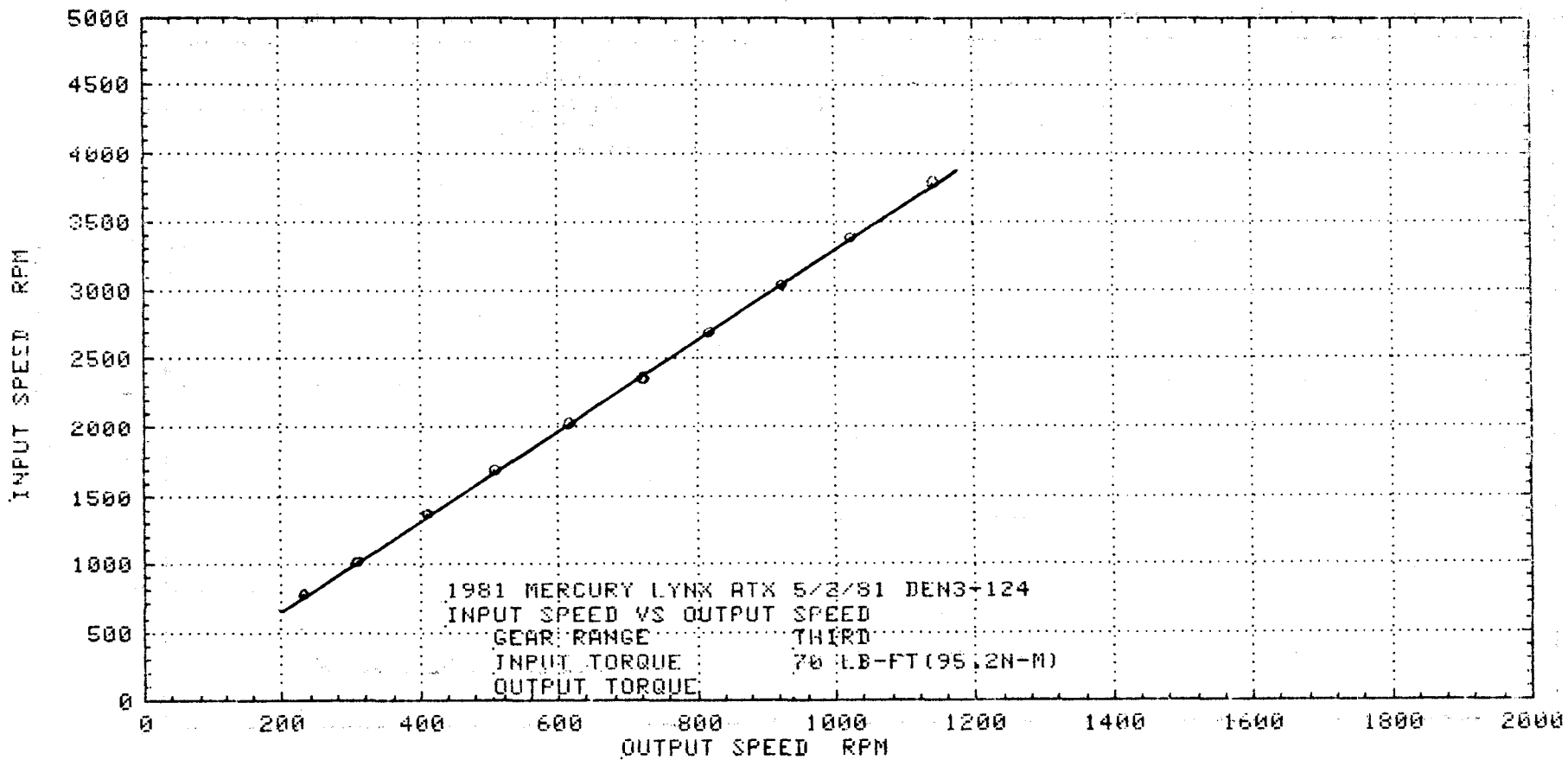

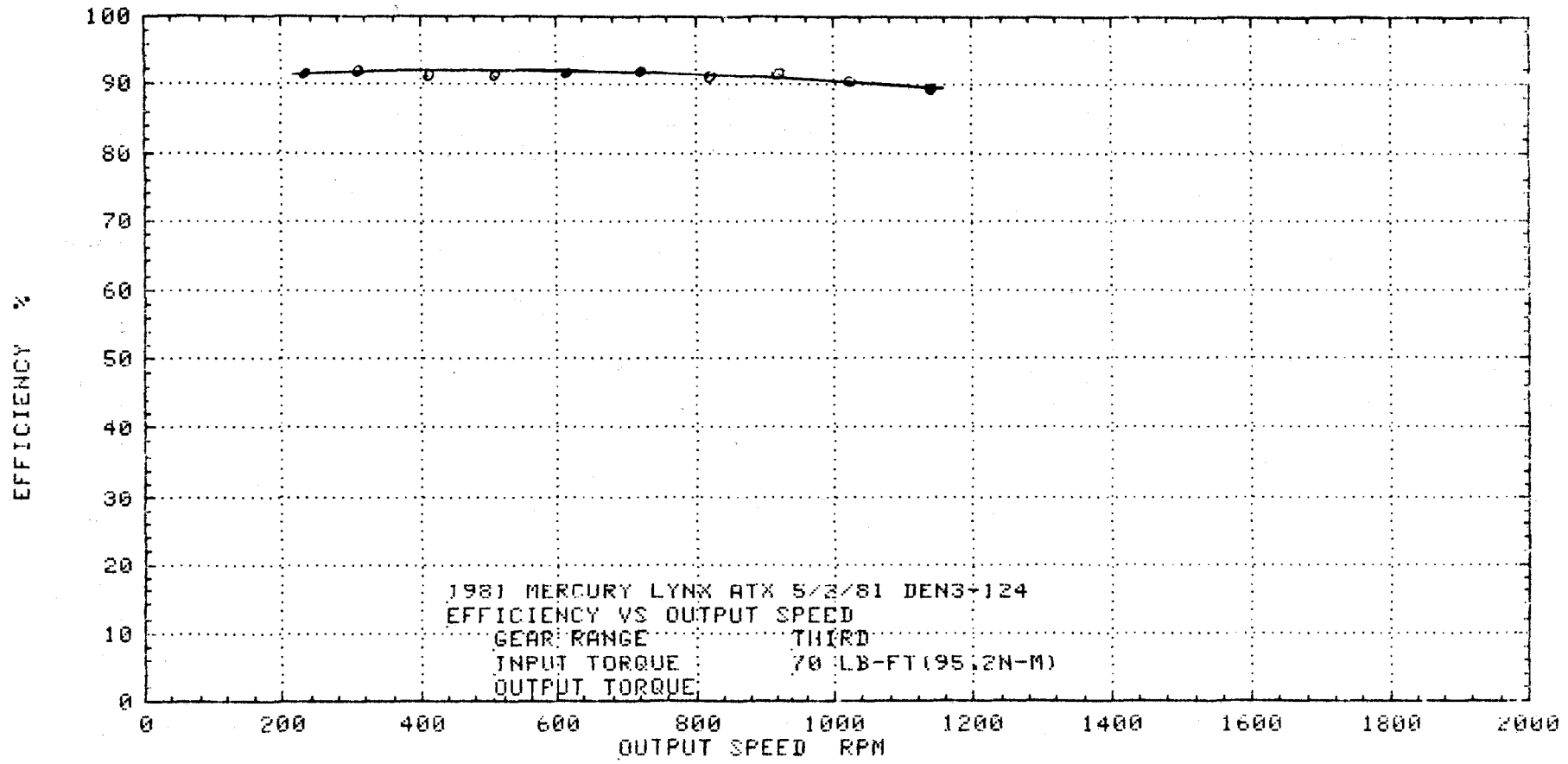

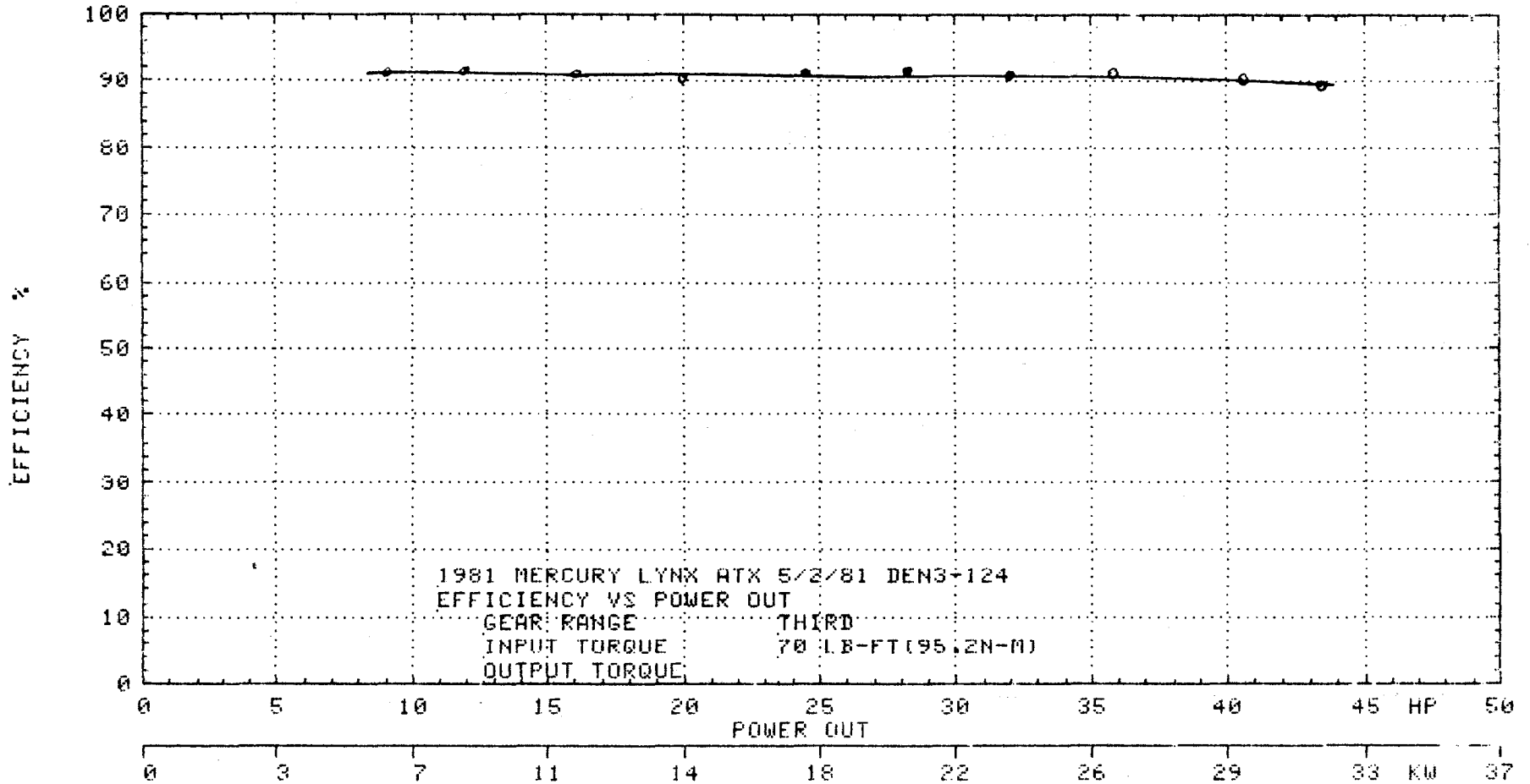

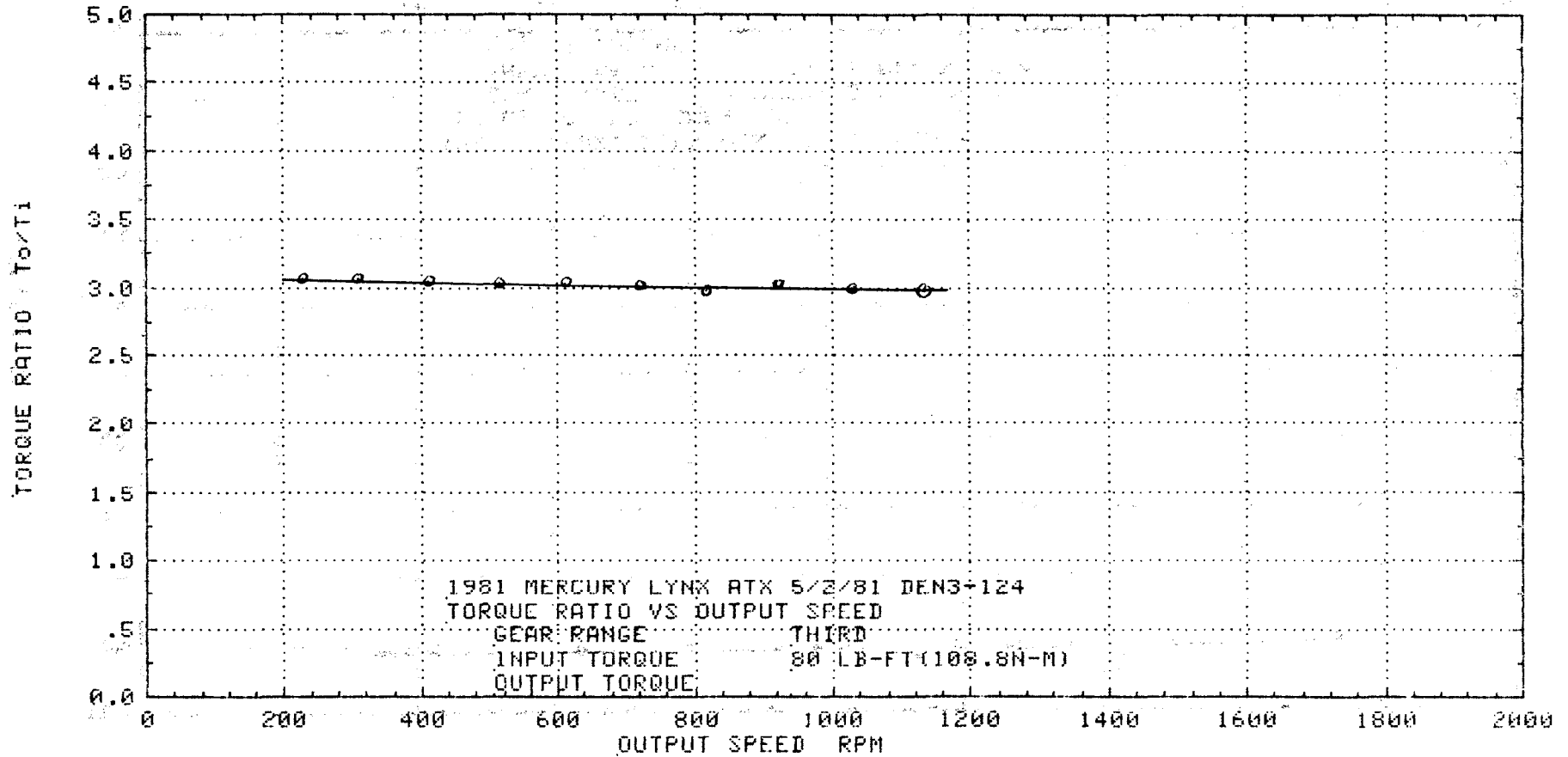

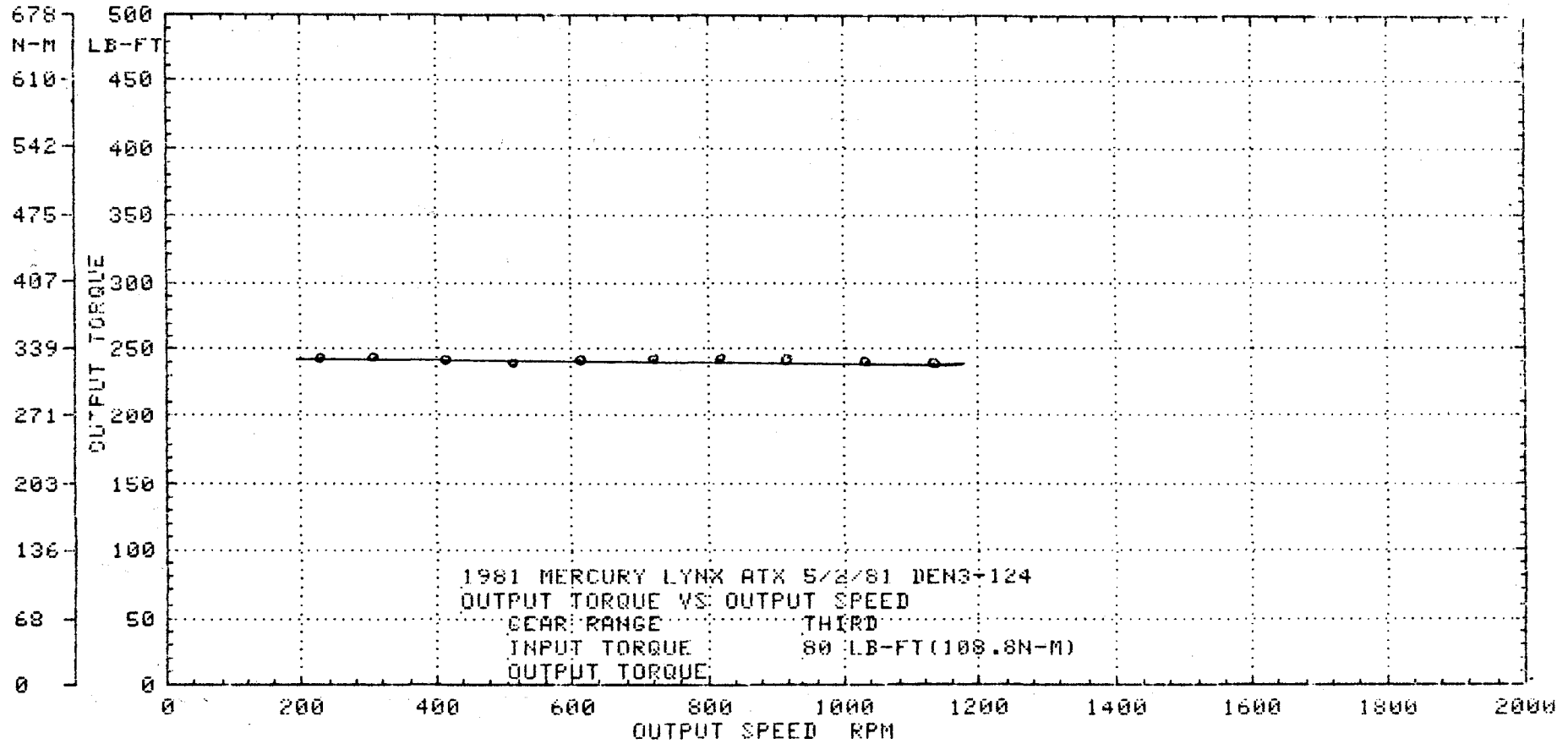

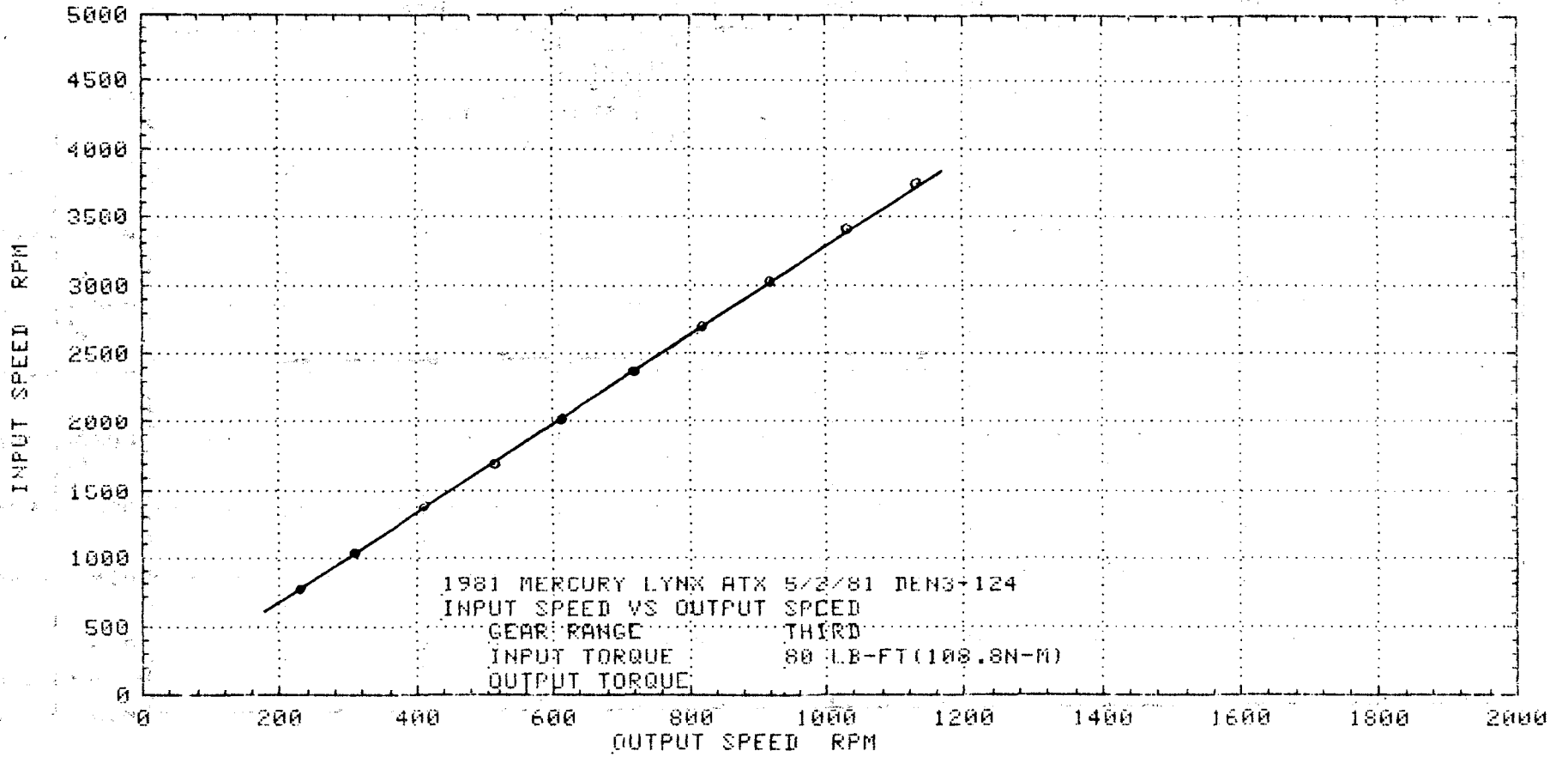

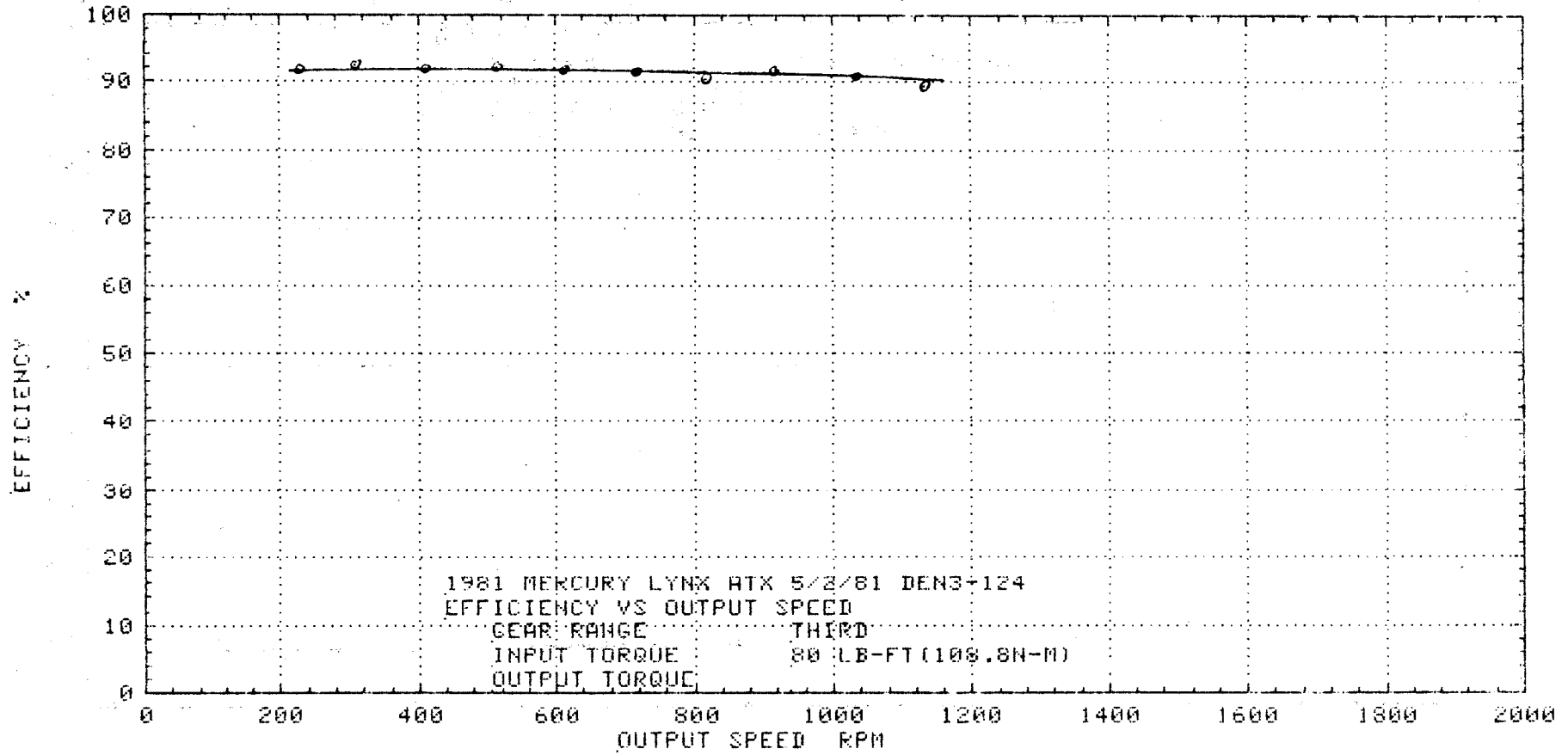

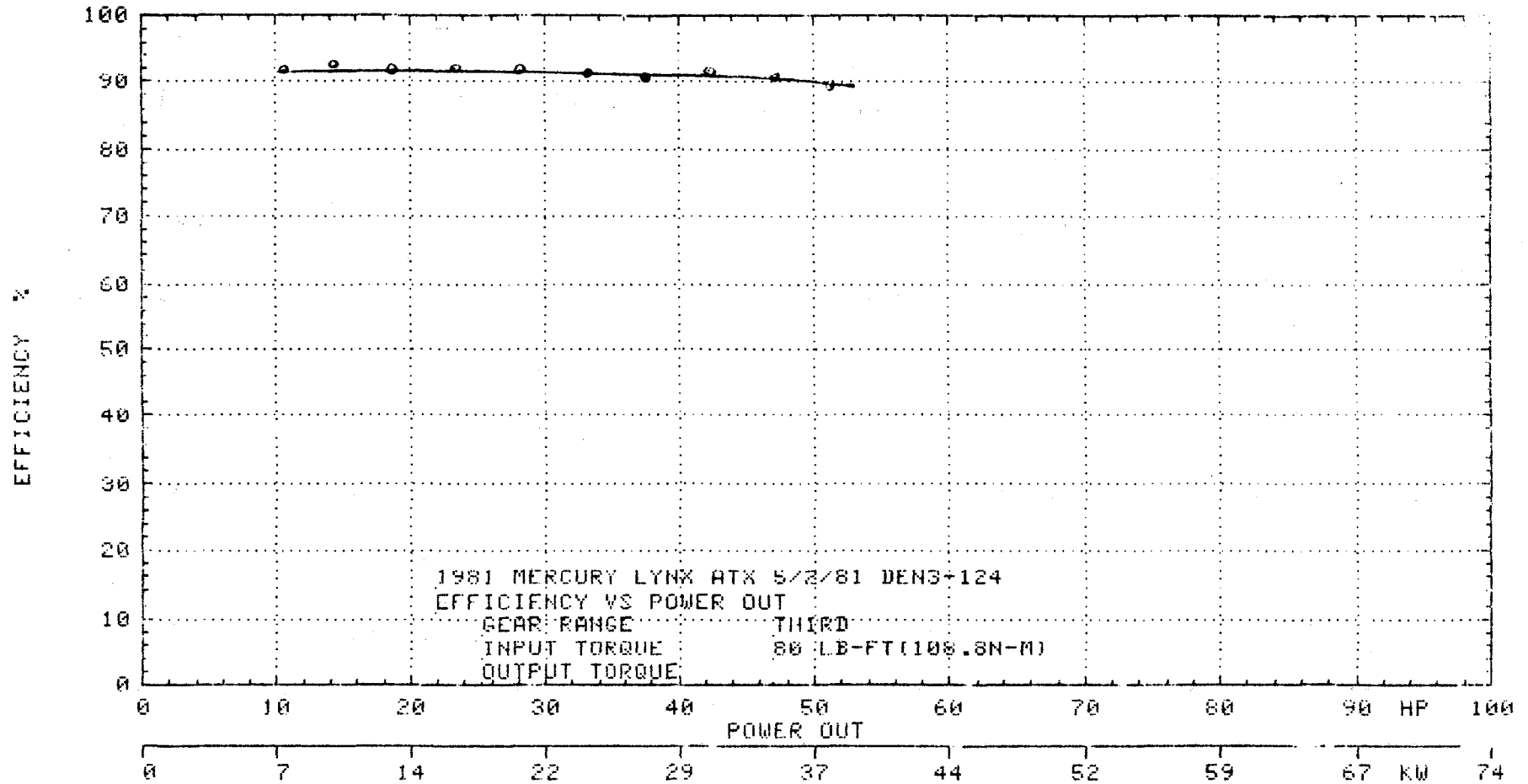

CROSS SECTIONAL ROAD LOAD PERFORMANCE

3rd Gear

Graphs Contained in This Section

Torque Ratio -vs- Output Speed

Output Torque -vs- Output Speed

Input Speed -vs- Output Speed

Efficiency -vs- Output Speed

Efficiency -vs- Power Out

154

Torque In

Speed In

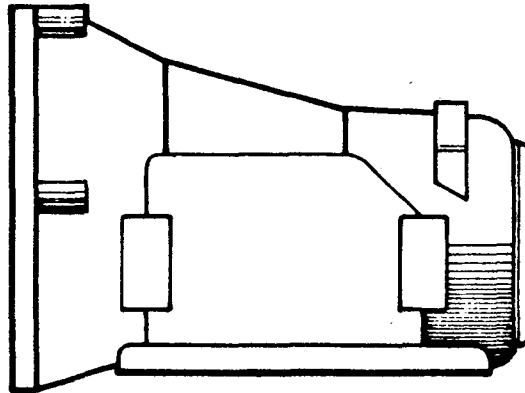

Torque Out

Speed Out

Drive Performance Tests

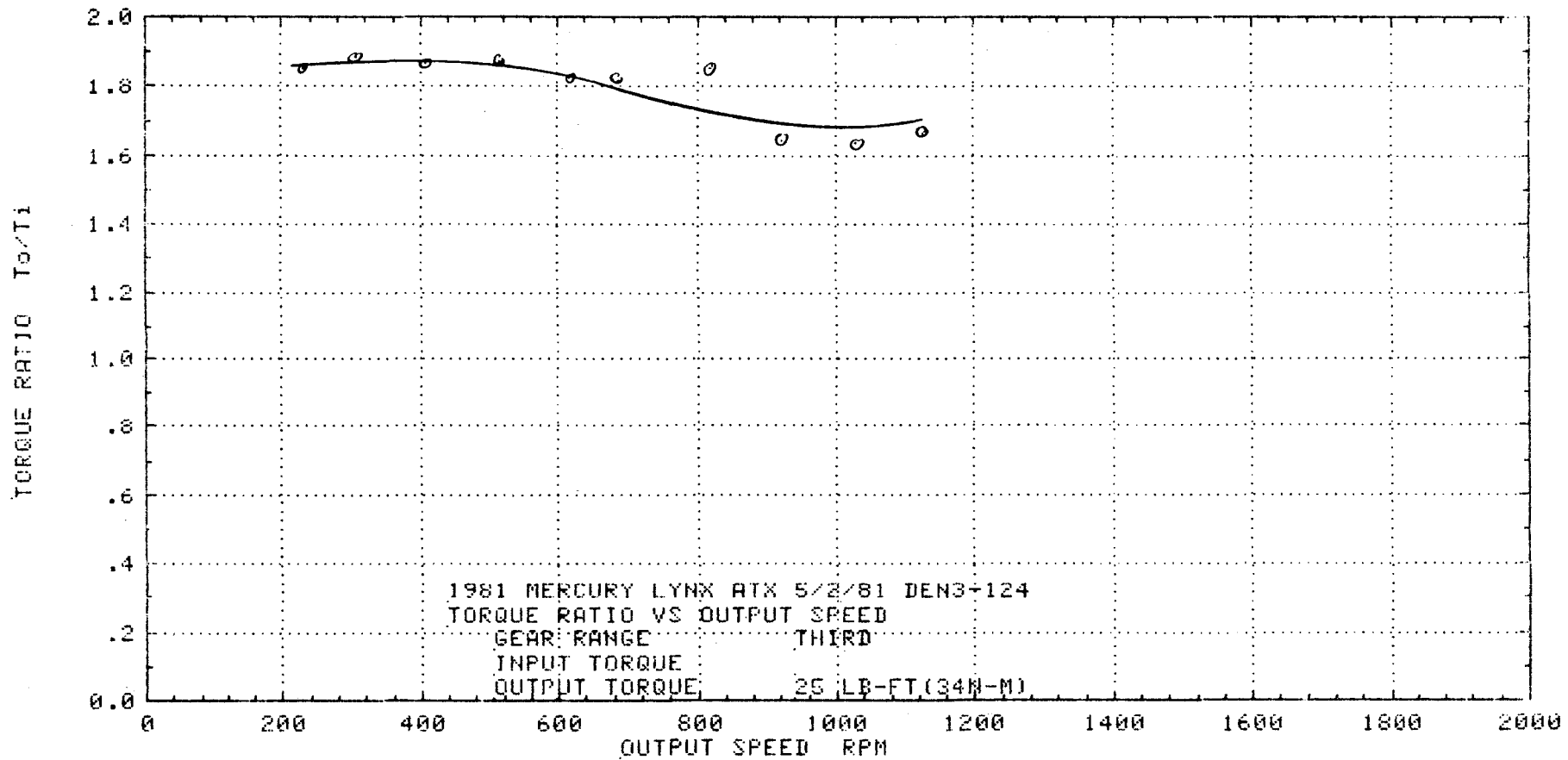

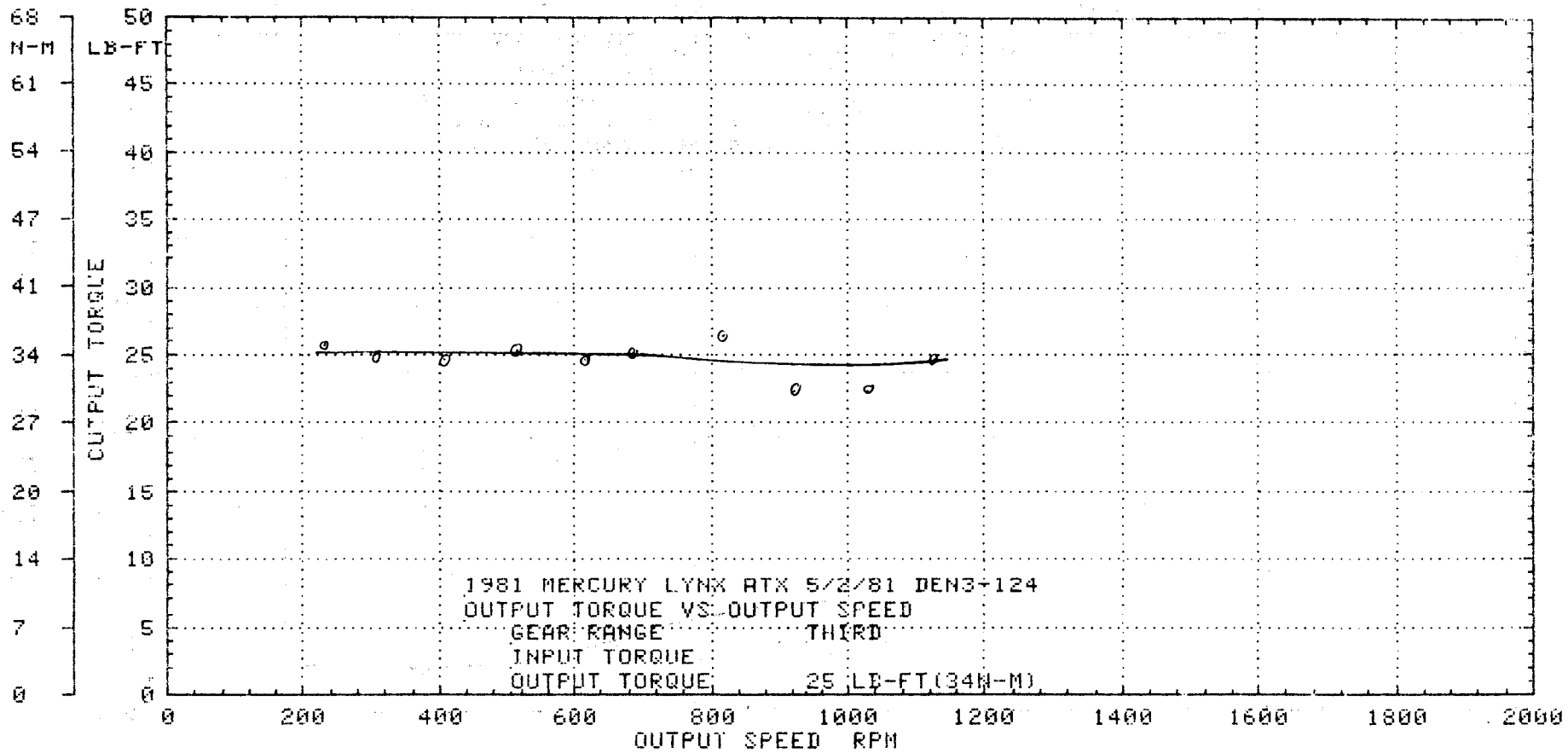

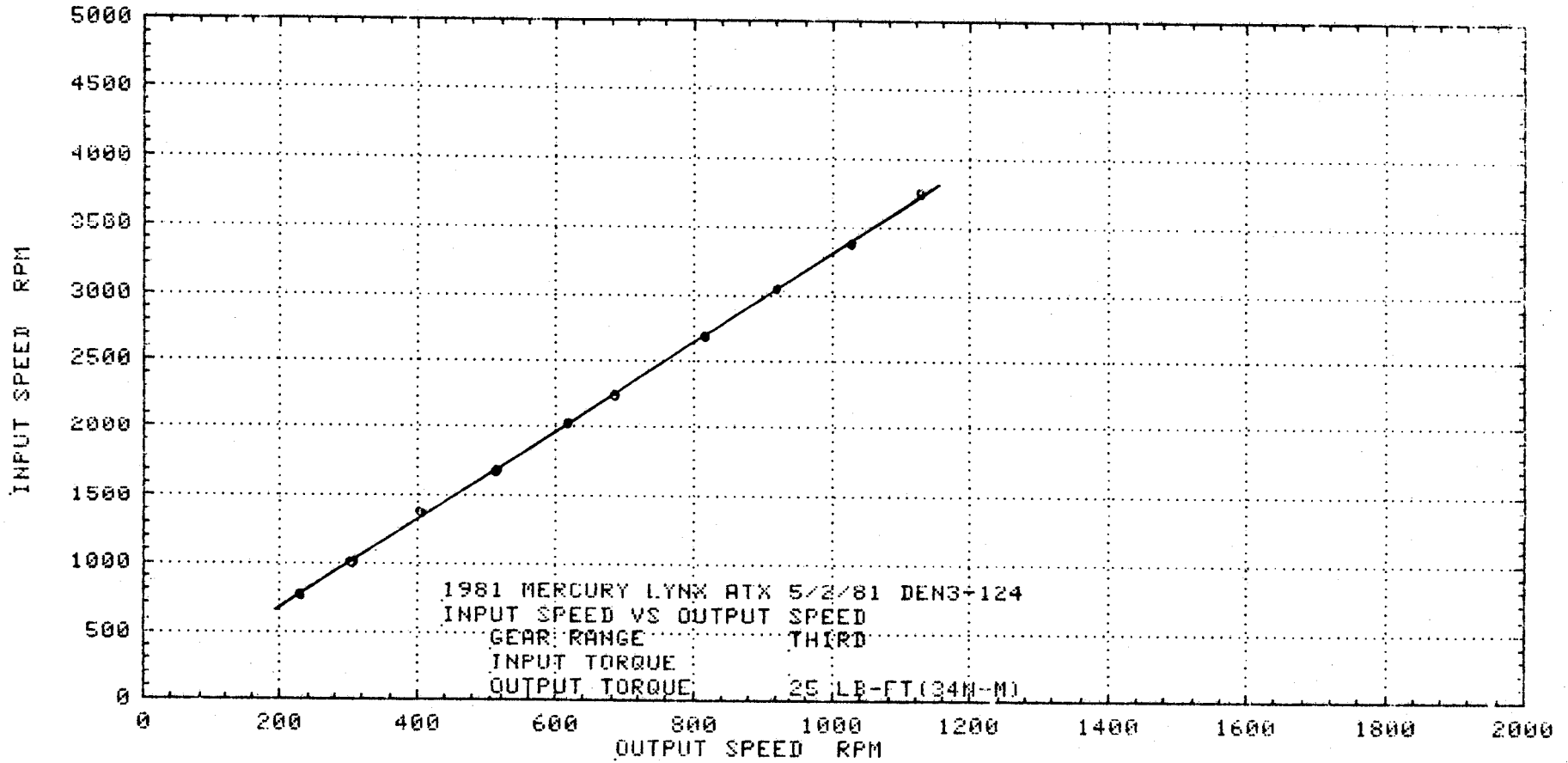

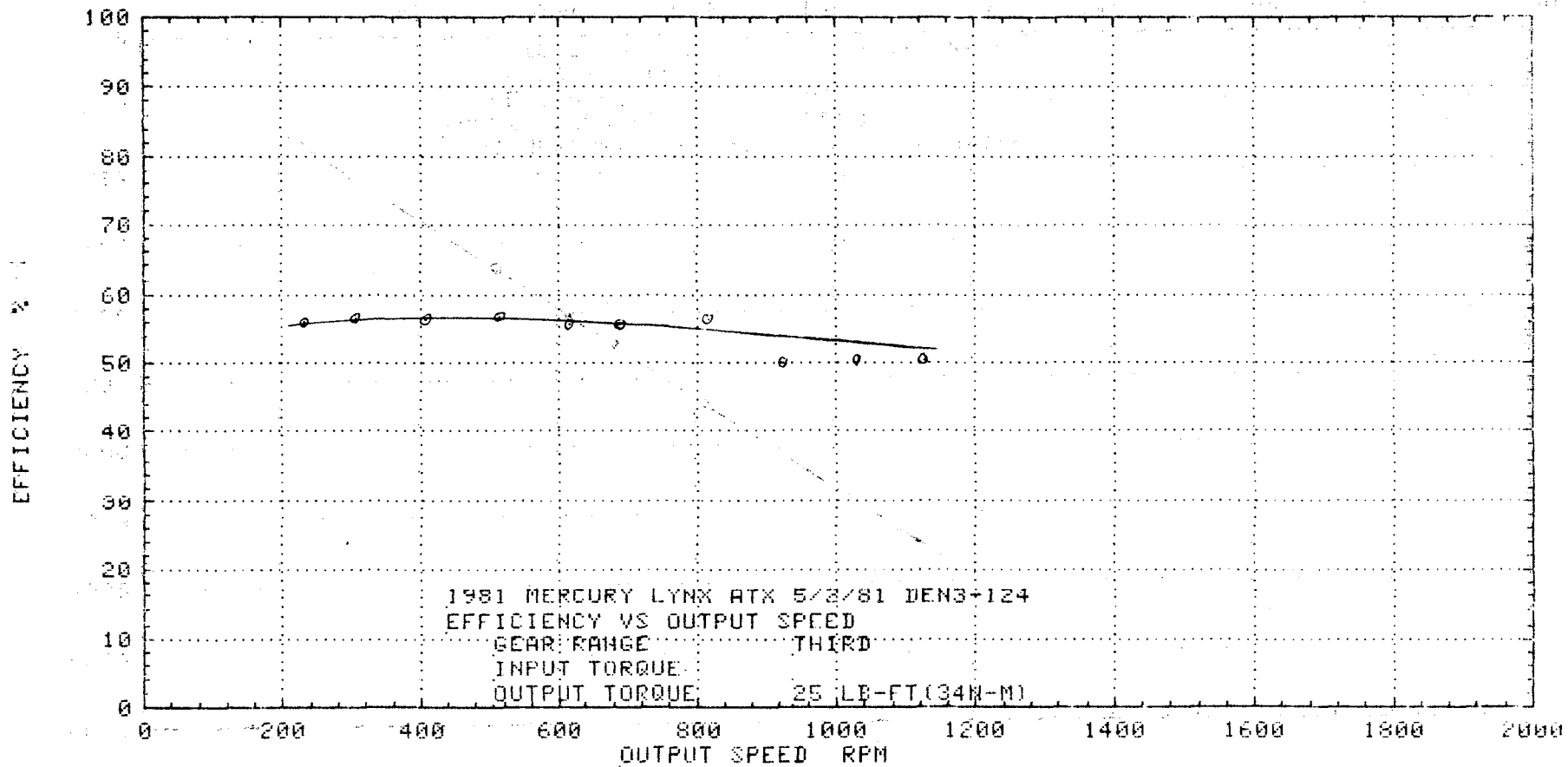

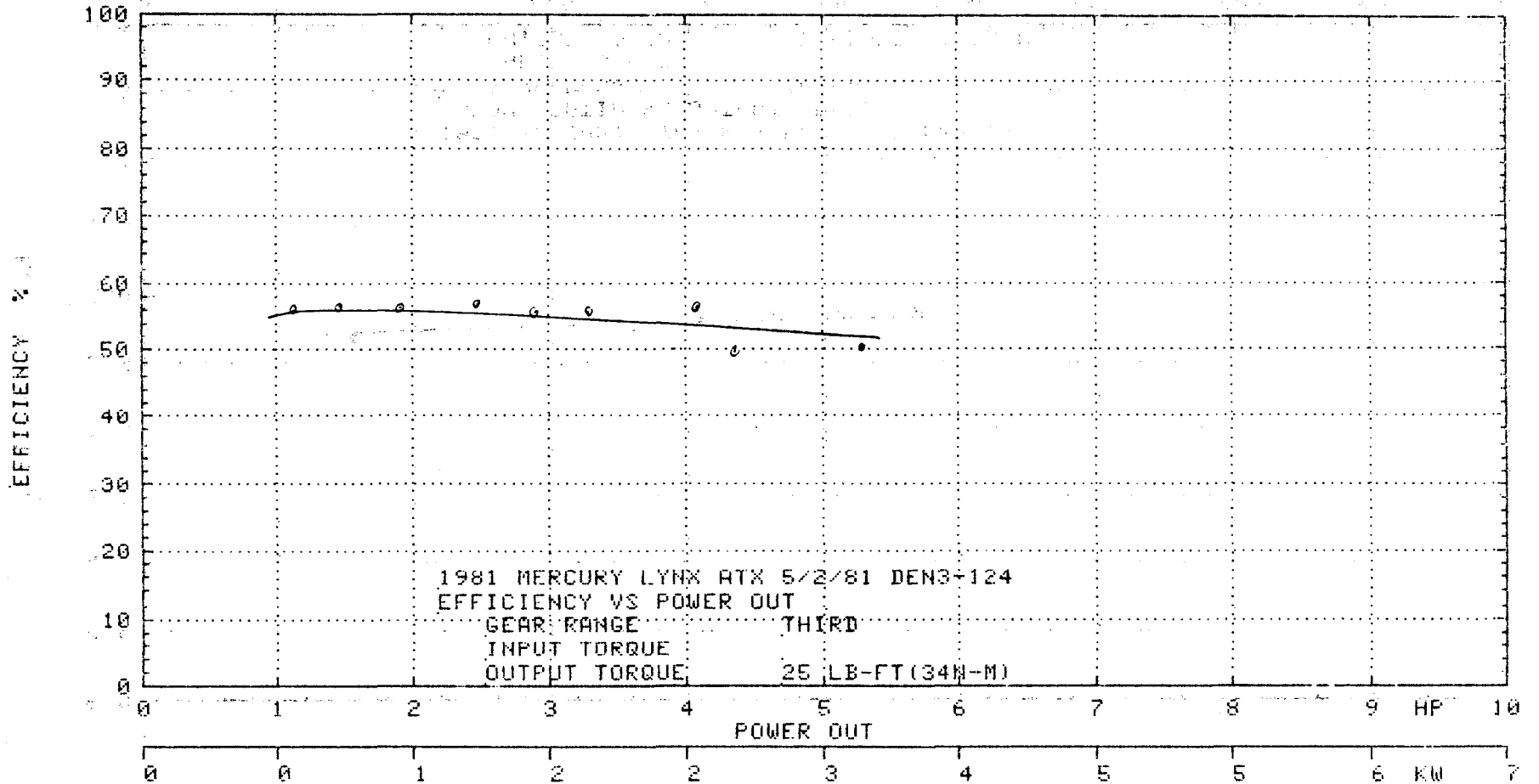

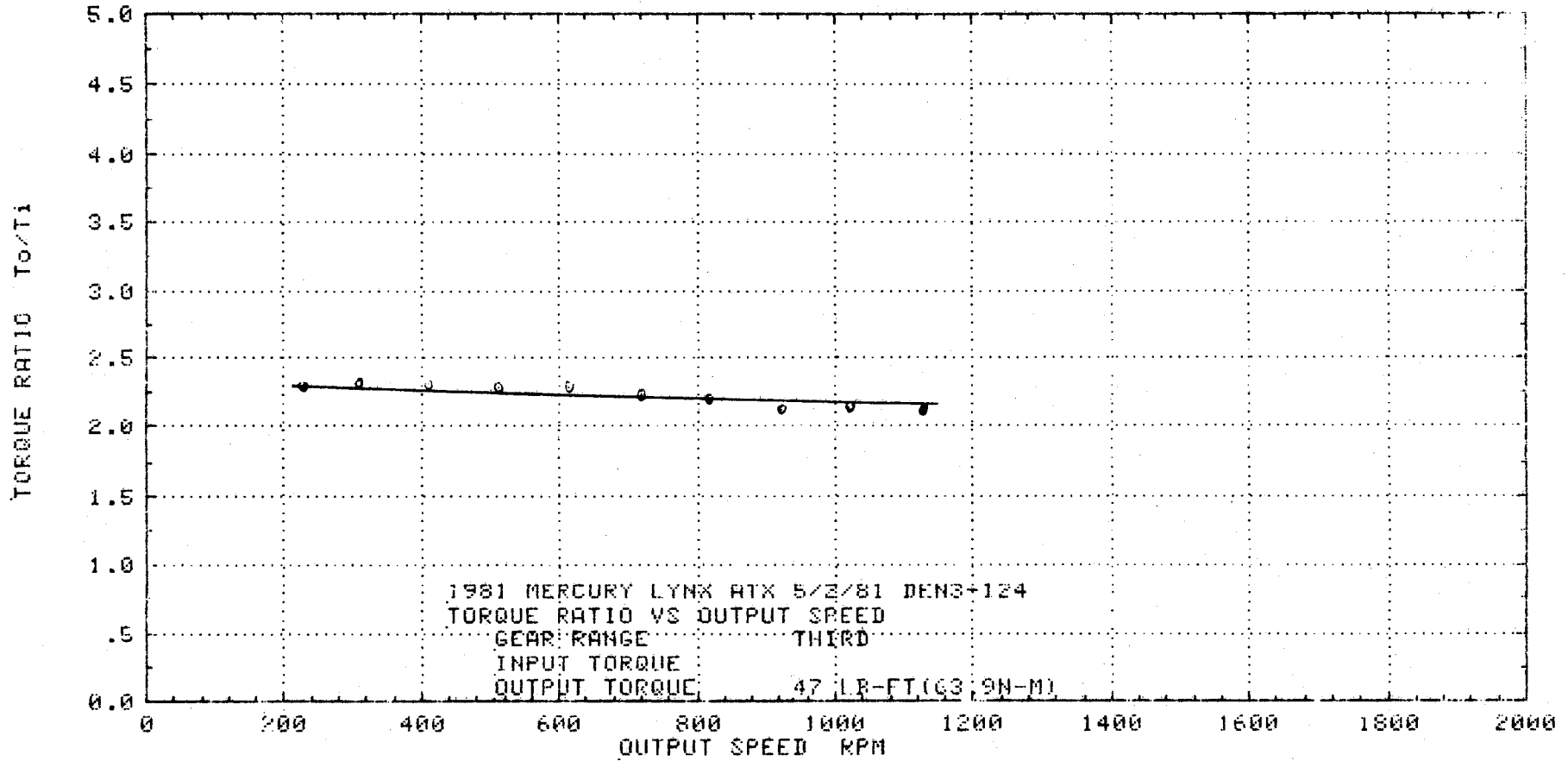

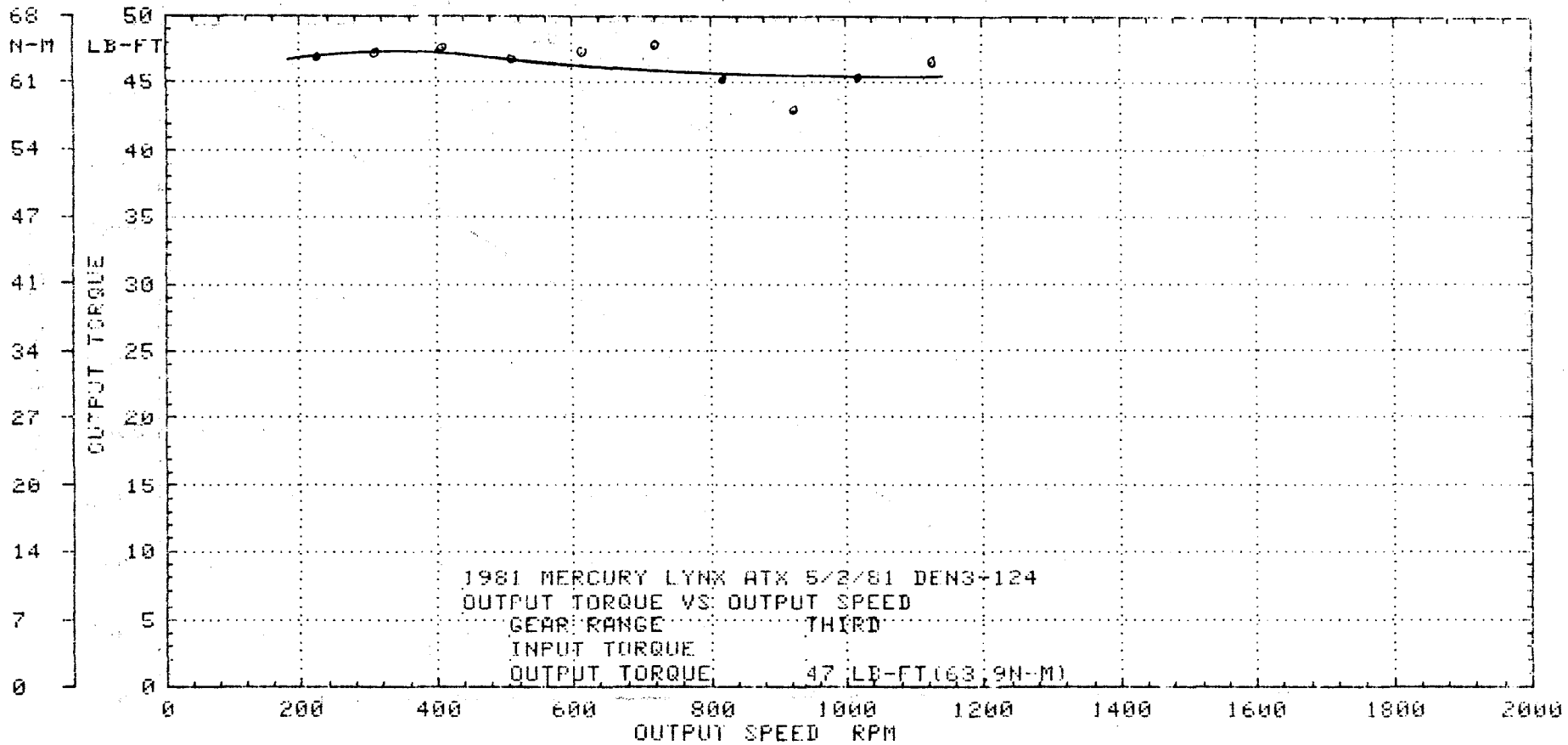

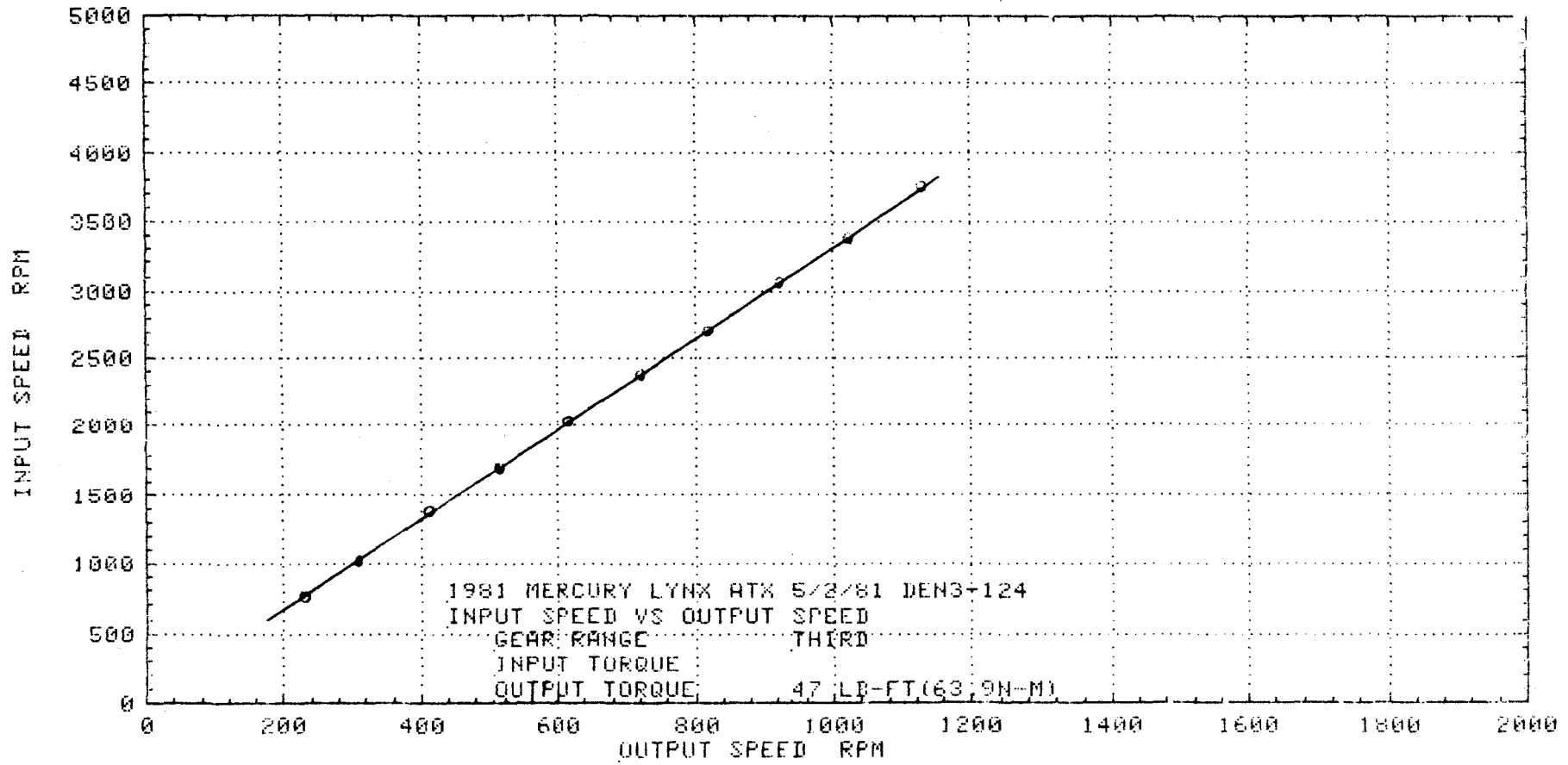

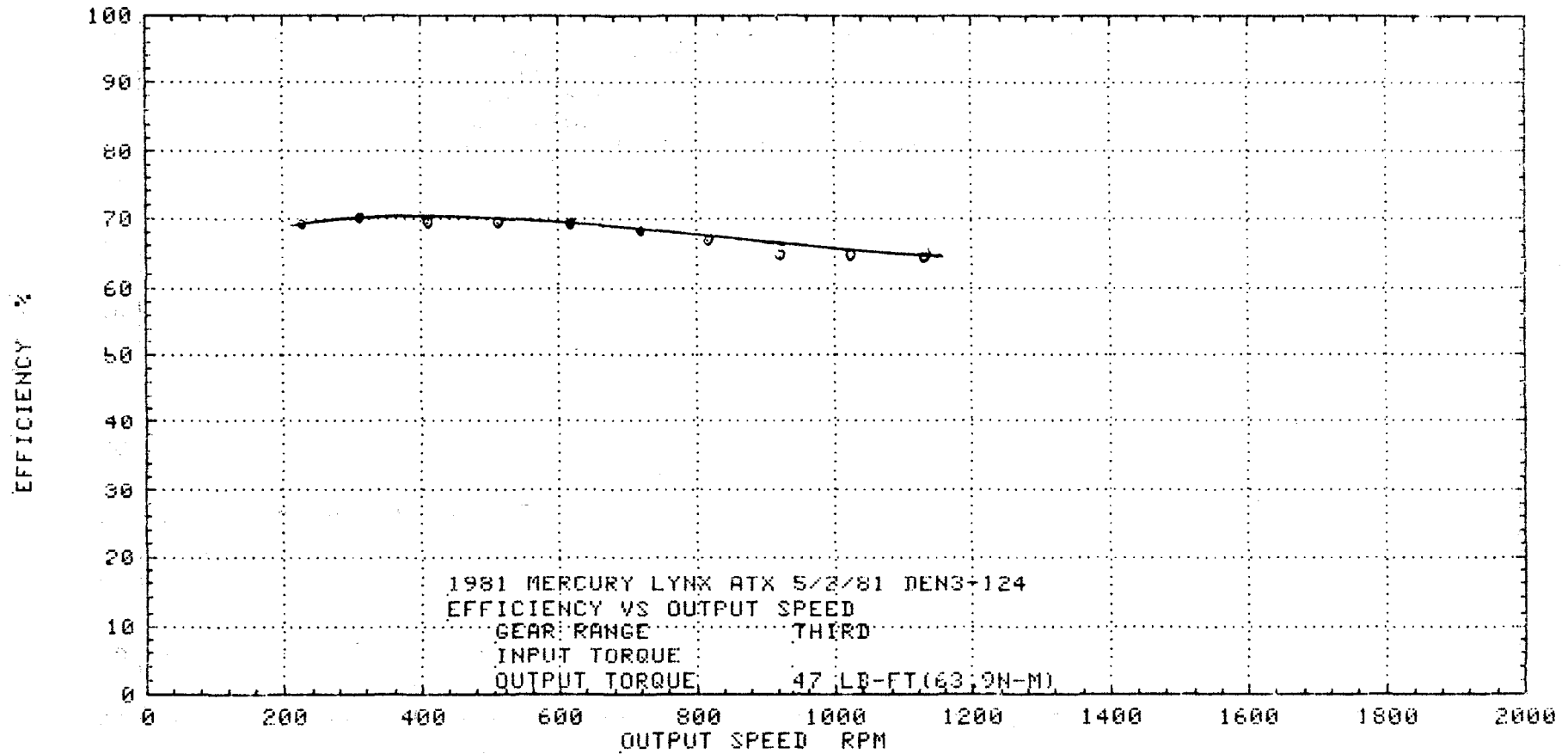

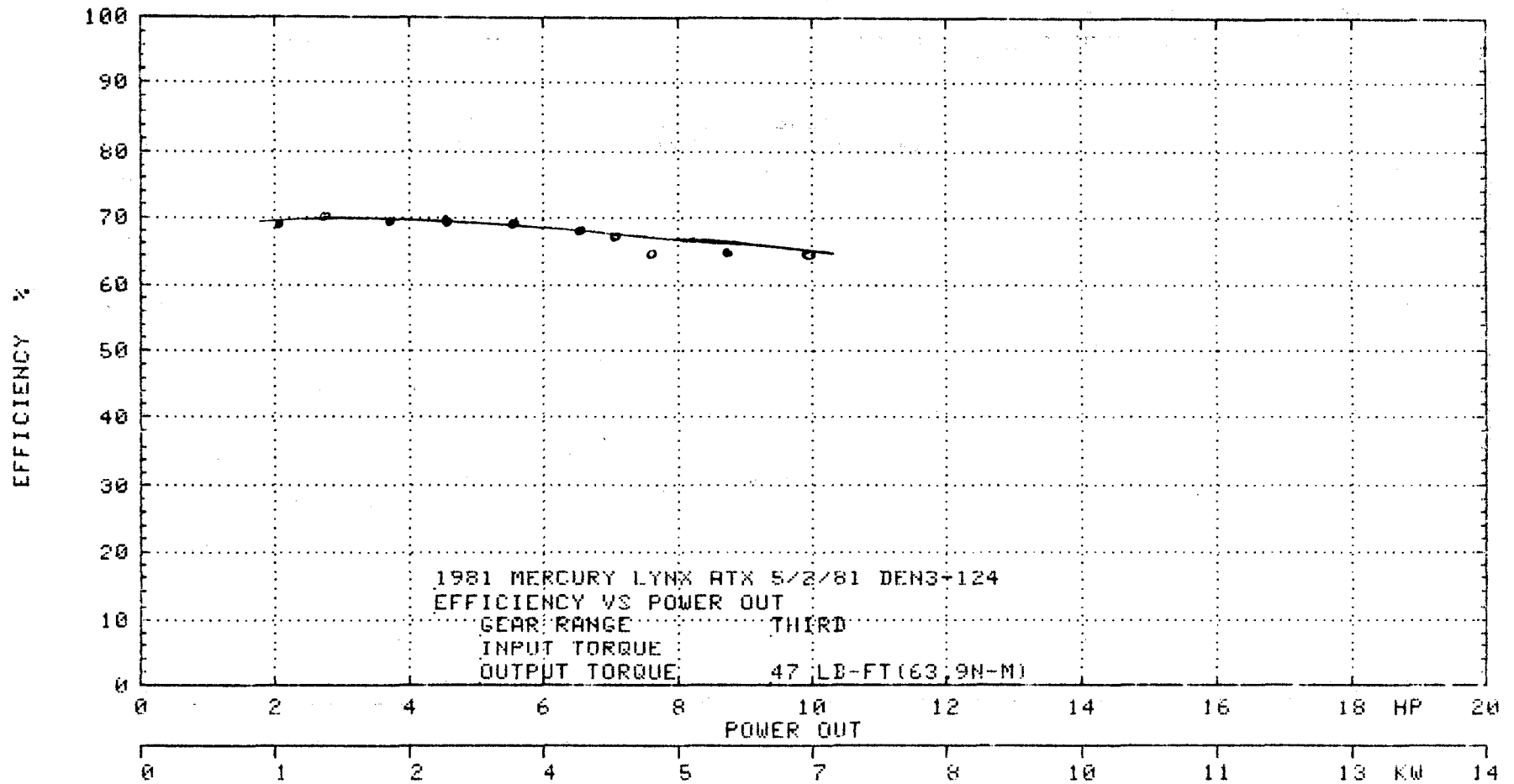

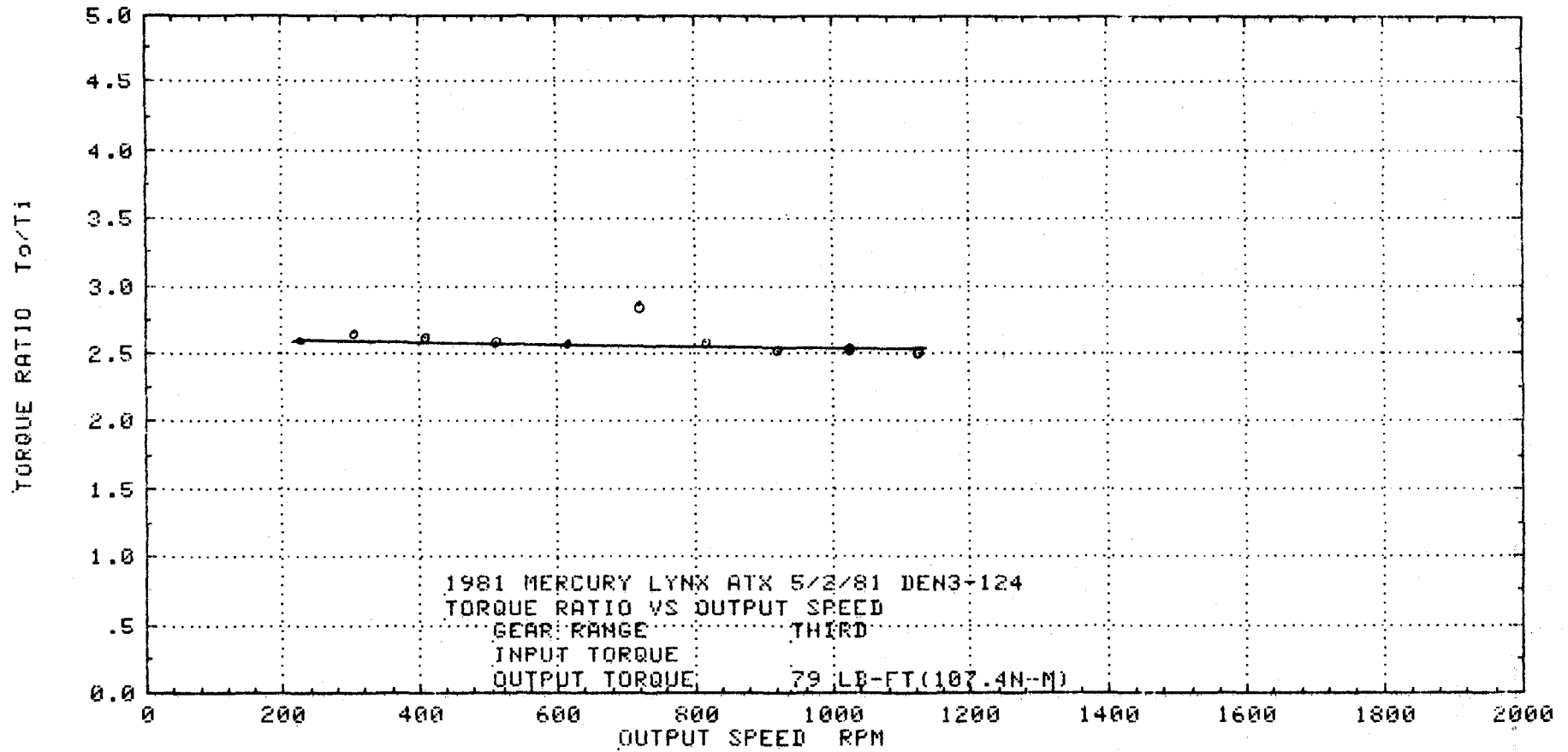

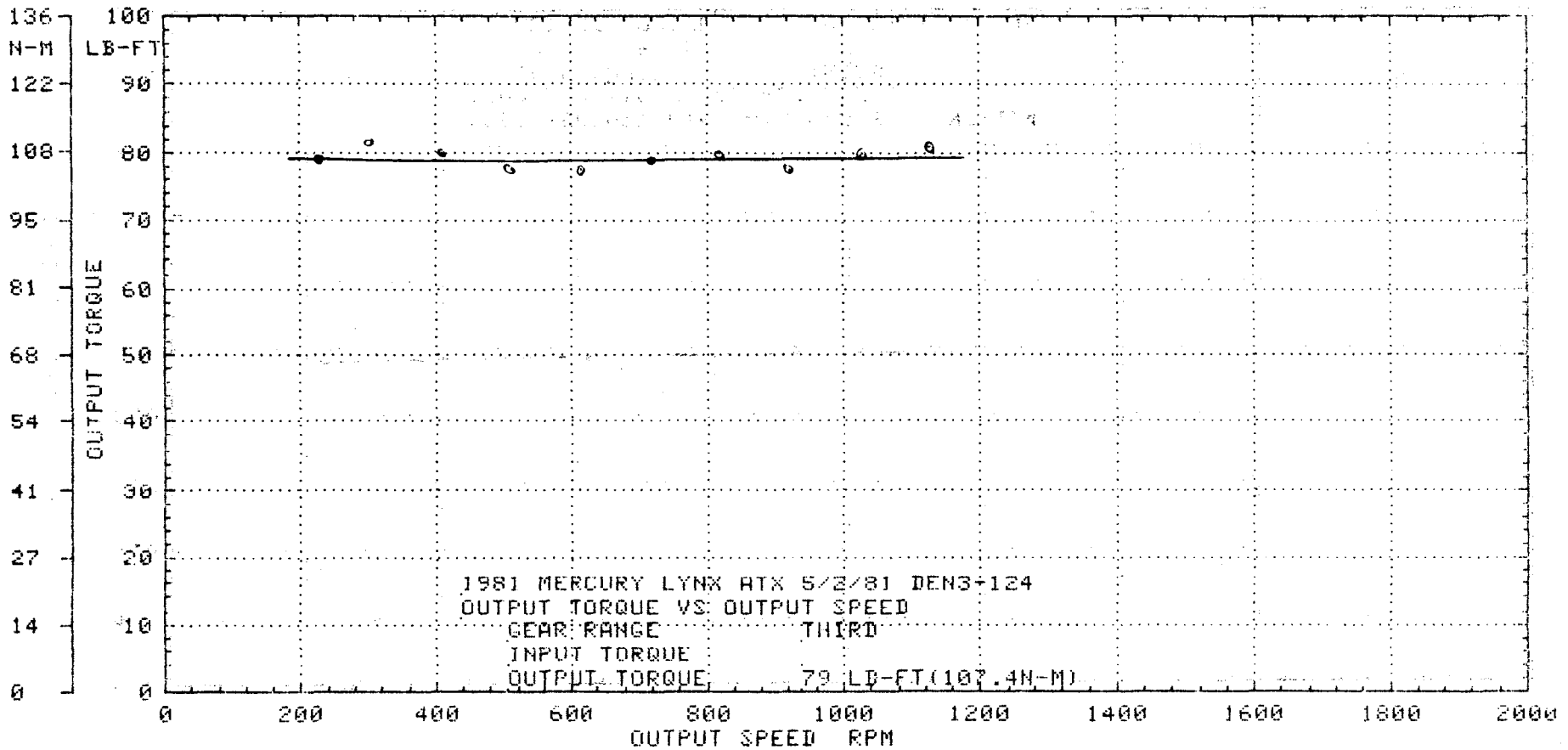

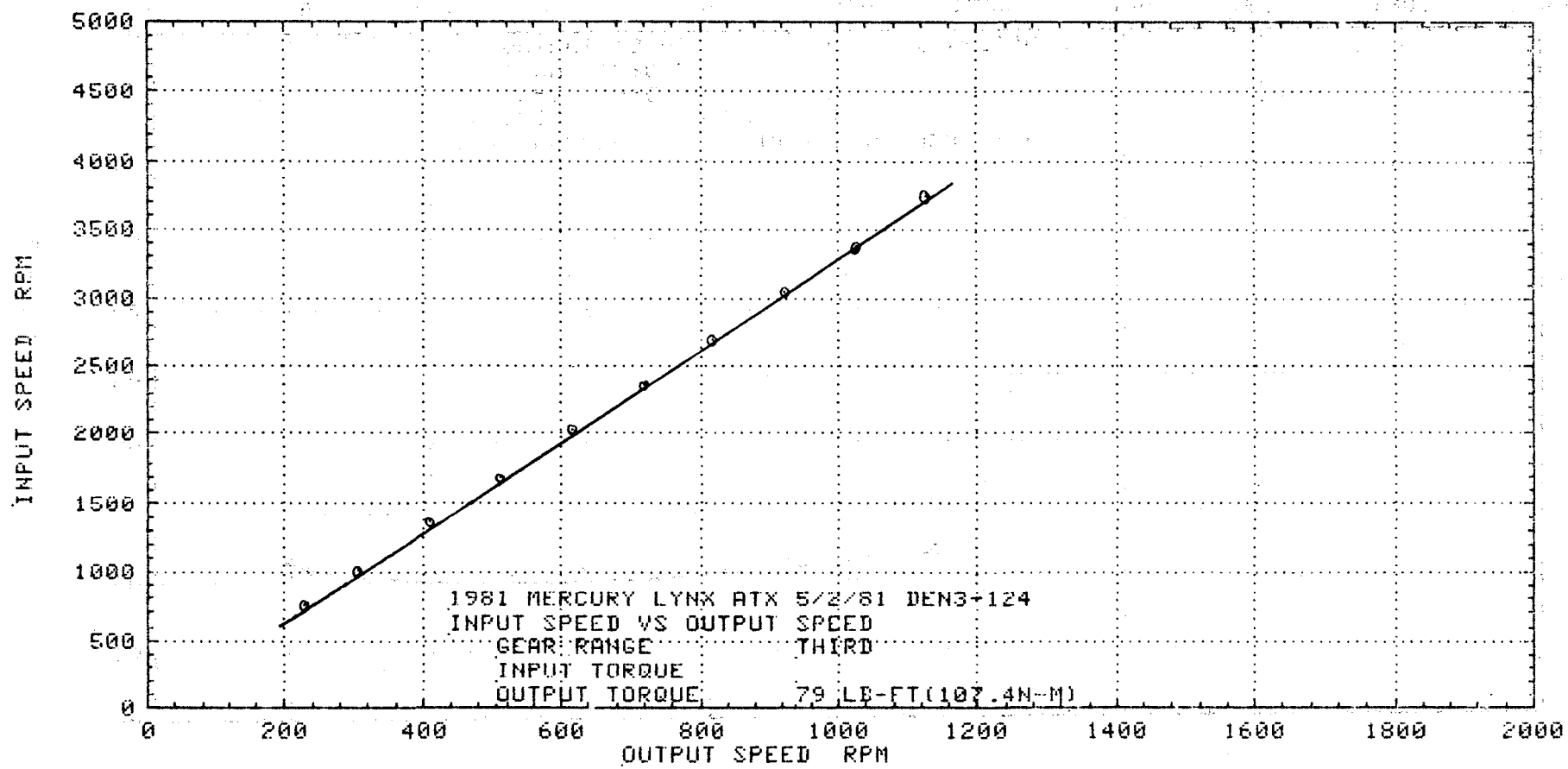

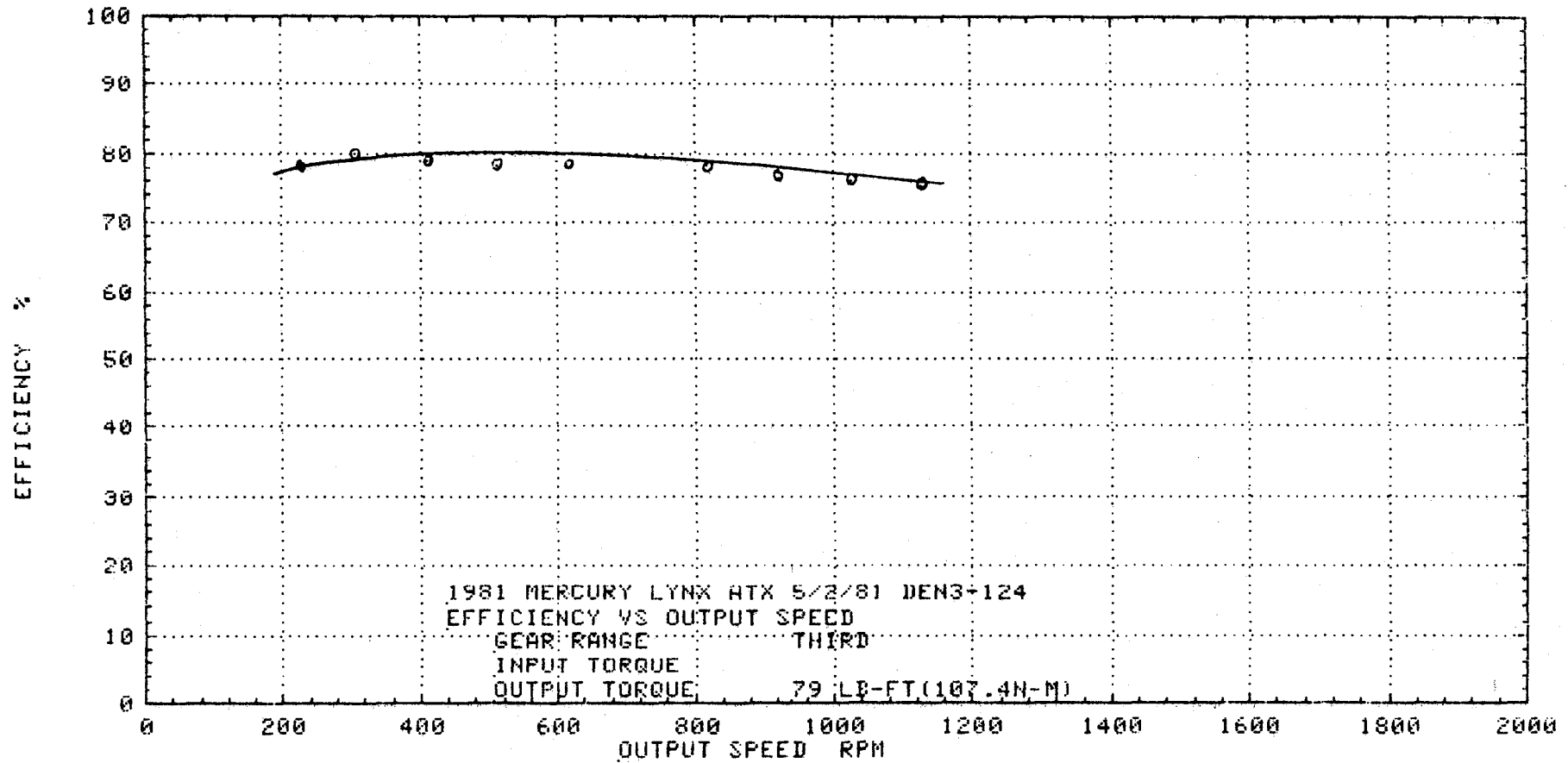

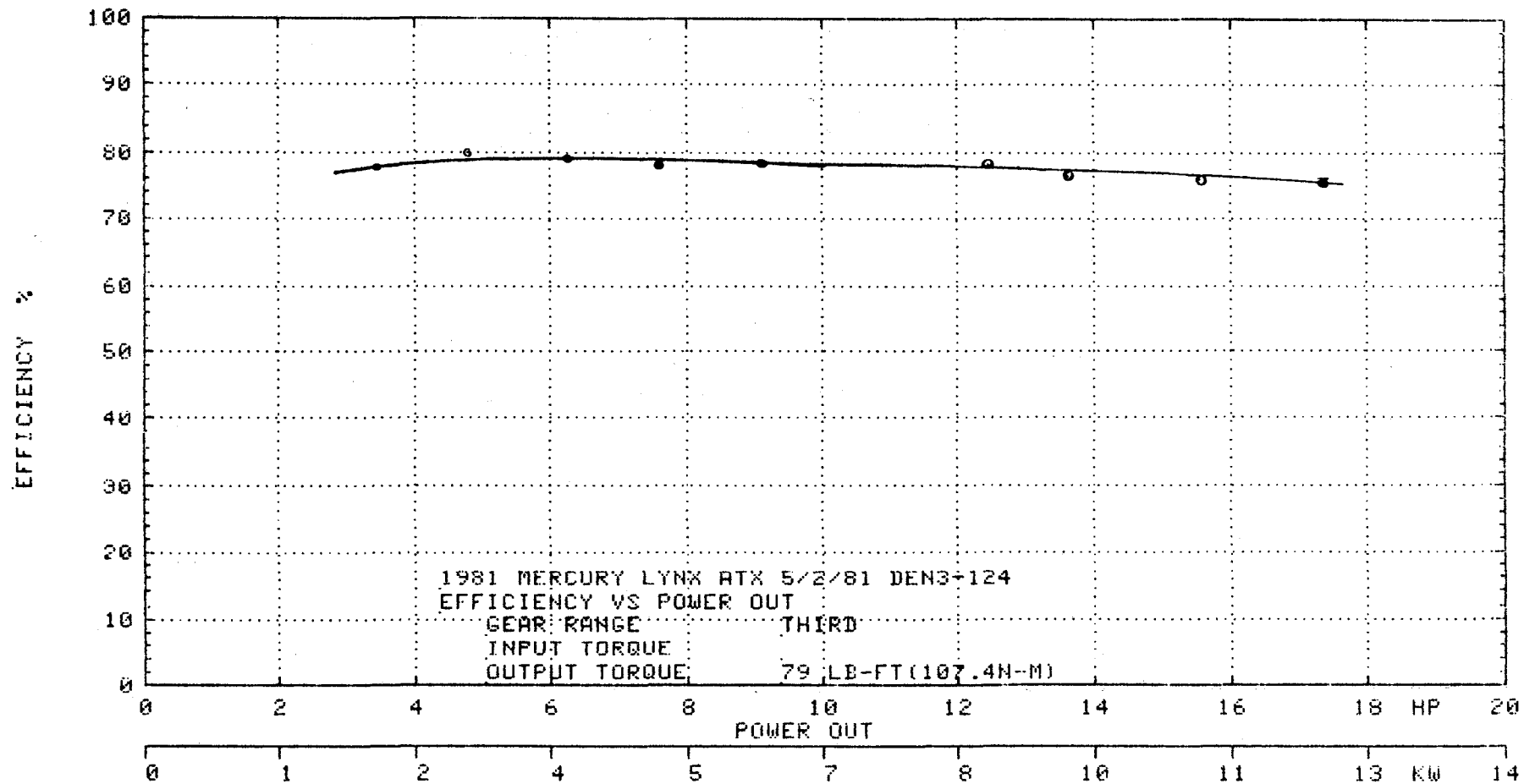

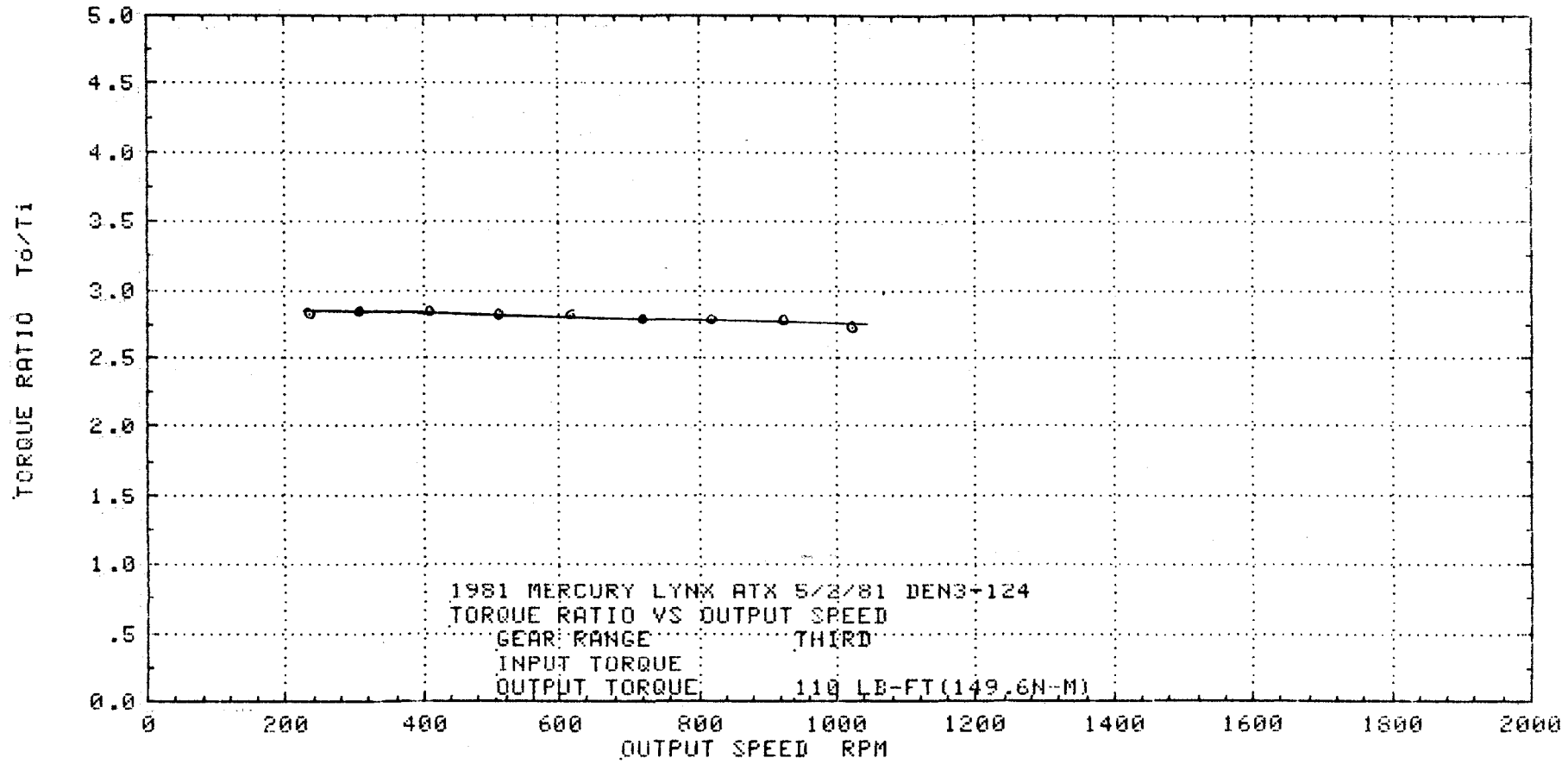

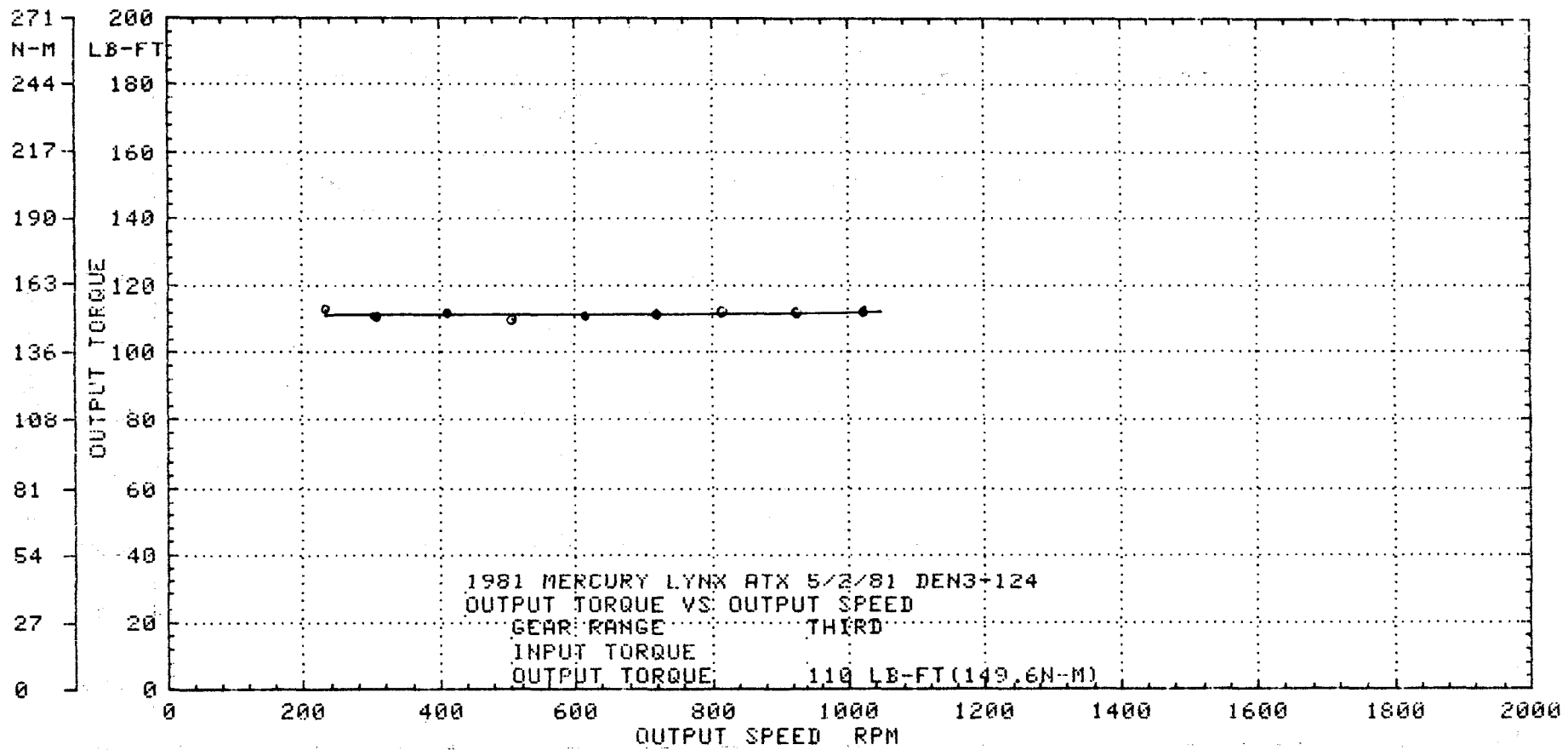

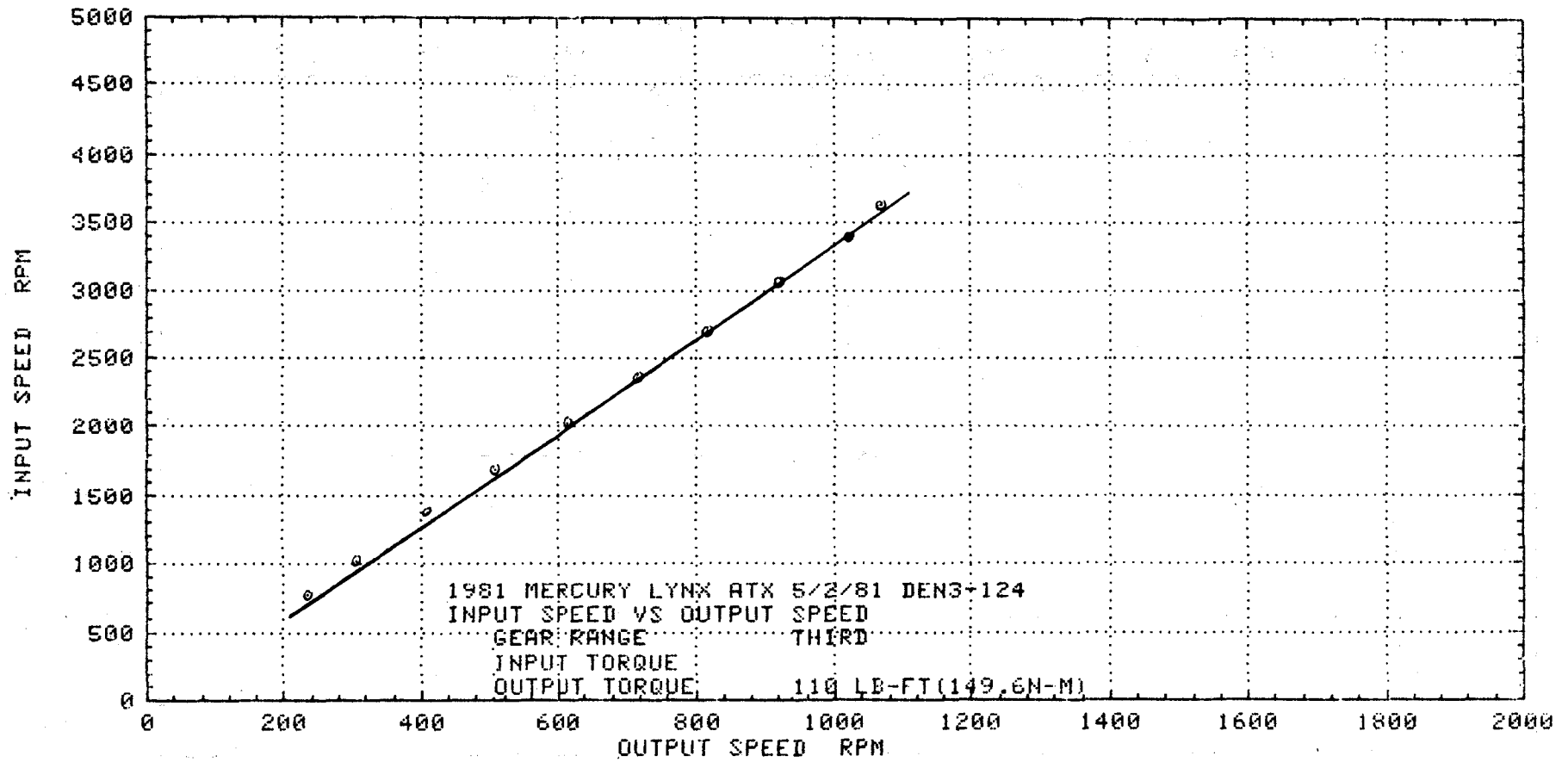

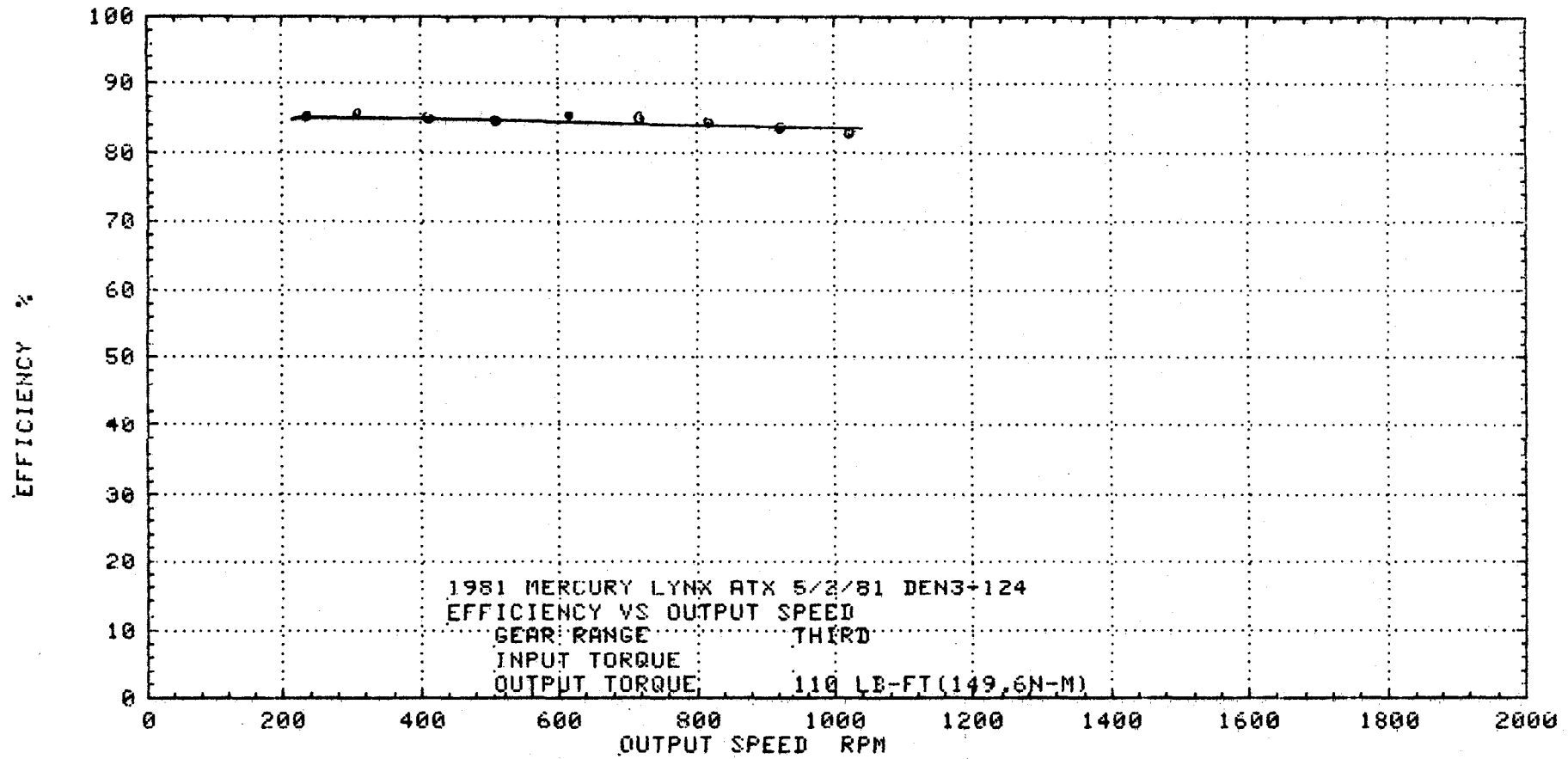

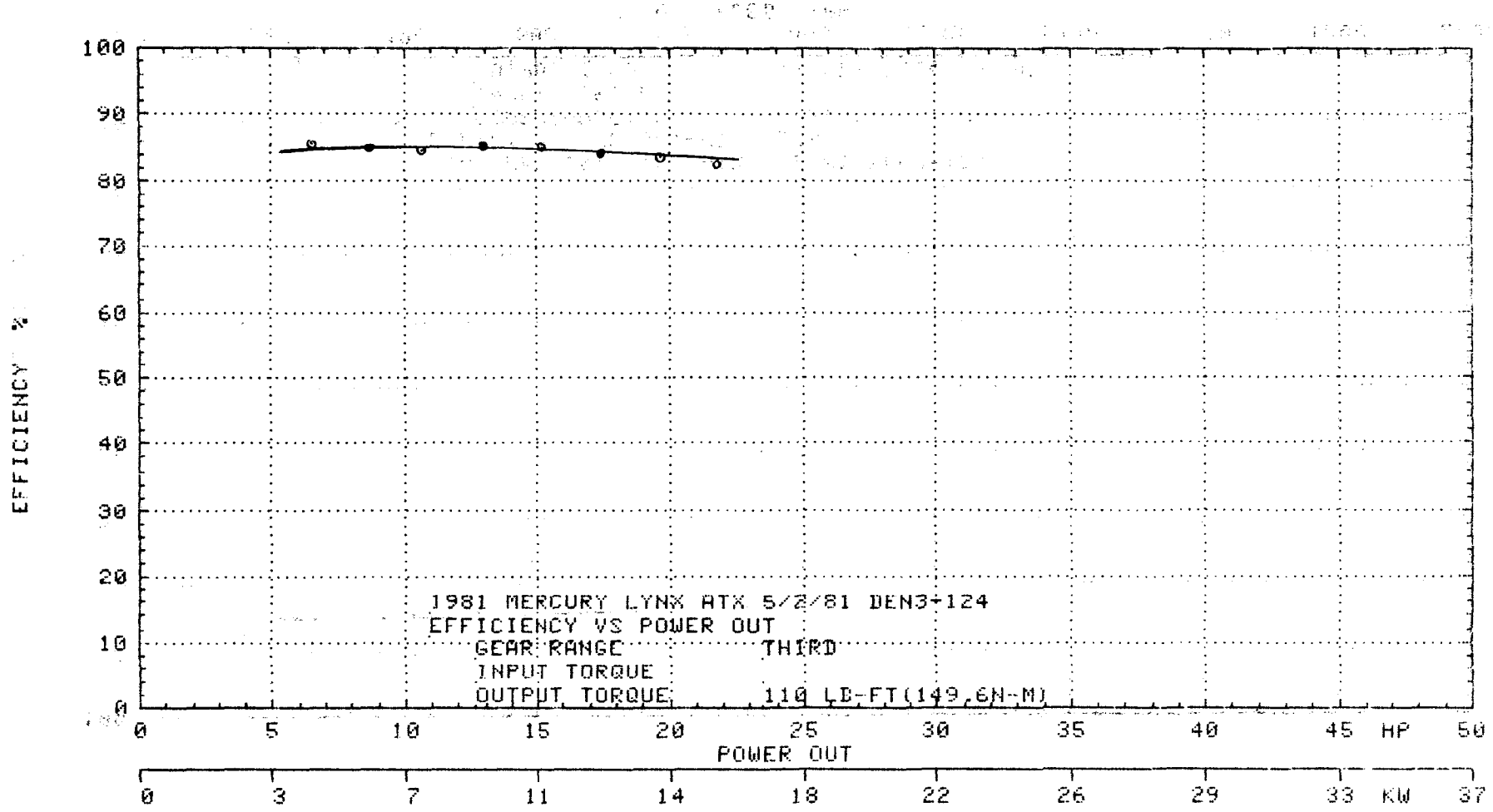

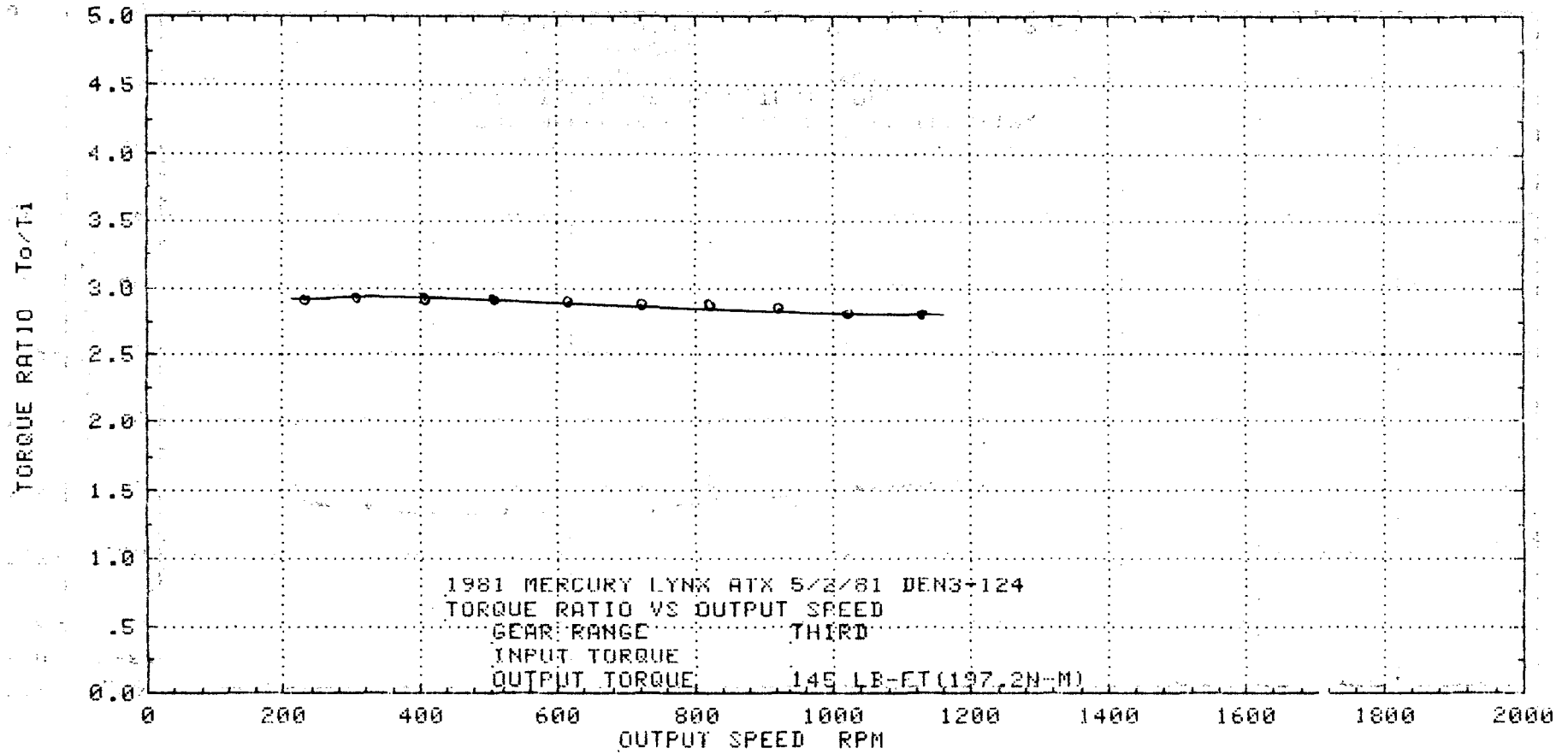

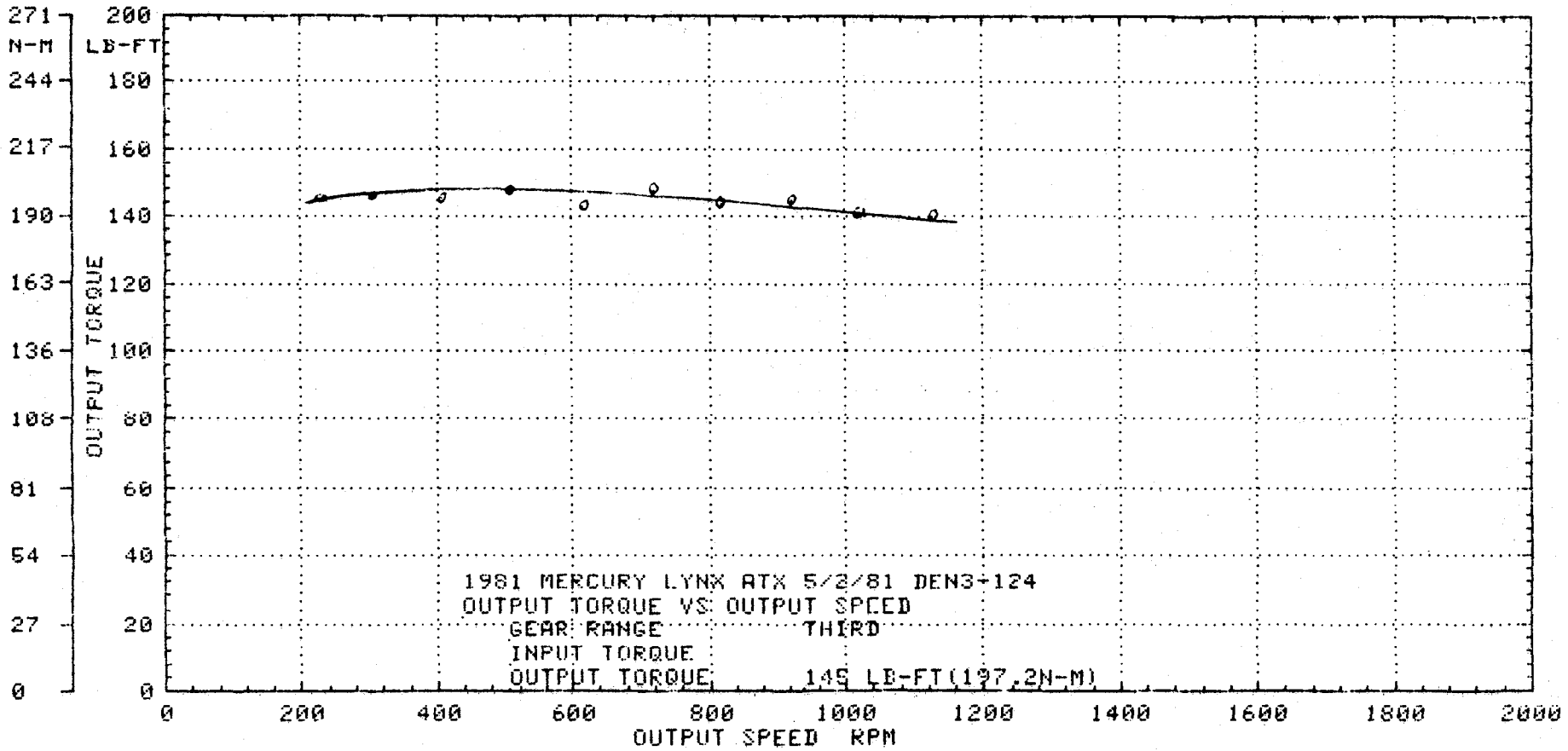

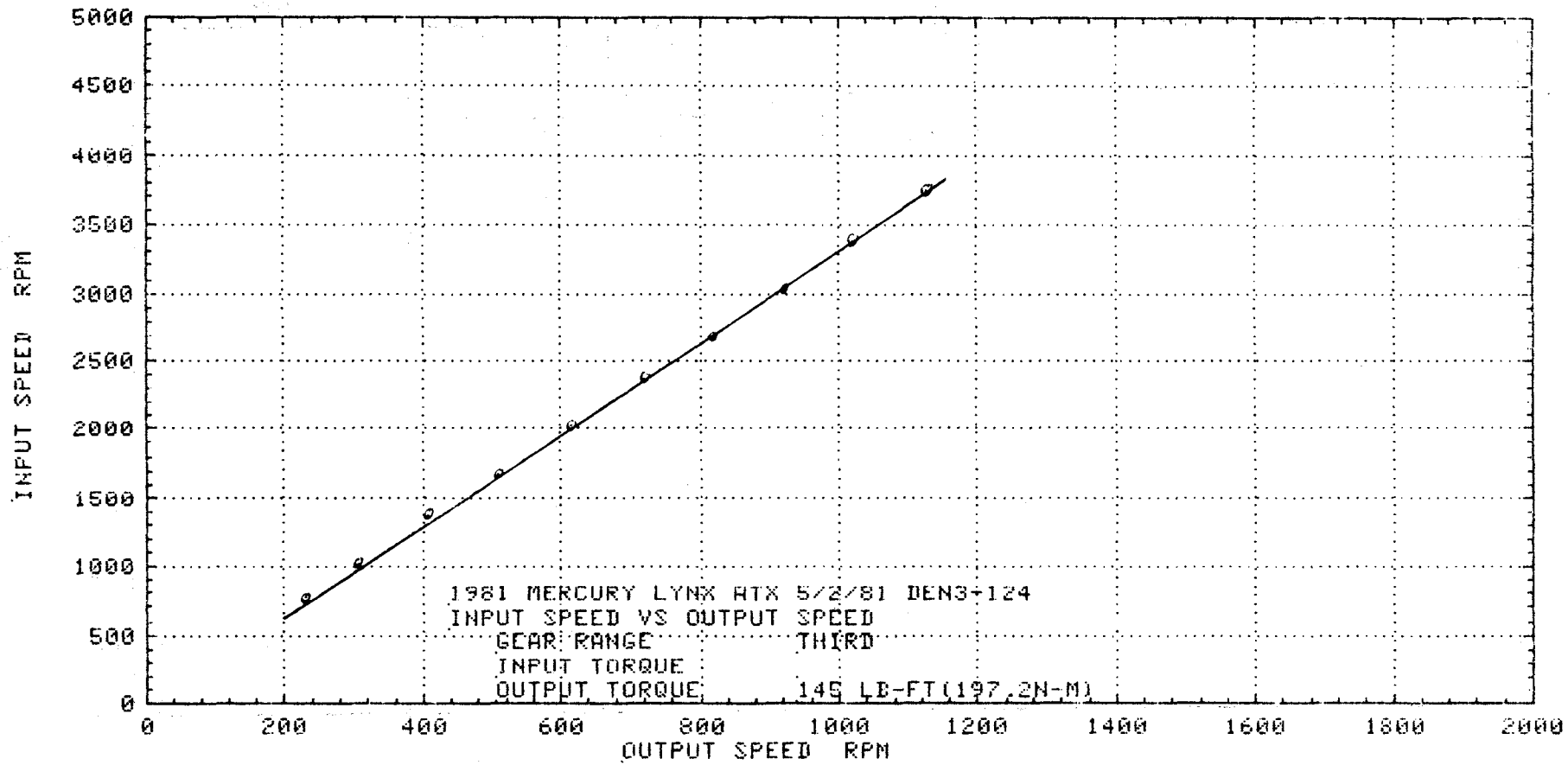

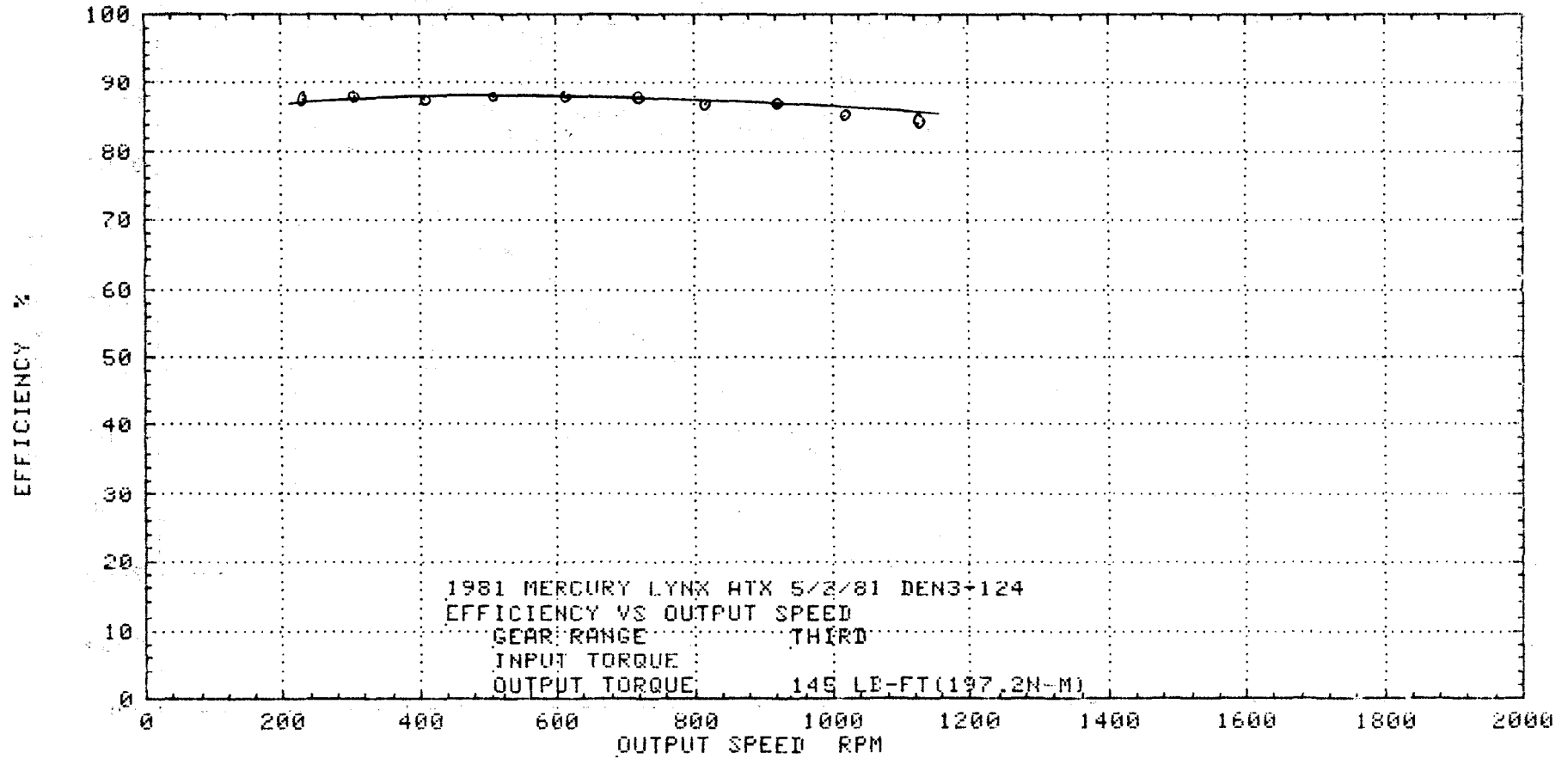

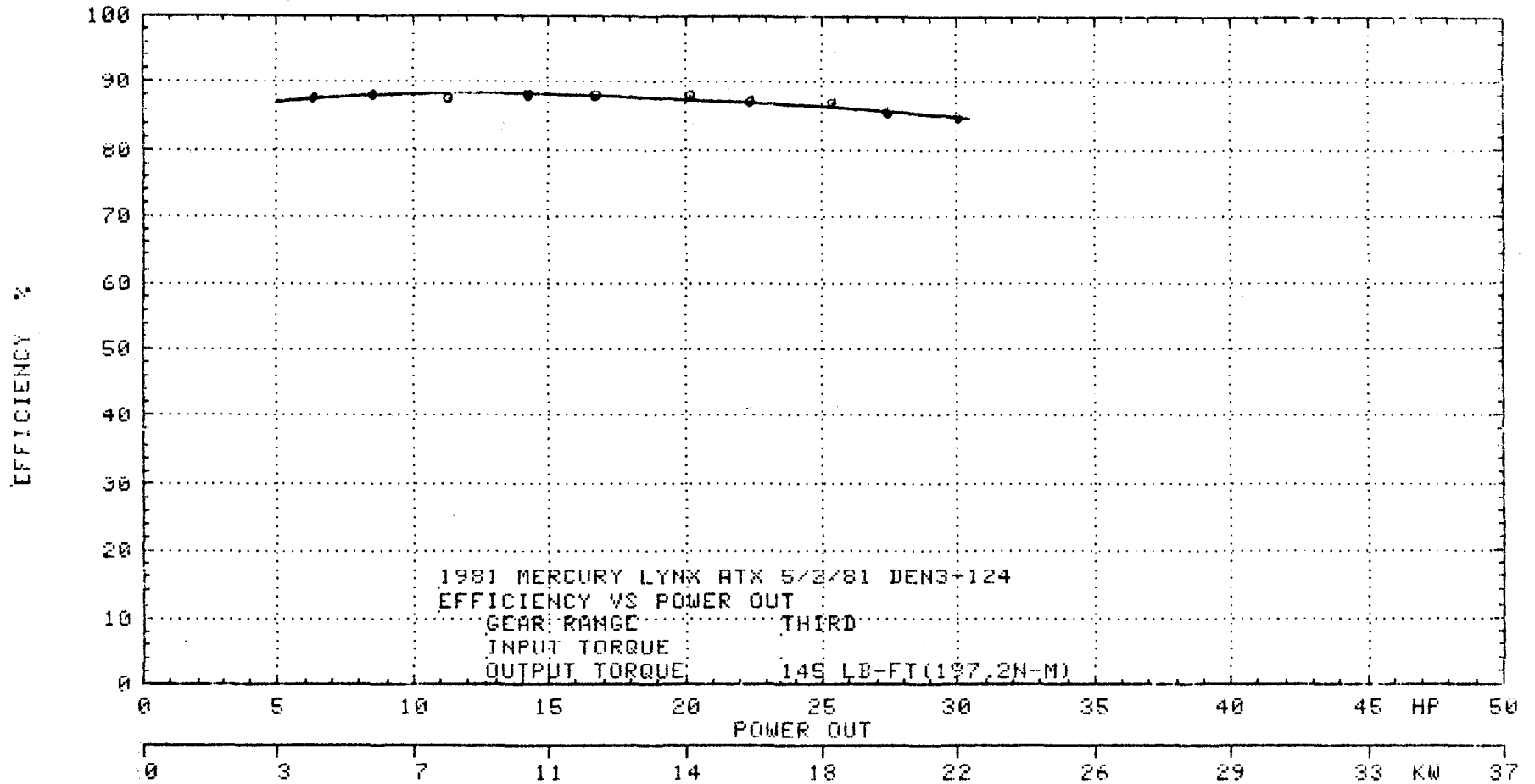

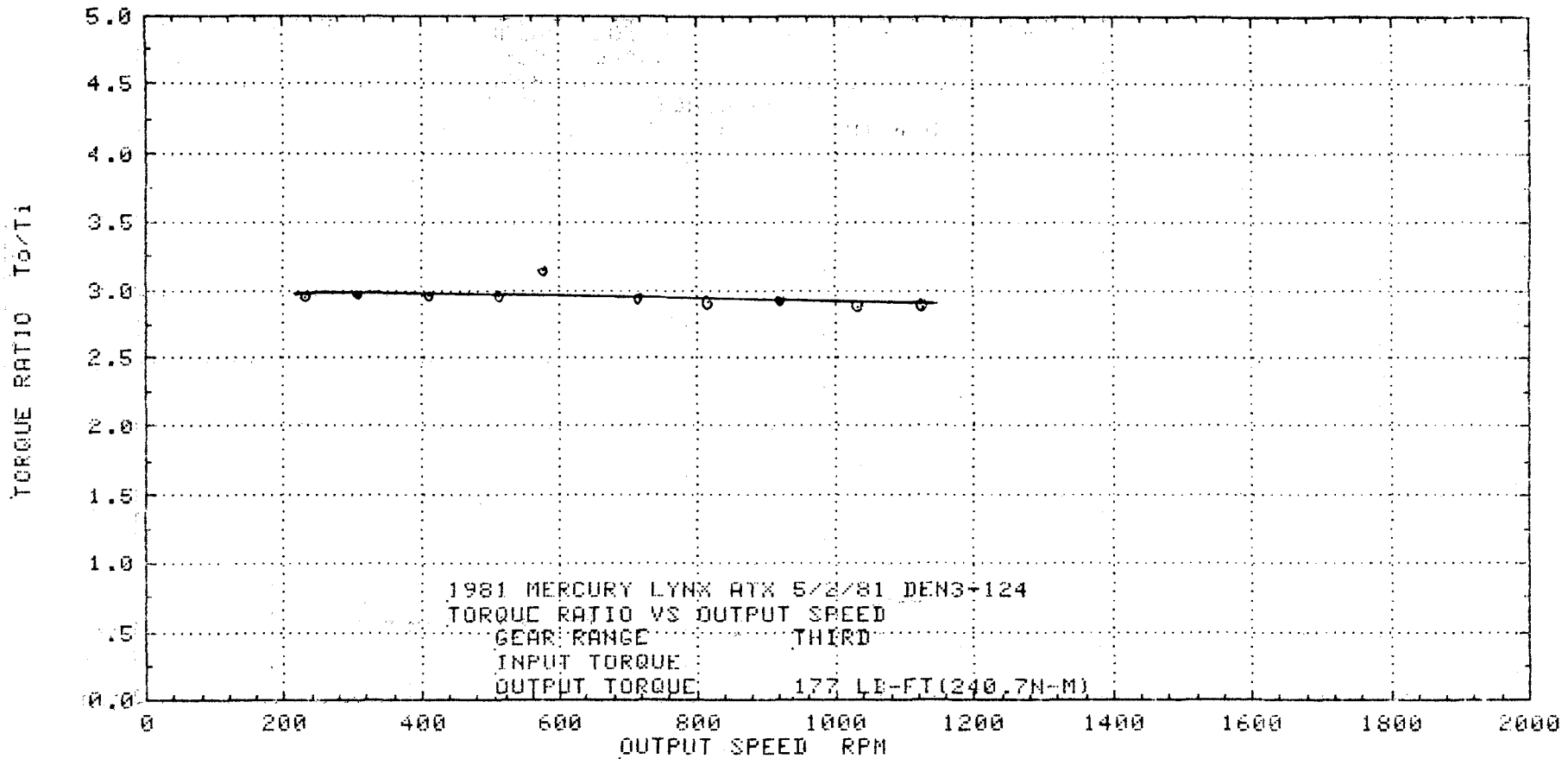

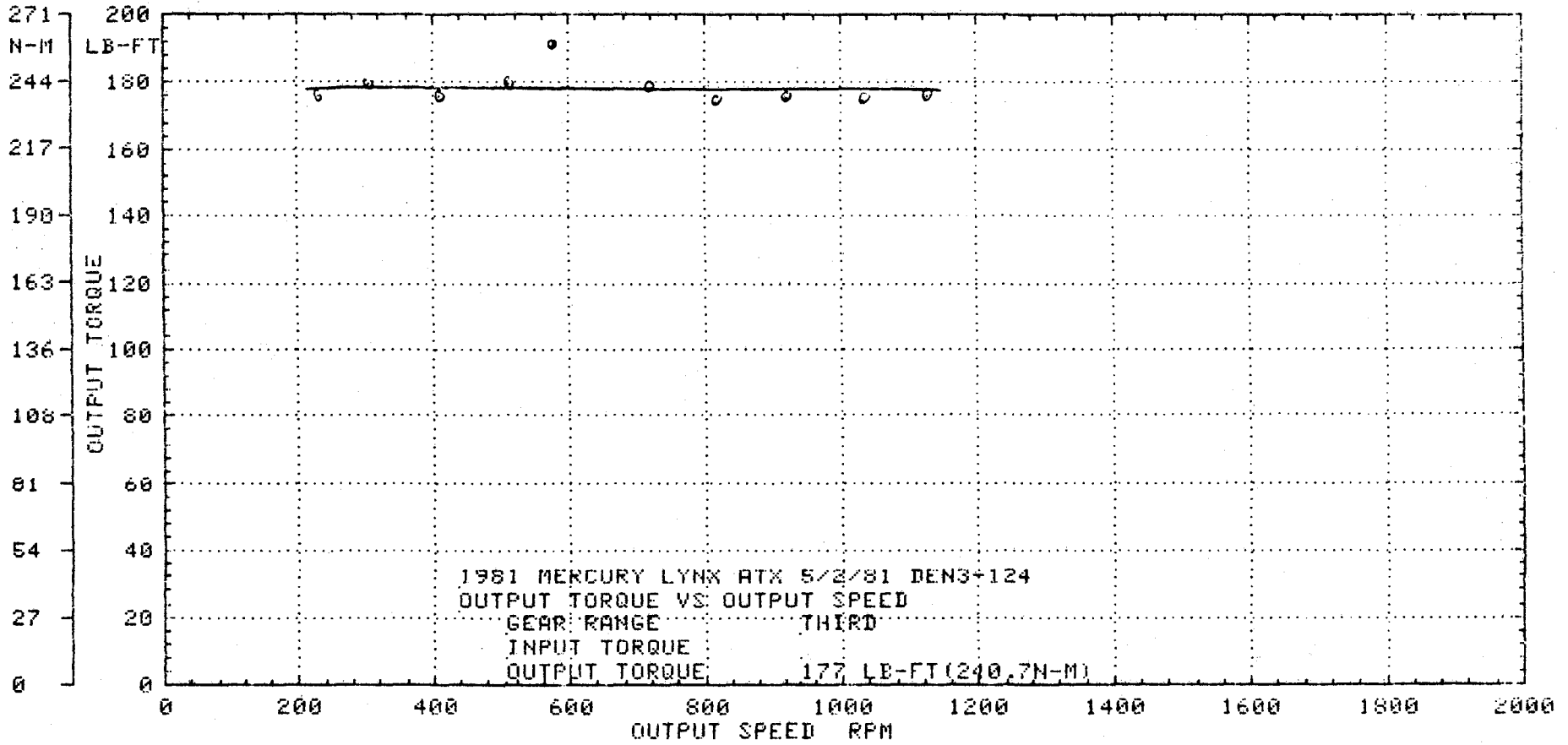

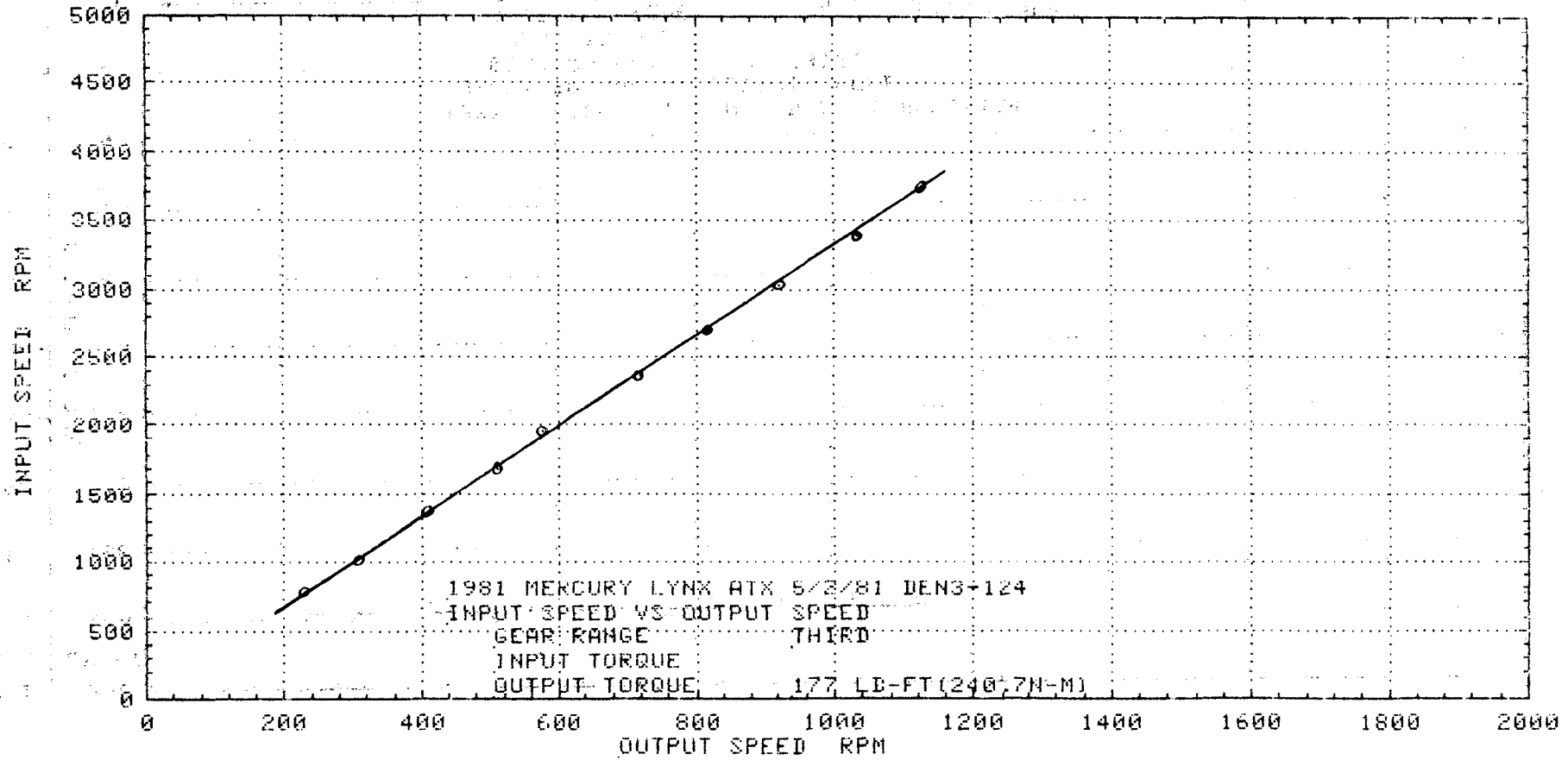

EFFICIENCY %

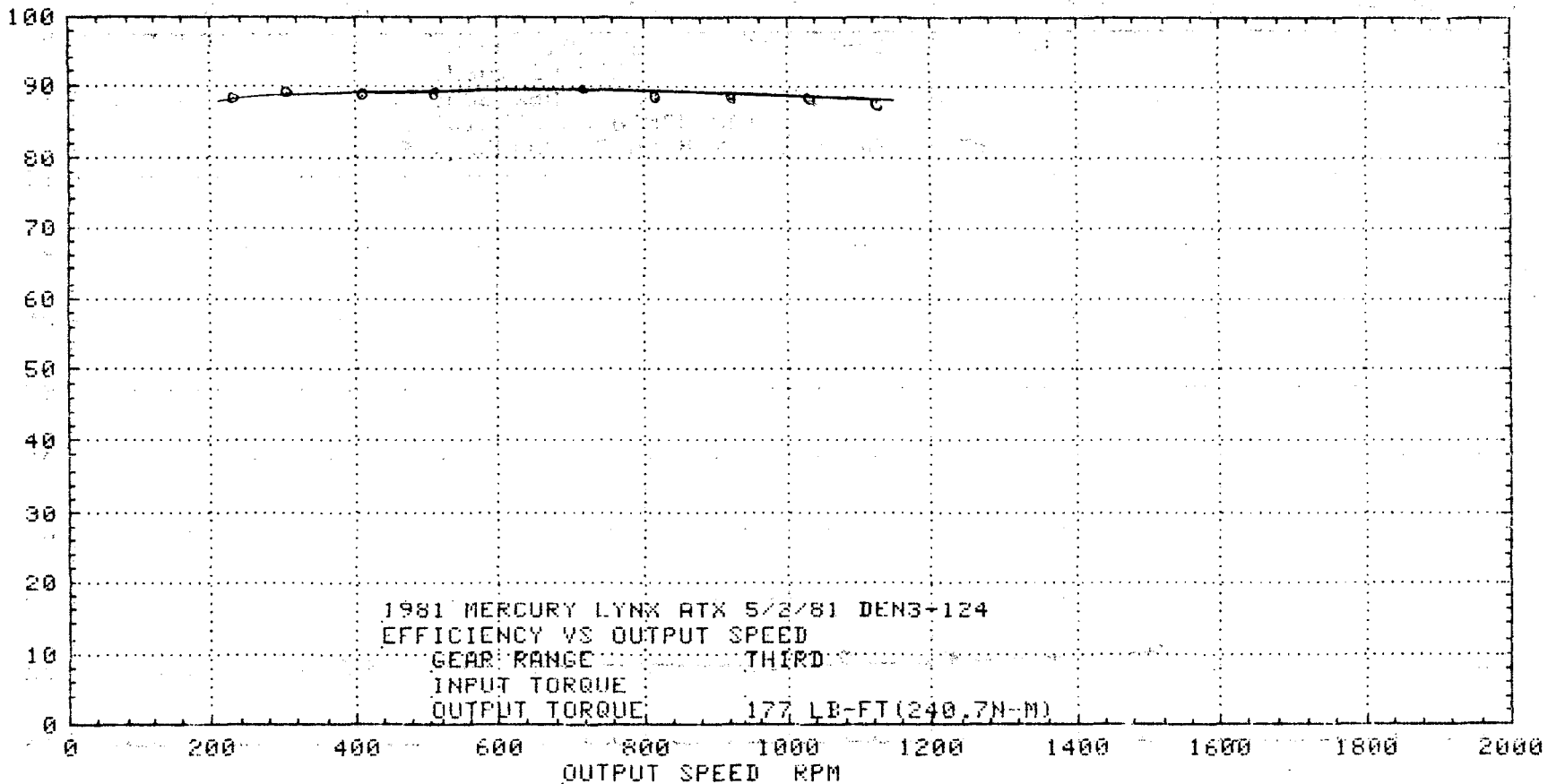

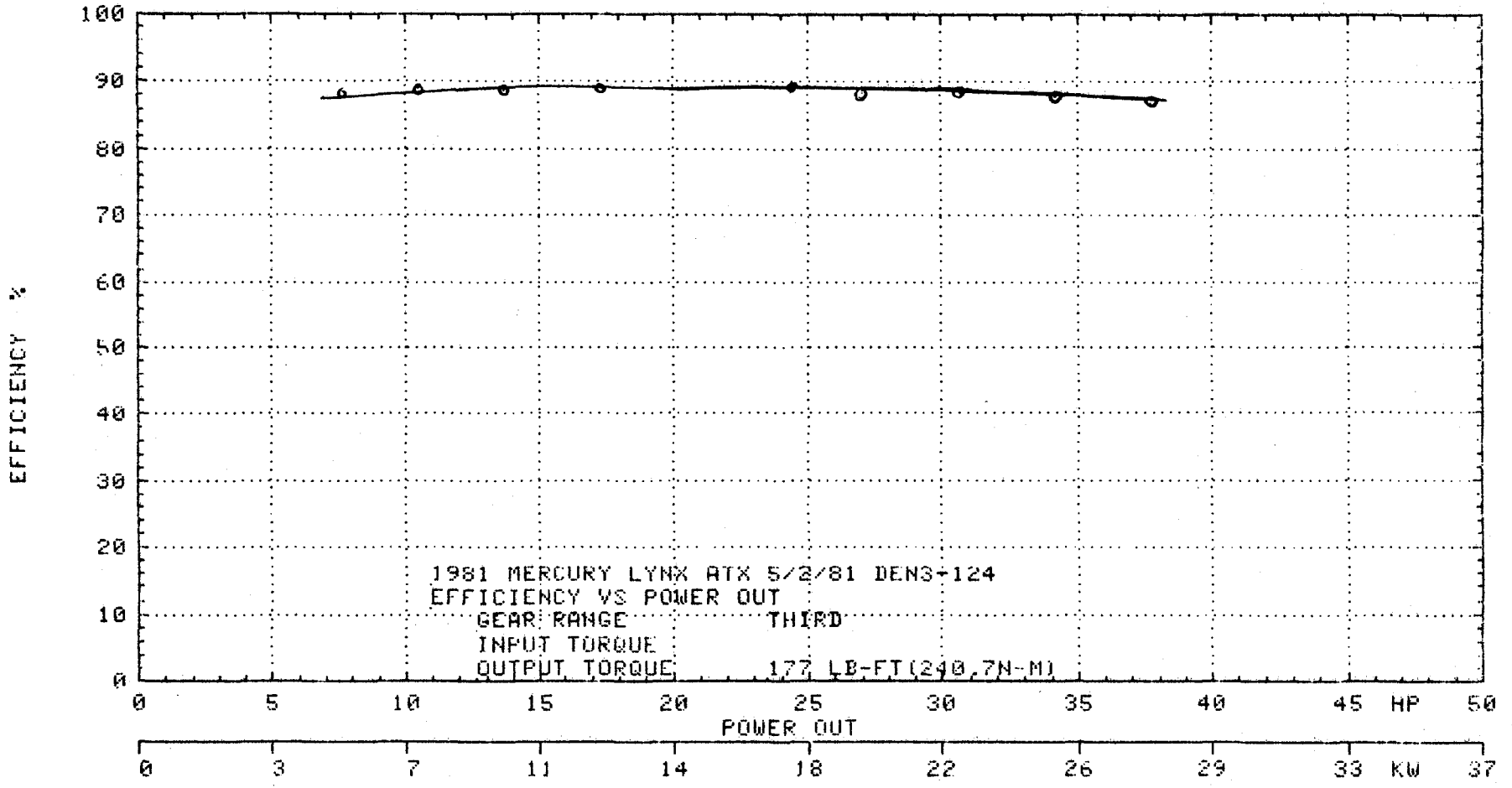

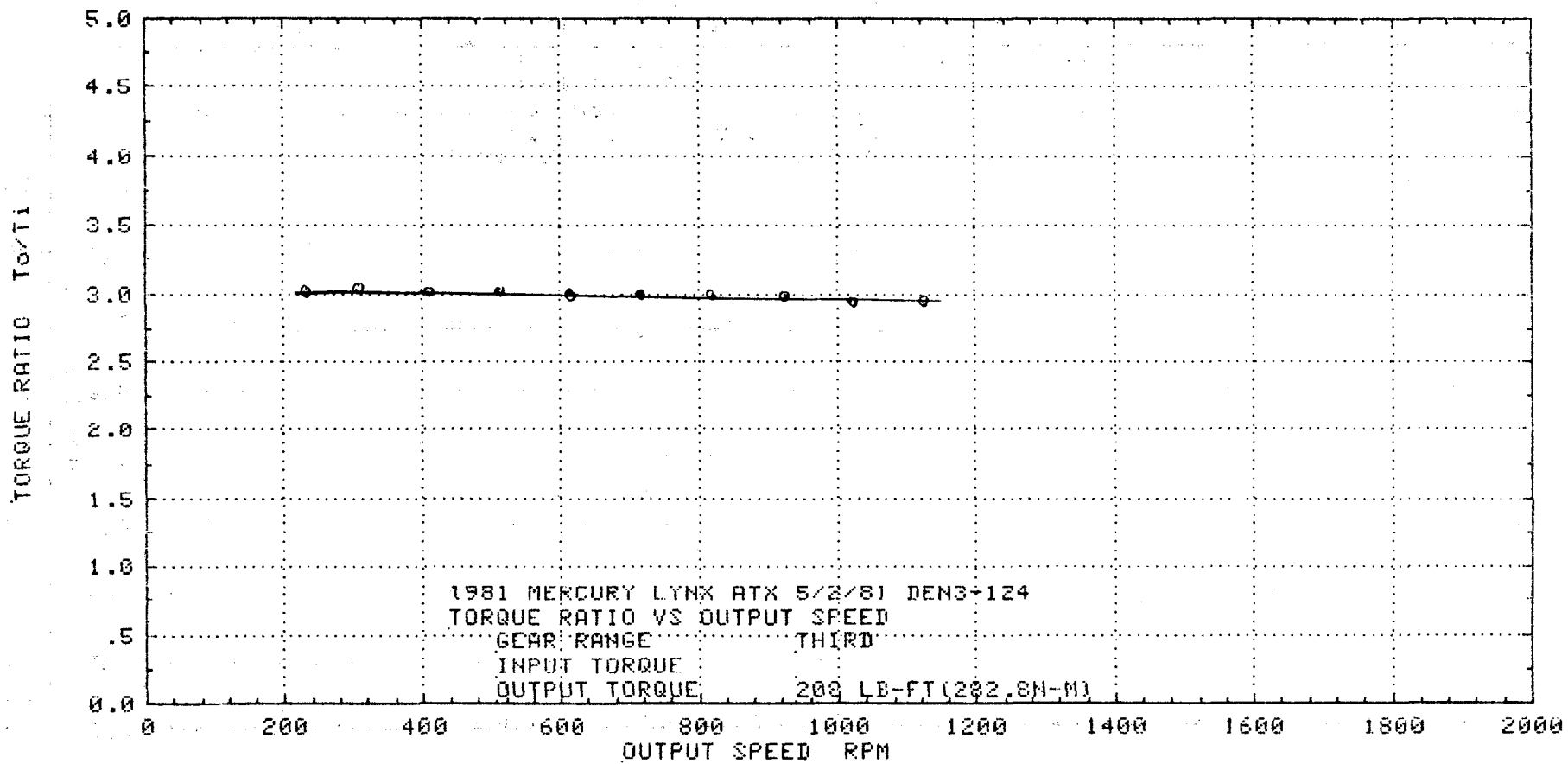

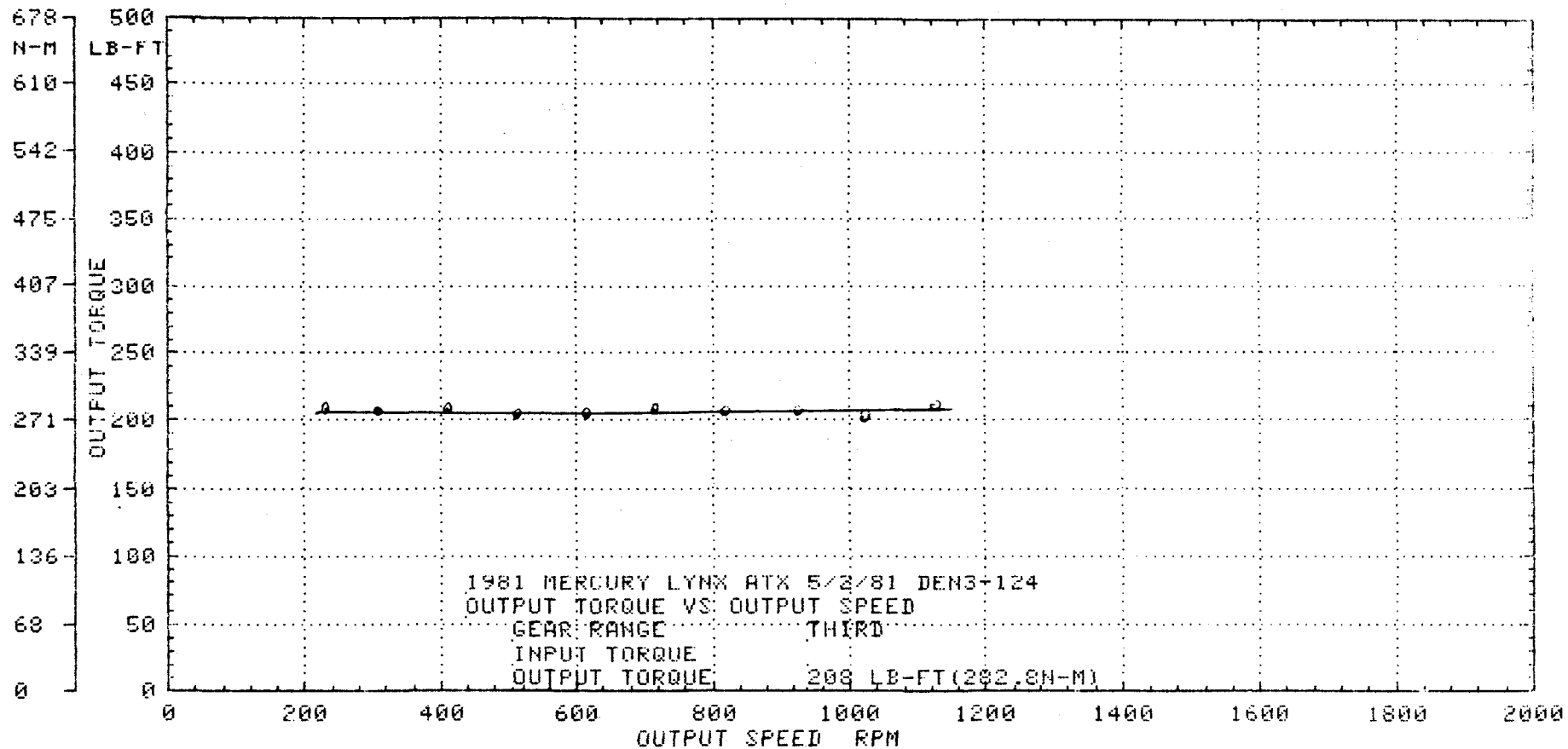

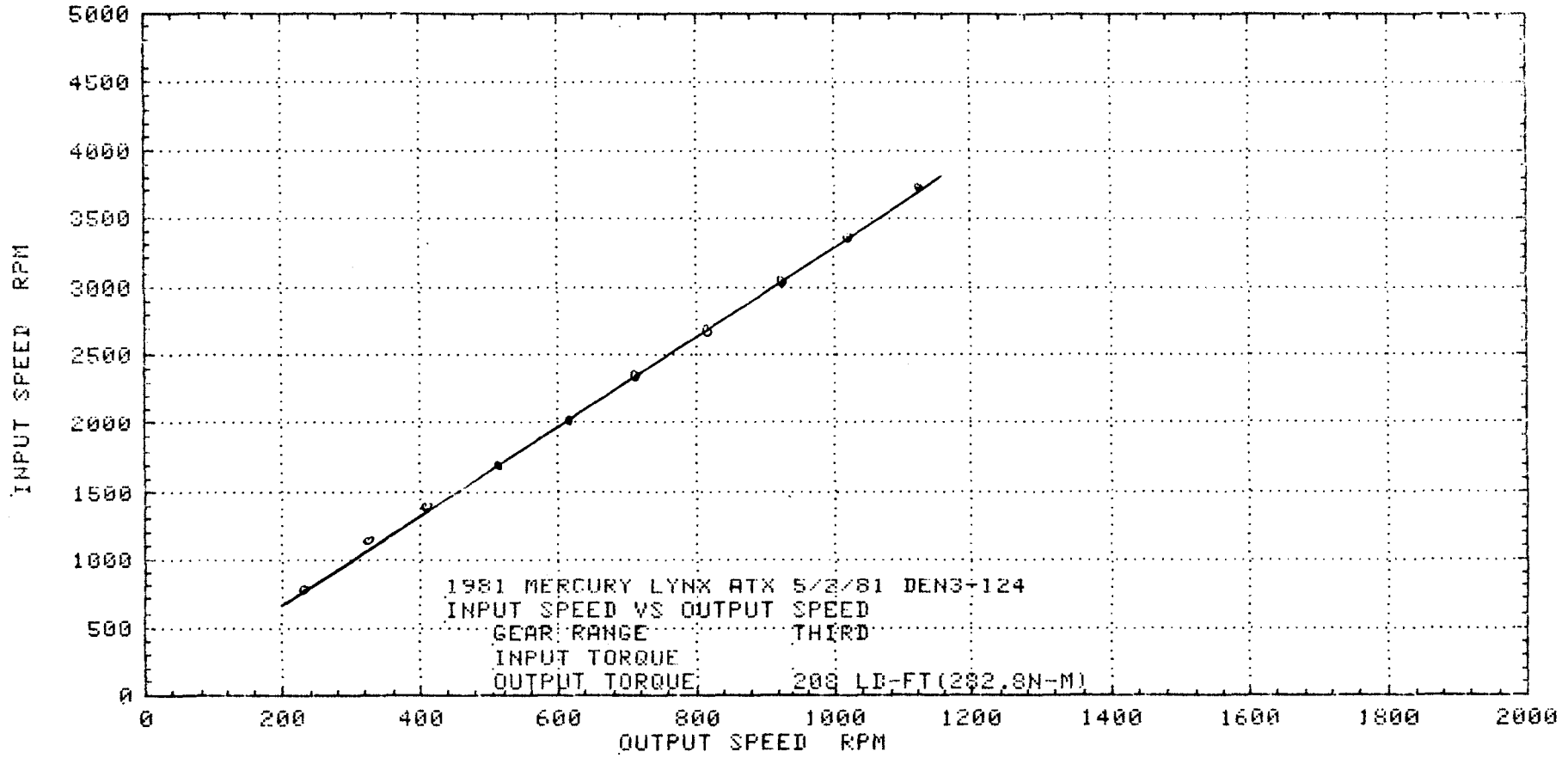

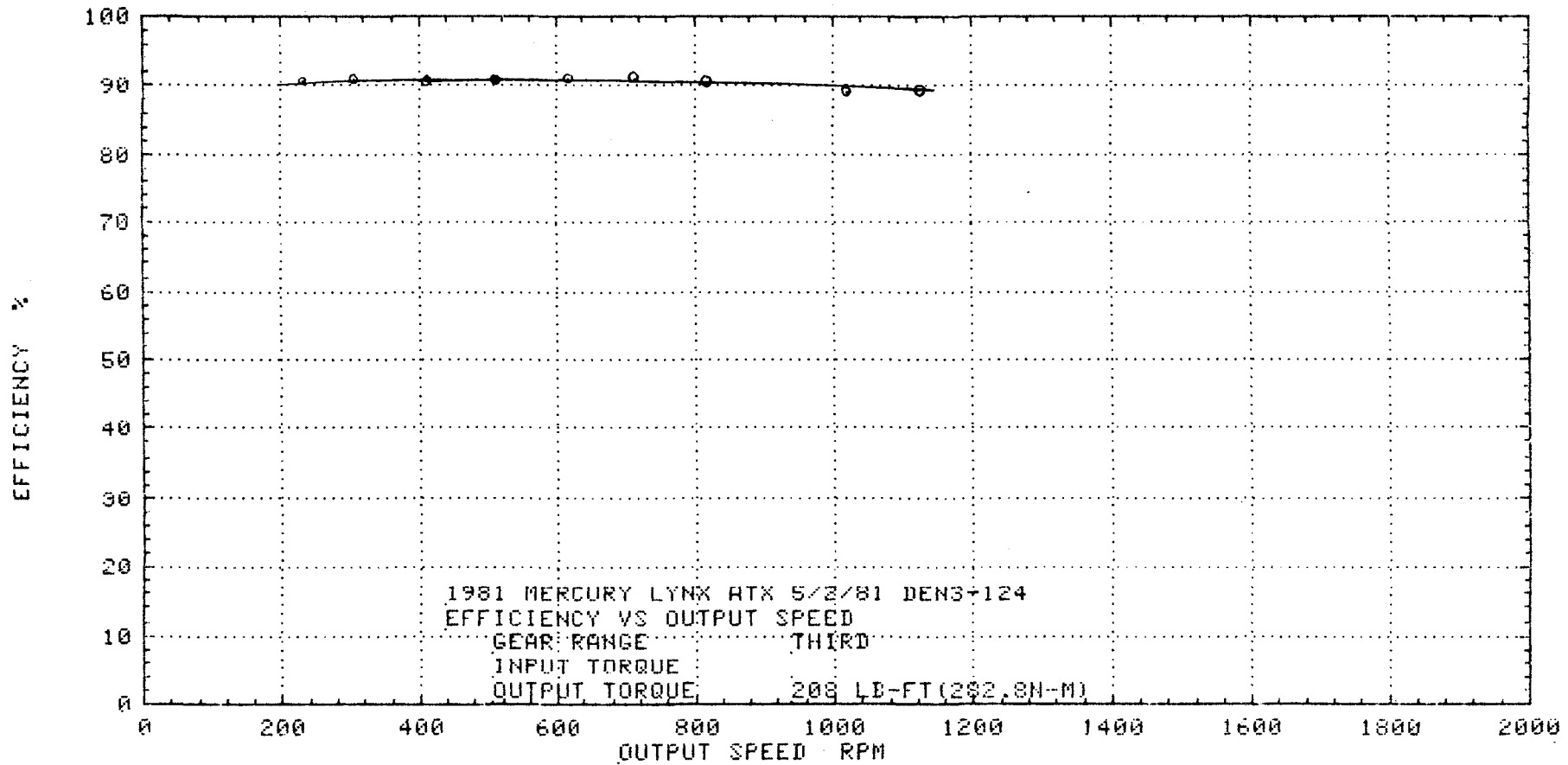

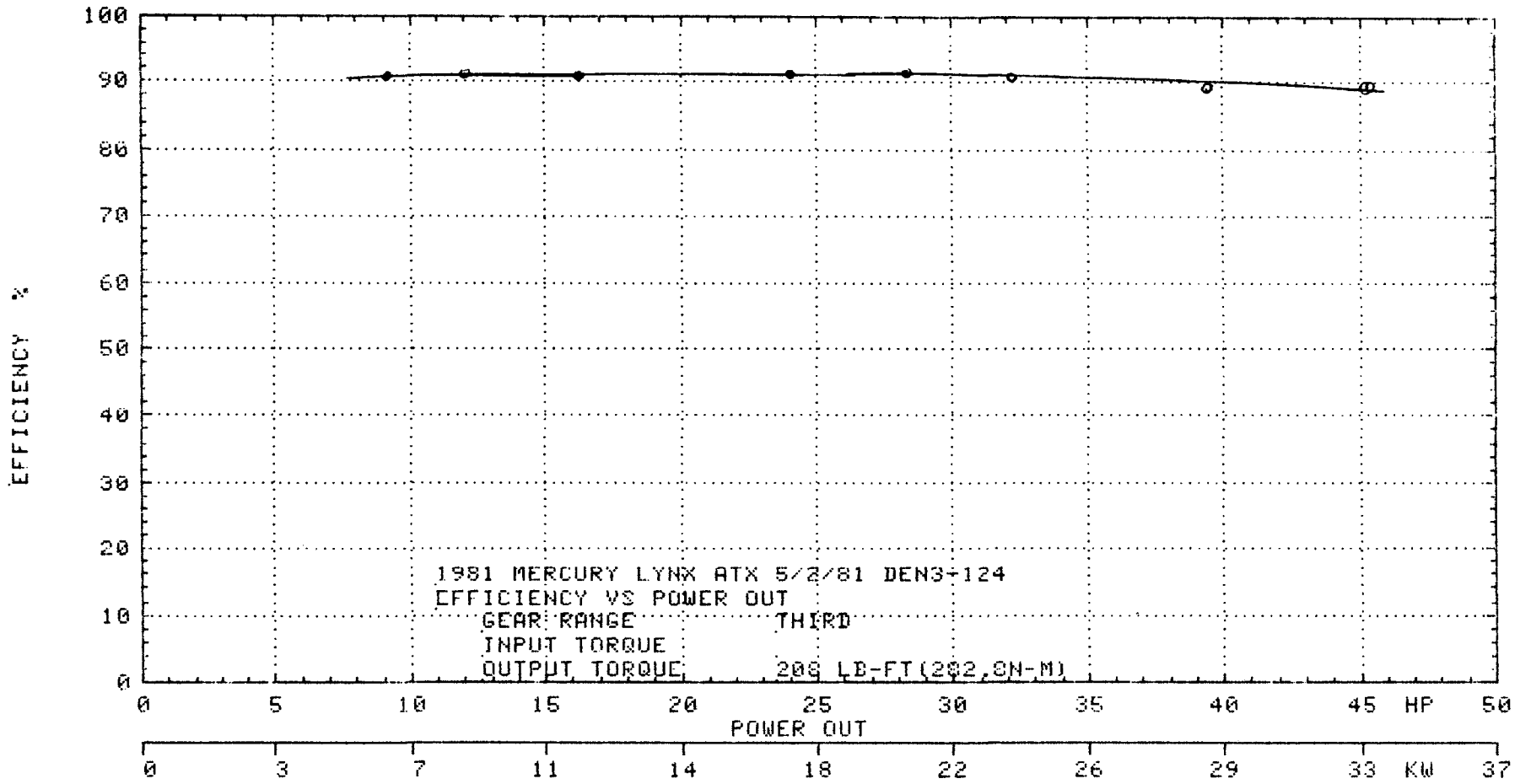

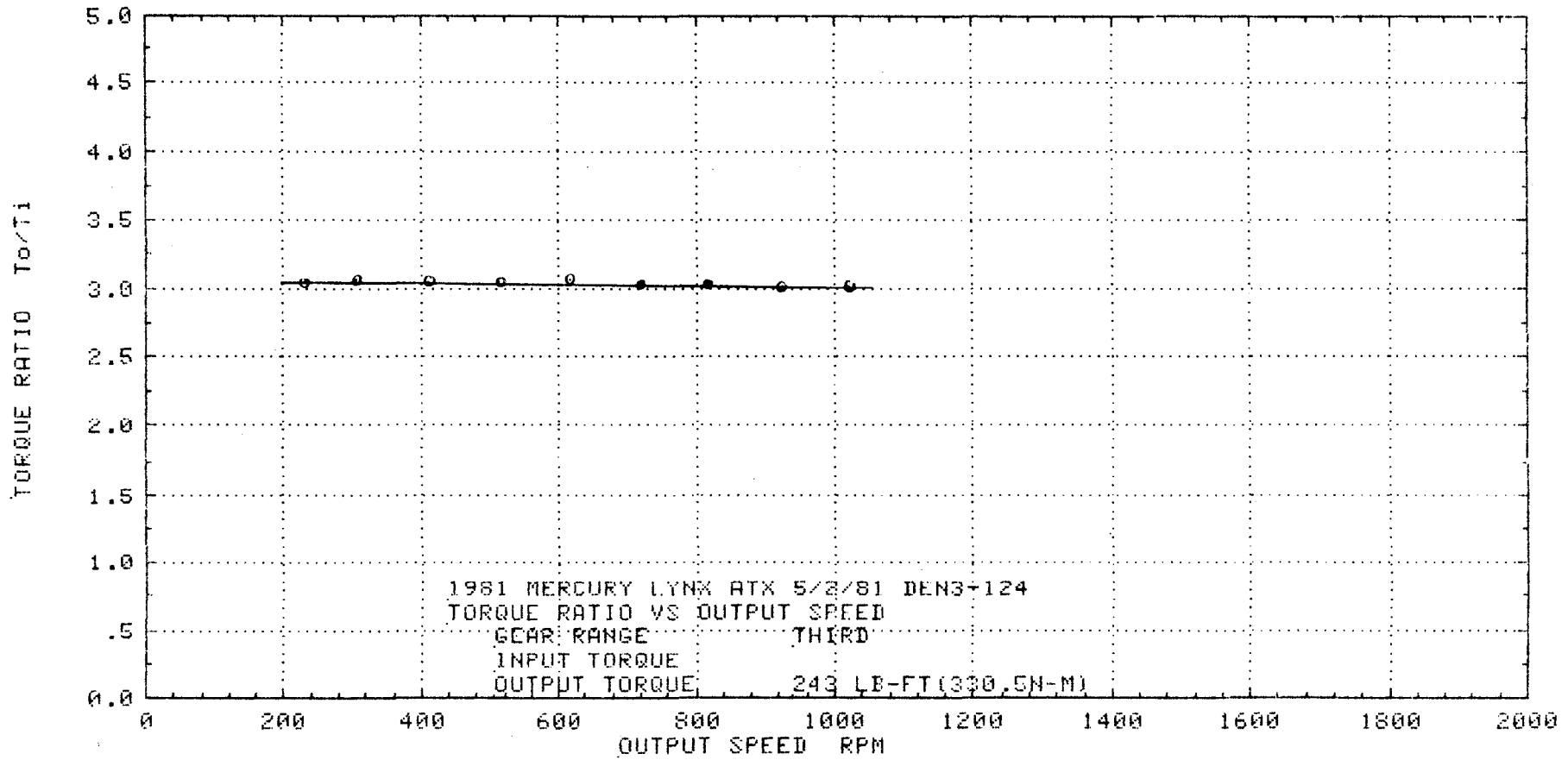

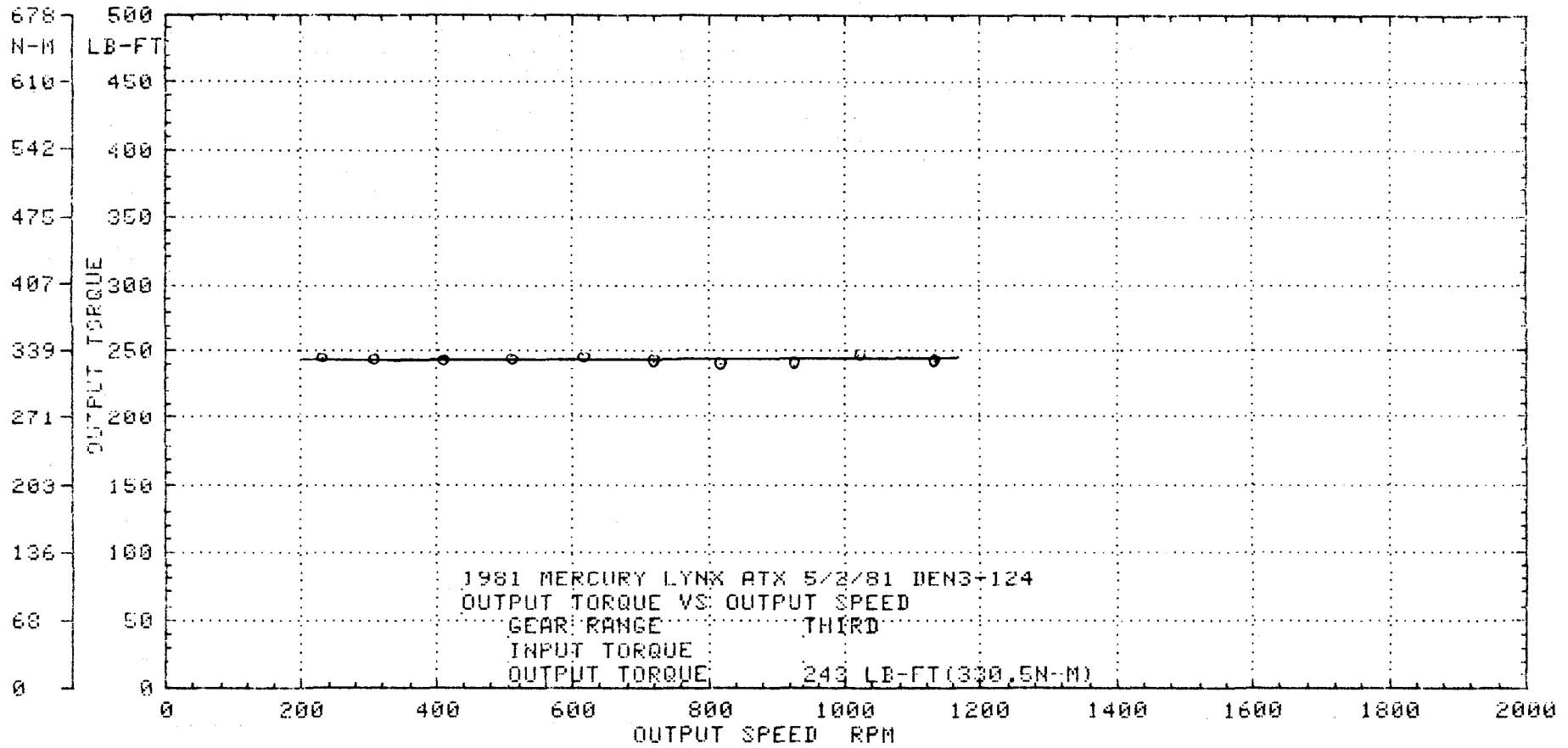

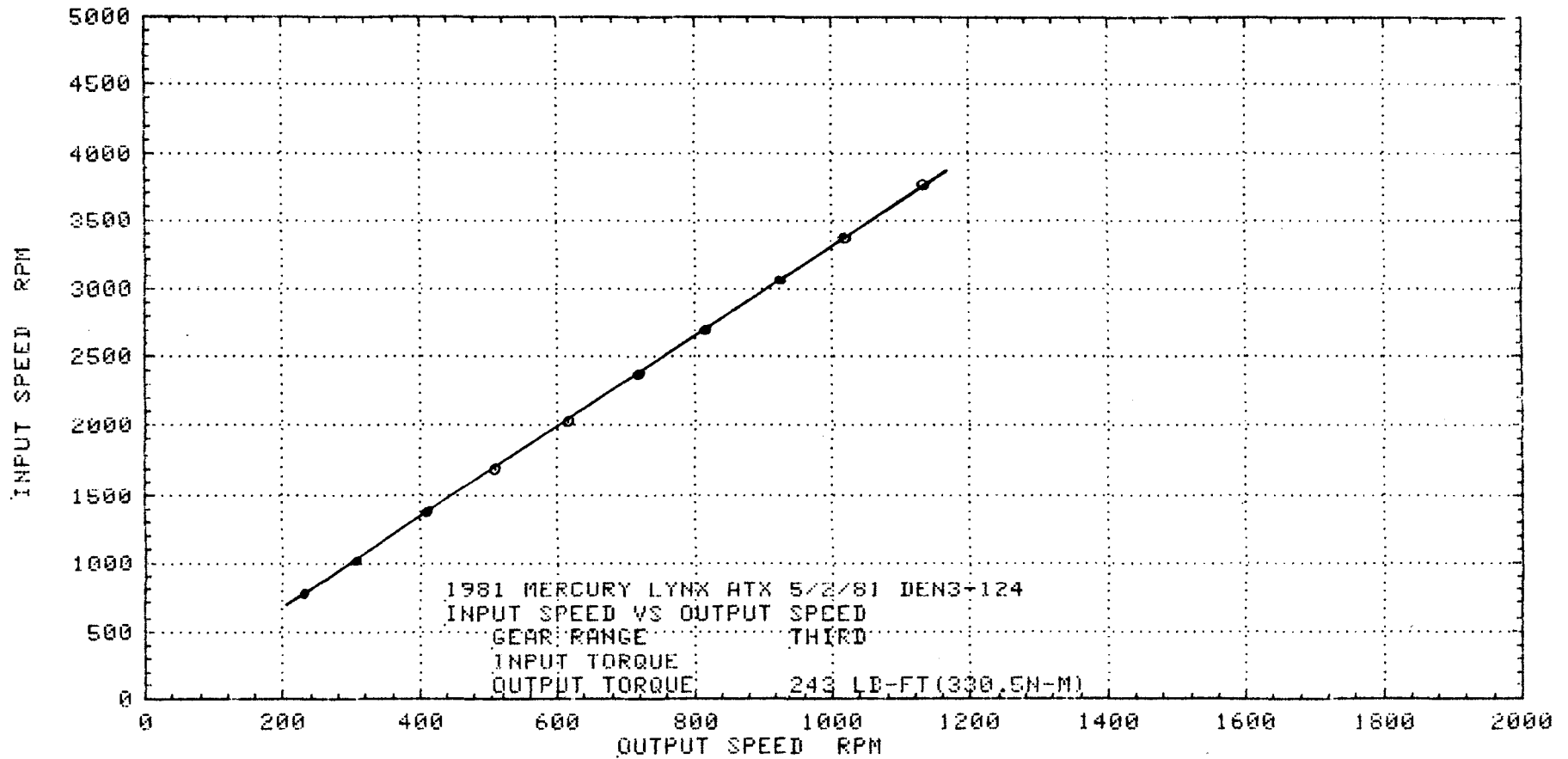

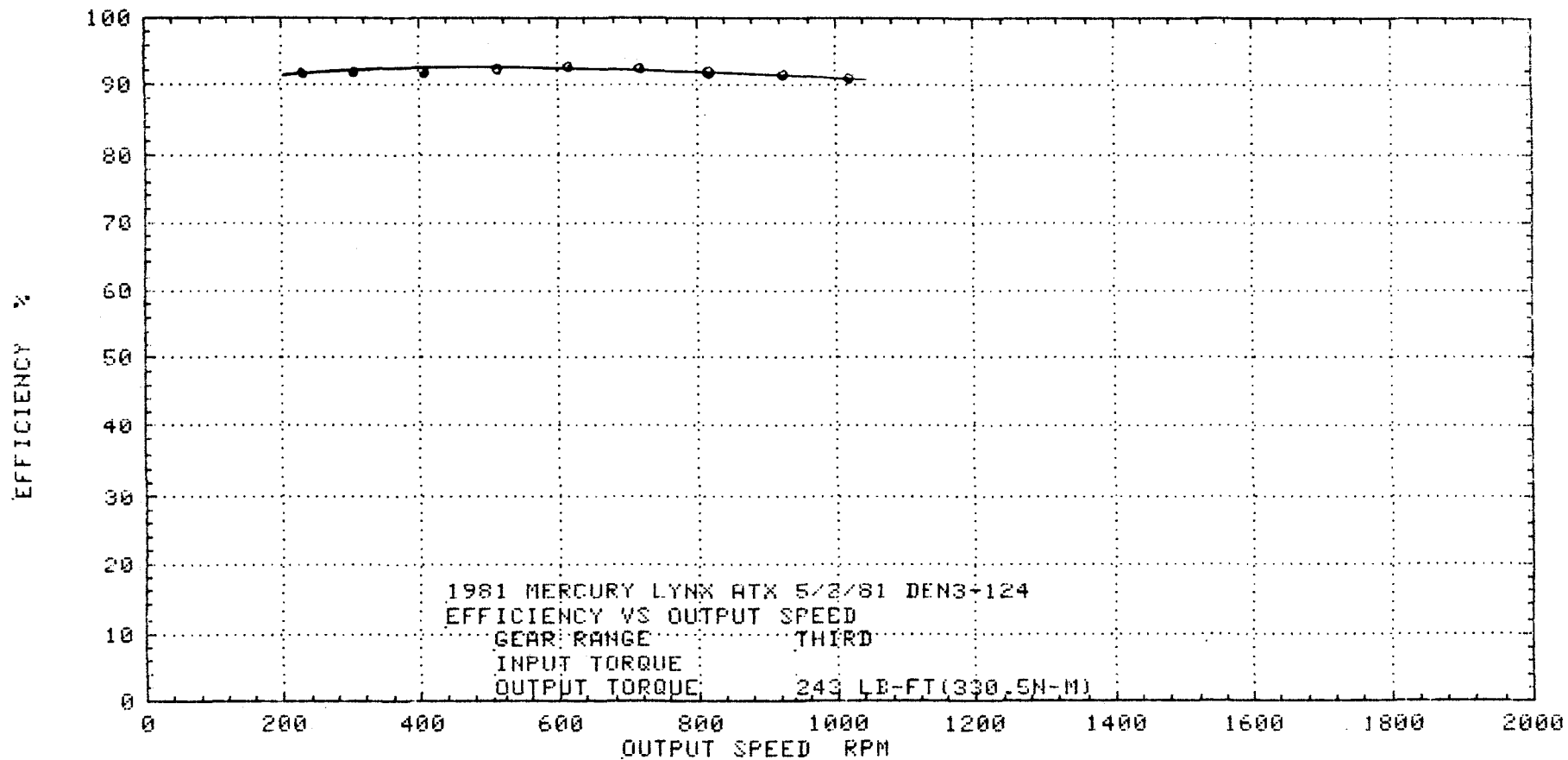

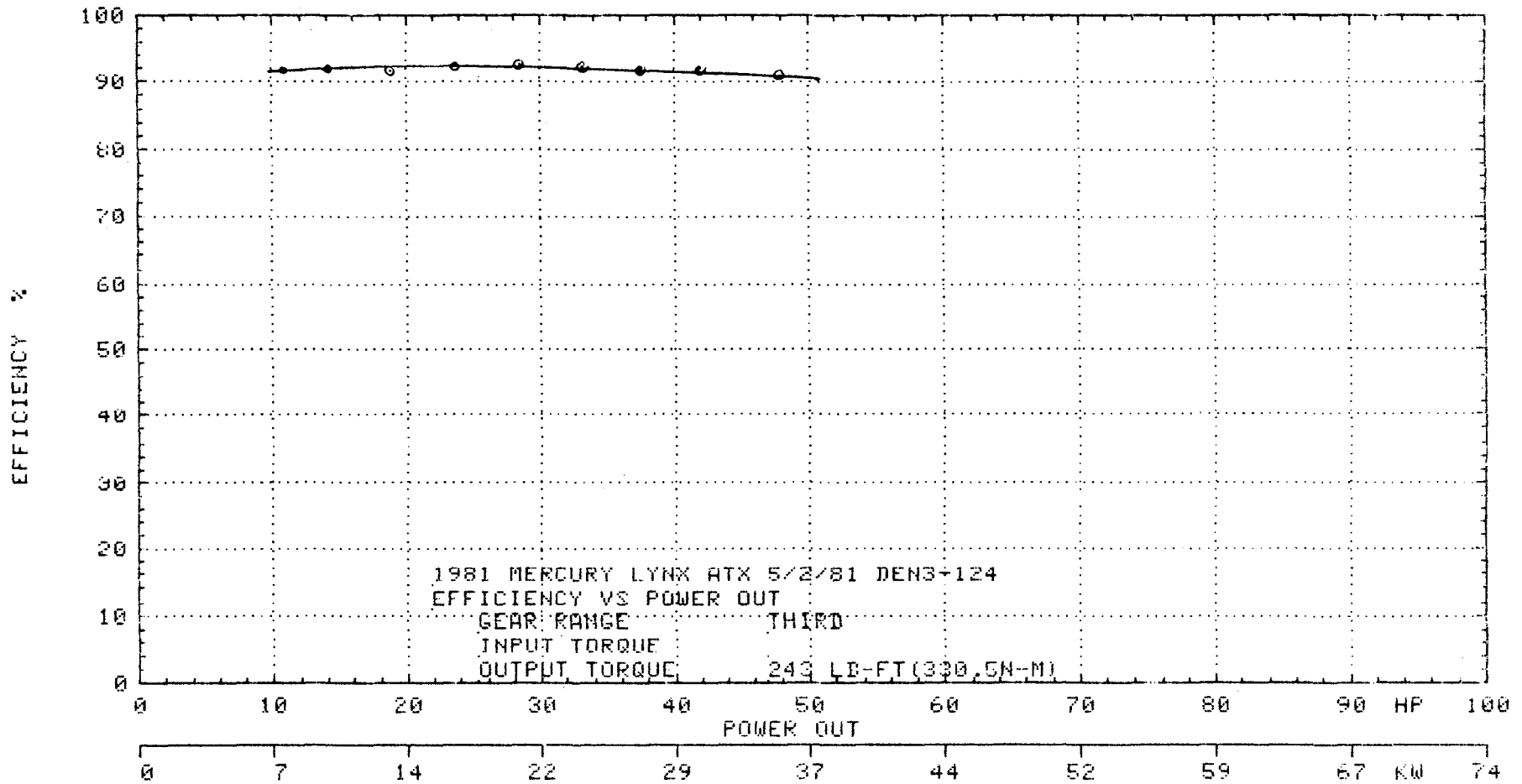

COAST PERFORMANCE

1st Gear

Graphs Contained in This Section

Torque Ratio -vs- Output Speed

Output Torque -vs- Output Speed

Input Speed -vs- Output Speed

Efficiency -vs- Output Speed

Efficiency -vs- Power Out

196

Torque In

Speed In

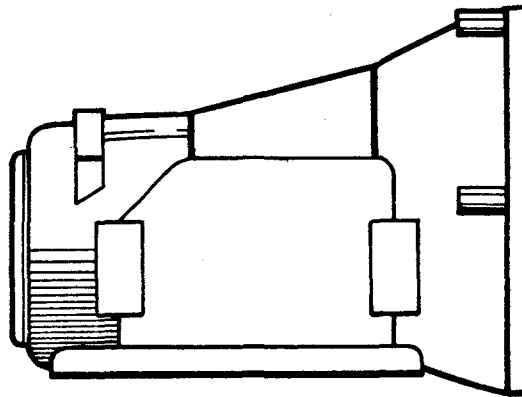

Torque Out

Speed Out

Coast Performance Tests

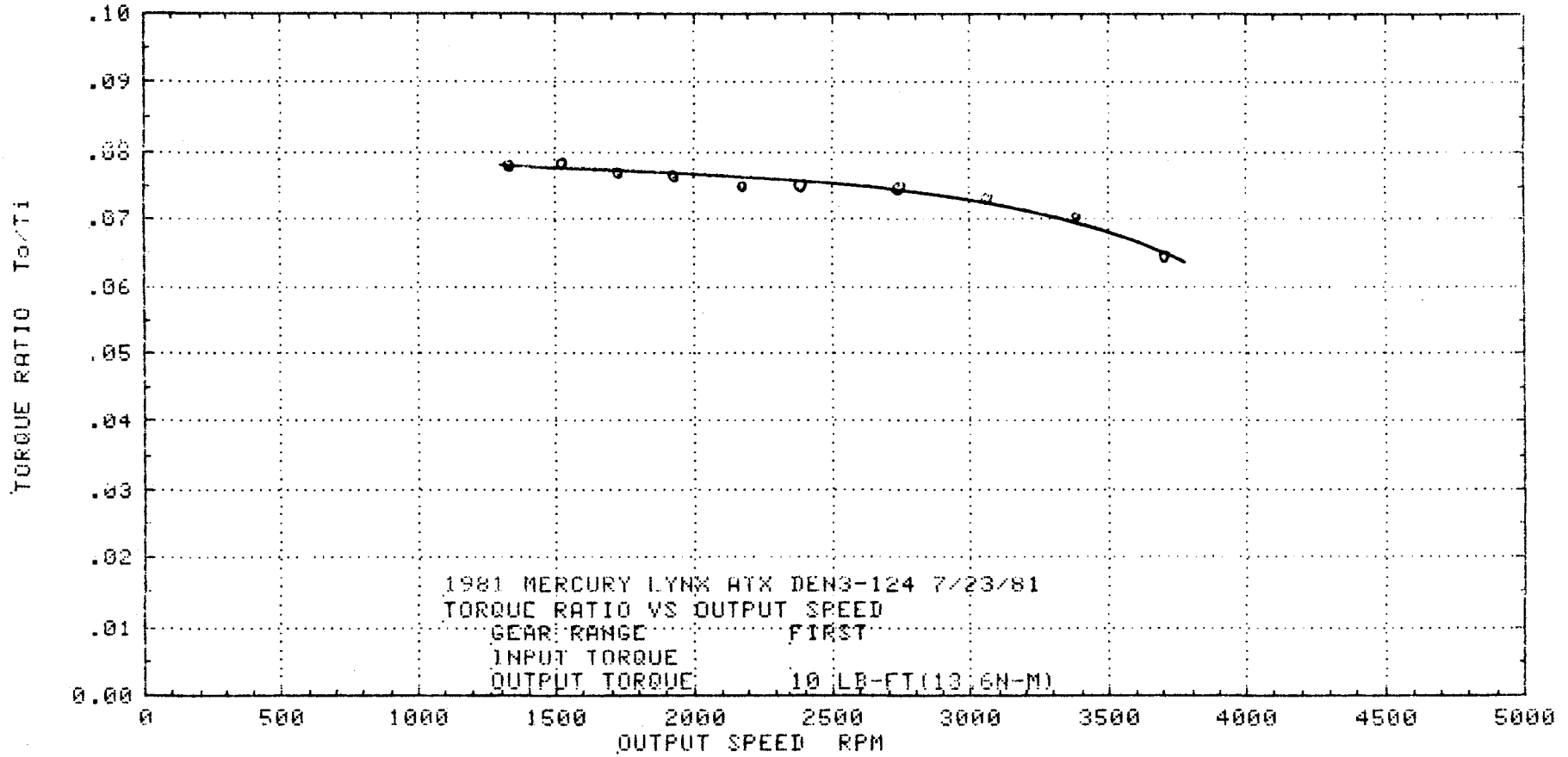

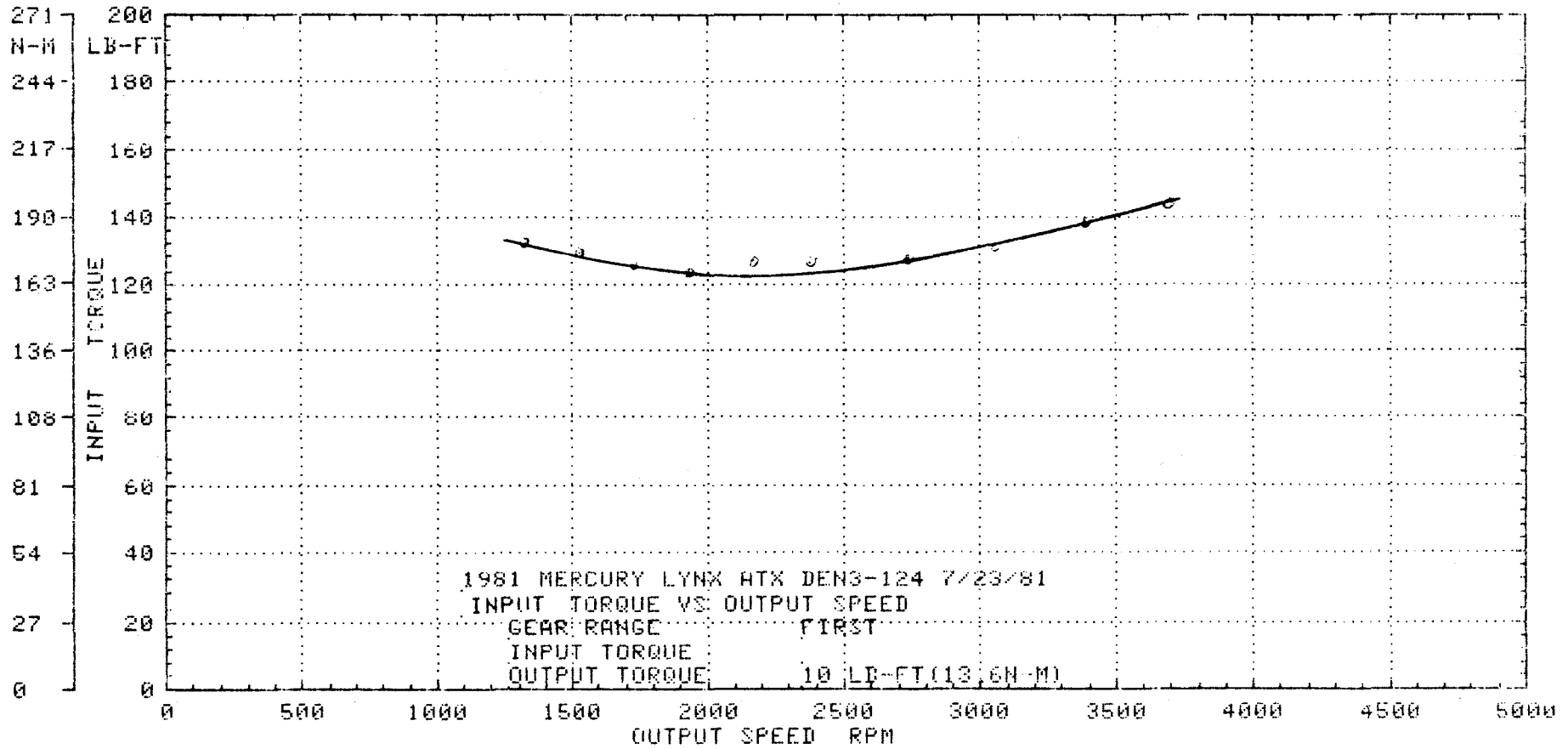

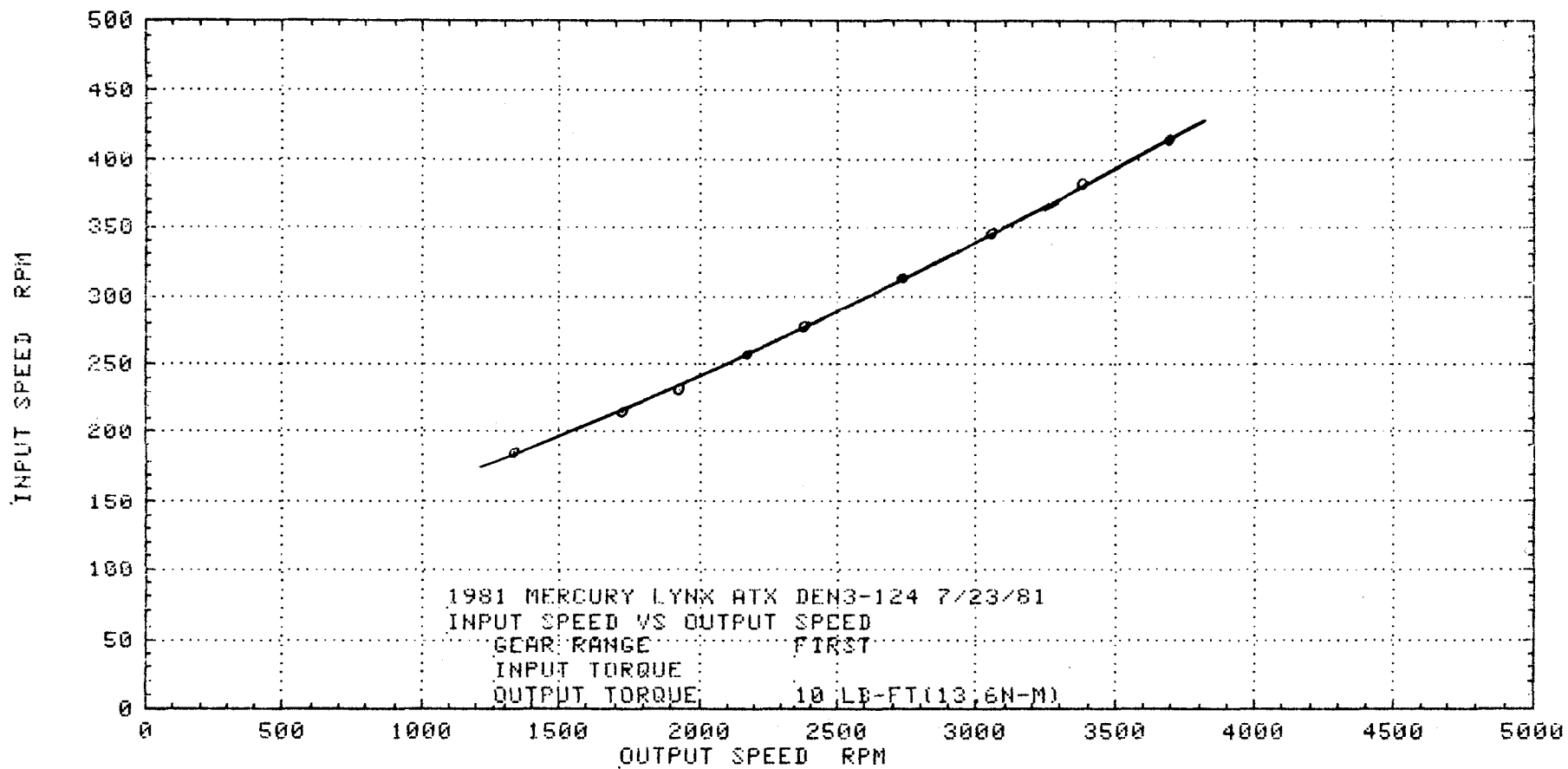

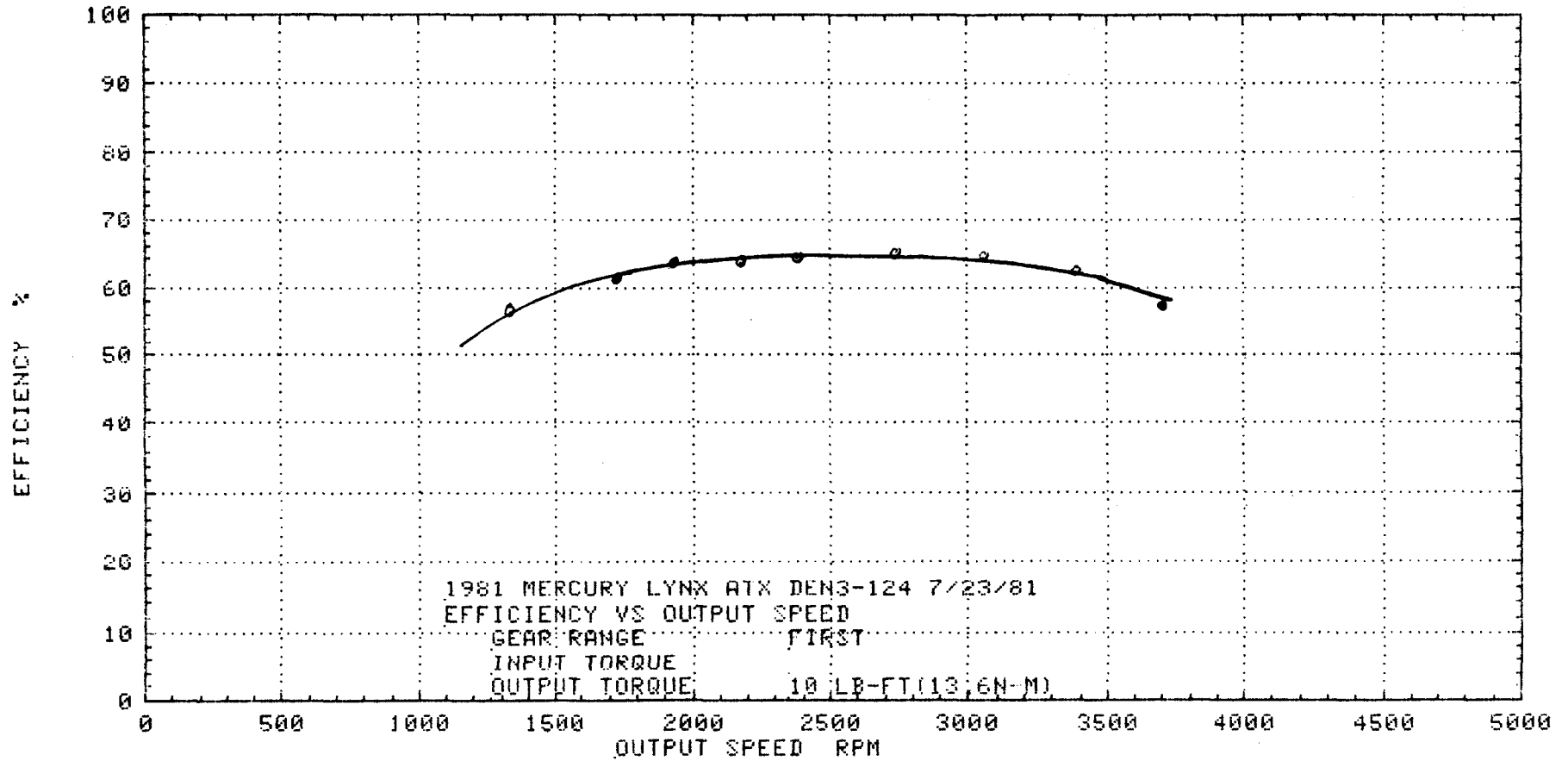

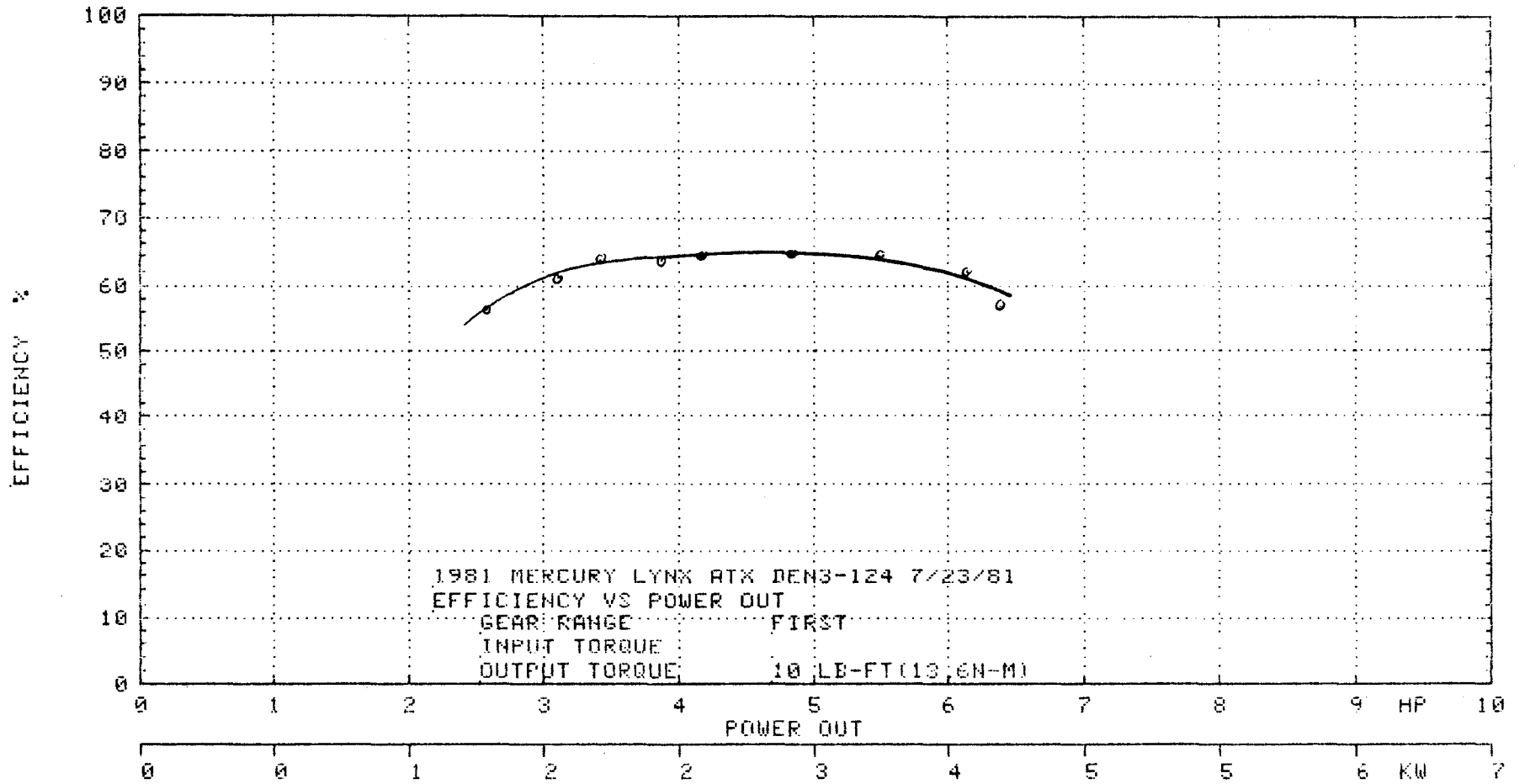

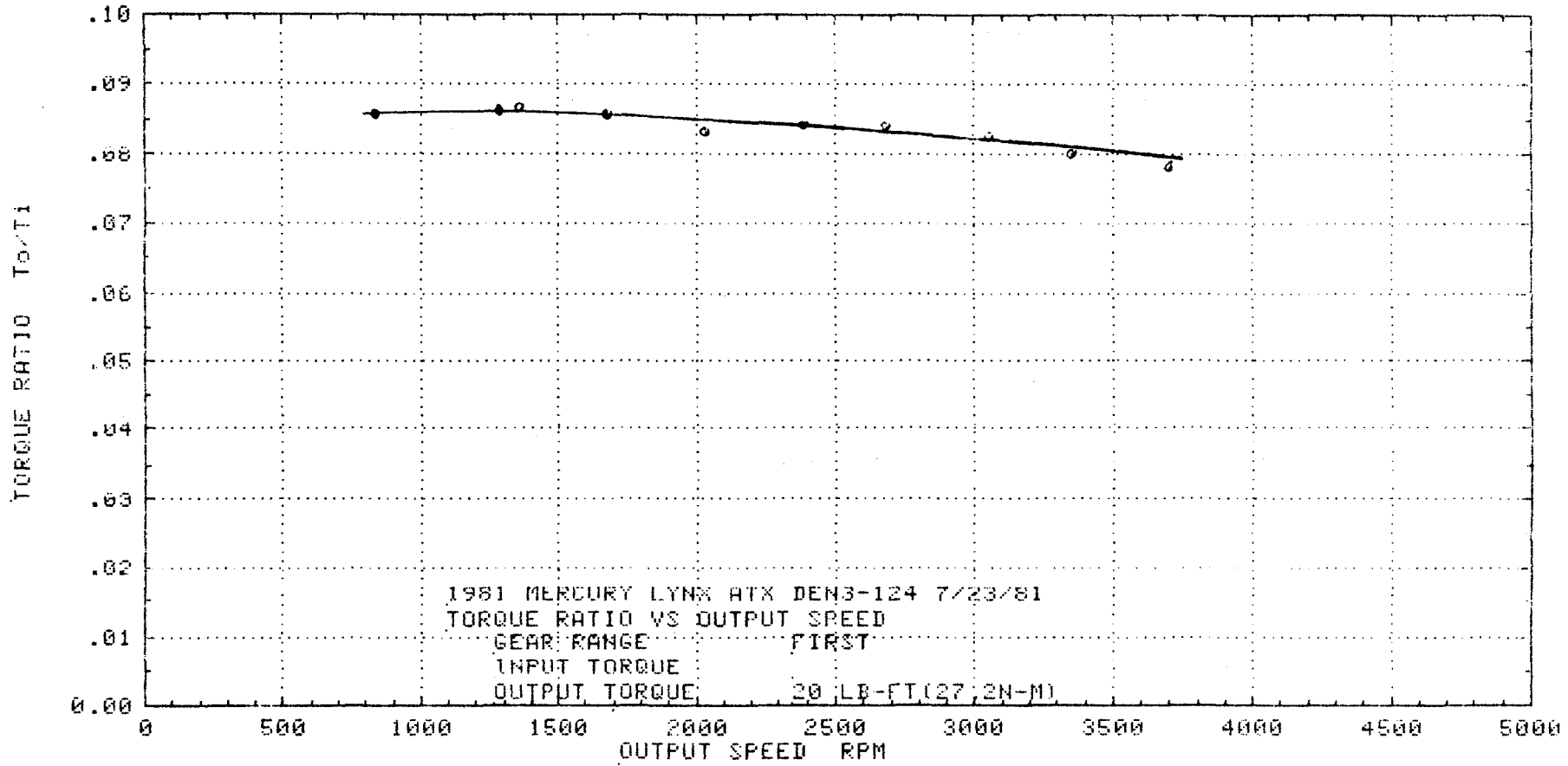

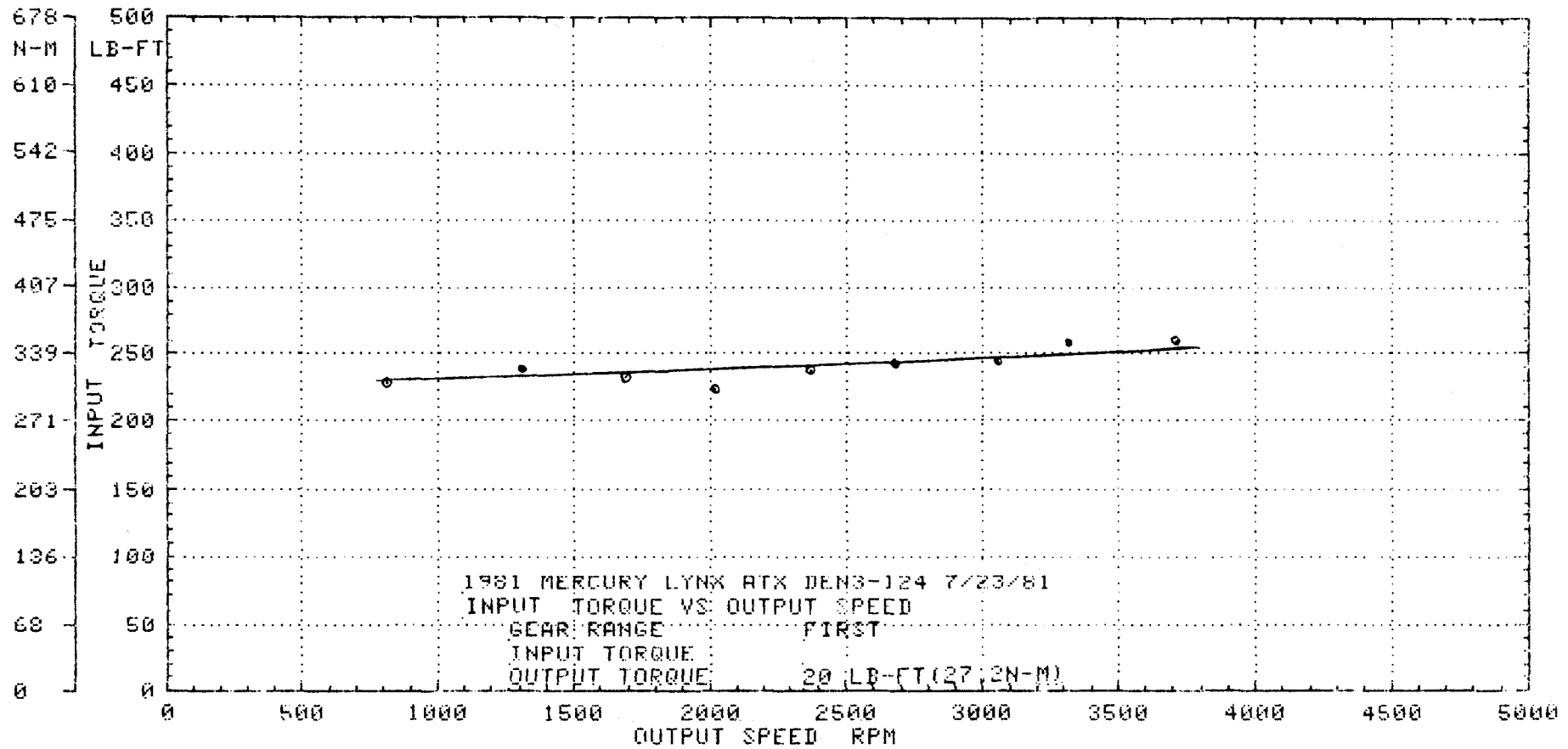

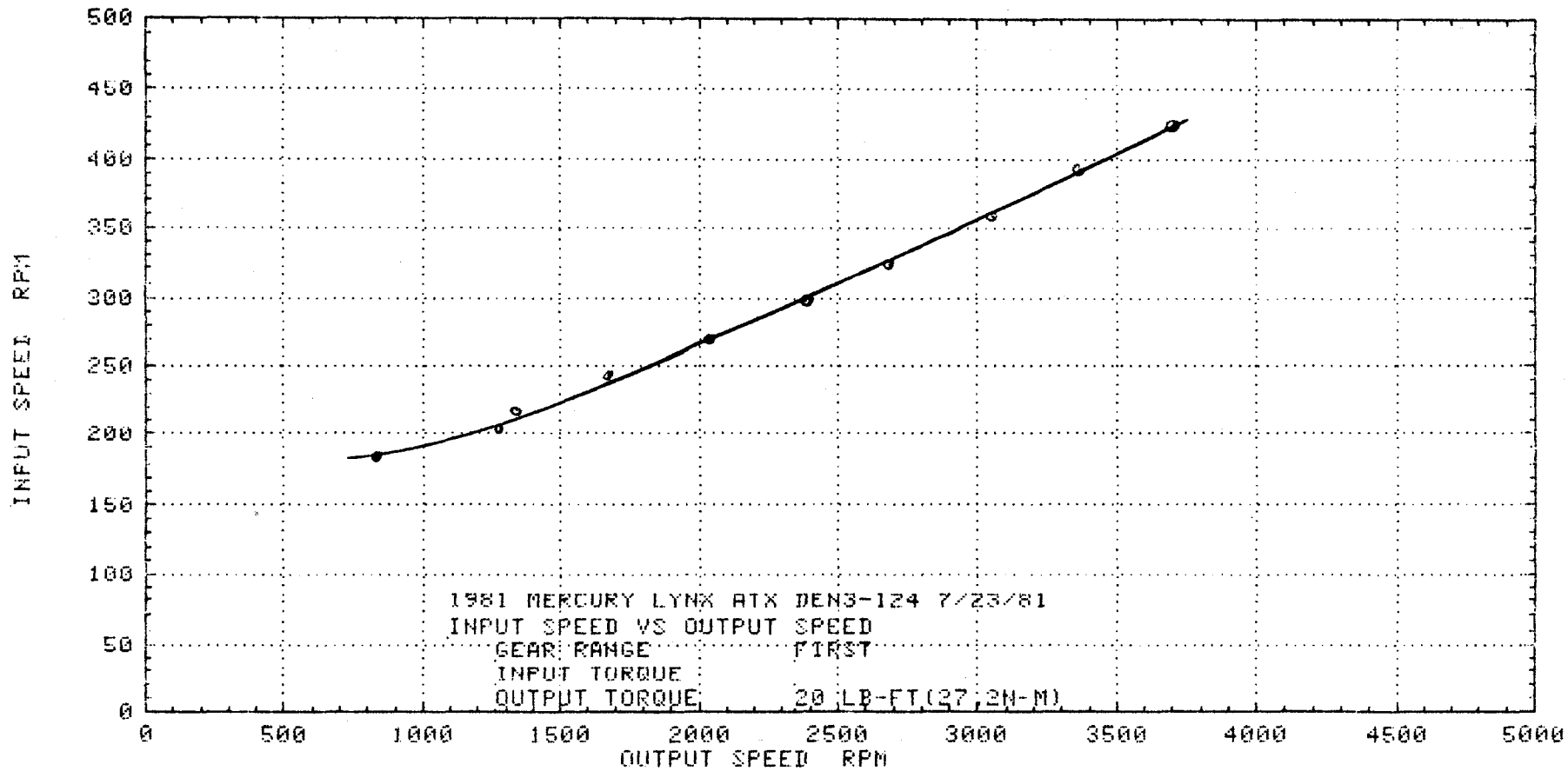

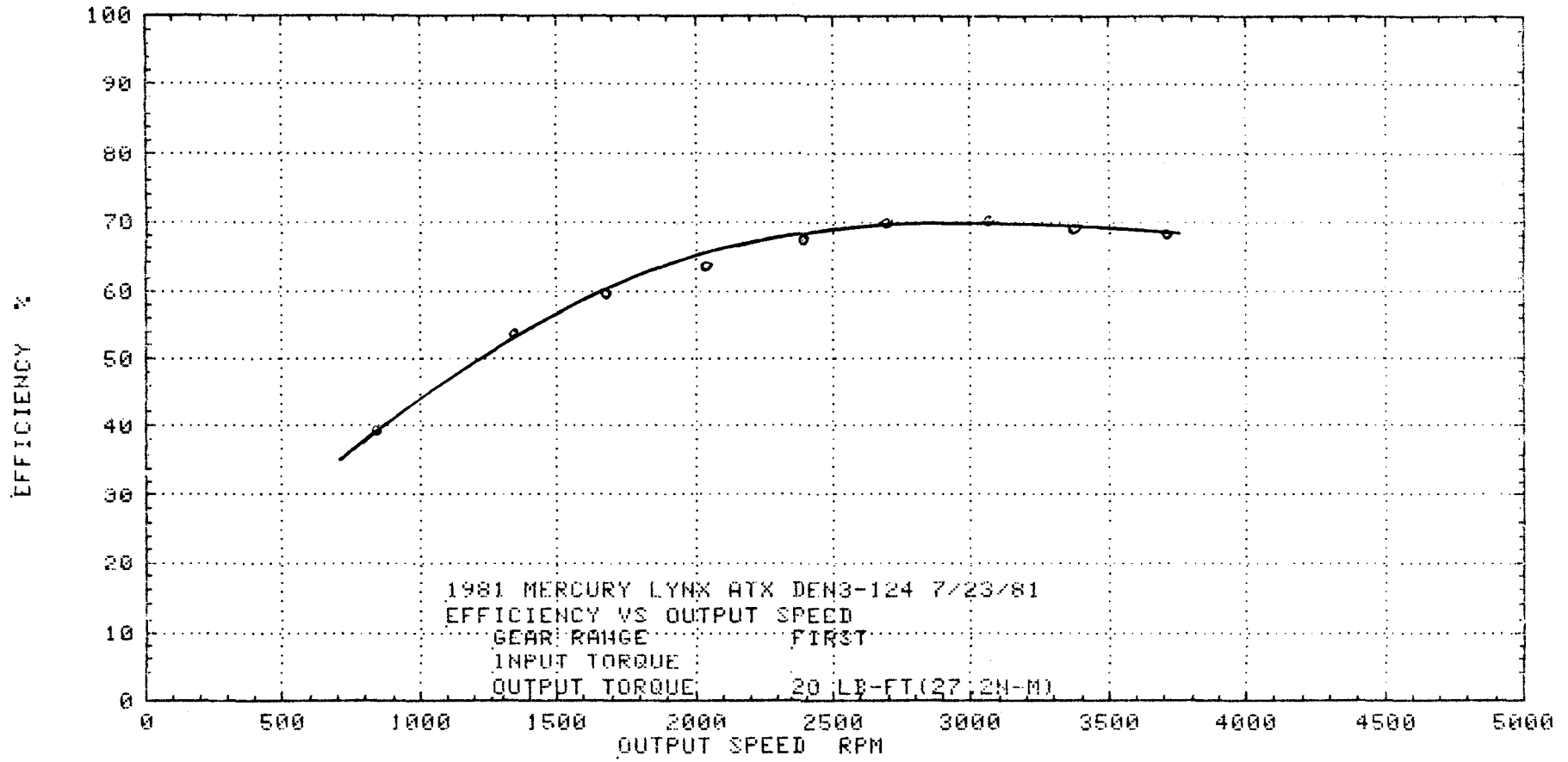

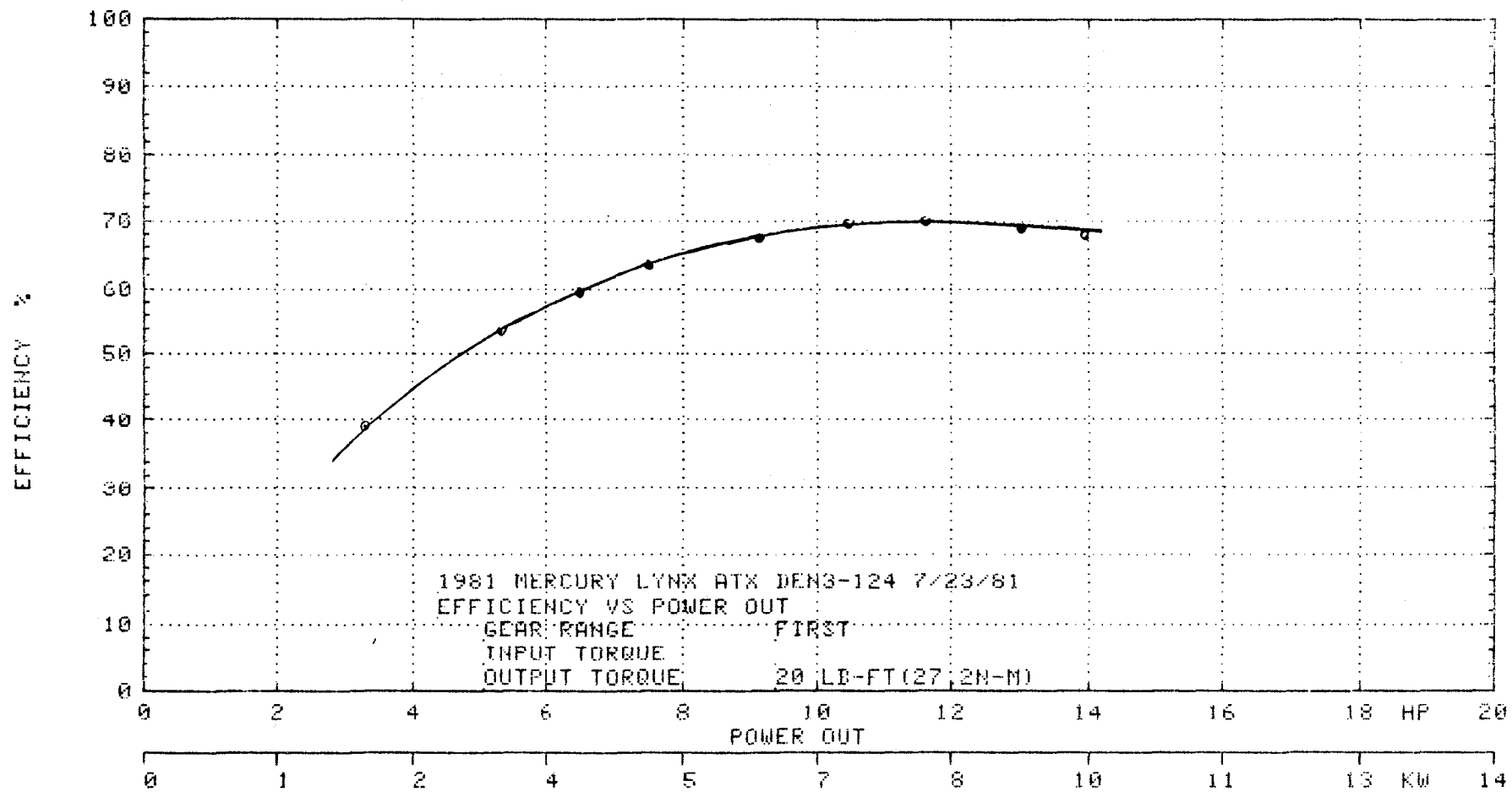

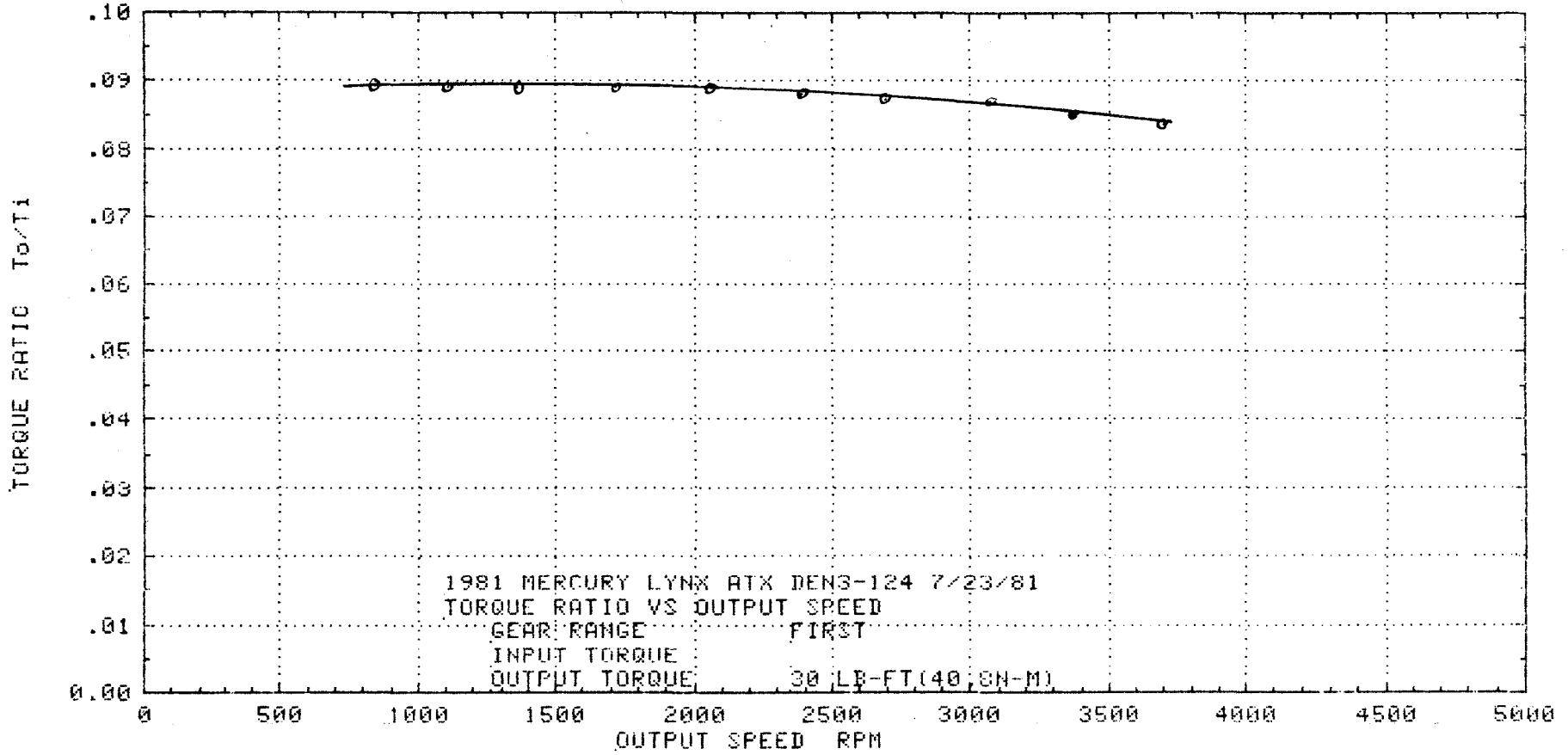

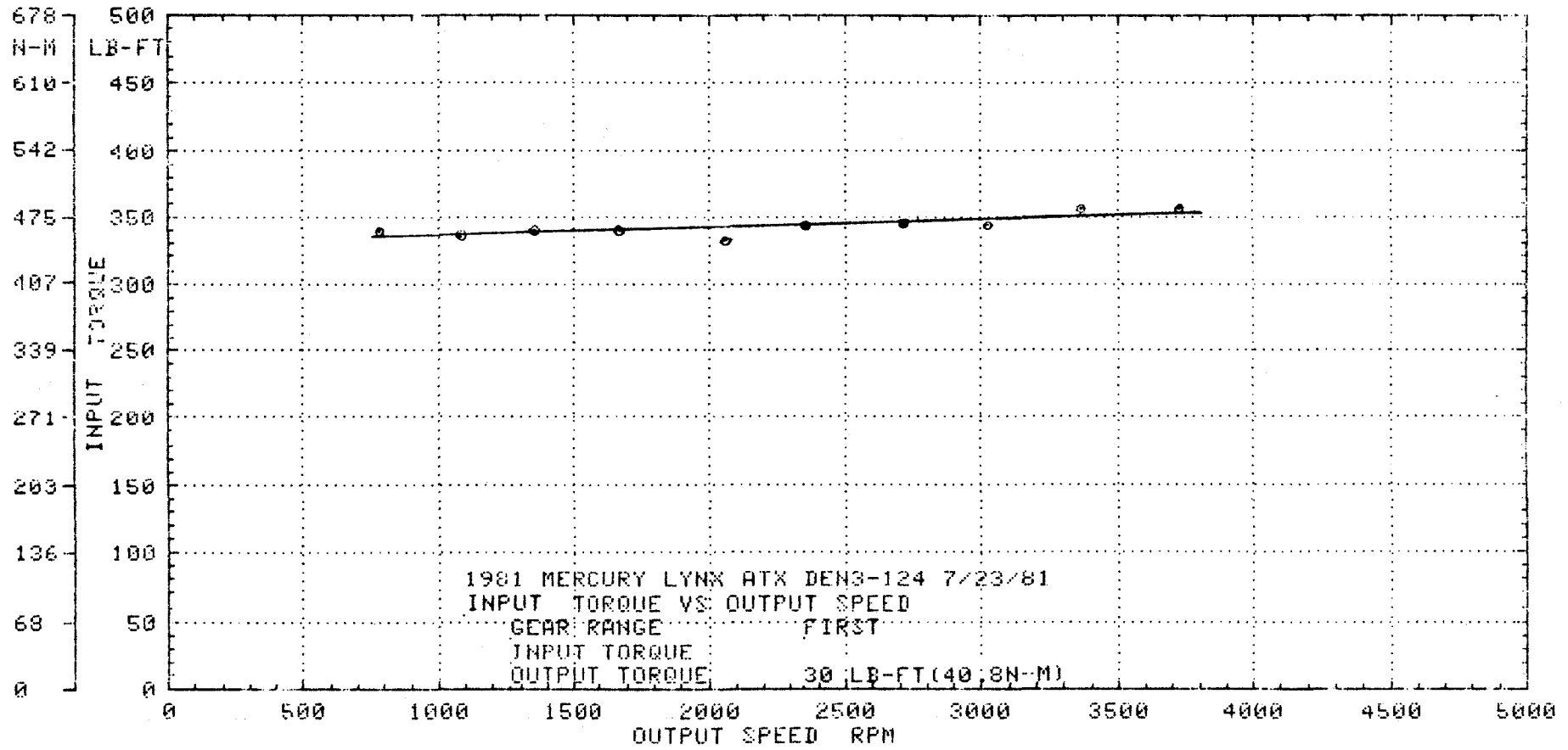

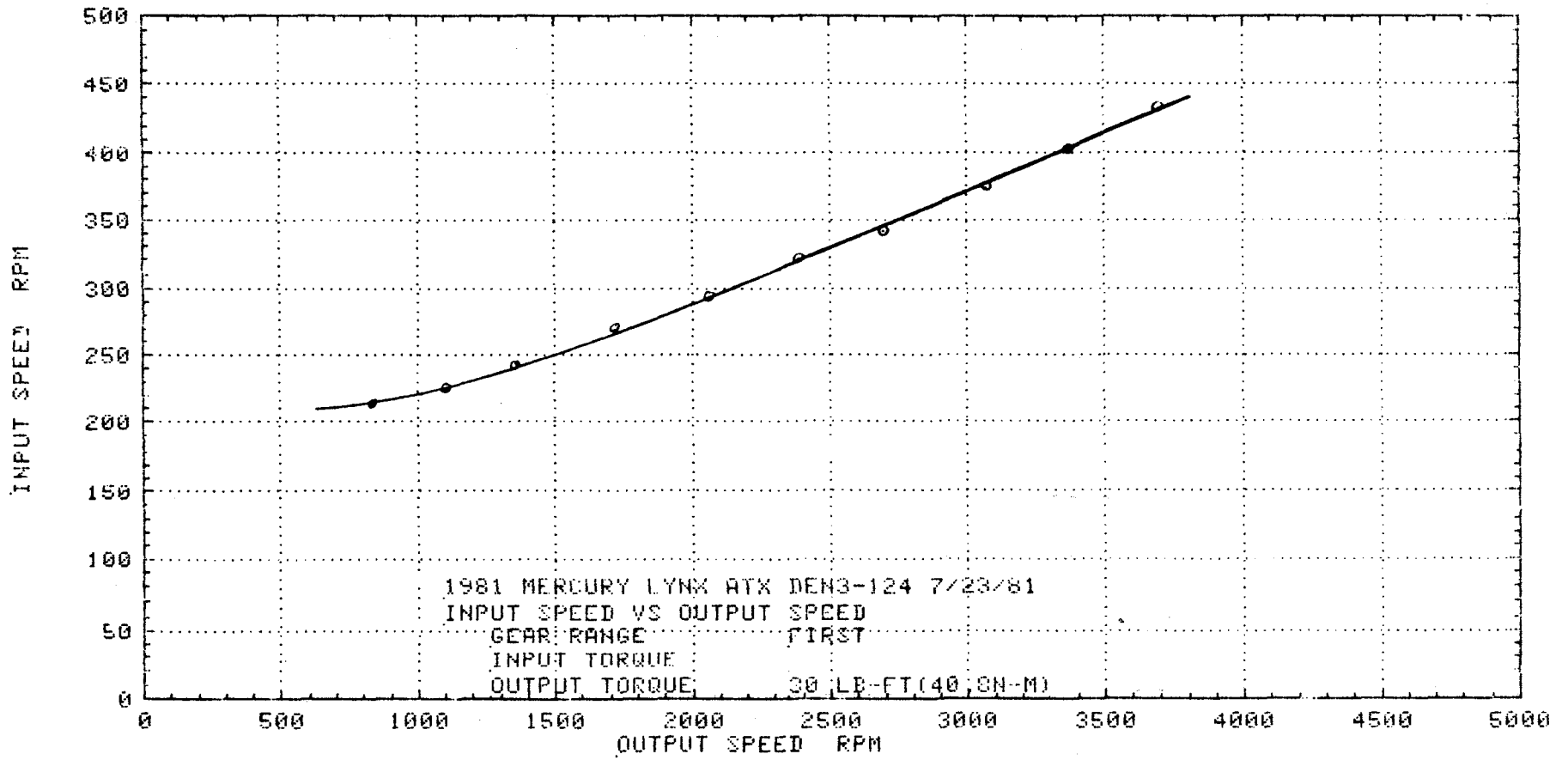

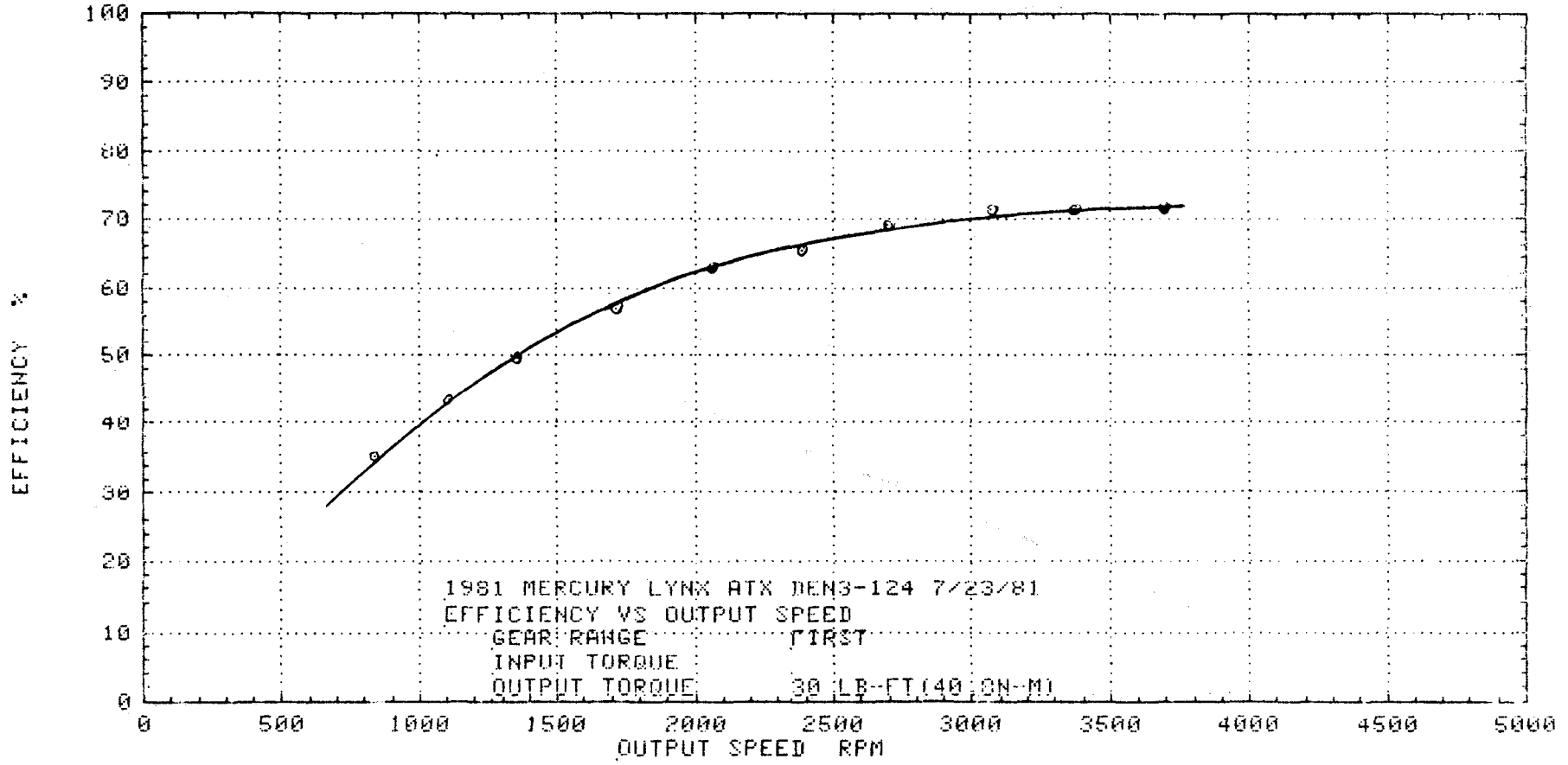

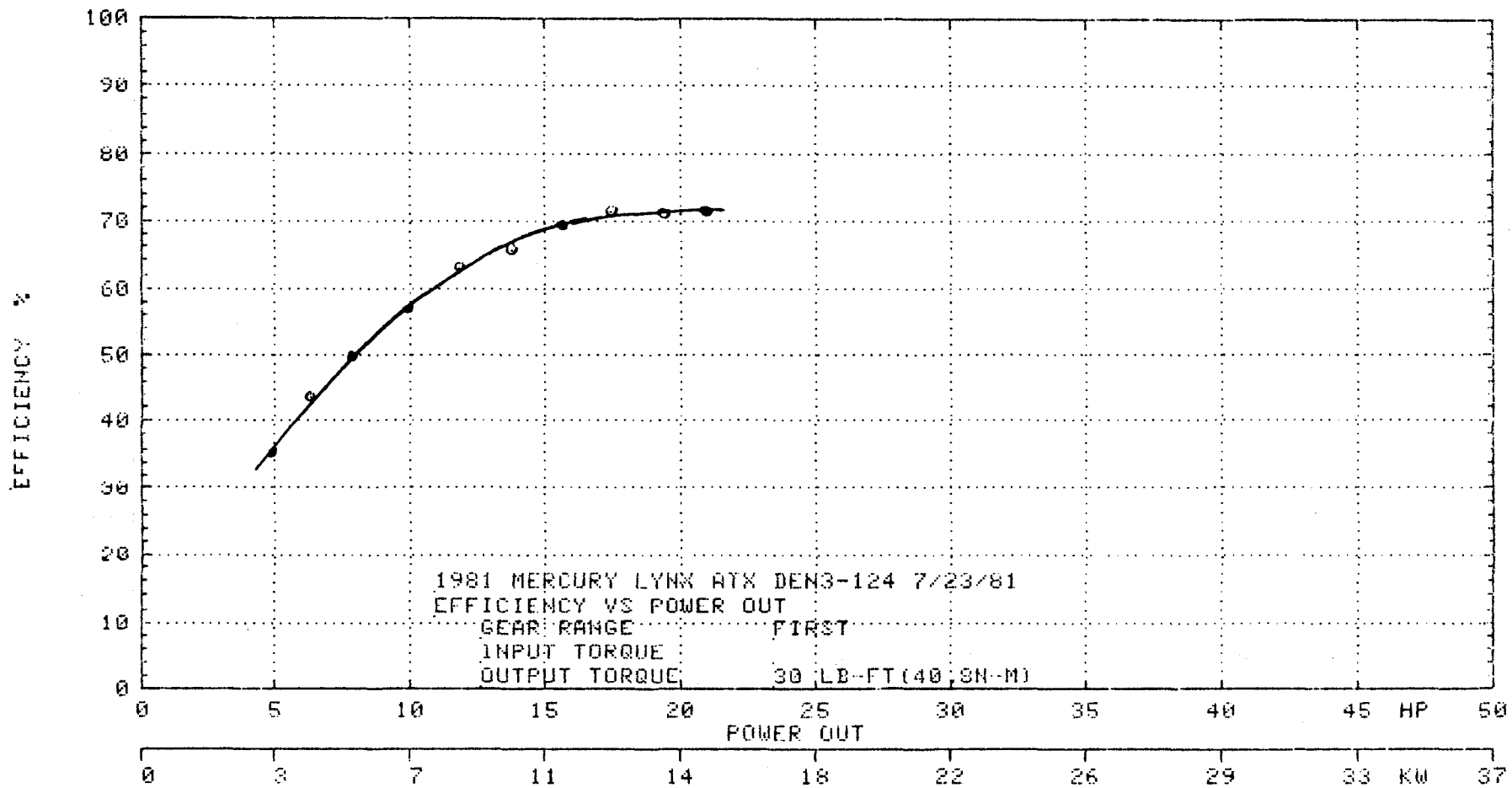

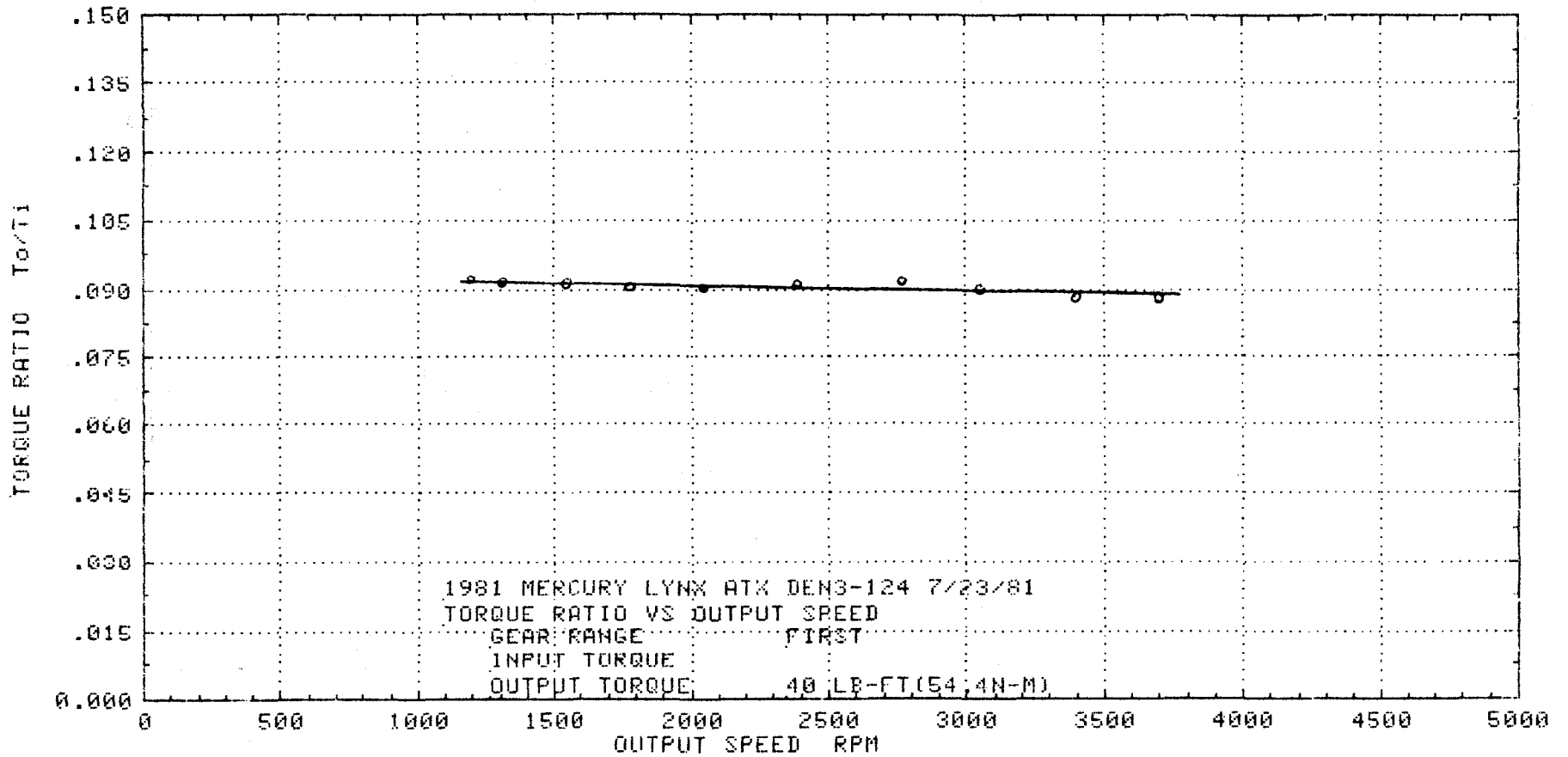

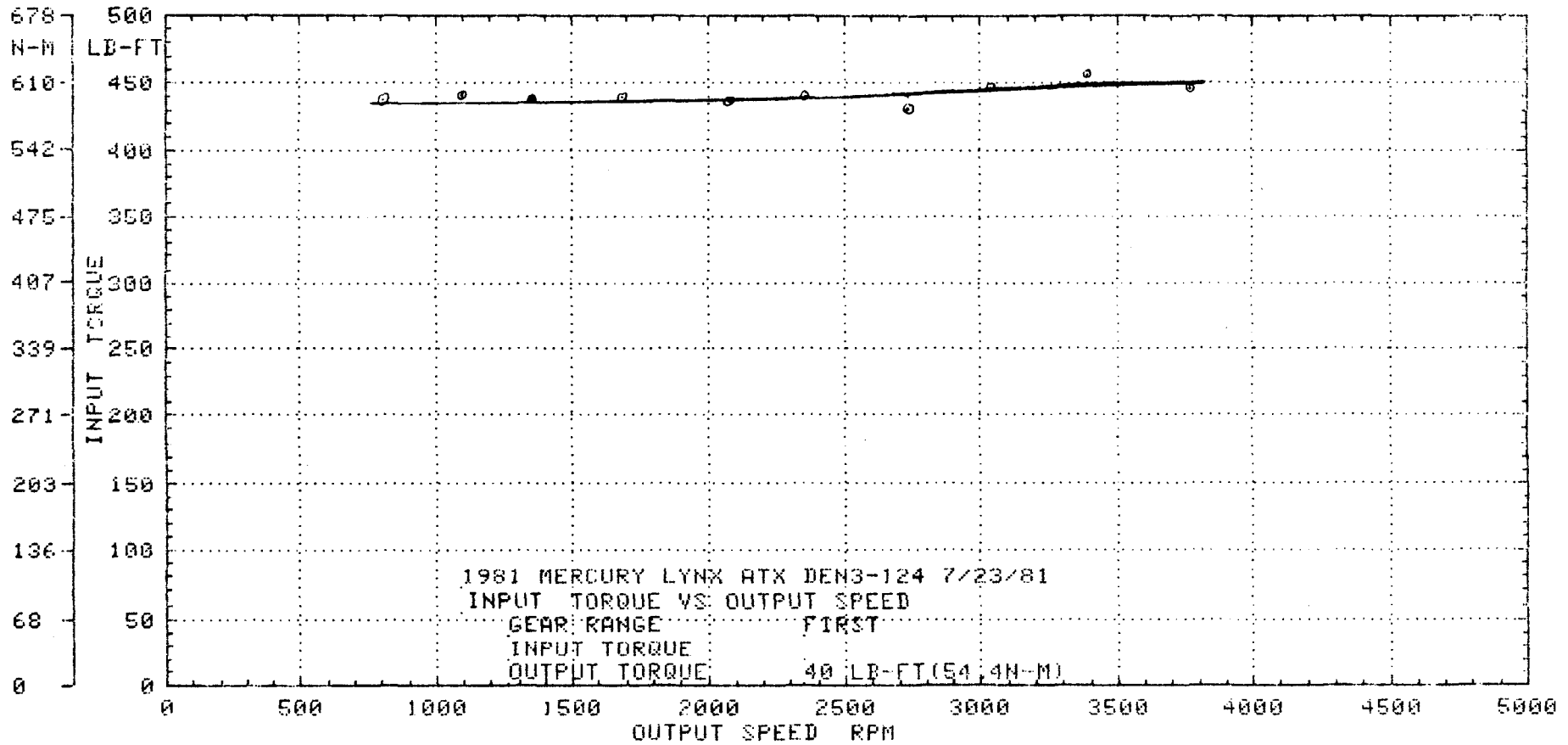

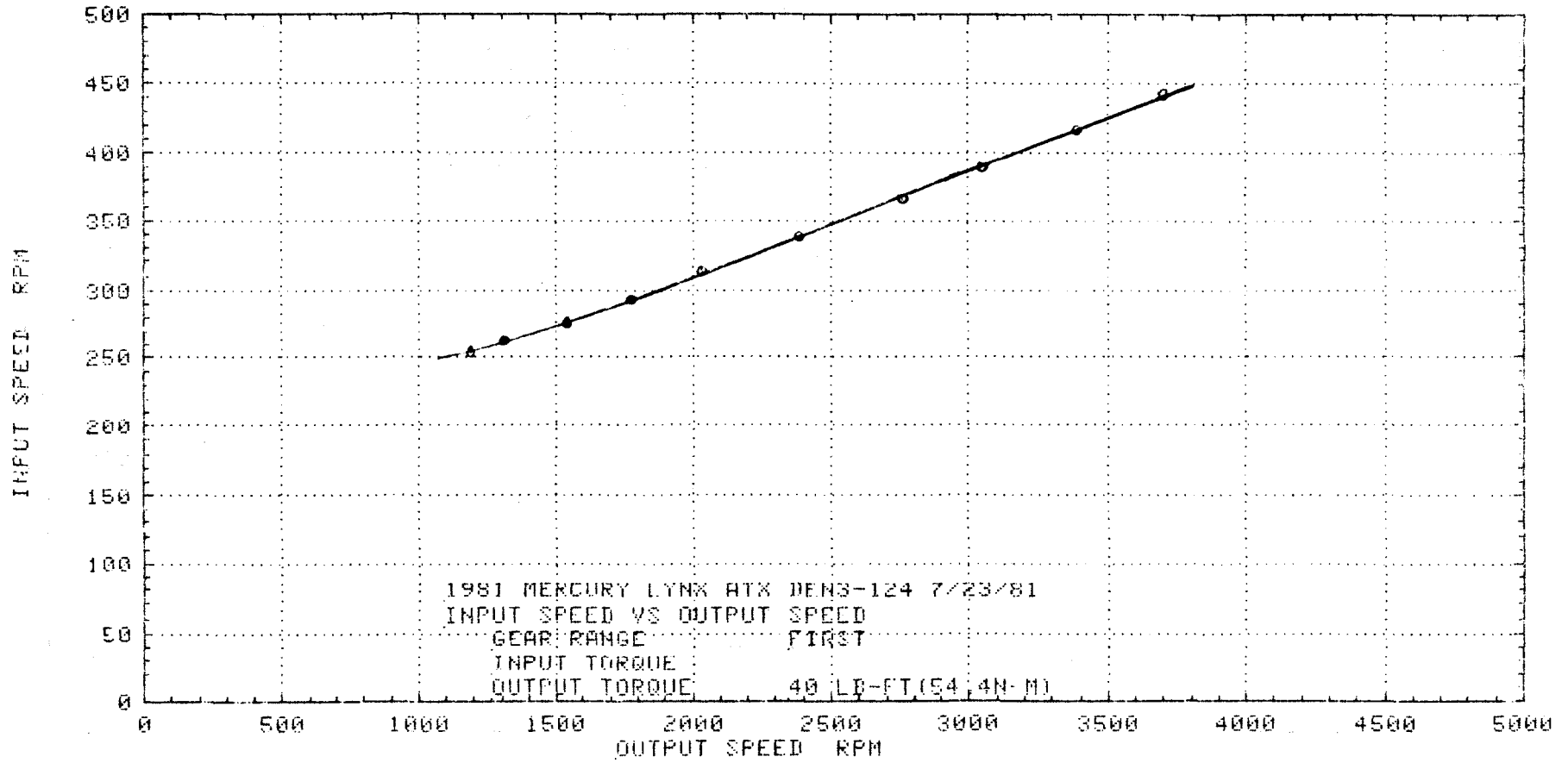

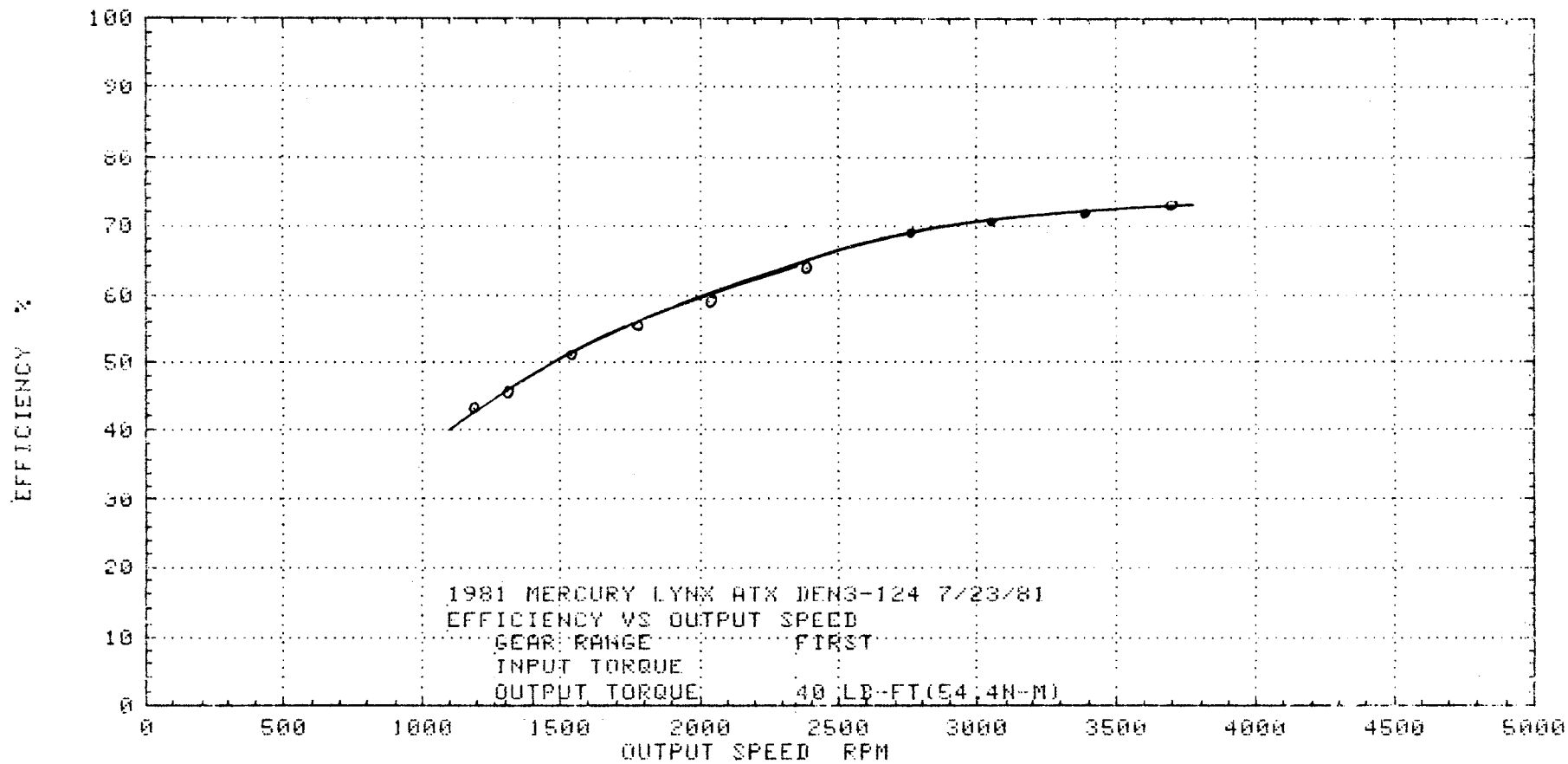

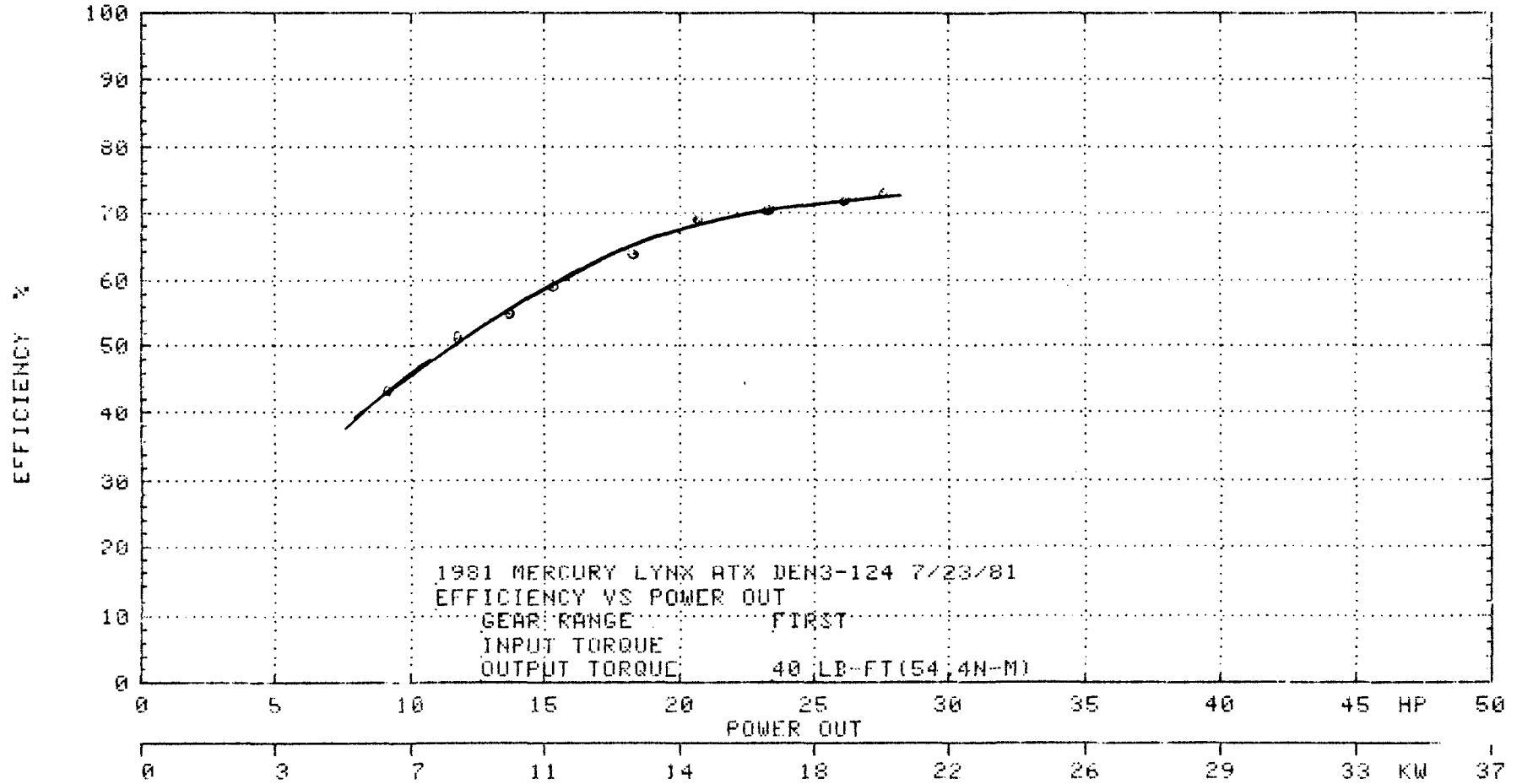

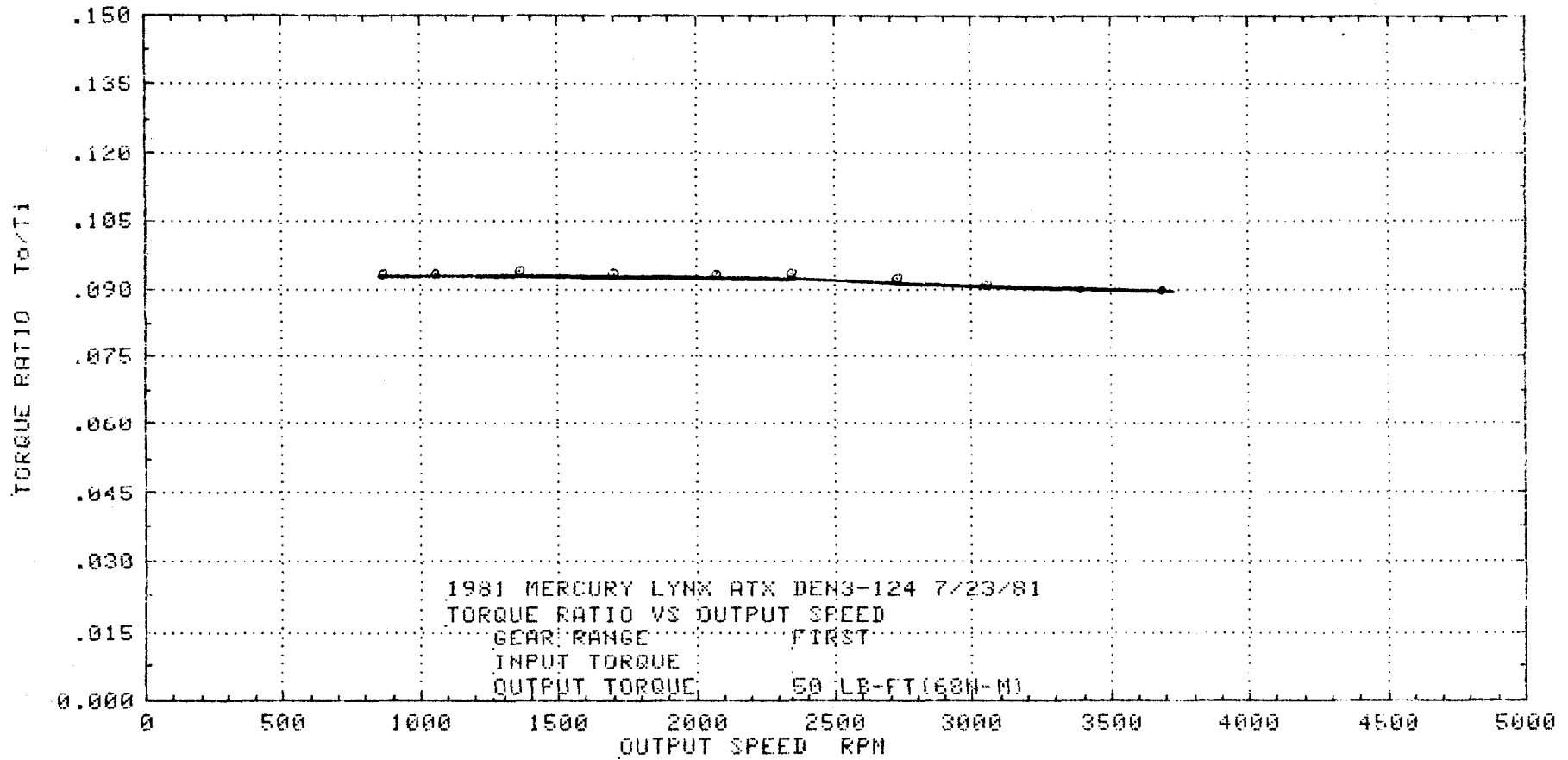

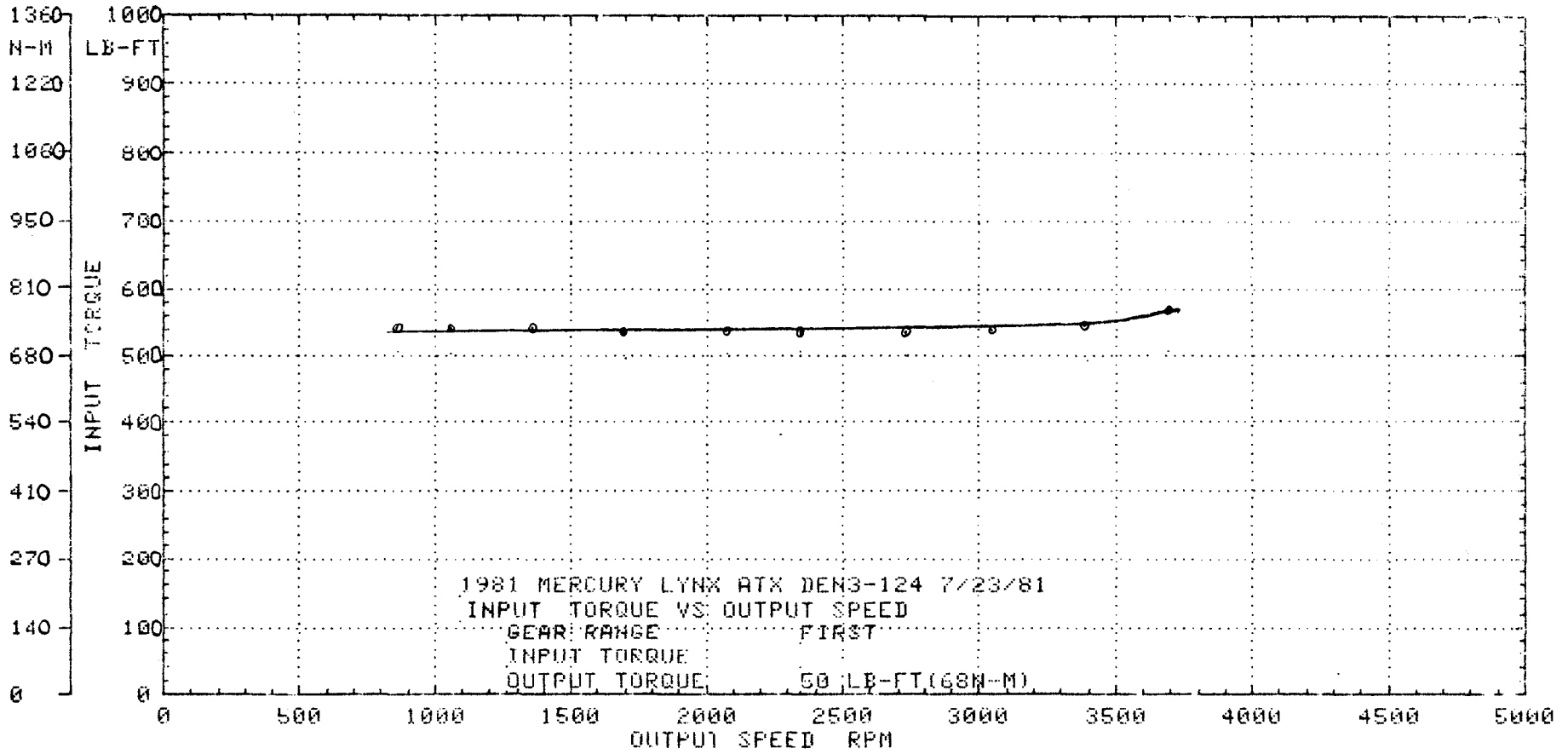

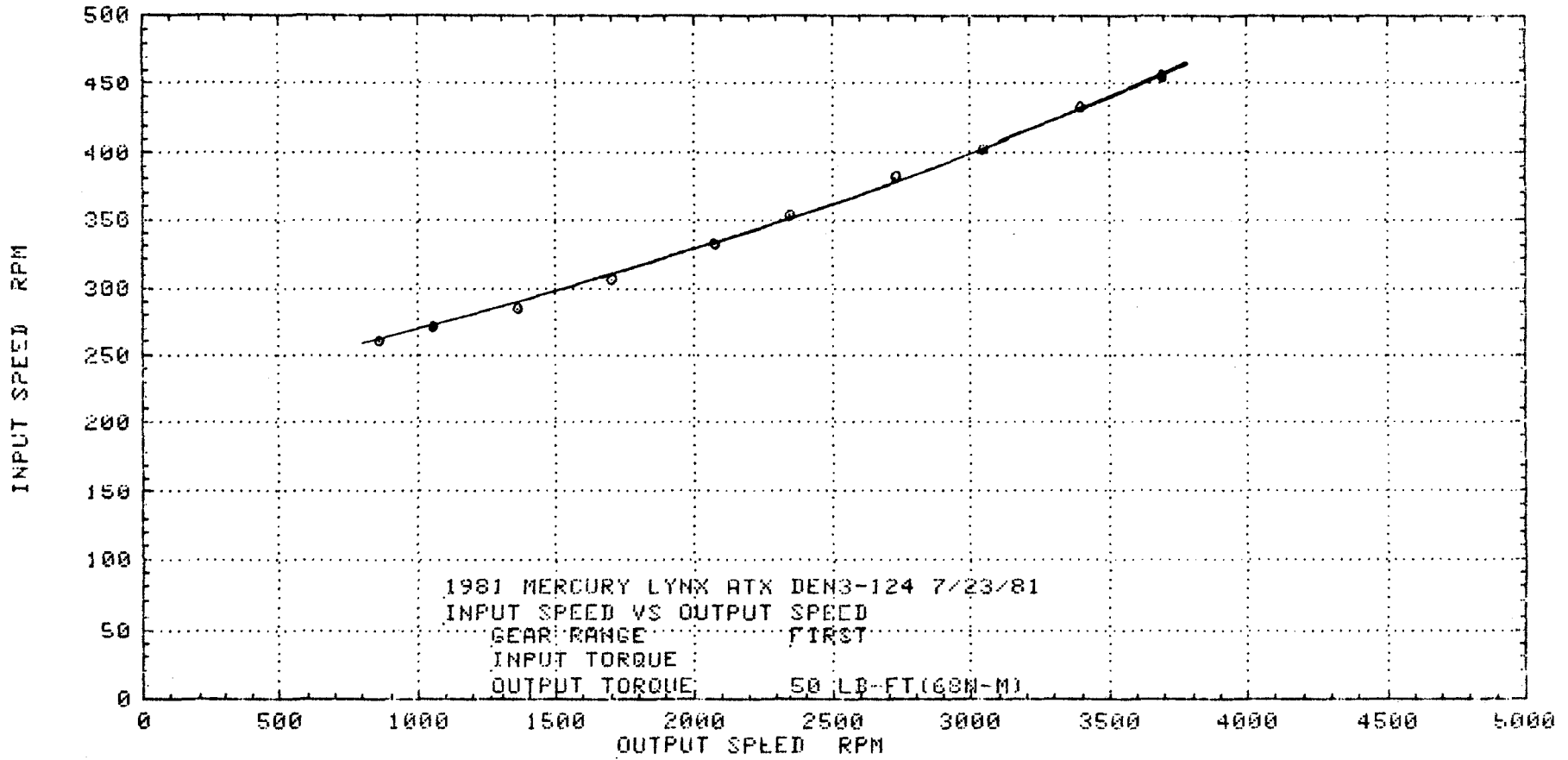

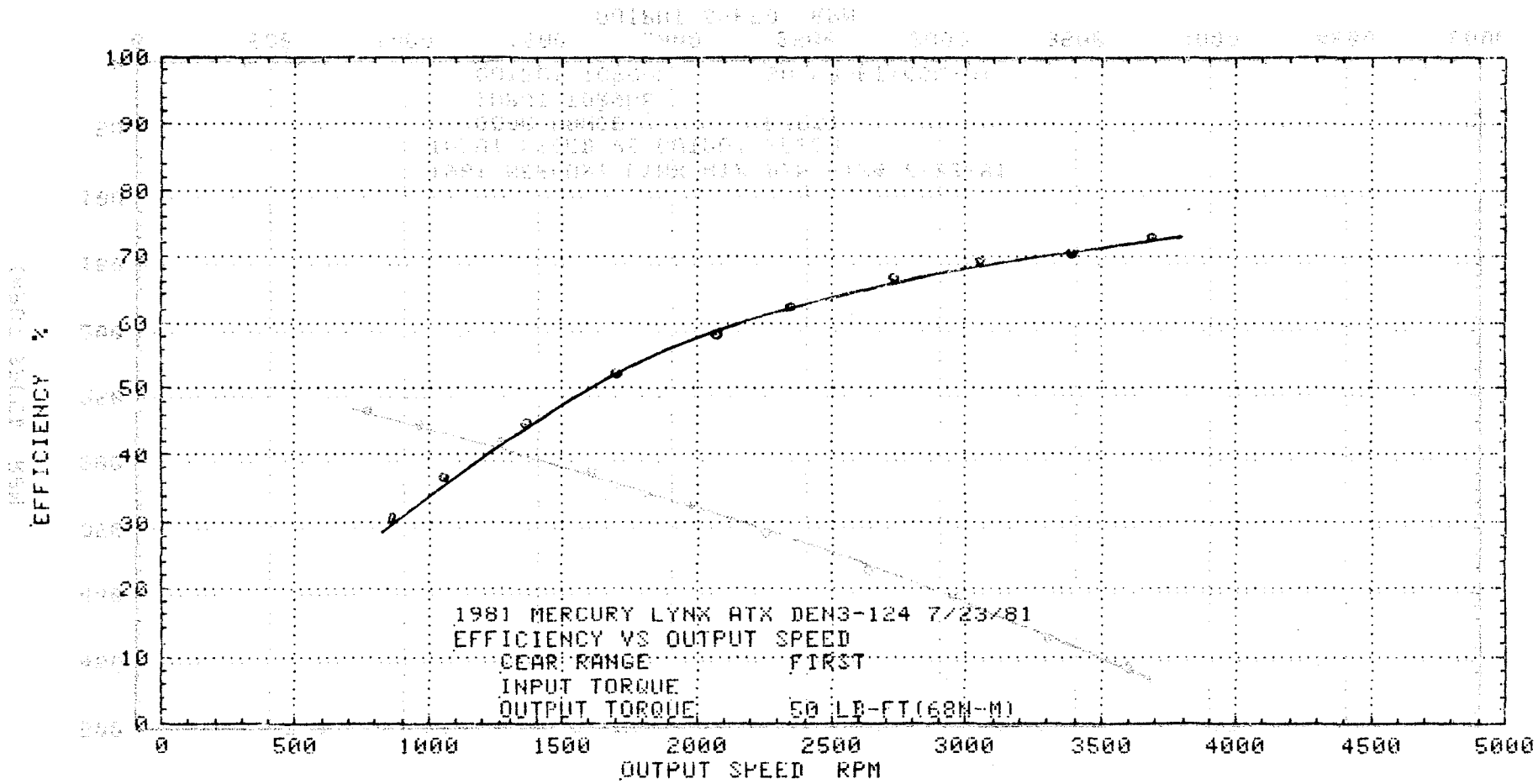

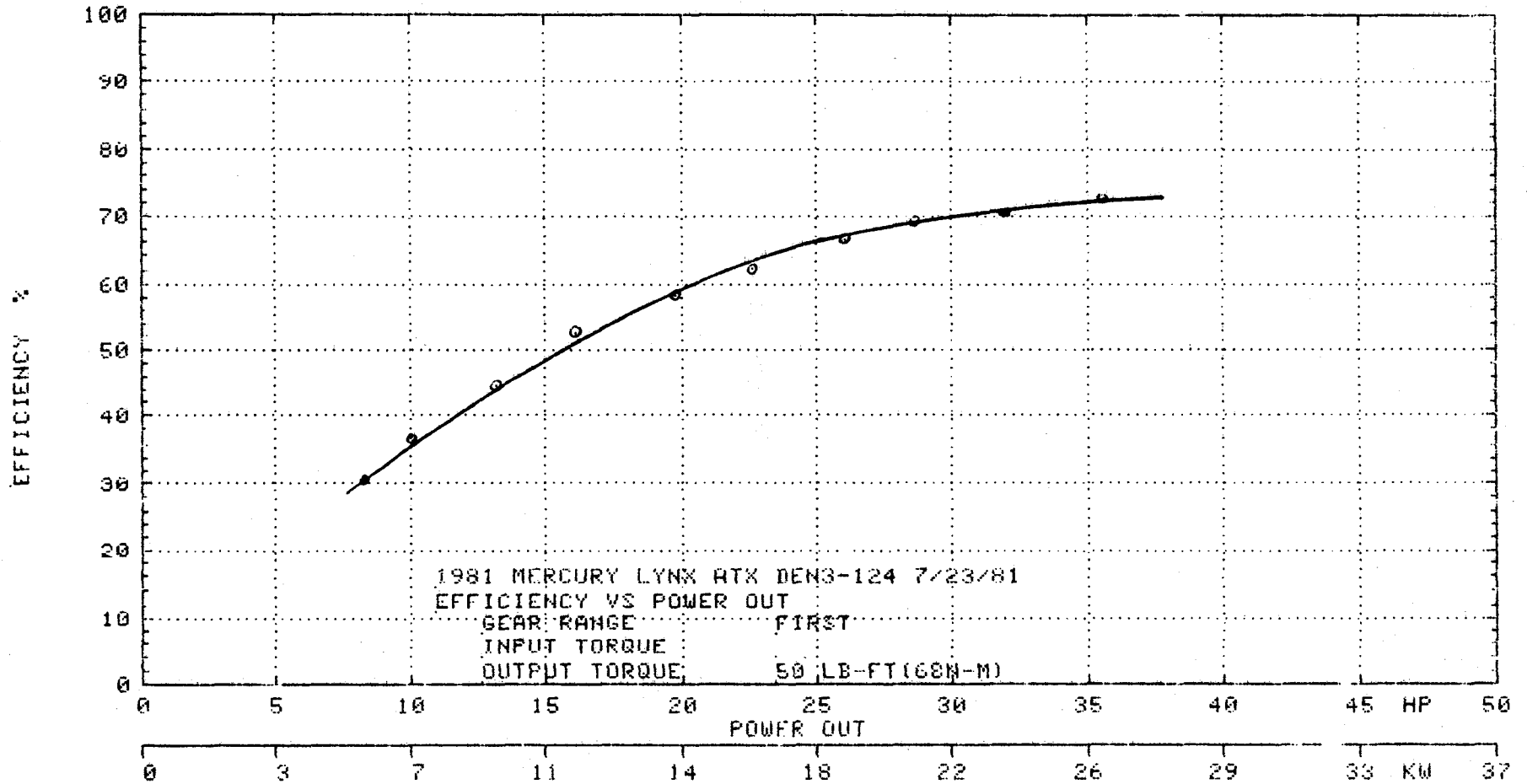

COAST PERFORMANCE

2nd Gear

Graphs Contained in This Section

Torque Ratio -vs- Output Speed

Output Torque -vs- Output Speed

Input Speed -vs- Output Speed

Efficiency -vs- Output Speed

Efficiency -vs- Power Out

223

Torque In

Speed In

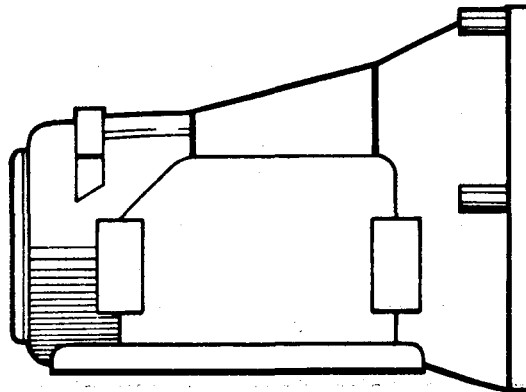

Torque Out

Speed Out

Coast Performance Tests

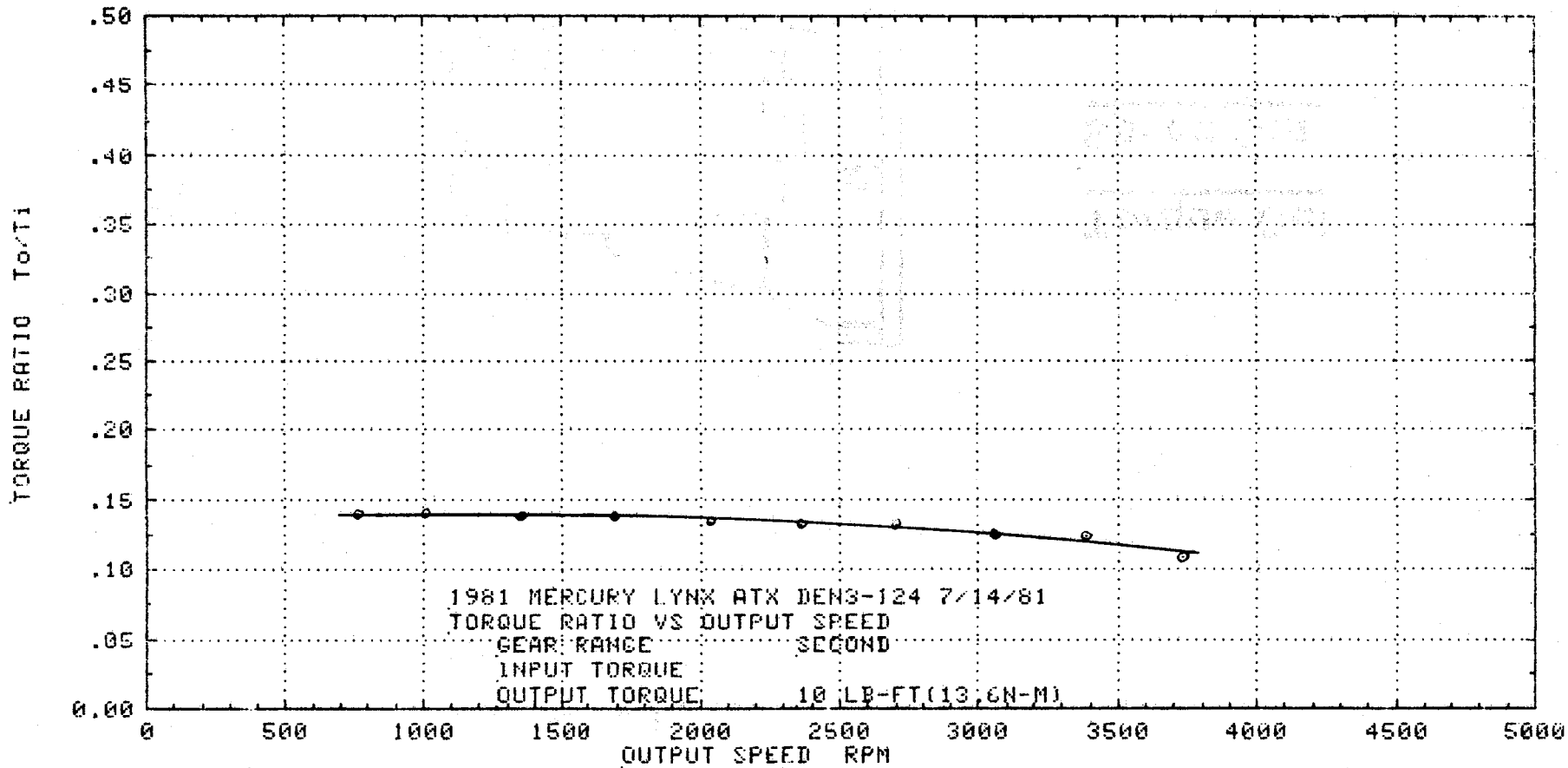

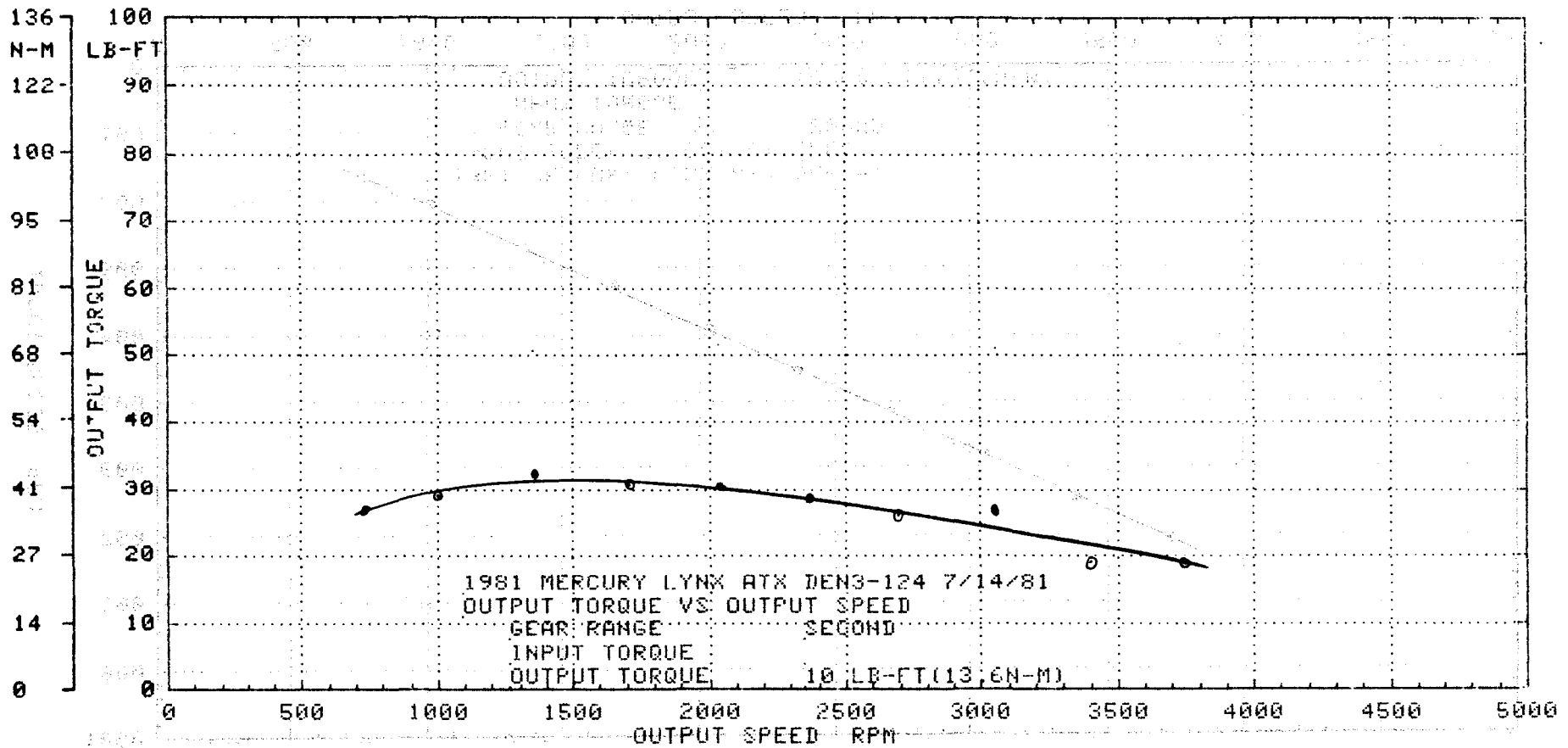

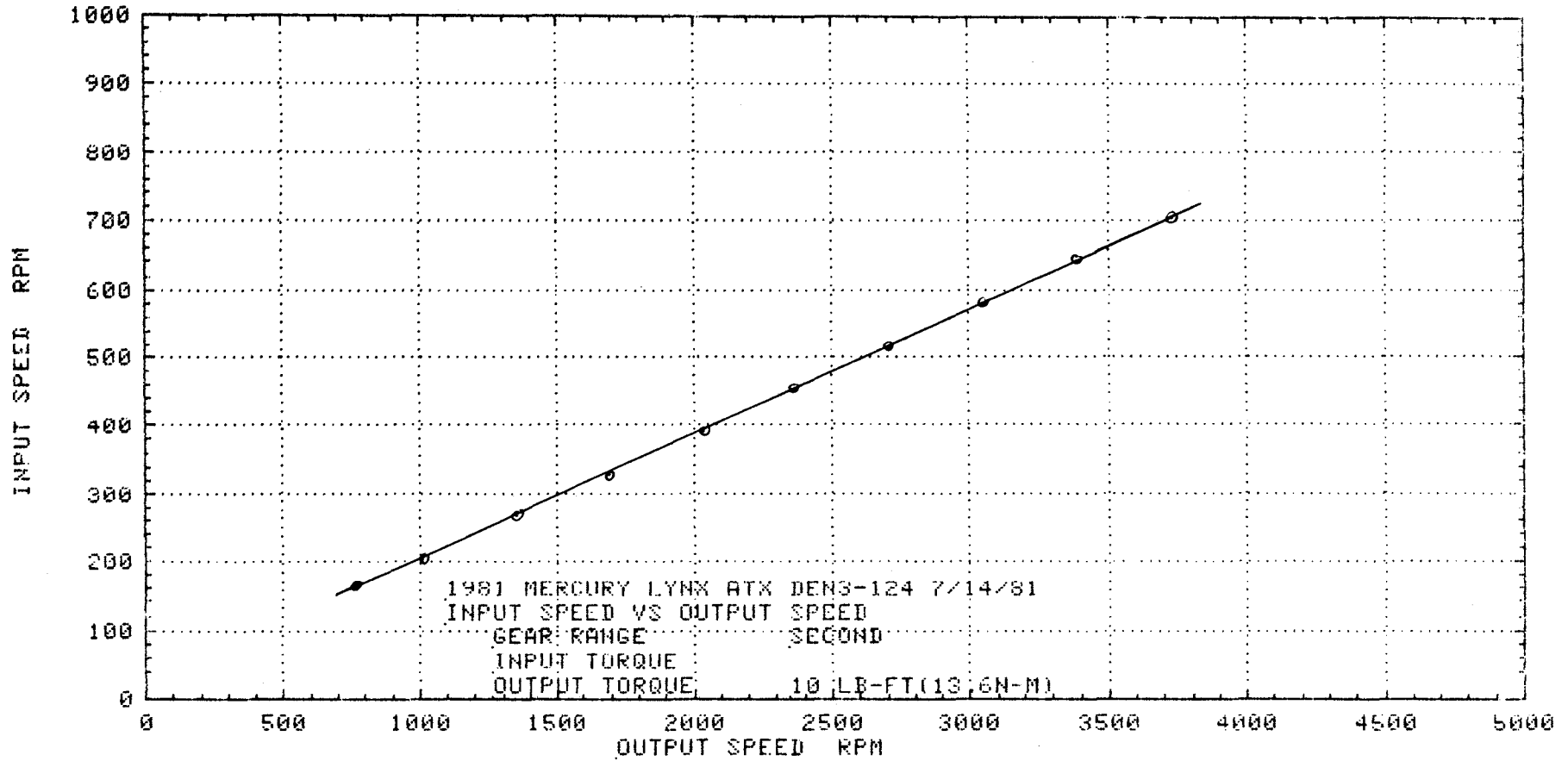

% EFFICIENCY

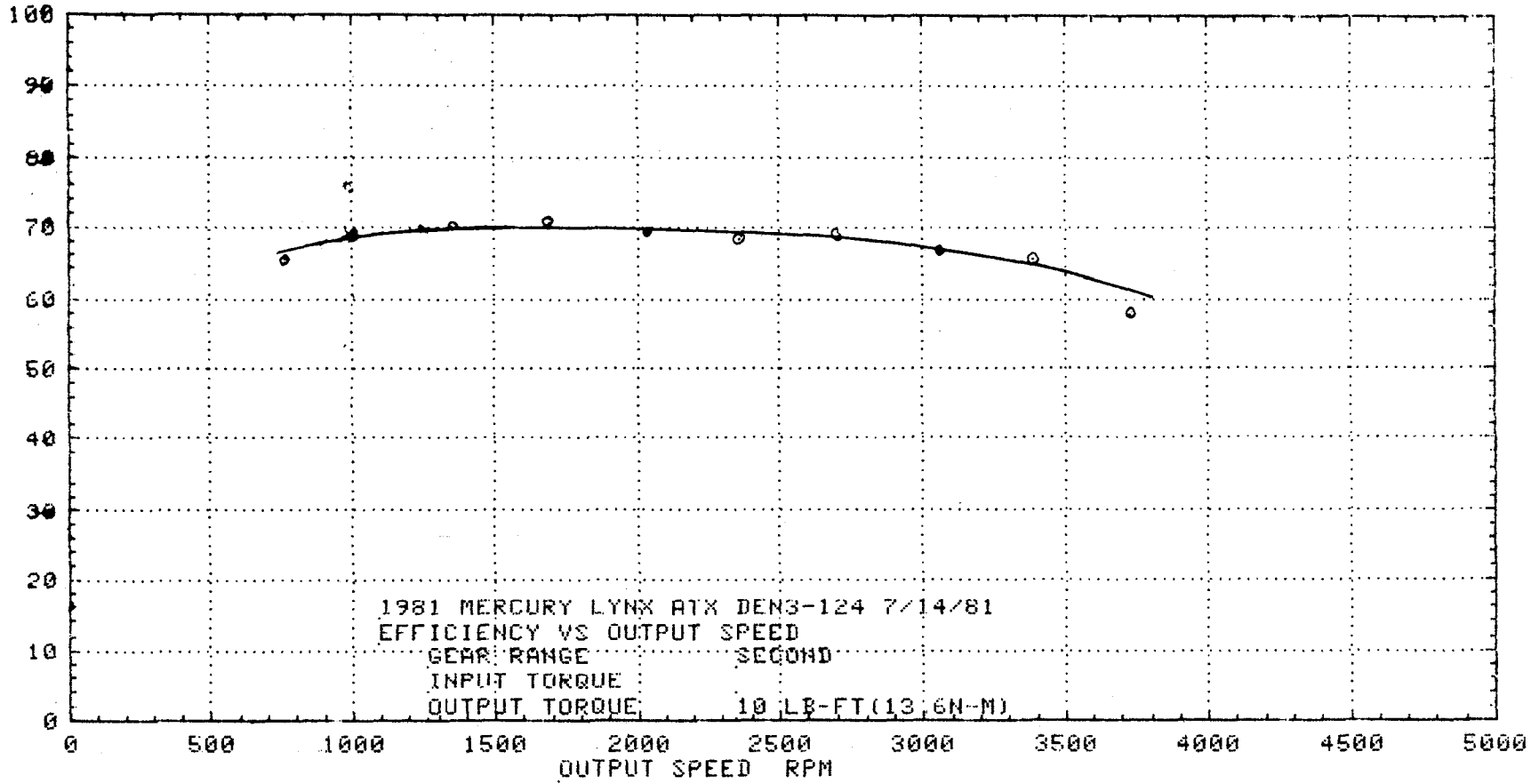

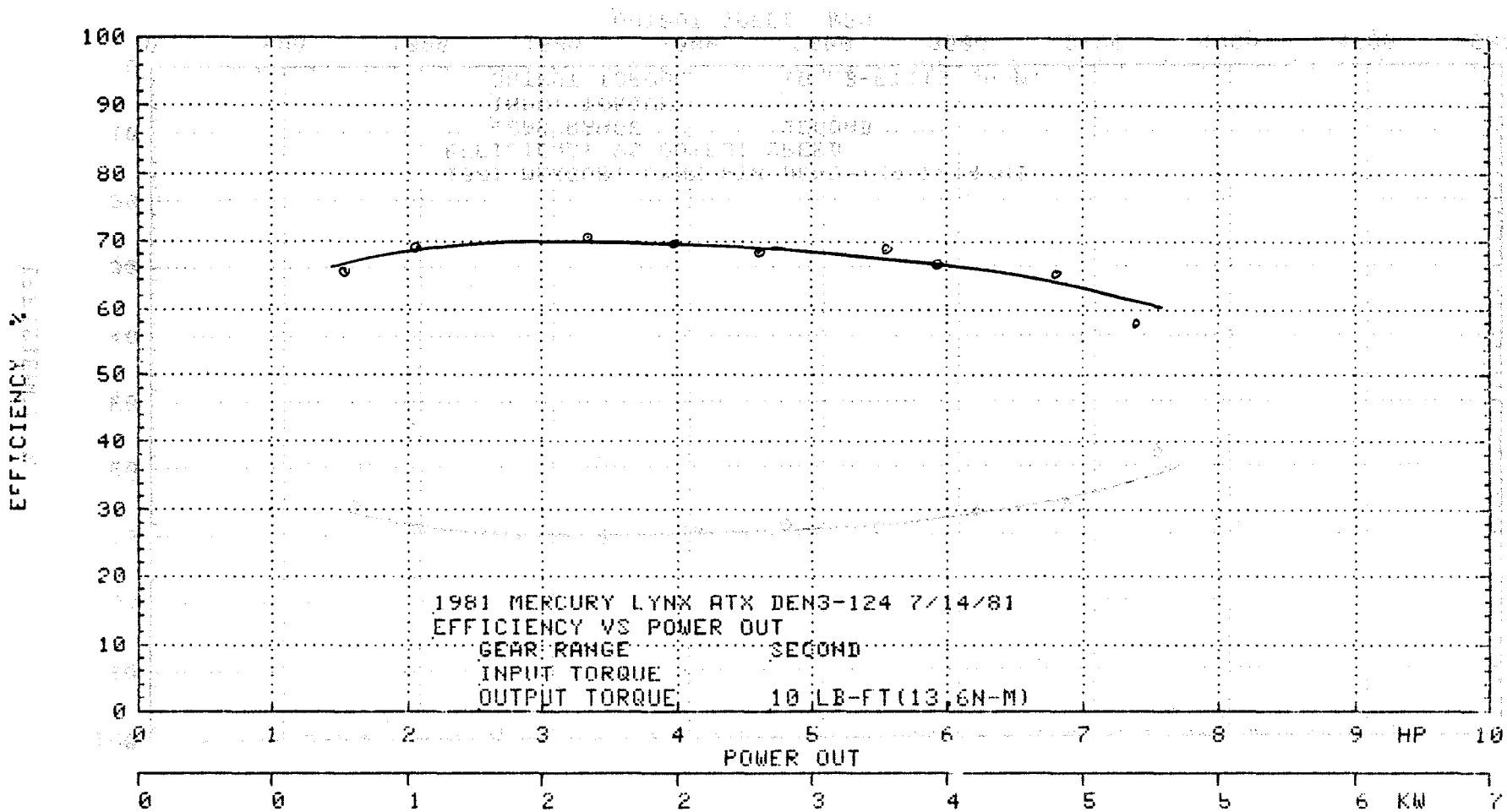

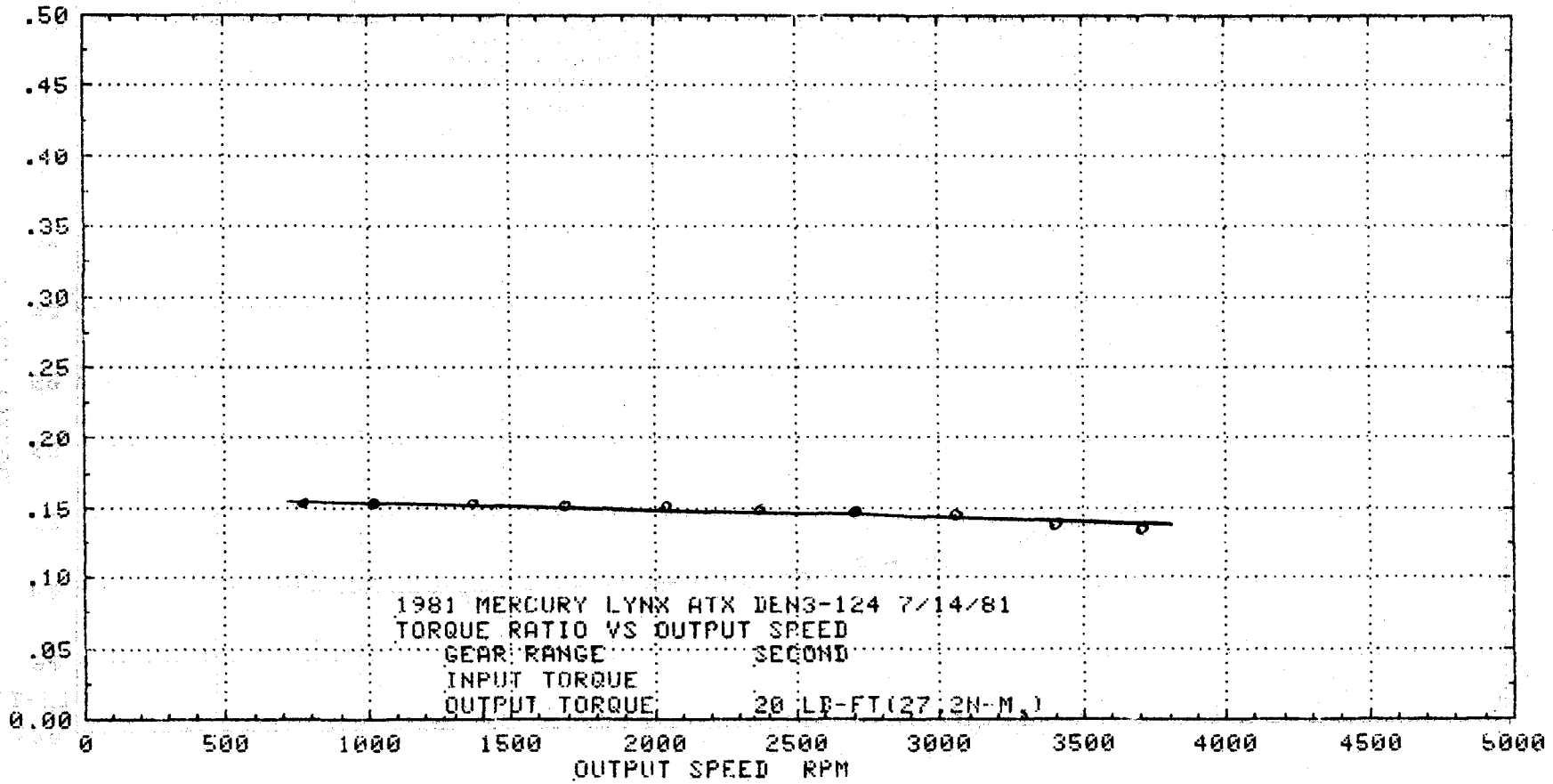
T_o/T_i OILIER ENDRCT

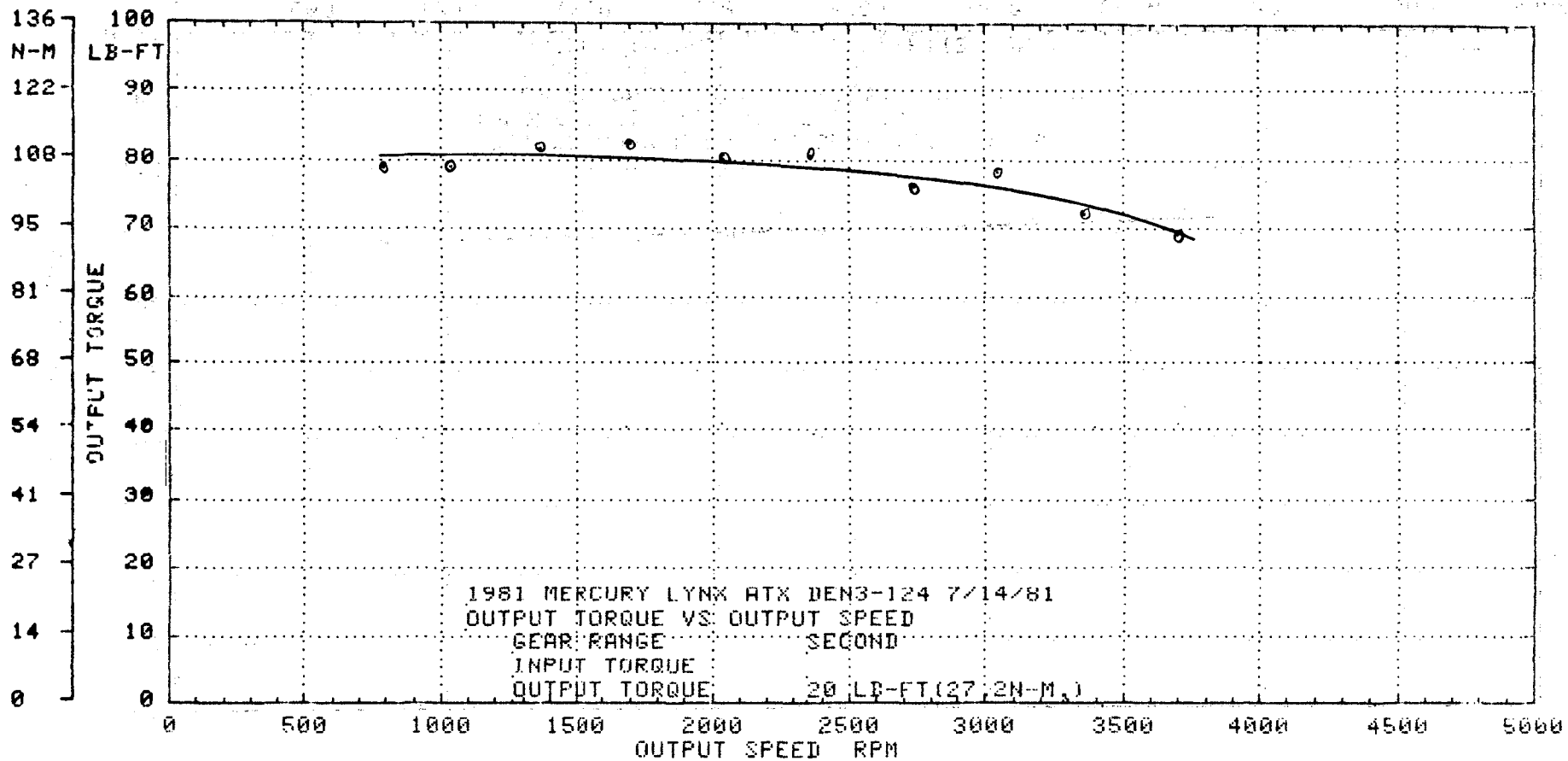

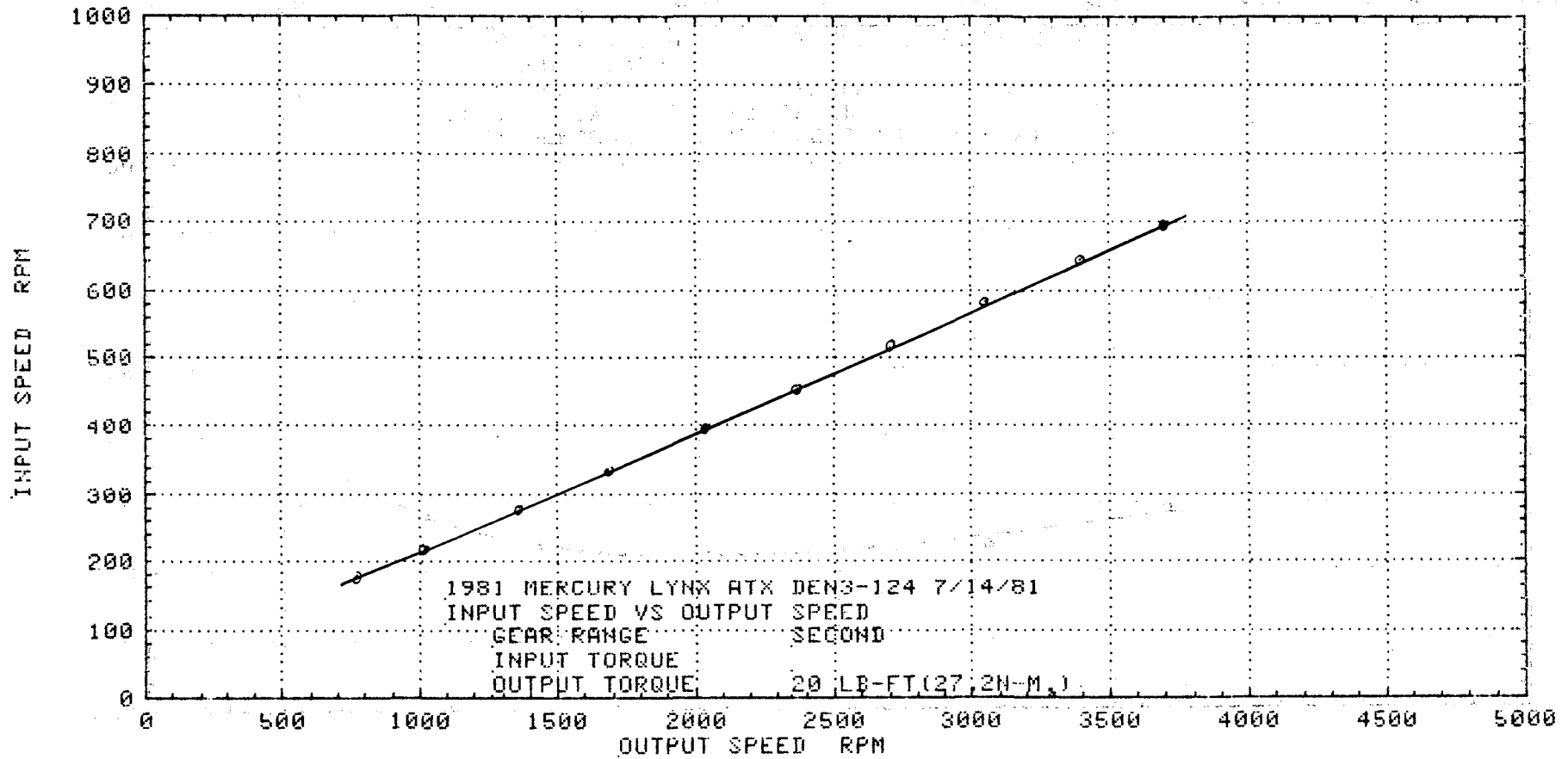

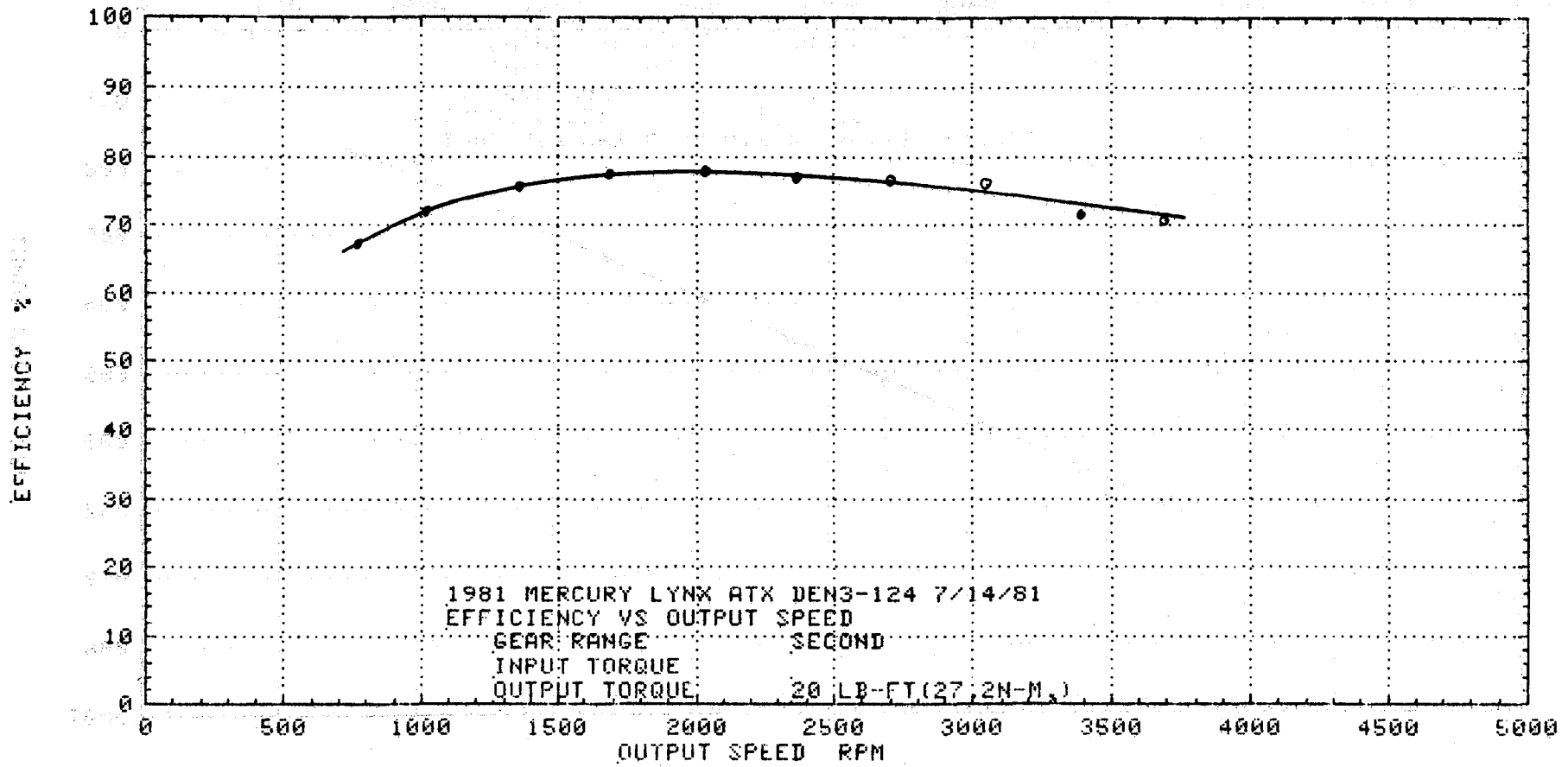

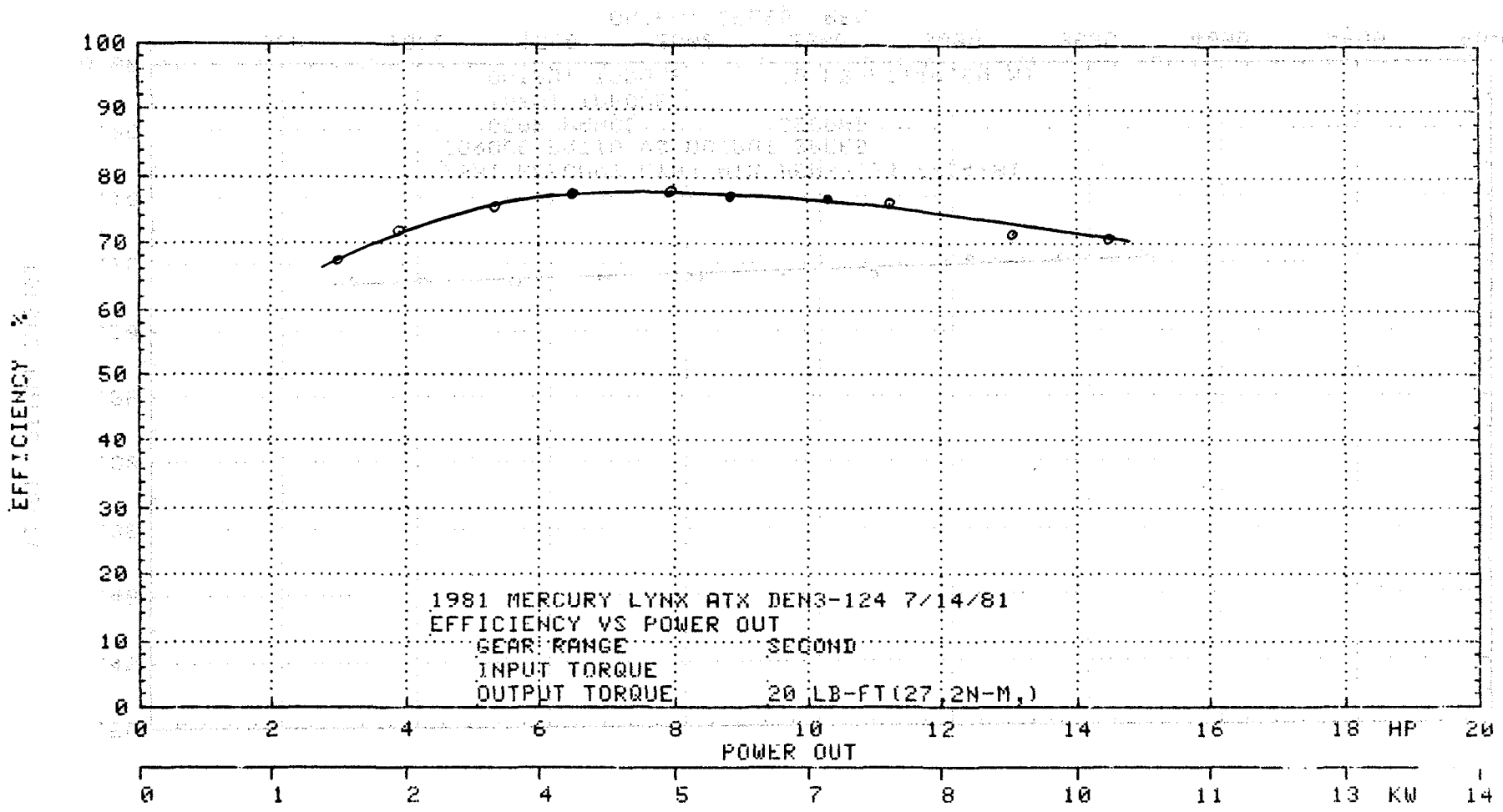

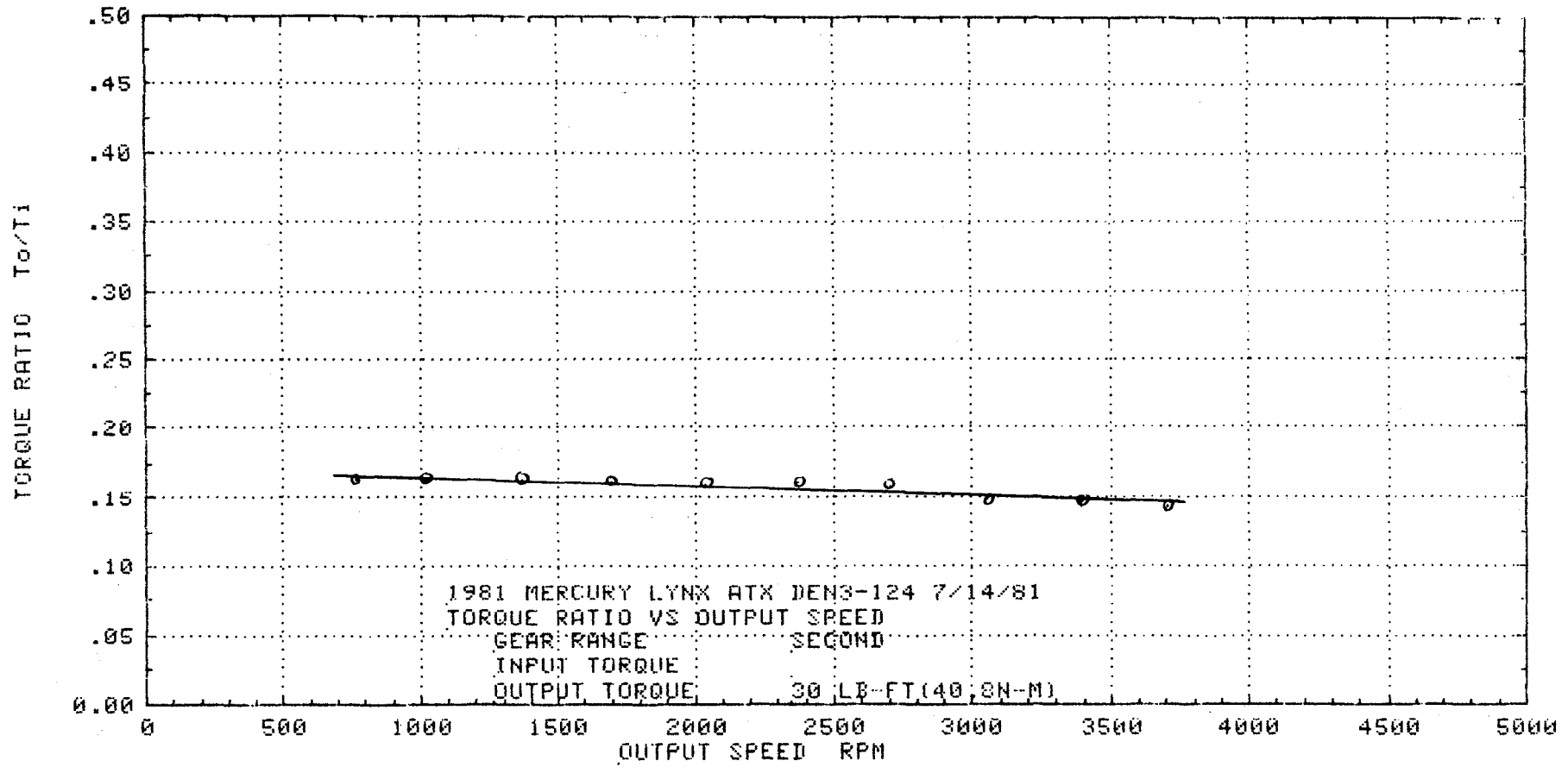

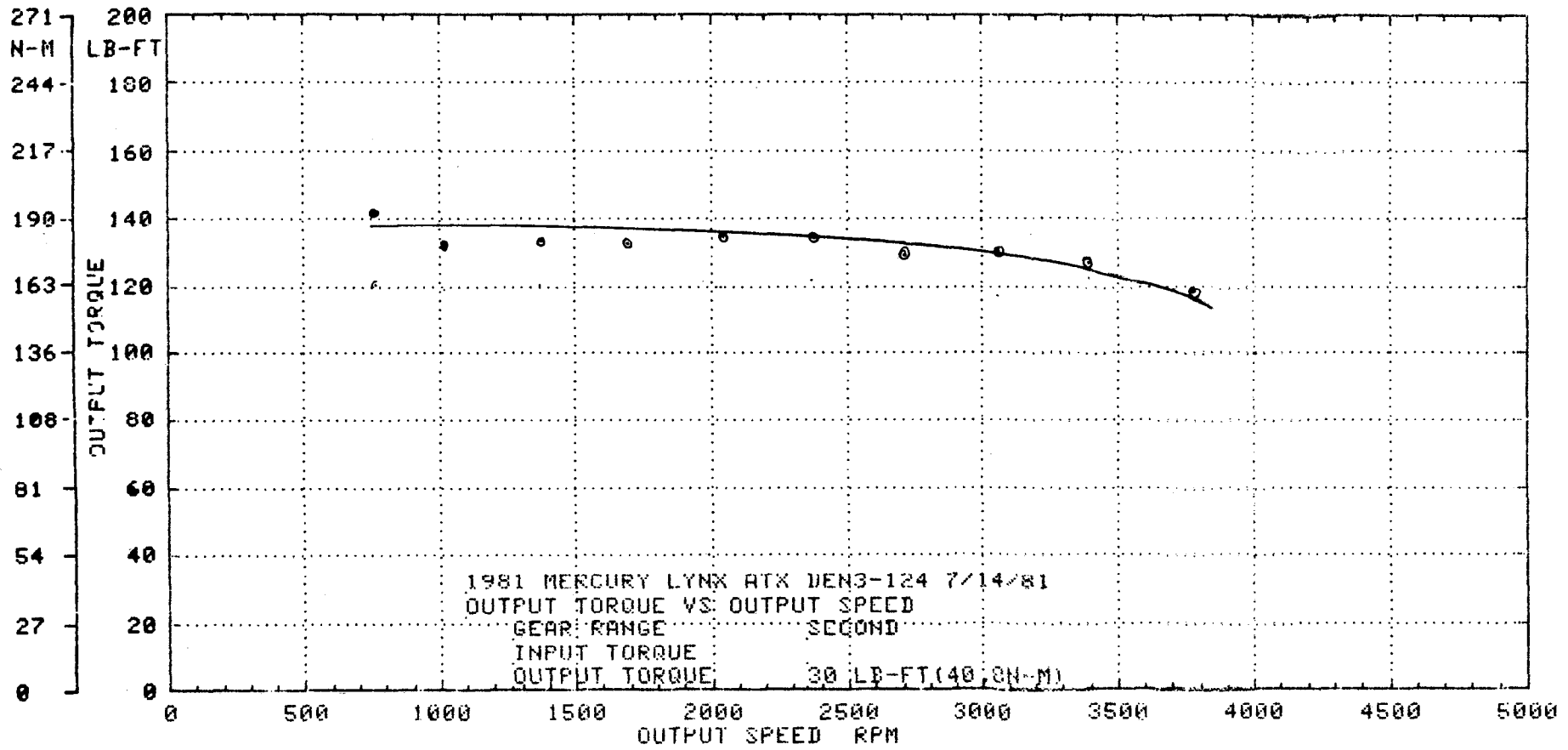

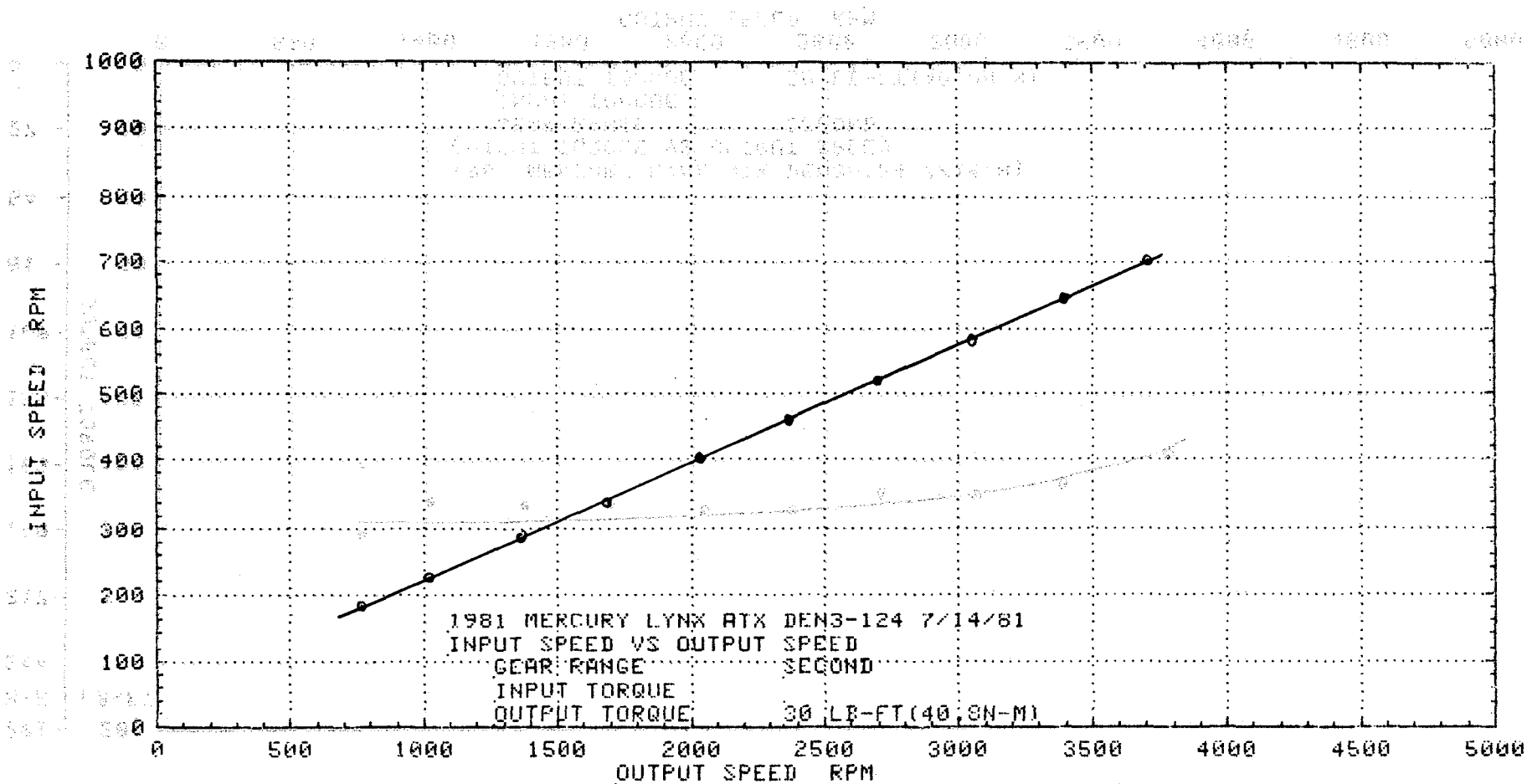

EFFICIENCY %

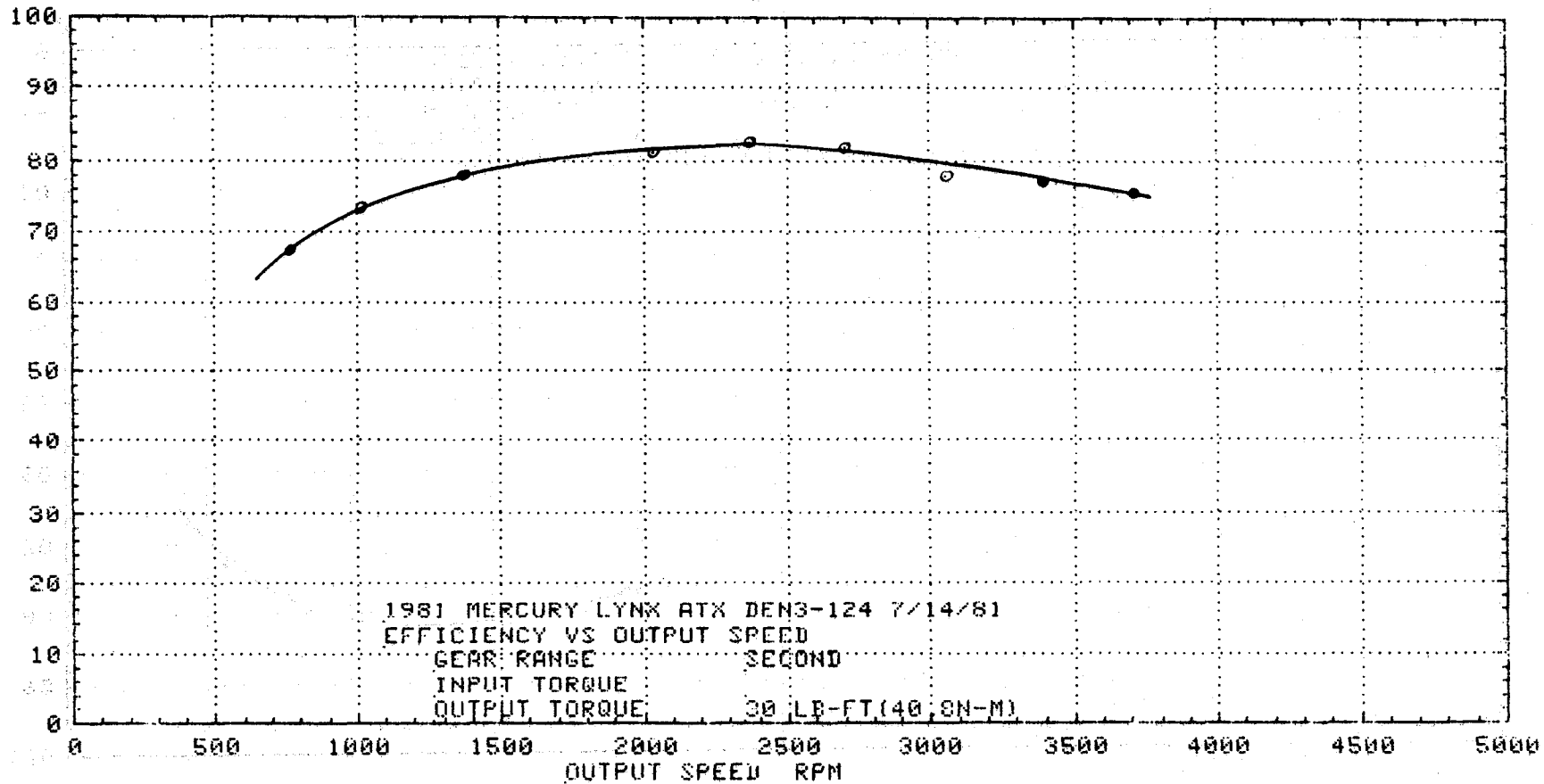

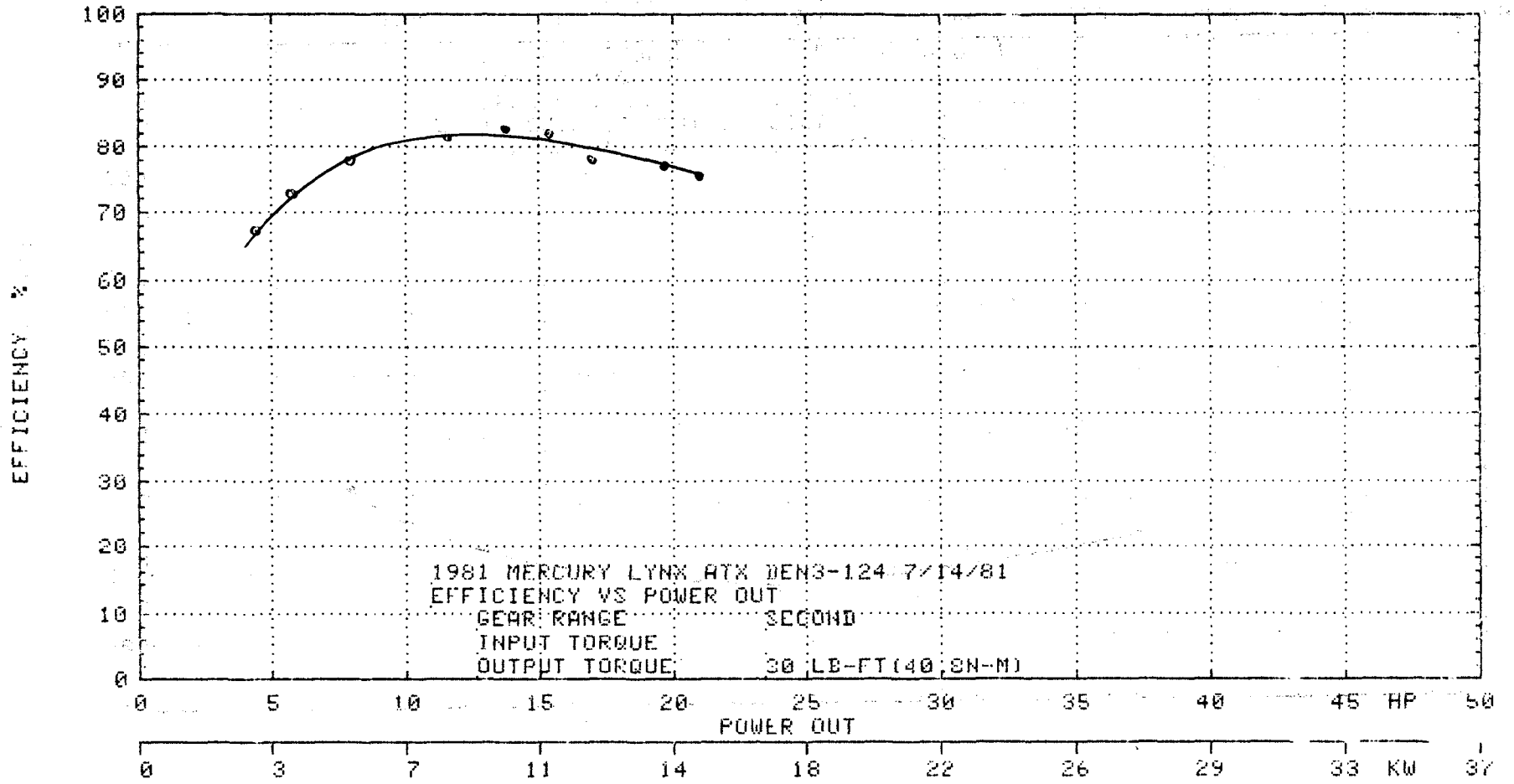

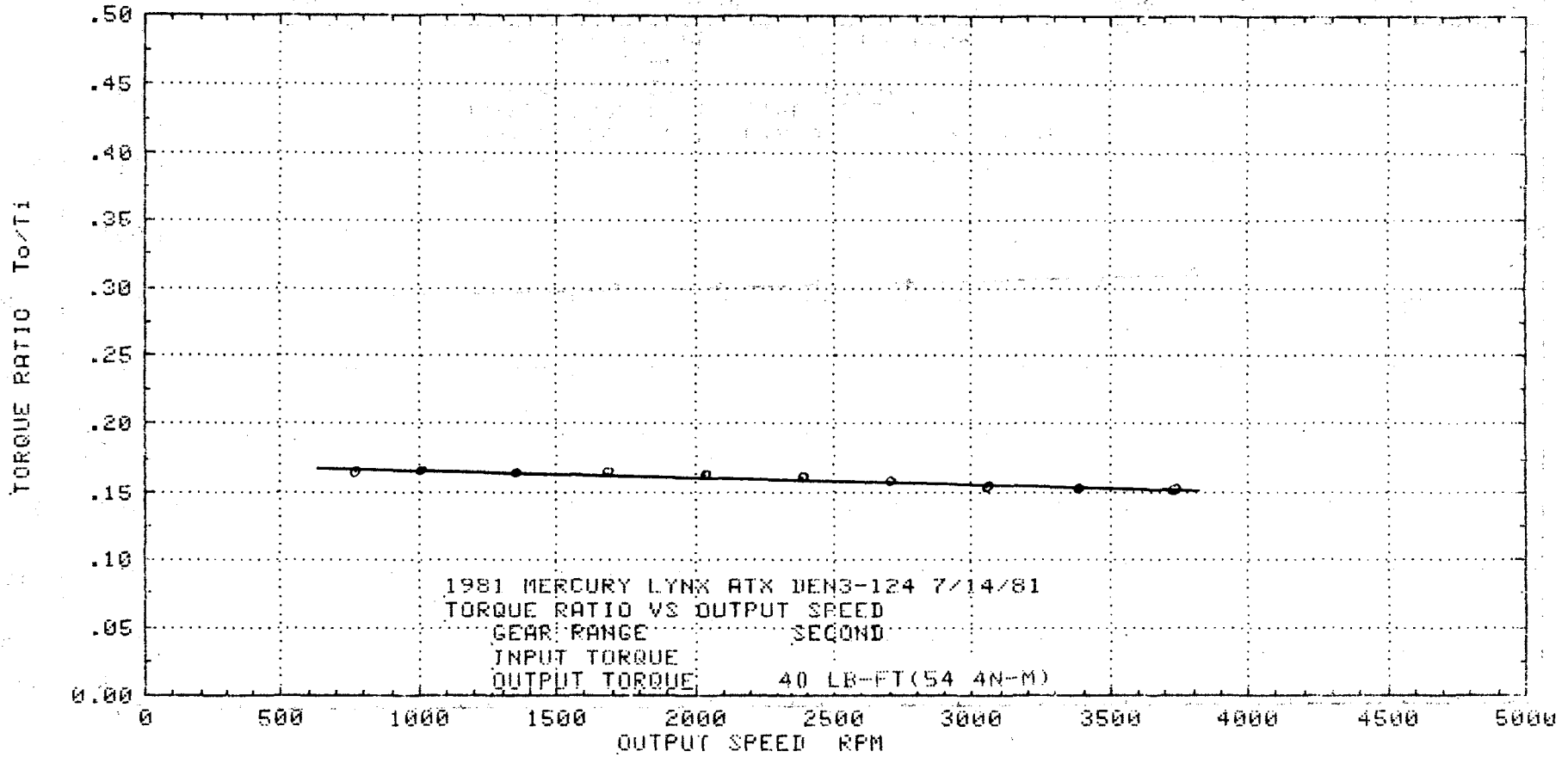

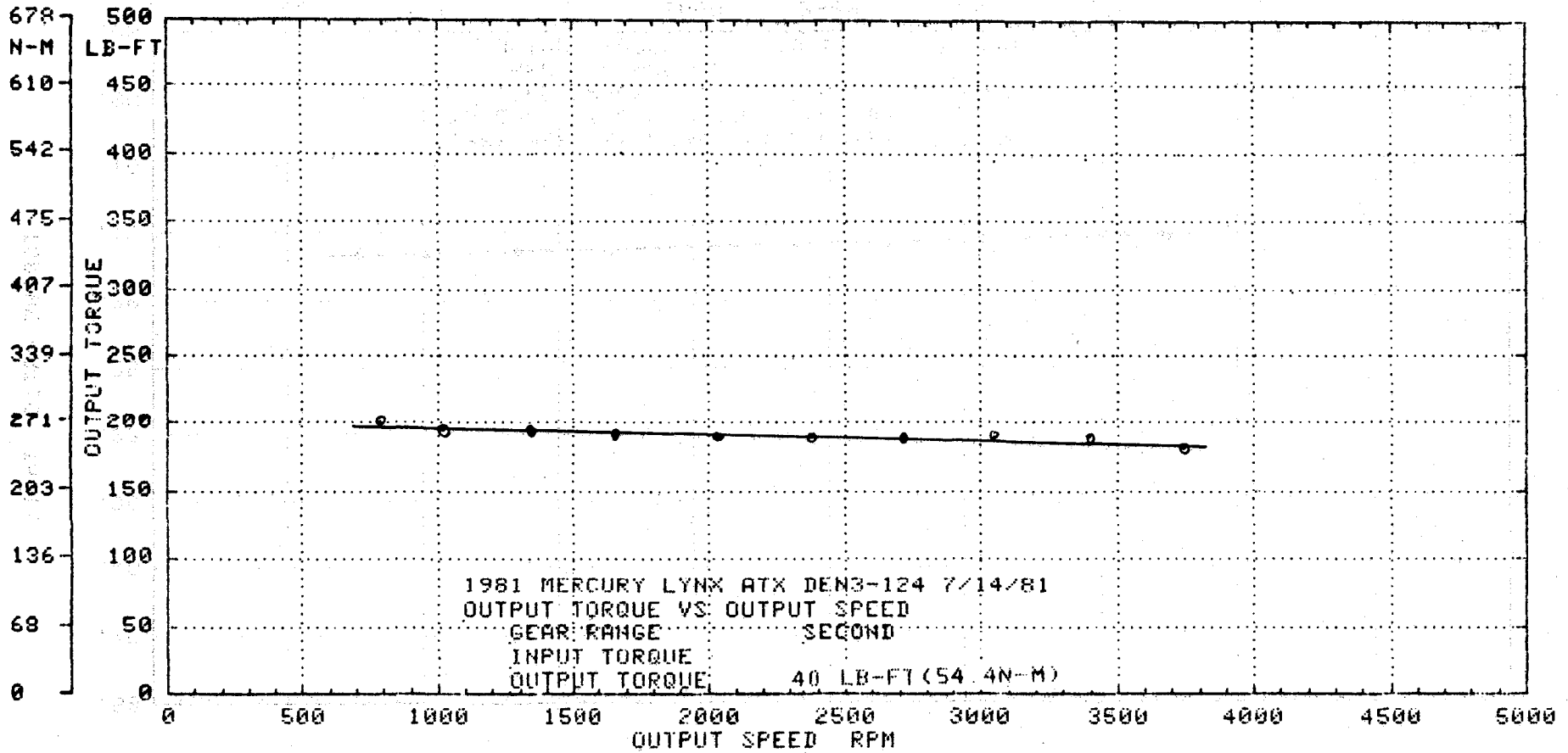

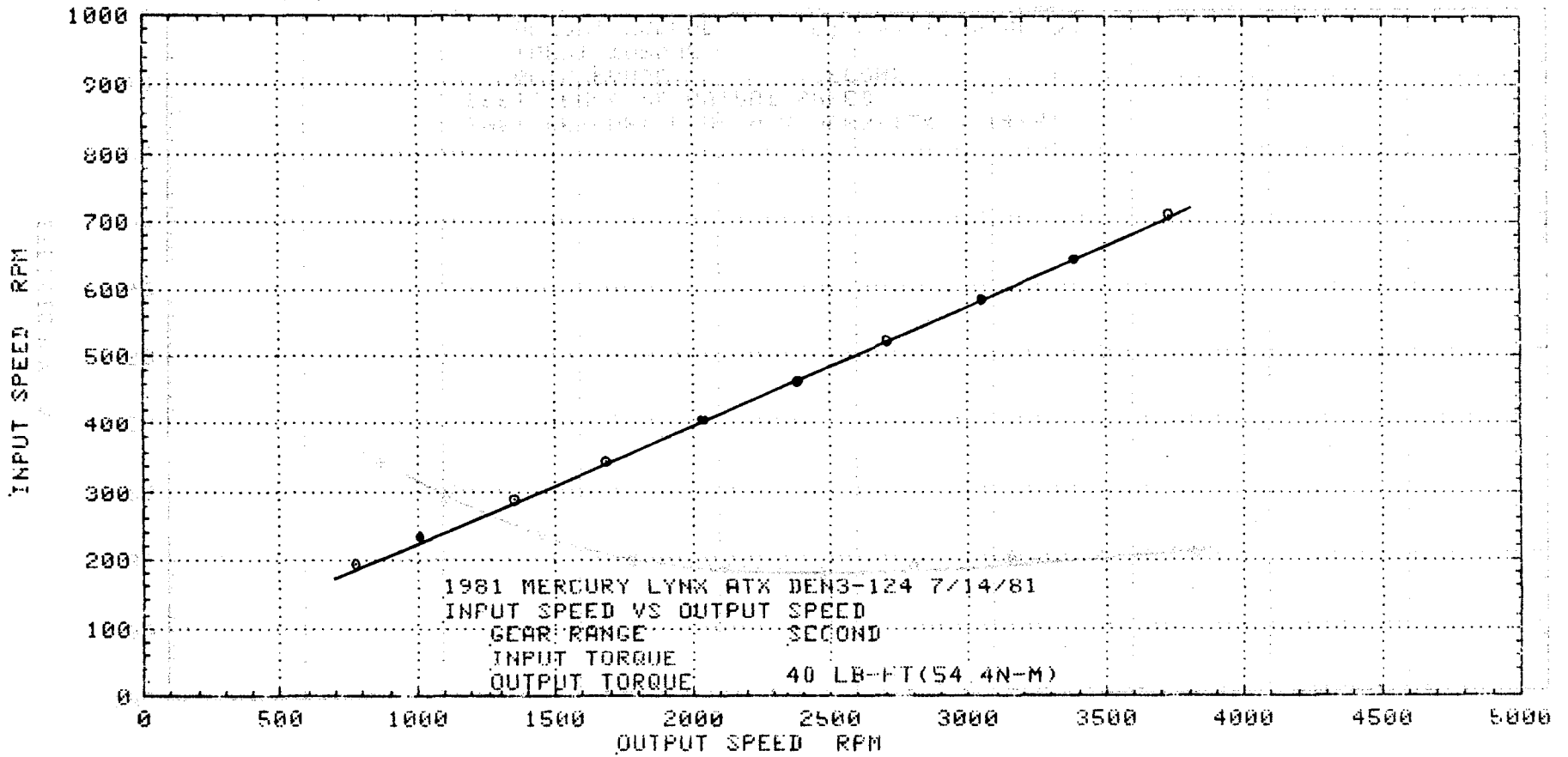

% EFFICIENCY

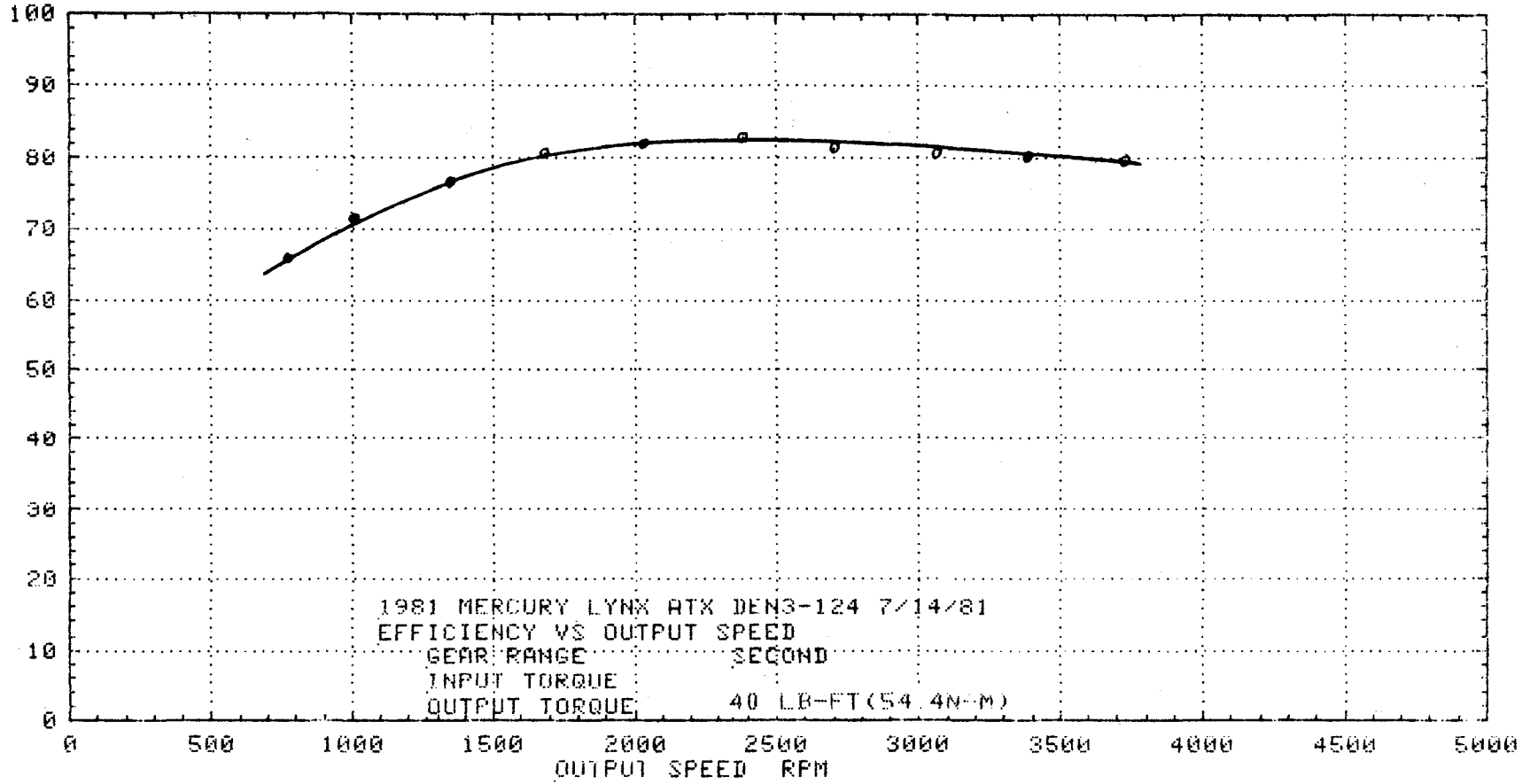

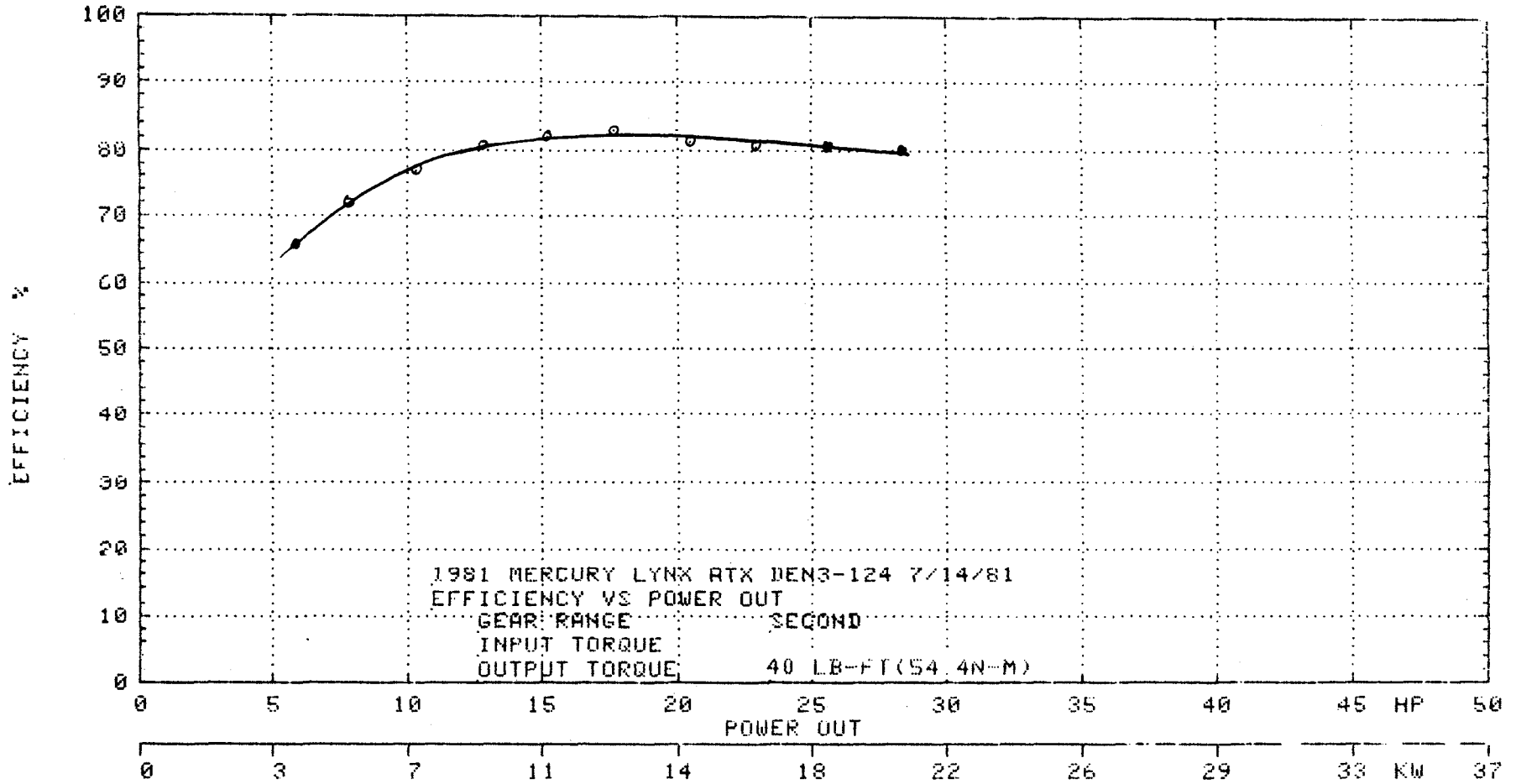

TORQUE RATIO

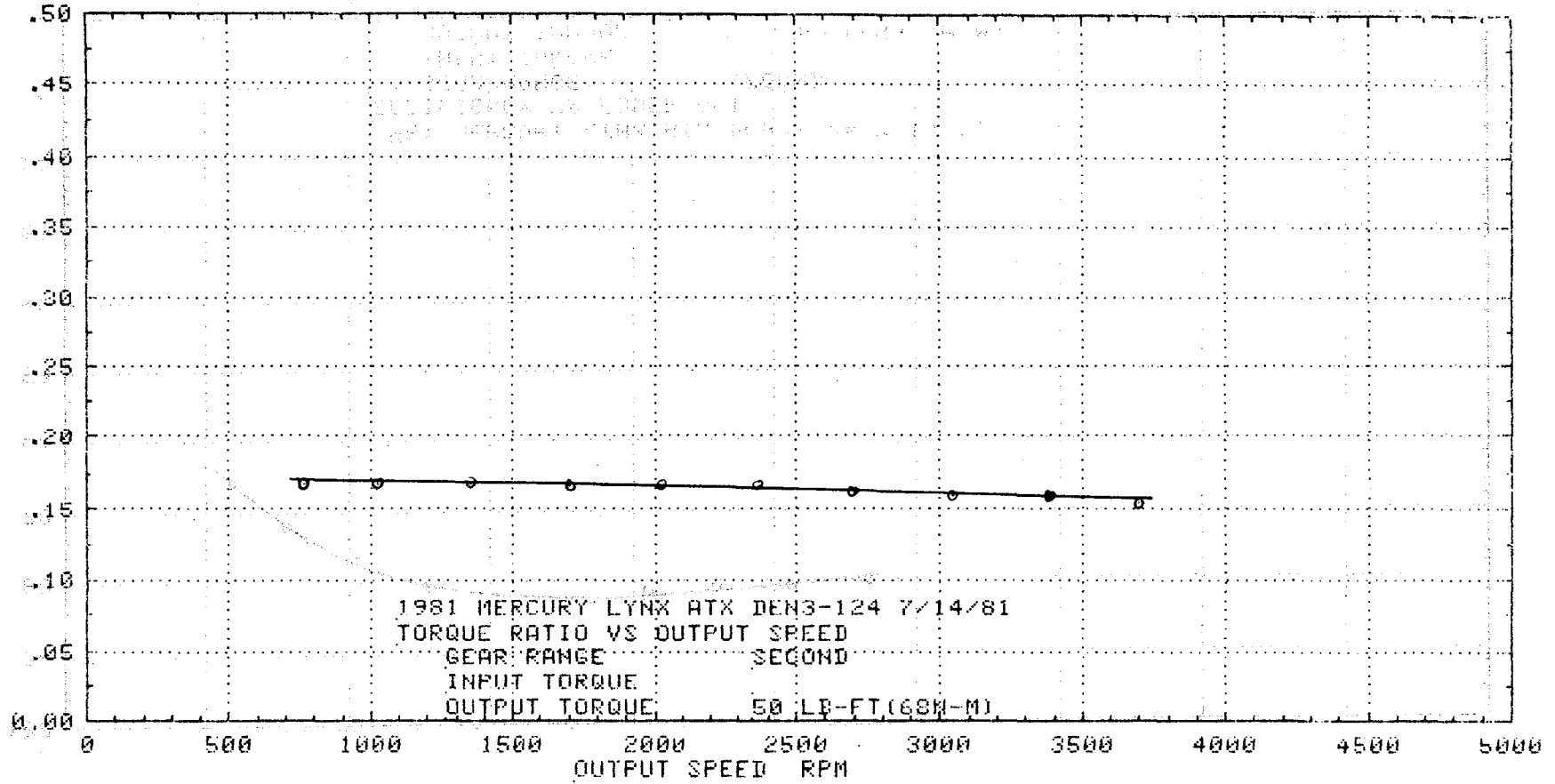

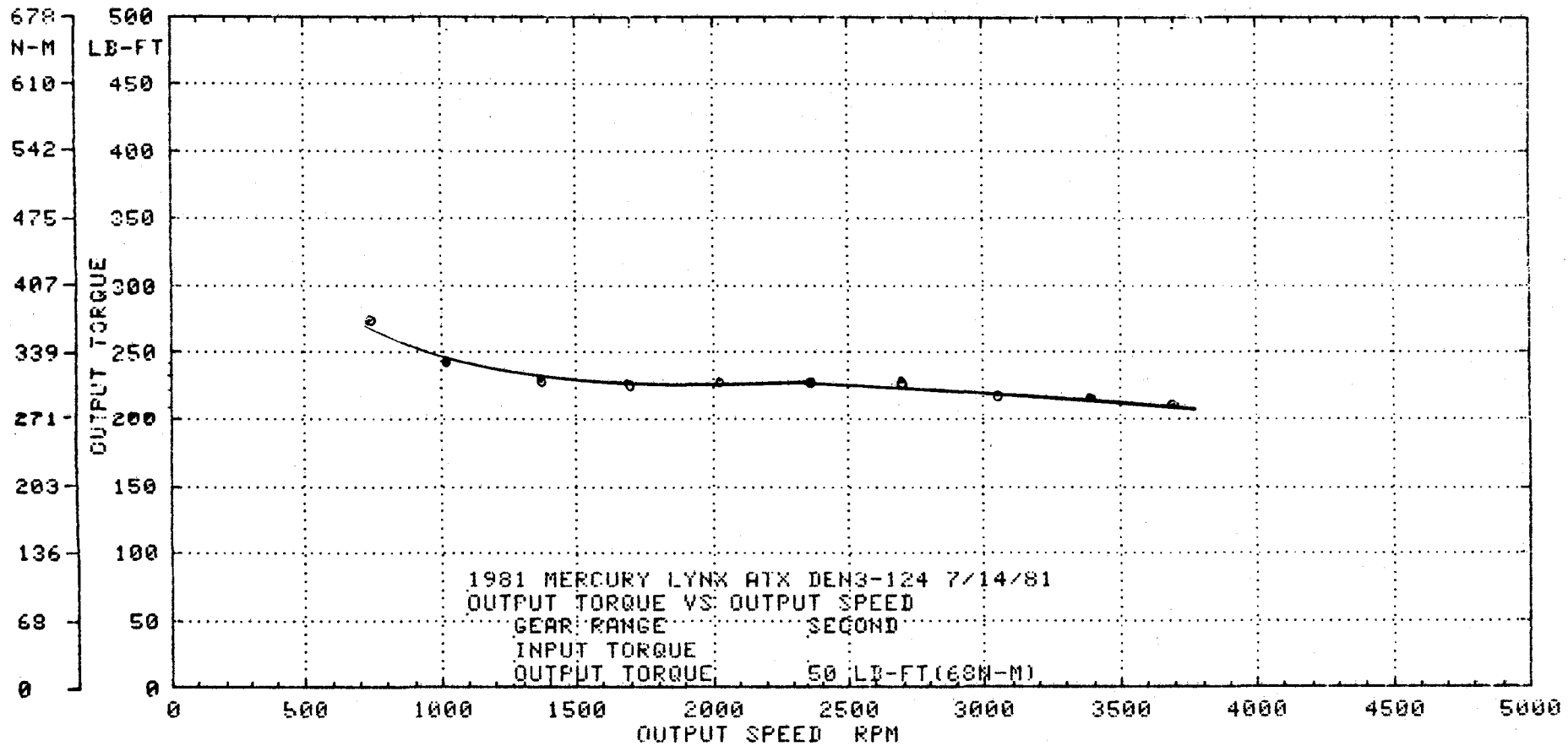

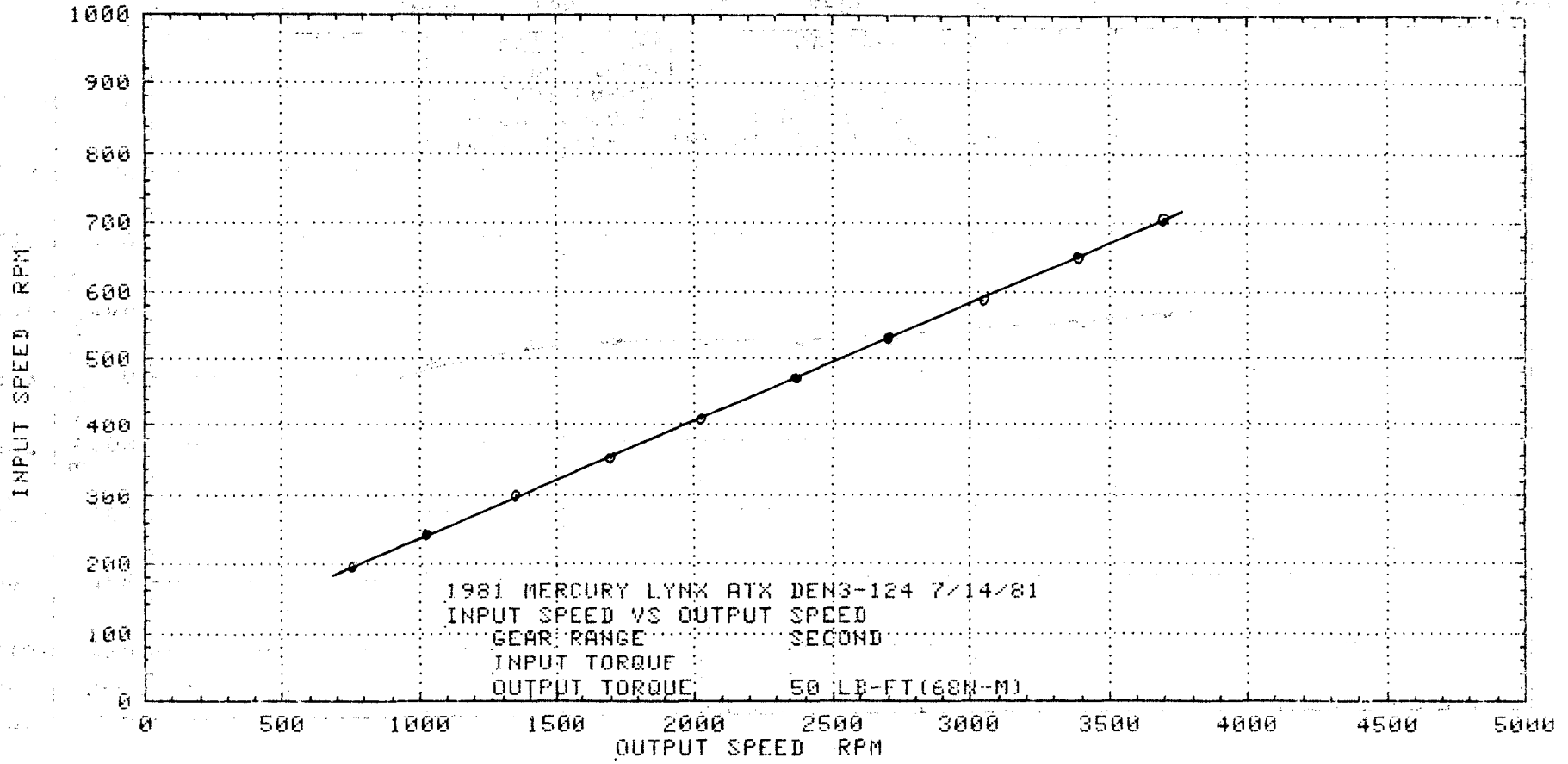

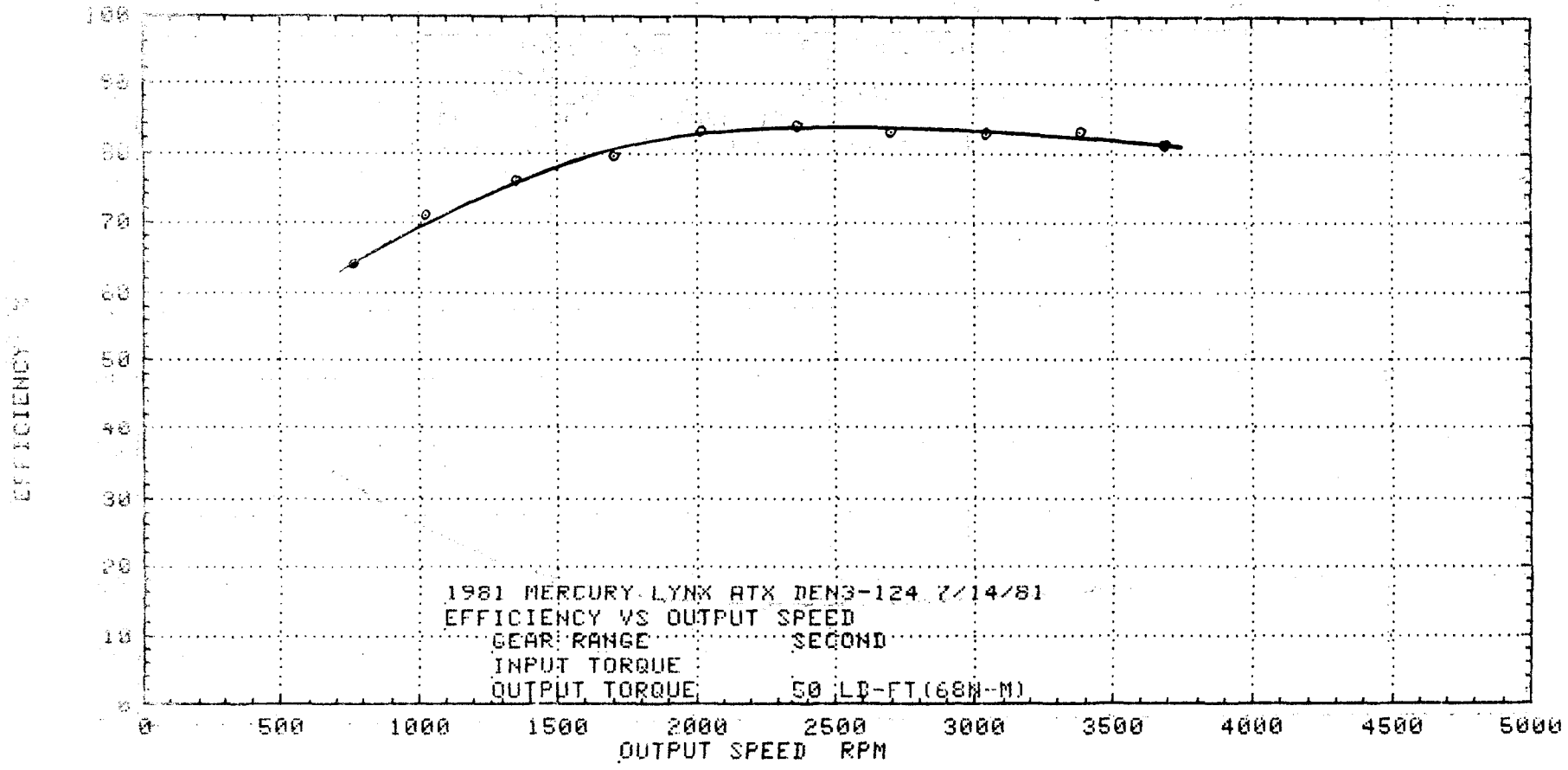

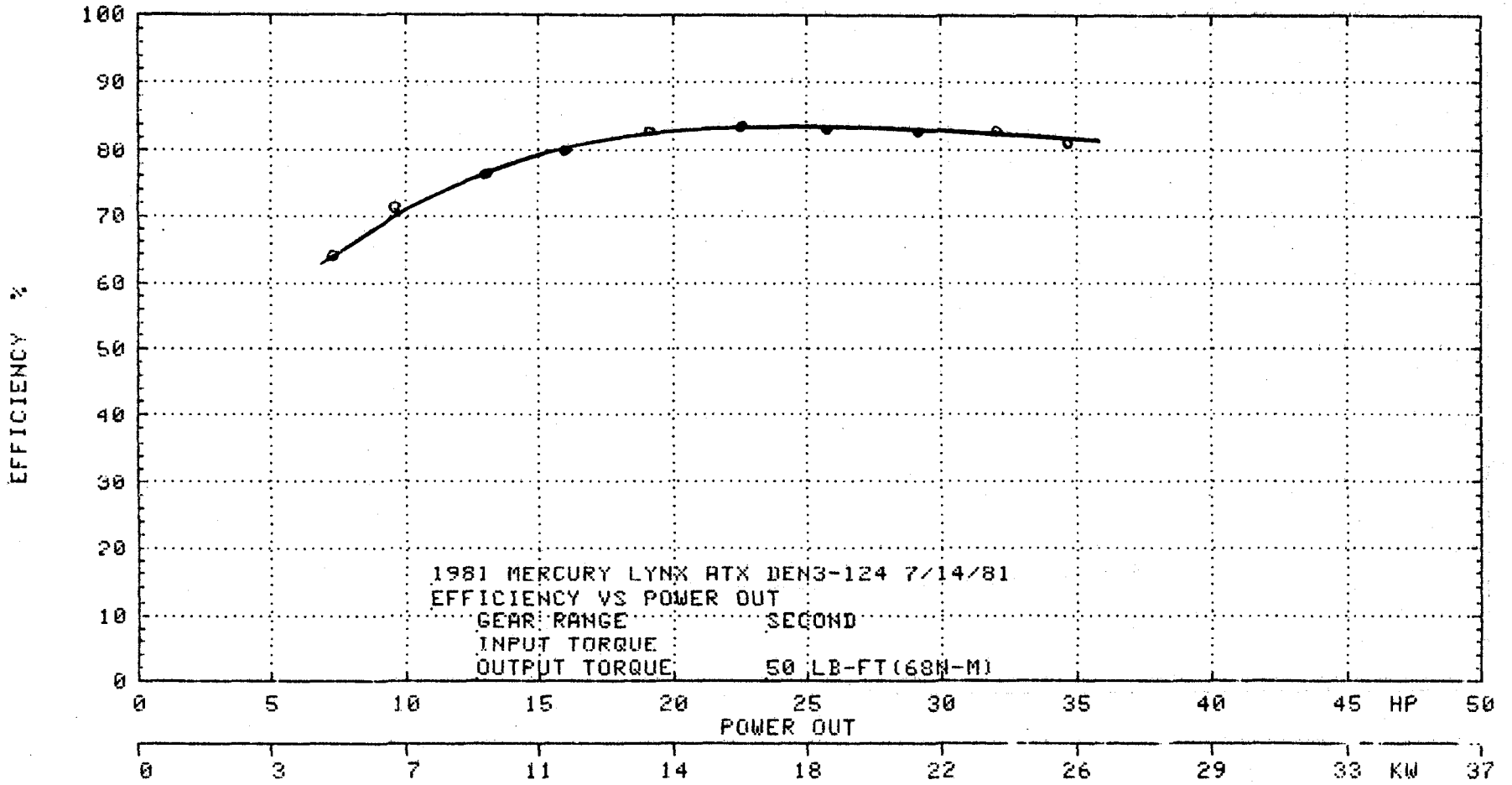

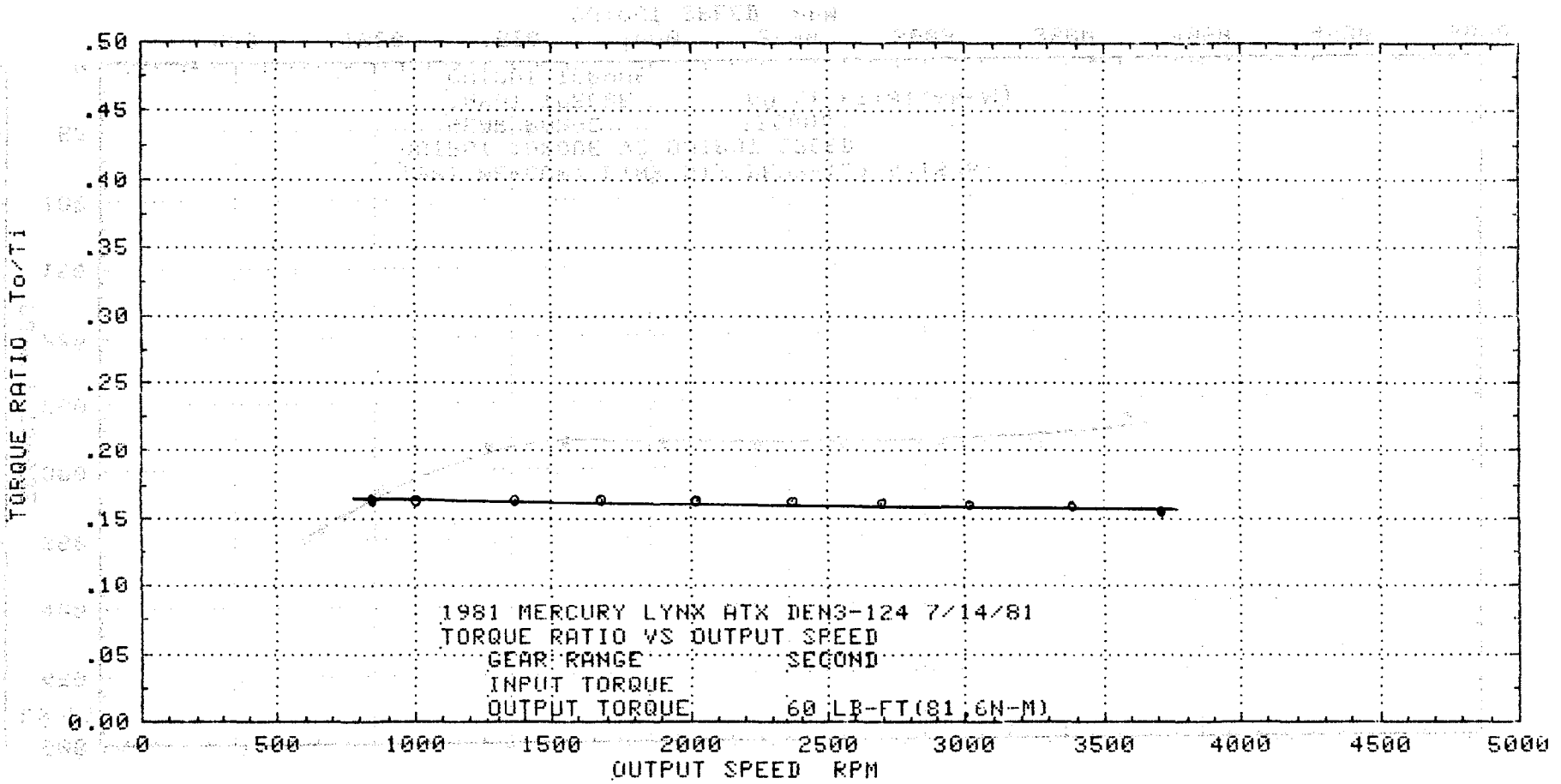

250

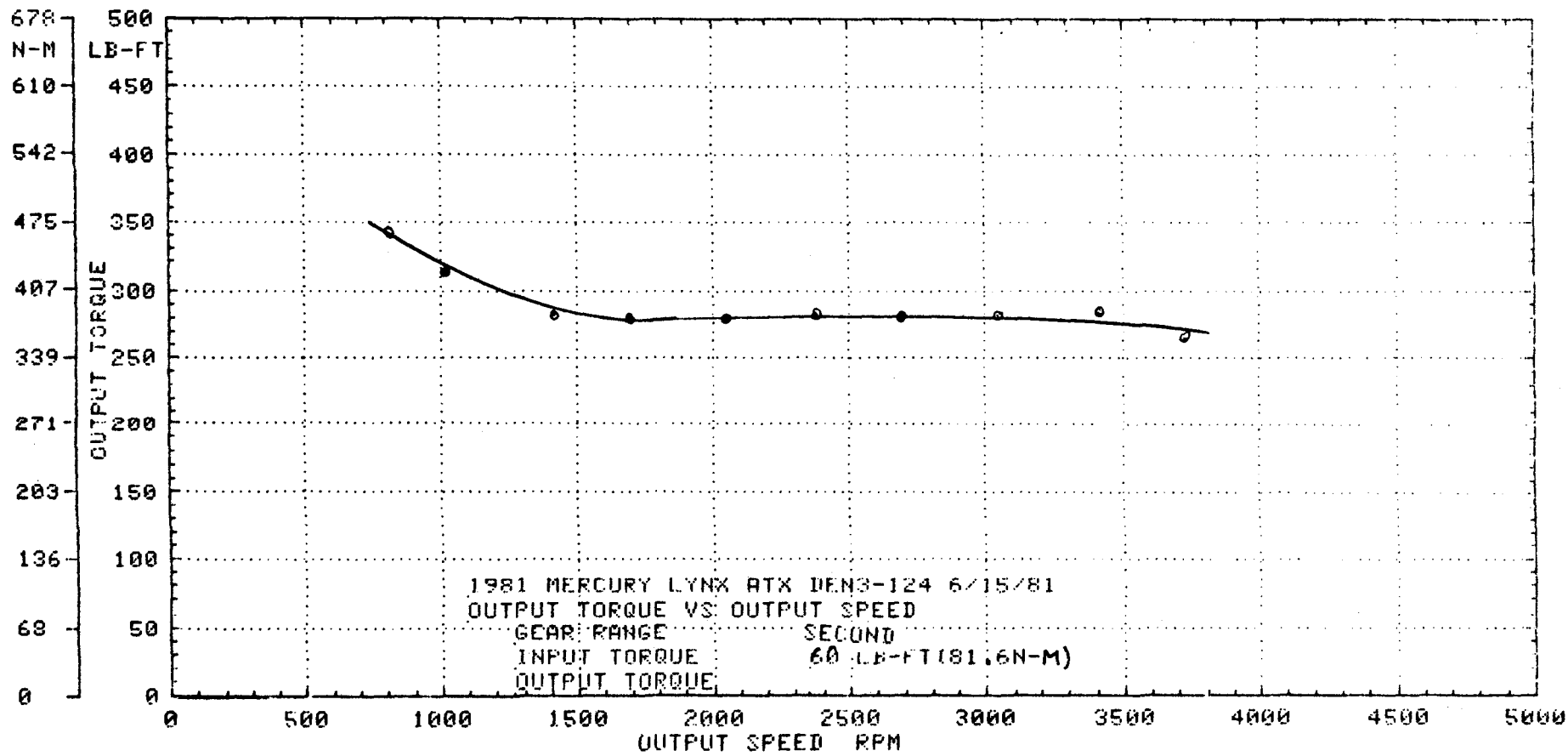

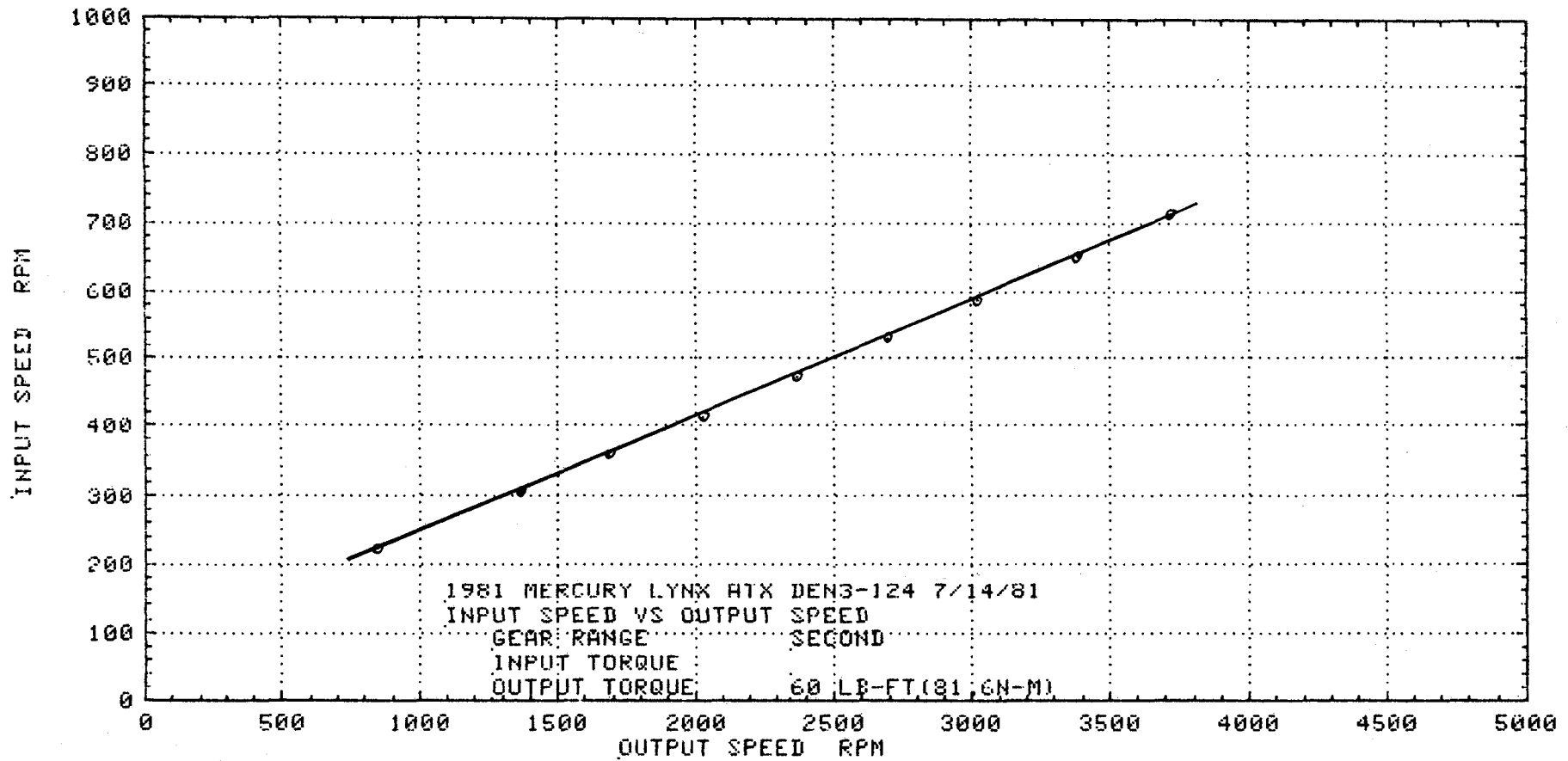

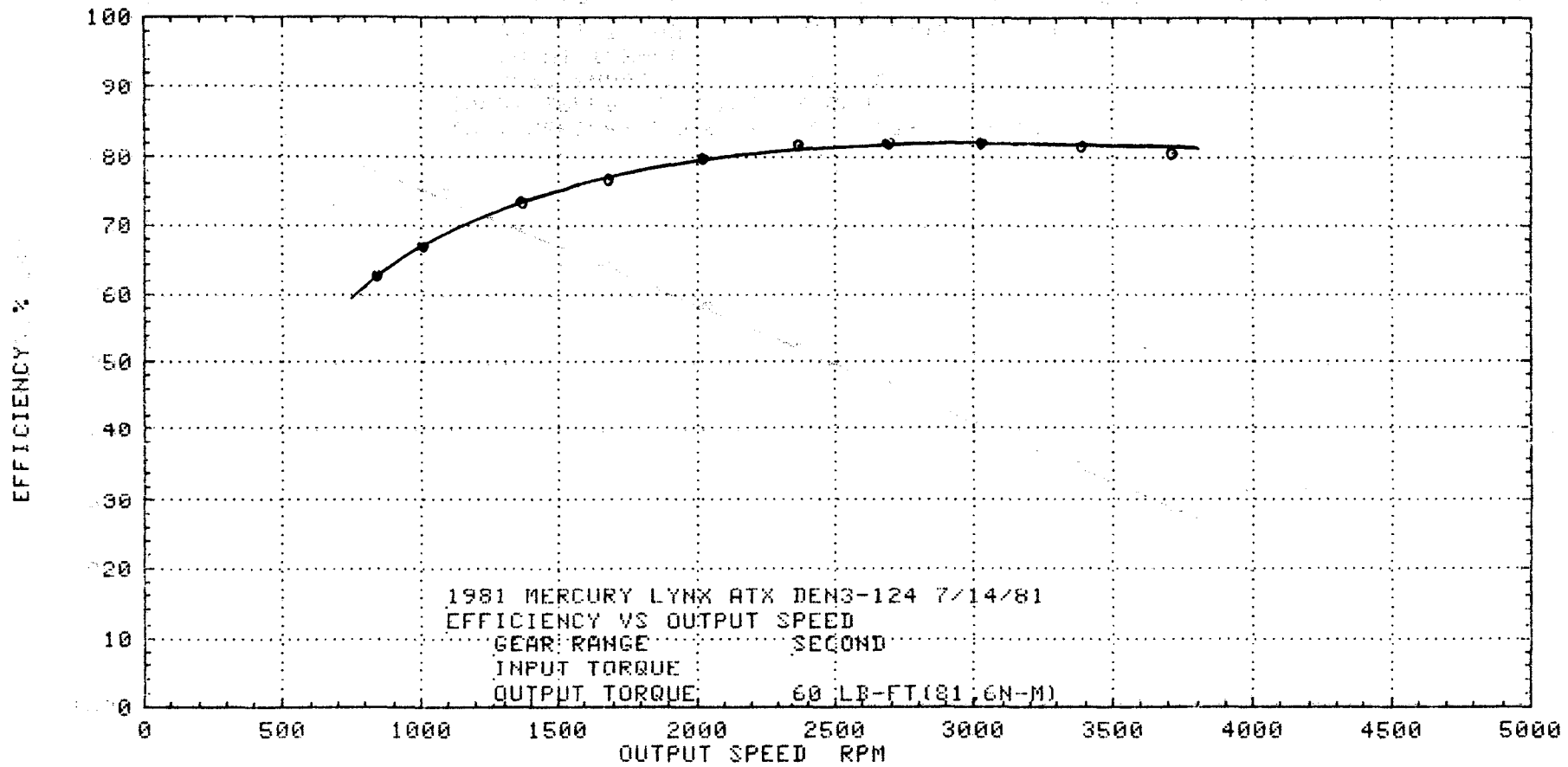

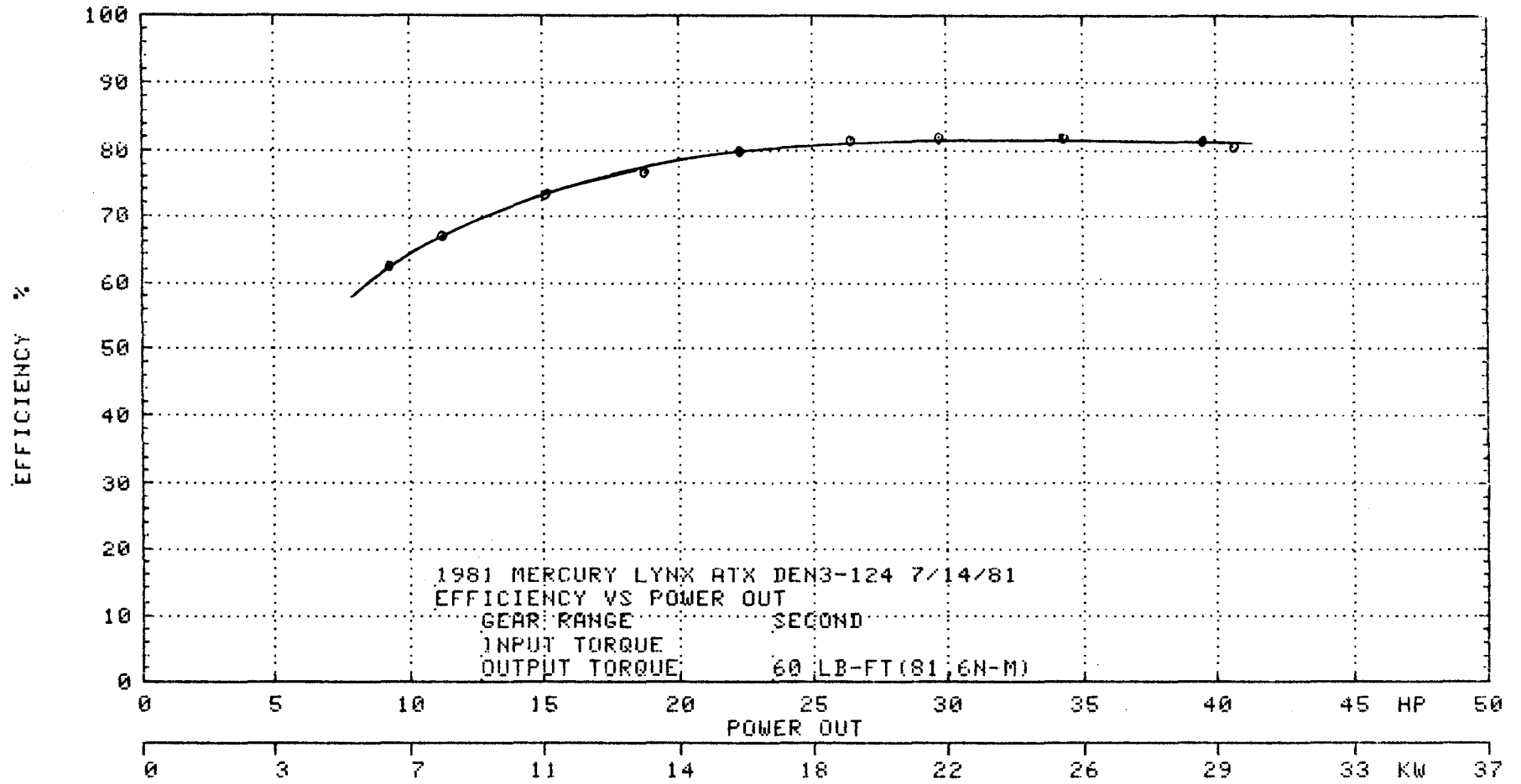

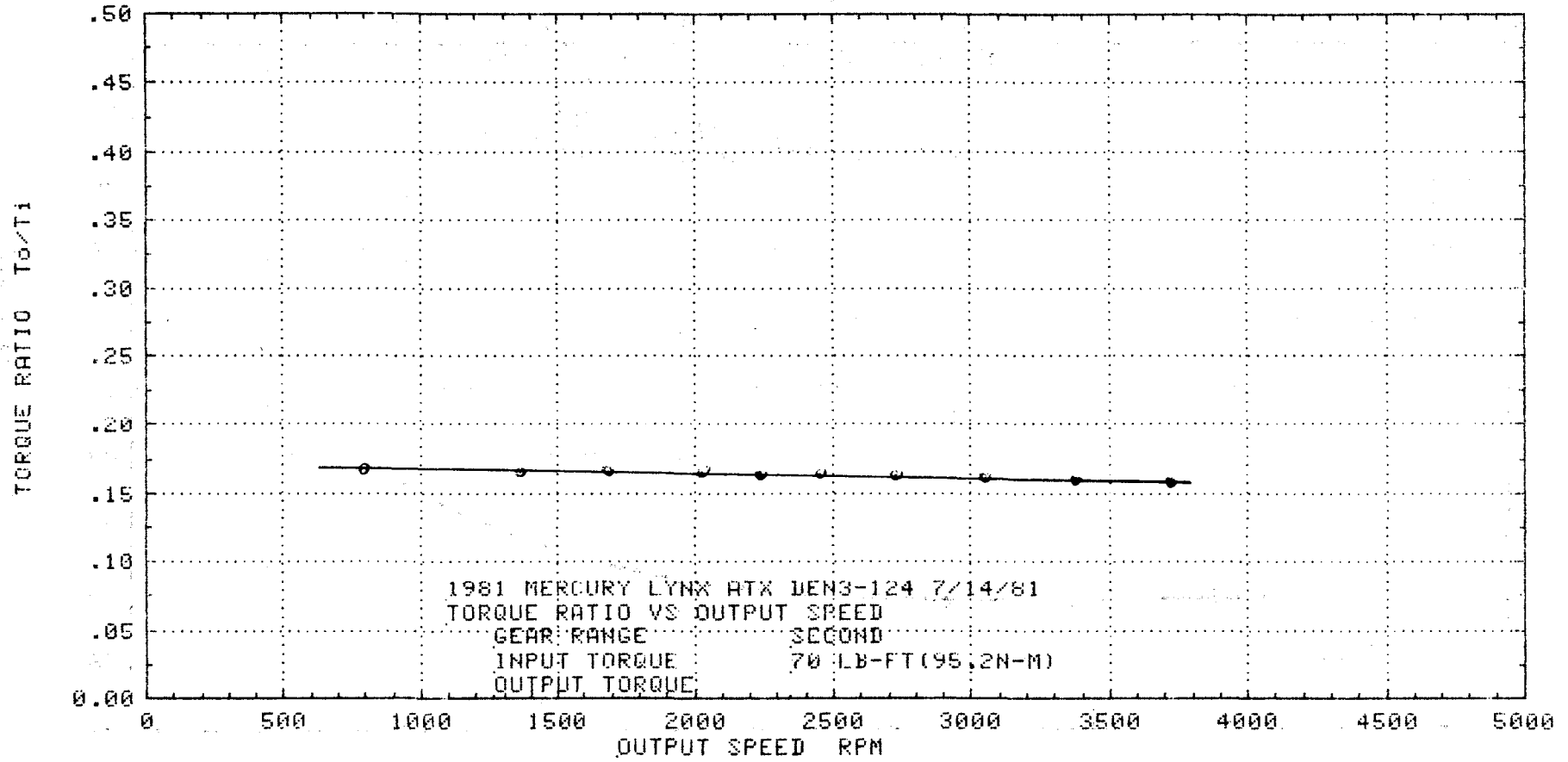

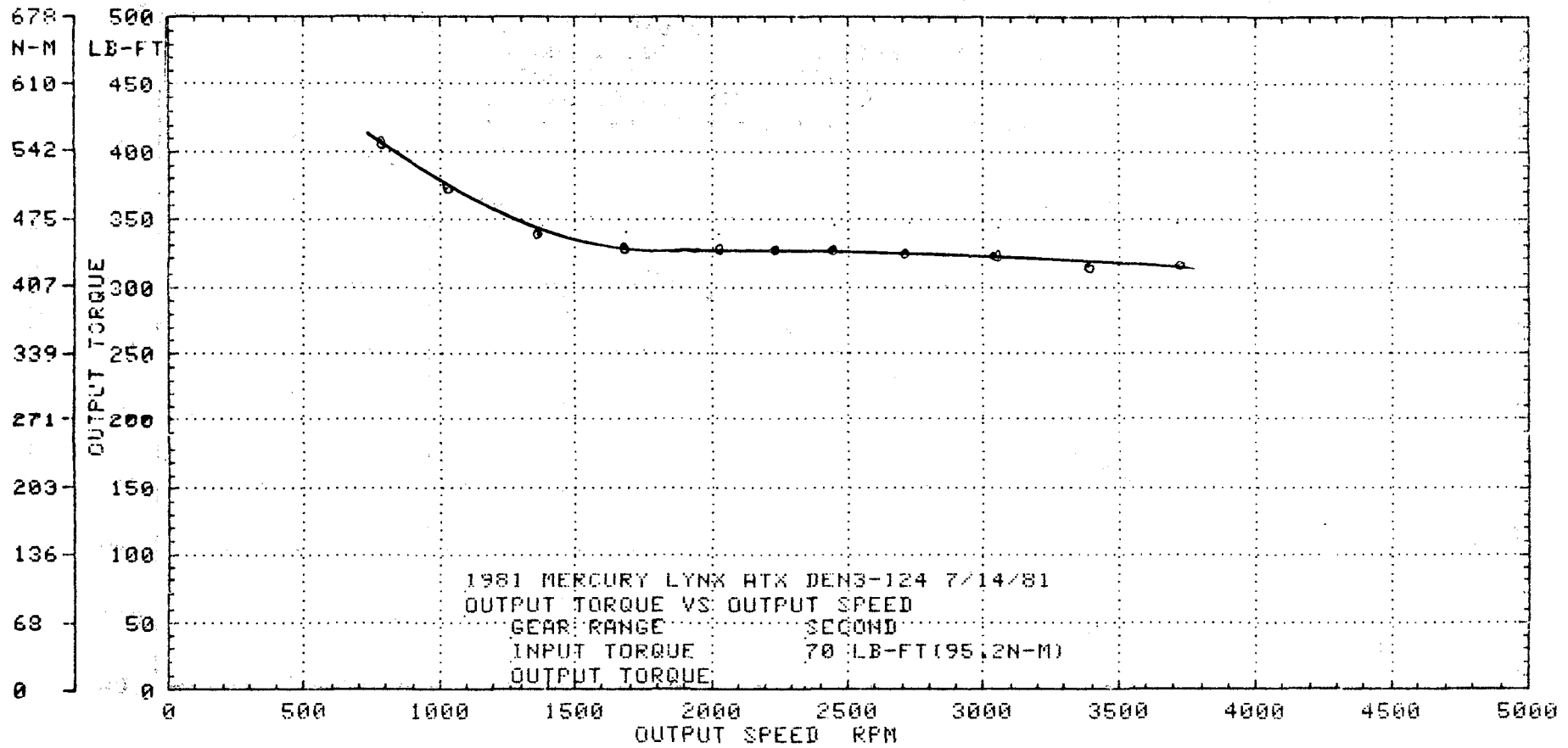

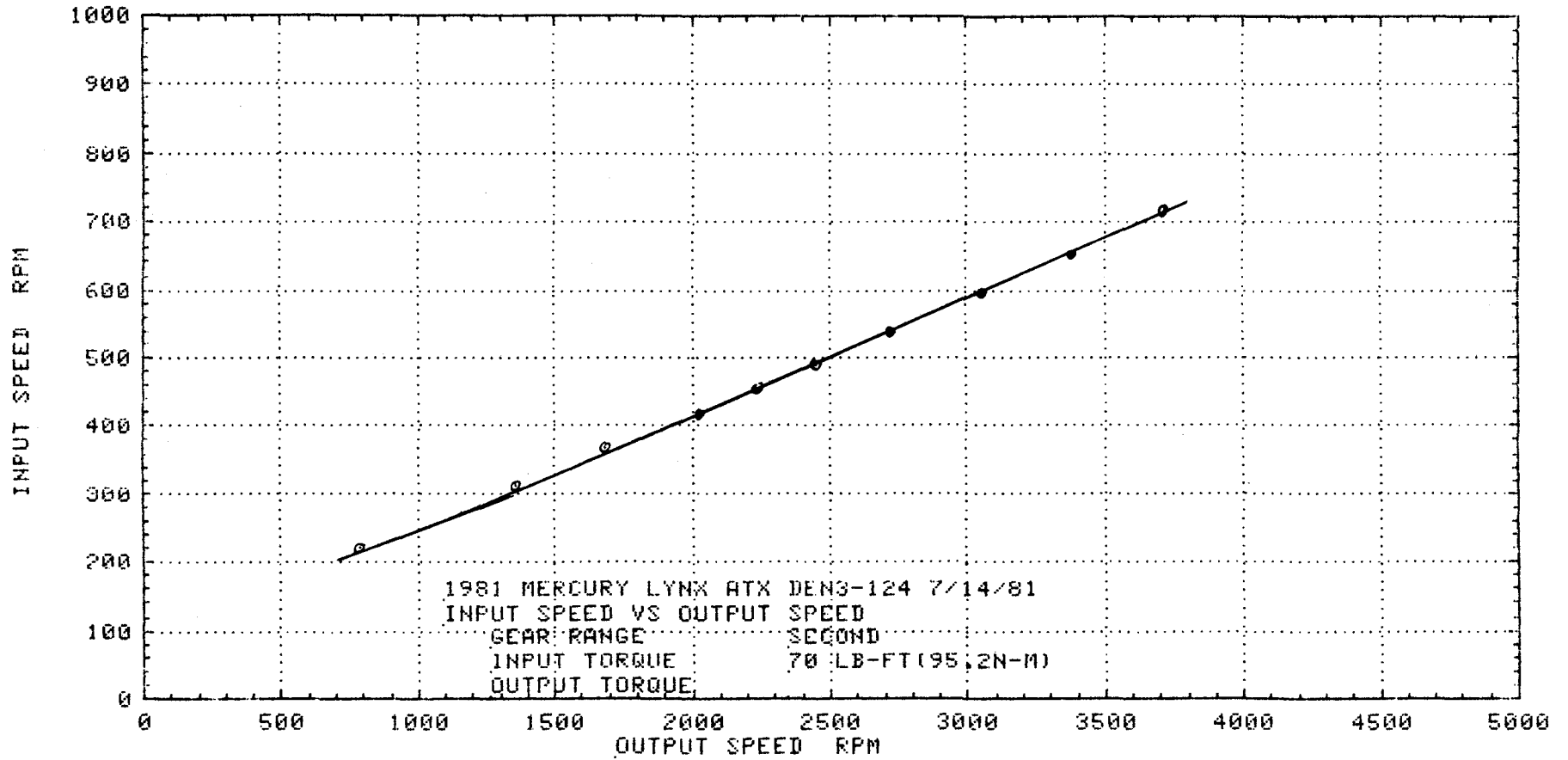

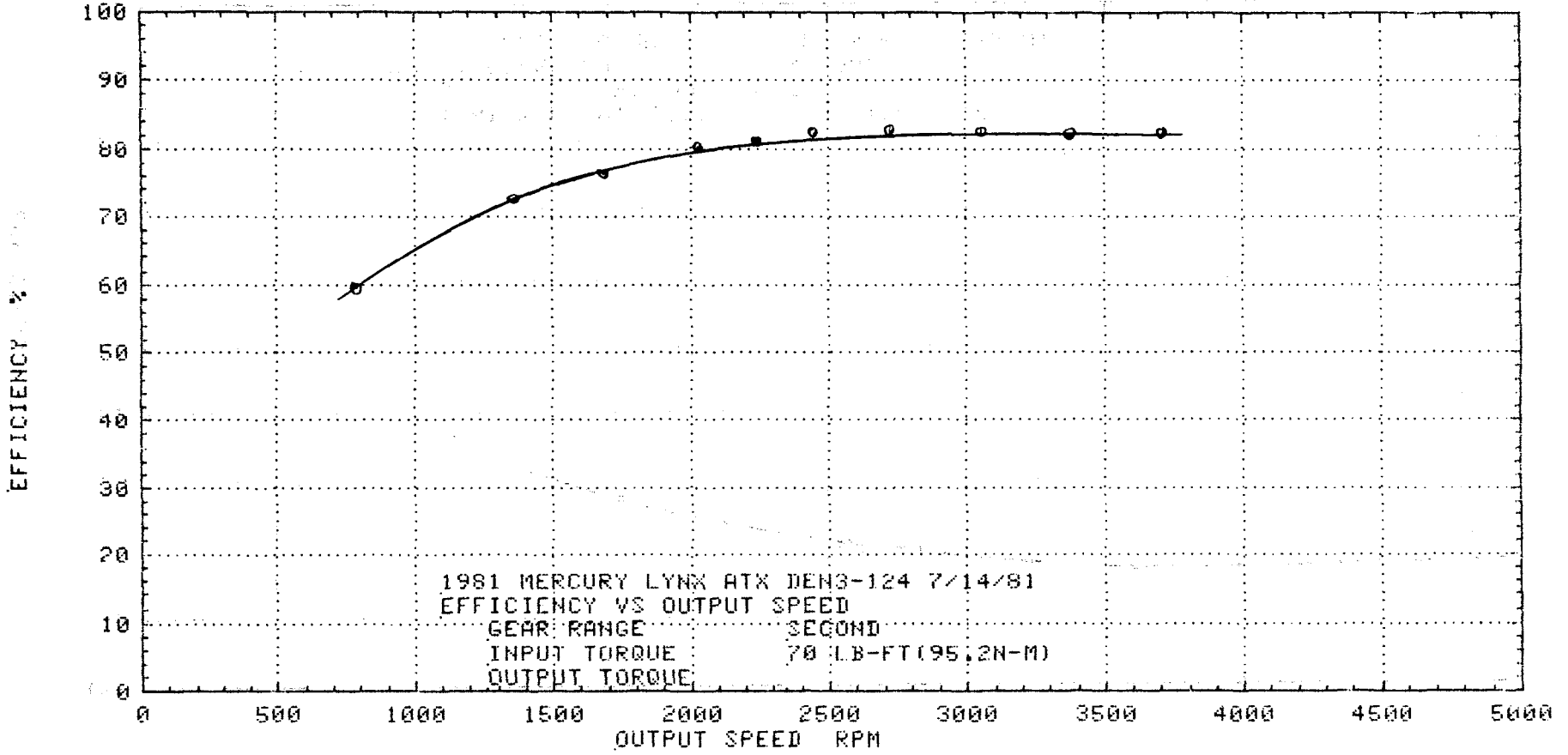

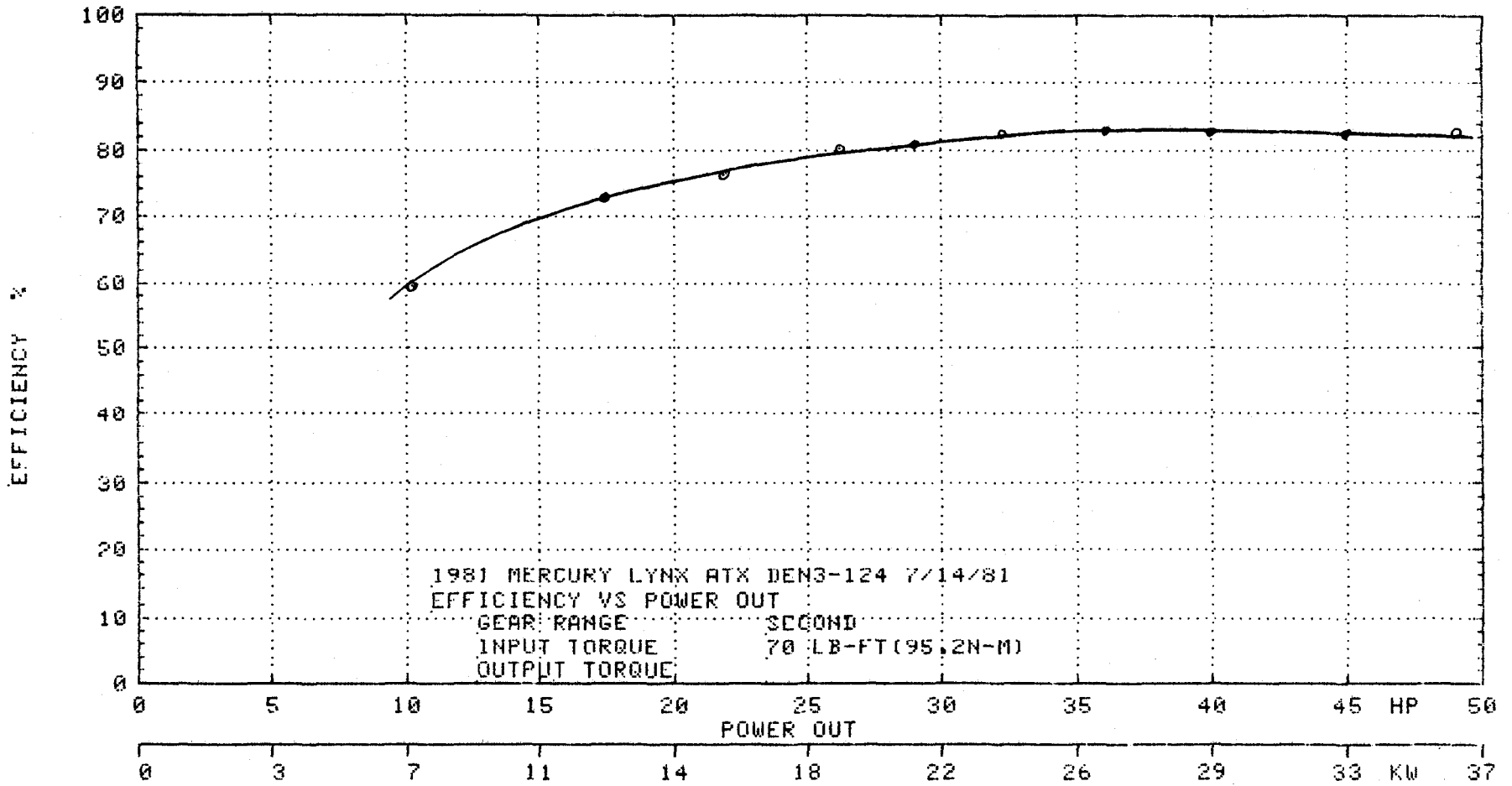

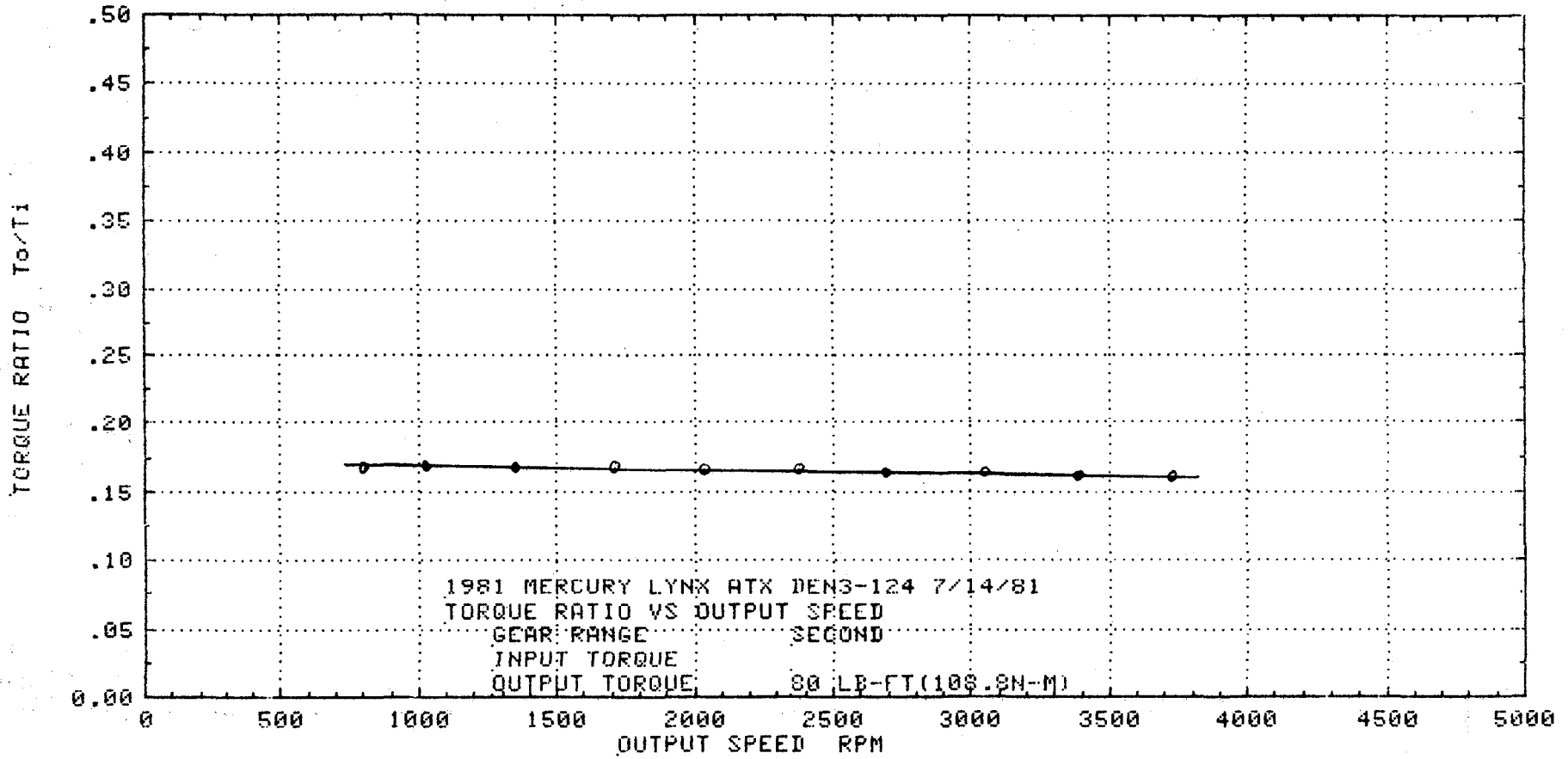

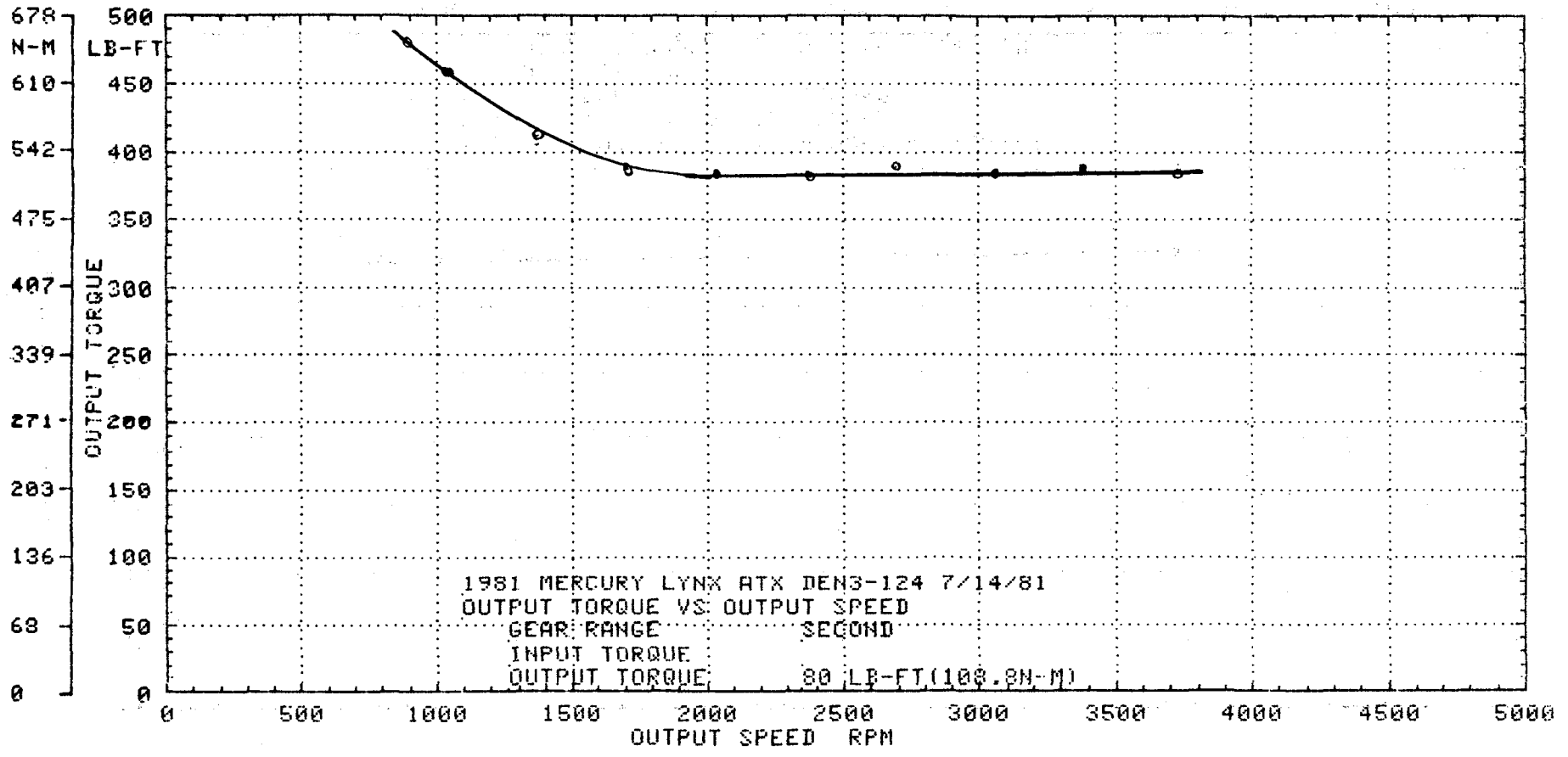

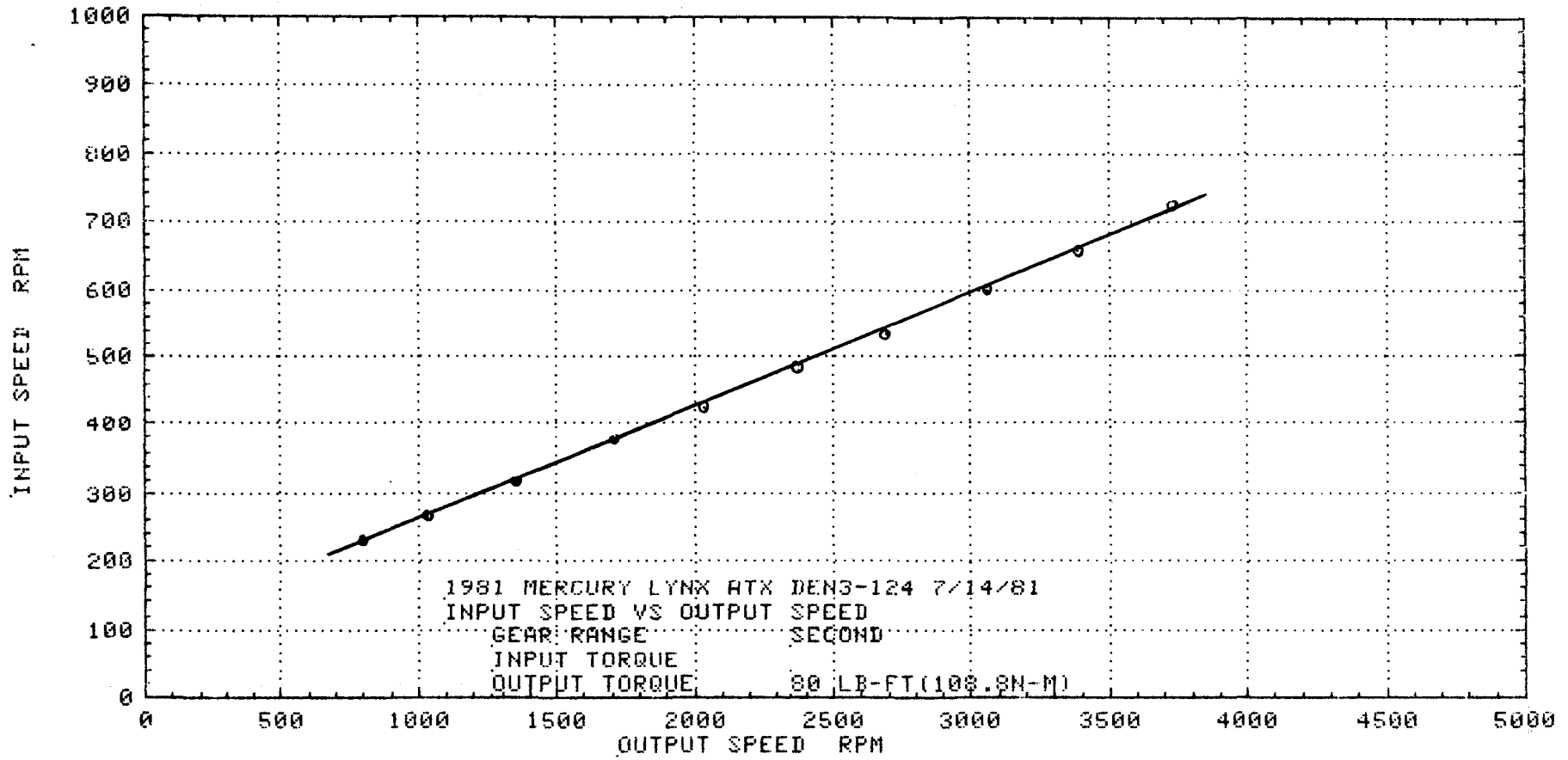

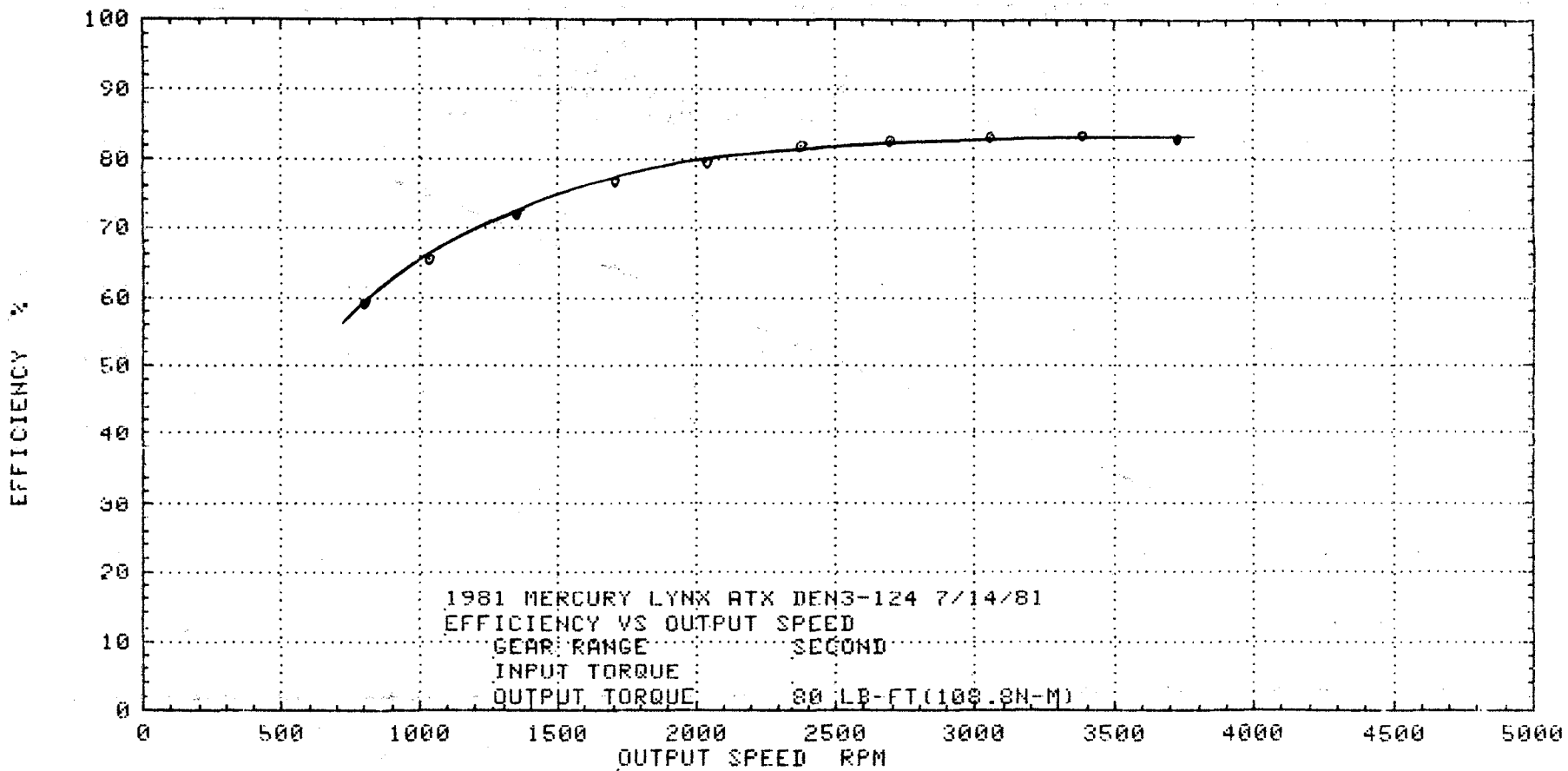

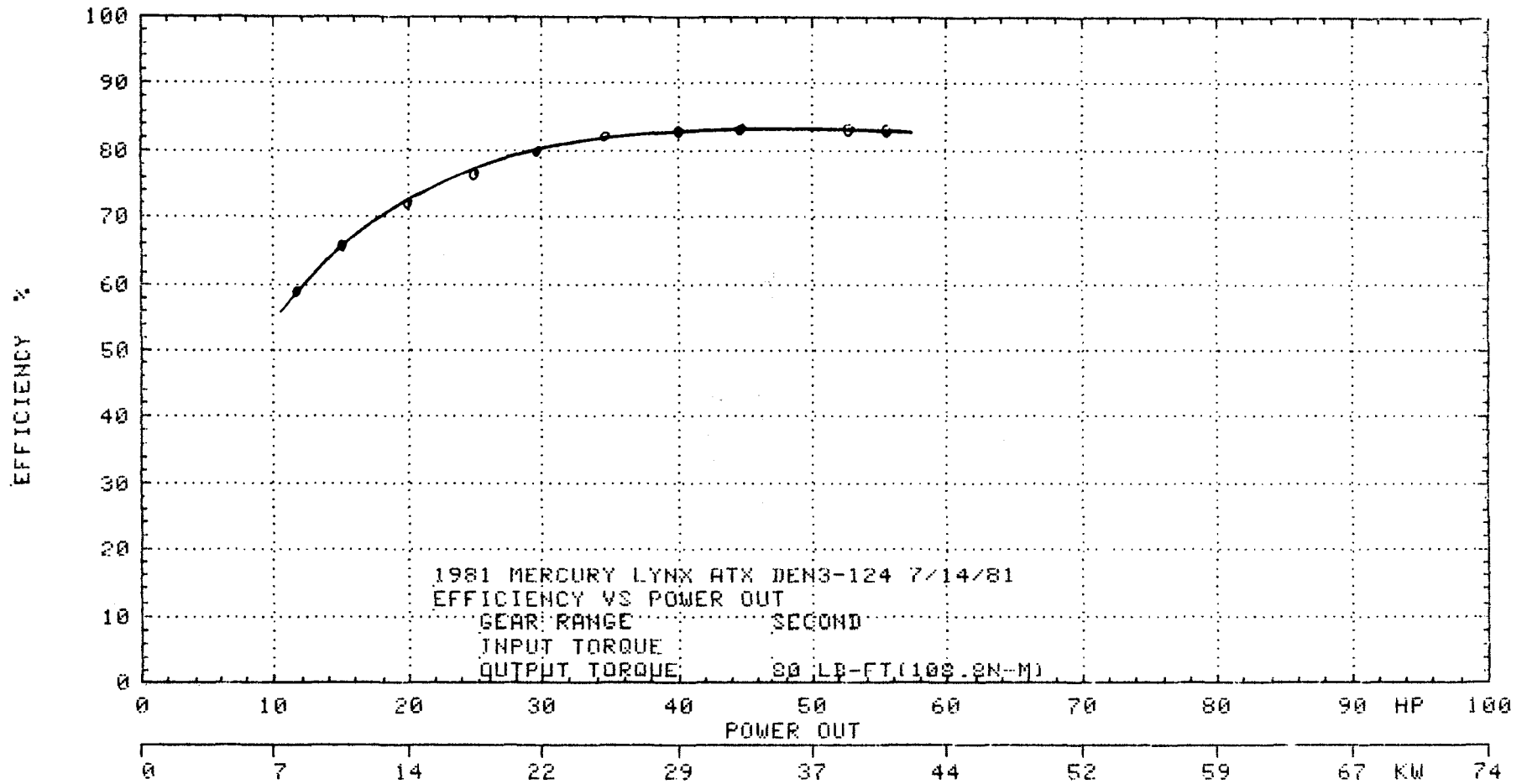

COAST PERFORMANCE

3rd Gear

Graphs Contained in This Section

Torque Ratio -vs- Output Speed

Output Torque -vs- Output Speed

Input Speed -vs- Output Speed

Efficiency -vs- Output Speed

Efficiency -vs- Power Out

265

Torque In

Speed In

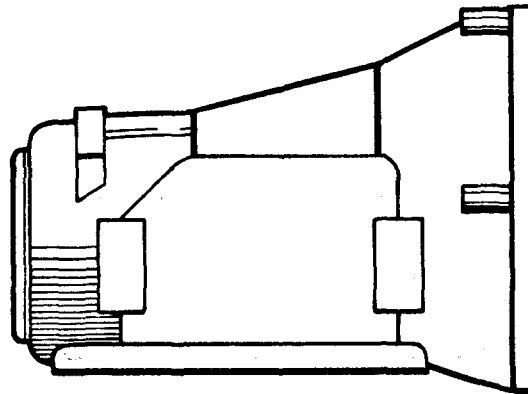

Torque Out

Speed Out

Coast Performance Tests

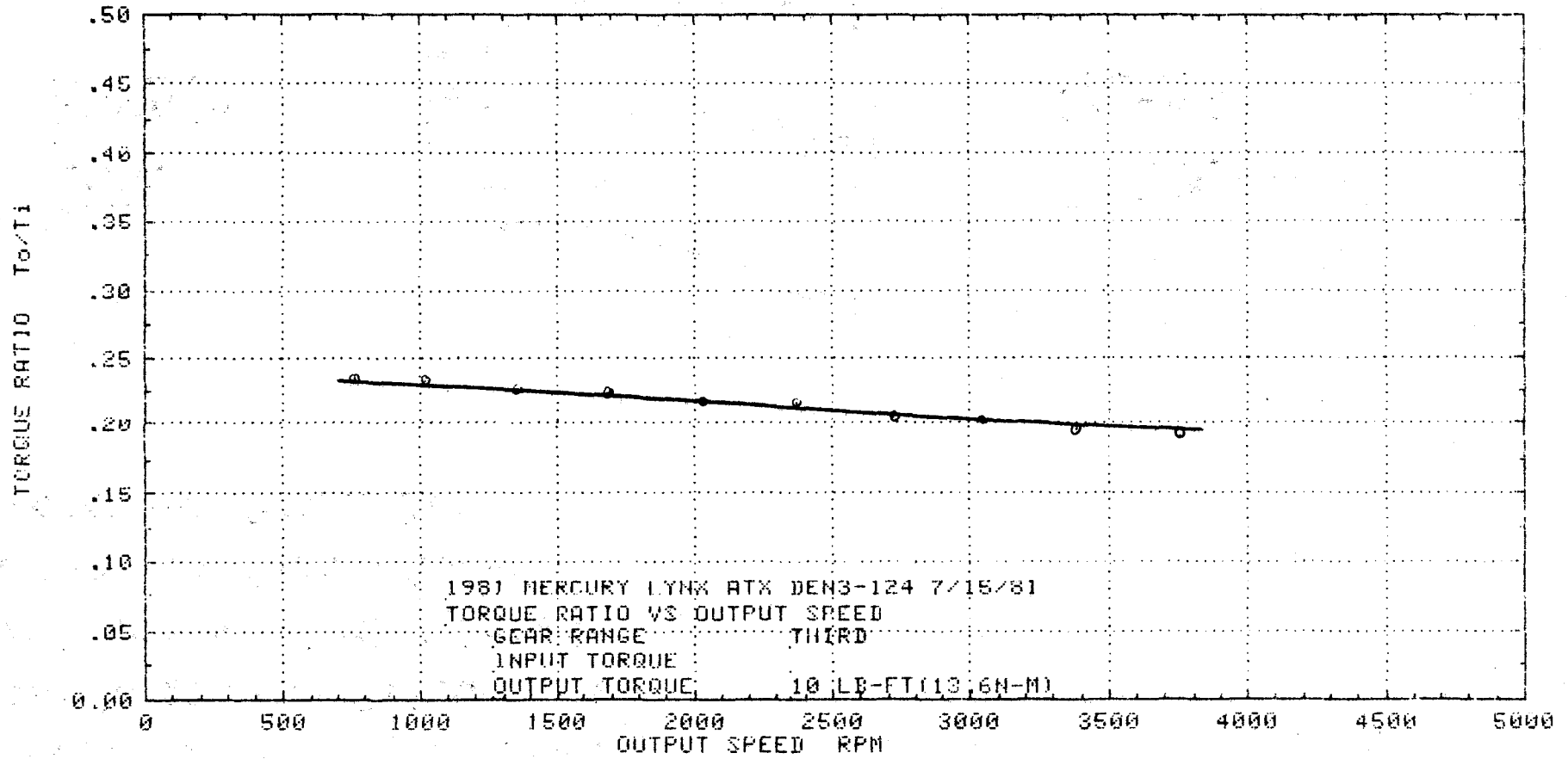

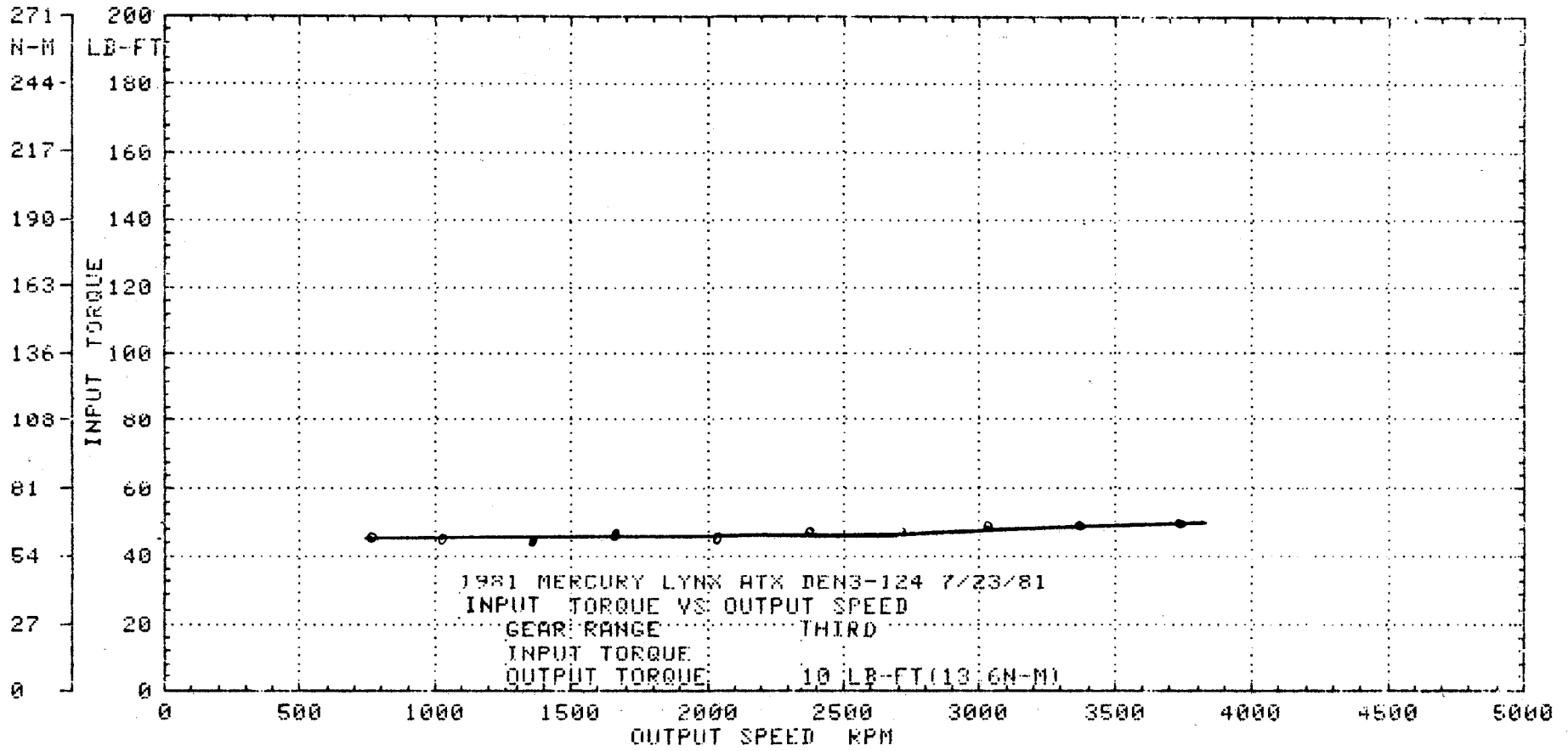

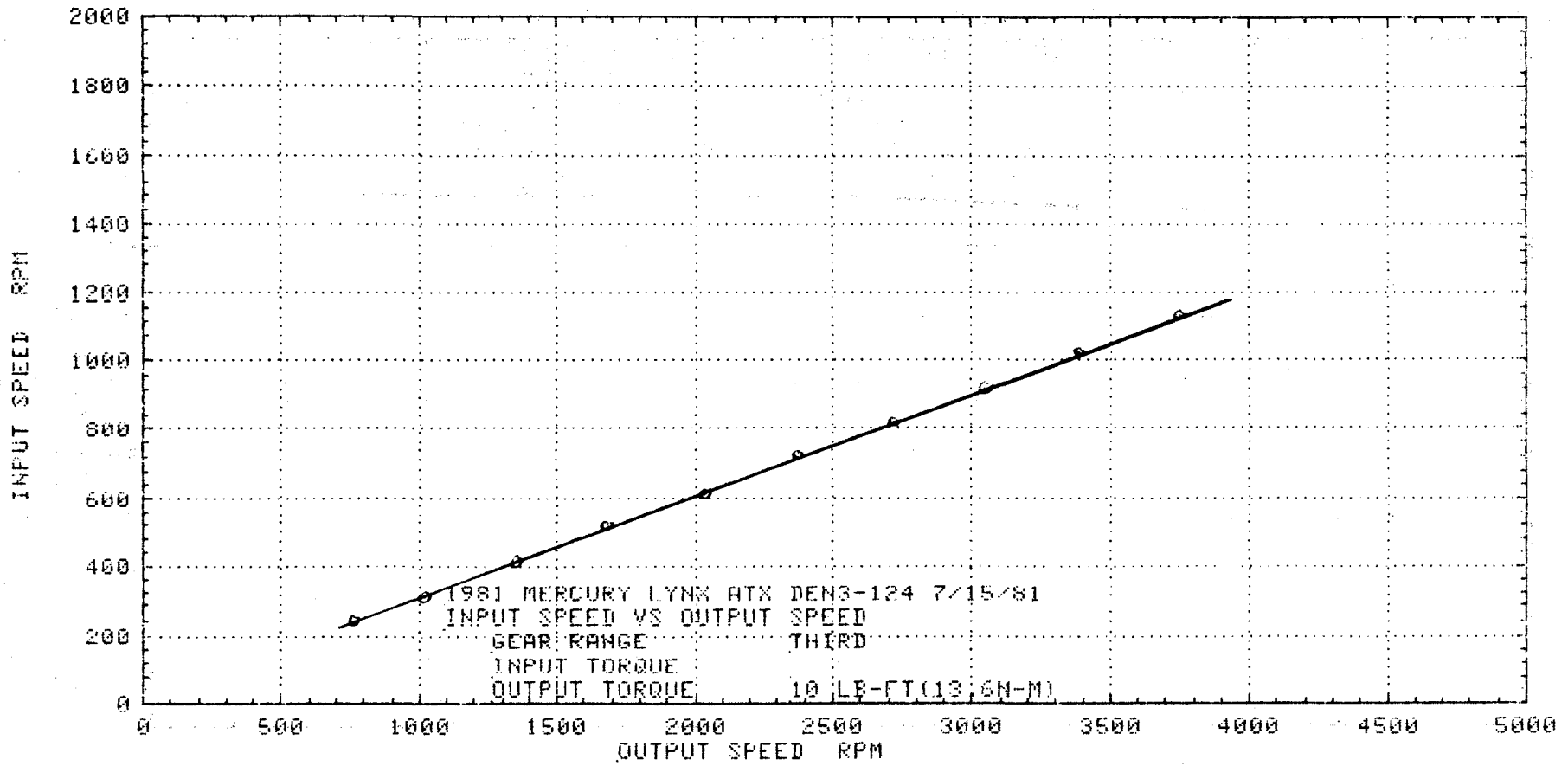

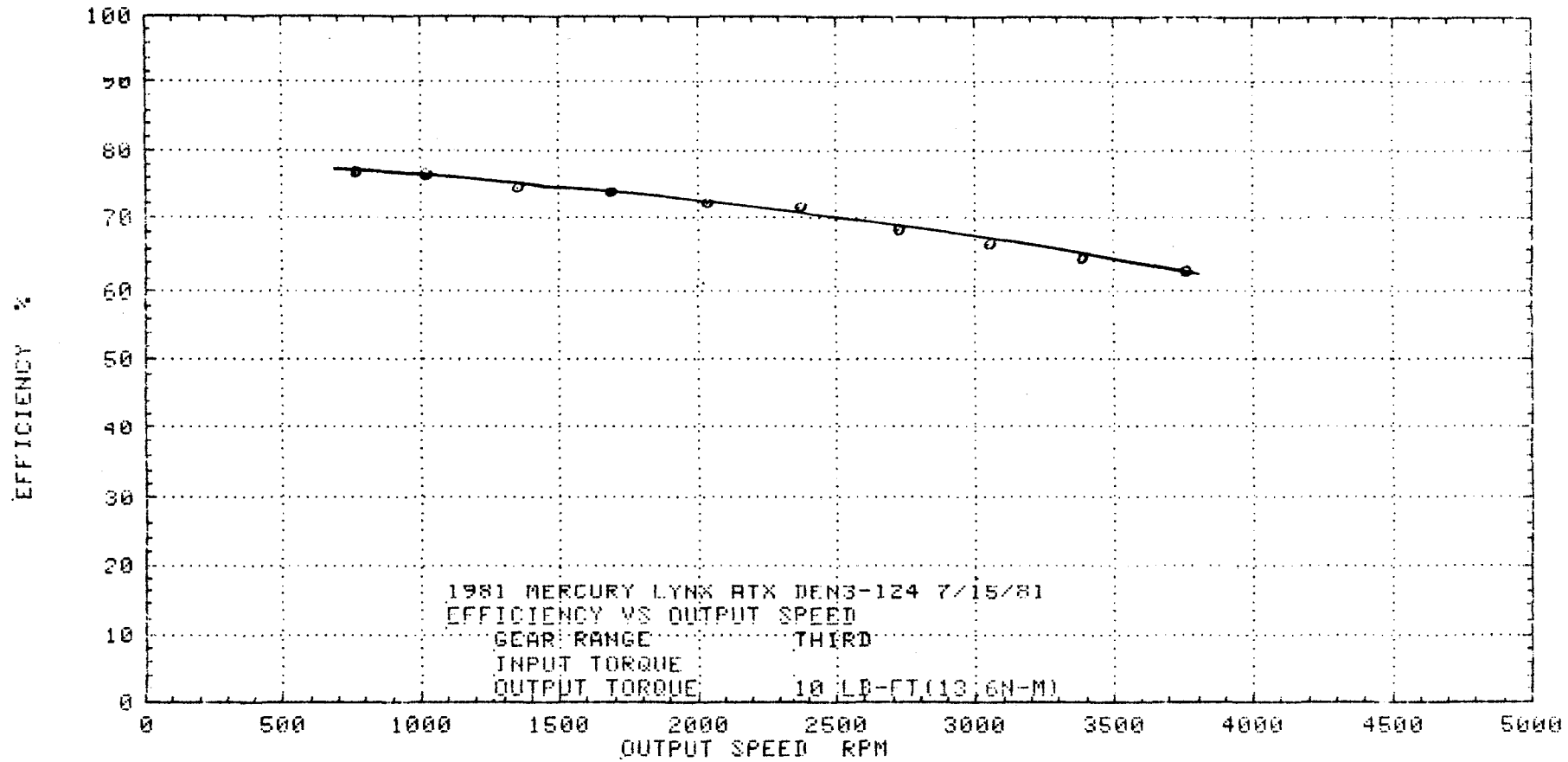

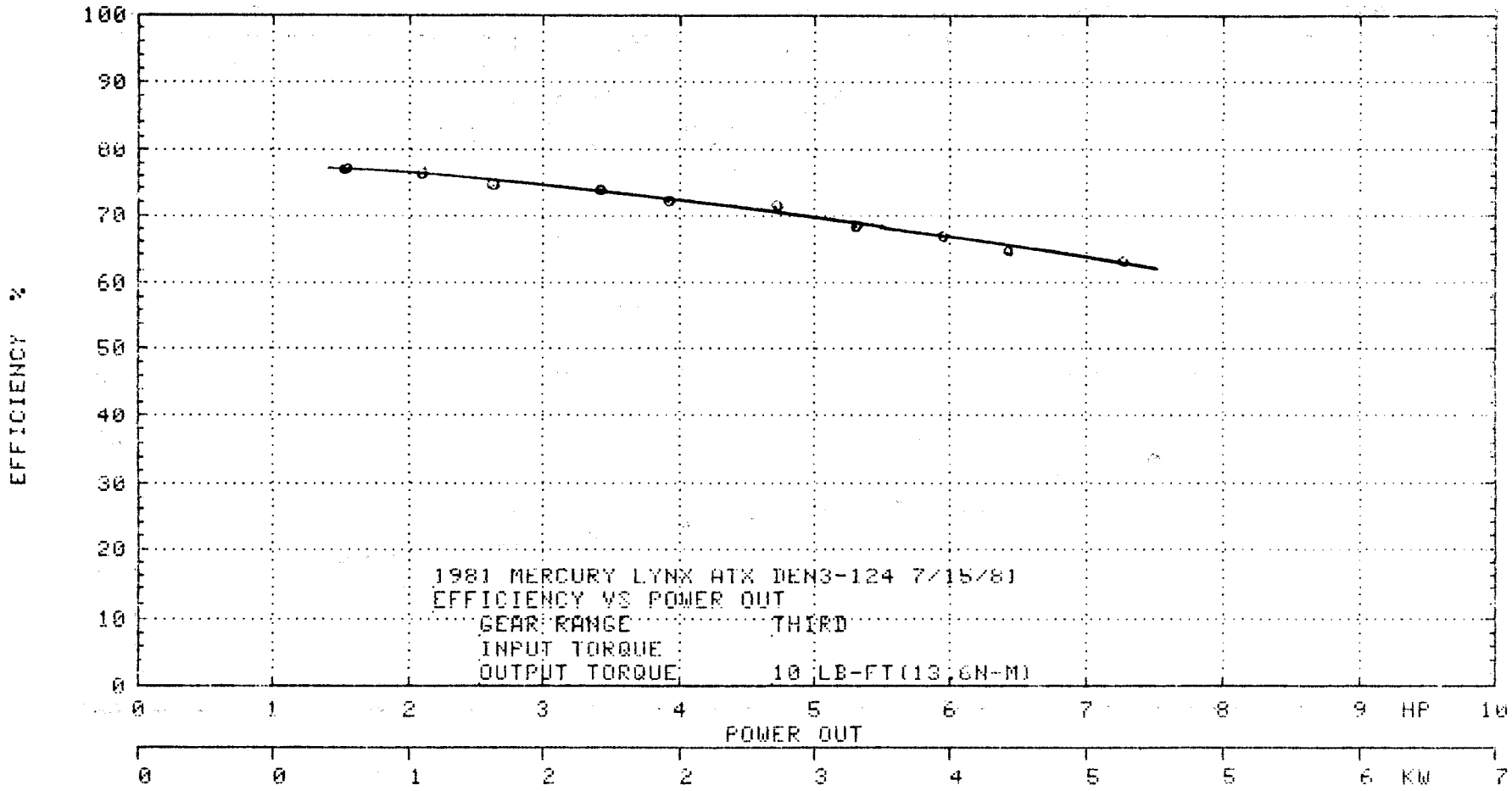

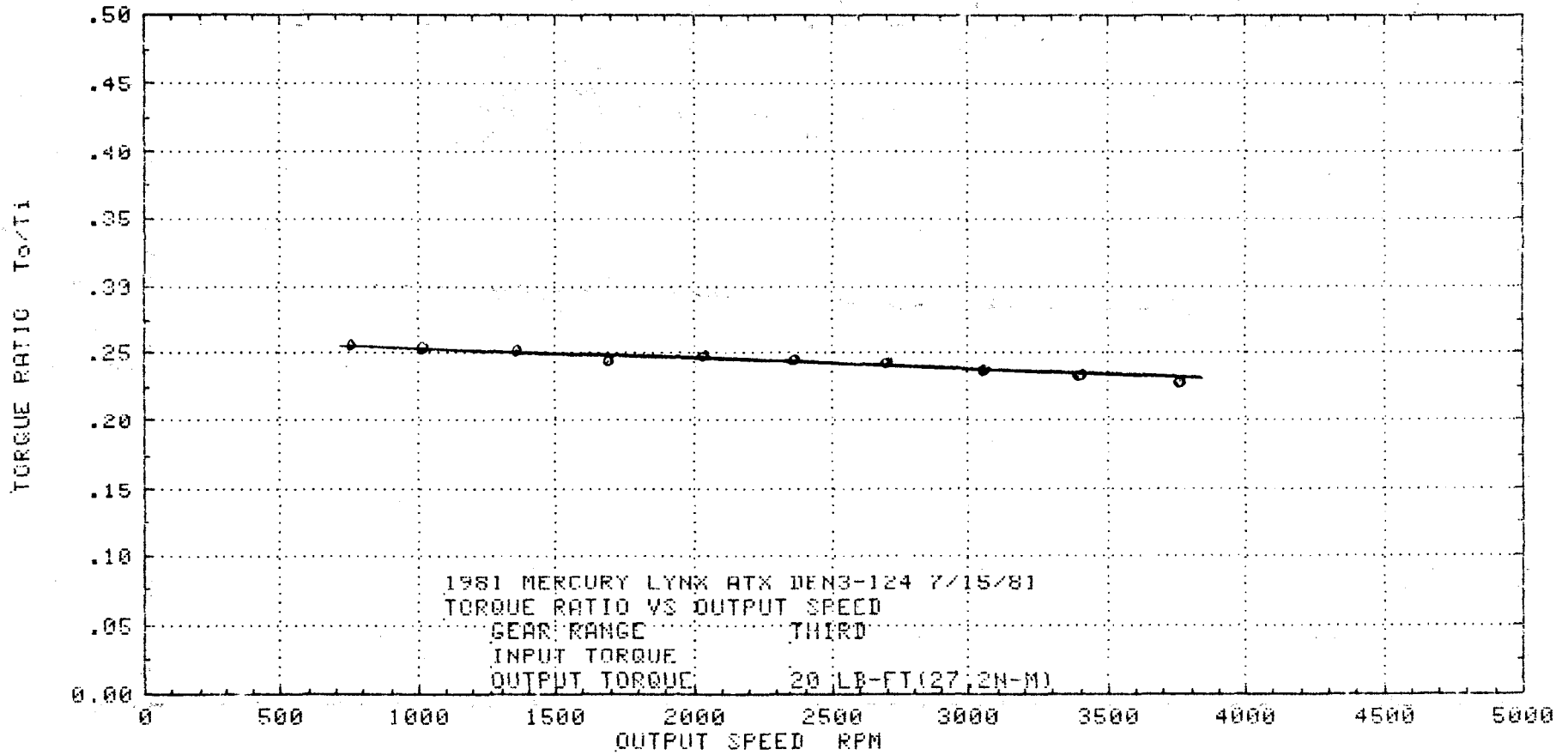

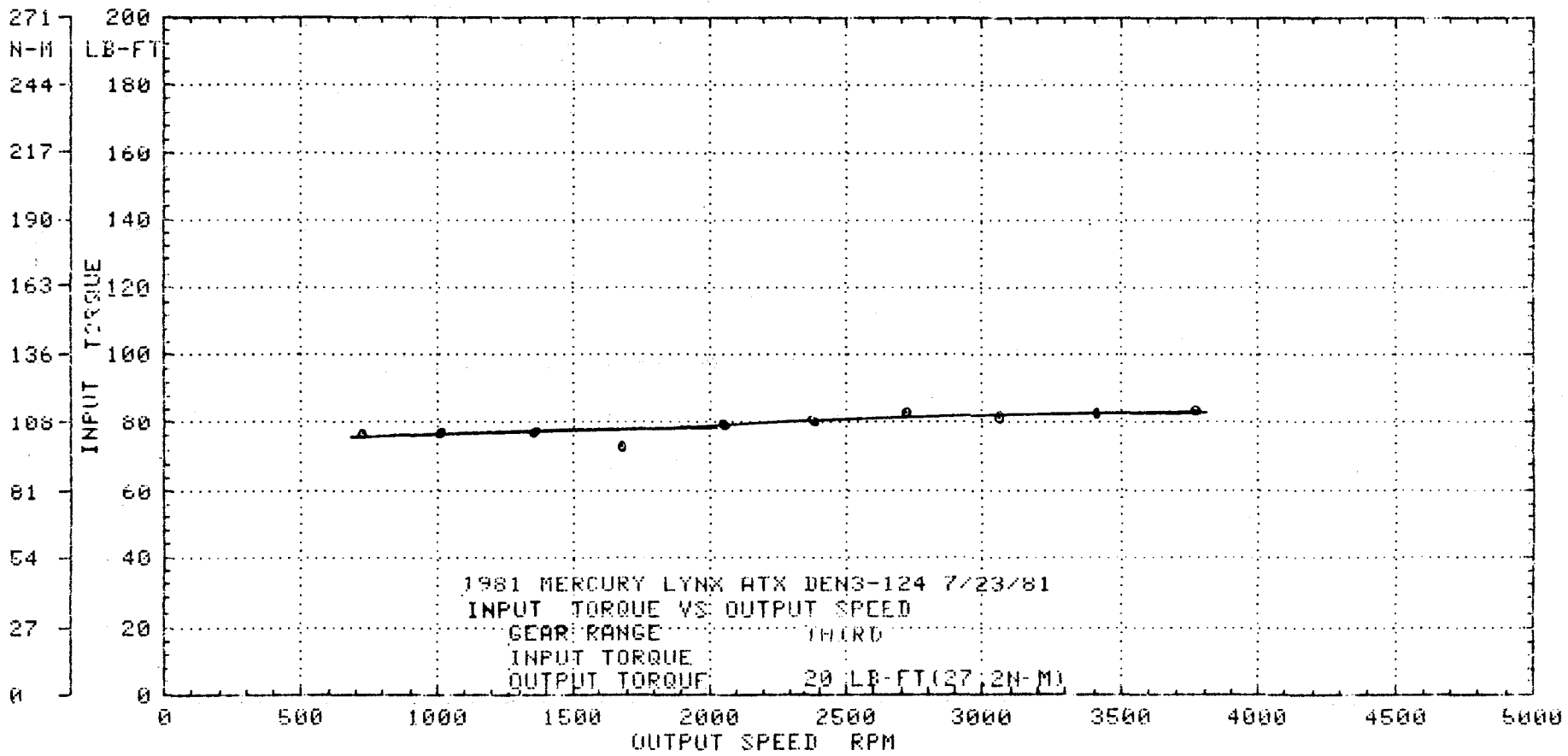

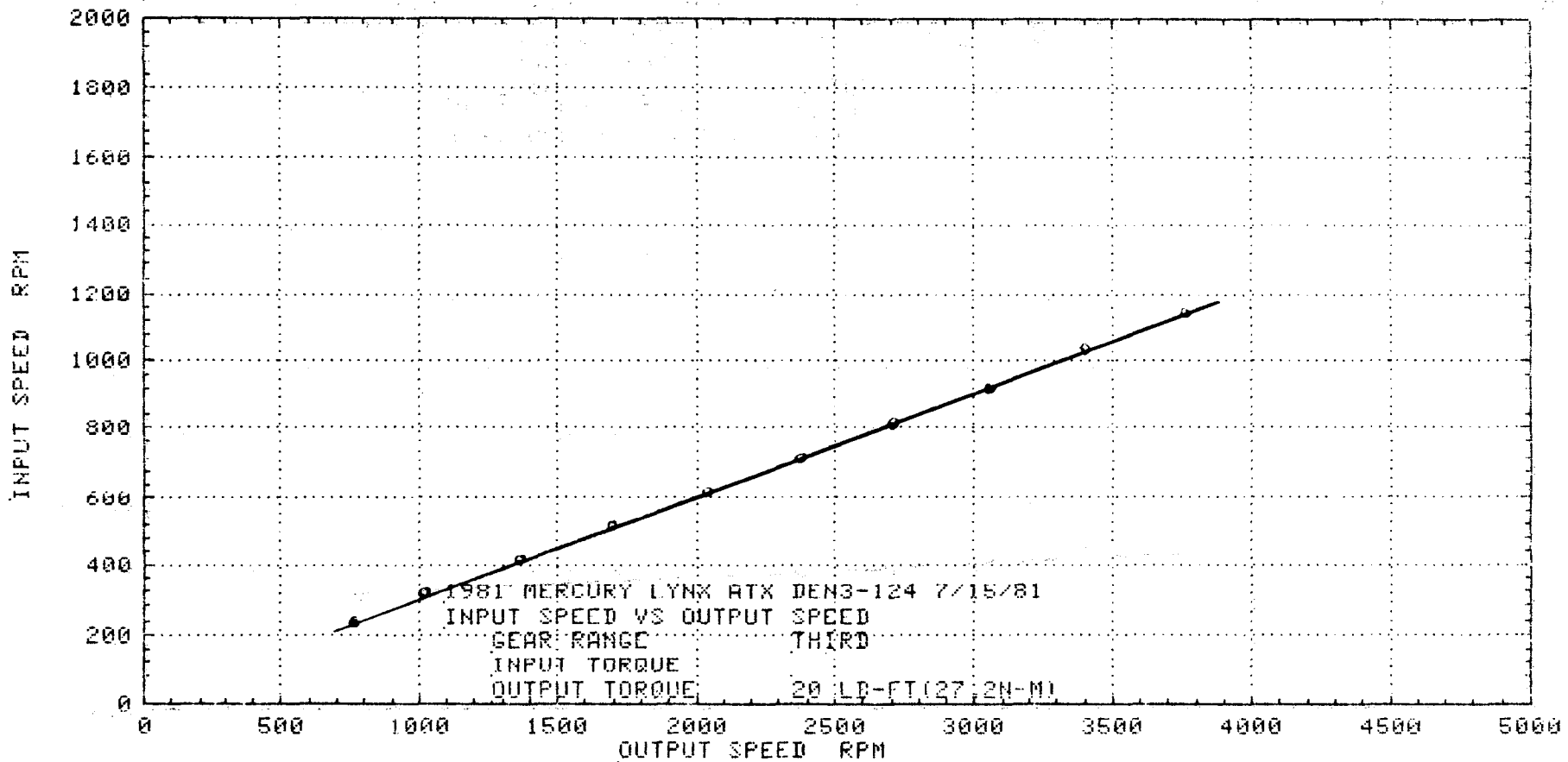

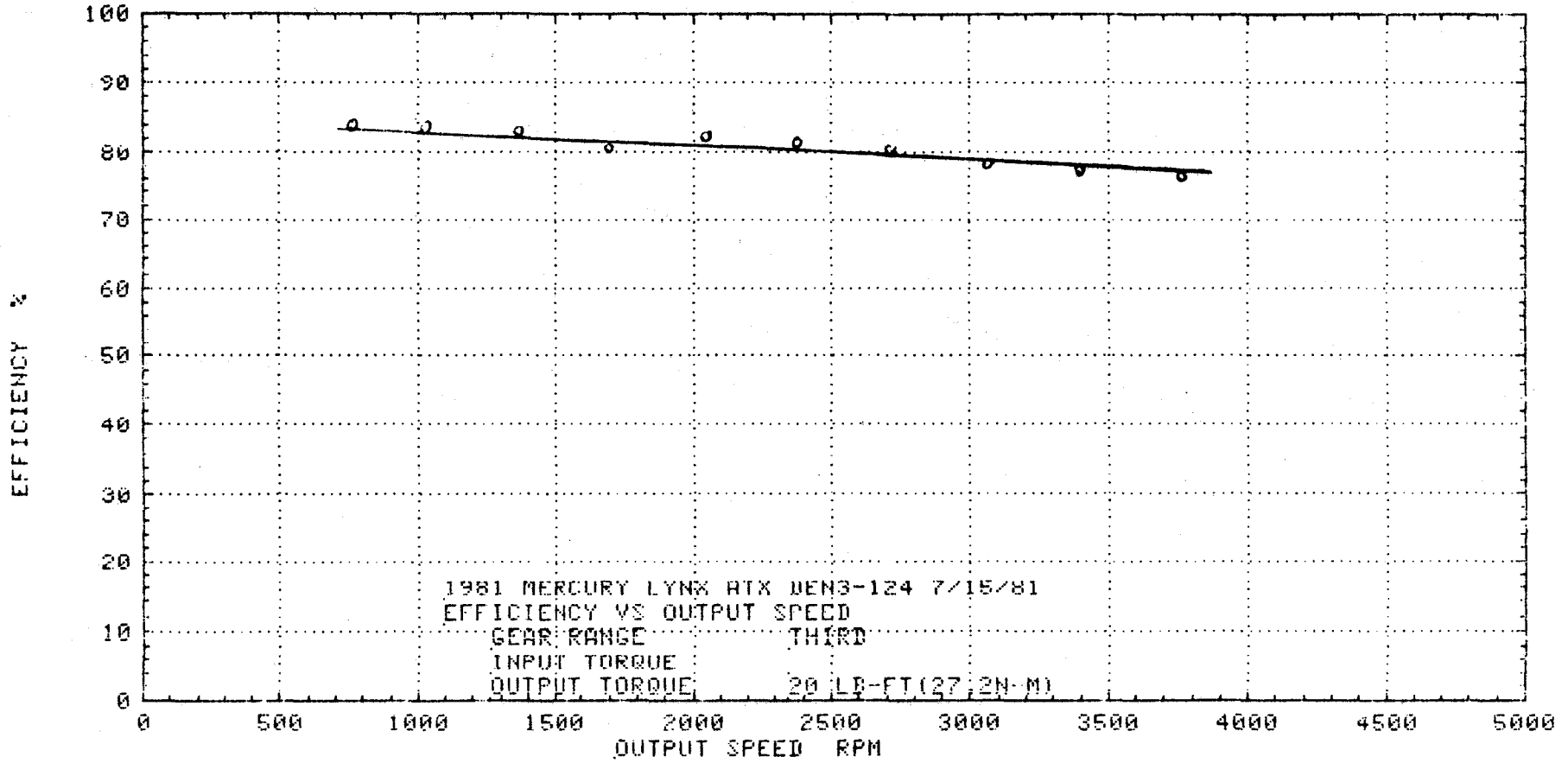

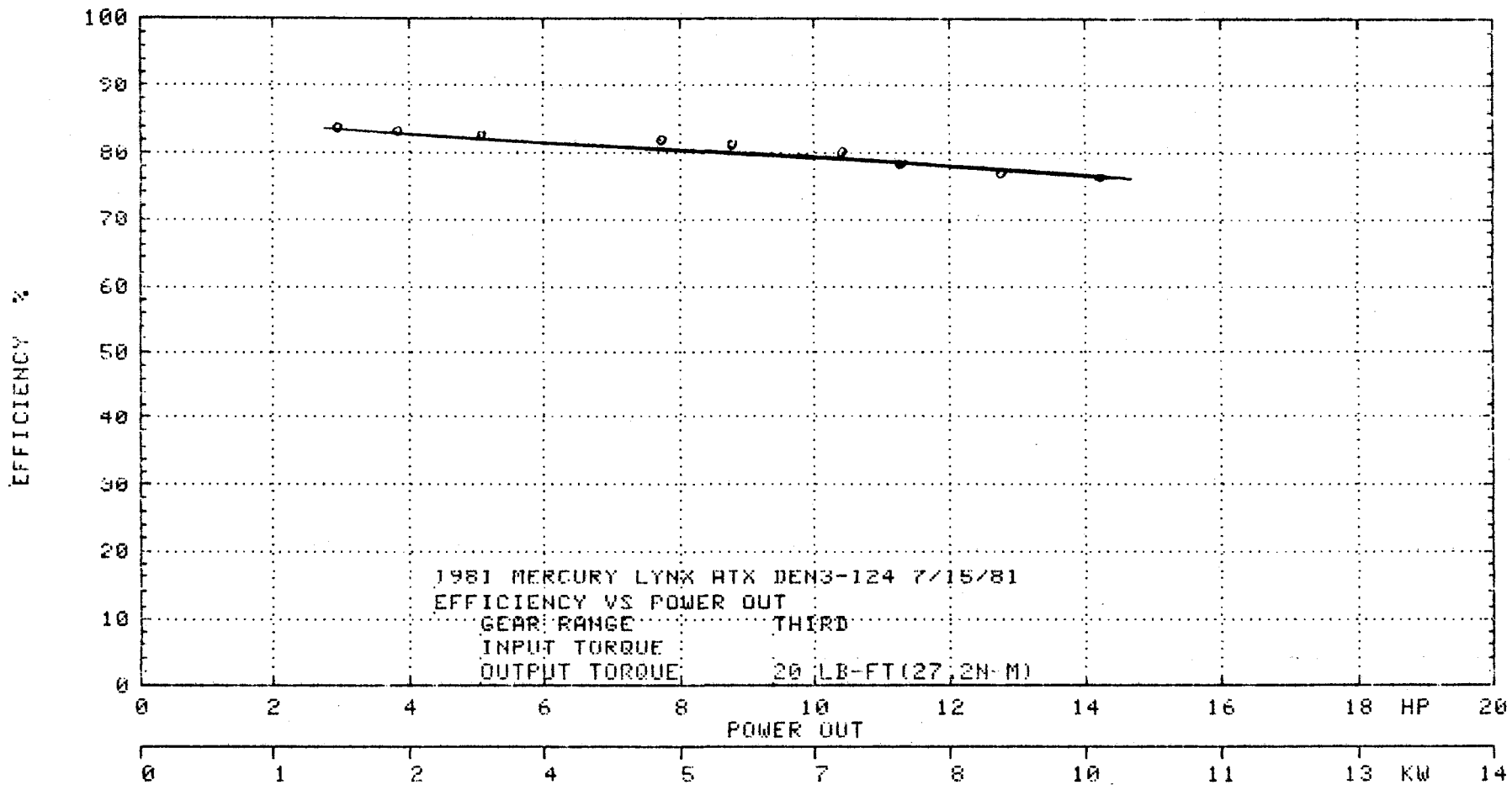

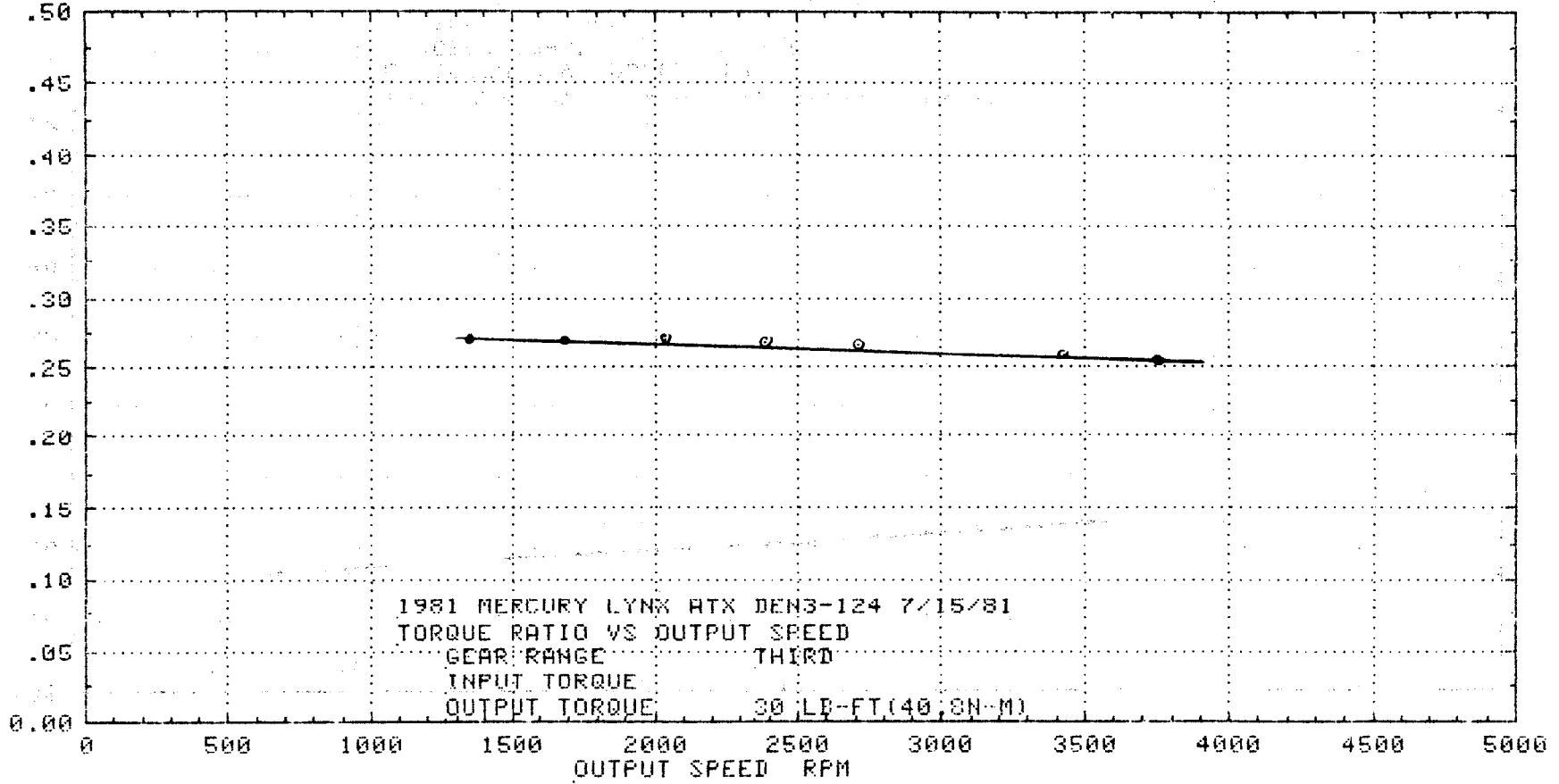
TORQUE RATIO T_o/T_i 

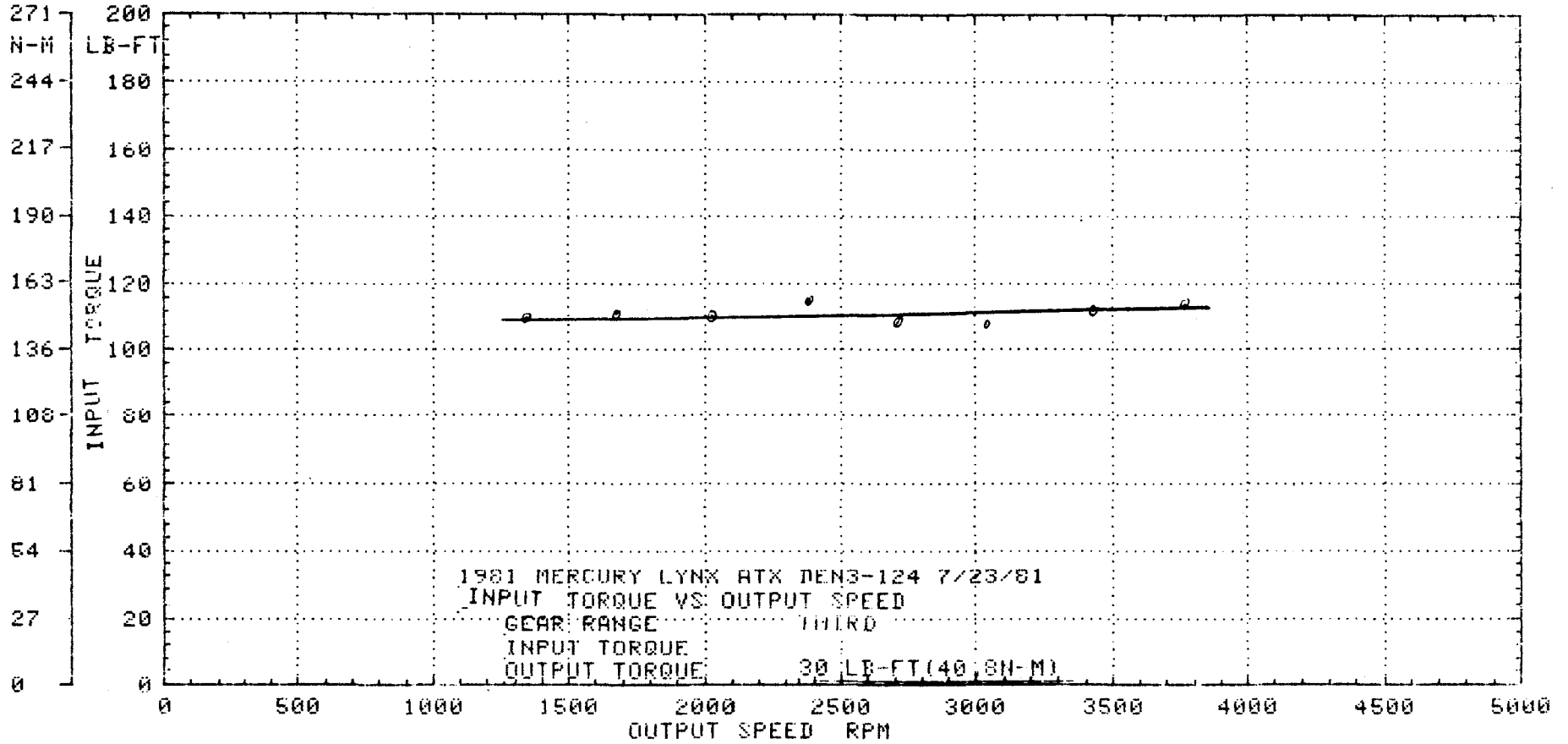

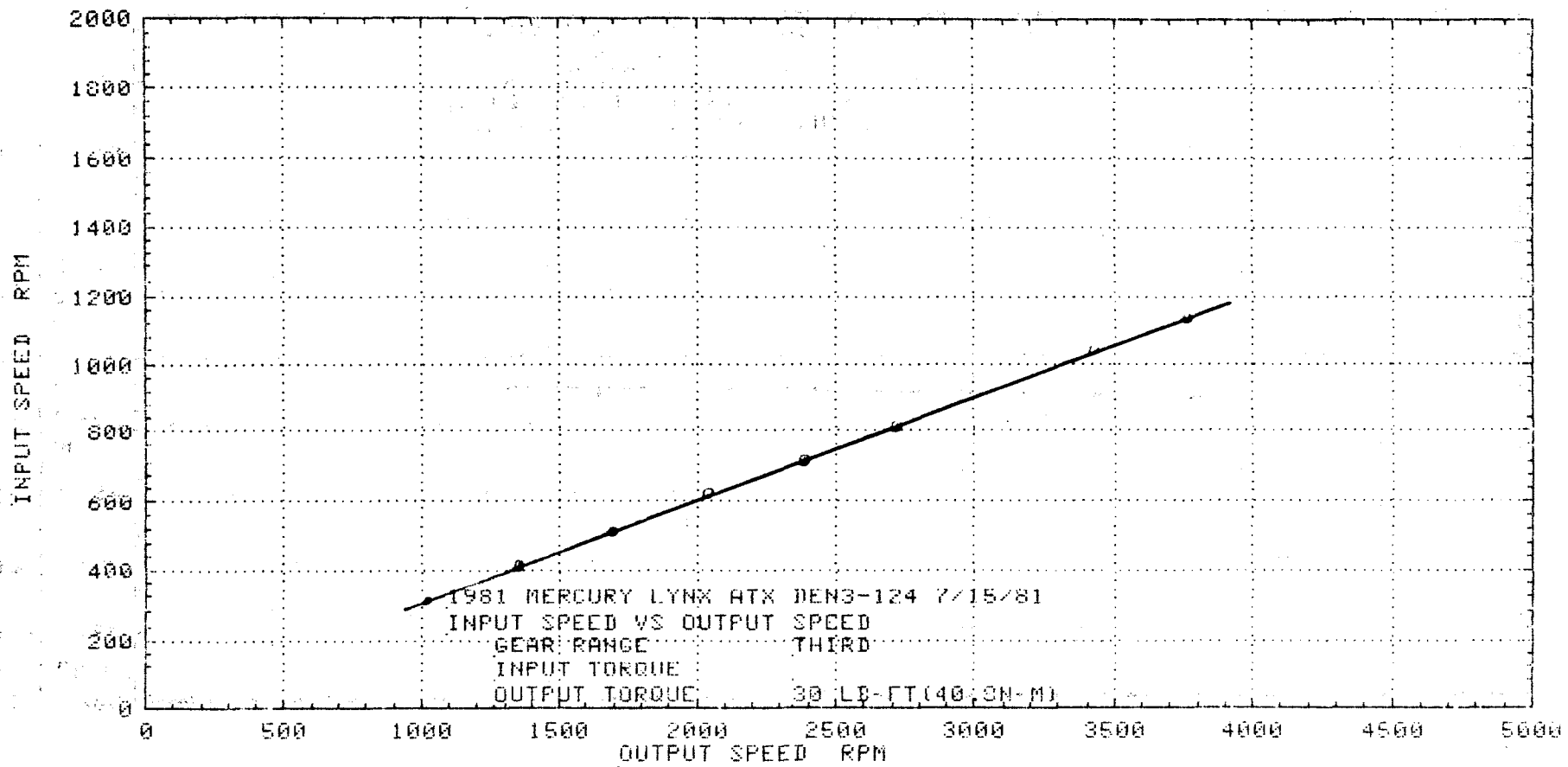

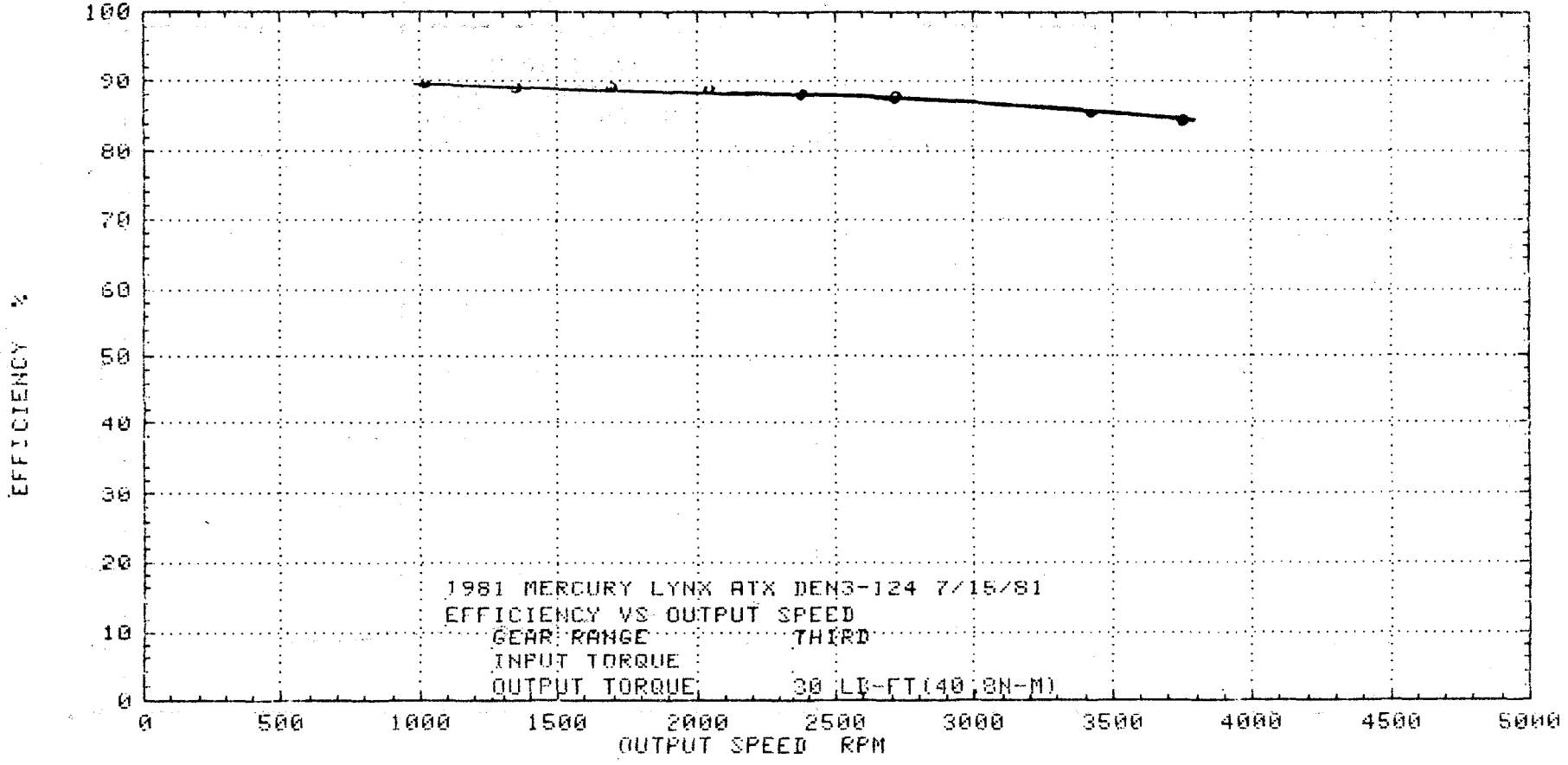

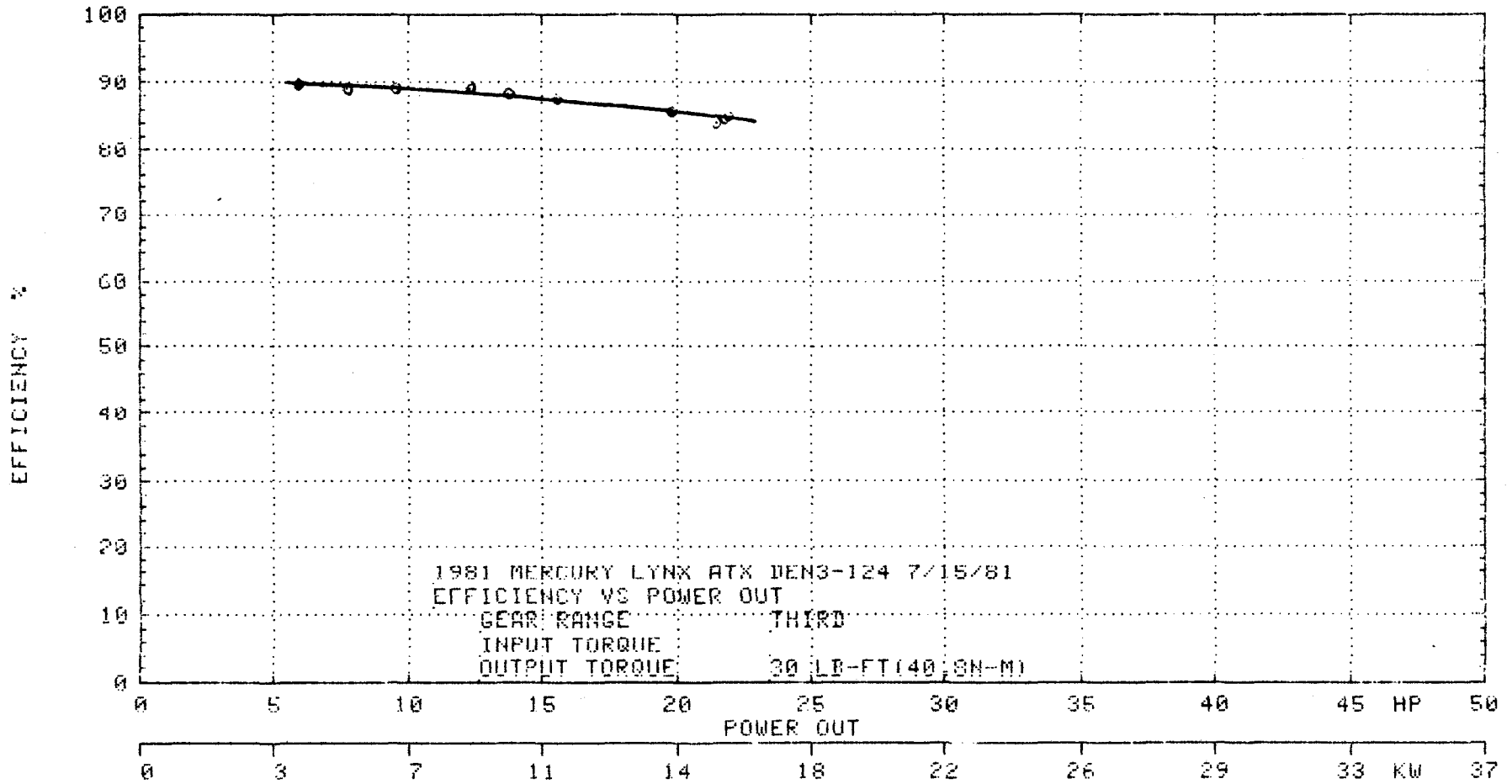

TORQUE RATIO T_o/T_i

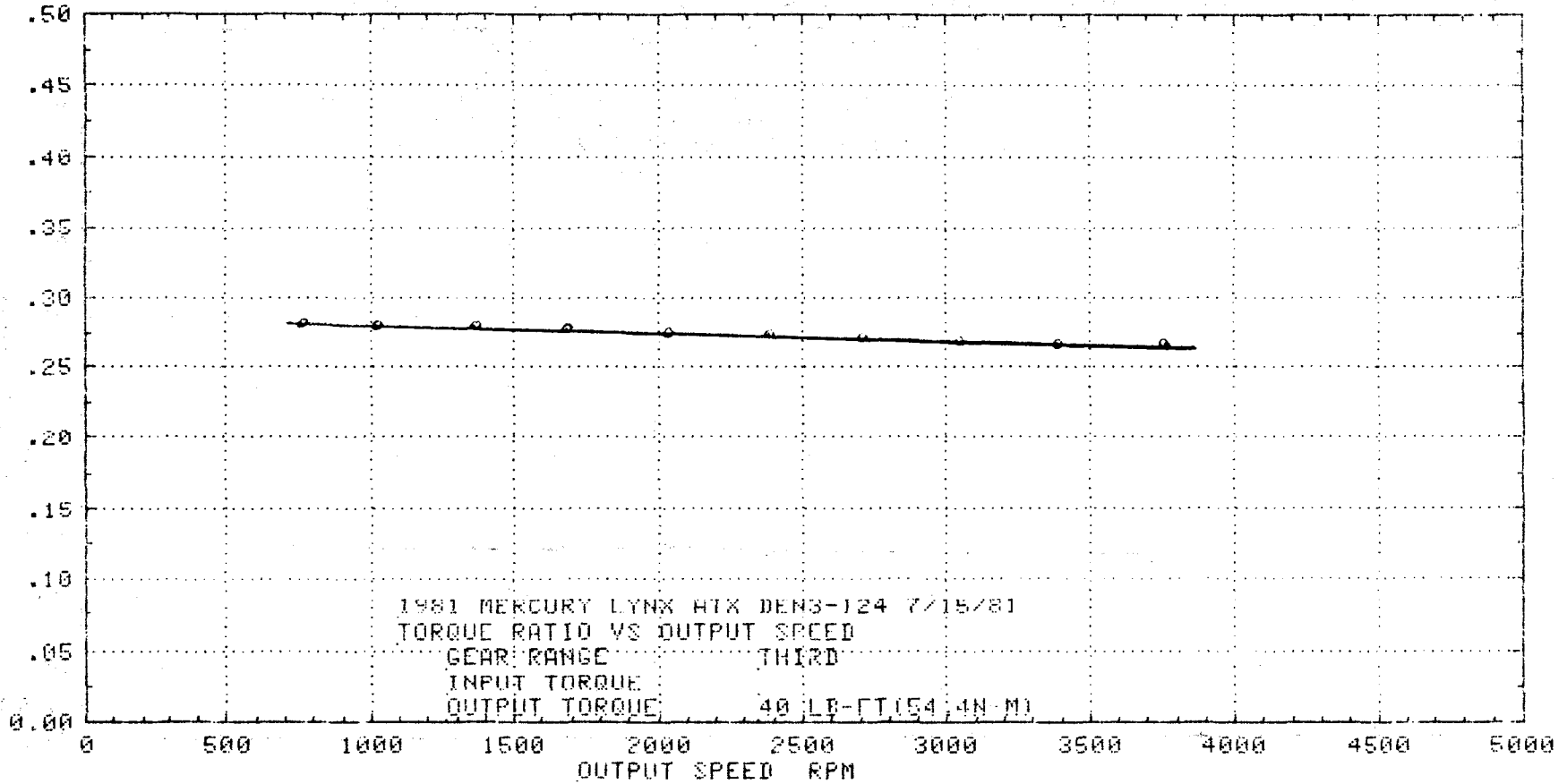

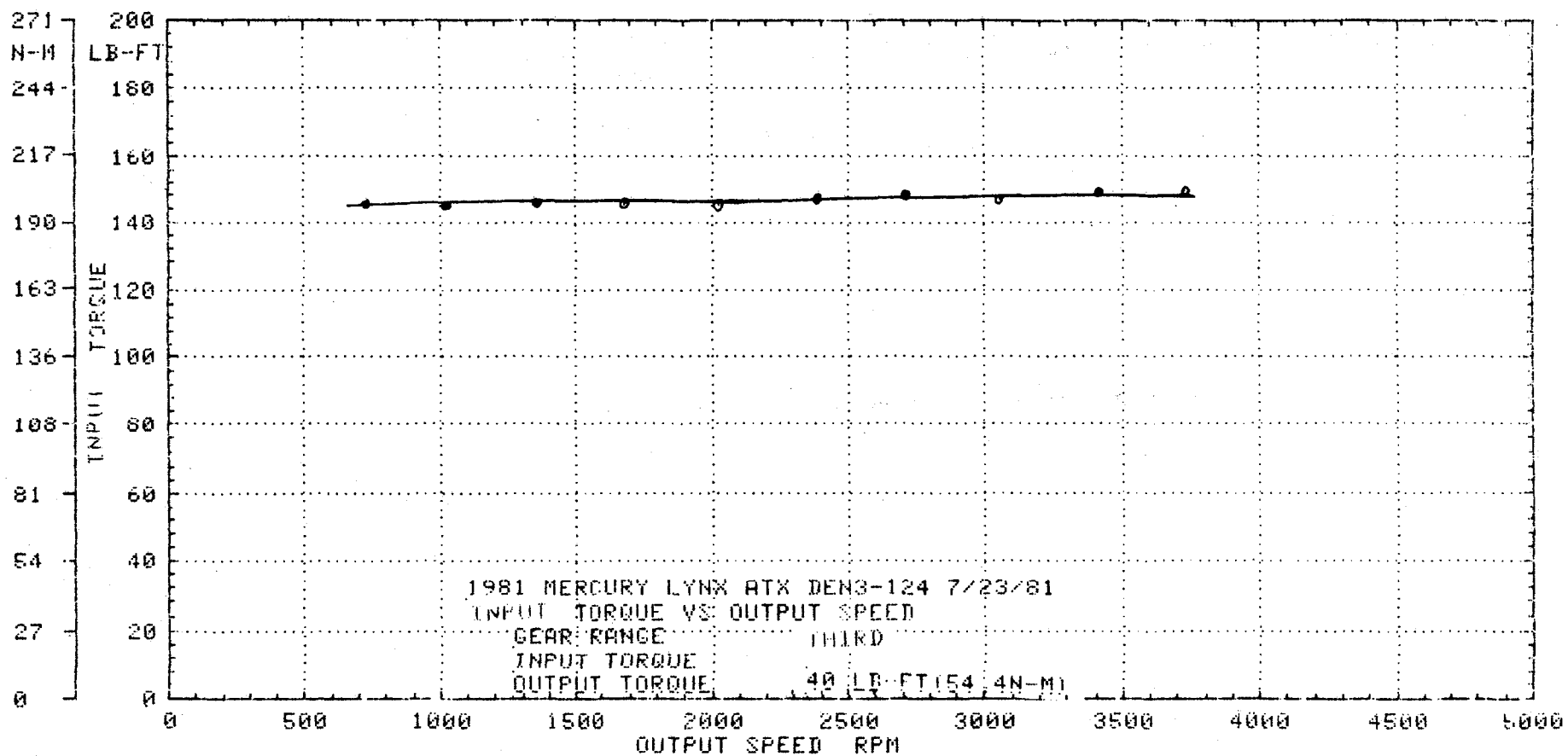

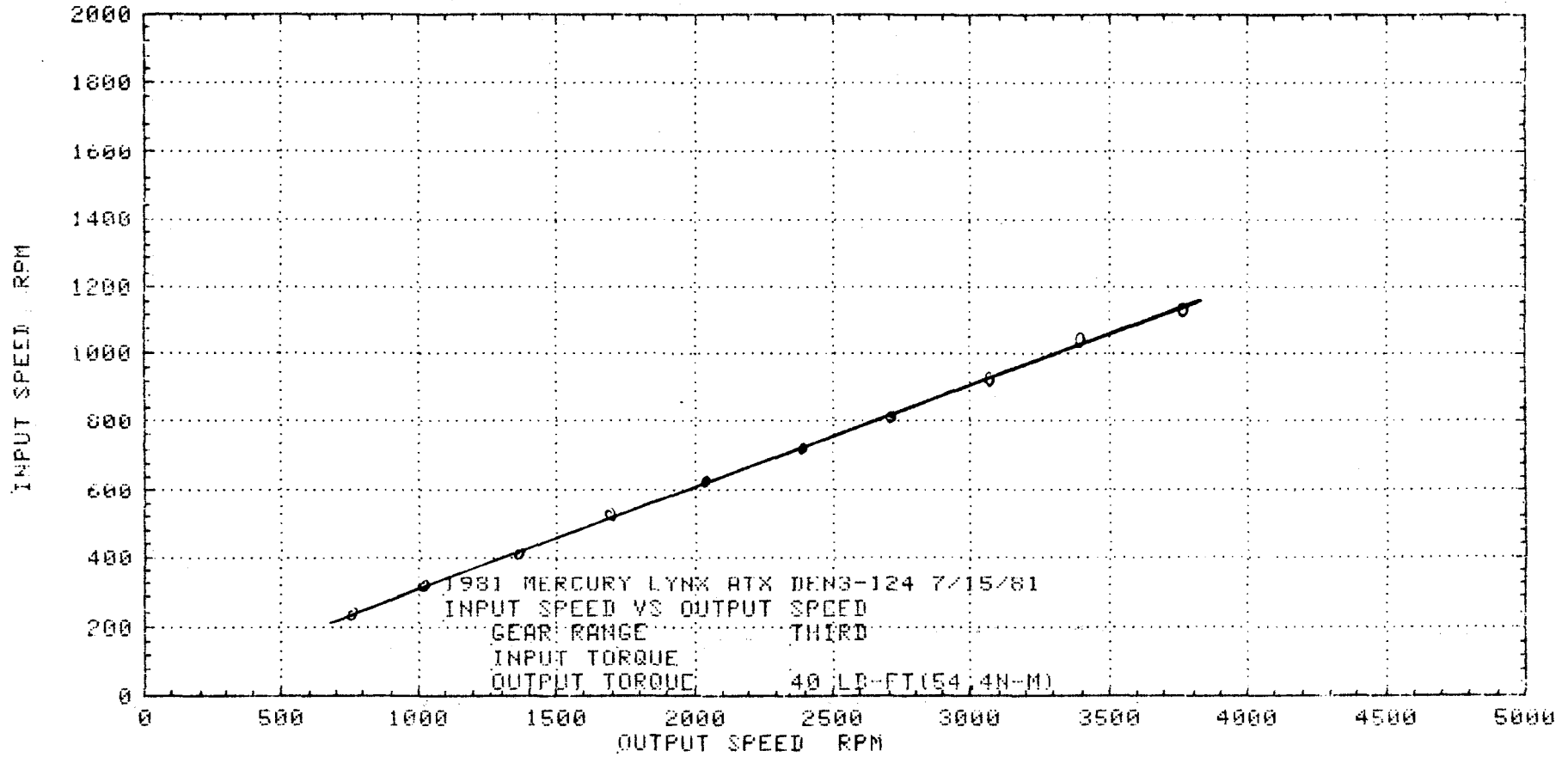

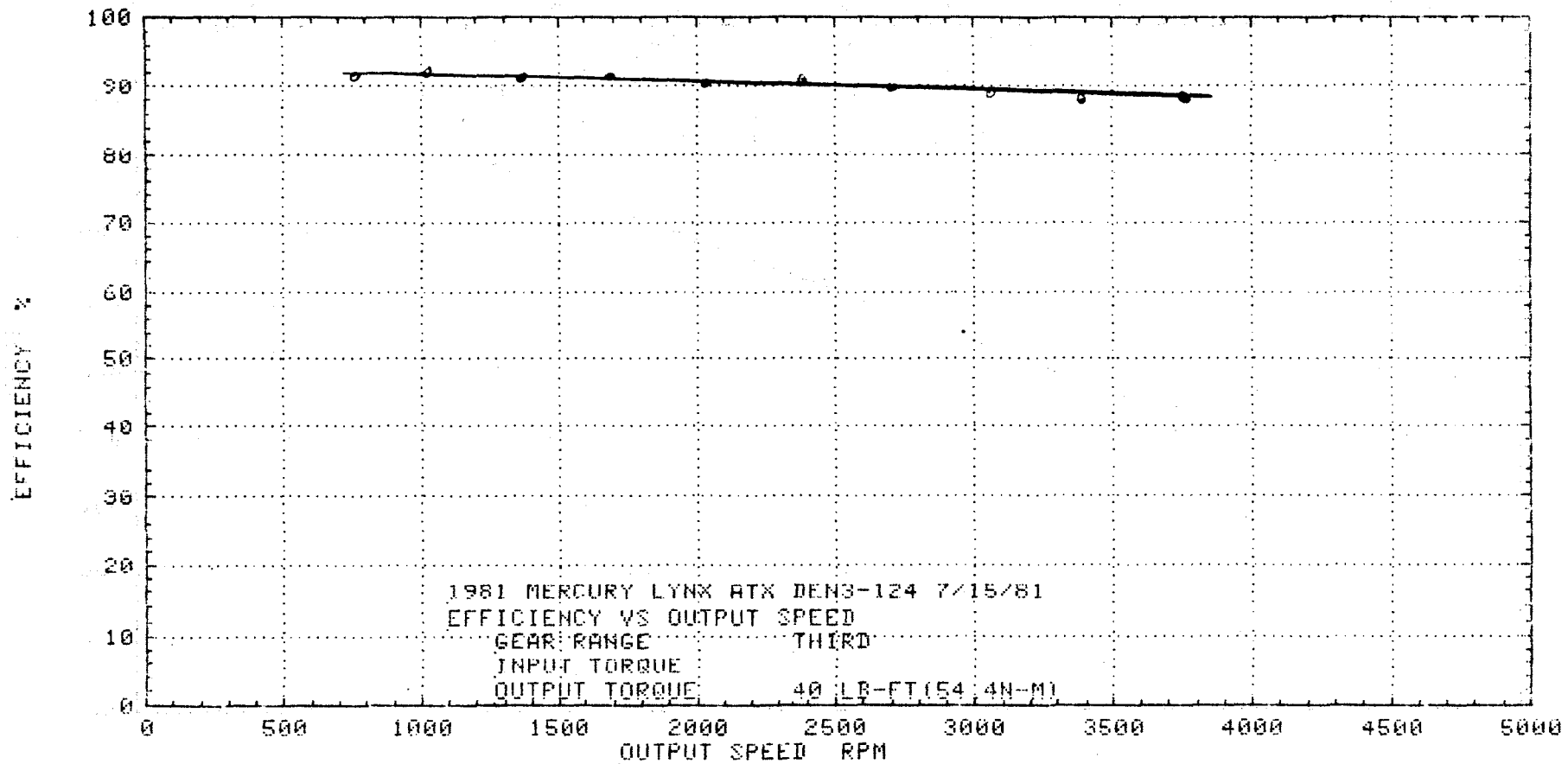

EFFICIENCY %

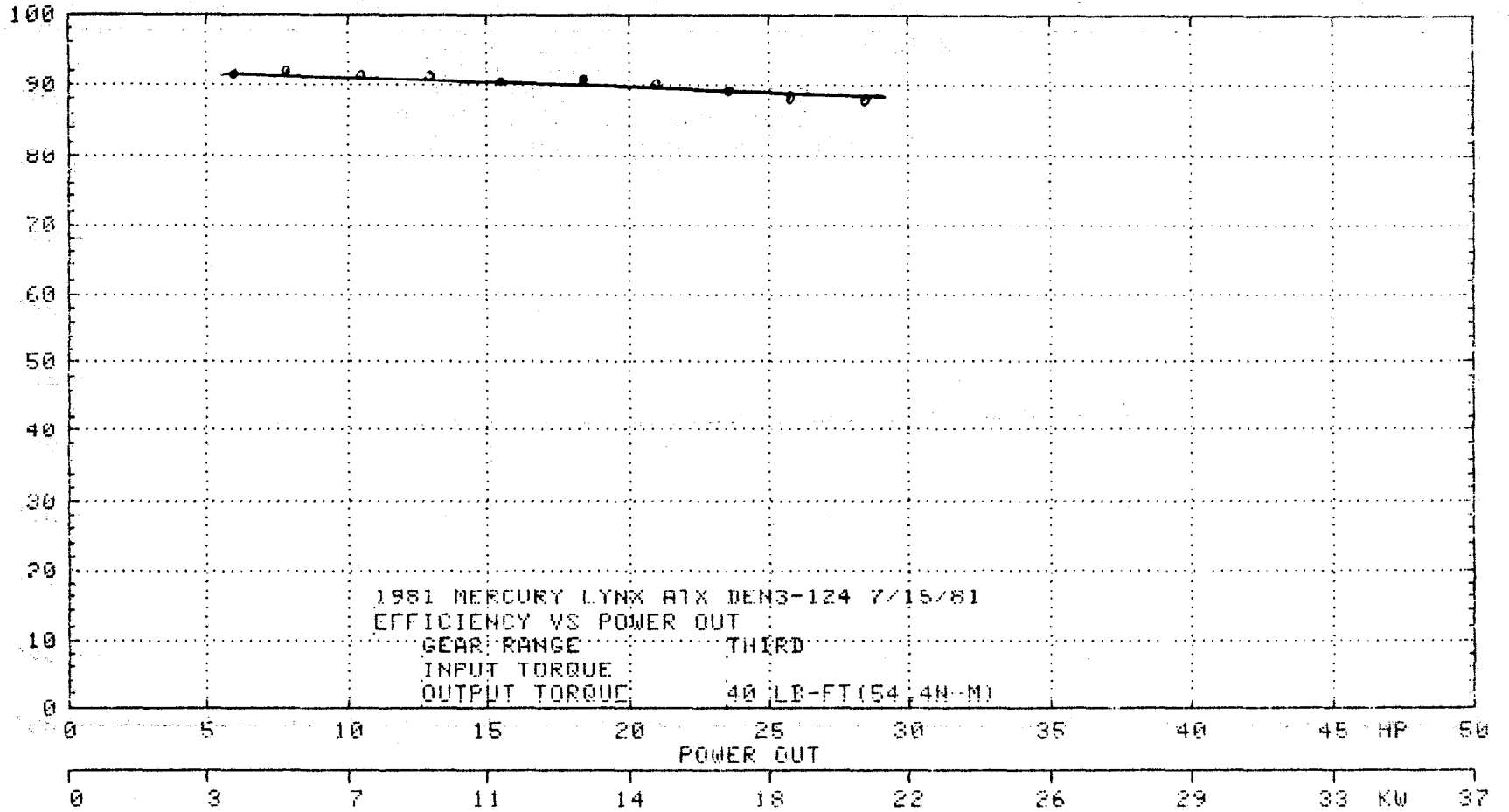

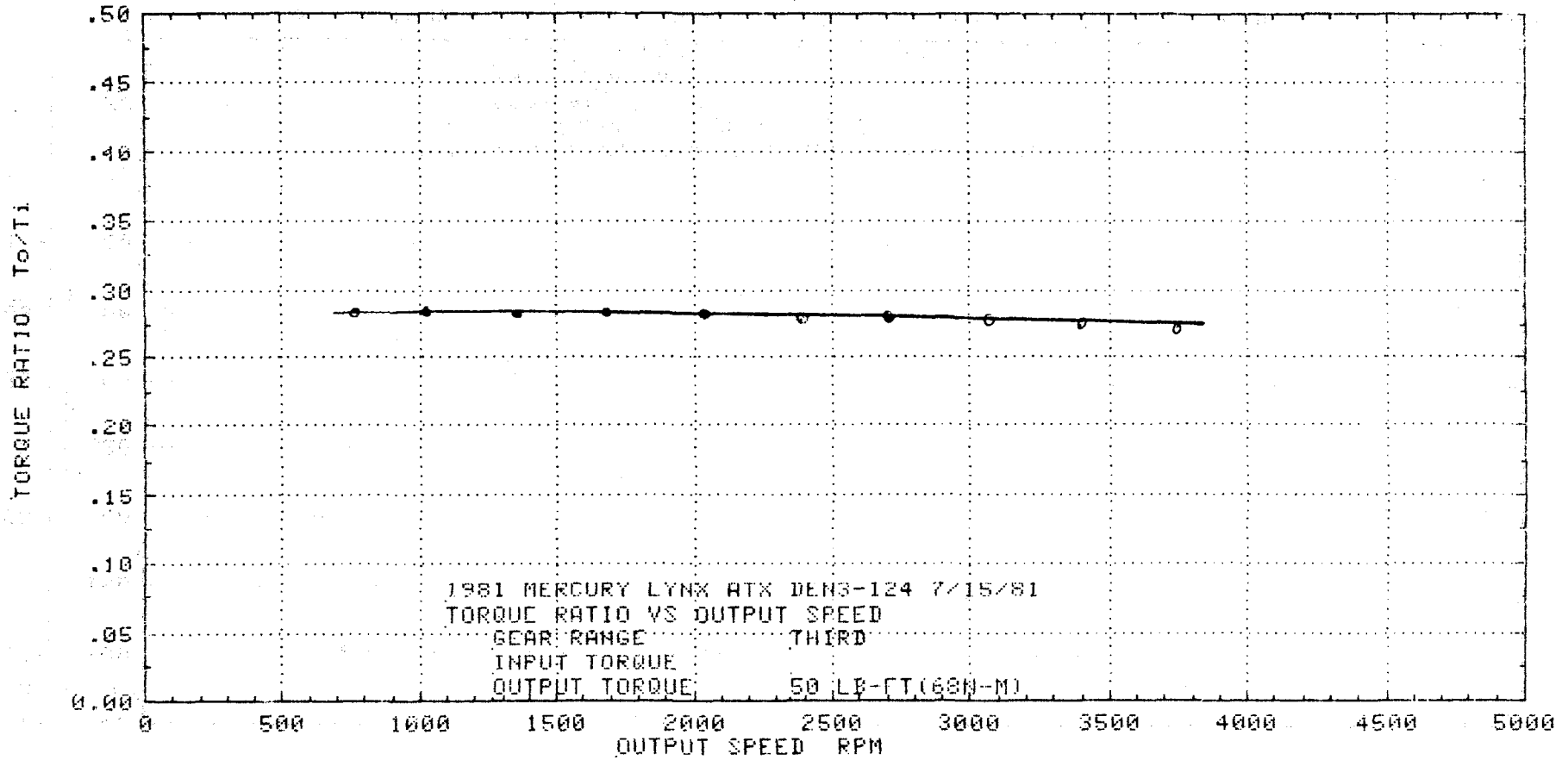

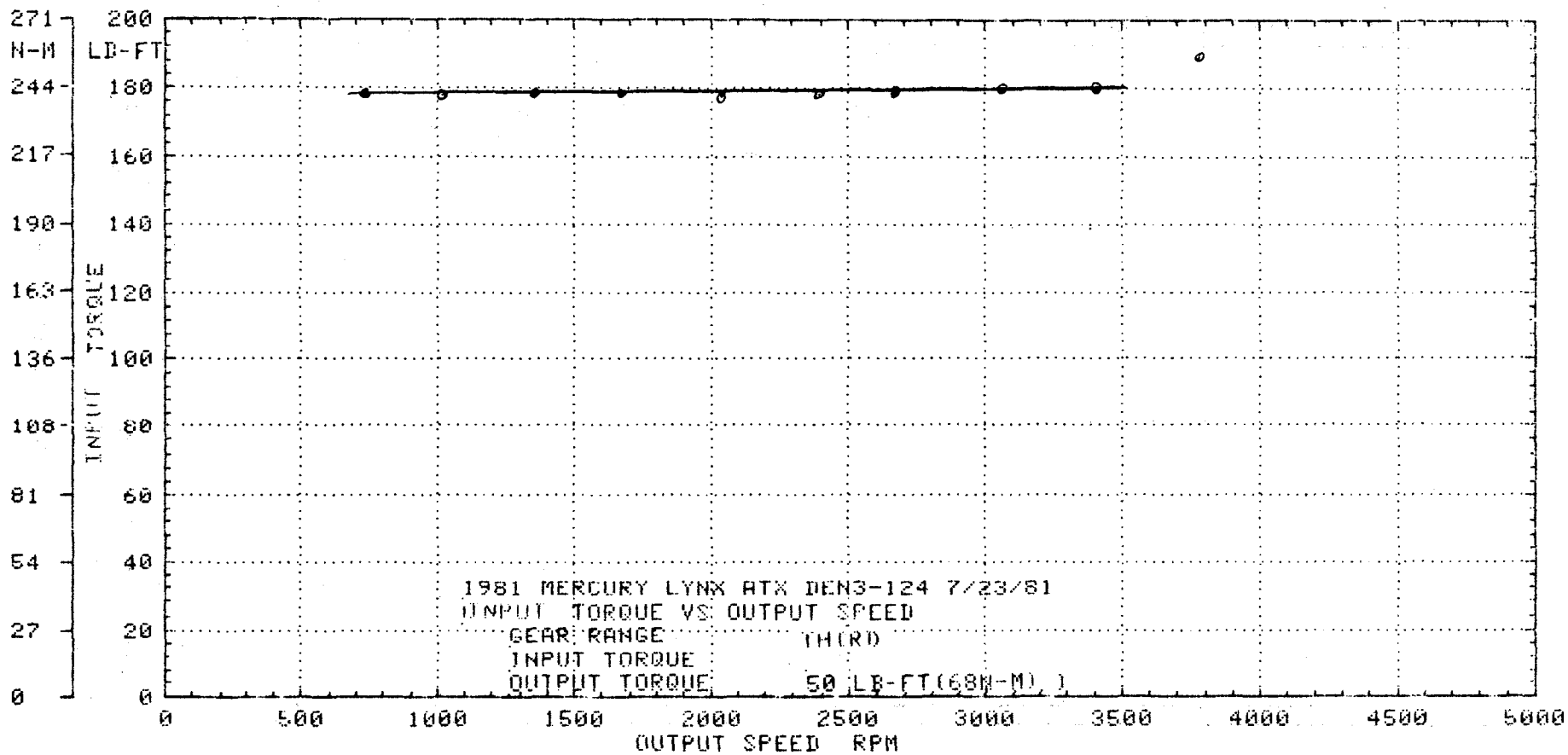

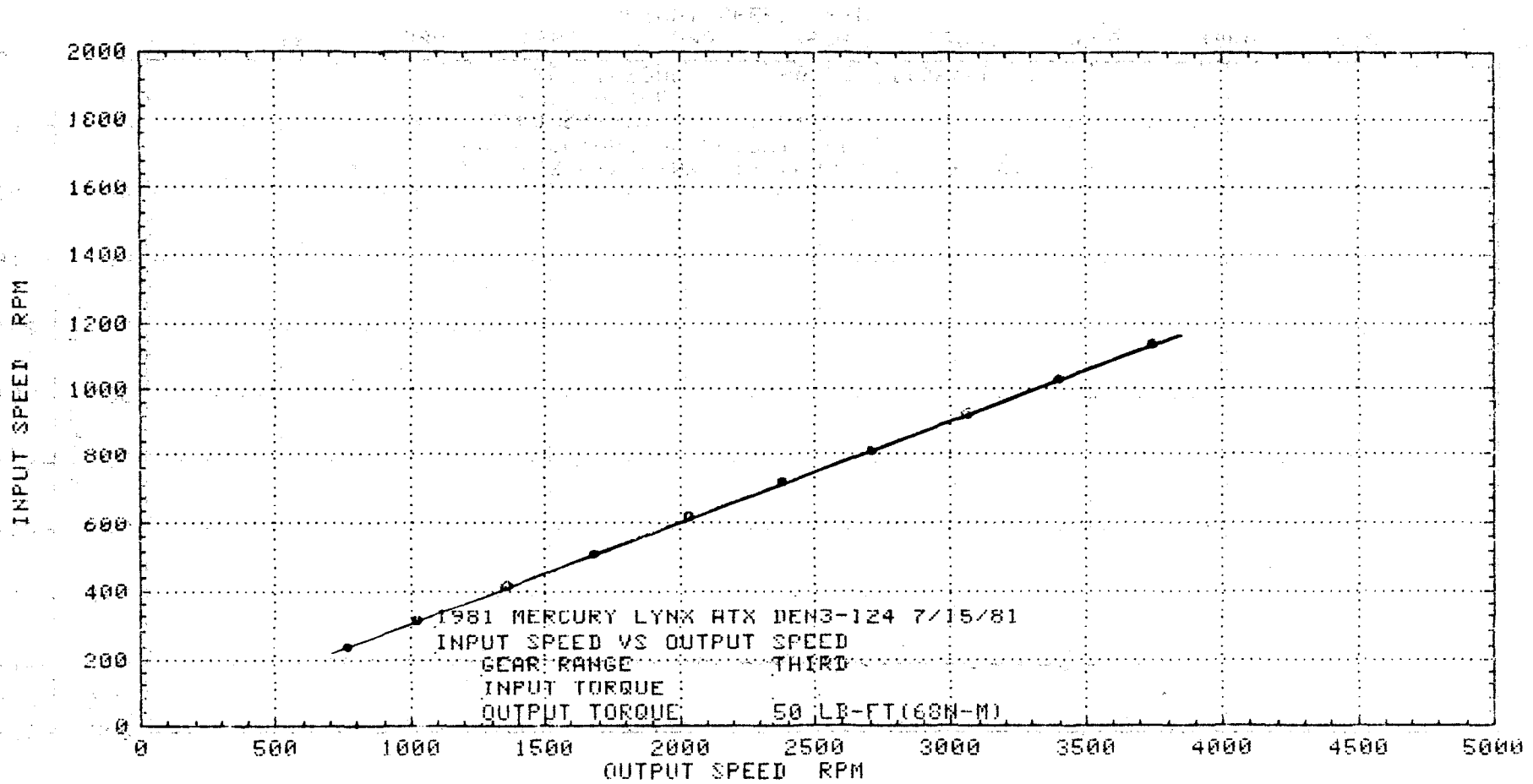

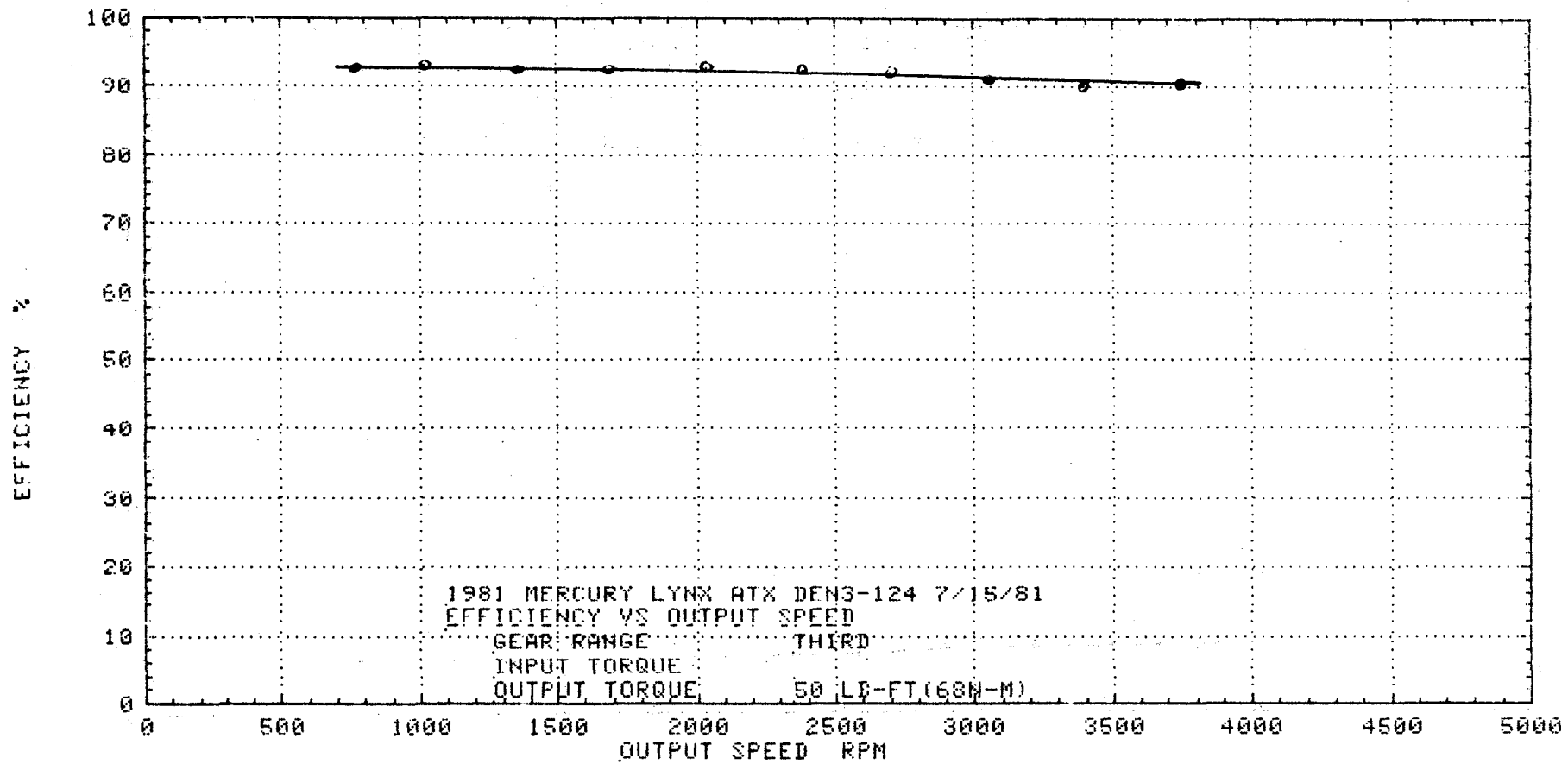

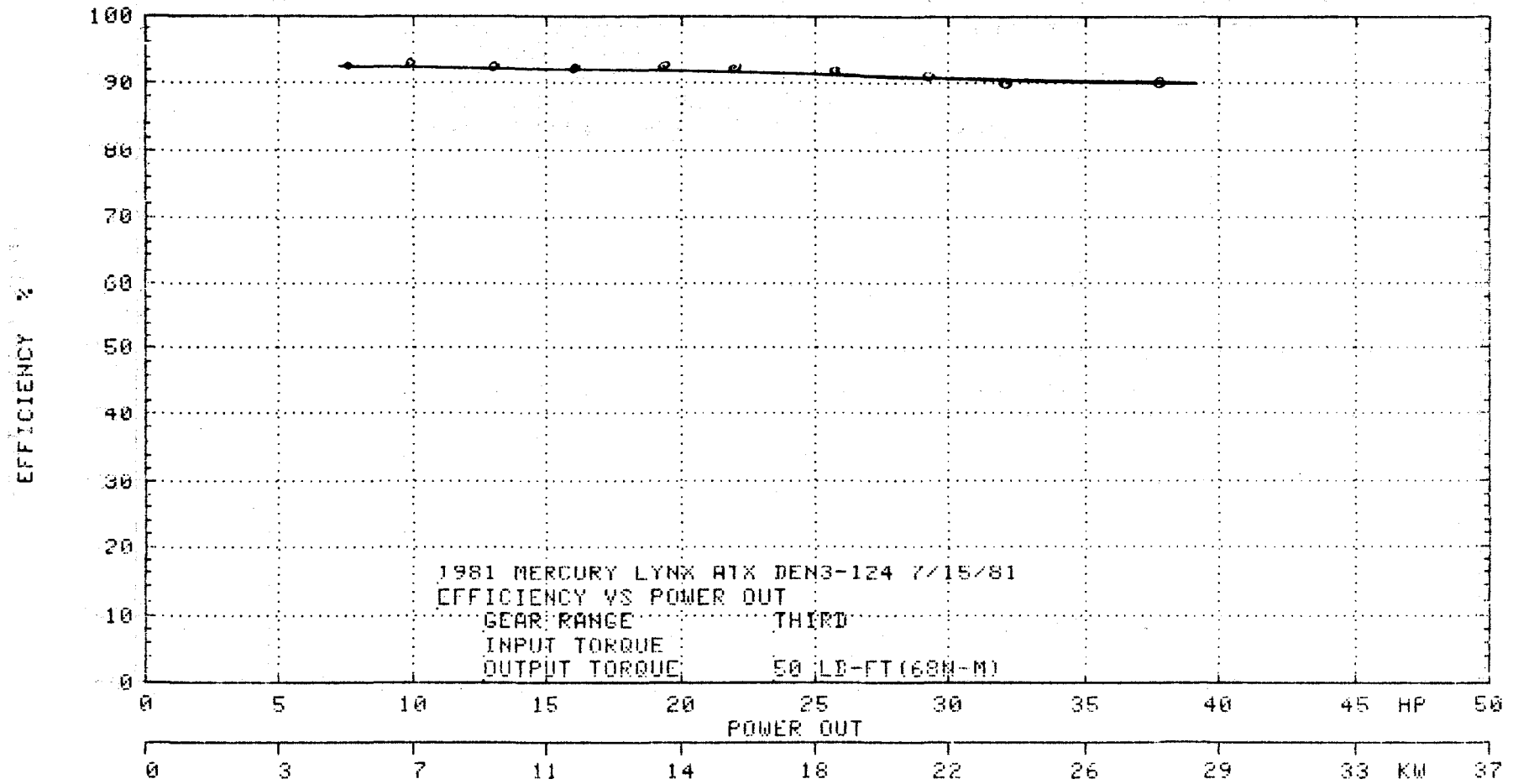

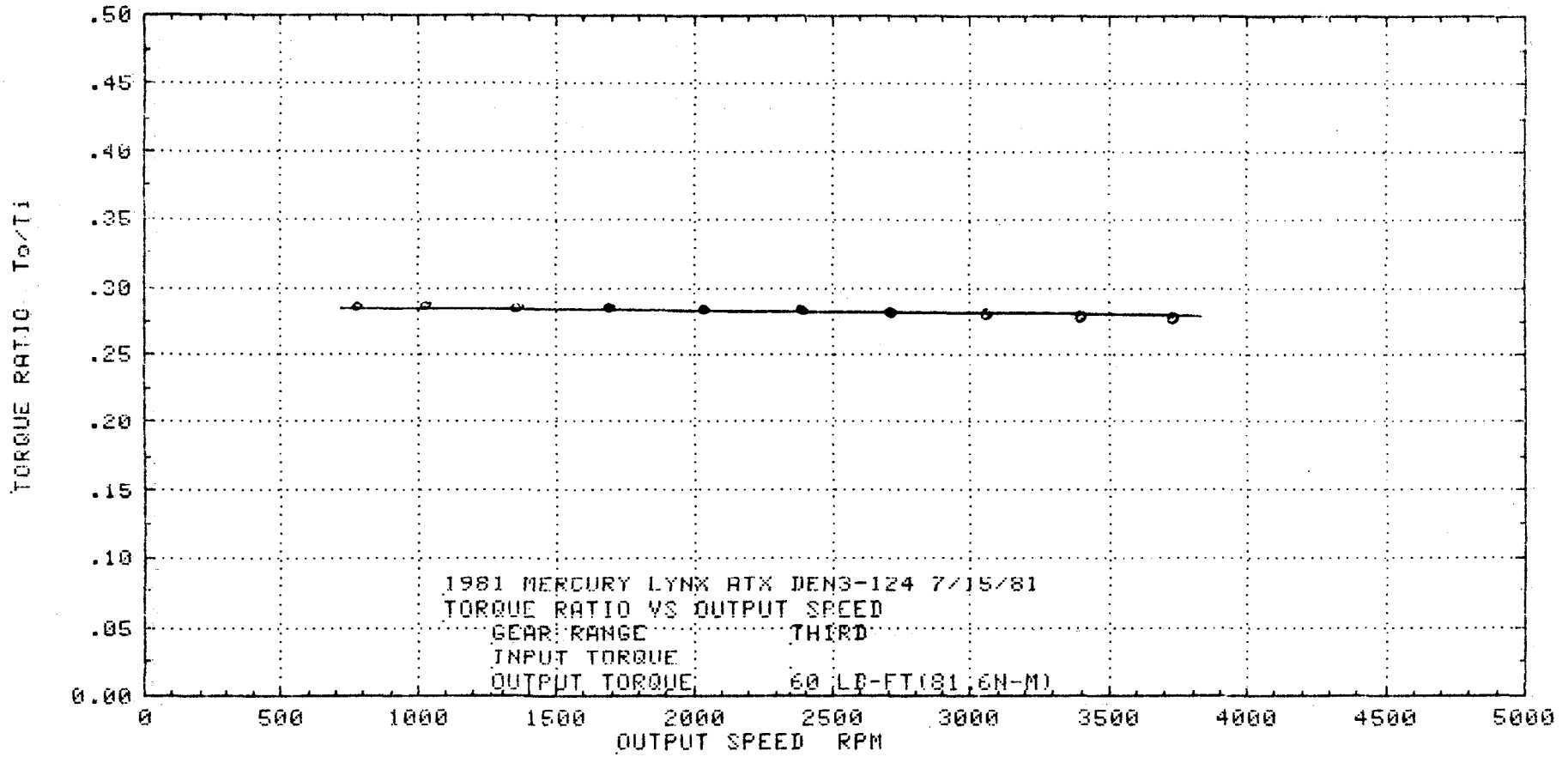

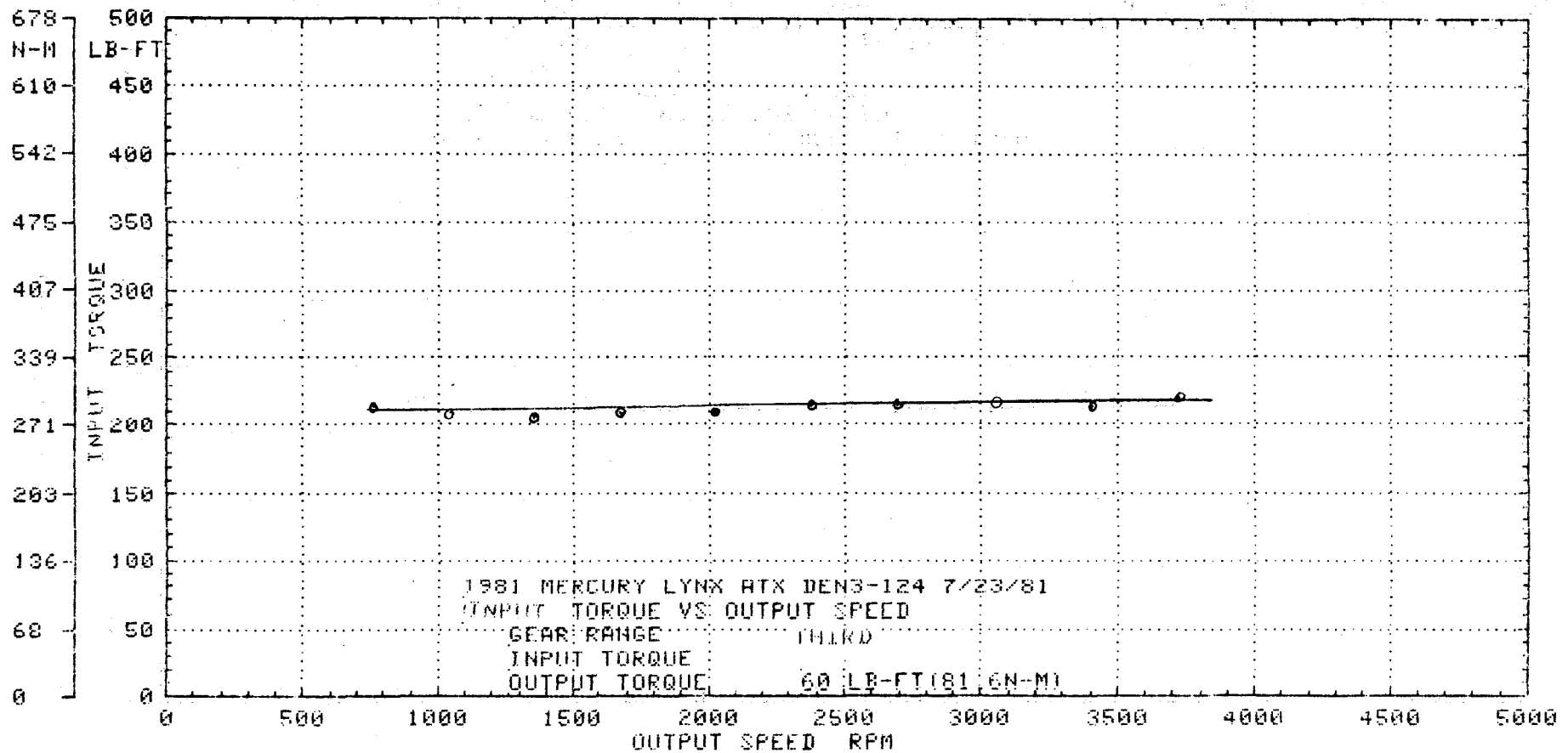

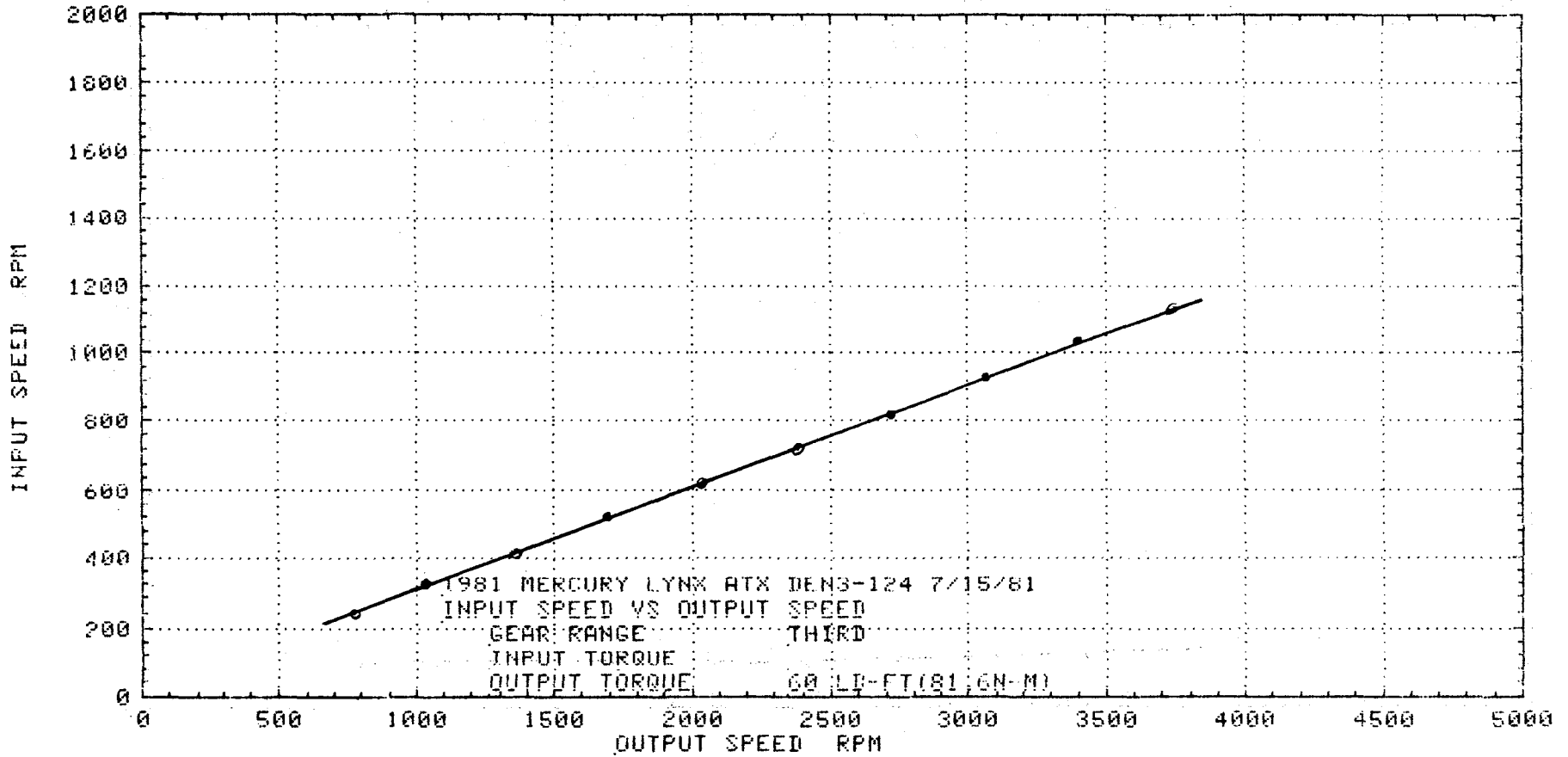

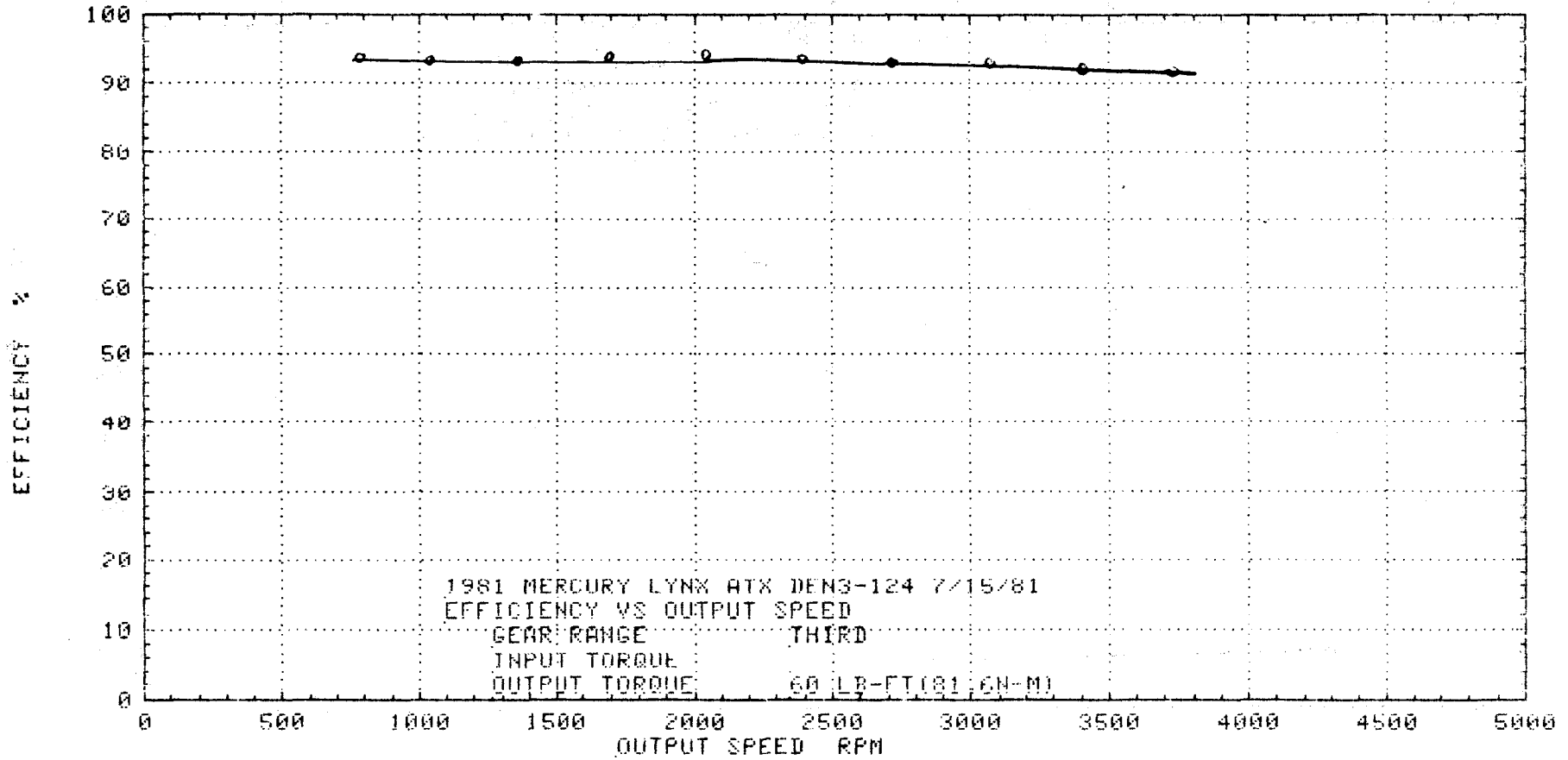

EFFICIENCY %

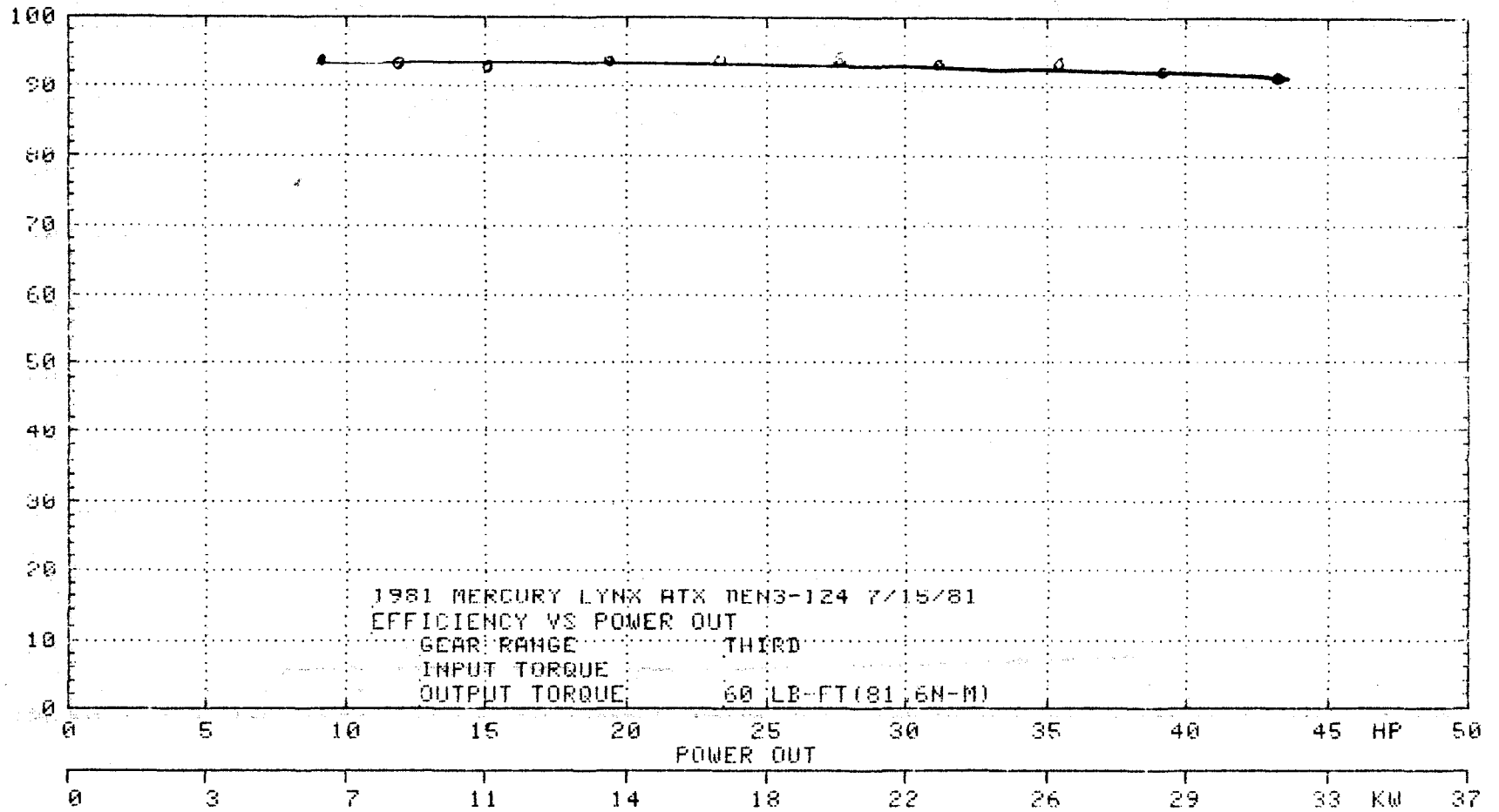

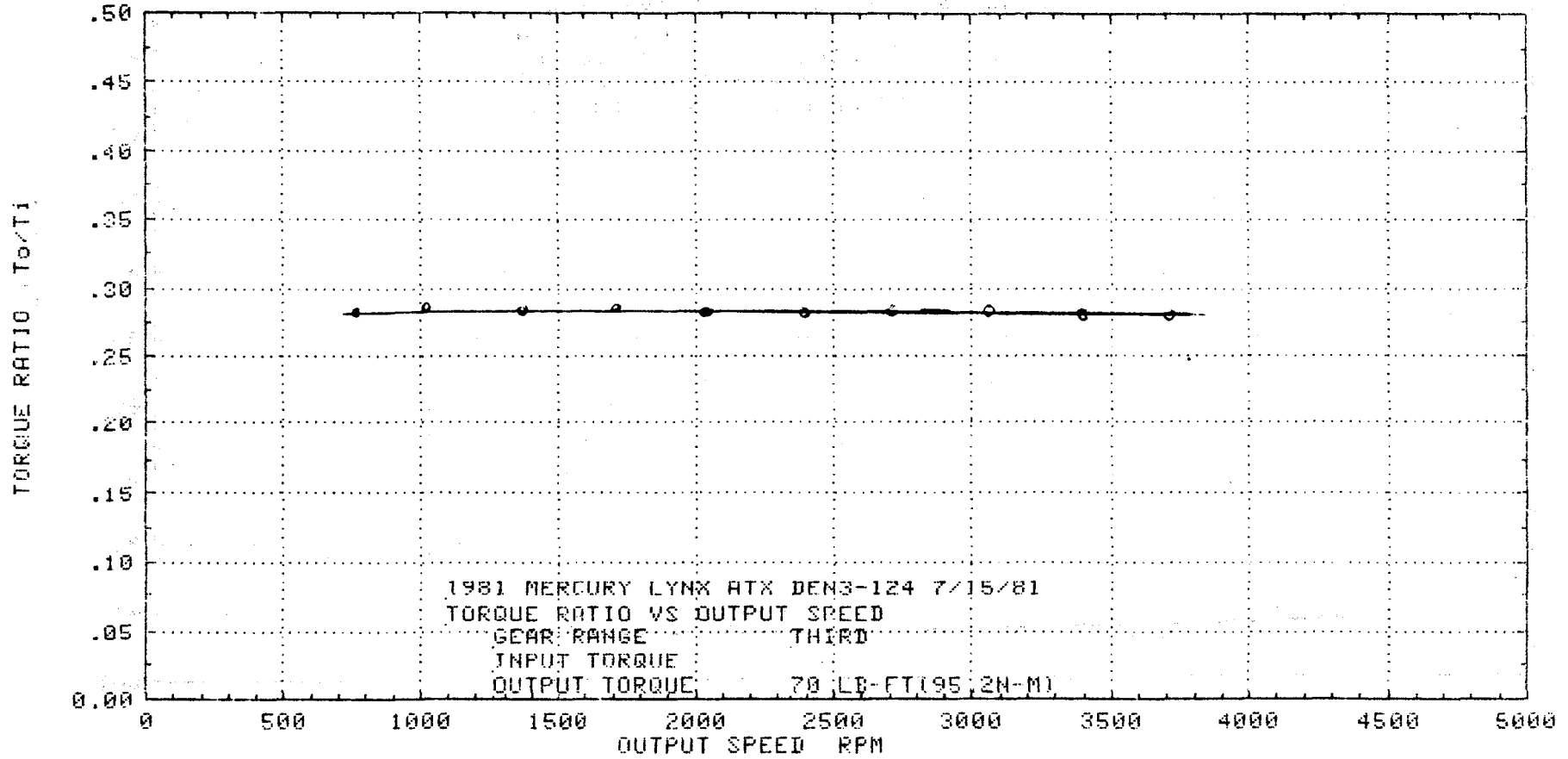

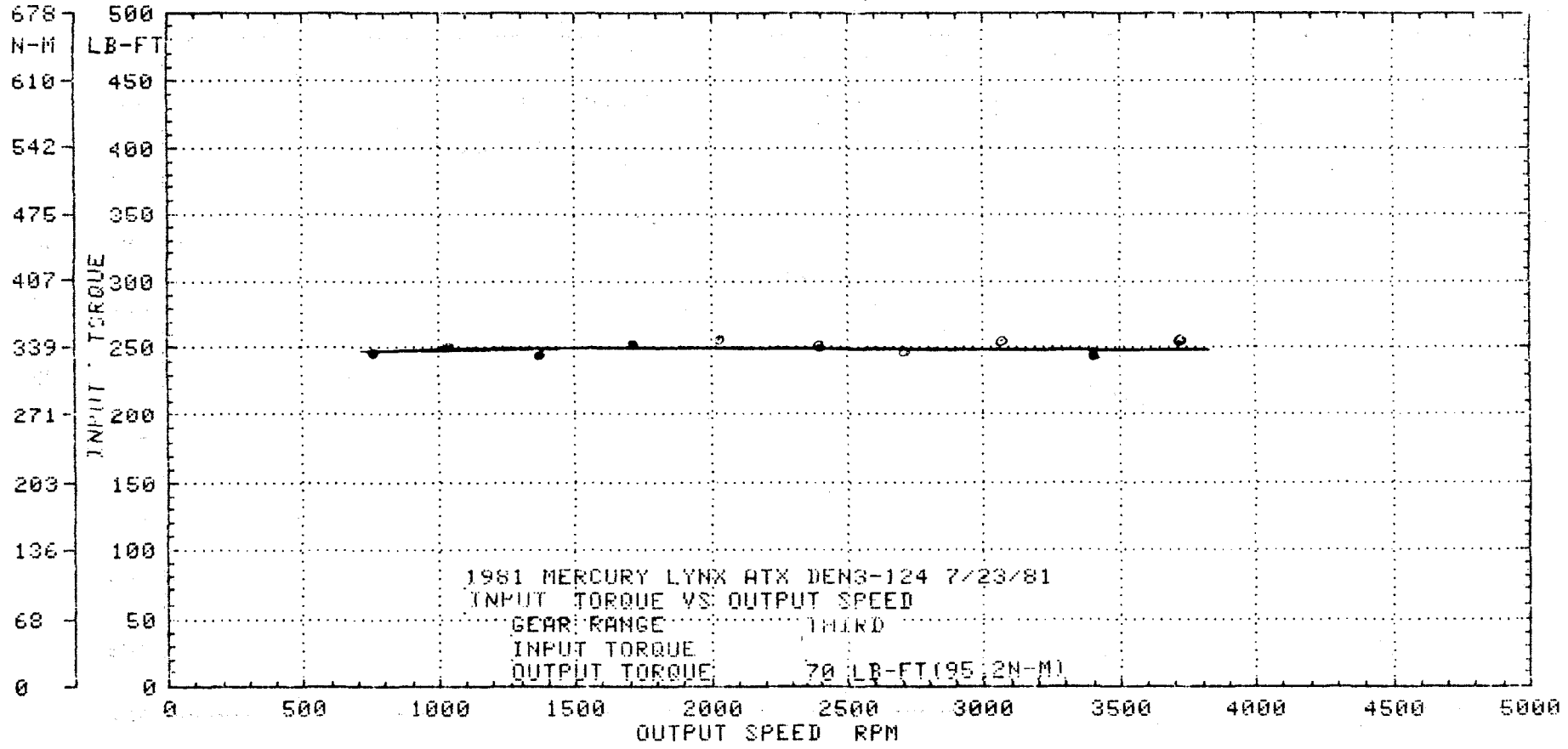

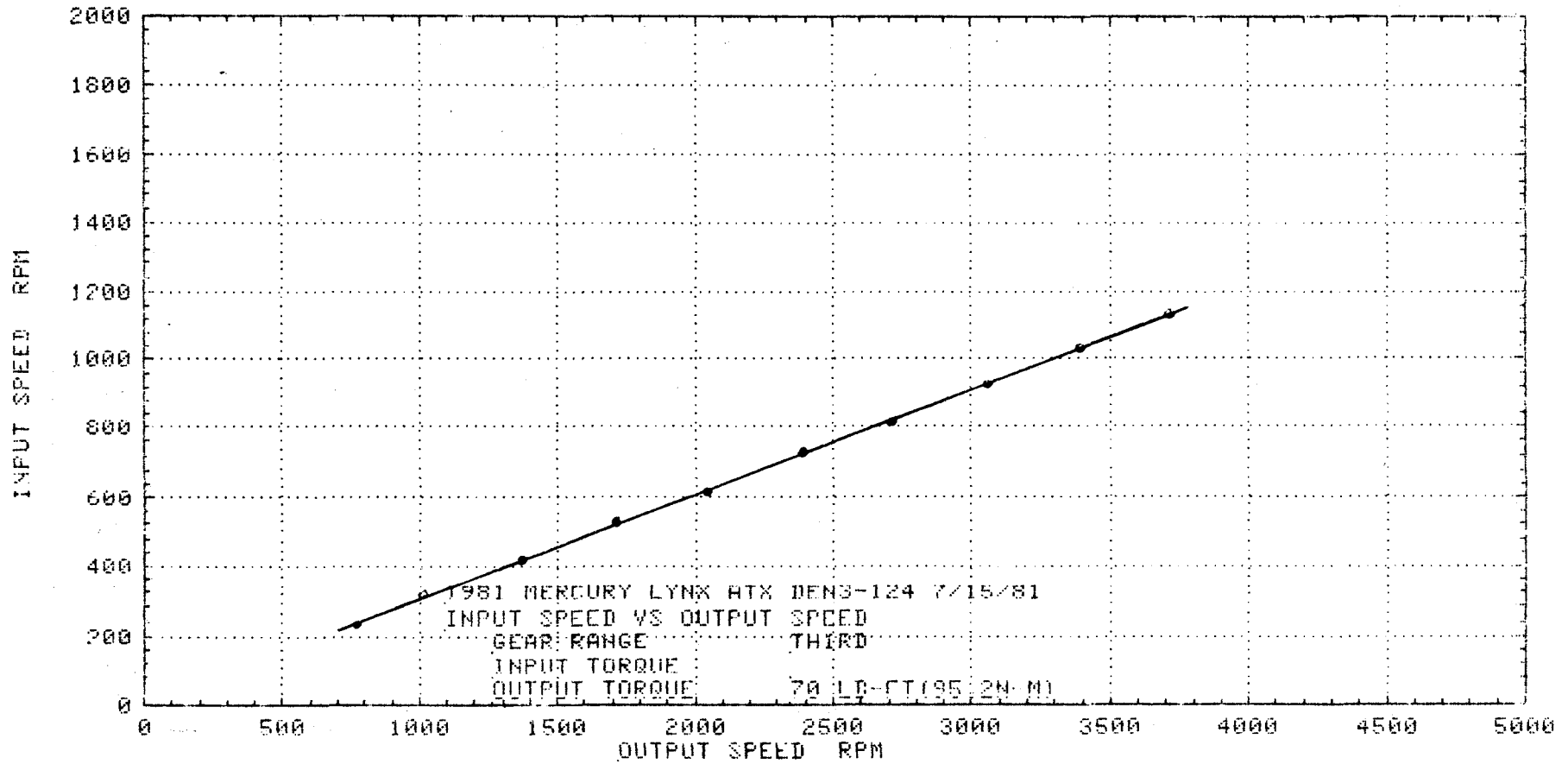

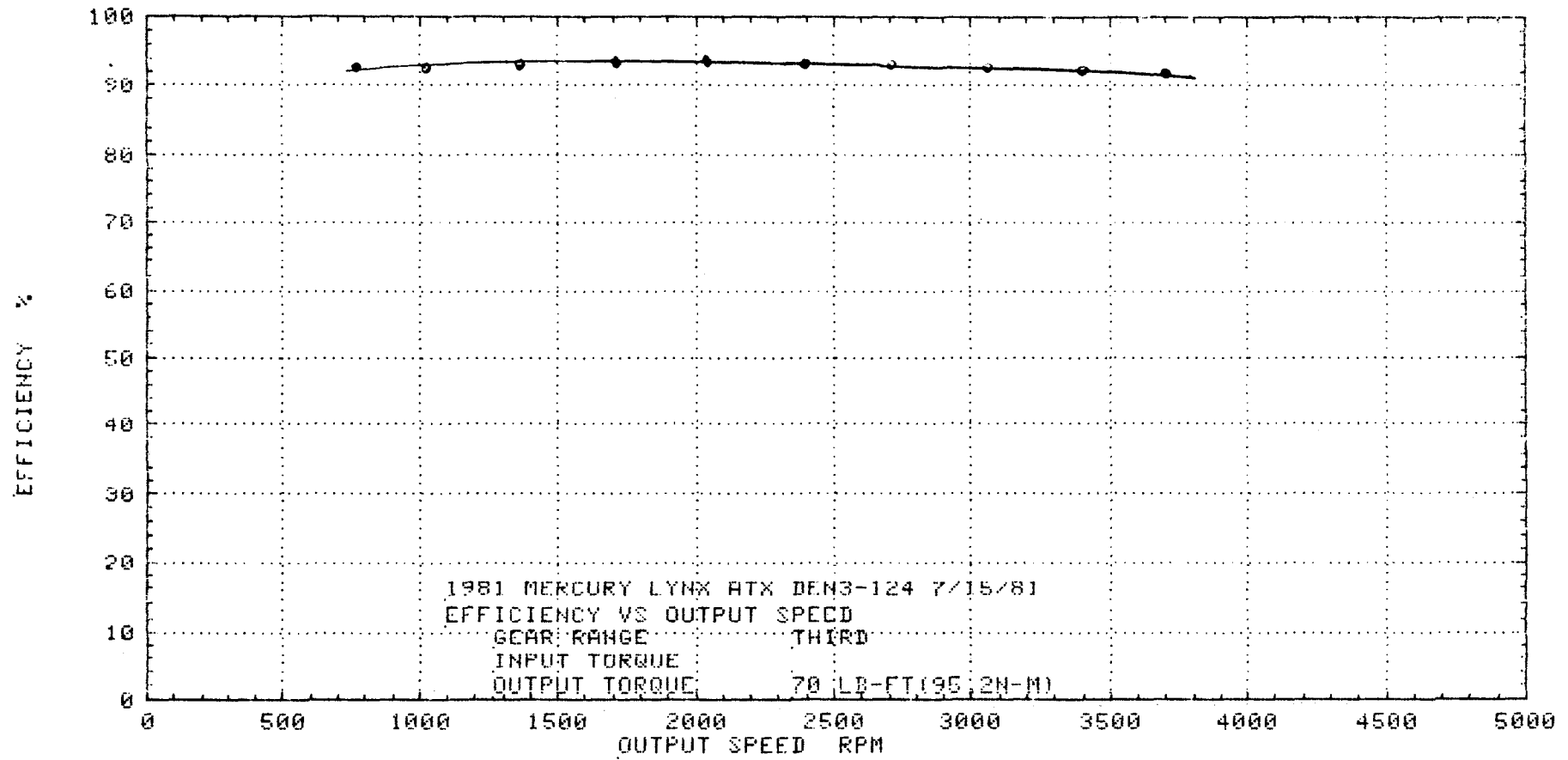

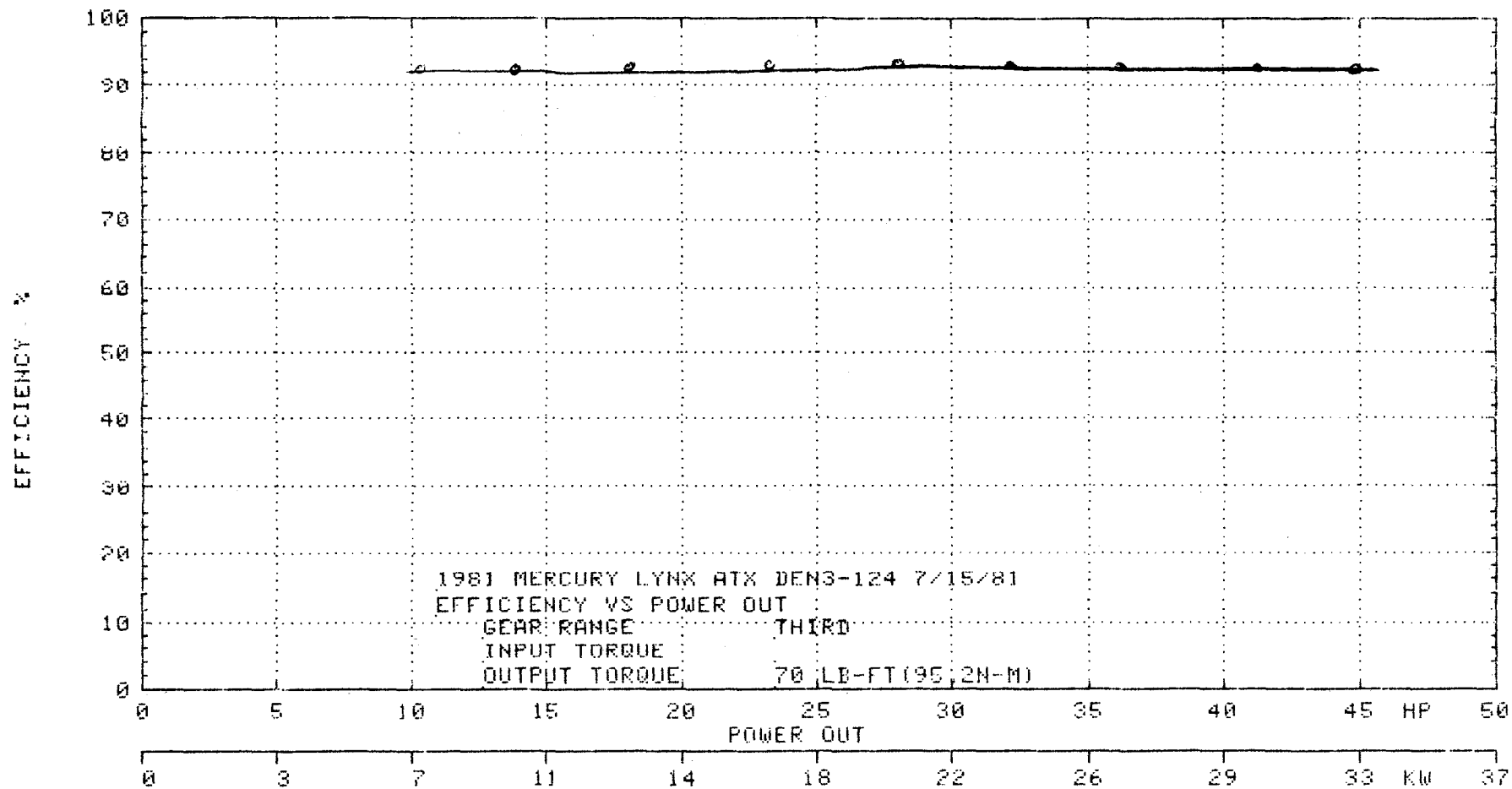

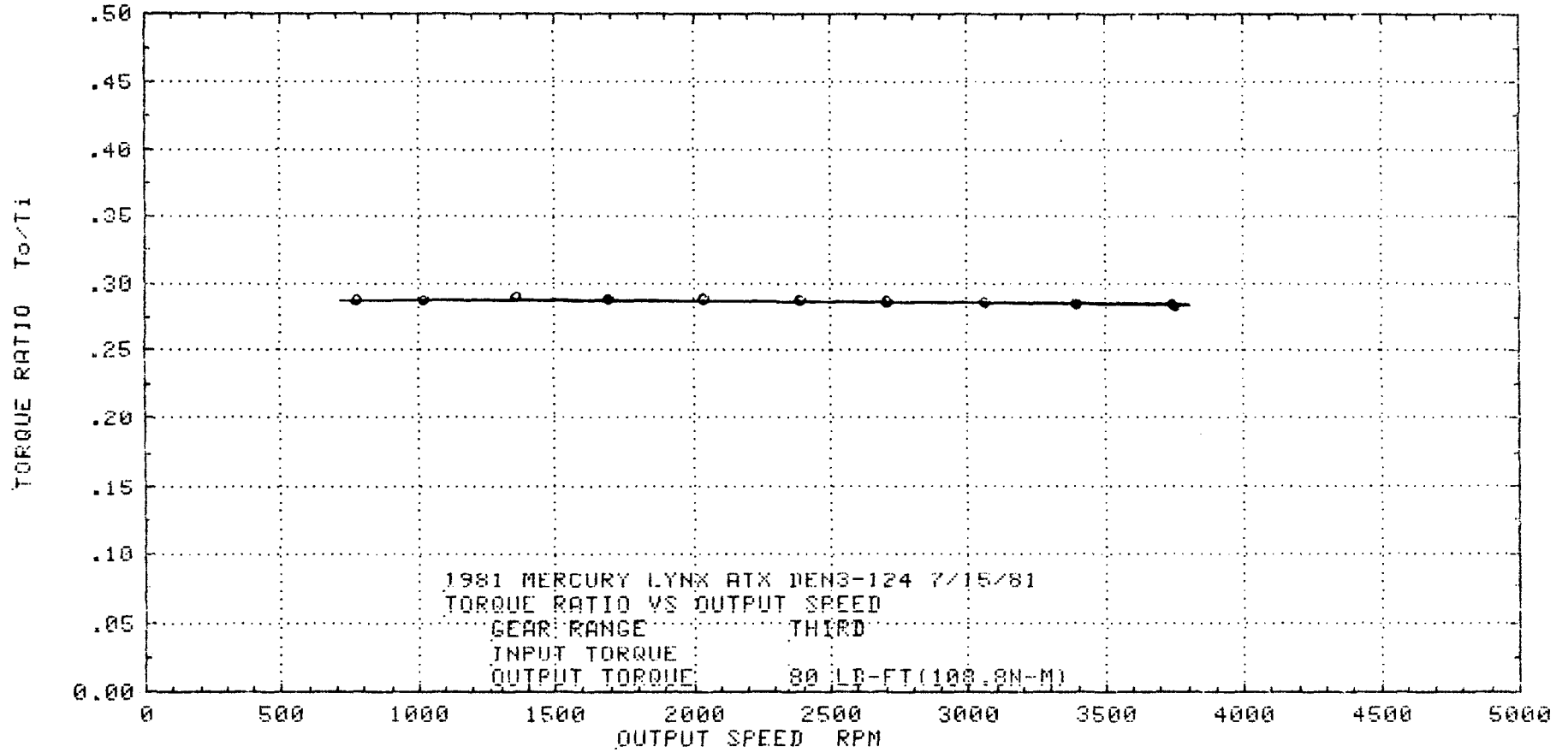

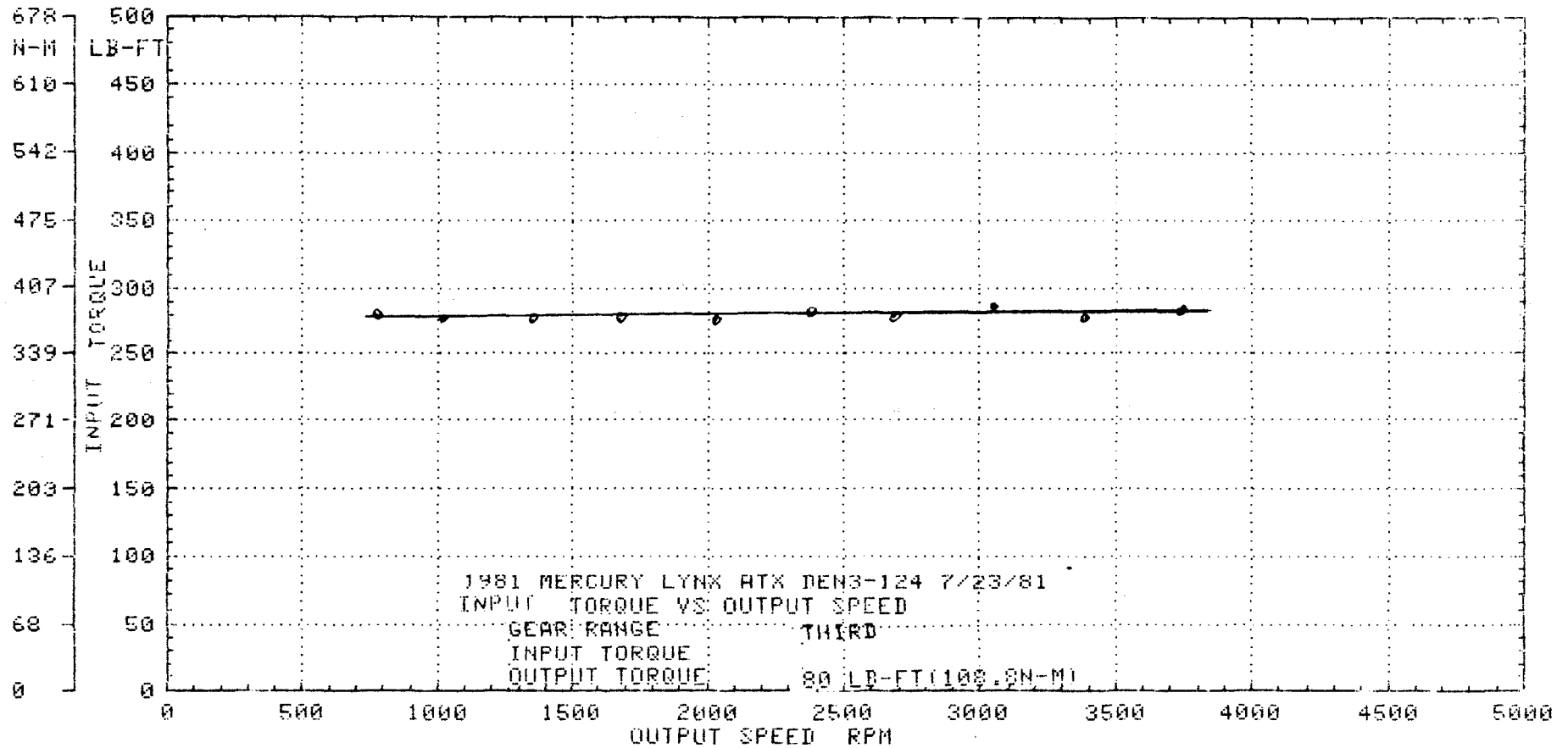

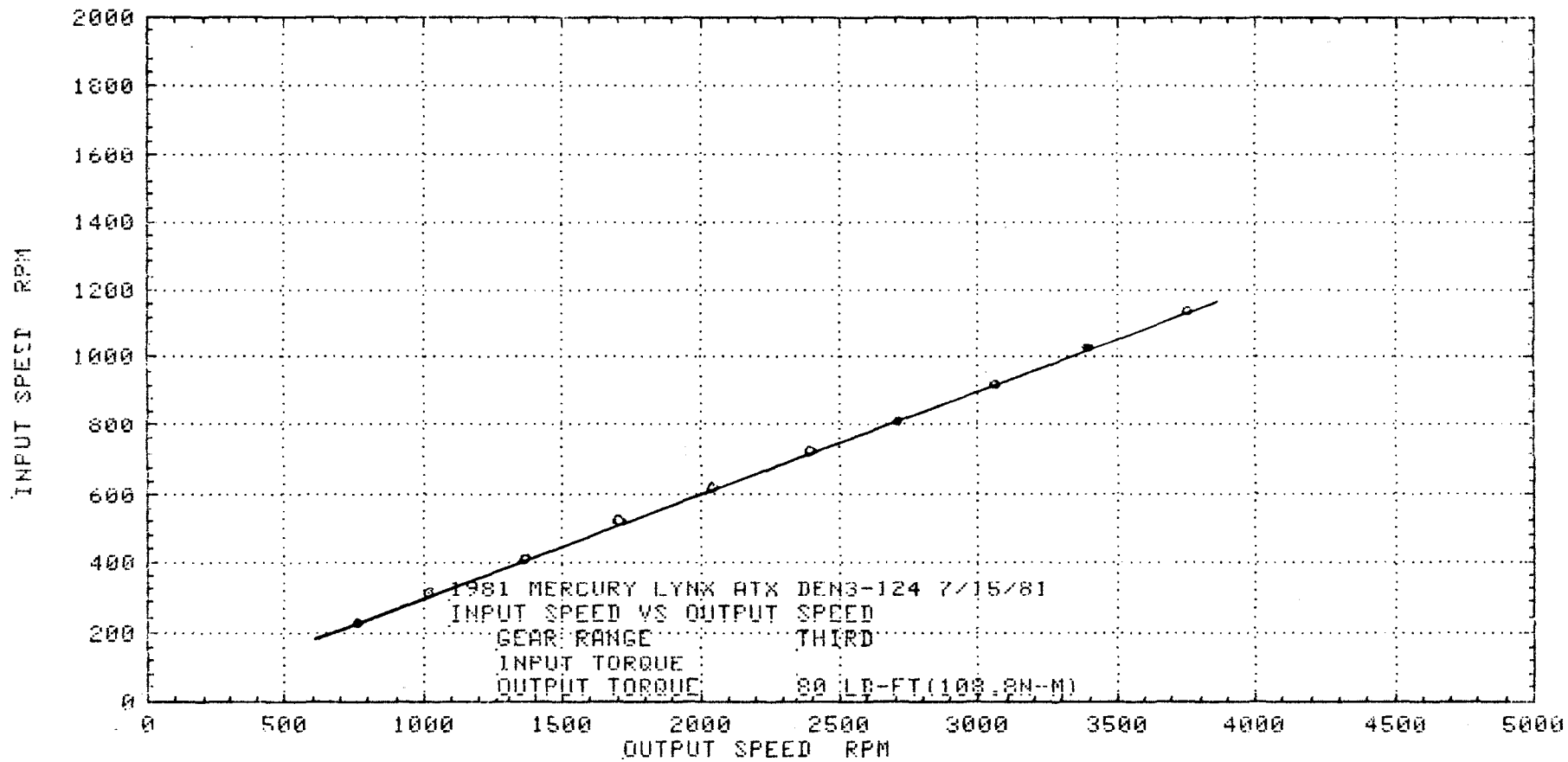

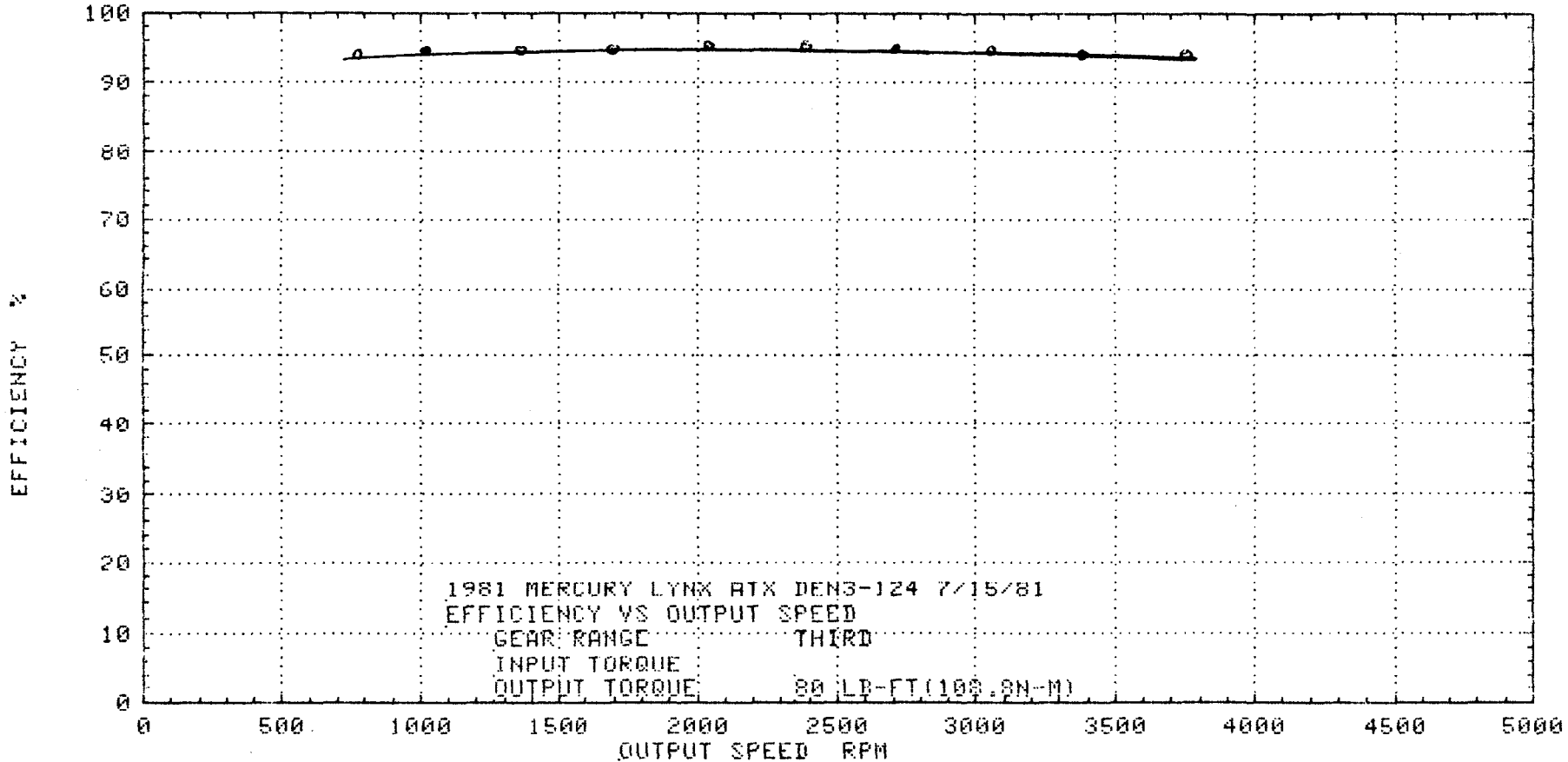

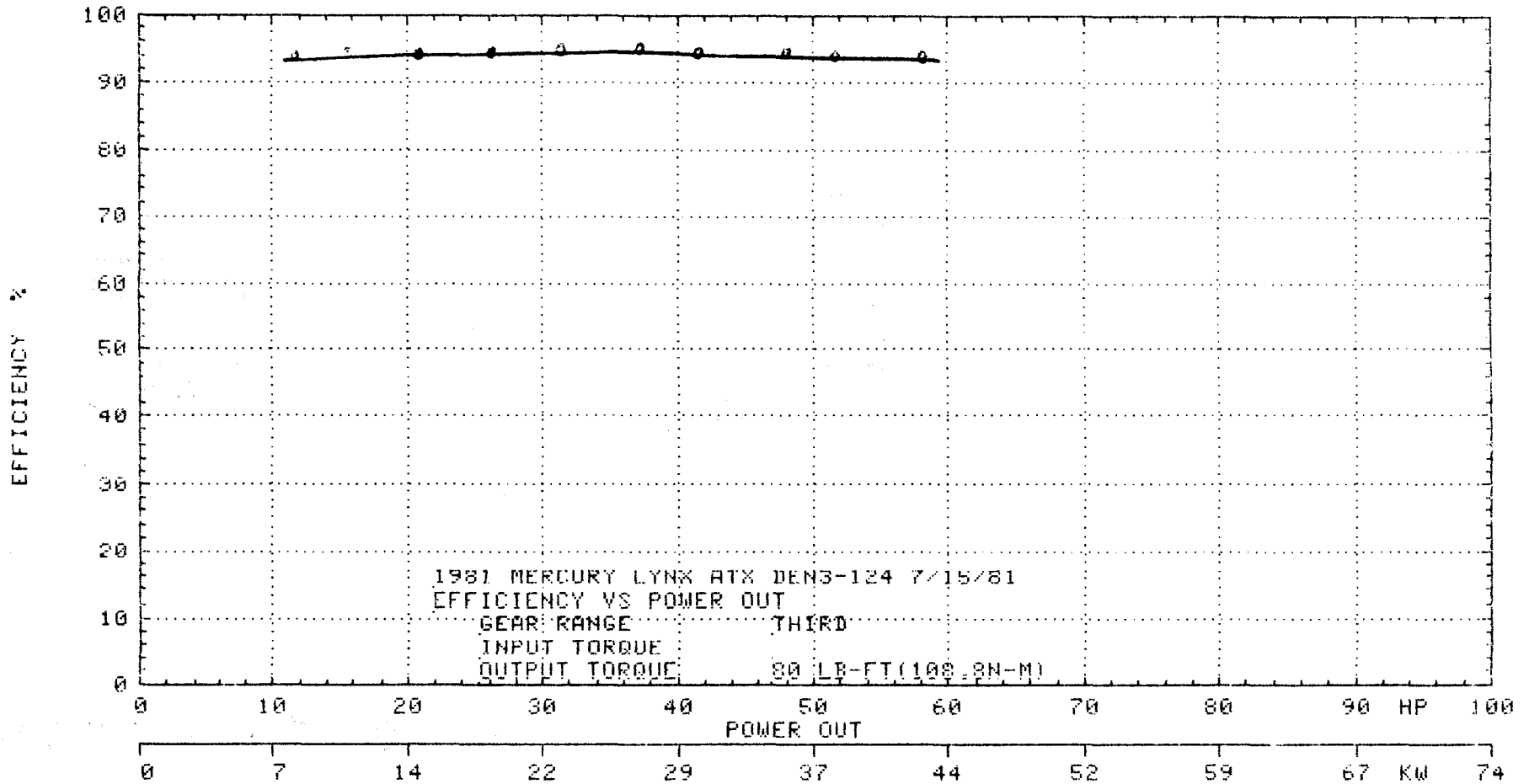

Graphs Contained in This Section

Torque Loss -vs- Input Speed

306

Torque In

Speed In

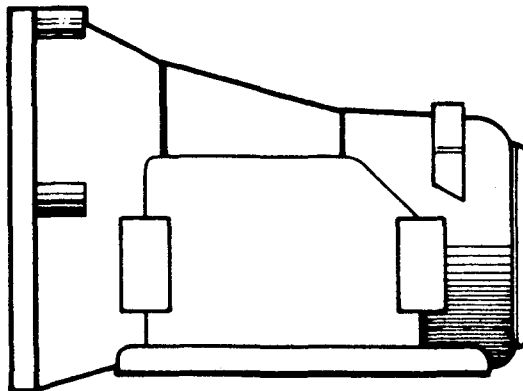

No Load Losses

NO LOAD LOSSES
1st Gear (Closed Throttle)

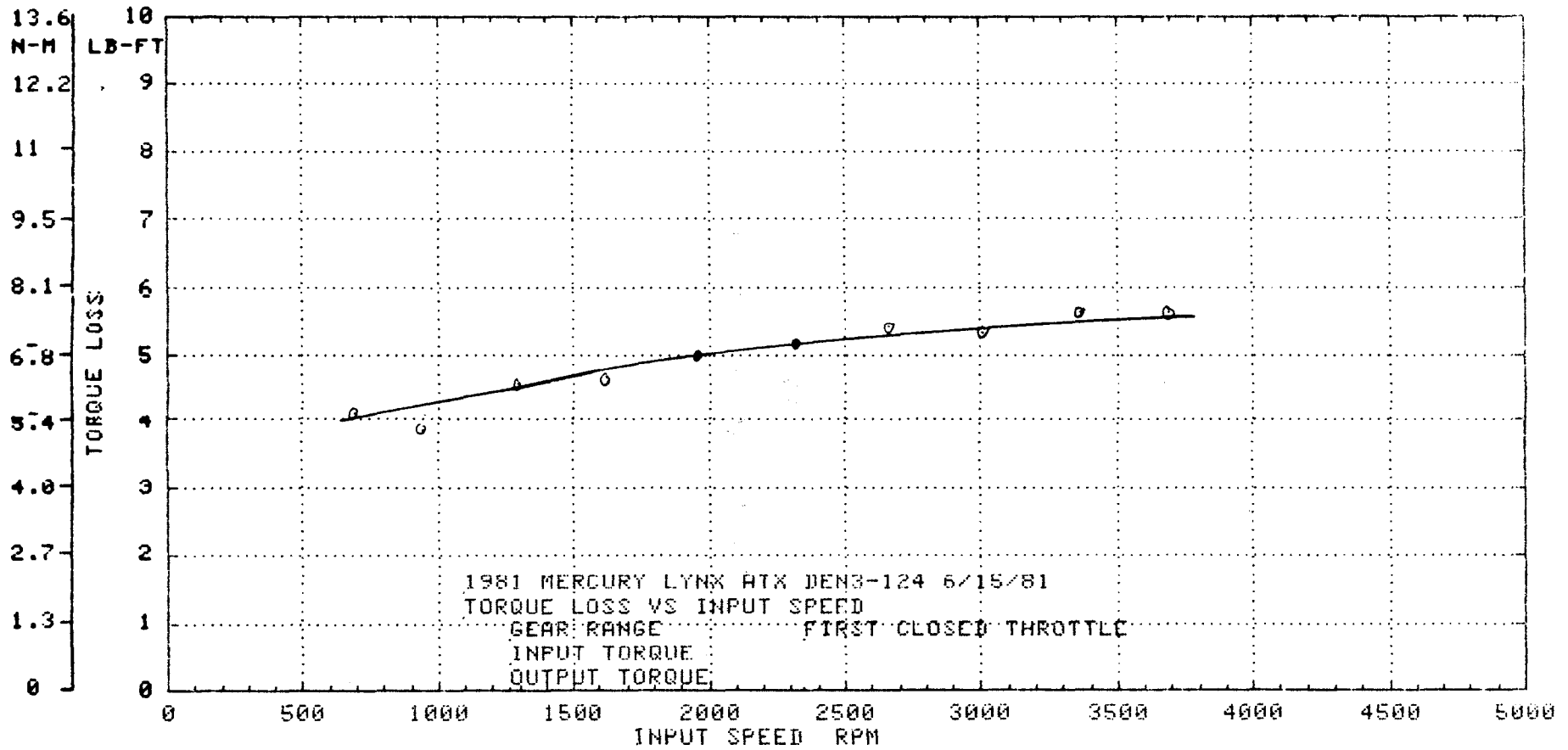

NO LOAD LOSSES
1st Gear (Open Throttle)

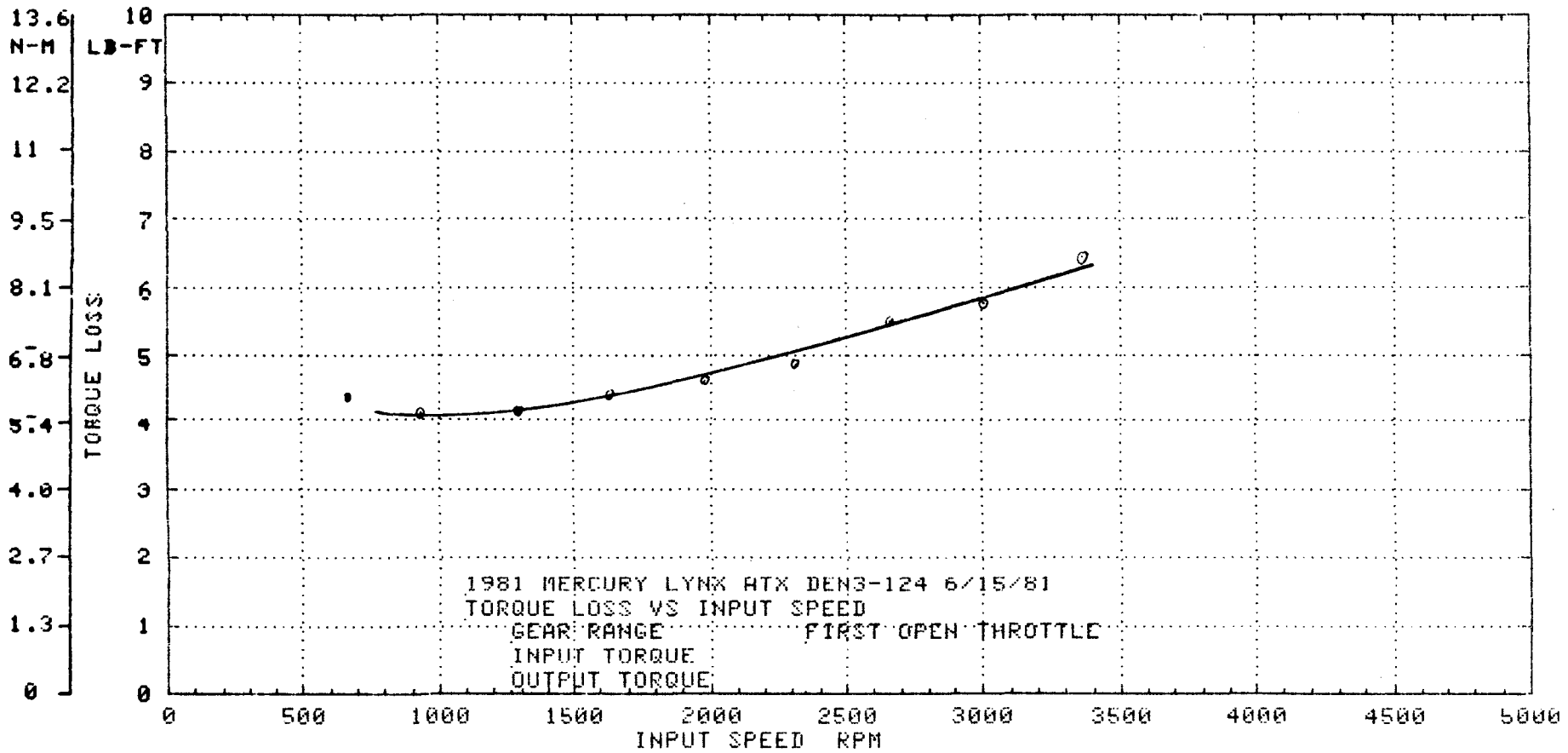

NO LOAD LOSSES
2nd Gear (Closed Throttle)

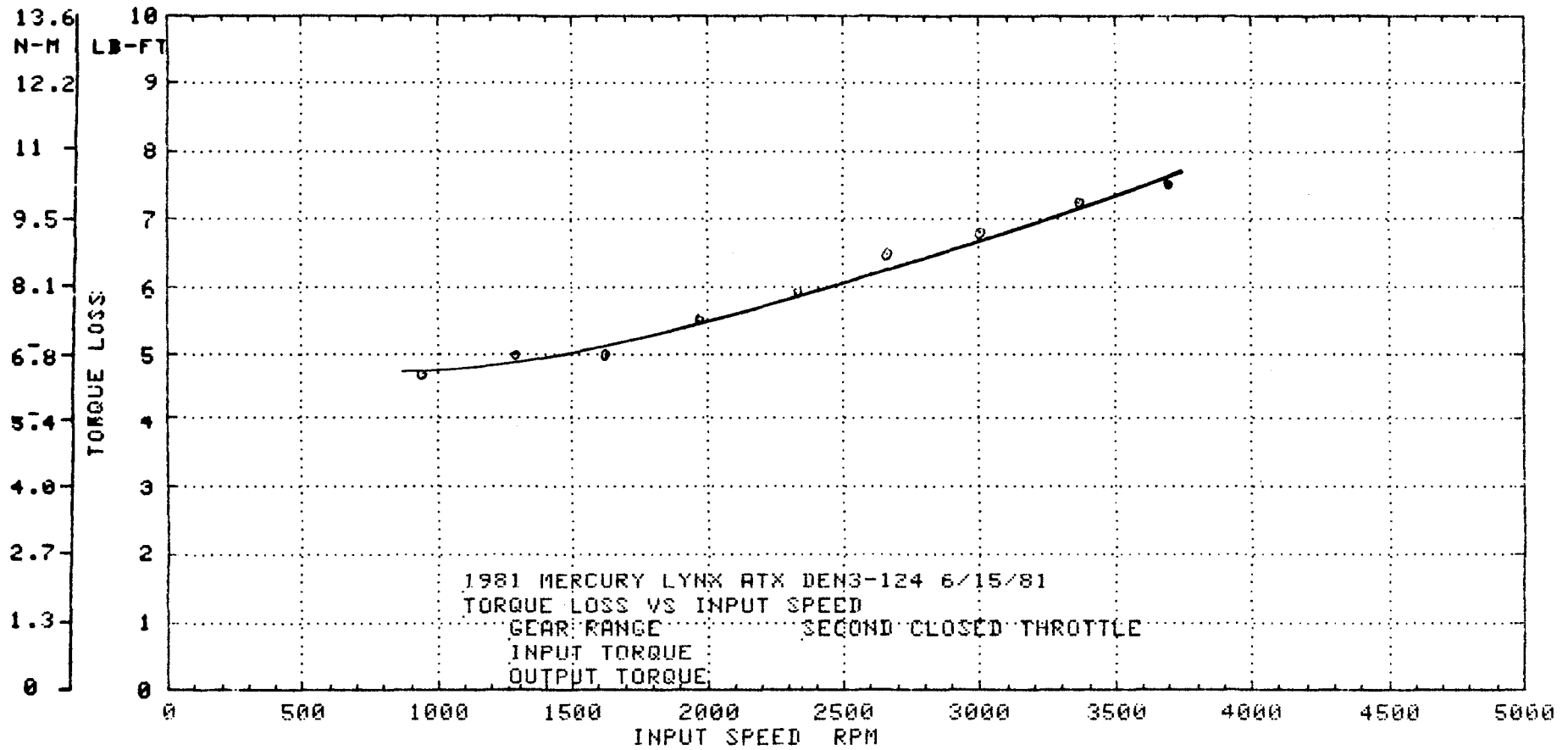

NO LOAD LOSSES
2nd Gear (Open Throttle)

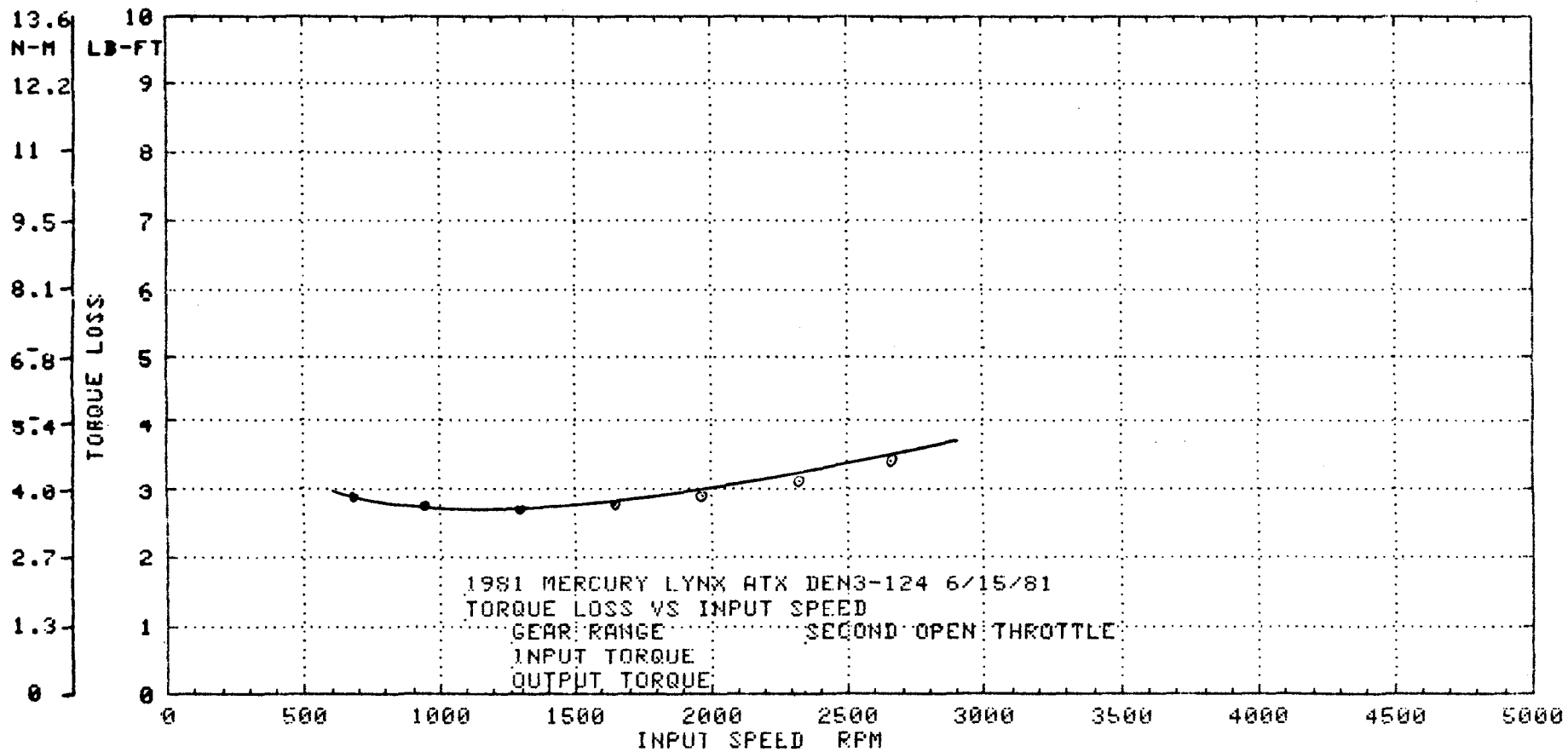

NO LOAD LOSSES
3rd Gear (Closed Throttle)

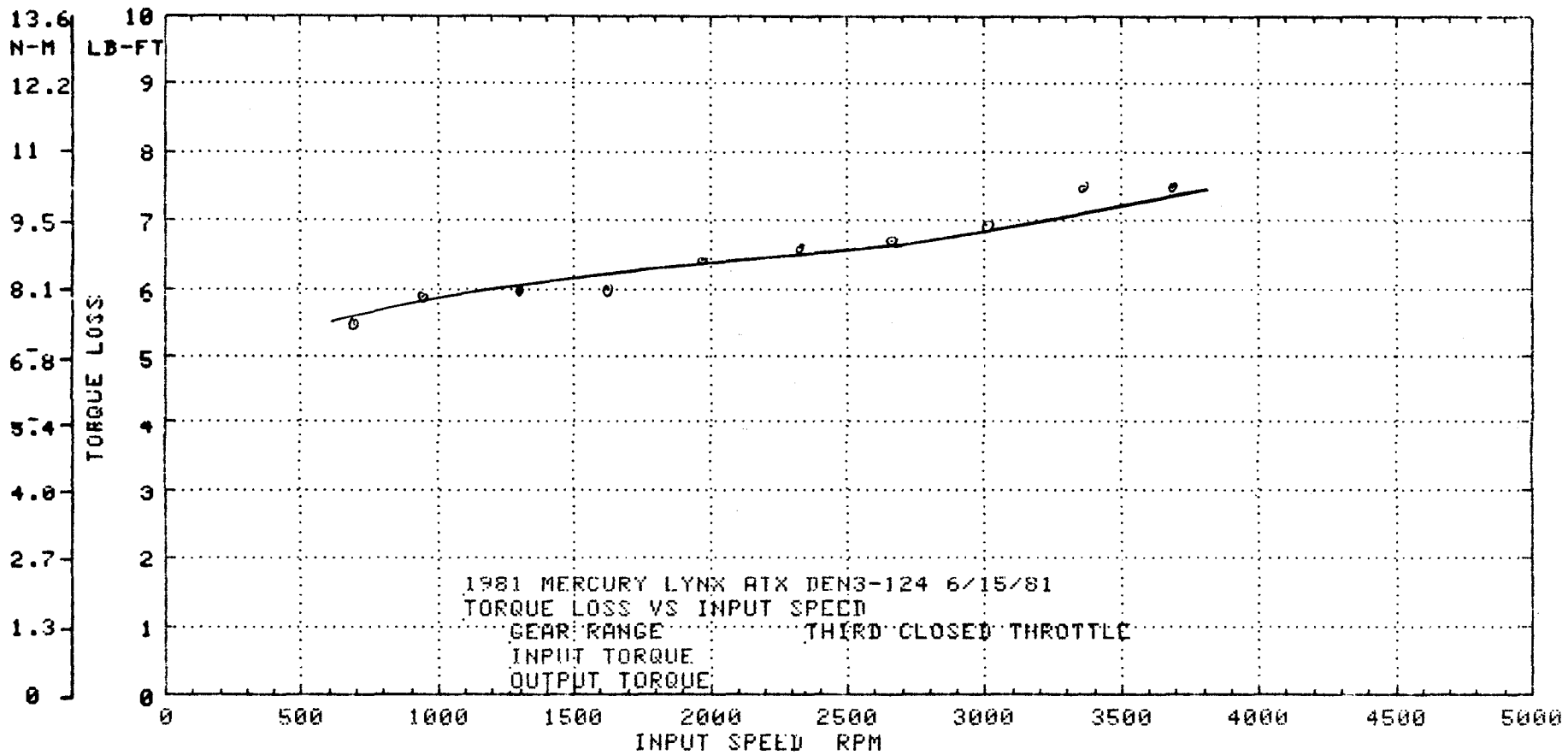

NO LOAD LOSSES
3rd Gear (Open Throttle)

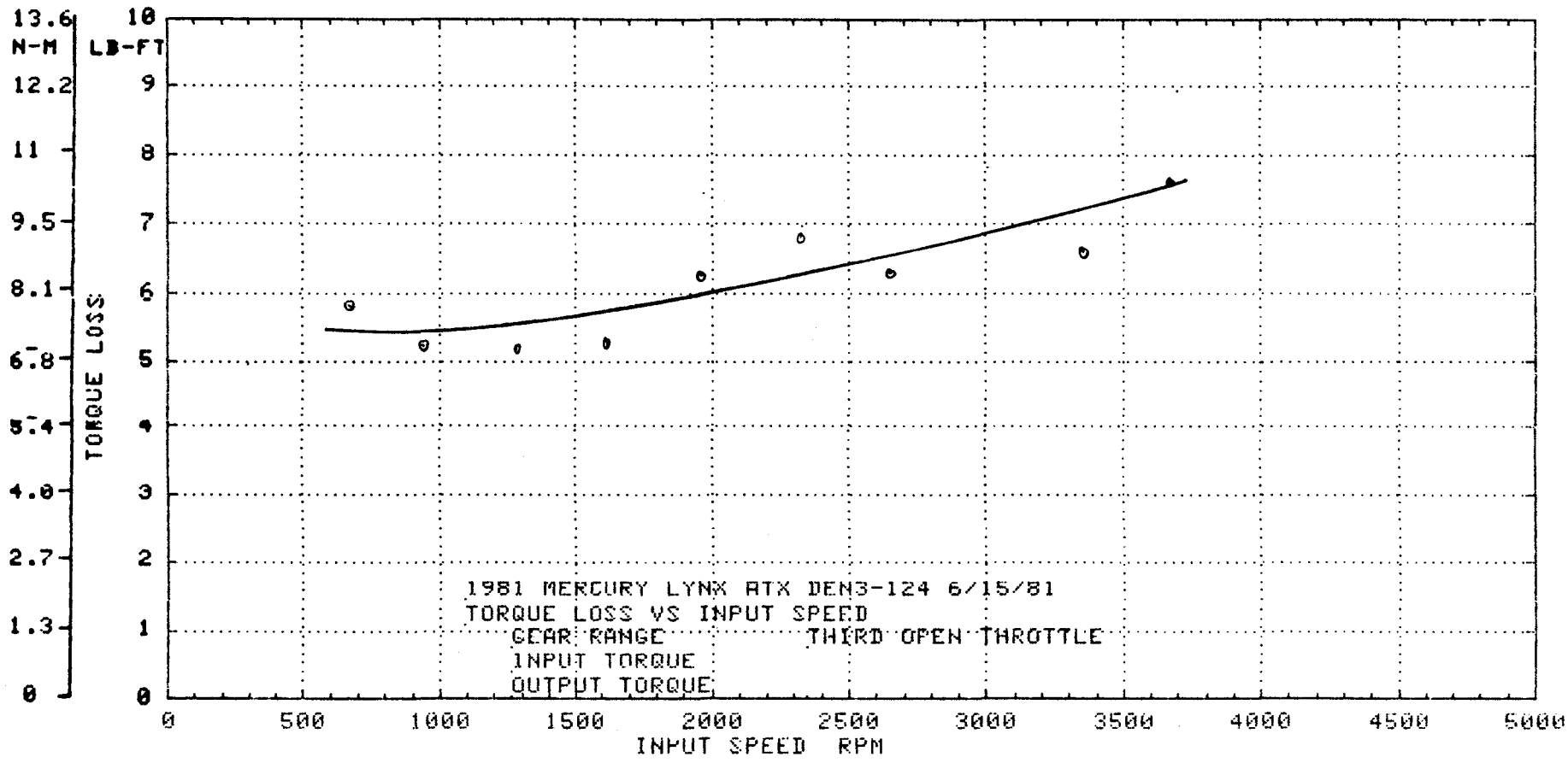

APPENDIX

ROOT MEAN SQUARE METHOD

$$\begin{aligned} \text{TORQUE ERROR (HIMMELSTEIN)} &= \sqrt{(\text{TORQUE TRANS. ERROR})^2 + (\text{TAPE RECORDER ERROR})^2 + (\text{ANALYZER ERROR})^2} \\ &= \sqrt{(0.18)^2 + (0.05)^2 + (0.048)^2} = \pm 0.193\% \text{ of Full Scale} \end{aligned}$$

$$\begin{aligned} \text{TORQUE ERROR (LEBOW)} &= \sqrt{(\text{TORQUE TRANS. ERROR})^2 + (\text{TAPE RECORDER ERROR})^2 + (\text{ANALYZER ERROR})^2} \\ &= \sqrt{(0.41)^2 + (0.05)^2 + (0.048)^2} = \pm 0.416\% \text{ of Full Scale} \end{aligned}$$

$$\begin{aligned} \text{SPEED ERROR} &= \sqrt{(\text{SPEED SENSOR})^2 + (\text{SPEED CONDITIONER})^2 + (\text{TAPE RECORDER ERROR})^2 + (\text{ANALYZER ERROR})^2} \\ &= \sqrt{(0.025)^2 + (0.10)^2 + (0.05)^2 + (0.048)^2} = \pm 0.124\% \text{ of Full Scale} \end{aligned}$$

$$\begin{aligned} \text{POWER OUT ERROR} &= \sqrt{(\text{TORQUE ERROR (LEBOW)})^2 + (\text{SPEED ERROR})^2 + (\text{COMPUTER CALCULATION ERROR})^2} \\ &= \sqrt{(0.416)^2 + (0.124)^2 + (0.5)^2} = \pm 0.662\% \text{ of Full Scale} \end{aligned}$$

$$\begin{aligned} \text{EFFICIENCY ERROR} &= \sqrt{(\text{TORQUE ERROR (LEBOW)})^2 + (\text{SPEED ERROR})^2 + (\text{TORQUE ERROR (HIMM)})^2 + (\text{SPEED ERROR})^2} \\ &\quad + (\text{COMPUTER CALCULATION ERROR})^2 \\ &= \sqrt{(0.416)^2 + (0.124)^2 + (0.193)^2 + (0.124)^2 + (0.5)^2} = \pm 0.701\% \text{ of Full Scale} \end{aligned}$$

SUM OF ERROR METHOD

$$\begin{aligned} \text{TORQUE ERROR (HIMMELSTEIN)} &= (\text{TORQUE TRANSDUCER ERROR}) + (\text{TAPE RECORDER ERROR}) + (\text{ANALYZER ERROR}) \\ &= (0.18) + (0.05) + (0.048) = \pm 0.278\% \text{ of Full Scale} \end{aligned}$$

$$\begin{aligned} \text{TORQUE ERROR (LEBOW)} &= (\text{TORQUE TRANS. ERROR}) + (\text{TAPE RECORDER ERROR}) + (\text{ANALYZER ERROR}) \\ &= (0.41) + (0.05) + (0.048) = \pm 0.508\% \text{ of Full Scale} \end{aligned}$$

$$\begin{aligned} \text{SPEED ERROR} &= (\text{SPEED SENSOR}) + (\text{SPEED CONDITIONER}) + (\text{TAPE RECORDER ERROR}) + (\text{ANALYZER ERROR}) \\ &= (0.025) + (0.1) + (0.05) + (0.048) = \pm 0.223\% \text{ of Full Scale} \end{aligned}$$

$$\begin{aligned} \text{POWER OUT ERROR} &= (\text{TORQUE ERROR (LEBOW)}) + (\text{SPEED ERROR}) + (\text{COMPUTER CALCULATION ERROR}) \\ &= (0.508) + (0.124) + (0.5) = \pm 1.132\% \text{ of Full Scale} \end{aligned}$$

$$\begin{aligned} \text{EFFICIENCY ERROR} &= (\text{TORQUE ERROR (LEBOW)}) + (\text{SPEED ERROR}) + (\text{TORQUE ERROR (HIMM)}) + (\text{SPEED ERROR}) \\ &\quad + (\text{COMPUTER CALCULATION ERROR}) \\ &= (0.508) + (0.223) + (0.278) + (0.223) + (0.5) = \pm 1.732\% \text{ of Full Scale} \end{aligned}$$

The inter number computer calculation error was determined by taking a set of sample calculations and comparing the accurate multiplication to the computer multiplication. A sample comparison is given below.

DATA DRIVE
PERFORMANCE

$T_i=80$ LB-FT ACCURACY CALCULATION COMPUTER CALCULATION

$T_i=80.8853$, $T_o=241.4830$ $T_o/T_i = 2.9855$ $T_o/T_i=2.9849$

Comparison = $((2.9855 - 2.9849)/2.9855) \times 100 = 0.020\%$

Since every calculation was not checked in this manner, a factor of safety was added to 0.020%, and 0.5% was used as the inter number computer calculation error.

OTHER MANUALS

To locate specific manuals in the documentation shipped with the system, refer to the System Configuration Notice for the contents of each binder.

SYSTEM SPECIFICATIONS & CHARACTERISTICS

The specifications in Table 1-1 describe the system's warranted performance. Those items under the heading of "Characteristics" go beyond the guaranteed specifications and give typical performance for some additional parameters and operations. These are included only to give you information which may be useful in applying the system.

Table 1-1. System Specifications and Characteristics

SPECIFICATIONS (Specifications describe the standard system's warranted performance.)	
ANALOG-TO-DIGITAL CONVERTER	EXECUTION TIMES*
Input Voltage Range: $\pm 0.125V$ to $\pm 8V$ peak in steps of 2.	Fourier Transform: < 55 ms
Input Coupling: dc or ac.	Stable Power Spectrum Average: < 80 ms
Input Channels: 2 channels wired for 4 standard. 4 channels optional with plug-in cards.	Stable Tri-Spectrum Average: < 220 ms
Resolution: 12 bits including sign.	REAL TIME BANDWIDTHS*
Input Frequency Range: dc to 50 kHz, 5 Hz to 50 kHz, ac coupled (100 kHz optional).	Fourier Transform: > 7.5 kHz
Sample Rate:	Stable Power Spectrum Average: 5.4 kHz
Internal: 100 kHz max. (1, 2, 3, or 4 channels simultaneously). (200 kHz optional on 1, 2, 3, or 4 channels.) [50 kHz max. (3 or 4 channels simultaneously).†]	Stable Tri-Spectrum Average: 1.9 kHz
External: An external time base may be used to allow external control of the sampling rate up to 100 kHz (200 kHz optional). One sample can be taken for each clock pulse (TTL level).	MASS STORAGE SOFTWARE
Internal Clock Accuracy: $\pm 0.01\%$.	MAXIMUM REAL TIME DATA ACQUISITION RATE (Single Channel):
DISPLAY UNIT	BS 256: 10 kHz
Vertical Scale Calibration: Data in memory is automatically scaled to give a maximum on-screen calibrated display. The scale factor is given in volts/division, volts ² /division, or in dB offset.	BS 1024: 39 kHz (25 kHz†)
Log Display Range: 80 dB with a scale factor ranging from 0 to +998 dB. Offset selectable in 4 dB steps.	BS 4096: 80 kHz (30 kHz†)
Linear Display Range: ± 4 divisions with scale factor ranging from 1×10^{-512} to 5×10^{512} in steps of 1, 2, and 5.	OFF-LINE BSFA SOFTWARE
Digital UP/DOWN Scale: Allows 8 up-scale and 2 down-scale steps (calibrated continuous scale factors).	Center Frequency Range: dc to one-half the Real Time Data Acquisition Rate.
Horizontal Scale Calibration:	Center Frequency Resolution: Continuous resolution to the limit of the frequency accuracy for center frequencies > 0.02% of the sampling frequency.
Linear Sweep Length: 10, 10.24 or 12.8 divisions.	Frequency Accuracy: $\pm 0.01\%$
Log Horizontal: 0.5 decades/division.	Bandwidth Selection: In steps of $f/5n$ where $n = 2, 3, 4$, etc.
Markers: Intensity markers every 8th or every 32nd point.	Max. Resolution Enhancement: > 400
BASE SOFTWARE	Dynamic Range:** 90 dB from peak out-of-band spectral component to the peak level of the passband noise. 80 dB from peak in-band spectral component to the peak level of the passband noise.
Transform Accuracy: The expected rms value of computational error introduced in either the forward or inverse FFT will not exceed 0.1% of the rms value of the transform result.	Out-of-Band Rejection: > 90 dB
Dynamic Range: > 75 dB for a minimum detectable spectral component in the presence of one full scale spectral component after twenty ensemble averages for a block size of 1024.	Passband Flatness of the Digital Filter: ± 0.01 dB
	ENVIRONMENTAL CONDITIONS
	Temperature Range: 0°C to 40°C (104°F).

*For band limited random noise type signals at block size 1024, no display, no Hanning.
**After eight ensemble averages of a power spectrum at block size 1024. Reduced by 10 dB at the exact center of the band.
†These rates apply to systems with modules 5466B and 54451A/B having a serial prefix lower than 1842.

FM RECORD/REPRODUCE SPECIFICATIONS

Input Sensitivity:	0.1 to 2.5 volts rms; adjustable with input attenuator for $\pm 40\%$ deviation. Can be extended to 10 volts.
Nominal Input Level:	± 1.4 volts peak.
Nominal Input Impedance:	100 K ohms resistive, shunted by less than 100 pf, unbalanced to ground.
Frequency Response:	
Flat Amplitude Filter	DC to 20 KHz, at 60 ips, ± 0.5 db; $\pm 40\%$ deviation.
Linear Phase Filter	DC to 12 KHz, at 60 ips, ± 0.5 db; $\pm 40\%$ deviation. DC to 20 KHz at 60 ips, ± 0.5 , -3 db; $\pm 40\%$ deviation.
Frequency Responses (Optional):	DC to 80 KHz at 120 ips using $\pm 40\%$ deviation with IRIG intermediate band center frequency of 432 KHz. Upper frequency limit and center frequencies are proportionately lower at lower speeds, to 3-3/4 ips. DC to 10 KHz at 60 ips using $\pm 40\%$ deviation with IRIG low band frequency of 54 KHz for improved S/N ratios. Upper frequency limit and center frequencies are proportionately lower at lower speeds.
DC Drift (Oscillator and Discriminator):	Less than $\pm 0.5\%$ of peak-to-peak deviation per 10° F after 20 minute warm-up.
Signal/Noise Ratio	46 db at 60 ips.

DC Linearity:	Less than $\pm 0.5\%$ of peak-to-peak deviation reference to best straight line through zero.
AC Distortion:	Less than 1.5% total harmonic distortion at all speeds.
Transient Response (60 ips):	
Flat Amplitude Filter ($\pm 1/2$ db)	Rise Time (10% to 90% points) - 22 microseconds. Overshoot - less than 15% .
Linear Phase Filter ($+1/2$, -3 db)	Rise Time (10% to 90% points) - 18 microseconds. Overshoot - less than 2.5% .
Output Level ($\pm 40\%$ deviation):	± 1.4 volts peak, into 1000 ohms, with short circuit protection (SCP).
Output Current ($\pm 40\%$ deviation):	± 3 milliamperes peak with SCP.
Output Impedance:	Less than 50 ohms, unbalanced to ground, with SCP.

GENERAL

Configuration:	One standard 19 inch wide equipment enclosure for 14 channel FM or Direct Record/Reproduce System. For 28-32 vdc operation. Additional enclosure furnished for operation from other power supplies. Optional Rack Mounting Kit available.
Recorder Size (28-32 v):	26-1/8 inches high by 19 inches wide by 12 inches deep for a 7 channel-6 speed record/reproduce system or a 14 channel-6 speed record, 2 speed reproduce system. Additional enclosure (7-1/2 inches height) which attaches to portable

Rotating Shaft Torque Sensors

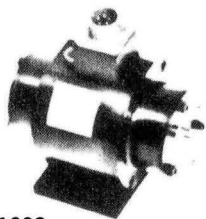

Model 1602

Low capacity torque sensors.

Capacity (Oz. In.)	Max. Speed (RPM)	Model	Protected for Overloads to (Oz. In.)	Torsional Stiffness (Lb. In./Rad.)	Rotating Inertia (Lb.-In. ²)	Weight (Lbs.)
50	20,000	1602-50	150	400	.35	3/4
100	20,000	-100	300	1,000	.35	3/4
200	20,000	-200	600	2,500	.35	3/4
500	20,000	-500	1,500	5,500	.35	3/4
1,000	20,000	-1K	1,500	8,000	.35	3/4

Models 1604, 1605 & 1607

Utility rotating shaft torque sensor recommended for general application.

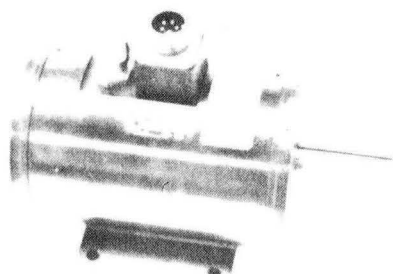

Capacity (Lb. In.)	Max. Speed (RPM)	Model	Protected for Overloads to (Lb. In.)	Torsional Stiffness (Lb. In./Rad.)	Rotating Inertia (Lb.-In. ²)	Weight (Lbs.)
50	15,000	1604-50	150	5,000	1.0	18
100	15,000	-100	300	13,500	1.0	18
200	15,000	-200	600	33,000	1.0	18
500	15,000	-500	1,500	85,000	1.0	18
1,000	15,000	-1K	3,000	150,000	1.0	18
2,000	15,000	-2K	6,000	225,000	1.0	18
2,000	15,000	1605-2K	6,000	700,000	3.25	28
5,000	15,000	-5K	15,000	950,000	3.25	28
10,000	15,000	-10K	20,000	1,000,000	3.25	28
20,000	4,000	1607-20K	60,000	6,800,000	52.0	75
50,000	4,000	-50K	150,000	11,800,000	57.0	75
100,000	4,000	-100K	150,000	19,950,000	180.0	75

Model 1615

Standard-flange housing mount with AND pads to match Army-Navy mountings standard.

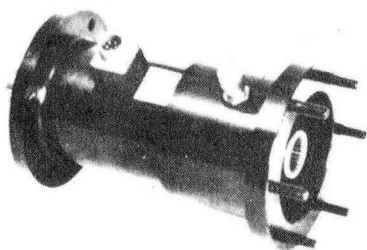

Capacity (Lb. In.)	Max. Speed (RPM)	Model	Protected for Overloads to (Lb. In.)	Torsional Stiffness (Lb. In./Rad.)	Rotating Inertia (Lb.-In. ²)	Weight (Lbs.)
50	15,000	1615A-50	150	1,500	1.0	24
100	15,000	-100	300	4,000	1.1	24
200	15,000	-200	600	10,000	1.2	24
500	15,000	-500	1,500	20,000	1.3	24
1K	15,000	-1K	1,500	25,000	1.4	24
50	15,000	1615 K-50	75	1,620	1.04	25
100	15,000	-100	150	4,570	1.05	25
200	15,000	-200	300	12,900	1.06	25
500	15,000	-500	750	940,000	1.97	25
1,000	15,000	-1K	1,500	204,000	2.00	25
2,000	15,000	-2K	3,000	347,000	2.08	26
5,000	15,000	-5K	7,500	500,000	2.38	26
10,000	15,000	-10K	15,000	574,000	2.76	26

Model 1648

Flange drive units recommended for use when short length is mandatory.

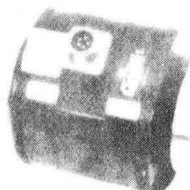

Capacity (Lb. In.)	Max. Speed (RPM)	Model	Protected for Overloads to (Lb. In.)	Torsional Stiffness (Lb. In./Rad.)	Rotating Inertia (Lb.-In. ²)	Weight (Lbs.)
2,000	5,000	1648-2K	3,000	742,000	23.0	23
5,000	5,000	-5K	7,500	1,811,000	23.0	23
10,000	5,000	-10K	15,000	2,248,000	23.0	23
20,000	5,000	-20K	30,000	3,507,000	23.5	23

GENERAL SPECIFICATIONS: (All Models)

SENSOR: Four arm bonded foil strain gage bridge
BRIDGE RESISTANCE: 350 ohms nominal
BRIDGE VOLTAGE: 20 volts maximum, 3 KHz
OUTPUT: 2 to 2.5 millivolt/volt nominal
LINEARITY: 0.1% of full scale

COMPENSATED TEMPERATURE RANGE: 30°F to 150°F
USEABLE TEMPERATURE RANGE: 0°F to 200°F
EFFECT OF TEMPERATURE ON ZERO: .002% of full scale/°F
EFFECT OF TEMPERATURE ON OUTPUT: .002% of reading/°F

MCRT[®] 6-02T Non-Contact Torquemeter

MAX. TORQUE—15,000 lb.-in.

SPEED — 0 - 7,500 rpm

GENERAL DESCRIPTION

The MCRT[®] 6-02T is a compact, high accuracy, flanged torquemeter well adapted for vehicle drive-line measurements and continuous monitoring and feedback applications. It uses a rotating strain gage torque bridge, temperature compensated for drift and modulus. The bridge is connected to a stationary electronic readout via integral, non-contact rotary transformers.

The torquemeter is immune to water, lubricants, coolants, vibration, etc. The elimination of slip-rings permits high accuracy low level measurements with long, maintenance-free life. Thrust and bending loads are inherently cancelled by the transducer design. An optional, integral non-contact speed pickup may be specified when ordering.

Linearity: 0.1%

Temperature Effects: From 75 to 175° F maximum drift is 0.2% of full scale and maximum error due to modulus change is 0.2% of reading.

Maximum Operating Temperature: 220° F, assuming permanent lubrication. Above 175° F, the maximum shaft speed may have to be de-rated.

Readout: Any carrier amplifier suitable for strain gage service may be used.

Excitation Voltage: 10 volts rms, maximum.

Nominal Output: 0.75 millivolts/volt (open circuit).

Standard Ratings:

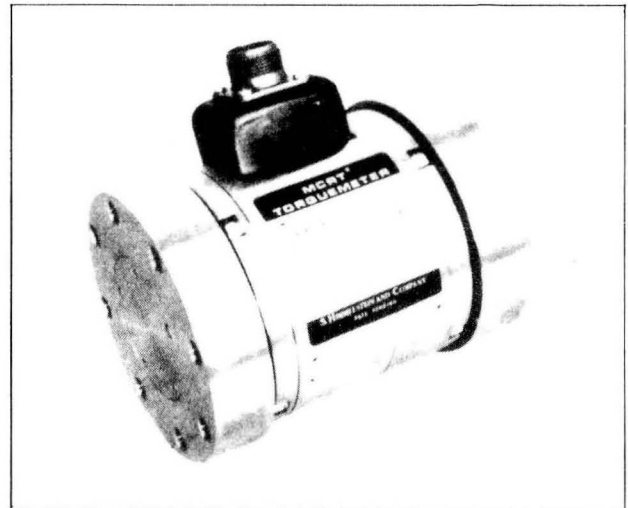

MODEL	FULL SCALE TORQUE (lb. - in.)	TORSIONAL STIFFNESS (lb. - in./rad.)	MAXIMUM BENDING MOMENT (lb. - in.)	MAXIMUM ROTATING INERTIA (in. - oz. sec. ²)	MAXIMUM WEIGHT (lbs.)
MCRT [®] 6-02T					
-(1-3)	1,000	602,000	500	0.60	13.8
-(2-3)	2,000	1,375,000	1,000	0.60	13.8
-(4-3)	4,000	2,640,000	2,000	0.60	13.8
-(6-3)	6,000	2,430,000	3,000	0.90	17.0
-(10-3)	10,000	2,930,000	5,000	0.90	17.0
-(15-3)	15,000	3,530,000	5,500	0.90	17.0

Overload Capacity: 2 times full scale rating.

Shaft Speed: 0 to 7,500 rpm, bi-directional. Optional speed pickup produces 60 pulses per shaft revolution.

Construction: Load carrying members (flanges, shaft) are 17-4 PH high strength stainless steel.

NOTES:

[1] Maximum speed rating assumes permanent lubrication. Consult factory for higher speed operation.

[2] When combined axial and bending loads are present, the bending capacity must be de-rated. Consult factory.

[3] Stator should be compliantly restrained from rotating.

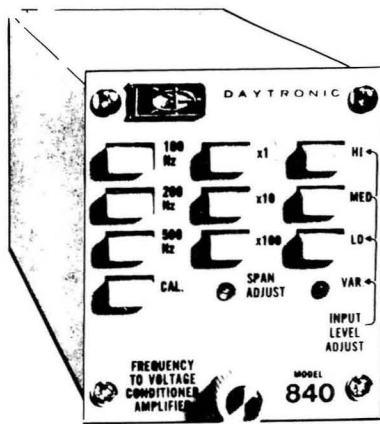

**MODEL
840**

**FREQUENCY-TO-VOLTAGE
CONVERTER**

The Model 840 Frequency-to-Voltage Converter is a conditioner-amplifier module that accepts input signals in a wide range of frequencies, wave shapes, and voltage levels and produces standard system output voltages precisely proportional to the frequency or repetition rate of the input signal. It is intended for use in "800" systems for measurement of **flow, rpm,** and similar phenomena that can be derived from magnetic pickups, turbine flowmeters, or other frequency-producing sources.

Nine selectable frequency ranges accommodate virtually all mechanical measurement requirements. An internal crystal oscillator reference and adjustable output span allow precise calibration of the indicating device in terms of *frequency, rpm,* or any other chosen units appropriate to the particular measurement. In flow measurement, for example, the Model 840 can be used with the Model 890 Digital Indicator and calibrated, using the front panel controls, so as to indicate directly in *gallons per minute* or *gallons per hour,* provided only that the flowmeter **K Factor** (*cycles per gallon*) is known.*

The Model 840 is also used in conjunction with the Model 862 Multiplier Module in an instrument that can display *torque, rpm, and shaft horsepower* in digital engineering units. Additional information on this and other instrument combinations is contained under the Model 862 description.

* If fluid specific gravity is also known, calibration can be made in units of *mass flow,* such as Pounds per Hour. For applications where specific gravity is subject to change, corrections can be entered manually on a calibrated dial (see Model 868, p 46) or applied automatically by a temperature sensing channel (see Model 862, page 42).

SPECIFICATIONS

Input:

Type: any AC signal, grounded or floating, irrespective of waveform.
 Sensitivity: . . . Three ranges (Lo, Med, & Hi), plus vernier, allow adjustment of threshold level from 5 mv to 50 volts (peak). Maximum continuous input voltage is 25 v, 100 v, & 250 v (RMS), respectively. Input is undamaged by momentary peak voltage of 500 volts on any range. Differential input impedance is 20K ohms, 400K ohms, and 8 Megohms, respectively.
 Common mode rejection: . . . greater than 60 dB to 2 kHz and greater than 30 dB to 100 kHz.
 Frequency ranges: 100 Hz, 200 Hz, and 500 Hz; with multipliers of X1, X10, and X100; each with 100% overrange.

Output:

Standard One Volt Data Signal: (see Table One, page 7).
 Standard Ten Volt Output Signal: (see Table One, page 7).
 Step-function response (to 99% of final value): 800 ms for X1 multiplier, 80 ms for X10 and X100 multipliers.
 Step-function response (to 99.9% of final value): 2.5 sec for X1 multiplier, 250 ms for X10 and X100 multipliers.
 Ripple and noise (max.): less than 0.2% of full scale from 10% to 100% of scale.
 Accuracy: 0.05% of scale (based on average value of DC output).
 Housing: standard full-width module.
 Operating temperature range: +50 to +120 degrees F.
 Power requirements: 105-130 volts, 50 400 Hz.

PRICE: Model 840 Frequency-to-Voltage Converter \$495.00

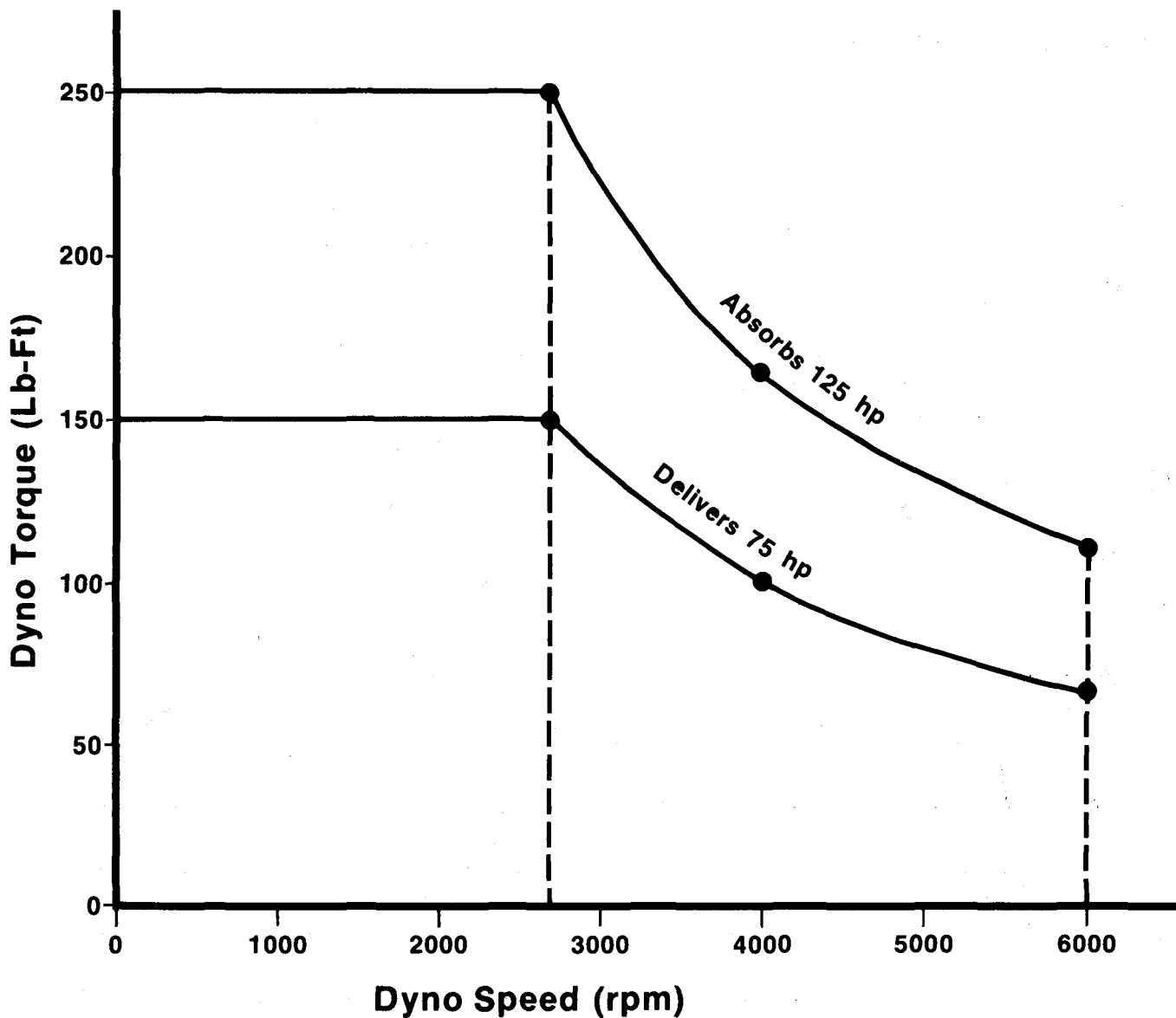

Dynamometer Characteristics

General Electric

No 1739498
Amperes 360
Absorbs 125 hp
Speeds 2700/6000
Torque Arm 15.756

Type TCL-20
Volts 250
Delivers 75 hp
Insts. GE I-7360-B

Class 4-125-2700

Absorption Model 1014WIG • Speed-Torque Curve

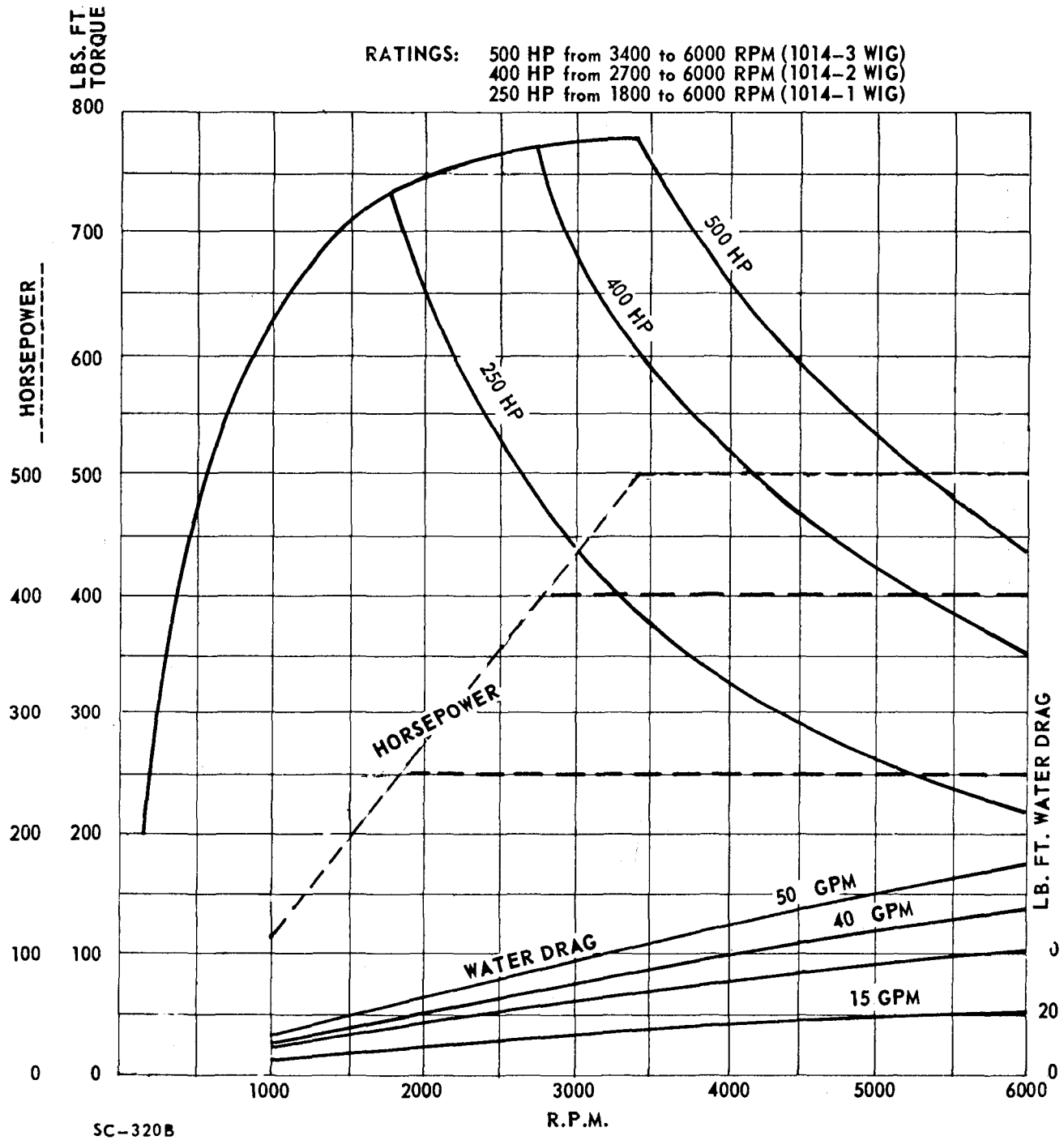

Dynumatic
 DEN3-124

SLIP RING TORQUE SENSORS

Model 1102

Low capacity torque sensors.

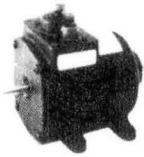

Model 1103

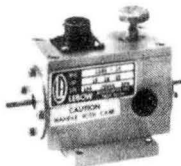

Capacity (Oz. In.)	Max. Speed (RPM)	Model	Protected for overloads to (Oz. In.)	Torsional Stiffness (Lb. In./Rad.)	Rotating Inertia (Lb.-In. ²)	Weight (Lbs.)	Brush Life Factor × 10 ⁴	Ring Diameter (In.)
10	20,000	1103-10	20	112	.01	¾	NA	NA
20	20,000	-20	40	113	.01	¾	NA	NA
50	20,000	1102-50	150	665	.676	2	8.2	0.750
100	20,000	-100	300	1,070	.678	2	8.2	0.750
200	20,000	-200	600	1,790	.680	2	8.2	0.750
500	20,000	-500	1,000	3,480	.682	2	8.2	0.750
1,000	20,000	-1K	1,500	4,850	.685	2	8.2	0.750

Models 1104 thru 1109, 1114, 1118 and 1121

Standard rotating shaft torque sensor for general application.

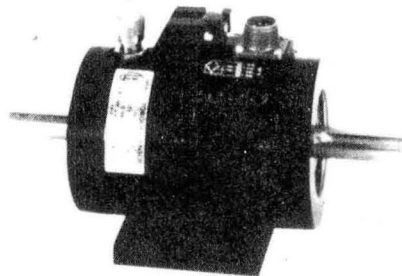

Capacity (Lb. In.)	Max. Speed (RPM)	Model	Protected for overloads to (Lb. In.)	Torsional Stiffness (Lb. In./Rad.)	Rotating Inertia (Lb.-In. ²)	Weight (Lbs.)	Brush Life Factor × 10 ⁴	Ring Diameter (In.)
100	16,000	1114-100	300	7,800	1.11	11	25.9	1.187
200	16,000	-200	600	17,200	1.12	11	25.9	1.187
500	16,000	-500	1,000	25,300	1.09	11	25.9	1.187
1,000	16,000	-1K	1,500	36,200	1.10	11	25.9	1.187
100	9,000	1104-100	150	6,430	1.52	11	15.4	2.000
200	9,000	-200	300	17,000	1.53	11	15.4	2.000
500	9,000	-500	750	45,200	1.59	11	15.4	2.000
1,000	9,000	-1K	1,500	103,000	1.59	11	15.4	2.000
2,000	9,000	-2K	3,000	182,500	1.60	11	15.4	2.000
5,000	8,500	1105-5K	7,500	475,000	3.59	28	14.0	2.187
10,000	8,500	-10K	15,000	750,000	4.09	28	14.0	2.187
20,000	6,500	1106-20K	30,000	2,610,000	15.18	42	10.2	3.000
50,000	4,000	1107-50K	75,000	7,220,000	53.06	74	7.2	4.250
100,000	4,000	-100K	150,000	12,450,000	58.14	74	7.2	4.250
120,000	2,400	1108-120K	180,000	15,400,000	265.41	162	5.3	5.750
240,000	2,400	-240K	360,000	23,300,000	285.35	162	5.3	5.750
360,000	2,100	1109-360K	540,000	28,000,000	400.00	240	4.4	7.000
600,000	2,100	-600K	900,000	40,000,000	577.00	240	4.4	7.000
840,000	450	1118-840K	1,260,000	Consult Factory			3.3	9.000
1,200,000	450	-1200K	1,800,000	Consult Factory			3.3	9.000
1,800,000	450	-1800K	2,700,000	Consult Factory			3.3	9.000
2,400,000	350	1121-2400K	3,600,000	Consult Factory			3.0	10.000
3,000,000	350	-3000K	4,500,000	Consult Factory			3.0	10.000

Model 1115

Flange housing mount with AND pads to match Army-Navy mountings standard. Spline drive.

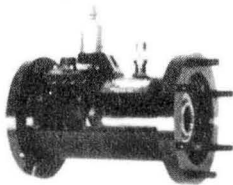

Capacity (Lb. In.)	Max. Speed (RPM)	Model	Protected for overloads to (Lb. In.)	Torsional Stiffness (Lb. In./Rad.)	Rotating Inertia (Lb.-In. ²)	Weight (Lbs.)	Brush Life Factor × 10 ⁴	Ring Diameter (In.)
100	24,000	1115A-100	300	5,230	2.44	24	25.9	1.187
200	24,000	-200	600	14,700	2.92	24	25.9	1.187
500	24,000	-500	1,000	25,900	2.43	24	25.9	1.187
1,000	24,000	-1K	1,500	37,600	2.44	24	25.9	1.187
100	8,000*	1115K-100	300	5,740	3.01	28	15.4	2.000
200	8,000*	-200	600	19,600	3.49	28	15.4	2.000
500	8,000*	-500	1,000	46,400	3.00	28	15.4	2.000
1,000	8,000*	-1K	1,500	103,000	3.01	28	15.4	2.000
2,000	8,000*	-2K	3,000	156,000	3.03	28	15.4	2.000
5,000	8,000*	-5K	7,500	342,000	3.05	28	15.4	2.000
10,000	8,000*	-10K	12,000	420,000	3.25	28	15.4	2.000

*12,000 RPM with air-oil mist lubrication.

Models 1228, 1248, 1241

Flange drive for use when short length is mandatory.



Capacity (Lb. In.)	Max. Speed (RPM)	Model	Protected for overloads to (Lb. In.)	Torsional Stiffness (Lb. In./Rad.)	Rotating Inertia (Lb.-In. ²)	Weight (Lbs.)	Brush Life Factor × 10 ⁴	Ring Diameter (In.)
2,000	5,000	1228-2K	3,000	1,455,000	4.38	8	12.7	2.530
5,000	5,000	-5K	7,500	2,141,000	4.39	8	12.7	2.530
10,000	5,000	-10K	15,000	2,820,000	4.59	8	12.7	2.530
20,000	5,000	1248-20K	30,000	4,657,000	15.53	17	9.4	3.250
50,000	3,000	1241-50K	75,000	12,840,000	193.7	54	6.5	4.750
100,000	3,000	-100K	150,000	23,460,000	196.3	54	6.5	4.750

Specifications	Standard		"H" Option	
	Standard	"H" Option	Standard	"H" Option
Output at rated capacity millivolts per volt nominal	2 to 2.5	5		
Nonlinearity of rated output	-0.1%	-0.15%		
Hysteresis of rated output	-0.1%	-0.15%		
Repeatability of rated output	-0.05%	-0.07%		
Zero balance of rated output	-1.0%	-1.0%		
Bridge resistance ohms nominal	350	350		
Temperature range, compensated F	-70 to -170	-70 to -170		
Temperature range, useable F	65 to -200	65 to -200		
Temperature effect on output of reading per F	-0.002%	-0.003%		
Temperature effect on zero of rated output per F	-0.002%	-0.003%		
Excitation voltage, maximum volts DC or AC rms	20	20		
Insulation resistance, bridge/case megohms at 50 VDC	5000	5000		
Number of bridges	1	1		

1. Report No. NASA CR-165510		2. Government Accession No.		3. Recipient's Catalog No.	
4. Title and Subtitle SMALL PASSENGER CAR TRANSMISSION TEST MERCURY LYNX ATX TRANSMISSION				5. Report Date September 1981	
				6. Performing Organization Code 778-36-06	
7. Author(s) M. P. Bujold				8. Performing Organization Report No. ERC TR-8191	
				10. Work Unit No.	
9. Performing Organization Name and Address Eaton Corporation Engineering & Research Center 26201 Northwestern Hwy., P. O. Box 766 Southfield, MI 48037				11. Contract or Grant No. DEN 3-124	
				13. Type of Report and Period Covered Contractor Report	
12. Sponsoring Agency Name and Address U.S. Department of Energy Office of Vehicle and Engine R & D Washington, D.C. 20585				14. Sponsoring Agency Code DOE/NASA/0124-7	
				15. Supplementary Notes Final report. Prepared under Interagency Agreement DE-AI01-77CS51044. Project Manager, Henry B. Tryon, Transportation Propulsion Division, NASA Lewis Research Center, Cleveland, Ohio 44135.	
16. Abstract The small passenger car transmission test was initiated to supply electric vehicle manufacturers with technical information regarding the performance of commercially available transmissions. This information would enable EV manufacturers to design a more energy efficient vehicle. With this information the manufacturers would be able to estimate vehicle driving range as well as speed and torque requirements for specific road load performance characteristics. This report covers the testing of a Mercury Lynx automatic transmission. This transmission was tested in accordance with a passenger car automatic transmission test code (SAE J651b) which required drive performance, coast performance, and no load test conditions. Under these conditions, the transmission attained maximum efficiencies in the mid-ninety percent range both for drive performance test and coast performance tests. The major results of this test are the torque, speed and efficiency curves which are located in the data section of this report. These graphs map the complete performance characteristics for the Mercury Lynx automatic transmission.					
17. Key Words (Suggested by Author(s)) Electric vehicles Transmissions Torque converters			18. Distribution Statement Unclassified - unlimited STAR Category 37 DOE Category UC-96		
19. Security Classif. (of this report) Unclassified		20. Security Classif. (of this page) Unclassified		21. No. of Pages	22. Price*

* For sale by the National Technical Information Service, Springfield, Virginia 22161

*USGPO: 1982 - 559-091/3224



