

N O T I C E

THIS DOCUMENT HAS BEEN REPRODUCED FROM
MICROFICHE. ALTHOUGH IT IS RECOGNIZED THAT
CERTAIN PORTIONS ARE ILLEGIBLE, IT IS BEING RELEASED
IN THE INTEREST OF MAKING AVAILABLE AS MUCH
INFORMATION AS POSSIBLE

E82-10263

FC-L1-04109
JSC-17151

NASA-CR-167547

A Joint Program for
Agriculture and
Resources Inventory
Surveys Through
Aerospace
Remote Sensing

December 1981

AgRISTARS

"Made available under NASA sponsorship
in the interest of early and wide dis-
semination of Earth Resources Survey
Program information and without liability
for use made thereof."

Foreign Commodity Production Forecasting

FISCAL YEAR 1981 U.S. CORN AND SOYBEANS PILOT PRELIMINARY EXPERIMENT PLAN, PHASE I

(E82-10263) FISCAL YEAR 1981 US CORN AND
SOYBEANS PILOT PRELIMINARY EXPERIMENT PLAN,
PHASE I (Lockheed Engineering and
Management) 153 p HC A08/AF A01

N82-24541

CSCI 02C

UNCLAS

G3/43 00263

G. P. Livingston, K. S. Nedelman, D. F. Norwood, and J. H. Smith

This draft document consists of technical working material that has not been formally reviewed. It has been prepared in this manner in order to provide timely documentation to personnel supporting the Foreign Commodity Production Forecasting project of the Agriculture and Resources Inventory Surveys Through Aerospace Remote Sensing program and to provide others in the technical community with a means of staying informed of project tasks.

Lockheed Engineering and Management Services Company, Inc.
1830 NASA Road 1, Houston, Texas 77058



Lyndon B. Johnson Space Center
Houston, Texas 77058

1 Report No FC-L1-04109, JSC-17151		2 Government Accession No		3 Recipient Catalog No	
4 Title and Subtitle Fiscal Year 1981 U.S. Corn and Soybeans Pilot Preliminary Experiment Plan, Phase I				5 Report Date December 1981	
				6 Performing Organization Code	
7 Author(s) G. P. Livingston, K. S. Nedelman, D. F. Norwood, and J. H. Smith Lockheed Engineering and Management Services Company, Inc.				8 Performing Organization Report No LEMSCO-16575	
				10 Work Unit No	
9 Performing Organization Name and Address Lockheed Engineering and Management Services Company, Inc. 1830 NASA Road 1 Houston, Texas 77058				11 Contract or Grant No NAS 9-15800	
				13 Type of Report and Period Covered Technical Report	
12 Sponsoring Agency Name and Address National Aeronautics and Space Administration Lyndon B. Johnson Space Center Houston, Texas 77058 Technical Monitor: J. L. Dragg				14 Sponsoring Agency Code	
5 Supplementary Notes The Agriculture and Resources Inventory Surveys Through Aerospace Remote Sensing is a joint program of the U.S. Department of Agriculture, the National Aeronautics and Space Administration, the National Oceanic and Atmospheric Administration (U.S. Department of Commerce), the Agency for International Development (U.S. Department of State), and the U.S. Department of the Interior.					
16 Abstract This document is a draft of the preliminary experiment plan for the Foreign Commodity Production Forecasting Project Fiscal Year 1981 U.S. Corn and Soybeans Pilot Experiment, Phase I, as presented at the Preliminary Design Review to National Aeronautics and Space Administration FCPF project management in January 1981. This draft plan includes: (1) definition of the Phase I and II U.S. pilot objectives; (2) the proposed experiment design to evaluate crop calendar, area estimation, and area aggregation components for corn and soybean technologies using 1978/1979 crop-year data; (3) description of individual sensitivity evaluations of the "Baseline Corn and Soybean Segment Classification Procedure"; and (4) technology and data assessment in support of the corn and soybean estimation technology for use in the U.S. Central Corn Belt.					
17 Key Words (Suggested by Author(s)) U.S. AgRISTARS Remote sensing Area proportion estimation Corn Soybeans				18 Distribution Statement	
19 Security Classif. (of this report) Unclassified		20 Security Classif. (of this page) Unclassified		21 No. of Pages 152	22 Price

*For sale by the National Technical Information Service, Springfield, Virginia 22161

PRECEDING PAGE BLANK NOT FILMED

FC-L1-04109
JSC-17151

FISCAL YEAR 1981 U.S. CORN AND SOYBEANS PILOT
PRELIMINARY EXPERIMENT PLAN, PHASE I

Job Order 72-415

This report describes the Experiment Design Activities of the Foreign
Commodity Production Forecasting project of the AgRISTARS program.

PREPARED BY

G. P. Livingston, K. S. Nedelman, D. F. Norwood, and J. H. Smith

APPROVED BY

D. T. Register, Supervisor
Design and Integration Section

B. L. Carroll, Manager
Crop Applications Department

LOCKHEED ENGINEERING AND MANAGEMENT SERVICES COMPANY, INC.

Under Contract NAS 9-15800

For

Earth Resources Applications Division
Space and Life Sciences Directorate
NATIONAL AERONAUTICS AND SPACE ADMINISTRATION
LYNDON B. JOHNSON SPACE CENTER
HOUSTON, TEXAS

December 1981

LEMSCO-16575

PREFACE

This draft document consists of technical working material that has not been formally reviewed. It has been prepared in this manner to provide timely documentation to personnel supporting the Foreign Commodity Production Forecasting (FCPF) project and to provide others in the technical community with a means for staying abreast of FCPF project tasks.

A high priority goal in the Agriculture and Resources Inventory Surveys Through Aerospace Remote Sensing (AgRISTARS) FCPF project is the development of Landsat dependent-area estimation technologies to support at-harvest foreign corn and soybean production forecasting. The first large-scale test and evaluation of these technologies has been scheduled for Fiscal Year (FY) 1981/1982 in a pilot experiment in the U.S. Central Corn Belt (Iowa, Illinois, and Indiana). The basic objectives of the U.S. Pilot experiment have been outlined in the January FCPF Project Implementation Plan. Results of the expected evaluations will support adaptation of corn and soybean area estimation technologies for Argentina and Brazil and provide insight into the experiment design issues for the Argentina Exploratory Experiment scheduled for FY1983.

The major area estimation technology scheduled for evaluation in the pilot experiment is the U.S. Baseline Corn and Soybean Segment Classification Procedure developed and delivered to the FCPF Project by the Environmental Research Institute of Michigan and the Space Sciences Laboratory of the University of California at Berkeley. The baseline procedure, derived from previous experiences for small grains and exploratory corn and soybeans procedures, generates stratified areal estimates from analyst-labeled field-like targets.

Prior to the Preliminary Design Review (PDR), budgetary and data procurement considerations resulted in definition of the following generalized experiment schedule: intensive evaluation of technologies on 1978/1979 crop-year data beginning in FY1981 followed by a regional test of the integrated component technologies on 1980 crop-year data. The accompanying draft documentation represents the Preliminary Experiment Design and Plan for the 1978/1979

crop-year data evaluations as presented to National Aeronautics and Space Administration (NASA) FCPF project management. Review comments were submitted to the Experiments Manager as written requests or recommendations for experiment plan and/or design changes (RID's). The RID's were to be reviewed and recommendations provided to NASA FCPF project management on their proper disposition prior to a critical design review of the final Experiment Plan. A summary of these RID's is attached.

However, revised budgetary considerations and changes in project objectives immediately subsequent to the PDR necessitated the U.S. Pilot Experiment be redesigned. As a result, modified versions of the Pilot Experiment Plans presented herein for the 1978/1979 crop-year data evaluations will be synthesized with the 1980 crop-year data evaluations in a FY1981/1982 U.S. Corn/Soybean Pilot Experiment Plan. This new plan is currently scheduled to be completed and presented to NASA FCPF project management in June 1981.

CONTENTS

GENERAL OBJECTIVES

- Role of Experiment within AgRISTARS.....	1
- General Objectives.....	4

EXPERIMENT TECHNOLOGY

- Functional Flow of each Component and Subcomponent of DARSIS.....	7
---	---

DATA AND TECHNOLOGY ASSESSMENT.....	10
-------------------------------------	----

GENERAL OVERVIEW OF APPROACH.....	25
-----------------------------------	----

BASELINE PROCEDURE DESCRIPTION.....	27
-------------------------------------	----

SUMMARY OF EVALUATIONS.....	42
-----------------------------	----

DESCRIPTION OF INDIVIDUAL EVALUATIONS.....	47
--	----

CORN/SOYBEAN BASELINE.....	55
----------------------------	----

- Overall Evaluation.....	55
---------------------------	----

- Analyst Functions.....	69
--------------------------	----

- Machine Functions.....	94
--------------------------	----

ACQUISITION HISTORY.....	110
--------------------------	-----

CROP CALENDAR.....	111
--------------------	-----

WEIGHTED AGGREGATION PROCEDURE.....	112
-------------------------------------	-----

DATA AND DATA SYSTEM REQUIREMENTS.....	114
--	-----

FCPF PROJECT RISKS.....	115
-------------------------	-----

RESOURCE SUMMARY.....	116
-----------------------	-----

EVALUATIONS NOT PERFORMED.....	120
--------------------------------	-----

SUMMARY OF RID'S RECEIVED.....	121
--------------------------------	-----

RID'S RECEIVED.....	123
---------------------	-----

RESPONSE TO RID'S.....	143
------------------------	-----

FY1981 U.S. CORN/SOYBEANS PILOT EXPERIMENT DESIGN

FOREIGN COMMODITY PRODUCTION FORECASTING (FCPF) PROJECT

OBJECTIVES WITHIN THE AGRISTARS PROGRAM

- GENERAL - DEVELOP TECHNOLOGIES FOR MAKING IMPROVED CROP PRODUCTION FORECASTS IN FOREIGN AREAS FOR POSSIBLE INTEGRATION INTO THE USDA CROP INFORMATION SYSTEM.
- SPECIFIC - DEVELOP AND EVALUATE AEROSPACE REMOTE SENSING AND RELATED TECHNOLOGIES TO PROVIDE MORE OBJECTIVE AND RELIABLE CROP PRODUCTION FORECASTS AT SEVERAL TIMES THROUGHOUT THE GROWING SEASON FOR A RANGE OF CROPS AND COUNTRIES.

FY1981 OBJECTIVES SPECIFIC TO CORN AND SOYBEANS EXPERIMENTS

- COMPLETE DEVELOPMENT OF BASELINED CORN/SOYBEANS ESTIMATION TECHNOLOGY.
- INTEGRATE MACHINE/ANALYST LABELING FUNCTIONS.
- PREPARE FY1980 U.S. CORN/SOYBEANS EXPLORATORY EXPERIMENT REPORT.
- TEST AND EVALUATE TECHNOLOGY FOR GENERATING AT-HARVEST CORN AND SOYBEANS AREA, YIELD, AND PRODUCTION ESTIMATES IN THE U.S. CENTRAL CORN BELT (IOWA, ILLINOIS, AND INDIANA).

PROPOSED AGRISTARS FCPF PROJECT CORN/SOYBEANS EXPERIMENTS

- FY1981/82 - U.S. PILOT
- FY1982 - ARGENTINA EXPLORATORY
- FY1983 - BRAZIL EXPLORATORY
ARGENTINA PILOT
- FY1984 - U.S. EXPLORATORY - PROCEDURE 2
BRAZIL PILOT
- FY1985 - U.S. PILOT - PROCEDURE 2
ARGENTINA LSAT
BRAZIL LSAT
- FY1986 - U.S. EXPLORATORY - TM
- FY1987 - BRAZIL EXPLORATORY - PROCEDURE 2/TM
U.S. PILOT - TM

FY1981 FCPF PROJECT U.S. CORN/SOYBEAN PILOT EXPERIMENT
PLAN TO SUPPORT ARGENTINA AND BRAZIL CORN/SOYBEAN EXPERIMENTS

TECHNICAL OBJECTIVES

- ESTABLISH BASELINE TECHNOLOGY FOR CORN AND SOYBEANS PRODUCTION FORECASTING.
- EVALUATE STATE-OF-THE-ART:
 - REMOTE-SENSING-BASED AT-HARVEST PRODUCTION FORECASTING TECHNOLOGY FOR CORN AND SOYBEANS.
 - REMOTE-SENSING-BASED AT-HARVEST AREA ESTIMATION TECHNOLOGY FOR CORN AND SOYBEANS.
 - AT-HARVEST YIELD ESTIMATES FOR CORN AND SOYBEANS IN CONTEXT OF PRODUCTION.
 - AGROMET ADJUSTED MODELS FOR ESTIMATING CROP DEVELOPMENT STAGE FOR CORN AND SOYBEANS.

RATIONALE FOR A TWO-PHASED U.S. CORN AND SOYBEANS PILOT EXPERIMENT

STATUS DATE NOVEMBER 6

FCPF PROJECT PERSONNEL REEXAMINED THE PROPOSED U.S. CORN/SOYBEANS PILOT OBJECTIVES, SCOPE AND SCHEDULE AS OUTLINED IN THE PROJECT IMPLEMENTATION PLAN (PIP), DUE TO DIFFICULTIES IN PROCURING ACCEPTABLE 1980 CROP YEAR LANDSAT IMAGE AND/OR DIGITAL DATA.

- SEVERE LANDSAT DIGITAL DATA PROBLEMS.
- HEAVY WORK BACKLOG ON LACIE PROCESSOR.
- SEVERE DIFFICULTIES IN GENERATING PFC FILM PRODUCTS.

DECISION

DIVIDE THE U.S. CORN/SOYBEANS PILOT INTO A TWO-PHASE EXPERIMENT.

- PHASE 1 - REDUCE THE PROPOSED EXPERIMENT SCOPE AND OBJECTIVE.
 - PROCEED WITH THE EXISTING 1978/1979 MULTICROP DATA BASE ON SCHEDULE.
 - RESERVE OPTION TO TERMINATE PHASE 1 AND INITIATE PHASE 2 IF THE 1980 CROP YEAR DATA BASE BECAME AVAILABLE.
- PHASE 2 - PROCEED WITH THE EXPERIMENT SCOPE AND OBJECTIVE OUTLINED IN THE PIP.
 - UTILIZE THE 1980 CROP YEAR DATA BASE.

RATIONALE

A TWO-PHASE EXPERIMENT AS DEFINED WOULD ALLOW:

- SHAKEDOWN ON EODLS DATA SYSTEM AND PROCEDURE SOFTWARE.
- MAINTAIN SUPPORT CONTINUITY AND SCHEDULING FOR FOLLOW-ON EXPERIMENT BY ESTABLISHING BASELINE EVALUATIONS OF AREA AND PRODUCTION TECHNOLOGY COMPONENTS.
- TIMELY RECOMMENDATIONS FOR POSSIBLE TECHNOLOGICAL IMPROVEMENTS PRIOR TO THE ARGENTINA EXPLORATORY.

GENERAL OBJECTIVES OF THE FY1981 U.S. CORN/SOYBEANS PILOT EXPERIMENT

PHASE ONE

- EVALUATE CROP GROWTH STAGE MODELS FOR CORN AND SOYBEANS.
- EVALUATE THE BASELINE CORN/SOYBEANS SEGMENT PROPORTION ESTIMATION TECHNOLOGY FOR ACCURACY, CONSISTENCY, AND EFFICIENCY OF AT-HARVEST ESTIMATES IN THE U.S. CORN BELT.
- EVALUATE THE SUBCOMPONENTS OF THE BASELINE SEGMENT AREA PROPORTION ESTIMATION PROCEDURE (E.G., ACQUISITION SELECTION, TARGET LABELING, ETC.).
- EVALUATE A BASELINE AREA AGGREGATION TECHNOLOGY FOR CORN AND SOYBEANS.
- SUPPORT DEVELOPMENT OF AREA ESTIMATION TECHNOLOGY FOR THE FY1982 U.S. CORN/SOYBEANS PILOT EXPERIMENT (PHASE TWO), AND THE FY1982 ARGENTINA CORN/SOYBEANS EXPLORATORY EXPERIMENT.

GENERAL OBJECTIVES OF THE FY1982 U.S. CORN/SOYBEANS PILOT EXPERIMENT

PHASE TWO

- TEST AND EVALUATE AN INTEGRATED TECHNOLOGY DESIGNED FOR AT-HARVEST AREA, YIELD, AND PRODUCTION ESTIMATES FOR CORN AND SOYBEANS IN THE U.S. CENTRAL CORN BELT.
- TEST AND EVALUATE EACH OF THE MAJOR COMPONENTS OF THE PRODUCTION SYSTEM; I.E., SAMPLING, CROP CALENDAR, AREA ESTIMATION, YIELD ESTIMATION, AND AREA AGGREGATION & PRODUCTION.
- VALIDATE AN IMPROVED BASELINE AT-HARVEST AREA ESTIMATION TECHNOLOGY FOR CORN AND SOYBEANS.
- TEST AND EVALUATE THE BASELINE MULTICROP SAMPLING AND AGGREGATION PROCEDURES FOR CORN AND SOYBEANS TO OBTAIN FINAL PERFORMANCE ASSESSMENTS.
- RECOMMEND SUBSEQUENT REFINEMENTS/IMPROVEMENTS IN THE TECHNOLOGY TO SUPPORT FCPF PROJECT OBJECTIVES.
- IDENTIFY TECHNOLOGIES FOR USE AND/OR FURTHER DEVELOPMENT FOR APPLICATION IN FOREIGN AREAS, PARTICULARLY BRAZIL.

DEVELOPMENTAL AGRICULTURE REMOTE SENSING INFORMATION SYSTEM (DARSIS)

FUNCTIONAL COMPONENTS

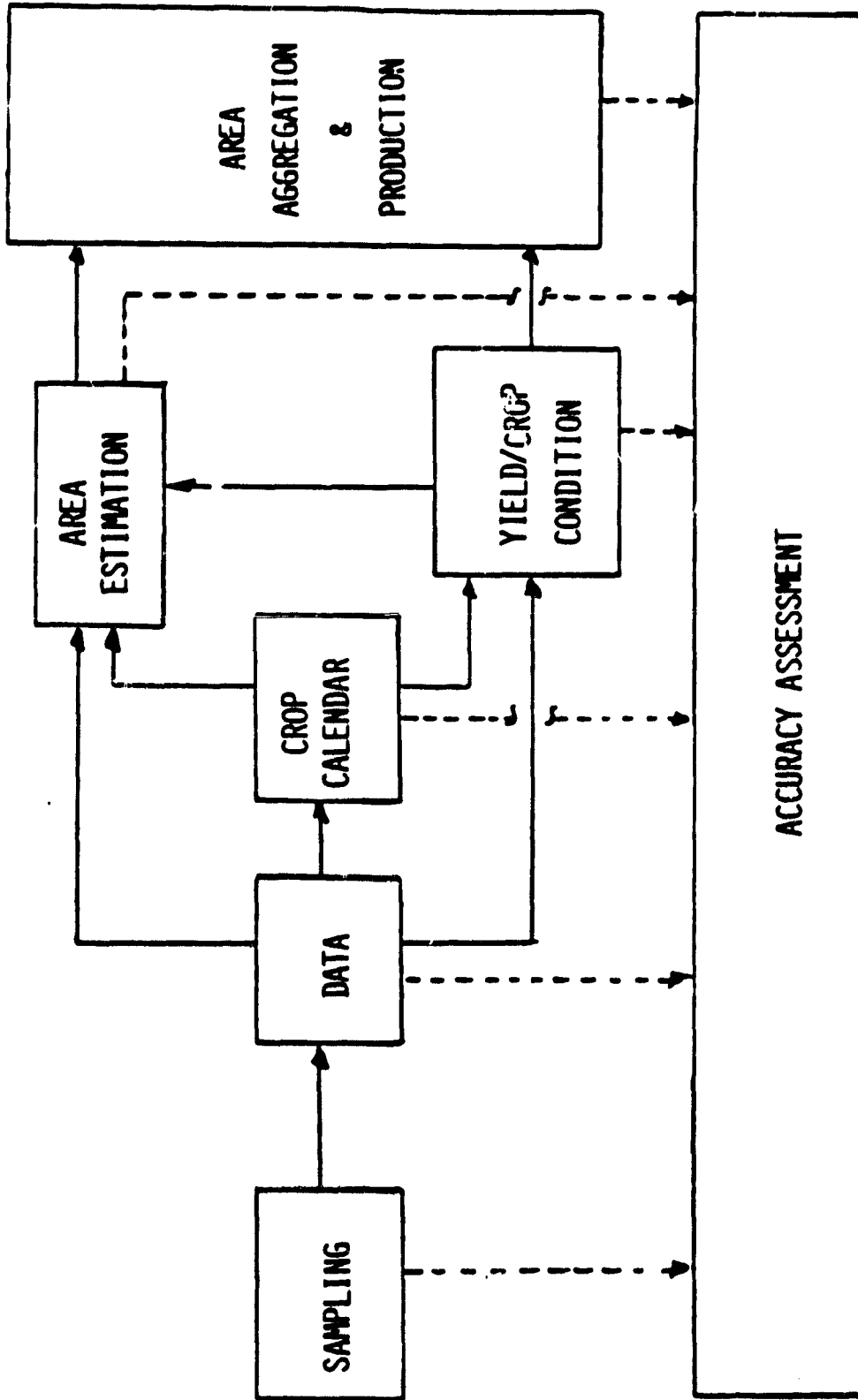

CROP CALENDAR COMPONENT

- **CROP GROWTH STAGE MODELS FOR CORN AND SOYBEANS**

AREA AGGREGATION & PRODUCTION COMPONENT

- **WEIGHTED AGGREGATION PROCEDURE (WAP)**

AREA ESTIMATION COMPONENT

MAJOR SUBCOMPONENTS AND FUNCTIONAL FLOW

CORN/SOYBEANS BASELINE PROCEDURE

- ACQUISITION SELECTION.
- SPECTRAL-MULTITEMPORAL CROP GROUP STRATIFICATION.
- CORN/SOYBEAN SEPARATION WITHIN THE SUMMER CROP GROUP.
- SPATIAL-SPECTRAL STRATIFICATION.
- MIDZUNO SAMPLING.
- TARGET LABELING (BLOBS).
- STRATIFIED AREA PROPORTION ESTIMATION.

DATA ASSESSMENT

● FY1978-1979 U.S. MULTICROP DATA

- PURPOSE OF ALLOCATION
 - DEVELOPMENT AND EVALUATION OF TECHNOLOGIES FOR CLASSIFICATION OF CORN AND SOYBEAN CROPLANDS IN THE U.S.
- ALLOCATION
 - THREE SEPARATE ALLOCATIONS:
 1. LOW DENSITY - 20 SEGMENTS RANDOMLY ALLOCATED TO EACH OF 8 PRODUCTION DENSITY STRATA (PDS) WITHOUT REPLACEMENT.
 2. HIGH DENSITY - 2-3 SEGMENTS ALLOCATED PER COUNTY IN EACH OF FOUR DIFFERENT INTENSIVE TEST AREAS ACROSS THE CORN BELT.
 3. DIRECTED ALLOCATION WITHIN THE CENTRAL CORN BELT.
- PRODUCTION DENSITY STRATIFICATION
 - THE STRATIFICATION WAS PERFORMED USING THREE VARIABLES: NORMALIZED PRODUCTION OF CORN, SOYBEANS AND AVERAGE FARM SIZE.
 - EIGHT STRATA WERE CREATED WITHIN FOURTEEN STATES OF THE U.S. CORN AND SOYBEAN PRODUCING REGIONS. EACH STRATUM WAS RELATIVELY HOMOGENEOUS WITH RESPECT TO THE RELATIVE IMPORTANCE OF CORN AND SOYBEANS IN THE AGRICULTURAL SCENE AND THE AVERAGE FARM SIZE.
 - AVERAGE FARM SIZE WAS REPRESENTED IN TWO GROUPS:
 - SMALL \leq 190 ACRES
 - LARGE \geq 190 ACRES

DATA ASSESSMENT - (CONTINUED)

● CHARACTERISTICS OF AVAILABLE DATA FROM THE NORTH CENTRAL U.S. CORN BELT (IOWA, ILLINOIS, INDIANA)

- ONLY THOSE SEGMENTS FOR WHICH GROUND-TRUTH TAPES (UGT's) WERE CREATED ARE ACCEPTABLE AS CANDIDATE SEGMENTS FOR THE AREA PROPORTION ESTIMATION COMPONENT.
- ALL PROCEDURE DEVELOPMENT SEGMENTS HAVE BEEN EXCLUDED FROM THE CANDIDATE DATA SET TO BE USED IN THE SEGMENT ANALYSIS EVALUATIONS. HOWEVER, THESE SEGMENT DATA WILL BE AVAILABLE TO THE AREA AGGREGATION COMPONENT OF THE EXPERIMENT.

● STRATIFICATION

- BASELINE SEGMENT ANALYSIS PROCEDURES:
 - PREVIOUS PDS STRATIFICATIONS WERE IGNORED FOR THIS EXPERIMENT PLAN AS CORN/ SOYBEAN RATIOS EVEN WITHIN A SINGLE STRATUM VARIED AS MUCH AS FROM 1.2 - 2.7 AND DID NOT CORRESPOND TO THE DESIGN REQUIREMENTS.
 - SEGMENTS USED IN THE EXPERIMENT DESIGN WERE CONSIDERED TO REPRESENT THE U.S. CENTRAL CORN BELT.
- AGGREGATION TECHNOLOGY:
 - THE PRODUCTION DENSITY STRATA WILL BE INTERSECTED WITH THE STATES TO PROVIDE AGGREGATION STRATA.

SUMMARY OF THE NUMBER OF AVAILABLE SEGMENTS

	CROP YEAR		
	1978	1979	1978/1979
POTENTIALLY AVAILABLE SEGMENTS	56	18	13
PROCEDURE DEVELOPMENT	9		
SHAKEDOWN TEST	6		
SEGMENTS REQUIRED BY THE EXPERIMENT DESIGN	26+	12	
		TOTAL NUMBER	

1978 MULTICROP DATA SET
 FOR WHICH GROUND-TRUTH TAPES (UGTT'S) ARE AVAILABLE.

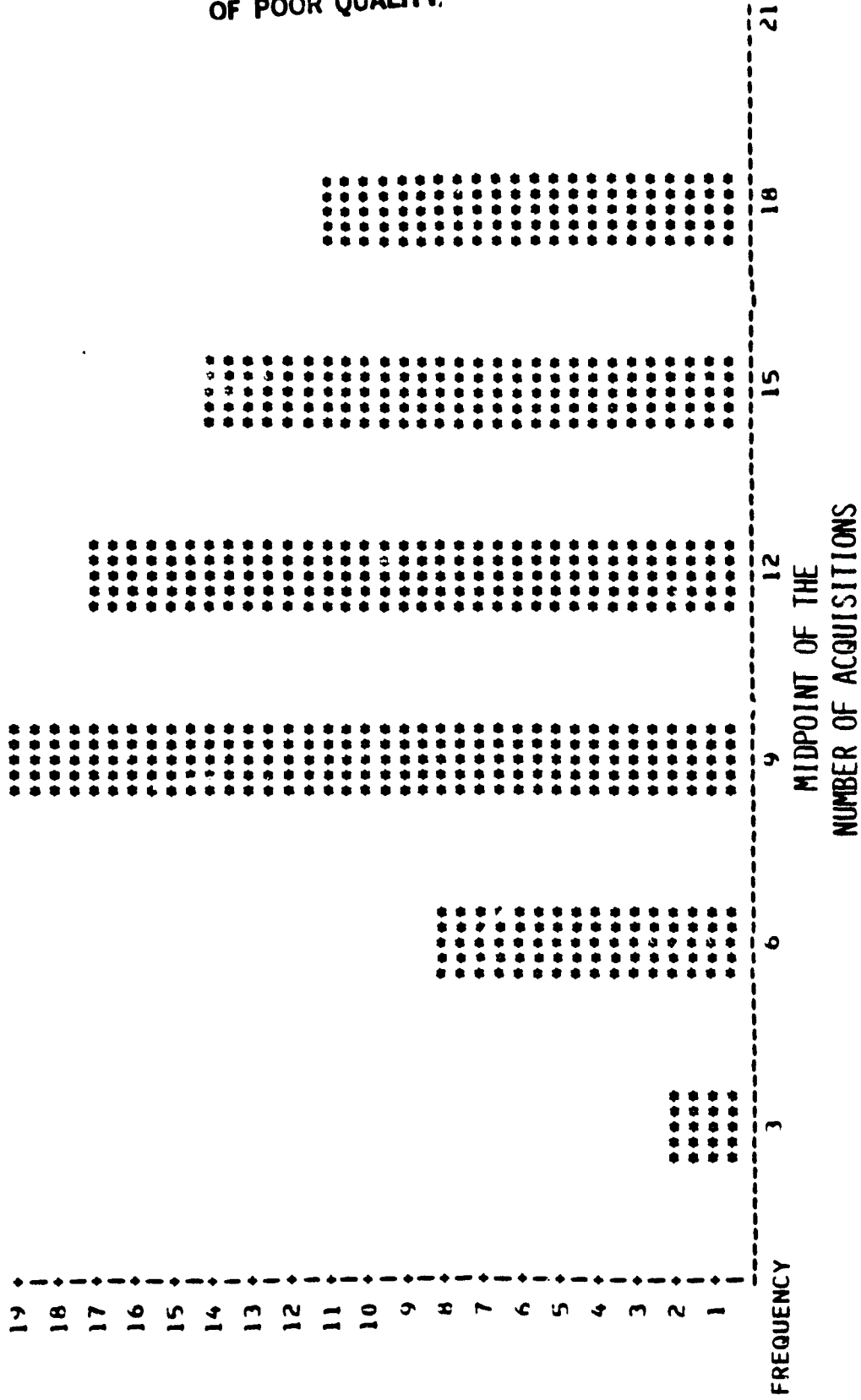

ORIGINAL PAGE IS
 OF POOR QUALITY.

ORIGINAL PAGE IS
OF POOR QUALITY

1979 MULTICROP DATA SET
FOR WHICH GROUND-TRUTH TAPES (UGTT'S) ARE AVAILABLE

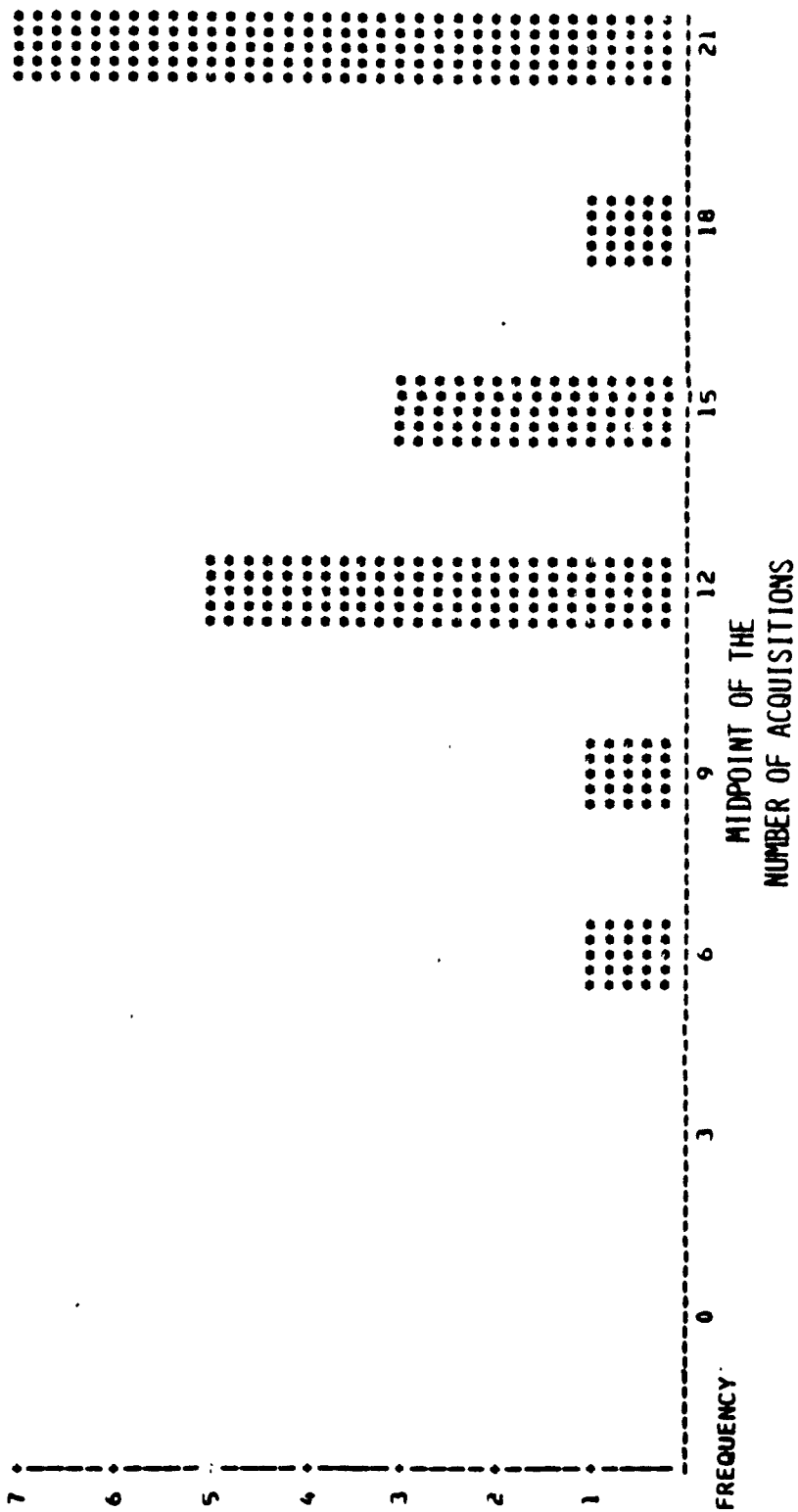

TECHNOLOGY ASSESSMENT

- PREVIOUS MULTICROP DATA ANALYSES
 - FY1980 U.S. CORN/SOYBEANS EXPLORATORY EXPERIMENT
- DATA
- TOTAL OF 58 GROUND-TRUTH SEGMENTS FROM THE 1978 MULTICROP DATA SET
- OBJECTIVES
- EVALUATE THE PROPORTION ESTIMATION ERRORS AND LABELING ACCURACIES AS A FUNCTION OF ANALYST GROUP EFFECTS AND APU EFFECTS

RESULTS

LABELING ACCURACIES

VERIFICATION TEST (N = 25)	C/S	S/S	O/O
TYPE ONE DOTS	86	79	93
TYPE TWO DOTS	73	64	86

SIMULATED AGGREGATION TEST (N = 58)

93	88	96
----	----	----

QUANTITATIVE EVIDENCE THAT PROCEDURES MUST DEAL WITH BOUNDARY/MIXED PIXELS

PROPORTION ESTIMATION

LARGEST SOURCE OF ERRORS WAS IDENTIFIED AS DOT LABELING ERRORS

- ABSOLUTE ERROR	CORN	-4%
	SOYBEAN	-6%

MACHINE PROCESSING (P1) DID NOT SHOW IMPROVEMENT OVER RANDOM SAMPLING
BASED PROPORTION ESTIMATES RESULT WHEN ONLY PURE AREAS ARE CONSIDERED

SUBJECTIVITY

ANALYST GROUP EFFECTS WERE SIGNIFICANT

REGIONAL SENSITIVITY

PROCEDURE PERFORMANCE WAS SIGNIFICANTLY DEPENDENT UPON LOCATION

ACCURACY ASSESSMENT

DIAGNOSIS OF ERROR TYPES AND CAUSES READILY OBTAINABLE

EFFICIENCY

LABELING EFFICIENT RELATIVE TO INTEGRATED ANALYSES

CORN/SOYBEANS BASELINE PROCEDURE vs PROCEDURE I

SOURCES OF ERROR - - - - - PROPOSED IMPROVEMENTS

LABELING

- - - - - PREPROCESSING

NORMALIZATION INCLUDES SPATIAL

HAZE CORRECTION

FEATURE EXTRACTION

GRABS

SPECTRAL MULTITEMPORAL

STRATIFICATION (TPC)

TARGET TYPE

SPATIAL/SPECTRAL CLUSTER (BLOB)

LABELING METHOD

"CONVERGENCE OF EVIDENCE"

DECISION LOGIC

ANALYST/MACHINE INTERACTION INTEGRATED

MACHINE PROCESSING - - - - -

STRATIFICATION METHOD

CROP GROUP STRATA

SPECTRAL CLUSTER (B-CLUSTER)

SAMPLING METHOD

MIDZUNO

COMPARISON OF ATTRIBUTES
BETWEEN PROCEDURES

ATTRIBUTE	BASELINE C/S PROCEDURE	PROCEDURE 1	PROCEDURE M FOR SPRING GRAINS
PREPROCESSING	HAZE SUN ANGLE SENSOR	SUN ANGLE SENSOR	HAZE SUN ANGLE SENSOR
FEATURE EXTRACTION	TASCAP B GRABS TPC	TASCAP G, B	TASCAP G, B
TARGET TYPE	BLOB	DOT	BLOB
STRATIFICATION METHOD	CROP GROUP STRATA B CLUSTER	ISOCLAS	BCLUSTER
SUPERVISION REQUIRED	NONE	40 DOT LABELS	NONE
SAMPLING METHOD	MIDZUMO 40-100 BLOBS	SYSTEMATIC- RANDOM 60 DOTS	MIDZUMO 40-100 BLOBS
LABELING METHOD	'CONVERGENCE OF EVIDENCE' DECISION LOGIC	HIERARCHICAL DECISION LOGIC	INTEGRATED

(CONT.)

ATTRIBUTE	BASELINE C/S PROCEDURE	PROCEDURE 1	PROCEDURE M FOR SPRING GRAINS
ESTIMATION METHOD	STRATIFIED AREA1 ESTIMATE	STRATIFIED AREA1 ESTIMATE	STRATIFIED AREA1 ESTIMATE
ANALYST/ MACHINE INTERACTION	INTEGRATED	DISJOINT	DISJOINT

IBM STUDY OF QUASI-FIELD PURITY AND BIAS MODELING USING PROCEDURE M

DATA

TWO SEGMENTS FROM THE 1978 MULTICROP DATA SET

RESULTS

- SUGGESTS IMPORTANT FACTORS AFFECTING PERFORMANCE ARE:
 - WITHIN SEGMENT CROP PROPORTIONS
 - CONFUSION CROPS
 - FIELD SIZE
- CROP PROPORTIONS ARE SIGNIFICANTLY DIFFERENT FROM TRUE SEGMENT-LEVEL CROP PROPORTIONS
 - EMPIRICAL EVIDENCE SUGGESTS A STRONG CORRELATION BETWEEN FIELD SIZE AND CROP TYPE
 - BIAS OCCURS DUE TO SAMPLING WITHIN THE SCENE OF LARGE BLOBS, I.E., QUASI-FIELD WITH INTERIOR PIXELS
- RECOMMEND MODELING SAMPLE BIAS FOR CROP PROPORTION ESTIMATES

ERIM STUDY OF TWO CROP SAMPLING WITH PRIORS

DATA

NINE SEGMENTS FROM THE 1978 MULTICROP DATA SET

RESULTS

**RECOMMEND INCORPORATION OF FINITE CORRECTION FACTOR INTO THE
SAMPLING ALLOCATION SUBCOMPONENT OF THE BASELINE CORN AND
SOYBEAN PROCEDURE**

EXPECTED EFFICIENCY GAIN OF -10 TO 20%

FY1981 U.S. PILOT - PHASE I - SHAKEDOWN TEST

DATA

SIX SEGMENTS FROM THE 1978 MULTICROP DATA SET

PRELIMINARY RESULTS

**STRICT ADHERENCE TO THE CORN/SOYBEAN BASELINE PROCEDURE
IS VERY TIME INEFFICIENT**

EVALUATION OF WEIGHTED AGGREGATION PROCEDURE (WAP)*

● BACKGROUND

WAP REPRESENTS AT LEAST TWO DISTINCT IMPROVEMENTS OVER LACIE TECHNOLOGY:

1. IN LACIE, STRATUM-LEVEL ACREAGE ESTIMATE WAS BASED EXCLUSIVELY ON CURRENT YEAR SEGMENT PROPORTION ESTIMATES, EVEN IF STRATUM CONTAINED ONLY ONE SEGMENT. WAP CONSIDERS ACREAGE ESTIMATE FOR EACH STRATUM TO BE A LINEAR COMBINATION OF DIRECT AND RATIO ESTIMATES. (IN BOTH CASES, RATIOING IS DONE BASED ON HISTORICAL DATA.)
 2. WHEN RATIOING WAS PERFORMED IN LACIE, RATIOS WERE BASED ON ARBITRARY COLLECTIONS OF STRATA.
- WAP FINDS OPTIMAL GROUPING FOR DETERMINING RATIOS.

SIMULATION STUDIES HAVE INDICATED:

- WAP HAS NO PROCEDURAL BIAS.
- WAP IS ROBUST AGAINST MISSING DATA.
- WAP PROVIDES GOOD ESTIMATES OF VARIANCE.

*SUBSEQUENT TO THE PDR, THIS TECHNOLOGY WAS RENAMED "GROUPED OPTIMAL AGGREGATION TECHNIQUE."

WAP vs SINGLE-YEAR AGGREGATION

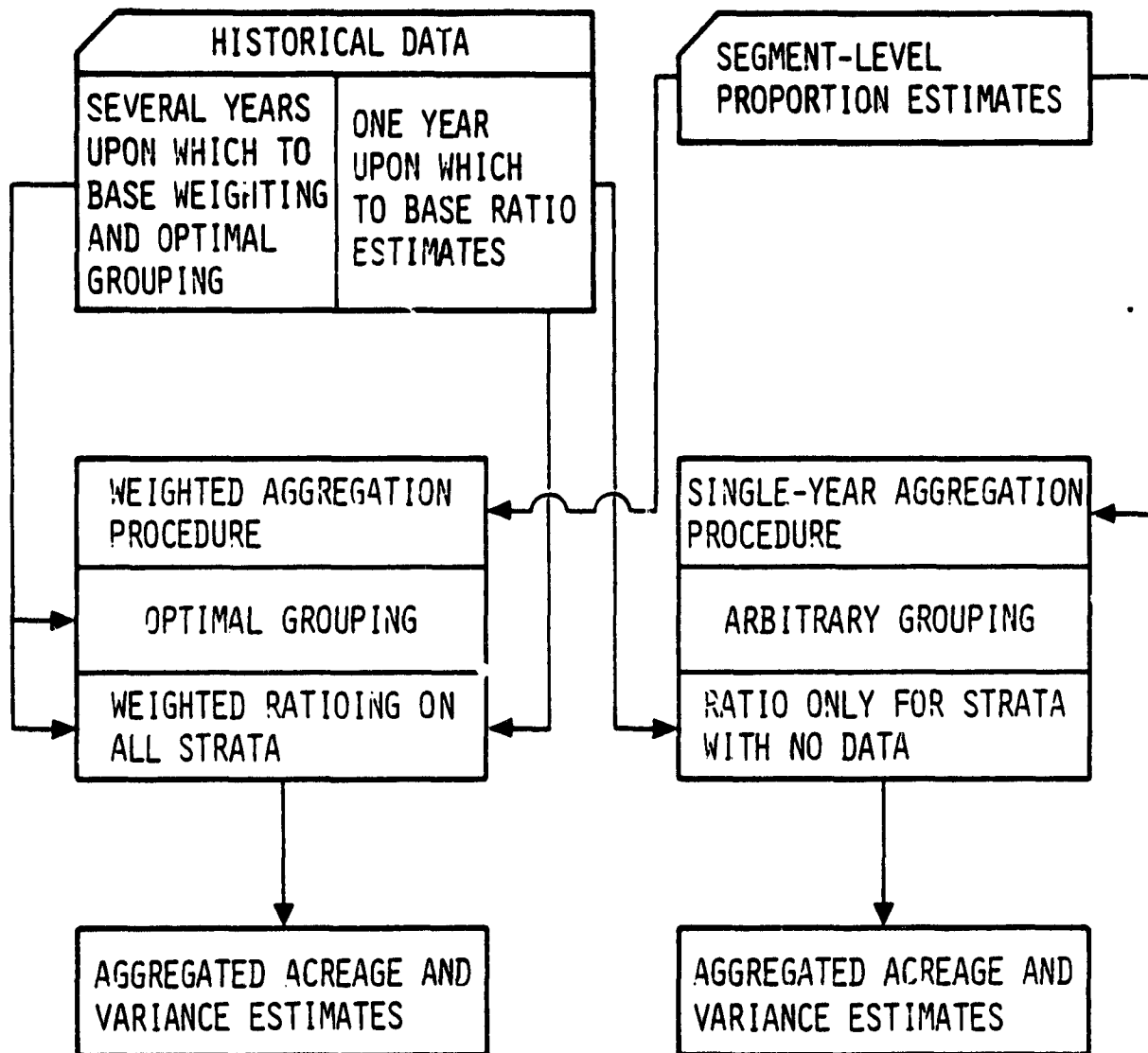

GENERAL OVERVIEW OF APPROACH

● CROP CALIBRATION COMPONENT

- EVALUATION OF CROP GROWTH STAGE MODELS FOR CORN AND SOYBEANS.

● AREA PROPORTION ESTIMATION COMPONENT

- EVALUATION OF PERFORMANCE IMPROVEMENT OF BASELINE CORN/SOYBEAN PROCEDURE OVER THE LACIE TY CORN/SOYBEAN PROCEDURE.
- EVALUATION OF ADAPTABILITY OF BASELINE CORN/SOYBEAN PROCEDURE TO DIFFERENT CROP YEARS.
- EVALUATION OF EFFECT OF FIELD SIZE ON LABELING ACCURACY FOR CORN/SOYBEAN BASELINE PROCEDURE.
- EVALUATION OF OVERALL PERFORMANCE OF THE BASELINE SEGMENT-LEVEL AREA PROPORTION ESTIMATION PROCEDURE.
- EVALUATION OF ANALYST FUNCTIONS
 - DETERMINATION OF SPECTRAL BIOWINDOWS FOR ALL ACQUISITIONS.
 - SELECTION OF ACQUISITIONS FOR SPECTRAL FEATURE EXTRACTION, AND DEFINITION OF CROP GROUP.
 - SELECTION OF CORN/SOYBEANS SEPARATION ACQUISITIONS, AND PLACEMENT OF LINEAR DISCRIMINANTS ON SCATTER PLOTS.
 - SELECTION OF ACQUISITIONS FOR SPATIAL/SPECTRAL CLUSTERING AND ASSIGNMENT OF "STAGE ONE" LABELS FOR SAMPLED TARGETS.
 - ASSIGNMENT OF "STAGE TWO" LABELS TO SAMPLED TARGETS.

GENERAL OVERVIEW OF APPROACH - (CONTINUED)

- EVALUATION OF MACHINE FUNCTIONS.
- MACHINE CONTRIBUTIONS TO BIAS OF AREA PROPORTION ESTIMATES.
- MACHINE CONTRIBUTIONS TO VARIANCE OF AREA PROPORTION ESTIMATES.
- MACHINE STRATIFICATIONS.
- EVALUATION OF THE EFFECT OF A REDUCED ACQUISITION HISTORY ON THE PERFORMANCE OF THE AREA ESTIMATION PROCEDURE.
- AREA AGGREGATION & PRODUCTION COMPONENT
- EVALUATION OF WEIGHTED AGGREGATION PROCEDURE (WAP).

RECOMMENDATIONS FOR DEVELOPMENT OF AREA ESTIMATION TECHNOLOGY FOR THE FY 198 U.S. CORN/SOYBEANS PILOT EXPERIMENT (PHASE TWO), AND THE FY1982 ARGENTINA CORN/SOYBEANS EXPLORATORY EXPERIMENT.

PURPOSES OF BASELINE CORN AND SOYBEANS PROPORTION ESTIMATION PROCEDURE

1. TO PROVIDE AT-HARVEST ESTIMATES OF CORN AND SOYBEAN ACREAGE IN THE U.S. CORN BELT BASED ON LANDSAT MSS DATA, PHENOLOGICAL CROP CALENDARS, AND ANCILLARY DATA (EXCLUDING GROUND-TRUTH).
2. TO CONSTITUTE A BASELINE FROM WHICH ACREAGE ESTIMATION TECHNOLOGY FOR CORN AND SOYBEANS IN ARGENTINA AND BRAZIL WILL BE DEVELOPED AND EVALUATED.

FUNCTIONAL FLOW OF THE BASELINE CORN AND SOYBEANS PROCEDURE

ORIGINAL PAGE IS
OF POOR QUALITY

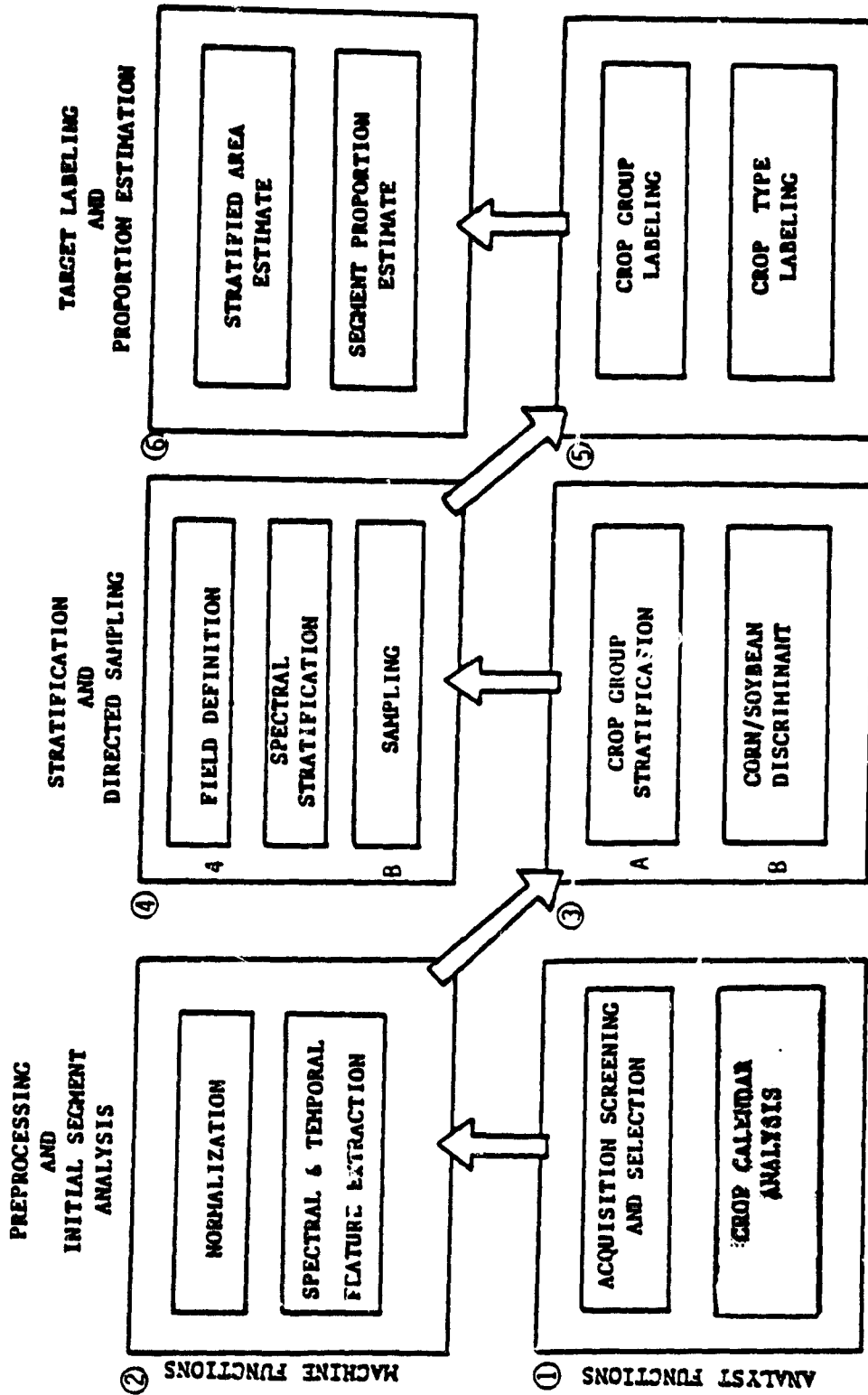

*DESCRIPTIONS OF FUNCTIONS ON FOLLOWING PAGES.

① INPUTS

- AVAILABLE ACQUISITIONS
- CROP CALENDAR (PHENOLOGICAL)
- ANCILLARY INFORMATION

TEAM

ANALYST FUNCTIONS

- SCREEN ACQUISITIONS
- CROP CALENDAR VERIFICATION
- ACQUISITION SELECTION FOR TPC EXTRACTION, POTENTIAL BLOB DELINEATION SET
- TPC EXPECTATIONS RECORDED

OUTPUTS

- TPC ACQUISITIONS
- POTENTIAL BLOB DELINEATION ACQUISITIONS

ORIGINAL PAGE IS
OF POOR QUALITY

TEMPORAL PATTERN DETERMINATION

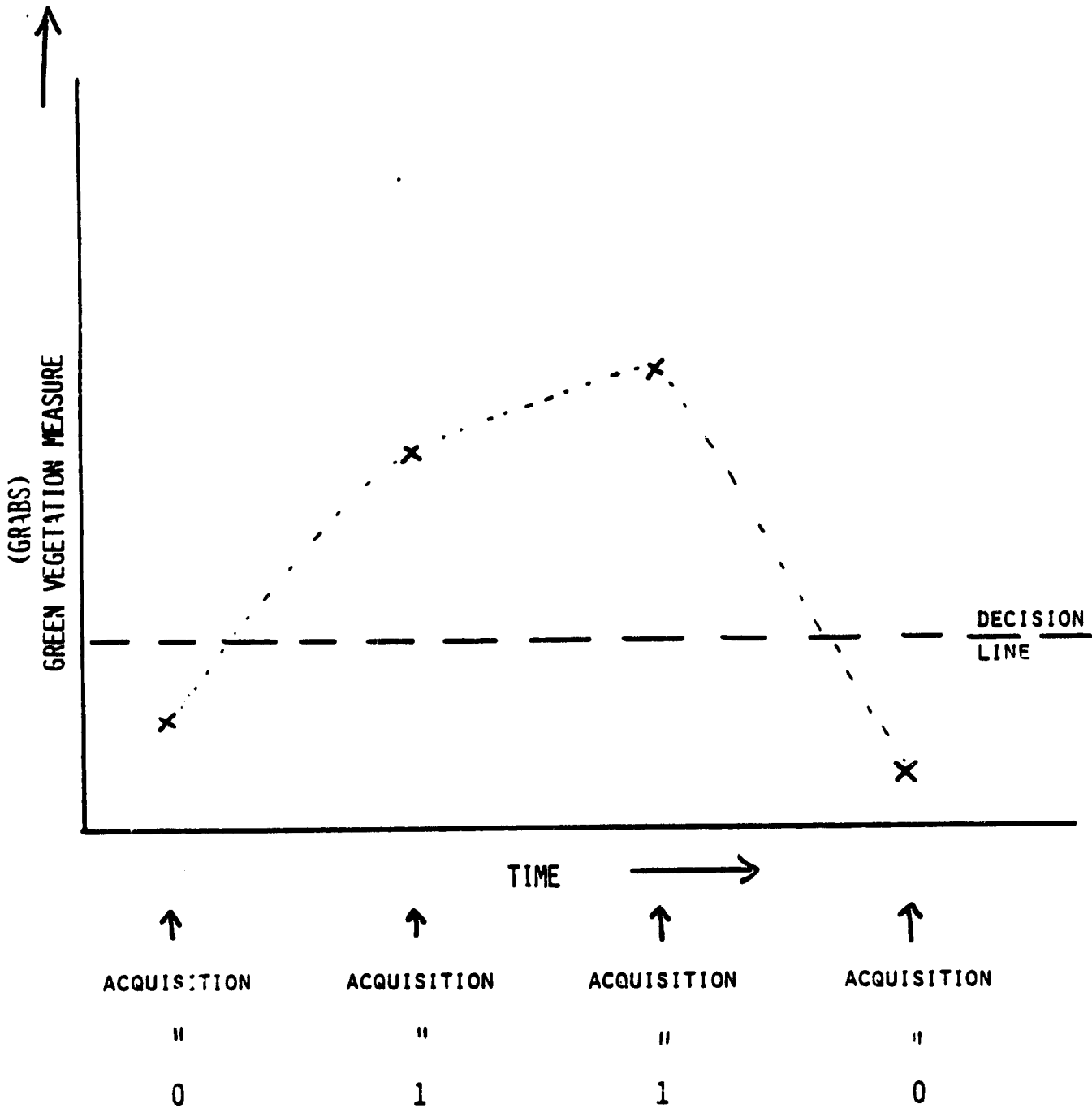

② INPUTS

- TPC ACQUISITION SET
- POTENTIAL BLOB ACQUISITION SET

MACHINE FUNCTIONS

- NORMALIZATION
- TPC EXTRACTION

OUTPUT

- TPC REPORT
WHICH TELLS HOW MANY PIXELS FALL INTO
EACH OF THE OCCURRING PATTERNS

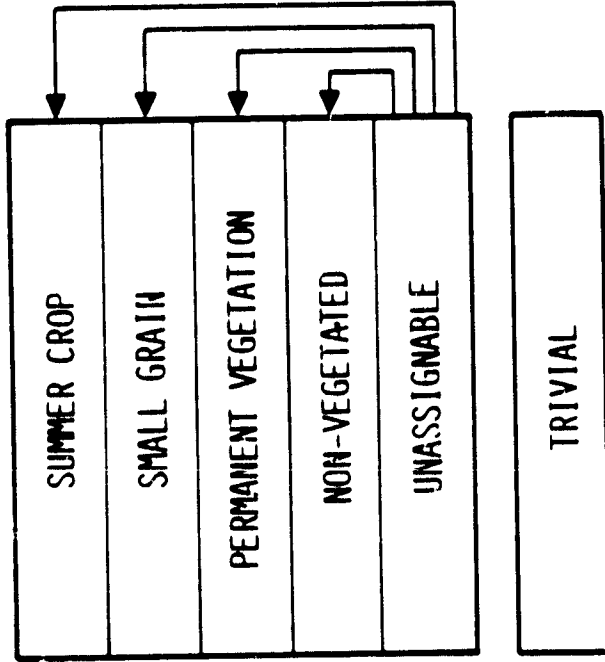

3A) INPUTS

- TPC REPORT

TEAM

ANALYST FUNCTION

- CROP GROUP STRATIFICATION (DFS)

- THIS STRATIFICATION IS DEFINED BY THE ASSIGNMENT OF ALL TPCS TO ONE OF SIX DEFINED STRATA.
- THIS IS A PIXEL LEVEL STRATIFICATION.

ORIGINAL PAGE IS
OF POOR QUALITY

TEMPORAL/SPECTRAL SEQUENCE

TEMPORAL PATTERN (TPC)

SPECTRAL GREEN DEVELOPMENT →

(X REPRESENTS AN ACQUISITION)
(-- REPRESENTS THE DECISION LINE)

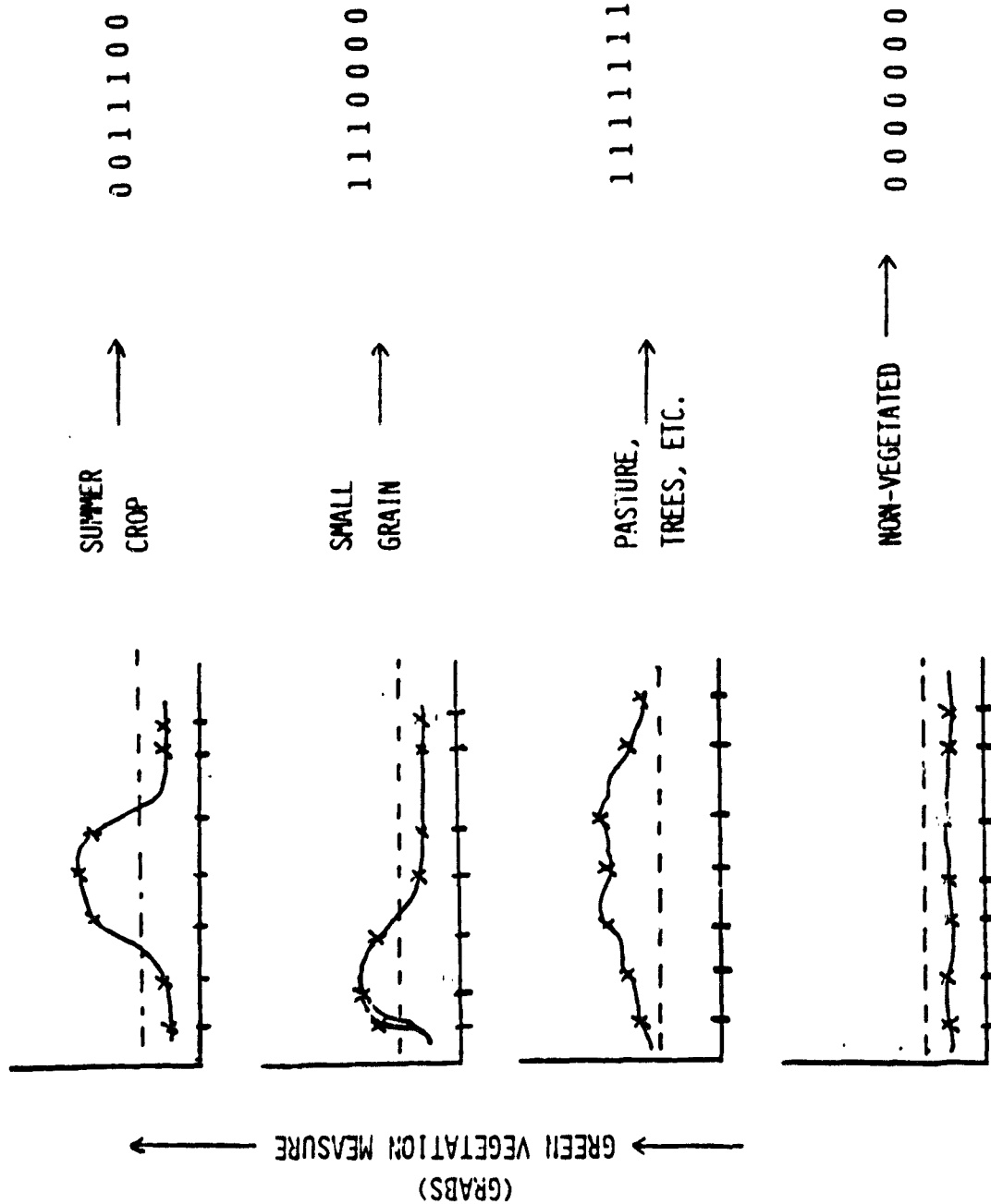

3B INPUTS

- SCATTER PLOT OF SUMMER CROP PIXELS.
- CANDIDATE BLOB ACQUISITIONS.

TEAM

ANALYST FUNCTIONS

- VERIFY SEPARATION ACQUISITIONS.
- PLACE DISCRIMINANT AND LIMITORS ON SCATTER PLOT(S).
- SELECT ACQUISITIONS FOR BLOB DELINEATION.

OUTPUTS

- ZONES DELINEATED ON SCATTER PLOTS.
- BLOB ACQUISITION SET.

ORIGINAL PAGE IS
OF POOR QUALITY

SCATTER PLOT OF SUMMER CROP PIXELS

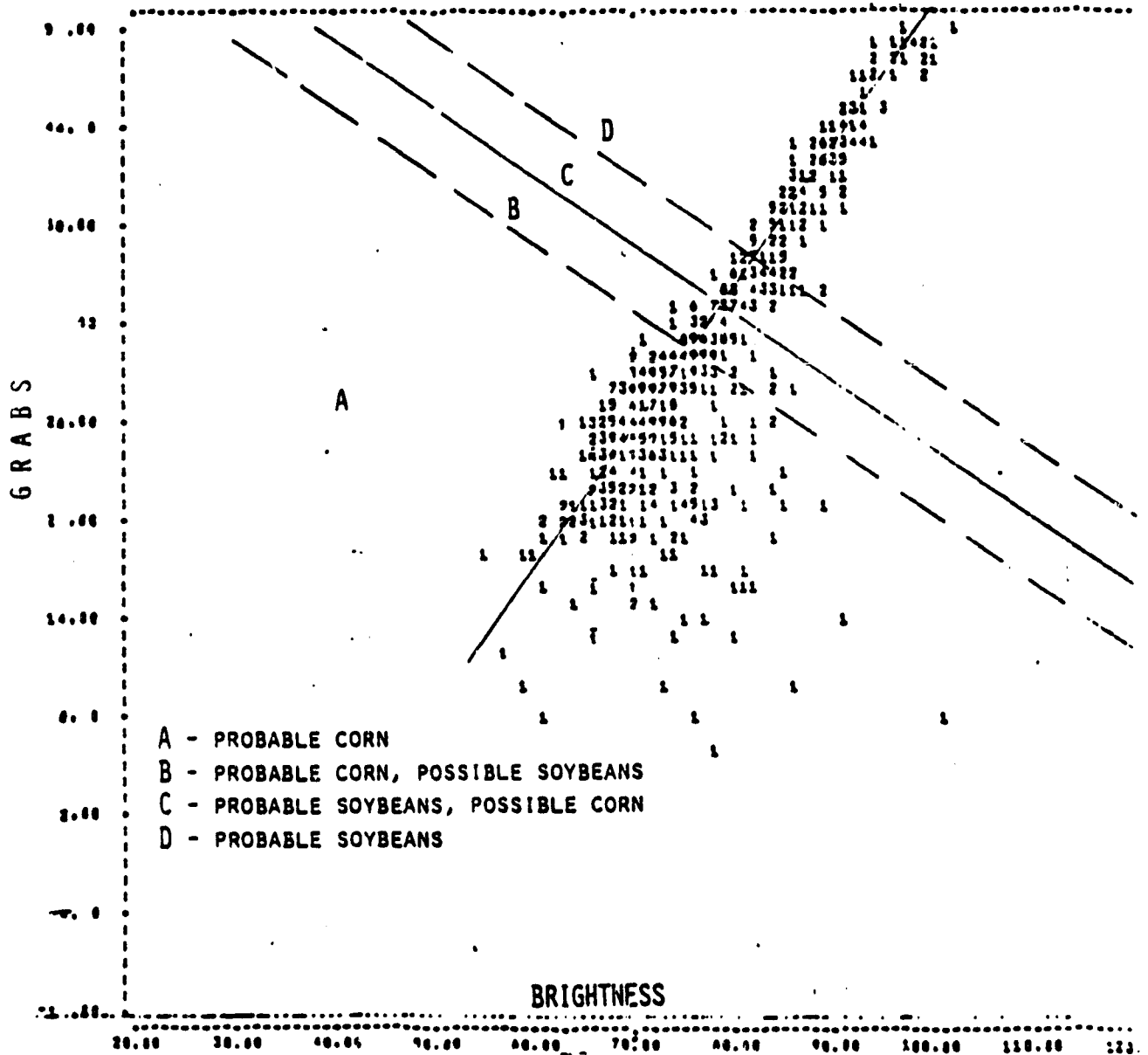

4A INPUTS

- BLOB ACQUISITION SET

MACHINE FUNCTIONS

- SPATIALLY AND SPECTRALLY DEFINE BLOBS
- ASSIGN BLOBS TO CROP GROUP STRATA BASED ON THEIR SPECTRAL MEANS' TPC
- REASSIGN BIG BLOBS WITH MEANS IN THE UNKNOWN STRATUM TO KNOWN STRATA BASED ON SPECTRAL SIMILARITY.

OUTPUT

- STRATIFICATION OF BIG AND LITTLE BLOBS

BIG BLOBS	LITTLE BLOBS
SUMMER CROP	
SMALL GRAINS	
PERMANENT VEGETATION	
NON-VEGETATED	
	UNKNOWN BIG AND LITTLE BLOBS

ORIGINAL PAGE IS
OF POOR QUALITY

- THIS STRATIFICATION IS DEFINED BY SPECTRAL AND SPATIAL CHARACTERISTICS OF THE SCENE.
- THIS IS A BLOB LEVEL STRATIFICATION WHERE BLOBS ARE STRATIFIED BY THE TPCS OF THEIR MEANS.

4B) INPUTS

- STRATIFIED BIG AND LITTLE BLOBS.
- ZONES DELINEATED ON SCATTER PLOTS.

MACHINE FUNCTIONS

- SPECTRALLY DEFINE B-CLUSTERS WITHIN BIG BLOB COMPARTMENTS OF KNOWN CROP GROUP STRATA.
- ALLOCATE THE NUMBER OF BLOBS TO BE SAMPLED FROM EACH B-CLUSTER IN PROPORTION TO THE SIZE OF THE B-CLUSTERS.
- SAMPLE B-CLUSTERS

OUTPUT

- SET OF SAMPLED BLOBS.

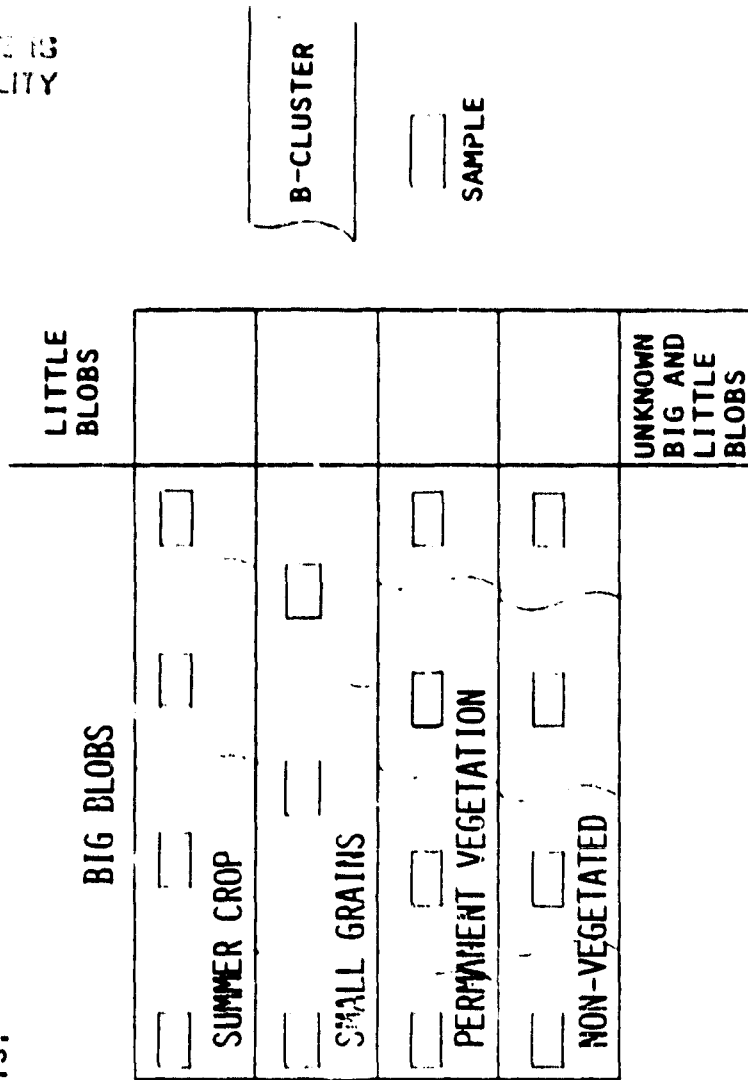

- THIS STRATIFICATION IS DEFINED BY SPECTRAL AND SPATIAL CHARACTERISTICS OF THE SCENE.
- THIS IS A BLOB LEVEL STRATIFICATION WHERE BLOBS ARE STRATIFIED BY THEIR MEANS.
- ONLY BIG BLOBS WITHIN KNOWN CROP GROUP STRATA ARE B-CLUSTERED AND SAMPLED.

⑤ INPUTS

- SAMPLED BLOBS AND ACCOMPANYING INFORMATION INCLUDING STAGE ONE LABELS.
- IMAGE PRODUCTS 1 & 3.
- DECISION LOGIC.
- REQUIRED OVERLAYS AND FORMS.

INDIVIDUAL

ANALYST FUNCTION

- STAGE ONE LABELS ARE RECORDED AND VERIFIED OR CHANGED TO STAGE TWO LABELS.
- ANALYST CONFIDENCE CODES ARE RECORDED.

LITTLE BLOBS

BIG BLOBS

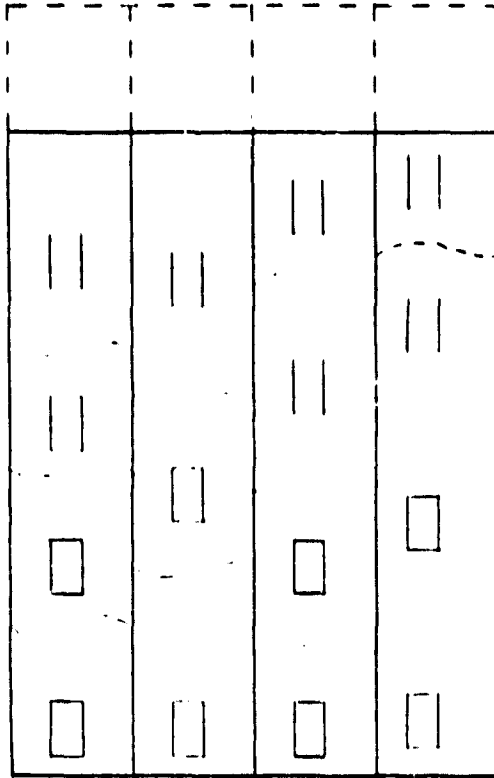

THIS PAGE IS
OF POOR QUALITY

- THIS STRATIFICATION IS DEFINED BY SPECTRAL AND SPATIAL CHARACTERISTICS OF THE SCENE.
- THIS IS A BLOB LEVEL STRATIFICATION WHERE BLOBS ARE STRATIFIED BY THEIR MEANS.
- ONLY BIG BLOBS WITHIN KNOWN CRJP GROUP STRATA ARE B-CLUSTERED AND SAMPLED.

⑥ INPUTS

- LABELED BLOBS AND CONFIDENCE CODES

MACHINE FUNCTION

- ESTIMATION

SAMPLED		UNSAMPLED
BIG BLOBS		LITTLE BLOBS
<input checked="" type="checkbox"/> SUMMER CROP	<input checked="" type="checkbox"/> <input checked="" type="checkbox"/> <input checked="" type="checkbox"/>	<input checked="" type="checkbox"/>
<input checked="" type="checkbox"/> SMALL GRAIN	<input checked="" type="checkbox"/> <input checked="" type="checkbox"/>	<input checked="" type="checkbox"/>
<input checked="" type="checkbox"/> PERMANENT VEGETATION	<input checked="" type="checkbox"/> <input checked="" type="checkbox"/> <input checked="" type="checkbox"/>	<input checked="" type="checkbox"/>
<input checked="" type="checkbox"/> NON-VEGETATION	<input checked="" type="checkbox"/> <input checked="" type="checkbox"/> <input checked="" type="checkbox"/>	<input checked="" type="checkbox"/>

↓ P

SEGMENT PROPORTION
ESTIMATION

BASELINE CORN/SOYBEANS ESTIMATION

P = PROPORTION

A = AREA (OR NO. PIXELS)

STRATA ACREAGES

$$P_1 A_1 = P_{11} A_{11} + P_{12} A_{12} + \dots + P_{16} A_{16}$$

$$P_2 A_2 = P_{21} A_{21} + P_{22} A_{22} + \dots + P_{24} A_{24}$$

$$P_3 A_3 = P_{31} A_{31} + P_{32} A_{32} + \dots + P_{35} A_{35}$$

$$P_4 A_4 = P_{41} A_{41} + P_{42} A_{42} + \dots + P_{45} A_{45}$$

SAMPLED

P_{11}	P_{12}	P_{13}	P_{14}	P_{15}	P_{16}	P_i	$P_i = P_1$
	P_{21}		P_{22}		P_{23}	P_{24}	$P_i = P_2$
	P_{31}		P_{32}		P_{33}	P_{34}	$P_i = P_3$
	P_{41}		P_{42}		P_{43}	P_{44}	$P_i = P_4$
					P_{45}	P_5	$P_i = \hat{P}$

UNSAMPLED

SEGMENT PROPORTION

$$P = \frac{P_1(A_1 + A_1') + P_2(A_2 + A_2') + P_3(A_3 + A_3') + P_4(A_4 + A_4')}{A_1 + A_1' + A_2 + A_2' + A_3 + A_3' + A_4 + A_4'}$$

ORIGINAL PAGE IS
OF POOR QUALITY

PARTIAL SUMMARY OF THE FUNCTIONAL FLOW OF THE BASELINE PROCEDURE

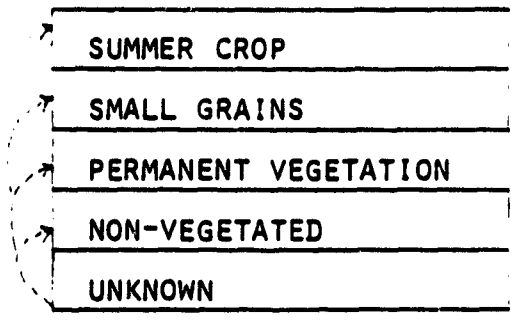

PIXEL LEVEL
TPC DEFINED

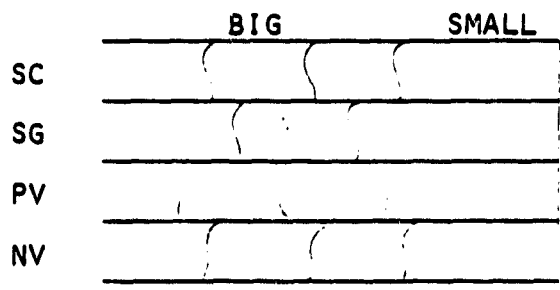

BLOB LEVEL
SPECTRALLY)
SPATIALLY) DEFINED

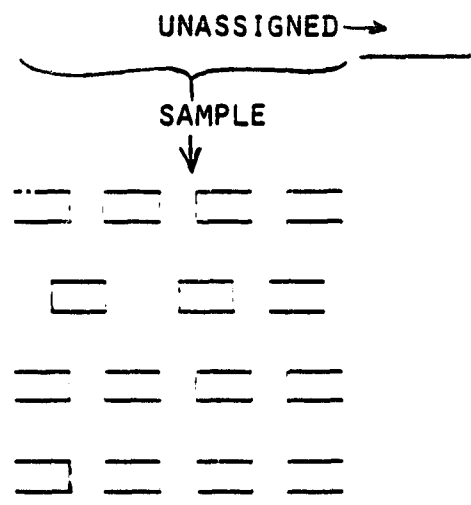

SAMPLES DRAWN
FROM B-CLUSTERS,
BIG BLOBS ONLY

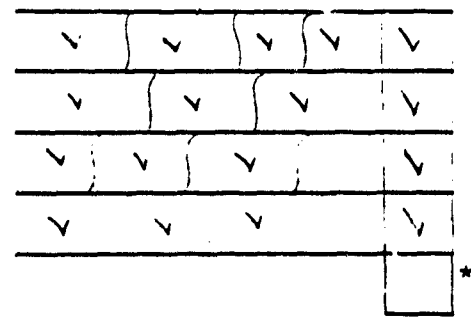

✓ → ESTIMATE
* → UNASSIGNED BLOBS NOT INCLUDED IN ESTIMATE

SUMMARY OF EVALUATIONS

1. EVALUATE THE OVERALL ACCURACY AND CONSISTENCY OF THE INTERMEDIATE AND TARGET LABELS.
2. EVALUATE THE OVERALL ACCURACY AND CONSISTENCY OF THE CSBP SEGMENT LEVEL AT-HARVEST AREA PROPORTION ESTIMATES IN THE U.S. CENTRAL CORN BELT.
3. COMPARE THE CSBP TO THE TY CORN/SOYBEAN PROCEDURE.
4. COMPARE THE ACCURACY OF TARGET LABELS AND OF SEGMENT LEVEL PROPORTION ESTIMATES FOR 1978 AND 1979 CROP YEAR DATA.
5. IDENTIFY AND EVALUATE FACTORS AFFECTING THE ACCURACY AND CONSISTENCY OF THE TARGET LABELS AND OF THE SEGMENT LEVEL AREA PROPORTION ESTIMATES. SPECIFICALLY:
 - A. DATA CHARACTERISTICS
 - SEGMENT CHARACTERISTICS: CROP PROPORTIONS (CROP GROUP, CROP TYPE) CROP RATIOS FIELD SIZES
 - ACQUISITION HISTORIES
 - B. CHARACTERISTICS OF THE CORN/SOYBEANS BASELINE SEGMENT AREA PROPORTION ESTIMATION PROCEDURE AND ITS SUBCOMPONENTS:
 - (1) THE LABELING TARGETS
 - SIZES OF CANDIDATES FOR SAMPLING
 - PURITIES OF CANDIDATES FOR SAMPLING
 - NUMBER OF CANDIDATES FOR SAMPLING
 - PERCENTAGE OF SEGMENT AREA COVERED BY CANDIDATE FOR SAMPLING

SUMMARY OF EVALUATIONS - (CONTINUED)
B(1) -

- NUMBER OF CANDIDATES FOR SAMPLING
- PERCENTAGE OF SEGMENT AREA COVERED BY CANDIDATES FOR SAMPLING

(2) - ANALYST FUNCTIONS:

- TEAM FUNCTIONS
 - DEFINITION OF BIOWINDOWS
 - SELECTION OF ACQUISITIONS
 - SEPARATION OF CORN/SOYBEANS
- INDIVIDUAL FUNCTIONS
 - LABELING OF SAMPLED TARGETS

(3) - MACHINE FUNCTIONS:

- HOMOGENEITY OF STRATIFICATIONS
- BIAS ATTRIBUTABLE TO THE STRATIFIED SAMPLING SCHEME AND THE WEIGHTING OF THE STRATUM-LEVEL PROPORTION ESTIMATES
- VARIANCE ATTRIBUTABLE TO THE STRATIFIED SAMPLING SCHEME

QUESTIONS ADDRESSED BY THE EVALUATIONS

1. DOES THE PROCEDURE MAKE IT POSSIBLE TO SEPARATE FROM OTHER CROPS AND FROM EACH OTHER, AND TO IDENTIFY, THE PRINCIPAL CROPS OF INTEREST IN THE U.S. CORN BELT: CORN AND SOYBEANS?
2. DOES THE PROCEDURE PRODUCE ACCURATE AND RELIABLE AREA-PROPORTION ESTIMATES FOR CORN AND SOYBEANS IN THE U.S. CORN BELT?
3. HOW DOES THE PERFORMANCE OF THE CSBP COMPARE WITH THE PRECEDING TY CORN/SOYBEAN PROCEDURE USED IN THE FY 1980 U.S. EXPLORATORY EXPERIMENT IN TERMS OF:
 - SEGMENT LEVEL AREA PROPORTION ESTIMATES?
 - TARGET LABELING ACCURACY?
 - OBJECTIVITY?
4. DOES THE PROCEDURE PERFORM ACCEPTABLY IN A CROP YEAR INDEPENDENT OF THE PROCEDURE DEVELOPMENT?
5. WHAT ARE THE EFFECT ON THE PERFORMANCE OF THE PROCEDURE (BIAS, VARIANCE OR MEAN-SQUARE-ERROR) DUE TO:
 - A. DATA CHARACTERISTICS
 - WITHIN SEGMENTS - ACQUISITION HISTORY?
 - BETWEEN SEGMENTS - FIELD SIZE?
 - CROP PROPORTION?
 - SUMMER CROP RATIOS?

QUESTIONS ADDRESSED BY THE EVALUATIONS - (CONTINUED)

B. (1)- THE USE OF "QUASI-FIELD" (BLOBS) RATHER THAN INDIVIDUAL PIXELS OR "DOTS" AS PRIMARY SAMPLING AND LABELING TARGETS (IN PARTICULAR, "LARGE" BLOBS, I.E., THOSE WITH "INTERIOR" PIXELS)?

- DO BLOBS TEND TO CORRESPOND TO ACTUAL FIELDS ON THE GROUND IN TERMS OF NUMBER/SEGMENT, SITE AND HOMOGENEITY OF CROPS?

- DO SMALL BLOBS TEND TO BE "MIXED"?

- DO LARGE BLOBS TEND TO BE "PURE" ENOUGH TO JUSTIFY LABELING ENTIRE BLOBS ON AN "ALL OR NONE, OR 50-50" BASIS, RATHER THAN ESTIMATING ACTUAL PROPORTIONS?

- DO THE CROPS OF INTEREST APPEAR IN DIFFERENT RELATIVE PROPORTIONS IN BLOBS OF DIFFERENT SIZES?

- DOES THE METHOD OF SELECTING SAMPLE BLOBS FOR LABELING INTRODUCE A BIAS IN FAVOR OF ONE CROP?

- ARE PURE PIXELS MORE LIKELY TO BE LABELED ACCURATELY ACCORDING TO THE LABELS OF THE BLOB WHICH CONTAIN THEM, THAN THEY ARE ACCORDING TO THE AI LABELS FOR INDIVIDUAL DOTS?

(2)- PERFORMANCE OF ANALYST(S)?

- BLOB LABELING: WHAT ACCURACY AND CONSISTENCY ARE ACHIEVED? WHAT ARE THE FACTORS THAT CONTRIBUTE TO ERROR?

- HOW WELL CAN THE ANALYSTS RECOGNIZE AND LABEL "MIXED" BLOBS?

- CAN LABELING BE COMPLETED IN A REASONABLE AMOUNT OF TIME?

QUESTIONS ADDRESSED BY THE EVALUATIONS - (CONTINUED)

- B. (3) - THE USE OF VARIOUS LEVELS OF STRATIFICATION?
 - CROP-GROUP STRATA (DFS): DO THE "TEMPORAL PATTERN CLASSES" (TPC'S) TEND TO SEPARATE AND IDENTIFY CORRECTLY THE CROP-GROUPS ACTUALLY PRESENT AT THE PIXEL LEVEL? AT THE BLOB LEVEL?
 - BLOBS: WHAT FACTORS AFFECT BLOB SITES AND PURITIES?
 - SEPARATION BETWEEN "BIG BLOBS" AND "LITTLE BLOBS" WITHIN CROP-GROUP STRATA: WHAT DIFFERENCES APPEAR BETWEEN CROP-TYPE PROPORTIONS CONTAINED IN "BIG BLOBS" AND "LITTLE BLOBS"?
 - SPECTRAL CLUSTERING OF "BIG BLOBS" ONLY WITHIN CROP-GROUP STRATA: HOW PURE ARE THESE CLUSTERS REGARDING CROP-TYPES?
- PROPORTION ESTIMATION PROCEDURE FOR THE SAMPLED PORTIONS OF THE SEGMENT.
 - WHAT IS THE RESULTANT SEGMENT BIAS DUE TO:
 - USING DISCRETE PROPORTION ESTIMATES FOR SAMPLED BLOBS?
 - NOT SAMPLING "SMALL" BLOBS?
 - WEIGHTING DFS-LEVEL ESTIMATES BY TOTAL NUMBER OF PIXELS IN "BIG" BLOBS ONLY VS ALL BLOBS IN DFS?
- WHAT IS THE VARIANCE DUE TO SAMPLING?

SELECTED CHARACTERISTICS OF SEGMENTS OR BLOBS
(CANDIDATES FOR INDEPENDENT VARIABLES)

- CHARACTERISTICS OF SEGMENTS
 - CROP PROPORTIONS: TRUE PROPORTIONS OF CROP GROUPS OR CROP TYPES.
 - CROP TYPES: CORN, SOYBEANS, CORN + SOYBEANS.
 - CROP GROUPS:
 - "SEASONAL": SUMMER CROPS, WINTER SMALL GRAINS, SPRING SMALL GRAINS.
 - "DFS": SUMMER CROPS (SC), SMALL GRAINS (SG), PERMANENT VEG. (P-V), NON-VEG. (N-V).
 - CROP RATIO: RATIO OF TRUE PROPORTIONS OF CORN TO SOYBEANS
 - FIELD SIZE (GROUND TRUTH).
 - ACQUISITION HISTORY.
- CHARACTERISTICS OF BLOBS
 - TOTAL NUMBER OF "BIG" BLOBS.
 - % OF SEGMENT'S PIXELS CONTAINED IN "BIG" BLOBS.
 - % OF SEGMENT'S PIXELS CONTAINED IN INTERIORS OF "BIG" BLOBS.
 - AVERAGE NUMBER OF INTERIOR PIXELS PER "BIG" BLOB.
 - WEIGHTED AVERAGE OF "BIG" BLOB PURITIES FOR ...
 - ... MOST PREVALENT CROP TYPE: C, S, OR O.
 - ... MOST PREVALENT DFS CROP GROUP: SC, SG, P-V, N-V.

ORIGINAL PAGE IS
OF POOR QUALITY

CRITERIA FOR GROUND-TRUTH
CROP-GROUP LABELS FOR "BIG" BLOBS

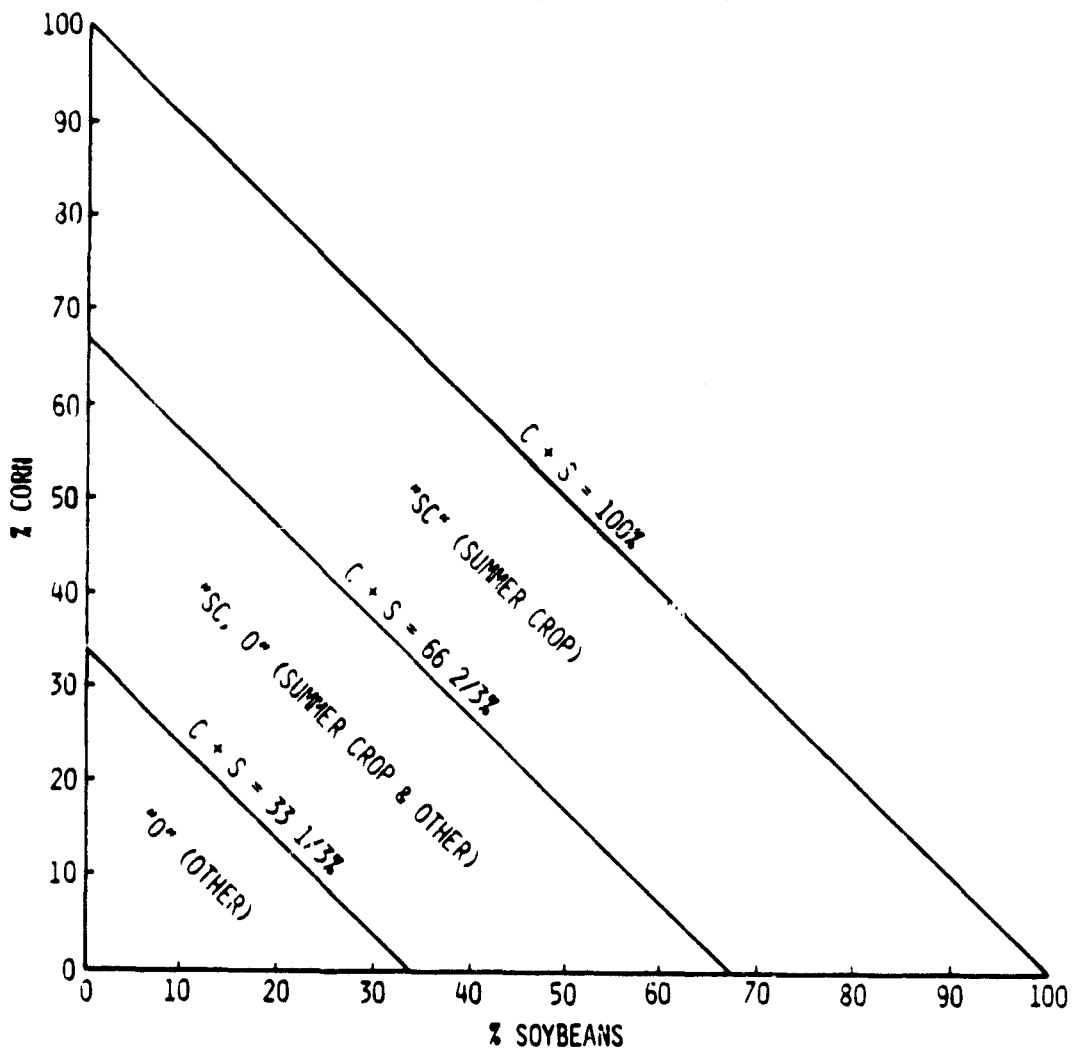

RANGES OF %'S OF PIXELS CORRESPONDING TO "CORRECT" BLOB LABELS:

<u>"SC"</u>	<u>"0"</u>	<u>"SC, 0"</u>
$66 \frac{2}{3} < (C+S)$	$66 \frac{2}{3} < "0"$	$33 \frac{1}{3} \leq (C+S) \leq 66 \frac{2}{3}$
$"0" < 33 \frac{1}{3}$	$(C+S) < 33 \frac{1}{3}$	$33 \frac{1}{3} \leq "0" \leq 66 \frac{2}{3}$

CRITERIA FOR ASSIGNING GROUND-TRUTH CROP-TYPE LABELS
TO "BIG" BLOBS ACCORDING TO PERCENTAGES OF INTERIOR PIXELS

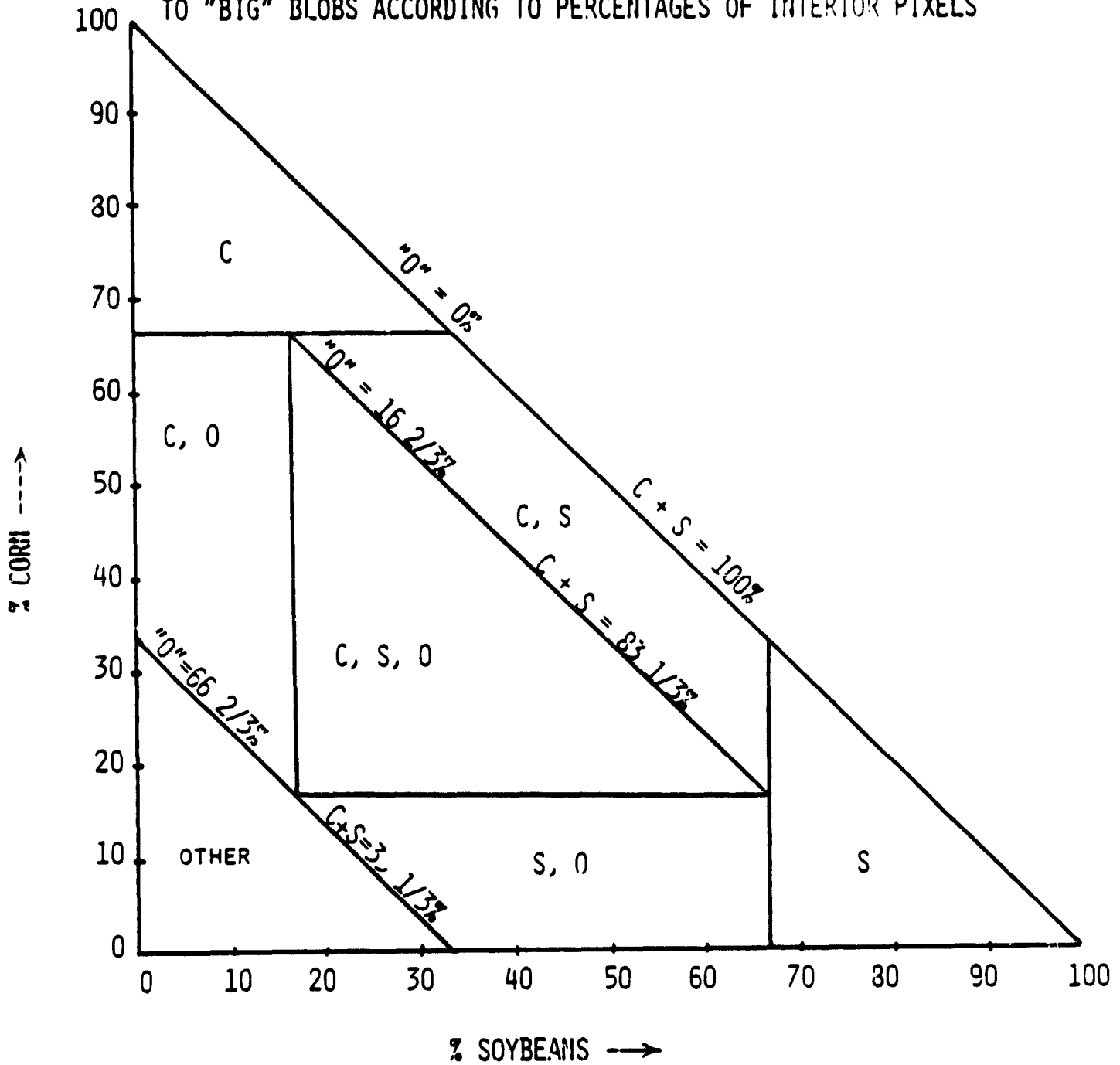

CRITERIA FOR ASSIGNING GROUND-TRUTH CROP-TYPE LABELS
TO "BIG" BLOBS ACCORDING TO PERCENTAGES OF INTERIOR PIXELS

<u>"C"</u>	<u>"S"</u>	<u>"0"</u>
66 2/3 < C	66 2/3 < S	66 2/3 < "0"
S < 33 1/3	C < 33 1/3	C < 33 1/3
"0" < 33 1/3	"0" < 33 1/3	S < 33 1/3
<u>"C, S"</u>	<u>"C, 0"</u>	<u>S, 0"</u>
16 2/3 < C ≤ 66 2/3	16 2/3 ≤ C ≤ 66 2/3	16 2/3 ≤ S ≤ 66 2/3
16 2/3 < S ≤ 66 2/3	16 2/3 ≤ "0" ≤ 66 2/3	16 2/3 ≤ "0" ≤ 66 2/3
"0" ≤ 16 2/3	S ≤ 16 2/3	C ≤ 16 2/3
<u>"C, S, 0"</u>		
16 2/3 < C < 66 2/3		
16 2/3 < S < 66 2/3		
16 2/3 < "0" < 66 2/3		

ORIGINAL PAGE IS
OF POOR QUALITY

ORIGINAL PAGE IS
OF POOR QUALITY

GROUND TRUTH CROP TYPE PROPORTIONS OF SAMPLED BLOBS FROM SEVERAL SEGMENTS
ERIM RESULTS - OCTOBER 7, 1980

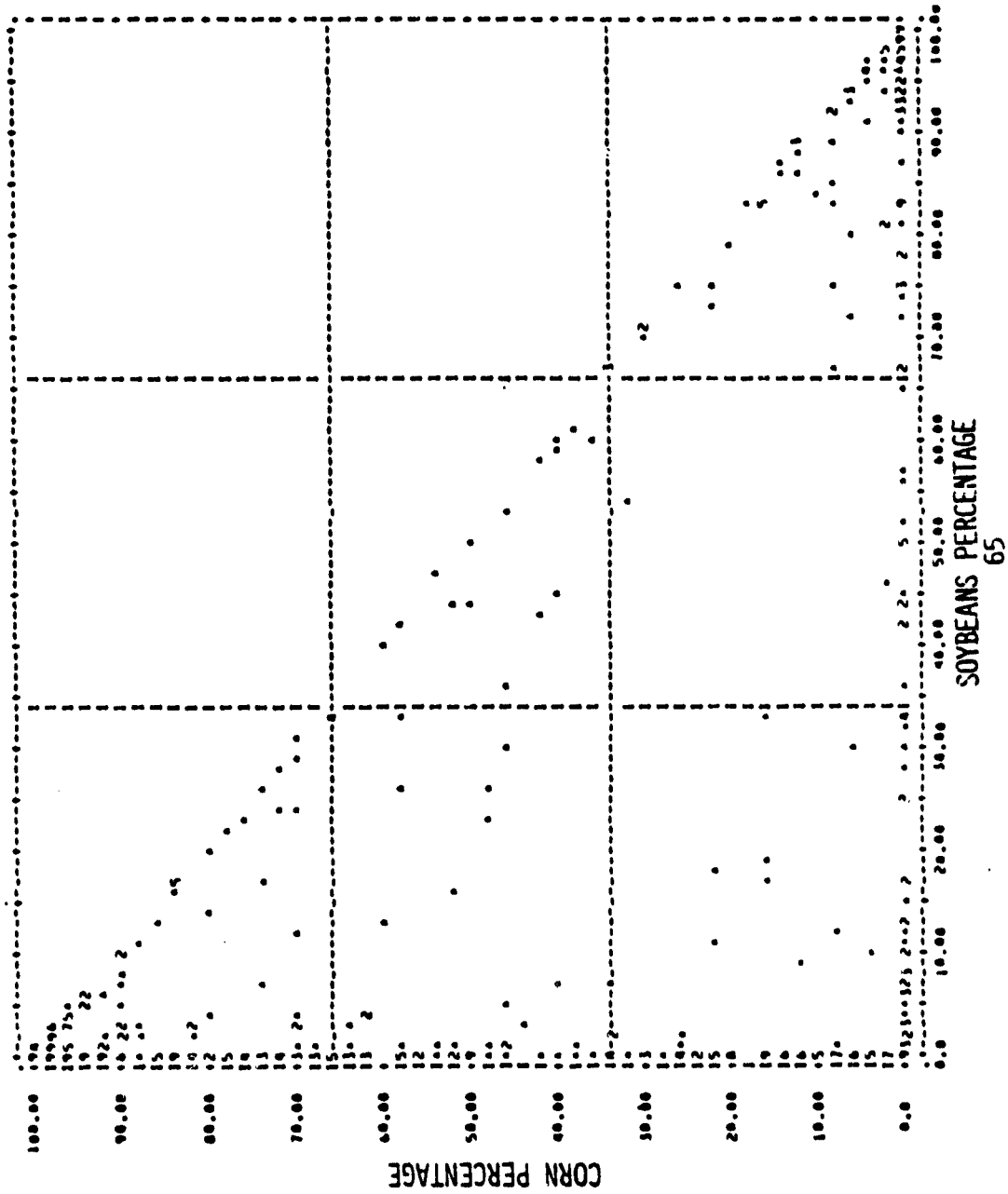

SUMMARY OF THE ERIM STUDY RESULTS

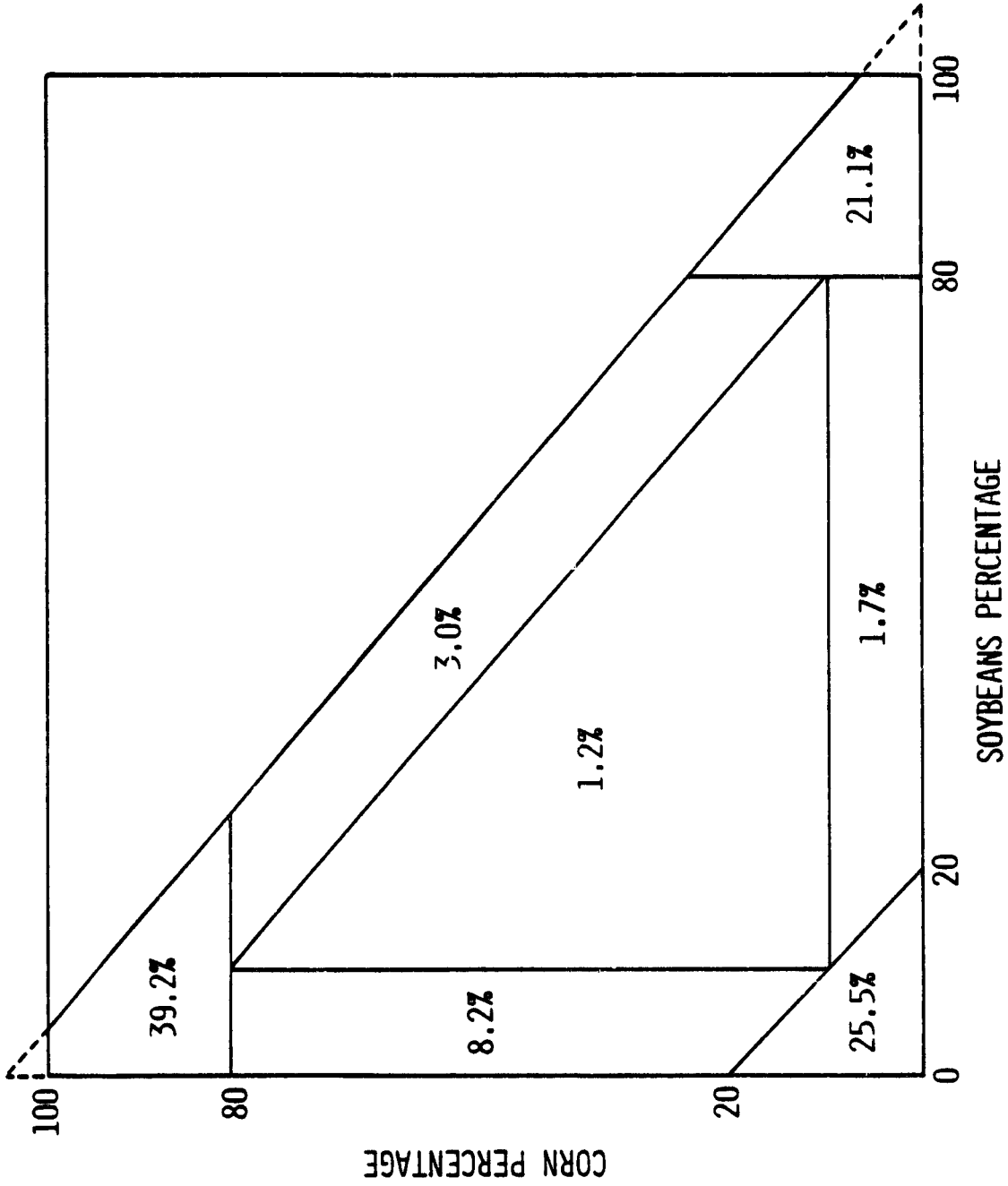

ORIGINAL PAGE IS
OF POOR QUALITY.

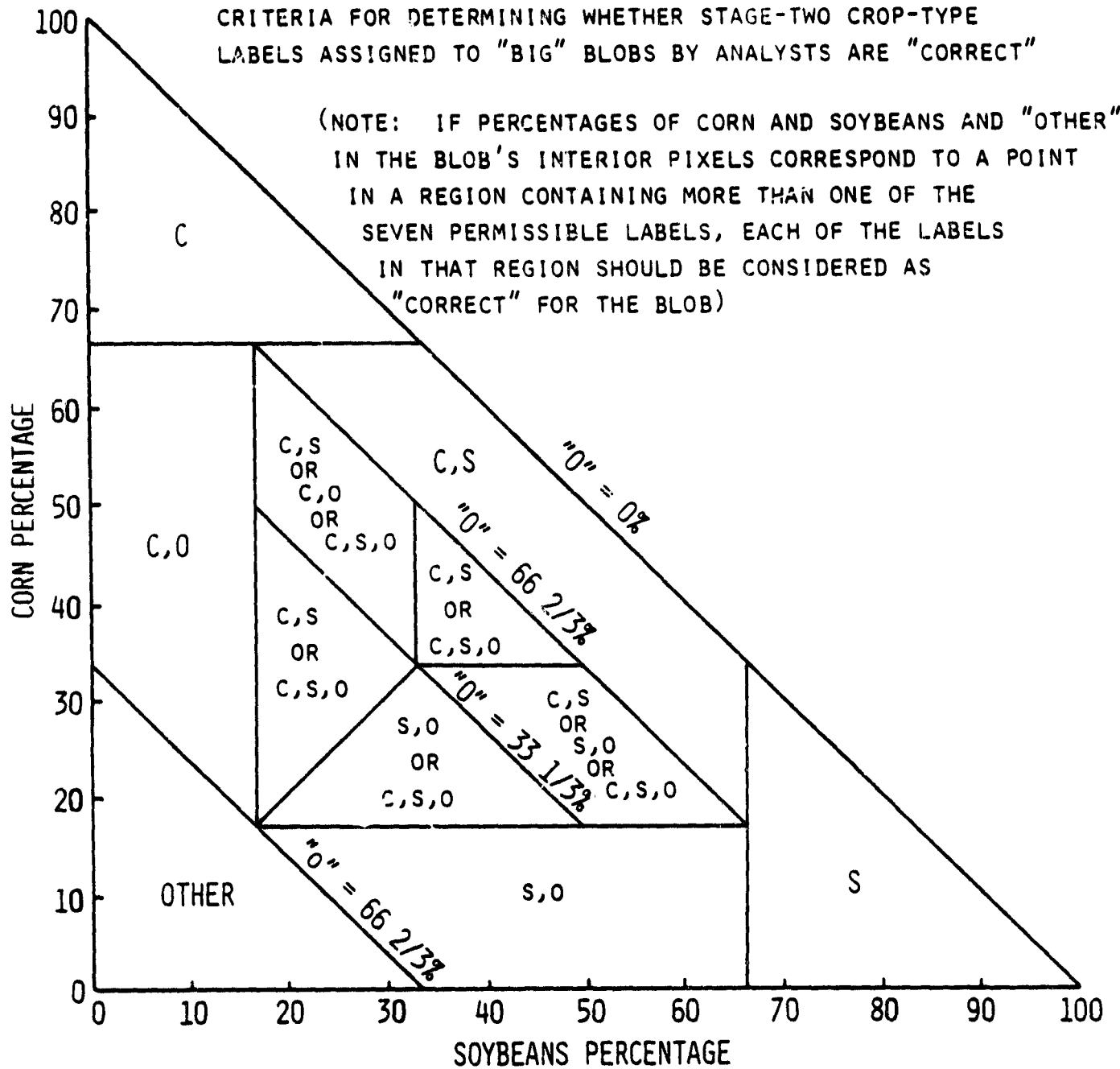

ORIGINAL PAGE IS
OF POOR QUALITY

CRITERIA FOR DETERMINING WHETHER STAGE-TWO CROP-TYPE
LABELS ASSIGNED TO "BIG" BLOBS BY ANALYSTS ARE "CORRECT"

(NOTE: WHERE MORE THAN ONE OF THE SEVEN PERMISSIBLE
LABELS ARE SHOWN BELOW, EACH OF THE LABELS SHOWN
SHOULD BE CONSIDERED "CORRECT" FOR A BLOB WHOSE INTERIOR
PIXELS CONTAIN CORN, SOYBEANS, AND "OTHER" IN THE PERCENTAGES
SHOWN)

<hr/> "C" <hr/> $66 \frac{2}{3} < C$ $S < 33 \frac{1}{3}$ $"O" < 33 \frac{1}{3}$	<hr/> "S" <hr/> $66 \frac{2}{3} < S$ $C < 33 \frac{1}{3}$ $"O" < 33 \frac{1}{3}$	<hr/> "O" <hr/> $66 \frac{2}{3} < "O"$ $C < 33 \frac{1}{3}$ $"O" < 33 \frac{1}{3}$
<hr/> "C,S" <hr/> $16 \frac{2}{3} < C \leq 66 \frac{2}{3}$ $16 \frac{2}{3} < S \leq 66 \frac{2}{3}$ $"O" \leq 16 \frac{2}{3}$	<hr/> "C,O" <hr/> $16 \frac{2}{3} \leq C \leq 66 \frac{2}{3}$ $16 \frac{2}{3} \leq "O" \leq 66 \frac{2}{3}$ $S \leq 16 \frac{2}{3}$	<hr/> "S,O" <hr/> $16 \frac{2}{3} < S \leq 66 \frac{2}{3}$ $16 \frac{2}{3} < "O" \leq 66 \frac{2}{3}$ $C \leq 16 \frac{2}{3}$
"C,S" OR "C,S,O"	"C,O" OR "C,S,O"	"S,O" OR "C,S,O"
<hr/> $33 \frac{1}{3} \leq C < 50$ $33 \frac{1}{3} \leq S < 50$ $16 \frac{2}{3} < "O" \leq 33 \frac{1}{3}$	<hr/> $33 \frac{1}{3} < "O" \leq 66 \frac{2}{3}$ $16 \frac{2}{3} < C < 50$ $16 \frac{2}{3} < S < 33 \frac{1}{3}$ $S \leq C$	<hr/> $33 \frac{1}{3} < "O" \leq 66 \frac{2}{3}$ $16 \frac{2}{3} < S < 50$ $16 \frac{2}{3} < C < 33 \frac{1}{3}$ $C < S$
<hr/> "C,S" OR "C,O" OR "C,S,O"	<hr/> "C,S," OR "S,O" OR "C,S,O"	
<hr/> $33 \frac{1}{3} < C \leq 66 \frac{2}{3}$ $16 \frac{2}{3} < S \leq 33 \frac{1}{3}$ $16 \frac{2}{3} < "O" \leq 33 \frac{1}{3}$	<hr/> $33 \frac{1}{3} < S \leq 66 \frac{2}{3}$ $16 \frac{2}{3} < C \leq 33 \frac{1}{3}$ $16 \frac{2}{3} < "O" \leq 33 \frac{1}{3}$	

TESTS AND EVALUATIONS OF THE BASELINE
SEGMENT-LEVEL AREA PROPORTION ESTIMATION
PROCEDURE AND ITS SUBCOMPONENTS

OVERALL PERFORMANCE OF THE BASELINE
SEGMENT-LEVEL AREA PROPORTION ESTIMATION PROCEDURE

ANALYST FUNCTIONS

- DETERMINATION OF SPECTRAL BOWWINDOWS INTO WHICH EACH ACQUISITION FALLS.
- SELECTION OF TPC ACQUISITIONS AND ASSIGNMENT OF TPC'S TO DFS STRATA.
- FINAL SELECTION OF CORN/SOYBEANS SEPARATION ACQUISITIONS, AND PLACEMENT OF LINEAR DISCRIMINANTS ON SCATTER PLOTS.
- FINAL SELECTION OF ACQUISITIONS FOR BLOBBING, AND ASSIGNMENT OF "STAGE ONE" LABELS FOR SAMPLED "BIG" BLOBS.
- ASSIGNMENT OF "STAGE TWO" LABELS TO SAMPLED "BIG" BLOBS.

55

MACHINE FUNCTIONS

- MACHINE CONTRIBUTIONS TO BIAS OF AREA PROPORTION ESTIMATES.
- MACHINE CONTRIBUTIONS TO VARIANCE OF AREA PROPORTION ESTIMATES.
- MACHINE STRATIFICATIONS: BLOBS, CLUSTERS.

ACQUISITION HISTORY STUDY

OVERALL PERFORMANCE OF THE BASELINE SEGMENT-LEVEL AREA PROPORTION ESTIMATION PROCEDURE

● OBJECTIVES

- EVALUATE OVERALL ACCURACY AND CONSISTENCY OF SEGMENT-LEVEL AREA PROPORTION ESTIMATES PRODUCED BY THE BASELINE PROCEDURE.
- EVALUATE OVERALL ACCURACY AND CONSISTENCY OF SEGMENT-LEVEL AREA PROPORTION ESTIMATES PRODUCED BY THE BASELINE PROCEDURE ON THE BASIS OF STAGE ONE LABELS, AND ON THE BASIS OF GROUND-TRUTH LABELS, FOR TARGETS.

● APPROACH

- ON THE BASIS OF EACH OF THE FOLLOWING SOURCES FOR TARGET LABELS, CALCULATE MEAN ERROR, MEAN ABSOLUTE ERROR, STANDARD DEVIATION, AND MEAN SQUARE ERROR OF AREA PROPORTION ESTIMATES FOR CORN, SOYBEANS, AND OTHER, FOR ALL SEGMENT PROCESSINGS.
 - STAGE TWO LABELS (BY ANALYST)
 - STAGE ONE LABELS (GENERATED BY MACHINE)
 - GROUND TRUTH LABELS
- ARRANGE PROCESSINGS IN INCREASING ORDER OF PROPORTION ESTIMATION ERROR FOR EACH OF C, S, O, AND DETERMINE FOR EACH PROCESSING THE "CORRECT" SPECTRAL BIOWINDOW DECISIONS FOR THE ACQUISITIONS THAT WERE AVAILABLE.

OVERALL PERFORMANCE OF THE BASELINE SEGMENT-LEVEL AREA PROPORTION ESTIMATION PROCEDURE
(CONTINUED)

● EVALUATIONS

- TABULATE AVERAGE ERRORS; AVERAGE ABSOLUTE ERRORS, STANDARD DEVIATIONS, AND MEAN SQUARE ERRORS OF ESTIMATES FOR C, S, O.
- FOR EACH SOURCE OF LABELS, AND FOR EACH OF C, S, O, PLOT ESTIMATION ERROR VS. TRUE PROPORTION FOR ALL PROCESSINGS.
- FOR EACH OF C, S, O, TABULATE THE PROPORTION ESTIMATION ERRORS AND "CORRECT" BLOWINDOW DECISIONS FOR ALL PROCESSINGS.

EVALUATION OF PERFORMANCE IMPROVEMENT OF BASELINE CORN/SOYBEAN PROPORTION ESTIMATION PROCEDURE

OVER LACIE TY PROPORTION ESTIMATION PROCEDURE

● OBJECTIVES

- COMPARE PERFORMANCE OF THE BASELINE PROCEDURE WITH THAT OF LACIE TY PROCEDURE.
(DOES BASELINE PROCEDURE REPRESENT AN IMPROVEMENT?)
- DETERMINE WHETHER LABELING ACCURACY IS INDEPENDENT OF ANALYST TEAMS IN THE BASELINE PROCEDURE. (HOW OBJECTIVE IS BASELINE PROCEDURE?)

● APPROACH

- REPLICATE THE BALANCED INCOMPLETE BLOCK DESIGN USED IN EVALUATION OF LACIE TY PROCEDURE, USING BASELINE PROCEDURE.
- PROCESS TWICE USING BASELINE PROCEDURE EACH OF 18 SEGMENTS FROM THE 1978 CORN/SOYBEANS EXPLORATORY EXPERIMENT.

EVALUATION OF PERFORMANCE IMPROVEMENT OF BASELINE CORN/SOYBEAN PROPORTION ESTIMATION PROCEDURE
 OVER LACIE TY PROPORTION ESTIMATION PROCEDURE

● EVALUATION

- CANDIDATE DEPENDENT VARIABLES INCLUDE:

- A. $\hat{P} - P$,
- B. $(\hat{P} - P)^2$,
- C. $|\hat{P} - P|$, WHERE \hat{P} IS GROUND-TRUTH SEGMENT-LEVEL PROPORTION OF CORN, SOYBEANS,
 SUMMER CROP, AND \hat{P} IS ESTIMATE OF \hat{P} .
- D. PCL = % OF TARGETS CORRECTLY LABELED.
- E. P(A|A) = % OF TARGETS OF TYPE A (CORN, SOYBEANS, SUMMER CROPS) CORRECTLY LABELED
 AS TYPE A.

5

- BASELINE PROCEDURE VS LACIE TY PROCEDURE:

- MODEL: $Y_{ijk} = \mu_j + P_i + T_j(i) + S_k + PS_{ik} + ST_{jk}(i)$

Y_{ijk} = DEPENDENT VARIABLE

P_i = EFFECT OF PROCEDURE i , $i = 1, 2$.

$T_j(i)$ = EFFECT OF ANALYST TEAM j , $j = 1, 2, 3$, NESTED WITHIN PROCEDURE i .

S_k = EFFECT OF SEGMENT k , $k = 1, 2, \dots, 18$.

PS_{ik} = PROCEDURE X SEGMENT INTERACTION.

$ST_{jk}(i)$ = ERROR.

EVALUATION OF PERFORMANCE IMPROVEMENT OF BASELINE CORN/SOYBEAN PROPORTION ESTIMATION PROCEDURE
OVER LACIE TY PROPORTION ESTIMATION PROCEDURE

EVALUATION - (CONTINUED)

-HYPOTHESES:

$H_0: P_1 = P_2$ (NO DIFFERENCE IN PROCEDURES)

$H_A: P_1 \neq P_2$

-METHODOLOGY: ANALYSIS OF VARIANCE (ANOVA) FOR BALANCED INCOMPLETE BLOCK DESIGN
WITH NESTED EFFECT.

- TEAM EFFECTS (OBJECTIVITY)

- MODEL: $Y_{jk} = \mu_2 + T_j + S_k + TS_{jk}$

Y_{jk} = DEPENDENT VARIABLE

T_j = EFFECT OF ANALYST TEAM j , $j = 1, 2, 3$.

S_k = EFFECT OF SEGMENT k , $k = 1, 2, \dots, 18$.

TS_{jk} = ERROR.

- HYPOTHESES:

$H_0: T_1 = T_2 = T_3$ (NO TEAM EFFECT)

$H_A: T_1 \neq T_2, T_2 \neq T_3, \text{ OR } T_1 \neq T_3$

- METHODOLOGY: ANOVA FOR BALANCED INCOMPLETE BLOCK DESIGN.

EVALUATION OF PERFORMANCE IMPROVEMENT OF BASELINE CORN/SOYBEAN PROPORTION ESTIMATION PROCEDURE
OVER LACIE TY PROPORTION ESTIMATION PROCEDURE

● DATA REQUIREMENTS

- FOR EACH OF 18 SEGMENTS PROCESSED IN 1980 CORN/SOYBEANS EXPLORATORY EXPERIMENT:
 - A. LACIE-TY SEGMENT-LEVEL PROPORTION ESTIMATES.
 - B. LACIE-TY DOT LOCATIONS AND LABELS.

BASELINE CORN/SOYBEAN vs LACIE TY CORN/SOYBEAN PROCEDURE EXPERIMENTAL PLAN

SEGMENT	LACIE TY ANALYST TEAM			C/S BASELINE ANALYST TEAM		
	A1	A2	A3	B1	B2	B3
1.	x	x		x	x	
2.	x	x		x		x
3.	x	x			x	x
4.	x		x	x	x	
5.	x		x	x		x
6.	x		x		x	x
7.		x	x	x	x	
8.		x	x	x		x
9.		x	x		x	x
10.	x	x		x	x	
11.	x	x		x		x
12.	x	x			x	x
13.	x		x	x	x	
14.	x		x	x		x
15.	x		x		x	x
16.		x	x	x	x	
17.		x	x	x		x
18.		x	x		x	x

EACH SEGMENT WILL BE PROCESSED BY TWO OF THE THREE ANALYST TEAMS
USING BASELINE C-S PROCEDURE.

EVALUATION OF ADAPTABILITY OF BASELINE CORN/SOYBEAN PROPORTION ESTIMATION PROCEDURE

TO DIFFERENT CROP YEARS

- OBJECTIVE

COMPARE PERFORMANCE OF BASELINE PROCEDURE ON 1979 SEGMENTS WITH PERFORMANCE ON 1978 (DEVELOPMENTAL YEAR) SEGMENTS. (IS BASELINE PROCEDURE ADAPTABLE TO DIFFERENT YEARS?)

- APPROACH

PROCESS 12 SEGMENTS USING 1978 IMAGERY AND 1979 IMAGERY, USING ANALYSTS FROM DIFFERENT TEAMS TO PROCESS EACH SEGMENT.

- EVALUATION

CANDIDATE DEPENDENT VARIABLES INCLUDE:

- A. $\hat{P} - P$,
- B. $(\hat{P} - P)^2$,
- C. $|\hat{P} - P|$, WHERE \hat{P} IS GROUND-TRUTH SEGMENT-LEVEL PROPORTION OF CORN, SOYBEANS, SUMMER CROP, AND \hat{P} IS ESTIMATE OF P .
- D. PCL = % OF TARGETS CORRECTLY LABELED.
- E. $P(A|A) = \%$ OF TARGETS OF TYPE A (CORN, SOYBEANS, SUMMER CROPS) CORRECTLY LABELED AS TYPE A.

EVALUATION OF ADAPTABILITY OF BASELINE CORN/SOYBEAN PROPORTION ESTIMATION PROCEDURE
TO DIFFERENT CROP YEARS

TEST OF YEAR EFFECT ON LABELING ACCURACY:

- MODEL: $Y_{ij} = \mu + C_i + S_j(i)$

Y_{ij} = DEPENDENT VARIABLE.

μ = OVERALL MEAN.

C_i = EFFECT OF CROP YEAR i , $i = 1, 2$.

$S_j(i)$ = EFFECT OF j 'TH SEGMENT IN i 'TH YEAR (ERROR).

HYPOTHESES:

$H_0: C_1 = C_2$ (NO YEAR EFFECT)

$H_A: C_1 \neq C_2$

METHODOLOGY: PAIRED T-TEST OR NONPARAMETRIC ANALOG.

EFFECT OF YEAR ON BASELINE CORN/SOYBEAN PROCEDURE EXPERIMENT PLAN

TEAMS:	A	ANALYSTS:	A1, A2
	B		B1, B2
	C		C1, C2

SEGMENT/	1978 ANALYST	1979 ANALYST
1.	A1	B1
2.	A1	C1
3.	B2	A1
4.	C2	A1
5.	B2	C1
6.	C2	B1
7.	A2	B2
8.	A2	C2
9.	B1	A2
10.	C1	A2
11.	B1	C1
12.	C1	B2

EVALUATION OF EFFECT OF FIELD SIZE ON LABELING ACCURACY AND PROPORTION ESTIMATION ERROR
FOR BASELINE CORN/SOYBEAN PROPORTION ESTIMATION PROCEDURE

● OBJECTIVE

- ASSESS THE SENSITIVITY OF LABELING ACCURACY TO FIELD SIZE FOR THE CROP OF INTEREST.
- DETERMINE THE RELATIONSHIP OF FIELD SIZE TO LANDSAT OBSERVABLE PARAMETERS.

● APPROACH

- DETERMINE THE AVERAGE FIELD SIZE FOR EACH CROP OF INTEREST FOR 1978 FOR EACH SEGMENT.
- REGRESS LABELING ACCURACY AND PROPORTION ESTIMATION ERROR ON AVERAGE FIELD SIZE FOR CROP OF INTEREST.
- DETERMINE AVERAGE SIZE OF BLOBS LABELED AS CROP OF INTEREST.
- REGRESS LABELING ACCURACY AND PROPORTION ESTIMATION ERROR ON AVERAGE SIZE OF BLOBS LABELED AS CROP OF INTEREST.
- REGRESS AVERAGE BLOB SIZE ON AVERAGE FIELD SIZE FOR EACH CROP OF INTEREST.

EVALUATION OF EFFECT OF FIELD SIZE ON LABELING ACCURACY AND PROPORTION ESTIMATION ERROR
FOR BASELINE CORN/SOYBEAN PROPORTION ESTIMATION PROCEDURE

● EVALUATION:

ASSESSMENT OF EFFECT OF FIELD SIZE ON LABELING ACCURACY AND PROPORTION ESTIMATION ERROR.

- CANDIDATE DEPENDENT VARIABLES INCLUDE:

A. $\hat{P} - P$

B. $(\hat{P} - P)^2$

C. $|\hat{P} - P|$, WHERE P IS GROUND-TRUTH SEGMENT-LEVEL PROPORTION OF CROP OF INTEREST,
AND \hat{P} IS ESTIMATE OF P .

D. PCL = % OF TARGETS CORRECTLY LABELED.

E. $P(A|A)$ = % OF TARGETS OF TYPE A (CORN, SOYBEANS, SUMMER CROPS) CORRECTLY LABELED
AS TYPE A.

- MODEL: $Y = A + BX + E$

Y = DEPENDENT VARIABLE

X = INDEPENDENT VARIABLE

E = RANDOM ERROR

EVALUATION OF EFFECT OF FIELD SIZE ON LABELING ACCURACY AND PROPORTION ESTIMATION ERROR
FOR BASELINE CORN/SOYBEAN PROPORTION ESTIMATION PROCEDURE

EVALUATION - (CONTINUED)

- INDEPENDENT VARIABLES ARE:

- A. AVERAGE FIELD SIZE (GROUND-TRUTH) FOR CROP OF INTEREST.
- B. AVERAGE SIZE OF BLOBS LABELED AS CROP OF INTEREST.

- METHODOLOGY:

STATISTICAL LINEAR (NONLINEAR) REGRESSION.

DETERMINATION OF RELATIONSHIP OF FIELD SIZE TO LAIDSAT OBSERVABLE PARAMETERS.

- DEPENDENT VARIABLE: AVERAGE SIZE OF BLOBS LABELED AS CROP OF INTEREST.

- MODEL: $Y = A + BX + E$

Y = DEPENDENT VARIABLE

X = INDEPENDENT VARIABLE

E = RANDOM ERROR

INDEPENDENT VARIABLE IS AVERAGE FIELD SIZE (GROUND-TRUTH).

- METHODOLOGY: STATISTICAL LINEAR (NONLINEAR) REGRESSION.

ANALYST FUNCTIONS

I. FUNCTIONS OF TEAMS OF TWO ANALYSTS

- A. DETERMINATION OF SPECTRAL BIOWINDOWS INTO WHICH EACH ACQUISITION FALLS.
- A SPECTRAL BIOWINDOW (1, 2, 3, 4, OR 5) FOR EACH OF THREE SEASONAL CROP GROUPS:
 - SUMMER CROPS (SC)
 - WINTER SMALL GRAINS (WSG)
 - SPRING SMALL GRAINS (SSG)

- OBJECTIVES: TO DESCRIBE THE PERFORMANCE, AND TO IDENTIFY AND ASSESS FACTORS WHICH AFFECT THE PERFORMANCE, OF ANALYST TEAMS IN DETERMINING THE STAGE OF SPECTRAL EMERGENCE FOR EACH OF THE SEASONAL CROP GROUPS FOR EACH ACQUISITION.

ANALYST FUNCTIONS (CONT.)

● APPROACH:

FOR EACH SEGMENT PROCESSING:

- DETERMINE THE "CORRECT" BIOWINDOWS BY COMPUTING THE PERCENTAGE OF THE PIXELS IN EACH GROUND-TRUTH CROP GROUP WHICH ARE "SPECTRALLY EMERGED" FOR THE ACQUISITION (I.E., HAVE GRABS NUMBERS ABOVE THE THRESHOLD OF SIX), AND BY APPLYING THE DEFINITIONS IN THE PROCEDURE FOR THE BIOWINDOWS.
- TABULATE ANALYSTS' DECISIONS VS. "CORRECT" DECISIONS IN A CONFUSION MATRIX FOR EACH SEASONAL CROP GROUP.
- FOR EACH SEASONAL CROP GROUP AND FOR EACH OF ITS FIVE BIOWINDOWS, CALCULATE, FOR EACH ACQUISITION FOR WHICH THAT BIOWINDOW IS "CORRECT", THE "DEVIATION" OF THE ANALYST-TEAM'S DECISION FROM THE CORRECT DECISION, I.E., (ANALYSTS' DECISION) MINUS (CORRECT DECISION).

ANALYST FUNCTIONS (CONT.)

FORM OF CONFUSION MATRIX OF
ANALYSTS' DECISIONS VS. "CORRECT"
DECISIONS FOR EACH SEASONAL CROP
GROUP

# OF DECISIONS % OF GRND. TOT. % OF ROW TOT. % OF COL. TOT.	ANALYSTS' DECISIONS					ROW TOTALS
	1	2	3	4	5	
"CORRECT" DECISIONS	1					
	2					
	3					
	4					
	5					
COLUMN TOTALS						GRAND TOTAL

ANALYST FUNCTIONS (CONT.)

● **EVALUATION:**

FOR EACH SEASONAL CROP GROUP, PLOT THE RELATIONSHIPS, FOR EACH OF ITS FIVE BIOWINDOWS, BETWEEN THE "DEVIATION" (AS THE DEPENDENT VARIABLE) AND SELECTED SEGMENT OR RLOB CHARACTERISTICS (AS INDEPENDENT VARIABLES).

ORIGINAL PAGE IS
OF POOR QUALITY

ANALYST FUNCTIONS (CONT.)

EXAMPLE: SUMMER-CROP BWINDOW #3

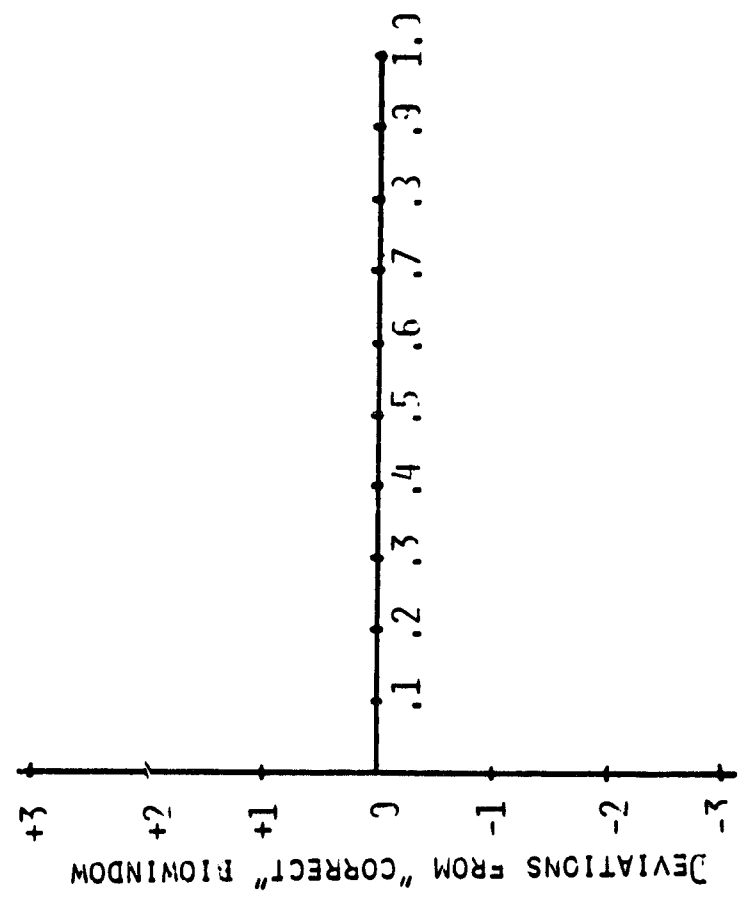

TRUE PROPORTION OF SUMMER CROPS IN SEGMENT.

ANALYST FUNCTIONS (CONT.)

B. SELECTION OF TPC ACQUISITIONS AND ASSIGNMENT OF TPC'S TO DFS STRATA.

- OBJECTIVES: DESCRIBE THE ACCURACY, AND IDENTIFY AND ASSESS FACTORS WHICH AFFECT THE ACCURACY, OF THE SEPARATION OF THE PIXELS IN EACH SEGMENT INTO DFS STRATA ACCORDING TO TPC'S.

NOTES:

- THIS FUNCTION FORMS THE BASIS FOR INCLUDING "SUMMER CROP" PIXELS ON, AND EXCLUDING "OTHER" PIXELS FROM, THE SCATTER PLOTS.
- THE SCATTER PLOT ZONES FORM THE BASIS FOR THE SPECTRAL SEPARATION OF CORN FROM SOYBEANS.
- THE STAGE ONE LABELS FOR SAMPLED BLOBS ARE BASED ON BLOB LEVEL DFS STRATA AND SCATTER PLOT ZONES.

● APPROACH:

- FOR EACH SEGMENT PROCESSING, TABULATE TWO "CONFUSION MATRICES" FOR PIXEL-LEVEL GROUND-TRUTH CATEGORIES VS. TPC-DETERMINED DFS'S:
 - ONE FOR GROUND-TRUTH DFS'S (CROP GROUPS).
 - ONE FOR GROUND-TRUTH SPECIFICS (CROP TYPES).

ORIGINAL PAGE IS
OF POOR QUALITY

FORMAT OF CONFUSION MATRIX OF GROUND TRUTH CROP TYPES VS. TPC-DETERMINED DELTA FUNCTION STRATA

NUMBER OF PIXELS % OF GRAND TOTAL % OF ROW TOTAL % OF COLUMN TOTAL		TPC - DETERMINED OFS (PIXEL-LEVEL)						ROW TOTALS
		SUMMER CROPS	SMALL GRAINS	PERM. VEG.	NON VEG.	UNASSIGN-ABLE	TRIVIAL	
PIXEL GROUND TRUTH LABELS	CORN							
	SOYBEANS							
	ALL "OTHER"							
	COTTON							
	SUNFLOWERS							
	SORGHUM							
	WHEAT							
	BARLEY							
	RICE							
	PASTURE							
	GRASS							
	TREES							
	WATER							
	URBAN							
	ETC.							
COLUMN TOTALS								GRAND TOTAL

ANALYST FUNCTIONS (CONT.)

FORMAT OF CONFUSION MATRIX OF GROUND TRUTH CROP GROUPS VS. TPC-DETERMINED DELTA FUNCTION STRATA

NUMBER OF PIXELS % OF GRAND TOTAL % OF ROW TOTAL % OF COLUMN TOTAL	TPC-DETERMINED PIXEL-LEVEL DFS STRATUM						ROW TOTALS
	SUMMER CROPS	SMALL GRAINS	PERM. VEG.	NONVEG.	UNASSIGN- ABLE	TRIVIAL	
SUMMER CROPS							
SMALL GRAINS							
PERM. VEG.							
NONVEG.							
COLUMN TOTALS							GRAND TOTAL

ANALYST FUNCTIONS (CONT.)

- **EVALUATION: PLOT RELATIONSHIPS BETWEEN SELECTED ENTRIES IN THE CONFUSION MATRICES (AS DEPENDENT VARIABLES) AND SELECTED SEGMENT OR BLOB CHARACTERISTICS (AS INDEPENDENT VARIABLES):**
 - **INDEPENDENT VARIABLES:**
 - **TRUE PROPORTION OF CORN**
 - **TRUE PROPORTION OF SOYBEANS**
 - **TRUE PROPORTION OF (CORN + SOYBEANS)**
 - **TRUE PROPORTION OF "SUMMER CROPS"**
 - **AVERAGE SIZE OF ACTUAL FIELDS ON THE GROUND**
 - **% PIXELS IN SEGMENT CONTAINED IN "BIG" BLOBS**
 - **TOTAL NUMBER OF "BIG" BLOBS IN SEGMENT**
 - **DEPENDENT VARIABLES: AS SUGGESTED BY MATRICES.**

ANALYST FUNCTIONS (CONT.)

C. FINAL SELECTION OF CORN/SOYBEAN SEPARATION ACQUISITIONS, AND PLACEMENT OF LINEAR DISCRIMINANTS ON SCATTER PLOTS.

- OBJECTIVE: DESCRIBE THE ACCURACY OF THE SEPARATION OF CORN PIXELS FROM SOYBEANS PIXELS WITHIN THE SUMMER-CROP DFS STRATUM, ACCORDING TO LINEAR DISCRIMINANTS DRAWN ON SPECTRAL SCATTER PLOTS BY THE ANALYST TEAMS FOR SEPARATION ACQUISITIONS.

NOTE: THIS FUNCTION MAY BE AUTOMATED WHEN THE BASELINE PROCEDURE IS DEVELOPED FURTHER.

78

● APPROACH:

- FOR EACH SEGMENT PROCESSING, AND FOR EACH SCATTER PLOT ON WHICH THE ANALYST TEAM DREW A LINEAR DISCRIMINANT, TABULATE A "CONFUSION MATRIX" FOR THE PIXELS REPRESENTED ON THE PLOT.
- TABULATE A "COMPOSITE CONFUSION MATRIX" FOR ALL OF THOSE PIXELS FOR ALL PROCESSINGS.

FORMAT OF CONFUSION MATRIX OF GROUND TRUTH LABELS VS. SCATTER PLOT PIXEL LOCATIONS

NUMBER OF PIXELS % OF GRAND TOTAL % OF ROW TOTAL % OF COLUMN TOTAL		PIXEL-LEVEL SCATTER-PLOT ZONES				ROW TOTALS
		A	B	C	D	
GROUND TRUTH FOR SCATTER PLOT PIXELS	CORN					
	SOYBEANS					
	OTHER					
COLUMN TOTALS						GRAND TOTAL

ANALYST FUNCTIONS (CONT.)

II. ANALYST FUNCTIONS LEADING DIRECTLY TO LABELS FOR SAMPLED "BIG BLOBS.

A. FINAL SELECTION OF ACQUISITIONS FOR BLOBBING, AND ASSIGNMENT OF "STAGE ONE" LABELS FOR SAMPLED "BIG" BLOBS.

- CROP GROUP LABELS: "SC" (SUMMER CROP); "O" (OTHER).
- CROP TYPE LABELS, FOR SAMPLED "BIG" BLOBS WITH "SC" CROP GROUP LABEL: "C" (CORN); "S" (SOYBEANS)

(NOTE: AFTER ACQUISITIONS ARE SELECTED FOR BLOBBING, "STAGE ONE" LABELS ARE BASED UPON MACHINE ASSIGNMENTS OF BLOBS TO DFS STRATA ACCORDING TO BLOB-MEAN TPC'S, AND TO SCATTER-PLOT ZONES ACCORDING TO BLOB-MEAN SPECTRAL VALUES.)

ANALYST FUNCTIONS (CONT.)

● OBJECTIVES:

- DESCRIBE THE ACCURACY, AND IDENTIFY AND ASSESS FACTORS WHICH AFFECT THE ACCURACY, WITH WHICH THE "STAGE ONE" LABELS ASSIGNED TO SAMPLED "BIG" BLOBS REPRESENT THE PIXELS CONTAINED IN THOSE BLOBS.
- DESCRIBE, AND IDENTIFY AND ASSESS FACTORS WHICH AFFECT, THE IMPROVEMENT OR THE DEGRADATION OF IDENTIFICATION ACCURACIES FOR PIXELS CONTAINED IN SAMPLED "BIG" BLOBS, WHEN THE "STAGE ONE" LABELS OF THOSE BLOBS ARE USED INSTEAD OF THE CROP-GROUP AND CROP-TYPE LABELS THE PIXELS WOULD BE ASSIGNED ACCORDING TO PIXEL-LEVEL DFS'S AND SCATTER-PLOT ZONES.

ANALYST FUNCTIONS (CONT.)

● APPROACH:

- FOR EACH SEGMENT PROCESSING, TABULATE A "CONFUSION MATRIX" FOR THE PIXELS IN THE SAMPLED "BIG" BLOBS, SHOWING SPECIFIC GROUND-TRUTH LABELS FOR THE PIXELS VS. "STAGE ONE" LABELS FOR THE BLOBS CONTAINING THEM.
- FOR EACH SEGMENT PROCESSING, FOR EACH PIXEL CONTAINED IN A SAMPLED "BIG" BLOB, DETERMINE THE LABELS WHICH WOULD BE ASSIGNED TO THE PIXEL ACCORDING TO ITS PIXEL-LEVEL DFS, AND ITS PIXEL-LEVEL SCATTER PLOT ZONES (WHEN THE PIXEL IS IN THE SUMMER-CROP DFS).
- FOR EACH SEGMENT PROCESSING, SEPARATE THE PIXELS CONTAINED IN SAMPLED "BIG" BLOBS INTO THREE CATEGORIES ACCORDING TO THEIR GROUND-TRUTH LABELS AS "CORN", "SOYBEANS", OR "OTHER", AND TABULATE A "CONFUSION MATRIX" FOR THE PIXELS IN EACH CATEGORY, SHOWING THE LABELS DETERMINED AS ABOVE VS. THE "STAGE ONE" BLOB LABELS.
- FOR EACH OF THE PIXEL-LEVEL GROUND-TRUTH CATEGORIES "CORN", "SOYBEANS", "OTHER", AS DESCRIBED ABOVE, TABULATE A "COMPOSITE CONFUSION MATRIX" FOR ALL SEGMENT PROCESSINGS FOR ALL PIXELS IN THE CATEGORY THAT ARE CONTAINED IN SAMPLED "BIG" BLOBS.

ORIGINAL PAGE IS
OF POOR QUALITY

NUMBER OF PIXELS % OF GRAND TOTAL % OF ROW TOTAL % OF COLUMN TOTAL		STAGE ONE LABELS FOR BLOBS CONTAINING THE PIXELS			ROW TOTALS
		"SC" (SUMMER CROP) BY BLOB DFS		"O" (OTHER) BY BLOB DFS	
		"C" (CORN) BLOB ZONES A, B	"S" (SOYBEANS) BLOB ZONES C, D		
PIXEL GROUND TRUTH LABELS	CORN				
	SOYBEANS				
	ALL "OTHER"				
	COTTON				
	SUNFLOWERS				
	SORGHUM				
	WHEAT				
	BARLEY				
	RICE				
	PASTURE				
	GRASS				
	TREES				
	WATER				
	URBAN				
ETC. ⋮					
COLUMN TOTALS				GRAND TOTAL	

**ORIGINAL PAGE IS
OF POOR QUALITY**

ANALYST FUNCTIONS (CONT.)

FORMAT OF CONFUSION MATRIX OF PIXEL - LEVEL LABELS .S
STAGE ONE BLOB LABELS FOR EACH SUMMER CROP PIXEL IN
IN SAMPLED BLOBS

NUMBER OF PIXELS % OF GRAND TOTAL % OF ROW TOTAL % OF COL. TOTAL		STAGE ONE LABELS FOR BLOBS CONTAINING THE PIXELS			ROW TOTALS
				"O" (OTHER) BY BLOB DFS	
		"C" (CORN) BLOB ZONES A, B	"S" (SOYBEANS) BLOB ZONES C, D		
PIXEL LABELS BASED ON PIXEL-LEVEL DFS'S AND PIXEL-LEVEL SCATTER-PILOT ZONES	"SC" (SUMMER CROP) BY PIXEL DFS	"C" (CORN) PIXEL ZONES A, B			
	NOT REPRESENTED ON SCATTER PLOTS	"S" (SOYBEANS) PIXEL ZONES C, D			
	"C" (OTHER) BY PIXEL DFS				
COLUMN TOTALS					GRAND TOTAL

ANALYST FUNCTIONS (CONT.)

- EVALUATION: PLOT RELATIONSHIPS BETWEEN SELECTED ENTRIES IN THE CONFUSION MATRICES (AS DEPENDENT VARIABLES) AND SELECTED SEGMENT OR BLOB CHARACTERISTICS (AS INDEPENDENT VARIABLES):
 - INDEPENDENT VARIABLES:
 - TRUE PROPORTION OF CORN
 - TRUE PROPORTION OF SOYBEANS
 - TRUE PROPORTION OF (CORN + SOYBEANS)
 - TRUE PROPORTION OF "SUMMER CROPS"
 - AVERAGE SIZE OF ACTUAL FIELDS ON THE GROUND
 - % PIXELS IN SEGMENT CONTAINED IN "BIG" BLOBS
 - TOTAL NUMBER OF "BIG" BLOBS IN SEGMENT
 - % PURITY (AVERAGE) OF "BIG" BLOBS FOR MOST-PREVALENT CROP TYPE OR CROP GROUP
 - DEPENDENT VARIABLES: AS SUGGESTED BY THE CONFUSION MATRICES.

ANALYST FUNCTIONS (CONT.)

3. ASSIGNMENT OF "STAGE TWO" LABELS TO SAMPLED "BIG" BLOBS (BY INDIVIDUAL ANALYST)

- CROP GROUP LABELS: "SC", "J", "SC,0"
- CROP TYPE LABELS: "C", "S", "O", "C,S", "C,0", "S,0", "C,S,0"

NOTE: THE DECISION AS TO WHETHER SAMPLED BLOBS WILL BE LABELED ONLY TO THE CROP GROUP LEVEL, OR TO BOTH CROP GROUP AND CROP TYPE LEVELS, DEPENDS ON THE ANALYST'S JUDGEMENT REGARDING THE AVAILABILITY OF A SEPARATION ACQUISITION.

OBJECTIVES: DESCRIBE, AND IDENTIFY AND ASSESS FACTORS RELATED TO, EACH OF THE FOLLOWING:

- THE ACCURACY AND CONSISTENCY OF THE "STAGE TWO" LABELS, AND POSSIBLE SOURCES OF ERRORS
- THE ACCURACY WITH WHICH THE "STAGE TWO" LABELS (INCLUDING "MIXED" LABELS) REPRESENT THE PROPORTIONS OF THE PIXELS CONTAINED IN THE SAMPLED BLOBS
- THE IMPROVEMENT, OR THE DEGRADATION, OF THE PROPORTION ESTIMATES FOR THE PIXELS CONTAINED IN SAMPLED BLOBS WHOSE "STAGE TWO" LABELS ARE DIFFERENT FROM THEIR "STAGE ONE" LABELS

ANALYST FUNCTIONS (CONT.)

0 APPROACH:

- FOR EACH SEGMENT PROCESSING, TABULATE A CONFUSION MATRIX SHOWING GROUND-TRUTH "CORRECT" LABELS VS. "STAGE TWO" LABELS, FOR EACH LEVEL OF LABELING (CROP GROUP, CROP TYPE)
- FOR EACH SEGMENT PROCESSING, FOR SELECTED SUBSETS OF THE SAMPLED BLOBS, TABULATE CONFUSION MATRICES FOR STAGE-TWO CROP-GROUP AND CROP-TYPE LABELS, AS WAS DONE ABOVE FOR ALL SAMPLED BLOBS:
 - BLOBS WHOSE LABELS RESULTED FROM SELECTED DECISION-LOGIC PATHS, OR GROUPS OF PATHS
 - BLOBS WHOSE LABELS WERE ASSIGNED SELECTED CONFIDENCE-CODES BY THE ANALYST
- FOR EACH SEGMENT PROCESSING, TABULATE A CONFUSION MATRIX SHOWING SPECIFIC GROUND-TRUTH LABELS FOR PIXELS IN SAMPLED BLOBS VS. "STAGE TWO" LABELS FOR THOSE BLOBS, FOR EACH LEVEL OF LABELING (GROUP, TYPE), WITH COLUMNS AS ABOVE, BUT ROWS AS IN MATRICES FOR STAGE ONE

ORIGINAL PAGE IS
OF POOR QUALITY

ANALYST FUNCTIONS (CONT.)

FORMAT OF CONFUSION MATRIX OF GROUND TRUTH LABELS VS ANALYST BLOB LABELS

NUMBER OF PIXELS % OF GRAND TOTAL % OF ROW TOTAL % OF COLUMN TOTAL		"STAGE TWO" (AI) CROP-TYPE LABELS FOR BLOBS						ROW TOTALS
		C	S	O	C,S	C,O	S,O	
PIXEL GROUND TRUTH LABELS	CORN							
	SOYBEANS							
	ALL "OTHER"							
	COTTON							
	SUNFLOWERS							
	SORGHUM							
	WHEAT							
	BARLEY							
	RICE							
	PASTURE							
	GRASS							
	TREES							
	WATER							
	URBAN							
ETC. ⋮								
COLUMN TOTALS							GRAND TOTAL	

ANALYST FUNCTION (CONT.)

FORMAT OF CONFUSION MATRIX OF GROUND TRUTH VS ANALYST BLOB LABELS

NO. OF BLOBS % OF G. TOTAL % OF ROW TOTAL % OF COL. TOTAL		"STAGE TWO" (AI) CROP-TYPE LABELS						ROW TOTALS
		C	S	O	C,S	C,O	S,O	
GROUND-TRUTH CROP-TYPE LABELS	C							
	S							
	O							
	C,S							
	C,O							
	S,O							
	C,S,O							
COLUMN TOTALS								GRAND TOTALS

LABELING ACCURACY MATRIX: CROP-GROUP LEVEL
 (NUMBERS OF BLOBS, WITH JOINT- AND CONDITIONAL-PROBABILITIES)
 (HYPOTHETICAL EXAMPLE-NOT ACTUAL RESULTS OF ANY EXPERIMENT)

# OF BLOBS % OF TOTAL % OF AI LABEL % OF GT LABEL	A. I. LABELS			G.T. TOTALS
	SC	0	SC,0	
SC	72 36% 90% 75%	8 4% 16% 8 1/3 %	16 8% 22 6/7% 16 2/3%	96 48% — 100%
G.T. LABELS 0	6 3% 7 1/2% 15%	30 15% 60% 75%	4 2% 5 5/7% 10%	40 20% — 100%
SC,0	2 1% 2% 3 1/8%	12 6% 24% 18 3/4%	50 25% 71 3/7% 78 1/8%	64 32% — 100%
A. I. TOTALS	80 40% 100% —	50 25% 100% —	70 35% 100% —	200 100% — —

ANALYST FUNCTIONS (CONT.)

- FOR EACH SEGMENT PROCESSING, FOR EACH SAMPLED BLOB WHOSE "STAGE TWO" LABEL IS DIFFERENT FROM ITS "STAGE ONE" LABEL, CALCULATE FOR EACH OF "CO3N", SOYBEANS", AND "OTHER" THE TRUE ERROR $\hat{P}_1 - P$, AND THE ABSOLUTE ERROR $|\hat{P}_1 - P|$, BETWEEN THE "DISCRETE" PROPORTION ESTIMATE \hat{P}_1 CORRESPONDING TO THE STAGE ONE LABEL, AND THE TRUE PROPORTION P FOR THE PIXELS IN THE BLOB; AFTER DOING THE SAME FOR THE BLOB'S STAGE TWO LABEL, TABULATE FOR ALL SUCH BLOBS THE WEIGHTED AVERAGES OF THESE ERRORS, WITH WEIGHTS ACCORDING TO THE NUMBER OF PIXELS (ALL PIXELS) IN THE BLOB:

ANALYST FUNCTIONS (CONT.)

FORMAT OF TABULATED PROPORTION ESTIMATION ERRORS FOR BLOBS WHOSE "STAGE TWO" LABELS DIFFER FROM THEIR "STAGE ONE" LABELS

	WEIGHTED AVERAGES OF TRUE PROPORTIONS OF PIXELS		WEIGHTED AVERAGES OF ERRORS FOR "DISCRETE" PROPORTION ESTIMATES			
			"STAGE ONE"		"STAGE TWO"	
			TRUE ERRORS	ABSOLUTE ERRORS	TRUE ERRORS	ABSOLUTE ERRORS
CORN						
SOYBEANS						
OTHER						

C-2

ANALYST FUNCTIONS (CONT.)

0 EVALUATION:

- FOR SELECTED SUBSETS OF THE SAMPLED BLOBS (FROM ALL SEGMENTS, OR FROM SELECTED SEGMENTS), TABULATE AVERAGE "PROBABILITY OF CORRECT LABELING" (PCL), AND VARIANCE OF PCL, FOR EACH LABEL
- PLOT RELATIONSHIPS BETWEEN SELECTED ENTRIES IN THE CONFUSION MATRICES (AS DEPENDENT VARIABLES) AND SELECTED SEGMENT OR BLOB CHARACTERISTICS (AS INDEPENDENT VARIABLES)
 - INDEPENDENT VARIABLES:
 - AS IN THE STUDY OF STAGE ONE LABELS
 - DECISION-LOGIC PATHS, OR GROUPS OF PATHS
 - ANALYST'S CONFIDENCE CODES
 - DEPENDENT VARIABLES: AS SUGGESTED BY THE CONFUSION MATRICES

0 REQUIREMENTS:

- ANTICIPATE THE NECESSARY SOFTWARE TO BE DELIVERED BY ERIM

MACHINE FUNCTIONS

- I. MACHINE CONTRIBUTIONS TO BIAS OF AREA PROPORTION ESTIMATES
 - O OBJECTIVE: EVALUATION OF ASSUMPTIONS IN THE AREA PROPORTION ESTIMATION TECHNOLOGY AS SOURCES FOR BIAS
 - O APPROACH: APPLY EIGHT PROPORTION ESTIMATION ALTERNATIVES TO ALL OF THE 1973 - 1979 SEGMENTS PROCESSED FOR WHICH CROP TYPE LABELS WERE ASSIGNED TO SAMPLES
 - O EVALUATIONS:
 - TABULATIONS OF DIFFERENCES BETWEEN PROPORTION ESTIMATES, AS BIASES DUE TO ASSUMPTIONS
 - PLOTS OF OVERALL MACHINE BIAS VS. TRUE PROPORTIONS, FOR EACH CROP
 - O REQUIREMENTS: ANTICIPATE THE NECESSARY SOFTWARE TO BE DELIVERED BY ERM

MACHINE FUNCTIONS (CONT.)

EIGHT PROPORTION ESTIMATION ALTERNATIVES FOR EVALUATION OF MACHINE CONTRIBUTIONS TO BIAS

1. TRUE PROPORTION OF ALL OF THE PIXELS IN THE SEGMENT
2. TRUE PROPORTION OF ALL OF THE PIXELS IN ALL OF THE BLOBS IN ALL OF THE "KNOWN" DFS'S
3. TRUE PROPORTION OF ALL OF THE PIXELS IN ALL OF THE "BIG" BLOBS IN ALL OF THE "KNOWN DFS'S"
4. PROPORTION ESTIMATE PRODUCED BY THE BASELINE PROCEDURE, USING 'DISCRETE' PROPORTIONS BASED ON "CORRECT" LABELS FOR SAMPLED BLOBS, AS DETERMINED BY THEIR INTERIOR PIXELS, BUT WEIGHTED BY THE FULL BLOBS.
5. THE "ALTERNATE" PROPORTION ESTIMATE PRODUCED BY THE BASELINE PROCEDURE: DETERMINED BY WEIGHTING THE PROPORTION ESTIMATE FOR EACH "KNOWN" DFS ACCORDING TO THE NUMBER OF PIXELS IN ALL OF ITS "BIG" BLOB, RATHER THAN ALL OF ITS BLOBS.

MACHINE FUNC. (CONT.)

NOTE: FOR ALTERNATIVES 5 THROUGH 5, THE PROPORTION ESTIMATE FOR EACH "KNOWN" DFS WILL BE CALCULATED AS DESCRIBED, AND THEN WEIGHTED ACCORDING TO THE NUMBER OF PIXELS IN ALL OF ITS BLOBS

6. TRUE PROPORTION OF ALL OF THE PIXELS IN ALL OF THE "BIG" BLOBS IN THE KNOWN DFS
7. WEIGHTED AVERAGE OF THE TRUE PROPORTIONS OF THE INTERIOR PIXELS FOR ALL OF THE "BIG" BLOBS IN THE "KNOWN" DFS, WEIGHTED BY THE FULL BLOBS
8. WEIGHTED AVERAGE OF THE "DISCRETE" PROPORTIONS BASED ON "CORRECT" LABELS FOR ALL OF THE "BIG" BLOBS IN THE "KNOWN" DFS, AS DETERMINED BY THEIR INTERIOR PIXELS, BUT WEIGHTED BY THE FULL BLOBS

ORIGINAL PAGE 16
OF POOR QUALITY

MACHINE FUNC. (CONT.)

MACHINE CONTRIBUTIONS TO BIAS DUE TO PROPORTIONAL ESTIMATION ASSUMPTIONS

$\hat{P}_2 - \hat{P}_1$: BIAS DUE TO ASSUMING THAT THE BLOBS REMAINING IN THE "UNKNOWN" DFS HAVE THE SAME AVERAGE PROPORTIONS AS THE BLOBS IN THE "KNOWN" DFS'S

$\hat{P}_3 - \hat{P}_2$: BIAS FOR THE "KNOWN" DFS'S, DUE TO ASSUMING THAT THE PROPORTION IN ALL OF THEIR "BIG" BLOBS IS THE SAME AS THE PROPORTION IN ALL OF THEIR BLOBS

$\hat{P}_6 - \hat{P}_2$: BIAS FOR THE "KNOWN" DFS'S, DUE TO ASSUMING THAT THE "SMALL" BLOBS IN EACH "KNOWN" DFS HAVE THE SAME AVERAGE PROPORTIONS AS THE "BIG" BLOBS IN THE SAME DFS

$\hat{P}_7 - \hat{P}_6$: BIAS FOR THE "KNOWN" DFS'S, DUE TO ASSUMING THAT THE BOUNDARY PIXELS HAVE THE SAME AVERAGE PROPORTIONS AS THE INTERIOR PIXELS IN THE SAME "BIG" BLOB

ORIGINAL PAGE IS
OF POOR QUALITY

MACHINE FUNC. (CONT.)

$\hat{P}_3 - \hat{P}_7$: BIAS FOR THE "KNOWN" DFS'S, DUE TO ASSIGNING "DISCRETE" RATHER THAN "TRUE" PROPORTIONS TO THE INTERIORS OF ALL "BIG" BLOBS

$\hat{P}_4 - \hat{P}_3$: BIAS FOR THE "KNOWN" DFS'S, DUE TO ASSIGNING "DISCRETE" PROPORTIONS TO THE INTERIORS OF 100 SAMPLED "BIG" BLOBS, RATHER THAN ALL "BIG" BLOBS IN THE "KNOWN" DFS'S

$\hat{P}_4 - \hat{P}_1$: BIAS WHICH WOULD HAVE EXISTED FOR THE ACTUAL PROCESSINGS EVEN IF THERE HAD BEEN NO NO ERRORS IN THE LABELS ASSIGNED TO THE 100 SAMPLED BLOBS (OVERALL MACHINE BIAS)

$\hat{P}_5 - \hat{P}_1$: BIAS WHICH WOULD HAVE EXISTED FOR THE ACTUAL PROCESSINGS USING THE "ALTERNATE" BASELINE PROCEDURE ESTIMATES, EVEN IF THERE HAD BEEN NO ERRORS IN THE LABELS ASSIGNED TO THE 100 SAMPLED BLOBS (OVERALL MACHINE BIAS FOR "ALTERNATE" ESTIMATES)

MACHINE FUNC. (CONT.)

II. MACHINE CONTRIBUTIONS TO VARIANCE OF AREA PROPORTION ESTIMATES

0 OBJECTIVES:

- ESTIMATE THE SAMPLING VARIANCE FOR THE NUMBER OF STRATA AND THE TOTAL SAMPLE SIZE PRESCRIBED BY THE BASELINE PROCEDURE
- EVALUATE THE EFFECTS ON SAMPLING VARIANCE OF REDUCING THE TOTAL SAMPLE SIZE AND THE NUMBER OF STRATA

MACHINE FUNCTION (CONT.)

0 APPROACH:

- USING THE POPULATIONS OF BLOBS FORMED DURING ALL ACTUAL PROCESSING OF SEGMENTS, USE MONTE CARLO METHODS TO SELECT β DIFFERENT SAMPLES FOR EACH SEGMENT FOR EACH COMBINATION OF TOTAL SAMPLE SIZE AND NUMBER OF STRATA:
 - SAMPLE SIZE: 40, 50, 60, 100
 - NO. OF STRATA: 1, 2, 3
- USING GROUND-TRUTH LABELS FOR SAMPLED BLOBS, GENERATE AREA PROPORTION ESTIMATES FOR C, S, O FOR EACH SEGMENT FOR EACH SAMPLE SELECTED
- FOR EACH SEGMENT I AND EACH COMBINATION OF TOTAL SAMPLE SIZE N AND NUMBER OF STRATA M, CALCULATE THE STANDARD DEVIATION σ_{MNI} FOR EACH OF C, S, O FOR THE β SAMPLES
- FOR EACH COMBINATION OF THE SAMPLE SIZE N AND NUMBER OF STRATA M, FOR EACH CROP, CALCULATE " σ_{IN} " TO BE $\sqrt{\text{AVERAGE, FOR ALL SEGMENTS, OF } \sigma_{MNI}^2}$.

ORIGINAL PAGE IS
OF POOR QUALITY

MACHINE FUNC. (CONT.)

0 EVALUATIONS:

- PLOT, FOR EACH OF C,S,O, THE RELATIONSHIPS BETWEEN σ_{MN} AND TOTAL SAMPLE SIZE FOR EACH NUMBER OF STRATA, E.G.,

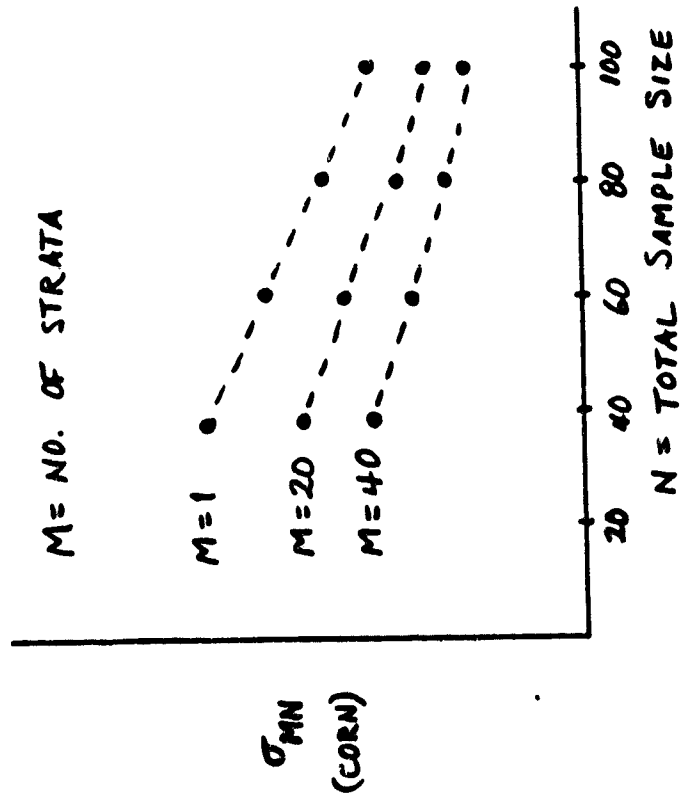

ORIGINAL PAGE IS
OF POOR QUALITY

- TABULATE, FOR EACH OF C,S,O AN "R-FACTOR MATRIX" SHOWING THE RATIOS OF

$$R = \frac{\sigma_{MN}^2}{\sigma^2} \cdot 1.N, \text{ E.G.,}$$

FORMAT OF TABULATED R-FACTORS FOR CORN
(REDUCTION IN VARIANCE)

		No. of SAMPLES (N)			
		40	60	80	100
No. of STRATA (M)	1	1.00	1.00	1.00	1.00
	20				
	40				

ORIGINAL PAGE IS
OF POOR QUALITY

MACHINE FUNC. (CONT.)

III. MACHINE STRATIFICATIONS; BLOBS, CLUSTERS

- **OBJECTIVES: DESCRIBE, AND IDENTIFY AND ASSESS FACTORS RELATED TO, THE HOMOGENEITY OF MACHINE-GENERATED STRATA**
- **APPROACH:**
 - **FOR EACH SEGMENT PROCESSED, TABULATE A CONFUSION MATRIX FOR ALL PIXELS IN THE SEGMENT, SHOWING SPECIFIC GROUND-TRUTH LABELS FOR PIXELS VS. CATEGORIES DEFINED BY THE BLOBS CONTAINING THEM:**
 - **FOR A BLOB OR A CLUSTER, DEFINE:
CROP TYPE PURITY: PERCENTAGE OF THE PIXELS WHICH ARE OF THE MOST PREVALENT CROP TYPE (C,S,O)**
 - DFS CROP GROUP PURITY: PERCENTAGE OF THE PIXELS WHICH ARE OF THE MOST PREVALENT DFS CROP GROUP**
- **FOR EACH BLOB, AND FOR EACH CLUSTER, DETERMINE:
 - **MOST PREVALENT CROP TYPE (C,S,O)**
 - **CROP TYPE PURITY**
 - **MOST PREVALENT DFS CROP GROUPS (SC,SG,P-V, N-V)**
 - **DFS CROP GROUP PURITY****

ORNL
CONFIDENTIAL

FORMAT OF CONFUSION MATRIX OF GROUND TRUTH PIXEL LABELS VS. VARIOUS
BLOB CATEGORIZATIONS

	NUMBER OF PIXELS % OF GRAND TOTAL % OF ROW TOTAL % OF COLUMN TOTAL	"BIG" BLOBS			"SMALL" BLOBS	ROW TOTALS
		INTERIOR	BOUNDARY	FULL BLOB		
PIXEL GROUND TRUTH LABELS	CORN					
	SOYBEANS					
	ALL "OTHER"					
	COTTON					
	SUNFLOWERS					
	SORGHUM					
	WHEAT					
	BARLEY					
	RICE					
	PASTURE					
	GRASS					
	TREES					
	WATER					
	URBAN					
	ETC. ⋮					
	COLUMN TOTALS					GRAND TOTAL

STATE OF ILLINOIS
DEPARTMENT OF AGRICULTURE

● EVALUATIONS

- USING (ALL "BIG"/ALL "SMALL"/ALL) BLOBS IN EACH SEGMENT WHICH HAVE THE APPROPRIATE "MOST PREVALENT CROP TYPE", PLOT THE FOLLOWING RELATIONSHIPS FOR ALL SEGMENT PROCESSINGS:

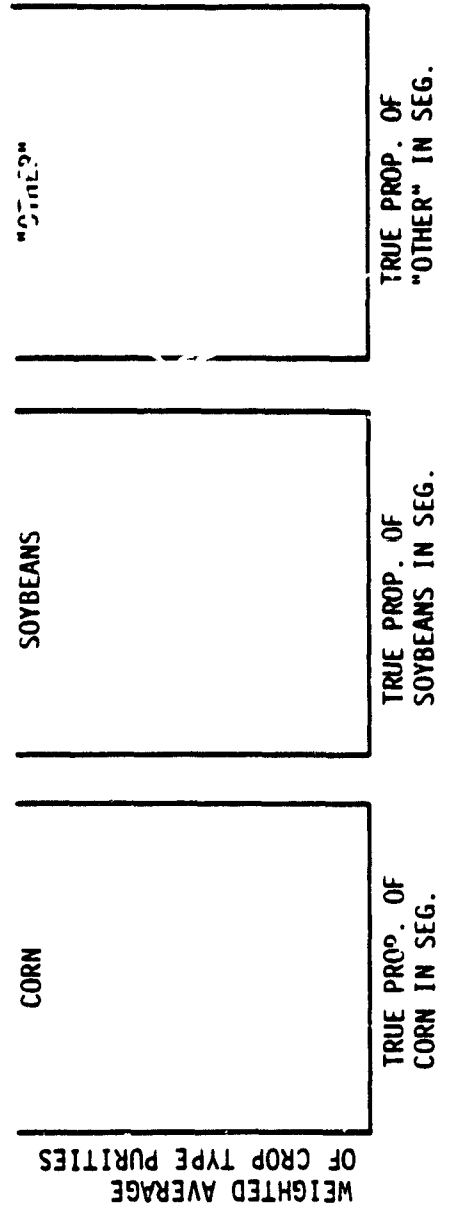
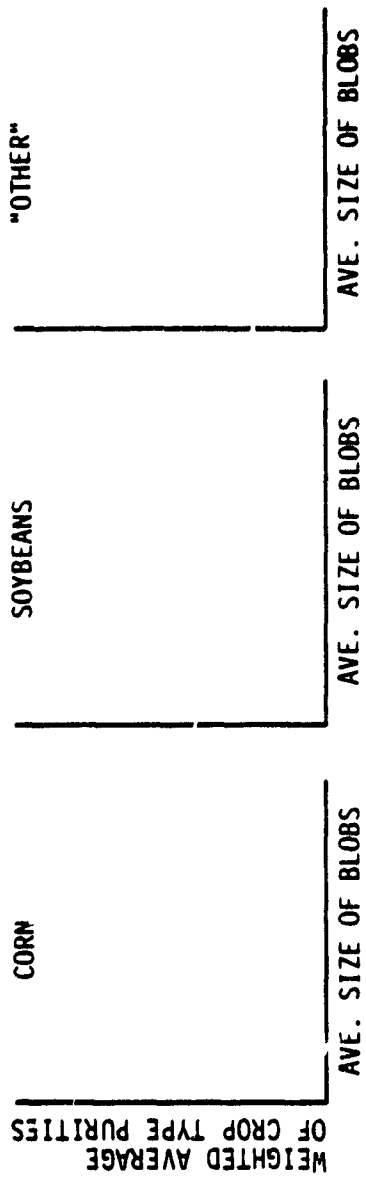

- USING (ALL "BIG"/ALL "SMALL"/ALL) BLOBS IN EACH SEGMENT WHICH HAVE THE APPROPRIATE
"MOST PREVALENT DFS CROP GROUP", PLOT RELATIONSHIPS AS ABOVE FOR ALL SEGMENT PROCESS-
INGS

- USING (ALL "BIG"/ALL "SMALL"/ALL) BLOBS IN ALL SEGMENTS, MAKE HISTOGRAMS OF TRUE PROPORTIONS IN BLOBS:

TRUE CROP TYPE PROPORTIONS IN BLOBS

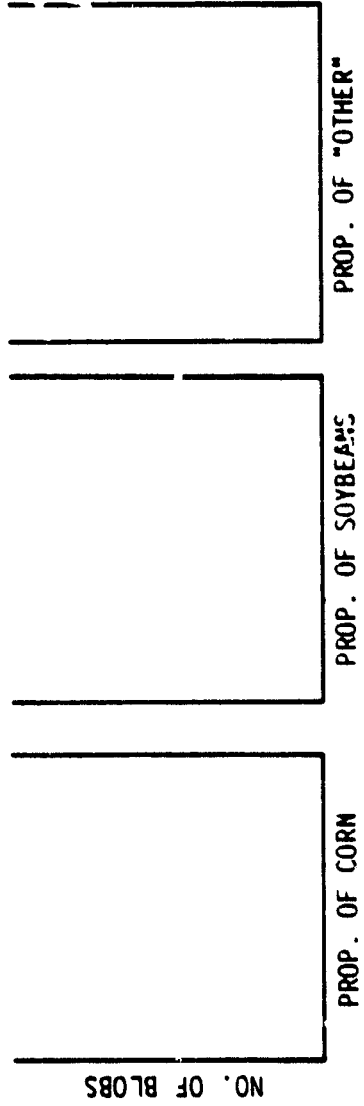

TRUE DFS CROP GROUP PROPORTIONS IN BLOBS

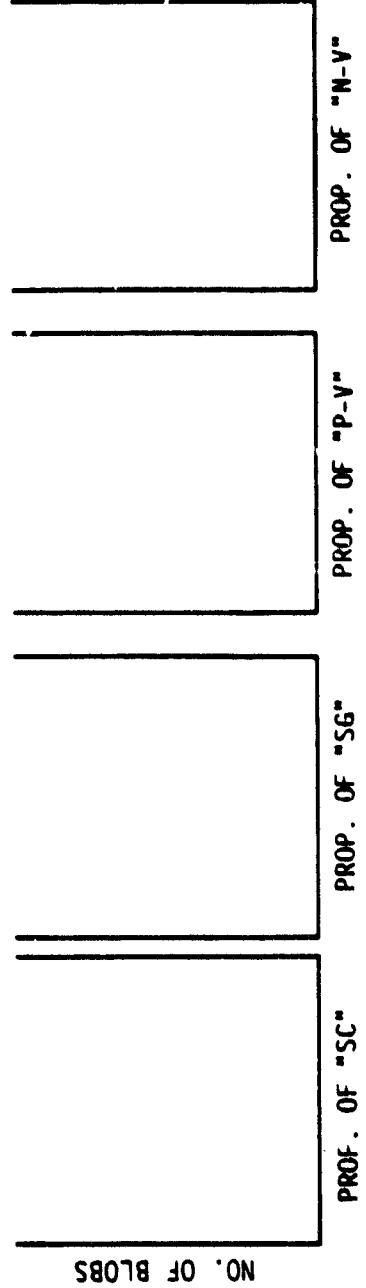

ORIGINAL PAGE IS OF POOR QUALITY

- FOR EACH DFS CROP GROUP (SC,SG,P-V, N-V), USING ALL CLUSTERS FROM ALL SEGMENTS WITHIN THAT CROP GROUP, MAKE HISTOGRAMS CORRESPONDING TO THOSE ABOVE
- USING ALL CLUSTERS FROM ALL DFS CROP GROUPS FROM ALL SEGMENTS, MAKE HISTOGRAMS CORRESPONDING TO THOSE ABOVE

- USING ALL "BIG" BLOBS IN ALL SEGMENT PROCESSINGS, PLOT THE FOLLOWING RELATIONSHIPS:

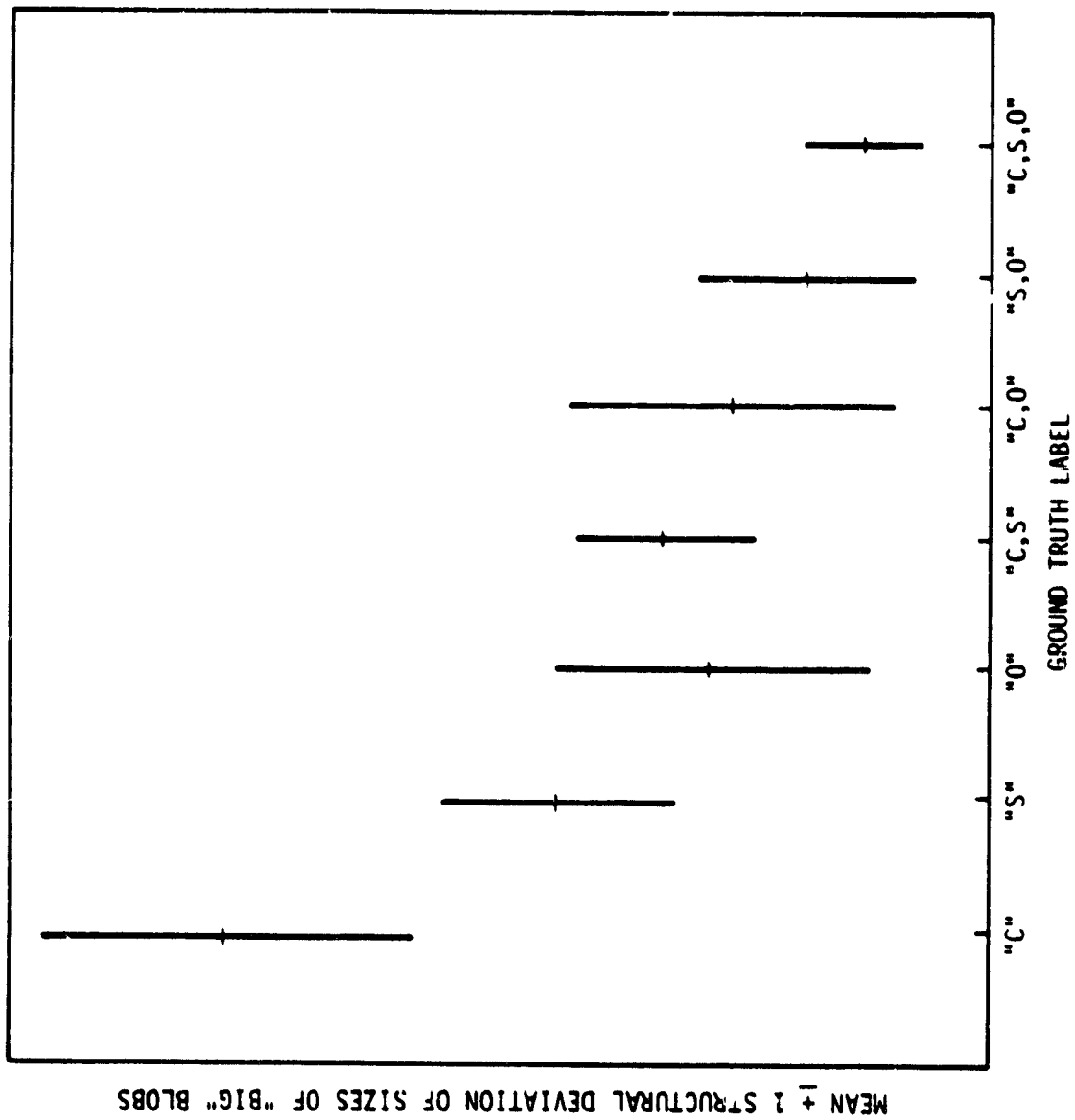

ACQUISITION HISTORY STUDY

- **OBJECTIVE:**
EVALUATE THE PERFORMANCE OF THE AREA ESTIMATION PROCEDURE UNDER A REDUCED ACQUISITION HISTORY.
- **APPROACH:**
DEFINE A SET OF 4 "OPTIMAL" ACQUISITIONS FOR 18-24 SEGMENTS FROM THE SET OF SEGMENTS PROCESSED IN PHASE ONE.

ASSIGN THESE ACQUISITIONS TO THE ANALYST TEAM NOT HAVING PREVIOUSLY PROCESSED THE SEGMENT FOR COMPLETE LABELING OF SAMPLED TARGETS.
- **EVALUATION:**
REPEAT ALL ANALYST FUNCTIONS AND MACHINE STRATIFICATION EVALUATIONS.

EVALUATION OF CROP DEVELOPMENT STAGE MODELS FOR CORN AND SOYBEANS

● OBJECTIVE

- ASSESS THE IMPROVEMENT OF THE AGROMET ADJUSTED MODELS TO PREDICT CROP GROWTH STAGES FOR CORN AND FOR SOYBEANS OVER HISTORICAL NORMALS IN THE U.S. CORN BELT.

● APPROACH

- THE CROP DEVELOPMENT MODELS WILL BE EVALUATED USING THE 1978, 1979 AND 1980 PERIODIC OBSERVATIONS FOR THE GROUND TRUTH SEGMENTS IN ILLINOIS, IOWA, AND INDIANA.

- THE EVALUATIONS WILL BE PERFORMED ON A REGIONAL BASIS TO TEST SENSITIVITY TO LOCATION.

- THE GROWTH STAGE MODELS WILL BE STARTED USING THE OBSERVED MEDIAN PLANTING DATE AND THE HISTORICAL NORMAL PLANTING DATE TO TEST FOR ADEQUACY OF NORMAL STARTING DATES (1979-1980). NO OBSERVED PLANTING DATES FOR 1978.

- THE BASIS FOR EVALUATION WILL BE THE MODEL'S ABILITY TO PREDICT THE MEDIAN GROWTH STAGES.

- THE ACCURACY WILL BE EVALUATED AT EACH CROP GROWTH STAGE/DATE-OF-STAGE.

- THE MEASURES OF ACCURACY WILL BE:

- MEAN ERRORS IN CROP GROWTH STAGE/DATE-OF-STAGE
- DISTRIBUTION OF ERRORS
- PERCENT OF ESTIMATES IN WHICH THE MODEL STARTED WITH THE OBSERVED PLANTING DATES IS MORE ACCURATE THAN THE MODEL STARTED WITH THE HISTORICAL NORMAL DATES.

EVALUATION OF HEIGHTED AGGREGATION PROCEDURE (MAP)

● OBJECTIVES

SHAKEDOWN OF MAP IN SPARSELY SAMPLED CORN/SOYBEAN AREA;

- EVALUATE PERFORMANCE OF MAP ON UNSIMULATED DATA UNDER CONDITIONS WHICH ARE FAR FROM IDEAL.
- LOOK FOR POTENTIAL PROBLEMS IN PRODUCTION-LINE ENVIRONMENT.

PRELIMINARY INDICATION OF EFFECT OF STRATUM SIZE ON PROCEDURE.

● APPROACH

DIVIDE THREE-STATE REGION (IOWA, ILLINOIS, INDIANA) INTO LARGE STRATA AND INTO SMALL STRATA.

- LARGE STRATA: PRODUCTION DENSITY STRATUM (PDS) \cap STATE.
- SMALL STRATA: UNIONS OF THREE TO FIVE COUNTIES.

AGGREGATE 1978 GROUND-TRUTH PROPORTIONS USING MAP TO OBTAIN AGGREGATED ACREAGE ESTIMATES FOR CORN, SOYBEANS, SUMMER CROPS, IN THREE-STATE REGION.

EVALUATION OF WEIGHTED AGGREGATION PROCEDURE (MAP)

● EVALUATION

- SUBJECTIVE EVALUATION OF UTILITY OF PROCEDURE IN PRODUCTION-LINE ENVIRONMENT.
- COMPARISON OF AGGREGATED ESTIMATES WITH SRS DATA (INSUFFICIENT DEGREES OF FREEDOM TO TEST HYPOTHESIS).
- COMPARISON OF AGGREGATED ESTIMATES, LARGE VS. SMALL STRATA (AGAIN, INSUFFICIENT DEGREES OF FREEDOM TO TEST).

● DATA REQUIREMENTS

- ALL 1978 GROUND-TRUTH SEGMENT-LEVEL PROPORTIONS IN THREE-STATE REGION.
- SRS COUNTY-LEVEL STATISTICS FOR 1972-1978 IN THREE-STATE REGION.
- FINAL 1978 SRS ACREAGE ESTIMATES FOR COMPARISON.

DATA AND DATA SYSTEM REQUIREMENTS

EODLS
TOTAL DISK STORAGE CAPACITY ≈ 200 MEGABYTES
TAPES ≈ 30 TAPES CERTIFIED TO 6250 BPI
6 USER ID'S
2 PILOT ID'S
PRINTER CAPABILITIES

PFC
TARGET OVERLAY PRODUCT

CSBP
SOFTWARE

CSBP
DATA MANAGEMENT SOFTWARE

PERSONNEL SUPPORT FROM S62
- TIMELY EXECUTION OF SOFTWARE
- STATUS AND TRACKING FUNCTION

FCPF PROJECT RISKS

- NO STARTER MODELS FOR CROP CALENDARS
- PHASE I WILL BE THE ONLY FULL EVALUATION OF THE BASELINE PROCEDURE POSSIBLE WITHIN THE FCPF PROPOSED PROGRAM

U.S. CORN SOYBEANS PILOT PHASE I RESOURCE SUMMARY

- RESOURCES DRAWN FROM THOSE PROVIDED FOR U.S. CORN/SOYBEANS PILOT AS DEFINED BY TASK SHEETS IN FCPF AND SR PROGRESS IMPLEMENTATION PLANS
- SCOPING CONSISTENT WITH TASK SHEET ESTIMATES
- FUNCTIONAL RESPONSIBILITIES ARE SUMMARIZED AS FOLLOWS;

ORIGINAL PAGE IS
OF POOR QUALITY

0 LOCKHEED
SH3
EXPERIMENT INTEGRATION/MANAGEMENT
EXPERIMENT DESIGN
SEGMENT ANALYSIS
AGGREGATION
EXPERIMENT REPORTING/DOCUMENTATION
CROP CALENDARS
WEATHER ANALYSIS
DATA/DATA SYSTEMS REQUIREMENTS
EVALUATION

0 ERIK/UCB
PROPORTION ESTIMATION PROCEDURE IMPLEMENTATION
SUPPORT TO EXPERIMENT DESIGN, SEGMENT ANALYSIS
AND EVALUATION

CIVIL SERVICE - SH3
EXPERIMENT
-S62
DATA PROVISIONING
DATA SYSTEMS

ACCURACY ASSESSMENT SOFTWARE REQUIRED

GROUND TRUTH READERS

- CALCULATE THE PERCENTAGE OF PIXELS IN EACH SEASONAL CROP-YEAR WHICH ARE "SPECTRALLY EMERGED"
- CALCULATE ACCURACY WITHIN THE SUMMER CROP STRATUM OF STAGE 1 LABELS
- LOCATE A GIVEN TARGET AND IDENTIFY PIXELS WITHIN
- CALCULATE PURITY OF VARIOUS STRATA
 - CROP GROUP STRATA (DFS)
 - B-CLUSTERS
 - BLOBS
- PROPORTION ESTIMATES
- COMPUTE \hat{P} FOR EACH OF THE DEFINITIONS OUTLINED UNDER MACHINE BIAS

SPECIAL SCENARIO - COMPUTE MACHINE VARIANCE

- EMPLOY MONTE CARLO TECHNIQUE TO SAMPLE A SCENE
- THEN LABEL TARGETS WITH GT

DATA

PROVISIONING PLAN - STILL OPEN

GROUND TRUTH FOR FIELD SIZE - TAPES AVAILABLE

CHANGES TO LEVEL B DATA REQUIREMENTS

- REDUCE PACKET REQUIREMENT TO 250 SEGMENTS
- REDUCE GT OVERLAY, AIRCRAFT PHOTO, AND 418 DOT PRODUCT REQUIREMENTS
- DROP REQUIREMENT FOR CRD/STATE OVERLAYS

HEADER INFORMATION ON LANDSAT DIGITAL TAPES

- REQUIRE INFORMATION TO RECOGNIZE AND CORRECT INCORRECT INFORMATION
 - SOLAR ELEVATION
 - SATELLITE IDENTIFICATION

EVALUATIONS NOT PERFORMED

1. NUMBER OF TARGETS TO BE LABELED
 - OBJECTIVE: WOULD A REDUCED NUMBER OF TARGETS (60) PRODUCE ACCEPTABLE SEGMENT-LEVEL PROPORTION ESTIMATES RELATIVE TO THE RECOMMENDED 100 TARGETS?
 - THIS WOULD REDUCE LABELING COST
 - PROVIDE INSIGHT INTO MSE OF THE CSRP
 - MAY LEAVE TO 2 EXPERIMENT
 - DECISION TEMPERED BETWEEN IMPORTANCE OF WITHIN-SEGMENT VARIANCE AND REGIONAL VARIANCE AFTER AGGREGATION
2. HOW WELL CAN A LINEAR DISCRIMINANT SEPARATE CORN AND SOYBEANS WITHIN THE SUMMER CROP DFS?
3. STABILITY OF DECISION LOGIC FOR LABELING (BETWEEN ANALYST EFFECT ON LABELING)
4. SENSITIVITY OF THE PROCEDURE TO PERFORMANCE OF SUBCOMPONENTS WHICH INVOLVE ANALYSTS DECISIONS
5. ACQUISITION HISTORY EFFECTS

ORIGINAL PAGE IS
OF POOR QUALITY

SUMMARY OF RID's RECEIVED

- An experiment overview and the general significance of the individual evaluations is needed in the Experiment Design to support the technical evaluations presented.
- A prioritization of tests and evaluations is requested by rank of importance to support upcoming experiments in the event that resources become not available to perform all proposed evaluations.
- Evaluation criteria for the planned quantitative evaluations are needed.
- Qualification of the evaluation of machine bias contributions to the area proportion estimates is needed.
- An evaluation of the impact of eliminating analyst team requirements on the procedure performance is needed.
- Operations plans and a defense of the experiment schedule within scheduled resources are needed to assure the feasibility of the experiment design.
- The ERIM/UCB corn/soybean consortium's role in the Pilot Experiment needs to be defined.
- Organization of the experiment design such that "segment effects" can be clearly designated is needed.
- A description of the data set in terms of agronomic features is needed to aid post-processing stratifications.
- Evaluation of the procedure performance under an acquisition history representative of single satellite coverage is requested.
- Evaluation of the effect of observed acquisition histories on the procedure performance is needed.

- Evaluation of the effect of crop calendar accuracy on the procedure performance is needed.
- Evaluation of the procedure subcomponent accuracies on the procedure performance is needed.
- Evaluation of the effect of film product quality on analyst performance is needed.

RID'S RECEIVED

RID NO.		SOURCE
1	Experiment overview lacking	T. Pendleton, NASA
2	Experiment overview lacking	M. Metzler, ERIM
3	Prioritization of evaluations	M. Metzler, ERIM
4	Power of quantitative evaluations	T. Pendleton, NASA
5	Power of quantitative evaluations	T. Pendleton, NASA
6	Analyst team requirements	T. Pendleton, NASA
7	Quantification of machine biases	B. Thelen, ERIM
8	Analyst team requirements	M. Metzler, ERIM
9	Operations plans and experiment schedule	K. Baker, NASA
10	C/S consortium's role in the pilot experiment	M. Metzler, ERIM
11	Interface definition - role of ERIM	R. McKinney, ERIM
12	CHARLIE access software requirements	K. Baker, NASA
13	Quantification of "Segment" effects	M. Metzler, ERIM
14	Description of segment characteristics	M. Metzler, ERIM
15	Acquisition history study	M. Metzler, ERIM
16	Crop calendar accuracy	M. Metzler, ERIM
17	Subcomponent accuracies and procedure performance	K. Baker, NASA
18	Film product quality and analyst performance	R. McKinney, NASA
19	Acquisition history and procedure performance	R. McKinney, NASA

DOCUMENT REVIEWED	LEVEL	REVIEW ITEM DISPOSITION		NUMBER
DATE OF REVIEW	27 Jan			1
REQUIREMENT REF	REQ ORIGINATOR	ORGANIZATION	EXTENSION	
	Pendleton	SH2	3611	
SUBJECT				
PDR of BL C/S Procedure				
DESCRIPTION OF PROBLEM				
<p>The preliminary design of the experiment, as presented, appears to contain many worthwhile tasks, both statistical tests and parameter collection and display. However, the presented design lacks an overview of what questions are being addressed, what tasks address each question, and what type of result is expected from each task. ("Result" is meant to imply "power of test", utility parameter collection, etc.)</p>				
IMPACT IF RECOMMENDATION NOT ACCEPTED				
<p>High probability that important aspects of the BL C/S procedures will not be evaluated adequately.</p>				
ORIGINATOR'S RECOMMENDATION				
<p>Develop the experiment overview, have the overview reviewed by FCPF and appropriate personnel, and hold another PDR.</p>				
ORIGINATING ORGANIZATION APPROVAL	NAME	SIGNATURE	DATE	
	T. Pendleton		22 Jan 81	
IMPLEMENTER'S RECOMMENDATION				
NAME		SIGNATURE		DATE
DISPOSITION				
<input type="checkbox"/> APPROVED AS WRITTEN <input type="checkbox"/> APPROVED WITH MODIFICATION <input type="checkbox"/> DISAPPROVED				
SCREENING BOARD CHAIRMAN		DATE	CONTROL BOARD CHAIRMAN	

DOCUMENT REVIEWED US C/S PDR for PILOT	LEVEL	REVIEW ITEM DISPOSITION		NUMBER 2
DATE OF REVIEW 26/27 January 81				
REQUIREMENT REF	REQ ORIGINATOR M. Metzler	ORGANIZATION ERIM	EXTENSION	
SUBJECT Key experiment design questions				
DESCRIPTION OF PROBLEM In description of tests, key questions or goals of tests were difficult to perceive.				
IMPACT IF RECOMMENDATION NOT ACCEPTED Value of tests may be lost due to lack of perceived focus.				
ORIGINATOR'S RECOMMENDATION Experiment design questions should be clearly identified and listed according to importance. Organization under major headings like: 1. analyst effects; 2. machine effects; 3. segment; 4. year; 5. sensor; and 6. procedure effects.				
ORIGINATING ORGANIZATION APPROVAL	NAME ERIM	SIGNATURE	DATE 28 Jan 81	
IMPLEMENTER'S RECOMMENDATION				
NAME		SIGNATURE		DATE
DISPOSITION <input type="checkbox"/> APPROVED AS WRITTEN <input type="checkbox"/> APPROVED WITH MODIFICATION <input type="checkbox"/> DISAPPROVED				
SCREENING BOARD CHAIRMAN	DATE	CONTROL BOARD CHAIRMAN	DATE	

ORIGINAL PAGE IS
OF POOR QUALITY

DOCUMENT REVIEWED US C/S Pilot PDR	LEVEL	REVIEW ITEM DISPOSITION		NUMBER 3
DATE OF REVIEW 26-27 Jan 81				
REQUIREMENT REF	AID ORIGINATOR M. Metzler	ORGANIZATION ERIM	EXTENSION	
SUBJECT Scope of experiment				
DESCRIPTION OF PROBLEM A large number of tests have been proposed which address many aspects of the performance of the procedure. It is unclear which tests are more important or should be eliminated in case of a resource impact.				
IMPACT IF RECOMMENDATION NOT ACCEPTED Important tests may be eliminated.				
ORIGINATOR'S RECOMMENDATION Prioritize tests.				
ORIGINATING ORGANIZATION APPROVAL	NAME ERIM	SIGNATURE	DATE 27 Jan 81	
IMPLEMENTER'S RECOMMENDATION				
NAME		SIGNATURE		DATE
DISPOSITION <input type="checkbox"/> APPROVED AS WRITTEN <input type="checkbox"/> APPROVED WITH MODIFICATION <input type="checkbox"/> DISAPPROVED				
SCREENING BOARD CHAIRMAN	DATE	CONTROL BOARD CHAIRMAN	DATE	

ORIGINAL DOCUMENT IS
OF POOR QUALITY

DOCUMENT REVIEWED		LEVEL	REVIEW ITEM DISPOSITION		NUMBER
DATE OF REVIEW				4	
REQUIREMENT REF	SIC ORIGINATOR	ORGANIZATION	EXTENSION		
	Pendleton	SH2	3611		
SUBJECT PDR of BL C/S Procedure					
DESCRIPTION OF PROBLEM In some instances, it appears not possible to estimate the power of the individual tests or experiments prior to running the experiments but it will be possible to estimate the power after the experiment is run. The experiment design does not provide for such analysis.					
IMPACT IF RECOMMENDATION NOT ACCEPTED Analysis may not take place because the appropriate data was not acquired during the experiment.					
ORIGINATOR'S RECOMMENDATION Plan, where required, analysis of experiment power.					
ORIGINATING ORGANIZATION APPROVAL	NAME	SIGNATURE		DATE	
	T. Pendleton			27 Jan 81	
IMPLEMENTER'S RECOMMENDATION					
NAME		SIGNATURE		DATE	
DISPOSITION <input type="checkbox"/> APPROVED AS WRITTEN <input type="checkbox"/> APPROVED WITH MODIFICATION <input type="checkbox"/> DISAPPROVED					
SCREENING BOARD CHAIRMAN		DATE	CONTROL BOARD CHAIRMAN		DATE

ORIGINAL NUMBER
OF POOR QUALITY

DOCUMENT REVIEWED	LEVEL	REVIEW ITEM DISPOSITION		NUMBER
DATE OF REVIEW				5
26 Jan 81				
REQUIREMENT REF	REQ ORIGINATOR	ORGANIZATION	EXTENSION	
	T. Pendleton	SH2	3611	
SUBJECT				
Power of tests to be applied to BL C/S P				
DESCRIPTION OF PROBLEM				
The experiment design does not appear to address the power of the tests to be conducted.				
IMPACT IF RECOMMENDATION NOT ACCEPTED				
Inappropriate tests may be conducted or tests which will give no information will be conducted.				
ORIGINATOR'S RECOMMENDATION				
Address the power of each of the tests to determine the significance level at which the affects will be detected, since the data set available for the experiment				
ORIGINATING ORGANIZATION APPROVAL	NAME	SIGNATURE	DATE	
	T. Pendleton		26 Jan 81	
IMPLEMENTER'S RECOMMENDATION				
NAME	SIGNATURE		DATE	
DISPOSITION				
<input type="checkbox"/> APPROVED AS WRITTEN <input type="checkbox"/> APPROVED WITH MODIFICATION <input type="checkbox"/> DISAPPROVED				
SCREENING BOARD CHAIRMAN	DATE	CONTROL BOARD CHAIRMAN	DATE	

DOCUMENT REVIEWER	LEVEL	REVIEW ITEM DISPOSITION		NUMBER
DATE OF REVIEW				6
REQUIREMENT REF	RIS ORIGINATOR	ORGANIZATION	EXTENSION	
	Pendleton	SH2	3611	
SUBJECT PDR of BL C/S Procedure				
DESCRIPTION OF PROBLEM The BL procedure requires analyst teams for the purpose of improving consistency. The trade-off is efficiency. The experiment plan does not address this trade-off between consistency and efficiency.				
IMPACT IF RECOMMENDATION NOT ACCEPTED A major factor in the use of remote sensing technology for commodity estimation is being ignored.				
ORIGINATOR'S RECOMMENDATION Design an experiment to address the trade-off between consistency and efficiency relating to analyst teams.				
ORIGINATING ORGANIZATION APPROVAL	NAME	SIGNATURE	DATE	
	T. Pendleton		27 Jan 81	
IMPLEMENTER'S RECOMMENDATION				
NAME		SIGNATURE		DATE
DISPOSITION <input type="checkbox"/> APPROVED AS WRITTEN <input type="checkbox"/> APPROVED WITH MODIFICATION <input type="checkbox"/> DISAPPROVED				
SCREENING BOARD CHAIRMAN	DATE	CONTROL BOARD CHAIRMAN	DATE	

ORIGINAL
OF POOR QUALITY

DOCUMENT REVIEWED US C/S PDR for Pilot	LEVEL	REVIEW ITEM DISPOSITION		NUMBER 7
DATE OF REVIEW 26/27 January				
REQUIREMENT REF	REQ ORIGINATOR B. Thelen	ORGANIZATION ERIM	EXTENSION	
SUBJECT				
DESCRIPTION OF PROBLEM Biases need to be summarized in a statistical type of setting.				
IMPACT IF RECOMMENDATION NOT ACCEPTED Difficult to analyze biases and characterize them if this is not done, especially if they are not large in magnitude.				
ORIGINATOR'S RECOMMENDATION By subsetting segments, determine subset effects. Finally, give average of all biases, as well as variance.				
ORIGINATING ORGANIZATION APPROVAL	NAME ERIM	SIGNATURE	DATE 27 Jan '81	
IMPLEMENTER'S RECOMMENDATION				
NAME	SIGNATURE		DATE	
DISPOSITION <input type="checkbox"/> APPROVED AS WRITTEN <input type="checkbox"/> APPROVED WITH MODIFICATION <input type="checkbox"/> DISAPPROVED				
SCREENING BOARD CHAIRMAN	DATE	CONTROL BOARD CHAIRMAN	DATE	

ORIGINAL PAGE IS
OF POOR QUALITY.

DOCUMENT REVIEWED JSC/S PDR for PILOT		LEVEL	REVIEW ITEM DISPOSITION		NUMBER 8
DATE OF REVIEW 26/27 January 81					
REQUIREMENT SET	REQ ORIGINATOR M. Metzler	ORGANIZATION ERIM	EXTENSION		
SUBJECT Analyst Teams					
DESCRIPTION OF PROBLEM Reduction of analyst contract time of 33 percent would be gained by not using an analyst team.					
IMPACT IF RECOMMENDATION NOT ACCEPTED A more efficient team must be developed to support phase II pilot.					
ORIGINATOR'S RECOMMENDATION Consider impact on experiment design to evaluate impact of eliminating team on Procedure performance (especially consistency in Stage 1 labels).					
ORIGINATOR'S ORGANIZATION APPROVAL	NAME ERIM	SIGNATURE		DATE 28 Jan 81	
IMPLEMENTER'S RECOMMENDATION					
NAME		SIGNATURE		DATE	
DISPOSITION <input type="checkbox"/> APPROVED AS WRITTEN <input type="checkbox"/> APPROVED WITH MODIFICATION <input type="checkbox"/> DISAPPROVED					
SCREENING BOARD CHAIRMAN		DATE	CONTROL BOARD CHAIRMAN		DATE

DOCUMENT REVIEWED C/S Exp. CDR		LEVEL	REVIEW ITEM DISPOSITION		NUMBER 9
DATE OF REVIEW 1/26-27/81					
REQUIREMENT REF	RFD ORIGINATOR K. Baker	ORGANIZATION SH3	EXTENSION 6451		
SUBJECT Segment Throughput Rate					
DESCRIPTION OF PROBLEM No operations analysis of the segment area estimation process was presented to indicate whether or not the resources planned are sufficient to carry out the number of segment processings that are planned on the current schedule. The amounts of analyst and calendar time consumed in the shakedown so far suggest that the experiment will not be completed within the planned experiment size, schedule, and resources.					
IMPACT IF RECOMMENDATION NOT ACCEPTED We may get an unpleasant surprise part way through the experiment by discovering then that the experiment is overscoped when we could have predicted it before we started.					
ORIGINATOR'S RECOMMENDATION Perform a throughput study of the segment analysis process that will quantify the relation between experiment design, schedule and manpower for the ERIM procedure and the JSC facilities for carrying it out. Use results to advise management as to whether planned experiment can be completed on schedule and within budget.					
ORIGINATING ORGANIZATION APPROVAL	NAME Ken Baker	SIGNATURE		DATE 1-30-81	
IMPLEMENTER'S RECOMMENDATION					
NAME		SIGNATURE		DATE	
DISPOSITION <input type="checkbox"/> APPROVED AS WRITTEN <input type="checkbox"/> APPROVED WITH MODIFICATION <input type="checkbox"/> DISAPPROVED					
SCREENING BOARD CHAIRMAN		DATE	CONTROL BOARD CHAIRMAN		DATE

DOCUMENT REVIEWED US C/S Pilot PDR	LEVEL	REVIEW ITEM DISPOSITION		NUMBER 10
DATE OF REVIEW 26-27 January 81				
REQUIREMENT REF	RTO ORIGINATOR M. Metzler	ORGANIZATION ERIM	EXTENSION	
SUBJECT ERIM's Role in Quality Assurance				
DESCRIPTION OF PROBLEM ERIM's role in quality assurance has not been identified.				
IMPACT IF RECOMMENDATION NOT ACCEPTED ERIM will be unable to confirm the results of the experiment.				
ORIGINATOR'S RECOMMENDATION ERIM examined the analyst's decisions, etc. for subset (10%) of segments processed as well as independently processed some of the segments in totality.				
ORIGINATING ORGANIZATION APPROVAL	NAME ERIM	SIGNATURE		DATE 28 Jan 81
IMPLEMENTER'S RECOMMENDATION				
NAME		SIGNATURE		DATE
DISPOSITION <input type="checkbox"/> APPROVED AS WRITTEN <input type="checkbox"/> APPROVED WITH MODIFICATION <input type="checkbox"/> DISAPPROVED				
SCREENING BOARD CHAIRMAN	DATE	CONTROL BOARD CHAIRMAN	DATE	

ONCE THE PROBLEM IS
OF POOR QUALITY

DOCUMENT REVIEWED	LEVEL	REVIEW ITEM DISPOSITION		NUMBER
DATE OF REVIEW 1/27/81				11
REQUIREMENT REF	JTD ORIGINATOR	ORGANIZATION	EXTENSION	
	R. McKinney	SH3	X 3155	
SUBJECT Interface Definition				
DESCRIPTION OF PROBLEM The interface between the U.S. C/S Pilot experiment and other organizations such as ERIM and LARS has not been defined nor acknowledged.				
IMPACT IF RECOMMENDATION NOT ACCEPTED The essential interfaces may not occur for efficient project completion.				
ORIGINATOR'S RECOMMENDATION Define and formalize the interfaces between LEMSCO and other agencies necessary to complete the project.				
ORIGINATING ORGANIZATION APPROVAL	NAME	SIGNATURE	DATE	
	Ramon McKinney		1/27/81	
IMPLEMENTER'S RECOMMENDATION				
NAME		SIGNATURE		DATE
DISPOSITION				
<input type="checkbox"/> APPROVED AS WRITTEN <input type="checkbox"/> APPROVED WITH MODIFICATION <input type="checkbox"/> DISAPPROVED				
SCREENING BOARD CHAIRMAN		DATE	CONTROL BOARD CHAIRMAN	

ORIGINAL PAGE IS
OF POOR QUALITY

DOCUMENT REVIEWED C/S Pilot Exp. PDR		LEVEL	REVIEW ITEM DISPOSITION		NUMBER 12
DATE OF REVIEW 1/26-27/81					
REQUIREMENT REF	REQ ORIGINATOR K. Baker	ORGANIZATION SH3	EXTENSION 6451		
SUBJECT Requirements for CHARLIE Access Software for Accuracy Assessment					
DESCRIPTION OF PROBLEM Many of the studies planned by accuracy assessment to evaluate various steps on the Area Estimation Procedure require results that are stored by the ERIM area estimation software in the segment analysis data base called CHARLIE. Thus, access routines to retrieve this data for use by accuracy assessment programs are needed. No written requirements exist that describe these needs, and ERIM, by their own statement, does not know exactly what is needed.					
IMPACT IF RECOMMENDATION NOT ACCEPTED Accuracy Assessment will either not have access to the segment analysis results they need or they will have to spend their own resources writing access routines for a data base whose internal structure they are not familiar with, since no program documentation has been delivered by ERIM yet.					
ORIGINATOR'S RECOMMENDATION Accuracy assessment would document in writing their requirements for access routines that would return to their programs from CHARLIE the segment analysis results that they need.					
ORIGINATING ORGANIZATION APPROVAL	NAME Ken Baker	SIGNATURE		DATE 1-30-81	
IMPLEMENTER'S RECOMMENDATION					
NAME		SIGNATURE		DATE	
DISPOSITION <input type="checkbox"/> APPROVED AS WRITTEN <input type="checkbox"/> APPROVED WITH MODIFICATION <input type="checkbox"/> DISAPPROVED					
SCREENING BOARD CHAIRMAN		DATE	CONTROL BOARD CHAIRMAN		DATE

ORIGINAL PAGE IS
OF POOR QUALITY

DOCUMENT REVIEWED US C/S PDR for Pilot		LEVEL	REVIEW ITEM DISPOSITION		NUMBER 13
DATE OF REVIEW 26/27 January 81					
REQUIREMENT REF	AID ORIGINATOR M. Metzler	ORGANIZATION ERIM	EXTENSION		
SUBJECT Segment effects					
DESCRIPTION OF PROBLEM A cohesive design for uncovering segment effects was missing, though it appeared in several spots. The power of the experiment with segment effects is unclear.					
IMPACT IF RECOMMENDATION NOT ACCEPTED The power of segment effect analyses will not be understood.					
ORIGINATOR'S RECOMMENDATION Design the experiment in a manner that organizes all segment effects under a single umbrella. Use a model to explain this: (eg $y = \mu + A + S + e$, where A is acquisition effect, and S is signature effect).					
ORIGINATING ORGANIZATION APPROVAL	NAME ERIM	SIGNATURE		DATE 28 Jan 81	
IMPLEMENTER'S RECOMMENDATION					
NAME		SIGNATURE		DATE	
DISPOSITION <input type="checkbox"/> APPROVED AS WRITTEN <input type="checkbox"/> APPROVED WITH MODIFICATION <input type="checkbox"/> DISAPPROVED					
SCREENING BOARD CHAIRMAN		DATE	CONTROL BOARD CHAIRMAN		DATE

DOCUMENT REVIEWED US C/S PDR for Pilot		LEVEL	REVIEW ITEM DISPOSITION		NUMBER 14
DATE OF REVIEW 26/27 January 81					
REQUIREMENT REF	REQ ORIGINATOR M. Metzler	ORGANIZATION ERIM	EXTENSION		
SUBJECT Data Set					
DESCRIPTION OF PROBLEM A description of the data set in terms of agronomical features (e.g. crop mix; field size, crop calendar) is needed.					
IMPACT IF RECOMMENDATION NOT ACCEPTED Segment effect analyses cannot be conducted.					
ORIGINATOR'S RECOMMENDATION Select a set of descriptive variables and stratify the data set (or rank the segments) according to these variables.					
ORIGINATING ORGANIZATION APPROVAL	NAME ERIM	SIGNATURE		DATE 28 Jan 81	
IMPLEMENTER'S RECOMMENDATION					
NAME		SIGNATURE		DATE	
DISPOSITION <input type="checkbox"/> APPROVED AS WRITTEN <input type="checkbox"/> APPROVED WITH MODIFICATION <input type="checkbox"/> DISAPPROVED					
SCREENING BOARD CHAIRMAN		DATE	CONTROL BOARD CHAIRMAN		DATE

DOCUMENT REVIEWED US C/S PILOT PDR		LEVEL	REVIEW ITEM DISPOSITION		NUMBER 15
DATE OF REVIEW 26-27 January 81					
REQUIREMENT REF	REQ ORIGINATOR M. Metzler	ORGANIZATION ERIM	EXTENSION		
SUBJECT Satellite Effect					
DESCRIPTION OF PROBLEM A programatically important question relates to the need of a 9-day versus a 18-day coverage requirement for crop inventory; there is some potential in the 1978 data set to address this issue.					
IMPACT IF RECOMMENDATION NOT ACCEPTED Postpone, but possibly will need to plan as exploratory with the emphasis.					
ORIGINATOR'S RECOMMENDATION Process a subset of segments (resources permitting) with one and two sensors, and test hypothesis that two sensors result in better performance.					
ORIGINATING ORGANIZATION APPROVAL	NAME ERIM	SIGNATURE		DATE 27 Jan 81	
IMPLEMENTER'S RECOMMENDATION					
NAME		SIGNATURE		DATE	
DISPOSITION <input type="checkbox"/> APPROVED AS WRITTEN <input type="checkbox"/> APPROVED WITH MODIFICATION <input type="checkbox"/> DISAPPROVED					
SCREENING BOARD CHAIRMAN		DATE	CONTROL BOARD CHAIRMAN		DATE

ORIGINAL PAGE 10
OF PDR QUALITY

DOCUMENT REVIEWED US C/S PILOT PDR		LEVEL	REVIEW ITEM DISPOSITION		NUMBER
DATE OF REVIEW 26-27 Jan 81				16	
REQUIREMENT SET	RIS ORIGINATOR M. Metzler	ORGANIZATION ERIM	EXTENSION		
SUBJECT Value of crop calendar experiments.					
DESCRIPTION OF PROBLEM Although accuracy of the crop calendar adjustment is tested, the accuracy required for the procedure is not addressed.					
IMPACT IF RECOMMENDATION NOT ACCEPTED It will not be known how important (good) crop calendars are to the proportion estimates.					
ORIGINATOR'S RECOMMENDATION Process subset of segments using various crop calendars (analyst historical, "correct") and evaluate proportion estimates produced.					
ORIGINATING ORGANIZATION APPROVAL	NAME ERIM	SIGNATURE		DATE 28 Jan 81	
IMPLEMENTER'S RECOMMENDATION					
NAME		SIGNATURE		DATE	
DISPOSITION <input type="checkbox"/> APPROVED AS WRITTEN <input type="checkbox"/> APPROVED WITH MODIFICATION <input type="checkbox"/> DISAPPROVED					
SCREENING BOARD CHAIRMAN		DATE	CONTROL BOARD CHAIRMAN		DATE

ORIGINAL PAGE IS
OF POOR QUALITY

DOCUMENT REVIEWED C/S Exp. PDR		LEVEL	REVIEW ITEM DISPOSITION		NUMBER 17
DATE OF REVIEW 1/26-27/81					
REQUIREMENT REF	REQ ORIGINATOR K. Baker	ORGANIZATION SH3	EXTENSION 6451		
SUBJECT Experiment Design					
DESCRIPTION OF PROBLEM The experiment design includes many small studies of the performance of various individual steps in the segment area estimation process. However, few plans appear to have been made to directly determine the effect of these steps on the quality of the final answer.					
IMPACT IF RECOMMENDATION NOT ACCEPTED The experiment may not produce any estimate of how much the overall accuracy of the procedure could be improved nor any reliable indicators as to which steps in the procedure are most important in its overall performance.					
ORIGINATOR'S RECOMMENDATION The experiment design should be modified to include more study of the effect that the accuracy with which the various intermediate steps are carried out has on the accuracy of the final result.					
ORIGINATING ORGANIZATION APPROVAL	NAME Ken Baker	SIGNATURE		DATE 1-30-81	
IMPLEMENTER'S RECOMMENDATION					
NAME		SIGNATURE		DATE	
DISPOSITION <input type="checkbox"/> APPROVED AS WRITTEN <input type="checkbox"/> APPROVED WITH MODIFICATION <input type="checkbox"/> DISAPPROVED					
SCREENING BOARD CHAIRMAN		DATE	CONTROL BOARD CHAIRMAN		DATE

ORIGINAL
OF PUBLICATION

DOCUMENT REVIEWED	LEVEL	REVIEW ITEM DISPOSITION		NUMBER
DATE OF REVIEW				18
REQUIREMENT REF	REQ DISTRIBUTOR	ORGANIZATION	EXTENSION	
	R. McKinney	SH3	3155	
SUBJECT				
Establish Relationship Between Film Products Quality and Analyst Performance				
DESCRIPTION OF PROBLEM				
Light/dark contrast, textural distribution, and other physical qualities of the film products used by the analysts in labeling vary widely between acquisitions and sample segments. These qualities seriously affect the accuracy of analyst performance. This fact is ignored in the design of the many experimental studies proposed to study various aspects of procedure involving analyst performance. The visual perception quality of film products should be considered.				
IMPACT IF RECOMMENDATION NOT ACCEPTED				
The influence of film product quality and its effect on analyst performance, if ignored, may lead to erroneous conclusions regarding the importance of other experimental variables.				
ORIGINATOR'S RECOMMENDATION				
Attempt to scientifically establish the relative perceptual qualities of film products used in the proposed experimental studies that this influence can be rationally evaluated.				
ORIGINATING ORGANIZATION APPROVAL	NAME	SIGNATURE	DATE	
	Ramon McKinney		1/27/81	
IMPLEMENTER'S RECOMMENDATION				
NAME		SIGNATURE		DATE
DISPOSITION				
<input type="checkbox"/> APPROVED AS WRITTEN <input type="checkbox"/> APPROVED WITH MODIFICATION <input type="checkbox"/> DISAPPROVED				
SCREENING BOARD CHAIRMAN		DATE	CONTROL BOARD CHAIRMAN	DATE

**ORIGINAL PAGE IS
OF POOR QUALITY**

DOCUMENT REVIEWED	LEVEL	REVIEW ITEM DISPOSITION	NUMBER
DATE OF REVIEW			19
REQUIREMENT REF	PILOT SIGNATURE	ORGANIZATION	EXPERIMENT
	R. McKinney	SH3	3155
SUBJECT Establish relationship between number and distribution of sample segment acquisitions and analyst performance			
DESCRIPTION OF PROBLEM			
<p>Experimental studies proposed comparing sample segments and involving analyst performance did not reflect consideration of the total number of acquisitions per sample segment, nor their distribution over the growing season. Differences between such sets seriously affect analyst performance.</p>			
IMPACT IF RECOMMENDATION NOT ACCEPTED			
<p>Relationships between changes in experimental variables of interest may be obscured by the effect of differences between sets of acquisitions for different sample segments.</p>			
ORIGINATOR'S RECOMMENDATION			
<p>Attempt to scientifically establish the differences between sets of acquisitions for various sample segments, rating them both for a combination of total number of interest and their distribution over the growing season.</p>			
ORIGINATING ORGANIZATION APPROVAL	NAME	SIGNATURE	DATE
	K. McKinney		1/27/81
IMPLEMENTER'S RECOMMENDATION			
NAME	SIGNATURE		DATE
DISPOSITION			
<input type="checkbox"/> APPROVED AS WRITTEN <input type="checkbox"/> APPROVED WITH MODIFICATION <input type="checkbox"/> DISAPPROVED			
SCREENING BOARD CHAIRMAN	DATE	CONTROL BOARD CHAIRMAN	DATE

RESPONSE TO RID's

No.

1, 2 EXPERIMENT OVERVIEW AND GENERAL SIGNIFICANCE OF EVALUATIONS WERE LACKING

1. A summary of the planned evaluations has been prepared and included in the experiment plan which defines for each individual evaluation:
 - a. The general purpose and significance.
 - b. The general approach to meeting the evaluation objectives.
1. Detailed information has been added to each individual evaluation plan to define:
 - a. The specific purpose, significance and key questions addressed by the evaluations.
 - b. The detailed description of the evaluations including the evaluation criteria.

3 PRIORITIZATION OF EVALUATIONS

The tests for the 1978, 1979, and 1980 data have been reviewed in terms of the project objectives: (1) Processing of the 12 1978 segments in the year-to-year study have been delayed until all team objectivity and 1979 data processings are complete. (2) Evaluations of the results to be completed in FY1981 have been prioritized and presented to NASA management.

Otherwise at this time, it appears that all proposed evaluations can be accomplished prior to completion of the pilot experiment in FY1982.

4, 5 POWER OF THE QUANTITATIVE EVALUATIONS

Evaluation criteria have been incorporated into the evaluation plans where a priori estimates of performance were available. For example, the power of the team objectivity and the procedure comparison analyses of variance have been estimated using empirical results from the LACIE TY exploratory experiment.

No.

7 QUANTIFICATION OF MACHINE BIASES

The biases inherent in the proportion estimation calculations will be estimated as defined in the preliminary experiment design. In addition, evaluations of these biases have been quantified and included in the evaluation plan. Simultaneous confidence limits will be completed and the importance of each machine bias and defined linear combination of biases will be addressed.

6, 8 ANALYST TEAM REQUIREMENTS

To improve the processing efficiency of the baseline procedure in the pilot experiment over the shakedown test performance, the number of functions requiring full participation of an analyst team has been reduced (11). At the end of the processing of the 1978-79 data set, several analysts will have considerable experience. It is felt that they will be able to judge what functions will require team decisions. Otherwise, considerable resources would be drawn from existing evaluations to process a separate set of segments to quantify the difference in the individual analyst and team performances.

9 OPERATIONS PLANS AND DEFENSE OF EXPERIMENT SCHEDULE WITHIN SCHEDULED RESOURCES ARE NEEDED

Proportion estimation has prepared and presented to project management an operations plan (17) to define whether the segment processings required to support the experiment design are within the scope of the pilot experiment. This operations plan was based upon the result of the shakedown test. The latest version of the plan based upon the early processings of the 1978-79 data set is included in the experiment plan.

10, 11, 12 ERIM/UCB CONSORTIUM'S ROLE(S) IN THE PILOT EXPERIMENT

Several roles supporting the pilot experiment have now been formally identified. These include:

1. Image and CHARLIE library access software is anticipated to be delivered by ERIM. Accuracy assessment has identified for NASA the respective access software requirements to support the pilot experiment (8).
2. For quality assurance, ERIM will verify the procedure interpretation of the Lockheed personnel for a subset of segments in the team objectivity evaluation. If substantial problems with procedure interpretation are identified, ERIM will present the results

No.

to a configuration control team composed of the C/S Consortium, NASA, and Lockheed personnel. Upon review of the problem, this team will specify what action may be required.

13 QUALIFICATION OF SEGMENT EFFECTS

The current experiment design addresses the segment effects of field size, crop proportions, and crop ratios. These tests are uncontrolled. However, they will capture whatever range the available segment data offers. The segment-level effects suggested in the RID (i.e., acquisition and signature effects) are also uncontrolled. Those effects are not easily quantifiable in a manner which can be modeled to an analysis of variance as suggested.

14 DESCRIPTION OF SEGMENT CHARACTERISTICS

The data set for the 1978-79 crop year evaluations has been strictly defined by the limits of the available data to support the experiment design for the team objectivity, procedure, and year-to-year evaluations. Subsequent to the PDR, accuracy assessment has summarized from UGTT ground truth information the proportions of the major crops in the 1978 crop year data. The additional segments are expected to be characterized when the necessary information becomes available. These will be used to stratify the results in the course of the evaluations.

15 ACQUISITION HISTORY STUDY

To quantify the effect of acquisition history on the procedure performance would require drawing resources from the existing studies:

1. Rankings of performance within the observed acquisition histories.
2. Segment processings within the planned evaluations have been defined to be performed under either 10- or 9-day acquisition histories.

Therefore, insight into the question can be gained by comparison of the results of the planned evaluations.

16 CROP CALENDAR ACCURACY

To quantify in a controlled experiment the effect of crop calendar accuracy on the overall procedure performance would be at present very costly. It is preferable to defer such an analysis until the procedure is automated to the level that the evaluation is affordable. However, in an uncontrolled evaluation, the effect of correctly defined biowindows resulting from analyst interpretation of spectral

No.

and crop calendar information will be quantified as defined in the experiment plan.

17 EFFECTS OF SUBCOMPONENT ACCURACIES ON THE PROCEDURE PERFORMANCE

Quantitative evaluation of the subcomponent effects on the procedure performance would require standardization of the procedure preceding the subcomponent under assessment. The large number of processings that would be required to quantify the many combinations would be extremely costly. The experiment design was limited by the number of processings allowed within the scope of the experiment and the time demands of the procedure. Hence, the design was prepared to learn the most within the resources available, 60 processings. In addition, the experiment design addresses the question of subcomponent effect upon procedure performance in uncontrolled evaluations.

18 EFFECT OF FILM PRODUCT QUALITY ON ANALYST PERFORMANCE

It is not apparent that variables related to film quality can be operationally defined. Experiment design is open to suggestions on how image quality can be classified. Perhaps if a method is conceived, this problem can be addressed in a later experiment design or techniques development.

19 ACQUISITION HISTORY VS. PERFORMANCE:

It appears difficult to define variables regarding the quality and the temporal distribution of available acquisitions whose relationships with other variables regarding procedure performance could be interpreted. Such variables would have to take into account:

1. The "quality" of the imagery for each available acquisition.
2. The spectral biowindows of the crops of interest for the growing seasons covered by the available acquisitions.
3. The spectral separability of the crops of interest on the imagery for each available acquisition.
4. The criteria, the non-imagery data (crop calendars, etc.), and the procedures prescribed for estimating 1., 2., and 3.
5. The criteria and the procedures prescribed for selecting acquisitions for processing from among the available ones.

No.

6. The methods for "errors" in estimating 1., 2., and 3., and "errors" in selecting acquisitions for processing.

It is not clear how the relative effects of these factors can be determined, for they seem to be interrelated and to require subjective judgment.

It is clear that the quality and the temporal distribution of the available acquisitions place an upper limit on the potential performance of any area proportion estimation procedure. But it is not clear how to determine for a particular set of available acquisitions what is the best possible performance without testing it for every permissible combination of selected acquisitions. This is so because it is not clear how to determine in advance what is the "best possible" combination of selected acquisitions. For the same reason, it is not clear how to assess the relationships between available acquisitions and analyst performance.