

NASA TM-84483

*See ref. 10 ref  
note date*

# NASA Technical Memorandum 84483

*H. Benz,*

*Info.*

*Hub H*

NASA-TM-84483 19820017567

# Multimode Fiber Optic Wavelength Division Multiplexing

**J. Larry Spencer**

**April 1982**

**LIBRARY COPY**

**MAY 18 1982**

**LANGLEY RESEARCH CENTER  
LIBRARY, NASA  
HAMPTON, VIRGINIA**



**National Aeronautics and  
Space Administration**

**Langley Research Center  
Hampton, Virginia 23665**

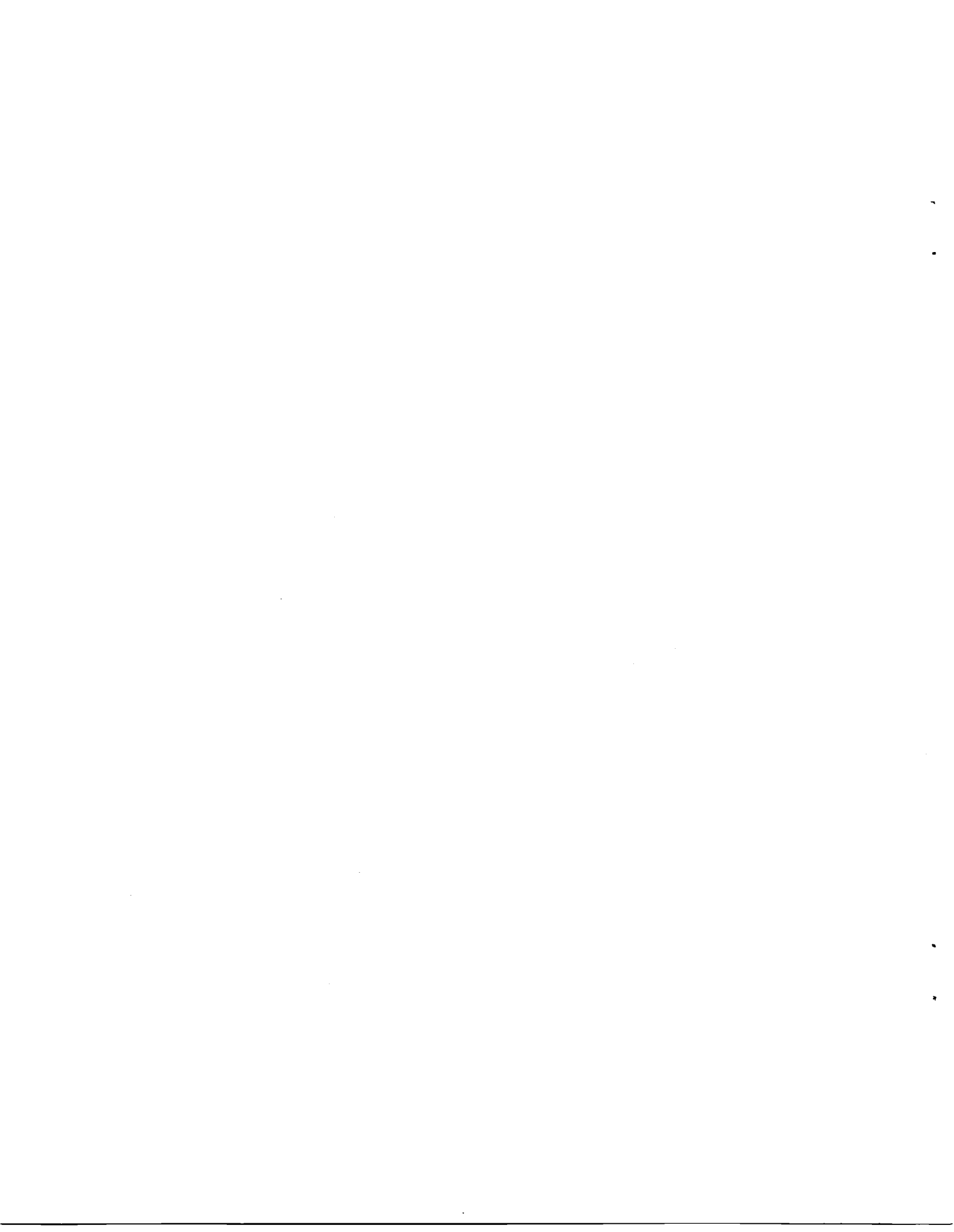

# MULTIMODE FIBER OPTIC WAVELENGTH DIVISION MULTIPLEXING

by J. Larry Spencer  
NASA Langley Research Center  
Hampton, Virginia 23665

## ABSTRACT

Optical wavelength division multiplexing (WDM) systems, with signals transmitted on different wavelengths through a single optical fiber, can have increased bandwidth and fault isolation properties over single wavelength optical systems. This paper considers two WDM system designs that might be used with multimode fibers and gives a general description of the components which could be used to implement the system. The components described are sources, multiplexers, demultiplexers, and detectors. Emphasis is given to the demultiplexer technique which is the major developmental component in the WDM system.

## INTRODUCTION

Optical wavelength division multiplexing (WDM) involves the simultaneous transmittal of information via different wavelengths of light. The various wavelengths after generation by separate optical sources are mixed by a multiplexer and transmitted over an optical communication link. At the receiving end of the link, the distinct wavelengths of light are separated by a demultiplexer and converted to electrical signals by a photo detector. By using WDM a single optical fiber will provide multiple transmission paths. WDM increases the information capacity of a single optical fiber and also provides a means for two-way simultaneous transmission (full duplex). For a given data transmission requirement a WDM system would require less optical fibers, repeaters, splices and/or connectors than a single wavelength system.

The WDM systems also have the standard advantages of single wavelength optical systems such as reduced weight and cost and immunity to lightning-induced transients.

An additional attribute of WDM is that a faulty or failed transmitter will be confined to a single communication path and will not disturb the information transmitted on the same fiber at different wavelengths. This fault containment attribute makes WDM a prime candidate for application in NASA-Langley's research program in flight crucial fault tolerant systems for advanced aerospace vehicles.

## GENERAL SYSTEM DESCRIPTIONS

As discussed in the introduction, there are two general system design advantages using WDM techniques. The one for increasing the capacity of the transmission system and the second pertains to fault containment in the system. An N channel WDM system block diagram of the increased capacity type is shown in figure 1. Each input channel has an optical source transmitting light at a given wavelength. The output of these sources are combined onto a single transmission fiber using a passive multiplexer.

#  
N82-25443

The multiplexed optical signals travel through the transmission fiber to a passive demultiplexer that separates the multiplexed signals into their optical wavelength components. A nonwavelength selective detector is used to convert each optical signal out of the demultiplexer into an electrical signal. For a WDM system, various signals such as analog and digital data, video signals, and audio signal can be transmitted simultaneously on the single transmission fiber. Systems of this type have been demonstrated for up to 12 channels (ref. 1).

A block diagram of a fault containment type WDM system for a four subsystem version is shown in figure 2. Each optical transmitter at the subsystem will transmit at the given wavelengths ( $\lambda_1, \lambda_2, \lambda_3, \lambda_4$ ). These transmitted signals are mixed in the multiplexer and produce four identical outputs. These outputs are distributed to the four subsystems via the fiber optic links. At each subsystem the output of the multiplexer is separated into its four optical components ( $\lambda_1, \lambda_2, \lambda_3, \lambda_4$ ) by a demultiplexer. Each of the four optical outputs of the demultiplexer is converted from an optical signal to an electrical signal by the detector. If one of the transmitters fails in a mode of transmitting erroneous data on the bus or transmitting continuous noise, it will not effect the other data transmissions because of the separation of optical wavelengths. Such a fault will be confined to its own transmission path. For a flight crucial application, the system shown in figure 2 would be one channel of a redundant data distribution system. The redundancy level would be determined by the criticality of the application. NASA-Langley with a contract to Hughes Research Labs is developing a four wavelength system as shown in figure 2 (ref. 2). The remainder of this paper will describe the components that make up a WDM system which are the optical sources, multiplexers, demultiplexers, and detectors.

## OPTICAL SOURCES

Optical communication sources for aerospace applications can be divided into two classes: Sources that transmit light in the wavelength region of 780nm through 860nm, which are usually Al Ga As devices, and sources that transmit light in the wavelength regions of 1100nm through 1700nm, which are usually In Ga As P devices. Currently for short distance data transmission systems Al Ga As sources are the solution but for long-distance optical communications In Ga As P devices are extremely attractive. Both Light Emitting Diodes (LED) and Laser Diodes (LD) can be made of Al Ga As or In Ga As P for the optical sources in a communication system. For a WDM system, the LD is more attractive than the LED. The LED has a relatively wide output spectral bandwidth (one or two orders of magnitude larger than the laser diode) and much poorer coupling efficiency to the fiber (at least 10db less than laser-to-fiber coupling efficiency)(ref. 3). The emission spectra of a typical laser diode is less than 1.0nm wide at the half amplitude point. This measurement is called the full width half max (FWHM) in the literature. For an LED source, the FWHM is typically 30.0nm for the Al Ga As device and 100.0nm for the In Ga As P devices. If optical filters were not used on each source, the WDM system using LEDs would be limited to two wavelengths, one source constructed of Al Ga As and the second source constructed of In Ga As P. Optical filters can be used to increase the number of wavelengths in a WDM system using LEDs but each filter will introduce an insertion loss in the

optical link. The laser diode also has the advantage of a larger modulation bandwidth. Two disadvantages of laser diodes are cost and more temperature effects on the emitted optical output. The schematic representation and operating characteristics of a typical Al Ga As laser diode is shown in figure 3 (ref. 4). The photograph in figure 4 shows a typical laser diode transmitter. The laser diode is located in the center of the printed circuit (PC) board and is mounted on a thermo-electric (TE) cooler. All the electronics on the PC board except one dual-in-line package are controlling the temperature of the laser via the TE cooler. The other IC is controlling the input current to the laser.

## MULTIPLEXERS

The function of the optical multiplexer is to combine the outputs of the optical sources to form a signal to be transferred to the demultiplexer via the transmission fiber. The multiplexer required for the system shown in figure 1 combines the outputs of the optical sources onto a single fiber whereas the multiplexer used in the system shown in figure 2 combines the outputs of the optical sources onto a multiple number of fibers.

For the multiplexer used in the system in figure 1, a wavelength sensitive component will be the most efficient. The system multiplexer will probably be the same component as the demultiplexer but it will be used in a reciprocal manner. For these wavelength sensitive devices, the attenuation of each optical signal through the device is not related to the number of channels being multiplexed. This means that channel expansion of the system will not be limited by the additional insertion losses caused by increasing the number of channels of the multiplexer and demultiplexer. A more detailed description of the wavelength sensitive multiplexing components will be given in the next section of this paper.

An interesting concept concerning the integration of optical sources and multiplexer onto a single chip has been described in the literature (ref. 5). This single chip could be used for the sources and multiplexer in the system shown in figure 1. In figure 5a, an array of six distributed-feedback (DFB) lasers are shown coupled to a single-channel waveguide. A cross section view of the DFB laser construction is shown in figure 5b. The lasers have gratings of different spacings (.9nm apart) and as a result, emit different wavelengths (2.0nm apart) of light. The light from each laser is combined in a passive channel waveguide. The output of the chip waveguide is butt-coupled to a single transmission fiber.

The multiplexer used in the system in figure 2 will have an output for each subsystem in the data distribution system. A nonwavelength sensitive star coupler is used for the system multiplexer. The two basic types of star couplers are reflective and transmissive as shown in figure 6. Reflective star couplers are typically designed using a mixing rod with a mirror end plate that diffuses the light and reflects it back to all the fibers. The most popular type of transmission star is the biconical tapered coupler. The component is constructed by cutting the desired number of fibers, stripping the cladding from an area in the middle of the cut length of fiber and twisting together this uncladded portion of the fibers into a bundle or other close-packed formation. By putting the

fibers under tension and subjecting them to a closely controlled heat, the fibers will soften and fuse together. By placing tension on the fibers during this fusing process, a biconical tapered region will form (figure 7). As light from the optical sources travels through the input fibers to this fused region, the taper will keep the light trapped in this fused portion of the fiber. If the device is constructed properly, the input light will be equally distributed to the output fibers. The throughput attenuation of an optical star coupler is equal to the reciprocal of the number of outputs of the star plus the excess loss in the coupler. This excess loss is typically 2db. There are many other ways of mechanizing star couplers such as the use of lenses and optical planar devices but an indepth discussion of this subject is beyond the scope of this tutorial paper. Most of the devices require more elaborate fabrication techniques with little performance improvement.

### DEMULTIPLEXER

The function of the demultiplexer is to separate the multiplexed optical signal into the individual wavelength components. The demultiplexer is the major developments component in a WDM system.

The success of a WDM system is directly proportional to the crosstalk level and insertion loss associated with the demultiplexer. The demultiplexer must separate each wavelength despite the modal, linear, and angular dispersion of the transmission fiber waveguide supply in the demultiplexer with its signal. For the transmission system to operate with a  $10^{-9}$  bit error rate, the crosstalk levels between the outputs should be less than 30db. The spectral width of each output should be narrow so no infringement of light occurs on the spacial region of the other outputs. This infringement causes interchannel crosstalk. The insertion loss requirements of the demultiplexer is dependent on the WDM overall system design but with sources and detectors available today, allowable losses between transmitters and receivers of 50db or more are possible (ref. 6).

The primary components used for performing the demultiplexing are (ref. 7) prisms, filters, and gratings. In this section of the paper, a general description of the principle of operation for each demultiplexing component will be given along with general performance comments.

#### Prisms

A functional schematic of a typical prism demultiplexer is shown in figure 8. A prism demultiplexer is classified as an angular dispersing device (ref. 8). The radiation from the input fiber is collimated by a lens and passed through the prism which disperses the radiation according to wavelength. The separated wavelengths are focused on the output fibers by a second lens. Prism demultiplexers are expensive to produce because the design requires two lenses and an expensive, high-quality prism. A prism demultiplexer is also bulky. Few prism demultiplexers have been built because of high cost and difficulty of miniaturization and therefore, performance characteristics are sparse. In addition, precise mounting of the input and output fibers, both lenses, and the prism element is required.

## Filters

In many WDM systems, filters are used to help improve the signal to noise ratio of the detected signals, but few are used as the wavelength discriminating device. In general, there are two classes of optical filters, the bandpass filter or interference filter and the high or low pass filter or the dichroic filter. For the interference filter there are essentially two types: (1) absorption filters, and (2) dielectric (non-absorbing) filters. The absorption filters are generally made of gelatin containing various organic and inorganic dyes. The filters are sensitive to temperature, humidity, and prolonged exposure to light. The filters are quite broadband (typical 100.0nm) with a transmittance of approximately 50 percent. Because absorption filters are broadband and environmentally sensitive, they are not viable for use in WDM systems (ref. 9). The dielectric filters are usually made of multilayers of different refractive index dielectric materials. These filters are sealed against humidity effects and are quite flexible. The filters have bandwidths between .5nm to 50.0nm and a transmittance of 50 percent or greater. The dielectric filters are very sensitive to the angle and collimation of the entering light.

A dichroic filter is an optical component that discriminates wavelengths by transmitting certain wavelengths while reflecting energy of higher or lower wavelengths. These filters are usually used at an angle of incidence of  $45^{\circ}$  with the light beam. The longer wavelengths of light are passed through the filter while the shorter wavelengths of light are reflected at  $90^{\circ}$  to the passed beam. Temperature changes have about the same reaction, approximately 0.8 percent to 2.2 percent per 100 degrees C, on dichroic filters as on dielectric filters.

Since a properly designed filter will only select a single wavelength out of a composite signal, an N channel WDM system would require at least N-1 filters and N+1 separate collimators. The insertion loss of a filter type demultiplexer using filters will be proportional to the number of channels in the WDM system. The more channels the more a given wavelength may be attenuated as it passes through the demultiplexer. Also, the size of the demultiplexer is proportional to the number of wavelengths being separated. The attractive features of interference filters are ease of production, small size capability, and low cost.

Shown in figure 9 is a simplified schematic of a demultiplexer using interference filters. A four wavelength system (ref. 10) with 20 to 30db isolation between channels and 8 to 11db of insertion loss has been built and tested. A simplified schematic of a demultiplexer using dichroic filters is shown in figure 10. A full duplex bidirectional link has been built and tested using dichroic filters (ref. 11). The two wavelength system had approximate 12db attenuation with -30db to -40db crosstalk. There are other systems for which each channel has equal path lengths (ref. 9) and for an eight wavelength system each channel passes through only three filters. Other demultiplexers have been tried using dichroic filters. One type uses fibers cut and polished at 45 degrees to their longitudinal axis. The filters are sandwiched between the fibers. By sending two wavelength signals down the fiber, one will pass through the filter while the other will be reflected  $90^{\circ}$  into a second fiber (ref.11).

Very little experimental data have been published on demultiplexers using dichroic filters.

Other demultiplexer approaches have been described in the literature (ref. 8) using multiple-grating filters. This approach has the advantage of eliminating all except one collimating lens and a single output focusing lens, thereby simplifying the packaging of the demultiplexer. Because of the difficulty of producing a photosensitive material suitable for making these devices, they are not reliable at this time but such a material might be developed in the future.

## Diffraction Gratings

A diffraction grating operates in a similar manner as a prism in that it spreads out a light beam into its component wavelengths. This process, which is called dispersion, is performed in parallel with prisms and diffraction grating demultiplexers, and in series with filter demultiplexers. Any device which is equivalent in its action to a number of parallel equidistance slits of the same width is called a diffraction grating. There are two types of diffraction gratings; the transmission grating and reflection grating. All of the demultiplexers described in this section of the paper use the reflection type of grating. A reflection grating can be made by ruling parallel lines on a polished plate. The surface between the ruled lines is capable of reflecting light while the ruled lines will not reflect light. The surface reflecting the light in effect form reflecting slits. The efficiency of a diffraction grating can be improved by blazing the grooves. To blaze the grooves, each reflecting surface is constructed at an angle proportional to the wavelength at which the diffraction grating is designed to disperse. Blazed reflective gratings can be 75 percent or more efficient. Blazed gratings are constructed by ruling with a diamond point, chemical etching, photo etching, or ion milling.

To use a diffraction grating as the wavelength separating element in a demultiplexer, the light before diffraction must be collimated and after diffraction must be focused on each output fiber. The methods of performing this collimation and focusing form the major differences in the demultiplexer designs. Demultiplexers which use lenses, Graded-Refractive-Index (GRIN) rods, and planar waveguides will be described.

The optical demultiplexer described in reference 12 uses two conventional lenses as the collimator and focuses and a blazed reflective diffraction grating as the wavelength sensitive element. The demultiplexer is mounted in a Littrow configuration as shown in figure 11. Radiation of wavelengths  $\lambda_1, \lambda_2, \lambda_3, \dots, \lambda_n$  enters the device through the input fiber and is collimated by the lenses. The collimated light strikes the reflection diffraction grating and is dispersed according to the wavelength components of the input. The lens focuses the diffraction reflected beam of each wavelength on the receiving output fibers. A system of five channels with a wavelength spacing of 20.0nm in the 800nm region has been constructed and tested (ref. 12). The insertion loss was about 1.7db in each channel, and crosstalk was less than -30db. The optical demultiplexers described in references 13 and 14 use a GRIN rod lens (also



known as selfoc lens) for the collimating component. A GRIN rod lens consists of a cylinder of dielectric material with a refractive-index distribution that has a maximum at the rod axis and decreases approximately as the order of the square of the radial distance from the rod axis. In a GRIN rod lens, light rays follow approximately sinusoidal paths with nearly constant periods ( $L$ ). In the demultiplexer, the GRIN rod lens is cut to length  $L/4$ . The lenses are used to convert the small-diameter, large-numerical-aperture beams from the input fibers of the demultiplexer into a large-diameter collimated output beam. An excellent description of GRIN rod lenses is given in reference 13. A schematic of a demultiplexer which uses a GRIN rod lens is shown in figure 12. As the demultiplexer receives the combined light radiation ( $\lambda_1, \lambda_2, \lambda_3, \dots, \lambda_n$ ) from the input fiber the GRIN rod lens collimates the beam. The collimated beam strikes the reflection diffraction grating and is separated into its wavelength components. The reflected beams then reenter the GRIN rod lens which focuses each wavelength to a distinct position on the face of the rod. The output fibers of the demultiplexer are butted to the rod face where the output rays of the demultiplexer are focused. The space between the lens and the grating can be filled with a wedge-shaped dielectric spacer so that the entire device can be cemented together into a stable solid assembly. Experimental models of demultiplexers using the GRIN rod lens have been built to be about the size of a paper clip. A twelve-channel demultiplexer has also been reported (reference 14) which has an average channel spacing of 17.0nm. The insertion loss averaged approximately 3db and the average adjacent channel crosstalk was -32db.

A planar Rowland spectrometer for an optical wavelength demultiplexer was described and reported in the literature (ref. 15). A schematic of the planar Rowland demultiplexer is shown in figure 13. If, in a Rowland spectrometer, a concave grating of radius of curvature  $R$  is placed tangentially to a circle of diameter  $R$  such that the grating center lies upon the circumference, then the spectrum of an illuminated point lying upon the circle will be focused upon this circle (known as a Rowland circle). The Rowland geometry is unique in that, in the absence of aberration, the optics of the device produce a one-to-one image of the input spot at the output plane. If a planar waveguide is incorporated in the structure no external collimating or focusing devices between the input and output fibers are required.

The demultiplexer is constructed by epoxying a thin optical waveguide (approximately .075mm) between two support microscope slides. To the end face of the device, which has a radius of curvature  $R$ , a reflection diffraction grating is attached. At the front face of the structure, which is cut to radius  $R/2$ , the input and output fibers are butt coupled to the planar waveguide. The input beam to the demultiplexer, consisting of the wavelength components ( $\lambda_1, \lambda_2, \lambda_3, \dots, \lambda_n$ ), enters the planar waveguide from the input fiber. The light travels through the planar waveguide where it strikes the blazed reflective diffraction grating at the end face of the structure. The beam is separated into its wavelength components where each component is reflected towards the front of the structure. Because of the Rowland geometry, each wavelength is focused to a different spot along the front face. For each wavelength position, there will be a fiber to collect the output signal. A four-channel device has been constructed and tested with 10.0nm separation of wavelengths. The cross talk measured was -18db

and typical insertion loss from input fiber to output fiber was approximately -9db. More than half of the insertion loss was due to the poor diffraction grating efficiency (5db). A demultiplexer using the Rowland geometry similar to the GRIN rod lens device can be cemented together into a stable solid assembly.

### Optical Detectors

None of the WDM systems described in this paper require wavelength sensitive optical detectors. Depending on the particular WDM system design, a decision will have to be made on whether to use a PIN photodiode or an Avalanche photodiode. The avalanche photodiode is a more sensitive detector but it requires a 100 to 400 volt bias. A detailed discussion of optical detection is beyond the scope of this paper.

In many WDM system implementations, the overall optical losses could be improved by mounting the photodetectors directly on the demultiplexing component. This technique would eliminate the losses associated with coupling the demultiplexer to the receiving fiber and the losses associated with coupling the receiving fiber to the photodetector. A drawing of such an arrangement using the planar Rowland demultiplexer is shown in figure 14. In this representation, many of the optical receiver components are mounted on top of the structure using a ceramic hybrid circuit wafer.

### Concluding Remarks

WDM is a viable technology for optical fiber transmission systems for both increased channel capacity and fault containment. Both the wavelength multiplexing and demultiplexing can be performed in optically passive components with the demultiplexer being the critical element in the system. The use of prisms as the wavelength sensitive element has the advantage over filters for separating the wavelengths in parallel but has the disadvantages of requiring collimating and focusing of all input and output fiber signals respectively. A prism has additional disadvantages at being large and expensive to construct with currently available materials. The use of optical filters has the advantage of being low in cost but a disadvantage of requiring collimating and focusing on all input and output signals respectively. Also, the wavelengths are separated in a serial manner. With a filter demultiplexer, the insertion losses are a function of the number of channels. Also, the physical size of the demultiplexer increases with increasing number of channels to be demultiplexed. At the present time, diffraction gratings are the best wavelength sensitive elements to be used in optical demultiplexers. Practical devices with currently available materials have been constructed and tested. The differences between the designs using diffraction gratings are that different elements are used to collimate and focus the input and output optical signals. Conventional lenses, GRIN rod lenses and Rowland configured planar waveguides are all viable candidates. Additional work is needed in evaluating the environmental effects on the components, reducing the component sizes and cost, and gathering field experience with the WDM system.

## REFERENCES

1. Metcalf, B. D.; and Providakes, J. F.: High-Capacity Wavelength Demultiplexer with a Large-Diameter GRIN-Rod Lens. *Applied Optics*, vol. 21, no. 5, Mar.1, 1982, pp. 794-796.
2. Spencer, J. Larry; and Himka, Roger L.: Description and Planned Use of a Data Distribution Evaluation System for Fiber Optic Data Buses. Paper to be presented at the National Aerospace and Electronics Conference, Dayton, Ohio, May 18-20, 1982.
3. Bolz, Don; and Herskowitz, Gerald J.: Components for Optical Communications Systems: A Review. *Proceedings of the IEEE*, vol. 68, no. 6, June 1980, pp. 689-731.
4. Ladany, I; and Hammer, J. M.: Single-Mode Laser Studies: (I) Design and Performance of a Fixed-Wavelength Laser Source and (II) Coupling of Lasers to Thin-Film Optical Waveguides. NASA CR-3341, 1980.
5. Aiki, K.; Nakamura; and Umeda, J.: Frequency Multiplexing Light Sources with Monolithically Integrated Distributed Feedback Diode Lasers. *Applied Physics Letters*, vol. 29, no. 8, Oct. 1976, pp. 506-508.
6. Barnoski, Michael K., ed.: *Fundamentals of Optical Fiber Communications*. Chapter 6. Academic Press, Inc., 1976, pp. 183-201.
7. Rickard, Eric: Wavelength Division Multiplexing: Overview of the State of the Art. RADC-TR-81-47, Mar. 1981.
8. Tomlinson, W. J.: Wavelength Multiplexing in Multimode Optical Fibers. *Applied Optics*, vol. 16, no. 8, Aug. 1977, pp. 2180-2194.
9. Stigliani, Daniel J., Jr.; Hanna, D. W.; and Lynch, R. J.: Wavelength Division Multiplexing in Light Interface Technology. IBM Report, NR 71-531-001, Mar. 18, 1971.
10. Hendricks, Herbert D.; Spencer, J. Larry; and Magee, Carl J.: Fiber Optics Wavelength Division Multiplexing for Data Systems. *Future Connections-NASA*, vol. 1, no. 2, Nov. 1981, pp. 9-12.
11. Nelson, A. R.; Gasparian, G. A.; and Beckel, G. W.: Bidirectional Coupler for Full Duplex Transmission on a Single Fiber. CODACOM-77-1798-F, ITT Electro-Optical Products Div., Aug. 1979.
12. Aoyama, Koh-ichi; and Minowa, Jun-ichiro: Low-Loss Optical Demultiplexer for WDM Systems in the 0.8- m Wavelength Region. *Applied Optics*, vol. 18, no. 16., Aug. 15, 1979, pp. 2834-2836.
13. Tomlinson, W. J.: Application of GRIN-Rod Lenses in Optical Fiber Communication Systems. *Applied Optics*, vol. 19, no. 7, Apr. 1, 1980, pp. 1127-1138.
14. Yen, H. W.; Friedrich, H. R.; and Morrison, R. J.: Planar Rowland Spectrometer for Fiber-Optic Wavelength Demultiplexing. *Optics Letters*, vol. 6, no. 12, Dec. 1981, pp. 639-641.

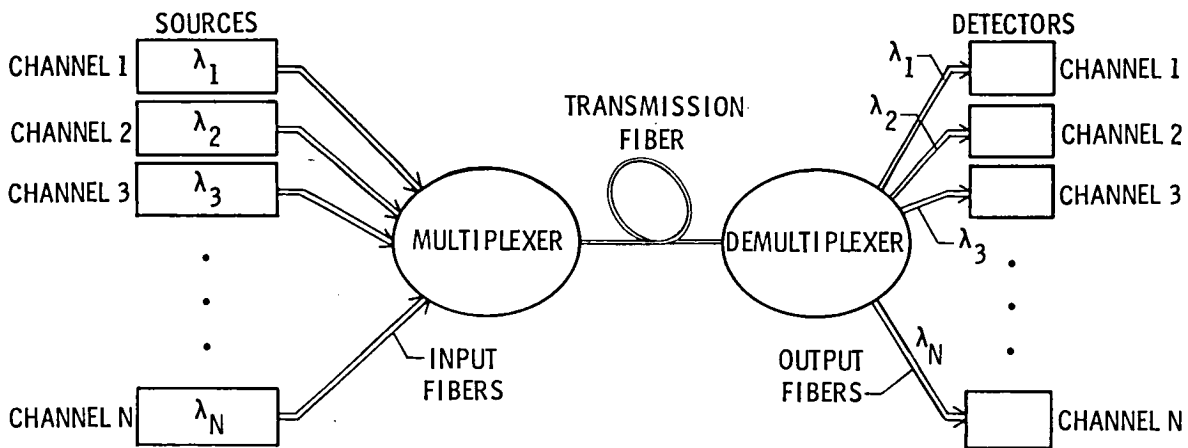

Figure 1. - WDM system for increased channel capacity.

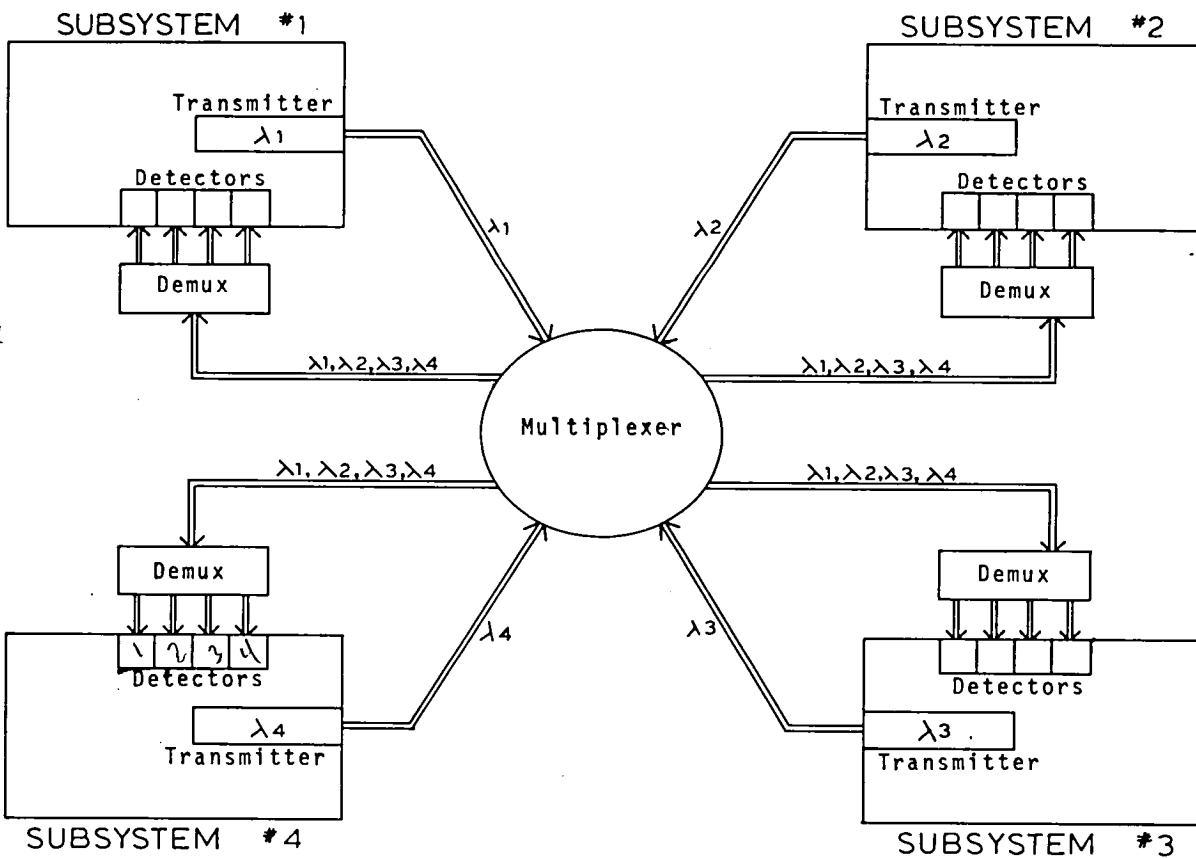

Figure 2. - WDM system for fault isolation.

*RCA report*

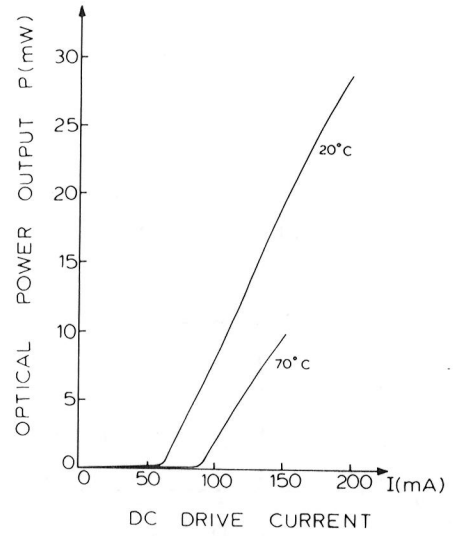
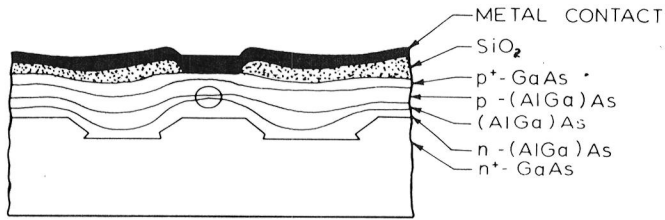
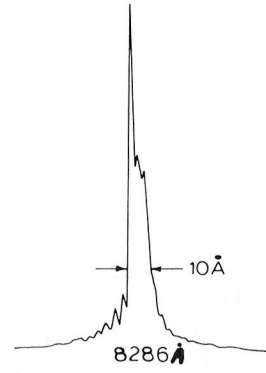
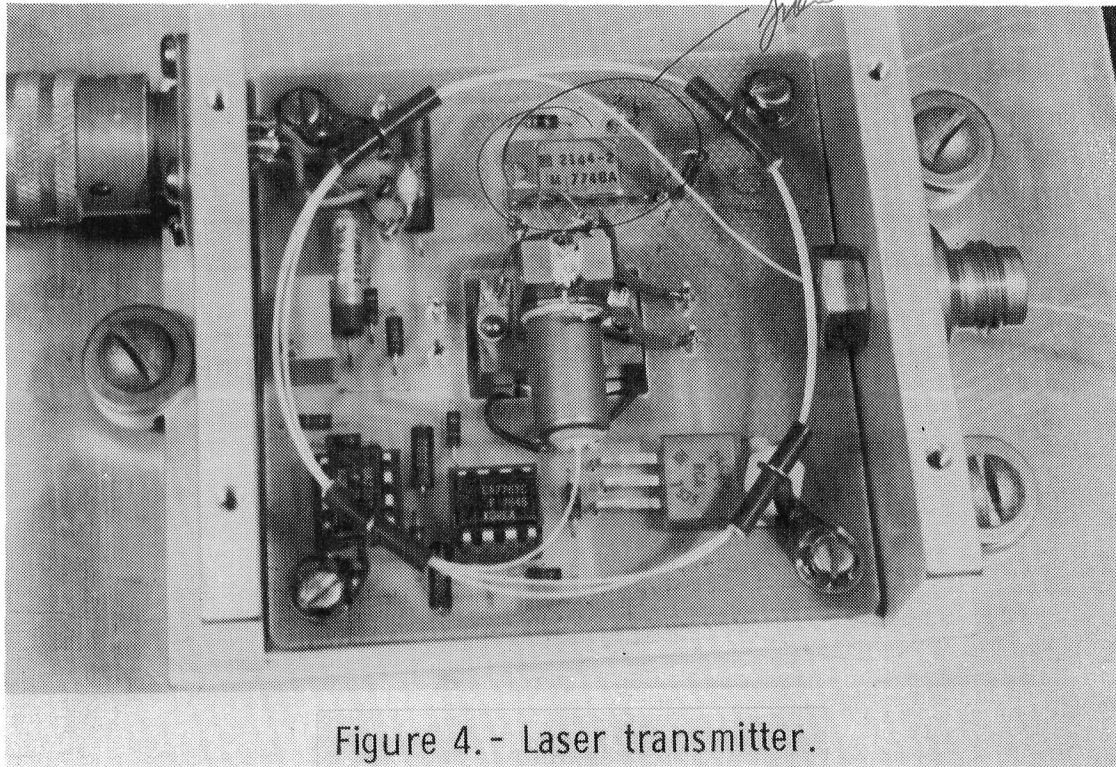

Figure 3. - Laser diode.

*from WPAFB*



*H.D.H.  
receiving design  
RCA - Los Alamos*

Figure 4. - Laser transmitter.

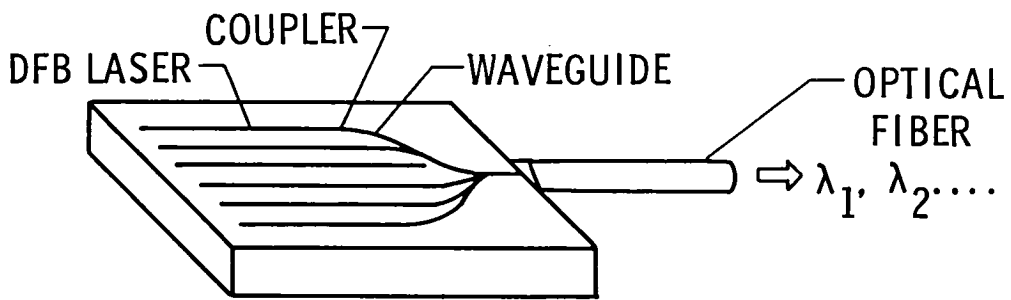

(a) Schematic

*Japanese*

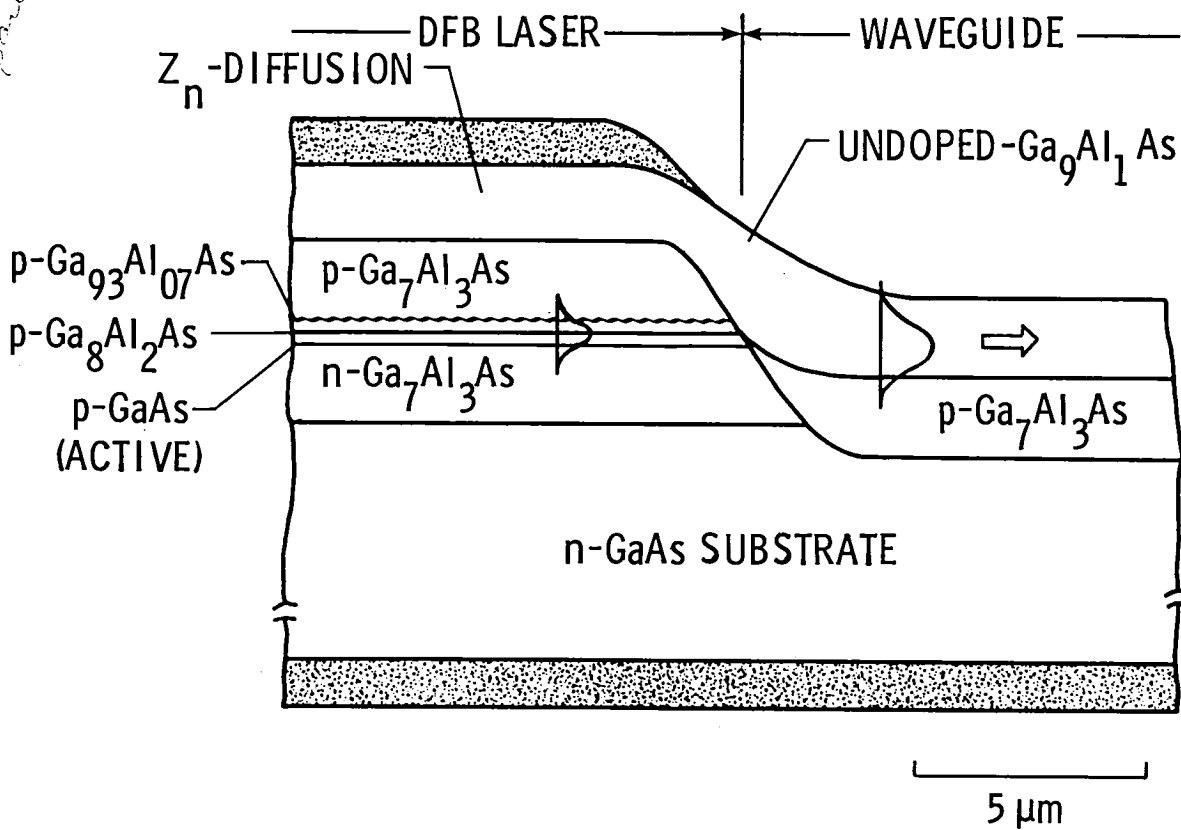

(b) Cross-sectional view

Figure 5. - Array of 6 DFB lasers.

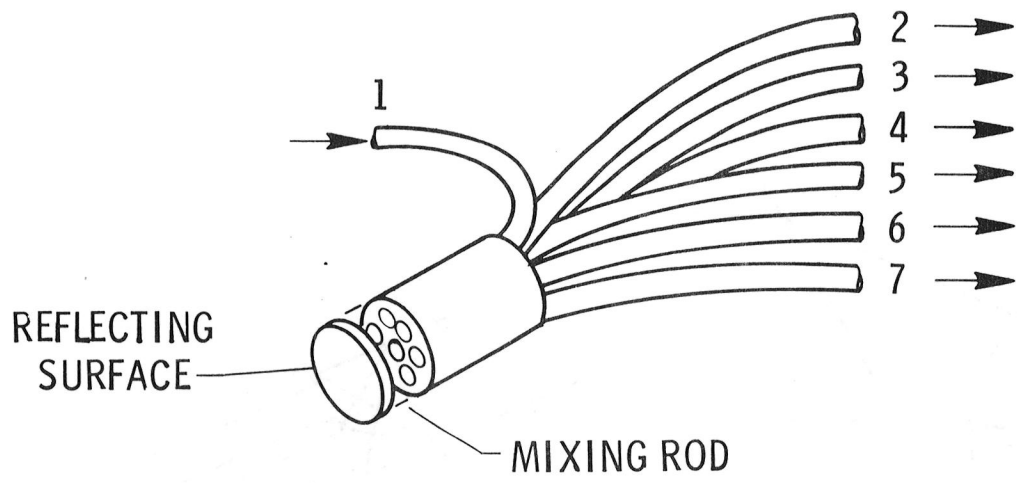

● REFLECTIVE STAR

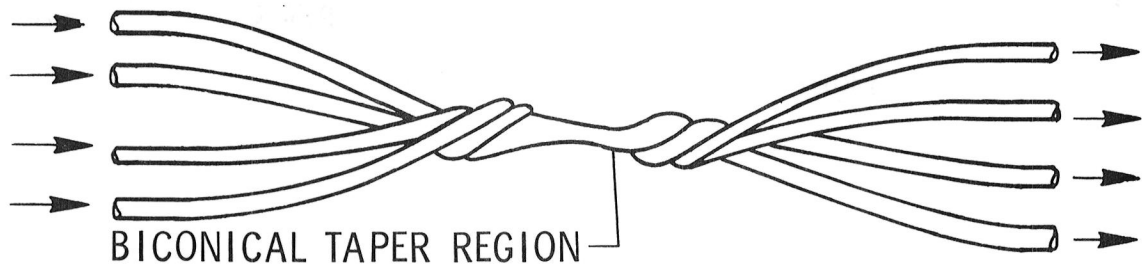

● TRANSMISSIVE STAR

*Xerox*

**Figure 6.- Optical Couplers**

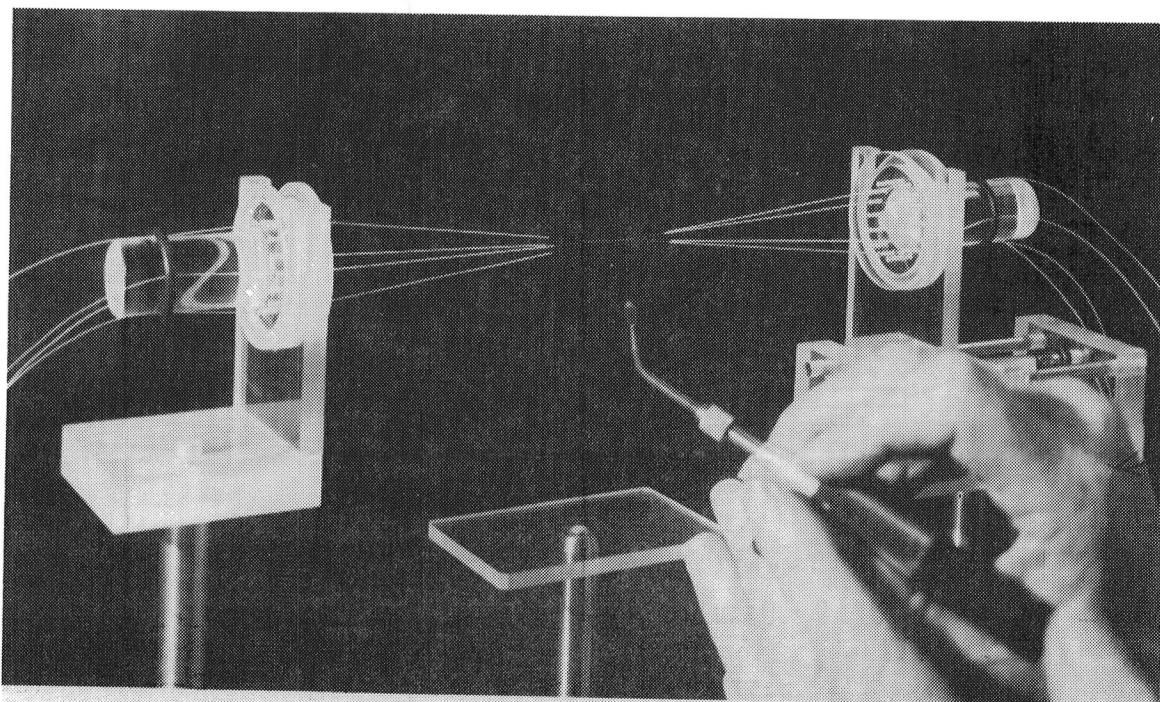

*HGH*  
*J. Burgess made*

Figure 7.- Making of a fused biconical taper coupler.

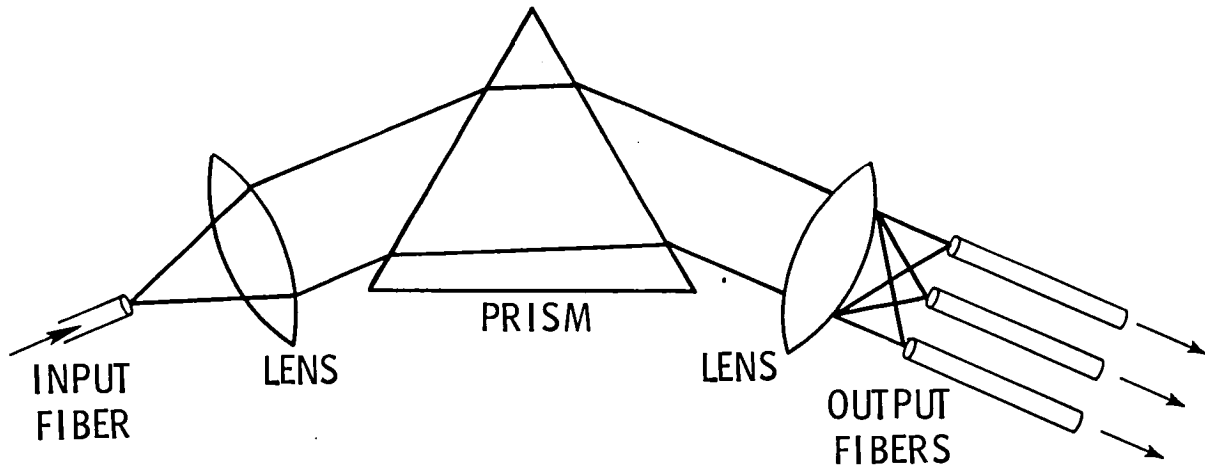

Figure 8. - Prism demultiplexer

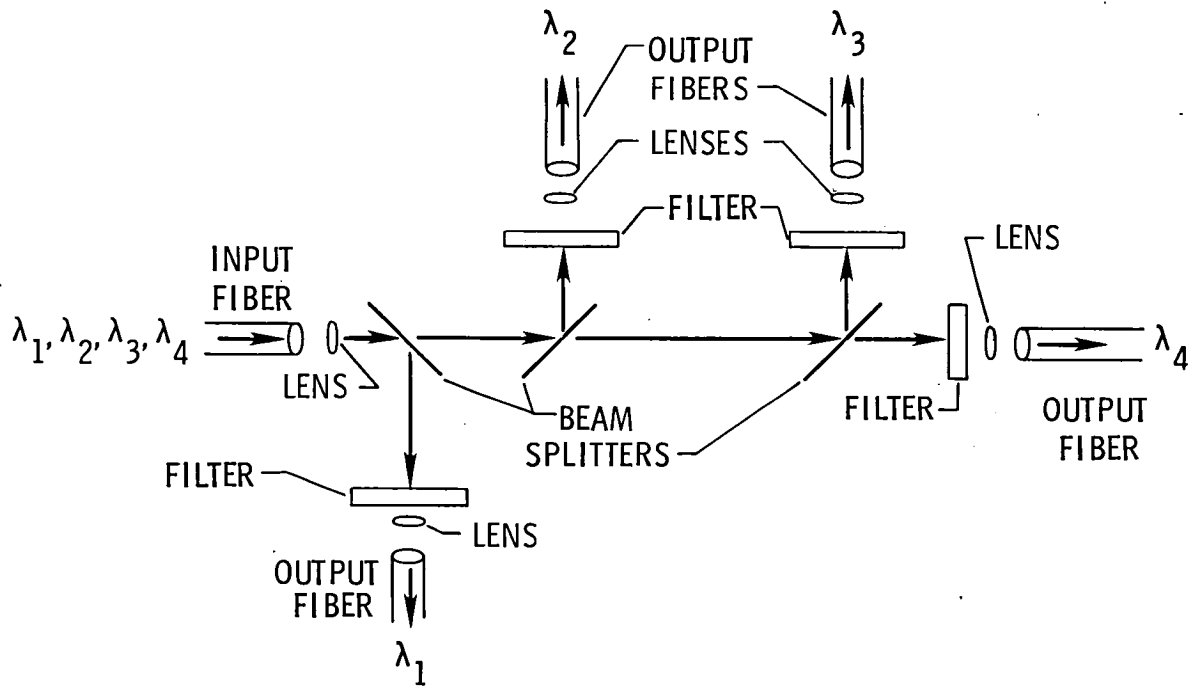

Figure 9. - Demultiplexer using interference filters.



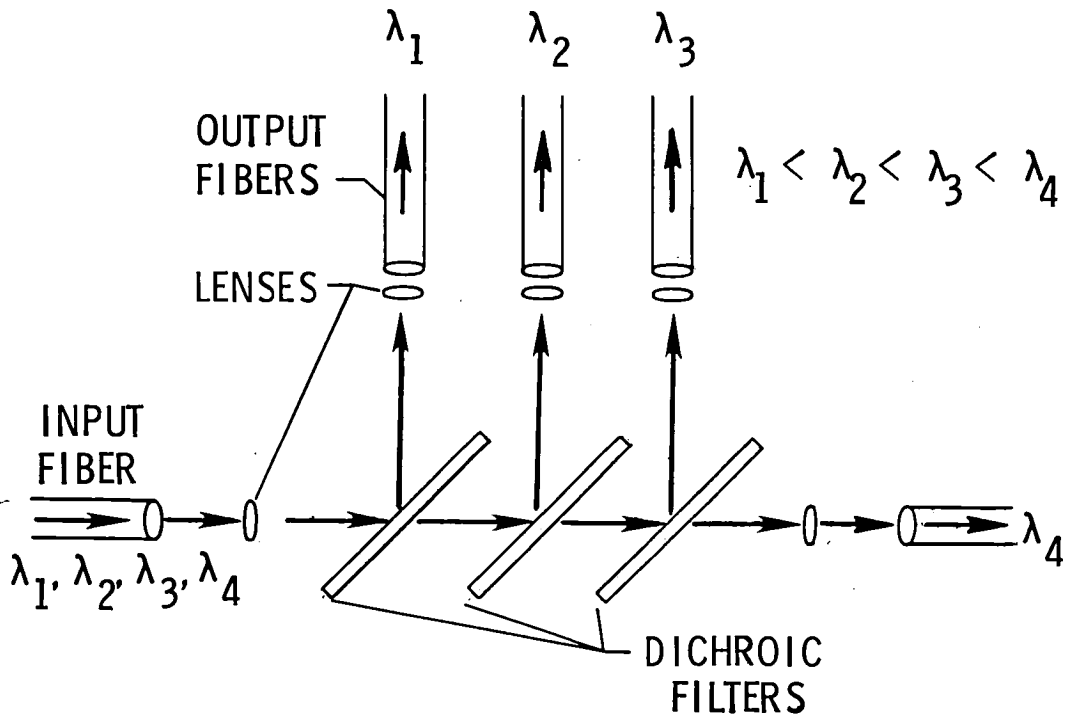
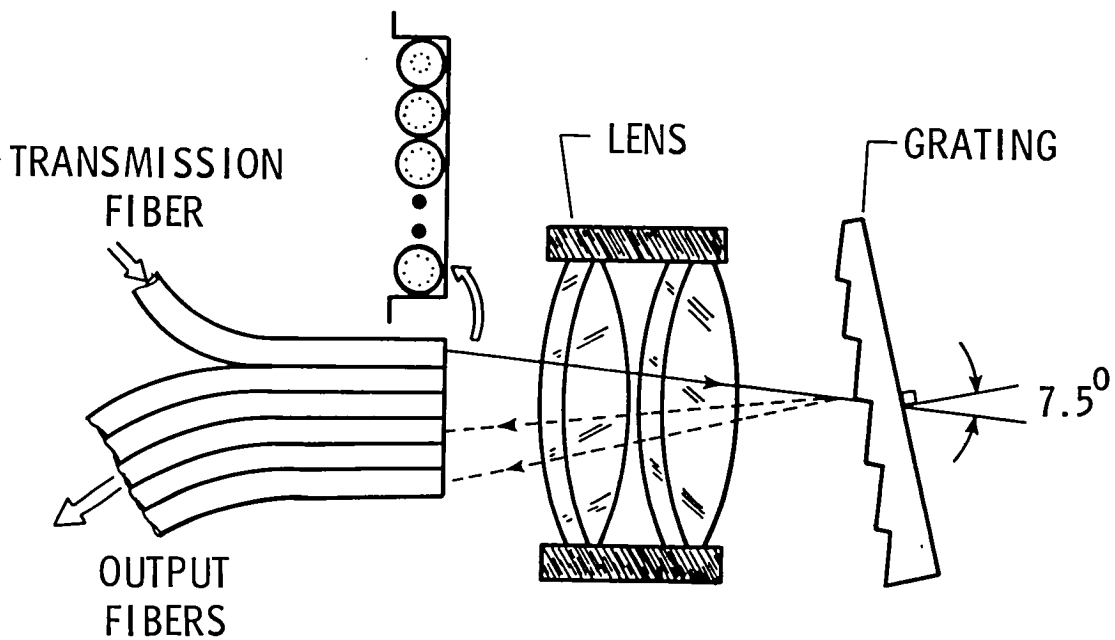

Figure 10.- Demultiplexer using dichroic filters.



*Japanese*

Figure 11.- Demultiplexer using conventional lenses in a Littrow mount.

*Tonlin*

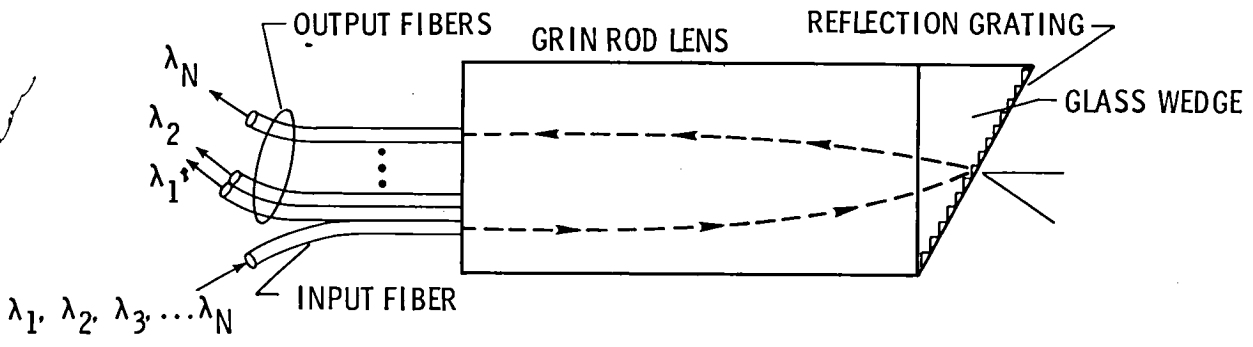

Figure 12. - Demultiplexer using a GRIN rod lens.

*HRC*

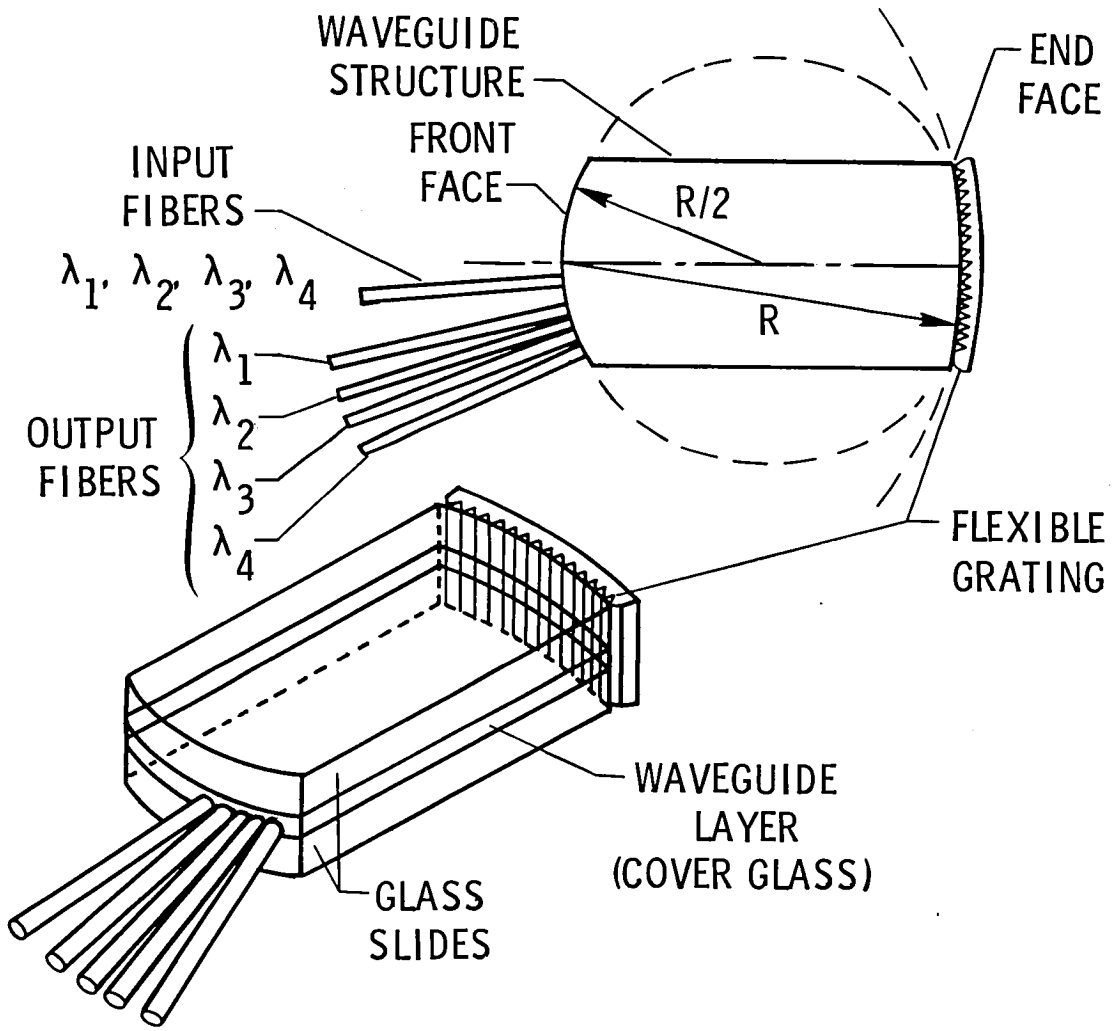

Figure 13. - Demultiplexer using a planar Rowland structure.

*H&H  
design  
now original*

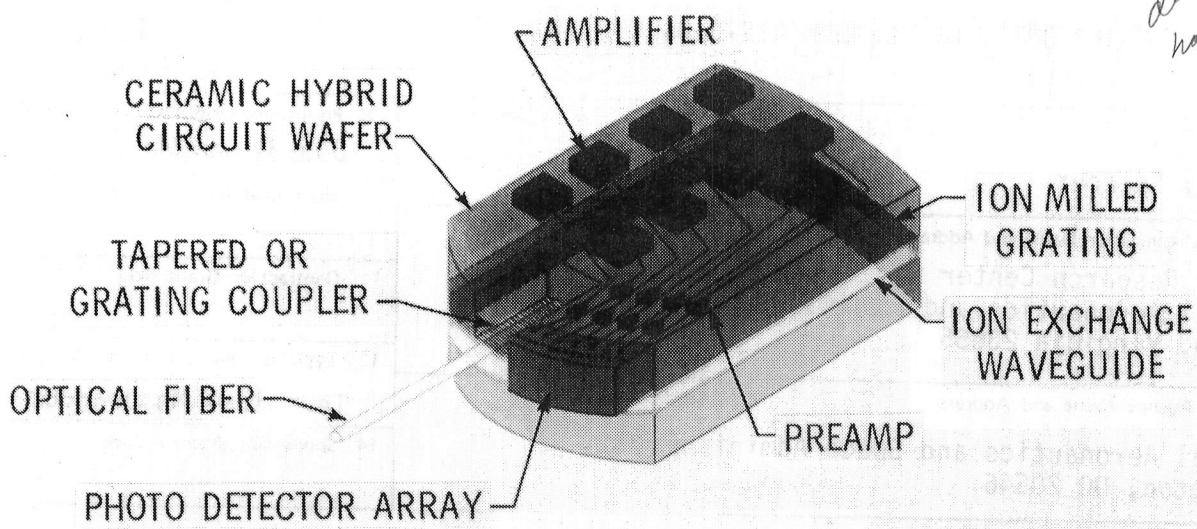
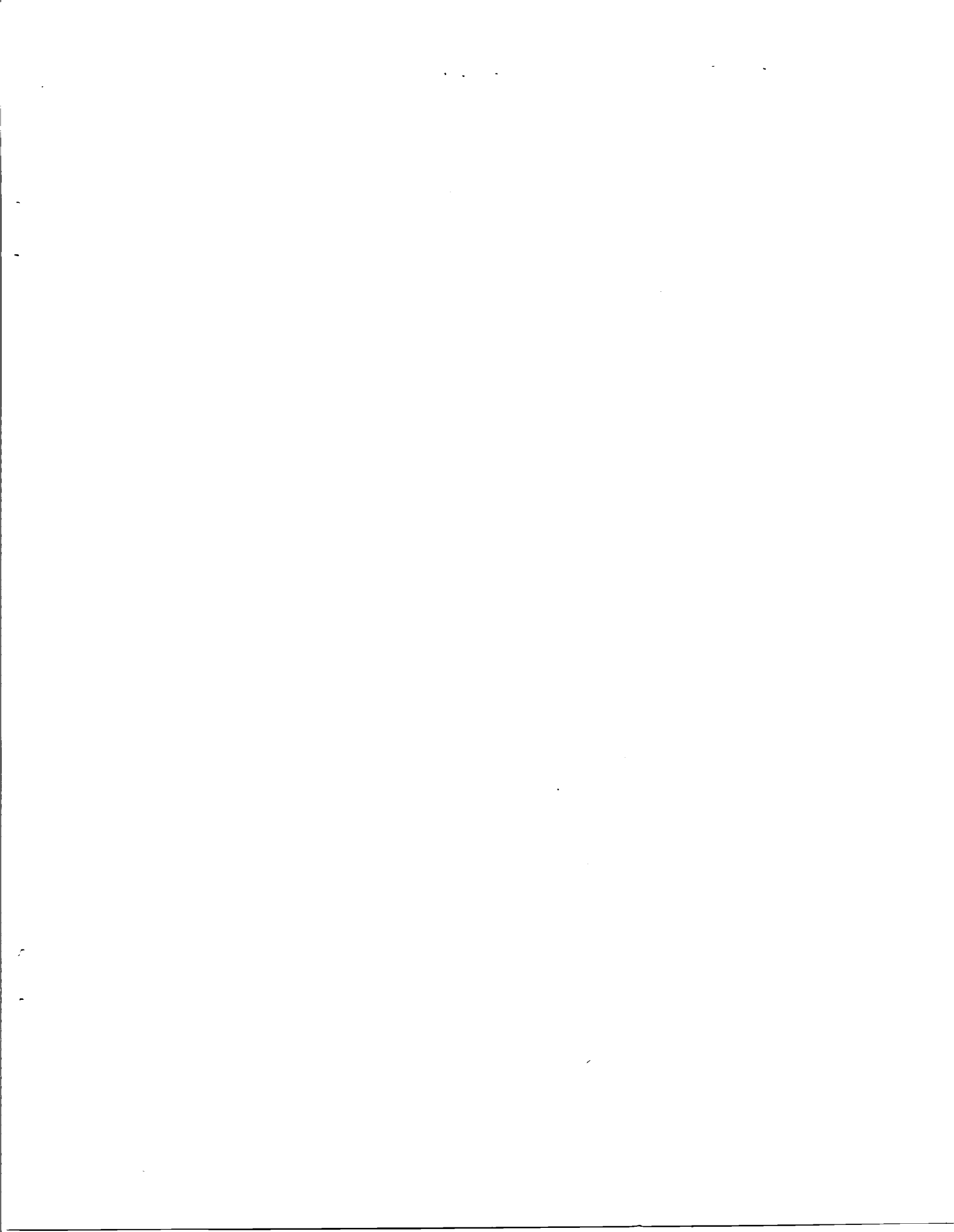

Figure 14. - Demultiplexer with adjacent photo detectors.

|   |  |  |   |   |                  |
|---|--|--|---|---|------------------|
| 1. Report No.<br>NASA TM 84483  |  | 2. Government Accession No.                          |   | 3. Recipient's Catalog No.                                    |                  |
| 4. Title and Subtitle<br>MULTIMODE FIBER OPTIC WAVELENGTH DIVISION MULTIPLEXING   |  |  |   | 5. Report Date<br>April 1982                                  |                  |
|   |  |  |   | 6. Performing Organization Code                               |                  |
| 7. Author(s)<br>J. Larry Spencer  |  |  |   | 8. Performing Organization Report No.<br>505-34-43-04         |                  |
|   |  |  |   | 10. Work Unit No.   |                  |
| 9. Performing Organization Name and Address<br>Langley Research Center<br>National Aeronautics and Space Administration<br>Hampton, Virginia 23665  |  |  |   | 11. Contract or Grant No.                                     |                  |
|   |  |  |   | 13. Type of Report and Period Covered<br>Technical Memorandum |                  |
| 12. Sponsoring Agency Name and Address<br>National Aeronautics and Space Administration<br>Washington, DC 20546   |  |  |   | 14. Sponsoring Agency Code                                    |                  |
|   |  |  |   |   |                  |
| 15. Supplementary Notes   |  |  |   |   |                  |
| 16. Abstract<br>Optical wavelength division multiplexing (WDM) systems, with signals transmitted on different wavelengths through a single optical fiber, can have increased bandwidth and fault isolation properties over single wavelength optical systems. This paper considers two WDM system designs that might be used with multimode fibers and gives a general description of the components which could be used to implement the system. The components described are sources, multiplexers, demultiplexers, and detectors. Emphasis is given to the demultiplexer technique which is the major developmental component in the WDM system. |  |  |   |   |                  |
| 17. Key Words (Suggested by Author(s))<br>Multiplexing<br>Wavelength multiplexing<br>Wavelength division multiplexing<br>Fiber optic<br>Data distribution   |  |  | 18. Distribution Statement<br>Unclassified - unlimited<br><br>Subject Category 33, 62 |   |                  |
| 19. Security Classif. (of this report)<br>Unclassified  |  | 20. Security Classif. (of this page)<br>Unclassified |   | 21. No. of Pages<br>18  | 22. Price<br>A02 |



LANGLEY RESEARCH CENTER



3 1176 00504 1471