

N82 26085

30 567

SPECTROSCOPY FROM 2 to 200 keV

David J. Helfand, Gary A. Chanan, and R. Novick
Columbia Astrophysics Laboratory, Columbia University

Crawford J. MacCallum

Sandia Laboratories

and

Marvin Leventhal

Bell Telephone Laboratories

ABSTRACT

The astrophysical processes responsible for line and continuum emission in the spectral range 2 keV to 200 keV are examined from the viewpoint of designing a spectrometer which would operate in this regime. Phenomena considered include fluorescent line radiation in X-ray binaries, magnetically shifted iron lines and cyclotron emission from neutron star surfaces, line emission from cosmically abundant elements in thermal plasmas, and nuclear deexcitation lines in fresh nucleosynthetically produced matter. An instrument consisting of a $\sim 100 \text{ cm}^2$ array of planar germanium detectors surrounded by a large sodium-iodide anticoincidence shield is described and detailed consideration of projected background rates and sensitivities are presented. A sample observing program for a two-day Shuttle-based mission is included as an example of the wide range of scientific questions which could be addressed by such an instrument.

I. INTRODUCTION

From the serendipitous discovery of the first celestial X-ray source less than 20 years ago, X-ray astronomy has catapulted to the forefront in many of the most exciting areas of current astrophysical research: neutron stars, black holes, supernovae and their remnants, quasars and other galactic nuclei, the interstellar medium, and cosmology. The detection and identification of numerous classes of X-ray emitters, along with the recognition and interpretation of the wide variety of temporal variability they exhibit, constituted the driving force behind the early growth of the field. More recently, the launch of the Einstein Observatory extended sensitivities by a factor of $\sim 10^3$ and provided the capability for imaging X-ray emitters with spatial resolution comparable to that achievable in the radio and optical regimes. Major missions planned for the future include a larger soft X-ray telescope facility and a satellite dedicated primarily to detailed timing studies of bright galactic sources.

The development of cosmic X-ray spectroscopy has been slower than that of spatial and temporal studies, although recent advances indicate that this field holds great potential for providing important new insights into many areas of astrophysical research. Lines from silicon, sulfur, neon, oxygen, and other cosmically abundant elements have been detected from thermal plasmas in a variety of settings with the spectrometers on Einstein. Iron line emission has been discovered in the spectra of galaxy clusters, confirming the hypothesis that these X-rays arise from partially processed material. At higher energies, cyclotron features have been seen in the spectra of several

galactic X-ray sources thought to contain magnetized neutron stars including Her X-1 and other binaries, the Crab pulsar, and γ -ray bursters.

A wide variety of radiation processes are involved in producing the high energy photons we detect from celestial objects and X-ray spectroscopy is an essential tool in identifying these mechanisms and characterizing the physical environments in which they operate. Hot thermal and nonthermal plasmas produce the intense continuum and line emission we observe from X-ray binary stars, supernova remnants, and clusters of galaxies. Synchrotron radiation and inverse Compton emission are thought to be responsible for the energy output of active galactic nuclei (e.g., Seyferts, BL Lac objects, and quasars), while cyclotron radiation is dominant in the region of intense magnetic fields near the surface of a neutron star. Explosively produced radioactive nuclei from novae and supernovae as well as excited nuclei produced via the interaction of cosmic rays with the interstellar medium are expected to emit characteristic X- and gamma-ray lines. Finally the radiation from all of these processes is modified by the material through which it passes, both in the near source environment and along our line of sight to the source.

The instrumental limitations encountered thus far in X-ray spectroscopy can be summarized as the need to make unsatisfactory tradeoffs among three fundamental parameters: the resolution of the instrument, its sensitivity to line and continuum emission, and the total range of energies over which it can operate. Traditional proportional counters (with which the iron emission features in clusters have been detected) have good sensitivity and reasonable spectral range, but inherently poor resolution. On the other hand, the high resolution obtainable with crystal spectrometers requires severe sacrifices in sensitivity and spectral range, while scintillation detectors (such as the one

used to discover the Her X-1 cyclotron line) are limited in resolution and, thus, in their sensitivity to narrow lines. Finally, any spectrometer located at the focus of a grazing incidence telescope is limited to the spectral regime below ~ 8 keV. For instruments flown to date, the cutoff has been ~ 4 keV.

We have designed a wide-band germanium X-ray spectrometer capable of obtaining high resolution spectra over two decades of energy in the region of the spectrum most crucial to our understanding of the origin of both the line and continuum emission from celestial X-ray sources. At the lower end of the instrument's spectral range, it offers an improvement in energy resolution of a factor of 3 over traditional proportional counter experiments, while in the hard X-ray region (50 keV to 200 keV) it provides a gain in sensitivity and resolution of more than an order of magnitude over existing instruments. It is this unique combination of sensitivity, resolution, and spectral range which would allow one to carry out, in the brief period available on a Shuttle mission, an extensive, variegated observational program addressing many important questions of current astrophysical interest. Below, we discuss several of the sources of X-ray line emission which would be detectable with this instrument (§II) including a summary of previous work and estimates of the observing time required to meet various objectives. In §III, we describe the instrument design and develop detailed estimates of the backgrounds expected and the sensitivities achievable. In the final section, we comment briefly on the place such experiments might occupy in the space science program of the future.

II. SPECTROSCOPY FROM 2-200 KEV

a) Lines from Thermal Plasmas

Emission lines from highly ionized species of iron in the energy range from 6 to 7 keV have been discovered in the spectra of a wide variety of celestial X-ray emitters including supernova remnants (Charles et al. 1978), clusters of galaxies (Mushotzky et al. 1978), cataclysmic variable stars (Swank et al. 1978), and binary X-ray sources (Pravdo 1978). The latter sources are particularly interesting in that their continua cannot be characterized simply as thermal emission from an optically thin hot plasma; a superposed source of fluorescing material is required to account for the line emission. Potential locations for this material include the atmosphere of the companion star, a shell at the Alfvén surface of the neutron star, and an accretion disk (Pravdo 1978). Evidence for a dependence of line energy and intensity on pulse and orbital phases has been reported for several sources including Her X-1 and Cyg X-3 (Becker et al. 1977; Becker et al. 1978). In addition, iron-abundance determinations for the binary sources indicate an enhancement of metal-rich material in these systems over that found in the thermal sources (supernova remnants and clusters of galaxies). This may, however, be more indicative of our crude knowledge of the excitation and emission mechanisms involved than of an overabundance of high-Z matter.

A wealth of information can be obtained from the determination of precise line energies and the measurement of high-resolution line profiles. The exact species responsible for the emission can be determined, with the relative contributions of each yielding information on the ionization balance of the emitting region. In addition, more reliable abundance determinations become

possible, and kinematic conditions in the source can be explored. Such information is crucial, for example, in choosing among the various models proposed for the source of the fluorescing plasma in X-ray binaries.

Most of the existing iron-line measurements have been made with proportional counters which have typical energy resolutions at 6 keV of ~ 1 keV. Thus, in many cases, the intrinsic line widths are unknown and, even in the few sources where resolved features are seen, the detailed structure of the line cannot be determined. The resolution of the proposed spectrometer is ~ 370 eV at 6 keV; this represents nearly a factor of 3 improvement over most proportional counter experiments and will allow one to pursue many of the important questions outlined above. The sensitivity of the instrument is such that in less than three hours' observing time, we could obtain high signal-to-noise ($\geq 10 \sigma$ iron lines), high-resolution spectra for all of the eight binary X-ray sources known to exhibit iron features, easily resolving emission due to neutral iron ($K\alpha$ at 6.4 keV) from that of various highly ionized species (e.g., Fe XXV at 6.7 keV and Fe XXVI at 6.93 keV). In 12 hours, we could detect these same lines (at the 5σ level) from a dozen thermal sources including four supernova remnants, six clusters of galaxies, and two cataclysmic variable stars. Observations over one complete 4.8 hour binary orbit of Cyg X-3 would yield high resolution iron-line profiles (at the 20σ level) in each of 30 orbital phase intervals. A six-hour observation of any one of the brighter X-ray binaries could lead to the first detection of the nucleosynthetically important nickel line at 7.5 keV.

Similar duration pointings would detect the strong sulfur, silicon, and neon lines observed in several galactic SNR with the Einstein Solid State Spectrometer (SSS), albeit with nearly a factor of 2 worse resolution. How-

ever, the wider field of view of the Germanium experiment will yield total spectra of the larger remnants (e.g., Vela, Puppis A, and the Cygnus Loop) for the first time. In addition, the simultaneous determination of the line strengths for iron and the silicon group elements will be invaluable in sorting out some of the abundance anomalies found in the SSS data. Such broad spectral coverage of both the line and continuum radiation is required for determining the run of temperatures and the resulting ionization distribution in these objects.

b) Line Emission from Magnetic Neutron Stars

The exciting possibility of studying the intense magnetic fields (10^{12} to 10^{13} gauss) at the poles of a neutron star via X-ray spectroscopy was first pointed out by Gnedin and Sunyaev (1974) and Basko and Sunyaev (1975). Electrons in the ionized plasma accreting onto the surface of X-ray pulsars will undergo cyclotron motion in the magnetic field. Transitions between discrete Landau levels can occur, giving rise to a series of X-ray lines at the fundamental cyclotron frequency and its harmonics. Observations of these lines constitute a direct measurement of the magnetic field intensity, and a determination of the line profiles could yield important new information about the spatial distribution of the field and the accreting matter. Recently, the observation of such a line from Her X-1 at 55 keV was announced by Trumper et al. (1977) and Coe et al. (1977). The line emission is reportedly pulsed, with a flux of $\sim 10^{-3}$ photons $(\text{cm}^2 \text{ s})^{-1}$ and an instrumentally determined width of $\lesssim 12$ keV. The implied magnetic field in the line-forming region is 4.6×10^{12} gauss.

The existing observations are insufficient even to determine whether the line is seen in emission at 55 keV or in absorption around 45 keV. High

spectral resolution data are the only way to choose between these two possibilities and to provide the input required in modeling kinematic and plasma conditions in and around the source. If the reported line from Her X-1 is intrinsically narrow (~ 1 keV), it will appear as a 40σ detection in a 12-hour observation with the proposed instrument (a 10 keV wide line will yield a 30σ result). The entire 40-70 keV continuum will be measured at a resolution of 1 keV and both the second (reported at 110 keV) and third cyclotron harmonics should be detectable.

The amount of line broadening due to Doppler (1978) and self-absorption effects (Meszaros 1978) helps to determine the angle between the magnetic field and the observer's line of sight. The proposed instrument will be able to specify this angle unambiguously, and its variation as a function of pulse phase could provide an important clue to the geometry of the emitting region and the relative orientation of the star's magnetic and rotation axes. The relativistic fine structure (Daugherty 1978) of the proposed line emission provides another estimate of the viewing angle. More importantly, however, the splitting of the fine structure levels ($\omega_{1,0}$, $\omega_{2,1}$, $\omega_{3,2}$, etc.) is related to the field strength; thus, a measurement of this splitting provides a determination of the field strength which is independent of the line energy. This in turn allows one to calculate the gravitational redshift at the emitting region, locating it precisely above the surface of the neutron star (whose mass is known from observations of its binary companion). Such a result is well within the capabilities of the proposed spectrometer and would yield the first firm upper limit on the radius of a neutron star (an extremely important input for calculations of the equation of state for matter at ultra-high densities) as well as providing a wealth of information on the magnetospheric

structure at the base of the accretion column (Meszaros 1978).

The radiative transfer calculations of Weaver (1978) and others indicate that a large fraction of the cyclotron-line radiation should be scattered to lower energies. Detailed line and continuum shapes can choose between models in which the line photons escape through holes in the circumstellar shell above the magnetic poles of the star and those in which the radiation passes directly through the shell. Thus, the line can also be used as a probe of plasma conditions at the Alfvén radius of the star, yielding data relevant to the problems of the soft component of the X-ray emission from Her X-1 and the overall accretion process.

Observations of other pulsating X-ray binaries such as Cen X-3, Vela X-1, and the transient source 4U0115+63 (in which evidence for a 25 keV line has been reported) as well as of isolated neutron stars such as the Crab pulsar (in which a transient 77 keV emission feature was seen [Strickman, Kurtess, and Johnson 1981] could extend the usefulness of this sensitive probe to other objects. A feature ten times weaker than the reported Her X-1 line would be easily detected in Vela X-1 in half a day's time. These observations would, of course, all be simultaneous with those examining plasma conditions in these systems farther from the neutron star via high-resolution spectroscopy of the iron lines as discussed above.

Recently, it has been suggested that atomic lines of iron, strongly shifted by the intense magnetic field, might also be detectable from neutron star surface regions. Energies and strengths of the Lyman lines have been calculated by Ruder et al. (1981) for a variety of surface temperatures, abundances, and field strengths. The detection of these lines would yield the first direct observation of neutron star surface material, and would add

substantially to our knowledge of plasma conditions in the region where the accreting material impacts the star and the primary radiation is produced. Wunner et al (this volume), have calculated the requirements of a spectrometer necessary to observe such lines: $10 \text{ keV} \lesssim E \lesssim 20 \text{ keV}$; $E/\Delta E \sim 10 \text{ to } 100$; and line sensitivity of $\gtrsim 10^{-4} \text{ ph cm}^{-2} \text{ s}^{-1}$. All of these specifications are exceeded by this proposed instrument.

c) Explosive Nucleosynthesis in Supernovae

The modern era of theoretical nucleosynthesis may be dated from 1957 with the publication of the classic paper Burbidge et al. (1957) (B²FH). Set down therein is the basis for the currently held belief that the elemental abundances as we know them derive from stellar evolutionary processes rather than being a primordial arrangement of matter. These workers gave, for the first time, a characterization of the specific physical processes (r-, s-process, etc.) which lead to the formation of different classes of isotopes. In a sense, most of the research in this field for the past 25 years represents a search for the astrophysical sites of these processes, originally delineated by B²FH. From the beginning, with the advocacy of the californium hypothesis (Baade et al. 1956) to explain their light curves, supernovae were believed to play an important role in nucleosynthesis. During the latter part of the 1960s and early 1970s, large, fast computers became available for general use. This made it possible to follow phenomenologically the complex nuclear reaction matrix that takes place when a highly evolved star explodes and hydrodynamically expands. The calculations of Arnett, Cameron, Clayton, Colgate, Fowler, Schramm, Tinsley, Truran, Woosley, and others (Schramm and Arnett 1973) led to the remarkable result that many of the elements can be produced explosively in the correct cosmic abundance. This conclusion lent

great credence to the theories of explosive nucleosynthesis. An important objective of a germanium spectrometer would be to provide an observational basis for these theories. Many of the stable species are first produced as unstable radioactive elements which then decay, often with the emission of characteristic X-ray and gamma-ray lines (Clayton 1973). The unequivocal detection of even a single line from explosively produced radioactive matter would represent a fundamental breakthrough in this area of research.

Predictions of line fluxes to be expected from radioactive species produced in the various shells of a presupernova star have been pursued most actively by Clayton, Colgate, and Fishman (1969), Clayton (1973, 1974, 1975), and Ramaty and Lingenfelter (1977). Several lines of particular interest fall within the spectral range of our proposed instrument: three lines from the $^{55}\text{Co} \rightarrow ^{55}\text{Fe}$ decay at 14 keV, 122 keV, and 136 keV, the 59 keV line from the $^{60}\text{Fe} \rightarrow ^{60}\text{Co} \rightarrow ^{60}\text{Ni}$ chain, and a doublet at 68 keV and 78 keV from the reaction $^{44}\text{Ti} \rightarrow ^{44}\text{Sc} \rightarrow ^{44}\text{Ca}$. These decay schemes have average lifetimes t_{av} of 1.1 years, 4.3×10^5 years, and 68 years, respectively. (See Table 1 for a summary of potential sources and required observing times.) At a time t following the supernova explosion, the flux F observable in lines such as these is given by

$$F = \frac{N \eta \exp(-t/t_{av})}{4\pi t_{av} D^2} \quad (1)$$

where N is the number of nuclei produced in the explosion, η is the number of photons produced per disintegration, and D is the distance to the source.

Using some typical values for these quantities, equation (1) becomes:

$$F = 2.6 \times 10^{-1} \left(\frac{N}{10^{51}} \right) \left(\frac{\eta}{1.0} \right) \left(\frac{1 \text{ yr}}{t_{\text{av}}} \right) \left(\frac{1 \text{ kpc}}{D} \right)^2 e^{-t/t_{\text{av}}} \text{ photons (cm}^2 \text{ s)}^{-1} \quad (2)$$

To observe a gamma-ray line from the short-lived process $^{57}\text{Co} \rightarrow ^{57}\text{Fe}$, a very young ($t < 10$ years) supernova remnant is required. Current estimates of galactic supernova rates range from one per five years to one per fifty years (Tammann 1977; Clark and Stephenson 1977; Manchester and Taylor 1977), with some recent results (Jones 1975; Taylor 1978) tending to favor the higher rate. Thus, it is not at all unlikely that a remnant less than 5 to 10 years old exists somewhere in the Galaxy; such an object would provide a 122 keV line flux of 4×10^{-4} photons $(\text{cm}^2 \text{ s})^{-1}$ at 20 kpc. With our $1^\circ.5$ field of view pointed along the galactic plane, we could search over 75% of the entire volume of the Galaxy in which supernova remnants are known to exist ($R < 12$ kpc; $|z| < 150$ pc) to this level of sensitivity in less than two days. The only excluded regions would be within a few kiloparsecs of the earth within which we are quite certain no such recent event has occurred.

While the prospect of detecting such a young remnant is an exciting one indeed, the initial program for such a spectrometer would probably concentrate on the other two disintegration chains noted above, since their longer half-lives allow us to search for these lines in known objects. The ^{44}Ca doublet will be detectable with our instrument in a three-hour integration if it is present in the Cas A remnant at the expected level. These searches for nuclear lines from the explosively produced matter can, of course, be carried out simultaneously with the detailed study of the atomic spectra of both the ejected and swept-up material via the 6-7 keV iron and nickel lines.

Although less energetic by several orders of magnitude, galactic novae are also thought to be the site of significant nucleosynthesis, and their

frequent occurrence (>25 per year in the Galaxy) makes them an important potential target. Assuming a yield of unstable nuclei of $10^{-3.5}$ times that for supernovae (Lingenfelter and Ramaty 1978), we could easily detect both the ^{57}Co and ^{44}Ti lines from a nova 3 kpc away for the first year or two after its outburst. In addition, the potentially quick response time of the Shuttle suggests the exciting possibility of observing one of the most abundant of the iron peak isotopes (^{56}Ni , 163 keV) despite its short lifetime of ~ 10 days (a launch within 3-4 months of the outburst of a nearby [~ 2 kpc] nova would be required). In conclusion, then, our spectrometer offers the first opportunity to put the so-far brilliantly successful theory of explosive nucleosynthesis to a direct test at the sources of the created material.

d) Continuum Spectra

No instrument has ever been flown which covers the entire energy range from soft X-rays to soft gamma-rays. Consequently, all of the currently available X-ray source spectra are composites of data taken with different instruments and, more importantly for these variable sources, at different times. Detailed continuum spectra are a valuable discriminant among various emission and radiative transfer models, and with the current observational situation, progress in understanding these sources has been slow.

An obvious by-product of the spectral line observations proposed above is the determination of source continuum spectra over the spectrometer's range of 2 to 200 keV. The high resolution available over the entire band will enable us to pinpoint spectral breaks and absorption edges, and will provide data which will be most useful in studying detailed models for source emission components. Assuming a Crab-like spectrum and a 1 keV resolution element, we can detect in three hours all sources brighter than 15 Uhuru counts out to 50

keV and all sources brighter than 300 Uhuru counts (~25 sources) out to 200 keV.

e) Solar Physics

High resolution solar spectra have never been obtained in the energy range from 50 to 200 keV and standard, free-flying spacecraft constraints often preclude solar observations entirely. Thus, the closest object in the universe of interest to high energy astrophysicists remains an enigma. The relationship of radio noise storms and bursts to the energetic particles evident in X-ray flares is not well understood, and detailed continuum shapes are required to make progress in the theories of particle acceleration and storage mechanisms. Lines from the hot thermal plasma of the corona will be easily observable. Jacobsen (1977) has reported the detection of a 73 keV line which may have originated in the quiet Sun, and although theoretical estimates of their strengths are quite low, lines from the deexcitation of nuclei produced in surface nuclear reactions and in the spallation of the thermal nuclei of the photosphere by the high energy flare particles might well be detected. Detailed line shapes can yield kinematic and positional information about the emitting particles. By following the time development of the spectrum through a solar flare, densities and temperatures in the emitting volume can be obtained (see, for example, Parkinson 1975). Although solar astronomy would probably not be the primary objective of the initial flight of the proposed instrument, its spectral range and resolution make it an obvious candidate for use in studying the Sun. We have included a solar observation of a few hours in our sample observing plan to obtain the first high resolution spectrum of the quiet Sun available in this energy regime. If an active region is present at launch time, we could specify a more extended

pointing in an attempt to obtain a flare spectrum which would contribute substantially to our knowledge of the energetic phenomena taking place on our closest star.

f) Sample Observing Program

In Table 2 we present a sample observing program that could be carried out with this instrument in two days of pointed observations on a Shuttle mission. We have assumed that on-source data will be collected during only 40% of our observing time and have based our integration time requirements on the sensitivity calculations found in §III.f. A wide range of targets is possible in this short time, and there are manifest advantages in being able to combine search program (e.g., for cyclotron and nuclear deexcitation lines) with observations which we are confident will yield positive, important results (the high-resolution spectroscopy of the 6 keV iron lines and the detailed continuum spectra).

III. EXPERIMENT DESCRIPTION

a) Overall Design

The Wide-Band Germanium X-Ray Spectrometer is illustrated in Figure 1. The detector package, consisting of 19 planar germanium crystals and their associated low-noise preamplifiers in a vacuum cryostat, is surrounded by a massive active Polyscin (NaI) shield/collimator and its associated complement of phototubes. The two-section collimator provides each detector with a 1.05° FWHM field of view, and includes two movable shutters used in acquiring background data, along with an aluminum filter to allow solar observations. A solid Argon refrigerator sits at the base of the unit, providing sufficient

cooling capacity to maintain the detector cryostat at $T \lesssim 90$ K for a period of up to five weeks. This experiment will provide the first single-instrument coverage of this entire energy range, a factor of 3 improvement over the resolution of proportional counters in the 6-7 keV iron-line region, and more than an order of magnitude increment in both resolution and line sensitivity in the 30 to 200 keV region. The design details for each of the system's components, along with questions of sensitivity and background rates, are discussed below.

b) Detector Package

The detector itself consists of a hexagonal close-packed array of 19 planar high-purity germanium crystals of 1 inch diameter (5 cm^2). These individual intrinsic detectors are readily available commercially in a variety of thicknesses; we have chosen 10 mm as the optimum value for energy range and resolution (but see §III.g below). The quantum efficiency of the detectors is greater than 80% from 3 to 90 keV and remains greater than 25% between 1.5 and 200 keV; the resolution is better than 400 eV at the low end of this energy range and degrades only slowly to a value of ~ 650 eV (0.4%) at the upper end. The detectors are mounted on a cold plate to minimize thermal generation of electron/hole pairs and to increase the mobility of the pairs created by the ionizing X-rays from the source.

Each crystal is equipped with a low-noise FET preamplifier which resides inside the detector cryostat. The preamplifier output signals are sent to the electronics box mounted beneath the shield assembly where they are amplified, shaped, and processed in a pulse-height analyzer. Four multiplexed 12-bit analog-to-digital converters (one for each five detectors) assign each event to one of the 4096 50-eV wide energy channels. The data are serially

transferred to the Shuttle telemetry system through a buffer; anticoincidence triggers recorded by the phototubes and other secondary science and housekeeping data are subcommutated with the primary data stream by a microprocessor.

c) Shield/Collimator System

In the low-energy X-ray regime (< 20 keV), large anticoincidence scintillator shields have not traditionally been employed, since the instrument background is typically dominated by diffuse X-ray emission. At high energies, however, the spectrum of the diffuse background steepens, and the charged particle background becomes the sensitivity-limiting factor. In addition, passive collimators become increasingly difficult to build as the energy increases above 40 keV. In the proposed spectrometer, the shield allows for good collimation over the entire spectral range, diffuse background-limited observations out to nearly 50 keV, and remarkably low [$\sim 10^{-3}$ counts (s keV) $^{-1}$] total background rates throughout the hard X-ray portion of the spectrum.

The shield/collimator assembly consists of four pieces of sodium iodide housed in hermetically sealed containers with glass windows for their associated phototube arrays. The shield design assures that the path to any detector from the outside world is at least 4 inches. The sodium iodide pieces surrounding the detector box on the bottom and sides are each viewed through symmetrical arrays of six 5-inch ruggedized phototubes. The 18-inch high collimator section on top of the detector is a honeycomb of nineteen 1-inch holes (one above each detector) and requires a dozen phototubes for effective light collection. Similar drilled collimators have been flown successfully with solid-state detectors in several experiments (e.g., on OSO-7 and HEAO-1). The forward collimator section with its own set of 3-inch photo-

tubes resides 18 inches above the top of the instrument to provide a reduction of a factor of 2 over the unprecollimated field of view to 1.5 FWHM (5.4×10^{-4} ster).

With an effective geometric area of $\sim 4000 \text{ cm}^2$, the instrument should experience incident background rates of $\sim 4 \times 10^4$ events s^{-1} . A bilevel anti-coincidence trigger mechanism will provide a short (1-2 μs) gate for normal background events and a wider ($\sim 50 \mu\text{s}$), adjustable gate for those events that deposit very large amounts of energy in the shield ("stars"). The dead time from the normal events will be $\sim 5\%$; we estimate that there may be 10^3 "stars" per second, leading to an additional 5% dead time. Since the rate of "stars" is difficult to predict accurately, the exact veto width of the "star" gate can be uplinked once the background orbit is determined.

d) Background Shutters

Mounted atop the main collimator are two motor-driven interlocking shutters, each with its own phototube. They can be commanded closed individually or together to cover either 9, 10, or all 19 of the detectors for the purposes of obtaining simultaneous background data while the source is in the field of view. Such simultaneity may be required to extract, for example, the weak nuclear deexcitation lines from the strong, time-varying background spectrum. For most observations, however, we will be able to obtain sufficient background data during portions of the orbit when the source of interest is not accessible (e.g., Earth occultation) and thus will utilize the full effective area of the detectors for source observation.

e) Background Calculations

The calculated instrument background spectrum is shown in Figure 2. The following background components have been included in our considerations:

- (1) The diffuse X-ray background (both inside the field of view and incident on the remainder of the instrument)
- (2) Cosmic gamma-ray-induced spallation in the germanium crystals
- (3) Trapped gamma-ray-induced spallation in the germanium crystals
- (4) Charged particle-induced radioactivity in the NaI shield, and
- (5) Neutron activation in the germanium.

We have taken the diffuse background spectrum dF_{bl}/dE from Schwartz (1978); for our 95 cm² detector with its 1.05 field of view, this implies

$$\frac{dF_{bl}}{dE} = \begin{cases} 0.50 E^{-1.4} & (1 < E < 21 \text{ keV}) \\ 9.90 E^{-2.38} & (21 < E \text{ keV}) \end{cases}$$

This contribution dominates the instrument background up to ~40 keV and then is rapidly swamped by the non-X-ray background, contributing less than 10% above 95 keV. Due to the thick NaI shield which completely surrounds the detector, the contribution to the background from the isotropic diffuse flux incident on the instrument is negligible; calculations indicate it can be neglected completely below ~400 keV.

We have performed detailed Monte Carlo simulations using the computer codes at Sandia Laboratories¹ to estimate the contribution to the background from long-lived (compared to the veto time gate width) radioactivity induced in the germanium crystals from both cosmic rays and trapped protons. The cosmic-ray proton flux was taken from Figure 17 of Webber's review (1967),

¹ We wish to acknowledge the invaluable assistance of Jim Morel and John Halbleib of Sandia Laboratories for performing these important simulations.

using the values for sunspot maximum. The South Atlantic Anomaly protons and electrons were treated using Proton Model AP8 Max (Sawyer and Vette 1976) and solar maximum models AE4 and AE6 (Teague, Chan, and Vette 1976). The trapped proton flux was calculated for a time corresponding to one orbit after the last South Atlantic Anomaly passage on the tenth day of the mission. The simulations were performed for shield geometries closely approximating our present design and with minimum shield thicknesses of 8 cm and 12 cm. There were no statistically significant differences between the two runs, although the assumption of neglecting the noncollimated diffuse radiation begins to break down for thinner shields.

In principle, one can calculate the background contribution due to charged particle-induced radioactive spallation products in the NaI shield itself with the same detailed procedures used above for the germanium. However, since the vast majority of these nonvetoed events leave the instrument without interacting in the detector, a vast number of particle and photon histories must be followed before statistically meaningful results are achieved, and the computing costs become prohibitive. Thus, we have modeled this contribution to the background by calculating the particle and photon flux out of the surface of a block of NaI with the appropriate amount of induced, nonvetoed radioactivity. This has then been treated as an isotropic background bathing the Ge crystals and can be converted to a background counting rate by simply multiplying by the isotropic efficiency of each detector and summing over all detectors. This contribution turns out to be roughly comparable to that from the spallation in the germanium over most of the energy range of interest (see Fig. 2).

In addition to the continuous background produced by charged particles

and diffuse X-rays, several sharp lines typically appear in the background spectrum of germanium detectors due to transitions in the crystals induced by incident neutrons. While a massive active NaI shield is effective in rejecting charged-particle and uncollimated X-ray events, it is not particularly useful in reducing the flux of these neutrons. Earth albedo and spacecraft-generated neutrons ranging in energy from a fraction of a keV to >100 keV contribute in two ways to the production of a metastable excited state of ^{76}Ge : (1) neutron capture in ^{76}Ge , and (2) inelastic scattering off ^{76}Ge . Two of the strong background lines produced by the decay of this metastable state occur at inauspicious locations in the spectrum: at 54 keV (near the Her X-1 cyclotron line) and at 67 keV (near the 68 keV nuclear deexcitation line of ^{44}Ti). The high gain stability and attention to obtaining background data inherent in the instrument design will allow the accurate subtraction of such background features.

f) Instrument Sensitivity

The minimum line flux F_L detectable at an M-sigma level in orbit time t is given by

$$F_L = \frac{M (2B \Delta E)^{1/2}}{A \epsilon_A (\epsilon_t \cdot t)^{1/2}},$$

where ΔE (keV) is the instrumental resolution or the intrinsic line width (whichever is greater), A (cm^2) is the geometric area of the detector with efficiency ϵ_A , ϵ_t is the fraction of orbit time in which good data are collected, and B is the background counting rate, consisting of both the non-X-ray counting rate plus the diffuse X-ray background, dF_b/dE , and the source

continuum flux, dF_c/dE , in the vicinity of the line (in counts $[\text{cm}^2 \text{ s keV}]^{-1}$). Thus, the time to detect a feature of known strength is given by

$$t = \frac{M^2}{\epsilon_t \cdot F_L \cdot A \cdot \epsilon_A} \left(1 + \frac{2 \frac{dF_b}{dE} \Delta E}{F_L \cdot \epsilon_A} + \frac{2 \frac{dF_c}{dE} \Delta E}{F_L} \right) .$$

The geometric area of the detector is 95 cm^2 and the resolution in the iron line region of the spectrum is $\sim 400 \text{ eV}$. We have assumed that useful data will be obtained during 40% of our observing time (i.e., $\epsilon_t = 0.40$). Note that for many of the strong X-ray binary targets, the source continuum is the dominant contribution to the "background" counting rate. In estimating the observing times required for the observations of bright binary sources discussed in §II.a), we have used the 6 keV continuum fluxes reported in the references from which the line fluxes were taken and have extrapolated these values to the sulfur, argon, and nickel energies using an E^{-1} power law spectrum (a good approximation of these objects over this narrow spectral range [Pravdo 1978]).

Using these parameters, the $3\text{-}\sigma$ sensitivity obtainable in 10^4 s of orbit time is approximately

$$F_{L(\text{min})} \approx 6 \times 10^{-4} \left(\frac{dF_b}{dE} \right) + \left(\frac{dF_c}{dE} \right)^{1/2} \text{ photons } (\text{cm}^2 \text{ s})^{-1} ,$$

implying line sensitivities of $\sim 10^{-4}$ photons $(\text{cm}^2 \text{ s})^{-1}$ and $\lesssim 4 \times 10^{-5}$ photons $(\text{cm}^2 \text{ s})^{-1}$ at 6 and 60 keV, respectively.

g) Other Detector Configurations

The detector system described above was chosen to optimize sensitivity and resolution while extending the useful spectral range down to 2 keV. In view of the extensive spectroscopic results from the Einstein SSS in the 2-4

keV range, it is useful to consider other possible detector configurations which deemphasize this soft X-ray regime. One such possibility would be to substitute thicker germanium crystals for those in the baseline design to provide increased sensitivity at the higher energies. For example, 1.6 cm planar crystals retain 10% of their efficiency up to 550 keV. Thus, a 19-element array would provide $\sim 10 \text{ cm}^2$ of effective area in the region of the 511 keV position annihilation line which has been observed from the direction of the galactic center. The narrow field of view and high spectral resolution of this experiment would provide new information on the source of this line. The price of such a change is a worsening of the resolution in the 6-7 keV iron line region by nearly a factor of two (to $\sim 10\%$, i.e., comparable to that achievable with gas scintillation proportional counters - see Hailey et al. and Culhane, this volume). Alternatively, the complexity of the detector and shield assemblies could be reduced considerably by choosing an array of seven 15-cm^2 crystals in place of the nineteen 5-cm^2 array in the current design. Again, however, the resolution is degraded from 360 eV to 560 eV at 6 keV. Detailed scientific/engineering tradeoff studies are currently under way to determine the optimum configuration for a flight design.

IV. CONCLUSIONS

A number of outstanding astrophysical problems require critical inputs from moderate-to-high resolution X-ray spectroscopy in the 2-200 keV band and beyond. A large number of the atomic, nuclear, and cyclotron transitions that occur in the regime offer unique probes of the physical conditions which

obtain in sources ranging from neutron star binaries to clusters of galaxies. We have designed a planar germanium spectrometer which would operate in this rich spectral domain to address such questions as the structure of neutron star magnetospheres and accretion disks and the origin of the chemical elements. With the elimination of the germanium spectrometer on the Gamma Ray Observatory, no currently planned NASA mission will be able to meet the patent need for such a spectrometer.

The sample observing program displayed in Table 2 illustrates that a substantive scientific program can be carried out by such an experiment in the brief observing time available on a week-long Shuttle flight. As the cost of a free-flying mission escalates past \$100 M and the funds available for new starts declines precipitously, it is perhaps appropriate to reexamine the premises on which the space science program of the past decade was built. Ten experiments of the class described here and elsewhere in this volume can all be built for half the cost of one free-flyer in less than half the time. The continued existence of an American program in high energy astrophysics may well turn on which of these options is chosen.

This work was supported by the National Aeronautics and Space Administration under Contract NAS 5-26041. This is Columbia Astrophysics Laboratory Contribution No. 216.

ORIGINAL PAGE IS
OF POOR QUALITY

TABLE 1
Nuclear Deexcitation Lines from the Sites
of Explosive Nucleosynthesis

Nuclei	Energy (keV)	Life- time (yr)	Nuclei Produced per Event	Photons per Decay	Source	Dis- tance (kpc)	Time Required* (hr)
$^{57}\text{Co} \rightarrow ^{57}\text{Fe}$	14,122	1.1	7×10^{52}	0.88	5 yr SNR	20	0.34
	136	1.1	7×10^{52}	0.11			4.8
$^{57}\text{Co} \rightarrow ^{57}\text{Fe}$	14,122	1.1	2×10^{49}	0.88	1 yr Nova	3	0.61
	136	1.1	2×10^{49}	0.11			14
$^{60}\text{Fe} \rightarrow ^{60}\text{Co}$ $\rightarrow ^{60}\text{Ni}$	59	4.3 $\times 10^5$	5×10^{50}	1.0	Sof : X-Ray loop	0.2	38
$^{44}\text{Ti} \rightarrow ^{44}\text{Sc}$ $\rightarrow ^{44}\text{Ca}$	68, 78	68	6×10^{51}	1.0	Cas A	2.8	2.4
$^{56}\text{Ni} \rightarrow ^{56}\text{Co}$ $\rightarrow ^{56}\text{Fe}$	163	0.025	9×10^{50}	0.85	1 mo Nova	3	0.01
					3 mo Nova		5.9

*To detect a 3σ detection based on line strength calculations discussed above.

ORIGINAL PAGE IS
OF POOR QUALITY

TABLE 2
Sample Observing Program for Two Days' Observing Time

Source	Time (hr)	Objectives					
		Fe Line ($\geq 6 \sigma$)	Ni Line (4σ)	Other Lines (3σ)	Con- tinuum Spectra	Cyclotron Lines ($>10 \sigma$)	Nuclear Lines (3σ)
<i>X-Ray Binaries</i>							
Cyg X-3*	5	✓	✓	✓	✓	✓	...
Cen X-3	0.1	✓	✓
Vela X-1	6	✓	✓	✓	✓	✓	...
Her X-1	12	✓	✓	...	✓	✓	...
GX 301-2	0.1	✓	✓
1626-67	0.1	✓	✓
Cir A-1	0.3	✓	✓
<i>Supernova Remnants</i>							
Cas A	20	✓	✓(6σ)	...	✓	...	✓
GX 287.8-0.5	1	✓	✓
Recent nova	0.2	✓	...	✓
<i>Clusters of Galaxies</i>							
Perseus	0.15	✓	✓
Virgo	0.25	✓	✓
Coma	0.8	✓	✓
0251+41	1.0	✓	✓
<i>The Sun</i>	3	✓	✓	...	✓
Total	50						

*One complete orbit.

REFERENCES

- Armstrong, T. W., Chandler, K. C., and Barish, J. 1973, J. Geophys Res.,
78, 2715.
- Baade, W. et al. 1956, P.A.S.P., 68, 296.
- Basko, M. M., and Sunyaev. R. A. 1974, Astron.Ap., 42, 311.
- Becker, R. H., Boldt, E. A., Holt, S. S., Pravdo, S. H., Rothschild, R. E.,
Serlemitsos, P. J., Smith, B. W., and Swank, J. H. 1977,
Ap. J., 214, 879.
- Becker, R. H., Rothschild, R. E., Boldt, E. A., Holt, S. S., Pravdo, S. H.,
Serlemitsos, P. J., and Swank, J. H. 1978, preprint.
- Burbidge, E. M., Burbidge, G. R., Fowler, W. A., and Hoyle, F. 1957, Rev.
Mod. Phys., 29, 597.
- Charles, P. A., Mason, K., Cash, W., Lampton, M., and Bowyer, S. 1978, Bull.
A.A.S., 10, 420.
- Clark, D. H., and Stephenson, F. R. 1977, M.N.R.A.S., 179, 878.
- Clayton, D. D. 1973, in Explosive Nucleosynthesis, eds. D. N. Schramm and
W. D. Arnett, (Texas: U. Texas Press), and references
therein, p. 264.
- Clayton, D. D. 1973, in Explosive Nucleosynthesis, eds. D. N. Schramm and
W. D. Arnett, (Texas: U. Texas Press), and references
therein, p. 265.
- Clayton, D. D. 1974, Ap. J., 188, 155.
- Clayton, D. D. 1975, Ap. J., 198, 151.
- Clayton, D. D., Colgate, S., and Fishman, G. J. 1969, Ap. J., 155, 75.
- Coe M. J. et al. 1977, Nature, 268, 509.

- Daugherty, J. K. 1978, "Gamma Ray Spectroscopy in Astrophysics," NASA Technical Memorandum 79619, p. 364.
- Dyer, C. S. 1977, "Assessment of Background Radiation Effects in Low-Energy Gamma Ray Astronomy," 1977 Gamma-Ray Symposium, Frascati, Section 7.
- Gnedin, Y. N., and Sunyaev, R. A. 1974, Astron. Ap., 36, 379.
- Hess, W. N., Canfield, E. H., and Lingenfelter, R. E. 1961, J. Geophys. Res., 66, 665.
- Hess, W. N., private communication.
- Jacobsen, A. S. 1977, "High Resolution Gamma Ray Spectroscopy," invited paper presented at Spring Meeting of APS.
- Jacobsen, A. S. et. al. 1975, N.I.M., 127, 115.
- Jones, E. M. 1975, Ap. J., 201, 377.
- Kanbach, G., Reppin, C., and Schonfelder, V. 1974, J. Geophys. Res., 79, 5159.
- Lingenfelter, R. F., and Ramaty, R. 1978, Physics Today, 31, 40.
- Manchester, R. N., and Taylor, J. H. 1977, Pulsars (San Francisco: Freeman), 160.
- Meszáros, P. 1978, Astron. Ap., 63, 19.
- Meszáros, P. 1978, in "Gamma-Ray Spectroscopy in Astrophysics," NASA Technical Memorandum 79619, p. 425.
- Mushotzky, R. F., Serlemitsos, P. J., Smith, B. W., Boldt, E. A., and Holt, S. S. 1978, preprint.
- Parkinson, J. H. 1975, Solar Phys., 42, 183.
- Pravdo, S. H. 1978, presented at the 21st COSPAR Plenary Meeting, Innsbruck, Austria.

- Preszler, A. M., Sinett, G. M., and White, R. S. 1974, J. Geophys. Res., **79**, 17.
- Ramaty R., and Lingenfelter, R. E. 1977, Ap. J. (Letters), **213**, L5.
- Ruder, H., Wunner, G., Harold, H., and Trumper, J. 1981, Phys. Rev. Lett., **46**, 1700.
- Sawyer, D. M., and Vette, J. I. 1976, NSSDC/WDC-AR&S 76-06, National Space Science Data Center, NASA GSFC, Greenbelt, Maryland.
- Schramm, D. N., and Arnett, W. D. eds., 1973, Explosive Nucleosynthesis (Texas: University of Texas Press), and references therein.
- Schwartz, D. A. 1978, presented at 21st COSPAR Plenary Meeting, Innsbruck, Austria.
- Swank, J. H., Boldt, E. A., Holt, S. S., Pravdo, S. H., Rothschild, R. E., and Serlemitsos, P. J. 1978, Bull. A. A. S., **23**, 581.
- Tamman, G. A. 1977, Proceedings of Eighth Texas Symposium on Relativistic Astrophysics, Ann. N. Y. Acad. Sci., **302**, 61.
- Taylor, J. H. 1978, private communication.
- Teague, M. J., Chan, K. W., and Bette, J. I. 1976, NSSDC/WDC-AR&S 76-04, National Space Science Data Center, NASA GSFC, Greenbelt, Maryland.
- Trumper, J. et al., 1978, "Gamma-Ray Spectroscopy in Astrophysics," NASA Technical Memorandum 79619, p. 331.
- Weaver, R. P. 1978, "Gamma-Ray Spectroscopy in Astrophysics," NASA Technical Memorandum 79619, p. 418.
- Webber, W. R. 1967, Handbuch der Physik, **46**, (Springer-Verlag).
- White, R. S. 1973, Rev. Geophys. and Space Phys., II, 595.

FIGURE CAPTIONS

FIG. 1 - Schematic diagram of Wide-Band Germanium X-Ray Spectrometer.

FIG. 2 - Background counting rates for the Wide Band Germanium X-Ray Spectrometer as a function of energy including contributions from nonvetoed charged-particle events in the detectors (Ge) and shield (NaI), and the diffuse X-ray background.

ORIGINAL PAGE IS
OF POOR QUALITY

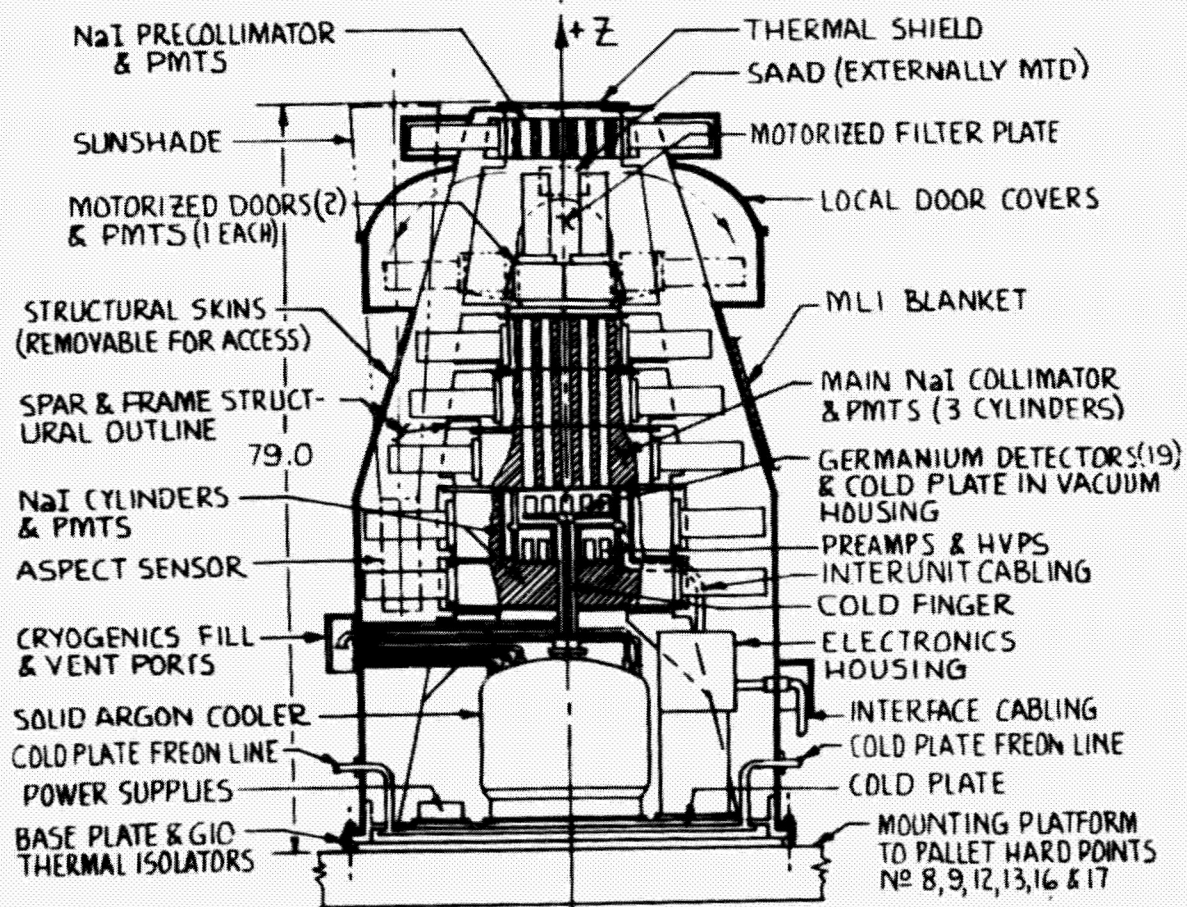
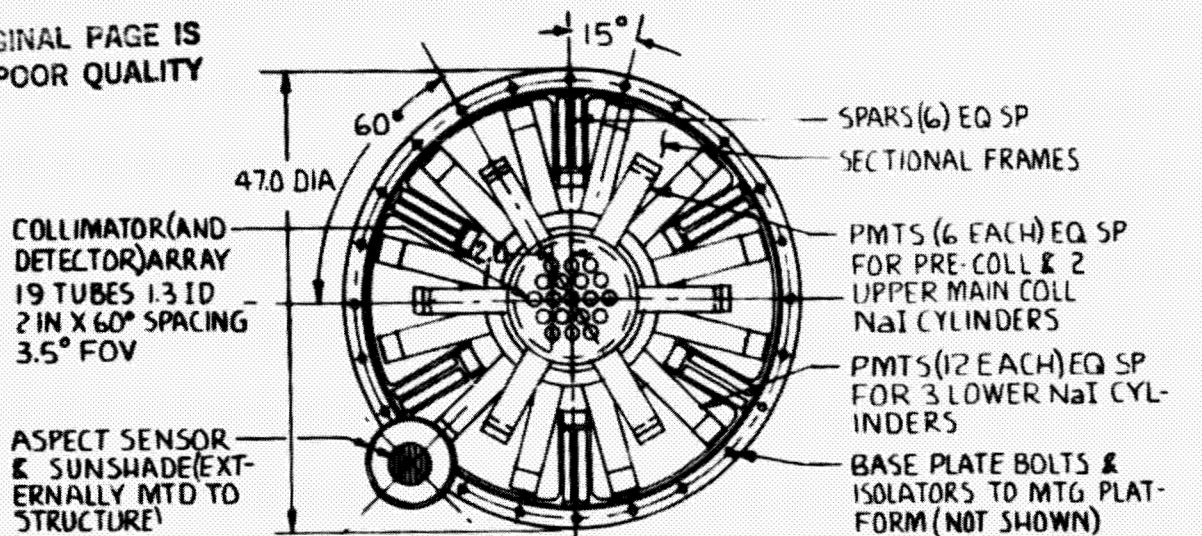

GENERAL ARRANGEMENT
WIDE-BAND GERMANIUM X-RAY SPECTROMETER
SCALE: APPROX 1/16

FIGURE 1

ORIGINAL PAGE IS
OF POOR QUALITY

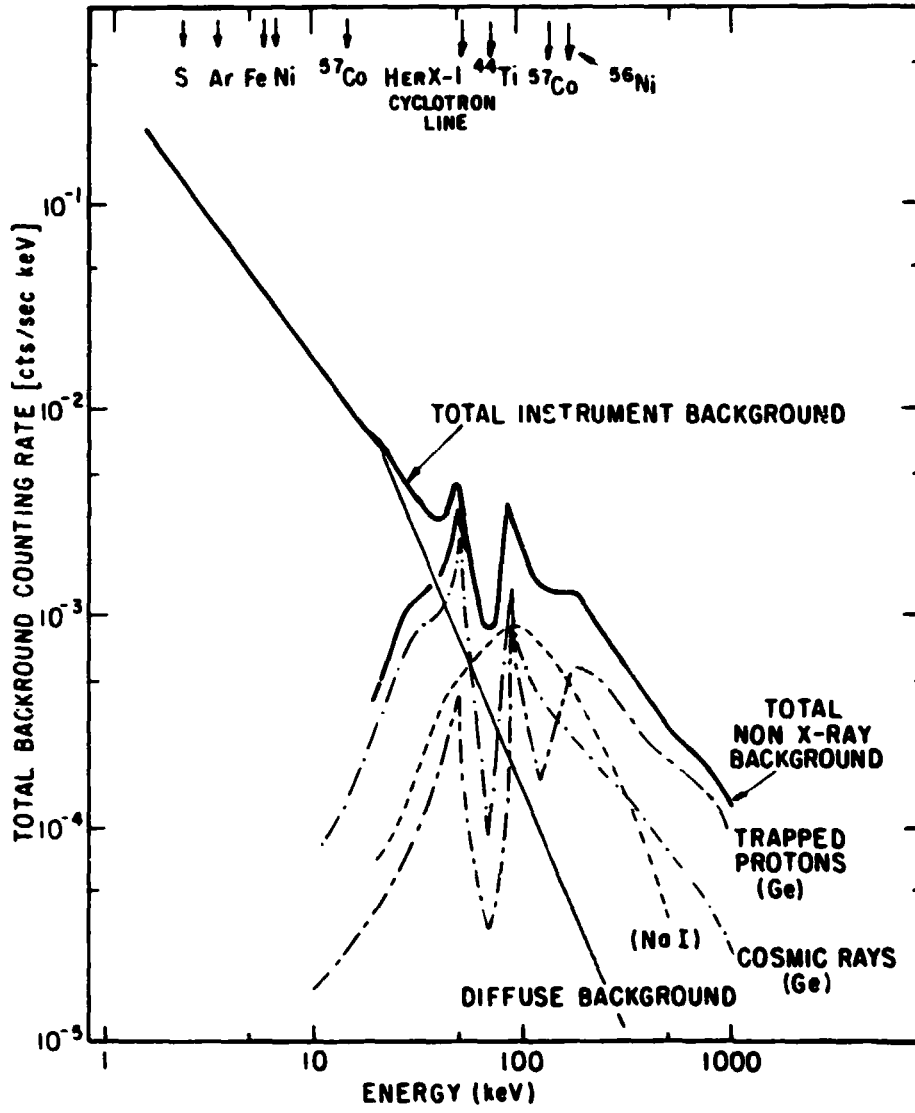

FIGURE 2