

NASA Contractor Report 165839

NASA-CR-165839
19820018589

Develop, Demonstrate, and Verify Large Area Composite Structural Bonding With Polyimide Adhesives

Bashir D. Bhombal
Donald H. Wykes
Keith C. Hong
Arnold A. Stenersen

Rockwell International
Downey, CA 90241

Contract NAS 1-15843
May 1982

LIBRARY COPY

JUN 9 1982

LANGLEY RESEARCH CENTER
LIBRARY, NASA
HAMPTON, VIRGINIA



National Aeronautics and
Space Administration

Langley Research Center
Hampton, Virginia 23665



NF01350

NASA Contractor Report 165839

Develop, Demonstrate, and Verify Large Area Composite Structural Bonding With Polyimide Adhesives

**Bashir D. Bhombal
Donald H. Wykes
Keith C. Hong
Arnold A. Stenersen**

**Rockwell International
Downey, CA 90241**

**Contract NAS 1-15843
May 1982**

NASA

National Aeronautics and
Space Administration

Langley Research Center
Hampton, Virginia 23665

N82-26465 #

This Page Intentionally Left Blank

FOREWARD

This is the final report on an effort to develop, demonstrate, and verify large area composite structural bonding with polyimide adhesive. This program was conducted by the Advanced Manufacturing Technology of Space Transportation and Systems Group of Rockwell International, under Contract NAS1-15843, for the Materials Division of NASA's Langley Research Center, Hampton, Virginia. Robert M. Baucom was the NASA Technical Monitor.

The Program Manager during the Process Development phase was Arnold A. Stenersen. Donald H. Wykes assumed program management responsibilities of Technology Demonstrator Segment and final report phases of the Contract.

Bashir D. Bhombal was the Technical Project Manager.

The following Rockwell personnel were principal contributors to this program.

J. D. Leahy	Materials Technology
R. L. Crabb	Materials Technology
D. W. Houston	Chemical Testing
R. L. Long	Specification Development
S. R. Graves	Advanced System

This Page Intentionally Left Blank

CONTENTS

<u>SECTION</u>		<u>PAGE NO.</u>
1.0	INTRODUCTION	1
2.0	SCREENING OF ADHESIVE SYSTEMS	2
2.1	Selection Criteria for the Adhesives	2
2.2	Industry Survey.	2
2.3	Polyimide Resin Chemistry	4
2.4	Condensation vs. Addition Type PI Resins	5
2.5	Adhesive Screening Tests	6
2.6	Lap Shear Test	7
2.7	Flatwise Tensile Test	8
2.8	Climbing Drum Peel Test.	8
2.9	Glass Transition Temperature	8
2.10	Out-Time Study	8
2.11	Mid-Plane Bonded Large Area Panels	9
2.12	Evaluation of Primers and Surface Treatments	9
2.13	Selection of Three Adhesive Systems	9
3.0	PROCESS DEVELOPMENT	10
3.1	Celion/PMR-15 and Celion/LaRC-160 Adherends.	10
3.2	Surface Treatment Study.	11
3.3	Primer Evaluation	11
3.4	Processing of Adhesive	12
3.5	Process for Mid-Plane Bonding Large Area Panels	12

CONTENTS

<u>SECTION</u>		<u>PAGE NO.</u>
	3.6 Process for Bonding Honeycomb Sandwich Panels	13
	3.7 Core-Coating of Paste Adhesives	13
	3.8 Aging Stability of Selected Adhesives	14
	3.9 Out-time of Selected Adhesives	14
	3.10 Effect of Water Immersion on Lap Shear	15
	3.11 Final Selection of Adhesives	15
4.0	QUALIFICATION OF SELECTED ADHESIVES	15
	4.1 Process for Fabrication of Honeycomb Sandwich Panels	15
	4.2 Process for Mid-Plane Bonding Large Area Panels	16
	4.3 Effect of Bond-Line Thickness on Lap Shear Strength	16
	4.4 Effect of Out-Time on Filletting Properties of LaRC-13	16
	4.5 Evaluation of Catalysts to Reduce Cure Temperature	17
5.0	SUMMARY	17
6.0	TECHNOLOGY DEMONSTRATOR SEGMENT	19
7.0	FABRICATION OF STRUCTURAL TEST ASSEMBLY	20
	7.1 Prepreg Tape	20
	7.2 Leading Edge Cover Panel	20
	7.2.1 Skin	21
	7.2.2 Closeout Channel	22
	7.2.3 Assembly of Leading Edge - Bonding Tool	24
	7.2.4 Prefit of Details	24

CONTENTS

<u>SECTION</u>	<u>PAGE NO.</u>
7.2.5	Cleaning and Priming of Details 25
7.2.6	Assembly of Details on Tool 26
7.3	Stability Rib 27
7.3.1	Stability Rib Sandwich Panel. 27
7.3.2	Pi Cap Element 28
7.3.3	Bonding of Closeout Channel and Pi Cap to Web . Sandwich Panel 28
7.4	Lower and Upper Cover Panels. 29
7.4.1	Honeycomb Core 29
7.4.2	Skin. 29
7.4.3	Close-Out Edge Member 30
7.4.4	Honeycomb Sandwich Assembly 30
8.0	DEMONSTRATOR SEGMENT TEST PROGRAM 31
8.1	Test Approach 32
8.2	Test Constraints. 32
8.3	Technology Demonstrator Segment NASTRAN Model 32
8.4	Room Temperature and 533 ^o K Mechanical Tests 33
8.5	400 Cycle Simulated Fatigue Test. 34
8.6	Thermal Cycling Test 34
8.7	Acoustic Fatigue Test 35
8.8	Internal Pressure Test 35
8.9	Summary 36
DOCUMENTATION 37
APPENDIX A 115

This Page Intentionally Left Blank

ILLUSTRATIONS

<u>FIGURE</u>		<u>PAGE NO.</u>
1	LARC-13 Monomer Reactants	39
2	LARC-13 Polyimide Reaction Sequence	39
3	Adhesive Prepreg Mill	40
4	Reaction Scheme of NR150B2G Adhesive	41
5	Flatwise Tensile Test Specimen	42
6	Flatwise Tensile Test Specimen After Testing.	43
7	Climbing Drum Peel Test Apparatus	44
8	C-Scan of 76 x 46 cm (30"x 18") Panel, 8 Ply, Unidirectional	45
9	C-Scan of 76 x 46 cm (31" x 18") Panel of Celion/. . . . PMR-15 Composite Panel, 8-ply, Unidirectional	46
10	C-Scan of Honeycomb Sandwich Panel with FM34B-18 Adhesive	47
11	C-Scan of Honeycomb Sandwich Panel with LARC-13 Adhesive	48
12	Comparison of Primers for Bonding Celion 6000/PMR-15 Panels with LARC-13	49
13	C-Scan of 30.5 by 30.5 cm (12 x 12 in.) Mid-Plane Bonded Panel with LARC-13 Adhesive on Style 104 Carrier	50
14	C-Scan of 30.5 cm (12 x 12 in.), Mid-Plane Bonded Panel with M-LARC-13E Adhesive on Style 104 Carrier	51
15	C-Scan of 30.5 cm by 30.5 cm (12 x 12 in.) Mid-Plane Bonded Panel with FM34B-18 Adhesive on Style 104 Carrier	52
16	Cure Cycle for the Fabrication of Honeycomb Sandwich Panels with LARC-13 M-LARC-13E and FM34B-18 Adheives	53

ILLUSTRATIONS

<u>FIGURE</u>		<u>PAGE NO.</u>
17	Technology Demonstrator Segment Completed Structure . . .	54
18	Staging Lay-up for Flat Laminates	55
19	Autoclave Cure for Flat Laminates	56
20	"U" Channel Lay-up Mold	57
21	Staging Lay-up for "U" Shape Laminate	58
22	Curing Lay-up for "U" Shape Laminate	59
23	Alternate Curing Lay-up for "U" Shape Laminate	60
24	Curing Lay-up for Honeycomb Sandwich Panel.	61
25	Cure Cycle for Cover Panels	62
26	Tool Configuration for Stability Rib Close-out. Channel	63
27	Curved "Pi" Joint Element Design	64
28	Cure Cycle for Skins	65
29	Oven Post Cure Cycle for Skins	66
30	C-Scan of 76.2 cm x 157.5 cm (30" x 62" Skin for Leading. Edge	67
31	Skin for the Leading Edge	68
32	Vacuum Forming of the Close-out Channels	69
33	Leading Edge Panel Bonding Jig.	70
34	Leading Edge Bonding Assembly-Cross Section View. . . .	71
35	Leading Edge Cover Panel on Bonding Jig	72
36	Leading Edge/Cover Panel	73
37	Primer Being Applied on Rib Web for Bonding of "U". . . Channel	74

ILLUSTRATIONS

<u>FIGURE</u>		<u>PAGE NO.</u>
38	Primer Being Applied to the Inner Section "U" Channel . .	75
39	"U" Channel Being Inserted to Web Sandwich Panel	76
40	"U" Channel Complete for Bonding	77
41	Drilling Fixture for Bonding Close-out Channel and Pi. . .	78
	Cap to Web Sandwich Panel	
42	Close up View of Forward Section of the Fixture	79
43	Gr/PI Composite Body Flap Technology Demonstrator	80
	Segment (TDS)	
44	Gr/PI Technology Verification TDS (All Bonded Structure) .	81
45	Demonstrator Segment Test Concept Constraints.	82
46	Technology Demonstrator Segment NASTRAN Model.	83
47	R.T. Mechanical Load Test	84
48	Typical Cover Panel Stress Contours	85
49	High Temperature Mechanical Load Test.	86
50	Simulated Fatigue Test	87
51	Thermal Cycle Test	88
52	Acoustic Fatigue Test	89
53	Internal Pressure Test	90

This Page Intentionally Left Blank

TABLES

<u>TABLE</u>		<u>PAGE NO.</u>
1	Lap-Shear Strength of Polyimide Adhesives	91
2	Flatwise Tensile Strength of Polyimide Adhesives . . .	92
3	Climbing Drum Peel Strength of Polyimide Adhesives. . .	93
4	Glass Transition Temperature of Polyimide Adhesives . .	94
5	Effect of Out-Time on Lap-Shear Strength of Polyimide . Adhesives	95
6	Effect of Out-Time in Humid Environment of Lap-Shear . Strength	96
7	Comparison of Primers for Bonding Celion 6000/PMR-15 . Panels with LARC-13 Adhesive	97
8	Comparison of Surface Treatment for Bonding Celion/ PMR-15 Laminates with LARC-13 Adhesives	98
9	Comparison of Polyimide Adhesives	99
10	Comparison of FM34B-18, LARC-13 and LARC-13E Adhesives.	100
11	Properties of Celion 6000/PMR-15 Prepreg and Cured. . . Laminates	101
12	Flatwise Tensile Strength of FM34B-18 LARC-13 and . . . M-LARC-13E Adhesives	102
13	Lap-Shear Strength of LARC-13 Adhesive Prepared by . . Anhydride and Ester Methods	103
14	Short Beam Shear Strength of LARC-13 and FM34B-18 . . .	104
15	Slotted Shear Strength of Test Specimens from Mid- . . Plane Bonded 30.5 by 30.5 cm Panels	105
16	Aging Stability of Polyimide Adhesives Wrapped in . . . Aluminum Foil	106

TABLES

<u>TABLE</u>		<u>PAGE NO.</u>
17	Aging Stability of Polyimide Adhesives Not Wrapped in Aluminum Foil	107
18	Aging Stability of Selected Adhesives	108
19	Effect of Water Immersion on Lap-Shear Strength of . . . LARC-13 and FM34B-18	109
20	Effect of Bondline Thickness on Lap-Shear Strength . . .	110
21	Out of Refrigeration Effect of Filletting Properties. . . of LARC-13	111
22	Use of Catalyst in LARC-13 to Reduce Cure Temperature . .	112
23	Orbiter Body Flap/Demo Segment Stress Comparison . . .	113

1.0 INTRODUCTION

Contract NAS1-15843 is a NASA LaRC Program under Project CASTS (Composites for Advanced Space Transportation Systems). This project was established to develop and demonstrate the technology required to produce graphite/polyimide structural components with operational capability at 589°K (600°F).

The CASTS project includes several current research contracts to develop and demonstrate processes for fabricating graphite/polyimide composites materials and nondestructive inspection (NDI) of structures. The fabrication of structural elements in these studies includes flat laminates, honeycomb panels, skin stringer panels and chopped fiber moldings. These elements are assembled and joined primarily by adhesive bonding. Techniques for assembling and bonding the structural elements into a completed structure were developed in this program.

The objective of this contractual study program was to develop processes for joining large area structural subcomponents by bonding with polyimide adhesives, to verify the reliability of the adhesive bonds by mechanical and nondestructive testing and to demonstrate the quality of the large area bonding technique by fabrication of a large completed structure. The original plan to fabricate a box beam as a demonstration component was changed to the fabrication of components for a deliverable structural test assembly representative of the Space Shuttle aft body flap.

Identification of commercial products in this report is to adequately describe the materials and does not constitute official endorsement, expressed or implied, of such products or manufacturers by the National Aeronautics and Space Administration.

The NASA "A" standard to ultrasonic evaluation of composites referenced on p. 10 is a sensitivity level that is utilized at NASA as an indication

of high quality, voidfree composites. Rockwell used the NASA "A" standard as a point of reference only in this report since this standard is not universal in the art.

2.0 SCREENING OF ADHESIVE SYSTEMS

2.1 Selection Criteria for Adhesives

The criteria used in selecting adhesive systems suitable for (1) bonding large area Celion graphite reinforced PMR-15 polyimide laminates; and (2) fabricating large area honeycomb and skin/stringer panels with Celion 6000/PMR-15 or Celion 6000/LARC-160 face sheets were:

- o Commercial availability
- o Existing data base
- o Processability
 - Resin processability
 - Processability of supported film adhesive (adhesive prepreg)
 - Processing and cure of primer and adhesive 589^oK (600^oF) and 1.379 MPa (200 psi) nominal upper processing limits).
- o Handleability
- o Stability under normal storage conditions
- o Filletting capability
- o Low areal weight
- o Mechanical properties
 - Lap shear strength
 - Climbing drum peel strength
 - Flatwise tension strength
- o Ability to form low porosity bond lines in mid-plane bonded panels.

2.2 Industry Survey

An industry survey was made to assess the status of development of polyimide adhesive with operational capability at 589^oK (600^oF). The data obtained in this survey indicated that the LARC-13 adhesive,

developed by NASA-LARC, was the most promising polyimide adhesive available for large area bonding. Other potential polyimide adhesives with operational capability at 589°K (600°F) included several systems based on duPont's NR-150B2 polyimide resins, the FM34B-18 adhesive and adhesive systems based on the PMR-15 and LARC-160 polyimide resins. The FM34B-18 adhesive is commercially available from American Cyanamid Company both in paste and scrim-supported film form. The NR-150 polyimide resins are available in solution form at resin solids concentrations of about 50 percent. The LARC-13, LARC-160, and PMR-15 polyimide resins are produced from monomer reactants. Most of these monomer reactants are readily available from several commercial suppliers.

For production of scrim-supported film adhesives, based on these polyimide resin systems, a hot-melt process and a solvent evaporation process had been evaluated at Rockwell. The hot-melt process was found to be the most suitable of these methods in regard to production rate, film quality, film uniformity, and reproducibility. As a result of the industry survey, the hot-melt polyimide adhesive systems listed below were selected for initial screening.

- o FM34B-18 American Cyanamide Company
- o LARC-13 NASA Process
- o Mod LARC-13 Use of methyl and ethyl esters of BTDA and NA used in place of anhydrides, and flexibilizers such as silicon and rubber materials.
- o Mod LARC-13 Use of amine substitutes by replacing part or all of 3,3' MDA compared with the aromatic diamines such as 4,4' MDA and 3,3' and 4,4' DADS (Diamino di Sulphone).
- o NR-150B2 Linear and cross-linked systems duPont
- o PMR-15 NASA formulation prepared by Rockwell
- o Mod PMR-15 Use of amine substitutes by replacing part or all of 3,3' MDA compared with other aromatic diamines such as 4,4' MDA and 3,3' and 4,4' DADS.

- o LARC-160 NASA formulation, prepared by Rockwell
- o Mod LARC-160 Use of flexibilizers such as silicon and rubber materials.

2.3 Polyimide Resin Chemistry

The LARC-13 addition-type polyimide polymer is formed by reactions of benzophenone tetracarboxylic dianhydride (BTDA), nadic anhydride (NA), and 3,3'-methylenedianiline (3,3'-MDA). This polymer also can be formed by reacting the methyl or ethyl esters of BTDA and NA with 3,3'-MDA. The chemical structures of these monomer reactants are shown in Figure 1.

When the anhydrides, BTDA and NA are used, the sequence of the polymer reactions generally is reported to take place in a simplified manner as shown in Figure 2. At first, 3,3'-MDA reacts with PMDA nadic groups. These reactions are followed by the imidization intermediate. This imidization reaction is generally carried out on staging of the adhesive prepreg at normal pressure and temperatures from 422°K(300°F) to 449°K (350°F). On application of higher temperatures, 533°K (500°F) to 589°K (600°F), and increased pressure, addition-type reactions occur at the norbornene groups. These addition-type reactions, reverse Diels-Alder reactions, result in chain extension and cross-linking.

When the methyl esters of PMDA and NA are used in place of the anhydrides, these esters at first react with 3,3'-MDA to form amide acid and methanol. These reactions are followed by imidization, chain extension, and cross-linking reactions, as shown in Figure 2.

The PMR-15 and LARC-160 resins are similar to LARC-13 in chemical structure and polymer reactions. Several other polyimide resins evaluated also contained PMDA, and NA as monomer reactants along with different aromatic diamines such as diaminodiphenyl sulfone (DADS).

Initially, the LARC-13, LARC-160 and PMR-15 resins used for the polyimide adhesives were processed with methyl esters of BTDA and NA and an aromatic diamine used as monomer reactants. Later the anhydrides, BTDA, and NA were used as monomer reactants with aromatic diamines.

The methyl esters of BTDA and NA were prepared by refluxing a mixture of these anhydrides with methanol for two hours. The aromatic amine then was added in several portions and mixed for one-half hour. Filler and other additives then were added and mixed at room temperature.

The adhesive prepreg, or film adhesive was processed on a laboratory scale with use of a coating device as shown in Figure 3. Glass fabrics were used as carrier materials for the film adhesives.

2.4 Condensation vs. Addition Type P.I. Resins

The PMR-15 and LARC-160 resins are similar to LARC-13 in chemical structure and polymer reactions. Several other polyimide resins evaluated also contained PMDA and NA as monomer reactants along with different aromatic diamines such as diaminodiphenyl sulfone (DADS).

The NR-150B2G and NR-056X polyimide resins are condensation type polyimide systems structured as shown in Figure 4. The polymers are formed by reacting 4,4' (Hexafluoroisopropylidene)-bis (phthalic acid) ("6F tetra acid) with 4,4' phenylene diamine and 3,3' -phenylene diamine. Water is split off as a condensation product.

The PMR-15 (II) on the other hand can be classified as an addition type resin. It contains 4,4' (Hexafluoroisopropylidene)-bis (phthalic acid) and phenylenediamine, as does NR150-B2G but in addition, it contains NA and end-capper. The reaction sequence for this monomer reaction is similar to that of LARC-13. At first amic acids is formed which on heating to a temperature such as 450°K (350°F)

is converted into a polyimide prepolymer. On further heating at higher temperature, such as 589°K (600°F) and application of pressure such as 100 psi, chain extension and cross-linking takes place at the norbornene groups as for LARC-13. The chain extension and cross-linking reactions are addition type reactions by which no condensation products are formed. Therefore, the PMR-15 (II) resin solution also should be suitable for large area bonding.

2.5 Adhesive Screening Tests

The tests used for screening of the selected polyimide adhesives are shown below. The initial tests included a lap shear test (Table 1) and a flatwise tensile test (Table 2) at R.T. and 589°K (600°F) and a climbing drum peel test (Table 3) at R.T. The glass transition temperature (T_g), the storage stability or out-time, and ability to form low porosity, large area bonded also were evaluated for the most promising adhesives.

Lap-shear strength at R.T. and 589°K (600°F)	12.7 mm (0.5 in.) overlap specimen of unidirectional, 8 ply, 1.02 to 1.115 mm (0.040 to 0.045 inch) thick composite laminates, Fed. spec. MMM-132A.
Flatwise tensile strength at R.T. and 589°K (600°F)	5.1 by 5.1 cm (2 by 2 in.) sandwich panels of HRH 327-3/16-4 T = 1.27 (0.5) honeycomb with 8 ply composite face-sheet MIL-A-25463A.
Glass transition temperature T _g .	6.25 mm diameter 1.02 to 1.14 mm (0.040 to 0.045 in.) thick adhesive panels.

Storage stability of adhesive film prior to use (out-time) by lap-shear tests.	12.77 mm (0.5 in.) overlap specimen of unidirectional, 8 ply, 1.02 to 1.14 mm (0.040 to 0.045 inch) thick composite laminates. Fed Spec. MMM-132A.
Ability to form low porosity bond lines in Mid-plane bonded panels.	15.2 by 1.52 cm (6 by 6 in.) composite panels and steel panels, T = 0.12 (0.5).

2.6 Lap Shear Test

The adhesive systems screened for lap-shear strength to Celion/PMR-15 laminates and the test data obtained are shown in Table 1. A unidirectional, 8 ply laminate of Celion 6000/PMR-15 composite of 1.02 to 1.14 mm (0.040 to 0.045 inch) thickness was selected for this test to provide strain compatibility (equal strain under a given load) with one inch wide titanium adherends. (Titanium finger panels, 25.4 mm wide and 1.27 mm thick (1 inch wide and 0.050 inch thick), of 6AL-4V titanium, had been used in several research and development programs at Rockwell for evaluations of polyimide adhesives for use in the Space Shuttle). The selected thickness of the Celion/PMR-15 composite was obtained from the following relationship:

$$A_{comp} \times E_{comp} = A_{Ti} \times E_{Ti}$$

$$A_{comp} = \frac{A_{Ti} \times E_{Ti}}{E_{comp}}$$

$$A_{comp} = \frac{(1 \times 0.05) (15 \times 10^6)}{18 \times 10^6}$$

$$A_{comp} = 0.042$$

$$1 \times T = 0.042$$

$$T = .042 = 1.07 \text{ mm}$$

Where

$A_{comp} = (1 \times T)$ = Cross sectional area of one inch wide composite lap shear specimen.

$A_{Ti} = (1 \times 0.05)$ = Cross sectional area of one inch wide by 0.05" thick titanium lap shear specimen.

$E_{comp} = 18 \times 10^6$ = Modulus of Celion/PMR-15 composite.

$E_{Ti} = 15 \times 10^6$ = Modulus of 6AL4V titanium.

T = Thickness of one inch wide Celion/PMR-15 composite.

2.7 Flatwise Tension Test

A series of adhesives that appeared promising in the lap-shear test were evaluated further by a flatwise tensile test (Table 2) using test specimens as illustrated in Figure 5 and 6.

2.8 Climbing Drum Peel Test

A climbing drum peel test, according to specification MIL-A-2546A, Figure 7 was selected as a measure of the peel strength of the polyimide adhesives. This test was used primarily to provide data for design and handleability of honeycomb sandwich components to be fabricated. The target value set for the climbing drum peel test of the polyimide adhesives was 900 g/cm width (5 in. lb/in.) at R.T. (Table 3).

2.9 Glass Transition Temperature

Measurements of the glass transition T_g were made for a series of adhesives using a Dupont 941 TMA-900TA analyzer. The adhesive samples were fabricated into laminates of about 1.14 mm (0.045 in.) thickness. The samples were cured for two hours at 589^oK (600^oF) and postcured for ten hours at 589^oK (600^oF). The test data is shown in Table 4.

2.10 Out-Time Study

A series of six adhesives were evaluated for storage stability

over an 11-day period. The relative humidity during this period varied between 6 and 40 percent and the temperature varied between 291 and 299°K (65 and 80°F). The test data obtained as shown in Table 5 shows that the lap-shear strength of the six adhesives was not affected by exposure to this dry environment. A similar study was conducted when the relative humidity in the storage area was 40 - 90 percent. The lap shear data obtained as shown in Table 6 shows that the strength values of FM34B-18 adhesive are significantly reduced after the three and seven days out-time periods. In comparison, the lap-shear properties of the LARC-13 and M-LARC-13 adhesives were not detrimentally affected by these exposures. The results show that exposure of the FM34B-18 to a humid environment must be avoided prior to application.

2.11 Mid-Plane Bonded Large Area Panels

Several of the selected polyimide adhesives that looked promising by the lap-shear climbing drum peel and the flatwise tensile tests were screened for ability to produce low porosity bond-line in mid-plane bonded panels. The dimensions of the panels used were 1.52 by 15.2 cm (6 by 6 in.). The porosity in the bond-line was inspected by ultrasonic c-scanning, using the NASA "A" sensitivity standard.

2.12 Evaluation of Primers and Surface Treatments

The primers evaluated in the initial experiment consisted of an alcohol/diglyme solution of condensation and addition type polyimide adhesive. The use of primers resulted in increased bond strength, apparently because their polymer chains are linear, more flexible, and tougher than the cross-linked addition type polymers. The result is increased load carrying capacity, as shown in Table 7 and Table 8.

2.13 Selection of Three Polyimide Adhesive Systems

Table 9 shows a comparison of availability and physical properties for six of the most promising adhesive systems. Based on this data, the following three adhesive systems were selected for

further study and evaluation:

LARC-13 - Produced by NASA process

Modified LARC-13 - Partial substitution of 3,3' MDA with
4,4' MDA

FM34B-18 - American Cyanamid Company

A more in-depth comparison of the three selected systems is shown in Table 10.

The laminate surface treatment selected was light abrading followed by a diglyme wash. BR34B-18 was chosen as the laminate primer through lap shear tests as shown in Table 7.

3.0 PROCESS DEVELOPMENT

3.1 Celion/PMR-15 and Celion/LARC-160 Adherend

All of the Celion/PMR-15 test panels used for evaluation of the polyimide adhesives were fabricated using procedures developed in Contract NAS1-15183 (Design, Fabrication, and Test of Graphite Polyimide Structural Elements and Specimens).

The composite materials fabricated for the lap shear tests were unidirectional eight-ply panels of Celion 6K/PMR-15 prepreg tape. The prepreg tape was furnished by U.S. Polymeric and Fiberite Corporation.

The quality control tests used for these lap shear panels included specific gravity, fiber volume, fiber weight, and void fraction. The test data obtained for a series of 76.2 by 45.7 cm (30 by 18 in.) panels, fabricated for this test, are shown in Table 11. These panels also were inspected by ultrasonic c-scanning. The c-scan recordings show that all of the panels met the NASA "A" sensitivity standard with few detectable defects as indicated for the panels in Figures 8 and 9.

The flatwise tensile tests panels were fabricated using eight-ply prepreg with symmetrical (0, +45, -45, 90)_s construction. The

test data for these panels are included in Table 12. The c-scans of these panels also met the NASA "A" sensitivity standard as illustrated in Figure 10 and 11.

Two composite panels used for the climbing drum peel tests were fabricated using two plies of Celion 6K/PMR-15 in a (0,90-degree) lay-up constructions. The cured thicknesses of these laminates were about 0.2 mm (0.008 in.). A four-ply laminate of symmetrical construction (0, + 45, 90) of Celion 3K/LARC-160 tape also was fabricated for this test. After cure the two ply laminates curled up into a cylindrical form while the symmetrical laminates retained their flat shape.

3.2 Surface Treatment Study

A series of seven surface treatments were evaluated by lap shear tests for bonding Celion 6000/PMR-15 composite laminates with LARC-13 adhesive. The BR34B-18 material was used as primer for all adherends in this study. The surface treatments used and the test results obtained are shown in Table 8. The highest bond strength values were obtained with light grit blasting followed by a diglyme wipe.

3.3 Primer Evaluation

The standard lap shear test used for screening of the adhesives was used for evaluation of a series of primers. The BR34B-18 primer, used in all of the screening tests, was used for comparison. Table 7 shows the primer systems evaluated and the test results obtained at RT and 589°K (600°F). A bar chart for comparison of the test values is shown in Figure 12.

The data shows that the highest bond strength values at RT were obtained with the linear polyimide primers, BR34B-18, NR-150B2, and 050X, respectively. At 589°K (600°F), the highest bond values were obtained with NR-150B2, PMR-15E, and BR34B-18 primers, respectively. Since BR34B-18 was among the best primers evaluated and is

a commercially available product, it was selected for use.

3.4 Processing of Adhesive

The LARC-13 adhesive can be produced either by the standard anhydride method developed by NASA or by an ester method. In the anhydride method, the amine component, 3.3' MDA, is first dissolved in the DMF solvent. Then the anhydride components, BTDA and NA, are added gradually to the amine solution and stirred until they are dissolved.

By the ester method, the BTDA and NA components are first converted in methyl or ethyl esters. Then the amine component is added and mixed until it is dissolved.

A study to evaluate and compare the safety and economics of these methods was conducted both at Hexcel and Rockwell. Hexcel found the ester method to have the following advantages over the anhydride method for large scale production: (1) better control of the advancement of the resin mix, (2) a shorter mixing period, and (3) less toxic solvents. Therefore, tests were conducted to compare the lap shear strength of the LARC-13 adhesive prepared by the two processes. The results in Table 13 show that there is not significant difference in lap shear strength resulting from the two processing methods. The only advantage observed for the anhydride process was slightly better flow of the adhesive in cure.

3.5 Process for Mid-Plane Bonding Large Area Panels

Processes for mid-plane bonding 30.5 by 30.5 cm (12 by 12 inch) composite panels were developed. The porosity in the bond lines was examined by c-scanning, using NASA standard "A" sensitivity. Void free or near void free bond lines were obtained using several bonding methods for LARC-13 and M-LARC-13E film adhesives with style 112 carrier. The simplest of these processes had the following cure cycle:

1. Pull full vacuum and apply 100 psi pressure
2. Heat to 600°F at 5°F/min.
3. Cure at 600°F for 1 hour
4. Cool to 150°F before releasing pressure and vacuum

The c-scans obtained for the LARC-13 and M-LARC-13E adhesives with this cure cycle, Figures 13 and 14, show practically void free bond lines. The best c-scans obtained in mid-plane bonded 30.5 by 30.5 cm (12 by 12 inch) composite panel with FM34B-18 is shown in Figure 15.

A study of shear beam and slotted shear was done, which was prepared from mid-plane bonded panels. They are shown in Tables 14 and 15.

3.6 Process for Bonding Honeycomb Sandwich Panels

The use of scrim-supported film adhesive resulted in good filleting and high flatwise tensile strength values for each of the three selected adhesives with the porous HRH 327-3/16-4 core, as shown in Table 12. In this process, the core and the Celion 6000/PMR-15 face sheets were at first cleaned and primed with the BR34B-18 primer. Then a layer of the adhesive film, having an areal weight of 293 g/m² (0.06 lb/sq. ft.), was applied on each side of the core, permitting the panel to be cured in one operation. A suitable cure cycle for the FM34B-18, LARC-13 and the M-LARC-13E adhesive is shown in Figure 16. In this cure cycle, a maximum pressure of 2.75MPa (40 psi) and a maximum temperature of 589°K (600°F) were used. The application of lower pressures around 1.72 MPa (25 psi) produced good panels while the use of 3.45 MPa (50 psi) pressure resulted in slight damage to the honeycomb core.

3.7 Core Coating of Paste Adhesives

The purpose of applying the polyimide paste adhesive by a core-coating process is to optimize distribution of the adhesive at the core-face sheet interface, thereby reducing the required adhesive weight. This process requires proper surface tension and thixotropic

properties for the adhesive. To evaluate the core-coating ability of the LARC-13 and M-LARC-13E adhesives, (FM34B-18 was available as a supported film only) experiments were conducted with rubber paint rollers and a laboratory coater. It was apparent that the surface tension and the viscosity of the adhesives were too low to produce sufficient quantity and uniform distribution of the adhesives in one application, as required for an automated core-coating process. However, good distribution of the adhesives was obtained using a rubber paint roller and three or four layers of the adhesive.

3.8 Aging Stability of Selected Adhesives

A study was undertaken to evaluate the aging stability of LARC-13 and FM34B-18 adhesives. Honeycomb sandwich panels were fabricated and flatwise tensile specimens 5.08 cm (2") x 5.08 cm (2") were machined. Half of these specimens were wrapped in aluminum foil and aged at 589^oK at (600^oF) for 125 hours in an air circulating oven. The other half of the specimens were exposed directly to the hot air stream in the oven. It was observed that the flatwise tensile strength decreased on aging, but the decrease was much smaller for the specimens wrapped in aluminum foil than for those subjected directly to the air stream. The results are shown in Table 16 and 17.

An evaluation of the physical properties of the three adhesives was continued with an aging study of lap shear specimens at 589^oK (600^oF) using Celion 6000/PMR-15 adherends. The test data obtained after exposure of the lap shear specimens in an air circulating oven at this temperature is shown in Table 18. The values for the three adhesives were reduced significantly by exposure at 589^oK (600^oF) for periods of 125 and 250 hours. However, the lap shear specimens failed partly in the laminates, indicating that the aging stability of the adhesives is as good as that of the laminates.

3.9 Out-Time of the Selected Adhesives

An out-time study was made of the FM34B-18, LARC-13, and the

M-LARC-13E adhesives for periods up to 11 days in a very dry atmosphere (6-40 percent RH). The effect of this storage environment was evaluated, using lap shear tests with Celion 6000/PMR-15 adherends. None of the three adhesives were significantly affected by storage in the dry atmosphere prior to the bonding operation. To determine effects of out-time exposure in a humid environment, a similar study was conducted during the month of December, when the relative humidity in the storage area was 40 - 90 percent. The lap shear data obtained (Table 6) shows that strength values of the FM34B-18 adhesive are significantly reduced after the three and seven day out-time periods. In comparison, the lap shear strength properties of the LARC-13 and M-LARC-13E adhesives were not detrimentally affected by these exposures. The results show that exposure of the FM34B-18 adhesives to a humid environment must be avoided prior to application.

3.10 Effect of Water Immersion on Lap-Shear Strength

The data in Table 19 shows that the lap-shear strength of LARC-13 and FM34B-18 adhesives are only slightly affected by water immersion at RT for 7 days.

3.11 Final Selection of Adhesives

The selection of an adhesive for fabrication of a structural test assembly was made by a comparison of 14 factors as shown in Table 10 for the FM34B-18, LARC-13 and the M-LARC-13 adhesives. These factors included commercial availability, material cost, out-time, tack and drape, filleting, tooling and processing cost, mechanical and adhesive properties. Each factor was given a significance rating of 1, 2, or 3. By this comparison, the LARC-13 adhesive had the highest point rating and was selected for qualification tests.

4.0 QUALIFICATION OF SELECTED ADHESIVES

4.1 Process for Fabrication of Honeycomb Sandwich Panels

A method for fabrication of honeycomb sandwich panels with the LARC-13 adhesive was developed. The materials to be used for the fabrication of honeycomb sandwich panels are HRH 3/16-4 core of 1.27 cms (0.5") thickness and eight plies of Celion 6000/PMR-15 or Celion 6000/LARC-160.

4.2 Process for Mid-Plane Bonding Large Area Panels

Composite laminates of Celion 6000/PMR-15 or Celion 6000/LARC-160 were used for fabrication of mid-plane bonded panels.

The 30.5 cms (12") x 30.5 cms (12") mid-plane bonded panel fabricated with LARC-13 and FM34B-18 adhesives were c-scanned as shown in Figure 13 and 15 and subsequently cut into slotted shear and short beam shear specimens to evaluate bond properties. Test results are shown in Tables 14 and 15.

4.3 Effect of Bond Line Thickness on Lap-Shear Strength

Several lap shear specimens with varying numbers of LARC-13 adhesive layers 0.034 gm/cm^2 (0.07 lbs/ft^2 per layer) were fabricated. These specimens were subjected to destructive testing after the bond line thickness had been determined. It was concluded from the data obtained, as shown in Table 20 that the lap-shear strength decreases as the bond-line thickness increases. These lower bond strength values, with increased bond-line thickness, is apparently due to high porosity in the thick bond lines.

4.4 Effect of Out-Time on Filletting Properties of LARC-13

A study to observe the effects of out of refrigerator time vs filletting was completed. A series of $17.8 \times 11.4 \times 1.27 \text{ cms}$ ($7 \times 4\frac{1}{2} \times \frac{1}{2}$ ") thick sandwich panels were bonded with a single batch of LARC-13 adhesive that was exposed to normal atmospheric temperature for up to 8 days. 2×2 " flatwise tensile specimens were cut from each panel and tested at R.T. and 589°K (600°F) after measuring fillet thickness. Results of these tests are shown in Table 21. It is concluded through

the data obtained that the adhesive LaRC-13 is not significantly affected and there is no remarkable difference in filleting as well.

4.5 Evaluation of Catalyst

A study to evaluate catalysts to reduce the required cure temperature for LARC-13 adhesive was undertaken. Initial studies, (with organic peroxides like USP-138 which is a new cyclic peroxyketal recommended for broad high temperature applications as a polymerization catalyst and cross linking agent and Experox-10 which is tertiary butyl perbenzoate recommended for the same reasons from WITCO chemicals), showed promising results when the adhesive was cured at 533^oK while maintaining the same 589^oK (600^oF) post oven cure cycle. Preliminary specimen tests resulted in lap-shear strength in excess of 13.6MPa (2000 psi). Catalyst used is in the amount of 2% by weight.

Further work indicated that if the cure temperature is reduced to as low as 505^oK (450^oF), poor bonding results and the laminates debond while being post cured. Therefore, based on the study and the data shown in Table 22, it was concluded that by using a catalyst we can reduce the cure temperature at 533^oK (500^oF) and still maintain the lap-shear strength above 13.6 MPa (2000 psi).

Thus, our initial efforts with catalyzed product indicated that a drastic change from the conventional LARC-13 cure temperature of 589^oK (600^oF) to below 533^oK (500^oF) could not be made by the addition of the organic peroxide and still achieve adequate cure. From this evidence, it was concluded that the material cannot be cured as are current aerospace grade epoxies.

5.0 SUMMARY

During the course of this program, a series of polyimide adhesives were screened for mechanical and physical properties and for processibility in fabrication of large mid-plane bonded panels and honeycomb sandwich panels. The mid-plane bonded panels were fabri-

cated using Celion 6000/PMR-15, composite sheets and honeycomb panels of HRH 327 3/16-4 core with face-sheets of Celion 6000/PMR-15. From a series of 41 adhesive formulations, the LaRC-13, FM34B-18, and a modified LaRC-13 adhesive designated as M-LaRC-13E were selected for process evaluation studies. On the basis of the data obtained during these studies as shown in Table 10, LaRC-13 adhesive was rated as the best of the three adhesives in terms of availability, cost, processability, properties and ability to produce void free large area (12"x12") midplane bonds.

An evaluation also was made of surface treatment and primers for the graphite/polyimide adhesives to be used in bonding studies. The selected surface treatment consisted of light-abrading with Behr-Tex pads followed by diglyme wash. One selected primer was BR34B-18. Processes also were developed for fabrication of honeycomb sandwich panels of very good quality for the LaRC-13, M-LaRC-13E, and the FM34B-18 adhesives. The good quality was evidenced by rupture in the honeycomb core rather than in the honeycomb facesheet bands on flatwise tensile strength testing.

In future studies on polyimide adhesives, it is recommended that the following areas be addressed:

- o Polyimide adhesives investigated to date tend to be brittle and fail in peel mode more readily than lower temperature, higher strength epoxy systems. To overcome this disadvantage, plasticizers must be studied to determine if a more flexible PI adhesive can be produced with improved peel strength, increased handleability, and minimum effect on lap shear and other adhesive qualities.
- o A low cost substitute for 3,3' MDA should be located and evaluated to study the overall affect on adhesive cost, mechanical properties, and processing characteristics.

6.0 TECHNOLOGY DEMONSTRATOR SEGMENT

The initial intent of this task was to fabricate a representative demonstration component of the Space Shuttle aft body flap. It was intended that the component design would incorporate all developed processes and structural configurations to demonstrate manufacturing feasibility of graphite/LARC-160 to full-scale structures.

The requirement "to fabricate a representative demonstration component" was later changed "to fabricate a representative structural test component". This structural test component has been given the designation of Technology Demonstrator Segment (TDS). The completed TDS, ready for installation of instrumentation for ground testing, is shown in Figure 17.

In changing from a demonstration to a structural test component, the complexity of the task changed correspondingly: All aspects of design, tooling, NDI, fabrication, and assembly became more critical. To implement this change, the scope of Contract NAS1-15843 (Develop, Demonstrate, and Verify Large Area Composite Structural Bond with Polyimide Adhesive) was amended to fabricate the cover panels, ribs, and leading edge covers of the TDS. Fabrication of the remaining TDS components and final assembly was accomplished under Contract NAS1-15371, Development and Demonstration of Manufacturing Processes for Fabricating Graphite/LARC-160 Polyimide Structural Elements.

Design details of the TDS test component as shown in Appendix drawings, all fabricated elements of the TDS i.e., solid laminate structures, laminate skins, and bonded honeycomb panels were non-destructively inspected to assure that high quality structure within the state-of-the-art was fabricated. Typical NDI records for the TDS are included in the report to indicate the high quality of the laminates and sandwich assemblies produced.

7.0 FABRICATION OF STRUCTURAL TEST ASSEMBLY

7.1 Prepreg Tape

Unidirectional prepreg tape used in fabrication of all details was supplied by U. S. Polymeric, Inc., Santa Ana, California. The tape consisted of 3000 graphite fiber filaments in the basic tows impregnated with high temperature polyimide resin. The filaments were high modulus (typical 234 GPa or 34×10^6 psi) and high strength (typical 2.758 MPa or 400×10^3 psi) PAN-based carbon/graphite fibers manufactured by Celanese, Inc. (under the trade name of Celion 3000) and sized with polyimide resin NR150-B2, had a typical fiber density of 1.76 g/cm^3 (0.064 lb/in^3). The polyimide resin (originally developed by NASA-Langley Research Center with designation LARC-160) was prepared via addition-type reaction or reverse Diel-Alder reaction and had a upper operating temperature limit of 589°K (600°F).

The composite tape was stored inside sealed bag at 255°K (0°F) in a freezer until it was ready to be used. The sealed bag was removed from freezer and thawed to room temperature before opening to avoid any deposit of moisture on the tape. They were inspected visually to examine overall quality, such as drape, tack, amount of tow splice, fibers collimation, uniformity of resin on the tape and thickness of tape. The nominal cured ply thickness was 0.0064 cm (0.0025"). The supplier provided samples of resin and fiber for reference. Several feet of the tape from each roll underwent quality control tests to confirm the reported properties from supplier. The cover consisted of three major components, honeycomb core, upper and lower skins, and forward and aft closeout edge members as shown on Appendix A drawings.

7.2 Leading Edge Cover Panel

7.2.1 Skin

Prepreg tape was removed from freezer and allowed to thaw to room temperature before any work would start. It was cut according to its specific orientation with aid of templates. The lay up was done with great care and once it was completed the skins were weighed and arranged under vacuum bag as shown in Figure 18. It was imidized following the cycle below:

1. Apply 5.1 cm (2") Hg vacuum and maintain throughout the cycle.
2. Raise temperature to 491°K (425°F) at a rate of 2.2°K (4°F) per minute.
3. Stage the skin at 491°K (425°F) for 30 minutes.
4. Cool to 338°K (150°F) before removing the part from oven.

After imidization, the laminate was weighed and examined visually to determine any abnormality being committed to further work. The staged laminates were prepared as in Figure 19 to be autoclave cured with the following cycle (Figure 28):

1. Apply full vacuum and 1.4 MPa (200 psi) autoclave pressure and maintain throughout cure.
2. Raise temperature to 519°K (475°F) at a rate of 4°F per minute.
3. Hold 514°K (466°F) for 42 minutes.
4. Increase temperature to 602°K (625°F) at a rate of 4°F per minute.
5. Hold at 602°K (625°F) for 2 hours and 45 minutes.
6. Lower temperature to 422°K (300°F) at a rate of 2°K (3.7°F) per minute.
7. Below 413°K (284°F), cooling rate may be increased to 4.5°K (8°F) per minute.

8. Release autoclave pressure at 338^oK (150^oF) and remove part from autoclave.

The curing temperature of 602^oK (625^oF) has substantially decreased the post cure time. The cured laminate was free standing post cured in the oven at 589^oK (600^oF) for 2 hours. The heating and cooling rate for this process were not closely monitored. The heating rate was at 2.5^oK (5^oF) to 4.5^oK (8^oF) per minute and cooling rate varied even more. After the assembly was completed, the skin was post cured for an additional 4 hours (Figure 29). Several parameters were used to assess the condition of the skins after autoclave cure. These included total resin loss, fiber volume (calculated through several methods), skin thickness, skin final weight, glass transition temperature (T_g) and overall cosmetic appearance. A computer program was developed earlier to relate most of these variables.

Ultrasonic transmission c-scan tests were performed as part of quality control effort on skins and all other assemblies in the cured and post-cured conditions. Established NASA-LARC "A" sensitivity standard specimens were used as a control in setting equipment sensitivity for quality verification. This particular nondestructive testing has been a very useful and time-saving method to detect any voids or delaminations. C-scan recording of both skins were made and no defects were detected. One of the recordings is shown in Figure 30.

Because of its unsymmetrical orientation, the skins curled up after autoclave cure (Figure 31). These skins were thin (0.031 cm or 0.021 inch) and very fragile; to minimize damage during handling for ultrasonic c-scanning and clearing for water-broken surface, aluminum picture frame was designed and fabricated to the correct size to hold skin stretched out and lay flat.

7.2.2 Closeout Channel

Same material for the fabrication of skins was used to fabricate the closeout channels. These are closeout "U" shape edge members on

the honeycomb sandwich cover assemblies. One of the cover panels will be mechanically fastened to the final body flap segment. A 16-ply internal doubler was incorporated to one of the flanges. The difference in thickness on both flanges required a specially designed tool for layup, staging and curing. The layup was a time-consuming and tedious process. Four plies of prepreg tapes were laid up, debulked and consolidated under full vacuum at room temperature for 2 hours, then vacuum formed onto the tool (on the tape that was already laid up) at room temperature, heat was applied to facilitate the transfer. Layup of more than 4-ply debulked tape would make the vacuum form difficult and increase the formation of fiber twisting and wrinkle. Transparent vacuum bagging material was used to provide maximum visibility (Figure 32).

The arrangement for staging and curing these channels are shown in Figures 21 and 22, respectively. For staging, autoclave cure and post cure, same cycles as those for the skins were used on closeout channels. During the bagging for autoclave cure, the channel should be placed on the correct side on the layup die as the flanges had different thickness; wrinkles could be introduced very easily and more care should be exercised to avoid, or at least to minimize, any wrinkles.

Several modifications in the staging cycle were needed to obtain void free and targeted-fiber-volume or targeted-thickness channels. These are primarily higher staging temperature (up to 497°K or 435°F), longer staging time (up to 1-1/2 hour) and different numbers of bleeder/breather or combination of these.

Because of unbalanced channel design (thicker on one leg) it assumed the expected moderately bowed condition when removed from mold lay-up die (LUD). This bow caused some difficulty during next assembly bonding. In a production mode either the part or the tool should be revised to produce a straight part at ambient temperature.

Cured channels were submitted for c-scan inspection and confirmed to be void free before trimming was done.

7.2.3 Assembly of Leading Edge - Bonding Tool

Because of its favorable thermal expansion coefficient, stainless steel was used for fabrication of the hinged cover bonding tool. The tool was roll formed to the desired curvature as close as possible. However, it was not stiff enough and two additional flat stainless steel sheets were bolted to the inside of the curved sheet to avoid rocking and stabilize the bonding tool. Two L-shape steel angle members were fastened to the bonding tool along its length to protect the sandwich assembly from crushing during bonding operation. The angle members were located so that no additional positioning on the width was needed. The completed bonding tool was sprayed with a thin coat releasing agent FREKOTE-33, the agent was dried in the oven at 366°K (200°F) minimum for 30 minutes or more (Figure 33).

7.2.4 Profit of Details

The relatively small value of radius over of radius over core thickness ratio of sandwich panel indicated a potential difficulty in fitting the core to the curvature of the tool. A plain core segment was forced to follow the contour of the bonding tool with vacuum bag pressure employed at room temperature. A vacuum level of approximately 500 mm Hg (20 inches) was sufficient to have the core fitting nicely to the tool, but upon removing the vacuum bag pressure, the core sprang back to its original shape. Another approach was tried. A segment of this 1.91 cm (0.75 inch) thick core was heated in oven (free standing) at 589°K (600°F) for about an hour. Immediately following its removal from the oven, the core was tied down to the bonding tool by heat-sensitive shrink tape and dead weight for about 30 minutes. However, once the tapes were removed, the core again returned to its flat shape. Preforming this cured honeycomb core to the bonding tool before assembly for sandwich panel bonding was impossible.

In order to determine the exact contour of cured panels fabricated from this tool and at the same time develop the bonding process, several smaller sandwich panels were fabricated at different

locations on the bonding tool. The arrangement for the autoclave bonding was similar to that shown in Figure 34. Three of these small panels were fabricated and the exact number of 0.0076 cm (0.0030 inch) porous separators and 0.013 cm (0.005 inch) non-porous separators to be used as tooling shims to make panel fit the stability rib front curved segment better was determined.

7.2.5 Cleaning and Priming of Details

Some sort of surface treatment of the bonding areas must be carried out to achieve optimum strength.

For skin and closeout channel bonding surface, heavy duty "Behrtex" type scrubbing pad and "Comet" cleaning agent were used to remove all grease and other contaminants. Parts were rinsed with deionized water to check the waterbreak condition. Then they were dried in oven at 394°K (250°F) for about 30 minutes and the details were ready to be primed and bonded.

The honeycomb core used for the fabrication of hinged covers were supplied by Hexcel Corporation. It was HRH-327 high temperature glass-fabric reinforced polyimide honeycomb core with 0.47 cm (3/16 inch) cell size, 1.91 cm (0.75 inch) thickness and 0.048 g/cc (3 lb/ft³) density. This core did not need to be degreased. Methyl ethyl ketone was sprayed into core cells to remove dust and any contaminants.

The liquid paste adhesive counterpart of FM34B-18 film adhesive, BR34B-18, was used for priming all bonding surfaces. This primer has an aluminum-powder filled adhesive with 90% solid content. (Aluminum powder + organic polymer). It was diluted into 35% solid content with ketone/alcohol thinner, this diluted primer was sprayed on skins and closeout channels. A thin coat of 25.4 cm or 0.001 inch thick primer solution on the surface was sufficient. Roller was used to apply a thicker coat of primer solution onto the cores. The primer was air dried at room temperature for 30 minutes and oven dried at 366°K (200°F) for 2 hours.

7.2.6 Assembly of Details On Tool

Up to 5 plies of 0.0076 cm (0.0030 inch) 3TLL porous teflon-coated glass fabric separator were used on the bonding tool at different locations. The separators were stacked with different width and length to avoid any sudden change on tool surfaces; up to 3 plies of thicker 0.013 cm (0.005 inch) 5TB non-porous teflon-coated glass fabric separators were used for the same purpose of shimming. One ply of 5TB separator was used to cover the entire bonding tool for the panel assembly.

The adhesive used for the bonding was supplied by American Cyanamid Company. It was scrim-cloth-carrier polyimide adhesive FM34B-18, aerial density 0.04 g/cm^2 (0.09 lb/ft^2). In order to achieve the desired ribbon direction on the core, 3 pieces of core were spliced together with FM34B-18. The splicing adhesive was cured together with the sandwich panel assembly.

As mentioned earlier the cores would not form to the contour of the bonding tool. Great care and effort were needed to ensure that the cores were positioned correctly. After the cores were in their proper positions, several openings existed between cores and the closeout channels. Beads and stacks of FM34B-18 adhesive were used to fill up and bridge these areas.

One layer of FM34B-18 adhesive was put on top and bottom of the cores to be bonded to the skins. The top skin was covered with one layer of porous separator and stainless steel caul plate to obtain smooth outer surface. The lay-up die (with straight sides) of the closeout channels were used to avoid channel crushing and maintain proper alignment. Pieces of wood wrapped with teflon were taped down to bonding tool to protect sides of sandwich panel. The whole assembly was arranged as shown in Figure 34 and cured in autoclave with the following cycle (Figure 25).

1. Apply full vacuum and 17.6 KPa (25 psi) autoclave pressure and maintain throughout cure cycle.

2. Raise temperature to 463°K (375°F) at a rate of 2.5°K (5°F) per minute.
3. Cure adhesive at 456°K (362°F) for 2 hours.
4. Cool to 338°K (150°F) at a rate of 2°K (3.7°F) per minute before releasing autoclave pressure.

The assembly was free standing oven post cured with the same cycle as the skins and closeout channels.

The leading edge cover was visually inspected for its bonding quality. Adhesive filleting on the honeycomb core cell wall indicated good flow was achieved and good quality bonding was expected. The cover had uniform thickness and retained its curved configuration (Figure 35 and 36). It was checked against the stability ribs and some change on the contour would give a better fit (Figure 36).

During the fabrication on the second leading edge cover, two additional plies of 5TB separators were put on the straight portion of the bonding tool on top of the shimming that was used for the first cover panel. The fabrication procedure for the second cover was identical to the first one. With this extra shimming, the second hinged cover fitted the stability ribs better and was used as the bonded, lower hinged cover of TDS. The first cover was used as the bolted, upper hinged cover.

7.3 STABILITY RIB

The stability ribs have honeycomb sandwich panel webs with secondard bonded pi shaped closeout out channels top and bottom completing the "I" beam configuration. A "U" channel closed out the front edge with a Pi shaped channel at rear.

7.3.1 Stability Rib Sandwich Panel

The skins for these ribs were rather thin, the nominal thickness was 0.020 cm (0.008") and had unsymmetrical ply orientation of (90, + 45). All skins were fabricated as in section 7.2.1.

The honeycomb core was the same material as used in leading edge panels except they were 1.27 cm (0.50") thick and no splicing was needed to obtain the desired ribbon direction. The panel was bonded as in section 7.2.6.

The front U shape closeout channels were fabricated from woven fabric broadgoods, Thornell 300/LARC 160. The nominal thickness of cured laminate was 0.018 cm (0.007"). The channel was laid up on the tooling shown in Figure 26 and held in place by heat-sensitive plastic tapes, the channels were staged and cured with cycles used in section 7.2.1.

Undiluted 80% solid BR34B-18 primer was used in place of adhesive FM34B-18 for bonding of closeout channels to stability ribs, a thick coat of primer was applied on the bonding surface using a paint brush.

7.3.2 Pi Cap Element

The configuration of the Pi joints is shown in Figure 27, special tooling had been designed and machined for the fabrication of these joints. These joints were autoclave cured with cycle similar to those described in section 7.2.1 except that lower cure temperature of 560^oK (550^oF) was used to prevent degradation to the silicone rubber tool details. To obtain the desired 625^oF Tg the Pi joints were subsequently post cured in an oven for four (4) hours.

7.3.3 Bonding of Closeout Channel and Pi Cap to Web Sandwich Panel

All faying surface of the web sandwich panel, closeout channel and Pi cap were cleaned and oven dried with the same procedure as above. Similar priming process used in Section 7.2.5 for leading edge cover was carried out. The flanges of Pi cap were clamped down to an aluminum tool that would increase the width of center opening to ease the fitting of Pi cap on web panel.

For the forward closeout channel to web bonding area, FM34B-18 film adhesive was not used because it was so tacky that installing the channel to web would produce non-uniform bond line. Undiluted

80% primer solution of BR34B-18 was applied by paint brush to all areas (Figures 37 and 38). The channel was installed relatively easy (Figures 39 and 40). After FM34B-18 adhesive was wrapped on the upper and lower bonding areas on the web, additional undiluted primer solution was brushed on. This lubricated the entire areas. Graphite pin passing through both Pi cap and web after the assembly was positioned and indexed in the drilling fixture which was shown in Figures 41 and 42. This fixture was modified to allow to be used as bonding fixture for stability rib assembly fabrication.

NDI technique was performed to verify bonding quality.

7.4 Lower and Upper Cover Panels

7.4.1 Honeycomb Core

High temperature glass-fabric reinforced polyimide honeycomb core HRH-327 (supplied by Hexcel Corp.) was used-cell size 0.47 cm (3/16"), thickness 1.91 cm (0.75"), density 0.048 g/cc (3 lb/ft³). Several pieces of honeycomb core were spliced together with high temperature polyimide adhesive (FM34B-18) to obtain the size required in the ribbon direction. The splice lines added a mere 45 gm to the total weight of 3.9Kg of full size honeycomb core.

The aft edge of the spliced core was recessed to fit the outer skin spar recess joggle.

7.4.2 Skin

The skin for cover panel was laid up, staged and cured following the same procedure used in fabricating skin leading edge cover in Section 7.2.1. During autoclave cure, a stainless steel metal strip was placed under the aft edge of laminate to mold into the skin to form a joggle of 0.051 cm (0.020") thick; this would allow for the flush fit of the rear spar to cover panels.

7.4.3 Closeout Edge Member

A typical edge member layup die (LUD) is shown in Figure 20. These molds were made of aluminum. For production use steel would be more appropriate considering the 602^oK (625^oF) cure temperature.

Eight ply 0.051 cm (0.020" thick) forward and aft channels were laid up and bagged as shown in Figure 21, (for oven staging). The staging cycle was similar to the one used for cover skins. The staged channels were prepared as in Figure 22 and autoclave cured using cover skins cure cycle. They underwent similar post cure and NDI procedures.

In order to get a completely wrinkle-free outer surface on the channels, a different bagging system was used as shown in Figure 23. The high-temperature-resistant silicone rubber bag improved the cosmetics quality of channels due to its wiping action as vacuum was applied. One pair of forward and aft channels were fabricated using this preferred method.

7.4.4 Honeycomb Sandwich Assembly

To achieve optimum bonding strength the faying surfaces of skins, core, and fore and aft edge members were cleaned and primed following the procedure used in section 7.2.5. All the detail parts were assembled without adhesive and a vinyl impression check was carried out in the autoclave under 25 psi autoclave pressure and full vacuum at 422^oK (300^oF) for 30 minutes. The impression check verified fit up of details.

The detail parts were assembled with the same polyimide adhesive used for leading edge cover fabrication and autoclave cured under the same cycle used in Section 7.2.6. The cover was a large flat honeycomb sandwich panel and no bonding fixture other than a modified picture frame was used as arm around the whole panel. After cure NDI ultrasonic c-scanning was also used to check bonding quality.

8.0 DEMONSTRATOR SEGMENT TEST PROGRAM

A preliminary test program has been defined for the graphite/polyimide body flap Technology Demonstrator Segment (TDS) shown in Figure 43. The test objective is to verify the structural adequacy of a typical composite body flap section to sustain acoustic, mechanical, and thermal load cycles representative of 100 Space Shuttle missions. The proposed TDS test program is outlined below and involves mechanical testing at room temperature and 533^oK (500^oF) and thermal cycling and acoustic testing under overall sound pressure level (OASPL), resources permitting. The 533^oK (500^oF) maximum temperature is based on Orbiter entry and Terminal Area Energy Management (TAEM) environment. The fabrication of a large, all bonded graphite/polyimide structure is advanced state-of-the-art, and as a result the integrity of the major bonded joints is open to question. Loading conditions have been determined to subject these joints to stress levels equivalent to the composite body flap stress levels. The TDS will also be subjected to internal pressure to test the adhesive bonds in flatwise tension.

The TDS is stiffness, rather than strength, due to the structure/TPS deflection requirements. Therefore, failure under mechanical loads is not anticipated. Due to the location of the body flap relative to the Orbiter main engines, acoustic fatigue is the predicted failure mode.

The primary purpose for testing the TDS is to develop confidence in the structural capabilities of graphite/polyimide. The confidence is high that a static test will verify the reliability of the NASTRAN model and other TDS static analysis techniques. The confidence level associated with the thermal models is relatively high. However, the confidence in the acoustic model is low, and acoustic fatigue is the predicted failure mode. These relative confidence levels are illustrated in Figure 44. If the TDS can survive all of the tests, the confidence level in GR/Pi structure will be high, and the all bonded GR/Pi structure technology will be verified.

8.1 Test Approach

The body flap is loaded and supported through four-hinge ribs. However, lack of a hinge rib on the TDS precludes actual body flap loads. Test conditions to adequately simulate the stress state in the region of the body flap stability ribs were input to the TDS NASTRAN model for several loading and support conditions. The technology demonstration segment test approach is outlined below:

MECHANICAL LOAD TEST

- o Simulated Load at Room Temperature (RT) and 533^oK (500^oF).
- o 400 Cycle Simulated Fatigue 533^oK (500^oF)
- o Internal Pressure at RT

THERMAL CYCLING TEST

- o 100 Cycles (222K and 589^oF) for 100 missions

ACOUSTIC FATIGUE TEST

- o 165 dB OASPL for 34 Minutes (lift Off)
- o 161.5 dB OASPL for 38 Minutes (Aerodynamic)
- o 157 dB OASPL for 60 Minutes (Aero/Shock)

8.2 Test Constraints

Test constraints for the TDS are summarized in Figure 45. Acoustic test constraints require attachment to all three stability ribs. Thermal test constraints make application of distributed loads at elevated temperature complex. Mechanical test constraints require the TDS to be cantilevered from the outer ribs, while loading is to be applied at the trailing edge. Funding constraints preclude spectrum fatigue and thermal cycling tests.

8.3 Technology Demonstrator Segment NASTRAN Model

The TDS NASTRAN model was used to define the loading condition for the mechanical load test and is presented in Figure 46. The

374 node model was extracted from the 1000+ node body flap model. The cover panels are represented by QUAD 1 sandwich elements which model the honeycomb core and laminate face-sheets. The spars and ribs are modeled by SHEAR panels stabilized by ROD elements. Spar and rib caps are represented by offset BAR elements.

8.4 Room Temperature and 533⁰K Mechanical Load Tests

Lack of a hinge rib (through which the body flap is loaded and supported) on the Technology Demonstration Segment makes application of actual body flap loads impossible. The objective of the mechanical load test is to simulate the body flap stress state and verify the structural adequacy of the TDS to sustain Orbiter static stress levels. A combination of supports and loads that would reproduce the stress state in the vicinity of the body flap stability ribs were determined from several test conditions input to the TDS NASTRAN model. Test program loading support concept is described in the following paragraph.

As shown in Figure 47, the TDS is cantilever supported at the outer ribs, has the middle rib displaced to stress the front spar, and has concentrated loads at the trailing edge. These concentrated loads do not require the attachment of a special loading fixture. A TDS/body flap cover panel stress contour comparison is presented in Figure 48 and the stress levels in the caps, webs, and cover panels are compared in Table 23. The stress state of the load concepts adequately compare with the body flap stress state. The stability rib web shear, and stability rib cap compressive stress are somewhat larger than the body flap stress levels, but a large factor of safety is still apparent.

The loads applied at the rear spar cause a twisting downward moment, and flex the rear spar. These loads simulate the ultimate stress levels, and will also be applied at 533⁰K as shown in Figure 49.

8.5 400 Cycle Simulated Fatigue Test

The objective of the fatigue test is to verify the TDS structural integrity to sustain mechanical loads simulating 100 missions. Because of the high cost, spectrum loads will not be applied. Instead four lifetimes (400 cycles) of limit loads will be applied ($R = + 0.10$) at 533°K (Figure 50). Spectrum loads would have only a few cycles approaching limit loads, making the test condition more severe than an actual service environment. Due to test fixture limitations, however, load reversals will not be applied.

8.6 Thermal Cycling Test

The body flap is subjected to a thermal environment with a temperature range from 222°K (-60°F) to 589°K (600°F). The maximum applied mechanical loads occur at body flap temperatures between 166°K and 533°K , with maximum temperature 589°K (600°F) resulting from heat soak back after the orbiter is on the ground. The objectives of the thermal cycling test are: (1) verification of the TDS structure under 125 thermal load cycles, and (2) verification of the analytically predicted thermal strains.

The selected thermal cycle is shown in Figure 51. The cycle represents the temperatures and thermal gradients obtained during an abort-once-around (AOA) thermal trajectory for the upper 589°K (600°F) temperatures, and the cold temperatures 166°K (-160.8°F) are from a severe cold on orbit mission. The structure would not be subjected to these extremes on a single mission.

The baseline aluminum body flap was not tested under thermal cycling. However, some of the body flap joints and other components were subjected to thermal cycling. The components were exposed to a temperature range of 199°K (101.4°F) to 449°K (348.5°F) for 150 cycles. The baseline graphite/epoxy OMS Pods were subjected to 400 mechanical load cycles and 100 thermal cycles (166°K to 449°K) to simulate 100 space missions. It therefore appears that a similar

test program is required for the composite body flap structure.

8.7 Acoustic Fatigue Test

Due to the location of the body flap relative to the orbiter main engines, acoustic fatigue is potential failure mode. The TDS should be exposed to acoustically induced random vibration simulating overall sound pressure levels as high as 165 dB anticipated during Space Shuttle Vehicle (SSV) ascent. The objectives of the acoustic test are as follows: verify the primary structure acoustic fatigue life (100 Space Shuttle missions), demonstrate the integrity of selected regions of the direct-bond TPS, and verify the analytically predicted cover panel RMS strain and frequency.

The body flap acoustic environment is shown in Figure 52. Upon successful completion of the mechanical and thermal cycling tests, the TDS will be modified for acoustic test, funding permitting. Modifications will include adding direct-bond fibrous reflects the composite insulation (FRCI) tiles, and closing out the TDS open bays. Testing is to be conducted by NASA.

8.8 Internal Pressure Test

The TDS may be tested under internal pressure (approximately .02 MPa (3 psi)) to assess the integrity of the major adhesive bonds by placing them in flatwise tension. The TDS torque box would be filled with styrofoam to reduce danger due to the pressure. The test article would be sealed by replacing the front spar access panels with metal panels equipped with pressure seals and fittings.

The front spar attachment "T" members were designed for shear loads. Concern has been expressed over the integrity of these members under internal pressure loads (see Figure 53). Analytical models predict failure at .03 MPa (5 psi), but confidence in the analysis is low. It is recommended that this test be conducted last, predicated on successful completion of a subelement test.

Summary

The test objective is to verify the structural adequacy of a typical composite body flap section to sustain acoustic, mechanical, and thermal load cycles representative of 100 Space Shuttle missions. The lack of a hinge rib on the TDS precludes actual body flap loads, therefore, loading conditions to simulate the body flap stress state were determined by using a NASTRAN model of the TDS.

Since it would be very difficult to perform mechanical and thermal cycling simultaneously, an alternate method is suggested: First, perform the mechanical testing; Second, perform the thermal cycling and acoustic testing; and finally, the mechanical test could be performed again to assess the structural degradation from the previous testing. It is assumed that the acoustic testing would take place in a NASA facility -- JSC.

Because the TDS is stiffness rather than strength critical, failure under mechanical loads is not anticipated. However, due to the extreme sonic environment (165 dB OASPL), acoustic fatigue is a significant failure mode. The body flap must also be able to withstand the Orbiter thermal environment 166°K to 589°K (-160 to 600°F for 100 space missions.

The TDS design was updated to provide for cantilever support during testing. The stability rib caps were beefed up in the leading edge area, and potting and inserts were added to the bolt holes.

When testing is complete, analytical predictions for stress levels, deflections, and acoustic fatigue will be correlated with test data. The analytical models for the GR/Pi Orbiter Body Flap can then be updated.

DOCUMENTATION

1. AS-EMR-80-053, "Technology Demonstration Segment NASTRAN Model", dated April 14, 1980.
2. AS-EMR-80-052, "GR/PI Technology Demonstration Segment Design Update", dated April 14, 1980.
3. AS-EMR-80-072, "Technology Demonstration Segment Test Definition", dated May 2, 1980.
4. SSV80-22, "GR/PI Technology Demonstration Segment Test Concepts:", dated April 14, 1980.
5. AS-EMR-80-164, "Composite Body Flap Segment Test Program", dated September 2, 1980.

This Page Intentionally Left Blank

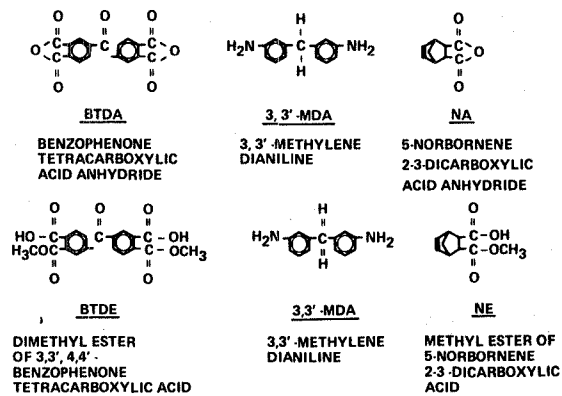

Figure 1. LARC 13 Monomer Reactants

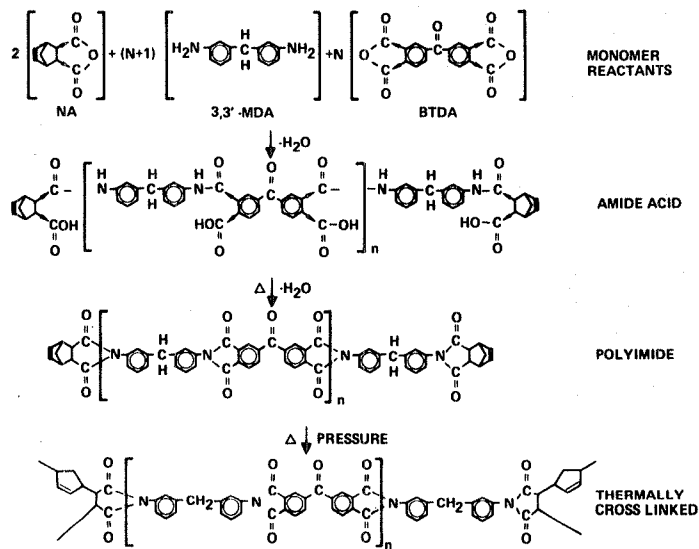

Figure 2. LARC 13 Polyimide Reaction Sequence

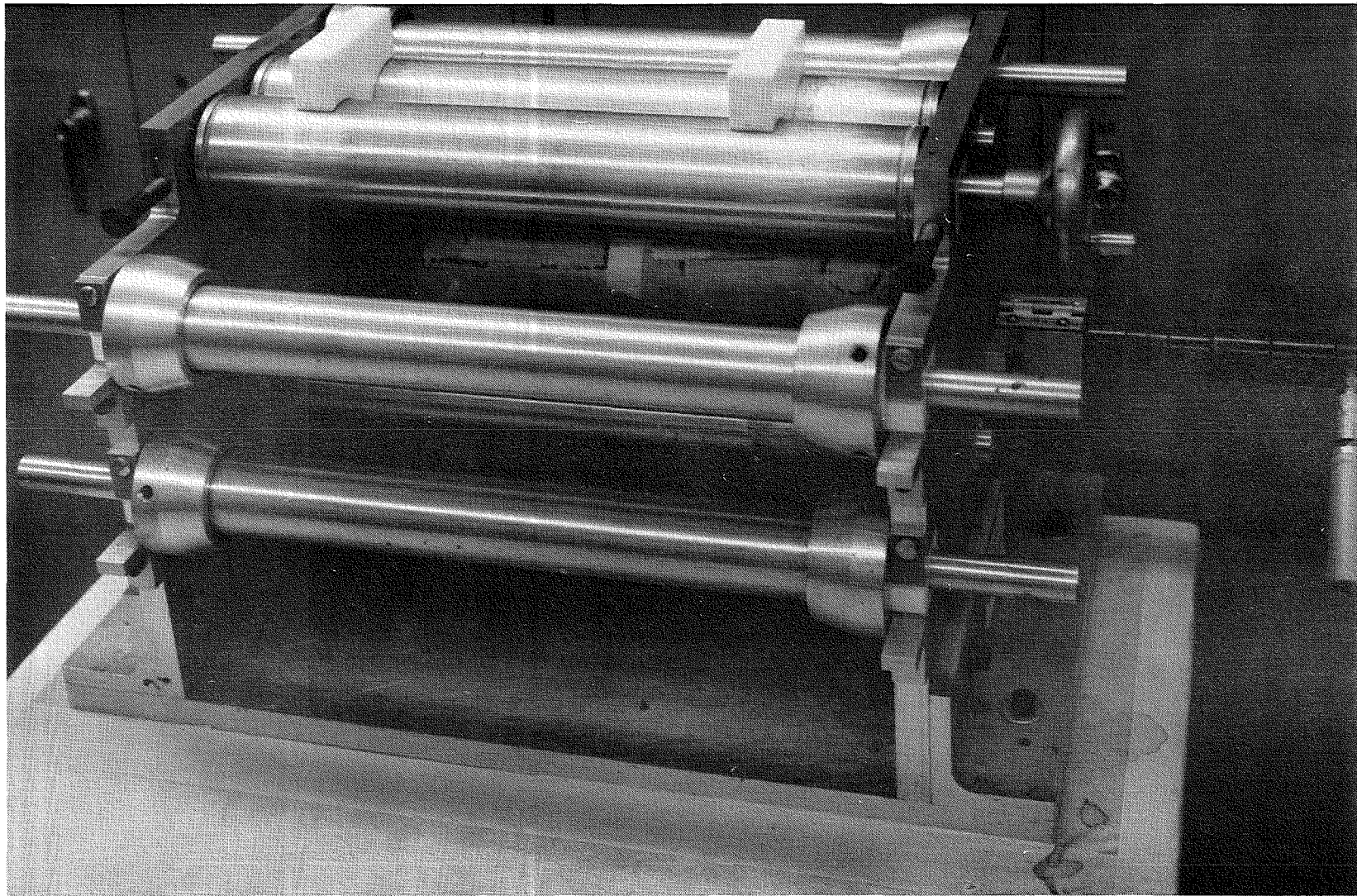

Figure 3. Adhesive Prepreg Mill

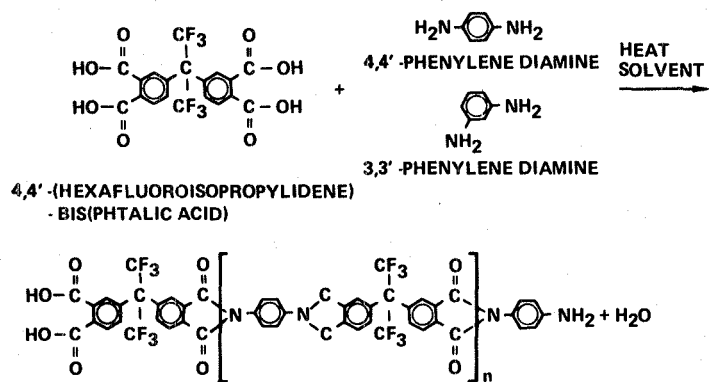

Figure 4. Reaction Scheme of NR150B2G

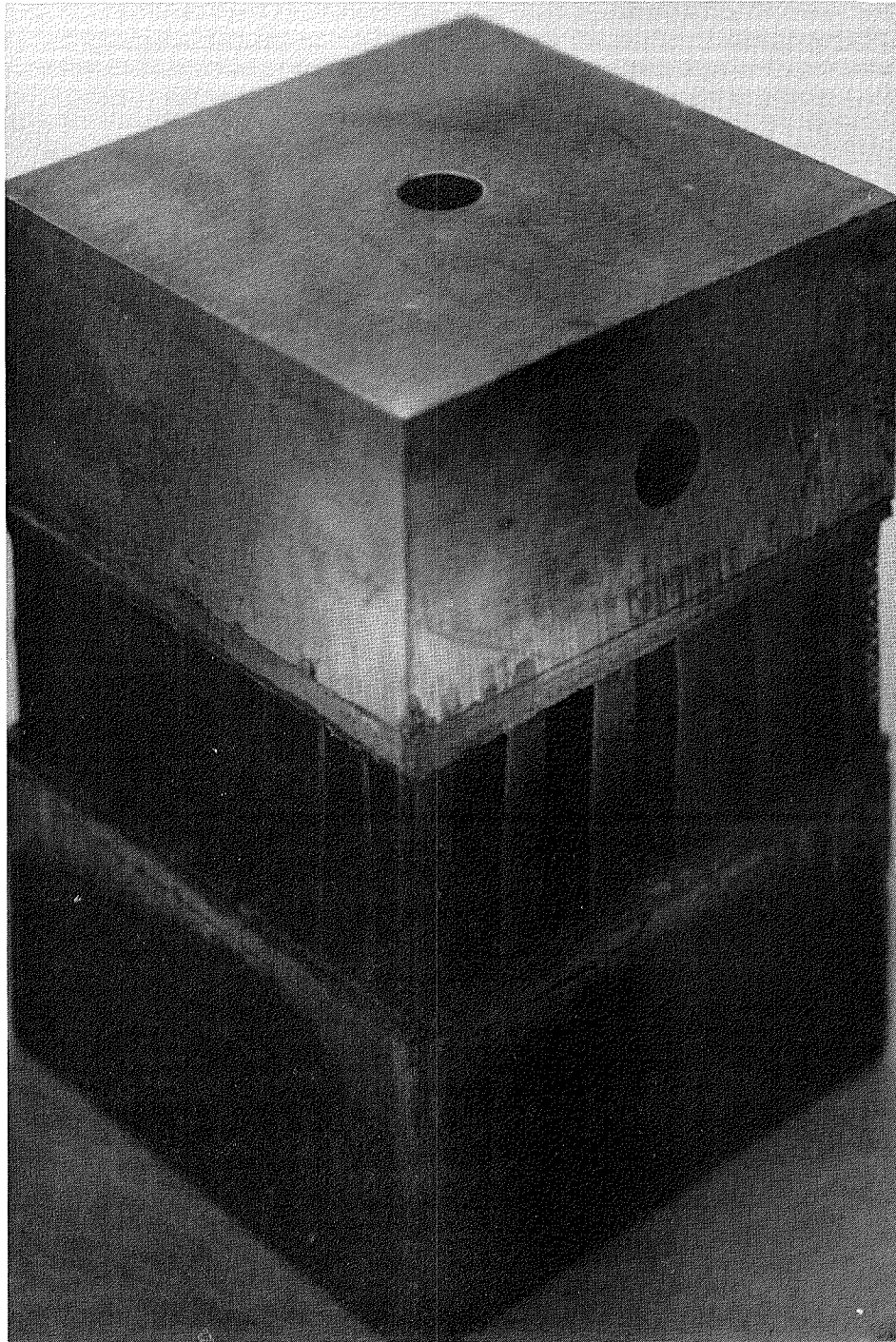

Figure 5. Flatwise Tensile Test Specimen

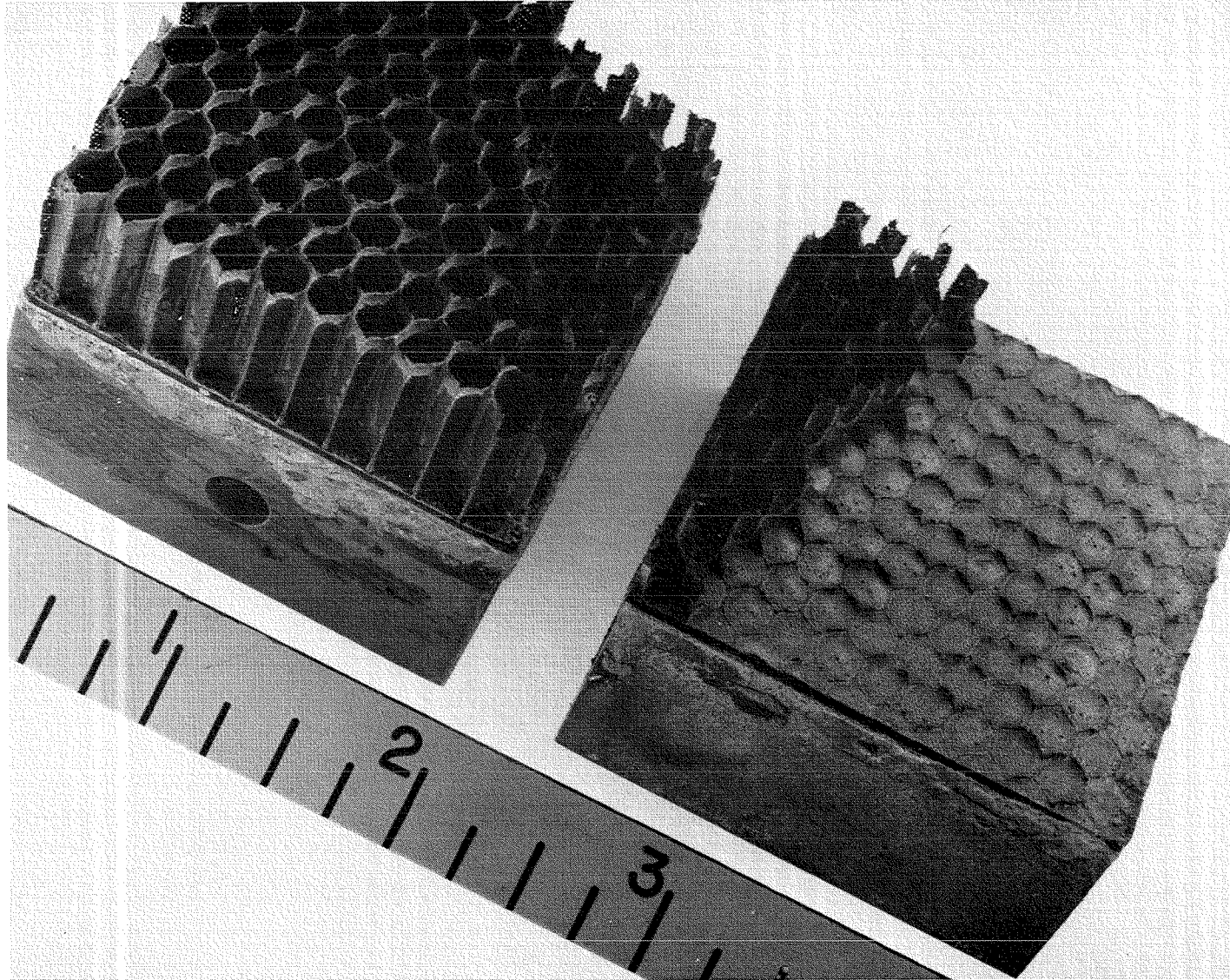

Figure 6. Flatwise Tensile Test Specimen After Testing

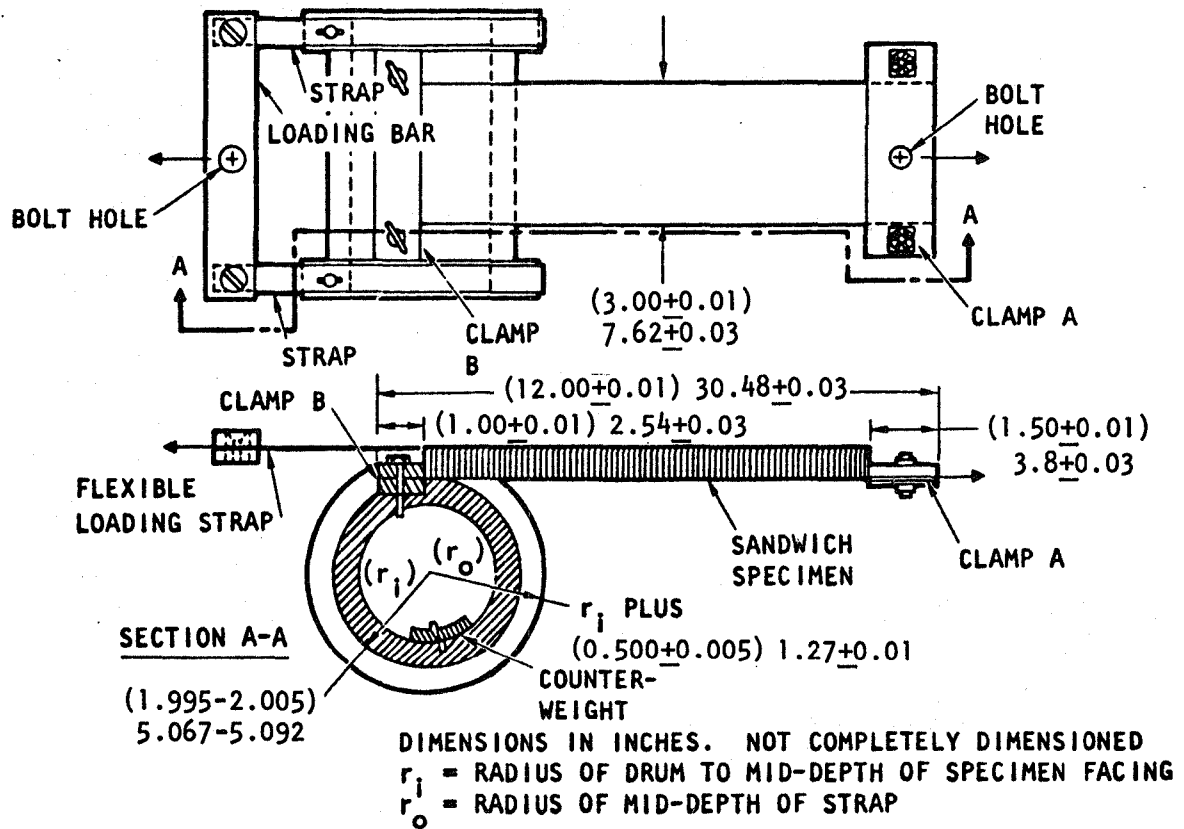

Figure 7. Climbing Drum Peel Test Apparatus

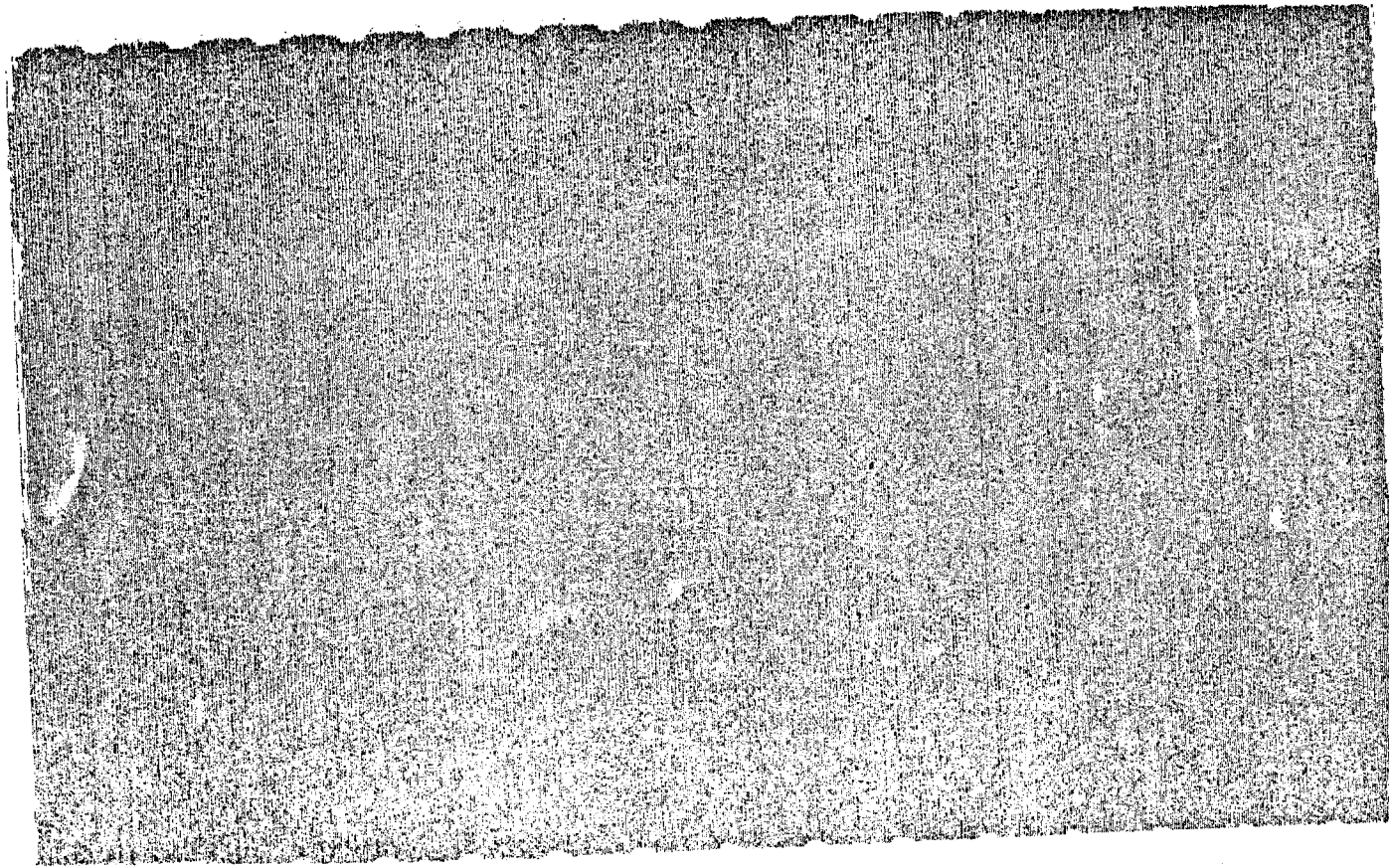

Figure 8. C-Scan of 76 x 46 cm (30" x 18") Panel of Celion 6000/PMR-15
Composite Panel, 8 Ply, Unidirectional

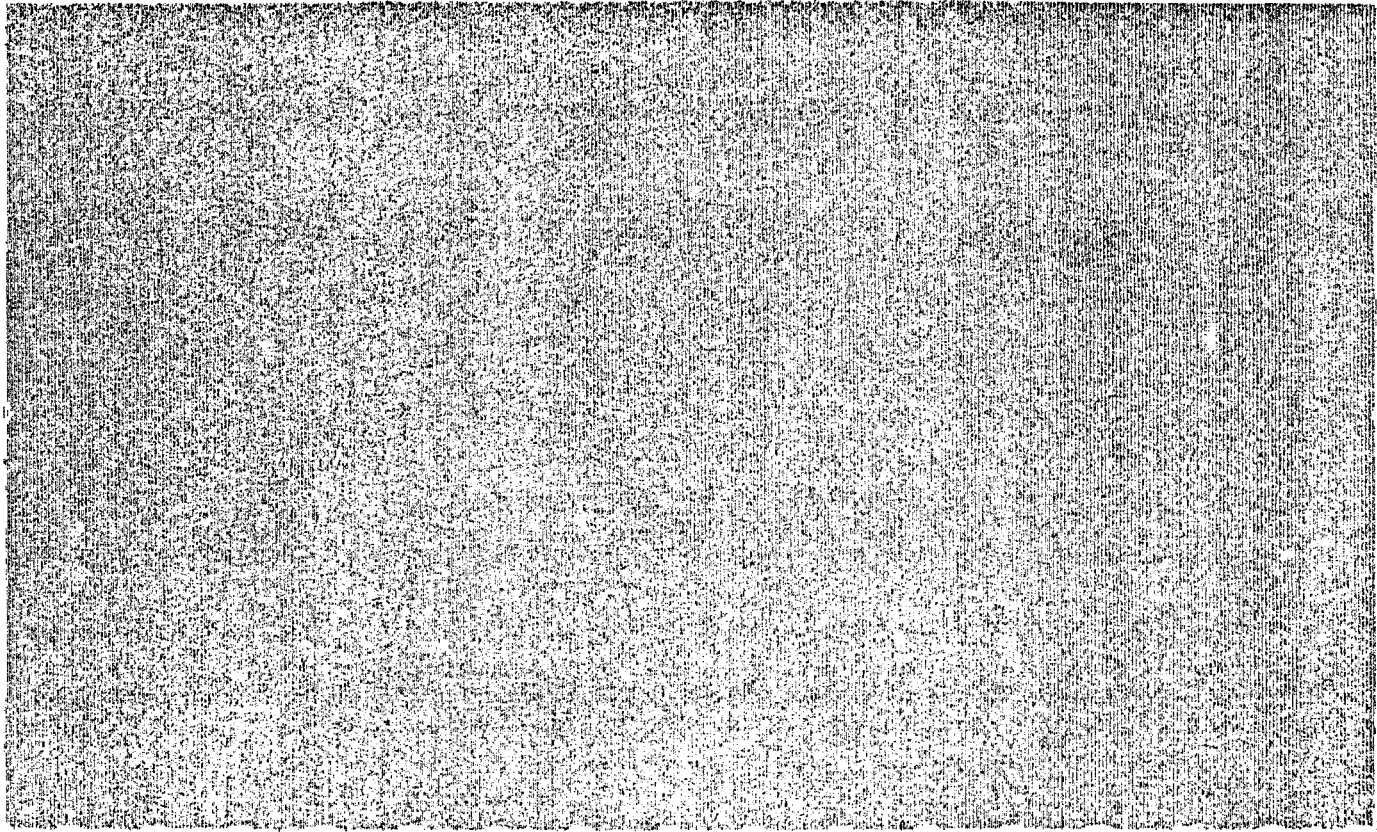

Figure 9. C-Scan of 76 x 46 cm (30" x 18") Panel of Celion 6000/PMR-15
Composite Panel, 8 Ply, Unidirectional

NASA STANDARD 'A' SENSITIVITY

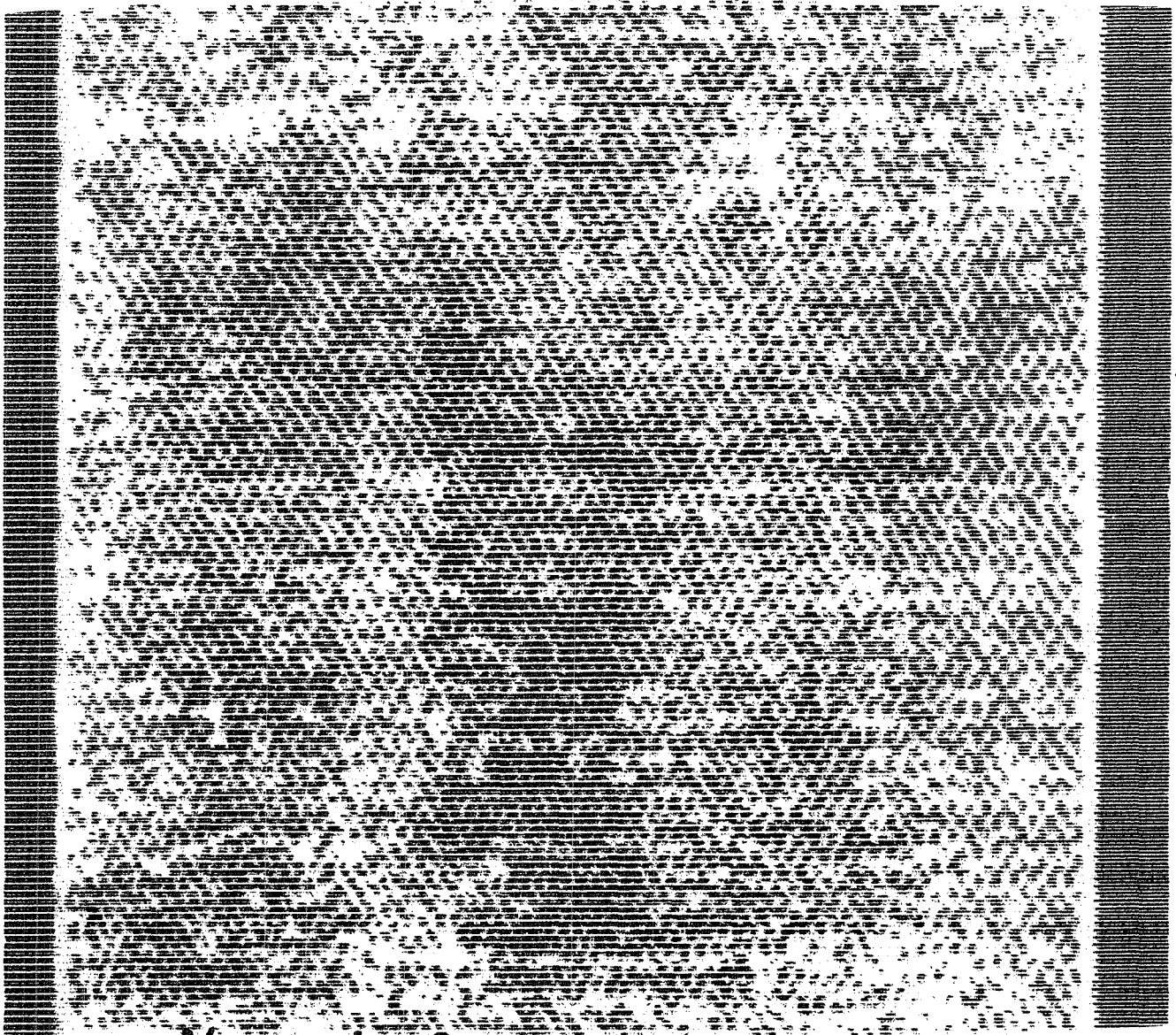

Figure 10. C-Scan of Honeycomb Sandwich Panel With FM34B-18 Adhesive

NASA STANDARD 'A' SENSITIVITY

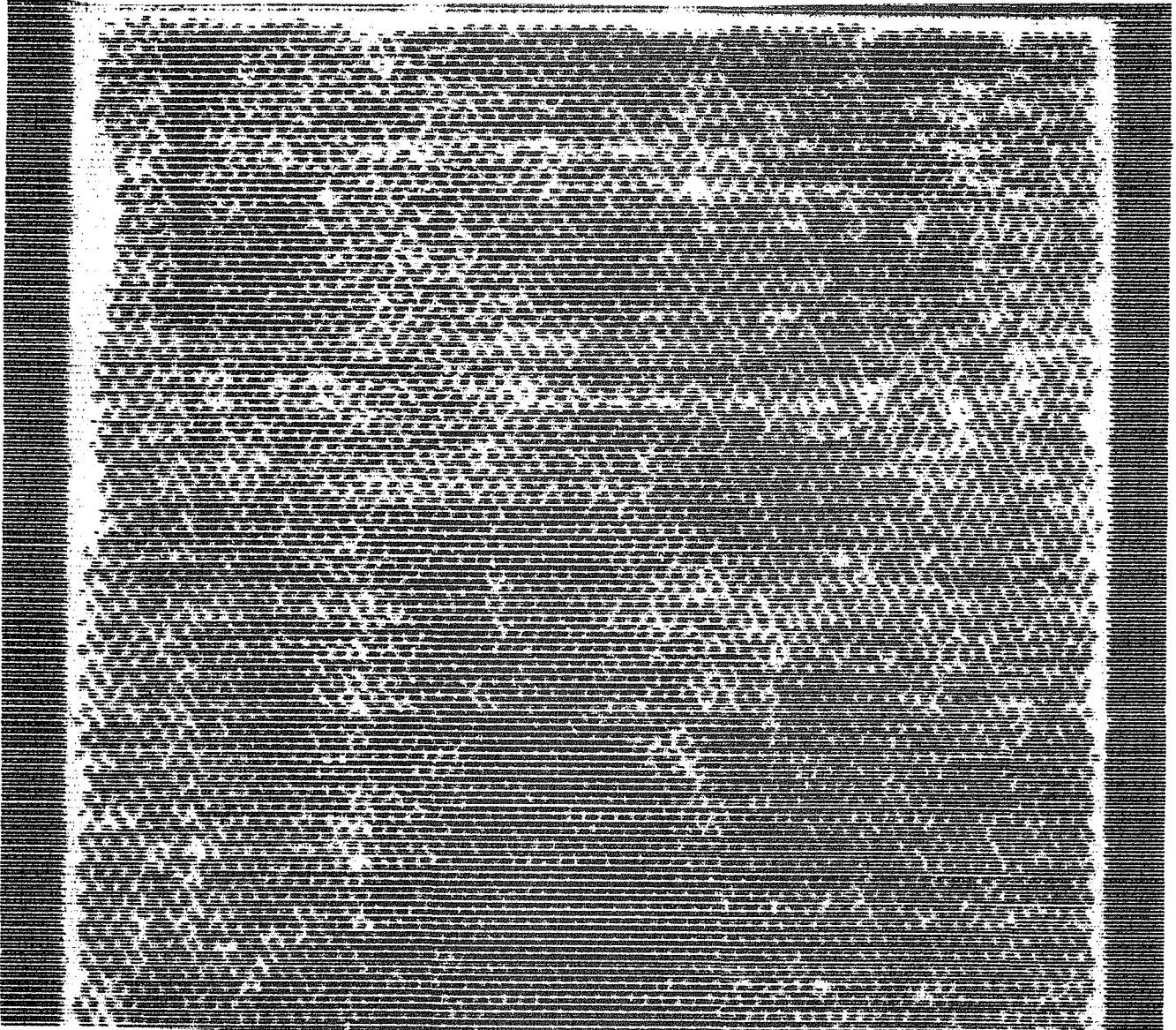

Figure 11. C-Scan of Honeycomb Sandwich Panel With LARC 13 Adhesive

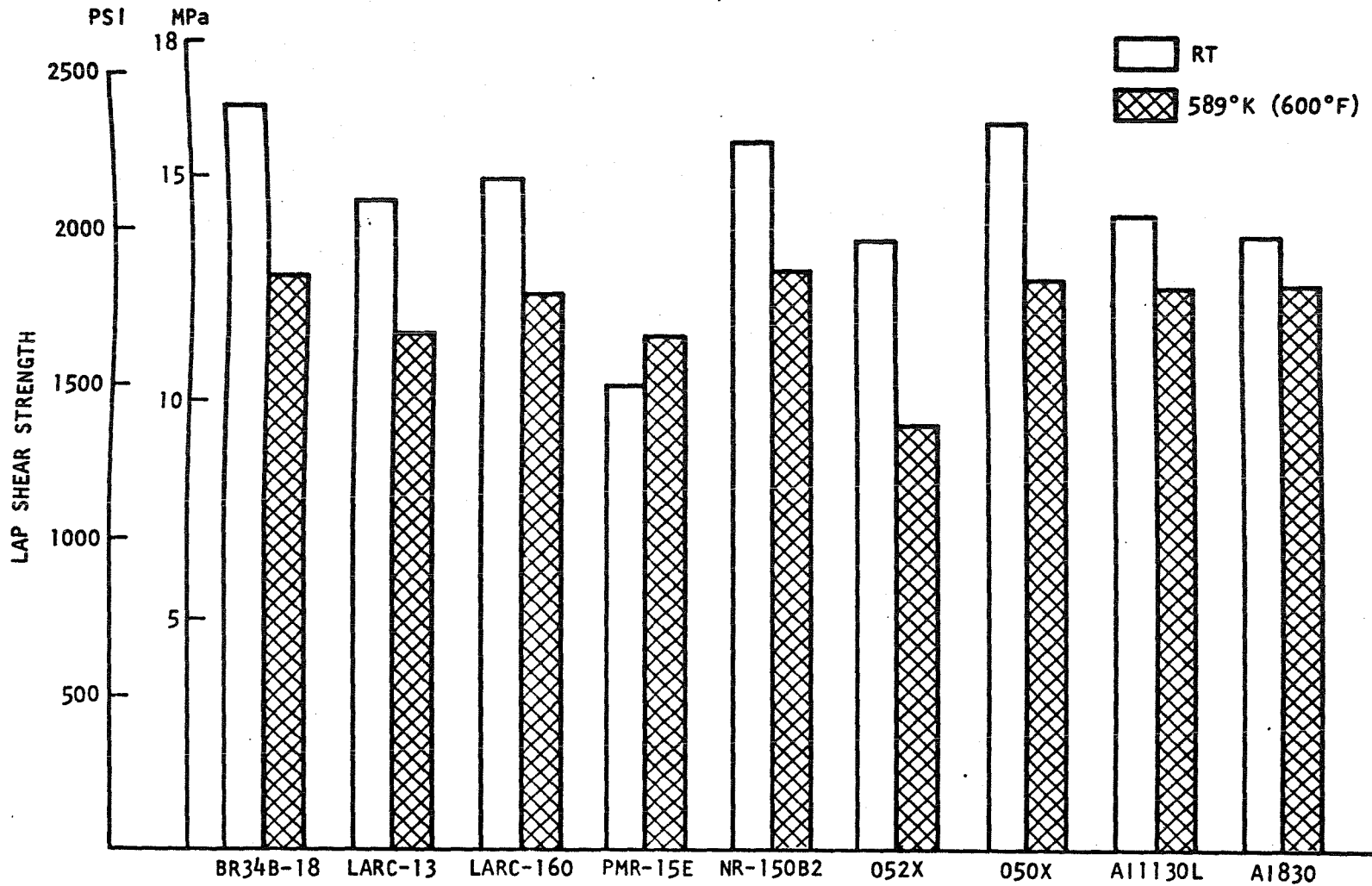

Figure 12. Comparison of Primers For Bonding Celion 6000/PMR-15 Panels With LARC 13 Adhesive

MBS-56. NASA STANDARD "A" SENSITIVITY

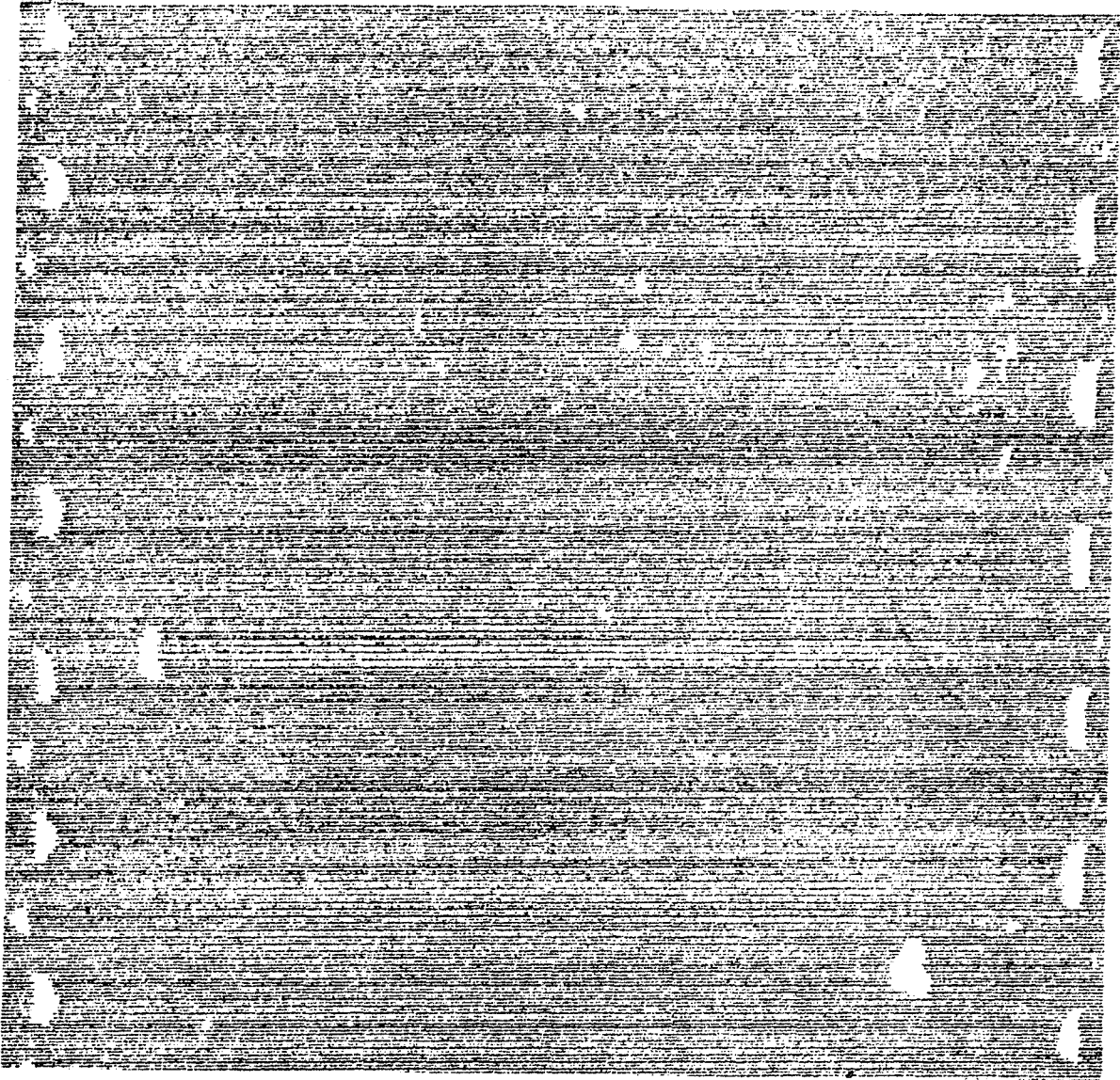

Figure 13. C-Scan of 30.5 by 30.5 cm (12 x 12 in.) Mid-Plane Bonded Panel
With LARC 13 Adhesive on Style 104 Carrier

MBS-48. NASA STANDARD "A" SENSITIVITY

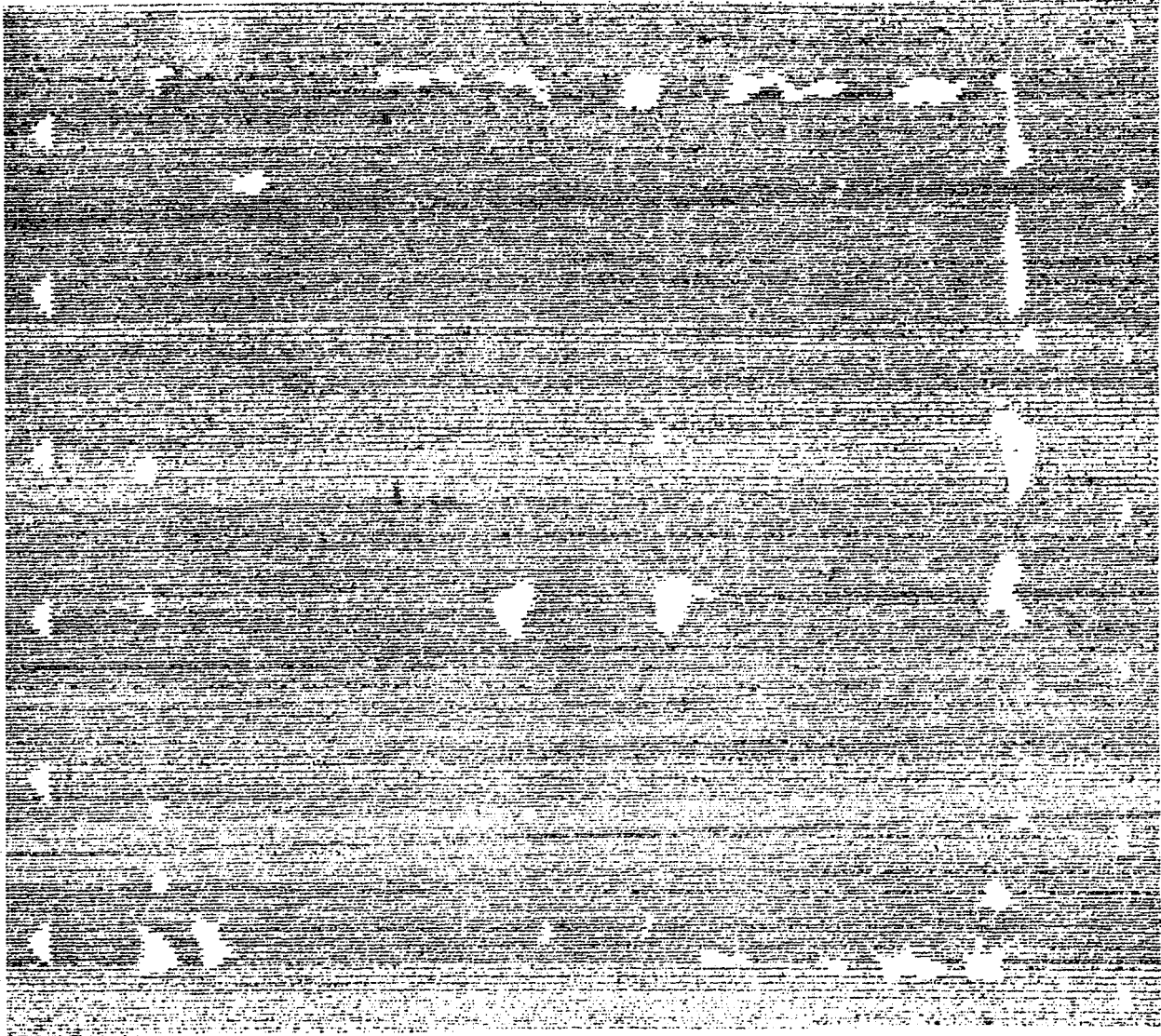

Figure 14. C-Scan of 30.5 cm by 30.5 cm (12 x 12 in.), Mid-Plane Bonded Panel
With M-LARC-13E Adhesive on Style 104 Carrier

MBS-16 NASA STANDARD "A" SENSITIVITY

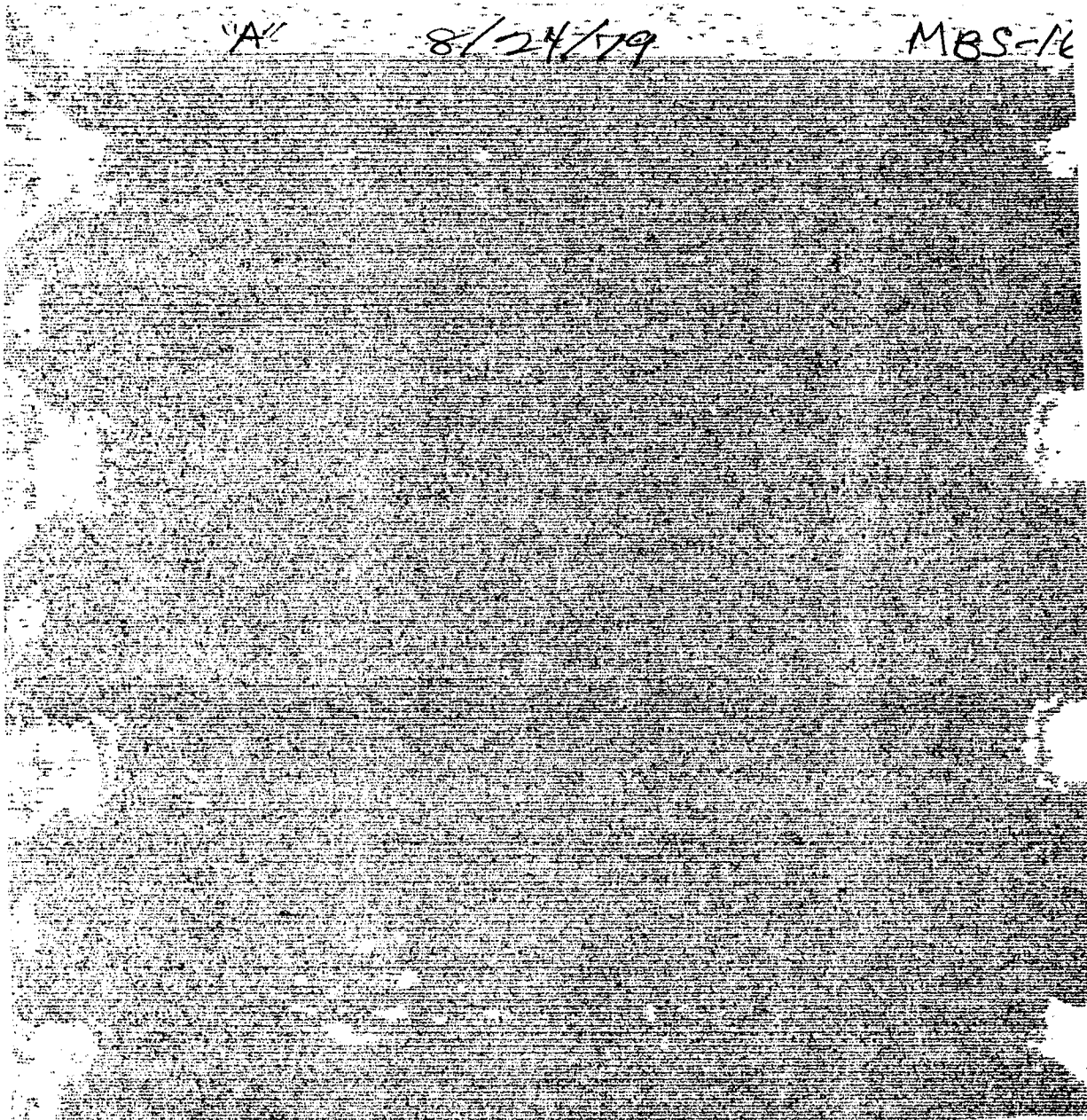

Figure 15. C-Scan of 30.5 cm by 30.5 cm (12 x 12 in.) Mid-Plane Bonded Panel With FM 34B-18 Adhesive on Style 104 Carrier

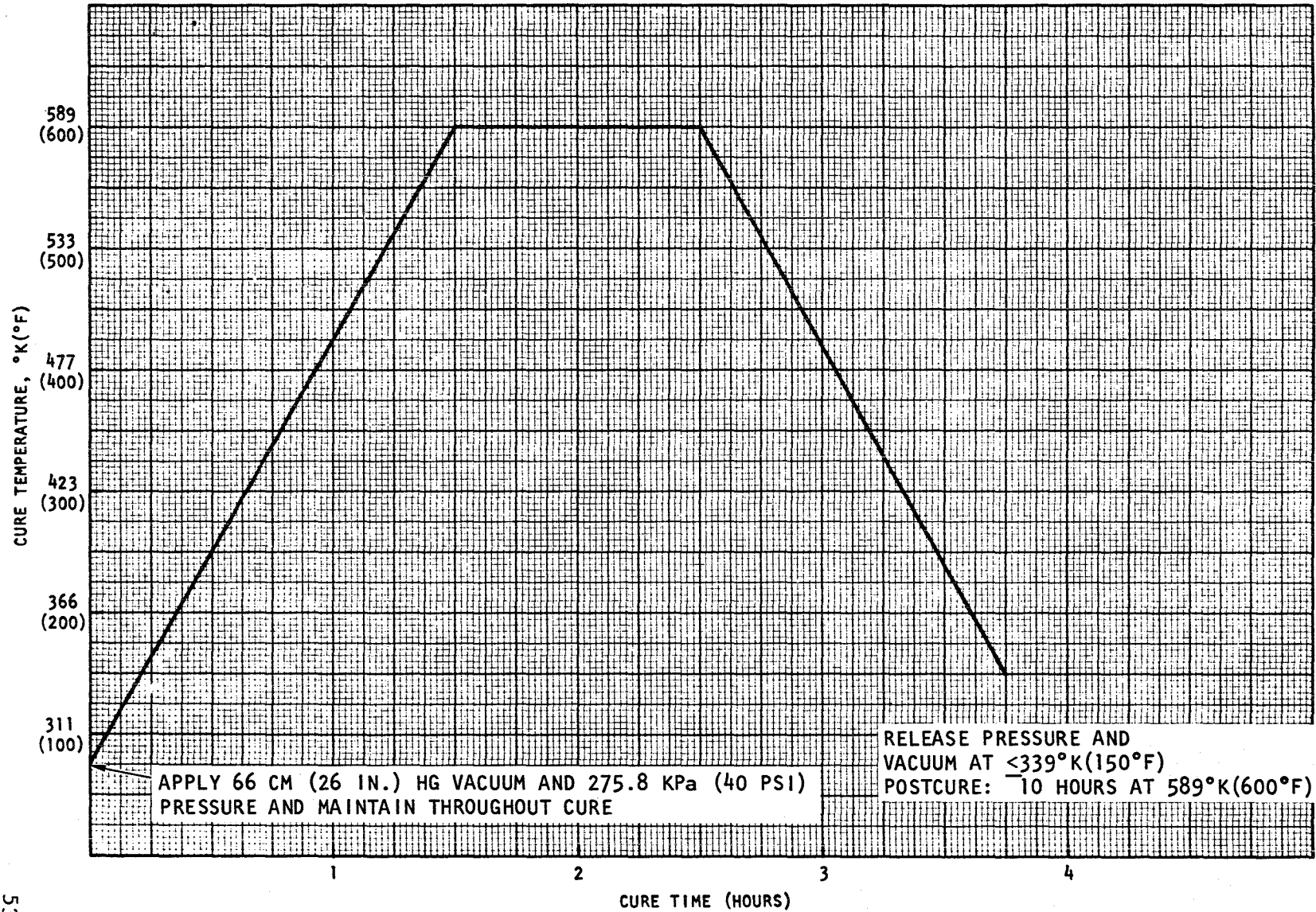

Figure 16. Cure Cycle for the Fabrication of Honeycomb Sandwich Panels with FM34B-18 LARC-13 and M-LARC-13E

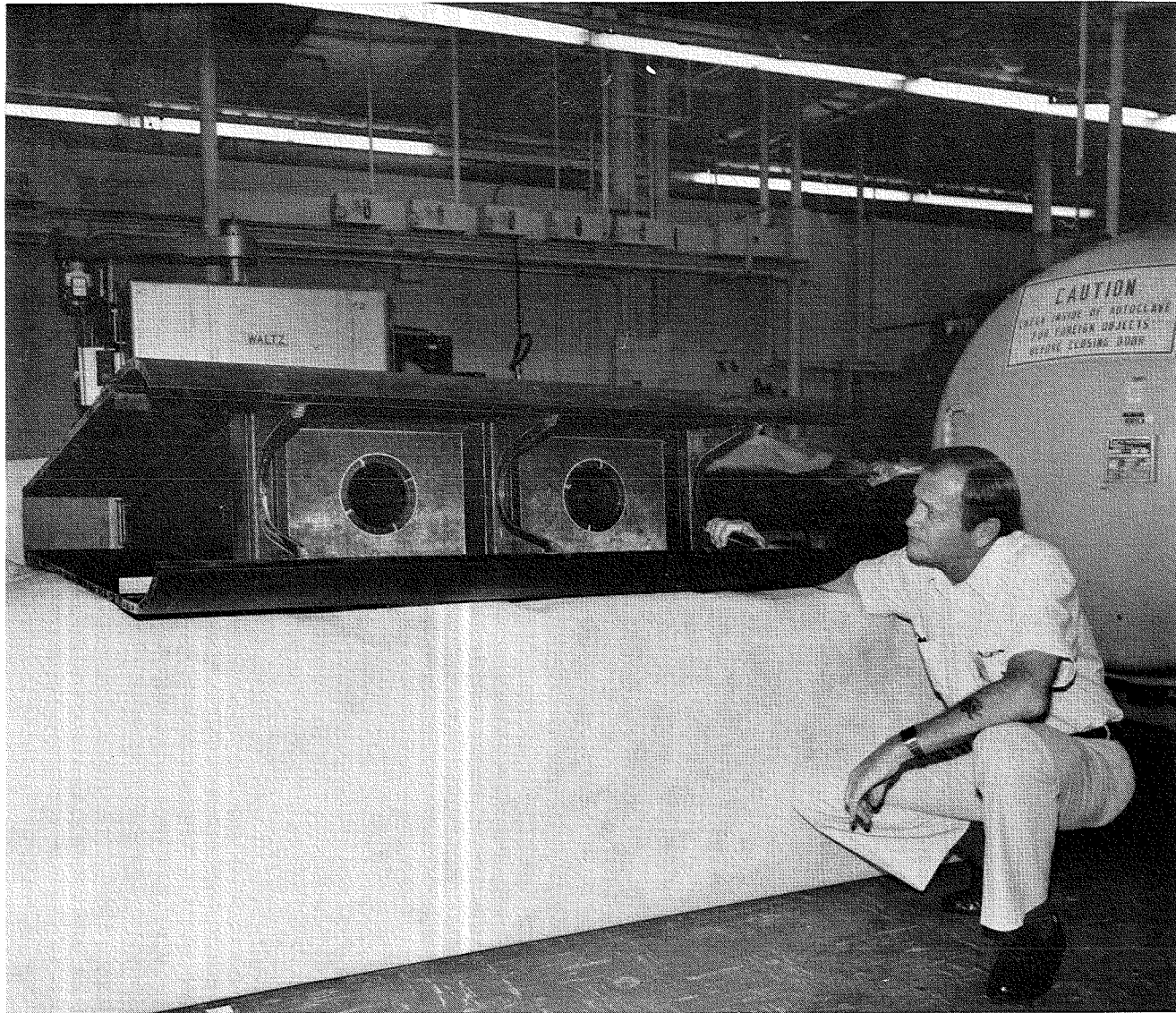

Figure 17. Technology Demonstrator Segment Completed Structure

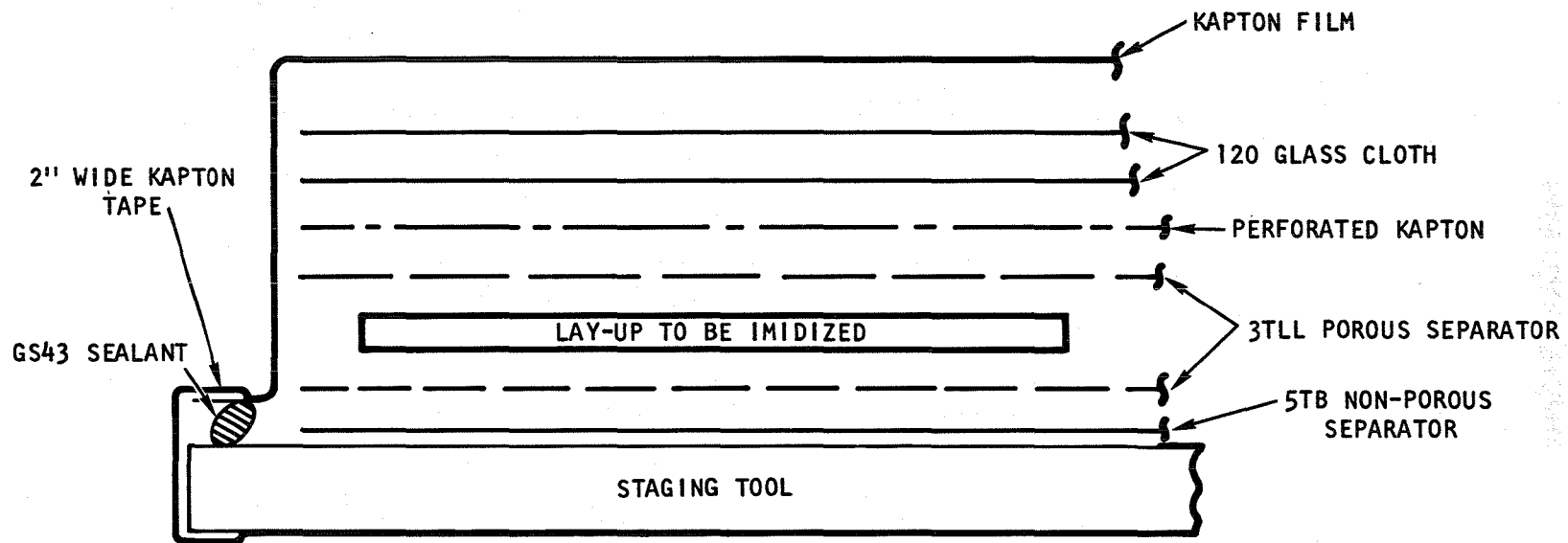

Figure 18. Oven Imidization For Flat Laminate

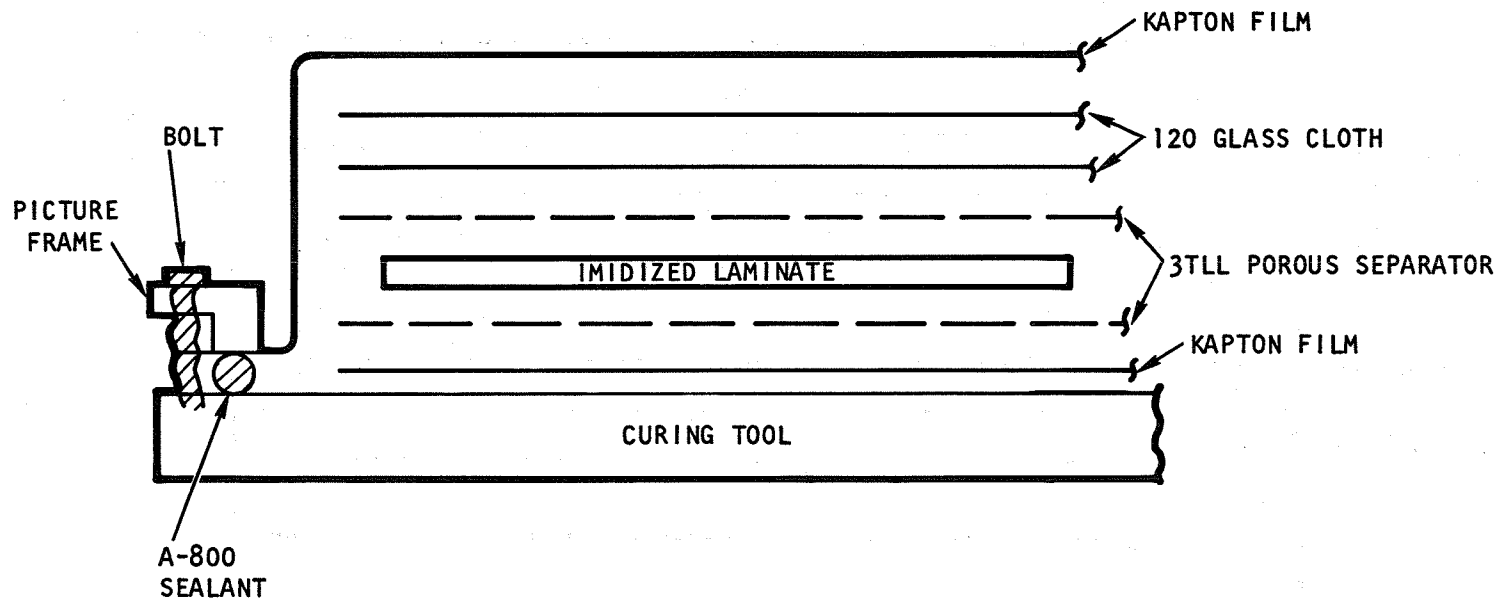

Figure 19. Autoclave Cure For Flat Laminate

A810430 A-8C

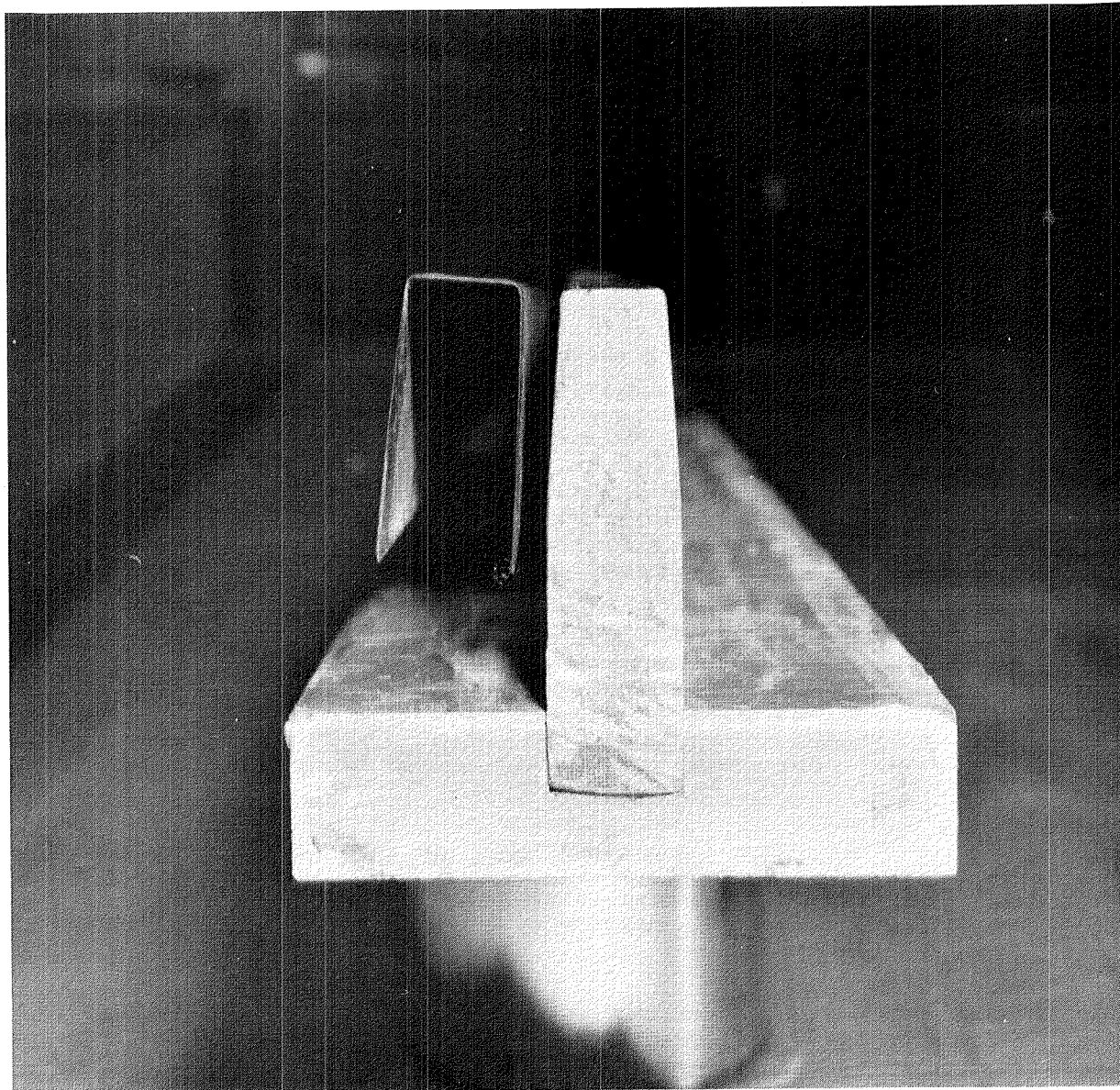
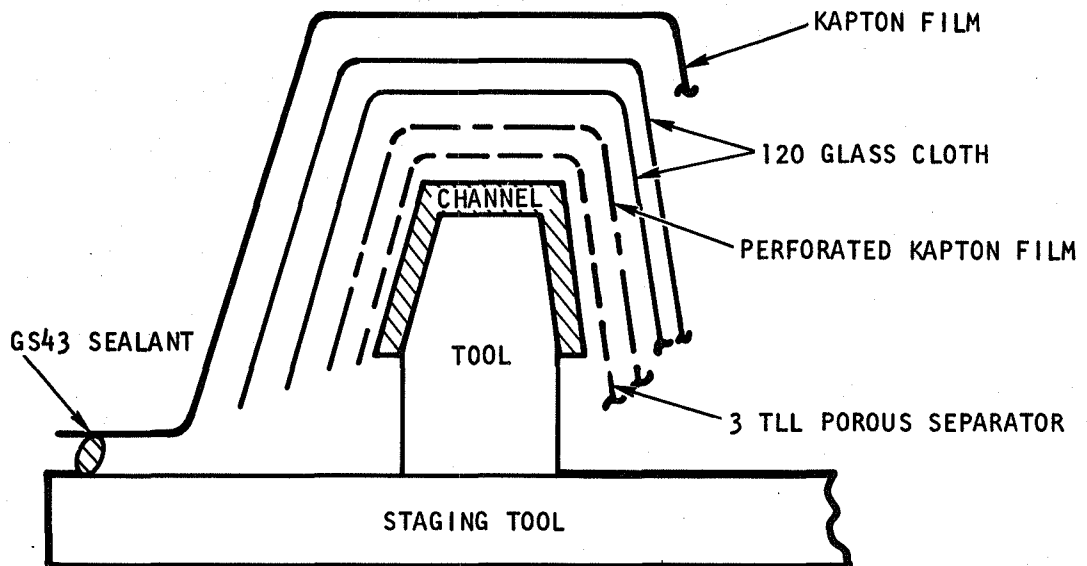

Figure 20. "U" Channel Lay-Up Mold



NOTE: TOOL SECTION HAS BEEN COATED WITH FREKOTE 33 OR SIMILAR TYPE OF RELEASING AGENT.

Figure 21. Staging Lay-Up For "U" Shape Laminate
(In Oven)

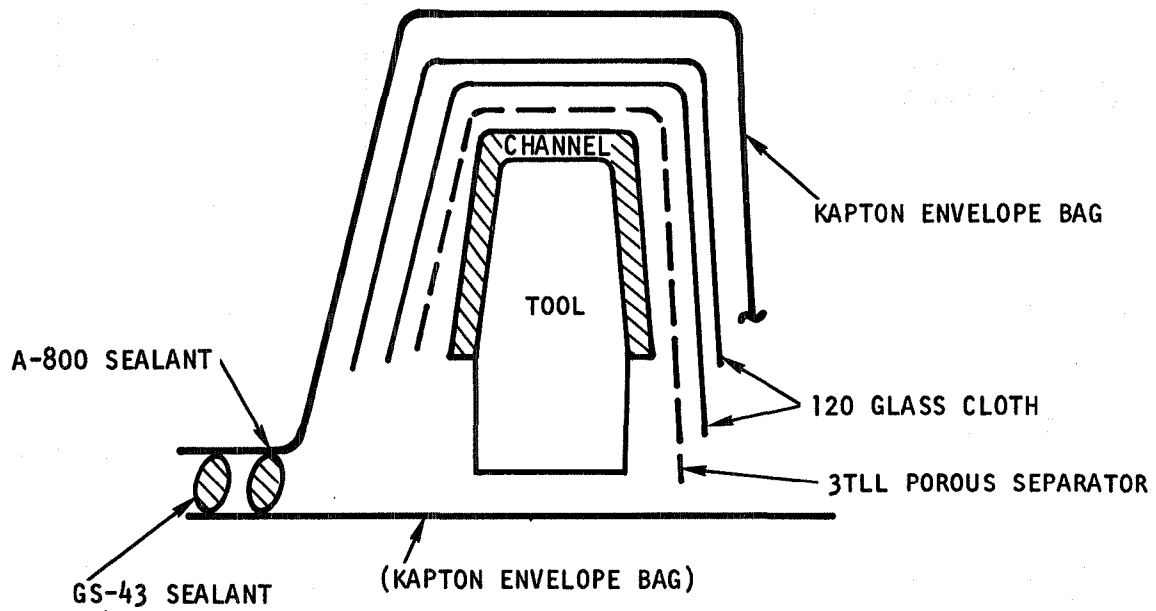

Figure 22. Curing Lay-Up For "U" Shape Laminate
(End View)

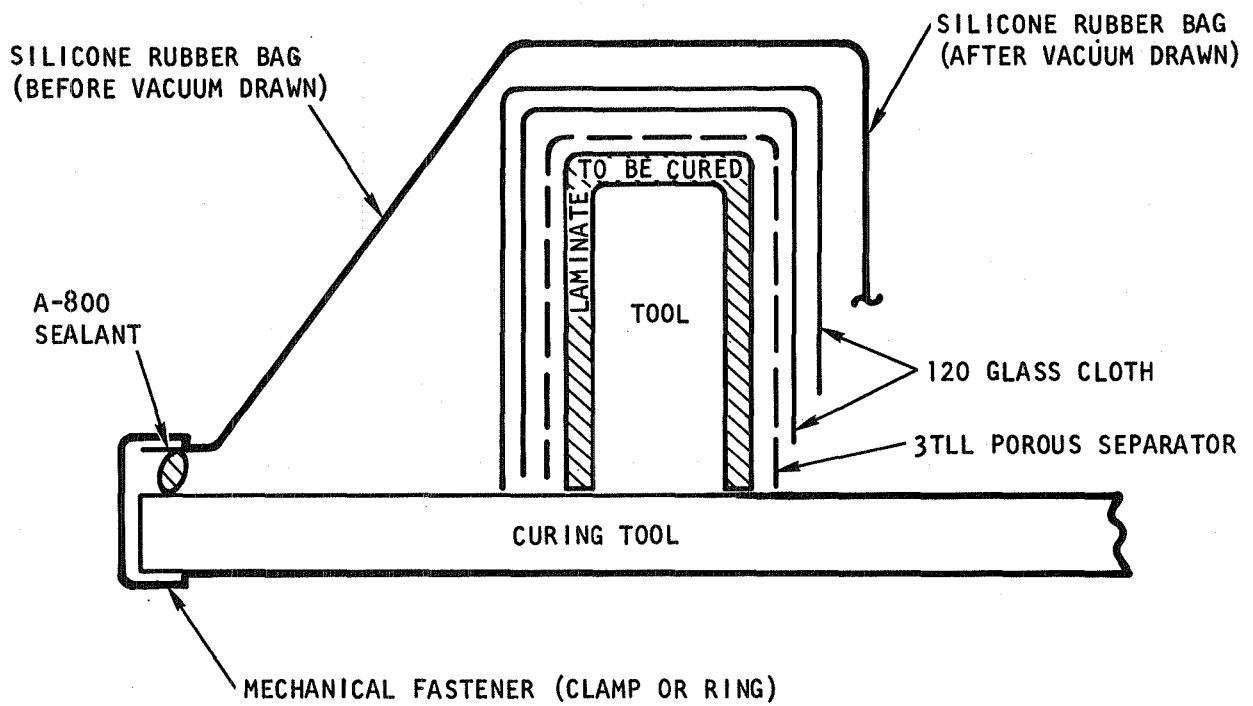

Figure 23. Alternate Curing Lay-Up For "U" Shape Laminate

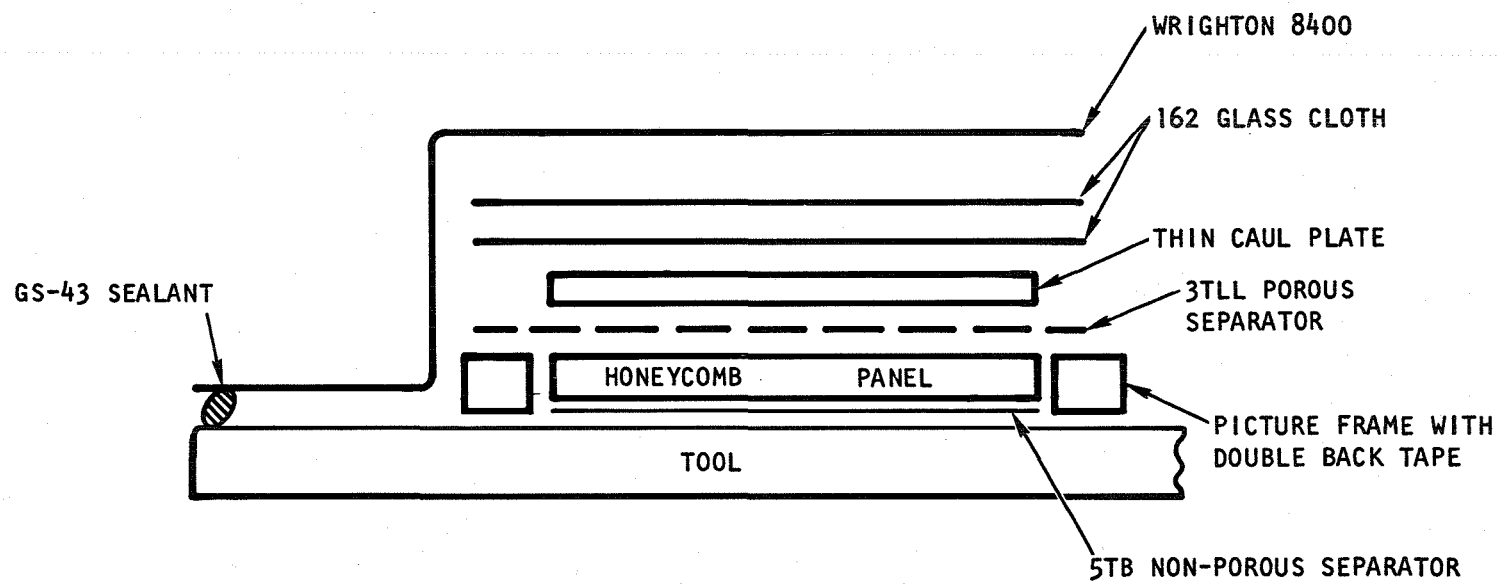

Figure 24. Curing Lay-Up For Honeycomb Sandwich Panel

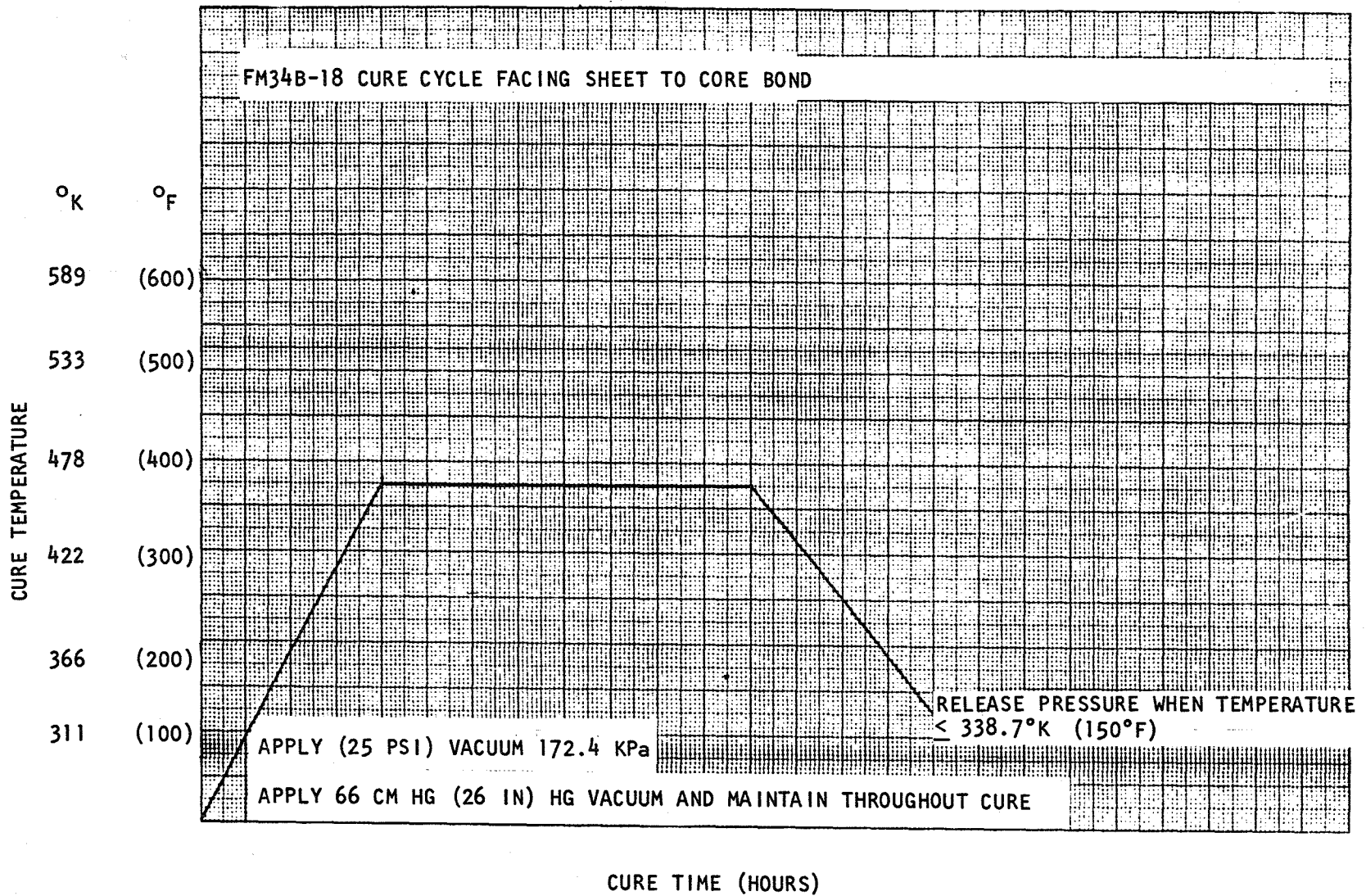

Figure 25. Cure Cycle For Cover Panels

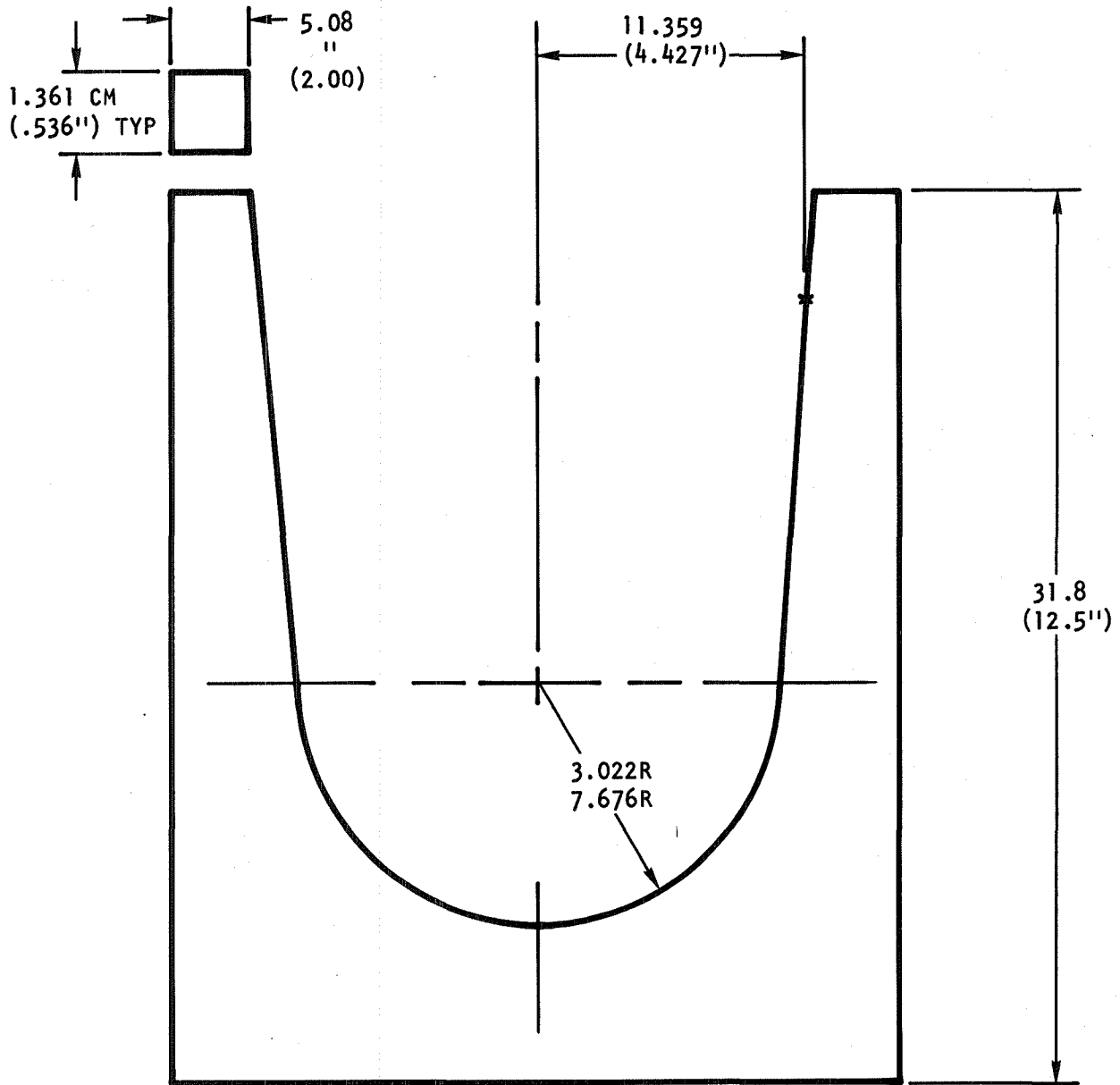

Figure 26. Tool Configuration For Stability Rib Closeout Channel

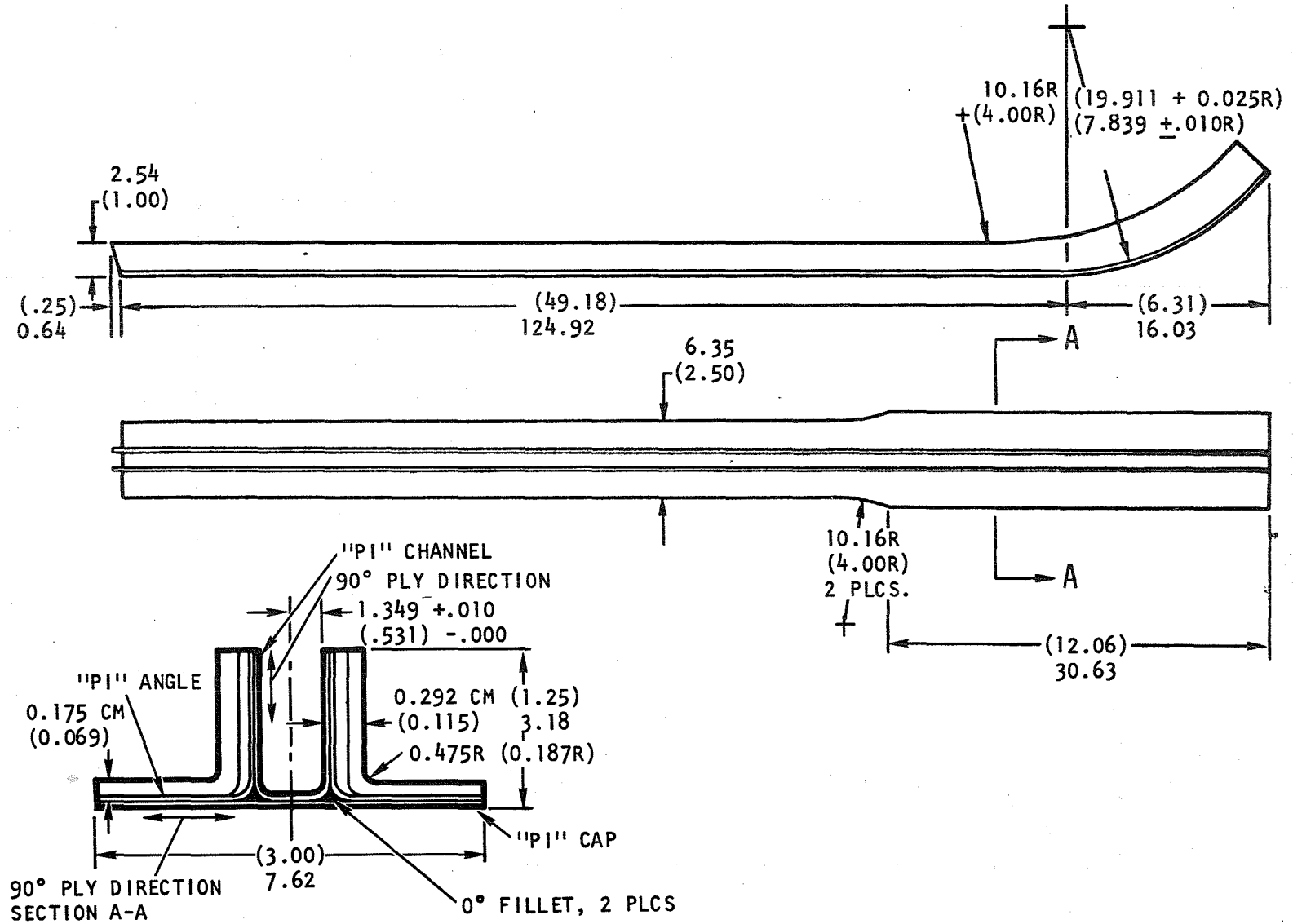

Figure 27. Curved "PI" Joint Element Design SS79-00250-007 (and -011)

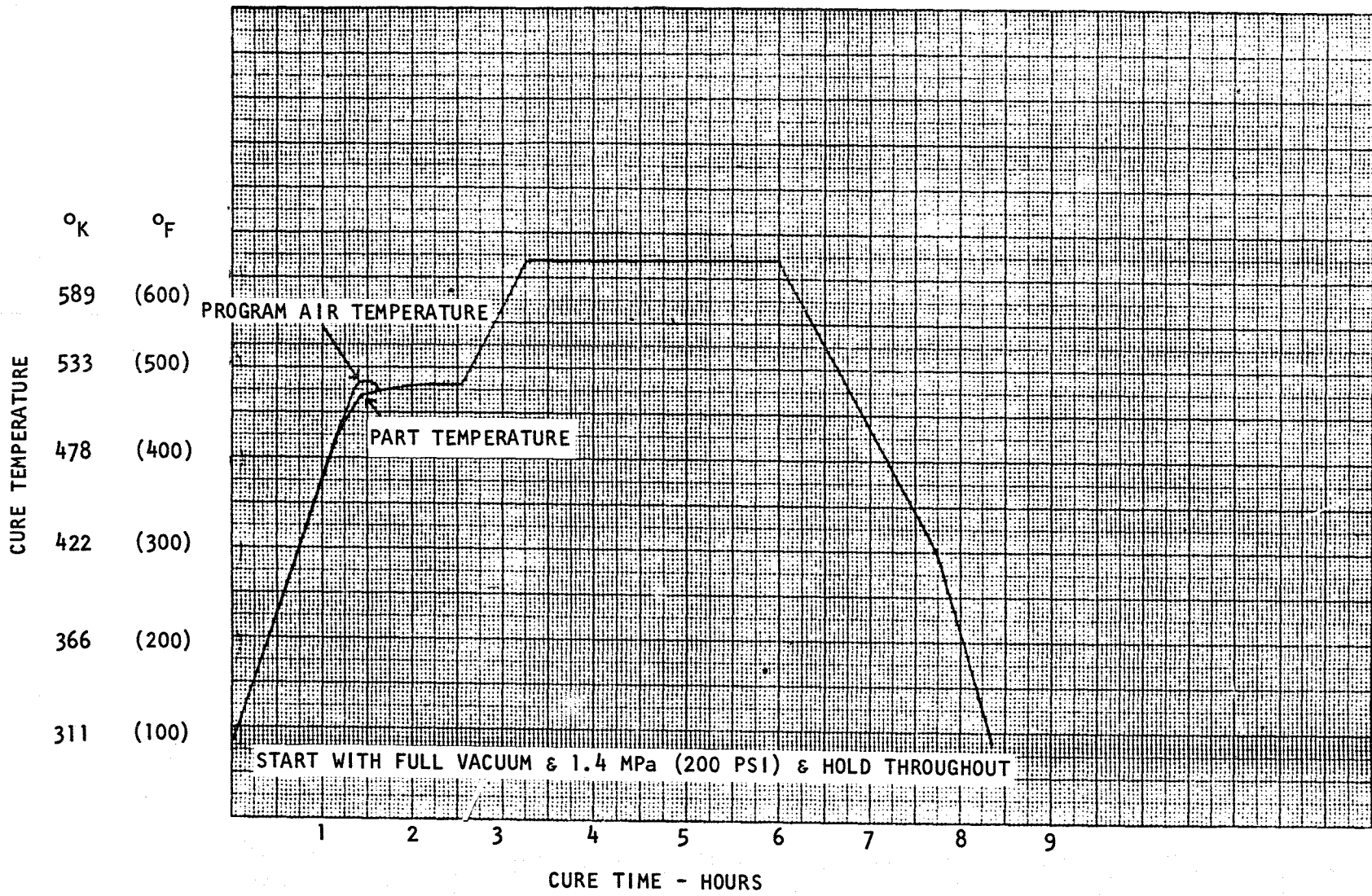

Figure 28. Cure Cycle For Skins

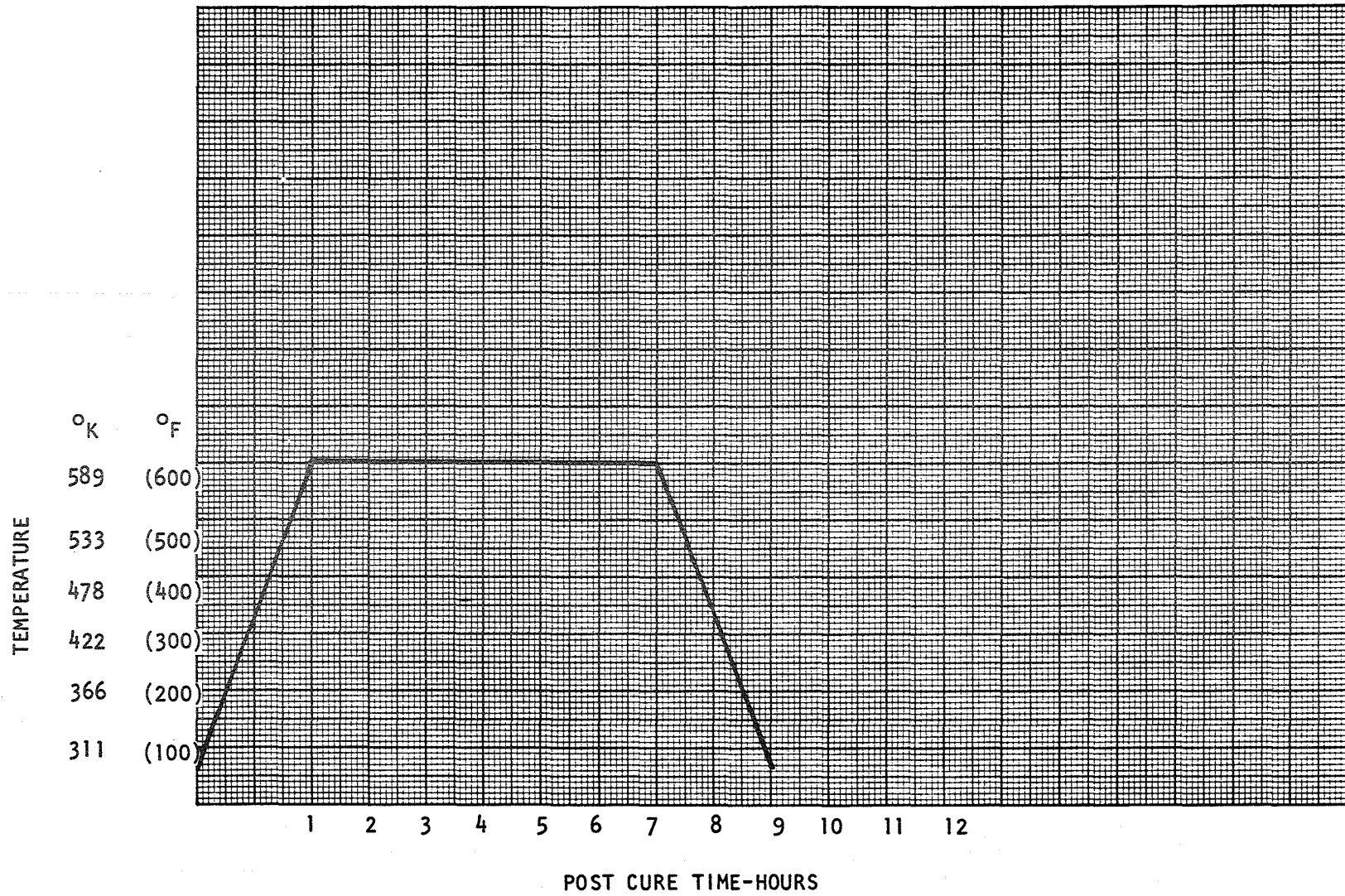

Figure 29. Oven Post Cure Cycle For Skins

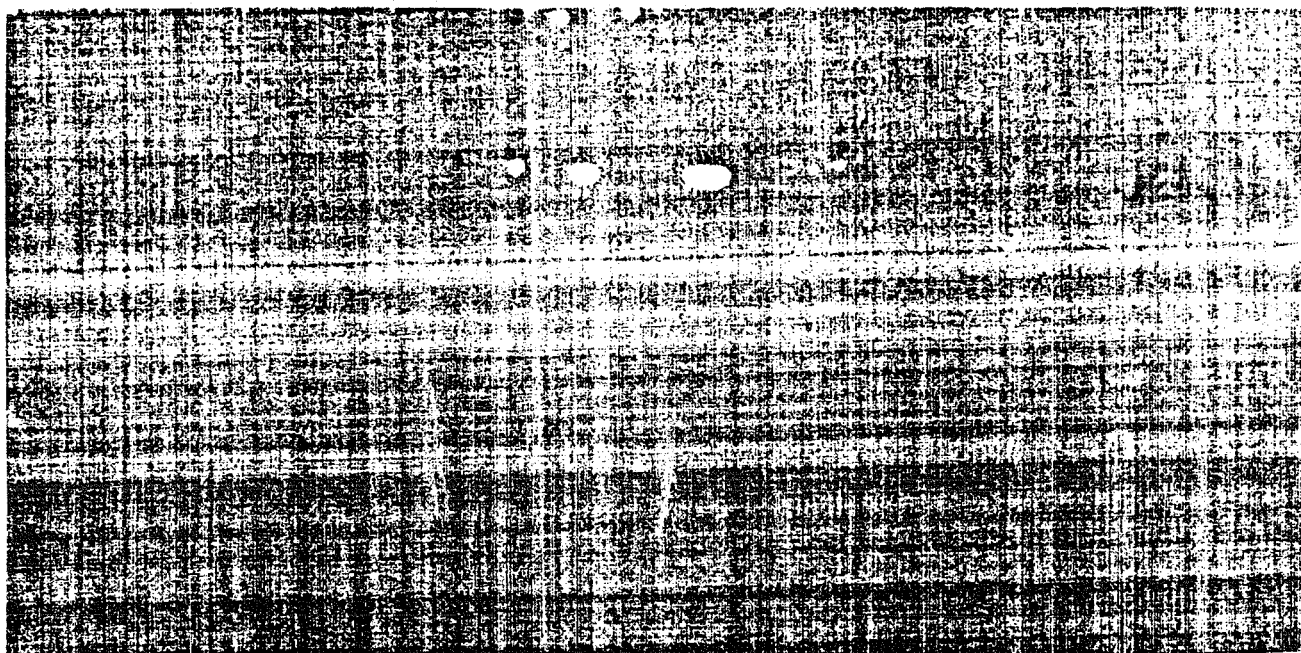

Figure 30. C-Scan of 76.2 cm by 157.5 cm (30" x 62") Skin For Leading Edge

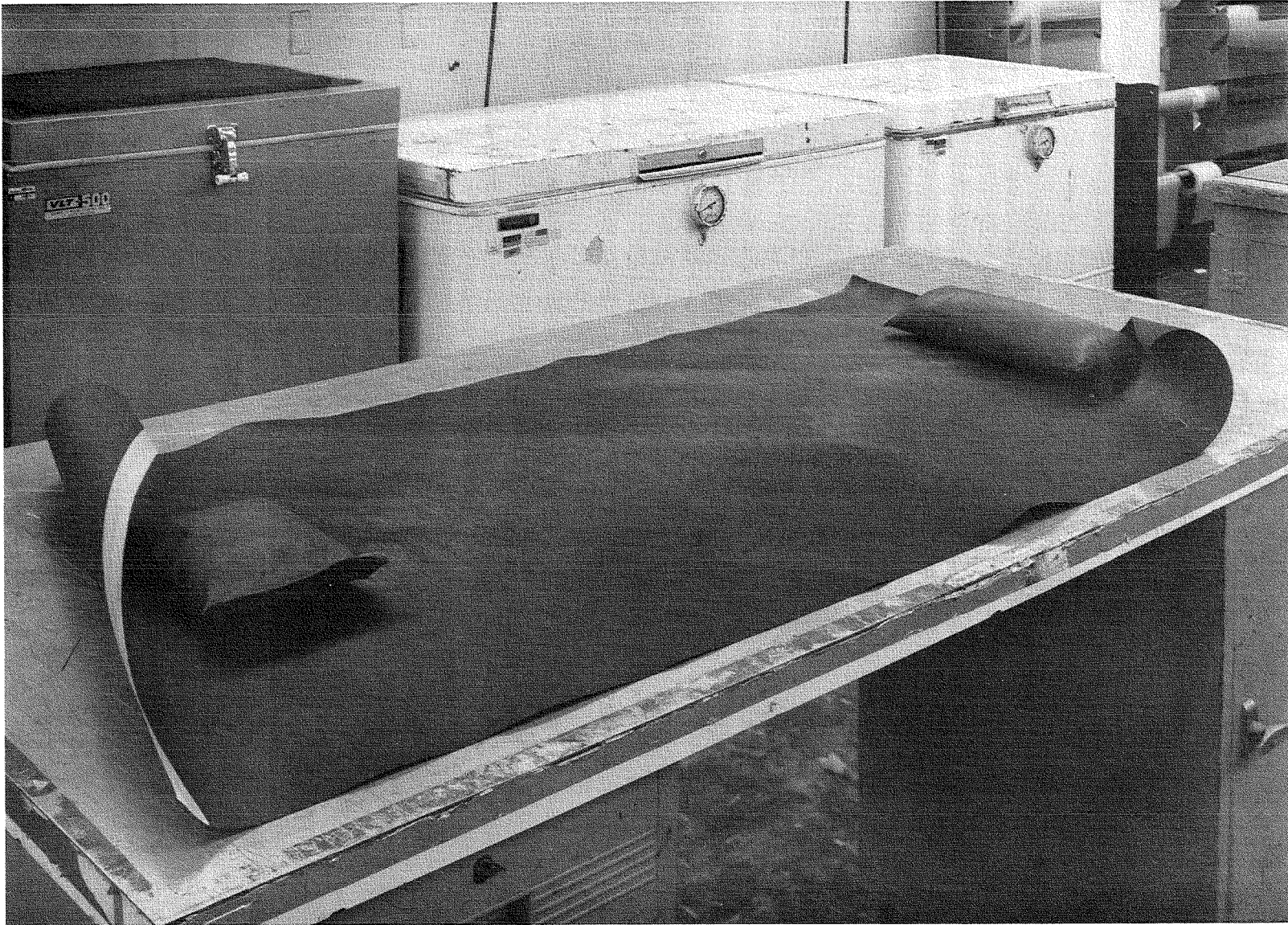

Figure 31. Skin For the Leading Edge

A810430 A-7C

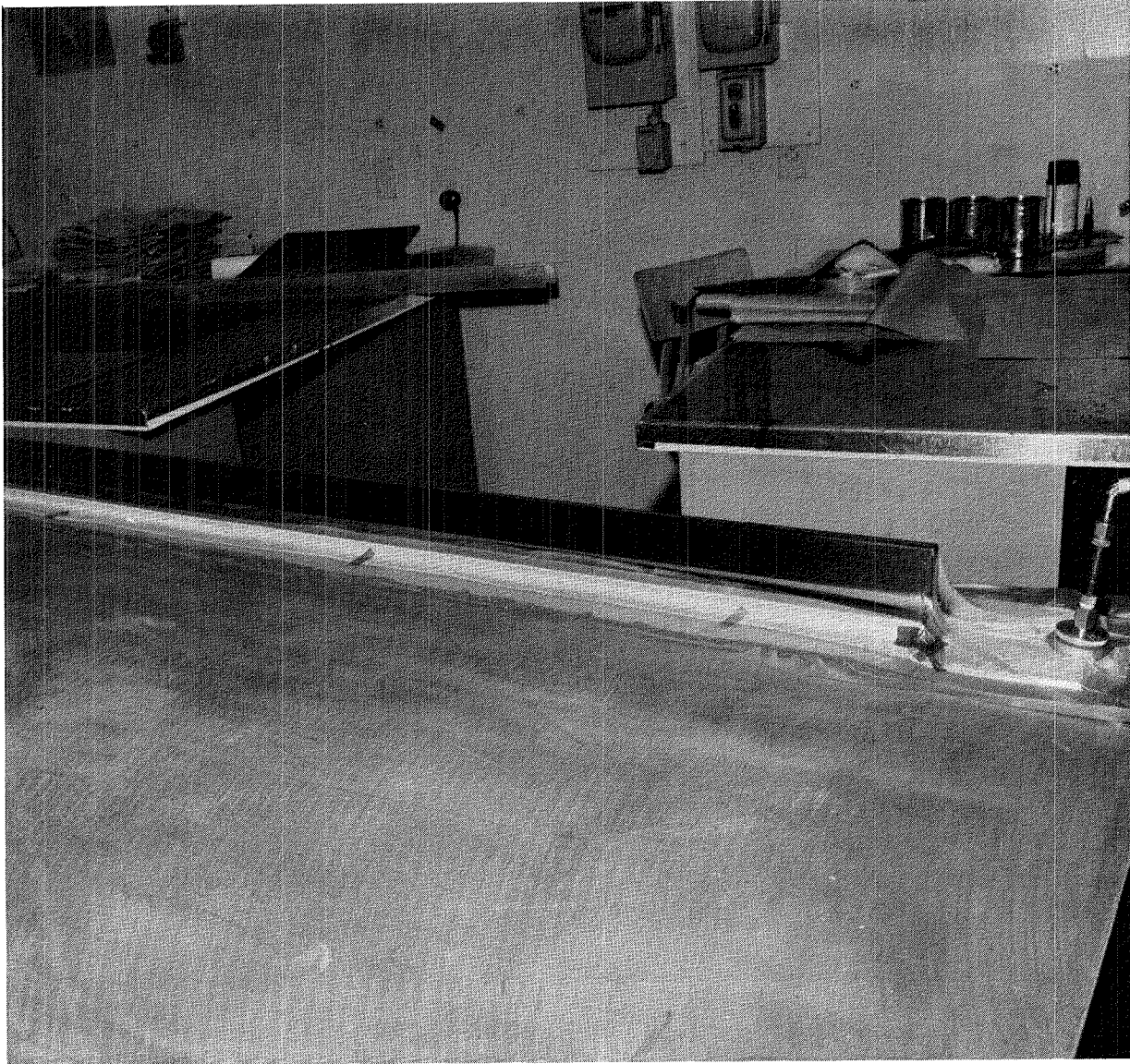

Figure 32. Vacuum Forming of the Close-Out Channels

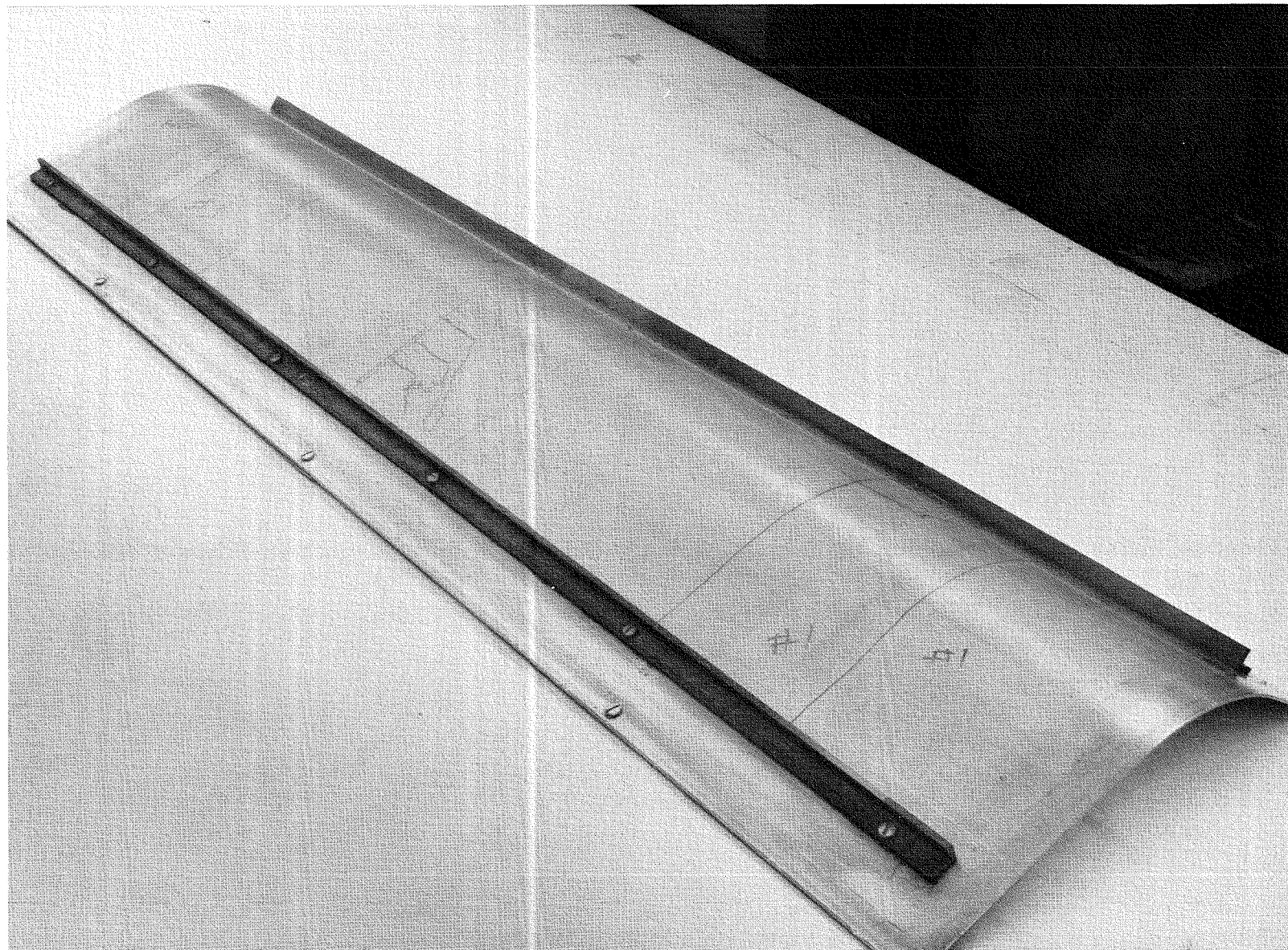

Figure 33. Leading Edge Panel Bonding Jig

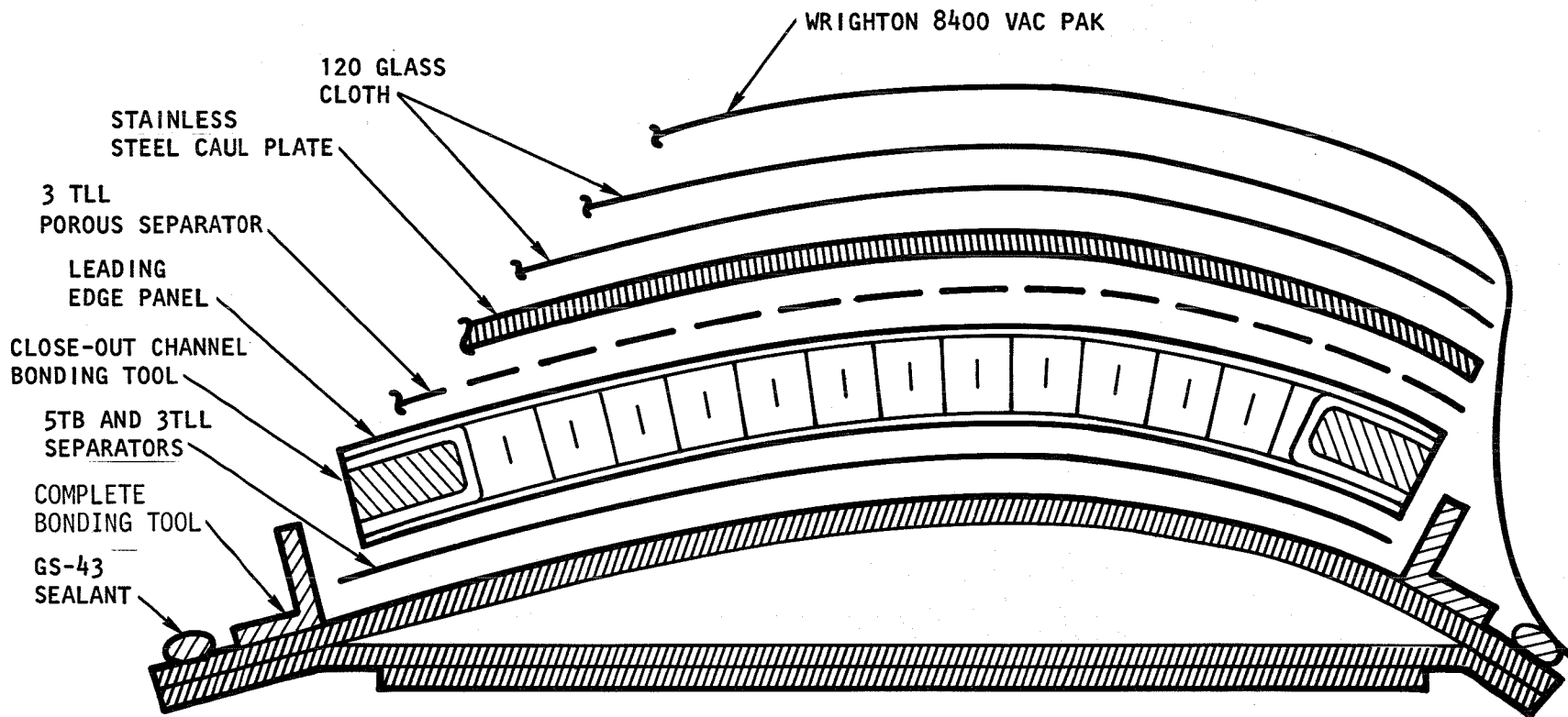

Figure 34. Leading Edge Bonding Assembly-Cross Sectional View

A810803 A-22C

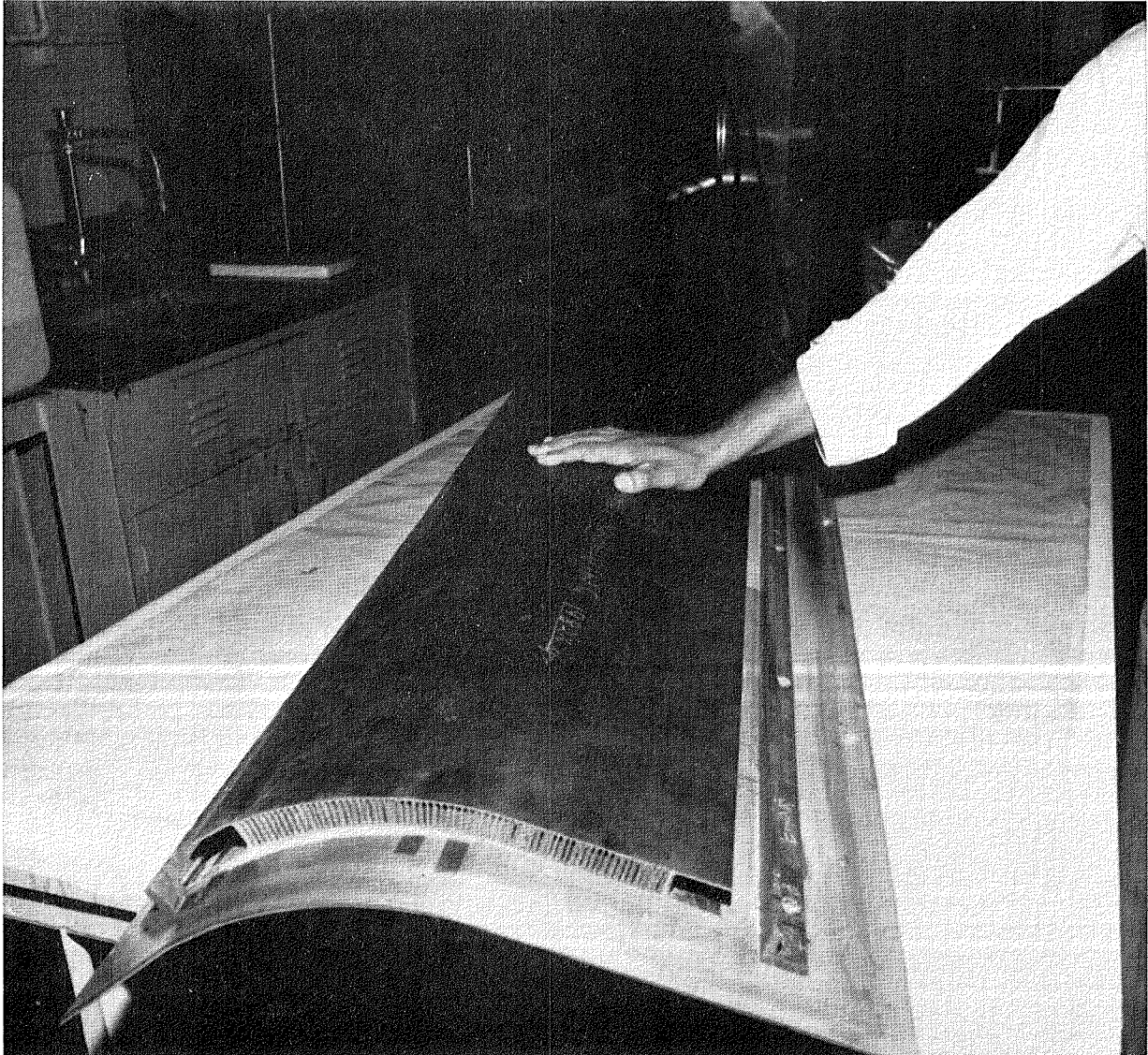

Figure 35. Leading Edge Cover Panel on Bonding Tool

Leading Edge Cover Panel

A810803 A-19C

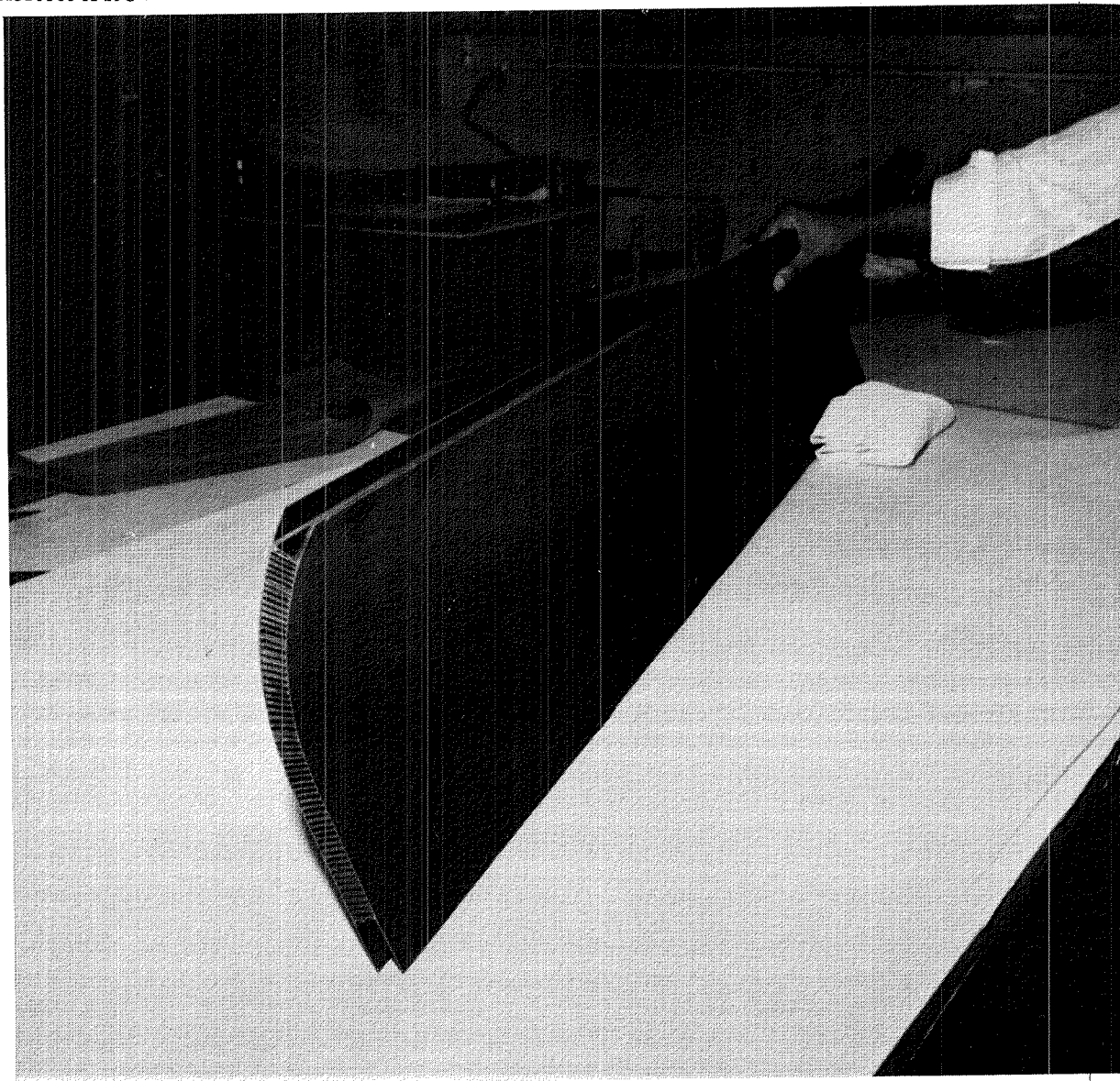

Figure 36. Leading Edge Cover Panel

A810420 C-2

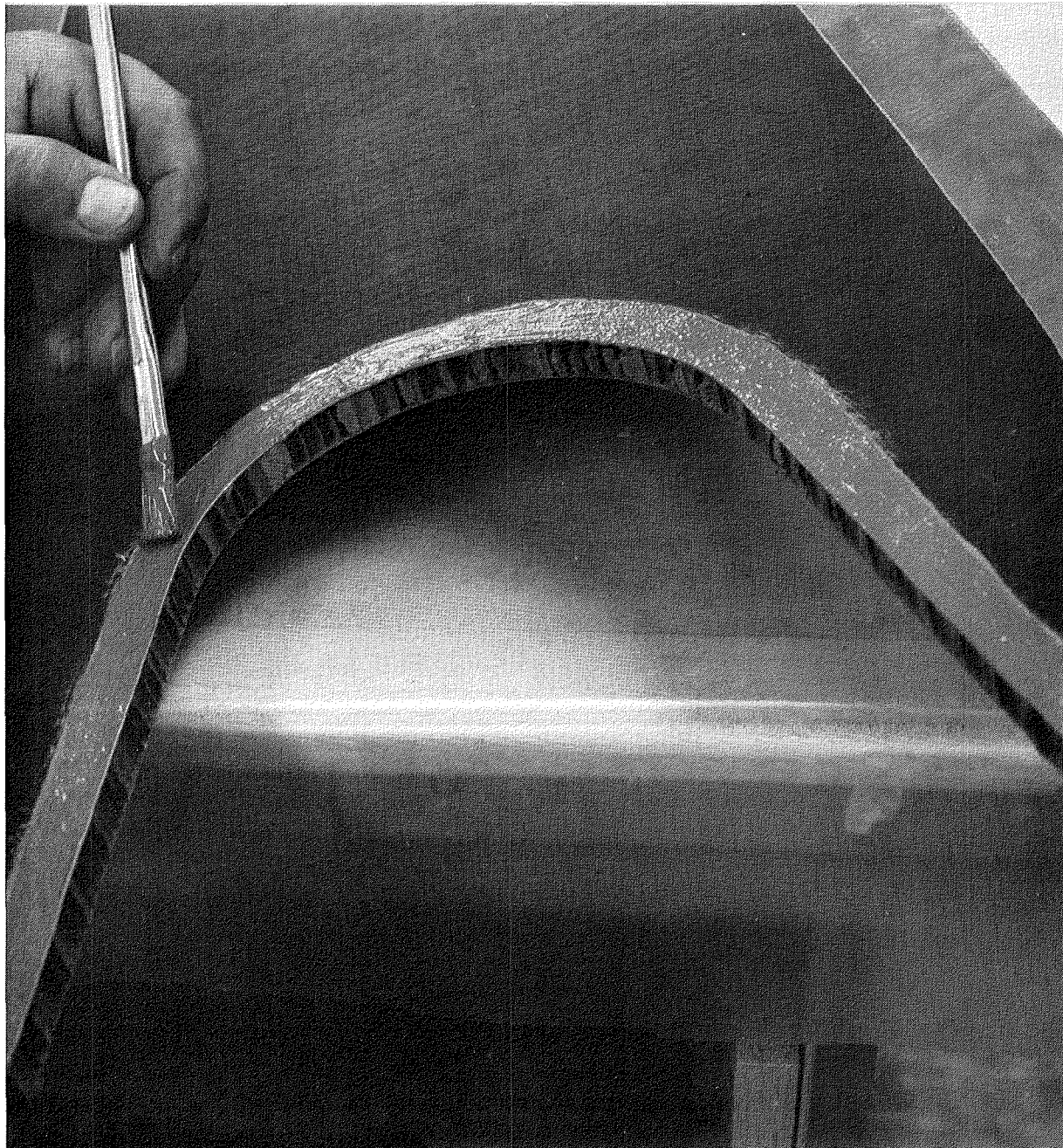

Figure 37. Primer Being Applied on Rib Web For Bonding "U" Channel

A810420 C-3

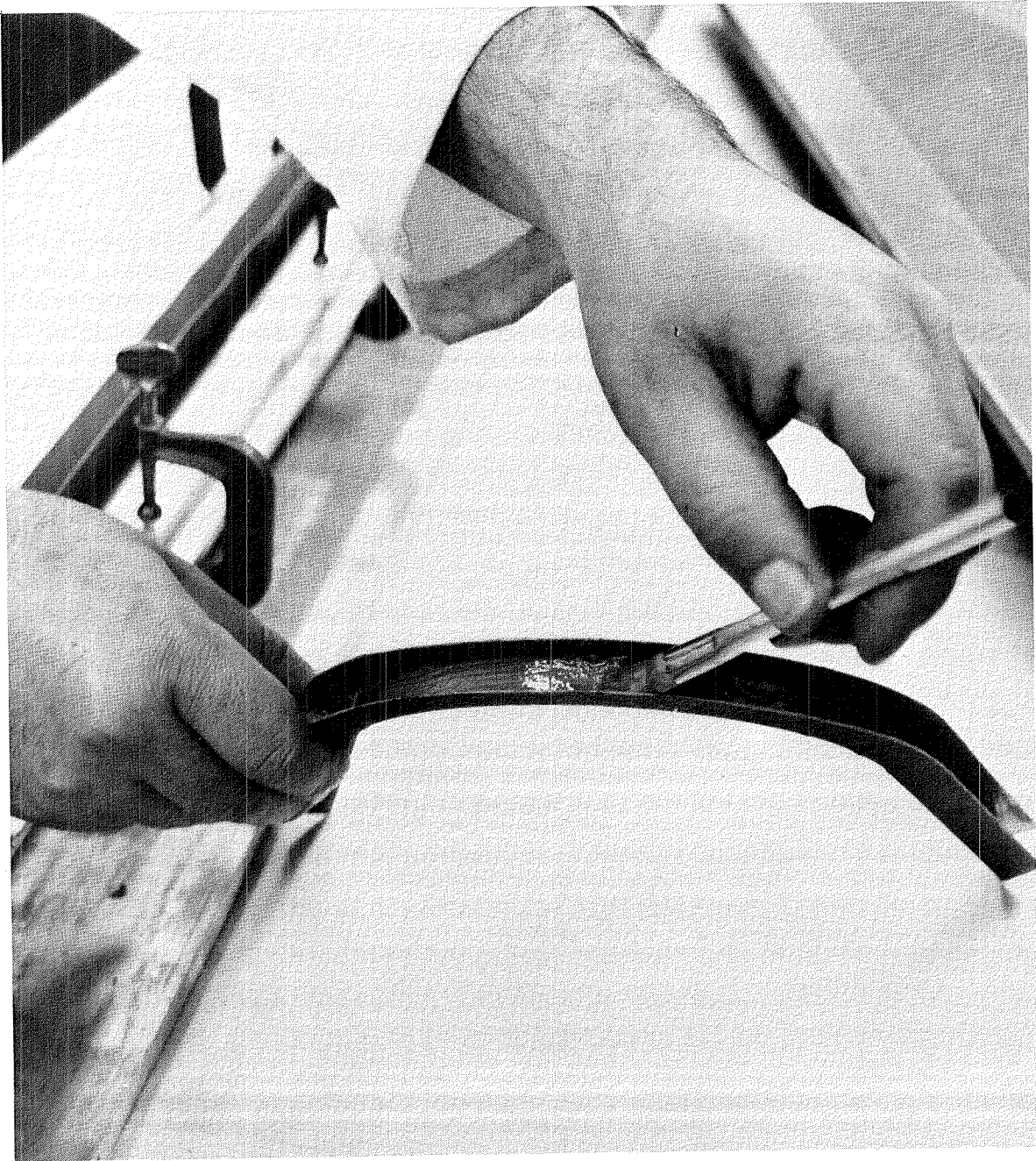

Figure 38. Primer Being Applied to the Inner Section of "U" Channel

A810420 C-4

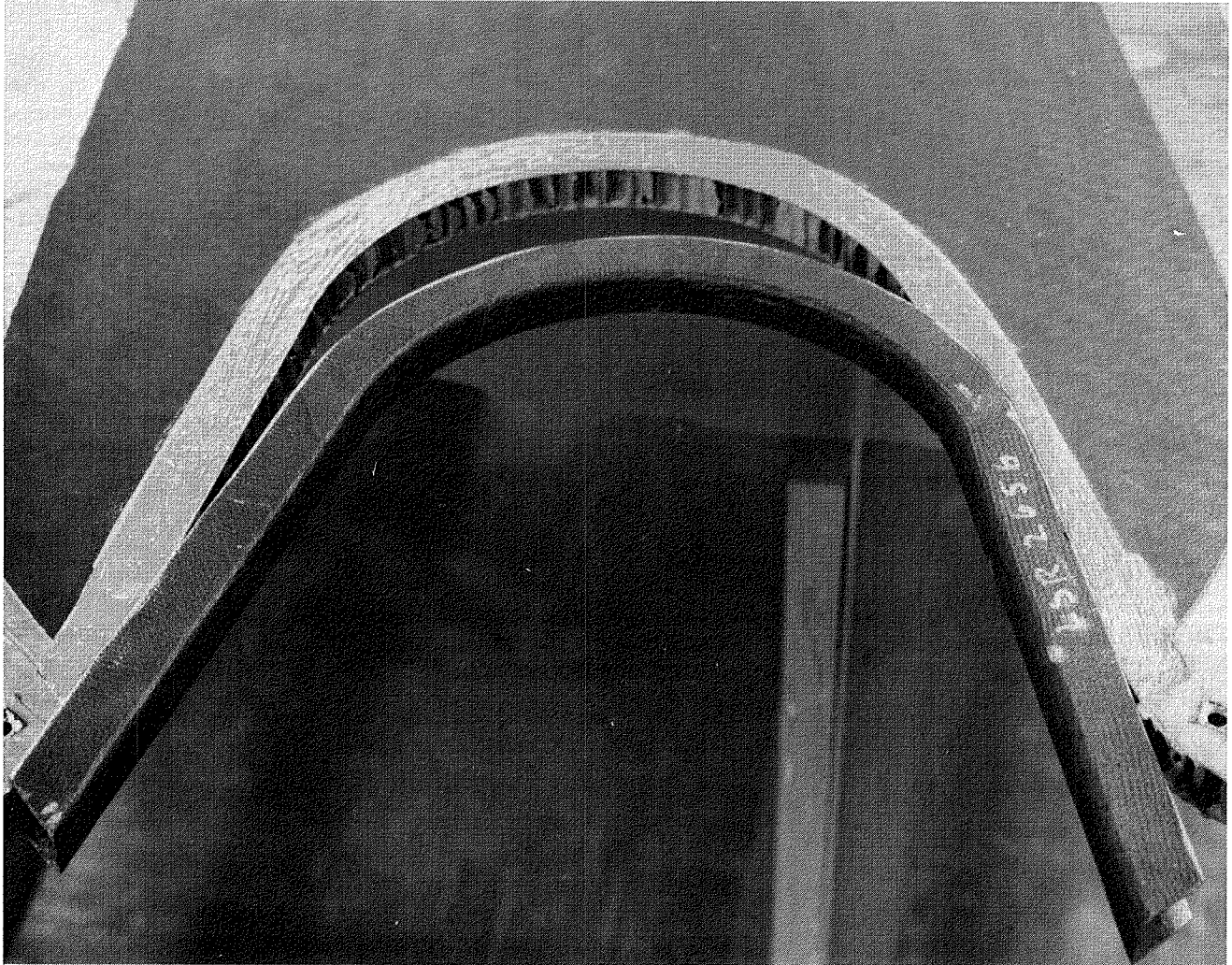

Figure 39. "U" Channel Being Inserted to Web Sandwich Panel

A810420 C-5

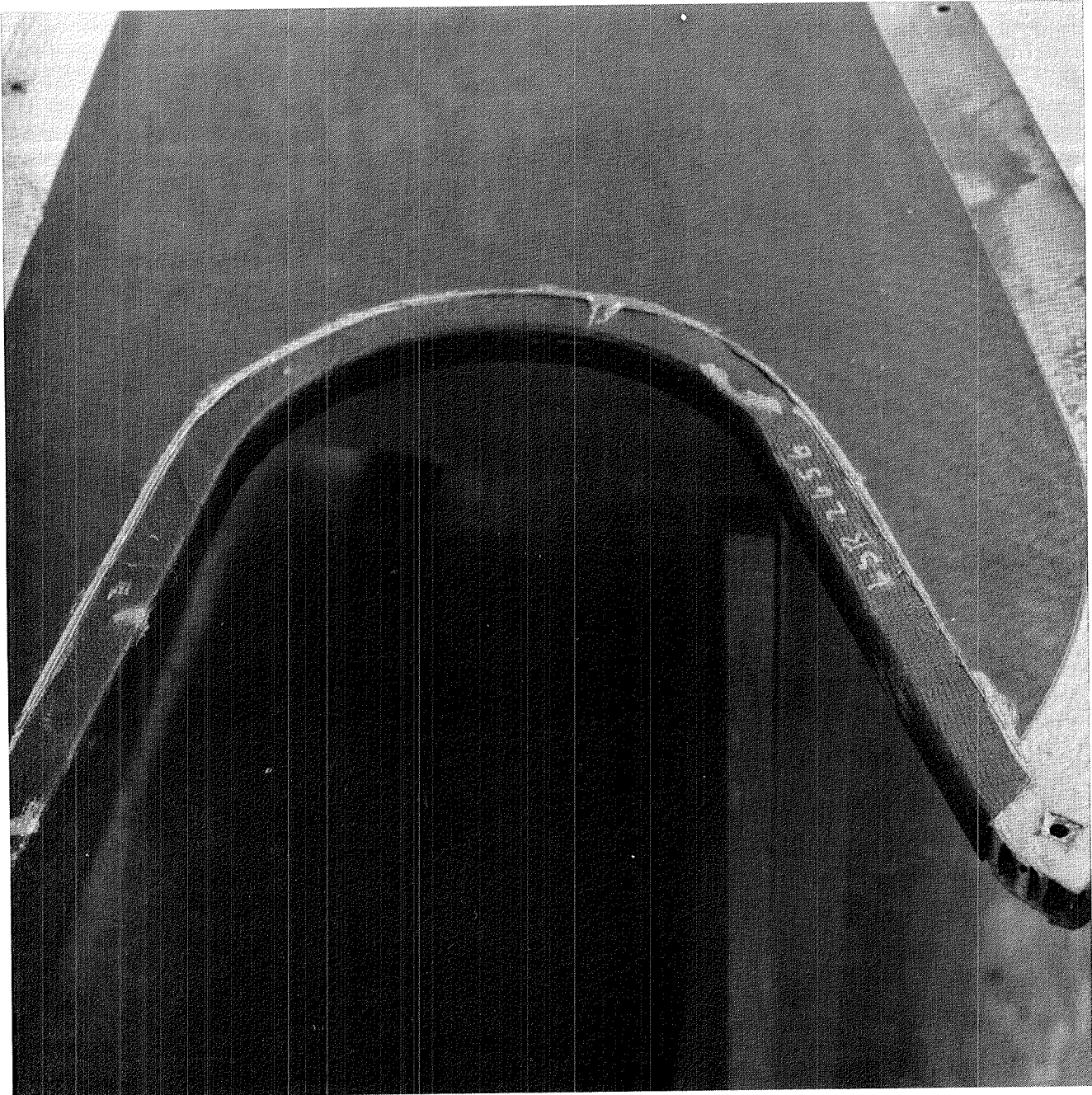

Figure 40. "U" Channel Complete For Bonding

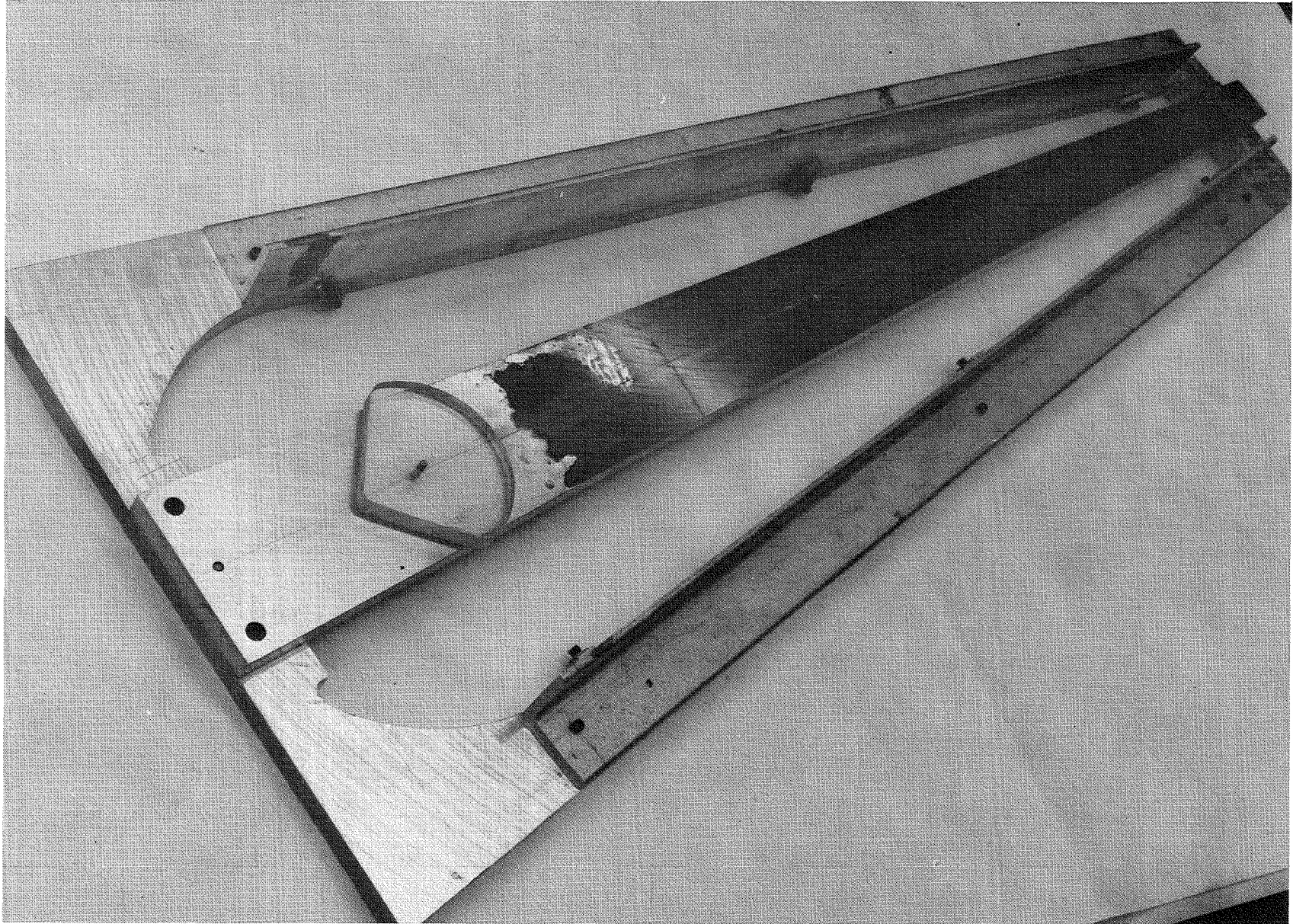

Figure 41. Drilling Fixture For Close-Out Channel & Pi Cap
to Web Sandwich Panel

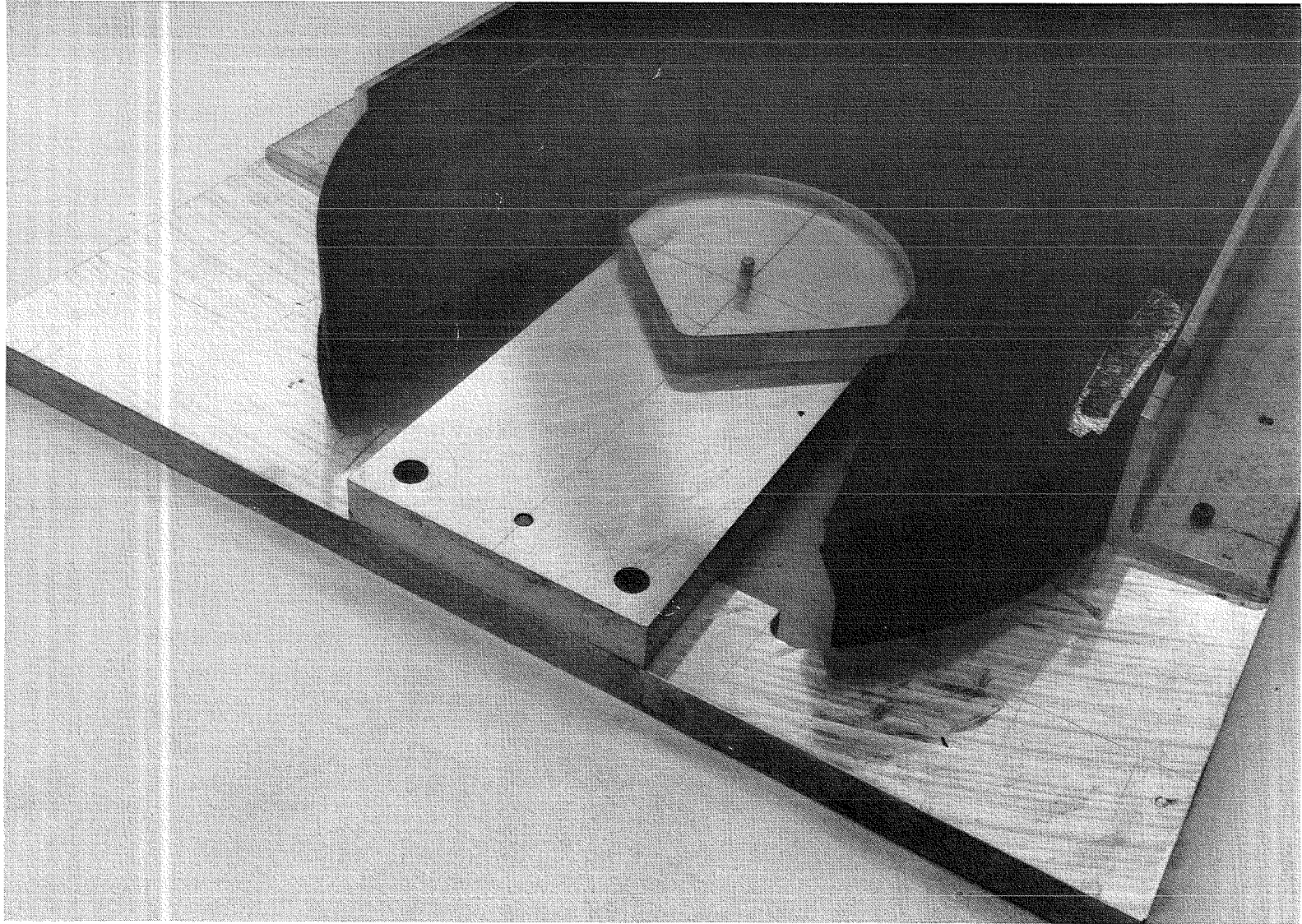

Figure 42. Close-Up View of Forward Section of the Fixture

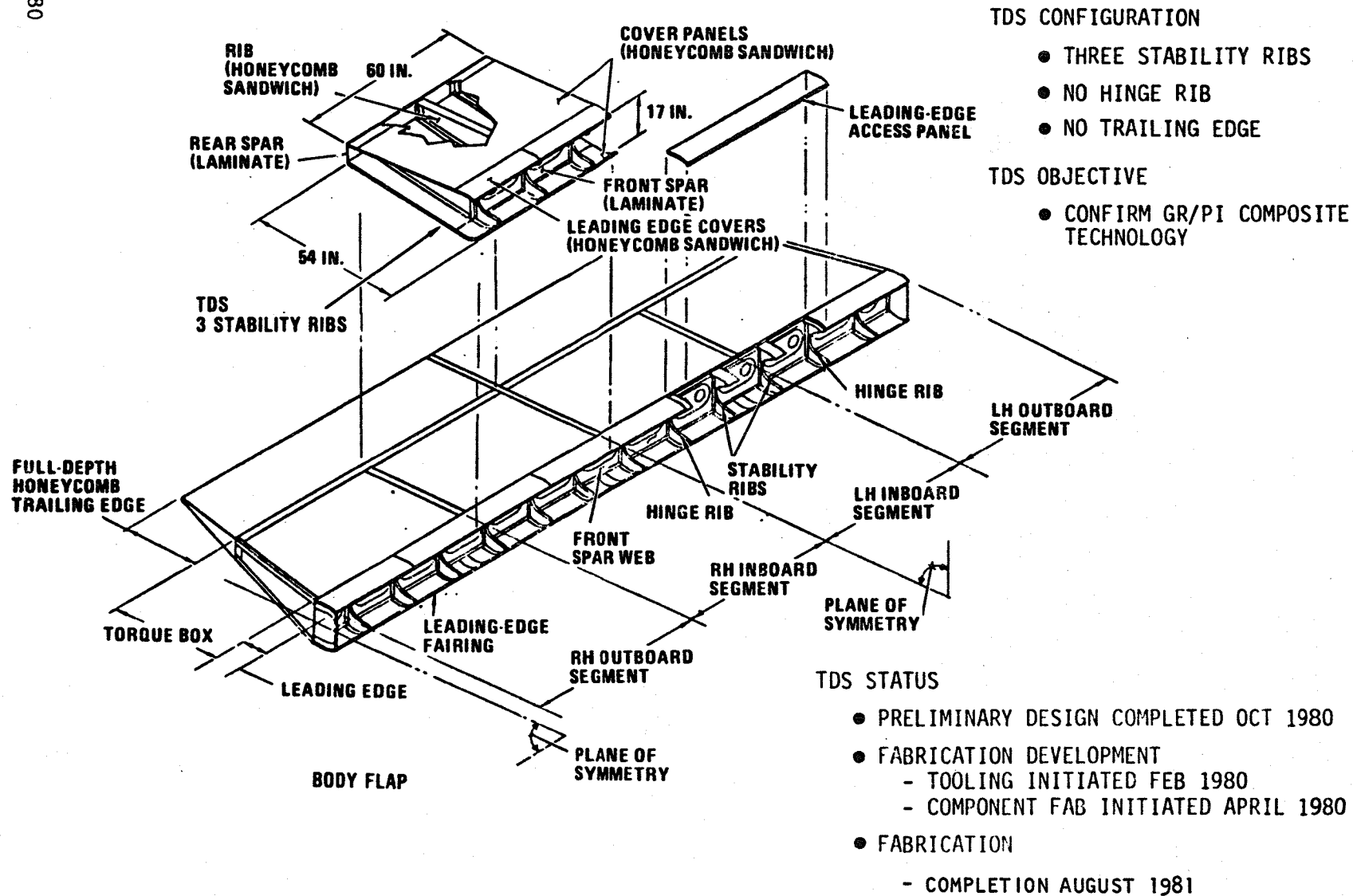

Figure 43. GR/PI Composite Body Flap Technology Demonstrator Segment (TDS)

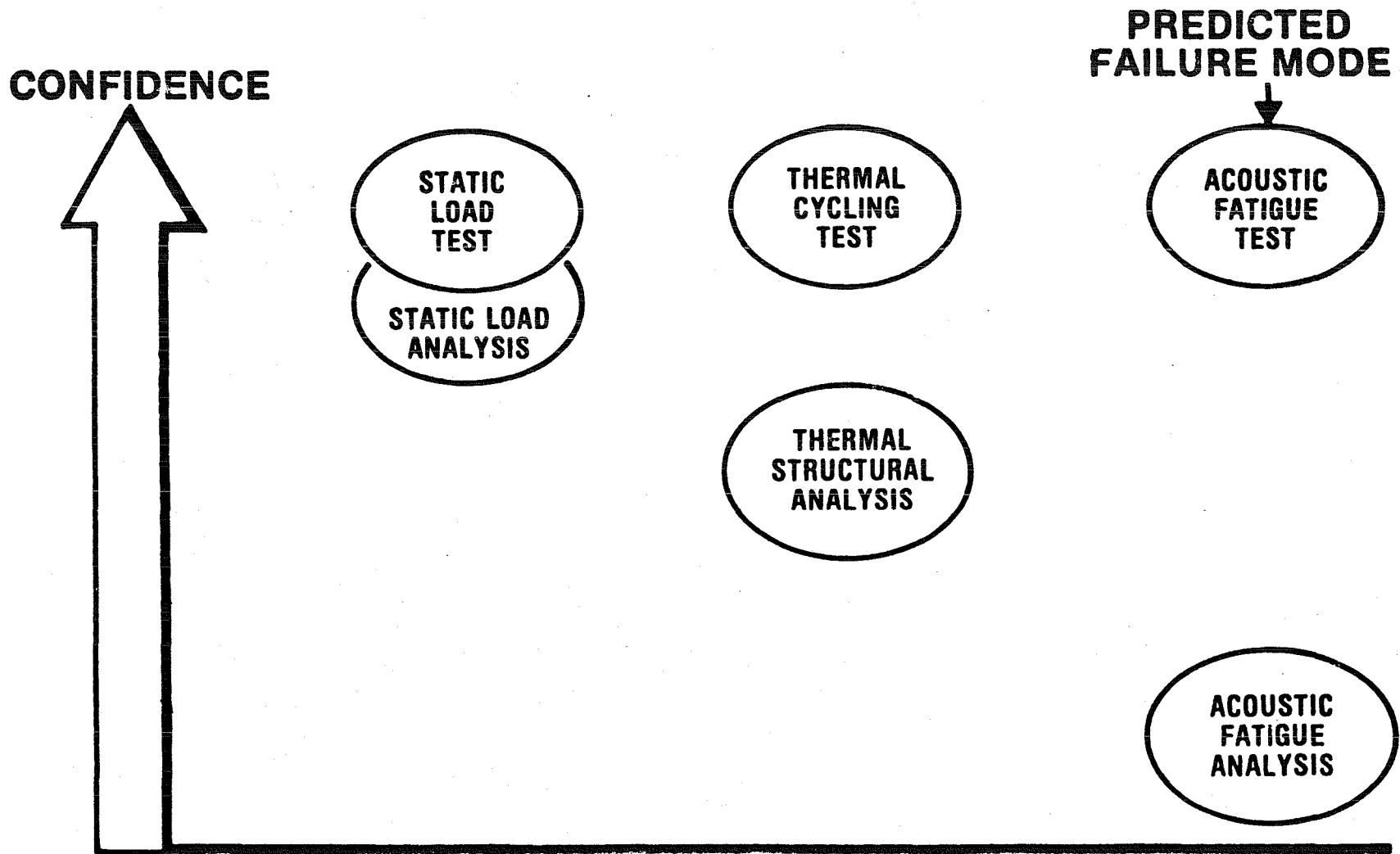
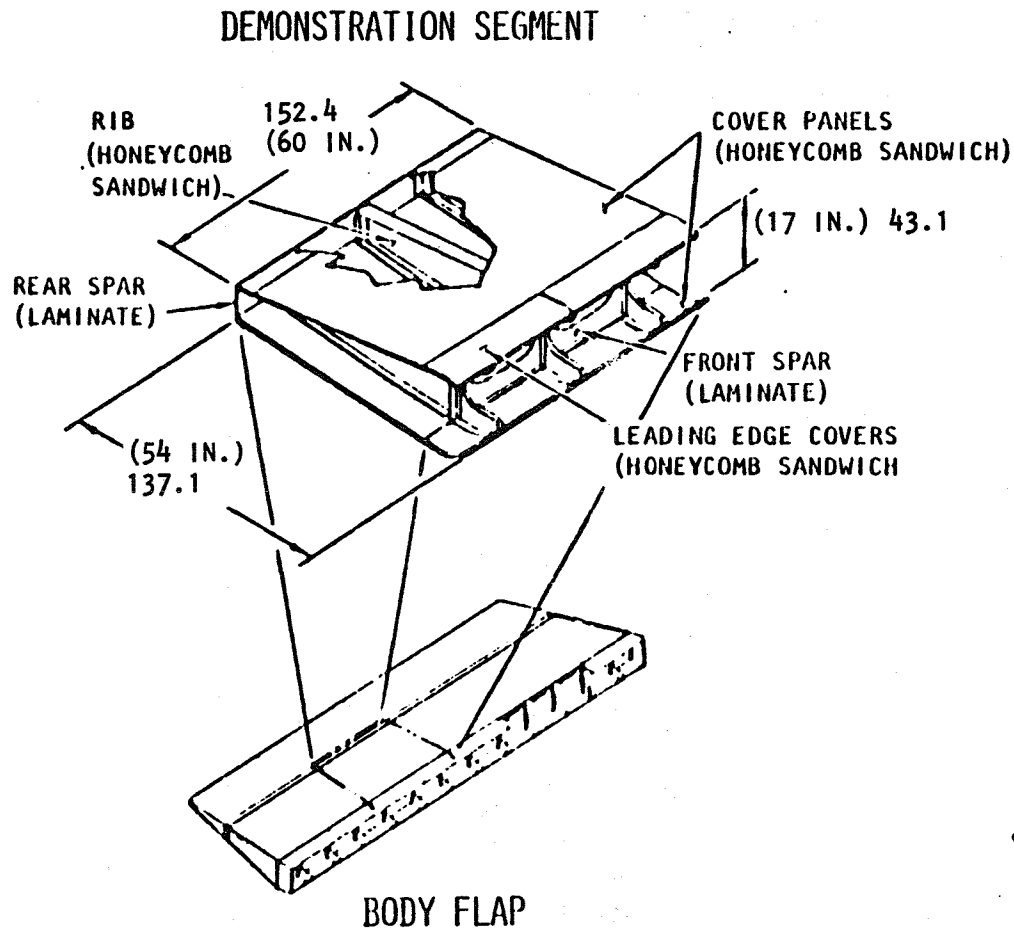

Figure 44. GR/PI Technology Verification (TDS - All Bonded Structure)



• MECHANICAL TEST CONSTRAINT

- LACK OF HINGE RIB PRECLUDES ACTUAL BODY FLAP LOADS
- CAN SIMULATE LOCAL STRESS FIELDS

• THERMAL TEST CONSTRAINT

- APPLICATION OF DISTRIBUTED LOADS AT ELEVATED TEMPERATURE ($\approx 500^{\circ}\text{F}$) 528°K COMPLEX
- THERMAL & LOAD CYCLING RESOURCE REQUIREMENTS ARE HIGH

• ACOUSTIC TEST CONSTRAINT

- LACK OF HINGE RIB REQUIRES DEMO SEGMENT TO BE SUPPORTED ON STABILITY RIB
- TEST FACILITY AVAILABILITY LIMITED

Figure 45. Demonstrator Segment Test Concept Constraints

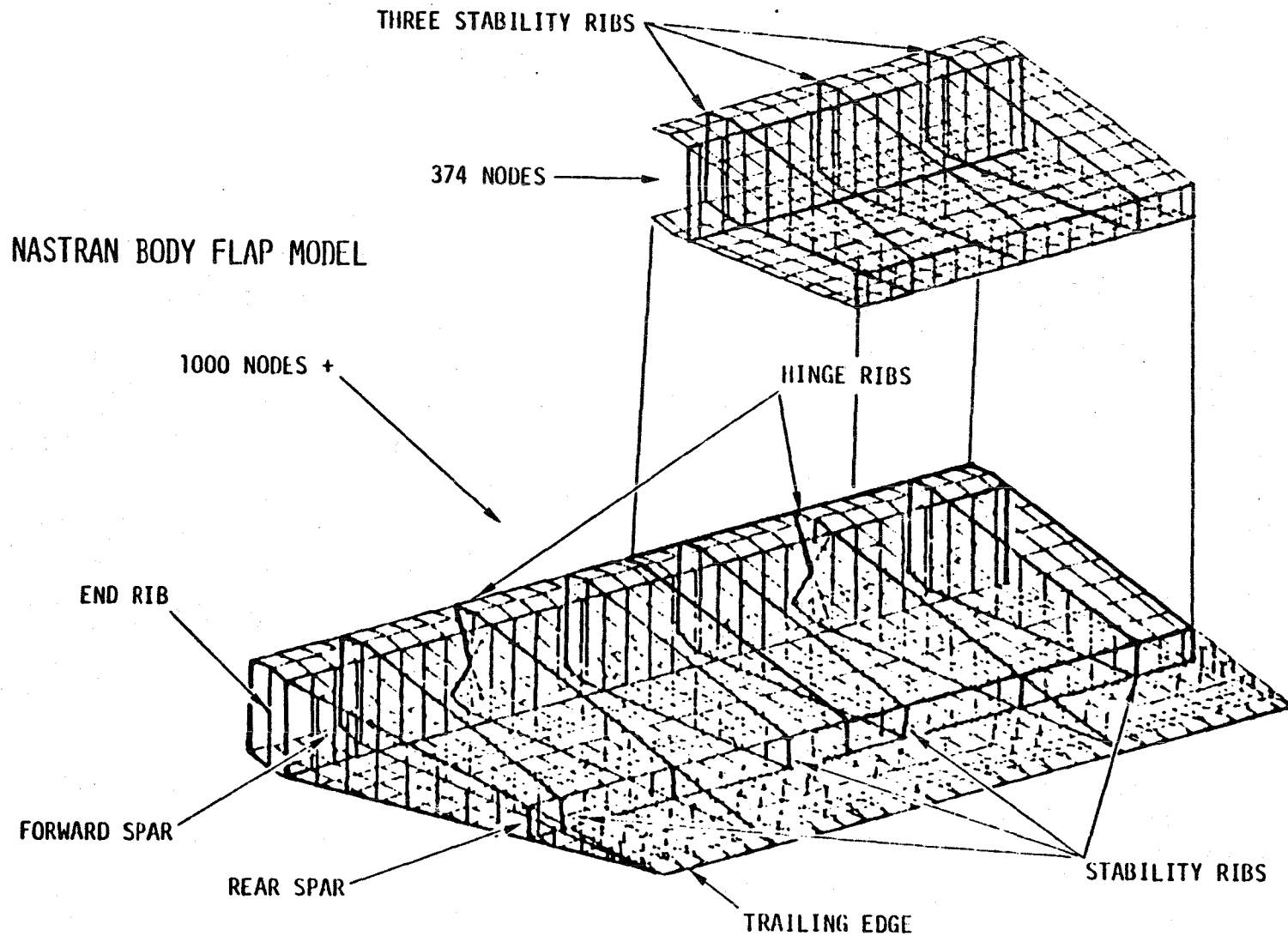
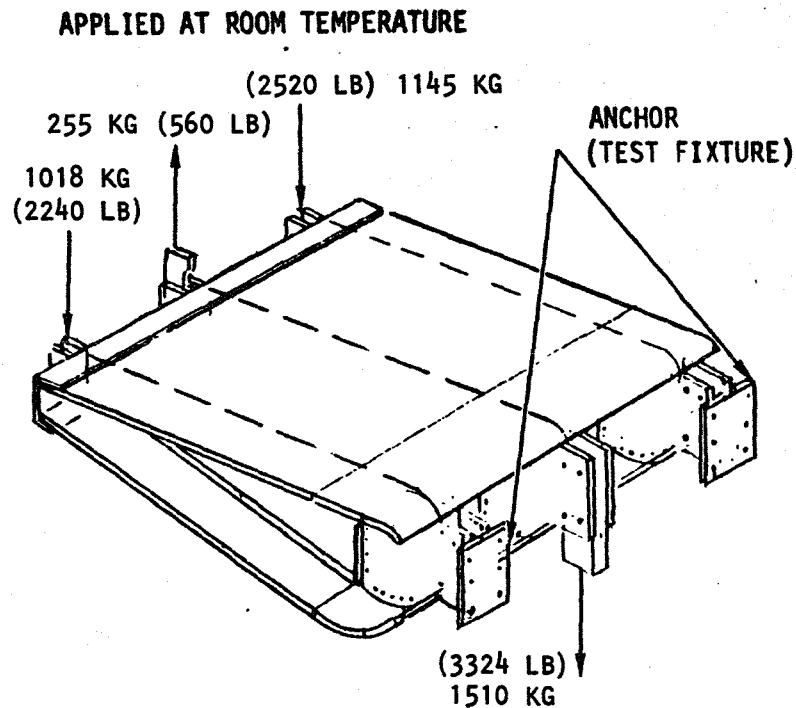

Figure 46. Technology Demonstrator Segment - NASTRAN MODEL



TEST OBJECTIVES

- SIMULATE BODY FLAP STRESS STATE & VERIFY GR/PI STRUCTURAL INTEGRITY UNDER ORBITER ULTIMATE STATIC STRESS LEVELS
- VERIFY ANALYTICALLY PREDICTED STRAIN LEVELS

TEST CONSTRAINTS

- LACK OF A HINGE RIB PRECLUDES ACTUAL BODY FLAP LOADS — LOCAL STRESS FIELDS IN THE VICINITY OF THE BODY FLAP STABILITY RIBS SIMULATED

APPROACH

- LOADING CONDITIONS DEFINED TO REPRODUCE THE BODY FLAP STRESS LEVELS AS DETERMINED FROM TDS NASTRAN MODEL
 - APPLY CONCENTRATED LOADS AT TDS TRAILING EDGE
 - DISPLACE CENTER SUPPORT
 - CANTILEVER FROM OUTER RIBS LEADING EDGE

Figure 47. R.T. Mechanical Load Test

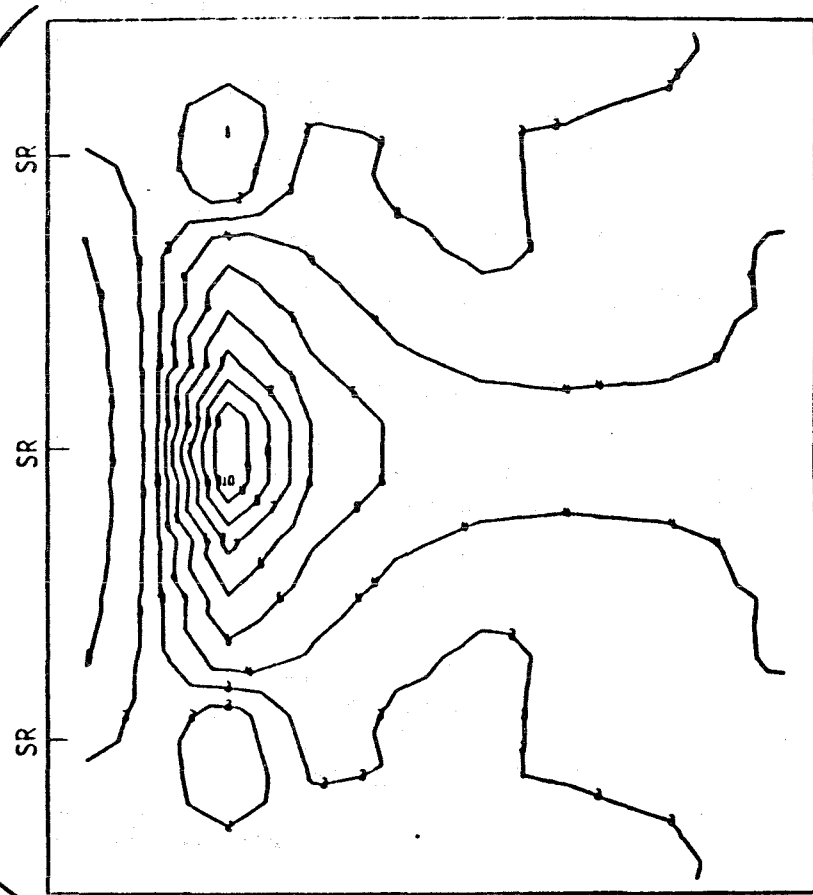
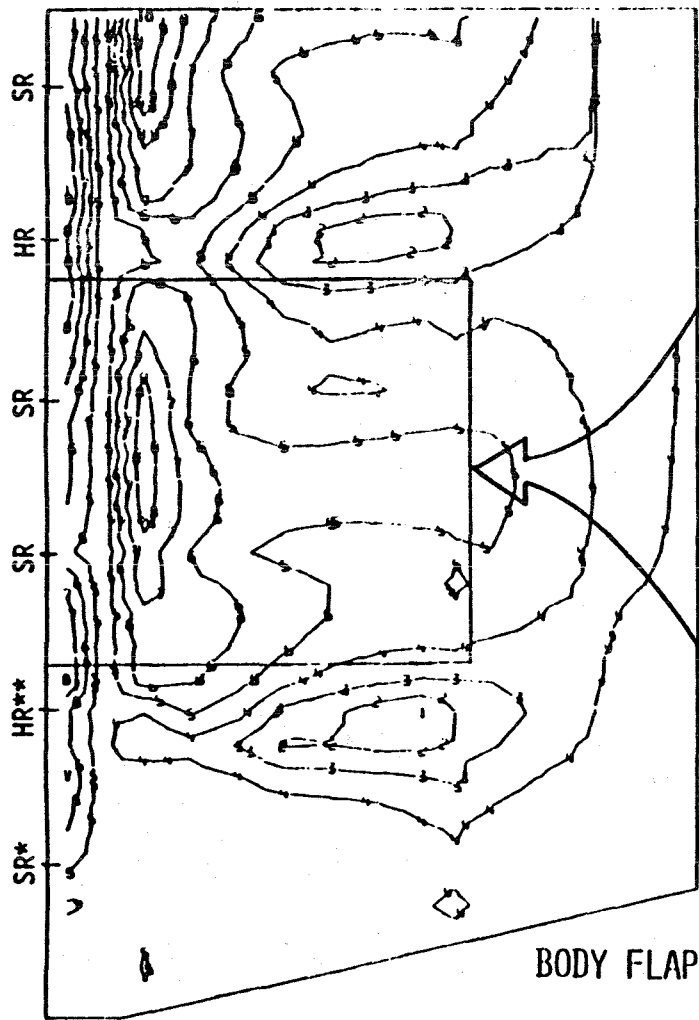

*STABILITY RIB
 **HINGE RIB

- DEFINE LOAD CONCEPTS TO SIMULATE STRESS FIELD BETWEEN BODY FLAP STABILITY RIBS

Figure 48. Typical Cover Panel Stress Contours

APPLIED AT (500°F) 528°K

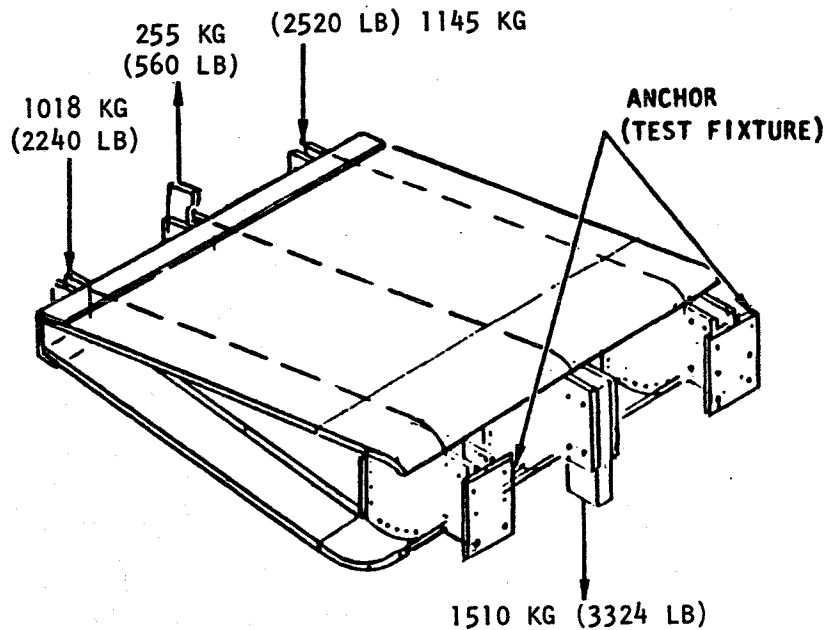

TEST OBJECTIVES

- SIMULATE BODY FLAP STRESS STATE & VERIFY GR/PI STRUCTURAL INTEGRITY UNDER ORBITER ULTIMATE STATIC STRESS LEVELS AT (500°F) 528°K
- VERIFY ANALYTICALLY PREDICTED THERMAL & MECHANICAL STRAINS

TEST CONSTRAINTS

- LACK OF A HINGE RIB PRECLUDES ACTUAL BODY FLAP LOADS
 - STRESS FIELD IN THE VICINITY OF THE BODY FLAP STABILITY RIBS SIMULATED

APPROACH

- LOADING CONDITIONS DEFINED TO REPRODUCE THE BODY FLAP STRESS LEVELS AS DETERMINED FROM TDS NASTRAN MODEL
- APPLY CONCENTRATED LOADS AT THE TRAILING EDGE
- DISPLACE CENTER SUPPORT AT LEADING EDGE
- CANTILEVER SUPPORT FROM OUTER RIBS AT LEADING EDGE
- APPLY 528°K (500°F) TO THE LOWER COVER & 444°K (340°F) TO THE UPPER COVER. INTERNAL TEMPERATURE WILL BE 485°K (415°F)

Figure 49. High Temperature Mechanical Load Test

400 CYCLES OF LIMIT LOAD
APPLIED AT 528°K (500°F)

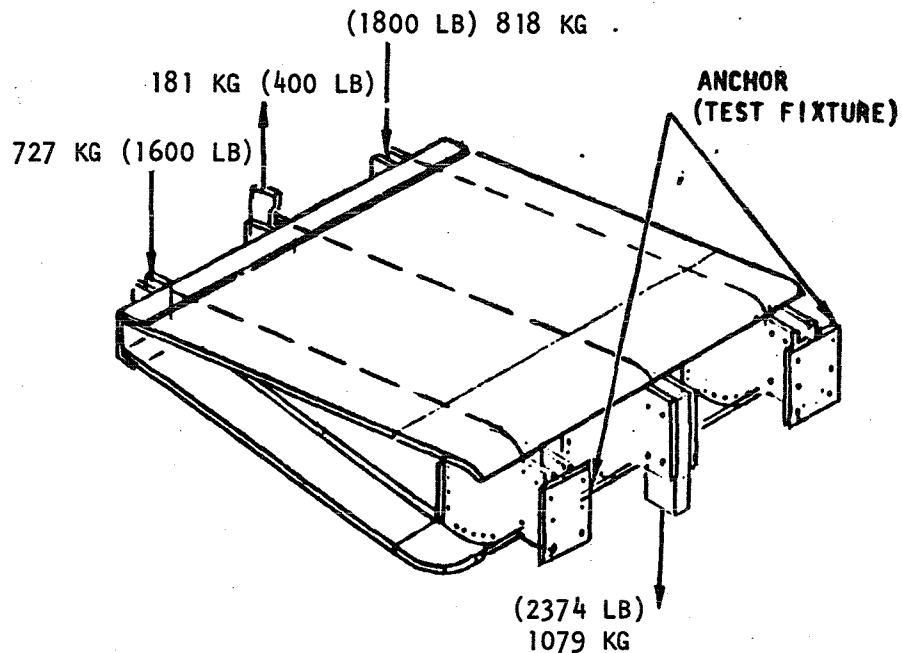

TEST OBJECTIVES

- VERIFY TDS STRUCTURAL INTEGRITY TO SUSTAIN MECHANICAL LOADS SIMULATING 100 MISSIONS
- DEVELOP CONFIDENCE IN ALL-BONDED STRUCTURE SUBJECTED TO A HIGH-TEMP SIMULATED FATIGUE ENVIRONMENT

APPROACH

- APPLY 4 LIFETIMES (400 CYCLES) OF $R = (+0.10) 0.25$
- MAINTAIN UPPER COVER AT 528°K (500°F), LOWER COVER AT 444°K (340°F) FOR INDUCED THERMAL STRESSES

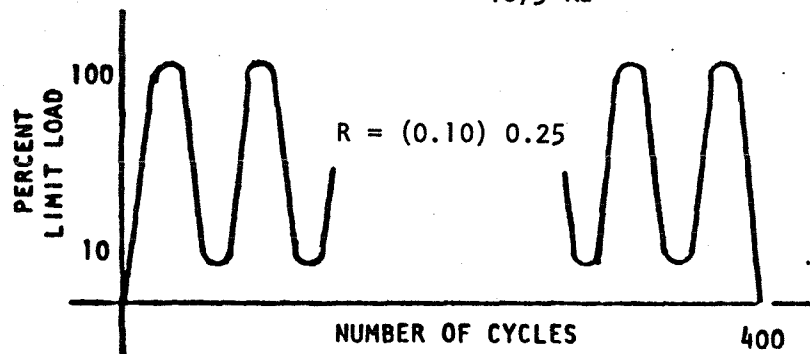

RATIONALE

- 400 LIMIT CYCLES AT 528°K (500°F) IS HIGHER LOADING CONDITION THAN SPECTRUM LOADS WOULD APPLY

Figure 50. Simulated Fatigue Test

SELECTED THERMAL CYCLE

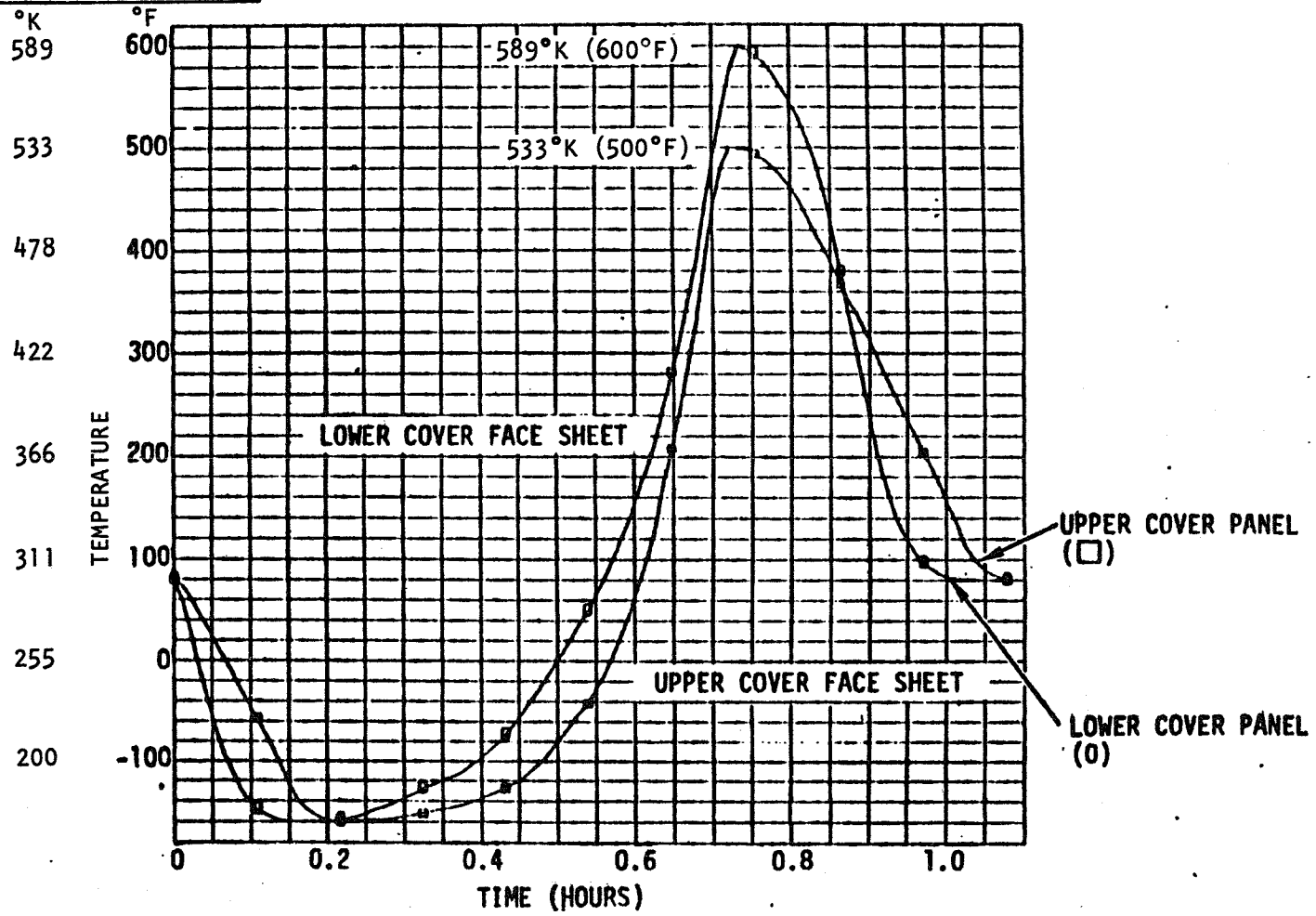
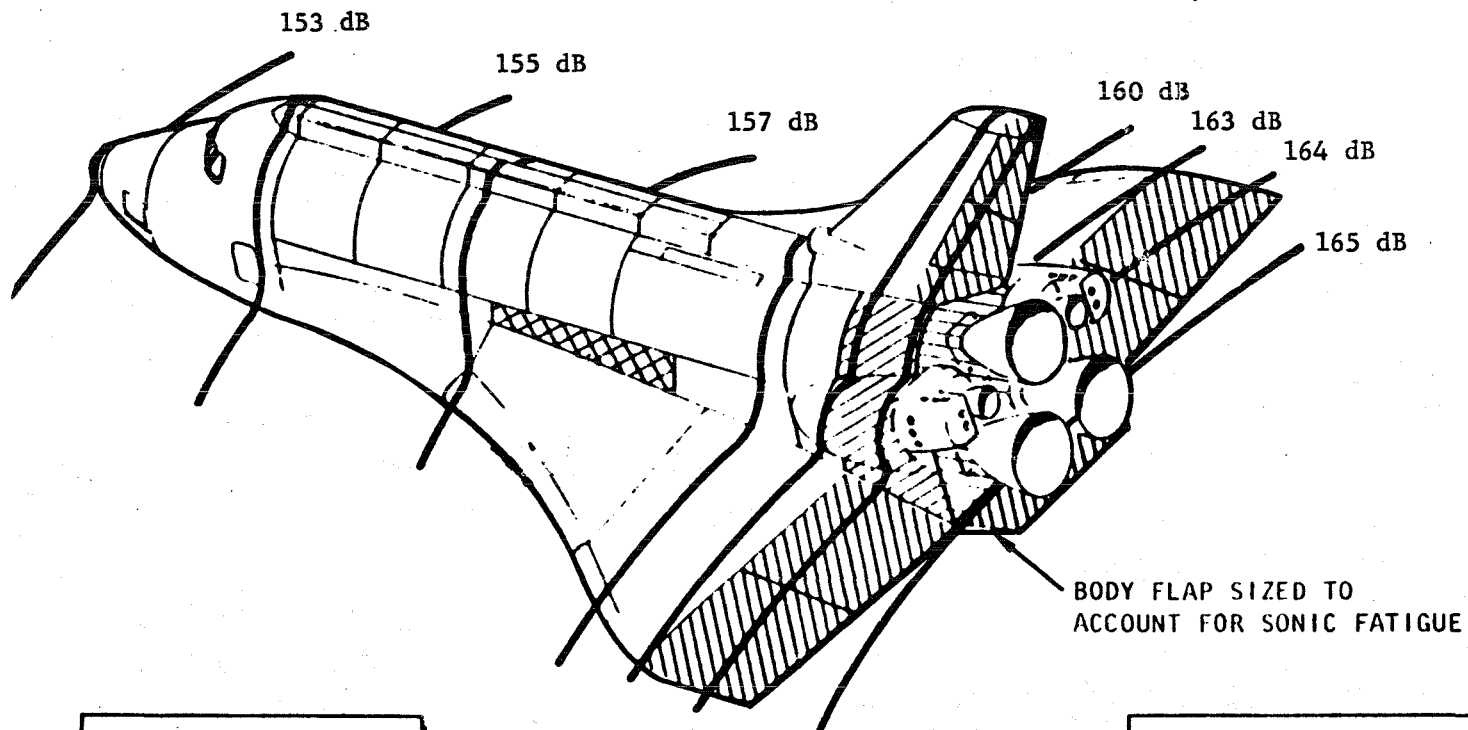





Figure 51. Thermal Cycle Test

ACOUSTICALLY DRIVEN AREAS (LIFT-OFF CRITICAL)

- 165 dB OASPL FOR 34 MINUTES (LIFT-OFF)
- 161.5 dB OASPL FOR 38 MINUTES (AERODYNAMIC)
- 157 dB OASPL FOR 60 MINUTES (AEROSHOCK)



	PANEL FLUTTER ISSUE
	SONIC FATIGUE ISSUE
	BASIC STRENGTH AREA

•	BODY FLAP IS SUBJECTED TO 165 dB SOUND PRESSURE LEVELS
•	ACOUSTIC FATIGUE IS THE PREDICTED FAILURE MODE
•	TEST IS PROPOSED TO BE CONDUCTED AT NASA/JSC

Figure 52. Acoustic Fatigue Test

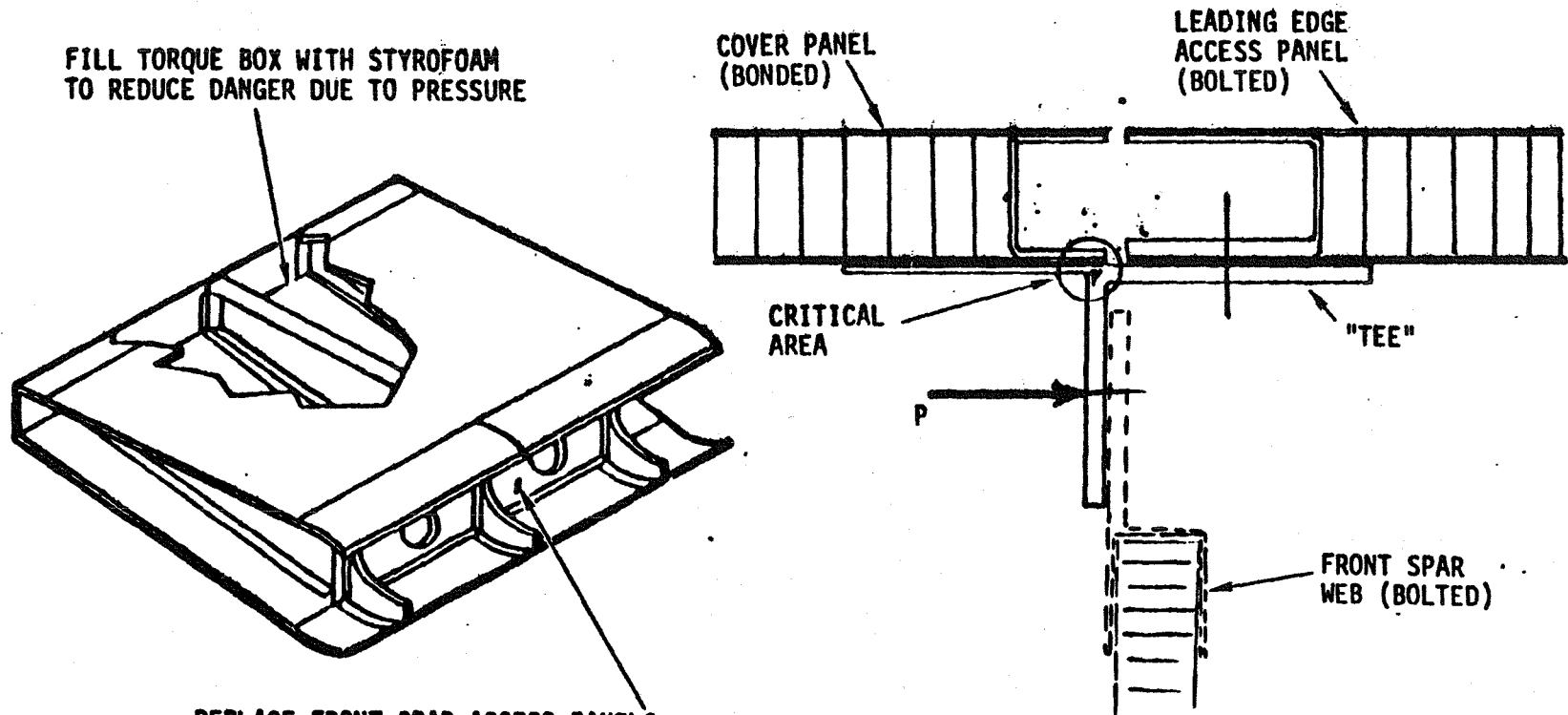

FILL TORQUE BOX WITH STYROFOAM
TO REDUCE DANGER DUE TO PRESSURE

REPLACE FRONT SPAR ACCESS PANELS
WITH METAL PANELS EQUIPPED WITH
PRESSURE SEALS & FITTINGS

- PRESSURIZE TO APPROXIMATELY 0.02 MPa (3.0 PSI)

- INTERNAL PRESSURE MAY DAMAGE FROM SPAR "T"
- MAX LOAD ON "T" AT 0.02 MPa (3 PSI) =
(20 LB/IN.) 3579 GMS/CM
- PREDICTED FAILURE AT 5 PSI
- LITTLE CONFIDENCE IN ANALYSIS
- SUBELEMENT TEST REQUIRED
- RECOMMEND TEST BE DEFERRED PENDING
SUBELEMENT TEST

Figure 53. Internal Pressure Test

Table 1. Lap-Shear Strength of Polyimide Adhesives

Adhesive	Type Scrim	Basic P.I. Resin System	Average Lap Shear Strength, MPa (psi)			
			RT	Mode of Failure	589°K (600°F)	Mode of Failure
FM34-18 No. 1	104	FM34B-18	19.3 (2800)	80%L 20%C	11.9 (1730)	- 100%C
FM34-18 No. 2	104	FM34B-18	15.1 (2190)	- 100%C	11.6 (1680)	- 100%
LARC 13A No. 1	104	LARC 13 NASA process	19.6 (2850)	35%L 65%C	15.6 (2260)	10%L 90%C
LARC 13A No. 2	104	LARC 13 NASA process, DMF	17.7 (2450)	40%L 60%C	12.7 (1845)	- 100%C
LARC 13A	108	LARC 13 NASA process, DMF	16.6 (2410)	40%L 60%C	13.0 (1880)	- 100%C
LARC 13A	112	LARC 13 NASA process, DMF	15.4 (2240)	30%L 70%C	12.5 (1810)	- 100%C
LARC 13E	104	LARC 13 ester, diglyme*	19.2 (2780)	40%L 60%C	15.2 (2200)	20%L 80%C
LARC 13E	108	LARC 13 ester, diglyme	17.1 (2480)	25%L 75%C	12.7 (1840)	50%L 95%C
LARC 13E	112	LARC 13 ester, diglyme	17.1 (2480)	50%L 50%C	12.7 (1840)	10%L 90%C
17-5E	104	BTDE/NE, 3,3'/4,4' - MDA=100/0	15.4 (2240)	80%L 20%C	12.8 (1860)	15%L 85%C
17-6E	104	BTDE/NE, 3,3'/4,4' - MDA=80/20	17.4 (2530)	30%L 70%C	15.4 (2240)	95%L 5%C
17-7E	104	BTDE/NE, 3,3'/4,4' - MDA=60/40	15.8 (2300)	20%L 80%C	13.2 (1920)	5%L 95%C
17-8E	104	BTDE/NE, 3,3'/4,4' - MDA=40/60	15.7 (2270)	70%L 30%C	15.7 (2280)	100%L -
17-9E	104	BTDE/NE, 3,3'/4,4' - MDA=20/80	14.2 (2060)	100%L -	14.6 (2120)	100%L -
17-10E	104	BTDE/NE, 3,3'/4,4' - MDA=0/100	16.4 (2380)	30%L 80%C	14.1 (2140)	30%L 70%C
18-6	104	BTDE/NE, 3,3'/4,4' - MDA=25/75	17.1 (2480)	95%L 5%C	16.0 (2330)	- 100%C
18-6A	104	BTDE/NE, 3,3'/4,4' - MDA=25/75	16.0 (2325)	90%L 10%C	15.8 (2290)	- 100%C
18-6B	104	BTDE/NE, 3,3'/4,4' - MDA=25/75	15.5 (2250)	30%L 70%C	11.6 (1680)	30%L 70%C
18-6C	104	BTDE/NE, 3,3'/4,4' - MDA=25/75	15.3 (2220)	95%L 5%C	15.0 (2185)	60%L 40%C
21-5	104	BTDE/NE,M,M' - phenylenediamine	12.0 (1750)	30%L 70%C	13.7 (1990)	60%L 40%C
18-1	112	BTDE/NE, DADS, DMF	12.3 (1790)	- 100%C	15.2 (2200)	- 100%C
18-2	112	BTDE/NE, DADS/4,4' - MDA	13.5 (1960)	- 100%C	11.4 (1660)	- 100%C
18-3	104	BTDE/NE, DADS/3,3' - MDA	11.4 (1660)	- 100%C		
18-4	104	BTDE/NE, DADS, 4,4' - MDA	13.4 (1940)	10%L 90%C	14.2 (2070)	- 100%C
15-1	104	BTDA/NA, DADS, DMF	9.9 (1430)	10%L 90%C		
15-2	104	BTDA/NA, DADS, diglyme	8.9 (1260)	- 100%C		
150-1	104	056X (NR-150B2)	17/0 (2470)	20%L 80%C	13.5 (1970)	- 100%C
150-2 No. 1	104	050X (NR-150B2)	12.5 (1820)	- 100%C	12.8 (1860)	- 100%C
150-2 No. 2	108	050X (NR-150B2)	13.5 (1910)	25%L 75%C	12.7 (1850)	30%L 70%C
150-3 No. 1	104	052X (NR-150B2)	15.8 (2300)	10%L 90%C	15.2 (2200)	10%L 90%C
150-3 No. 2	108	052X (NR-150E2)	15.8 (2290)	30%L 70%C	14.3 (2080)	30%L 70%C
150-4	104	051X (NR-150B2)	15.8 (2300)	20%L 80%C	12.7 (1840)	15%L 85%C
18-1B	104	PMR-15, diglyme	16.9 (2450)	70%L 30%C	14.6 (2120)	40%L 60%C
20-1	104	PMR-15, tackifier, diglyme	14.1 (2050)	30%L 70%C	15.5 (2250)	30%L 70%C
17-11B	104	PMR-15, NR-150B2, DMF	12.7 (1840)	50%L 95%C	12.1 (1750)	- 100%C
17-11C	104	PMR-15, AI-1130L, DMF	11.2 (1625)	- 100%C	8.0 (1160)	- 100%C
18-12C	104	LARC 160*, diglyme	12.3 (1790)	- 100%C	12.0 (1745)	- 100%C
18-8	104	LARC 160, DADS, tackifier diglyme	15.2 (2210)	60%L 40%C	15.2 (2200)	50%L 50%C
18-12B	104	LARC 160, AI325	17.0 (2460)	- 100%C	13.9 (2020)	- 100%C
18-12D	104	LARC 160, AI1130L	11.4 (1650)	- 100%C	7.7 (1120)	- 100%C
21-4	104	LARC 160,4,4' - MDA, diglyme	13.8 (2000)	50%L 95%C	10.8 (1560)	100%L -

Unidirectional eight-ply laminates

Average of four tests; all adhesives cured two hours at 589°K (600°F)

and 0.6895 MPa (100 psi) pressure plus 10 hours at 539°K (600°F)

All adherends primed with BR34B-18 after light abrading and diglyme wipe

L: Failure in composite laminate, C: Cohesive failure in bond line

Table 2 - Flatwise Tensile Strength of Polyimide Adhesives

Adhesive/Scrim	Base Polyimide Resin System	Fillet, mm (in.)		Flatwise Tensile Strength, MPa (psi) (1)	
		Top	Bottom	RT	589 ^o K (600 ^o F)
FM34B-18/104	FM-34	3.0 (0.12)	1.2 (0.05)	1.93 (280)	2.34 (340)
LARC-13A/104 (Hexcel)	LARC-13A	0.50(0.02)	0.50(0.02)	2.51 (365)	2.07 (300)
LARC-13E/112 (Hexcel)	LARC-13E	0.50(0.02)	0.50(0.02)	1.86 (270)	2.48 (215)
21-1/104	PMR-15	2.7 (0.11)	0.50(0.02)	2.72 (395)	2.96 (430)
21-4/104	MOD. LARC-160	1.5 (0.06)	1.2 (0.05)	2.90 (420)	2.31 (335)
18-6/104	MOD. LARC-13 3,3'/4,4'-MDA	2.5 (0.10)	0.50(0.02)	2.48 (360)	2.41 (350)
18-7/104	MOD. LARC-13 3,3'/4,4'-MDA	3.8 (0.15)	3.0 (0.12)	2.58 (375)	2.55 (370)
18-4/104	BTDE/NE/DADS	3.8 (0.15)	0.7 (0.03)	2.44 (355)	2.44 (355)
18-2/104	BTDE/NE/DADS	1.2 (0.05)	0.25(0.01)	1.72 (250)	1.93 (280)
18-12C/104	LARC-160	3.3 (0.13)	2.54(0.10)	2.0 (295)	1.86 (270)
150-3/104	NR-150B(052X)	0.38(0.015)	0.25(0.01)	1.51 (220)	-
150-2/104	NR-150B(050X)	3.8 (0.15)	0.2 (0.01)	1.37 (200)	-

(1) Average of three tests. All adhesive cured (in autoclave) for two hours at 589^oK (600^oF) under full vacuum and 0.1724 MPa (25 psi) pressure and postcured for 10 hours at 589^oK (600^oF) and normal pressure.

Table 3 - Climbing Drum Peel Strength of Polyimide Adhesives

Adhesive		Peel Strength at RT ⁽¹⁾	
Form No.	Resin System	g/cm Width	in. lb/in.
FM34B-18	FM34	630	3.5
LARC-13A	LARC-13, anhydride process	756	4.2
LARC-13E	LARC-13, ester process	486	2.7
18-12C	Modified LARC-160	90	0.5
17-6E	Mod. LARC-13, 3,3'/4,4'MDA=80/20	594	3.3
17-9E	Mod. LARC-13, 3,3'/4,4'MDA=20/80	360	2.0
17-10E	Mod. LARC-13, 3,3'/4,4'MDA=0/100	486	2.7
18-6B	Mod. LARC-13, 3,3'/4,4'MDA=25/75	594	3.3
18-4	BTDE/NE,DADS,4,4'MDA	300	1.7

(1) HRH 327-3/16-4 honeycomb core, Celion 6000/PMR-15 face sheets in two-ply (0,90) construction

Test specimens, 30.5 cm (12 in.) long and 7.6 cm (3 in.) wide, were tested according to Spec. MIL-A-25463A.

The average skin load was 11.24 Kg (25 lb)

Table 4. Glass Transition Temperature of Polyimide Adhesives⁽¹⁾

Adhesive		Glass Transition Temperature, T _g , °K (°F) ⁽¹⁾
Form No.	Resin System	
FM34B-18	FM34B-18	Not measurable
LARC-13 on 112 glass scrim	LARC-13 NASA Process	588°K (599°F)
18-6A	Mod LARC-13 amine substitute	639°K (690°F)
18-6B	Mod LARC-13 amine substitute	629°K (672°F)
17-11B	PMR-15 modified with NR-150B2	608°K (634°F)
17-11C	PMR-15 modified with AI 1130L	Not measurable
18-12J	Mod LARC-13 amine substitute	628°K (671°F)
18-12K	Mod LARC-13 amine substitute	598°K (617°F)

⁽¹⁾ T_g measured on a duPont 941 TMA-900TA analyzer at a heating rate of 5°K (9°F) per min. The expansion probe used had a 0.25 cm (0.1-inch) diameter. The adhesives cured for two hours at 589°K (600°F) under 0.6895 MPa (100 psi) pressure and postcured for ten hours and 589°K (600°F) under normal pressure.

Table 5. Effect of Out Time in Dry Environment on Lap-Shear Strength

Adhesive	Out-Time Days	Lap Shear Strength ⁽²⁾ , MPa (psi)	
		RT	589°K (600°F)
FM34B-18	1	19.3 (2800)	11.9 (1730)
	5	18.4 (2670)	15.6 (2270)
	11	15.9 (2320)	15.3 (2225)
LARC-13A/104	1	16.6 (2415)	12.7 (1845)
	5	16.6 (2350)	14.3 (2085)
	11	14.7 (2130)	14.5 (2100)
LARC-13E/104	1	16.0 (2335)	14.3 (2080)
	5	15.7 (2250)	
	11	11.7 (1706)	14.3 (2075)
18-6A (MOD. LARC-13E)	1	14.2 (2050)	13.9 (2010)
	5	16.2 (2360)	16.0 (2330)
	11	15.1 (2200)	13.6 (1980)
18-6C	1	15.0 (2185)	15.3 (2225)
	5	13.6 (1980)	13.4 (1950)
	11	15.2 (2210)	15.6 (2270)

(1) Storage condition: 6-40% RH, 291-299°K (65-80°F)
 Adherends: Celion 6000/PMR-15, eight-ply, unidirectional
 Primer: BR34B-18
 Surface treatment: light abrading, diglyme wipe

(2) Cure: Two hours at 589°K (600°F) and 0.6895 MPa (100 psi) pressure
 Postcure: 10 hours at 589°K, (600°F) normal pressure

Table 6

EFFECT OF OUT-TIME IN HUMID ENVIRONMENT ON LAP SHEAR STRENGTH

Adhesive	Out-Time Days	Lap Shear Strength, MPa (psi) (1)			
		RT	Mode of (2) Failure (%)	589°K (600°F)	Mode of (2) Failure (%)
FM34B-18	0	15.8 (2300)	L40, C60	13.4 (1950)	L40, C60
	3	11.4 (1660)	L15, C85	12.2 (1770)	L10, C90
	7	11.7 (1700)	L5, C95	11.2 (1620)	L45, C55
LARC-13	0	15.0 (2175)	L20, C80	13.2 (1910)	L15, C85
	3	16.1 (2340)	L90, C10	16.1 (2330)	L80, C20
	7	15.0 (2190)	L30, C70	14.8 (2140)	L50, C50
M-LARC-13E	0	14.1 (2055)	L15, C85	12.3 (1790)	L30, C70
	3	16.1 (2195)	L30, C70	11.8 (1710)	L50, C50
	7	14.2 (2080)	L55, C45	14.0 (2030)	L60, C40

(1) Environment: 40-90% RH, 288-294 (60 - 70°F)

Adherends: Celion 6000/PMR-15, 8-ply, unidirectional

Surface Treatment: Light abrading, diglyme wipe

Primer: BR 34B-18

(2) Mode of Failure: L - Laminate failure, C - Cohesive failure in adhesive

Table 7 - Comparison of Primers for Bonding Celion 6000/PMR-15 Panels with LARC-13 Adhesive

Primer		Lap Shear Strength MPa (psi)	
Form No.	Batch No.	RT	600°F
BR34B-18	B-673	16.6 (2410)	12.9 (1880)
LARC-13A	8-23-1	14.3 (2085)	11.1 (1623)
LARC-160	8-23-2	14.6 (2125)	11.7 (1705)
PMR-15E	8-23-3	13.7 (1995)	14.8 (2150)
NR150-B2	8-23-4	15.3 (2235)	12.9 (1880)
052X	8-23-5	13.5 (1970)	9.6 (1400)
050X	8-23-6	15.6 (2265)	12.1 (1760)
AI II3oL	8-23-7	13.9 (2030)	11.9 (1725)
AI 830	8-23-8	13.5 (1960)	11.9 (1740)

Adherends: Celion 6000/PMR-15 composites; eight-ply, unidirectional construction
 Adhesive: LARC-13 (NASA process) with style 108 scrim
 Surface Treatment: Light abrading (Behr Tex) diglyme wipe
 Average of three or four test specimens
 Cure: Two hours at 589°K (600°F) and 0.6895 MPa (100 psi) pressure + 10 hours at 589°K (600°F) under normal pressure

Table 8 - Comparison of Surface Treatments for Bonding Celion/PMR-15 Laminates with LARC-13 Adhesive

Surface Treatment	Bond Line mm (mils)	Test Temperature	Lap Shear Strength, MPa (psi)	Mode of Failure
Behr Tex MEK	0.15 (6)	RT 589K (600°F)	20.3 (2950) 9.4 (1360)	laminate cohesive
NMP	0.15 (6)	RT 589K (600°F)	17.9 (2600) 15.6 (2260)	laminate cohesive
MEK	0.19 (8)	RT 589K (600°F)	14.9 (2160) 13.4 (1950)	cohesive cohesive
Grit blasting, diglyme	0.15 (6)	RT 589K (600°F)	20.5 (2970) 19.3 (2800)	laminate laminate
Alkaline etch	0.15 (6)	RT 589K (600°F)	16.7 (2430) 15.9 (2310)	cohesive cohesive
Acid etch	0.15 (6)	RT 589K (600°F)	13.6 (2010) 15.0 (2180)	cohesive cohesive
Grit blasting, (sand)-MEK	0.15 (6)	RT 589K (600°F)	17.6 (2550) 19.8 (2870)	laminate laminate
Adherends: Celion/PMR-15 composite laminates, eight-ply, unidirectional Cure: 2 hours at 589°K (600°F) and 0.6895 MPa (100 psi) pressure Postcure: Ten hours at 589°K (600°F) and normal pressure				

Table 9 - Comparison Availabilities and Properties of Polyimide Adhesives

Availabilities and Properties	FM34B-18	LARC-13 NASA Process	Mod. LARC-13 18-6	Mod. PMR-15 20-1	Mod. LARC-160 18-8	NR-150B 150-3
Commercially available	Yes	No	No	No	No	No
Production method developed or under development		Yes	Yes	Yes	Yes	No
Can be supplied by Hexcel on request		Yes	Yes	Yes	Yes	No
Resin processability		Fair	Good	Good	Good	
Hot melt processability		Good	Good	Good	Good	Poor
Tack and drape	Good	Good	Good	Good	Good	Fair
Flow on cure	Good	Good	Good	Good	Good	Fair
Filleting ability	Good	Good	Good	Good	Good	Poor
Lap shear strength Composite-to-composite (1)						
MPa (psi), RT	15.1-19.3 (2190-2800)	17.7-19.6 (2450-2850)	19.2 (2780)	15.3 (2225)	15.2 (2210)	16.9 (2450)
589°K (600°F)	11.6-11.9 (1680-1730)	12.7-15.6 (1845-2260)	15.2 (2200)	13.9 (2010)	15.2 (2200)	
Flatwise tensile strength (1)						
MPa (psi), RT	1.93 (280)	2.52 (365)	2.48 (360)	2.92 (395)	2.03 (295)	1.52 (220)
589°K (600°F)	2.34 (340)	2.07 (300)	2.41 (350)	2.96 (430)	1.86 (270)	-
Climbing drum peel strength at RT, g/cm width (2) (in.lb/in.)	630 (3.5)	756 (4.2)	594 (3.3)	360 (2.0)	90 (0.5)	-
Glass transition temp., (T _g)°C	Not Measurable	315 (599°F)	366 (690°F)	-	-	-
Ability to form low porosity large area bonds	Poor	Good	Good	Good	Good	Poor
<p>(1) Adherends: Celion 6000/PMR-15 composite laminates, eight-ply unidirectional Primer: BR34B-18; surface treatment: light abrading, diglyme wipe</p> <p>(2) Adherends: Celion 6000/PMR-15 composite, two-ply (0.90) construction Primer: BR34B-18; surface treatment: light abrading, diglyme wipe</p>						

Table 10 - Comparison of FM 34B-18, LARC-13 and LARC-13E Adhesives

100

FACTOR	FM34B-18				LARC-13				M-LARC-13E			
	RATING	PTS.	S.F. (1)	(2)	RATING	PTS.	S.F.	(2)	RATING	PTS.	S.F.	(2)
1. Commercial Availability	V. Good	3	2	6	Good	2	2	4	Good	2	2	4
2. Material Cost	High	2	2	4	High	2	2	4	High	2	2	4
3. Out-Time	Fair	1	2	2	V.Good	3	2	6	V.Good	3	2	6
4. Tack and Drape	Good	2	2	4	Good	2	2	4	Good	2	2	4
5. Filletting	Good	2	3	6	Good	2	2	4	Good	2	2	4
6. Tooling & Processing Cost	Excel.	4	3	12	Fair	1	3	3	Fair	1	3	3
7. Ability to provide void-free large area bonds, mid-plane bonding	Poor	0	3	0	V.Good	3	3	9	V.Good	3	3	9
8. Ability to provide large area bonded H/C sandwich panels	Fair	1	3	3	V.Good	3	3	9	V.Good	3	3	9
9. Lap shear strength vs. overlap shear area	Fair	1	3	3	V.Good	3	3	9	V.Good	3	3	9
10. Load-carrying capacity in shear of mid-plane bonded panels	Poor	0	3	0	V.Good	3	3	9	V.Good	3	3	9
11. Peel strength (climbing drum)	Fair	1	2	2	Fair	1	2	2	Fair	1	2	2
12. Flatwise tensile Str. H/C core to Gr/Pi composite	Good	2	3	6	Good	2	3	6	Good	2	3	6
13. Aging stability @589°K(600°F)	Fair	1	3	3	Fair	1	3	3	Fair	1	3	3
14. Amount of Industry Experience	V.Good	3	3	9	Good	2	3	6	Fair	1	3	3
(1) S.F.: Significance Factor	TOTALS		61		78				75			
(2) T: Total												

Table 11. Properties of Celion 6000/PMR-15 Prepreg and Cured Laminates

Panel No.	CP8U-A1	CP8U-A2	CP8U-A3	CP8U-A4	CP8U-A5	CP8U-A6	CP8U-A17	CP8U-A18	CP8U-A19	CP8U-A20	CP8U-A21	CP8U-A22	CP8U-A23	CP8U-A24
Prepreg Lot No.	2W4474	2W4474	2W4474	2W4474	2W4474	2W4474	CO-015	CO-015	CO-015	CO-015	CO-015	CO-015	CO-015	CO-015
Supplier	USP	USP	USP	USP	USP	USP	Fiberite	Fiberite	Fiberite	Fiberite	Fiberite	Fiberite	Fiberite	Fiberite
Prepreg Physical Properties														
1. Fiber areal weight, g/m ²	148.5	148.5	148.5	148.5	148.5	148.5	156.2	156.2	156.2	156.2	156.2	156.2	156.2	156.2
2. Resin solids (%)	36.5	36.5	36.5	36.5	36.5	36.5	33.8	33.8	33.8	33.8	33.8	33.8	33.8	33.8
3. Calculated thickness per ply, mm (mils)	0.127(5)	0.127(5)	0.127(5)	0.127(5)	0.127(5)	0.127(5)	0.127(5)	0.127(5)	0.127(5)	0.127(5)	0.127(5)	0.127(5)	0.127(5)	0.127(5)
Composite Physical Properties														
1. Specific gravity	1.58	1.59	1.59	1.56	1.59	1.59	1.58	1.58	1.58	1.57	1.59	1.60	1.60	1.60
2. Fiber volume (%)	61.6	63.3	63.6	56.6	63.7	62.9	60.1	61.4	60.3	58.1	64.3	64.8	64.5	65.4
3. Void fraction (%)	0.4	0.2	0.3	0.3	0.3	0.0	-0.1	0.3	-0.1	0.0	0.5	-0.1	-0.2	0.1
4. Cured thickness mm (mils)	1.06(42)	1.09(43)	1.06(42)	1.19(47)	1.09(43)	1.09(43)	1.14(45)	1.09(43)	1.06(42)	1.09(43)	1.43(45)	1.11(44)	1.09(43)	1.11(44)
5. Weight loss on cure (%)	17.8	18.0	17.9	17.8	18.2	13.0	12.7	12.0	12.0	12.7	11.9	11.8	13.2	13.6
6. Tg °K (°F)	600°K (620°F)	599°K (618°F)	588°K (599°F)	587°K (597°F)	599°K (618°F)	592°K (606°F)	615°K (647°F)	616°K (649°F)	615°K (648°F)	611°K (640°F)	613°K (644°F)	614°K (645°F)	608°K (635°F)	613°K (643°F)
7. C-scan transmission (%)	100	100	100	995	100	100	100	100	100	100	100	100	100	100

TABLE 12 - FLATWISE TENSILE STRENGTH OF FM34B-18
LARC-13 AND M-LARC-13E ADHESIVES

Adhesive/Scrim	Filletts, mm(in.)		Test Temp °K(°F)	Flatwise Tensile Strength MPa(psi) (1)	Mode of Failure (%) (2)
	Top	Bottom			
FM34B-18/104	2.0 (0.10)	1.0 (0.05)	RT	3.17 (460)	Core 5, C95
	2.0 (0.10)	1.0 (0.05)	589 (600)	1.72 (250)	Core 20, C80
LARC-13/104	2.0 (0.10)	1.0 (0.05)	RT	3.17 (460)	Core 10, C90
	2.0 (0.10)	1.0 (0.05)	589 (600)	2.76 (400)	Core 50, C50
M-LARC-13E/104	1.0 (0.05)	1.0 (0.05)	RT	2.76 (400)	C100
	1.0 (0.05)	1.0 (0.05)	589 (600)	1.86 (270)	Core 50, C50

(1) Face Sheets: Celion 6000/PMR-15, 8-ply, crossplied construction
Primer: BR34B-18
Core: HRH327-3/16-4, T=0.5

(2) Core: Rupture in the honeycomb core
C: Cohesive failure in the adhesive

TABLE 13 - LAP SHEAR STRENGTH OF LARC-13 ADHESIVE PREPARED BY ANHYDRIDE AND ESTER METHODS

Method	Test Temp. °K (°F)	Lap Shear Strength MPa (psi)	Mode of Failure (%) (1)
Anhydride	RT	17.4 (2525)	L95, C5
Anhydride	589°K (600°F)	16.6 (2410)	L80, C20
Ester	RT	16.9 (2445)	L70, C30
Ester	589°K (600°F)	18.3 (2660)	L80, C20

(1) L: Laminate failure; C: cohesive failure in adhesive
 Adherends: Celion 6000/PMR-15, eight-ply, unidirectional
 Surface Treatment: Light abrading, diglyme wipe
 Primer: BR34B-18

Table 14 - Short Beam Shear Strength of LARC-13 and FM34B-18

ADHESIVE	TEMP	SHORT BEAM STRENGTH -MPa(psi)					
		1	2	3	4	5	AVE
LARC-13/108 0.07 Lb/ft ²	R.T.	0.09(14.3)	0.09(14.4)	0.10(15.5)	0.10(15.9)	0.10(15.5)	0.10(15.1)
	589°K (600°F)	0.04(6.9)	0.04(6.7)	0.04(6.5)	0.04(6.4)	0.03(5.0)	0.04(6.3)
FM34B-18/104 0.07 Lb/ft ²	R.T.	0.09(13.0)	0.09(13.3)	0.09(13.5)	0.09(13.5)	0.09(13.2)	0.09(13.3)
	589°K (600°F)	0.04(6.1)	0.04(6.3)	0.04(6.1)	0.04(6.1)	0.04(6.2)	0.04(6.2)

(1) Adherends: Celion 6000/PMR-15, 8 Ply, unidirectional
 Surface Treatment: Light Abrading, diglyme wipe
 Primer: BR34B-18
 Test Methods: MMM-A-132

Table 15. Slotted Shear Strength of Test Specimens From Mid-Plane
Bonded 30.5 cm (12.0 in.) by 30.5 cm (12.0 in.) Panels

Adhesive	Cm (in.)	Test Temp.	Ultimate Load		Lap Shear Strength		Mode of Failure
			MPa	(psi)	MPa	(psi)	
FM34B-18	1.27 (0.50)	RT	1.9	275	3.8	(550)	C100%
	5.18 (2.00)		3.2	460	1.6	(230)	C100%
	1.27 (.50)	589°K (600°F)	1.55	225	3.1	(450)	C100%
	5.18 (2.0)		5.4	770	2.7	(385)	C100%
LARC-13	1.27 (.50)	RT	8.05	1170	16.1	2340	L40, C60
	5.18 (2.0)		19.6	2840	9.8	1420	L50, C50
	1.27 (.50)	589°K (600°F)	7.25	1055	14.5	2110	L35, C65
	5.18 (2.0)		18.2	2640	9.1	1320	L35, C65
<p>Adherends: Celion 6000/PMR-15, 8 ply, unidirectional</p> <p>Surface Treatment: Light abrading, diglyme wipe</p> <p>Primer: BR34B-18</p> <p>Test Method: MMM-A-132</p>							

Table 16. Aging (1) Stability of Polyimide Adhesives Wrapped in Aluminum Foil

Adhesive	FLATWISE TENSILE STRENGTH MPa (psi) (2)							
	R.T.				589°K(600°F)			
	1	2	3	AVE	1	2	3	AVE
FM34B-18	1.41(203.8)	0.86(125.0)	1.38(200.0)	1.22(176.3)	.95(732.5)	0.97(140.0)	1.0(146.3)	0.97(139.6)
LARC-13	1.57(227.5)	1.59(2300)	1.17(170.0)	1.44(209.1)	1.10(160.0)	1.55(225.0)	0.88(127.0)	1.18(170.7)

(1) Specimens were aged for 125 Hr. at 589°K (600°F) in air circulated oven. All specimens were wrapped in aluminum foil.

(2) All adhesives cured in autoclave for two hours at 589°K under full vacuum and 0.1724 MPa (40 psi) pressure and post cured for 10 hours at 589°K (600°F) free standing in oven.

Table 17. Aging (1) Stability of Polyimide Adhesives Not Wrapped in Aluminum Foil

ADHESIVE	FLATWISE TENSILE STRENGTH, MPa (psi) (2)					
	RT			589°K (600°F)		
	1	2	AVE	1	2	AVE
FM34B-18	0.70(102.5)	0.64(92.5)	0.67(97.5)	0.84(122.5)	0.55(80.0)	0.69(101.2)
LARC-13	1.10(152.5)	1.38(200.0)	1.24(176.3)	1.34(195.0)	1.26(182.5)	1.30(188.8)

(1) Specimens were aged for 125 hours at 589°K (600°F) in air circulated oven. All specimens were not wrapped in aluminum foil.

(2) All adhesives were cured in autoclave for two hours at 589°K (600°F) under full vacuum and 0.1724 MPa (40 psi) pressure and post cured for 10 hours at 589°K (600°F) free standing in oven.

Table 18 - Aging Stability of Selected Adhesives at 589°K (600°F)

ADHESIVE	AGING PERIODS HOURS	LAP SHEAR STRENGTH, MPa (psi) (1)			
		RT	MODE OF FAILURE AT RT(2)	589°K(600°F)	MODE OF FAILURE AT 589°K (600°F)(2)
FM34B-18/104 0.06 lb/ft ²	0	15.5(2250)	L20%, C80%	13.4(1945)	L40%, C60%
	125	8.7(1255)	L15, C85	7.9(1145)	L5, C95
	250	7.7(1115)	L10, C90	8.1(1180)	L15, C85
LARC-13/108 0.07 lb/ft ²	0	14.0(2030)	L70, C30	14.5(2100)	L35, C65
	125	9.2(1330)	L5, C95	8.3(1210)	L5, C95
	250	7.0(1020)	L5, C95	8.1(1180)	C100
M-LARC-13E/108 0.07 lb/ft ²	0	15.8(2295)	L65, C35	12.7(1845)	L25, C75
	125	8.9(1290)	L15, C85	9.7(1400)	L10, C90
	250	6.7(965)	L20, C80	8.1(1180)	L10, C90
<p>(1) Aging Environment: Lap shear specimens exposed directly to air current in circulating oven at 589°K(600°F)</p> <p>Adherends: Celion 6000/PMR-15, 8 ply, unidirectional</p> <p>Surface Treatment: Light abrading, diglyme wipe</p> <p>Primer: BR34B-18</p> <p>(2) L: Laminate failure, C: Cohesive failure</p>					

Table 19 - Effect of Water Immersion on Lap Shear Strength of LARC-13 and FM34B-18 Adhesives.

ADHESIVE	WATER-IMMERSION PERIODS, DAYS	TEST TEMP °K(°F)	LAP SHEAR STRENGTH MPa (psi) (1)	MODE OF FAILURE (2)
FM34B-18/104 0.06 lb/ft ²	0	RT 589°K (600°F)	16.5 (2390) 11.4 (1660)	L80%, C20% L5 , C95
	7	RT 589°K (600°F)	12.2 (1770)	L5 C95
LARC-13/108 0.07 lb/ft ²	0	RT 589°K (600°F)	15.4 (2240) 14.9 2165	L25 C75 L5 C95
	7	RT 589°K(600°F)	14.4 (2095) 12.0 (1745)	L5, C95 C100
<p>(1) Adherends: Celion 6000/PMR-15 8-ply, unidirectional Surface Treatment: Light abrading, diglyme wipe Primer: BR34B-18</p> <p>(2) Laminate failure, C-Cohesive failure</p>				

Table 20. Effect of Bondline Thickness on Lap/Shear Strength⁽¹⁾

Adhesive	No. of Layers	Test Temp. °K (°F)	Bondline Thickness After Cure	Lap Shear Strength-PSI				Mode of Failure	
				1	2	3	AVE	%	(2)
LARC-13/108	1	R.T. 589°K	0.0020	2590	2790	2700	2693	L95	C5
LARC-13/108	1	(600°F)	0.0015	2400	2300	2600	2433	L75	C25
LARC-13/108	2	R.T. 589°K	0.0050	2830	2880	3150	2955	L95	C5
LARC-13/108	2	(600°F)	0.0040	2020	2550	2240	2270	L50	C50
LARC-13/108	3	R.T. 589°K	0.0055	2760	2630	2790	2725	L90	C10
LARC-13/108	3	(600°F)	0.0050	1740	2580	1760	2026	L5	C95
LARC-13/108	4	R.T. 589°K	0.008	2340	2870	2460	2556	L85	C15
LARC-13/108	4	(600°F)	0.008	1700	1740	1990	1810	L25	C75
LARC-13/108	5	R.T. 589°K	0.010	2800	3280	3140	3073	L45	C55
LARC-13/108	5	(600°F)	0.010	1920	1910	1910	1913	L10	C90
LARC-13/108	6	R.T. 589°K	0.011	2900	2530	1960	1796	L50	C50
LARC-13/108	6	(600°F)	0.011	1460	1560	1660	1560	L10	C90
LARC-13/108	7	R.T. 589°K	0.012	1680	1350	1580	1536	L80	C20
LARC-13/108	7	(600°F)	0.012	1120	1250	980	1116	L10	C90
LARC-13/108	8	R.T. 589°K	0.015	1590	1600	1530	1573	L60	C40
LARC-13/108	8	(600°F)	0.015	1340	1450	1300	1363	L5	C95

(1) Adherend: Celion 6000/PMR-15, 8 ply unidirectional Primer: BR-34B-18 Cure: 2 hours at 589°K (600°F) and 0.6895 MPa (100 psi) pressure, Postcure: 10 hours at 589°K (600°F) and normal pressure.

(2) L: Laminate failure, C: Cohesive failure in the adhesive

Table 21. Out of Refrigeration Effect on Filleting Properties of LARC 13⁽²⁾

Spec No.	Out of Refrigeration Time	Test Temp. °K (°F)	Fillet Thickness mm (Inch)	Flatwise Tensile Strength (1) MPa (psi)	Mode of Failure
HCS104	1 Hr.	R.T.	0.8(0.035")	2.34(340)	Core to Adhesive
HCS104	1 "	589°K (600°F)	"	2.24(326)	" " "
HCS105	2 Hrs.	R.T.	0.70(0.030")	2.48(360)	Core to Adhesive
HCS105	" "	589°K (600°F)	"	2.20(320)	" " "
HCS106	8 Hrs.	R.T.	0.5(0.020")	4.06(590)	Core to Adhesive
HCS106	" "	589°K (600°F)	"	2.27(330)	" " "
HCS109	8 Days	R.T.	0.2(0.010")	3.37(490)	Core to Adhesive
HCS109	" "	589°K (600°F)	"	2.58(375)	" " "

(1) Face-Sheets: Celion 6000/PMR-15 8-ply, crossplied Construction
 Primer: BR34B-18
 Core: HRH 327-3/16-4, T = 0.5

(2) LARC-13/108, 0.07 lb/ft²

Table 22. Use of Catalyst in LARC 13 to Reduce Cure Temperature

ADHESIVE	CURE TEMP	TEST TEMP.	LAP SHEAR STRENGTH-PSI(3)				MODE OF FAILURE %	
			1	2	3	AVE		
LARC-13 ⁽¹⁾	528°K (500°F)	R.T.	2260	2320	2460	2346	L25	C75
	528°K (500°F)	600°F	2340	2040	2420	2266	L5	C95
LARC-13 ⁽¹⁾	505°K (450°F)	R.T.	1380	1530	1740	1550	L65	C35
		600°F	830	1320	1600	1050	-	C100
LARC-13 ⁽²⁾	528°K (500°F)	R.T.	1980	1860	2160	2000	L100	C-
		600°F	1640	1820	1840	1766	L20	C80
LARC-13 ⁽²⁾	505°K (450°F)	DID NOT GET CURED - TOO BRITTLE. PANEL SEPARATED						

(1) Catalyst: USP-138, 2% by Weight

(2) Catalyst: Experox - 10, 2% by Weight

(3) Adherend: Celion/PMR-15, 8 Ply Unidirectional
Primer: BR34B-18

Table 23. Orbiter Body Flap/Demo Segment Stress Comparison

	BODY FLAP (ULT) MPA (KSI)			LOAD CONCEPT NO. 8 MPA (KSI)					
	MAX STRESS	MIN STRESS	MAX SHEAR STRESS	MAX STRESS		MIN STRESS		MAX SHEAR	
				RT	ET	RT	ET	RT	ET
STABILITY RIB CAP	241 (35.0)	-73.0 (-10.6)	-	197.1 (28.6)	184 (26.7)	-197.1 (-28.6)	-121.3 (-17.6)	-	-
FRONT SPAR CAP	43.4 (6.3)	-48.2 (-7.0)	-	32.4 (4.7)	28.2 (4.1)	-121.3 (-4.9)	-40.6 (-5.9)	-	-
REAR SPAR CAP	9.6 (1.4)	-31.7 (-4.6)	-	28.3 (2.6)	10.4 (1.5)	-17.9 (-2.6)	-27.5 (-4.0)	-	-
STABILITY RIB WEB	-	-	37.9 (5.5)	-	-	-	-	146 (20.9)	140 (20.3)
FRONT SPAR WEB	-	-	43.4 (6.3)	-	-	-	-	49 (7.1)	49.6 (7.2)
REAR SPAR WEB	-	-	33.7 (4.9)	-	-	-	-	34.4 (5.0)	35 (5.1)
H/C COVER PANELS	91.7 (13.3)	-82.7 (-12.0)	53.8 (7.8)	62.0 (9.0)	75.8 (11.0)	-71.4 (-10.4)	-97.2 (-14.1)	50.3 (7.3)	63.4 (9.2)

This Page Intentionally Left Blank

APPENDIX A

This appendix contains the Engineering Design drawings which define the TDS. The drawing list is as follows:

SS79-00249 2 Sheets	Technology Demonstration Segment - Graphite/Polyimide, Shuttle Body Flap
SS79-00250	Cover - Body Flap Segment
SS79-00251 2 Sheets	Rib-Stability Technology Demonstra- tion Segment, Graphite/Polyimide
SS79-00252	Leading Edge Panels - Body Flap Segment
SS79-00253 3 Sheets	Spar Webs - Body Flap Segment

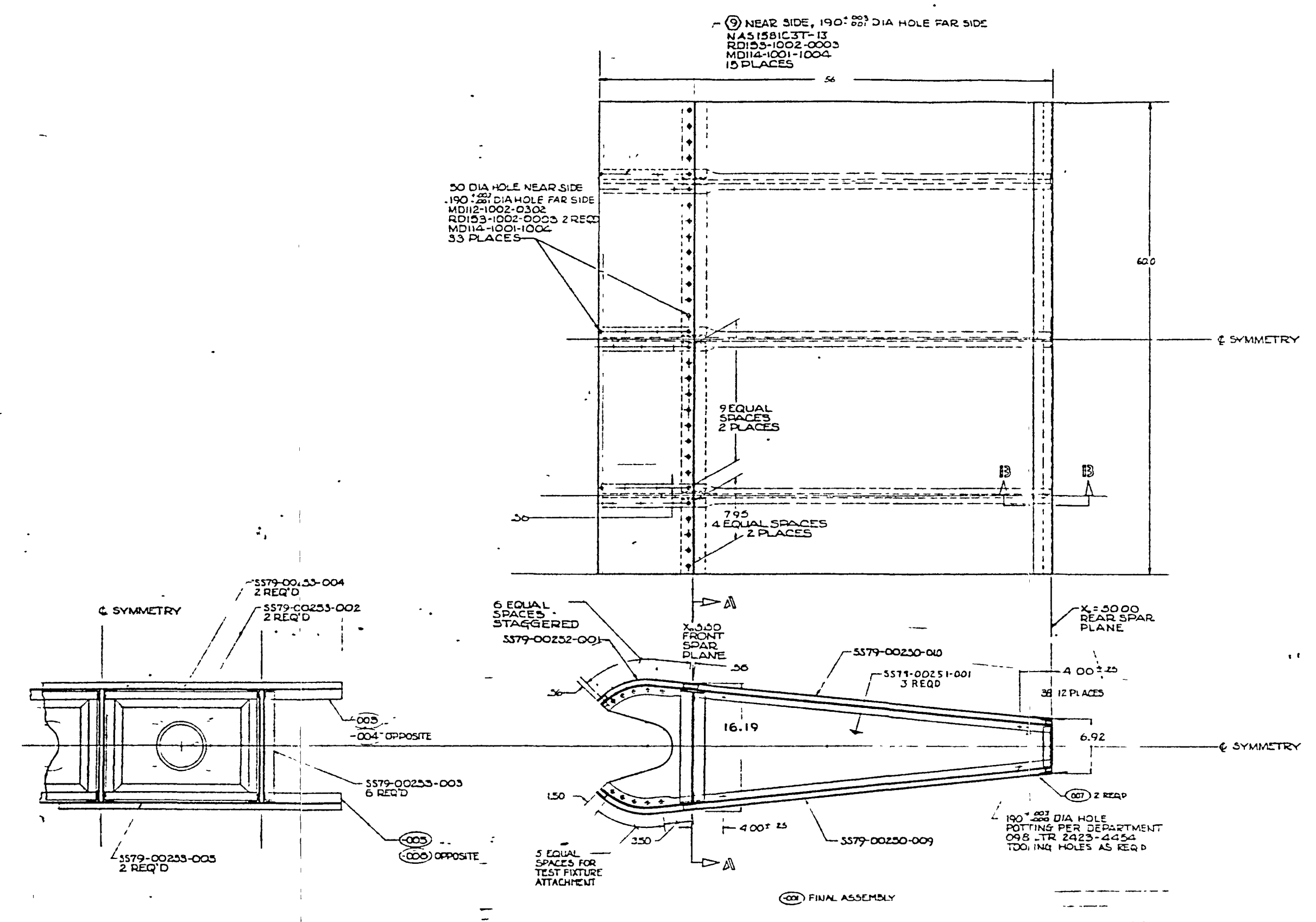

- TO INSTALL FASTENERS PER MADI01-301 CLASS 1
- ① DRILL 9/16 DIAMETER HOLE AND INSTALL SLO149-5-770 TYPE B INSERTS WITH POTTING COMPOUND PER DEPARTMENT 098 LTR 2423-4454
 - ② BOND WITH MBO20-01 FM32 ADHESIVE SYSTEM CURE PER D/098 LTR 2423-4454
 - ③ ULTRASONIC INSPECT PER MT0501-010
 - ④ INSPECT LAMINATE MATERIALS PER LTR 2433-4462
 - ⑤ FABRICATE GFR/PI LAMINATES PER PROCESS SPECIFICATION MADI05-833A, CURE CYCLE SOD79-893 & SPECIFIC PROCESS PER D/098 LTR 2423-4454
 - ⑥ GRAPHITE/POLYIMIDE TAPE 0.0025 THICK CELION 6000/LARC 160 PER MBO130-102A
3. LAMINATE ORIENTATION TOLERANCE ± 2°
 2. DIMENSIONAL LENGTH TOLERANCE ± 0.03
 1. DIMENSIONS ARE IN INCHES ± 0° 30'
- NOTES: UNLESS OTHERWISE NOTED

REV	DESCRIPTION	DATE	BY	CHKD
10	MOCS FOR TEST FIXTURE ATTACHMENT			
11				

QTY	DESCRIPTION	UNIT	REMARKS
277	RD 531002-0003 WASHER		
146	MD14-001-1004 NUT		
60	MD12-002-05-03 SCREW		
8	MD12-002-05-04 SCREW		
15	MD12-002-03-11 SCREW		
33	MD 12 1002-03-02 SCREW		
15	SL0149-5-770 INSERT		
1	SS79-00251-001 R SPAR		
2	SS79-00241-007 STRAP	3X5X6 7/8"	
1	SS79-00247-006 TEE		
1	SS79-00249-005 TEE		
1	SS79-00249-004 TEE		
1	SS79-00247-003 TEE		
2	SS79-00253-005 TEE		
2	SS79-00253-004 TEE		
6			
2	SS79-00250-021 WEB		
1	SS79-00252-001 PANEL		
3	SS79-00254-005 RIB ASSEMBLY		
1	SS79-00250-009 COVER		
1	SS79-00250-008 COVER		
1	CO2 BONDASSY (7X8)		
1	SS79-00249-003 SEGMENT		

REV	DESCRIPTION	DATE	BY	CHKD
1				
2				
3				
4				
5				
6				
7				
8				
9				
10				
11				
12				
13				
14				

SS79-00249

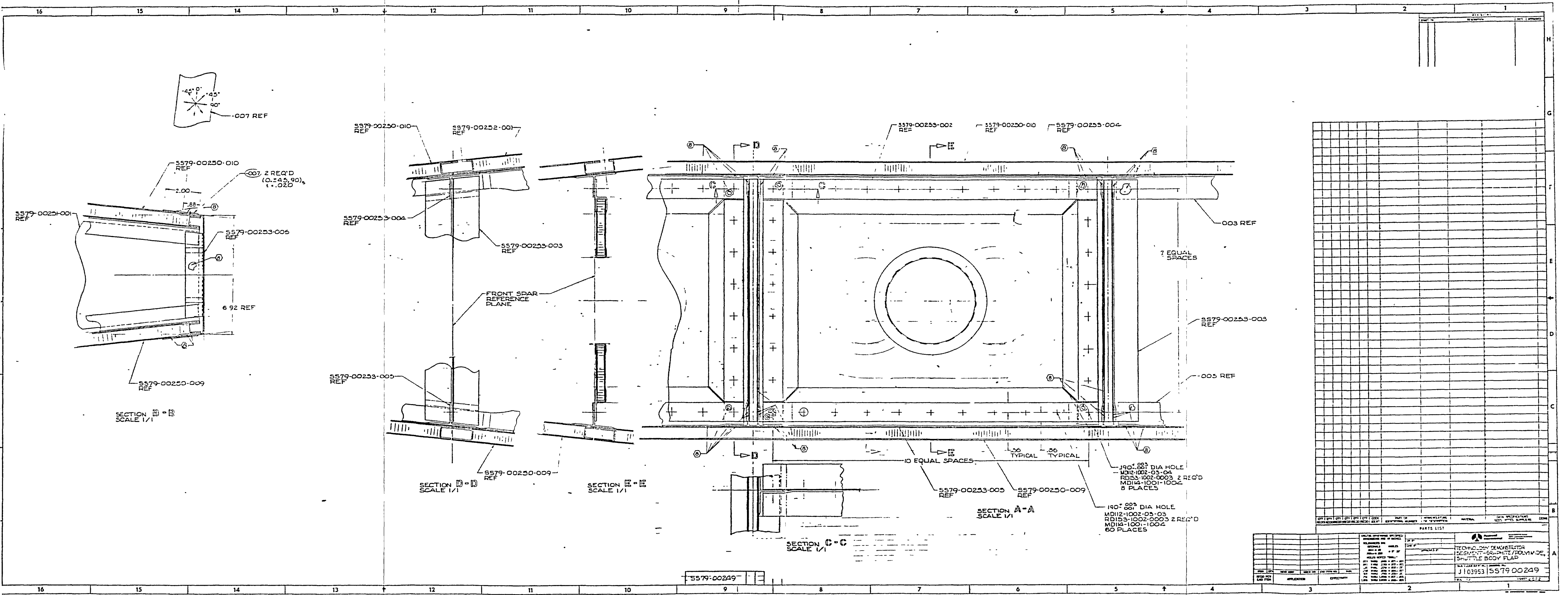

REV	DATE	BY	CHK	APP	DESCRIPTION

PARTS LIST			
QTY	DESCRIPTION	REF	REMARKS

REV	DATE	BY	CHK	APP	DESCRIPTION

TITLE: SHUTTLE BODY FLAP
 PROJECT: TECHNOLOGY DEMONSTRATOR
 DRAWING NO: J103953 | 5579 00249
 DATE: 1974-12-12

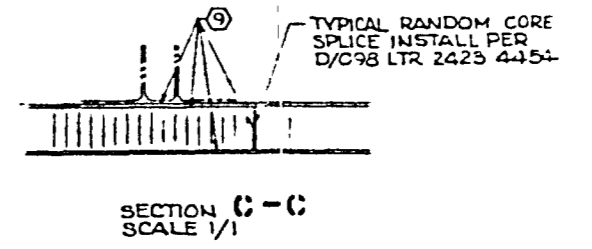
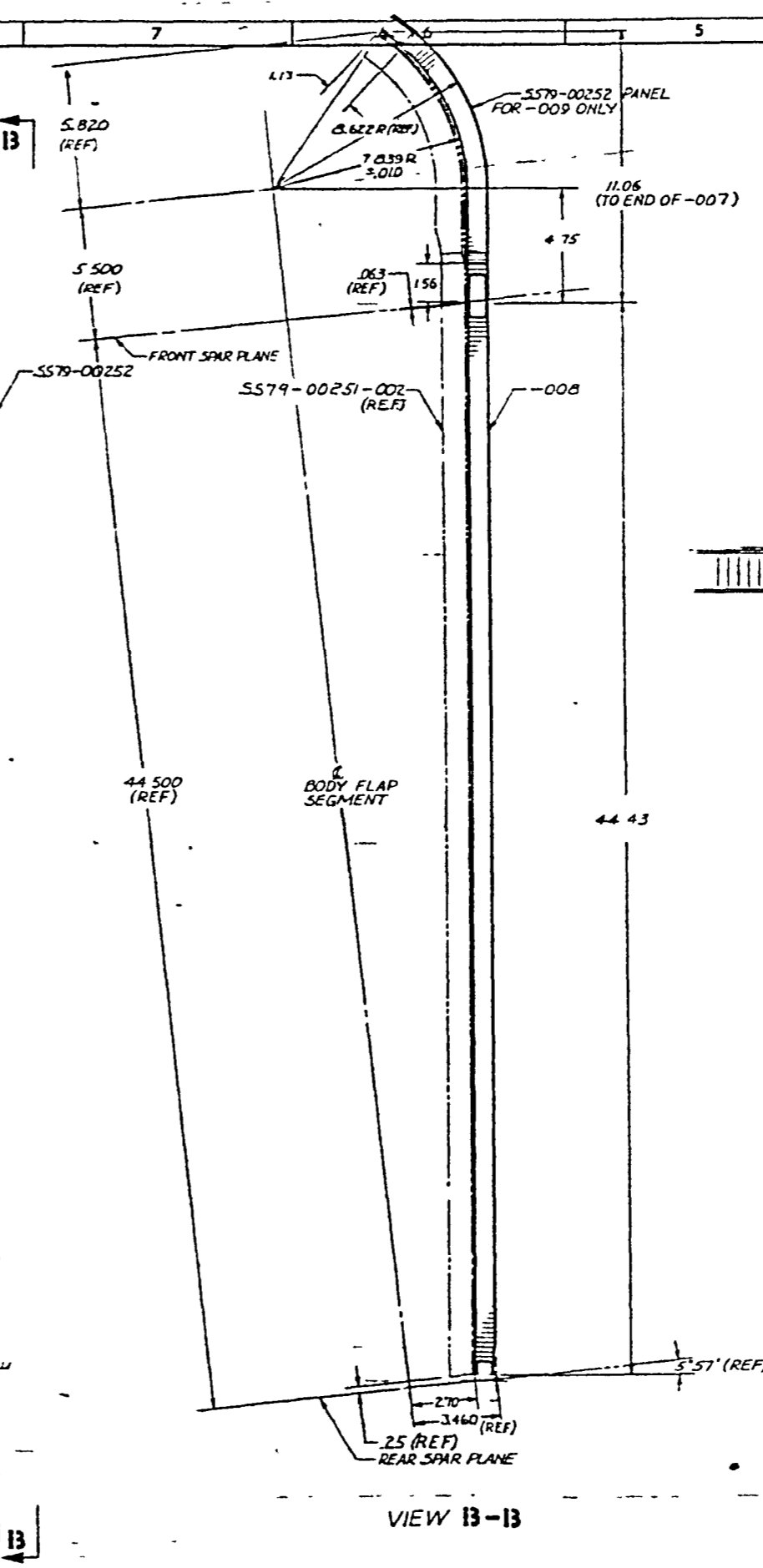
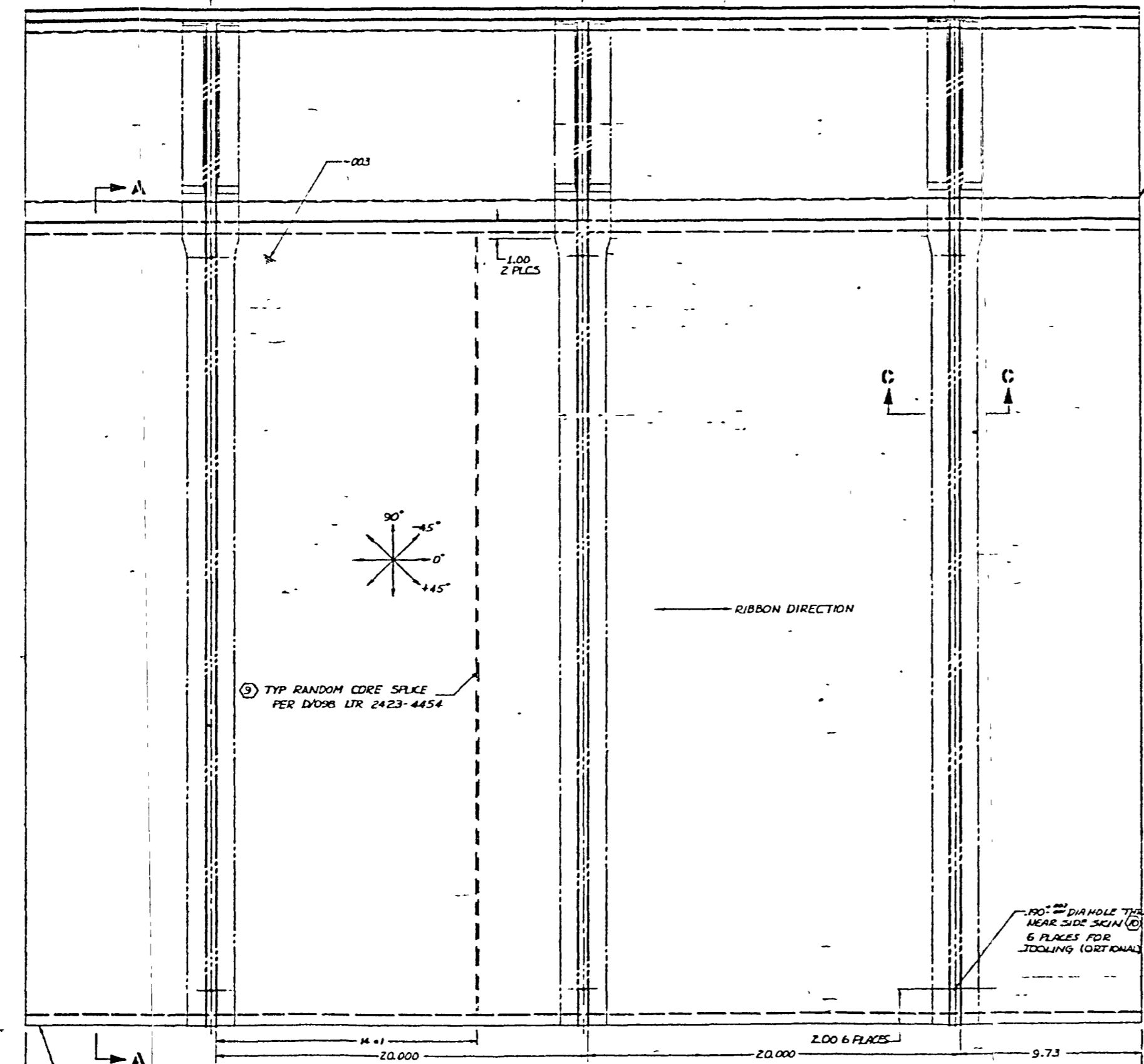
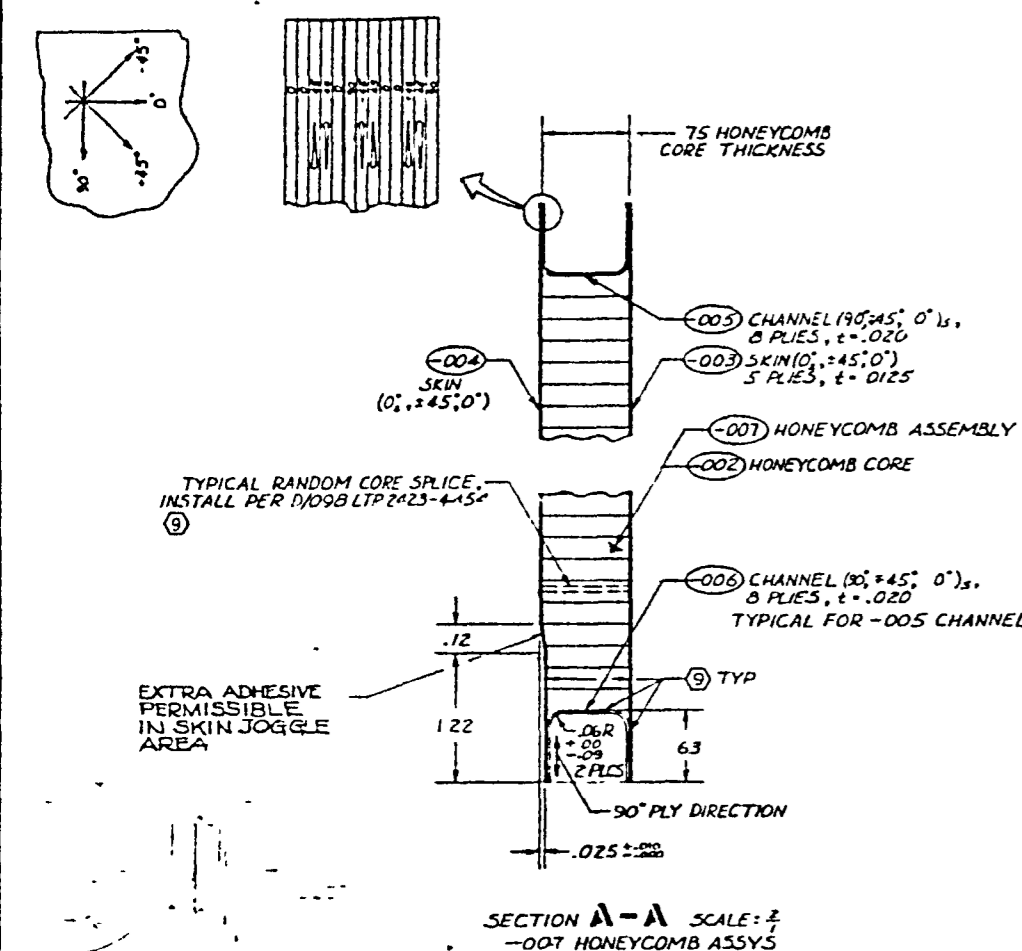

- ① NOTTING COMPOUND PER DEPARTMENT D/O9B LTR 2023-4423
 - ② ADHESIVE WITH HONEYCOMB-002 FM34 LONGSHE SYSTEM PER D/O9B LTR 2423-4454
 - ③ ULTRASONIC INSPECT PER MTDSCH-010
 - ④ INSPECT LAMINATE MATERIALS PER LTR 2433-4462
 - ⑤ FABRICATE GRIP LAMINATE PER PROCESS SPEC ANA093 2333, CURB CYCLE PER 50079-333, & SPECIFIC PROCESSES PER D/O9B-2423-4454
 - ⑥ WIRECEL CORR. CODE NPH-327-3/4-.75-3.0
 - ⑦ GRAPHITE/POLYIMIDE TAPE 0.0025 THICK LELON 6000/LARC 160 PER MS-30-152A
 - ⑧ ANIMATE ORIENTATION TOLERANCE ± 2°
 - ⑨ DIMENSIONAL LENGTH TOLERANCE ± 0.03
 - ⑩ ANGULAR TOLERANCE ± 0.30
 - ⑪ DIMENSIONS ARE IN INCHES
- NOTES: UNLESS OTHERWISE SPECIFIED

QTY	DESCRIPTION	REVISIONS	DATE	BY	CHKD	APP'D
1	SS79-00252	LEADING EDGE PANEL				
1	-005	UPPER LOWER ASSEMBLY				
1	-008	LOWER COVER				
1	-007	HC ASSY	SEE NOTES			
1	-006	CHANNEL	SEE NOTES			
1	-005	CHANNEL	SEE NOTES			
1	-004	SKIN	SEE NOTES			
1	-003	SKIN	SEE NOTES			
1	-002	HC CORE	SEE NOTE			
1	-001	COVER				

QTY	DESCRIPTION	REVISIONS	DATE	BY	CHKD	APP'D
1	SS79-00250	COVER - BODY FLAP SEGMENT				

5579-00250

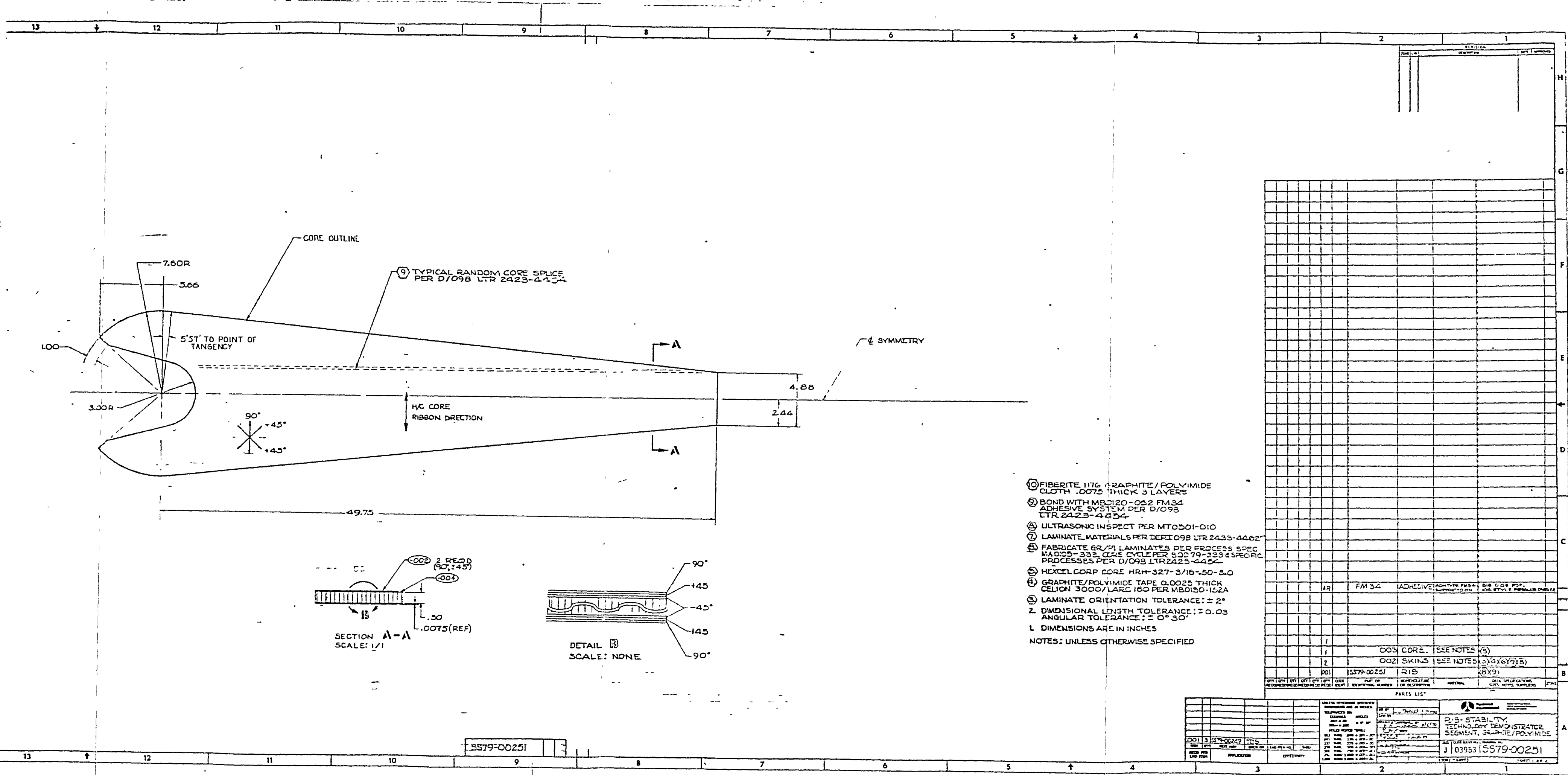

- (1) FIBERITE 1176 GRAPHITE/POLYIMIDE CLOTH .0075 THICK 3 LAYERS
 - (2) BOND WITH MBO120-052 FM34 ADHESIVE SYSTEM PER D/O98 LTR 24-23-4434
 - (3) ULTRASONIC INSPECT PER MT0501-010
 - (4) LAMINATE MATERIALS PER DEPT 098 LTR 2433-4462
 - (5) FABRICATE GR/PI LAMINATES PER PROCESS SPEC MBO120-052 CYCLE PER 50079-129 & SPECIFIC PROCESSES PER D/O98 LTR 2423-4454
 - (6) HEXCEL CORP CORE HRH-327-3/16-.50-8.0
 - (7) GRAPHITE/POLYIMIDE TAPE 0.0025 THICK CELION 3000/LARC 160 PER MBO120-152A
 - (8) LAMINATE ORIENTATION TOLERANCE: ± 2°
 - (9) 2 DIMENSIONAL LENGTH TOLERANCE: ± 0.03
 - (10) ANGULAR TOLERANCE: ± 0° 30'
 - (11) DIMENSIONS ARE IN INCHES
- NOTES: UNLESS OTHERWISE SPECIFIED

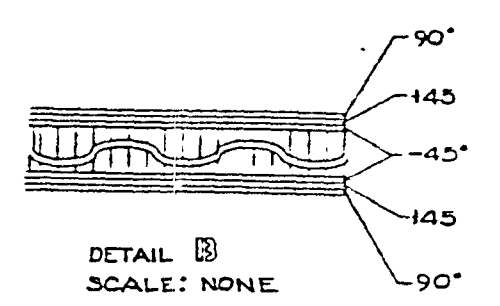
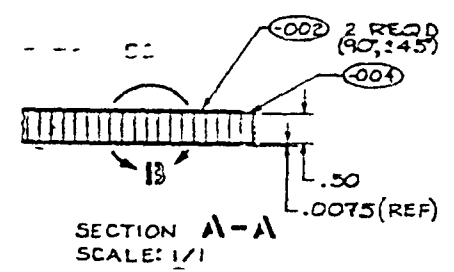

PARTS LIST		QTY	UNIT	DESCRIPTION	REF. DESIG.	QTY	UNIT	DESCRIPTION	REF. DESIG.
1	003	1	CORE	SEE NOTES (5)					
2	001	1	SKINS	SEE NOTES (6)(7)(8)					
3	001	1	5579-00251	RIB					

5579-00251

5579-00251 REV. 001 DATE 08/18/93	5579-00251 REV. 001 DATE 08/18/93	5579-00251 REV. 001 DATE 08/18/93	5579-00251 REV. 001 DATE 08/18/93	5579-00251 REV. 001 DATE 08/18/93	5579-00251 REV. 001 DATE 08/18/93	5579-00251 REV. 001 DATE 08/18/93	5579-00251 REV. 001 DATE 08/18/93	5579-00251 REV. 001 DATE 08/18/93	5579-00251 REV. 001 DATE 08/18/93	5579-00251 REV. 001 DATE 08/18/93
---	---	---	---	---	---	---	---	---	---	---

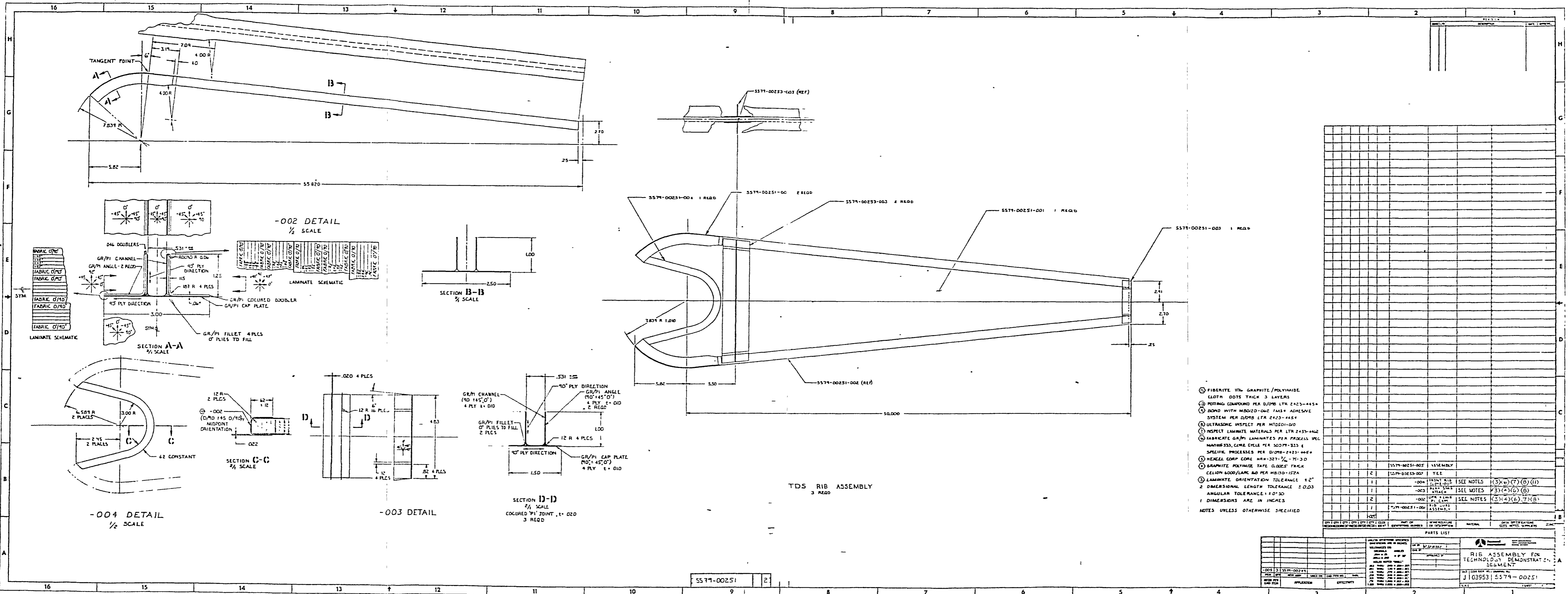

- (1) FIBERITE 17% GRAPHITE/POLYIMIDE CLOTH .0075 THICK 3 LAYERS
 - (2) POTTING COMPOUND PER D/OPS LTR 2423-4454
 - (3) BOND WITH MBO/2D-ONE 7MS4 ADHESIVE SYSTEM PER D/OPS LTR 2423-4454
 - (4) ULTRASONIC INSPECT PER MTO201-00
 - (5) INSPECT LAMINATE MATERIALS PER LTR 2423-4462
 - (6) FABRICATE GR/PI LAMINATES PER PROCESS SPEC MAB0533, CAME CYCLE PER 50079-323 & SPECIFIC PROCESSES PER D/OPS-2423-4454
 - (7) HEXCEL CORP CORE HAN-327-1/4-75-3.0
 - (8) GRAPHITE POLYIMIDE TAPE CLODES' TRICK CELION 6000/LARC 90 PER MB130-152A
 - (9) LAMINATE ORIENTATION TOLERANCE ± 2°
 - (10) DIMENSIONAL LENGTH TOLERANCE ± 0.03
 - (11) ANGULAR TOLERANCE ± 0° 30'
 - (12) DIMENSIONS ARE IN INCHES
- NOTES UNLESS OTHERWISE SPECIFIED

QTY	PART NUMBER	DESCRIPTION	MATERIAL	DATE
1	5579-00251-001	RIB - 1/4" DIA	FIBERITE 17% GRAPHITE/POLYIMIDE	
2	5579-00251-002	RIB - 1/2" DIA	FIBERITE 17% GRAPHITE/POLYIMIDE	
1	5579-00251-003	RIB - 3/4" DIA	FIBERITE 17% GRAPHITE/POLYIMIDE	
1	5579-00251-004	RIB - 1" DIA	FIBERITE 17% GRAPHITE/POLYIMIDE	

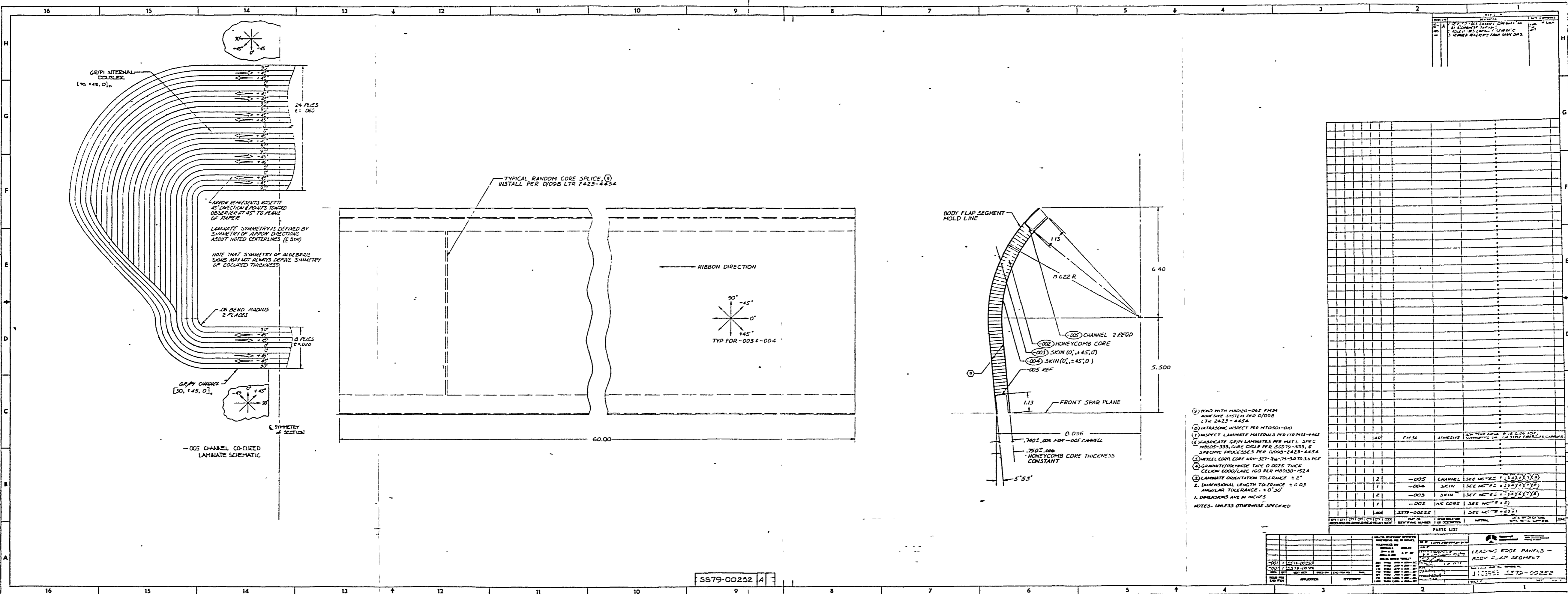

REV	DESCRIPTION	DATE	BY	CHKD
1	ISSUED FOR FABRICATION			
2	REVISION			

QTY	SYMBOL	DESCRIPTION	UNIT	REMARKS
2	-005	CHANNEL	SEE NOTES (1)(2)(3)(4)	
1	-004	SKIN	SEE NOTE (5)	
2	-003	SKIN	SEE NOTES (5)(6)(7)(8)	
1	-002	HC CORE	SEE NOTE (9)	
1	-001	ADHESIVE	SEE NOTE (10)	

QTY	SYMBOL	DESCRIPTION	UNIT	REMARKS
1	1	LEADING EDGE PANELS - BODY FLAP SEGMENT		

SS79-00252 A

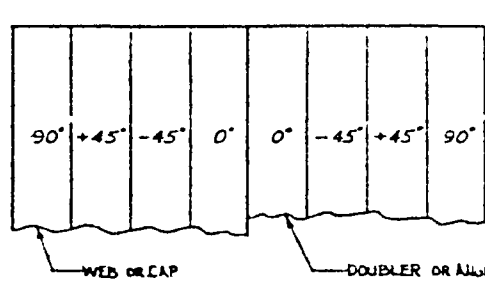
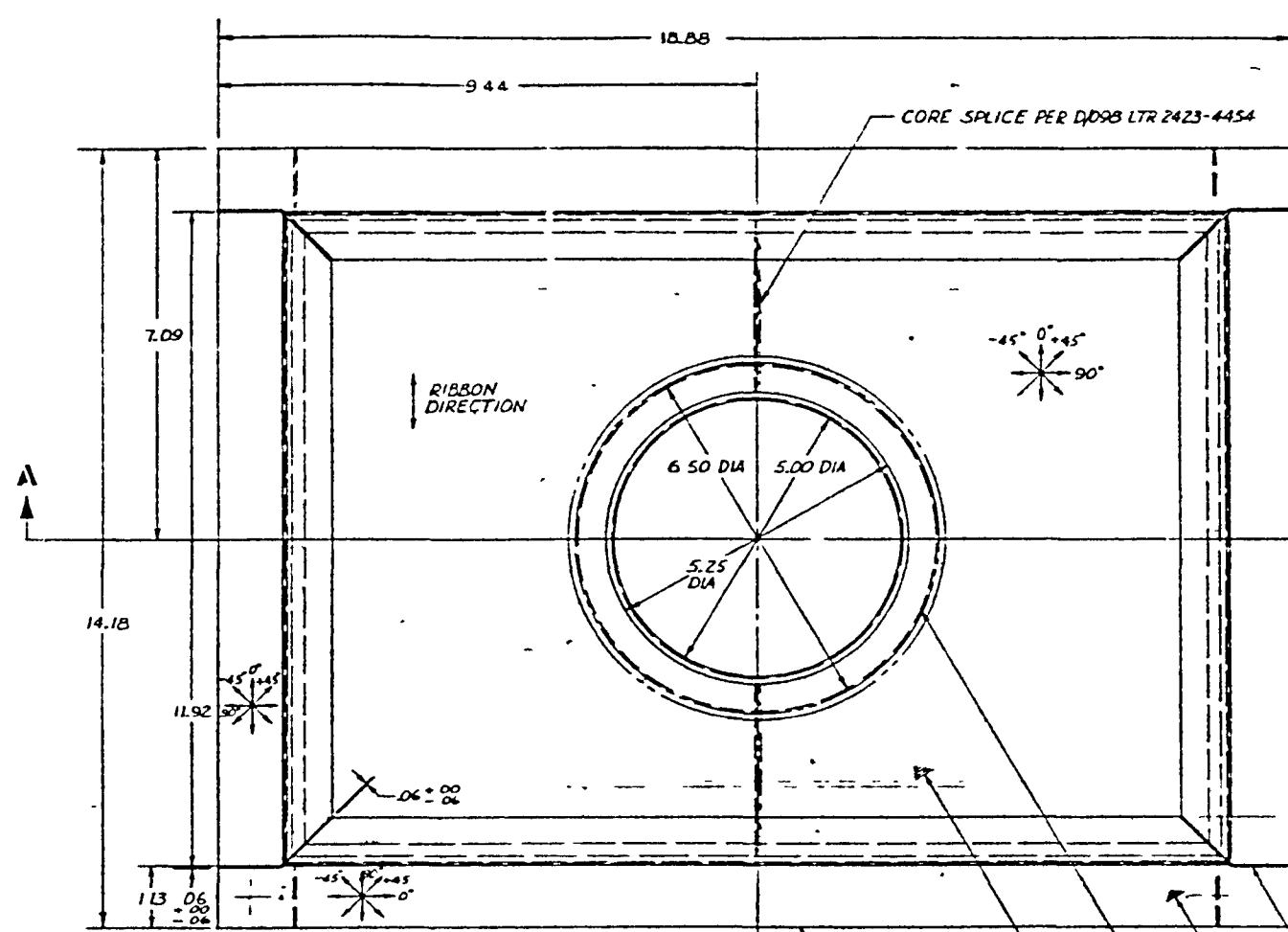
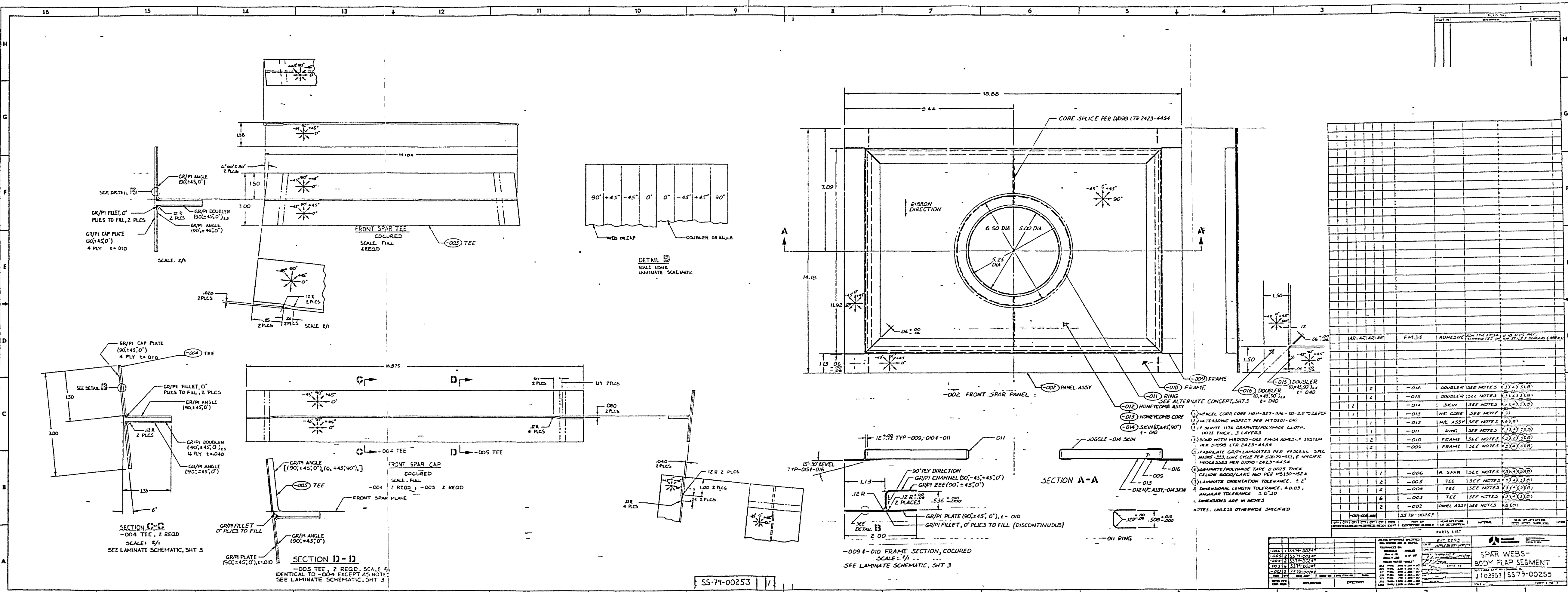

DETAIL 13
SCALE: NONE
LAMINATE SCHEMATIC

- (1) HONEYCOMB CORE H11-327-3K-50-30-36PCS
- (2) ULTRASONIC INSPECT PER MTDSDI-010
- (3) 1176 GRANITE/POLYIMIDE CLOTH, 0.025 THICK, 3 LAYERS
- (4) SAND WITH MBD20-06L FM-34 ADHESIVE SYSTEM PER D1090 LTR 2423-4454
- (5) FRAGILE GR/Pi LAMINATES PER PROCESS SPEC AND/OR LARC 160 PER M3130-152A
- (6) GRANITE/POLYIMIDE TAPE 0.0025 THICK CELON 6000/LARC 160 PER M3130-152A
- (7) LAMINATE ORIENTATION TOLERANCE = ± 2°
- (8) DIMENSIONAL LENGTH TOLERANCE = ± 0.03
- (9) ANGULAR TOLERANCE = ± 0°30
- (10) DIMENSIONS ARE IN INCHES

QTY	DESCRIPTION	REVISION	DATE
2	-016 DOUBLER	SEE NOTES	(3) X (3) X (3)
2	-015 DOUBLER	SEE NOTES	(3) X (3) X (3)
12	-014 SKIN	SEE NOTES	(3) X (3) X (3)
1	-013 H/C CORE	SEE NOTE	(3)
1	-012 H/C ASSY	SEE NOTES	(3) X (3) X (3)
2	-011 RING	SEE NOTES	(3) X (3) X (3)
2	-010 FRAME	SEE NOTES	(3) X (3) X (3)
2	-009 FRAME	SEE NOTES	(3) X (3) X (3)
1	-006 IR SPAR	SEE NOTES	(3) X (3) X (3)
2	-005 TEE	SEE NOTES	(3) X (3) X (3)
2	-004 TEE	SEE NOTES	(3) X (3) X (3)
6	-003 TEE	SEE NOTES	(3) X (3) X (3)
2	-002 PANEL ASSY	SEE NOTES	(3) X (3) X (3)

REV	DESCRIPTION	DATE
1	ISSUED FOR MANUFACTURE	11/11/79
2	REVISION	11/11/79
3	REVISION	11/11/79
4	REVISION	11/11/79
5	REVISION	11/11/79
6	REVISION	11/11/79
7	REVISION	11/11/79
8	REVISION	11/11/79
9	REVISION	11/11/79
10	REVISION	11/11/79
11	REVISION	11/11/79
12	REVISION	11/11/79
13	REVISION	11/11/79
14	REVISION	11/11/79
15	REVISION	11/11/79
16	REVISION	11/11/79

SS-79-00253

J 03953 | SS79-00253

SS-71-00253 | 2

27 26 25 24 23 22 21 20 19 18 17

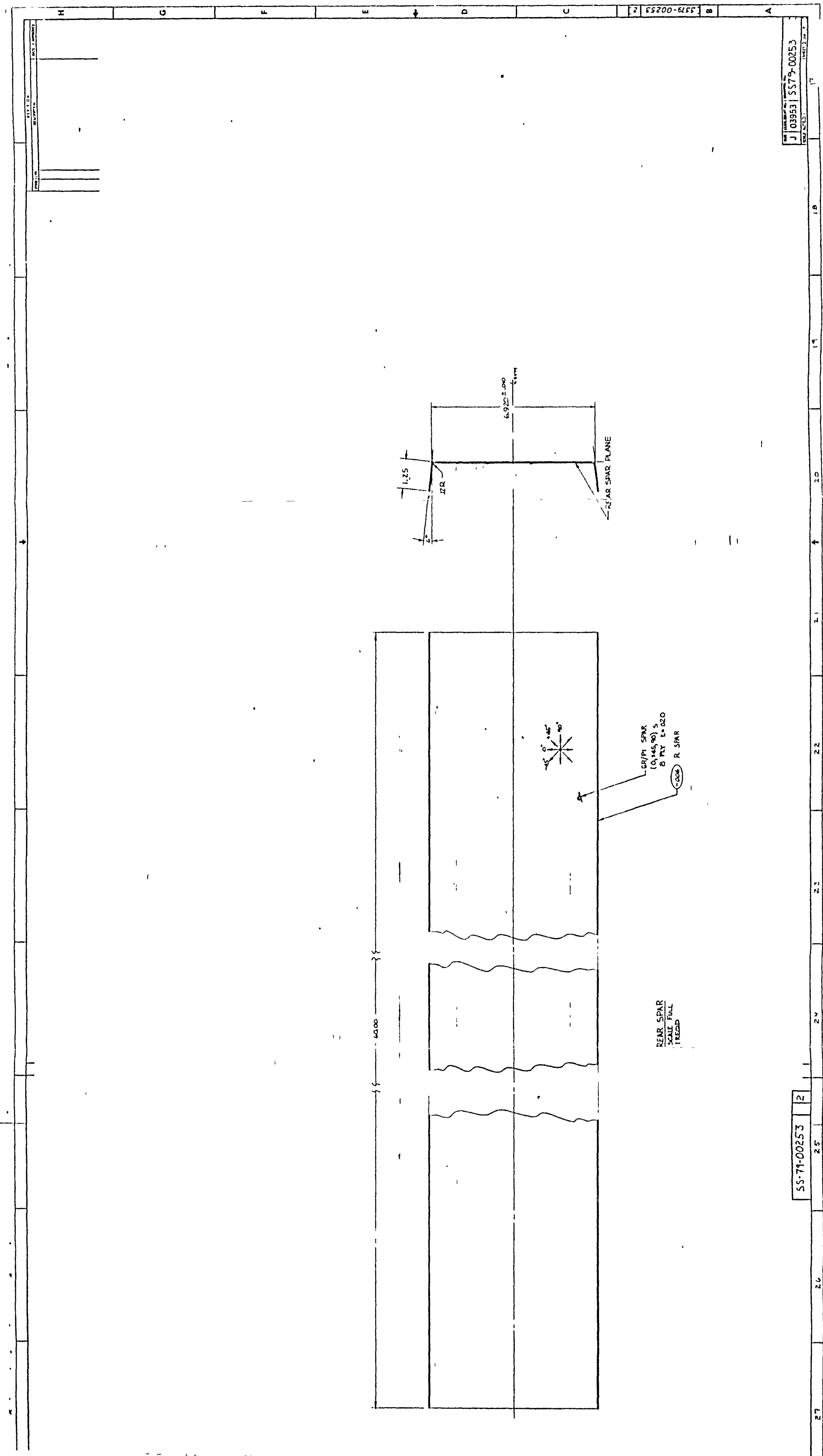

REAR SPAR
SCALE FULL
1 REQD

CR/P1 SPAR
(0, 45, 90) 5
B PLY L=0.020
R SPAR

REAR SPAR PLANE

40.00

6.920 ± .000

1.25

1.75

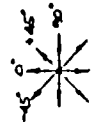

REAR SPAR PLANE

27 26 25 24 23 22 21 20 19 18 17

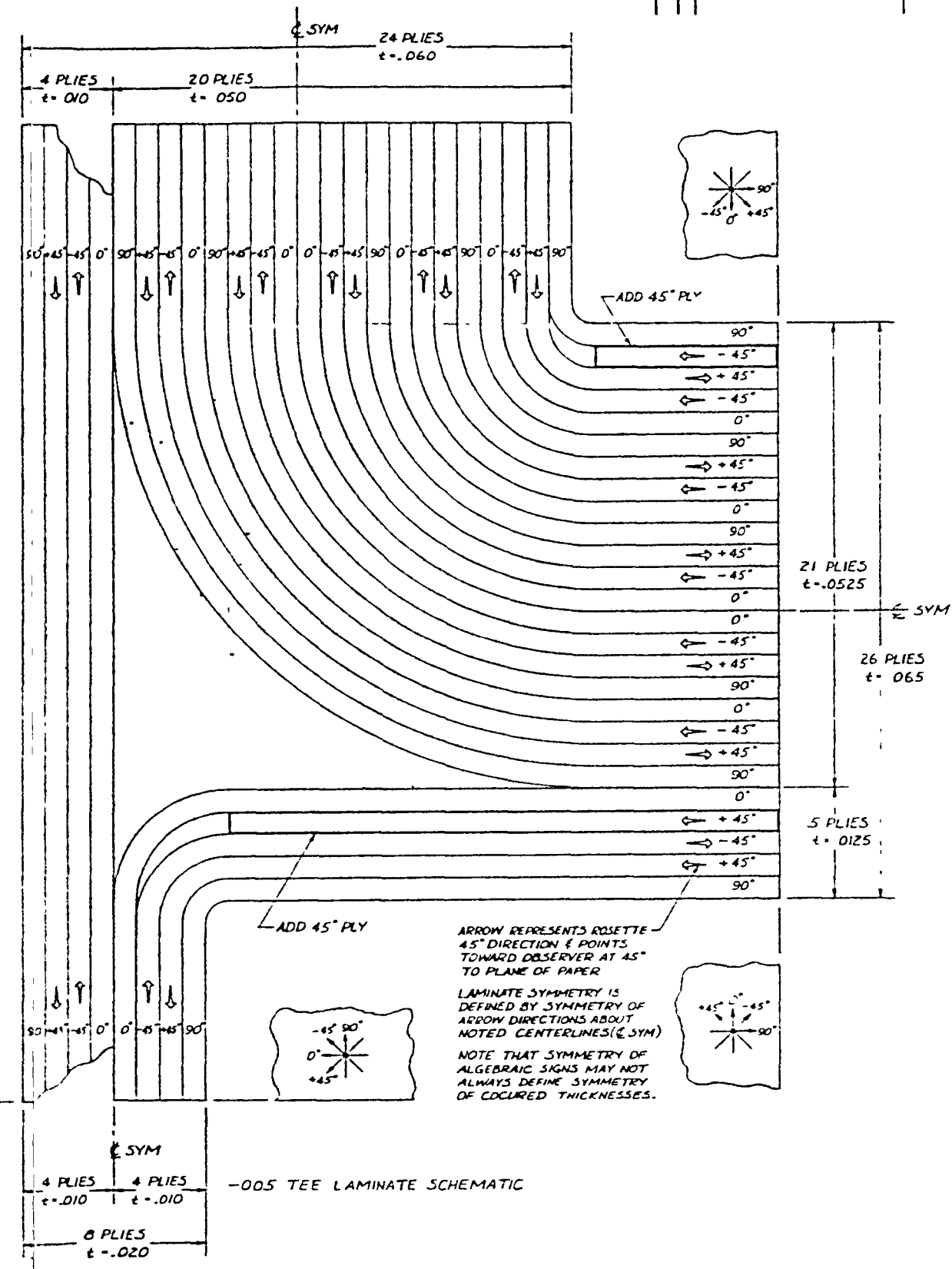
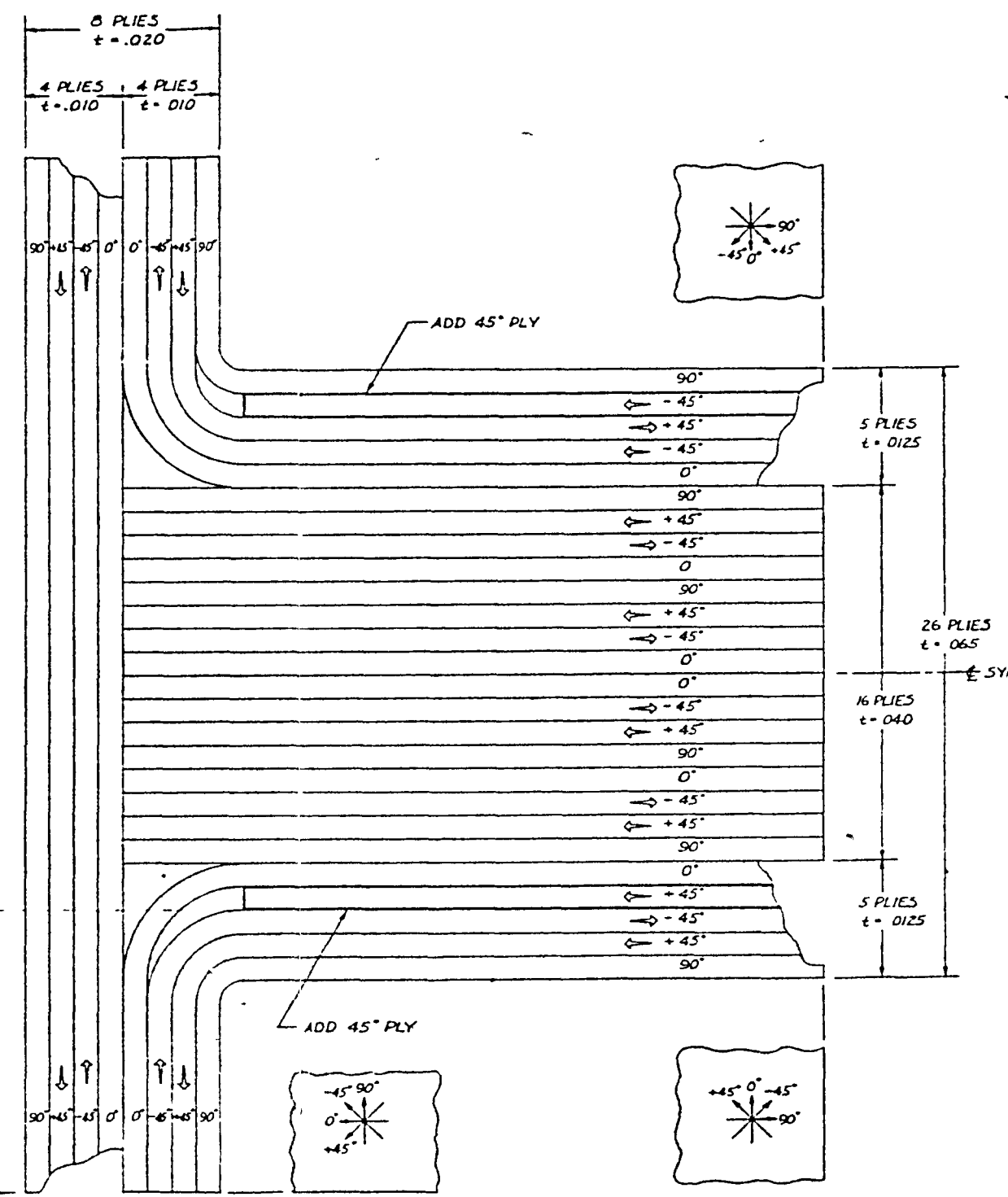
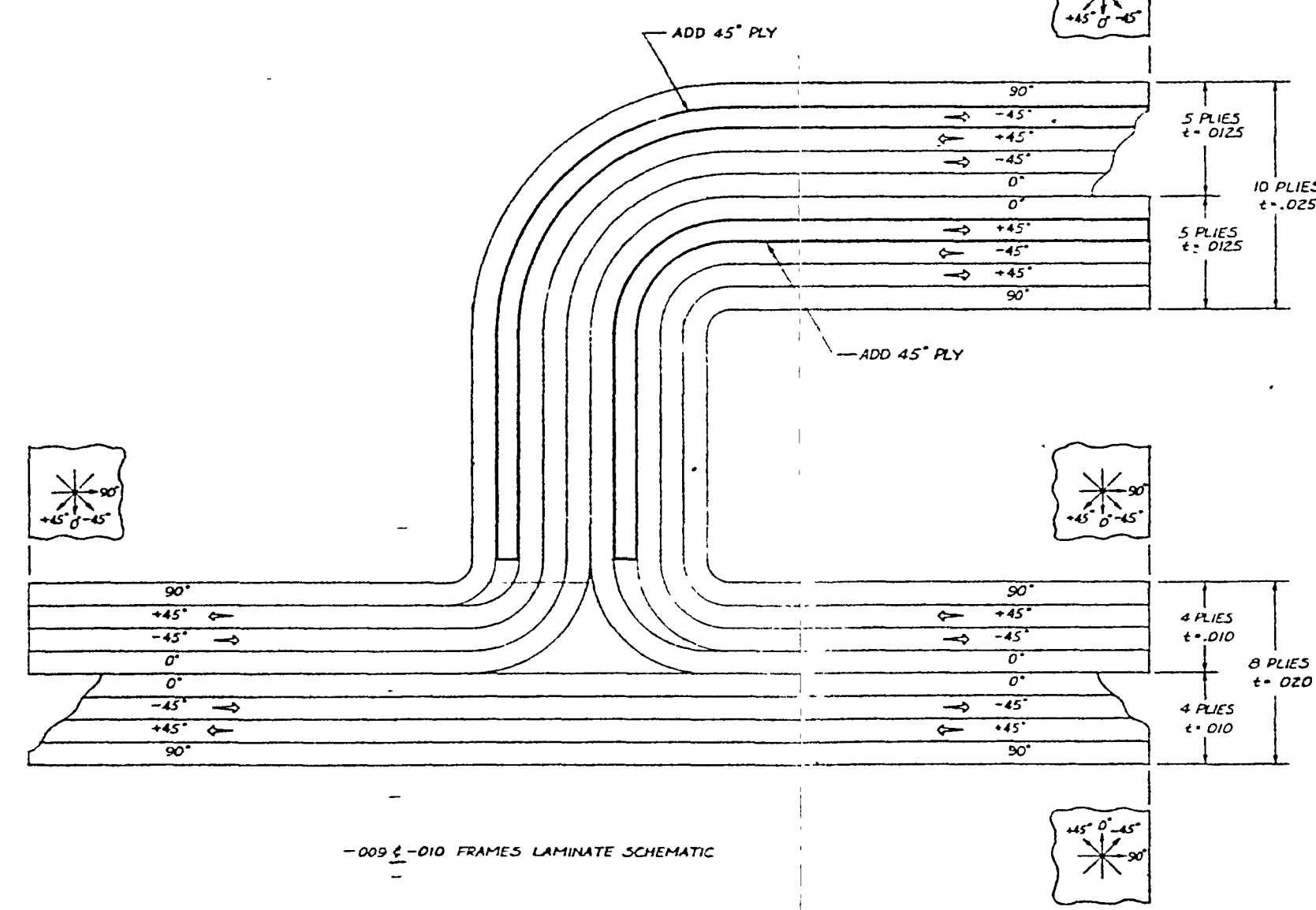
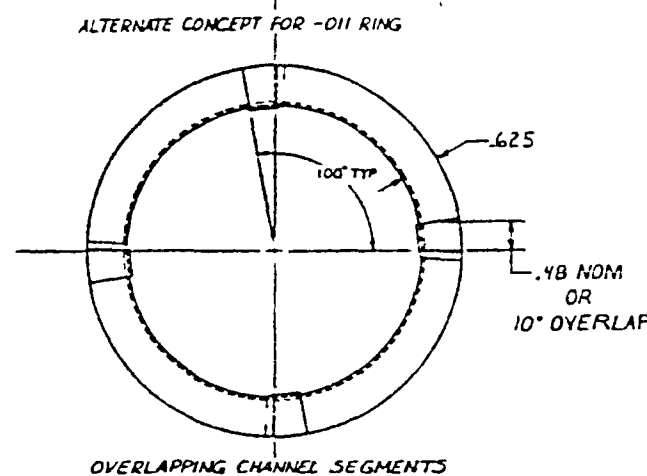

5579-00253 3

J 03953 5579-00253

1. Report No NASA CR 165839		2. Government Accession No.		3. Recipient's Catalog No	
4 Title and Subtitle Develop, Demonstrate and Verify Large Area Composite Structural Bonding with Polyimide Adhesives.				5. Report Date May 1982	
				6. Performing Organization Code	
7 Author(s) Bashir D. Bhombal, Donald H. Wykes, Keith C. Hong, Arnold A. Stenersen				8 Performing Organization Report No	
9 Performing Organization Name and Address Rockwell International 12214 Lakewood Blvd. Downey, Ca. 90241				10 Work Unit No	
				11 Contract or Grant No NAS1-15843	
12 Sponsoring Agency Name and Address National Aeronautics and Space Administration - Washington, D.C. 20546				13 Type of Report and Period Covered Contractor Report	
				14 Sponsoring Agency Code	
15 Supplementary Notes Langley Technical Monitor: Robert M. Baucom Final Report					
16 Abstract <p>This program was conducted to develop and demonstrate processes for large area structural bonding with polyimide adhesives. The program consisted of two parts: Process Development for PI resin systems and fabrication of Demonstration components. Process development included establishing quality assurance of the basic PI adhesives, non-destructive inspection of fabricated components, developing processes for specific structural forms and qualification of processes through mechanical testing. In the second part of the program, demonstration components were fabricated using the processes developed in part one. The demonstration components consisted of adhesively bonded honeycomb sandwich cover panels, ribs, and leading edge covers of Celion graphite/LARC-160 polyimide laminates, and a Technology Demonstration Segment (TDS) representative of the Space Shuttle aft body flap.</p>					
17 Key Words (Suggested by Author(s)) Polyimide Resin Systems, Celion/LARC-160, Graphite/Polyimide Polyimide Adhesive Bonding Non-Destructive Inspection			18 Distribution Statement Unclassified - Unlimited		
19 Security Classif (of this report) Unclassified	20 Security Classif (of this page) Unclassified	21 No of Pages 134	22 Price		

End of Document