

NASA Contractor Report 165989

NASA-CR-165989
19820018832

TRANSIENT THERMAL STRESS PROBLEM FOR A
CIRCUMFERENTIALLY CRACKED HOLLOW CYLINDER

H. F. Nied and F. Erdogan

LEHIGH UNIVERSITY
Bethlehem, Pennsylvania 18015



NF02100

Grant NGR 39-007-011
September 1982

LIBRARY COPY

SEP 24 1982

LANGLEY RESEARCH CENTER
LIBRARY, NASA
HAMPTON, VIRGINIA

NASA

National Aeronautics and
Space Administration

Langley Research Center
Hampton, Virginia 23665

TRANSIENT THERMAL STRESS PROBLEM FOR A CIRCUMFERENTIALLY CRACKED HOLLOW CYLINDER^(*)

by

H.F. Nied and F. Erdogan
Lehigh University, Bethlehem, PA

ABSTRACT

In this paper the transient thermal stress problem for a hollow elastic cylinder containing an internal circumferential edge crack is considered. It is assumed that the problem is axisymmetric with regard to the crack geometry and the loading, and that the inertia effects are negligible. The problem is solved for a cylinder which is suddenly cooled from inside. First the transient temperature and stress distributions in an uncracked cylinder are calculated. By using the equal and opposite of this thermal stress as the crack surface traction in the isothermal cylinder the crack problem is then solved and the stress intensity factor is calculated. The numerical results are obtained as a function of the Fourier number tD/b^2 representing the time for various inner-to-outer radius ratios and relative crack depths, where D and b are respectively the coefficient of diffusivity and the outer radius of the cylinder.

INTRODUCTION

Cracking of brittle solids due to thermal stresses is a well-known phenomenon. In the absence of additional external loads, under thermal stresses, because of the self-equilibrating nature of the stress state, the cracking may not always lead to a through-thickness or catastrophic fracture. For example, in [1] it was shown that in a suddenly cooled hollow glass cylinder an axial initial flaw penetrated into the cylinder wall only partially but propagated axially the entire length of the cylinder as a part-through crack. Similarly, one would expect that if

(*) This work was supported by NSF under the Grant CME-78-08737 and by NASA-Langley under the Grant NGR 39-007-011.

NS2 212 718

the initial flaw were to be circumferential a part-through crack could form and propagate along the entire circumference of the cylinder. In either case, the depth of the part-through crack may be estimated by comparing crack arrest fracture toughness of the material with the stress intensity factor. This, in turn, requires the calculation of the stress intensity factor for the combination of given mechanical, thermal, and residual stresses as a function of the crack depth. If the consideration is restricted to linearly elastic materials, then for each loading condition the crack problem may be treated separately.

In this paper only the transient thermal stress problem is considered. The problem is that of a long hollow circular cylinder containing an internal axisymmetric circumferential edge crack which is suddenly cooled from inside (Fig. 1, $c=a$, $d<b$). It is assumed that the resulting transient thermal stress problem is quasi-static; that is, the inertia effects are negligible. Previous studies on dynamic thermoelasticity seem to bear out the validity of this assumption which, of course, simplify the problem quite considerably (see, for example, [2] and [3]). Also, all thermoelastic coupling effects and the possible temperature dependence of the thermoelastic constants are neglected. By taking advantage of the linearity of the material the thermal stress problem in the cracked cylinder is considered in two parts. The first problem is the evaluation of transient thermal stresses in a hollow cylinder without the crack. The second is the isothermal perturbation problem for the cracked cylinder in which the crack surface tractions equal and opposite to the thermal stresses obtained from the first problem are the only external loads. The superposition of the two solutions gives results for the thermal stress problem for the cracked cylinder. Needless to say, the important information with regard to fracture initiation and propagation in the cylinder is contained in the second problem.

THE THERMAL STRESSES

In the solution of the basic crack problem given in [4] it was assumed that the $z=0$ plane is a plane of symmetry with respect to the

external loads as well as the crack geometry. Consequently, the crack surface traction $\sigma_{zz}(r,\theta)$ was the only external load and the crack problem was one of Mode I. On the other hand, if $z=0$ is not a plane of symmetry, then the shear tractions τ_{rz} and $\tau_{\theta z}$ on the crack surfaces would not be zero, the problem would become one of mixed mode, and extremely complicated. Even though any quasi-static transient thermal stress problem giving

$$\sigma_{zz}(r,\theta,0,t) = f(r,\theta,t), \tau_{rz}(r,\theta,0,t) = \tau_{\theta z}(r,\theta,0,t) = 0 \quad (1)$$

for the uncracked cylinder can be solved by using the technique developed in [4] (with f as a known arbitrary function), in this paper, for simplicity, it is assumed that the thermal stresses are independent of θ and z . The thermal stress problem is, therefore, very simple (see, for example, [5], [6], [7]). Thus, if T_0 is the initial temperature of the cylinder corresponding to zero stress state and $T(r,t)$ is the temperature distribution at time t , then defining

$$\theta(r,t) = T(r,t) - T_0 \quad , \quad (2)$$

the stress component of primary interest may be expressed as

$$\sigma_{zz}^T(r,t) = \frac{E\alpha}{1-\nu} \left[\frac{2}{b^2-a^2} \int_a^b \theta(r,t)r \, dr - \theta(r,t) \right] \quad , \quad (3)$$

where E , ν , and α are respectively the Young's modulus, the Poisson's ratio, and the coefficient of thermal expansion of the material.

The temperature distribution is obtained by solving the diffusion equation

$$\nabla^2 \theta = \frac{1}{D} \frac{\partial \theta}{\partial t} \quad , \quad (4)$$

under the initial condition $\theta(r,0) = 0$ and appropriate boundary conditions, where D is the coefficient of diffusion (i.e., $D = k/\rho c$; k , ρ , c

being the coefficient of heat conduction, the mass density and the specific heat). A simple set of boundary conditions which would lead to conservative results for many transient cooling problems may be stated as

$$\theta(a,t) = (T_\infty - T_0)H(t) = \theta_\infty H(t), \quad (t > 0), \quad (5)$$

$$\frac{\partial}{\partial r} \theta(b,t) = 0, \quad (t > 0) \quad (6)$$

where $H(t)$ is the Heaviside function and for cooling problems θ_∞ is a negative constant.

Equation (4) may be solved by defining $\theta = \theta_\infty + u(r,t)$ and by using the standard technique of separation of variables. However, in this case, for small values of time (which is the period of main practical interest) the resulting series converges very slowly. An alternative technique much more suitable for our purpose is the use of Laplace transform. In this case, adequately accurate representation of the solution for small times may be obtained by approximating the Laplace transform of $\theta(r,t)$ by its asymptotic expansion for large values of the transform variable. The temperature distribution may thus be obtained as

$$\begin{aligned} \frac{\theta(r,t)}{\theta_\infty} = & \sum_{n=1}^4 E_n \operatorname{erfc} \left[\frac{x_n}{2(Dt)^{1/2}} \right] + F_n \left[2 \left(\frac{Dt}{\pi} \right)^{1/2} e^{-x_n^2/4Dt} \right. \\ & \left. - x_n \operatorname{erfc} \left[\frac{x_n}{2(Dt)^{1/2}} \right] \right] + G_n D \left[\left(t + \frac{x_n^2}{2D} \right) \operatorname{erfc} \left[\frac{x_n}{2(Dt)^{1/2}} \right] \right. \\ & \left. - x_n \left(\frac{t}{\pi D} \right)^{1/2} e^{-x_n^2/4Dt} \right] \end{aligned} \quad (7)$$

where

$$x_1 = r-a, \quad x_2 = 2b-r-a, \quad x_3 = 2b+r-3a, \quad x_4 = 4b-4-3a, \quad (8)$$

and the functions $E_n(r)$, $F_n(r)$, and $G_n(r)$ ($n=1, \dots, 4$) are given by

$$\begin{aligned}
 E_1 &= E_2 = -E_3 = -E_4 = A_1/B_1, \\
 F_1 &= (A_2B_1 - A_1B_2)/B_1^2, \quad F_2 = -(A_1B_2 + A_2B_1)/B_1^2, \\
 F_3 &= (3A_1B_2 - A_2B_1)/B_1^2, \quad F_4 = (3A_1B_2 + A_2B_1)/B_1^2, \\
 G_1 &= (B_1A_3 - A_1B_3 - A_2B_2)/B_1^2, \quad G_2 = (B_1A_3 - A_1B_3 + A_2B_2)/B_1^2, \\
 G_3 &= (-B_1A_3 + A_1B_3 + 3A_2B_2)/B_1^2 - 2A_1B_2^2/B_1^3, \\
 G_4 &= (-B_1A_3 + A_1B_3 - 3A_2B_2)/B_1^2 - 2A_1B_2^2/B_1^3, \\
 A_1 &= (br)^{-\frac{1}{2}}, \quad A_2 = -(3r+b)/[8(br)^{\frac{3}{2}}], \\
 A_3 &= 3(5r+3b)(b-r)/[128(br)^{\frac{5}{2}}], \\
 B_1 &= (ba)^{-\frac{1}{2}}, \quad B_2 = -(3a+b)/[8(ba)^{\frac{3}{2}}], \\
 B_3 &= 3(5a+3b)(b-a)/[128(ba)^{\frac{5}{2}}]. \tag{9}
 \end{aligned}$$

Substituting from (7) into (3) the axial thermal stress may then be calculated. This step is carried out numerically as the evaluation of the related integrals in closed form is rather difficult.

THE CRACK PROBLEM

The crack problem may be solved by using equal and opposite of the axial stress obtained from (3) as the crack surface traction in the cylinder containing a circumferential crack and by treating the problem as being isothermal and quasi-static. The details of the formulation of the general nonaxisymmetric problem is given in [4]. In the solution

given in [4] the r , θ , and z components of the displacement vector are expressed in terms of the sum of a harmonic potential associated with an infinite elastic space containing a plane of symmetry and a set of four harmonic functions which are equivalent to Papkovitch-Neuber potentials in cylindrical coordinates [8]. Fourier and Hankel transforms are used to formulate the problem. The elasticity problem (which is considered only for $0 \leq z < \infty$) is subject to the following boundary conditions

$$\sigma_{rr}(a,z,t) = 0, \sigma_{rz}(a,z,t) = 0, (0 \leq z < \infty, 0 \leq t < \infty), \quad (10)$$

$$\sigma_{rr}(b,z,t) = 0, \sigma_{rz}(b,z,t) = 0, (0 \leq z < \infty, 0 \leq t < \infty), \quad (11)$$

$$\sigma_{rz}(r,0,t) = 0, (a \leq r \leq b, 0 \leq t < \infty), \quad (12)$$

$$\sigma_{zz}(r,0,t) = -\sigma_{zz}^T(r,t), (a \leq r < d, 0 \leq t < \infty),$$

$$u_z(r,0,t) = 0, (d \leq r \leq b, 0 \leq t < \infty). \quad (13)$$

The homogeneous conditions (10)-(12) are used to eliminate some of the unknown functions arising from the integration of the differential equations and the mixed boundary conditions (13) gives an integral equation. By defining the derivative of the crack surface displacement as the unknown function, namely

$$\frac{\partial}{\partial r} u_z(r,0^+,t) = \phi(r,t), (a \leq r < d, 0 \leq t < \infty), \quad (14)$$

after a rather lengthy analysis the integral equation for ϕ was found to be [4]

$$\int_a^d \left\{ \frac{1}{\pi} \left[\left(\frac{s}{r} \right)^{\frac{1}{2}} \frac{1}{s-r} - \left(\frac{a}{r} \right)^{\frac{1}{2}} \frac{1}{a-r} \right] + L_1(s,r) - L_1(a,r) \right. \\ \left. + L_2(s,r) - L_2(a,r) \right\} \phi(s,t) ds = - \frac{1-\nu}{\mu} \sigma_{zz}^T(r,t), \\ (a < r < d, 0 \leq t < \infty), \quad (15)$$

where μ is the shear modulus and the kernels L_1 and L_2 are given in [4]. Note that in this problem time t enters into the analysis through σ_{zz}^T only and (15) must be solved for each value of t separately. The integral equation (15) is singular and corresponds to an "edge crack" problem. Its numerical solution may be obtained by using a Gaussian integration procedure in a relatively straightforward manner^(*) [9]. The solution of (15) is of the following form [10]:

$$\phi(r,t) = \frac{f(r,t)}{\sqrt{d-r}}, \quad (a < r < d), \quad (16)$$

where f is a bounded function.

The quantity of primary interest here is in the stress intensity factor k which is the fracture mechanics parameter and is defined by

$$k = \lim_{r \rightarrow d} \sqrt{2(d-r)} \sigma_{zz}(r,0,t) \quad (17)$$

After solving the integral equation k may be obtained from

$$k = \lim_{r \rightarrow d} \sqrt{2(d-r)} \left(\frac{\mu}{1-\nu} \right) \phi(r,t) \quad (18)$$

RESULTS

The numerical results giving the temperature $\theta(r,t)$, the thermal stress $\sigma_{zz}^T(r,t)$, and the stress intensity factor $k(d,t)$ have been obtained for the radius ratios $a/b = 0.3, 0.5, 0.7,$ and 0.9 (Fig. 1). Time is represented through the dimensionless Fourier number which is defined by

$$F_0 = Dt/b^2 \quad (19)$$

^(*)See [10] for the treatment of an edge crack problem.

where D , t , and b are the coefficient of diffusivity, time, and the outer radius of the cylinder, respectively.

The calculated temperature distribution and the corresponding axial stress in the cylinder are shown in Figures 2-9. Note that in the cooling problem the normalizing temperature $\theta_\infty = T_\infty - T_0$ and $\theta = T - T_0$ are both negative. As time goes to infinity the temperature ratio θ/θ_∞ approaches one and the stress σ_{zz}^T approaches zero. The figures show that these limits are approached much faster for the larger values of a/b , that is, for relatively thinner cylinders. The peak value of the stress which occurs at $t=0$ has the expected value of $E\alpha\theta_\infty/(1-\nu)$. This is the thermal stress in a fully constrained plate undergoing a sudden uniform temperature change θ_∞ .

The stress intensity factor obtained from (15) and (18) and normalized as

$$k_T(d) = \frac{k(d,t)}{E\alpha\theta_\infty\sqrt{\ell}/(1-\nu)} \quad (20)$$

is shown in Tables 1-5, where $\ell = d-a$ is the crack depth (Fig. 1). Note that the thermal stress σ_{zz}^T is statically self-equilibrating. Therefore, for $\ell < h = b-a$ the resultant force on the crack surface is compressive and its magnitude decreases with increasing ℓ . Consequently, at a given time t (or for constant F_0) the stress intensity factor ratio k_T will decrease as ℓ increases. From the tables it may also be observed that for a given crack depth ℓ generally k_T first increases, goes through a maximum, and then decreases as F_0 increases. This may be explained by the change in stress profile with increasing time.

REFERENCES

1. D. Stahn und J.G. Blauel, "Experimentelle Untersuchungen zur Rissausbreitung in Glashohlzylindern unter Thermoschockbelastung", Vortrag XI. Intern. Glaskongress Prag, Sammelband II, pp. 435-445, 1977.
2. E. Sternberg and J.G. Chakravorty, "On Inertia Effects in a Transient Thermoelastic Problem", J. Appl. Mech., Vol. 26, Trans. ASME, p. 503, 1959.

3. E. Sternberg and J.G. Chakravorty, "Thermal Shock in an Elastic Body with a Spherical Cavity", Q. Appl. Math. Vol. 17, p. 205, 1959.
4. H.F. Nied, "Circumferentially Cracked Cylinders under Extension and Bending", Ph.D. Dissertation, Lehigh University, Bethlehem, PA, 1981.
5. B.A. Boley and J.H. Weiner, Theory of Thermal Stresses, John Wiley & Sons, Inc., 1960.
6. W. Nowacki, Thermoelasticity, Addison-Wesley Publ. Co., Inc., 1962.
7. S. Timoshenko and J.N. Goodier, Theory of Elasticity, McGraw-Hill Book Co., Inc. 1951.
8. A.I. Lure, Three-Dimensional Problems of the Theory of Elasticity, Interscience Publishers-John Wiley, 1964.
9. F. Erdogan, "Mixed Boundary Value Problems in Mechanics", Mechanics Today, S. Nemat-Nasser, ed. Vol. 4, pp. 1-86, 1978.
10. G.D. Gupta and F. Erdogan, "The Problem of Edge Cracks in an Infinite Strip", J. Appl. Mech. Vol. 41, Trans. ASME, pp. 1001-1006, 1974.

Table 1. Stress intensity factors for internal edge cracks subjected to transient thermal stresses ($k_T(d) = -\frac{k(d)}{\sqrt{L}} \frac{1-\nu}{E\alpha\theta_\infty}$, $\frac{a}{b} = 0.1$, $Fo = \frac{Dt}{b^2}$, $h=b-a$, $\theta_\infty = T_\infty - T_0$)

$\frac{L}{h}$	$Fo = .0001$	$Fo = .0005$	$Fo = .001$	$Fo = .005$	$Fo = .01$	$Fo = .05$
	$\frac{k_T(d)}{k_T(d)}$	$\frac{k_T(d)}{k_T(d)}$	$\frac{k_T(d)}{k_T(d)}$	$\frac{k_T(d)}{k_T(d)}$	$\frac{k_T(d)}{k_T(d)}$	$\frac{k_T(d)}{k_T(d)}$
0.01	0.721	0.885	0.923	0.957	0.945	0.789
0.1	0.045	0.110	0.169	0.364	0.427	0.414
0.2	0.014	0.032	0.048	0.135	0.198	0.261
0.3	0.006	0.015	0.022	0.059	0.095	0.173
0.4	0.004	0.008	0.012	0.031	0.050	0.114
0.5	0.002	0.005	0.007	0.018	0.029	0.075
0.6	0.002	0.003	0.005	0.012	0.018	0.049

Table 2. Stress intensity factors for internal edge cracks subjected to transient thermal stresses. ($k_T(d) = -\frac{k(d)}{\sqrt{L}} \frac{1-\nu}{E\alpha\theta_\infty}$, $\frac{a}{b} = 0.3$, $Fo = \frac{Dt}{b^2}$, $h=b-a$, $\theta_\infty = T_\infty - T_0$)

$\frac{L}{h}$	$Fo = .0001$	$Fo = .0005$	$Fo = .001$	$Fo = .005$	$Fo = .01$	$Fo = .05$
	$\frac{k_T(d)}{k_T(d)}$	$\frac{k_T(d)}{k_T(d)}$	$\frac{k_T(d)}{k_T(d)}$	$\frac{k_T(d)}{k_T(d)}$	$\frac{k_T(d)}{k_T(d)}$	$\frac{k_T(d)}{k_T(d)}$
0.01	0.832	0.961	0.987	0.994	0.972	0.820
0.1	0.094	0.235	0.329	0.566	0.624	0.601
0.2	0.035	0.080	0.117	0.288	0.373	0.437
0.3	0.018	0.041	0.059	0.150	0.220	0.318
0.4	0.011	0.025	0.035	0.086	0.131	0.231
0.5	0.007	0.016	0.023	0.054	0.082	0.165
0.6	0.005	0.012	0.016	0.037	0.054	0.117

Table 3. Stress intensity factors for internal edge cracks subjected to transient thermal stresses. $(k_T(d) = -\frac{k(d)}{\sqrt{x}} \frac{1-\nu}{E\alpha\theta_\infty}, \frac{a}{b} = 0.5, F_0 = \frac{Dt}{b^2}, h=b-a, \theta_\infty=T_\infty-T_0)$

$\frac{x}{h}$	$F_0=.0001$	$F_0=.0005$	$F_0=.001$	$F_0=.005$	$F_0=.01$	$F_0=.05$
	$\frac{k_T(d)}{k_T(d)}$	$\frac{k_T(d)}{k_T(d)}$	$\frac{k_T(d)}{k_T(d)}$	$\frac{k_T(d)}{k_T(d)}$	$\frac{k_T(d)}{k_T(d)}$	$\frac{k_T(d)}{k_T(d)}$
0.01	0.906	0.988	0.997	0.957	0.907	0.644
0.1	0.154	0.364	0.485	0.671	0.686	0.525
0.2	0.064	0.146	0.214	0.435	0.495	0.420
0.3	0.037	0.082	0.117	0.277	0.351	0.334
0.4	0.024	0.054	0.076	0.179	0.246	0.262
0.5	0.018	0.038	0.053	0.121	0.173	0.203
0.6	0.013	0.029	0.040	0.087	0.123	0.154

Table 4. Stress intensity factors for internal edge cracks subjected to transient thermal stresses. $(k_T(d) = -\frac{k(d)}{\sqrt{x}} \frac{1-\nu}{E\alpha\theta_\infty}, \frac{a}{b} = 0.7, F_0 = \frac{Dt}{b^2}, h=b-a, \theta_\infty=T_\infty-T_0)$

$\frac{x}{h}$	$F_0=.0001$	$F_0=.0005$	$F_0=.001$	$F_0=.005$	$F_0=.01$	$F_0=.05$
	$\frac{k_T(d)}{k_T(d)}$	$\frac{k_T(d)}{k_T(d)}$	$\frac{k_T(d)}{k_T(d)}$	$\frac{k_T(d)}{k_T(d)}$	$\frac{k_T(d)}{k_T(d)}$	$\frac{k_T(d)}{k_T(d)}$
0.01	0.968	0.988	0.969	0.844	0.736	0.276
0.1	0.285	0.562	0.650	0.689	0.622	0.237
0.2	0.125	0.292	0.399	0.548	0.519	0.202
0.3	0.079	0.176	0.253	0.432	0.431	0.171
0.4	0.057	0.124	0.175	0.337	0.354	0.144
0.5	0.045	0.095	0.131	0.263	0.288	0.119
0.6	0.036	0.076	0.104	0.205	0.230	0.097

Table 5. Stress intensity factors for internal edge cracks subjected to transient thermal stresses. ($k_T(d) = \frac{k(d)}{\sqrt{d}} \frac{1-\nu}{E\alpha\theta_\infty}$, $\frac{a}{b} = 0.9$, $Fo = \frac{Dt}{b^2}$, $h=b-a$, $\theta_\infty = T_\infty - T_0$)

$\frac{d}{h}$	$Fo = .0001$	$Fo = .0005$	$Fo = .001$	$Fo = .005$
	$\frac{k_T(d)}{\sqrt{d}}$	$\frac{k_T(d)}{\sqrt{d}}$	$\frac{k_T(d)}{\sqrt{d}}$	$\frac{k_T(d)}{\sqrt{d}}$
0.01	0.962	0.833	0.724	0.277
0.1	0.657	0.701	0.633	0.247
0.2	0.426	0.589	0.560	0.224
0.3	0.300	0.501	0.502	0.206
0.4	0.238	0.432	0.453	0.190
0.5	0.205	0.378	0.408	0.174
0.6	0.185	0.334	0.367	0.158

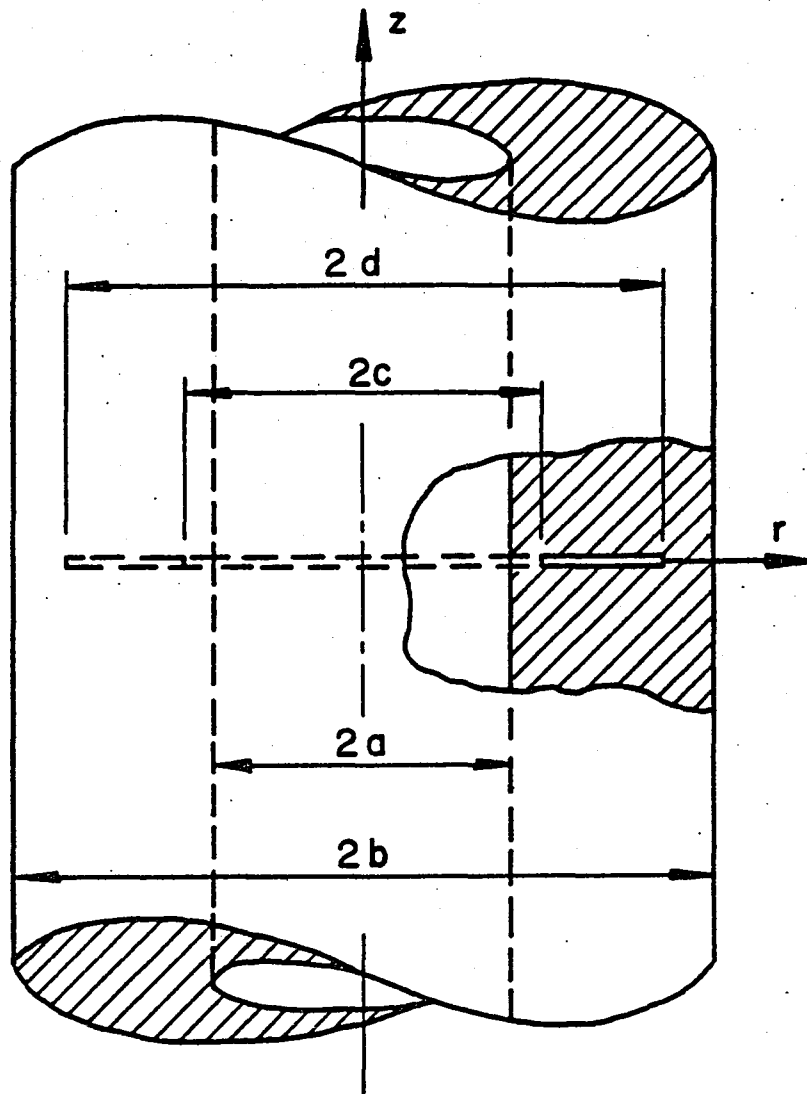

Fig. 1 Geometry of a thick-walled cylinder containing an axisymmetric circumferential crack.

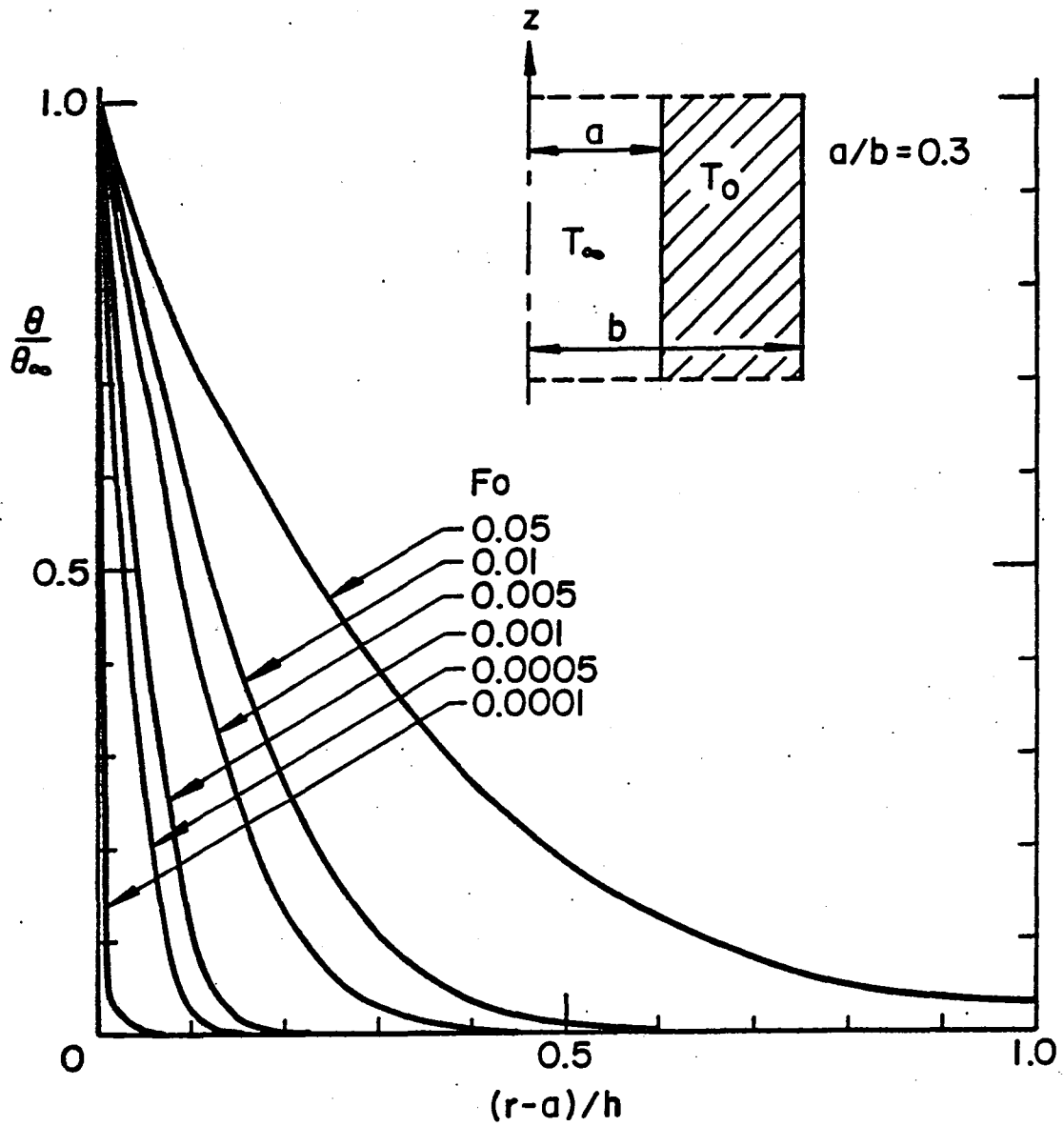

Fig. 2 Transient temperature distribution θ/θ_{∞} in a hollow cylinder due to a sudden temperature change on the inner radius. $a/b=0.3$, $h=b-a$, $Fo=Dt/b^2$, $\theta/\theta_{\infty} = (T(r,t)-T_0)/(T_{\infty}-T_0)$.

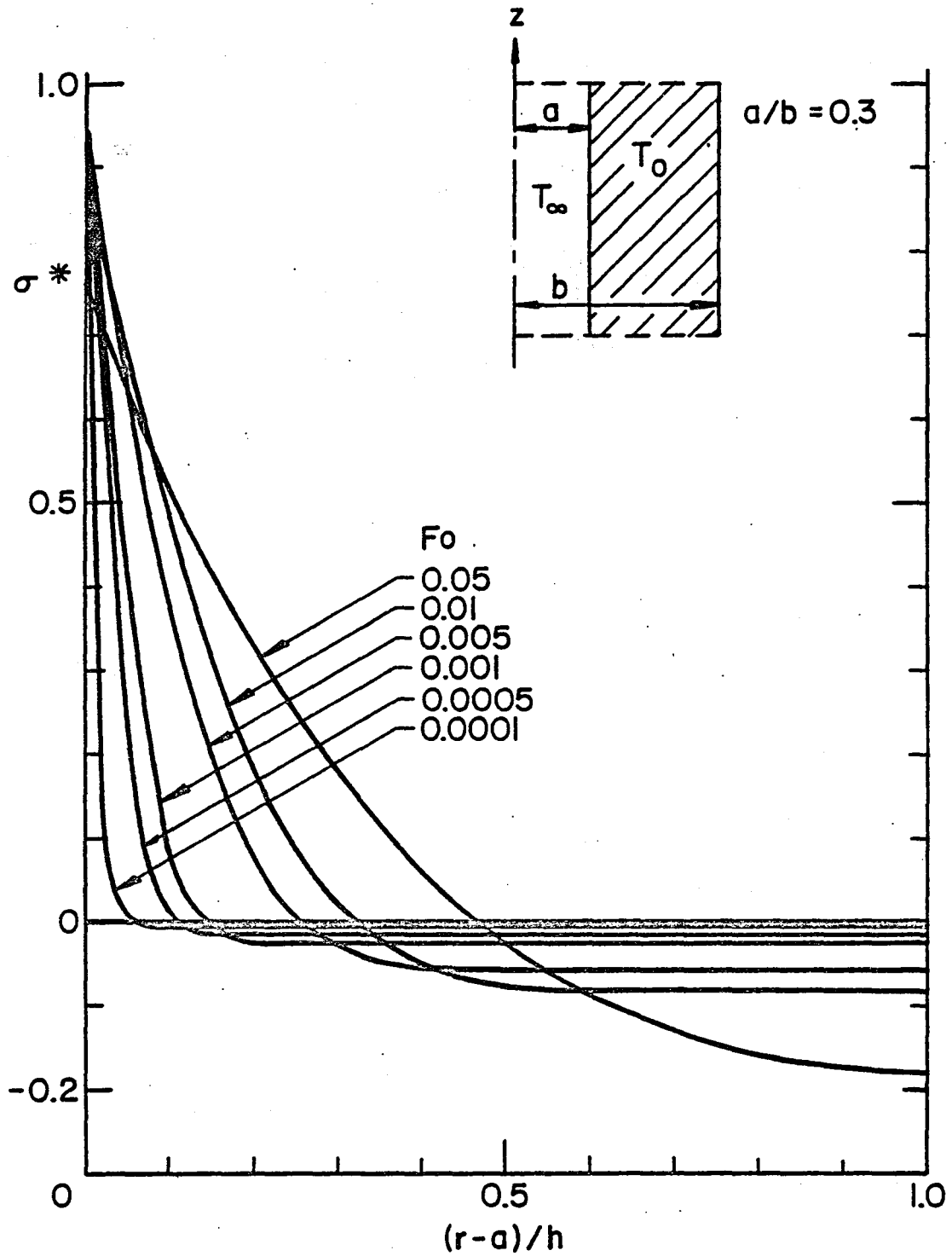

Fig. 3 Transient thermal stresses in a hollow cylinder which has been suddenly cooled by a temperature T_∞ on its inner radius. $a/b=0.3$, $h=b-a$, $Fo=Dt/b^2$, $\sigma^* = -\frac{(1-\nu)}{E\alpha} \sigma_{zz}^T/\theta_\infty$.

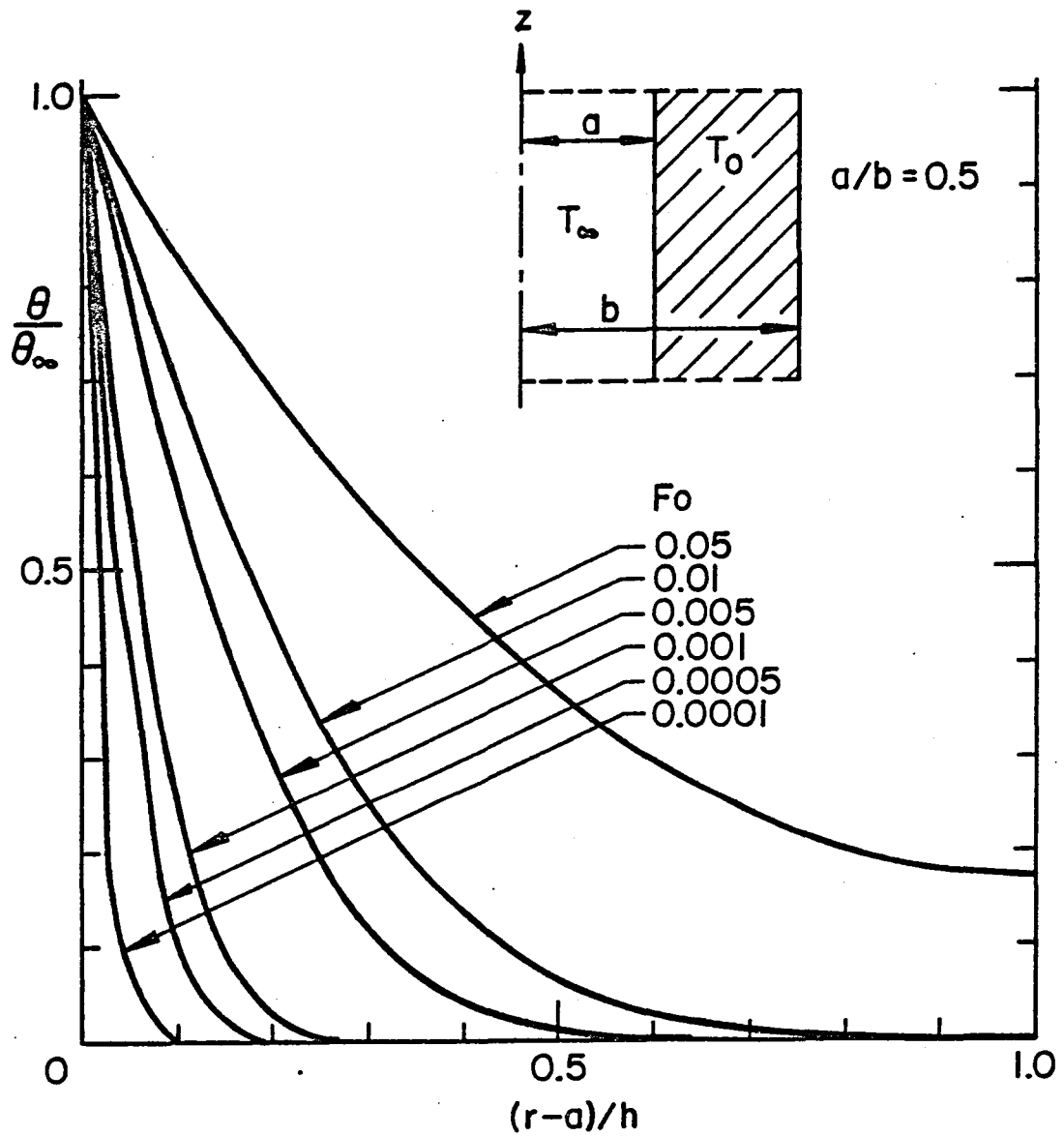

Fig. 4 Transient temperature distribution θ/θ_{∞} in a hollow cylinder due to a sudden temperature change on the inner radius. $a/b=0.5$, $h=b-a$, $Fo=Dt/b^2$, $\theta/\theta_{\infty} = (T(r,t)-T_0)/(T_{\infty}-T_0)$.

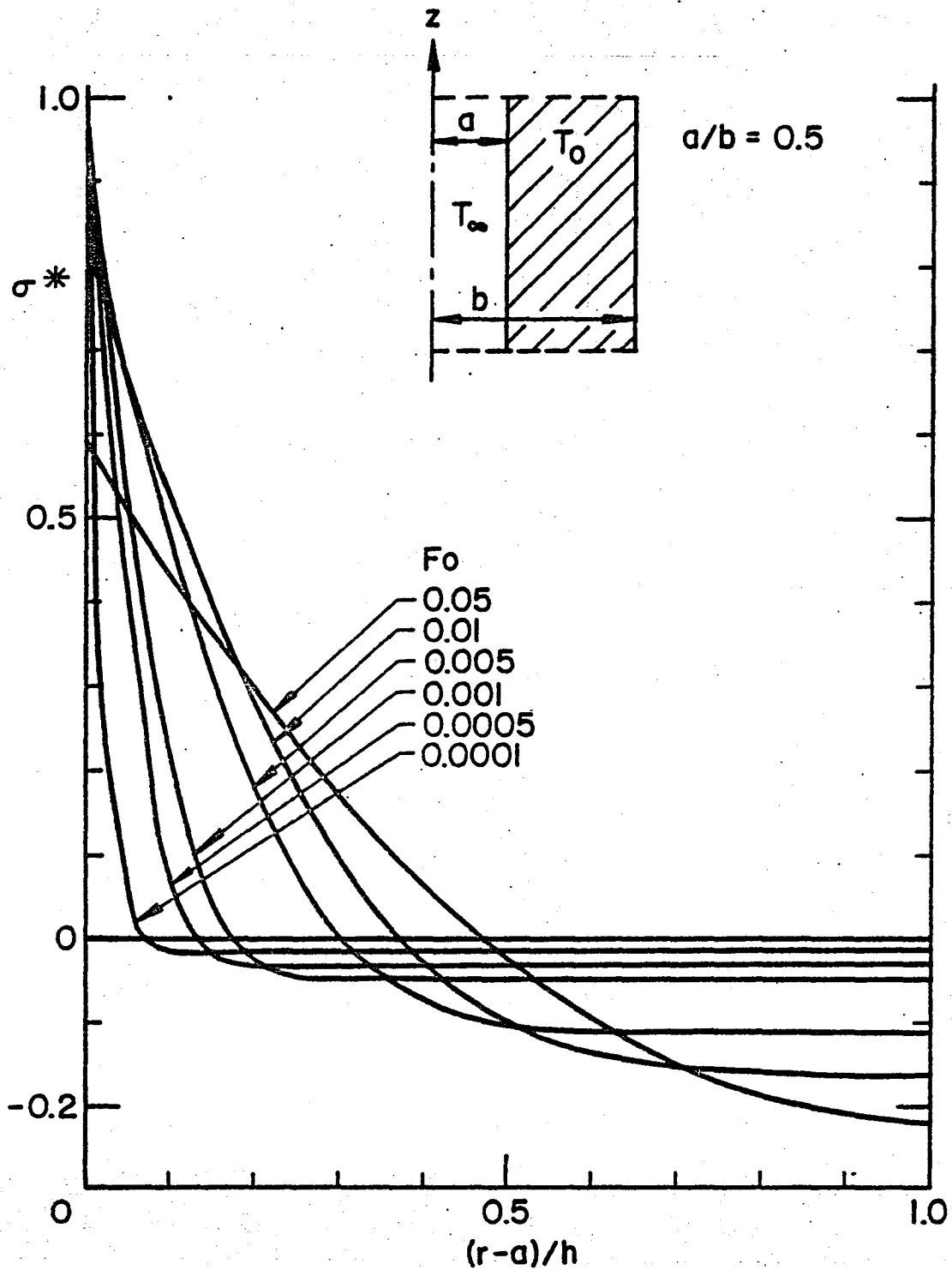

Fig. 5 Transient thermal stresses in a hollow cylinder which has been suddenly cooled by a temperature T_∞ on its inner radius. $a/b = 0.5$, $h=b-a$, $Fo=Dt/b^2$, $\sigma^* = -\left(\frac{1-\nu}{E\alpha}\right) \sigma_{zz}^T/\theta_\infty$.

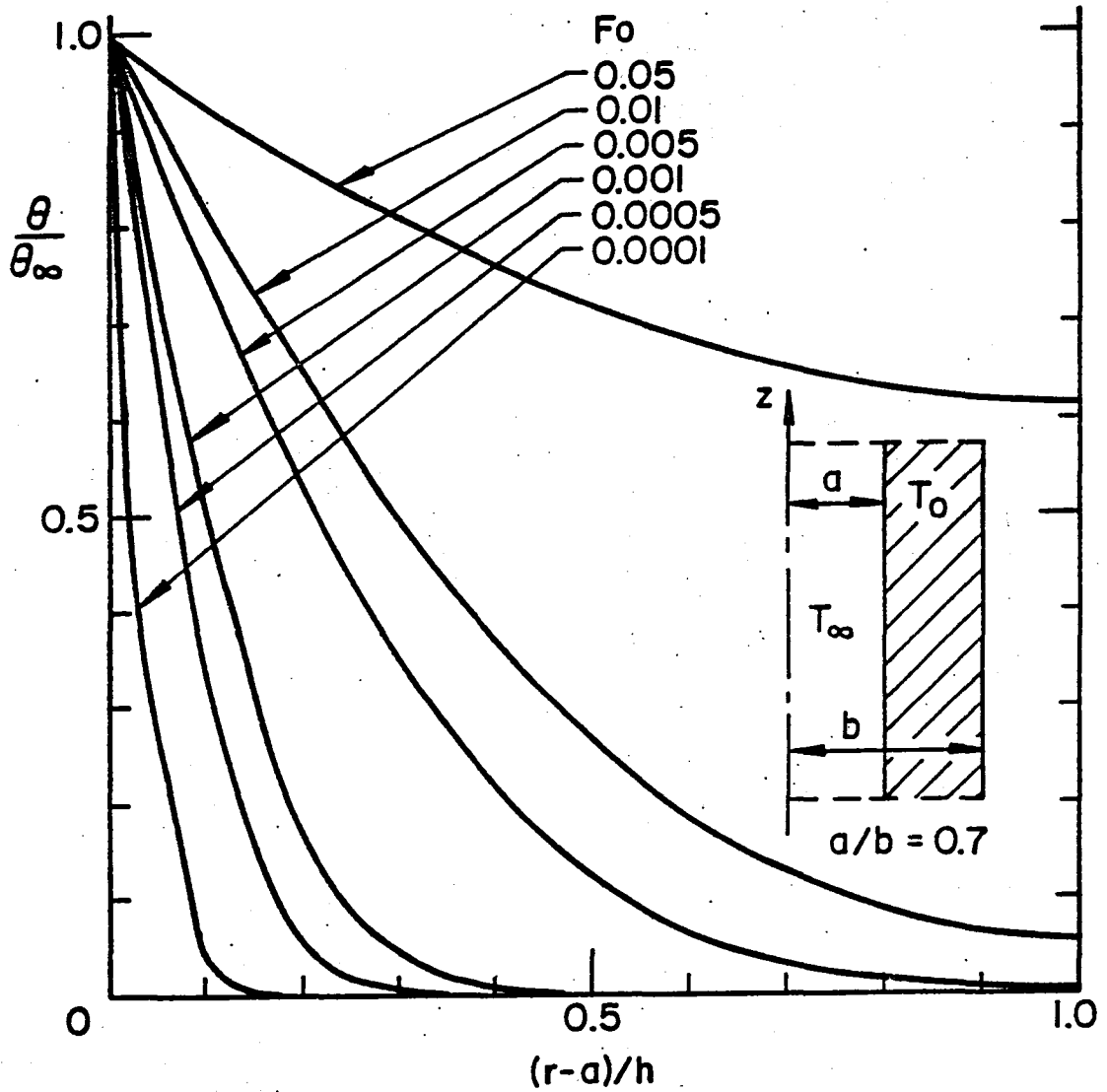

Fig. 6 Transient temperature distribution θ/θ_∞ in a hollow cylinder due to a sudden temperature change on the inner radius. $a/b=0.7$, $h=b-a$, $Fo=Dt/b^2$, $\theta/\theta_\infty = (T(r,t)-T_0)/(T_\infty-T_0)$.

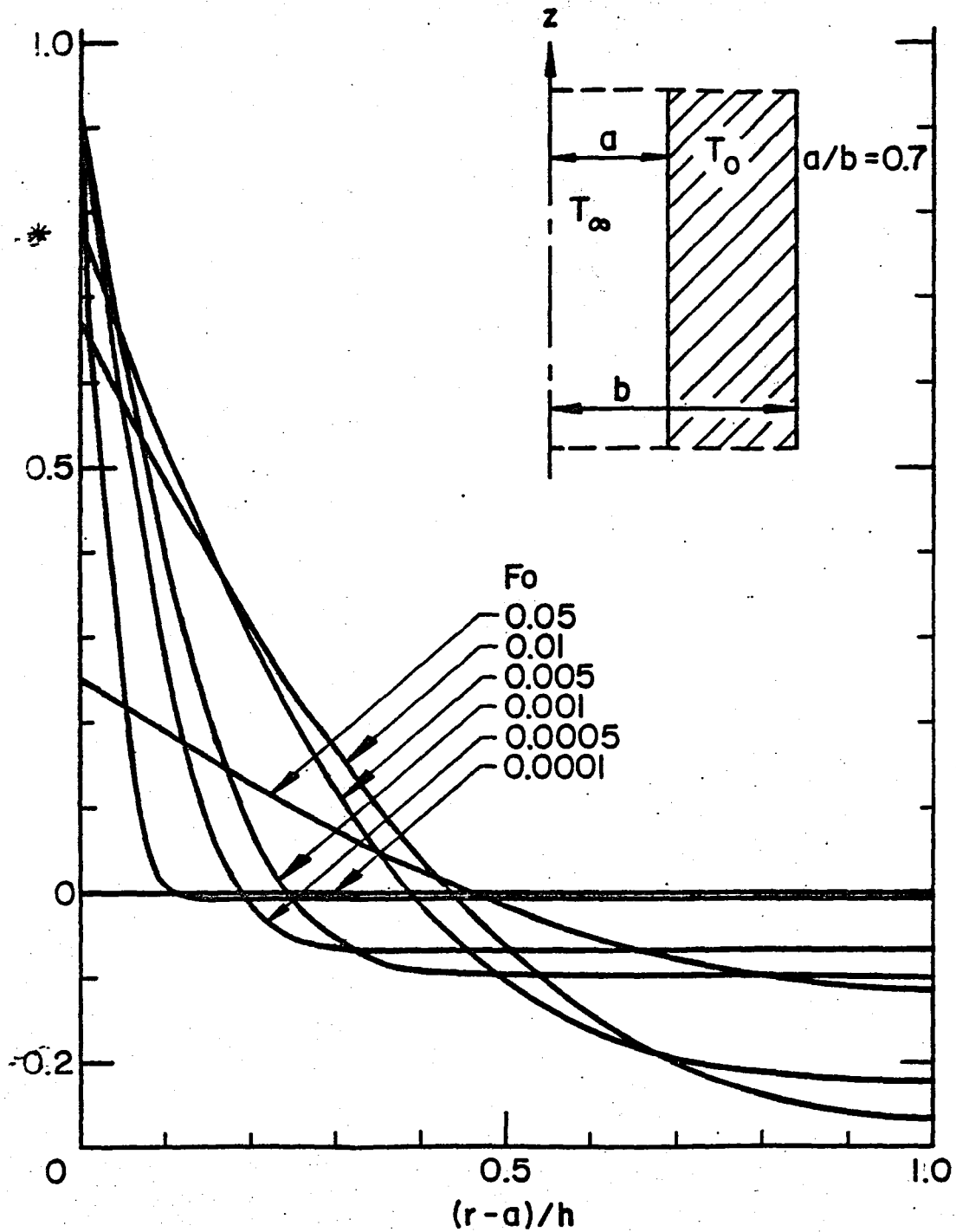

Fig. 7 Transient thermal stresses in a hollow cylinder which has been suddenly cooled by a temperature T_∞ on its inner radius. $a/b = 0.7$, $h=b-a$, $F_0=Dt/b^2$, $\sigma^* = -\left(\frac{1-\nu}{E\alpha}\right) \sigma_{zz} T/\theta_\infty$.

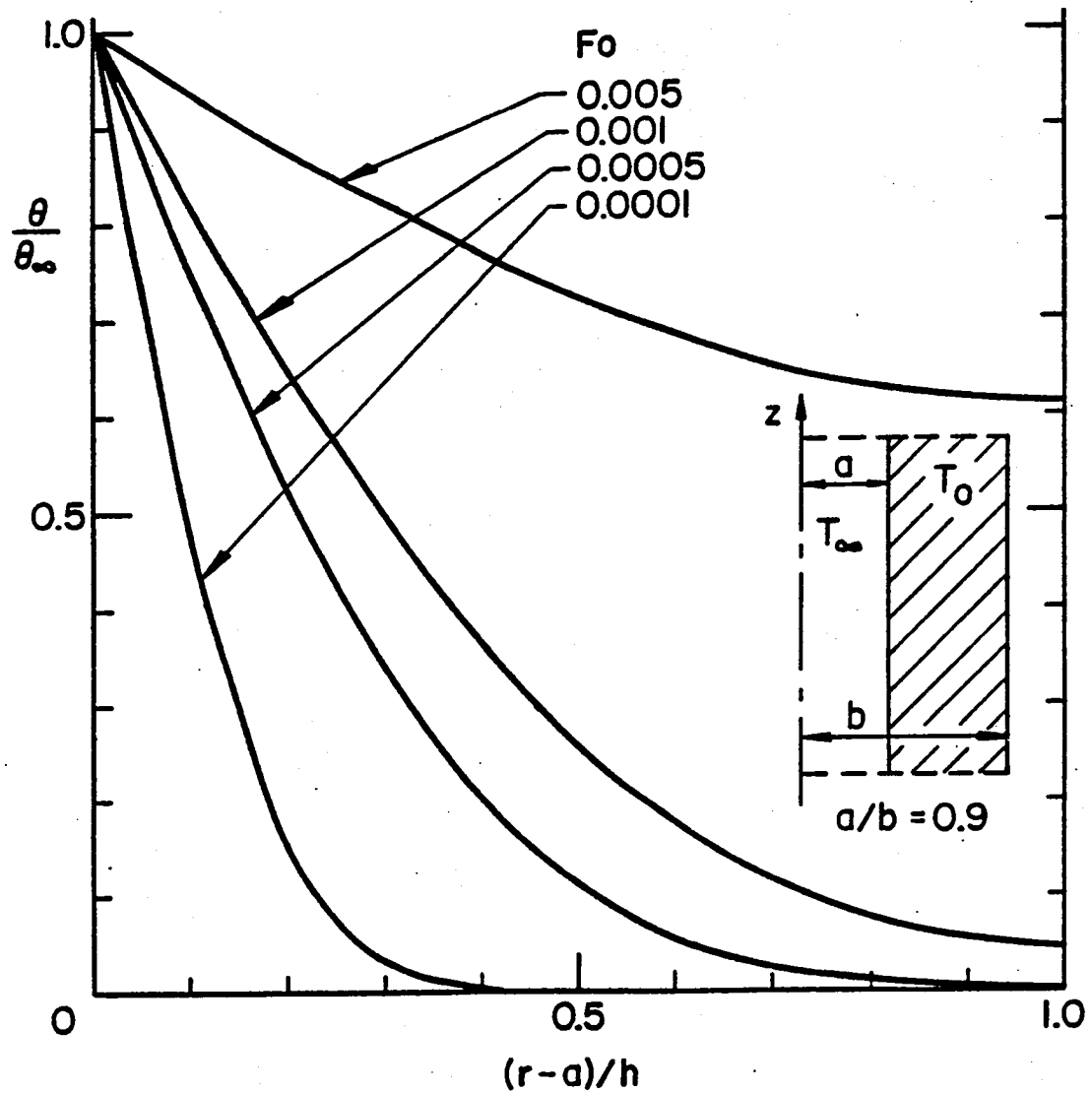

Fig. 8 Transient temperature distribution θ/θ_∞ in a hollow cylinder due to a sudden temperature change on the inner radius. $a/b=0.9$, $h=b-a$, $Fo=Dt/b^2$, $\theta/\theta_\infty = (T(r,t)-T_0)/(T_\infty-T_0)$.

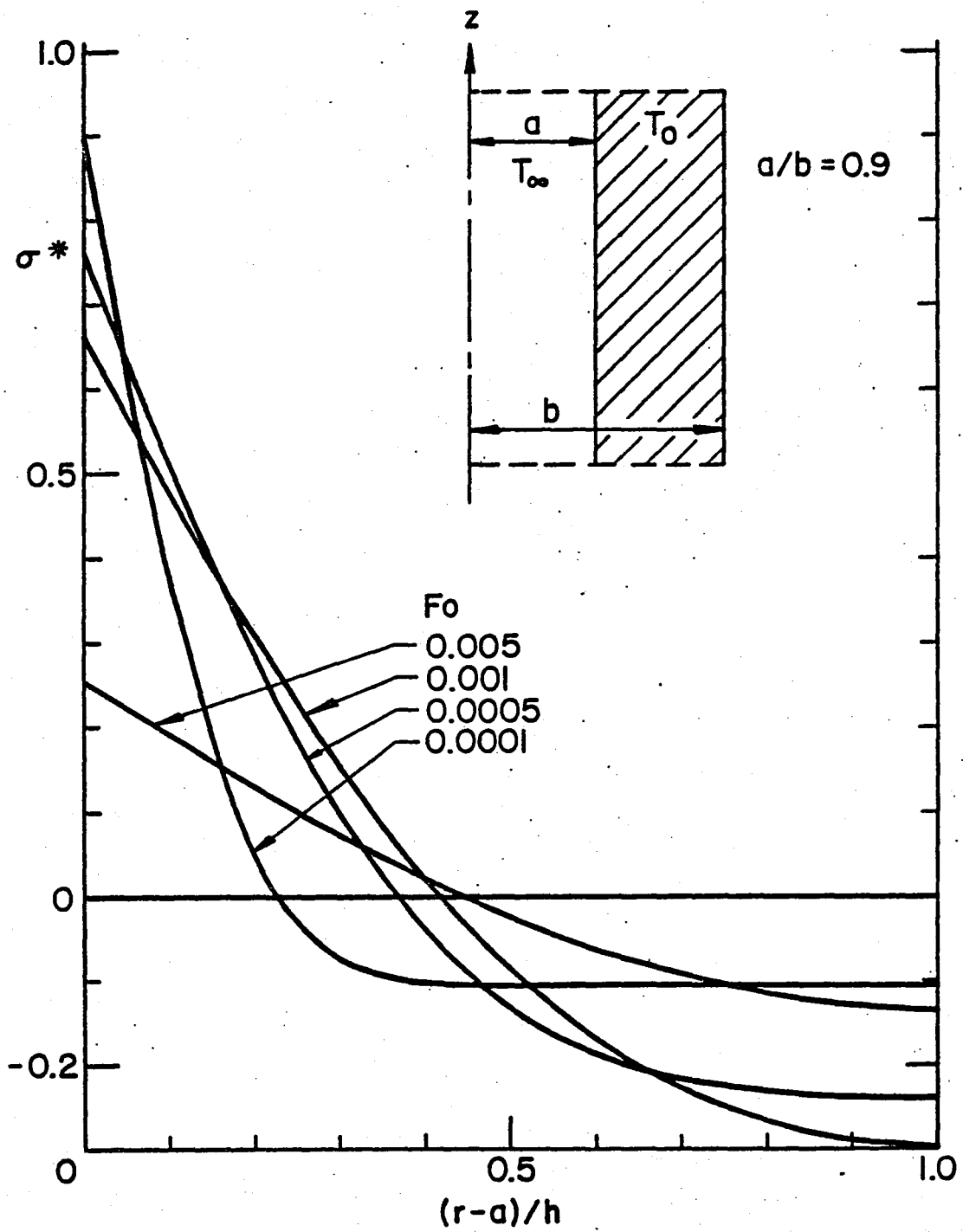

Fig. 9 Transient thermal stresses in a hollow cylinder which has been suddenly cooled by a temperature T_∞ on its inner radius. $a/b = 0.9$, $h=b-a$, $Fo=Dt/b^2$, $\sigma^* = -\frac{(1-\nu)}{E\alpha} \sigma_{zz}^T/\theta_\infty$.

1. Report No. NASA CR-165989		2. Government Accession No.		3. Recipient's Catalog No.	
4. Title and Subtitle TRANSIENT THERMAL STRESS PROBLEM FOR A CIRCUMFERENTIALLY CRACKED HOLLOW CYLINDER				5. Report Date September 1982	
				6. Performing Organization Code	
7. Author(s) H. F. Nied and F. Erdogan				8. Performing Organization Report No.	
				10. Work Unit No.	
9. Performing Organization Name and Address Lehigh University Bethlehem, PA 18015				11. Contract or Grant No. NGR 39-007-011	
				13. Type of Report and Period Covered Contractor Report	
12. Sponsoring Agency Name and Address National Aeronautics and Space Administration Washington, DC 20546				14. Sponsoring Agency Code	
15. Supplementary Notes Langley technical monitor: Dr. John H. Crews, Jr.					
16. Abstract <p>In this paper, the transient thermal stress problem for a hollow elastic cylinder containing an internal circumferential edge crack is considered. It is assumed that the problem is axisymmetric with regard to the crack geometry and the loading, and that the inertia effects are negligible. The problem is solved for a cylinder which is suddenly cooled from inside. First, the transient temperature and stress distributions in an uncracked cylinder are calculated. By using the equal and opposite of this thermal stress as the crack surface traction in the isothermal cylinder, the crack problem is then solved and the stress-intensity factor is calculated. The numerical results are obtained as a function of the Fourier number tD/b^2 representing the time for various inner-to-outer radius ratios and relative crack depths, where D and b are, respectively, the coefficient of diffusivity and the outer radius of the cylinder.</p>					
17. Key Words (Suggested by Author(s)) Hollow cylinder Circumferential crack Transient temperature Thermal stress Stress-intensity factor			18. Distribution Statement Unclassified - Unlimited Subject Category 39		
19. Security Classif. (of this report) Unclassified	20. Security Classif. (of this page) Unclassified	21. No. of Pages 22	22. Price* A02		

End of Document