

N O T I C E

THIS DOCUMENT HAS BEEN REPRODUCED FROM
MICROFICHE. ALTHOUGH IT IS RECOGNIZED THAT
CERTAIN PORTIONS ARE ILLEGIBLE, IT IS BEING RELEASED
IN THE INTEREST OF MAKING AVAILABLE AS MUCH
INFORMATION AS POSSIBLE

(NASA-CR-169035) A RESEARCH PROGRAM TO
REDUCE INTERIOR NOISE IN GENERAL AVIATION
AIRPLANES. INFLUENCE OF DEPRESSURIZATION
AND DAMPING MATERIAL ON THE NOISE REDUCTION
(Kansas Univ. Center for Research, Inc.)

N82-27088

Unclass
23285

G3/71

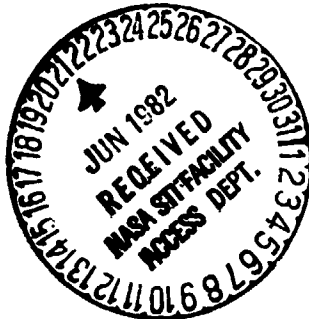
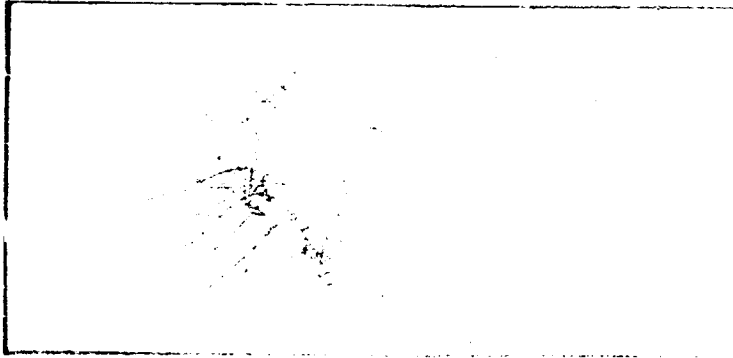

THE UNIVERSITY OF KANSAS CENTER FOR RESEARCH, INC.

2291 Irving Hill Drive—Campus West
Lawrence, Kansas 66045



**Progress Report for
A RESEARCH PROGRAM TO REDUCE INTERIOR NOISE
IN GENERAL AVIATION AIRPLANES**

NASA Contract NCCI-6

**INFLUENCE OF DEPRESSURIZATION AND DAMPING
MATERIAL ON THE NOISE REDUCTION
CHARACTERISTICS OF FLAT AND CURVED
STIFFENED PANELS**

KU-FRL-417-17

**Prepared by: Ramasamy Navaneethan, Project Manager
Barry Streeter
Stephen Koontz**

Approved by: Jan Roskam, Principal Investigator

**Flight Research Laboratory
University of Kansas
Lawrence, Kansas
October 1981**

SUMMARY

In this report, the work carried out to investigate the noise reduction characteristics of general aviation type flat and curved, stiffened panels at the University of Kansas Flight Research Laboratory noise research facility are presented. The effects of depressurization, damping material, and noise source are described.

The experimental study was carried out on 20 x 20 inch panels in a frequency range of interest from 20 Hz to 5000 Hz. The noise sources used were a swept sine wave generator and a random noise generator.

The results indicate that under the conditions tested, the effect of noise source was negligible. Increasing the pressure differential across the panel gives better noise reduction below the fundamental resonance frequency due to an increase in stiffness. The largest increase occurs in the first 1 psi pressure differential. The curved, stiffened panel exhibited similar behavior, but with a lower increase of low frequency noise reduction. Depressurization on curved, stiffened panels results in a decrease of the noise reduction at higher frequencies, confirming theoretical work done by Koval. The effect of damping tapes on the overall noise reduction values of the test specimens was small away from the resonance frequency. In the mass-law region a slight and proportional improvement in noise reduction is observed by the addition of damping material. Adding sound absorption material to a panel with damping material increases beneficially noise reduction at high frequencies.

TABLE OF CONTENTS

	<u>Page</u>
<u>LIST OF FIGURES</u>	iv
<u>LIST OF SYMBOLS</u>	x
<u>LIST OF ACRONYMS</u>	x
CHAPTER 1. <u>INTRODUCTION</u>	1
CHAPTER 2. <u>DETAILS OF THE MODIFICATIONS AND THE TEST PANELS</u>	8
2.1 MODIFICATIONS TO THE ACOUSTIC TEST FACILITY.	8
2.1.1 <u>Depressurization System</u>	8
2.1.2 <u>Extension Tube for Curved Panel</u>	8
2.2 DESCRIPTION OF THE TEST PANELS AND THE DAMPING TAPES.	10
2.2.1 <u>Flat Panel</u>	10
2.2.2 <u>Curved Panel</u>	10
2.2.3 <u>Damping Tapes</u>	13
2.2.4 <u>Insulation Material</u>	13
CHAPTER 3. <u>NOISE REDUCTION CHARACTERISTICS OF BARE FLAT AND CURVED PANELS</u>	14
3.1 FLAT PANEL RESULTS	14
3.1.1 <u>Effect of Noise Source</u>	14
3.1.2 <u>Effect of Depressurization</u>	16
3.2 CURVED PANEL RESULTS	18
3.2.1 <u>Effect of Noise Source</u>	18
3.2.2 <u>Effect of Depressurization</u>	20
CHAPTER 4. <u>NOISE REDUCTION CHARACTERISTICS OF STIFFENED, FLAT AND CURVED PANELS WITH Y-370 DAMPING MATERIAL</u>	21
4.1 TESTS PERFORMED ON PANELS COVERED WITH Y-370	21

TABLE OF CONTENTS (continued)

	<u>Page</u>
4.2 FLAT PANEL RESULTS	23
4.2.1 <u>30% Panel Coverage</u>	23
4.2.2 <u>60% Panel Coverage</u>	25
4.2.3 <u>100% Panel Coverage</u>	28
4.2.4 <u>Effect of Percentage of Coverage</u>	28
4.3 CURVED PANEL RESULTS	33
4.3.1 <u>30% Panel Coverage</u>	34
4.3.2 <u>60% Panel Coverage</u>	37
4.3.3 <u>100% Panel Coverage</u>	37
4.3.4 <u>Effect of Percentage of Coverage</u>	39
CHAPTER 5. <u>NOISE REDUCTION CHARACTERISTICS OF STIFFENED, FLAT AND CURVED PANELS WITH Y-434 DAMPING MATERIAL</u>	43
5.1 TESTS PERFORMED ON THE PANELS COVERED WITH Y-434	43
5.2 FLAT PANEL RESULTS	43
5.2.1 <u>30% Panel Coverage</u>	43
5.2.2 <u>60% Panel Coverage</u>	47
5.2.3 <u>100% Panel Coverage</u>	47
5.2.4 <u>Effect of Percentage of Coverage</u>	51
5.3 CURVED PANEL RESULTS	55
5.3.1 30% Panel Coverage.	55
5.3.2 60% Panel Coverage.	57
5.3.3 100% Panel Coverage	59
5.3.4 Effect of Percentage of Coverage.	61
CHAPTER 6. <u>NOISE REDUCTION CHARACTERISTICS OF STIFFENED, FLAT AND CURVED PANELS WITH Y-436 DAMPING TAPE</u>	65

TABLE OF CONTENTS (continued)

	<u>Page</u>
6.1 TESTS PERFORMED ON THE PANELS COVERED WITH Y-436 . . .	65
6.2 FLAT PANEL RESULTS	65
6.2.1 <u>30% Panel Coverage.</u>	67
6.2.2 <u>60% Panel Coverage.</u>	67
6.2.3 <u>100% Panel Coverage</u>	71
6.2.4 <u>Effect of Percentage of Coverage.</u>	75
6.3 CURVED PANEL RESULTS	75
6.3.1 <u>30% Panel Coverage.</u>	75
6.3.2 <u>60% Panel Coverage.</u>	78
6.3.3 <u>100% Panel Coverage</u>	81
6.3.4 <u>Effect of Percentage of Coverage.</u>	82
CHAPTER 7. <u>NOISE REDUCTION CHARACTERISTICS OF STIFFENED, FLAT AND CURVED PANELS WITH Y-370 DAMPING TAPE AND FIBERGLASS INSULATION</u>	85
7.1 TESTS PERFORMED ON THE PANELS COVERED WITH Y-370 AND FIBERGLASS	85
7.2 FLAT PANEL RESULTS	86
7.2.1 <u>Y-370 and Light Insulation.</u>	86
7.2.2 <u>Y-370 and Heavy Insulation.</u>	89
7.3 CURVED PANEL RESULTS	92
7.3.1 <u>Y-370 and Light Insulation.</u>	92
7.3.2 <u>Y-370 and Heavy Insulation.</u>	92
CHAPTER 8. <u>DISCUSSION, CONCLUSIONS, AND RECOMMENDATIONS</u>	96
<u>REFERENCES</u>	101
<u>APPENDIX A</u>	103
<u>APPENDIX B</u>	200

LIST OF FIGURES

<u>Number</u>	<u>Title</u>	<u>Page</u>
1.1	Test Set-Up in the KU-FRL Acoustic Test Facility.	2
1.2	Beranek Tube Set-Up for Flat Panel.	3
1.3	Beranek Tube Set-Up for Curved Panel.	4
1.4	Noise Generation and Data Acquisition Equipment	5
1.5	Depressurization Subsystem.	6
2.1	Flat Panel Dimensions	11
2.2	Curved Panel Dimensions	12
3.1	Effect of Pressure Differential on Noise Reduction Characteristics of a Bare, Flat Panel at Low and High Frequencies	15
3.2	Effect of Pressure Differential on the Fundamental Resonance Frequency for Flat and Curved, Stiffened Panels.	17
3.3	Effect of Pressure Differential on Noise Reduction Characteristics of a Bare, Curved Panel at Low and High Frequencies	19
4.1	Effect of Pressure Differential on Noise Reduction Characteristics of a Flat, Stiffened Panel with 30% Y-370 Damping Tape at Low and High Frequencies	22
4.2	Effect of Pressure Differential on the Fundamental Resonance Frequency for Flat and Curved, Stiffened Panels with 30% Y-370 . . .	24
4.3	Effect of Pressure Differential on Noise Reduction Characteristics of a Flat, Stiffened Panel with 60% Y-370 Damping Tape at Low and High Frequencies	26
4.4	Effect of Pressure Differential on the Fundamental Resonance Frequency for Flat and Curved, Stiffened Panels with 60% Y-370 . . .	27
4.5	Effect of Pressure Differential on Noise Reduction Characteristics of a Flat, Stiffened Panel with 100% Y-370 Damping Tape at Low and High Frequencies	29

LIST OF FIGURES (continued)

<u>Number</u>	<u>Title</u>	<u>Page</u>
4.6	Effect of Pressure Differential on the Fundamental Resonance Frequency for Flat and Curved, Stiffened Panels with 100% Y-370. . .	30
4.7	Effect of Coverage of Y-370 Damping Tape on Low Frequency Noise Reduction Characteristics for a Flat, Stiffened Panel at Different Pressure Differentials.	31
4.8	Effect of Coverage of Y-370 Damping Tape on High Frequency Noise Reduction Characteristics for a Flat, Stiffened Panel at Different Pressure Differentials.	32
4.9	Effect of Pressure Differential on Noise Reduction Characteristics of a Curved, Stiffened Panel with 30% Y-370 Damping Tape at Low and High Frequencies	35
4.10	Effect of Pressure Differential on Noise Reduction Characteristics of a Curved, Stiffened Panel with 60% Y-370 Damping Tape at Low and High Frequencies	36
4.11	Effect of Pressure Differential on Noise Reduction Characteristics of a Curved, Stiffened Panel with 100% Y-370 Damping Tape at Low and High Frequencies	38
4.12	Effect of Coverage of Y-370 Damping Tape on Low Frequency Noise Reduction Characteristics for a Curved, Stiffened Panel at Different Pressure Differentials.	40
4.13	Effect of Coverage of Y-370 Damping Tape on High Frequency Noise Reduction Characteristics for a Curved, Stiffened Panel at Different Pressure Differentials.	41
5.1	Effect of Pressure Differential on Noise Reduction Characteristics of a Flat, Stiffened Panel with 30% Y-434 Damping Tape at Low and High Frequencies	44
5.2	Effect of Pressure Differential on the Fundamental Resonance Frequency for Flat and Curved, Stiffened Panels with 30% Y-434 . . .	46

LIST OF FIGURES (continued)

<u>Number</u>	<u>Title</u>	<u>Page</u>
5.3	Effect of Pressure Differential on Noise Reduction Characteristics of a Flat, Stiffened Panel with 60% Y-434 Damping Tape at Low and High Frequencies	48
5.4	Effect of Pressure Differential on the Fundamental Resonance Frequency for Flat and Curved, Stiffened Panels with 60% Y-434 . . .	49
5.5	Effect of Pressure Differential on Noise Reduction Characteristics of a Flat, Stiffened Panel with 100% Y-434 Damping Tape at Low and High Frequencies	50
5.6	Effect of Pressure Differential on the Fundamental Resonance Frequency for Flat and Curved, Stiffened Panels with 100% Y-434. . .	52
5.7	Effect of Coverage of Y-434 Damping Tape on Low Frequency Noise Reduction Characteristics for a Flat, Stiffened Panel at Different Pressure Differentials.	53
5.8	Effect of Coverage of Y-434 Damping Tape on High Frequency Noise Reduction Characteristics for a Flat, Stiffened Panel at Different Pressure Differentials.	54
5.9	Effect of Pressure Differential on Noise Reduction Characteristics of a Curved, Stiffened Panel with 30% Y-434 Damping Tape at Low and High Frequencies	56
5.10	Effect of Pressure Differential on Noise Reduction Characteristics of a Curved, Stiffened Panel with 60% Y-434 Damping Tape at Low and High Frequencies	58
5.11	Effect of Pressure Differential on Noise Reduction Characteristics of a Curved, Stiffened Panel with 100% Y-434 Damping Tape at Low and High Frequencies	60
5.12	Effect of Coverage of Y-434 Damping Tape on Low Frequency Noise Reduction Characteristics for a Curved, Stiffened Panel at Different Pressure Differentials.	62

LIST OF FIGURES (continued)

<u>Number</u>	<u>Title</u>	<u>Page</u>
5.13	Effect of Coverage of Y-434 Damping Tape on High Frequency Noise Reduction Characteristics on a Curved, Stiffened Panel at Different Pressure Differentials.	63
6.1	Effect of Pressure Differential on Noise Reduction Characteristics of a Flat, Stiffened Panel with 30% Y-436 Damping Tape at Low and High Frequencies	66
6.2	Effect of Pressure Differential on the Fundamental Resonance Frequency for Flat and Curved, Stiffened Panels with 30% Y-436 . . .	68
6.3	Effect of Pressure Differential on Noise Reduction Characteristics of a Flat, Stiffened Panel with 60% Y-436 Damping Tape at Low and High Frequencies	69
6.4	Effect of Pressure Differential on the Fundamental Resonance Frequency for Flat and Curved, Stiffened Panels with 60% Y-436 . . .	70
6.5	Effect of Pressure Differential on Noise Reduction Characteristics of a Flat, Stiffened Panel with 100% Y-436 Damping Tape at Low and High Frequencies	72
6.6	Effect of Pressure Differential on the Fundamental Resonance Frequency for Flat and Curved, Stiffened Panels with 100% Y-436. . .	73
6.7	Effect of Coverage of Y-436 Damping Tape on Low Frequency Noise Reduction Characteristics for a Flat, Stiffened Panel at Different Pressure Differentials.	74
6.8	Effect of Coverage of Y-436 Damping Tape on High Frequency Noise Reduction Characteristics for a Flat, Stiffened Panel at Different Pressure Differentials.	76
6.9	Effect of Pressure Differentials on Noise Reduction Characteristics of a Curved, Stiffened Panel with 30% Y-436 Damping Tape at Low and High Frequencies	77

LIST OF FIGURES (continued)

<u>Number</u>	<u>Title</u>	<u>Page</u>
6.10	Effect of Pressure Differential on Noise Reduction Characteristics of a Curved, Stiffened Panel with 60% Y-436 Damping Tape at Low and High Frequencies	79
6.11	Effect of Pressure Differential on Noise Reduction Characteristics of a Curved, Stiffened Panel with 100% Y-436 Damping Tape at Low and High Frequencies.	80
6.12	Effect of Coverage of Y-436 Damping Tape on Low Frequency Noise Reduction Characteristics for a Curved, Stiffened Panel at Different Pressure Differentials.	83
6.13	Effect of Coverage of Y-436 Damping Tape on High Frequency Noise Reduction Characteristics for a Curved, Stiffened Panel at Different Pressure Differentials.	84
7.1	Effect of Pressure Differential on Noise Reduction Characteristics of a Flat, Stiffened Panel with 100% Y-370 Damping Tape and Light Insulation at Low and High Frequencies	7.1
7.2	Effect of Pressure Differential on the Fundamental Resonance Frequency for Flat and Curved, Stiffened Panels with 100% Y-370 and Light Fiberglass Insulation	88
7.3	Effect of Pressure Differential on Noise Reduction Characteristics of a Flat, Stiffened Panel with 100% Y-370 Damping Tape and Heavy Insulation at Low and High Frequencies	7.3
7.4	Effect of Pressure Differential on the Fundamental Resonance Frequency for Flat and Curved, Stiffened Panels with 100% Y-370 and Heavy Fiberglass Insulation	91
7.5	Effect of Pressure Differential on Noise Reduction Characteristics of a Curved, Stiffened Panel with 100% Y-370 Damping Tape and Light Insulation at Low and High Frequencies	93

LIST OF FIGURES (continued)

<u>Number</u>	<u>Title</u>	<u>Page</u>
7.6	Effect of Pressure Differential on Noise Reduction Characteristics of a Curved, Stiffened Panel with 100% Y-370 and Heavy Insulation at Low and High Frequencies.	94
8.1	Comparison of Original Noise Reduction Characteristics of a Flat, Stiffened Panel with Data from a Later Test Run	97

LIST OF SYMBOLS

<u>Symbol</u>	<u>Definition</u>	<u>Dimension</u>
t	panel thickness	{in}
ρ	density	{lb/ft ³ }

LIST OF ACRONYMS

<u>Abbreviation</u>	<u>Definition</u>
DB (dB)	Decibel
FRL	Flight Research Laboratory
Hz	Herz, cycles per second
KU	University of Kansas
NR	Noise Reduction
ΔP	Pressure Differential

CHAPTER 1

INTRODUCTION

This report is a continuation of the documentation of the research accomplished under the continuing NASA cooperative agreement NCCI-6. The progress of the research accomplished during the period February 1, 1981, through April 30, 1981, of the previous project year (May 1, 1980, through April 30, 1981) was included in the previous report, KU-FRL-417-16 (Reference 1).

The present report covers the period from May 1, 1981, through September 31, 1981, of the current project year (May 1, 1981, through April 30, 1982). During this period in time, all of the tests concerning the flat and curved panels were completed. Both panels were provided by the Gates Learjet Corporation. These tests were performed in the Flight Research Laboratory of the University of Kansas (KU-FRL) in Raymond Nichols Hall on the west campus of the University of Kansas.

The KU-FRL acoustic test facility consists of three main subsystems. These three can be generally divided into the testing apparatus (Beranek tube), the signal generation and analyzer equipment, and the depressurization system. Figure 1.1 shows the entire integrated test set-up. The test set-up is the most current system that has been used at the KU-FRL acoustic test facility. To better understand the test set-up, the subsystems have been more fully illustrated in Figures 1.2 through 1.5. Figures 1.2 and 1.3 illustrate the differences in the test apparatus for the flat and curved, stiffened panels. The data acquisition system and noise generation units are illustrated in Figure 1.4. Finally, the diagram of the depressurization subsystem is presented in Figure 1.5.

ORIGINAL PAGE IS
OF POOR QUALITY

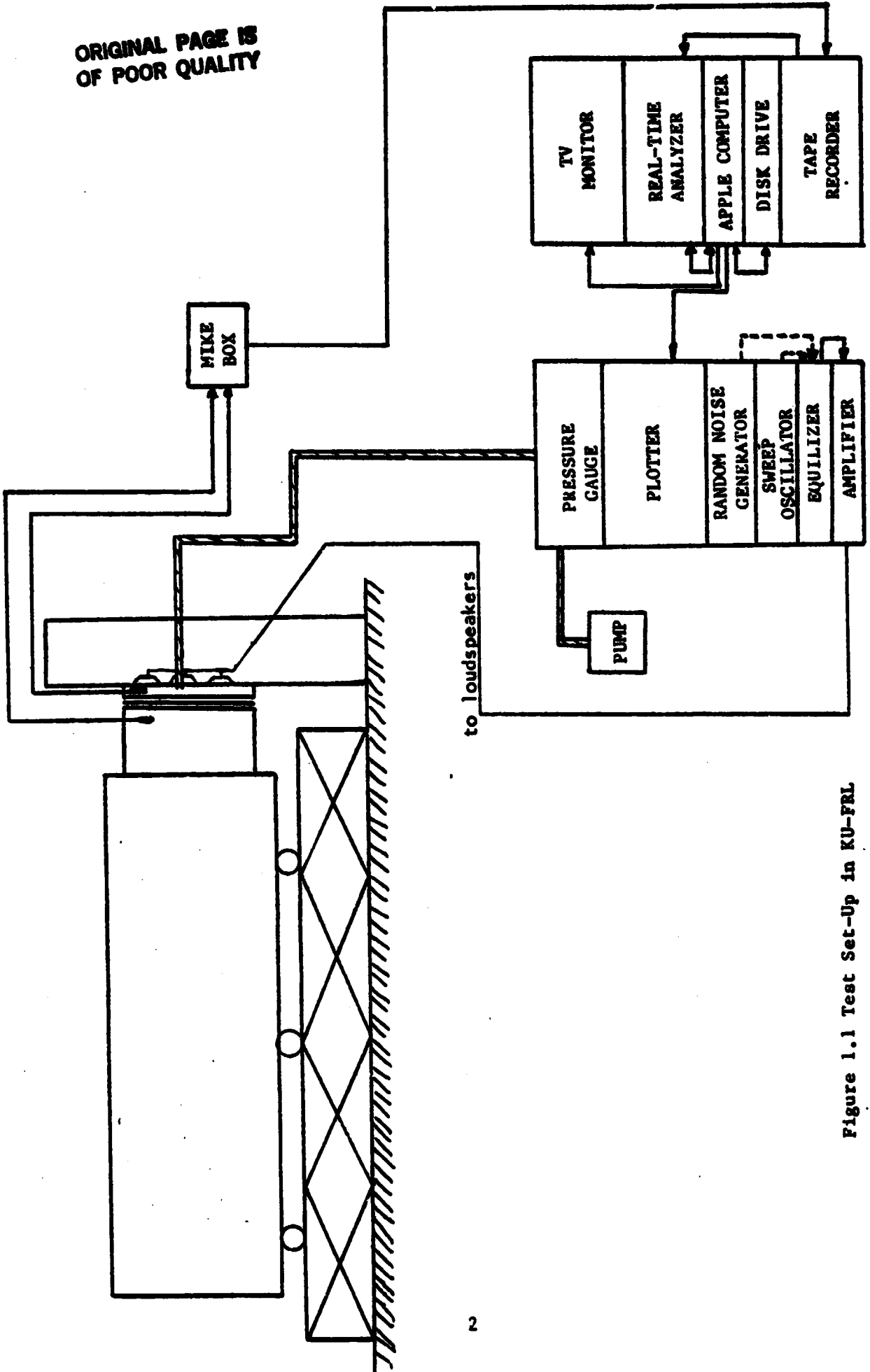

Figure 1.1 Test Set-Up in KU-FRL

ORIGINAL PAGE IS
OF POOR QUALITY.

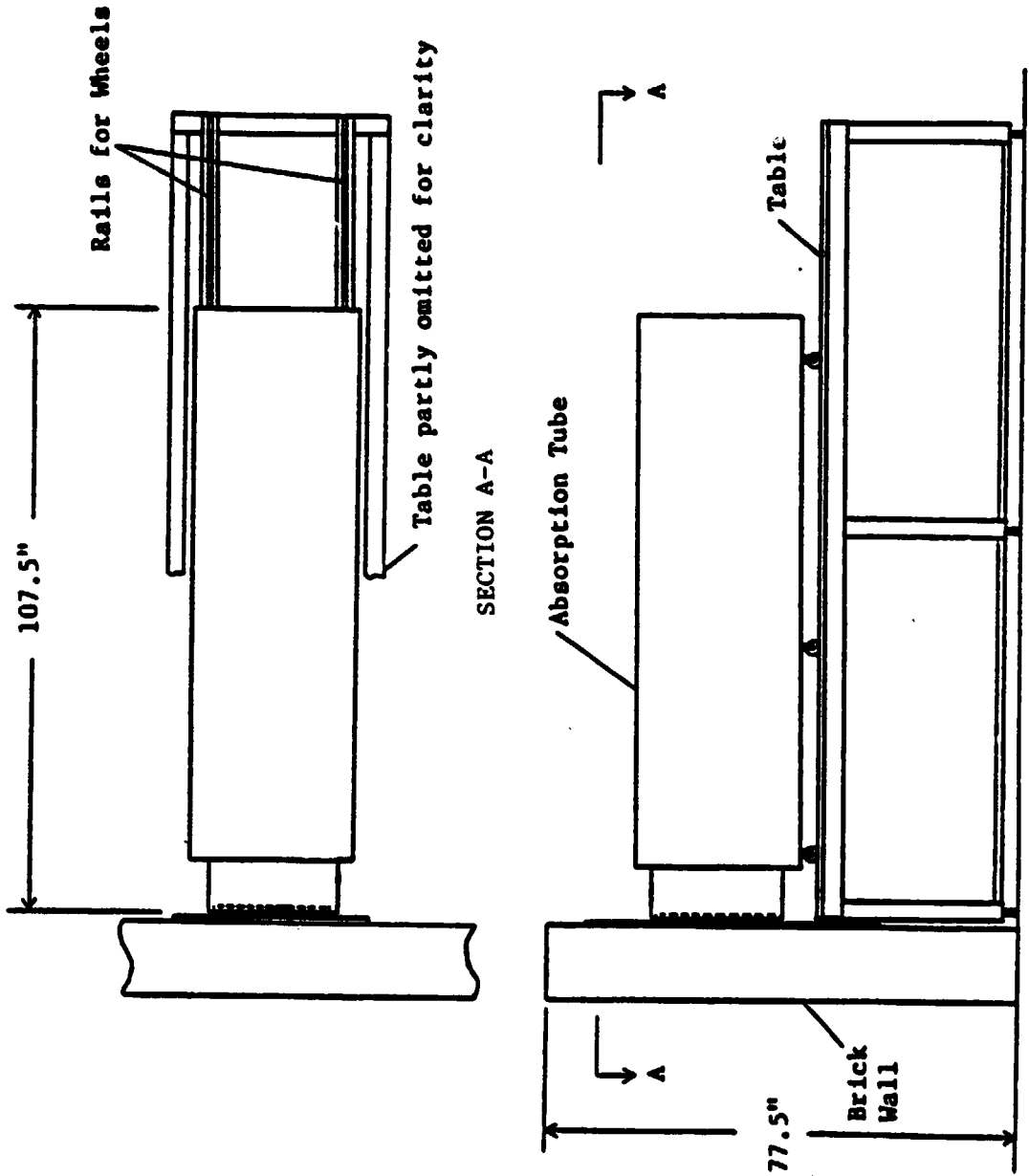

Figure 1.2 Beranek Tube with Flat Panel.

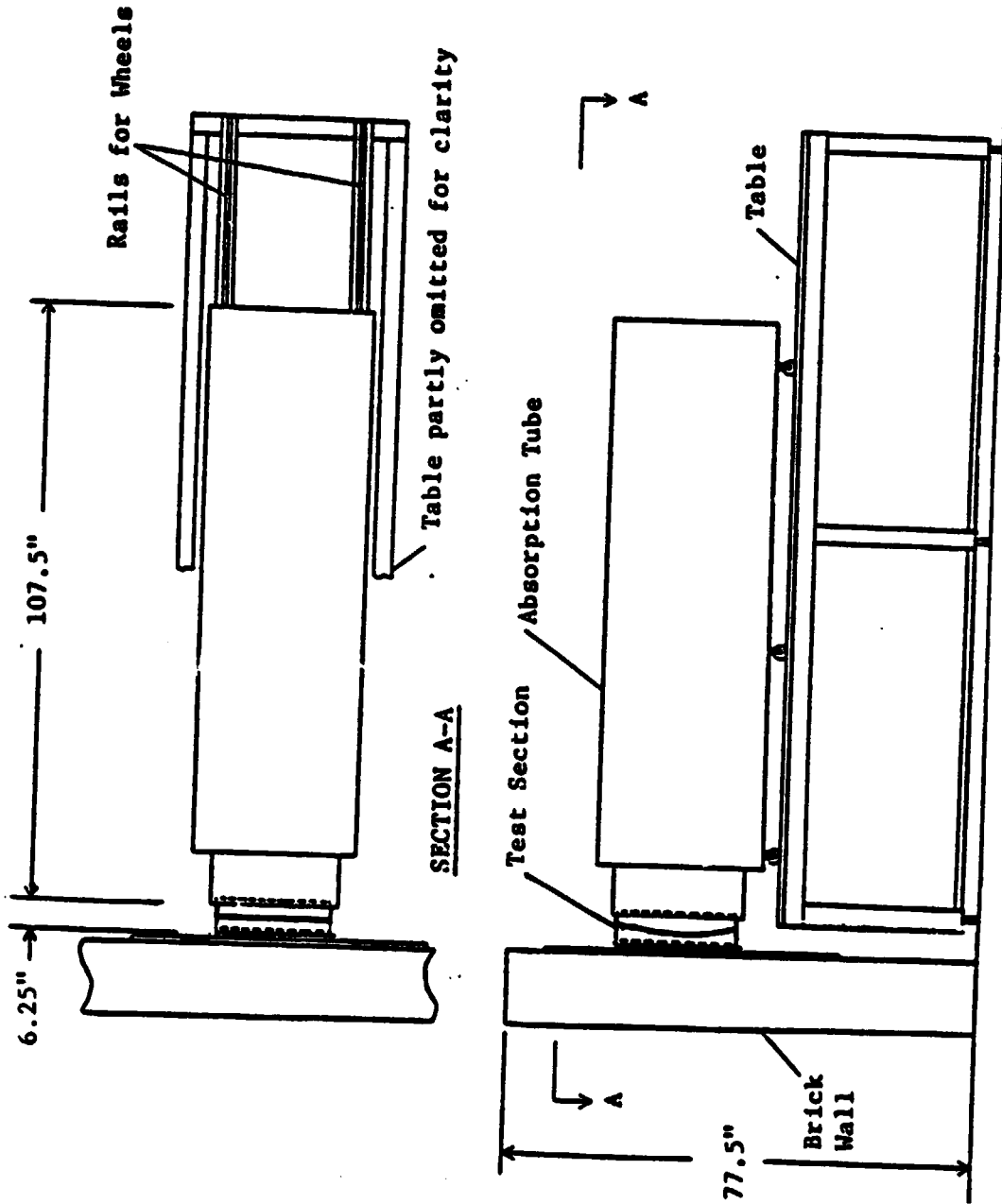
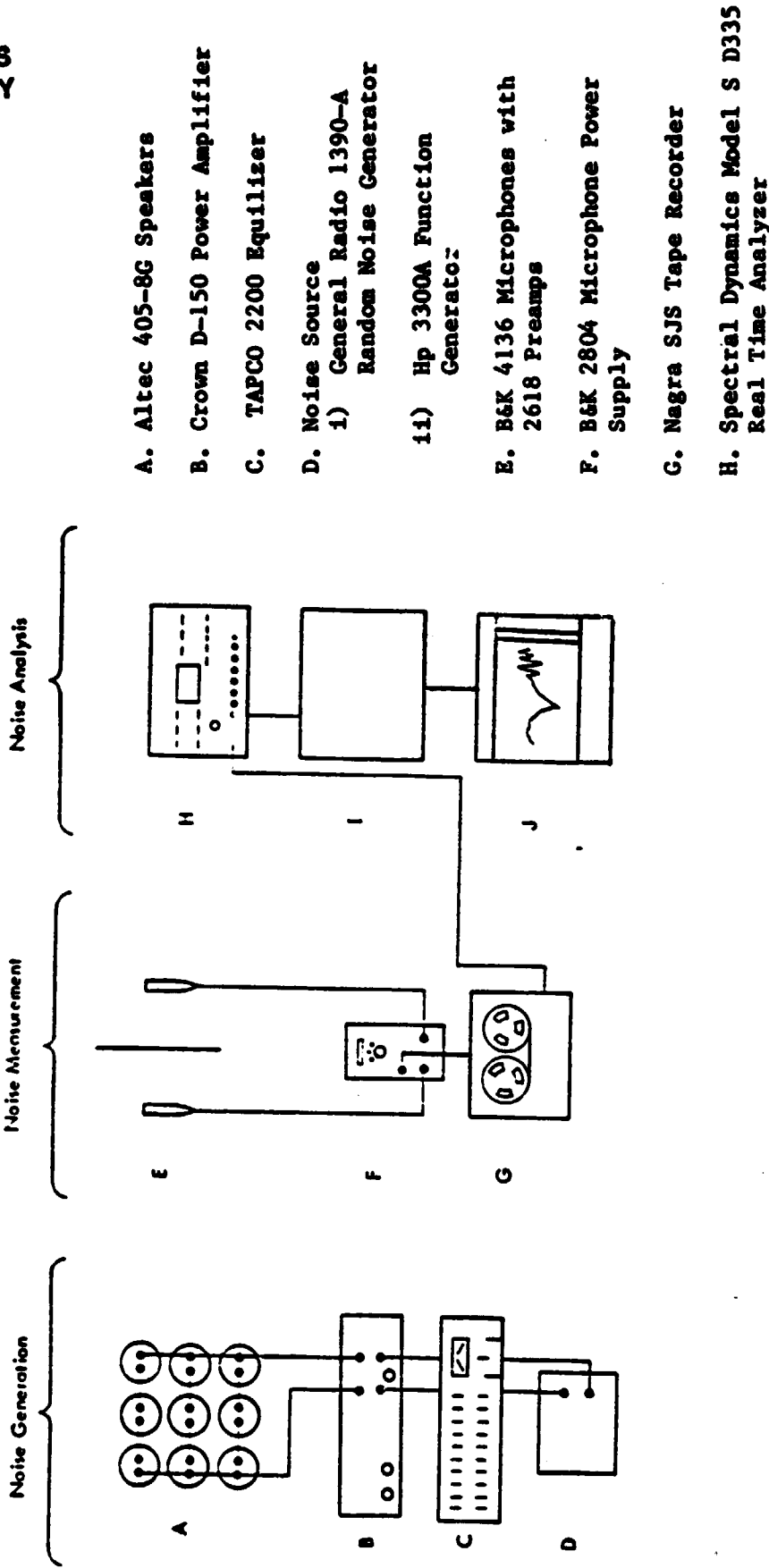

Figure 1.3 Beranek Tube with Curved Panel



- A. Altec 405-8G Speakers
- B. Crown D-150 Power Amplifier
- C. TAPCO 2200 Equilizer
- D. Noise Source
 - i) General Radio 1390-A Random Noise Generator
 - ii) Hp 3300A Function Generator:
- E. B&K 4136 Microphones with 2618 Preamps
- F. B&K 2804 Microphone Power Supply
- G. Nagra SJS Tape Recorder
- H. Spectral Dynamics Model S D335 Real Time Analyzer
- I. Apple 2+ Computer
- J. HP 7045-A X-Y Recorder

Figure 1.4: Noise Generation and Data Acquisition Equipment.

ORIGINAL PAGE IS
OF POOR QUALITY

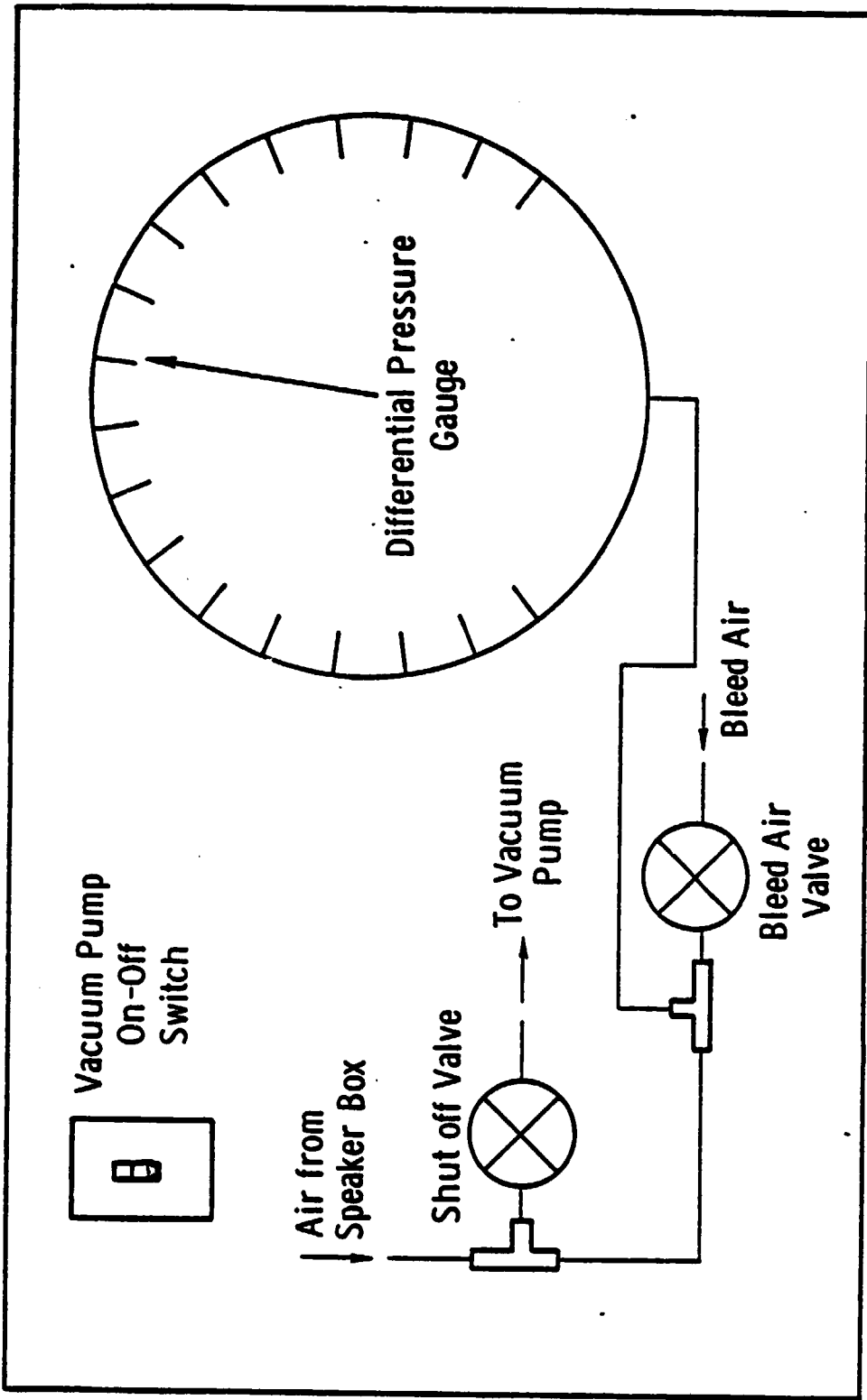

Figure 1.5 Pressure Systems for the Plane Wave Tube.

The following chapters (Chapters 2-7) discuss the different aspects of the testing and also present in an ordered fashion the results for each group of tests performed. Chapter 2 presents the details of the modifications that were made to the test facility for testing and also describes the panels tested. Chapter 3 gives the noise reduction characteristics of the bare panels. Chapter 4 discusses the noise reduction characteristics of the curved and flat panels with Y-370 damping tape applied. Chapter 5 presents the noise reduction characteristics of the panels with Y-434 damping tape applied. The effect of applying Y-436 damping tape to the panels is given in Chapter 6. The noise reduction characteristics of applying both Y-370 damping tape and two types of insulation is presented in Chapter 7. Chapter 8 concludes this report with conclusions and recommendations.

CHAPTER 2

DETAILS OF THE MODIFICATIONS AND THE TEST PANELS

The present series of tests with flat and curved panels with pressure differential across the test specimen demanded modifications to the KU-FRL acoustic test facility. These are detailed in Section 2.1 of this chapter. The details of the test specimens, damping tapes, and the insulation material are presented in Section 2.2. Table 1 summarizes the variables in the conducted tests.

2.1 MODIFICATIONS TO THE ACOUSTIC TEST FACILITY

2.1.1 Depressurization System

As previously mentioned, testing was done with pressure differentials across the test panel. A depressurization system was already used in the KU-FRL acoustic test facility (Reference 2) for previous testing and was reactivated for usage in this testing phase of the research project. The schematic diagram of the system has already been shown in Figure 1.5. The system was calibrated prior to the tests to determine the line losses for proper calibration of the tests. The system was reliable and posed little problem during the tests. Pressure differentials up to 3 psi were used.

2.1.2 Extension Tube for Curved Panel

To test the curved stiffened panel, there were some modifications that had to be made to the test facility, specifically to the Beranek tube. Unlike the flat panel which can be directly clamped to the

Table 1. List of variables in the conducted tests.

Panels:

- a) Flat Stiffened Aluminum, thickness = .040"
- b) Curved Stiffened Aluminum, thickness = .040"

Noise Source:

- a) Sine Wave Sweep Oscillator
- b) Random Noise Generator

Depressurization, ΔP :*

- a) 0 psi
- b) 1 psi
- c) 2 psi
- d) 3 psi

Damping Material:

- a) Y-370
- b) Y-434
- c) Y-436
- d) Y-370 + Light Insulation (Fiberglass, $\rho = 0.817 \text{ lb/ft}^3$)
- e) Y-370 + Heavy Insulation (Fiberglass, $\rho = 7.345 \text{ lb/ft}^3$)

Percentage of Coverage:

- a) 0 % (Bare Panel)
- b) 30 %
- c) 60 %
- d) 100 % (18" x 18" area)

* Some of the test are conducted at 2.5 psi instead of 3 psi.

test section, the curved panel required an additional curved support on both sides of the panel so that a simply supported edge condition could be simulated. Figure 1.3 shows the extension tube in place on the Beranek tube with the curved panel in place. This extension was constructed from 3/4 inch particle board and had the same outside dimensions as the standard Beranek tube. The extension tube shifted the centerline of the test specimen back by 3 inches from the noise source, compared to the standard 1 inch for the flat panel. No corrections have been made for the cavity effects of this extension. However, the distance between the microphones was maintained constant (8 inches).

2.2 DESCRIPTION OF THE TEST PANELS AND THE DAMPING TAPES

2.2.1 Flat Panel

The flat panel, made from standard aluminum sheet, was stiffened in one direction by "L" stringers. The sheet was .04 inch thick and 20 inches by 20 inches in outside dimensions. The extruded stiffeners were riveted to the skin. Figure 2.1 gives the geometrical and the mass properties of the stringers.

2.2.2 Curved Panel

The aluminum curved panel was stiffened in two directions. The sheet thickness was .04 inch. The panel was curved in one direction and stiffened in both directions, thus approximating a typical general aviation type sidewall. The radius of curvature of the panel was 33 1/2 inches. The stiffeners and the frames were riveted to the skin. The geometric and the mass properties are

ORIGINAL PAGE IS
OF POOR QUALITY

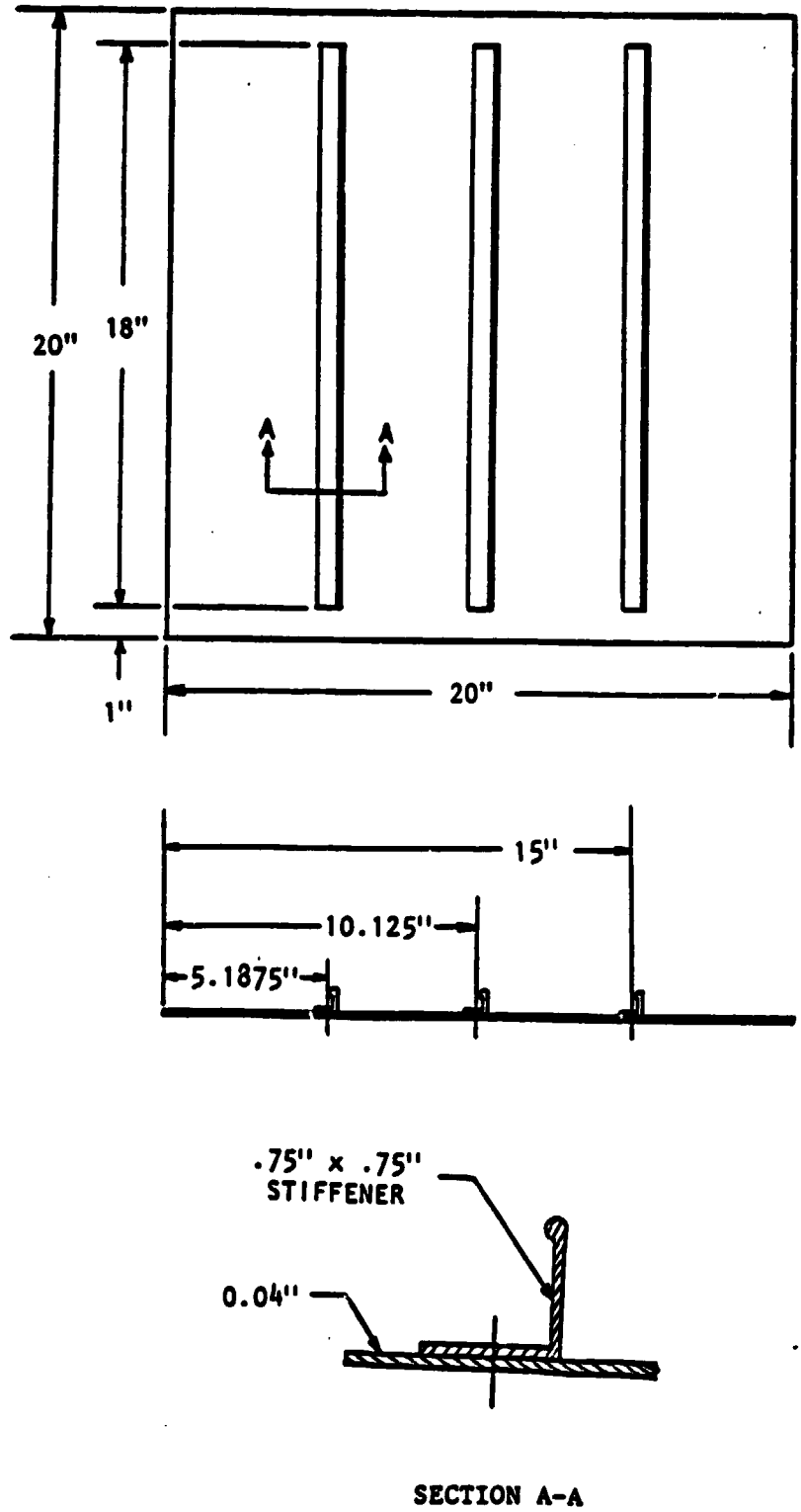

Figure 2.1 Flat Panel Dimensions

ORIGINAL PAGE IS
OF POOR QUALITY

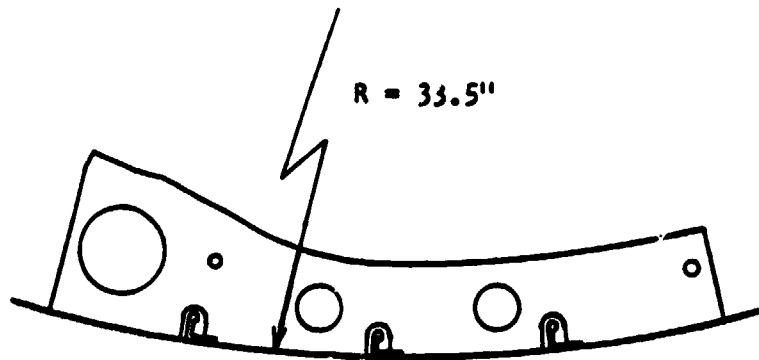
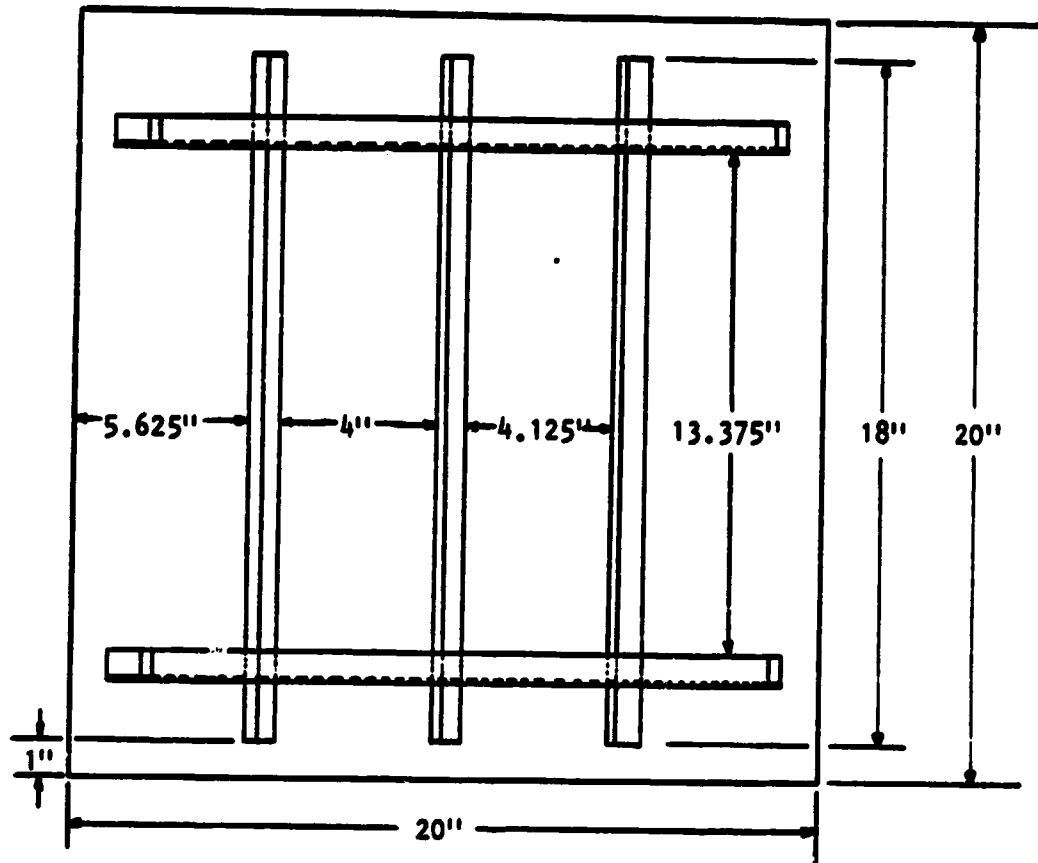

Figure 2.2 Curved Panel Dimensions

given in Figure 2.2. The outside panel dimensions are 20 inches by 20 inches.

2.2.3 Damping Tapes

Three damping tapes were used in the investigations. They were Y-370, Y-434, and Y-436, manufactured by the 3M Company. They provided constrained layer damping. The Y-434 has a 7 mil constraining layer, and the Y-436 has a 17 mil constraining layer. They were self adhesive, and as a result application to the test specimen was easy. The tapes were applied in amounts of 30%, 60%, and 100% of the panel test area (18 inch x 18 inch). During tests with partial coverage, the application was limited to the central part of the test panel. The stringers and the frames were not treated with the damping tape. It should be noted that the damping properties, in particular the loss factor, of these materials will degrade when it is exposed to low temperatures, as it will be during cruise flight. Because it is not possible to conduct the tests at other temperatures than at room temperature in the KU-FRL facility, the results of these tests should be judged in this context.

2.2.4 Insulation Material

To study the effects of porous fiberglass materials, two densities (0.817 lb/ft³ and 7.345 lb/ft³) of fiberglass were used. These were manufactured by the Forty-Eight Insulation Corporation. These materials were loosely placed over the test panels with the Y-370 damping tape.

CHAPTER 3

NOISE REDUCTION CHARACTERISTICS OF BARE FLAT AND CURVED PANELS

In this chapter, the noise reduction characteristics of stiffened flat and curved panels without any treatment are discussed. Section 3.1 covers the flat panel; in Section 3.2 the curved panel noise reduction characteristics are discussed.

3.1 FLAT PANEL RESULTS

Tests have been carried out in the Beranek tube with two different noise sources: a sweep oscillator and a random noise generator. The effects of depressurization have also been investigated.

3.1.1 Effects of Noise Source

Tests with a sweep oscillator were carried out in two steps to improve the resolution at lower frequencies. In the first sweep, a frequency range of 20 Hz to 500 Hz was covered with an effective bandwidth of 3 Hz. The second sweep covered a frequency range of 500 Hz to 5000 Hz with an effective bandwidth of 15 Hz. In both cases the linear sweep time was 100 seconds. Tests with the random noise generator were carried out in two steps to improve the resolution in the low frequency region.

The results of the tests are given in Appendix A (Figure A.1 and Figure A.5) for both cases. With these selections the results obtained matched within the experimental scatter in the low frequency

ORIGINAL PAGE IS
OF POOR QUALITY

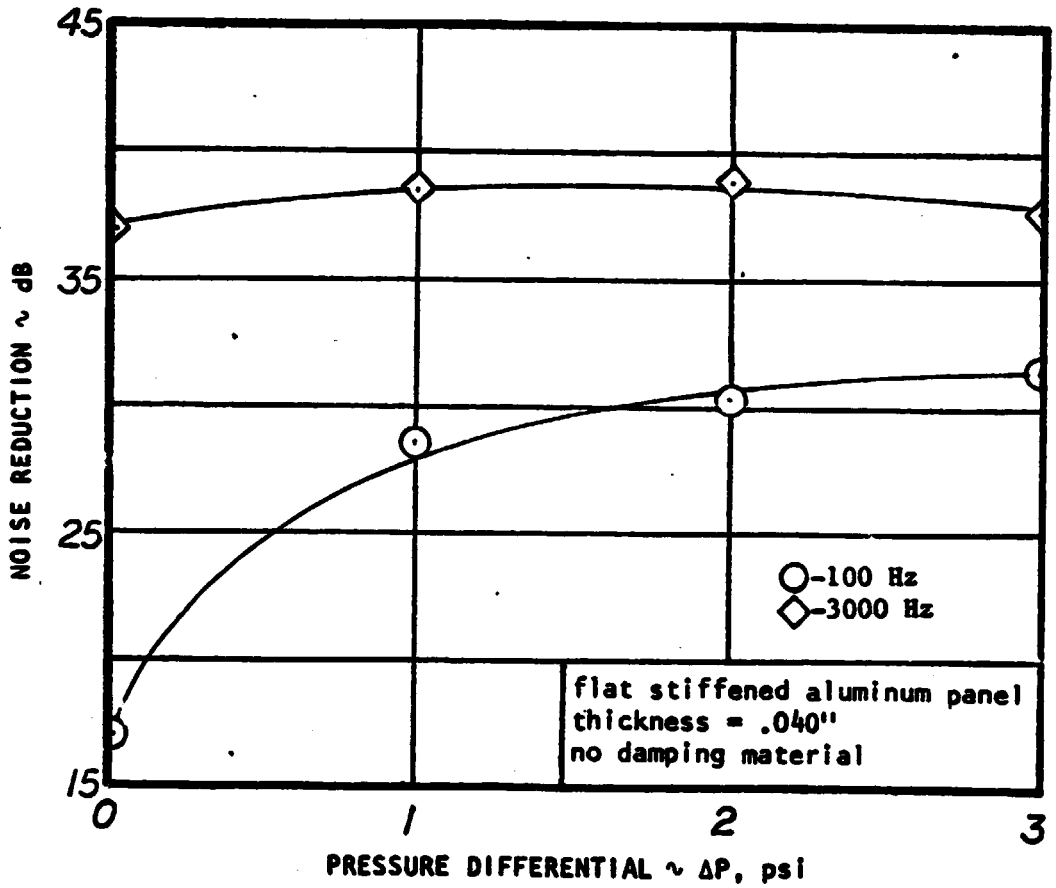

Figure 3.1: Effect of Pressure Differential on Noise Reduction Characteristics of a Bare, Flat Panel at Low and High Frequencies

region. The mean root square values of the results in the high frequency region were also nearly the same. These results are consistent with results obtained earlier with unstiffened panels (Reference 3). It should be noted that even with a random noise generator, the source microphone signal was not "flat" due to the cavity effects on the source side. From Figures A.1 through A.8, it can be concluded that no significant differences in the results exist between these two noise excitations, even when there is a pressure differential across the source and the receiver microphones.

3.1.2 Effect of Depressurization

Earlier studies have indicated that depressurization increases the low frequency noise reduction due to the stiffening effect (Reference 3). The purpose of these tests was to check the effect on already stiffened panels. In all cases the pressure on the source side was reduced to simulate actual aircraft conditions. Depressurizations up to 3 psi pressure differentials were investigated. Narrow band results and one-third octave band results for both types of excitation are given in Appendix A (Figures A.1 through A.8). The cross plot of the results as a function of the pressure differentials is given for two frequencies, 100 Hz and 3000 Hz, in Figure 3.1.

The effects observed were similar to the results in Reference 3. However, the increase in low frequency noise reduction was not high. Since the panel is already stiffened, the increase in stiffness is not proportionally high. This can be seen in the increase in resonance frequency. In this case it increased from 112 Hz to 230 Hz. The

ORIGINAL PAGE IS
OF POOR QUALITY

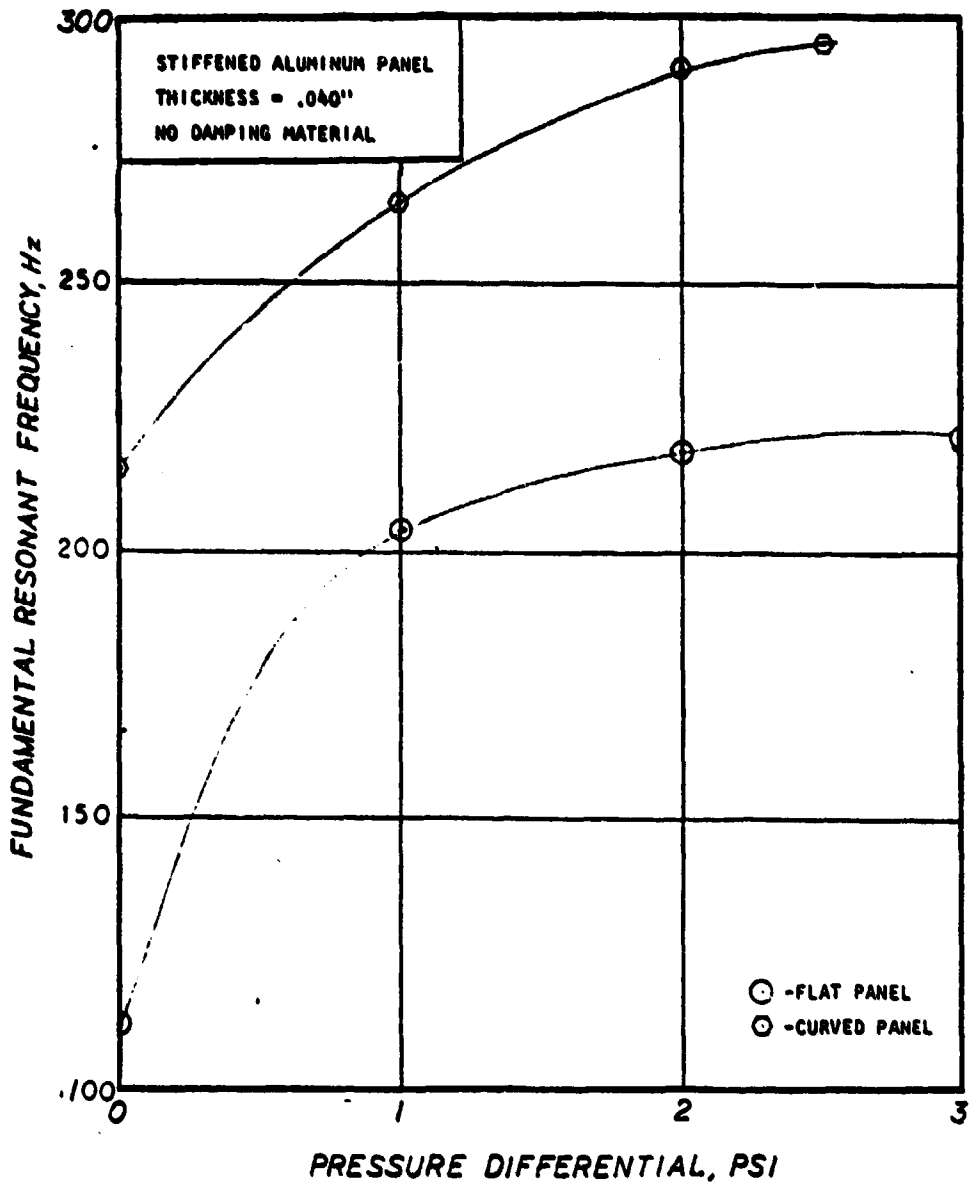

Figure 3.2: Effect of Pressure Differential on the Fundamental Resonance Frequency for Flat and Curved, Stiffened Panels

change in resonance frequency due to pressure differential is shown in Figure 3.2. The major part of the increase occurs in the first 1 psi pressure differential. The noise reduction values at low frequencies increased from 17 dB to 28 dB for the first 1 psi pressure differential and from 28 dB to 32 dB when the pressure differential was increased from 1 psi to 3 psi. The high frequency noise reduction showed a slight decrease, 1-3 dB, due to the pressure differential. This result is at variance with the earlier results for the unstiffened panel, when it was reported that it remained the same (Reference 3). However, the present results tend to confirm the published results by Koval (Reference 4).

3.2 CURVED PANEL RESULTS

Test results for unstiffened, curved panels have already been published in Reference 5. The results indicated that low frequency noise reduction of an unstiffened, curved panel increases with increasing curvature up to a certain value and then decreases. Curving a panel stiffenes the panel, but the angle of incidence of the panel is no longer normal. The combination of these two effects determines the final low frequency noise reduction. During the present series, the noise reduction characteristics of one curved, stiffened panel was investigated.

3.2.1 Effect of Noise Source

The results of noise reduction tests with the stiffened, curved panel without any pressure differential for both the noise excitations are given in Appendix B (Figure B.1 and Figure B.4).

ORIGINAL PAGE IS
OF POOR QUALITY

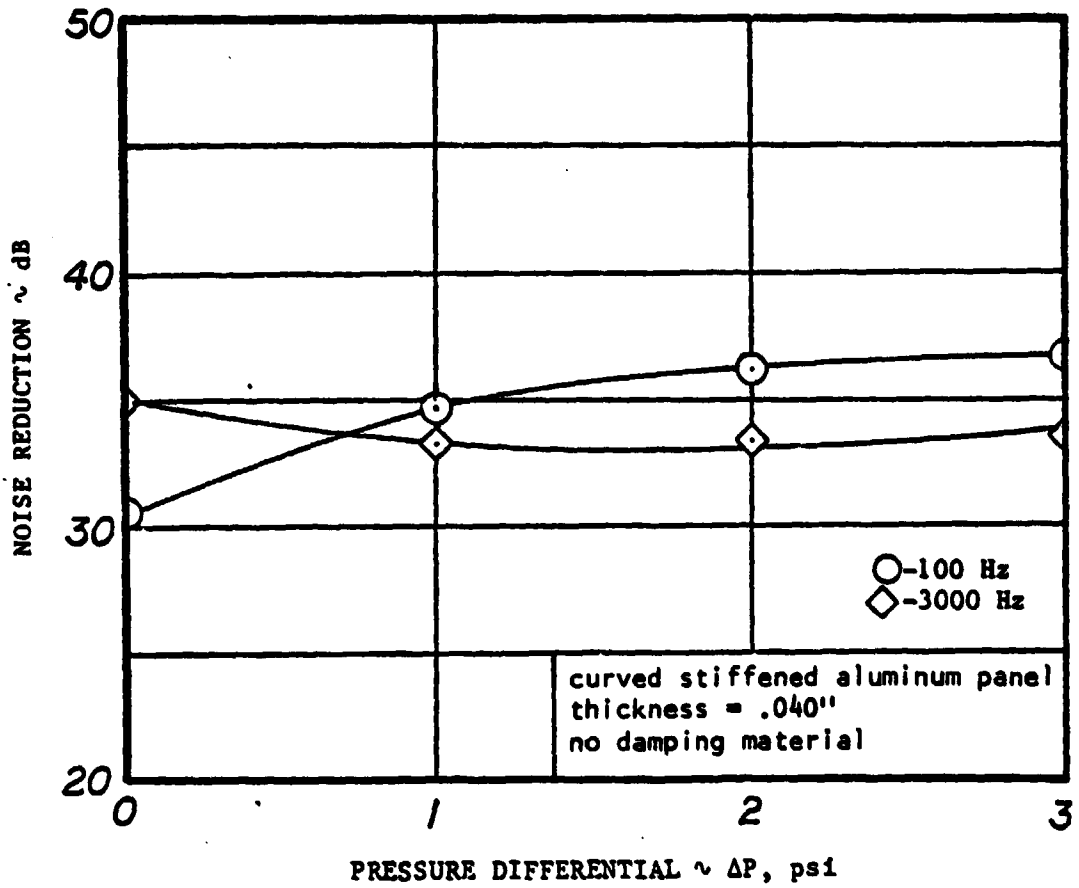

Figure 3.3: Effect of Pressure Differential on Noise Reduction Characteristics of a Bare, Curved Panel at Low and High Frequencies

Once again, the same conclusions as in Section 3.1 are reached.

This is true even when there is a pressure differential.

3.2.2 Effect of Depressurization

Narrow band and one-third octave band results for these tests are given in Appendix B (Figures B.1 through B.7). A cross plot of these results as a function of pressure differential is given in Figure 3.3. Since the panel is already stiff, the increase in stiffness due to depressurization is small. The resonance frequency of the panel at zero pressure differential is 220 Hz and increases to 290 Hz at 2.5 pressure differential (see Figure 3.2). Low frequency noise reduction increased from 31 dB to 37 dB due to 3 psi pressure differential (Figure 3.3). Once again, the major part (5 dB) of the increase occurs in the first 1 psi pressure differential. In the mass law region the pressure differential across the test specimen decreases the mean consistent with Koval's results (Reference 4).

CHAPTER 4

NOISE REDUCTION CHARACTERISTICS OF STIFFENED FLAT AND CURVED PANELS WITH Y-370 DAMPING MATERIAL

In this chapter, noise reduction tests performed to assess the effects of Y-370 material on flat and curved panels are described and the results obtained are discussed. Investigation of flat, stiffened aluminum panel with and without 100% treatment of Y-370 material has been discussed in an earlier report (Reference 1). In the same report a simple single degree of freedom analytical model was developed which predicted the low frequency noise reduction reasonably well. The effect of the damping material was found to decrease the fundamental resonance frequency and also the noise reduction values in the stiffness-controlled region. However, at the resonance frequency itself, the noise reduction was increased. Also, in the high frequency region the resonance peaks and dips were smoothed out.

4.1 TESTS PERFORMED ON PANELS COVERED WITH Y-370

During the present phase of the investigation, tests have been performed to assess the effects of percent coverage, pressure differential, and noise source. Three percent coverages were tested (30%, 60%, and 100%). These percentages correspond to the exposed area of the test panel, as indicated in Chapter 2. Three pressure differentials were investigated (1, 2, 3 psi) under two types of noise sources, swept noise and random noise. In addition to the flat panel, a curved panel with stiffeners in both directions was used. The results, both narrow band and one-third octave plots, obtained

ORIGINAL PAGE IS
OF POOR QUALITY

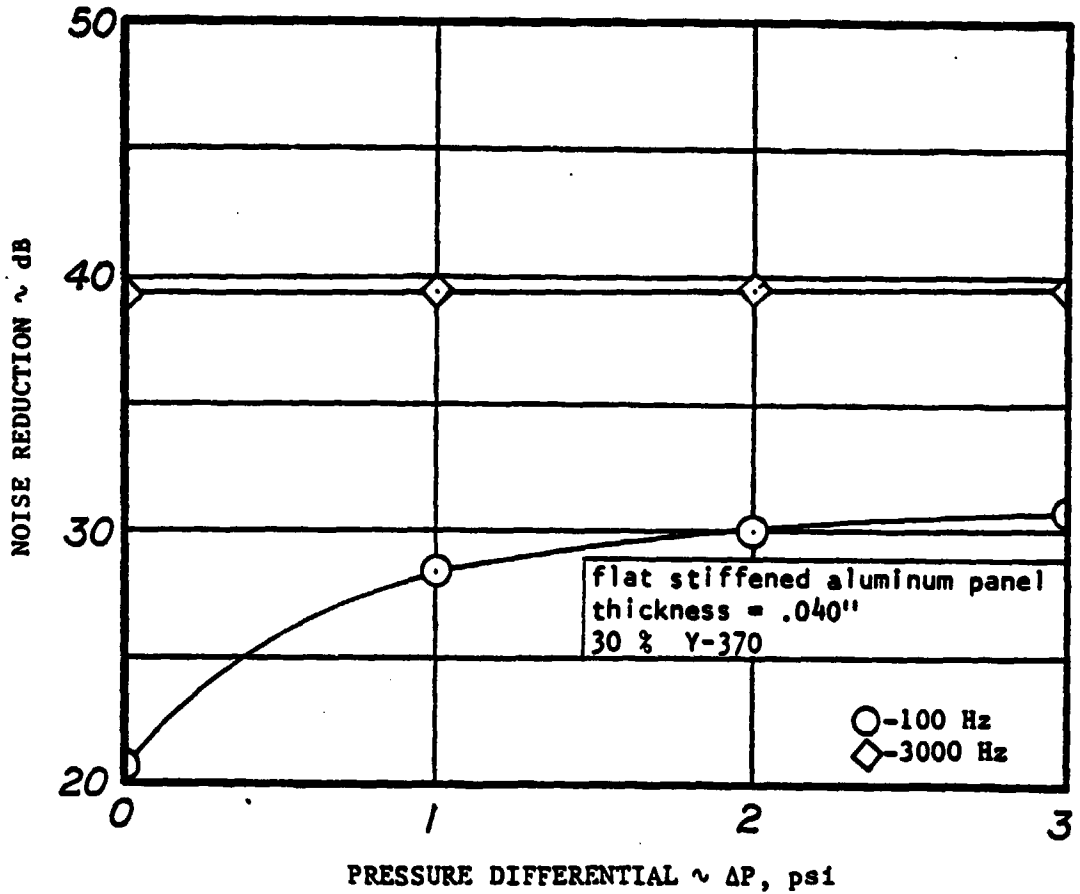

Figure 4.1: Effect of Pressure Differential on Noise Reduction Characteristics of a Flat, Stiffened Panel with 30% Y-370 Damping Tape at Low and High Frequencies

for the flat panel are given in Appendix A (Figures A.9 through A.32). Similar results for the curved panel are given in Appendix B (Figures B.9 through B.32).

4.2 FLAT PANEL RESULTS

The stiffened flat panel, as described in Chapter 2, was tested with 30%, 60%, and 100% coverage of damping materials. The results obtained with each of the percent coverages are discussed next.

4.2.1 30% Panel Coverage

Results of eight tests carried out for this assessment are shown in Appendix A (Figures A.9 through A.16). The difference in the noise reduction values due to the two noise sources were negligible. The results matched within the experimental scatter. Similar conclusions were reached for the untreated panels.

The effect of depressurization for this configuration is shown as a crossplot in Figure 4.1. This figure shows that in the low frequency domain, the noise reduction characteristics of the panel are basically the same as the bare, flat panel for all pressure differentials except at 0 psi. Here, the panel treated with 30% damping tape has a noise reduction value of 21 dB as compared to 17 dB of the bare panel. An increased noise reduction is only seen from a 0 psi pressure differential to a 1 psi pressure differential. From 1 psi onward, there is no appreciable noise reduction gained from an increased pressure differential. High frequency noise reduction characteristics of the panel covered with 30% Y-370 gain

ORIGINAL PAGE IS
OF POOR QUALITY

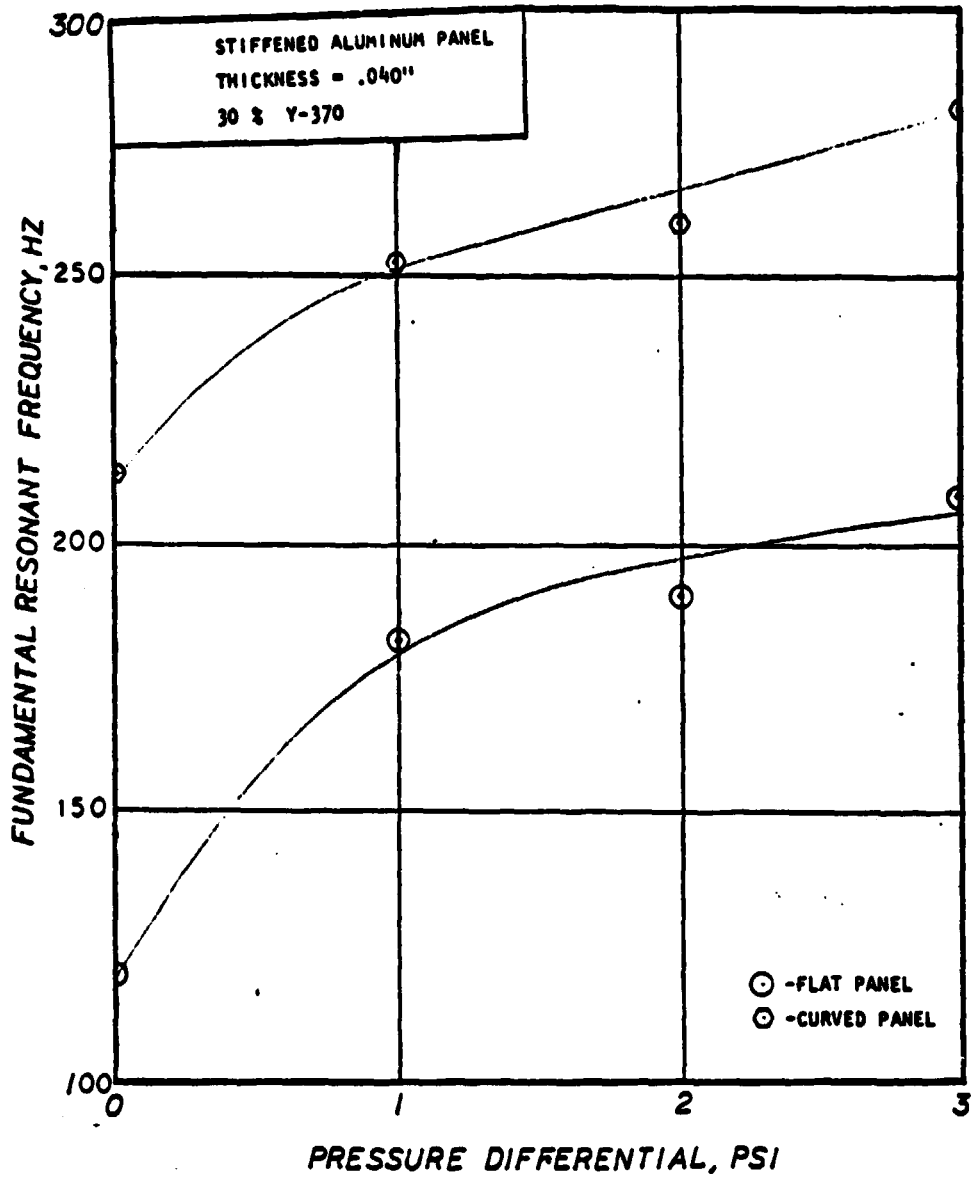

Figure 4.2: Effect of Pressure Differential on the Fundamental Resonance Frequency for Flat and Curved, Stiffened Panels with 30% Y-370

2 dB over the bare panel, but the effect of pressurization is negligible over the entire pressure differential range tested.

Figure 4.2 shows the effect of the increased pressure differential on the resonance frequency of the panel. The panel at 0 psi pressure differential has a resonance frequency of 120 Hz. This frequency increases to a value of 215 Hz at 3 psi for an increase of 95 Hz. However, most of this increased noise reduction occurs in the first half of the curve from 0 psi to about 1.5 psi.

4.2.2 60% Panel Coverage

Results of eight tests carried out under this configuration (two noise sources and four pressure differentials) are given in Appendix A (Figures A.17 through A.24).

Once again, tests indicated no difference in results between the noise sources. The general trend of the results obtained with depressurization was also similar to previous tests (Figure 4.3). Noise reduction values increased from 19 dB at 0 psi to 23 dB at 1 psi at a low frequency. From 1 psi to 3 psi, the noise reduction values flatten out at around 30 dB. High frequency noise reduction values remain at a constant 40 dB noise reduction throughout the entire depressurization range.

The change in resonance frequency as a function of the pressure differential is plotted in Figure 4.4. The panel subjected to no pressure differential exhibits a resonance frequency of 120 Hz. The first 1 psi pressure differential gives the greatest increase in resonant frequency to a value of 180 Hz at 1 psi. The curve flattens out after this to a final value of 192 Hz at 3 psi.

ORIGINAL PAGE IS
OF POOR QUALITY

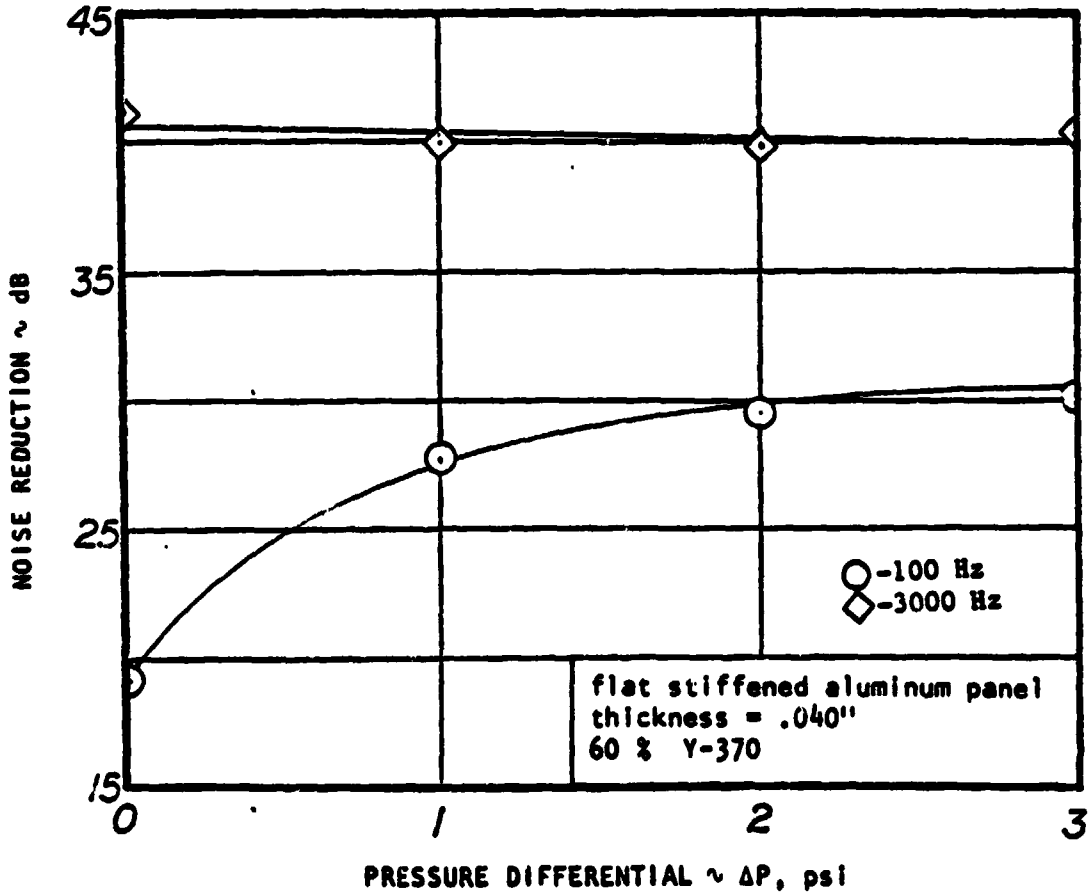

Figure 4.3: Effect of Pressure Differential on Noise Reduction Characteristics of a Flat, Stiffened Panel with 60% Y-370 Damping Tape at Low and High Frequencies

ORIGINAL PAGE IS
OF POOR QUALITY

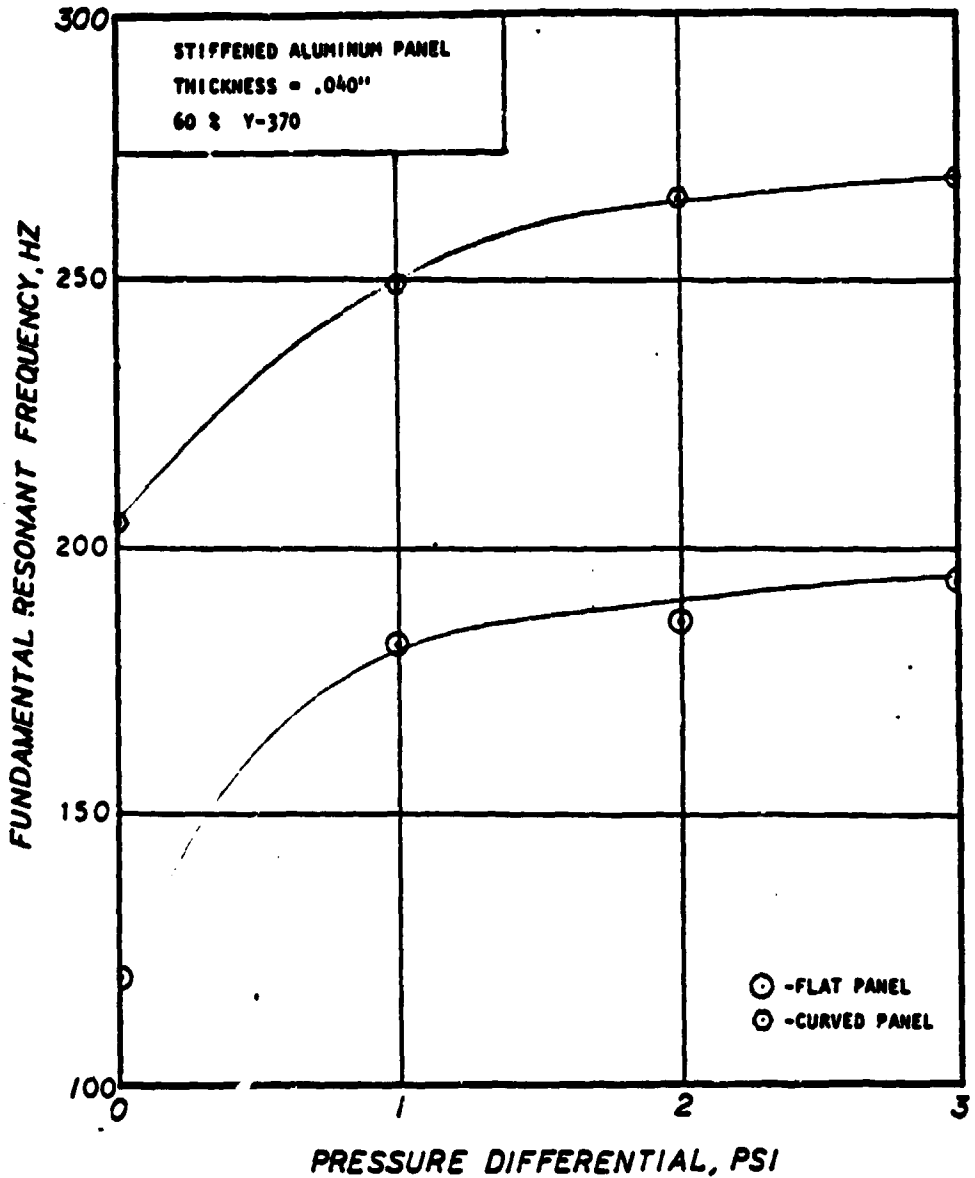

Figure 4.4: Effect of Pressure Differential on the Fundamental Resonance Frequency for Flat and Curved, Stiffened Panels with 60% Y-370

4.2.3 100% Panel Coverage

Results of the tests with this configuration are shown in Appendix A (Figures A.25 through A.32). The conclusions reached with these results are also similar to the test results obtained with 30% and 60% coverage. Specifically, 7.5 dB gain is achieved for the first 1 psi pressure differential (Figure 4.5) at low frequency (100 Hz). In the high frequency region (3000 Hz), the noise reduction levels do not change appreciably with a changing pressure differential. In the high frequency region, the noise reduction stays at a level of approximately 41 dB.

For this configuration the change in resonance frequency as a function of the pressure differential is given in a cross plot in Figure 4.6. The results obtained are similar to other percent coverages tested. This figure shows that the resonance frequency of the panel is 140 Hz with no pressure differential and increases to 190 Hz at a pressure differential of 3 psi.

4.2.4 Effect of Percentage of Coverage

The effect of percentage of coverage on the noise reduction characteristics of the panel is given in Figures 4.7 and 4.8. Figure 4.7 gives the results of the low frequency region. This figure shows that the effect of coverage on the noise reduction abilities of the flat panel covered with Y-370 damping tape is fairly negligible. What this figure does show, however, is that the greatest effect of the damping tape occurs in the first 1 psi pressure differential, as previously stated. The noise reduction

ORIGINAL PAGE IS
OF POOR QUALITY

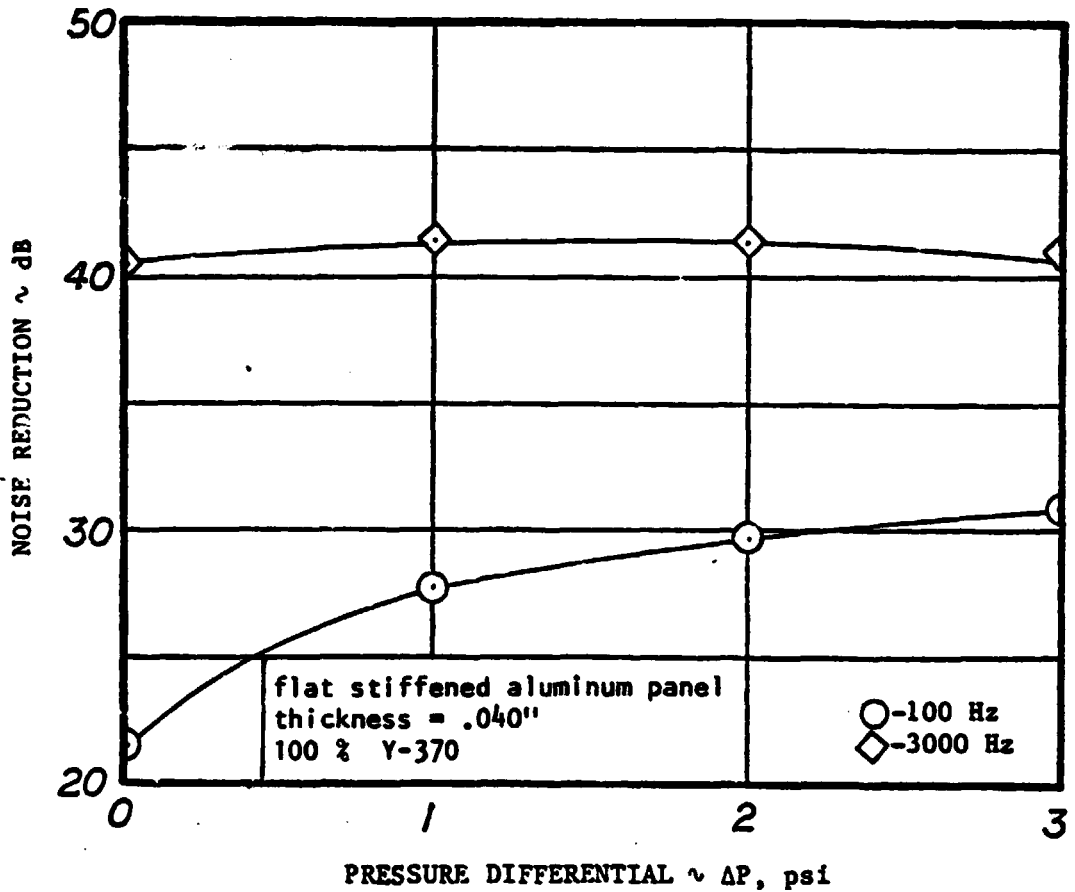

Figure 4.5: Effect of Pressure Differential on Noise Reduction Characteristics of a Flat, Stiffened Panel with 100% Y-370 Damping Tape at Low and High Frequencies

ORIGINAL PAGE IS
OF POOR QUALITY

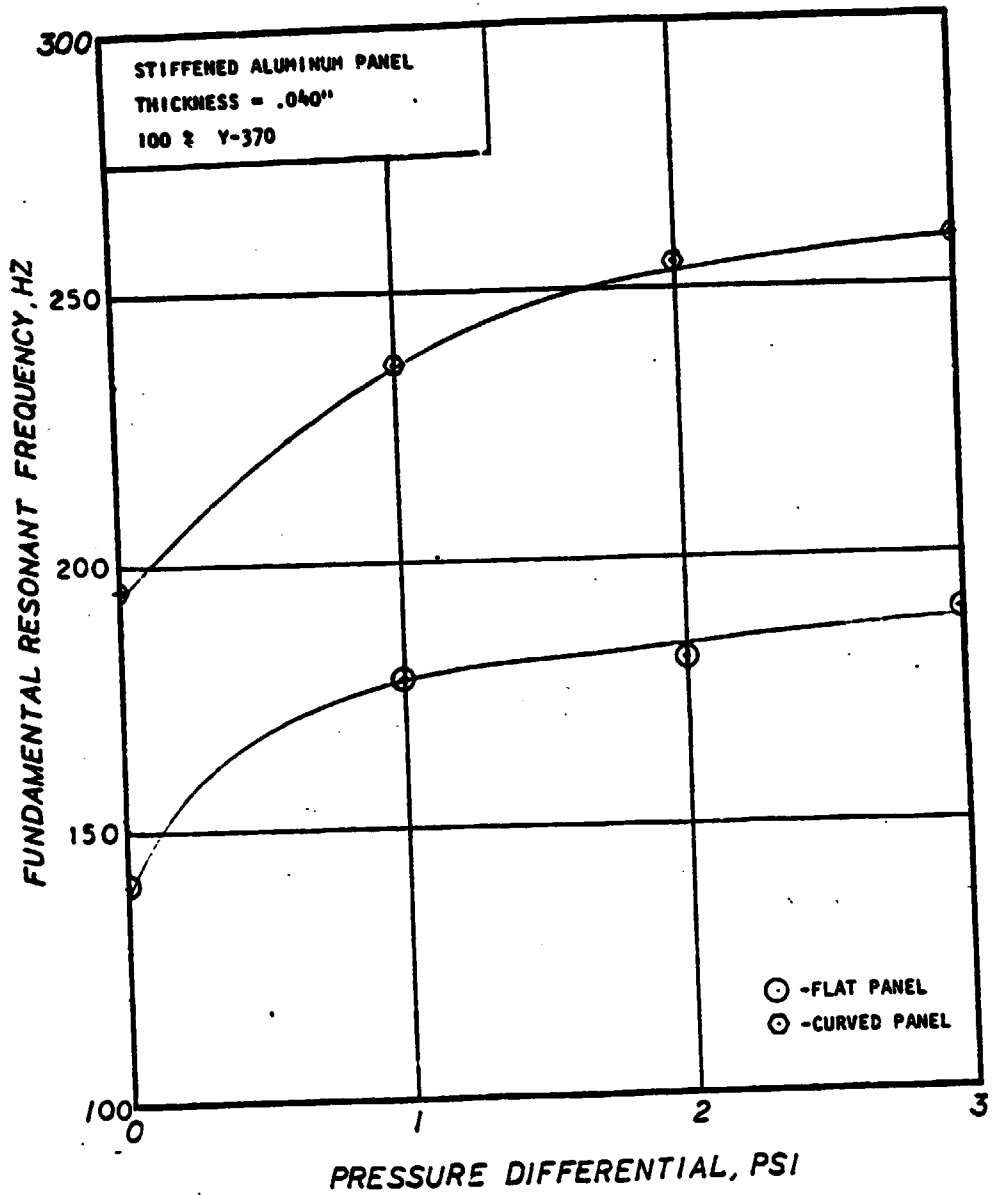
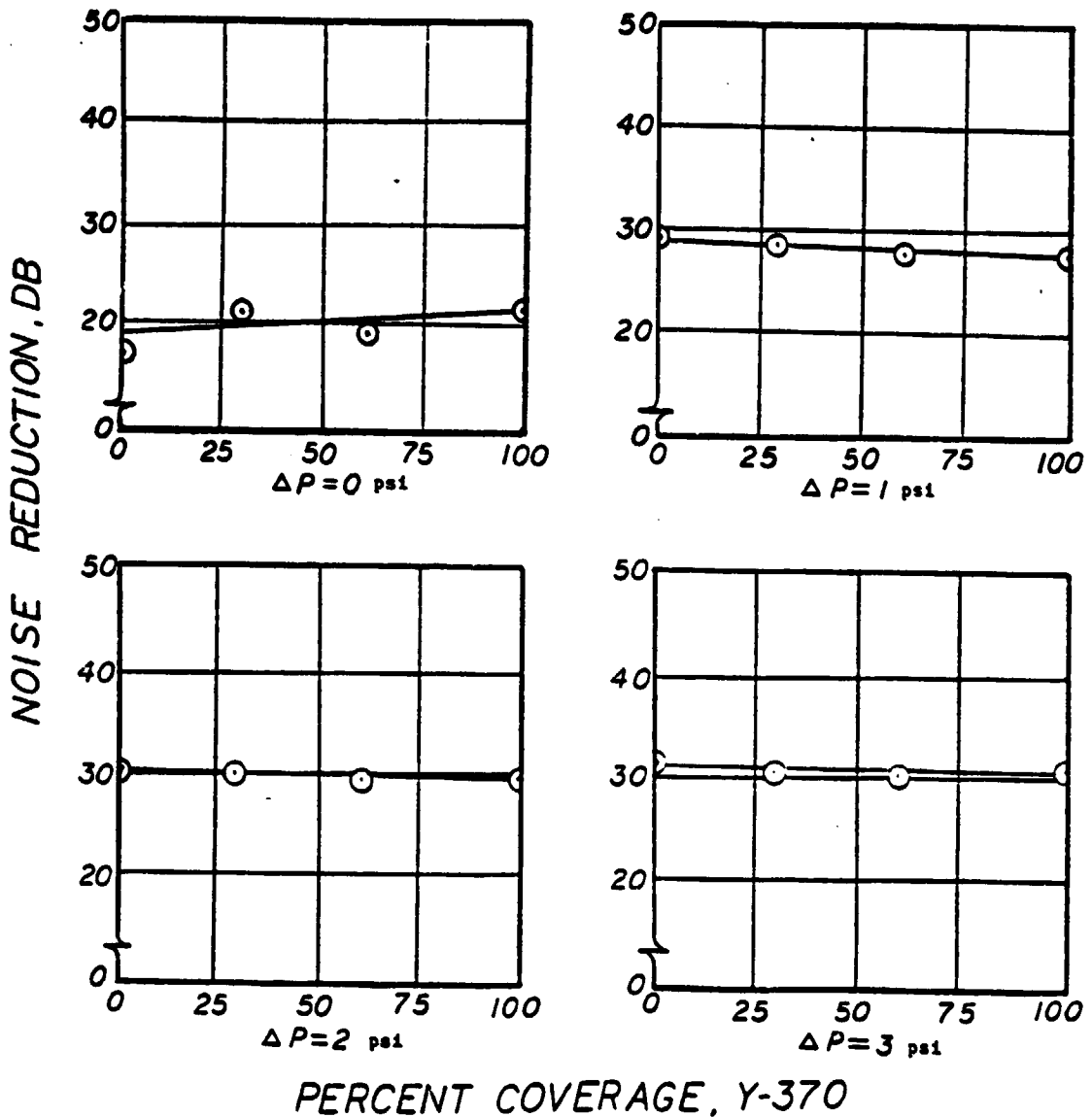

Figure 4.6: Effect of Pressure Differential on the Fundamental Resonance Frequency for Flat and Curved, Stiffened Panels with 100% Y-370

ORIGINAL PAGE IS
OF POOR QUALITY



FLAT STIFFENED ALUMINUM PANEL THICKNESS = .040" FREQUENCY = 100 Hz

Figure 4.7: Effect of Coverage of Y-370 Damping Tape on Low Frequency Noise Reduction Characteristics for a Flat, Stiffened Panel at Different Pressure Differentials

ORIGINAL PAGE IS
OF POOR QUALITY

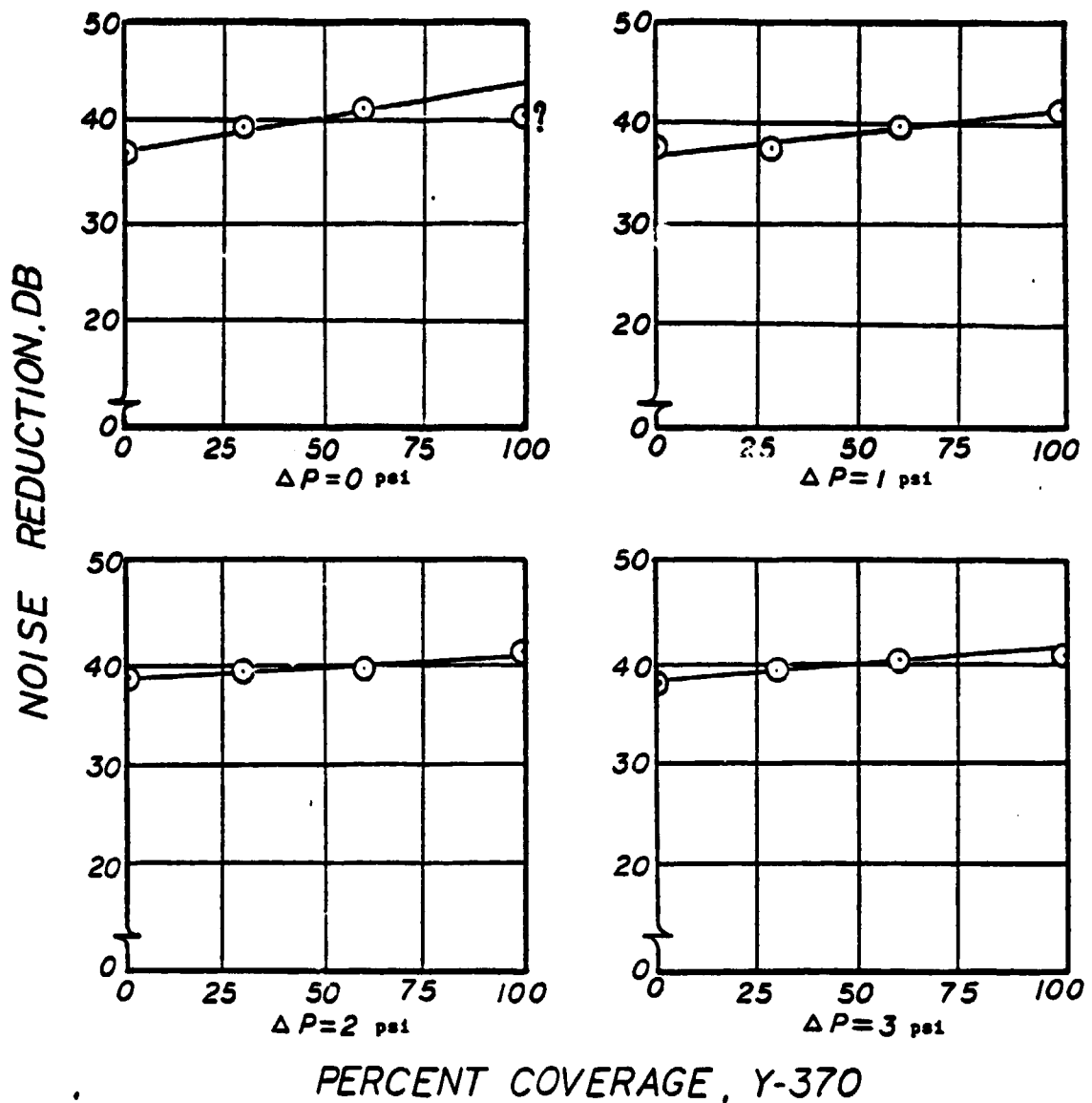

FLAT STIFFENED ALUMINUM PANEL THICKNESS = .040" FREQUENCY = 3000 Hz

Figure 4.8: Effect of Coverage of Y-370 Damping Tape on High Frequency Noise Reduction Characteristics for a Flat, Stiffened Panel at Different Pressure Differentials

level for a 0 psi pressure differential is about 20 dB and goes to a constant level of about 30 dB at a 3 psi pressure differential, regardless of the change in coverage.

The effect of coverage in the high frequency region (3000 Hz) is given in a cross plot in Figure 4.8. This figure shows that there is very little change in noise reduction as a function of pressure differential, as verified in the previous paragraphs and figures. The effect of coverage is very slight, with a general upward trend from 38 dB to 41 dB due to increased mass of the panel from the damping tape.

4.3 CURVED PANEL RESULTS

Similar tests as those described in Section 4.2 for the flat panel were carried out, essentially to make a one-to-one comparison between a curved and a flat panel. The purpose of the percentage of coverage is to determine the effectiveness of the damping tape under actual flight conditions. However, due to the limitation of the test facility, the effect of temperature on the damping tape could not be investigated. A curved panel stiffened in both directions with partial coverage of damping material is a good simulation of actual aircraft structures. Hence, individual noise reduction curves with these specimens are representative of actual noise reduction values obtainable in an aircraft, within the constraints of receiving space impedance of the Beranek tube.

4.3.1 30% Panel Coverage

Results given in Appendix B (Figures B.9 through B.16) for two noise sources (swept sine wave and random noise) and four pressure differentials (0, 1, 2, and 3 psi) indicate essentially the same results as obtained for the untreated panel for the two noise sources. The results of depressurization tests are shown in Figure 4.9. In the low frequency region (100 Hz), the noise reduction obtained with no pressure across the panel is 31 Hz. This value rises to 37 Hz at 3 psi pressure differential along a gradual slope. It has been shown with the untreated panel that the effect of depressurization in the high frequency region is to lessen the noise reduction characteristics of the curved panel. Similar results are also obtained with 30% coverage. Noise reduction values in the high frequency region vary from 37 dB at 0 psi to 34 dB at 3 psi pressure differential.

The pressure differential also affects the frequency of panel resonance. Figure 4.2 shows that the higher the pressure differential, the higher the resonance frequency of the panel. Unlike the flat panel which tended to level out at higher pressure differentials, the curved panel shows no tendency to flatten out at these higher pressure differentials. The panel exhibits an increasing behavior of the resonance frequency from 220 Hz with no pressure across the panel to 280 Hz at 3 psi pressure differential. Therefore, the effect of increasing pressure differentials on a curved, stiffened panel is to push the resonant frequency up to higher frequencies but not to affect significantly the value of the noise reduction itself at the low and high frequency values investigated.

ORIGINAL PAGE IS
OF POOR QUALITY

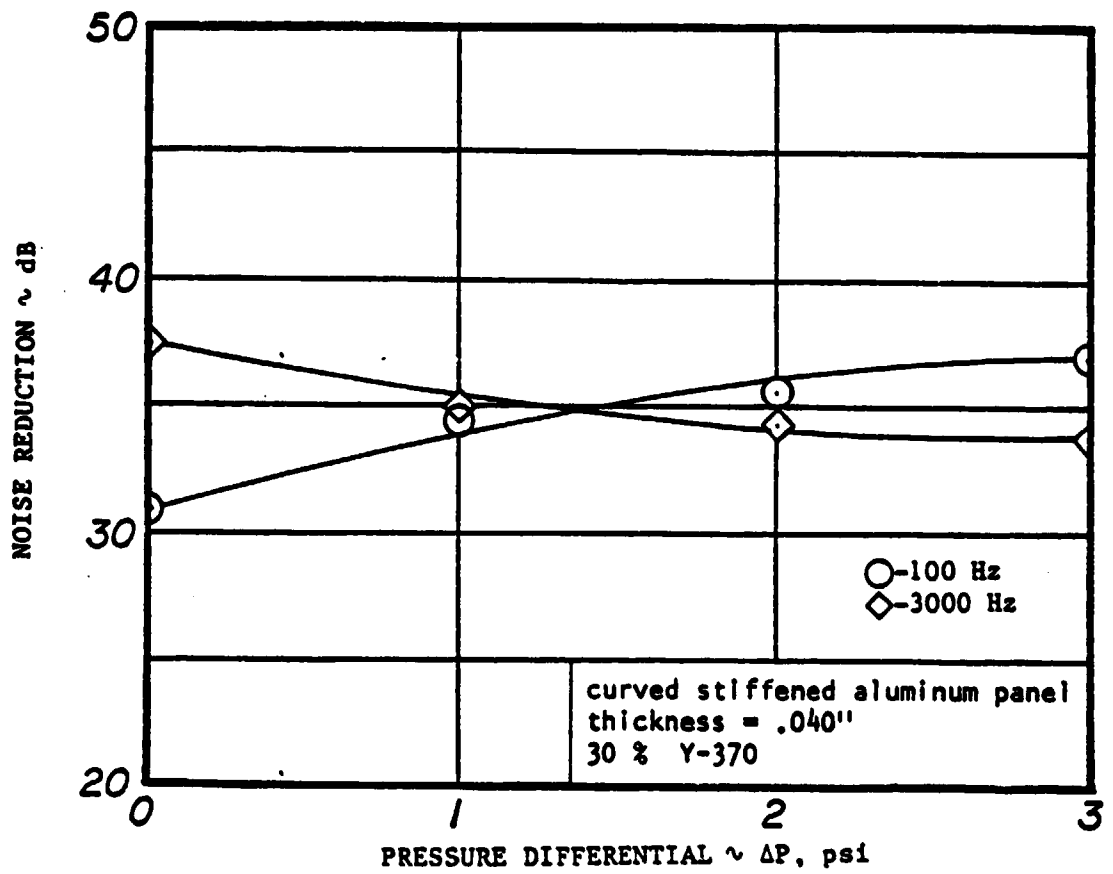

Figure 4.9: Effect of Pressure Differential on Noise Reduction Characteristics of a Curved, Stiffened Panel with 30% Y-370 Damping Tape at Low and High Frequencies

ORIGINAL PAGE IS
OF POOR QUALITY

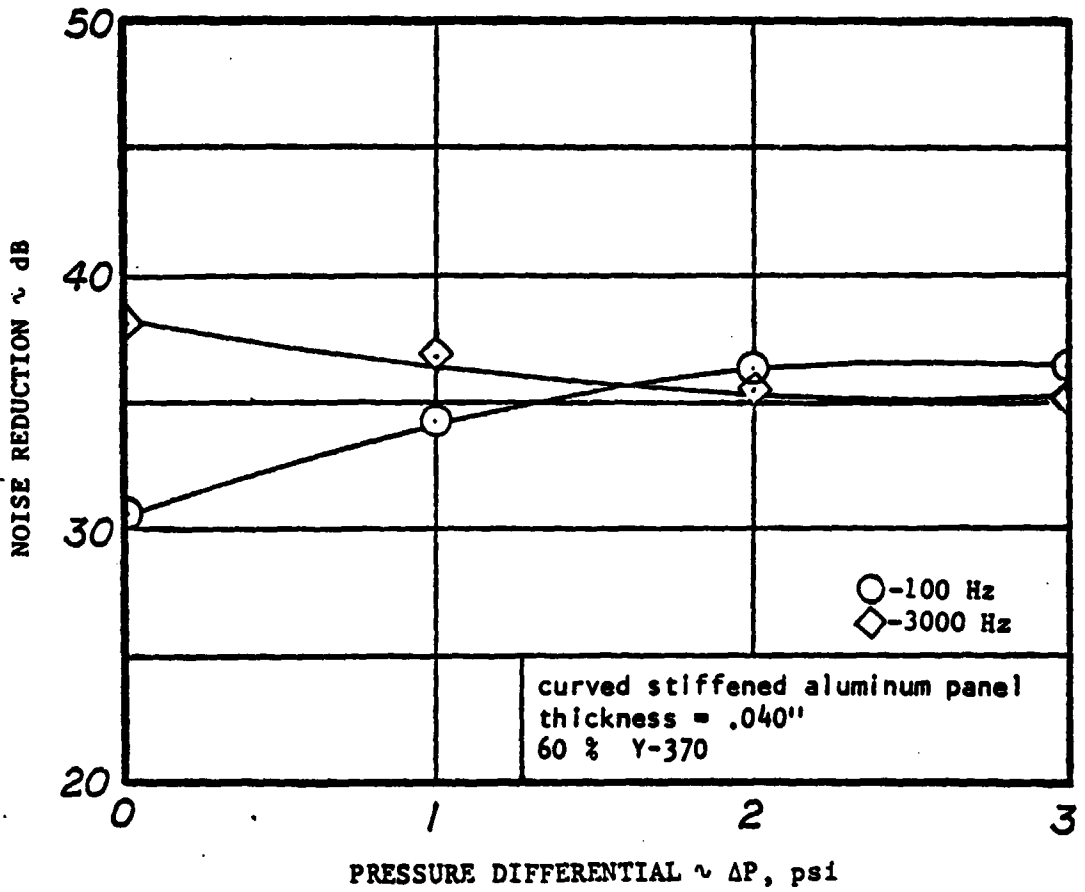

Figure 4.10: Effect of Pressure Differential on Noise Reduction Characteristics of a Curved, Stiffened Panel with 60% Y-370 Damping Tape at Low and High Frequencies

4.3.2 60% Panel Coverage

Results of tests with 60% coverage with pressure differentials and two different noise sources are shown in Appendix B (Figures B.17 through B.24). The conclusions about the noise source are the same. The cross plot for pressure differential indicates a nearly similar trend as in previous cases (Figure 4.10). The low frequency curve has noise reduction values of 30 dB at 0 psi to 37.5 dB at a high pressure differential of 3 psi. Once again, most of the increase occurs in the first half of the curve with a general flattening out around 2 psi. The high frequency curve (3000 Hz) has noise reduction values that decrease with increasing pressure differential. The noise reduction at 0 psi is 38 dB and drops to 35 dB at 3 psi. This drop is relatively gradual with a flattening out around the 2 psi value.

The change in resonance frequency due to a changing pressure differential is plotted in Figure 4.4. This figure shows the resonance frequency to be rapidly increasing between 0 psi and 1 psi from 205 Hz to a value of 250 Hz. After the 1 psi pressure differential, the curve does not have such a large slope and increases to a value of only 270 Hz at 3 psi pressure differential.

4.3.3 100% Panel Coverage

Appendix B (Figures B.25 through B.32) gives the results for 100% panel coverage for the eight tests carried out. Once again, the noise source was not a significant parameter. Results of depressurization tests are shown in Figure 4.11 for 100 Hz and 3000 Hz.

ORIGINAL PAGE IS
OF POOR QUALITY

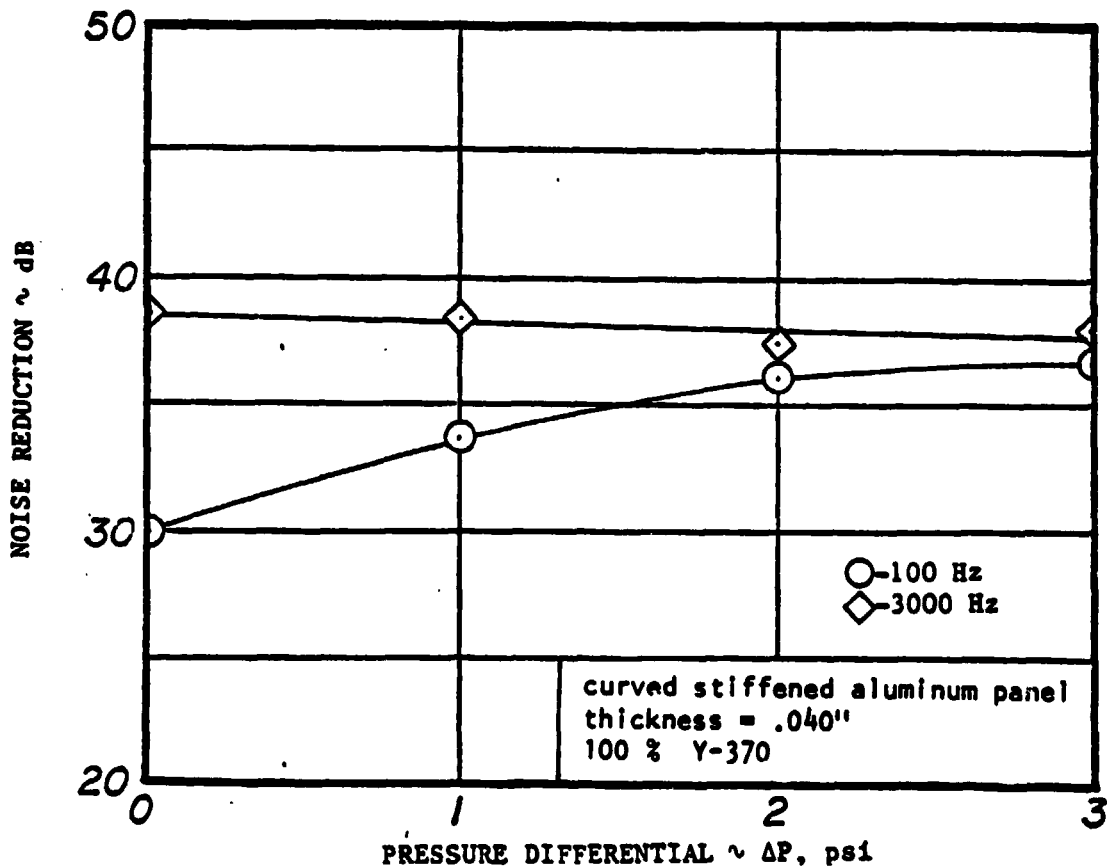

Figure 4:11: Effect of Pressure Differential on Noise Reduction Characteristics of a Curved, Stiffened Panel with 100% Y-370 Damping Tape at Low and High Frequencies

This figure shows that the low frequency noise reduction values increase from 30 dB at 0 psi to 37 dB at 3 psi pressure differential. Low frequency noise reduction values increase steadily from 0 psi to 2 psi, then level off to 37 dB. The decrease in mass law region in this case is negligible (from 38.5 dB at 0 psi to 38 dB at 3 psi).

4.3.4 Effect of Percentage of Coverage

Cross plots were made to show the effect of percentage of coverage of Y-370 applied to the panel at different pressure levels. Figures 4.12 and 4.13 depict the results in a series of eight graphs. Figure 4.12 shows the low frequency noise reduction values with a varying coverage. The results are much the same as those obtained with the flat panel curves (Figure 4.7). Here, as in the case with the flat panel, the effect of coverage was virtually nil. This figure verifies the results obtained from the other cross plots concerning the rise in noise reduction values from 0 psi to 1 psi with a flattening out after this value. Again, the effect of increasing the amount of damping material on a curved panel is to lower the resonance frequency but not to increase the noise reduction values significantly.

From Figures 4.7, 4.8, 4.12, and 4.13, it is concluded that the presence of damping tape has negligible effect on the overall noise reduction characteristics away from the resonance frequencies. When the mass of the damping tape constitutes a large percentage of the total panel and tape mass, the effect is essentially to increase the least squares lines noise reduction in the high frequency domain.

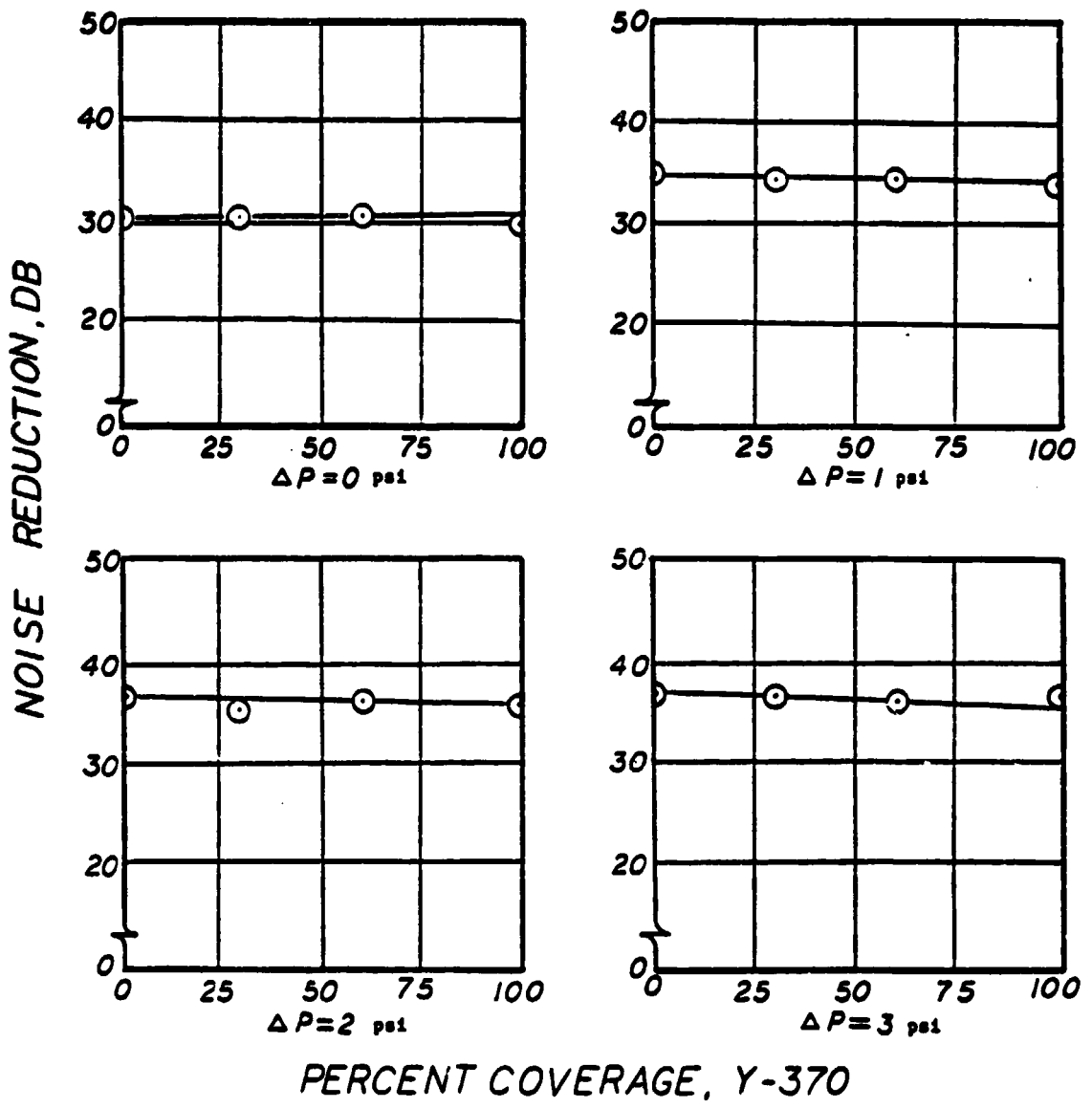

CURVED STIFFENED ALUMINUM PANEL THICKNESS = .040" FREQUENCY = 100 Hz

Figure 4.12: Effect of Coverage of Y-370 Damping Tape on Low Frequency Noise Reduction Characteristics for a Curved, Stiffened Panel at Different Pressure Differentials

ORIGINAL PAGE IS
OF POOR QUALITY.

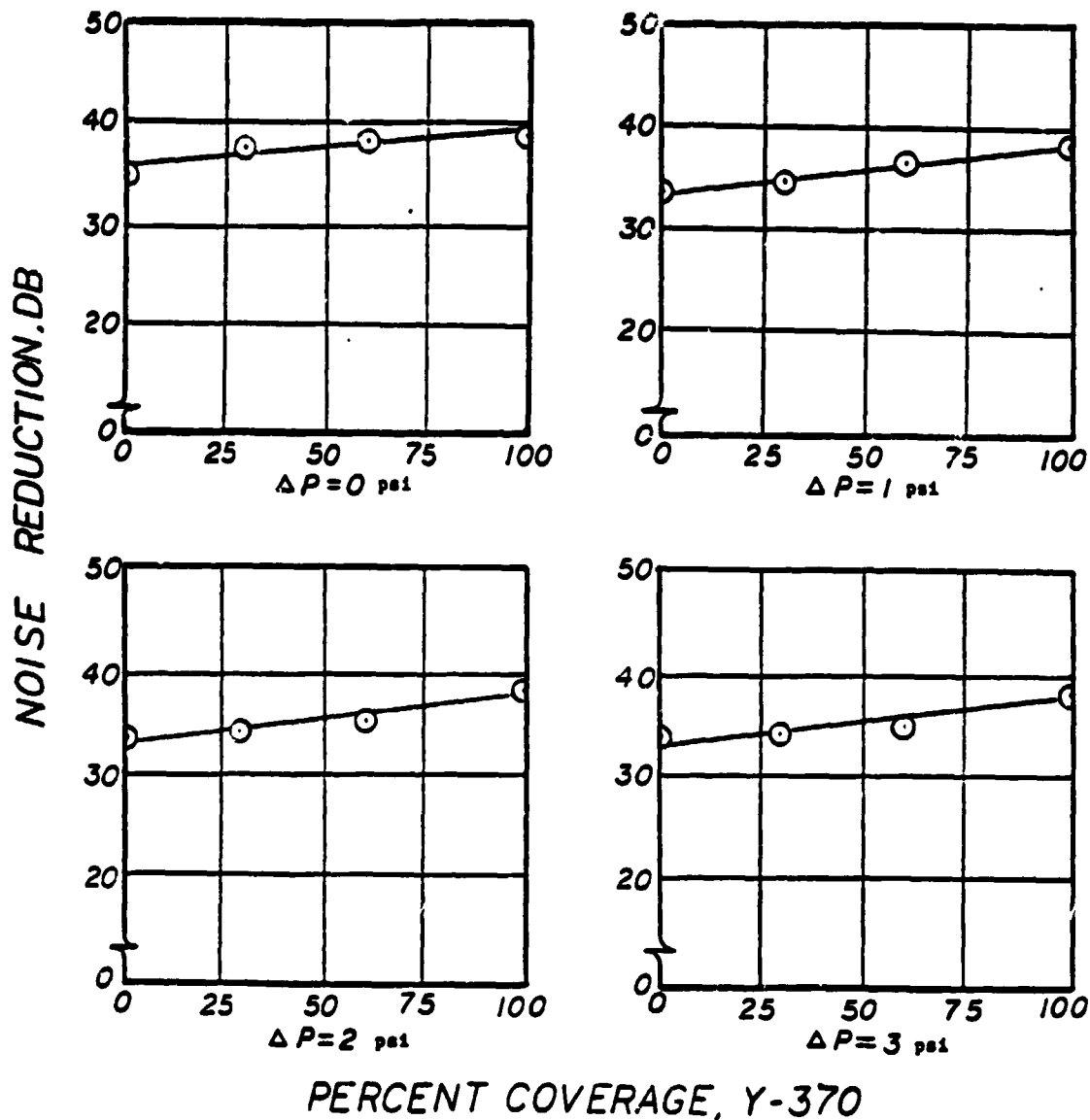

CURVED STIFFENED ALUMINUM PANEL THICKNESS = .040" FREQUENCY = 3000 Hz

Figure 4.13: Effect of Coverage of Y-370 Damping Tape on High Frequency Noise Reduction Characteristics for a Curved, Stiffened Panel at Different Pressure Differentials

Due to the scatter of the experimental results, no general trend of noise reduction values at the fundamental resonance frequency could be observed as a function of damping tape coverage. But for the resonance frequency itself, a gradual decrease in frequency is observed for an increasing area of damping tape coverage. This type of damping tape adds very little additional stiffness to the base panel. Hence, as the mass alone increases, the fundamental resonance frequency decreases.

CHAPTER 5

NOISE REDUCTION CHARACTERISTICS OF STIFFENED FLAT AND CURVED PANELS WITH Y-434 DAMPING MATERIAL

In this chapter, noise reduction tests performed to assess the effects of Y-434 damping tape on flat and curved panels are described, and the results obtained are discussed. Y-434 and Y-436 materials are damping tapes which provide increased damping action due to the constrained aluminum outer layer. Y-434 has a 7 mil constraining layer. The purpose of these tests is to compare the noise reduction values of panels with this damping material with those of Y-370.

5.1 TESTS PERFORMED ON PANELS COVERED WITH Y-434

The parameters investigated were the same as for damping tape Y-370: four pressure differentials were examined (0, 1, 2, and 3 psi); two types of noise sources, white noise and discrete noise; and three different coverages (30%, 60%, and 100%) of the Y-434 damping tape. The results of these tests, both narrow-band and one-third octave plots, for the flat panel are given in Appendix A (Figures A.33 through A.56). The results for the curved panel, both narrow-band and one-third octave, are given in Appendix B (Figures B.33 through B.56).

5.2 FLAT PANEL RESULTS

5.2.1 30% Panel Coverage

Results of these tests are given in Appendix A (Figures A.33 through A.40). The effect of noise source is negligible for these tests.

ORIGINAL PAGE IS
OF POOR QUALITY

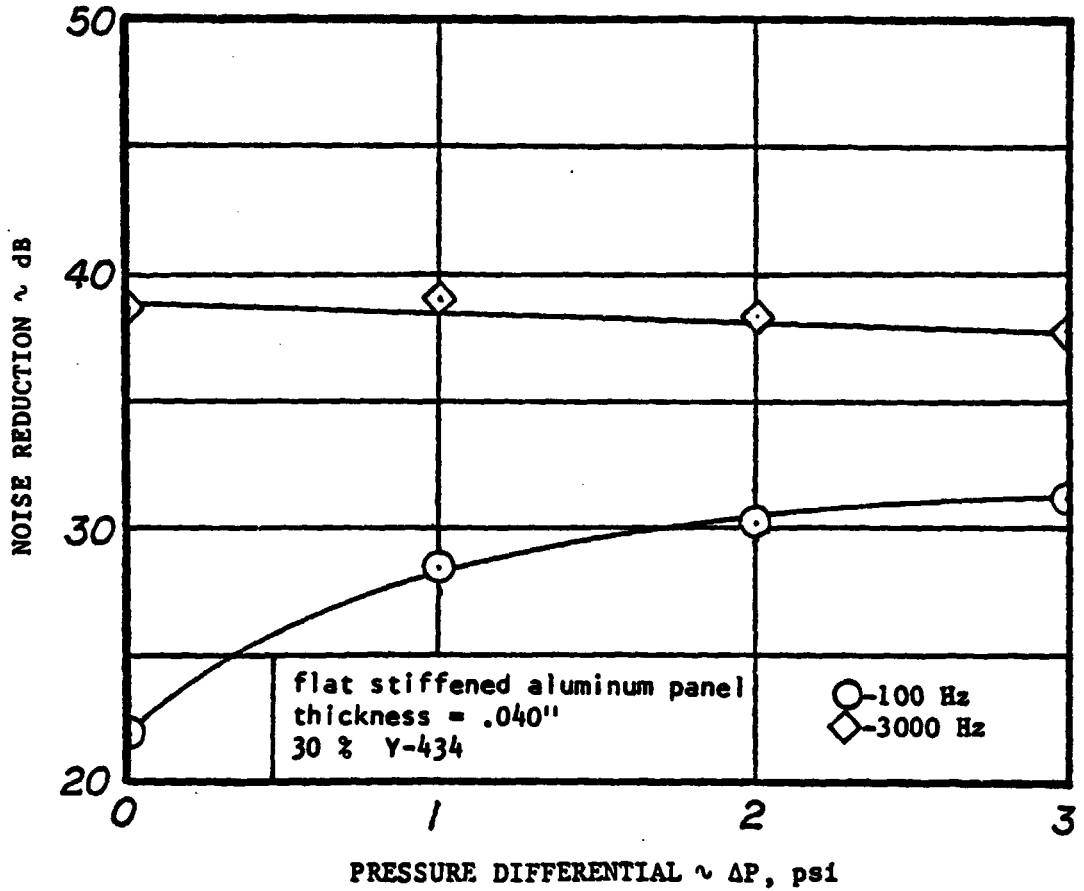

Figure 5.1: Effect of Pressure Differential on Noise Reduction Characteristics of a Flat, Stiffened Panel with 30% Y-434 Damping Tape at Low and High Frequencies

A cross plot of the noise reduction versus the pressure differential for this panel is given in Figure 5.1. This figure shows that low frequency reduction increases with increasing pressure differentials across the panel from 22 dB at 0 psi to 31.5 dB at 3 psi pressure differential. Most of this increase is seen in the first 1 psi of the curve, where the noise reduction value is 28.5 dB at 1 psi. The curve tends to flatten out after this value. In the high frequency region the noise reduction values are relatively constant around 38 dB. There is a slight drop in the noise reduction with increasing pressure differential, but the trend is slight. Therefore, it is concluded that the effect of increasing the pressure differential with this treatment is to increase the low frequency noise reduction value about 10 dB but not to affect the high frequency noise reduction characteristics to any significant effect.

Increasing the pressure differential also affects the position of the resonance frequency. Figure 5.2 shows the results of increasing the pressure differential across the panel. The value of the resonance frequency is 125 Hz with no pressure differential, and it increases to 220 Hz when the pressure differential is 3 psi. This increase is gradual, not as sudden as was seen with the panels with Y-370 damping tape. Even though the resonance frequency does not show the trend of flattening out at the higher pressure differentials associated with the Y-370 damping tape, it is considered that it could be due to experimental scatter, rather than any significant trend.

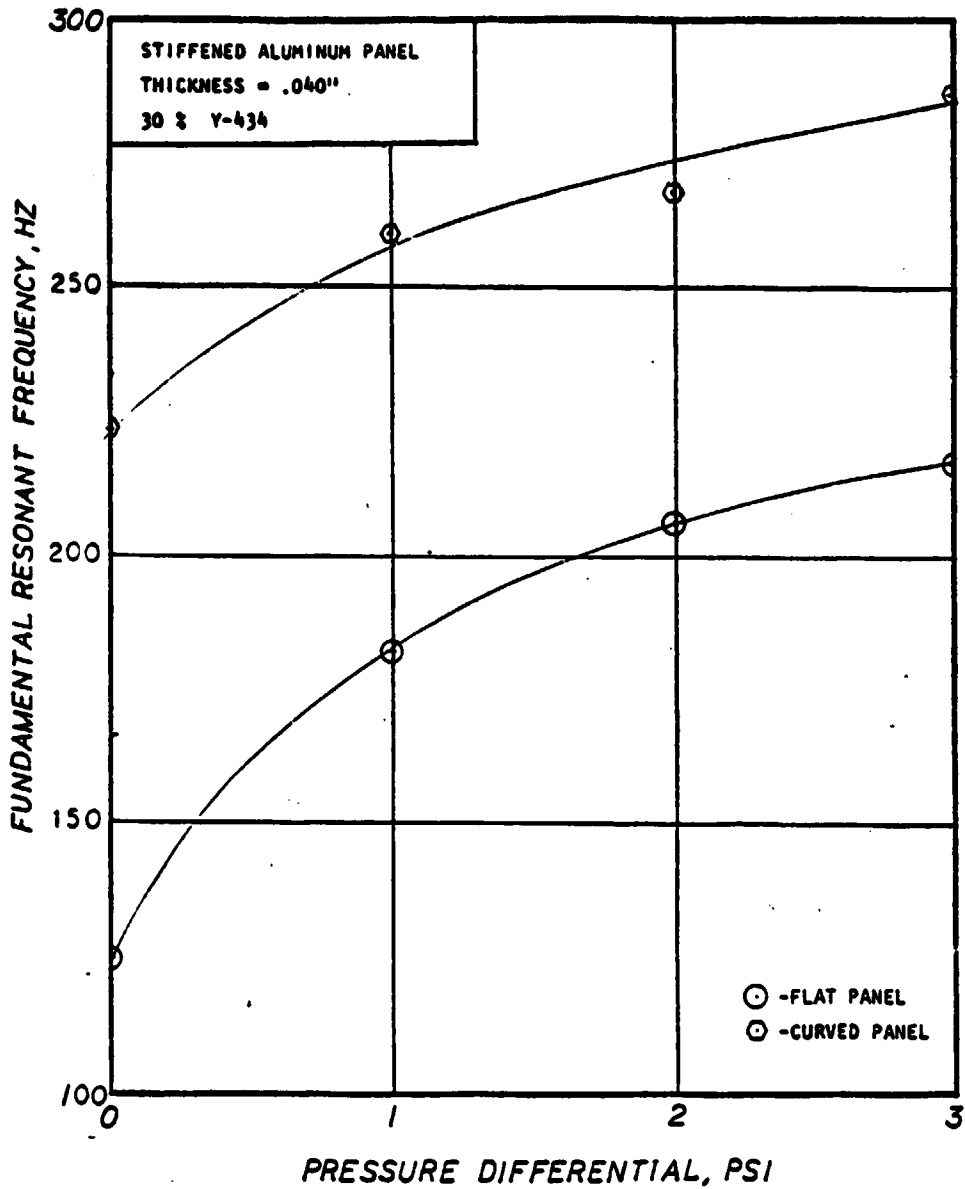

Figure 5.2: Effect of Pressure Differential on the Fundamental Resonance Frequency for Flat and Curved, Stiffened Panels with 30% Y-434

5.2.2 60% Panel Coverage

Results of these tests are given in Appendix A (Figures A.41 through A.48). Comparison of the graphs indicate that there is little difference in the two noise sources as there is in previous cases. A cross plot of the noise reduction versus the pressure differential is given in Figure 5.3. This figure shows that initial noise reduction of the panel without any pressure differential is 22 dB and that it rises to 31.5 dB at a pressure differential at 3 psi. After the 1 psi value, the curve tends to level off around 32 dB. The high frequency noise reduction characteristics of the panel did not change in the pressure ranges tested. The noise reduction value is approximately 40 dB at 0 psi, where it stays throughout the test region within the range of scatter. So it is seen that the effect of a pressure differential is to increase the low frequency noise reduction characteristics of the panel but not to affect the high frequency noise reduction values.

The fundamental resonance frequency of the panel is changed by an increasing pressure differential, as witnessed in Figure 5.4. This figure shows the resonance frequency being 120 Hz at 0 psi differential and increasing rapidly to a value of 210 Hz at 2 psi pressure differential, where it flattens out to a final value of 212 Hz at 3 psi.

5.2.3 100% Panel Coverage

Results of these tests are given in Appendix A (Figures A.49 through A.56). Once again, it is concluded that there is little

ORIGINAL PAGE IS
OF POOR QUALITY

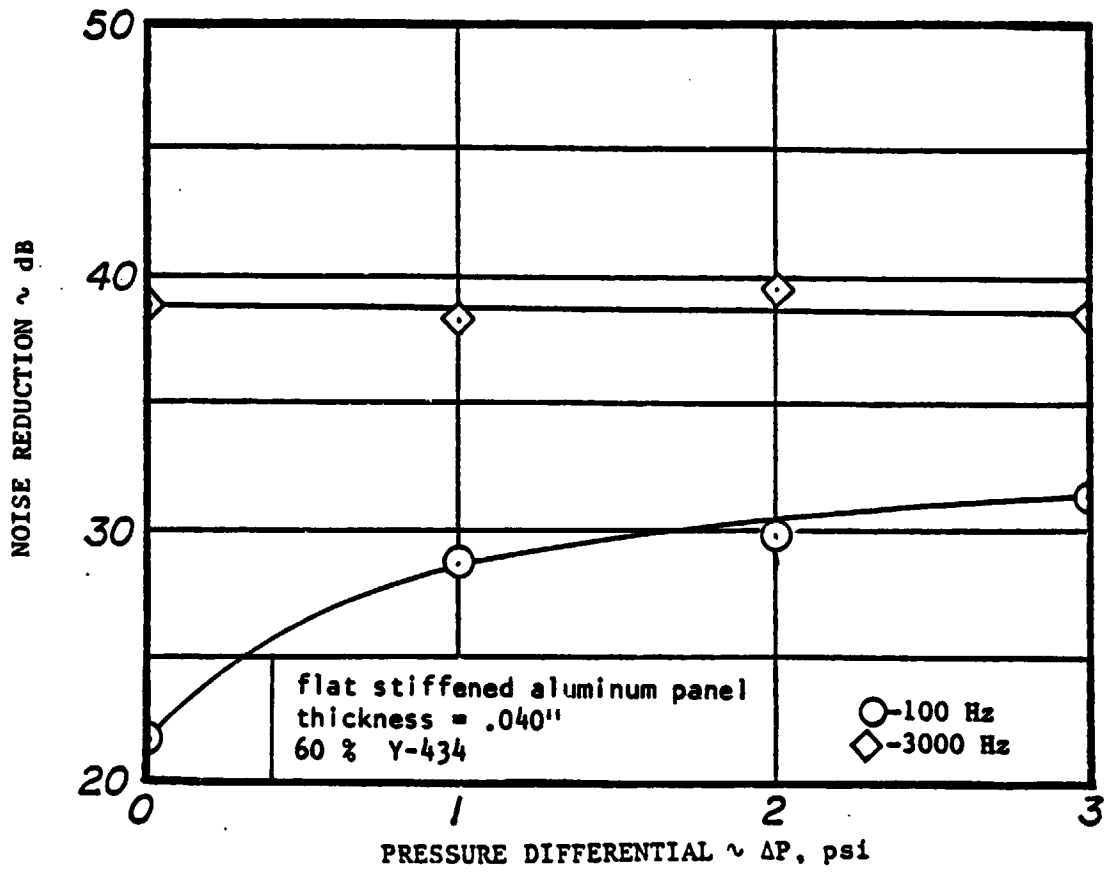

Figure 5.3: Effect of Pressure Differential on Noise Reduction Characteristics of a Flat, Stiffened Panel with 60% Y-434 Damping Tape at Low and High Frequencies

ORIGINAL PAGE IS
OF POOR QUALITY

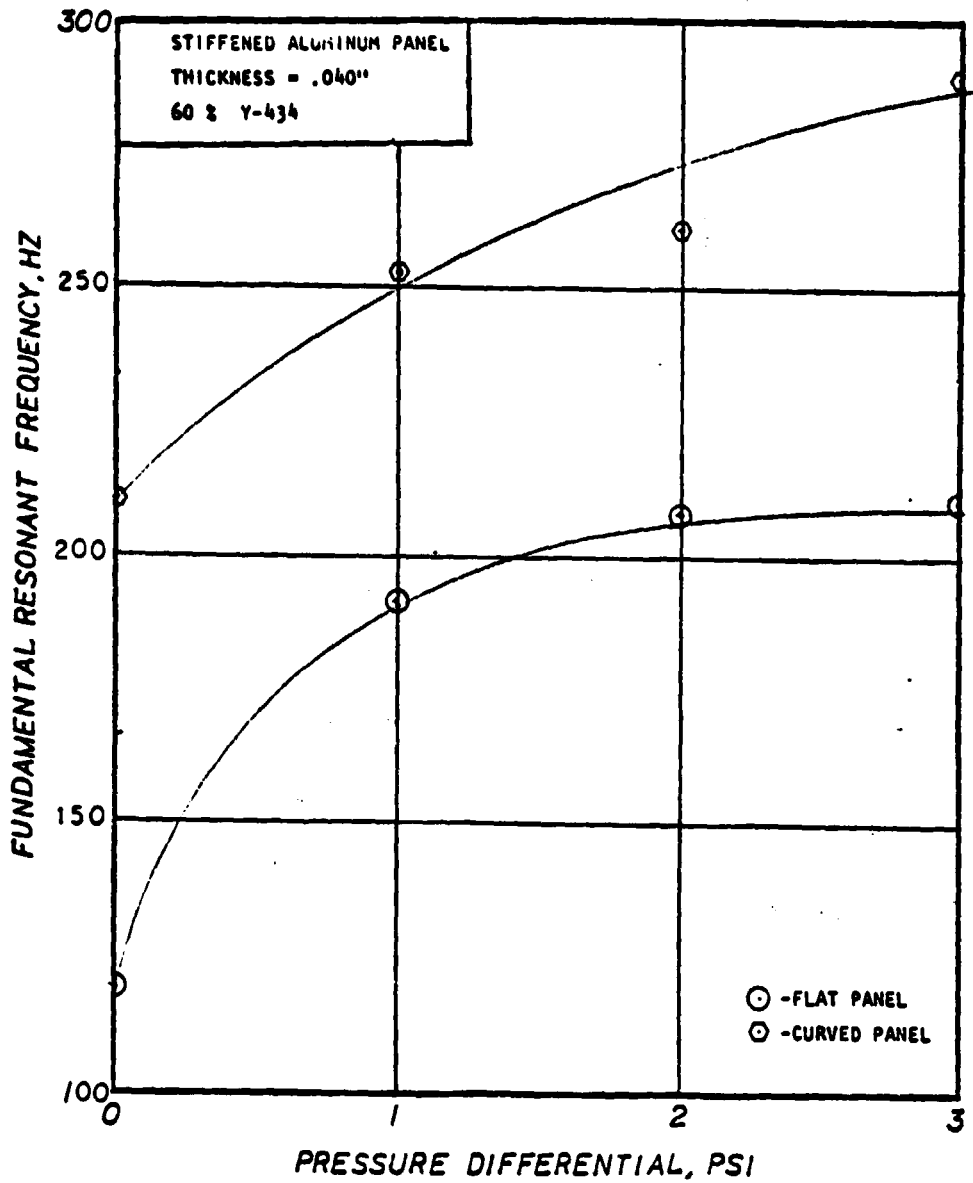

Figure 5.4: Effect of Pressure Differential on the Fundamental Resonance Frequency for Flat and Curved, Stiffened Panels with 60% Y-434

ORIGINAL PAGE IS
OF POOR QUALITY

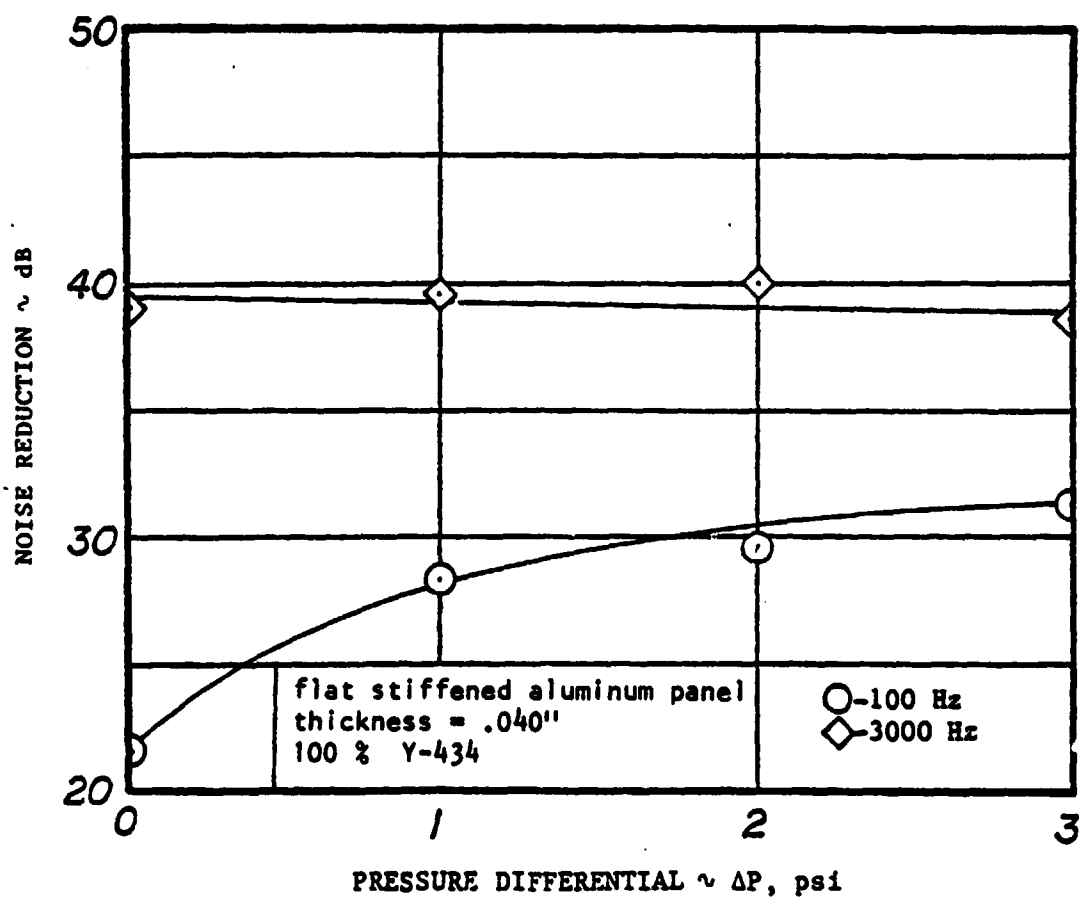

Figure 5.5: Effect of Pressure Differential on Noise Reduction Characteristics of a Flat, Stiffened Panel with 100% Y-434 Damping Tape at Low and High Frequencies

difference between the two noise sources. For this panel, the initial value of noise reduction at 100 Hz is 21.5 dB at 0 psi, which rises to 31.5 dB at 3 psi pressure differential (see Figure 5.5). Once again, most of the gain in noise reduction for this panel occurs in the first 1 psi. After the 1 psi differential, the curve levels out to the final value of 31.5 dB. Noise reduction at 3000 Hz starts at approximately 39 dB and stays constant at this level throughout the entire pressure differential region. The pressure differential has little effect on the high frequency noise reduction characteristics of this treated panel.

The resonance frequency of the panel is increased as a result of the increased pressure differential, and this is shown in Figure 5.6. The initial resonance frequency of 130 Hz is rapidly increased by the pressure differential up to the 1 psi level of 196 Hz. The final resonance frequency of 215 Hz is realized at a pressure differential of 3 psi, showing the earlier trend to level off. The effect of pressurization is still to increase the stiffness. The maximum increase occurs in the initial 1 psi. Additional increase in stiffness does not increase the resonance frequency.

5.2.4 Effect of Percentage of Coverage

Results from Figures 5.1, 5.3, and 5.5 were cross plotted to investigate the effect of percentage of coverage. Figure 5.7 and Figure 5.8 show the effect of coverage on the noise reduction characteristics of a flat, stiffened panel for the low and high frequencies that have been singled out in this report (100 Hz and 3000 Hz).

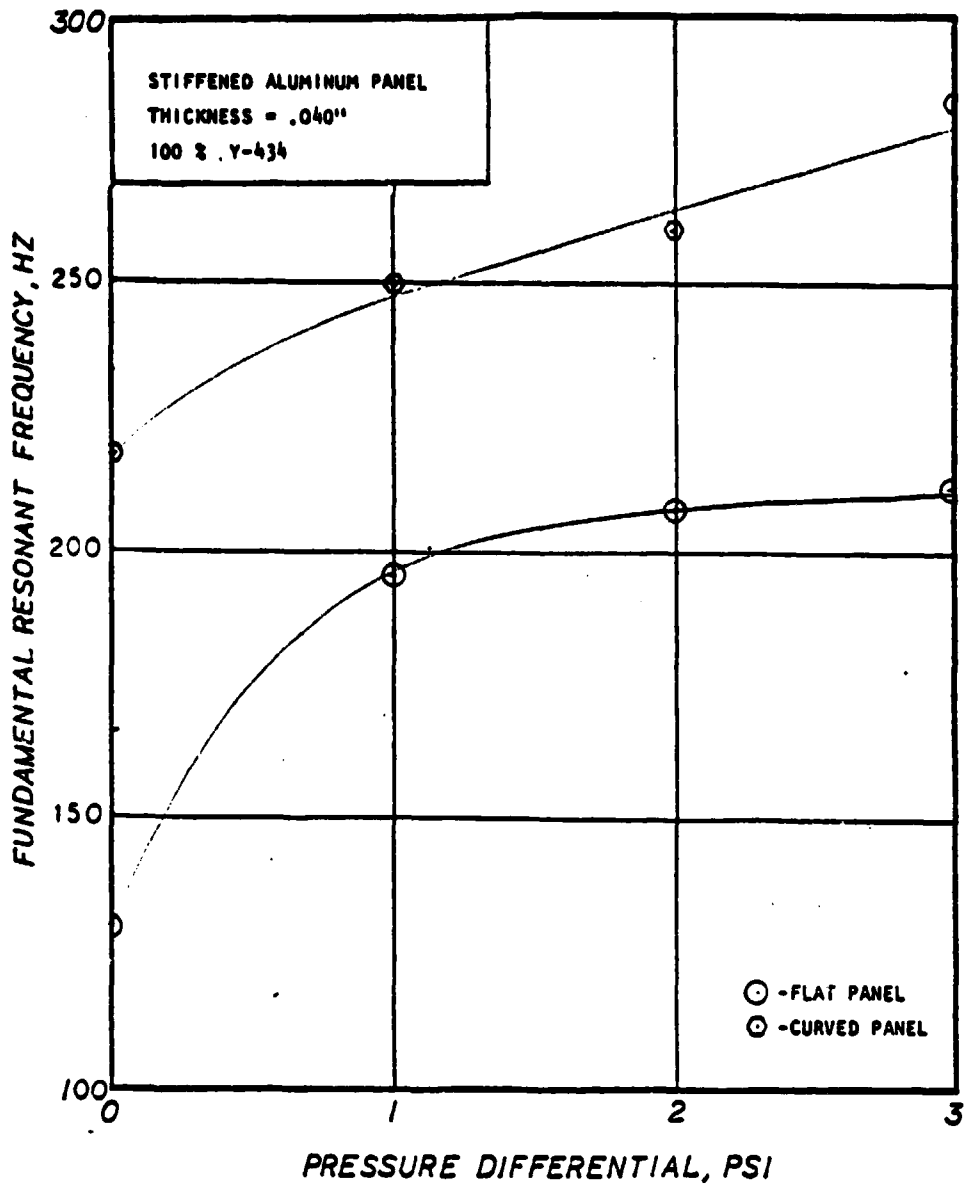

Figure 5.6: Effect of Pressure Differential on the Fundamental Resonance Frequency for Flat and Curved, Stiffened Panels with 100% Y-434

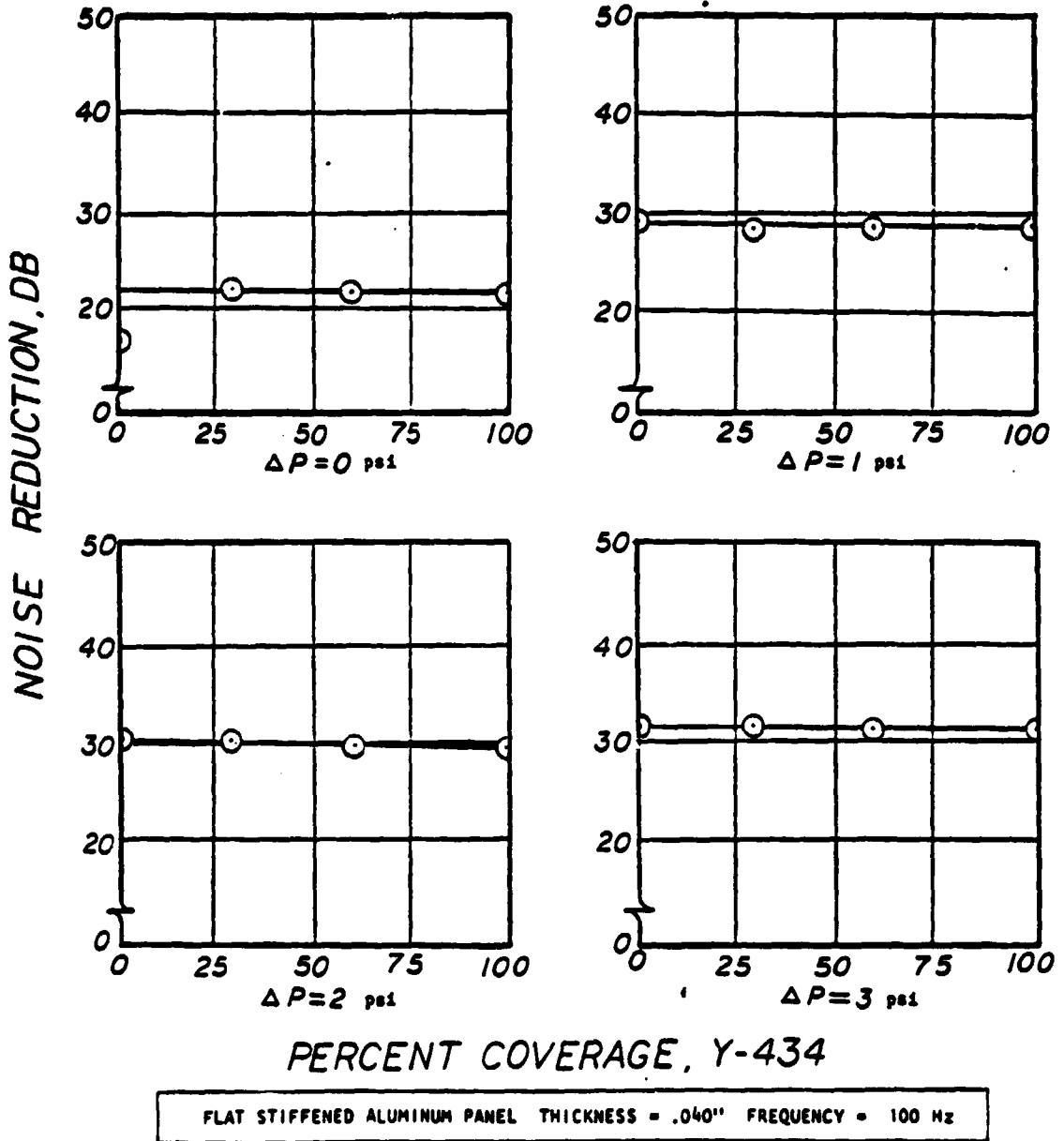
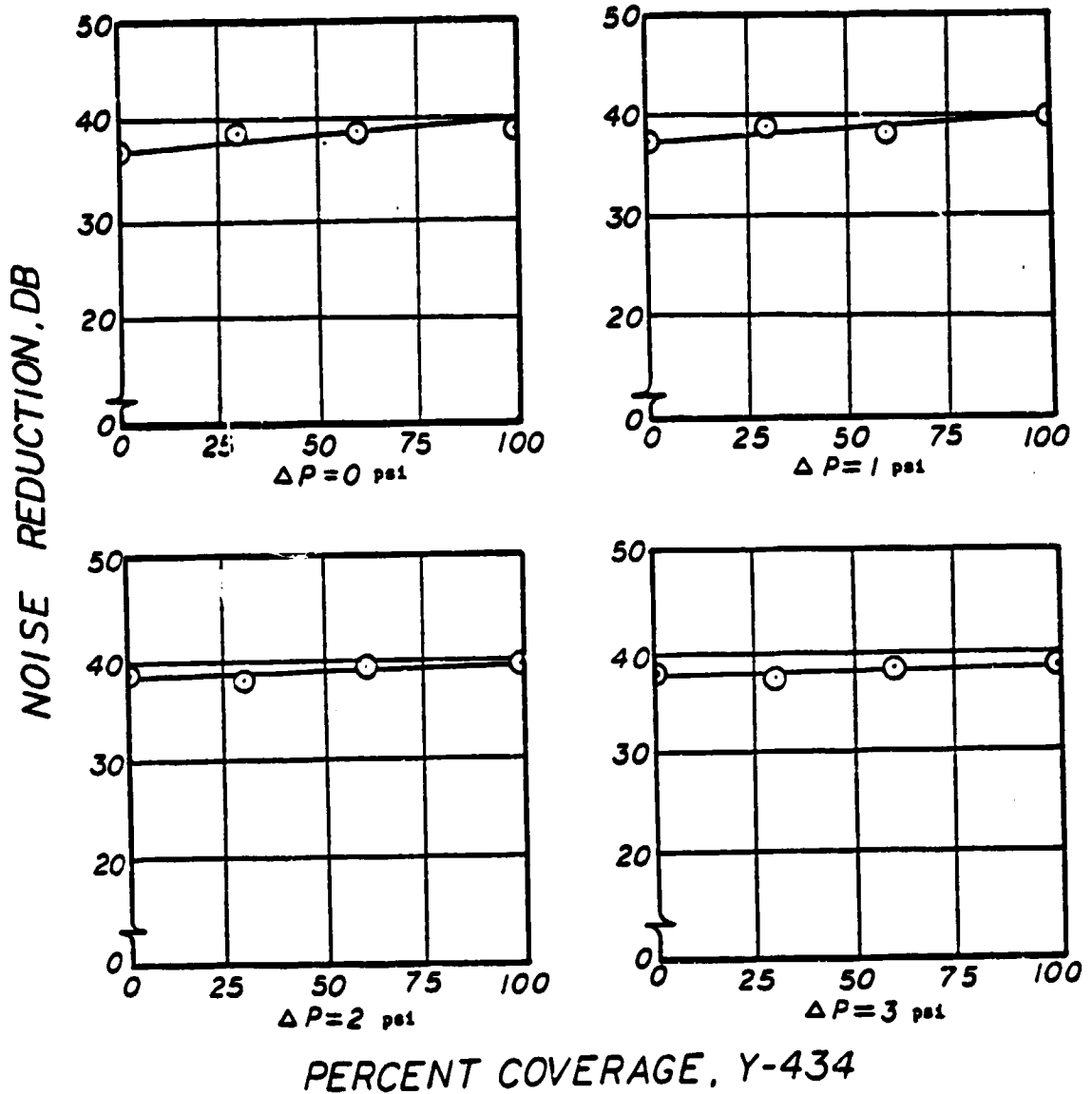

Figure 5.7: Effect of Coverage of Y-434 Damping Tape on Low Frequency Noise Reduction Characteristics for a Flat, Stiffened Panel at Different Pressure Differentials



FLAT STIFFENED ALUMINUM PANEL THICKNESS = .040" FREQUENCY = 3000 Hz

Figure 5.8: Effect of Coverage of Y-434 Damping Tape on High Frequency Noise Reduction Characteristics for a Flat, Stiffened Panel at Different Pressure Differentials

Figure 5.7 shows that the low frequency noise reduction characteristics of the panel are not significantly changed as a result of adding Y-434 damping material to it. With a possible exception at 0 psi pressure differential, the noise reduction values remain constant throughout the coverage range tested.

Figure 5.8 shows the effect of percentage of coverage on high frequency noise reduction characteristics at different pressure differentials. These graphs show that the effect of adding Y-434 damping tape to the panel is to increase the noise reduction ability by approximately 1-2 dB. These figures show quite graphically the relative importance of the higher mass in the high frequency region.

5.3 CURVED PANEL RESULTS

Tests similar to those for the flat panel were carried out for the curved, stiffened panel.

5.3.1 30% Panel Coverage

Results of these tests are given in Appendix B in Figures B.33 through B.40. A cross plot of the noise reduction characteristics versus the pressure differential is given in Figure 5.9. This figure shows the familiar trend of the curves exhibited in the figures presented for the Y-370 damping tape in Chapter 4. The low frequency noise reduction value for no pressure differential is originally 31.5 dB. This noise reduction value rises slowly with increasing pressure differential up to a final value of 37.3 dB at 3 psi pressure

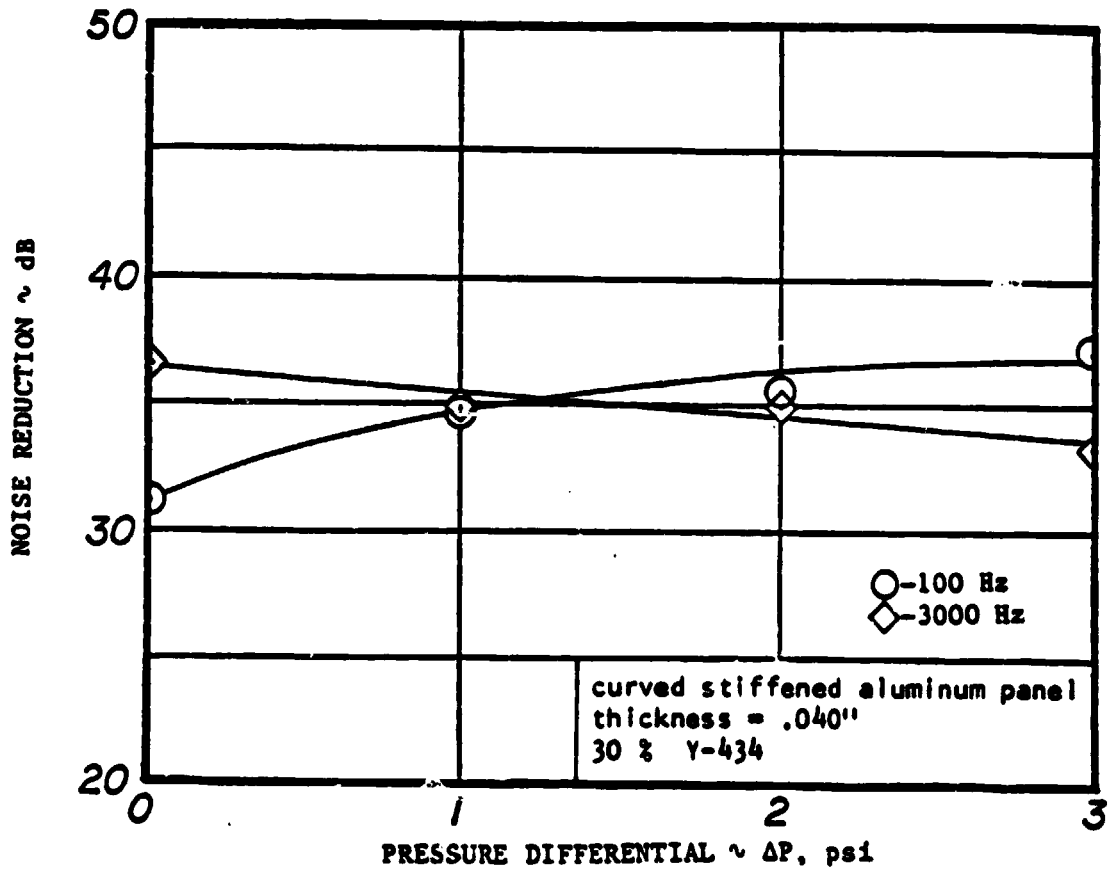

Figure 5.9: Effect of Pressure Differential on Noise Reduction Characteristics of a Curved, Stiffened Panel with 30% Y-434 Damping Tape at Low and High Frequencies

differential. As with the flat panels, there is no big jump in noise reduction in the first 1 psi for this treatment of the curved panel. High frequency noise reduction characteristics of the curved panel treated with 30% Y-434 are also shown in Figure 5.9. The graph shows that the noise reduction level of this panel starts at 36.5 dB and then drops to a final value of 33.5 dB at 3 psi pressure differential at 3000 Hz. This tendency to drop off is consistent with those discussed in Chapter 4 for the curved panel.

The change in resonance frequency due to a changing pressure differential is shown graphically in Figure 5.2. The resonant frequency is 225 Hz at 0 psi pressure differential and increases rapidly in the first 1 psi pressure differential to 260 Hz. After this value, the resonant frequency increases more slowly to a final value of 285 Hz at 3 psi. The increase in resonance frequency as a result of increasing pressure differential does not level off like the flat panel resonant frequencies; thus, the effect of increasing pressure differential is to increase the resonance frequency.

5.3.2 60% Panel Coverage

Results of these tests are given in Appendix B (Figures B.41 through B.48). By comparison of similar graphs, it can be seen that there is little difference between the sweep oscillator and the white noise source. A cross plot of the effect of increasing pressure differential on noise reduction characteristics is given in Figure 5.10. This figure shows a modest rise in noise reduction values for the low frequency range. Noise reduction in the low frequency region is initially 30 dB. The effect of pressure differential is seen to

ORIGINAL PAGE IS
OF POOR QUALITY

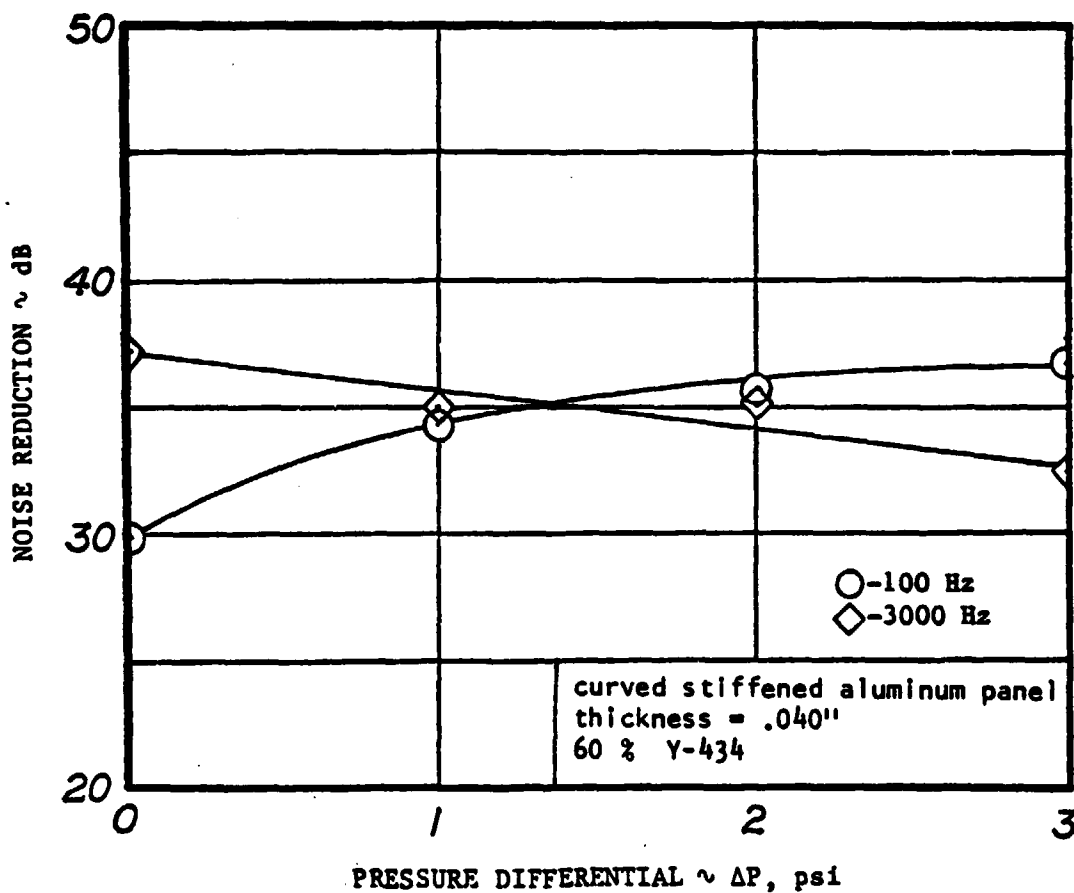

Figure 5.10: Effect of Pressure Differential on Noise Reduction Characteristics of a Curved, Stiffened Panel with 60% Y-434 Damping Tape at Low and High Frequencies

push the noise reduction up to a value of 36.5 dB at 3 psi pressure differential, a gain of 6.5 dB. The most marked increase in noise reduction is seen in the first 1 psi of this graph. In the high frequency region (Figure 5.11) the decrease in noise reduction corresponded with similar observations at other percentages of Y-434 or Y-370 for curved panels. A decrease of approximately 5 dB occurs within 3 psi pressure differential.

There is an increase in the resonant frequency, as shown in Figure 5.4, as a result of increasing the pressure differential across the panel. From an initial value at 220 Hz, the curve quickly rises to a value of 290 Hz at a 3 psi pressure differential.

5.3.3 100% Panel Coverage

Results of the tests are given in Appendix B in Figures B.49 through B.56. A cross plot of the values obtained for the frequencies representative of each region is found in Figure 5.11. This plot shows a similar behavior for the two curves as it was seen in the previous plots. The low frequency noise reduction shows a modest rise from a 31 dB at 0 psi to a 37 dB noise reduction at 3 psi pressure differential. Although most of the noise reduction gained is obtained in the first 1 psi, the gain is not so marked as the previous ones. The high frequency noise reduction suffers a little as a result of increasing the pressure differential; however, the decrease is only about 2 dB.

The resonance frequency of this treated panel also increases as a result of increasing the pressure differential across the panel, as seen in Figure 5.6. The resonance frequency is originally 220 Hz

ORIGINAL PAGE IS
OF POOR QUALITY

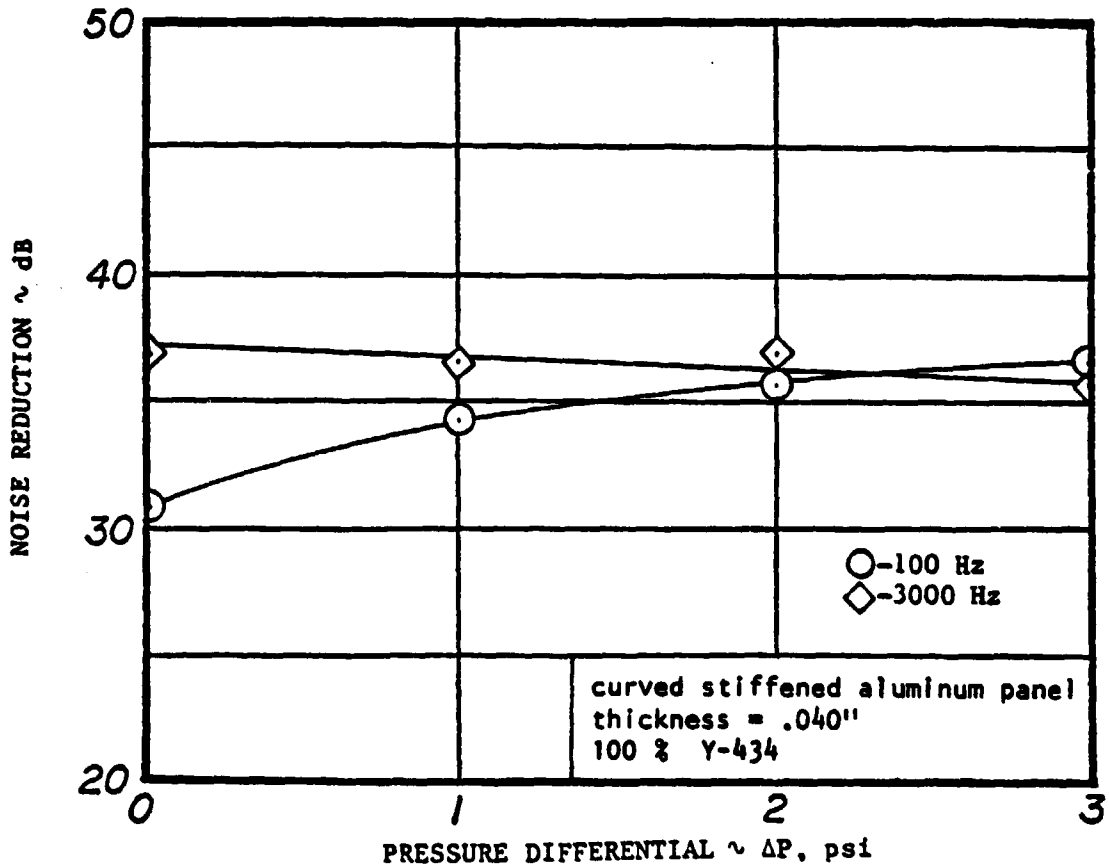
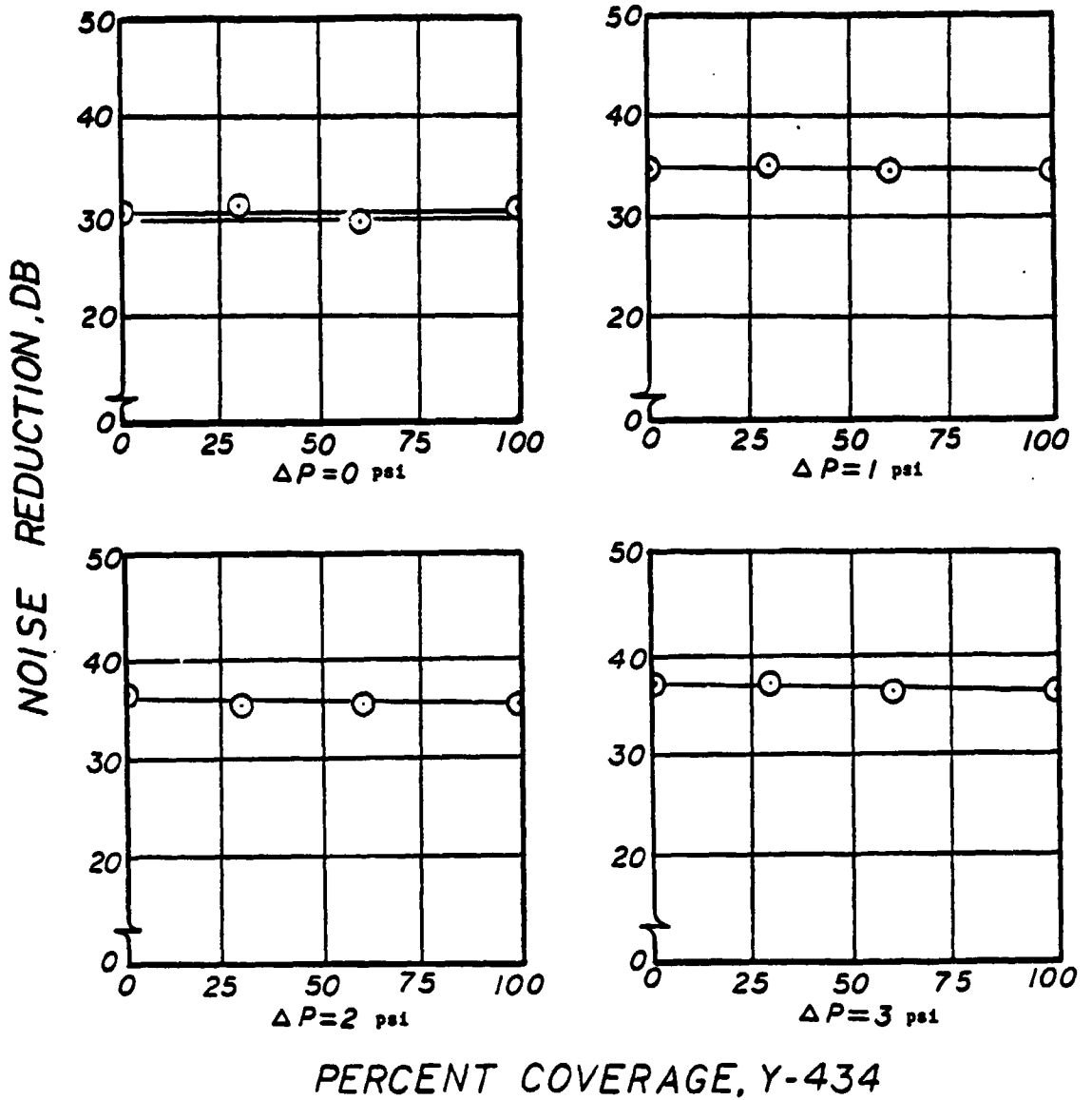

Figure 5.11: Effect of Pressure Differential on Noise Reduction Characteristics of a Curved, Stiffened Panel with 100% Y-434 Damping Tape at Low and High Frequencies

with no pressure differential across the panel, and it steadily increases to a final value of 285 Hz at 3 psi. The largest gain in noise reduction is again seen in the first 1 psi pressure differential, where the value of the resonant frequency is 250 Hz. The effect of increasing pressure differential on this treated panel is to push up the resonance frequency and to increase the low frequency noise reduction characteristics while virtually ignoring the high frequency noise reduction characteristics.

5.3.4 Effect of Percentage of Coverage

The effect of percentage of coverage of Y-434 damping tape is seen in Figure 5.12 and Figure 5.13. Figure 5.12 gives the results of the low frequency noise reduction noise reduction characteristics at 100 Hz. This figure shows that the effect of percentage of coverage does not affect the noise reduction capability of a curved panel. The curves given in this figure are flat, indicating the negligible effect of the coverage. The curves in Figure 5.13 for high frequencies exhibit about the same behavior as those seen in the similar plots for a flat panel. Calling a trend for these graphs would be difficult at best, although it seems that a slight upward trend in noise reduction would be the right conclusion for high frequencies. At 0 psi, a slight decrease in resonance frequency occurs with an increase in coverage. This could be due to the fact that the mass of the panel increases, without a corresponding increase in stiffness. Comparison with results of a bare panel (Chapter 3) indicates that the change in the fundamental resonance frequency is



CURVED STIFFENED ALUMINUM PANEL THICKNESS = .040" FREQUENCY = 100 Hz

Figure 5.12: Effect of Coverage of Y-434 Damping Tape on Low Frequency Noise Reduction Characteristics for a Curved, Stiffened Panel at Different Pressure Differentials

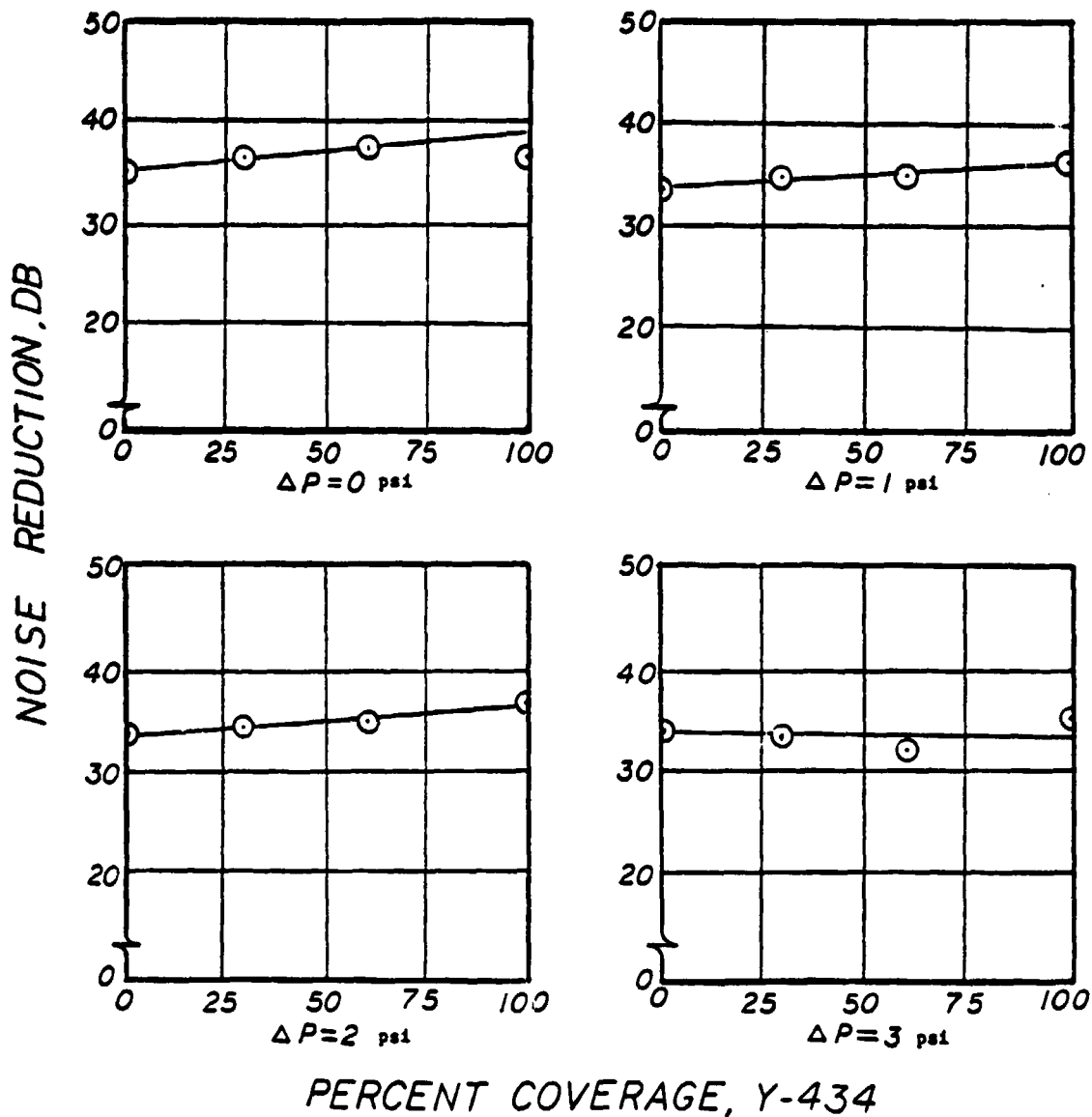

CURVED STIFFENED ALUMINUM PANEL THICKNESS = .040" FREQUENCY = 3000 Hz

Figure 5.13: Effect of Coverage of Y-434 Damping Tape on High-Frequency Noise Reduction Characteristics on a Curved, Stiffened Panel at Different Pressure Differentials

very small with application of damping tape. The additional stiffening effect of the constraining layer is balanced out by the additional mass added. Once again, the values of resonance frequencies are ill-defined precluding any general conclusions.

CHAPTER 6

NOISE REDUCTION CHARACTERISTICS OF STIFFENED FLAT AND CURVED PANELS WITH Y-436 DAMPING TAPE

6.1 TESTS PERFORMED ON PANELS COVERED WITH Y-436

During the present series of investigations for noise reduction characteristics, panels covered with the Y-436 were tested for the effect of varying pressure differentials, percent of damping material coverage, and noise source effects. Four pressure differentials were examined (0, 1, 2, and 3 psi) under two types of noise sources, white noise and swept sine wave noise, with three different coverages (30%, 60%, and 100%) of the Y-436 damping tape. Two panels were tested for their noise reduction characteristics: a flat, stiffened panel and a curved, stiffened panel. Results of these tests, both narrow-band and one-third octave plots, for the Y-436 damping tape applied to the flat panel are given in Appendix A (Figures A.57 through A.80). Results for the curved panel are given in Appendix B (Figures B.56 through B.80).

6.2 FLAT PANEL RESULTS

Tests were carried out to determine the effect of noise source on the panels. These tests were done with the same procedure as those outlined in the first paragraph of Section 3.1.1 of this report. The effect of noise source is once again negligible.

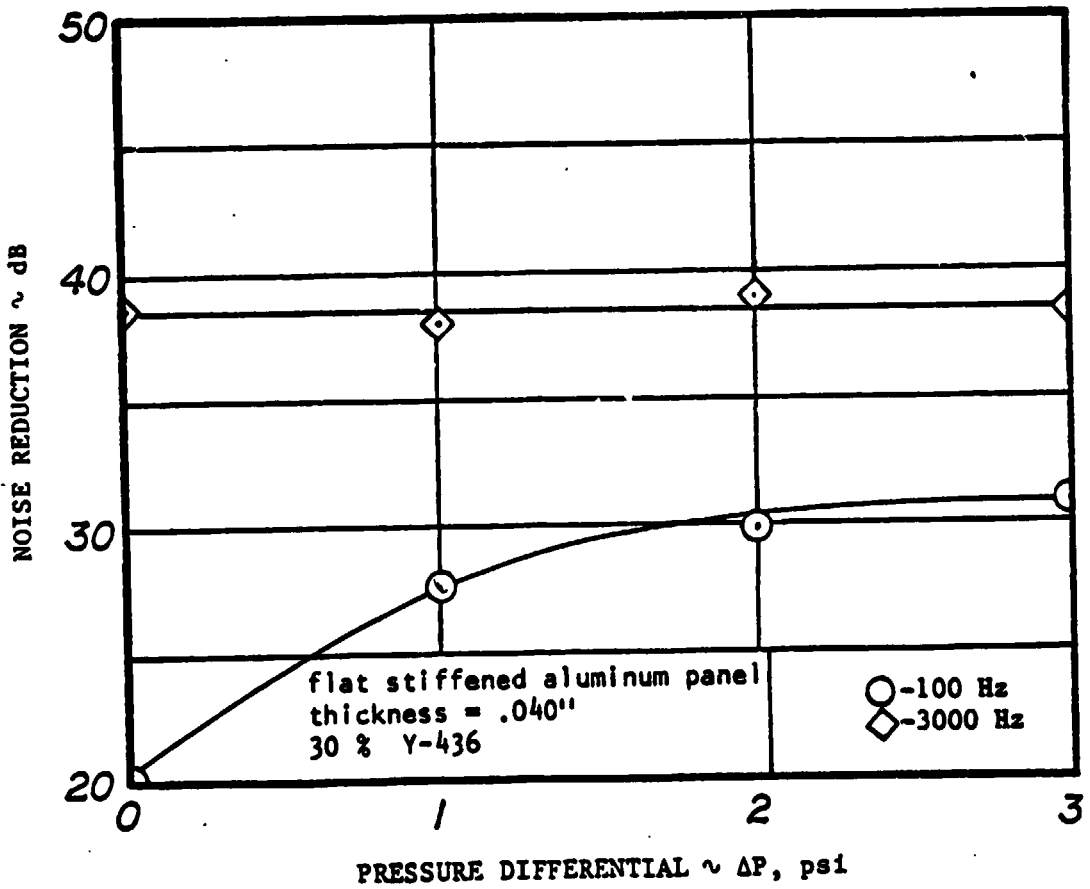

Figure 6.1: Effect of Pressure Differential on Noise Reduction Characteristics of a Flat, Stiffened Panel with 30% Y-436 Damping Tape at Low and High Frequencies

6.2.1 30% Panel Coverage

Results of the tests are given in Appendix A (Figures A.57 through A.64). A crossplot of the results for the effect of pressure differential on noise reduction is given in Figure 6.1. This figure shows that the effect of increasing the pressure differential is to increase the noise reduction ability of the panel in the low frequency region. Noise reduction is increased from 20 dB at 0 psi pressure differential to 31 dB at 3 psi. The slope of the curve is large in the first 1 psi region, giving a large increase in noise reduction, but then flattens out in the higher pressure differentials to a final value of 31 dB. The high frequency noise reduction characteristics as a result of pressure differential are unchanged. The high frequency values are relatively unaffected by the depressurization and stay at approximately 38.5 dB noise reduction.

The resonance frequency changes according to the graph in Figure 6.2. An increasing pressure differential pushes the resonance frequency up from its initial value of 120 Hz to about 190 Hz in the first 1 psi pressure differential. This value is further increased to 213 Hz with a differential of 3 psi. So the effect of increasing pressure differential is to increase the resonance frequency and to increase the low frequency noise reduction characteristics, while not affecting the high frequency characteristics.

6.2.2 60% Panel Coverage

Results of the tests for this coverage are presented in Appendix A (Figures A.65 through A.72). A cross plot of the effect of pressure

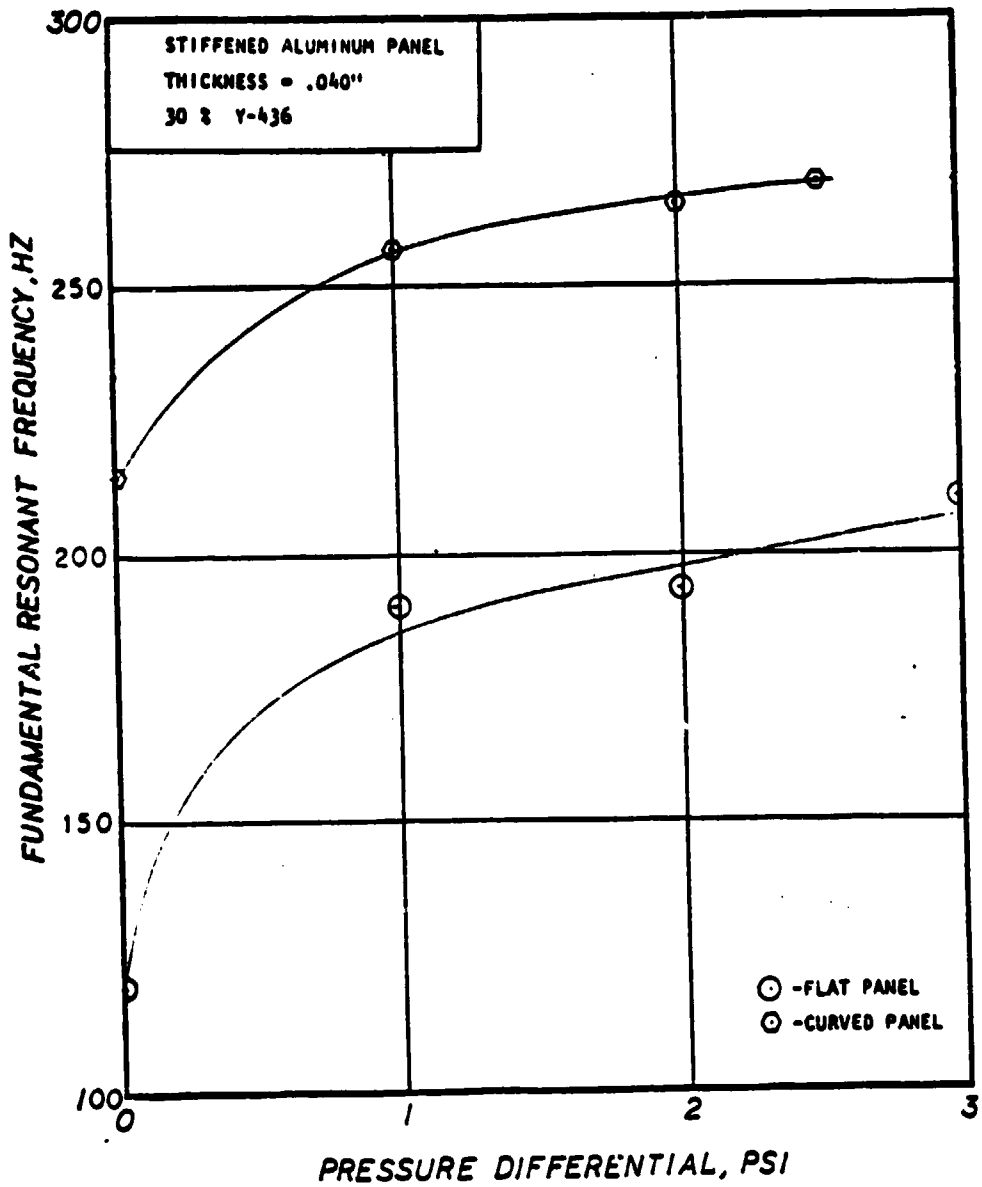

Figure 6.2: Effect of Pressure Differential on the Fundamental Resonance Frequency for Flat and Curved, Stiffened Panels with 30% Y-436

ORIGINAL PAGE IS
OF POOR QUALITY

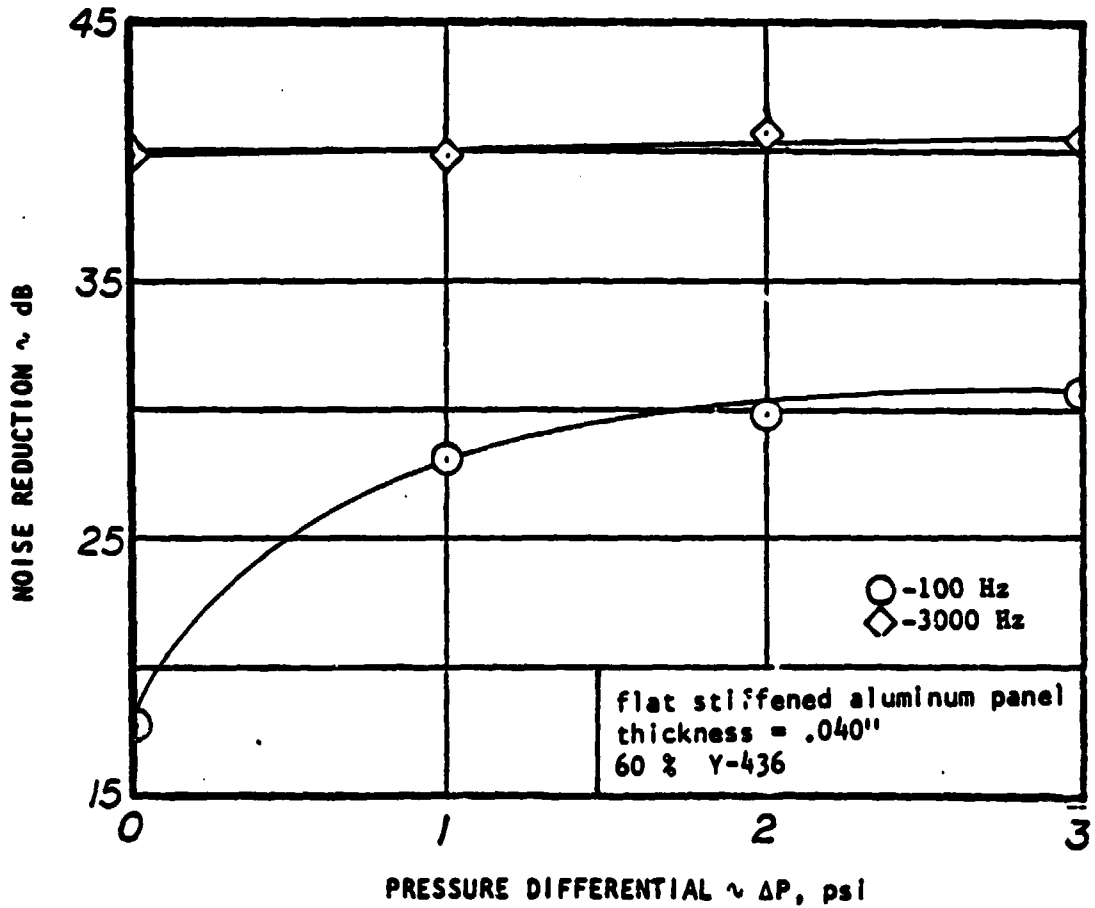

Figure 6.3: Effect of Pressure Differential on Noise Reduction Characteristics of a Flat, Stiffened Panel with 60% Y-436 Damping Tape at Low and High Frequencies

ORIGINAL PAGE IS
OF POOR QUALITY

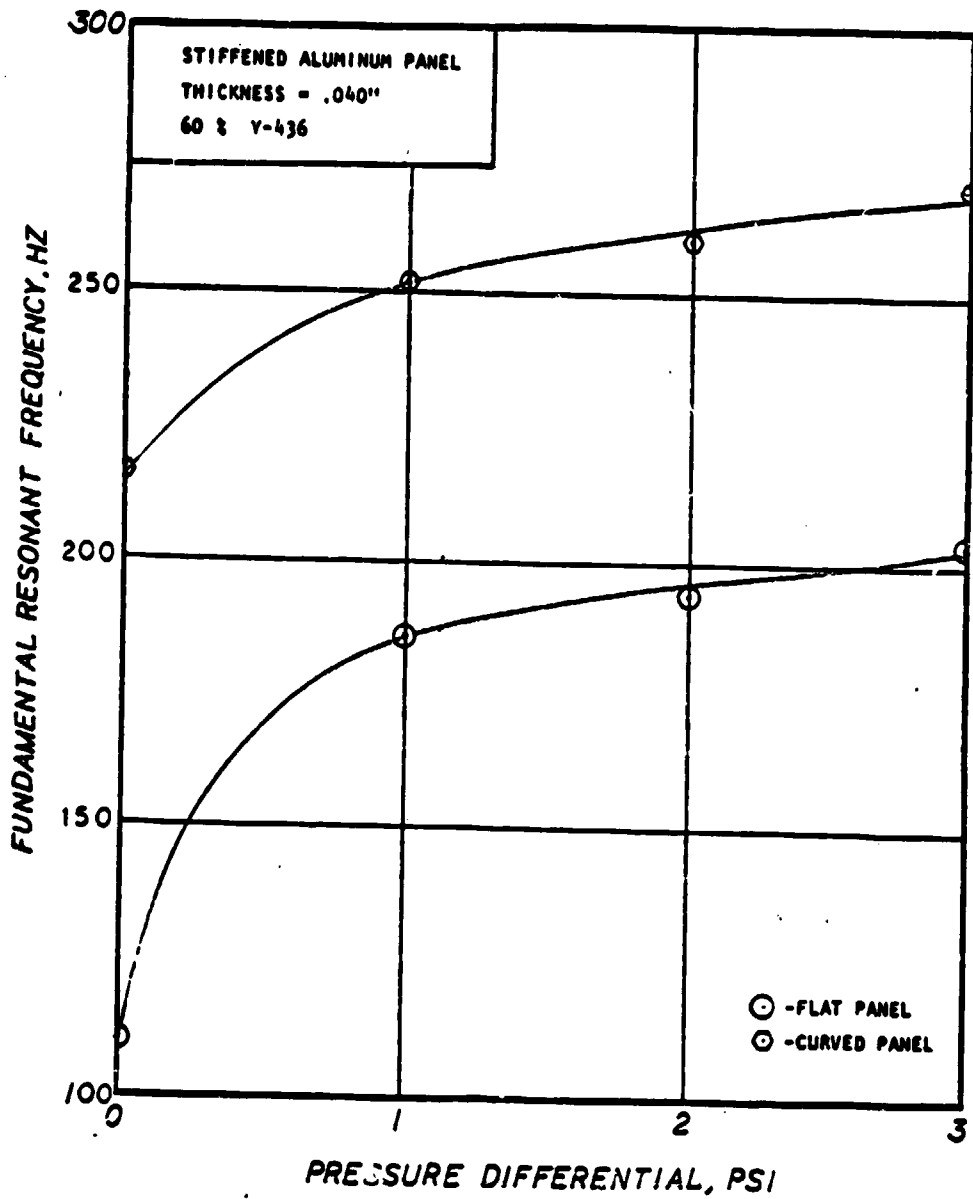

Figure 6.4: Effect of Pressure Differential on the Fundamental Resonance Frequency for Flat and Curved, Stiffened Panels with 60% Y-436

differential on the noise reduction characteristics of the panel is given in Figure 6.3. This figure shows that by increasing the pressure differential across the panel from 0 psi to 1 psi, the noise reduction gained is 10.5 dB. At 0 psi pressure differential the noise reduction is 17.5 dB, so the increase gives a value of 28 dB at 1 psi. This value is increased to 31 dB at 3 psi. High frequency noise reduction is again not changed by stiffening the panel. High frequency reduction is constant throughout at 40 dB.

Figure 6.4 shows the results of stiffening the panel on the value of the resonance frequency. With this treatment, the flat panel has an initial resonance frequency of 110 Hz. This value increases to 207 Hz at 3 psi, with a major increase occurring in the first 1 psi.

6.2.3 100% Panel Coverage

Results of these tests on the flat panel are given in Appendix A in Figures A.73 through A.80. A cross plot of the effect of pressure differential of the noise reduction characteristics of this panel is given in Figure 6.5. The noise reduction value at 100 Hz increases from 17.5 dB at 0 psi to 28 dB at 1 psi, an increase of 10.5 dB. From 1 psi, the noise reduction increases to 30 dB at 3 psi pressure differential. There is no effect on the noise reduction characteristics in the high frequency domain. The noise reduction stays constant at 42 dB.

The resonance frequency also increases as a result of depressurization of the panel, as shown in Figure 6.6. Here the resonance frequency rises from 112 Hz to 210 Hz at a pressure differential of

ORIGINAL PAGE IS
OF POOR QUALITY

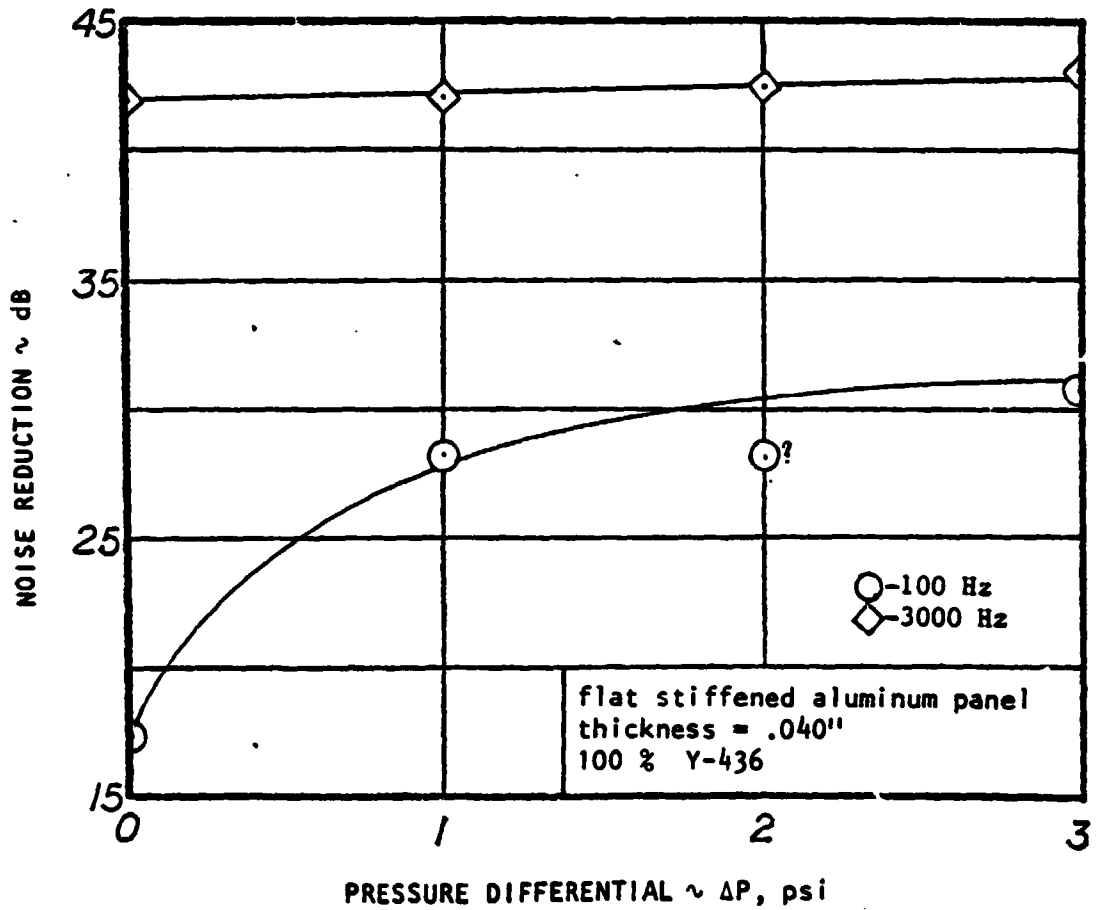

Figure 6.5: Effect of Pressure Differential on Noise Reduction Characteristics of a Flat, Stiffened Panel with 100% Y-436 Damping Tape at Low and High Frequencies

ORIGINAL PAGE IS
OF POOR QUALITY

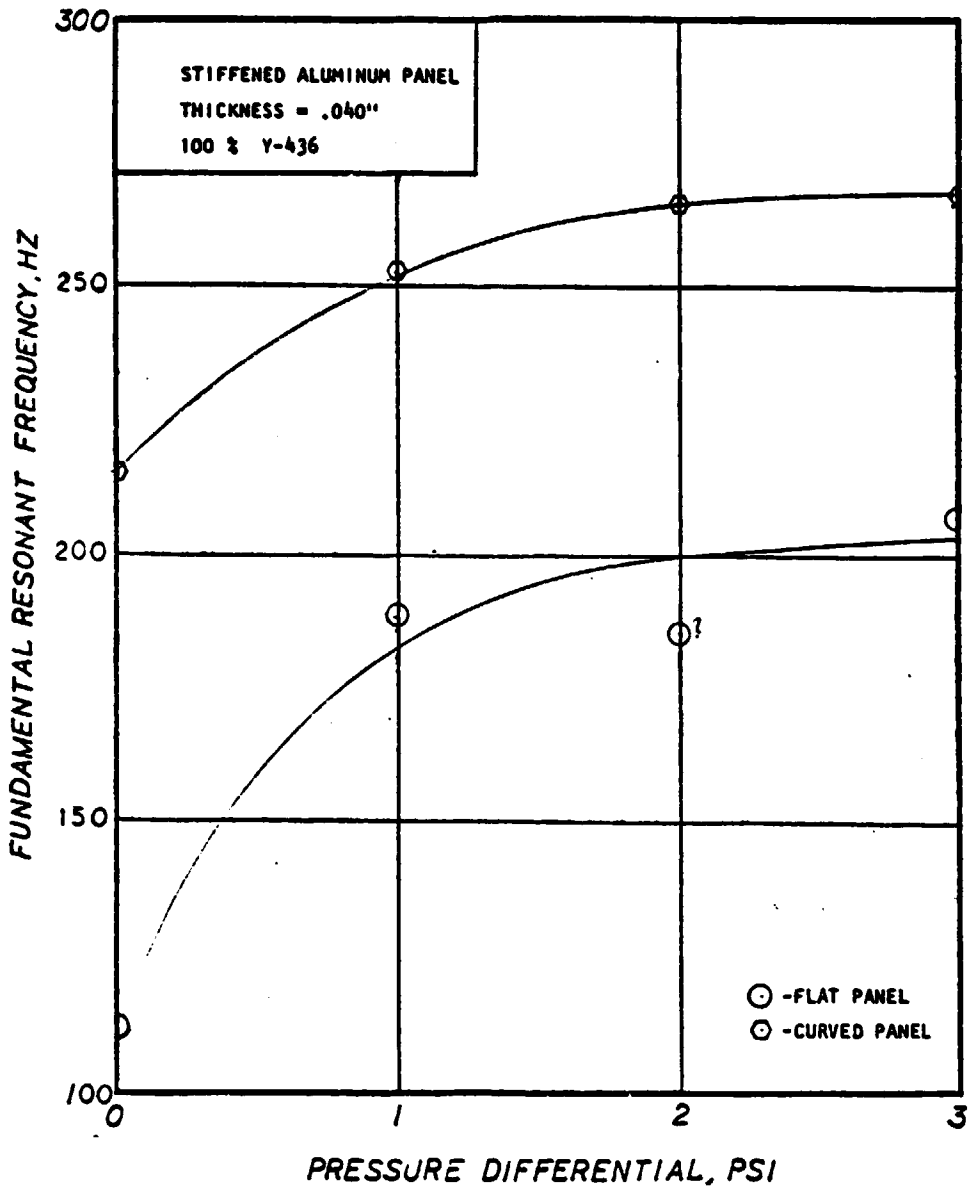
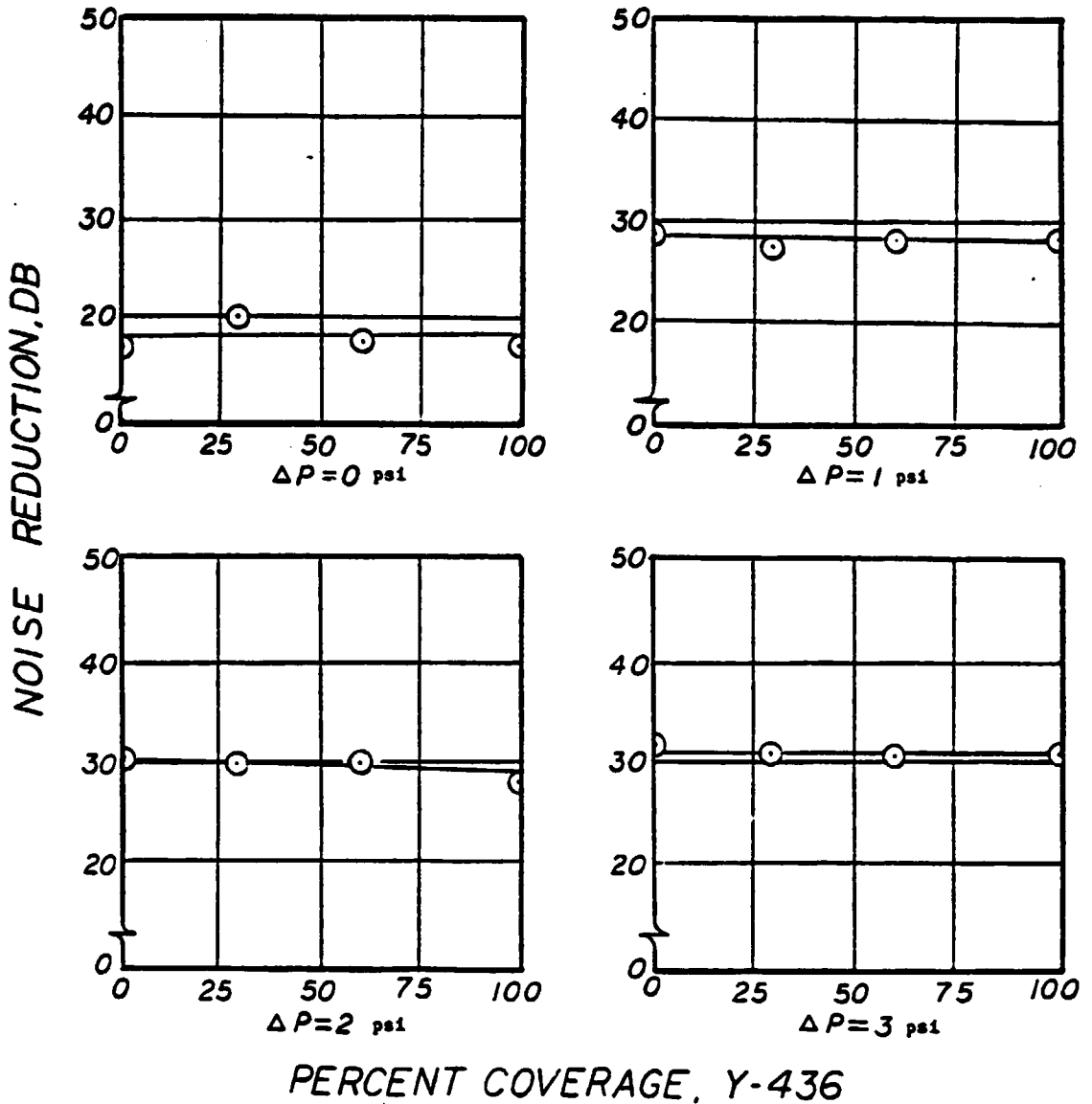

Figure 6.6: Effect of Pressure Differential on the Fundamental Resonance Frequency for Flat and Curved, Stiffened Panels with 100% Y-436



FLAT STIFFENED ALUMINUM PANEL THICKNESS = .040" FREQUENCY = 100 Hz

Figure 6.7: Effect of Coverage of Y-436 Damping Tape on Low Frequency Noise Reduction Characteristics for a Flat, Stiffened Panel at Different Pressure Differentials

3 psi. The familiar large increase in resonance frequency is exhibited in the first 1 psi pressure differential. The value at this pressure differential is 180 Hz.

6.2.4 Effect of Percentage of Coverage

The effects of percentage of coverage on the noise reduction characteristics of the flat panel are given in graphs in Figures 6.7 and 6.8. Low frequency characteristics given in Figure 6.7 show that the effect of coverage is again negligible when considering the noise reduction of the panel. High frequency noise reduction characteristics shown in Figure 6.8 show a slight upward trend as a function of increasing coverage. This trend occurs in all of the pressure differential graphs, having a larger slope as the pressure differential increases. The resonance frequency remains nearly the same, indicating that the additional mass of the coverage is balanced out by the additional stiffness provided by the constraining layer.

6.3 CURVED PANEL RESULTS

Results of these tests are given in Appendix B (Figures B.57 through B.64). It can be concluded that there is no difference in results due to the white noise and the noise from the sweep oscillator.

6.3.1 30% Panel Coverage

A cross plot of the noise reduction characteristics versus pressure differential is given in Figure 6.9. This plot shows that

ORIGINAL PAGE IS
OF POOR QUALITY

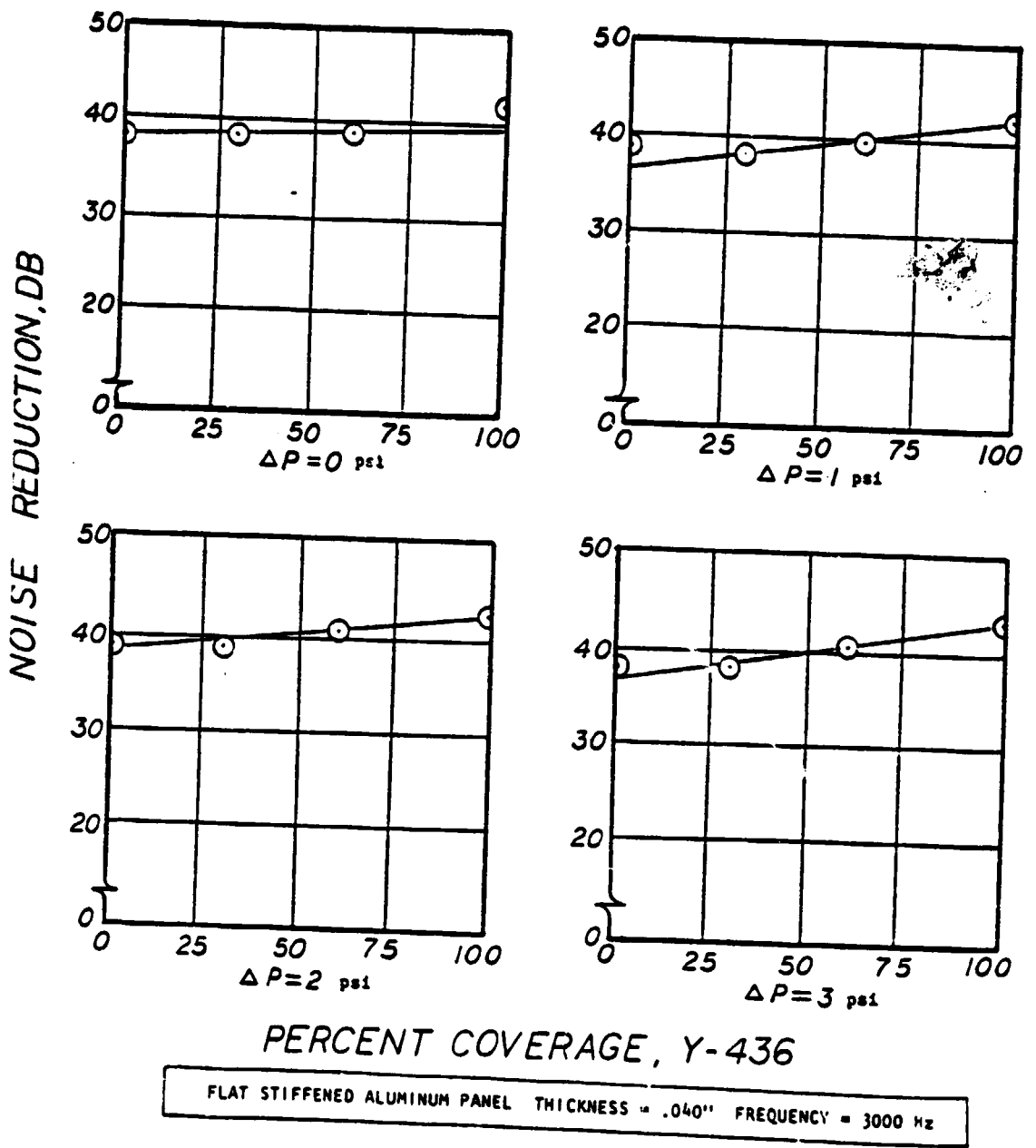

Figure 6.8: Effect of Coverage of Y-436 Damping Tape on High Frequency Noise Reduction Characteristics for a Flat, Stiffened Panel at Different Pressure Differentials

ORIGINAL PAGE IS
OF POOR QUALITY

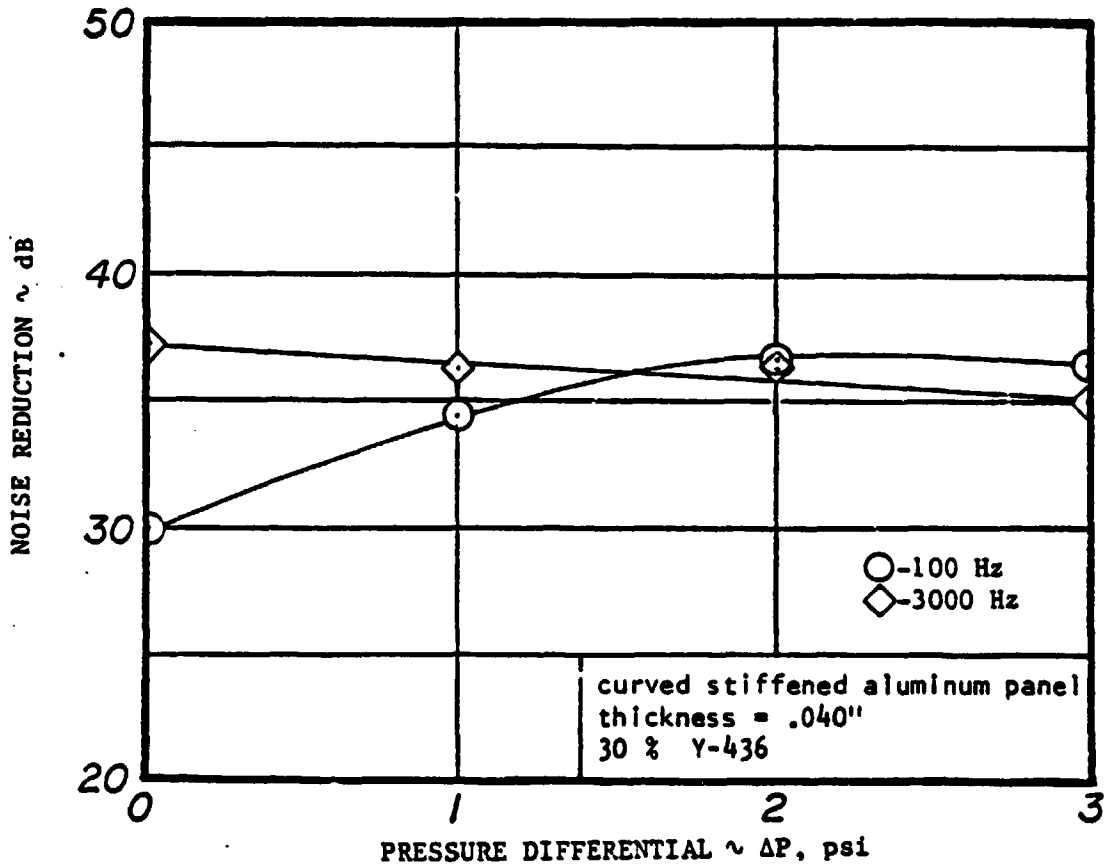

Figure 6.9: Effect of Pressure Differential on Noise Reduction Characteristics of a Curved, Stiffened Panel with 30% Y-436 Damping Tape at Low and High Frequencies

the effect of the increased pressure differential on low frequency noise reduction is to sharply increase the initial value of 30 dB at 0 psi to 34.7 dB at 1 psi. After this point, noise reduction increases steadily to 36.5 dB at 3 psi pressure differential. High frequency noise reduction decreases as the pressure differential goes up. The value drops from 37 dB to 35 dB for 3 psi. The effect of the pressure differential on the resonance frequency is shown in Figure 6.2. The resonance frequency sharply rises from 220 Hz at 0 psi to 257 Hz at 1 psi pressure differential, a gain of 42 Hz. The increase is not nearly as big at the higher pressure differentials tested, where the final value is 273 Hz at 2.5 psi pressure differential. So the effect of increasing the pressure differential is to increase both the resonance frequency and low frequency noise reduction while decreasing high frequency noise reduction.

6.3.2 60% Panel Coverage

Results of tests with 60% panel coverage of Y-436 are given in Appendix B (Figures B.65 through B.72). A cross plot of the noise reduction characteristics of this treated panel as a function of pressure differential is given in Figure 6.10. This figure shows that with increasing pressure differential the noise reduction ability increases from 30.5 dB to 37.5 dB at 3 psi pressure differential along the low frequency curve. Like the previous high frequency noise reduction curve, the noise reduction characteristics decrease as pressure differential increases. The value at 3000 Hz drops from 38 dB at 0 psi to 34.5 at 3 psi.

ORIGINAL PAGE IS
OF POOR QUALITY

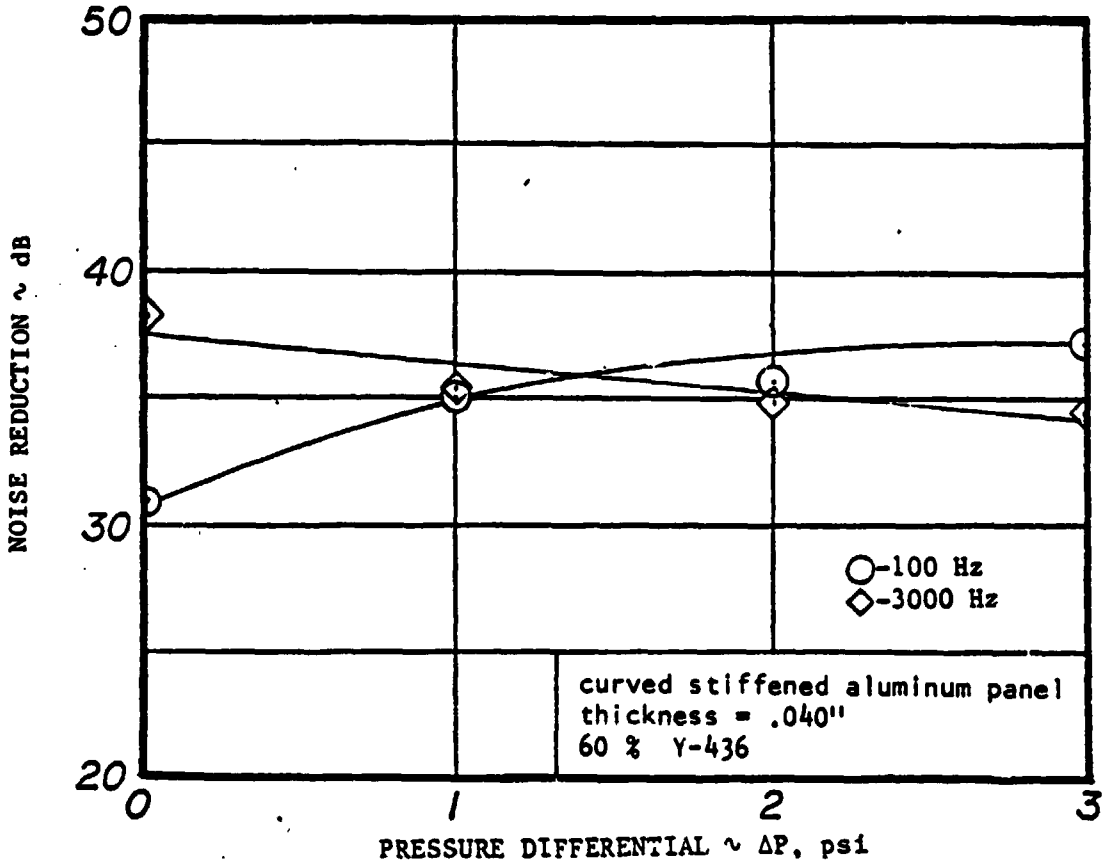

Figure 6.10: Effect of Pressure Differential on Noise Reduction Characteristics of a Curved, Stiffened Panel with 60% Y-436 Damping Tape at Low and High Frequencies

ORIGINAL PAGE IS
OF POOR QUALITY.

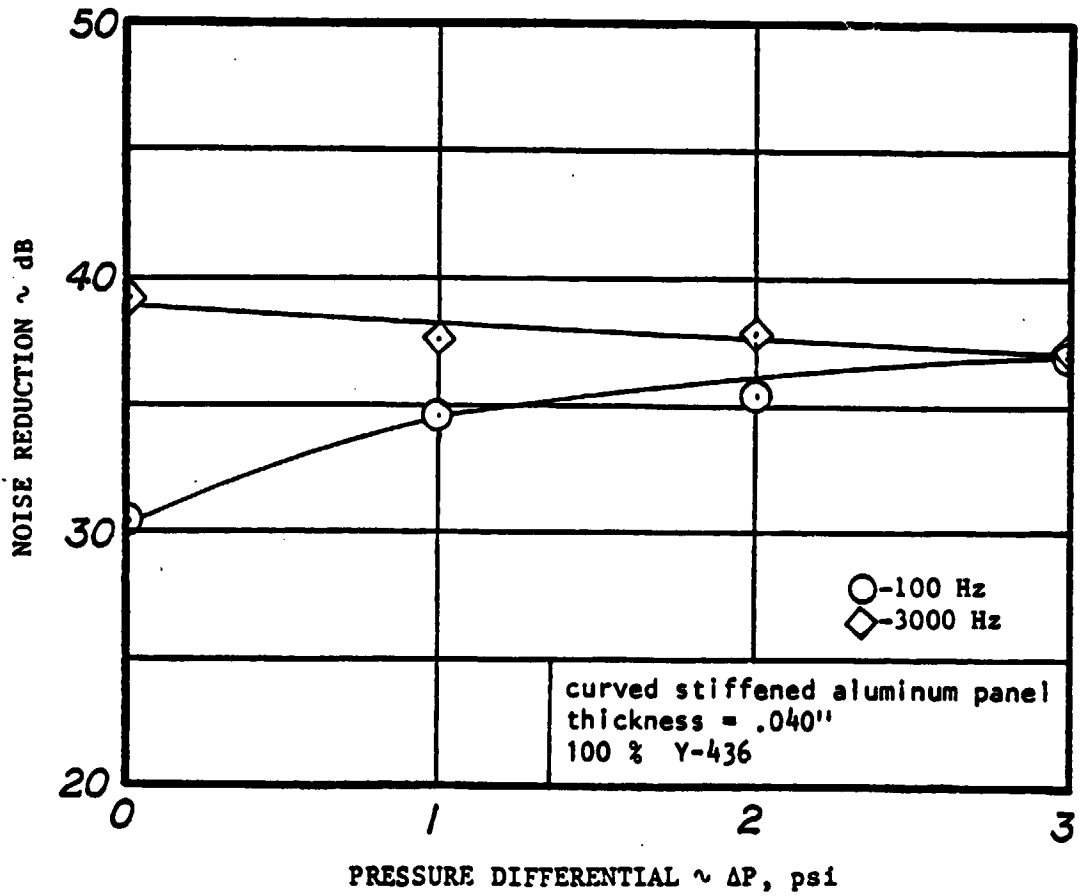

Figure 6.11: Effect of Pressure Differential on Noise Reduction Characteristics of a Curved, Stiffened Panel with 100% Y-436 Damping Tape at Low and High Frequencies

The resonance frequency is shown as a function of pressure differential in Figure 6.4. This figure shows the familiar increase in resonance frequency from 220 Hz at 0 psi to 270 Hz at 3 psi pressure differential. The big gain is once again from 0 psi to 1 psi where the resonance frequency is 252 Hz.

6.3.3 100% Panel Coverage

Results of the tests for this coverage are presented in Appendix B (Figures B.73 through B.80). A cross plot of the effect of pressure differential on the noise reduction characteristics of the panel is given in Figure 6.11. The trends of the results are similar to those of the 30% and 60% coverage. The noise reduction increases from 30.3 dB to 37 dB for 3 psi with a major stiffening effect occurring between 0 and 1 psi in the lower frequency region. The high frequency noise reduction values once again are reduced as a result of depressurizing the panel. The high frequency values fall from 39 dB at 0 psi to 37 dB at a 3 psi pressure differential.

Figure 6.6 shows that the resonance frequency is increased from a value of 220 Hz at 0 psi to 253 Hz at 1 psi pressure differential, a gain of 33 Hz in the first 1 psi. The resonance frequency further flattens out slowly to a final value of 270 Hz. Again, stiffening the panel increases both the resonant frequency and the low frequency noise reduction characteristics while decreasing the high frequency values.

6.3.4 Effect of Percentage of Coverage

The effects of percentage of coverage on the noise reduction characteristics of the flat panel are given as graphs in Figures 6.12 and 6.13. The low frequency graphs given in Figure 6.12 show that the effect of coverage is again negligible on the noise reduction characteristics for a curved panel. At high frequencies, due to the increased mass, high frequency noise reduction increases slightly. The effect of the constraining layer is to increase the stiffness of the base panel. However, the increase in stiffness is not high enough to overcome the effect of the increased mass. Hence, the resonance frequency remains nearly the same. The values of the noise reduction at the resonance frequency are consistently lower than the values observed with Y-434 material.

ORIGINAL PAGE IS
OF POOR QUALITY

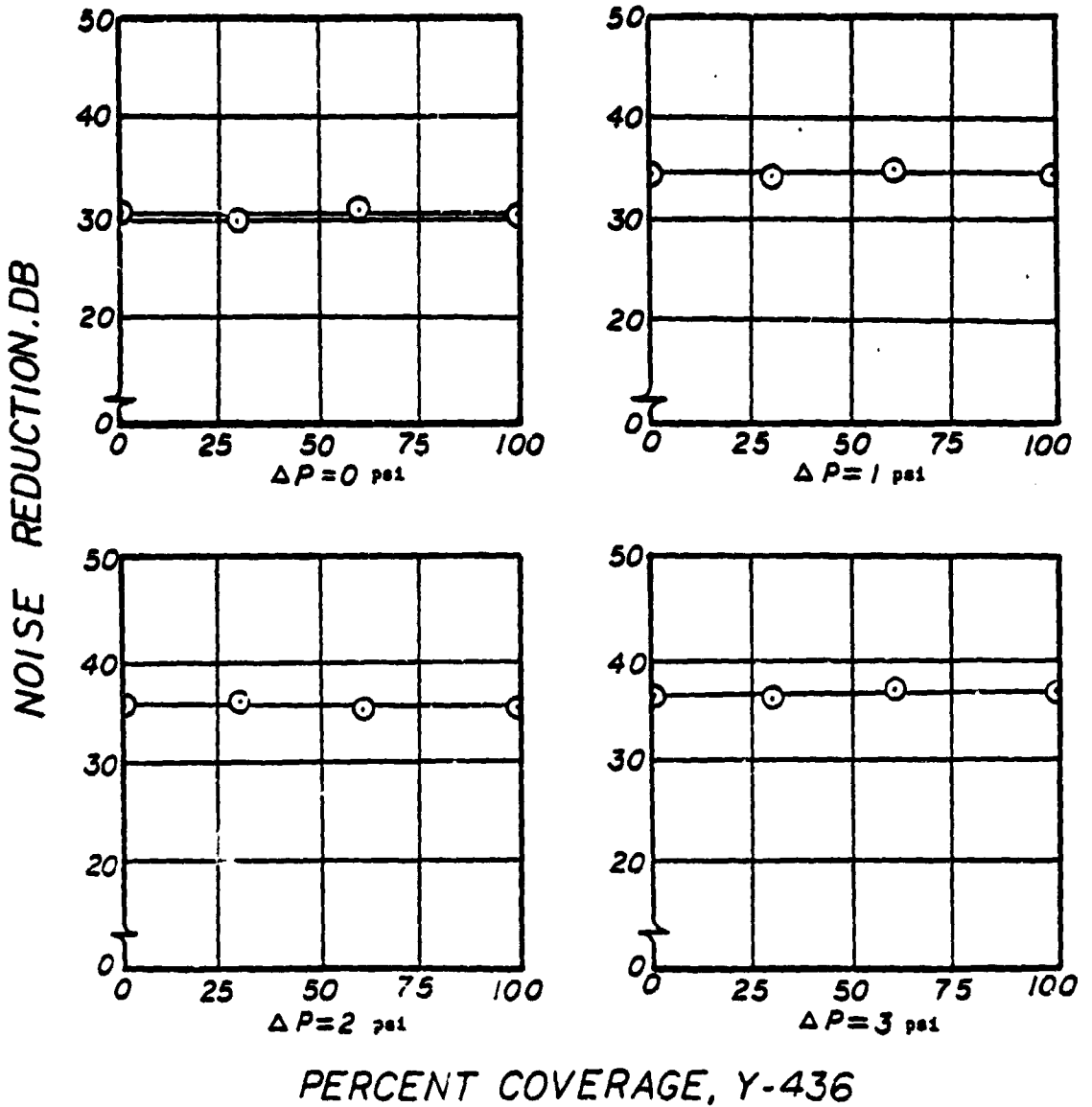

CURVED STIFFENED ALUMINUM PANEL THICKNESS = .040" FREQUENCY = 100 Hz

Figure 6.12: Effect of Coverage of Y-436 Damping Tape on Low Frequency Noise Reduction Characteristics for a Curved, Stiffened Panel at Different Pressure Differentials

ORIGINAL PAGE IS
OF POOR QUALITY.

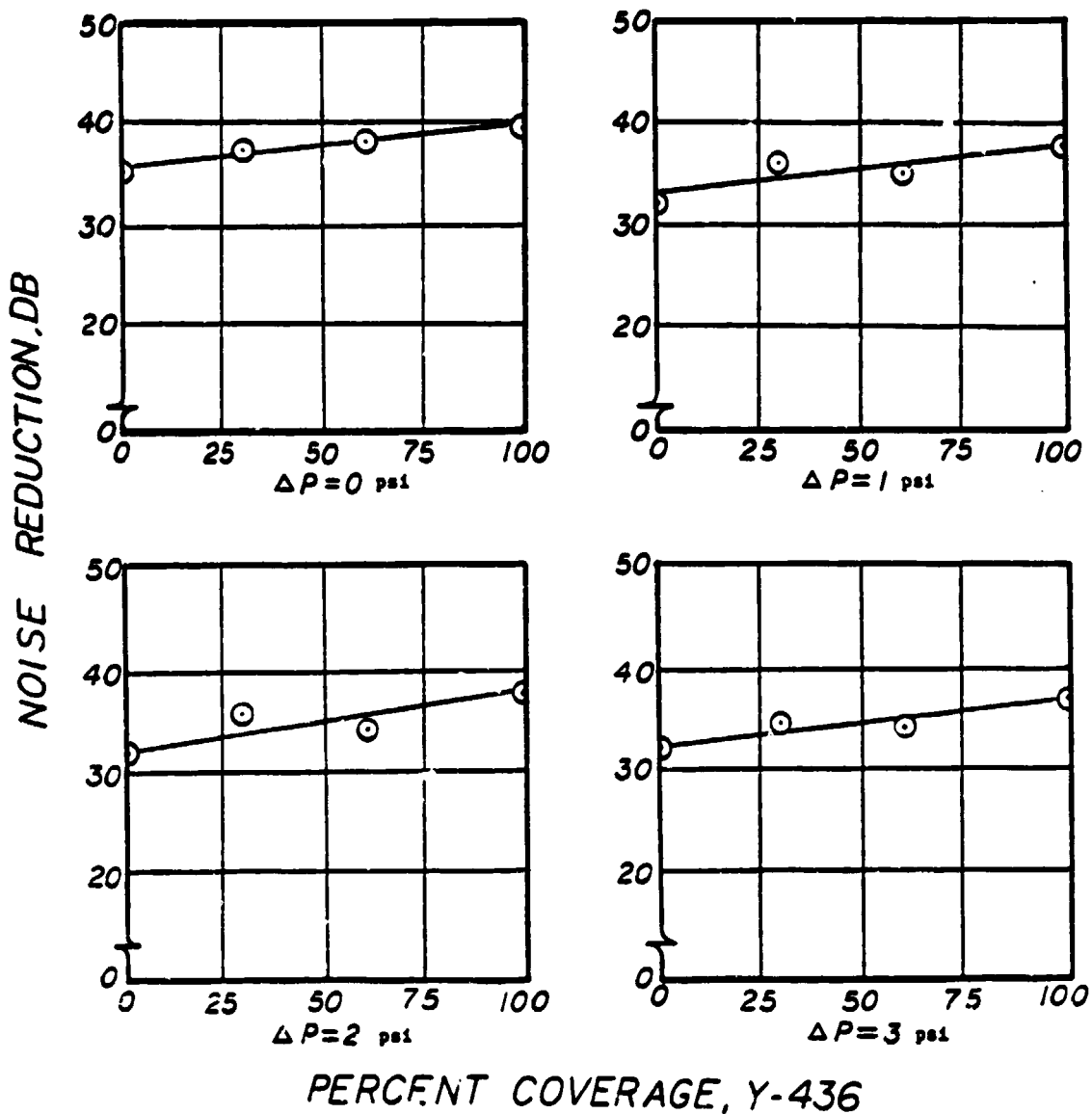

CURVED STIFFENED ALUMINUM PANEL THICKNESS = .040" FREQUENCY = 3000 Hz

Figure 6.13: Effect of Coverage of Y-436 Damping Tape on High Frequency Noise Reduction Characteristics for a Curved, Stiffened Panel at Different Pressure Differentials

CHAPTER 7

NOISE REDUCTION CHARACTERISTICS OF STIFFENED FLAT AND CURVED PANELS WITH Y-370 DAMPING TAPE AND FIBERGLASS INSULATION

In this chapter, noise reduction tests performed to assess the effects of Y-370 damping tape and two types of fiberglass insulation on flat and curved panels are described and the results obtained are discussed. The Y-370 damping tape alone was described in an earlier chapter. The fiberglass used in the testing is described as a light insulation (density = 0.817 lb/ft^3) and a heavy insulation (density = 7.345 lb/ft^3).

7.1 TESTS PERFORMED ON PANELS COVERED WITH Y-370 AND INSULATION

Typical aircraft acoustic insulation consists of damping tape, acoustic (or thermal) insulation, and interior trim. Hence, the noise reduction values of these panels in the presence of a fiberglass blanket were investigated. Panels covered with both Y-370 damping tape and fiberglass insulation were tested for the effect of varying pressure differentials and noise source. Four pressure differentials were examined (0, 1, 2, and 3 psi) under two types of noise sources, white noise and discrete noise. Two panels were tested for their noise reduction characteristics: a flat, stiffened panel and a curved, stiffened panel. All of the tests were run on these panels with 100% of the exposed area covered by both the Y-370 damping tape and the fiberglass insulation. Results are presented in the form of narrow-band and one-third octave plots in Appendix A for the flat, stiffened panel and in Appendix B for the curved,

C-2

stiffened panel. Test results for the light fiberglass insulation combination are shown in Figures A.81 through A.88, and those for the heavy insulation combination in Figures A.89 through A.96 for the flat panels. The data corresponding with both treatments for the curved panel are presented in Figures B.81 through B.88 and B.89 through B.96.

7.2 FLAT PANEL RESULTS

Results of these tests for this treatment are given in Appendix B (Figures B.81 through B.96). By comparing the similar graphs for the differing noise sources, it was determined that there is little difference between the two. It can be therefore concluded that under the test conditions there is no difference between the two sources.

7.2.1 Y-370 and Light Insulation

The flat panel was tested for its noise reduction characteristics with 100% of its exposed area covered by a layer of Y-370 damping tape and a layer of light fiberglass insulation. The insulation has a density of 0.817 lb/ft³. The insulation was loosely placed over the Y-370 tape.

A cross plot of the effect of pressure differential on the noise reduction characteristics of this panel is given in Figure 7.1. This figure shows that for the flat panel, the noise reduction values increase from 22 dB at 0 psi to 30.3 dB at 3 psi pressure differential. Most of the increase occurs in the first 1 psi where the noise

ORIGINAL PAGE IS
OF POOR QUALITY

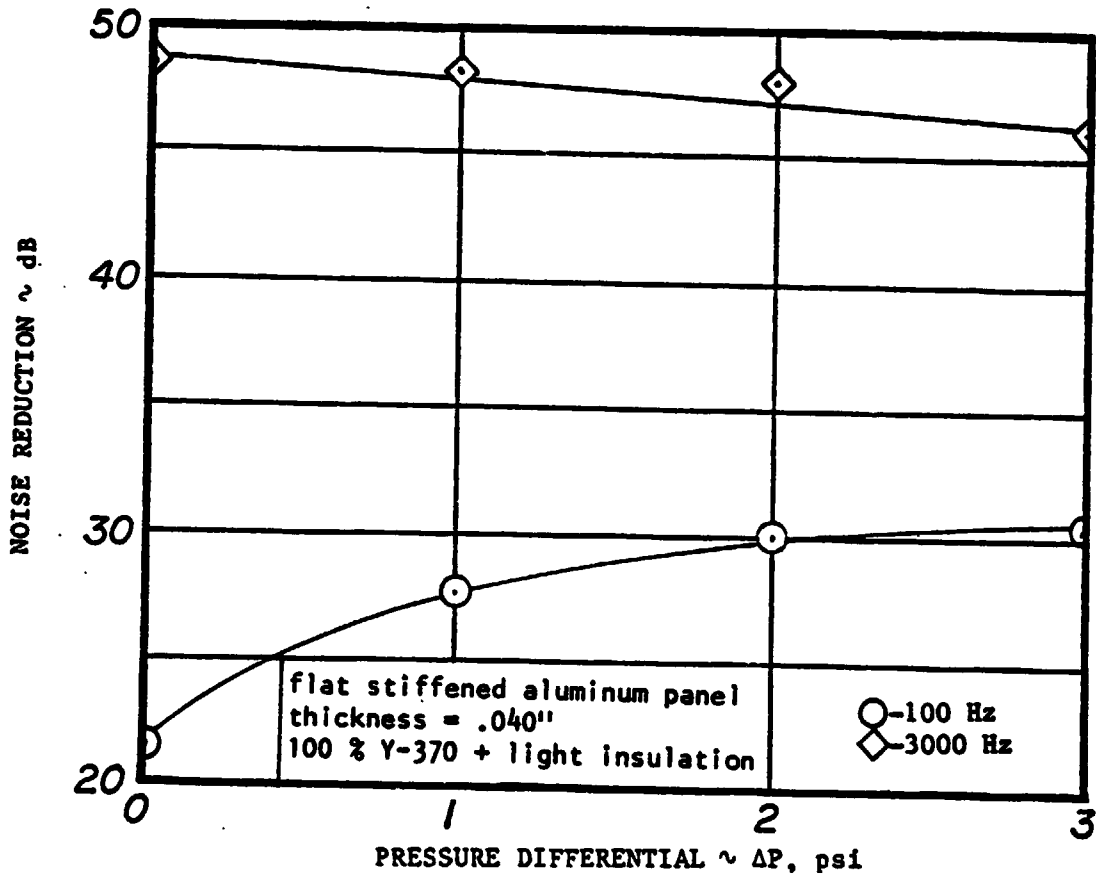

Figure 7.1: Effect of Pressure Differential on Noise Reduction Characteristics of a Flat, Stiffened Panel with 100% Y-370 Damping Tape and Light Insulation at Low and High Frequencies

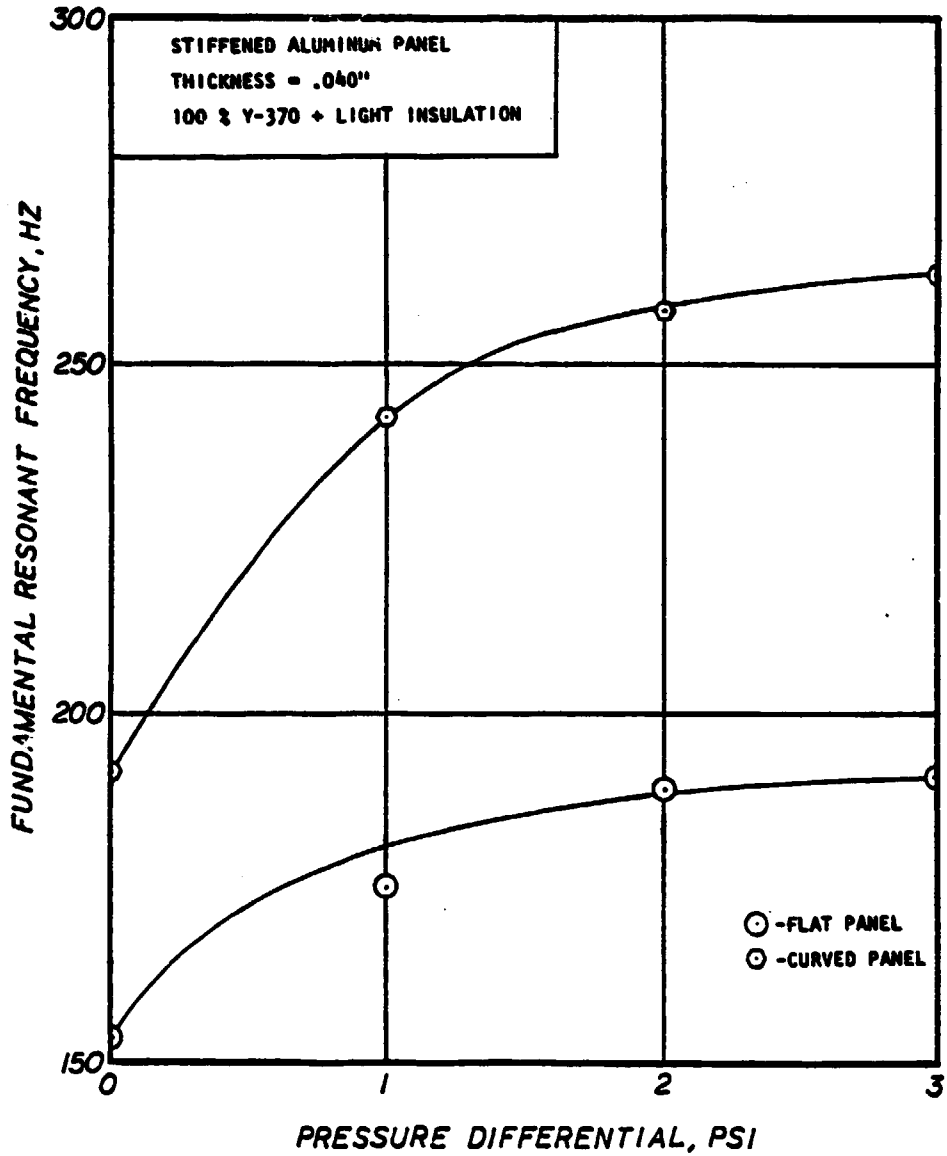

Figure 7.2: Effect of Pressure Differential on the Fundamental Resonance Frequency for Flat and Curved, Stiffened Panels with 100% Y-370 and Light Fiberglass Insulation

reduction value is 27.5 dB. The high frequency noise reduction characteristics fall from 48.5 dB at 0 psi to 46 dB at 3 psi pressure differential along a straight line.

Figure 7.2 shows the effect of pressure differential on the resonance frequency. The resonance frequency rises from 150.4 Hz at 0 psi to approximately 180 Hz at 1 psi pressure differential. From this point, the curve levels out to a final value of 190 Hz at 3 psi. The effect of increasing pressure differential is to increase the resonance frequency and low frequency noise reduction while decreasing the high frequency characteristics.

7.2.2 Y-370 and Heavy Insulation

The flat panel was tested for its noise reduction characteristics with 100% of its exposed area covered by a layer of Y-370 damping tape and a layer of heavy fiberglass insulation. The insulation has a density of 7.345 lb/ft³ and was loosely placed over the Y-370 tape.

Results of these tests for the flat panel are given in Appendix A (Figures A.89 through A.96). A cross plot of these results is given in Figure 7.3. This figure shows that the noise reduction rises from 22 dB at 0 psi to 30 dB at 3 psi pressure differential. A big increase is seen in the first 1 psi where the value is 27.7 dB. The high frequency noise reduction characteristics are level throughout the entire pressure differentials tested. This value is about 51.5 dB.

Figure 7.4 shows the effect of increasing pressure differential on the resonance frequency. In this graph, the resonance frequency starts at 150 Hz and swiftly increases to 180 Hz at 1 psi. The resonance frequency levels out at 190 Hz at 3 psi pressure differential.

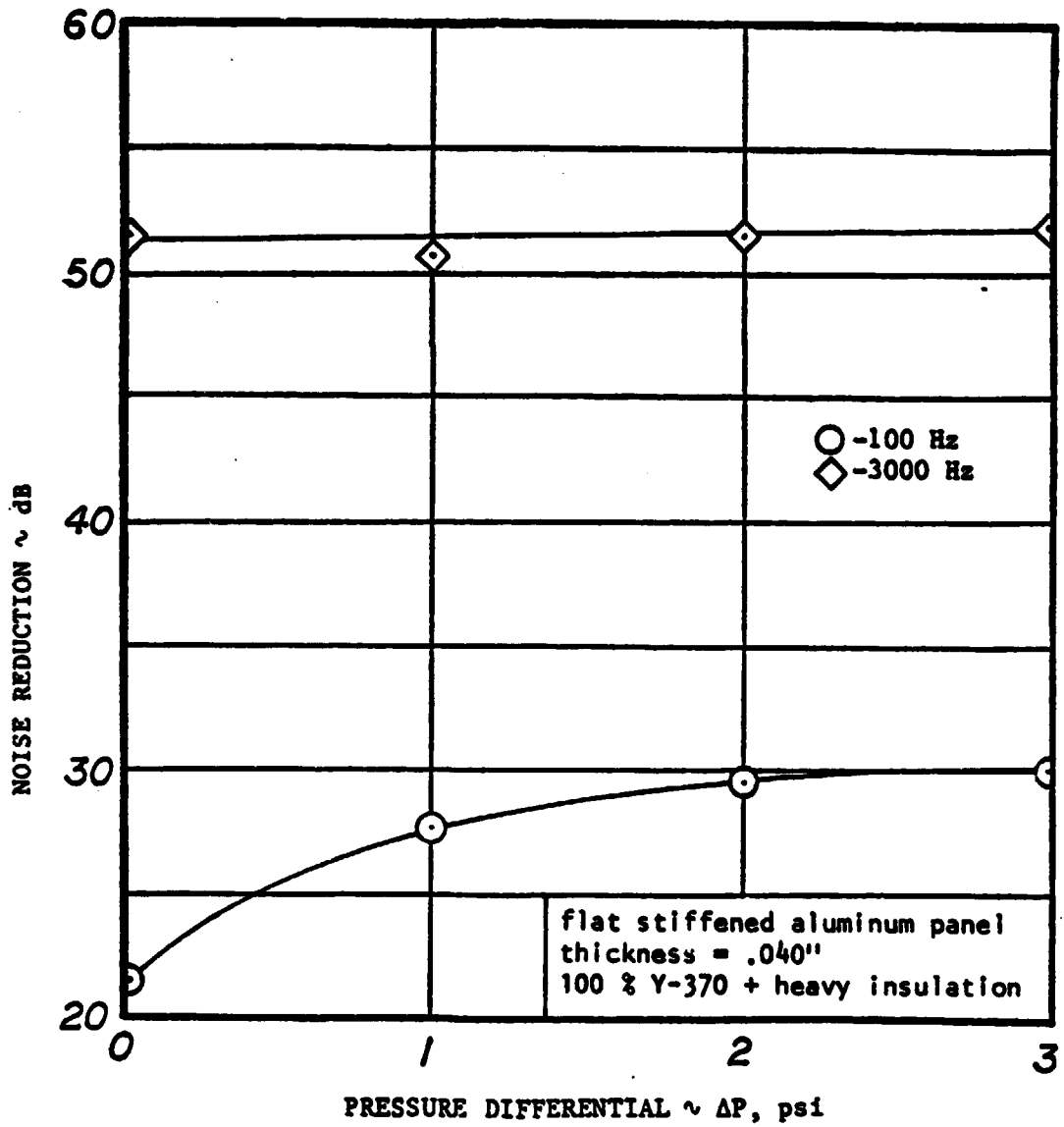

Figure 7.3: Effect of Pressure Differential on Noise Reduction Characteristics of a Flat, Stiffened Panel with 100% Y-370 Damping Tape and Heavy Insulation at Low and High Frequencies

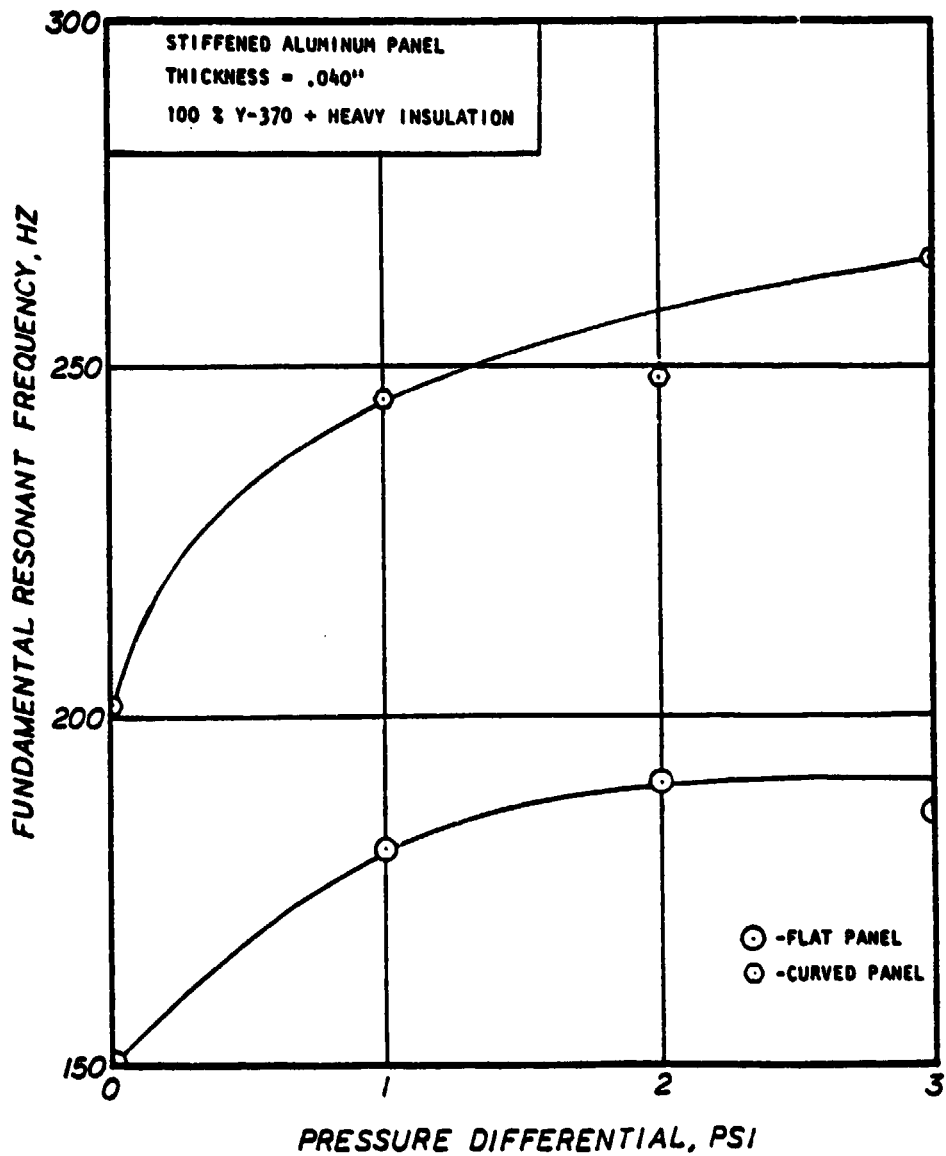

Figure 7.4: Effect of Pressure Differential on the Fundamental Resonance Frequency for Flat and Curved, Stiffened Panels with 100% Y-370 and Heavy Fiberglass Insulation

Fiberglass insulation loosely placed on the panel does not alter the low frequency noise reduction characteristics. A very slight decrease in resonance frequency is noticed which is within the experimental error. However, it becomes effective at high frequencies. Of the two fiberglass samples tested, the low density insulation increases the noise reduction with 7 dB at 3000 Hz. Additional increase in density does not increase the noise reduction in the same proportion.

7.3 CURVED PANEL RESULTS

7.3.1 Y-370 and Light Insulation

Results of these tests are shown in Appendix B (Figures B.81 through Figure B.88). A cross plot of the results is given in Figure 7.5. This cross plot shows the familiar increase in noise reduction in the low frequency region, from 29 dB at 0 psi to 37 dB at 3 psi pressure differential. High frequency values remain constant at 43.5 dB.

The resonance frequency increases from 190 Hz to a value of 240 Hz at 1 psi very rapidly, as shown in Figure 7.2. The resonance frequency has a final value of 265 Hz at 3 psi pressure differential.

7.3.2 Y-370 and Heavy Insulation

Results of the tests for this treatment are given in Appendix B (Figures B.89 through B.96). A cross plot of the results is given in Figure 7.6. This graph shows that the effect of increasing the pressure differential is to increase the low frequency noise reduction

ORIGINAL PAGE IS
OF POOR QUALITY

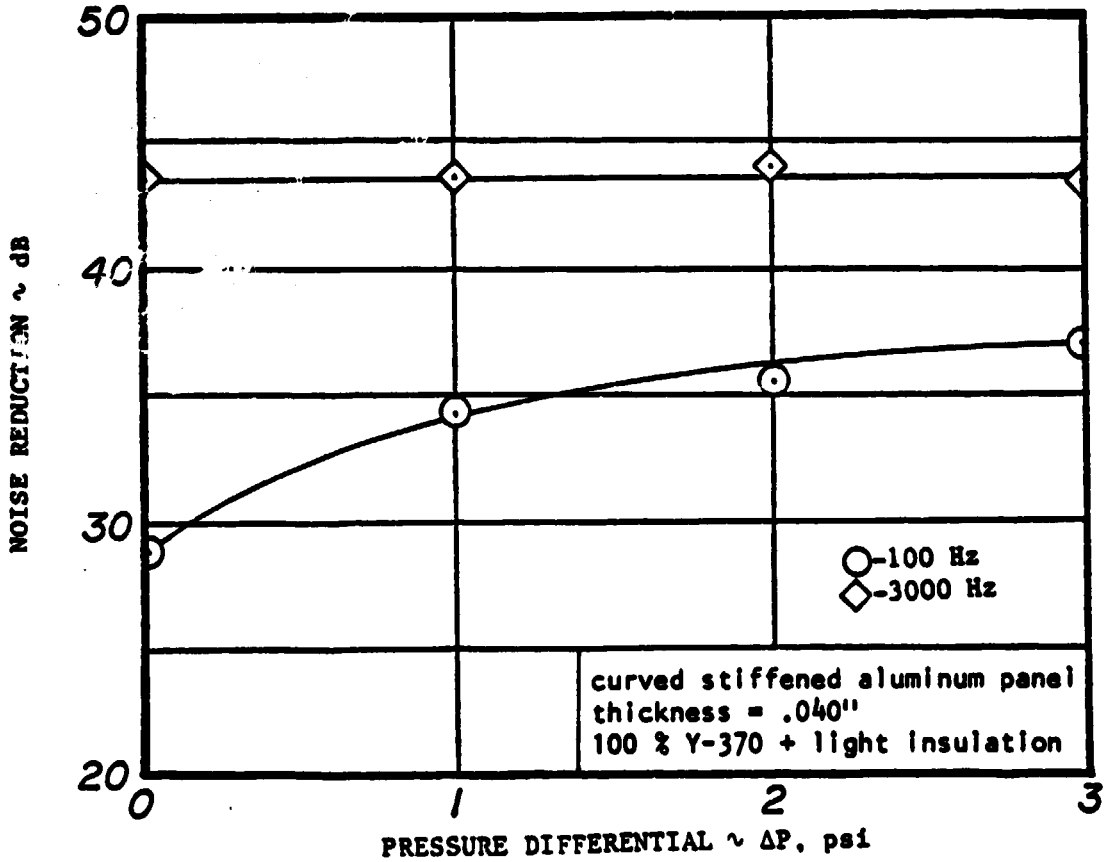

Figure 7.5: Effect of Pressure Differential on Noise Reduction Characteristics of a Curved, Stiffened Panel with 100% Y-370 Damping Tape and Light Insulation at Low and High Frequencies

ORIGINAL PAGE IS
OF POOR QUALITY

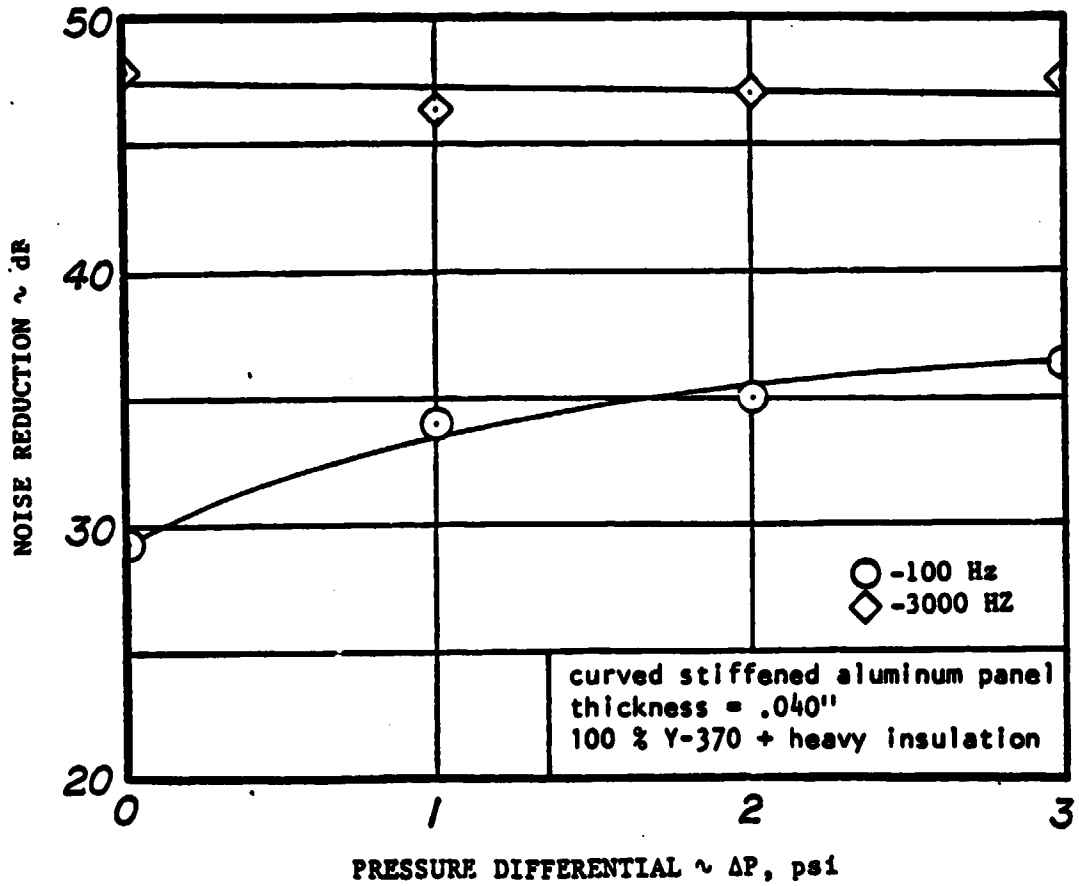

Figure 7.6: Effect of Pressure Differential on Noise Reduction Characteristics of a Curved, Stiffened Panel with 100% Y-370 and Heavy Insulation at Low and High Frequencies

values from 29 dB at 0 psi to 36.5 dB at 3 psi along a modest slope. For a high frequency the noise reduction stays almost constant, ranging from 48.5 dB to 47 dB between 0 and 3 psi pressure differential.

The resonance frequency increases from 202 Hz to 240 Hz very rapidly between 0 and 1 psi pressure differential, as shown in Figure 7.4. The increase is not so severe after this when it rises to 265 Hz at 3 psi pressure differential. The effect of the pressure differential is to raise the resonance frequency and low frequency noise reduction characteristics, and to reduce the high frequency noise reduction values. Once again, as in the case of the flat panel, the fiberglass insulation, when placed loosely on the panel, has no effect at all on the noise reduction at low frequencies. High frequency noise reduction increases from 38 dB to 43.5 dB with a light insulation and 48.5 dB with a heavy insulation. The resonance frequency decreases with a light insulation but increases with a heavy insulation. The reason for this is not understood at present.

CHAPTER 8

DISCUSSION, CONCLUSIONS, AND RECOMMENDATIONS

After the testing it was discovered that all the tests with the flat, stiffened panel, conducted at zero pressure differential, had an unusual drop in noise reduction directly above the fundamental panel resonance frequency. This drop in the noise reduction curve around 155 Hz does not appear at higher pressure differentials or in all the earlier tests with different types of panels (Reference 2). A similar dip is also present in some of the curved panel tests, but no consistent relationship between these tests can be detected. The absence of this particular drop at higher pressure differentials does not necessarily mean that it does not exist at higher pressurizations. It can be hidden within the stiffening effect of the depressurization. Despite an extensive checking of the equipment, it was not possible to pinpoint the cause of this phenomenon. Several possible reasons can be proposed, but a unique relationship between them and this phenomenon cannot be demonstrated. A non-uniform excitation of the panel caused by malfunctioning of 3 of the 9 loudspeakers has sometimes resulted in a similar result. In another case a leak in the cavity between the speaker wall and the test panel has caused an additional drop in noise reduction above the fundamental resonance frequency. However, in later tests this additional resonance disappeared and could not be repeated. Additional tests with different variables such as speaker output, sealing, etc., did not result in a repeat of the phenomenon. These tests did show that the trends in the noise reduction character-

Figure 8.1 Comparison of Original Noise Reduction Characteristics of a Flat Stiffened Panel with Data from a Later Test Run.

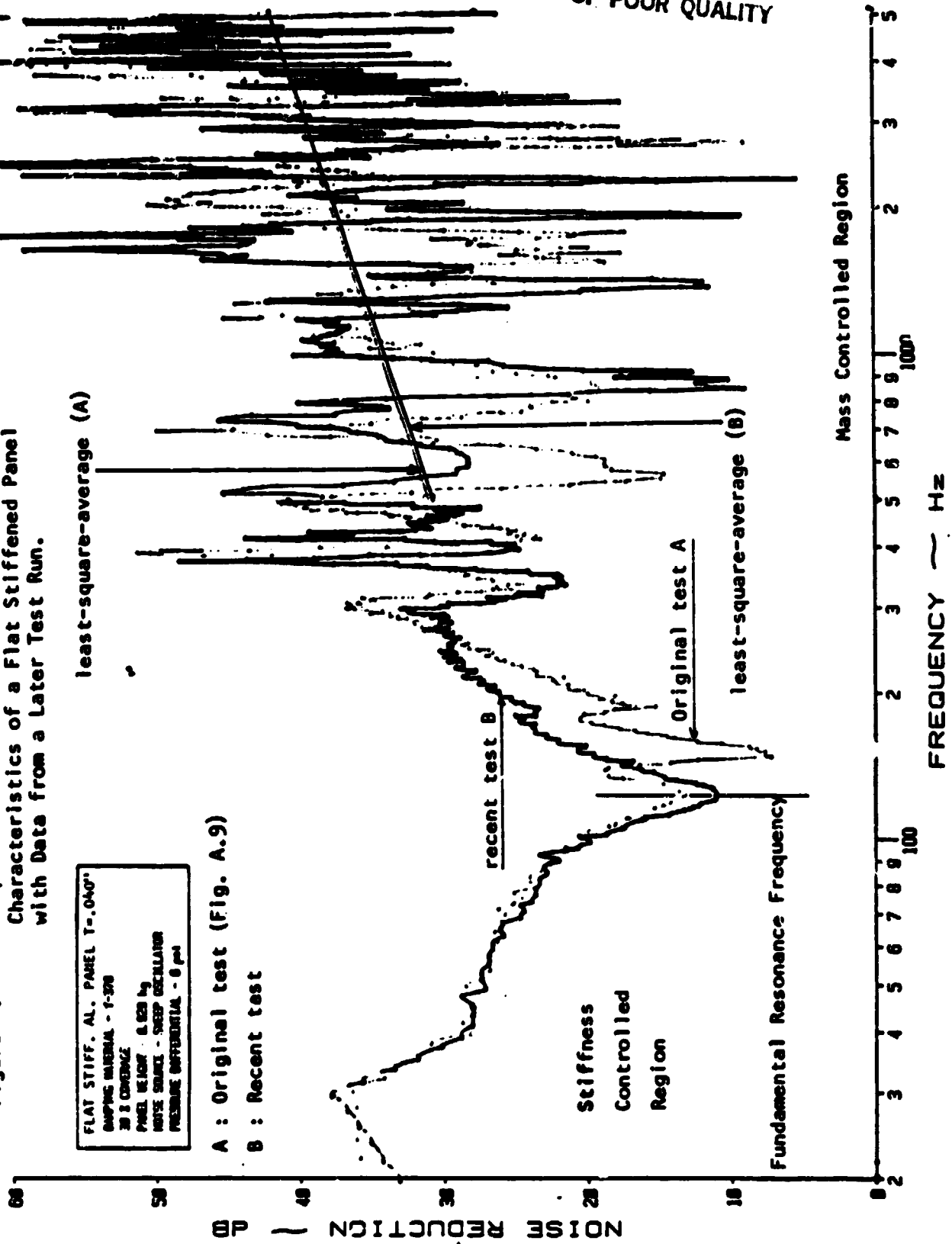

istics observed in all the flat panel tests did not change with the disappearance of the additional drop in noise reduction. Figure 8.1 shows a comparison between the original test data and the data of a recent test for the same panel. Noise reduction values in the stiffness-controlled region are almost equal for both tests up to the fundamental resonance frequency. In the mass-controlled region the difference in the least-square-average lines for both tests is minimal. Despite an unexplainable drop in noise reduction around 155 Hz in all the flat panel tests conducted at zero pressure differential and in some of the curved panel tests, the trends observed and the conclusions based on them are still valid. In general, the tests could be repeated within 1-2 dB accuracy, with the largest difference in the values of the higher panel resonance frequencies.

In this report, experimental noise reduction characteristics of flat and curved general aviation type structures are presented. The effects of pressure differentials, damping tape, and noise sources are described. Based on the experimental investigations, it is concluded that the noise source has negligible effect on the noise attenuation characteristics of the specimens under all conditions tested. This is considered to be so, due to the normal incidence of the panel in the Beranek tube and the very high sweep time of the sweep oscillator. The effect of curvature on a bare panel is to stiffen the panel, thereby increasing low frequency noise reduction. The maximum increase in noise reduction occurs in the first 1 psi pressure differential in all cases. The gain in noise reduction for the curved panel is smaller compared to that of the flat panel, since it is inherently stiffer. In the

high frequency region the noise reduction decreases by 1-3 dB due to pressurization. This result is consistent with published theoretical results (Reference 4).

Even at room temperature, the effect of damping tapes on the overall noise reduction is negligible away from the resonance frequency. When the mass of the damping tapes constitutes a large percentage of the mass of the specimen, as in the case of 100% coverage, the effect is essentially to increase the noise reduction in the high frequency region. The test results indicate that with greater application of Y-370 material, the fundamental resonance frequency decreases. This is due to the fact that only mass is added, not stiffness (Chapter 4). With Y-436 and Y-434 materials, which have constraining layers, the resonance frequency shift is negligible, indicating that the additional stiffness produced by the constraining layer balances out the effect of added mass on the resonance frequency (Chapters 5 and 6). The effect of percentage of coverage is to decrease low frequency noise reduction and to increase noise reduction at high frequencies. Decreases were very slight for all the pressure differentials tested.

Scatter of the noise reduction values at the fundamental resonance frequency precludes any general conclusion about the effect of percentage of coverage of the damping material. In general, the resonance peaks and dips are reduced by the application of damping material. The effect of fiberglass insulation materials is to increase high frequency noise reduction. Fiberglass material loosely placed over the test panel has no effect on low frequency noise reduction (Chapter 7).

The experimental investigations were carried out only at normal incidence. It is recommended that the effect of angle of incidence on the noise attenuation characteristics of these specimens be investigated. More testing is also recommended to find the composite loss factor of the test specimens. Studies are also recommended to investigate why the additions of light and heavy sound absorption materials produce opposing effects on the resonance frequency of panels with damping material.

REFERENCES

1. Navaneethan, R., "Study of Noise Reduction Characteristics of Multilayered Panels and Dual Pane Windows with Helmholtz Resonators," KU-FRL-417-16, Flight Research Laboratory, University of Kansas, Lawrence, Kansas 66045, May 1981.
2. Grosveld, J., "Study of Typical Parameters that Affect Sound Transmission through General Aviation Aircraft Structures," KU-FRL-417-13, Flight Research Laboratory, University of Kansas, Lawrence, Kansas 66045, August 1980.
3. Roskam, J., Van Dam, C., Grosveld, F., and Durenberger, D., "Some Noise Transmission Loss Characteristics of Typical General Aviation Structural Materials," AIAA Paper 78-1480, presented at AIAA Aircraft Systems and Technology Conference, Los Angeles, California, August 21-23, 1978.
4. Koval, L. R., "Effect of Air Flow, Panel Curvature, and Internal Pressurization on Field-Incidence Transmission Loss," Journal of Acoustic Society of America, Vol. 59, No. 6, June 1978.
5. Roskam, J., and Grosveld, F., "Structural Parameters that Influence the Noise Reduction Characteristics of Typical General Aviation Materials," AIAA Paper 80-0038, presented at AIAA 18th Aerospace Sciences Meeting, Pasadena, California, January 1980.
6. Peschier, T., Durenberger, D., Van Dam, C., and Shu, T. C., "Progress Report for a Research Program to Reduce Interior Noise

**in General Aviation Airplanes," KU-FRL-317-5, Flight Research
Laboratory, University of Kansas, Lawrence, Kansas 66045,
October 1977.**

APPENDIX A

EXPERIMENTAL NOISE REDUCTION DATA FOR
FLAT STIFFENED PANEL

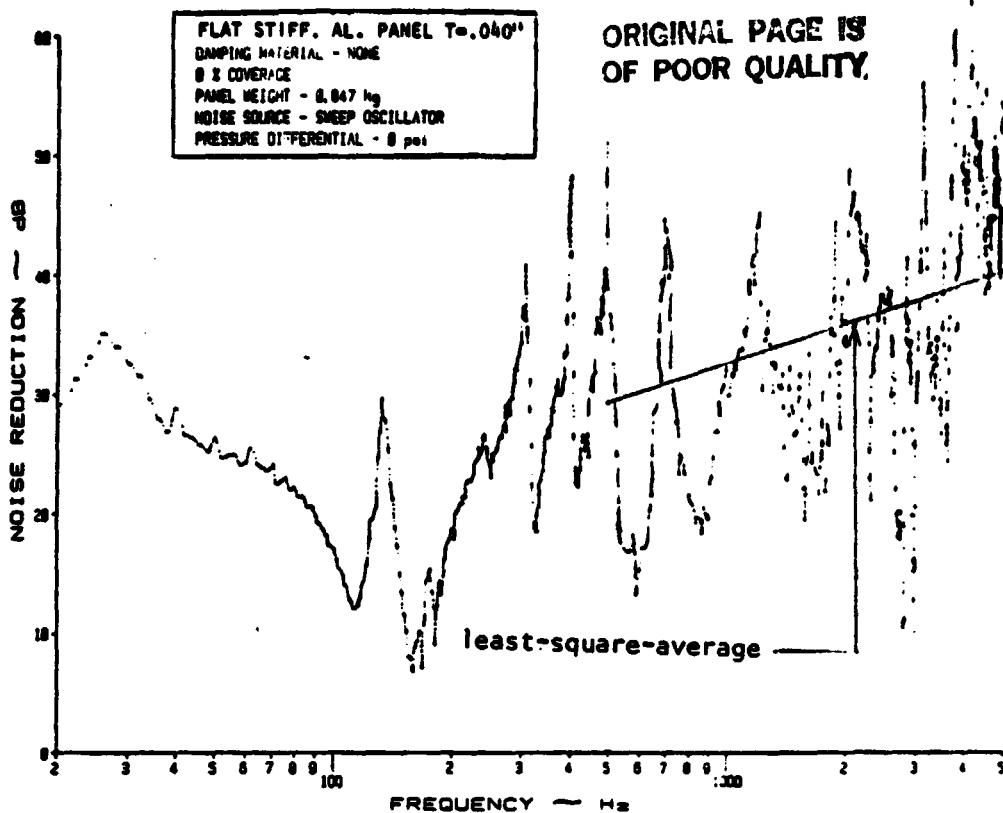

(a) Narrow Band Analysis

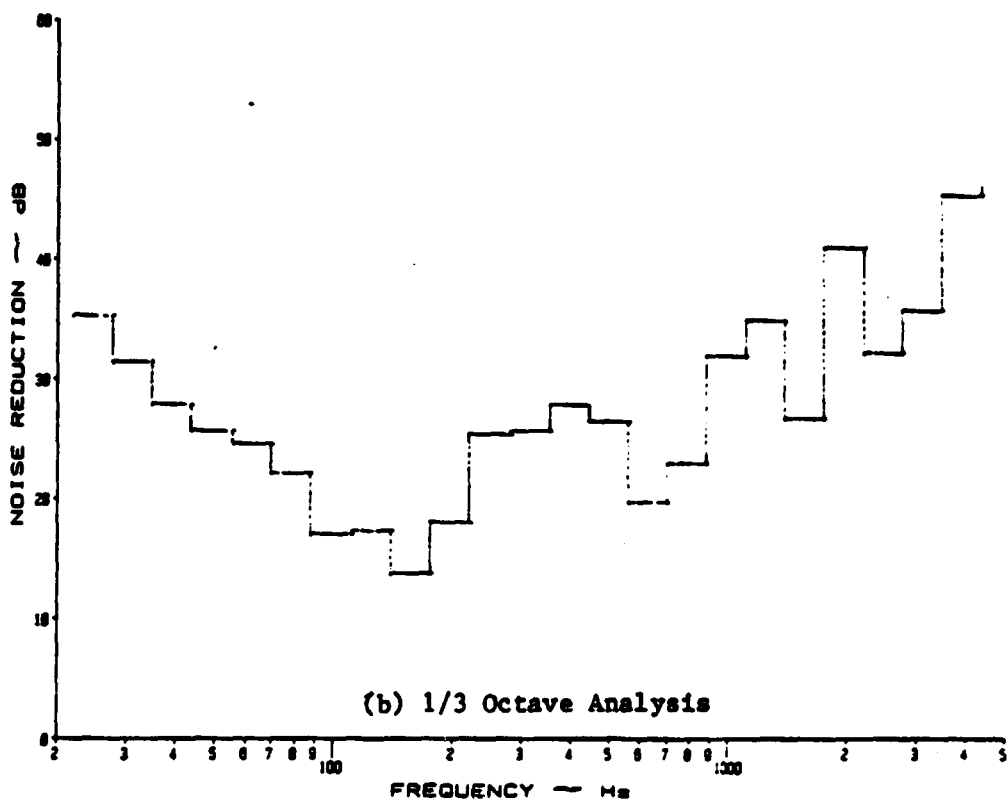

(b) 1/3 Octave Analysis

Figure A.1: Noise Reduction Characteristics of a Flat, Stiffened Panel at 0 psi Pressure Differential with No Treatment under a Discrete Noise Source

ORIGINAL PAGE IS
OF POOR QUALITY

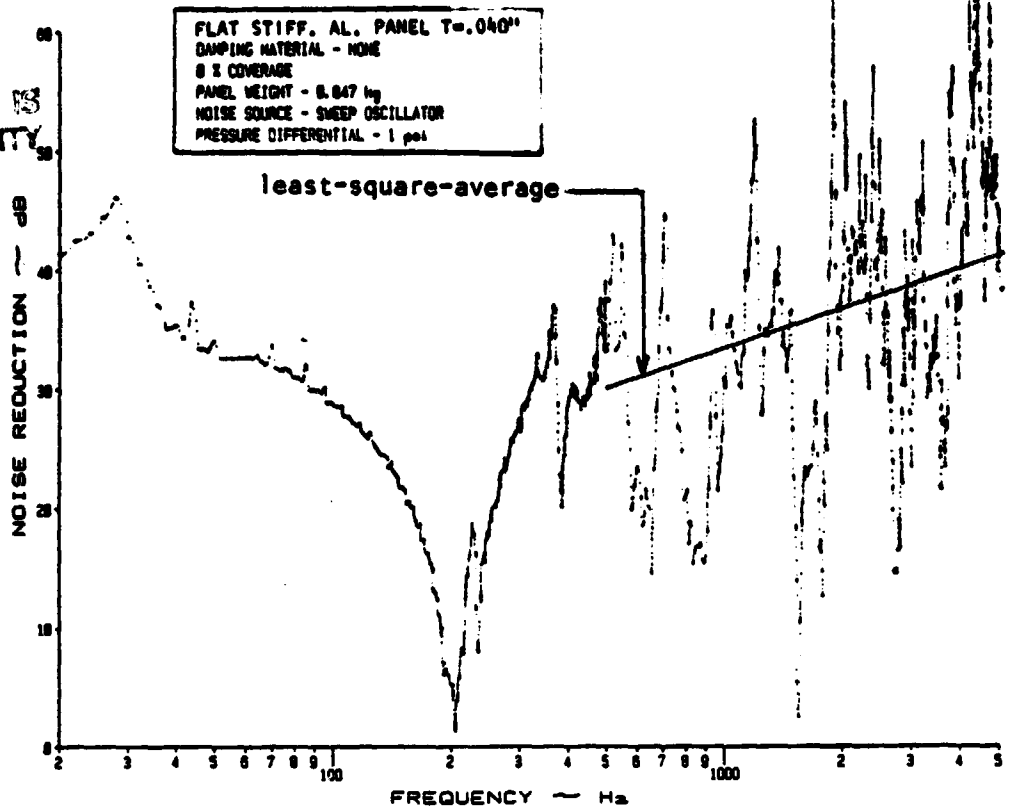

(a) Narrow Band Analysis

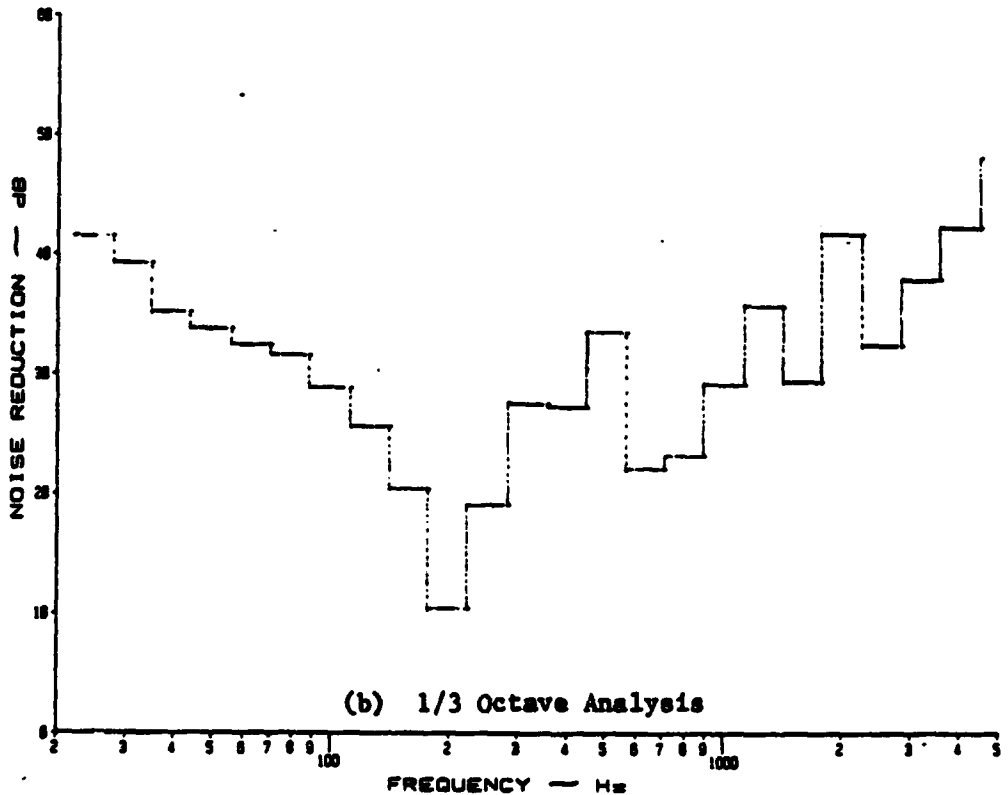

(b) 1/3 Octave Analysis

Figure A.2: Noise Reduction Characteristics of a Flat, Stiffened Panel at 1 psi Pressure Differential with No Treatment under a Discrete Noise Source

FLAT STIFF. AL. PANEL T=.040"
DAMPING MATERIAL - NONE
0 % COVERAGE
PANEL WEIGHT - 0.847 kg
NOISE SOURCE - SHEEP OSCILLATOR
PRESSURE DIFFERENTIAL - 2 psi

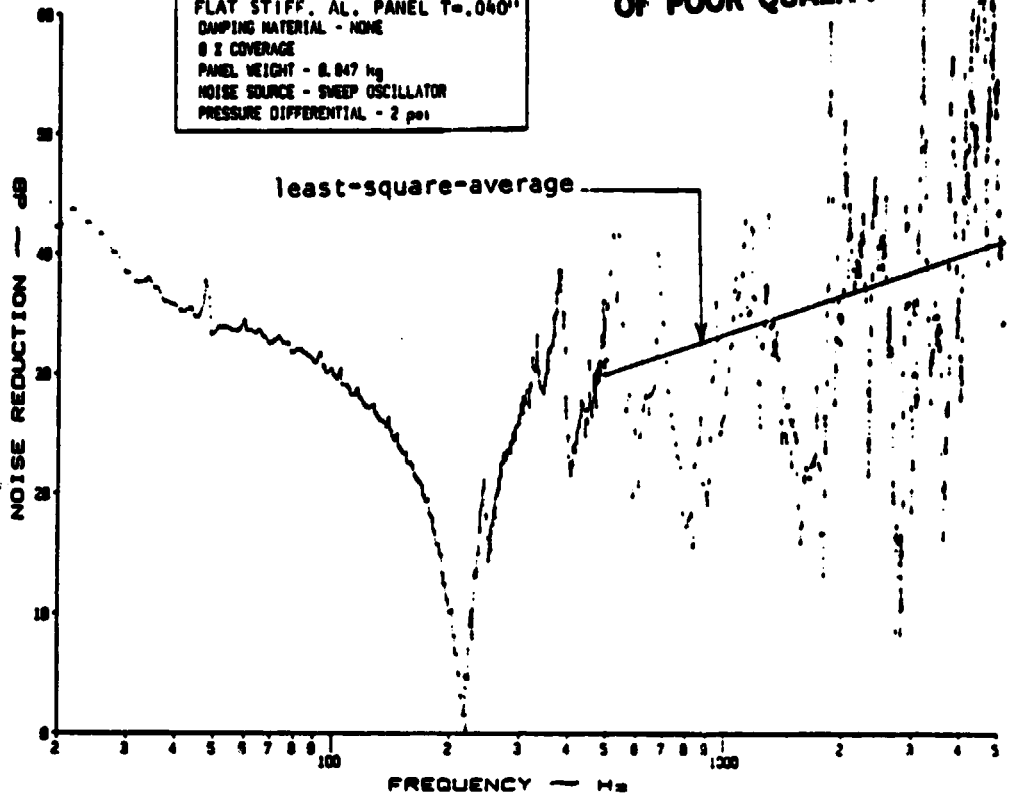

(a) Narrow Band Analysis

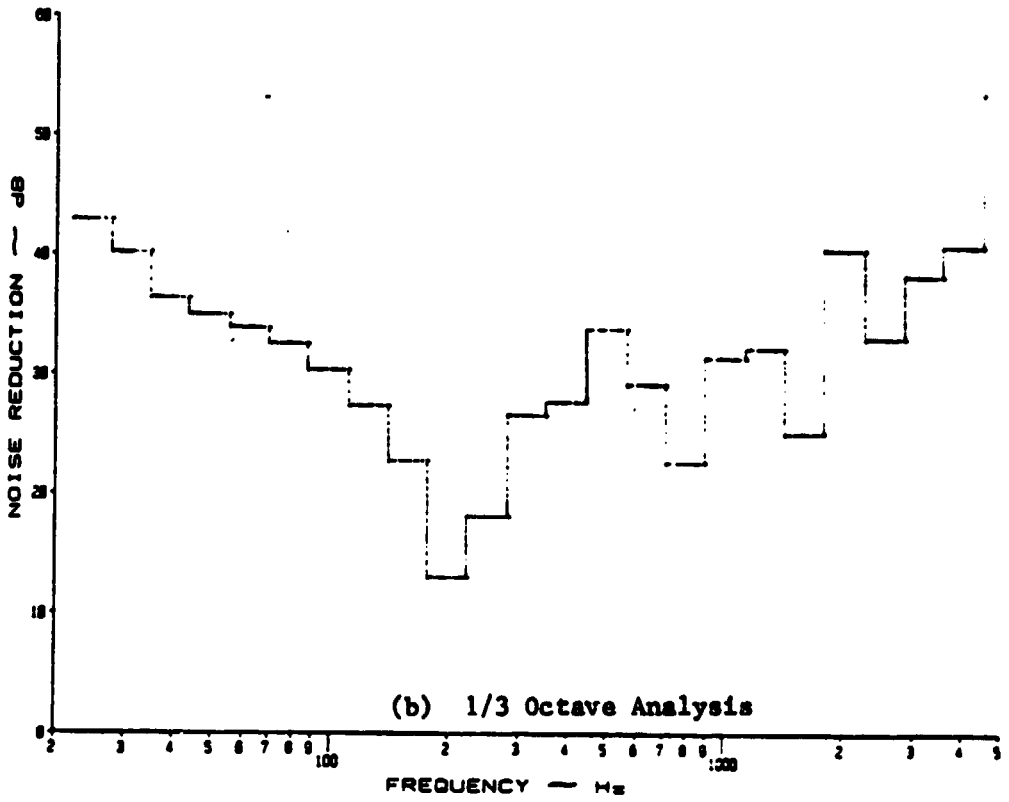

(b) 1/3 Octave Analysis

Figure A.3: Noise Reduction Characteristics of a Flat, Stiffened Panel at a 2 psi Pressure Differential with No Treatment under a Discrete Noise Source

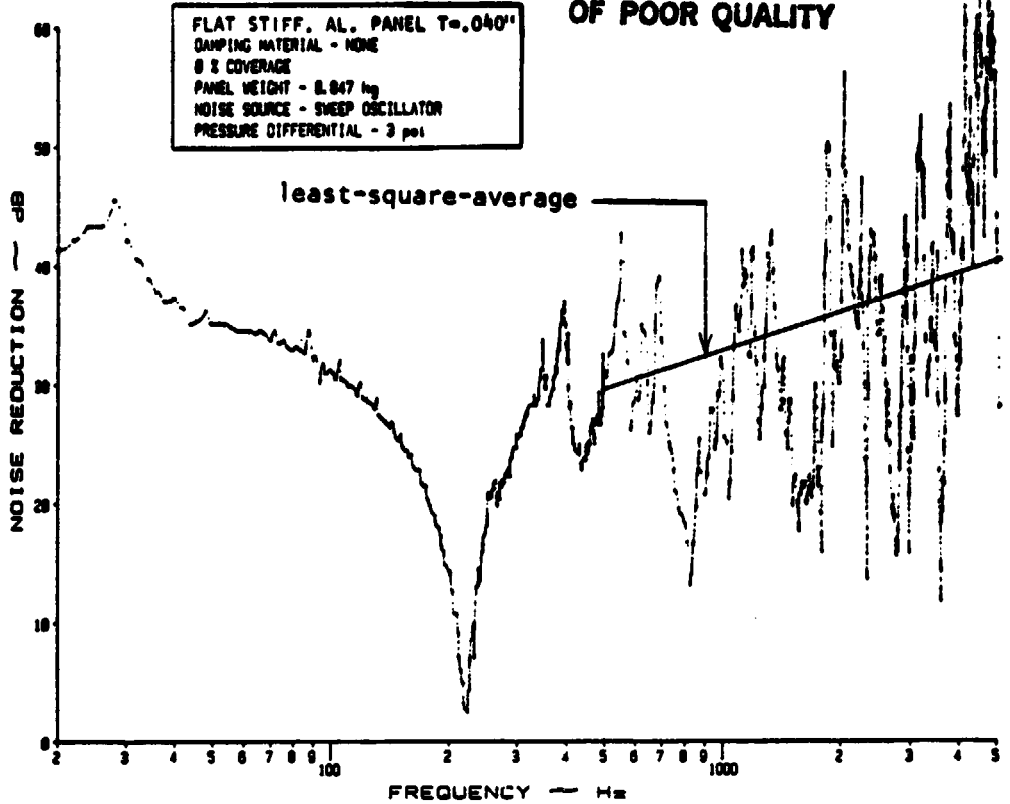

(a) Narrow Band Analysis

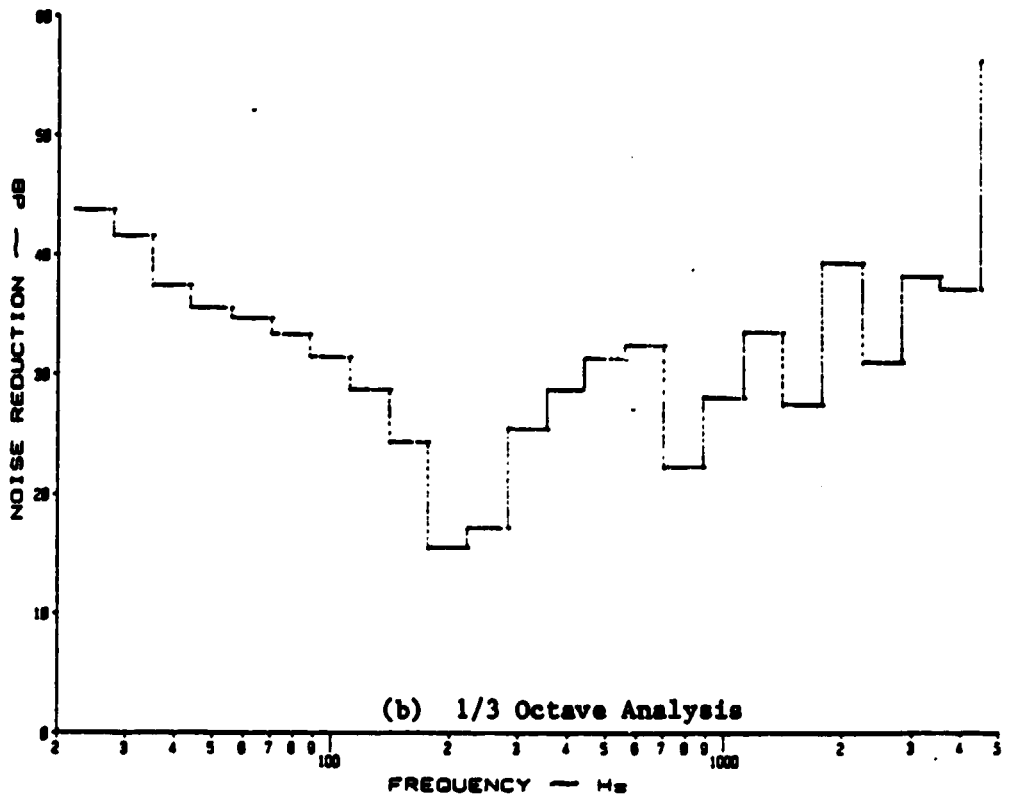

(b) 1/3 Octave Analysis

Figure A.4: Noise Reduction Characteristics of a Flat, Stiffened Panel at 3 psi Pressure Differential with No Treatment under a Discrete Noise Source

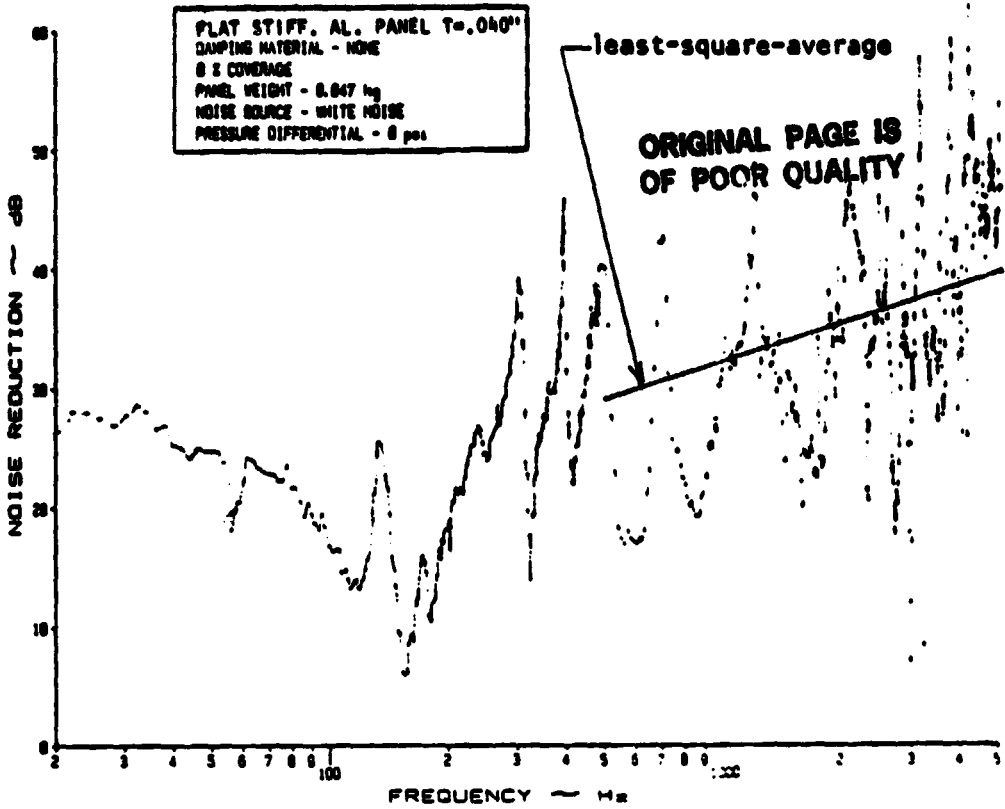

(a) Narrow Band Analysis

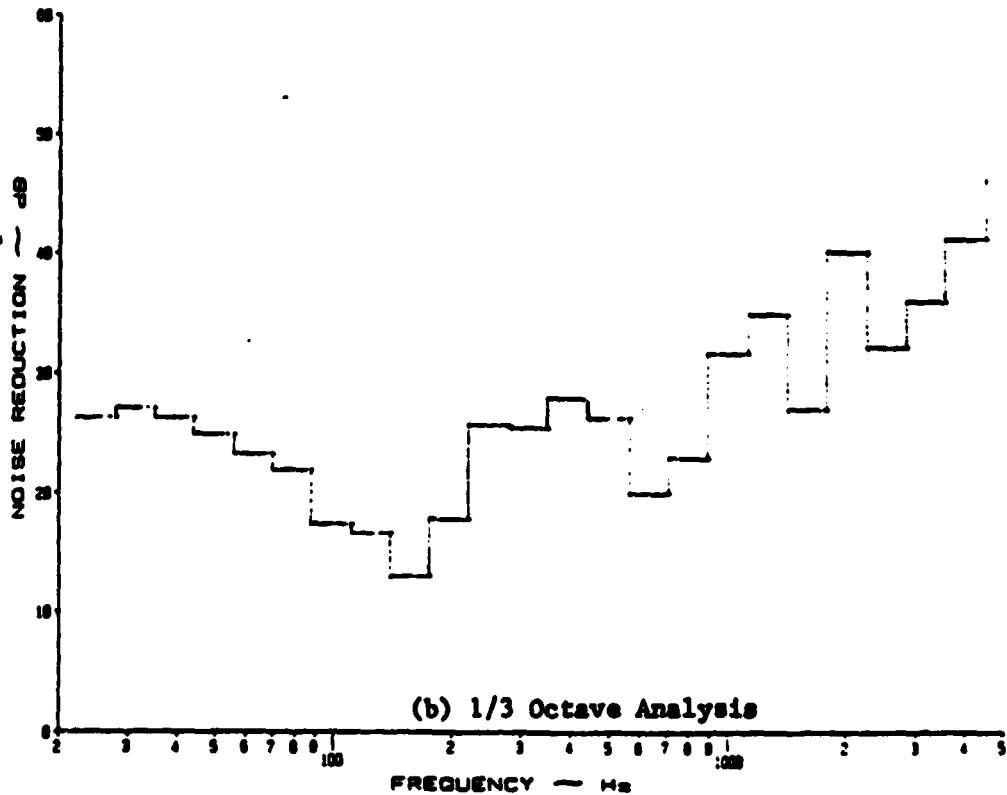

(b) 1/3 Octave Analysis

Figure A.5: Noise Reduction Characteristics of a Flat, Stiffened Panel at 0 psi Pressure Differential with No Treatment under White Noise

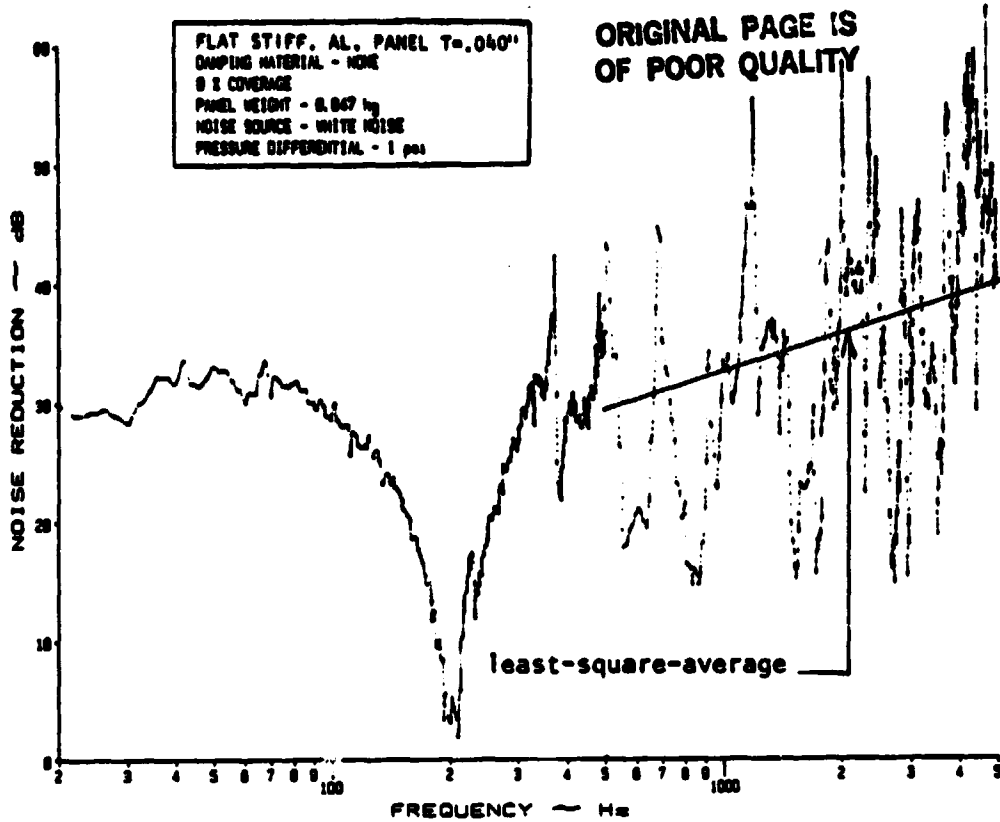

(a) Narrow Band Analysis

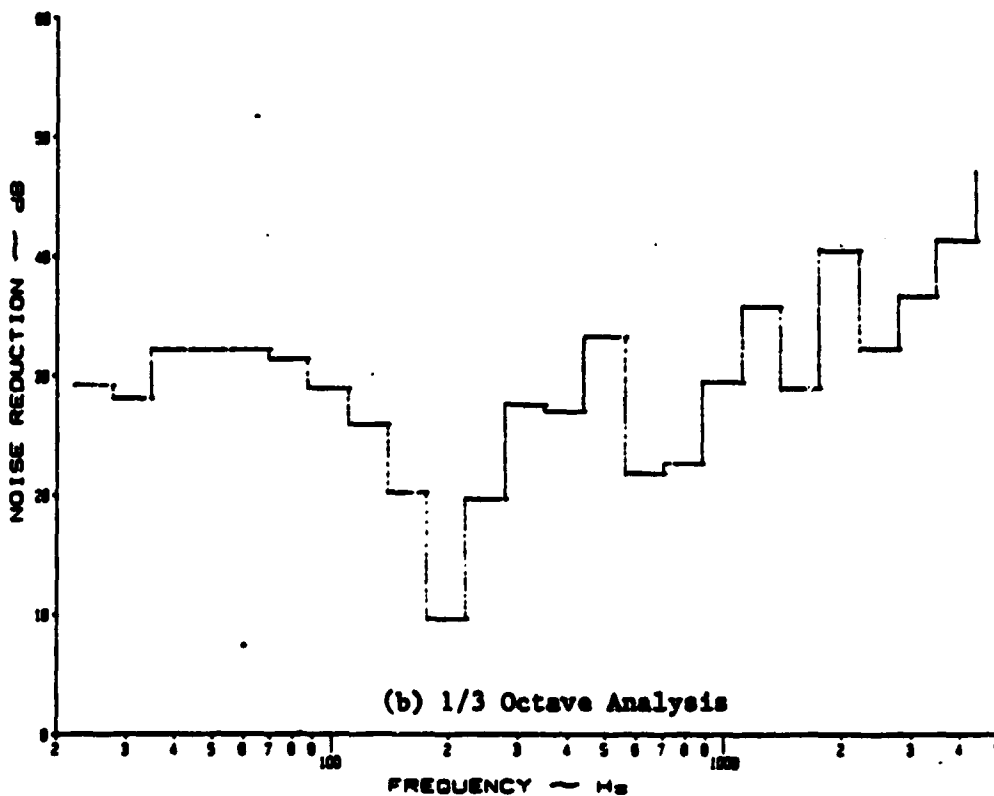

(b) 1/3 Octave Analysis

Figure A.6: Noise Reduction Characteristics of a Flat, Stiffened Panel at 1 psi Pressure Differential with No Treatment under White Noise

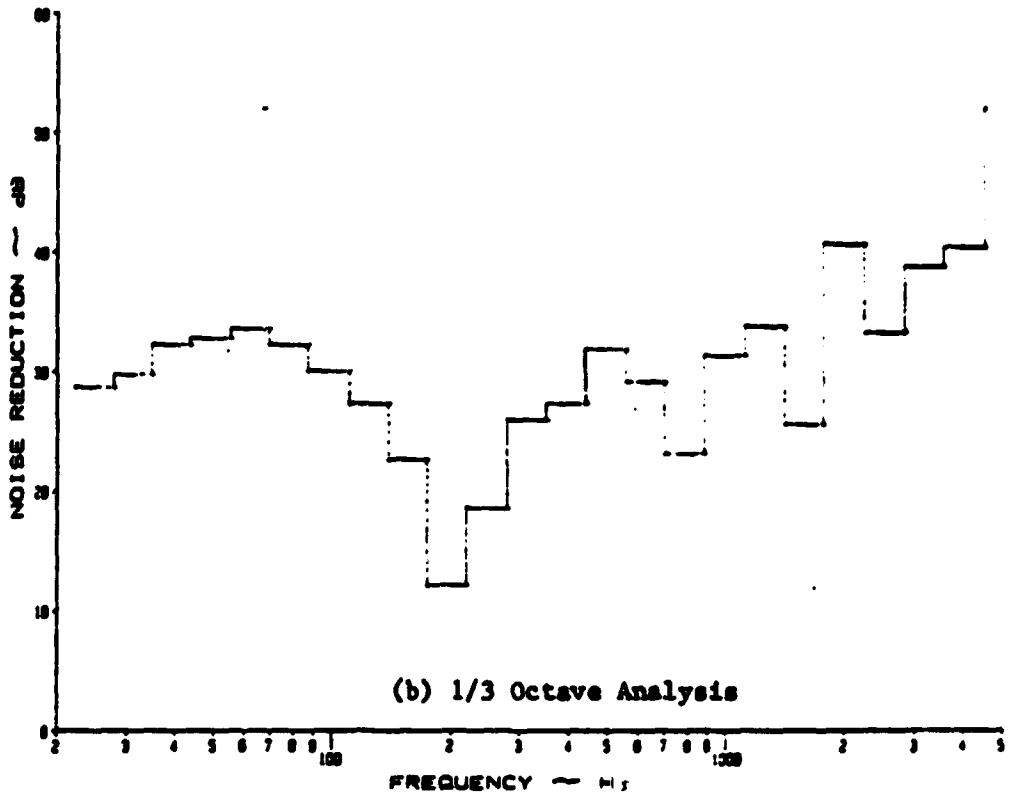
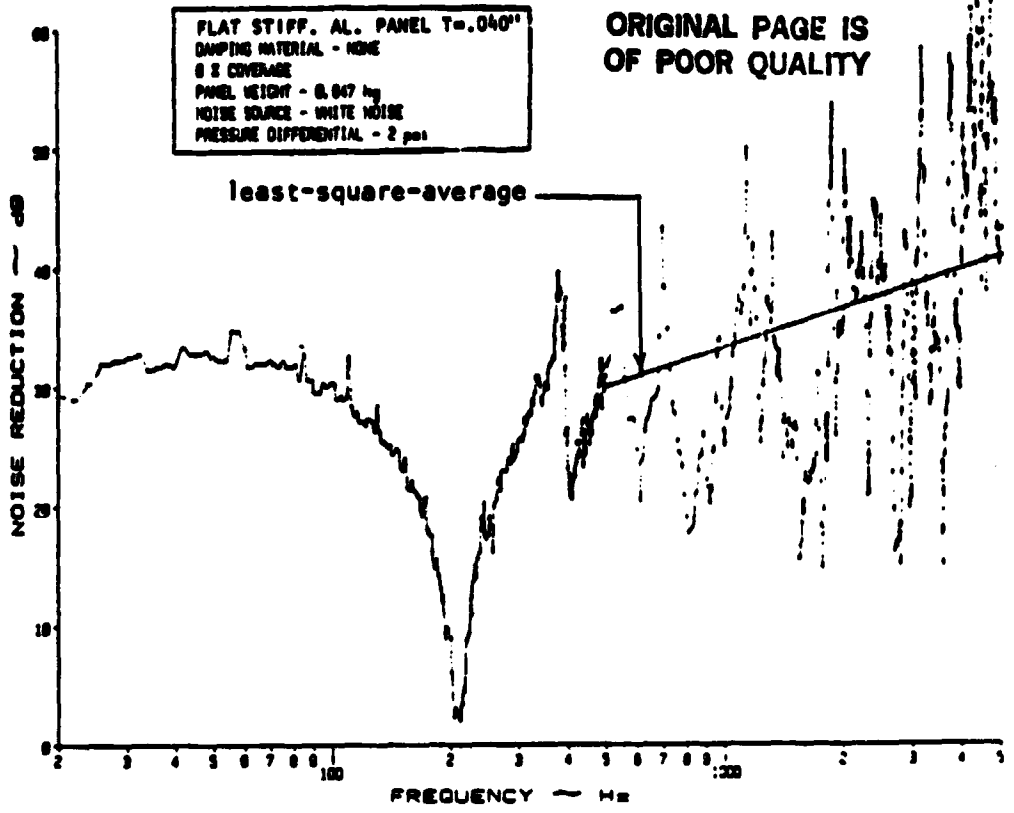
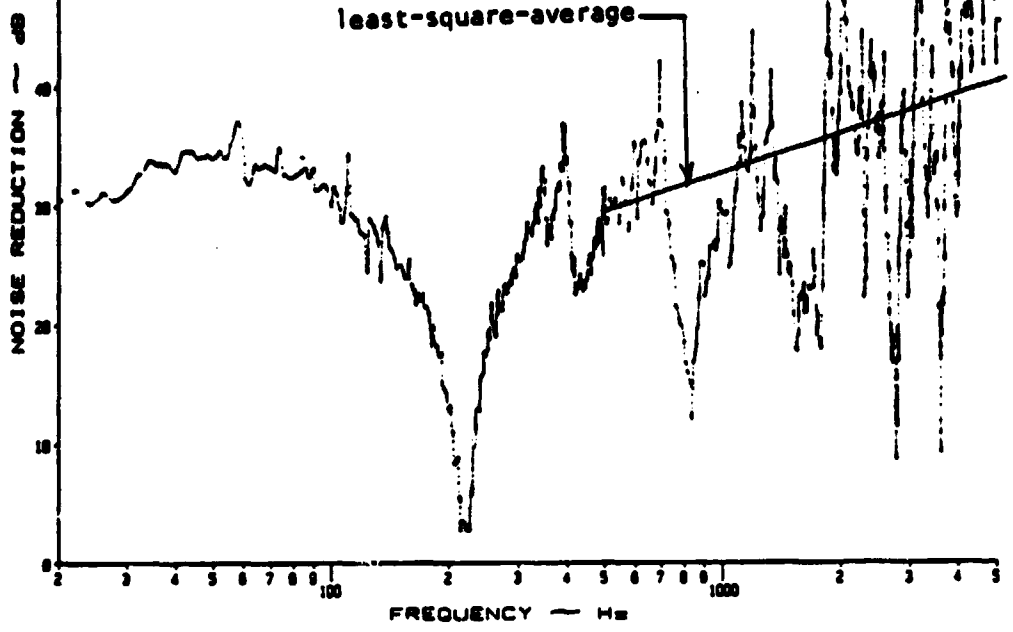

Figure A.7: Noise Reduction Characteristics of a Flat, Stiffened Panel at 2 psi Pressure Differential with No Treatment under White Noise

ORIGINAL PAGE IS
OF POOR QUALITY

FLAT STIFF. AL. PANEL $T=0.040"$
DAMPING MATERIAL - NONE
S X COVERAGE
PANEL WEIGHT - 0.047 kg
NOISE SOURCE - WHITE NOISE
PRESSURE DIFFERENTIAL - 3 psi



(a) Narrow Band Analysis

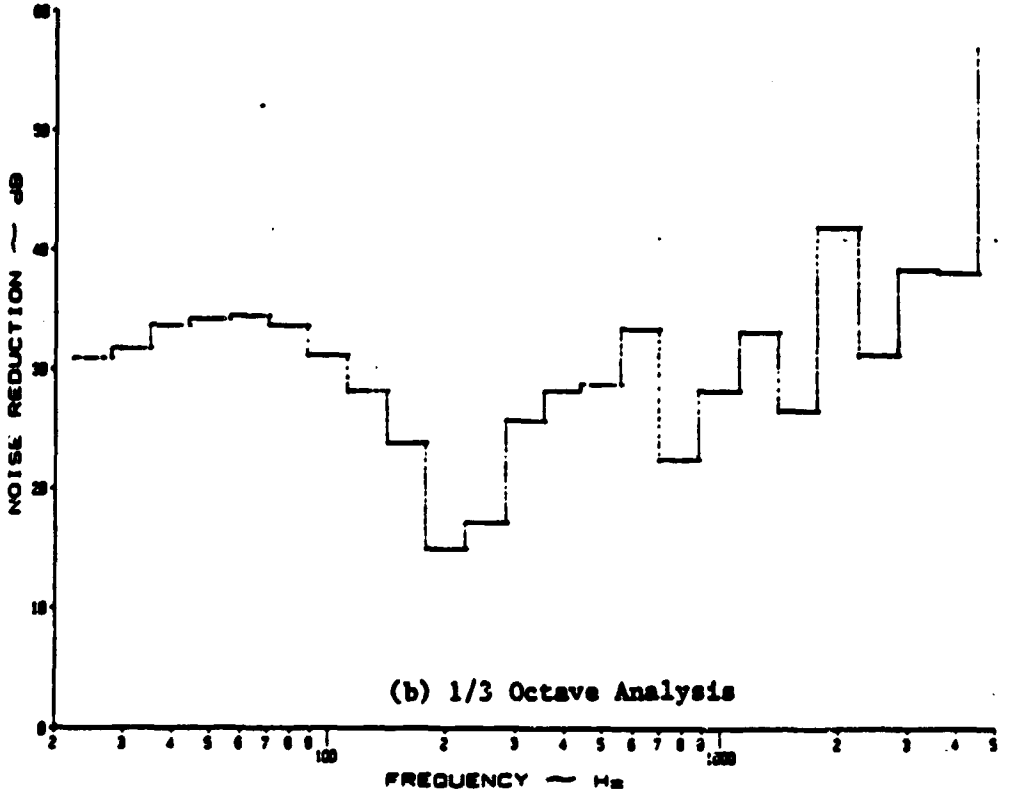

(b) 1/3 Octave Analysis

Figure A.8: Noise Reduction Characteristics of a Flat, Stiffened Panel at 3 psi Pressure Differential with No Treatment under White Noise

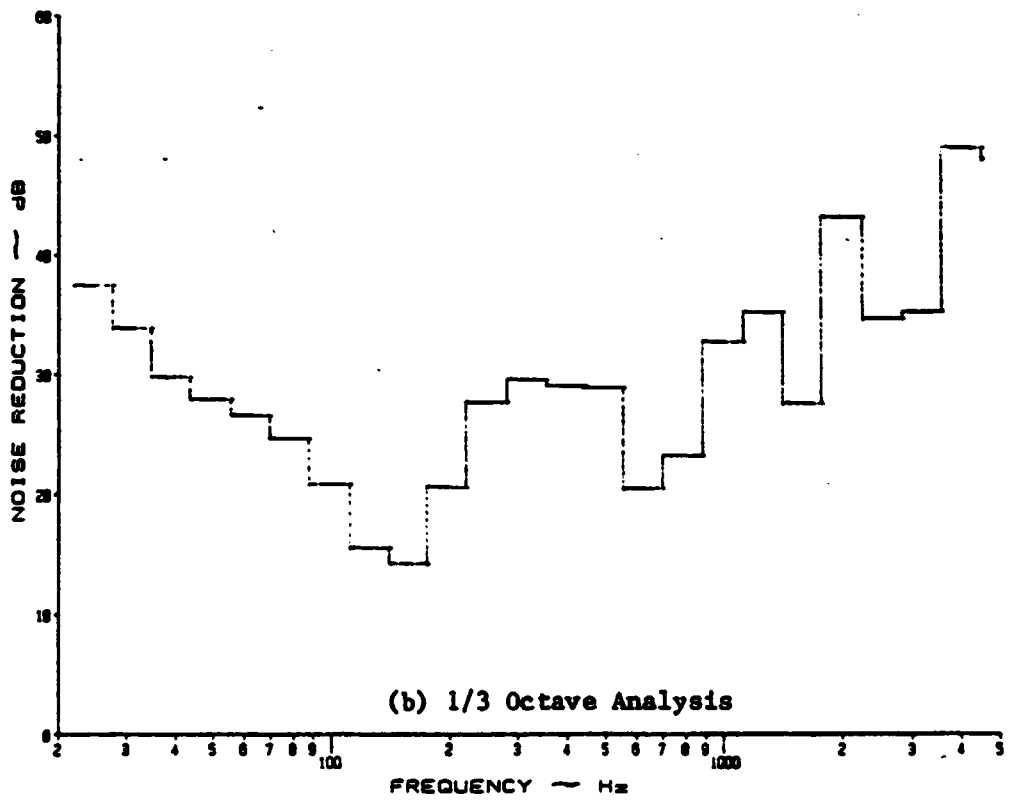
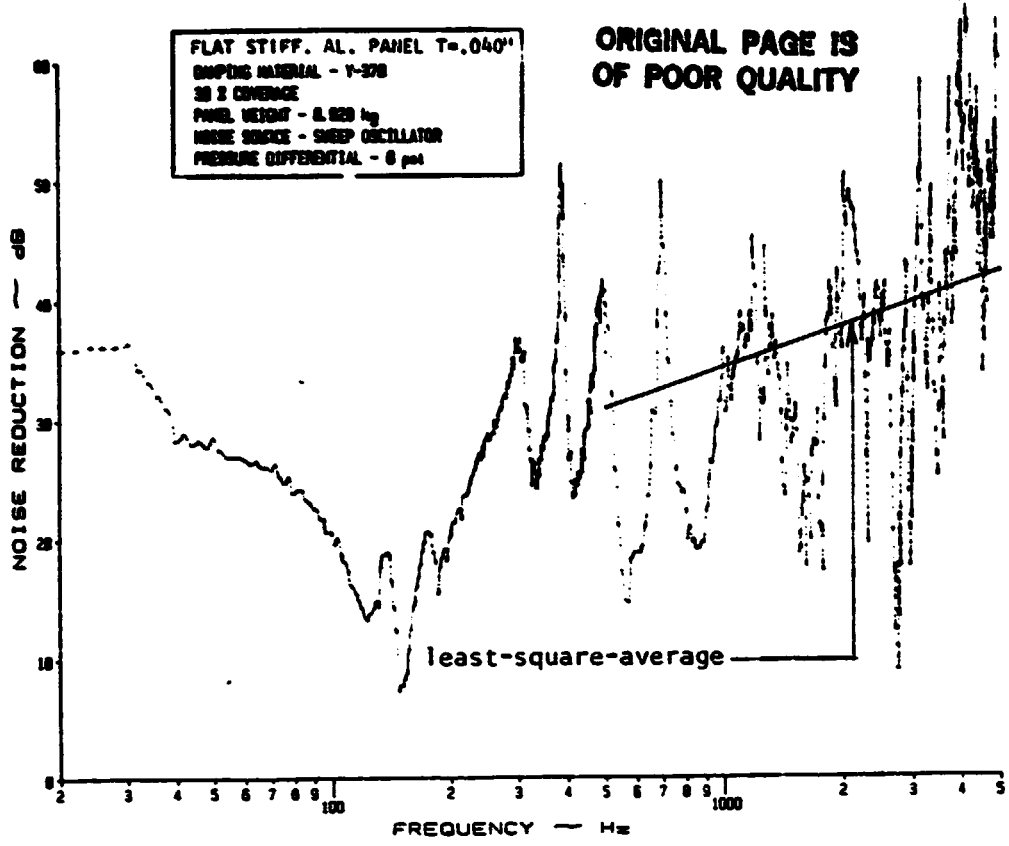
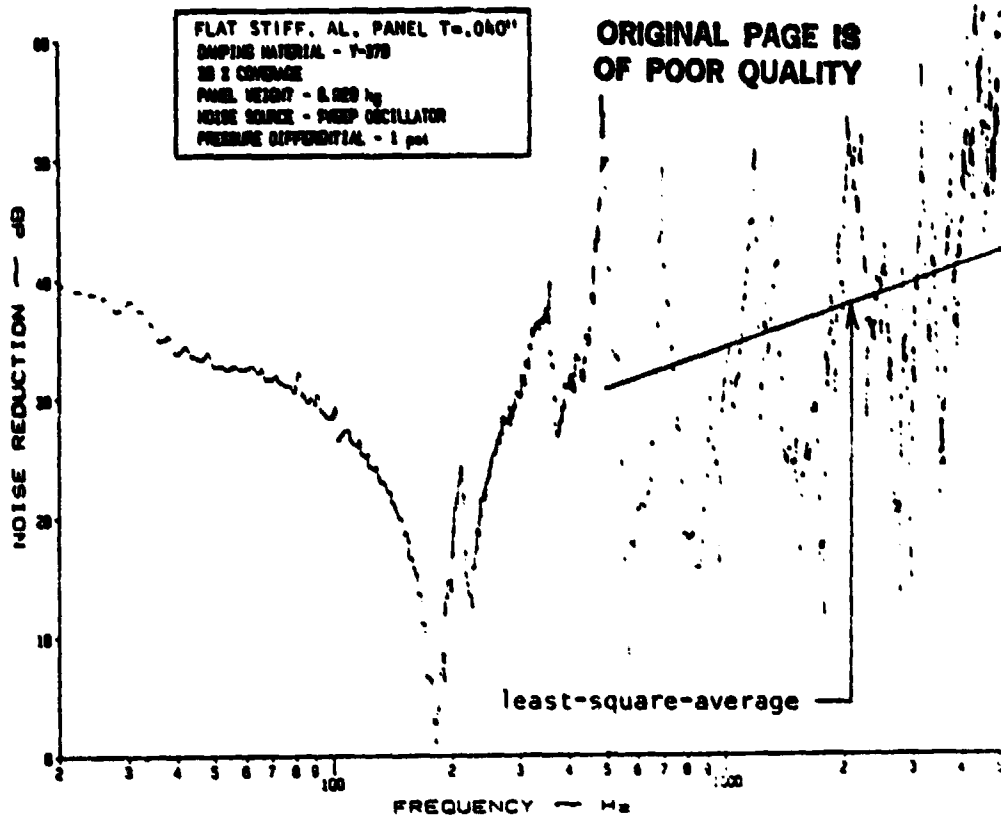
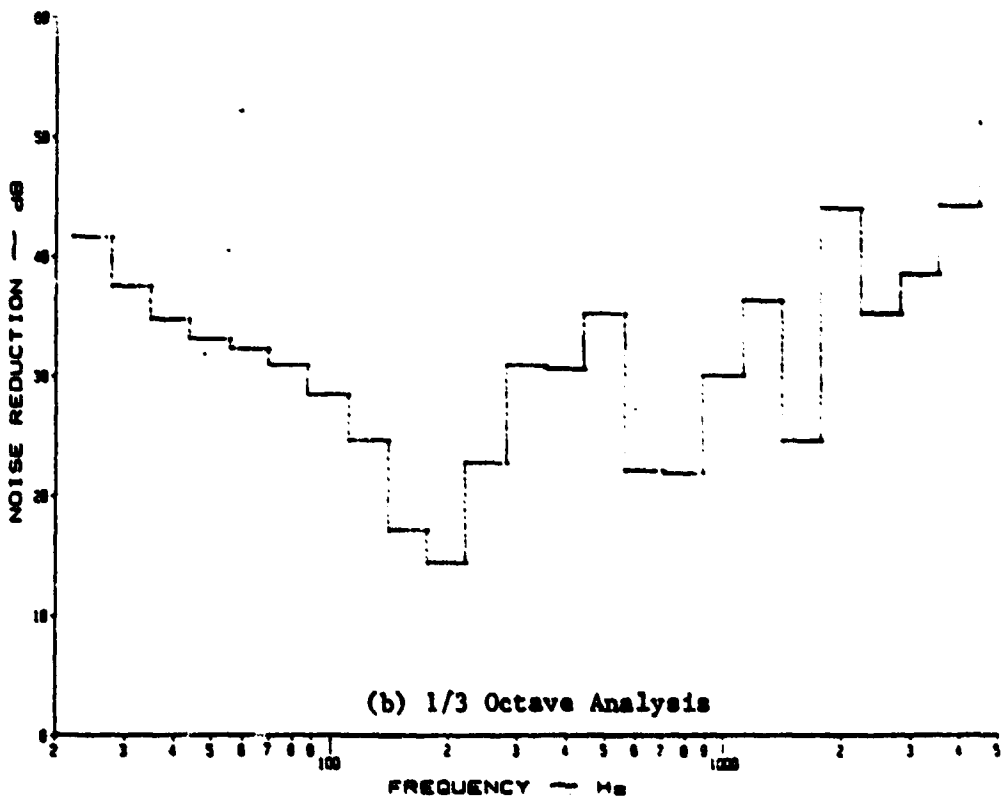

Figure A.9: Noise Reduction Characteristics of a Flat, Stiffened Panel at 0 psi Pressure Differential with Y-370 Damping Tape under a Discrete Noise Source



(a) Narrow Band Analysis



(b) 1/3 Octave Analysis

Figure A.10: Noise Reduction Characteristics of a Flat, Stiffened Panel at 1 psi Pressure Differential with Y-370 Damping Tape under a Discrete Noise Source

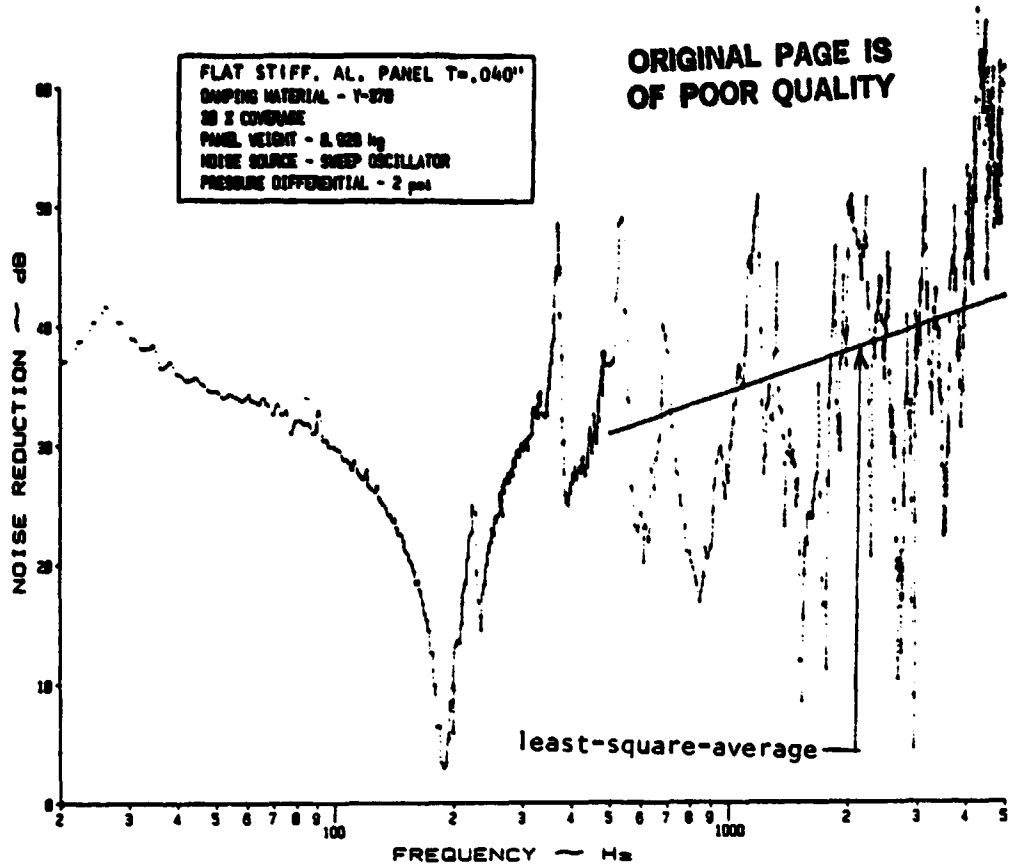

(a) Narrow Band Analysis

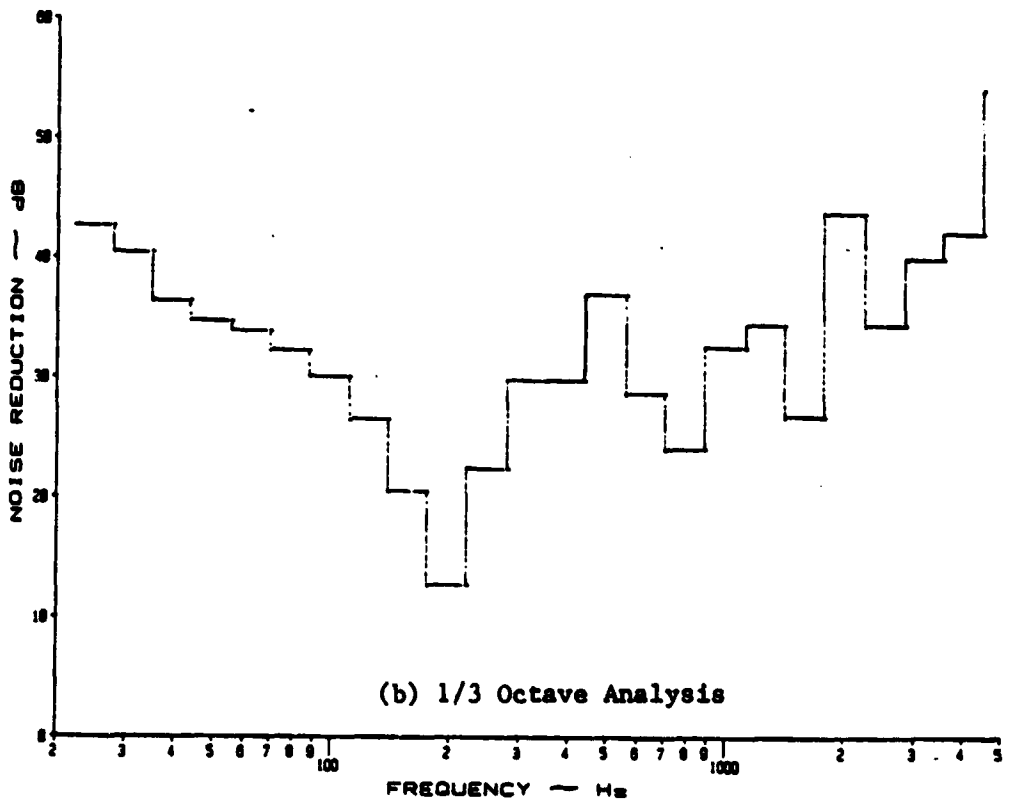

(b) 1/3 Octave Analysis

Figure A.11: Noise Reduction Characteristics of a Flat, Stiffened Panel at 2 psi Pressure Differential with Y-370 Damping Tape under a Discrete Noise Source

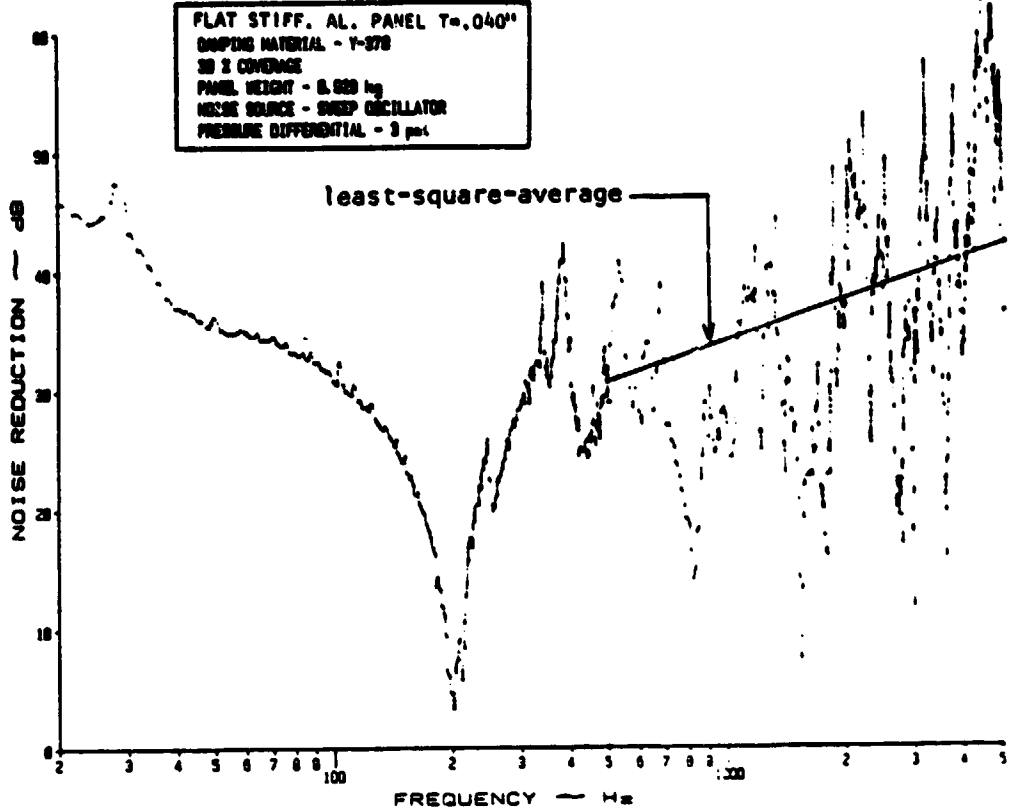

(a) Narrow Band Analysis

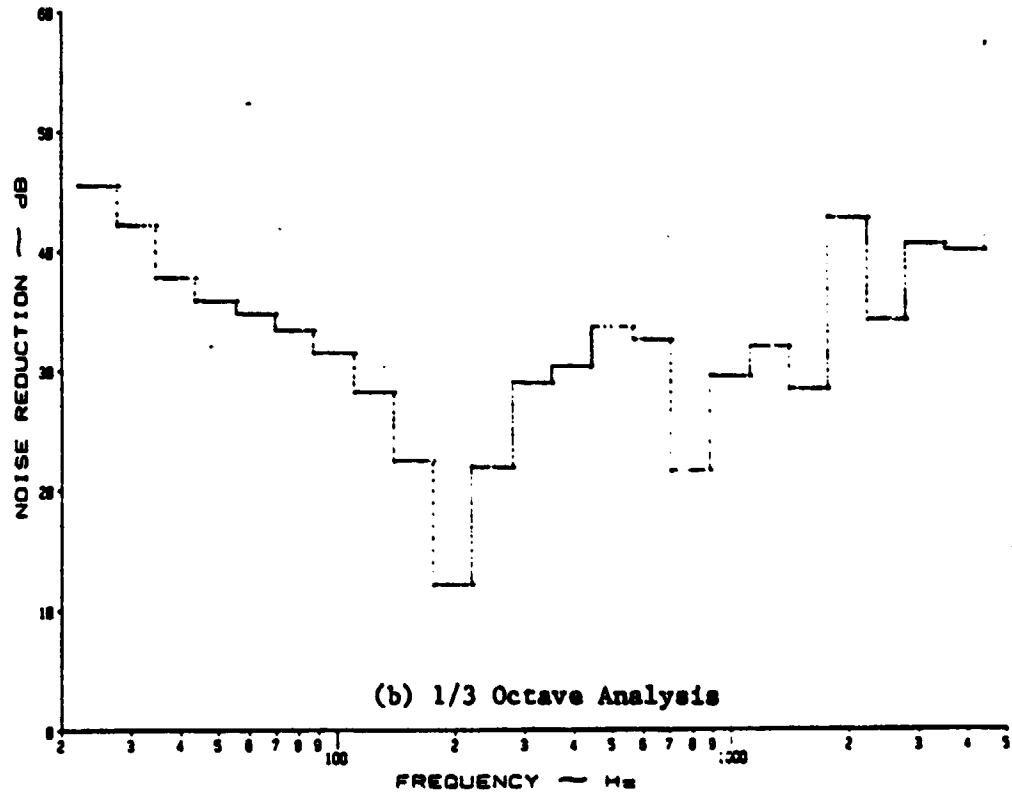

(b) 1/3 Octave Analysis

Figure A.12: Noise Reduction Characteristics of a Flat, Stiffened Panel at 3 psi Pressure Differential with Y-370 Damping Tape under a Discrete Noise Source

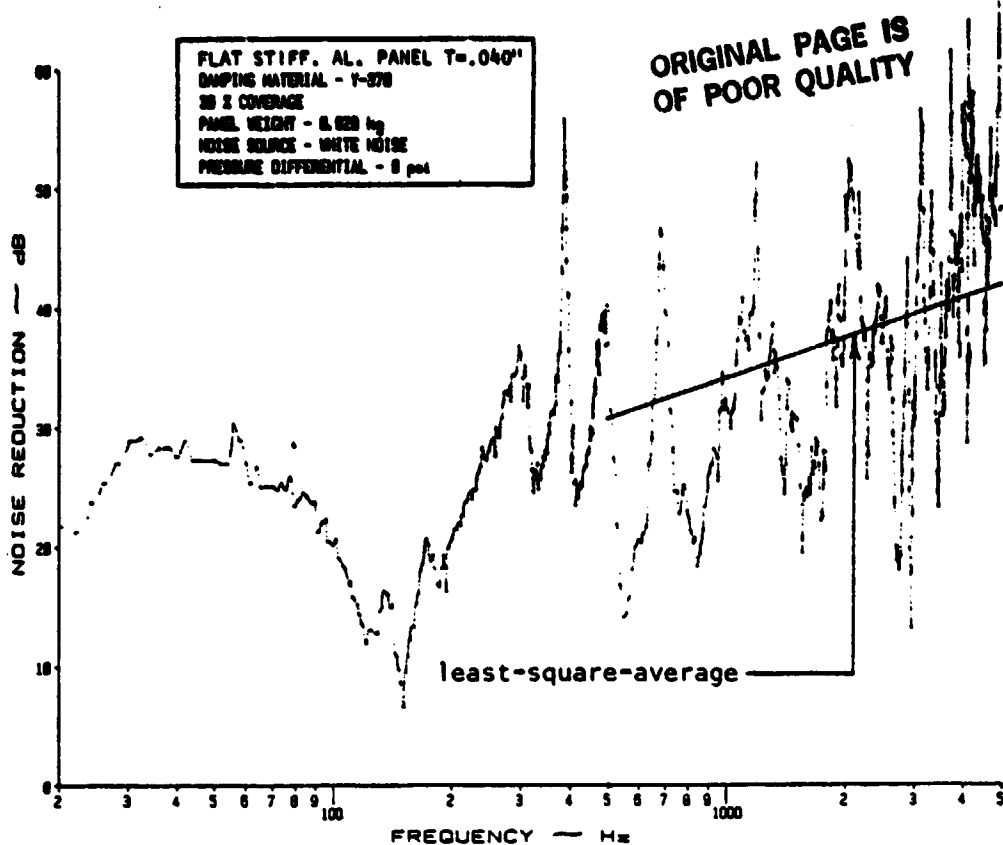

(a) Narrow Band Analysis

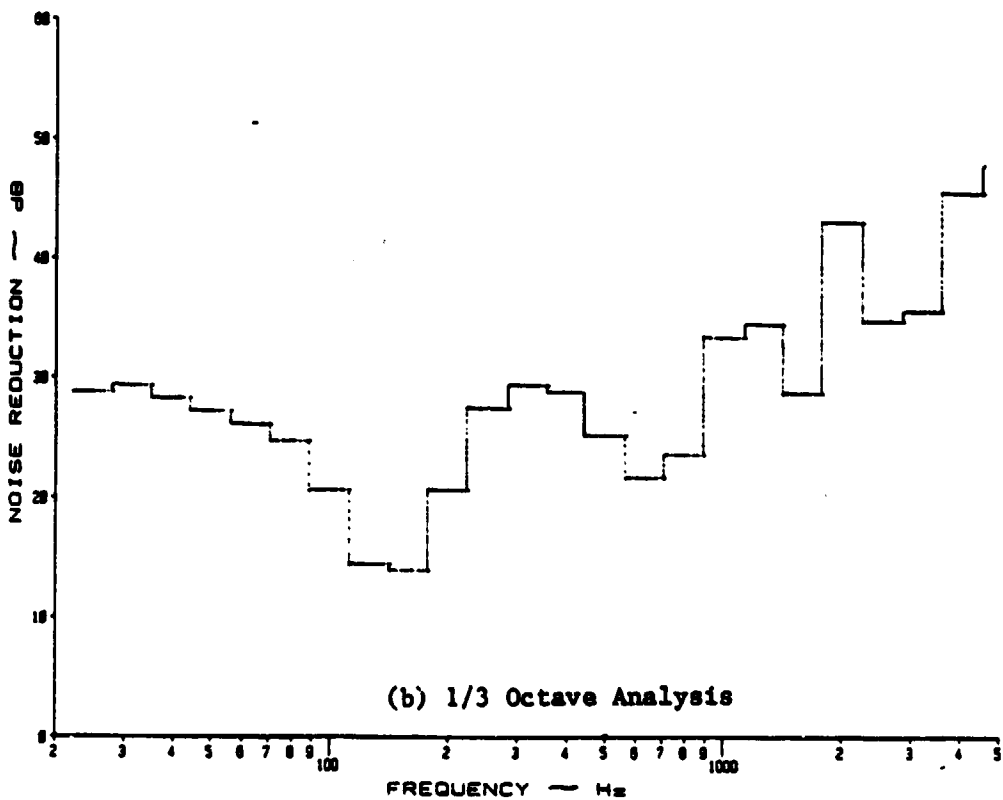
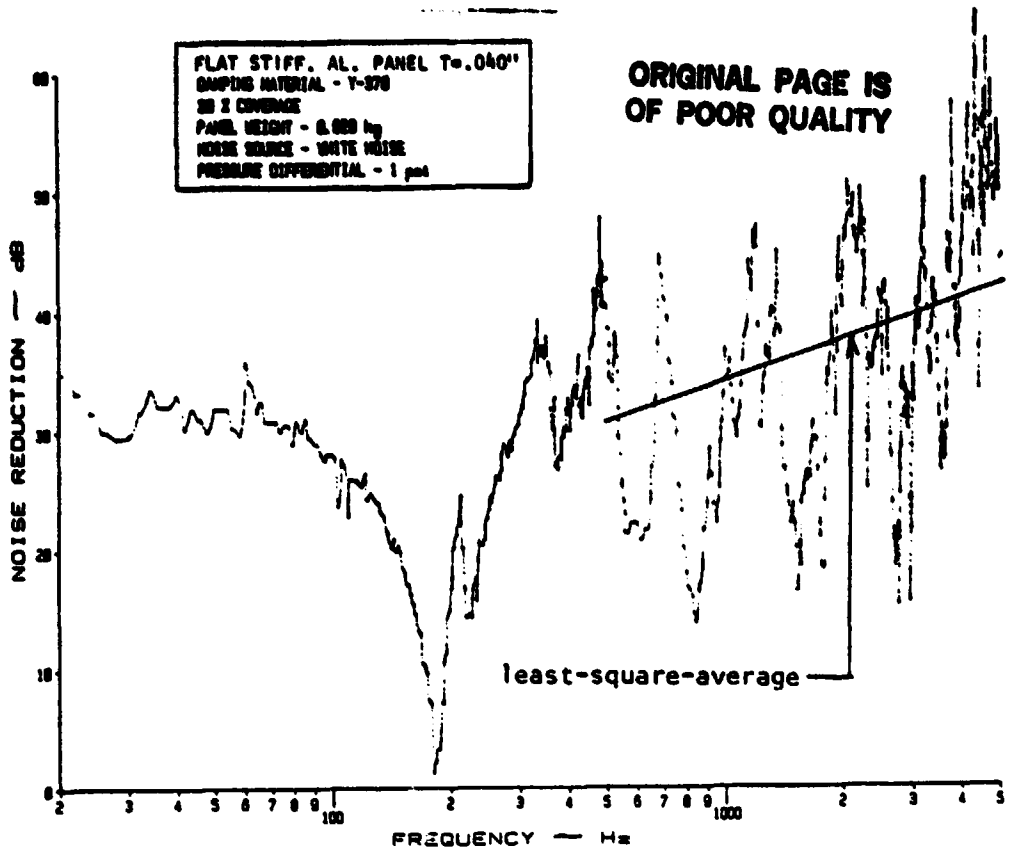
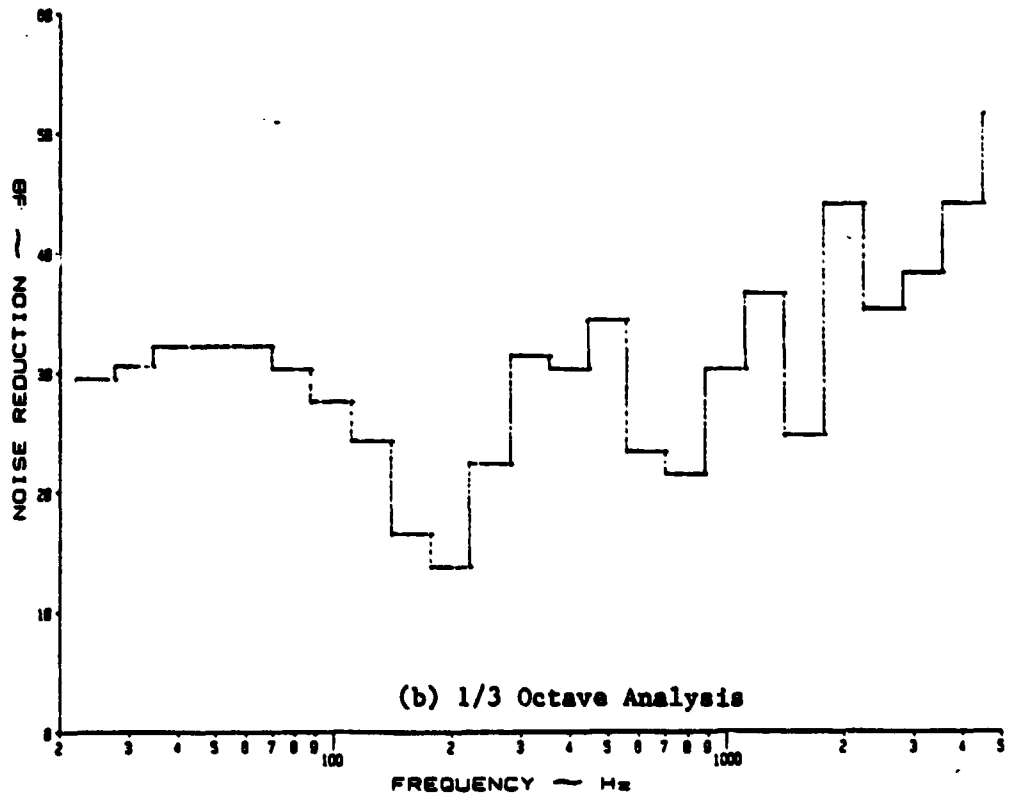

Figure A.13: Noise Reduction Characteristics of a Flat, Stiffened Panel at 0 psi Pressure Differential with Y-370 Damping Tape under White Noise



(a) Narrow Band Analysis



(b) 1/3 Octave Analysis

Figure A.14: Noise Reduction Characteristics of a Flat, Stiffened Panel at 1 psi Pressure Differential with Y-370 Damping Tape under White Noise

ORIGINAL PAGE IS
OF POOR QUALITY

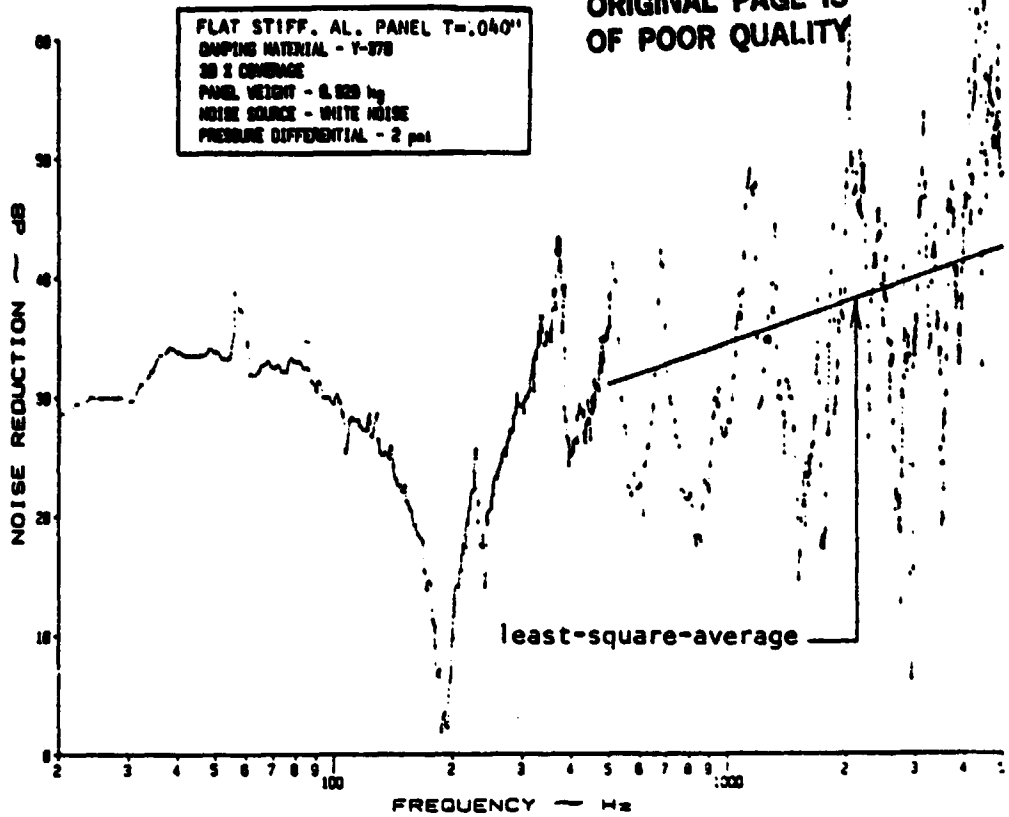

(a) Narrow Band Analysis

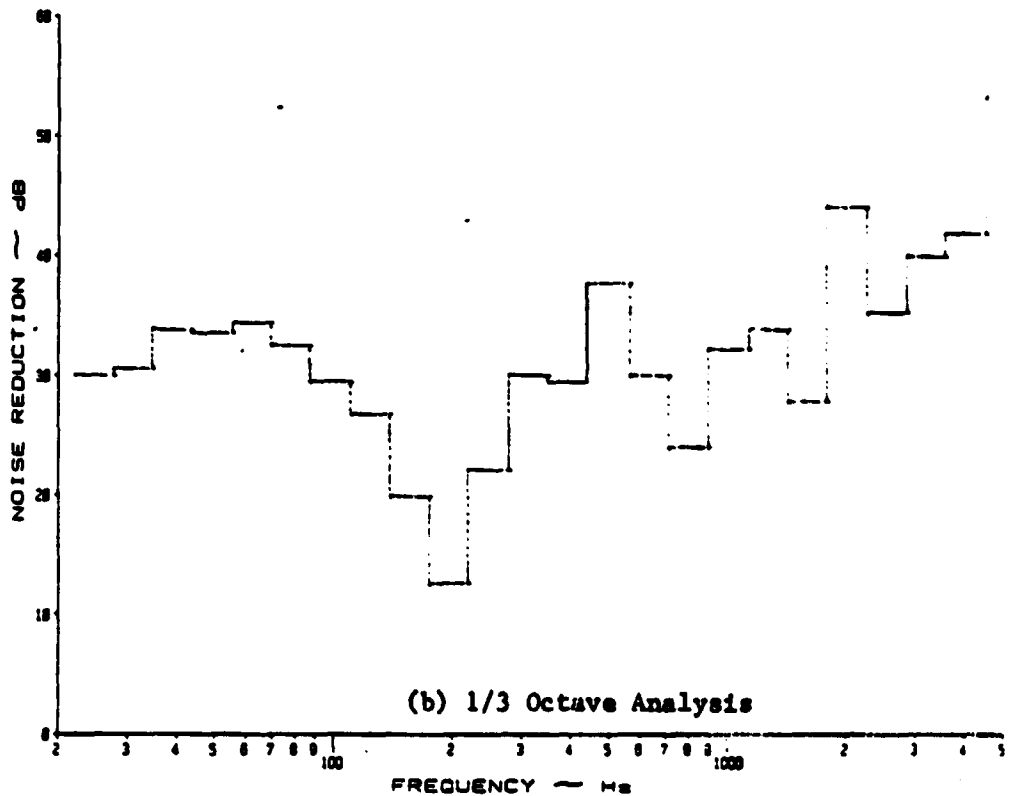

(b) 1/3 Octave Analysis

Figure A.15: Noise Reduction Characteristics of a Flat, Stiffened Panel at 2 psi Pressure Differential with Y-370 Damping Tape under White Noise

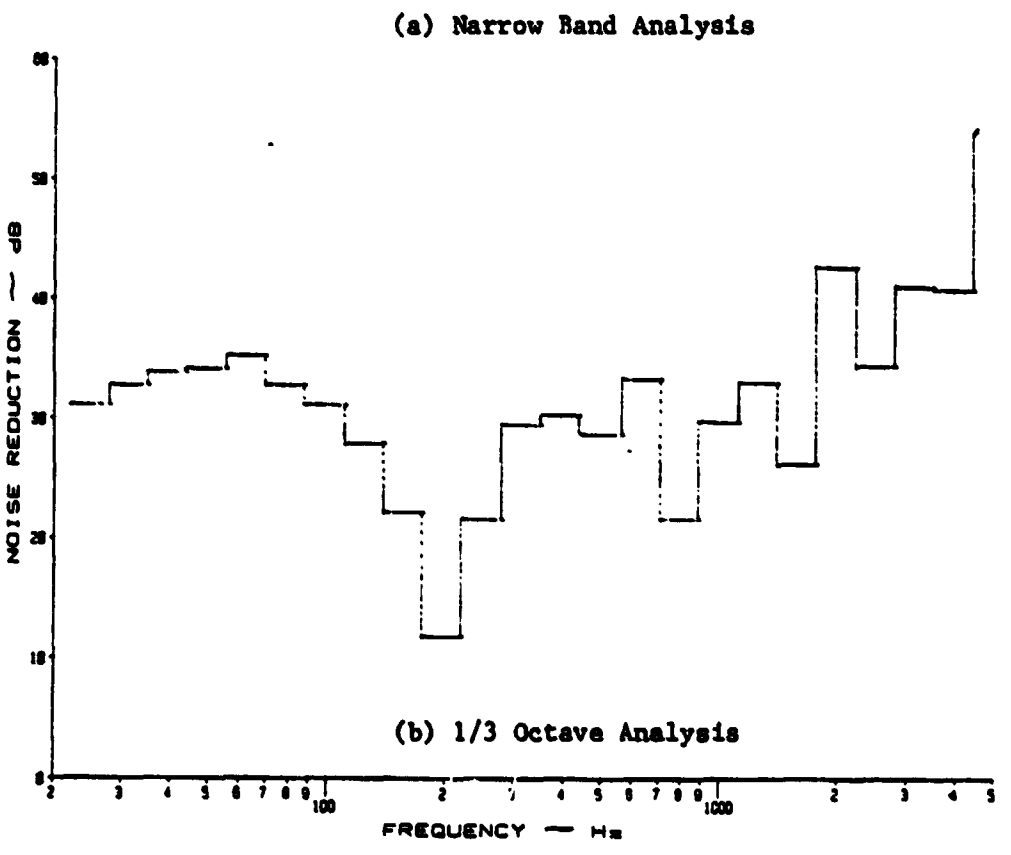
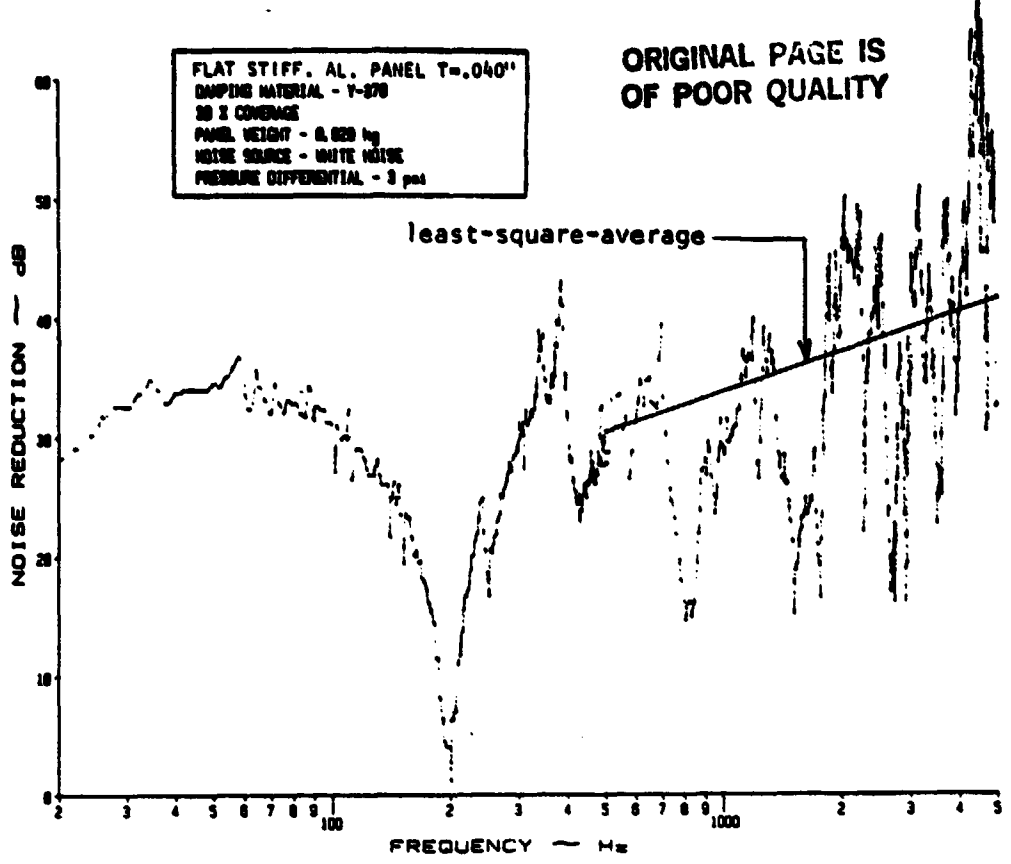
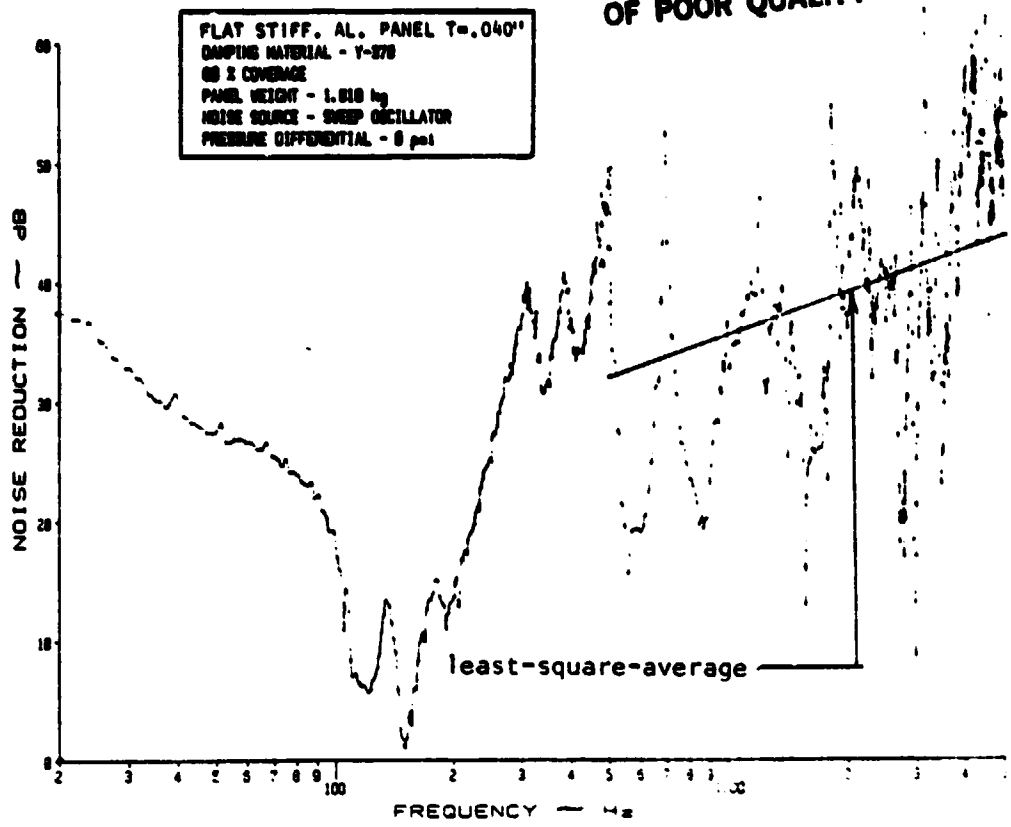
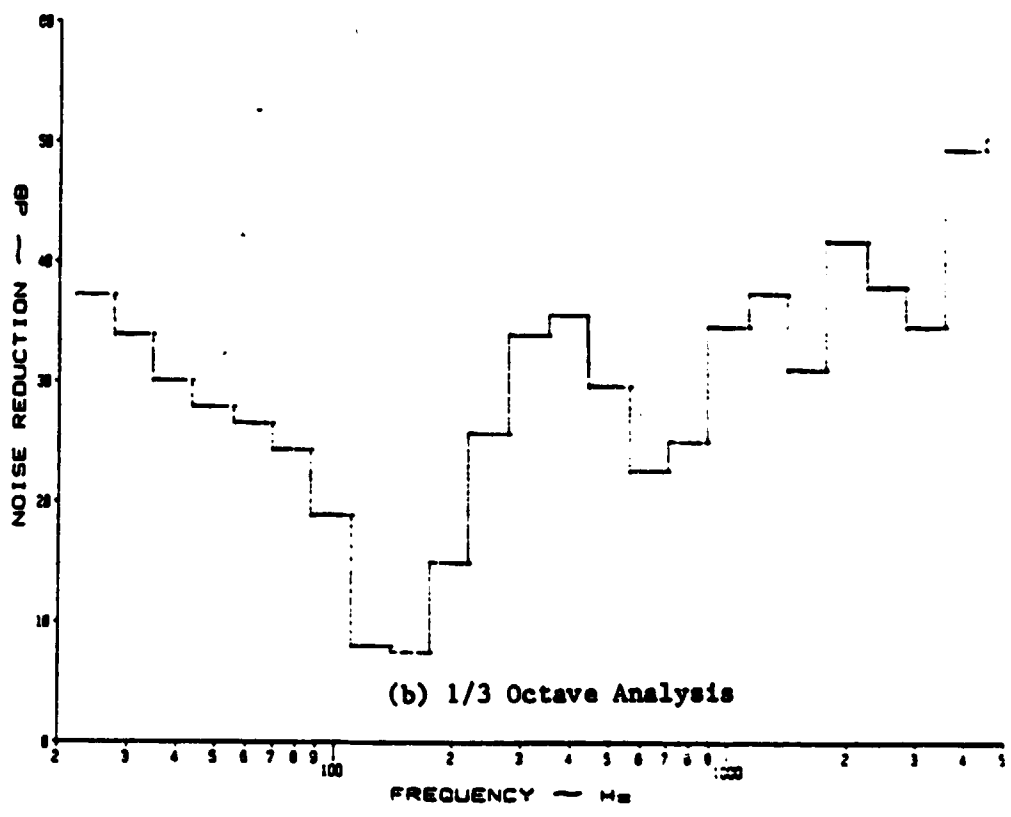

Figure A.16: Noise Reduction Characteristics of a Flat, Stiffened Panel at 3 psi Pressure Differential with Y-370 Damping Tape under White Noise

ORIGINAL PAGE IS
OF POOR QUALITY



(a) Narrow Band Analysis



(b) 1/3 Octave Analysis

Figure A.17: Noise Reduction Characteristics of a Flat, Stiffened Panel at 0 psi Pressure Differential with Y-370 Damping Tape under a Discrete Noise Source

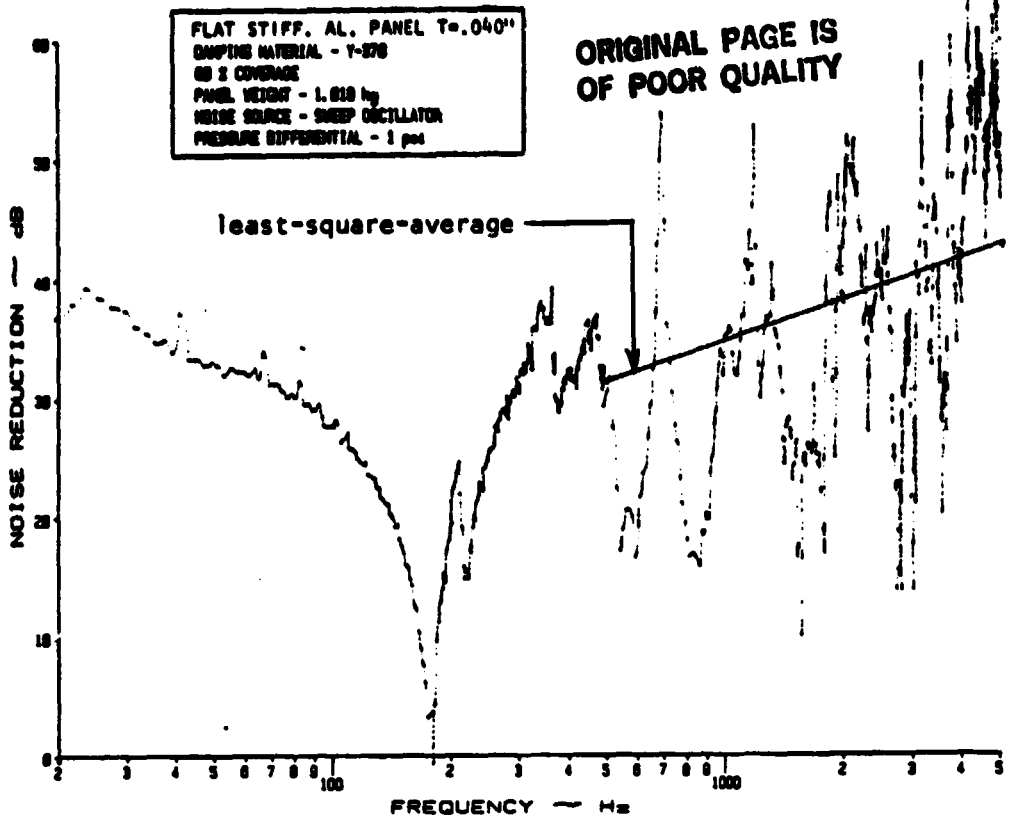

(a) Narrow Band Analysis

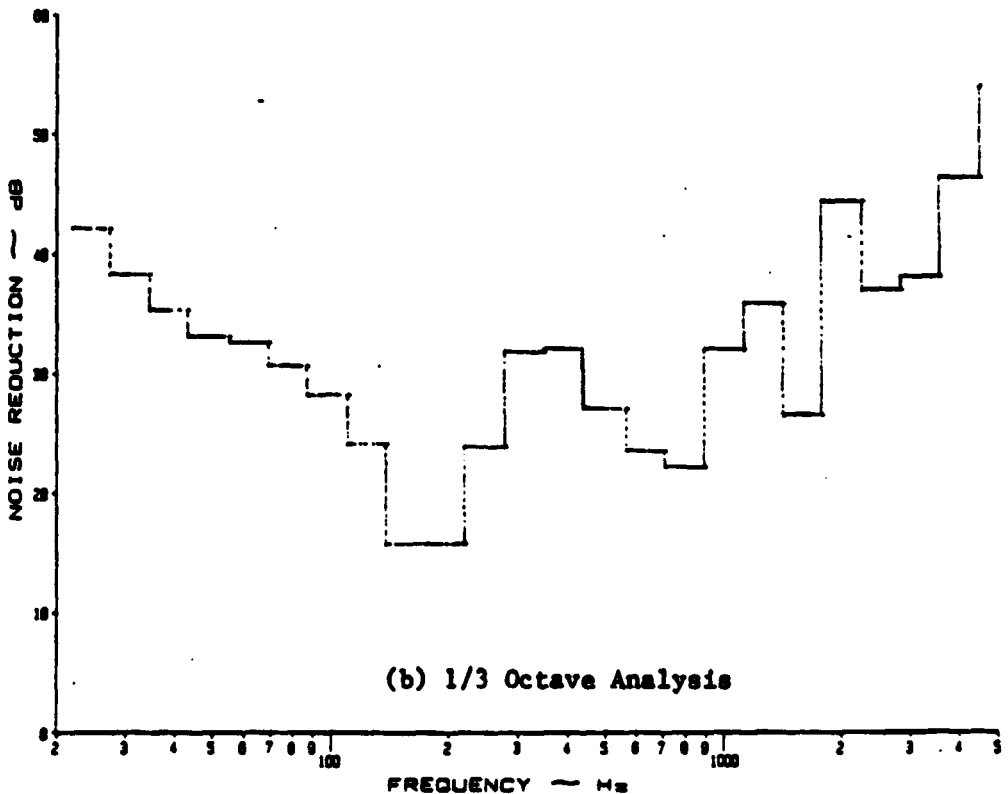

(b) 1/3 Octave Analysis

Figure A.18: Noise Reduction Characteristics of a Flat, Stiffened Panel at 1 psi Pressure Differential with Y-370 Damping Tape under a Discrete Noise Source

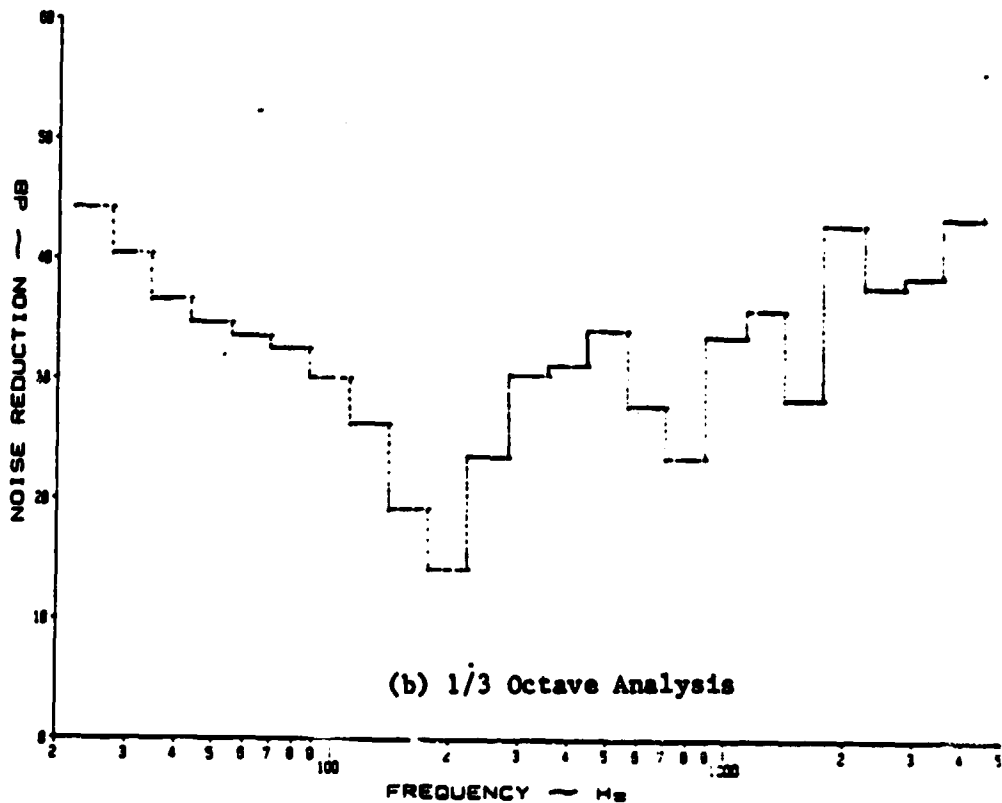
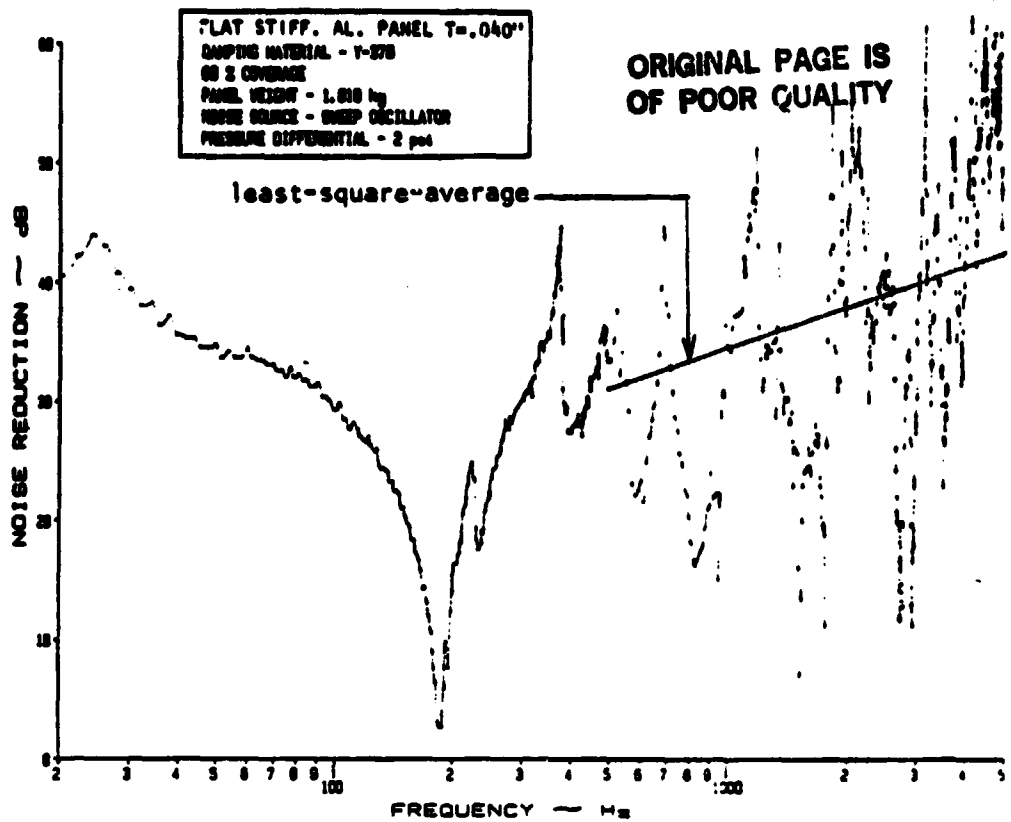
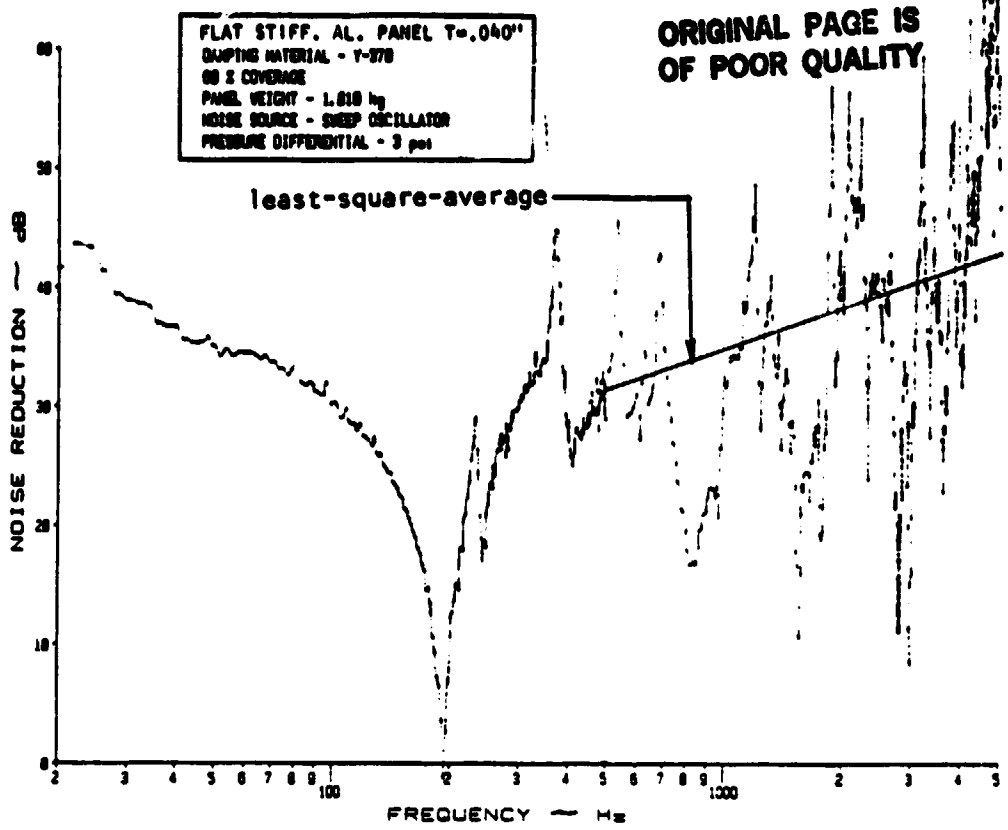
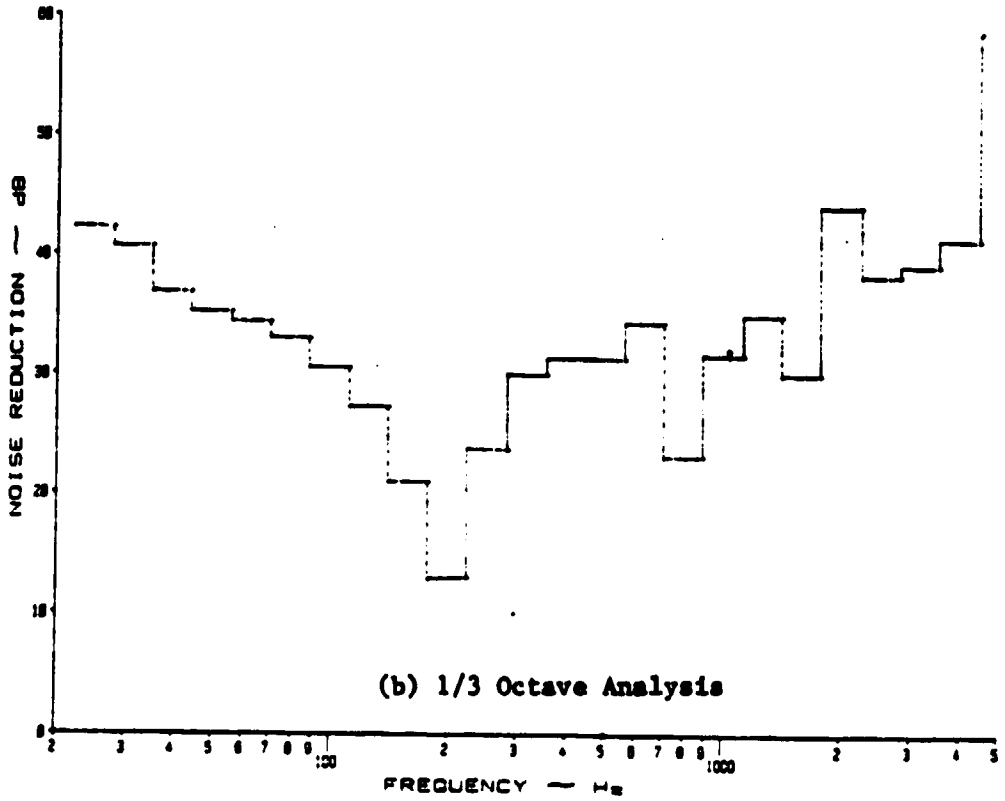

Figure A.19: Noise Reduction Characteristics of a Flat, Stiffened Panel at 2 psi Pressure Differential with Y-370 Damping Tape under a Discrete Noise Source



(a) Narrow Band Analysis



(b) 1/3 Octave Analysis

Figure A.20: Noise Reduction Characteristics of a Flat, Stiffened Panel at 3 psi Pressure Differential with Y-370 Damping Tape under a Discrete Noise Source

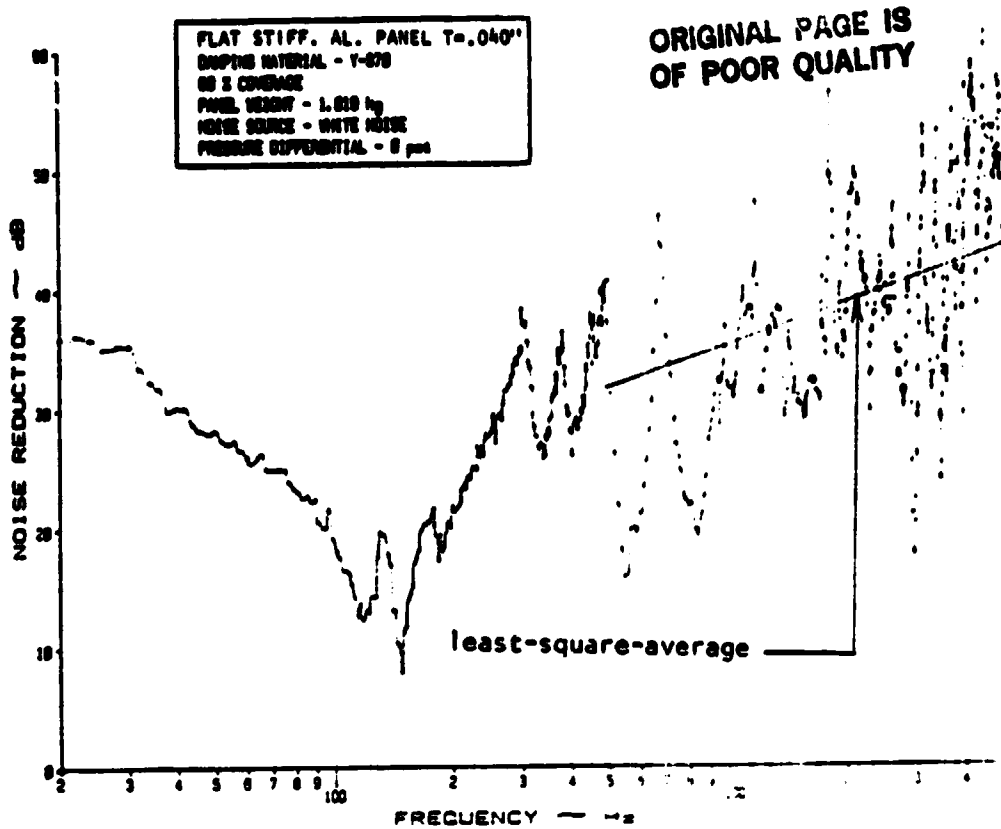

(a) Narrow Band Analysis

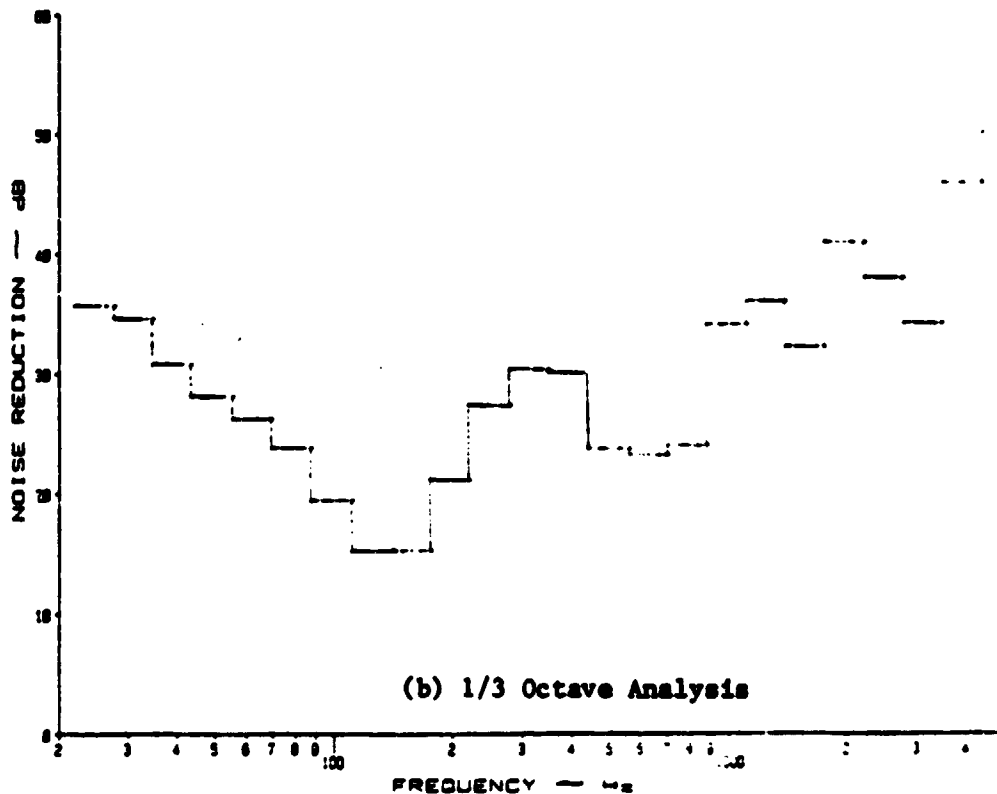
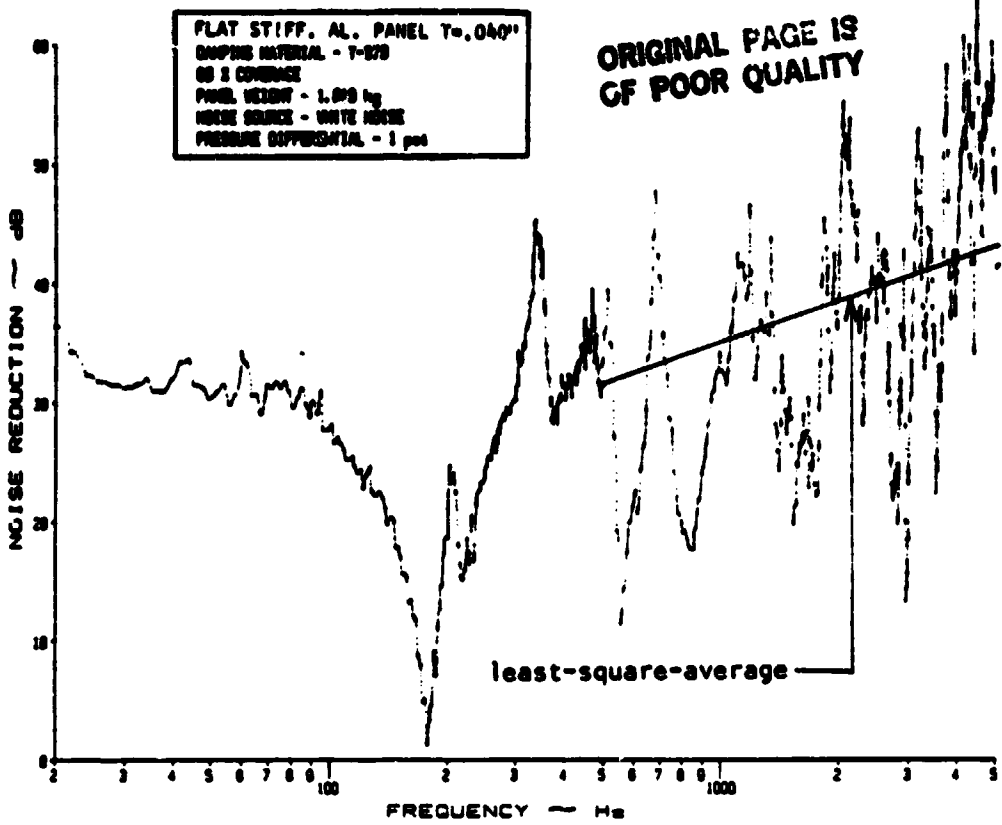
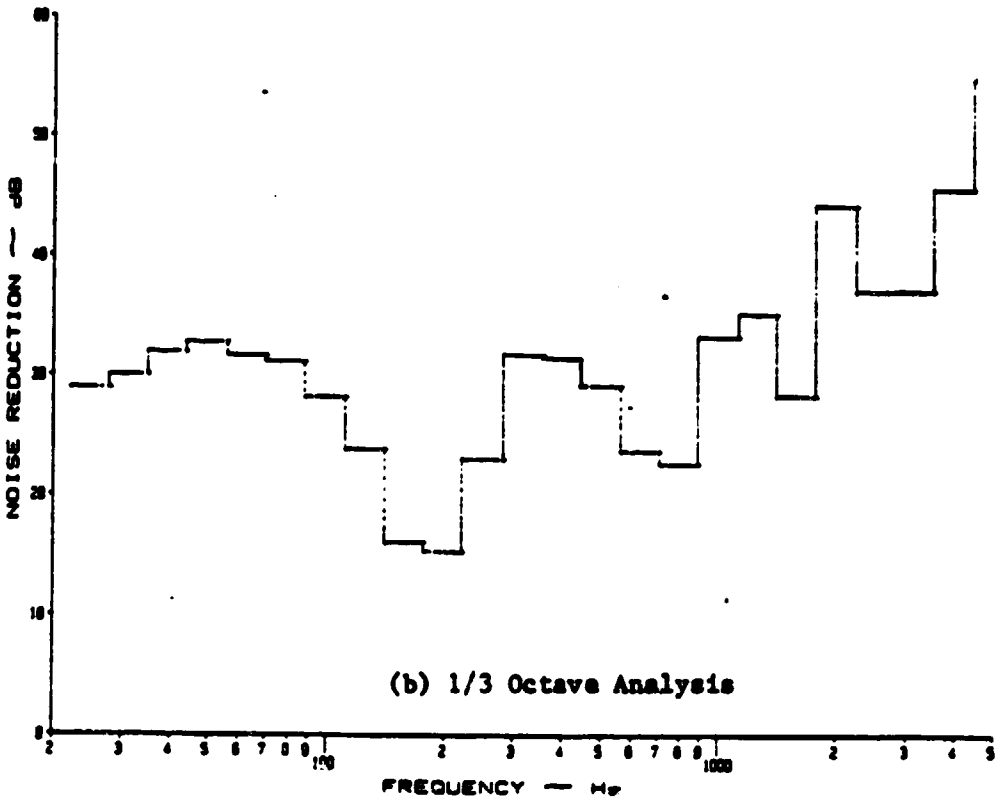

Figure A.21: Noise Reduction Characteristics of a Flat, Stiffened Panel at 0 psi Pressure Differential with Y-370 Damping Tape under White Noise



(a) Narrow Band Analysis



(b) 1/3 Octave Analysis

Figure A.22: Noise Reduction Characteristics of a Flat, Stiffened Panel at 1 psi Pressure Differential with Y-379 Damping Tape under White Noise

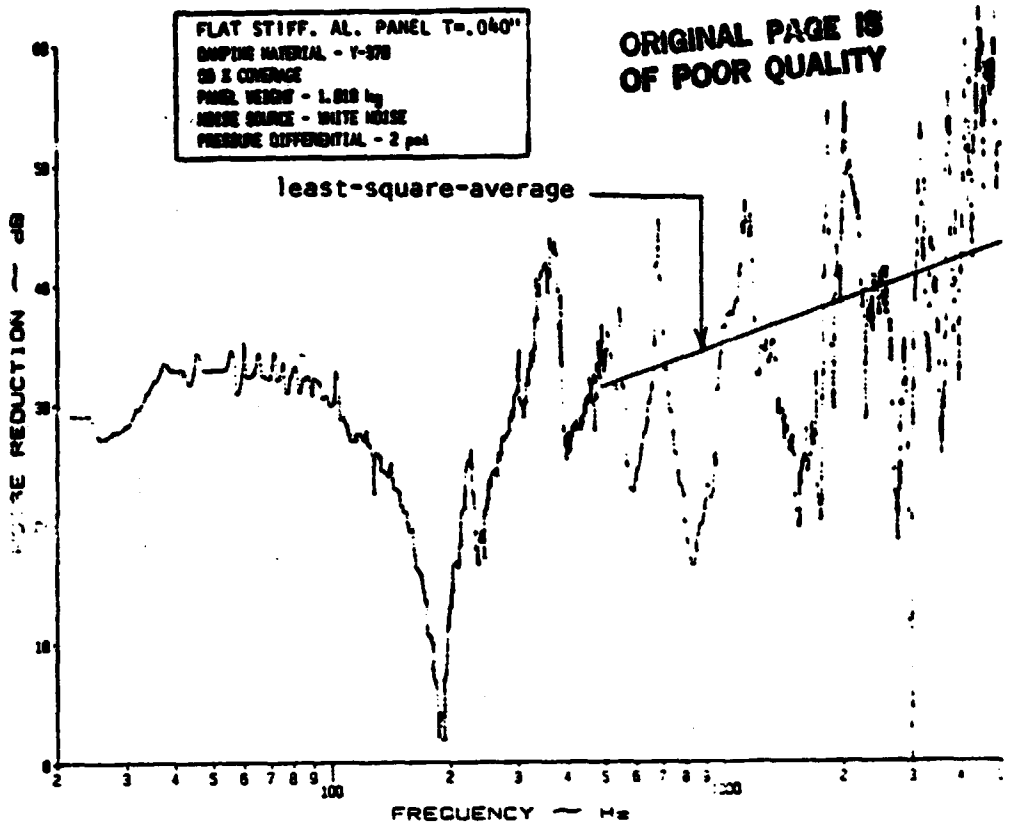

(a) Narrow Band Analysis

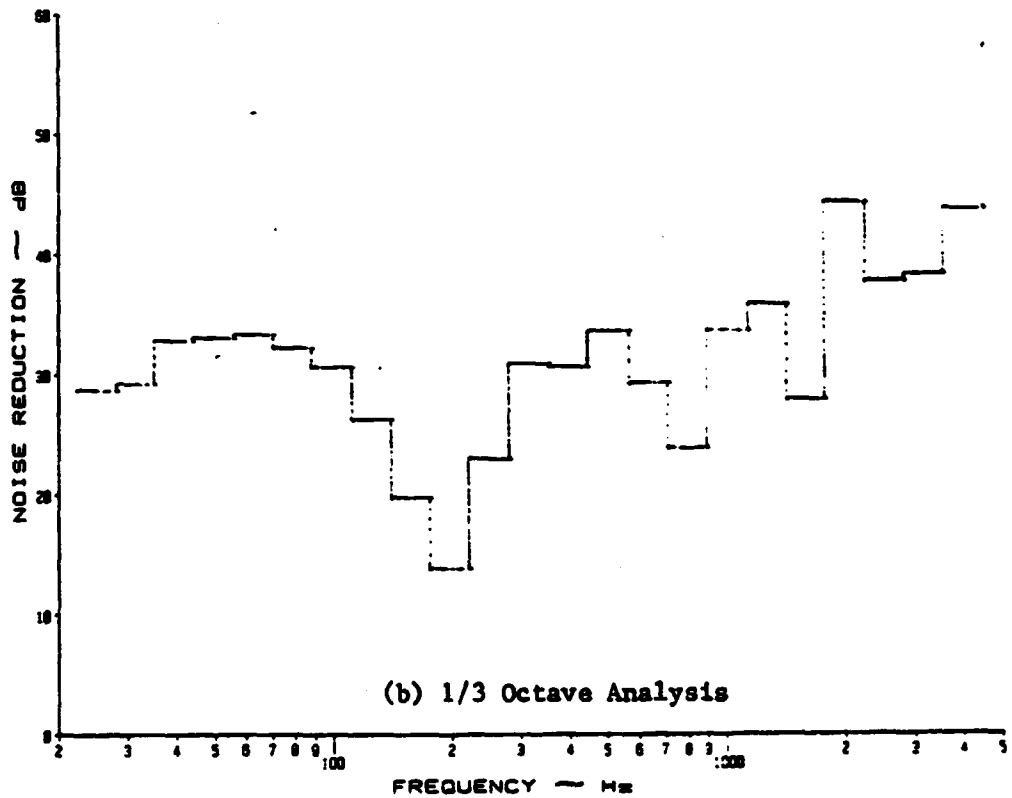

(b) 1/3 Octave Analysis

Figure A.23: Noise Reduction Characteristics of a Flat, Stiffened Panel at 2 psi Pressure Differential with Y-370 Damping Tape under White Noise

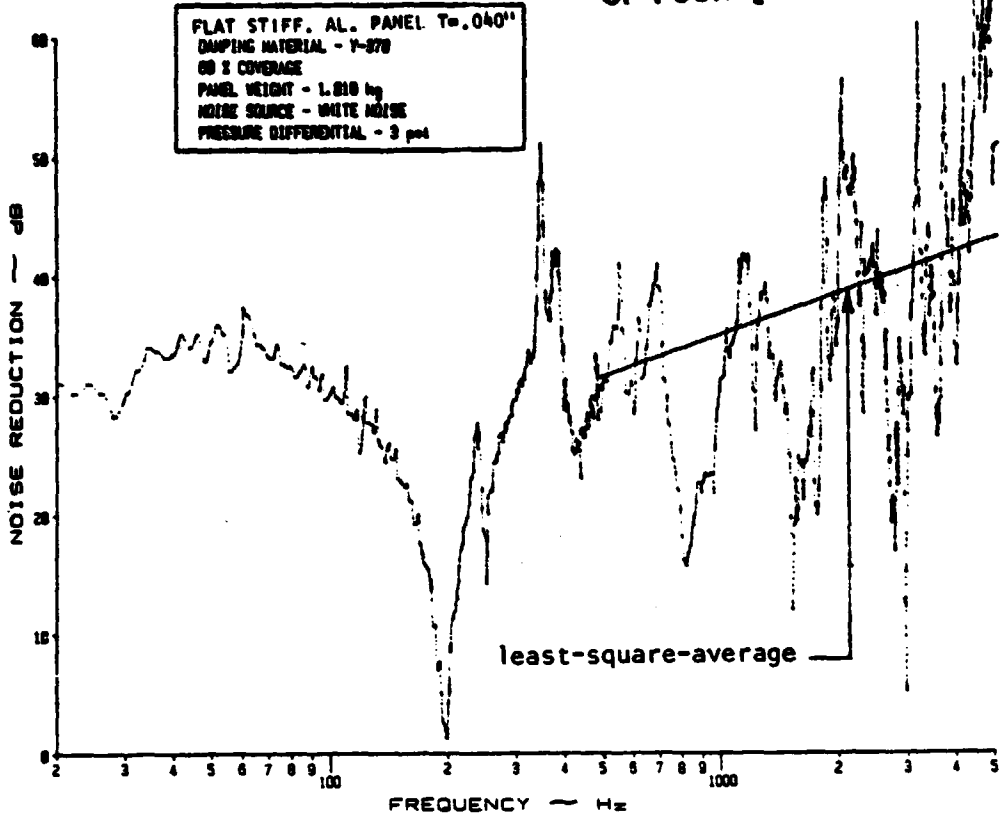

(a) Narrow Band Analysis

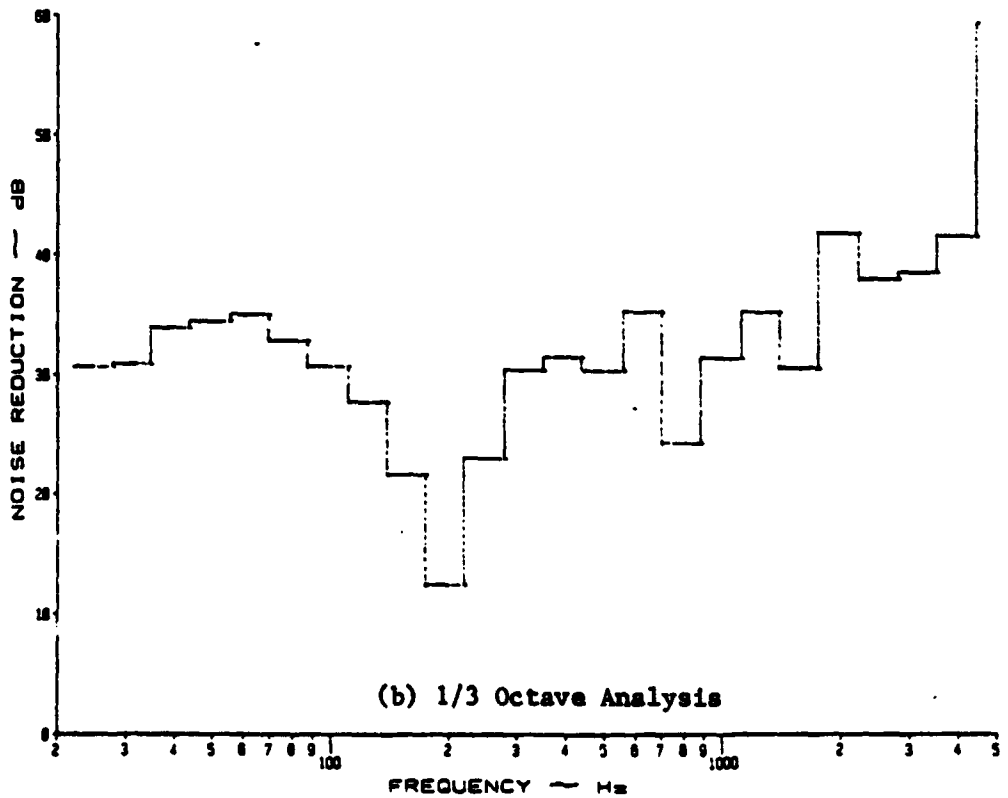

(b) 1/3 Octave Analysis

Figure A.24: Noise Reduction Characteristics of a Flat, Stiffened Panel at 3 psi Pressure Differential with Y-370 Damping Tape under White Noise

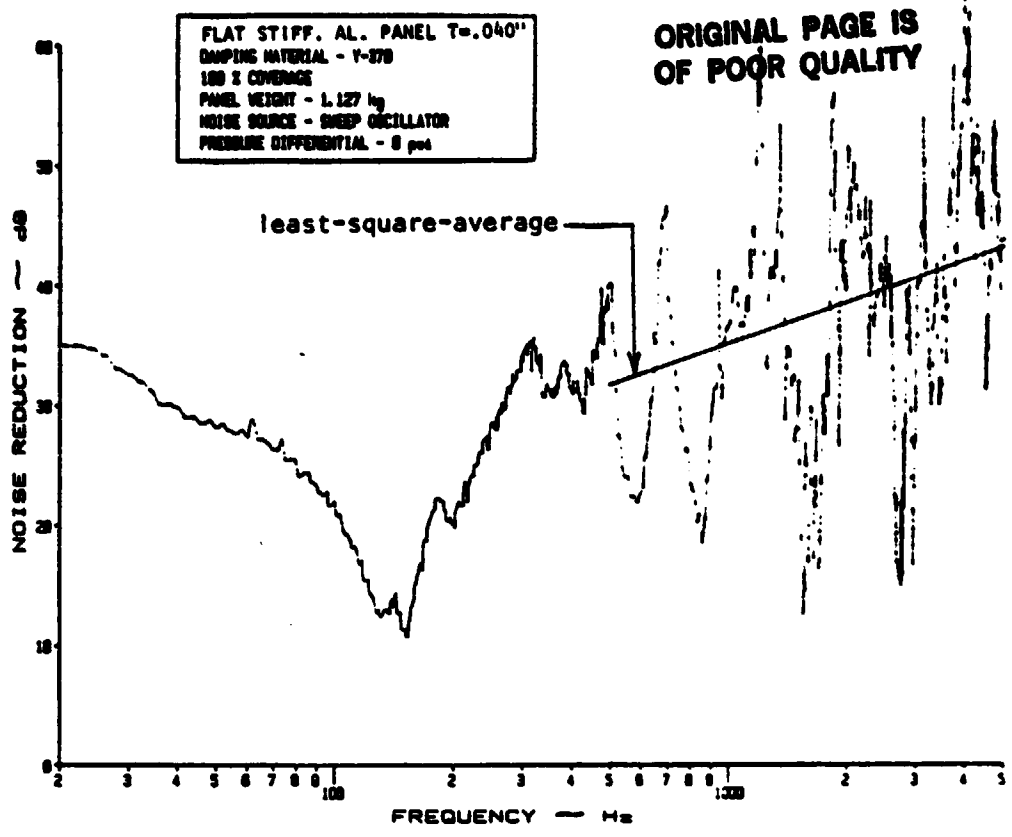

(a) Narrow Band Analysis

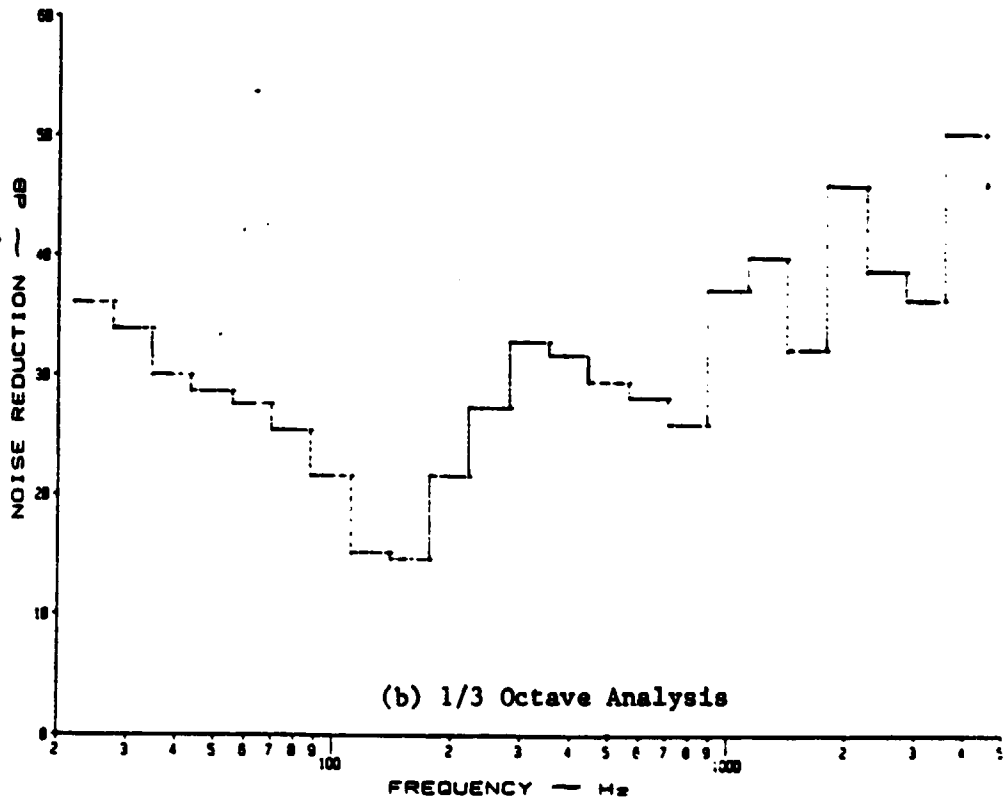
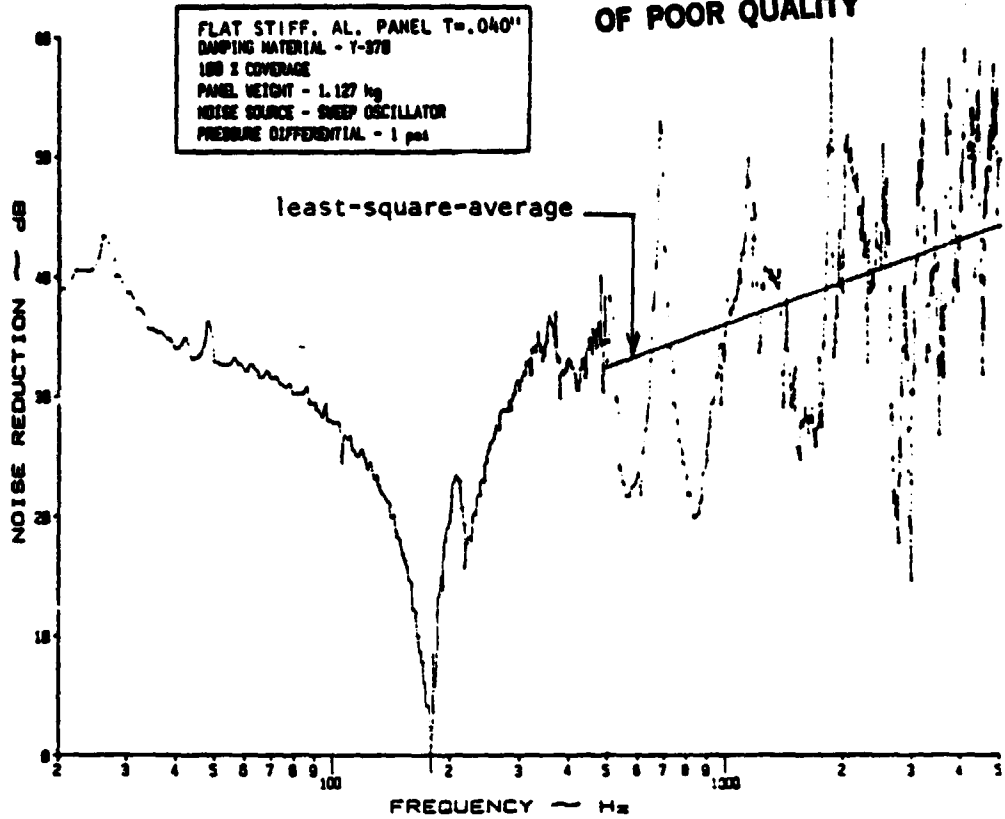
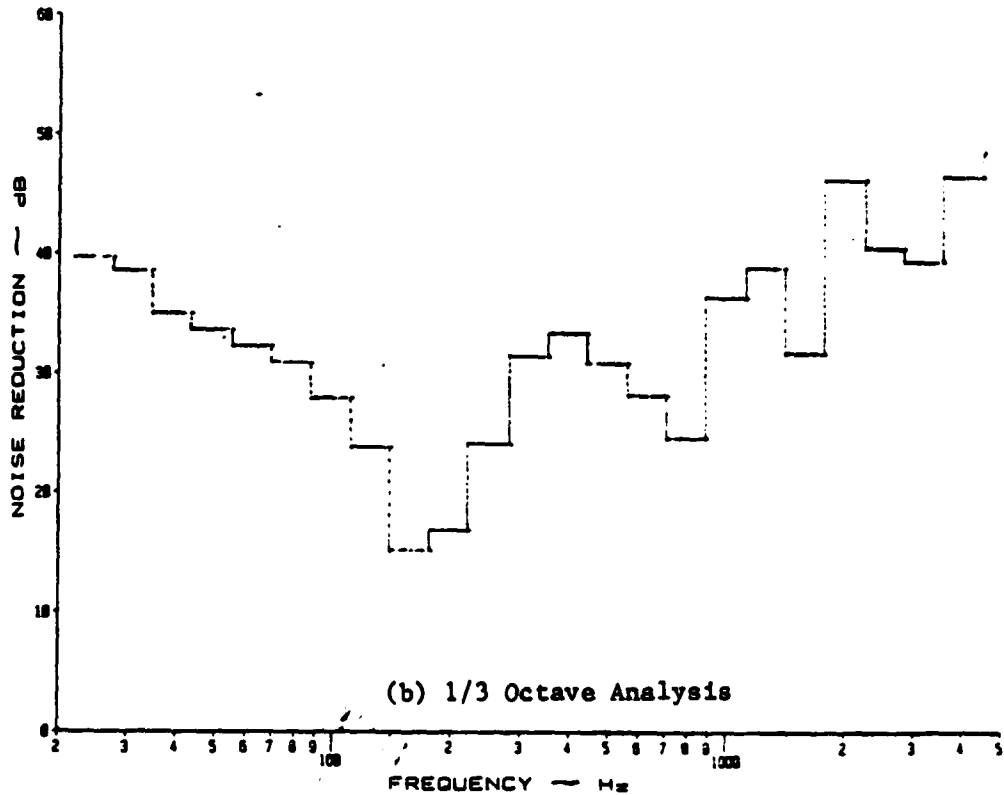

Figure A.25: Noise Reduction Characteristics of a Flat, Stiffened Panel at 0 psi Pressure Differential with Y-370 Damping Tape under a Discrete Noise Source



(a) Narrow Band Analysis



(b) 1/3 Octave Analysis

Figure A.26: Noise Reduction Characteristics of a Flat, Stiffened Panel at 1 psi Pressure Differential with Y-370 Damping Tape under a Discrete Noise Source

ORIGINAL PAGE IS
OF POOR QUALITY

FLAT STIFF. AL. PANEL T=.040"
DAMPING MATERIAL - Y-370
100 % COVERAGE
PANEL WEIGHT - 1.127 kg
NOISE SOURCE - SHEEP OSCILLATOR
PRESSURE DIFFERENTIAL - 2 psi

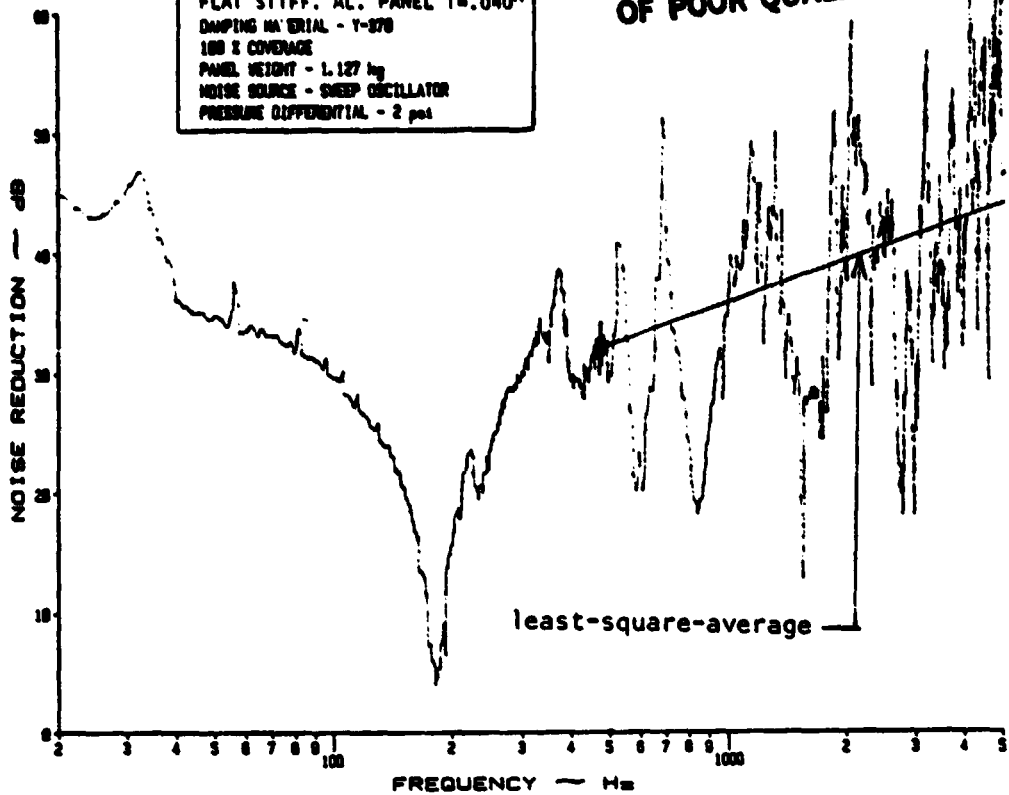

(a) Narrow Band Analysis

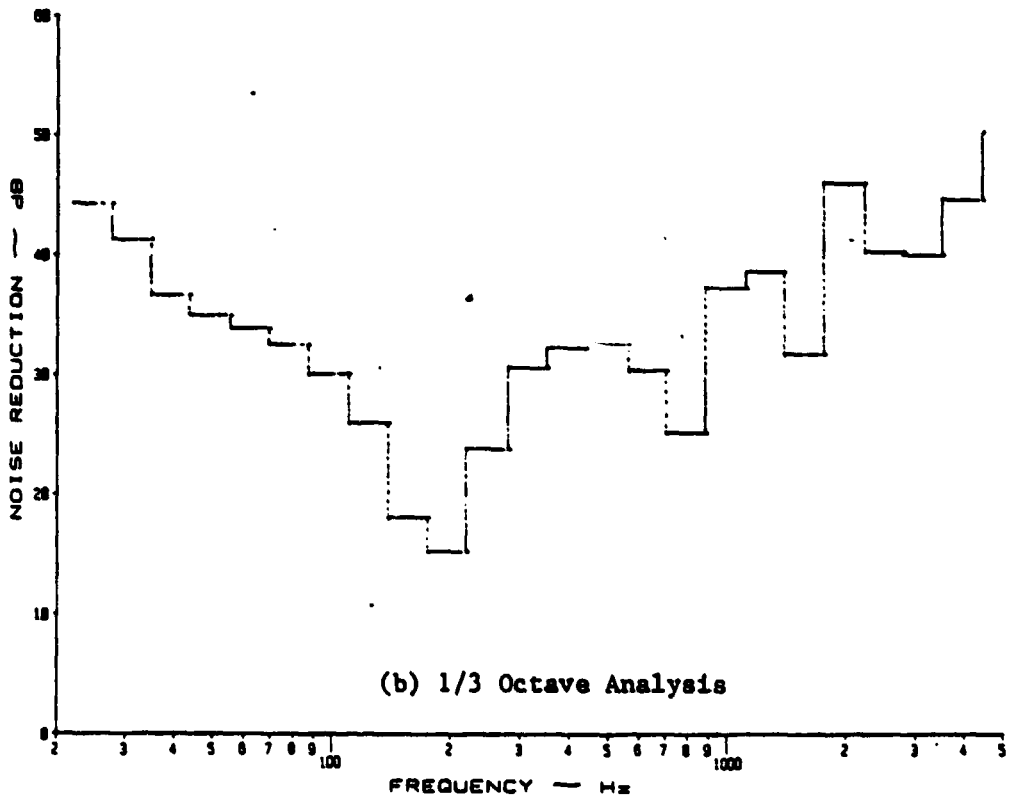
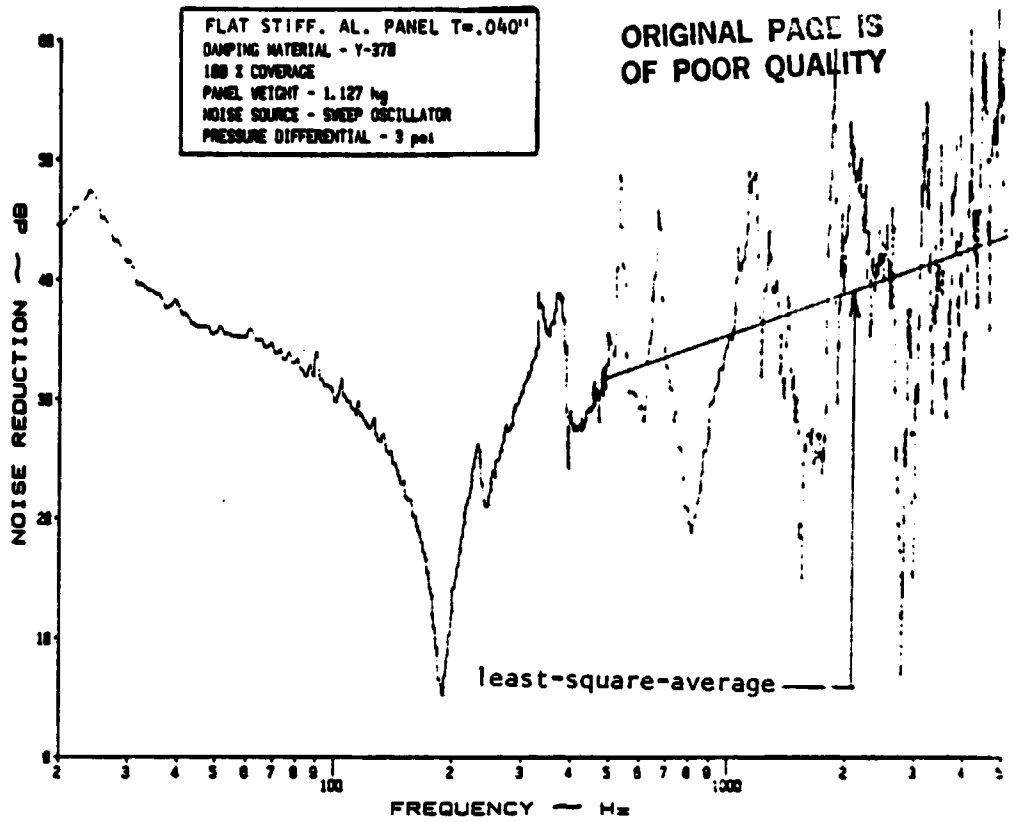
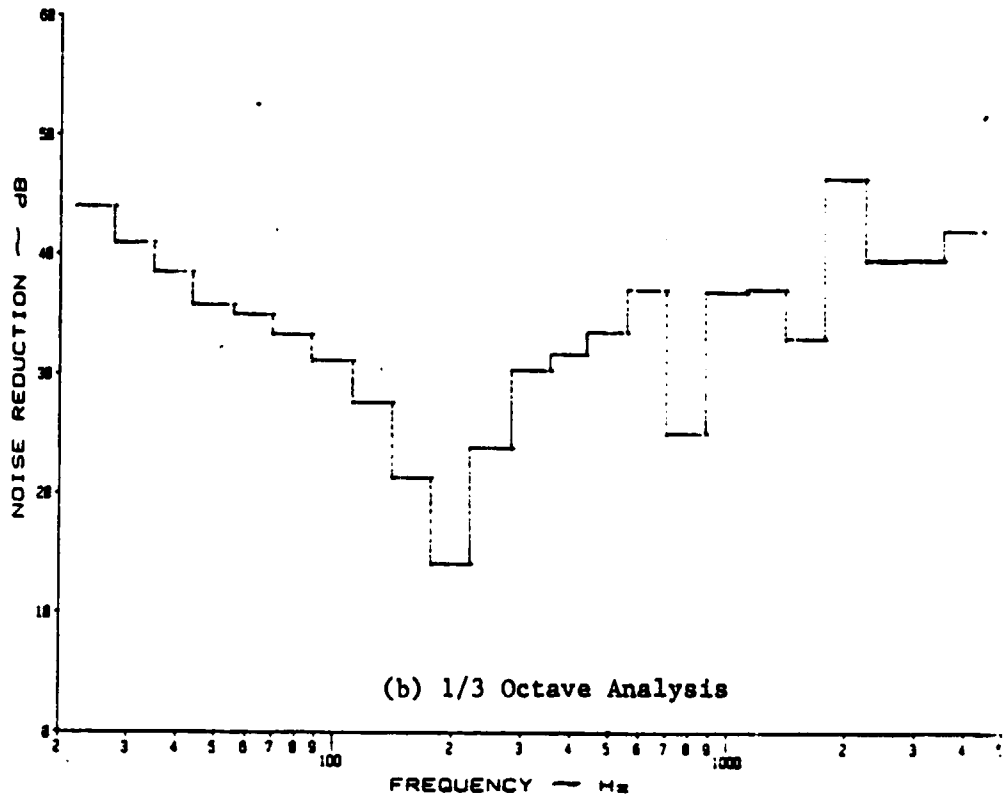

Figure A.27: Noise Reduction Characteristics of a Flat, Stiffened at 2 psi Pressure Differential with Y-370 Damping Tape under a Discrete Noise Source



(a) Narrow Band Analysis



(b) 1/3 Octave Analysis

Figure A.28: Noise Reduction Characteristics of a Flat, Stiffened Panel at 3 psi Pressure Differential with Y-370 Damping Tape under a Discrete Noise Source

ORIGINAL PAGE IS
OF POOR QUALITY

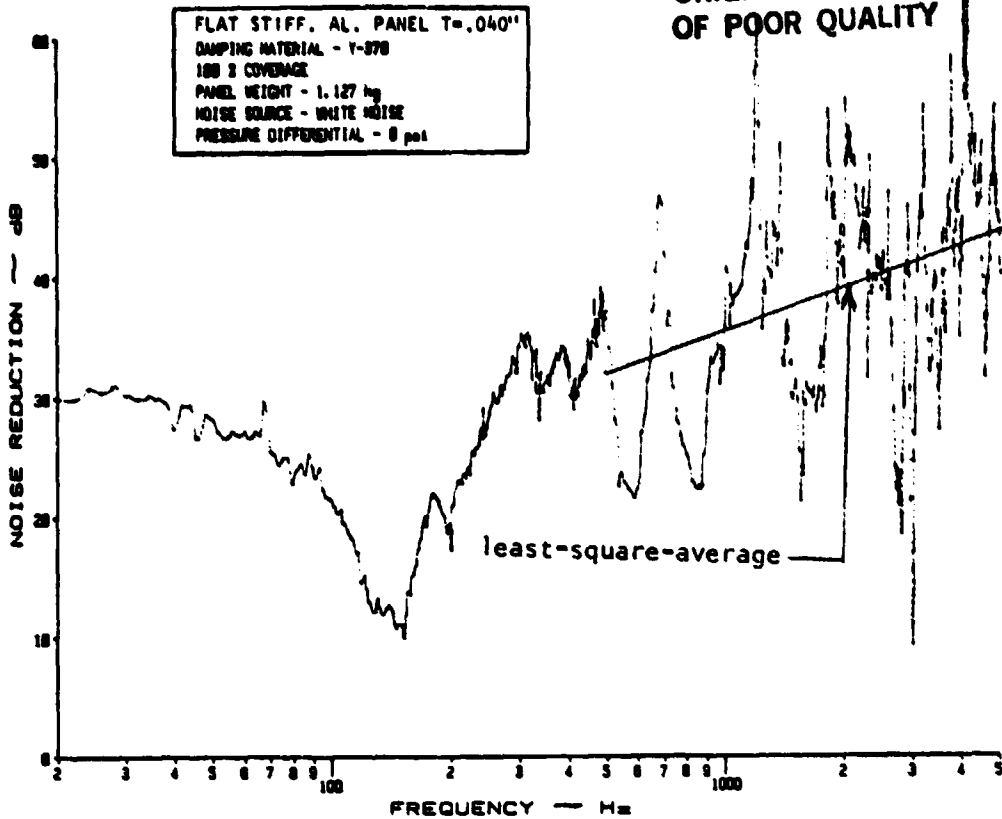

(a) Narrow Band Analysis

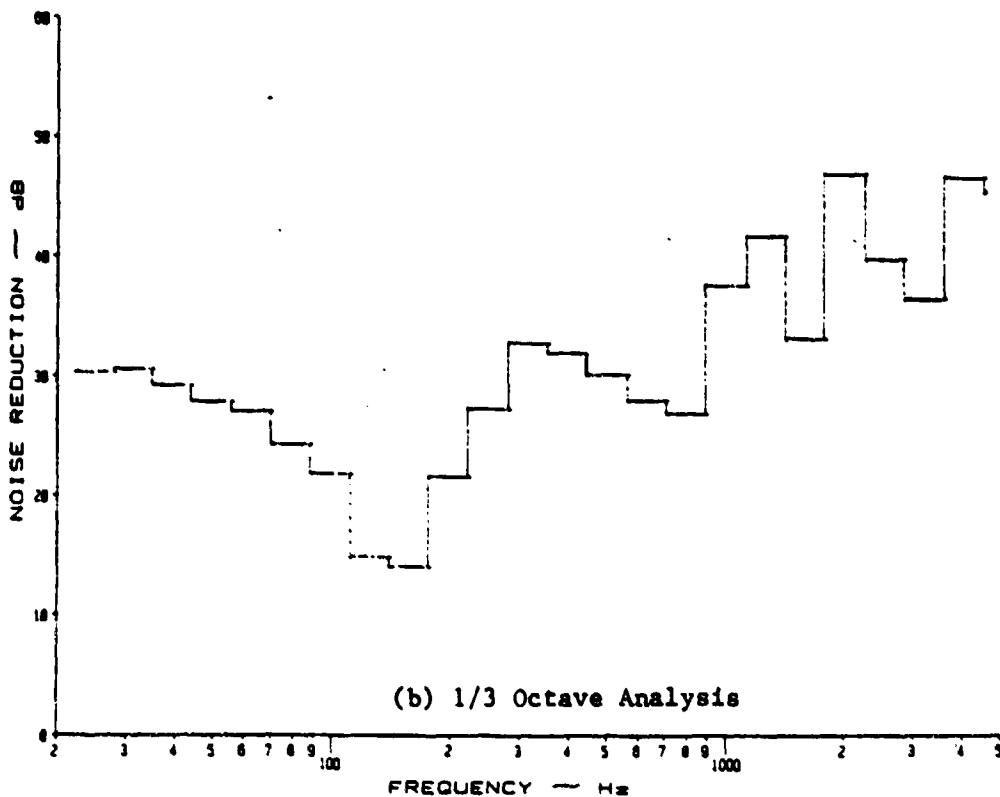

(b) 1/3 Octave Analysis

Figure A.29: Noise Reduction Characteristics of a Flat, Stiffened Panel at 0 psi Pressure Differential with Y-370 Damping Material under White Noise

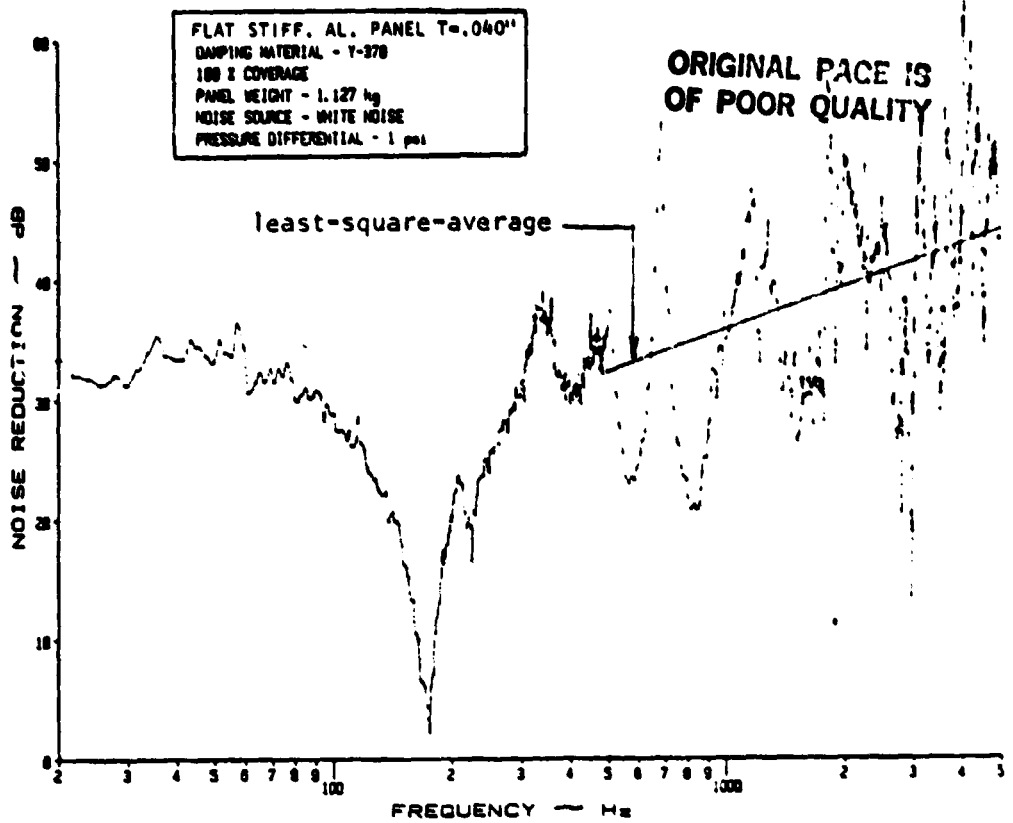

(a) Narrow Band Analysis

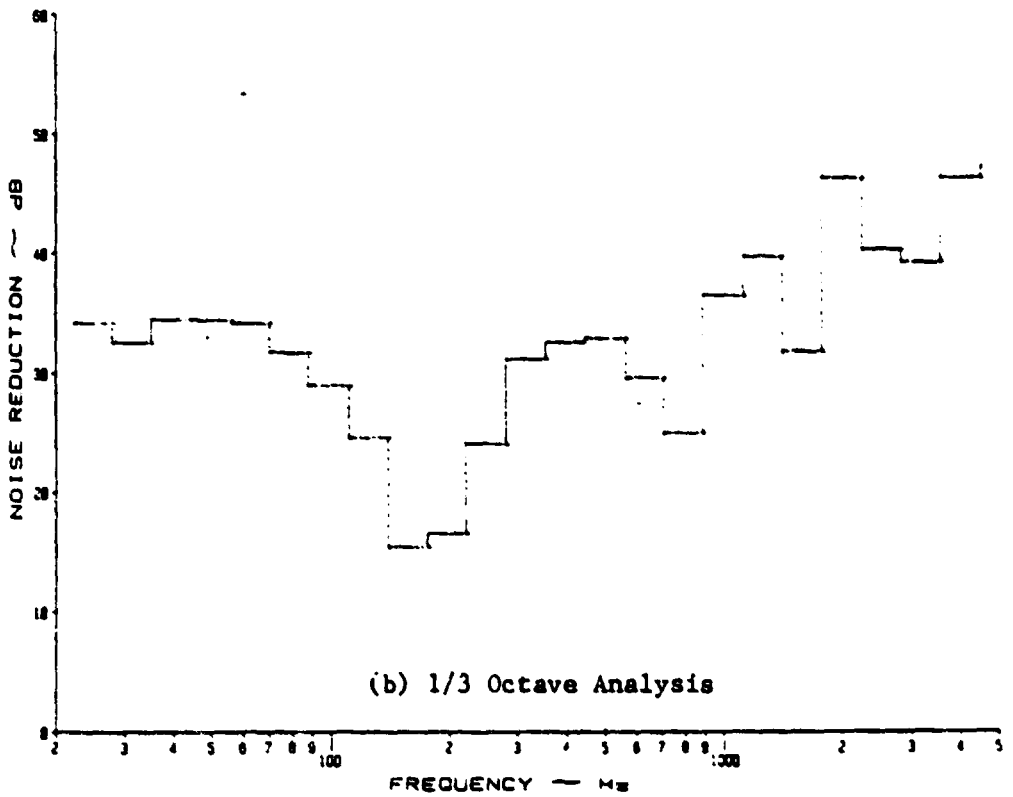
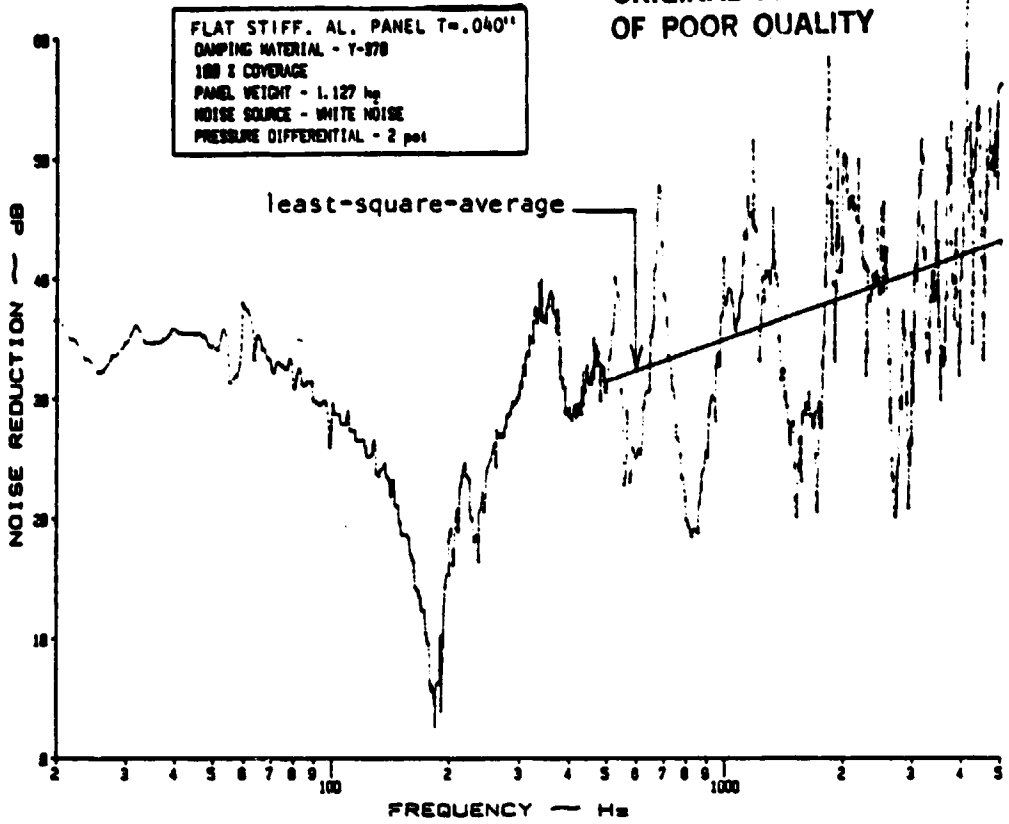
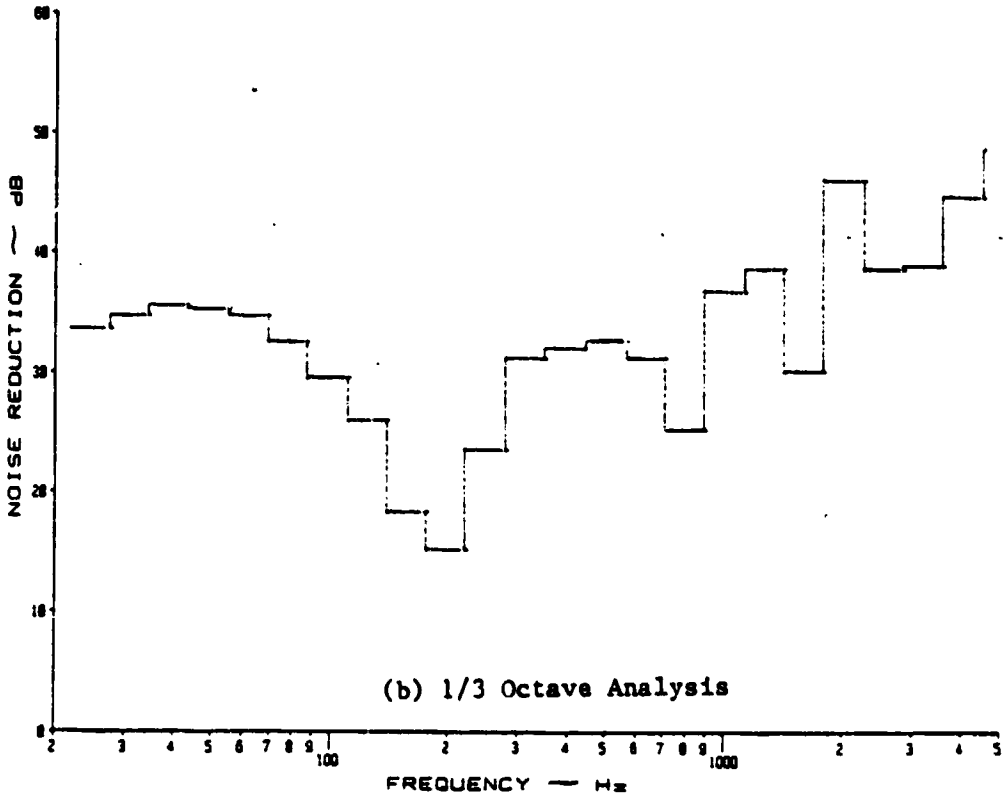

Figure A.30: Noise Reduction Characteristics of a Flat, Stiffened Panel at 1 psi Pressure Differential with Y-370 Damping Tape under White Noise



(a) Narrow Band Analysis



(b) 1/3 Octave Analysis

Figure A.31: Noise Reduction Characteristics of a Flat, Stiffened Panel at 2 psi Pressure Differential with Y-370 Damping Tape under White Noise

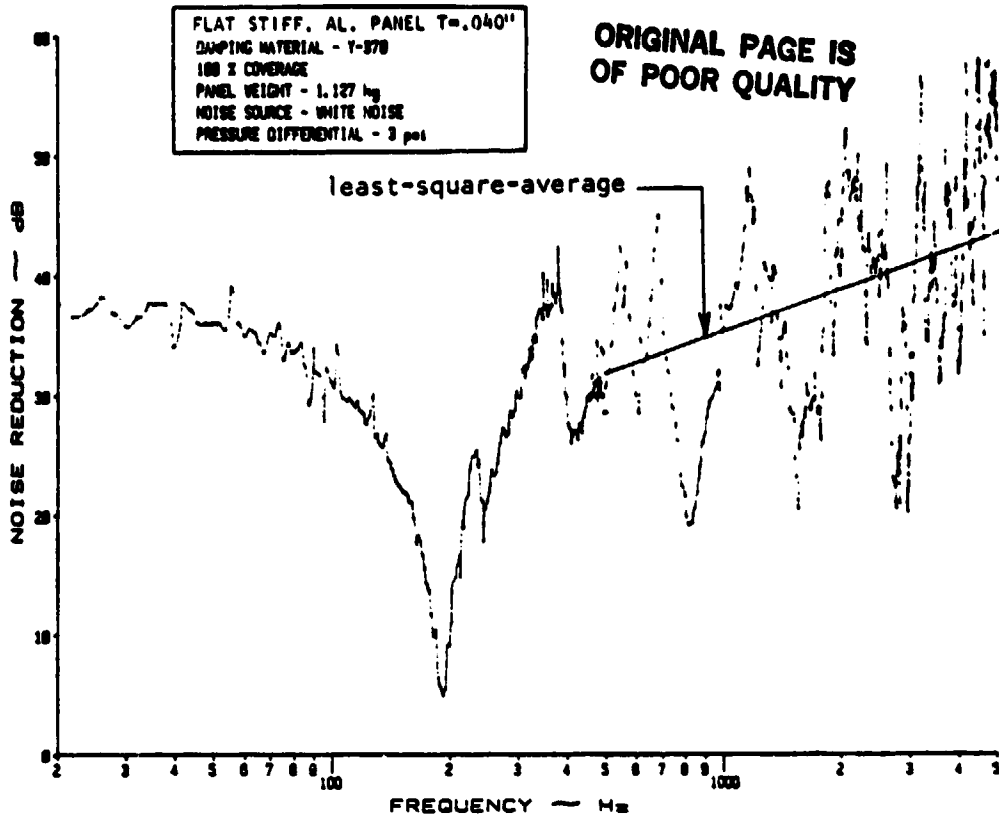

(a) Narrow Band Analysis

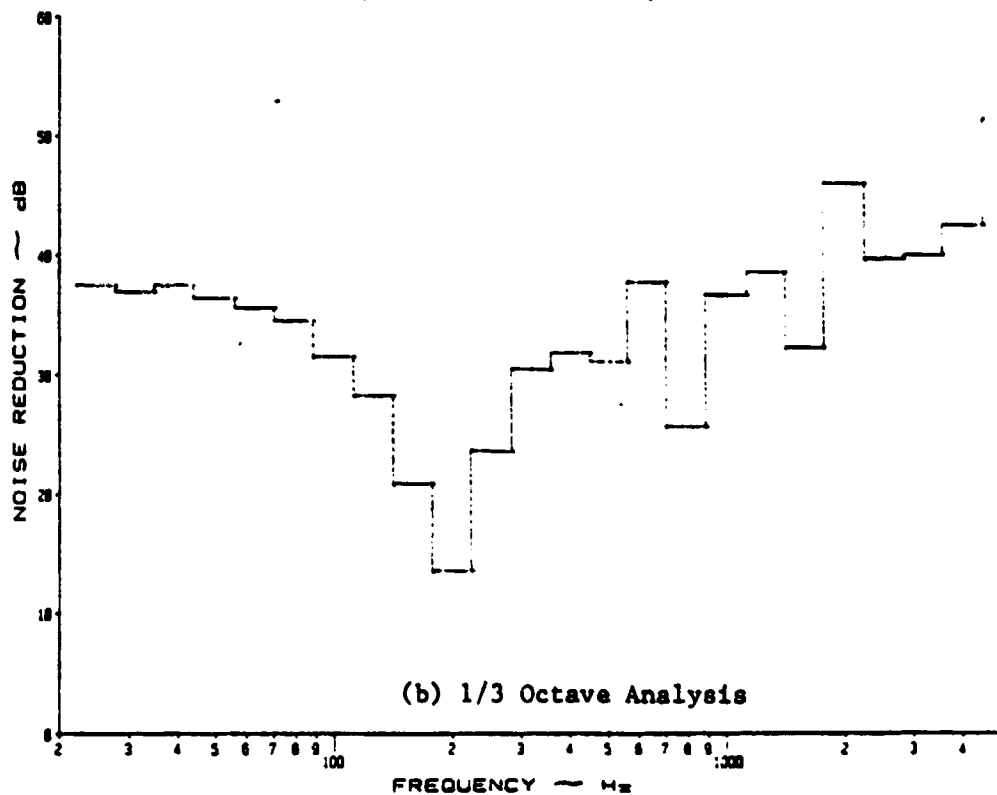

(b) 1/3 Octave Analysis

Figure A.32: Noise Reduction Characteristics of a Flat, Stiffened Panel at 3 psi Pressure Differential with Y-370 Damping Tape under White Noise

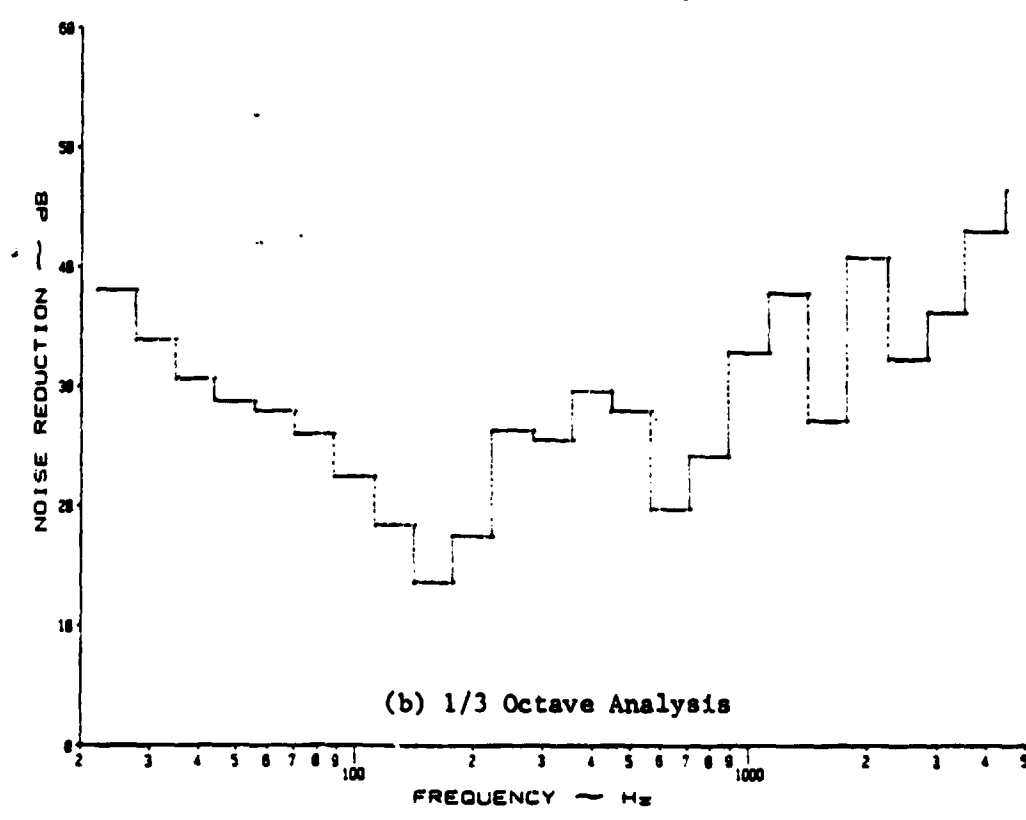
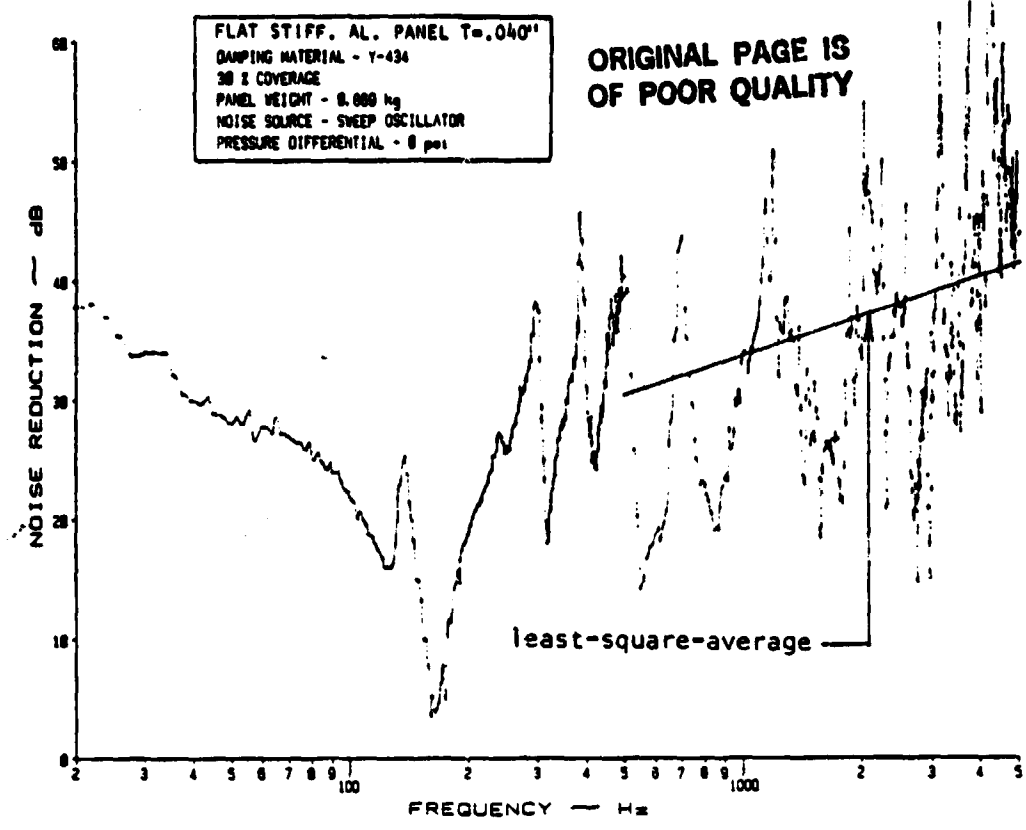
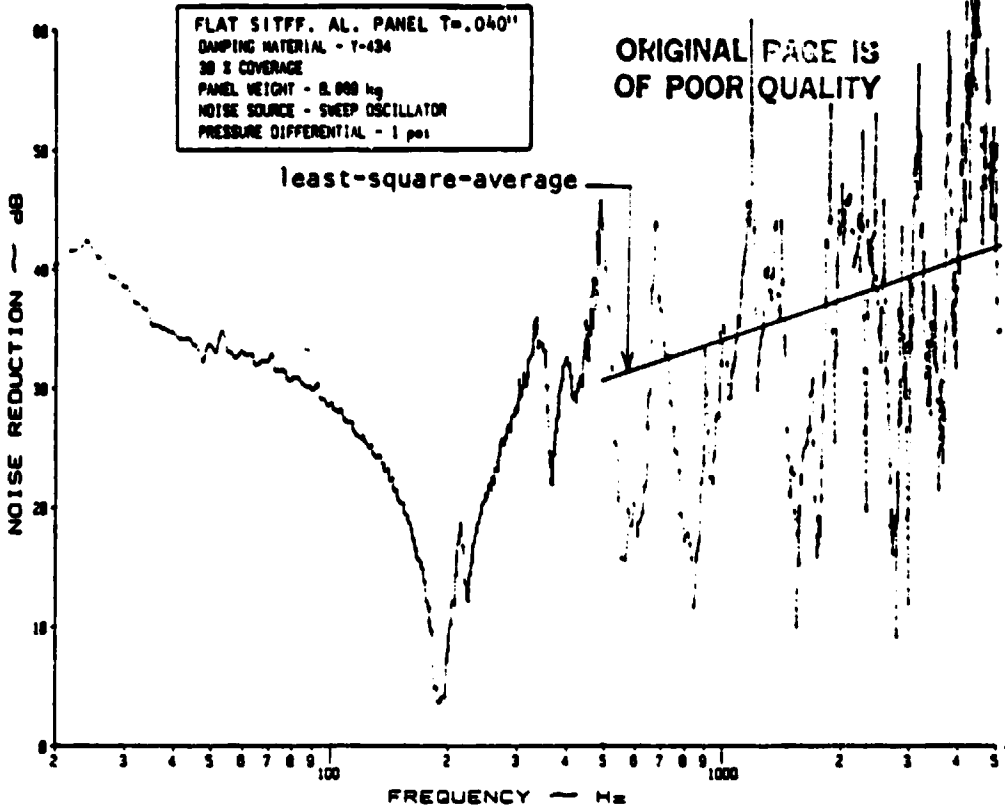
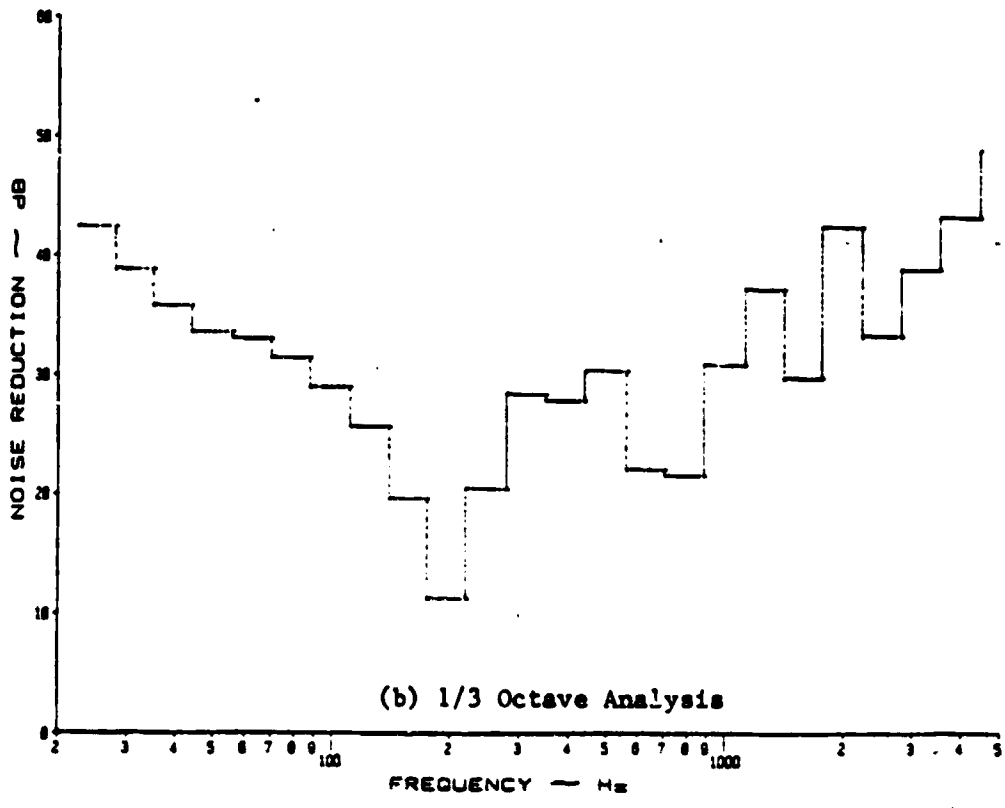

Figure A.33: Noise Reduction Characteristics of a Flat, Stiffened Panel at 0 psi Pressure Differential with Y-434 Damping Tape under a Discrete Noise Source



(a) Narrow Band Analysis



(b) 1/3 Octave Analysis

Figure A.34: Noise Reduction Characteristics of a Flat, Stiffened Panel at 1 psi Pressure Differential with Y-434 Damping Tape under a Discrete Noise Source

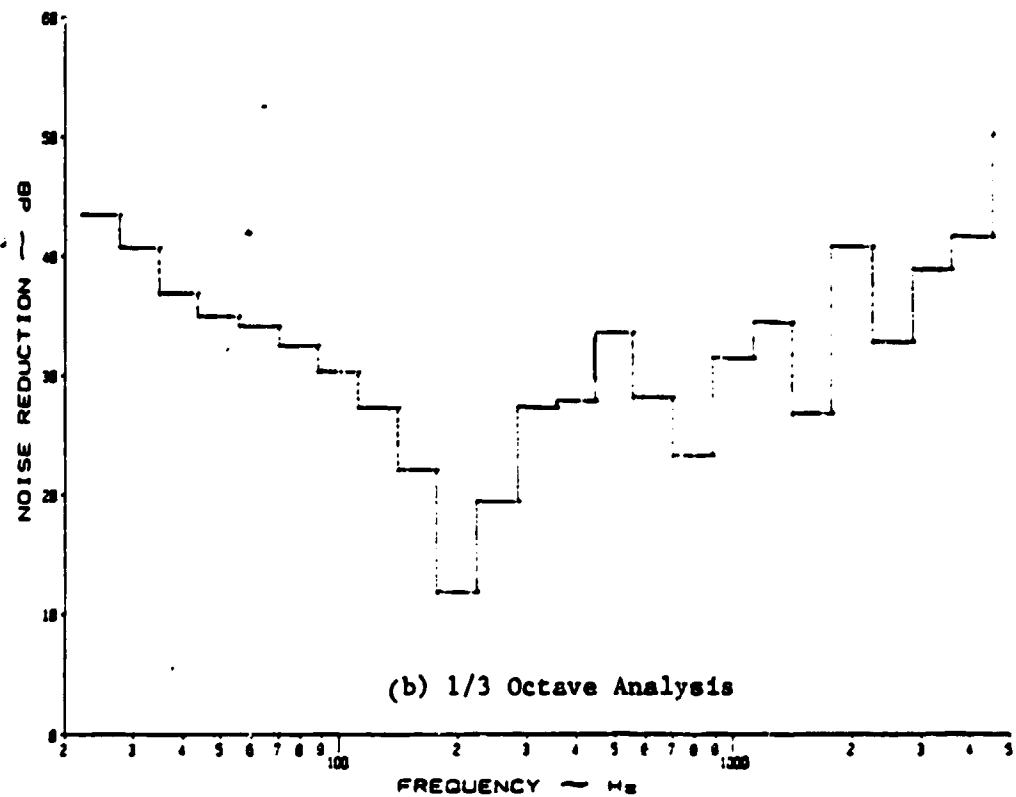
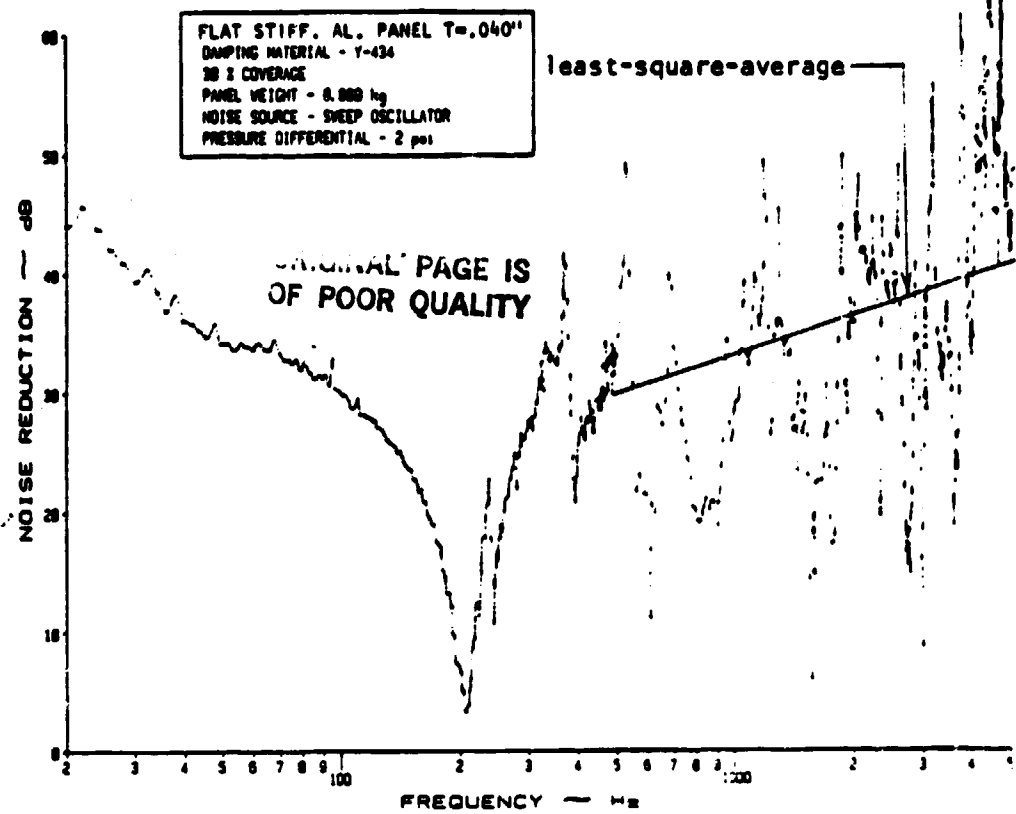
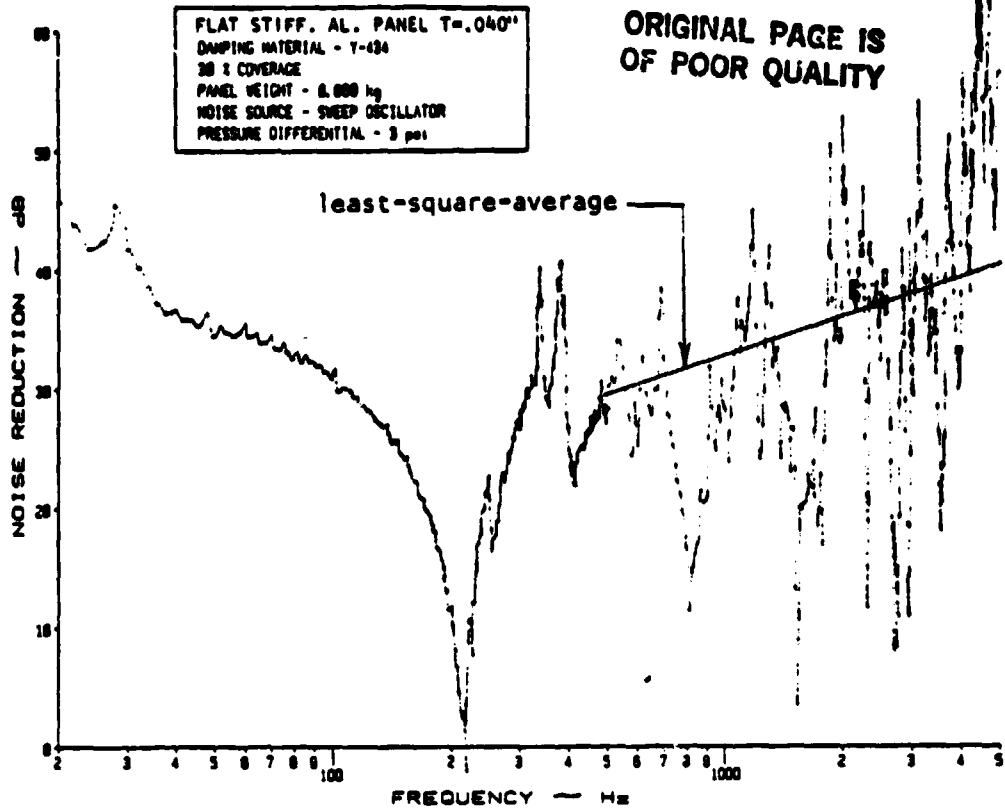
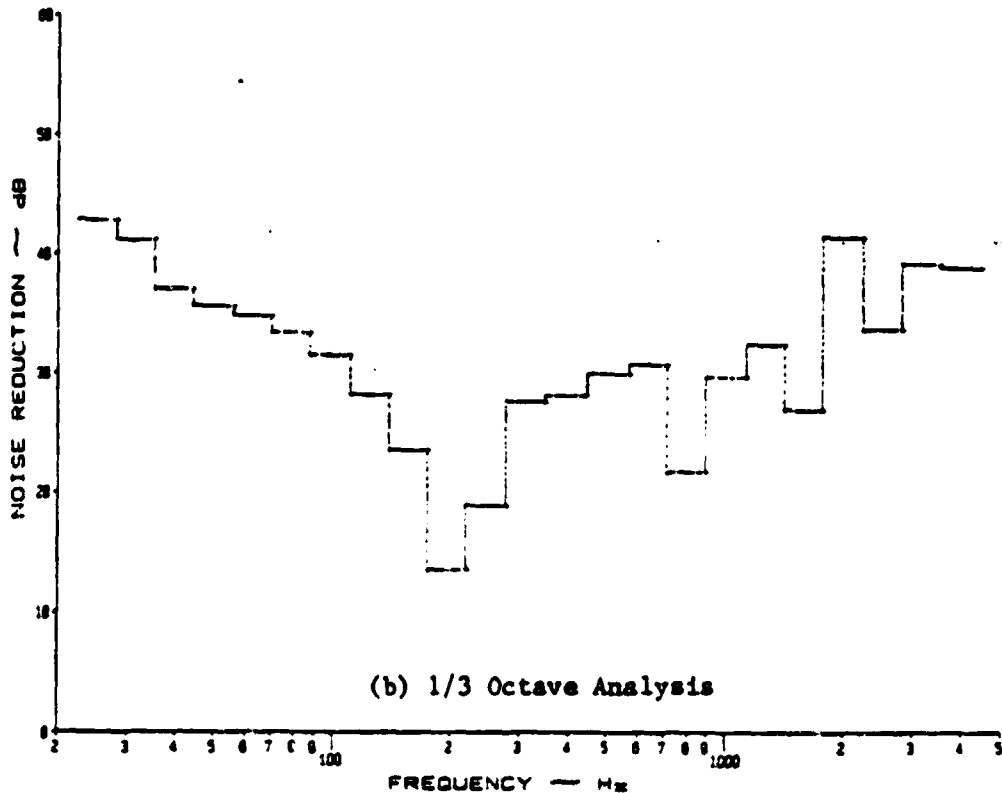

Figure A.35: Noise Reduction Characteristics of a Flat, Stiffened Panel at 2 psi Pressure Differential with Y-434 Damping Tape under a Discrete Noised Source



(a) Narrow Band Analysis



(b) 1/3 Octave Analysis

Figure A.36: Noise Reduction Characteristics of a Flat, Stiffened Panel at 3 psi Pressure Differential with Y-434 Damping Tape under a Discrete Noise Source

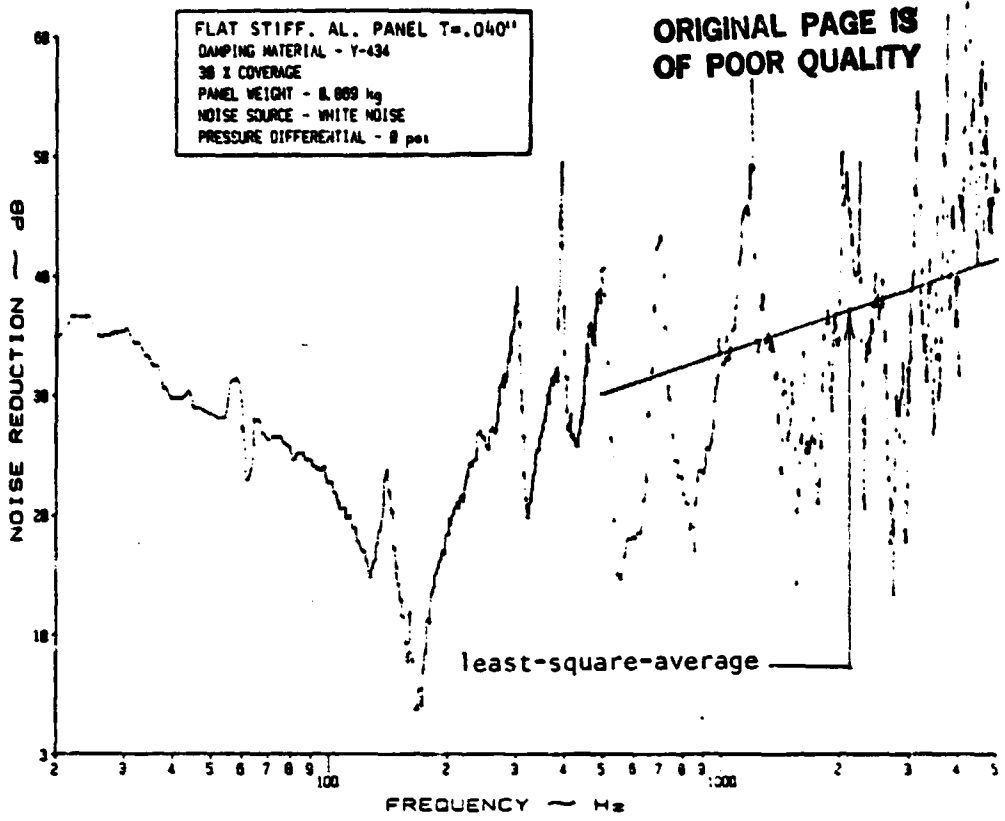

(a) Narrow Band Analysis

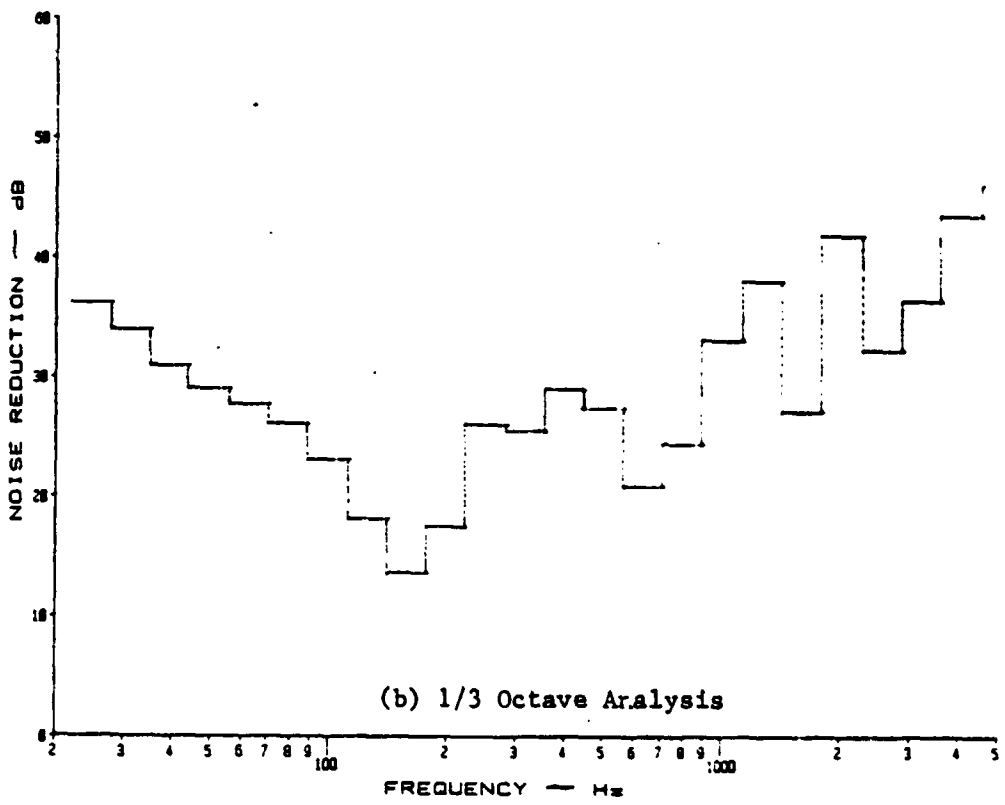
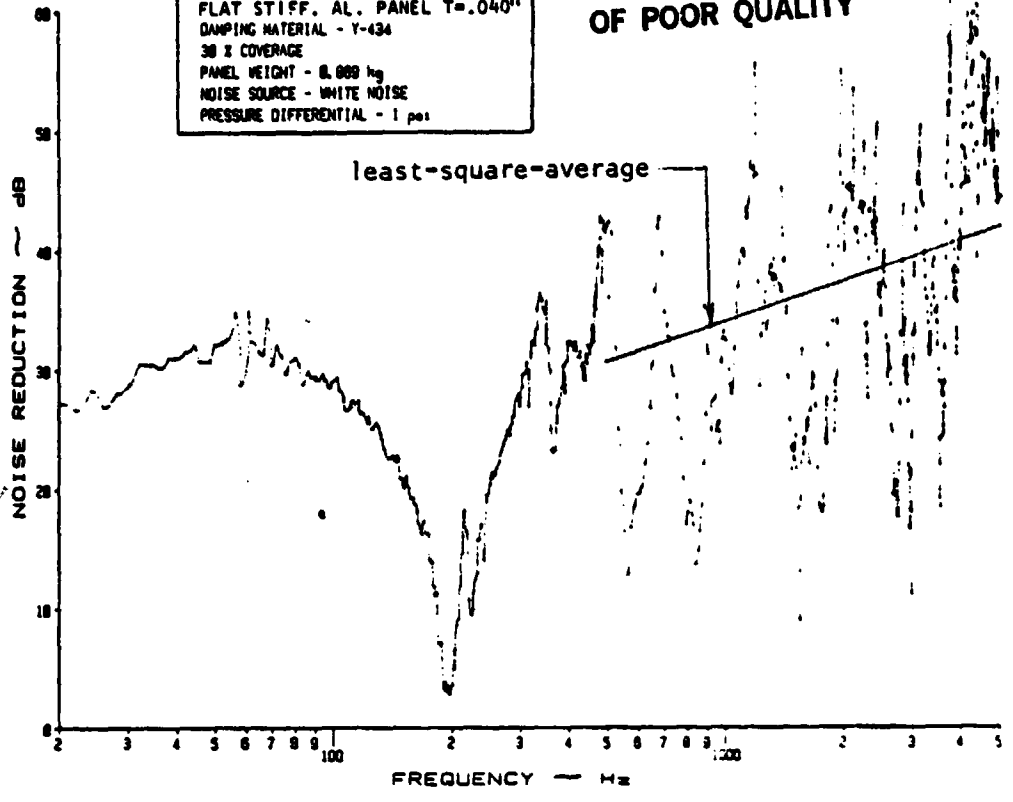

Figure A.37: Noise Reduction Characteristics of a Flat, Stiffened Panel at 0 psi Pressure Differential with Y-434 Damping Tape under White Noise

ORIGINAL PAGE IS
OF POOR QUALITY

FLAT STIFF. AL. PANEL T=.040"
DAMPING MATERIAL - Y-434
30 X COVERAGE
PANEL WEIGHT - 8.000 kg
NOISE SOURCE - WHITE NOISE
PRESSURE DIFFERENTIAL - 1 psi



(a) Narrow Band Analysis

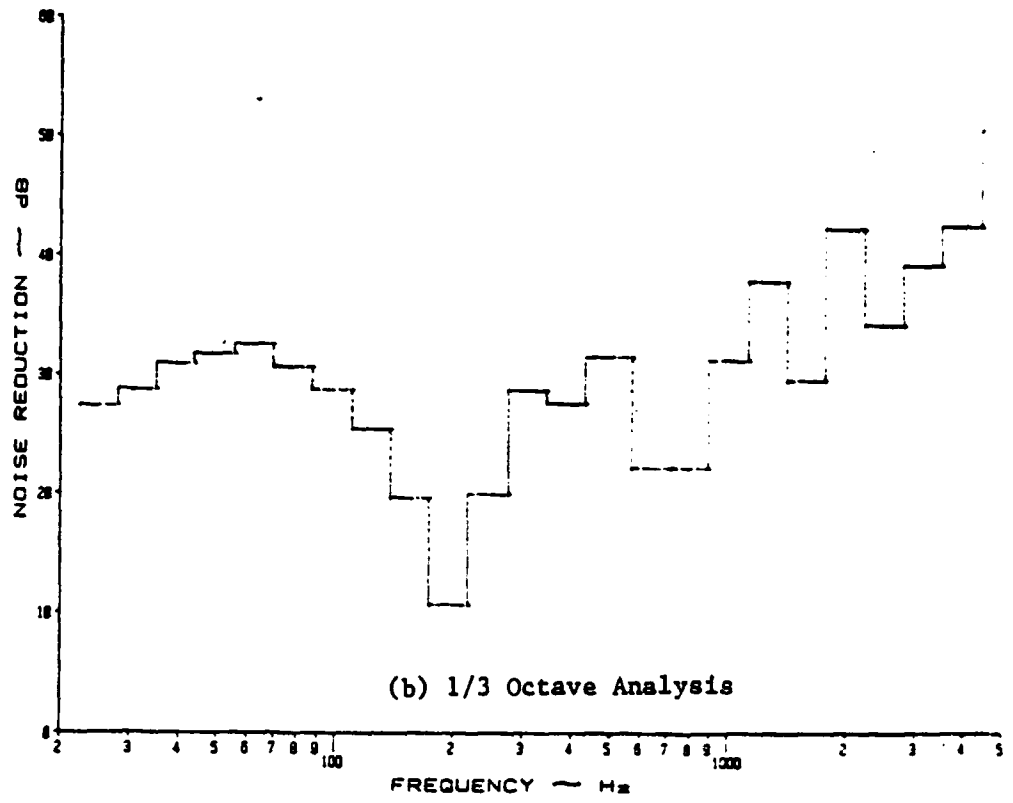

(b) 1/3 Octave Analysis

Figure A.38: Noise Reduction Characteristics of a Flat, Stiffened Panel at 1 psi Pressure Differential with Y-434 Damping Tape under White Noise

ORIGINAL PAGE IS
OF POOR QUALITY

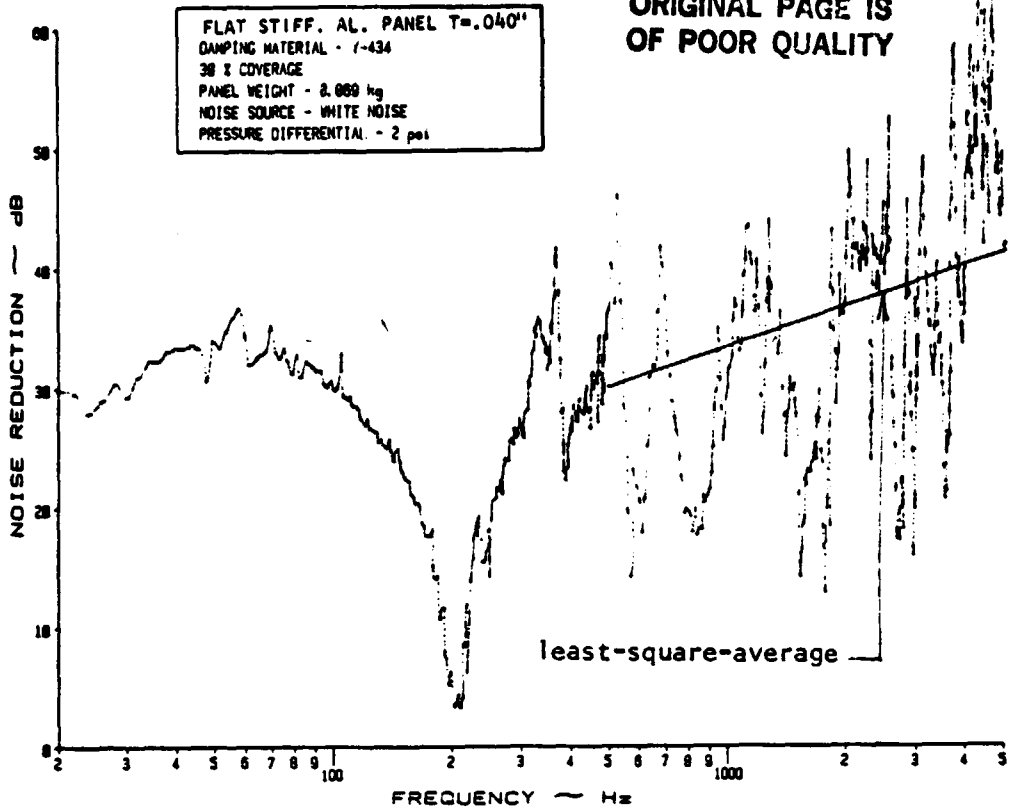

(a) Narrow Band Analysis

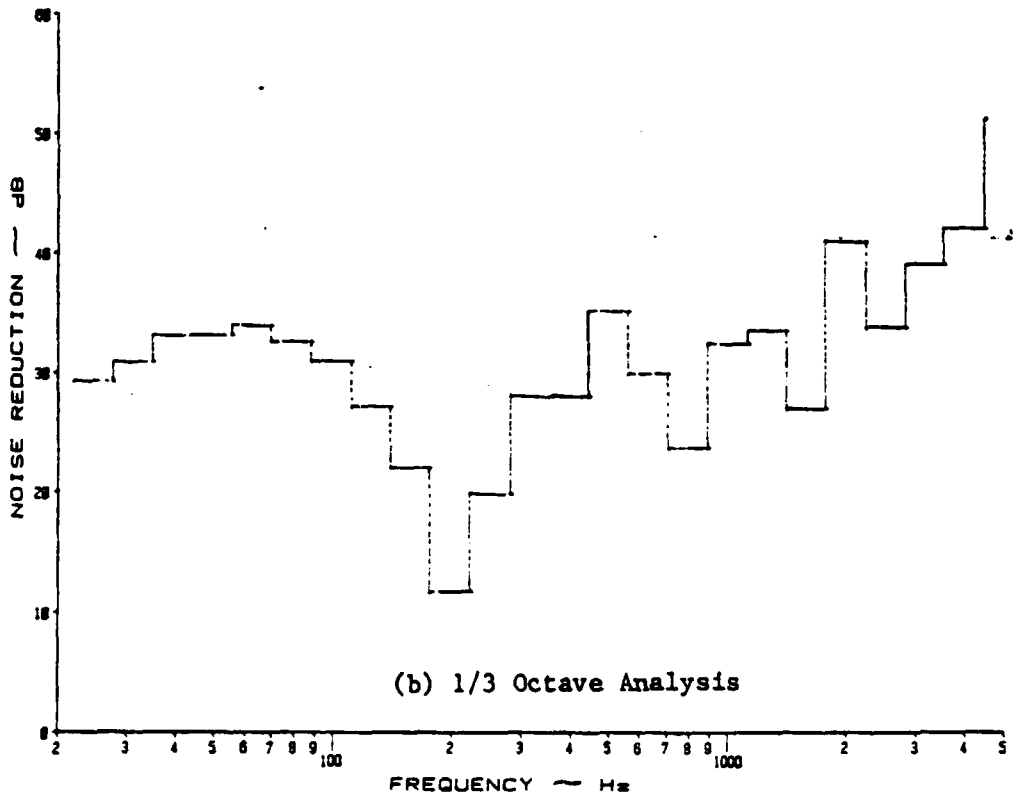

Figure A.39: Noise Reduction Characteristics of a Flat, Stiffened Panel at 2 psi Pressure Differential with Y-434 Damping Tape under White Noise

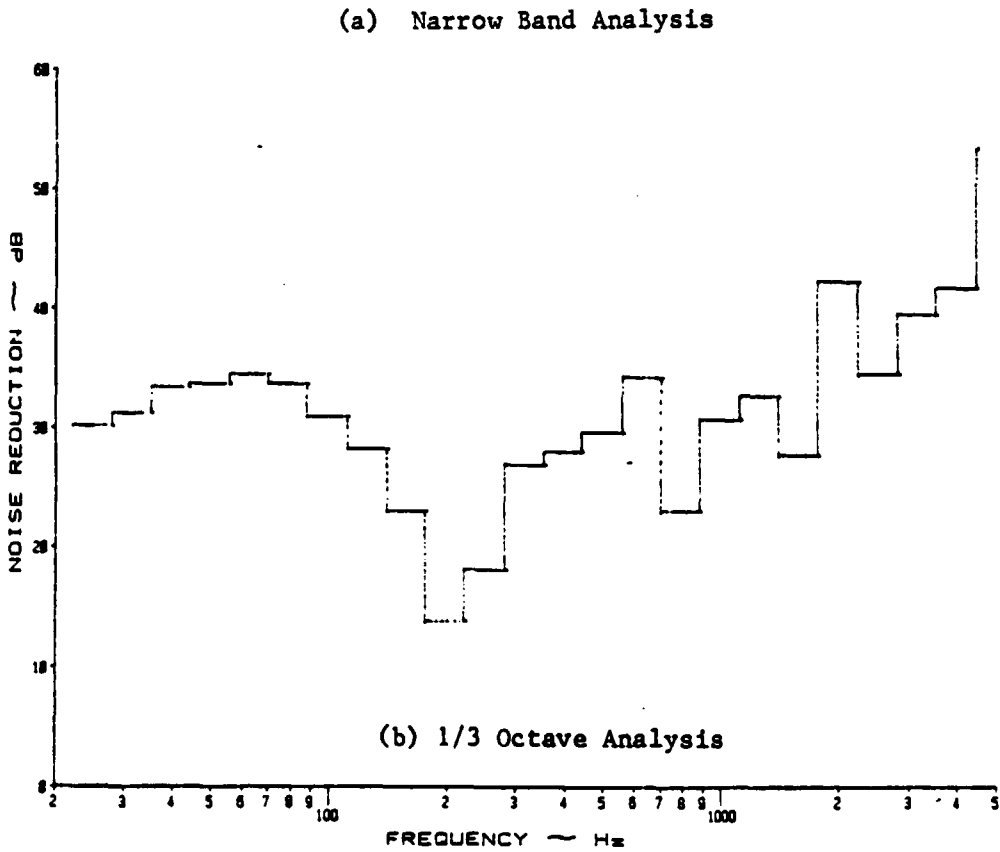
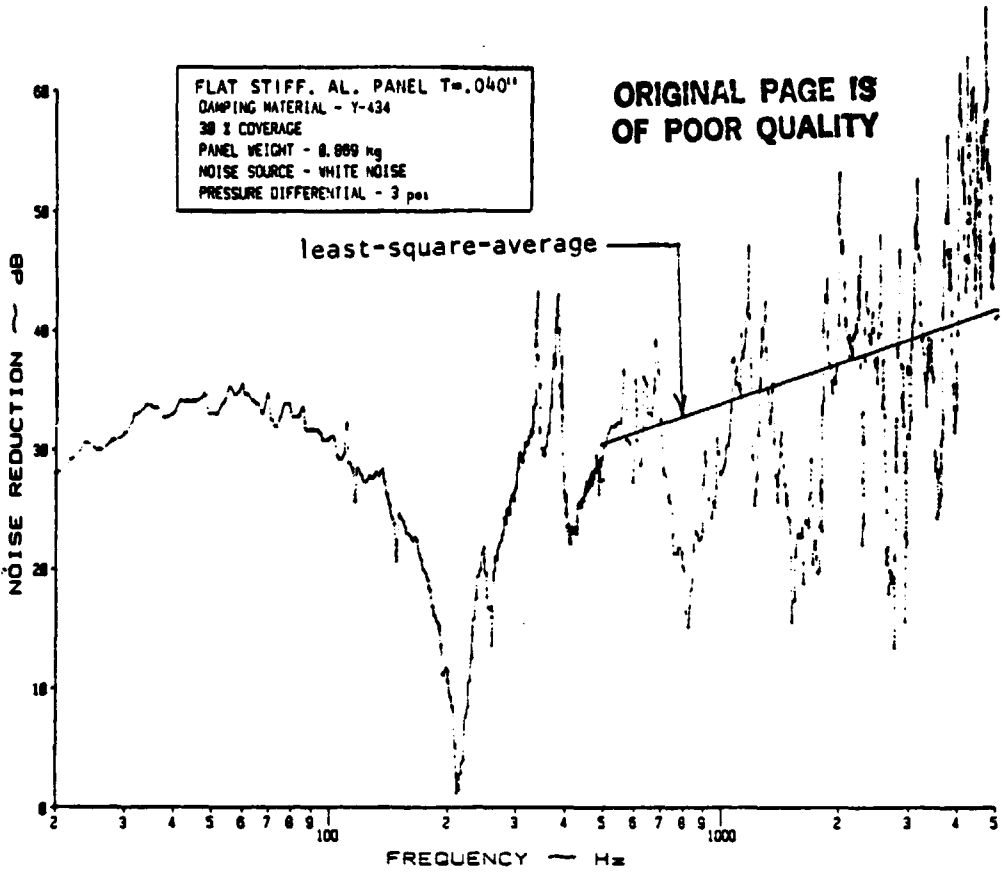
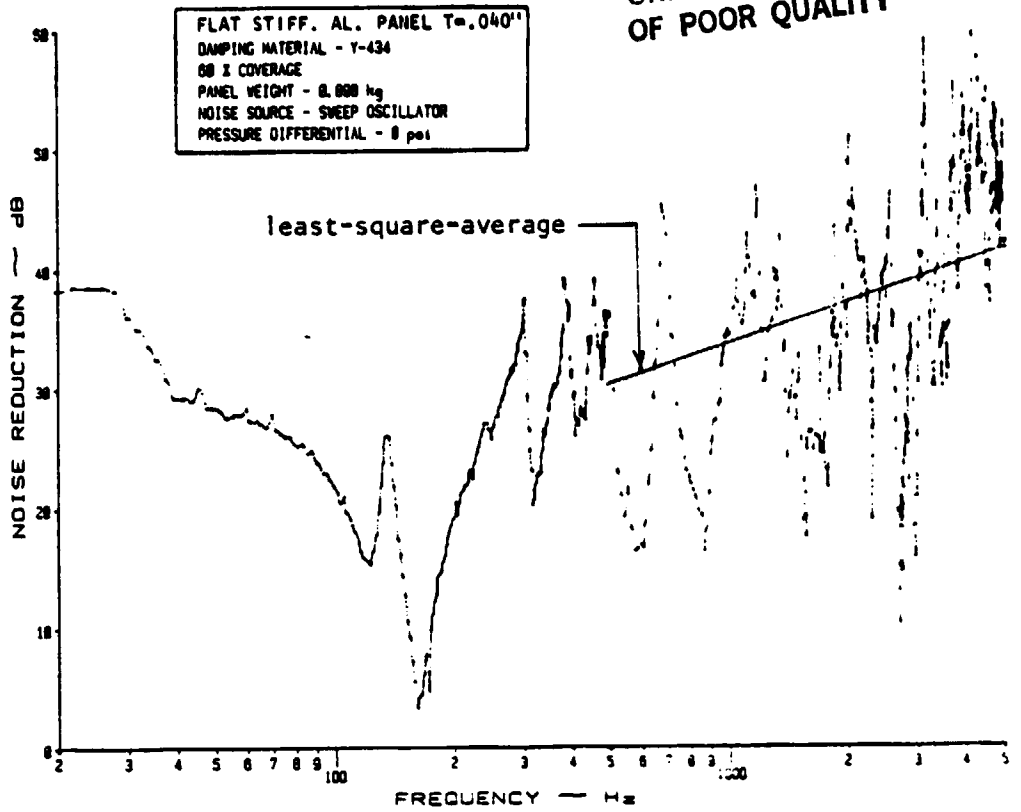
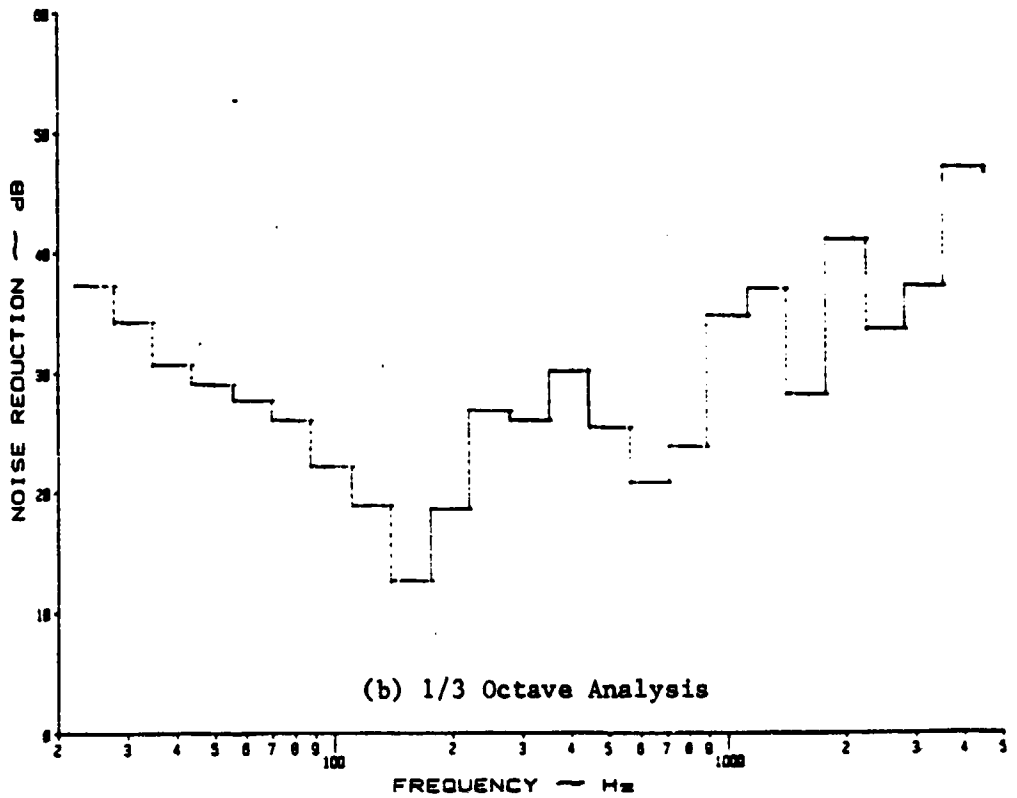

Figure A.40: Noise Reduction Characteristics of a Flat, Stiffened Panel at 3 psi Pressure Differential with Y-434 Damping Tape under White Noise



(a) Narrow Band Analysis



(b) 1/3 Octave Analysis

Figure A.41: Noise Reduction Characteristics of a Flat, Stiffened Panel at 0 psi Pressure Differential with Y-434 Damping Tape under a Discrete Noise Source

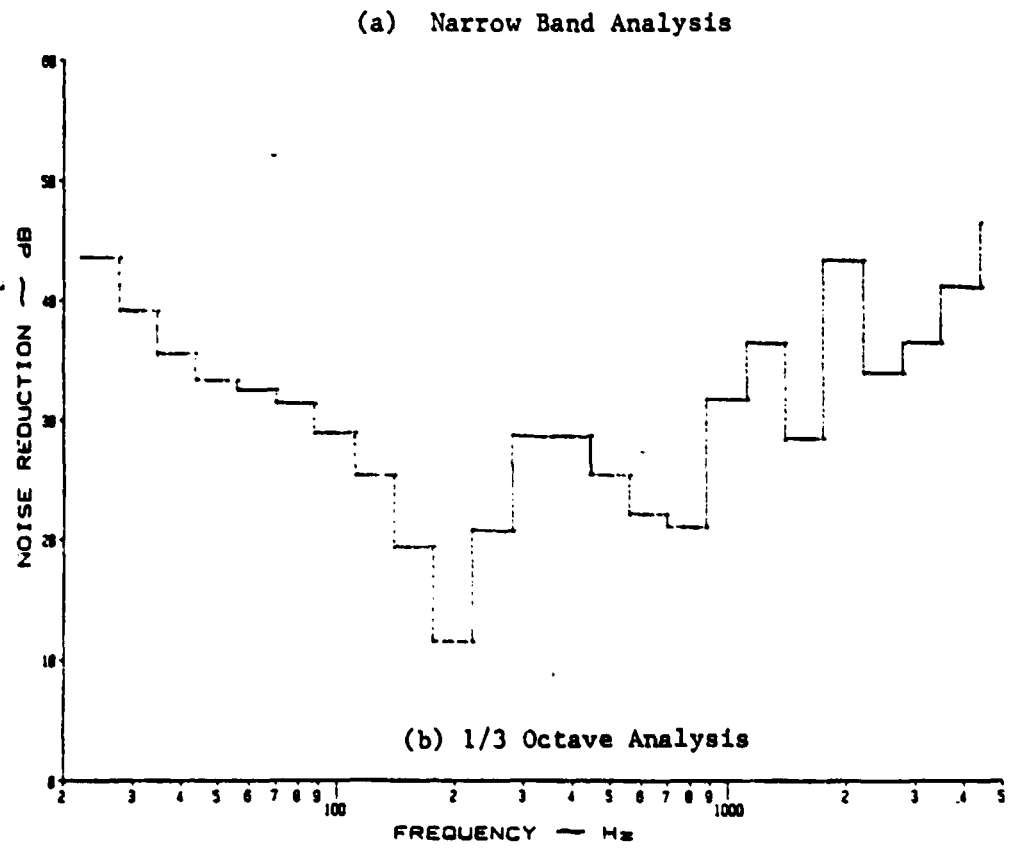
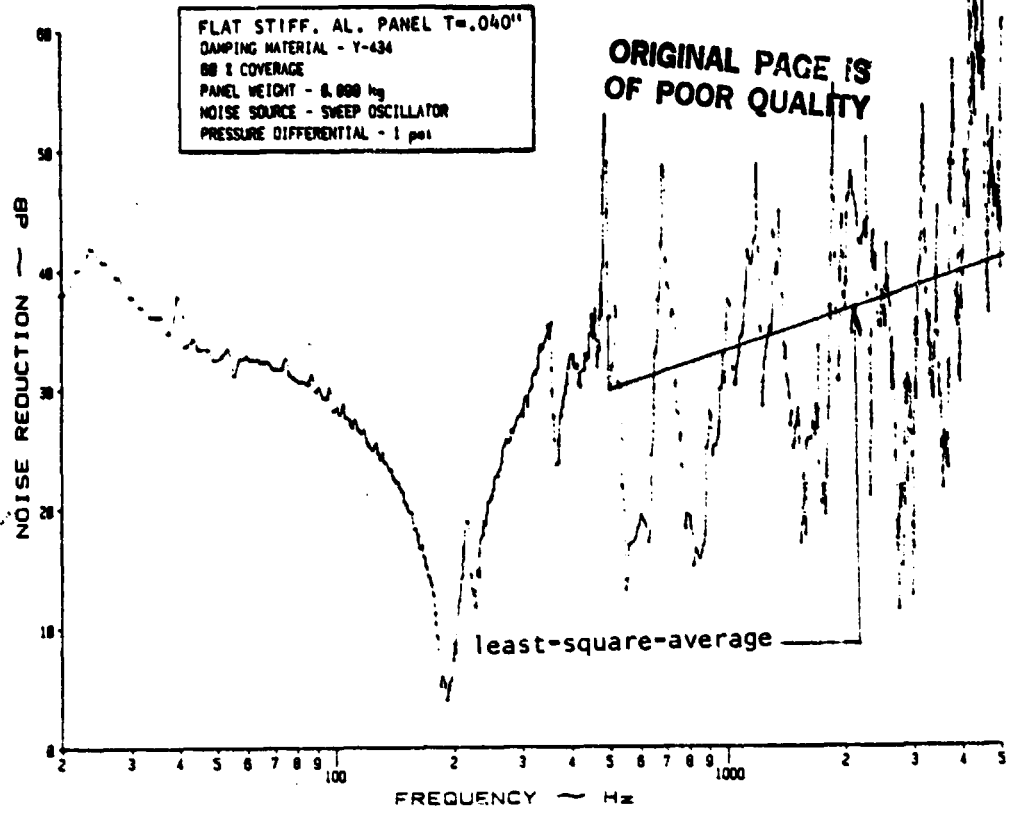
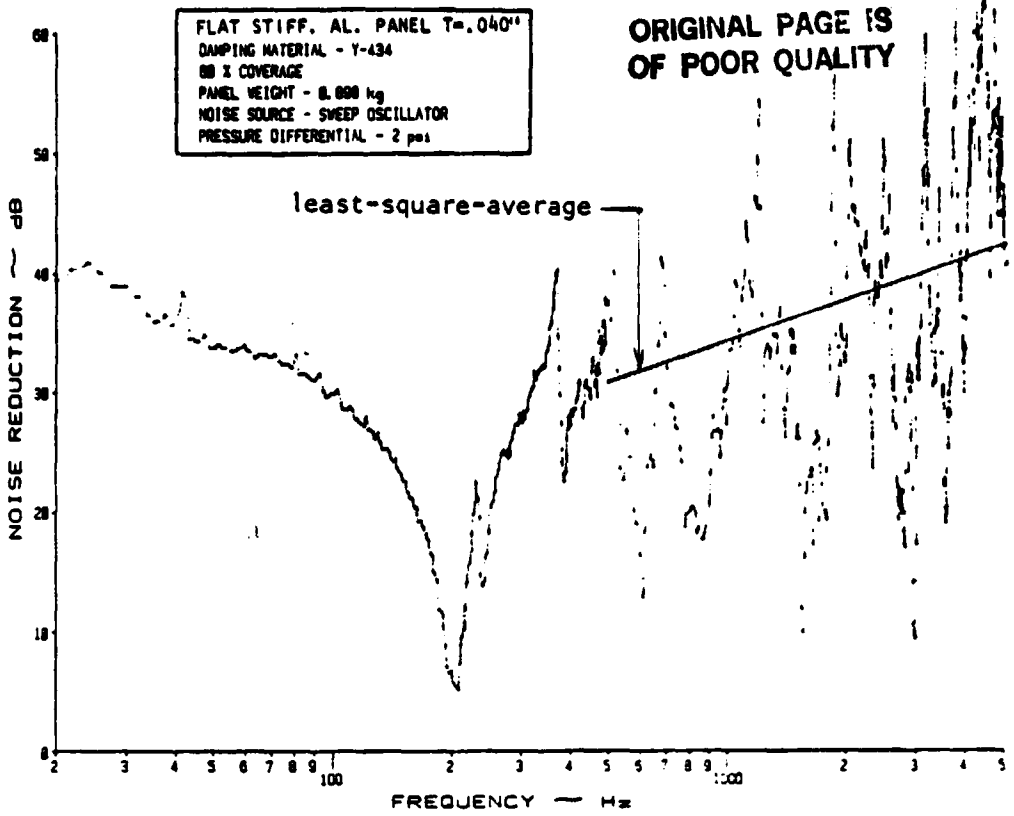
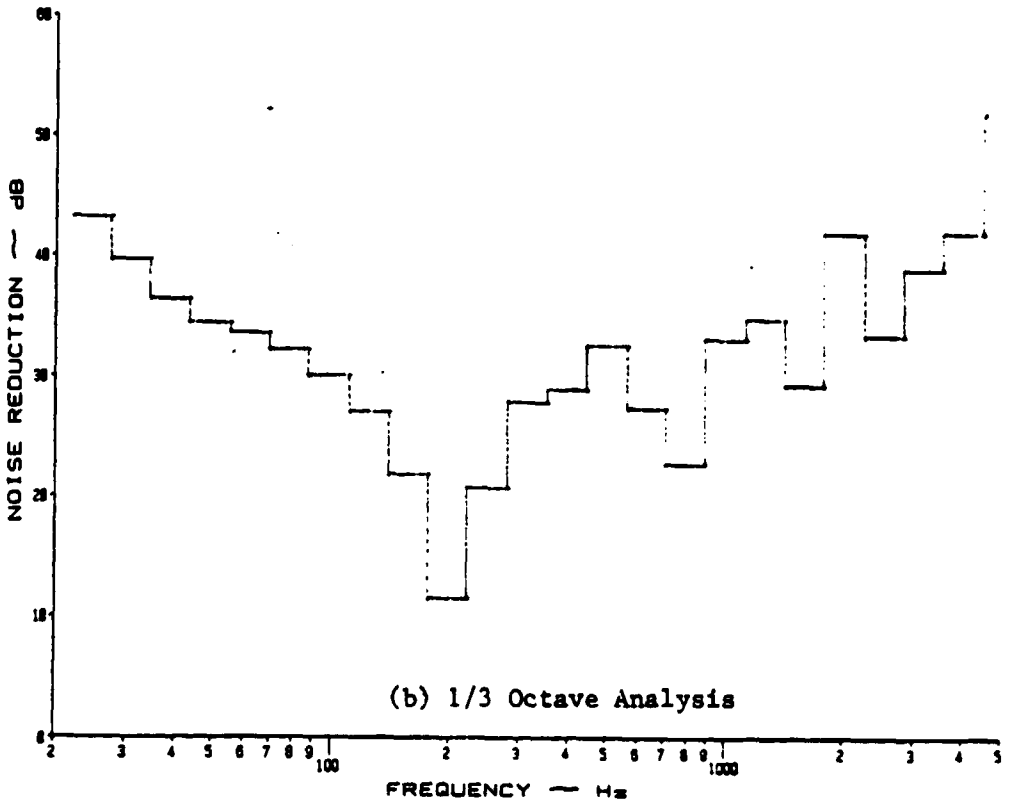

Figure A.42: Noise Reduction Characteristics of a Flat, Stiffened Panel at 1 psi Pressure Differential with Y-434 Damping Tape under a Discrete Noise Source



(a) Narrow Band Analysis



(b) 1/3 Octave Analysis

Figure A.43: Noise Reduction Characteristics of a Flat, Stiffened Panel at 2 psi Pressure Differential with Y-434 Damping Tape under a Discrete Noise Source

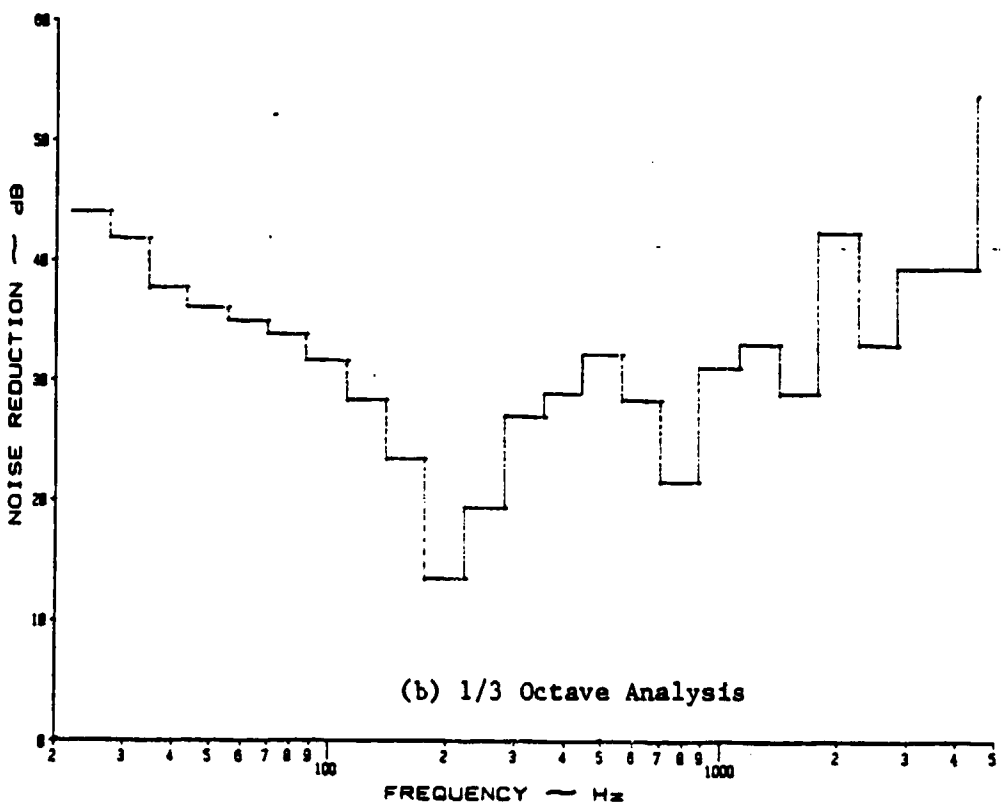
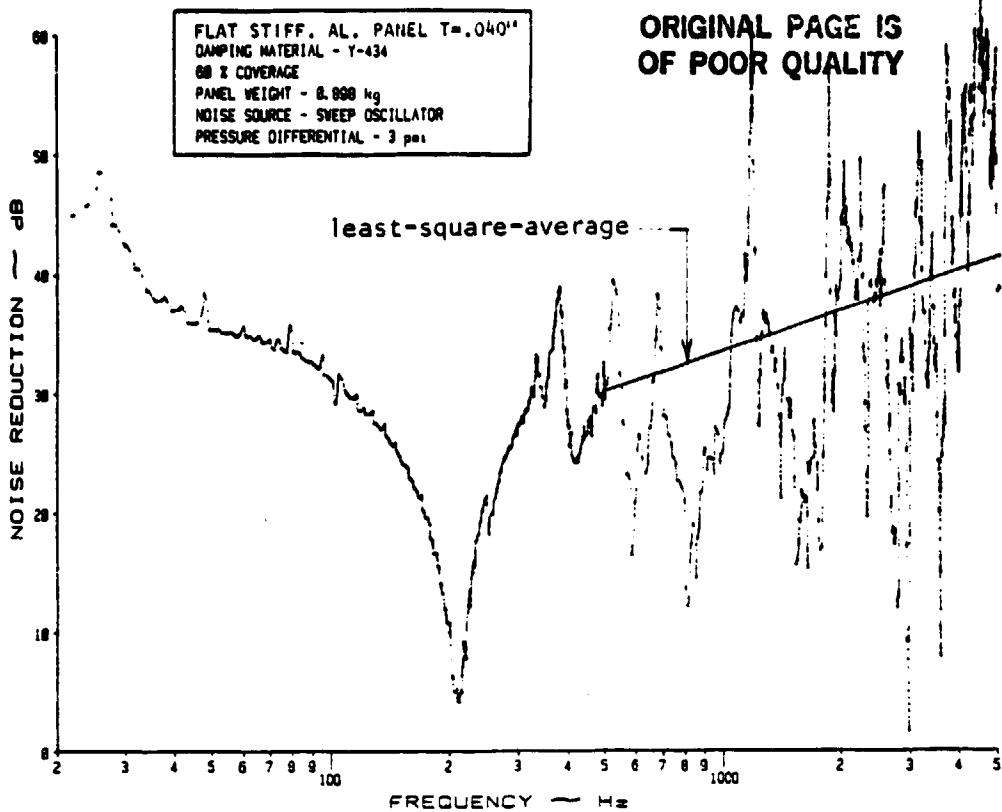
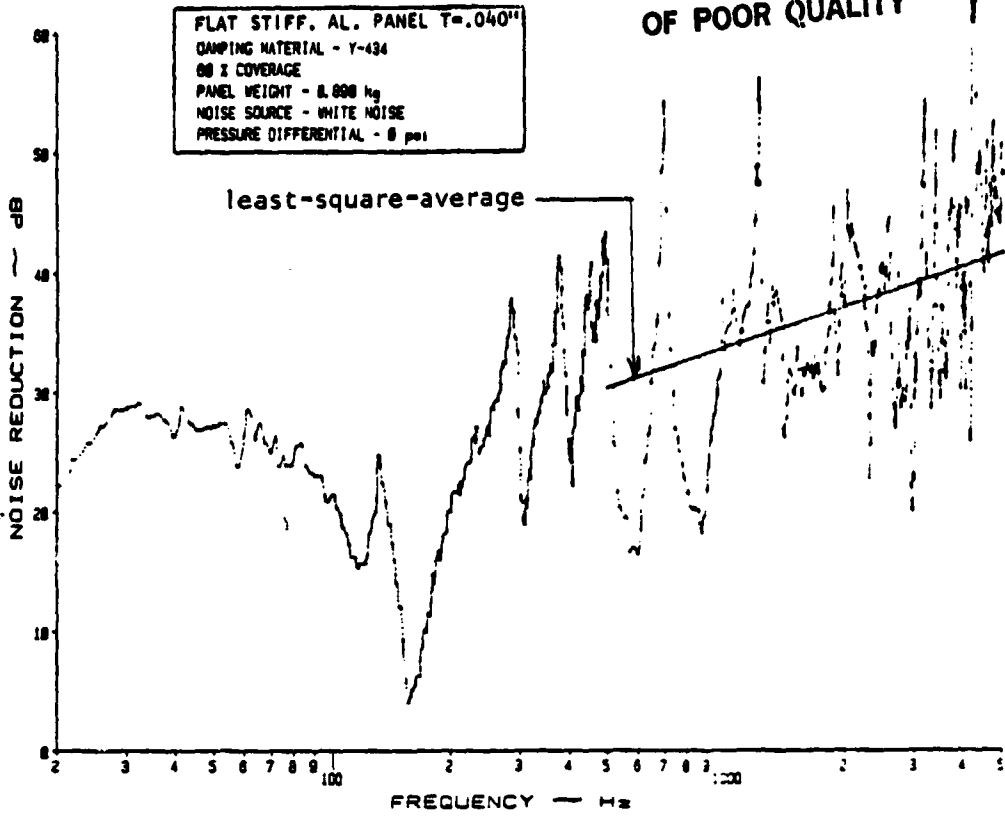
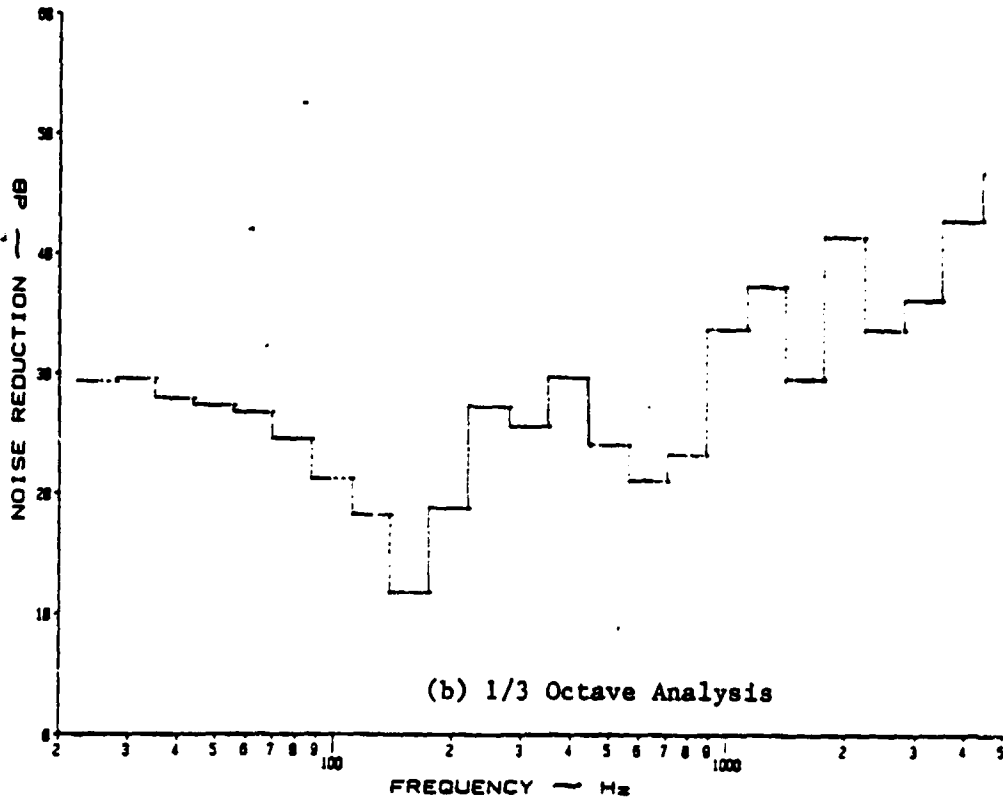

Figure A.44: Noise Reduction Characteristics of a Flat, Stiffened Panel at 3 psi Pressure Differential with Y-434 Damping Tape under a Discrete Noise Source



(a) Narrow Band Analysis



(b) 1/3 Octave Analysis

Figure A.45: Noise Reduction Characteristics of a Flat, Stiffened Panel at 0 psi Pressure Differential with Y-434 Damping Tape under White Noise

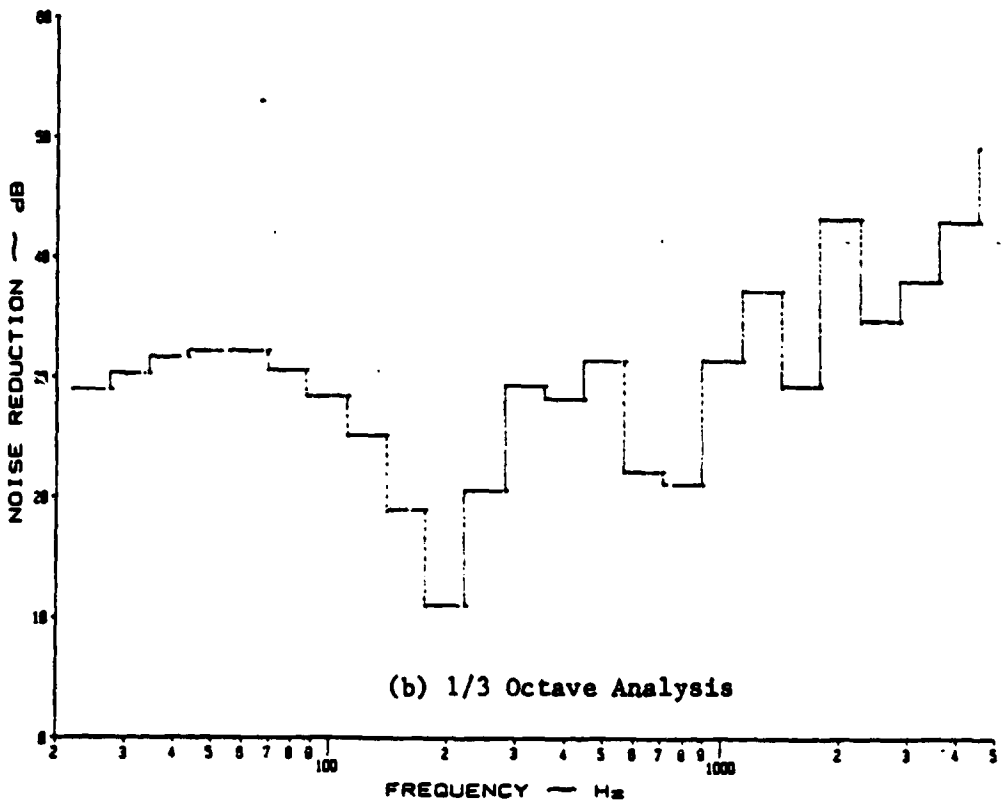
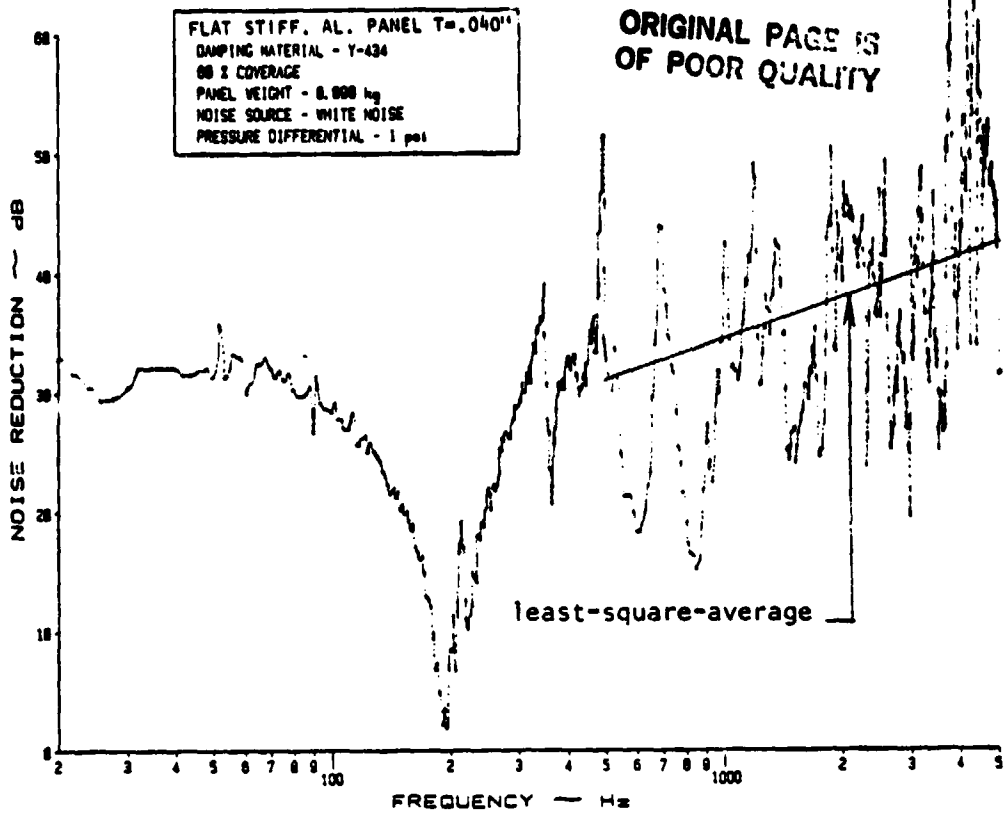
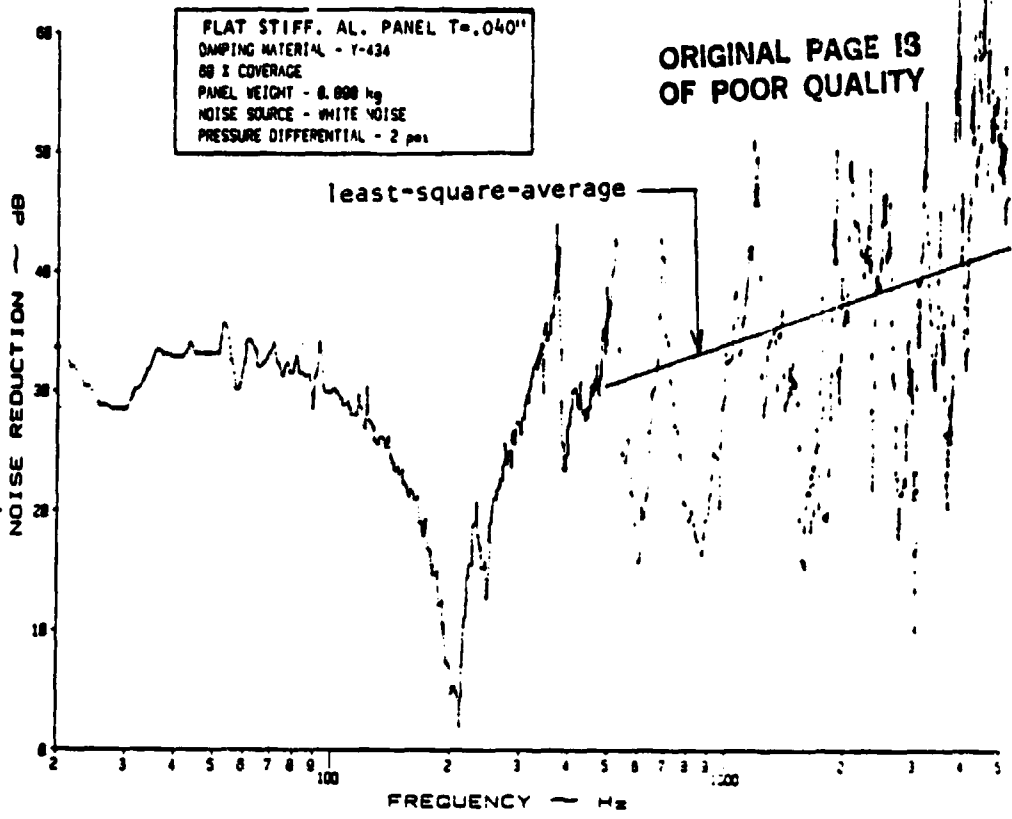
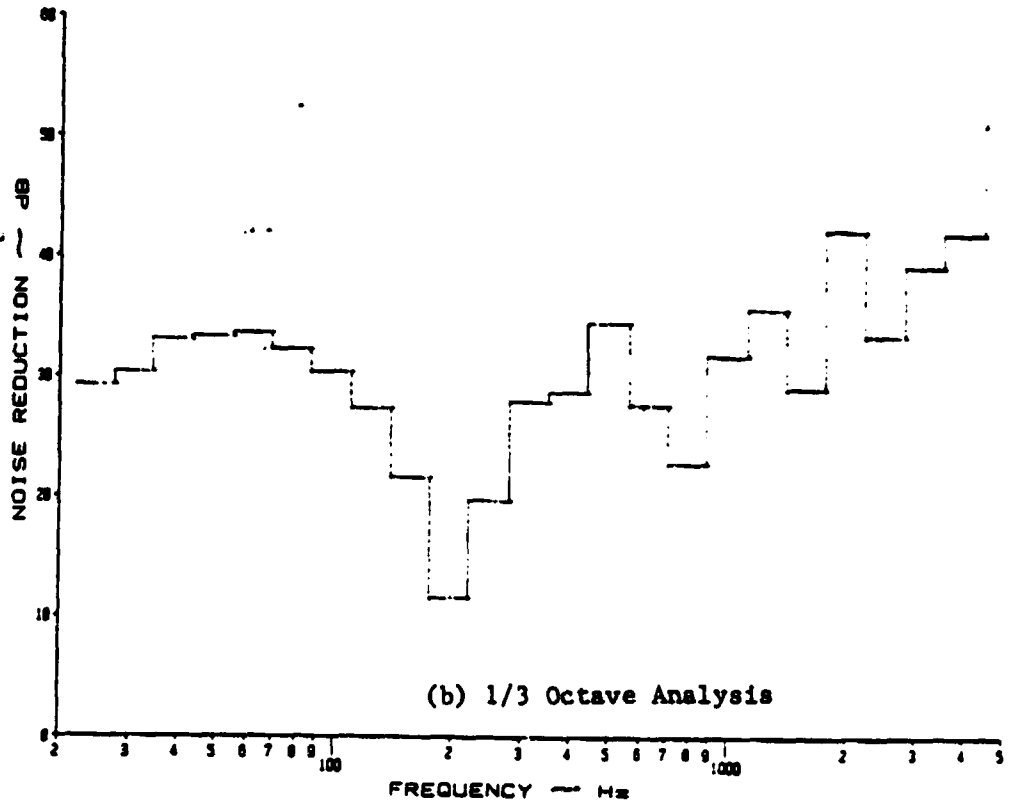

Figure A.46: Noise Reduction Characteristics of a Flat, Stiffened Panel at 1 psi Pressure Differential with Y-434 Damping Tape under White Noise



(a) Narrow Band Analysis



(b) 1/3 Octave Analysis

Figure A.47: Noise Reduction Characteristics of a Flat, Stiffened Panel at 2 psi Pressure Differential with Y-434 Damping Tape under White Noise

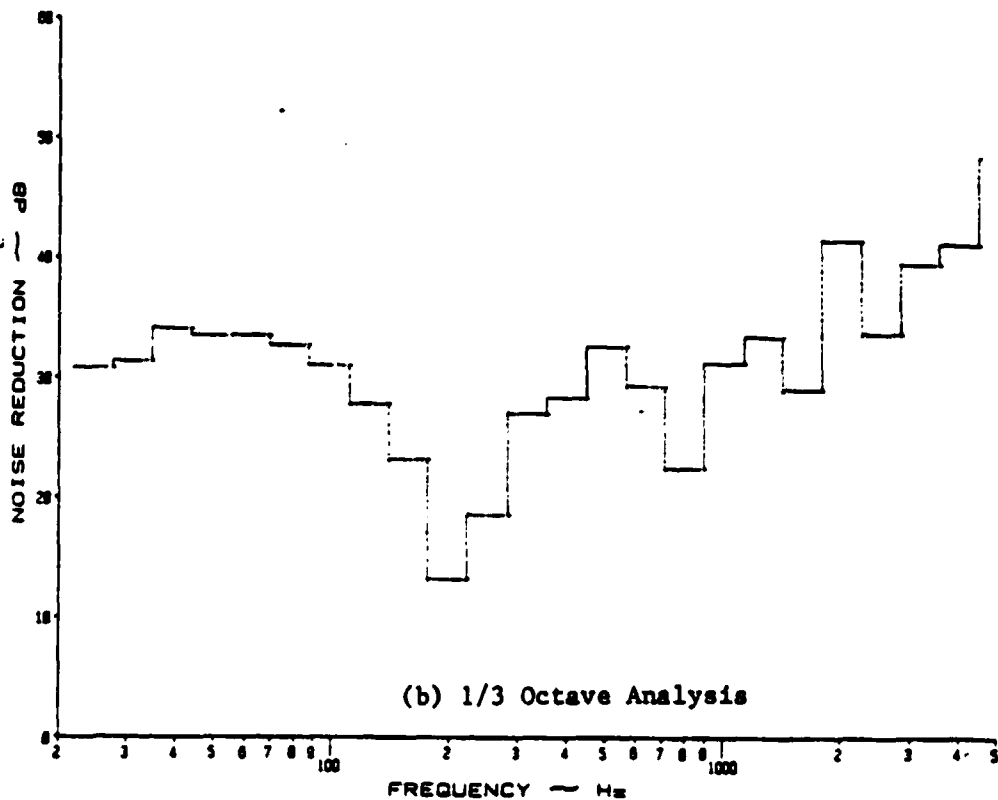
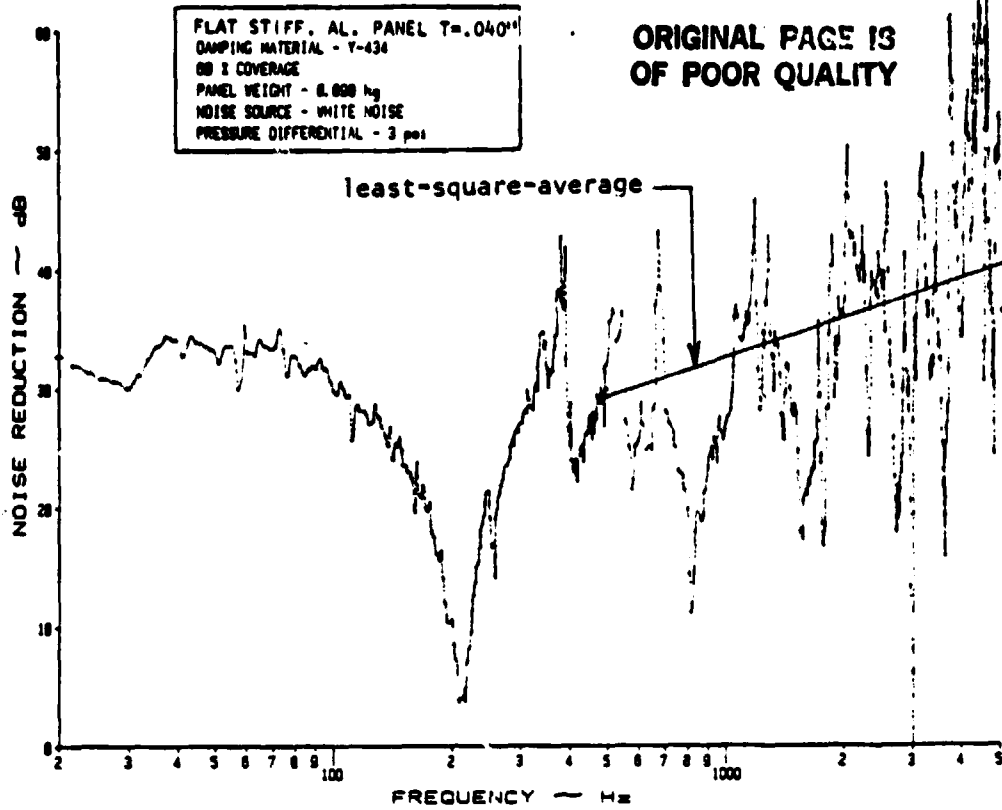
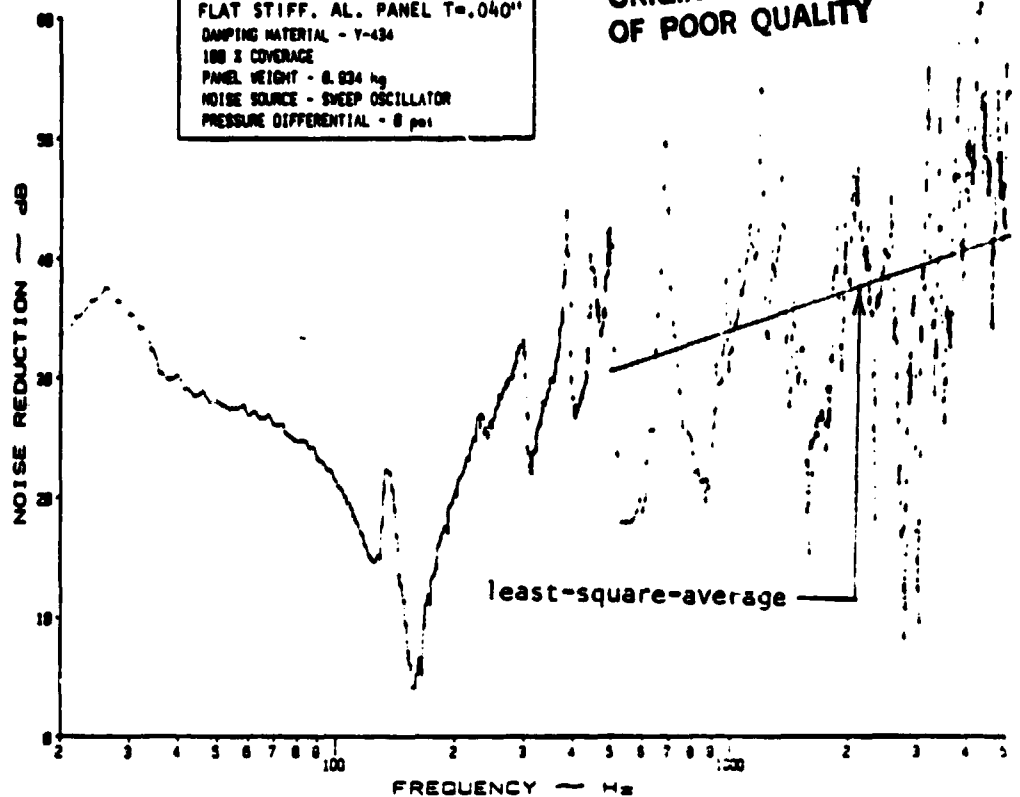

Figure A.48: Noise Reduction Characteristics of a Flat, Stiffened Panel at 3 psi Pressure Differential with Y-434 Damping Tape under White Noise

ORIGINAL PAGE IS
OF POOR QUALITY

FLAT STIFF. AL. PANEL T=.040"
DAMPING MATERIAL - Y-434
100 % COVERAGE
PANEL WEIGHT - 8.834 kg
NOISE SOURCE - SWEEP OSCILLATOR
PRESSURE DIFFERENTIAL - 0 psi



(a) Narrow Band Analysis

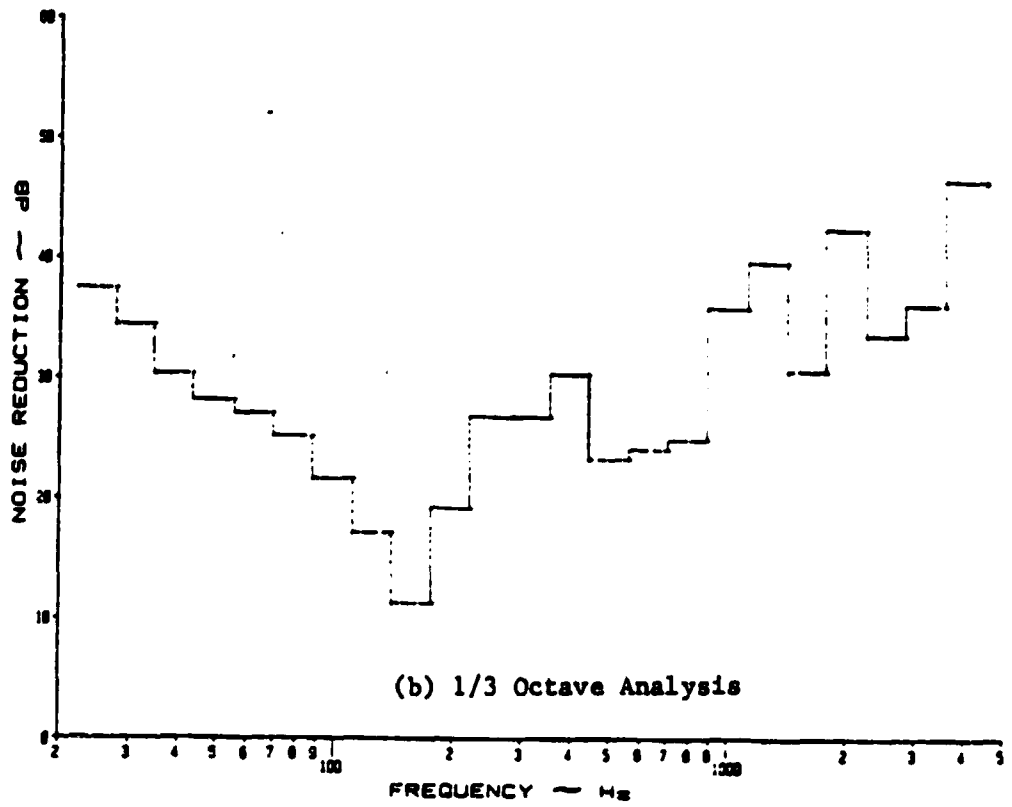

(b) 1/3 Octave Analysis

Figure A.49: Noise Reduction Characteristics of a Flat, Stiffened Panel at 0 psi Pressure Differential with Y-434 Damping Tape under a Discrete Noise Source

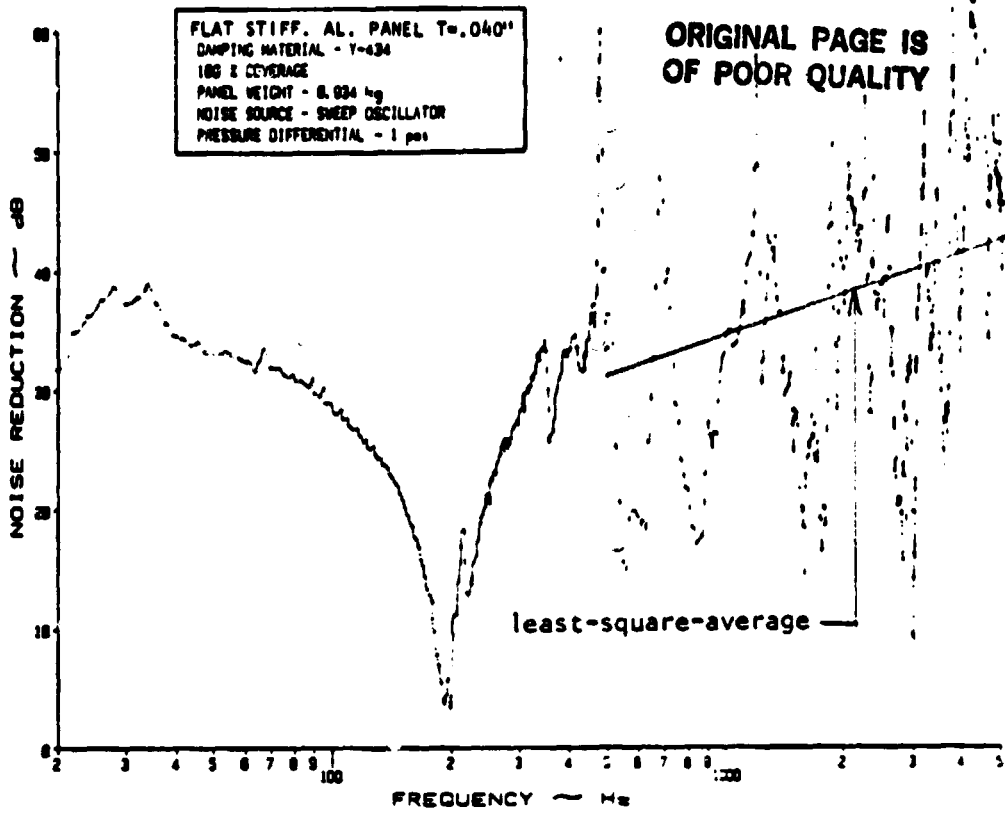

(a) Narrow Band Analysis

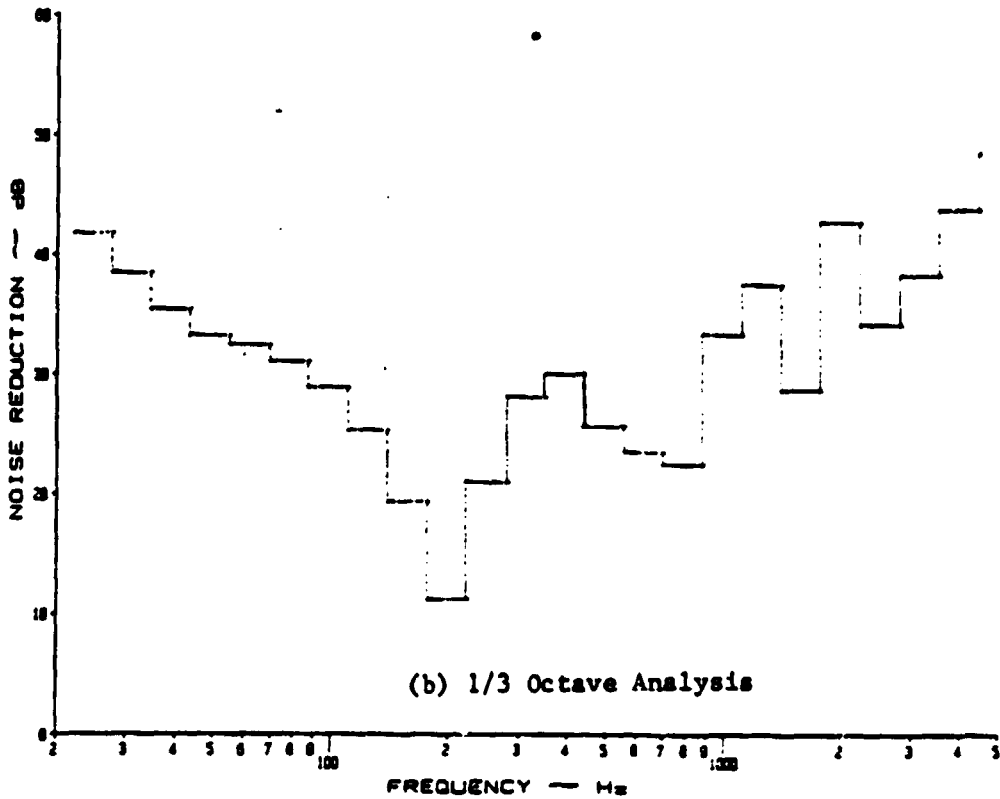
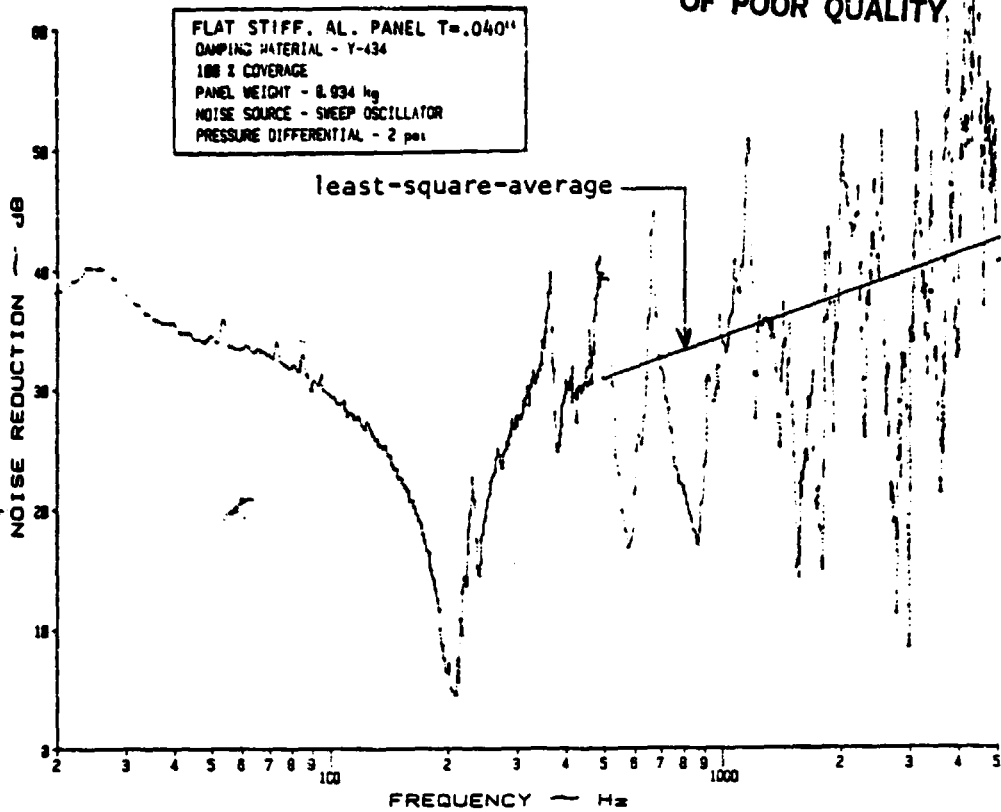
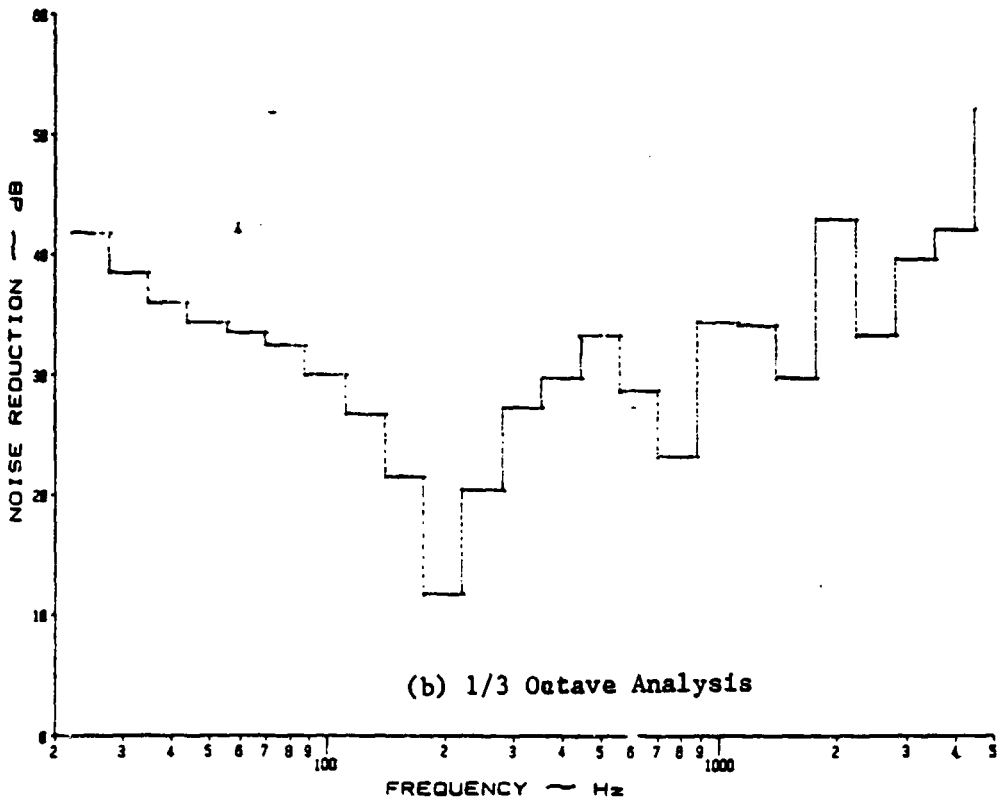

Figure A.50: Noise Reduction Characteristics of a Flat, Stiffened Panel at 1 psi Pressure Differential with Y-434 Damping Tape under a Discrete Noise Source



(a) Narrow Band Analysis



(b) 1/3 Octave Analysis

Figure A.51: Noise Reduction Characteristics of a Flat, Stiffened Panel at 2 psi Pressure Differential with Y-434 Damping Tape under a Discrete Noise Source

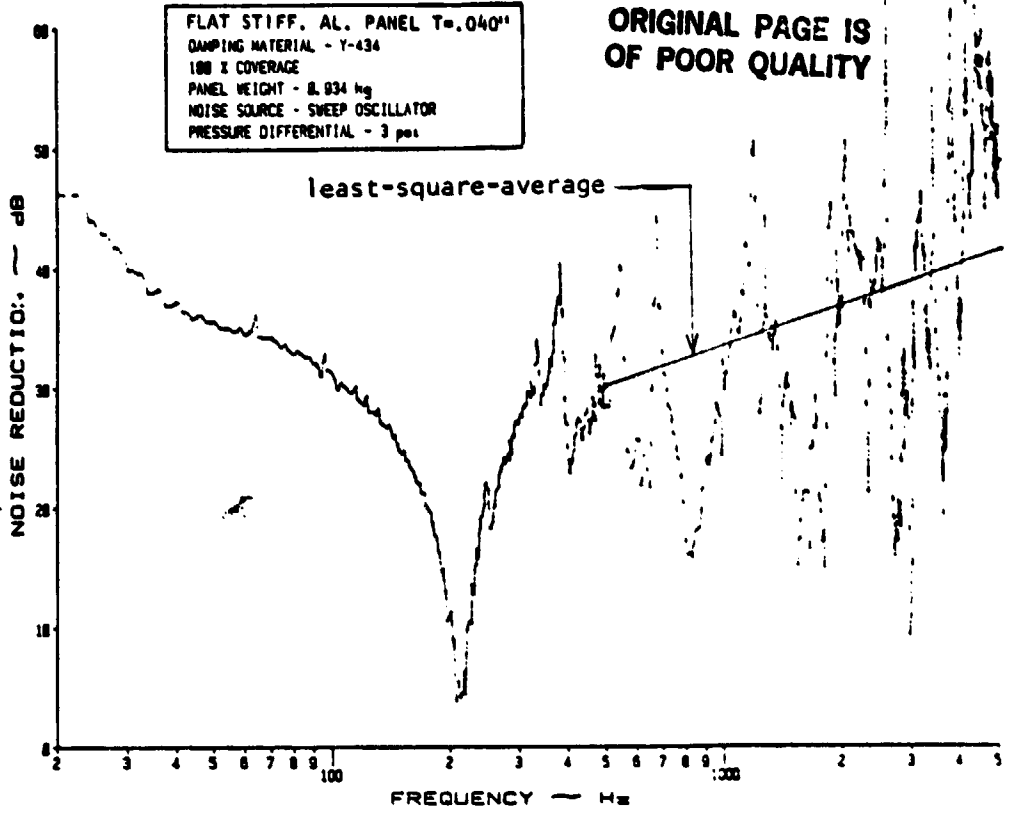

(a) Narrow Band Analysis

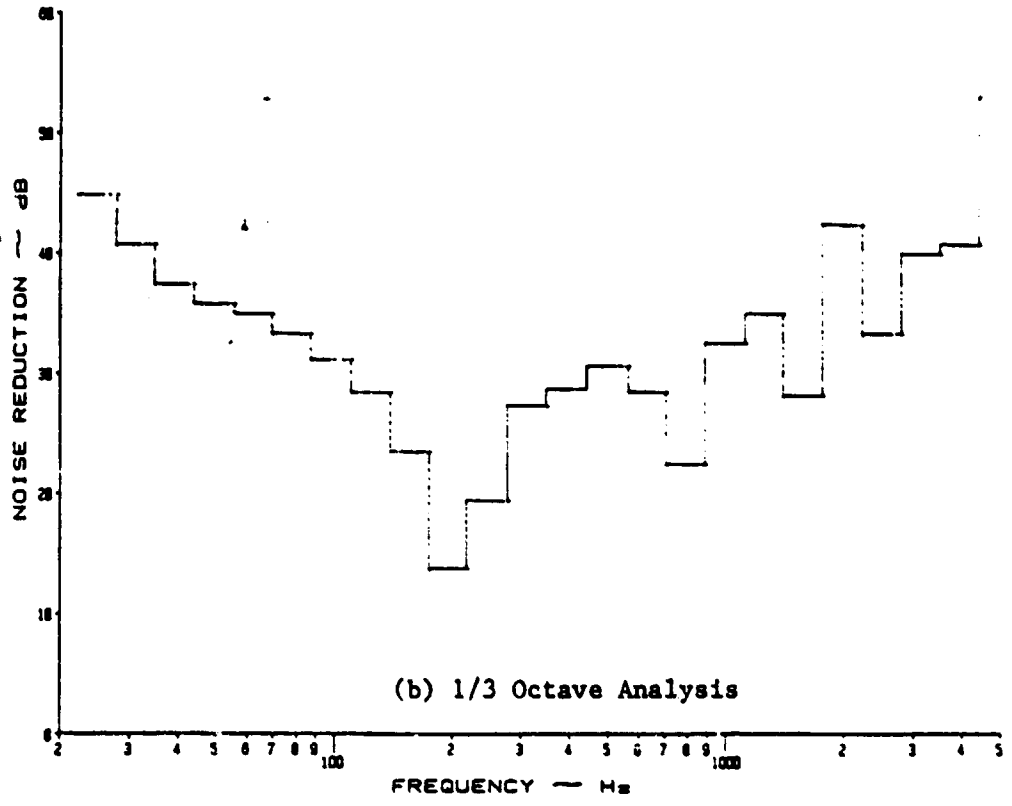

(b) 1/3 Octave Analysis

Figure A.52: Noise Reduction Characteristics of a Flat, Stiffened Panel at 3 psi Pressure Differential with Y-434 Damping Tape under a Discrete Noise Source

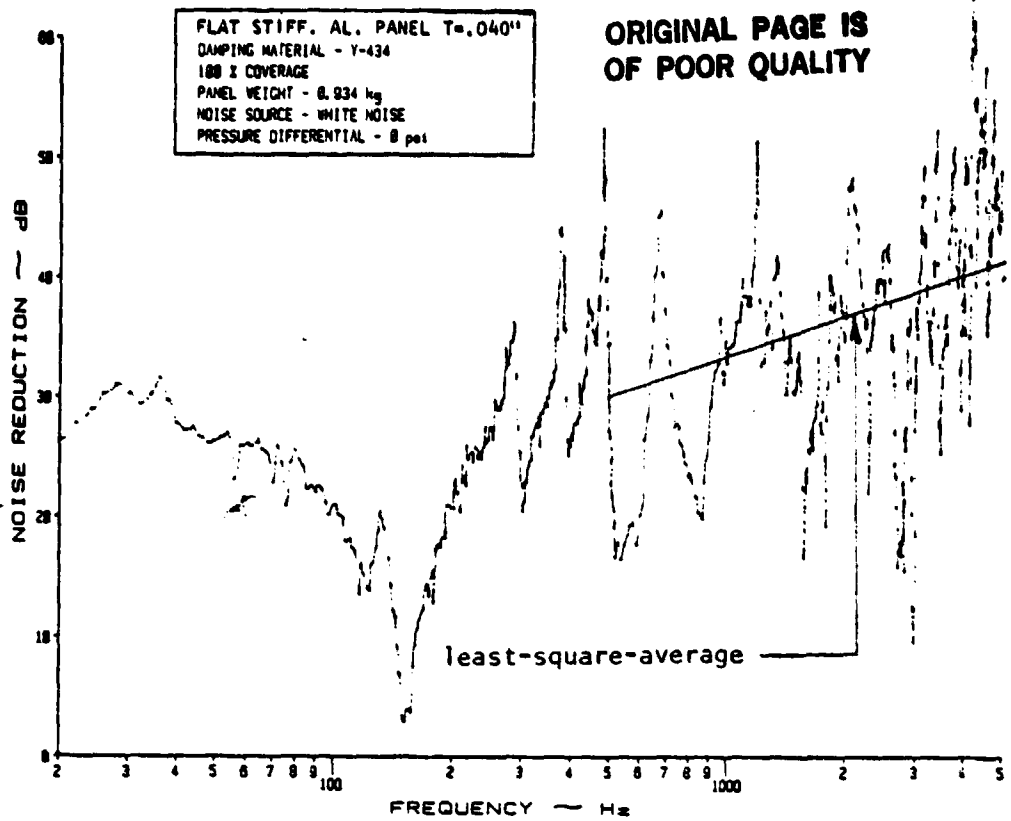

(a) Narrow Band Analysis

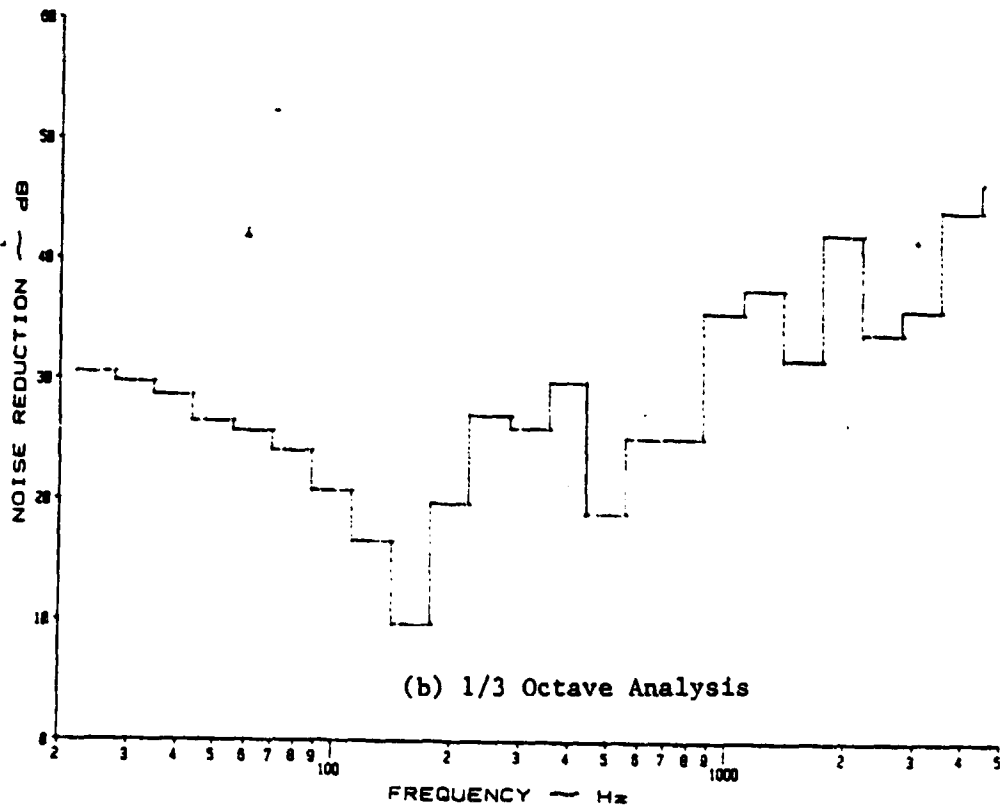

(b) 1/3 Octave Analysis

Figure A.53: Noise Reduction Characteristics of a Flat, Stiffened Panel at 0 psi Pressure Differential with Y-434 Damping Tape under White Noise

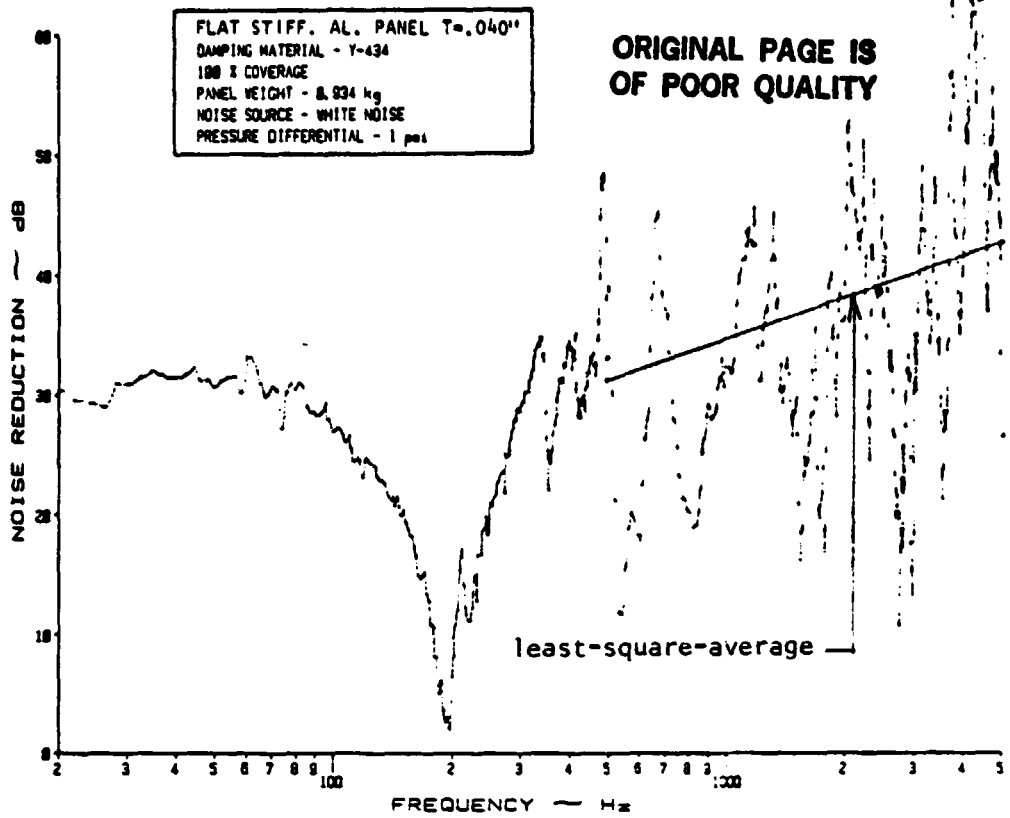

(a) Narrow Band Analysis

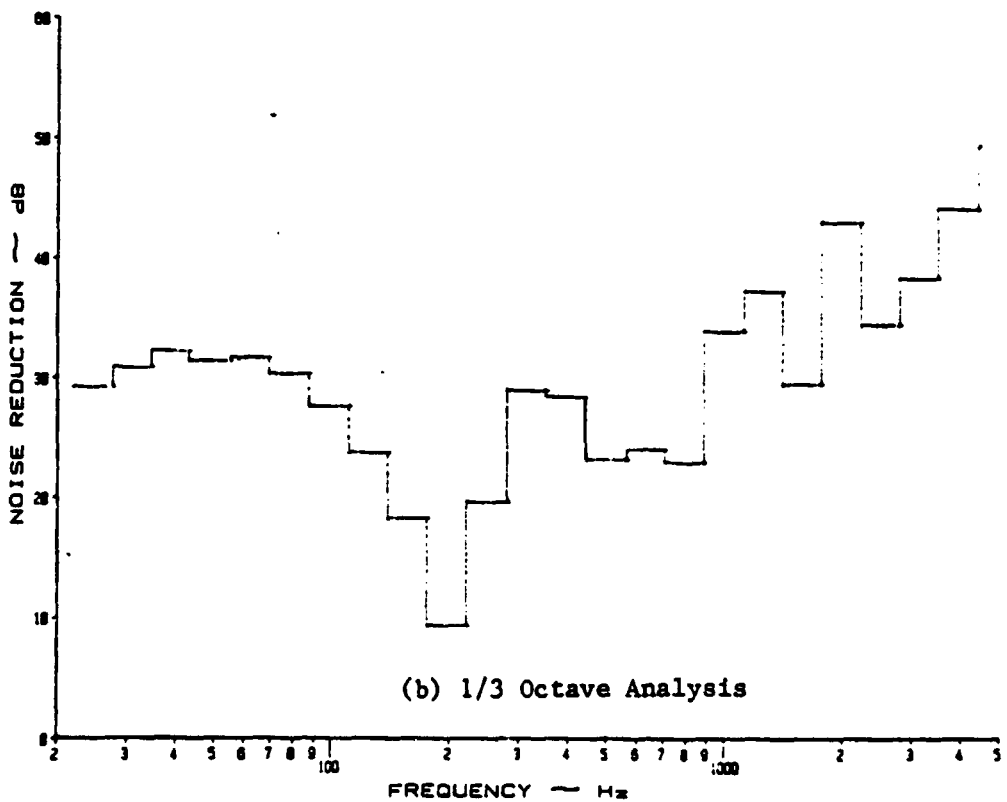
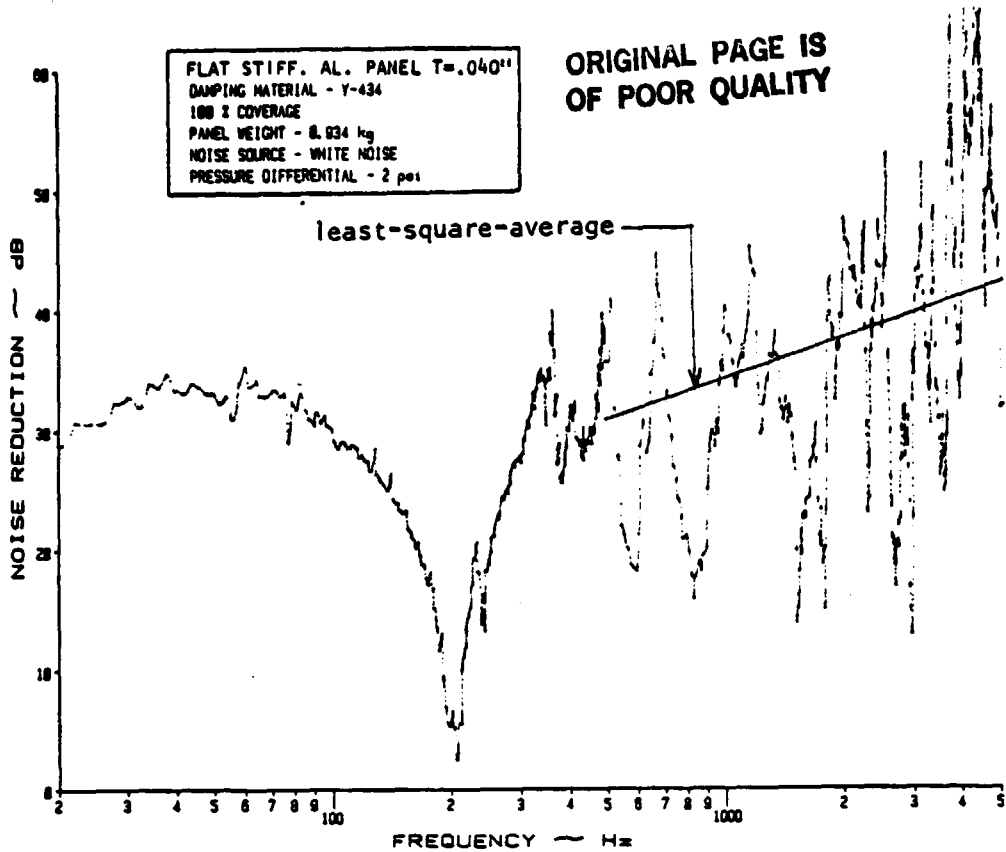

Figure A.54: Noise Reduction Characteristics of a Flat, Stiffened Panel at 1 psi Pressure Differential with Y-434 Damping Tape under White Noise



(a) Narrow Band Analysis

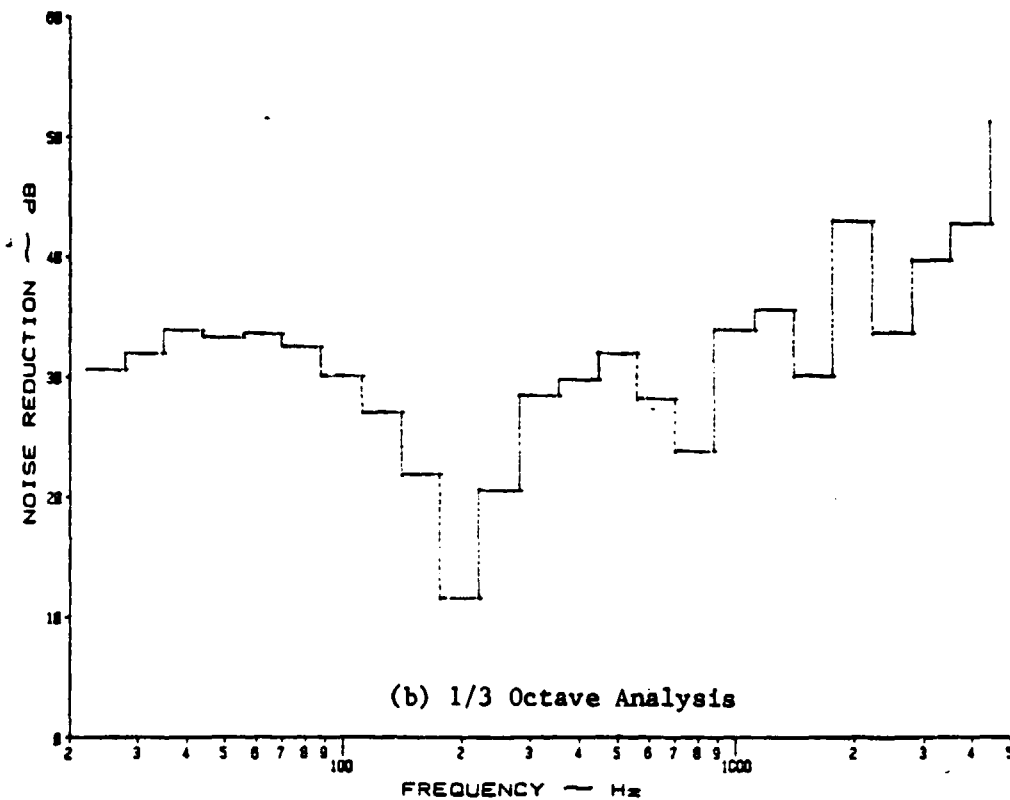
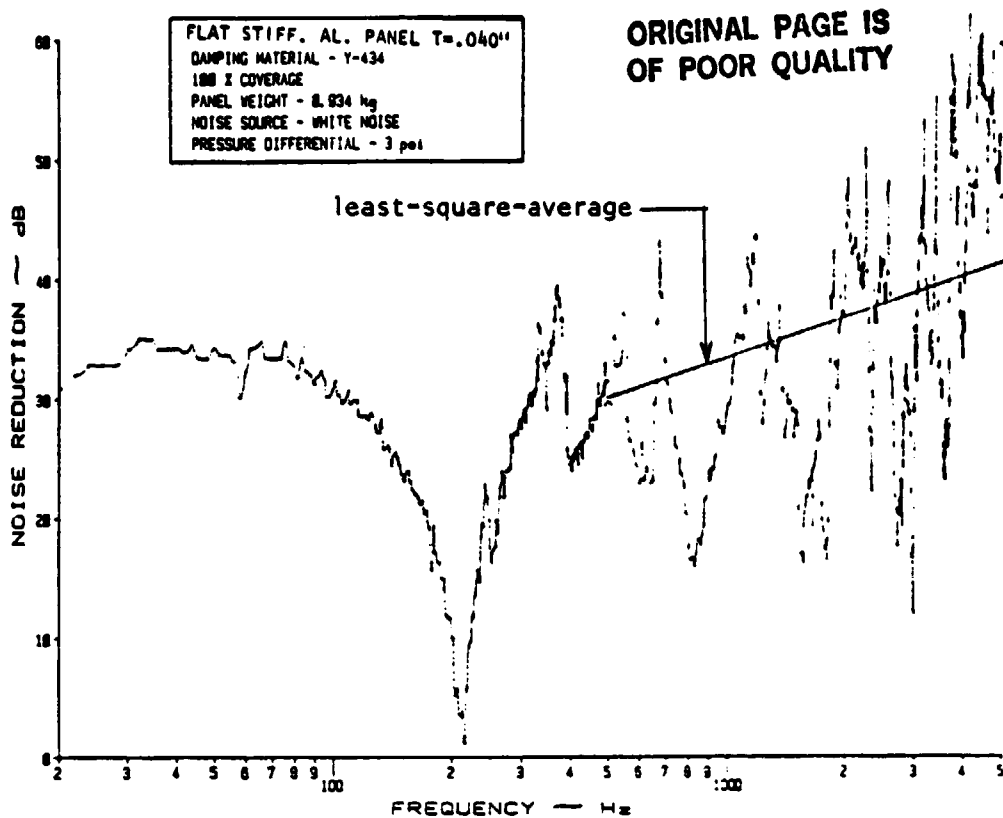
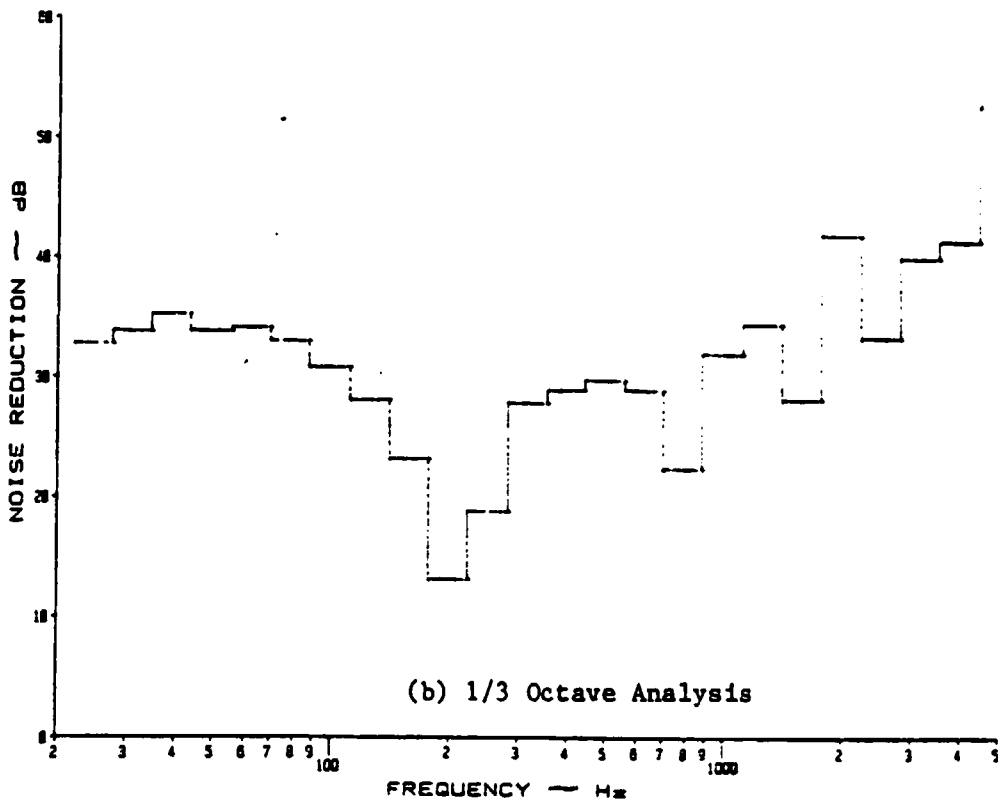

Figure A.55: Noise Reduction Characteristics of a Flat, Stiffened Panel at 2 psi Pressure Differential with Y-434 Damping Tape under White Noise



(a) Narrow Band Analysis



(b) 1/3 Octave Analysis

Figure A.56: Noise Reduction Characteristics of a Flat, Stiffened Panel at 3 psi Pressure Differential with Y-434 Damping Tape under White Noise

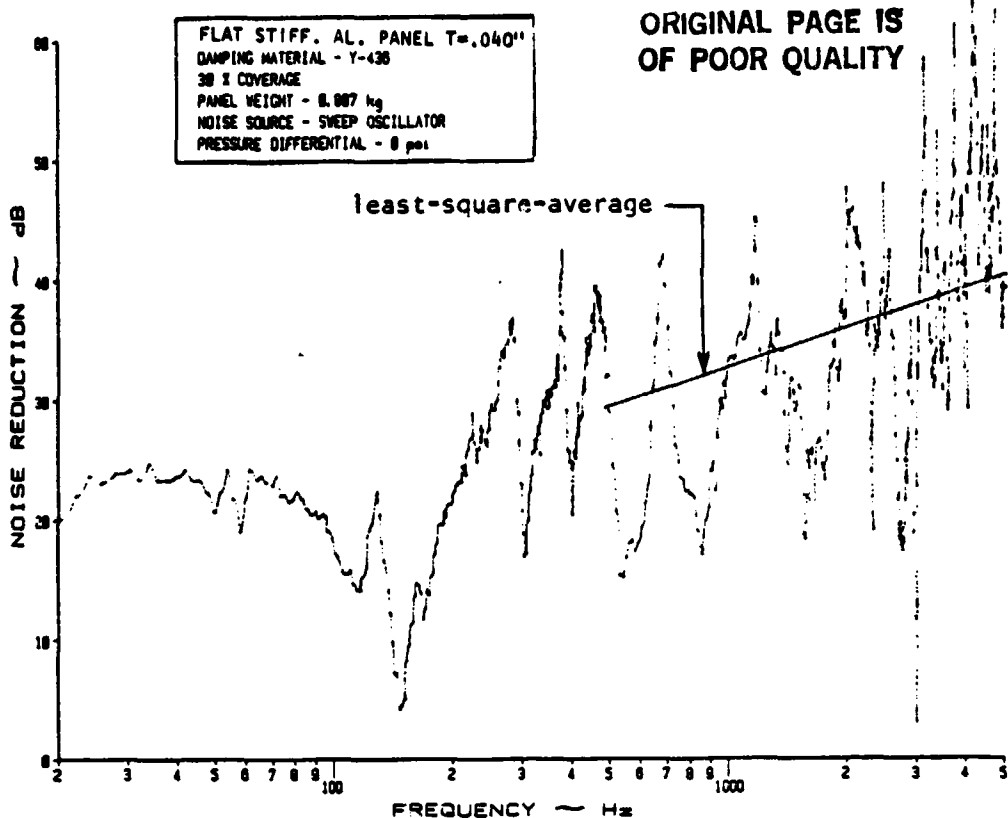

(a) Narrow Band Analysis

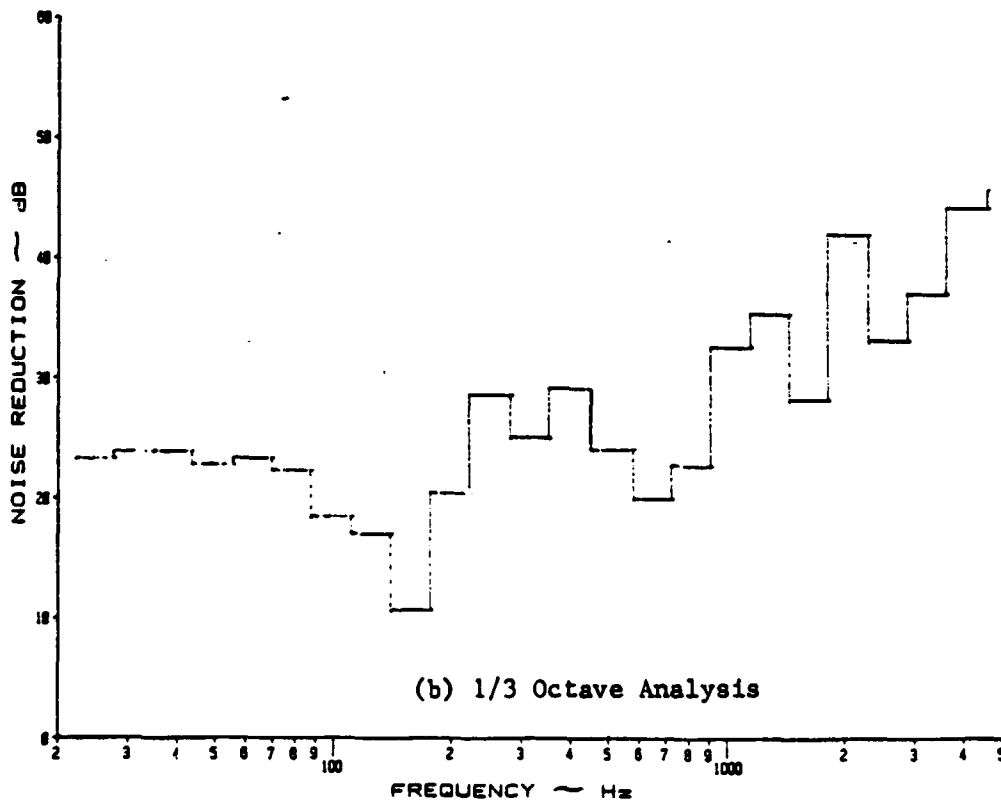

(b) 1/3 Octave Analysis

Figure A.57 Noise Reduction Characteristics of a Flat, Stiffened Panel at 0 psi Pressure Differential with Y-436 Damping Tape under a Discrete Noise Source

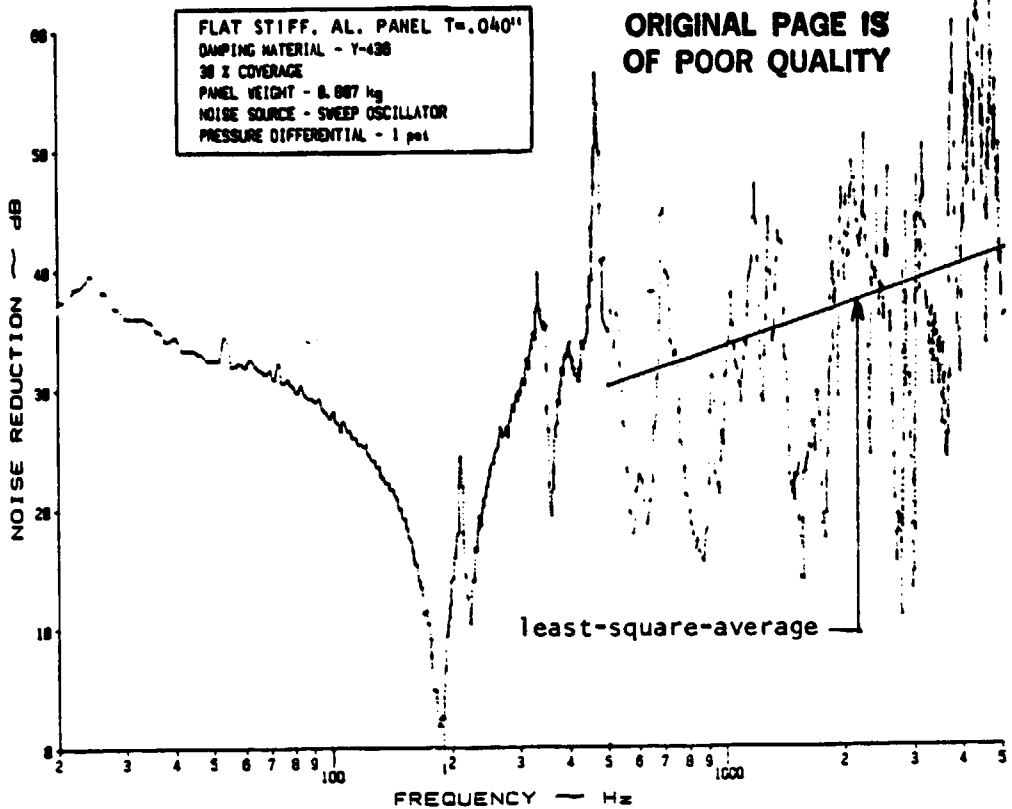

(a) Narrow Band Analysis

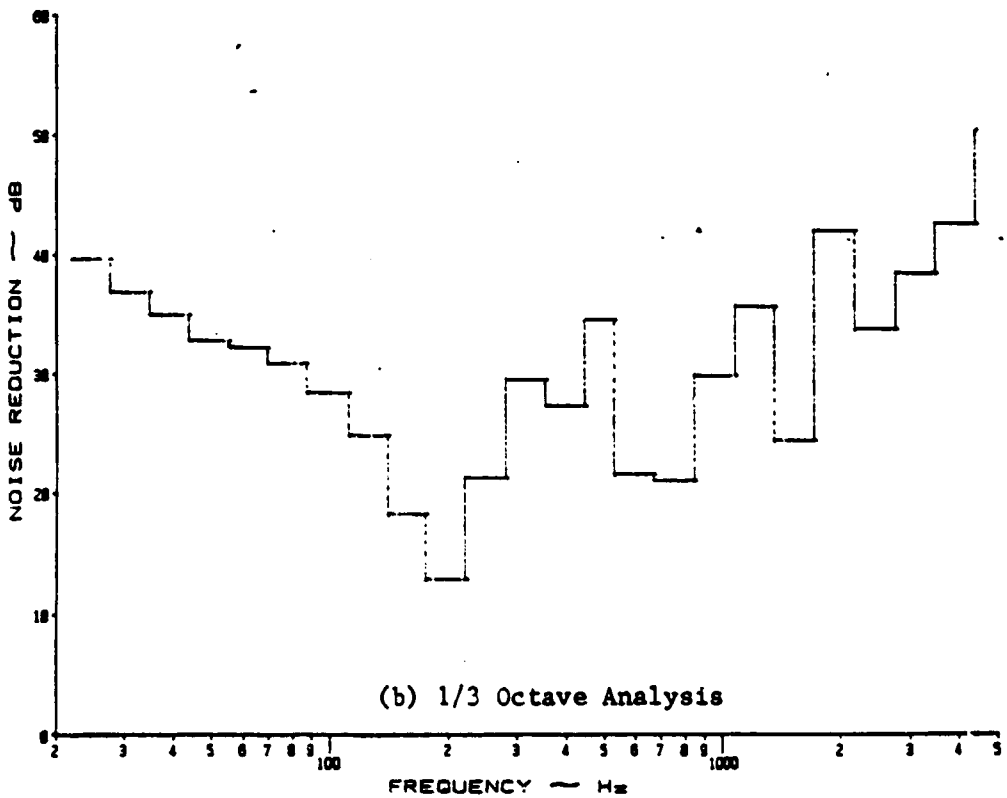

(b) 1/3 Octave Analysis

Figure A.58: Noise Reduction Characteristics of a Flat, Stiffened Panel at 1 psi Pressure Differential with Y-436 Damping Tape under a Discrete Noise Source

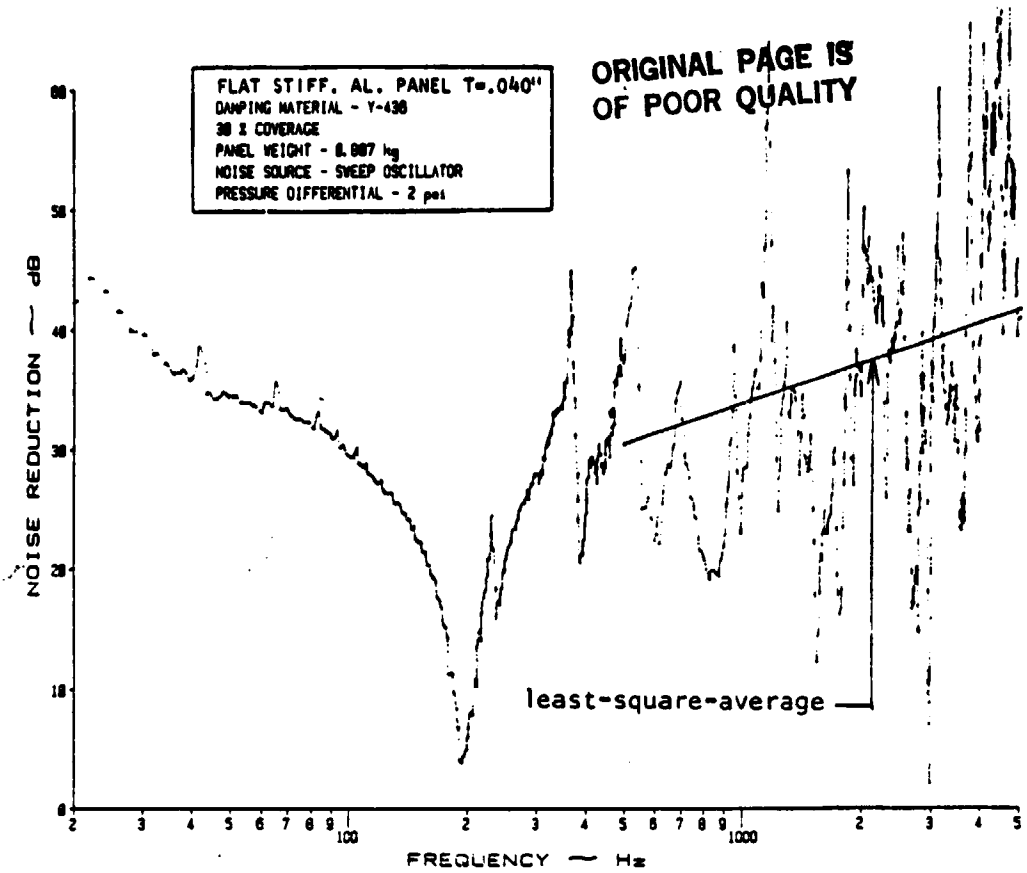

(a) Narrow Band Analysis

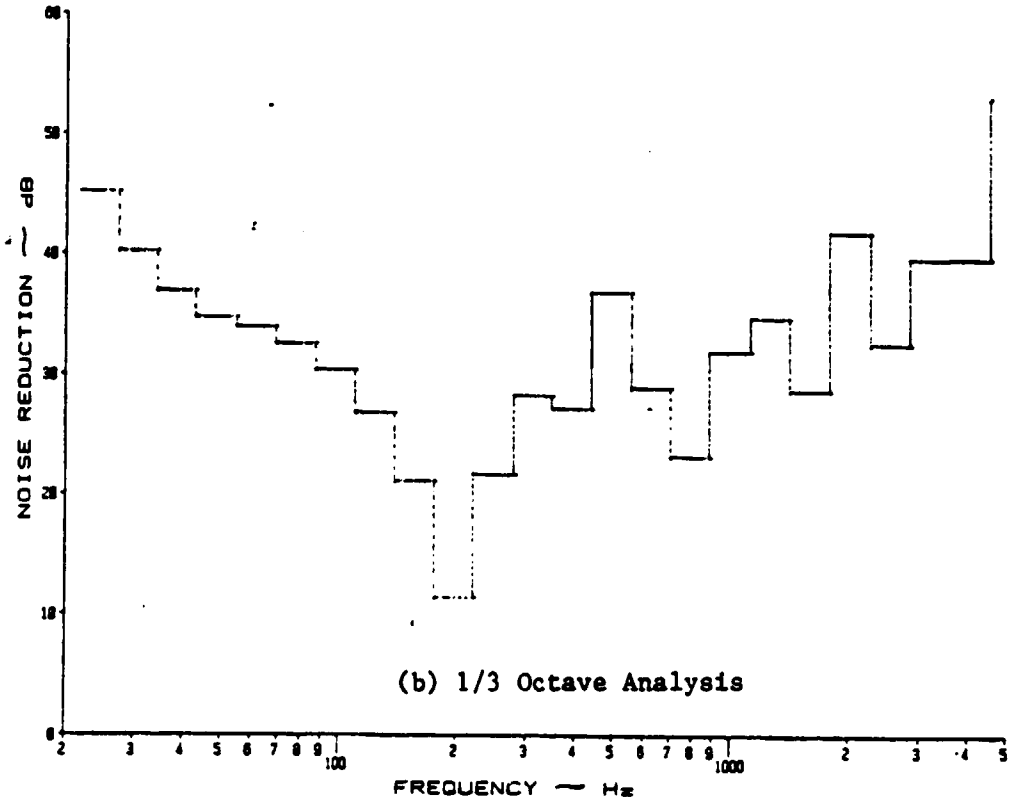

(b) 1/3 Octave Analysis

Figure A.59: Noise Reduction Characteristics of a Flat, Stiffened Panel at 2 psi Pressure Differential with Y-436 Damping Tape under a Discrete Noise Source

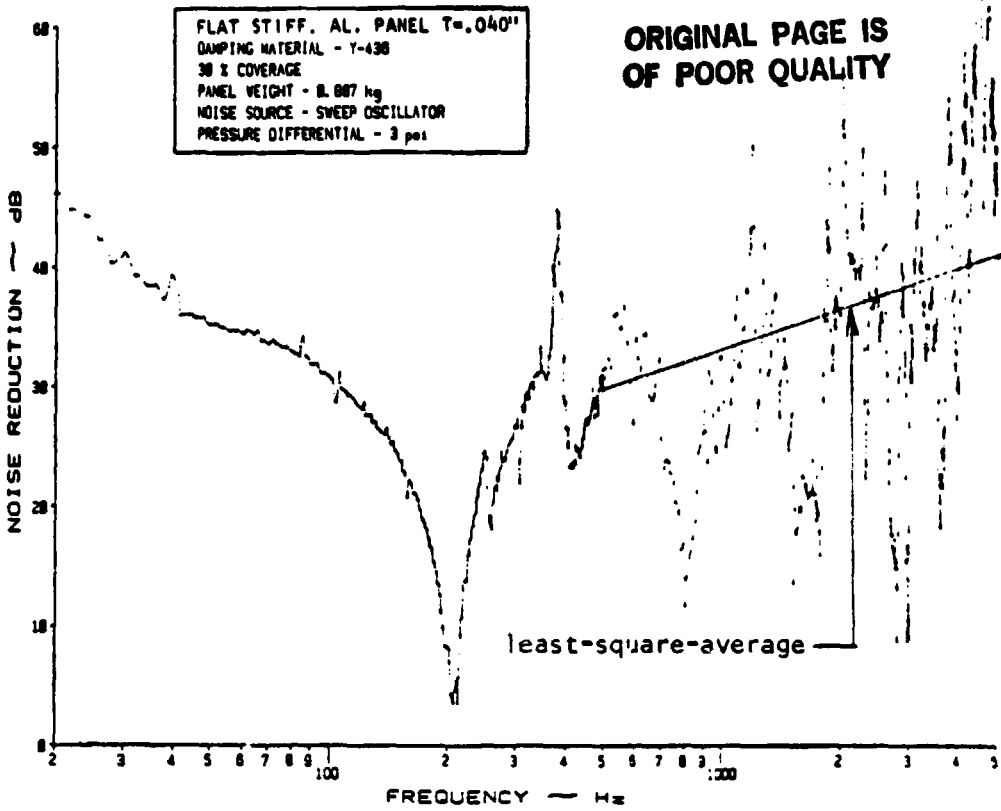

(a) Narrow Band Analysis

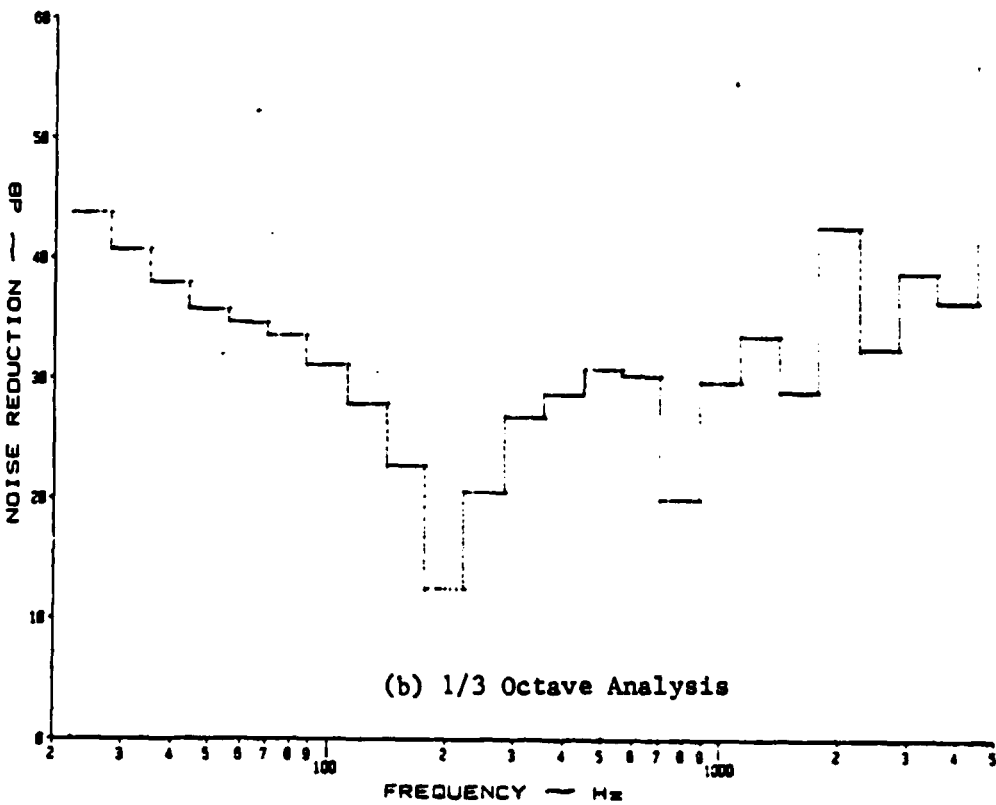

(b) 1/3 Octave Analysis

Figure A.60: Noise Reduction Characteristics of a Flat, Stiffened Panel at 3 psi Pressure Differential with Y-436 Damping Tape under a Discrete Noise Source

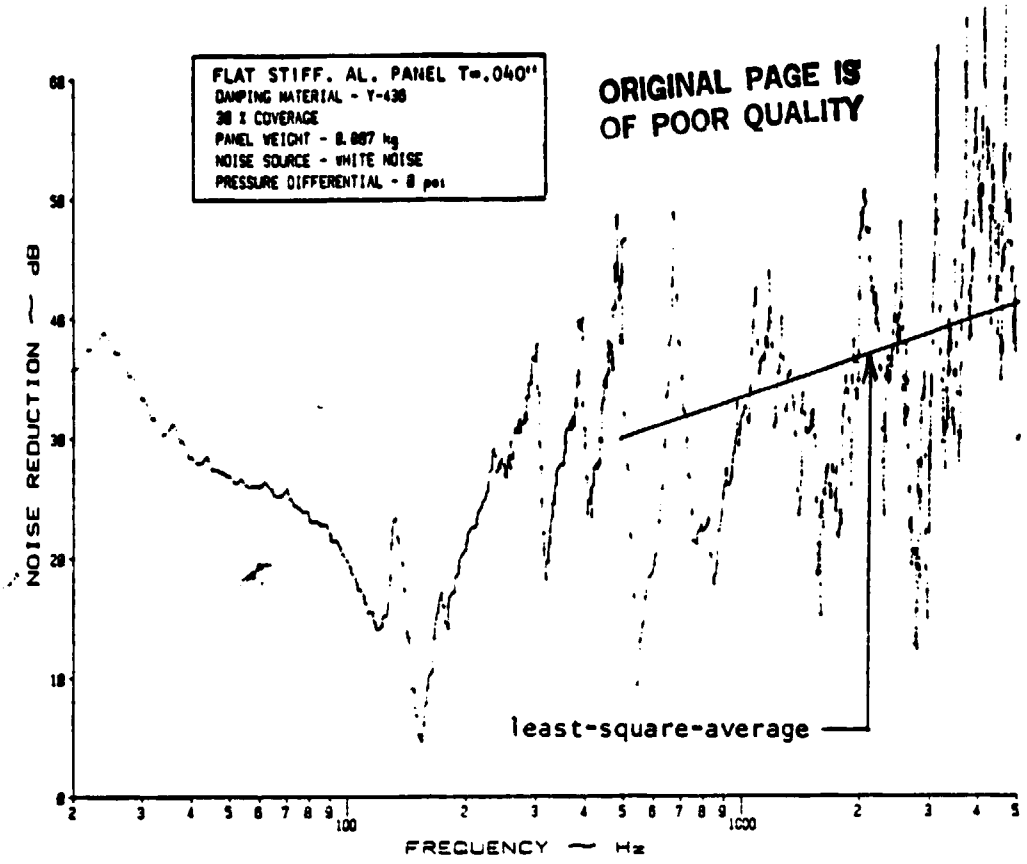

(a) Narrow Band Analysis

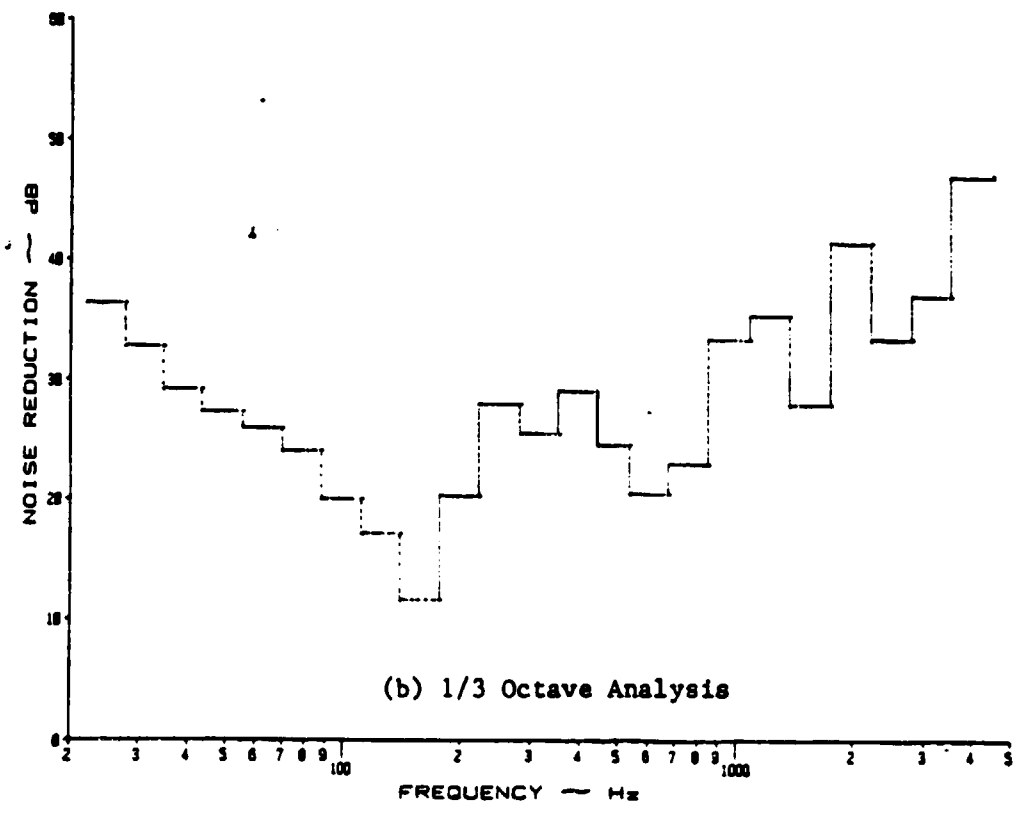
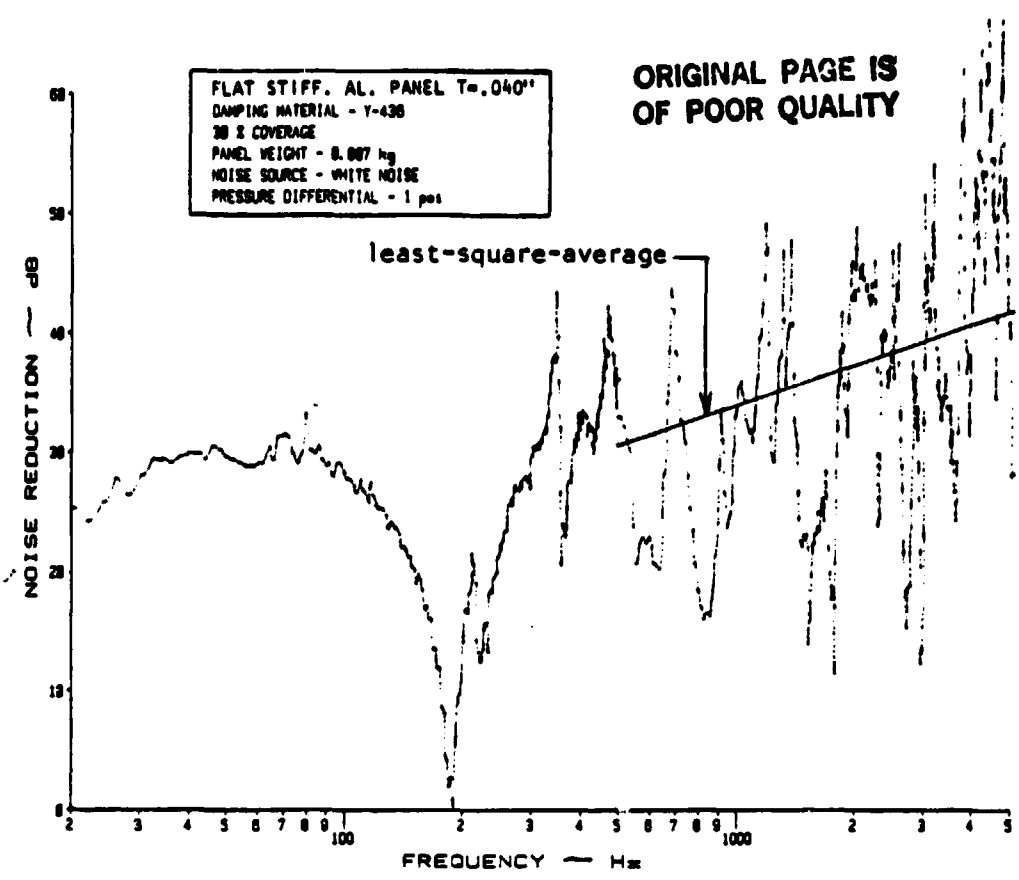
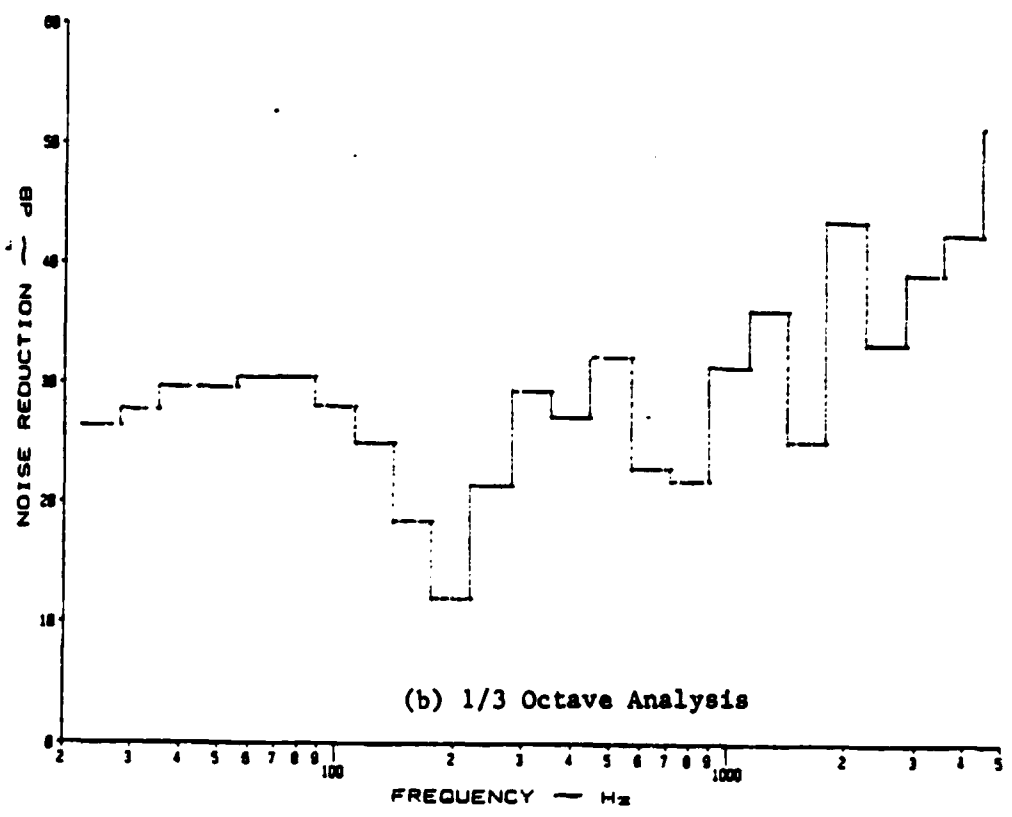

Figure A.61: Noise Reduction Characteristics of a Flat, Stiffened Panel at 0 psi Pressure Differential with Y-436 Damping Tape under White Noise



(a) Narrow Band Analysis



(b) 1/3 Octave Analysis

Figure A.62: Noise Reduction Characteristics of a Flat, Stiffened Panel at 1 psi Pressure Differential with Y-436 Damping Tape under White Noise

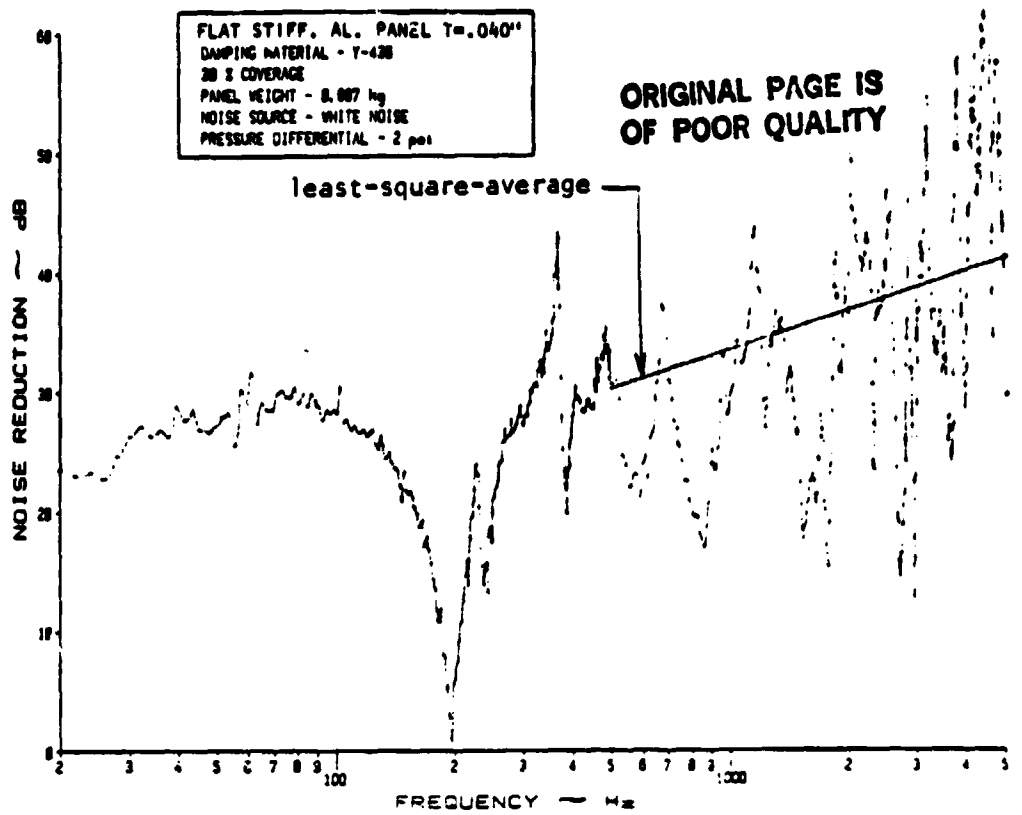

(a) Narrow Band Analysis

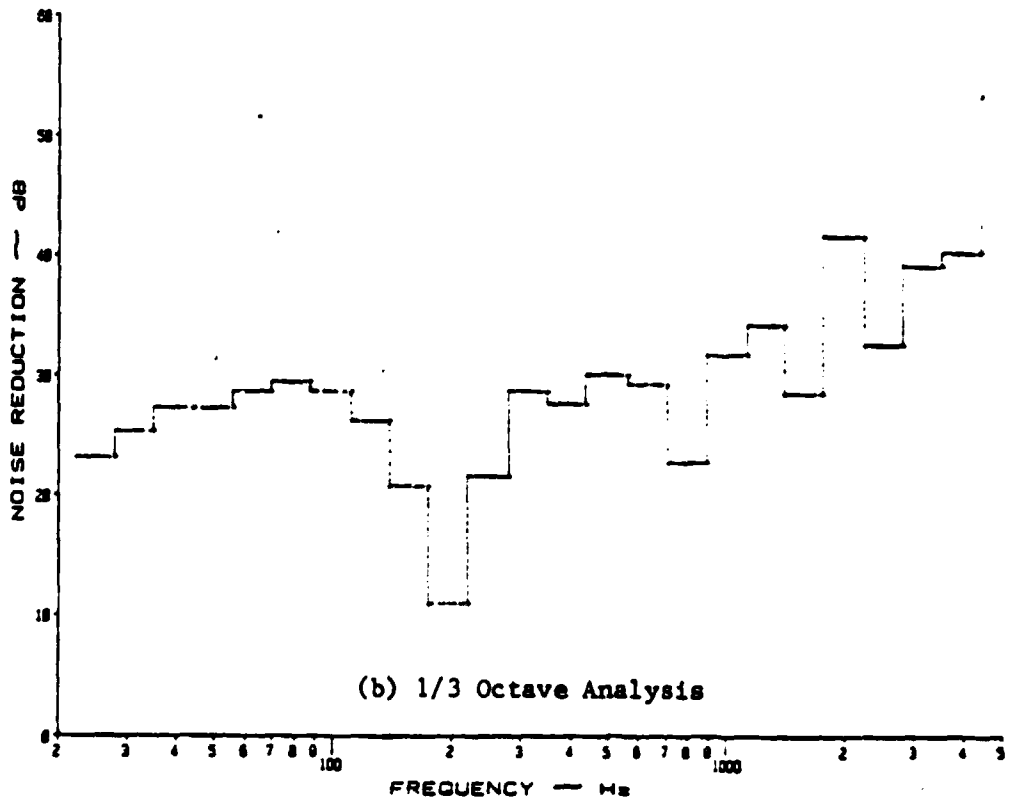

(b) 1/3 Octave Analysis

Figure A.63: Noise Reduction Characteristics of a Flat, Stiffened Panel — at 2 psi Pressure Differential with Y-436 Damping Tape under White Noise

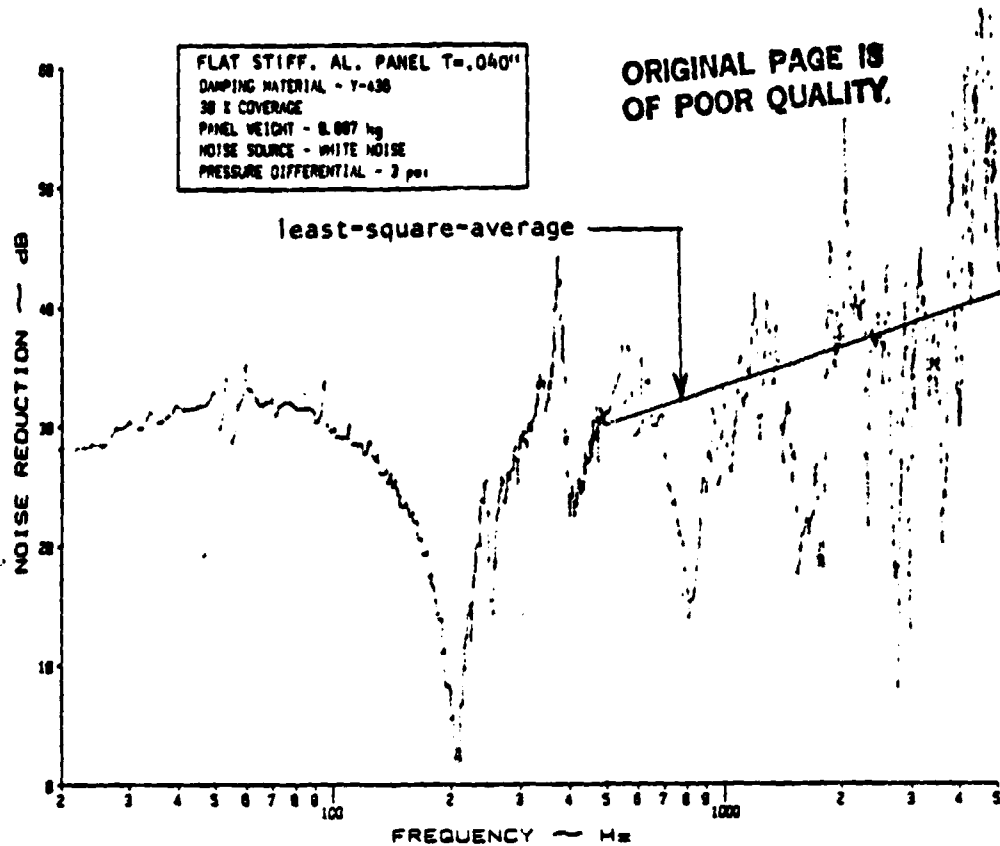

(a) Narrow Band Analysis

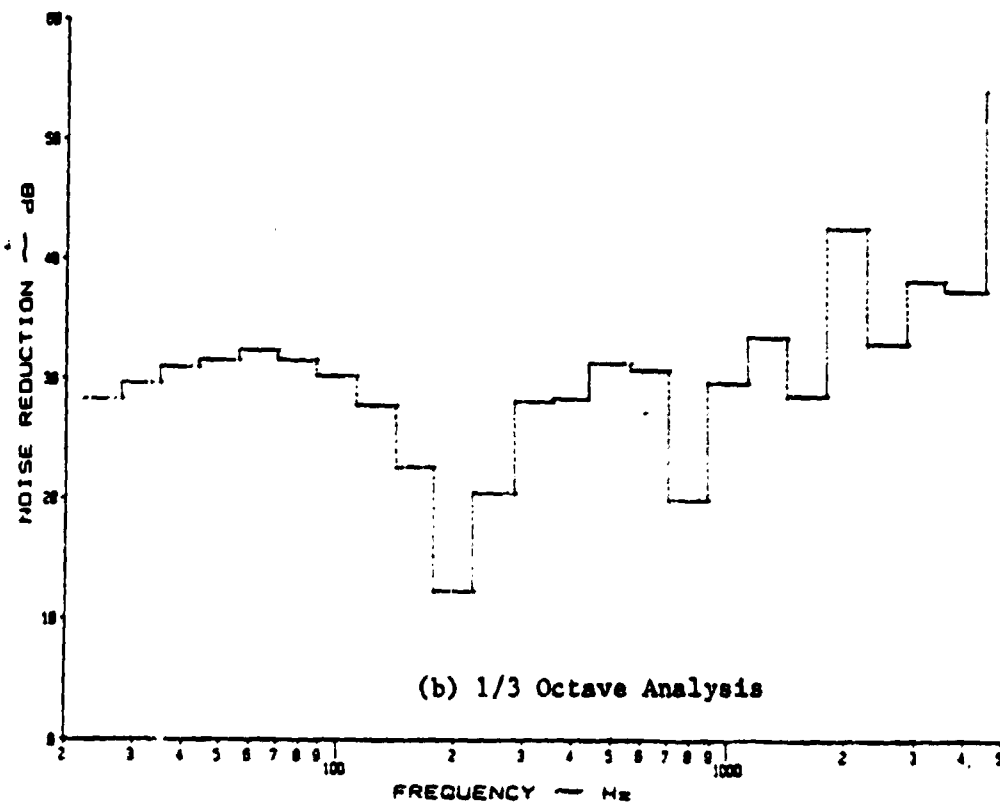

(b) 1/3 Octave Analysis

Figure A.64: Noise Reduction Characteristics of a Flat, Stiffened Panel at 3 psi Pressure Differential with Y-436 Damping Tape under White Noise

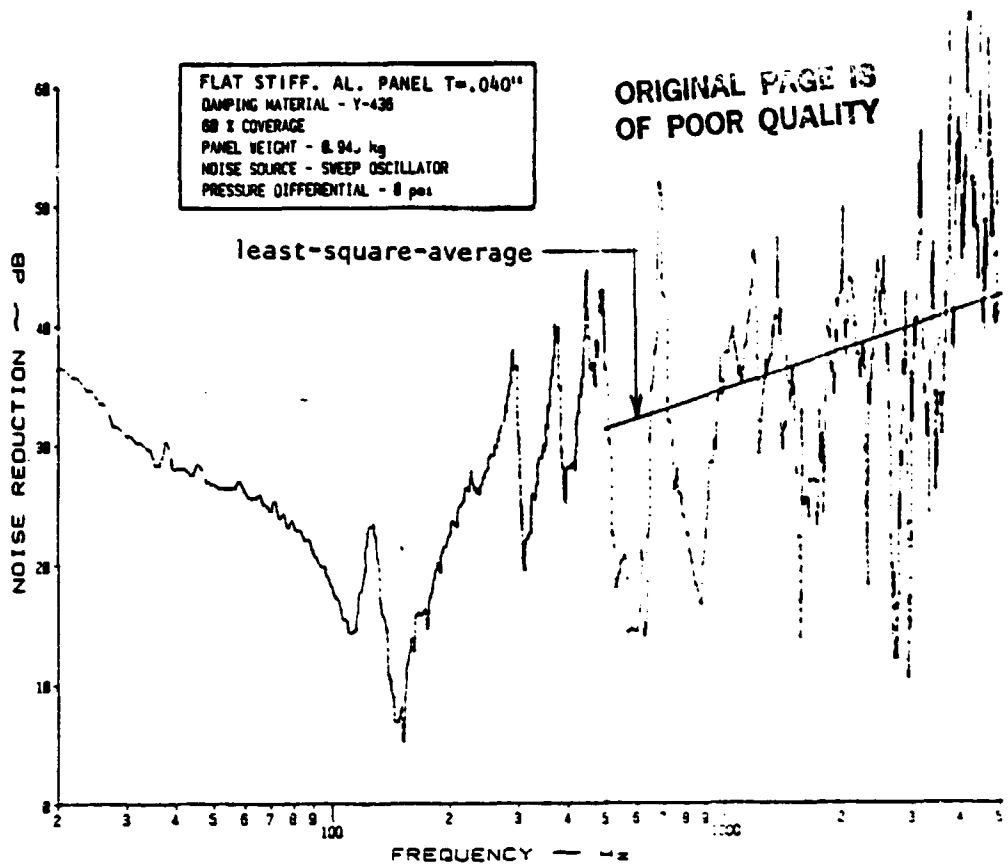

(a) Narrow Band Analysis

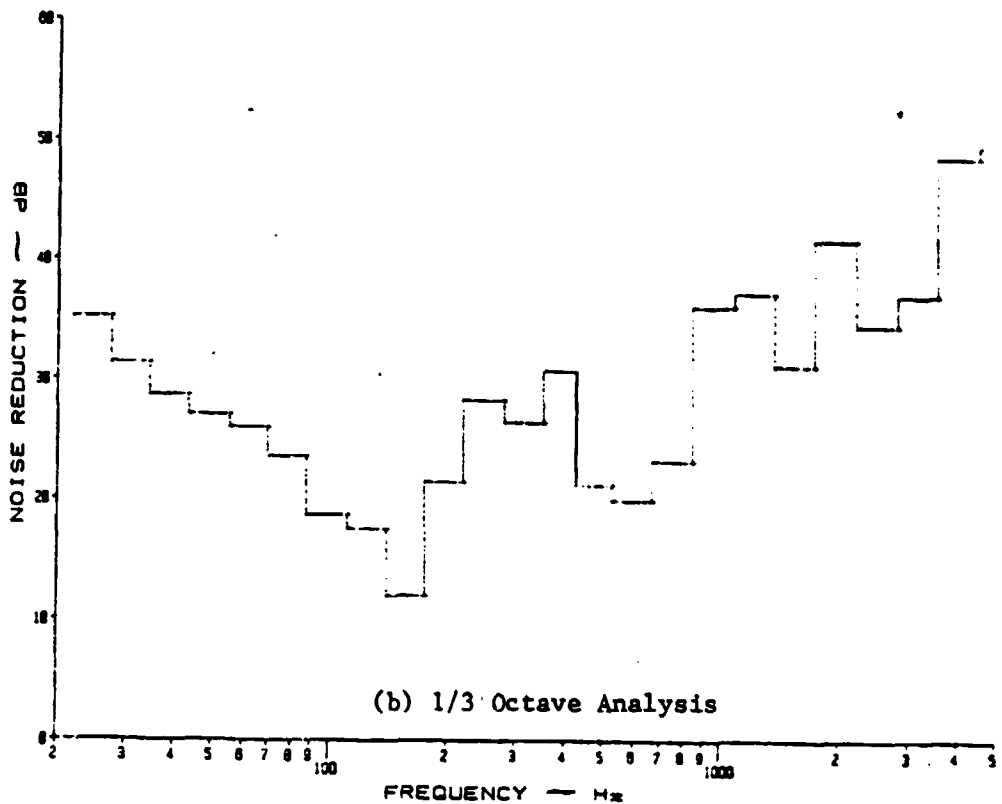
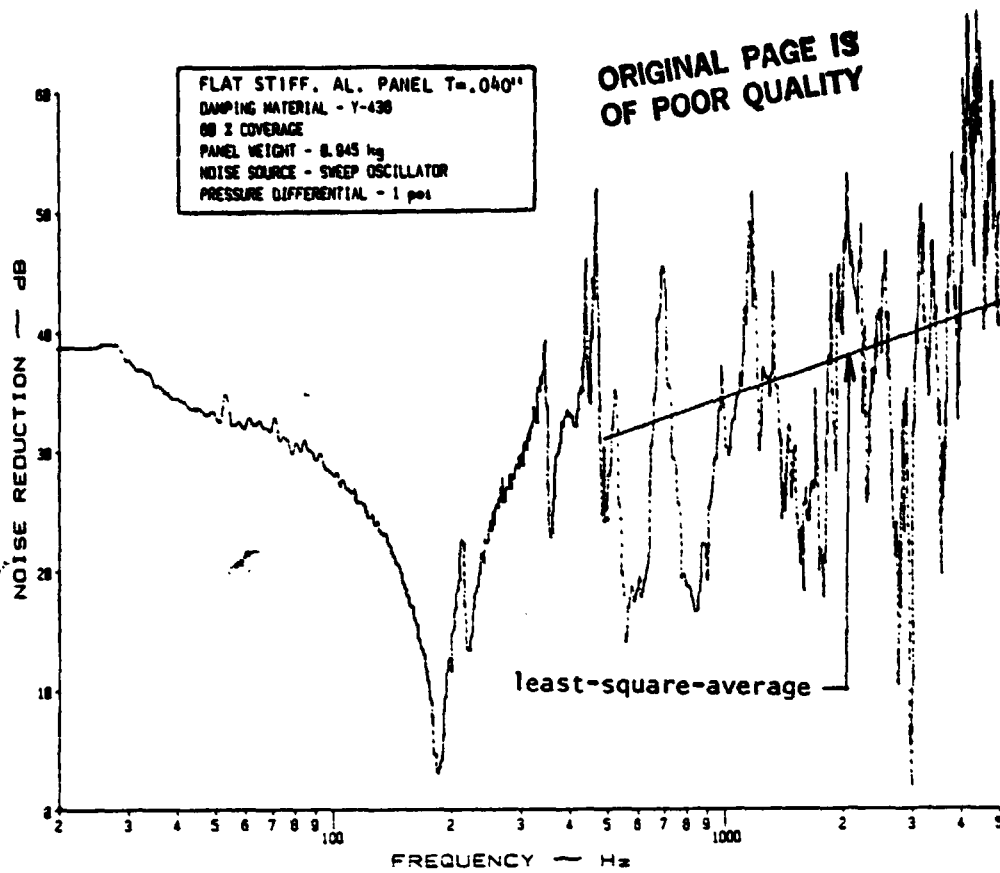
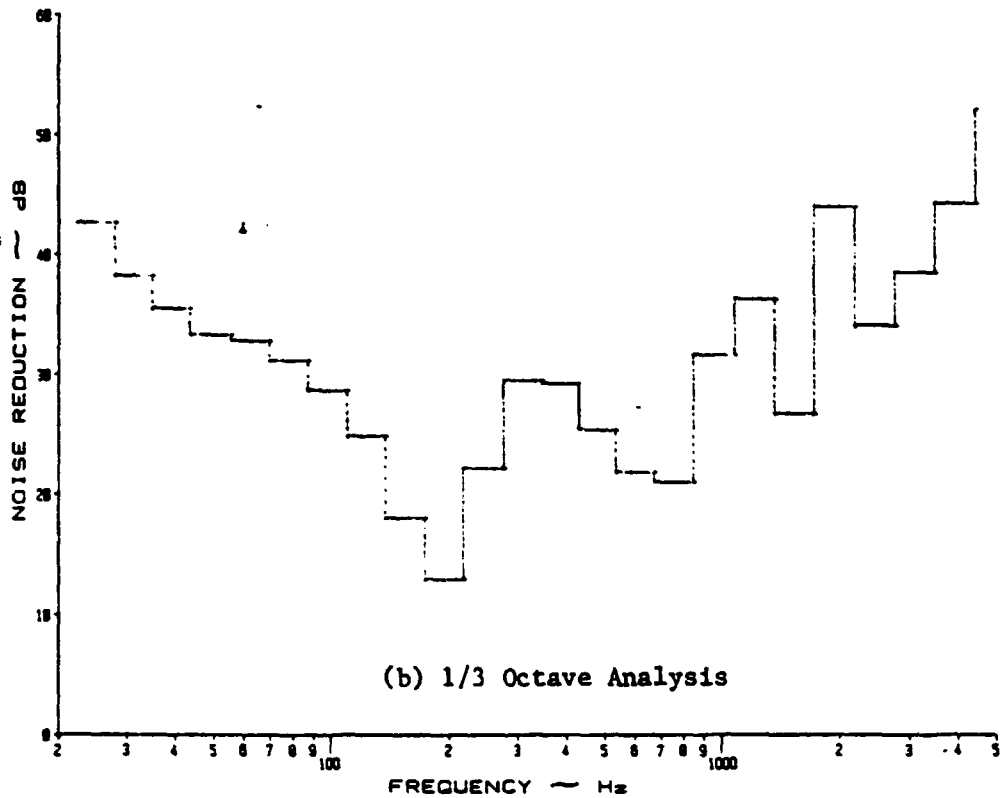

Figure A.65: Noise Reduction Characteristics of a Flat, Stiffened Panel at 0 psi Pressure Differential with Y-436 Damping Tape under a Discrete Noise Source



(a) Narrow Band Analysis



(b) 1/3 Octave Analysis

Figure A.66: Noise Reduction Characteristics of a Flat, Stiffened Panel at 1 psi Pressure Differential with Y-436 Damping Tape under a Discrete Noise Source

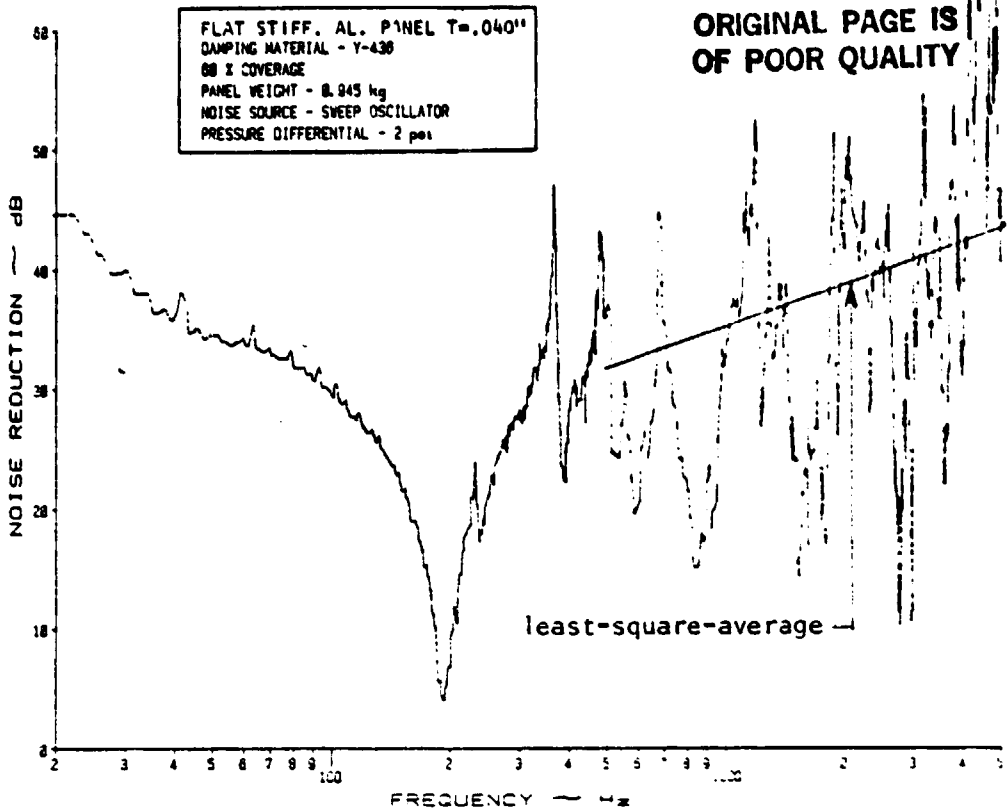

(a) Narrow Band Analysis

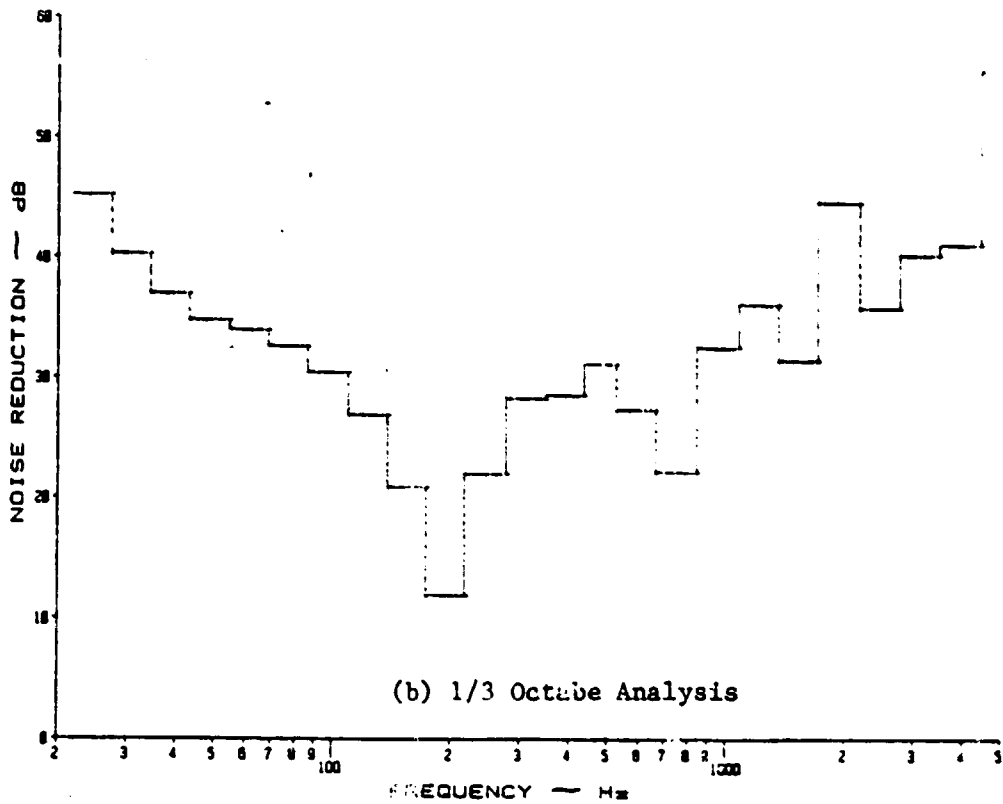
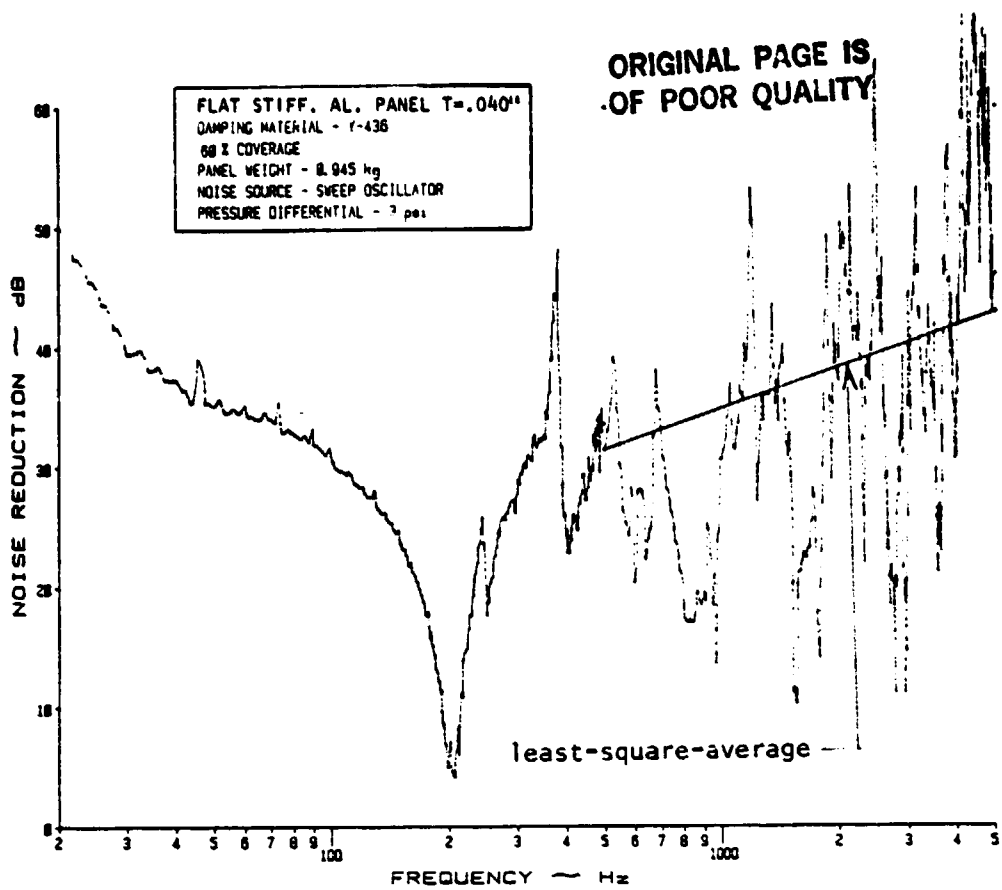
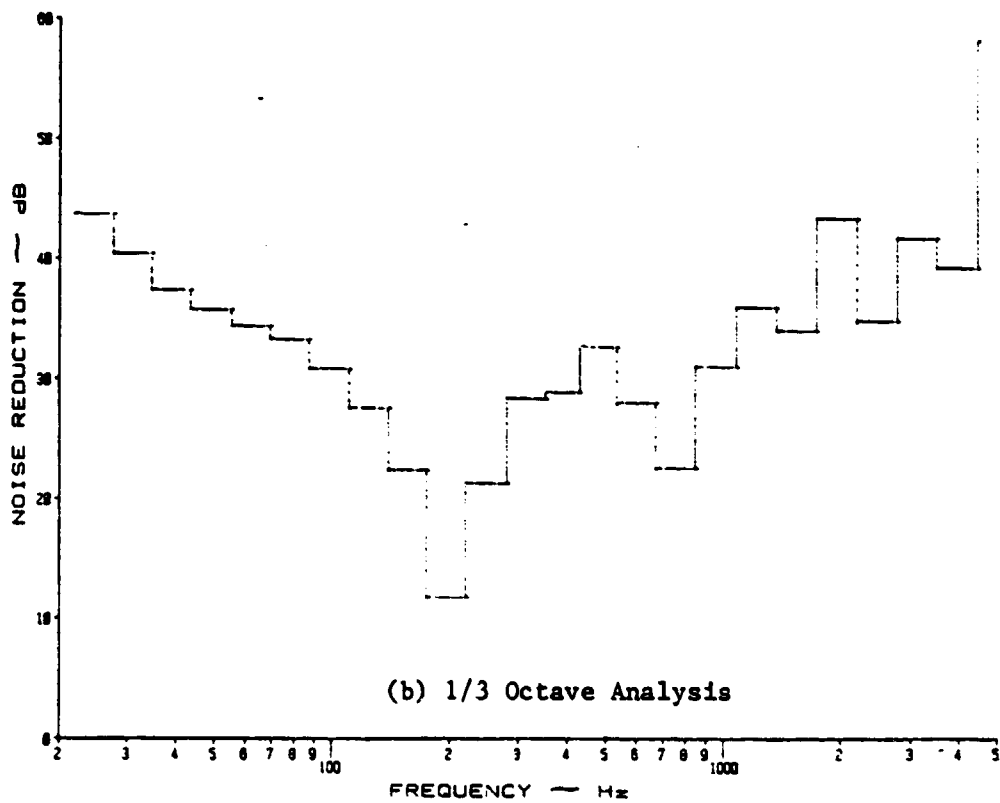

Figure A.67: Noise Reduction Characteristics of a Flat, Stiffened Panel at 2 psi Pressure Differential with Y-436 Damping Tape under a Discrete Noise Source



(a) Narrow Band Analysis



(b) 1/3 Octave Analysis

Figure A.68: Noise Reduction Characteristics of a Flat, Stiffened Panel at 3 psi Pressure Differential with Y-436 Damping Tape under a Discrete Noise Source

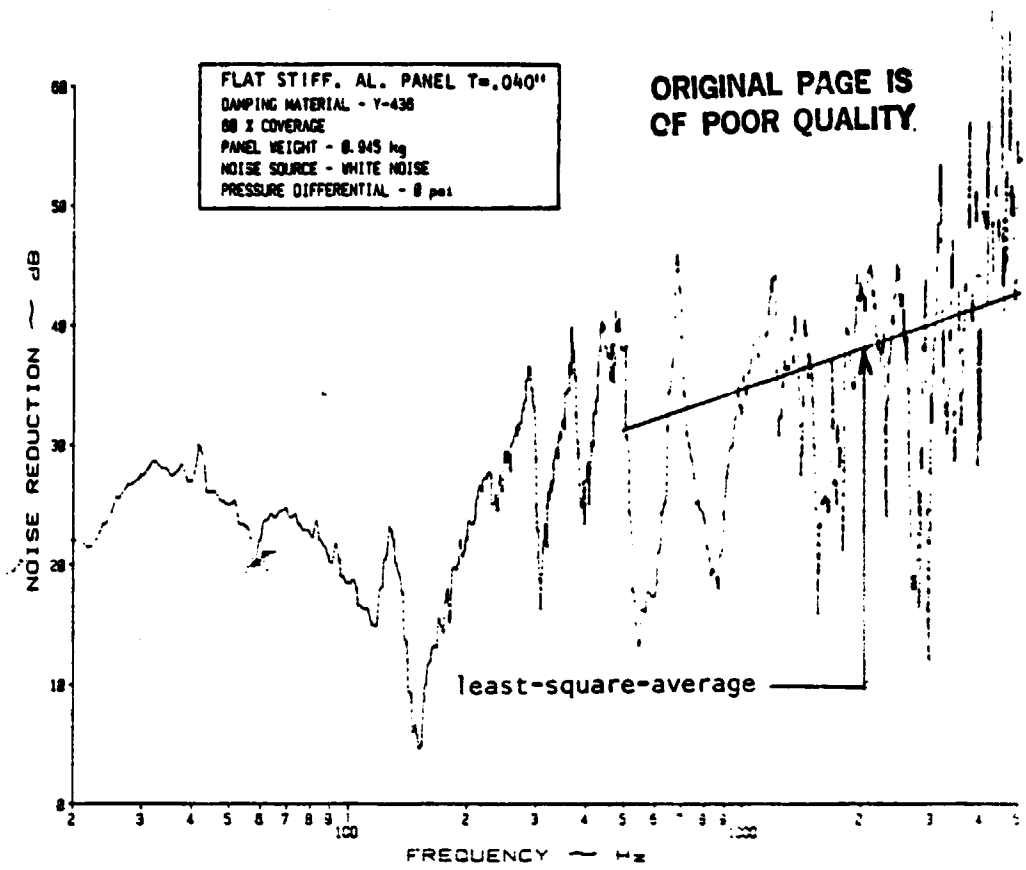

(a) Narrow Band Analysis

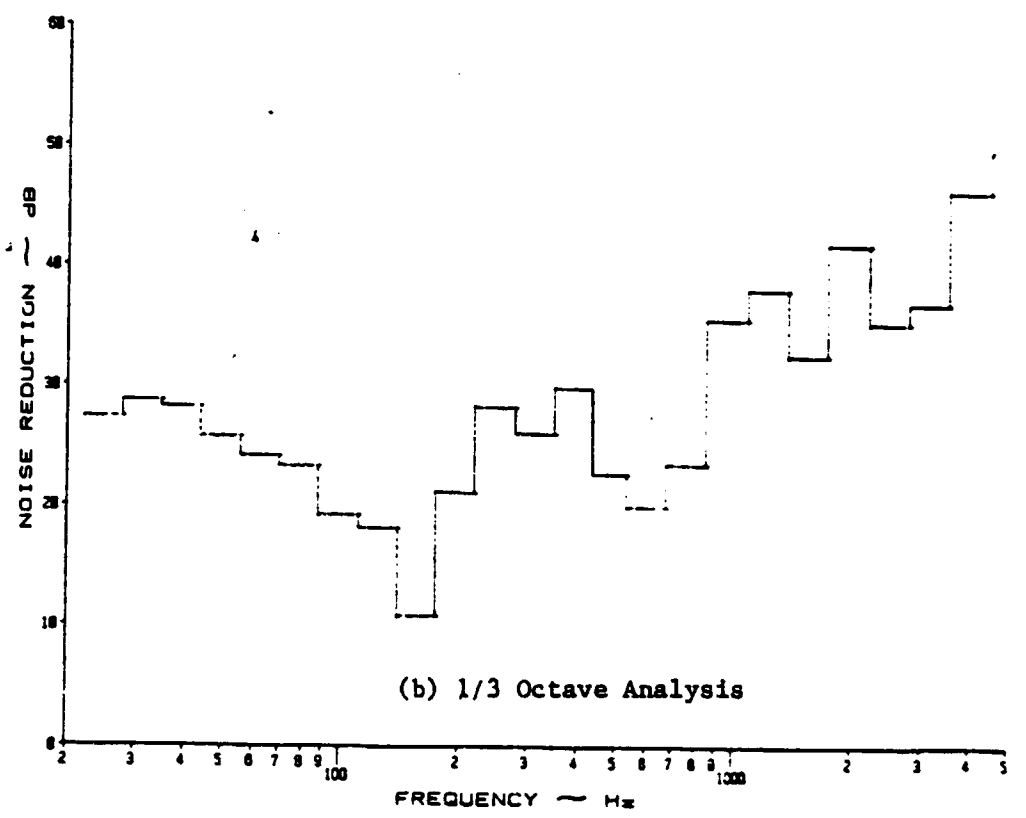
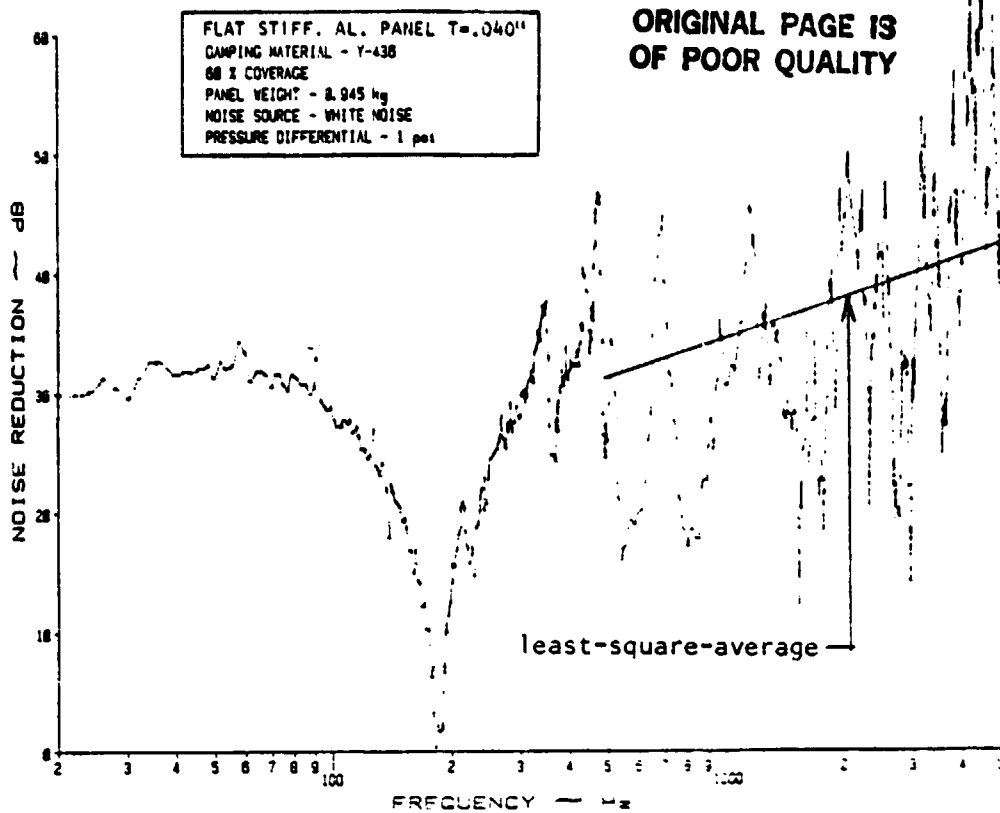

Figure A.69: Noise Reduction Characteristics of a Flat, Stiffened Panel at . 0 psi Pressure Differential with Y-436 Damping Tape under White Noise



(a) Narrow Band Analysis

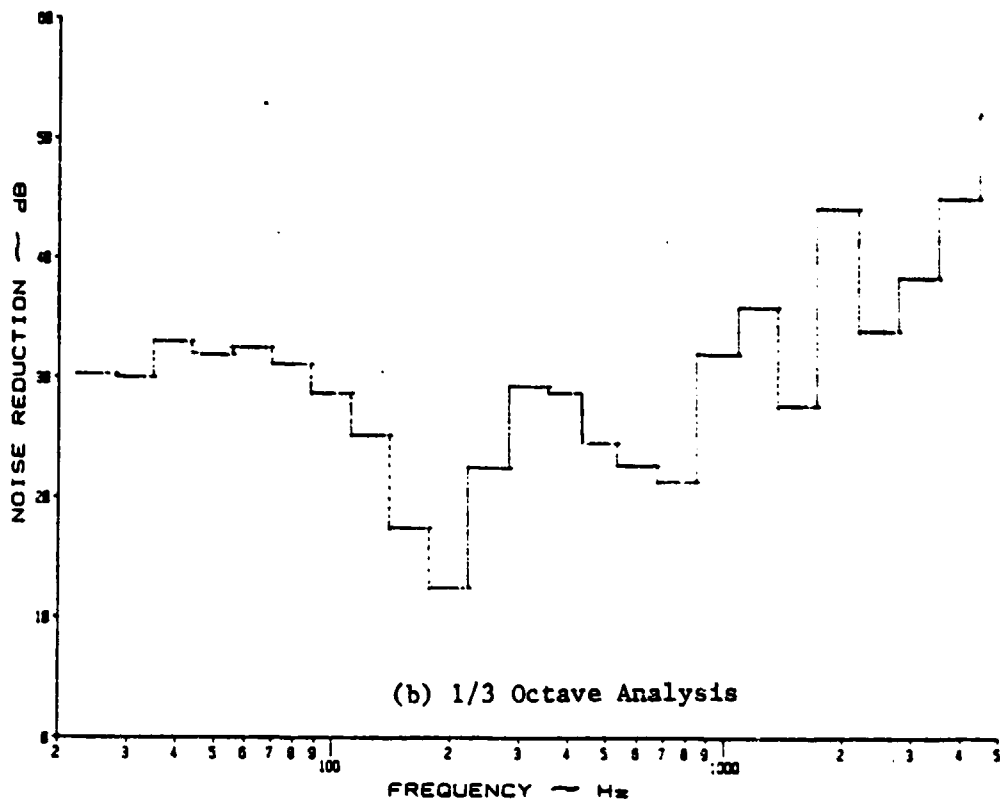
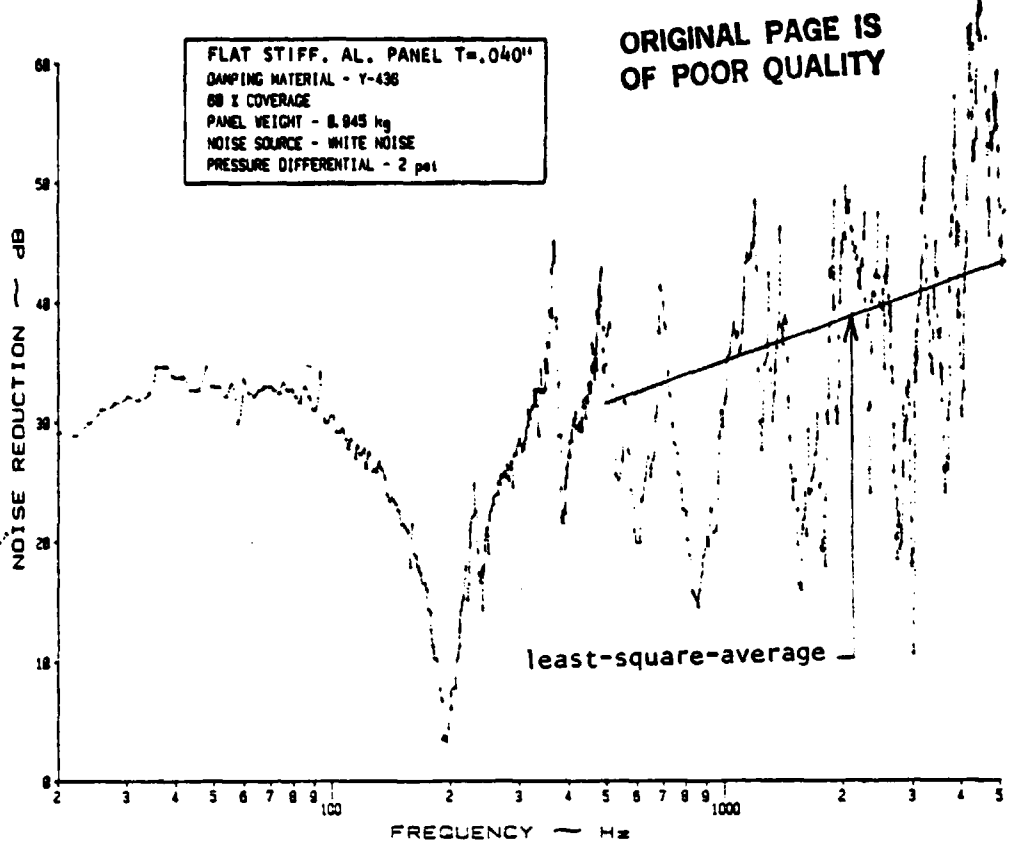
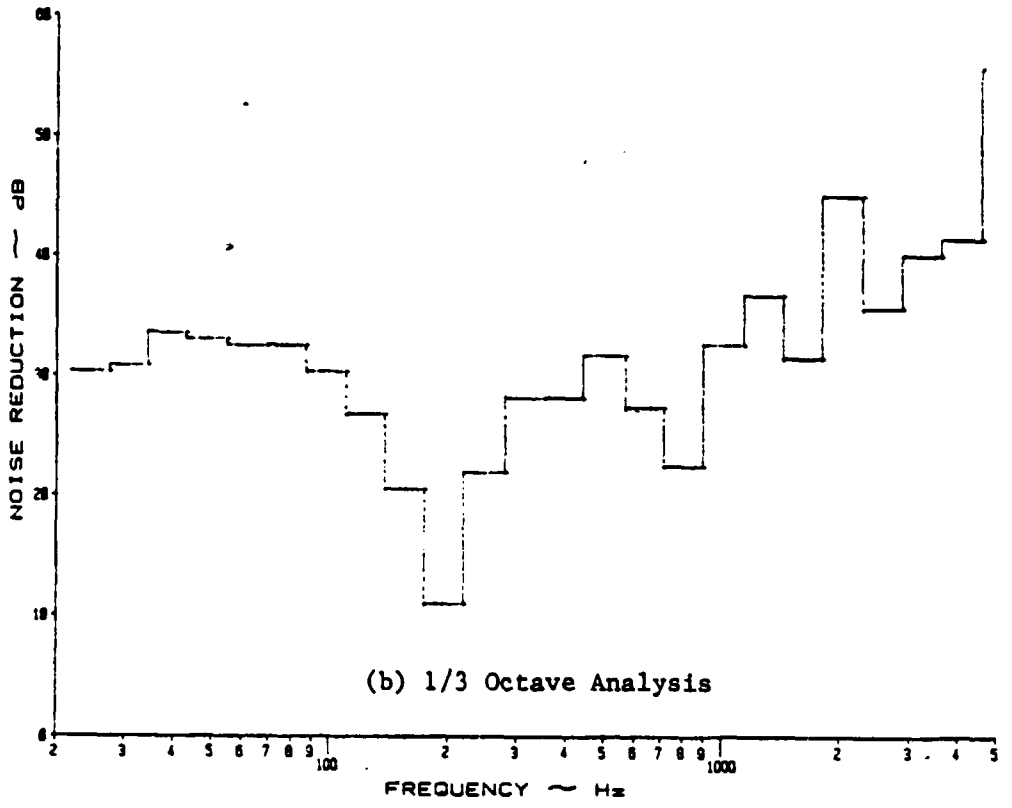

Figure A.70: Noise Reduction Characteristics of a Flat, Stiffened Panel at 1 psi Pressure Differential with Y-436 Damping Tape under White Noise



(a) Narrow Band Analysis



(b) 1/3 Octave Analysis

Figure A.71: Noise Reduction Characteristics of a Flat, Stiffened Panel at 2 psi Pressure Differential with Y-436 Damping Tape under White Noise

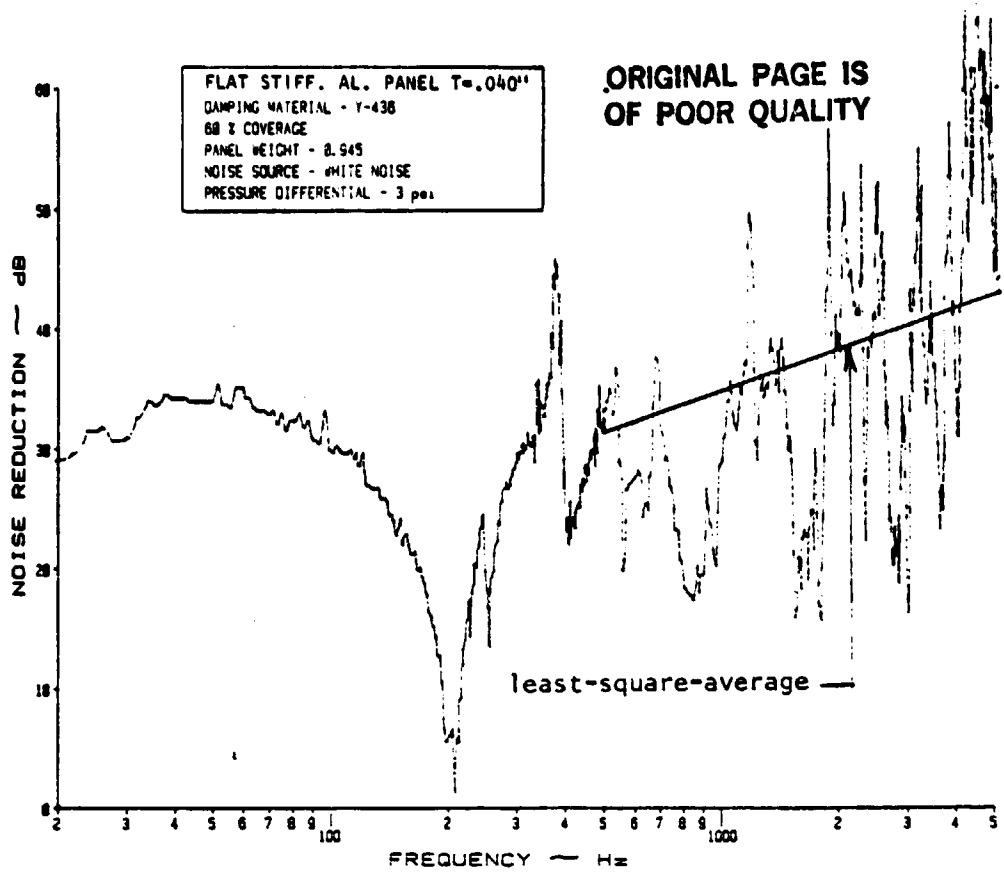

(a) Narrow Band Analysis

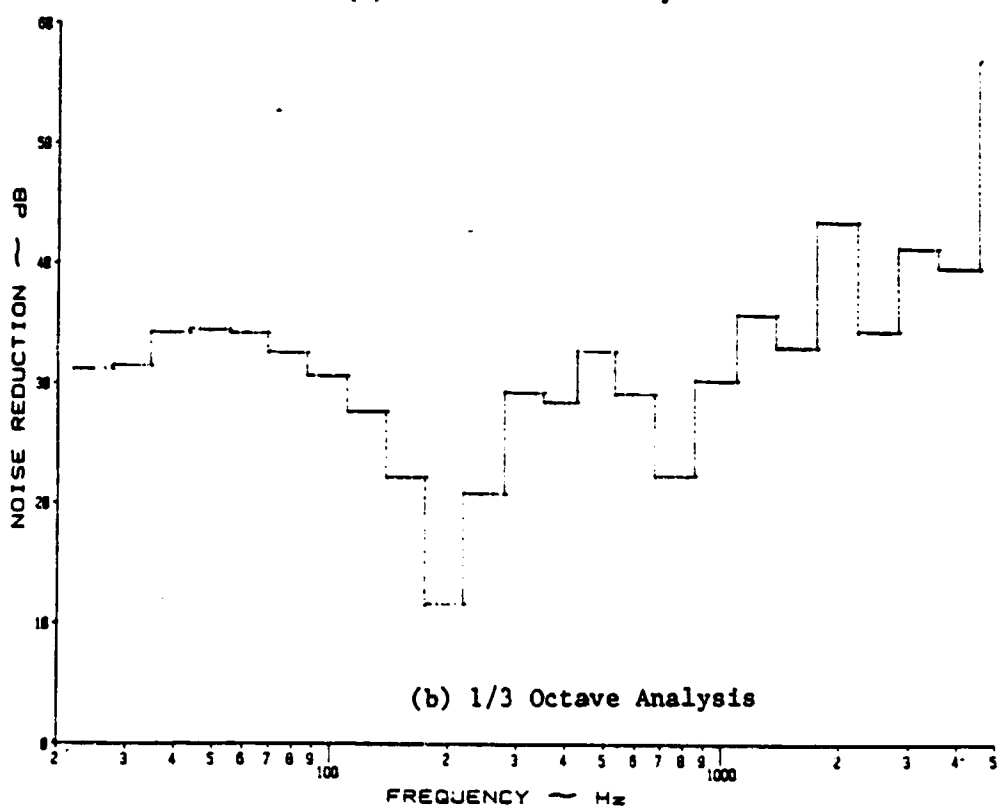

(b) 1/3 Octave Analysis

Figure A.72: Noise Reduction Characteristics of a Flat, Stiffened Panel at 3 psi Pressure Differential with Y-436 Damping Tape under White Noise

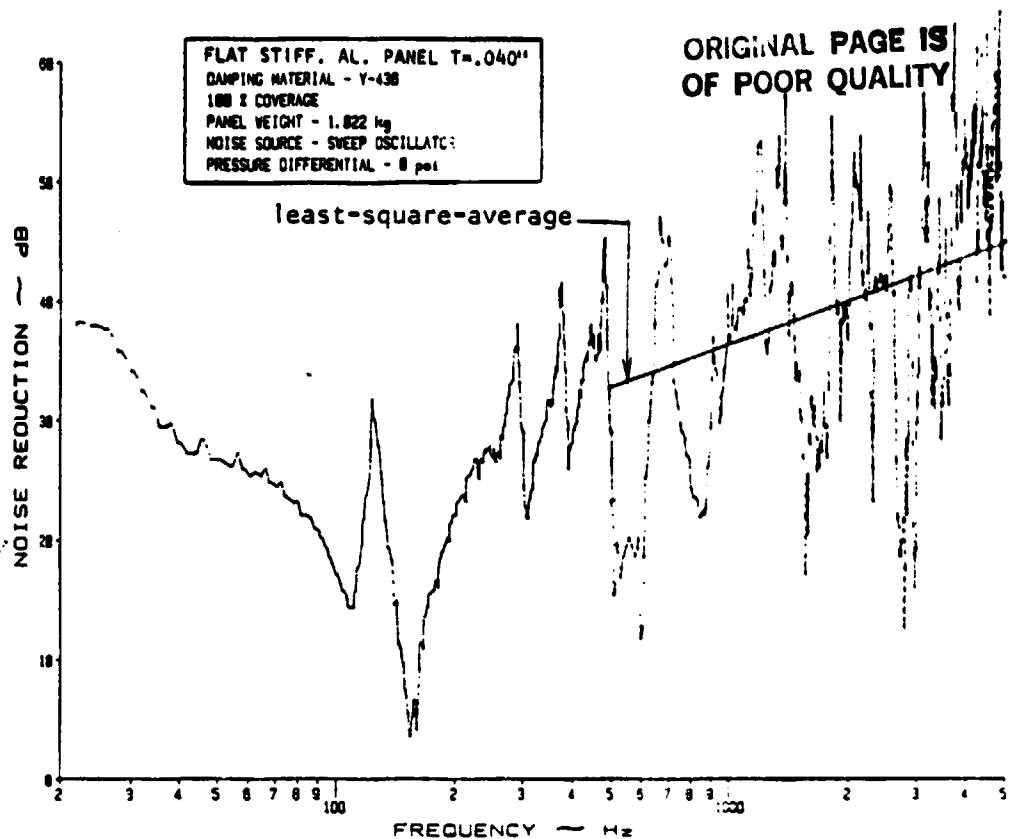

(a) Narrow Band Analysis

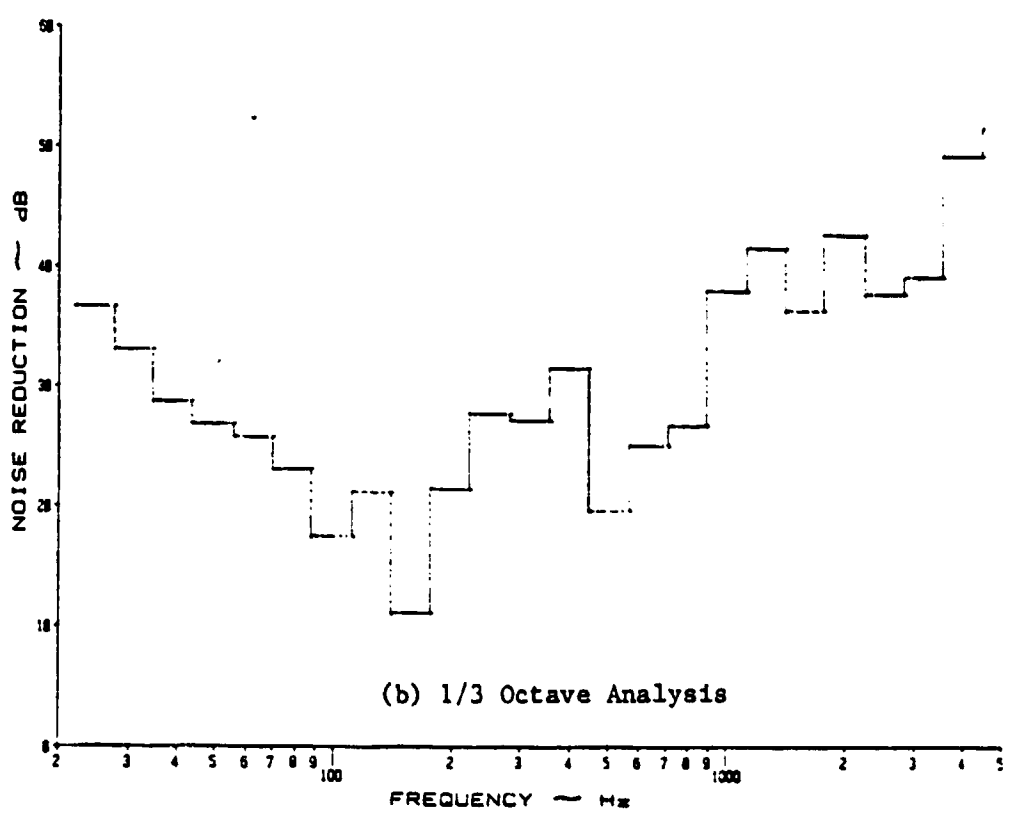

(b) 1/3 Octave Analysis

Figure A.73: Noise Reduction Characteristics of a Flat, Stiffened Panel at 0 psi Pressure Differential with Y-436 Damping Tape under a Discrete Noise Source

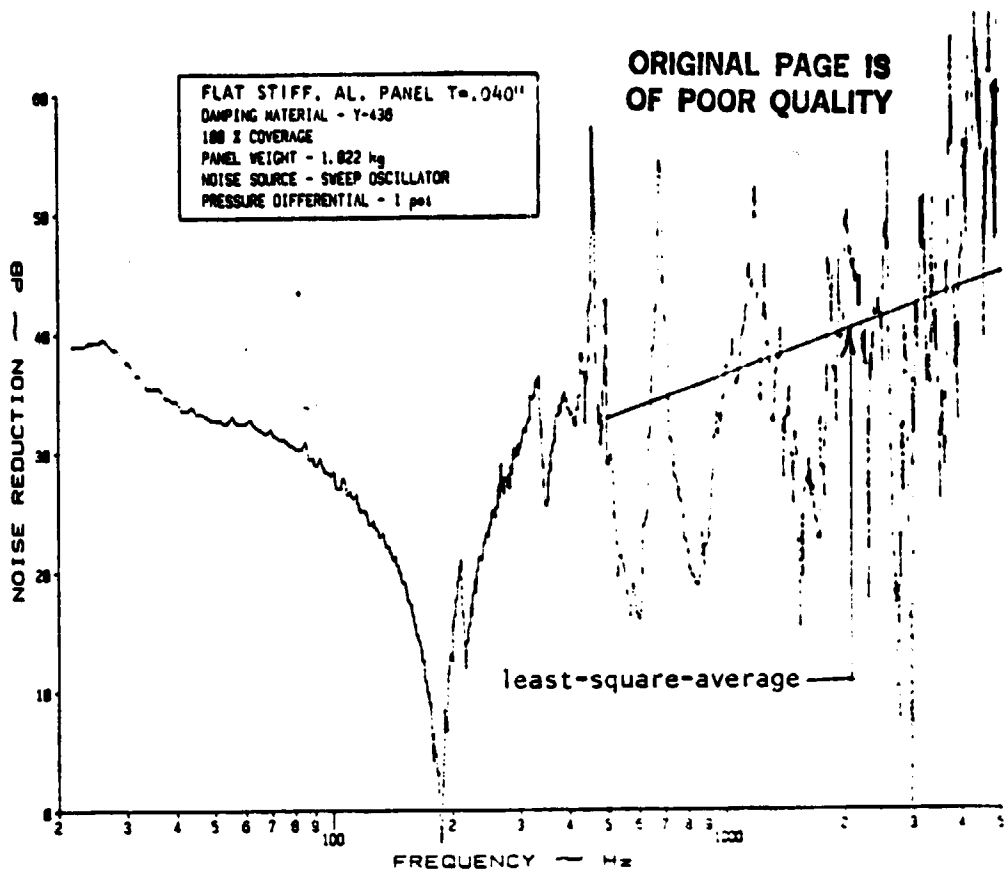

(a) Narrow Band Analysis

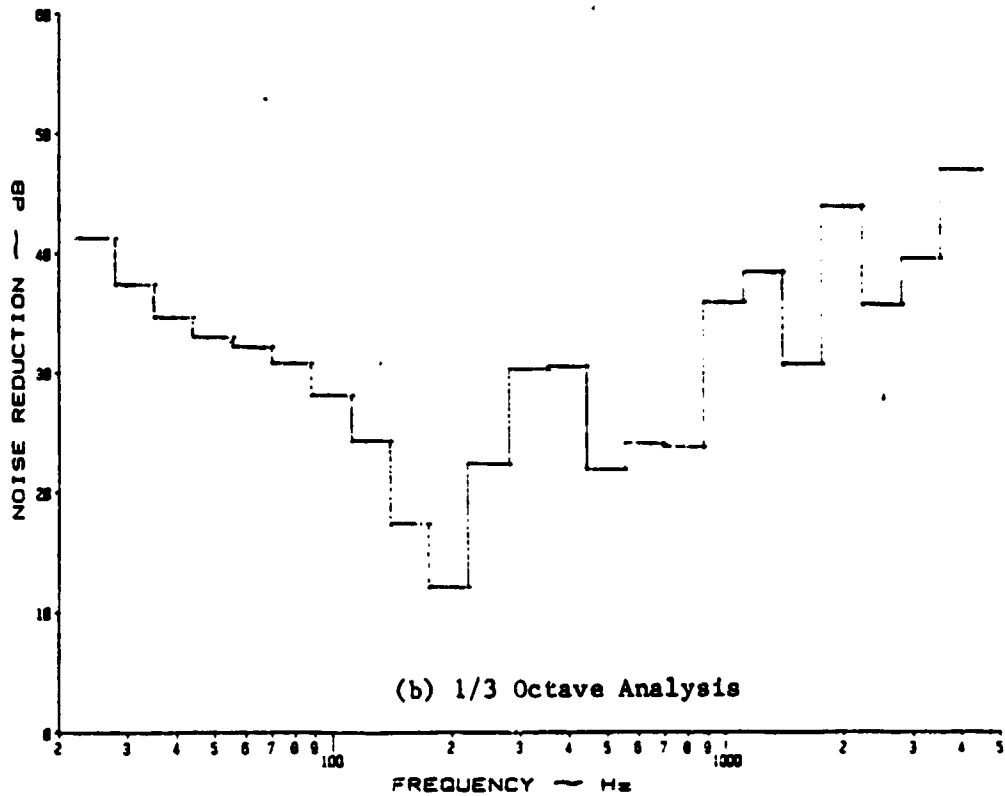

(b) 1/3 Octave Analysis

Figure A.74: Noise Reduction Characteristics of a Flat, Stiffened Panel at 1 psi Pressure Differential with Y-436 Damping Tape under a Discrete Noise Source

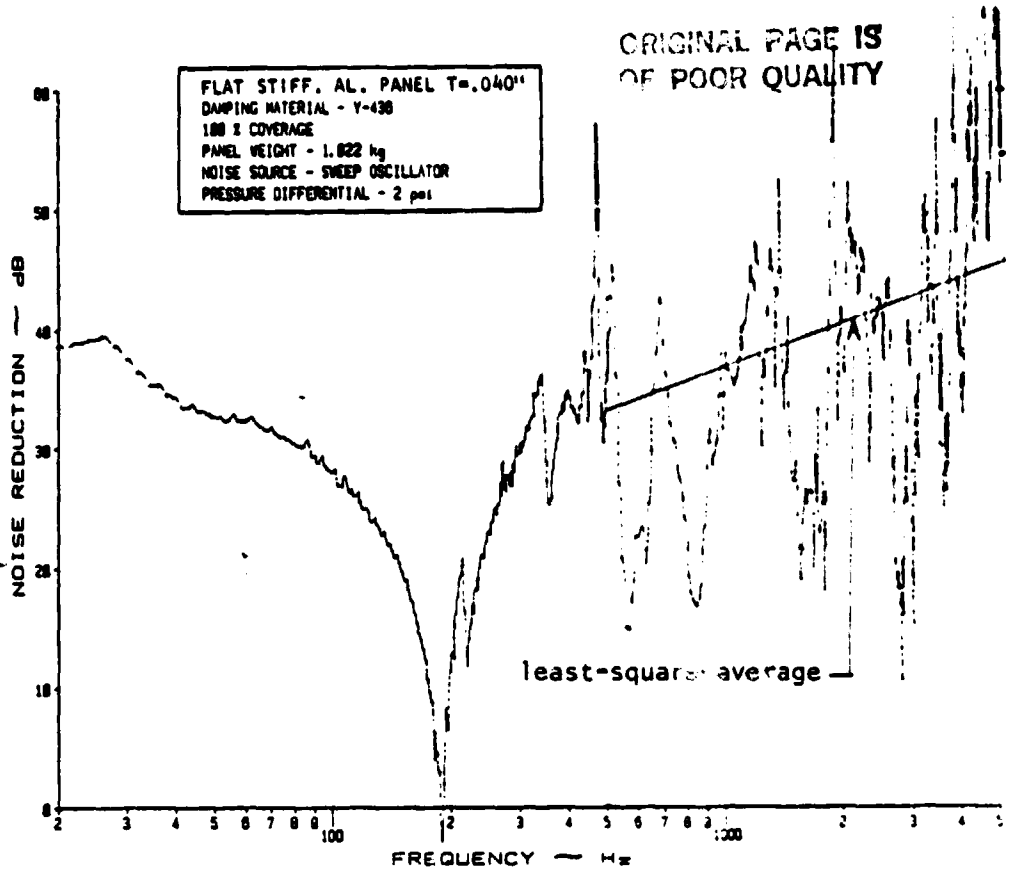

(a) Narrow Band Analysis

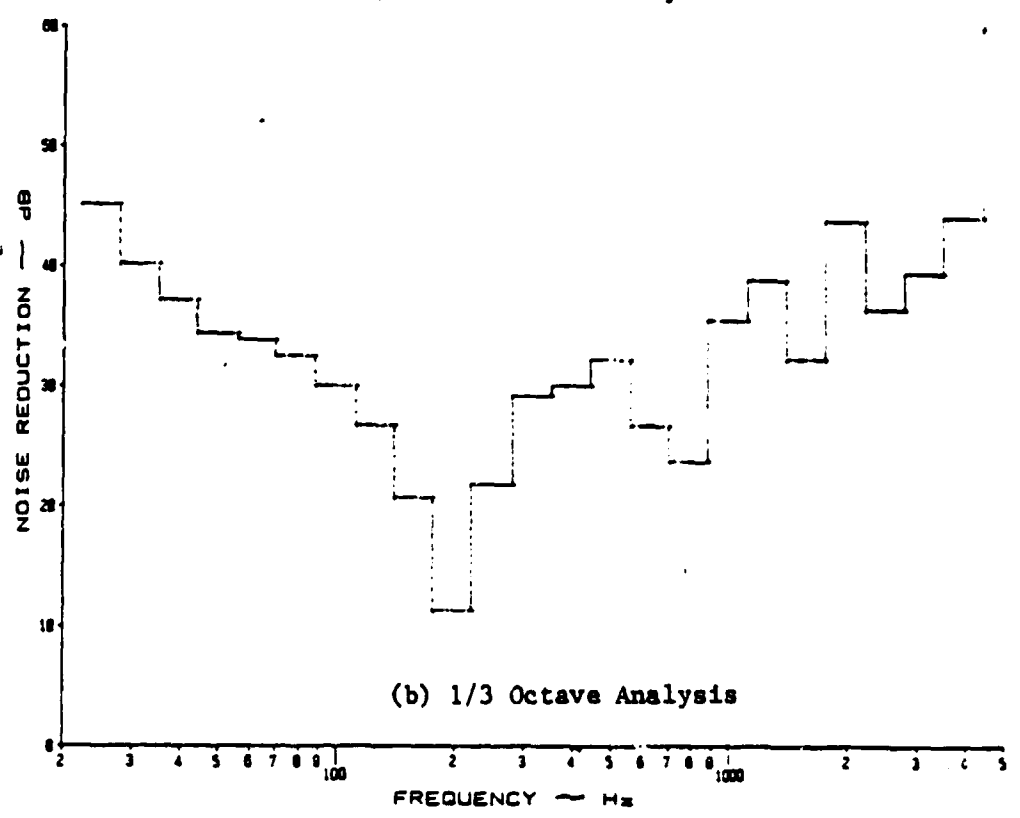

(b) 1/3 Octave Analysis

Figure A.75: Noise Reduction Characteristics of a Flat, Stiffened Panel at 2 psi Pressure Differential with Y-436 Damping Tape under a Discrete Noise Source

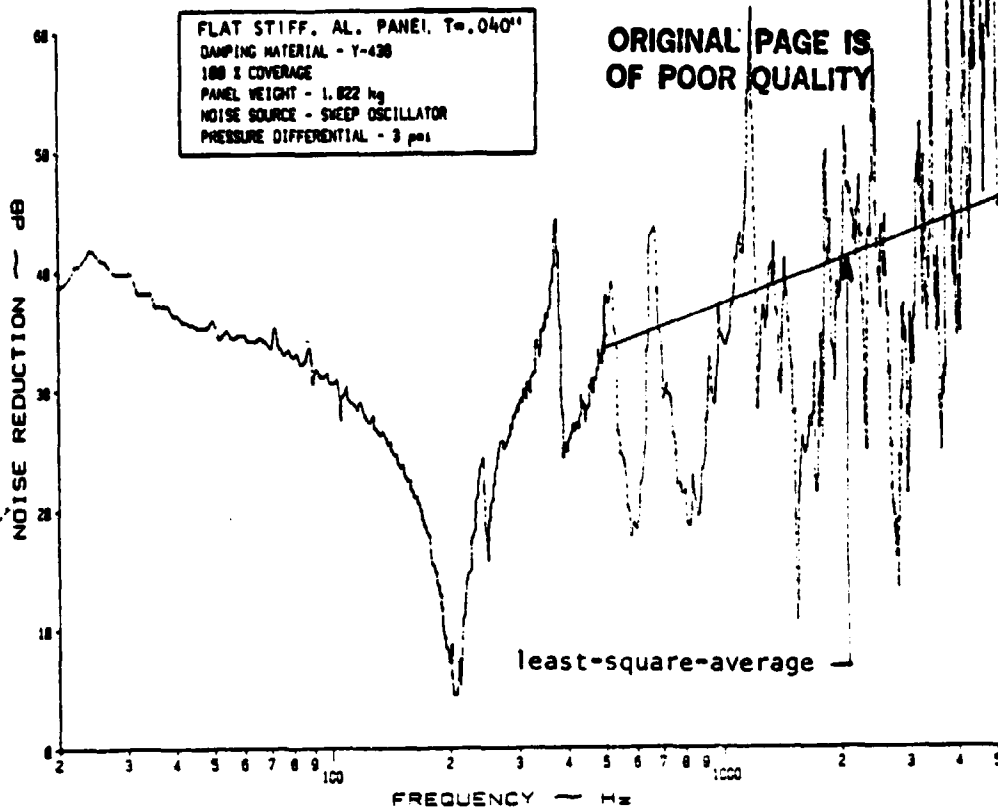

(a) Narrow Band Analysis

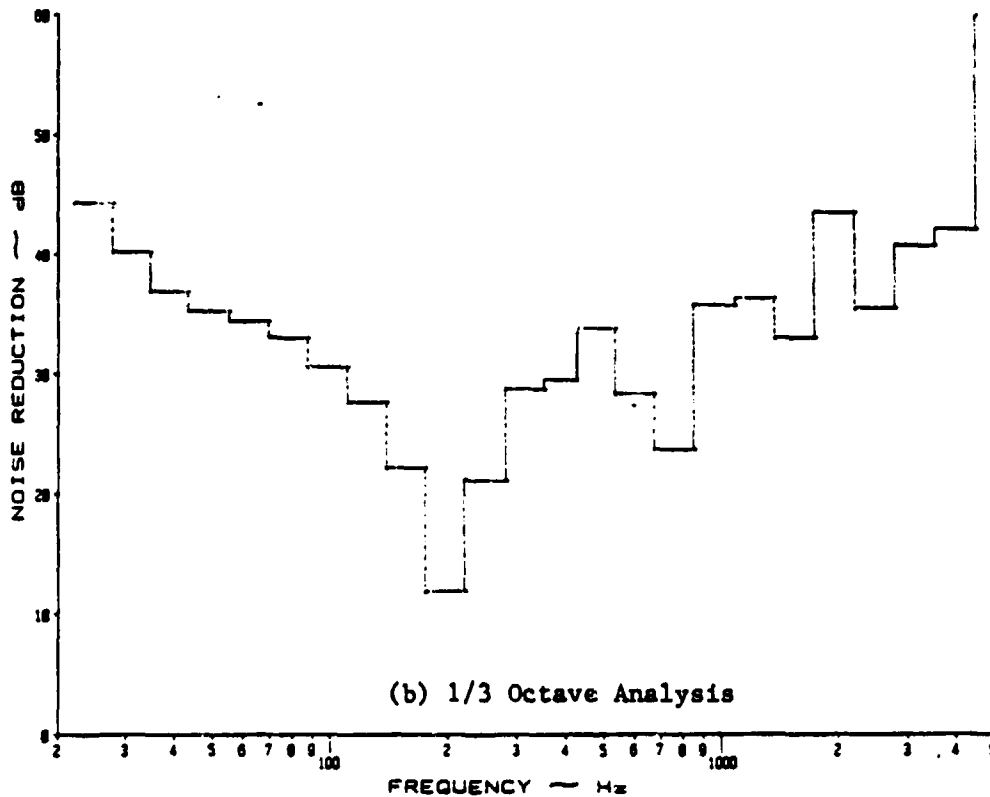

(b) 1/3 Octave Analysis

Figure A.76: Noise Reduction Characteristics of a Flat, Stiffened Panel at 3 psi Pressure Differential with Y-436 Damping Tape under a Discrete Noise Source

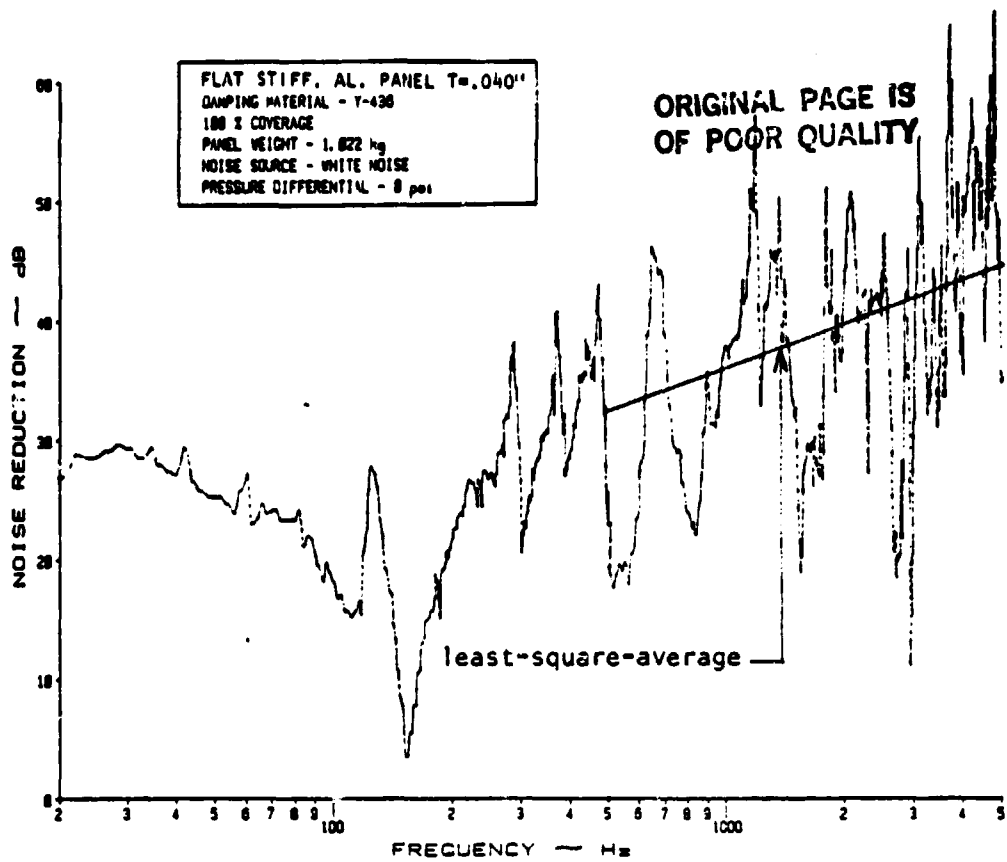

(a) Narrow Band Analysis

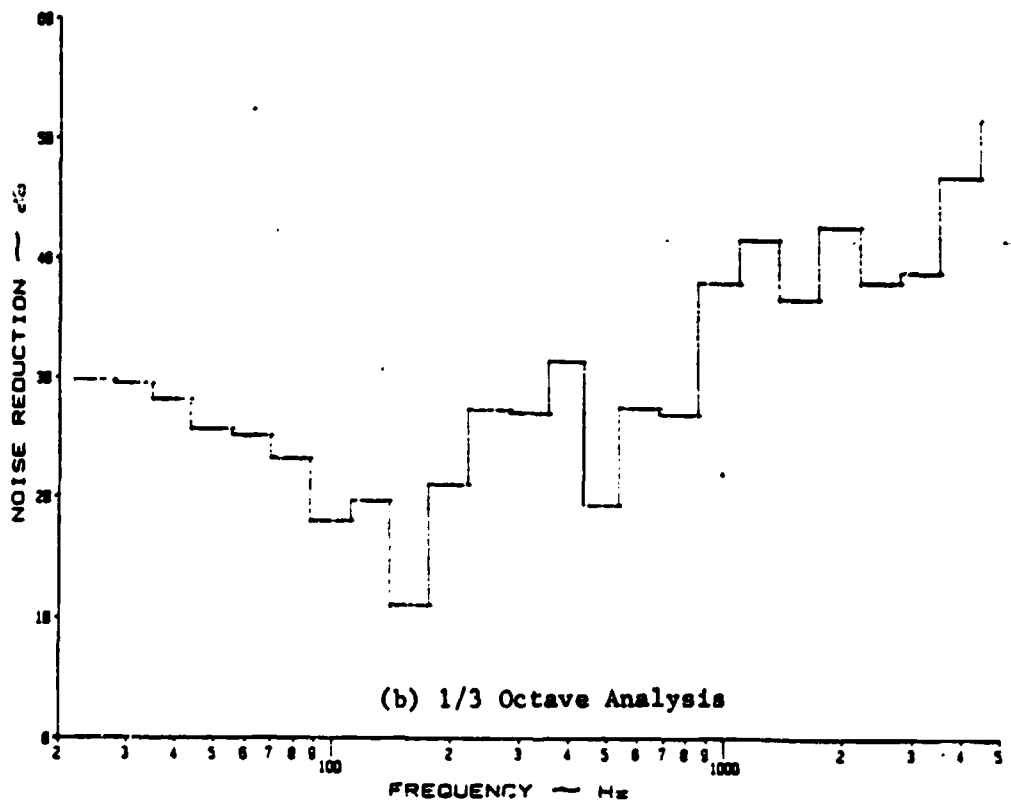
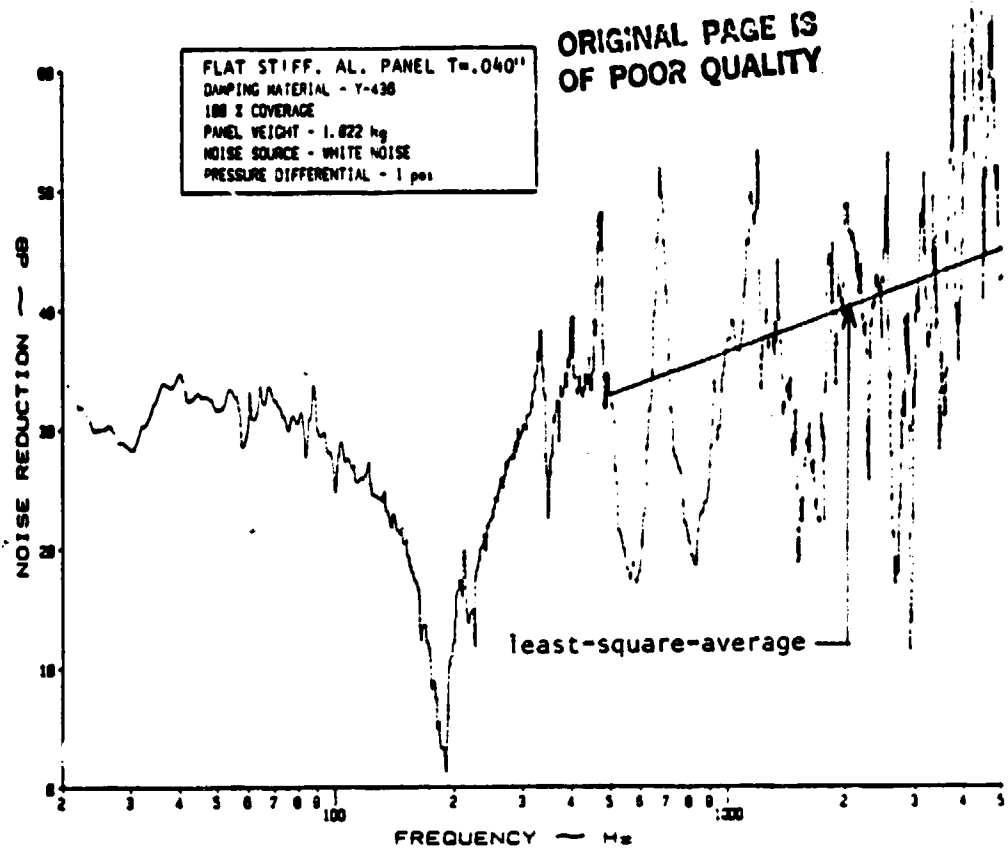
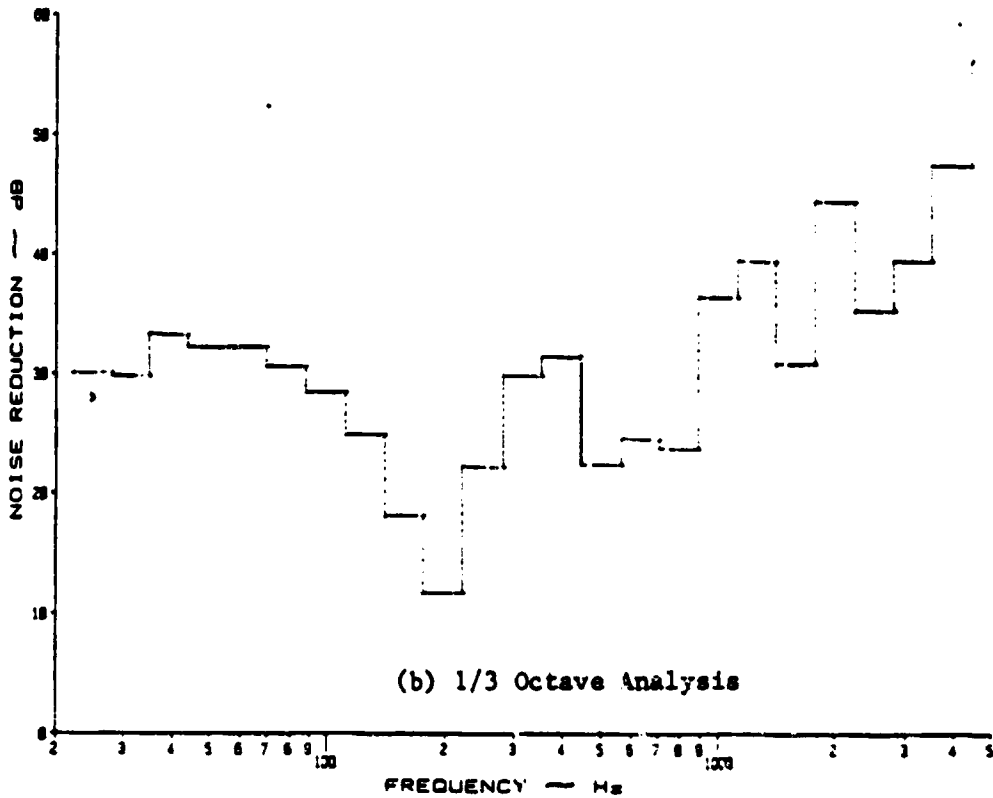

Figure A.77: Noise Reduction Characteristics of a Flat, Stiffened Panel at 0 psi Pressure Differential with Y-436 Damping Tape under White Noise



(a) Narrow Band Analysis



(b) 1/3 Octave Analysis

Figure A.78: Noise Reduction Characteristics of a Flat, Stiffened Panel at 1 psi Pressure Differential with Y-436 Damping Tape under White Noise

ORIGINAL PAGE IS
OF POOR QUALITY

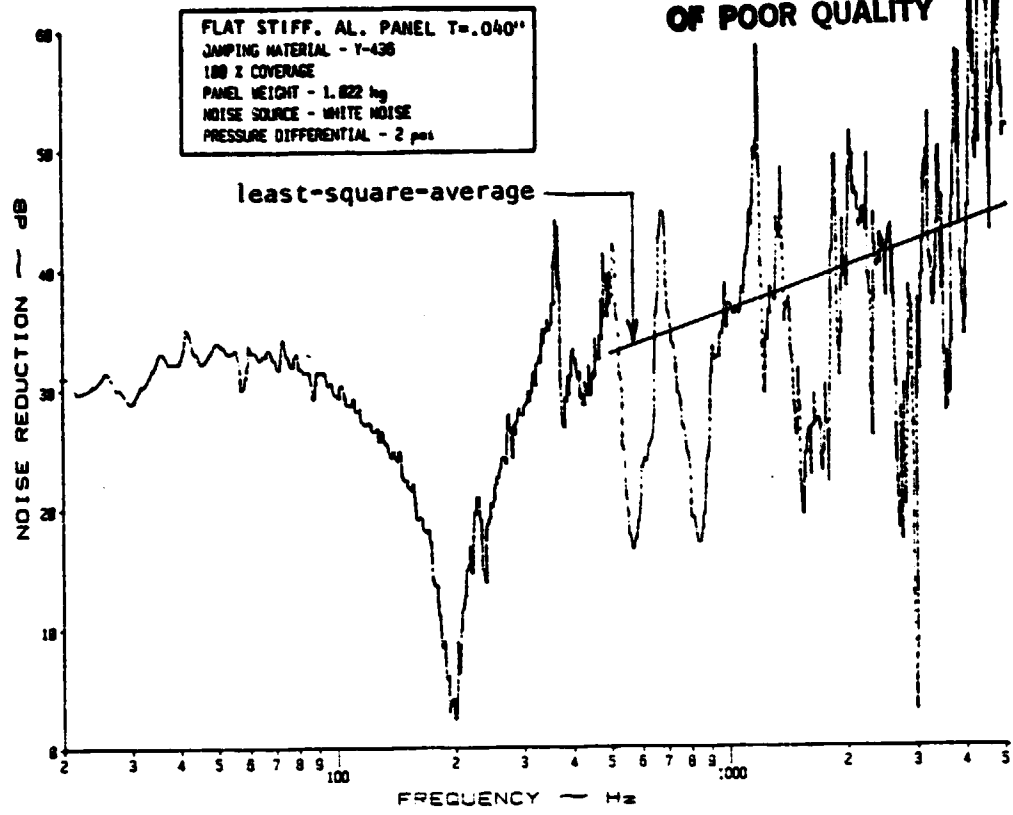

(a) Narrow Band Analysis

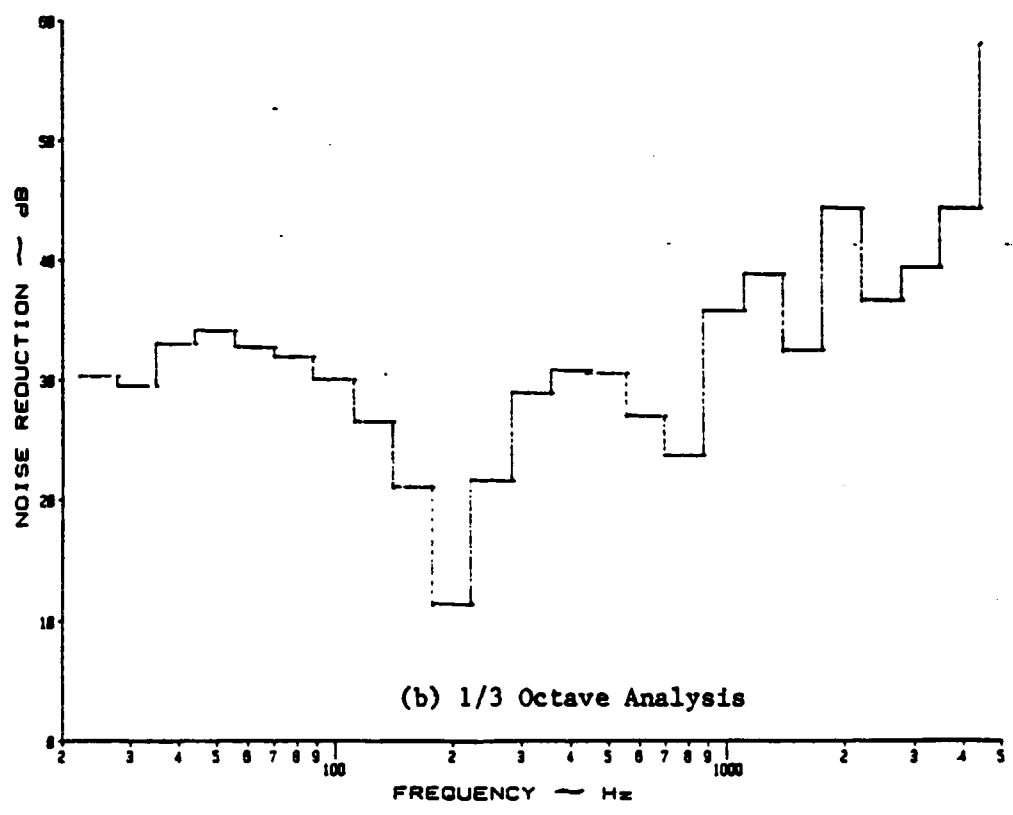

(b) 1/3 Octave Analysis

Figure A.79: Noise Reduction Characteristics of a Flat, Stiffened Panel at 2 psi Pressure Differential with Y-436 Damping Tape under White Noise

C-3

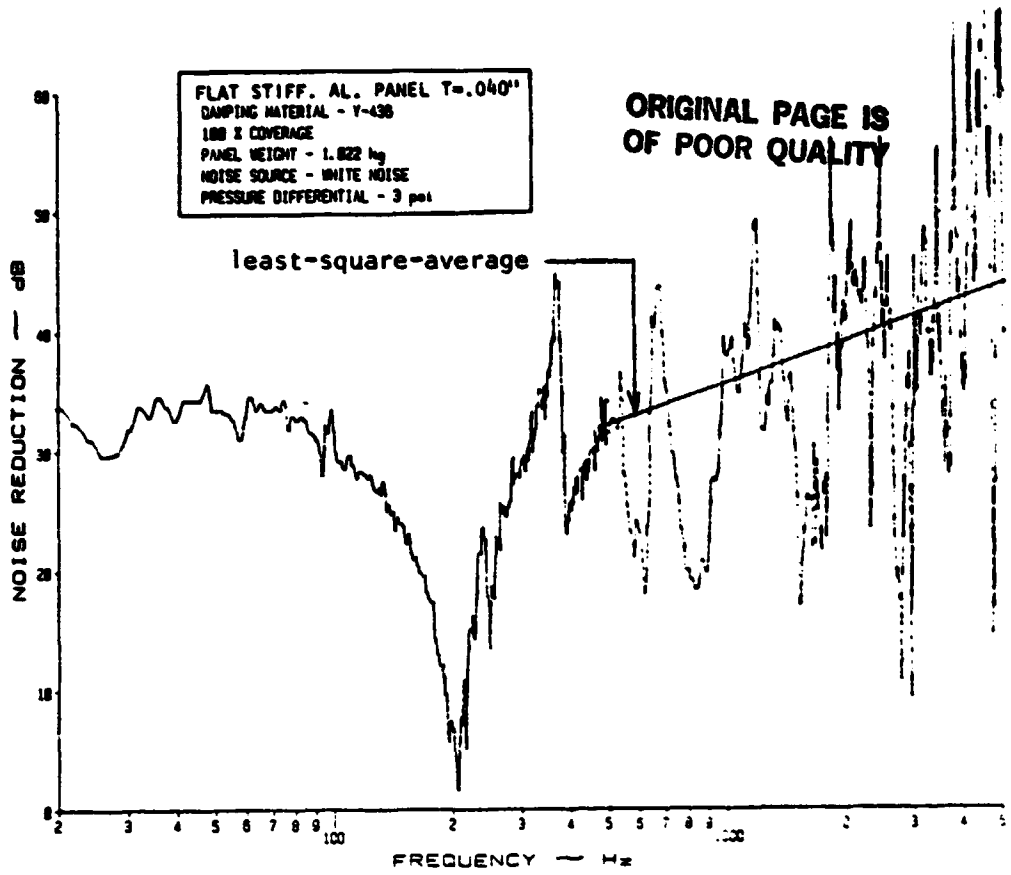

(a) Narrow Band Analysis

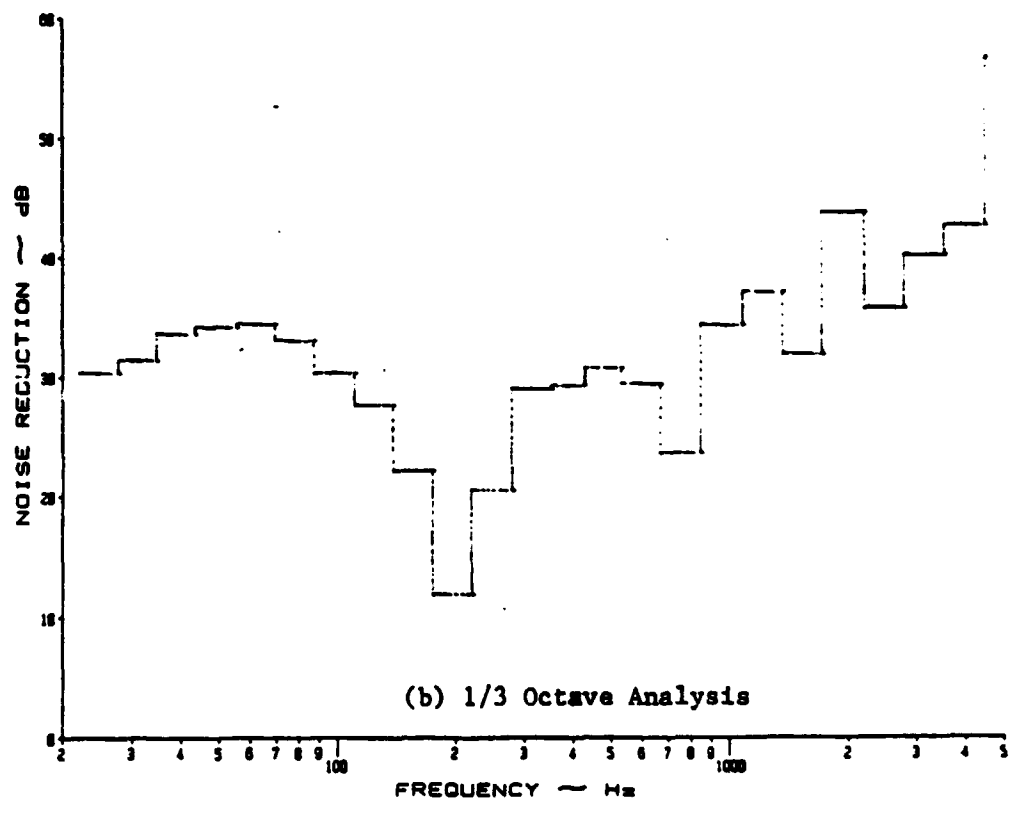
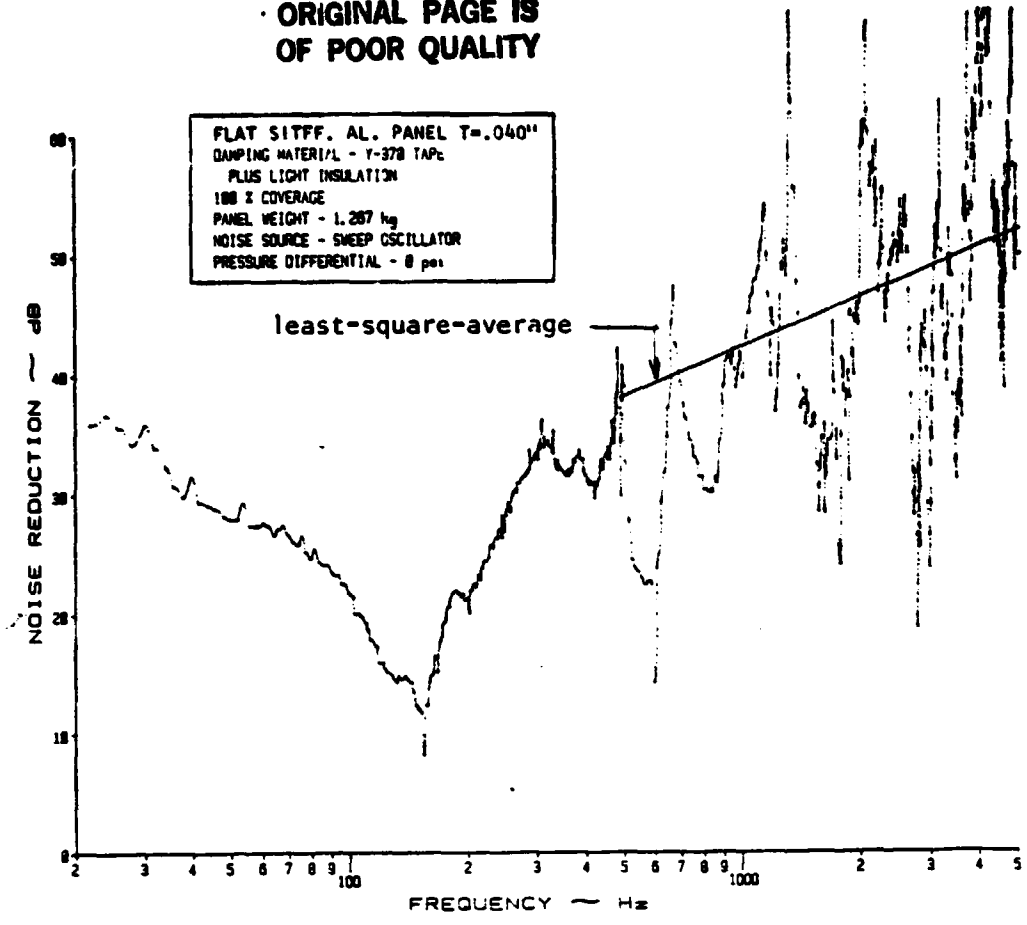
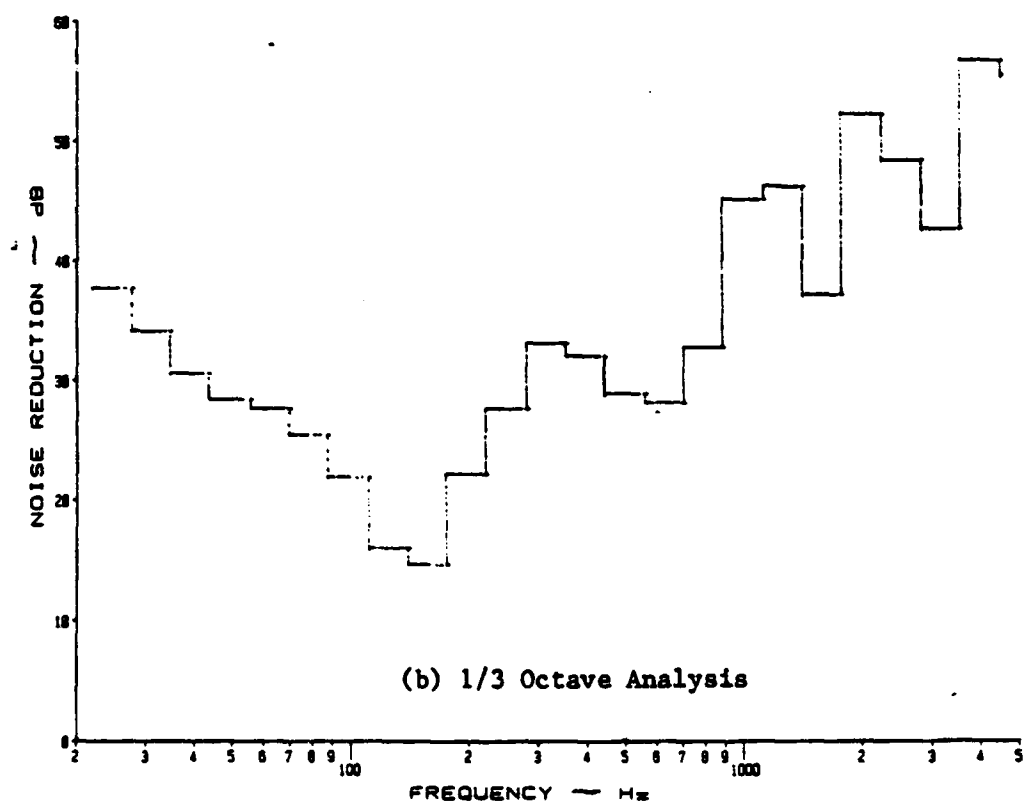

Figure A.80: Noise Reduction Characteristics of a Flat, Stiffened Panel at 3 Psi Pressure Differential with Y-436 Damping Tape under White Noise

ORIGINAL PAGE IS
OF POOR QUALITY



(a) Narrow Band Analysis



(b) 1/3 Octave Analysis

Figure A.81: NoiseReduction Characteristics of a Flat, Stiffened Panel at 0 psi Pressure Differential with Y-370 Damping Tape and 0.817 lb/ft³ Insulation under a Discrete Noise Source

ORIGINAL PAGE IS
OF POOR QUALITY

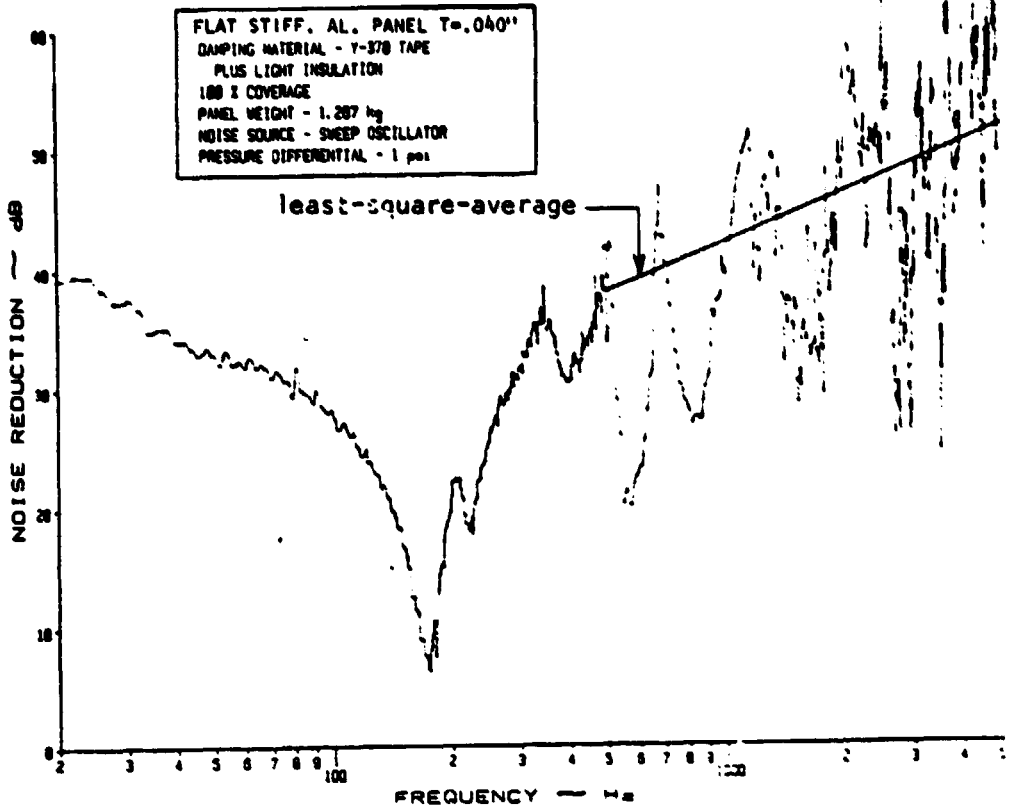

(a) Narrow Band Analysis

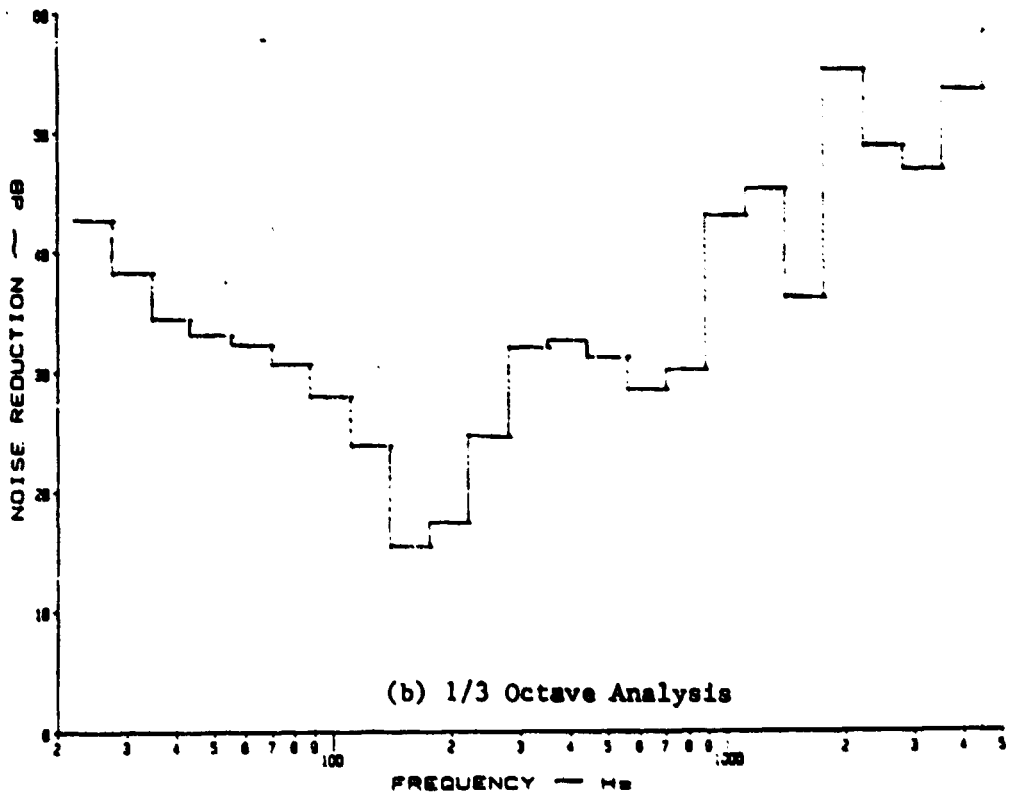

(b) 1/3 Octave Analysis

Figure A.82: Noise Reduction Characteristics of a Flat, Stiffened Panel at 1 psi Pressure Differential with Y-370 Damping Tape and 0.817 lb/ft³ Insulation under a Discrete Noise Source

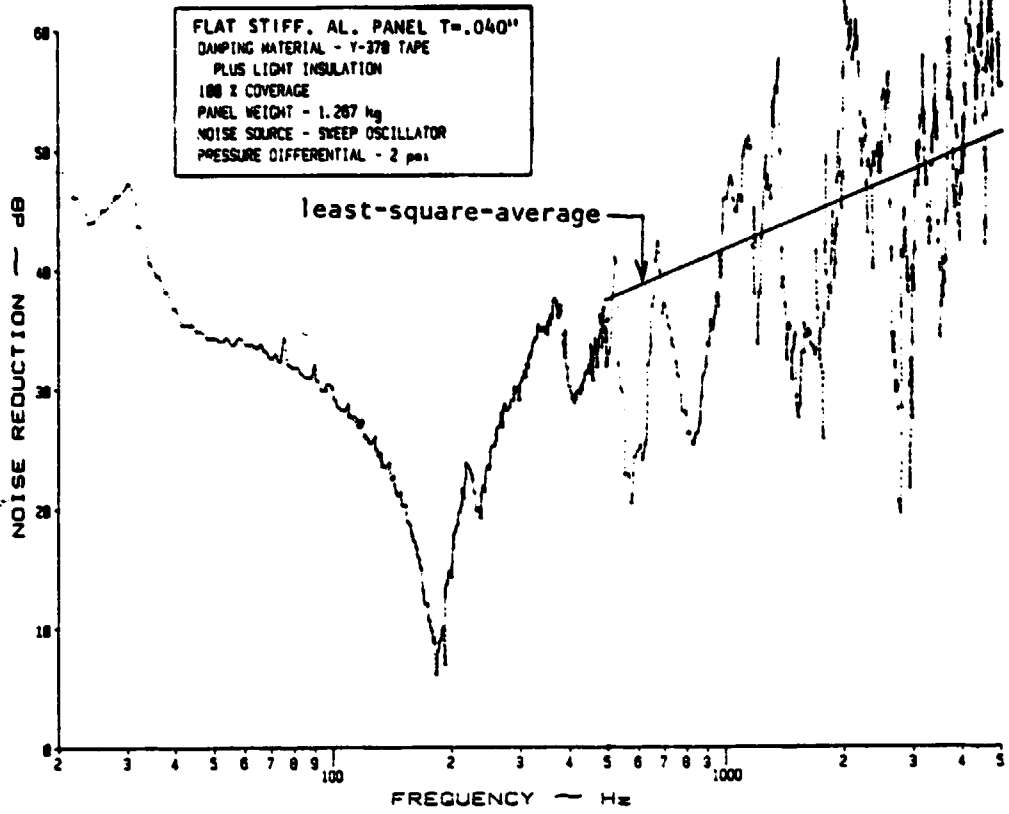

(a) Narrow Band Analysis

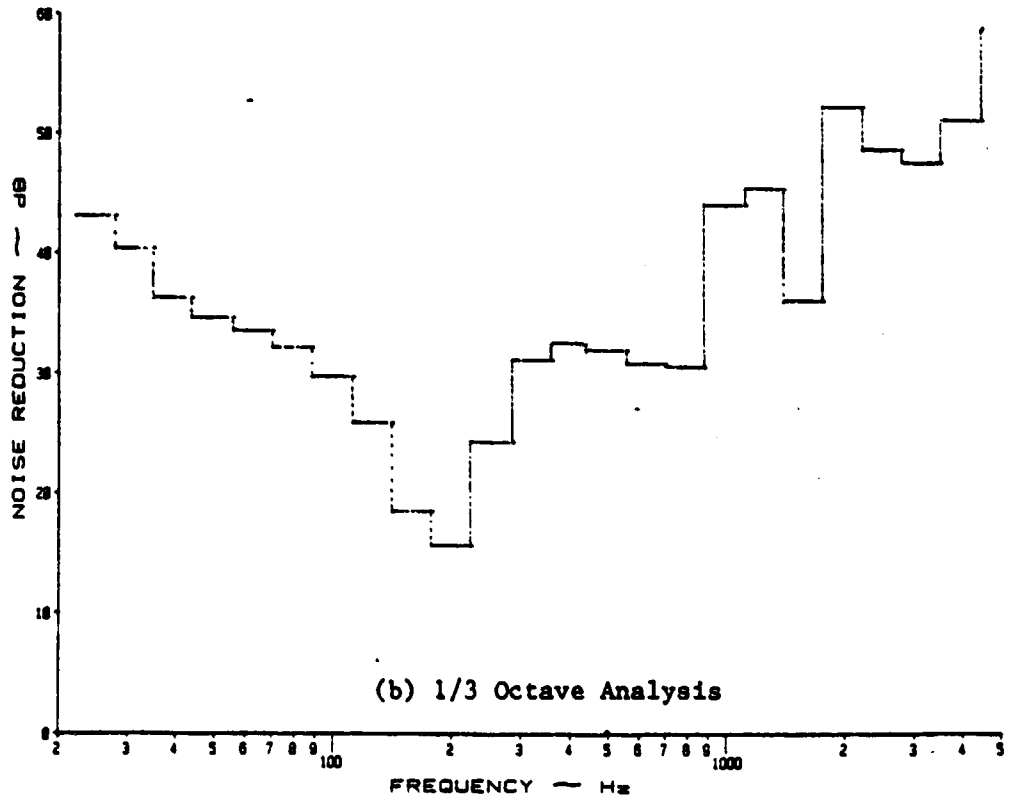

(b) 1/3 Octave Analysis

Figure A.83: Noise Reduction Characteristics of a Flat, Stiffened Panel at 2 psi Pressure Differential with Y-370 Damping Tape and 0.817 lb/ft³ Insulation under a Discrete Noise Source

ORIGINAL PAGE IS
OF POOR QUALITY

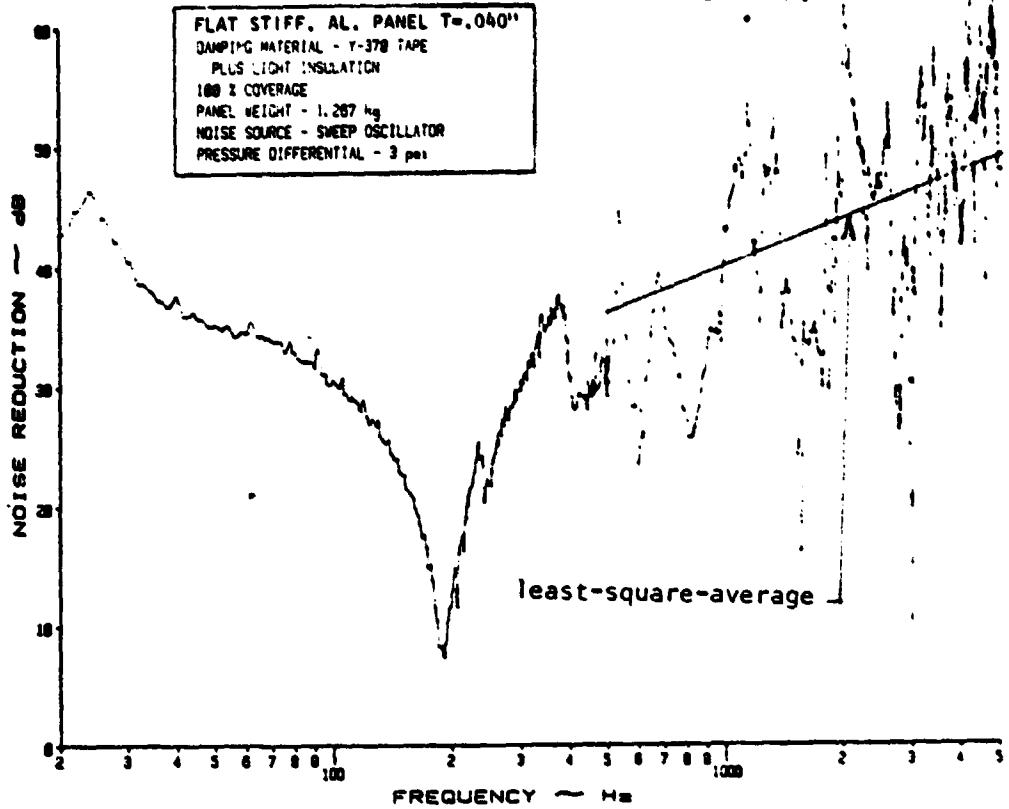

(a) Narrow Band Analysis

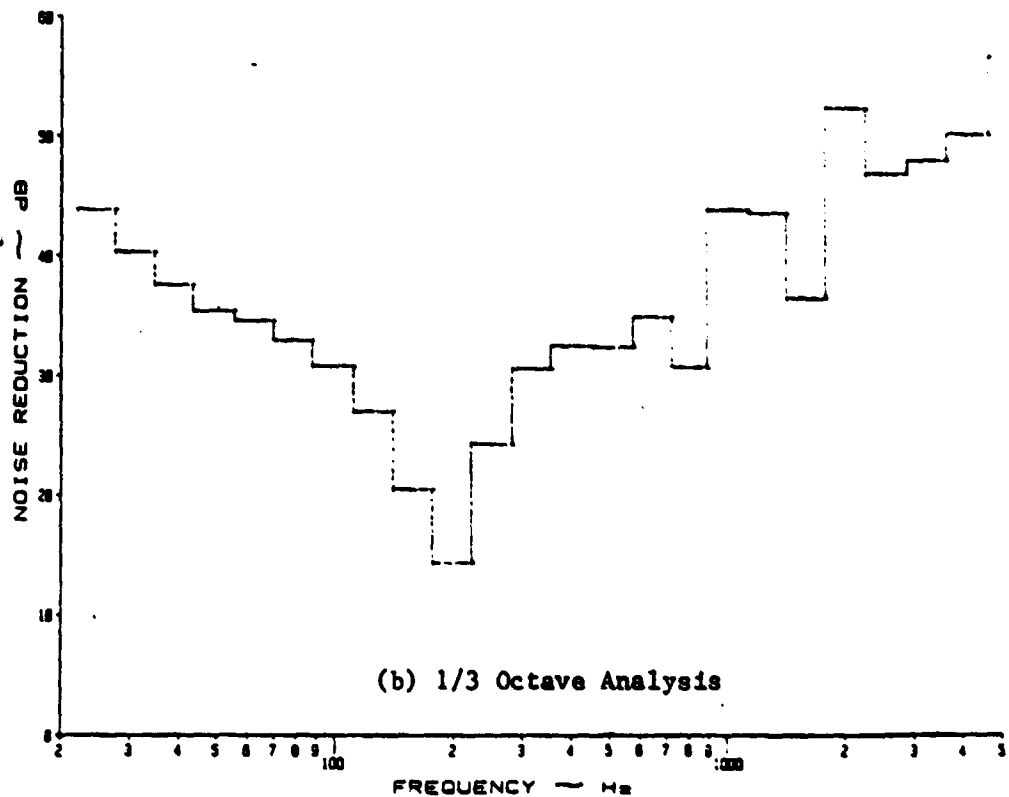
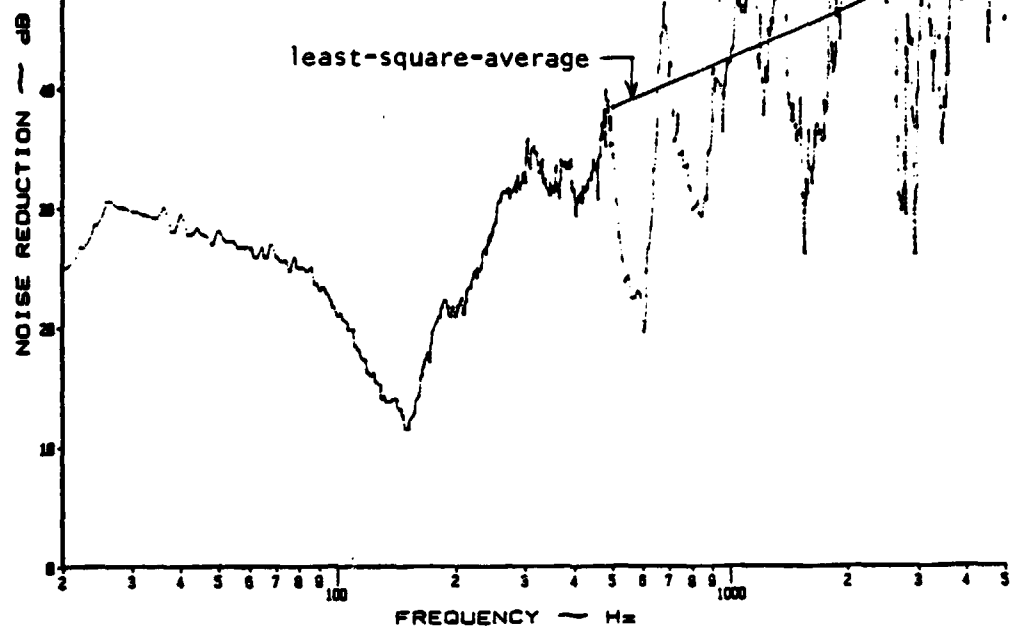

Figure A.84: Noise Reduction Characteristics of a Flat, Stiffened Panel at 3 psi Pressure Differential with Y-370 Damping Tape and 0.817 lb/ft³ Insulation under a Discrete Noise Source

ORIGINAL PAGE IS
OF POOR QUALITY

FLAT STIFF. AL. PANEL $T=0.040''$
DAMPING MATERIAL - Y-378 TAPE
PLUS LIGHT INSULATION
100 % COVERAGE
PANEL WEIGHT - 1.287 kg
NOISE SOURCE - WHITE NOISE
PRESSURE DIFFERENTIAL - 0 psi



(a) Narrow Band Analysis

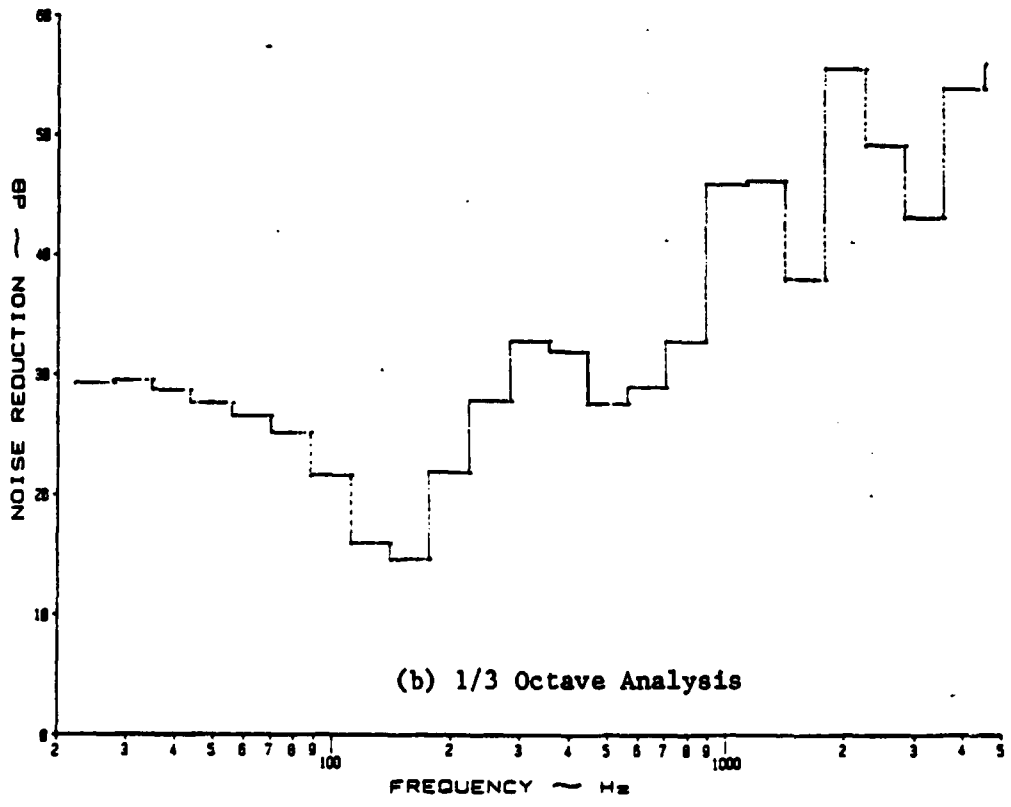

(b) 1/3 Octave Analysis

Figure A.85: Noise Reduction Characteristics of a Flat, Stiffened Panel at 0 psi Pressure Differential with Y-370 Damping Tape and 0.817 lb/ft³ Insulation under White Noise

ORIGINAL PAGE IS
OF POOR QUALITY

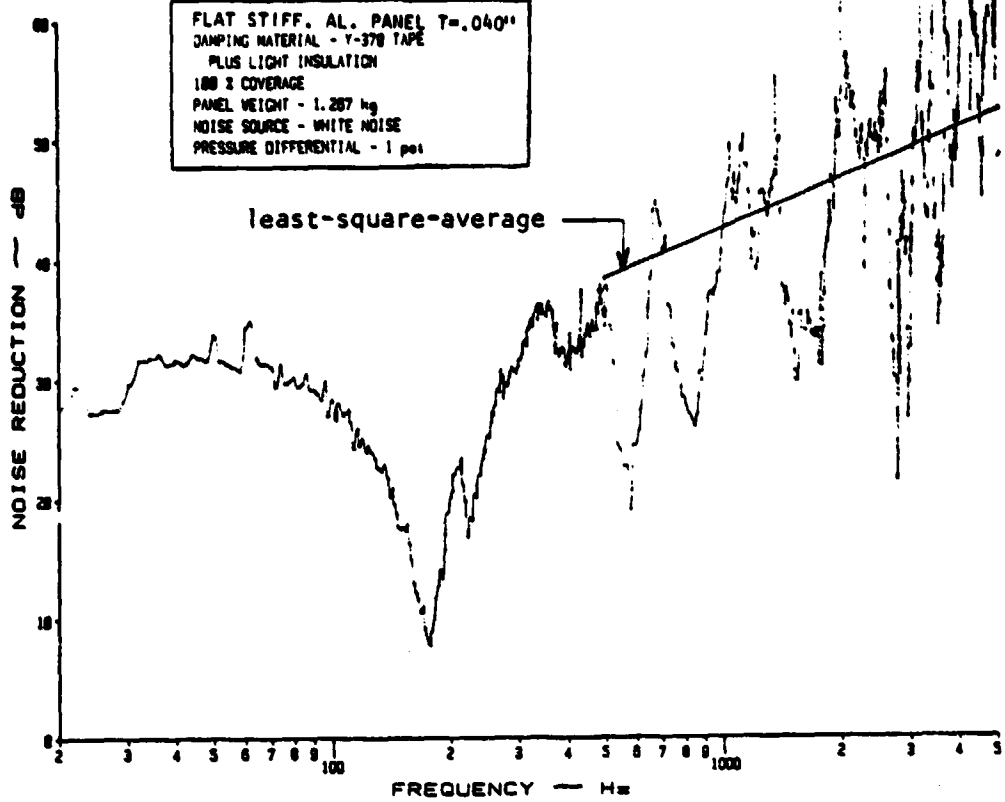

(a) Narrow Band Analysis

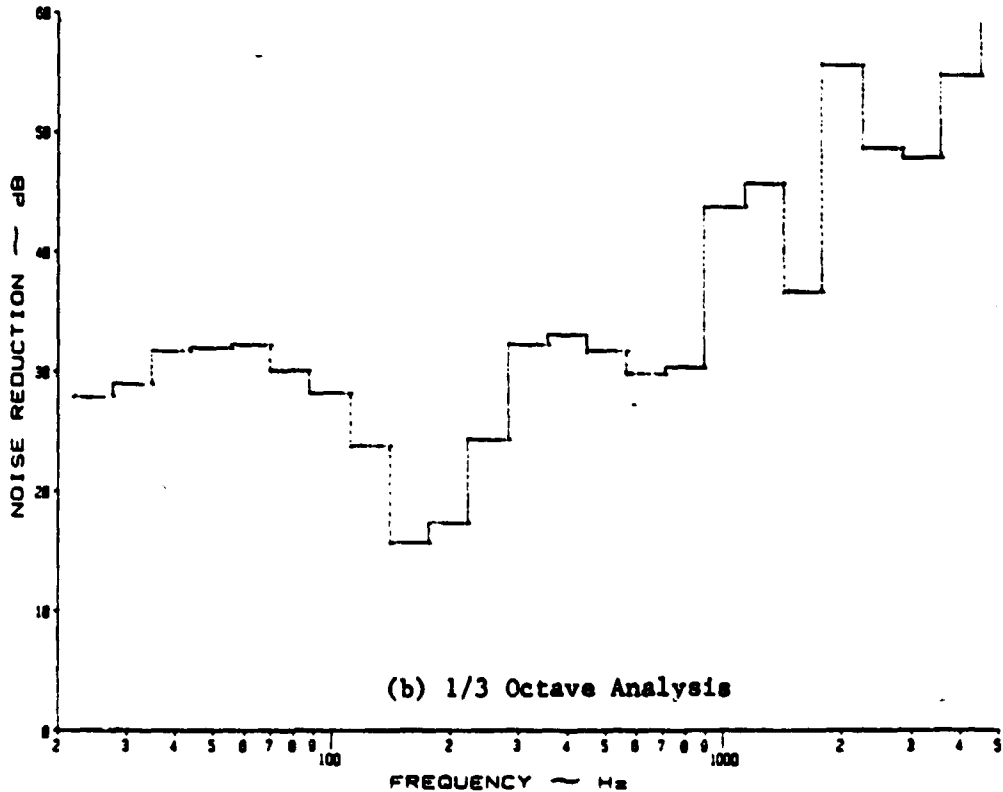

(b) 1/3 Octave Analysis

Figure A.86: Noise Reduction Characteristics of a Flat, Stiffened Panel at 1 psi Pressure Differential with Y-379 Damping Tape and 0.817 lb/ft³ Insulation under White Noise

ORIGINAL PAGE IS
OF POOR QUALITY

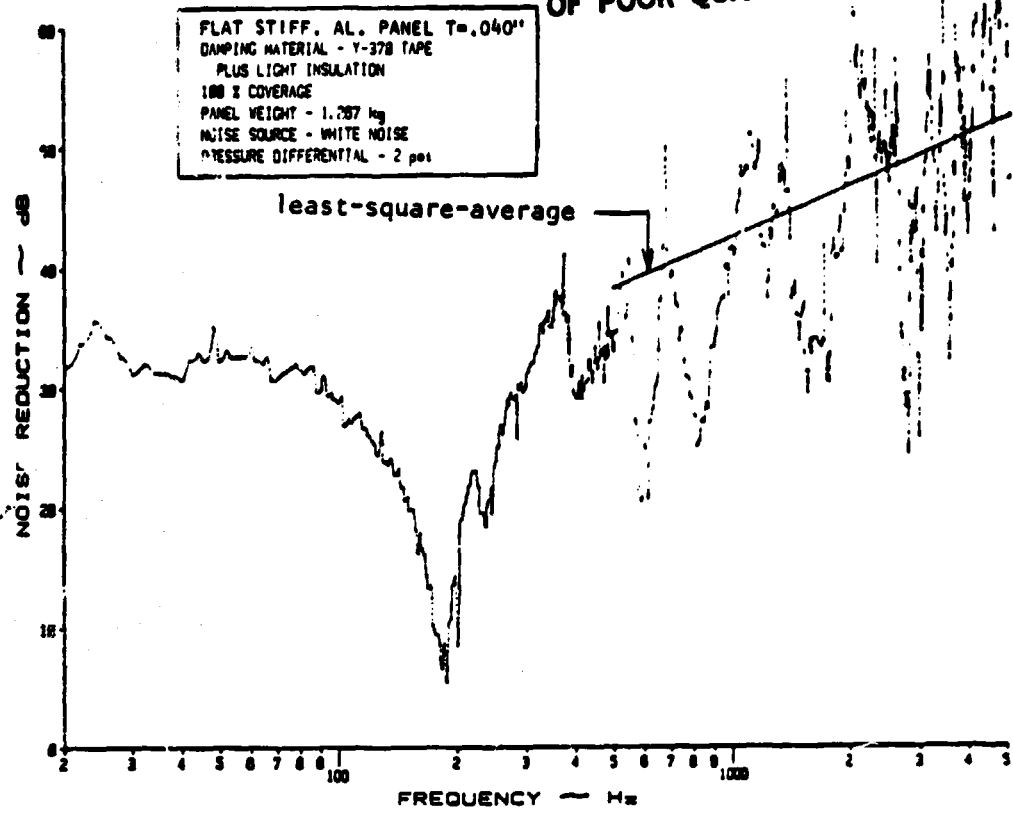

(a) Narrow Band Analysis

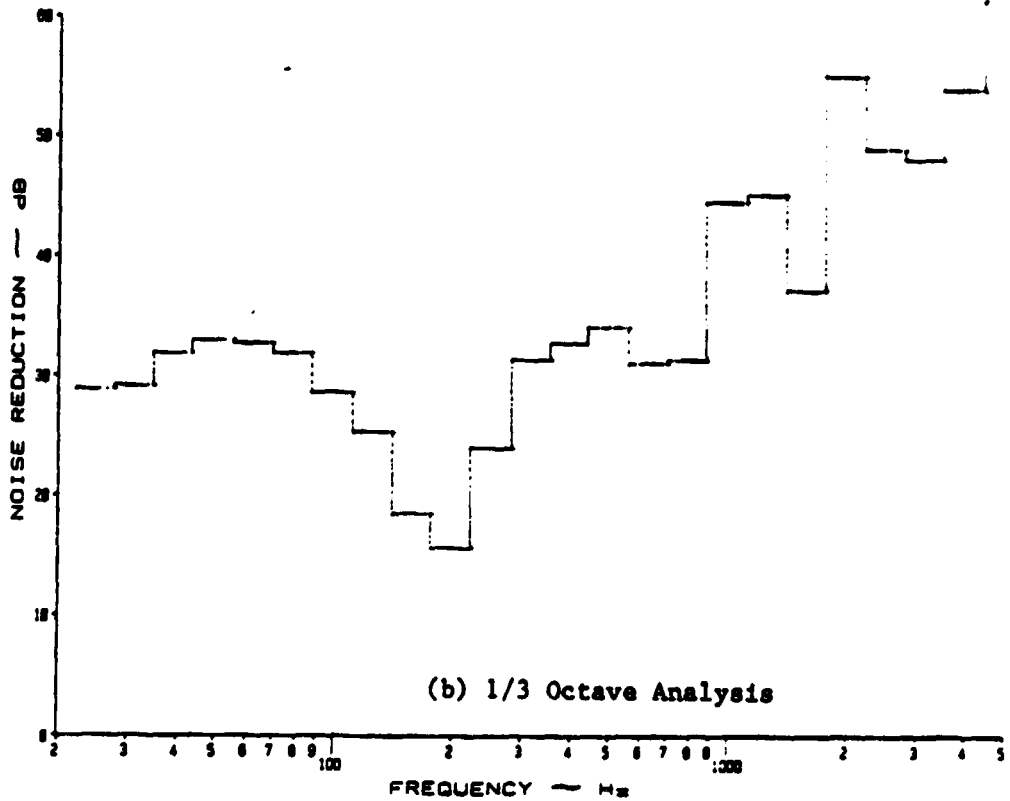

(b) 1/3 Octave Analysis

Figure A.87: Noise Reduction Characteristics of a Flat, Stiffened Panel at 2 psi Pressure Differential with Y-370 Damping Tape and 0.817 lb/ft³ Insulation under White Noise

ORIGINAL PAGE IS
OF POOR QUALITY

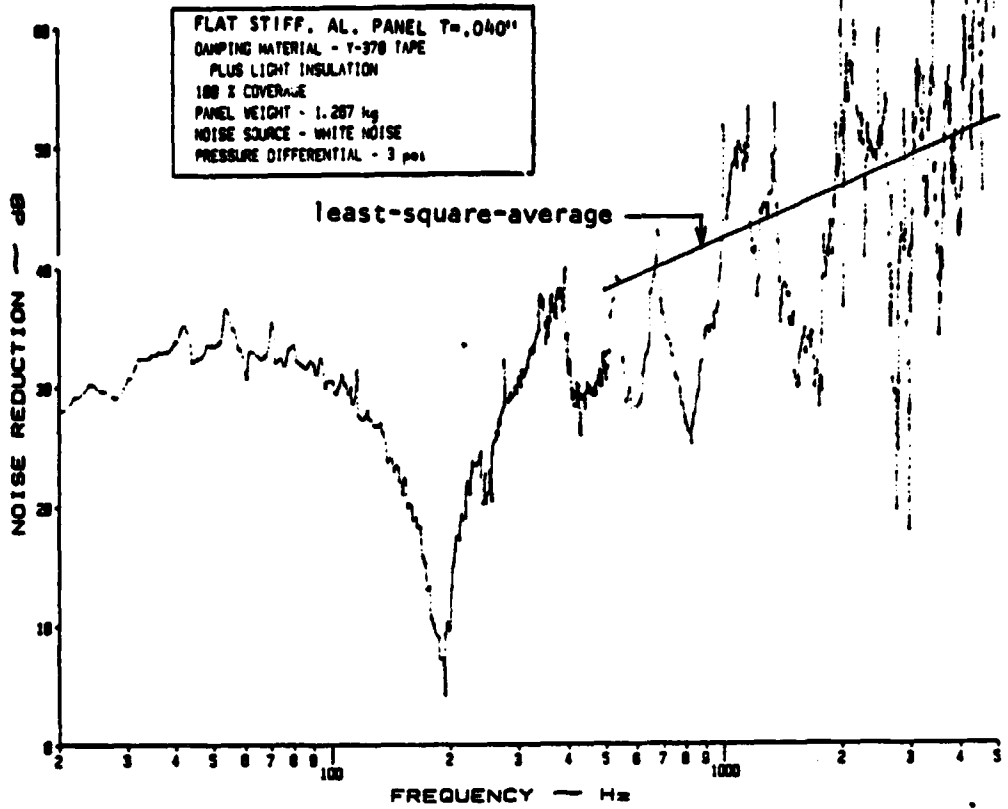

(a) Narrow Band Analysis

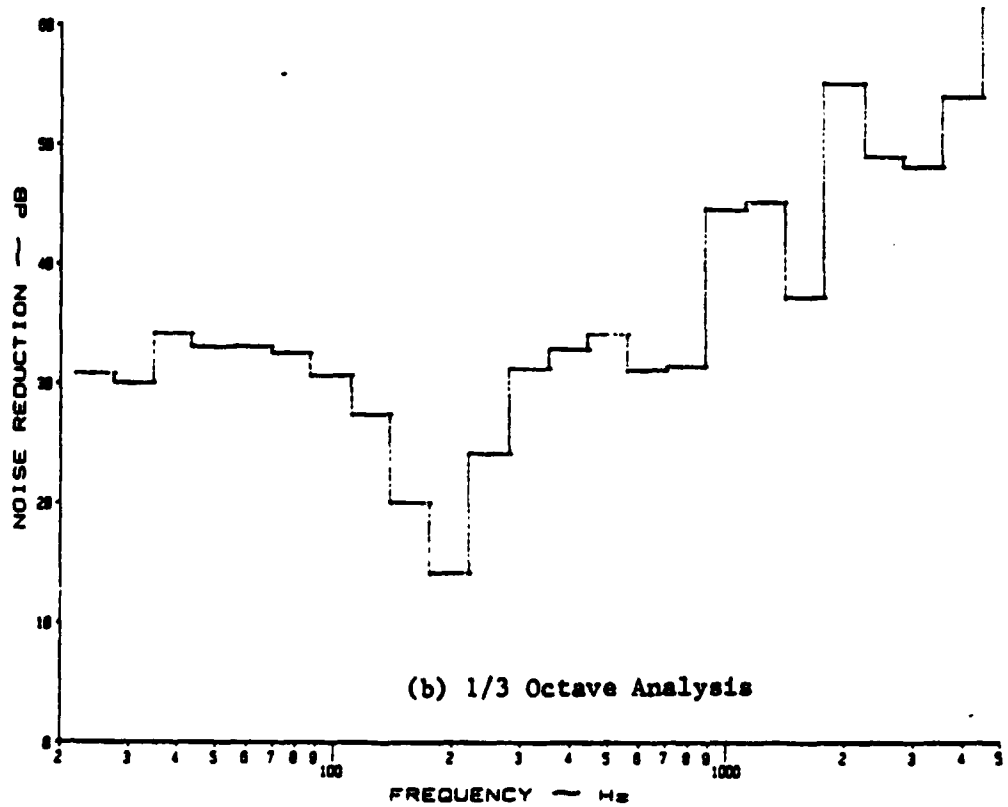

(b) 1/3 Octave Analysis

Figure A.88: Noise Reduction Characteristics of a Flat, Stiffened Panel at 3 psi Pressure Differential with Y-370 Damping Tape and 0.817 lb/ft³ Insulation under White Noise

ORIGINAL PAGE IS
OF POOR QUALITY

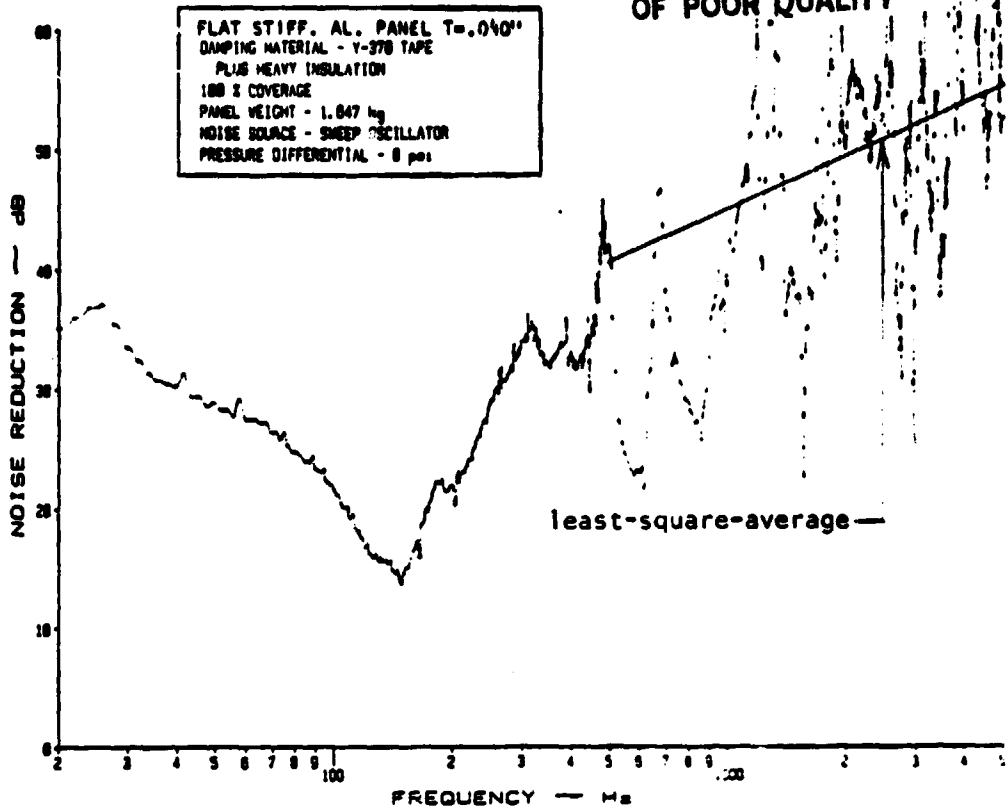

(a) Narrow Band Analysis

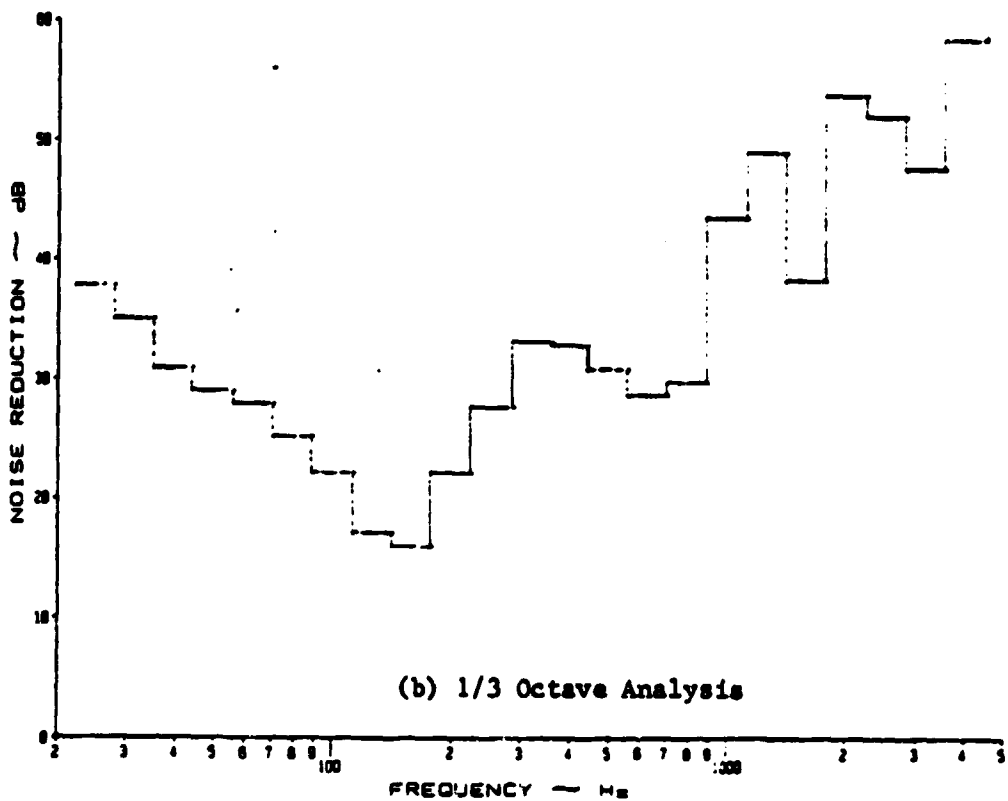

(b) 1/3 Octave Analysis

Figure A.89: Noise Reduction Characteristics of a Flat, Stiffened Panel at 0 psi Pressure Differential with Y-370 Damping Tape and 7.345 lb/ft³ Insulation under a Discrete Noise Source

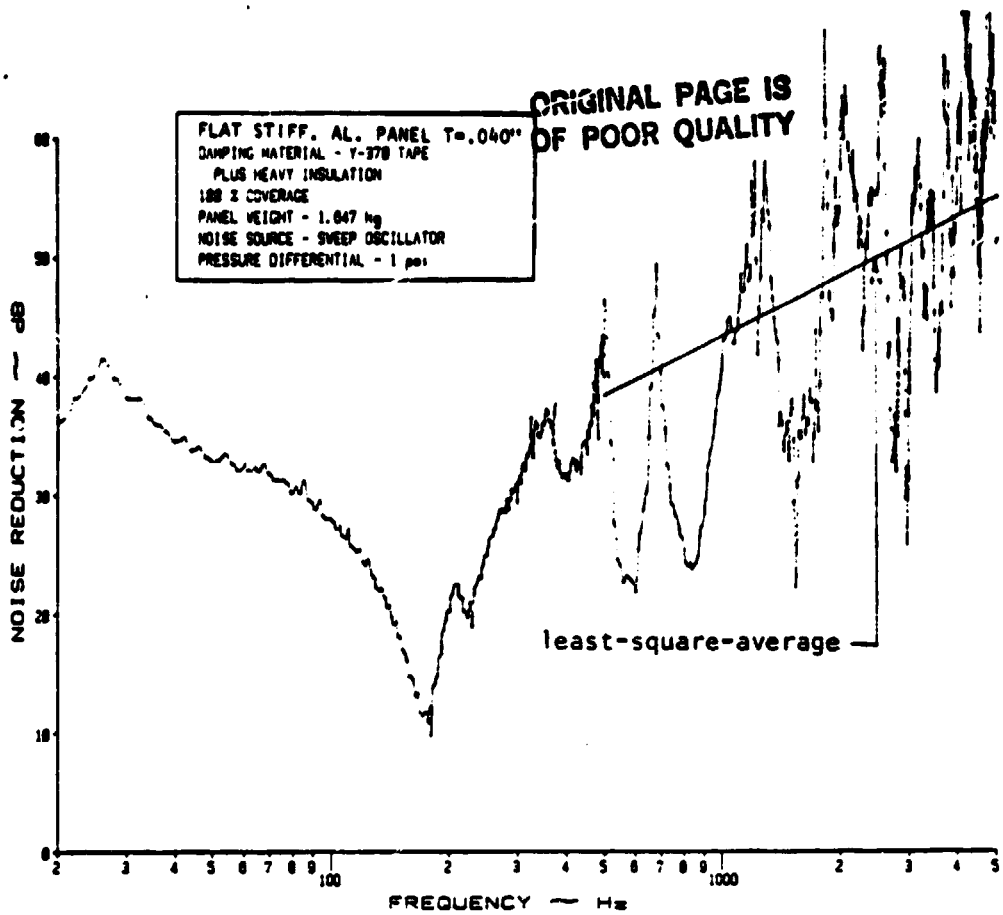

(a) Narrow Band Analysis

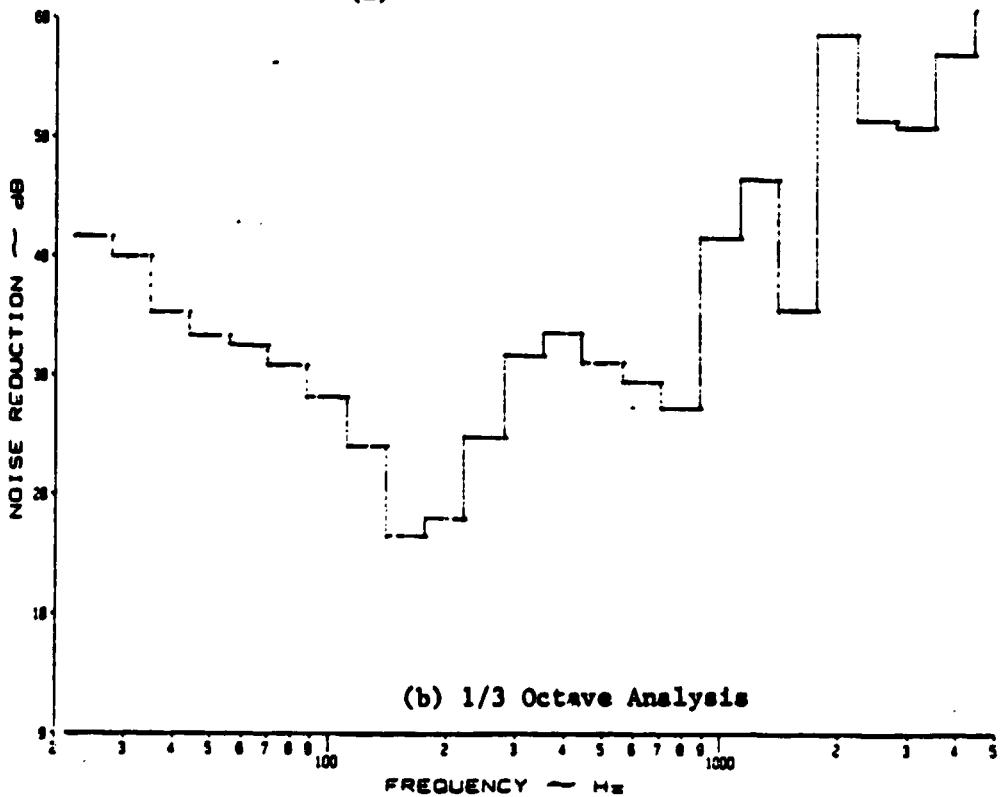
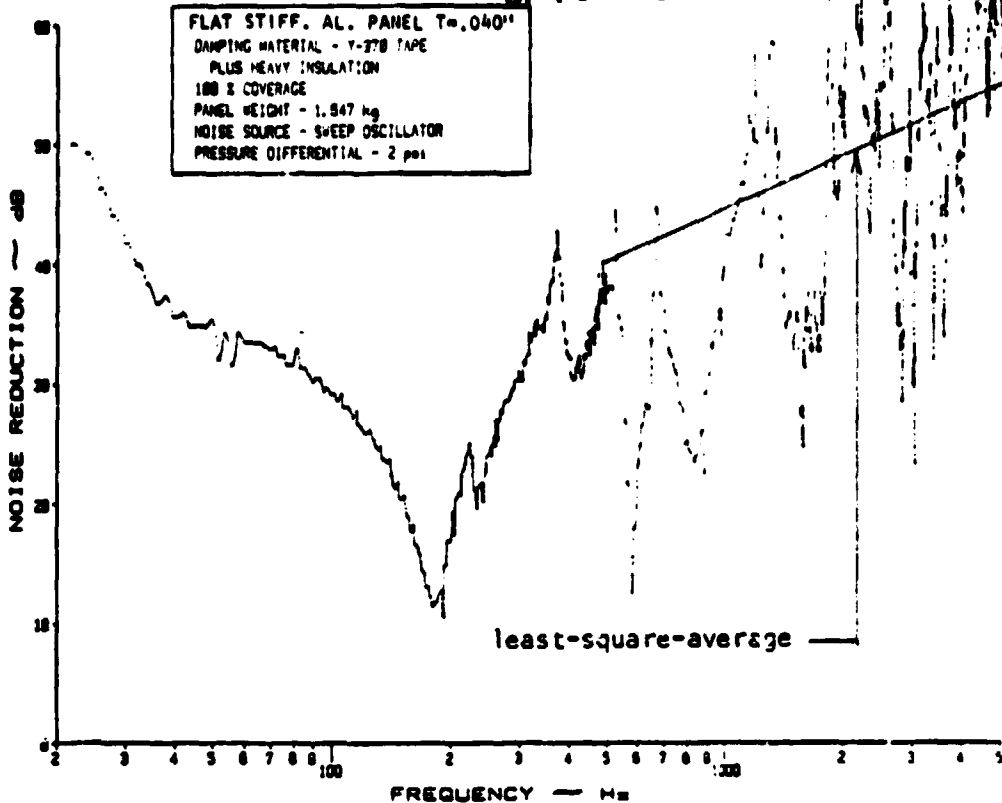
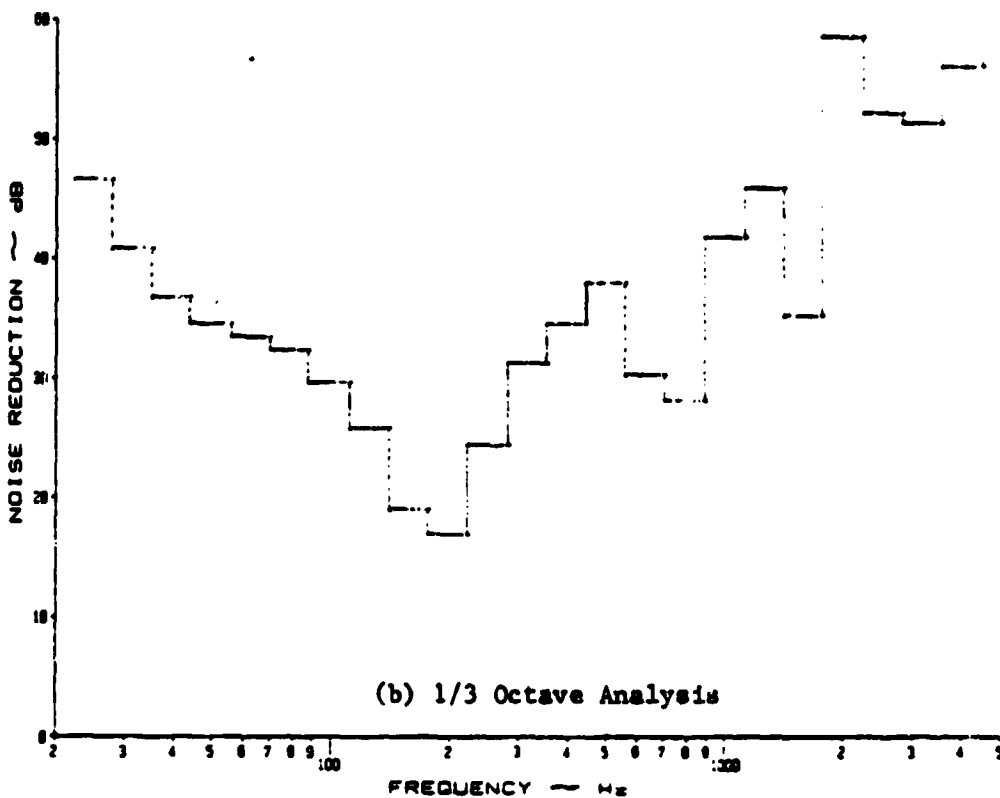

Figure A.90: Noise Reduction Characteristics of a Flat, Stiffened Panel at 1 psi Pressure Differential with Y-370 Damping Tape, and 7.345 lb/ft³ Insulation under a Discrete Noise Source

ORIGINAL PAGE IS
OF POOR QUALITY



(a) Narrow Band Analysis



(b) 1/3 Octave Analysis

Figure A.91: Noise Reduction Characteristics of a Flat, Stiffened Panel at 2 psi Pressure Differential with Y-370 Damping Tape and 7.345 lb/ft³ Insulation under a Discrete Noise Source

ORIGINAL PAGE IS
OF POOR QUALITY

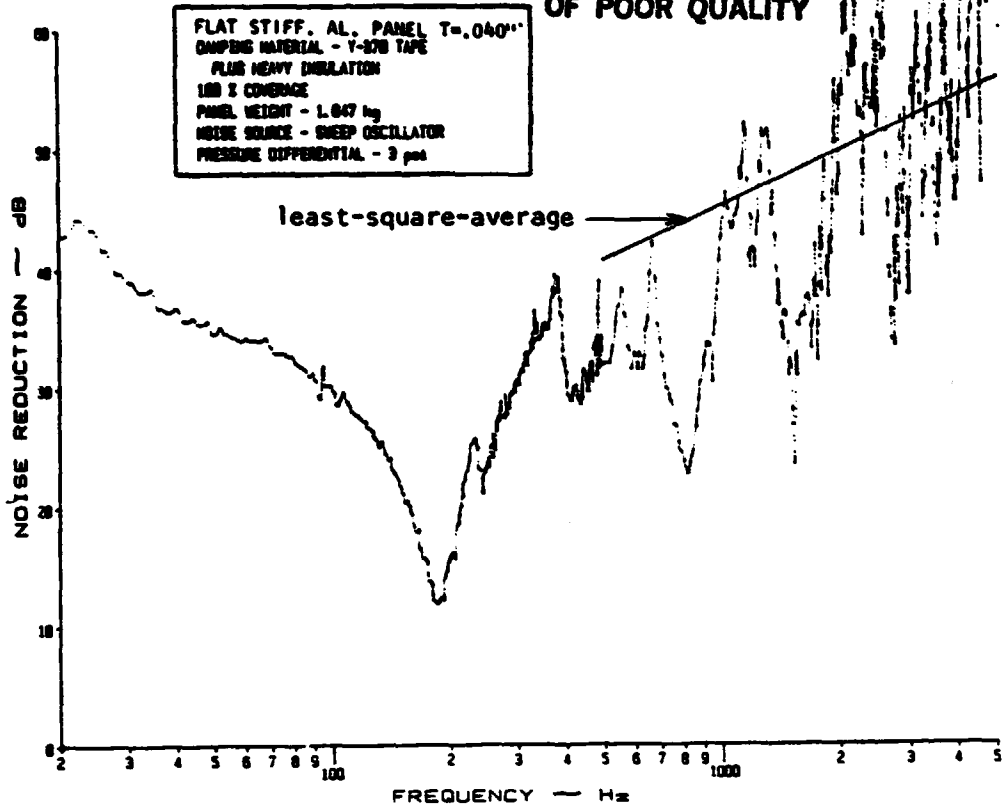

(a) Narrow Band Analysis

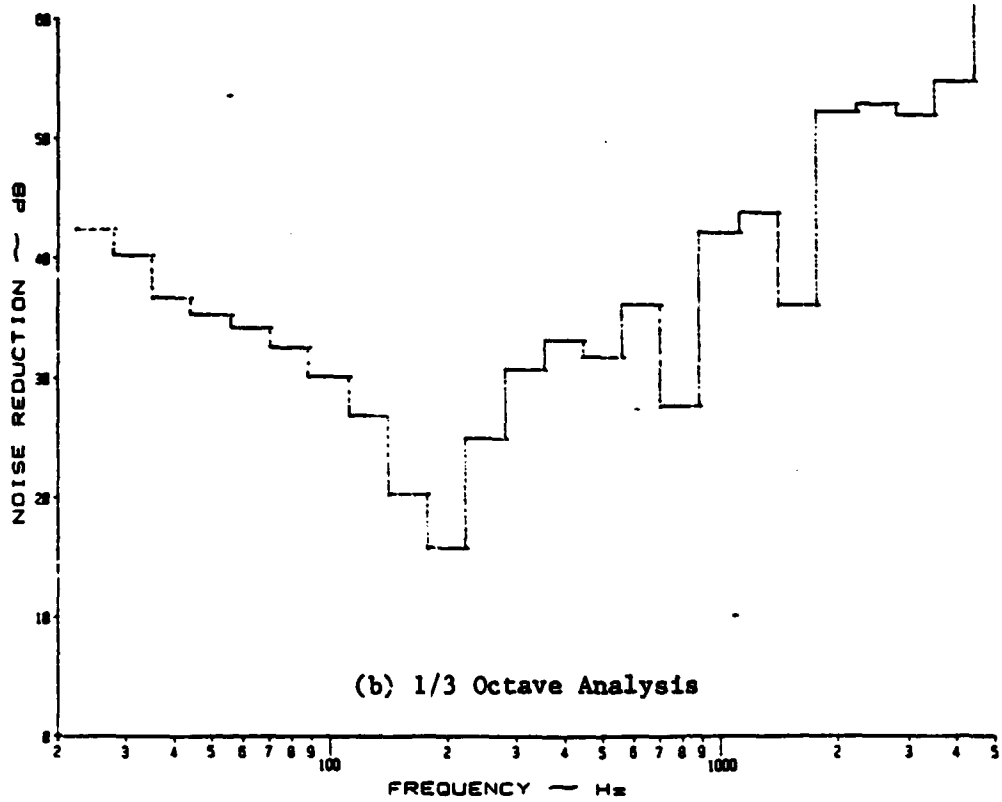

(b) 1/3 Octave Analysis

Figure A.92: Noise Reduction Characteristics of a Flat, Stiffened Panel at 3 psi Pressure Differential with Y-378 Damping Tape and 7.345 lb/ft³ Insulation under a Discrete Noise Source

ORIGINAL PAGE IS
OF POOR QUALITY

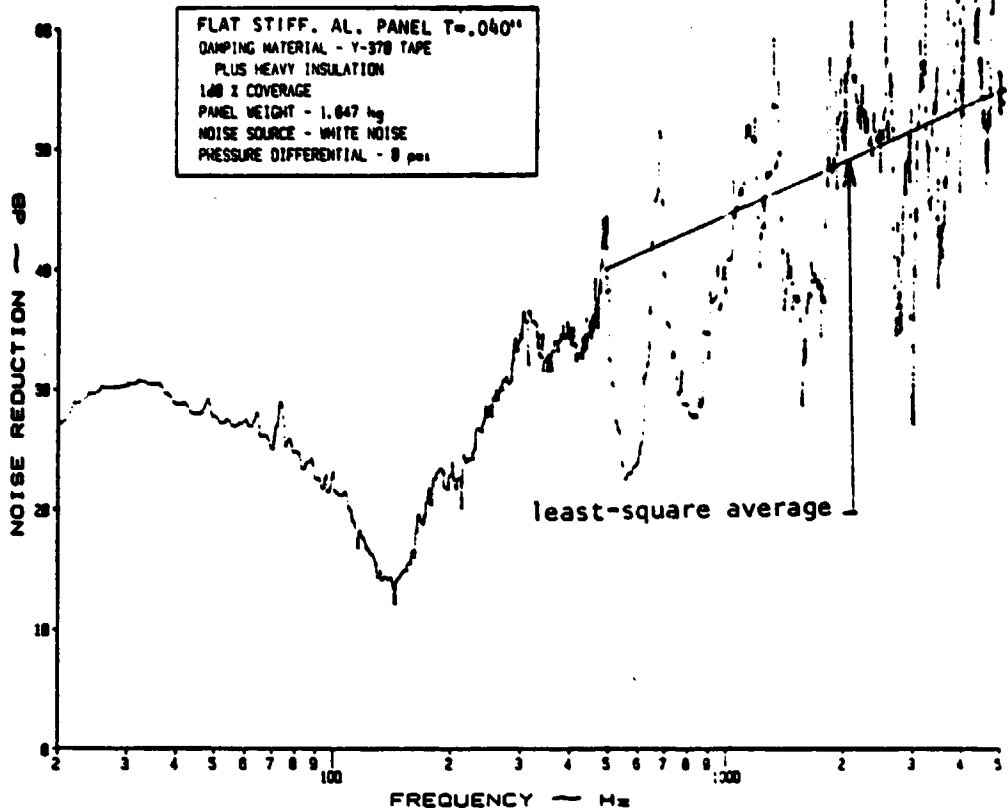

(a) Narrow Band Analysis

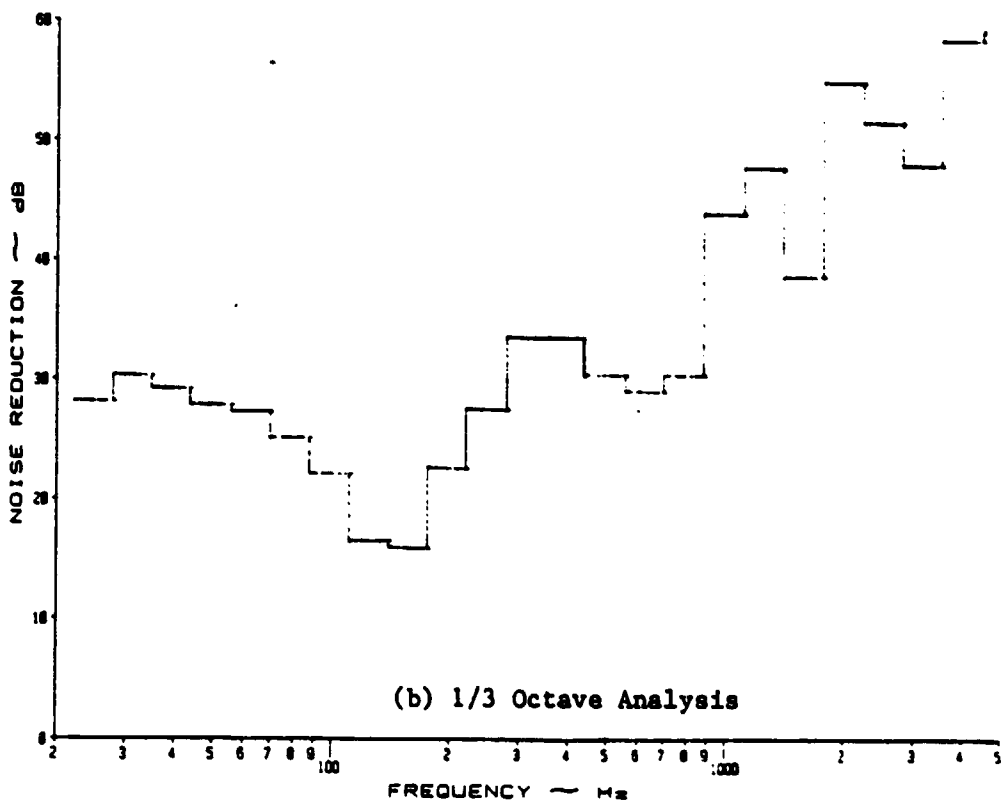

(b) 1/3 Octave Analysis

Figure A.93: Noise Reduction Characteristics of a Flat, Stiffened Panel at 0 psi Pressure Differential with Y-370 Damping Tape and 7.345 lb/ft³ Insulation under White Noise

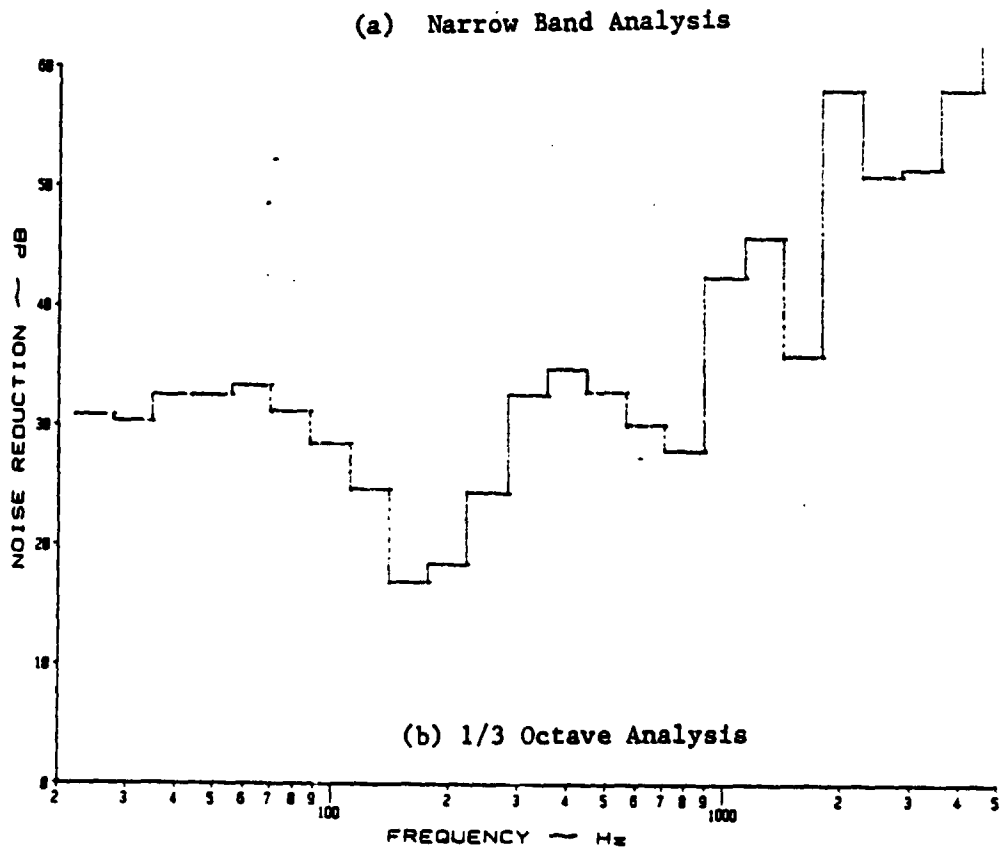
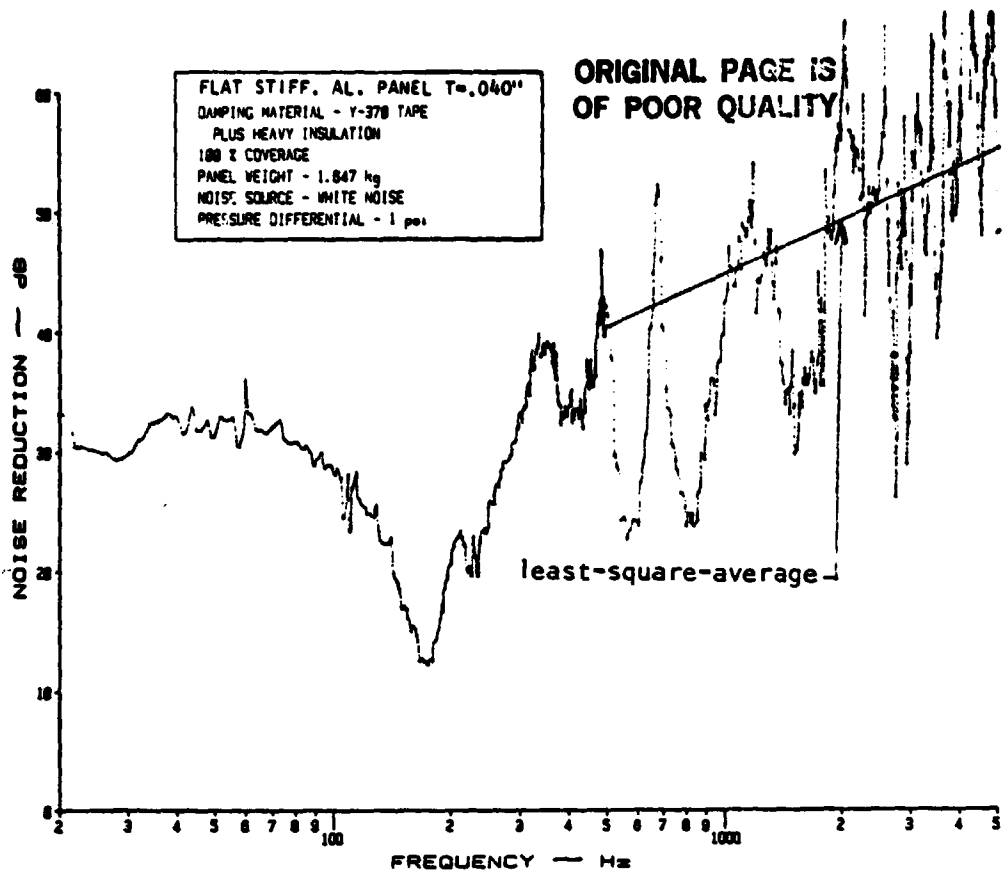
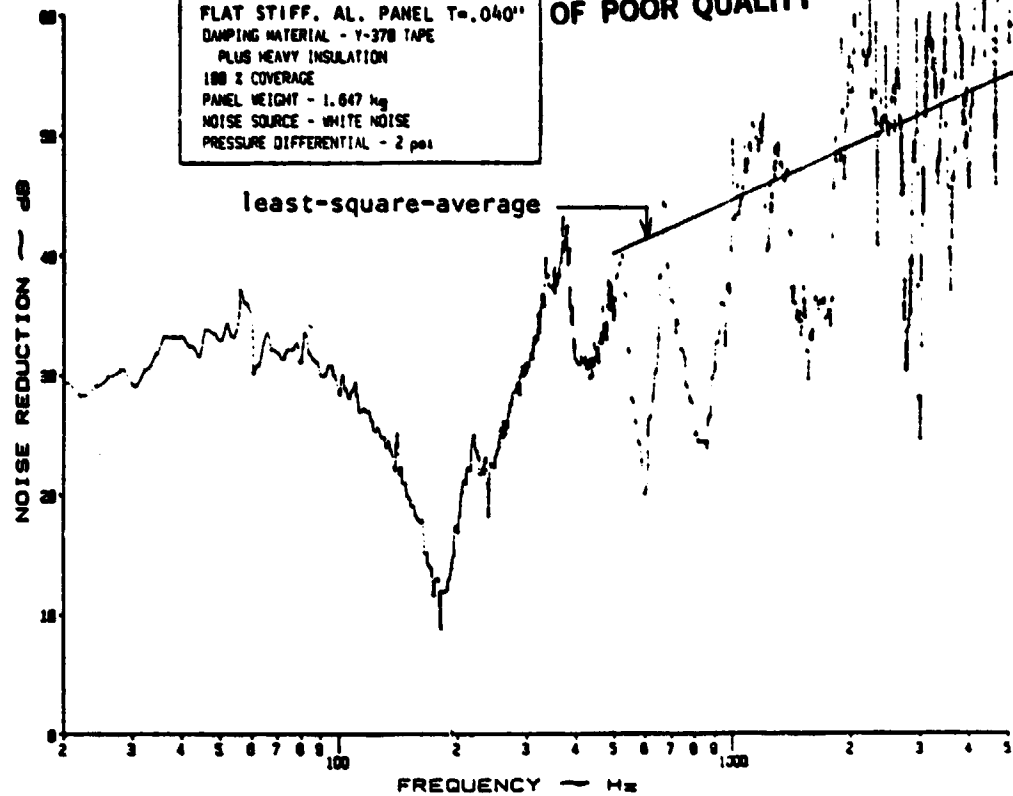

Figure A.94: Noise Reduction Characteristics of a Flat, Stiffened Panel at 1 psi Pressure Differential with Y-370 Damping Tape and 7.345 lb/ft³ Insulation under White Noise

ORIGINAL PAGE IS
OF POOR QUALITY

FLAT STIFF. AL. PANEL T=.040"
DAMPING MATERIAL - Y-370 TAPE
PLUS HEAVY INSULATION
100% COVERAGE
PANEL WEIGHT - 1.647 kg
NOISE SOURCE - WHITE NOISE
PRESSURE DIFFERENTIAL - 2 psi



(a) Narrow Band Analysis

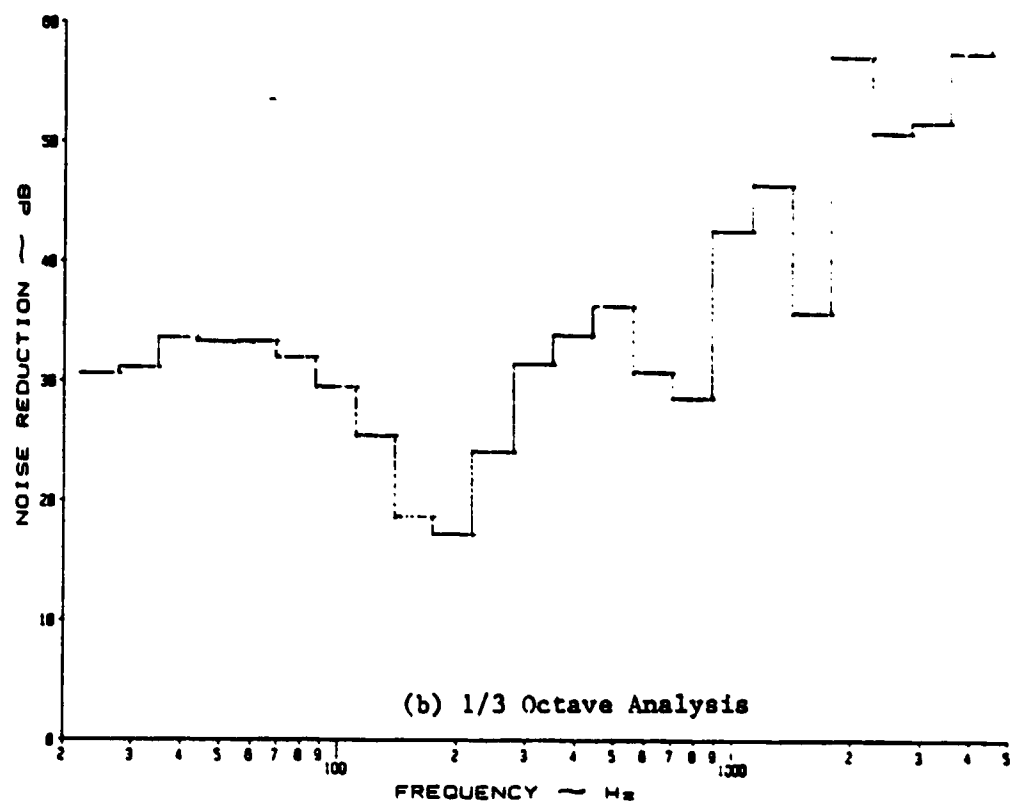

(b) 1/3 Octave Analysis

Figure A.95: Noise Reduction Characteristics of a Flat, Stiffened Panel at 2 psi Pressure Differential with Y-370 Damping tape and 7.345 lb/ft³ Insulation under White Noise

ORIGINAL PAGE IS
OF POOR QUALITY

FLAT STIFF. AL. PANEL $T = .040$
DAMPING MATERIAL - Y-370 TAPE
PLUS HEAVY INSULATION
100% COVERAGE
PANEL WEIGHT - 1.847 kg
NOISE SOURCE - WHITE NOISE
PRESSURE DIFFERENTIAL - 3 psi

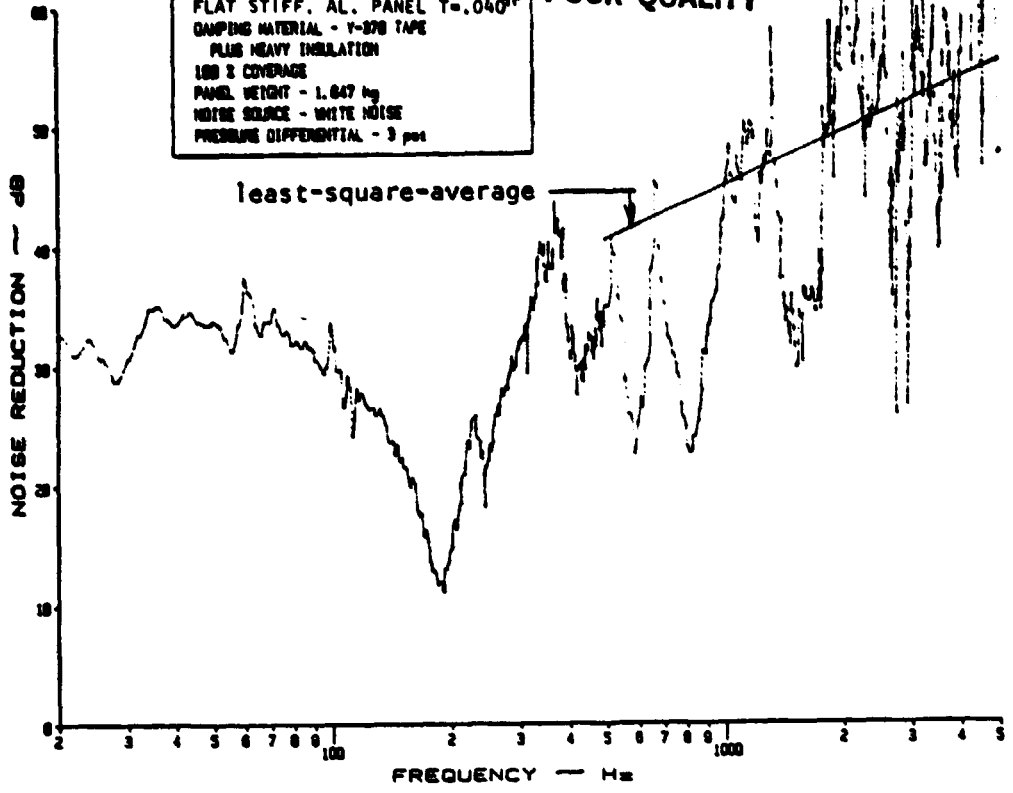

(a) Narrow Band Analysis

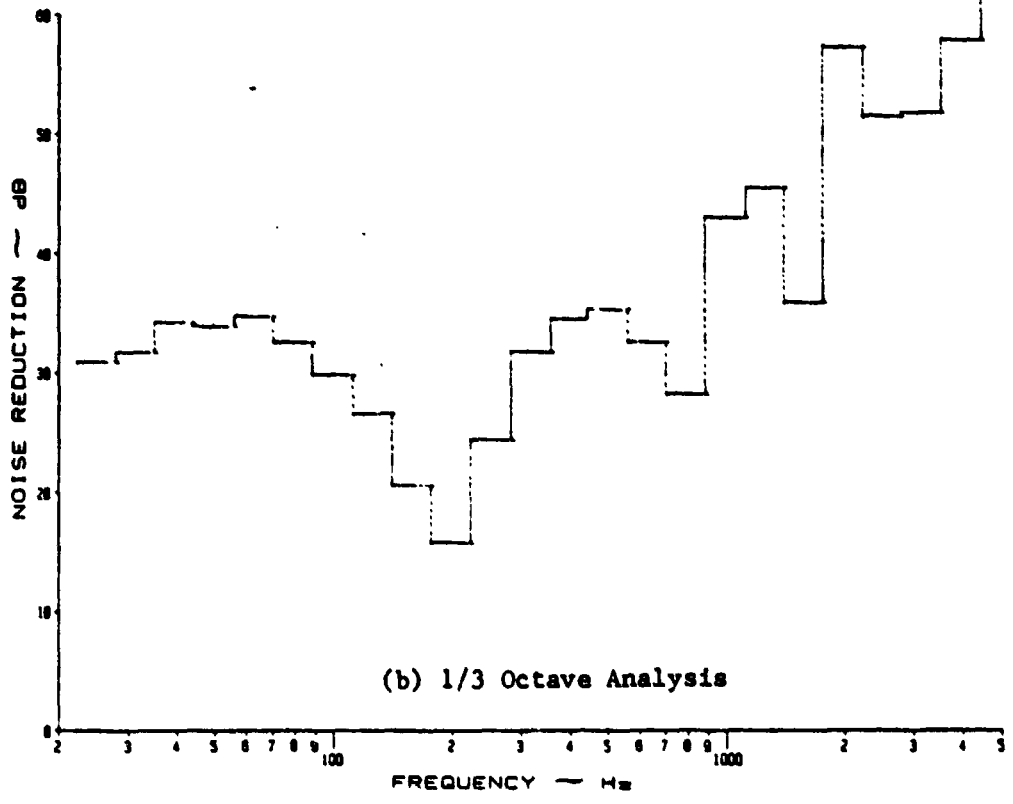

(b) 1/3 Octave Analysis

Figure A.96: Noise Reduction Characteristics of a Flat, Stiffened Panel at 3 psi Pressure Differential with Y-370 Damping Tape and 7.345 lb/ft³ Insulation under White Noise

APPENDIX B

EXPERIMENTAL NOISE REDUCTION DATA FOR
CURVED STIFFENED PANEL

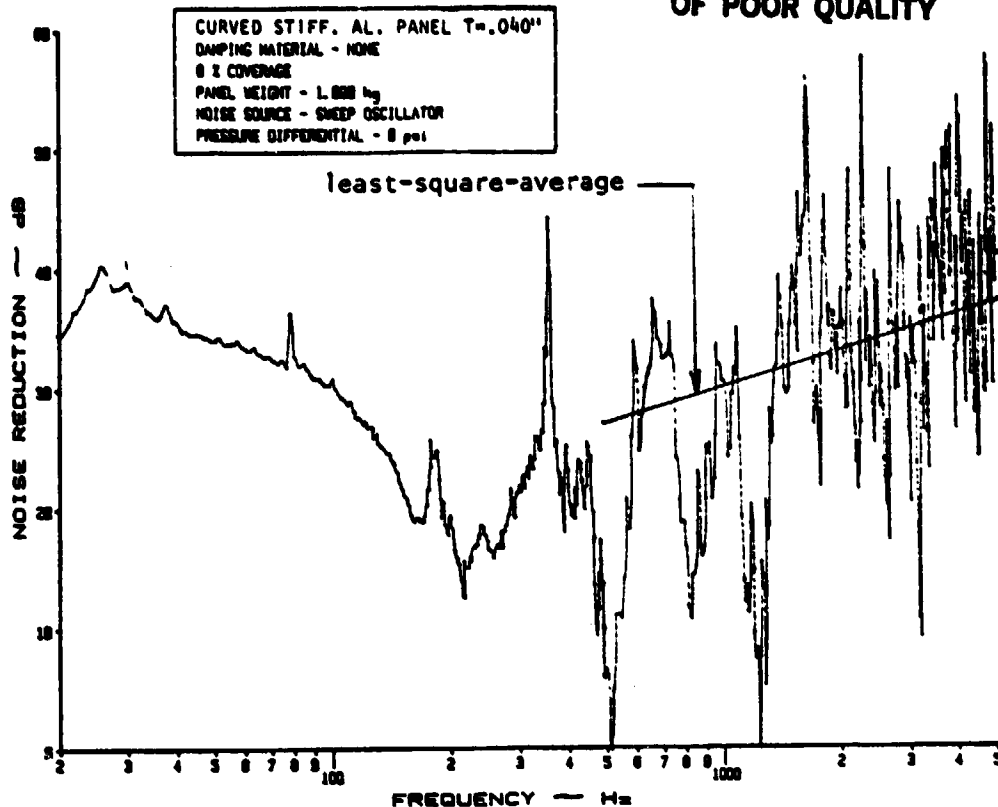

(a) Narrow Band Analysis

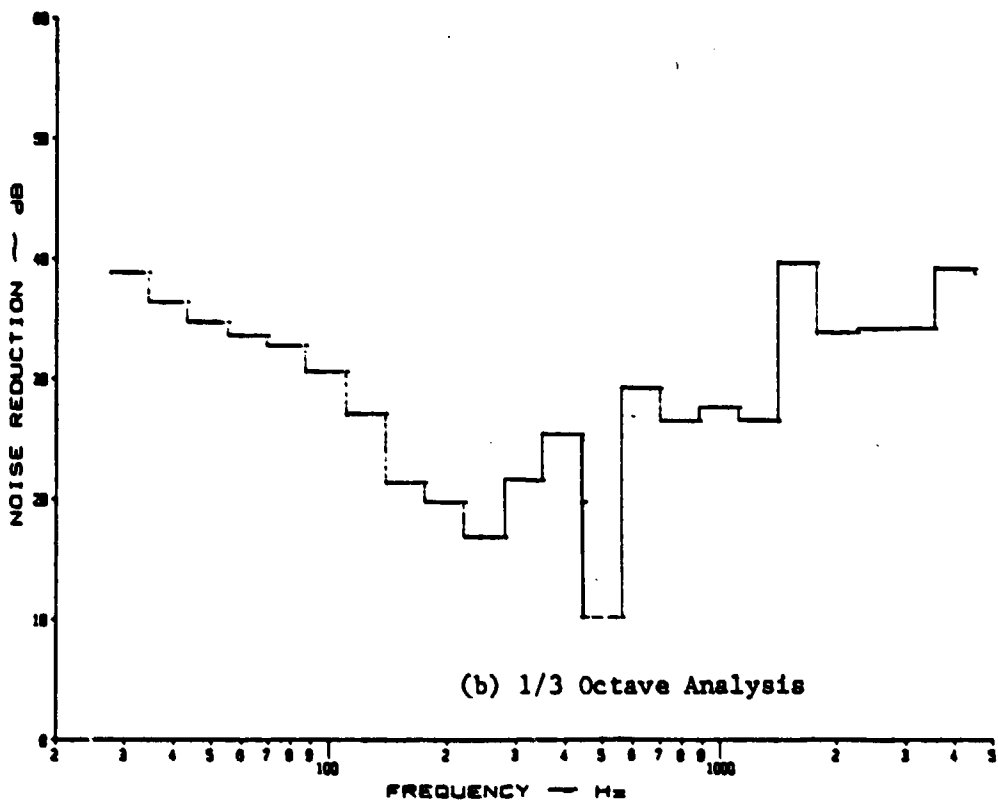

(b) 1/3 Octave Analysis

Figure B.1: Bare Curved Panel Noise Reduction Characteristics at 0psi pressure differential under discrete noise

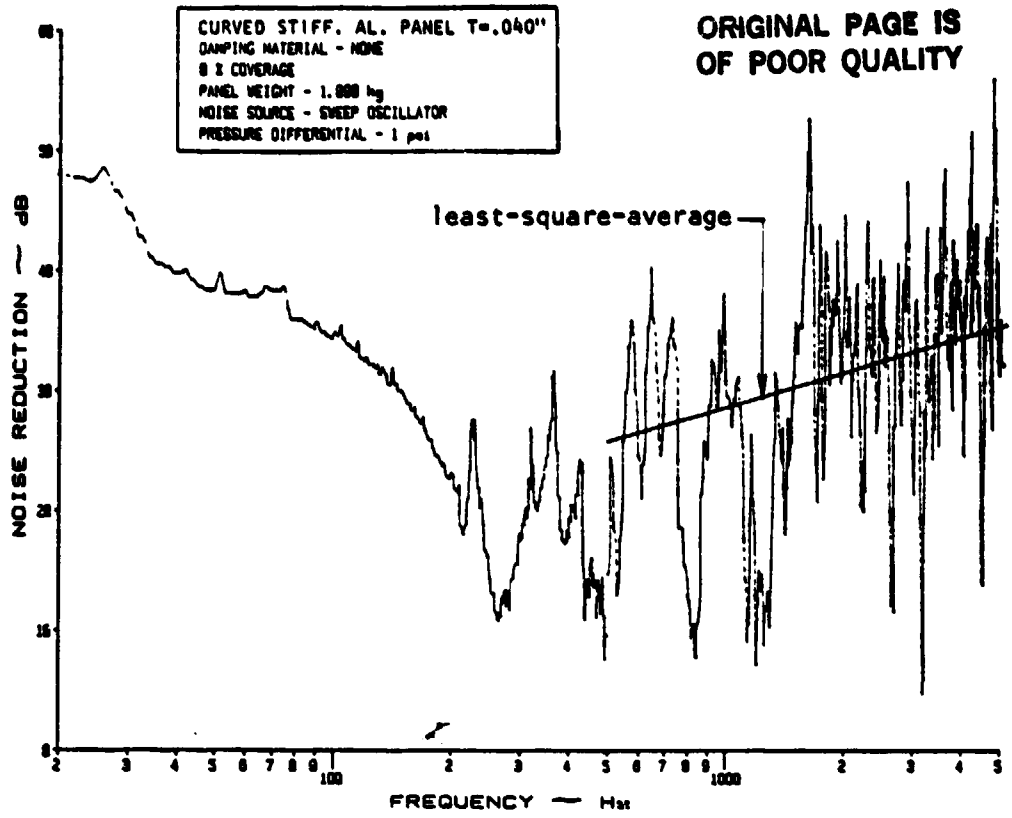

(a) Narrow Band Analysis

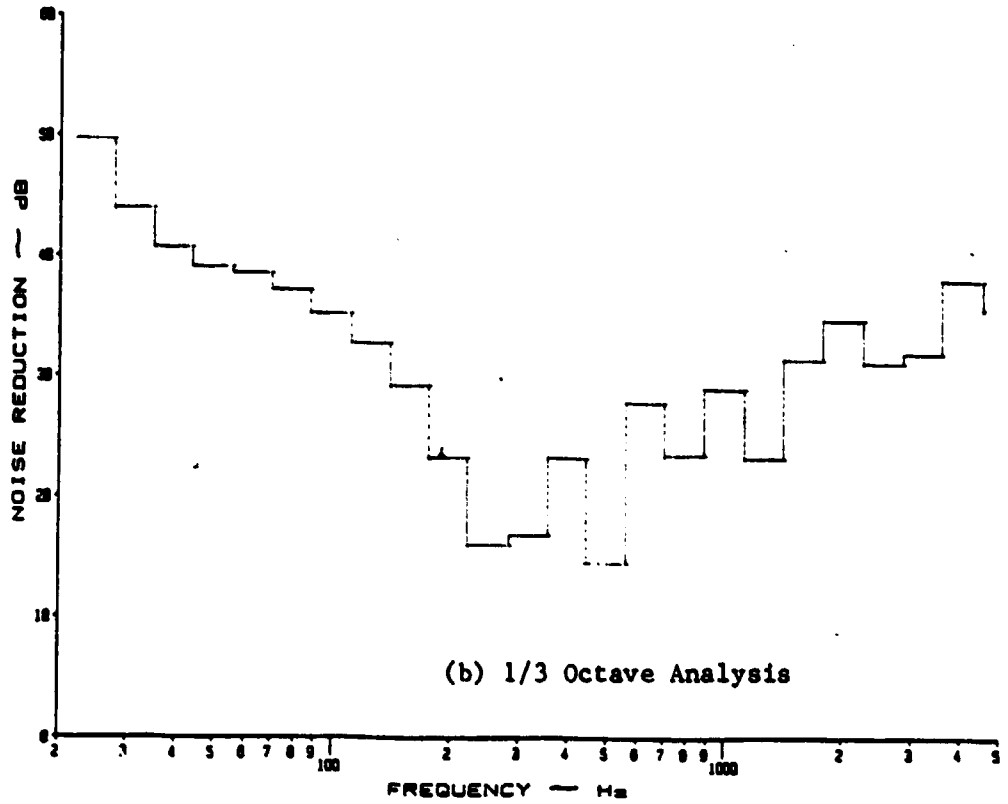

(b) 1/3 Octave Analysis

Figure B.2: Noise Reduction Characteristics of a Curved, Bare Panel at 1 psi pressure differential under discrete noise

ORIGINAL PAGE IS
OF POOR QUALITY

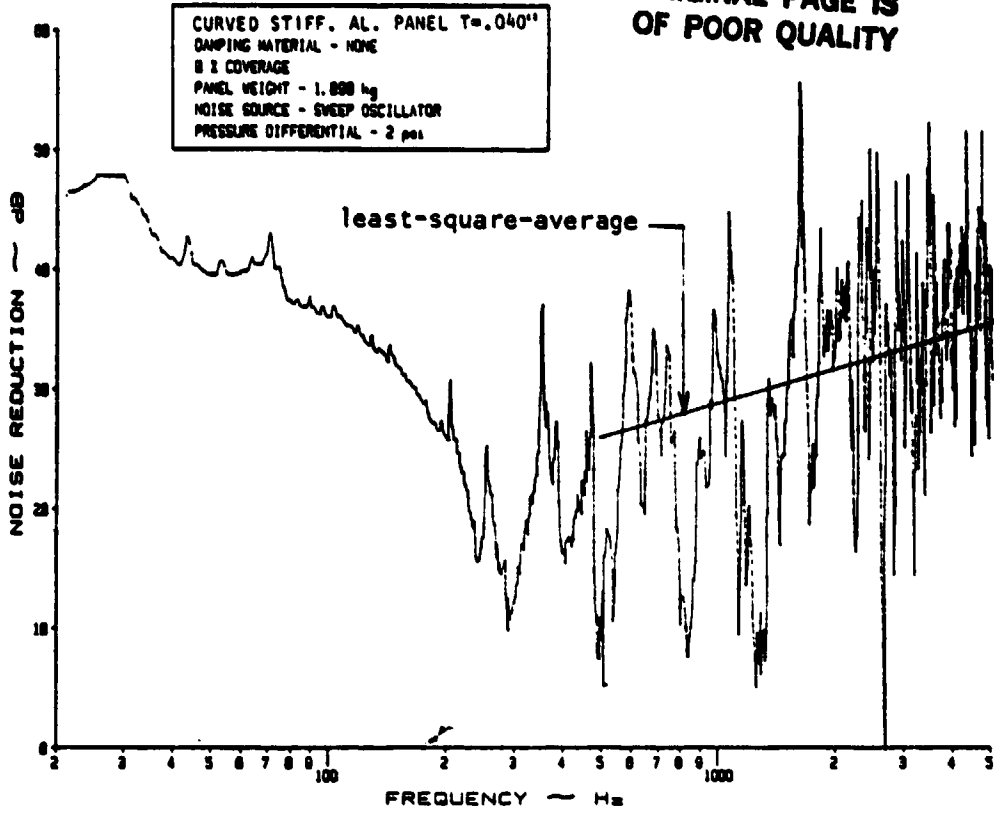

(a) Narrow Band Analysis

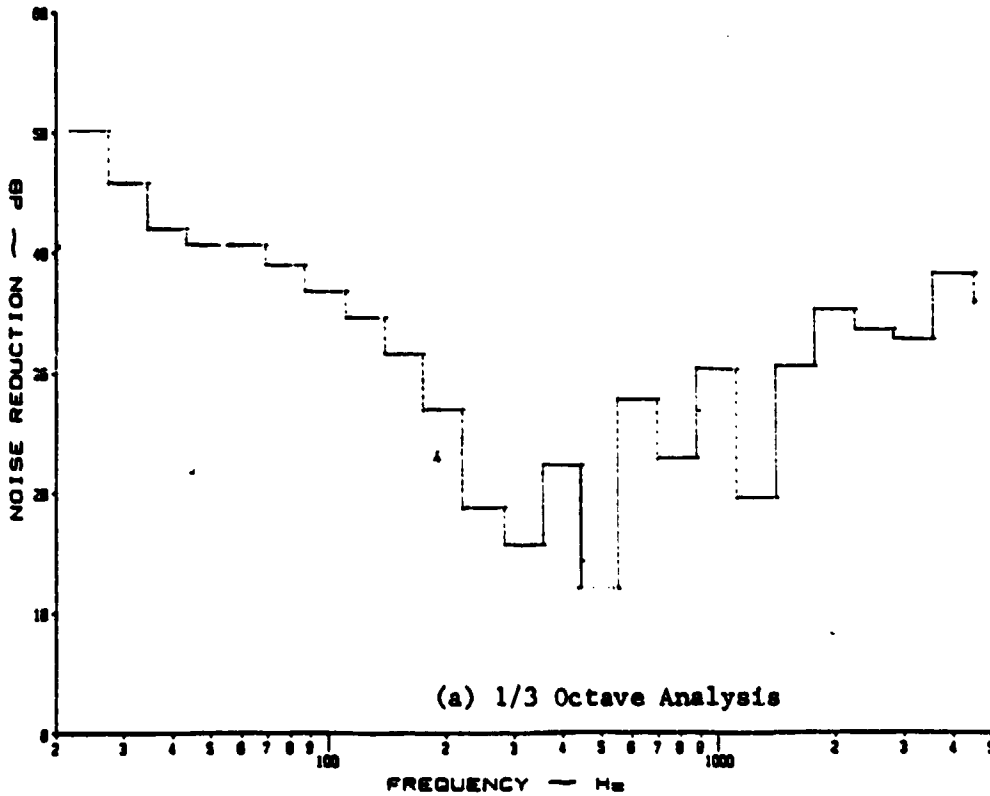

(a) 1/3 Octave Analysis

Figure B.3: Noise Reduction Characteristics of a Bare, Curved Panel at 2 psi pressure differential under discrete noise

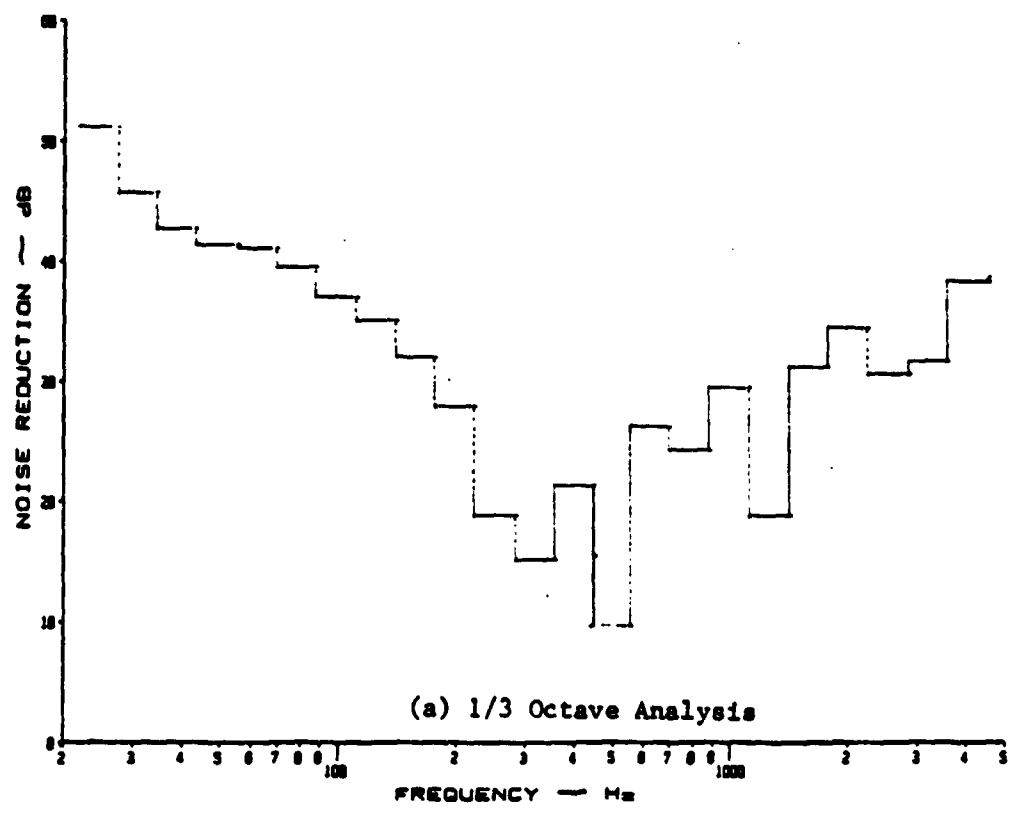
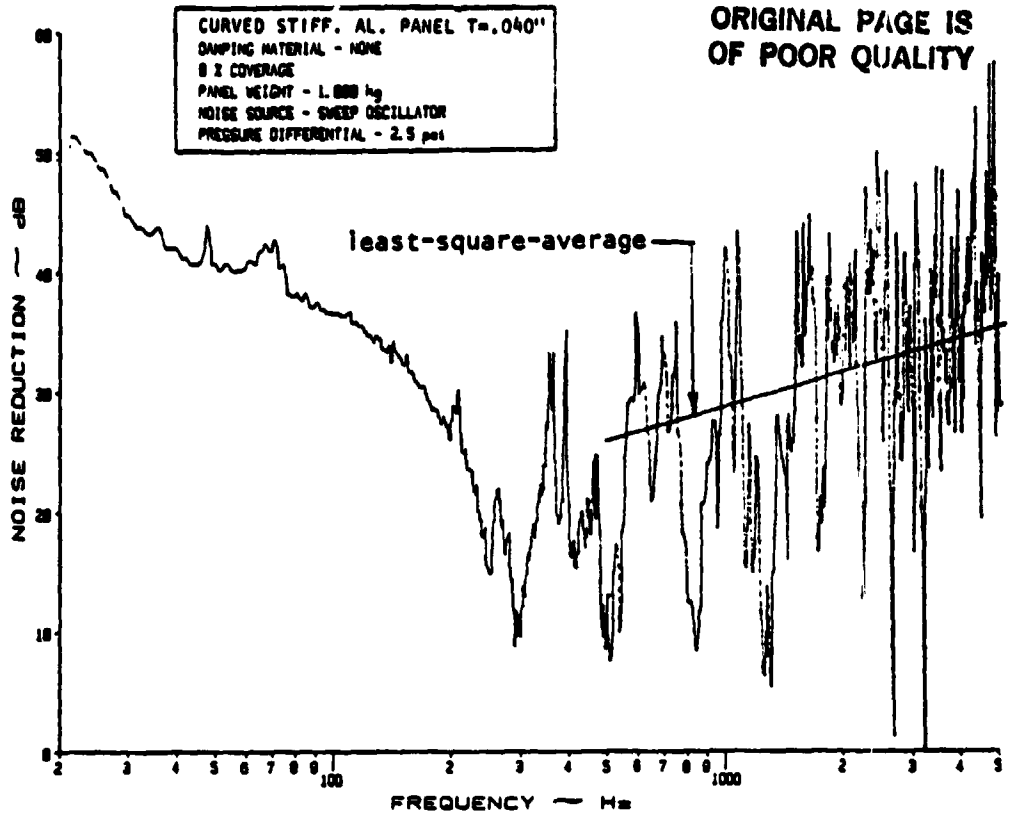

Figure B.4: Noise Reduction Characteristics of a Curved, Bare Panel at 2.5 psi pressure differential under discrete noise

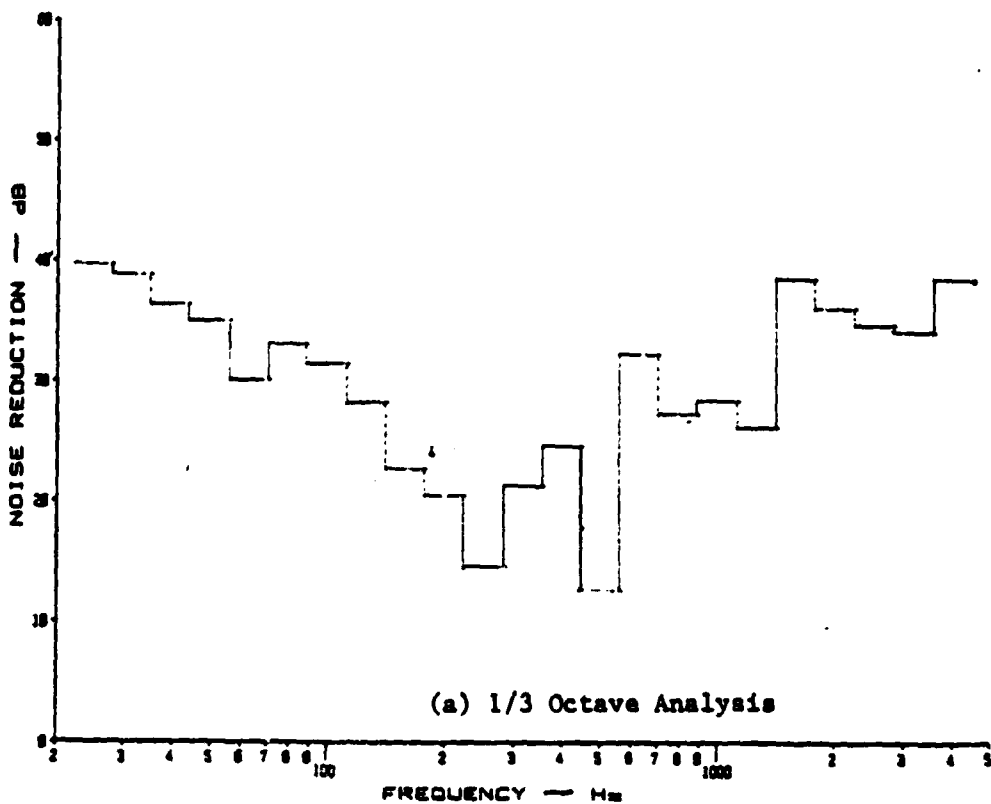
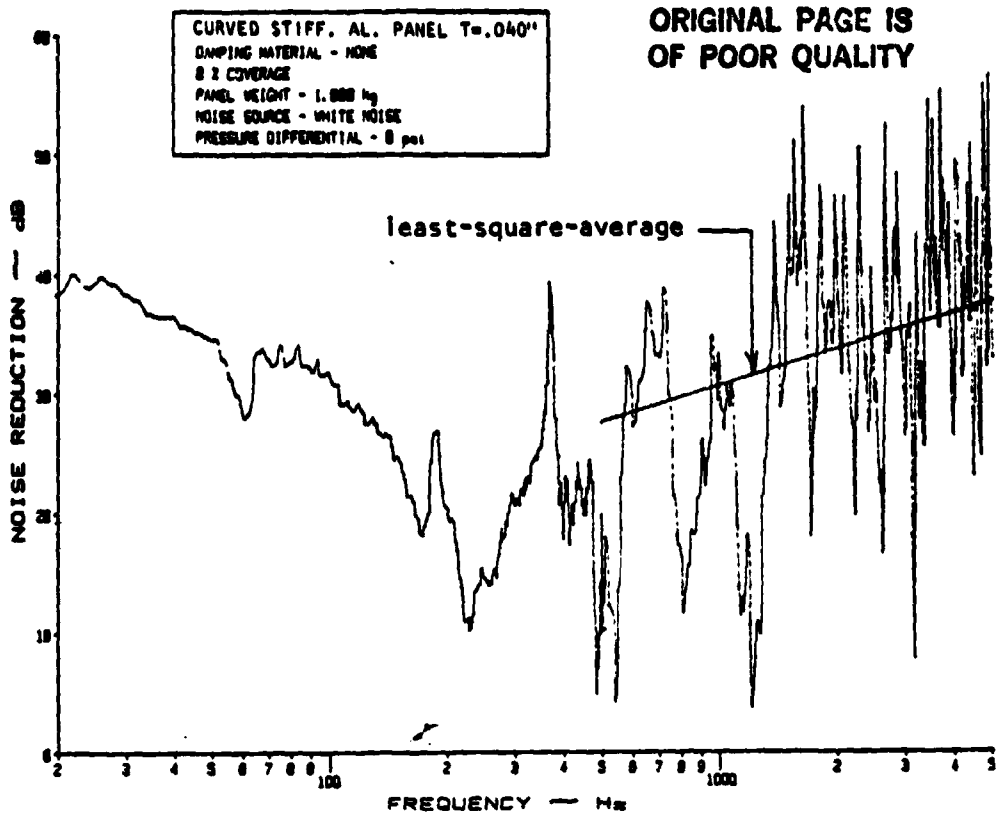
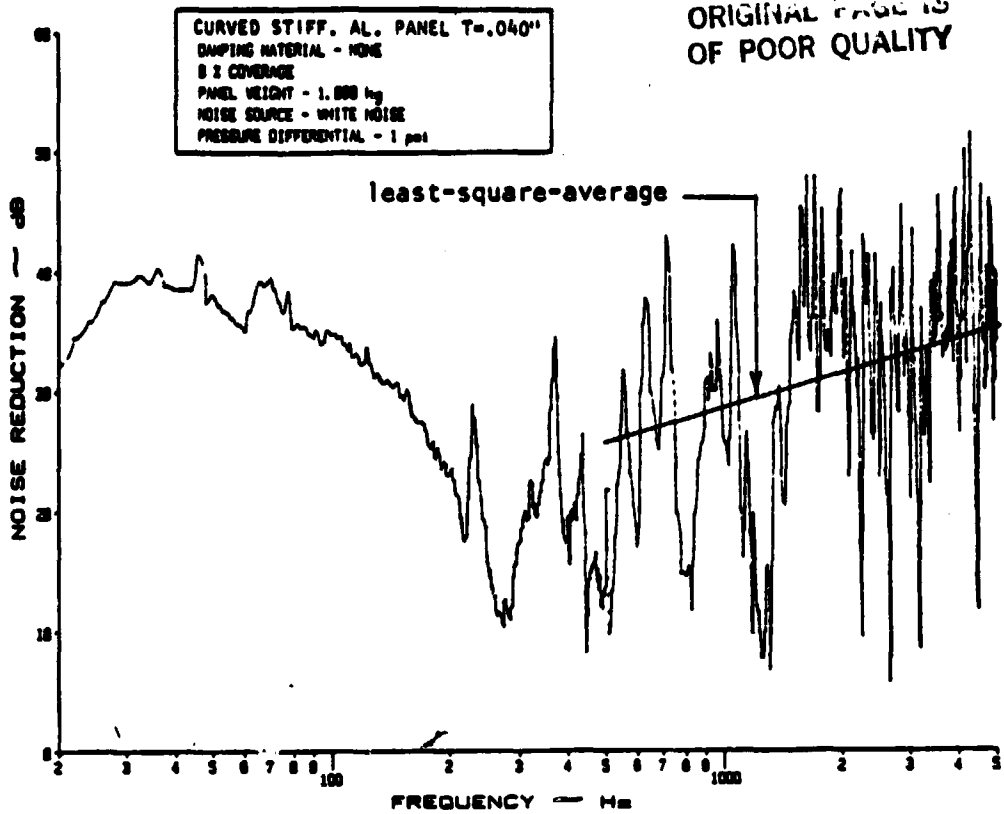
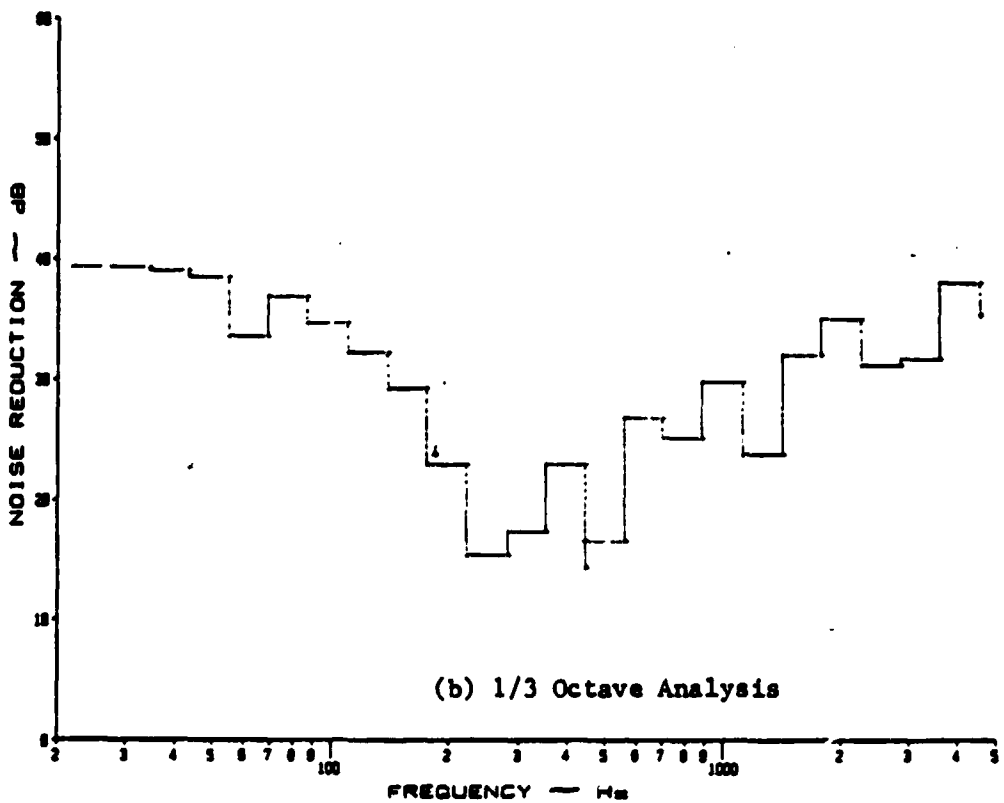

Figure B.5: Noise Reduction Characteristics of a Curved, Bare Panel at 0 psi pressure differential under white noise



(a) Narrow Band Analysis



(b) 1/3 Octave Analysis

Figure B.6: Noise Reduction Characteristics of a Curved, Bare Panel at 1 psi Pressure Differential under White Noise

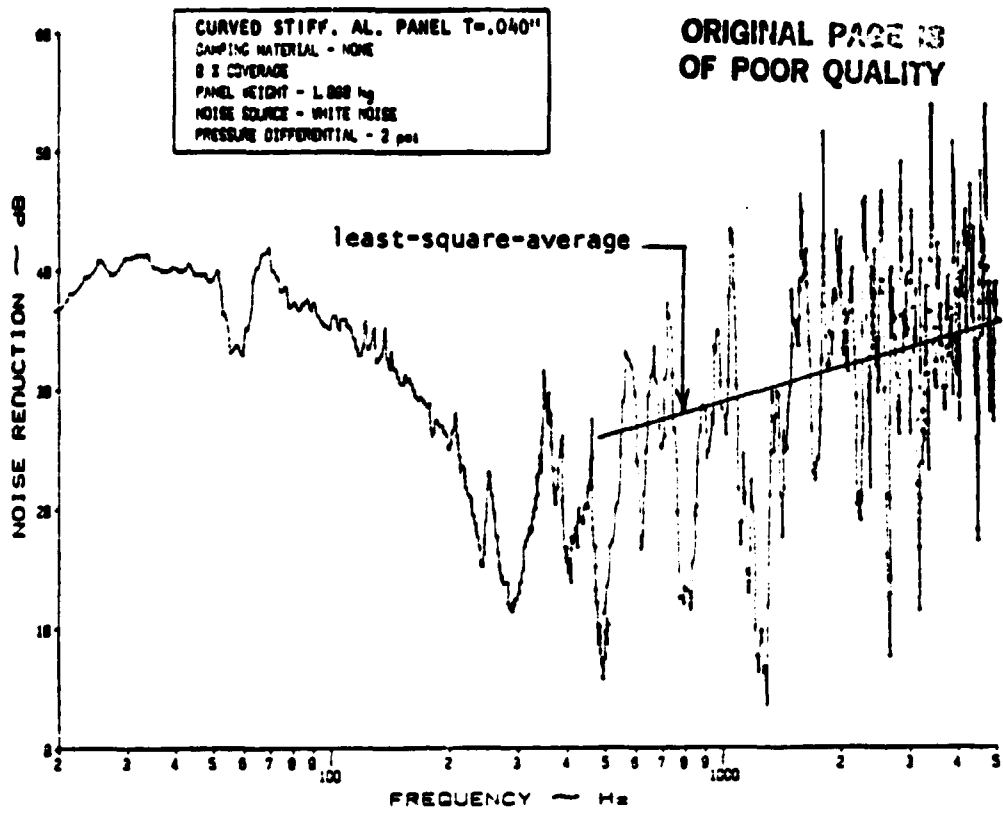

(a) Narrow Band Analysis

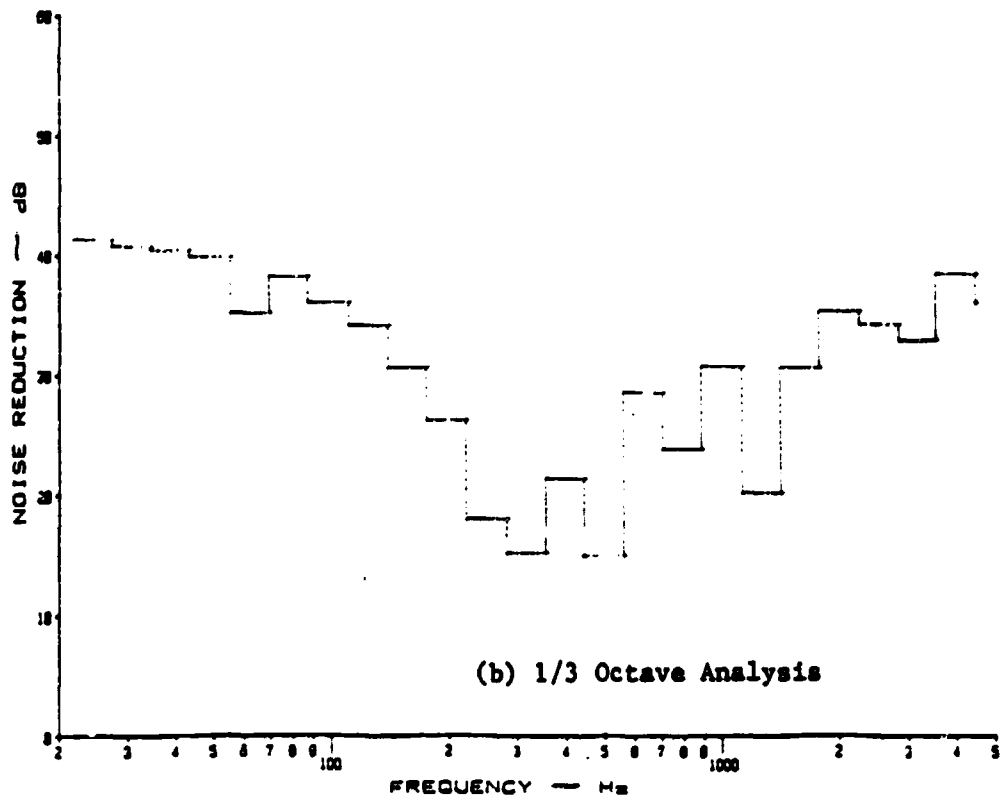

(b) 1/3 Octave Analysis

Figure B.7: Noise Reduction Characteristics of a Curved, Stiffened Panel at 2 psi Pressure Differential with no treatment under White Noise

Figure B.8 does not exist.

**Page intentionally left blank for reasons
of convenience in comparing test data for
curved panel with flat panel results in
Appendix A.**

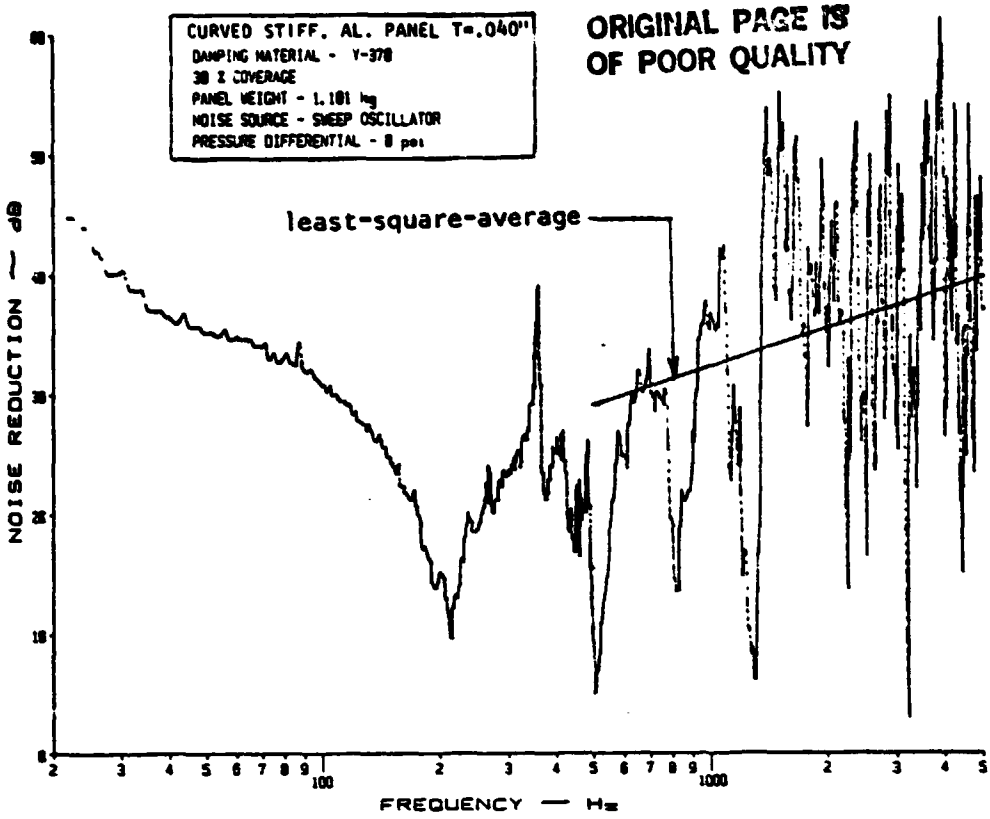

(a) Narrow Band Analysis

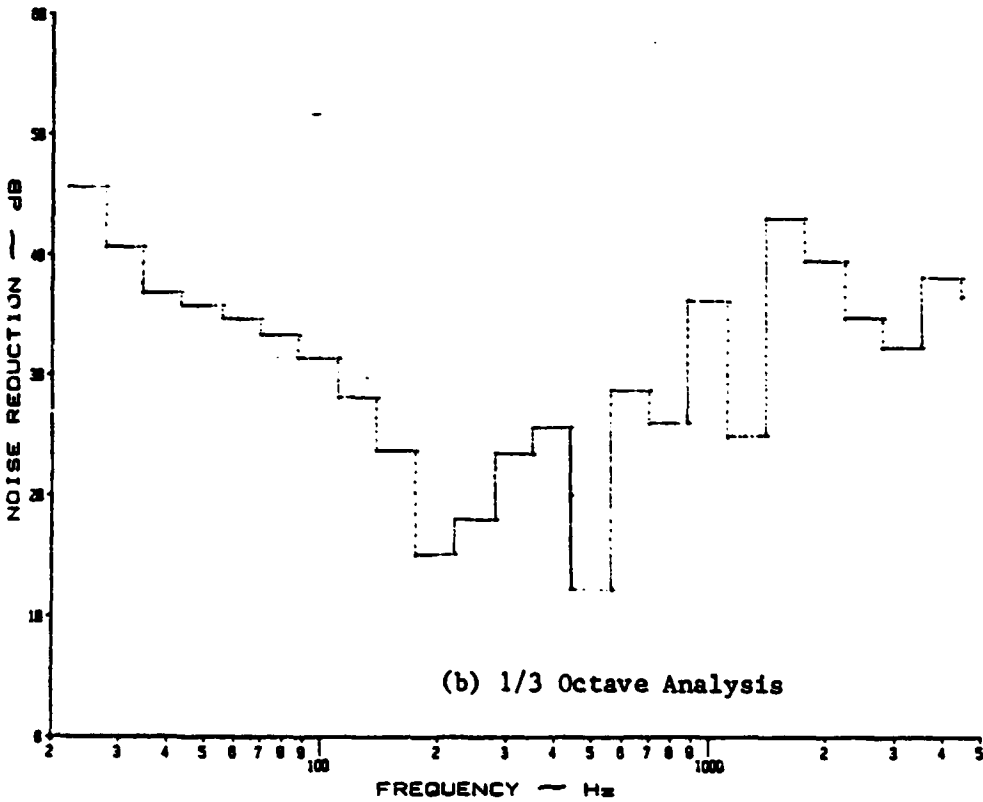

(b) 1/3 Octave Analysis

Figure B.9: Noise Reduction Characteristics of a Curved, Stiffened Panel at 0 psi Pressure Differential with Y-370 Damping Tape under a Discrete Noise Source

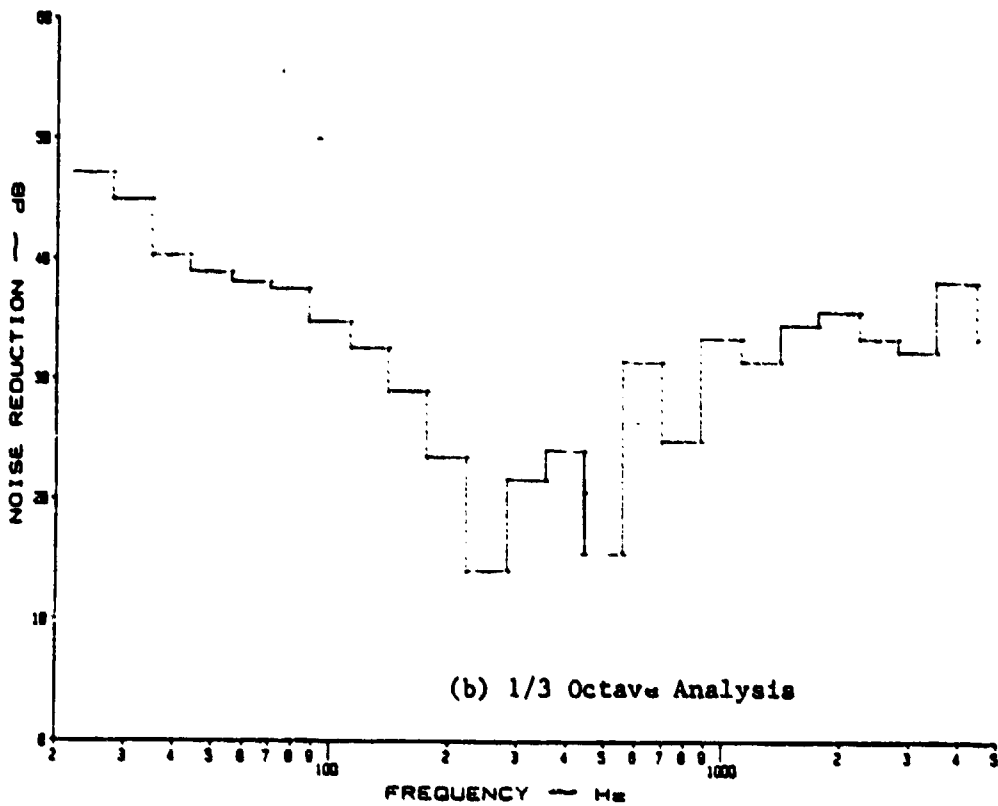
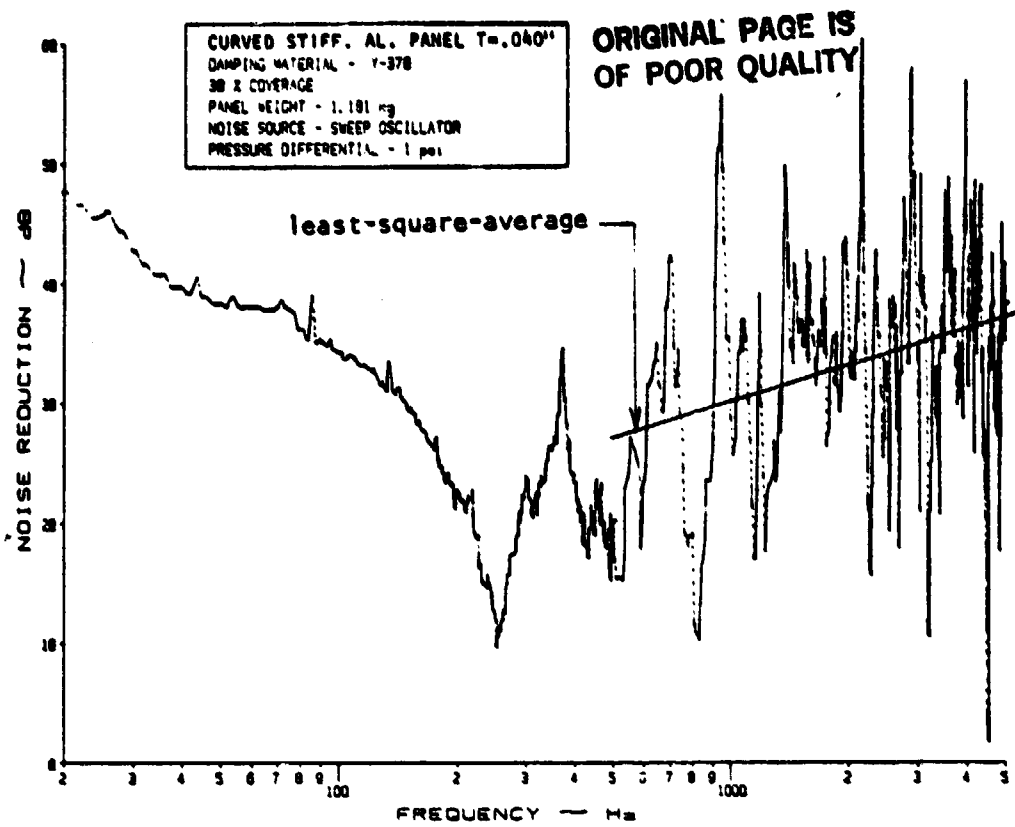
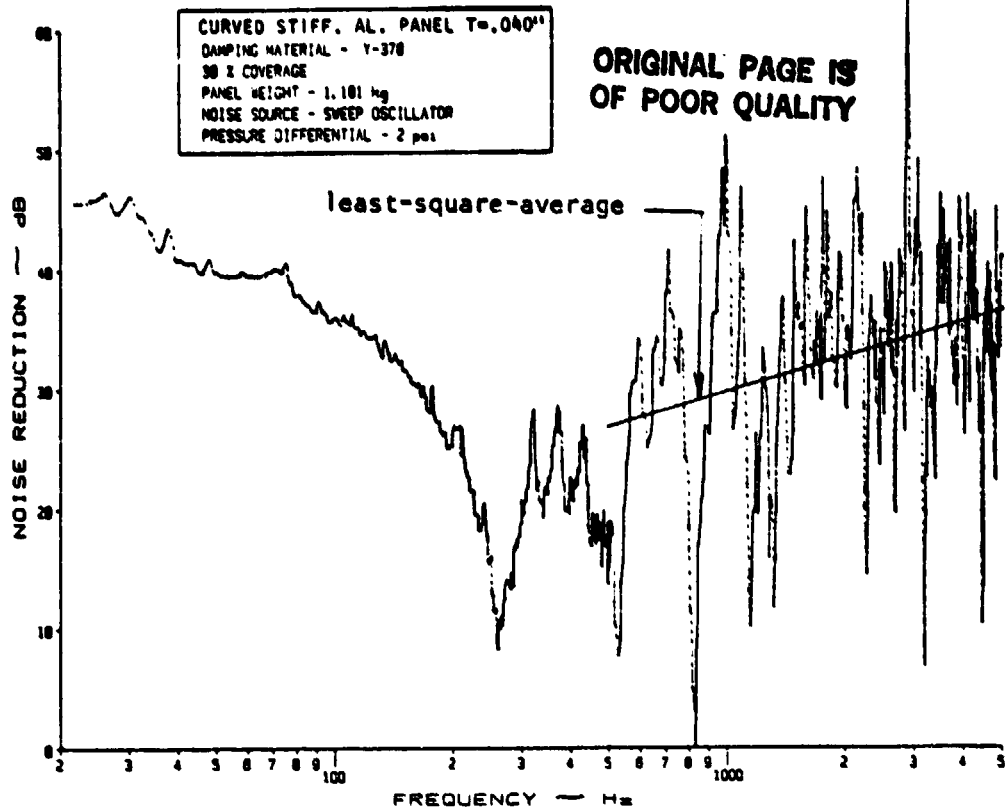
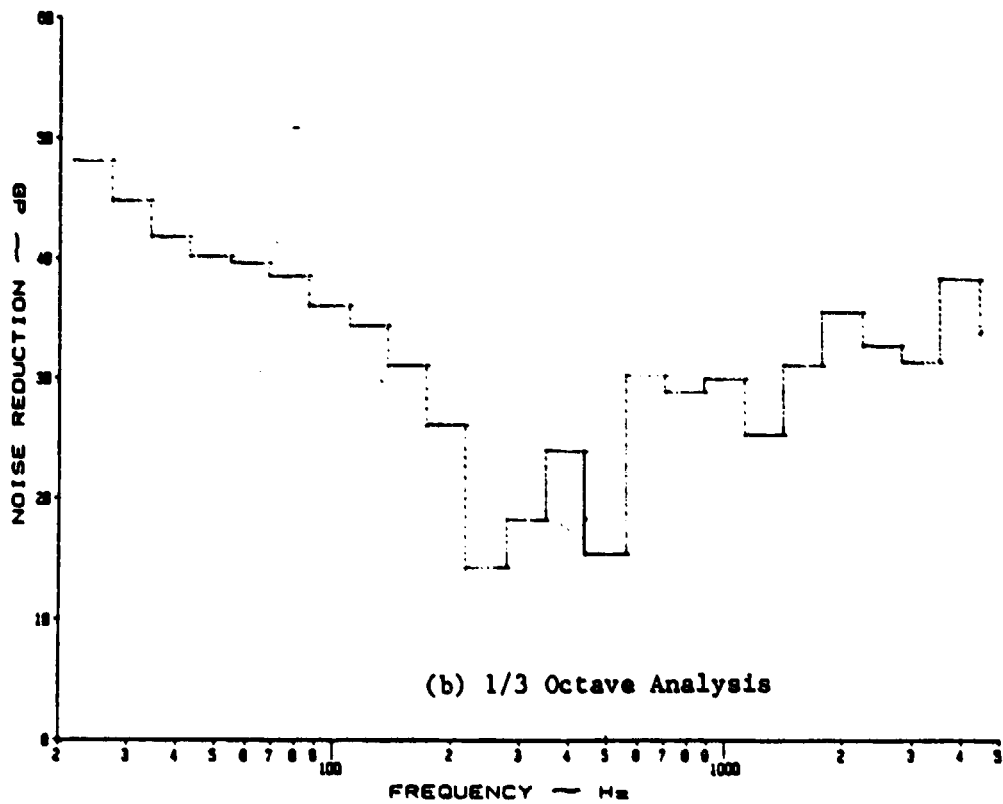

Figure B.10: Noise Reduction Characteristics of a Curved, Stiffened Panel at 1 psi Pressure Differential with Y-370 Damping Tape under a Discrete Noise Source



(a) Narrow Band Analysis



(b) 1/3 Octave Analysis

Figure B.11: Noise Reduction Characteristics of a Curved, Stiffened Panel at 2 psi Pressure Differential with Y-370 Damping Tape under a Discrete Noise Source.

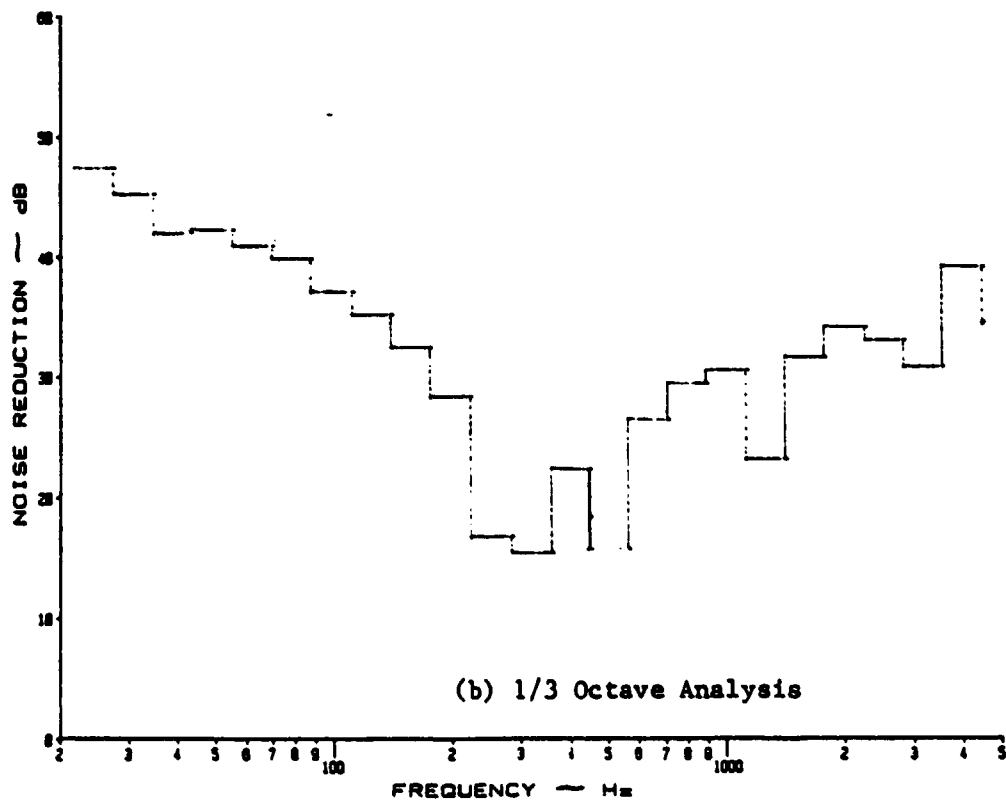
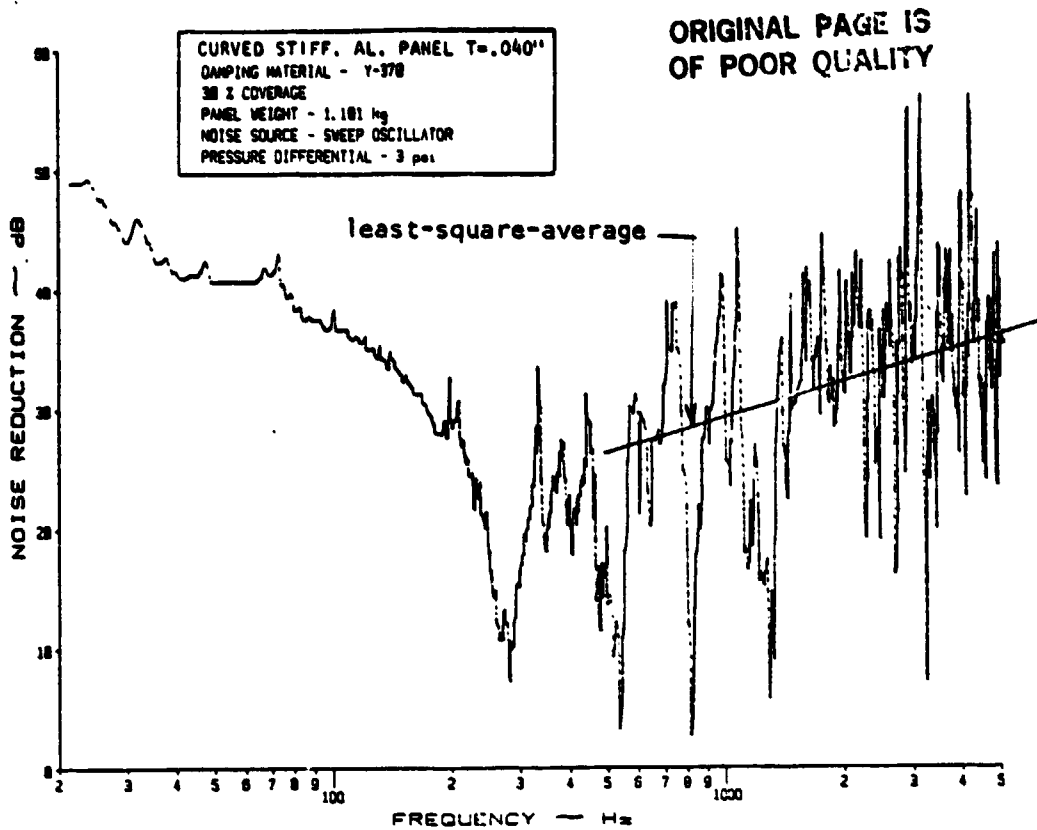
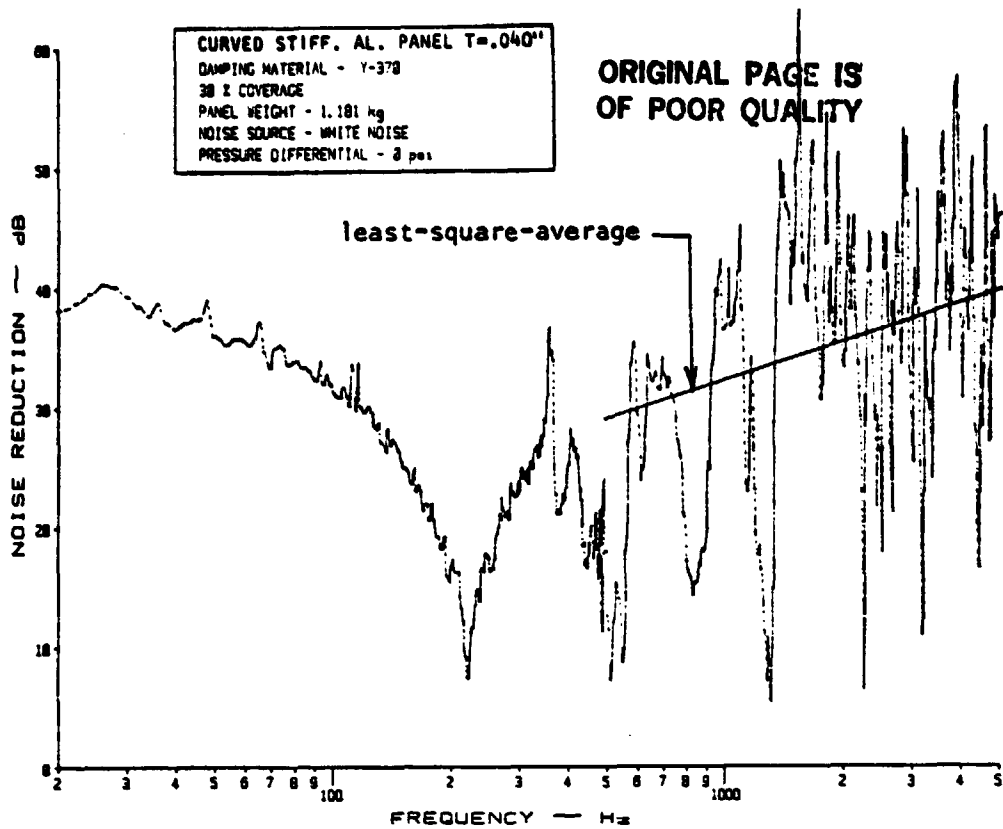
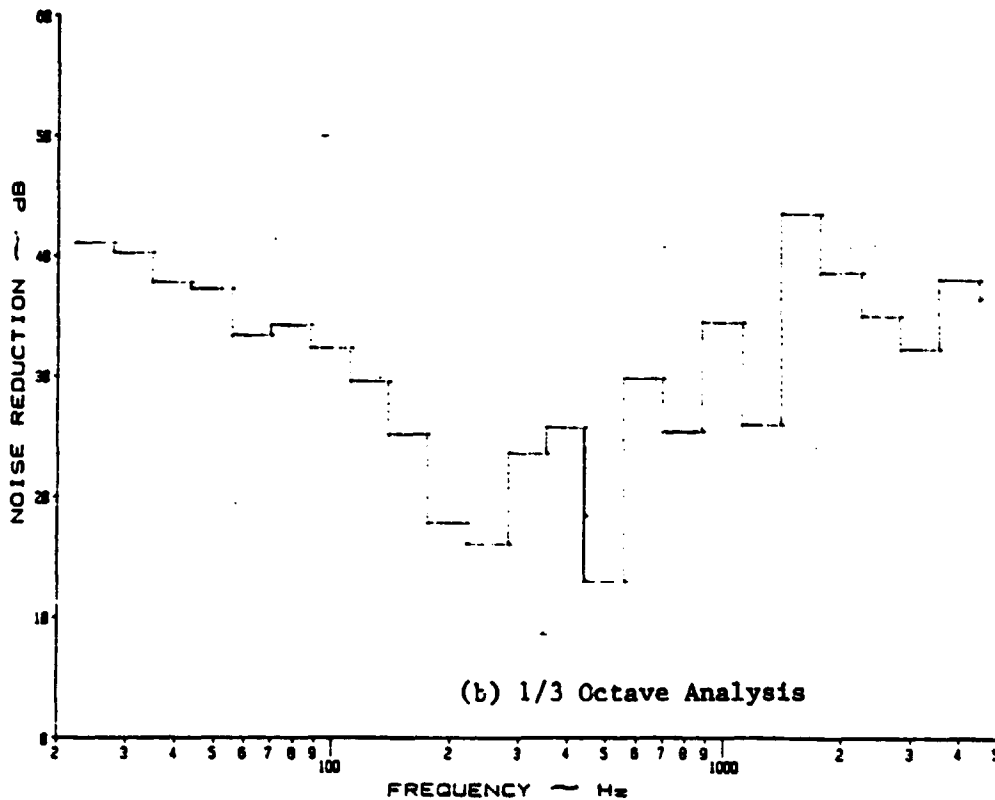

Figure B.12: Noise Reduction Characteristics of a Curved, Stiffened Panel at 3 psi Pressure Differential with Y-370 Damping Tape under a Discrete Noise Source



(a) Narrow Band Analysis



(b) 1/3 Octave Analysis

Figure B.13: Noise Reduction Characteristics of a Curved, Stiffened Panel at 0 psi Pressure Differential with Y-370 Damping Tape under White Noise

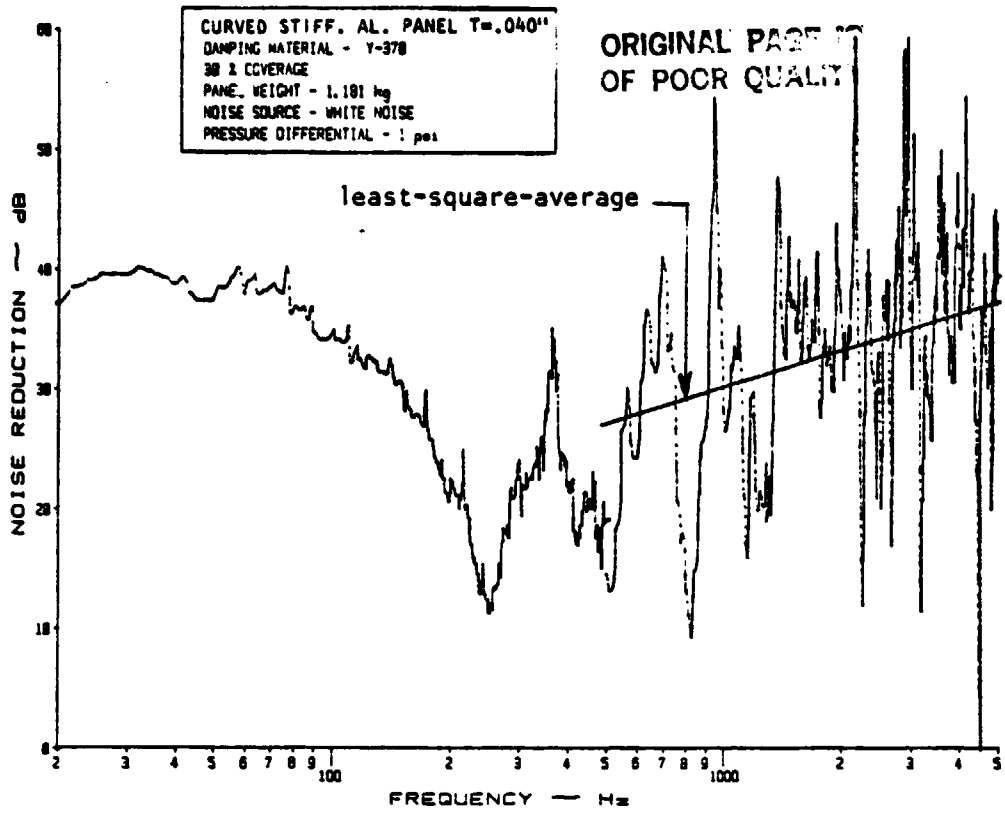

(a) Narrow Band Analysis

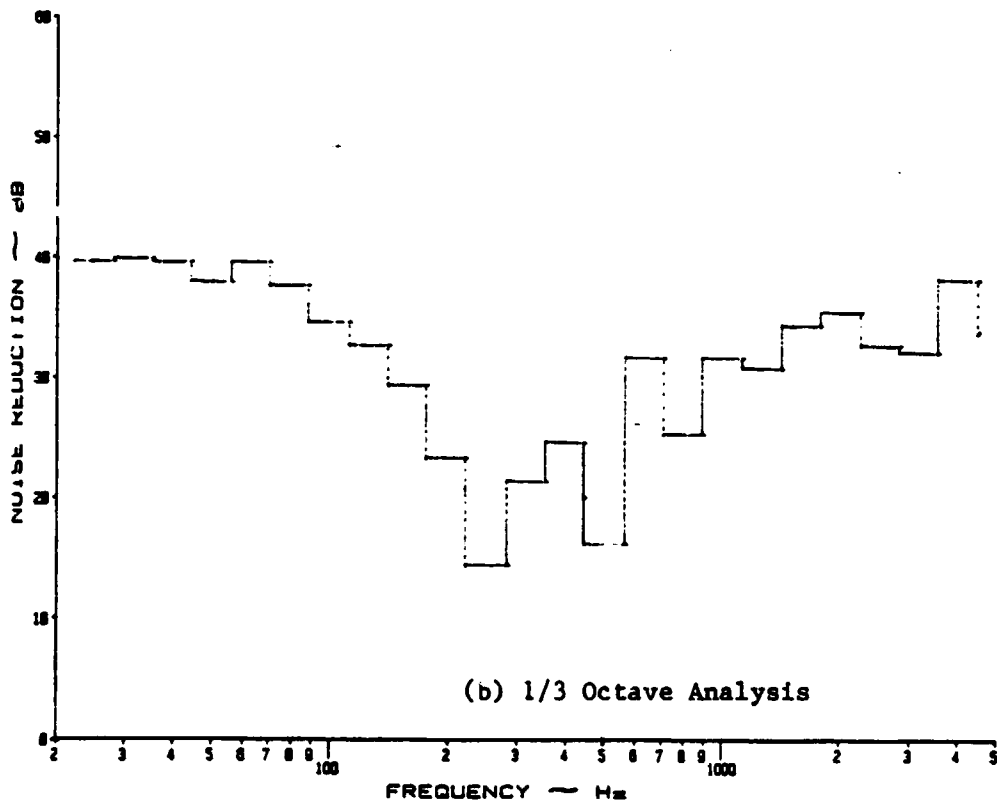
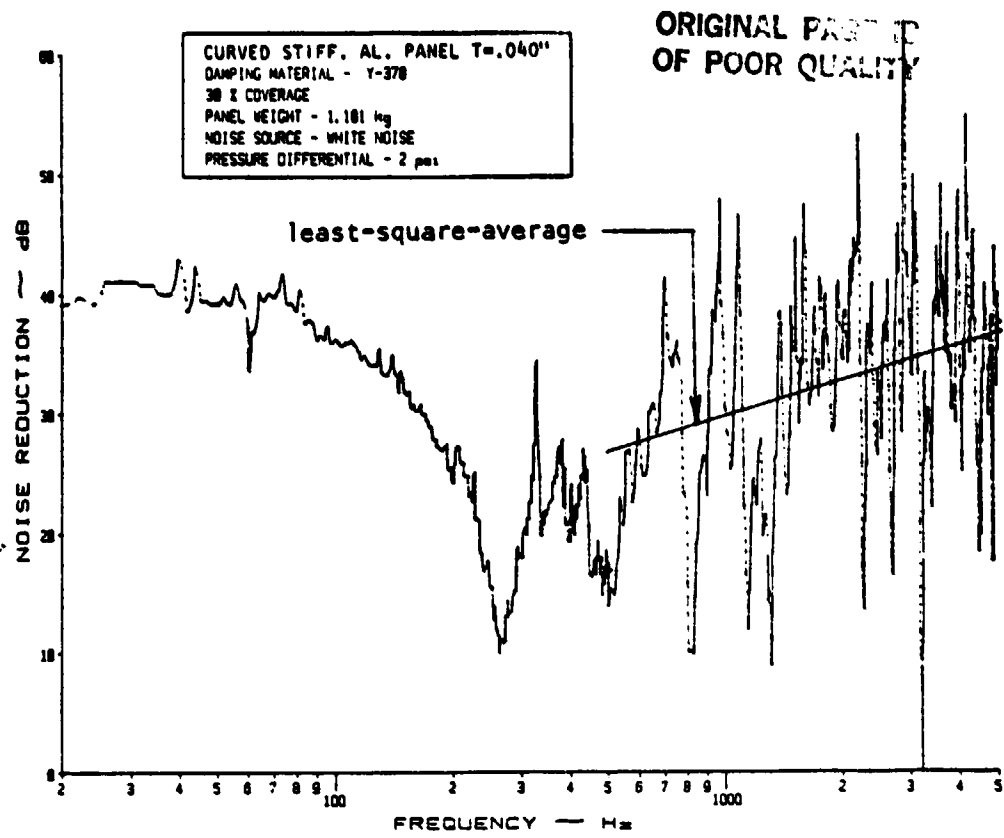
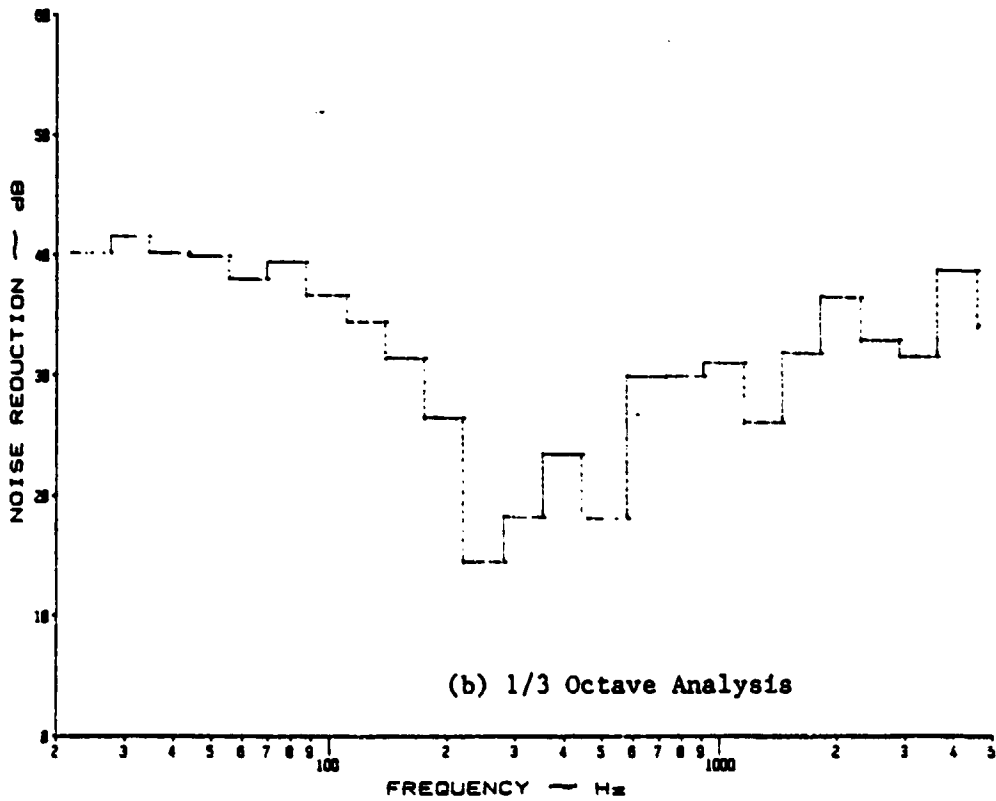

Figure B.14: Noise Reduction Characteristics of a Curved, Stiffened Panel at 1 psi Pressure Differential with Y-370 Damping Tape under White Noise



(a) Narrow Band Analysis



(b) 1/3 Octave Analysis

Figure B.15: Noise Reduction Characteristics of a Curved, Stiffened Panel at 2 psi Pressure Differential with Y-370 Damping Tape under White Noise

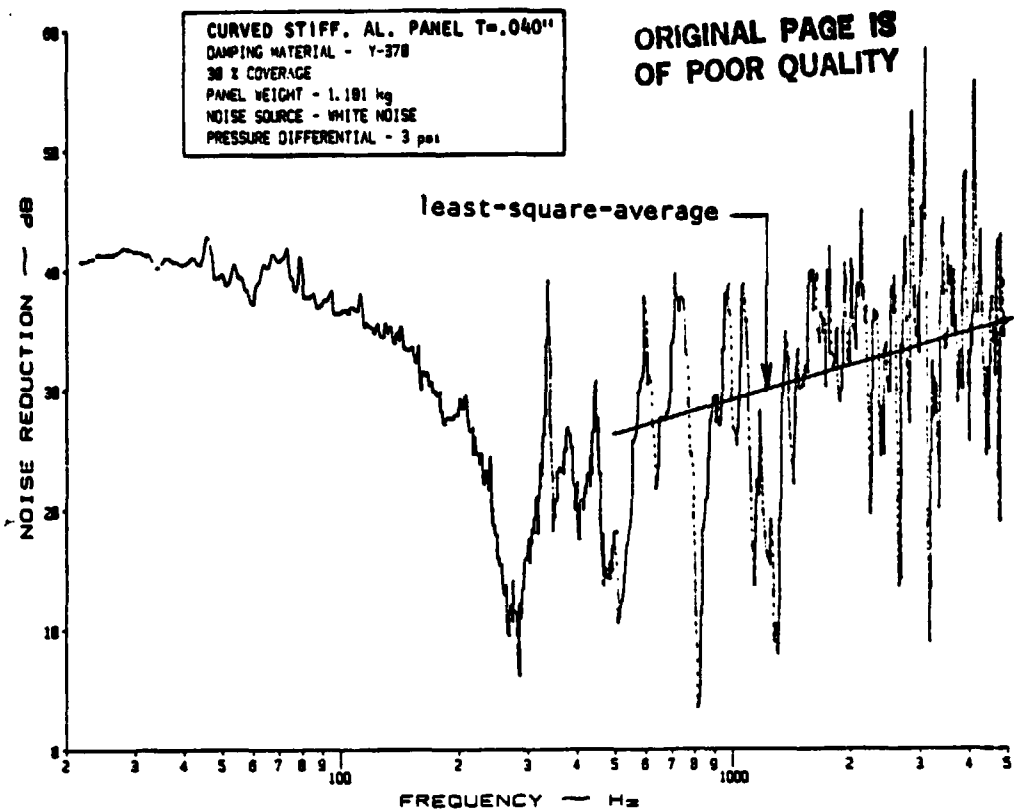

(a) Narrow Band Analysis

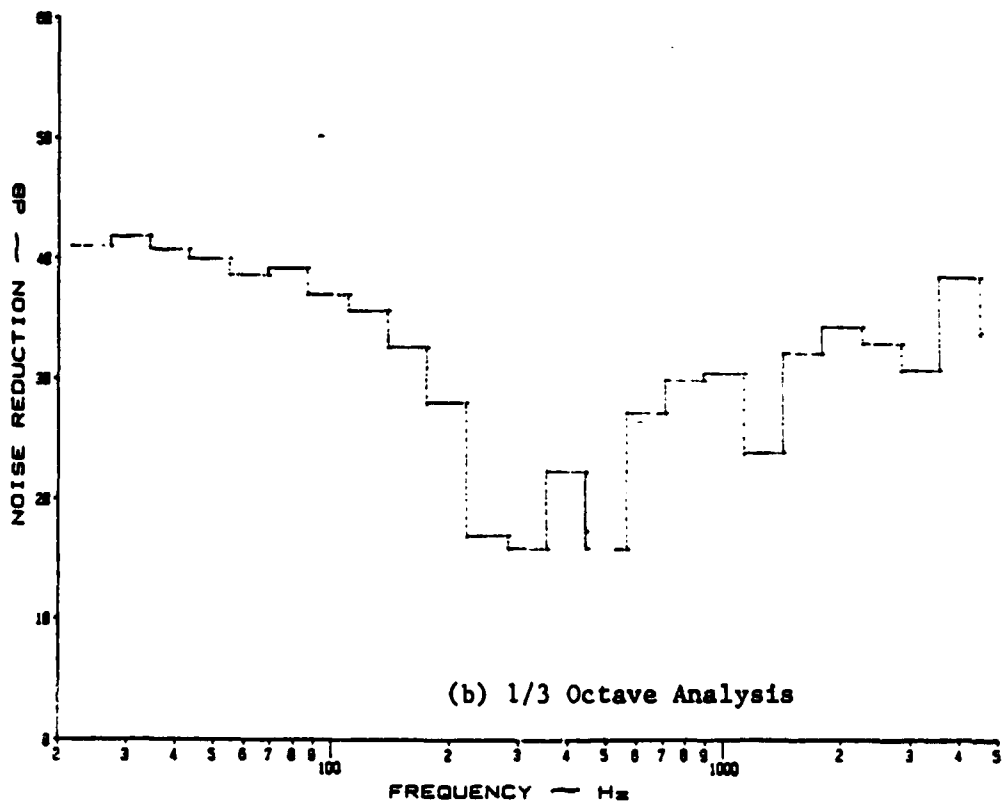

(b) 1/3 Octave Analysis

Figure B.16: Noise Reduction Characteristics of a Curved, Stiffened Panel at 3 psi Pressure Differential with Y-370 Damping Tape under White Noise

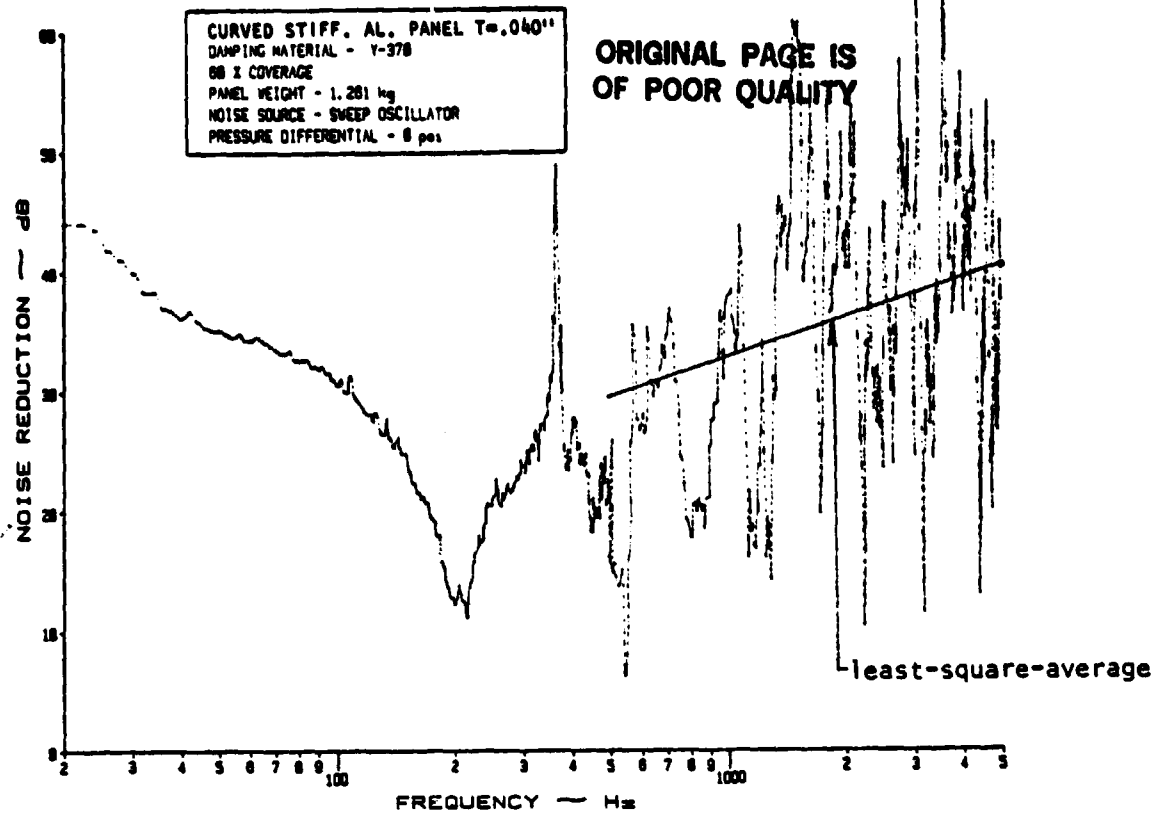

(a) Narrow Band Analysis

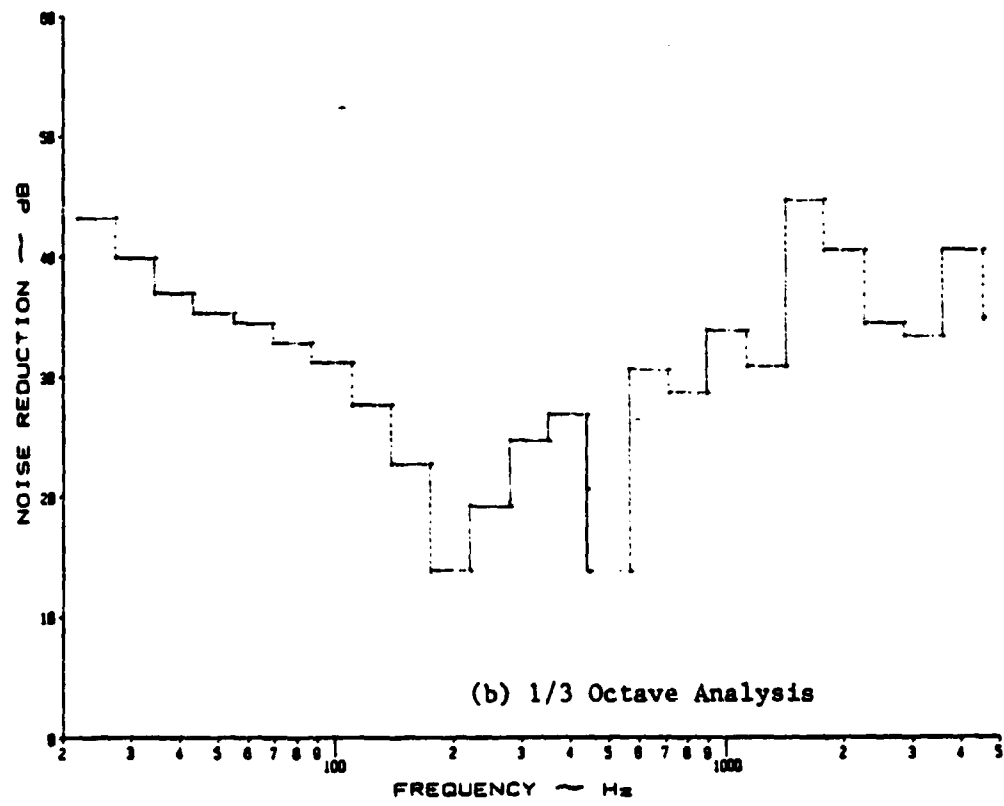

(b) 1/3 Octave Analysis

Figure B.17: Noise Reduction Characteristics of a Curved, Stiffened Panel at 0 psi Pressure Differential with Y-370 Damping Tape under a Discrete Noise Source

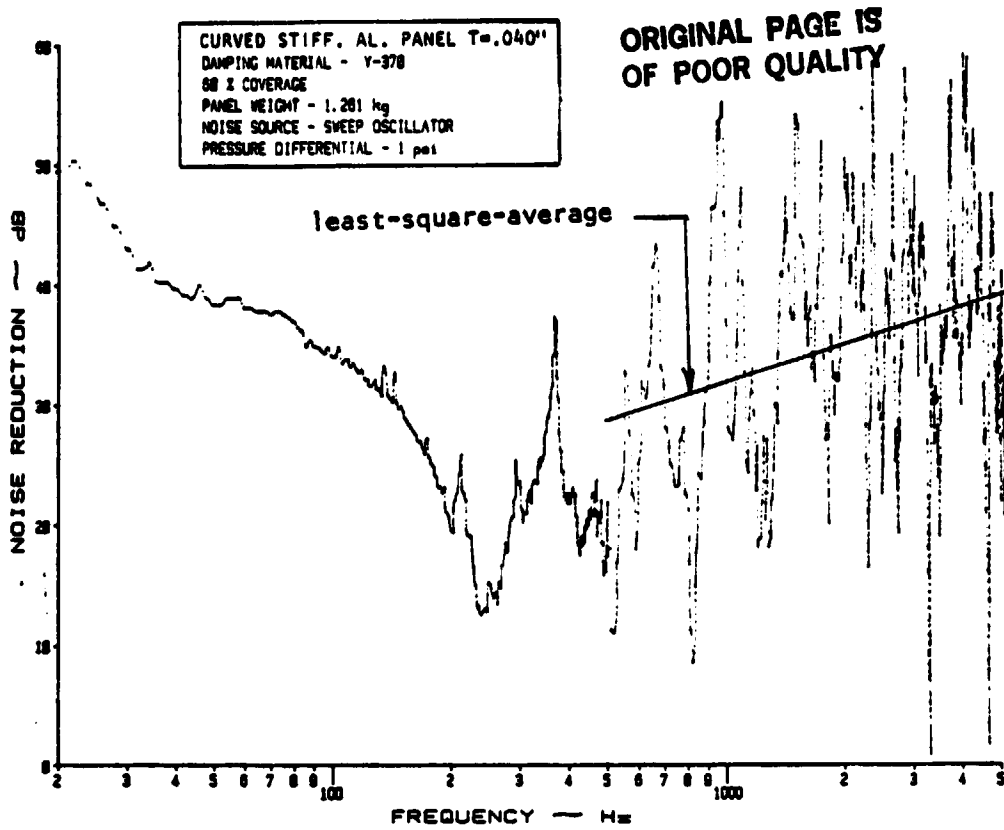

(a) Narrow Band Analysis

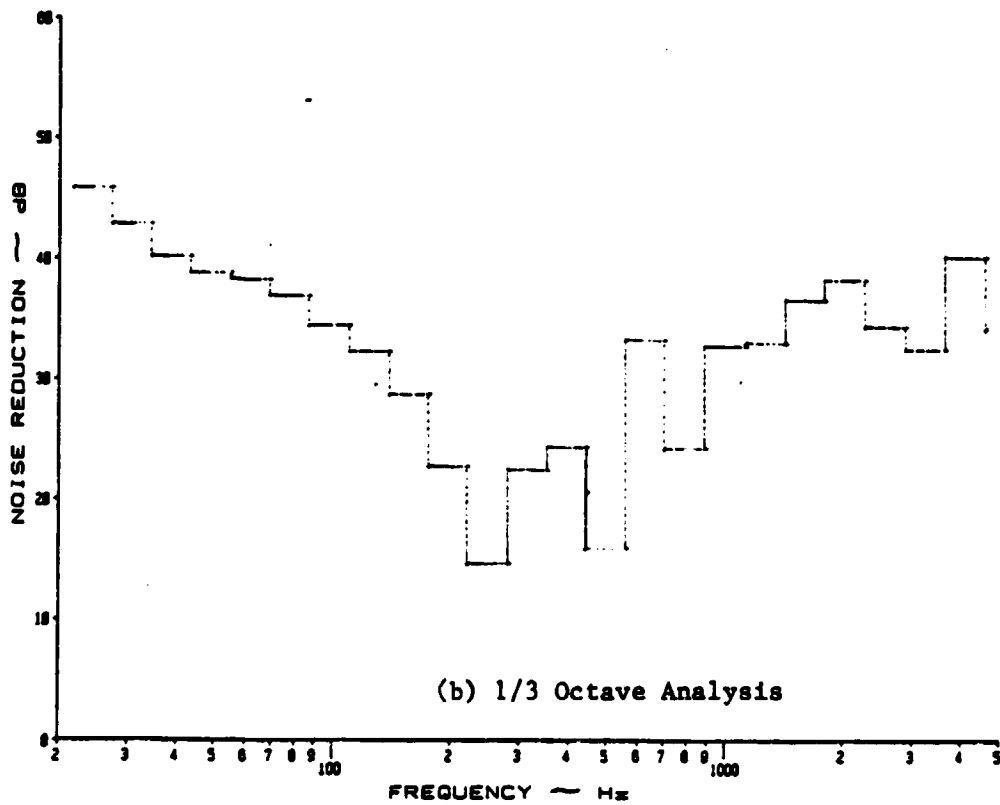

(b) 1/3 Octave Analysis

Figure B.18: Noise Reduction Characteristics of a Curved, Stiffened Panel at 1 psi Pressure Differential with Y-378 Damping Tape under a Discrete Noise Source

ORIGINAL PAGE IS
OF POOR QUALITY

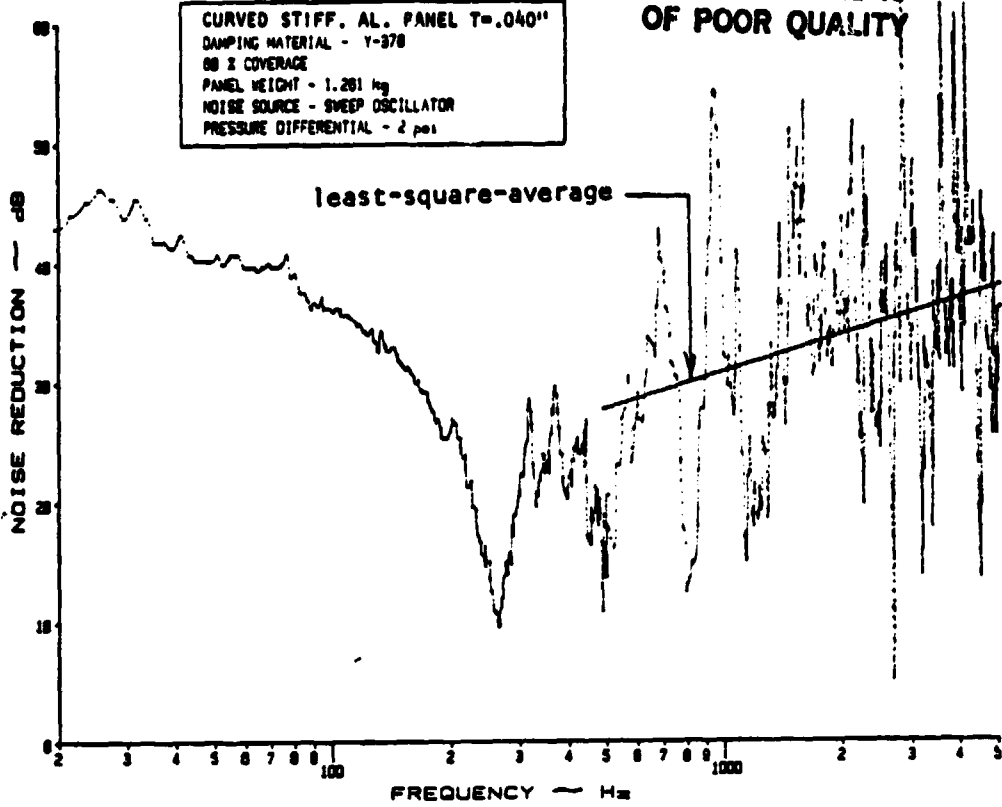

(a) Narrow Band Analysis

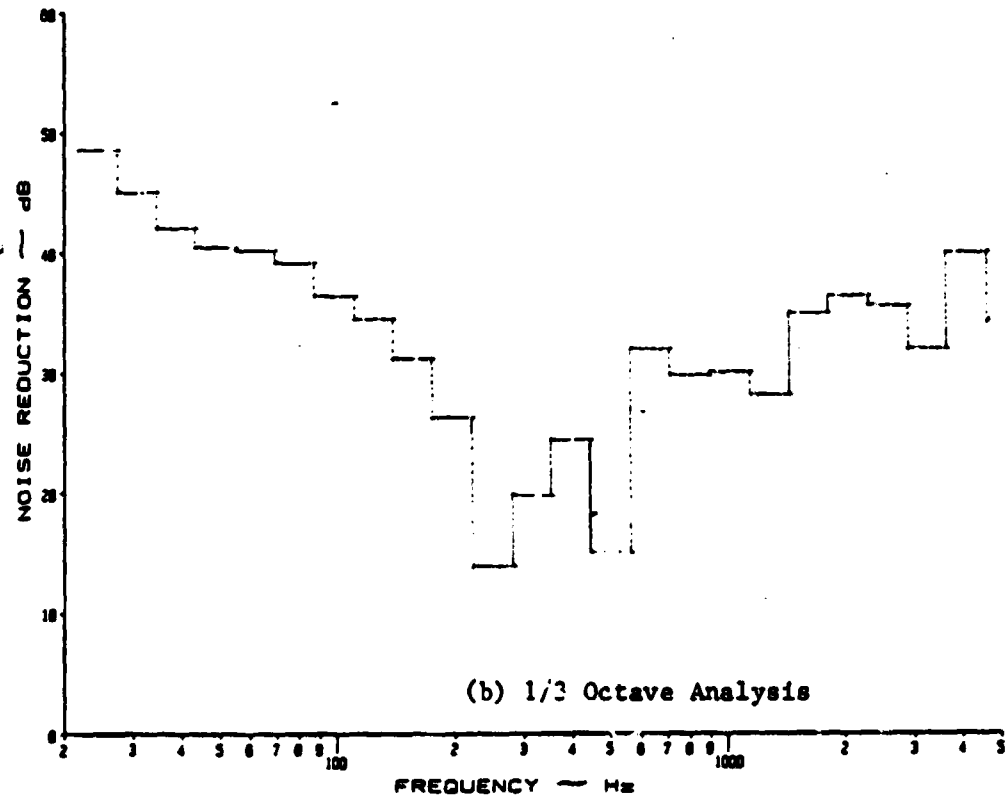

(b) 1/3 Octave Analysis

Figure B.19: Noise Reduction Characteristics of a Curved, Stiffened Panel at 2 psi Pressure Differential with Y-370 Damping Tape under a Discrete Noise Source

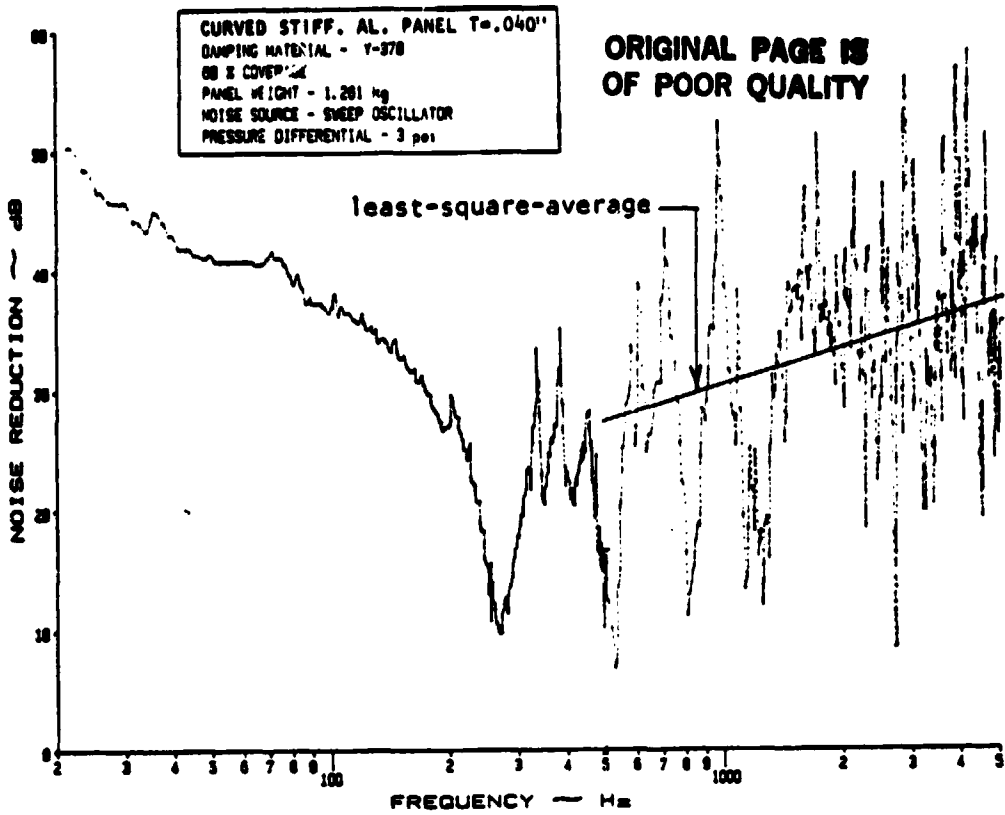

(a) Narrow Band Analysis

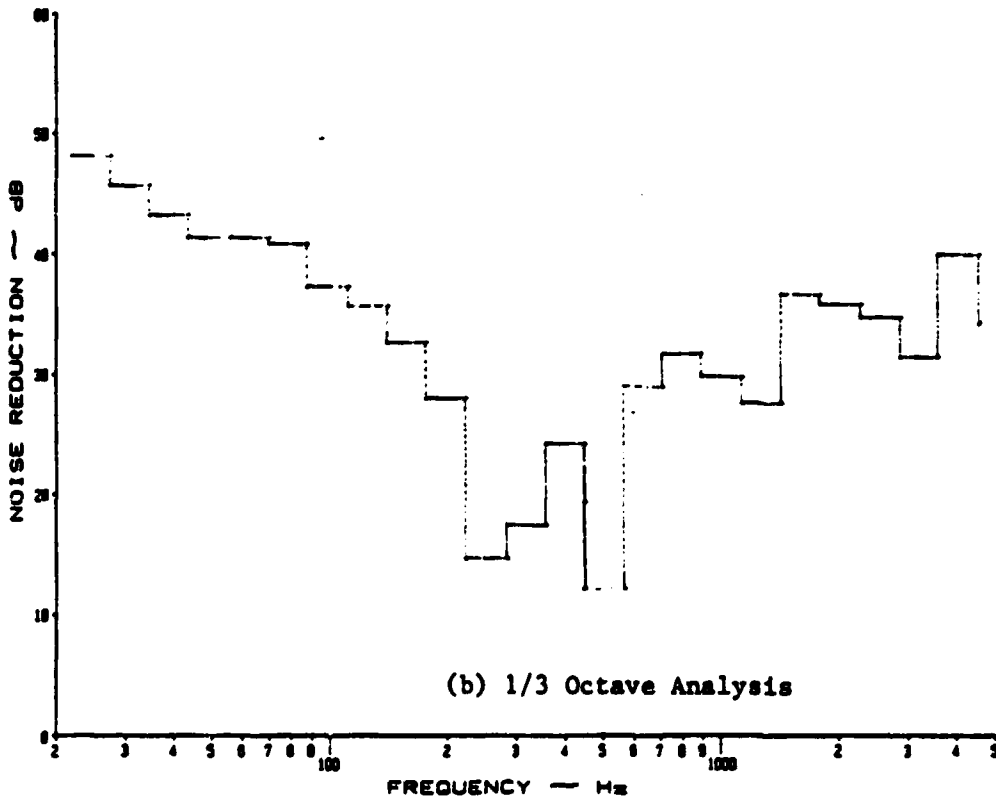

(b) 1/3 Octave Analysis

Figure B.20: Noise Reduction Characteristics of a Curved, Stiffened Panel at 3 psi Pressure Differential with Y-370 Damping Tape under a Discrete Noise Source

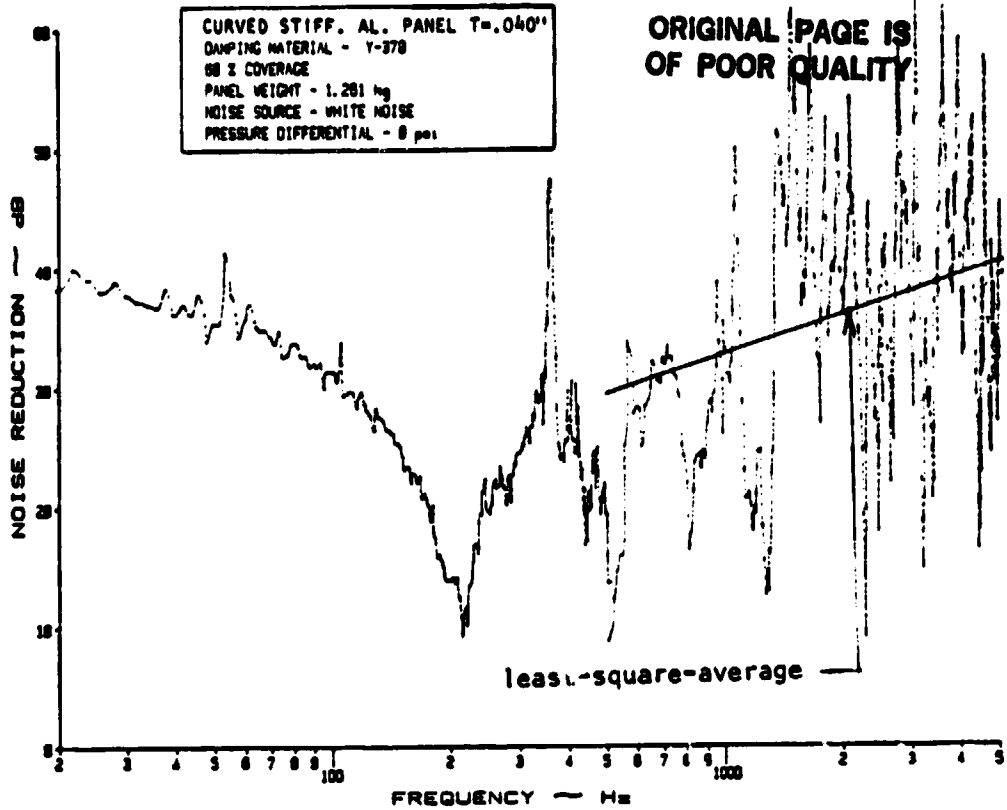

(a) Narrow Band Analysis

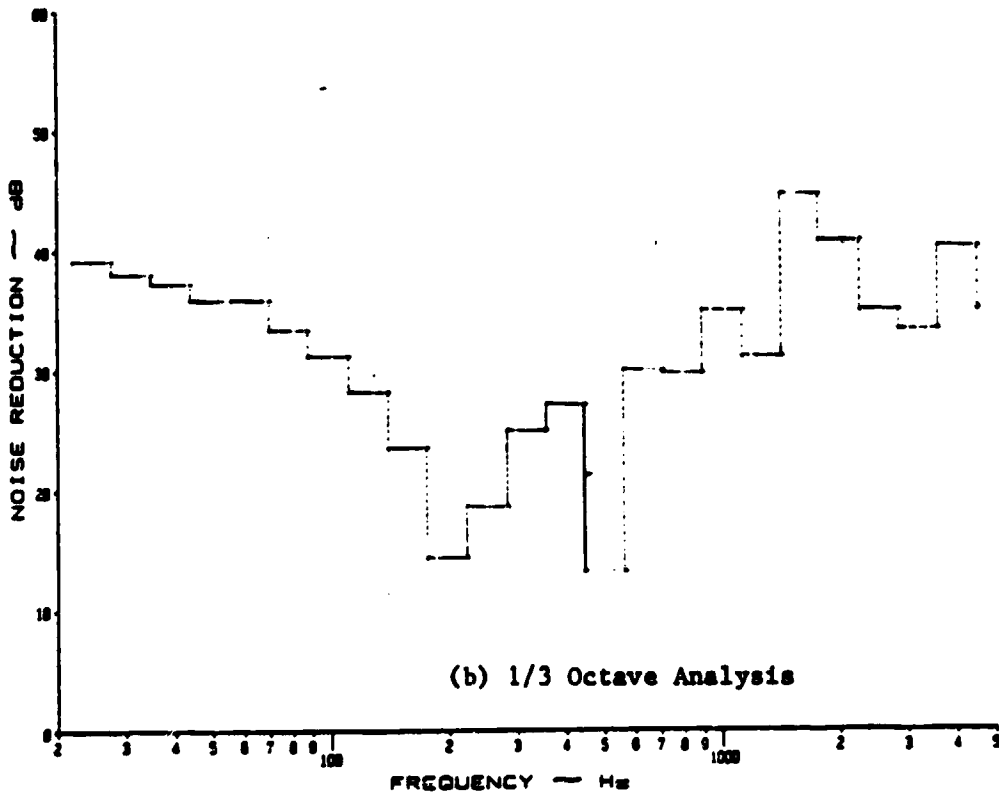

(b) 1/3 Octave Analysis

Figure B.21: Noise Reduction Characteristics of a Curved, Stiffened Panel at 0 psi Pressure Differential with Y-370 Damping Tape under White Noise

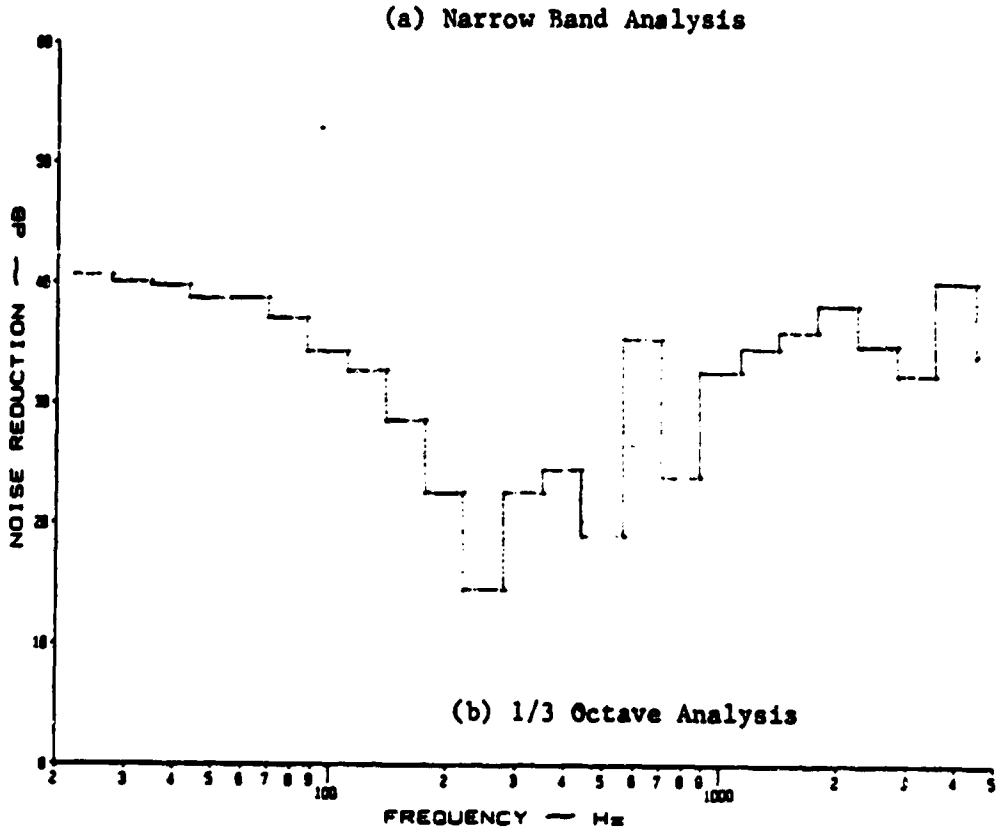
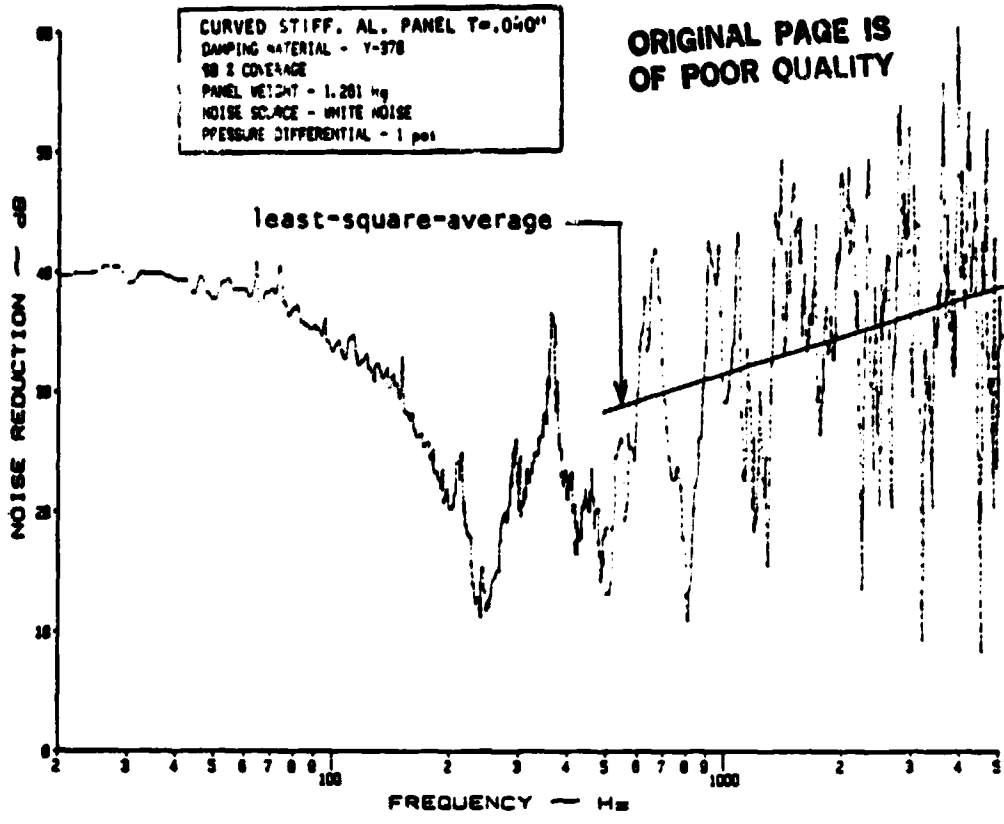
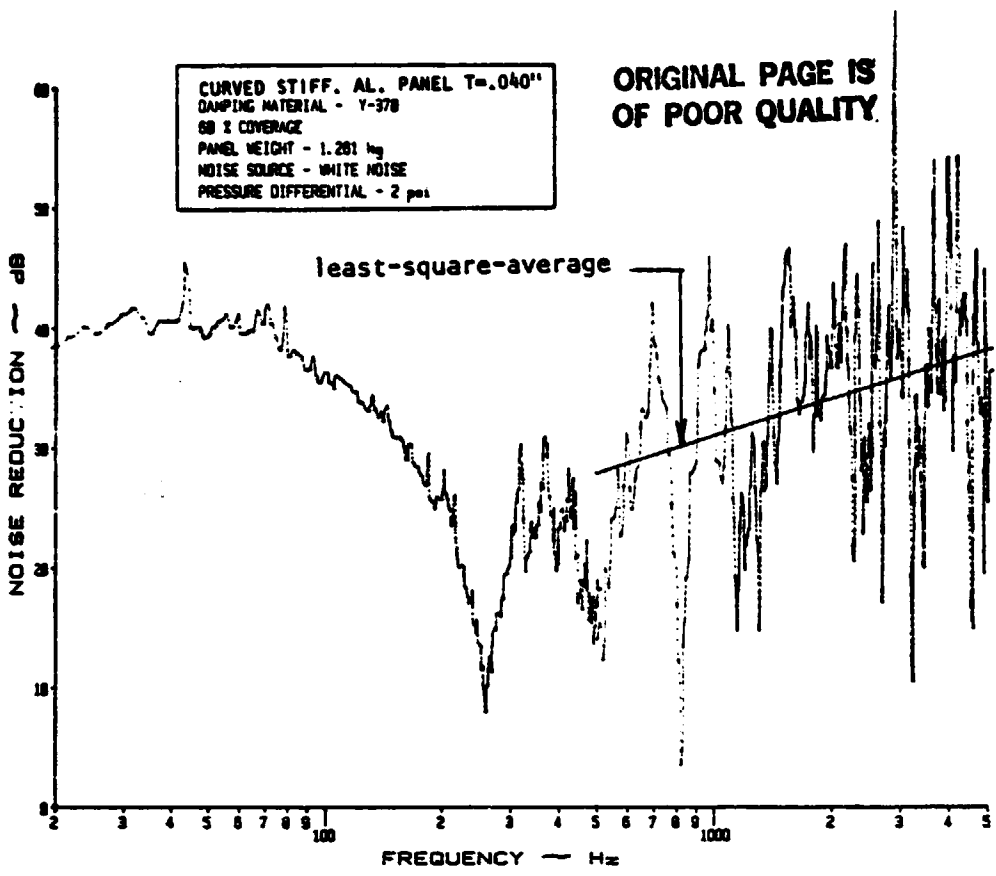
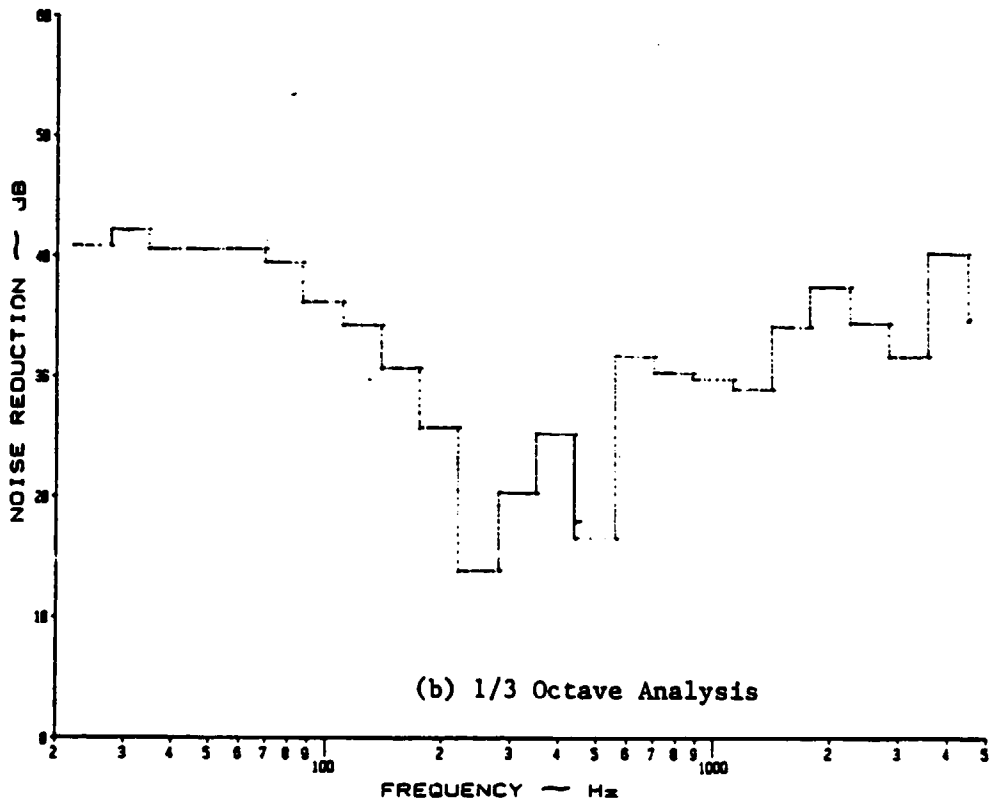

Figure B.22: Noise Reduction Characteristics of a Curved, Stiffened Panel at 1 psi Pressure Differential with Y-370 Damping Tape under White Noise



(a) Narrow Band Analysis



(b) 1/3 Octave Analysis

Figure B.23: Noise Reduction Characteristics of a Curved, Stiffened Panel at 2 psi Pressure Differential with Y-370 Damping Tape under White Noise

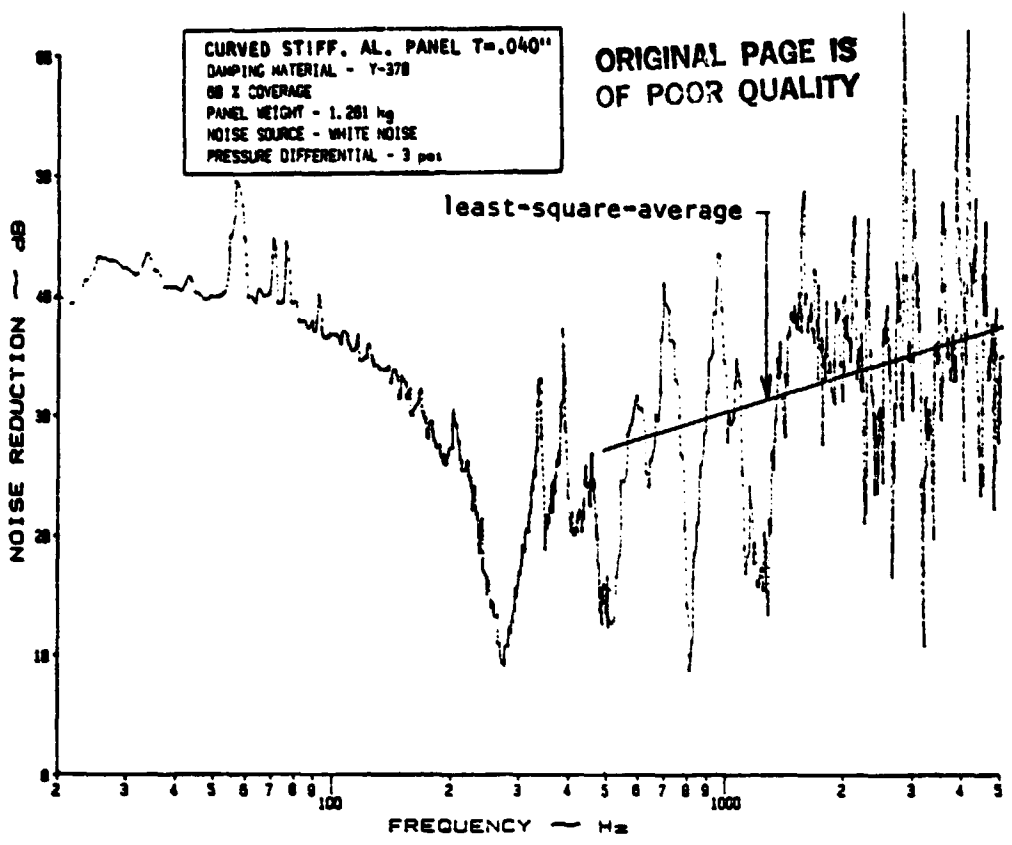

(a) Narrow Band Analysis

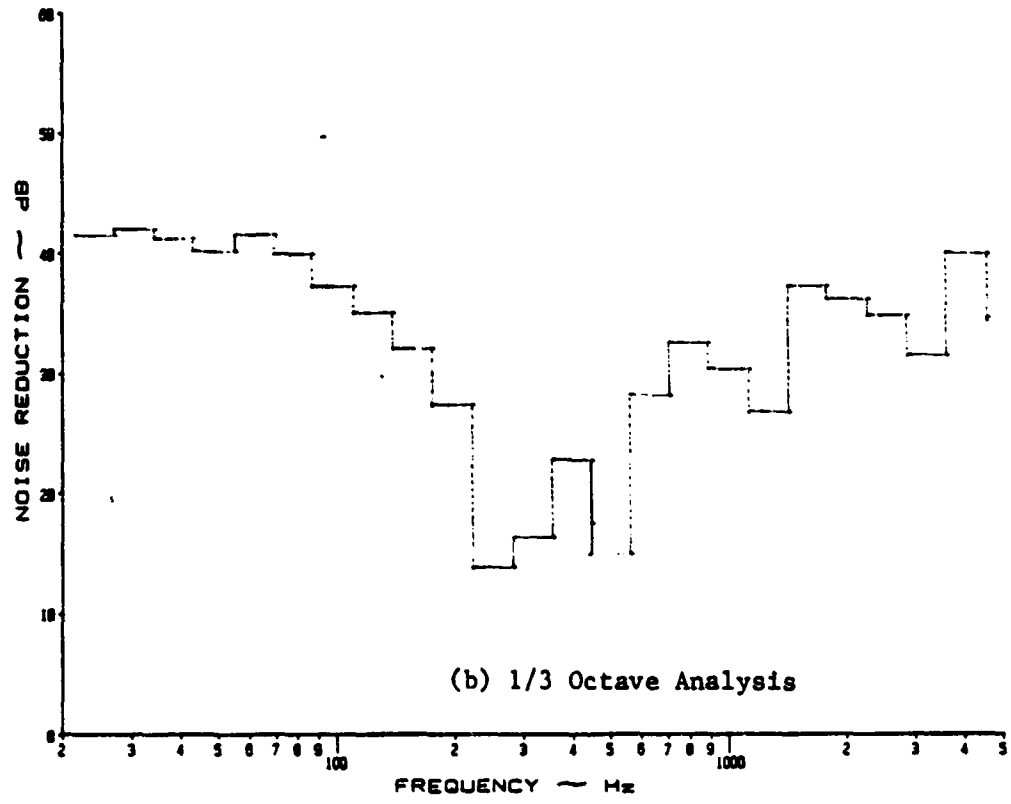
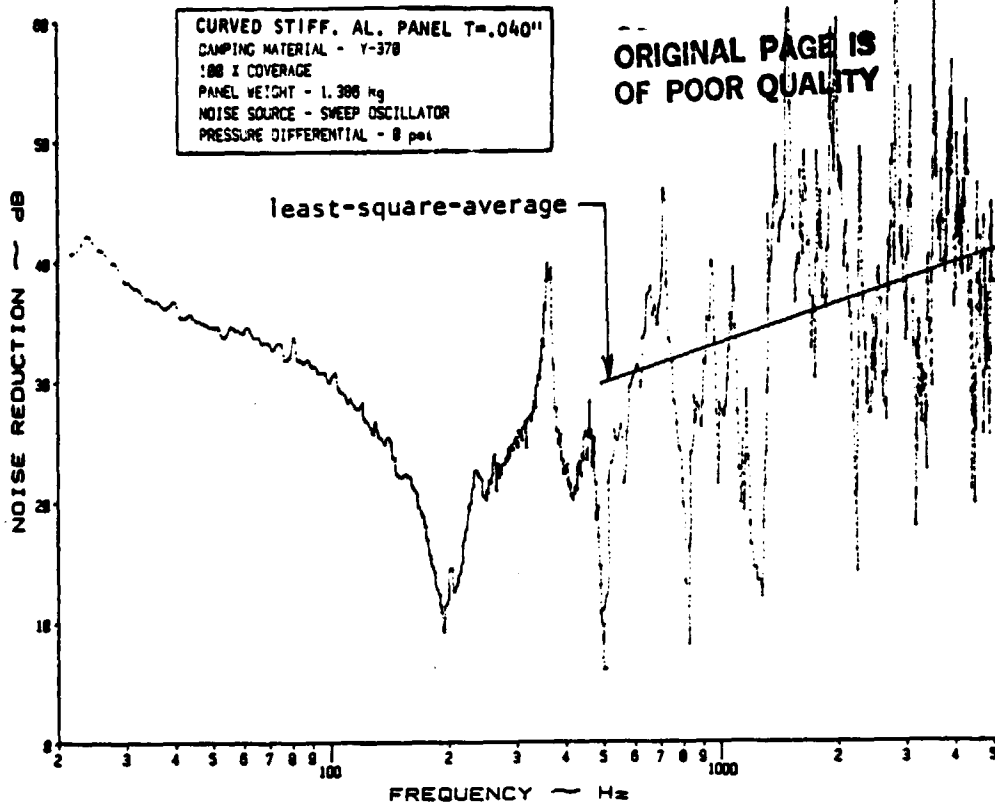

Figure B.24: Noise Reduction Characteristics of a Curved, Stiffened Panel at 3 psi Pressure Differential with Y-370 Damping Tape under White Noise



(a) Narrow Band Analysis

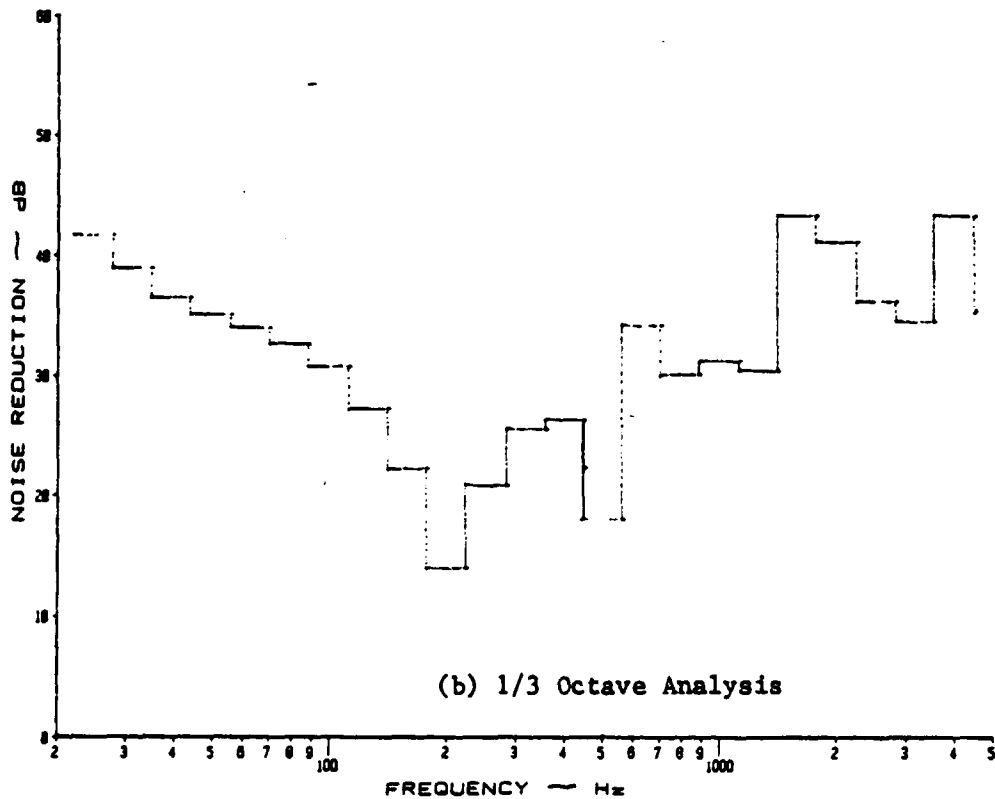
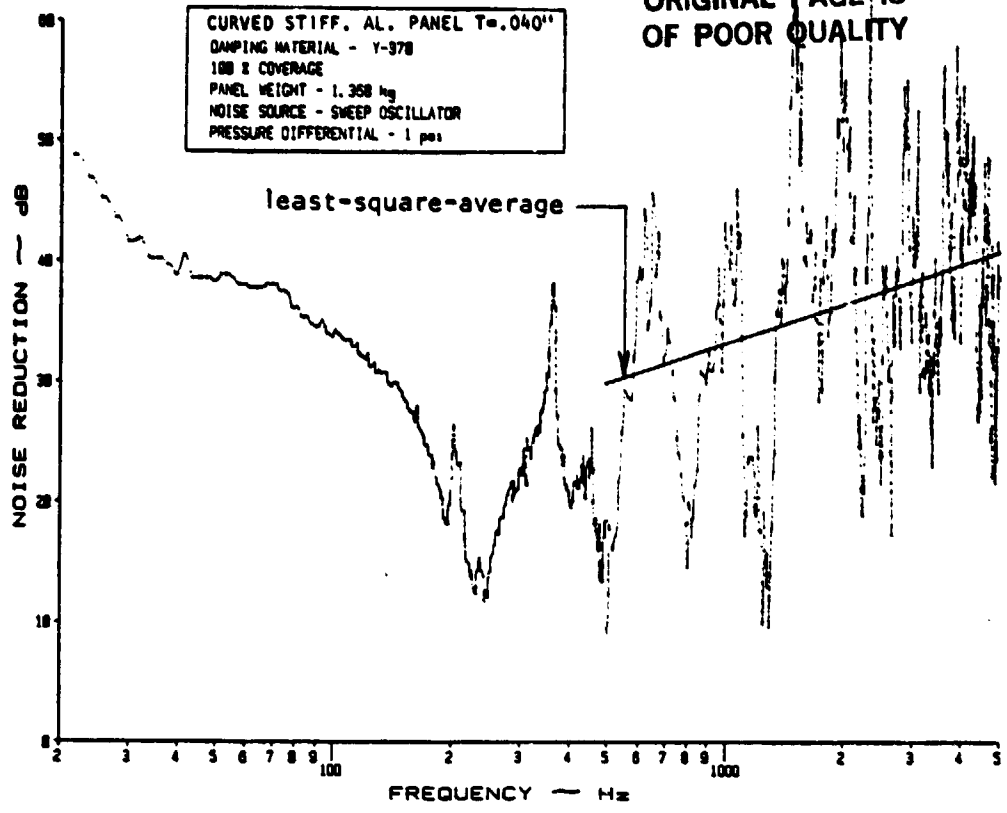
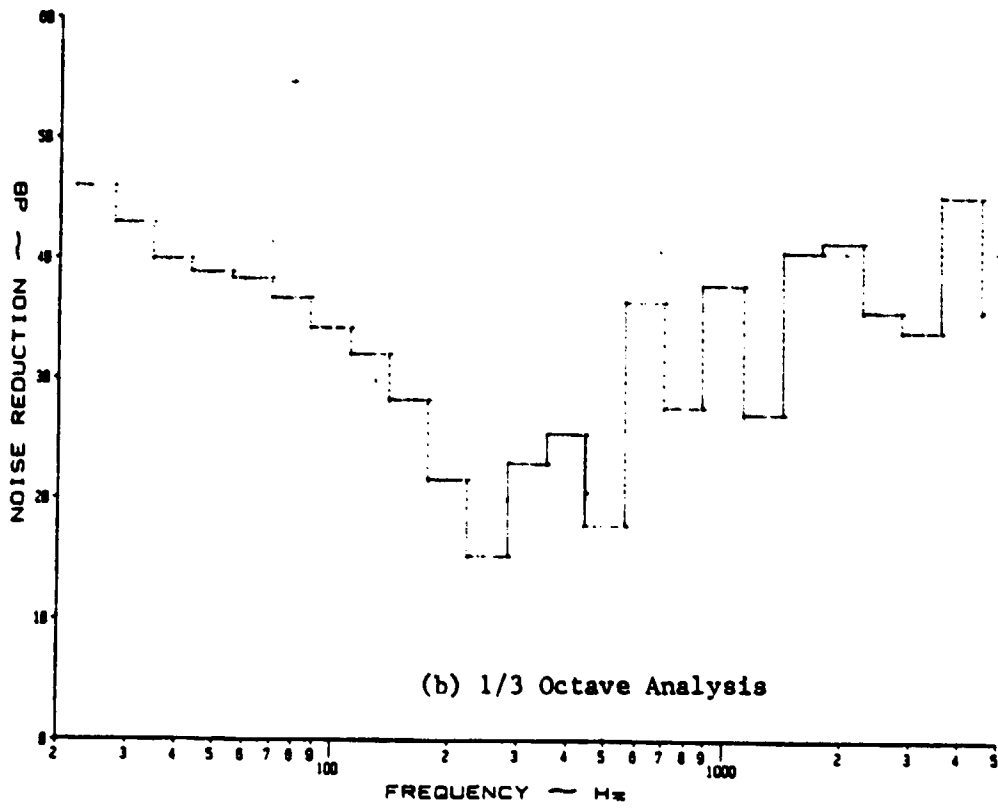

Figure B.25: Noise Reduction Characteristics of a Curved, Stiffened Panel at 0 psi Pressure Differential with Y-370 Damping Tape under a Discrete Noise Source

ORIGINAL PAGE IS
OF POOR QUALITY



(a) Narrow Band Analysis



(b) 1/3 Octave Analysis

Figure B.26: Noise Reduction Characteristics of a Curved, Stiffened Panel at 1 psi Pressure Differential with Y-370 Damping Tape under a Discrete Noise Source

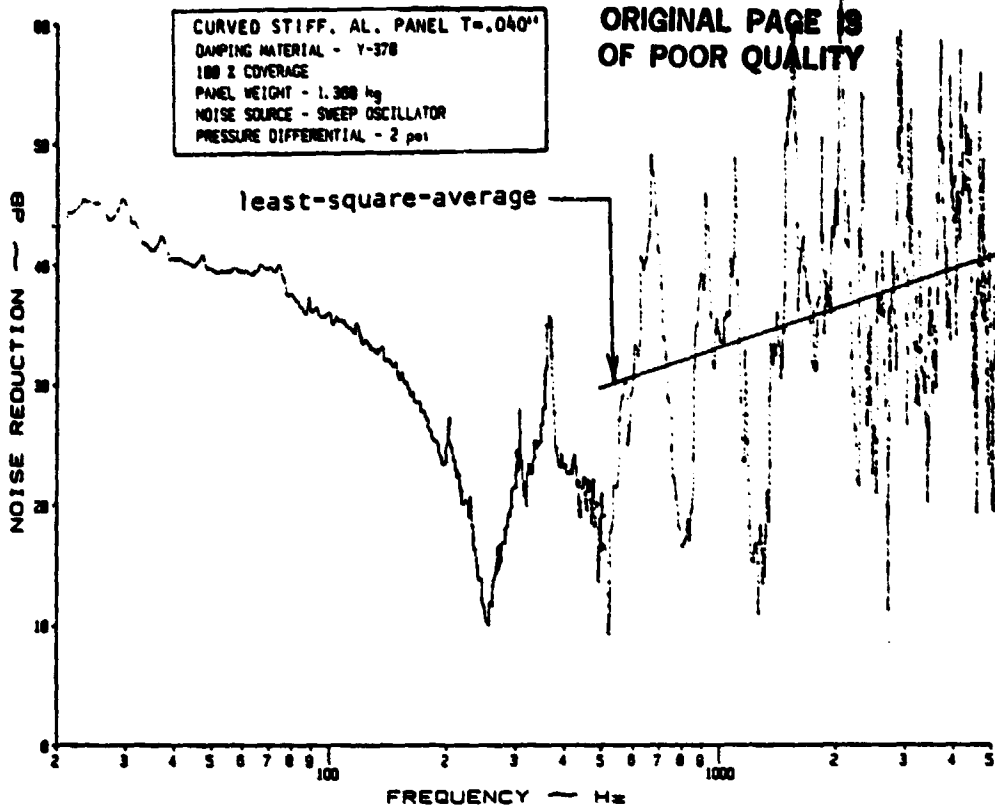

(a) Narrow Band Analysis

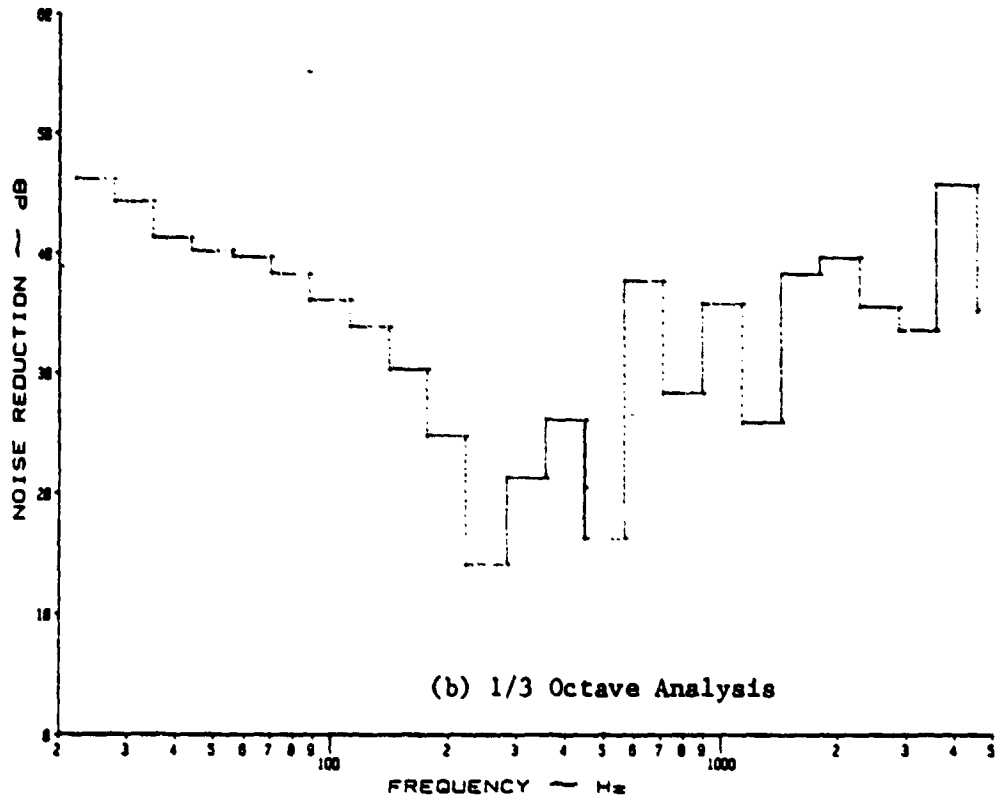

(b) 1/3 Octave Analysis

Figure B.27: Noise Reduction Characteristics of a Curved, Stiffened Panel at 2 psi Pressure Differential with Y-370 Damping Tape under a Discrete Noise Source

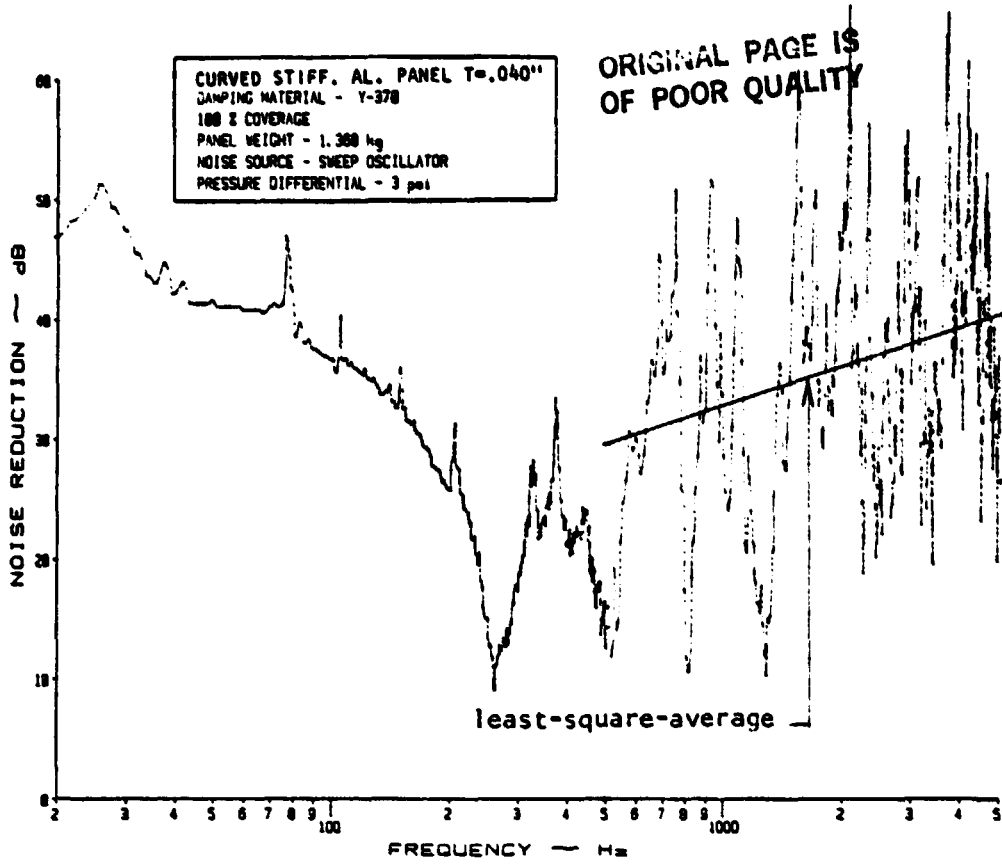

(a) Narrow Band Analysis

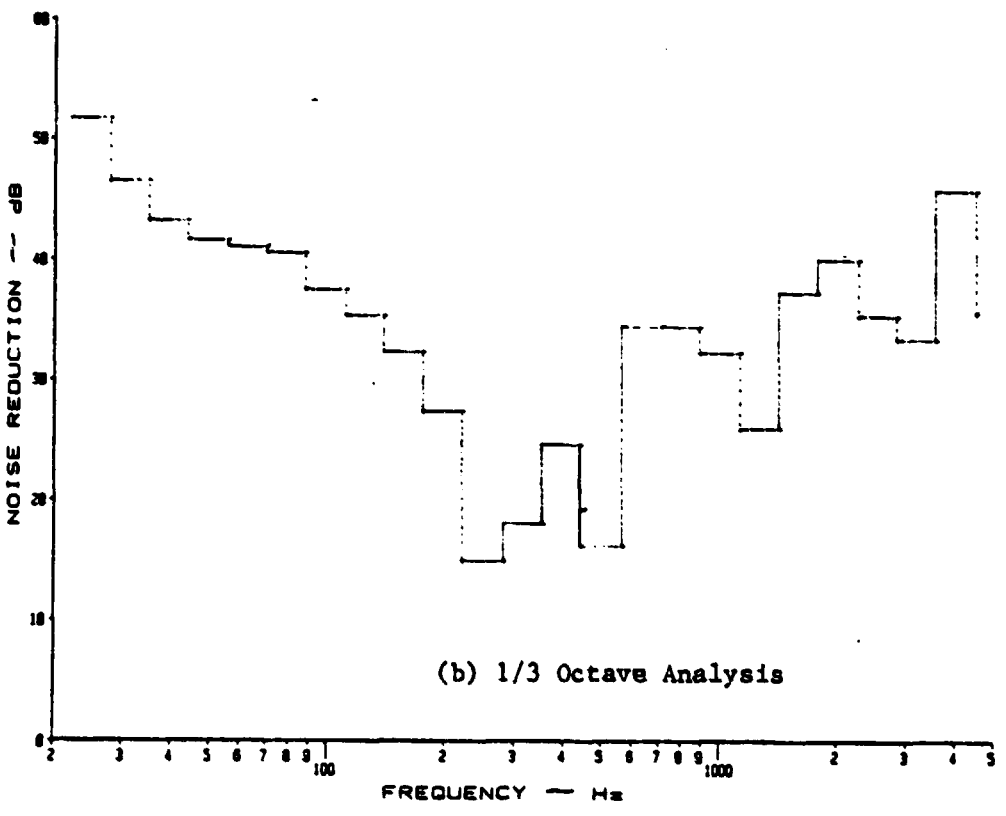

(b) 1/3 Octave Analysis

Figure B.28: Noise Reduction Characteristics of a Curved, Stiffened Panel at 3 psi Pressure Differential with Y-370 Damping Tape under a Discrete Noise Source

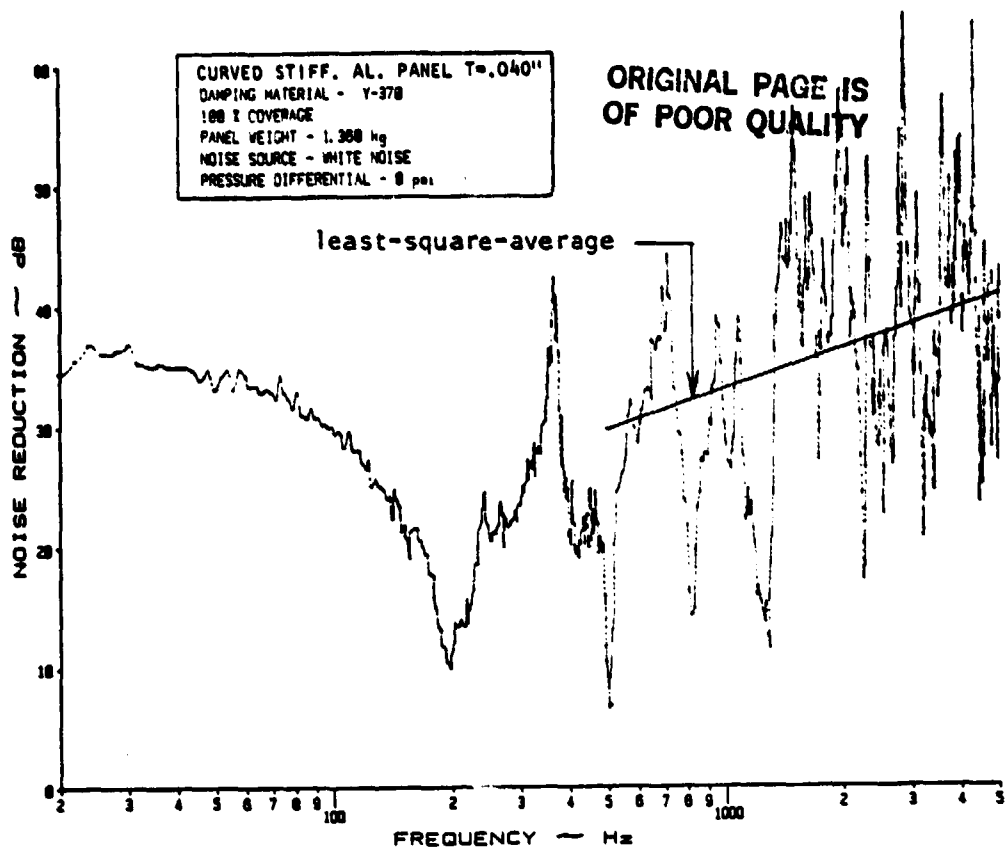

(a) Narrow Band Analysis

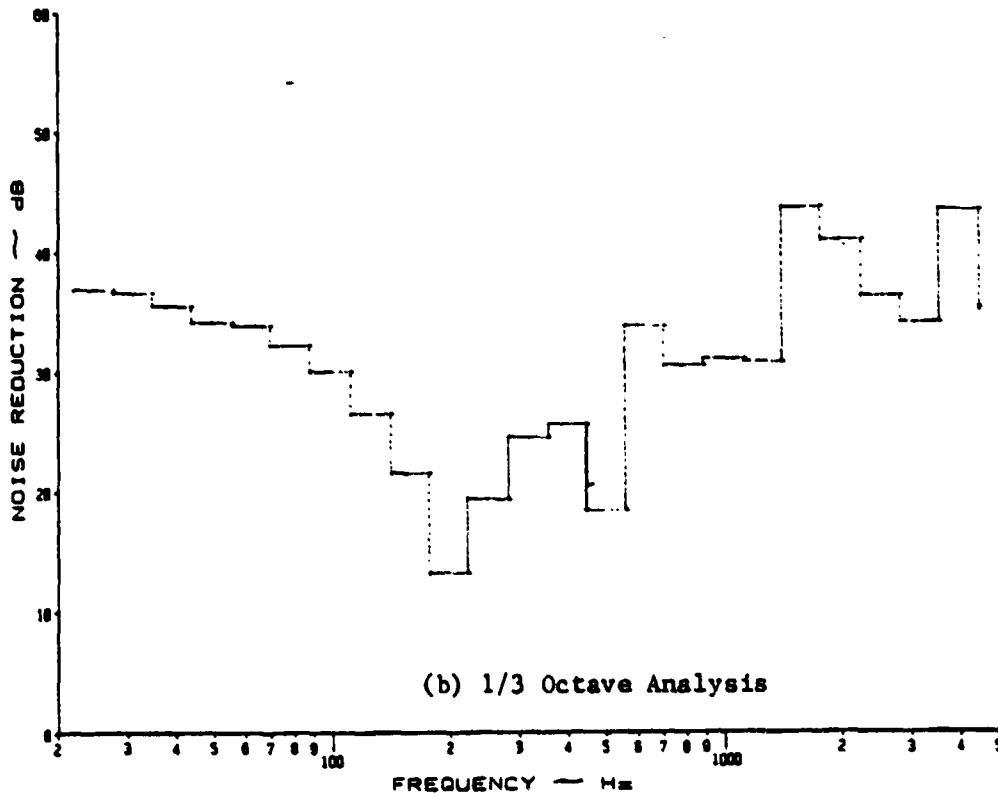
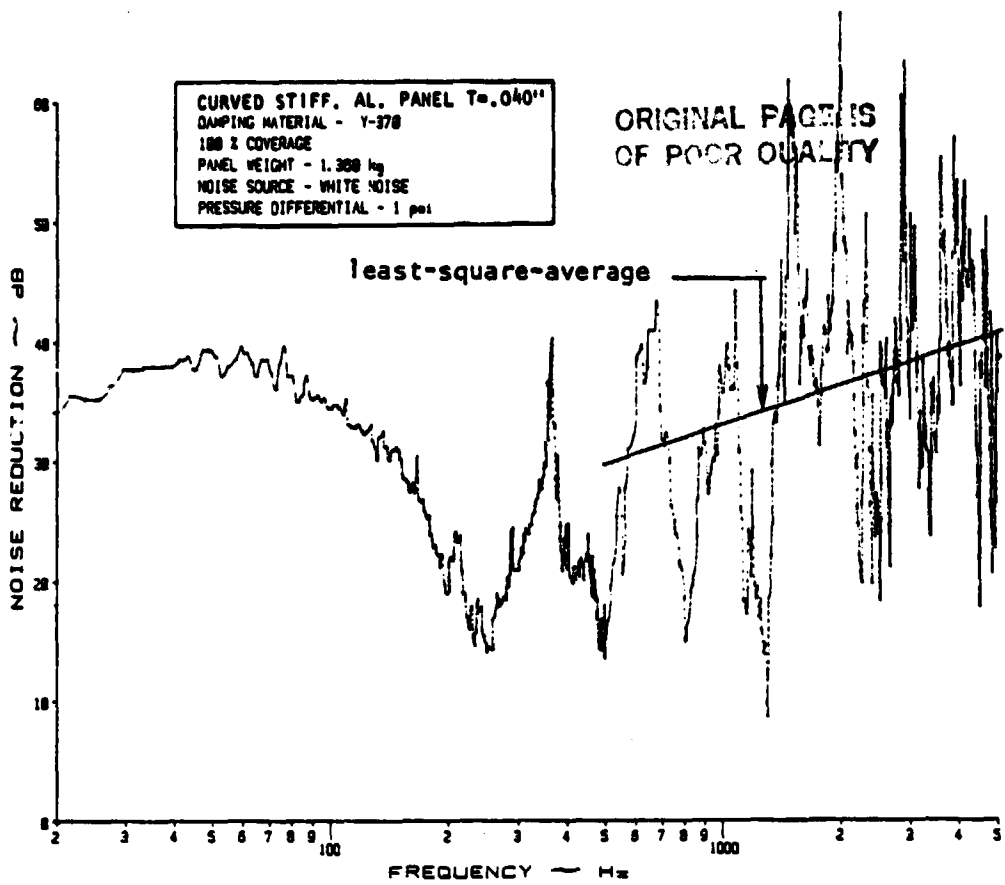
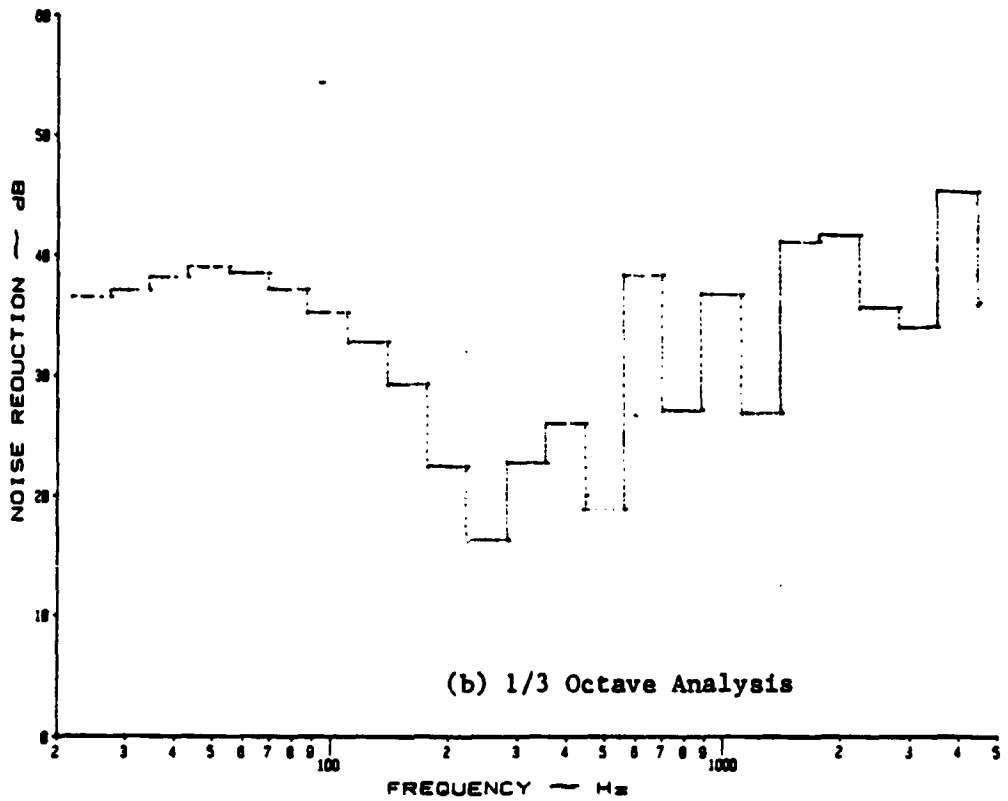

Figure B.29: Noise Reduction Characteristics of a Curved, Stiffened Panel at 0 psi Pressure Differential with Y-370 Damping Tape under White Noise



(a) Narrow Band Analysis



(b) 1/3 Octave Analysis

Figure B.30: Noise Reduction Characteristics of a Curved, Stiffened Panel at 1 psi Pressure Differential with Y-370 Damping Tape under White Noise

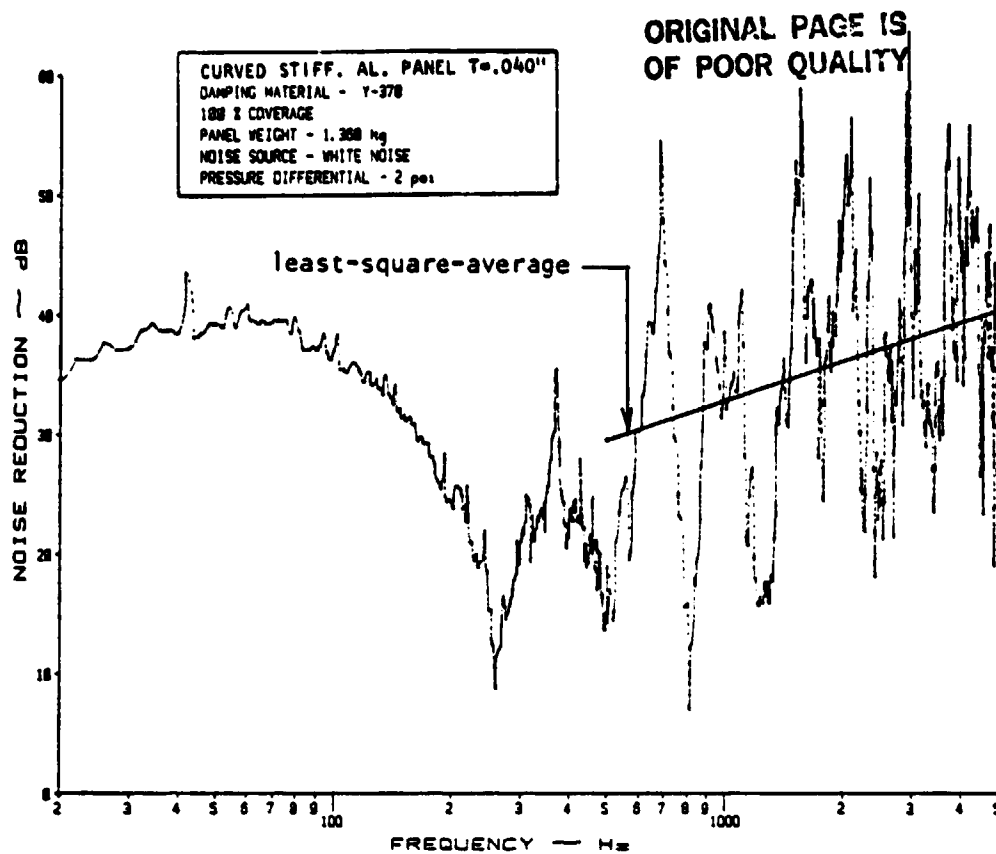

(a) Narrow Band Analysis

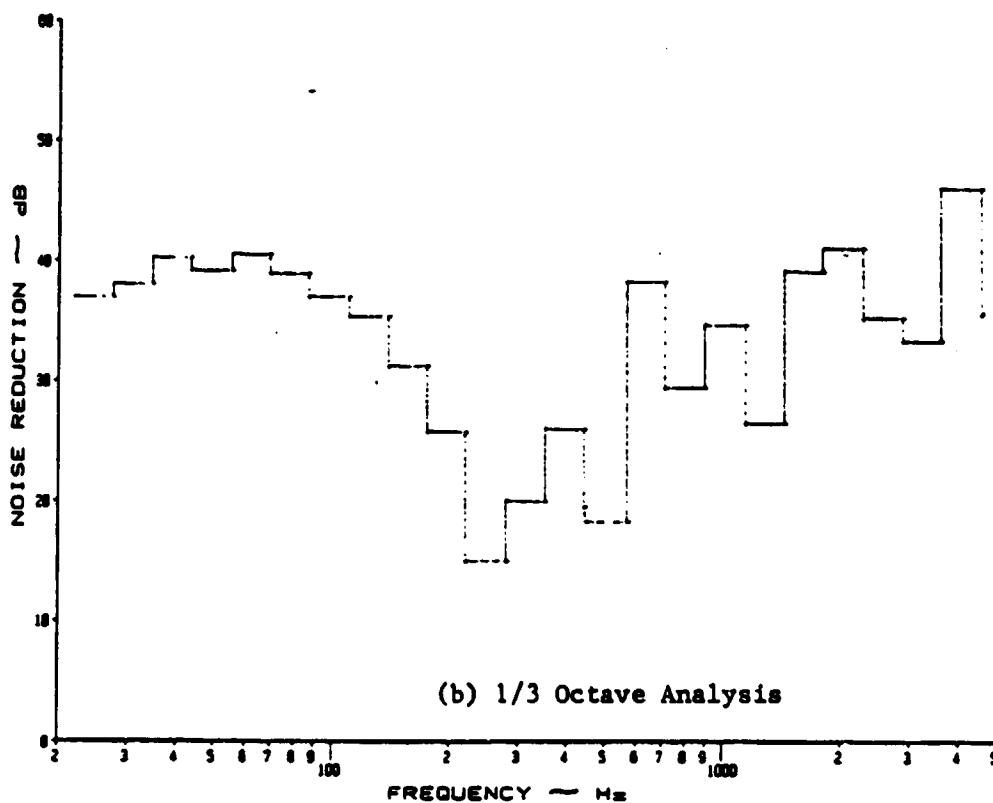

(b) 1/3 Octave Analysis

Figure B.31: Noise Reduction Characteristics of a Curved, Stiffened Panel at 2 psi Pressure Differential with Y-370 Damping Tape under White Noise

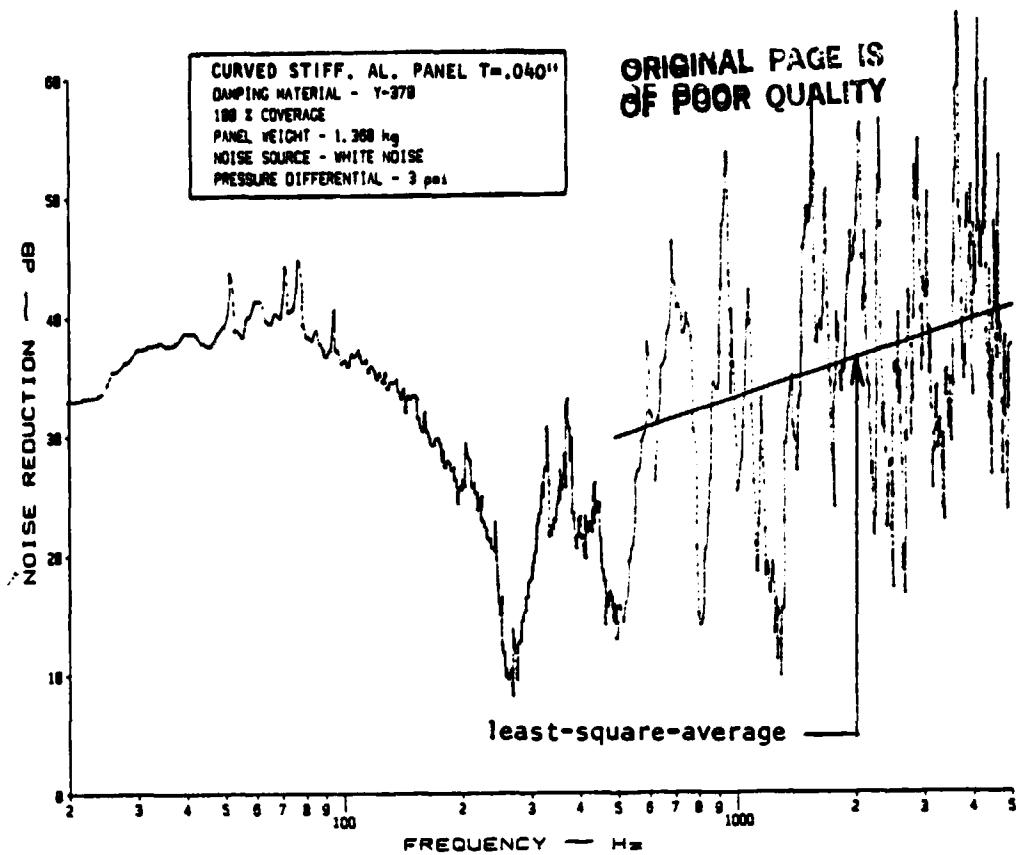

(a) Narrow Band Analysis

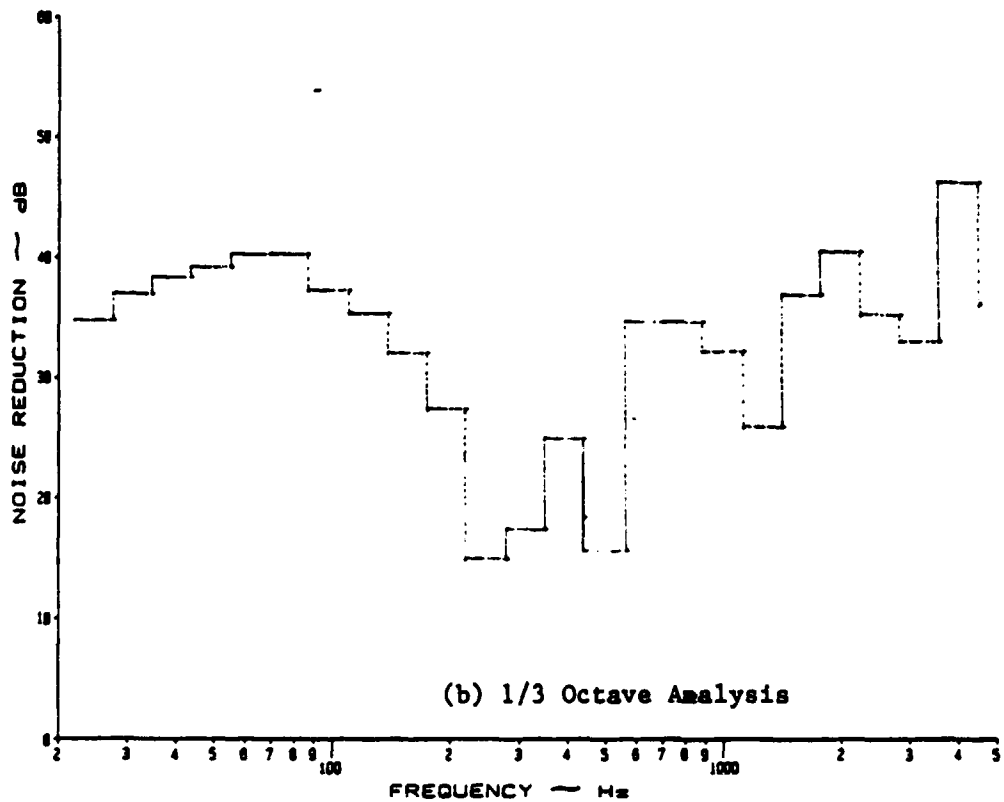

(b) 1/3 Octave Analysis

Figure B.32: Noise Reduction Characteristics of a Curved, Stiffened Panel at 3 psi Pressure Differential with Y-370 Damping Tape under White Noise

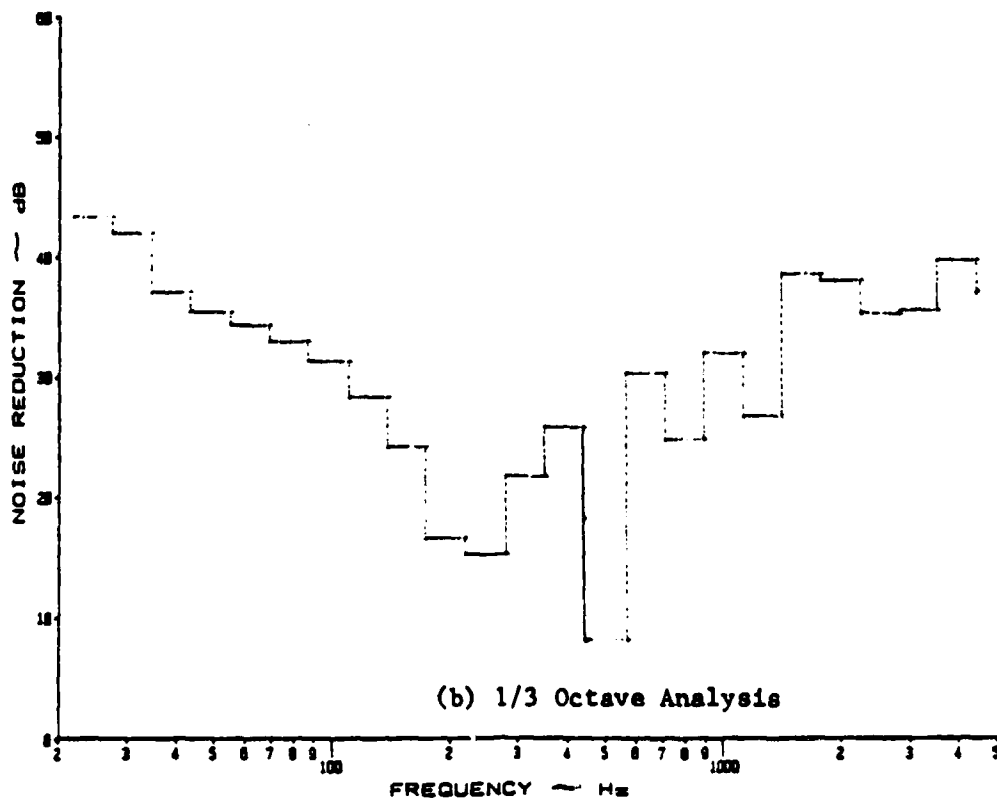
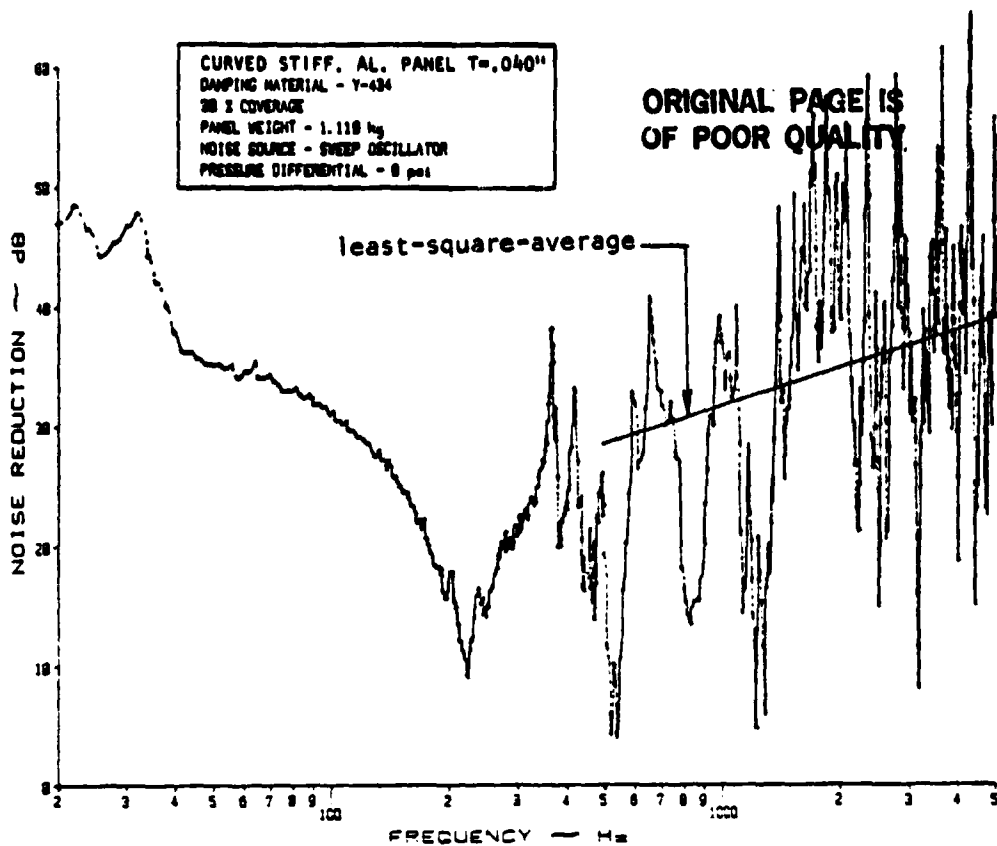

Figure B.33: Noise Reduction Characteristics of a Curved, Stiffened Panel at 0 psi Pressure Differential with Y-434 Damping Tape under a Discrete Noise Source

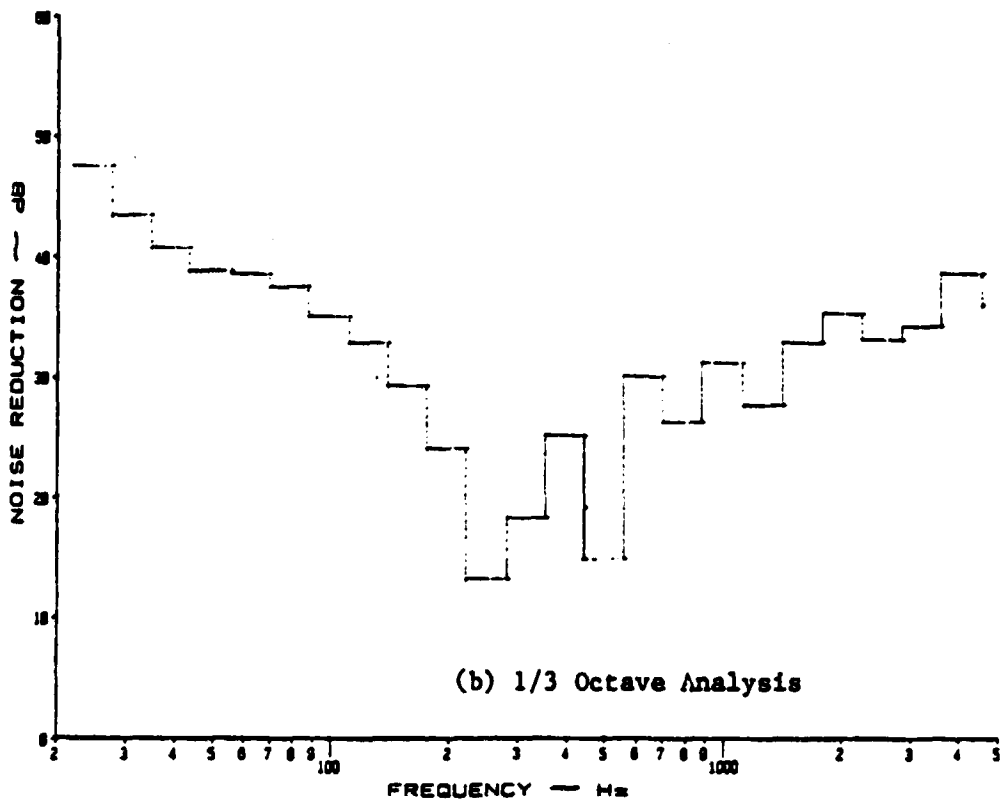
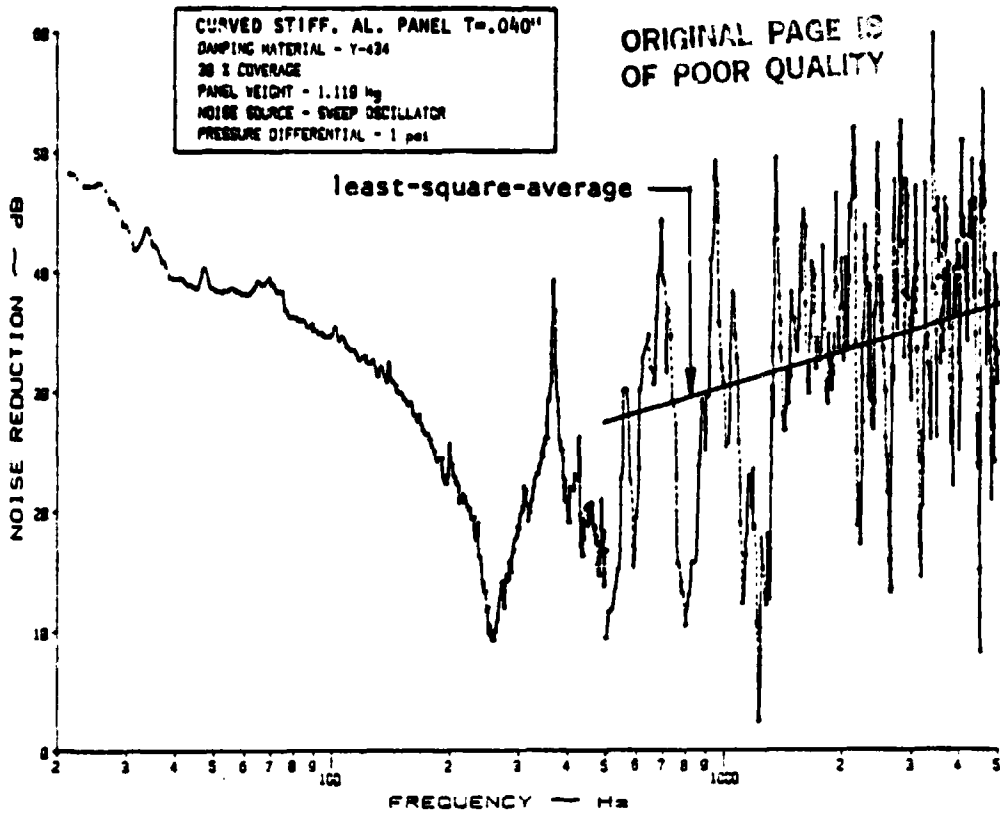
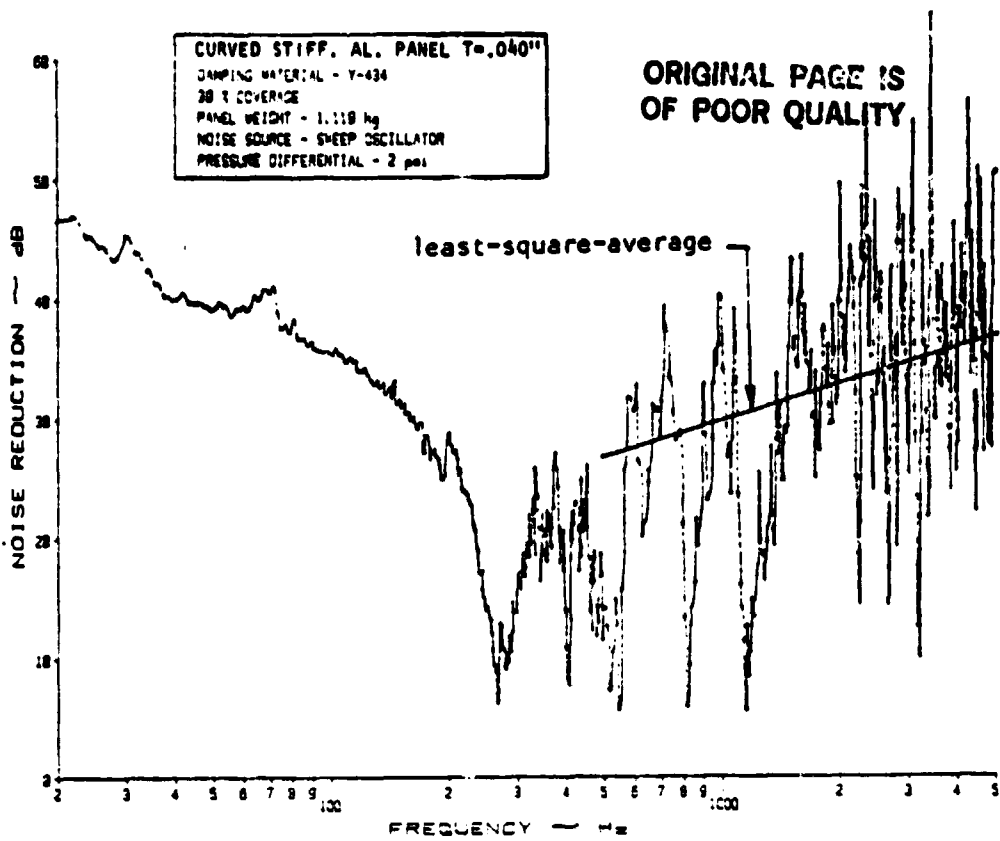
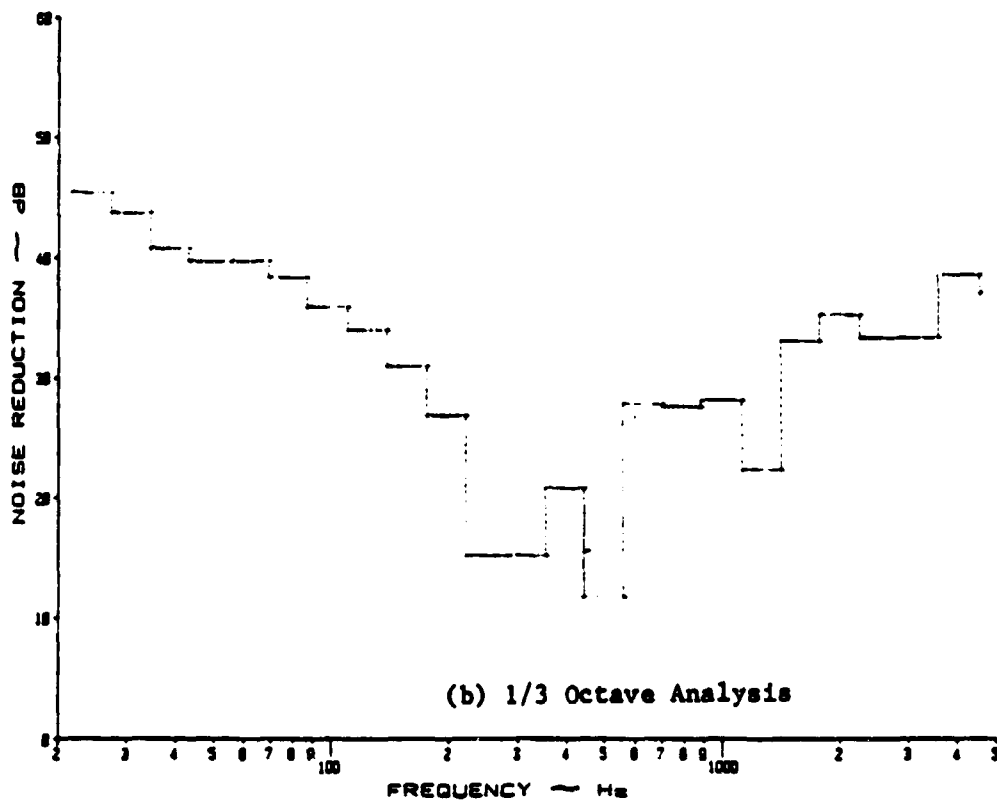

Figure B.34: Noise Reduction Characteristics of a Curved, Stiffened Panel at 1 psi Pressure Differential with Y-434 Damping Tape under a Discrete Noise Source



(a) Narrow Band Analysis



(b) 1/3 Octave Analysis

Figure B.35: Noise Reduction Characteristics of a Curved, Stiffened Panel at 2 psi Pressure Differential with Y-434 Damping Tape under a Discrete Noise Source

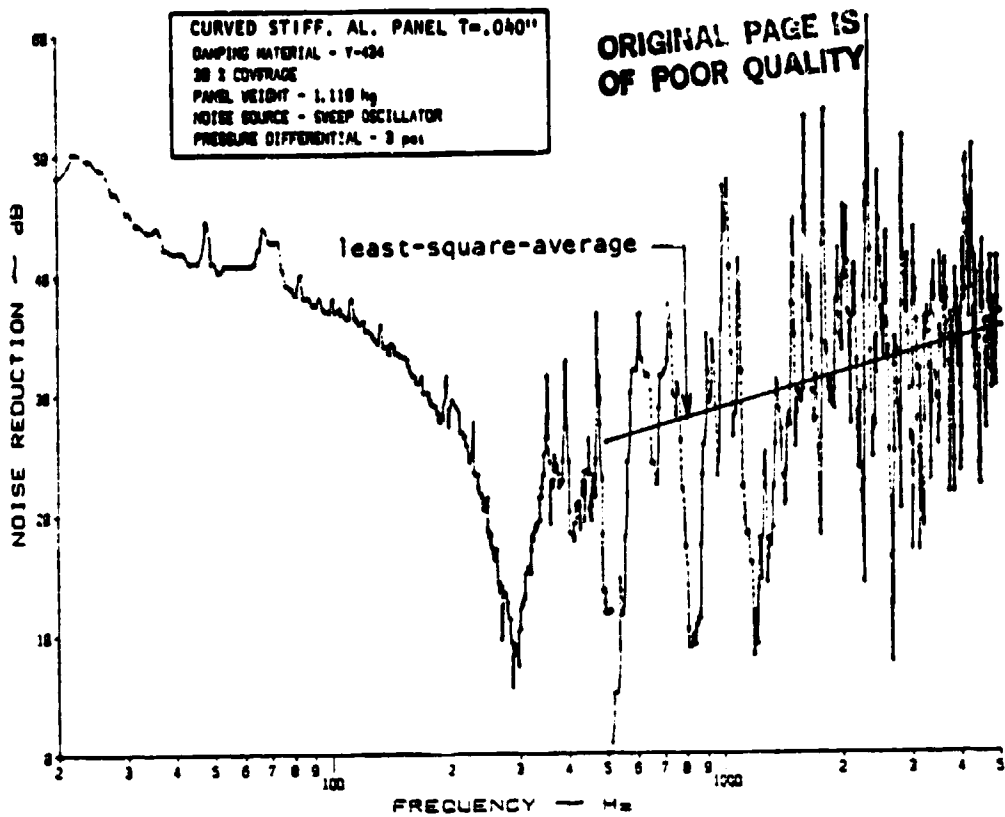

(a) Narrow Band Analysis

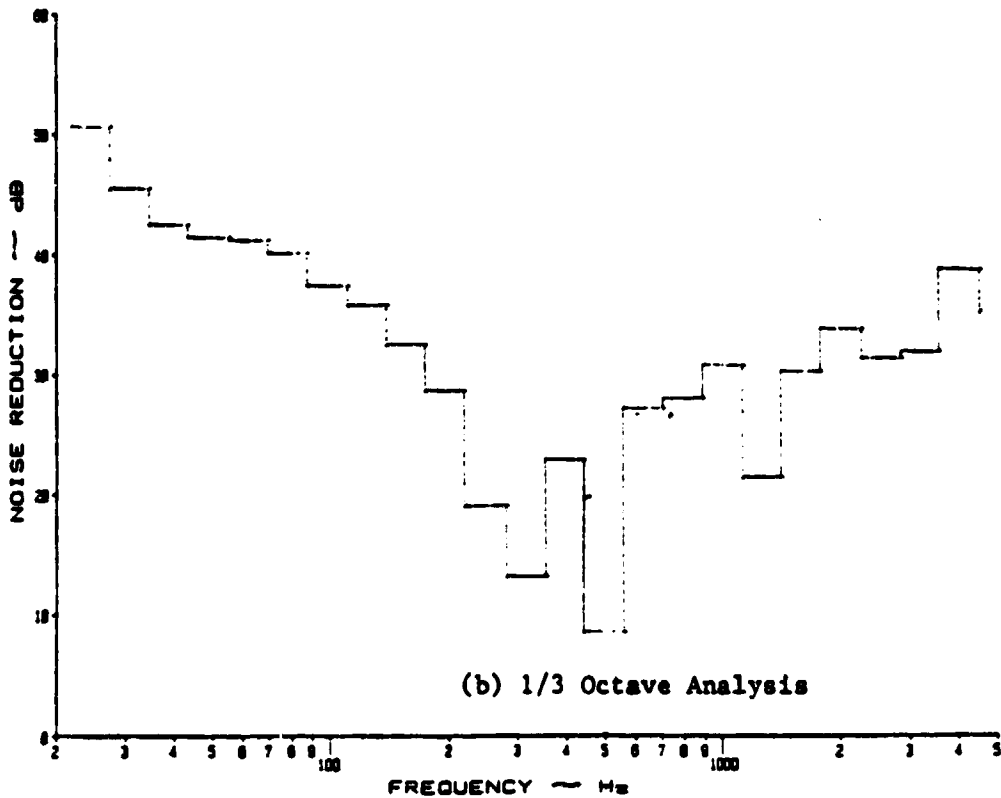

(b) 1/3 Octave Analysis

Figure B.36: Noise Reduction Characteristics of a Curved, Stiffened Panel at 3 psi Pressure Differential with Y-434 Damping Tape under a Discrete Noise Source

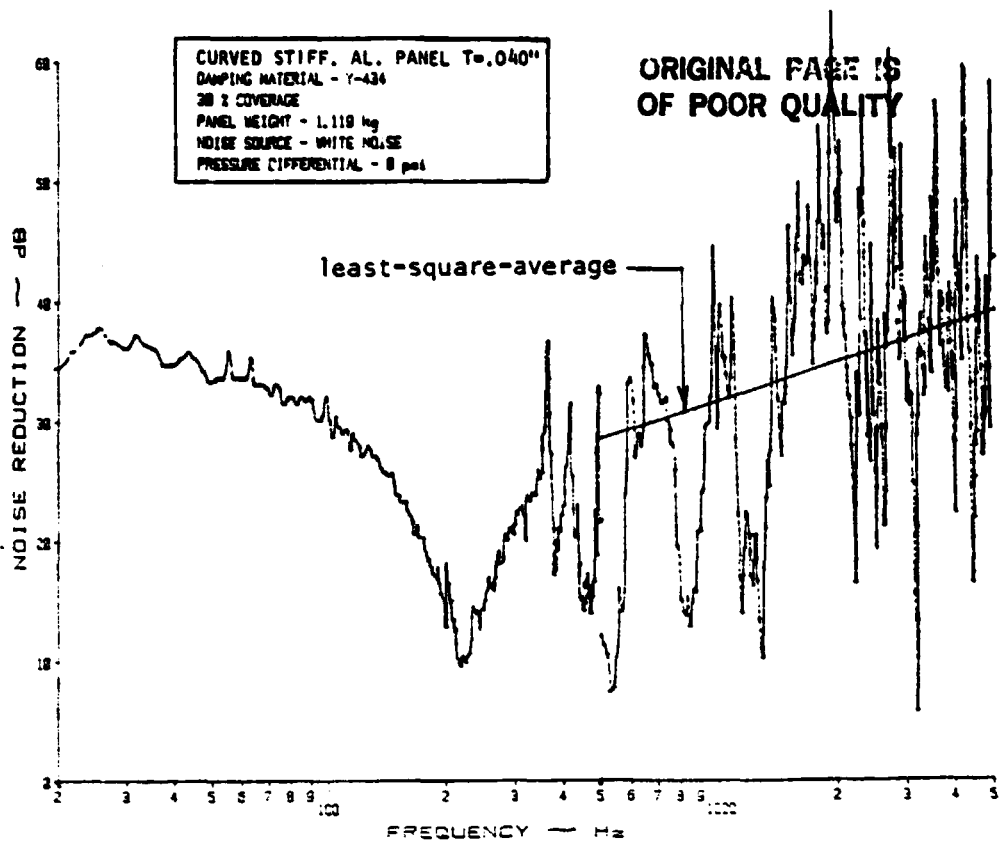

(a) Narrow Band Analysis

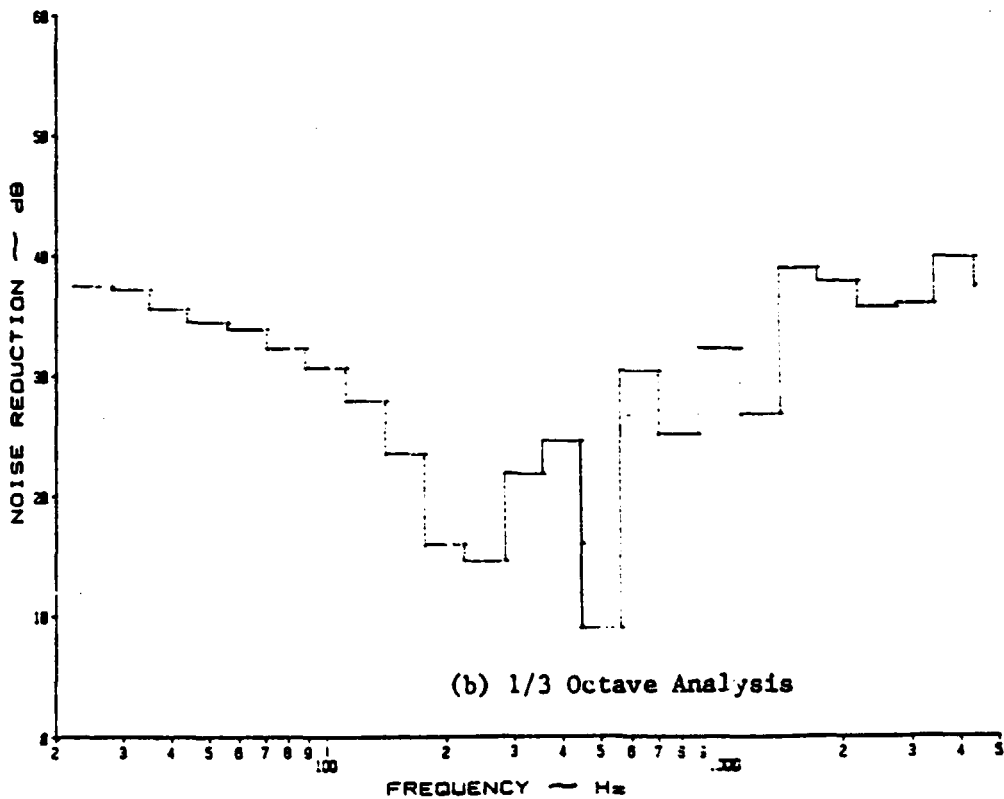

(b) 1/3 Octave Analysis

Figure B.37: Noise Reduction Characteristics of a Curved, Stiffened Panel at 0 psi Pressure Differential with Y-434 Damping Tape under White Noise

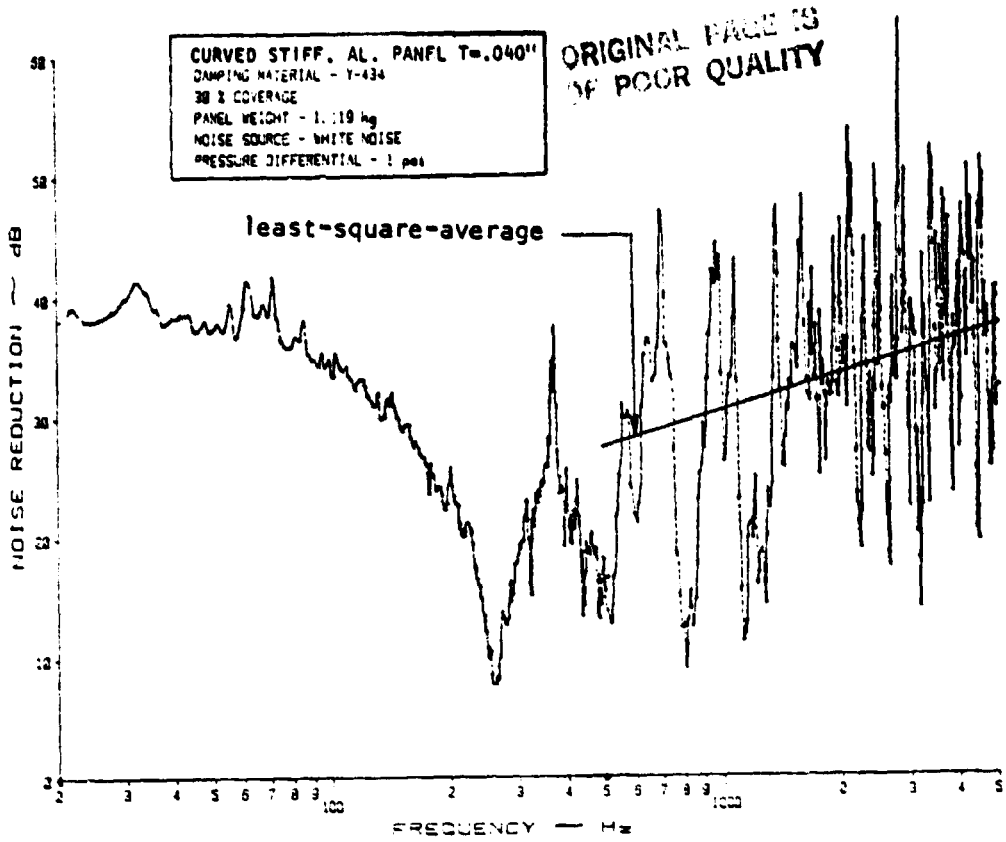

(a) Narrow Band Analysis

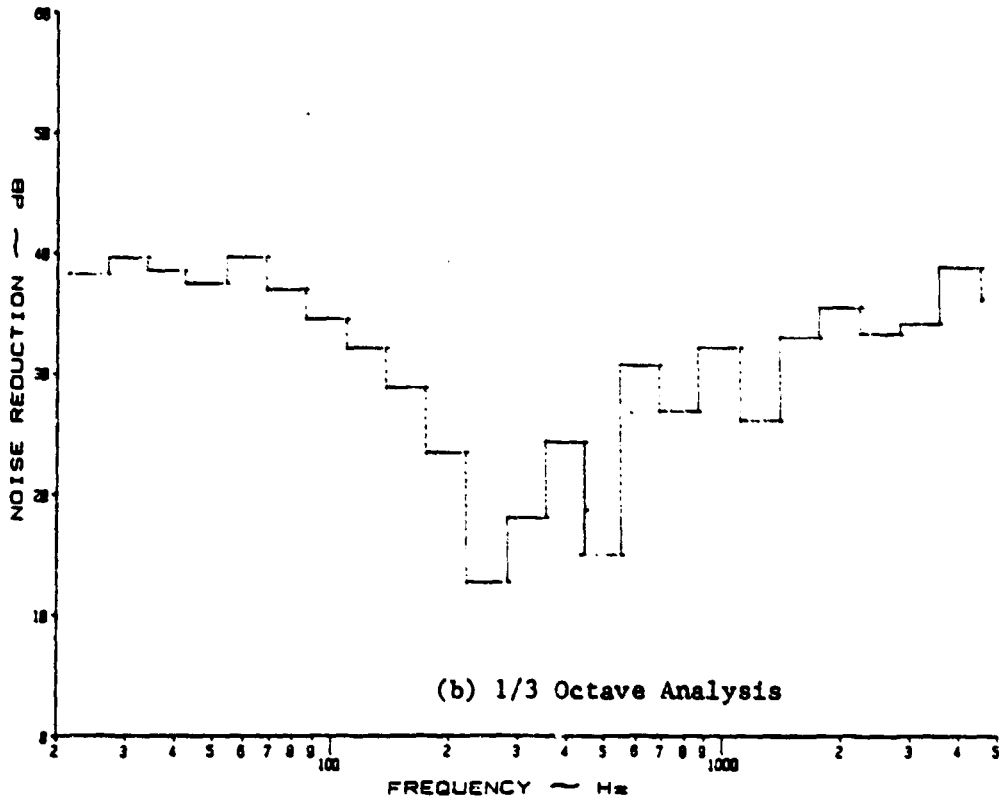

(b) 1/3 Octave Analysis

Figure B.38: Noise Reduction Characteristics of a Curved, Stiffened Panel at 1 psi Pressure Differential with Y-434 Damping Tape under White Noise

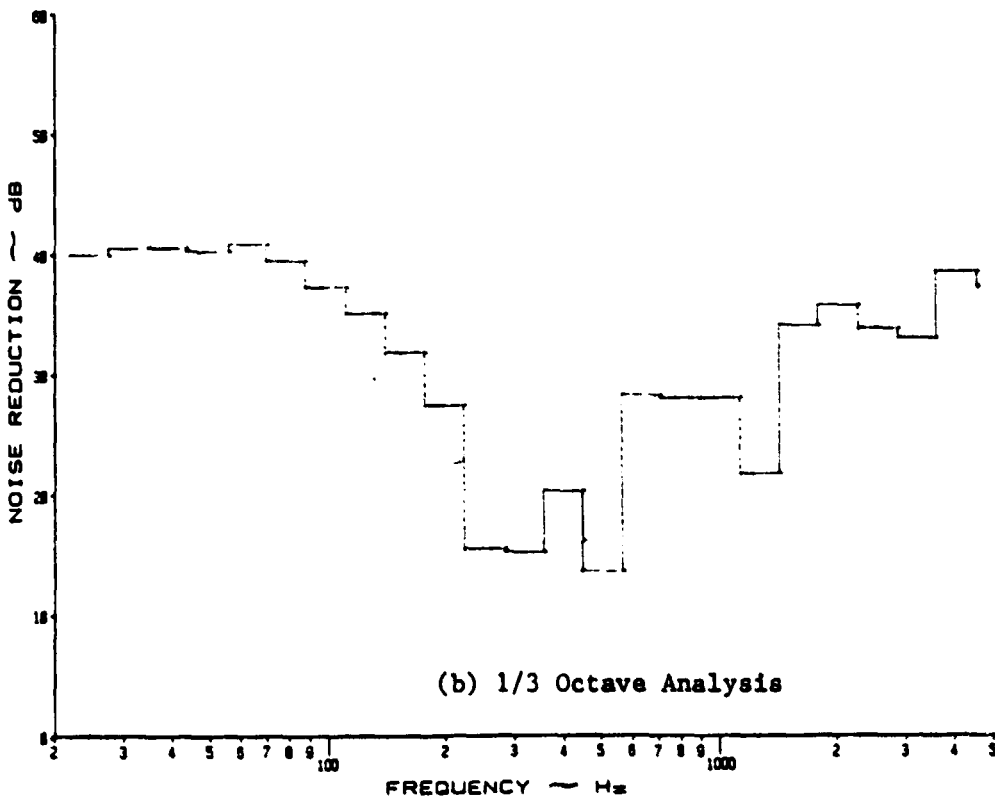
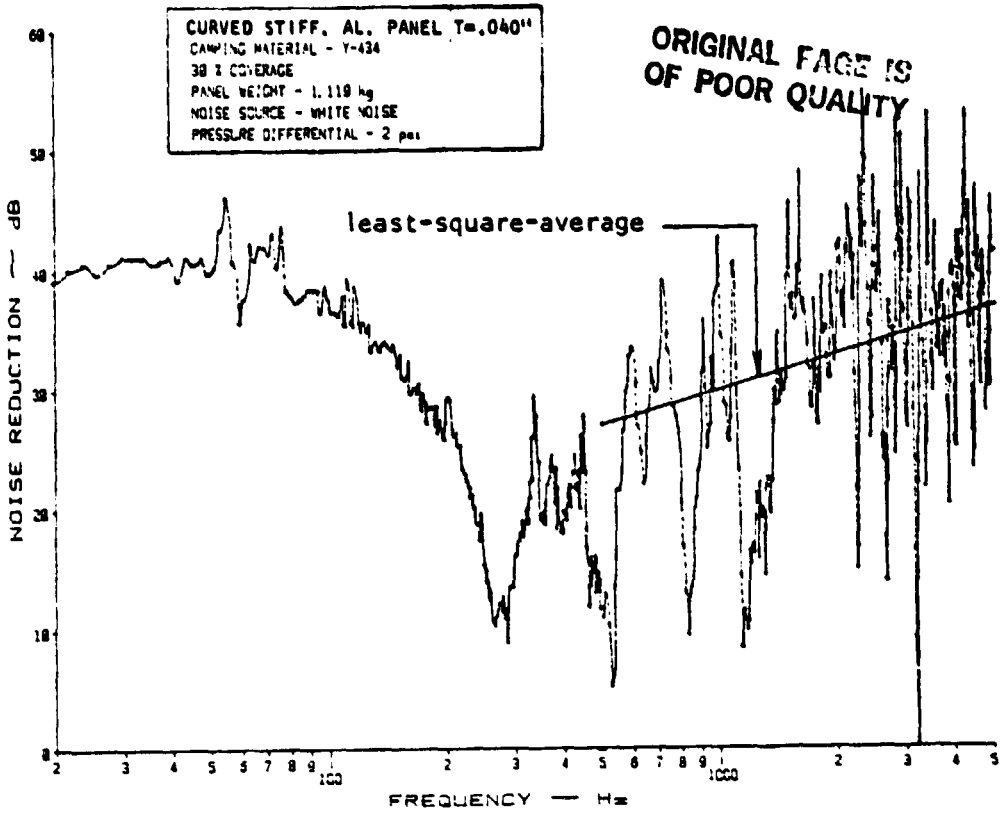
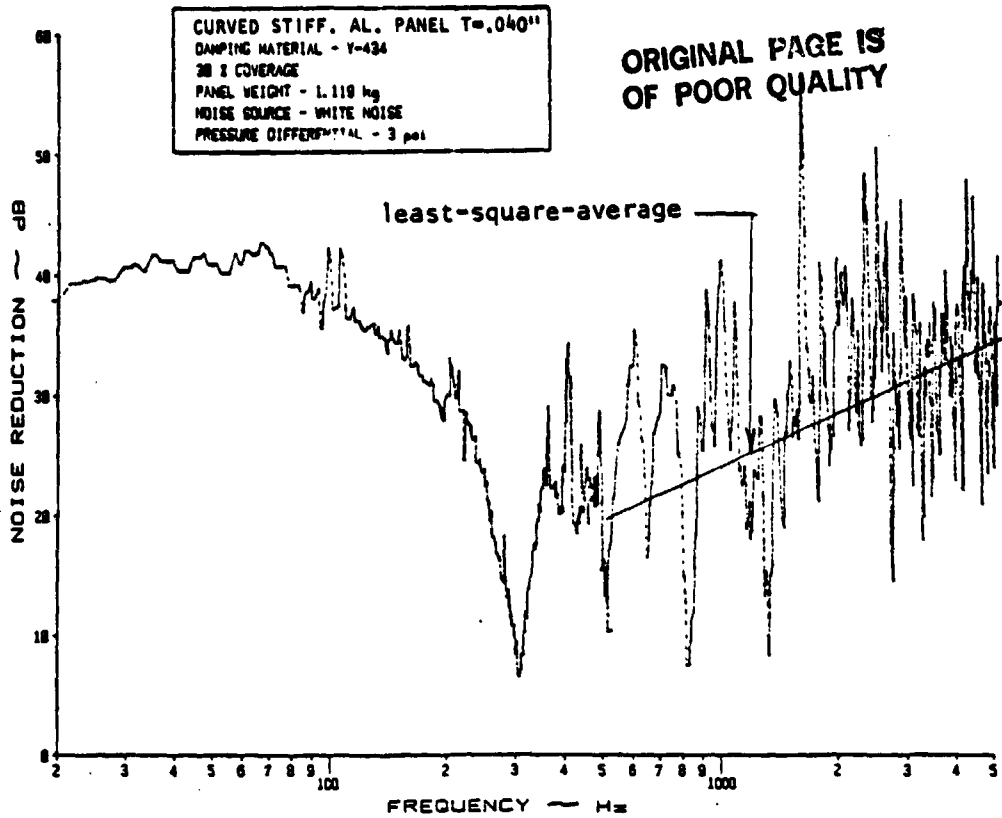

Figure B.39: Noise Reduction Characteristics of a Curved, Stiffened Panel at 2 psi Pressure Differential with Y-434 Damping Tape under White Noise



(a) Narrow Band Analysis

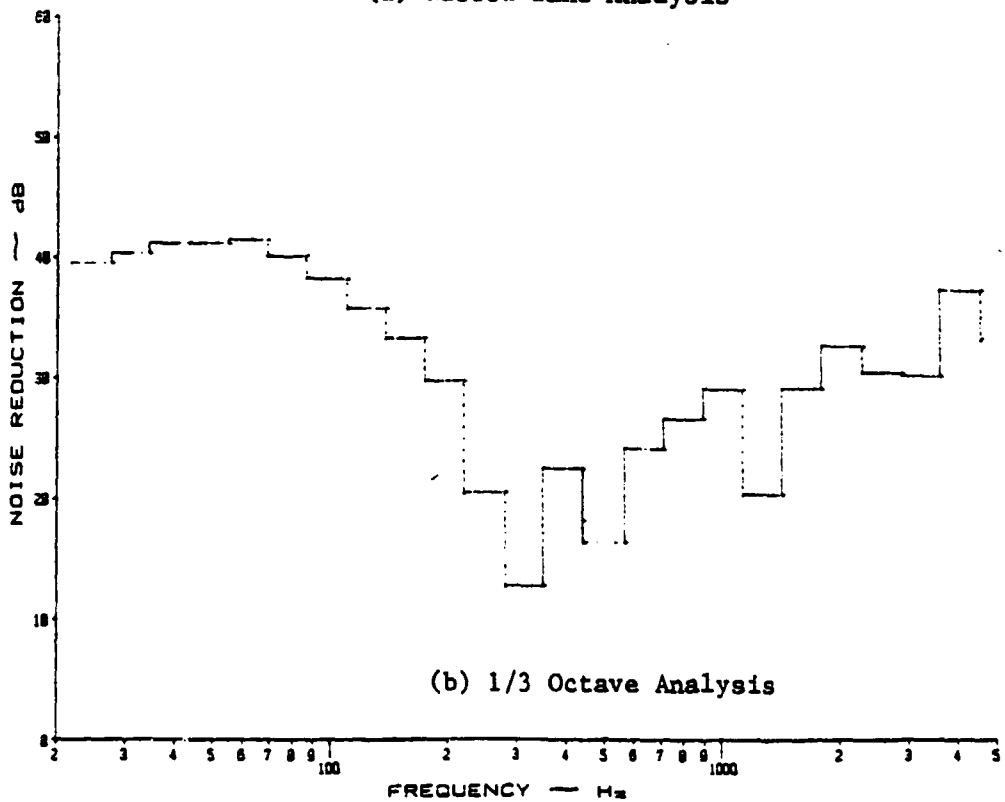
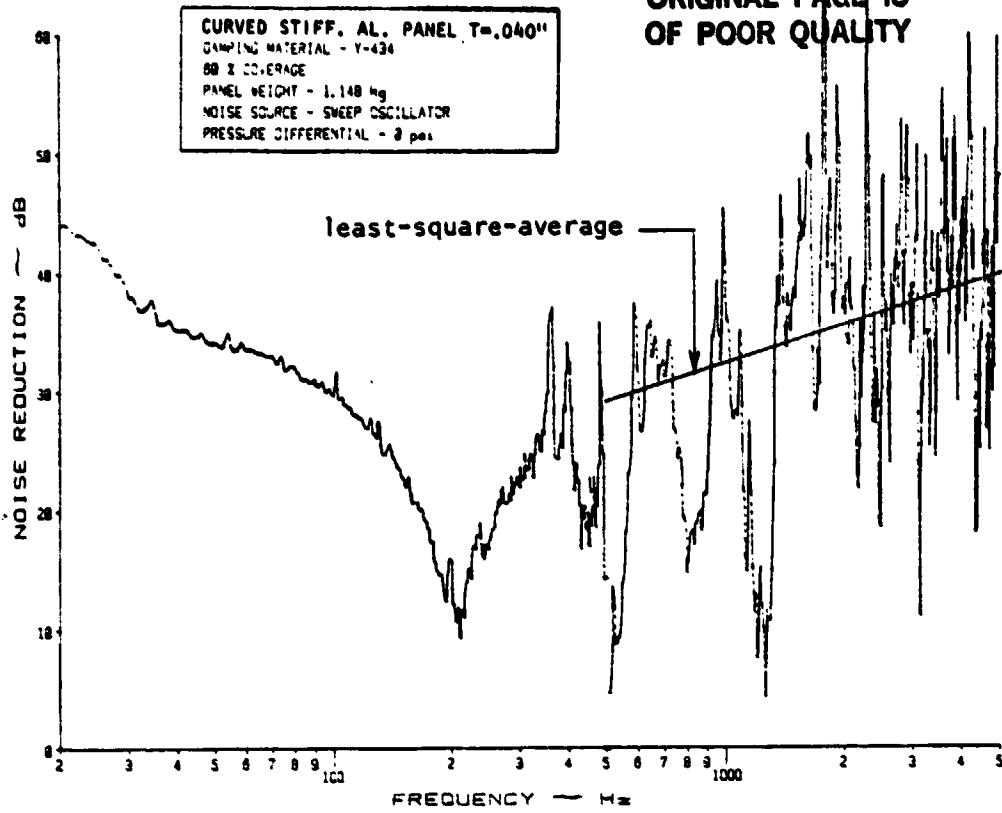
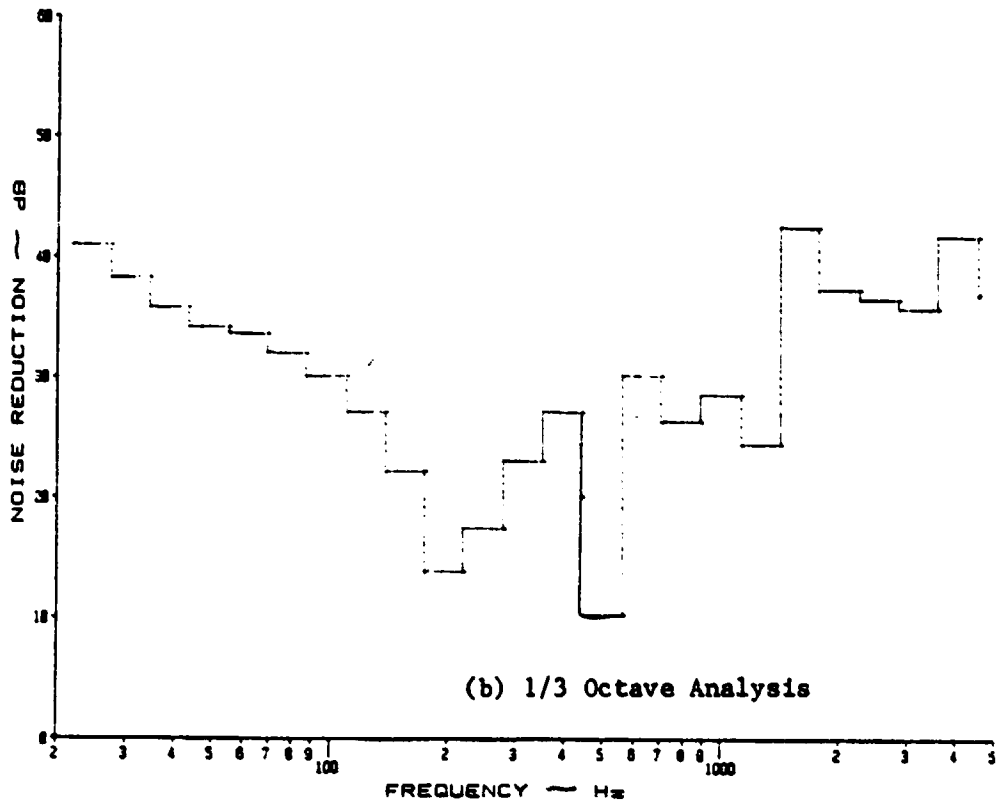

Figure B.40: Noise Reduction Characteristics of a Curved, Stiffened Panel at 3 psi Pressure Differential with Y-434 Damping Tape under White Noise

ORIGINAL PAGE IS
OF POOR QUALITY



(a) Narrow Band Analysis



(b) 1/3 Octave Analysis

Figure B.41: Noise Reduction Characteristics of a Curved, Stiffened Panel at 0 psi Pressure Differential with Y-434 Damping Tape under a Discrete Noise Source

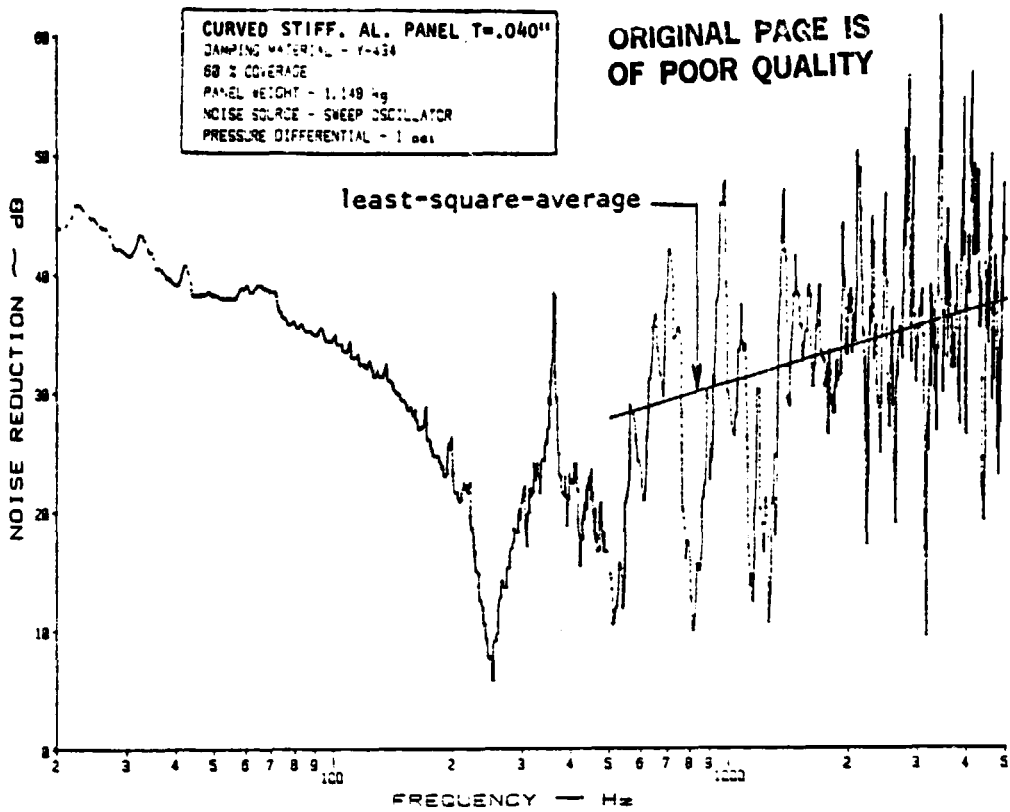

(a) Narrow Band Analysis

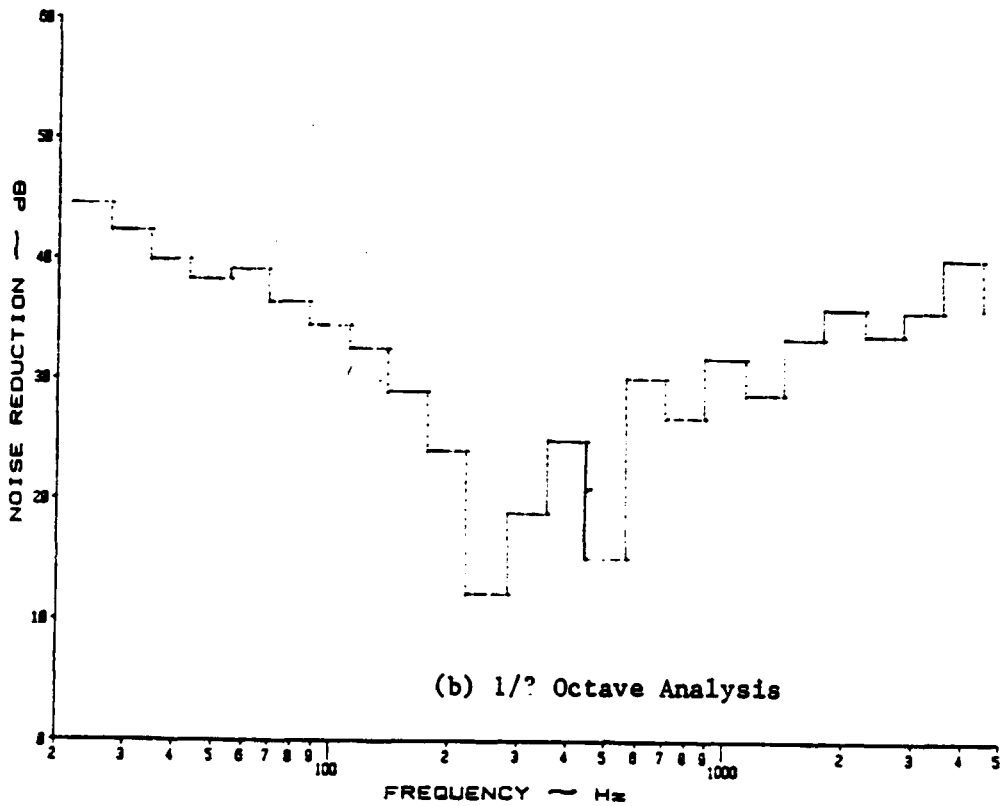

(b) 1/2 Octave Analysis

Figure B.42: Noise Reduction Characteristics of a Curved, Stiffened Panel at 1 psi Pressure Differential with Y-434 Damping Tape under a Discrete Noise Source

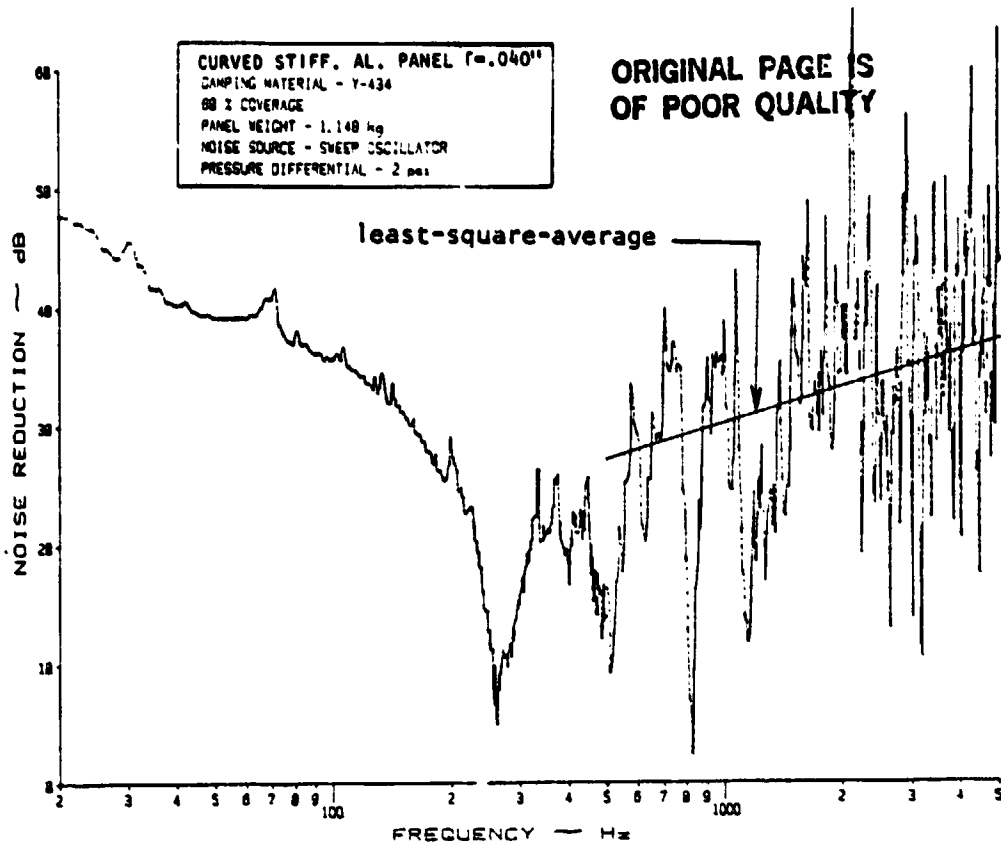

(a) Narrow Band Analysis

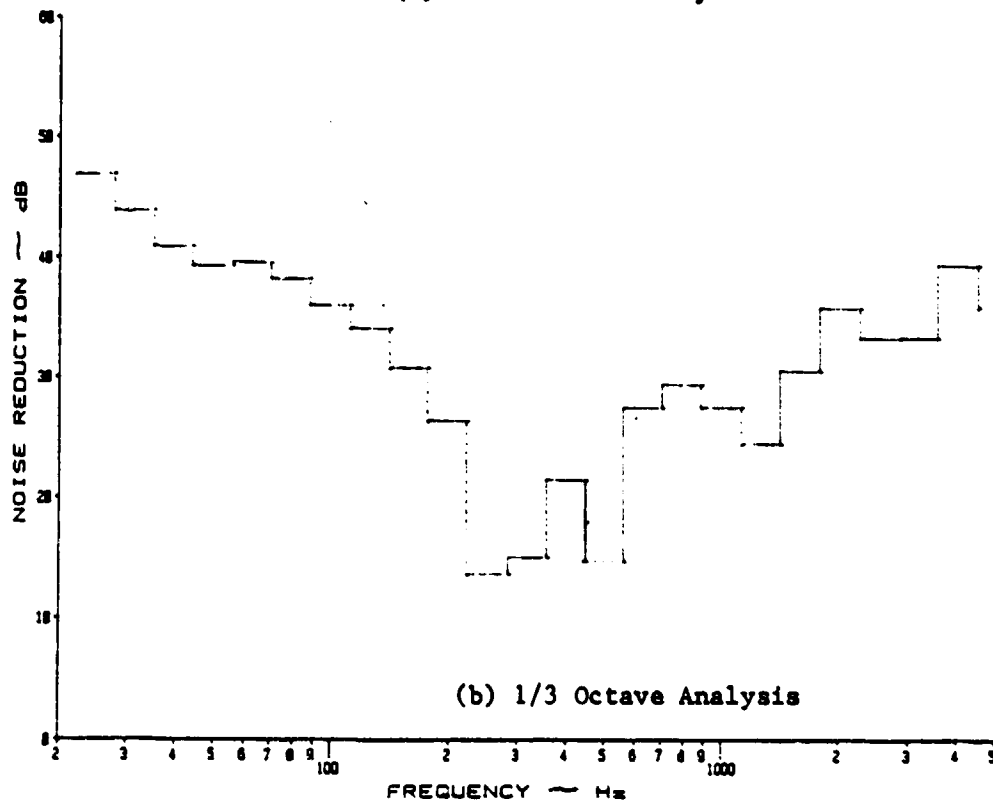
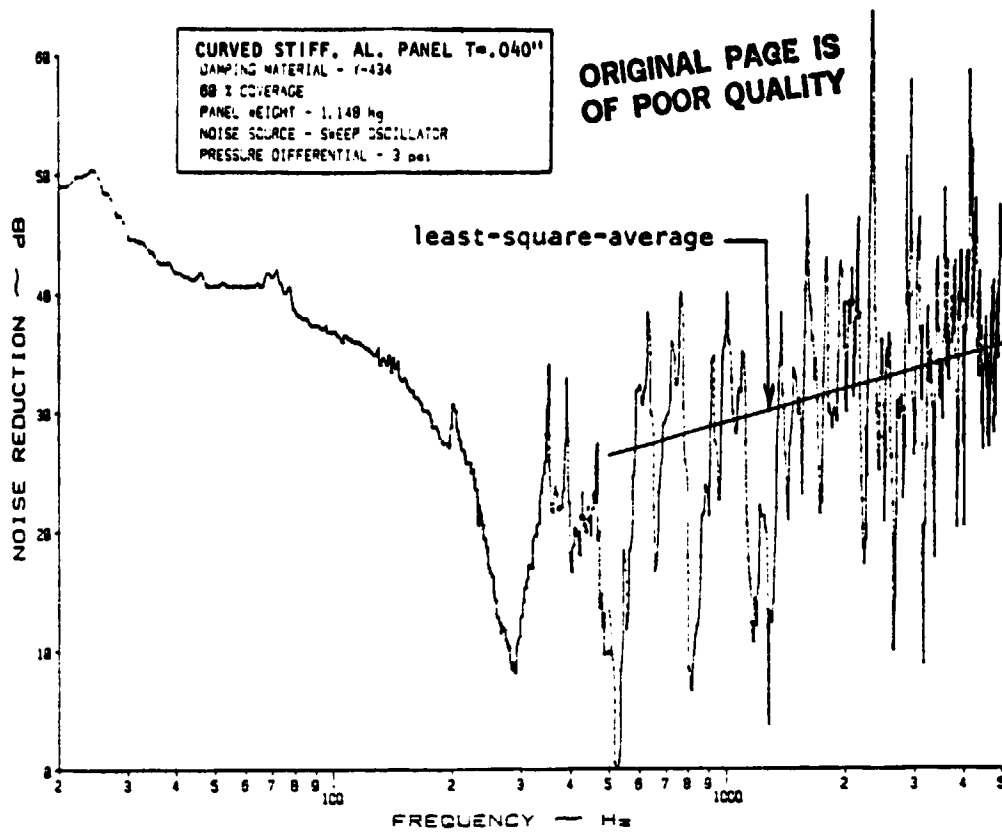
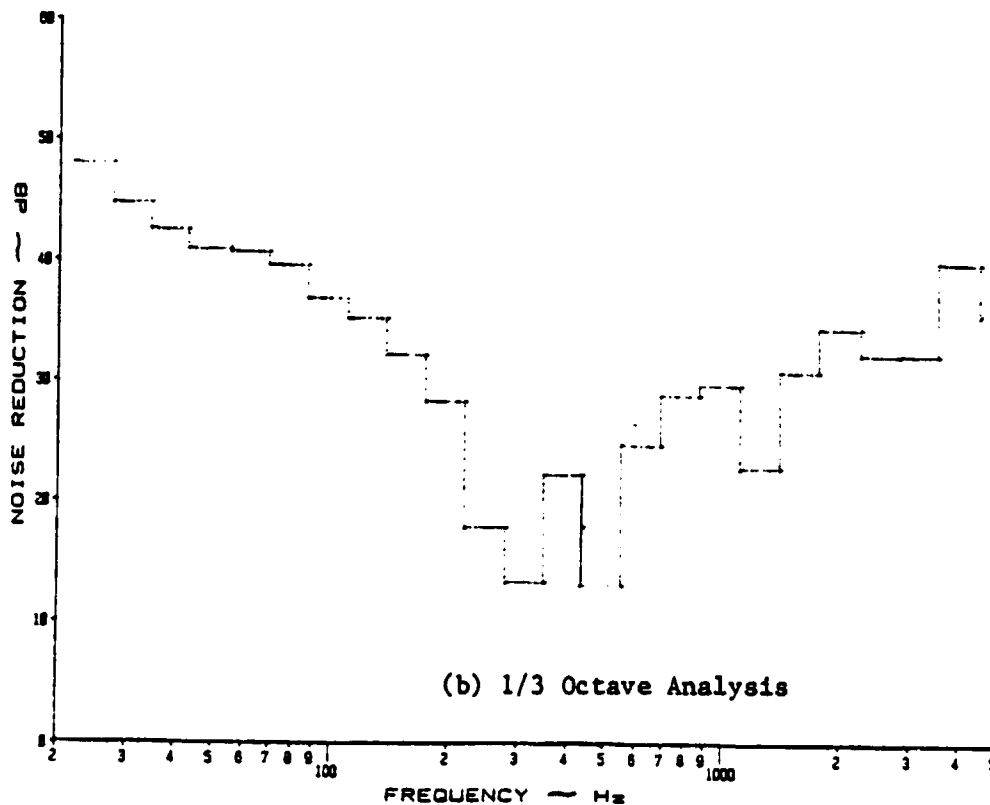

Figure B.43: Noise Reduction Characteristics of a Curved, Stiffened Panel at 2 psi Pressure Differential with Y-434 Damping Tape under a Discrete Noise Source



(a) Narrow Band Analysis



(b) 1/3 Octave Analysis

Figure B.44: Noise Reduction Characteristics of a Curved, Stiffened Panel at 3 psi Pressure Differential with Y-434 Damping Tape under a Discrete Noise Source

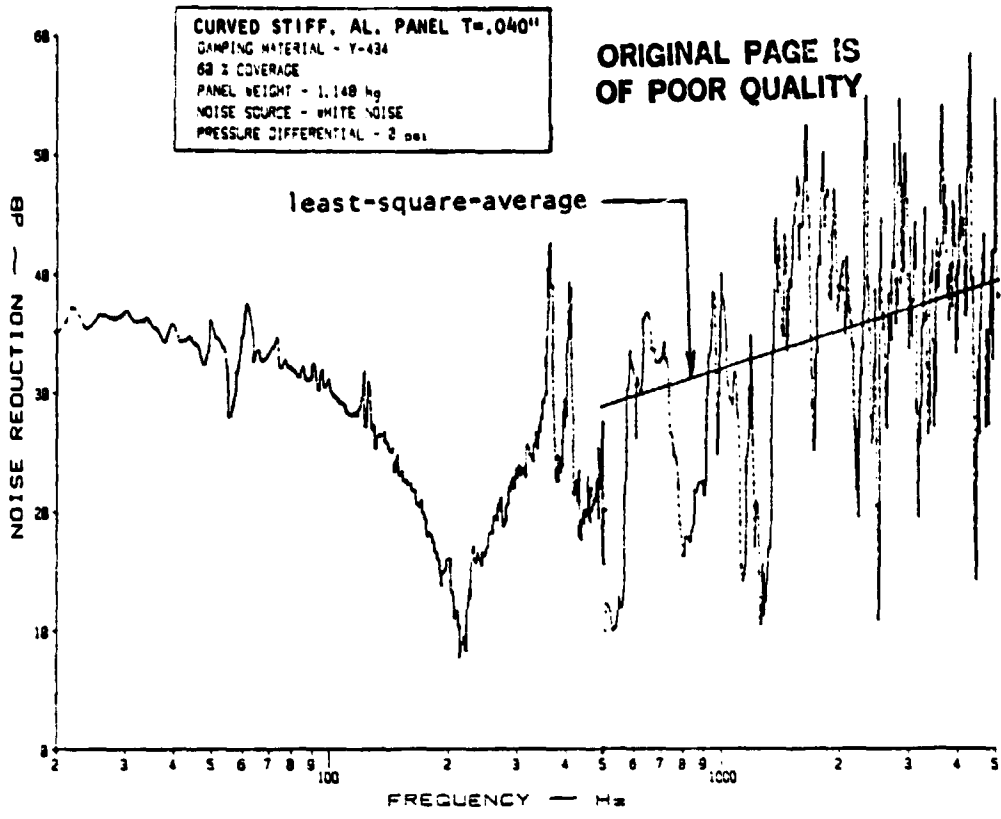

(a) Narrow Band Analysis

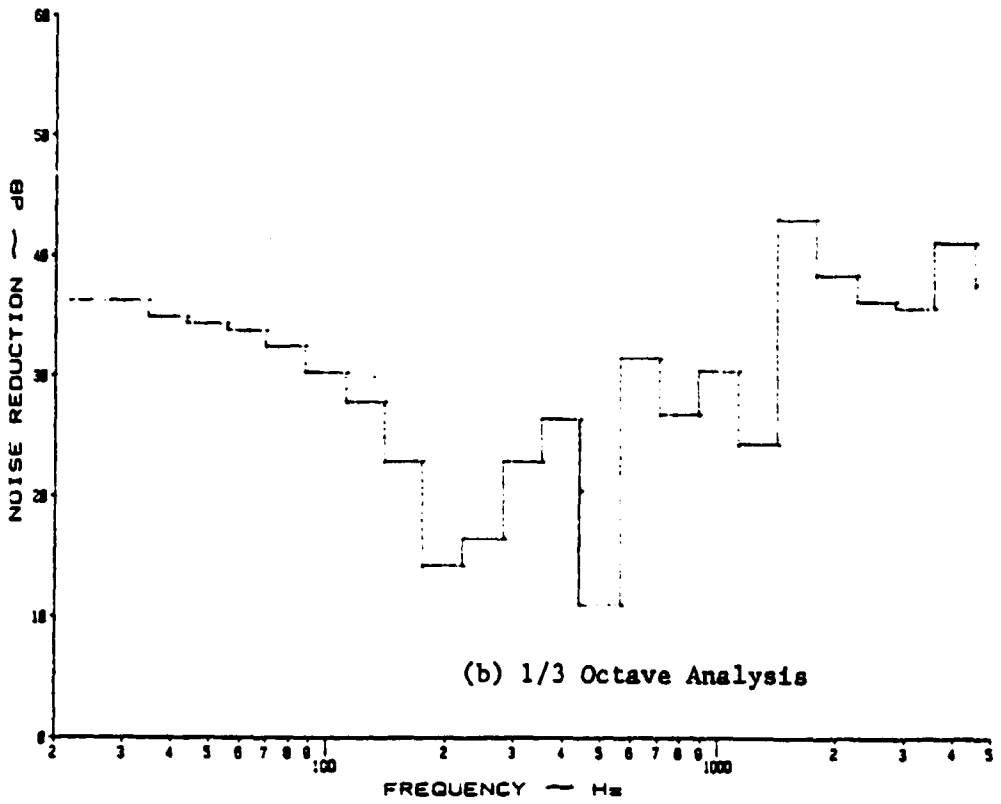

(b) 1/3 Octave Analysis

Figure B.45: Noise Reduction Characteristics of a Curved, Stiffened Panel at 0 psi Pressure Differential with Y-434 Damping Tape under White Noise

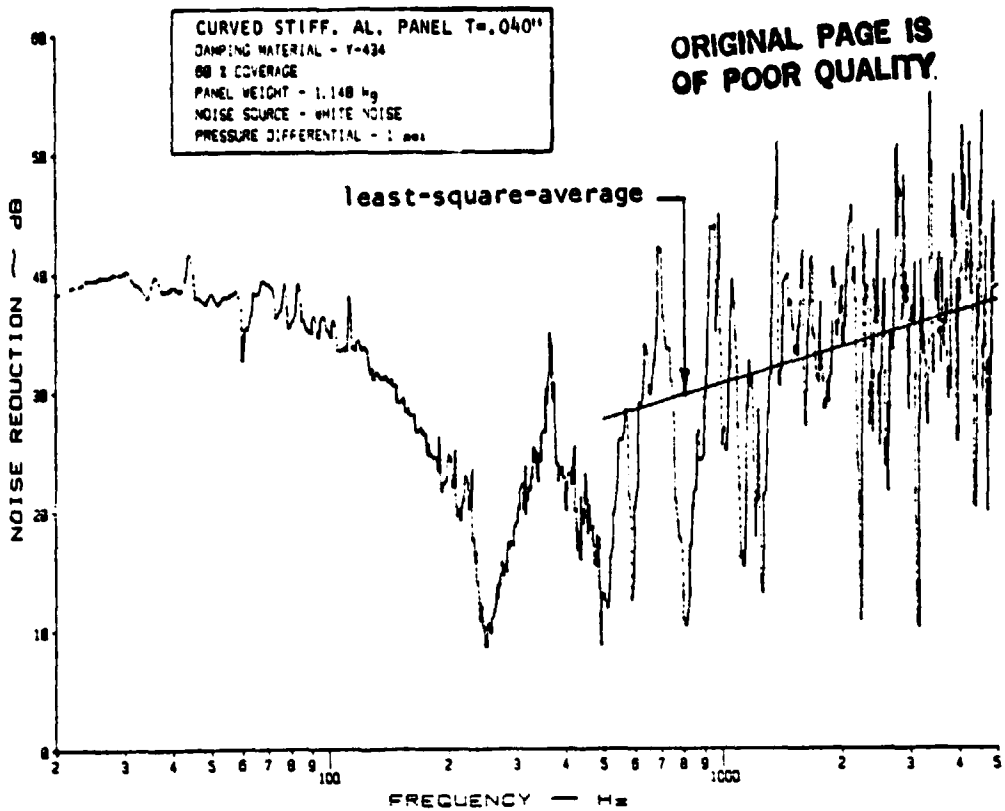

(a) Narrow Band Analysis

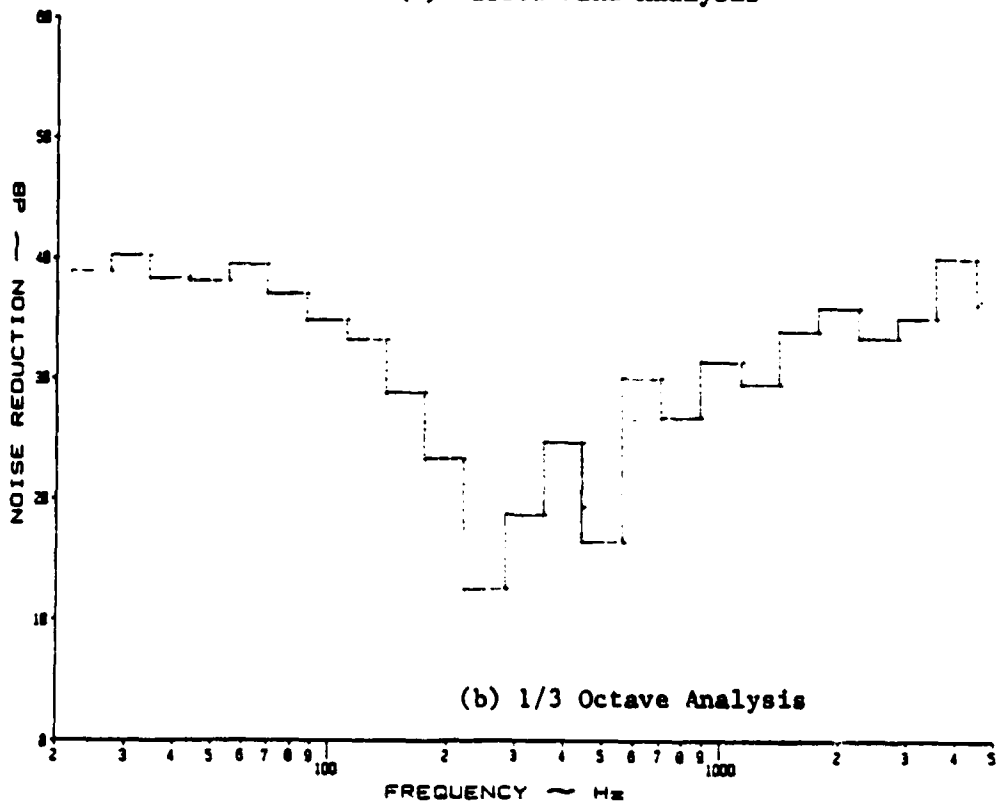

Figure B.46: Noise Reduction Characteristics of a Curved, Stiffened Panel at 1 psi Pressure Differential with Y-434 Damping Tape under White Noise

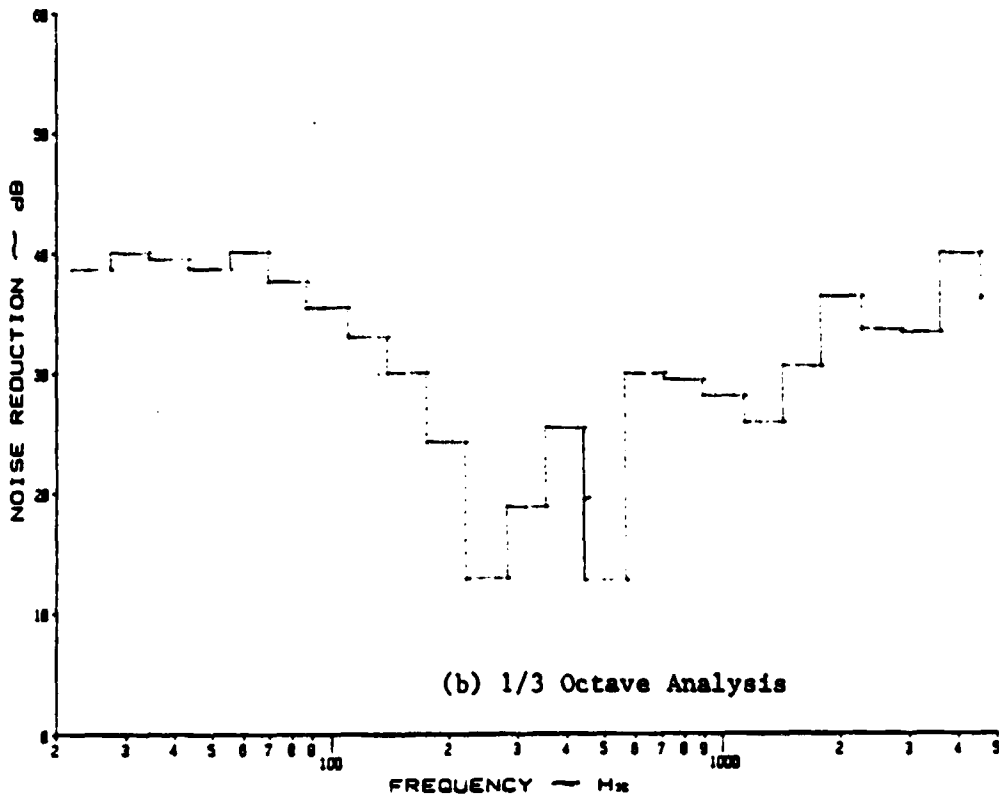
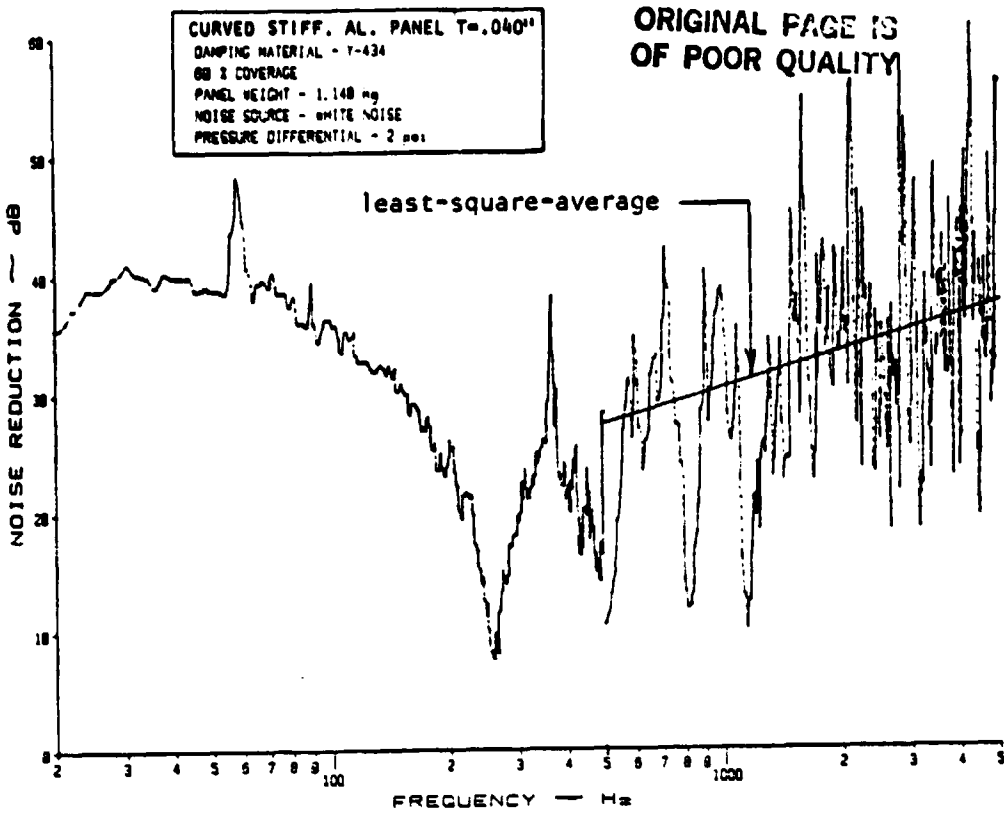
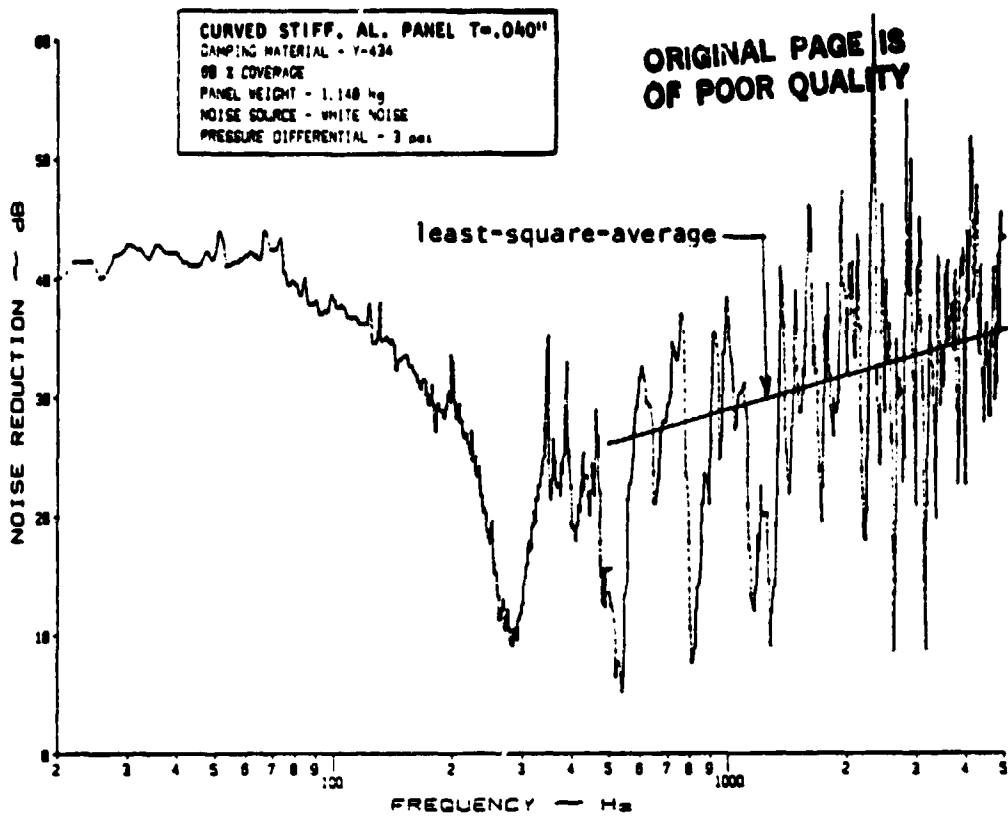

Figure B.47: Noise Reduction Characteristics of a Curved, Stiffened Panel at 2 Psi Pressure Differential with Y-434 Damping Tape under White Noise



(a) Narrow Band Analysis

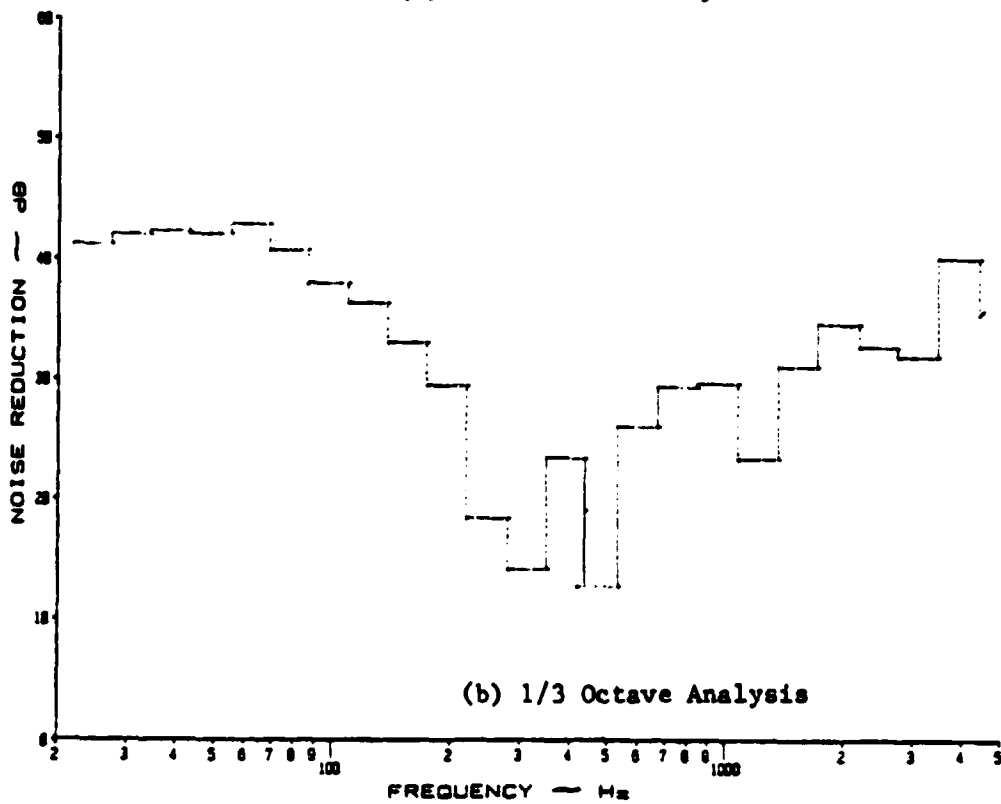
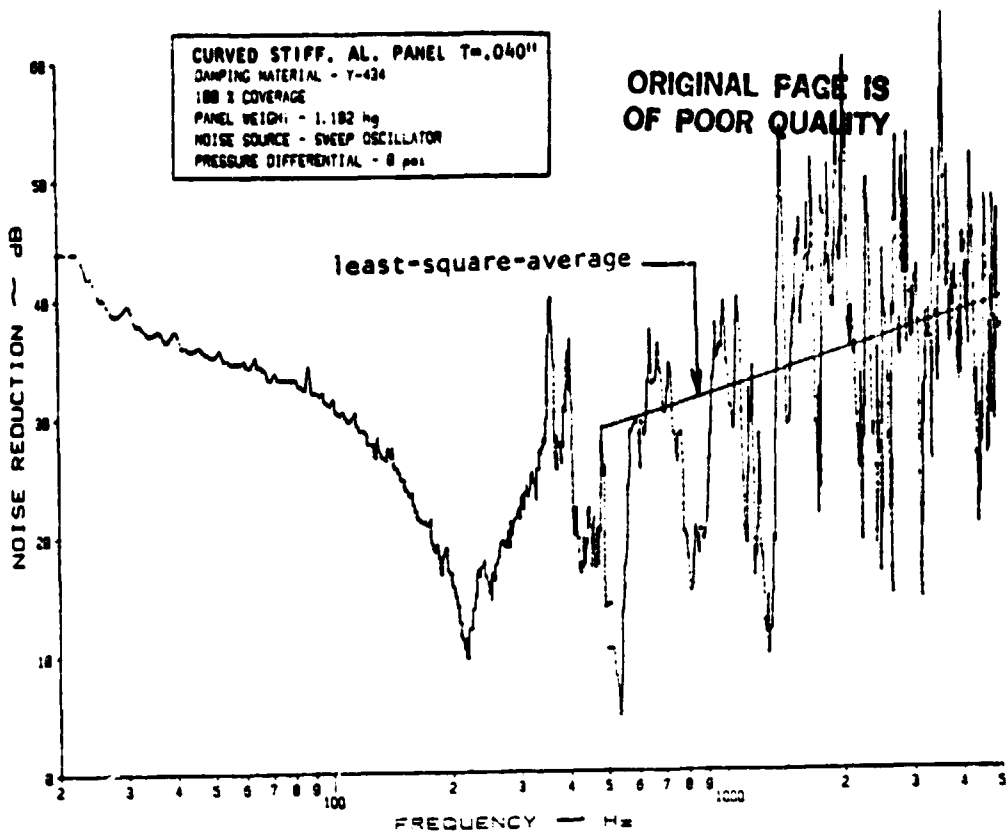
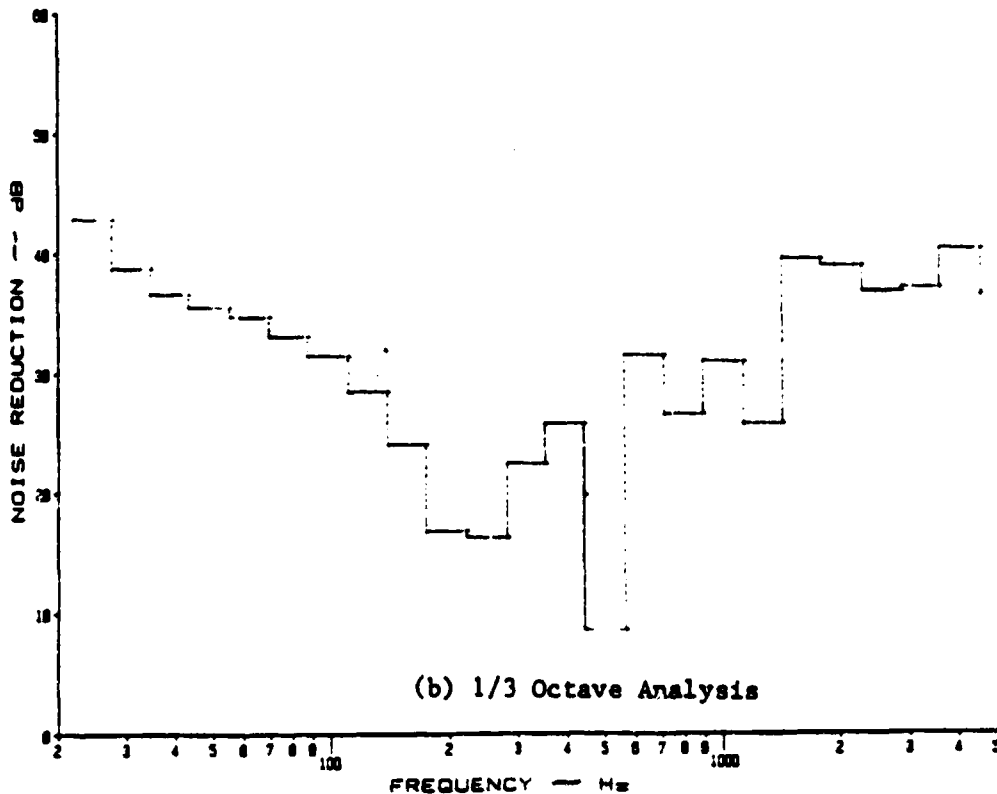

Figure B.48: Noise Reduction Characteristics of a Curved, Stiff-panel at a 3 psi Pressure Differential with Y-434 Damping Tape under White Noise



(a) Narrow Band Analysis



(b) 1/3 Octave Analysis

Figure B.49: Noise Reduction Characteristics of a Curved, Stiffened Panel at 0 psi Pressure Differential with Y-434 Damping Tape under a Discrete Noise Source

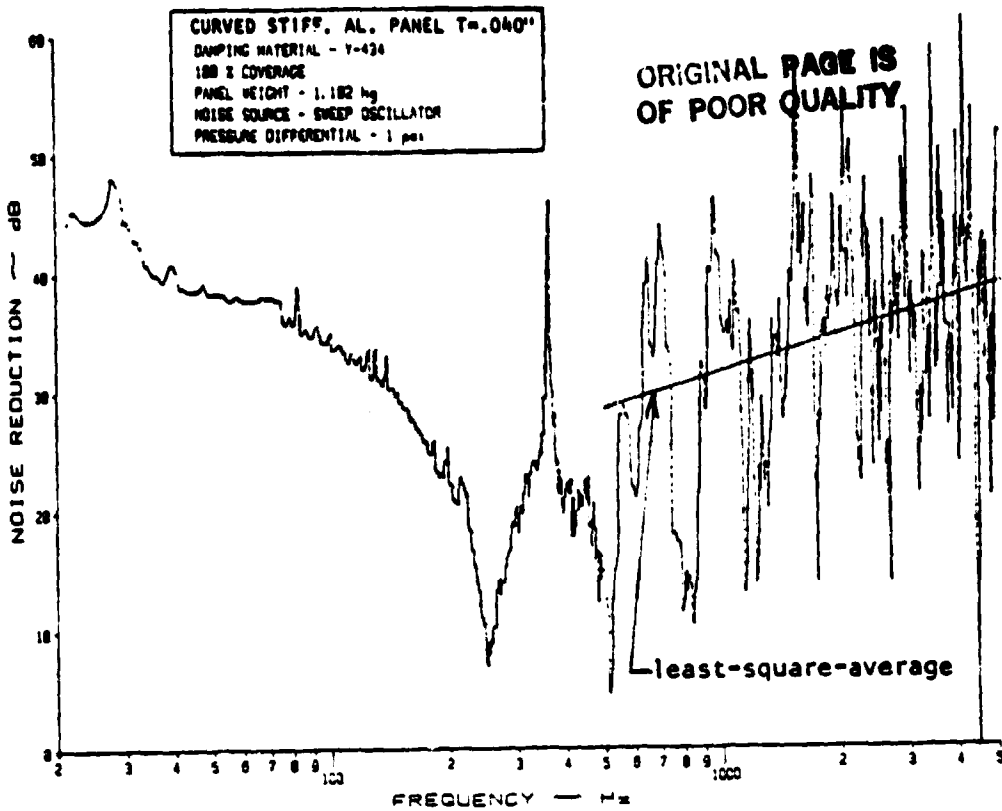

(a) Narrow Band Analysis

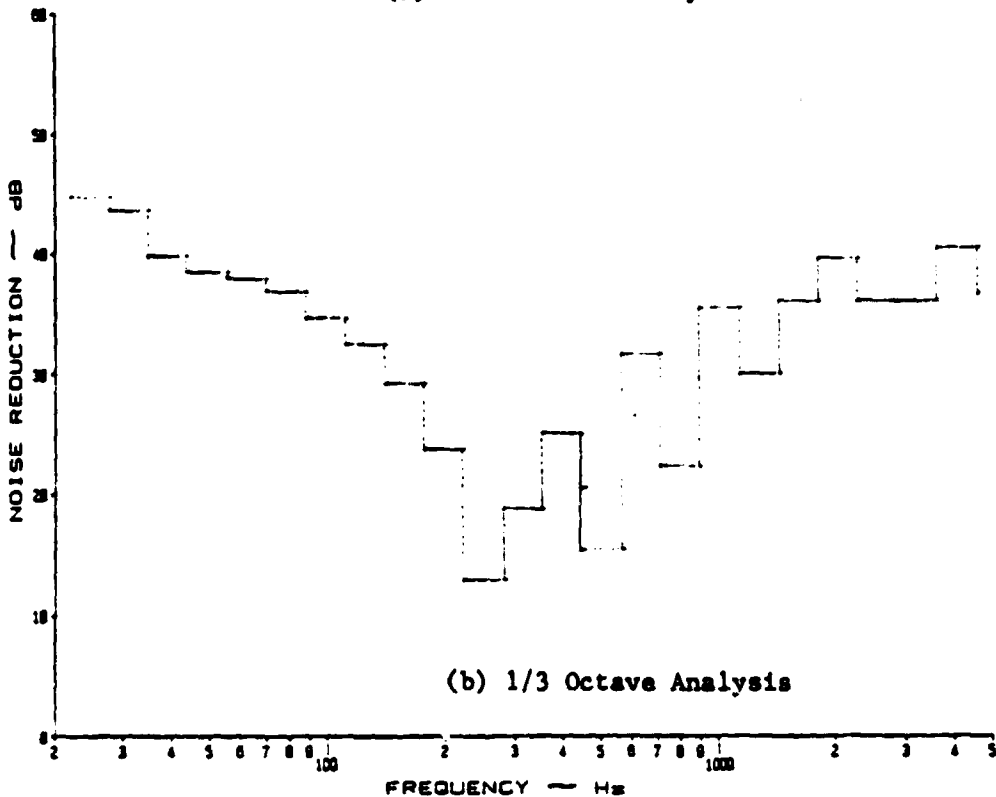

(b) 1/3 Octave Analysis

Figure B.50: Noise Reduction Characteristics of a Curved, Stiffened Panel at 1 psi Pressure Differential with Y-434 Damping Tape under a Discrete Noise Source

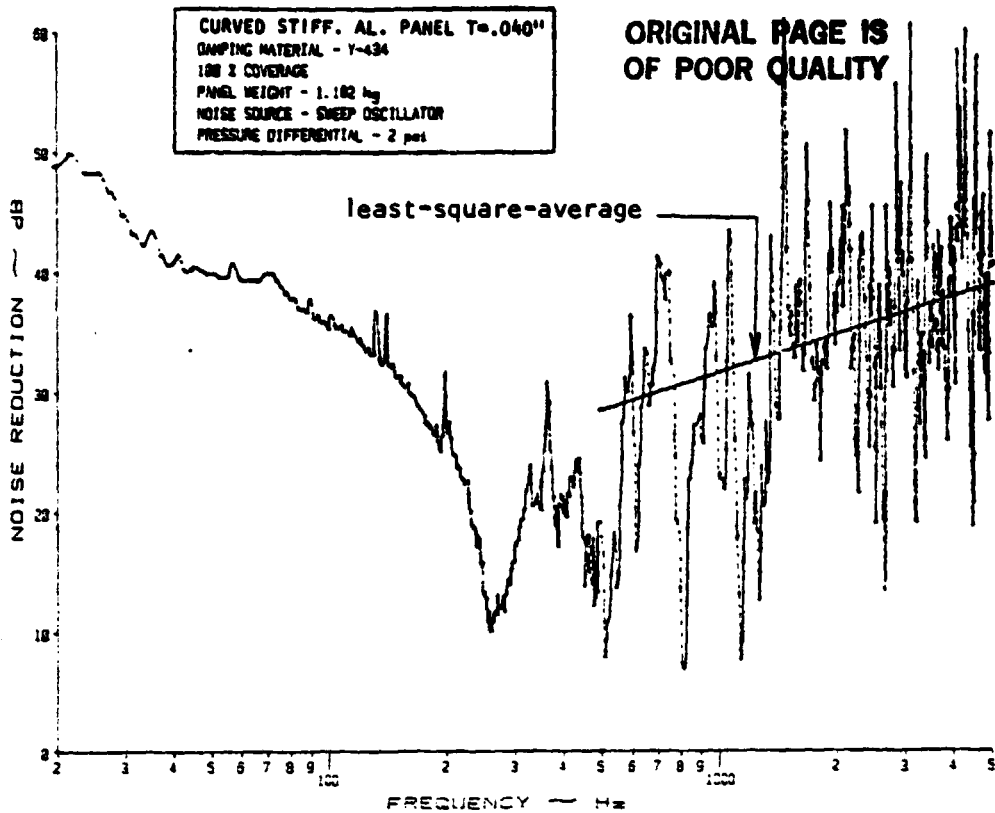

(a) Narrow Band Analysis

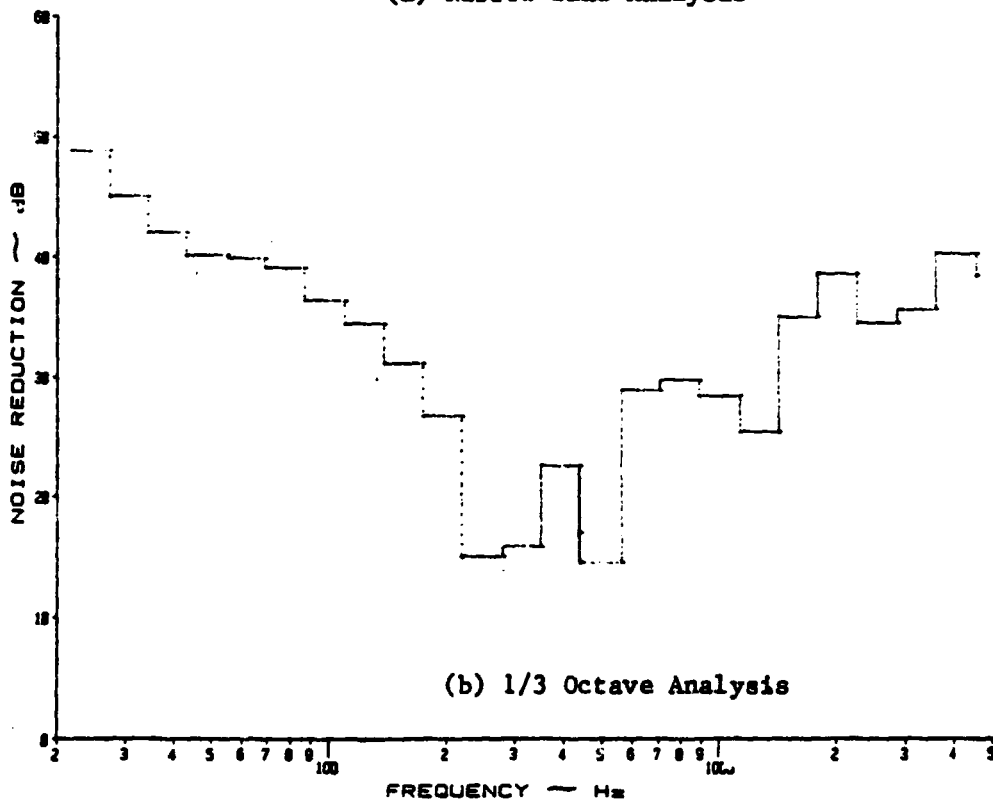

(b) 1/3 Octave Analysis

Figure B.51: Noise Reduction Characteristics of a Curved, Stiffened Panel at 2 psi Pressure Differential with Y-434 Damping Tape under a Discrete Noise Source

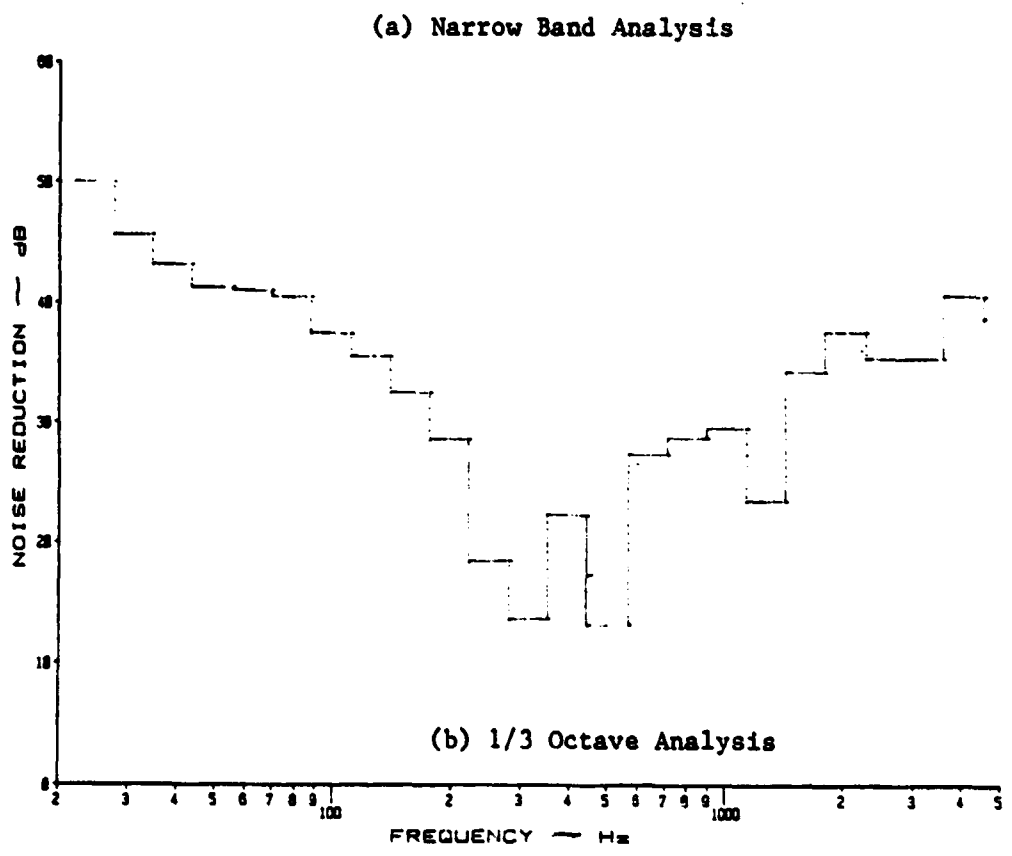
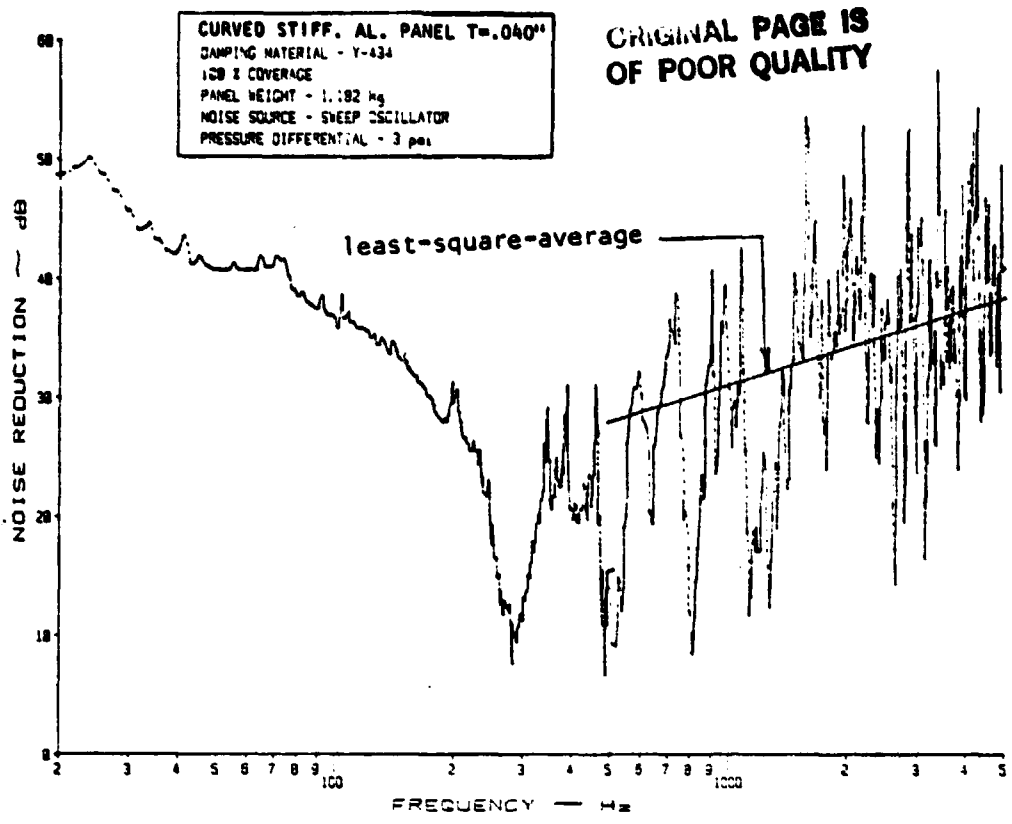
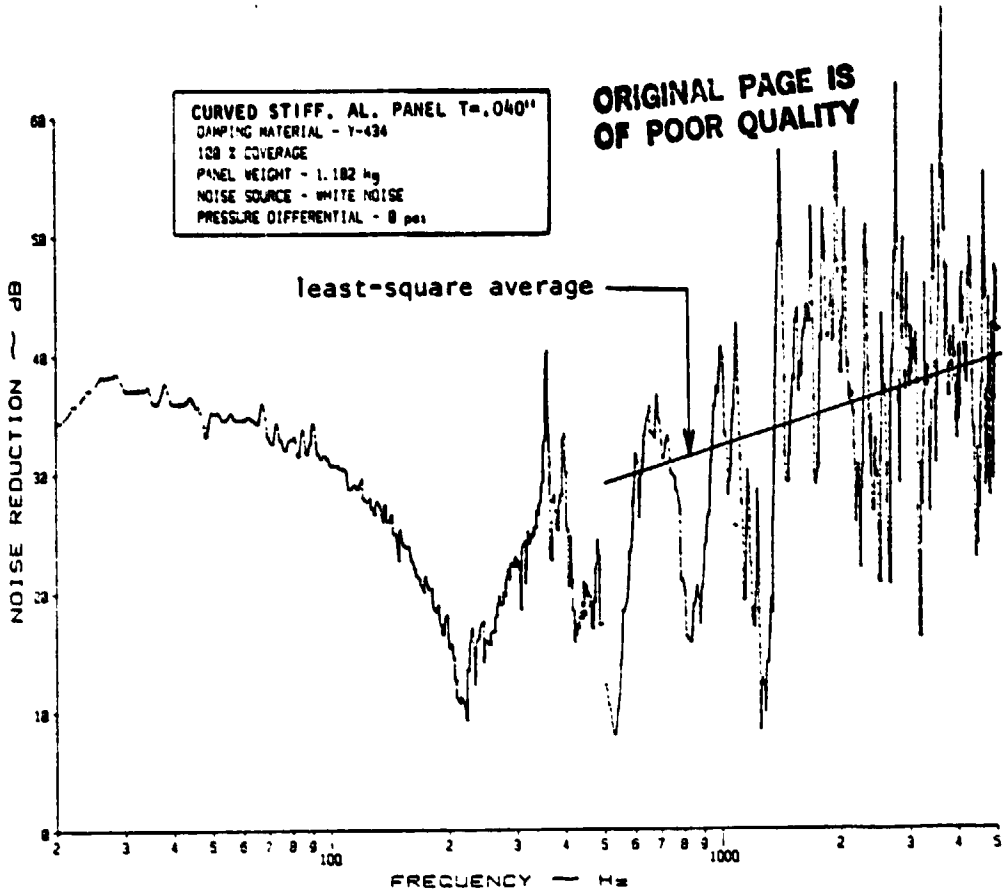
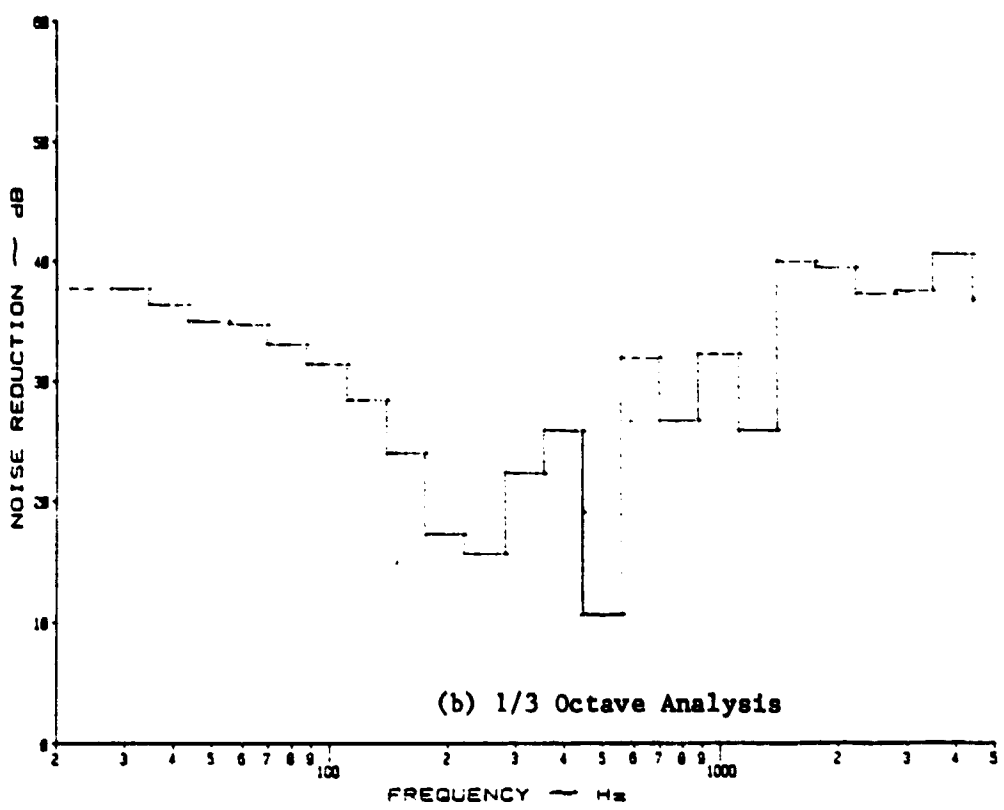

Figure B.52: Noise Reduction Characteristics of a Curved, Stiffened Panel at 3 psi Pressure Differential with Y-434 Damping Tape under a Discrete Noise Source



(a) Narrow Band Analysis



(b) 1/3 Octave Analysis

Figure B.53: Noise Reduction Characteristics of a Curved, Stiffened Panel at 0 psi Pressure Differential with Y-434 Damping Tape under White Noise

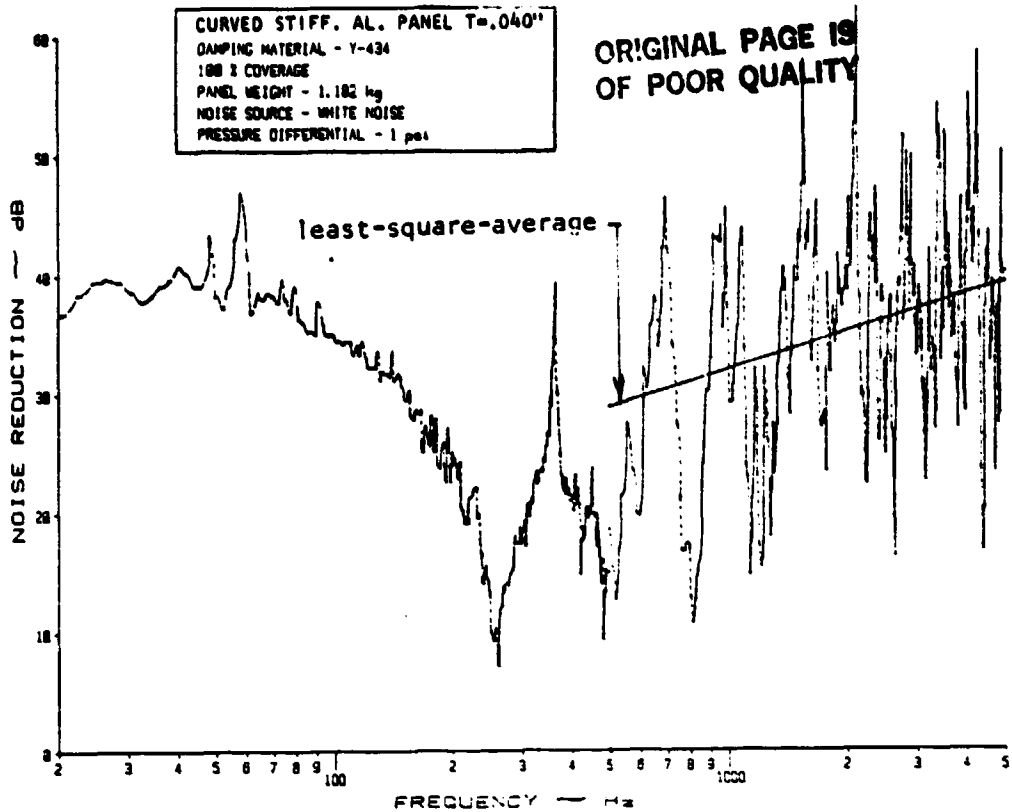

(a) Narrow Band Analysis

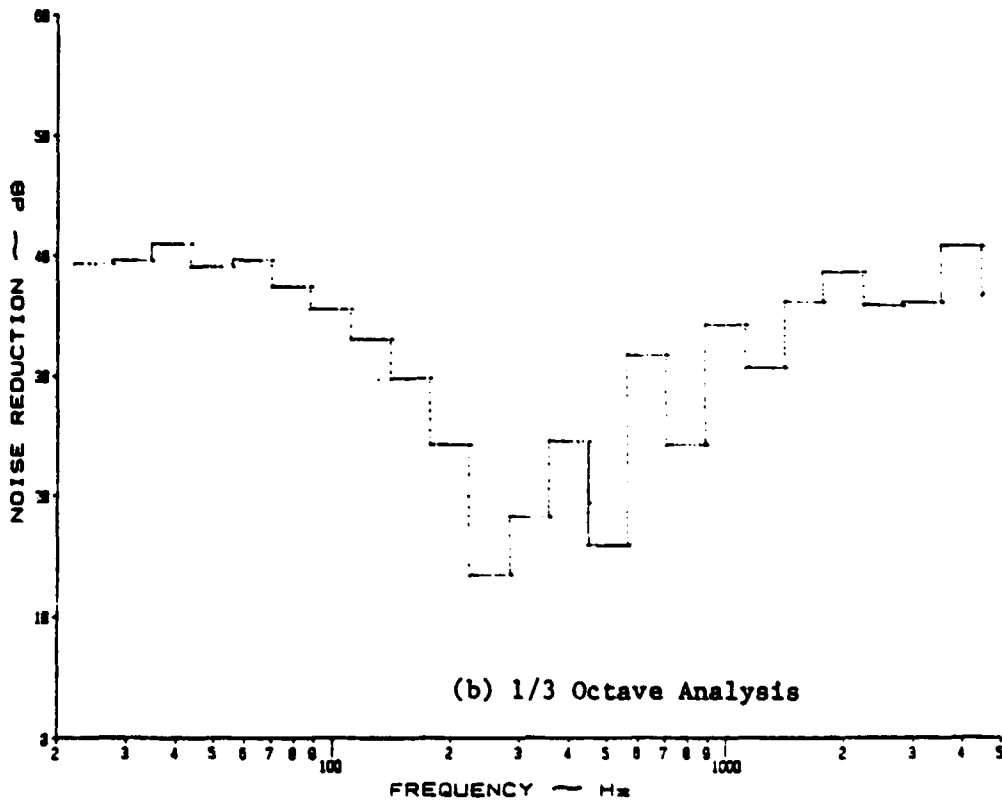

(b) 1/3 Octave Analysis

Figure B.54: Noise Reduction Characteristics of a Curved, Stiffened Panel at 1 psi Pressure Differential with Y-434 Damping Tape under White Noise

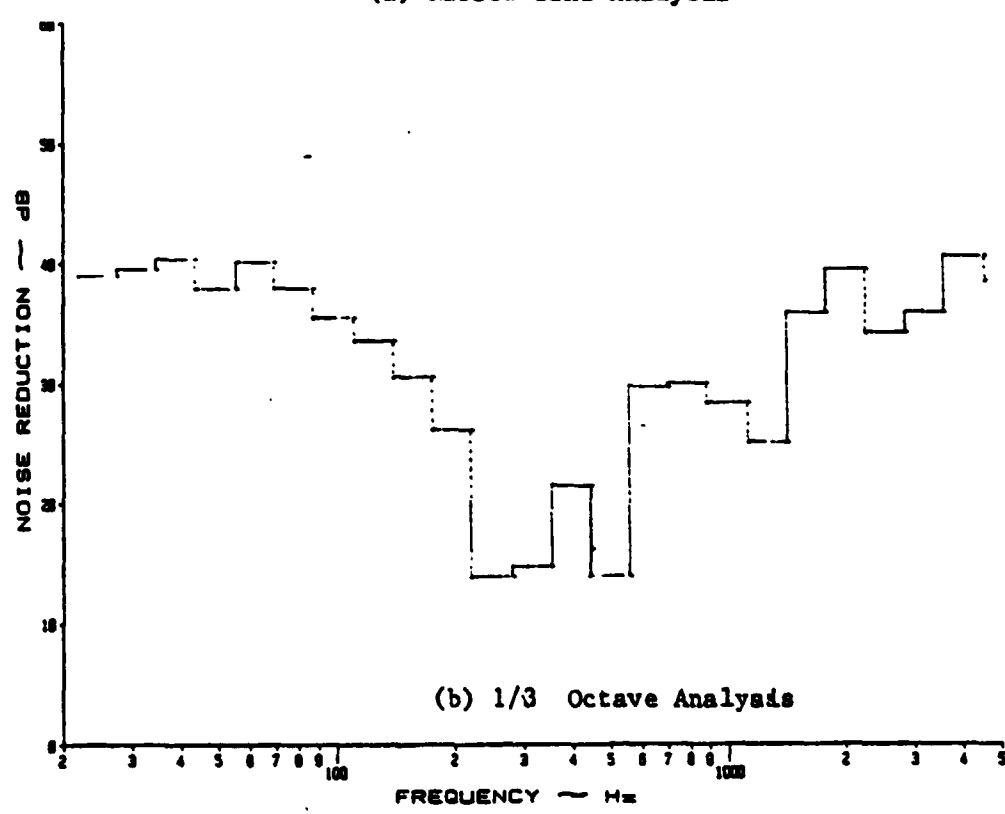
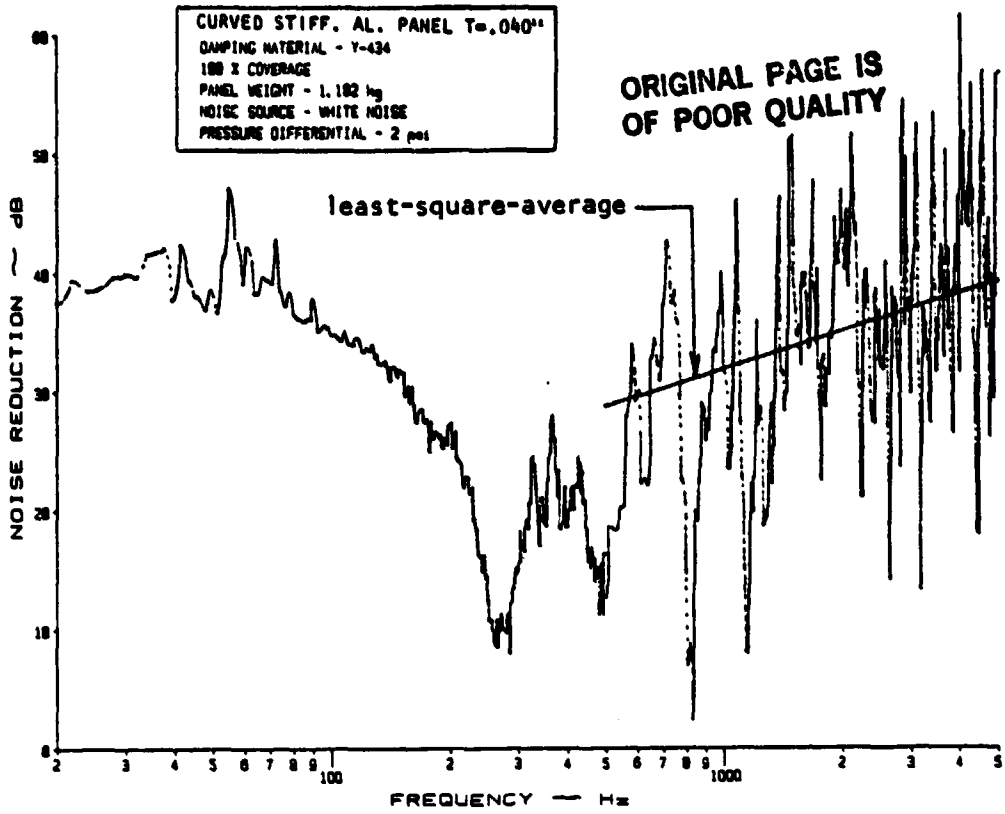
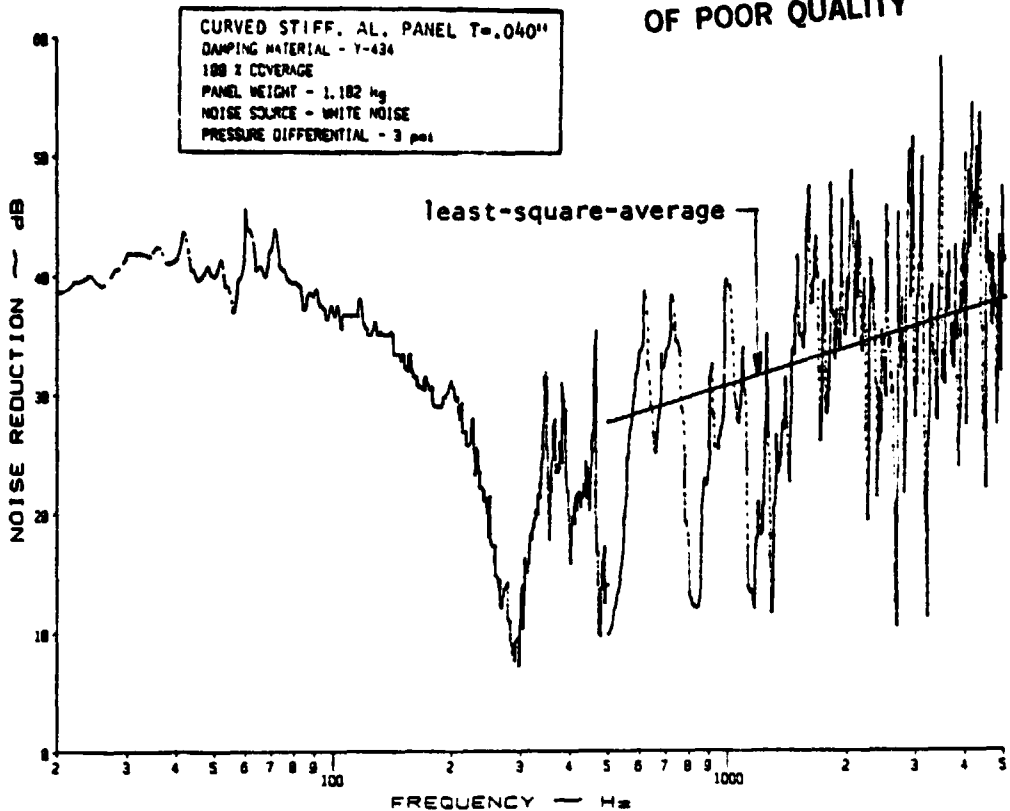
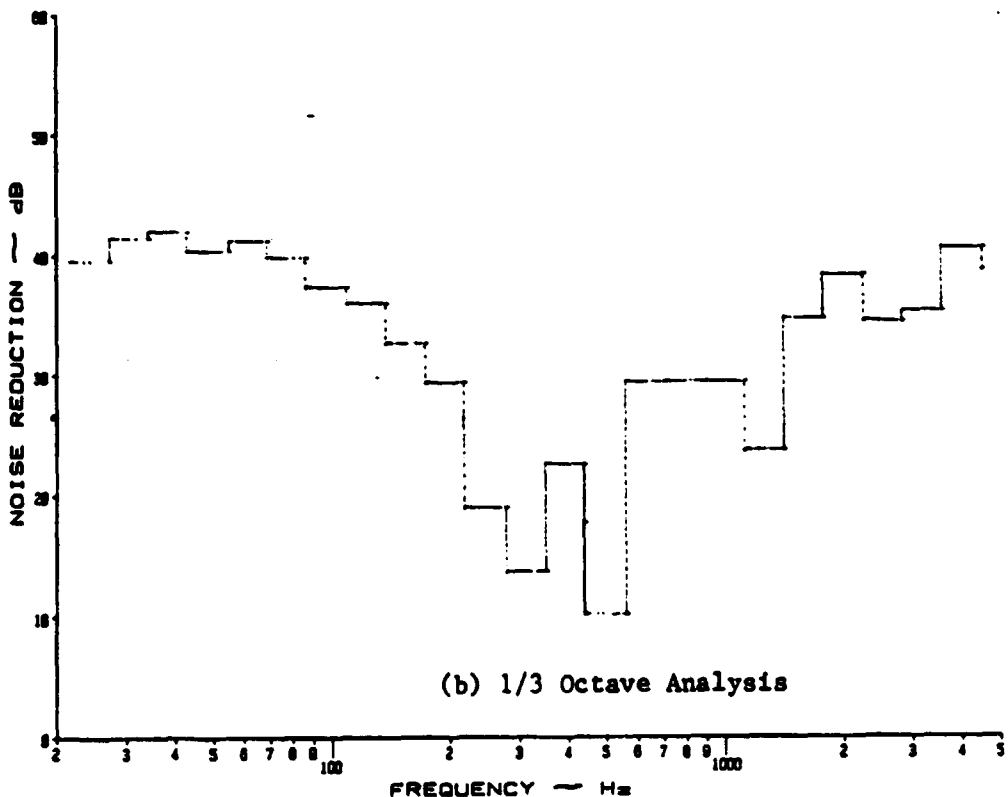

Figure B.55: Noise Reduction Characteristics of a Curved, Stiffened Panel at 2 psi Pressure Differential with Y-434 Damping Tape under White Noise



(a) Narrow Band Analysis



(b) 1/3 Octave Analysis

Figure B.56: Noise Reduction Characteristics of a Curved, Stiffened Panel at 3 psi Pressure Differential with Y-434 Damping Tape under White Noise

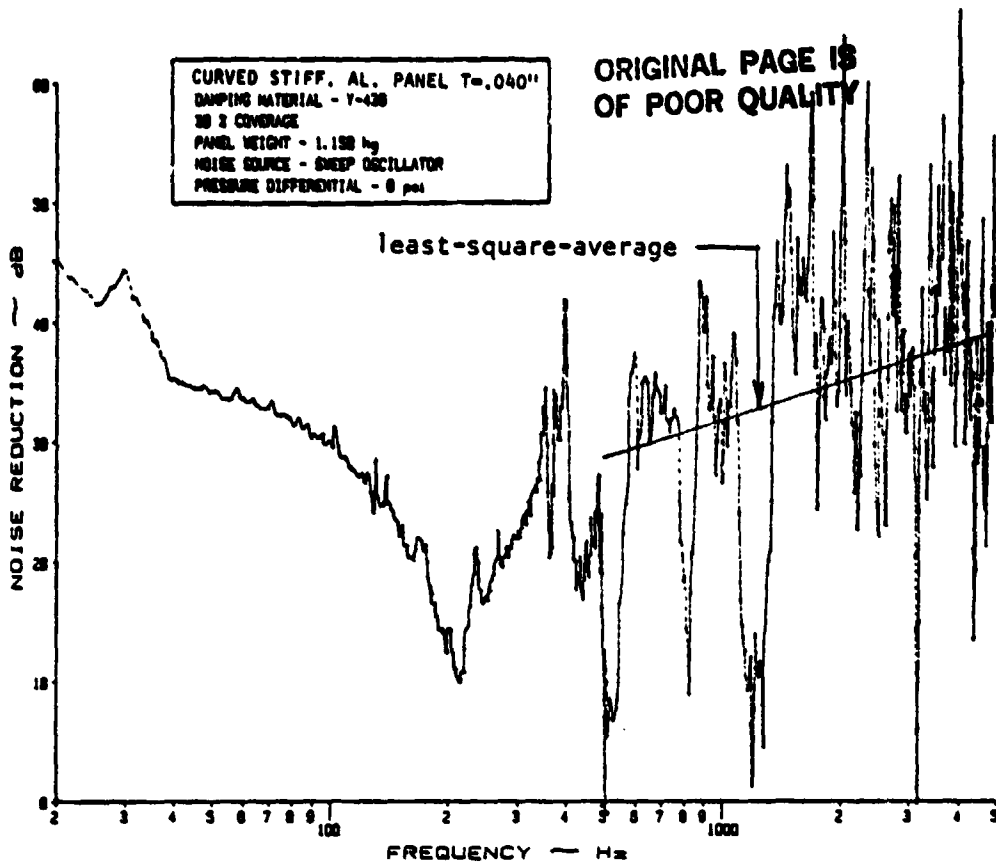

(a) Narrow Band Analysis

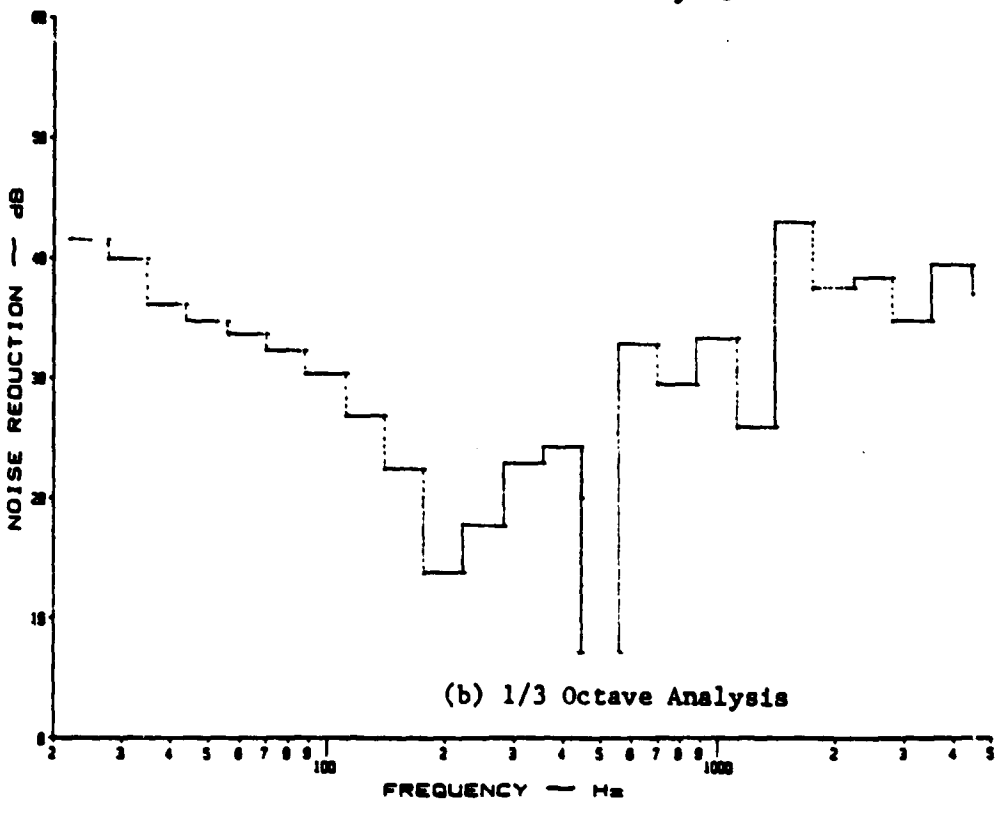

(b) 1/3 Octave Analysis

Figure B.57: Noise Reduction Characteristics of a Curved, Stiffened Panel at 0 psi Pressure Differential with Y-436 Damping Tape under a discrete noise source

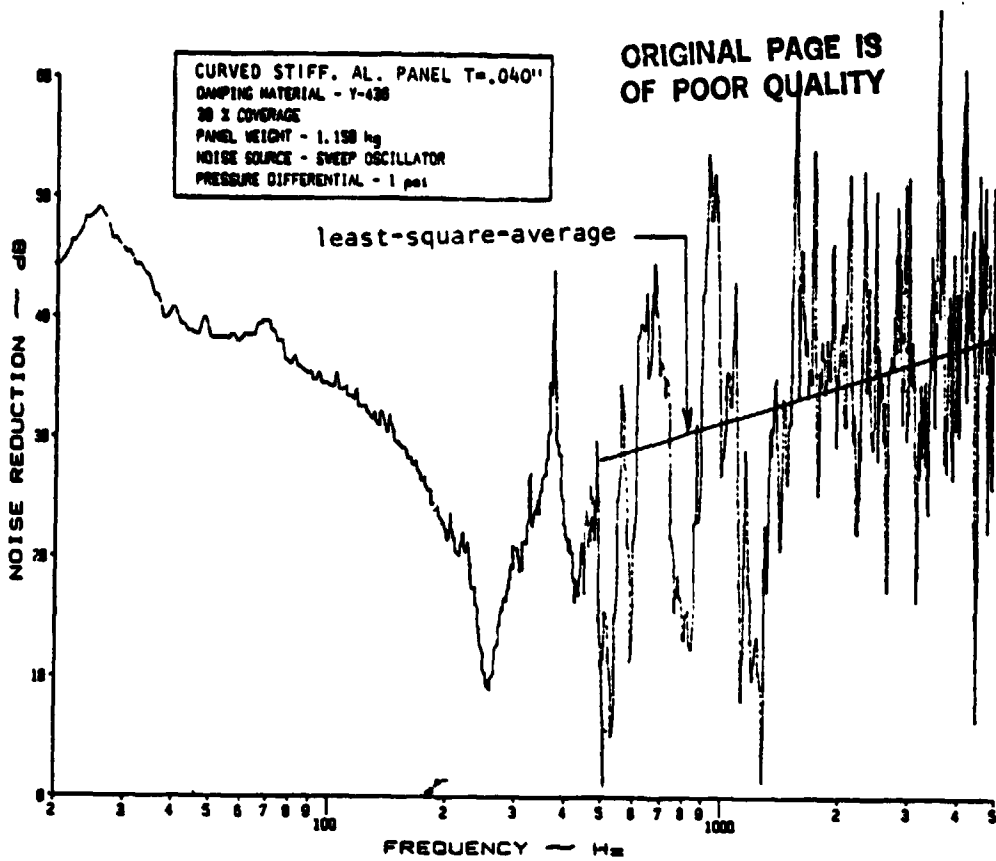

(a) Narrow Band Analysis

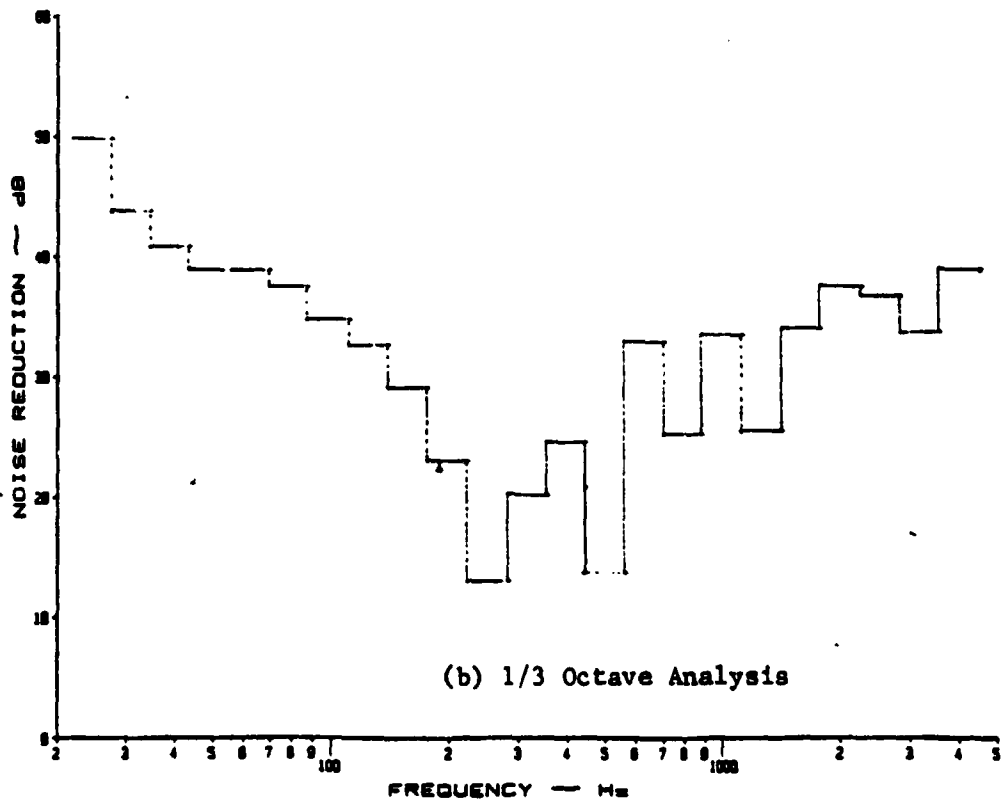

(b) 1/3 Octave Analysis

Figure B.58: Noise Reduction Characteristics of a Curved, Stiffened Panel at 1 psi Pressure Differential with Y-436 Damping Tape under a discrete noise source

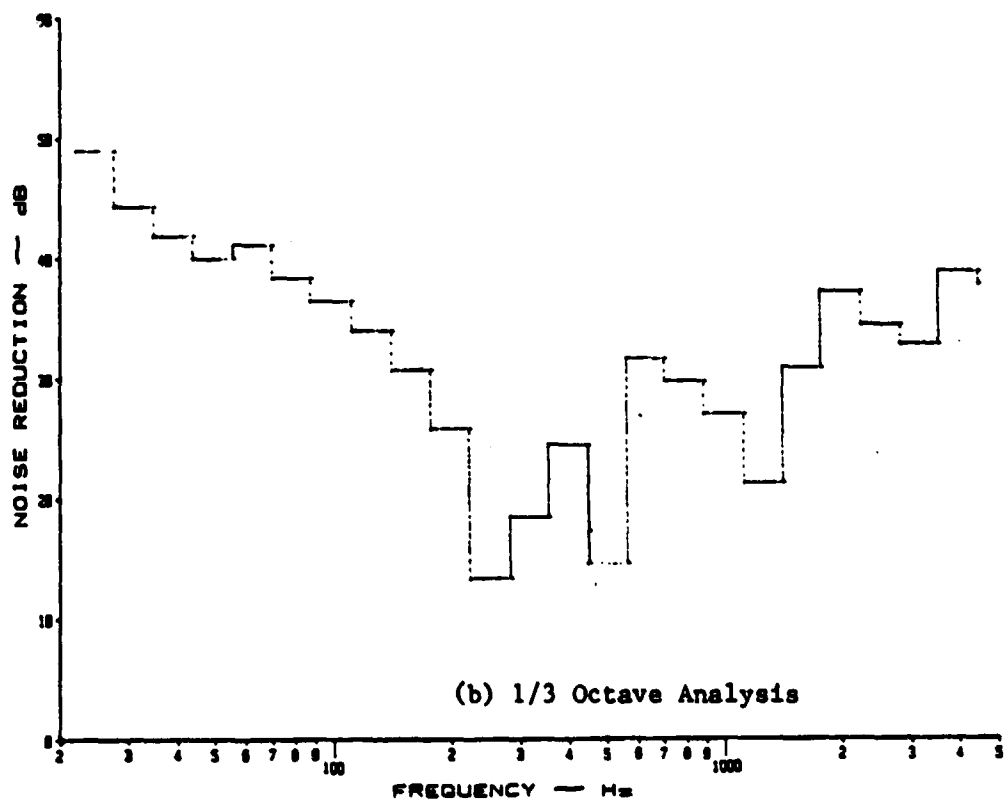
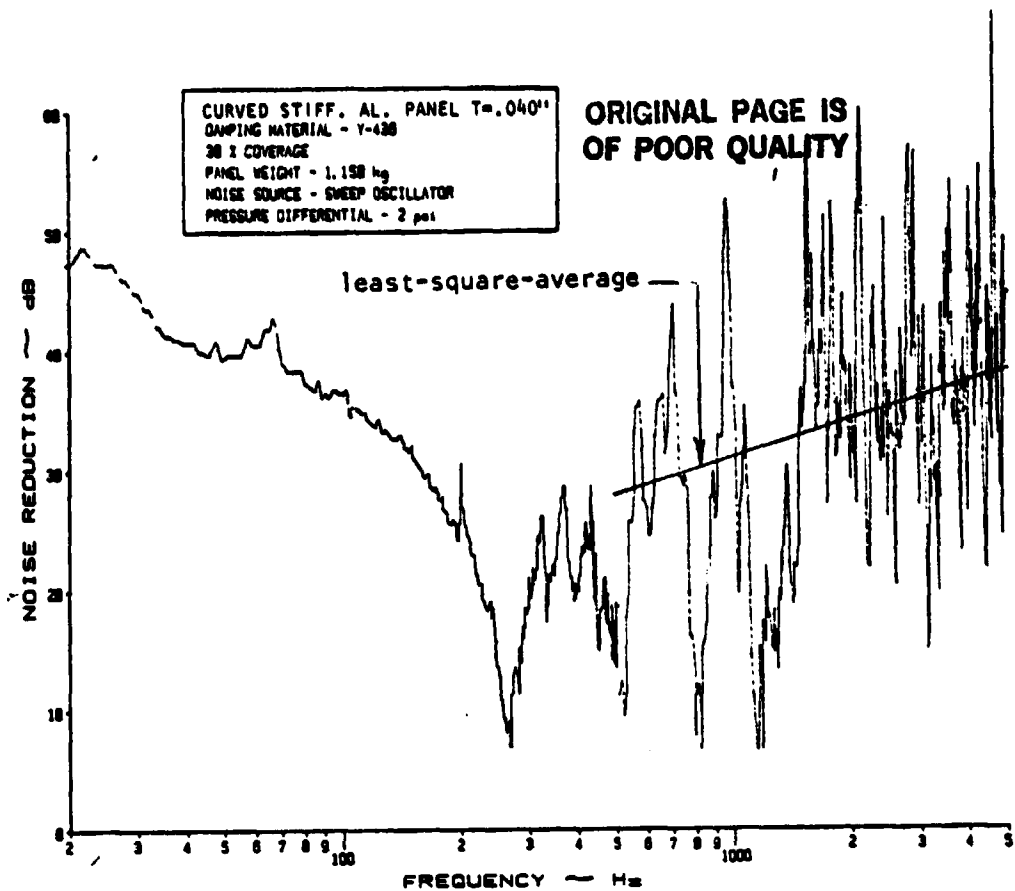
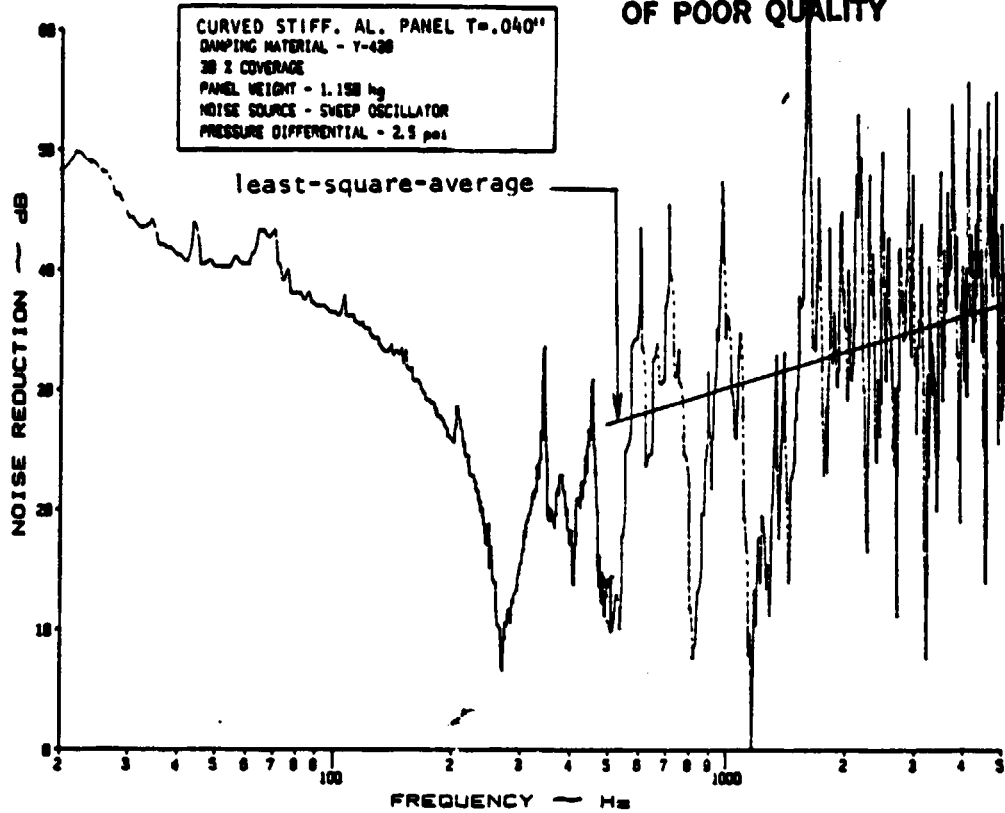
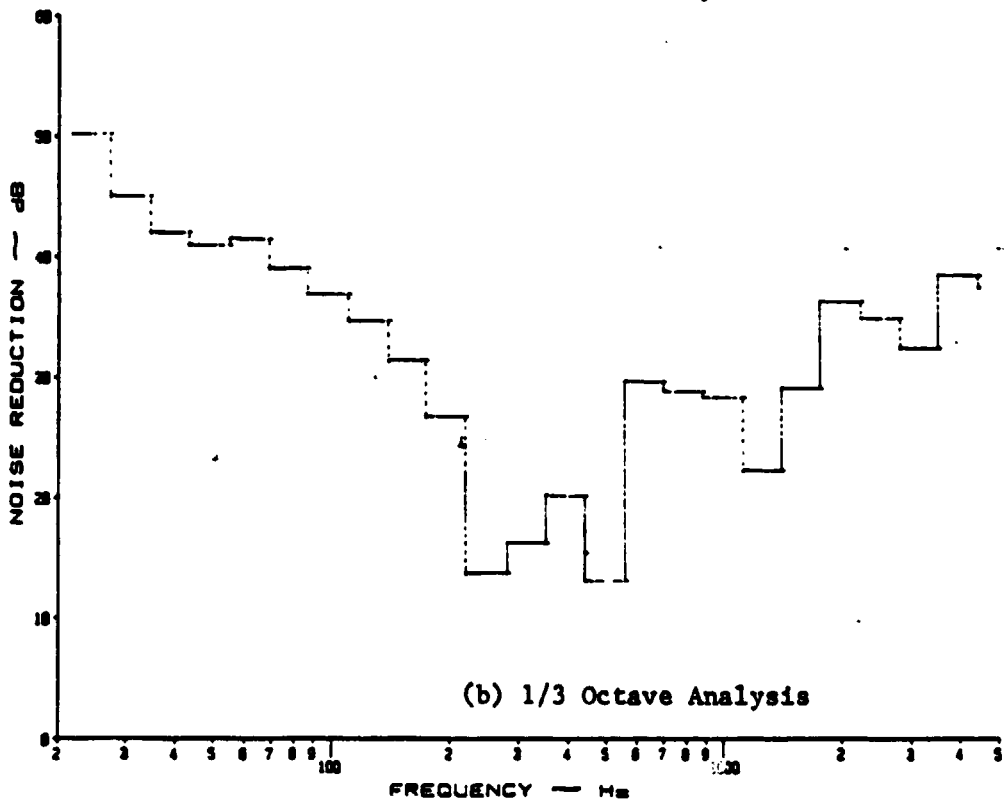

Figure B.59: Noise Reduction Characteristics of a Curved, Stiffened Panel at 2 psi Pressure Differential with Y-436 Damping Tape under a discrete noise source

ORIGINAL PAGE IS
OF POOR QUALITY



(a) Narrow Band Analysis



(b) 1/3 Octave Analysis

Figure B.60: Noise Reduction Characteristics of a Curved, Stiffened Panel at 2.5 psi Pressure Differential with Y-436 Damping Tape under a Discrete Noise Source

ORIGINAL PAGE IS
OF POOR QUALITY

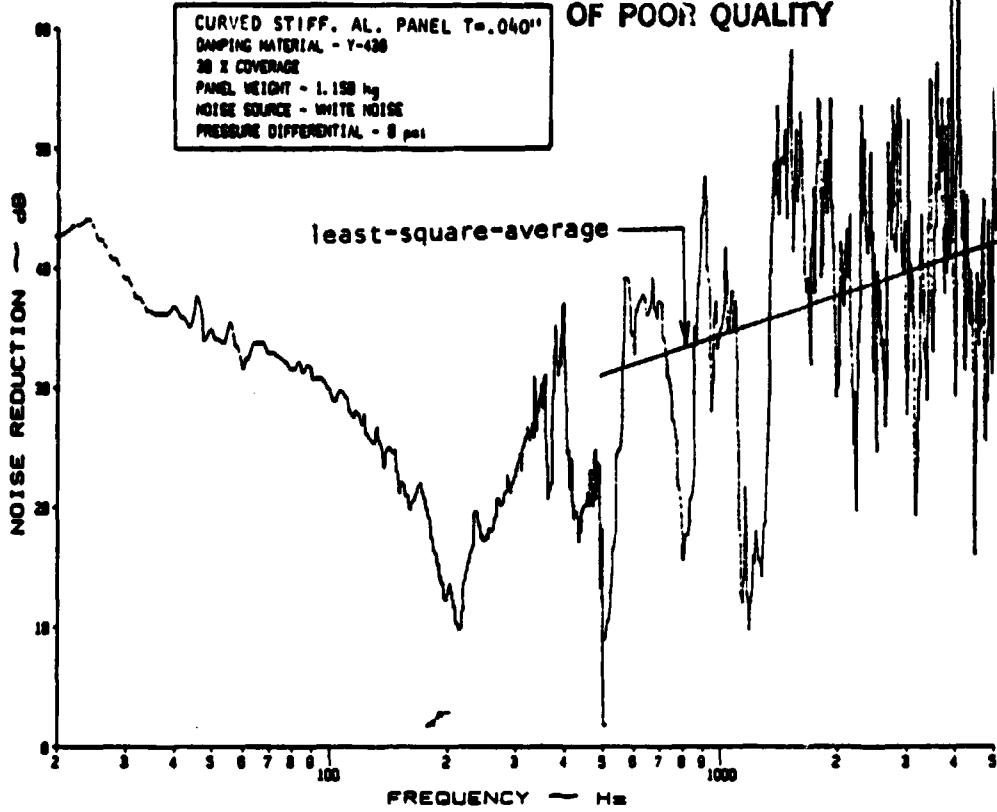

(a) Narrow Band Analysis

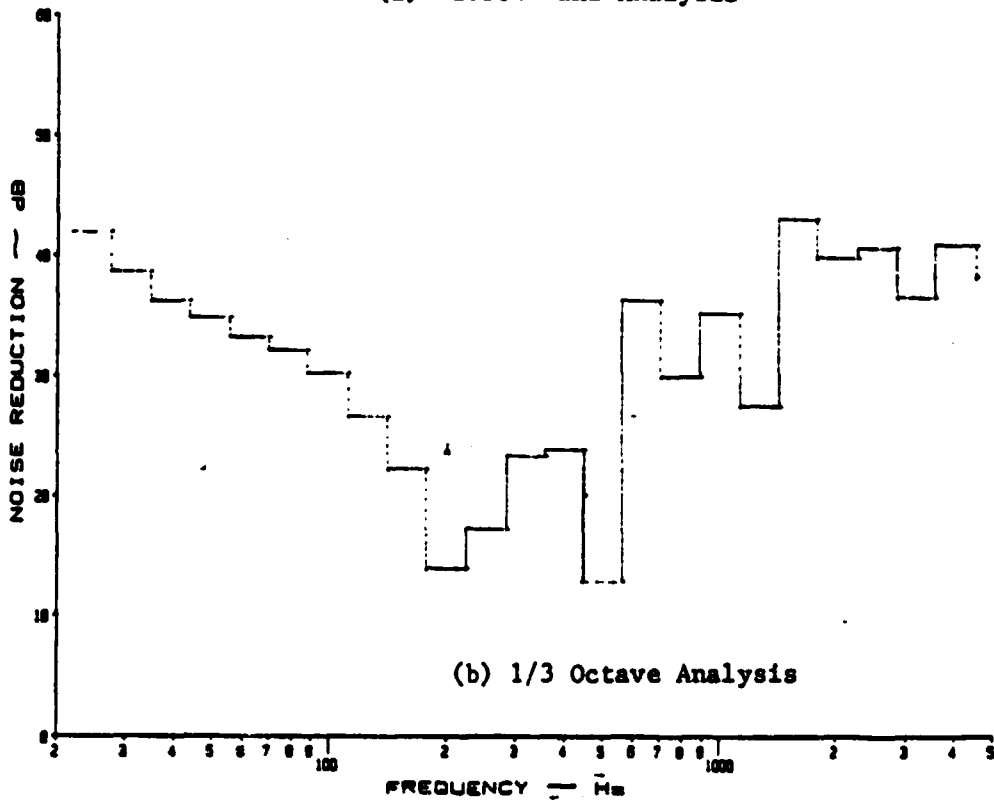

(b) 1/3 Octave Analysis

Figure B.61: Noise Reduction Characteristics of a Curved, Stiffened Panel at 0 psi Pressure Differential with Y-436 Damping Tape under White Noise

ORIGINAL PAGE IS
OF POOR QUALITY

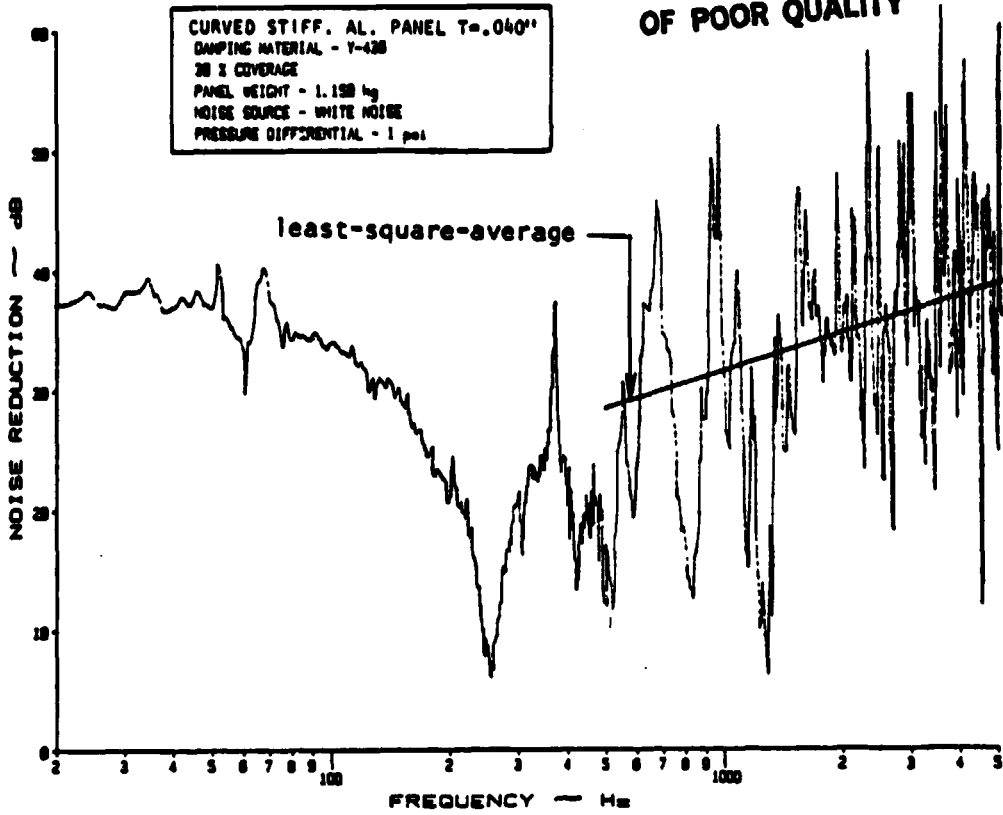

(a) Narrow Band Analysis

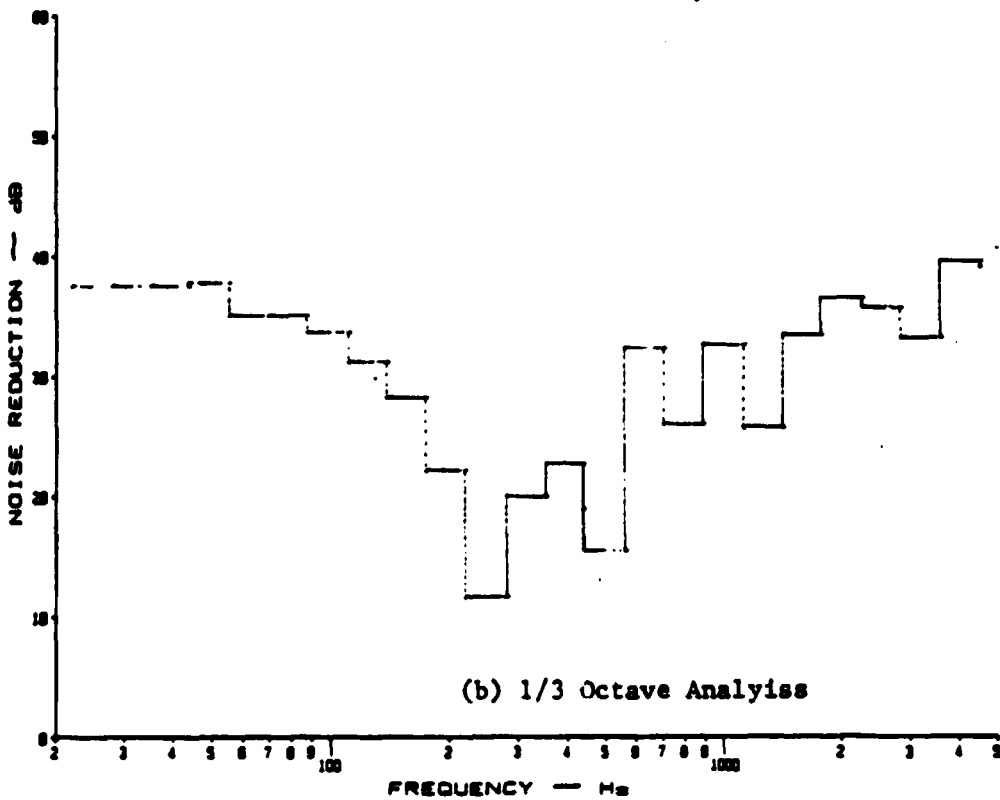

(b) 1/3 Octave Analysis

Figure B.62: Noise Reduction Characteristics of a Curved, Stiffened Panel at 1 psi Pressure Differential with Y-436 Damping Tape under White Noise

ORIGINAL PAGE IS
OF POOR QUALITY

CURVED STIFF. AL. PANEL $T=0.040''$
DAMPING MATERIAL - Y-436
38 % COVERAGE
PANEL WEIGHT - 1.198 kg
NOISE SOURCE - WHITE NOISE
PRESSURE DIFFERENTIAL - 2 psi

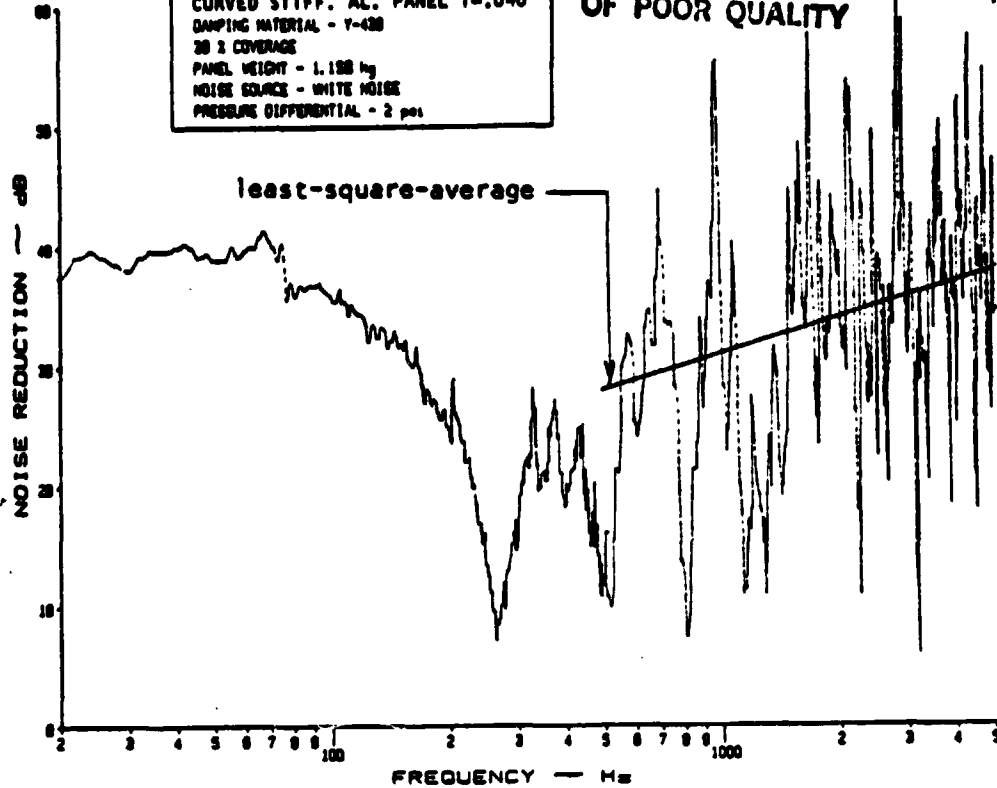

(a) Narrow Band Analysis

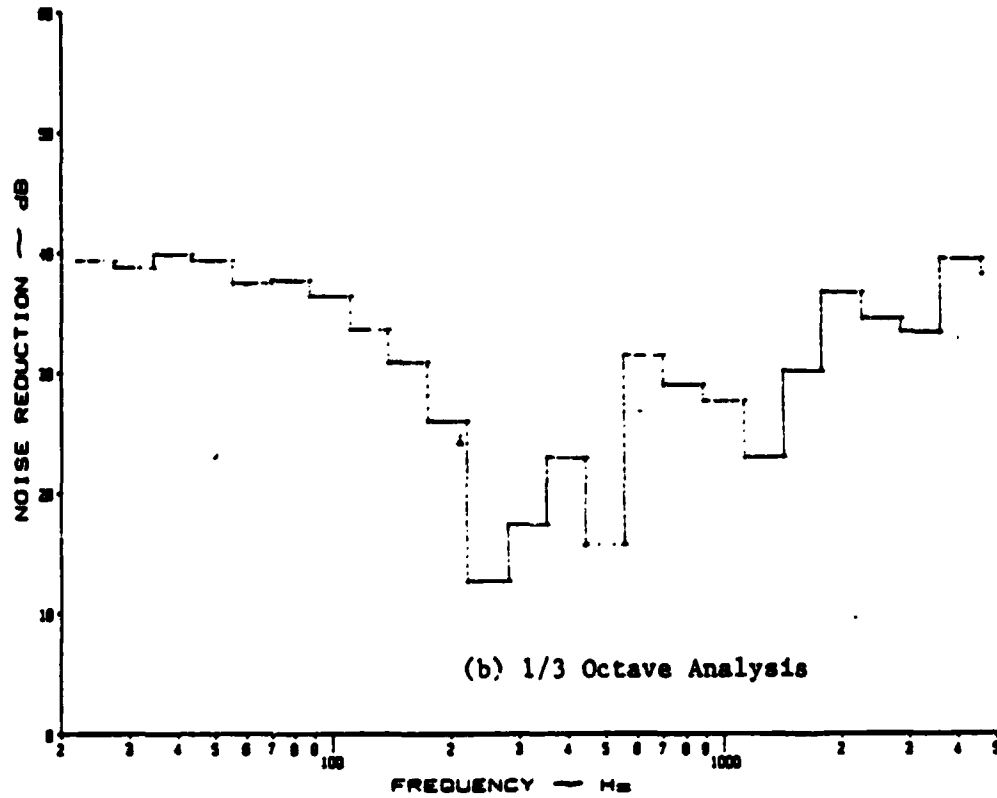

(b) 1/3 Octave Analysis

Figure B.63: Noise Reduction Characteristics of a Curved, Stiffened Panel at 2 psi Pressure Differential with Y-436 Damping Tape under White Noise

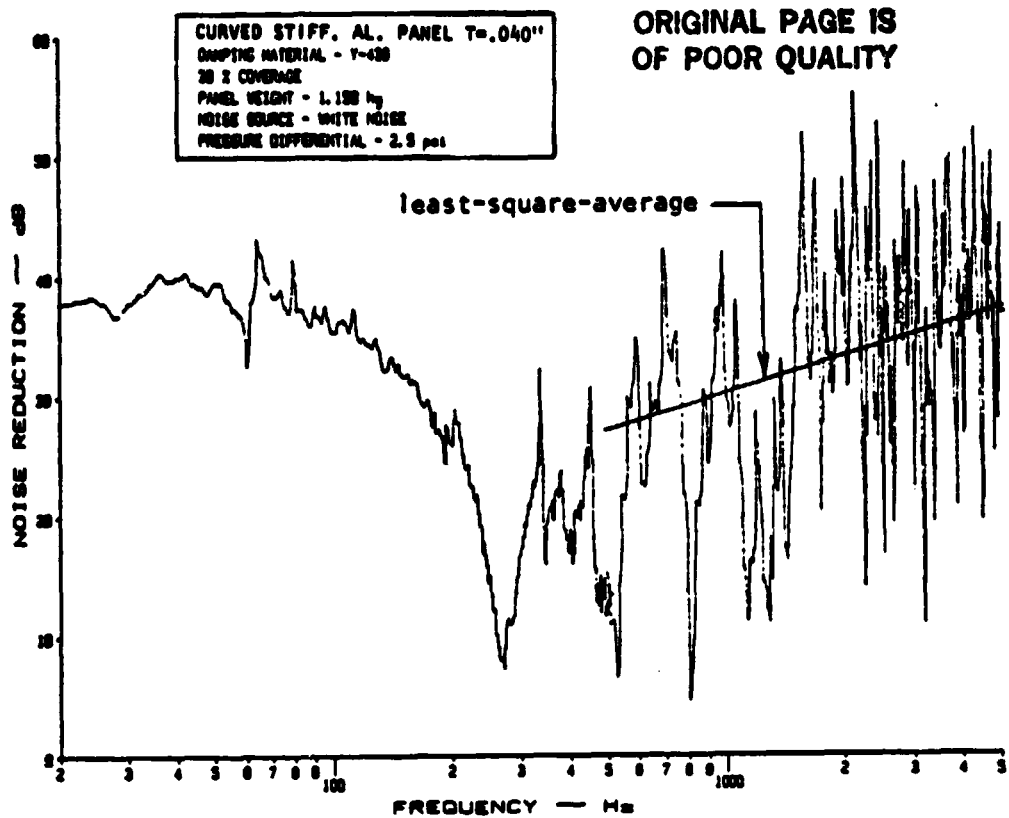

(a) Narrow Band Analysis

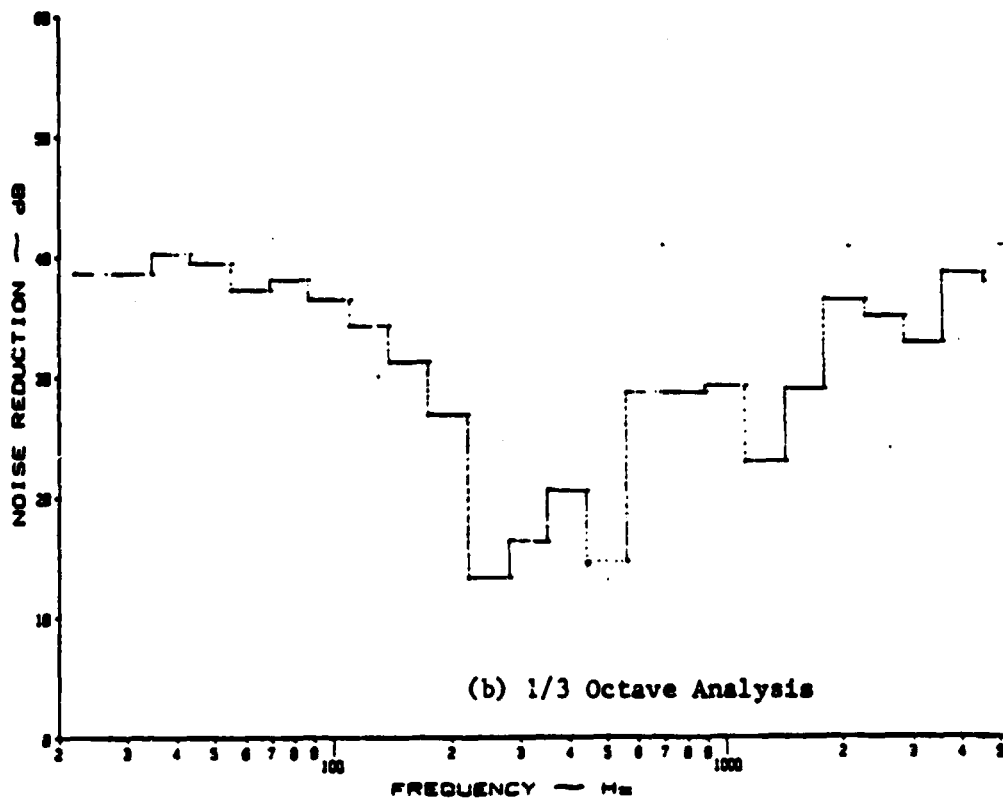

(b) 1/3 Octave Analysis

Figure B.64: Noise Reduction Characteristics of a Curved, Stiffened Panel at 2.5 psi Pressure Differential with Y-436 Damping Tape under White Noise

ORIGINAL PAGE IS
OF POOR QUALITY

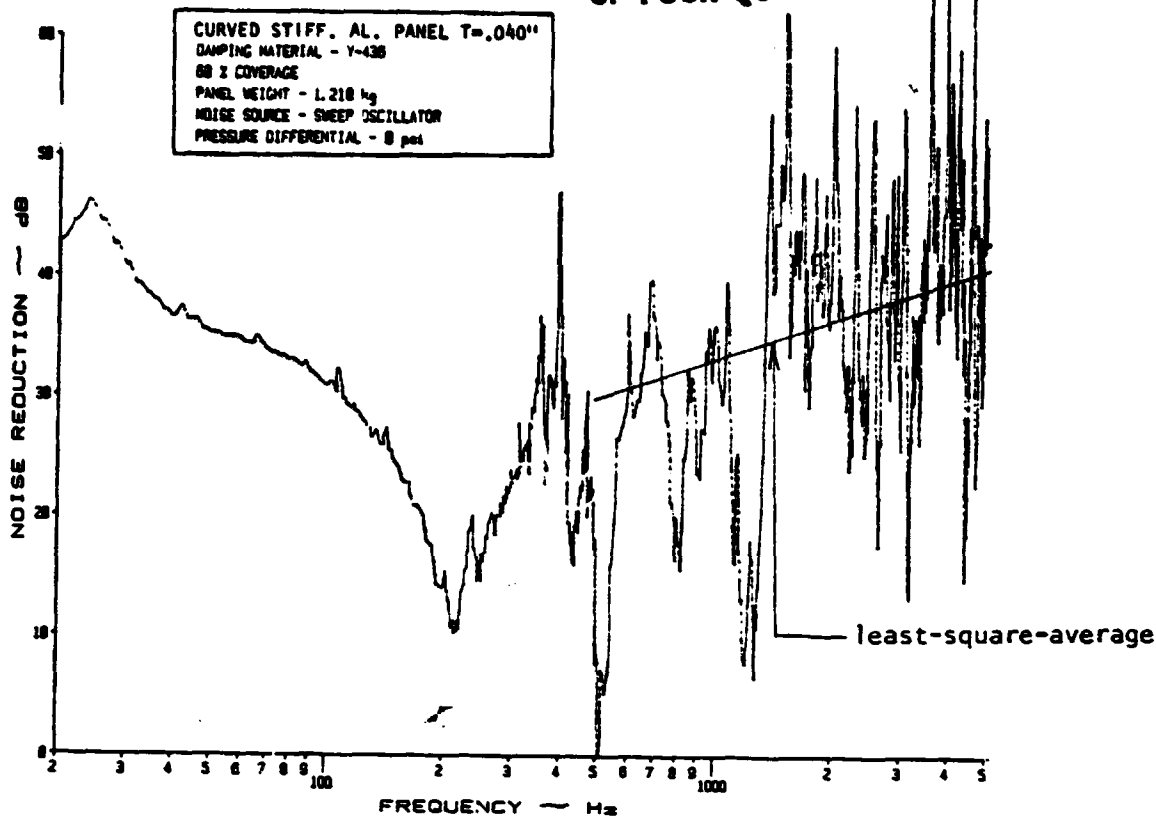

(a) Narrow Band Analysis

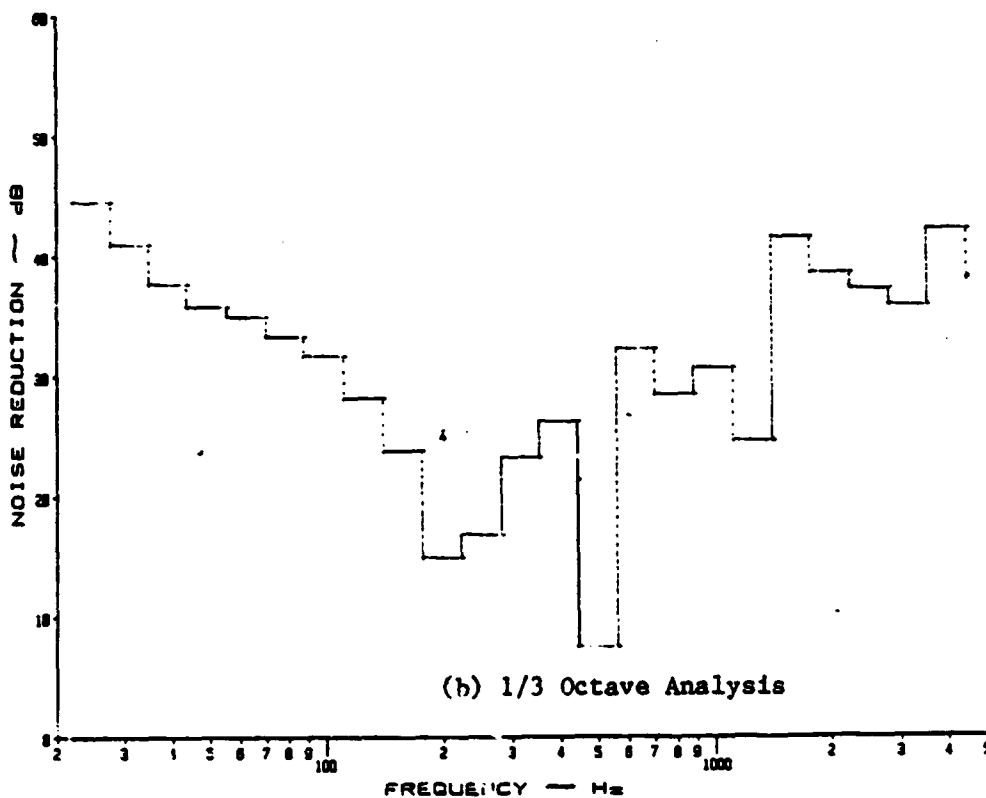

(b) 1/3 Octave Analysis

Figure B.65: Noise Reduction Characteristics of a Curved, Stiffened Panel at 0 psi Pressure Differential with Y-436 Damping Tape under a Discrete Noise Source

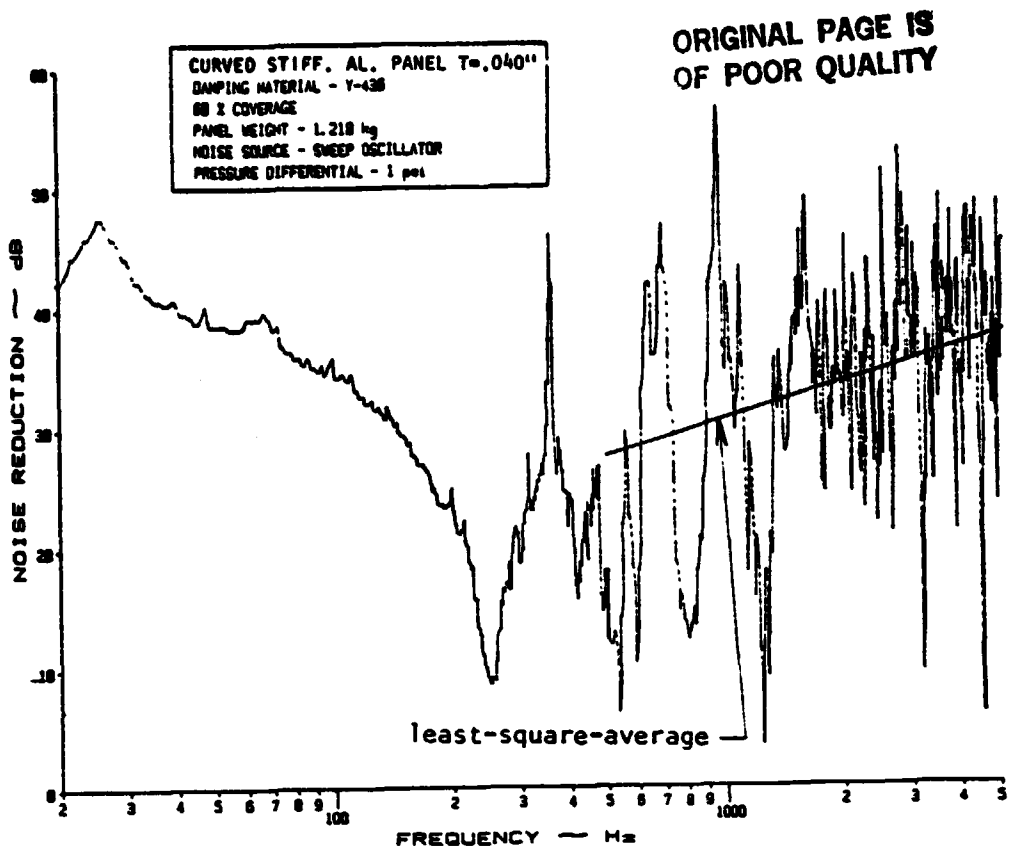

(a) Narrow Band Analysis

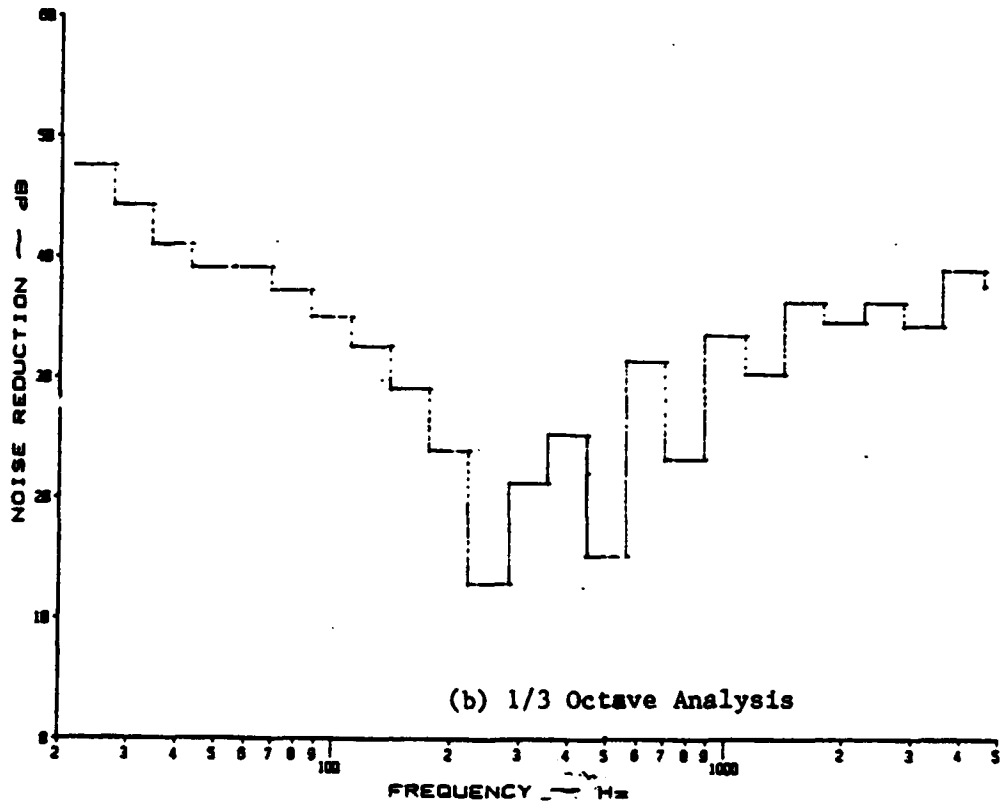

(b) 1/3 Octave Analysis

Figure B.66: Noise Reduction Characteristics of a Curved, Stiffened Panel at 1 psi Pressure Differential with Y-436 Damping Tape under a discrete noise source

ORIGINAL PAGE IS
OF POOR QUALITY

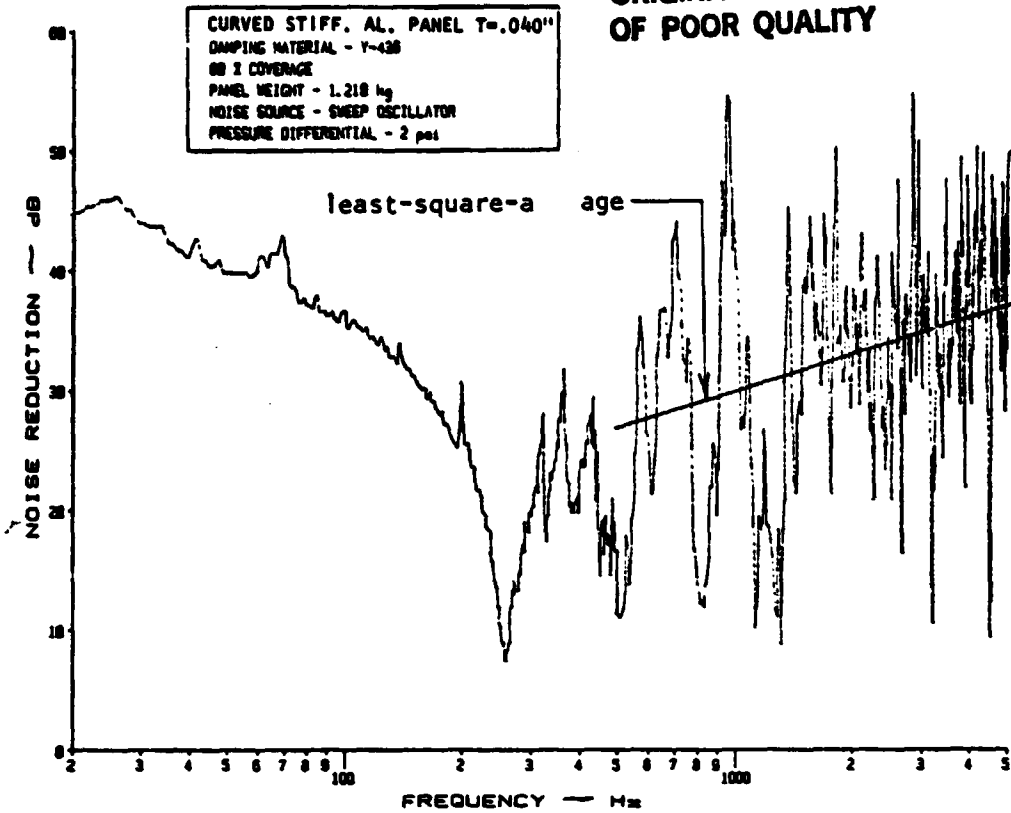

(a) Narrow Band Analysis

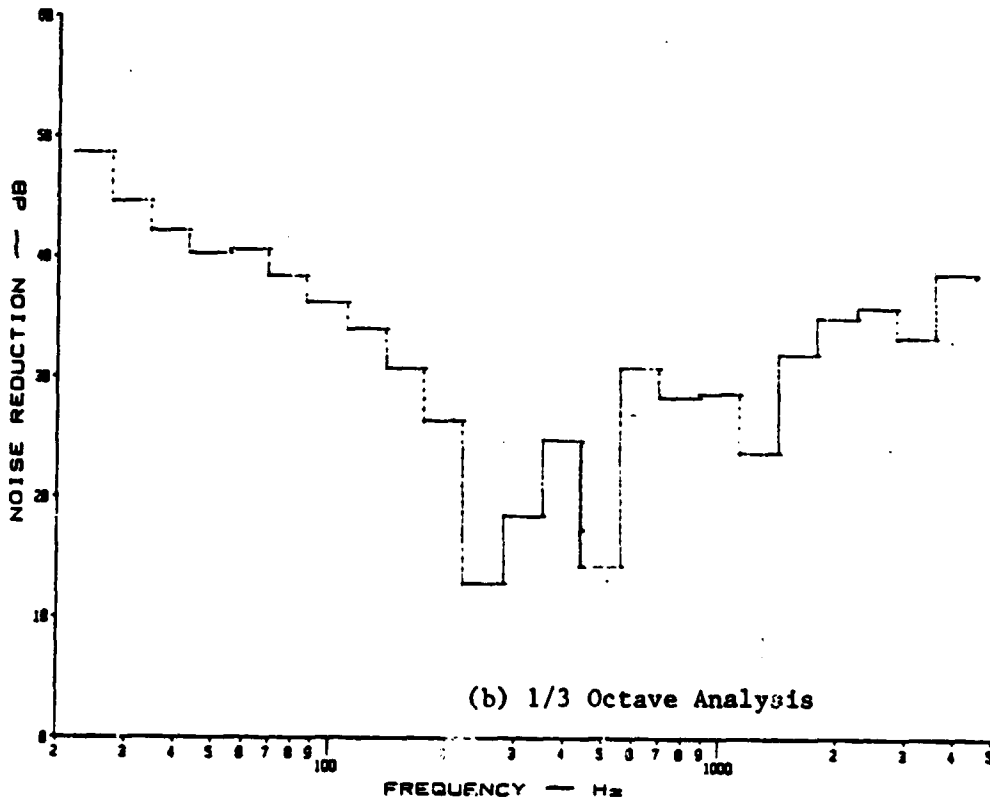

(b) 1/3 Octave Analysis

Figure B.67: Noise Reduction Characteristics of a Curved, Stiffened Panel
at 2 psi Pressure Differential with Y-436 Damping Tape under
a Discrete Noise Source

ORIGINAL PAGE IS
OF POOR QUALITY

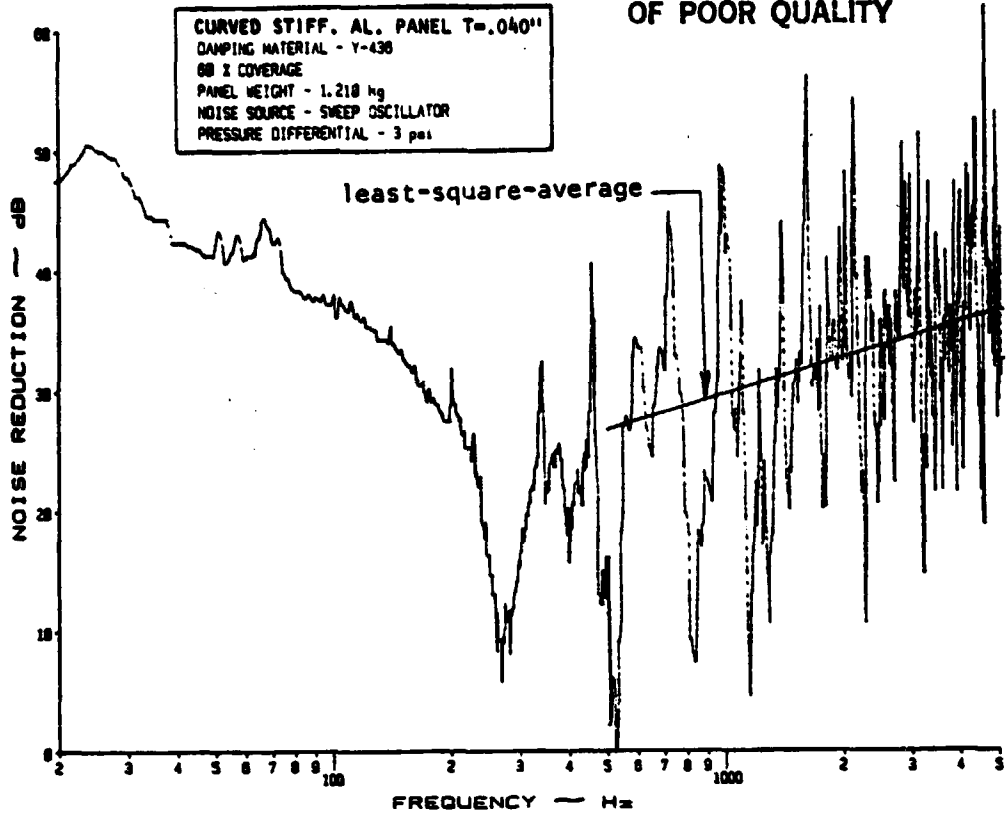

(a) Narrow Band Analysis

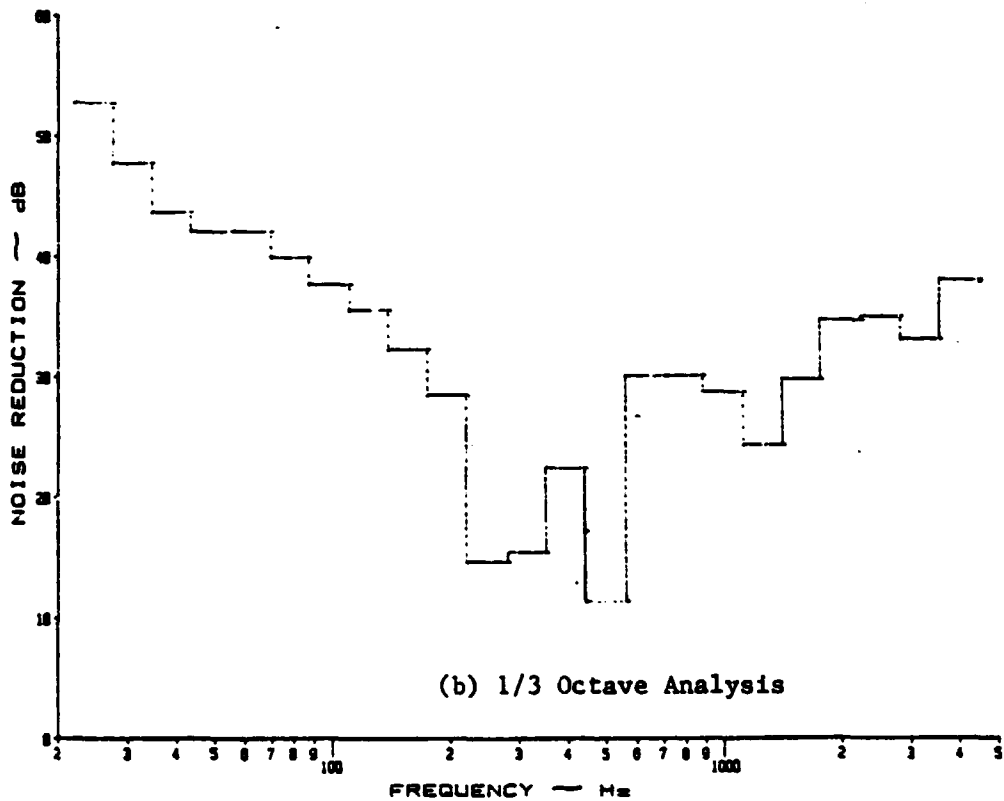

(b) 1/3 Octave Analysis

Figure B.68: Noise Reduction Characteristics of a Curved, Stiffened Panel at 3 psi Pressure Differential with Y-436 Damping Tape under a Discrete Noise Source

ORIGINAL PAGE IS
OF POOR QUALITY

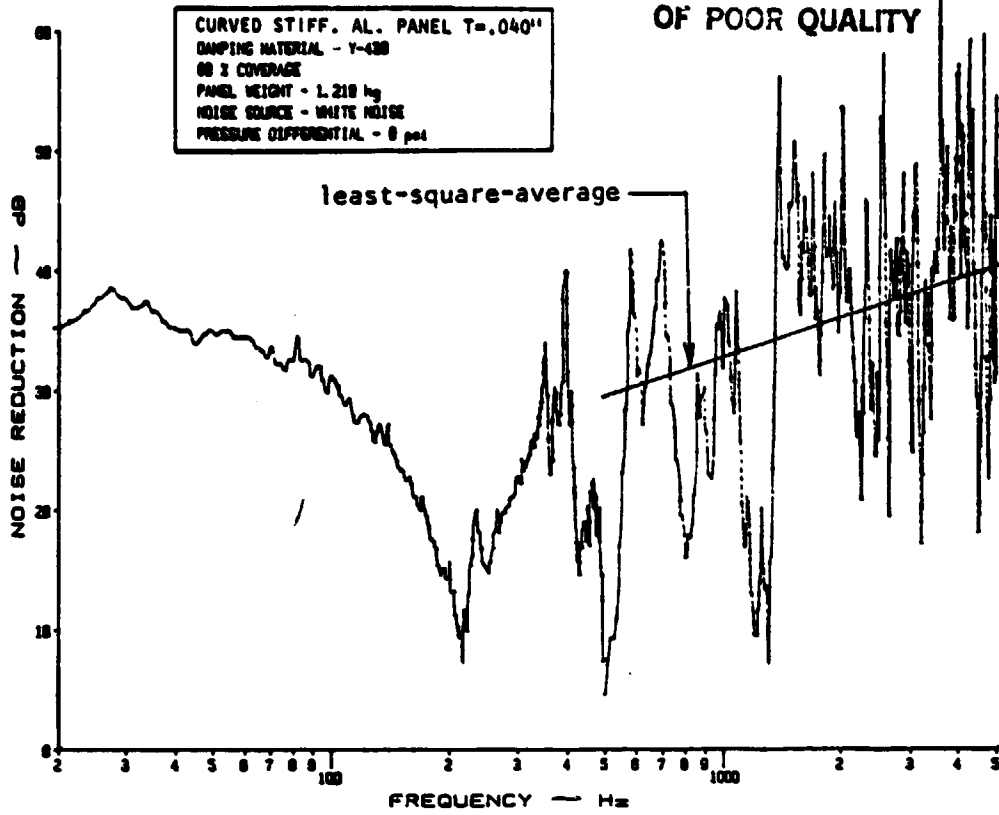

(a) Narrow Band Analysis

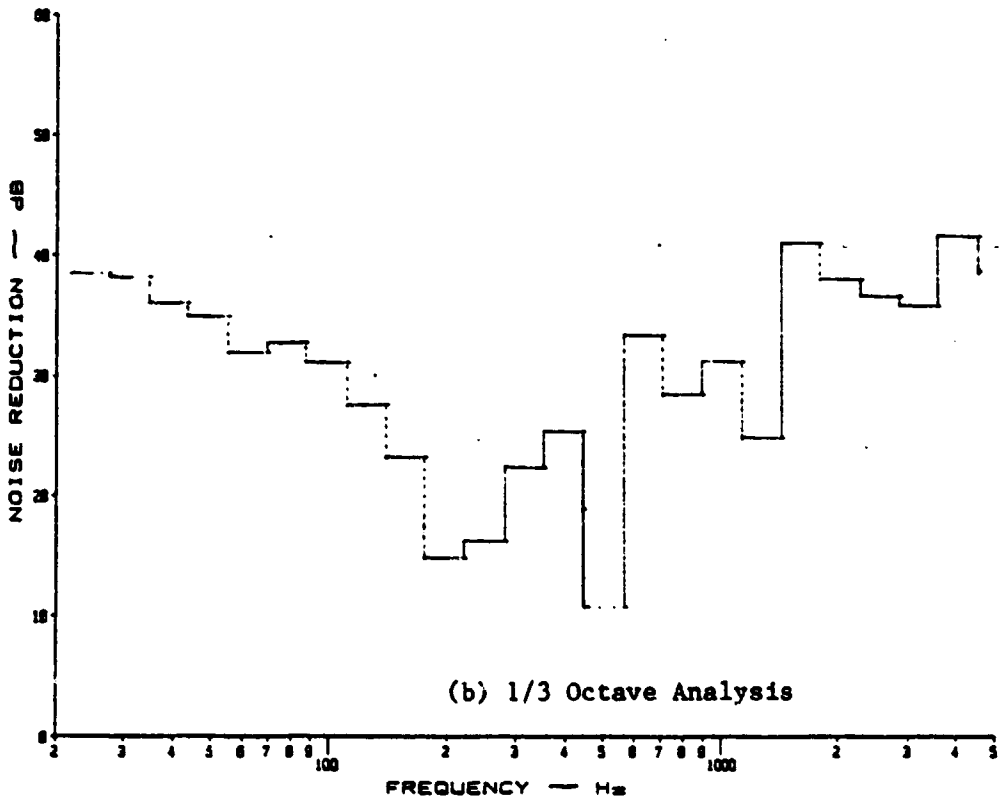

(b) 1/3 Octave Analysis

Figure B.69: Noise Reduction Characteristics of a Curved, Stiffened Panel at 0 psi Pressure Differential with Y-436 Damping Tape under White Noise

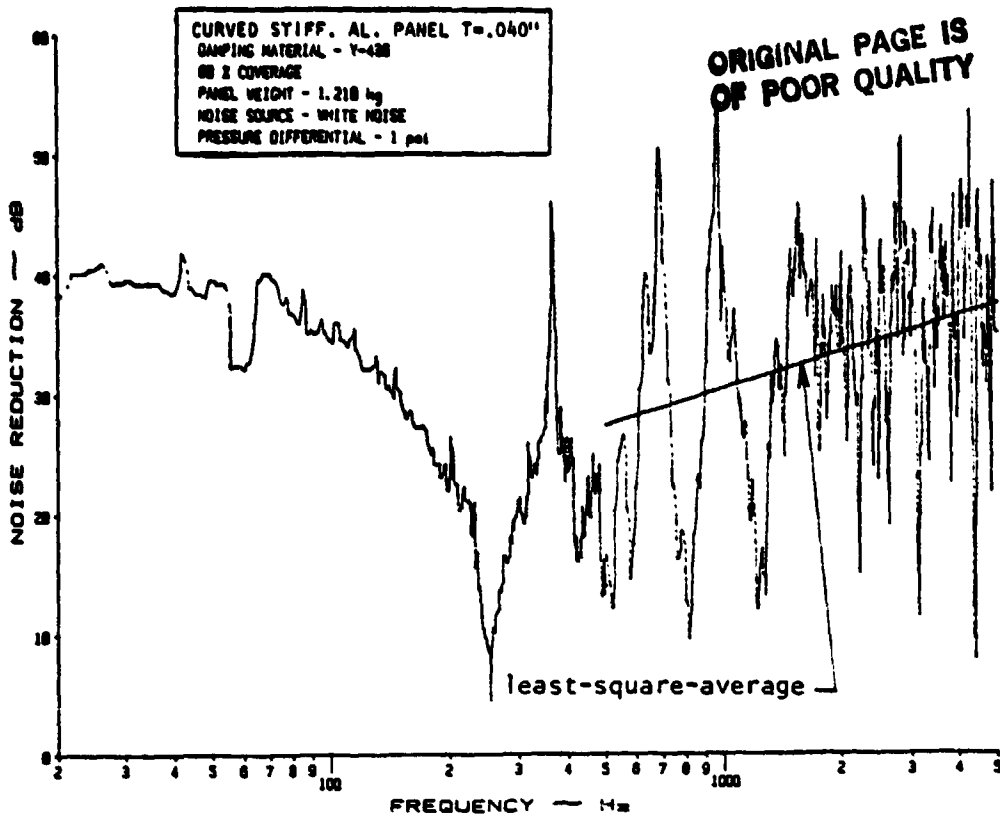

(a) Narrow Band Analysis

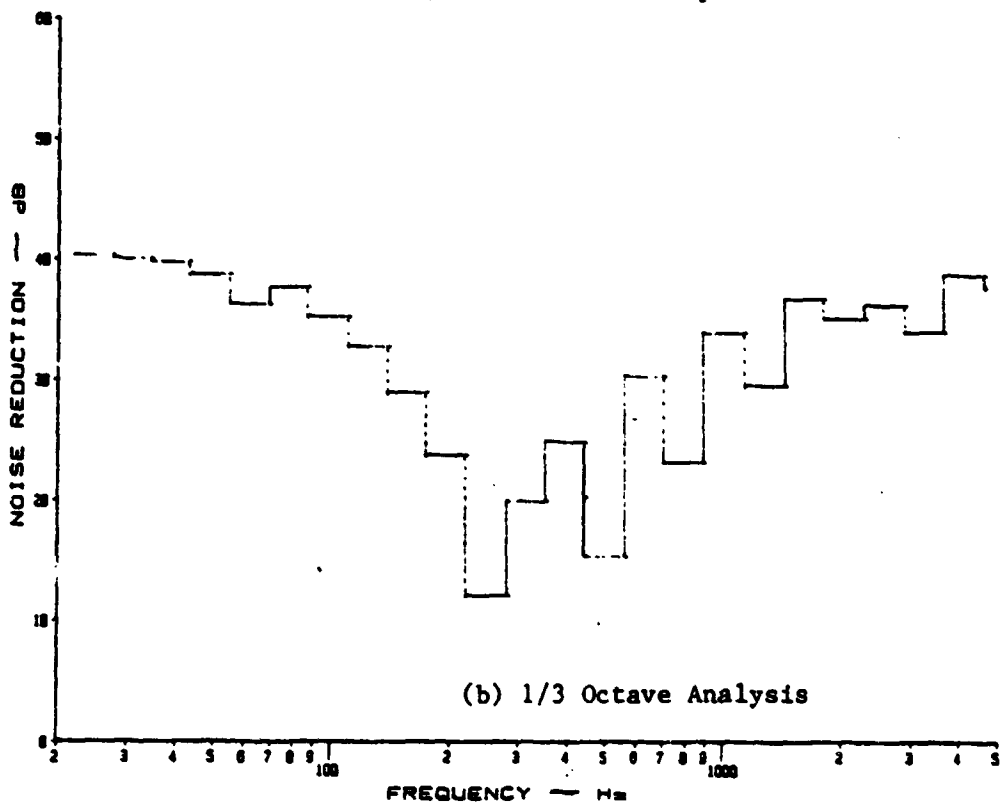

(b) 1/3 Octave Analysis

Figure B.70: Noise Reduction Characteristics of a Curved, Stiffened Panel at 1 psi Pressure Differential with Y-436 Damping Tape under White Noise

ORIGINAL PAGE IS
OF POOR QUALITY

CURVED STIFF. AL. PANEL $T=0.040''$
DAMPING MATERIAL - Y-436
88 % COVERAGE
PANEL WEIGHT - 1.218 kg
NOISE SOURCE - WHITE NOISE
PRESSURE DIFFERENTIAL - 2 psi

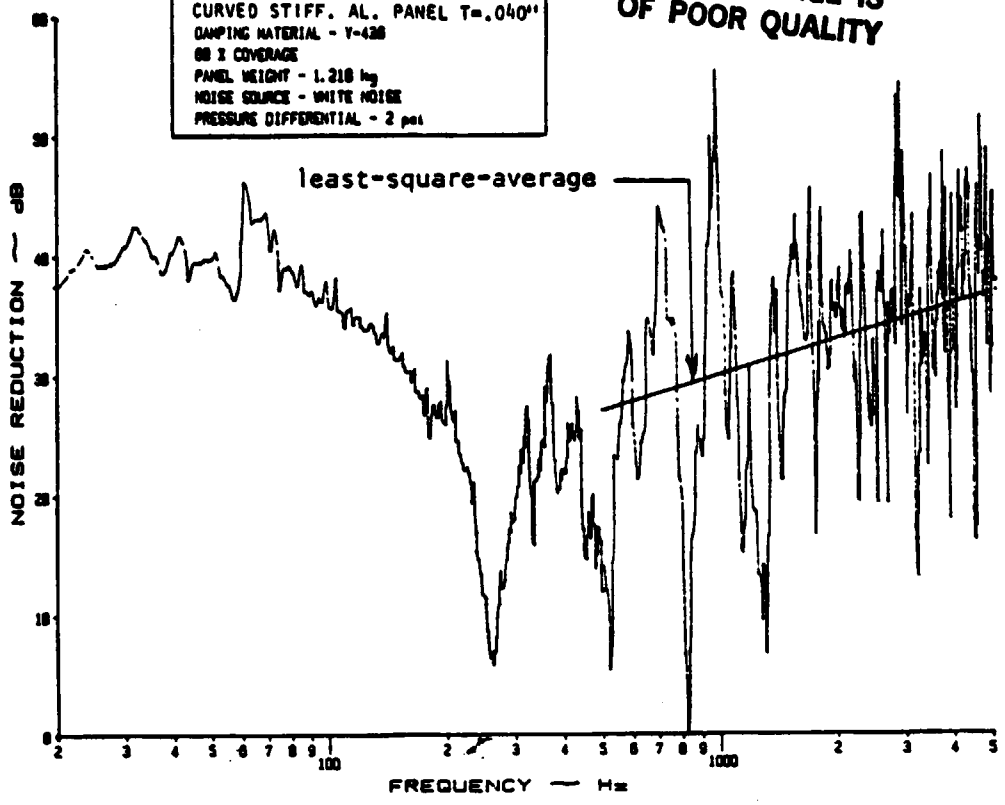

(a) Narrow Band Analysis

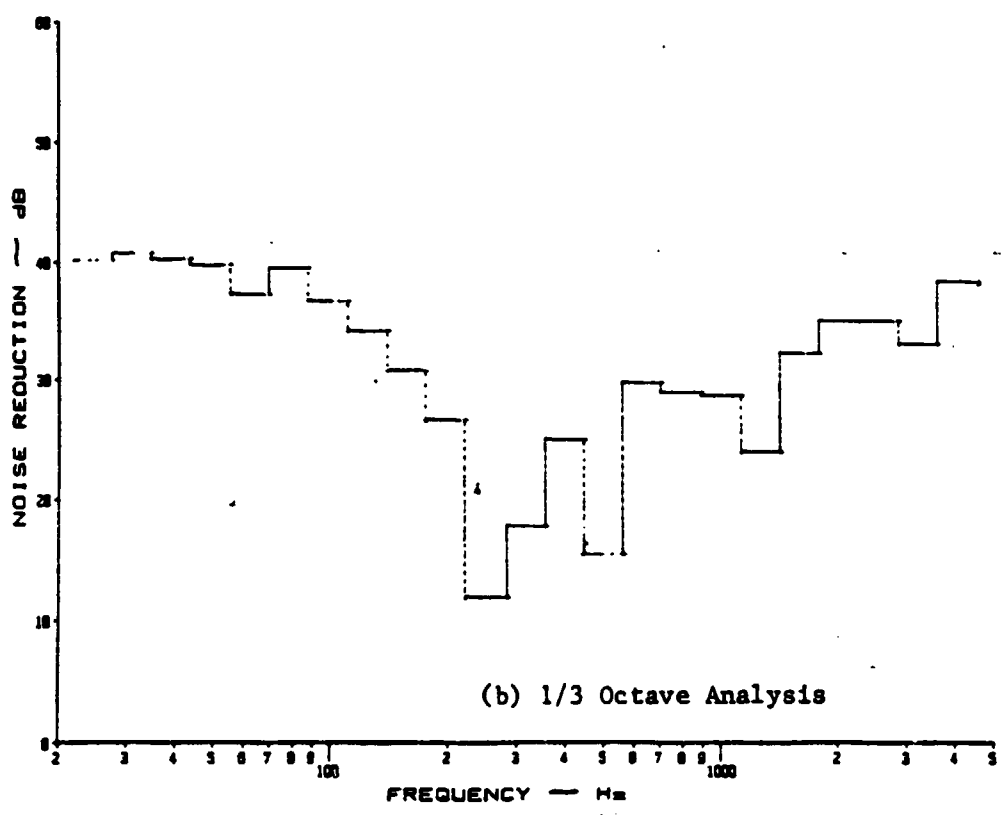

(b) 1/3 Octave Analysis

Figure B.71: Noise Reduction Characteristics of a Curved, Stiffened Panel at 2 psi Pressure Differential with Y-436 Damping Tape under White Noise

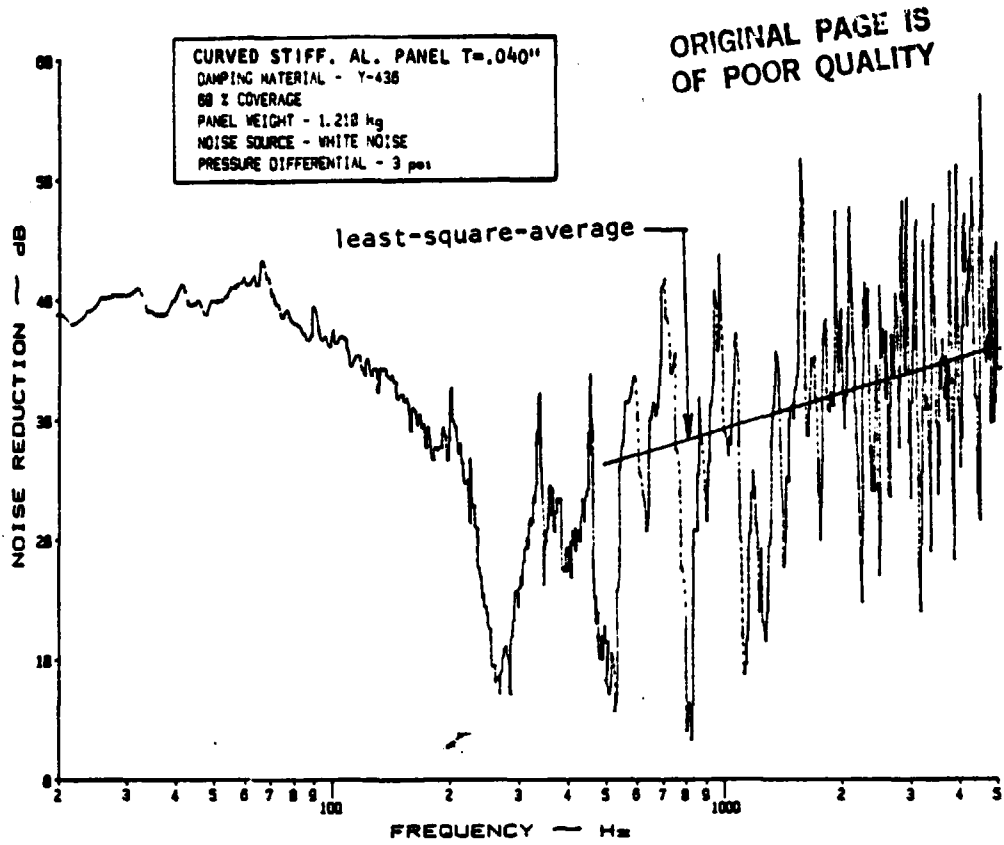

(a) Narrow Band Analysis

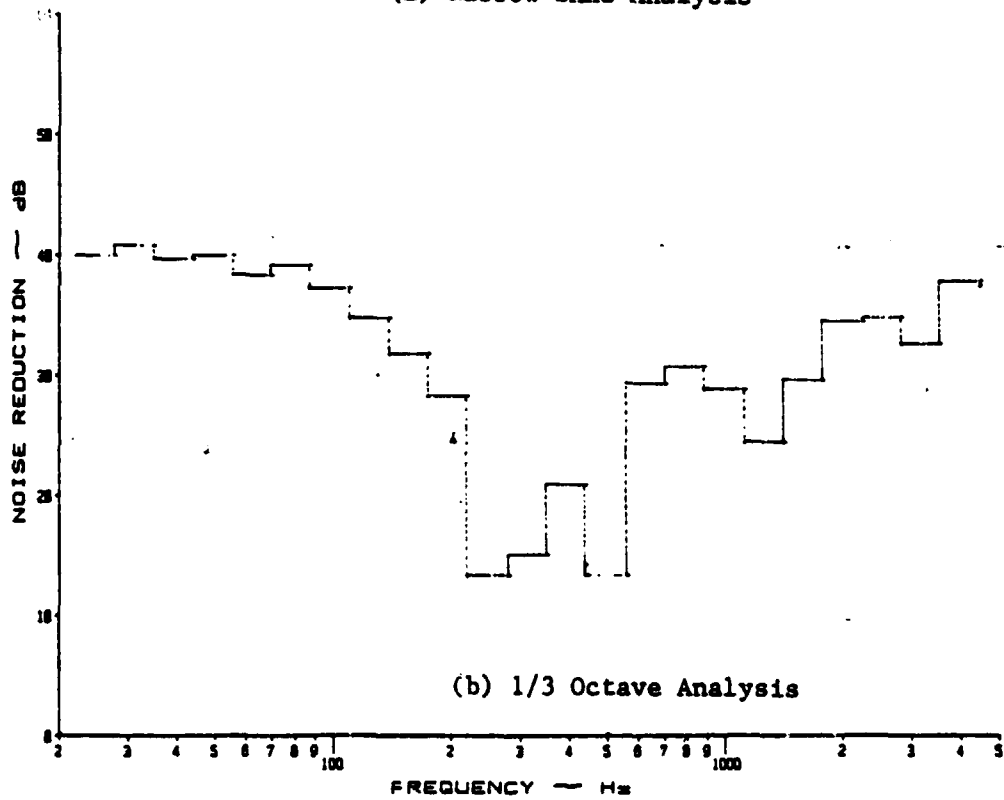

(b) 1/3 Octave Analysis

Figure B.72: Noise Reduction Characteristics of a Curved, Stiffened Panel at 3 psi Pressure Differential with Y-436 Damping Tape under White Noise

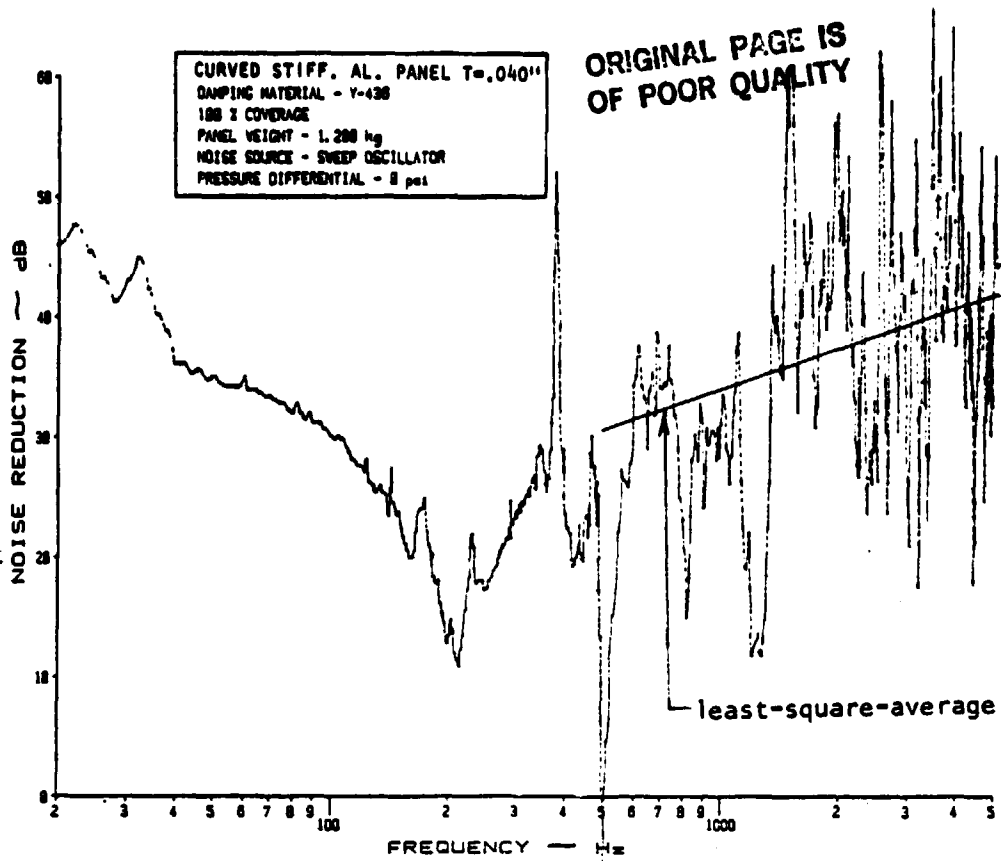

(a) Narrow Band Analysis

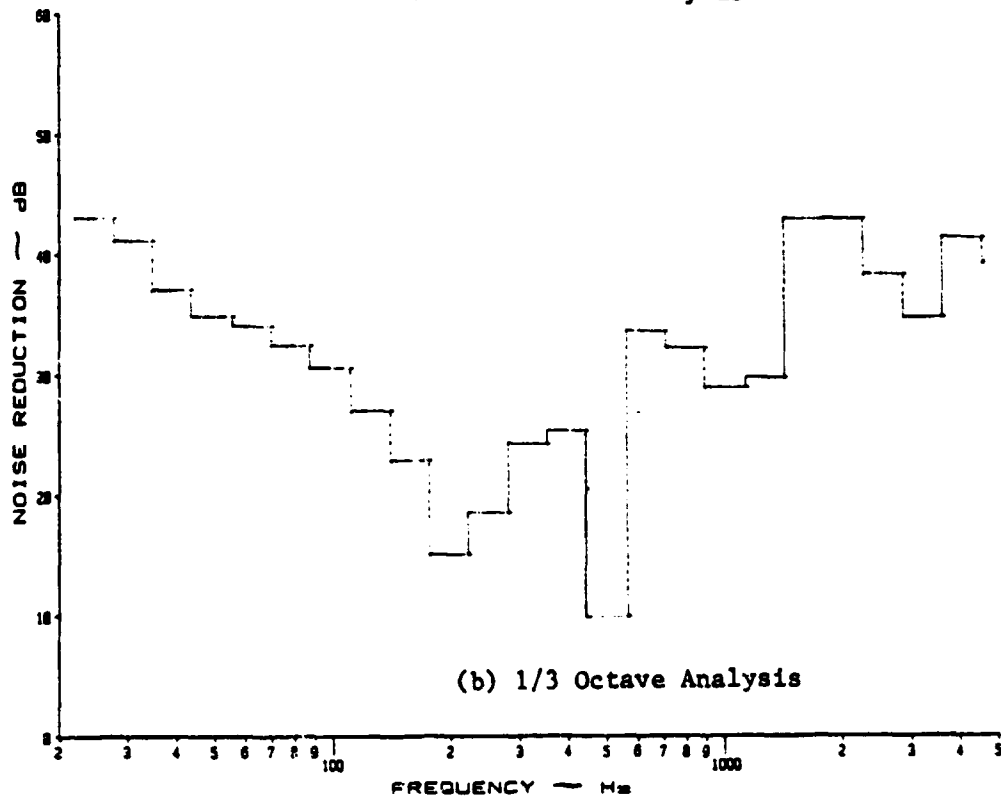

(b) 1/3 Octave Analysis

Figure B.73: Noise Reduction Characteristics of a Curved, Stiffened Panel at 0 psi Pressure Differential with Y-436 Damping Tape under a Discrete Noise Source

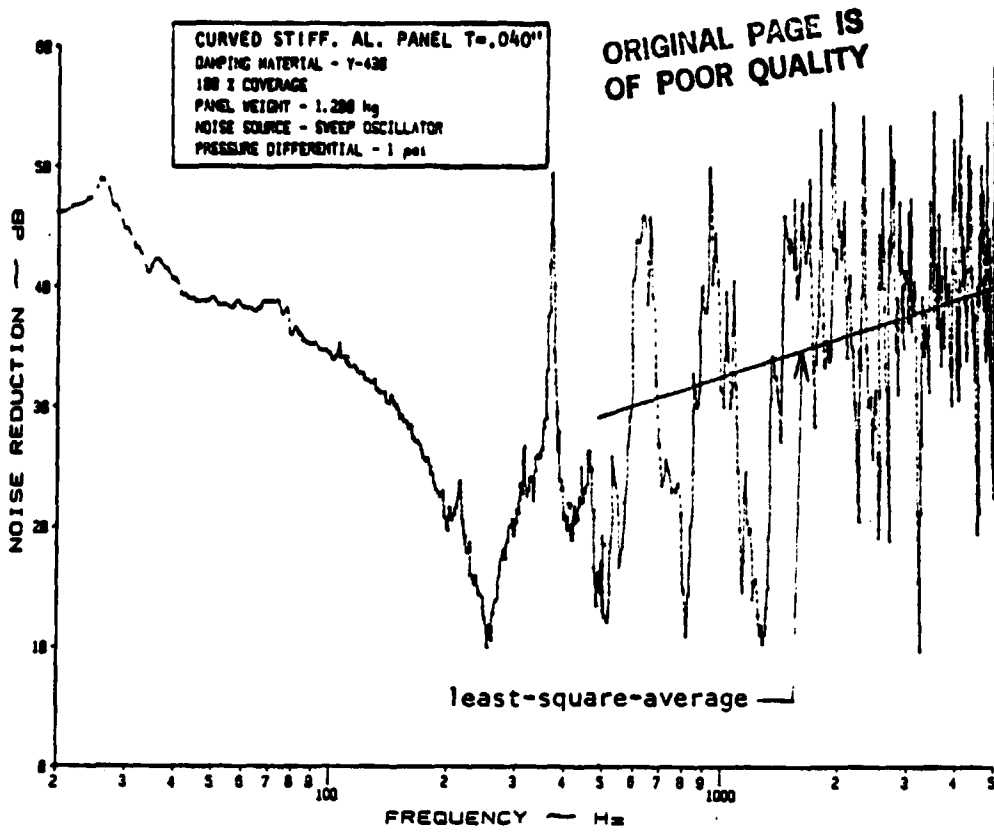

(a) Narrow Band Analysis

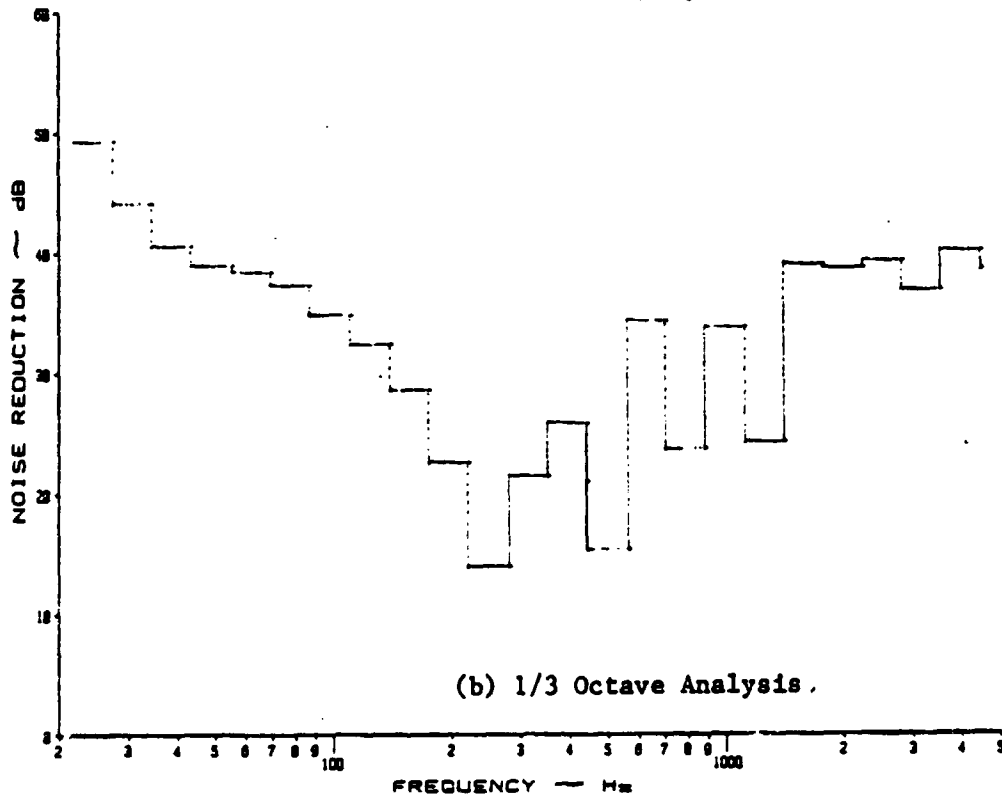

(b) 1/3 Octave Analysis.

Figure B.74: Noise Reduction Characteristics of a Curved, Stiffened Panel at 1 psi Pressure Differential with Y-436 Damping Tape under a Discrete Noise Source

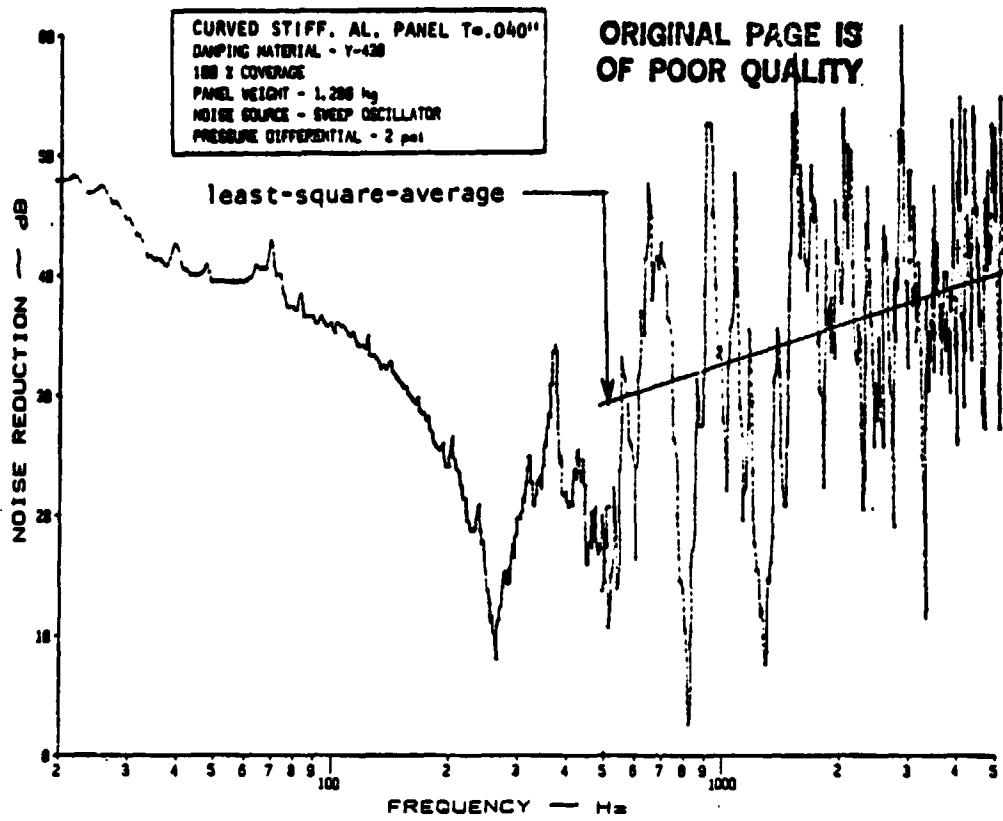

(a) Narrow Band Analysis

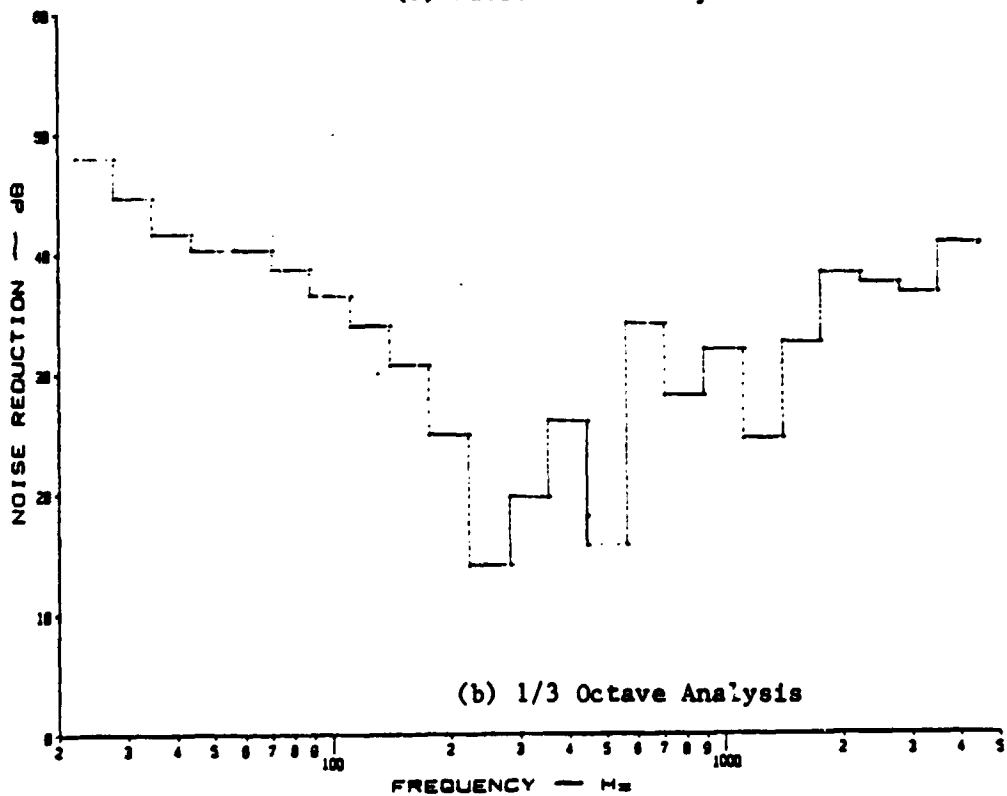

(b) 1/3 Octave Analysis

Figure B.75: Noise Reduction Characteristics of a Curved, Stiffened Panel at 2 psi Pressure Differential with Y-436 Damping Tape under a Discrete Noise Source

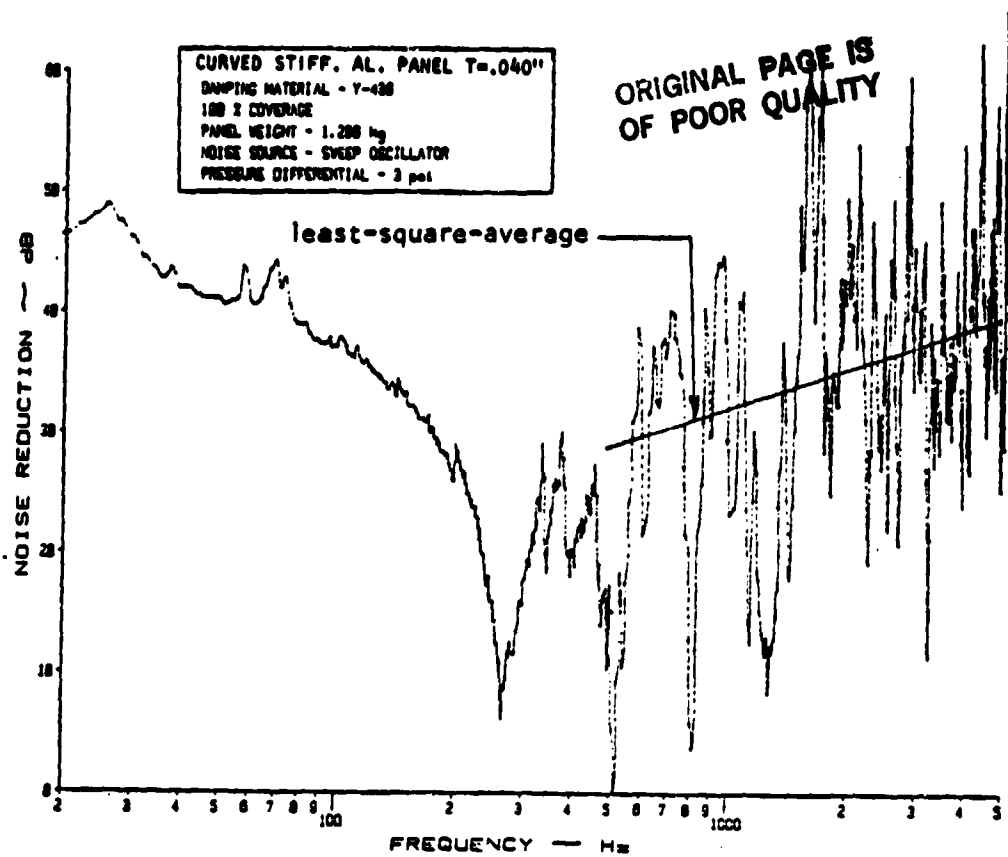

(a) Narrow Band Analysis

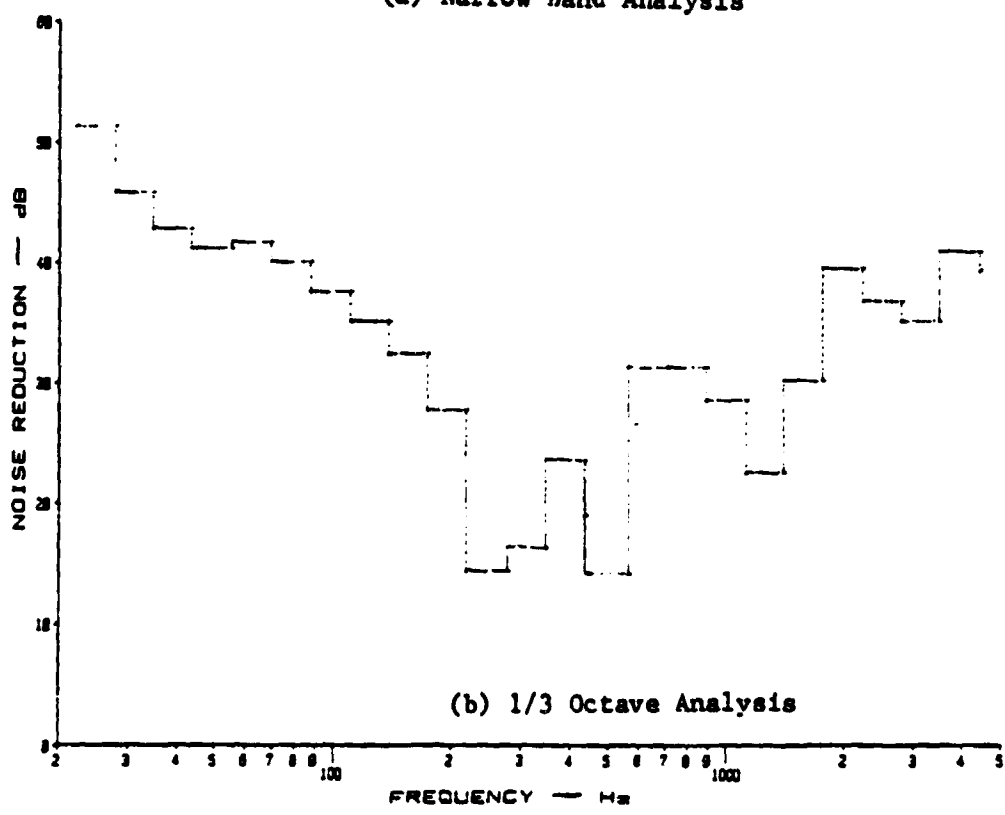

(b) 1/3 Octave Analysis

Figure B.76: Noise Reduction Characteristics of a Curved, Stiffened Panel at 3 psi Pressure Differential with Y-436 Damping Tape under a Discrete Noise Source

ORIGINAL PAGE IS
OF POOR QUALITY

CURVED STIFF. AL. PANEL T=.040"
DAMPING MATERIAL - Y-436
100 % COVERAGE
PANEL WEIGHT - 1.200 kg
NOISE SOURCE - WHITE NOISE
PRESSURE DIFFERENTIAL - 0 psi

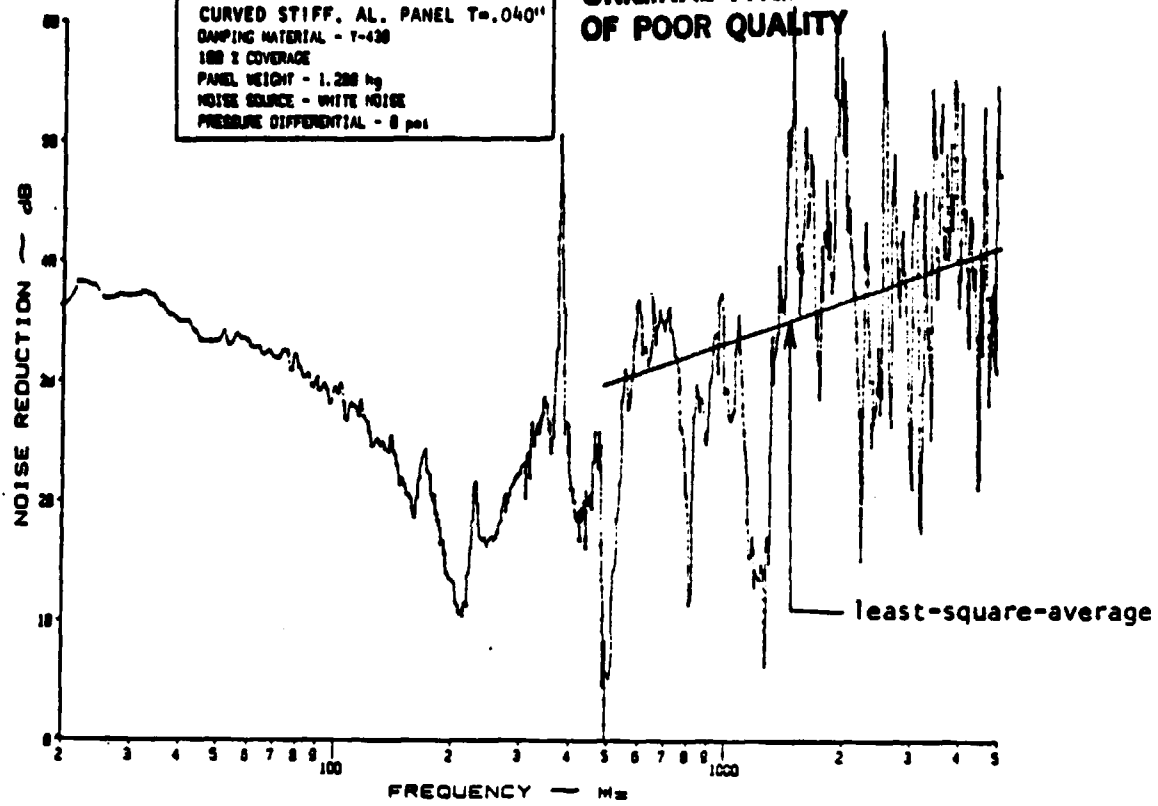

(a) Narrow Band Analysis

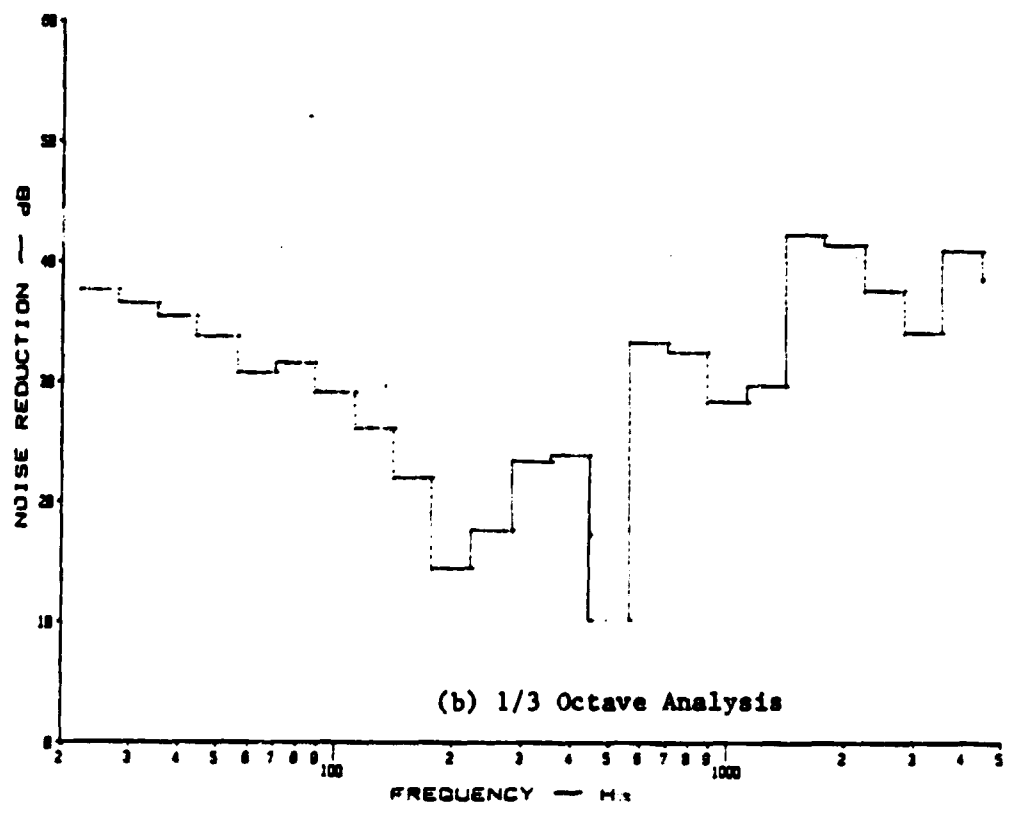

(b) 1/3 Octave Analysis

Figure B.77: Noise Reduction Characteristics of a Curved, Stiffened Panel at 0 psi Pressure Differential with Y-436 Damping Tape under White Noise

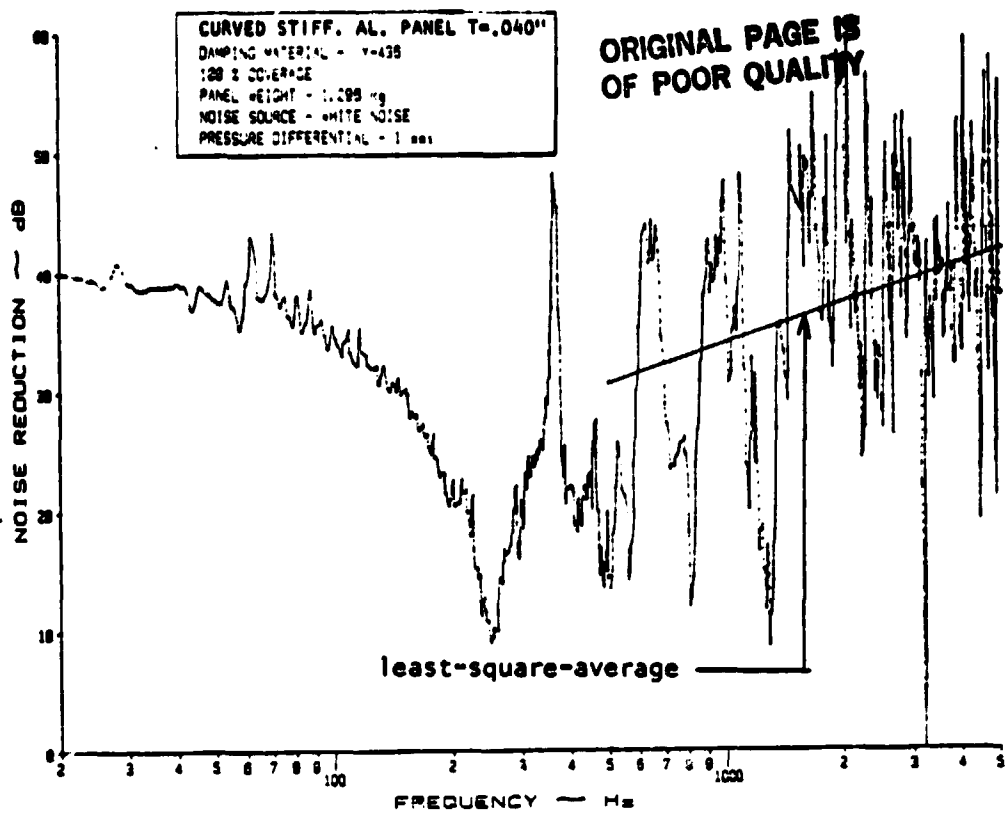

(a) Narrow Band Analysis

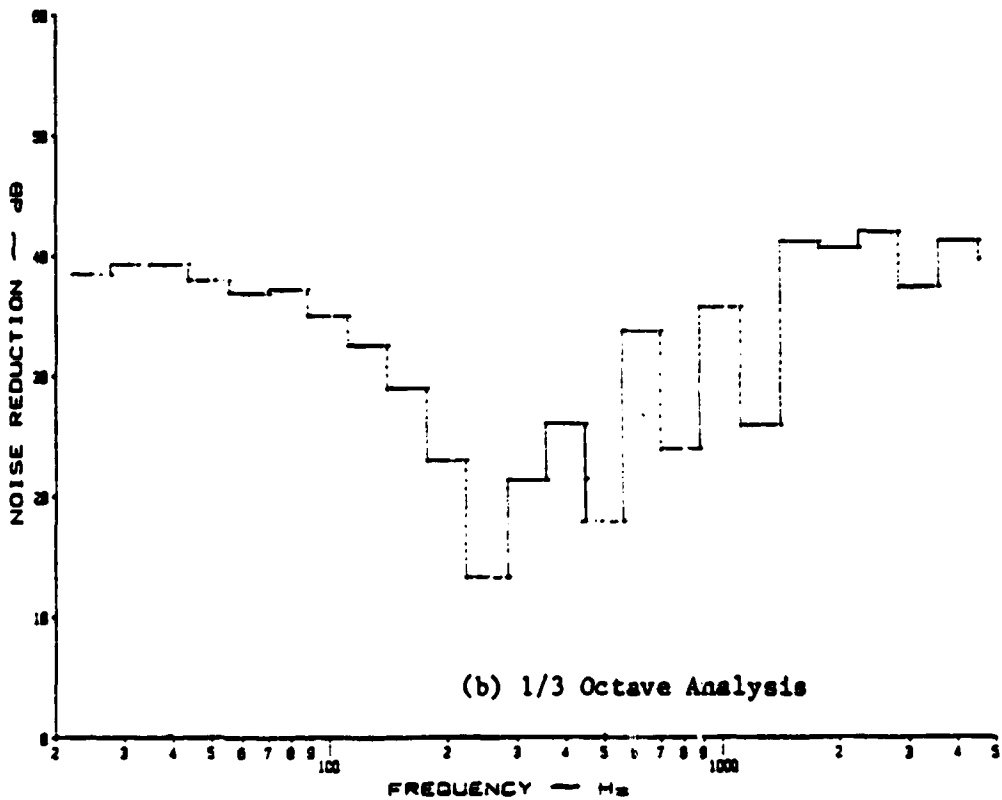

Figure B.78: Noise Reduction Characteristics of a Curved, Stiffened Panel at 1 psi Pressure Differential with Y-436 Damping Tape under White Noise

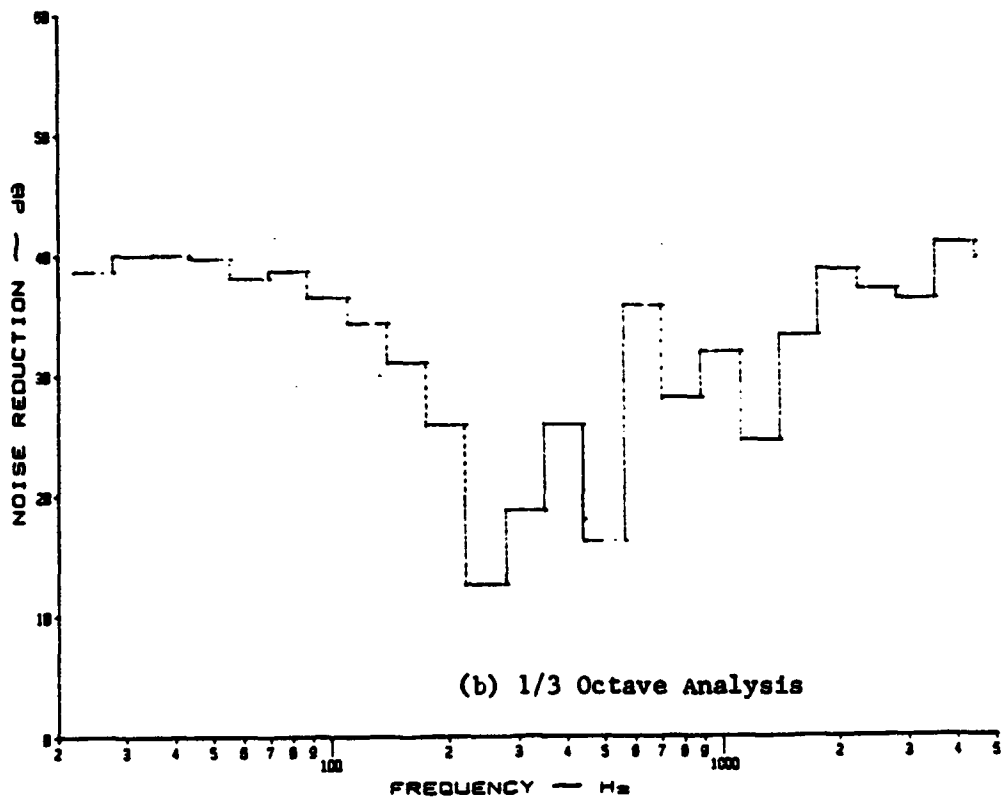
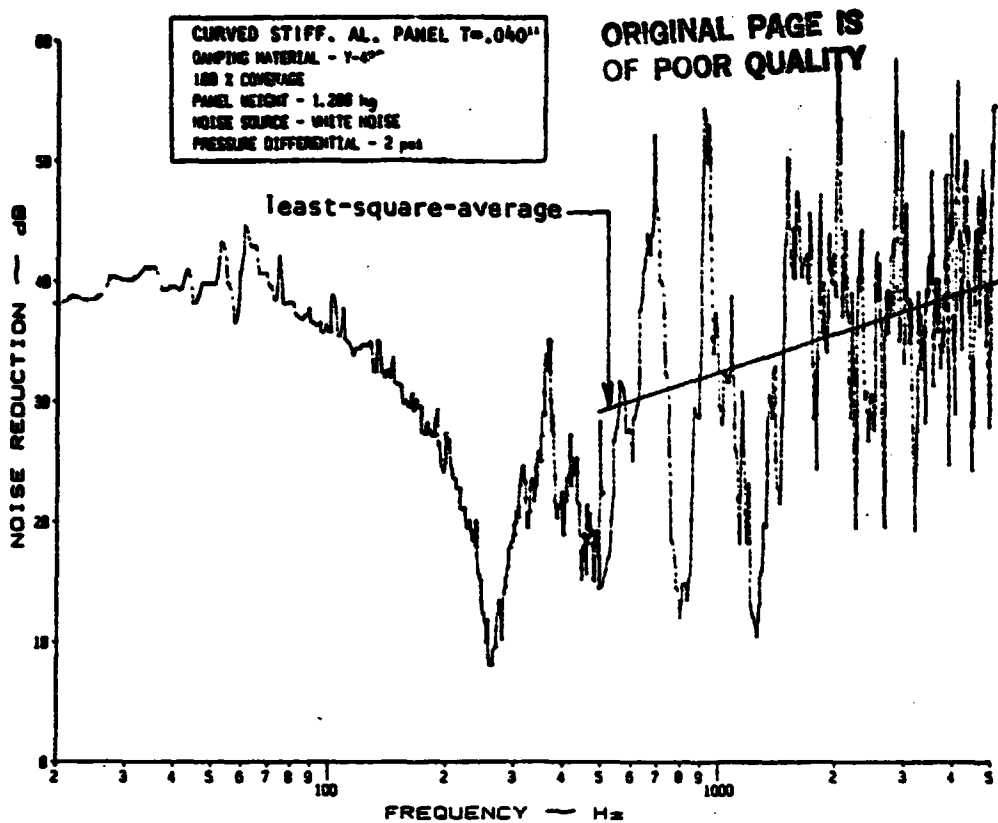
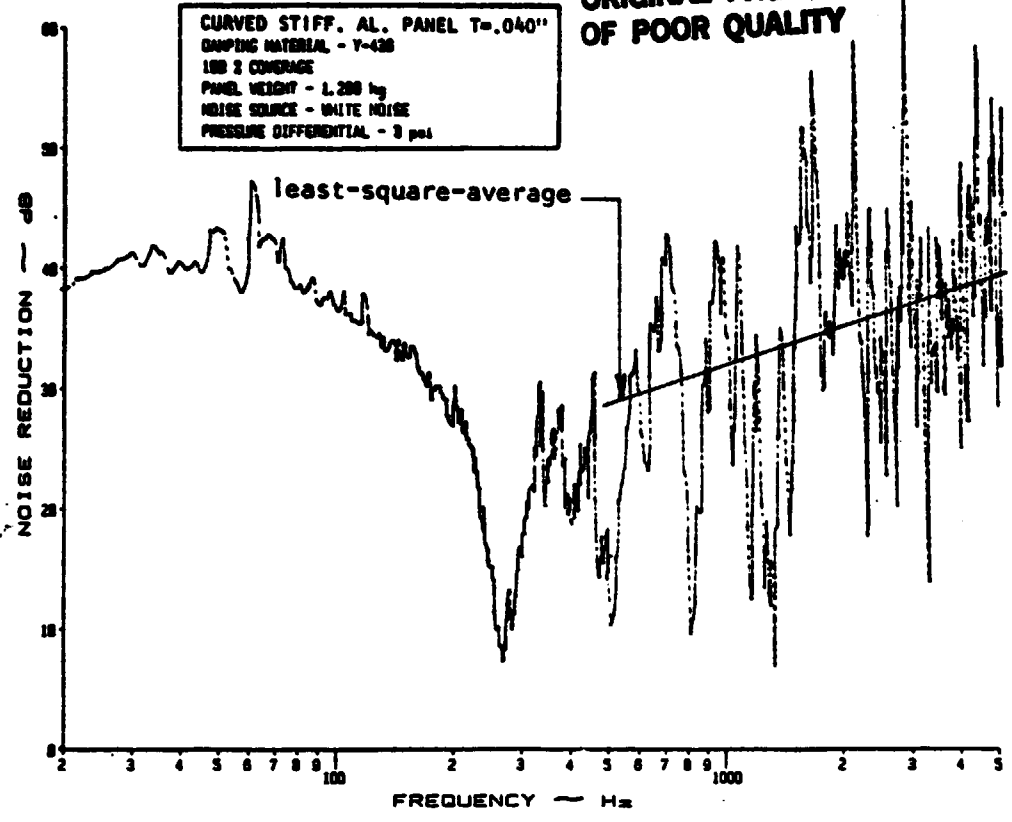

Figure B.79: Noise Reduction Characteristics of a Curved, Stiffened Panel at 2 psi Pressure Differential with Y-436 Damping Tape under White Noise

C-4

ORIGINAL PAGE IS
OF POOR QUALITY



(a) Narrow Band Analysis

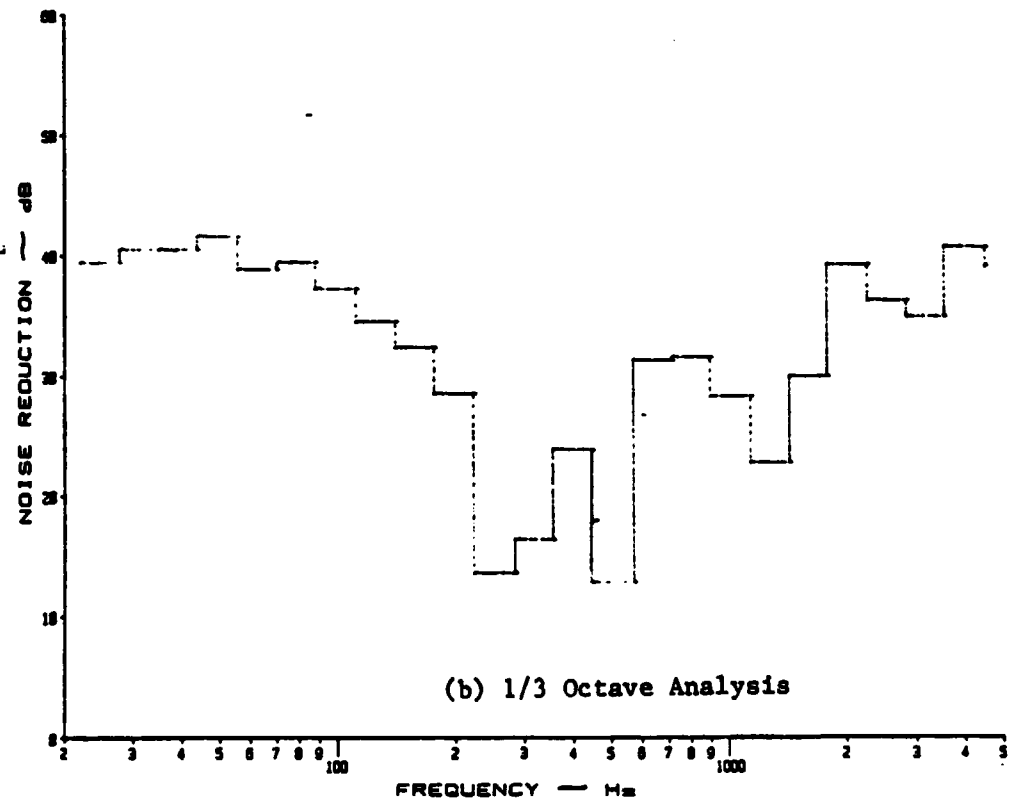

(b) 1/3 Octave Analysis

Figure B.80: Noise Reduction Characteristics of a Curved, Stiffened Panel at 3 psi Pressure Differential with Y-436 Damping Tape under White Noise

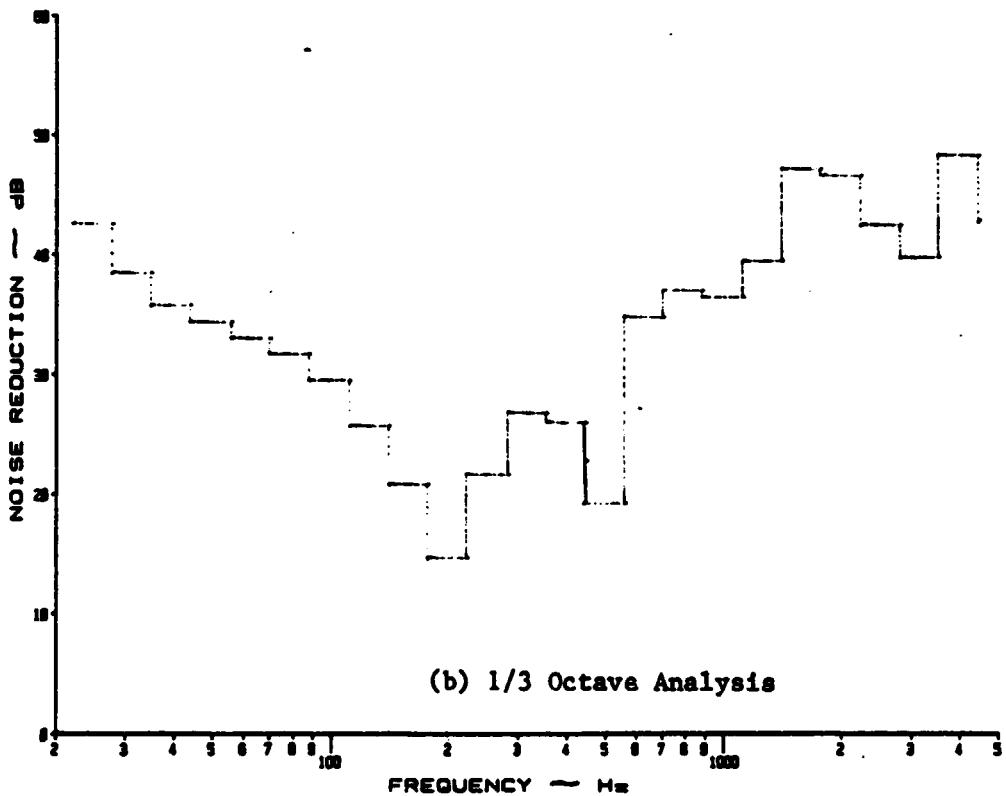
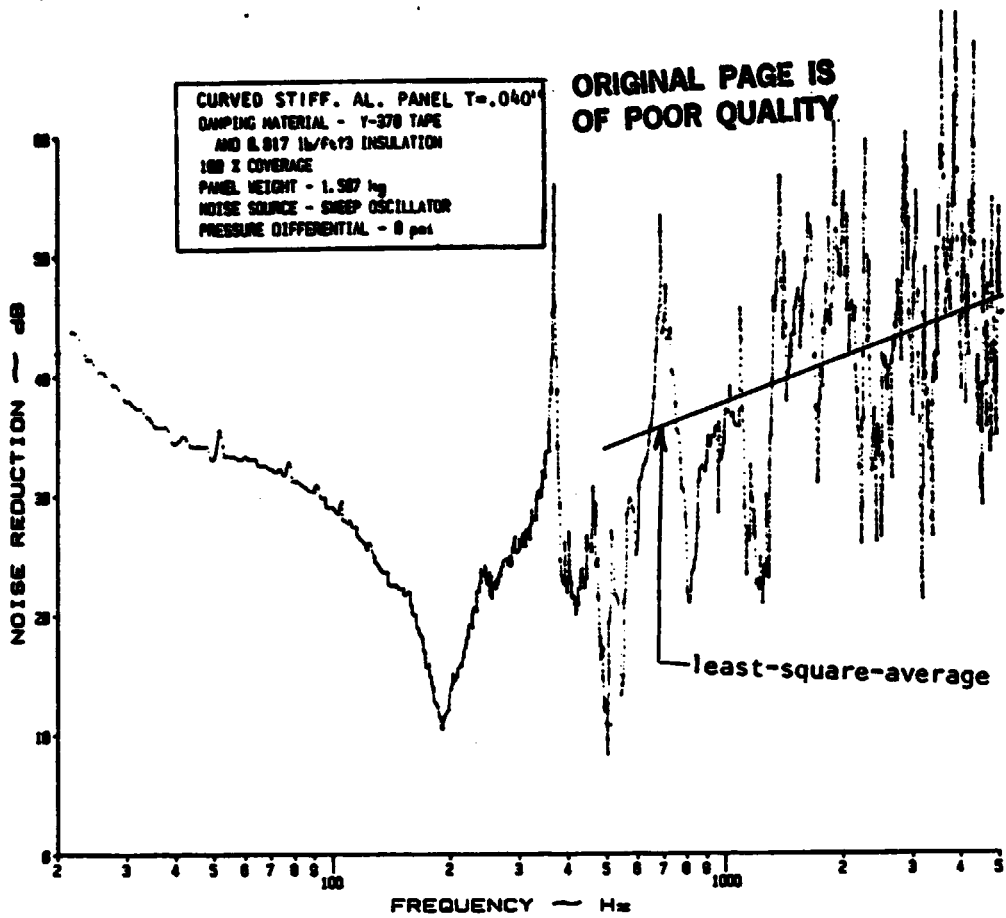

Figure B.81: Noise Reduction Characteristics of a Curved, Stiffened Panel at 0 psi Pressure Differential with Y-370 Damping Tape and 0.817 lb/ft³ Insulation under a Discrete Noise Source

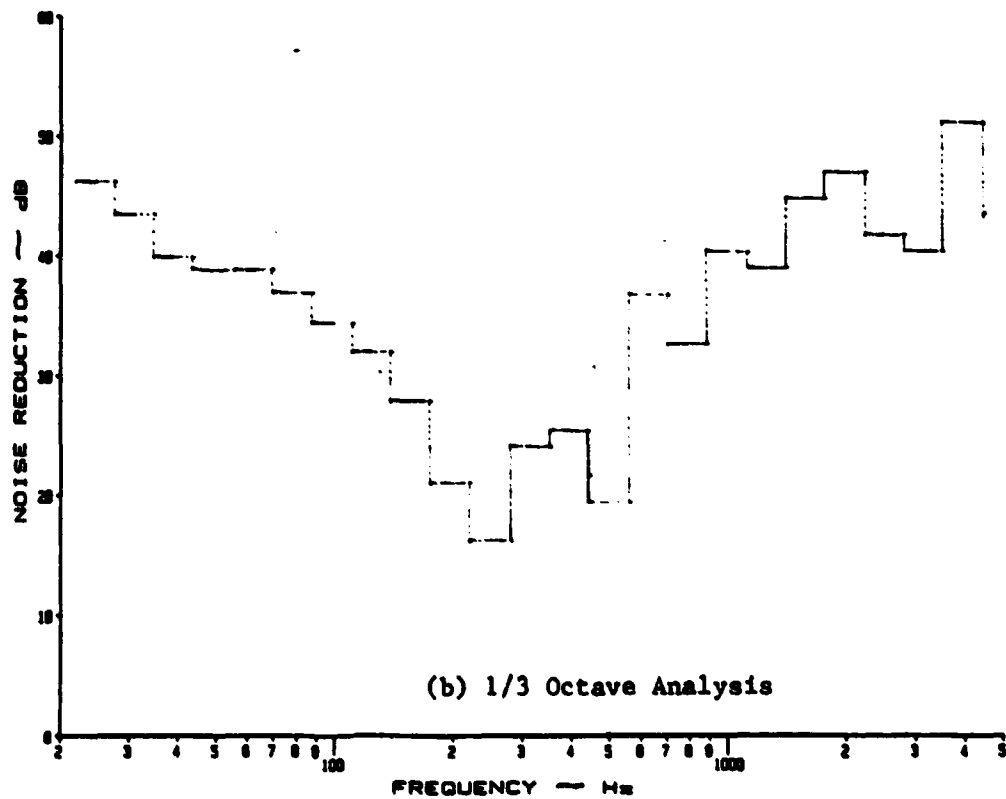
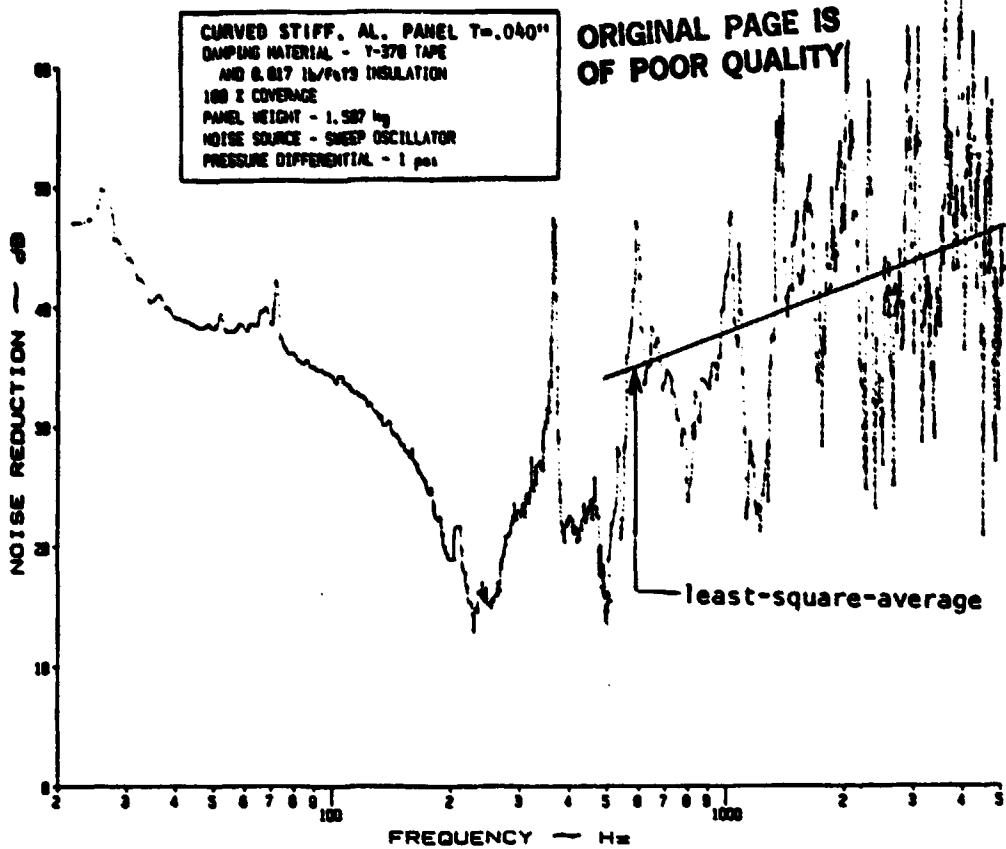
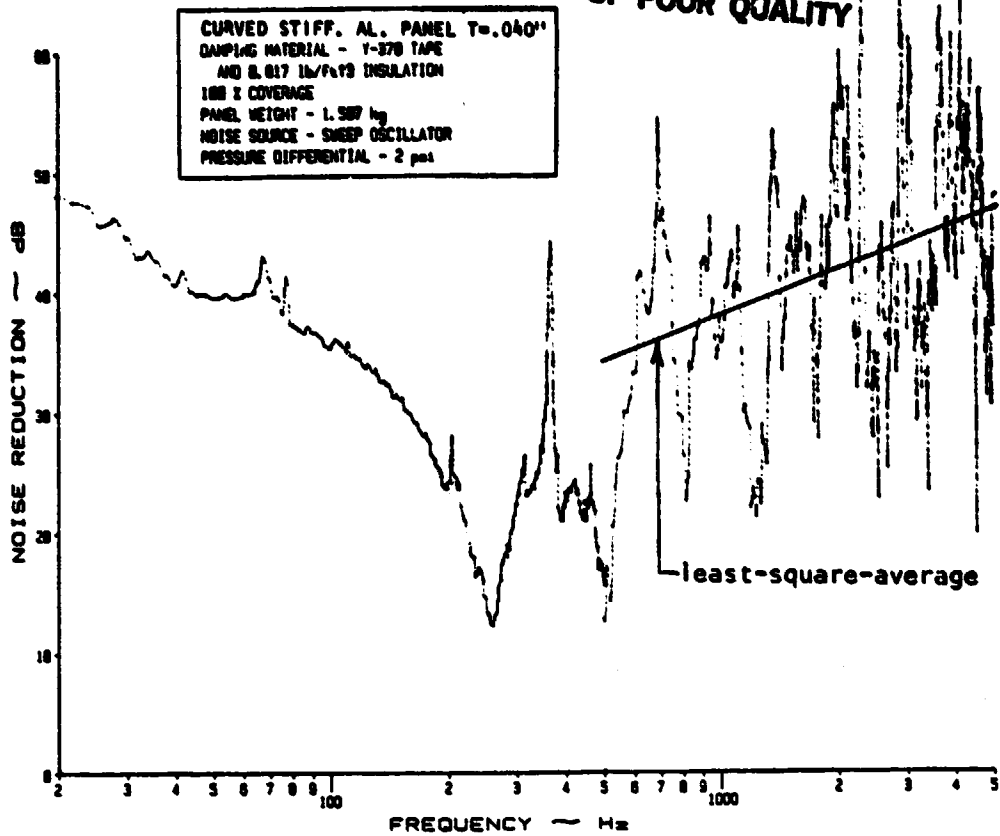
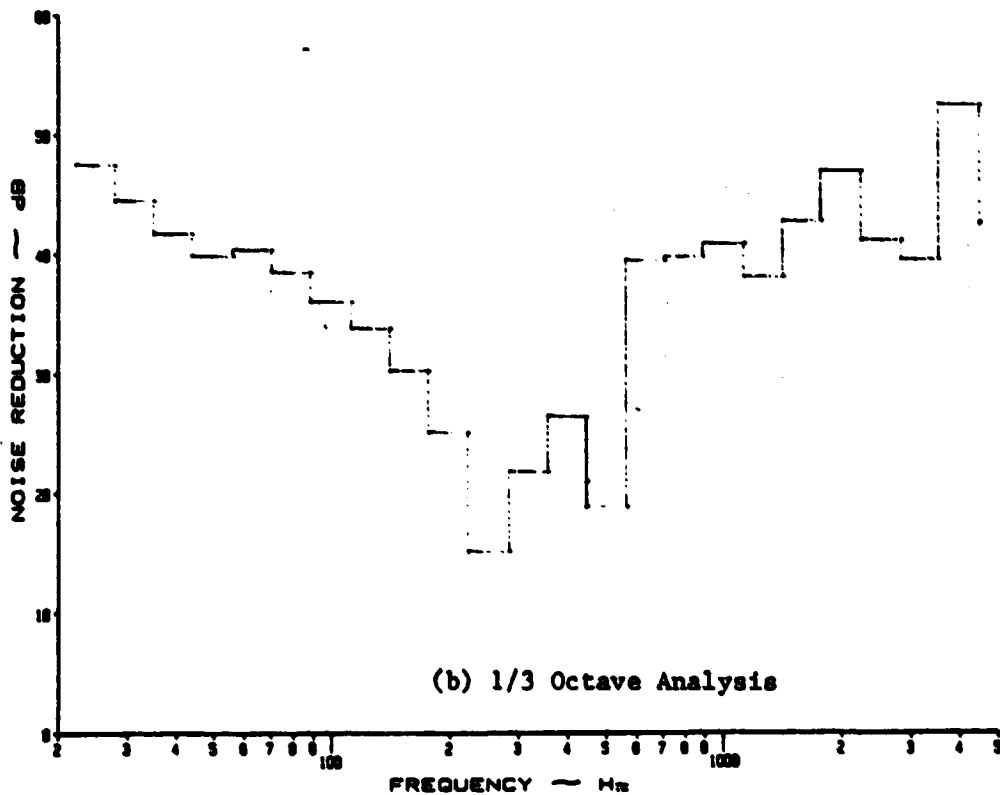

Figure B.82: Noise Reduction Characteristics of a Curved, Stiffened Panel at 1 psi Pressure Differential with Y-370 Damping Tape and 0.817 lb/ft³ Insulation under a Discrete Noise Source

ORIGINAL PAGE IS
OF POOR QUALITY



(a) Narrow Band Analysis



(b) 1/3 Octave Analysis

Figure B.83: Noise Reduction Characteristics of a Curved, Stiffened Panel at 2 psi Pressure Differential with Y-370 Damping Tape and 0.817 lb/ft³ Insulation under a Discrete Noise Source

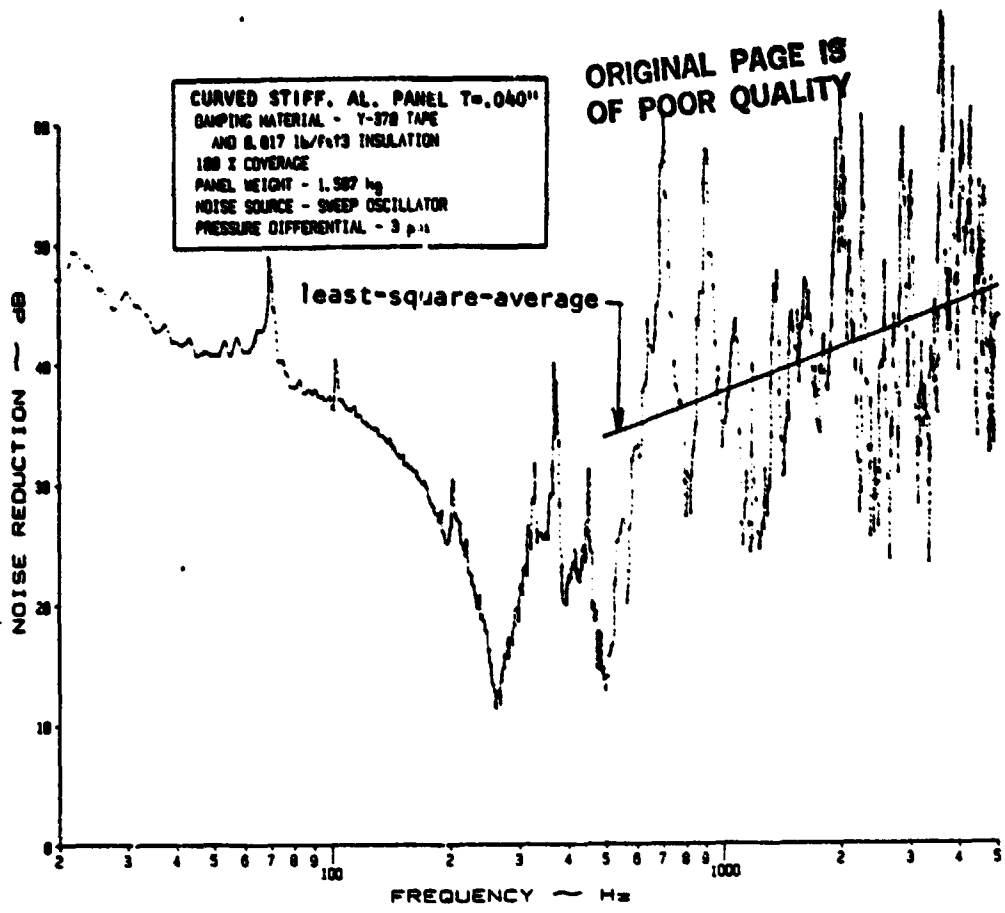

(a) Narrow Band Analysis

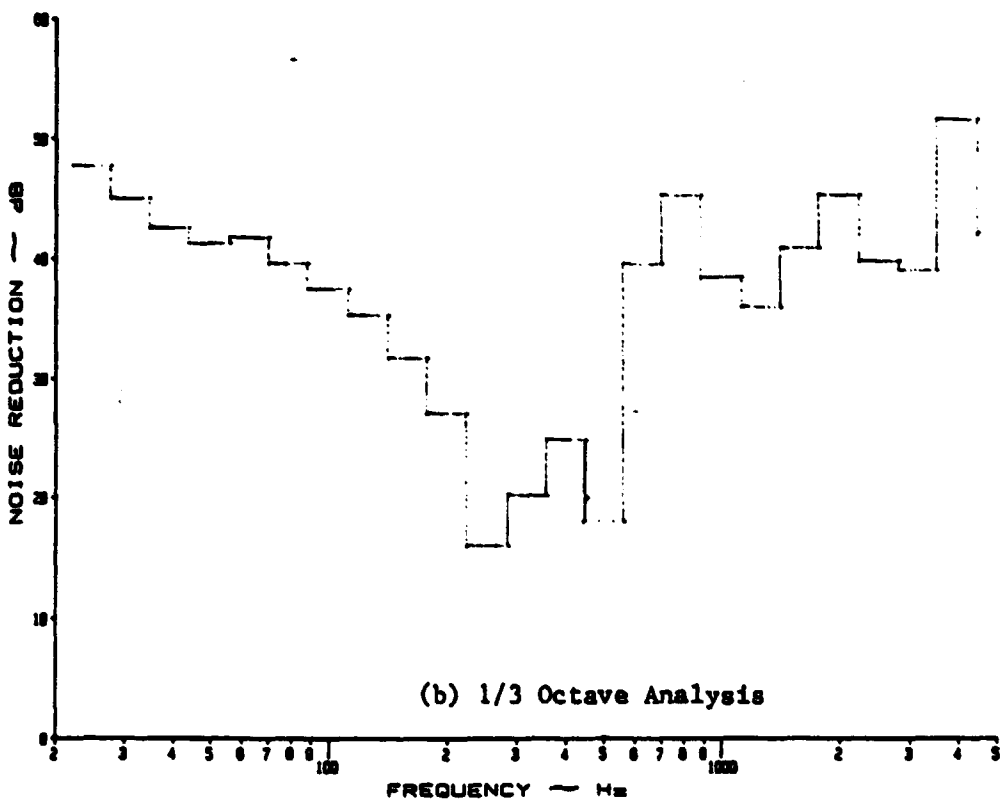

(b) 1/3 Octave Analysis

Figure B.84: Noise Reduction Characteristics of a Curved, Stiffened Panel at 3 psi Pressure Differential with Y-370 Damping Tape and 0.817 lb/ft³ Insulation under a Discrete Noise Source

ORIGINAL PAGE IS
OF POOR QUALITY

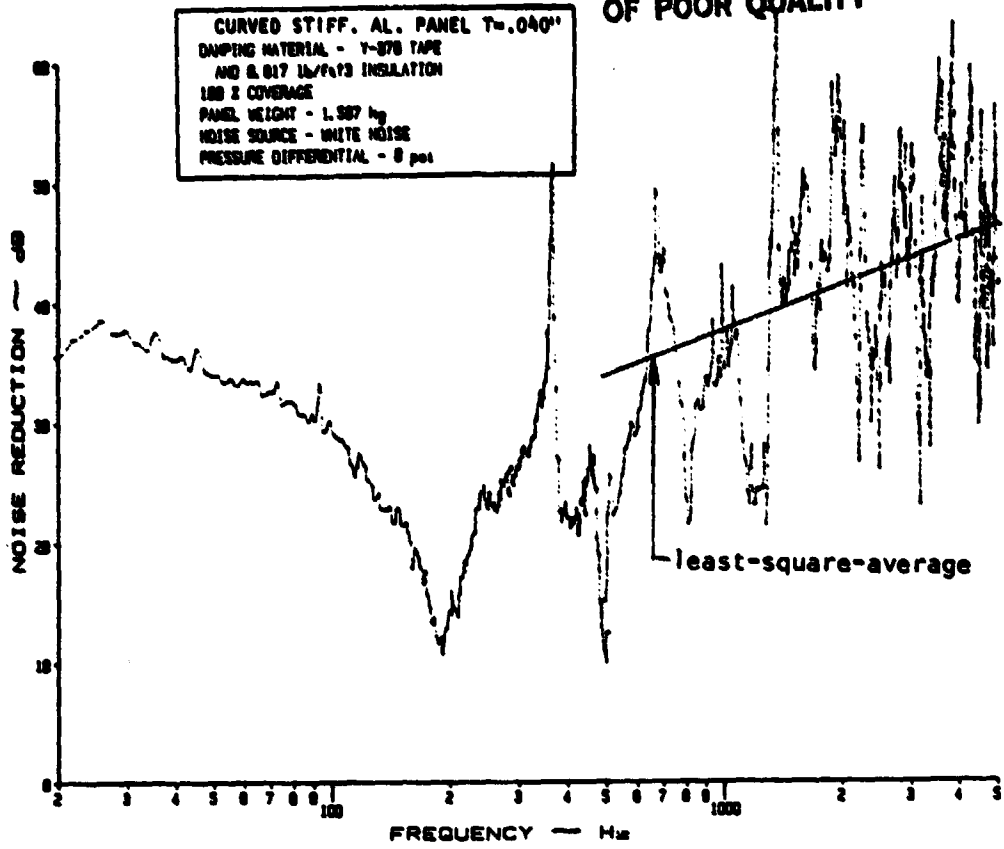

(a) Narrow Band Analysis

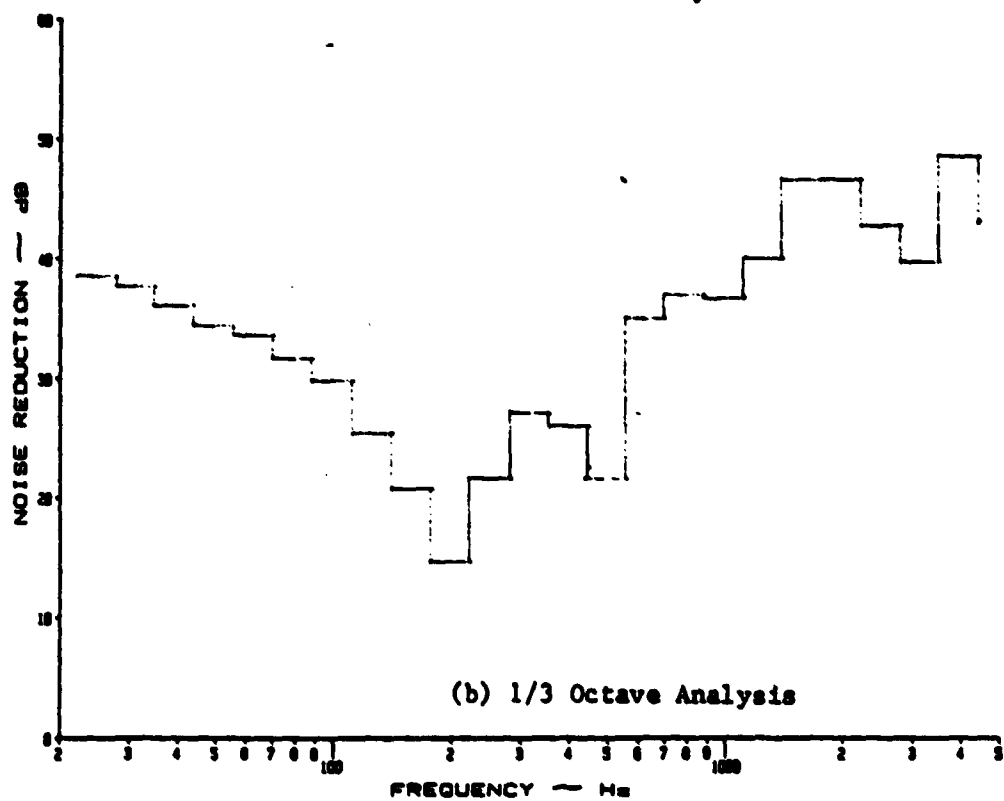

(b) 1/3 Octave Analysis

Figure B.85: Noise Reduction Characteristics of a Curved, Stiffened Panel at 0 psi Pressure Differential with Y-370 Damping Tape and 0.817 lb/ft³ Insulation under White Noise

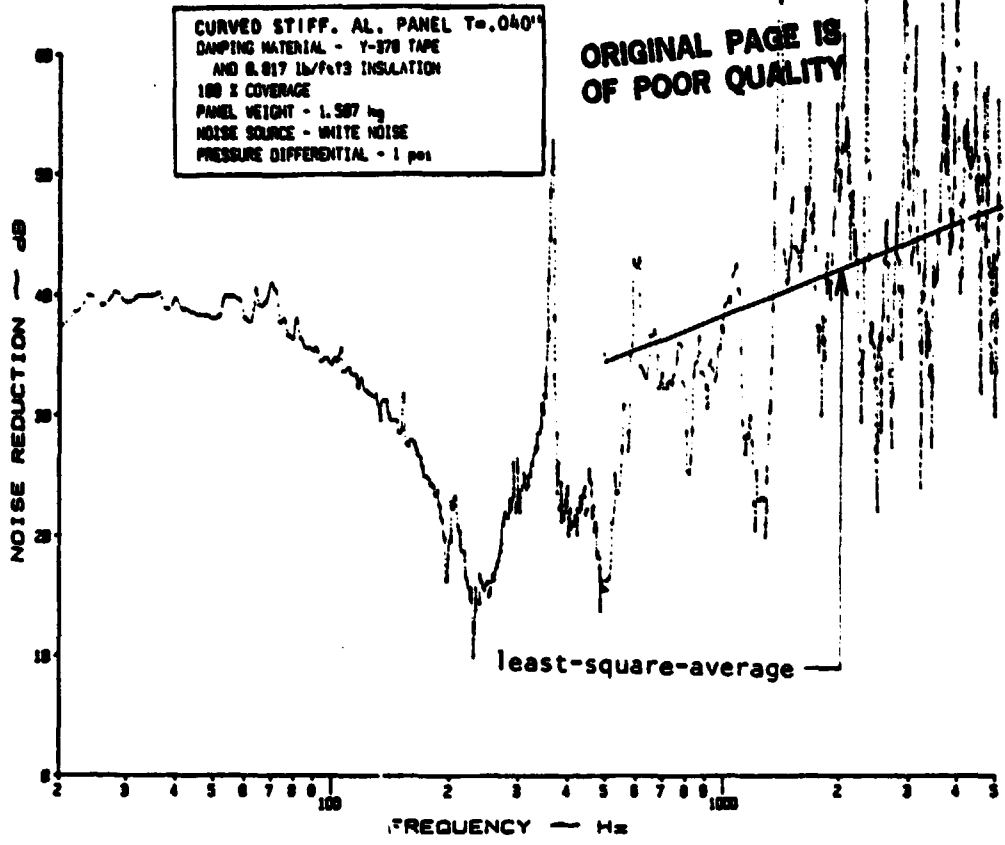

(a) Narrow Band Analysis

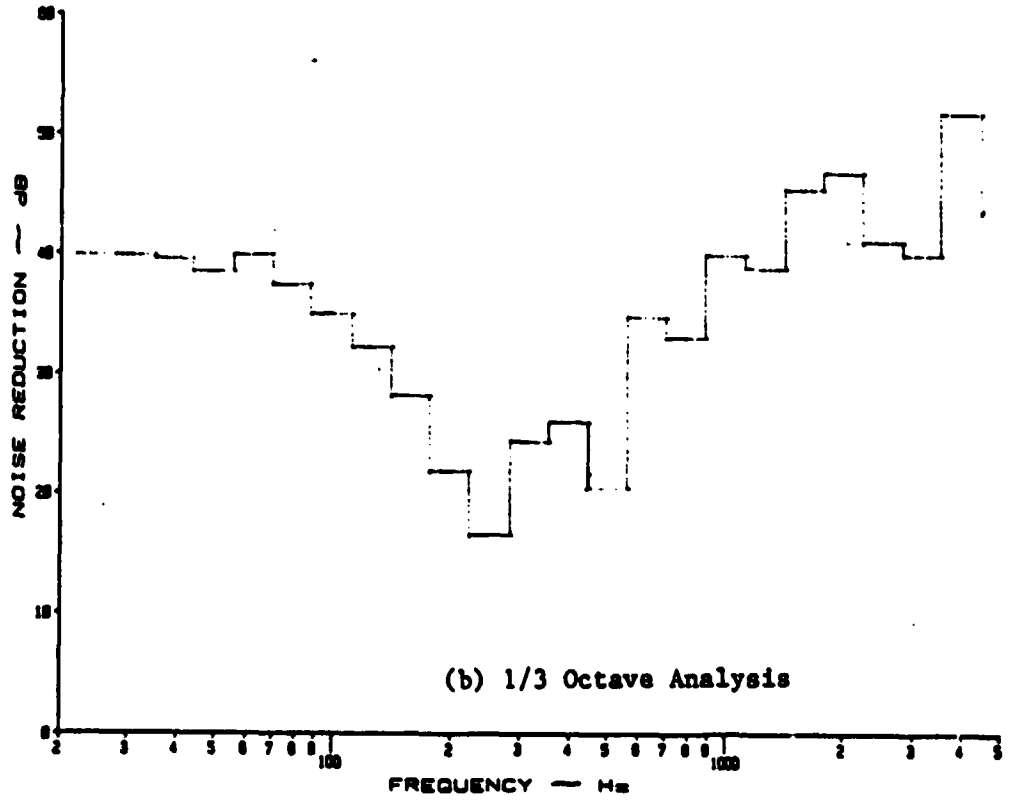
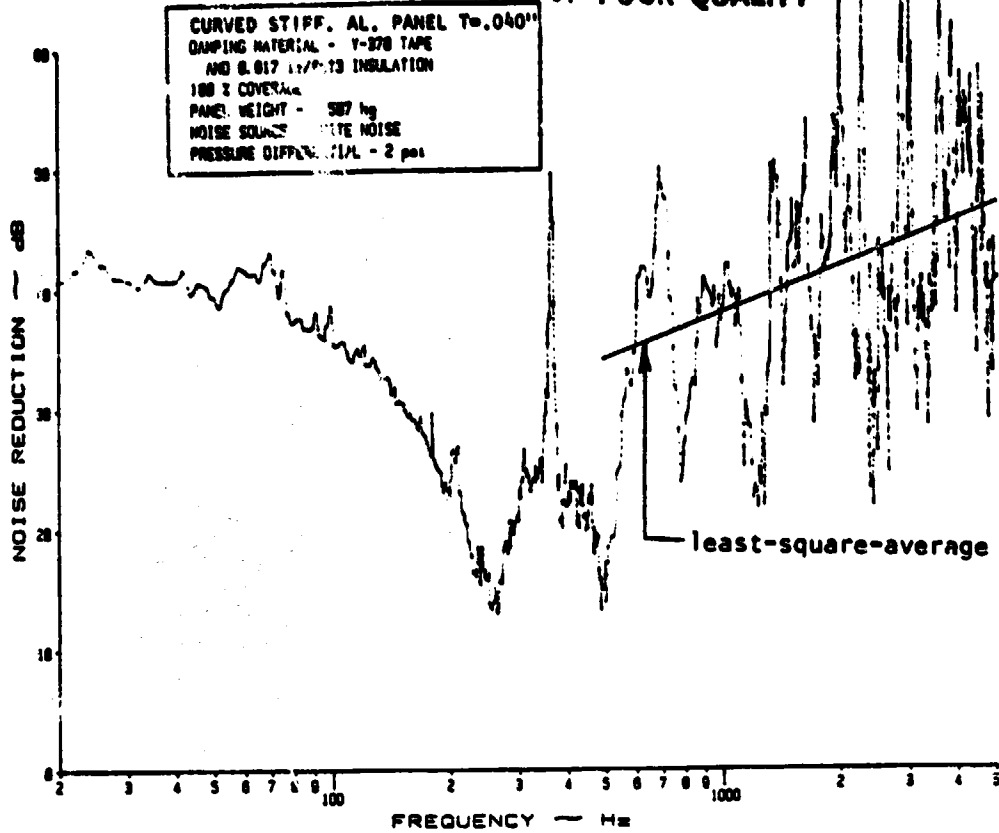
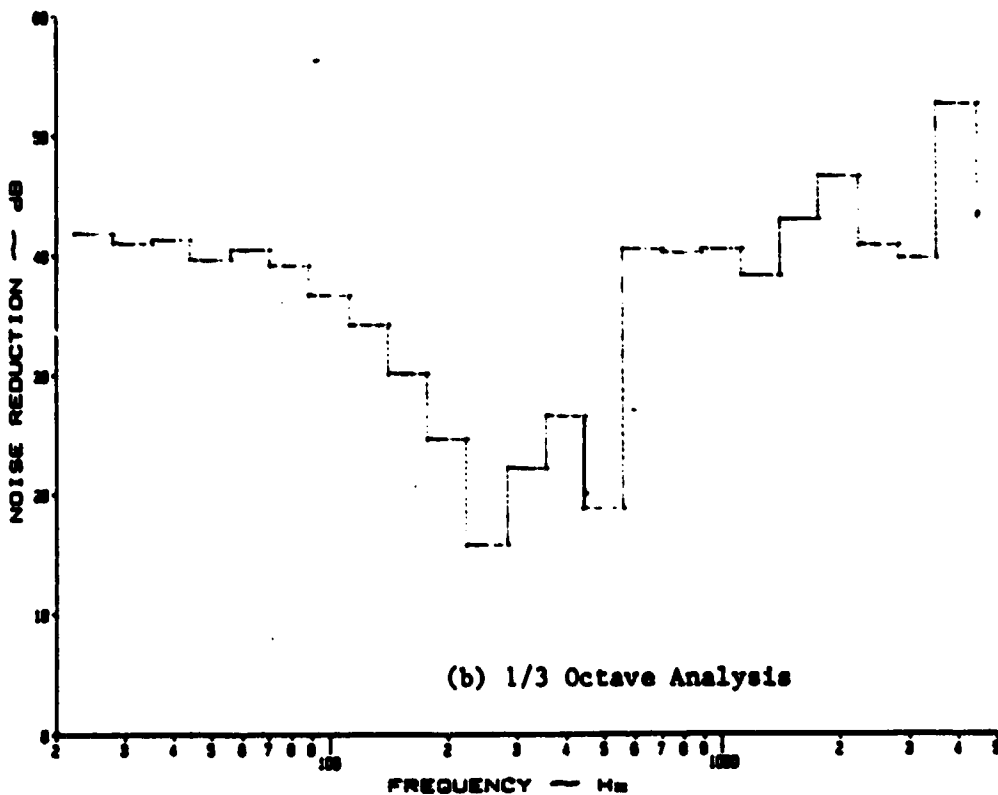

Figure B.86: Noise Reduction Characteristics of a Curved, Stiffened Panel at 1 psi Pressure Differential with Y-370 Damping Tape and 0.817 lb/ft³ Insulation under White Noise

ORIGINAL PAGE IS
OF POOR QUALITY



(a) Narrow Band Analysis



(b) 1/3 Octave Analysis

Figure B.87: Noise Reduction Characteristics of a Curved, Stiffened Panel at 2 psi Pressure Differential with Y-370 Damping Tape and 0.817 lb/ft³ Insulation under White Noise

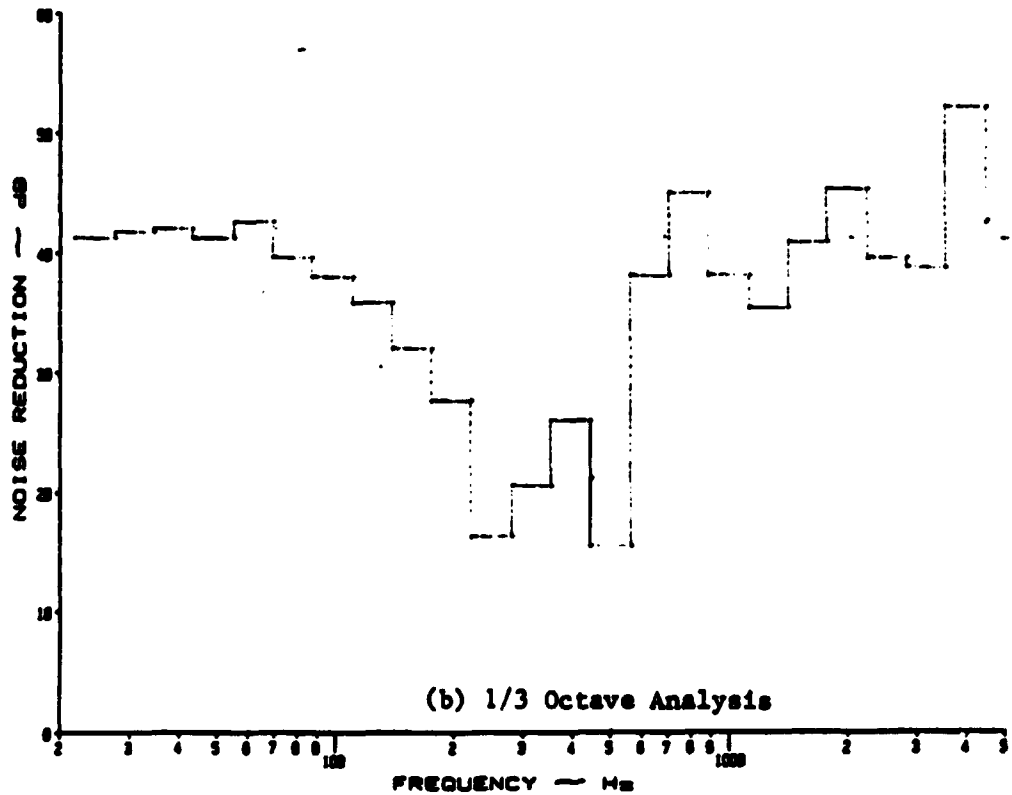
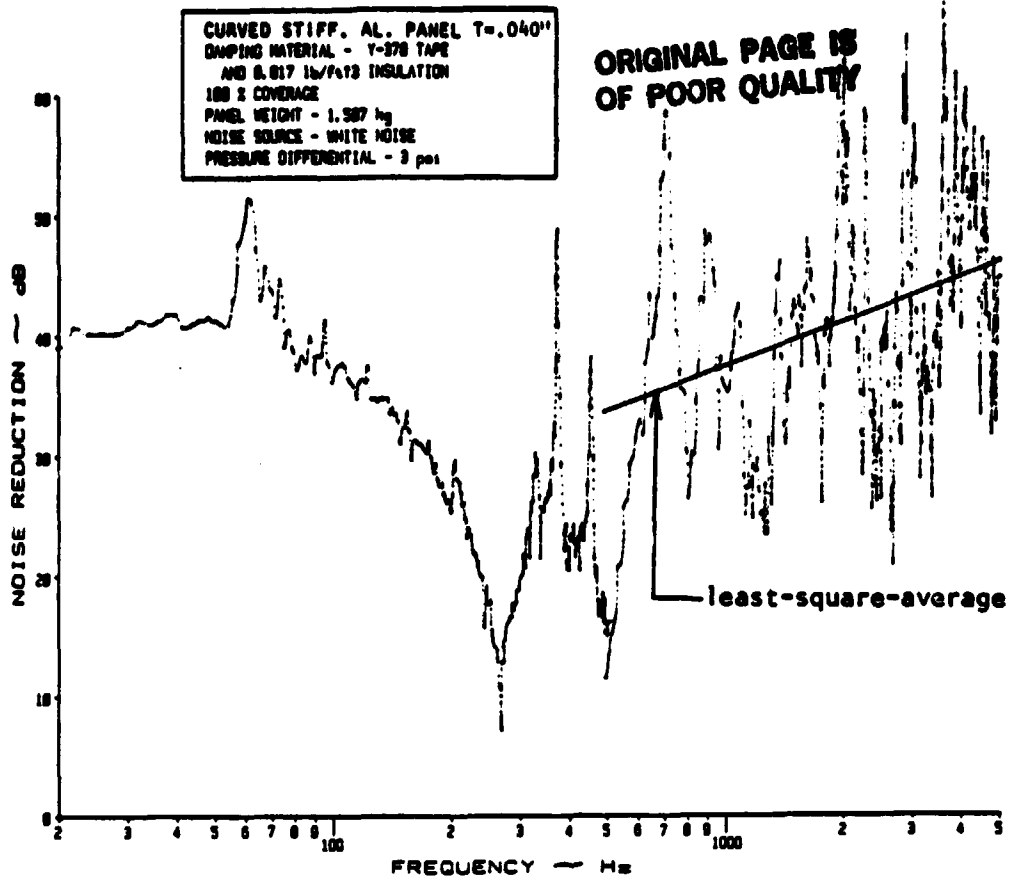
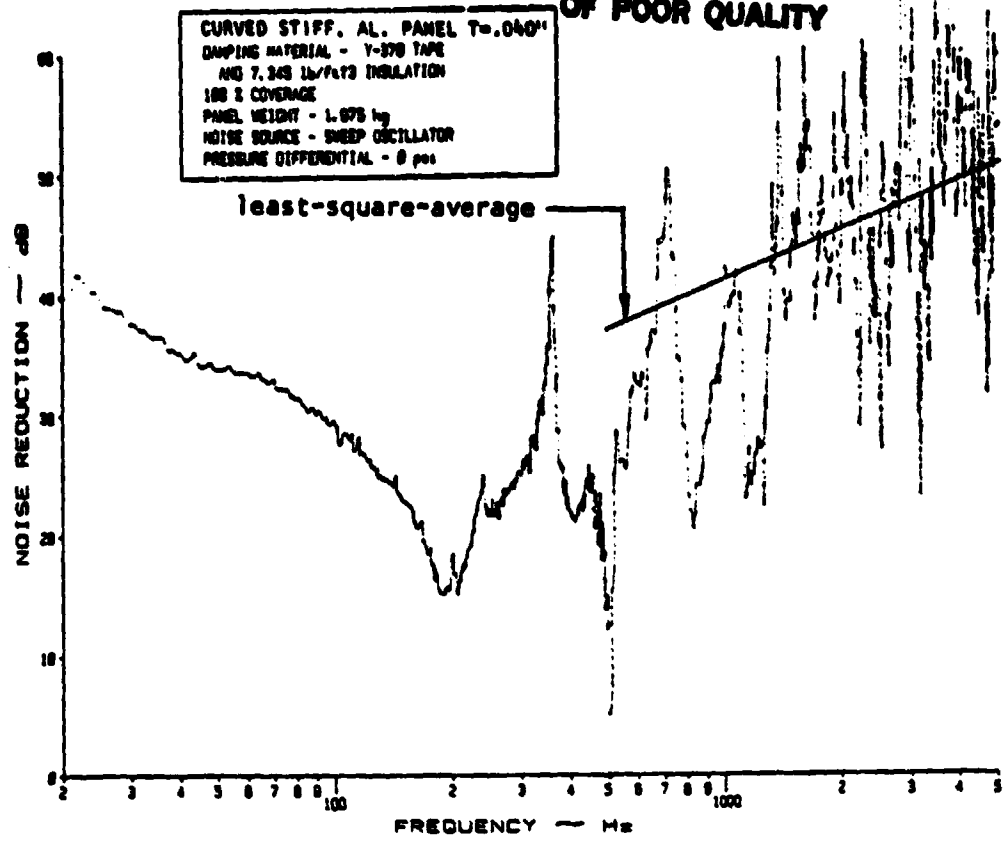
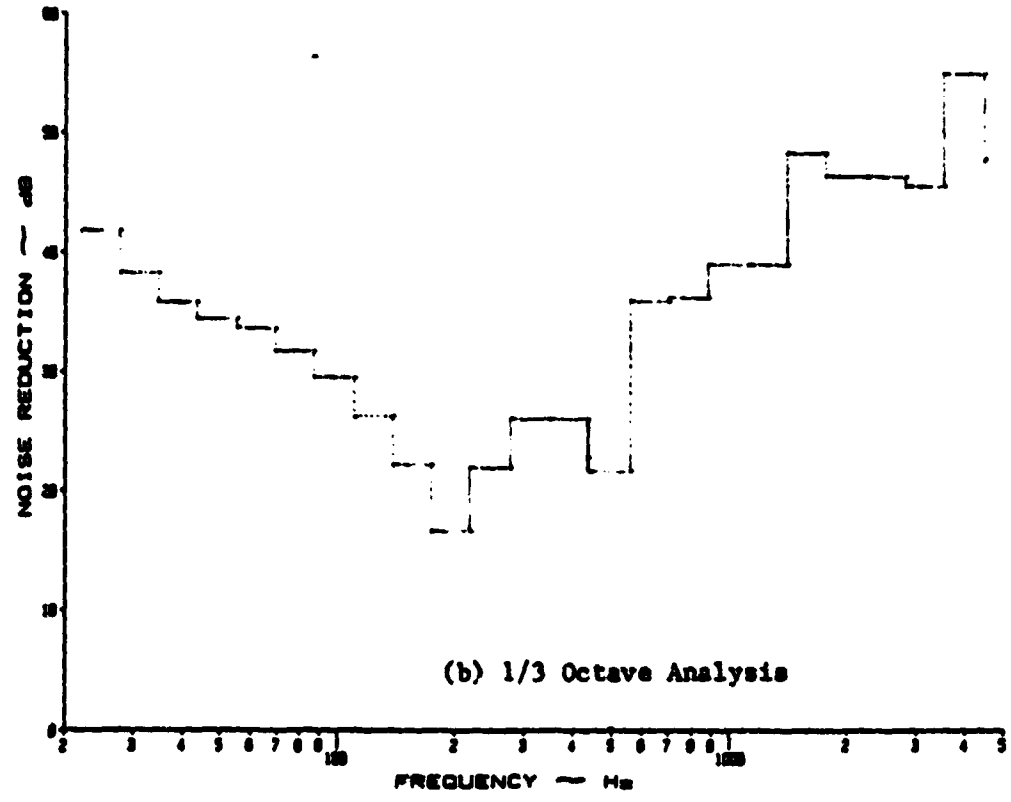

Figure B.88: Noise Reduction Characteristics of a Curved, Stiffened Panel at 3 psi Pressure Differential with Y-370 Damping Tape and 0.817 lb/ft³ Insulation under White Noise

ORIGINAL PAGE IS
OF POOR QUALITY



(a) Narrow Band Analysis



(b) 1/3 Octave Analysis

Figure B.89: Noise Reduction Characteristics of a Curved, Stiffened Panel at 0 psi Pressure Differential with Y-370 Damping Tape and 7.345 lb/ft³ Insulation under a Discrete Noise Source

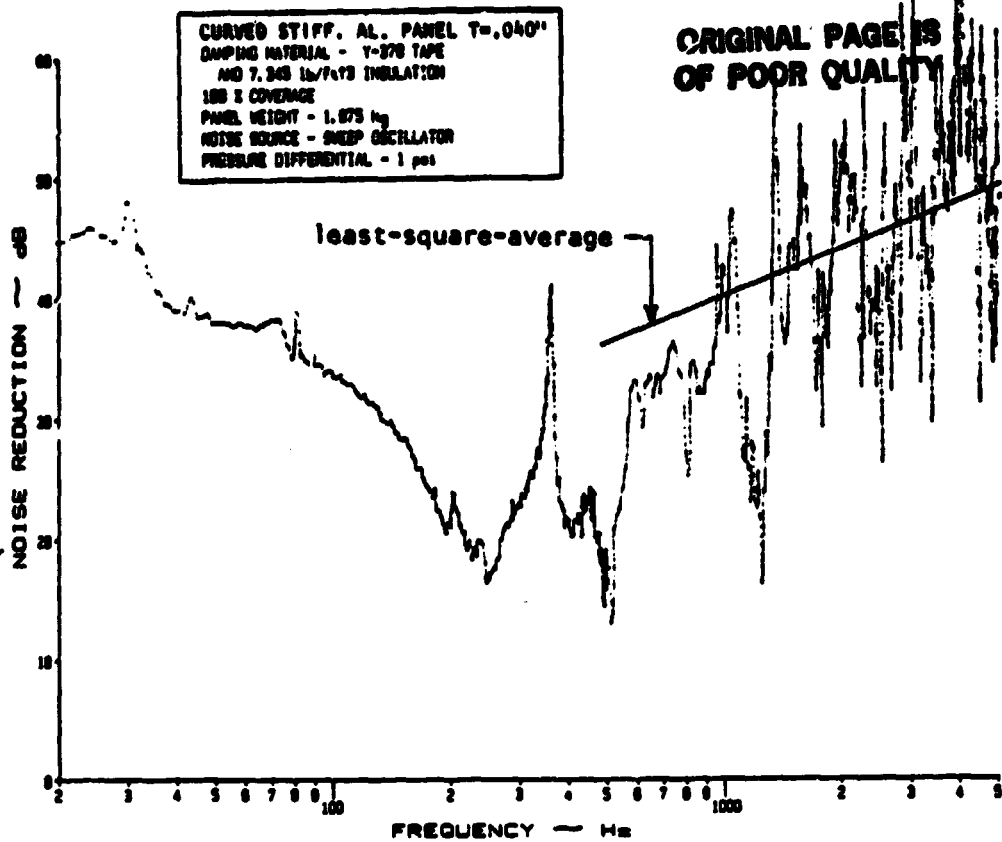

(a) Narrow Band Analysis

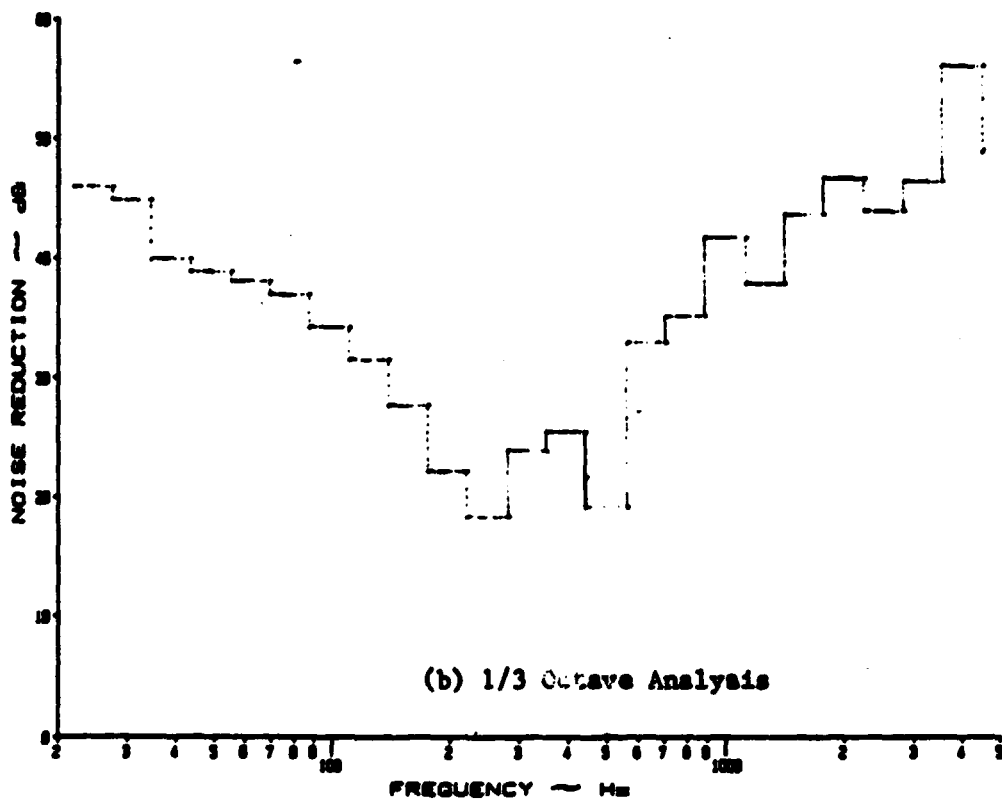

(b) 1/3 Octave Analysis

Figure B.90: Noise Reduction Characteristics of a Curved, Stiffened Panel at 1 psi Pressure Differential with Y-370 Damping Tape and 7.345 lb/ft³ Insulation under a Discrete Noise Source

ORIGINAL PAGE IS
OF POOR QUALITY

CURVED STIFF. AL. PANEL $T=0.040''$
DAMPING MATERIAL - Y-370 TAPE
AND 7.345 lb/ft³ INSULATION
100% COVERAGE
PANEL HEIGHT - 1.075 in
NOISE SOURCE - SINUSOIDAL OSCILLATOR
PRESSURE DIFFERENTIAL - 2 psi

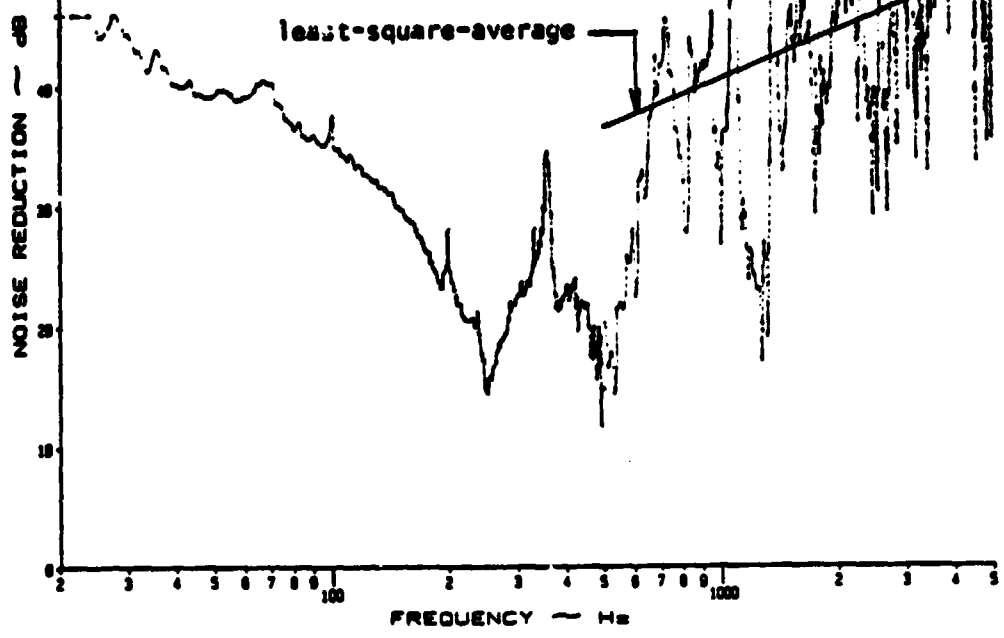

(a) Narrow Band Analysis

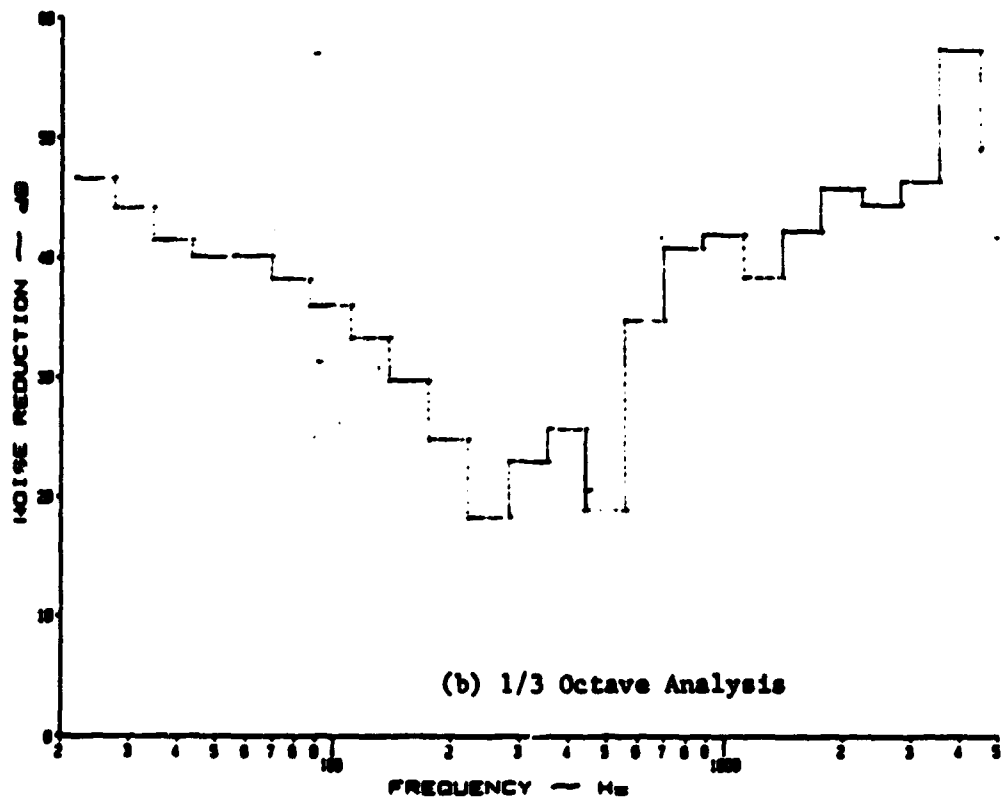

(b) 1/3 Octave Analysis

Figure B.91: Noise Reduction Characteristics of a Curved, Stiffened Panel at 2 psi Pressure Differential with Y-370 Damping Tape and 7.345 lb/ft³ Insulation under a Discrete Noise Source

ORIGINAL PAGE IS
OF POOR QUALITY.

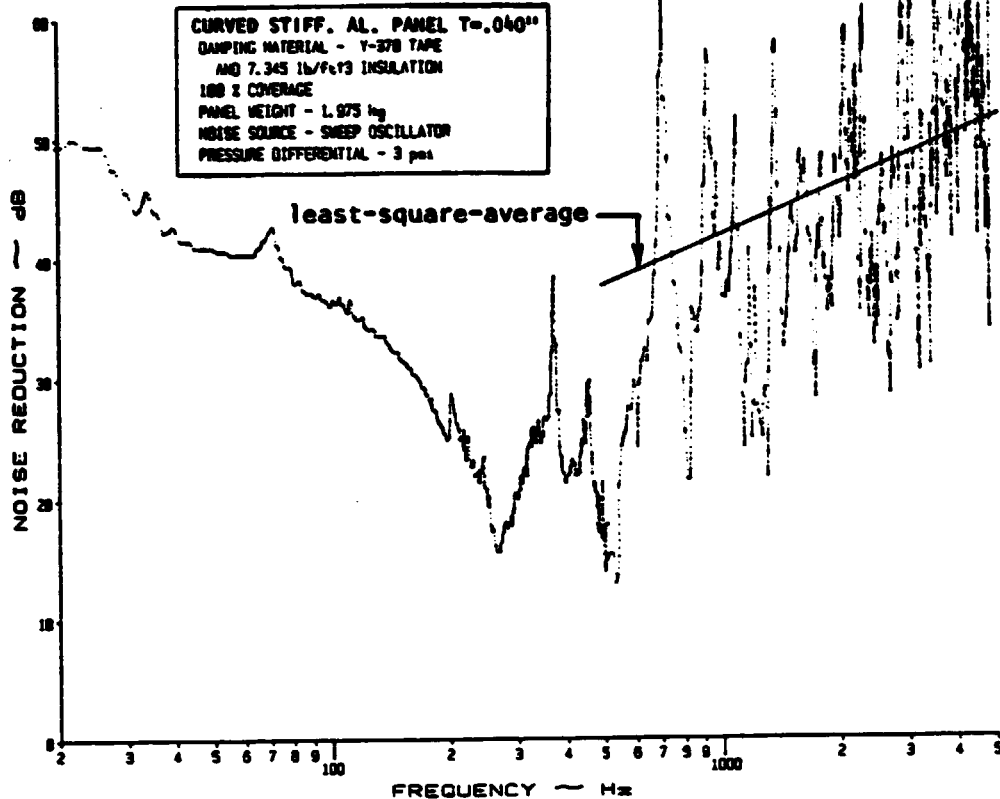

(a) Narrow Band Analysis

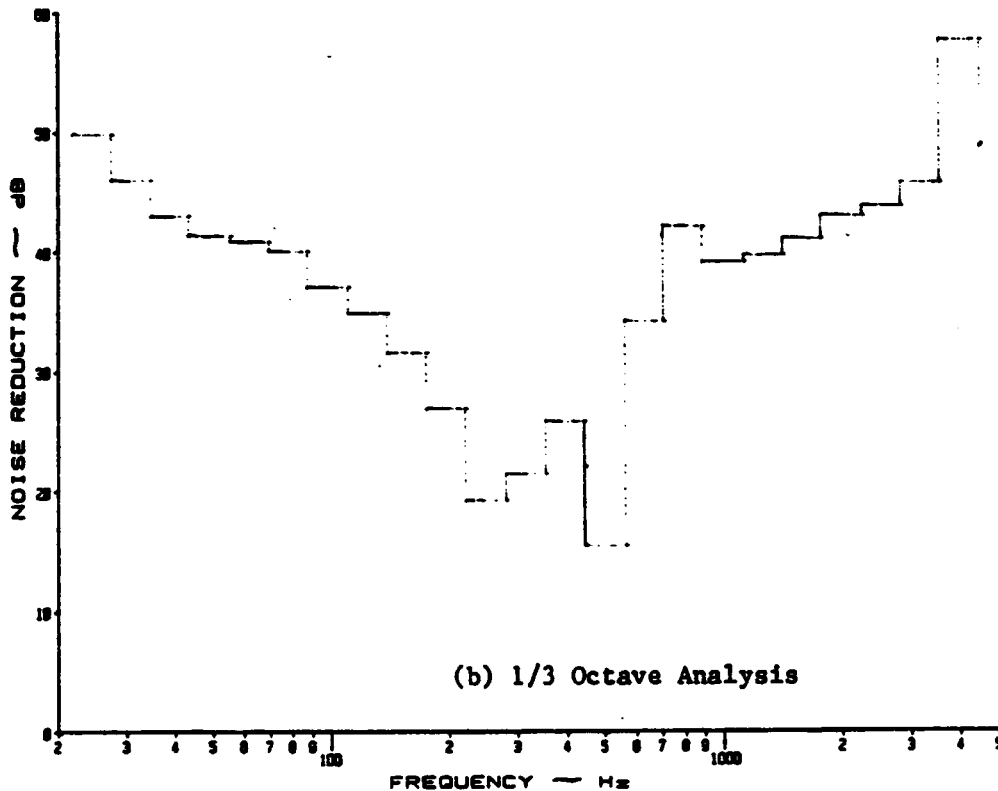

(b) 1/3 Octave Analysis

Figure B.92: Noise Reduction Characteristics of a Curved, Stiffened Panel at 3 psi Pressure Differential with Y-370 Damping Tape and 7.345 lb/ft³ Insulation under a Discrete Noise source

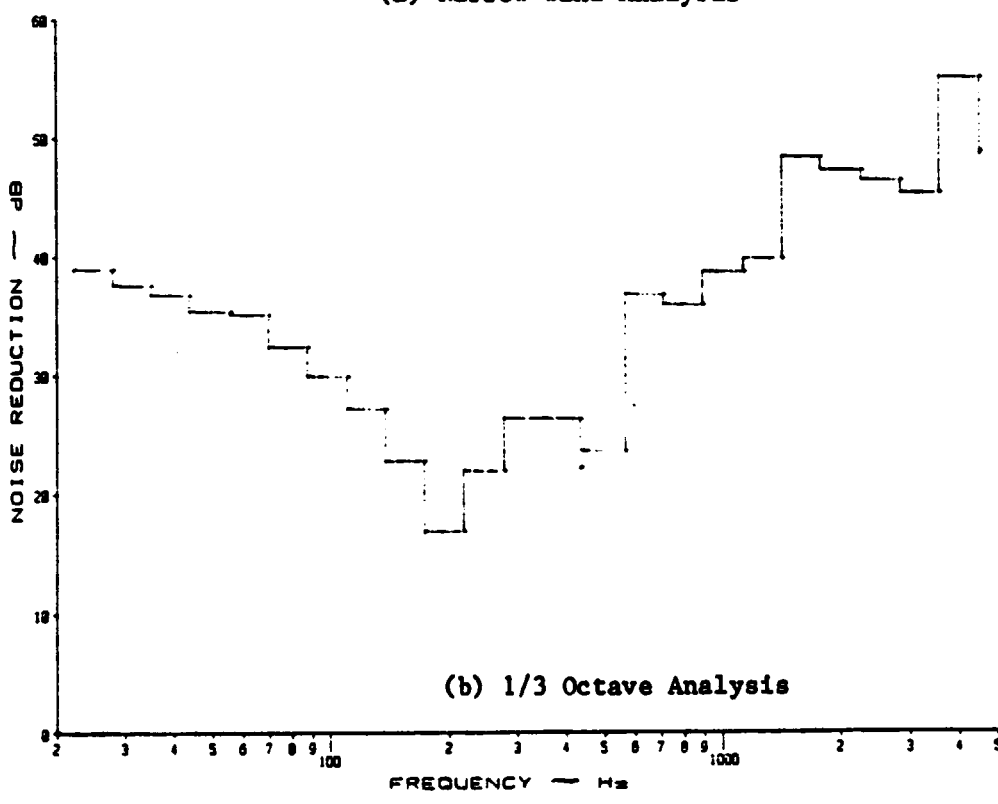
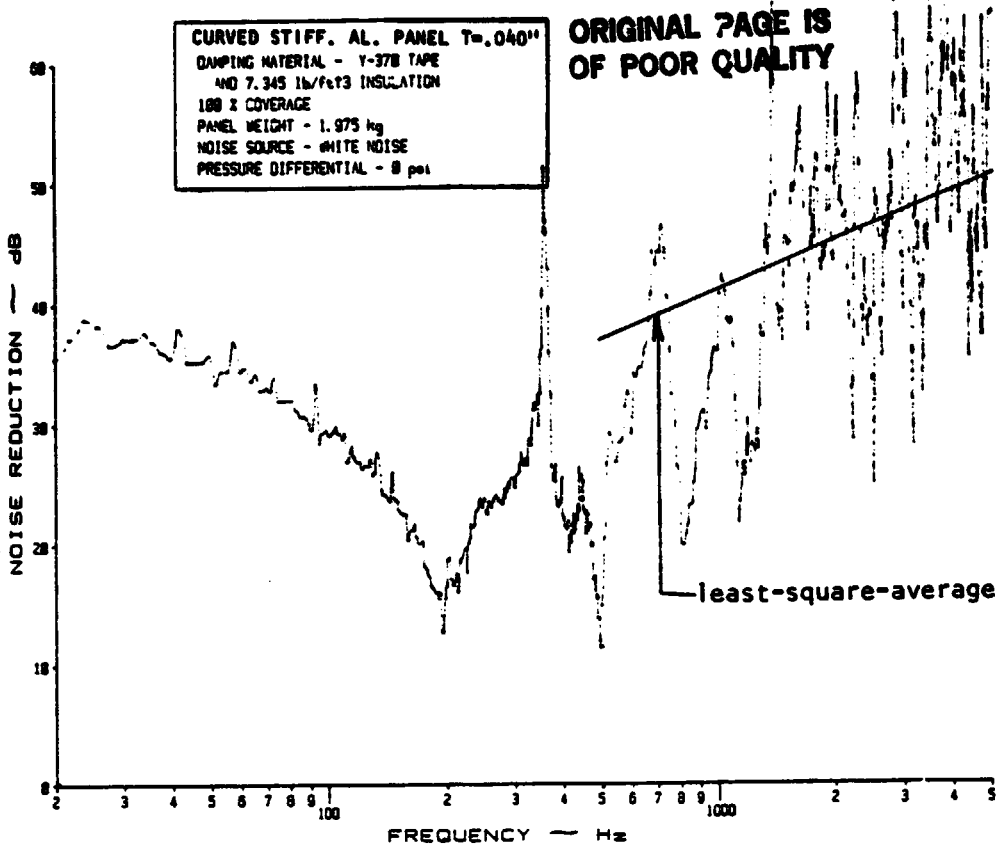
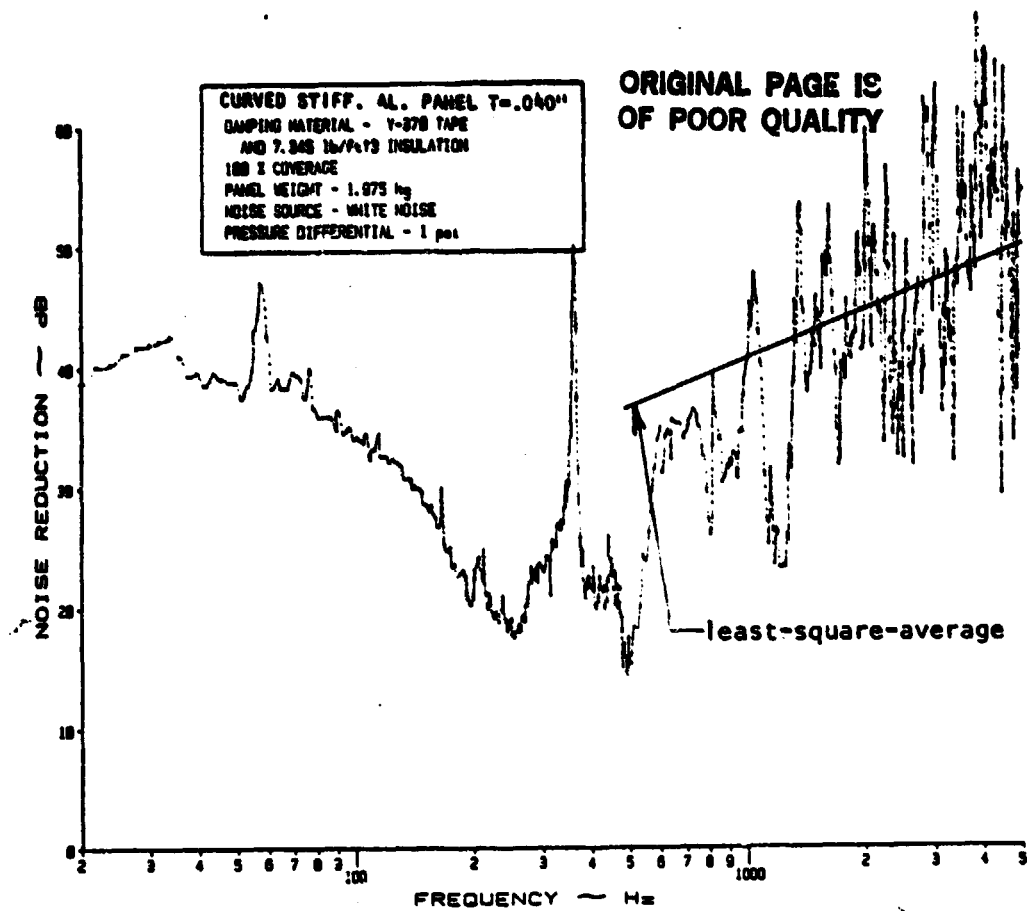
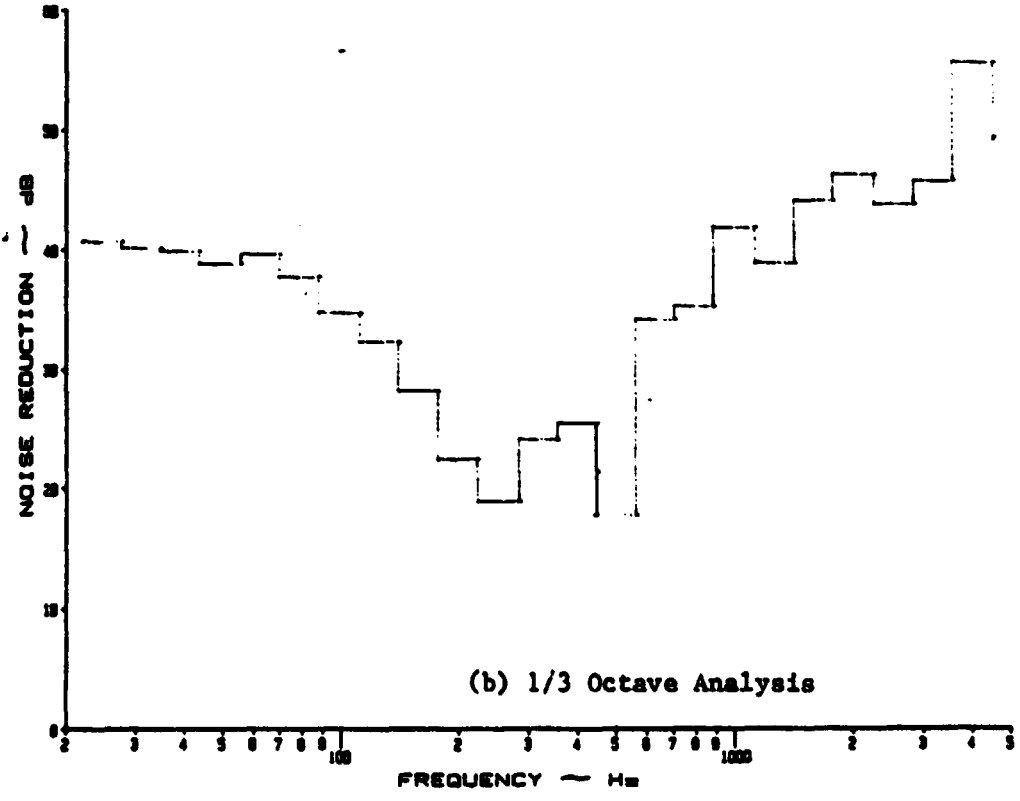

Figure B.93: Noise Reduction Characteristics of a Curved, Stiffened Panel at 0 psi Pressure Differential with Y-370 Damping Tape and 7.345 lb/ft³ Insulation under White Noise



(a) Narrow Band Analysis



(b) 1/3 Octave Analysis

Figure B.94: Noise Reduction Characteristics of a Curved, Stiffened Panel at 1 psi Pressure Differential with Y-370 Damping Tape and 7.345 lb/ft³ Insulation under White Noise

ORIGINAL PAGE IS
OF POOR QUALITY

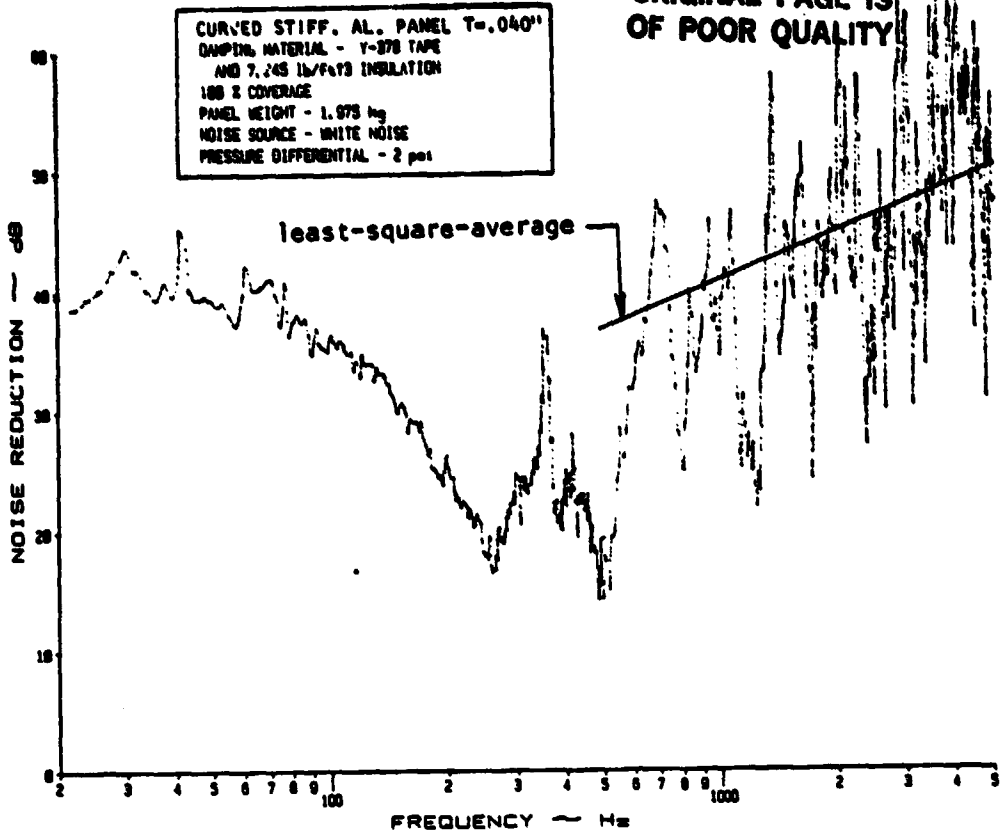

(a) Narrow Band Analysis

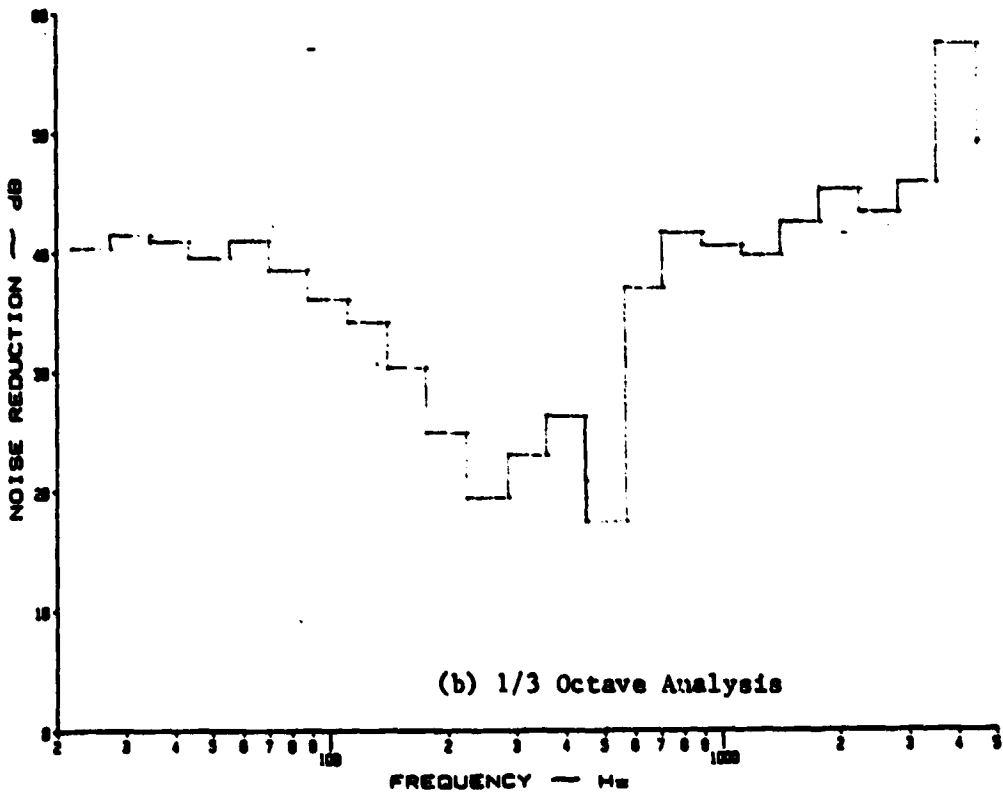

(b) 1/3 Octave Analysis

Figure B.95: Noise Reduction Characteristics of a Curved, Stiffened Panel at 2 psi Pressure Differential with Y-370 Damping Tape and 7.345 lb/ft³ Insulation under White Noise

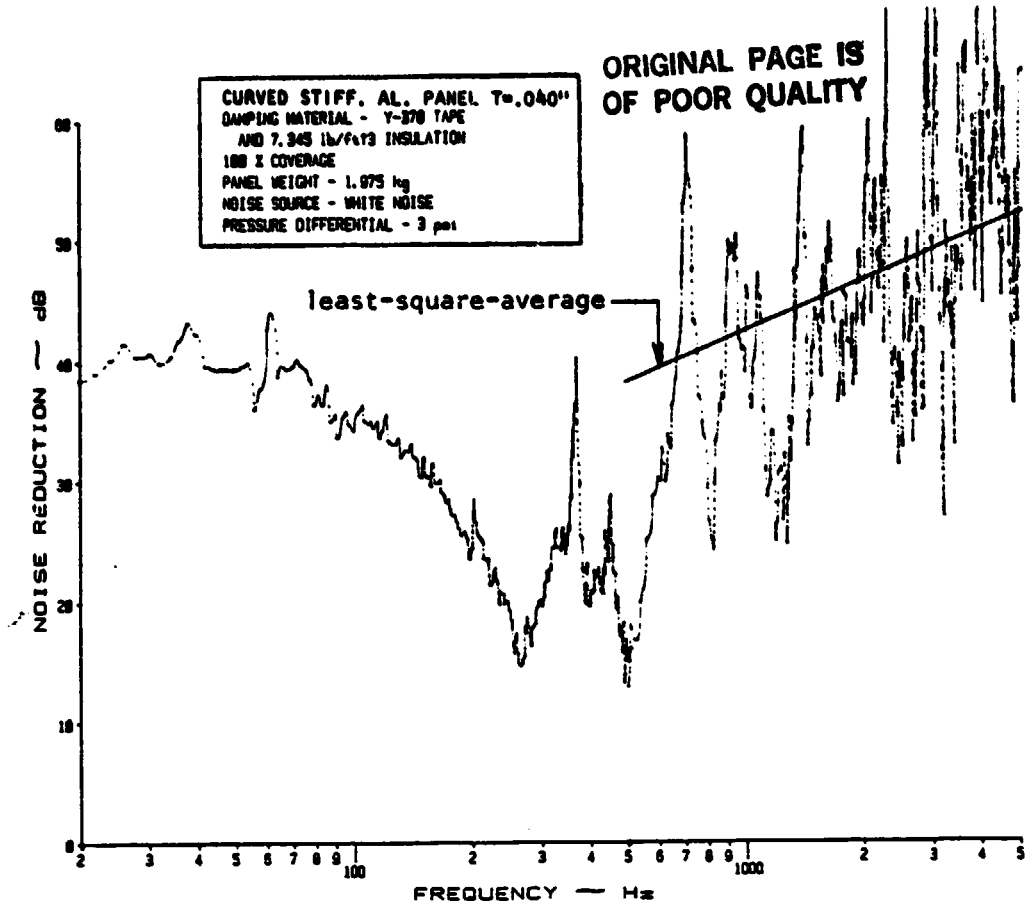

(a) Narrow Band Analysis

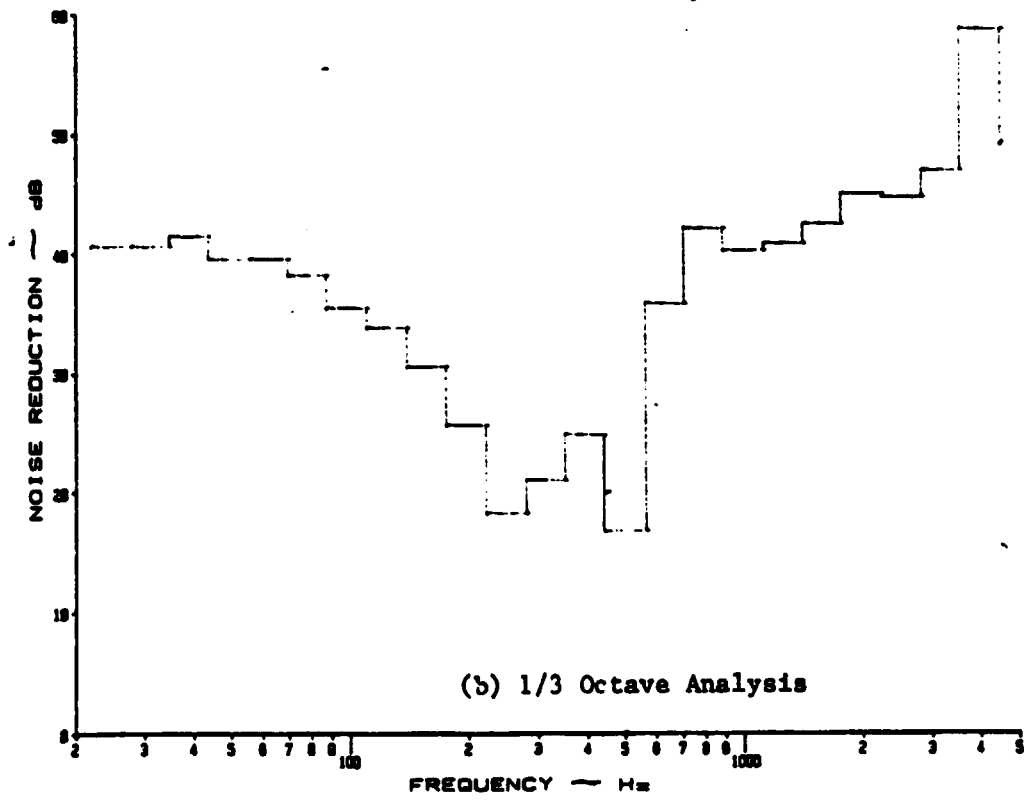

Figure B.96: Noise Reduction Characteristics of a Curved, Stiffened Panel at 3 psi Pressure Differential with Y-370 Damping Tape and 7.345 lb/ft³ Insulation under White Noise