

NASA Technical Memorandum 82910

Advances in High-Speed Rolling-Element Bearings

Erwin V. Zaretsky
Lewis Research Center
Cleveland, Ohio



(NASA-TM-82910) ADVANCES IN HIGH-SPEED
ROLLING-ELEMENT BEARINGS (NASA) 29 P
HC A03/MF A01 CSCL 13I

N82-28644

Unclas
G3/37 28291

Prepared for the
Sixteenth Annual Israel Conference on Mechanical Engineering
sponsored by Technion—Israel Institute of Technology
Haifa, Israel, July 12-14, 1982



ADVANCES IN HIGH-SPEED ROLLING-ELEMENT BEARINGS

by

Erwin V. Zaretsky

National Aeronautics and Space Administration
Lewis Research Center
Cleveland, Ohio 44135

ABSTRACT

Advances in airbreathing turbojet jet engines have dictated that bearing materials and lubricants operate at higher temperatures, higher speeds, and higher loads. Projections in the late 1950's indicated that the trends in engine operating speeds would dictate ball and roller bearings operating at speeds to three million DN and temperatures to 590 K (600° F). Helicopter transmission development in the 1960's suggested the need for tapered roller bearings to operate at speeds to two million DN. NASA research in collaboration with United States industry between 1960 and 1980 achieved these state-of-the-art advances. The NASA program was both experimental and analytic with the analytic effort verified by experiment. The reported work is a summary of aircraft engine and transmission rolling-element bearing state-of-the-art with emphasis on NASA contributions.

INTRODUCTION

Projections by the major United States aircraft turbine engine manufacturers in the late 1950's indicated that the trends in airbreathing turbojet engines would require ball and roller bearings to operate at speeds to 3 million DN (where DN equals the bearing bore in millimeters multiplied by the shaft speed in revolutions per minute) and temperatures to 590K (600° F). Helicopter transmission development in the 1960's suggested the need for tapered-roller bearings to operate at speeds to 2 million DN.

Current production engine bearings operate at speeds less than 2.3 million DN and at temperatures generally less than 490 K (425° F). Because compressor or turbine blade tip speeds and disk burst strengths begin to limit the maximum speed of rotating components, a bearing speed of 3 million DN is equivalent to the practical limit of aircraft engine operation.

At high speed the effect of centrifugal loading of the rolling elements against the outer race of a bearing can become extremely life limiting. Theoretical life calculations for a 150-mm-bore angular-contact ball bearing operating at 3 million DN (20 000 rpm) predict that this bearing has approximately 20 percent AFBMA-calculated life (1).¹ This extremely short bearing life is expressed both in actual running time (hr) and in total bearing inner-race revolutions.

Another problem associated with operating bearings at high speed is the need to adequately cool the bearing components because of relatively high heat

¹Numbers in parenthesis refer to references at end of text.

generation. One method used successfully to 3 million DN is to apply cooling lubricant under the race (2). Lubricant is centrifugally injected through the split inner race and shoulders of an angular-contact ball bearing through plurality of radial holes. As a result, both the cooling and lubricant function is accomplished.

Recirculating jet lubrication is most commonly used on air-breathing turbojet engines today. There have been many studies conducted to determine optimum lubricant jet arrangements - single, multiple, and multiple-opposed jets (3).

Research (4) with 30-mm-bore ball bearings studied the effect of cage location as well as jet lubrication to speeds up to 3 million DN. Unless significant cooling was provided, bearing failure was due to overheating at high speeds. Bearing limiting speed was dependent on bearing design, jet arrangement, and oil flow rate and velocity (4).

Tapered-roller bearings are being used in some helicopter transmissions to carry combined radial, thrust, and moment loads and, in particular, those loads from bevel gears such as high-speed input pinions (5). Tapered-roller bearings have greater load capacity for a given envelope or for a given bearing weight than the combinations of ball and cylindrical roller bearings commonly used in this application. Speed limitations have restricted the use of tapered-roller bearings to lower speed applications relative to ball and cylindrical roller bearings. The speed of tapered-roller bearings is limited to approximately 0.5 million DN (a cone-rib tangential velocity of approximately 36 m/s (7000 ft/min)) unless special attention is given to lubricating and designing the cone-rib/roller-large-end contact. At higher speeds centrifugal effects starve this critical contact of lubricant (5,6).

In 1959 NASA began a research program to encompass these projected temperature and speed requirements for large-bore ball and roller bearings. In the 1970's NASA expanded its program to encompass tapered-roller, and small-bore ball and roller bearings. The reported work is a summary of aircraft engine and transmission rolling-element bearing state-of-the-art with emphasis on NASA contributions.

MATERIAL AND LUBRICANTS

Lubricant Selection

The criteria for a liquid lubricant to function in a rolling-element bearing are that (a) it be thermally and oxidatively stable at the maximum bearing operating temperature and (b) it form an elastohydrodynamic (EHD) film between the rolling surfaces. The EHD film, which is generally dependent on lubricant base stock and viscosity, is 0.1 to 2.5 μm (5 to 100 μin) thick at high temperatures (7). When a sufficiently thick EHD film is present, rolling-element bearings will not usually fail from surface distress. Instead, they fail from rolling-element fatigue which usually manifests itself, in the early stages, as a shallow spall with a diameter about the same as the contact width. A typical fatigue spall of a bearing inner race is shown in figure 1.

A requirement for long-term high temperature bearing operation is that the EHD film thickness, h , divided by the composite surface roughness, $(\sigma_1^2 + \sigma_2^2)^{1/2}$, equal 1-1/2 or greater, where σ_1 and σ_2 are the surface finishes of the raceway and rolling elements, respectively (7). The EHD film thickness is a function of several lubricant and bearing operating variables (8). However, as a general rule, the minimum viscosity required of a lubricant is 1 centistoke at operating temperature (9). This same research indicated that the ester based lubricant (table 1) meeting the United States military specification MIL-L-23699 could provide the necessary lubrication requirements to 490 K (425° F) in an air environment. While other base stock lubricants could give satisfactory operation to 590 K (600° F) (9), they were precluded from further consideration because of their cost and/or commercial availability. Further, at temperatures above approximately 500 K (450° F) a low oxygen environment would be required to minimize lubricant oxidation for most of the lubricant types studied (9, 10).

Material Selection

Numerous studies have been performed to determine the rolling-element fatigue lives of various bearing materials (11-21). However, none maintained the required close control of operating and processing variables such as material hardness, melting technique, and lubricant type and batch for a completely unbiased material comparison. The more standard mechanical tests such as tension and compression tests or rotating beam tests are not correlatable with rolling-element fatigue results (16).

Rolling-element fatigue tests were run with 12.7-mm (1/2-in) diameter balls of eight through-hardened bearing materials at 340 K (150° F) (22-24) in the NASA five-ball fatigue tester. These materials were consumable-electrode vacuum melted (CVM) AISI 52100, M-1, M-2, M-10, M-42 (similar to WB-49), M-50, T-1 and Halmo. Care was taken to hold constant all variables known to affect rolling-element fatigue life. The longest lives at 340 K (150° F) were obtained with AISI 52100. The ten-percent lives of the other materials ranged from 7 to 78 percent of that obtained with AISI 52100. A trend is indicated toward decreased rolling-element fatigue life with increased total weight percent of alloying elements (figure 2).

Based on these data, 120-mm-bore angular-contact ball bearing life tests were conducted at 590 K (600° F). The bearings were manufactured from CVM AISI M-50, CVM AISI M-1, and CVM WB-49. Test conditions included an outer-race temperature of 590 K (600° F), a low-oxygen environment, a synthetic paraffinic oil with jet lubrication and a shaft speed of 12 000 rpm or 1.44 million DN. The results of these tests are shown in figure 3. These full-scale bearing tests correlated with the rig results.

A commonly accepted minimum hardness for rolling-element bearing components is 58 Rockwell C. At a hardness below this value brinelling of the bearing races can occur at stress levels normally experienced. Bearing life is also a function of material hardness (16, 17, 25-27). Since hardness decreases with temperature, conventional bearing materials such as AISI 52100, can be used only to temperatures of about 450 K (350° F). The M-series steels such as AISI M-50 can retain a minimum hardness of Rockwell C58 to approximately 645 K (700° F) (28-30). Because of its life potential and hardness retention, the AISI M-50 material is the choice material for ball and

roller bearings for aircraft application (table 2). To assure acceptable hardness at operating temperature, a room temperature Rockwell C hardness of 62 to 63 is specified.

Advanced helicopter transmissions require higher speed capability for tapered-roller bearings as well as higher temperature capability (31) than the conventional carburizing steels generally used for these bearings. The use of case hardened materials is desired where fracture of the bearing ring may be a mode of failure. Several carburized and other surface hardened steels have been developed for higher temperature use, primarily through the addition of alloying elements such as Cr and Mo. CBS-1000M, for example, has been developed for continuous service up to 590 K (600° F) (table 2). These materials have generally shown rolling-element fatigue lives comparable to AISI M-50 (31-33). The inherent problem with these materials is carburization and heat treatment quality control to assure the proper metallurgical structures required for rolling-element bearings.

Melting Techniques

One cause of rolling-element fatigue is nonmetallic inclusions (34-36), such as sulfides, aluminates, silicates, and globular oxides. These inclusions may act as stress raisers similar to notches in tension and compression specimens or in rotating beam specimens. Cracks emanate from these inclusions (figure 4), enlarge, and propagate under repeated stresses, forming a network of cracks which, in turn, form into a fatigue spall or pit (figure 1).

Rolling-element reliability and load capacity increases significantly when nonmetallic inclusions, entrapped gases, and trace elements are eliminated or reduced. Improvements in steel making processing, namely melting in a vacuum, can achieve this.

Vacuum induction melting (VIM) is the term applied to a process in which a cold charge is melted in an induction furnace and subsequently poured into ingots, the whole operation being performed while the melt is exposed to vacuum. The drawback of this process is a wide variation in quality.

A more improved method of making bearing steel is consumable electrode vacuum melting (CVM), or vacuum arc remelting. In this process electrodes made from a primary air-melted heat are remelted by an electric arc process. The product thus remelted is solidified in a water-cooled copper mold under vacuum. Under these solidification conditions a much more consistently clean high-quality steel (37) is produced.

Double vacuum-melted (VIM-VAR) AISI M-50 steel combines the above process and is now commercially available. Material thus processed is first vacuum-induction melted (VIM) and subsequently vacuum-arc remelted (VAR). Tests run at 490 K (425° F) with 120-mm-bore angular-contact ball bearings made from VIM-VAR AISI M-50 steel produced fatigue lives approximately seven times that achieved by normally processed CVM AISI M-50 steel (38).

LUBRICATION METHODS

Jet Lubrication

For aircraft engine and transmissions, where speeds are too high for grease or simple splash lubrication, jet lubrication is used to both lubricate and control bearing and gear temperatures by removing generated heat. In jet lubrication the placement and number of the nozzles, jet velocity, lubricant flow rates, and removal of lubricant from the bearing and immediate vicinity are all very important for satisfactory operation.

The placement of jets should take advantage of any natural pumping ability of the bearings. This is illustrated in figure 5 for a ball bearing with relieved races and for a tapered roller bearing. Centrifugal forces aid in moving the oil through the bearing to cool and lubricate the elements (39).

Directing jets in the radial gaps between the races and the cage is beneficial. The design of the cage and the lubrication of its surfaces sliding on the shoulders of the races greatly affects the high-speed performance. The cage has been typically the first element to fail in a high-speed bearing with improper lubrication.

It has been shown (4) that with proper bearing and cage design, nozzle placement, jet velocities, and adequate scavenging of the lubricant, jet lubrication can be successfully used for small-bore ball bearings at speeds to 3 million DN. For large (120-mm-bore) ball bearings (40), speeds to 2.5 million DN are attainable. For large (120.65-mm-bore) tapered roller bearings, jet lubrication was successfully demonstrated to 1.8 million DN (6), although a high lubricant flow rate of $0.0151 \text{ m}^3/\text{min}$ (4 gpm) and a relatively low oil-inlet temperature of 350 K (170° F) were required.

Under-Race Lubrication

A more effective and efficient means of lubricating rolling-element bearings is under-race lubrication. Conventional jet lubrication fails to adequately cool and lubricate the inner-race contact as the lubricant is thrown centrifugally outward. Unfortunately, increased flow rates add to heat generated from oil churning. An under-race lubrication system used in turbofan engines for ball and cylindrical roller bearings is shown in figure 6. Lubricant is directed under the inner race and centrifugally forced out through a plurality of holes in the race to cool and lubricate the bearing. Some lubricant may pass completely through under the bearing for cooling only as shown in figure 6(a). Although not shown in the figure, some radial holes may be used to supply lubricant to the cage side lands.

This lubricating technique has been thoroughly tested for large-bore ball and roller bearings up to 3 million DN (2, 42-44). Data for both under-race lubricated and jet lubricated bearings are presented in figure 7. The under-race lubricated bearings were provided with outer-race cooling. However, outer-race cooling generally had an insignificant effect on the inner-race temperature (44).

The results shown in figure 7(a) indicated that at all operating conditions the under-race lubricated bearings had lower temperatures than the

dual-orifice jet lubricated bearings. At 12 000 rpm (1.44 million DN) the temperature difference was approximately 22 K (40° F) and at 16 700 rpm (2 million DN), approximately 44 K (80° F). Beyond 2 million DN the bearing temperature with under-race lubrication increases only nominally, while the temperature of the jet lubricated bearings increases at an accelerated rate. Hence, proper thermal management using jet lubrication was not achievable in these tests at the higher speeds. From the above it was concluded that under-race lubrication results in lower operating temperatures.

The data of figure 7(b) compare power loss for the two different lubrication systems. As was reported in (41, 44) power loss is a function of the amount of lubricant penetrating the bearing cavity. This is due to viscous drag and lubricant churning (45). From figure 7(b) the power loss with under-race lubricated bearings is higher than with the jet lubricated bearings. At 12 000 rpm (1.44 million DN) the under-race lubricated bearing power loss was approximately 1 kW (1.2 hp) greater than the jet lubricated bearings. At 16 700 rpm (2 million DN), the difference was approximately 2.3 kW (3.1 hp). The power loss with the under-race lubricated bearing with a flow rate of 4920 cm³/min (1.3 gal/min) was equivalent to a jet lubricated flow rate of approximately 6812 cm³/min (1.8 gal/min). If bearing power loss is a function of lubricant flowing through or in the bearing cavity, then it can be reasonably concluded that, for a given jet lubricant flow, approximately 70 percent of the lubricant penetrates the bearing cavity at speeds to at least 2 million DN. At higher speeds this percentage probably decreases due to centrifugal force and windage effects.

Applying under-race lubrication to small bore bearings (40-mm bore) is more difficult because of limited space available for grooves and radial holes, the means of getting the lubricant under the race. For a given DN value, centrifugal effects are more severe with small bearings since centrifugal forces vary with DN². Heat generated per unit of surface area is much higher and heat removal is more difficult.

Although reference (4) reports that operations to 3 million DN can be successfully achieved with small-bore bearings with jet lubrication, further advantage may be attained if under-race lubrication can be used. Figure 8 shows significantly cooler inner-race temperatures with 35-mm (1.32780-in) bore ball bearings with under-race lubrication at speeds up to 72 000 rpm (2.5 million DN) (46).

Tapered roller bearings have been restricted to lower speed applications than have ball and cylindrical roller bearings. The speed limitation is primarily due to the cone-rib/roller-end contact which requires very careful lubrication and cooling consideration at higher speeds. The speed of tapered-roller bearings is limited to approximately 0.5 million DN (a cone-rib tangential velocity of approximately 36 m/sec (700 ft/min)) unless special attention is given to lubricating and designing this cone-rib/roller-end contact. At higher speeds centrifugal effects starve this critical contact of lubricant.

The technique of under-race lubrication has been applied to tapered-roller bearings to lubricate and cool the critical cone-rib/roller-end contact. As described in (47), 88.9-mm (3.5-in) bore tapered roller bearings were run under combined radial and thrust loads to 1.42 million DN with cone-rib

lubrication (the term used to denote under-race lubrication in tapered-roller bearings).

A comparison of cone-rib lubrication and jet lubrication was reported in (6) for 120.65-mm (4.75-in) bore tapered-roller bearings under combined radial and thrust loads. These bearings were standard catalog bearing design except for the large end of the roller, which was made spherical for a more favorable contact with the cone-rib. Those bearings that used cone-rib lubrication also had holes drilled through from a manifold in the cone bore to the undercut at the large end of the cone (figure 9). The results of (6) show very significant advantages of cone-rib lubrication (figure 10). At 15 000 rpm (1.8 million DN) the bearing with cone-rib lubrication had a cone face temperature 34 K (62° F) lower than one with jet lubrication. Furthermore, (6) shows that the tapered-roller bearing would operate at 15 000 rpm with cone-rib lubrication at less than half the flow rate required for jet lubrication at that speed.

Further work has shown successful operation with large-bore tapered-roller bearings at even higher speeds. Long-term operation of 107.94-mm (4.24-in) bore tapered roller bearings under pure thrust load to 3 million DN with a combination of cone-rib lubrication and jet lubrication was reported in (48). Successful operation of optimized design 120.65-mm (4.75-in) bore tapered-roller bearings under combined radial and thrust load with under-race lubrication to both large (cone-rib) and small ends to speeds up to 2.4 million DN was reported in (49, 50).

The use of outer-race cooling can be used to reduce the outer-race temperature to levels at or near the inner-race temperature. This would further add to the speed capability of under-race lubricated bearings and avoid large differentials in bearing temperatures that could cause excessive internal clearance.

The effect of outer-race cooling with 35-mm-bore ball bearings (46) is shown in figure 11. Outer-race cooling significantly decreased outer-race temperatures. In the case of tapered roller bearings, the cup outer-surface temperature is decreased relative to the cone bore temperature with cup cooling (50).

The use of under-race lubrication in all the previous work referenced includes the use of holes through the rotating inner race. It must be recognized that these holes weaken the inner-race structure and could increase to the possibility of inner race fracture at extremely high speeds when using through hardened seals. Additional studies are required in the area of inner-race fracture.

COMPUTER DESIGN

There are currently several comprehensive computer programs that are capable of predicting rolling-element bearing operating and performance characteristics. These programs generally accept input data of bearing internal geometry (such as sizes, clearance, and contact angles), bearing material and lubricant properties, and bearing operating conditions (load, speed, and ambient temperature). The programs then solve several sets of

equations that characterize rolling-element bearings. The output produced typically consists of rolling-element loads and Hertz stresses, operating contact angles, component speeds, heat generation, local temperatures, bearing fatigue life, and power loss.

Using the results of the calculations made by the computer program first described in (51) and subsequently updated by (52), 120-mm-bore angular-contact ball bearings capable of operating to 3 million DN were designed. This program is referred to as COMB.

To effect a direct comparison of predicted and experimental bearing performance, the computer program was run at the stated operating conditions of the bearings tested in (40). Later, comparisons were made with the experimental results using the different and somewhat more comprehensive bearing-shaft computer program SHABERTH described in (53). The effect of operating conditions on inner- and outer-race temperatures were made as well as determining power loss (54).

Representative calculations compared with experimental results are shown in figure 12. In general, the COMB program predicted bearing race temperatures reasonably well at low speeds. However, this program underestimated bearing power loss by a factor of 2. The SHABERTH program predicted temperatures and power losses reasonably well at the higher speeds.

A computer program referred to as CYBEAN has been developed for analyzing high-speed cylindrical roller bearings (55-57). The program is capable of calculating the thermal and kinematic performance of the bearing, including roller skew predictions for misaligned conditions. The high-speed 118-mm-bore roller bearing results reported in (43) were compared to computer predictions (58). A comparison of bearing temperature and power loss as a function of speed is shown in figure 13. The analysis can predict outer-race temperatures and the amount of heat transferred to the lubricant reasonably well. At the higher shaft speeds, the calculated inner-race temperatures were much lower than the corresponding experimental data. The program did not predict the high cage slip experimentally obtained with a roller bearing at low shaft speed.

The design of 120.65-mm (4.75-in) bore tapered roller bearings were computer optimized for high-speed operation. The computer program used is referenced to as TAROBE (59). The program SHABERTH (53), developed after TAROBE, can also be used to design and analyze tapered roller bearings. The optimized bearing was experimentally evaluated at speeds to 20 000 rpm. Temperature distribution and bearing heat generation were determined as a function of shaft speed, radial and thrust loads, lubricant flow rates, and lubricant inlet temperature. The high-speed design tapered roller bearing operated successfully at shaft speeds up to 20 000 rpm (2.4 million DN) under heavy thrust and radial loads. Comparisons of the cone face temperature and power loss of the high-speed design bearing and those of a modified standard bearing are shown in figure 14. The computer-designed bearing had lower temperatures and power losses than the standard bearing.

BEARING LIFE AT HIGH SPEED

Ball Bearings

Two groups of the 120-mm-bore ball bearings were fatigue tested with a tetraester (MIL-L-23699) lubricant at a bearing temperature of 492 K (425° F). Test conditions were a shaft speed of 12 000 or 25 000 rpm (1.44 or 3.0 million DN) and a bearing thrust load of 22 200 N (5000 lb).

The test bearings (38) were ABEC-5 grade, split inner-race angular-contact ball bearings. The inner and outer races, as well as the balls, were manufactured from one heat of vacuum-induction-melted, vacuum-arc-remelted (VIM-VAR) AISI M-50 steel. The nominal hardness of the balls and races was Rockwell C-63 at room temperature. Each bearing contained 15, 2.0638-cm (13/16-in.) diameter balls. The retained austenite content of the ball and race material was less than 3 percent. The inner- and outer-race curvatures of the bearing were 54 and 52 percent, respectively. The nominal contact angle was 24°.

The cage was a one-piece inner-land riding type, made out of an iron-base alloy (AMS 6415) heat treated to a Rockwell C hardness range of 28 to 35 and having a 0.005-cm (0.002-in.) maximum thickness of silver plate (AMS 2410). The cage was balanced within 3 g-cm (0.042 oz-in.).

All components with the exception of the cage were matched within ± 1 Rockwell C point. This match insured a nominal differential hardness in all bearings (i.e., the ball hardness minus the race hardness, commonly called ΔH) of zero (27). Surface finish of the balls was 2.5- μcm (1- $\mu\text{in.}$) AA, and the inner and outer raceways were held to a 5- μcm (2- $\mu\text{in.}$) AA maximum surface finish (38).

The fatigue life results of these tests were shown in figure 15. The experimental 10-percent life of the bearing is 2400×10^6 inner-race revolutions at 3 million DN. The predicted 10-percent life without any life adjustment factors was 21×10^6 inner-race revolutions at 3.0 million DN. The 10-percent life, based on experimental life previously obtained with the CVM AISI M-50 120-mm-bore angular-contact ball bearings at 1.44 million DN was approximately 105×10^6 inner-race revolutions (figure 15). At 1.44 and 3.0 million DN, 34 483 and 74 800 bearing test hours were accumulated respectively (38). The use of double vacuum melted (VIM-VAR) AISI M-50 improved bearing life by a factor of approximately 7 over single vacuum melted (CVM) AISI M-50.

Metallurgical analysis of the failed bearings established that the failures were initiated by classical subsurface rolling-element fatigue. In this failure mode a spall of subsurface origin is formed. The spall acts as a stress raiser which in the presence of higher hoop stresses, at higher speeds such as 3 million DN, can cause the inner race to fracture. Hence, race fracture at very high speeds can be a serious problem. Its solution must incorporate both fracture mechanics methodology and materials development, aimed at improving the fracture strength of the high-speed bearing steels (38).

Tapered-Roller Bearings

Endurance life tests were run with the standard design and the optimized high-speed design bearings at speeds of 12 500 and 18 500 rpm (1.5 and 2.2 million DN), respectively (60). The bearing geometry and specifications are given in tables 3 and 4. Standard design bearings of vacuum melted (CVM) AISI 4320 and CBS-1000M and high-speed design bearings of CVM CBS-1000M and through-hardened VIM-VAR AISI M-50 were run under heavy combined radial and thrust load until fatigue failure or until a preset cutoff time of 1100 hr was reached. The standard design bearings made from CBS-1000M ran to approximately six times predicted life. Twelve identical bearings of AISI 4320 material ran to 10 times the predicted life without failure. Cracking and fracture of the cones of AISI M-50 high-speed design bearings occurred at 18 500 rpm due to high tensile hoop stresses. Four CVM CBS-1000M high-speed design bearings ran to 24 times rated catalog life without any spalling, cracking or fracture failure (60).

SUMMARY

In 1959 NASA began a research program to encompass the projected temperature and speed requirements for large-bore ball and roller bearings. In the 1970's NASA expanded its program to encompass tapered-roller and small-bore and roller bearings. The following results were obtained:

1. High bearing speeds to 3 million DN and 2.4 million DN for ball and tapered-roller bearings, respectively, were achieved with fatigue life exceeding that which was common in commercial aircraft.
2. Computer analysis of rolling-element bearing operation gave reasonably accurate performance prediction to 3 million DN.
3. Under-race bearing lubrication improved bearing operation over more conventional jet lubrication methods at high bearing speeds.
4. The use of double vacuum melted (VIM-VAR) AISI M-50 improved bearing life by a factor of approximately 7 over single vacuum-melted (CVM) AISI M-50.
5. Tapered-roller bearings made from CBS-1000M material gave lives approximately 24 times predicted life at 2.4 million DN.
6. Lubricants meeting U.S. military MIL-L-23699 specification provided adequate elastohydrodynamic films for bearings operating to temperatures of 490 K (425° F) and speeds to 3 million DN.

REFERENCES

1. Scibbe, H. W., and Zaretsky, E. V., "Advanced Design Concepts for High Speed Bearings," ASME Paper No. 71-DE-50, 1971.
2. Holmes, P. W., "Evaluation of Drilled Ball Bearings at DN Values to Three Million," NASA CR-2004, NASA CR-2005, 1972.

3. Macks, E. F. and Nemeth, Z. N., "Lubrication and Cooling Studies of Cylindrical-Roller Bearings at High Speeds," NASA TR 1064, 1952.
4. Miyakawa, Y., Seki, K., and Yokoyama, M., "Study on the Performance of Ball Bearings at High DN Value," National Aerospace Lab., Tokyo (Japan), NAL-TR-284, 1972 (NASA TTF-15017, 1973).
5. Drago, R., "Heavy-Lift Helicopter Bring Up Drive Ideas", Power Transmission Design, Vol. 16, No. 3, March 1974, pp. 49-62.
6. Parker, R. J., and Signer, H. R., "Lubrication of High-Speed, Large Bore Tapered-Roller Bearings", J. Lubr. Technol., Trans. ASME, Ser. F, Vol. 100, No. 1, Jan. 1978, pp 31-38.
7. Tallian, T. E., etal, "Lubricant Films in Rolling Contact of Rough Surfaces," ASLE Trans., Vol. 7, No. 2, Apr. 1964, pp. 109-126.
8. Zaretsky, E. V., and Anderson, W. J., "EHD Lubrication," Machine Design, Vol. 40, No. 26, Nov. 7, 1968, pp. 167-173.
9. Zaretsky, E. V., and Anderson, W. J., "Preliminary Determinations of Temperature Limitations of Ester, Ether, and Hydrocarbon Base Lubricants in 25-mm Bore Ball Bearings," NASA TN D-4146, 1967.
10. Bamberger, E. N., Zaretsky, E. V., and Anderson, W. J., "Effect of Three Advanced Lubricants on High-Temperature Bearing Life," J. Lubr. Technol., Trans., ASME, Ser. F, Vol. 92, No. 1, Jan. 1970, pp. 23-33.
11. Morrison, T. W., Walp, H. O., and Remorenko, R. P., "Materials in Rolling Element Bearings for Normal and Elevated (450° F) Temperature," ASLE Trans., Vol. 2, No. 1, 1959, pp. 129-146.
12. Bamberger, E. N., "Effect of Materials - Metallurgy Viewpoint," Interdisciplinary Approach to the Lubrication of Concentrated Contacts, NASA SP-237, July 1970, pp. 409-437.
13. Carter, T. L., "A Study of Some Factors Affecting Rolling-Contact Fatigue Life," NASA TR R-60, 1960.
14. Bamberger, E. N., "The Effects of Ausforming on the Rolling Contact Fatigue Life of Typical Bearing Steel," J. Lubr. Technol., Trans., ASME, Ser. F, Vol. 89, No. 1, Jan. 1967, pp. 63-75.
15. Walp, H. O., Remorenko, R. P., and Porter, J. V., "Endurance Tests of Rolling-Contact Bearings of Conventional and High Temperature Steels Under Conditions Simulating Aircraft Gas Turbine Applications," WADC TR-58-392, July 1959, SKF Industries, Inc., King of Prussia, PA.
16. Carter, T. L., Zaretsky, E. V., and Anderson, W. J., "Effect of Hardness and Other Mechanical Properties on Rolling-Contact Fatigue Life of Four High-Temperature Bearing Steels," NASA TN D-270, 1960.

17. Zaretsky, E. V., and Anderson, W. J., "Rolling-Contact Fatigue Studies with Four Tool Steels and a Crystallized Glass Ceramic," J. Basic Eng., Trans. ASME, Vol. 83, No. 4, Dec. 1961, pp. 603-612.
18. Anderson, W. J., "Performance of 110-mm-Bore M-1 Tool Steel Ball Bearings at High Speeds, Loads, and Temperatures," NACA TN 3892, 1957.
19. Carter, T. L., "Preliminary Studies of Rolling-Contact Fatigue Life of High-Temperature Bearing Materials," NACA RM E57K12, 1958.
20. Jackson, E. R., "Rolling-Contact Fatigue Evaluations of Bearing Materials and Lubricants," ASLE Trans., Vol. 2, No. 1, 1959, pp. 121-128.
21. Scott, D., and Blackwell, J., "Study of the Effect of Material and Hardness Combination on Rolling-Contact," Nat. Eng. Lab., Rep. 239, July 1966.
22. Parker, R. J., Zaretsky, E. V., and Dietrich, M. W., "Rolling-Element Fatigue Lives of Four M-Series Steels and AISI 52100 at 150° F," NASA TN D-7033, 1971.
23. Parker, R. J., Zaretsky, E. V., and Dietrich, M. W., "Rolling-Element Fatigue Lives of AISI T-1, AISI M-42, AISI 52100, and Halmox at 150° F," NASA TN D-6179, 1971.
24. Parker, R. J., and Zaretsky, E. V., "Rolling-Element Fatigue Lives of Through-Hardened Bearing Materials," J. Lubr. Technol., Trans. ASME, Ser. F, Vol. 94, No. 2, Apr. 1972, pp. 165-173.
25. Zaretsky, E. V., Parker, R. J., and Anderson, W. J., "Effect of Component Differential Hardnesses on Rolling-Contact Fatigue and Load Capacity," NASA TN D-2640, 1965.
26. Zaretsky, E. V., Parker, R. J., Anderson, W. J., and Reichard, D. W., "Bearing Life and Failure Distribution as Affected by Actual Component Differential Hardness," NASA TN D-3101, 1965.
27. Zaretsky, E. V., Parker, R. J., and Anderson, W. J., "Component Hardness Differences and Their Effect on Bearing Fatigue," J. Lubr. Technol., Trans. ASME, Ser. F, Vol. 89, No. 1, Jan. 1967, pp. 47-62.
28. Chevalier, J. L., Dietrich, M. W., and Zaretsky, E. V., "Short-Term Hot Hardness Characteristics of Rolling-Element Steels," NASA TN D-6632, 1972.
29. Chevalier, J. L., Dietrich, M. W., and Zaretsky, E. V., "Hot Hardness Characteristics of Ausformed AISI M-50, Matrix II, WD-65, Modified AISI 440-C, and Super Nitralloy," NASA TN D-7244, 1973.
30. Anderson, N. E., "Long-Term Hot-Hardness Characteristics of Five Through-Hardened Bearing Steels," NASA TR 1341, 1978.

31. Lenski, J. W. Jr., "Test Results Report and Design Technology Development Report HLH/ATC High Speed Tapered Roller Bearing Development Program," T301-10248-1, Boeing Vertol Co., Philadelphia, PA, June 1974. (USAAMRDL-TR-74-33).
32. Nahm, A. H., "Rolling Element Fatigue Testing of Materials - Interim Report," NASA CR-135411, 1978.
33. Nahm, A. H., "Rolling Element Fatigue Testing of Gear Materials - Final Report," NASA CR-135450, 1978.
34. Jones, A. B., "Metallographic Observations of Ball Bearing Fatigue Phenomena," Symposium on Testing of Bearings, ASTM, 1947, pp. 35-52.
35. Bear, H. R., and Butler, R. H., "Preliminary Metallographic Studies of Ball Fatigue Under Rolling-Contact Conditions," NACA TN 3925, 1957.
36. Carter, T. L., and Butler, R. H., Bear, H. R., and Anderson, W. J., "Investigation of Factors Governing Fatigue Life with the Rolling-Contact Fatigue Spin Rig," ASLE Trans., Vol. 1, No. 1, Apr. 1953, pp. 23-32.
37. Norton, C. E., and Baker, P. S., "The Effect of New Material and Processing Developments on Ball Bearing Fatigue Life," Paper 779B, Jan. 1964, SAE, New York, NY.
38. Bamberger, E. N., Zaretsky, E. V., and Signer, H., "Endurance and Failure Characteristics of Main-Shaft Jet Engine Bearing at 3×10^6 DN," J. Lubr. Technol., Trans. ASME, Ser. F, Vol. 98, No. 4, Oct. 1976, pp. 580-585.
39. Parker, R. J., "Lubrication of Rolling-Element Bearings," Bearing Design - Historical Aspects, Present Technology and Future Problems, W. J. Anderson, ed, ASME, N.Y., N.Y., 1980, pp. 87-110.
40. Zaretsky, E. V., Signer, H., and Bamberger, E. N., "Operating Limitations of High-Speed Jet-Lubricated Ball Bearings," J. Lubr. Technol., Trans. ASME, Ser. F, Vol. 98, No. 1, Jan. 1976, pp. 32-39.
41. Signer, H., Bamberger, E. N., and Zaretsky, E. V., "Parametric Study of the Lubrication of Thrust Loaded 120-mm Bore Ball Bearings to 3 Million DN," J. Lubr. Technol., Trans. ASME, Ser. F, Vol. 96, No. 3, July 1974, pp. 515-524.
42. Brown, P. F., et al., "Mainshaft High Speed Cylindrical Roller Bearings for Gas Turbine Engines," PWA-FR-8615, Pratt-Whitney Aircraft Group, West Palm Beach, FL, Apr. 1977.
43. Schuller, F. T., "Operating Characteristics of a Large-Bore Roller Bearing to Speeds of 3×10^6 DN," NASA TP-1413, 1979.
44. Zaretsky, E. V., Bamberger, E. N., and Signer, H., "Operating Characteristics of 120-mm-Bore Ball Bearings at 3×10^6 DN," NASA TN D-7837, 1974.

45. Townsend, D. P., Allen, C. W., and Zaretsky, E. V., "Study of Ball Bearing Torque Under Elastohydrodynamic Lubrication," J. Lubr. Technol., Trans. ASME, Ser. F, Vol. 96, No. 4, Oct. 1974, pp. 561-571.
46. Schuller, F. T. and Signer, H. R., "Performance of Jet-and Inner-Ring-Lubricated 35-Millimeter-Bore Ball Bearings Operating to 2.5 Million DN," NASA TP 1808, 1981.
47. Lemanski, A. J., Lenski, J. W. Jr., and Drago, R. J., "Design, Fabrication, Test, and Evaluation of Spiral Bevel Support Bearings (Tapered Roller)," USAAMRD-L-TR-73-16, U. S. Army Aviation Materials Research and Development Lab., Fort Eustis, VA, 1973. (AD-769064)
48. Orvos, P. S., and Dressler, G. J., "Tapered Roller Bearing Development for Aircraft Turbine Engines," AFAPL-TR-79-2007, Air Force Aeropropulsion Lab., Wright-Patterson AFB, Ohio, Mar. 1979.
49. Parker, R. J., Pinel, S. I., and Signer, H. R., "Lubrication of Optimized-Design Tapered Roller Bearings to 2.4 Million DN," NASA TP 1714, 1980.
50. Parker, R. J., Pinel, S. I., and Signer, H. R., "Performance of Computer-Optimized Tapered Roller Bearings to 2.4 Million DN," J. Lubr. Technol., Trans. ASME, Ser. F, Vol. 103, No. 1, Jan. 1981, pp. 13-20.
51. Crecelius, W. J., and Harris, T. A., "Ultra-High Speed Ball Bearings Analysis," SKF-AE-71A009, SKF Industries, Inc., King of Prussia, PA, Nov. 1971, (NASA CR-120837).
52. Crecelius, W. J., Harris, T. A., and Mindel, M. H., "Dynamic Analysis of High Speed Ball Bearings Under Combined Loading," SKF-AE-72A004, SKF Industries, Inc., King of Prussia, PA, 1972.
53. Crecelius, W. J., Heller, S., and Chiu, Y. P., "Improved Flexible Shaft-Bearing Thermal Analysis with NASA Friction Models and Cage Effects," SKF-AL-76P003, SKF Industries, Inc., King of Prussia, PA, Feb. 1976.
54. Coe, H. H., and Zaretsky, E. V., "Predicted and Experimental Performance of Jet-Lubricated 120-Millimeter-Bore Ball Bearings Operating to 2.5 Million DN," NASA TP-1196, 1978.
55. Kleckner, R. J., and Pirvics, J., "High Speed Cylindrical Roller Bearing Analysis, SKF Computer Program CYBEAN, Volume I; Analysis," SKF-AL-78P022-Vol-1, SKF Industries, Inc., King of Prussia, PA, July 1978, (NASA CR-159460).
56. Kleckner, R. J., and Pirvics, J., "High Speed Cylindrical Roller Bearing Analysis. SKF Computer Program CYBEAN. Volume II: User's Manual," SKF-AL-78PU23-Vol-2, SKF Industries, Inc., King of Prussia, PA, July 1978, (NASA CR-159461).

57. Kleckner, R. J., Pirvics, J., and Castelli, V., "High Speed Cylindrical Rolling Element Bearing Analysis "CYBEAN" Analytical Formulation," J. Lubr. Technol., Trans. ASME, Ser. F, Vol. 102, No. 3, July, 1980, pp. 380-390.
58. Coe, H. H., and Schuller, F. T., "Calculated and Experimental Data for a 118-mm-Bore Roller Bearing to 3 Million DN," J. Lubr. Technol., Trans. ASME, Ser. F, Vol. 103, No. 2, Apr. 1981, pp. 274-283.
59. Crecelius, W. J., and Milke, D. R., "Dynamic and Thermal Analysis High Speed Tapered Roller Bearings Under Combined Loadings," SKF-AL-73P010, SKF Industries, Inc., King of Prussia, PA, Mar. 1973. (NASA CR-121207).
60. Parker, R. J., Signer, H. R., and Pinel, S. I., "Endurance Tests with Large-Bore Tapered-Roller Bearings to 2.2 Million DN," ASME Paper No. 81-Lub-56, 1981 (to be published J. Lubr. Technol., Trans. ASME, Ser. F, Vol. 108, No. 3, July 1982).

TABLE 1. - PROPERTIES OF TETRAESTER LUBRICANT

Additives	Antiwear, oxidation inhibitor, antifoam
Kinematic viscosity, cS, at -	
311 K (100° F)	28.5
372 K (210° F)	5.22
477 K (400° F)	1.31
Flash point, K (°F)	533 (500)
Autoignition temperature, K (°F)	694 (800)
Pour point, K (°F)	214 (-75)
Volatility (6.5 hr at 477 K (400° F)), wt. %	3.2
Specific heat at 477 K (400° F), J/(kg)(K)(Btu/(lb)(°F))	2340 (0.54)
Thermal conductivity at 477 K (400° F), J/(m)(sec)(K) (Btu/(hr)(ft)(°F))	0.13 (0.075)
Specific gravity at 477 K (400° F)	0.850

TABLE 2. - CHEMICAL COMPOSITION OF THE TEST BEARING MATERIALS

	Alloying element, weight percent (bal. Fe)						
	C	Mn	Si	Cr	Ni	Mo	V
CBS 1000M	0.12/0.16	0.40/0.60	0.40/0.60	0.90/1.20	2.75/3.25	4.75/5.25	0.25/0.50
AISI M-50	0.80/0.85	0.15/0.35	0.10/0.25	4.00/4.25	0.10 max.	4.00/4.50	0.90/1.10

TABLE 3. - TEST BEARING GEOMETRY

Dimension	Standard design	Computer optimized design
Cup half angle	17°	15° 53'
Roller half angle	1° 35'	1° 35'
Roller large end diameter, mm (in.)	18.29 (0.720)	18.29 (0.720)
Number of rollers	25	23
Total roller length, mm (in.)	34.17 (1.3452)	34.18 (1.3456)
Pitch diameter, mm (in.)	166.8 (6.569)	155.1 (6.105)
Bearing outside diameter, mm (in.)	206.4 (8.125)	190.5 (7.500)
Roller crown radius, mm (in.)	25.4x10 ³ (1000)	25.4x10 ³ (1000)
Roller spherical end radius, percent of apex length	80	80

TABLE 4. - TEST BEARING SPECIFICATIONS

	Standard design	Computer optimized design
Case hardness, Rockwell C	58 to 64	58 to 64
Core hardness, Rockwell C	25 to 48	25 to 48
Case depth (to 0.5 percent carbon level after final grind), cm (in.), of -		
Cup and cone	0.086 to 0.185 (0.034 to 0.073)	0.061 to 0.185 (0.024 to 0.073)
Roller	0.091 to 0.201 (0.036 to 0.079)	0.091 to 0.201 (0.036 to 0.079)
Surface finish, μm (μin.), rms, of -		
Cone raceway	0.15 (6)	0.10 (4)
Cup raceway	.20 (8)	.10 (4)
Cone rib	.18 (7)	.15 (6)
Roller taper	.13 (5)	.05 (2)
Roller spherical	.15 (6)	.08 (3)

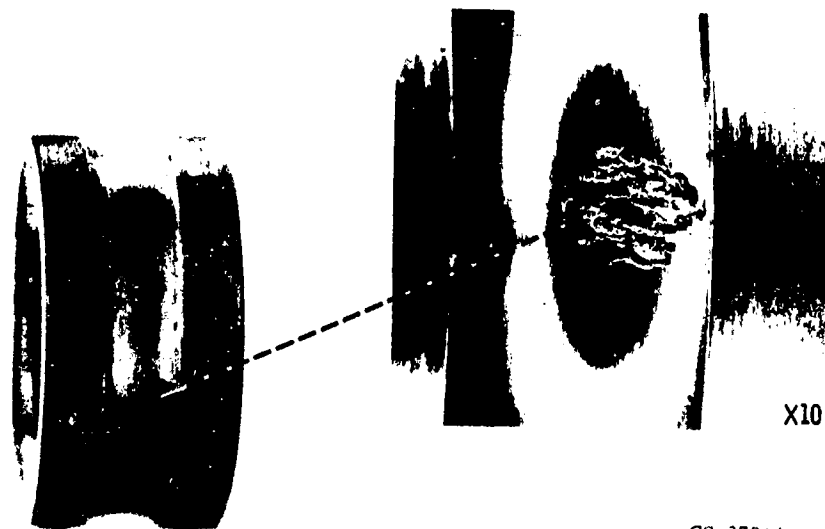

CS-37914

Figure 1. - Typical fatigue spall in bearing race.

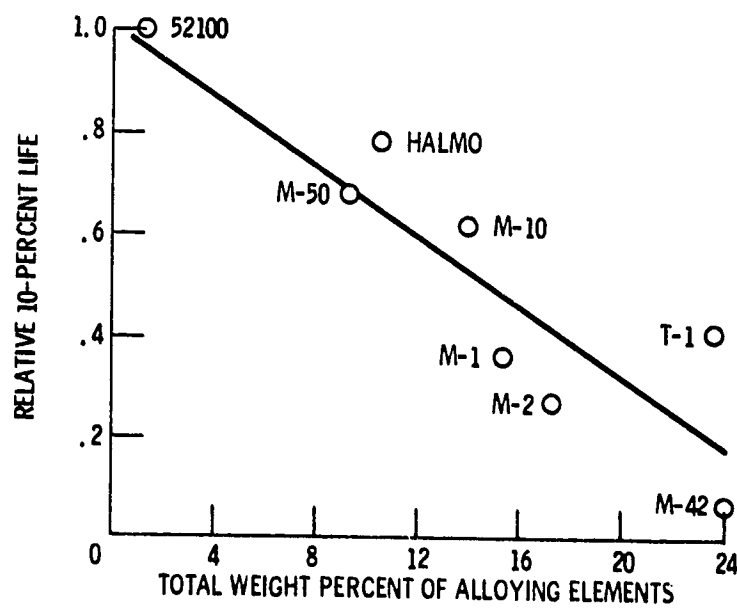

Figure 2. - Effect of total weight percent of alloying elements tungsten, chromium, vanadium, molybdenum, and cobalt on rolling element fatigue life at 340 K (150° F).

ORIGINAL PAGE
BLACK AND WHITE PHOTOGRAPH

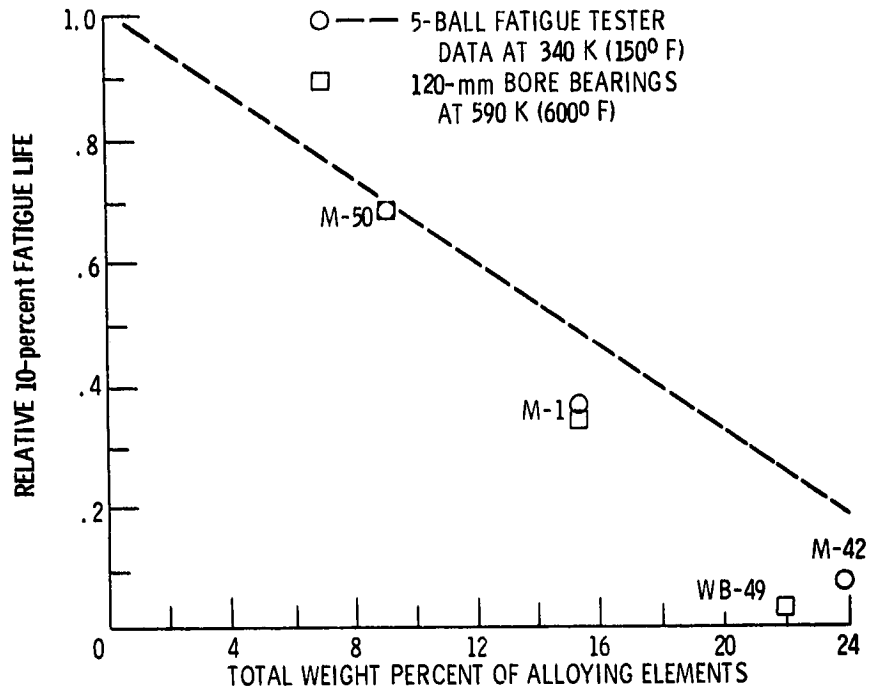
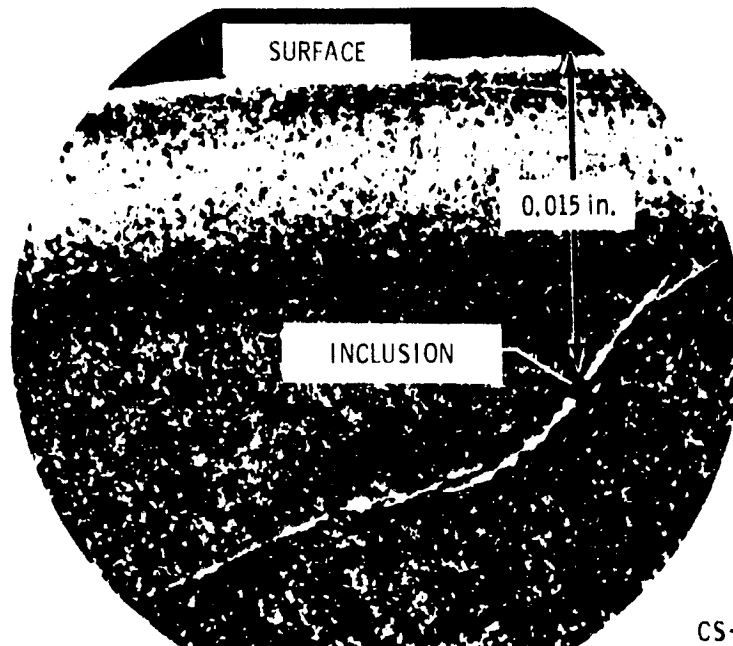

Figure 3. - Effect of total weight percent of alloying elements on fatigue life of 120-mm bore bearings at 590 K (600° F).



CS-67890

Figure 4. - Fatigue crack emanating from an inclusion.

ORIGINAL QUALITY
OF POOR QUALITY

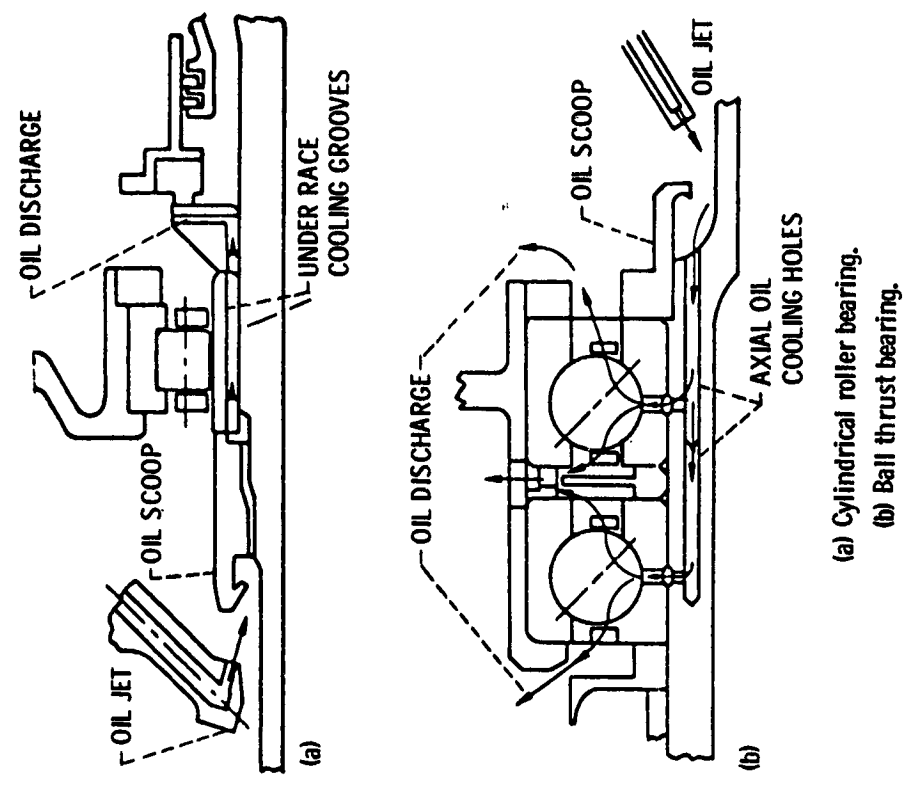

Figure 6. - Underrace oiling system for main shaft bearings on turbofan engine.

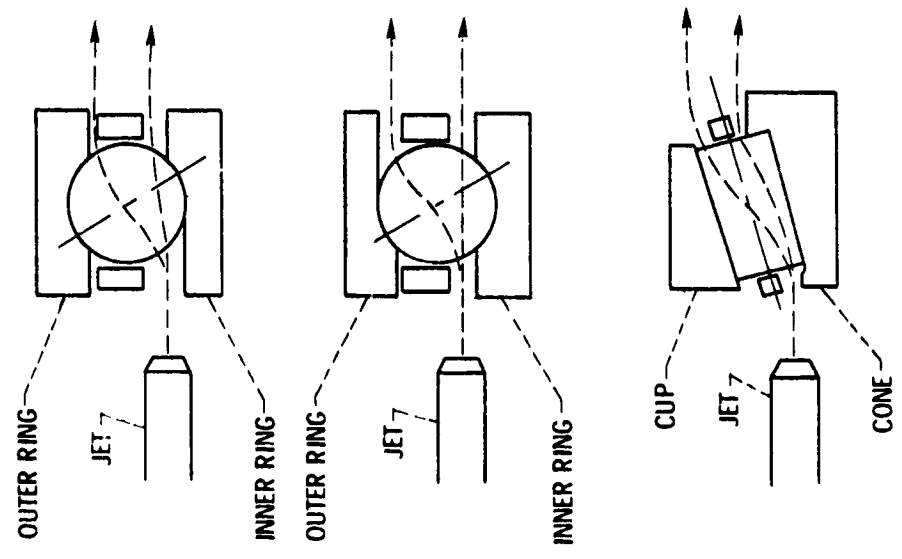

Figure 5. - Placement of jets for ball bearings with relieved rings and tapered-roller bearings.

ORIGINAL PAGE IS
OF POOR QUALITY

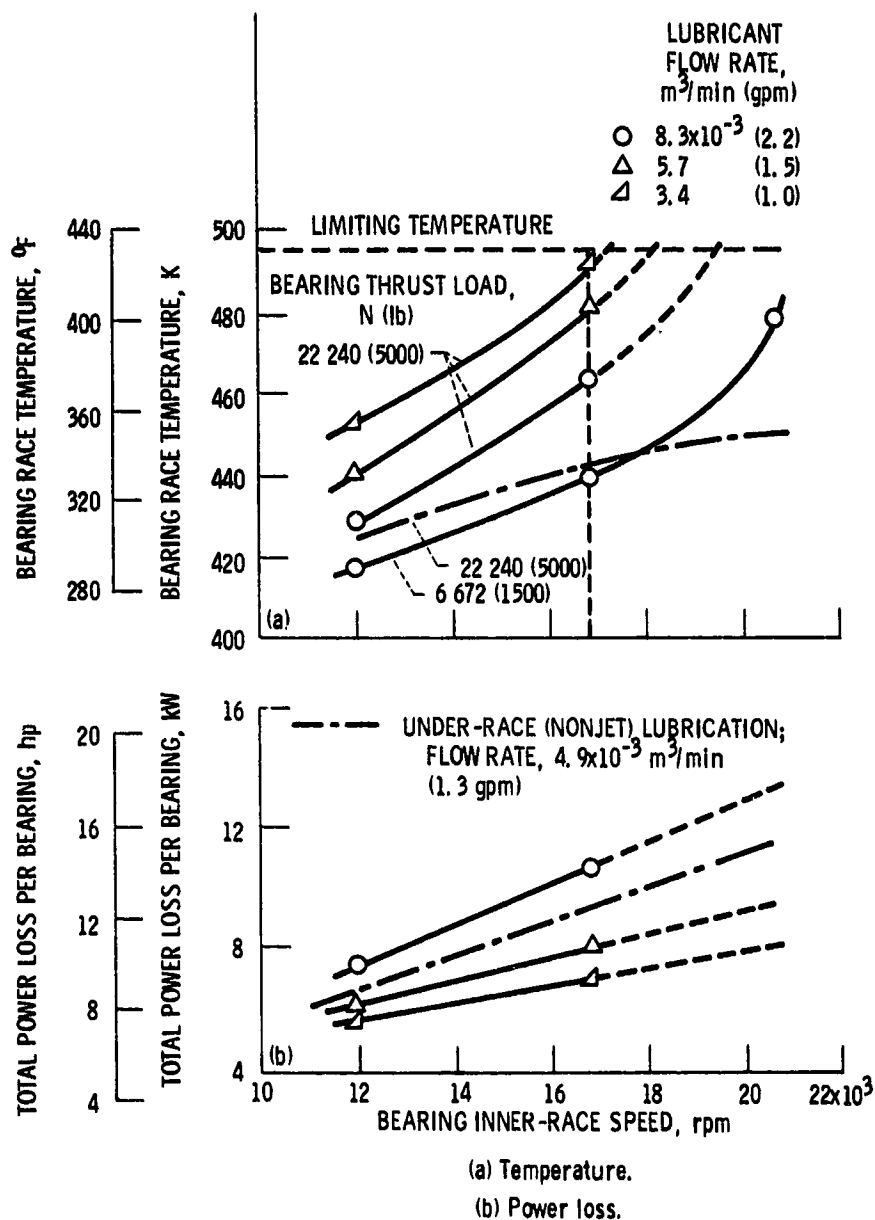

Figure 7. - Bearing inner-race temperature and power loss with jet lubrication as a function of speed for varying thrust loads and lubricant flow rates. Bearing type, 120-mm bore angular-contact ball bearing; lubricant jet, dual orifice; number of jets, 2 per bearing; oil inlet temperature, 395 K (250° F); contact angle, 20°.

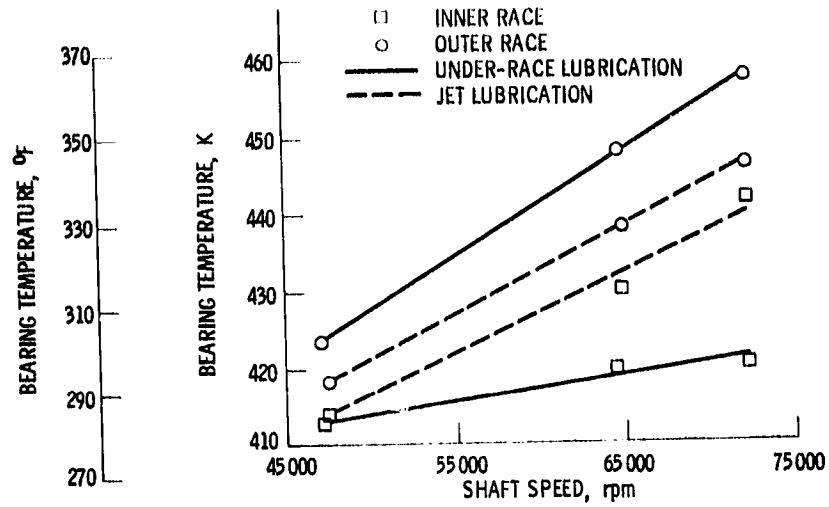

Figure 8. - Effect of under-race lubrication with 35-mm bore angular contact ball bearings. (Total oil flow rate, 1318 cm³/min (0.348 gpm); oil-in temperature, 395 K (250° F).)

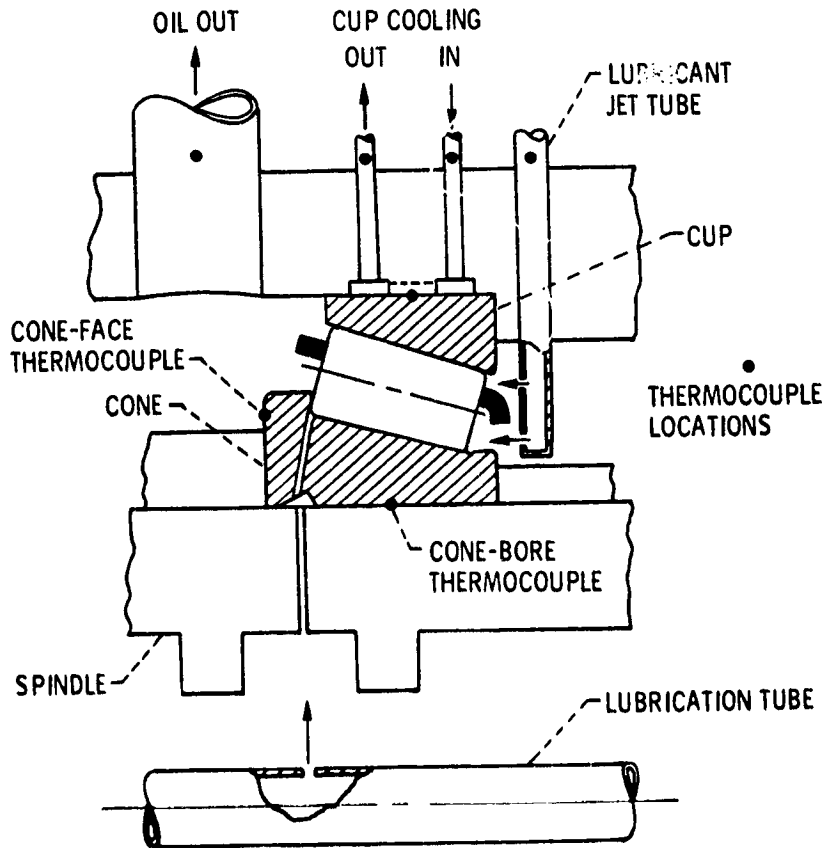

Figure 9. - Tapered-roller bearing with cone-rib and jet lubrication.

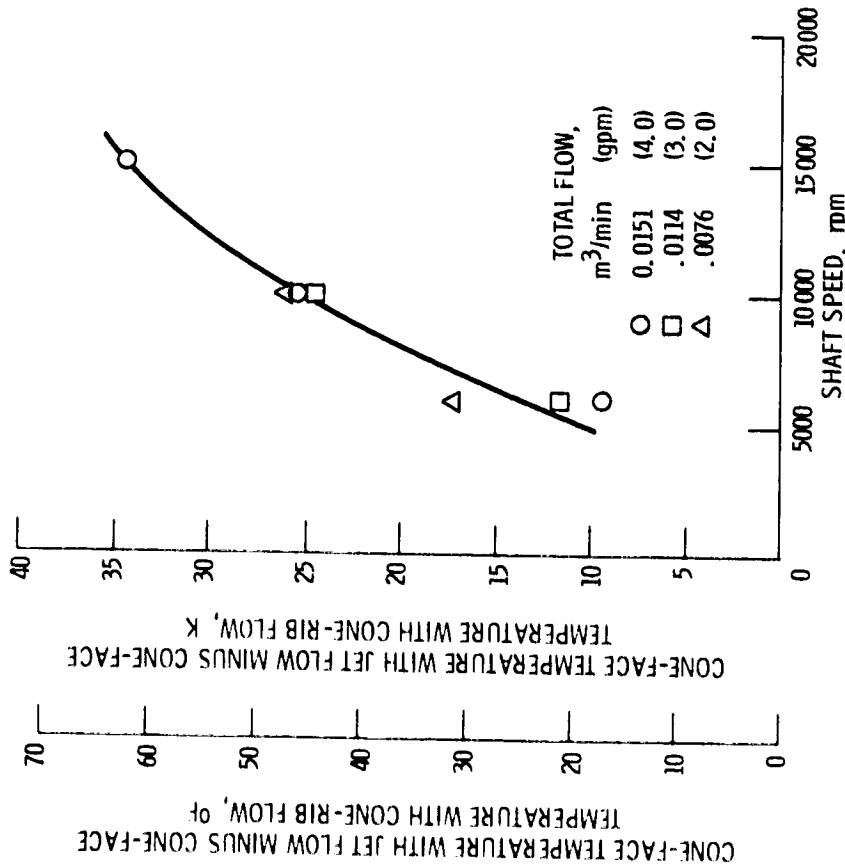

Figure 10. - Effect of shaft speed on cone-face temperature with jet lubrication minus that with cone-rib lubrication for 120.65-mm-bore tapered roller bearing. Oil-in temperature, 350 K (170° F); thrust load, 53 400 N (12 000 lb); radial load, 26 700 N (6000 lb).

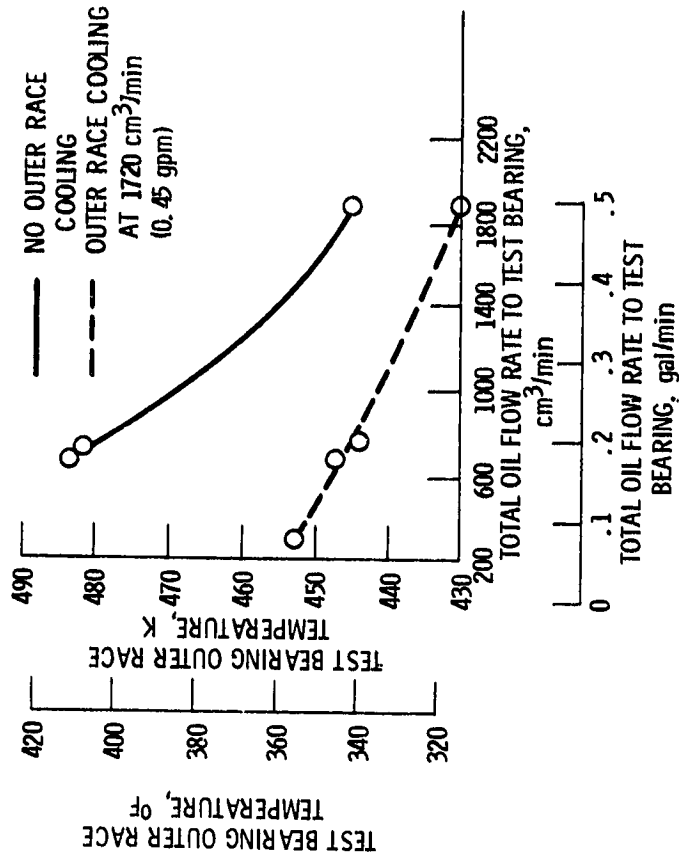
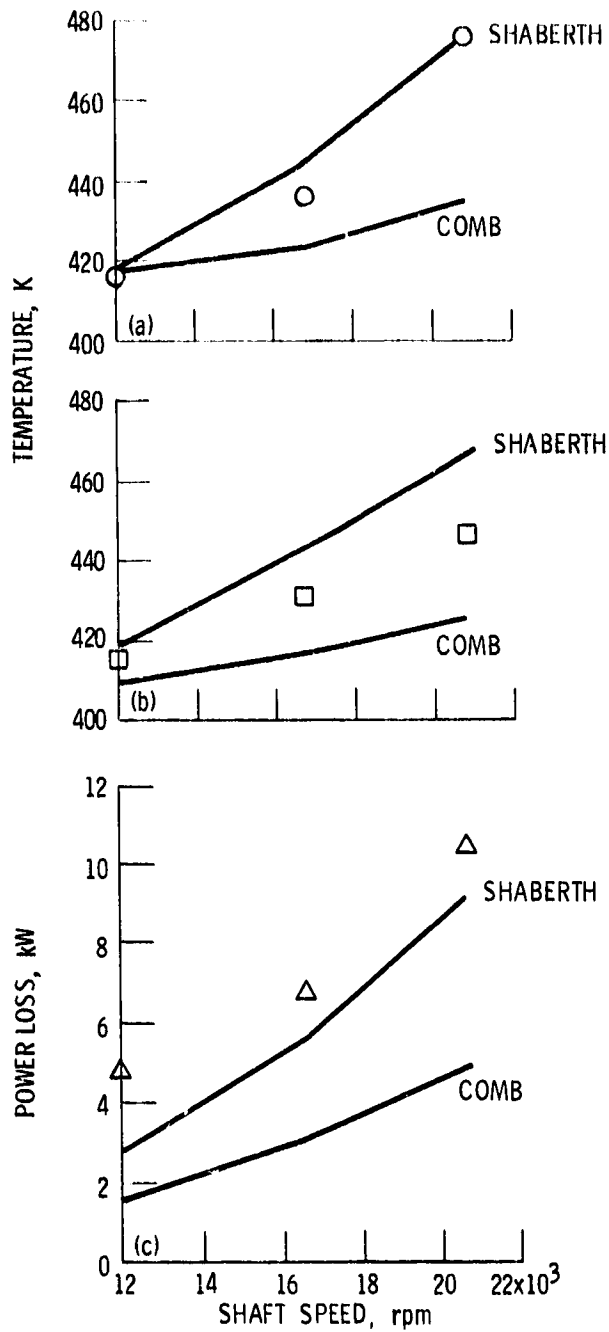

Figure 11. - Effect of outer race cooling on outer race temperature of 35-mm-bore ball bearings at 72300 rpm. Oil-in temperature, 395 K (250° F).

ORIGINAL PAGE IS
OF POOR QUALITY



(a) Inner race temperature.

(b) Outer race temperature.

(c) Bearing power loss.

Figure 12. - Calculated and experimental values of 120-mm-bore angular-contact ball bearing operating characteristics as a function of shaft speed. Thrust load, 6672 newtons (1500 lb); lubricant flow rate, 8.3×10^{-3} cubic meter per minute (2.2 gal/min); volume of lubricant, 2.0 percent.

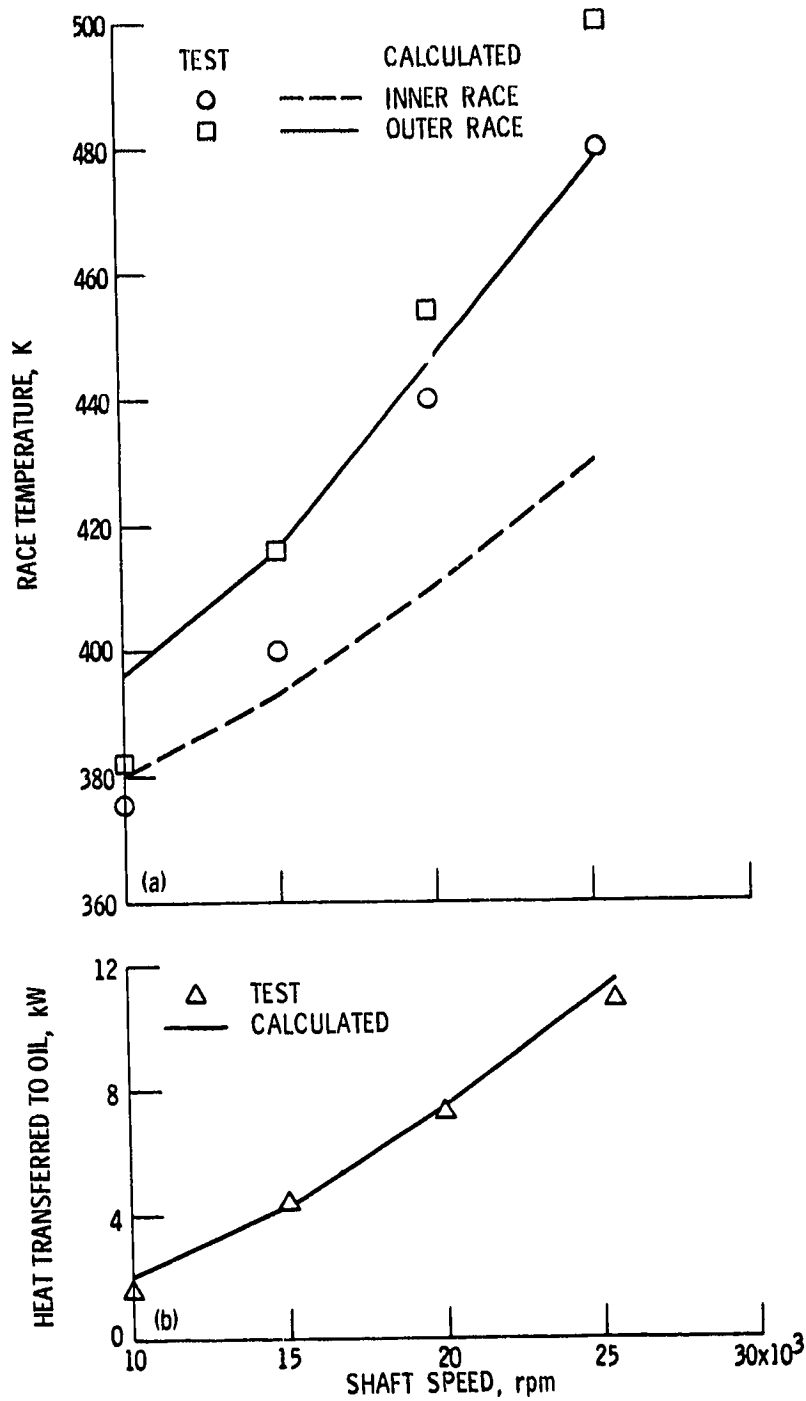

(a) Race temperatures.

(b) Heat transferred to lubricating oil.

Figure 13. - Calculated and experimental values of 118-mm-bore cylindrical roller bearing operating characteristics as a function of shaft speed, Load, 8900 N (2000 lb); lubricant flow rate, 0.0057 cubic meter per minute (1.5 gal/min); lubricant volume, 2 percent.

ORIGINAL PAGE IS
OF POOR QUALITY

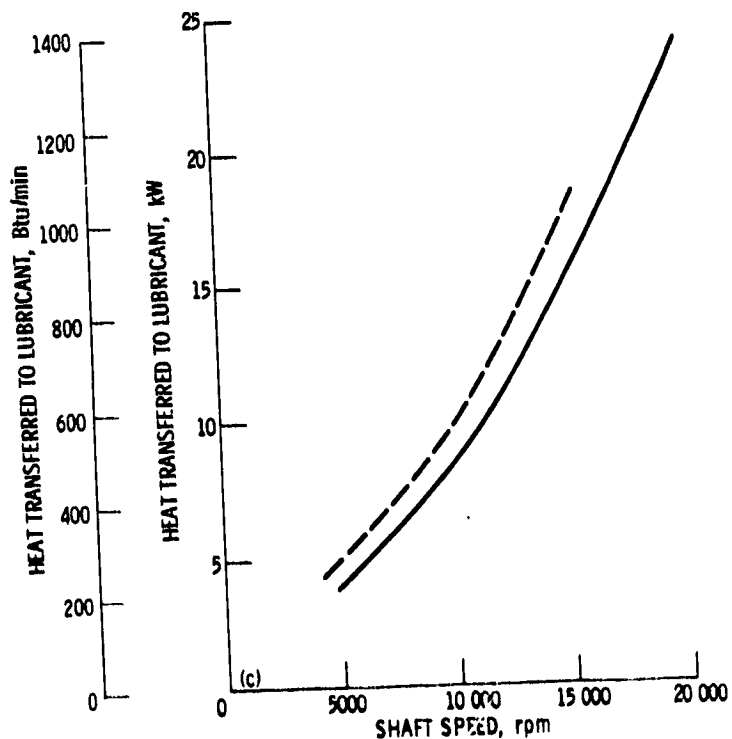
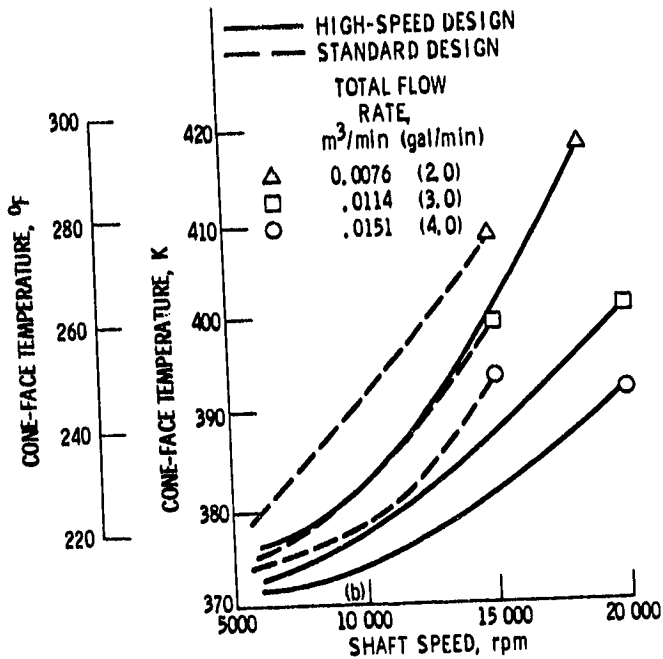
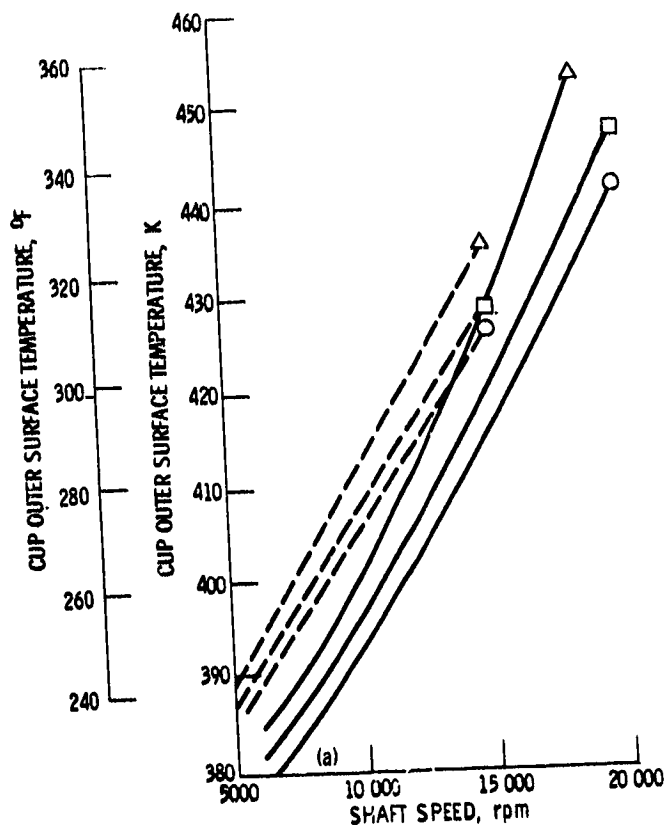

(a) Cup outer surface temperature.
(b) Cone-face temperature.
(c) Heat transferred to lubricant.

Figure 14. - Tapered-roller bearing high-speed design compared to that with standard design, Thrust load, 53 400 N (12 000 lb); radial load, 26 700 N (6000 lb); oil-in temperature, 365 K (195° F); small end flow rate, 0.0038 m³/min (1.0 gpm); bore size, 120.65 mm.

ORIGINAL PAGE IS
OF POOR QUALITY

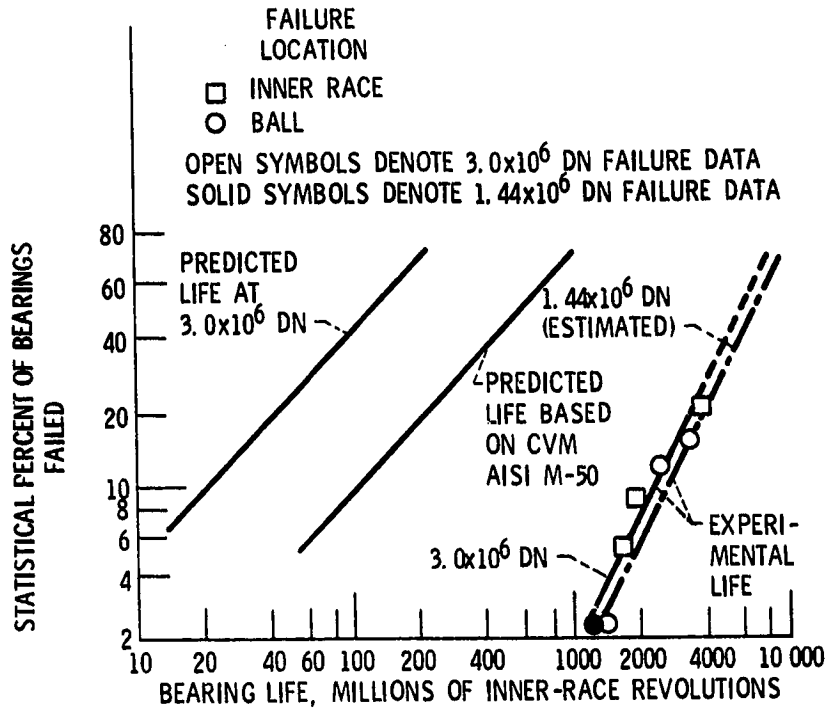

Figure 15. - Endurance characteristics of 120-mm bore angular-contact ball bearings. Thrust load, 22 240 N (5000 lb); temperature, 490 K (425° F); material, VIM-VAR AISI M-50 steel, lubricant, tetraester.