

DOE/NASA/1900-1
NASA CR-165589

NASA-CR-165589
19820022833

Vibration Analysis of Three Guyed Tower Designs for Intermediate Size Wind Turbines

Robert J. Christie
W. L. Tanksley & Associates, Inc.

March 1982

LIBRARY COPY

AUG 25 1982

LANGLEY RESEARCH CENTER
LIBRARY, NASA
HAMPTON, VIRGINIA

Prepared for
NATIONAL AERONAUTICS AND SPACE ADMINISTRATION
Lewis Research Center
Under Contract NAS3-21900

for
U.S. DEPARTMENT OF ENERGY
Conservation and Renewable Energy
Division of Wind Energy Systems

NOTICE

This report was prepared to document work sponsored by the United States Government. Neither the United States nor its agent, the United States Department of Energy, nor any Federal employees, nor any of their contractors, subcontractors or their employees, makes any warranty, express or implied, or assumes any legal liability or responsibility for the accuracy, completeness, or usefulness of any information, apparatus, product or process disclosed, or represents that its use would not infringe privately owned rights.

Vibration Analysis of Three Guyed Tower Designs for Intermediate Size Wind Turbines

Robert J. Christie
W. L. Tanksley & Associates, Inc.
Brook Park, Ohio 44142

March 1982

Prepared for
National Aeronautics and Space Administration
Lewis Research Center
Cleveland, Ohio 44135
Under Contract NAS3-21900

for
U.S. DEPARTMENT OF ENERGY
Conservation and Renewable Energy
Washington, D.C. 20545
Under Interagency Agreement DE-AI01-76ET20320

N82-30709

TABLE OF CONTENTS

VIBRATION ANALYSIS OF THREE GUYED TOWER DESIGNS
FOR INTERMEDIATE SIZE WIND TURBINES

	<u>PAGE</u>
SUMMARY OF VIBRATION ANALYSIS	1
INTRODUCTION	3
DESIGNS ANALYZED	4
Candidate Guyed Tower Designs	4
Case Studies	7
ANALYTICAL PROCEDURE FOR VIBRATION ANALYSIS	9
Inertia and Stiffness Coefficients of Wind Turbine Systems	9
Equations of Motion for Wind Turbine Systems	13
Natural Frequencies of Vibration	15
Computer Program for Vibration Analysis	16
RESULTS OF VIBRATION ANALYSIS	18
DISCUSSION OF RESULTS	19
CONCLUSIONS OF VIBRATION ANALYSIS	22
TABLES	23
FIGURES	29
APPENDICES	50
A FORTRAN COMPUTER PROGRAM, FREE VIBRATION APPROXIMATIONS FOR HORIZONTAL AXIS WIND TURBINES: NATURAL FREQUENCIES OF WIND TURBINE SYSTEMS	50
B COMPUTER PLOTS OF VIBRATION ANALYSIS, CONCEPTS I, II, AND III, CASES A THROUGH Q	57
C SYMBOLS	108

SUMMARY OF VIBRATION ANALYSIS

The objective of this study was to perform a vibration analysis of three guyed tower designs for intermediate size wind turbines. These tower designs consist of tubular steel sections totaling 28.6 m (94 ft) in length, mounted on a soft pad foundation and supported by guys. Each wind turbine design has a 38.1 m (125 ft) diameter rotor and a rated power of 200 to 400 kw with a rotor axis at an elevation of 30.5 m (100 ft) above ground.

This vibration analysis was conducted because there was some concern that these guyed towers might have natural frequencies of vibration close to the blade passing frequency of the rotor or some multiple thereof. This concern arose because of several facts.

The first is the knowledge that cantilever towers of propeller type wind turbines will vibrate violently if excited by the rotor. Secondly, guy cables are usually flexible, even with high pretension loads in them. As a result, there was concern that the tower frequencies might be too close to the rotor speed. Finally it is known that Darrieus type wind turbines, whose central column is stabilized by guys attached at the top, have experienced serious vibrations.

Another reason for conducting the vibration analysis was to determine how the tower natural frequencies were affected by the guy dynamic characteristics, the location of the guy attachment point on the tower and other factors.

The method of analysis used is one developed by R. W. Thresher, et al. in their report titled "Modeling the Response of Wind Turbines to Atmospheric Turbulence", Oregon State University Report No. RLO/2227-81/2, UC-60, August 1981. Their report was prepared for the United States Department of Energy, Division of Solar Technology, Federal Wind Energy Program. Because of the large number of analyses to be performed, a computer program was written in FORTRAN which determines the natural frequencies of vibration and plots these frequencies as a function of rotor rotational speed. The frequencies of vibration determined are for the first two modes of bending-pitch and the first two modes of bending-yaw. The program determines these frequencies of vibration using the inertia and stiffness coefficients of the wind turbine system which are calculated using the calculator program, Inertia and Stiffness Coefficients and Wind Turbines. This calculator program is included with the Oregon State University report.

Two designs in the analysis have two-bladed teetering hub rotors. Since the analysis presented by Thresher, et al is limited to three-bladed fixed hub rotors, it was necessary to modify their method. The analysis was modified by eliminating the rotational inertia of the rotor about its axis and evaluating the natural frequencies of vibration at zero rotor speed. For the three-bladed fixed hub rotor concept the method was not modified. Furthermore, the method of determining the spring rate of the guys used to support the tower had to be modified to account for the spring rate of the grouted anchors that the guys are attached to.

In the parametric study several of the system properties were varied to determine the sensitivity of the tower's natural frequencies of vibration to variances of these properties. Properties varied include the mass of the nacelle and rotor, effective guy stiffness, the height of the guy attachment point, the location of the nacelle and rotor center of gravity, the mass moment of inertias of the nacelle and rotor about the tower axes, and the rotor rotational speed. Then, by comparing the results of the different concepts, the effects of different tower section mass and stiffness properties can be determined and the effects of different rotor designs can be evaluated.

The results showed that only the lowest two frequencies of vibration were in an area where they could be excited by the rotation of the rotor. The analysis also indicated that these same two modes could be tuned by varying the effective guy stiffness, the height of the guy attachment, the mass of the nacelle and rotor, or the mass and stiffness properties of the tower sections. It was also shown that these same two modes are very close in frequency and that both change very little with the rotor's rotational speed.

In conclusion, the results of the analysis showed that the natural frequencies of vibration of all three tower designs are not in a range where they can be excited by the rotor. The effects on the natural frequencies of vibration caused by changing some of the wind turbine system characteristics were also shown.

INTRODUCTION

NASA is performing a conceptual design study to investigate the possibility of reducing the cost of intermediate size wind turbines. These wind turbines are 30.5 m (100 ft) high and have a rated power between 200 and 400 kw. Three concepts of tower designs for wind turbines are being considered. Each of these tower concepts are made of tubular steel sections mounted on a "soft pad" foundation and supported by guys with grouted anchors. The "soft pad" foundation is a concrete footing with a flexible pad interface between the tower base and the footing. This approximates a ball and socket type of joint and minimizes bending moments transferred to the footing. Two of the concepts have two-bladed teetering hub rotors; the other has a three-bladed fixed hub rotor. All three have a rotor diameter of 38.1 m (125 ft) with the axis at 30.5 m (100 ft) elevation.

Cantilever towers of propeller type wind turbines are known to vibrate if the tower natural frequencies are close to the blade passing frequency or some multiple thereof. Also, in recent years, some towers of Darrieus type wind turbines which use guys to stabilize the upper end of the tower have experienced severe vibrations. These two facts prompted the vibration analysis being reported here, namely, to determine the vibrational characteristics of the three guyed tower concepts under study as mentioned in the previous paragraph. This analysis should identify areas where the rotor might excite the tower's natural modes of vibration. Furthermore, since these tower designs are still in the preliminary design stage, it is important to determine the sensitivity of the natural frequencies of vibration to the various system properties. In this way problem areas can be identified and methods of rectification determined.

A method for vibration analysis of similar wind turbine configurations systems has previously been developed by R. W. Thresher, et al of Oregon State University. A major part of this analysis is based on their draft report titled "Modeling the Response of Wind Turbines to Atmospheric Turbulence", Oregon State University Report No. RLO/2227-81/2, UC-60, August 1981.

In the analysis of the three tower designs, the various tower and system properties of the preliminary designs were estimated and the natural frequencies determined. The system properties were then varied individually to determine their effect on the natural frequencies of vibration. The system properties varied include: effective guy stiffness; the height of the guy attachment; the mass of the nacelle and rotor; the location of the center of gravity of the nacelle and rotor; the mass moment of inertia of the nacelle and rotor about the tower's X, Y and Z axes; and the rotor's rotational speed. Due to the large number of analyses to be performed, and to expedite the calculations, a computer program was written in FORTRAN to calculate and plot the natural frequencies of vibration. The results of all the above and the computer plots are included in this report.

DESIGNS ANALYZED

Candidate Guyed Tower Designs

In this report three concepts of tower designs for wind turbines were analyzed. The three tower concepts have a hub height of 30.5 m (100 ft). One of the unique features of these tower designs is that the towers are not cantilevered but are supported by guy rods. These guy rods radiate out from the tower at three equally spaced positions. The guys are attached to the tower at 10.7 m (35 ft) above the ground and to concrete pads located 9.1 m (30 ft) from the tower's centerline. The concrete pads are anchored by grouted rock or soil anchors which extend below the surface to bedrock or to competent soil. This is shown in Figure 1.

To prevent the guys from becoming slack, the guys are pretensioned to a value greater than the change in tension experienced under maximum operating loads. Similarly, the anchor rods are pretensioned to prevent the anchor pads from unseating under all conditions. Thus, the pretension on the anchor rod is set to be greater than the maximum tension on the guy rod.

As mentioned above, the preload prevents the anchor pads from unseating, therefore, there is negligible movement of the anchor pads as loads change. This causes the effective spring rate of the anchors to be relatively high when compared to the spring rate of the guys.

For the vibration analysis, the effective stiffness of the guys must be determined. The derivation of the effective guy stiffness is presented in the Thresher, et al report. To include the spring rate of the grouted anchors and the soil, the guy system can be modeled as three springs.

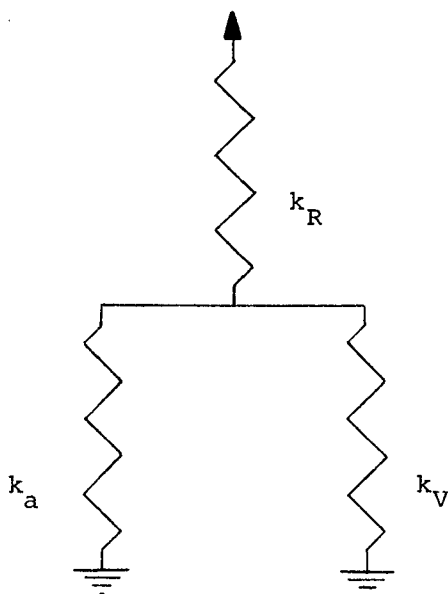

Thus, the total effective spring rate of the guys and anchors becomes

$$k_T = \frac{3}{2} N \left[\frac{1}{\frac{1}{k_R} + \frac{1}{k_a + k_V}} \right] \cos^2 \theta$$

where

k_T = Total effective guy and anchor spring rate

k_R = Spring rate of a guy rod

k_a = Spring rate of an anchor rod

k_V = Vertical spring rate of soil due to compression

N = Number of guys per position

θ = Angle between horizontal guys

This assumes that the guys and anchors are located at three equally spaced positions around the tower and that one guy is attached to one anchor.

The preliminary design of these towers specifies three guy rods and three anchors per position for each concept. Using a guy rod spring rate of $29.55E + 06$ N/m ($2.025E + 06$ lb/ft) and a combined anchor and soil spring rate of $218.9E + 06$ N/m ($15.0E + 06$ lb/ft), the total effective guy spring rate becomes $44.36E + 06$ N/m ($3.045E + 06$ lb/ft).

Each tower is made of several tubular steel sections; Concept I is made of three sections, Concept II has seven, and Concept III has eight. Each of these sections has a different wall thickness and, therefore, each have different inertia and stiffness properties. The lengths and wall thicknesses of these sections are listed in Table I and the inertia and stiffness values are listed in Table II. The sections are numbered vertically starting at the tower base. Additional sections were added to account for the extra mass and stiffness of the flanges and the segment from the top of the tower sections to the rotor's centerline.

Located at the top of the tower, as shown in Figures 2 and 3, are the gear box, generator, pitch change mechanism and controls. These are all mounted on a rotatable platform. The sum of all these parts will be referred to as the nacelle throughout this report. Also located at the top of the tower is the rotor, which consists of the rotor hub and blades. Concepts I and II both have two-bladed rotors with teetering hubs, whereas Concept III has a three-bladed rotor with a fixed hub. Furthermore, Concept I has variable pitch rotor blades, whereas Concepts II and III have fixed pitch blades.

The vibration analysis requires the total mass and location of the center of gravity for the nacelle and rotor to be calculated. For the various concepts,

the total mass and center of gravity locations were estimated as follows:

<u>CONCEPT</u>	TOTAL MASS OF NACELLE AND ROTOR,	CENTER OF GRAVITY
	$m_N + m_R$	LOCATION, g
I	16.19E + 03 kg (1110 lb sec ² /ft)	2.35 m (7.7 ft)
II	14.59E + 03 kg (1000 lb sec ² /ft)	2.16 m (7.1 ft)
III	14.18E + 03 kg (972 lb sec ² /ft)	-91.43E - 03 m (-0.3 ft)

Since a fixed hub rotor blade can be located much closer to the tower than can a teetering hub rotor blade, the rotor of Concept III is located only 1.52 m (5 ft) from the outside of the tower wall while Concepts I and II have their rotor located 3.96 m (13 ft) from the tower. This accounts for the large difference in center of gravity locations listed above. The center of gravity location is measured from the tower centerline and a negative value indicates that the center of gravity is located downwind of the tower centerline.

The mass moment of inertia of the nacelle and rotor about the tower axes were also calculated, including the mass moment of inertia of the rotor about its spin axis. Concepts I and II have teetering hubs; this allows the rotor to remain parallel to its plane of rotation during small angular changes in pitch and yaw of the nacelle. Thus the rotational inertia about the X and Z axes is greatly reduced on Concepts I and II.

The theory that this analysis is based on does not account for the flexibility of the blades, therefore, it is most applicable to small systems where the mass of the blades is a small percentage of the total mass. In this analysis the mass of the blades was about 10% of the total mass for Concepts I and II, and 13% for Concept III. Also, approximately half the mass of the blade was located within the first third of its span. Thus, this simplification is justified. Furthermore, this theory is based on a three-bladed fixed hub rotor, therefore, care should be taken in interpreting the results for Concepts I and II since they have two-bladed teetering hub rotors.

The total mass moments of inertia were calculated for each concept and are as follows:

<u>CONCEPT</u>	<u>MASS MOMENTS OF INERTIA</u>		
	I_{r2} kg m ² (lb ft sec ²)	I_{xx2} kg m ² (lb ft sec ²)	I_{zz2} kg m ² (lb ft sec ²)
I	113.8E + 03 (83.9E + 03)	113.5E + 03 (83.7E + 03)	169.8E + 03 (125.2E + 03)

CONCEPTMASS MOMENTS OF INERTIA

	I_r^2 kg m ² (lb ft sec ²)	I_{xx}^2 kg m ² (lb ft sec ²)	I_{zz}^2 kg m ² (lb ft sec ²)
II	156.6E + 03 (115.5E + 03)	125.4E + 03 (92.5E + 03)	132.3E + 03 (97.6E + 03)
III	164.1E + 03 (121.0E + 03)	133.0E + 03 (98.1E + 03)	139.9E + 03 (103.2E + 03)

I_r = Rotational mass moment of inertia of the rotor about its spin axis (Y)

I_{xx} = Mass moment of inertia of the nacelle and rotor about the tower's X axis

I_{zz} = Mass moment of inertia of the nacelle and rotor about the tower's Z axis

The calculator program for determining the inertia and stiffness coefficients also requires the number of intervals per tower section to be used for integration. The following number of intervals were chosen.

<u>CONCEPT</u>	<u>NUMBER OF INTEGRATION INTERVALS PER SECTION</u>	<u>NUMBER OF SECTIONS</u>	<u>TOTAL NUMBER OF INTEGRATION INTERVALS</u>
I	10	3	30
II	4	7	28
III	4	8	32

This completes the required input data for determining the inertia and stiffness coefficients for the tower designs.

Case Studies

To determine the effects of varying the properties of the tower, a parametric study was performed. In this study each of the tower properties were varied, one at a time, to determine their effect on the natural frequency of vibration of the tower. First, the effective guy stiffness was varied from 25% to 200% of the design value. Next, the height of the guy attachment was varied from 2/3 to 4/3 of the design height. Similarly, the mass of the nacelle and rotor was increased and decreased by 1/3 and the center of gravity location was also changed. Finally, the mass moments of inertia about the X and Z axes were increased and decreased. The following table lists all of the cases examined. Each case was analyzed on each of the three concepts.

<u>CASE</u>	<u>PROPERTY VARIED</u>
A	25% of design effective guy stiffness
B	50% of design effective guy stiffness
C	100% of design effective guy stiffness
D	150% of design effective guy stiffness
E	200% of design effective guy stiffness
F	Height of guy attachment increased by 1/3
G	Height of guy attachment decreased by 1/3
H	Nacelle and rotor mass increased by 1/3
I	Nacelle and rotor mass decreased by 1/3
J	Distance to center of gravity increased by 1/3
K	Distance to center of gravity decreased by 1/3
L	Nacelle and rotor inertia about the tower's Z axis increased by 1/3
M	Nacelle and rotor inertia about the tower's Z axis decreased by 1/3
N	Nacelle and rotor inertia about the tower's X axis increased by 1/3
O	Nacelle and rotor inertia about the tower's X axis decreased by 1/3
P	Both of the nacelle and rotor inertias about the X and Z axes increased simultaneously by 1/3
Q	Both of the nacelle and rotor inertias about the X and Z axes decreased simultaneously by 1/3

Case C is considered the norm in this analysis.

The rotor has a design operating rotational speed of 4.19 rad/sec (40 rpm). Since the natural frequency of vibration of a wind turbine system can vary with rotor's rotational speed, each concept was analyzed from 0 to 6.3 rad/sec (60 rpm) at ten equally spaced points. Since Concept I and II have teetering hubs, the natural frequencies of vibration will not change with the rotational speed of the rotor. Thus, the frequencies of vibration should be evaluated at zero rotor speed. On the other hand, Concept III has a fixed hub which causes the natural frequencies of vibration to change with rotor speed. Therefore, Concept III should be evaluated at operating speed.

ANALYTICAL PROCEDURE FOR VIBRATION ANALYSIS

Inertia and Stiffness Coefficients of Wind Turbine Systems

To determine the natural frequencies of vibration of wind turbine systems, the inertia and stiffness coefficients of the tower must be calculated. The determination of the inertia and stiffness coefficients is explained in detail in the Thresher, et al report.

For displacement of the top of the tower in the y direction, the stiffness coefficient is (see Figures 4 and 5)

$$k_{VV} = \int_0^L EI(z) (\Psi_V''(z))^2 dz + k_c \Psi_V^2(a)$$

where

V = Translational displacement in y direction

L = Length of tower

EI(z) = Tower bending stiffness

Ψ_V = Displacement function

k_c = Effective spring constant of guys

a = Distance from ground to guy connections

Ψ' , Ψ'' Represent the first and second derivatives with respect to Z

The stiffness coefficient for displacement due to pitching about the X axis is

$$k_{XX} = \int_0^L EI(z) (\Psi_X''(z))^2 dz + k_c \Psi_X^2(a)$$

where

χ = Rotational displacement about x axis at the upper end of the tower

For rotational displacement about the tower's Z axis the stiffness coefficient is

$$k_{\phi\phi} = \int_0^L GJ(z) (\Psi_\phi'(z))^2 dz$$

where

$GJ(z)$ = Tower torsional stiffness

ϕ = Rotational displacement about Z axis at the upper end of the tower

For displacement due to translation in the y direction (V) is influenced by the rotational displacement about the x axis (χ), and vice versa. The stiffness coefficient relating these two displacements is

$$k_{\chi V} = \int_0^L EI(z) \Psi_V''(z) \Psi_\chi''(z) dz + k_c \Psi_V(a) \Psi_\chi(a)$$

Finally, the stiffness coefficient for translational displacement along the x axis is

$$k_{UU} = k_{VV} - k_{V\chi}^2 / k_{\chi\chi}$$

where

U = Translational displacement in the x direction

$$k_{V\chi} = k_{\chi V}$$

The displacement functions (Ψ) are interpolating functions which relate the displacements within the tower to the displacements at the top of the tower. For a tower with a ball joint at its base, these displacement functions are

$$\Psi_V(z) = \frac{1}{2} (z/L) (3 - z/L)^2$$

$$\Psi_\chi(z) = z/2 (1 - (z/L)^2)$$

$$\Psi_\phi(z) = z/L$$

$$\Psi_V''(z) = -3z/L^3$$

$$\Psi_\chi''(z) = -3z/L^2$$

$$\Psi_\phi'(z) = 1/L$$

The equations for a tower with a ball joint at its base were chosen because the tower designs utilize bases mounted on flexible pads which reduce bending moments transmitted to the foundation. Similar equations for a cantilever based tower can be found in the Thresher, et al report.

The inertia coefficients of the tower are expressed in a similar fashion. They are

$$M_{VV} = \int_0^L m(z) \Psi_V^2(z) dz + (m_R + m_N)$$

where

$m(z)$ = Mass per unit length of the tower

$m_R = m_N$ = Mass of nacelle and rotor

and

$$M_{VX} = \int_0^L m(z) \Psi_V(z) \Psi_X(z) dz$$

$$M_{XX} = \int_0^L m(z) \Psi_X^2(z) dz + I_{xx}$$

$$M_{\phi\phi} = \int_0^L I_m(z) \Psi_\phi^2(z) dz + I_{zz}$$

where

I_{xx} = Mass moment of inertia of nacelle and rotor about the x axis

I_{zz} = Mass moment of inertia of nacelle and rotor about the z axis

$I_m(z)$ = Mass moment of inertia per unit length of tower about the tower centerline

also

$$M_{U\phi} = -(m_R + m_N) q$$

where

q = The distance from the tower centerline to the center of gravity of the nacelle and rotor

Finally

$$M_{UU} = M_{VV} - 2(k_{VX}/k_{XX}) M_{VX} + (k_{VX}/k_{XX})^2 (M_{XX} - I_{xx})$$

The displacement functions are the same as those used in determining the stiffness coefficients. These coordinate functions are used in a finite element technique and are explained in the Thresher, et al report.

The stiffness and inertia coefficients as outlined above can be calculated using the calculator program Inertia and Stiffness Coefficients of Wind Turbines which is included in the Thresher, et al report. The required input data include (see Figure 4):

- 1) The type of tower base.
- 2) The height of the tower (L).
- 3) The effective spring constant of the guys (k_c).
- 4) The height of the guy connection (a).
- 5) The length of the tower sections (L').
- 6) The bending stiffness of the tower section ($EI(z)$).
- 7) The torsional stiffness of the tower section ($GJ(z)$).
- 8) The mass per unit length of the tower section ($m(z)$).
- 9) The mass moment of inertia per unit length about the tower centerline ($I_m(z)$).
- 10) The number of intervals for integration (N).
- 11) The mass moment of inertia of the nacelle and rotor about the x and z axes (I_{xx} and I_{zz}).
- 12) The mass of the nacelle and rotor ($m_N + m_R$).
- 13) The distance from the tower centerline to the center of gravity of the nacelle and rotor (q).

The output from the above program is

$$M_{UU}, M_{U\phi}, M_{VV}, M_{V\chi}, M_{\phi\phi}, M_{\chi\chi}$$

and

$$k_{UU}, k_{VV}, k_{V\chi}, k_{\phi\phi}, k_{\chi\chi}$$

Equations of Motion for Wind Turbine Systems

Once the above mass and stiffness coefficients are calculated they can be entered into the equations of motion for wind turbine systems.

The equations of motion for a wind turbine system, excluding aerodynamic forces, are

$$\begin{bmatrix} M_{UU} & 0 & M_{U\phi} & 0 \\ 0 & M_{VV} & 0 & M_{V\chi} \\ M_{U\phi} & 0 & M_{\phi\phi} & 0 \\ 0 & M_{V\chi} & 0 & M_{\chi\chi} \end{bmatrix} \begin{bmatrix} \ddot{U} \\ \ddot{V} \\ \ddot{\phi} \\ \ddot{\chi} \end{bmatrix} + \begin{bmatrix} 0 & 0 & 0 & 0 \\ 0 & 0 & 0 & 0 \\ 0 & 0 & \Omega I_r & 0 \\ 0 & -\Omega I_r & 0 & 0 \end{bmatrix} \begin{bmatrix} \dot{U} \\ \dot{V} \\ \dot{\phi} \\ \dot{\chi} \end{bmatrix} + \begin{bmatrix} k_{UU} & 0 & 0 & 0 \\ 0 & k_{VV} & 0 & k_{V\chi} \\ 0 & 0 & k_{\phi\phi} & 0 \\ 0 & k_{V\chi} & 0 & k_{\chi\chi} \end{bmatrix} \begin{bmatrix} U \\ V \\ \phi \\ \chi \end{bmatrix} = \begin{bmatrix} 0 \\ 0 \\ 0 \\ 0 \end{bmatrix}$$

To obtain the natural frequencies of vibration, these equations of motion have the solution

$$\begin{bmatrix} U(t) \\ V(t) \\ \phi(t) \\ \chi(t) \end{bmatrix} = \begin{bmatrix} U_0 \\ V_0 \\ \phi_0 \\ \chi_0 \end{bmatrix} e^{i\omega t}$$

Substituting this into the equations of motion yields

$$\begin{bmatrix} (k_{UU} - M_{UU}\omega^2) & 0 & (-M_{U\phi}\omega^2) & 0 \\ 0 & (k_{VV} - M_{VV}\omega^2) & 0 & (k_{UX} - M_{UX}\omega^2) \\ (-M_{U\phi}\omega^2) & 0 & (k_{\phi\phi} - M_{\phi\phi}\omega^2) & (iI_r\Omega\omega) \\ 0 & (k_{VX} - M_{VX}\omega^2) & (-iI_r\Omega\omega) & (k_{XX} - M_{XX}\omega^2) \end{bmatrix}$$

$$\begin{bmatrix} U_0 \\ V_0 \\ \phi_0 \\ X_0 \end{bmatrix} = \begin{bmatrix} 0 \\ 0 \\ 0 \\ 0 \end{bmatrix}$$

where

$$i = \sqrt{-1}$$

ω = Natural frequency of vibration

I_r = Mass moment of inertia of the rotor about its spin axis

Ω = Rotor's rotational speed

This requires that the determinate of the square matrix be equal to zero. Expanding the determinate yields

$$\begin{aligned} & [k_{UU}k_{\phi\phi} - (k_{UU}M_{\phi\phi} + k_{\phi\phi}M_{UU})\omega^2 + (M_{UU}M_{\phi\phi} - M_{U\phi}^2)(\omega^2)^2] \times [k_{XX}k_{VV} - \\ & k_{VX}^2 - (k_{XX}M_{VV} + k_{VV}M_{XX} + 2k_{VX}M_{VX})\omega^2 + (M_{XX}M_{VV} + M_{VX}^2)(\omega^2)^2] - \\ & (I_r^2\Omega^2) [(k_{UU}k_{VV})\omega^2 - (k_{UU}M_{VV} + k_{VV}M_{UU})(\omega^2)^2 + (M_{UU}M_{VV})(\omega^2)^3] = 0 \end{aligned}$$

If we let

$$G_{\phi U}(\omega^2) = k_{UU}k_{\phi\phi} - (k_{UU}M_{\phi\phi} + k_{\phi\phi}M_{UU})\omega^2 + (M_{UU}M_{\phi\phi} - M_{U\phi}^2)(\omega^2)^2$$

$$H_{\chi V}(\omega^2) = k_{\chi\chi}k_{VV} - k_{V\chi}^2 - (k_{\chi\chi}M_{VV} + k_{VV}M_{\chi\chi} - 2k_{V\chi}M_{V\chi})(\omega^2) + (M_{VV}M_{\chi\chi} - M_{V\chi}^2)(\omega^2)^2$$

$$D_{UV}(\omega^2) = I_r^2 [(k_{UU}k_{VV})\omega^2 - (k_{UU}M_{VV} + k_{VV}M_{UU})(\omega^2) + (M_{UU}M_{VV})(\omega^2)^3]$$

The expanded determinate becomes

$$G_{\phi U}(\omega^2) H_{\chi V}(\omega^2) - \Omega^2 D_{UV}(\omega^2) = 0$$

Natural Frequencies of Vibration

At zero rotor speed ($\Omega = 0$), the above becomes

$$G_{\phi U}(\omega^2) H_{\chi V}(\omega^2) = 0$$

thus the roots of $G_{\phi U}$ and $H_{\chi V}$ will give the natural frequencies of vibration at zero speed.

The equation for D_{UV} can be factored to yield

$$D_{UV}(\omega^2) = I_r^2 \omega^2 (k_{UU} - M_{UU}\omega^2)(k_{VV} - M_{VV}\omega^2)$$

Rearranging the determinate

$$(k_{UU} - M_{UU}\omega^2)(k_{VV} - M_{VV}\omega^2) = \frac{G_{\phi U}(\omega^2) H_{\chi V}(\omega^2)}{\Omega^2 I_r^2 \omega^2}$$

At infinite rotor speed this becomes

$$(k_{UU} - M_{UU}\omega^2)(k_{VV} - M_{VV}\omega^2) = 0$$

The roots of these will give the natural frequency of vibration at infinite rotor speed.

The calculator program, Natural Frequencies of Wind Turbine Systems, included in the Thresher, et al report was written to determine the frequencies

of vibration at zero and infinite rotor speed. It can also be used to calculate the rotor speed at which a given frequency of vibration will occur.

In this analysis it was desirable to determine the natural frequencies of vibration as a function of rotor speed. Therefore, a computer program was written in FORTRAN that extracts the roots in ω^2 of the expanded determinate.

$$G_{\phi U}(\omega^2) H_{\chi V}(\omega^2) - \Omega^2 D_{UV}(\omega^2) = 0$$

Computer Program for Vibration Analysis

The FORTRAN program uses the inertia and stiffness coefficients calculated on the calculator program, Inertia and Stiffness Coefficients of Wind Turbines, and determines the coefficients of $(\omega^2)^0$, $(\omega^2)^1$, $(\omega^2)^2$, $(\omega^2)^3$ and $(\omega^2)^4$. In the program

$$AG = k_{UU} k_{\phi\phi}$$

$$BG = -(k_{UU} M_{\phi\phi} + k_{\phi\phi} M_{UU})$$

$$CG = M_{UU} M_{\phi\phi} - M_{U\phi}^2$$

$$AH = k_{XX} k_{VV} - k_{VX}^2$$

$$BH = -(k_{XX} M_{VV} + k_{VV} M_{XX} - 2k_{VX} M_{VX})$$

$$CH = M_{VV} M_{XX} - M_{VX}^2$$

$$AD = 0$$

$$BD = \Omega^2 I_r^2 k_{UU} k_{VV}$$

$$CD = -\Omega^2 I_r^2 (k_{UU} M_{VV} + k_{VV} M_{UU})$$

$$DD = \Omega^2 I_r^2 M_{UU} M_{VV}$$

Substituting these into the expanded determinate and collecting terms yields

$$(AG)(AH) + [(AG)(BH) + (BG)(AH) - (BD)]\omega^2 + [(AG)(CH) + (BG)(BH) +$$

$$(CG)(AH) - (CD)](\omega^2)^2 + [(BG)(CH) + (CG)(BH) - (DD)](\omega^2)^3 +$$

$$(CG)(CH)(\omega^2)^4 = 0$$

After summing like coefficients, the subroutine GNEWTN is called. This routine determines the roots of a polynomial using a modified Newton method and is capable of locating complex roots. This routine was supplied by NASA - Lewis Research Center and requires the subroutine SYNDIV for synthetic division. The program is also capable of plotting the natural frequencies of vibration as a function of rotor speed and uses plotting routines also supplied by NASA - Lewis Research Center.

The computer program requires the following input data:

- 1) Number of data sets (J).
- 2) Number of roots to be plotted (JPO).
- 3) Title.
- 4) Mass moment of inertia of the rotor about its spin axis (I_r).
- 5) The lowest rotor speed at which roots are to be found (R_{\min}).
- 6) The highest rotor speed at which roots are to be found (R_{\max}).
- 7) The number of points between the lowest and highest rotor speeds at which roots are to be found (NS).
- 8) M_{UU} , $M_{U\phi}$, MM_{VV} , $M_{V\chi}$, $M_{\phi\phi}$, and $M_{\chi\chi}$.
- 9) k_{UU} , k_{VV} , $k_{V\chi}$, $k_{\phi\phi}$, and $k_{\chi\chi}$.

The output includes:

- 1) The natural frequencies of vibration at zero rotor speed (i.e., the roots of $G_{\phi U}$ and $H_{\chi V}$).
- 2) The natural frequencies of vibration at infinite rotor speed (i.e., the roots of D_{UV}).
- 3) The natural frequencies of vibration at R_{\min} , R_{\max} , and the number of points requested between the minimum and maximum rotor speed.
- 4) A plot of the natural frequencies of vibration versus rotor spin rate.

A flow chart of this program is included in Figure 6 and a listing can be found in Appendix A.

RESULTS OF VIBRATION ANALYSIS

The appropriate tower properties for each case and concept were entered into the calculator program, Inertia and Stiffness Coefficients of Wind Turbines, presented in the Thresher, et al report. The output of the calculator program provides the inertia and stiffness coefficients of the wind turbine system. The inertia and stiffness coefficients were entered into the FORTRAN program, Natural Frequencies of Wind Turbine Systems, which was developed for this analysis. The output of the computer program provides natural frequencies of vibration as a function of rotor rotational speed. Listed in Tables III and IV are the first four modes of vibration for Concepts I and II evaluated at zero rotor speed. Table V lists the same modes of vibration for Concept III except they are evaluated at a rotor operating speed of 4.19 rad/sec (40 rpm). The results of the different cases are plotted and can be found in Appendix B. These four modes of vibration represent the first and second modes of vibration in bending coupled with yaw and the first and second mode of vibration in bending coupled with pitch. In these tables the first bending-pitch mode is labeled ω_1 (Mode I), the first bending-yaw mode is labeled ω_2 (Mode II), the second bending-yaw mode is labeled ω_3 (Mode III), and the second bending-pitch mode is labeled ω_4 (Mode IV).

Cases A through E for each concept are plotted in Figures 7 and 8. These show the effect of varying the effective guy stiffness on the frequencies of the four modes of vibration. Lines labeled 1P, 2P and 3P have also been plotted on Figure 7 and represent multiples of the rotor's rotational speed. Figures 9 and 10 show the results of Cases F and G and indicate the effect of changing the height of the guy attachment point. The effect of varying the mass of the nacelle and rotor, Cases H and L, is shown in Figures 11 and 12 and the effect of moving the nacelle and rotor center of gravity is plotted in Figure 13. Finally, Cases L through Q, which show the effect of changing the nacelle and rotor inertia about the X and Z axes, are plotted in Figures 14, 15 and 16. On all of the above plots ω_1 is the first bending-pitch mode, ω_2 is the first bending-yaw mode, ω_3 is the second bending-yaw mode, and ω_4 is the second bending-pitch mode. In all cases, ω_1 and ω_2 were very close and are plotted as one line.

The computer plot of the natural frequencies of vibration versus rotor rotational speed for the design case, Case C, can be found in Figures 17, 18 and 19. The computer plots of the other cases can be found in Appendix B.

The natural frequencies of vibration of ω_2 at infinite rotor rotational speed are listed in Table VI. Since Concepts I and II have teetering hubs which eliminate the gyroscopic effects encountered with a fixed hub, these results are not applicable. Even though these results are apparently not of any significance now, their importance will be pointed out later.

The mode shapes of vibration for a typical wind turbine system can be seen in Figures 20 and 21. These figures are excerpts from the Thresher, et al report and represent a non-guyed wind turbine tower.

DISCUSSION OF RESULTS

The results of the vibration analysis were analyzed to determine the important features and to determine the sensitivity of the wind turbine system to the variance of individual parameters. Note that in this analysis, in most cases, only one parameter at a time was varied, but in actuality when one parameter is changed so are several others. For example, if the mass of the rotor changes, the center of gravity of the nacelle and rotor would move and the mass moment of inertia about the tower's X and Z axes would also be affected. Therefore, several properties of the wind turbine system would change instead of just one.

While analyzing the results of Cases A through E, it was determined that all frequencies of vibration are affected by changing the effective guy stiffness (see Figures 7 and 8). This was expected because changing the effective guy stiffness changes the stiffness of the tower. As expected, as the effective guy stiffness decreased, so did the natural frequencies of vibration and as effective guy stiffness increased, so did the frequencies. Comparing Figures 7 and 8, we find that the lower two modes of vibration are affected the most.

Points of concern are where a multiple of a rotor's rotational speed coincides with a natural frequency of vibration. At these points the rotor would excite the mode of vibration and cause the tower to oscillate near resonance. Since Concepts I and II have two-bladed rotors, the first and second multiple (1P and 2P) of the rotor's rotational speed are of importance. Since Concept III has a three-bladed rotor, the first and third multiples (1P and 3P) are of interest. When the lowest modes of vibration occur at frequencies above the lower rotor orders, the tower is defined as being "stiff". If these lower modes of vibration occurred at a frequency below the first rotor order, the tower would be considered "soft". In this analysis, the lowest two modes of vibration, in most cases, occurred at frequencies well above the first two rotor orders for the two-bladed concepts and the first three rotor orders for the three-bladed concept. Therefore, all three tower concepts in this analysis proved to be "stiff".

In analyzing the results of Cases A through E (see Appendix B), it was found that the effective guy stiffness had to be decreased considerably before any natural frequency of vibration coincided with a lower rotor order. For Concepts I and II the effective guy stiffness had to be decreased to 25% of the design value before the lowest natural frequency of vibration would be excited by the second rotor order. For Concept III the effective guy stiffness had to be decreased to 50% of the design value before the lowest natural frequency could coincide with the third rotor order. This indicates the tower designs are very stiff and that the effective guy stiffness could vary significantly before reaching resonance. The high stiffness can be greatly attributed to the use of prestressed anchors and anchor pads. Note that the two second modes of vibration, ω_3 and ω_4 , occur at relatively high frequencies and, therefore, should not be of concern.

The results of Cases F and G show the effect of changing the height of the guy attaching point. Figures 9 and 10 show that as the height of the attaching point is raised, the natural frequencies of vibration increase. This implies that raising the guy attaching point increases the stiffness of the system and thus increases the frequency of vibration. On the other hand, if the height of the guy attaching point is lowered, the stiffness of the system decreases as well as the natural frequencies of vibration. In both of these cases, the first two modes of vibration were affected the most. The first two natural frequencies of vibration of Concept III became excited by the third rotor order (3P) when the height of the guy attachment was lowered to 2/3 of the design value. The first two natural frequencies of vibration for Concepts I and II did not coincide with the first two rotor orders in either case.

In Cases H and I, the mass of the nacelle and rotor was varied. As the mass was increased the frequency of vibration of the first two modes decreased and as the mass was decreased, frequency increased. Figure 11 shows that, within the range of the analysis, none of the concepts have their first two modes excited by the rotor orders of concern. Figure 12 shows that the second mode of bending-yaw (ω_3) is greatly affected by the mass of the nacelle and rotor but the second mode of bending-pitch (ω_4) is not.

Changing the distance from the tower centerline to the location of the nacelle and rotor center of gravity had little effect on Modes I, II and IV, but Mode III was greatly affected (see Figure 13). This plot shows that as the distance to the center of gravity is increased, the frequency of vibration of the second mode of bending-yaw also increases. The opposite happens when the distance is decreased.

The plots of Cases L through Q show the effect of changing the inertia of the nacelle and rotor about the tower's X and Z axes. As the inertia about the Z axis was varied, the second mode of bending-yaw (ω_2) was affected the most, but as the inertia about the X axis was varied, the second mode of bending-pitch (ω_4) was influenced. These effects can be seen in Figures 14 through 16. The lower modes showed little change and, therefore, were not plotted.

This analysis has shown that only the natural frequencies of the first modes of vibration are in a region of concern, i.e., in a region where they might be excited by the rotor. These first modes of vibration, ω_1 and ω_2 , were shown to be most greatly affected by changing the effective guy stiffness, the height of the guy attachment point, the tower mass and stiffness properties, and the mass of the nacelle and rotor.

Once the basic wind turbine system is designed, the designer cannot practically change the mass and stiffness of the tower nor the mass of the nacelle and rotor, but the effective guy stiffness can be varied without a great deal of redesigning. The effective guy stiffness can be varied by changing the size and/or the number of guy rods. For these tower designs, the minimum number and size of the guys were based on the cyclic loading under normal operating conditions and the static loads experienced during hurricane conditions. Thus, the practical design variables become, increasing the size or the number of guys. The effect of the guys can also be changed by varying

the height of the guy attachment point, but this would require significant redesigning of the tower sections.

Finally, the results in Table VI, which lists the natural frequencies of vibration at infinite rotor rotational speed, show that ω_2 changes very little with rotor speed, i.e., ω_2 at zero rotor speed is approximately the same frequency at infinite rotor speed. It was also shown earlier that at or near zero rotor speed, ω_1 and ω_2 were also approximately of the same frequency. Therefore, the frequency of ω_1 and ω_2 at zero rotor speed is approximately the same as the frequency of ω_2 at infinite rotor speed. As discussed in the Analytical Procedure, ω_2 at infinite rotor speed can be easily found by calculating the square root of k_{UU}/M_{UU} . Thus, the natural frequencies of vibration of the first modes can be easily approximated with one stiffness and one inertia coefficient.

CONCLUSIONS OF VIBRATION ANALYSIS

In conclusion, a vibration analysis was performed on three preliminary tower designs for intermediate size wind turbines. A parametric study was performed to determine the sensitivity of the wind turbine system to variances in inertia and stiffness properties. The following conclusions were made as a result of the vibration analysis.

- 1) Under design conditions none of the tower concepts are excited by the rotor at or below the operating speed of 40 rpm.
- 2) At present, only the lowest two natural frequencies of vibration are in frequency range of concern. It was also found in the operating range, that these first two modes are very close in frequency. Furthermore, the first bending-yaw mode frequency (ω_2) changes very little from zero to infinite rotor speed. Therefore, the frequency of vibration of most concern can be found by evaluating ω_2 at infinite rotor speed. This is simply:

$$\omega_2 = (k_{UU}/M_{UU})^{1/2}$$

where k_{UU} and M_{UU} are the stiffness and mass coefficients for translation in the x direction.

- 3) The frequencies of vibration of the lowest two modes are significantly affected by the effective guy and anchor stiffness, the height of the guy attachment, and the mass of the nacelle and rotor. These modes are also affected by the tower section properties, i.e., tower sections' mass and stiffness. Thus, the tower may be tuned to avoid excitation of the lower modes by changing the effective anchor and guy stiffness, the guy attaching height, the mass of the nacelle and rotor, or the tower sections' mass and stiffness properties. The most practical being the size and the number of the guys.
- 4) The center of gravity location of the nacelle and rotor had negligible effects on the lower modes of vibration. The same is true for the rotational inertia of the nacelle and rotor about the tower's X, Y and Z axes.
- 5) The frequencies of vibration of the upper two modes were affected in all cases, but were of so high a frequency that they are of little concern. The effective guy and anchor stiffness mostly affected the second bending-pitch mode (Mode IV), whereas the nacelle and rotor mass and the location of the center of gravity affected mostly the second bending-yaw mode (Mode III). The inertia about the Z axis had the greatest affect on Mode III, and the inertia about the Y axis mostly affected Mode IV.

TABLE I

TOWER SECTION LENGTHS AND THICKNESSES

TOWER CONCEPT	SECTION NUMBER	SECTION LENGTH		WALL THICKNESS	
		m (ft)		mm (in)	
I	1	7.62 (25.0)		7.94 (5/16)	
	2	10.67 (35.0)		9.52 (3/8)	
	3	10.36 (34.0)		7.94 (5/16)	
II	1	3.66 (12.0)		7.94 (5/16)	
	2	1.83 (6.0)		9.52 (3/8)	
	3	3.05 (10.0)		12.70 (1/2)	
	4	5.49 (18.0)		15.88 (5/8)	
	5	5.79 (19.0)		12.70 (1/2)	
	6	3.66 (12.0)		9.52 (3/8)	
	7	5.18 (17.0)		7.94 (5/16)	
III	1	3.66 (12.0)		14.29 (9/16)	
	2	2.44 (8.0)		11.11 (7/16)	
	3	2.44 (8.0)		14.29 (9/16)	
	4	4.57 (15.0)		19.05 (3/4)	
	5	4.57 (15.0)		15.88 (5/8)	
	6	4.88 (16.0)		12.70 (1/2)	
	7	2.74 (9.0)		9.52 (3/8)	
	8	3.35 (11.0)		7.94 (5/16)	

TABLE II

TOWER SECTION INERTIA AND STIFFNESS PROPERTIES

TOWER CONCEPT	SECTION NUMBER	BENDING	TORSIONAL	MASS PER	MASS MOMENT
		STIFFNESS	STIFFNESS	UNIT LENGTH	OF INERTIA PER
		EI(Z)	GJ(Z)	M(Z)	Im(Z)
		Nm ²	Nm ²	kg/m	kgm ²
		(lb ft ²)	(lb ft ²)	(lb sec ² /ft ²)	(lb ft sec ²)
I	1	1.861E+09	1.489E+09	279.9	44.27
		(4.502E+09)	(3.602E+09)	(5.845)	(32.65)
	2	2.226E+09	1.780E+09	335.4	54.23
		(5.385E+09)	(4.308E+09)	(7.006)	(39.99)
	3	1.861E+09	1.489E+09	279.9	44.27
		(4.502E+09)	(3.602E+09)	(5.845)	(32.65)
II	1	1.861E+09	1.489E+09	280.3	44.29
		(4.502E+09)	(3.602E+09)	(5.855)	(32.66)
	2	2.226E+09	1.780E+09	336.0	52.99
		(5.385E+09)	(4.308E+09)	(7.018)	(39.08)
	3	2.948E+09	2.358E+09	447.1	70.21
		(7.133E+09)	(5.706E+09)	(9.337)	(51.78)
	4	3.661E+09	2.929E+09	557.6	87.11
	(8.857E+09)	(7.086E+09)	(11.645)	(64.24)	
	5	2.948E+09	2.358E+09	447.1	70.21
		(7.133E+09)	(5.706E+09)	(9.337)	(51.78)
	6	2.226E+09	1.780E+09	336.0	52.99
		(5.385E+09)	(4.308E+09)	(7.018)	(39.08)
	7	1.861E+09	1.489E+09	280.3	44.29
		(4.502E+09)	(3.602E+09)	(5.855)	(32.66)
III	1	1.861E+09	1.489E+09	247.4	39.09
		(4.502E+09)	(3.602E+09)	(5.168)	(28.83)
	2	2.588E+09	2.070E+09	345.7	54.36
		(6.262E+09)	(5.009E+09)	(7.220)	(40.09)
	3	3.306E+09	2.644E+09	443.5	69.45
		(7.998E+09)	(6.398E+09)	(9.262)	(51.22)
	4	4.364E+09	3.491E+09	589.4	91.69
		(10.56E+09)	(8.447E+09)	(12.309)	(67.62)
	5	3.661E+09	2.929E+09	494.2	76.93
		(8.857E+09)	(7.086E+09)	(10.280)	(56.73)
	6	2.948E+09	2.358E+09	396.4	62.21
		(7.133E+09)	(5.706E+09)	(8.278)	(45.88)
	7	2.226E+09	1.780E+09	296.6	46.78
		(5.385E+09)	(4.308E+09)	(6.195)	(34.50)
	8	1.861E+09	1.489E+09	247.4	39.09
		(4.502E+09)	(3.602E+09)	(5.168)	(28.83)

TABLE III

NATURAL FREQUENCIES OF VIBRATION OF WIND TURBINE TOWER DESIGNSCONCEPT I AT $\Omega = 0$

CASE	CONDITION	FREQUENCY OF VIBRATION, HZ (CPM)			
		ω_1	ω_2	ω_3	ω_4
A	0.25 k_T	1.26 (75.9)	1.26 (75.9)	9.07 (544.2)	11.35 (681.0)
B	0.50 k_T	1.72 (103.2)	1.72 (103.2)	9.18 (550.9)	11.77 (706.4)
C (NORM)	1.0 k_T	2.26 (135.5)	2.28 (136.7)	9.37 (562.1)	12.60 (756.0)
D	1.5 k_T	2.59 (155.4)	2.62 (157.6)	9.51 (570.9)	13.39 (803.8)
E	2.0 k_T	2.82 (169.1)	2.86 (171.9)	9.63 (578.0)	14.15 (849.1)
F	1.33 a	2.83 (169.8)	2.88 (173.1)	9.59 (575.6)	13.05 (783.2)
G	0.66 a	1.65 (99.4)	1.66 (99.7)	9.17 (550.5)	11.90 (714.2)
H	1.33 ($m_R + m_N$)	2.02 (121.1)	2.04 (122.8)	11.02 (661.4)	12.52 (751.4)
I	0.66 ($m_R + m_N$)	2.61 (156.7)	2.61 (156.8)	8.30 (498.3)	12.73 (763.9)
J	1.33 q	2.22 (133.5)	2.28 (136.7)	13.52 (811.4)	12.60 (756.0)
K	0.66 q	2.28 (136.7)	2.28 (137.1)	7.95 (477.1)	12.60 (756.0)
L	1.33 I_{ZZ}	2.26 (135.4)	2.28 (136.7)	7.57 (454.5)	12.60 (756.0)
M	0.66 I_{ZZ}	2.26 (135.6)	2.28 (136.7)	13.68 (821.1)	12.60 (756.0)
N	1.33 I_{XX}	2.26 (135.5)	2.27 (136.3)	9.37 (562.1)	12.01 (720.7)
O	0.66 I_{XX}	2.26 (135.5)	2.28 (137.2)	9.37 (562.1)	13.29 (797.8)
P	1.33 (I_{ZZ}, I_{XX})	2.26 (135.4)	2.27 (136.3)	7.57 (454.5)	12.01 (720.7)
Q	0.66 (I_{ZZ}, I_{XX})	2.26 (135.6)	2.28 (137.2)	13.68 (821.1)	13.29 (797.8)

TABLE IV

NATURAL FREQUENCIES OF VIBRATION OF WIND TURBINE TOWER DESIGNSCONCEPT II AT $\Omega = 0$

CASE	CONDITION	FREQUENCY OF VIBRATION, HZ (CPM)			
		ω_1	ω_2	ω_3	ω_4
A	0.25 k_T	1.27 (76.2)	1.27 (76.4)	12.04 (722.3)	13.04 (782.3)
B	0.50 k_T	1.76 (105.6)	1.76 (105.8)	12.12 (727.7)	13.31 (798.7)
C (NORM)	1.0 k_T	2.39 (143.5)	2.39 (143.6)	12.29 (737.4)	13.86 (831.5)
D	1.5 k_T	2.81 (168.9)	2.82 (169.3)	12.42 (745.7)	14.39 (863.8)
E	2.0 k_T	3.12 (187.7)	3.14 (188.5)	12.54 (752.9)	14.92 (895.5)
F	1.33 a	3.07 (184.0)	3.08 (184.8)	12.47 (748.7)	14.12 (847.3)
G	0.66 a	1.70 (102.1)	1.70 (102.3)	12.12 (727.7)	13.40 (804.4)
H	1.33(m_R+m_N)	2.16 (129.9)	2.17 (130.4)	13.90 (834.2)	13.65 (819.1)
I	0.66(m_R+m_N)	2.69 (161.6)	2.71 (162.5)	11.18 (670.8)	14.20 (852.0)
J	1.33 q	2.37 (142.5)	2.39 (143.5)	15.53 (931.9)	13.86 (831.5)
K	0.66 q	2.39 (143.5)	2.40 (114.3)	10.89 (653.3)	13.86 (831.5)
L	1.33 I_{ZZ}	2.39 (143.5)	2.39 (143.6)	10.14 (608.7)	13.86 (831.5)
M	0.66 I_{ZZ}	2.39 (143.5)	2.39 (143.6)	16.84 (1010.8)	13.86 (831.5)
N	1.33 I_{XX}	2.39 (143.3)	2.39 (143.5)	12.29 (737.4)	13.37 (802.1)
O	0.66 I_{XX}	2.39 (143.5)	2.39 (143.8)	12.29 (737.4)	14.41 (864.6)
P	1.33(I_{ZZ}, I_{XX})	2.39 (143.3)	2.39 (143.5)	10.14 (608.7)	13.36 (802.1)
Q	0.66(I_{ZZ}, I_{XX})	2.39 (143.6)	2.39 (143.8)	16.84 (1010.8)	14.41 (864.6)

TABLE V

NATURAL FREQUENCIES OF VIBRATION OF WIND TURBINE TOWER DESIGNS

CONCEPT III AT $\Omega = 4.19$ RAD/SEC

CASE	CONDITION	FREQUENCY OF VIBRATION, HZ (CPM)			
		ω_1	ω_2	ω_3	ω_4
A	0.25 k_T	1.28 (77.3)	1.29 (77.6)	10.58 (635.1)	13.51 (811.0)
B	0.50 k_T	1.79 (107.4)	1.80 (108.1)	10.58 (635.2)	13.75 (825.1)
C (NORM)	1.0 k_T	2.44 (146.8)	2.47 (148.2)	10.58 (635.3)	14.22 (853.3)
D	1.5 k_T	2.90 (174.1)	2.93 (176.1)	10.59 (635.4)	14.69 (881.4)
E	2.0 k_T	3.24 (194.9)	3.29 (197.5)	10.59 (635.4)	15.15 (909.1)
F	1.33 a	3.16 (189.6)	3.20 (192.0)	10.58 (635.3)	14.44 (866.5)
G	0.66 a	1.73 (103.9)	1.74 (104.6)	10.58 (635.2)	13.83 (830.1)
H	1.33(m_R+m_N)	2.22 (133.6)	2.24 (134.6)	10.58 (635.3)	13.99 (839.8)
I	0.66(m_R+m_N)	2.74 (164.9)	2.78 (167.0)	10.58 (635.2)	14.59 (875.6)
J	q+0.52m(+1.7 ft)	2.44 (146.8)	2.47 (148.2)	10.65 (638.9)	14.22 (853.3)
K	q-0.52m(-1.7 ft)	2.44 (146.8)	2.47 (148.1)	10.71 (642.9)	14.22 (853.4)
L	1.33 I_{ZZ}	2.44 (146.8)	2.47 (148.2)	9.22 (553.2)	14.22 (853.0)
M	0.66 I_{ZZ}	2.44 (146.8)	2.47 (148.2)	12.81 (768.6)	14.25 (855.0)
N	1.33 I_{XX}	2.44 (146.5)	2.47 (148.2)	10.58 (635.2)	13.72 (823.4)
O	0.66 I_{XX}	2.45 (147.1)	2.47 (148.2)	10.58 (635.2)	14.78 (886.9)
P	1.33(I_{ZZ}, I_{XX})	2.44 (146.6)	2.47 (148.2)	9.22 (553.2)	13.72 (823.3)
Q	0.66(I_{ZZ}, I_{XX})	2.45 (146.6)	2.47 (148.2)	12.82 (767.6)	14.80 (886.9)

TABLE VI

NATURAL FREQUENCIES OF VIBRATION, HZ (CPM)AT INFINITE ROTOR ROTATIONAL VELOCITY

<u>CASE</u>	<u>CONCEPT I</u>	<u>CONCEPT II</u>	<u>CONCEPT III</u>
	ω_2	ω_2	ω_2
A	1.27 (76.2)	1.28 (76.8)	1.29 (77.4)
B	1.74 (104.4)	1.77 (106.2)	1.80 (108.0)
C	2.31 (138.6)	2.41 (144.6)	2.47 (148.2)
D	2.67 (160.2)	2.85 (171.0)	2.94 (176.4)
E	2.92 (175.2)	3.18 (190.8)	3.29 (197.4)
F	2.93 (175.8)	3.12 (187.2)	3.20 (192.0)
G	1.67 (100.2)	1.71 (102.6)	1.74 (104.4)
H	2.07 (124.2)	2.19 (131.4)	2.24 (134.4)
I	2.66 (159.6)	2.73 (163.8)	2.78 (166.8)
J	2.31 (138.6)	2.41 (144.6)	2.47 (148.2)
K	2.31 (138.6)	2.41 (144.6)	2.47 (148.2)
L	2.31 (138.6)	2.41 (144.6)	2.47 (148.2)
M	2.31 (138.6)	2.41 (144.6)	2.47 (148.2)
N	2.31 (138.6)	2.41 (144.6)	2.47 (148.2)
O	2.31 (138.6)	2.41 (144.6)	2.47 (148.2)
P	2.31 (138.6)	2.41 (144.6)	2.47 (148.2)
Q	2.31 (138.6)	2.41 (144.6)	2.47 (148.2)

NOTE: ALL GUYS ARE SHOWN BUT
ONLY ONE ANCHOR IS SHOWN

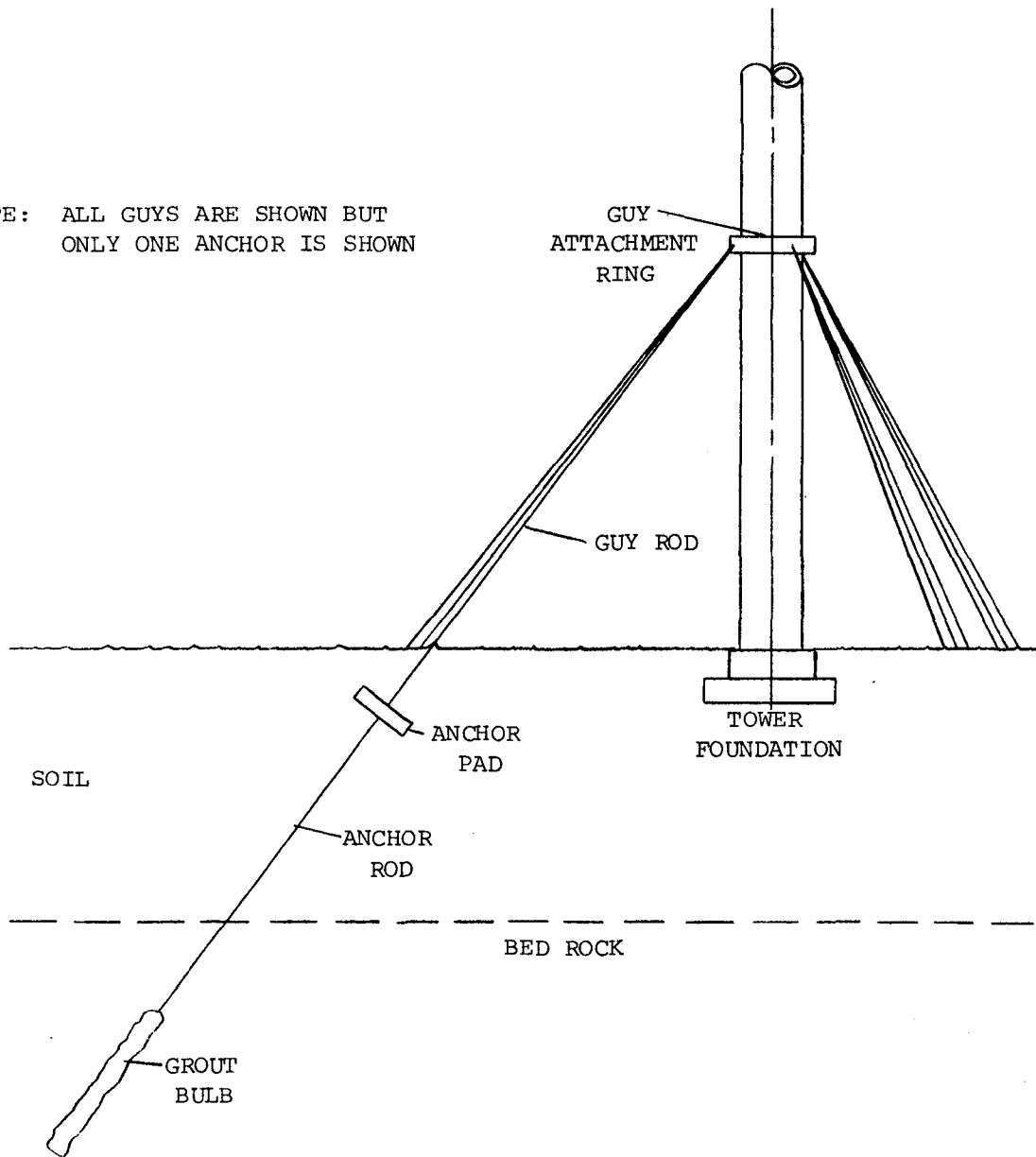

WIND TURBINE TOWER GUY AND ANCHOR ROD SYSTEM

Figure 1

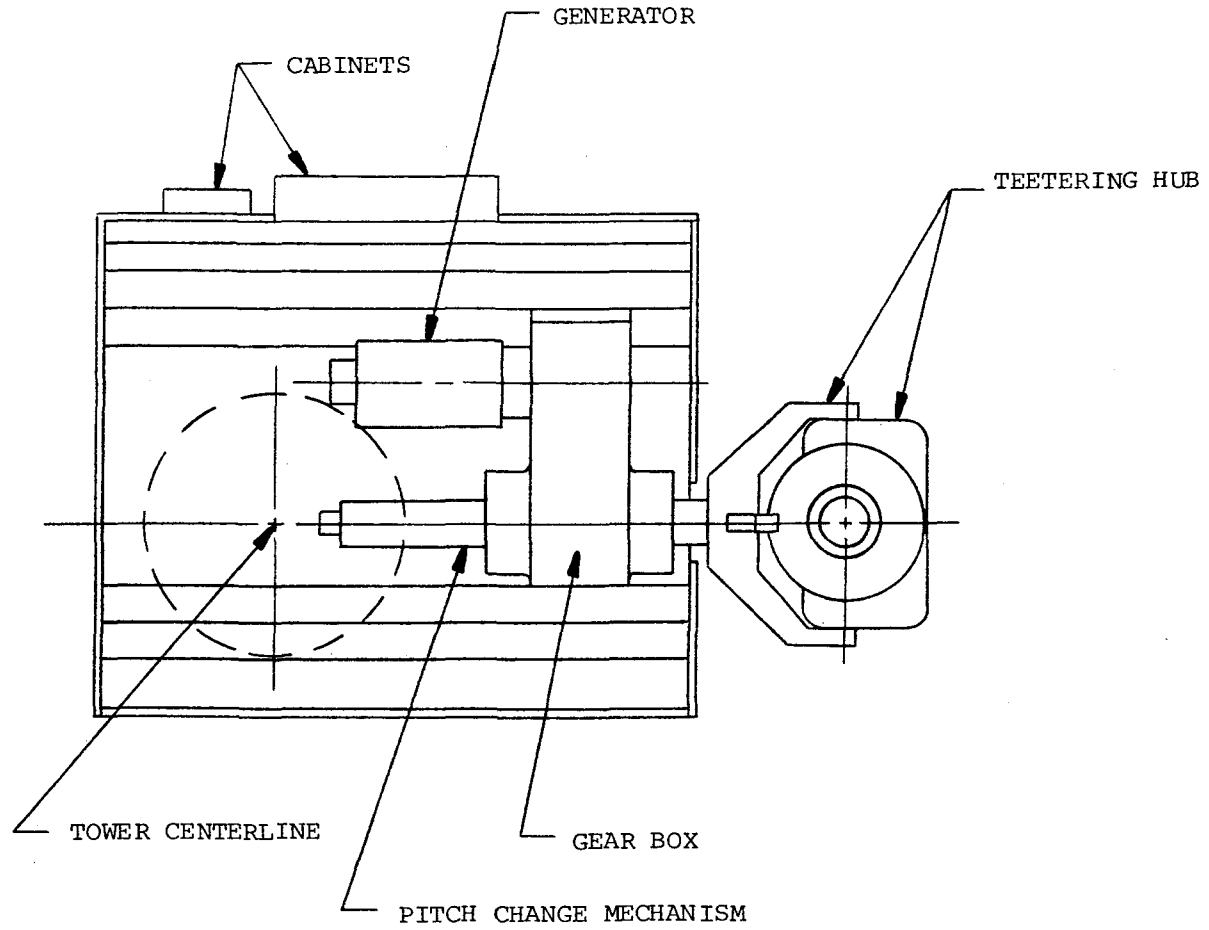

TOP VIEW OF AN INTERMEDIATE SIZE WIND TURBINE, CONCEPT I

Figure 2

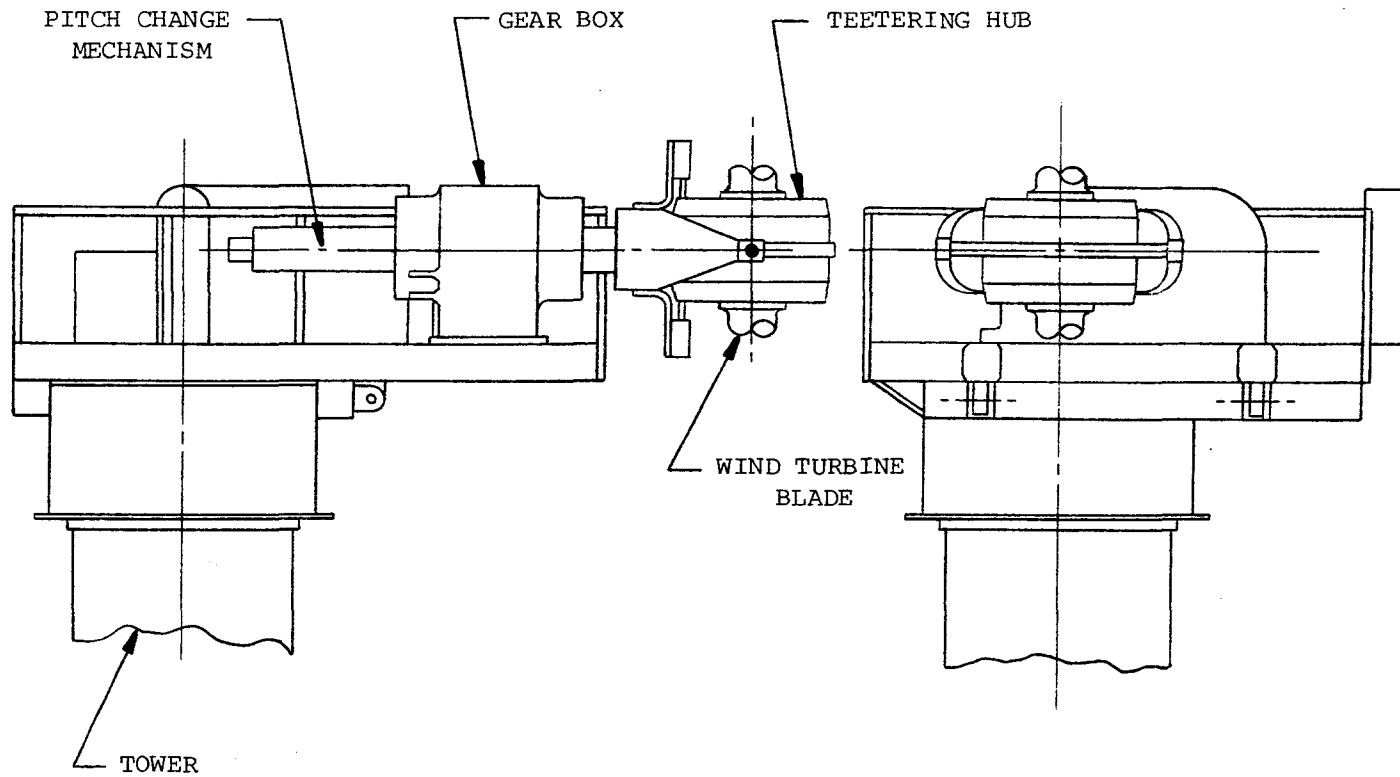

SIDE AND FRONT VIEWS OF WIND TURBINE, CONCEPT I

Figure 3

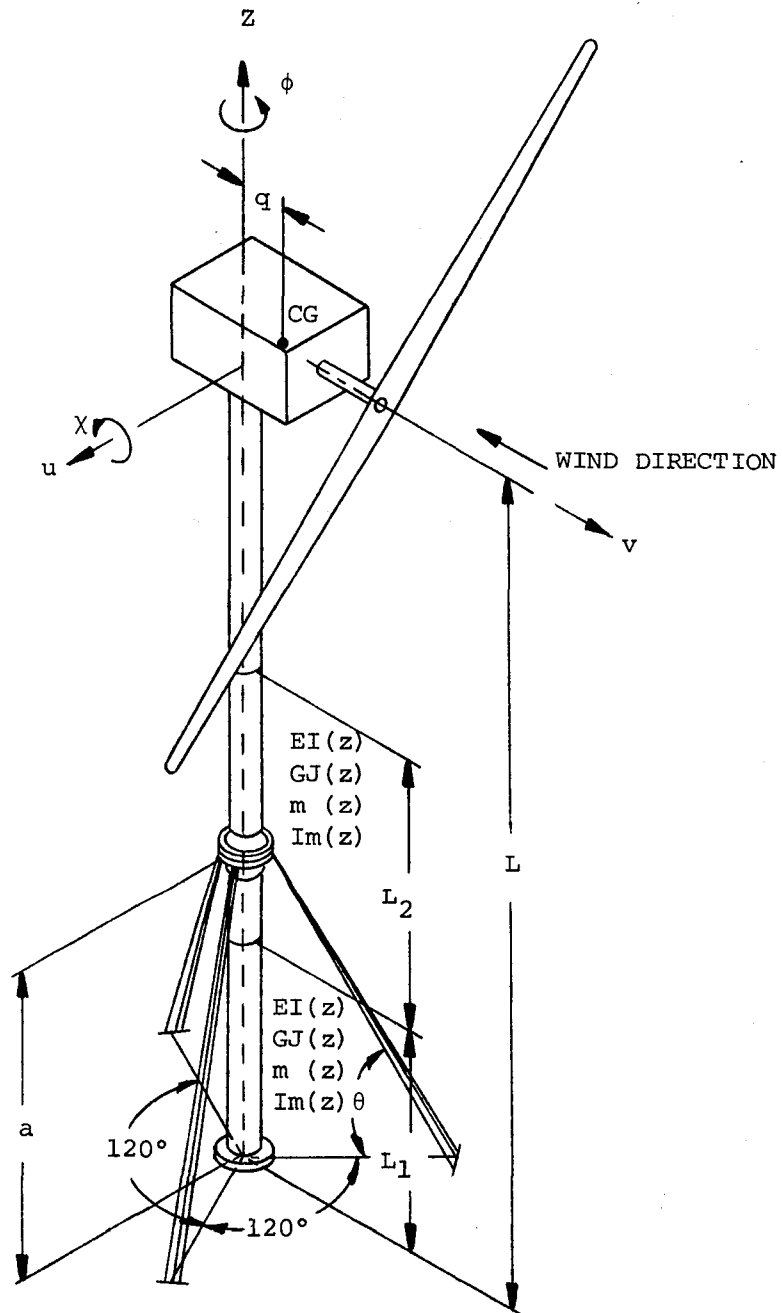

WIND TURBINE TOWER
STRUCTURAL AND DIMENSIONAL CHARACTERISTICS

Figure 4

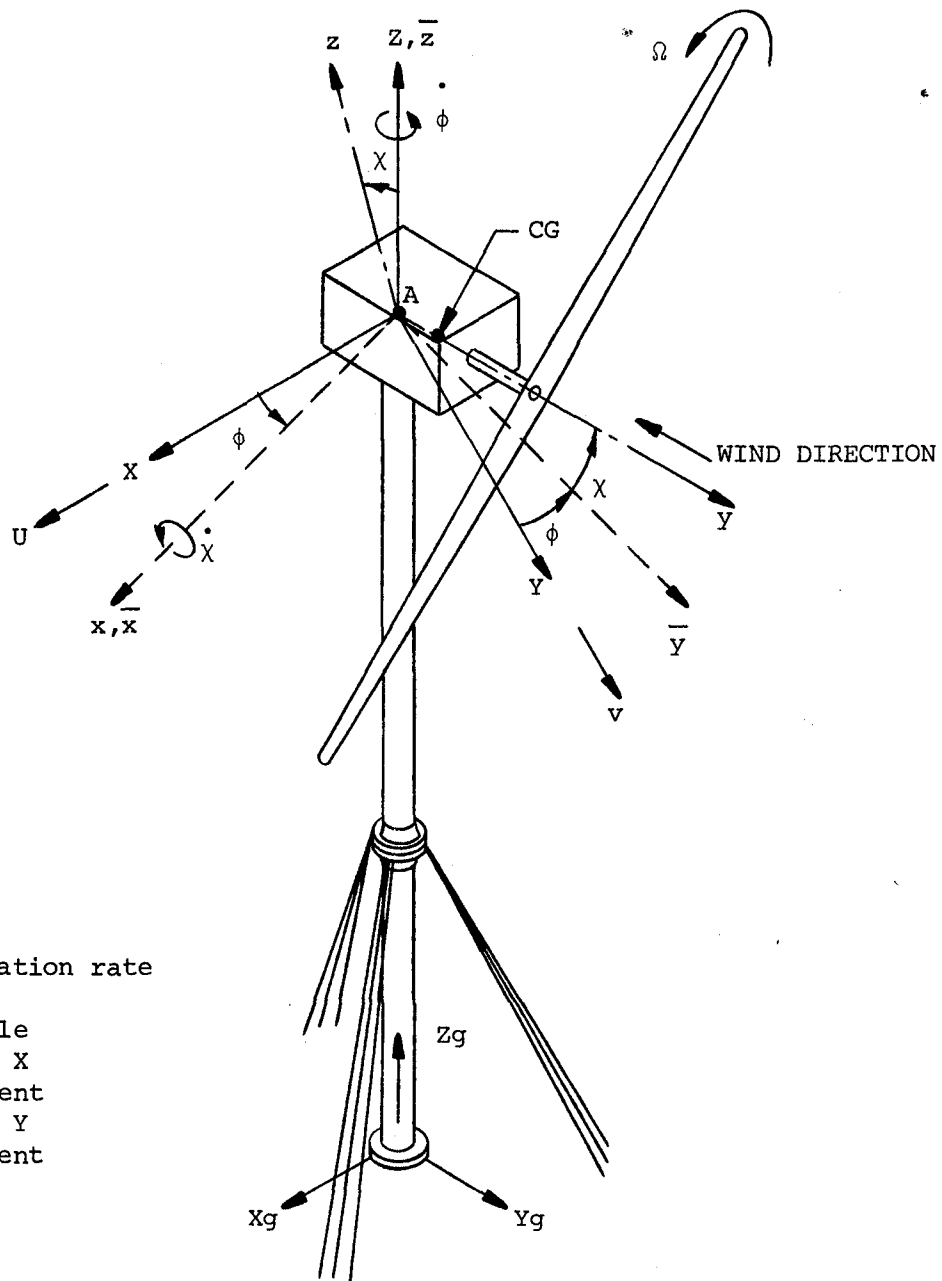

- Ω = Rotor rotation rate
- ϕ = Yaw angle
- χ = Pitch angle
- U = Tower top X displacement
- V = Tower top Y displacement

TOWER COORDINATE SYSTEM

Figure 5

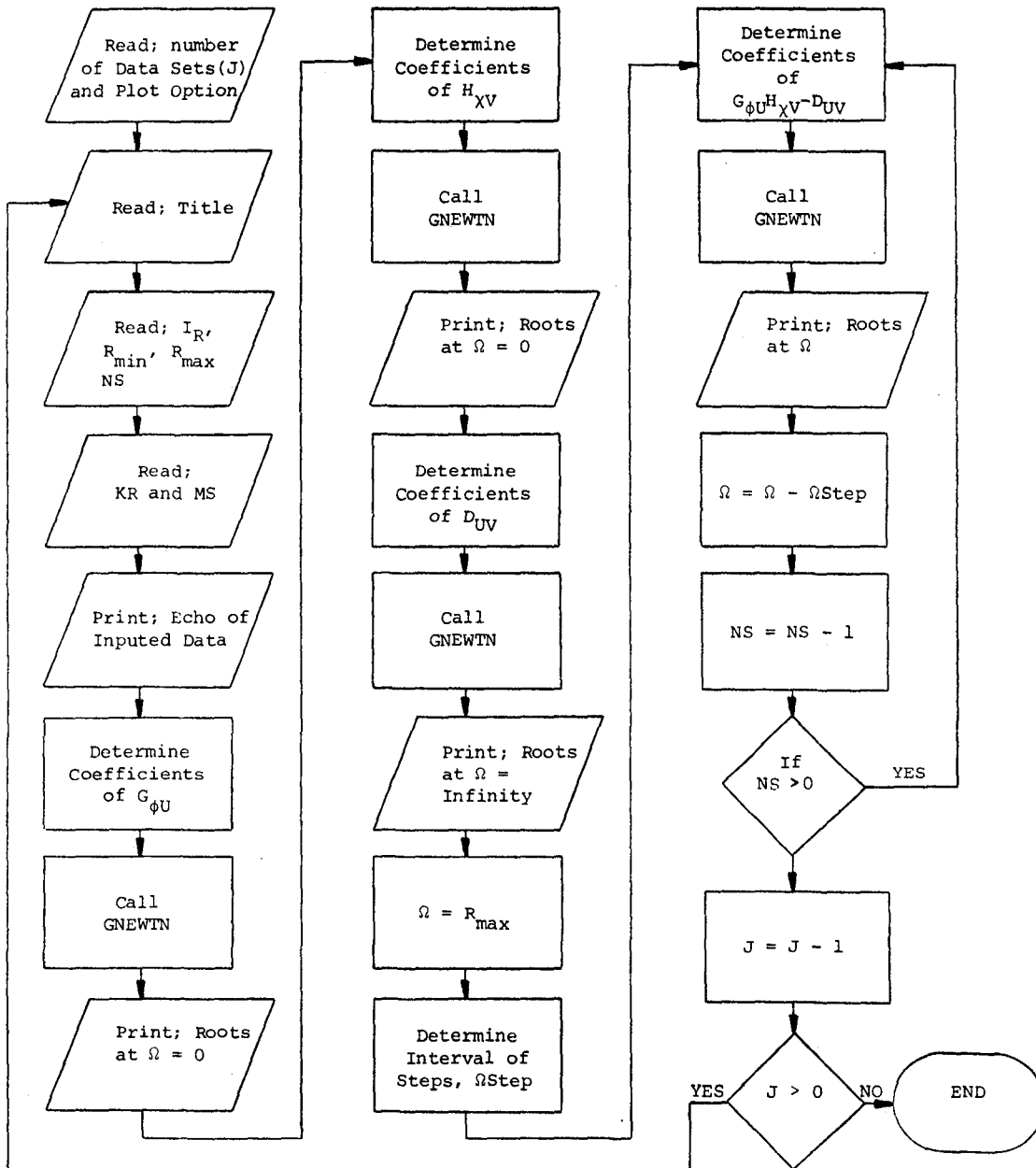

COMPUTER PROGRAM FLOW CHART

Figure 6

TOWER DESIGNS FOR INTERMEDIATE SIZE WIND TURBINES

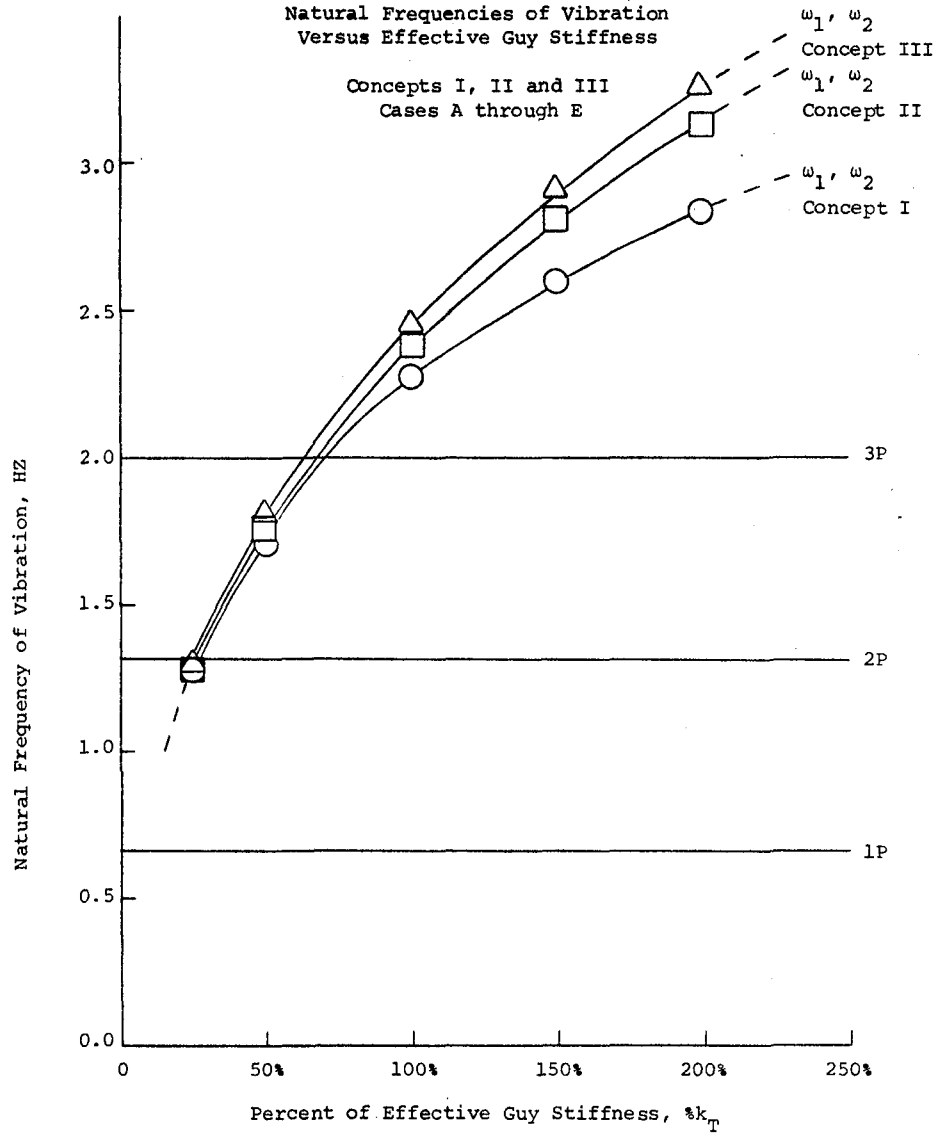

The frequencies of vibration of the first two modes as the effective guy stiffness is varied from 25% to 200% of the design value. $k_T = 44.36E + 06$ N/m

Figure 7

TOWER DESIGNS FOR INTERMEDIATE SIZE WIND TURBINES

Natural Frequencies of Vibration
Versus Effective Guy Stiffness

Concepts I, II and III
Cases A through E

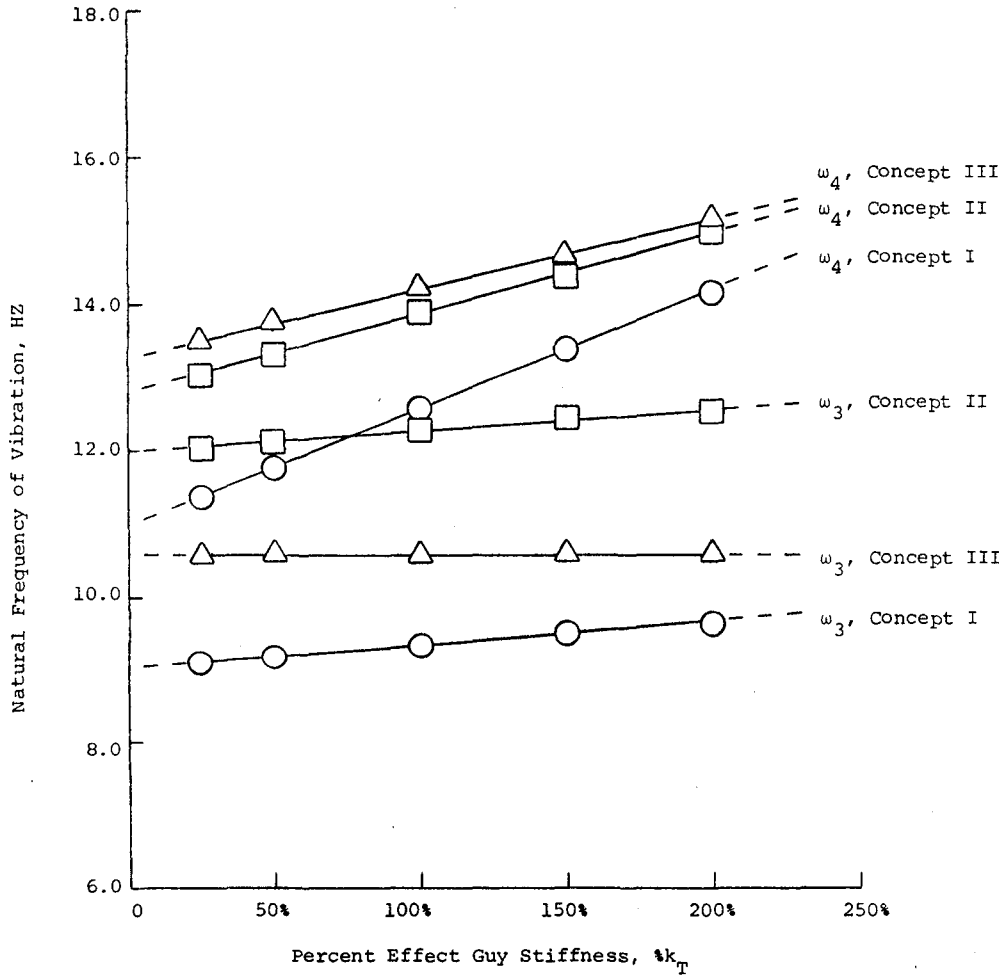

The frequencies of vibration of the second two modes as the effective guy stiffness is varied from 25% to 200% of the design value. $k_T = 44.36E + 06$ N/m

Figure 8

TOWER DESIGNS FOR INTERMEDIATE SIZE WIND TURBINES

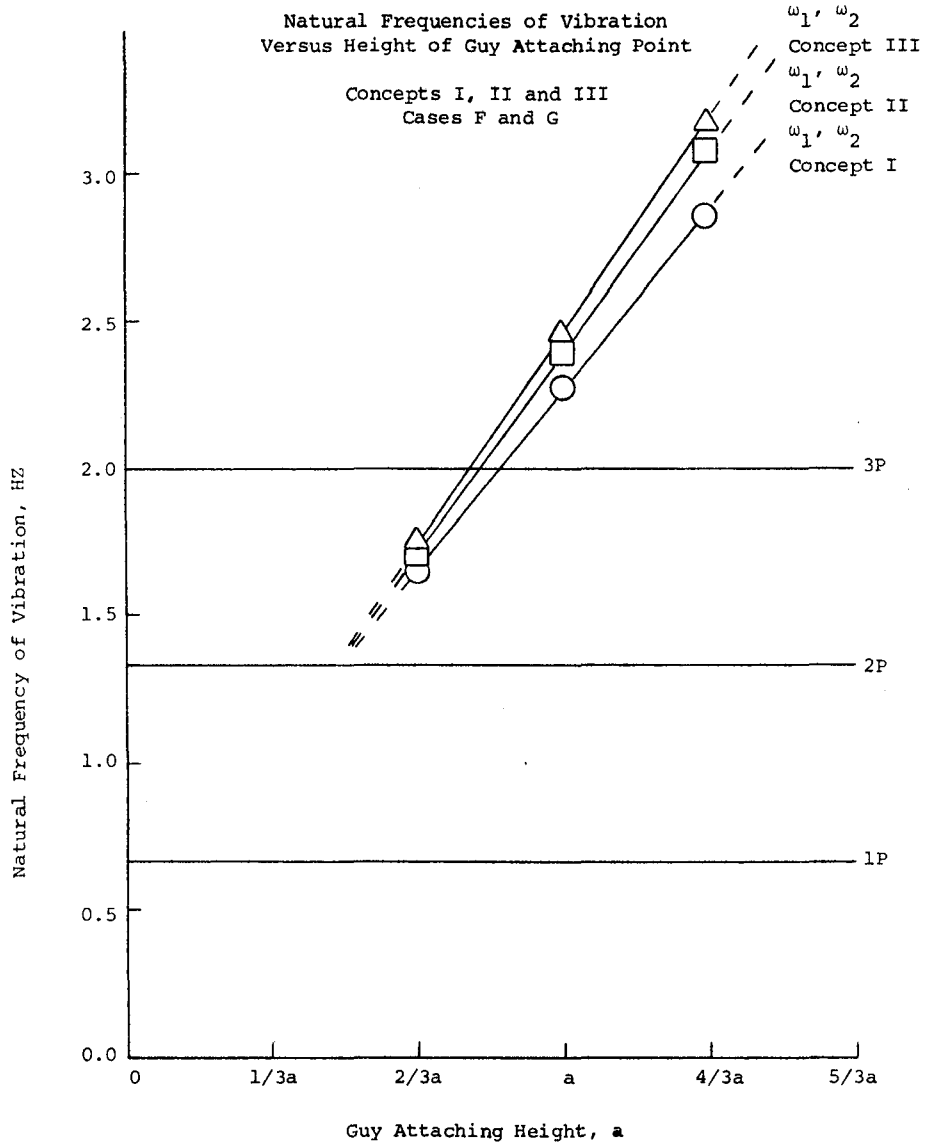

The frequencies of vibration of the first two modes as the height of the guy attaching point is varied.
a = 10.7m

Figure 9

TOWER DESIGNS FOR INTERMEDIATE SIZE WIND TURBINES

Natural Frequencies of Vibration
Versus Height of Guy Attaching Point

Concepts I, II and III
Cases F and G

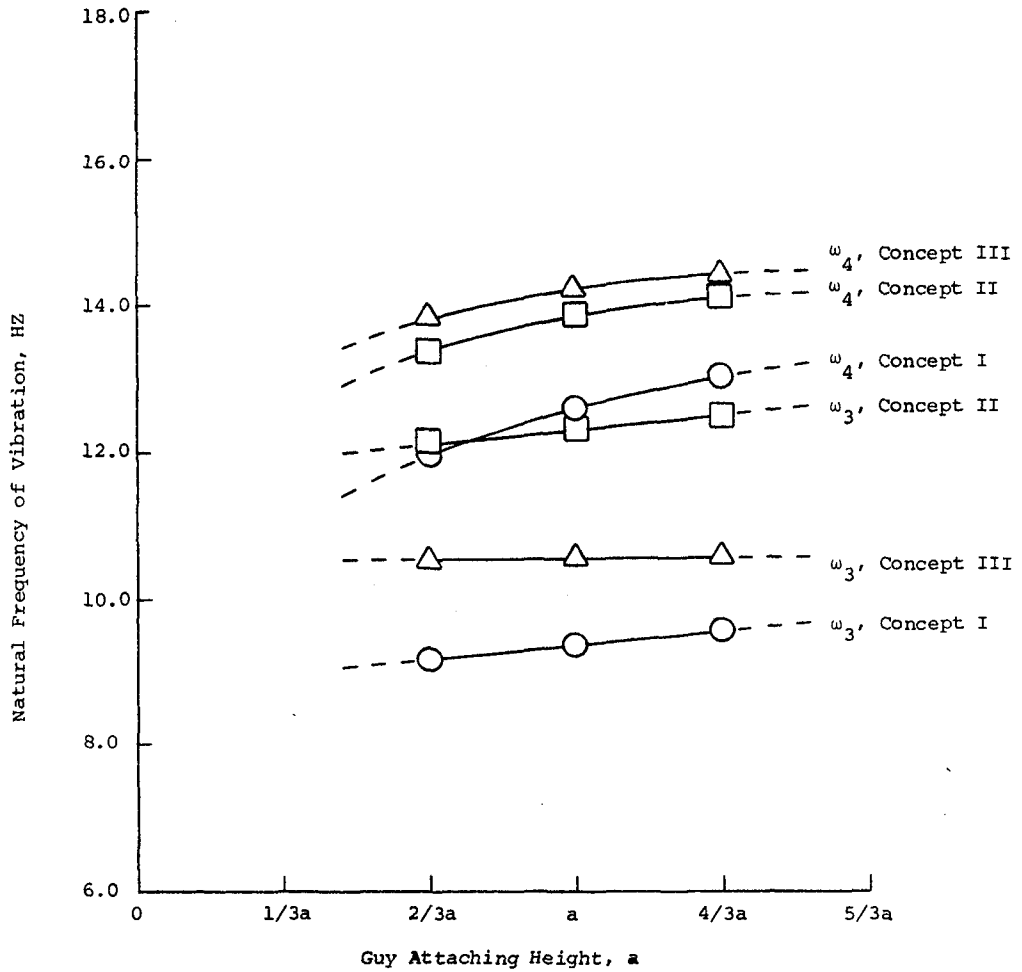

The frequency of vibration of the second two modes as
the height of the guy attaching point is varied.
 $a = 10.7\text{m}$

Figure 10

TOWER DESIGNS FOR INTERMEDIATE SIZE WIND TURBINES

Natural Frequencies of Vibration
Versus Nacelle and Rotor Mass

Concepts I, II and III
Cases H and I

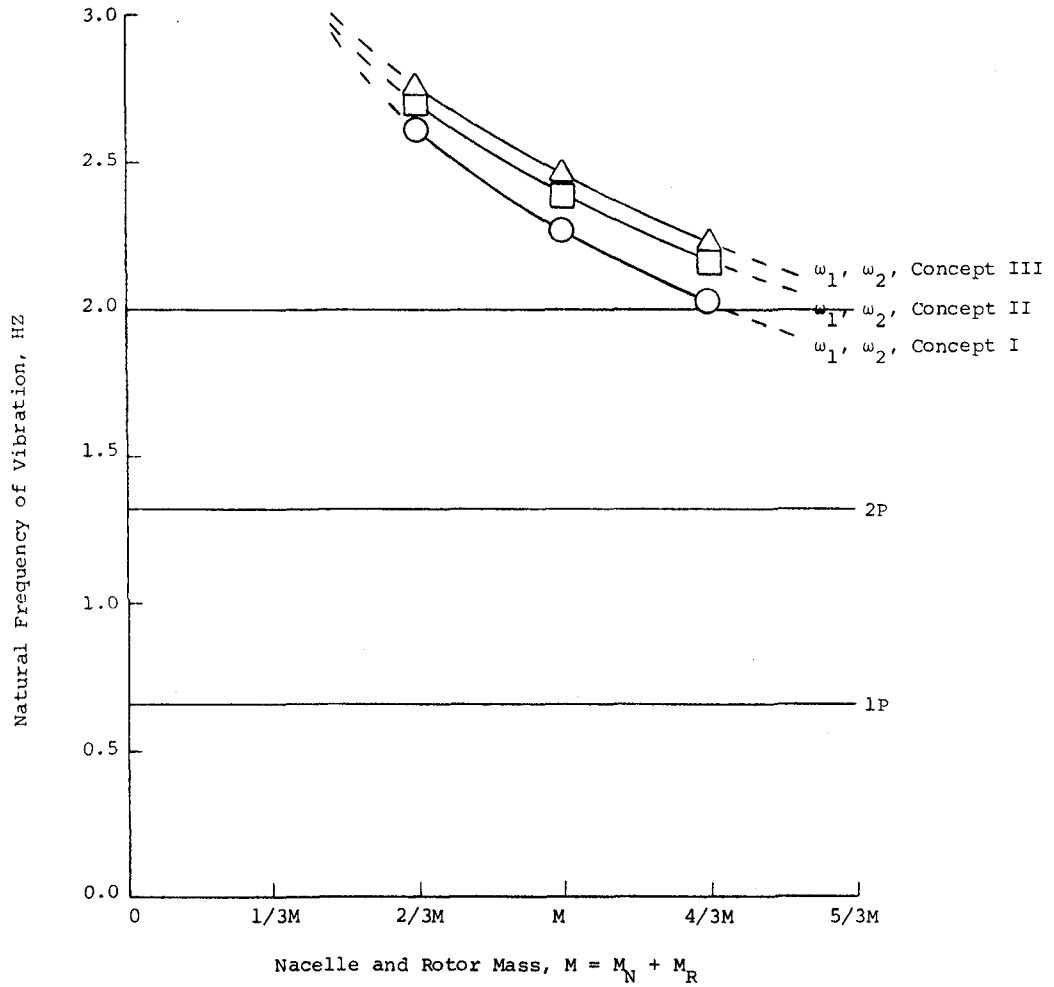

The frequencies of vibration of the first two modes as the Nacelle and Rotor Mass is varied.

Concept I $M = 16.19E + 03$ kg

Concept II $M = 14.59E + 03$ kg

Concept III $M = 14.18E + 03$ kg

Figure 11

TOWER DESIGNS FOR INTERMEDIATE SIZE WIND TURBINES

Natural Frequencies of Vibration
Versus Nacelle and Rotor Mass

Concepts I, II and III
Cases H and I

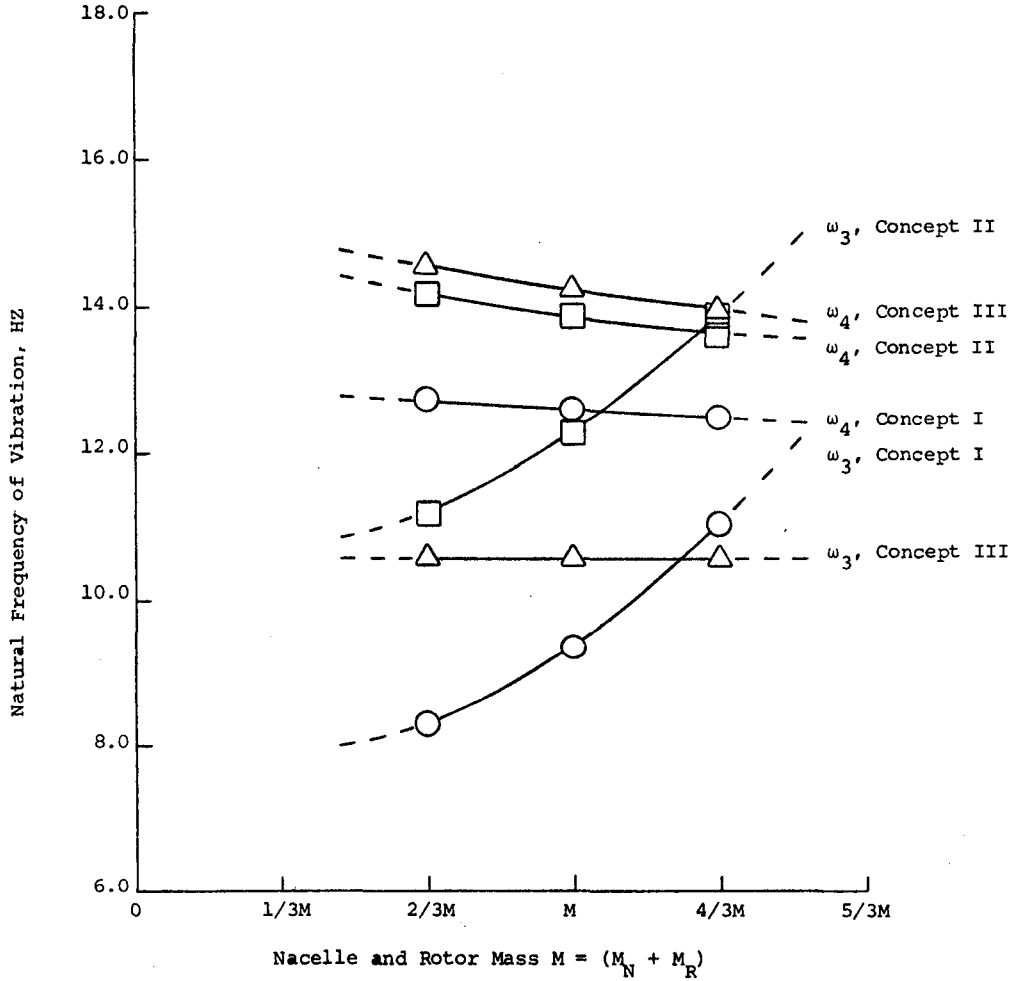

The frequencies of vibration of the second two modes as the Nacelle and Rotor Mass is varied.

Concept I $M = 16.19E + 03$ kg

Concept II $M = 14.59E + 03$ kg

Concept III $M = 14.18E + 03$ kg

Figure 12

TOWER DESIGNS FOR INTERMEDIATE SIZE WIND TURBINES

Natural Frequencies of Vibration
Versus Center of Gravity Location

Concepts I, II and III
Cases J and K

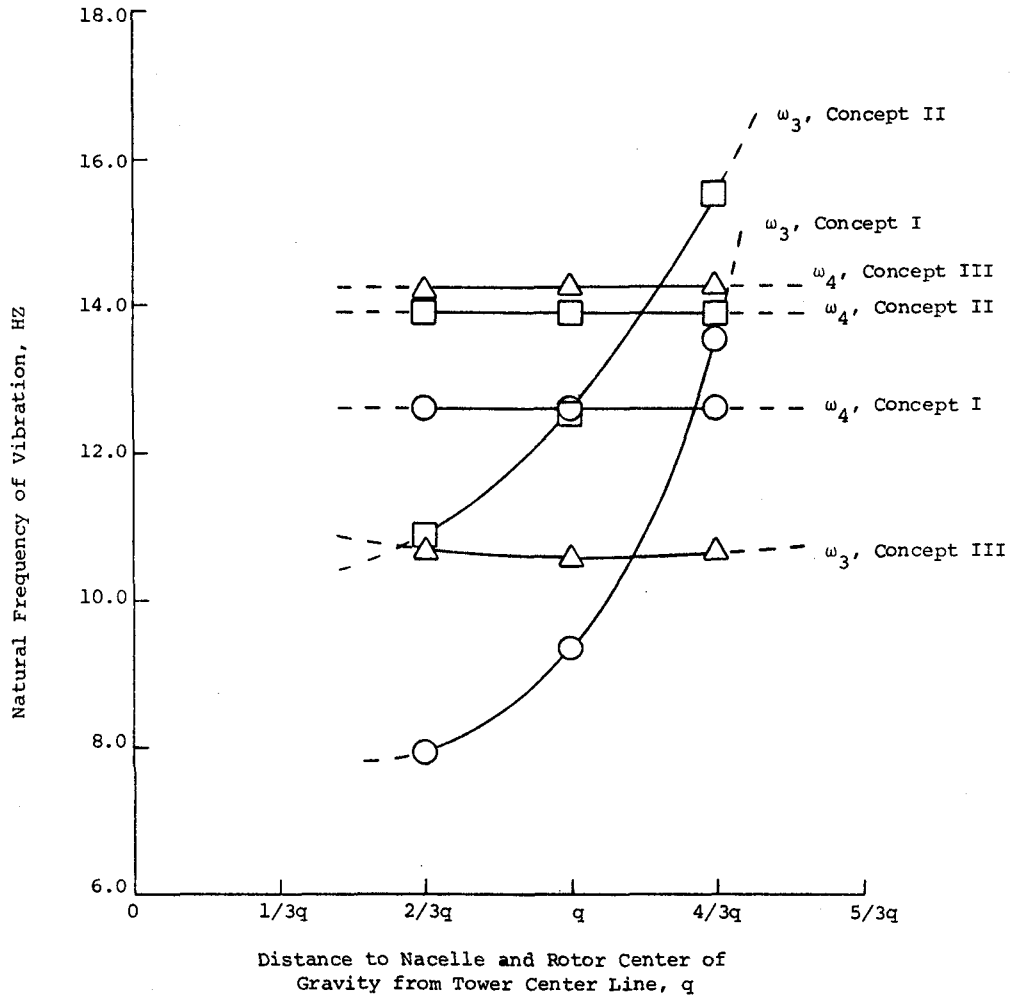

The frequencies of vibration of the second two modes as the location of the center of gravity is varied.
 Concept I $q = 2.35\text{m}$
 Concept II $q = 2.16\text{m}$
 Concept III $q = -.09\text{m}$

Figure 13

TOWER DESIGNS FOR INTERMEDIATE SIZE WIND TURBINES

Natural Frequencies of Vibration Versus
Mass Moment of Inertia of the Nacelle and
Rotor About the Tower's Z Axis

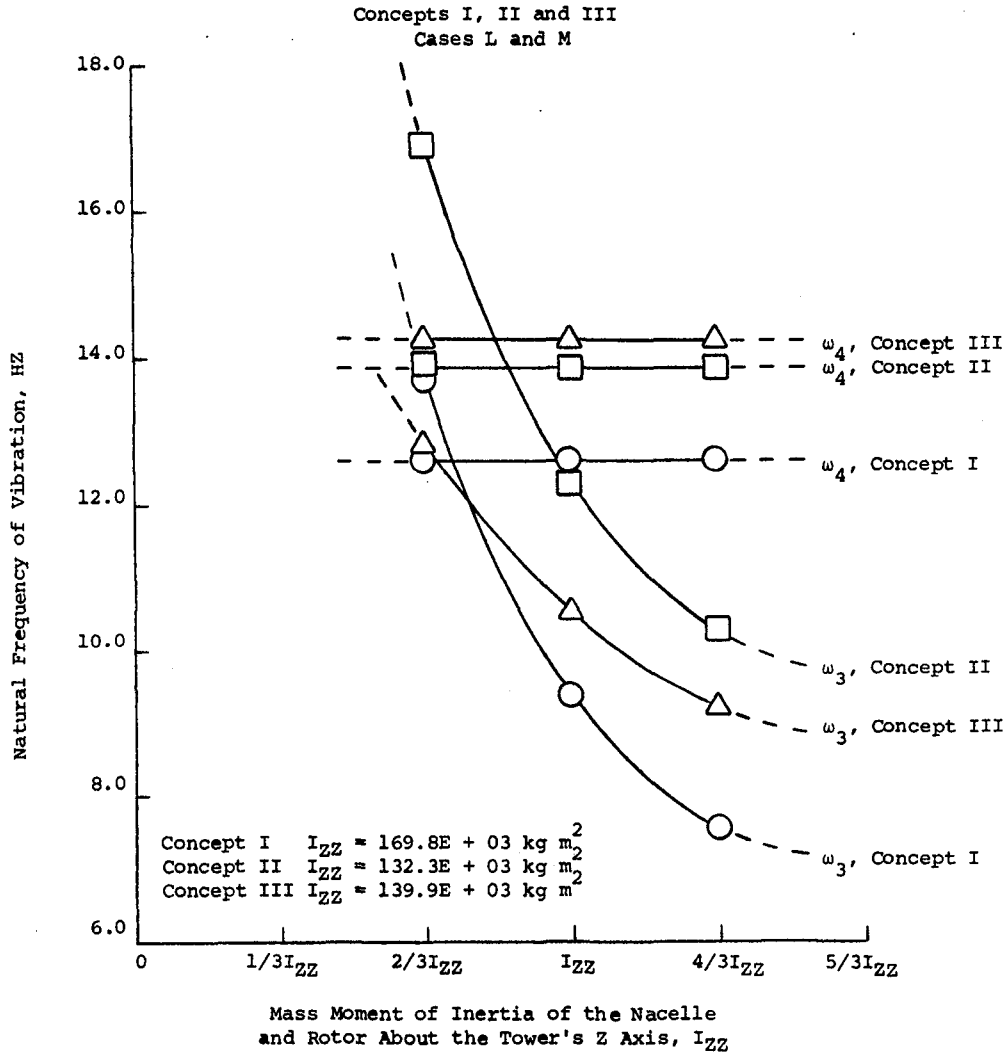

The frequencies of vibration of the second two modes
as the mass moment of inertia of the Nacelle and
Rotor about the tower's Z axis is varied.

Figure 14

TOWER DESIGNS FOR INTERMEDIATE SIZE WIND TURBINES

Natural Frequencies of Vibration Versus
Mass Moment of Inertia of the Nacelle and
Rotor About the Tower's X Axis

Concepts I, II and III
Cases N and O

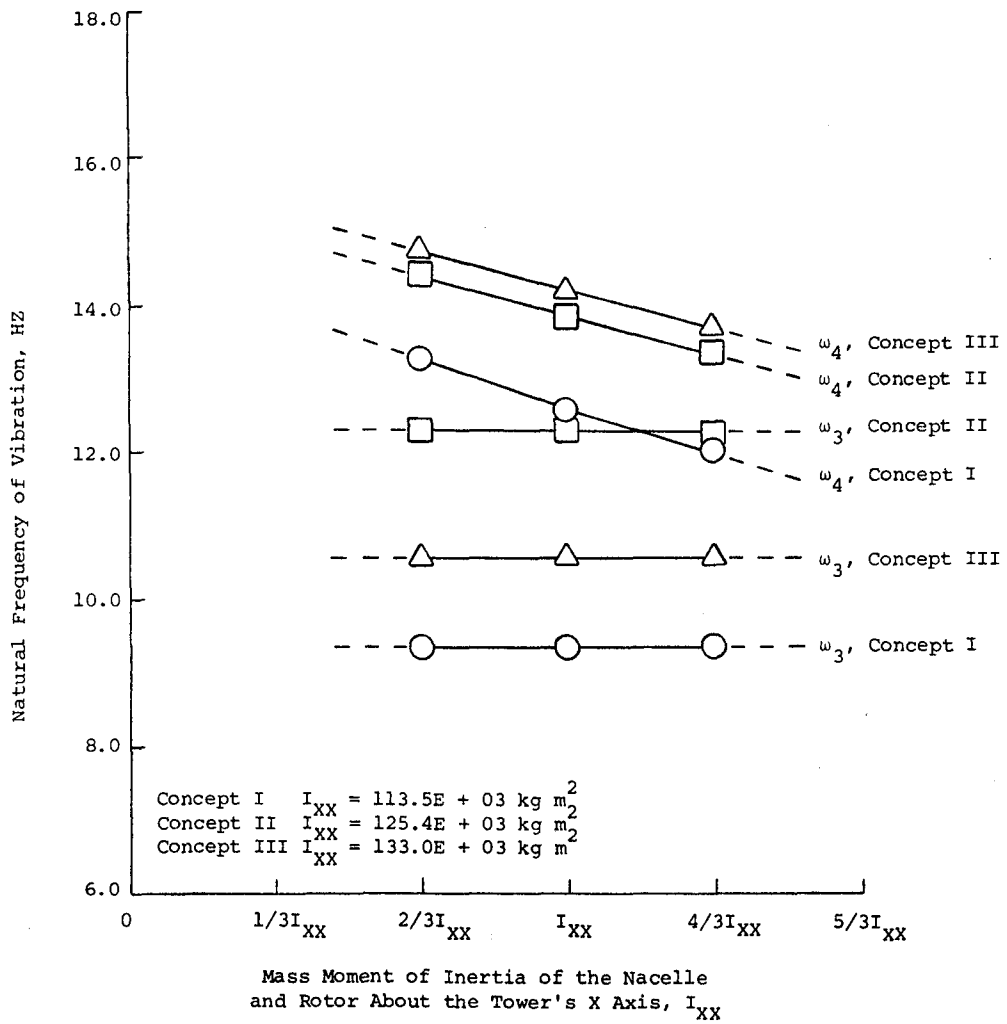

The frequencies of vibration of the second two modes as the mass moment of inertia of the Nacelle and Rotor about the tower's X axis is varied.

Figure 15

TOWER DESIGNS FOR INTERMEDIATE SIZE WIND TURBINES

Natural Frequencies of Vibration Versus
Mass Moment of Inertia of the Nacelle and
Rotor About the Tower's Z and X Axes

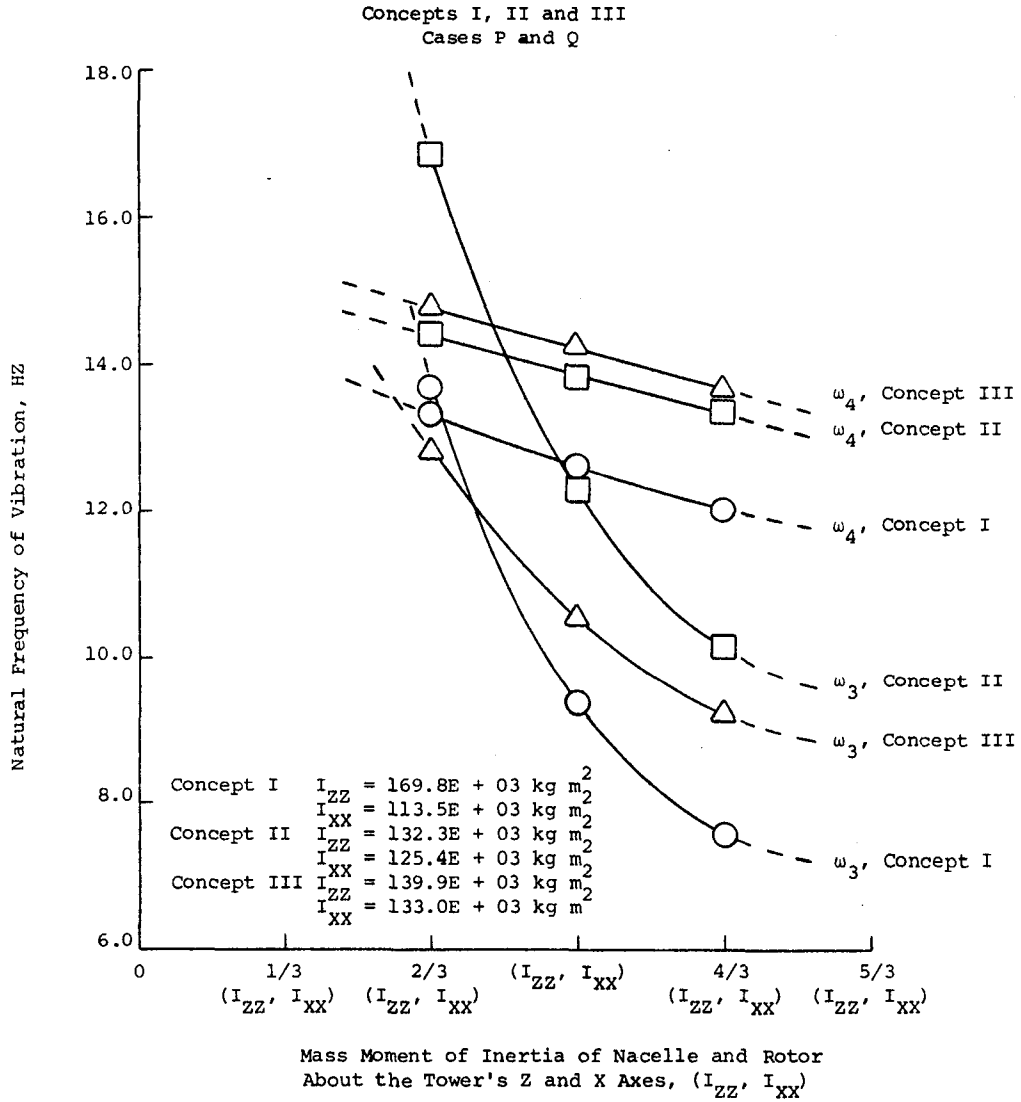

The frequencies of vibration of the second two modes
as the mass moment of inertia of the Nacelle and Rotor
about the Tower's Z and X Axes are varied simultaneously.

Figure 16

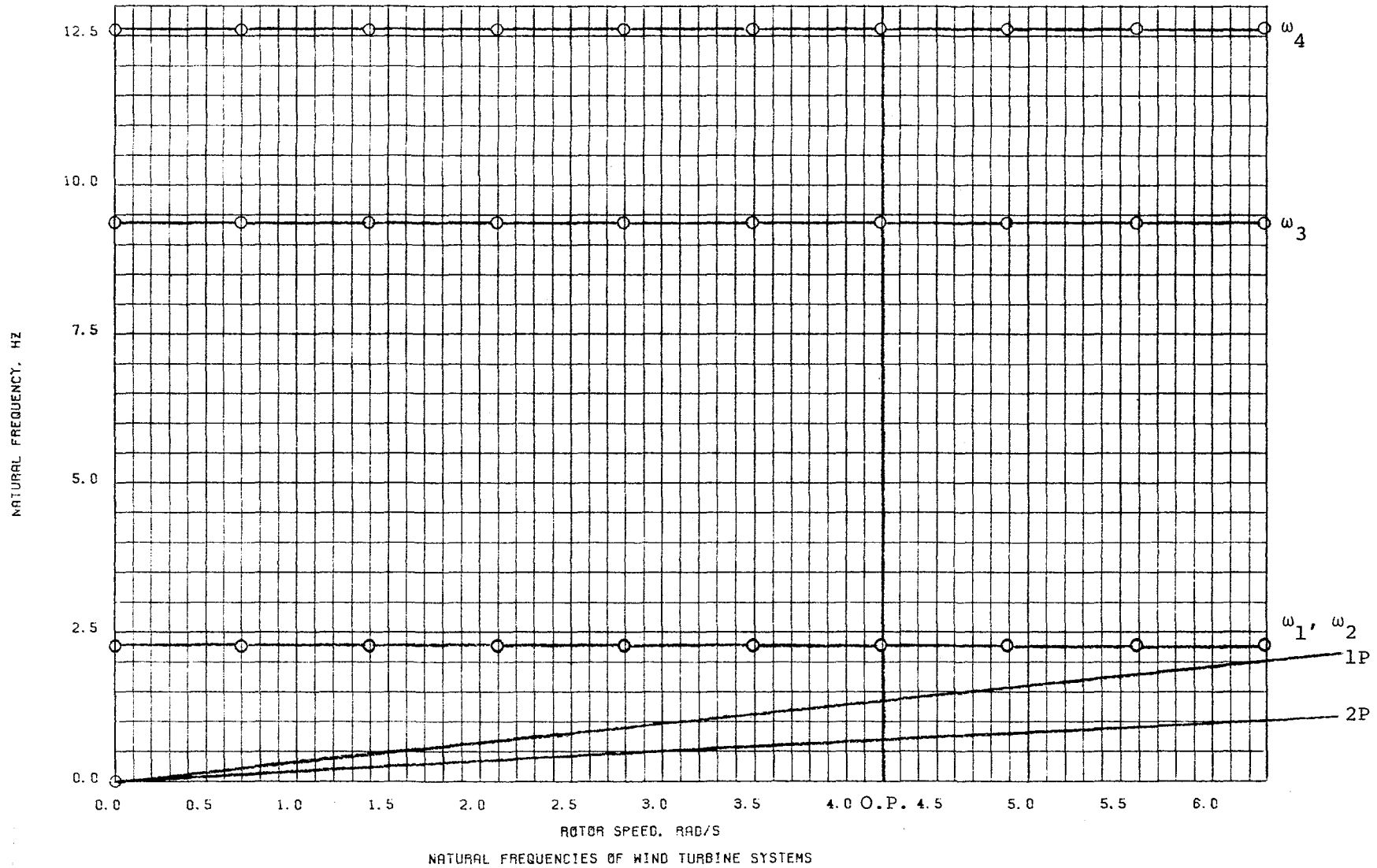

CONCEPT I, CASE C, 100% EFFECTIVE GUY STIFFNESS
Figure 17

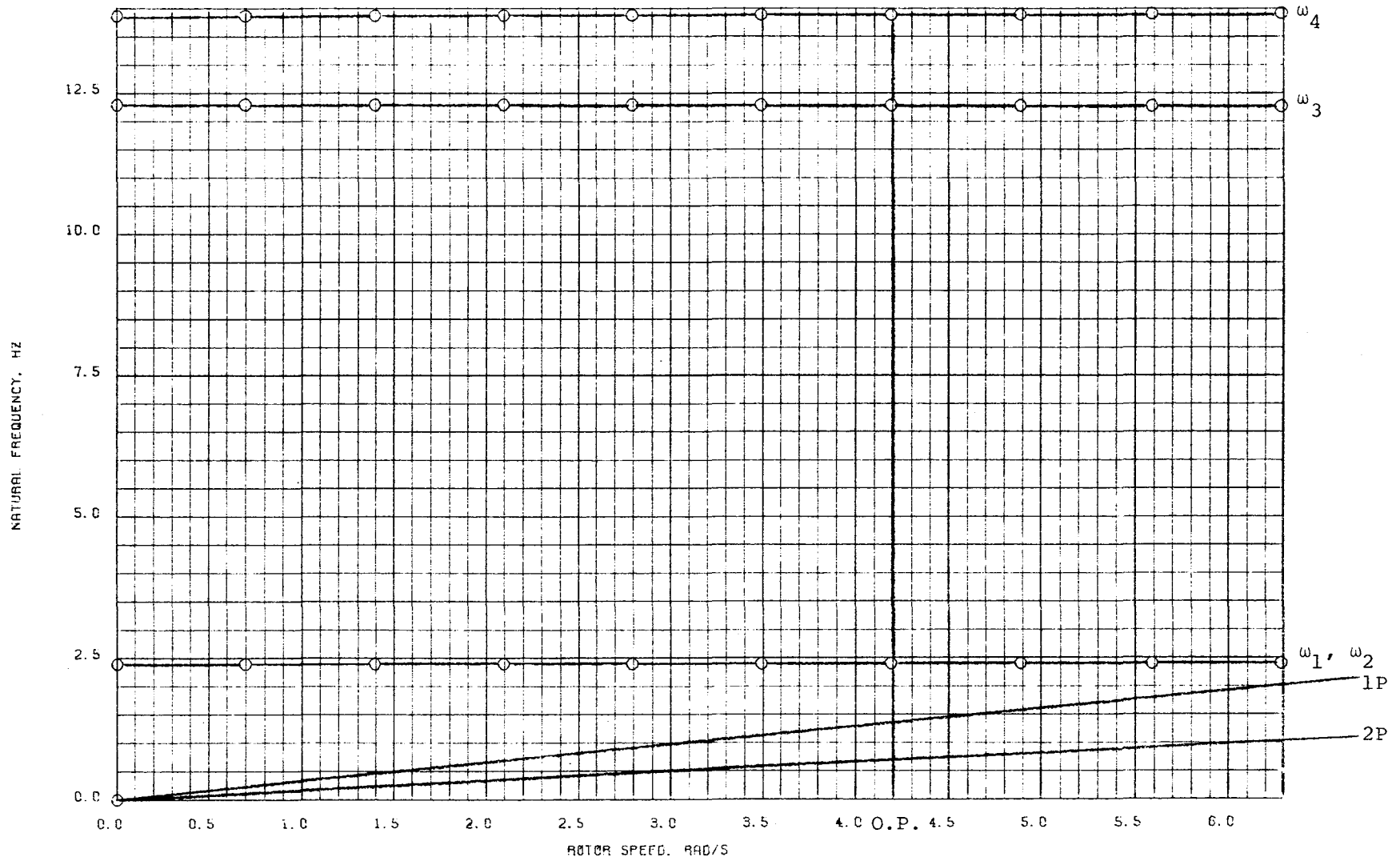

NATURAL FREQUENCIES OF WIND TURBINE SYSTEMS

CONCEPT II, CASE C, 100% EFFECTIVE GUY STIFFNESS
Figure 18

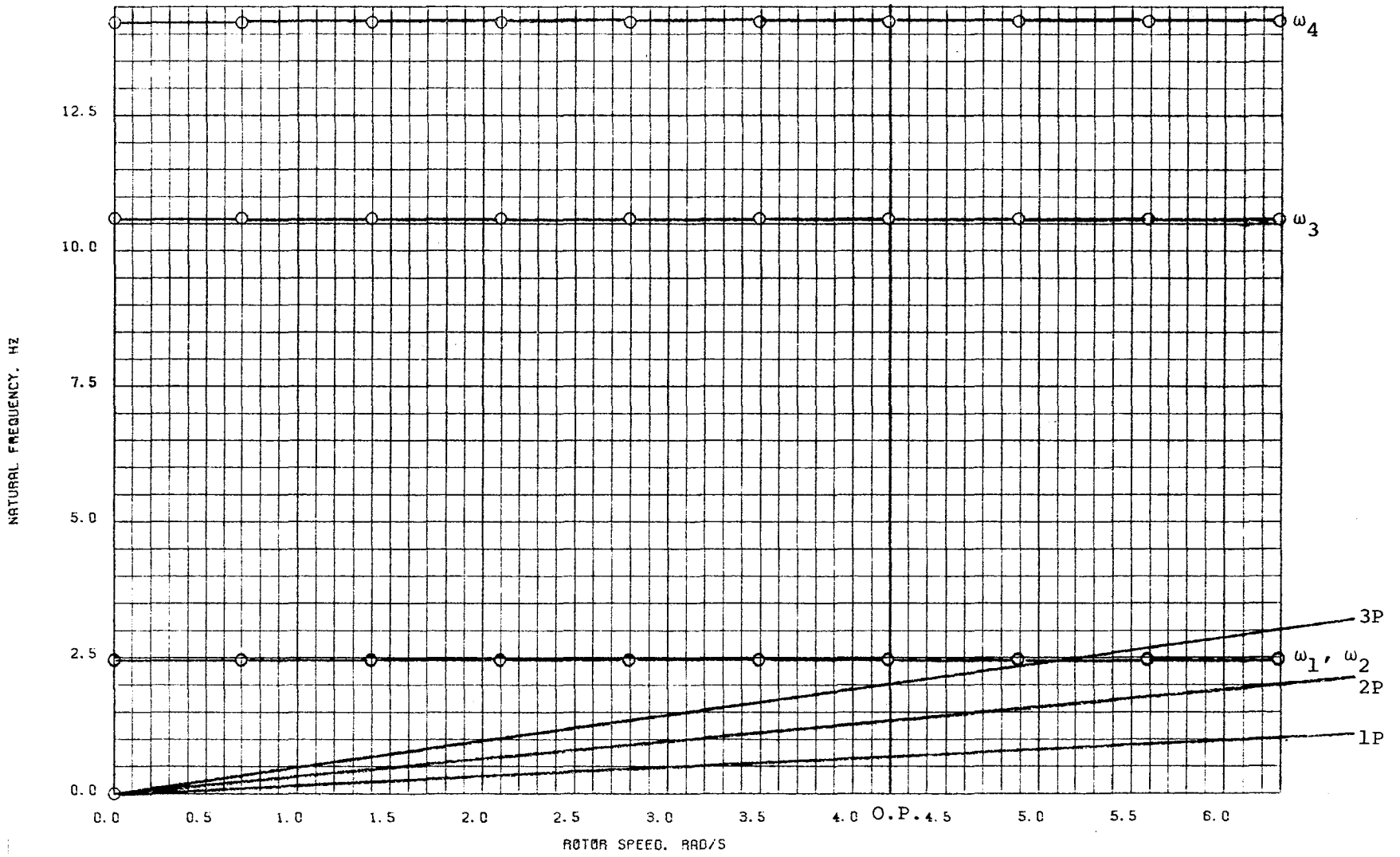

NATURAL FREQUENCIES OF WIND TURBINE SYSTEMS

CONCEPT III, CASE C, 100% EFFECTIVE GUY STIFFNESS
Figure 19

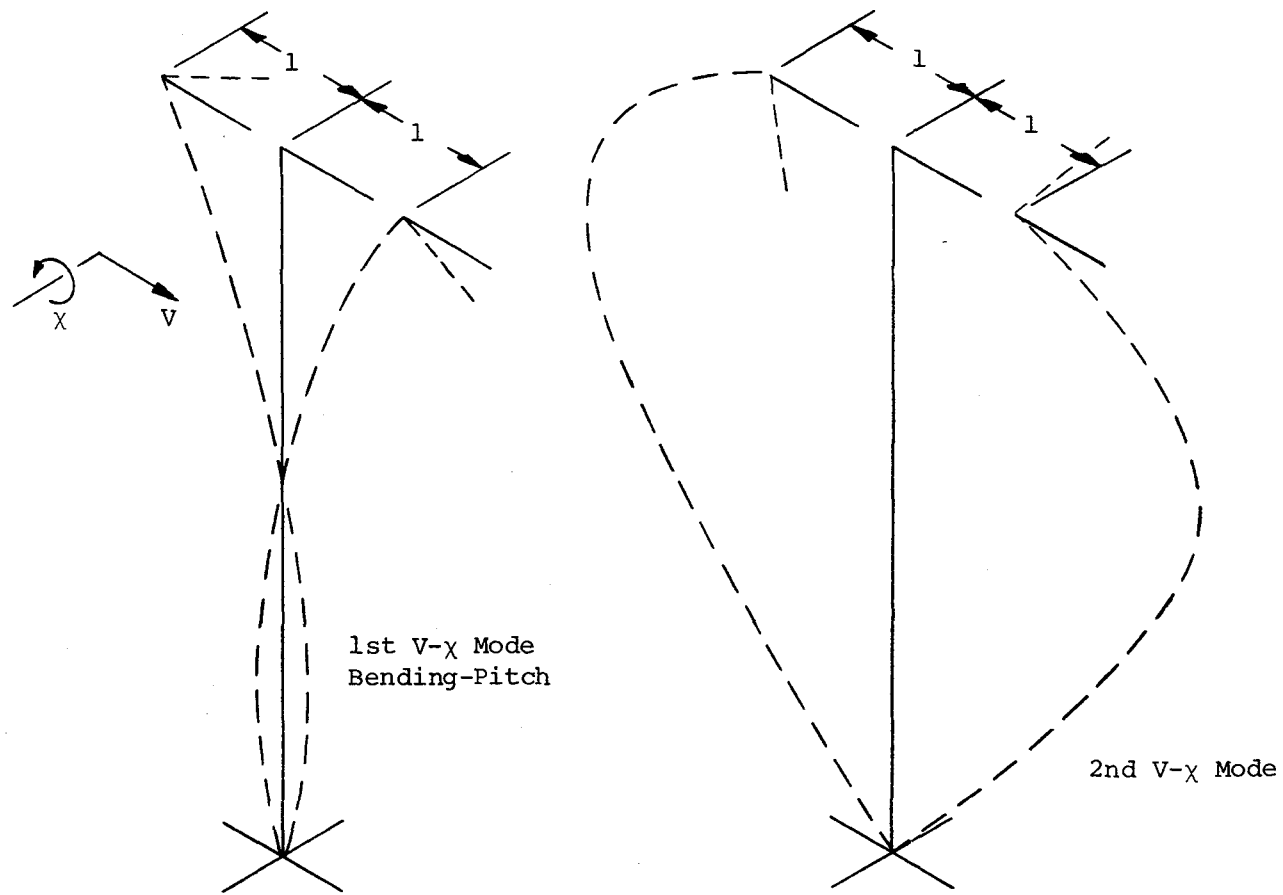

1st V- χ Mode
Bending-Pitch

2nd V- χ Mode

BENDING-PITCH VIBRATION MODES AT ZERO ROTOR SPEED

Figure 20
(Excerpt from Thresher, et al)

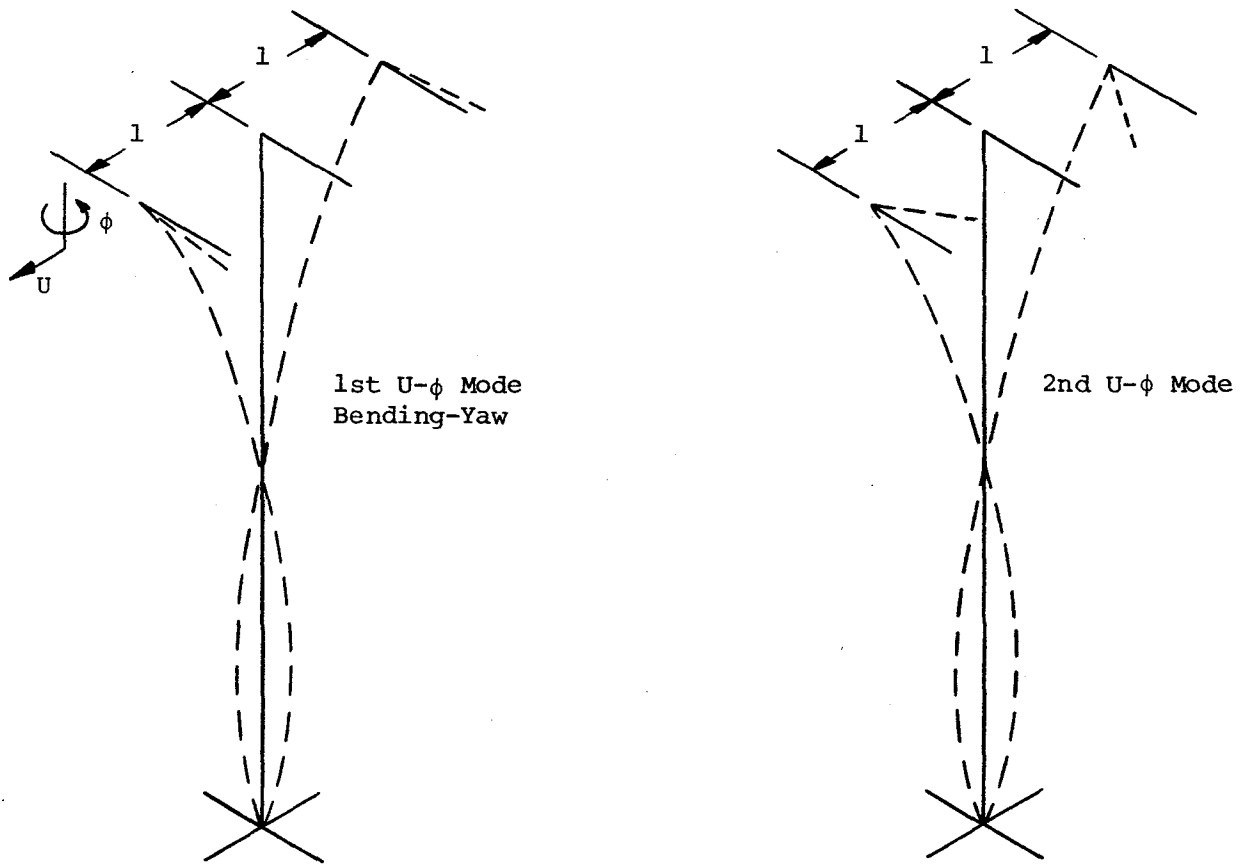

BENDING-YAW VIBRATION MODES AT ZERO ROTOR SPEED

Figure 21
(Excerpt from Thresher, et al)

APPENDIX A

FORTRAN COMPUTER PROGRAM

```
C*FREE VIBRATION APPROXIMATIONS FOR HORIZONTAL AXIS WIND TURBINES*
C NATURAL FREQUENCIES OF WIND TURBINE SYSTEMS
C
C THIS PROGRAM EVALUATES THE FREE VIBRATION FREQUENCIES FOR A WIND
C TURBINE SYSTEM. THE REQUIRED INPUTS ARE INERTIA AND STIFFNESS
C COEFFICIENTS DERIVED FROM CALCULATOR PROGRAM 'INERTIA AND STIFFNESS
C COEFFICIENTS OF WIND TURBINES'. ALSO REQUIRED ARE THE MASS MOMENT
C OF INERTIA OF THE ROTOR ABOUT IT'S SPIN AXIS, THE MINIMUM AND
C MAXIMUM ROTOR SPEEDS AND THE NUMBER OF ROTOR SPEEDS BETWEEN MINIMUM
C AND MAXIMUM THAT ROOTS ARE TO BE FOUND.
C
C THE OUTPUT WILL BE THE ROOTS IN FREQUENCY SQUARED OF THE NATURAL
C FREQUENCY OF VIBRATION AT ZERO ROTOR SPEED, INFINITE ROTOR SPEED,
C AND THOSE SPEEDS REQUESTED.
C
C THIS PROGRAM WAS WRITTEN FOR NASA LEWIS RESEARCH BY ROBERT J. CHRISTIE
C OF W. L. TANKSLEY BASED ON WORK OF R.W. THRESHER AND C.E. SMITH OF
C OREGON STATE UNIVERSITY.
C
C TASK ORDER 152-01 FOR NASA CONTRACT NAS3-21900
C
C * * * * *
C
C THIS PROGRAM REQUIRES SUBROUTINE GNEWTN AND SYNDIV
C
C R = ROTOR ROTATION SPEED
C W = NATURAL FREQUENCY OF VIBRATION
C PLOTTING ARRAYS
  DIMENSION ZZ(200),P(400),X1(400)
  DIMENSION CX(3),CY(4),CT(8)
  DIMENSION TITLE(12)
C
  COMMON /COEFS/ NDGREE,NC,NSF,EPS1,X,COEF(40),ROOT(40)
  COMPLEX COEF,X,ROOT
C PLOTTING DATA
  DATA NX/18/
  DATA CX/'ROTOR SPEED, RAD/S'/
  DATA NY/21/
  DATA CY/'NATURAL FREQUENCY, HZ'/
  DATA NT/43/
  DATA CT/'NATURAL FREQUENCIES OF WIND TURBINE SYSTEMS'/
C NUMBER OF SIGNIFICANT FIGURES IN ROOTS DESIRED
  NSF=4
C EPSILON TEST
  EPS1=.001
```



```

C NUMBER OF SETS OF INPUT DATA AND PLOT OPTION
  READ(5,10)J,JPO
10  FORMAT(2I6)
    CALL MODESG(ZZ,12)
C TITLE
120 READ(5,20) (TITLE(L),L=1,12)
20  FORMAT(12A6)
C MOMENT OF INERTIA, MINIMUM AND MAXIMUM ROTOR SPEEDS, NUMBER OF STEPS
C BETWEEN MINIMUM AND MAXIMUM ROTOR SPEED
  READ(5,30)RI,RMIN,RMAX,NS
30  FORMAT(3E12.6,I6)
C MASS COEFFICIENTS
  READ(5,40)RMUU,RMUO,RMVV,RMVX,RMOO,RMXX
40  FORMAT(6E12.6)
C STIFFNESS COEFFICIENTS
  READ(5,50)RKUU,RKVV,RKVX,RKOO,RKXX
  NP=NS+2
50  FORMAT(5E12.6)
C WRITE TITLE
  WRITE(6,180) (TITLE(L),L=1,12)
180 FORMAT(2H1,12A6)
C WRITE MASS MOMENT OF INERTIA AND ROTATIONAL SPEED LIMITS
  WRITE(6,130)RI,RMIN,RMAX
130 FORMAT(26H MASS MOMENT OF INERTIA = ,E12.6/
126H MINIMUM ROTATION SPEED = ,E12.6/
126H MAXIMUM ROTATION SPEED = ,E12.6///)
C WRITE MASS COEFFICIENTS
  WRITE(6,160)
  WRITE(6,140)RMUU,RMUO,RMVV,RMVX,RMOO,RMXX
140 FORMAT(7H MUU = ,E12.6/7H MUO = ,E12.6/7H MVV = ,E12.6/
17H MVX = ,E12.6/7H MOO = ,E12.6/7H MXX = ,E12.6///)
C WRITE STIFFNESS COEFFICIENTS
  WRITE(6,170)
170 FORMAT(23H STIFFNESS COEFFICIENTS//)
  WRITE (6,150)RKUU,RKVV,RKVX,RKOO,RKXX
150 FORMAT(7H KUU = ,E12.6/7H KVV = ,E12.6/7H KVX = ,E12.6/
17H KOO = ,E12.6/7H KXX = ,E12.6///)
160 FORMAT(18H MASS COEFFICIENTS//)
C ROTOR INERTIA SQUARED
  RISQ=RI**2
C COEFFICIENTS OF POLYNOMIALS
C *GOU*
  AG=RKUU*RKOO
  BG=(RKUU*RMOO+RKOO*RMUU) * (-1.)
  CG=RMUU*RMOO-RMUO**2
C *HXV*
  AH=RKXX*RKVV-RKVX**2
  BH=-(RKXX*RMVV+RKVV*RMXX-2*RKVX*RMVX)
  CH=RMVV*RMXX-RMVX**2

```

```

C FOR ZERO ROTATION SPEED
  COEF(3)=AG
  COEF(2)=BG
  COEF(1)=CG
C DEGREE OF POLYNOMIAL
  NDGREE=2
C NUMBER OF COEFFICIENTS
  NC=3
C SOLVE FOR ROOTS
  WRITE(6,190)
190  FORMAT(20(2H *))
  CALL GNEWTN
  WRITE(6,60)
60  FORMAT(50H ROOTS OF GOU IN W SQUARED AT ZERO ROTATION SPEED)
C FOR ZERO ROTATION
  COEF(3)=AH
  COEF(2)=BH
  COEF(1)=CH
  WRITE(6,190)
  CALL GNEWTN
  WRITE(6,70)
70  FORMAT(50H ROOTS OF HXV IN W SQUARED AT ZERO ROTATION SPEED)
C FOR INFINITE SPEED
  W2=RKUU/RMUU
  W3=RKVV/RMVV
  WRITE(6,190)
  WRITE(6,80) W2,W3
80  FORMAT(34H W SQUARED AT INFINITE ROTOR SPEED/ 2E12.6)
  R=RMAX
  RS=(RMAX-RMIN)/(NS+1)
  GO TO 100
110 R=R-RS
C COEFFICIENTS OF DUV
100  OMSQ=R**2
  BD=OMSQ*RISQ*RKUU*RKVV
  CD=-OMSQ*RISQ*(RKUU*RMVV+RKVV*RMUU)
  DD=OMSQ*RISQ*RMUU*RMVV
C COEFFICIENTS OF ENTIRE POLYNOMIAL AT R
  COEF(5)=AG*AH
  COEF(4)=AG*BH+BG*AH-BD
  COEF(3)=AG*CH+BG*BH+CG*AH-CD
  COEF(2)=BG*CH+CG*BH-DD
  COEF(1)=CG*CH
  NDGREE=4
  NC=5
  X=0.
  WRITE(6,190)
  CALL GNEWTN
  WRITE(6,90) R
90  FORMAT(27H ROOTS IN W SQUARED AT R = ,E12.6)

```

```

C BUILD VECTORS
  M=NS+2
  P(M)=R
  X1(M)=REAL(CSQRT(ROOT(1)))/6.2832
  M=M+NP
  P(M)=R
  X1(M)=REAL(CSQRT(ROOT(2)))/6.2832
  M=M+NP
  P(M)=R
  X1(M)=REAL(CSQRT(ROOT(3)))/6.2832
  M=M+NP
  P(M)=R
  X1(M)=REAL(CSQRT(ROOT(4)))/6.2832
C CHECK NUMBER OF ROTATION FREQUENCY STEPS
  NS=NS-1
  IF(NS.GT.-2)GO TO 110
  WRITE(6,190)
  WRITE(6,220)
220  FORMAT(55H ROTOR,RAD/S  W1 HZ          W2 HZ          W3 HZ          W4 HZ)
  WRITE(6,210) (P(L),X1(L),X1(L+NP),X1(L+2*NP),X1(L+3*NP),L=1,NP)
210  FORMAT(5(E12.6))
  IF(JPO.EQ.0)GO TO 230
  IF(JPO.EQ.1)N=NP
  IF(JPO.EQ.2)N=2*NP
  IF(JPO.EQ.3)N=3*NP
  IF(JPO.EQ.4)N=4*NP
  N=N+1
  X1(N)=0.
  P(N)=0.
  CALL GRAPHG(ZZ,N,P,X1,NX,CX,NY,CY,NT,CT)
  CALL PAGEG(ZZ,0,0,1)
230  J=J-1
  IF(J.GT.0)GO TO 120
  CALL EXITG(ZZ)
  STOP
  SUBROUTINE GNEWTN
C
C POLYNOMIAL ROOT FINDER, USES A MODIFIED NEWTON METHOD
C INPUT TO THIS SUBROUTINE IS AS FOLLOWS
C   NDGREE          DEGREE OF POLYNOMIAL      INTEGER
C   NSF             NO. OF SIGNIFICANT FIGURES ACCURACY DESIRED (INTEGER)
C   EPS1           AN EPSILON TEST,  USUALLY APPROX .0001
C   COEF(I),I=1,NC COEFFICIENTS      (COMPLEX)
C CALLING PROGRAM MUST HAVE THE FOLLOWING CARDS
C   COMMON /COEFFS/ NDGREE,NC,NSF,EPS1,X,COEF(40),ROOT(40)
C   COMPLEX COEF,X,ROOT
C   X              INITIAL GUESS OF A ROOT (SUB USES X=0 IF NOT SPECIFIED)
C

```

```

COMMON /COEFS/ NDGREE,NC,NSF,EPS1,X,COEF(40),ROOT(40)
COMMON /STORE/ C(40)
COMPLEX COEFFS
COMPLEX PVAL
COMPLEX COEF,C,F,DELTA,FPR,X,XO,ROOT
COMPLEX FO
DIMENSION PVAL(20),NP(21),COEFFS(40)
EQUIVALENCE (AVX,NAVX),(AVXO,NAVXO)
LOGICAL SKIPST
DATA MASK7/0777777777777777/
N=NDGREE
NC=N+1
IF(EPS1 .LE. 0.) EPS1=0.0001
2 NNSF=(9-NSF)*3
MASK=0
NZ=36-NNSF
FLD(0,NZ,MASK)=FLD(0,NZ,MASK7)
MTEST=MASK
DO 79 I=1,NC
NP(I)=NC-I
79 COEFFS(I)=COEF(I)
WRITE(6,200) N,(NP(I),COEFFS(I),I=1,NC)
200 FORMAT(22H POLYNOMIAL OF DEGREE I3/17H WITH COEFFICIENTS/
1 (5H X** I2,1P2E18.7))
WRITE(6,204) X
204 FORMAT(31HK USING STARTING VALUE FOR X= 2F15.8//
1 4X,1HM,4X,1HK,3X,2HIT,6X,4HABSF,14X,6HABSFPR,12X,1HX,32X,2HXO)
NR=0
K=0
IT=0
MN=0
19 CALL SYNDIV(N,X)
SKIPST=.FALSE.
F=C(NC)
AVF=CABS(F)
IF(AVF .LT. 1.0E-10 ) GO TO 50
M=1
DO 10 I=N,32767,32767
FPR=C(I)
AVFPR=CABS(FPR)
IF(AVF .EQ. 0.) GO TO 50
IF(AVFPR .EQ. 0.) GO TO 10
DELTA=-F/FPR
IF(M .EQ. 1) GO TO 9
IF(CABS(DELTA) .LT. 1.0E-14) GO TO 9
SM=M
DELTA=CLOG(DELTA)/SM
DELTA=CEXP(DELTA)
9 IF(CABS(DELTA) .LT. 2.*AVF) GO TO 11
10 M=M+1
11 IF(IT .EQ. 0) GO TO 6

```

```

IF(AVF .LT. STORE) GO TO 666
IF(M .NE. MS) GO TO 66
SKIPST= .TRUE.
GO TO 16
666 IF(REAL(F*FO) .GE. 0.) GO TO 6
SKIPST= .TRUE.
GO TO 16
6 XO=X
AVXO=CABS(XO)
STORE=AVF
IT=IT+1
IF(MOD(IT,15) .EQ. 0) MTEST=MTEST*2
SKIPST= .FALSE.
K=0
66 IF(M .EQ. 1) GO TO 15
H=2**K
DELTA=DELTA/H
15 X= X+2.*DELTA
16 X=(X +XO)/2.
K=K+1
WRITE(6,201) M,K,IT,AVF,AVFPR,X,XO
201 FORMAT(3I5,6G18.8)
IF(SKIPST .AND. K .LT. 10) GO TO 19
AVX=CABS(X)
NXMXO=NAVX-NAVXO
IF(CABS(X-XO) .LT. 1.0E-6 ) GO TO 50
IF(AND(NXMXO,MTEST) .EQ. 0.) GO TO 50
MS=M
GO TO 19
50 NR=NR+1
WRITE(6,505) NR,X
505 FORMAT(10HL ROOT NO. I4,9H FOUND, = 2G15.7)
ROOT(NR)=X
IF(NR .EQ. NDGREE) GO TO 100
MINUSN=-N
CALL SYNDIV(MINUSN,X)
N=N-1
NC=NC-1
DO 51 I=1,NC
51 COEF(I)=C(I)
IT=0
MTEST=MASK
X=CONJG(X)
GO TO 19
100 CONTINUE
NC=NDGREE+1
WRITE(6,200) NDGREE,(NP(I),COEFS(I),I=1,NC)
WRITE(6,202)
202 FORMAT(1HL,20X,32HTHE ROOTS OF THIS POLYNOMIAL ARE /
1 4HLNO.,8X,4HREAL,10X,9HIMAGINARY,10X,9HMAGNITUDE,9X,5HANGLE)
PROD=1.

```

```

DO 101 I=1,NDGREE
PVAL(I)=COEFFS(1)
DO 102 J=2,NC
102 PVAL(I)=PVAL(I)*ROOT(I)+COEFFS(J)
X MAG=CABS(ROOT(I))
PROD=PROD*X MAG
XANG=57.29578*AIMAG(CLOG(ROOT(I)))
101 WRITE(6,203) I,ROOT(I),X MAG,XANG,PVAL(I)
WRITE(6,205) PROD
203 FORMAT(I4,1P3G17.7,OPF11.1,5H DEG.,1P2G17.7)
205 FORMAT(27HL THE PRODUCT OF THE ROOTS = G20.8)
9999 CONTINUE
RETURN
SUBROUTINE SYNDIV(NDEG,D)

```

C

```

C SYNTHETIC DIVISION SUBROUTINE
C N= DEGREE OF POLY, AND IF N.L.T. 0, DO ONLY 1 LINE OF DIVISION
C D= DIVISOR
C C= ARRAY OF (N+1) COEFFICIENTS C1X**N+C2X**(N-1) --- CN
C

```

C

```

COMPLEX D,C,COEF,X,ROOT
COMMON /COEFS/ NDGREE,NC,NSF,EPS1,X,COEF(40),ROOT(40)
COMMON /STORE/ C(40)
L=NDEG
NN=IABS(L)
IF(L .LE. 0) L=1
DO 2 I=1,NC
2 C(I)=COEF(I)
DO 1 I=1,L
M=NN+2-I
DO 1 J=2,M
1 C(J)=C(J-1)*D +C(J)
RETURN
END

```

COMPUTER PLOTS OF VIBRATION ANALYSIS
CONCEPTS I, II, AND III,
CASES A THROUGH Q

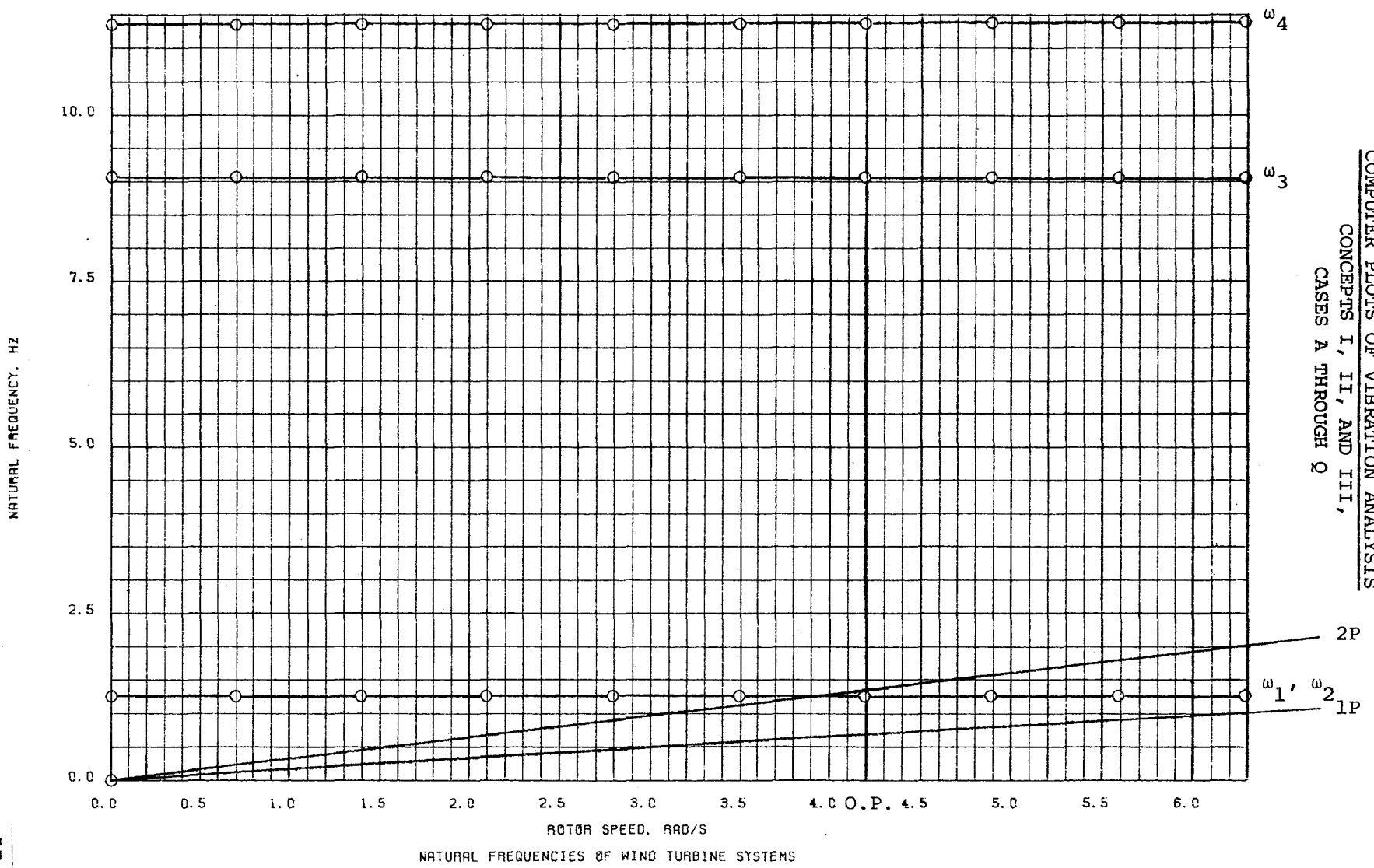

CONCEPT I, CASE A, 25% EFFECTIVE GUY STIFFNESS

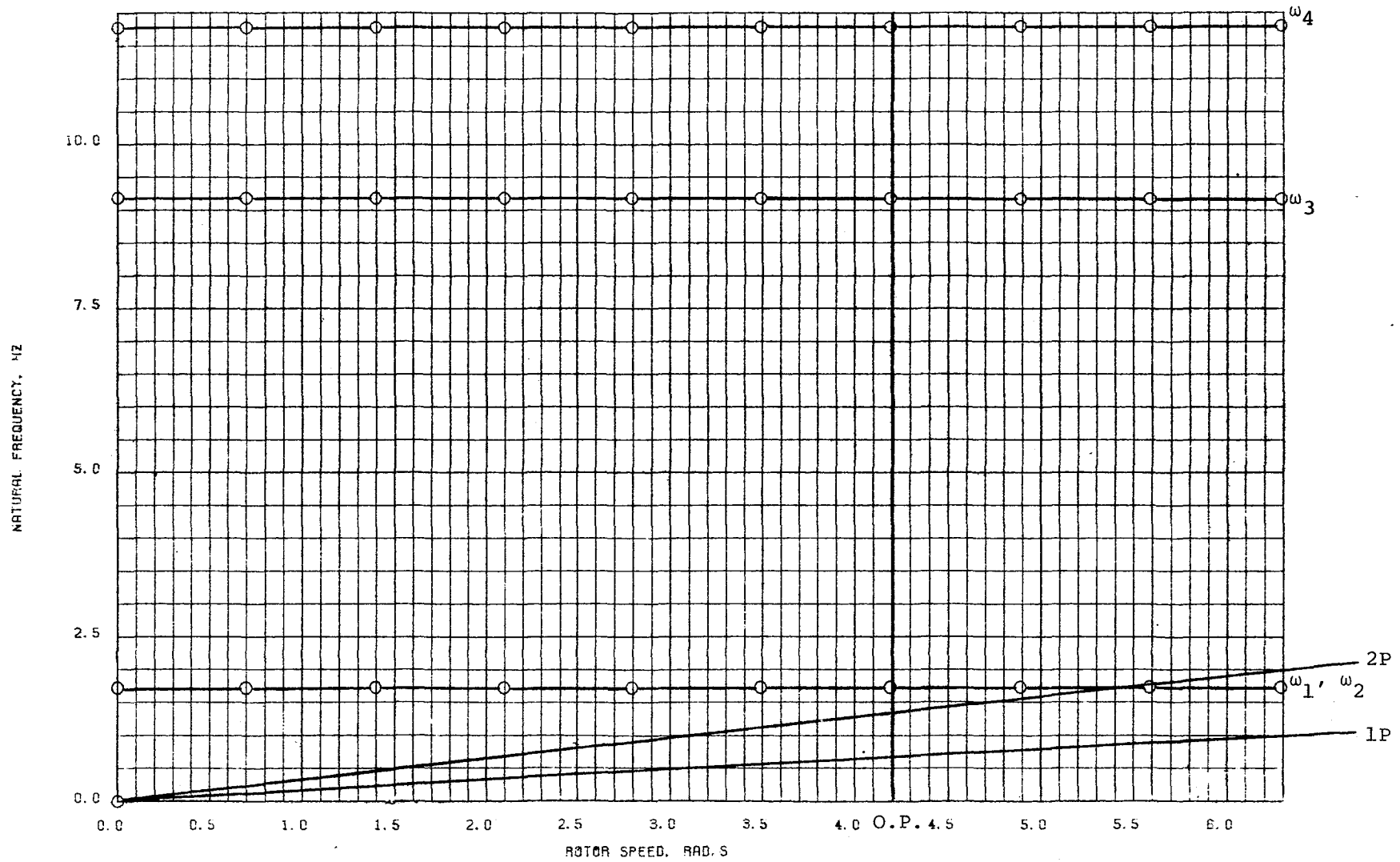

NATURAL FREQUENCIES OF WIND TURBINE SYSTEMS

CONCEPT I, CASE B, 50% EFFECTIVE GUY STIFFNESS

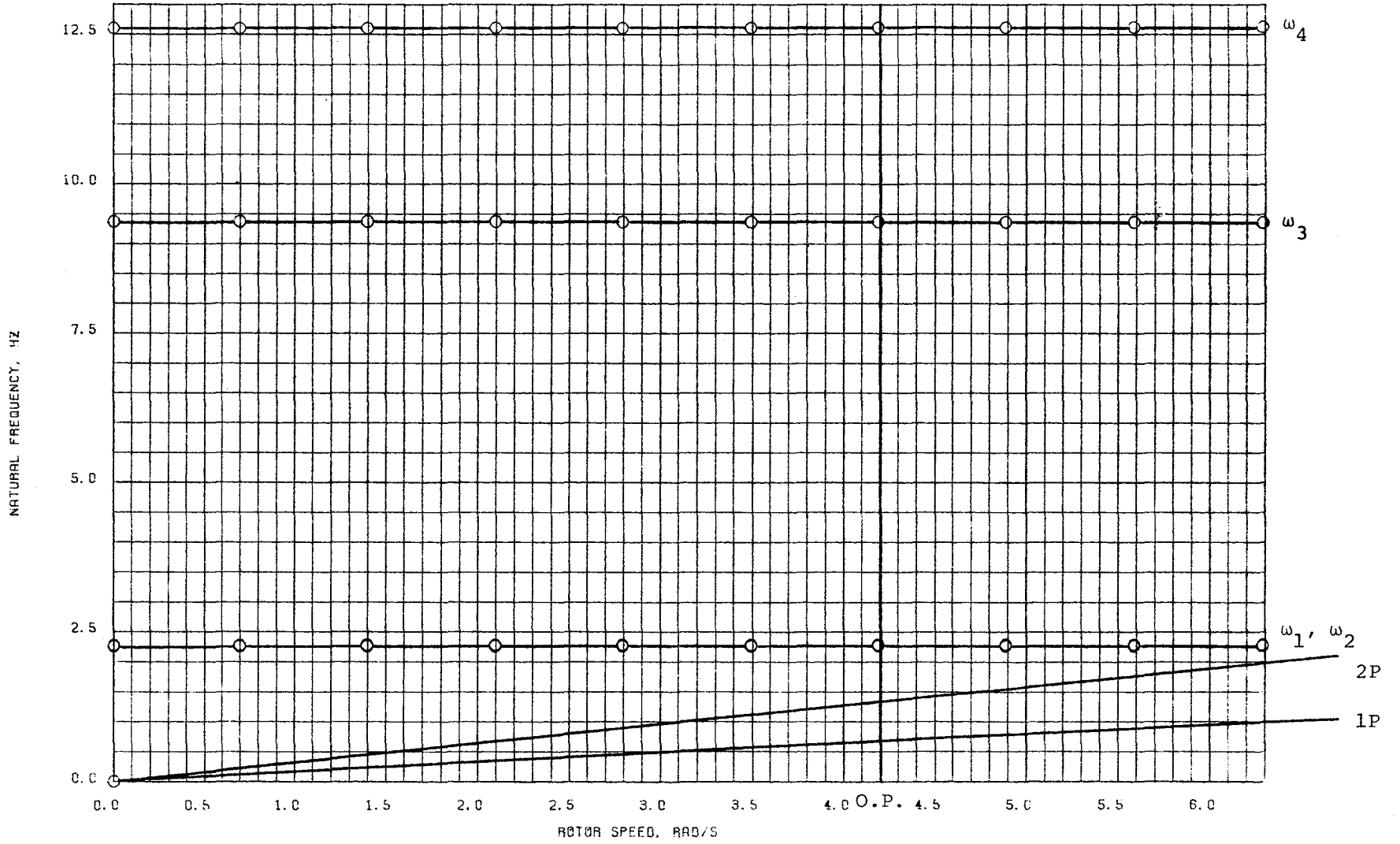

NATURAL FREQUENCIES OF WIND TURBINE SYSTEMS

CONCEPT I, CASE C, 100% EFFECTIVE GUY STIFFNESS

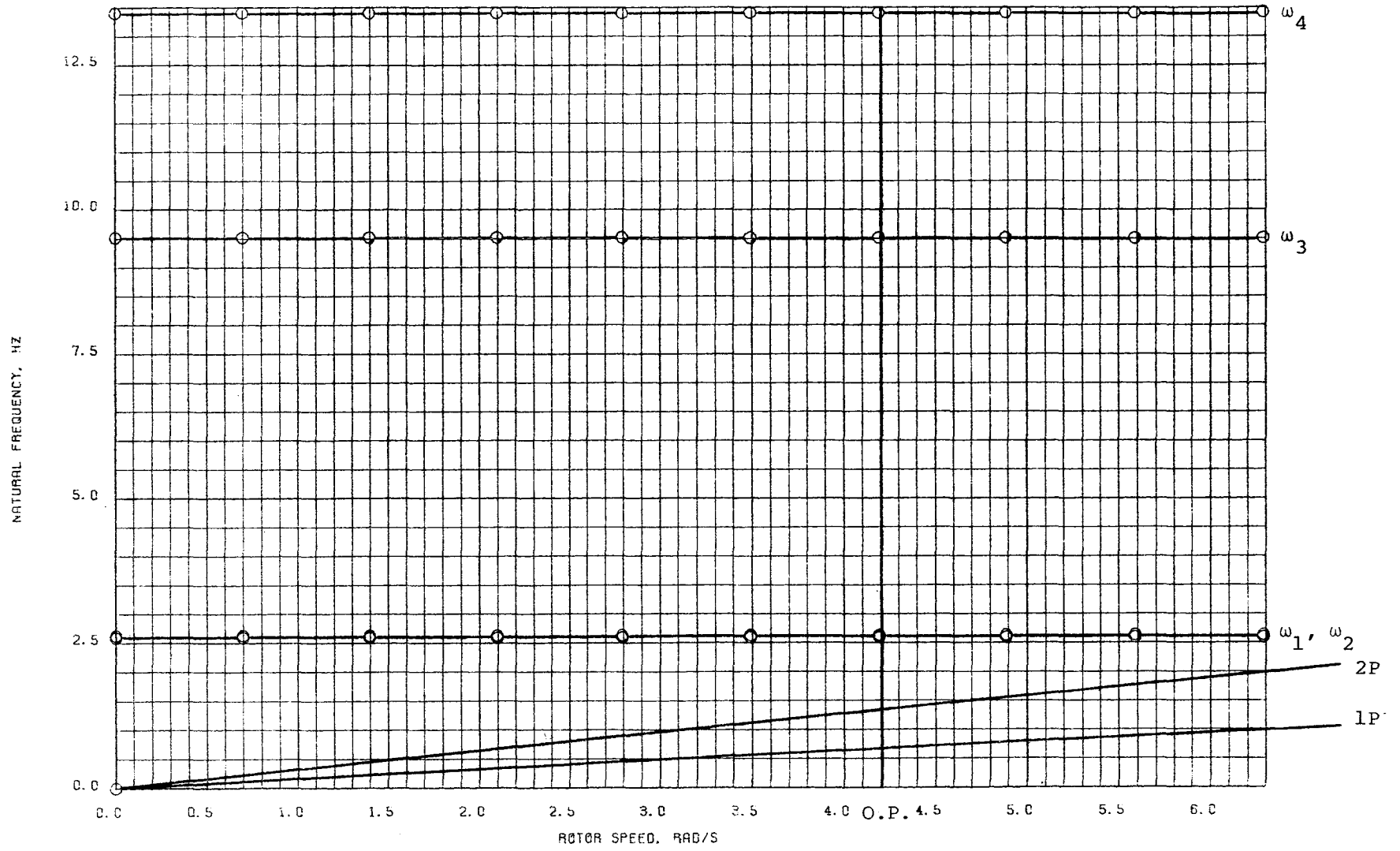

NATURAL FREQUENCIES OF WIND TURBINE SYSTEMS

CONCEPT I, CASE D, 150% EFFECTIVE GUY STIFFNESS

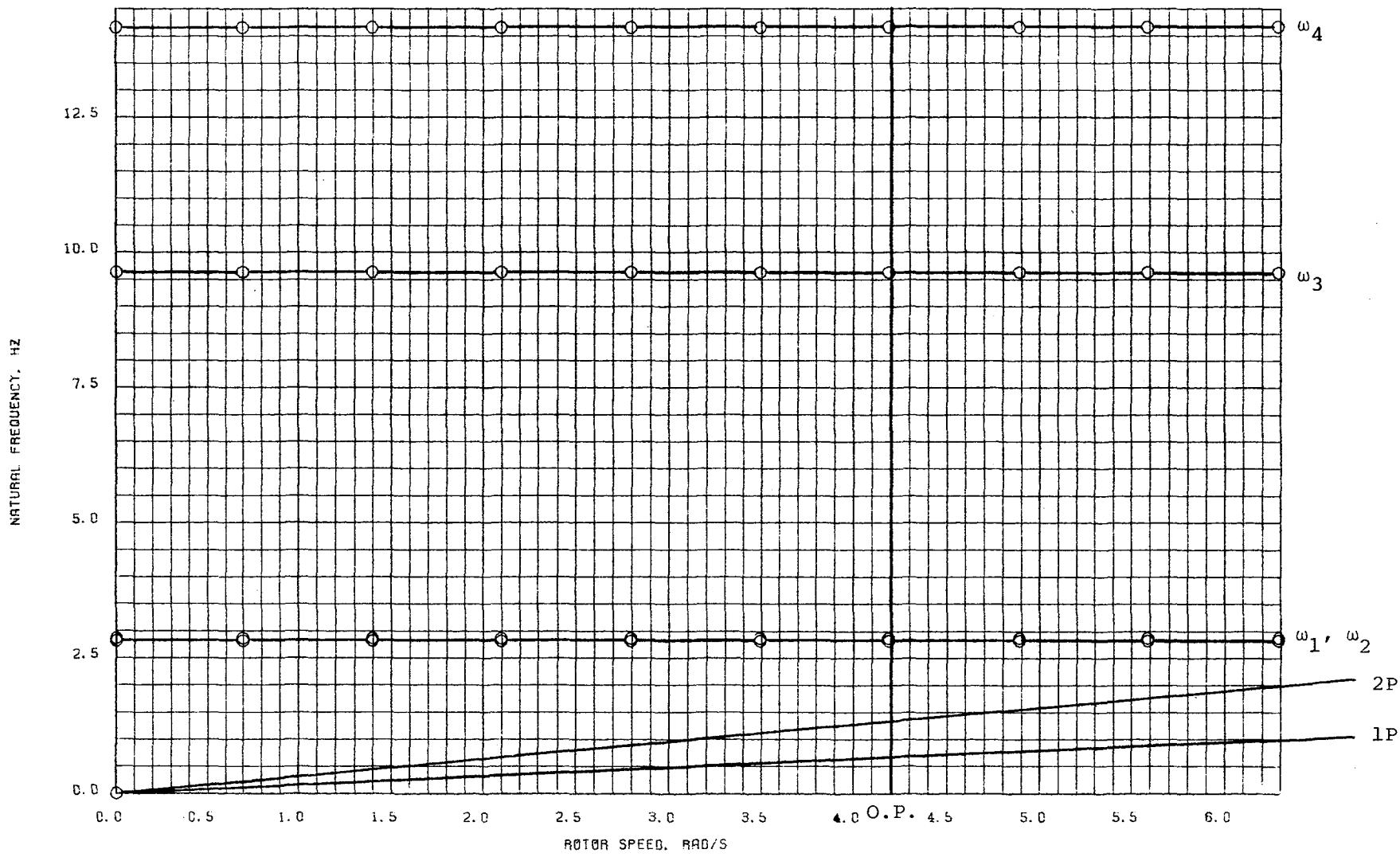

NATURAL FREQUENCIES OF WIND TURBINE SYSTEMS

CONCEPT I, CASE E, 200% EFFECTIVE GUY STIFFNESS

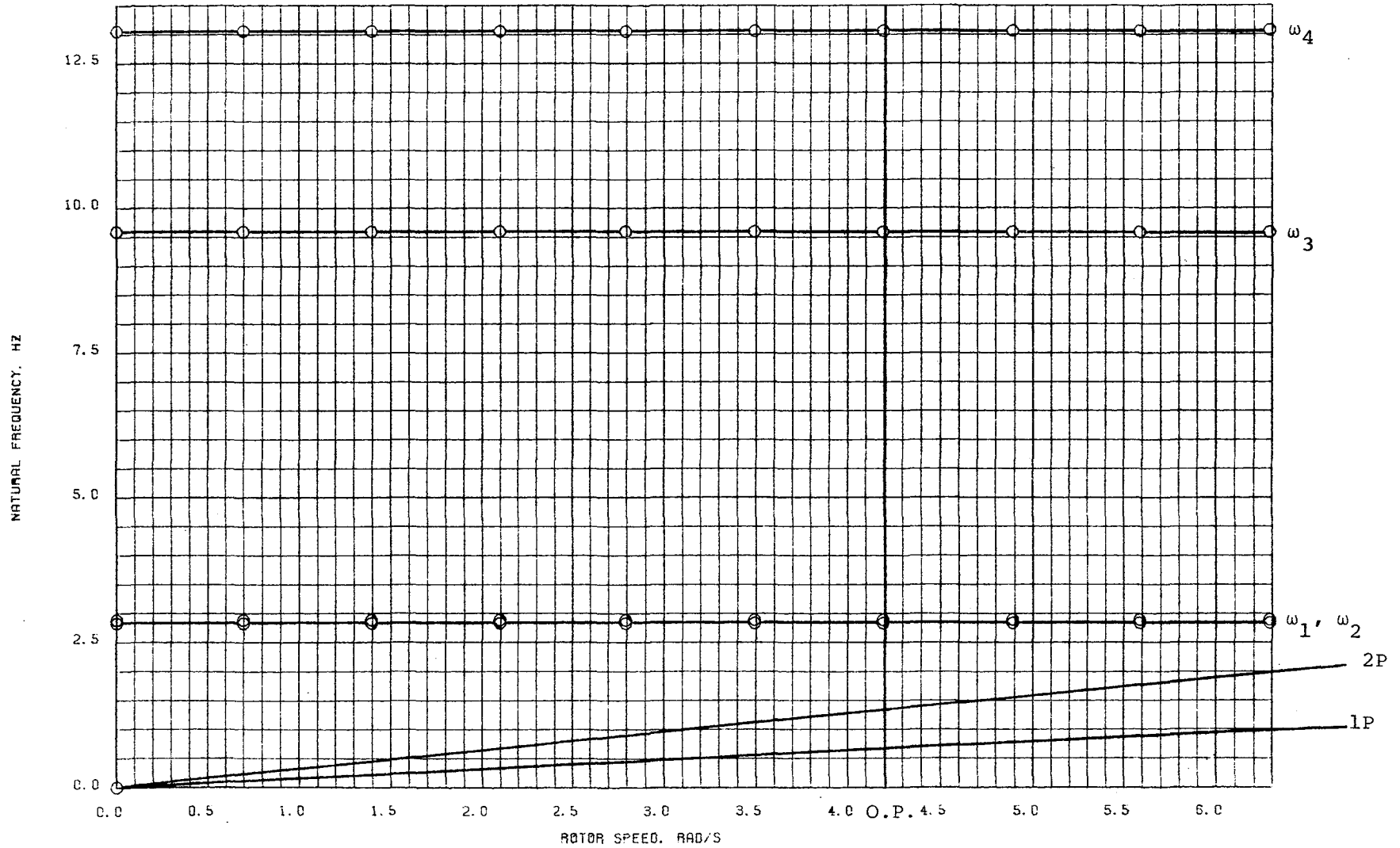

NATURAL FREQUENCIES OF WIND TURBINE SYSTEMS

CONCEPT I, CASE F, GUY ATTACHMENT POINT RAISED 12 FT

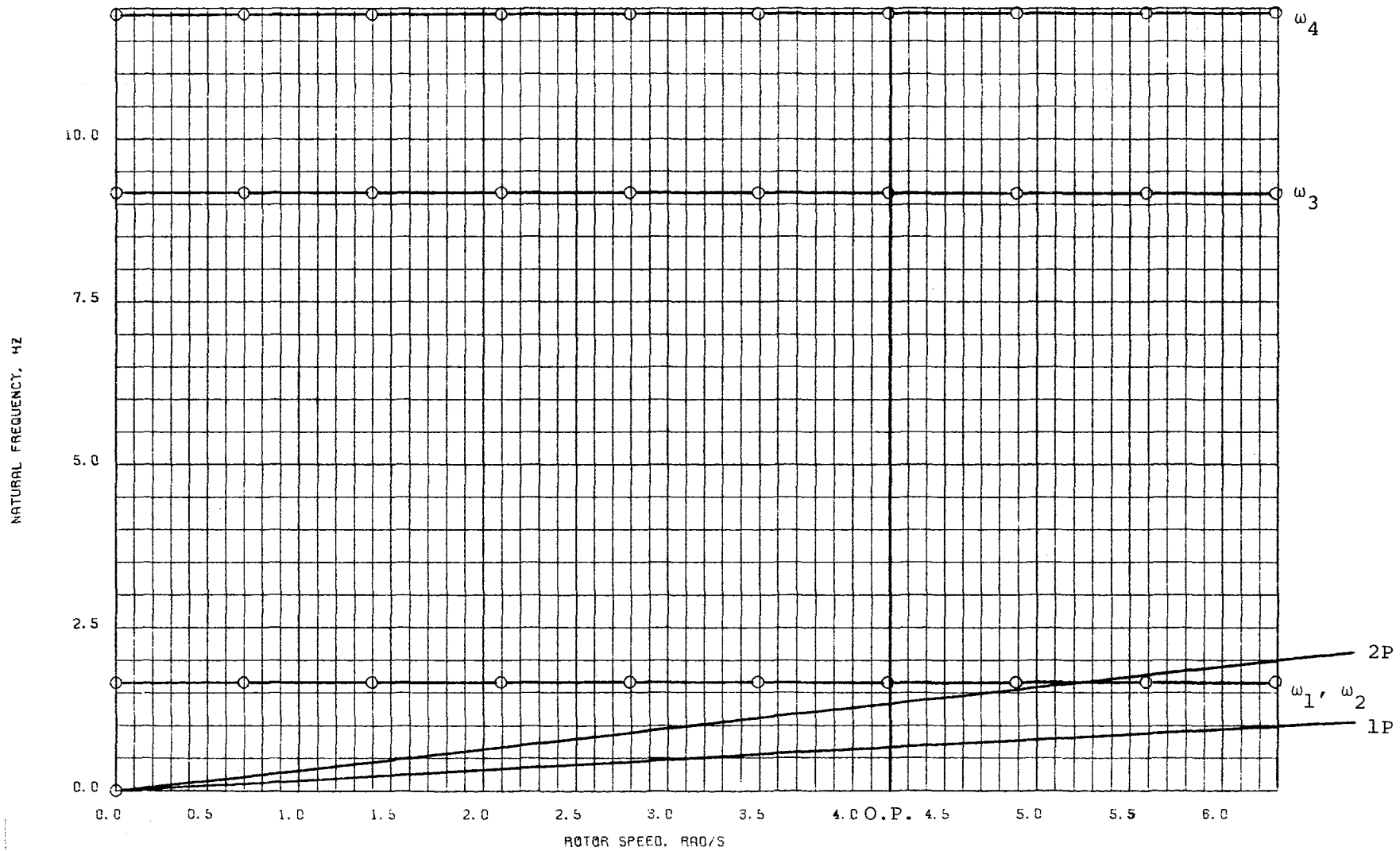

NATURAL FREQUENCIES OF WIND TURBINE SYSTEMS

CONCEPT I, CASE G, GUY ATTACHMENT POINT LOWERED 12 FT

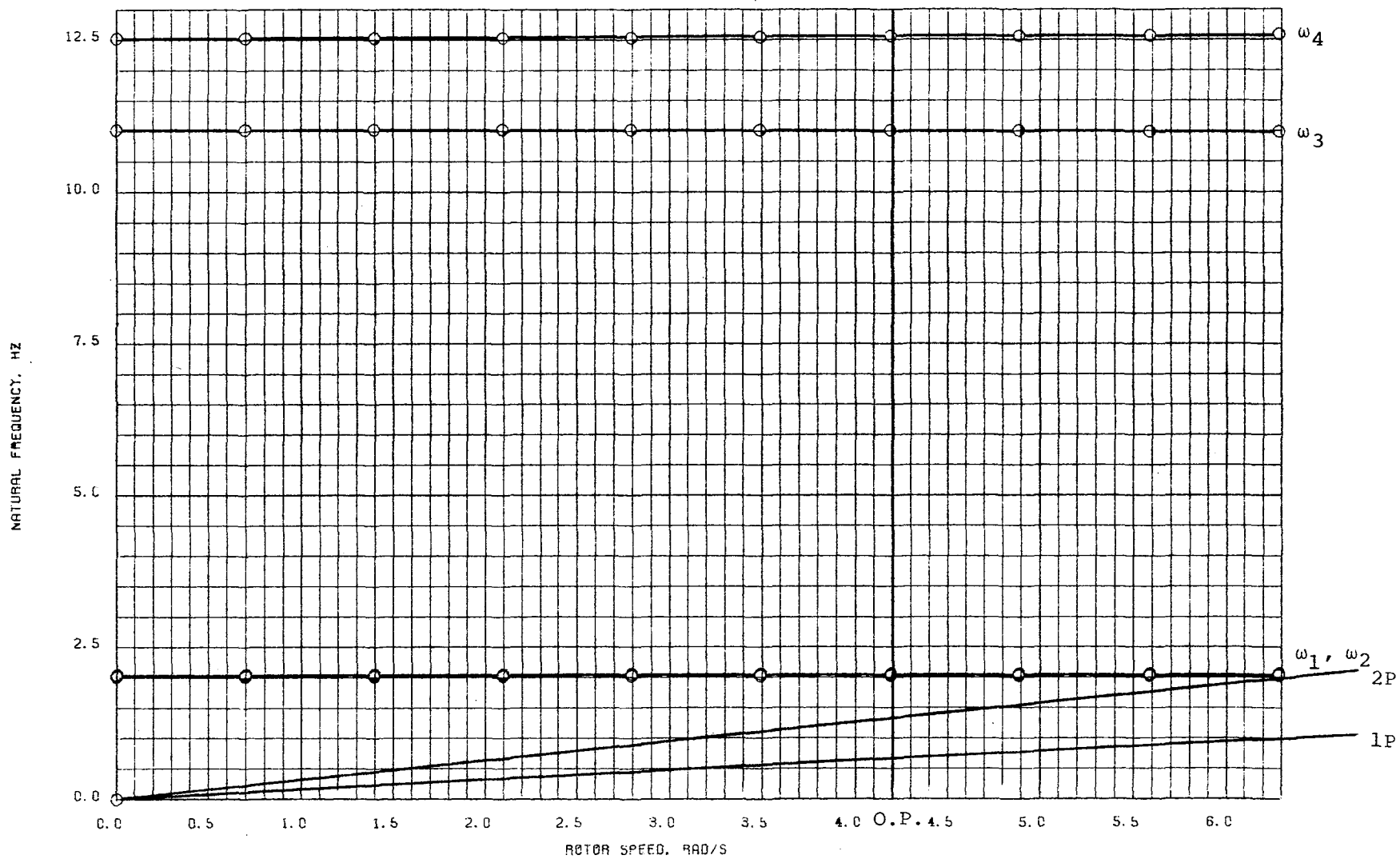

NATURAL FREQUENCIES OF WIND TURBINE SYSTEMS

CONCEPT I, CASE H, NACELLE AND ROTOR MASS INCREASED BY 1/3

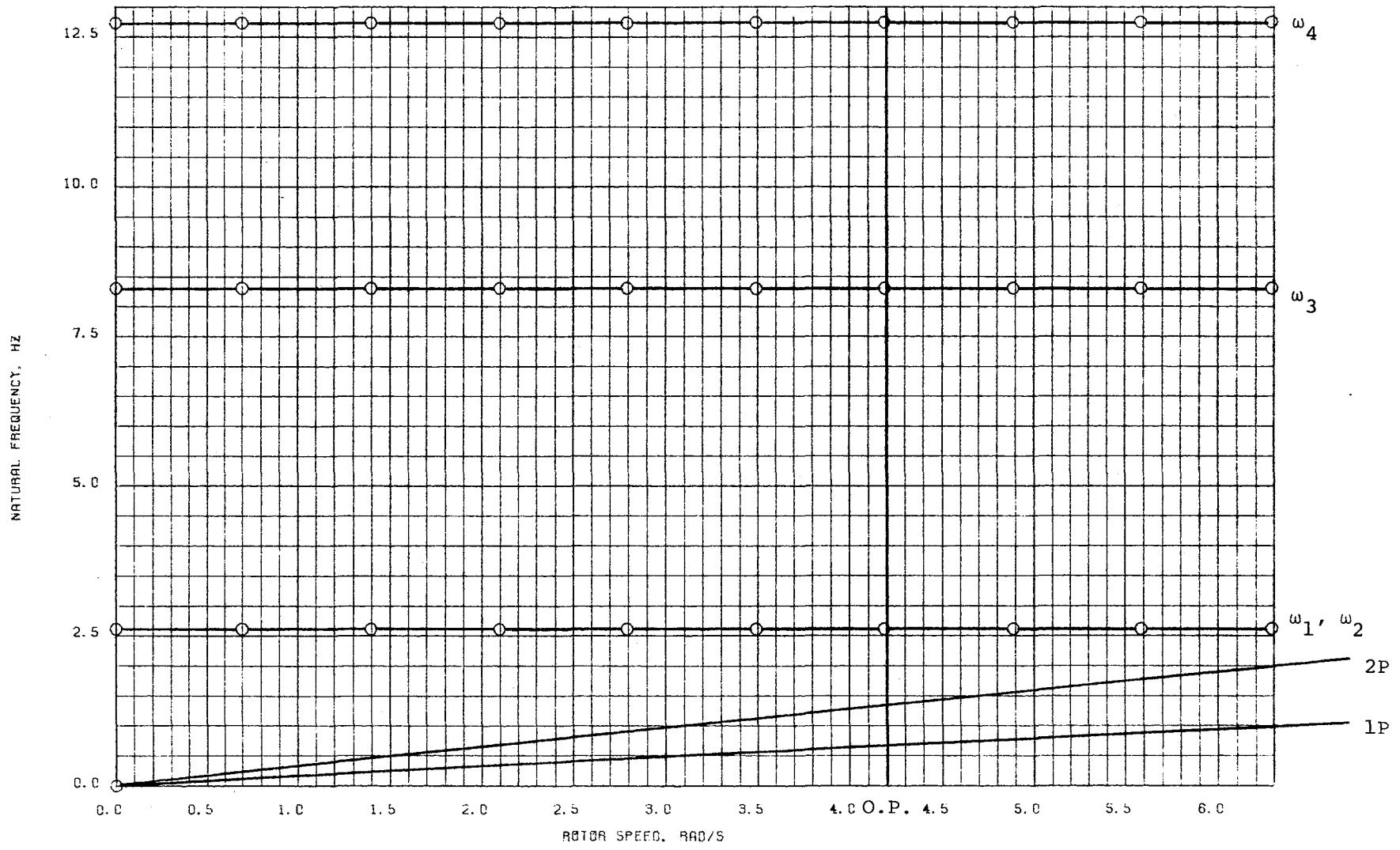

NATURAL FREQUENCIES OF WIND TURBINE SYSTEMS

CONCEPT I, CASE I, NACELLE AND ROTOR MASS DECREASED BY 1/3

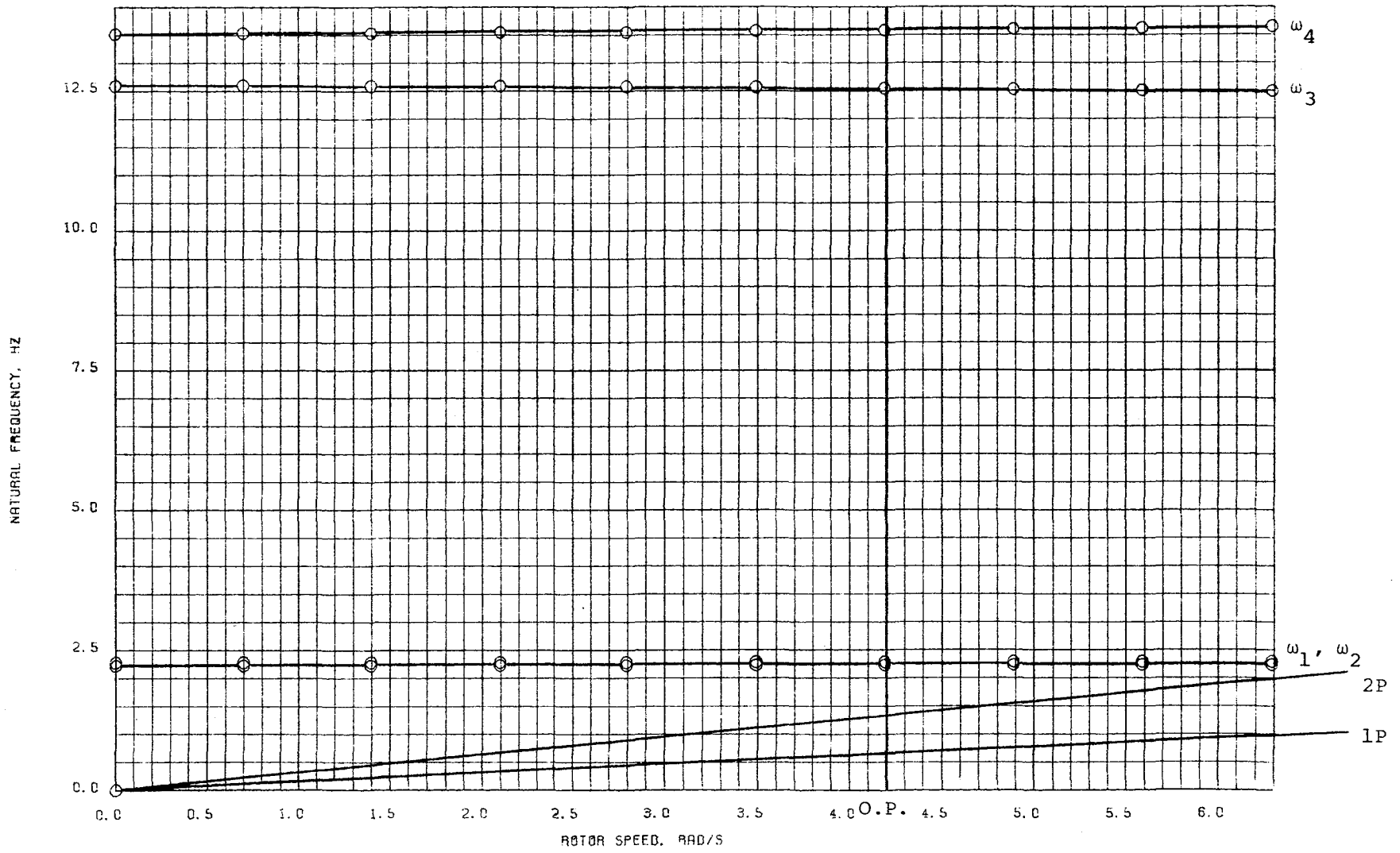

NATURAL FREQUENCIES OF WIND TURBINE SYSTEMS

CONCEPT I, CASE J, DISTANCE TO CENTER OF GRAVITY INCREASED BY 1/3

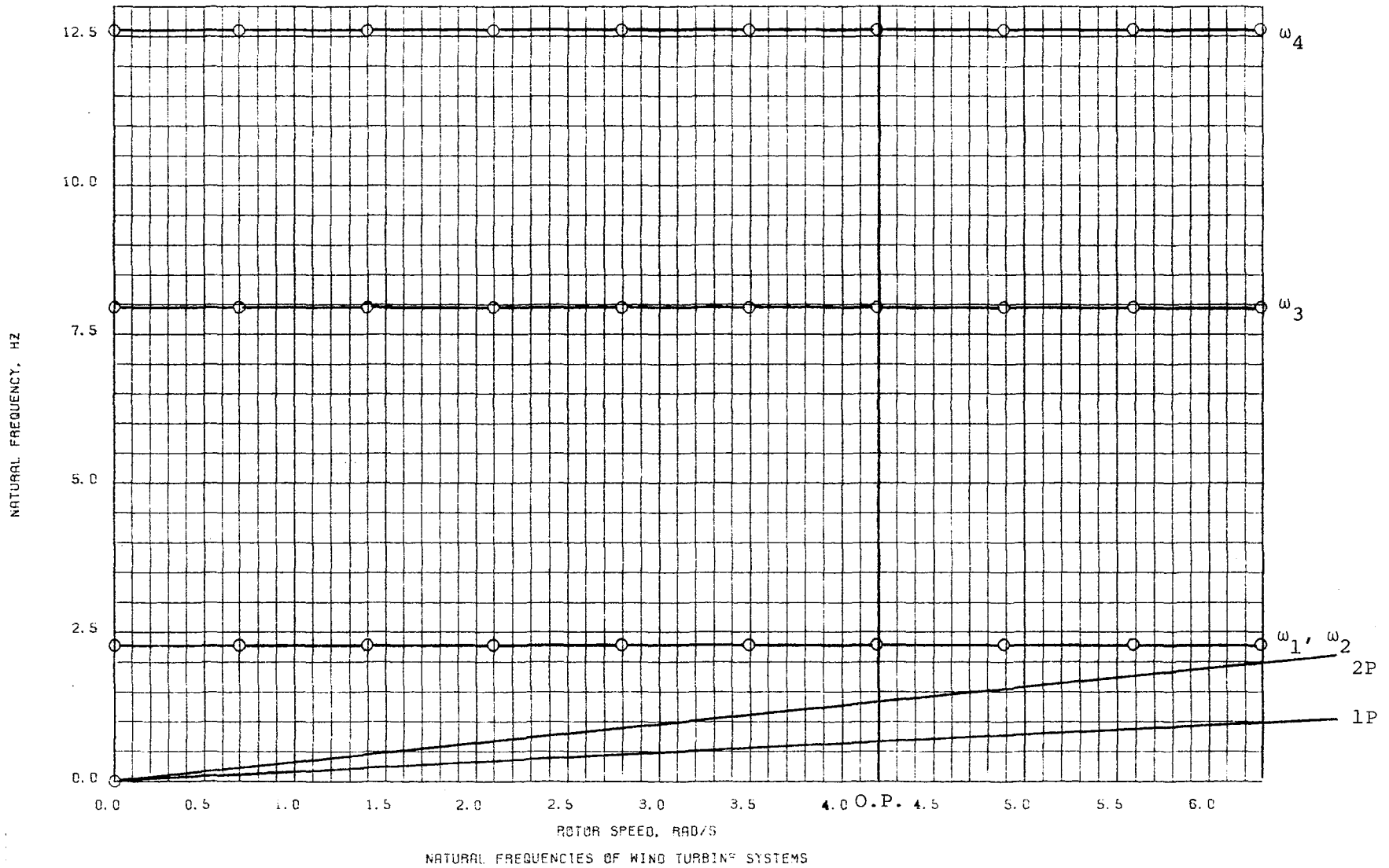

NATURAL FREQUENCIES OF WIND TURBINE SYSTEMS
 CONCEPT I, CASE K, DISTANCE TO CENTER OF GRAVITY DECREASED BY 1/3

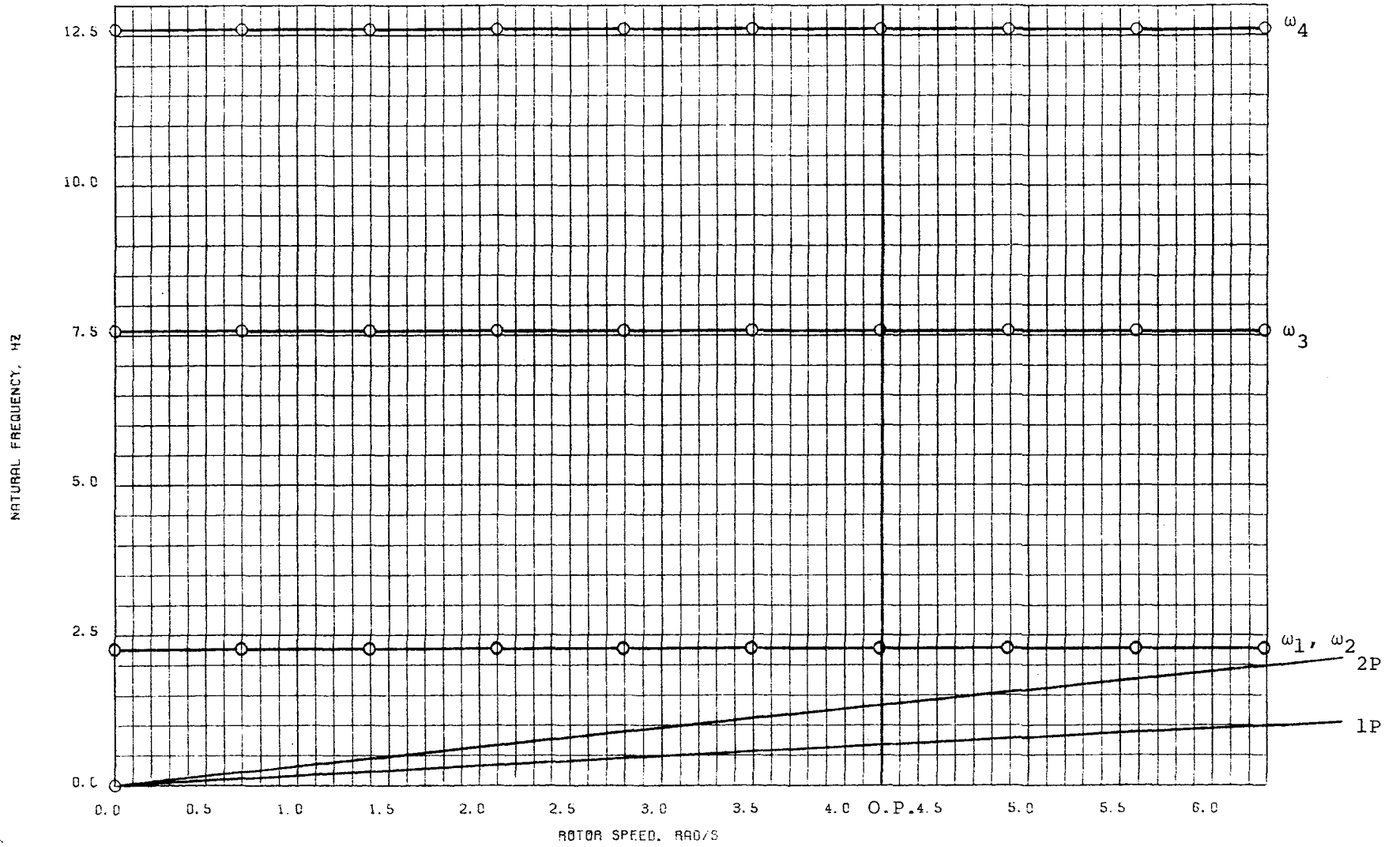

NATURAL FREQUENCIES OF WING TURBINE SYSTEMS

CONCEPT I, CASE L, NACELLE AND ROTOR INERTIA ABOUT Z AXIS INCREASED BY 1/3

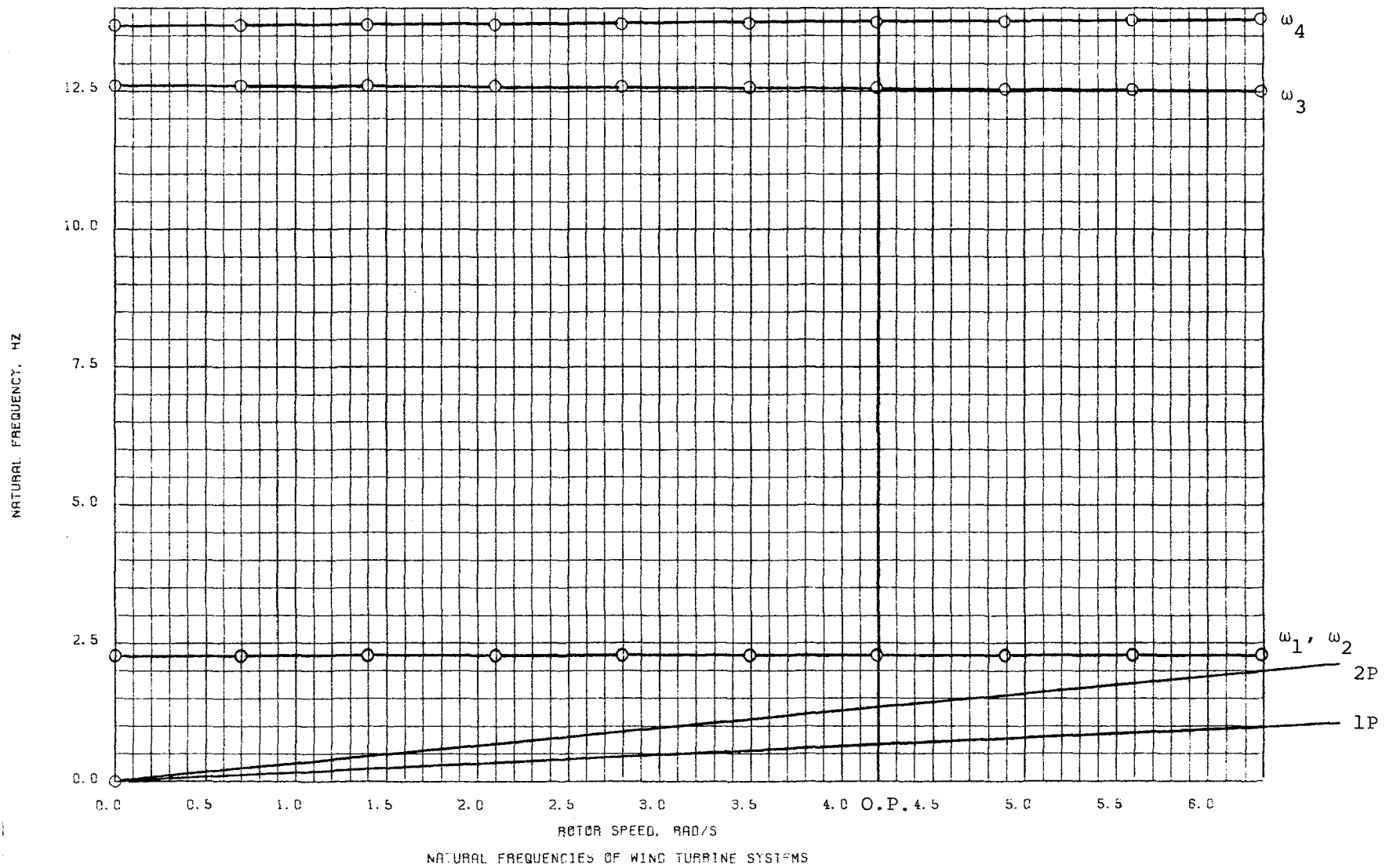

CONCEPT I, CASE M, NACELLE AND ROTOR INERTIA ABOUT Z AXIS DECREASED BY 1/3

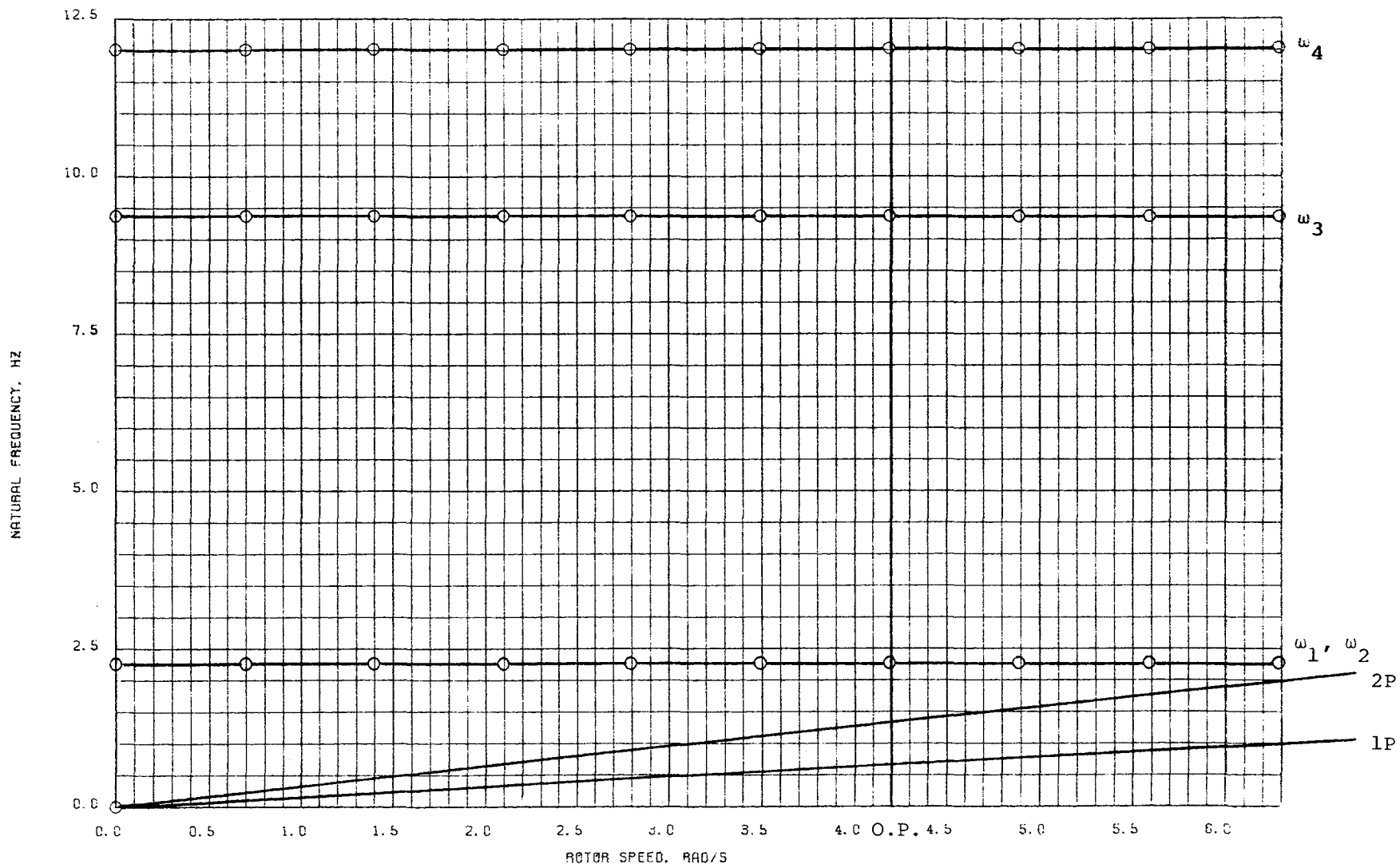

NATURAL FREQUENCIES OF WIND TURBINE SYSTEMS

CONCEPT I, CASE N, NACELLE AND ROTOR INERTIA ABOUT X AXIS INCREASED BY 1/3

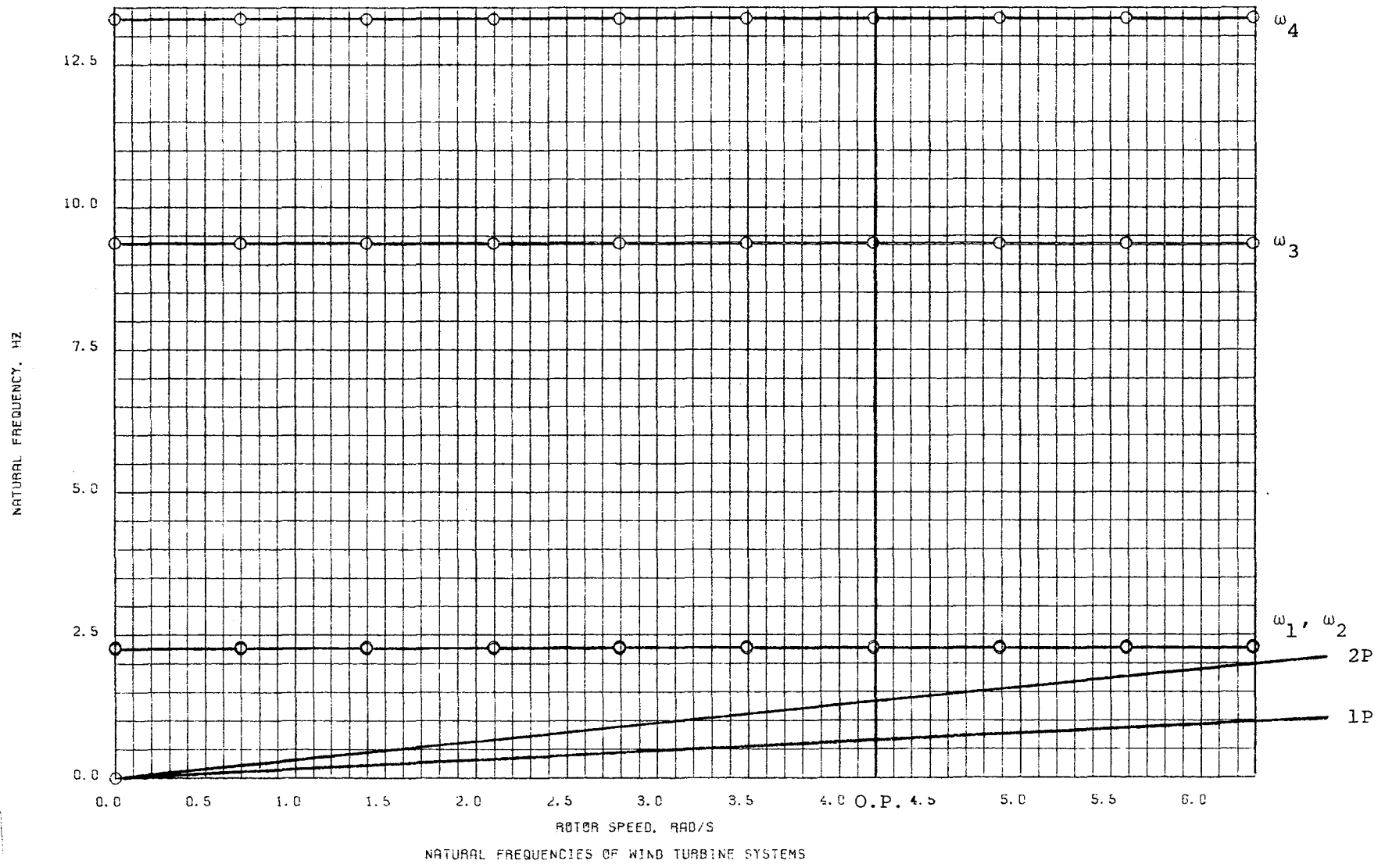

CONCEPT I, CASE O, NACELLE AND ROTOR INERTIA ABOUT X AXIS DECREASED BY 1/3

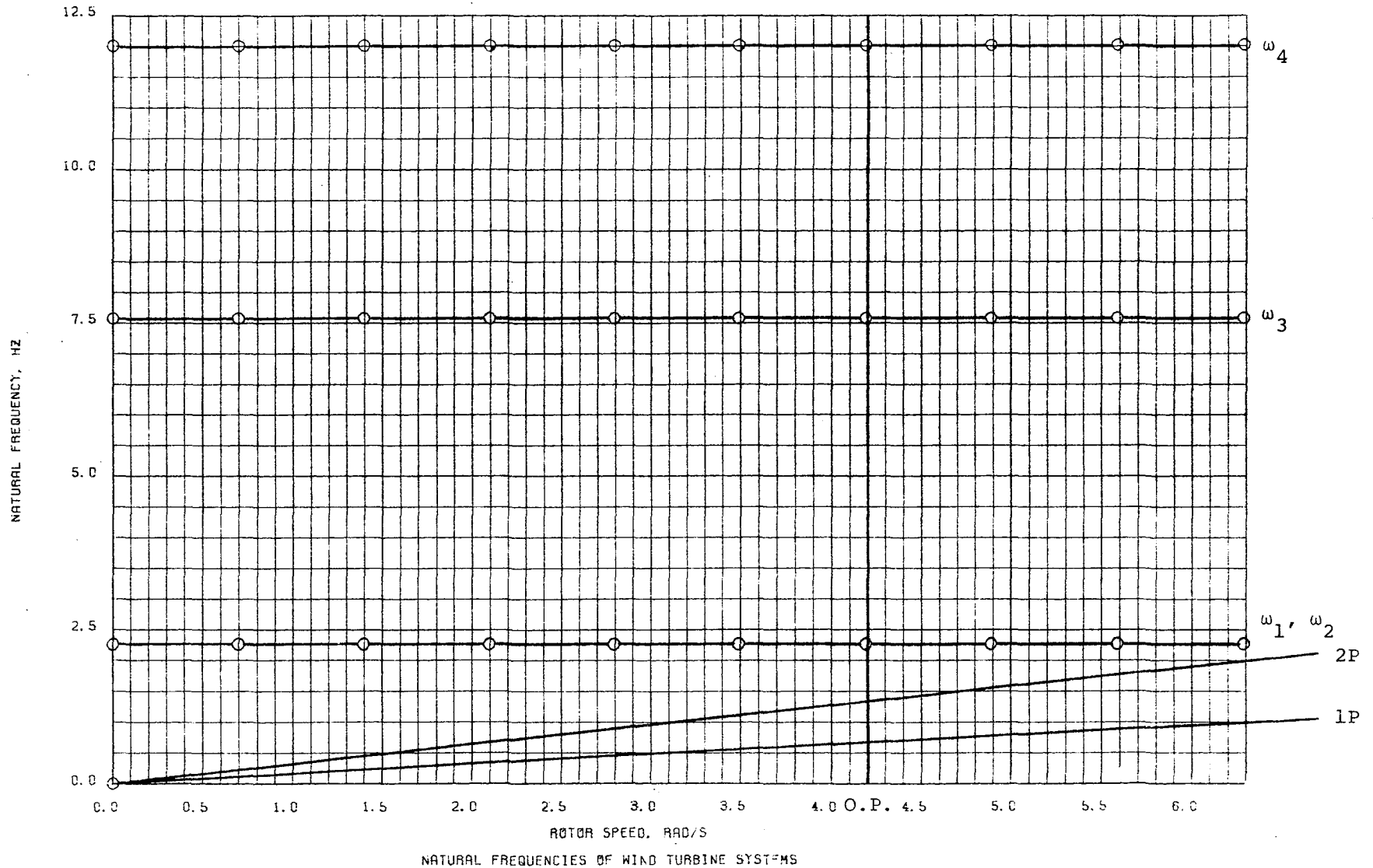

CONCEPT I, CASE P, NACELLE AND ROTOR INERTIA ABOUT X AND Z AXES INCREASED BY 1/3

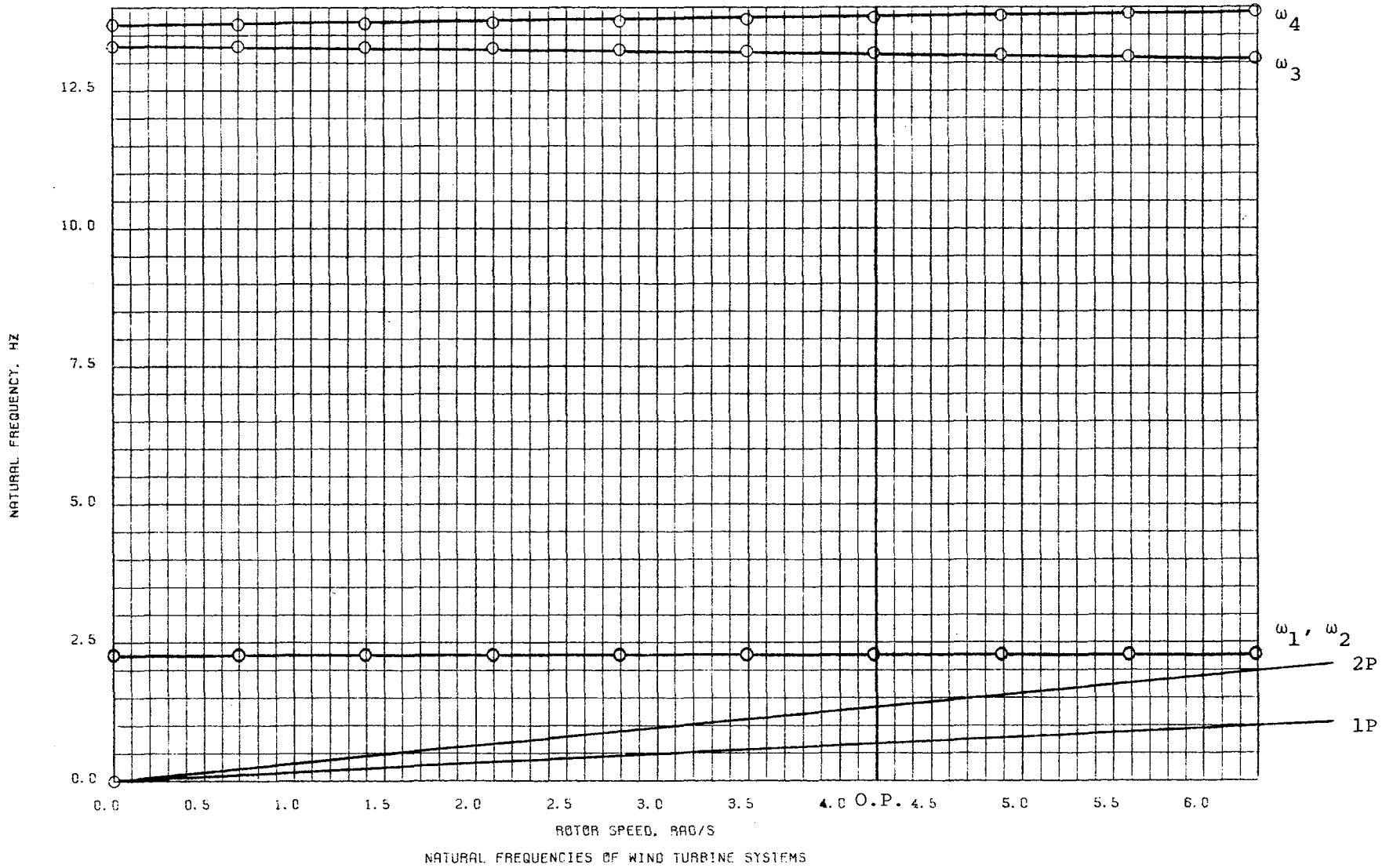

CONCEPT I, CASE Q, NACELLE AND ROTOR INERTIA ABOUT X AND Z AXES DECREASED BY 1/3

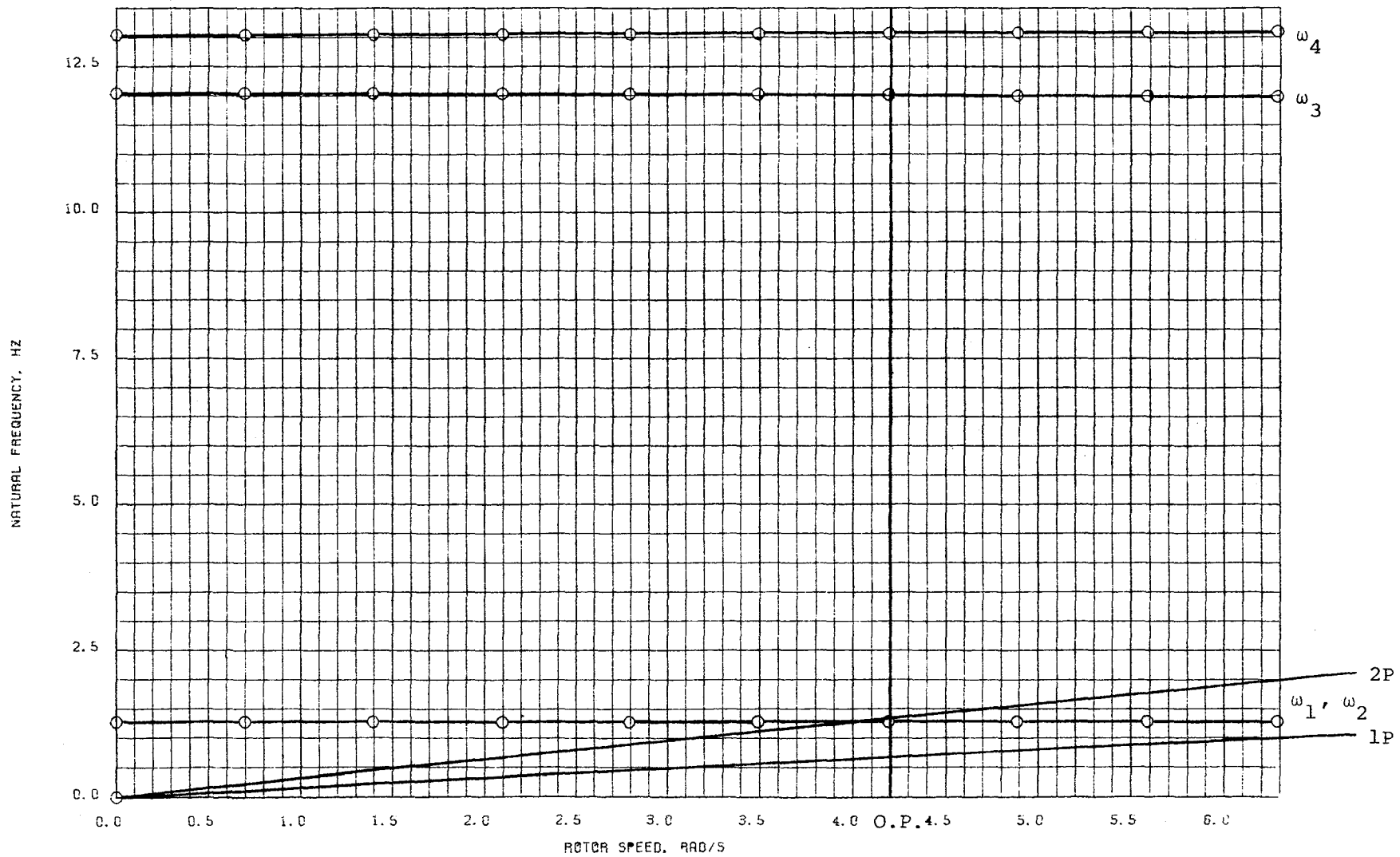

NATURAL FREQUENCIES OF WIND TURBINE SYSTEMS

CONCEPT II, CASE A, 25% EFFECTIVE GUY STIFFNESS

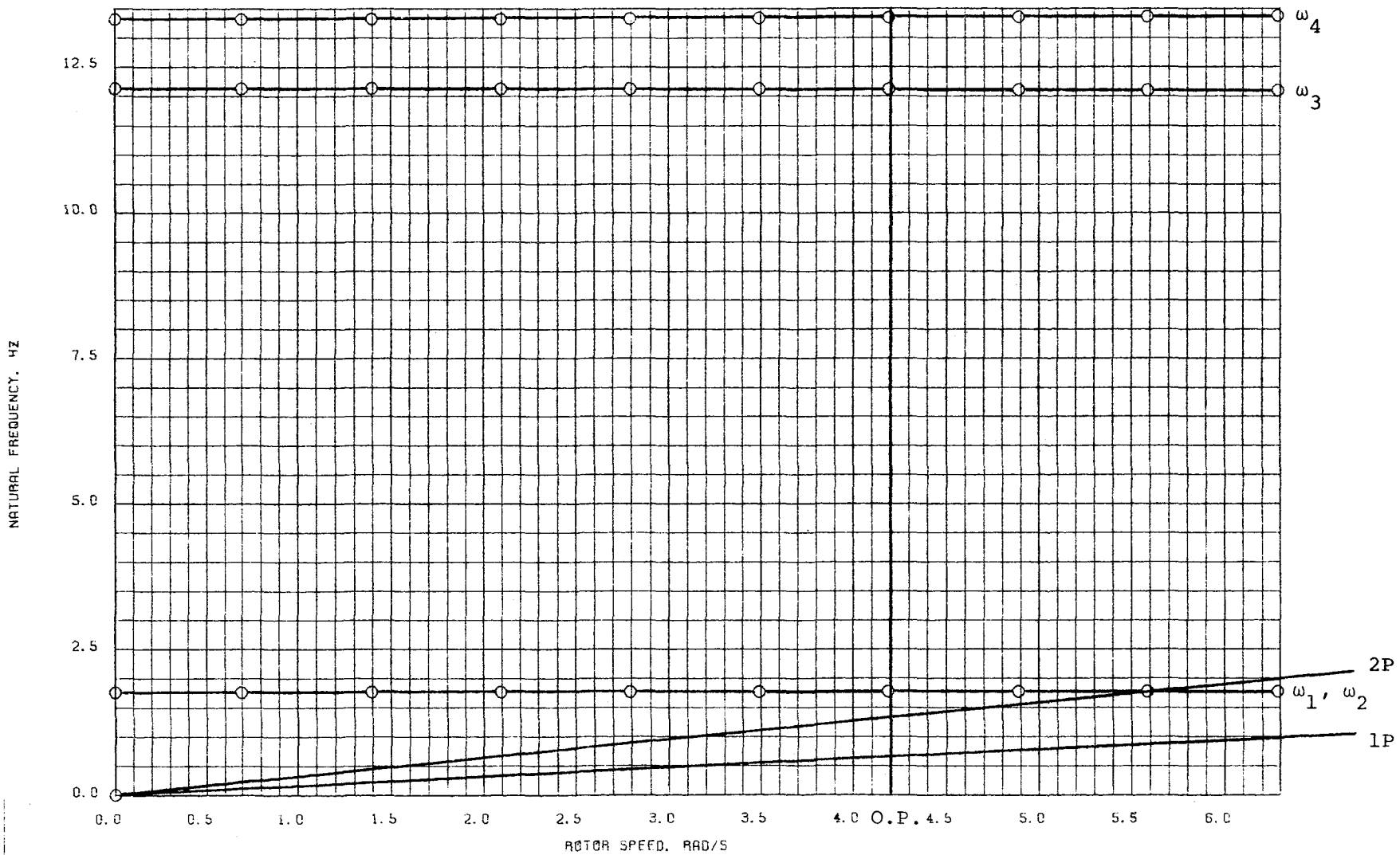

NATURAL FREQUENCIES OF WIND TURBINE SYSTEMS

CONCEPT II, CASE B, 50% EFFECTIVE GUY STIFFNESS

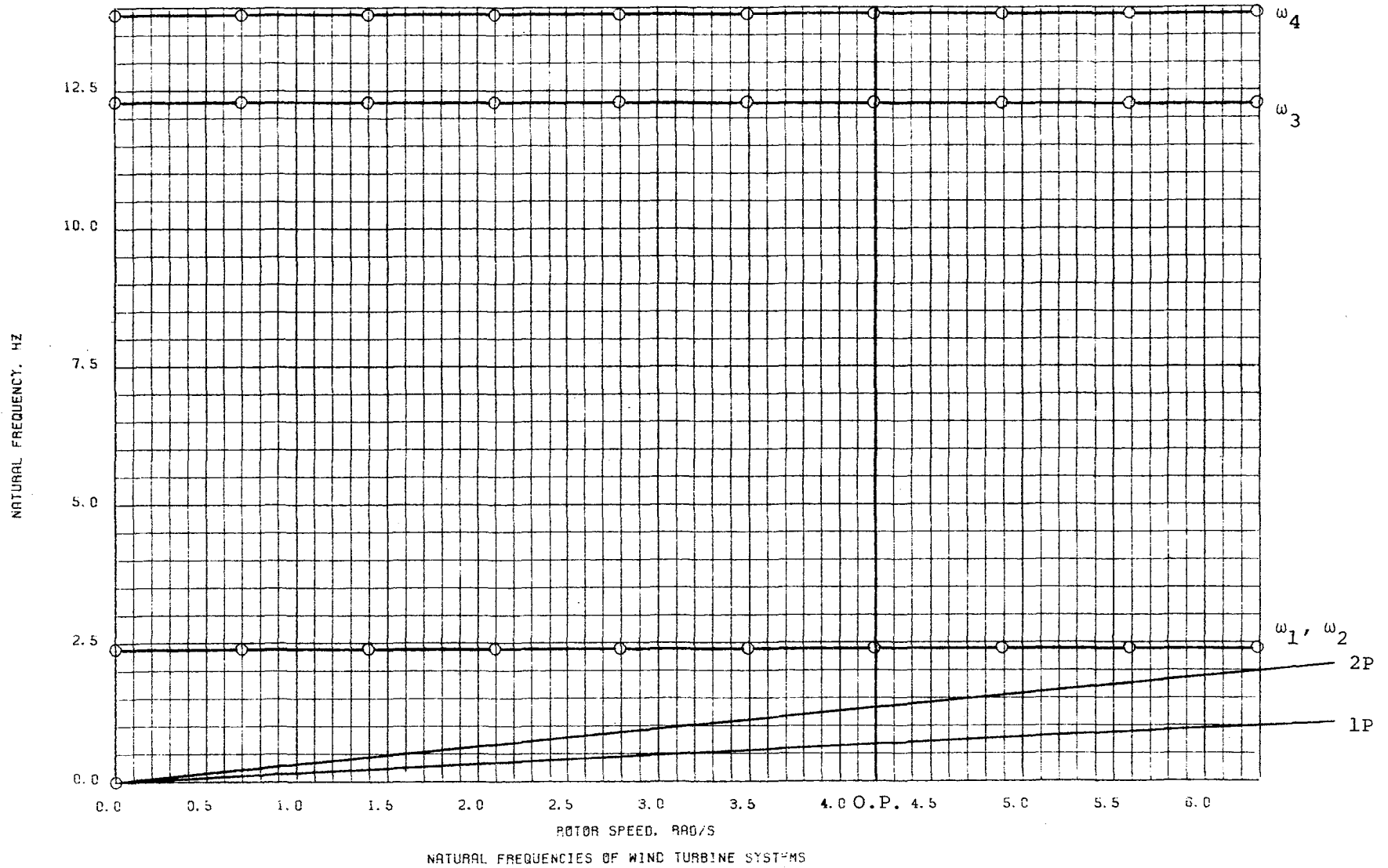

CONCEPT II, CASE C, 100% EFFECTIVE GUY STIFFNESS

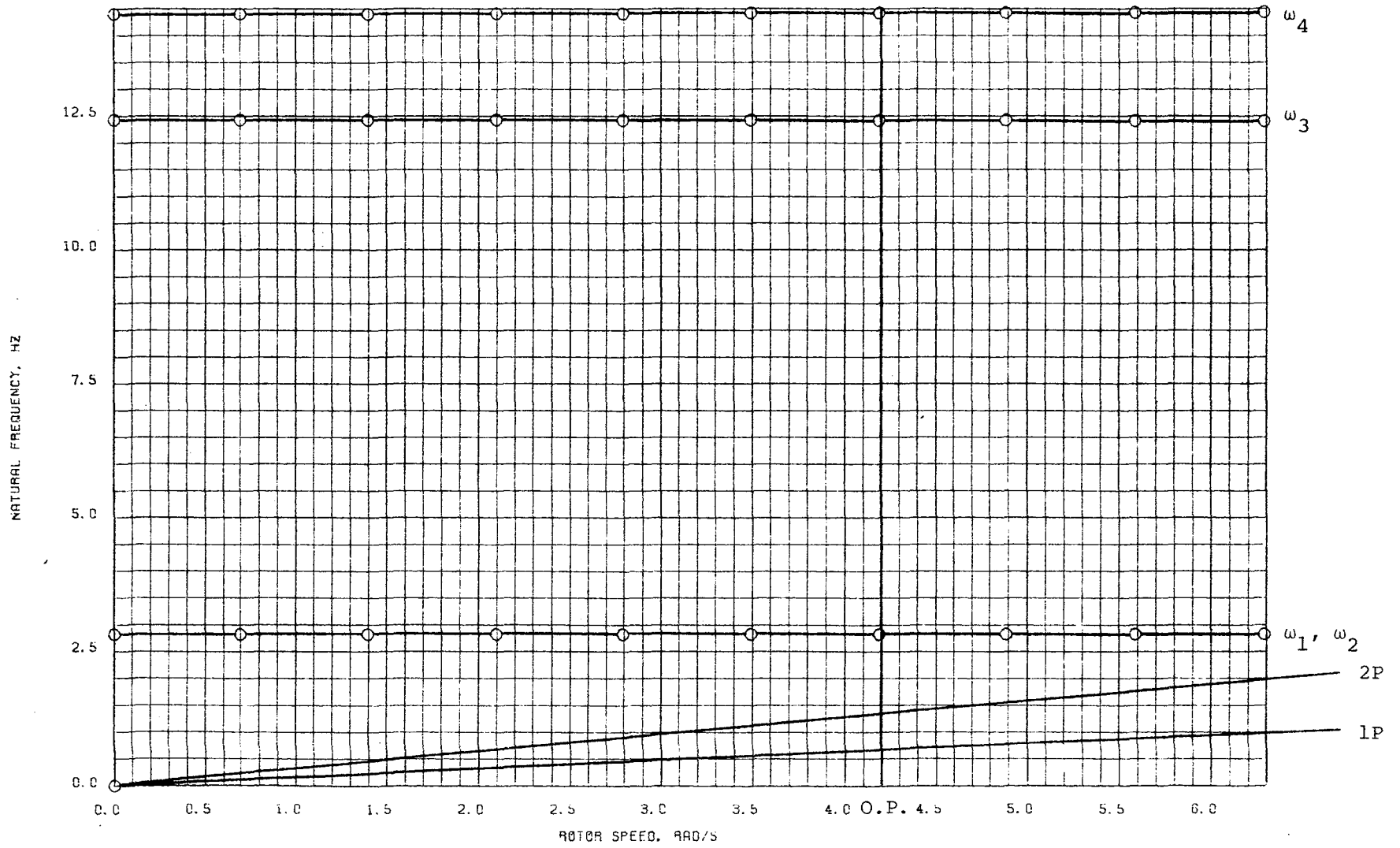

NATURAL FREQUENCIES OF WIND TURBINE SYSTEMS

CONCEPT II, CASE D, 150% EFFECTIVE GUY STIFFNESS

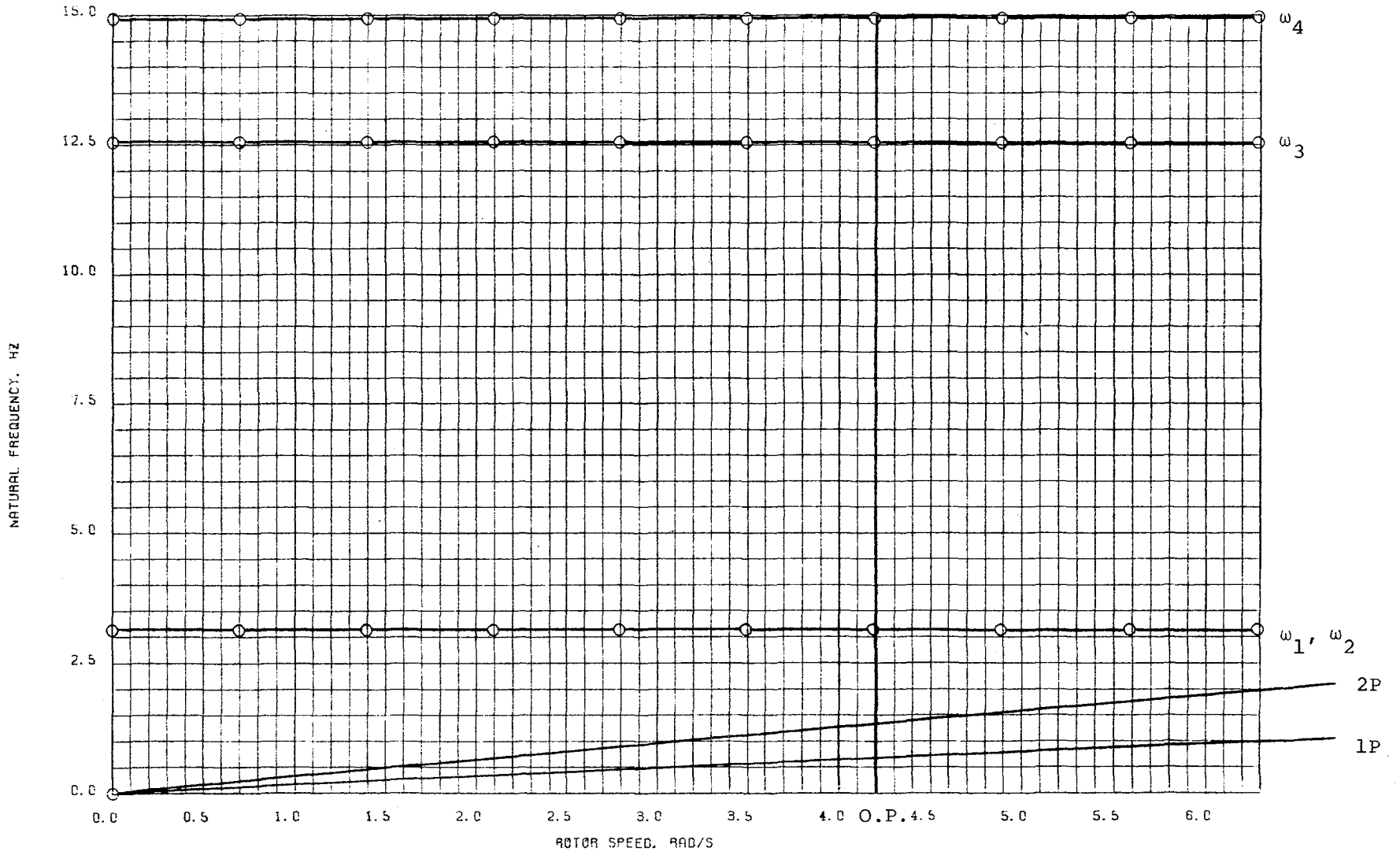

NATURAL FREQUENCIES OF WIND TURBINE SYSTEMS

CONCEPT II, CASE E, 200% EFFECTIVE GUY STIFFNESS

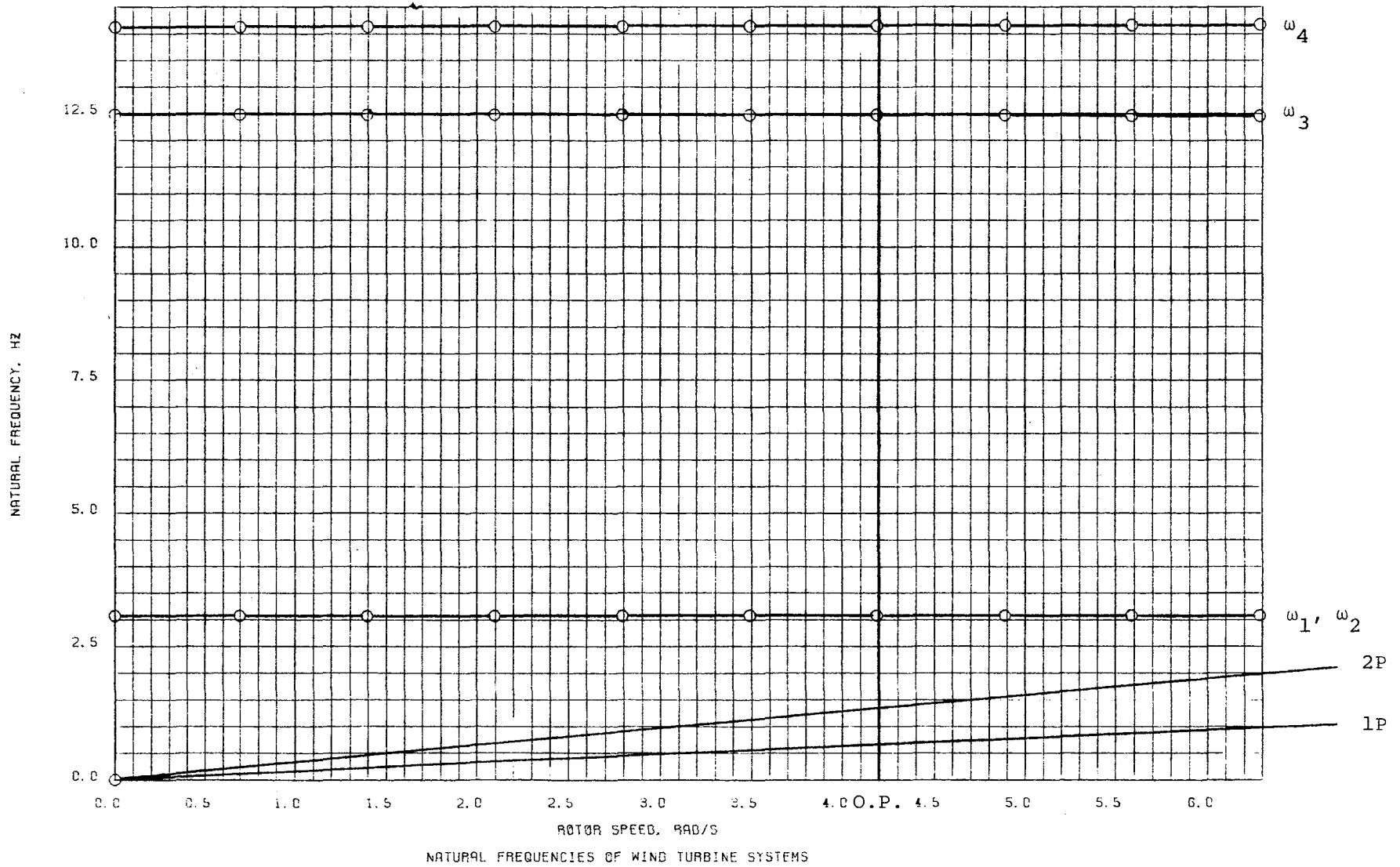

CONCEPT II, CASE F, GUY ATTACHMENT POINT RAISED 12 FT

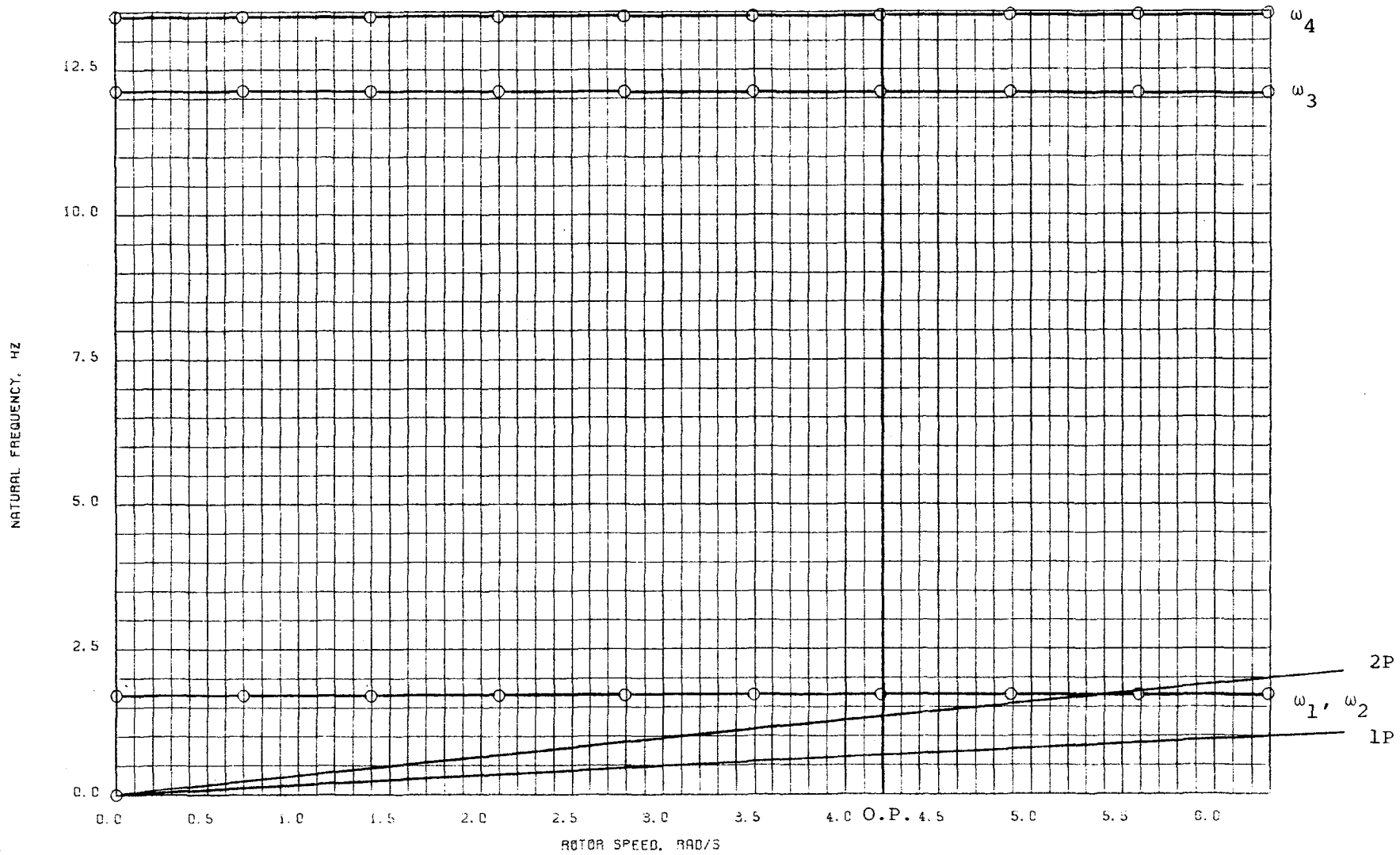

NATURAL FREQUENCIES OF WIND TURBINE SYSTEMS

CONCEPT II, CASE G, GUY ATTACHMENT POINT LOWERED 12 FT

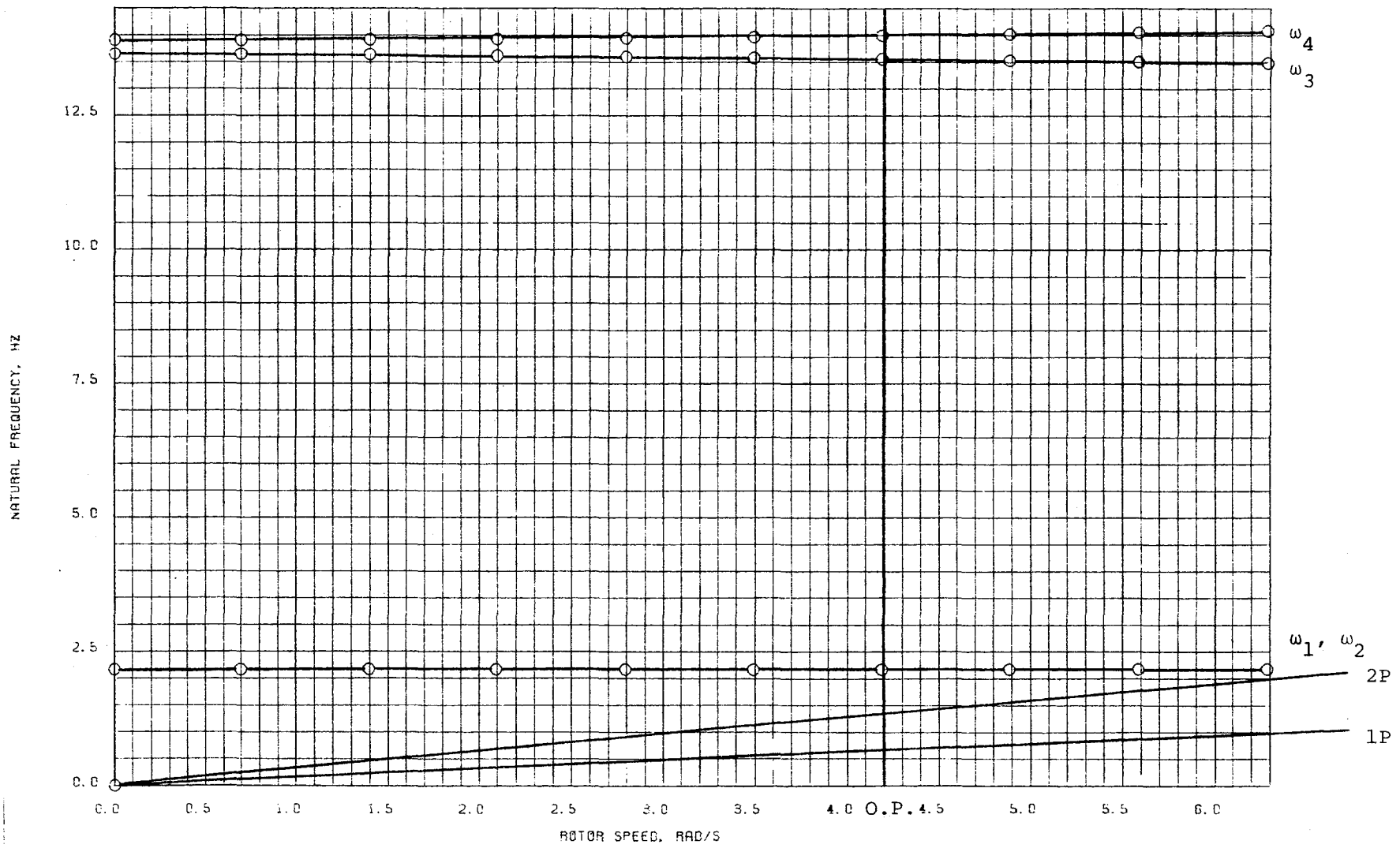

NATURAL FREQUENCIES OF WIND TURBINE SYSTEMS

CONCEPT II, CASE H, NACELLE AND ROTOR MASS INCREASED BY 1/3

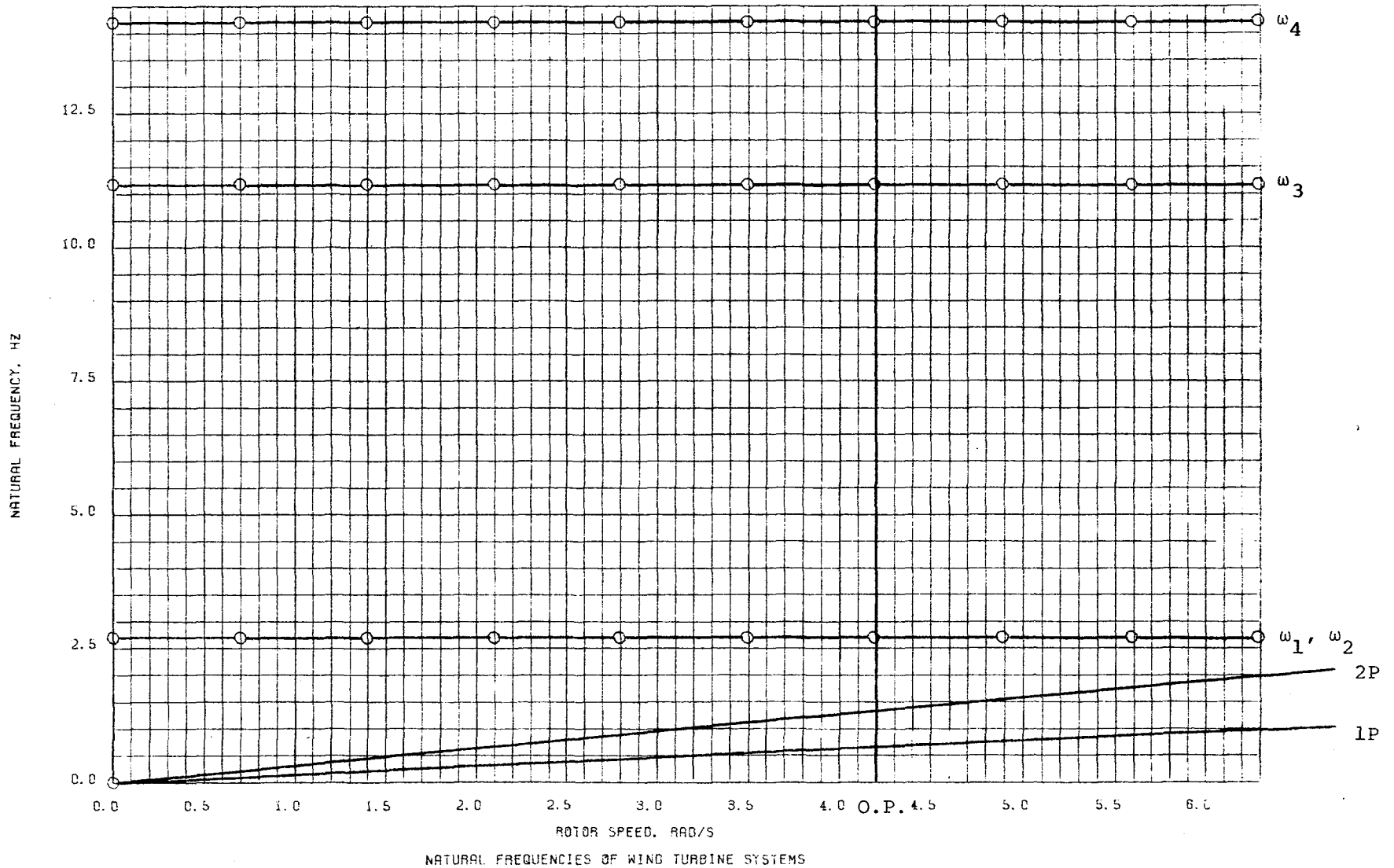

CONCEPT II, CASE I, NACELLE AND ROTOR MASS DECREASED BY 1/3

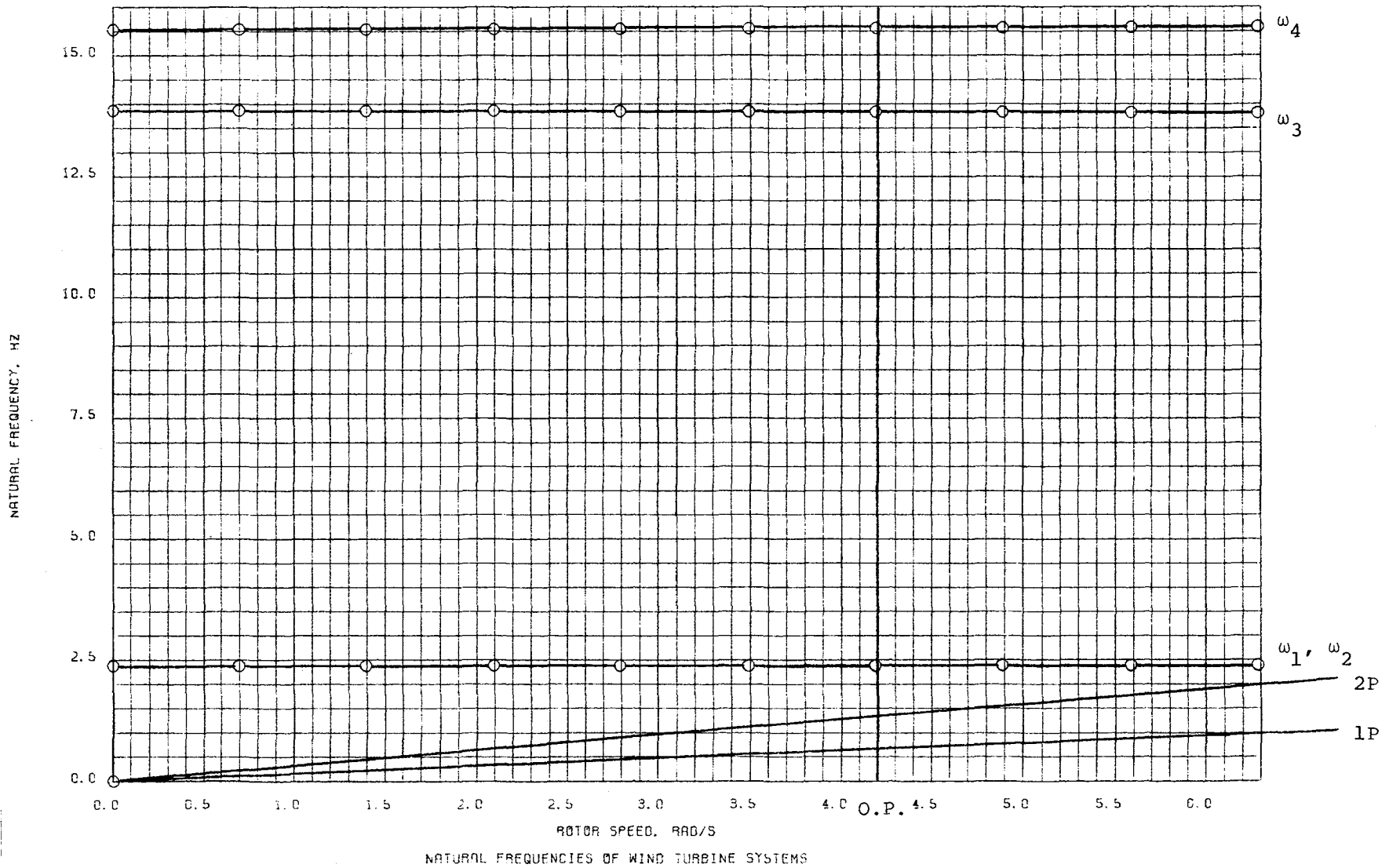

CONCEPT I, CASE J. DISTANCE TO CENTER OF GRAVITY INCREASED BY 1/3

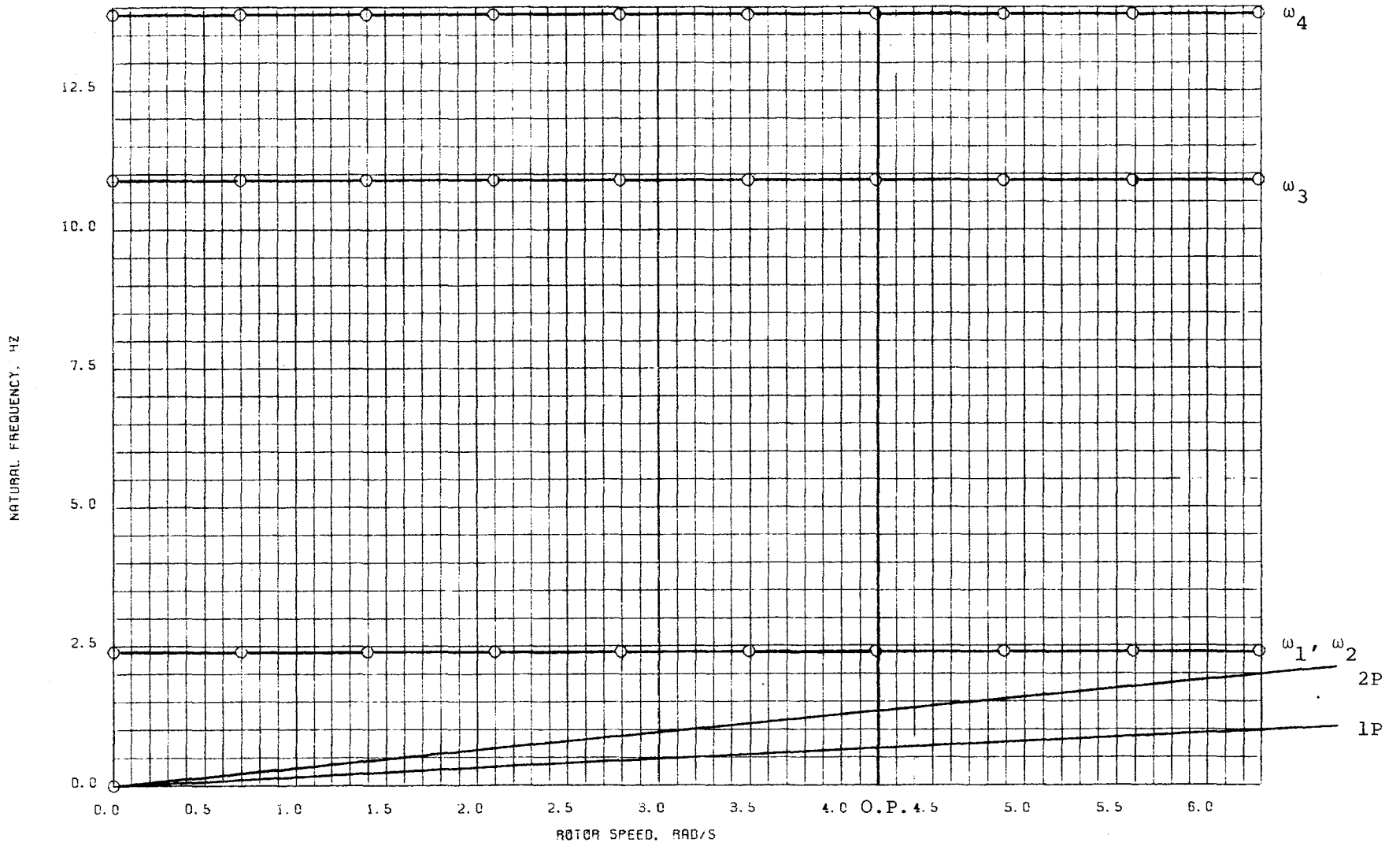

NATURAL FREQUENCIES OF WIND TURBINE SYSTEMS

CONCEPT II, CASE K, DISTANCE TO CENTER OF GRAVITY DECREASED BY 1/3

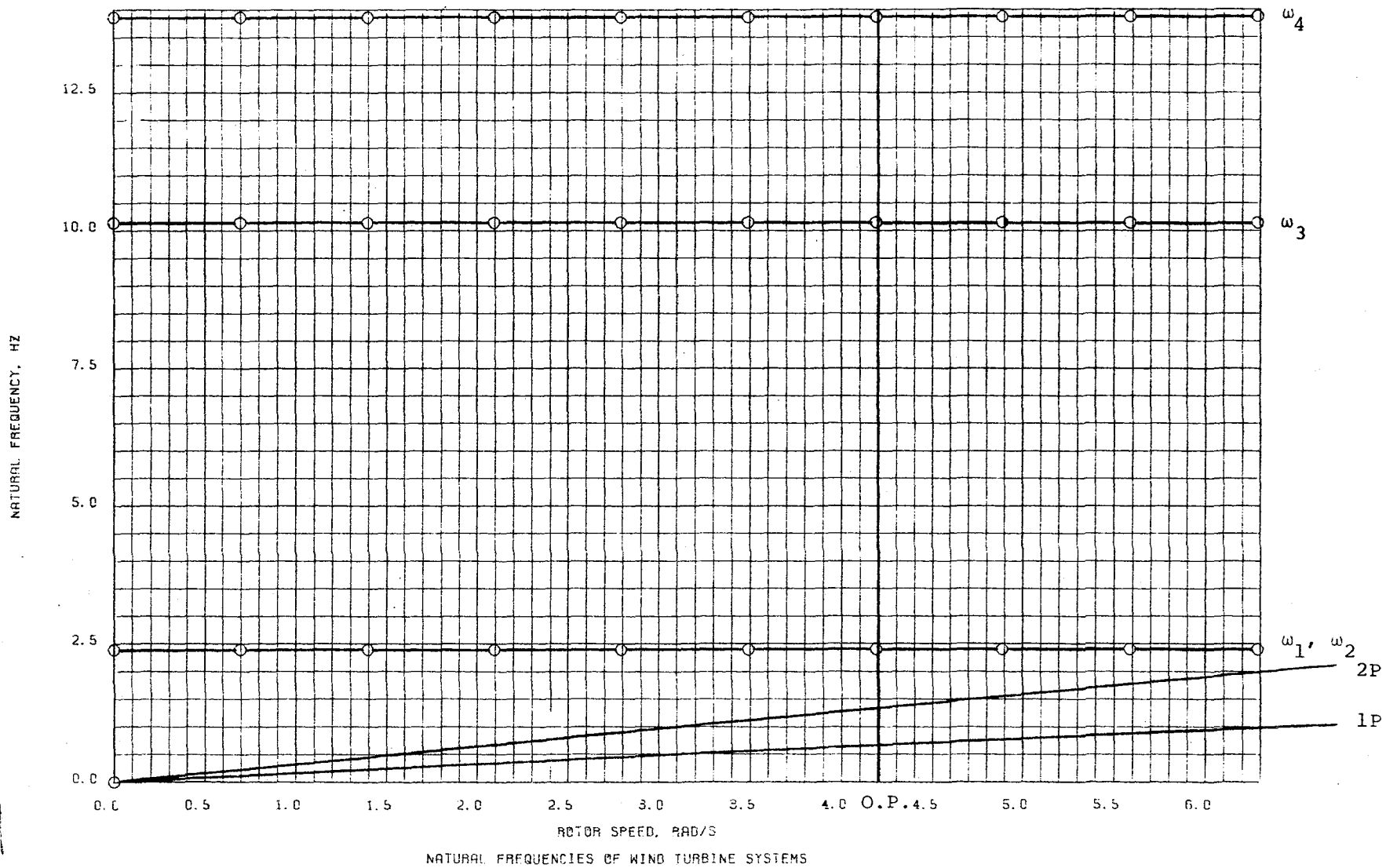

CONCEPT II, CASE L, NACELLE AND ROTOR INERTIA ABOUT Z AXIS INCREASED BY 1/3

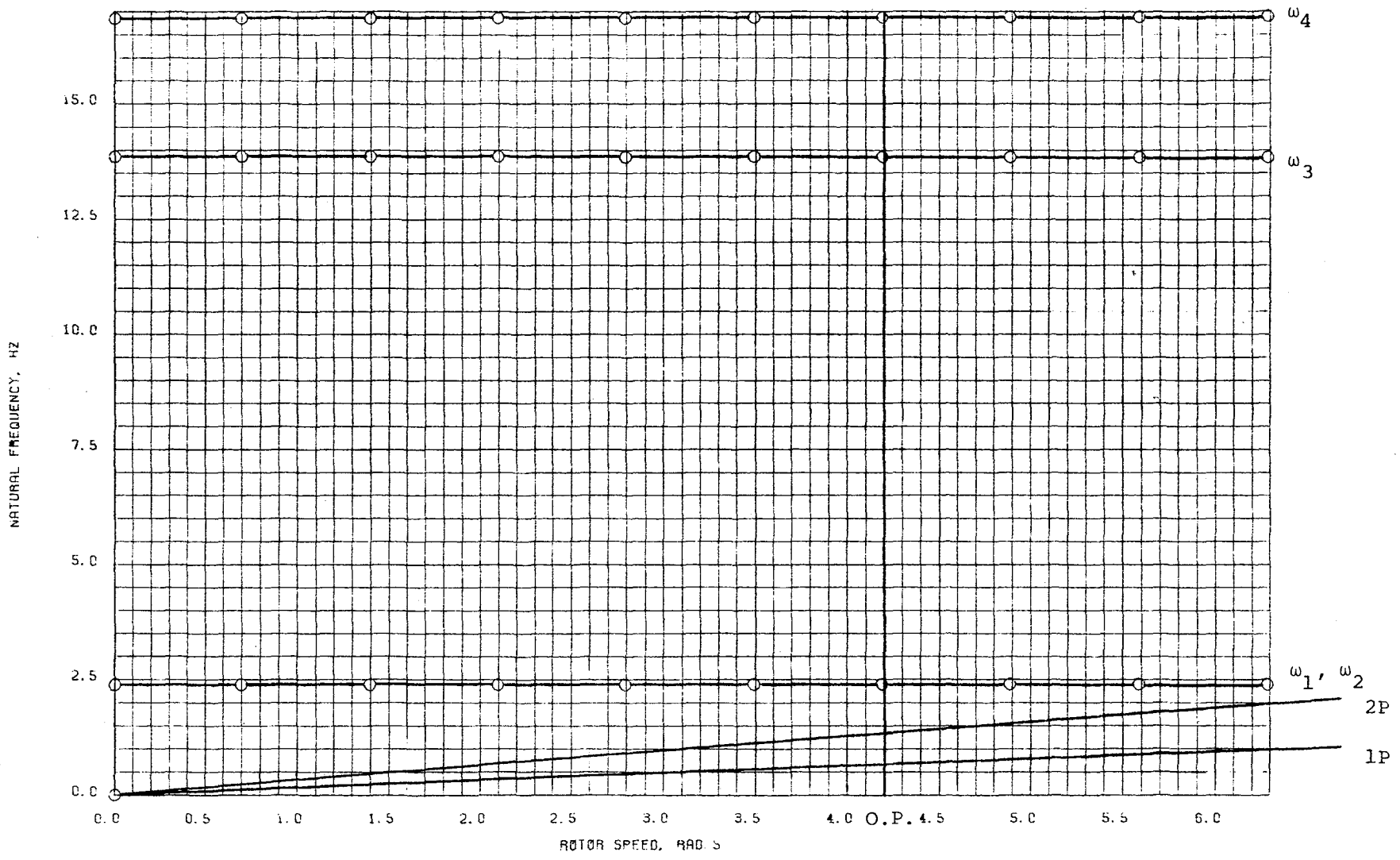

NATURAL FREQUENCIES OF WIND TURBINE SYSTEMS

CONCEPT II, CASE M, NACELLE AND ROTOR INERTIA ABOUT Z AXIS DECREASED BY 1/3

NATURAL FREQUENCY, HZ

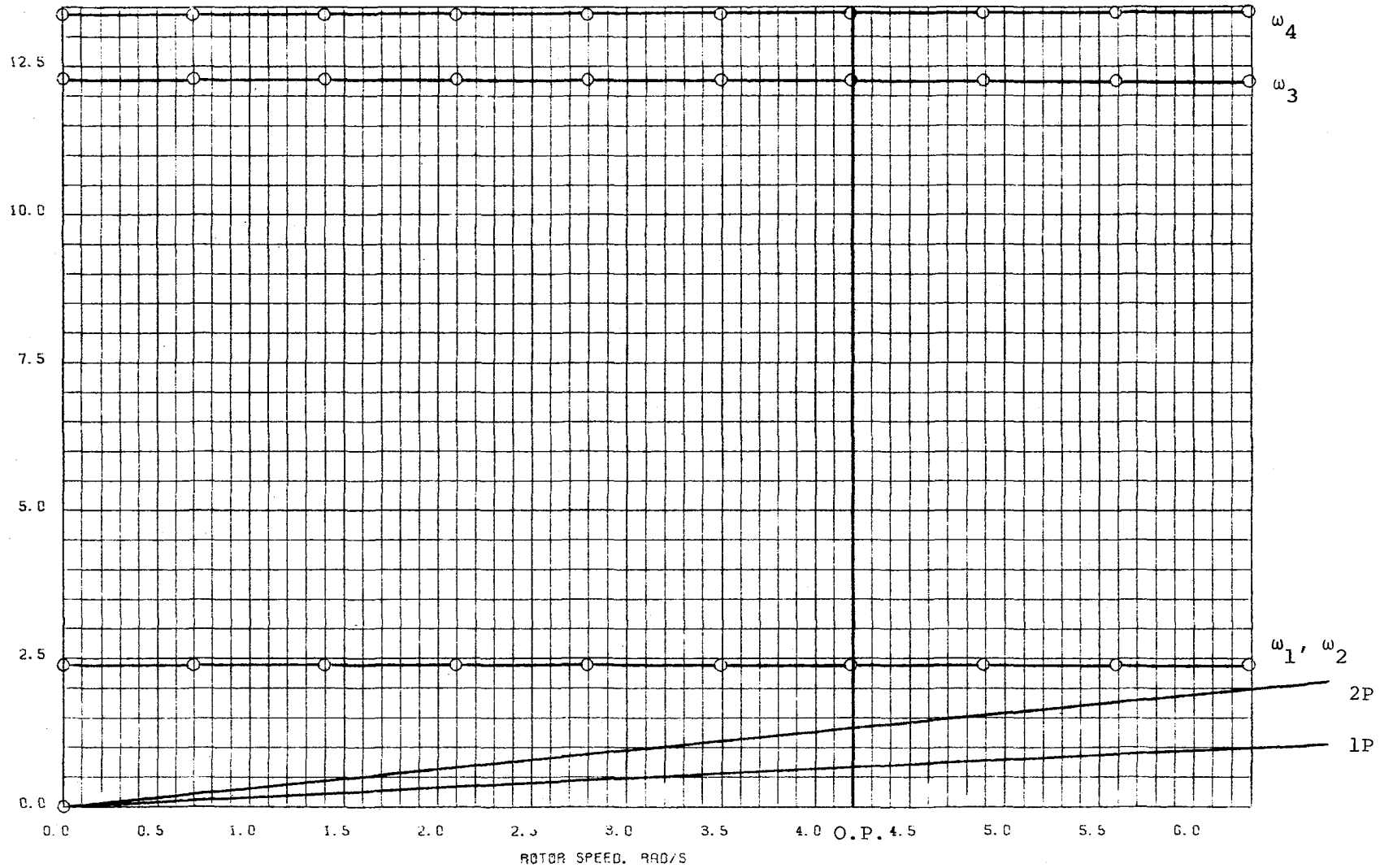

NATURAL FREQUENCIES OF WIND TURBINE SYSTEMS

CONCEPT II, CASE N, NACELLE AND ROTOR INERTIA ABOUT X AXIS INCREASED BY 1/3

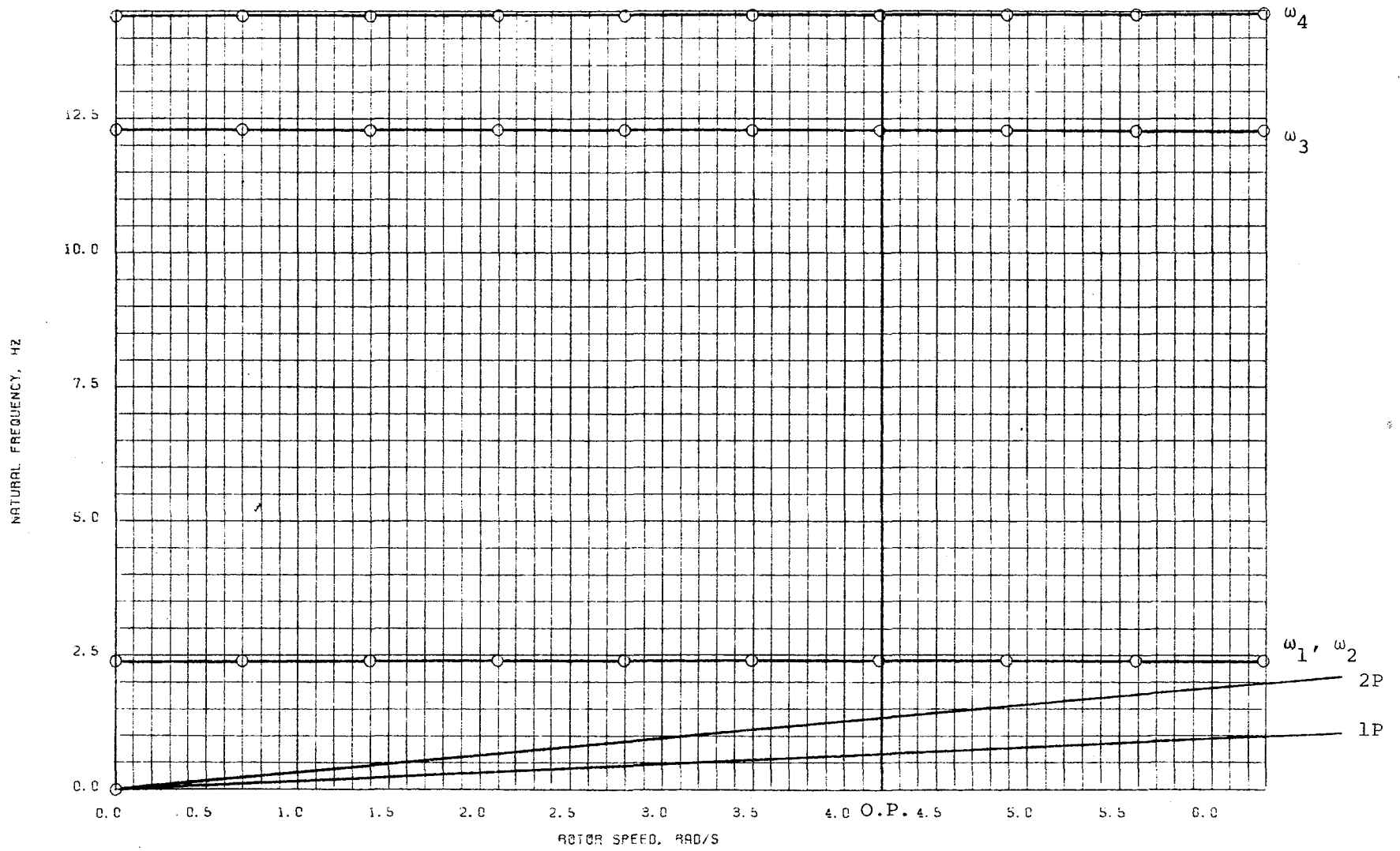

NATURAL FREQUENCIES OF WIND TURBINE SYSTEMS

CONCEPT II, CASE O, NACELLE AND ROTOR INERTIA ABOUT X AXIS DECREASED BY 1/3

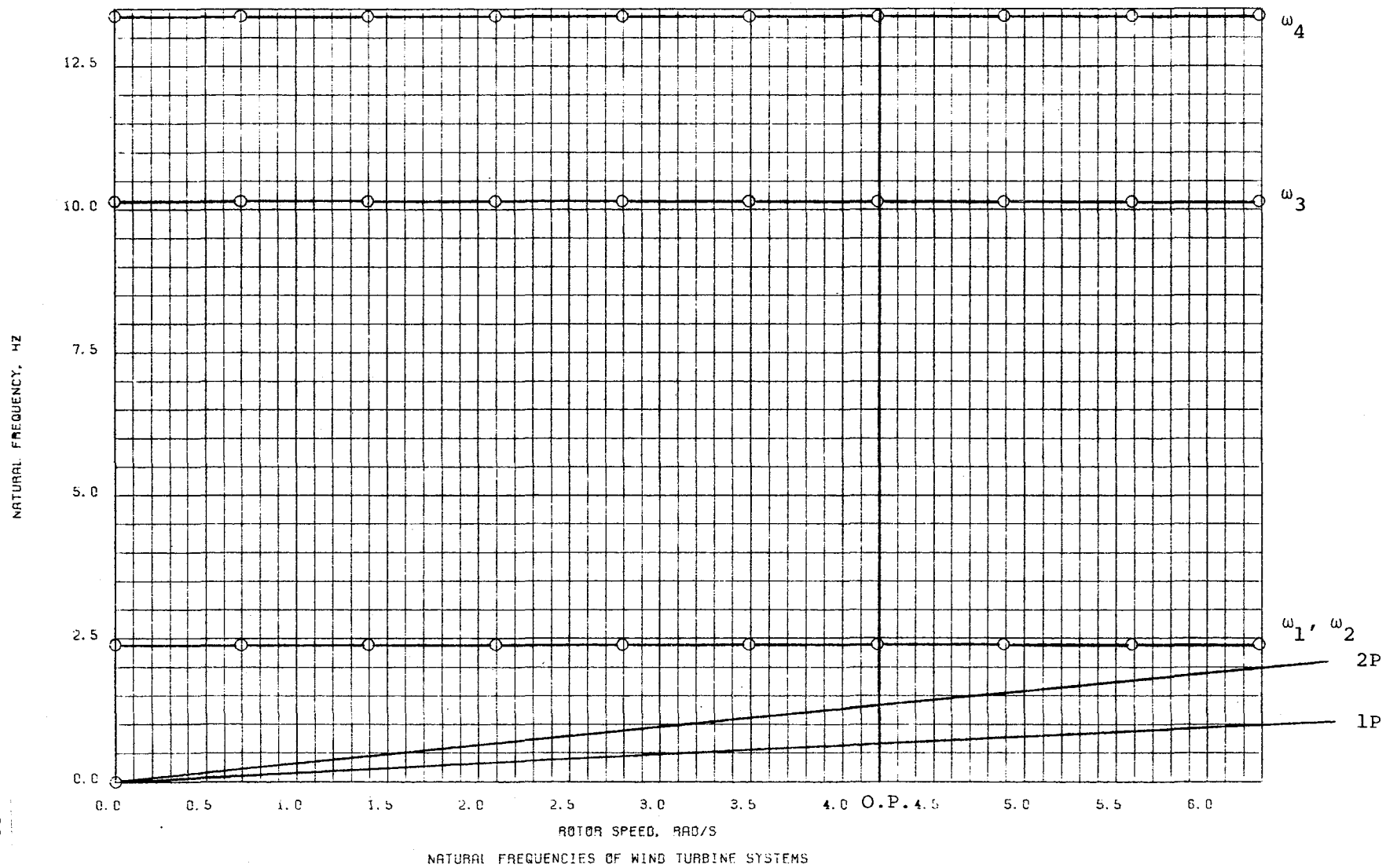

CONCEPT II, CASE P, NACELLE AND ROTOR INERTIA ABOUT X AND Z AXES INCREASED BY 1/3

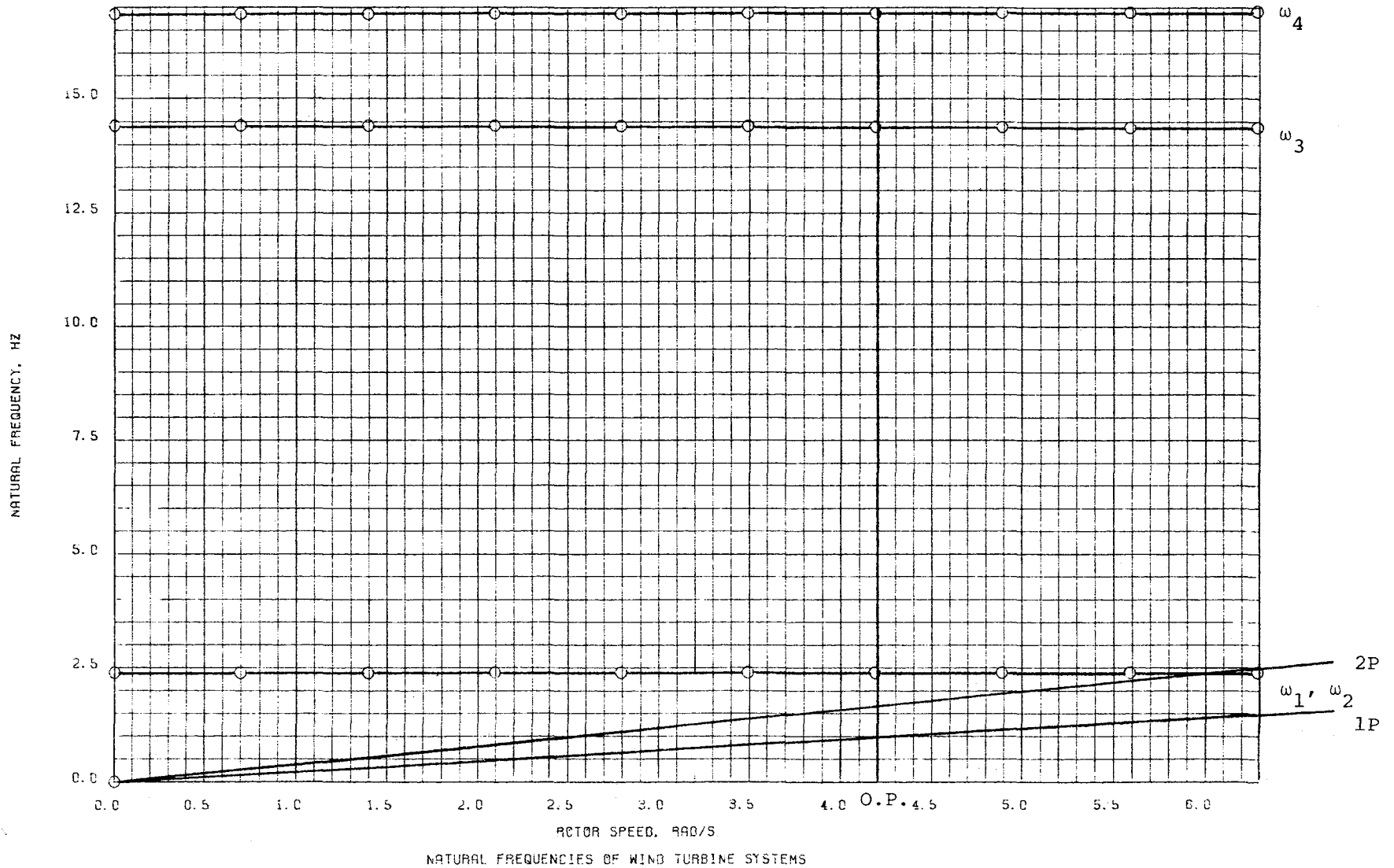

CONCEPT II, CASE Q, NACELLE AND ROTOR INERTIA ABOUT X AND Z AXES DECREASED BY 1/3

NATURAL FREQUENCY, HZ

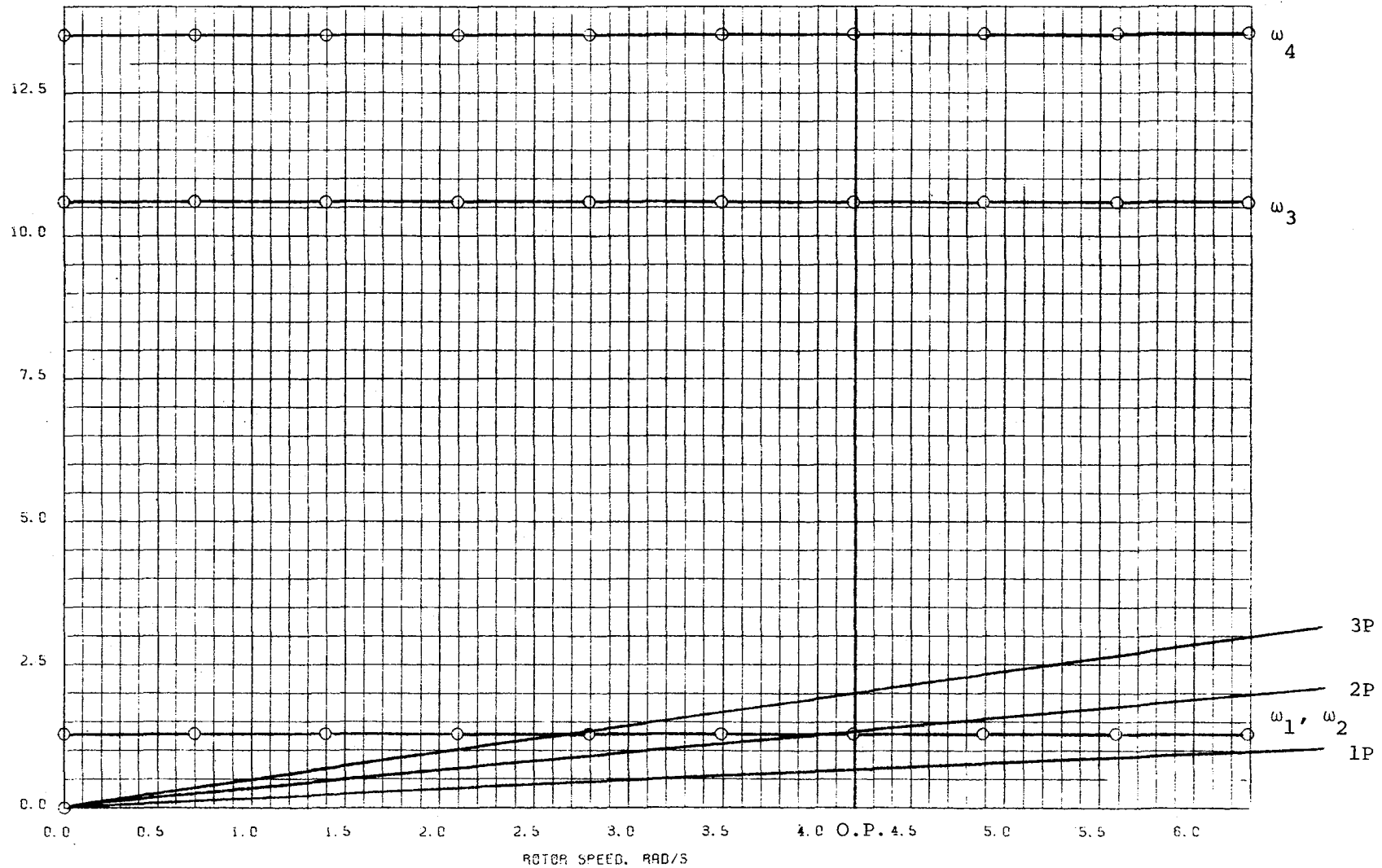

NATURAL FREQUENCIES OF WIND TURBINE SYSTEMS

CONCEPT III, CASE A, 25% EFFECTIVE GUY STIFFNESS

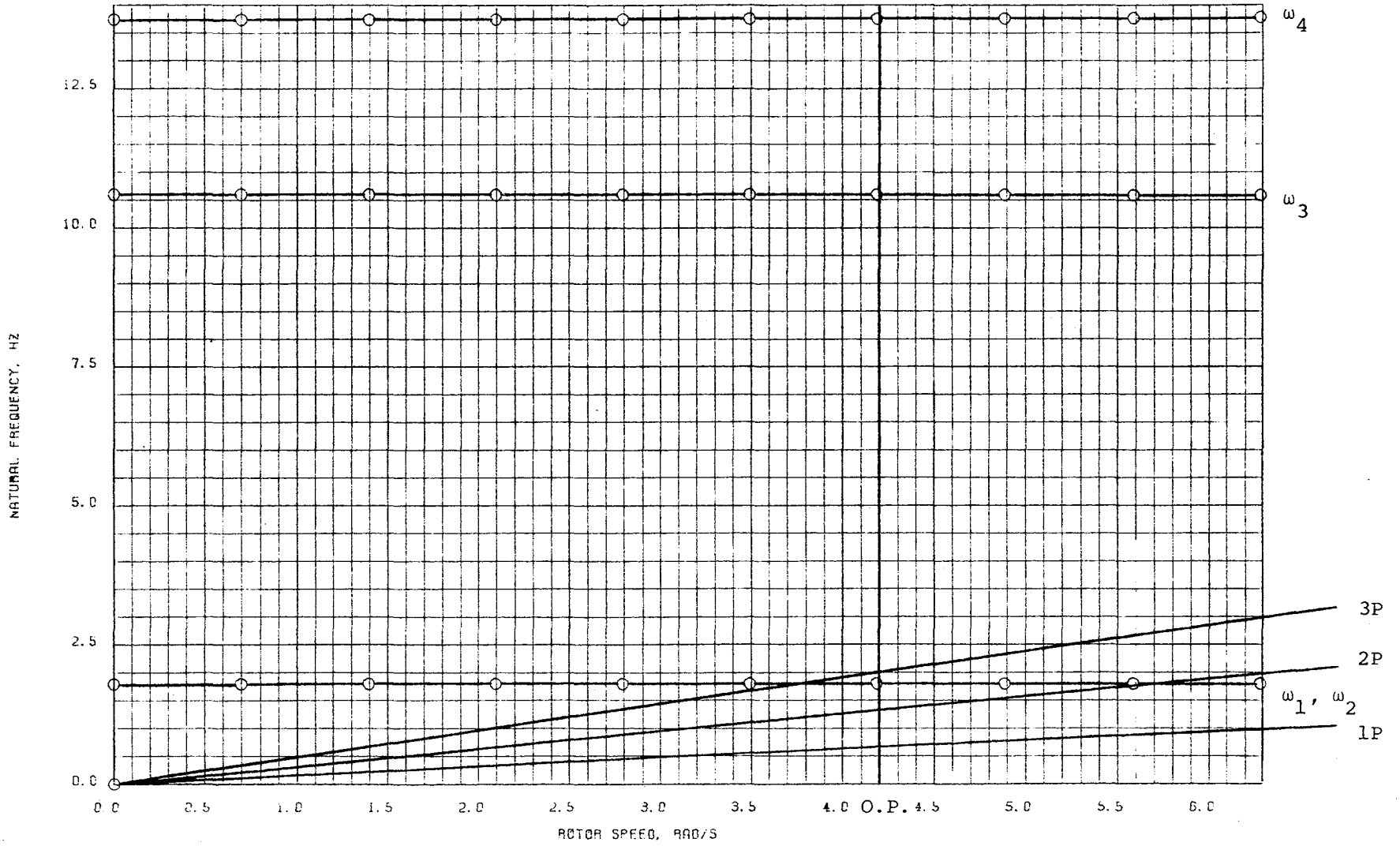

NATURAL FREQUENCIES OF WIND TURBINE SYSTEMS

CONCEPT III, CASE B, 50% EFFECTIVE GUY STIFFNESS

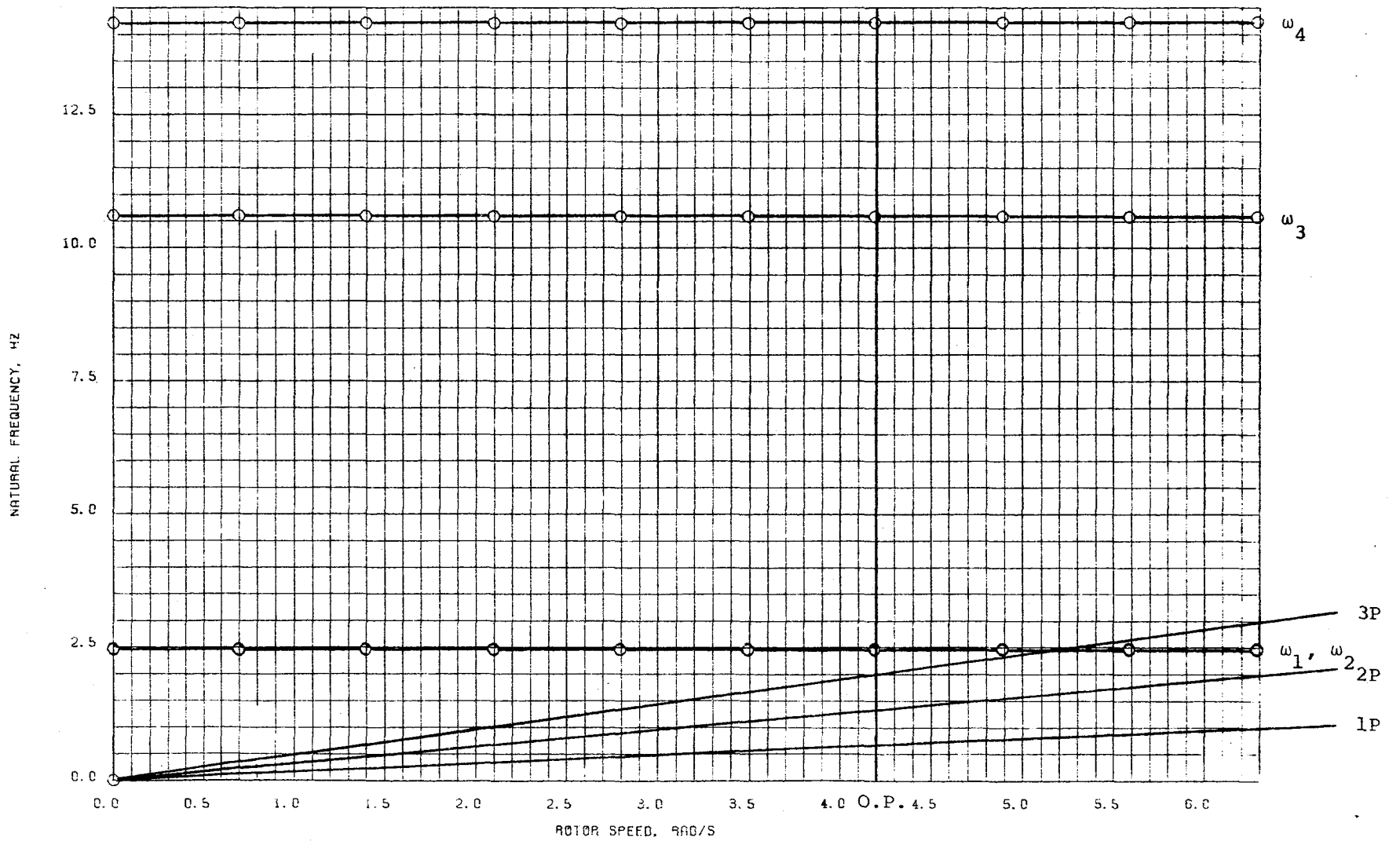

NATURAL FREQUENCIES OF WIND TURBINE SYSTEMS

CONCEPT III, CASE C, 100% EFFECTIVE GUY STIFFNESS

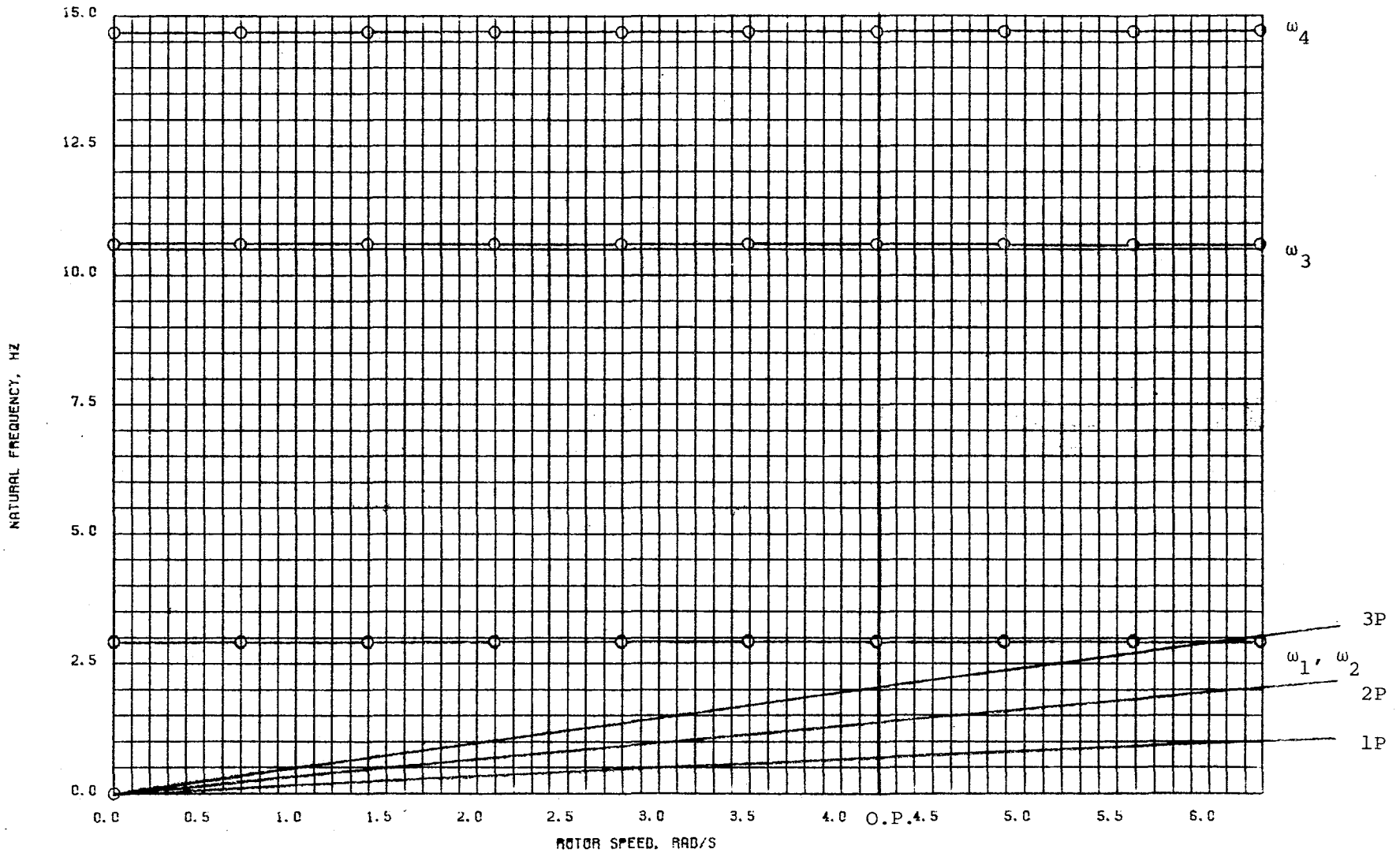

NATURAL FREQUENCIES OF WIND TURBINE SYSTEMS

CONCEPT III, CASE D, 150% EFFECTIVE GUY STIFFNESS

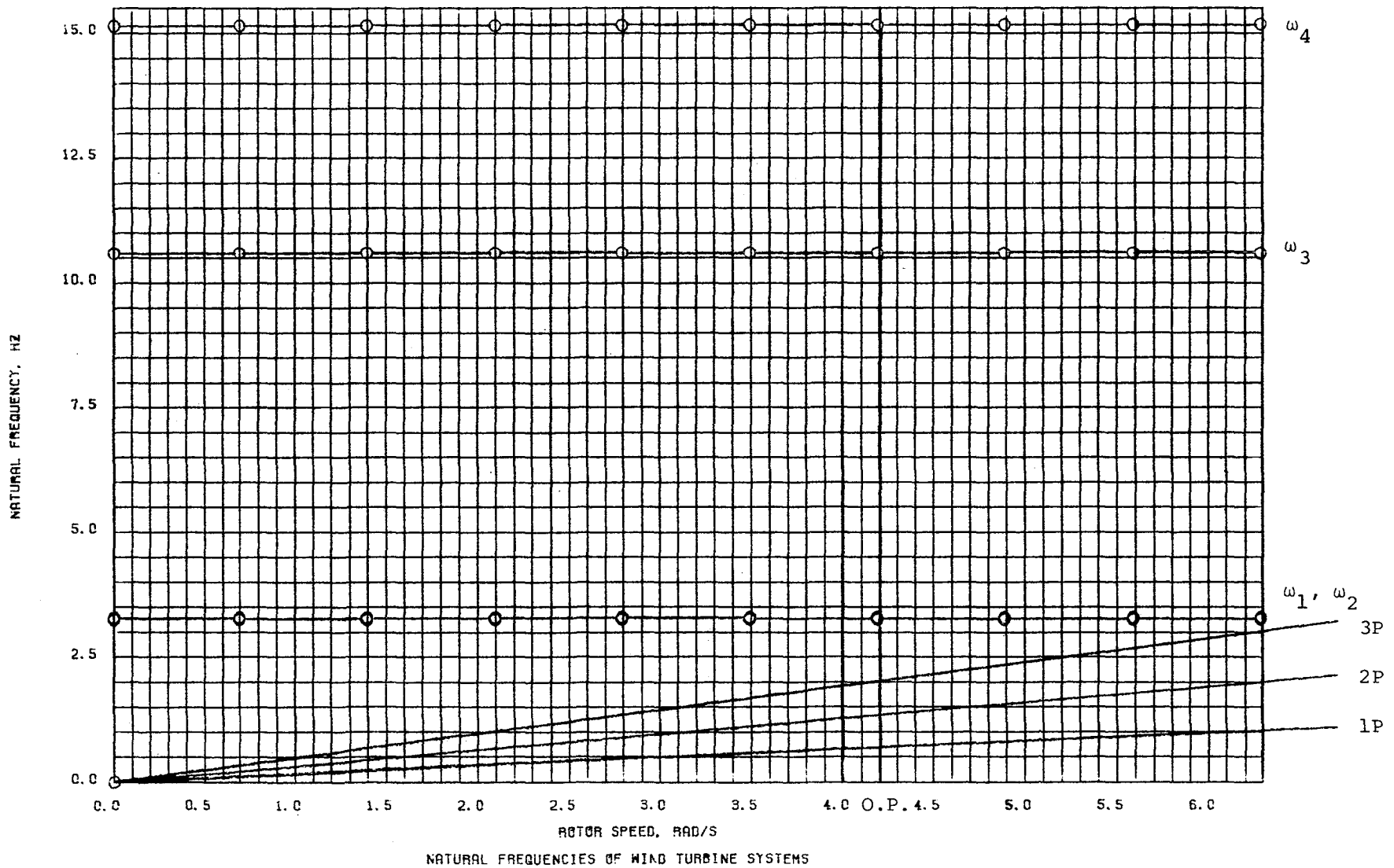

CONCEPT III, CASE E, 200% EFFECTIVE GUY STIFFNESS

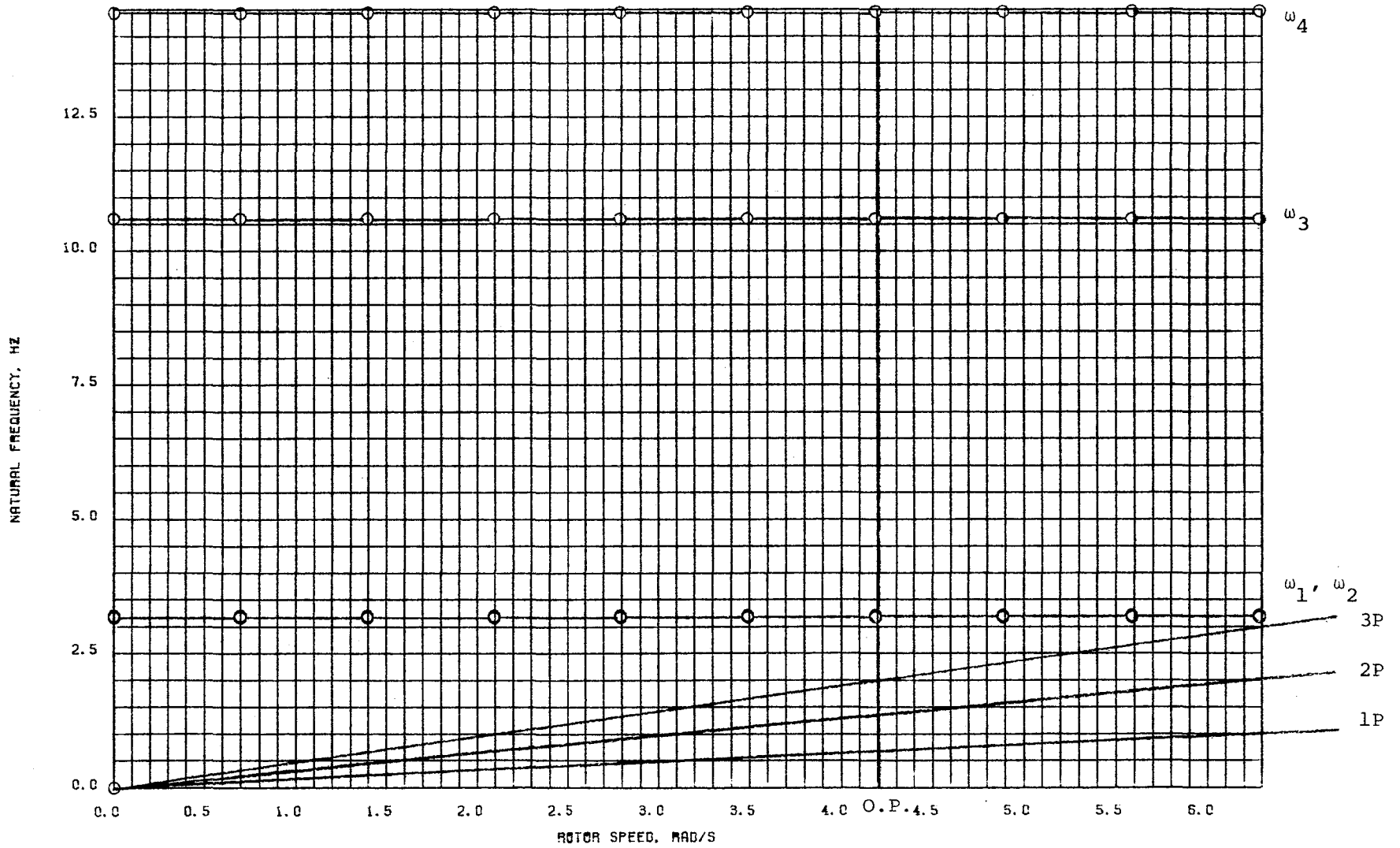

NATURAL FREQUENCIES OF WIND TURBINE SYSTEMS

CONCEPT III, CASE F, GUY ATTACHMENT POINT RAISED 12 FT

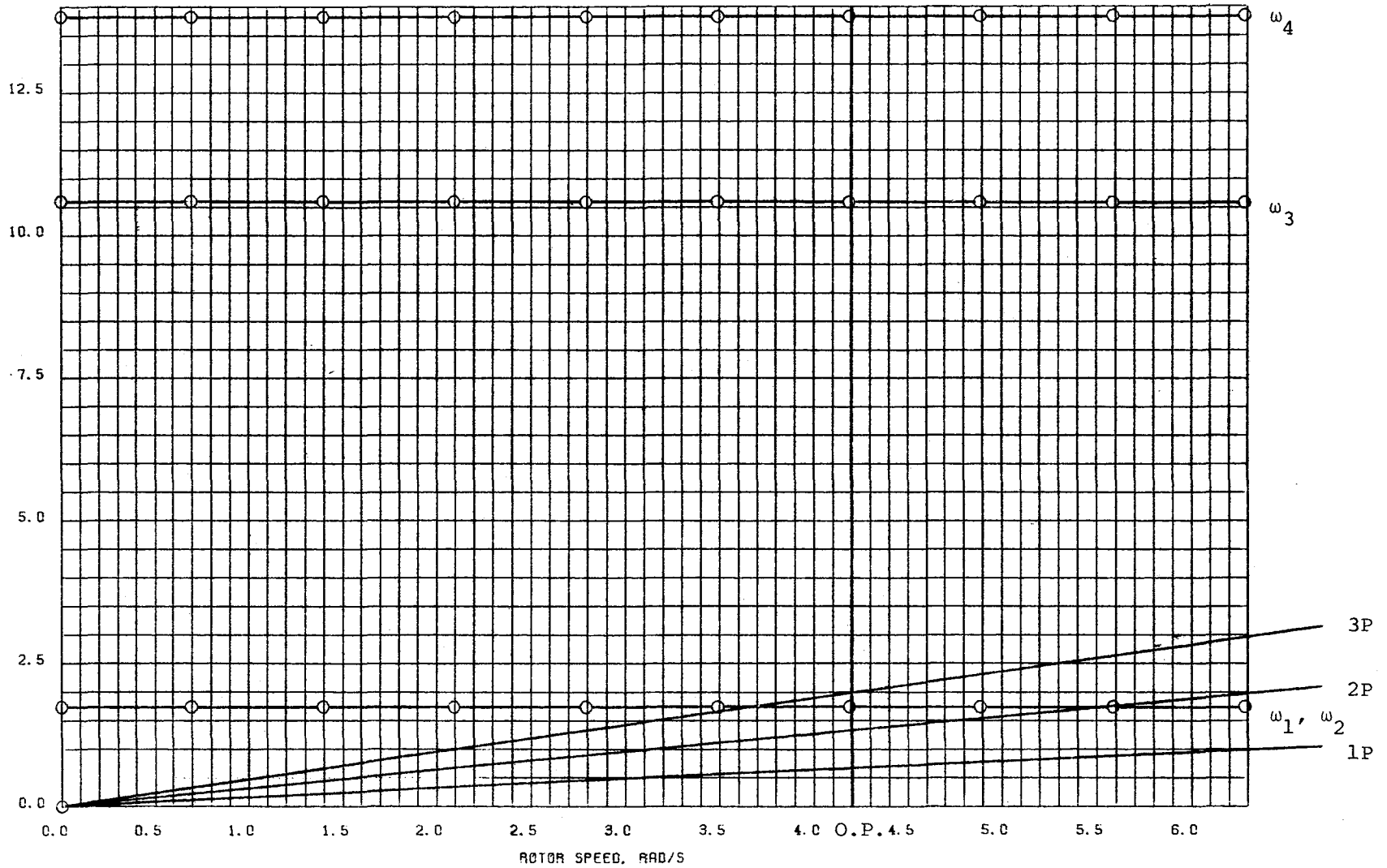

NATURAL FREQUENCIES OF WIND TURBINE SYSTEMS

CONCEPT III, CASE G, GUY ATTACHMENT POINT LOWERED 12 FT

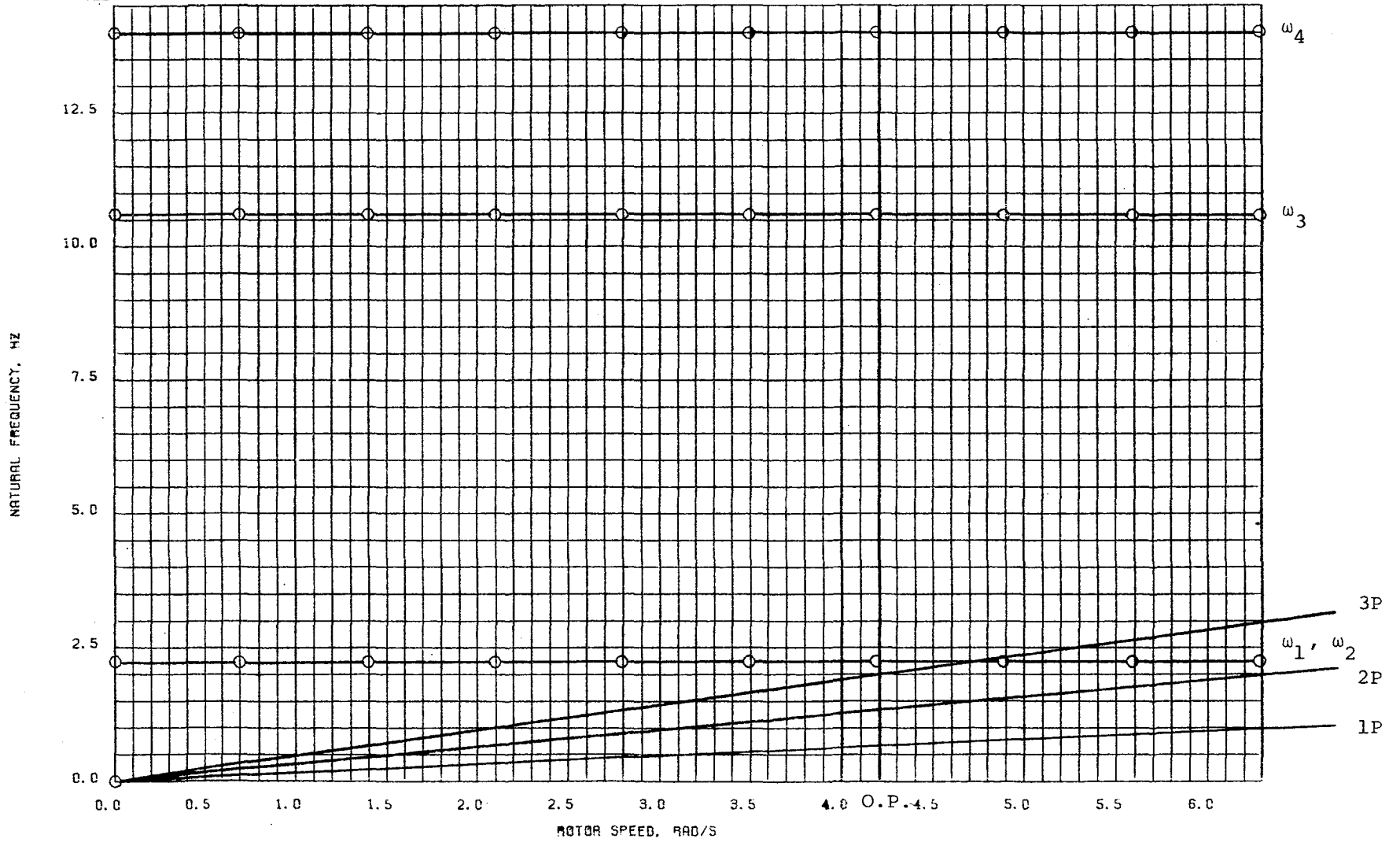

NATURAL FREQUENCIES OF WIND TURBINE SYSTEMS

CONCEPT III, CASE H. NACELLE AND ROTOR MASS INCREASED BY 1/3

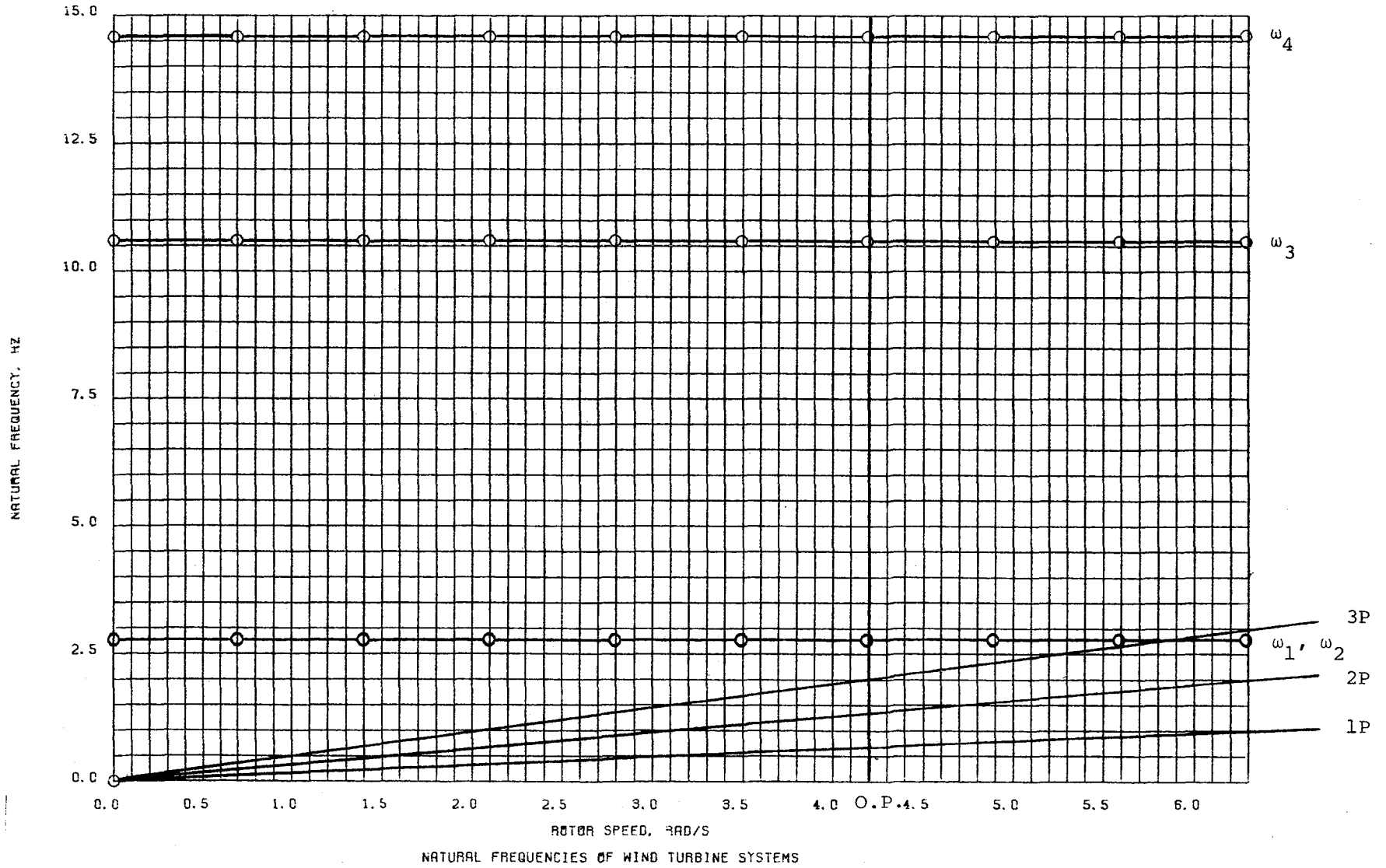

CONCEPT III, CASE I, NACELLE AND ROTOR MASS DECREASED BY 1/3

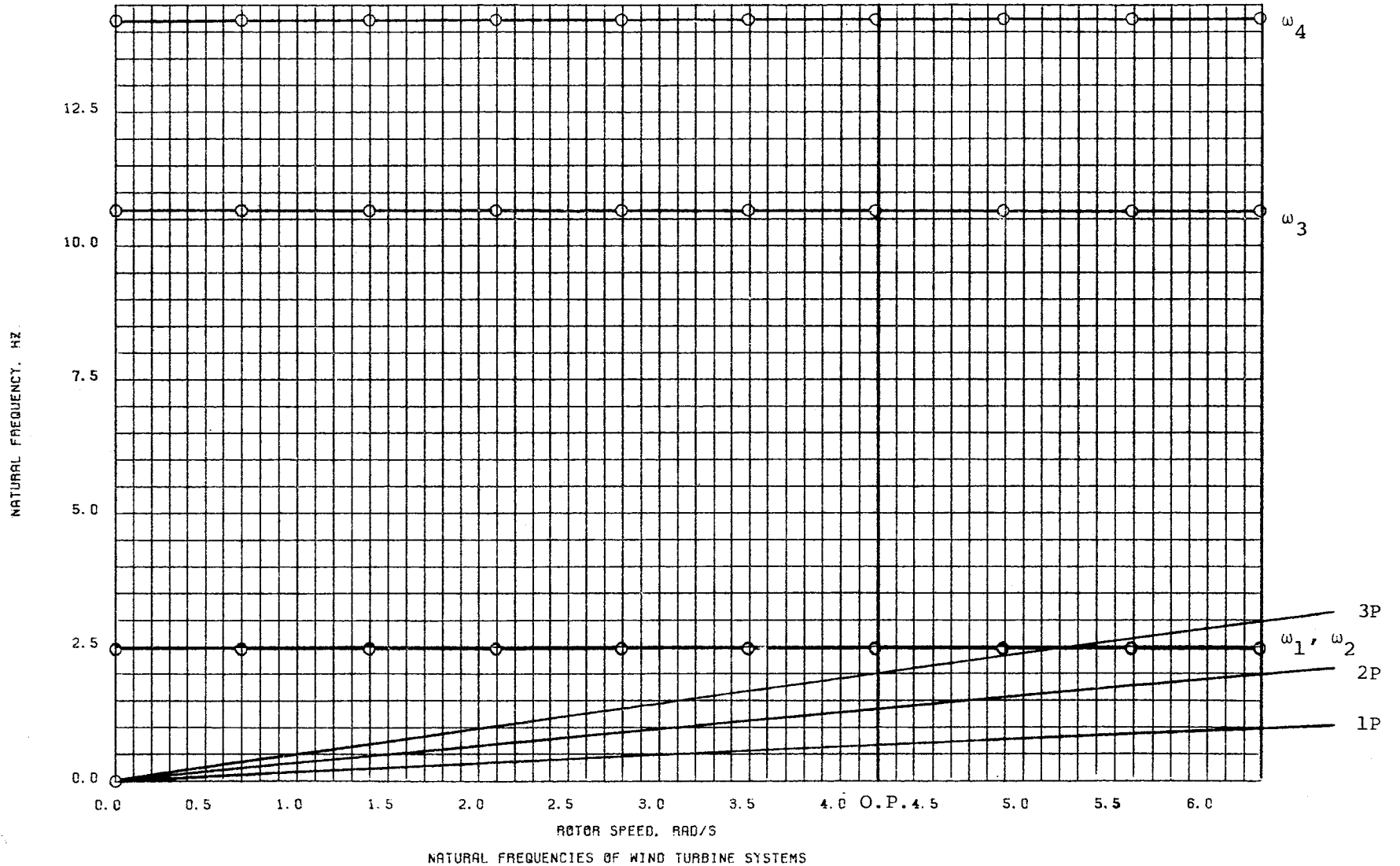

NATURAL FREQUENCIES OF WIND TURBINE SYSTEMS
CONCEPT III, CASE J, DISTANCE TO CENTER OF GRAVITY INCREASED BY 1.7 FT

101

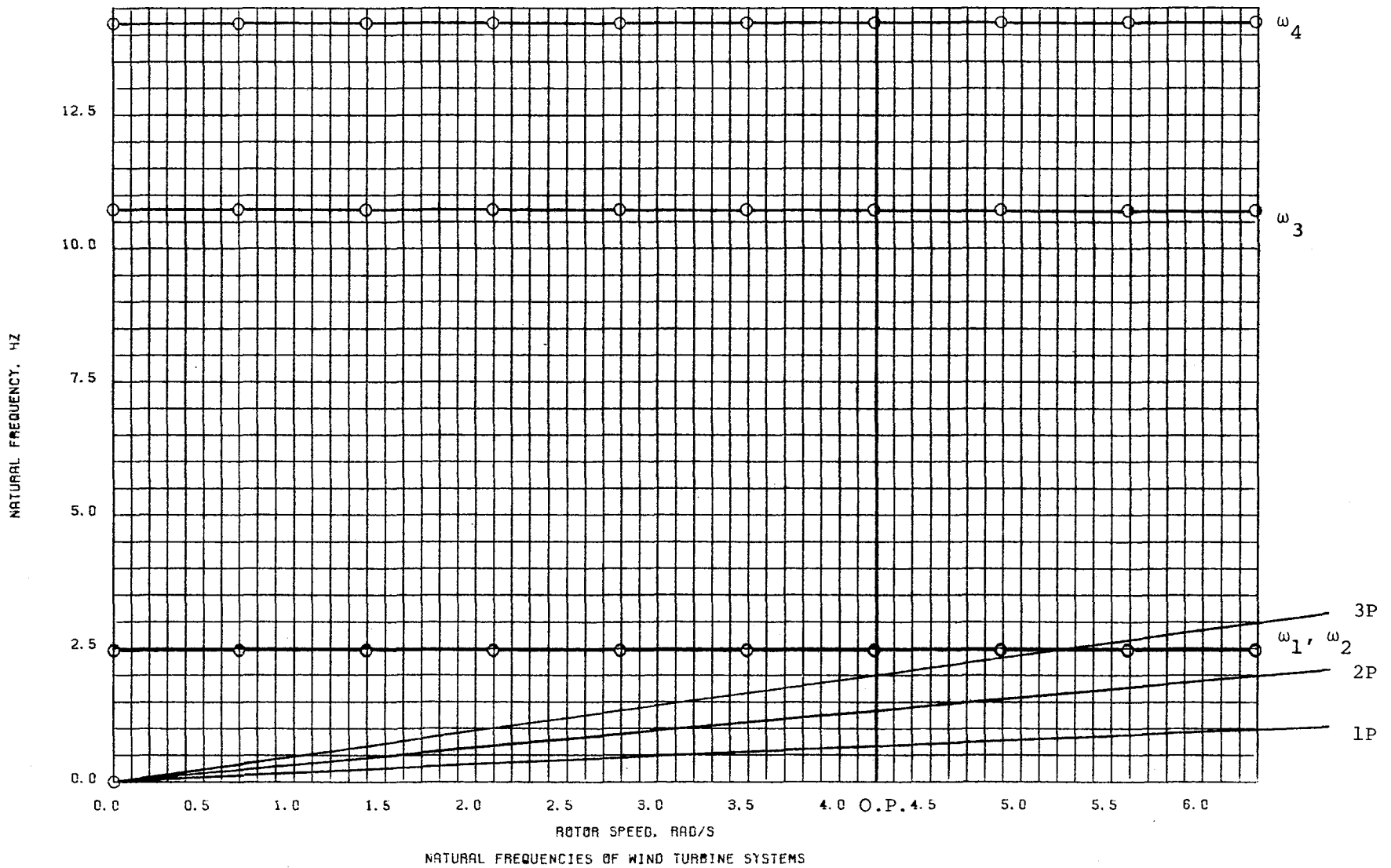

CONCEPT III, CASE K, DISTANCE TO CENTER OF GRAVITY DECREASED BY 1.7 FT

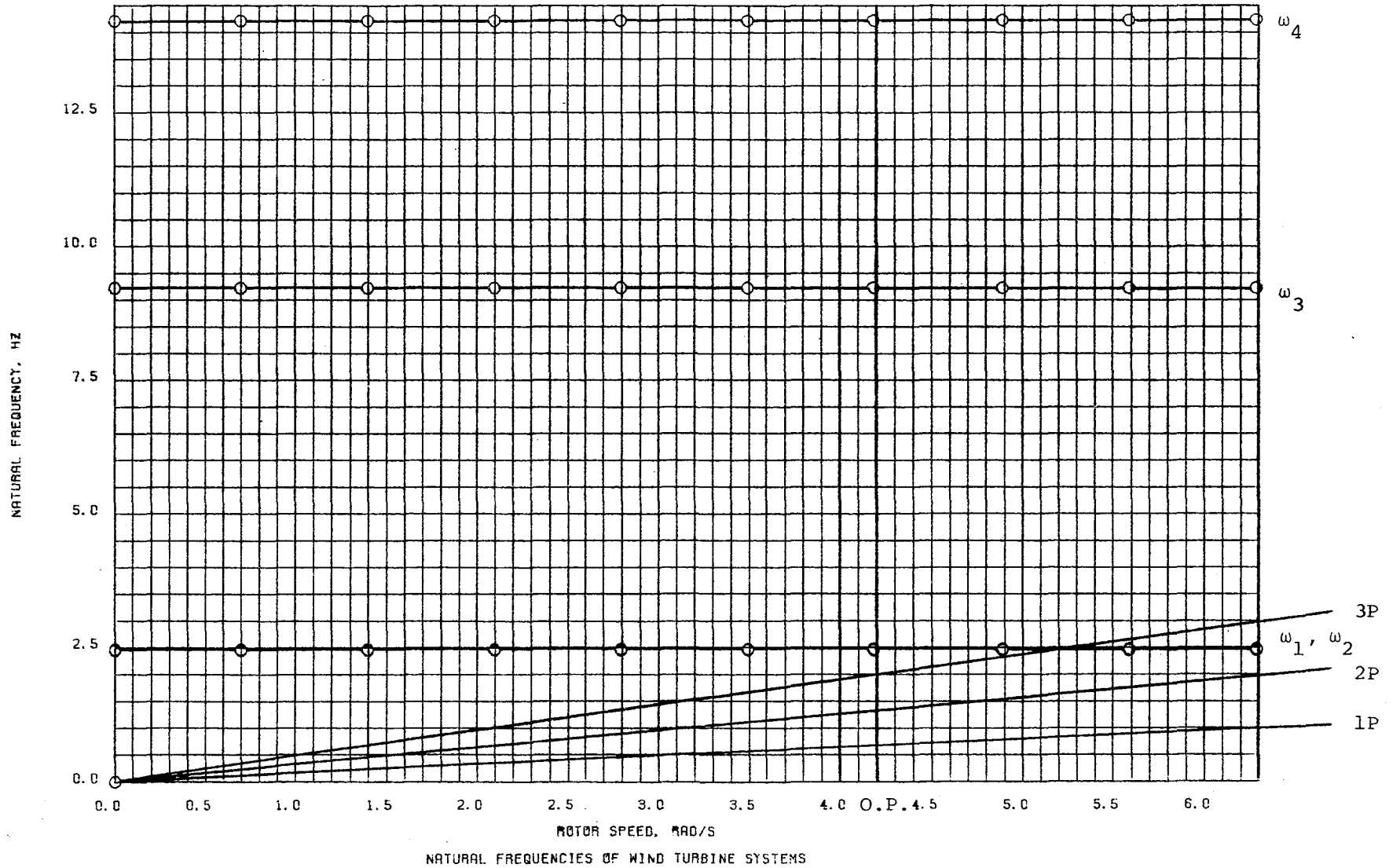

CONCEPT III, CASE L, NACELLE AND ROTOR INERTIA ABOUT Z AXIS INCREASED BY 1/3

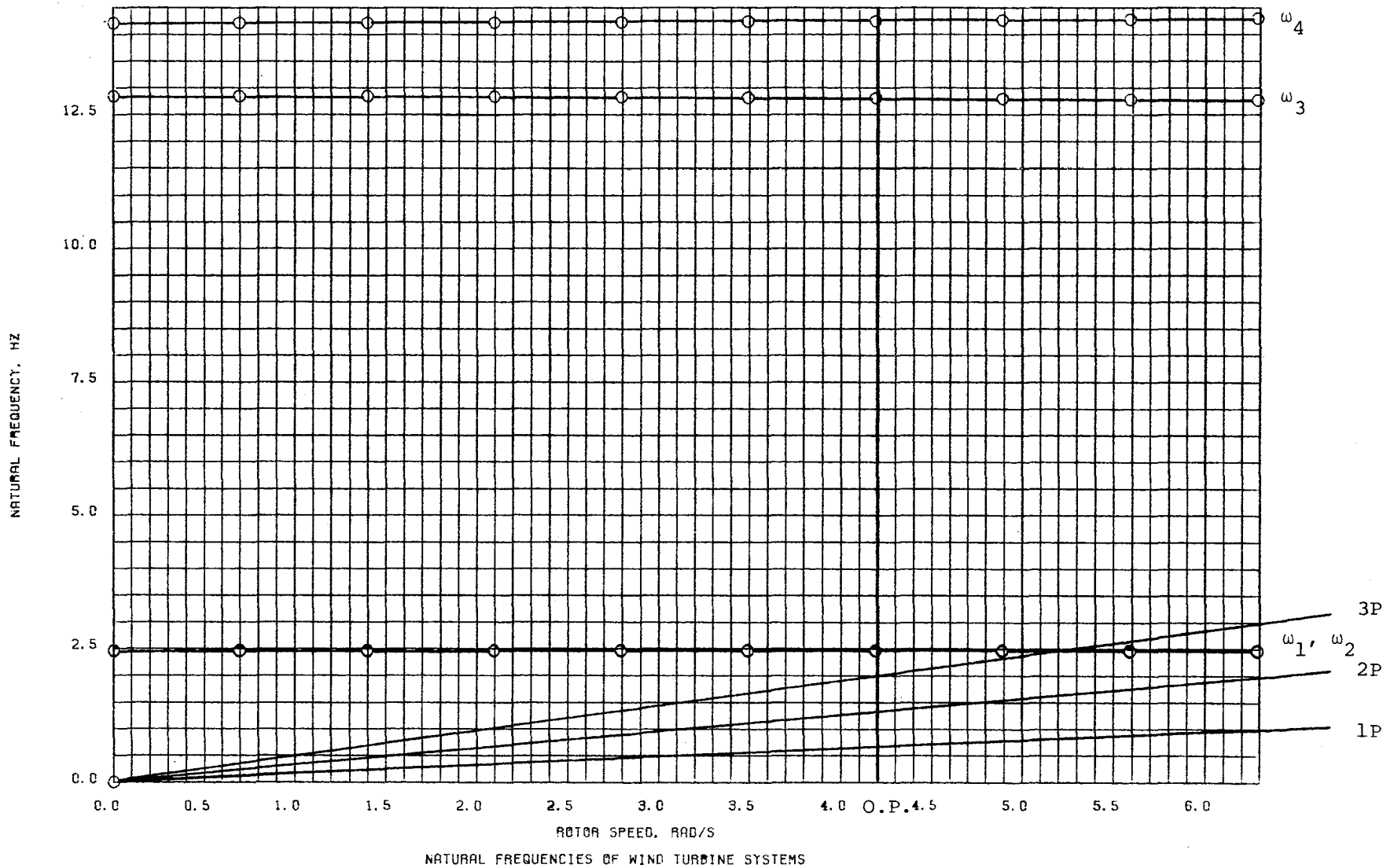

CONCEPT III, CASE M, NACELLE AND ROTOR INERTIA ABOUT Z AXIS DECREASED BY 1/3

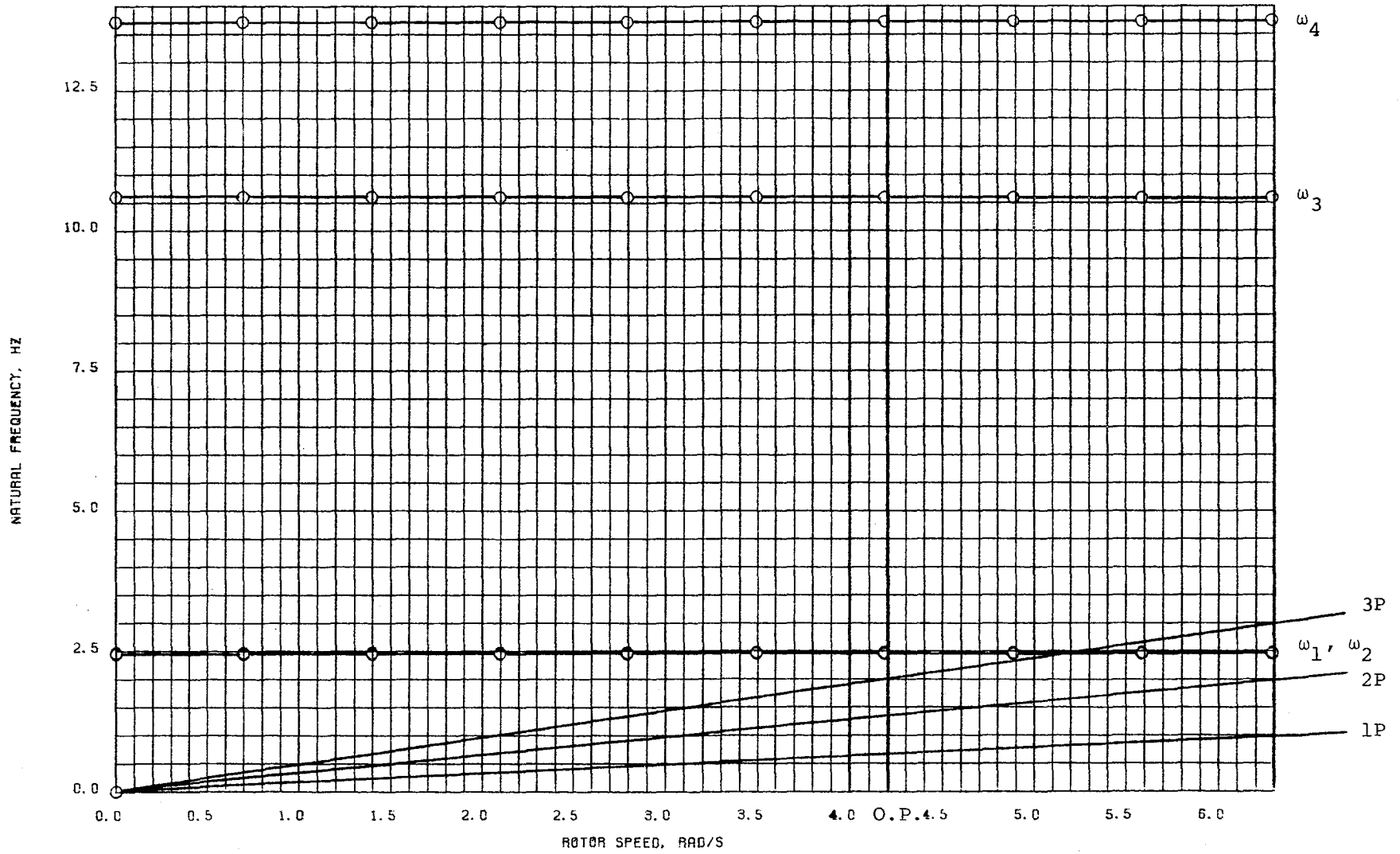

NATURAL FREQUENCIES OF WIND TURBINE SYSTEMS

CONCEPT III, CASE N, NACELLE AND ROTOR INERTIA ABOUT X AXIS INCREASED BY 1/3

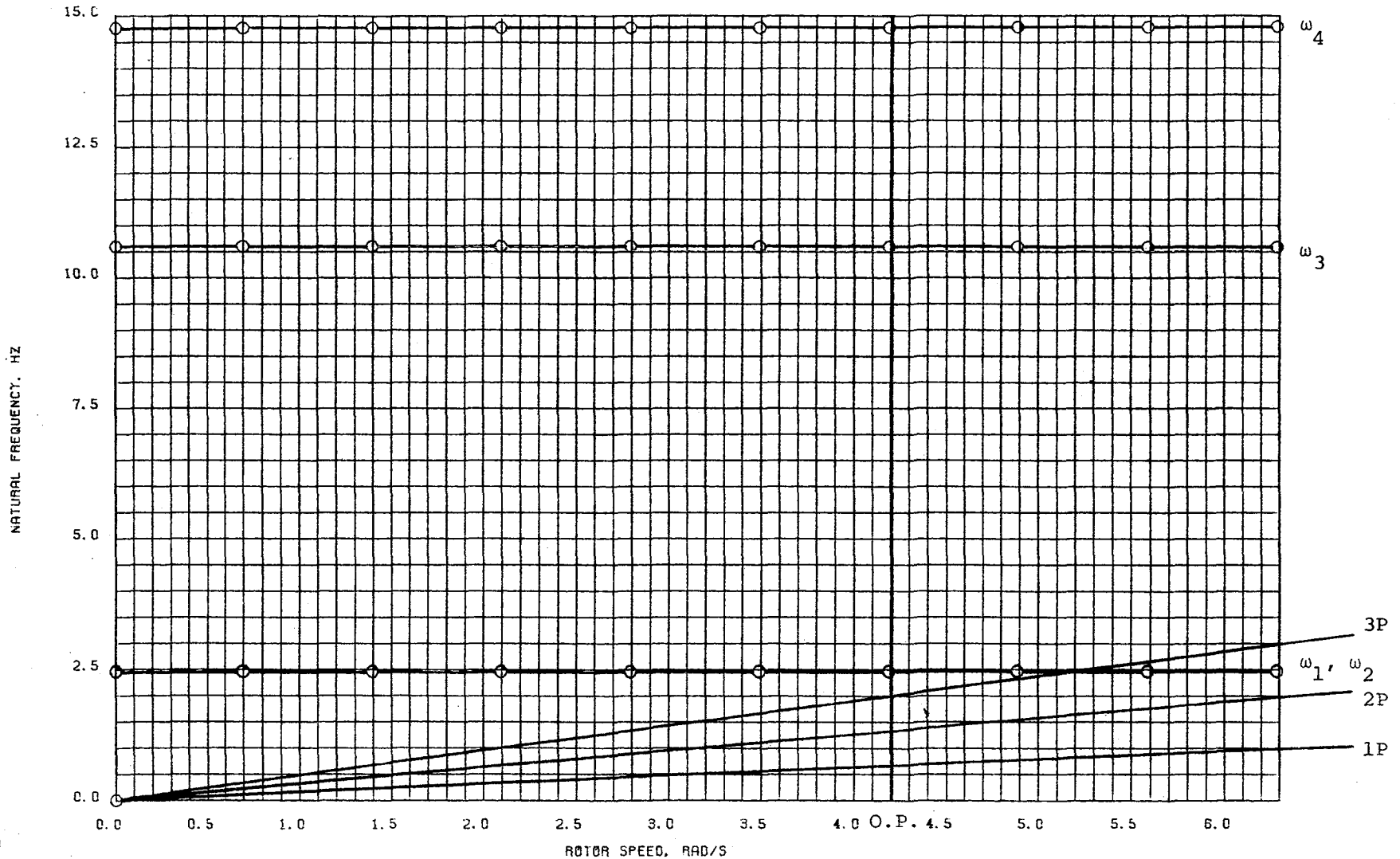

CONCEPT III, CASE O, NACELLE AND ROTOR INERTIA ABOUT X AXIS DECREASED BY 1/3

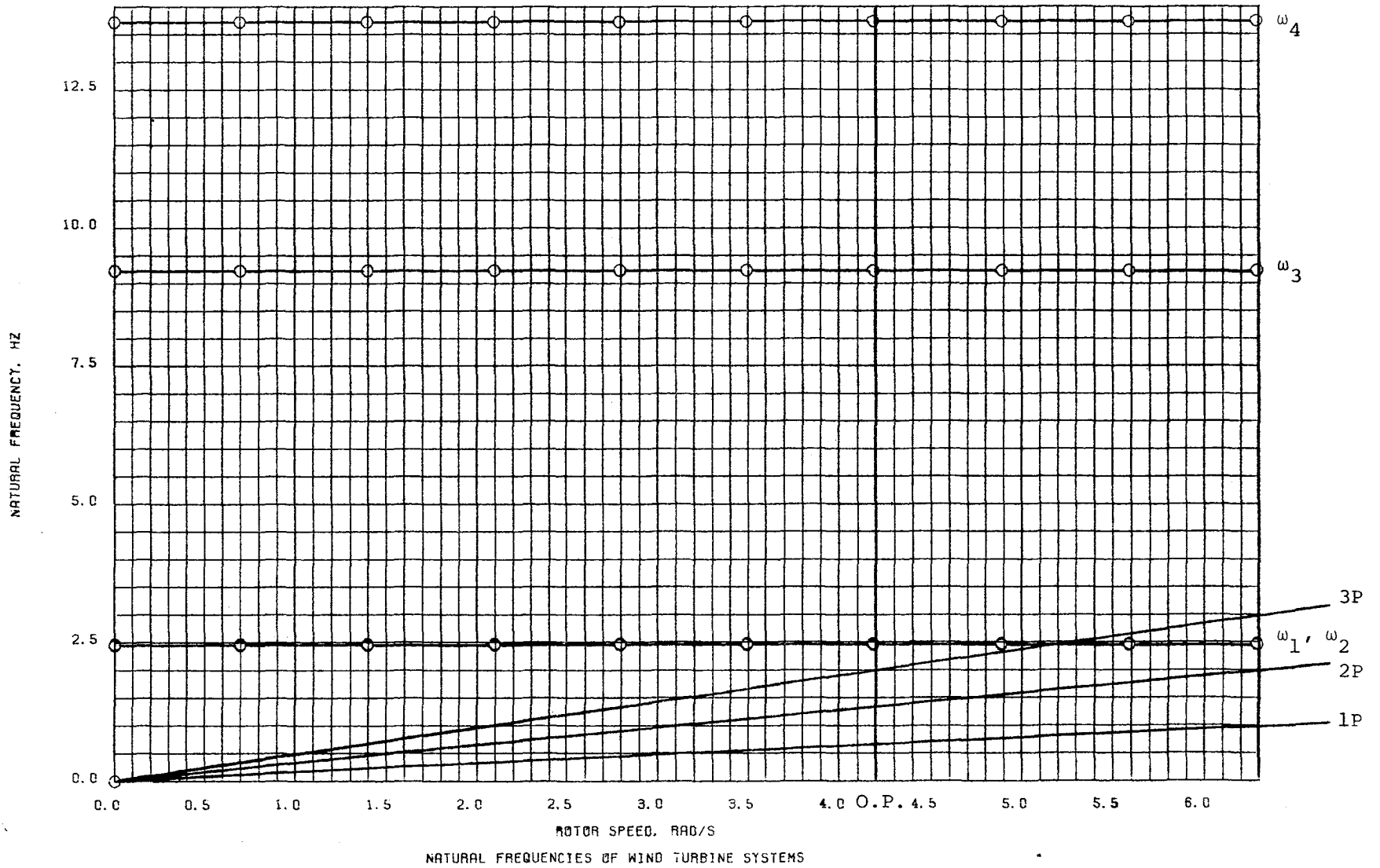

CONCEPT III, CASE P, NACELLE AND ROTOR INERTIA ABOUT X AND Z AXES INCREASED BY 1/3

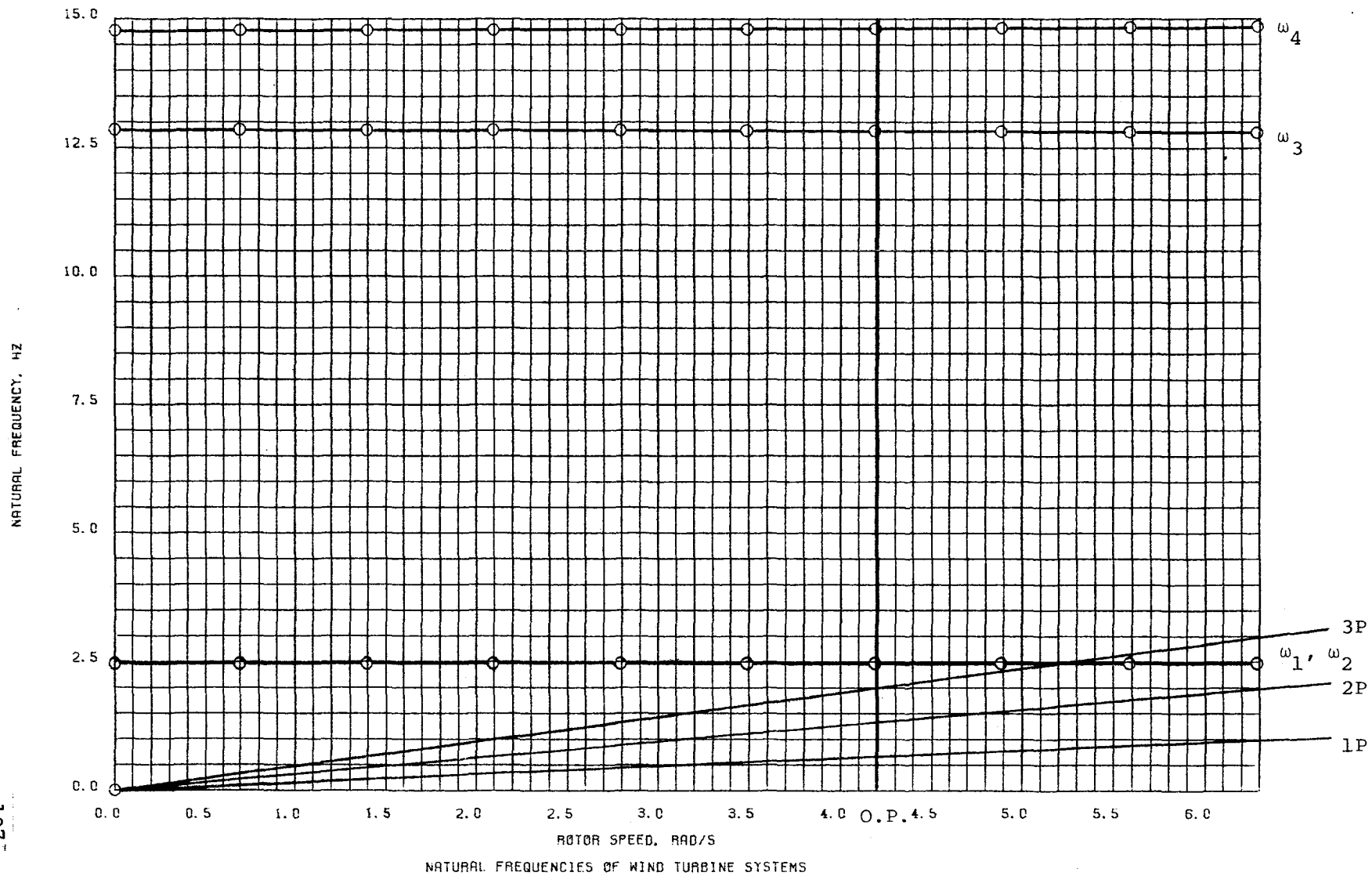

CONCEPT III, CASE Q, NACELLE AND ROTOR INERTIA ABOUT X AND Z AXES DECREASED BY 1/3

APPENDIX C

SYMBOLS

a	Distance from ground to guy connections
A	Cross sectional area
E	Modulus of elasticity
f_{ij}	Flexibility influence coefficients
F_u, F_v	Loads in u, v directions
G	Shear modulus of elasticity
h	Hub radius
I	Area moment of inertia
I_m	Mass moment of inertia per unit length about the centerline of tower
I_r	Mass moment of inertia about the rotor spin axis
I_{xx}, I_{zz}	Mass moment of inertia of nacelle-rotor around x, z axes
J	Polar moment of inertia
k_a	Anchor stiffness
k_c	Effective spring constant of guys
k_R	Spring rate of a guy rod
k_T	Effective guy and anchor stiffness
k_V	Vertical spring rate of soil due to compression
k_{ij}	Stiffness influence coefficients
l	Guy cable length
L	Beam, tower length
l'	Tower section length
m	Mass per unit length
m_{ij}	Tower inertia coefficients

m_N	Mass of nacelle
m_R	Mass of rotor
m_{ij}	System inertia coefficients
M_t	Total mass of tower
N	Number of integration intervals, also number of guys per position
O.P.	Operating point
P_i	Generalized load at i th location
P	Rotor's rotational velocity
q	Distance to nacelle-rotor C.G.
Q	Thermal energy
S	Strain energy
T	Kinetic energy
U, V	Displacements at tower upper end
w	Work
β	Approximate function for blade model deflections
θ	Angle between guys and ground
Λ	Dimensionless blade natural frequencies
ϕ, χ	Rotational displacements at tower upper end
ψ_i	Displacement functions
ω_i	Natural vibration frequencies
Ω	Rotor speed
$\bar{\Omega}$	Dimensionless rotor speed frequency

1. Report No. NASA CR-165589		2. Government Accession No.		3. Recipient's Catalog No.	
4. Title and Subtitle VIBRATION ANALYSIS OF THREE GUYED TOWER DESIGNS FOR INTERMEDIATE SIZE WIND TURBINES				5. Report Date March 1982	
				6. Performing Organization Code 776-33-41	
7. Author(s) Robert J. Christie				8. Performing Organization Report No. WLT T.O. 403-1	
9. Performing Organization Name and Address W. L. Tanksley and Associates, Inc. 16106 Snow Road Brook Park, Ohio 44142				10. Work Unit No.	
				11. Contract or Grant No. NAS3-21900	
12. Sponsoring Agency Name and Address U.S. Department of Energy Division of Wind Energy Systems Washington, D.C. 20545				13. Type of Report and Period Covered Contractor Report	
				14. Sponsoring Agency Code Report No. DOE/NASA/1900-1	
15. Supplementary Notes Final Report. Prepared under Interagency Agreement DE-AI01-76ET20320. Project Manager, J. Savino, Wind and Stationary Power Division, NASA Lewis Research Center, Cleveland, Ohio 44135.					
16. Abstract A method for analyzing the vibrations of horizontal axis wind turbines, developed by R.W. Thresher, W.E. Holley, C.E. Smith, N. Jafarey, and S.R. Lin of Oregon State University, was used to analyze three guyed tower designs for intermediate size wind turbines. The method, which uses a simple wind turbine structural model, was used to estimate the four lowest natural frequencies of vibration of the three towers concepts. A parametric study was performed on each tower to determine the effect of varying various tower properties such as the inertia and stiffness properties of the tower and guys, the inertia values of the nacelle and rotor, and the rotational speed of the rotor. The results showed that only the two lowest frequencies were in a range where they could be excited by the rotor blade passing frequencies. The analysis also showed that these two frequencies could be tuned by varying the guy stiffnesses, the guy attachment point on the tower, the tower mass and stiffness, and the nacelle/rotor/power train masses.					
17. Key Words (Suggested by Author(s)) Wind turbine Vibration analysis Tower designs Guyed tower dynamics			18. Distribution Statement Unclassified - unlimited STAR Category 44 DOE Category UC-60		
19. Security Classif. (of this report) Unclassified		20. Security Classif. (of this page) Unclassified		21. No. of Pages	22. Price*

* For sale by the National Technical Information Service, Springfield, Virginia 22161

UNITED STATES DEPARTMENT OF ENERGY

P.O. BOX 62
OAK RIDGE, TENNESSEE 37830

OFFICIAL BUSINESS
PENALTY FOR PRIVATE USE, \$300

POSTAGE AND FEES PAID

UNITED STATES
DEPARTMENT OF ENERGY



FS- 1

NATIONAL AERONAUTICS AND SPACE ADM
ATTN LIBRARY
LANGLEY RESEARCH CENTER
HAMPTON, VA 23665