

## **General Disclaimer**

### **One or more of the Following Statements may affect this Document**

- This document has been reproduced from the best copy furnished by the organizational source. It is being released in the interest of making available as much information as possible.
- This document may contain data, which exceeds the sheet parameters. It was furnished in this condition by the organizational source and is the best copy available.
- This document may contain tone-on-tone or color graphs, charts and/or pictures, which have been reproduced in black and white.
- This document is paginated as submitted by the original source.
- Portions of this document are not fully legible due to the historical nature of some of the material. However, it is the best reproduction available from the original submission.

NASA CASE NO. MSC-20,304-1

PRINT FIG. 5

NOTICE

The invention disclosed in this document resulted from research in aeronautical and space activities performed under programs of the National Aeronautics and Space Administration. The invention is owned by NASA and is, therefore, available for licensing in accordance with the NASA Patent Licensing Regulation (14 Code of Federal Regulations 1245.2).

To encourage commercial utilization of NASA-owned inventions, it is NASA policy to grant licenses to commercial concerns. Although NASA encourages nonexclusive licensing to promote competition and achieve the widest possible utilization, NASA will consider the granting of a limited exclusive license, pursuant to the NASA Patent Licensing Regulations, when such a license will provide the necessary incentive to the licensee to achieve early practical application of the invention.

Address inquiries and all applications for license for this invention to NASA Patent Counsel, Johnson Space Center, Mail Code AL3, Houston, TX 77058. Approved NASA forms for application for nonexclusive or exclusive license are available from the above address.



(NASA-Case-MS-20304-1) CAM CONTROLLED  
RETRACTABLE DOOR LATCH (NASA) 11 P  
HC A02/MF A01 CSCL 131

Unclas  
G3/37 27530

Awards Abstract

NASA Case No. MSC-20304

### CAM CONTROLLED RETRACTABLE DOOR LATCH

The invention relates to a latching mechanism in which there is linear movement and rotational movement.

The umbilical doors of the Space Shuttle Orbiter are required to be open during vehicle launch. After the external tank is released, the doors are closed. Presently, the device for maintaining the doors in an open position is mounted on the external tank and therefor has a single-mission life.

The latching mechanism of the present invention is mounted in the orbiter and therefore is returned and has multi-mission capability. The latching mechanism is comprised of a pair of concentric nested, cylindrical cams 20 and 21, motors 22 and 23 provided to actuate the cams, and latch pin 24 all contained within a cover mounted on a support bracket 26 carried by the substructure 27. A shaft 30 having latch pin 24 is mounted inside the inner cylindrical cam 21. Outer cylindrical cam 20 (FIG. 6) has a helical slot 38 and is rotatably supported at its bottom on bracket structure 26 by means of bearings 26a. Cam 20 may be rotated by motor 22 through pinon and gear 39. Inner cam 21 has a cam groove 21a with a lower, horizontal portion 21b shown with latch pin 24 therein insulated, and is supported on bracket 26 through bearings 26. Cam 21 may be rotated by a second motor 23 through pinon and gearing 40, or may be stationarily mounted.

Motors 22 and 23 are suitably controlled to advance the door latch pin 31 and turn latch pin 31 to engage slots and hold doors 10 and 11 open during launch (FIGS. 2 and 5). When the external tank is disconnected to unlatch the doors, by rotating latch pin 31, then retracting the latch (FIG. 4). When the doors are open, shaft 30 will be advanced and finger 31 rotated to move its lips 35 into slots 16 and 17 in the ends of the doors (FIG. 2). When the doors are closed, the latch pin is rotated so that its ends are not of engagement with the slots in the doors and then the latch pin is retracted so that it forms insulated part of the outer mould line of the orbiter.

The novelty appears to reside in a mechanism having a latching shaft mounted in the inner of two concentric cams, one having an L shaped slot, the other a helical slot whereby rotational movement of one cam will result in rotational and transverse movement of the latching shaft.

Inventor: Renton B. Carsley  
Employer: Rockwell International  
Initial Evaluator: Jerry E. McCullough

ORIGINAL PAGE IS  
OF POOR QUALITY

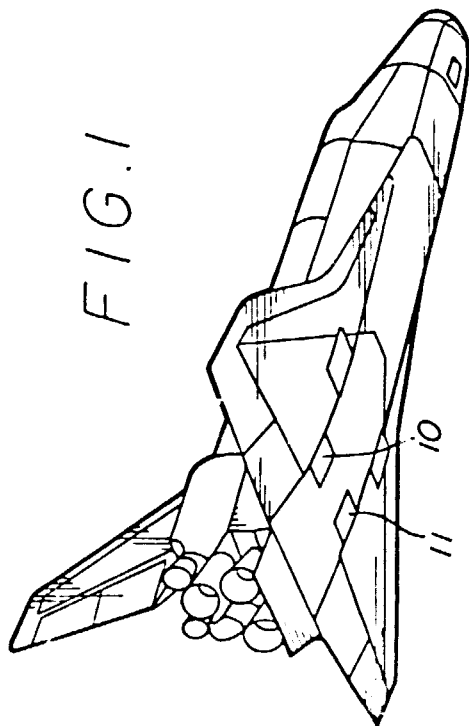

FIG. 1

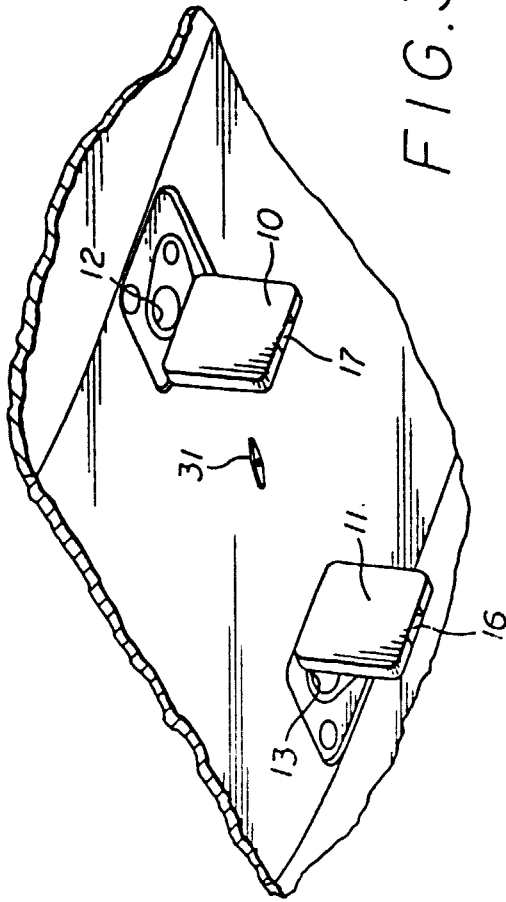

FIG. 3

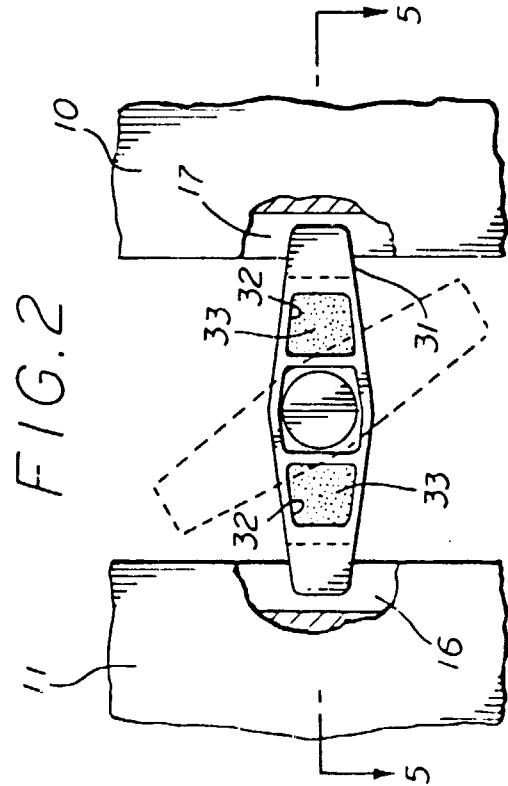

FIG. 2

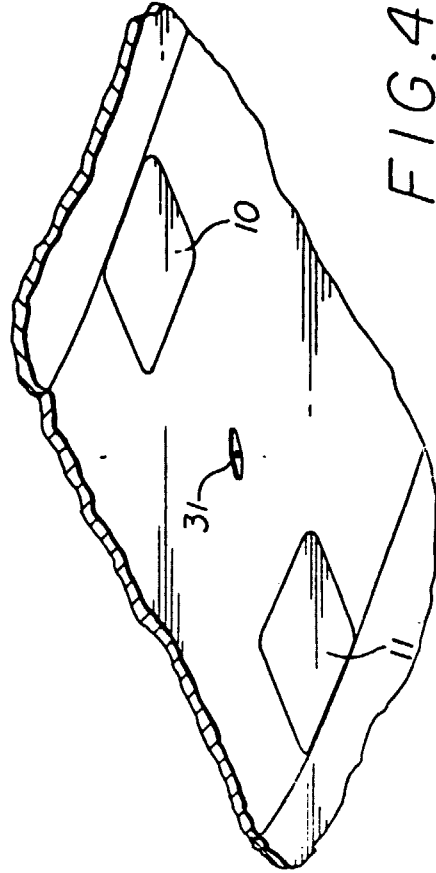

FIG. 4

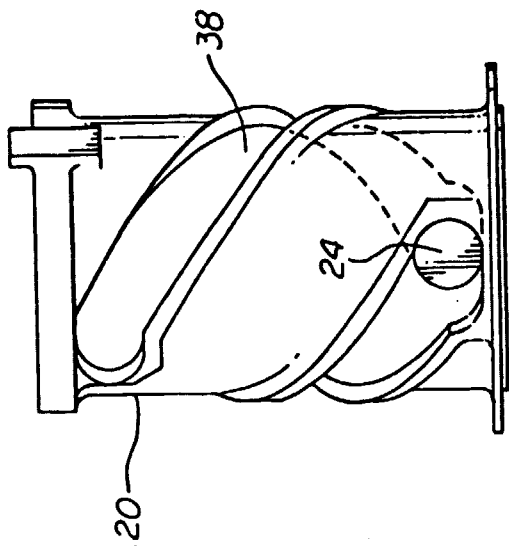

FIG. 6

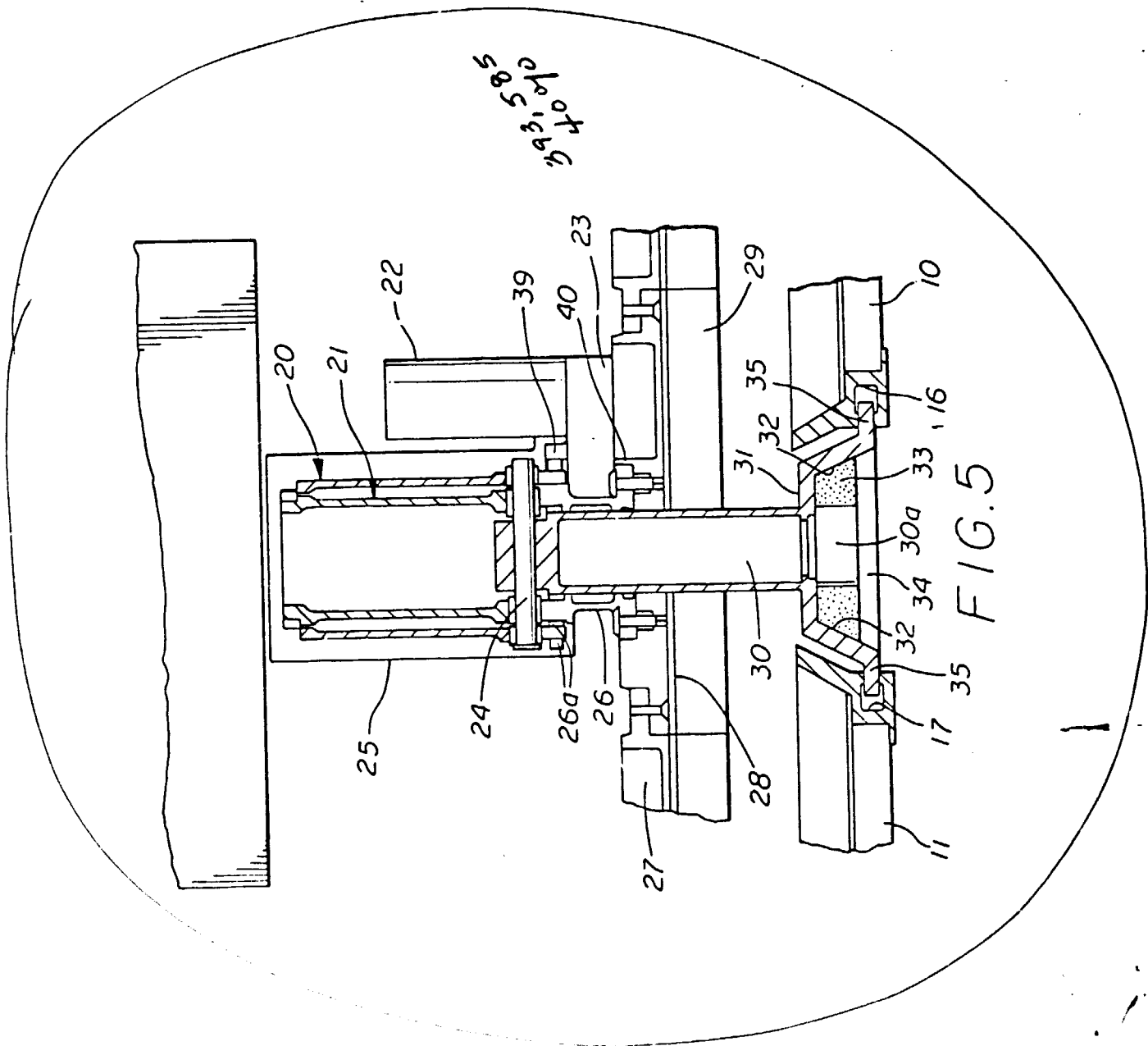

FIG. 5

ORIGINAL PAGE IS  
OF POOR QUALITY.

FIG. 7

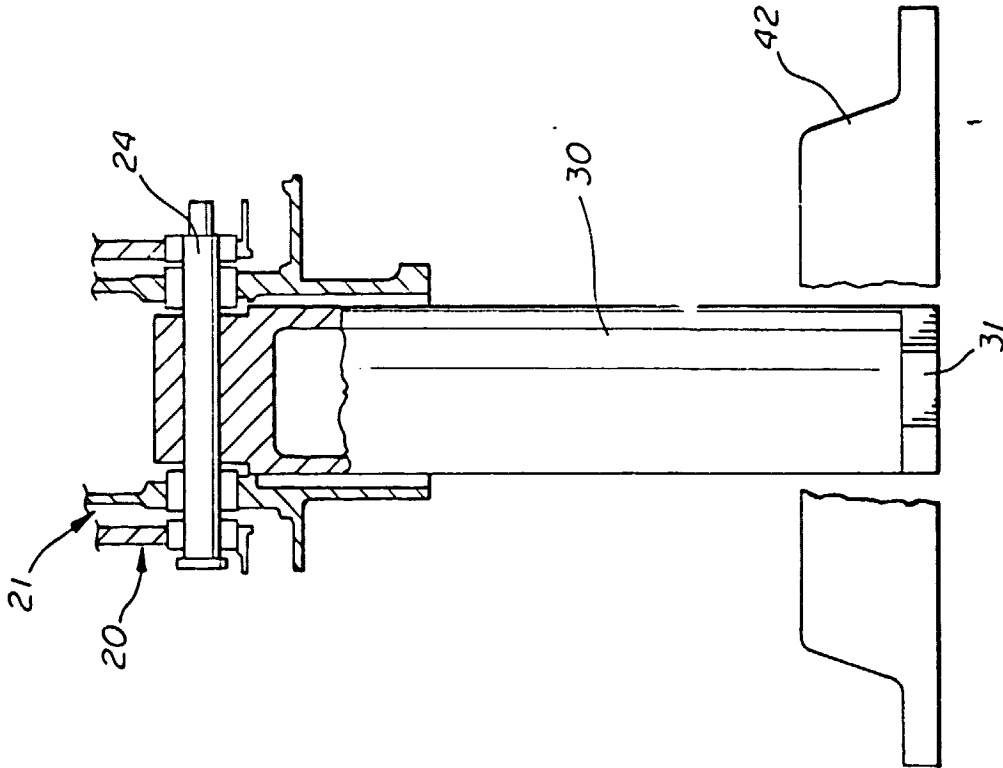
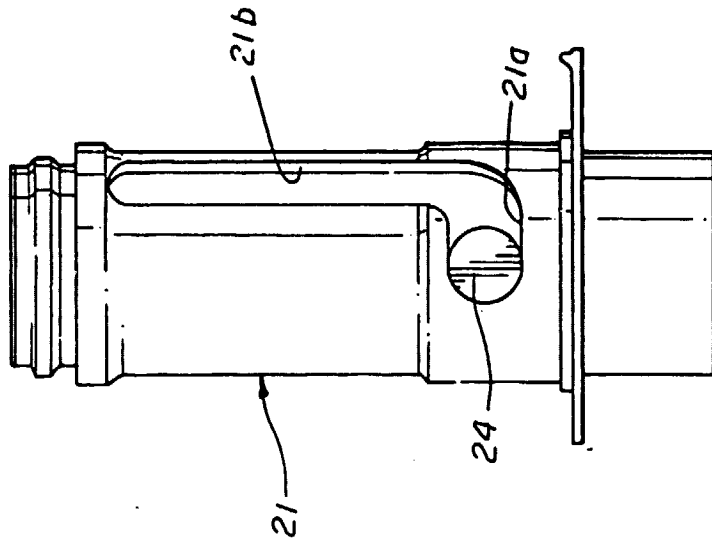

FIG. 8

Description

Title: Cam Controlled Retractable Door Latch

Origin of the Invention

5 The invention described herein was made in the performance of work under a NASA contract and is subject to the provisions of Section 305 of the National Aeronautics and Space Act of 1958, Public Law 85-568 (22 Stat. 435: U.S.C. 2457).

Technical Field

10 This invention relates to closure latches of the type which projects beyond a surface in the latching position and is retractable within the surface contour when unlatched, to leave the surface smooth, for instance, aerodynamically.

15 Background of the Invention

The Space Shuttle Orbiter has fittings on its under surface for connection to the external tank by umbilical conduits during the launch. Protective doors are provided for the fittings which open outwardly and are latched open during the launch and which are unlatched and closed when the tank is jettisoned. The latch presently used is carried by the tank structure and projects outwardly of the vehicle skin during latching and is lost during each flight.

25 The reusable character of the shuttle makes retention of the latch desirable and, accordingly, an object of the present invention is to provide a reusable latch for the umbilical doors which may be retracted linearly within the surface contour of the vehicle after disconnection of the umbilical connections.

30 Sequential rotary and linear mechanisms, some utilizing cams, are known. For instance, in Carlson U. S. Patent No. 3,751,995, a rotating shaft 14 has slots 46 and 48 for

receiving keys 52 and 54, respectively. When shaft 14 can no longer rotate in the initial direction, continued output torque of the motor 22 is shunted from shaft 24 to circular spline 32 which now drives spline teeth 42. At this time, spline 32, motor 22, shaft 14, and wing 12 are jointly linearly moved.

In Cary Patent No. 3,804,440, a rotary locking bolt 22 carries a cam follower pin 54, the ends of which ride in opposed cam slots 56 and barrel 18. The major portions of the cam slots are longitudinally straight to guide the bolt axially with end slot held in alignment. Adjacent end plate 20, the cam slots 56 have helical portions 58, which cause the bolt to be rotated as it is moved axially.

In Winn Patent No. 901,511, axial end rotational movements disengage a latch from a slot on a hinged door.

None of the above discloses sequential rotary and linear movements as in the present invention, nor the concept of employing concentric, contoured cams adaptable in sequence to advance a latch finger, rotate the finger into latching position, again rotate the finger to unlatched position, and finally retract the finger into non-exposed position.

#### Summary of This Invention

According to the present invention, a latch finger is linearly and pivotally mounted on a shaft between the adjacent free ends of adjacent umbilical doors. When the doors are open, i.e. swung together, to expose the umbilical connections, the finger is advanced to a position flush with the doors and rotated to latch in slots in the door ends. When the umbilical conduits are disconnected, the shaft and latch finger are first rotated to withdraw the finger from the slots, then retracted to lodge the finger in a recess substantially flush with the vehicle surface. The doors are opened and closed by other means to expose and cover the umbilical connections.



The sequential motions are programmed through a pair of nested cylindrical cams each operatively connected to one of a pair of motors.

#### Brief Descriptions of the Drawings

5 In the accompanying drawings:

FIG. 1 is an isometric view of the Space Shuttle Orbiter, particularly the underside including the umbilical doors referred to above.

10 FIG. 2 is an enlarged underside view of portions of the opened umbilical doors with the latch finger engaged in slots in the adjacent door ends.

FIG. 3 is a schematic underside view showing the doors partially open.

15 FIG. 4 is a similar view of the doors fully open and covering the umbilical connections.

FIG. 5 is a longitudinal center section, taken on line 5-5 of FIG. 2, showing the latch and operating mechanism.

FIG. 6 is a side view of the outer cam.

FIG. 7 is a similar view of the inner cam, and

20 FIG. 8 is a schematic view of portions of the operating mechanism with the shaft and latch finger retracted to stowed positions in the vehicle substructure.

#### Detail Descriptions of the Drawings

25 In FIGS. 1 and 4, the doors 10 and 11 are shown in closed positions, i.e. swung apart, as in flight, concealing the connections 12 and 13 (FIG. 2) in plates 14 and 15 upon which the door hinges are mounted. The mounting of the doors and door opening and closing means are conventional and not here illustrated. At the free ends of the doors  
30 are latch slots 16 and 17.

FIGS. 5-8 illustrate the latch, its actuating mechanism including a pair of concentric nested cylindrical cams 20 and 21, motors 22 and 23 for actuating the cams, and a latch pin 24, all within the cover mounted on a support  
35 bracket 26 carried by the substructure 27. Suitably

secured to the substructure is the vehicle skin 28 with thermal protective insulation 29. A shaft 30 has a transverse eye in its upper end closely receiving latch pin 24. The latch finger 31 rigidly secured to the lower end of shaft 30, has recesses 32 filled with insulation 33 which with the end 30a of the shaft, are protectively covered by a cover plate 34 of the densified fused silica insert. At the opposite ends of latch finger 31 are latching lips 35 for cooperating with latching slots 17 and 18 in the door ends, as will be described.

Outer cylindrical cam 20 (FIG. 6) has a helical slot 38 shown with latch pin 24 at its lower end and is rotatably supported at its bottom on bracket structure 26 by means of bearings 26a. Cam 20 may be rotated by motor 22 through pinion and gear 39. Inner cam 21 has a cam groove 21a with a lower, horizontal portion 21b, shown with latch pin 24 therein, and is supported on bracket 26 through bearings 26b. Cam 21 may be rotated by second motor 23 through pinion and gearing 40, or may be stationarily mounted. FIG. 8 shows, schematically, latch finger 31 retracted to a stowed position within substructure 42.

### Operation

Motors 22 and 23 are suitably controlled or programmed to advance the latch and hold doors 10 and 11 open while the umbilical conduits are connected thereto (FIGS. 2 and 5) and to unlatch the doors, and retract the latch (FIG. 4) when the umbilical conduits are disconnected. In the open positions of the doors, shaft 30 will be advanced and finger 31 rotated to move its lips 35 into slots 16 and 17 in the adjacent ends of the doors (Fig. 2). After the external tank is cast off, outer cam 20 is rotated clockwise by its motor 22, while inner cam 21 remains stationary, first to move latch pin 24 through inner cam slot portion 21a (horizontally), and with it, shaft 30 and latch finger 31 sufficiently to withdraw latching lips 35 from door slots 16 and 17 clearing

the doors for closure by conventional means. Continued rotation of the outer cam causes latch pin 24 to ascend spiral track 38 and thereby retract pin 30 and latch 31 to the stowed position of FIG. 4, flush with the Outer  
5 Mold Line (OML) of the vehicle with the latch itself protected by insulation means 33 and 34. Consequently, the umbilical door latch, when not in use, will be stored within the confines and protection of the Orbiter vehicle for reuse during each flight. This will result in sub-  
10 stantial savings and improved convenience. The provision of the dual motor controls will permit other kinds of programmed responses than the sequential actions shown.

The invention may be modified as will occur to those skilled in the art and the exclusive use of all modifications  
15 as come within the scope of the appended claims is contemplated.



ABSTRACT

A reusable latch for the umbilical doors of the Shuttle Orbiter comprises a latch finger 31 for engaging slots 16 and 17 in the adjacent free ends of the umbilical doors 10 and 11, when open prior to the launch, and for retraction to a stowed position within the outer mold line of the vehicle, when the umbilical conduits are disconnected. The latch finger is shifted linearly to and from a position abreast of the door ends for latching in slots in the door ends and is rotated into and out of latching engagement with the door slots. The latch actuating means includes concentric cylindrical cams 20 and 21 co-axial with a shaft 30 which carries the latching finger and individual motors 22 and 23 which drive the cams to actuate the latch shaft and finger.