

NASA-TP-2040 19820023815

**NASA  
Technical  
Paper  
2040**

August 1982

# Influence of Corrosive Solutions on Microhardness and Chemistry of Magnesium Oxide { 001 } Surfaces

Hiroyuki Ishigaki,  
Kazuhisa Miyoshi,  
and Donald H. Buckley

**NASA**



**NASA  
Technical  
Paper  
2040**

1982

# Influence of Corrosive Solutions on Microhardness and Chemistry of Magnesium Oxide { 001 } Surfaces

Hiroyuki Ishigaki,  
Kazuhisa Miyoshi,  
and Donald H. Buckley

*Lewis Research Center  
Cleveland, Ohio*

**NASA**

National Aeronautics  
and Space Administration

Scientific and Technical  
Information Branch



## Summary

An investigation was conducted to examine the surface of magnesium oxide by X-ray photoelectron spectroscopy. Also examined was the microhardness of the magnesium oxide surface. Surface analyses and static indentation experiments were conducted with the cleaved magnesium oxide {001} surface in various environments. The magnesium oxide bulk crystals were cleaved to a specimen size along the {001} surface in corrosive solutions containing HCl, NaOH, or HNO<sub>3</sub> and in water. Indentations were made on the cleaved surface in the desired corrosive solution without exposing the specimen surface to any other environment. Indentations were made on the magnesium oxide surface with a diamond indenter. All indentation experiments were conducted with a load of 0.1 N at room temperature. The time in contact was 20 sec.

The results indicate that chlorides (such as MgCl<sub>2</sub>) are formed on the magnesium oxide surface when an HCl-containing solution interacts with a cleaved magnesium oxide surface. The chloride films soften the magnesium oxide surface. In this case the microhardness is strongly influenced by the pH value of the solution. The smaller the pH value, the lower the microhardness. Sodium films are formed on the magnesium oxide surface as a result of an NaOH-containing solution interacting with a cleaved magnesium oxide surface. The sodium films do not soften the magnesium oxide surface.

## Introduction

The presence of surface-active agents on nonmetals, particularly on ionic solids, can influence the mechanical behavior of the surfaces of these solids. Surface-active films can influence the deformation behavior of ionic solids by various mechanisms. These include (1) strengthening by dissolution of the solid surface, or the Joffe effect (ref. 1); (2) surface hardening, or the Roscoe effect (refs. 2 and 3); (3) surface softening, or the Rehbinder effect (ref. 4); (4) correlation between hardness and the zeta-potential (refs. 5 and 6); and (5) the effect of adsorbed water on indentation creep (refs. 7 and 8). The significance of these effects to tribology has been recognized (refs. 9 to 14). Although considerable effort has been put forth in determining environmental effects on the hardness of nonmetals, neither the fundamentals of the surface chemistry involved nor the tribological properties of the solid surfaces in a variety of environments are clearly understood. This study was conducted to examine the surface chemistry and microhardness of single-crystal magnesium oxide in various environments. We have conducted microhardness and X-ray photoelectron spectroscopy

(XPS) studies on the magnesium oxide {001} surface exposed to various environments, such as air, nitrogen gas, and mineral oil with and without additives (refs. 15 and 16). The hardness and chemistry of magnesium oxide surfaces were found to be influenced by the environment. This was particularly true when the magnesium oxide crystals were cleaved in mineral oil with an additive containing ionic chloride. The ionic chloride softened the magnesium oxide surfaces. XPS analysis of the surface indicated that chloride (such as MgCl<sub>2</sub>) films are formed on the magnesium oxide surface as a result of the ionic-chloride-containing additive interacting with the cleaved magnesium oxide.

This study was conducted to examine the effect of corrosion on the microhardness of the magnesium oxide surface. Of particular interest was the influence of chemically active chlorine on the microhardness and chemistry of magnesium oxide because of the foregoing evidence of environmental effects.

The surface chemistry of magnesium oxide was analyzed by XPS. The magnesium oxide bulk crystals were cleaved to a specimen size along the {001} surface in corrosive solutions containing HCl, NaOH, or HNO<sub>3</sub> and in water. Indentations were made on the cleaved surface in the desired corrosive solution. Microhardness (Vickers) indentation experiments were conducted on magnesium oxide {001} surfaces with a diamond indenter. All indentations were made at a load of 0.1 newton at room temperature. The time in contact was 20 sec.

## Materials

The arc-melted, single-crystal magnesium oxide used in this investigation was 99.99 percent pure oxide as obtained from the manufacturer. Magnesium oxide was selected as the material to examine for a number of reasons: (1) Its slip and fracture behavior are very well understood, (2) the Rehbinder effect has been observed with it, (3) fresh, atomically clean surfaces can be prepared by cleavage, and (4) it can be used as a bearing material (ref. 17).

Magnesium oxide is an ionic crystal with a rock-salt structure (ref. 18). This structure consists of two interpenetrating face-centered cubic (fcc) lattices, one made up of positive ions and the other of negative ions. Because MgO is highly ionic, slip does not occur on the close-packed {001} cubic planes but instead occurs on the {011} cubic diagonals.

## Apparatus

Two apparatuses were used in this investigation. One was an XPS system contained in an ultra-high-vacuum

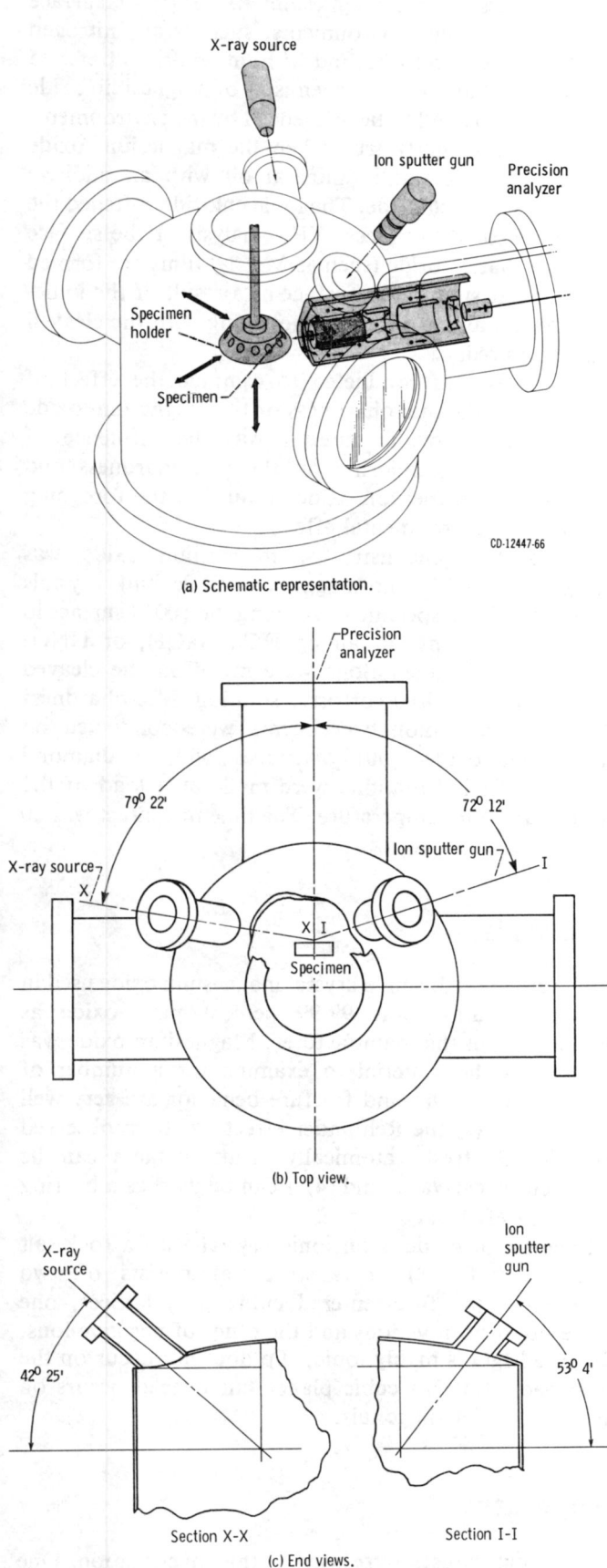

Figure 1. - X-ray photoelectron spectroscopy and vacuum chamber.

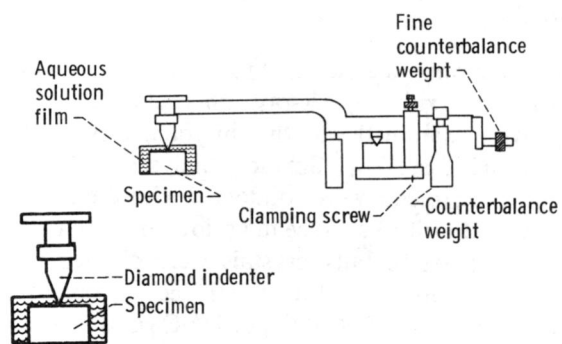

Figure 2. - Hardness apparatus.

system. It is shown schematically in figure 1, which indicates the major components, including the electron energy analyzer, the X-ray source, and the ion gun used for ion sputter-etching. The X-ray source contains a magnesium anode. The specimens were mounted on the end of the specimen probe at an angle of  $60^\circ$  from the analyzer axis. The X-ray source was located at an angle of  $79^\circ$  from the analyzer axis, and the ion gun was located at an angle of  $72^\circ$  from the analyzer axis in the top view.

The second apparatus was a microhardness (Vickers) tester with the capability of measuring indentation hardness in controlled environments (fig. 2). Indentation was conducted manually, with the tester fixed on a vibration-free table. A diamond indenter was attached to one end of a precision-balanced rod. The load was applied by placing deadweights on a pan on top of this end of the rod. The specimen holder was moved vertically by hand until the specimen was in contact with the diamond indenter.

## Experimental Procedure

### Specimen Preparation and Indentation Experiments

The magnesium oxide bulk crystals were immersed in room-temperature aqueous solutions with various pH values and then cleaved to a specimen size of 5 mm by 5 mm along the  $\{001\}$  surface by using a knife and hammer. The submerged specimens were then mounted on the microhardness tester as shown in figure 2. Indentations were made on cleaved  $\{001\}$  surfaces in the desired aqueous solution without exposing the specimen surface to the air or to any other environment.

To compare the hardness of magnesium oxide cleaved in aqueous solutions with that of magnesium oxide cleaved in laboratory air, the magnesium oxide bulk crystals were cleaved along the  $\{001\}$  surface in laboratory air in the plastic-box-housed microhardness tester at room temperature by using a knife edge and hammer. The specimen was mounted on the microhardness tester without exposing the specimen to

TABLE I. - SOLUTIONS WITH VARIOUS pH VALUES

Solution	pH value <sup>a</sup>
HCl added to 10 <sup>-2</sup> N aqueous NaCl solution	1.0 2.5 4.2
10 <sup>-2</sup> N aqueous NaCl solution	6.7
NaOH added to 10 <sup>-2</sup> N aqueous NaCl solution	10.5 12.3 13.5
HNO <sub>3</sub> added to distilled water	1.0

<sup>a</sup>Potentiometric method was employed for pH determination.

any other environment. The indentation diagonals were parallel to the <001> directions. The time in contact was 20 sec.

Macmillan, et al. (ref. 5) made indentation creep tests of magnesium oxide immersed in 10<sup>-2</sup> N sodium chloride solutions to which sodium hydroxide or hydrochloride had been added. They showed that the dislocation mobility is strongly affected by the zeta-potential of the surface, which varied with the pH value of the solutions. To examine the influence of this effect on microhardness, 10<sup>-2</sup> N sodium chloride solutions containing sodium hydroxide or hydrochloride were used in this study. Table I lists the aqueous solutions used in this investigation and their analyzed pH values.

### X-Ray Photoelectron Spectroscopy

The cleaved specimens were placed in the vacuum chamber shown in figure 1 without cleaning, and the system was evacuated and subsequently baked out to a pressure of 26 nPa (2x10<sup>-10</sup> torr). The surfaces were examined with the XPS at 26 nPa.

The specimens were cleaned by argon ion sputtering. The ion gun was outgassed for 2 min at a degas emission current of 20 mA. The sublimation pump was then flashed on for about 2 min at 48 A. The ion pumps were then shut off. An inert gas, argon, was bled in through the leak valve to the desired pressure of 7 mPa with the ion pumps turned off. Ion sputtering was performed with a beam energy of 3000 eV at 20-mA emission current with the argon pressure maintained at 7 mPa for the sputtering time of 30 min. The ion beam was continuously rastered over the specimen surface. After sputtering, the system was evacuated to 26 nPa or lower, and then the surface was examined with XPS.

To obtain reproducible results, a strict standardization of the order and time of recording was used. The instrument was regularly calibrated. The analyzer calibration was determined by assuming the binding energy for the gold 4f<sub>7/2</sub> peak to be 83.8 eV; that is, the

gold 4f<sub>7/2</sub> level was used as the reference line. All survey spectra, scans of 1000 or 1100 eV were taken at a pass energy of 50 or 100 eV providing an instrumentation resolution of 1 eV at room temperature. The magnesium K $\alpha$  X-ray was used with an X-ray power source of 400 W (10 kV, 40 mA). The narrow scans of Mg<sub>2p</sub>, O<sub>1s</sub>, Cl<sub>2p</sub>, and Na<sub>1s</sub> were just wide enough to encompass the peaks of interest and were obtained with a pass energy of 25 eV at room temperature.

During analysis, insulating specimens tend to acquire a steady-state charge of as much as several volts. To evaluate the charging effect and to determine accurately the energy of the peaks, the following approach was taken in this investigation: Measurement was made of the position of the C<sub>1s</sub> line from the hydrocarbons nearly always present on the specimen surface. These absorb from the laboratory environment (ref. 19). Because this line, on unsputtered inert metals such as gold, appears at 284.6 eV, any shift from this value can be taken as a measure of the static surface charge. Thus the value of 284.6 eV for the C<sub>1s</sub> line was used as the reference line for static surface charging on magnesium oxide.

## Results and Discussion

### Hardness

*Air and water.* - Hardness measurements were conducted on magnesium oxide surfaces cleaved in air and in water. The microhardnesses were 824 and 822, respectively. Essentially no difference in hardness was evident on the two surfaces.

Figure 3 presents a typical distribution of dislocation etch pits around an indentation made on the surface

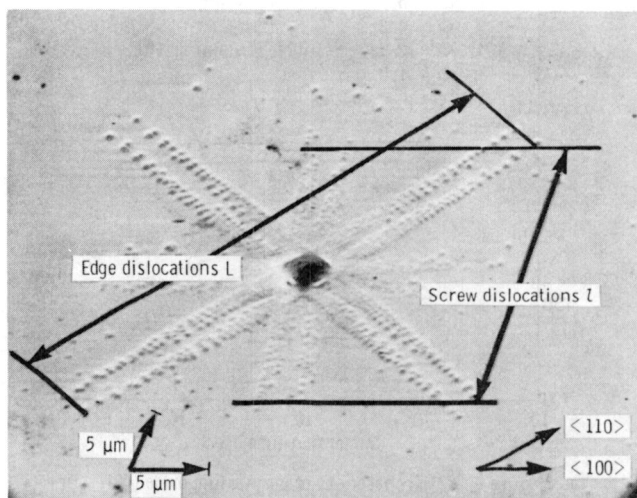

Figure 3. - Distribution of dislocation etch pits around Vickers indentation on magnesium oxide surface. Indenting surface, {001} plane cleaved in laboratory.

cleaved in air. Because magnesium oxide is highly ionic, slip does not occur on the close-packed {001} cubic planes but instead occurs on the {011} cubic diagonals. The actual dislocation-etch-pit pattern around the indentation on the {001} surface contains screw dislocations in the <001> directions and edge dislocations in the <011> directions, as indicated by the pit patterns in figure 3 (ref. 17). The widths of the screw and edge dislocations were 4.9 and 7.7 times larger, respectively, than the average length of the two diagonals of indentation.

**Corrosive solutions with various pH.**—Indentation experiments were conducted in various corrosive solutions. These solutions contained NaOH, NaCl, HNO<sub>3</sub>, and HCl with various pH values. The results are shown in figure 4, which presents the microhardness as a function of the time that the magnesium oxide crystal was immersed in the corrosive solution. Each hardness value is the average of 10 measurements. The 95 percent confidence intervals (ref. 21) of these averages are ±17. There is significance in the differences, with a 5 percent significance level (ref. 20) between the hardness values in the HCl-containing solutions.

There was no change in microhardness with immersion time on the surface immersed in the solution containing NaOH with a pH of 13.5 and that immersed in water containing NaCl with a pH of 6.7. The microhardnesses of the surfaces immersed in the HCl-containing solutions with pH values of 4.2, 2.5, and 1.0 generally decreased with an increase in immersion time. Thus the results indicate that the microhardness of a magnesium oxide surface immersed in HCl solutions is influenced by the

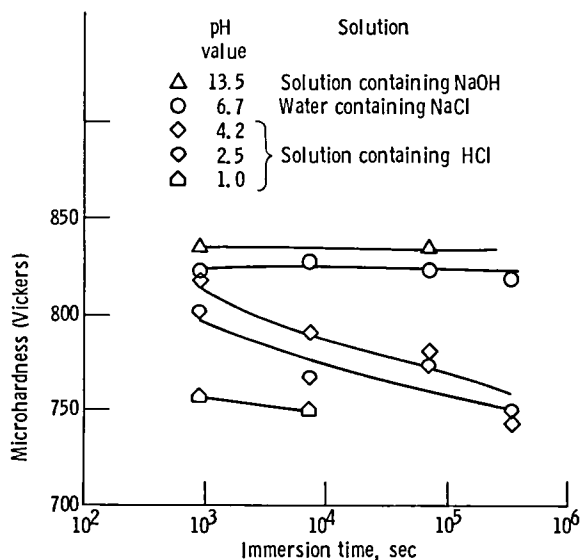

Figure 4. - Microhardness of magnesium oxide {001} surface as a function of immersion time. Load, 0.1 newton; indenter, diamond; room temperature. (MgO crystals were cleaved in various solutions, and indentations were made on surface immersed in solution.)

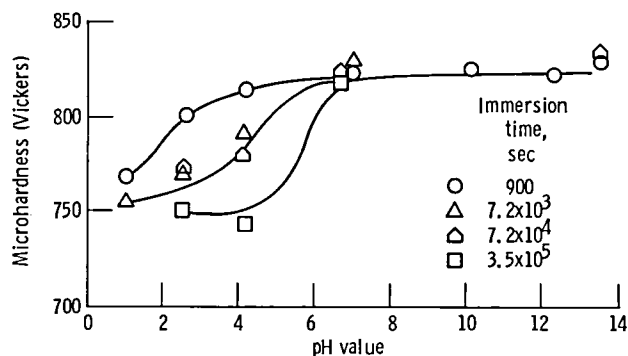

Figure 5. - Microhardness of magnesium oxide {001} surface immersed in various solutions as a function of pH value. Load, 0.1 newton; indenter, diamond; room temperature.

pH value as well as by the immersion time. The stronger the acid, the lower the microhardness observed. The microhardness of the surface immersed in the HCl solution with a pH of 1.0 for 900 sec was almost the same as those of surfaces immersed in solutions with pH values of 4.2 and 2.5 for 3.5x10<sup>5</sup> sec.

The microhardness data were reexamined as a function of the pH values of the corrosive solutions. The results are shown in figure 5. At an immersion time of 900 sec the microhardness increased with increasing pH value. At an immersion time of 3.5x10<sup>5</sup> sec even the microhardness of the surface immersed in the solution with a pH of 4.2, which is a relatively weak acid, was low.

In the NaOH-containing solution the pH value had little influence on microhardness. Macmillan, et al., made indentation creep experiments and measured dislocation mobility (ref. 5). They found that the environment in which the zeta-potential becomes zero, a pH of almost 12.3, gives minimum dislocation mobility and concluded that magnesium oxide has a maximum hardness in this environment. In figure 5, however, a pH of 12.3 does not have an evident effect on microhardness, and further the effect of the zeta-potential, if it exists, is negligibly small.

Figure 6 presents the distribution widths of the screw and edge dislocations as a function of pH value in various corrosive solutions for an immersion time of 900 sec. Each value is the average of 10 measurements. The 95 percent confidence intervals of the plotted values for edge and screw dislocations are ±1.1 and ±1.0, respectively. There is a significance in the difference (ref. 20) between the distribution width of edge dislocations in the solution with a pH of 1.0 and that in the solution with a pH of 6.7.

The length of the rows of etch pits on the solid surface reflects the extent of deformation. The longer the rows, the greater the deformation and the lower the microhardness. The distribution widths of the edge dislocations are consistent with the microhardness data



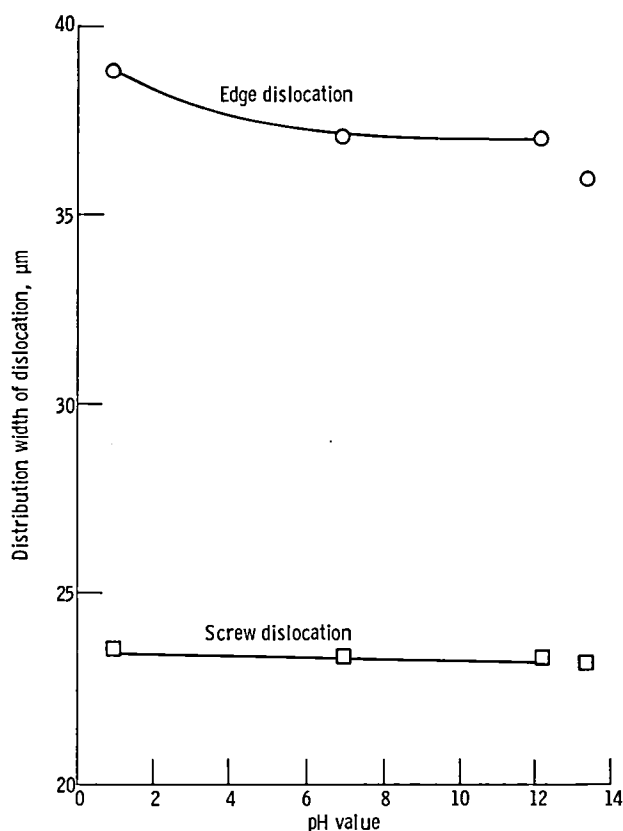

Figure 6. - Distribution widths of edge and screw dislocations around Vickers indentations on magnesium oxide {001} surface immersed in various solutions as a function of pH value. Load, 0.1 newton; indenter, diamond; immersion time, 900 sec; room temperature.

shown in figure 5. No influence of pH value on the screw dislocations was evident.

With respect to figure 5, the questions to be asked are what effect does pH have on microhardness? Further, what about other acids? Figure 7 compares the microhardness of surfaces immersed in distilled water containing HNO<sub>3</sub> with a pH of 1.0 with prior results shown in figure 4. The microhardness is almost the same as that of the NaCl solution with a pH of 6.7. Microhardness was not influenced by the immersion time. In HCl-containing solutions the magnesium oxide surface exhibited low hardness and was influenced by the pH value. In the HNO<sub>3</sub>-containing solutions the microhardnesses were the same as those of surfaces cleaved in air, water, or NaOH solutions. Hence, to gain an understanding of the surfaces of magnesium oxide in these various mediums, XPS analyses were conducted.

### XPS Analysis

The XPS spectra were taken for the surfaces of magnesium oxide cleaved in solutions containing HCl (pH = 1.0) or NaOH (pH = 13.5). The typical results obtained from narrow scans are shown in figures 8 to 11,

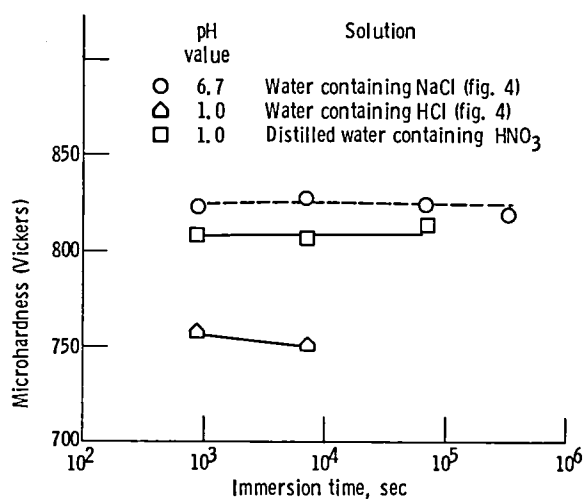

Figure 7. - Microhardness of magnesium oxide {001} surface as a function of immersion time - comparison with HNO<sub>3</sub> solution. Load, 0.1 newton; indenter, diamond; room temperature. (MgO crystals were cleaved in HNO<sub>3</sub> solution with pH = 1.0, in HCl solution with pH = 1.0, and in NaCl solution with pH = 6.7.

which present Cl<sub>2p</sub>, Na<sub>1s</sub>, Mg<sub>2p</sub>, and O<sub>1s</sub> peaks for the surfaces cleaved in the HCl solution with a pH of 1.0 and in the NaOH solution with a pH of 13.5, respectively.

Chlorine peaks (fig. 8) are clearly evident in the spectra of the surfaces exposed to both solutions before sputtering. But no chlorine is apparent on the surface exposed to the alkali solution with a pH of 13.5 after sputtering, although it is evident on the surface exposed to the acid solution with a pH of 1.0.

Sodium peaks (fig. 9) can be seen on the surfaces exposed to the acid and alkali solutions before and after sputtering. However, the sodium peak seen on the surface exposed to HCl acid after sputtering is larger than that on the surface before sputtering. On the other hand, the surface exposed to the NaOH solution exhibits the opposite trend, that is, the amount of sodium was decreased by sputtering.

Magnesium peaks (fig. 10) for the surface exposed to the HCl solution can be seen before and after sputtering. No magnesium peak, however, is observable on the surface exposed to the NaOH solution before sputtering. After sputter etching a magnesium peak appears in the spectrum.

Oxygen peaks (fig. 11) are evident on the surfaces exposed to the acid and alkali solutions.

Table II summarizes whether Cl<sub>2p</sub>, Na<sub>1s</sub>, Mg<sub>2p</sub>, or O<sub>1s</sub> peaks appear in the XPS spectra obtained from the magnesium oxide surfaces exposed to the solutions with pH values of 1.0 and 13.5.

In the case of the acid solution, the chemically reacted chloride and sodium films formed as a result of the

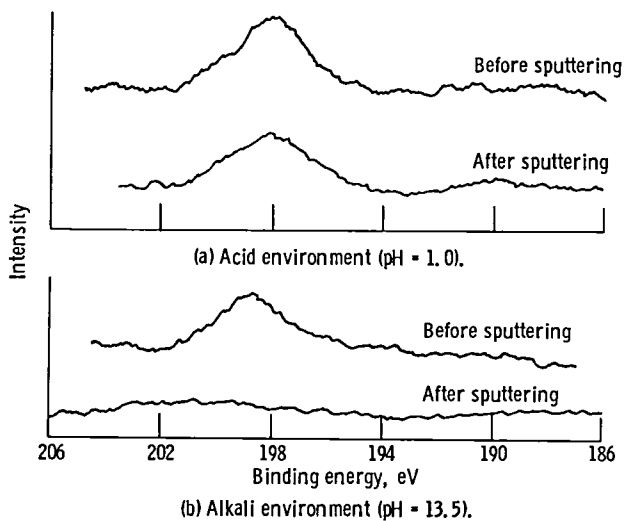

Figure 8. - Representative  $Cl_{2p}$  peaks on magnesium oxide surface cleaved in solutions containing HCl and NaOH.

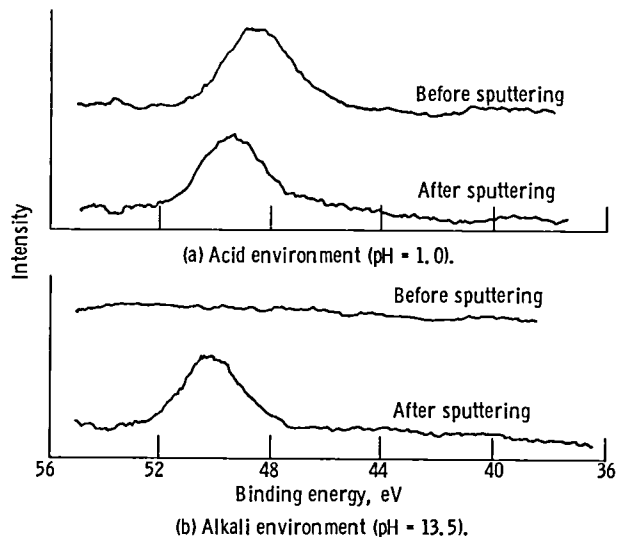

Figure 10. - Representative  $Mg_{2p}$  peaks on magnesium oxide surface cleaved in solutions containing HCl and NaOH.

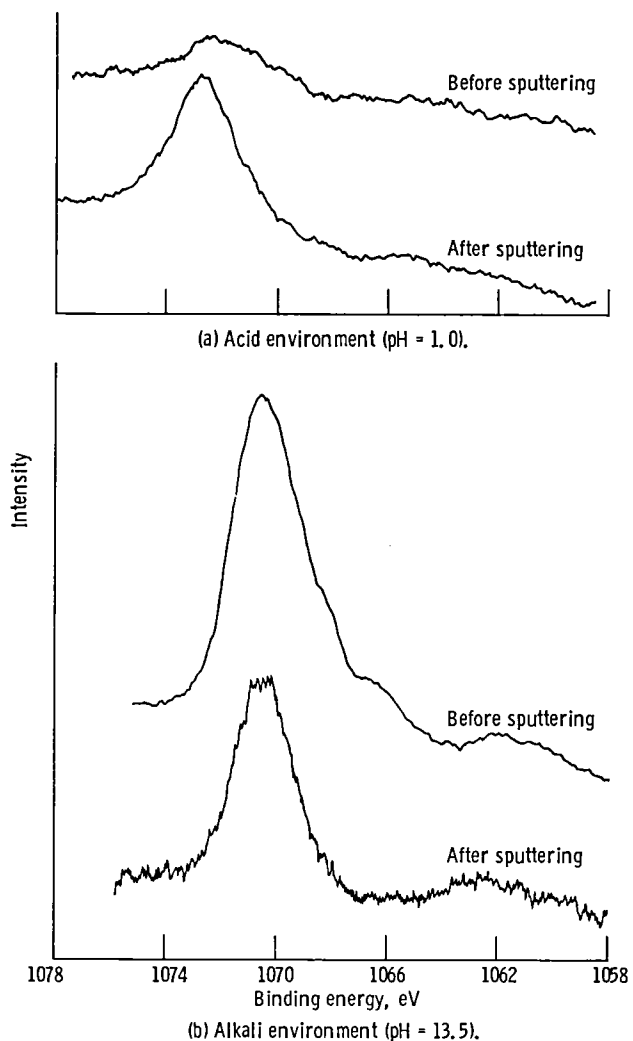

Figure 9. - Representative  $Na_{1s}$  peaks on magnesium oxide surface cleaved in solutions containing HCl and NaOH.

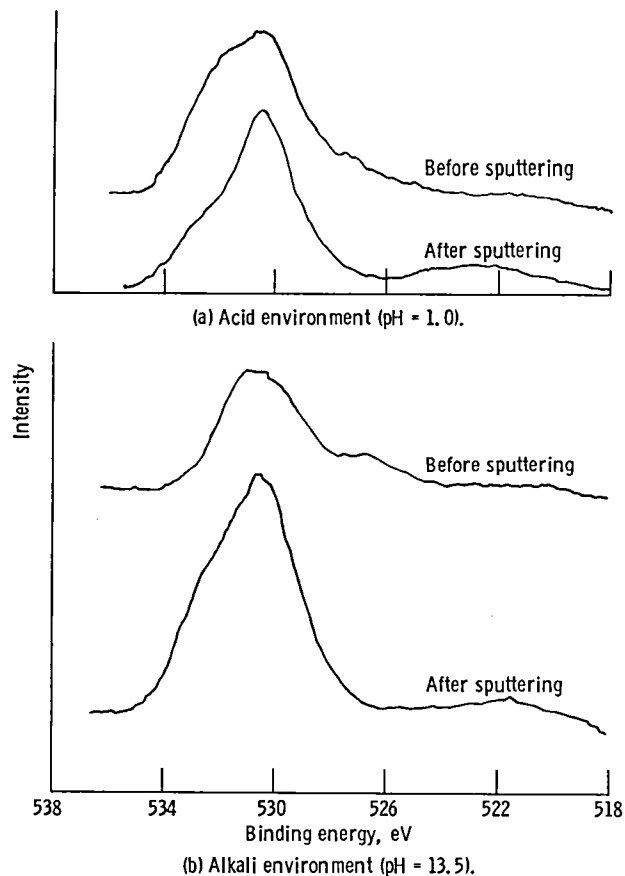

Figure 11. - Representative  $O_{1s}$  peaks on magnesium oxide surface cleaved in solutions containing HCl and NaOH.

TABLE II. - XPS PEAKS ON MAGNESIUM OXIDE SURFACES

## CLEAVED IN SOLUTIONS

XPS peak	Solution containing HCl, pH = 1.0		Solution containing NaOH, pH = 13.5	
	Before sputtering	After sputtering	Before sputtering	After sputtering
Cl <sub>2p</sub> Na <sub>1s</sub> Mg <sub>2p</sub> O <sub>1s</sub>	Yes ↓	Yes ↓	Yes Yes No Yes	No Yes Yes Yes

solution interacting with the magnesium oxide surface. Chlorine chemically reacted with the magnesium to form compounds such as MgCl<sub>2</sub> in the surface layer of magnesium oxide. Even after 30 min of sputtering the reacted films containing chloride and sodium peaks were not removed from the surface exposed to the solution with a pH of 1.0.

The magnesium oxide surface cleaved in the alkali solution was covered with chloride and sodium films. The chloride films, however, were completely removed from the surface, and the sodium films were partially removed from the surface, by argon ion sputtering. The chloride films in the surface layer of magnesium oxide exposed to the acid solution (HCl) may play a role in softening the magnesium oxide surface, as indicated in figure 4. That is, the lowest hardness obtained from the surface exposed to the HCl-containing solution with a pH of 1.0 indicated in figure 4 may be due to the formation of the thick chemically reacted films, particularly chlorine films in the surface layer of magnesium oxide.

The sodium films formed on the surface exposed to the alkaline solution (NaOH) with a pH of 13.5 do not play a role in softening the magnesium oxide surface, as indicated in figure 4.

## Conclusions

From XPS analyses and hardness measurements conducted with single-crystal magnesium oxide {001} surfaces exposed to corrosive solutions, the following conclusions were drawn:

1. Chloride (such as MgCl<sub>2</sub>) and sodium films are formed on the magnesium oxide surface as a result of an HCl-containing solution interacting with a cleaved magnesium oxide surface. The chloride films soften the magnesium oxide surface.

2. The pH value of acid solutions containing chlorine strongly influences microhardness. The smaller the pH value, the lower the microhardness.

3. Sodium films are formed on the magnesium oxide surface as a result of an NaOH-containing solution interacting with a cleaved magnesium oxide surface. The sodium films do not soften the magnesium oxide surface.

Lewis Research Center  
National Aeronautics and Space Administration  
Cleveland, Ohio, January 29, 1982

## References

- Joffe, A. F.: *The Physics of Crystals*. L. B. Loeb, ed., McGraw-Hill Book Co., Inc., 1928.
- Roscoe, R.: *The Plastic Deformation of Cadmium Single Crystals*. *Phil. Mag.*, vol. 21, 1936, pp. 399-406.
- Harper, S.; and Cottrell, A. H.: *Surface Effects and the Plasticity of Zinc Crystals*. *Proc. Phys. Soc.*, ser. B, vol. 63, pt. 5, May 1950, pp. 331-338.
- Rehbinder, P. A.; and Shchukin, E. D.: *Surface Phenomena in Solids During Deformation and Fracture Processes*. *Progress in Surface Science*, Vol. 3, Part 2, S. G. Davison, ed., Pergamon Press, Inc., 1973, pp. 97-188.
- Macmillan, N. H.; Huntington, R. D.; and Westwood, A. R. C.: *Relationship Between Zeta-Potential and Dislocation Mobility*. *Phil. Mag.*, vol. 28, no. 4, Oct. 1973, pp. 923-931.
- Macmillan, N. H.; and Westwood, A. R. C.: *Surface Charge-Dependent Mechanical Behavior of Non-metals*. *Surfaces and Interfaces of Glass and Ceramics*, V. D. Frechette, ed., Plenum Press, 1974, pp. 493-513.
- Westbrook, H. J.; and Jorgensen, P. J.: *Indentation Creep of Solids*. *Trans. Am. Inst. Min. Metall. Pet. Eng.*, vol. 233, no. 2, Feb. 1965, pp. 425-428.
- Westbrook, J. H.; and Jorgensen, P. J.: *Effects of Adsorbed Water on Indentation Hardness Anisotropy in Crystals*, *Anisotropy in Single-Crystal Refractory Compounds*, Vol. 2, F. W. Vahldiek, and S. A. Mersol, eds., Plenum Press, 1968, pp. 353-360.
- Buckley, D. H.: *Effect of Surface Active Media on Friction, Deformation, and Fracture of Calcium Fluoride*. NASA TN D-5580, 1969.
- Buckley, D. H.: *Effect of Surface Films on Deformation on Zinc Single-Crystal Surface During Sliding*. *Am. Soc. Lubr. Eng., Trans.*, vol. 15, no. 2, 1972, p. 96.
- Ciftan, M.; and Saibel, E.: *Rehbinder Effect and Wear*. *Wear of Materials*, 1979, K. C. Ludema, et al., eds., Am. Soc. Mech. Eng., 1979, pp. 659-664.

12. Ciftan, M.; and Saibel, E.: The Effect of Zeta Potential on Pitting. *Wear of Materials*, 1979, K. C. Ludema, et al., eds., Amer. Soc. Mech. Eng., 1979, pp. 653-658.
13. Wiederhorn, S. M.; and Roberts, D. E.: Influence of Normal Alcohols on the Abrasive Wear of Glass. *Wear*, vol. 32, no. 1, 1975, pp. 51-72.
14. Macmillan, N. H.; Huntington, R. D.; and Westwood, A. R. C.: Chemomechanical Control of Sliding Friction Behaviour in Non-metals. *J. Mater. Sci.*, vol. 9, no. 5, May 1974, p. 697-706.
15. Ishigaki, H.; and Buckley, D. H.: Effects of Environment on Microhardness of Magnesium Oxide. NASA TP-2002, 1982.
16. Miyoshi, K.; Ishigaki, H.; and Buckley, D. H.: Influence of Mineral Oil and Additives on Microhardness and Surface Chemistry of Magnesium Oxide {001} Surface. NASA TP-1986, 1982.
17. Dufrane, K. F.; and Glaeser, W. A.: Study of Rolling-Contact Phenomena in Magnesium Oxide. NASA CR-72295, 1967.
18. Wells, A. F.: *Structural Inorganic Chemistry*, Third ed., Oxford University Press, 1962.
19. Wagner, C. D.; et al.: *Handbook of X-Ray Photoelectron Spectroscopy*, G. E. Muilenberg, ed., Perkin-Elmer Corp., 1978.
20. Johnson, N. L.; and Leone, F. C.: *Statistics and Experimental Design in Engineering and Physical Science*. Vol. I. John Wiley & Sons, Inc., 1964, pp. 187-227.



1. Report No. NASA TP-2040	2. Government Accession No.	3. Recipient's Catalog No.	
4. Title and Subtitle <b>INFLUENCE OF CORROSIVE SOLUTIONS ON MICROHARDNESS AND CHEMISTRY OF MAGNESIUM OXIDE {001} SURFACES</b>		5. Report Date August 1982	6. Performing Organization Code 506-53-12
		8. Performing Organization Report No. E-1035	
7. Author(s) Hiroyuki Ishigaki, Kazuhisa Miyoshi, and Donald H. Buckley		10. Work Unit No.	
9. Performing Organization Name and Address National Aeronautics and Space Administration Lewis Research Center Cleveland, Ohio 44135		11. Contract or Grant No.	
		13. Type of Report and Period Covered Technical Paper	
12. Sponsoring Agency Name and Address National Aeronautics and Space Administration Washington, D. C. 20546		14. Sponsoring Agency Code	
		15. Supplementary Notes Hiroyuki Ishigaki, Univ. of Osaka Prefecture, Osaka, Japan, and National Research Council - NASA Research Associate; Kazuhisa Miyoshi and Donald H. Buckley, Lewis Research Center.	
16. Abstract X-ray photoelectron spectroscopy analyses and hardness experiments were conducted on cleaved magnesium oxide {001} surfaces. The magnesium oxide bulk crystals were cleaved to specimen size along the {001} surface, and indentations were made on the cleaved surface in corrosive solutions containing HCl, NaOH, or HNO <sub>3</sub> and in water without exposing the specimen to any other environment. The results indicated that chloride (such as MgCl <sub>2</sub> ) and sodium films are formed on the magnesium oxide surface as a result of interactions between an HCl-containing solution and a cleaved magnesium oxide surface. The chloride films soften the magnesium oxide surface. In this case microhardness is strongly influenced by the pH value of the solution. The lower the pH, the lower the microhardness. Sodium films, which are formed on the magnesium oxide surface exposed to an NaOH-containing solution, do not soften the magnesium oxide surface.			
17. Key Words (Suggested by Author(s)) XPS Microhardness Magnesium oxide Corrosion		18. Distribution Statement Unclassified - unlimited STAR Category 37	
19. Security Classif. (of this report) Unclassified	20. Security Classif. (of this page) Unclassified	21. No. of Pages 10	22. Price* A02

\* For sale by the National Technical Information Service, Springfield, Virginia 22161

NASA-Langley, 1982

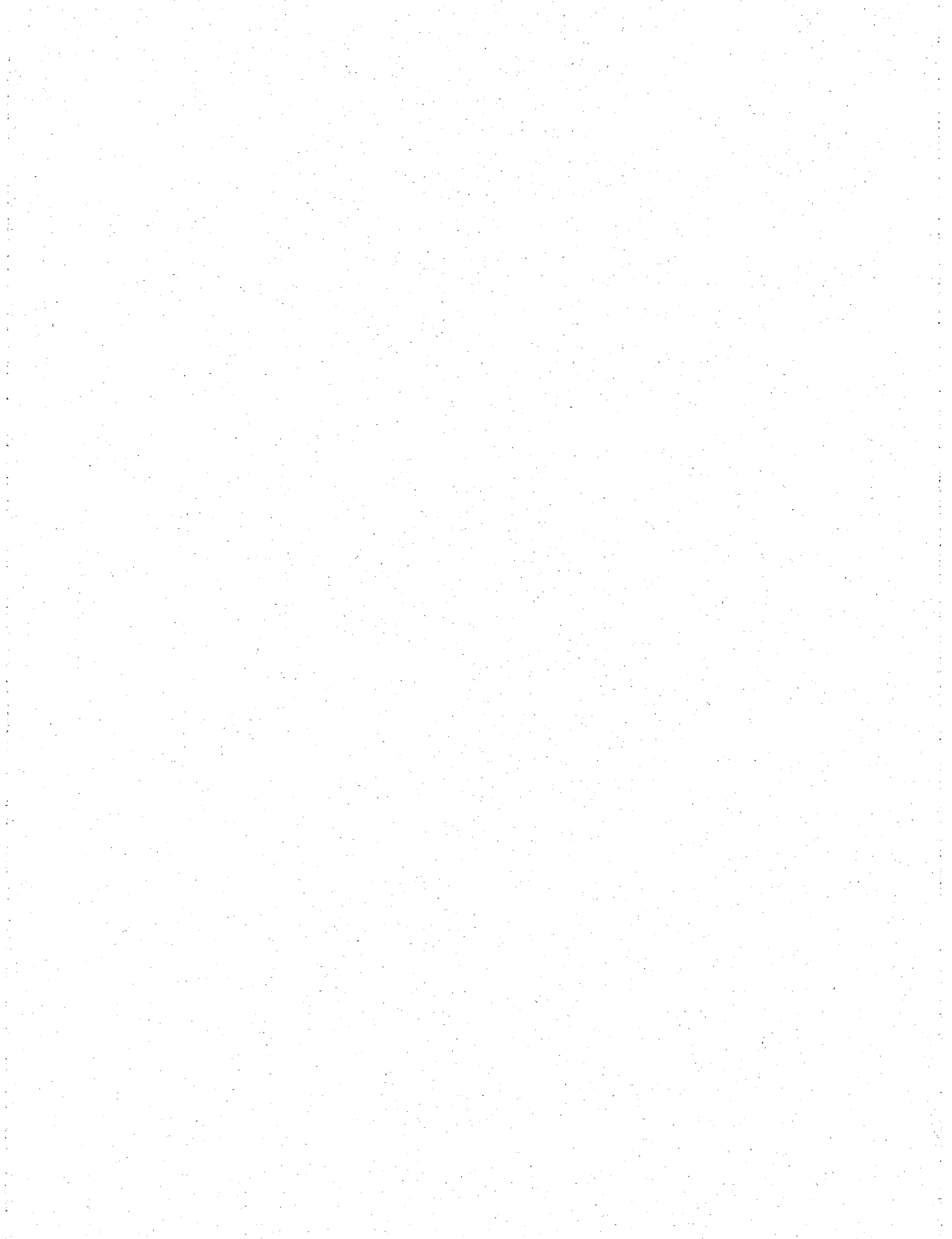

National Aeronautics and  
Space Administration

Washington, D.C.  
20546

Official Business  
Penalty for Private Use, \$300

SPECIAL FOURTH CLASS MAIL  
BOOK

Postage and Fees Paid  
National Aeronautics and  
Space Administration  
NASA-451



**NASA**

POSTMASTER: If Undeliverable (Section 158  
Postal Manual) Do Not Return

---