

PROVISIONS FOR NONINTRUSIVE FLOW-EVALUATION
TOOLS IN THE NATIONAL TRANSONIC FACILITY

Dennis E. Fuller
NASA Langley Research Center
Hampton, Virginia

NATIONAL TRANSONIC FACILITY - GENERAL DESCRIPTION

The National Transonic Facility (refs. 1 to 4) is a fan-driven, closed-circuit, continuous-flow, pressurized wind tunnel (fig. 1). The test section is 2.500 m x 2.500 m and 7.620 m long with a slotted-wall configuration. There are six slots each in the top and bottom walls and two slots per sidewall.

In order to maintain good flow quality and aerodynamic efficiency over the wide range of test capabilities the test-section geometry is variable. The position of the test-section top and bottom walls, the reentry flaps at the rear of the test-section slots, and the step height for reentering slot flow are remotely controlled.

The test gas may be dry air or nitrogen. For the elevated-temperature (340 K) mode of operation the test medium is normally air, and heat removal is by means of a water-cooled heat exchanger (cooling coil) located at the upstream end of the settling chamber. For the cryogenic mode of operation, heat removal is by means of evaporation of liquid nitrogen, which is sprayed into the circuit upstream of the fan. By utilizing liquid nitrogen as a coolant, the tunnel test-temperature range is variable from 340 to 78 K. When nitrogen is injected into the circuit, venting must occur to maintain a constant pressure. Thermal insulation is installed internal to the pressure shell to minimize energy consumption.

The pressure range for the National Transonic Facility is from 1 to 9 bar. The Reynolds number range (based on $\bar{c} = .25M$) is up to 120×10^6 at Mach = 1.0. The Mach number range is from .2 to 1.2.

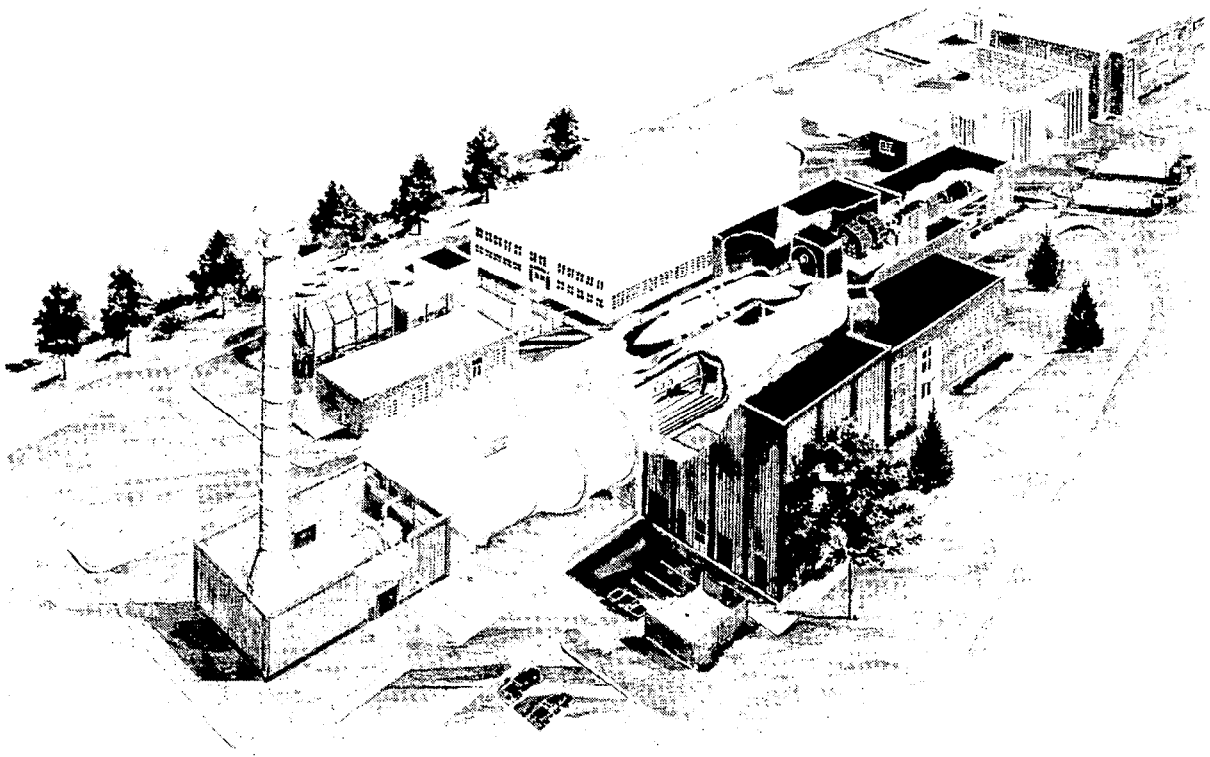

Figure 1

TEST PLENUM ISOLATION SYSTEM

To facilitate model access during a test series, with a minimum loss of nitrogen (energy) and time, gate valves upstream and downstream of the test section are provided which isolate the plenum (fig. 2). When the plenum is isolated it will be vented to the atmosphere and thermally conditioned to provide a work environment. This configuration provides personnel access to the plenum and any attendant instrumentation which may be mounted around the test section in either the floor, ceiling, or sidewalls.

Conditioning of the plenum area for access is estimated to take up to four hours, the time depending on the tunnel operational temperature. Approximately the same amount of time will be required to recondition the plenum to test conditions.

The relatively slow warmup/cooldown times of the plenum result from the structural components inside which must undergo large temperature swings without being subjected to excessive thermal gradients.

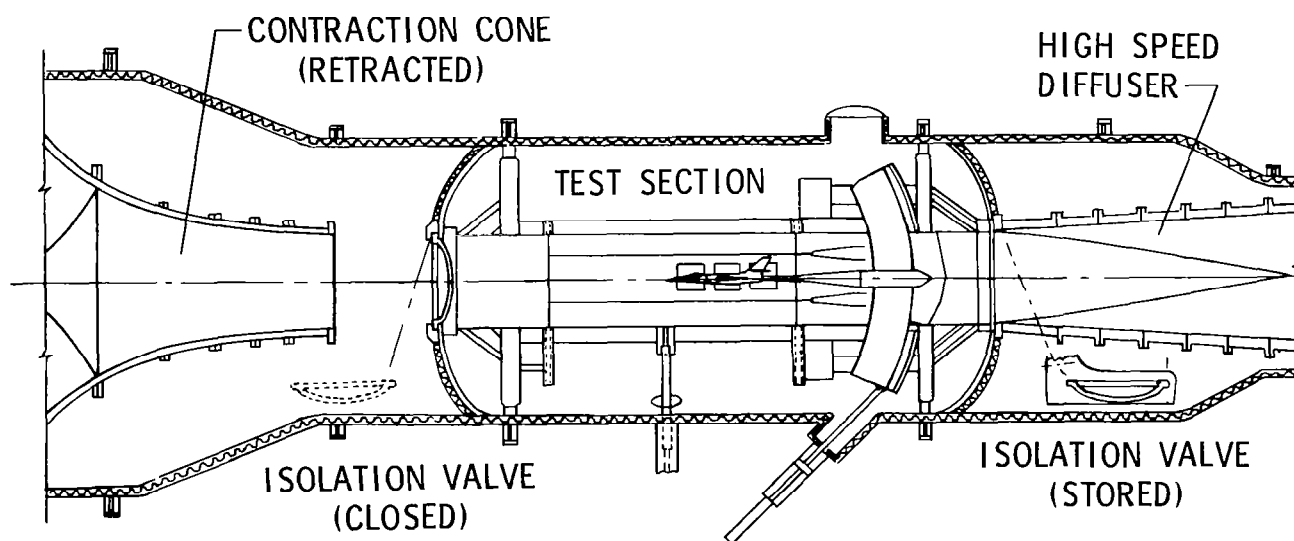

Figure 2

MODEL ACCESS SYSTEM

In addition to the plenum access mode shown in Figure 2, the test model, mounted in the test section, may be accessed by using two 7 X 10 ft access tubes (fig. 3). These tubes are inserted from either side of the plenum and close around the model to form a thermally insulated enclosure. This enclosure provides for personnel entry while the plenum is cold and circuit pressure is maintained behind the gate valves. Model access using the tubes is estimated to take about 45 minutes with another 45 minutes required to return the test section to the testing configuration.

The plenum and its associated instrumentation cannot be serviced during this mode of access.

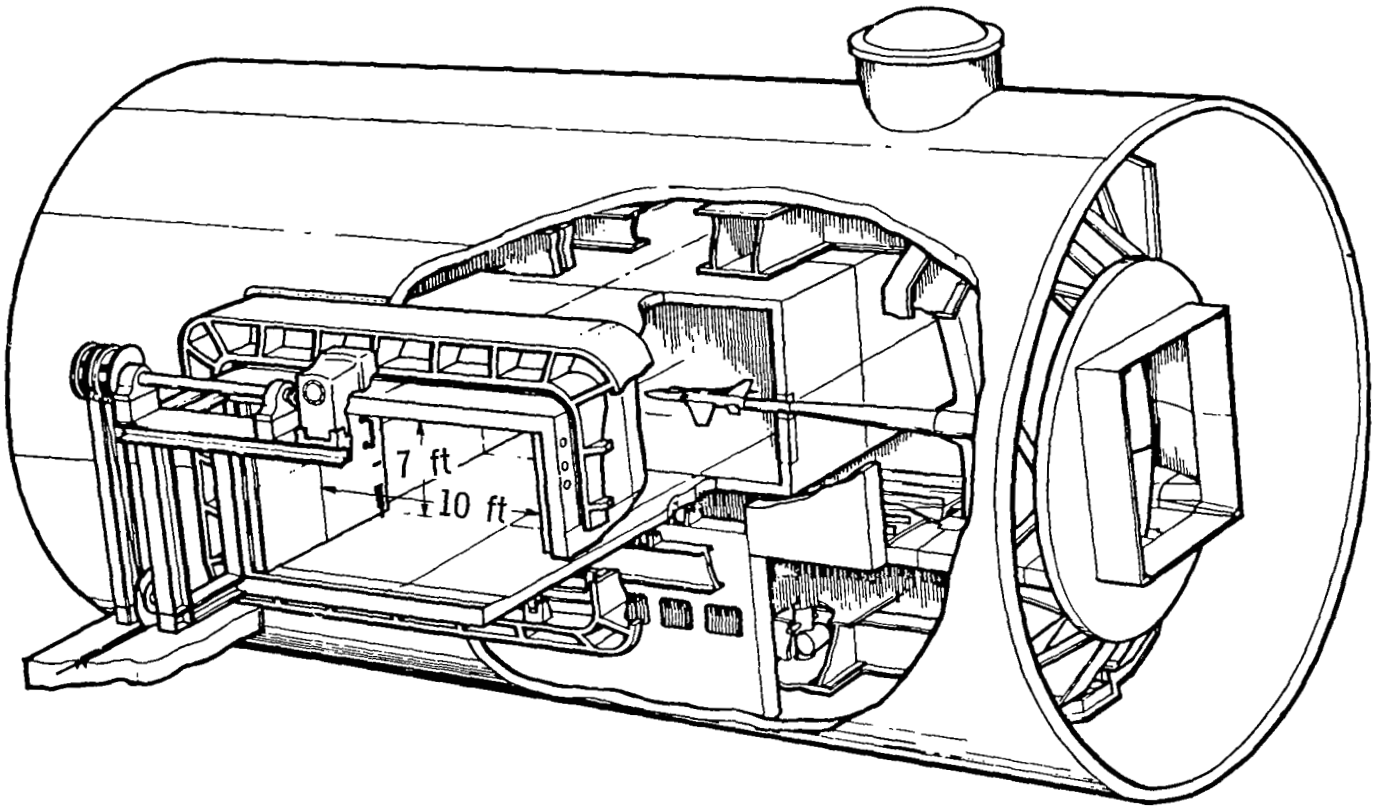

Figure 3

SECTION VIEW OF MODEL ACCESS SYSTEM

Figure 4 shows a section through the plenum/test section area with one model access tube inserted and one extracted. Viewing and lighting ports are located adjacent to the flow stream in the hollow beams located in the test section floor and ceiling. Space for instrumentation to be located inside the floor and ceiling beams is somewhat limited. The nominal dimensions inside the beams are 5 1/2 in. wide by 30 in. deep.

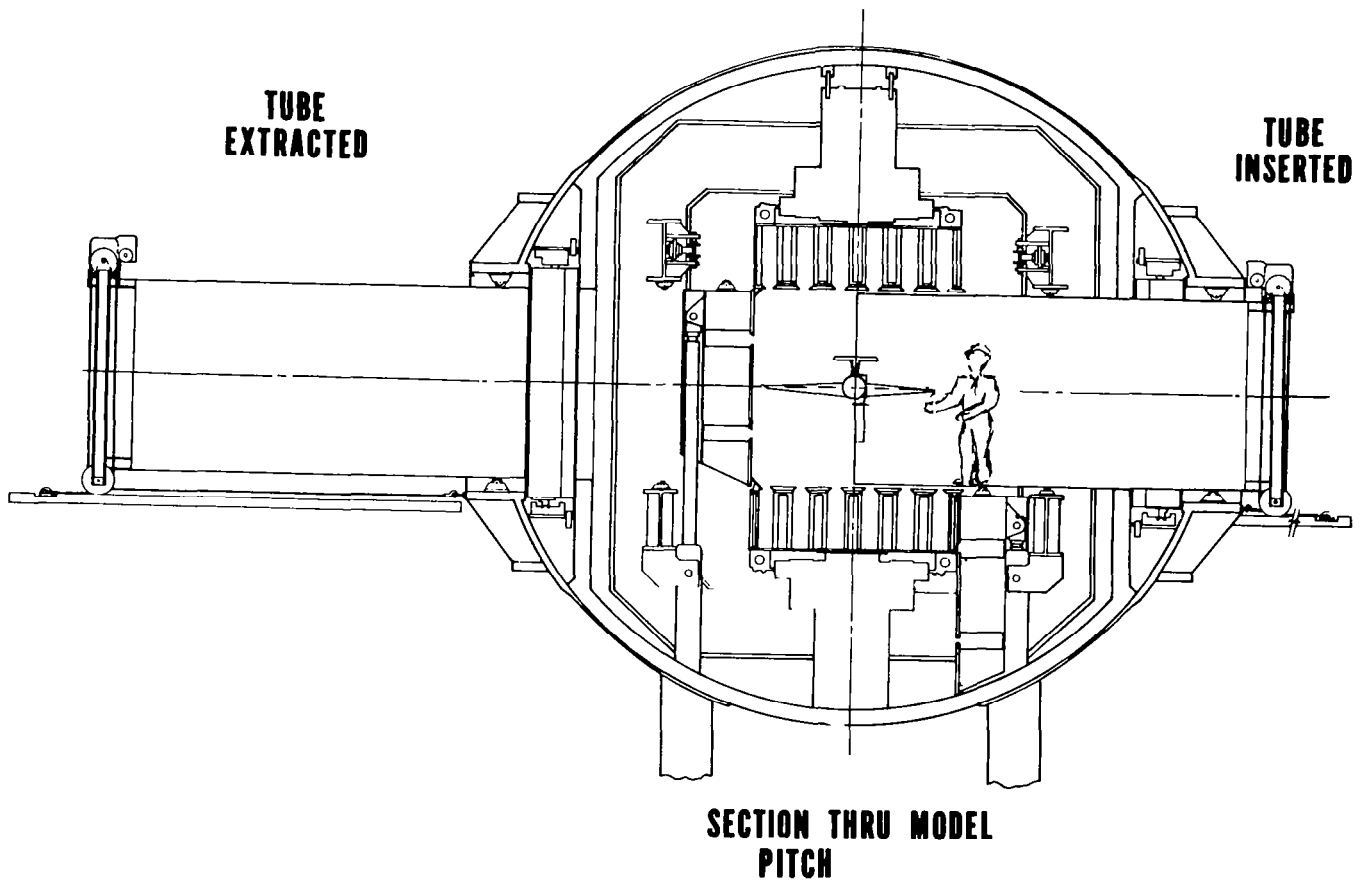

Figure 4

VIEWING PORTS FOR SIDEWALL DOORS

Viewing ports are also provided in the test section sidewall doors as shown in Figure 5. Each door has provision for three 24 X 30 in. windows (cross-hatched area). The length (or depth) of the instrumentation package that might use these windows is limited to 32 in. (see end view in fig. 5). Anything longer will not clear plenum structure when the door is lowered for plenum access. The window openings currently are filled with metal blanks which are fitted with smaller viewing/lighting ports.

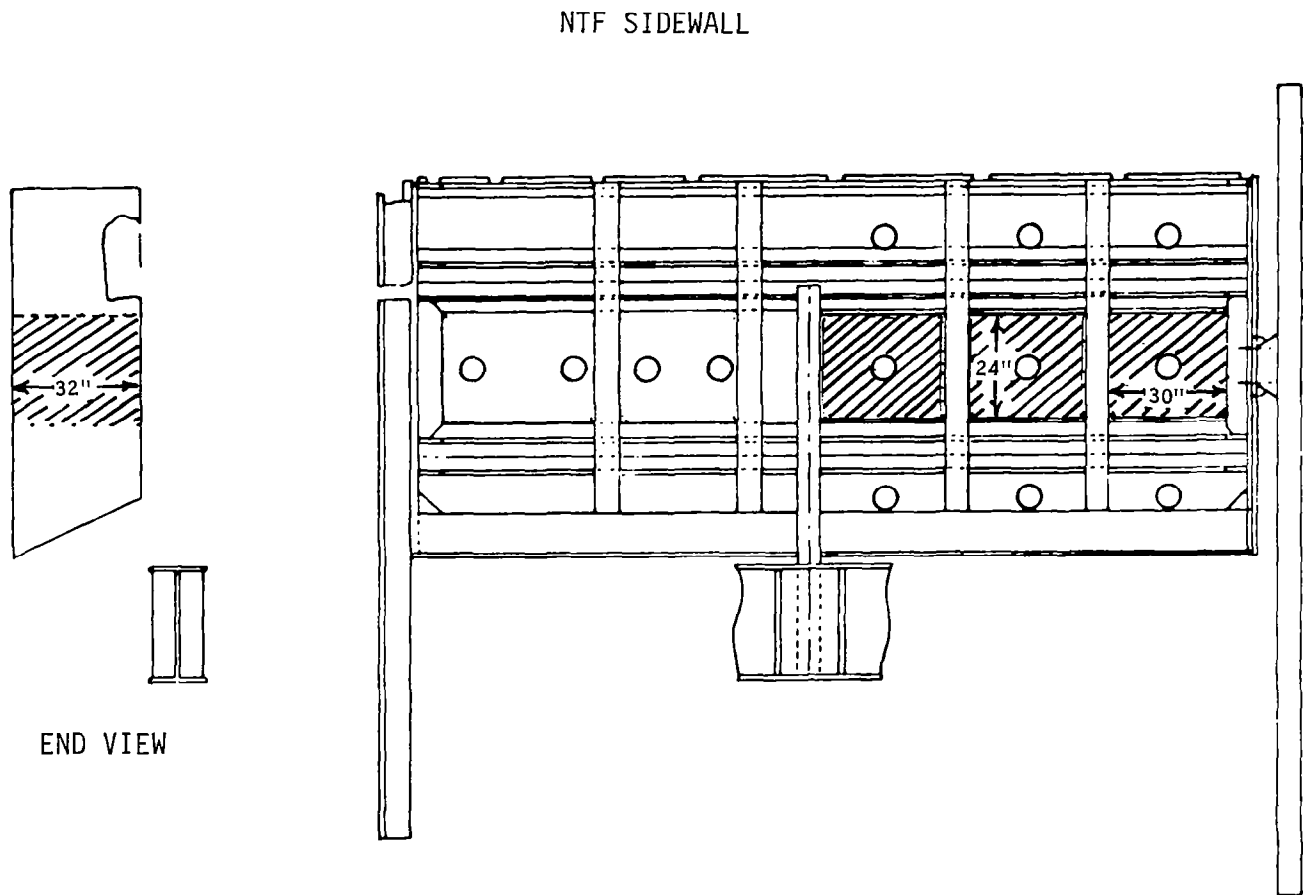

Figure 5

OVERALL WINDOW CAPABILITIES

The overall window capabilities for the NTF are illustrated in Figure 6 which is a folded-out view of the test section. There are a total of 56 openings around the test section that may be used for viewing or lighting. This includes the large sidewall window blanks which are currently fitted with smaller viewing/lighting ports.

LOOKING DOWNSTREAM

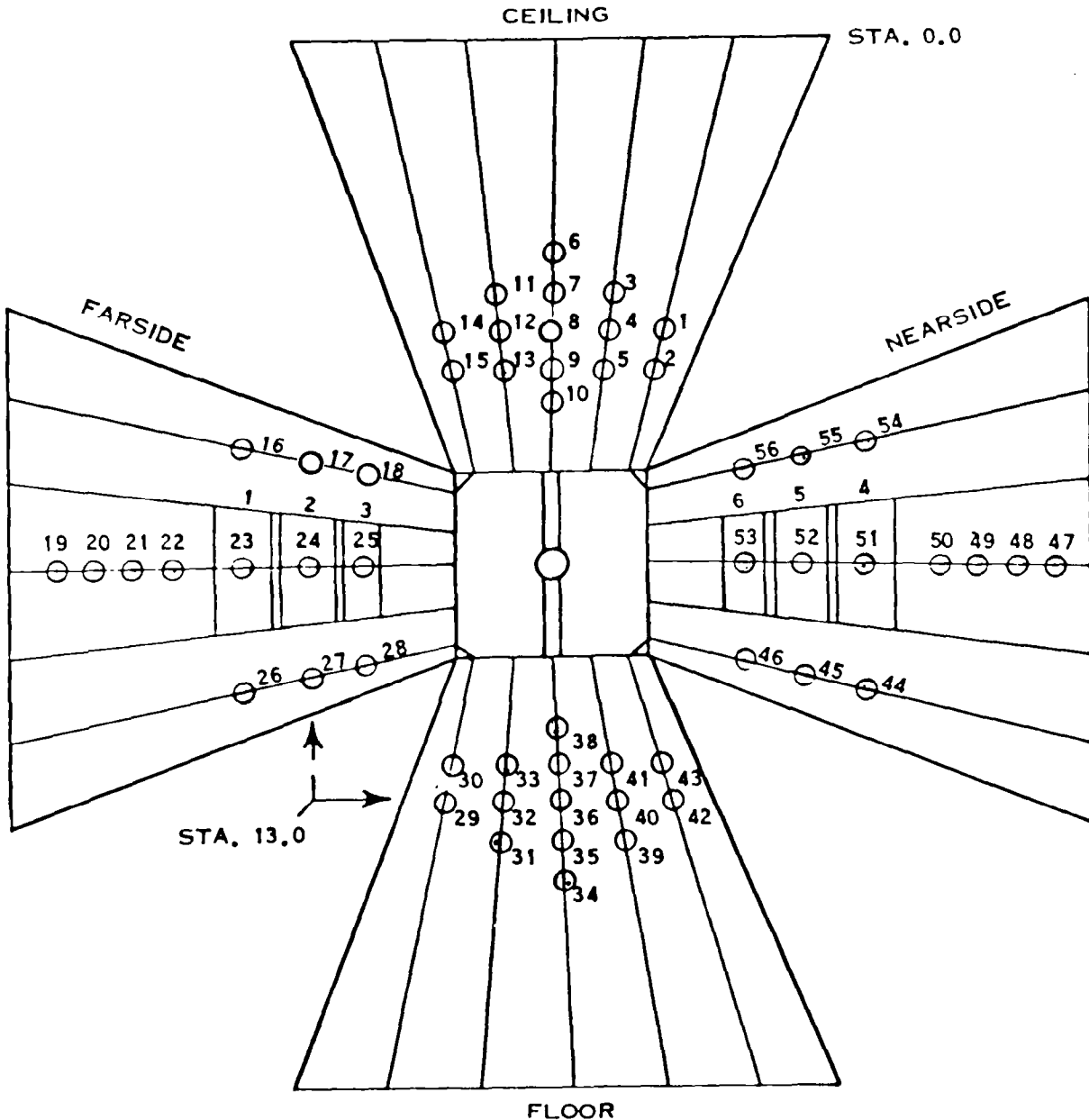

Figure 6

REFERENCES

1. McKinney, Linwood W.; and Howell, Robert R.: The Characteristics of the Planned National Transonic Facility. Proceedings - AIAA 9th Aerodynamic Testing Conference, June 1976, pp. 176-184.
2. Howell, Robert R.; and McKinney, Linwood W.: The U.S. 2.5-Meter Cryogenic High Reynolds Number Tunnel. ICAS Paper No. 76-04, Oct. 1976.
3. Nicks, Oran W.; and McKinney, Linwood W.: Status and Operational Characteristics of the National Transonic Facility. AIAA Paper 78-770, Apr. 1978.
4. Howell, Robert R.: The National Transonic Facility: Status and Operational Planning. A Collection of Technical Papers - AIAA 11th Aerodynamic Testing Conference, Mar. 1980, pp. 1-9. (Available as AIAA-80-0415.)