

**NASA  
Technical  
Paper  
2065**

NASA-TP-2065 19820025545

September 1982

# Illumination From Space With Orbiting Solar-Reflector Spacecraft

John E. Canady, Jr.,  
and John L. Allen, Jr.

**LIBRARY COPY**

SEP 17 1982

LANGLEY RESEARCH CENTER  
LIBRARY, NASA  
HAMPTON, VIRGINIA

**NASA**

3 1176 01315 6113

**NASA  
Technical  
Paper  
2065**

1982

# Illumination From Space With Orbiting Solar-Reflector Spacecraft

John E. Canady, Jr.,  
and John L. Allen, Jr.  
*Langley Research Center  
Hampton, Virginia*

**NASA**

National Aeronautics  
and Space Administration

Scientific and Technical  
Information Branch



## CONTENTS

SUMMARY .....	1
INTRODUCTION .....	2
BASIC PRINCIPLES .....	3
Basic Concept .....	3
Mirror Optics .....	3
Relationship of Image Size to Orbit Altitude .....	7
APPLICATIONS AND MISSIONS .....	7
Full-Time Illumination of Large Urban Areas .....	8
Part-Time Illumination of Large Urban Areas .....	8
Illumination of Space Shuttle In-Orbit Nighttime Operations .....	10
Illumination of Emergency Operations .....	11
Illumination of Farming Operations .....	12
Illumination of Ranches and Dairy Farms .....	12
Enhancement of Photosynthesis .....	12
Other Applications .....	13
MISSION DEFINITION AND DESIGN .....	13
Light-Intensity Requirements .....	13
Loss Factors .....	14
Relationship of Light Intensity to Altitude .....	18
Mission Analysis .....	19
ORBIT SELECTION .....	22
Low Earth Orbits .....	22
Sun-Synchronous Orbits .....	22
High Earth Orbits (Posigrade) .....	23
ORBIT TRANSFER AND STATION KEEPING .....	24
Insertion-Orbit Selection .....	25
Orbital Transfer Through Solar Sailing .....	26
Orbit Station Keeping .....	28
TRACKING AND ATTITUDE-CONTROL REQUIREMENTS .....	29
Tracking Over Ground Site .....	29
Reorientation Between Sites .....	30
Solar Sailing .....	31
Gravity-Gradient Forces .....	31
Combined Worst-Case Design Conditions .....	32
REFLECTOR SPACECRAFT DESIGN CONCEPTS .....	32
Baseline Reflector Spacecraft Concept .....	33
Attitude Control .....	34
Spacecraft Loads .....	35
Spacecraft Mass .....	35
COST ANALYSIS FOR ILLUMINATION OF URBAN AREAS ACROSS COUNTRY .....	36

ENVIRONMENTAL, ECOLOGICAL, AND SOCIETAL IMPACT .....	37
Environmental Impact .....	37
Ecological Impact .....	38
Societal Impact .....	39
Concluding Observations .....	40
PROGRAM REQUIREMENTS .....	40
Study Requirements .....	40
Technology-Development Requirements .....	42
Flight Test .....	45
CONCLUDING REMARKS .....	46
REFERENCES .....	47
SYMBOLS AND ABBREVIATIONS .....	49
Symbols .....	49
Abbreviations .....	50
TABLES .....	52
FIGURES .....	58

## SUMMARY

Studies performed at the Langley Research Center (LaRC) have identified several potentially beneficial applications of illumination from space that can be accomplished with two to forty 1-km solar-reflector spacecraft. Nighttime Space Shuttle operations can be illuminated to 11 lux (77 full Moons) with a light beam 100 m in diameter with 2 solar reflectors in 6-hour orbits. A constellation of 16 solar reflectors in geosynchronous Earth orbit (GEO) can illuminate to 8 lux (56 full Moons) an area approximately 333 km in diameter. This capability could enable the illumination of heavily populated industrialized areas such as the Northeastern United States all night long. In an alternate mode of operation, the same constellation of reflectors could illuminate 4 or 5 large urban areas across the country for approximately 2 hours each during the rush hour times of day when it is most needed. Other illumination scenarios include extending daylight hours in Alaska during winter and illuminating the poorly lighted Panama Canal on a routine daily basis or during emergencies. When required, a few reflectors from the constellation could be temporarily diverted for illuminating emergency situations such as floods, earthquakes, evacuation of communities threatened by nuclear attack or nuclear power plant failure, and farming operations threatened by bad weather. A possible futuristic use of orbiting solar reflectors that could be extremely important to the world food supply is to provide extra hours of illumination to the higher latitudes to stimulate plant growth through added photosynthesis and, thereby, increase the yield of single-season crops or enable the planting and harvesting of additional crops per season.

In companion studies performed by the Astro Research Corp., under contract to LaRC, a deployable (unfurlable), 1-km-diameter solar-reflector spacecraft with a mass of approximately 11 000 kg was designed. Initial studies indicate that it is feasible to package this spacecraft in the Space Shuttle, transport it to low Earth orbit where it will automatically unfurl, and solar sail it to a number of operational orbits up to and including GEO. It will take about 10 months to solar sail the spacecraft to GEO. Alternate orbit-transfer techniques would probably double the cost of the launch system, which would have a major impact on the economic feasibility of illumination-from-space missions. A 15-year lifetime, limited by battery life, has been assigned to solar-reflector spacecraft.

Improvements in several technical areas will enable more practical and economical missions. Probably the most important area of improvement is the development of the deployable, lightweight, 1-km hoop-column spacecraft structure. Almost of equal importance is the development of ultrathin, tear-resistant, highly reflective, wrinkle-free, planar membranes.

A preliminary cost-benefits analysis (using 1981 dollar values) was performed to gain some indication of the commercial potential for illumination-from-space applications. It was found that a constellation of 18 solar reflectors (includes 2 spares) in GEO can provide approximately 2 hours of illumination at a level of 8 lux during mornings and evenings to 5 large urban areas across the United States for a total cost of \$1.44 billion. Based on the savings in electricity alone in the areas served, the space system will pay for itself in 4.5 years. Since the system has a design lifetime of 15 years, there will be 10.5 years of profit which amounts to \$2.85 billion.

## INTRODUCTION

The use of orbiting mirrors to reflect sunlight to Earth for a multitude of interesting applications was originally described in 1929 by the German space pioneer Hermann Oberth in his book entitled "Ways to Spaceflight" (ref. 1). These applications included the illumination of cities, melting of frozen waterways, and modifications to the weather and climate. Professor Oberth was not content with just proposing the idea; he also went into considerable detail to support it mathematically and to show how it could be implemented. For his ideas on space lighting, he described and analyzed the launch system, the reflector spacecraft, the orbits, and an electrically propelled (ion) orbit-transfer vehicle. However, Oberth was so far ahead of his time that the technology was not available in 1929 to implement his advanced concepts.

The next thorough treatment of orbiting solar reflectors was presented about 38 years later by A. G. Buckingham. Buckingham's early efforts were primarily concerned with illumination from space for both civil and military applications. Much of the work was released in 1967 and 1968 in papers written by Buckingham and H. M. Watson (refs. 2 to 4). During this time period, solar reflectors were studied for use in the war in Vietnam by several companies. The technology existed for fabricating and launching the reflector sizes under consideration (approximately 250 ft in diameter), but even with the advocacy of NASA and the Air Force the project was cancelled, primarily because of an anticipated early end of the war.

Perhaps the most comprehensive treatment of orbiting solar reflectors, their missions, and applications has been by Krafft A. Ehricke, a renowned engineer responsible for many of this country's space age developments. Dr. Ehricke published papers on "space light" from 1970 to the present (refs. 5 to 9). His studies cover the broad spectrum of potential applications including illumination, increased plant yield by enhancing photosynthesis, electric power generation, and climate control.

The most intensive studies of solar reflectors for the production of electrical energy were conducted by Kenneth W. Billman and associates at the NASA Ames Research Center from 1976 to 1979, in a study program designated SOLARES. The results of these studies indicated that the SOLARES baseline concept, which used 80 000 1-km orbiting reflectors, could generate 220 GW of electricity, which is the equivalent of today's production of electricity in the United States. These studies were terminated in 1979 and the Ames Research Center is no longer working in this area. An artist's conception of the SOLARES reflector spacecraft is shown in figure 1(a). The SOLARES spacecraft is the predecessor of the spacecraft derived in the studies reported herein. The results of the Ames studies are published in references 10 to 13.

As a result of a proposal submitted to management, studies were conducted at the Langley Research Center (LaRC) from 1977 to 1981 to better define solar-reflector applications pertinent mainly to energy production and illumination from space. Mission definition and design studies of solar-reflector spacecraft were also performed. This paper presents the findings of these studies, but it is limited to only those concerning illumination from space. This work appears to differ somewhat from that of Dr. Ehricke. His concept mainly considered using many relatively small (16 to 360 m) solar reflectors for illuminating cities, whereas our efforts were directed primarily at using a constellation of a few 1-km-diameter reflectors in 12- or 24-hour Earth orbits to illuminate large urban areas, some containing several cities.



Each of these concepts has its own advantages and disadvantages, and tradeoff studies are required to make the proper choices after the particular application has been better defined and specified.

The approach to the illumination-from-space missions taken in these studies and reported herein was as follows:

1. Establish analytical techniques
2. Define applications and mission scenarios
3. Establish mission requirements
4. Perform mission analyses
5. Develop spacecraft design concepts
6. Identify potential problems
7. Identify future studies and technology development requirements

Use of trade names or names of manufacturers in this report does not constitute an official endorsement of such products or manufacturers, either expressed or implied, by the National Aeronautics and Space Administration.

## BASIC PRINCIPLES

This section describes the basic concept of using orbiting mirrors to reflect solar radiation to Earth and gives the derivation of the equations related to mirror optics.

### Basic Concept

The basic concept for illumination from space is shown in figure 1(b). In this figure, the viewer is looking down on the Earth's North Pole at mirrors (reflectors) in an equatorial orbit. The Sun's rays are emanating from the left and the Earth's shadow is shown to the right. Note that the mirror on the left, near  $270^\circ$ , is almost edgewise to the Sun's rays and is relatively ineffective. Also, this mirror reflects sunlight to areas already illuminated by the Sun. As the mirror approaches  $0^\circ$  on the diagram, it becomes more effective and can start illuminating sites near the terminator in the Earth's shadow. At  $45^\circ$  the mirror is very effective, and it becomes even more so just prior to entering the Earth's shadow when its surface is almost normal to the Sun's rays. At approximately  $80^\circ$ , occultation occurs and the mirror is no longer useful until it leaves the Earth's shadow. By placing multiple mirrors in orbit, it is possible to continuously illuminate a site.

### Mirror Optics

Figure 2 shows the basic geometry of the Sun/mirror/ground-spot system. Note that  $\alpha$  is the total included angle from the Earth (or Earth orbits) of the Sun and that  $d$  is the slant range from the ground spot to the mirror. (A list of symbols and abbreviations used in this paper appears after the references.) As indicated in

figures 2 and 3, the mirror image is an ellipse with semimajor axis  $a$  and semiminor axis  $b$ . Based on these dimensions and realizing that the mirror size is very small compared with  $d$ , the semiminor axis of the ground-spot ellipse is

$$b = d \tan(\alpha/2)$$

or

$$b = d(\alpha/2) \tag{1}$$

where  $\alpha$ , a very small angle, is expressed in radians. Note that  $b$  is not affected by  $\gamma$ , the angle of incidence of the central solar rays. Also note (figs. 2 and 3) that the semimajor axis  $a$  lies in the same direction as the mirror azimuth and is affected by the slant range and the related elevation angle  $\theta$  as shown in insert A of figure 3. Thus,

$$a = b/\sin \theta \tag{2}$$

when  $\theta = 90^\circ$ , the ellipse becomes a circle of radius  $b = a$ . As  $\theta$  varies from  $90^\circ$ , the circle becomes elongated and this elongation is a function of  $\theta$ .

The area  $A_s$  of the elliptical ground spot is:

$$A_s = \pi ab \tag{3}$$

If we refer again to figure 3 and assume only the loss related to the angle of incidence, the total energy  $E_m$  reflected by the mirror is

$$E_m = I_o A_m \cos \gamma \tag{4}$$

where  $I_o$  is the solar constant,  $A_m$  is the mirror area, and  $\gamma$  is the angle of incidence. To account for all significant losses, the above equation is modified as follows:

$$E_m = \mu \rho \tau \phi I_o A_m \cos \gamma \tag{5}$$

where  $\mu$  is the mirror-surface flatness coefficient,  $\rho$  is the mirror-surface coefficient of reflectivity,  $\tau$  is the atmospheric transmissivity, and  $\phi$  is the cloud-cover coefficient. The normal component of radiant intensity within the ellipse is  $I$ ; therefore, the total energy on the spot  $E_s$  is

$$E_s = I A_s$$

The following equation is derived by substituting the value for  $A_s$  in equation (3) into the above equation:

$$E_s = I\pi ab \quad (6)$$

With the losses in equation (5), the energy  $E_m$  reflected from the mirror is equal to the energy radiated on the ground spot:

$$E_m = E_s$$

or

$$E_m = \mu\tau\phi I_o A_m \cos \gamma = I\pi ab \quad (7)$$

Therefore,

$$I = \frac{\mu\tau\phi I_o A_m \cos \gamma}{\pi ab} \quad (8)$$

Substituting equations (1) and (2) into equation (8) gives

$$I = \frac{\mu\tau\phi I_o A_m \cos \gamma}{\pi(b/\sin \theta) d(\alpha/2)}$$

and, since  $b = d(\alpha/2)$ ,

$$I = \frac{\mu\tau\phi I_o A_m \sin \theta \cos \gamma}{\pi[d(\alpha/2)]^2} \quad (9)$$

This is the general equation for intensity of insolation. It contains factors for all significant losses except for occultation, which should be evaluated on a case-by-case basis. Losses associated with the increased area of the elliptical image, which becomes more elongated with increasing latitudes, are built into equation (9). Loss factors and their numerical values are discussed in a later section.

Figure 4 shows a special case of mirror optics when the mirror is at zenith ( $\theta = 90^\circ$  and  $\gamma = 45^\circ$ ). Therefore,

$$\sin \theta = \sin 90^\circ = 1.000$$

$$\cos \gamma = \cos 45^\circ = 0.707$$

Substituting the above numerical values into equation (9) gives

$$I = \frac{0.707\mu\rho\tau\phi I_{\odot} A_m}{\pi[d(\alpha/2)]^2} \quad (\theta = 90^\circ; \quad \gamma = 45^\circ)$$

If all the loss factors are neglected,

$$I = \frac{0.707I_{\odot} A_m}{\pi[d(\alpha/2)]^2} = \frac{0.707I_{\odot} A_m}{\pi b^2} \quad (\theta = 90^\circ; \quad \gamma = 45^\circ) \quad (10)$$

Since  $\theta$  was set at  $90^\circ$  in the derivation of equation (10), the ellipse becomes a circle and the semiminor axis  $b$  becomes its radius. Therefore, the area of the circular spot is

$$A_s = \pi b^2 \quad (\theta = 90^\circ; \quad \gamma = 45^\circ) \quad (11)$$

Substituting equation (11) into equation (10) gives

$$I = 0.707I_{\odot} \frac{A_m}{A_s} \quad (\theta = 90^\circ; \quad \gamma = 45^\circ) \quad (12)$$

or, in terms of mirror diameter  $D_m$  and spot diameter  $D_s$ ,

$$I = 0.707I_{\odot} \left(\frac{D_m}{D_s}\right)^2 \quad (\theta = 90^\circ; \quad \gamma = 45^\circ) \quad (13)$$

In reference once more to the ideal case of figure 4 where  $\theta = 90^\circ$  and  $\gamma = 45^\circ$ , the spot size is a function of the effective mirror diameter  $D_m \cos \gamma$  and the solar angle  $\alpha$ . Therefore,

$$D_s = D_m \cos \gamma + 2[d \tan(\alpha/2)] \quad (\theta = 90^\circ; \quad \gamma = 45^\circ)$$

or

$$D_s = 2d \tan(\alpha/2) + D_m \cos \gamma \quad (\theta = 90^\circ; \quad \gamma = 45^\circ) \quad (14)$$

When the altitude  $d$  is great compared to the mirror diameter  $D_m$ , which is the usual case for orbiting reflectors, the last term in equation (14) can be neglected. Therefore,

$$D_s = 2d \tan(\alpha/2) \quad (\theta = 90^\circ; \quad \gamma = 45^\circ)$$

The solar half-angle  $\alpha/2$  is approximately  $0^\circ 16'$  and its tangent is 0.00465. Therefore, the image diameter is

$$D_s = 2d(0.00465)$$

or

$$D_s = 0.0093d \quad (\theta = 90^\circ; \quad \gamma = 45^\circ) \quad (15)$$

Note that the spot size is approximately 1 percent of the orbit altitude. Also note that for a particular orbit altitude, the spot size is essentially independent of the reflector size, but the intensity of illumination on the spot increases in proportion to the reflector area as indicated by equation (12).

Again, it should be emphasized that equations (10) through (15) represent a special case where  $\theta = 90^\circ$  and  $\gamma = 45^\circ$  and are not valid for other angles. These equations are convenient when making approximate calculations or quick comparisons of various systems. When more accurate answers are required, equations (2) through (9) should be used.

#### Relationship of Image Size to Orbit Altitude

Values in figure 5 were calculated using equation (15), which is applicable to a mirror directly overhead resulting in a circular image (spot). Orbits investigated at LaRC with periods ranging from 2.4 to 24 hours are indicated by the dashed lines. Spot sizes range from 25.4 km for the 2.4-hour orbit to 333 km for the 24-hour geosynchronous Earth orbit (GEO). In general, the lower orbits (2.4 to 3 hours), which result in smaller spot sizes, are more suitable for energy production, especially for the needs of the near future when smaller collector sites could meet energy demands.

#### APPLICATIONS AND MISSIONS

This section describes several interesting applications of illumination from space and the mission scenarios recommended to achieve them. For illumination of large urban areas, the mission scenarios are based on the idea of using a constellation (cluster) of several 1-km-diameter solar-reflector spacecraft in the appropriate Earth orbit to meet predetermined specifications.

## Full-Time Illumination of Large Urban Areas

Full-time illumination, as used herein, means the lighting of a designated area all night long. If it is necessary to limit the illumination to a small city (e.g., approximately 40-km diameter) without excessive spillover, the orbit choice would probably be a 3-hour Sun-synchronous orbit. Such a mission would not be economical unless several similar-sized cities, spaced around the world, were served by the same spacecraft in the same orbit. These low-orbit missions have been thoroughly investigated by Dr. Ehricke (ref. 7) and will not be discussed herein. The studies reported herein were dedicated primarily to the illumination of regional-sized areas from GEO (24-hour orbits) with some consideration given to 12-hour orbits.

Figure 6 depicts an application whereby solar reflectors are used to illuminate a large urban area, namely, the heavily populated Middle Atlantic States. This area, already populated with approximately 25 million people, is rapidly growing into a megalopolis. The large, 350-km-wide by 630-km-long elliptical footprint represents the actual image size reflected from a mirror in GEO at this latitude. This footprint is centered at about Quakertown (Pa.) and includes many large cities such as New York (N.Y.), Trenton (N.J.), Philadelphia, Allentown, and Scranton (Pa.), Wilmington (Del.), and Baltimore (Md.).

The smaller ellipse, also shown in figure 6, represents the image reflected from a mirror in a 12-hour circular, equatorial orbit. This ellipse is approximately 190 km wide by 350 km long. This smaller image can also be directed to illuminate areas containing several major cities, but its image area is only 30 percent of that reflected from GEO.

The constellation of reflectors required to illuminate the area shown by the larger footprint in figure 6 would be located in a circular, equatorial, geosynchronous orbit. The constellation would be centered about the same longitude (75° W) as Philadelphia (Pa.). As shown later, to achieve an intensity of 8 lux from GEO, the constellation would consist of sixteen 1-km reflectors.

Figure 7 depicts the illumination of England from both 24- and 12-hour circular orbits. The reflected image from the 24-hour orbit covers most of England and Wales and extends northward almost to Scotland. The image from the 12-hour orbit covers many large industrial cities in southern England. Since the latitude of England is approximately 52° N, year-round service from reflectors in an equatorial orbit (0° inclined) would not be too effective during winter because of small look angles. If the orbit is inclined to increase the look angles during the wintertime, the look-angles during summer will become extremely small making summertime illumination impractical. Thus, for high-latitude regions such as England, trade-off studies involving economics as well as technical considerations must be conducted in order to choose the most feasible orbits.

## Part-Time Illumination of Large Urban Areas

The previous section described the full-time (all-night) illumination of a large urban area, namely, a large portion of the Middle Atlantic States. Although there may be many advantages to full-time illumination, there are also disadvantages that must be assessed. Initially, there may not be public acceptance of the idea. Astronomers are expected to object. There may be environmental and ecological concerns. These potential problems have not been investigated.

Part-time illumination of areas, for approximately 1.5 hours during morning and evening only, may be a method of avoiding many of the objections above and paving the way for full-time illumination of some large urban areas that become extremely populated in the future. Part-time illumination essentially results in extending the daylight hours similar to those experienced during summer. However, the intensity of the illumination reflected from space, although better than most existing good highway lighting systems, will still be significantly lower than natural daylight even on a cloudy day. Part-time illumination should be less objectionable to astronomers because the space light could be terminated, on a prescheduled basis, during special astronomical events occurring during the late morning or early evening hours. Finally, because of its short duration and because of its similarity with seasonal daylight changes, part-time illumination from space should not impact the ecology, although this aspect definitely needs to be studied prior to making commitments for commercial illumination systems in space.

Figure 8 illustrates how a constellation of 2 or 3 clusters of solar reflectors in GEO can provide extended daylight (at a lower intensity level) to several areas across the country on a year-round basis. In this example, 1 hour of reflected light will be provided to each area. As discussed later, this time period can be greater. At 6:00 p.m. eastern time (ET), both clusters 1 and 2 commence illuminating the large 350-km-wide area centered near Philadelphia (Pa.). After approximately 1 hour, the same clusters are rotated slightly to serve the Chicago (Ill.) area for 1 hour. Subsequently, the Denver (Colo.) and Los Angeles (Calif.) areas are illuminated. The right-hand diagram in figure 8 shows the locations of the clusters at 6:00 p.m. Pacific time (PT). Note that a third optional cluster would provide better "phasing in" of illumination into the areas.

A mission scenario very similar to that described above is shown in figure 9. Here, the Hawaiian Islands have been included as an area to be illuminated. For this scenario, the constellation of reflectors would be located in an equatorial geosynchronous orbit. The constellation would be located at 100° W longitude, which is the approximate longitude of Denver (Colo.). The times in the figure are for winter but can be adjusted seasonally for year-round service.

At 5:30 p.m. ET, the constellation of reflectors is directed towards the large urban area centered near Philadelphia (Pa.). This area is illuminated for 1.5 hours, or until 7:00 p.m. ET, and then the reflectors are directed towards the Chicago (Ill.) area from 6:00 to 7:30 p.m. central time (CT). Next, the Denver (Colo.) area is illuminated from 6:30 to 8:00 p.m. mountain time (MT) followed by the Los Angeles (Calif.) area, which is illuminated from 7:00 to 10:00 p.m. PT. Finally, the reflectors are directed to the Honolulu (Hawaii) area, which is illuminated from 8:00 to 11:00 p.m. Hawaiian time (HT). When it is 11:00 p.m. HT in Honolulu it is 4:00 a.m. ET on the east coast of the United States. If 0.5 hour is allowed to redirect (rotate) the reflectors towards the east coast, the morning sequence of illumination can be started in the Philadelphia area at 4:30 a.m. ET and terminated at 6:00 a.m. ET as indicated in figure 9. The sequence of events described above would be repeated for the morning hours with some adjustments made in the time durations as indicated in the figure. Again, the sequence would be terminated at Honolulu (at 7:00 a.m. HT). Between 7:00 a.m. HT and 5:30 p.m. ET there are 5.5 hours which could be used for spacecraft checkout, station keeping, and so forth, before repeating the complete sequence again. Note that during the 24-hour day, 18 hours of reflected solar illumination have been provided. As will be shown later, this has economic significance. This scenario was selected as the baseline mission in this study.

Figure 10 shows a scenario which includes Alaska in the wintertime sequence. Near winter solstice in Alaska there are only 3 to 4 hours of oblique sunlight around noon. Automobile headlights must be used until about 10:00 a.m. and after about 2:00 p.m. As shown in the figure, the reflectors are directed to illuminate the area including Fairbanks and Anchorage from 7:00 to 10:00 a.m. HT. This would extend the short Alaskan day by 3 hours. The reflectors are then directed to illuminate the large urban area centered about Philadelphia (Pa.) starting at 5:00 p.m. ET. As shown by the dashed lines, this scenario can be altered to serve the Hawaiian Islands also if the illumination of the Los Angeles area is constrained to about 1.5 hours.

Note that it is possible to provide even more hours of illumination to Alaska if desired, but this would reduce the periods for illuminating the more populated areas of the country and, perhaps, compromise the economic feasibility of this mission scenario.

To provide effective illumination from GEO to a high-latitude area such as Alaska, the orbit must be inclined considerably. This change precludes the illumination of the areas shown during both mornings and evenings since the reflectors would be located over the Southern Hemisphere during half of the orbit. Also, if the orbit is inclined to favor wintertime illumination of the Northern Hemisphere, as is the case with figure 10, the geometry will not be favorable for summertime illumination of the same areas. These aspects will require additional examination on a case-by-case basis in future studies. If it is desired to illuminate small sites located at high latitudes, such as Alaska's North Slope oil fields, retrograde Sun-synchronous orbits should also be considered.

Figure 11 shows a mission scenario that includes the Panama Canal Zone in the sequence of events. The waterways which make up the canal are so poorly lighted that shipping is slowed considerably at night. Thus, if illumination from space is to be of sufficient benefit to the canal, it must be supplied for the greater portion of the night. This requirement would make it feasible to provide the large urban areas across the United States with illumination from a single constellation of reflectors during mornings only.

In an alternate scenario (not shown), illumination could be provided to areas in the United States during mornings and evenings as previously discussed and diverted to Panama only during emergencies. Even though the United States no longer possesses the canal, it is still of great strategic importance to us. Space lighting of the canal would help increase the flow of ships through the canal during emergency situations anywhere in the world. Space lighting would also be of great benefit for nighttime shipping through the canal or repairs to canal facilities, in case of damage during an act of war or from sabotage.

#### Illumination of Space Shuttle In-Orbit Nighttime Operations

A major portion of every Space Shuttle orbit will be occulted by the Earth, and lighting systems onboard will illuminate operations in or near the Shuttle bay. Onboard lighting, however, will not be entirely satisfactory for missions involving rendezvous, recovery, rescue, and assembly and servicing of large space systems. Frequent interruptions in Shuttle operations because of darkness will be time consuming, risky, and costly.



Figure 12 is an artist's rendition of a Shuttle operation being illuminated by a solar reflector. The diagrams of figure 13 show how this would be accomplished. In the diagrams, the Shuttle is shown in a 280-km high orbit which has a period of 90 minutes. To assure coverage at nighttime on a regular basis, a reflector orbit must be selected such that the 90-minute Shuttle orbit is a harmonic of the reflector orbit and the reflector and Shuttle must be properly synchronized with each other. The diagrams show that a reflector orbit 10 380 km high with a 6-hour period satisfies this condition. Note from the diagram on the left that conditions are properly synchronized when the Shuttle is entering the Earth's shadow at position 1 and the reflector is at position 1 in its higher orbit. It takes the Shuttle 30 minutes to travel 120° to where it leaves the Earth's shadow at position 2. In this same 30-minute period, the reflector travels 30° to position 2 in its orbit. During this time the reflector is in sunlight and is able to illuminate the Shuttle while it traverses the Earth's shadow.

The Shuttle travels 240° from position 2 (in the left-hand diagram) to position 3 (in the right-hand diagram) in 60 minutes. During the same 60-minute interval, the reflector moves 60° through the Earth's shadow, where it is ineffective, to position 3 in the right-hand diagram. However, since the Shuttle is in sunlight during this period, there is no need to illuminate it with the reflector. At position 3, the reflector is in sunlight and illuminates the Shuttle as it again enters the Earth's shadow. While the Shuttle travels 120° from position 3 to position 4 in the Earth's shadow, the reflector travels 30° in its orbit from position 3 to position 4 illuminating the Shuttle as indicated. After 60 minutes the process is repeated. If it is desired to illuminate every Shuttle orbit, two reflectors can be located diametrically opposite in the 6-hour orbit and synchronized with the Shuttle as described above.

The reflector system described above can also be used to illuminate the proposed NASA space station and its operations. Some of these operations will be complex and demanding and will require good illumination.

#### Illumination of Emergency Operations

There are several potential emergency operations that could benefit from illumination from space. Some of these are listed below:

1. Earthquakes
2. Volcanic eruptions
3. Floods
4. Shipwrecks and sea search
5. Civil riots
6. Cities during power failures
7. Evacuation of cities during threats of nuclear attack
8. Evacuation of areas during nuclear power station emergencies

Because of costs, it is doubtful that there will be solar-reflector missions dedicated solely to the illumination of emergency operations. However, reflectors already in orbit for some other primary purpose could be diverted to emergency situations in accordance with prior agreements. For example, the baseline mission uses a constellation of sixteen 1-km reflectors (plus two spares) in GEO at 100° W longitude to illuminate to 8 lux several large urban areas across country during mornings and evenings. Four of these reflectors could be diverted to illuminate any place between the Virgin Islands and the Hawaiian Islands during an emergency. This would temporarily reduce the output of the primary 8-lux system to 6 lux, which is still ample for urban illumination. The four diverted reflectors would illuminate the emergency area to 2 lux, which is equal to low streetlight intensity, or 15 full Moons. It would only take 15 minutes to rotate the reflectors from a neutral position to any extreme position within the area of coverage.

### Illumination of Farming Operations

There are areas in the United States where back to back crops can be planted and harvested in a single growing season provided the turnaround time is fast enough. To speed up operations, farmers in these areas use equipment with headlights to plow, sow, and cultivate fields at night. Electric lights are installed temporarily in fields to enable harvesting at nighttime. These procedures are done on a routine basis in several areas of the country such as southern California.

There are several occasions in which farming operations must be accomplished on an emergency basis because of prior (or impending) adverse weather conditions. Such conditions usually affect state-sized areas. Most farms in the United States do not have adequate lighting equipment to handle these emergencies.

Because of their short durations, neither the routine nor emergency situations described above warrant dedicated orbiting solar-reflector systems. These farming operations could be performed by diverting a few reflectors from a constellation serving some other primary application, such as urban illumination, or a special multipurpose system could be considered.

### Illumination of Ranches and Dairy Farms

Tests have shown that beef cattle, when exposed to more than normal amounts of light imitating the spectrum of the Sun, are 10 to 15 percent heavier than cattle which are not exposed to additional light (ref. 14). Milk cattle, when exposed to 16 hours of imitation sunlight as compared with the normal 9 to 12 hours of natural light, yielded 10 to 15 percent more milk. These benefits were achieved without extra food consumption. Since the light from solar reflectors is essentially sunlight, it is believed that ranchers and dairy farmers could benefit from part-time illumination from space.

### Enhancement of Photosynthesis

Light provides the radiant energy necessary for the formation of carbohydrates (photosynthesis) in plants and is a key factor in plant growth and ripening time. Although light intensity up to a certain level (depending on the plant's ability to assimilate CO<sub>2</sub>) is an important factor in plant growth, the duration of the lighting cycle is equally important to blossoming. Some plants, including wheat, require

about 12 hours of light per day to blossom. Other plants blossom with shorter periods of light. Solar reflectors can be used to increase the intensity and duration of lighting in regions of the world where daylight is too short to enable important food crops such as wheat to blossom and flourish. Illumination from space may also be beneficial in regions where the daylight is not quite long enough to enable the growth of two crops per season. With the increasing growth of the world's population and with starvation already rampant in many countries, it is becoming more and more important to develop technology to increase the yield of farm lands.

Studies have not been conducted to determine the specifications (intensity, duration, and characteristics) of light needed for photosynthesis by specific crops in various regions of the world. Therefore, it is not yet possible to make estimates of the reflector area (i.e., number of reflectors) needed to enhance photosynthesis. The enhancement of photosynthesis could very well be the most important application of illumination from space, if it can be accomplished with a reasonable number of reflectors. This is an area that warrants more study.

### Other Applications

Solar reflectors can be used for several other applications, some of which are listed below:

1. Electrical energy production
2. Weather and climate control
3. Navigation
4. Desalination
5. Political and military operations
6. Surveillance of smuggling and illegal entry of foreigners

These applications are beyond the scope of this paper.

### MISSION DEFINITION AND DESIGN

In this section, those inputs which are necessary to define and design missions using illumination from space are discussed. Calculations are made to determine the number of reflectors required to meet mission requirements.

### Light-Intensity Requirements

The solar intensity on the Earth's surface at desert-high-noon conditions can be as high as 118 900 lux (ref. 15). The intensity of the full Moon on Earth at 40° latitude is 0.143 lux. These light intensities differ by a factor of 831 470. This indicates the human eye is a remarkable sensor, since it can make observations throughout this broad range.

Table I shows the light intensities required for a variety of applications. The lowest intensity in the table is auditorium illumination during performances, which is 1.07 lux. This is equivalent to approximately 7 full Moons and is sufficient for reading regular-sized newspaper print if one has normal eyesight. Note that the illumination intensities of street and highway lighting vary from 2.15 to 21.52 lux. The low intensity is for slow driving on city side streets with little traffic. The high intensity is for high speeds on congested urban highways. Most well-lighted highways are illuminated to intensities of 6 to 10 lux with uniformity ratios of approximately 1/3. This means that at no point between lights should the illumination be less than 1/3 the average illumination under the lights. Side streets in most cities are illuminated to approximately 2 lux with a uniformity ratio of only 1/6.

For this study, the following three light intensities were defined and investigated:

Low streetlights, lux .....	2.0
Medium streetlights, lux .....	8.0
High streetlights, lux .....	22.0

The uniformity ratios achieved with illumination from space will approach unity, which is a substantial improvement over the fractional values of conventional systems.

#### Loss Factors

Several losses should be considered when calculating the intensity of illumination from orbiting solar reflectors. Some losses are associated with the quality of the hardware used while others relate to prevailing natural conditions. These types of losses are discussed below and should be included in equation (9) for calculating intensity. Still other factors which affect intensity are related to the geometry of the Sun/reflector/Earth ground spot and are incorporated into equation (9) as slant range  $d$ , slant-range angle  $\theta$ , and incidence angle  $\gamma$ . Once an orbit altitude has been selected, the other orbit characteristics, such as inclination, should be chosen to provide favorable geometry. Generally, values of  $\theta$  should be large, values of  $\gamma$  should be small, and values of  $d$  should be as small as feasible. These geometric factors are not discussed in this section.

All losses combine to reduce intensity. Losses should be minimized where possible, since additional reflectors are required for compensation.

Mirror flatness  $\mu$ . Thin polymeric membranes, coated with highly reflective substances, are ideal for use as mirrors in space because they are lightweight and they can be used on unfurlable reflector structures. Ultrathin membranes are desirable because lower tensile loads are required to achieve a planar surface with fewer and shallower wrinkles. Deep wrinkles with steep slopes can disperse light rays entirely off the target area (ground site). Shallower wrinkles will also disperse some light off the target, but a larger percentage will still impinge upon the target area, though it may be dispersed somewhat unevenly. One of the advantages of using several reflectors simultaneously to illuminate a ground receiver site is that these dispersions will tend to "average out." During membrane configuration tests conducted at LaRC from 1980 to 1981, most of the loaded membrane was smooth except for

wrinkles, estimated at 10 percent, in some of the seams. These wrinkles were either eliminated or reduced in height by the application of heat from a hot-air gun. After such treatment, the root-mean-square (rms) edge gradient  $\sigma$  over the membrane surface was estimated to be approximately 0.0002 rad. Reference 15 gives the following formula for the linear dispersion of an image  $D_i$  resulting from imperfections in the configuration surface:

$$D_i = 2\sigma d$$

Here,  $d$  is the distance from the mirror to the image (ground spot). For a mirror at zenith in GEO,  $d$  is equal to 35 860 km and the error  $D_i$  is calculated to be about 14.5 km. From equation (15), the theoretical diameter of an image reflected from GEO is

$$D_{s,1} = 35\ 860(0.0093) = 333\ \text{km}$$

and its area  $A_1$  is 87 092 km<sup>2</sup>. Therefore, the diameter of the dispersed image is

$$D_{s,2} = 333 + 14.5 = 347.5\ \text{km}$$

and its area  $A_2$  is 94 842 km<sup>2</sup>. Therefore, the "spill-over" area caused by the dispersions is

$$A_2 - A_1 = 94\ 842 - 87\ 092 = 7750\ \text{km}^2$$

In reference to equation (12), note that the image intensity varies inversely as the image area. Thus, the loss in intensity resulting from surface wrinkles is a function of the dispersed-image area. The percentage loss is

$$\text{Loss} = \frac{7750}{87\ 092} \times 100 = 9$$

Thus, an efficiency factor of  $\mu = 91$  percent was used in these studies to compensate for imperfections in the configuration of the reflective membrane.

Mirror reflectance  $\rho$ . Mirrors made of Mylar or Kapton<sup>1</sup> may be coated with several substances to provide reflectivity. Shown below are coefficients of reflec-

---

<sup>1</sup>Mylar and Kapton are registered trade names of E. I. du Pont de Nemours & Co., Inc.

tivity for three possible coatings in the visible range (0.55  $\mu\text{m}$ ) of the solar spectrum.

Sodium (Na) .....	0.99
Silver (Ag) .....	0.98
Aluminum (Al) .....	0.92

From the viewpoint of reflectivity, sodium is the best coating. However, sodium is unstable in the atmosphere and, therefore, must be applied in orbit. For prefabricated unfurlable structures it is more feasible to coat the membrane on Earth. Therefore, sodium should not be used. However, sodium should be kept in mind, especially for applications where it may be desirable to apply the coating in space, as it is plentiful, lightweight, and easily vapor deposited.

Silver is also an excellent reflector, but it tarnishes badly when exposed as a bare metal to the atmosphere. When used as a second-surface mirror, silver can be protected from tarnishing by the substrate and suitable back coatings. However, materials for second-surface mirrors are expensive and heavy, and the exposed plastic substrate used for the spacecraft concept herein is more prone to radiation damage from the Sun's rays, which must pass through it twice. Also, particulate radiation will sputter and degrade the unprotected plastic (membrane) surface.

Vapor-deposited aluminum is favored as a membrane coating for the following reasons:

1. It is a good reflective material ( $\rho$  up to 92 percent).
2. It can be purchased precoated on the substrate.
3. It is durable in the atmosphere and in space.
4. It is lightweight.
5. It is relatively inexpensive.
6. It can be refurbished in space by vapor deposition.
7. It has some weak absorption bands in the infrared which help keep the mirror cooler.

Allowing for 2 percent degradation in space, the resulting efficiency factor for the aluminum-coated membrane used for these studies was 90 percent.

Atmospheric transmittance  $\tau$ .— The transmittance factor for the direct component of solar radiation through the atmosphere to a ground receiver site is discussed in reference 16 and is given as

$$\tau = 0.1283 + 0.7559e^{-0.3878 \sec z} \quad (16)$$

where  $z$  is the angle measured at the receiver site from zenith to the reflector. For the illumination of large urban areas during mornings and evenings (baseline

mission), the zenith angle can be held to a maximum of  $45^\circ$ . When this value is used in equation (16), the transmittance  $\tau$  is calculated to be 62 percent for a receiver site near sea level such as the large area centered at about Philadelphia (Pa.). This value will be higher for receiver site areas in the United States with higher elevations. Based on the difference between the "total" and the "direct" values of the solar constant given in table 2.4 of reference 15, the value of the coefficient of transmittance for the scattered component of transmittance is calculated to be 6 percent. When this is added to the direct component of 62 percent, the total transmittance at sea level and a zenith angle of  $45^\circ$  used herein is  $\tau = 68$  percent.

Cloud cover  $\phi$ .- Cloud cover can cause large losses in the intensity of light reflected from orbiting solar reflectors to Earth receiver sites. There appear to be no flight data on the effects of cloud cover on light reflected from orbiting mirrors. There are, however, data on the effects of cloud cover on the natural radiation of the Sun and Moon. Measurements of the solar flux taken with a Helio moving shadow-bar pyrliometer on a completely cloudy day with no direct sunlight show approximately 30 percent of the clear-day flux appearing as scattered sunlight (ref. 15). Since moonlight is reflected sunlight, measurements of cloud-cover effects on its intensity might be more applicable to solar reflectors. Figure 14 shows the effect of cloud cover on illumination from moonlight. This figure was taken from reference 2 and is the result of a study performed by Boston University for the Air Force in 1952. The figure shows that on a moderately cloudy (broken overcast) night, moonlight is attenuated by a factor of 1.5 to 2.0. Broken overcast cloud conditions are far more frequent than heavy overcast conditions. The figure also shows that on a heavily cloudy night, moonlight is attenuated by a factor of 3.5 to 4.5, not by an order of magnitude as reported in some of the literature. This finding is somewhat compatible with the previously mentioned pyrliometer measurements of sunlight on a heavily cloudy day.

Reflectors in GEO will deliver beams of light approximately 333 km in diameter. Such large beams will probably be attenuated by cloud cover at factors comparable to natural sunlight or moonlight because of the significance of the scattered component. It is conjectured that light with much smaller beam diameters reflected from low Earth orbits will be attenuated by cloud cover somewhat more.

The baseline study concept uses 16 reflectors, half of which are spaced  $24^\circ$  apart in GEO to reduce the effects of occultation. Such spacing also results in the light beam impinging on the ground site from different angles. Thus, during times of broken overcast clouds, some reflectors will still provide direct illumination while others will provide scattered light.

Dr. Ehrlicke reports in reference 8 that cloud cover rarely reduces the illumination below a factor of 4.0, and that for most parts of the world, a cloud cover loss factor of 3.0 should suffice. For some of the applications considered herein for which it may be desirable that specific levels of illumination be maintained (even during heavy overcast conditions), a loss factor of 4.0 should be applied.

For applications in which solar reflectors are used to illuminate areas already served by streetlights (saving the cost of electricity only), the reflector-system design does not necessarily have to incorporate cloud-cover loss factors since the streetlights will automatically activate when the illumination from space is overly dimmed by clouds (or occultation). For applications solely involving illumination from space, the lowest allowable lighting intensity should be specified and ample reflectors should be provided to assure that this intensity can be achieved during the heaviest possible overcast conditions.

In summary, the following cloud-cover factors should be applied when equation (9) is used:

$\psi = 100$  percent for areas with existing streetlights

$\psi = 33$  percent for areas with predominantly broken cloud-cover conditions year round

$\psi = 25$  percent for areas with no backup streetlights in which a minimum specified intensity from the space system, even during the heaviest cloud cover, is necessary

Occultation.- Generally, satellites in Earth orbits (except for high-altitude Sun-synchronous orbits) will experience some eclipsing (occultation) from the Earth's shadow. Occultations of equatorial geosynchronous orbits occur twice a year at the equinoxes. They are centered about local midnight over a period of 43 days and have a daily duration ranging from a few minutes to a maximum of 75 minutes. These occultations can be ignored for many but not all applications. When clusters of reflectors are used to illuminate a ground site, the effects of occultation can be minimized by spacing the reflectors so that no more than half are occulted at a time. Thus, the loss in intensity will depend on the number of reflectors in the cluster subjected to occultation at any one time. The effects of occultation must be judged independently for each application, and the number of reflectors should be adjusted accordingly. No predetermined loss factor can be assigned for occultation and, therefore, equation (9) does not provide for this condition.

#### Relationship of Light Intensity to Altitude

In previous sections of this paper, equations for calculating the intensity of reflected illumination were developed and loss factors were established. Figure 15 presents curves of intensity versus altitude for reflector diameters of 100 m, 500 m, and 1 km. These curves were plotted by using equation (13), modified as follows to include the loss factors  $\mu$  and  $\rho$  and the sea-level value of  $I_0$ .

$$I = 0.707\mu\rho I_0 \left(\frac{D_m}{D_s}\right)^2$$

where

$\mu$	membrane flatness coeff, 0.91
$\rho$	membrane reflectivity coeff, 0.90
$I_0$	solar intensity at sea level, 118 900 lux
$D_m$	reflector diameter
$D_s$	ground-spot diameter



Therefore,

$$I = 0.707(0.91)(0.90)(118\ 900)\left(\frac{D_m}{D_s}\right)^2$$

$$I = 68\ 850\left(\frac{D_m}{D_s}\right)^2$$

The above equation and, therefore, figure 15 contain nominal values for pertinent losses. The atmospheric transmittance loss is accommodated by using the desert, sea-level, high-noon value (118 900 lux) of the solar intensity. The intensity levels in figure 15 are somewhat optimistic and will conflict with values presented elsewhere in this document for specific missions. Calculations for the specific missions contain additional losses related to the particular requirements of the mission.

Figure 15 is based on selected orbit altitudes ranging from 600 to 35 860 km, the latter being GEO. Also shown for reference are intensity levels of 2 lux (low streetlights), 8 lux (medium streetlights), and 22 lux (high streetlights). Note that these are values established for this study and may not agree with those used by others. It is shown in figure 15 that the intensity from a single 1-km reflector in GEO is only 0.62 lux, but this is approximately 4 times brighter than light from a full Moon (0.143 lux). With thirteen 1-km reflectors in GEO focussed on the same site, an illumination intensity of 8 lux is obtained, which is equal to medium streetlight intensity indicated in the figure. To achieve this intensity with a single 1-km reflector, the orbit altitude would have to be reduced to approximately 10 000 km as shown in the figure.

Reflectors 1 km in nominal diameter were considered for the operational spacecraft sizes in these illumination-from-space studies. The 100-m diameter reflector size was considered for a scaled-down model to be used as a research spacecraft to obtain additional technical data and to verify new technology in flight. Calculations show that the 100-m reflector in GEO will deliver an intensity of 0.006 lux to Earth, which is 100 times less than the capability of a 1-km reflector from this altitude. Figure 15 shows that a 100-m reflector will deliver an intensity of 22 lux from a 600-km Shuttle-compatible orbit, which is 35 times more intense than the output of a 1-km reflector in GEO. Thus, for test purposes, the 100-m reflector would have to be in an orbit about 4000 km high to duplicate the intensity (0.62 lux) of a 1-km reflector in GEO.

An intensity curve for the 500-m reflector is also shown in figure 15 to provide an intermediate size for the sake of comparisons. The 500-m reflector was not included in these studies and will not be discussed herein.

#### Mission Analysis

As previously mentioned, GEO's were given primary attention for urban illumination in these studies, although some consideration was also given to 12-hour orbits. Table II presents the results of calculations for both orbit cases. Equation (9),

which accounts for all pertinent losses, was used for these calculations and is repeated below.

$$I = \frac{\mu \rho \tau \phi I_o A_m \sin \theta \cos \gamma}{\pi [d(\alpha/2)]^2}$$

Note that table II lists the nominal diameter of one of the reflectors as 1.0 km. At 45° N latitude, for which the table is applicable, the calculations and the table values are actually based on a reflector membrane area equivalent to the diameter of a 1.08-km circle, which means that the actual outside diameter of the reflector structure will be slightly greater than 1.08 km. This and other numerical values used in equation (9) for calculating the number of reflectors shown in table II are listed below.

Membrane flatness coeff $\mu$ .....	0.91
Membrane reflectance coeff $\rho$ .....	0.90
Atmospheric transmittance coeff $\tau$ .....	0.68
Cloud-cover coeff $\phi$ .....	1.0
Exospheric solar flux, $I_o$ , lux .....	136 700
Actual mirror area based on 1080-m diam, $A_m$ , m <sup>2</sup> .....	915 620
Slant-range angle $\theta$ :	
GEO, deg .....	45
12-hour orbit, deg .....	43
Angle of incidence $\gamma$ :	
GEO, deg .....	15.5
12-hour orbit, deg .....	33.5
Slant range $d$ :	
GEO, m .....	37 200 000
12-hour orbit, m .....	23 000 000
Included angle of Sun from Earth $\alpha$ .....	0°31'59.26"

The values selected for  $\theta$  and  $\gamma$  represent near worst-case geometric conditons, so the calculated intensities are the lowest levels expected for these orbits. Thus, the intensity levels presented in table II are the lowest levels expected from the number of reflectors indicated. The actual average intensity levels should be slightly better than the table values.

Table II is mainly applicable for regions in the United States with latitudes up to 45° N which can be served on a year-round basis by reflectors in 12- or 24-hour equatorial (0° inclination) orbits. Illumination of latitudes higher than 45° N will require inclined 12- and 24-hour orbits for effective lighting. If these orbits are inclined appreciably, say 10° or greater, the reflectors will be effective for only

half the year. To illuminate high-latitude sites on a year-round basis will require at least two sets of reflectors in 12- or 24-hour orbits inclined in opposite directions to accommodate seasonal changes in the Sun's direction. This will require about twice the number of reflectors shown in table II. The selection of lower posigrade or retrograde orbits would also result in many additional reflectors. To illuminate areas located on or adjacent to the Equator from 12- or 24-hour orbits will require somewhat fewer (or slightly smaller) reflectors than given in the table because of better geometric relationships.

An early commercial application of illumination from space may involve using a small constellation (cluster) of reflectors to illuminate an urban area to a low intensity level of approximately 2 lux. This, as shown in table II, can be accomplished with four 1.0-km reflectors located in either GEO or 12-hour orbit. This low-intensity system will enable evaluation of the performance and acceptance of the space system prior to commitments to larger, more expensive systems with greater intensities. It should also be possible to evaluate the ecological impact with the small 2-lux system. The small system could also be diverted for illuminating emergency situations such as floods, cities during blackouts, and so forth.

If the 2-lux system proves successful, additional reflectors can be added to provide medium streetlight intensity of 8 lux. As shown in table II, this can be accomplished with sixteen 1.0-km reflectors located in either GEO or 12-hour orbit. The 16-reflector, 8-lux GEO system was selected as the baseline system in these studies. This was done because the system produces excellent lighting conditions and, as will be seen later, appears to be economically and commercially feasible.

Note that it is not intended to replace existing street and highway lighting facilities with the 8-lux space system. The space system is designed so that existing lights can be turned off during conditions of light or broken clouds. When heavy clouds reduce the intensity of the space system to a predetermined level, for example 4.0 lux, the streetlights will automatically come on. One reason that an intensity of at least 8 lux was chosen as the baseline is that past studies for the Air Force indicate that heavy cloud cover will reduce the intensity level of light reflected from high altitudes by a factor of approximately 4. Therefore, even with heavy clouds the space system will supply 2 lux, which is equivalent to the intensity level of existing side-street lighting. Thus, even communities without conventional lighting systems will still receive reasonable illumination during bad weather conditions.

Table II shows that 44 reflectors in GEO or 40 reflectors in a 12-hour orbit can provide 22 lux, or high streetlight intensity, to large urban areas. This is an excellent level of illumination and is equivalent to the best of today's highway lighting systems. With such a system there would be no need for existing (or new) street lighting facilities (poles, wiring, and so forth) except at certain critical locations. Such a system would probably evolve from the previous 8-lux system to serve areas of the country that have grown into megalopolises.

Table II indicates that if the reflector diameter is increased from the nominal value of 1.0 km to 1.4 km, its area will double and the number of reflectors required to provide a specified intensity level will be reduced by a factor of 2. It is feasible to package and transport a 1.0-km reflector in a single Space Shuttle with a payload-weight margin of approximately 50 percent. Based on parametric studies reported in reference 17, it appears that a 1.4-km reflector will weigh 50 percent more than a 1.0-km reflector. Therefore, based on payload-weight capability, it may be possible to transport a 1.4-km reflector with the Space Shuttle, provided there is

sufficient volume in the cargo bay. The feasibility of flying larger reflectors will improve with the first enlargement of Shuttle. Thus, it appears that the costs of both the spacecraft and the launch systems could be substantially reduced by doubling the area of the solar reflectors.

## ORBIT SELECTION

The illumination of designated ground sites with sunlight reflected from orbiting mirrors can be accomplished from many types of orbits and orbit altitudes. Generally, the site location and specifications designating the image size, the light intensity, the time, and the duration will dictate the characteristics of the orbit, the reflector size, and the number and spacing of the reflectors in orbit.

### Low Earth Orbits

If small areas are to be illuminated, the reflectors should be placed in low Earth orbit (LEO) to reflect small images. The intensity of illumination on the site can be increased by increasing the size of the reflectors or by superimposing the reflected light of several reflectors on the same site. However, in low orbits each reflector flies over a site in just a few minutes and others must move into view to provide uninterrupted illumination. Thus, continuous illumination from LEO will require large numbers of reflectors and will create concern about keeping them controlled, avoiding collisions, avoiding radio frequency (RF) interference with other satellites, and avoiding conflicts with astronomers. There will also be economic considerations because of fabrication, launch, maintenance, and operational costs, all of which will increase with increases in reflector numbers. However, reflectors in low orbits can serve up to four equally spaced sites located around the Earth on the same orbit pass and can serve several other sites on subsequent passes, which tends to compensate for the large number of reflectors in LEO as compared with the number of reflectors in 12- and 24-hour high-altitude orbits. Thus, it is possible that illumination from low Earth orbits may actually require less reflector area in orbit if there is a requirement to illuminate several sites located around the world. Trade-off studies should be performed to determine the most desirable mission designs.

One major problem with typical posigrade, low Earth orbits is nodal precession caused by the oblateness of the Earth. For instance, a circular orbit 2400 km high, inclined at 45° N to serve middle-latitude cities in the United States, will precess approximately 2 revolutions per year relative to the Earth or 3 revolutions per year relative to the Sun. Each reflector spacecraft would require a propulsion system capable of making corrections of approximately 3° each day for the lifetime of the spacecraft (estimated at 15 years). Such a system would be unduly heavy. The use of solar sailing to make corrections for nodal precessions may be feasible but has not been studied.

### Sun-Synchronous Orbits

Probably the best method of avoiding the problems of nodal precession in low Earth orbits is to select retrograde, Sun-synchronous orbits. Such orbits precess at the same angular rate as the Earth around the Sun and maintain constant orientation with respect to a line from the Sun to the Earth. Sun-synchronous orbits, however, are restricted to a narrow range of inclination values near 100°. It appears there

are many solar-reflector missions that can be designed to operate within the limited bounds of Sun-synchronous orbits. However, the payload capability of launch systems, such as the Shuttle, is penalized considerably for the retrograde launches required to achieve Sun-synchronous orbits. Again, for ultralightweight spacecraft such as solar reflectors, solar sailing from posigrade to retrograde orbits using the "cranking" orbit technique advocated in the Jet Propulsion Laboratory Report 720-9, entitled "Solar Sailing Development Program (FY 1977) Final Report, Volume 1," may be feasible.

### High Earth Orbits (Posigrade)

Geosynchronous Earth orbits (GEO) are perhaps the most useful ones for illumination-from-space applications. Nodal precessions caused by the oblateness of the Earth are negligible at such high altitudes because the magnitude of the perturbing gravitational force decreases as the square of the distance from the Earth to the spacecraft. For GEO's, the spacecraft and the ground receiver sites maintain relatively fixed positions with each other since each rotates one revolution every 24 hours about the same geocentric point. Because of this feature, the same spacecraft (or cluster) can continually illuminate the ground receiver site except for the time loss because of occultation. The duration of occultation reaches a maximum of about 75 minutes at about local midnight at the time of the equinoxes. For most missions this occultation can be tolerated, but when absolutely no reduction of illumination is permissible, two spacecraft (or clusters) can be spaced a minimum of  $19^\circ$  apart to straddle the Earth's shadow. Thus, the  $24^\circ$  spacing shown in figure 16 guarantees that one spacecraft will always be in sunlight. The disadvantage of this technique is that twice the reflector area is required to maintain a specified minimum intensity level without interruption. Another solution is to space the spacecraft  $24^\circ$  apart and to accept an intensity level of one-half during those short, infrequent periods when one spacecraft enters the Earth's shadow. An added advantage of such spacing is that it would reduce the sharpness of shadows from buildings and so forth at the illuminated ground site. Spacing can also lessen the effects of broken cloud cover, since some of the rays will not be blocked by the scattered clouds.

Reflectors in equatorial GEO's will be at an altitude high enough to allow the year-round illumination of latitudes up to  $45^\circ$  north or south of the Equator. For latitudes greater than  $45^\circ$ , the GEO should be inclined so that the reflectors are over the ground receiver sites more at nighttime, especially during the desired season (usually winter). However, if the orbit is highly inclined, these reflectors will not be favorably located during the opposite season.

The image size of the light reflected from GEO is approximately 333 km in diameter. For a circular orbit with a 12-hour period, the image size is approximately 188 km in diameter. For some applications, a 188-km diameter is sufficient or perhaps desirable. Figure 17 shows how continuous illumination can be achieved from a 12-hour orbit. The spacecraft-reflector area is chosen so that only two reflectors (or two clusters) will provide the specified intensity. Four spacecraft (or four clusters) are spaced approximately  $36^\circ$  apart and are positioned relative to the ground receiver site as shown at 8:00 p.m. with spacecraft 1 and 2 providing the illumination at this time. The spatial center of the four spacecraft is located  $60^\circ$  from the horizontal reference line (solar noon). Note that in 2-hour increments the site moves  $30^\circ$  and the spacecraft moves  $60^\circ$ . Therefore, at 10:00 p.m. the four spacecraft have moved  $60^\circ$  to the  $120^\circ$  position, where the leading spacecraft is eclipsed by the Earth's shadow and the site is illuminated by spacecraft 2 and 3. At

12:00 p.m., the site is illuminated by all four spacecraft, but spacecraft 2 has just left the shadow and spacecraft 3 is ready to enter it. At 2:00 a.m., spacecraft 1 is almost out of view of the site, spacecraft 4 is eclipsed, and the site is illuminated by spacecraft 2 and 3. At 4:00 a.m., the site is illuminated by spacecraft 3 and 4, and at 6:00 a.m., spacecraft 4 is completing its track of the site just as the site enters daylight.

A comparison is now made between the 12- and 24-hour orbits for illuminating a near-equatorial site to an intensity of 4 lux with 1-km-diameter spacecraft. For this comparison it is assumed that a 188-km image (spot) size is sufficient. From the curve of figure 15, note that the intensity from the 12-hour, 20 230-km-high orbit is 2 lux. Thus, the 12-hour orbit will require four spacecraft spaced at  $36^\circ$  as discussed above, and since two spacecraft will always track the site, an uninterrupted intensity of at least 4.0 lux will illuminate the site. Referring again to figure 15, note that from the 24-hour orbit (GEO) the intensity is 0.62 lux. Thus, it will take a cluster of six spacecraft to provide slightly less than the specified 4 lux to the site. As previously discussed, there are two periods a year when spacecraft in GEO are occulted by the Earth's shadow. Therefore, to provide continuous illumination from GEO, two clusters, each containing six spacecraft, must be spaced approximately  $24^\circ$  apart (as shown in fig. 16) to assure the specified intensity of 4 lux on the site when one cluster enters the Earth's shadow. Thus, the 12-hour orbit appears far more efficient than GEO for illuminating sites near the Equator. For illuminating sites at higher latitudes, say above  $30^\circ$ , this may not be the case because of losses associated with the unfavorable geometry of the reflector and the site.

It should be noted that if the above comparison were based on image area, the GEO would provide almost four times more area than the 12-hour orbits. Furthermore, it is likely that a reduction of intensity by one-half can be tolerated for a few minutes at midnight during a few days twice a year. Thus, for the GEO case, two clusters of three spacecraft each could be spaced approximately  $24^\circ$  apart. During most of the year an intensity of almost 4 lux would be provided, the intensity dropping off to about 2 lux for short periods during occultation.

Again, as previously discussed, the requirements and problems associated with each application must be assessed before choosing the operational orbits. As indicated herein, GEO's were chosen for the baseline mission for the illumination of large urban areas across the United States.

#### ORBIT TRANSFER AND STATION KEEPING

An important result of this study is the determination that a 1-km-diameter solar-reflector spacecraft can be packaged in the Space Shuttle and transported to a 700-km circular orbit. After delivery into orbit, the spacecraft will be removed from the Shuttle cargo bay, automatically unfurled, and prepared for operation as a free-flying spacecraft which can be solar sailed to its higher operational orbit. A subsequent section describes the conceptual design of the spacecraft. The ensuing sections describe the reasons for selecting the 700-km insertion orbit, the transfer by solar sailing to the higher operational orbits, and station keeping once the final orbit has been achieved.

## Insertion-Orbit Selection

The 700-km Shuttle insertion orbit was selected because of the following reasons.

Shuttle capability.- Figure 18, extracted from reference 18, shows the Shuttle with its first orbital maneuvering subsystem (OMS) kit is capable of transporting a 10 000-kg payload into a circular orbit 700-km high. Astro Research Corp., under contract to LaRC, has designed a 1-km-reflector spacecraft. Calculations performed by them indicate the spacecraft will have a mass of 9368 kg, which would leave a margin of 632 kg for the payload. This margin would be used for structures to support the folded spacecraft in Shuttle. As seen in figure 18, when the second OMS kit is added to the Shuttle, the payload capability for a 700-km orbit will be approximately 21 000 kg at 28.5° inclination. If the basic Astro-designed spacecraft should grow in mass by a factor of 1.5 to about 14 050 kg, a payload margin of almost 7000 kg would exist. This appears more than adequate for payload support structure and other launch support equipment.

Atmospheric drag.- At 700-km altitude the atmospheric-drag forces are lower than the solar pressure except during the period of solar maximum, which occurs in 11-year cycles. The inputs and results of calculations in the following paragraphs substantiate this statement.

The following approximate values of atmospheric density were taken from figure 19 (from ref. 19) for an altitude of 700 km. These are the daytime maximum values.

High-solar-activity density, g/cm <sup>3</sup> .....	1 × 10 <sup>-15</sup>
Low-solar-activity density, g/cm <sup>3</sup> .....	9 × 10 <sup>-18</sup>
Average density, g/cm <sup>3</sup> .....	9 × 10 <sup>-17</sup>

The coefficient of atmospheric drag  $C_D$  at 700 km is 2.0 for a flat plate. The drag pressure  $F/A$  for the three densities was calculated from the following formula:

$$F/A = C_D \rho (v^2/2)$$

where  $v$  is the orbital velocity and  $\rho$  is the atmospheric density. When  $C_D = 2.0$ ,

$$F/A = \rho v^2 \tag{17}$$

For  $v = 750\,400$  cm/sec, the following drag pressures can be calculated:

F/A (high solar activity), μPa .....	56.35
F/A (low solar activity), μPa .....	0.51
F/A (average solar activity), μPa .....	5.07

The solar pressure is 9.05  $\mu\text{Pa}$ . A performance factor  $f_p$  is calculated for each condition by taking the ratio of solar pressure to drag pressure. The values from these calculations are as follows:

$f_p$ (high solar activity) .....	0.161
$f_p$ (low solar activity) .....	17.750
$f_p$ (average solar activity) .....	1.785

The performance factor of 17.750 assures that solar sailing alone is a feasible means of orbit transfer during the years of low solar activity. The performance factor of 1.785 was calculated with the median density at 700 km between the densities for high and low solar activity in figure 19. This is termed an average condition of solar activity. Even though it signifies that solar sailing is possible, the time for orbit transfer would be too long.

The atmospheric density during "mean" solar activity at 650 km is  $1 \times 10^{-17}$  g/cm<sup>3</sup>. "Mean" signifies the condition that is prevalent during the majority of time during the 11-year solar cycle and is a more realistic design condition than the average solar condition discussed above. The performance factor for a mean density of  $1 \times 10^{-17}$  g/cm<sup>3</sup> was calculated to be 16.075 which indicates that solar sailing is feasible during the majority of the 11-year solar cycle.

The fractional performance factor of 0.161, calculated for the high-solar-activity condition, signifies that solar sailing alone is insufficient at 700 km to transfer the spacecraft to higher operational orbits. An auxiliary propulsion system must be incorporated on the spacecraft to complement solar sailing during years of high solar activity. Even at 1000 km, auxiliary propulsion is desirable to shorten trip times during conditions of high solar activity. Thus, auxiliary propulsion should be incorporated in a spacecraft design to accommodate all solar-activity conditions. Some of its fuel can be unloaded during periods of the solar cycle when they are not needed. Details of the auxiliary propulsion system selected for this study are presented under the section entitled "Reflector Spacecraft Design Concepts."

Operational considerations.- Inspection or repair through extravehicular activity (EVA) is recommended during the sequential deployment of the solar-reflector spacecraft after orbit insertion by the Shuttle. Because of the intensity of particulate radiation, it is doubtful that routine EVA will be possible at altitudes of 800 km or higher. However, at 700 km altitude it is estimated that EVA can be performed for 9 to 10 days without overexposure to particulate radiation. This should be sufficient time to make emergency repairs or adjustments to the spacecraft prior to transfer to higher orbits. Because of the radiation hazard and the more limited payload capability at the higher altitudes, the 700-km orbit altitude was selected for deployment of solar-reflector spacecraft in these studies. Even though solar sailing is slightly compromised at 700 km, it still appears to be the most feasible method for orbit transfer. The solar-reflector spacecraft is an inherent solar sailer. Its specific weight of 12 to 14 g/m<sup>2</sup> is extremely low and it is already equipped with the type of guidance and computer necessary for solar sailing.

#### Orbital Transfer Through Solar Sailing

Figure 20 illustrates the solar-sailing technique for one typical spiral loop around the Earth. The various spacecraft maneuvers are shown starting from posi-



tion 1 in the initial Shuttle insertion orbit. In the lower orbits, where some atmospheric drag may be experienced, small propulsive impulses may be necessary as shown at position 4. These impulses will be provided by the thrusters of the auxiliary propulsion system, which will be used primarily for auxiliary attitude control.

The time it takes to solar sail a reflector spacecraft from the initial orbit to the higher operational orbit is a function of the following:

1. Altitudes and other characteristics of the initial and final orbits
2. Atmospheric drag in the lower orbits, which is related to solar conditions
3. Spacecraft mass-to-area ratio
4. Reflectivity of the reflective membrane (sail)
5. The solar force, which can be treated as a constant in Earth orbits
6. The gravitational force, which decreases as the square of the altitude

Solar-sailing times were calculated using the following equation taken from reference 17.

$$\Delta t = \frac{4.57\sqrt{g} R_e}{p_o/m_a} \left( \frac{1}{\sqrt{R_1}} - \frac{1}{\sqrt{R_2}} \right) \quad (18)$$

where

$g$	constant of gravitational acceleration, $9.8 \text{ m/sec}^2$
$p_o$	solar pressure, $92.3 \times 10^{-5} \text{ g/m}^2$
$m_a$	specific mass, $\text{W/g}$ , $\text{g-sec}^2/\text{m}^3$
$W$	specific weight, $\text{g/m}^2$
$R_e$	radius of the Earth, $6378 \times 10^3 \text{ m}$
$R_1$	initial orbit altitude measured from center of the Earth, $R_e + h_1 = 6378 \times 10^3 + 700 \times 10^3 = 7078 \times 10^3 \text{ m}$
$R_2$	final orbit altitude measured from center of the Earth, $R_e + h_2 = 6378 \times 10^3 + h_2 \text{ m}$
$h_1$	initial orbit altitude measured from Earth surface, $\text{m}$
$h_2$	final orbit altitude measured from Earth surface, $\text{m}$

Solar-sailing times were calculated for specific weights (mass-to-area ratios) of 12, 18, and  $24 \text{ g/m}^2$ , and for orbit altitudes (measured from the Earth surface) ranging from 700 to 100 000 km. The results of these calculations are plotted in fig-

ure 21. Atmospheric drag was not included in these calculations. For the baseline design case, for which the specific weight of the spacecraft can be as low as  $12 \text{ g/m}^2$  when some auxiliary fuel is unloaded, it takes 10.2 months to solar sail from 700 km to GEO. If the baseline design weight should increase by 50 percent to  $18 \text{ g/m}^2$ , the trip time to GEO would be 15.3 months, which is lengthy but still reasonable for long-duration illumination applications for which the spacecraft is designed to last 15 years.

### Orbit Station Keeping

Orbit control.- The section entitled "Orbit Selection" contains a description of orbit perturbations caused by the Earth's oblateness. For missions using altitudes lower than 5000 km, circular Sun-synchronous orbits which precess at the same angular rate as the orbit of the Earth about the Sun were chosen to avoid these perturbations. Also, orbit perturbations can be substantially minimized by using high-altitude orbits such as the 12- and 24-hour orbits of primary consideration in these studies. However, lightweight spacecraft can be significantly perturbed in any orbit by solar pressure. Thus, solar pressure, which can be used to great advantage for solar-sailing lightweight reflector spacecraft to their operation orbits, becomes a disadvantage once the orbit has been established. These studies did not investigate this problem. The following discussion on solar-pressure perturbations is from a private communication with Walter Hausz of the General Electric Co., Santa Barbara, California.

For a reflector weighing  $105 \text{ g/m}^2$  in an initially circular geostationary orbit, the solar pressure could cause an eccentricity of 0.22 within 6 months if uncompensated for. During the second 6 months this eccentricity would decrease and at the end of 12 months the orbit would again be circular. The 0.22 eccentricity would result in a nadir fluctuation of  $\pm 12^\circ$  which, although not desirable, will in most cases be tolerable. Mr. Hausz pointed out that dispersions of reflectors in lower orbits would also be large and that, depending upon the altitude, the reflectors might reenter the Earth's atmosphere instead of returning to their starting point at the end of a year.

Mr. Hausz recommended techniques for manipulating initial orbits in order to limit the magnitude of eccentricities resulting from the solar pressure. Since the illumination applications proposed use high-altitude orbits (mostly GEO), we are confident that the orbit dispersions can be controlled to acceptable limits by the combination of solar sailing and applying techniques similar to those recommended by General Electric and others. However, these studies did not address the potential problems that displaced solar-reflector spacecraft could present to other spacecraft in the already crowded GEO. These areas require additional in-depth study before committing to a specific mission or spacecraft design.

In-orbit maneuvering.- For some applications it may be desirable to change the orbital position of a reflector spacecraft. This aspect of station keeping through solar sailing was not studied. However, Mr. Hausz of General Electric determined that a  $20 \text{ g/m}^2$  spacecraft in GEO could be repositioned 150 orbital degrees in approximately 10 days (5 days of acceleration followed by 5 days of deceleration).

## TRACKING AND ATTITUDE-CONTROL REQUIREMENTS

Three types of maneuvers will be encountered for which the spacecraft structure and its attitude-control system must be designed. These maneuvers are as follows:

1. Tracking over ground site
2. Reorientation between sites
3. Solar sailing

The baseline reflector spacecraft was designed by Astro Research Corp. under contract to LaRC for two orbit altitudes (2400 and 4146 km). These low altitudes were selected for the applications involving electrical-energy production which were initially studied. Such energy applications require high intensities on relatively small collector sites. The low altitudes are also suitable for illuminating small cities. The results of these investigations are reported in detail in reference 17, from which most of the following discussions and supporting data were extracted.

### Tracking Over Ground Site

The geometry of the reflector spacecraft  $s$  relative to the Earth  $E$  and the Sun  $S$  is shown in figure 22, where the Earth receiver site, which is also the center of the reflected light beam, is  $P$  and the angle of the reflector is  $\delta$ . Tracking was assumed to commence at an elevation angle  $\theta$  of  $30^\circ$  above the local horizon and terminate at  $\theta = 150^\circ$ . Figures 23 and 24 present the kinematics of the tracking maneuvers for the 2400- and 4146-km orbits. Shown in the figures are the reflector-angle function  $\delta - (\epsilon/2)$ , the angular velocity  $\dot{\delta}$ , and the angular acceleration  $\ddot{\delta}$ . Note that the angular acceleration time history is antisymmetrical about the midpoint of the tracking maneuver. Thus, the angular velocity time history is symmetrical and has equal values at the beginning and at the end of the maneuver. Therefore, the net angular impulse that must be exerted by the control system during a maneuver is zero. This is indicated by the following equations:

$$T = I_Y \ddot{\delta}$$

where  $T$  is the control-system torque and  $I_Y$  is the mass moment of inertia about the spacecraft  $Y$ -axis. The angular impulse exerted during the tracking maneuver between times  $t_0$  and  $t_1$  is the following:

$$\int_{t_0}^{t_1} T dt = \int_{t_0}^{t_1} I_Y \ddot{\delta} dt = I_Y (\dot{\delta}_{t_1} - \dot{\delta}_{t_0}) = I_Y \Delta \dot{\delta} \quad (19)$$

where  $\Delta \dot{\delta}$  is the net change in angular velocity during the entire tracking maneuver. Since the velocity curve is symmetrical and the entry and exit velocities are equal, there is no net change in  $\dot{\delta}$  during the maneuver and, therefore, the control system does not use any net energy during the overall tracking maneuver.

Another important observation can be made from the curves of figures 23 and 24. The position curve  $\delta - (\epsilon/2)$  is almost linear. For the 2400-km-orbit case, the rotation rate is approximately  $[\delta - (\epsilon/2)]/\Delta t = 60/(955/60) = 3.75$  deg/min. A reflector freely tumbling at 1 revolution per orbit in a 2400-km orbit with a period of 120 minutes has a free tumble rate of 3 deg/min. This tumble rate is close to the controlled rotation rate of 3.75 deg/min calculated above. Similar calculations for the 4146-km (3-hour) orbit show a free tumble rate of 2 deg/min compared to a controlled rotation rate of 2.4 deg/min during tracking. Thus, the required angular orientation during the tracking maneuvers is about the same as a freely tumbling satellite rotating at a rate of one revolution per orbit, a condition which reduces the torque required from the attitude-control system.

#### Reorientation Between Sites

For spacecraft using low orbits to be economically feasible, the reflectors must be capable of illuminating several predesignated, equally spaced sites around the world during a single orbit pass. It is important, however, to limit the number of sites so that maneuvers between sites can be accomplished with the net expenditure of little energy, similar to the results for tracking over sites. Again, for the 2400-km orbit, it is important not to deviate appreciably from the mode of free tumbling at 1 revolution per orbit discussed previously. Reflectors which track sites spaced too close together must achieve large rotational accelerations and will require high-impulse control systems. Such conditions will result in control-system weights which are too high to be practical and in correspondingly heavy spacecraft structures necessary to maintain safe stresses and acceptable deflections.

The Astro Research Corp. determined that it is not feasible to track more than two sites per orbit from the 2400-km orbit because of the growth in weight of the control system. From figure 23, the maximum angular acceleration  $\delta$  of the reflector is about  $1.88 \times 10^{-3}$  mrad/sec<sup>2</sup> for maneuvering over sites. For reorientation maneuvers between sites and for tracking two sites per orbit pass, Astro calculated an angular acceleration of  $6.39 \times 10^{-4}$  mrad/sec<sup>2</sup>, which is less severe. Therefore, the over-site tracking angular acceleration ( $1.88 \times 10^{-3}$  mrad/sec<sup>2</sup>) at 2400-km altitude is one of the critical conditions upon which the design of the baseline solar-reflector spacecraft is based. Solar-sailing loads are discussed subsequently.

An analysis to determine the maximum angular acceleration during reorientation maneuvers while tracking four equally spaced sites around the world was performed at LaRC. This analysis was conducted for a 2.4-hour circular orbit 2720 km high, which provides less severe dynamic conditions than the lower 2400-km orbit analyzed by Astro Research Corp. For four sites there are 41° per site (referenced to the center of the Earth) for over-site tracking and 49° for the reorientation maneuvers between sites. The angular orbit velocity of the reflectors in a 2720-km orbit is 0.04 deg/sec. Therefore, the time available for reorientation is  $\Delta t = 49/0.04 = 1225$  sec, or 20.4 minutes. For four equally spaced sites, the reflector reorientation angle  $\Delta\delta$  between sites is 11° (0.19 rad). The angular acceleration during reorientation is

$$\ddot{\delta} = \frac{4 \Delta\delta}{(\Delta t)^2} = \frac{4(0.19)}{(1225)^2} = 0.507 \times 10^{-3} \text{ mrad/sec}^2$$

Since this value of reflector reorientation angular acceleration is approximately 3.7 times less than the spacecraft design value of  $1.88 \times 10^{-3}$  mrad/sec<sup>2</sup>, it appears feasible to track four equally spaced sites from a 2720-km orbit. Calculations indicate that it is not feasible to track five or six equally spaced sites during a single orbit pass because of the high angular accelerations previously mentioned.

### Solar Sailing

After orbit insertion by the Space Shuttle, solar sailing will be used to transfer the reflector spacecraft to both their low- or high-altitude operational orbits. Angular accelerations are also imposed on the reflector spacecraft during solar-sailing maneuvers. Here, again, it is desirable to limit these accelerations to the spacecraft design limit of  $1.88 \times 10^{-3}$  mrad/sec<sup>2</sup>. Angular accelerations will be larger in the initial low-altitude orbits. As previously discussed, a Shuttle insertion orbit of 700 km was selected. The solar-sailing technique requires the reflector to rotate 90° ( $\Delta\delta = \pi/2$ ) during one-third of the orbit. With this as the worst-case condition in the 700-km circular orbit, which has a period of 5926 sec, the maximum angular acceleration is calculated below.

The time for the 90° maneuver is  $\Delta t = 5926/3 = 1975$  sec. From the equation for uniformly accelerated motion, the maximum angular acceleration is

$$\ddot{\delta} = \frac{4 \Delta\delta}{(\Delta t)^2} = \frac{4\pi/2}{(1975)^2} = 1.61 \times 10^{-3} \text{ mrad/sec}^2$$

which is 14 percent lower than the Astro design value of  $1.88 \times 10^{-3}$  mrad/sec<sup>2</sup>.

### Gravity-Gradient Forces

For the 1-km-diameter reflector spacecraft (baseline mission), gravity-gradient forces are substantial. The spacecraft attitude-control system must be designed to perform its tracking maneuvers in the presence of these forces. Reference 17 notes that the component of gravitational torque  $T_G$  in the direction  $\delta$  (see fig. 22) has a maximum magnitude of

$$T_G = \frac{3}{2} \dot{\phi}^2 I_Y \left( \frac{I_Z - I_Y}{I_Y} \right) \quad (\delta = \phi + \pi/4) \quad (20)$$

where  $I_Z$  is the spacecraft polar mass moment of inertia and  $I_Y$  is the mass moment of inertia about the spacecraft diameter. For the baseline spacecraft,  $I_Y = 4.91 \times 10^8$  kg-m<sup>2</sup> and  $I_Z = 2I_Y$ , or  $9.82 \times 10^8$  kg-m<sup>2</sup>. The value of  $\phi$  is given by

$$\dot{\phi} = b^{-3/2} (g/R_e)^{1/2} \quad (21)$$

The nondimensional measure of the spacecraft orbit altitude  $b$  is given by

$$b = \frac{R}{R_e} = 1 + \frac{h}{R_e} \quad (22)$$

where the radius of the Earth  $R_e = 6372$  km and  $h$  is the orbit altitude of the spacecraft. The results of these calculations for the 2400- and 4146-km altitudes are presented in table III for the worst-case gravity-gradient torque  $T_G$  calculated with equations (20), (21), (22), and the two orbit altitudes above. Table III also gives values for the equivalent maximum angular acceleration, which is determined by dividing  $T_G$  by  $I_y$ . Conservative estimates of the maximum angular impulse and angular velocity change resulting from gravity-gradient forces were determined by multiplying the torque and angular acceleration values presented in the table by the total time duration of the tracking maneuver.

#### Combined Worst-Case Design Conditions

With the values of table III, the maximum conditions for which the baseline reflector was designed are found by summing the coplanar tracking kinematics and the worst-case gravity-gradient conditions, which occur at the 2400-km altitude. Thus

$$\text{Max. angular acceleration} = 1.87 \times 10^{-3} + 0.89 \times 10^{-3} = 2.76 \times 10^{-3} \text{ mrad/sec}^2$$

$$\text{Max. torque} = 918 + 432 = 1350 \text{ N-m}$$

and

$$\text{Max. angular impulse} = 3.33 \times 10^5 + 4.13 \times 10^5 = 7.46 \times 10^5 \text{ N-m-sec}$$

#### REFLECTOR SPACECRAFT DESIGN CONCEPTS

In the late 1970's, the NASA Ames Research Center proposed an ultralightweight, 1-km-diameter deployable reflector for its SOLARES study program. The Ames' SOLARES studies were terminated in 1979, and the study office at LaRC agreed to incorporate the SOLARES reflector concept in its own feasibility studies of illumination from space. The initial goal at LaRC was to advance the SOLARES deployable reflector concept from the idea stage to the design concept stage. Late in 1979, the Astro Research Corp., which had been involved in SOLARES spacecraft concept studies, was awarded a contract to perform parametric studies of deployable reflector concepts and to derive a "point" design based on these studies and on guidelines specified in the contract. The main guideline, or goal, was that the deployable spacecraft was to be 1 km or larger in diameter and was to be compatible with the volumetric and weight-carrying capabilities of the Space Shuttle. There were two major reasons for wanting a 1-km-diameter spacecraft. The first was to reduce to more acceptable levels the number of spacecraft in orbit required to perform SOLARES-type energy-producing missions. The second was to reduce the number of expensive Space Shuttle launches.

Since solar-reflector applications require orbits higher than those achievable with Shuttle, the costs of orbit-transfer vehicles must be added to launch costs. Thus, if an application is to be cost effective, methods must be found to reduce launch and orbit-transfer costs.

### Baseline Reflector Spacecraft Concept

The Astro solar-reflector spacecraft design is based on the maximum angular acceleration loads encountered while tracking ground sites from a 2400-km-high orbit specified for energy production. As indicated in the section entitled "Solar Sailing," comparable angular accelerations and loading conditions are experienced when solar sailing from the 700-km Shuttle insertion orbit to orbits ranging from 2400 km for energy production up to 35 860 km (GEO) for the illumination missions discussed herein. Thus, solar sailing, when specified as the method for orbit transfer, imposes approximately the same loading conditions for which both energy-producing and illuminating spacecraft must be designed. This is justification for using the Astro "point" design of reference 17 as the baseline reflector spacecraft in these illumination-from-space studies.

The Astro design concept is a Shuttle-compatible, deployable solar-reflector spacecraft shown in figure 25. This spacecraft is a hoop-column-type structure with a nominal diameter of 1 km after deployment. Each side of the central hub is a deployable Astromast<sup>2</sup> and so are the rim segments. Stabilization (Stay) tapes are stretched from the ends of the central hub to the rim segments. The membrane is Kapton 2 m thick and is coated with 0.2 m of vapor-deposited aluminum to provide a mirror surface. The spacecraft is steered by control-moment gyroscopes (CMG's) using two 40-m-diameter fabric rotors. Secondary control for desaturating the CMG's and counteracting solar-pressure misalignment torques is provided by a magnetic-loop control system, which is most efficient for the low-altitude (2400 to 4146 km) orbits used primarily for the energy-producing applications studied by Ames and later by LaRC. Magnetic-loop control would also be effective for illumination missions performed with reflectors in the relatively low altitude Sun-synchronous orbits. The characteristics of the magnetic-loop control system are presented in reference 17. For the higher equatorial orbits, which appear more feasible for the illumination applications presented herein, a liquid-fueled attitude-control system (ACS) using reaction jets will be used for secondary control. The spacecraft is powered with electricity produced by solar cells located around the two canisters which house the central masts before deployment. These canisters also contain the instrumentation, housekeeping systems, and attitude-control-system fuel (where applicable).

Figure 26 shows the reflector spacecraft packaged for installation in the Shuttle cargo bay. The packaged configuration occupies a cylindrical volume with a maximum diameter of 4.3 m and a length of 15.0 m. After installation, approximately 3.3 m of cargo bay length remains free for making adjustments in the payload center of gravity position and for stowing equipment peculiar to the mission.

In reference again to the packaged spacecraft configuration, the six slender canisters contain the rim trusses and the attachment rings, which are preconnected to the stay ends and the film-expansion compensators. The reflector film (membrane) is stowed in multiple folds in bins mounted between paired rim-truss canisters. The

---

<sup>2</sup>Astromast is a deployable mast developed by Astro Research Corp.

film-corner compensators and most of the stay tapes fold within the film. Omnidirectional antennas are mounted at each end of the central mast on the deployed Astromast canister covers. Stay-tape reels are located around the canister covers. The two deployable-fabric rotors of the CMG are stowed around their hubs, inboard the Astromast canisters.

The spacecraft is designed to be deployed in sequential steps. The deployment can be stopped and restarted at any point. This enables inspection or repair during or after each sequence to assure that each deployment step has taken place according to plan and that the ensuing steps can be undertaken with confidence. Thus, the total deployment sequence can be monitored by the crew of the Space Shuttle to assure that the spacecraft is fully deployed and operational prior to transfer to its higher operational orbit. Additional details on the deployment of the solar-reflector spacecraft are presented in reference 17.

### Attitude Control

The baseline reflector spacecraft concept studied at LaRC for 12- and 24-hour high-altitude orbits, which are especially suited for illumination applications, uses the Astro "point" design described above. The magnetic-loop control system, which is ineffective at these high altitudes, is not included in the concept. The baseline spacecraft concept uses the CMG system specified by Astro. Design details of the CMG system for the 2400-km orbit are shown in table IV. This CMG design can provide the higher torques necessary for the initial solar-sailing maneuvers. The baseline spacecraft concept is equipped with a liquid-fueled-thruster auxiliary propulsion system (APS) which serves both as an auxiliary attitude-control system and as a low-thrust propulsion system.

The APS is activated after the spacecraft is removed from the cargo bay of the Shuttle and unfurled. Here it is used to stabilize the spacecraft while the 40-m rotors of the CMG system are being spun up. The APS is also used periodically for attitude control when it is necessary to reset the CMG's after they have become saturated.

The APS is used as a low-thrust propulsion system to complement solar sailing in the low orbits from 700 to 1500 km where some atmospheric drag is experienced. Above 1500 km the drag forces are negligible and only solar sailing is required for the remaining orbit transfer.

The APS uses  $N_2O_4$ /Aerozine 50 fuel with a specific impulse of 320 sec, and uses four solenoid-operated thruster units equally spaced around the periphery of the 1-km reflector. Two of the opposing thruster units contain four small fixed jets each for attitude control about the Y-axis and for roll control. The other two opposing units contain three jets each for attitude control about the X-axis and for linear thrust coplanar with the reflector membrane.

The total mass of the APS is 1977 kg, which includes 1577 kg of fuel. The mass ratio of the system is approximately 5. The system is designed so that half of the fuel (789 kg) is consumed while assisting solar sailing in the lower orbits. Based on the assumption of resetting the CMG's twice a week for 16 years, it was estimated that 1664 30-minute maneuvers would be required. These attitude maneuvers would consume 556 kg of fuel. Approximately 232 kg of fuel would remain for orbit station keeping and for reserve. The specifications for the APS are summarized in table V.



## Spacecraft Loads

Several loading conditions are imposed upon solar-reflector spacecraft, the most significant of which are listed below.

1. Solar pressure
2. Atmospheric pressure (drag)
3. Gravity-gradient loads
4. Control loads (solar sailing and ground-site tracking)

Flight conditions which produce these loads have been discussed elsewhere in this paper and are discussed in detail in reference 17. Figure 27 shows plots of these loads on the reflective membrane of the 1-km baseline spacecraft at orbit altitudes up to GEO. To show comparisons between the various loads, the loads have been expressed as force per unit area (pascals). Each load is based on worst-case conditions and each is assumed to act normal to the surface of the membrane.

As shown in figure 27, the solar-pressure load is independent of orbit altitude. When the reflector membrane is normal to the Sun's rays, the maximum solar pressure is  $0.905 \times 10^{-5}$  Pa, as indicated.

The atmospheric-pressure (drag) load on the membrane is highest at low orbit altitudes and, as shown in the figure, is equal in magnitude to solar-pressure loads at approximately 700 km during the years of maximum solar activity when the upper atmosphere is denser. This load increases rapidly below 700 km.

The gravity-gradient load shown in the figure is based on a mass per unit area  $m_a$  of  $0.004 \text{ kg/m}^2$ , which is the unit mass of the reflective membrane. For worst-case conditions the maximum distance to the edge of the membrane ( $r = 500 \text{ m}$ ) has been chosen. Thus, the gravity-gradient curve is based on  $m_a r = 2.0 \text{ kg/m}$ . Gravity-gradient loads are higher at low orbit altitudes, where orbital angular velocities are higher. For the baseline spacecraft, gravity-gradient loads are always less than the solar-pressure loads.

The maximum control loads for solar sailing also occur at the rim. Thus, the value of  $m_a r$  is also  $2.0 \text{ kg/m}$ . Solar-sailing loads are approximately equal to the control system ground-site tracking loads which were used by Astro in the structural design of the baseline spacecraft. Solar-sailing loads are higher at low orbit altitudes, where orbital angular velocities are higher and the spacecraft must be rotated quicker to achieve the best orientation conducive to solar sailing.

## Spacecraft Mass

The mass summary for the baseline reflector spacecraft concept is presented in table VI. The total mass of this spacecraft is 11 000 kg. Its mass-to-area ratio is  $14 \text{ g/m}^2$ , which is similar to the unit mass of a single page of newsprint.

## COST ANALYSIS FOR ILLUMINATION OF URBAN AREAS ACROSS COUNTRY

Because of funding constraints of this study, an in-depth cost analysis of illumination-from-space missions could not be made. However, since most of the missions discussed in this document have industrial applications, some general indication of the economic feasibility appears desirable.

The rough cost estimate of table VII was made for the previously discussed scenario depicted in figure 9. For this application, a constellation of 16 solar reflectors provides an illumination of 8 lux during mornings and evenings to 5 large urban areas across the United States. A total of 18 hours of reflected illumination can be provided each day year round.

Some of the cost factors of table VII were taken from references 10 to 13 and from Westinghouse Electric Corp. informal documentation. In most cases, these costs have been adjusted to account for inflation and the quantities procured. The cost factors in table VII are considered in the following discussion.

1. Research and development cost - An informal 1977 Westinghouse document describes solar reflector research and development cost as \$50 million. This value has been adjusted upward to \$125 million to account for inflation and to include development of advanced technology pertinent to large space systems 1 km in diameter.

2. Ground control - The estimate for ground control of \$50 million was made assuming maximum use of some existing NASA and Comsat tracking and command facilities and equipment.

3. Operations cost per year - The figure of \$10 million is the estimated cost per year to operate the ground control facilities.

4. Reflector unit costs - The estimated cost of each 1-km solar reflector was \$2 million in reference 13. This value has been adjusted to \$12 million to account for inflation and for reduced quantities of reflectors necessary.

5. Number of reflectors - The illumination application considered in this estimate requires 16 reflectors to produce an intensity of 8 lux at the ground sites. Two more reflectors have been added as spares, making the total on which the estimate is based at 18.

6. Shuttle launch cost - A Space Shuttle will be required to launch each of the 18 solar reflectors. Since a reflector will fill the Shuttle bay, launch costs will not be shared by any other program. Cost of a dedicated Shuttle launch is projected at \$50 million per reflector including integration and is the major cost for this estimate.

7. Yearly energy savings - This cost factor of \$286.1 million was obtained after making several adjustments to Westinghouse data produced in 1976. The data were compiled for a 333 km-diameter area centered near Philadelphia (Pa.) and was based on the cost of providing outdoor lighting for both municipal- and private-sector uses. The cost of electrical energy (maintenance and other costs not included) is the basis for the estimates herein since the proposed 8-lux solar-reflector illumination system will not replace outdoor lighting facilities and equipment. As the space system allows the outdoor lights to be turned off during favorable weather conditions, these energy costs are considered savings. These savings were calculated as follows for the scenario depicted in figure 9.

From power company estimates, the cost of electricity used in the Philadelphia area is \$118 million for the municipal sector and \$82 million for the private sector for a total of \$200 million per year, based on a 12-hour day. For the part-time illumination scenario on which the savings estimate is based, assume an average usage of 3 hours per day. Therefore, the cost of electricity saved is 3/12 of \$200 million, or \$50 million per year for the Philadelphia area. If we allow for cloud cover 25 percent of the time, the cost of electricity saved is 0.75 of \$50 million, or \$37.5 million. Based on rough population estimates for each of the five areas served (see fig. 9) and a usage factor, the collective amount saved in the five depicted areas was calculated as 3.5 times the energy saved in the Philadelphia area. Therefore, the electrical-energy cost savings attributed to reflector illumination in the five urban areas will be 3.5 times \$37.5 million, or \$131.25 million per year. Since the 1976 time period of the above estimate, the cost of electricity has escalated by approximately 118 percent. Therefore, the yearly energy savings based on 1981 costs are 2.18 times \$131.25 million, or \$286.1 million as shown in table VII.

8. Total solar-reflector program savings - The maximum lifetime of a spacecraft is governed by the inherent life of critical components within the design. Based on an assessment of the present state of lifetime-limiting components within the proposed solar-reflector spacecraft and the scope of ongoing research and development programs in these same critical areas, a 15-year spacecraft lifetime is an achievable goal and this figure is used to calculate program cost benefits.

With the cost factors and the equation in footnote "a" of table VII, it was determined that it would take 4.68 years for the cost of the space system to equal the savings. The total program cost was calculated to be \$1.34 billion. Since the system is designed to last 15 years, there will be 10.32 years of "profit" at \$286.1 million per year minus the operations cost of \$10 million per year, which results in a total profit of \$2.85 billion, assuming that the constellation would be retired at the end of its design lifetime.

#### ENVIRONMENTAL, ECOLOGICAL, AND SOCIETAL IMPACT

To our knowledge, no studies have been performed to determine the environmental, ecological, or societal impact of using mirrors in orbit to reflect solar radiation to Earth, specifically for illumination purposes. The discussions below relate some of the concerns known intuitively or expressed during briefings on the solar-reflector program. We will attempt to put these concerns in their proper perspectives and in some cases we will indicate methods of minimizing them. It is not intended that this discussion serve as a substitute for in-depth examination. Such impact studies should be given high priority in the future.

#### Environmental Impact

A preliminary environmental-impact assessment, which was not formally published, was performed on the Ames SOLARES baseline concept. That concept used several thousand orbiting mirrors to reflect the approximate equivalent of the Sun ( $1 \text{ kW/m}^2$ ) at noontime, desert sea-level conditions continuously on a 40-km-diameter Earth receiver site covered with solar cells. A single SOLARES site could produce approximately 220 GW of electricity, which is equivalent to today's consumption in the United States. Six such sites, spaced evenly around the Earth, could meet world needs for electricity.

The results of the environmental-impact assessment of SOLARES indicated that the reflected plus the natural solar radiation on a 40-km site could create a "heat island" effect which could cause adverse weather conditions such as tornadic winds and hailstorms at adjacent areas. The Ames SOLARES team raised objections to these findings and the methods used to derive them. The contractor who made the assessment acknowledged that there were many interrelated effects which, for funding reasons, could not be addressed with the meteorological models used and strongly recommended that a more comprehensive (and expensive) modeling study be performed.

The energy reflected to Earth by SOLARES (about  $1 \text{ kW/m}^2$ ) is approximately 9500 times more intense than the 8 lux ( $0.106 \text{ W/m}^2$ ) reflected for the baseline illumination applications described herein. Another consideration pertinent to the baseline application is that no site is illuminated more than 5 hours in a 24-hour period. Thus, for illumination, there appears to be time for the reflected heat load, which is minimal to begin with, to dissipate through convection to the atmosphere and reradiation into space.

Solar radiation reflected from space to Earth can heat the atmosphere and modify its physical and chemical properties. The shorter wavelengths, including ultraviolet, are the main causes of changes in atmospheric chemistry. There are reflective coatings, such as silver, which will filter out most of the short wavelengths. However, there are other problems associated with such coatings and trade-off studies must be performed to make the best selection. As reported earlier, vapor-deposited aluminum was selected for the baseline design described herein because of past favorable satellite experience with this material and for other reasons. An aluminum-coated mirror will reflect most wavelengths of the solar spectrum, but the intensity levels for the illumination applications advocated herein are so low that the effects on the atmosphere should be trivial.

### Ecological Impact

Closely related to the environmental impact of illumination reflected from space is the impact on ecology. Even the low intensity levels (8 to 22 lux) proposed for the illumination applications herein are cause for concern. For instance, consider the numerous ways the Moon affects our daily lives and the ecology, and recall that the intensity of the full Moon is only 0.143 lux, which is a fraction of the output being advocated herein for illumination from reflectors. Unlike solar reflectors, however, the Moon is a massive body and some of the effects attributed to moonlight could actually come from the gravitational influence of the Moon on the Earth and its ecology. We have not made inquiries or searched the literature to determine the results of studies on the effects of moonlight on the ecology. Since the Moon is our only major source of reflected sunlight, we should take full advantage of research on moonlight effects and use this information to help predict the ecological effects of solar reflectors. For instance, research may show that the growth of certain plants is slightly enhanced by photosynthesis from moonlight. This would offer valuable insight on how higher intensity levels, achievable with solar reflectors, would affect the ecology of plant life and whether space light could be applied to benefit agriculture.

It has been speculated that illumination from space would adversely affect the nesting habits of birds and the habits of wildlife in general. It should be noted that even though the light intensity levels proposed herein are equal to several full Moons (8 lux equals 56 full Moons), they are substantially below natural daylight levels even for a heavily cloudy day. The point is that the levels being proposed

for illumination applications are several orders of magnitude below normal daylight conditions and, therefore, the impact on the ecology may be insignificant.

The high-latitude parts of the world, such as Alaska, experience 24 hours of daylight per day during summertime. This, of course, is a natural condition from which the ecology of these regions has evolved. Even so, many of the same plants and species of animals that are found at lower latitudes also thrive at high latitudes. At high latitudes many plants flourish under extended sunlight even though the growing season is short. The balance between predators and their prey seems normal, although the added daylight would appear to favor the predators. Of course, at latitudes approaching the polar regions, other natural forces come into play which are so pronounced that they nearly obliterate all other conditions. However, the point is that there are large parts of the world which experience extended periods of daylight at much higher light intensities than those proposed for the illumination-from-space applications discussed herein without apparent ill effects. Indeed, it appears that the ecological effects of the extended daylight at high latitudes are mostly good. This should not be taken as an indication that illumination from space will not have some adverse ecological effects. Again, this is an area which requires study prior to making a commitment on solar-reflector missions.

If there are adverse effects from illumination from space, they are more likely to result from full-time (all night), year-round illumination of the same site. The baseline mission described herein, in which several sites across the country are illuminated for 1 to 2 hours during mornings and evenings, was conceived, in part, to minimize potential adverse impact on the ecology. Part-time illumination only extends the length of the day similar to natural seasonal changes at middle latitudes but at reduced light intensities.

#### Societal Impact

In our opinion, most people would not like illumination all night long, especially at levels approaching natural daylight. However, the 8- to 22-lux intensity levels advocated in this study, which are only a fraction of the natural daylight intensity, would probably gain public acceptance. Statistics show (ref. 20) that crimes such as burglaries and muggings, which are usually committed at night, are greatly curtailed when a good lighting system is installed. Also, there are major reductions in automobile accidents on streets and highways that are well lighted. The extra hours of outdoor lighting should offer people greater opportunities for outdoor activities, especially recreation.

The baseline mission scenario (part-time illumination) discussed in this study should be even more acceptable to society in general. The illumination would be furnished during the times of rush-hour traffic in the evenings and mornings when it is mostly needed. Part-time illumination during the early evening hours would occur at a time of peak usage of electricity and should benefit electric power utilities which must provide extra equipment just to meet peak needs.

It is anticipated that one of the most vocal groups against illumination from space will be astronomers. The reflectors will only be seen from the areas which are lighted, but these 333-km-diameter areas are likely to contain observatories. Here again, the part-time illumination mission scenario is designed, in part, to overcome these objections. Illumination from space only during the twilight hours of mornings and evenings will leave most of the night available for astronomy. Should there be a special astronomical event occurring during morning or evening hours, the reflectors

could be directed away from the area on a prearranged basis and the area would be served by its existing streetlight system. It should be recalled that the 8-lux baseline reflector system, advocated herein for the part-time illumination scenario, does not replace existing outdoor lighting facilities; it enables the lights of existing facilities to be turned off except during very inclement weather conditions.

### Concluding Observations

Some evidence has been presented to lessen the concerns for environmental impact by comparing illumination from space with several similar natural illumination conditions which exist on Earth. The part-time illumination-from-space scenario, whereby several large industrial areas across country are illuminated only during morning and evening hours, appears to be a practical method of minimizing the environmental impact and, thus, the objections to illumination from space. However, as certain large areas of the country and the world become more and more populated, cities will take over the forest and crop lands that separate them from each other and grow into regional-sized megalopolises, uniformly blanketed with illumination from conventional street and highway lights. When such conditions arrive, full-time illumination from space should be no more objectionable, environmentally, than conventional illumination.

In summary, the world is growing to the point where illumination from space will have less overall adverse impact on the environment than conventional lighting. There are useful commercial applications which can be performed with as few as four 1-km reflectors, which can be used to demonstrate and assess the concept before we commit to larger, more ambitious systems.

### PROGRAM REQUIREMENTS

The purpose of this section is to identify the studies, the technical developments, and a flight test which should be performed to enable practical and economical illumination-from-space applications.

#### Study Requirements

This paper is based on the findings of preliminary mission and design studies performed to establish the justification and to determine the feasibility of using orbiting mirrors to reflect sunlight to Earth for illumination applications. Additional in-depth studies must be performed to firmly define mission modes and spacecraft design. These studies are identified and briefly discussed below.

Environmental, ecological, and societal impacts.- The purpose of these studies will be to determine the environmental, ecological, and societal impacts of illumination-from-space missions. If it is found that there are potentially serious problems, the direction of the program will be reassessed. If there are reasons to obtain actual environmental-impact data via flight, it could be done with a scaled-down, research solar-reflector spacecraft or a "starter" system of one or two full-sized spacecraft.

Orbit transfer and station keeping.- Even though the reflector spacecraft has a specific mass of only 14 g/m<sup>2</sup>, its total mass is 11 000 kg. As of January 1982, the United States had no means for transporting such payload masses to GEO. The two-

stage Shuttle inertial upper stage (IUS), which is being developed, will transfer only 3700 kg to GEO. The planned Shuttle Centaur will transport approximately 5900 kg to GEO, so an upper stage would have to be added to the Centaur to achieve the necessary transportation capability. However, at least one additional Shuttle would be required just to transport the Centaur and its upper stage to low Earth orbit, and this would add approximately \$50 million for the extra Shuttle plus the cost of the Centaur combination to the launch costs of the program. Launch costs must be constrained if economic applications of industrialization of space are to be realized. The proposed solar electric propulsion stage (SEPS) could be used to transfer the solar-reflector spacecraft to GEO. The assumption is that the SEPS would be one of a fleet of reusable vehicles already stationed in low Earth orbit to provide ferry services. However, the development of SEPS has been delayed and its future is uncertain.

Initial studies already performed point to the feasibility of using the solar-sailing technique for orbit transfer. Additional studies are necessary to investigate orbit-plane changing and the effects of dispersions during transfer to higher orbits. The use of solar sailing to control dispersions in the final operational orbits must be assessed. Solar electric propulsion should also be investigated for the sake of comparison and as a possible alternative to solar sailing.

Mission definition and design.- Ordinarily, this subject would be of higher priority than the preceding study on solar sailing. However, sufficient work has already been done to establish operational orbits for several potential illumination applications, and the orbit-transfer and station-keeping techniques must be verified to assure that the operational orbits can be achieved and maintained. Additional work is required to establish accurate illumination profiles and to better define the orbits and systems necessary to achieve mission goals.

Orbit radiation assessment.- An assessment should be made of the particulate radiation to which the spacecraft would be subjected during orbit transfer through the Van Allen belt and during its 15-year mission in its final orbit. This study should be performed simultaneously with the spacecraft design studies discussed below, and the findings should be used as inputs to the design of the spacecraft and for the development of supporting technologies.

Spacecraft design and analysis.- The study reported in this document has pointed to the feasibility of developing a deployable solar-reflector spacecraft with a nominal diameter of 1 km which can be packaged in the cargo bay of the Space Shuttle, transported to low Earth orbit, unfurled, and solar sailed to operational orbits up to GEO. This spacecraft design is an optimistic one incorporating several new features.

Initially, during the next study phase, alternative deployable reflector spacecraft concepts should be designed. A design review should be conducted by an independent team of experts to evaluate the candidate spacecraft (including the baseline concept herein) and to also evaluate newly proposed subsystems and features. The design-review team should select the spacecraft concept and features for the more comprehensive design studies and technology developments to follow. Based on the findings of work already accomplished, it is possible to establish the following guidelines for the next phase of spacecraft design studies:

1. The actual area of the reflective membrane should be on the order of  $1.0 \text{ km}^2$ .
2. The mass fraction of the complete spacecraft should be 12 to 15  $\text{g/m}^2$ .

3. The spacecraft should be stowable in Space Shuttle.
4. The spacecraft in orbit should be deployed automatically and in discrete sequential steps.
5. The spacecraft should be designed to withstand inertial loads from a maximum angular acceleration of  $2.75 \times 10^{-3}$  mrad/sec<sup>2</sup> resulting from combined solar-sailing and gravity-gradient loads.
6. The spacecraft design should be such that the reflective membrane is relatively flat and wrinkle free.
7. The minimum design lifetime of the spacecraft and its subsystems and components should be 15 years in its operational orbit without refurbishment.

Benefits and cost analyses.- Even though this item is presented last, it is an item of considerable importance and should be started early in the program. The reason it appears last is that inputs from the mission analysis and spacecraft design are necessary in order to make valid cost estimates. As soon as potential illumination applications are identified, a concerted effort must be made to gather data on conventional lighting facilities in the areas to be served and to define how the space system can be integrated with existing ground lighting systems, both technically and economically. The final output of this study will show the benefits of the space system and will give a strong indication of its value as an investment.

#### Technology-Development Requirements

From the preliminary studies already performed and reported herein, it is possible to identify several areas requiring technology development in order to enhance the feasibility of illumination from space. These areas are listed and discussed below.

Durable, lightweight structural materials.- Continued emphasis should be placed on the development of structural elements fabricated from thermally stable materials such as graphite/epoxy composites. Strong, lightweight materials capable of withstanding the space environment for at least 15 years without significant degradation should be developed.

Large-area ultrathin membranes.- This area of technology development is perhaps the most important one for solar reflectors. The aluminized Kapton membrane of the baseline design discussed herein is only 2 m thick but has a mass of 3142 kg, which is about one-third of the total mass of the 1-km spacecraft. Note that after several tests 2-m Kapton was selected as the sail material for the Jet Propulsion Laboratory solar-sailing spacecraft. This background provides considerable confidence that 2-m Kapton is also feasible for solar-reflector spacecraft, although there is concern that it may be difficult to handle during fabrication and packaging. If a thicker membrane material is selected, the weight of the spacecraft will increase because of the added weight of the membrane material itself, the added weight of the structure resulting from the additional tension load necessary to reduce wrinkling, and the added weight of the control system necessary to maneuver the added inertia of a heavier spacecraft. Based on earlier parametric studies performed by the Astro Research Corp., it is estimated that the weight of the 1-km spacecraft would almost double (9368 kg to about 16 000 kg) if the membrane thickness were increased



from 2 to 6  $\mu\text{m}$ . (Note that the thinnest Kapton currently manufactured is 6  $\mu\text{m}$ , but thinner material can be obtained on special order or by chemically etching the thicker material.) Such a heavy spacecraft would definitely require a second OMS kit on the Shuttle to achieve the desired 700-km-high insertion orbit, and solar-sailing times to GEO would increase from 10.2 months for the baseline spacecraft to 20 months for the heavier spacecraft.

Based largely on the above considerations, it is recommended that the following technology be developed for membranes:

1. Reduce the large environmental strains (thermal, radiation, and so forth) of existing thin films.
2. Lower the elastic modulus to reduce the stress required to remove wrinkles and to flatten films.
3. Improve the long-term stability of films.
4. Increase the tear resistance of films.
5. Develop techniques for manufacturing wider (about 6.1 m) sheets of film.
6. Develop film-joining techniques that do not contribute to wrinkling while the membrane is being fabricated or after it has been installed and preloaded.
7. Develop design concepts and membrane fabrication techniques for fabricating flat, wrinkle-free membranes up to 1 km in diameter.
8. Develop handling and packaging techniques.

Coatings.— The development of durable, highly reflective membrane coatings is also of high priority. Coatings for deployable (unfurlable) structures should be applied on Earth in order to avoid the potential problems and expense of application through EVA in orbit. Since these coatings will be exposed to the Earth's environment for long periods of time prior to flight, they must not tarnish or deteriorate in the atmosphere. Also, these coatings must not deteriorate when the membrane is tightly packaged on Earth and during transport to orbit by the Space Shuttle. Once in orbit, the coatings should remain stable for design lifetimes ranging from 15 to 25 years in the presence of solar and particulate radiation. Some applications require orbits ranging from 2400 to 6000 km in the Van Allen belt where the particulate radiation is harsh. The urban-area illumination missions described herein require 12- and 24-hour high-altitude orbits, but the spacecraft must spend considerable time in the Van Allen belt during orbit transfer by solar sailing from low Earth orbits to the operational orbits. Specific technology-development requirements for membrane reflective coatings are the following:

1. Earth- and space-stable membrane coatings with coefficients of reflectivity of at least 98 percent when new that do not deteriorate below 95 percent after 15 to 20 years in orbit.

2. Coatings which will reflect specific wavelengths at the above efficiencies while rejecting or filtering out other unwanted or undesirable wavelengths. For both illumination and electric power production it is desirable to reflect only visible wavelengths ranging from 0.38 to 0.72  $\mu\text{m}$  while rejecting shorter and longer values. For other types of missions, it might be desirable to reflect wavelengths other than visible.

3. Techniques for efficiently (and perhaps remotely) restoring the coatings in orbit.

Long-life electric energy storage.- The current lifetime for state-of-the-art, maintenance-free nickel-cadmium batteries operating in space is about 6 to 6.5 years. A nickel-hydrogen battery with a lifetime in orbit of 15 years is currently being developed by Comsat. This is the factor responsible for the 15-year lifetime of the baseline missions discussed herein. For illumination (and for other industrial applications) it is very desirable to develop electric energy storage methods with lifetimes of 25 years or more. An alternative power storage method for reflector spacecraft is to use the rotors of the CMG's. This technique should also be an area of technology development.

Attitude and pointing control.- The attitude-control system must be capable of maneuvering the 1-km-diameter reflector spacecraft to direct a beam of reflected sunlight to a prescribed site on Earth with an accuracy that assures a specified intensity is attained and that undesirable spillover is largely avoided. This must be accomplished by accurately controlling slew rates while the reflector is moving in orbit. A reasonable goal in pointing accuracy is to control the center of the reflected beam to within 5 percent of the diameter of the target area. This results in a pointing accuracy requirement of 0.5 mrad.

The study reported herein found CMG's to be the most efficient method for attitude control of solar-reflector spacecraft. Technology should be developed to provide CMG systems capable of the accuracy requirements prescribed above. The systems should also have the following characteristics, which are based on the control of a 1-km-diameter spacecraft with a specific weight of 14  $\text{g}/\text{m}^2$ .

Control torque capacity, N-m .....	1890
Angular impulse capacity, N-m-sec .....	$10.4 \times 10^5$
Angular momentum capacity, N-m-sec .....	$6.0 \times 10^6$
Maximum mass of CMG system, kg .....	2800
Peak power required, W .....	5.7

The CMG systems should be compatible with the design of a deployable (unfurlable) reflector spacecraft and the complete spacecraft, with the CMG systems, must be stowable in the Shuttle cargo bay.

Surface control of reflective membrane.- This area of technology development is different than that discussed above for large-area, ultrathin membranes. The above discussion was concerned with maintaining a flat, wrinkle-free surface by developing better membrane materials, membrane fabrication techniques, and structural supporting techniques. This discussion concerns unique lightweight methods of maintaining planar (flat) film shapes while the large membrane is being subjected to orbit tracking solar-pressure forces or to dynamic conditions which result in vibrational motions.

Also of interest are methods for changing a planar configuration to one that is slightly concave or convex. Surface control methods should be simple and lightweight. Electrostatic membrane control should be considered.

Large deployable structures.- Based on the spacecraft design and analysis studies discussed previously, a spacecraft structural concept will be selected. This is the concept for which technology will be developed. The guidelines for the development of spacecraft structure technology are essentially the same as the design guidelines presented above. The end item of this area of technology development will be a deployable reflector spacecraft structure with a nominal diameter of 1 km that is compatible with and incorporates the other individual technology developments discussed in this section. In addition, the spacecraft should be designed so that it can be packaged in the Space Shuttle and it can be deployed automatically, as a free-flyer, after insertion in orbit. The spacecraft is to have a minimum lifetime of 15 years.

#### Flight Test

In all probability it will not be possible to determine, by analytical techniques alone, many aspects of the performance and behavior of the 1-km-diameter, ultralightweight solar reflector. Ground testing will provide additional data, but it will not be possible to conduct fully realistic tests on a large flexible structure without altering its true dynamic characteristics.

Testing the spacecraft in the combined zero-gravity/vacuum/thermal environments of space may be the best and the only method of obtaining reliable structural data. The ideal flight-test specimen would be a full-sized (1-km-diameter) duplicate of the planned operational spacecraft. However, for the sake of simplicity and economics, it may be more practical to fly a scaled-down version of the operational spacecraft. A 1/10-scale flight research spacecraft has been suggested. In order to obtain reliable data, the structure of the research spacecraft should be constructed to duplicate (except for size) the type of structure used for the 1-km operational spacecraft to the greatest extent feasible and appropriate scaling laws should be applied. In addition, the flight research spacecraft should be fully instrumented, and this instrumentation should be accurately correlated with that of the companion ground test program and the data point locations of the analytical model. Once the flight-test data have been obtained, analytical techniques and computerized modeling can be verified or adjusted as necessary. Afterwards, the analytical and ground testing techniques may be applied to any size solar-reflector spacecraft or other spacecraft using a similar type of structure.

In figure 15, it is shown that a 100-m reflector in a 600-km-high orbit will illuminate an Earth site to an intensity of 22 lux, which is considerably brighter than most of today's best expressway lighting systems. If the orbit of the 100-m reflector is elevated to 1000 km, an intensity level of 8 lux is achieved. This approximates the intensity of the baseline system discussed earlier, which uses a constellation of sixteen 1-km reflectors in GEO to illuminate urban areas across the United States. Thus, a 100-m flight research spacecraft in an orbit 1000 km high can be used to duplicate and test many aspects of illumination associated with light reflected from the much larger and more expensive operational system. So a 100-m-diameter flight research spacecraft can obtain data on deployment dynamics, materials and coatings, reflective membrane characteristics versus time, controls, solar sailing, orbit station keeping, and illumination with reflected sunlight. Actual illumination intensities can be compared to calculated values. The effects of slant-range

angles and cloud cover can be assessed. Public acceptance and some aspects of the environmental impact can be evaluated. Finally, the feasibility of using the reflector to illuminate nighttime Shuttle operations can be demonstrated.

#### CONCLUDING REMARKS

There are several potentially beneficial illumination applications that can be performed with two to forty 1-km orbiting solar-reflector spacecraft. These applications include the illumination of nighttime Space Shuttle operations, the commercial illumination of large urban areas across the United States, and the illumination of emergency situations with a few reflectors diverted from the commercial system. There is a reasonable indication that a scenario using a constellation of 18 reflectors (includes 2 spares) in geosynchronous Earth orbit (GEO) to illuminate several large urban areas across the country during morning and evening hours only is commercially feasible. It is believed that such part-time illumination will not adversely impact the environment and will be accepted by the general public.

A 1-km-diameter deployable solar-reflector spacecraft concept capable of being stowed in the Shuttle cargo bay has been presented. This spacecraft can be transported to orbit by the Shuttle, deployed as a free-flying spacecraft, and solar sailed to its operational orbits up to GEO.

Improvements in the technology to make illumination-from-space missions more feasible have been identified. In addition, the necessary companion studies have been identified and described.

Much can be learned about the hardware systems and illumination from space by building and flying a scaled-down, instrumented, 100-m-diameter version of the 1-km operational spacecraft. This 100-m flight research spacecraft can be built as part of the technology development program. It is recommended that the government develop the technology to fabricate and fly 1-km solar-reflector spacecraft and that additional studies be performed to confirm the commercial feasibility of illumination from space.

Langley Research Center  
National Aeronautics and Space Administration  
Hampton, VA 23665  
July 22, 1982

## REFERENCES

1. Oberth, Hermann: Ways to Spaceflight. NASA TT F-622, 1972.
2. Buckingham, A. G.; and Watson, H. M.: The Uses of Orbiting Reflector Satellites. AIAA Paper 67-786, Oct. 1967.
3. Buckingham, A. G.; and Watson, H. M.: The Uses of Orbiting Reflector Satellites. Preprint 67-118, American Astronaut. Soc., May 1967.
4. Buckingham, Arthur G.; and Watson, Harold M.: Basic Concepts of Orbiting Reflectors. Spacecr. & Rockets, vol. 5, no. 7, July 1968, pp. 851-854.
5. Ehricke, Krafft A.: Space Industrial Productivity - New Options for the Future. North American Space Operations, Rockwell International, July 1975. (Presented to the Committee on Science and Technology and the Subcommittee on Space Science and Applications at the Hearings on Future Space Programs, July 22-30, 1975.)
6. Ehricke, K. A.: Socio-Economic Determinants of a Program for Lunar Industrialization in Support of Space Light Development Lunetta and Soletta. IAF Paper A-77-66, Sept. 1977.
7. Ehricke, Krafft A.: Space Light: Space Industrial Enhancement of the Solar Option. Acta Astronaut., vol. 6, no. 12, Dec. 1979, pp. 1515-1633.
8. Ehricke, Krafft A.: Lunetta System Analysis. IAF Paper 80-A-11, Sept. 1980.
9. Ehricke, Krafft A.: Contributions of Space Reflector Technology to Food Production, Local Weather Manipulation and Energy Supply. Space in the 1980's and Beyond, Volume 53 of the Science and Technology Series, Peter M. Bainum, ed., American Astronaut. Soc., c.1981, pp. 213-226.
10. Billman, Kenneth W.; Gilbreath, William P.; and Bowen, Stuart W.: Introductory Assessment of Orbiting Reflectors for Terrestrial Power Generation. NASA TM X-73230, 1977.
11. Billman, Kenneth W.; Gilbreath, William P.; and Bowen, Stuart W.: Satellite Mirror Systems for Providing Terrestrial Power: System Concept. The Industrialization of Space, Volume 36, Part 1 of the Advances in the Astronautical Sciences, Richard A. Van Patten, Paul Siegler, and E. V. B. Stearns, eds., American Astronaut. Soc., c.1978, pp. 391-414.
12. Billman, K. W.; Gilbreath, W. P.; and Bowen, S. W.: Orbiting Mirrors for Terrestrial Energy Supply. Radiation Energy Conversion in Space, Kenneth W. Billman, ed., 1978, pp. 61-80.
13. Billman, K. W.; Gilbreath, W. P.; and Bowen, S. W.: Space Reflector Technology and Its System Implications. AIAA Paper 79-0545, Feb. 1979.
14. McCormack, Patricia: Like Food and Water, Light's Got Its Problems. Daily Press (Newport News, Va.), 85th yr., no. 41, Feb. 10, 1980, section A, p. 11.
15. Meinel, Aden B.; and Meinel, Marjorie P.: Applied Solar Energy - An Introduction. Addison-Wesley Pub. Co., Inc., 1977.

16. Hottel, Hoyt C.: A Simple Model for Estimating the Transmittance of Direct Solar Radiation Through Clear Atmospheres. *Sol. Energy*, vol. 18, no. 2, Feb. 1976, pp. 129-134.
17. Hedgepeth, John M.; Miller, Richard K.; and Knapp, Karl: Conceptual Design Studies for Large Free-Flying Solar-Reflector Spacecraft. NASA CR-3438, 1981.
18. Space Transportation System - User Handbook. NASA, 1977.
19. Smith, Robert E., ed.: Space and Planetary Environment Criteria Guidelines for Use in Space Vehicle Development (1971 Revision). NASA TM X-64627, 1971.
20. Public Lighting Needs. *Illum. Eng.*, vol. LXI, no. 9, Sept. 1966, pp. 585-602.

## SYMBOLS AND ABBREVIATIONS

### Symbols

A	area
$A_m$	frontal area of reflector (mirror)
$A_s$	area of reflected images (illuminated ground spot)
a	semimajor axis of elliptical reflected image
b	semiminor axis of elliptical reflected image; nondimensional spacecraft altitude
$C_D$	coefficient of atmospheric drag
$D_i$	linear dispersion of image
$D_m$	diameter of mirror (reflector)
$D_s$	image (ground-spot) diameter
d	distance from ground receiver site to reflector in orbit (slant range)
E	Earth
$E_m$	total energy reflected by mirror
$E_s$	total energy received on ground receiver site
F	force; atmospheric-drag force
$f_p$	solar-sailing performance factor
g	constant of gravitational acceleration
h	orbit altitude measured from surface of Earth
I	intensity of illumination on ground receiver site
$I_0$	exospheric solar flux (solar constant)
$I_Y$	mass moment of inertia about spacecraft Y-axis
$I_Z$	mass moment of inertia about spacecraft Z-axis
$m_a$	mass per unit area
P	Earth receiver site
$P_0$	solar pressure
R	radius from center of Earth to reflector in orbit

$R_e$	radius of Earth
$r$	radius
$S$	Sun
$s$	reflector spacecraft
$T$	torque
$T_G$	gravity-gradient torque
$t$	time
$V$	velocity
$W$	specific weight
$z$	angle between local vertical at receiver site and reflector
$\alpha$	included angle of Sun from Earth or Earth orbits
	slant-range angle from local site vertical to reflector
$\gamma$	angle of incidence
$\delta$	reflector angle relative to local ground-site vertical
$\dot{\delta}$	angular velocity
$\ddot{\delta}$	angular acceleration
$\epsilon$	angle from local site vertical to Sun
$\theta$	slant-range angle from local site horizon to reflector
$\mu$	flatness coefficient of reflector surface
$\rho$	coefficient of reflectivity of reflector surface; atmospheric density
$\sigma$	root-mean-square edge gradient of reflective membrane
$\tau$	coefficient of transmittance of atmosphere
$\phi$	angle measured from Earth's center between lines to ground site and reflector
$\psi$	cloud-cover coefficient

#### Abbreviations

ACS	attitude-control system
APS	auxiliary propulsion system



CMG control-moment gyroscope  
EVA extravehicular activity  
GEO geosynchronous Earth orbit  
IUS inertial upper stage  
LEO low Earth orbit  
OMS orbital maneuvering subsystem  
RF radio frequency  
rms root mean square  
SEPS solar electric propulsion stage

TABLE I.- LIGHT INTENSITIES FOR VARIOUS APPLICATIONS

Application	Intensity, lux
Auditorium during performance	1.07
Urban side streets	2.15
Airport aprons	10
Rural freeways	10.76
Major freeways	15.10
Major arterial highways	21.52
Factories, poorly lighted	10 to 40
Factories, well lighted	100 to 400
Infrequent reading, 8-point type (fairly fine)	107
Prolonged reading or shop bench work	320 to 540
Nighttime sports	1070

TABLE II.- REFLECTORS REQUIRED IN 24- OR 12-HOUR ORBITS TO PROVIDE SPECIFIED LIGHT-INTENSITY LEVELS TO LARGE URBAN AREAS

[Areas located between 30° and 45° N latitude]

Orbit period, hours	Orbit altitude, km	Image size, km	Light intensity, lux (full Moons <sup>a</sup> ) (b)	No. of 1.0-km <sup>c</sup> reflectors	No. of 1.4-km reflectors
d <sub>24</sub>	35 860	333	2 (15) 8 (56) 22 (154)	4 16 44	2 8 22
12	20 230	188	2 (15) 8 (56) 22 (154)	4 16 40	Not applicable 8 20

<sup>a</sup>Intensity of full Moon at 40° N latitude is 0.143 lux.

<sup>b</sup>An intensity of 2 lux corresponds to low streetlights, 8 lux to medium streetlights, and 22 lux to high streetlights.

<sup>c</sup>The actual membrane area must be equivalent to a 1.08-km-diameter circle for ground sites at 45° N latitude.

<sup>d</sup>For 24-hour orbits (GEO), occultation will reduce intensity by 1/2 for very short periods around midnight during the equinoxes.

TABLE III.- REQUIRED TORQUES AND ANGULAR IMPULSES DURING OVER-SITE TRACKING MANEUVERS FOR BASELINE SATELLITE

$$[I_Y = 4.91 \times 10^8 \text{ kg-m}^2]$$

Source	Max. $\ddot{\delta}$ , mrad/sec <sup>2</sup>	Max. $\Delta\dot{\delta}$ , rad/sec	Max. torque, N-m	Max. angular impulse, N-m-sec
Alt = 2400 km; Orbital period = 7179 sec; Time over site = 955 sec				
Coplanar tracking kinematics	$1.87 \times 10^{-3}$	$6.79 \times 10^{-4}$	918	$3.33 \times 10^5$
Worst-case* gravity gradient ( $\delta = \phi + 45^\circ$ )	$8.85 \times 10^{-4}$	$8.45 \times 10^{-4}$	432	$4.13 \times 10^5$
Alt = 4146 km; Orbital period = 10 739 sec; Time over site = 1691 sec				
Coplanar tracking kinematics	$4.42 \times 10^{-4}$	$2.88 \times 10^{-4}$	217	$1.41 \times 10^5$
Worst-case* gravity gradient ( $\delta = \phi + 45^\circ$ )	$5.13 \times 10^{-4}$	$8.67 \times 10^{-4}$	252	$4.26 \times 10^5$

\*Maximum angular impulse and  $\Delta\dot{\delta}$  determined by assuming constant torque and  $\ddot{\delta}$  for total time over site.

TABLE IV.- DETAILS OF BIAXIAL TWIN-ROTOR CMG<sup>a</sup> AT  
h = 2400 km FOR BASELINE SPACECRAFT CONCEPT

Control torque capacity, N-m .....	1350
Angular impulse capacity, N-m-sec .....	7.46 10 <sup>5</sup>
Angular momentum capacity, N-m-sec .....	4.26 10 <sup>6</sup>
Mass of 2 flywheels, kg .....	1000
Flywheel:	
Radius, m .....	20
Material .....	Glass fiber
Spin velocity, rad/sec .....	42.8
Mass of bearings, motors, and linkages, kg .....	1000

---

<sup>a</sup>This CMG design is based on the tracking of two Earth sites per orbit.

TABLE V.- SPECIFICATIONS FOR APS USED FOR  
GEOSYNCHRONOUS ORBIT<sup>a</sup>

Fuel .....	N <sub>2</sub> O <sub>4</sub> /Aerozine 50
Fuel specific impulse, sec .....	320
Total impulse, kg-sec .....	504 640
Thruster force, N .....	0.09
APS mass (empty), kg .....	400
Mass of fuel, kg .....	1577
Total mass of APS, kg .....	1977

---

<sup>a</sup>Mission lifetime 15 years.

TABLE VI.- MASS SUMMARY FOR BASELINE REFLECTOR SPACECRAFT CONCEPT  
WITH CMG AND APS CONTROL

Reflector membrane, <sup>a</sup> kg .....	<u>3142</u>
Total, kg .....	<u>3142</u>
Structural components:	
Edge tendons (90), kg .....	12
Film-expansion compensators (90), kg .....	330
Rim truss, kg .....	1760
Storage canisters and mechanisms, kg .....	552
Rim hinges and motors (6), kg .....	30
Stay tapes, front and back (180), kg .....	367
Tape reels, kg .....	42
Central masts and canisters, kg .....	364
Center tube, kg .....	48
Total, kg .....	<u>3505</u>
Control Actuator:	
CMG twin rotors, kg .....	1000
CMG suspension .....	1000
APS, kg .....	<u>1977</u>
Total, kg .....	<u>3977</u>
Communications, power supply, and control electronics:	
Solar power supply, kg .....	150
Hemispherical antennas (2), kg .....	20
Rate gyroscopes and sensors, kg .....	60
Communications and data handling, kg .....	100
Computer, kg .....	<u>46</u>
Total, kg .....	<u>376</u>
Spacecraft total, kg .....	11 000

---


$$^a A = 785\,400 \text{ m}^2; \quad m_a = 0.004 \text{ kg/m}^2.$$

TABLE VII.- ROUGH ESTIMATE OF COST BENEFITS OF EXTENDING DAYLIGHT  
HOURS ACROSS COUNTRY

[Reflectors in GEO; I = 8 lux]

Cost factors:

Research and development cost, R, millions of dollars .....	125
Ground control cost, G, millions of dollars .....	50
Yearly operations cost, O, millions of dollars .....	10
Reflector unit cost, U, millions of dollars .....	12
Shuttle launch cost, L, millions of dollars per reflector .....	50
Yearly energy savings, S, millions of dollars .....	286.1
Number of reflectors (includes 2 spares), N .....	18
Time to break even, <sup>a</sup> Y, years .....	4.68
Design lifetime, T, years .....	15
Total program cost, <sup>b</sup> billions of dollars .....	1.34
Total program profit, <sup>c</sup> billions of dollars .....	2.85

<sup>a</sup>Based on the following equation:

$$SY = R + G + OY + NU + NL$$

$$286.1Y = 125 + 50 + 10Y + 18(12) + 18(50)$$

$$Y = 1291/276.1 = 4.68$$

<sup>b</sup>Based on (\$286.1 million per year)(4.68 years) = \$1.34 billion

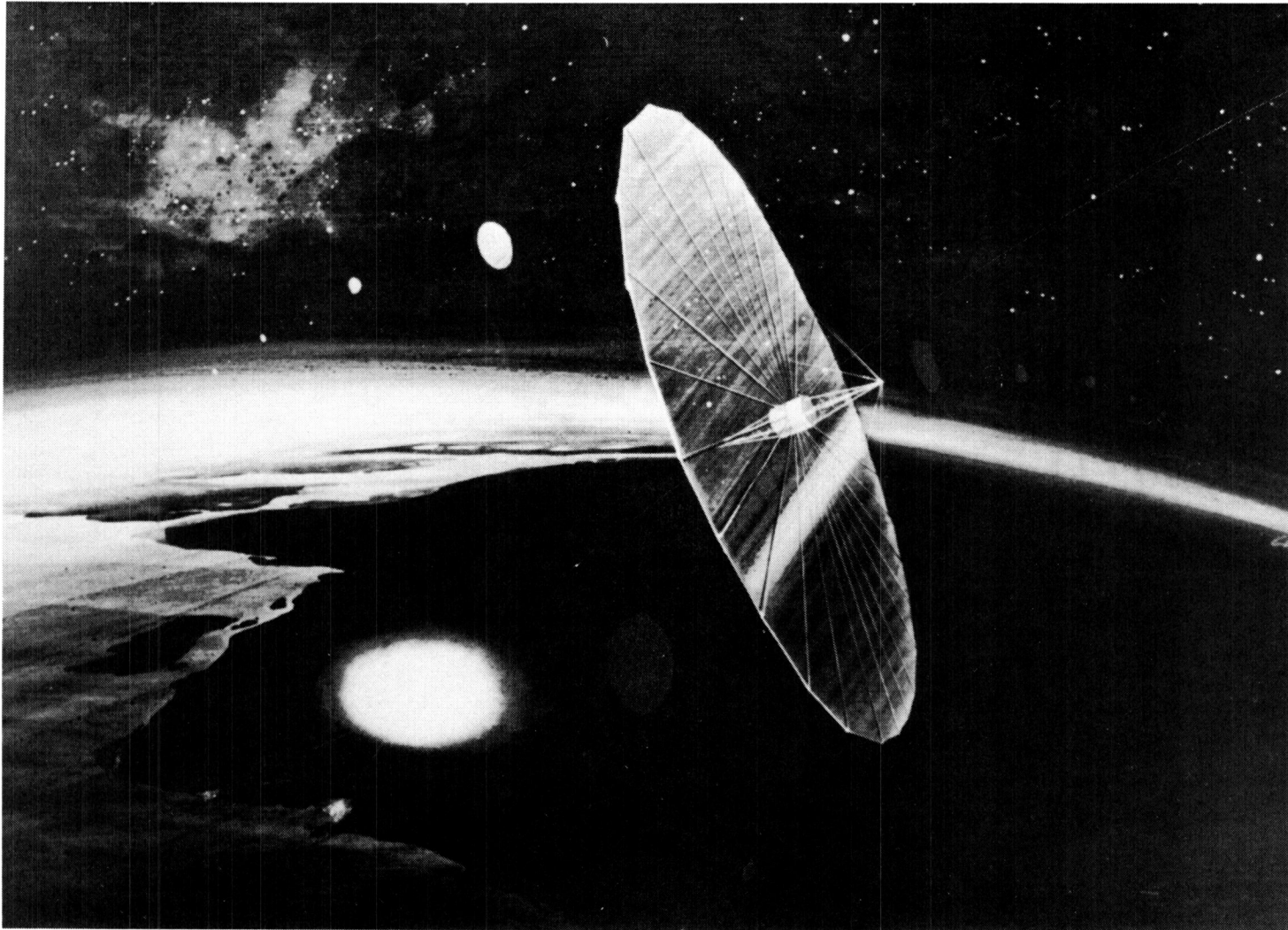
<sup>c</sup>Based on the following equation:

$$\text{Profit} = (T - Y)(S - O)$$

$$= (15 - 4.68)(286.1 - 10)$$

$$= (10.32)(276.1)$$

$$\text{Profit} = \$2.85 \text{ billion}$$

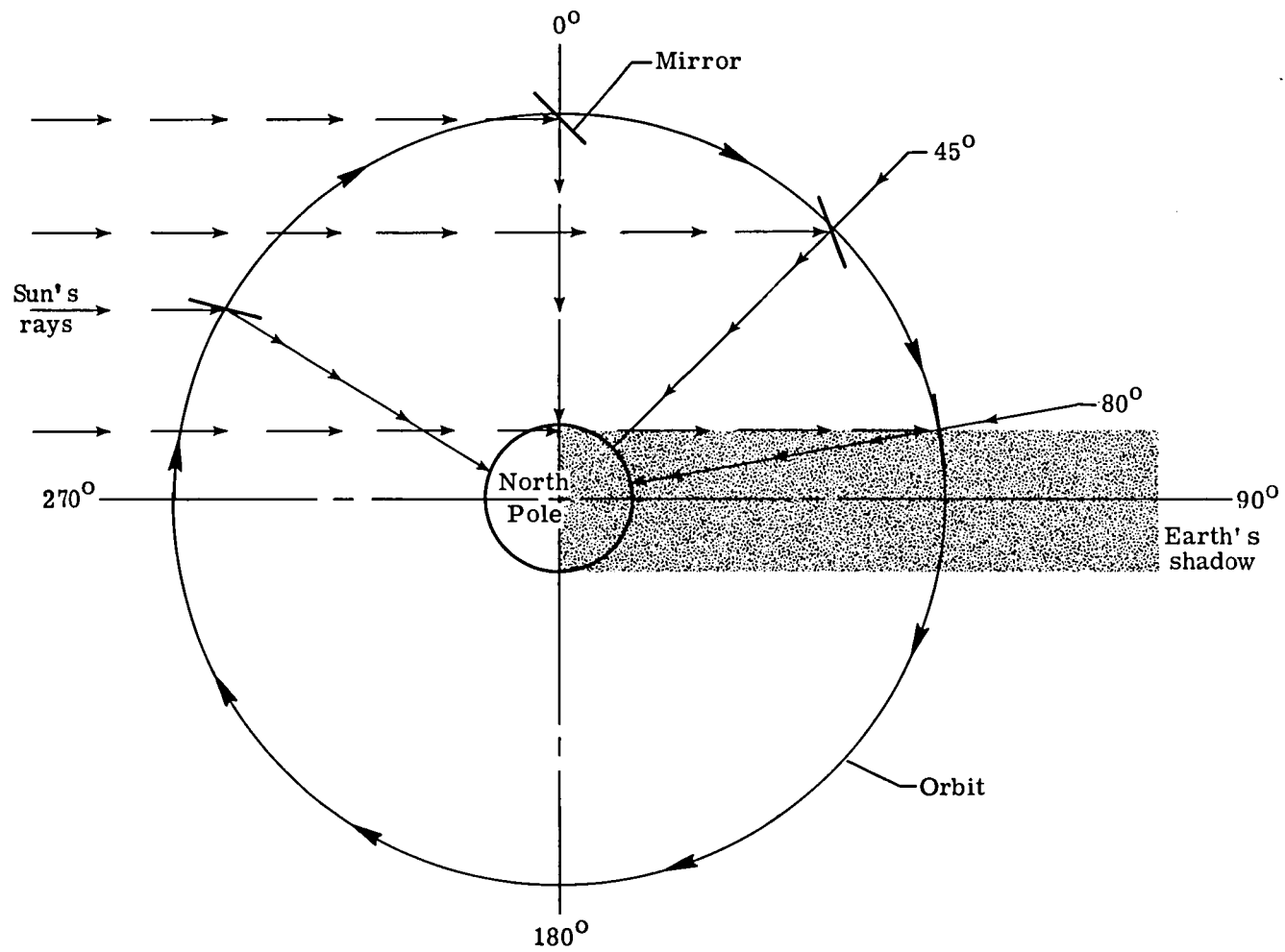


L-82-165

(a) Artist's conception of solar-reflector spacecraft.

Figure 1.- Illumination from space.





(b) Basic concept.

Figure 1.- Concluded.

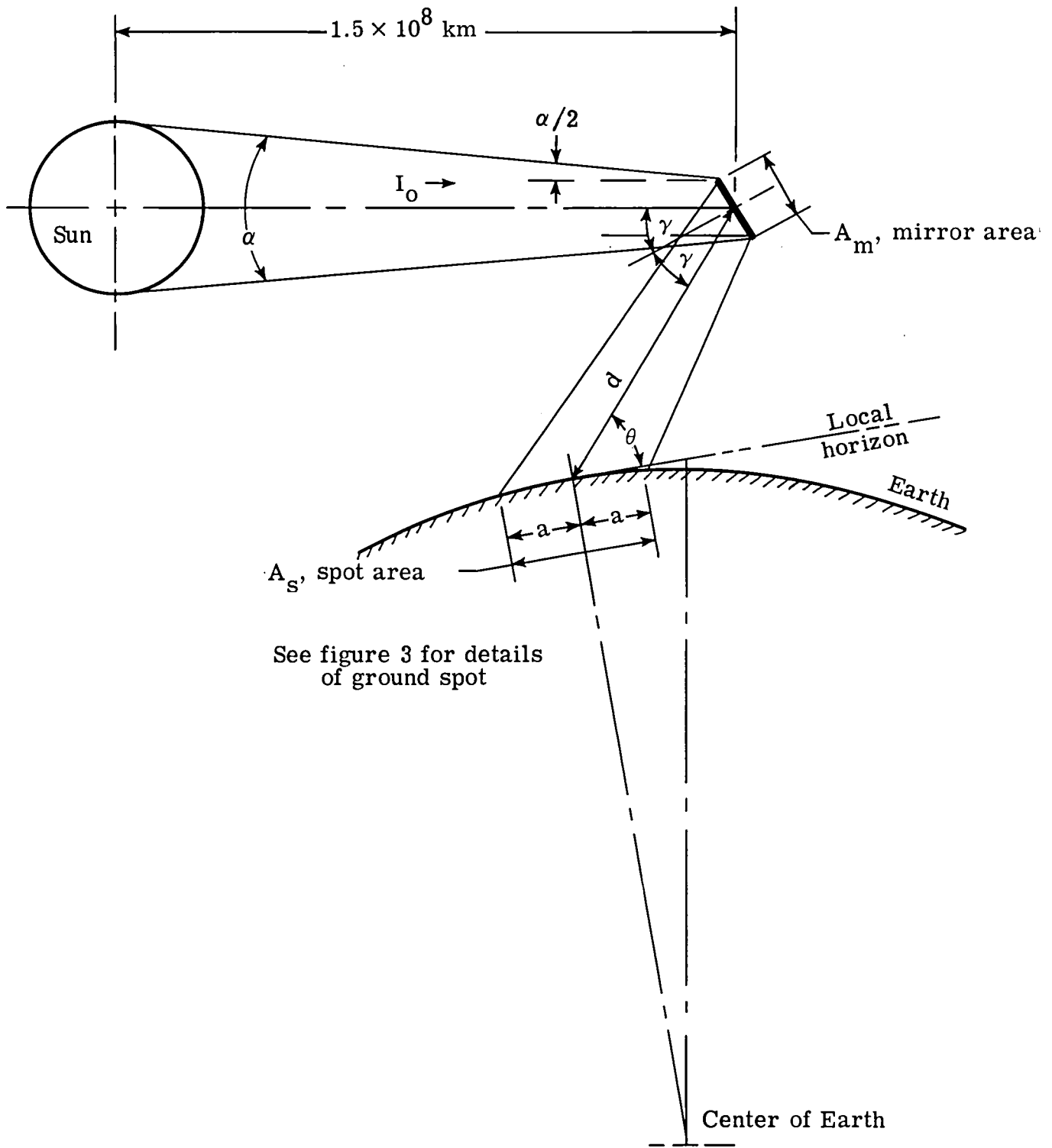
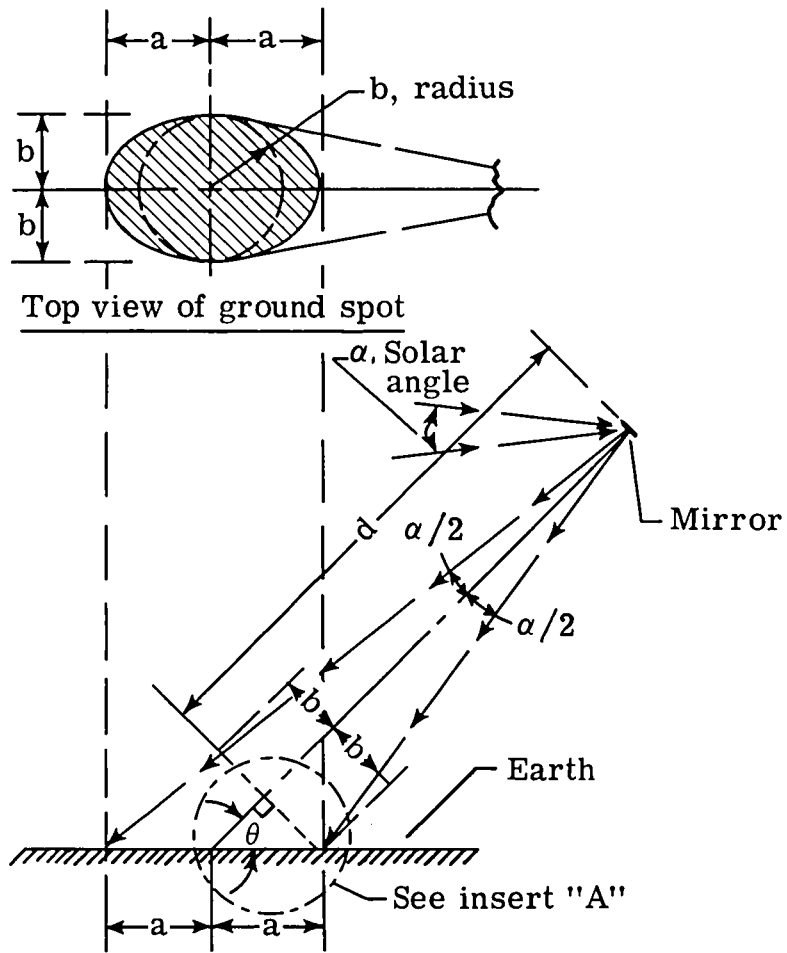
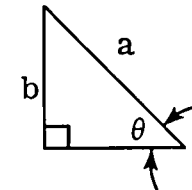


Figure 2.- Basic geometry of the mirror system.



From the above diagram:  
 $b = d \tan \alpha/2$

Side view of ground spot

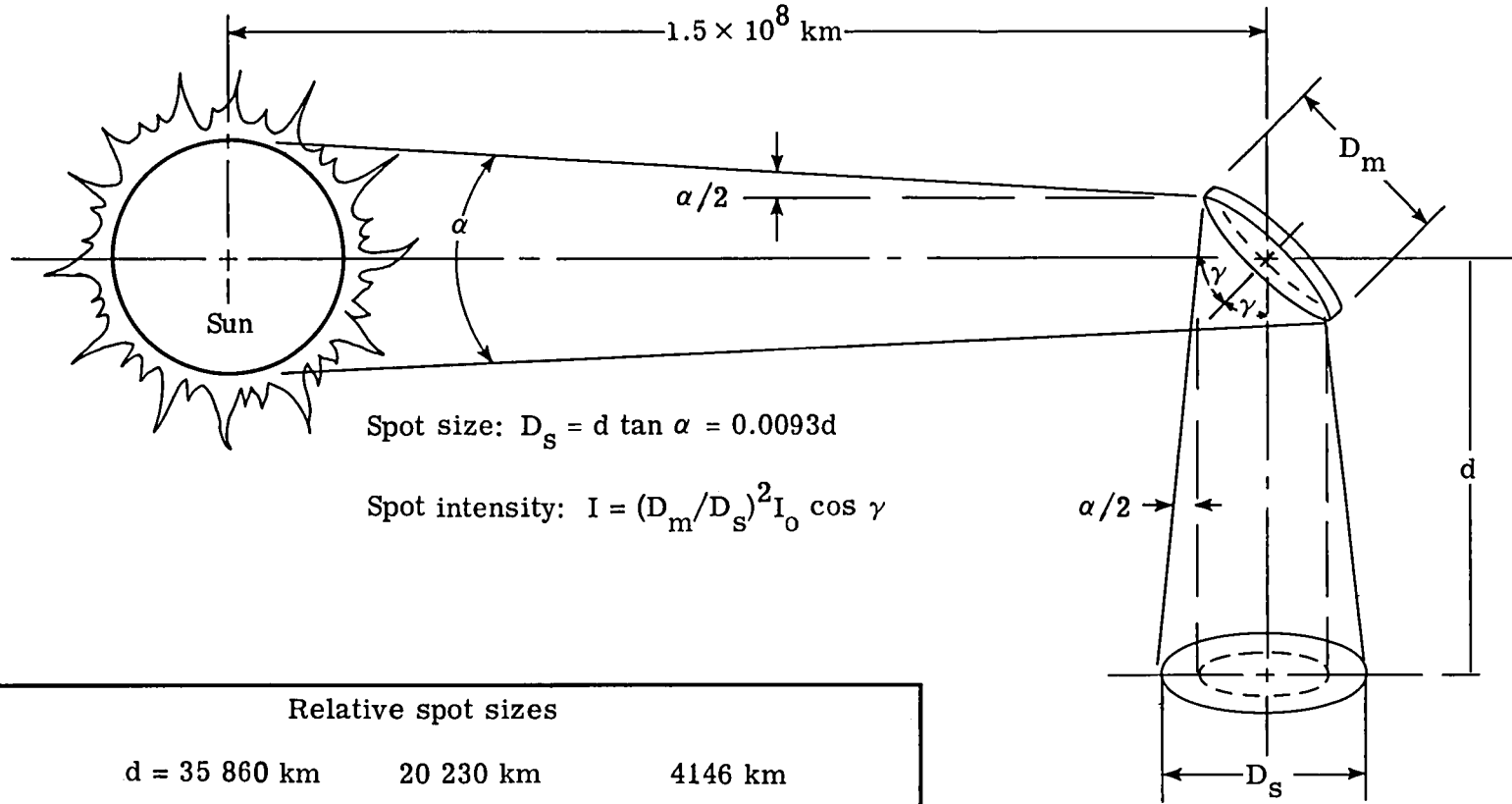


From the above diagram:

$$a = \frac{b}{\sin \theta}$$

Insert "A" (rotated)

Figure 3.- Geometry of illuminated ground spot.



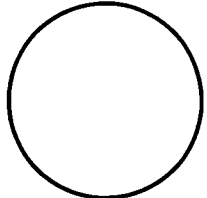
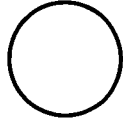

Relative spot sizes		
$d = 35\ 860\ \text{km}$	$20\ 230\ \text{km}$	$4146\ \text{km}$
		
$D_s = 333\ \text{km}$	$188\ \text{km}$	$39\ \text{km}$

Figure 4.- Geometry for ideal mirror optics.  $\alpha = 0^\circ 31' 59.26''$ ;  
 $I_0 = 136\ 700\ \text{lux}$ .

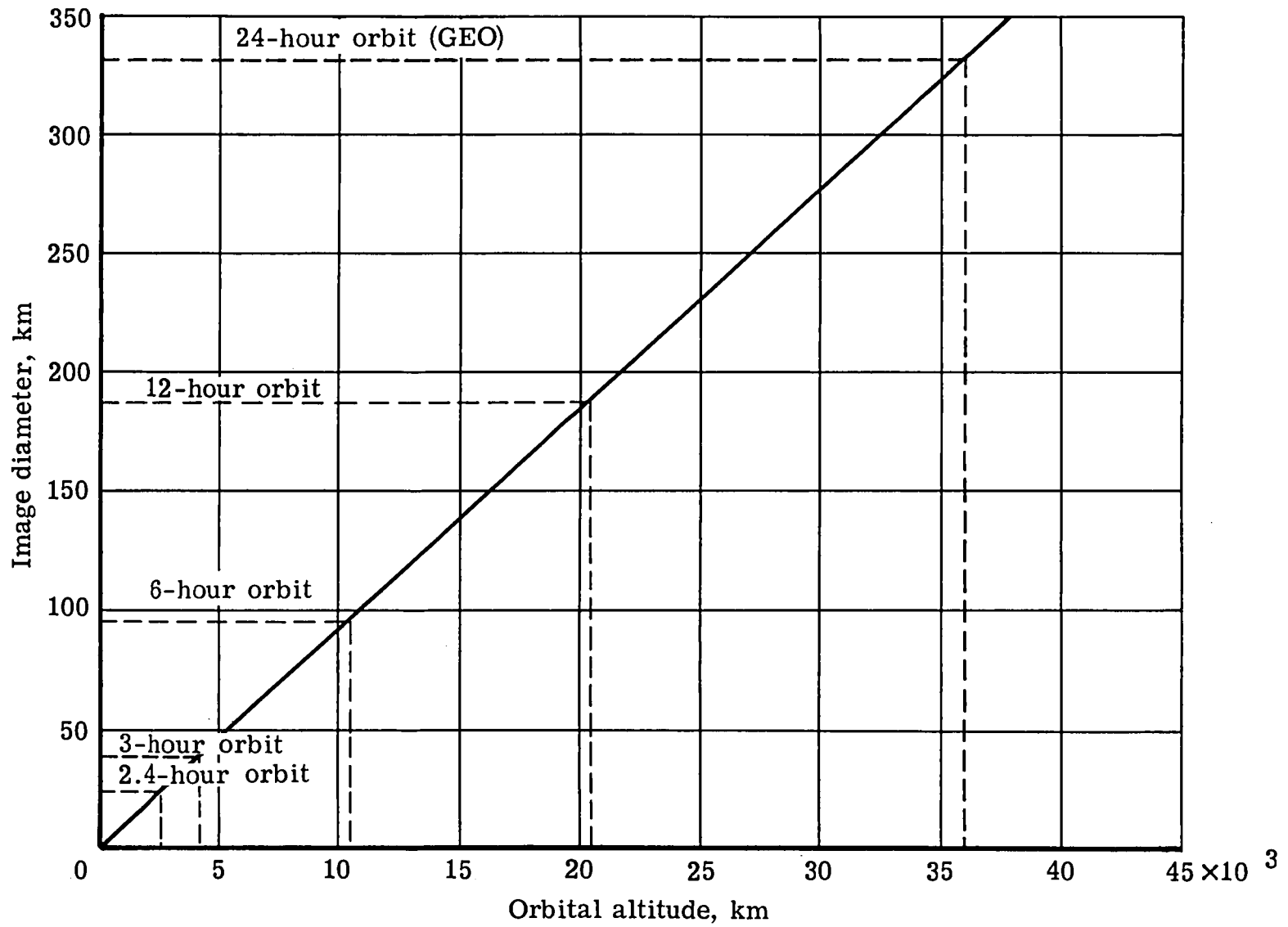


Figure 5.- Image size plotted against orbit altitude.

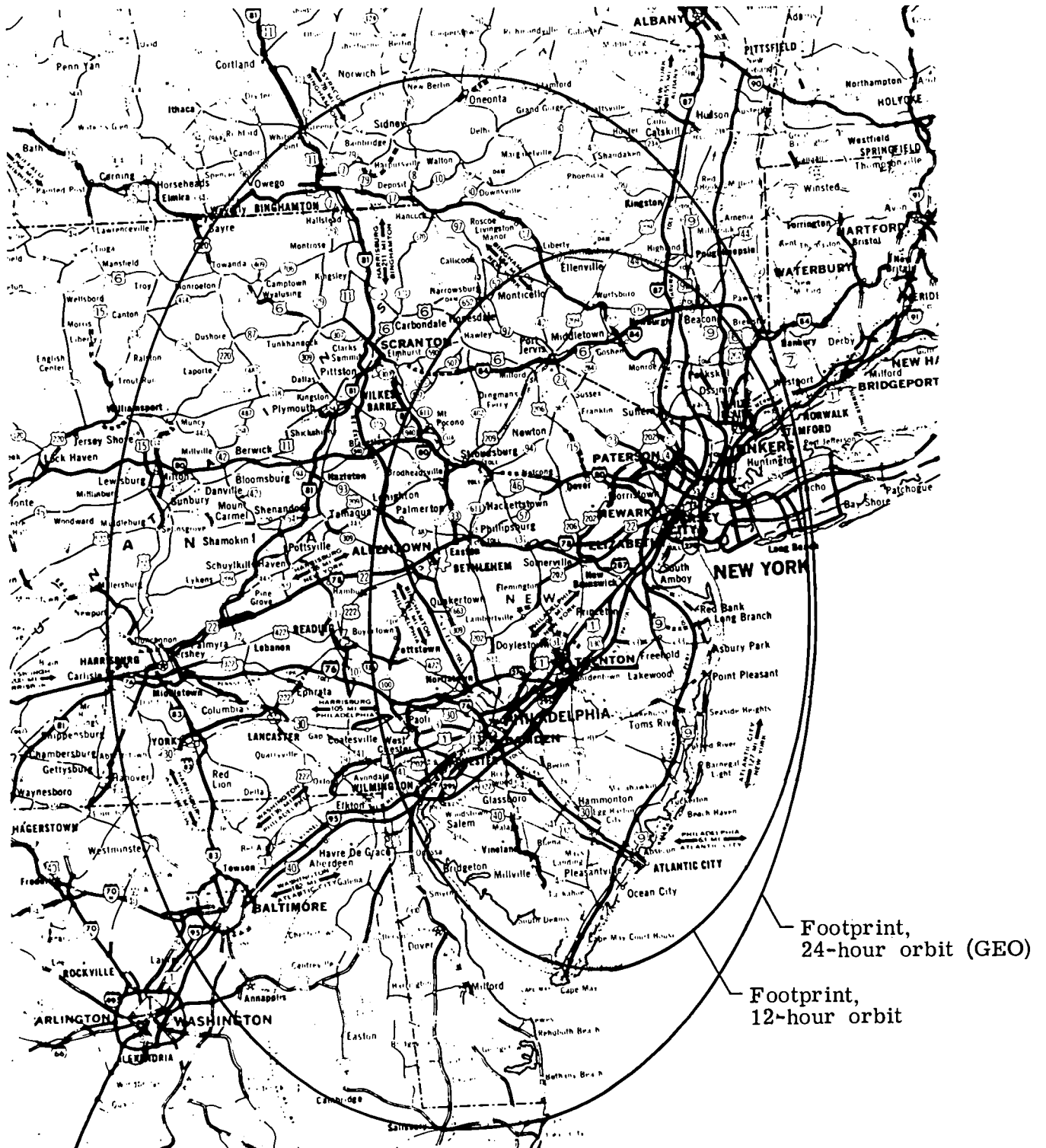


Figure 6.- Illumination of Middle Atlantic States from 12- and 24-hour orbits.



Figure 7.- Illumination of England from 12- and 24-hour orbits.

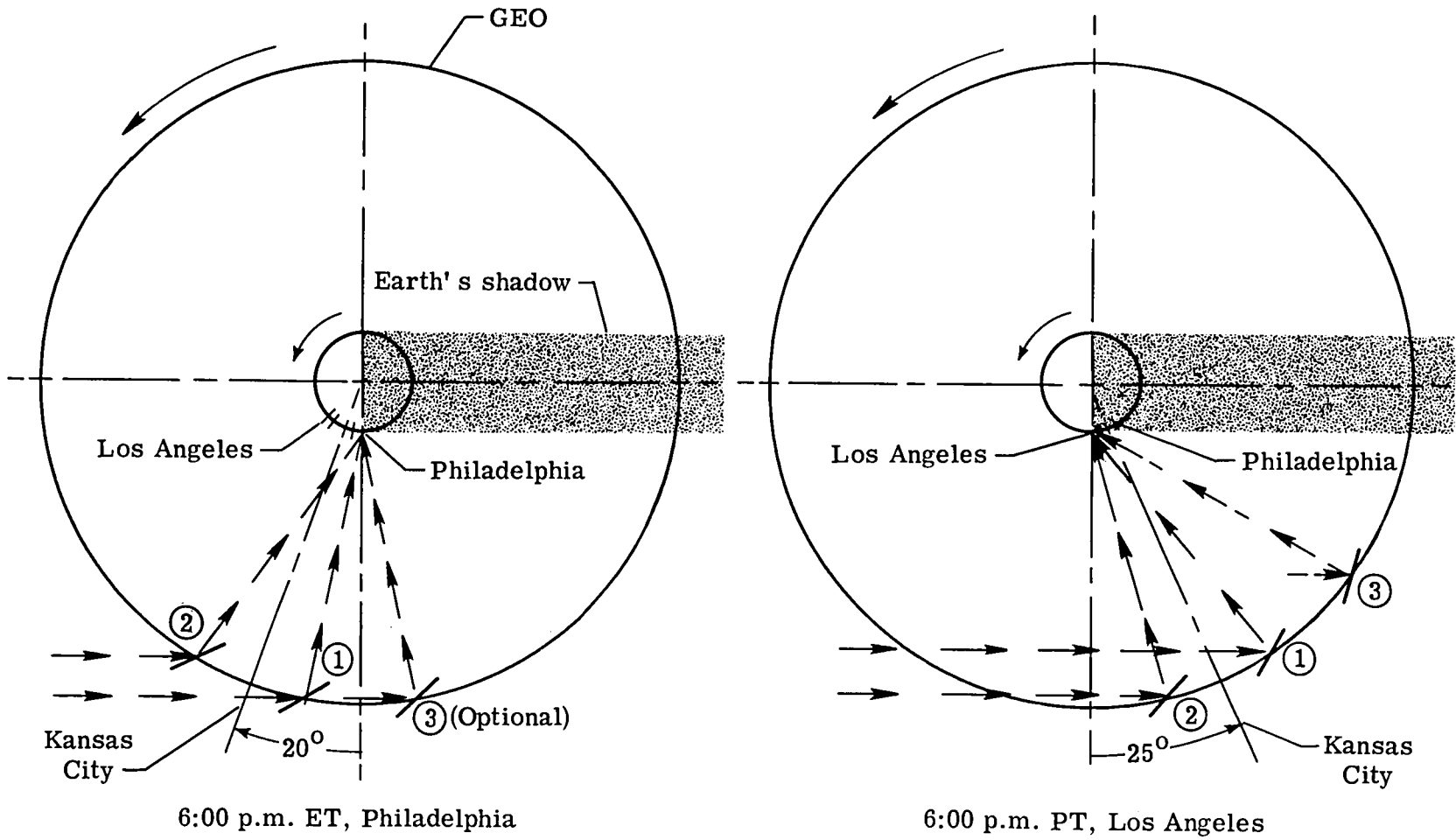


Figure 8.- Scenario extending daylight approximately 1 hour in the evening and morning in Philadelphia (Pa.), Chicago (Ill.), Kansas City (Mo.), Denver (Colo.), and Los Angeles (Calif.).



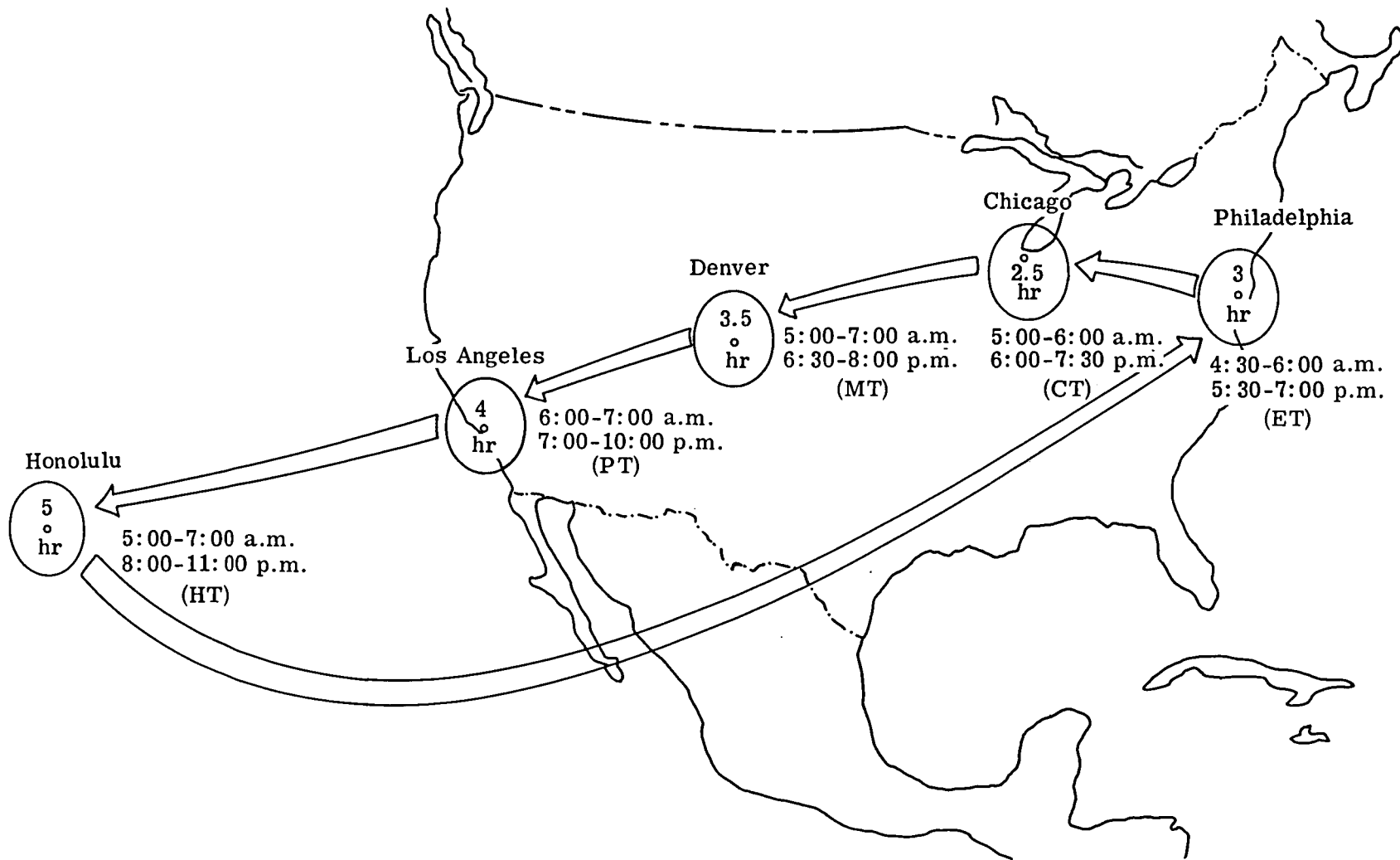


Figure 9.- Scenario for extending daylight hours across country during mornings and evenings (selected as baseline mission). Reflectors are in 0° inclined GEO centered at 100° W longitude; times given are for December.

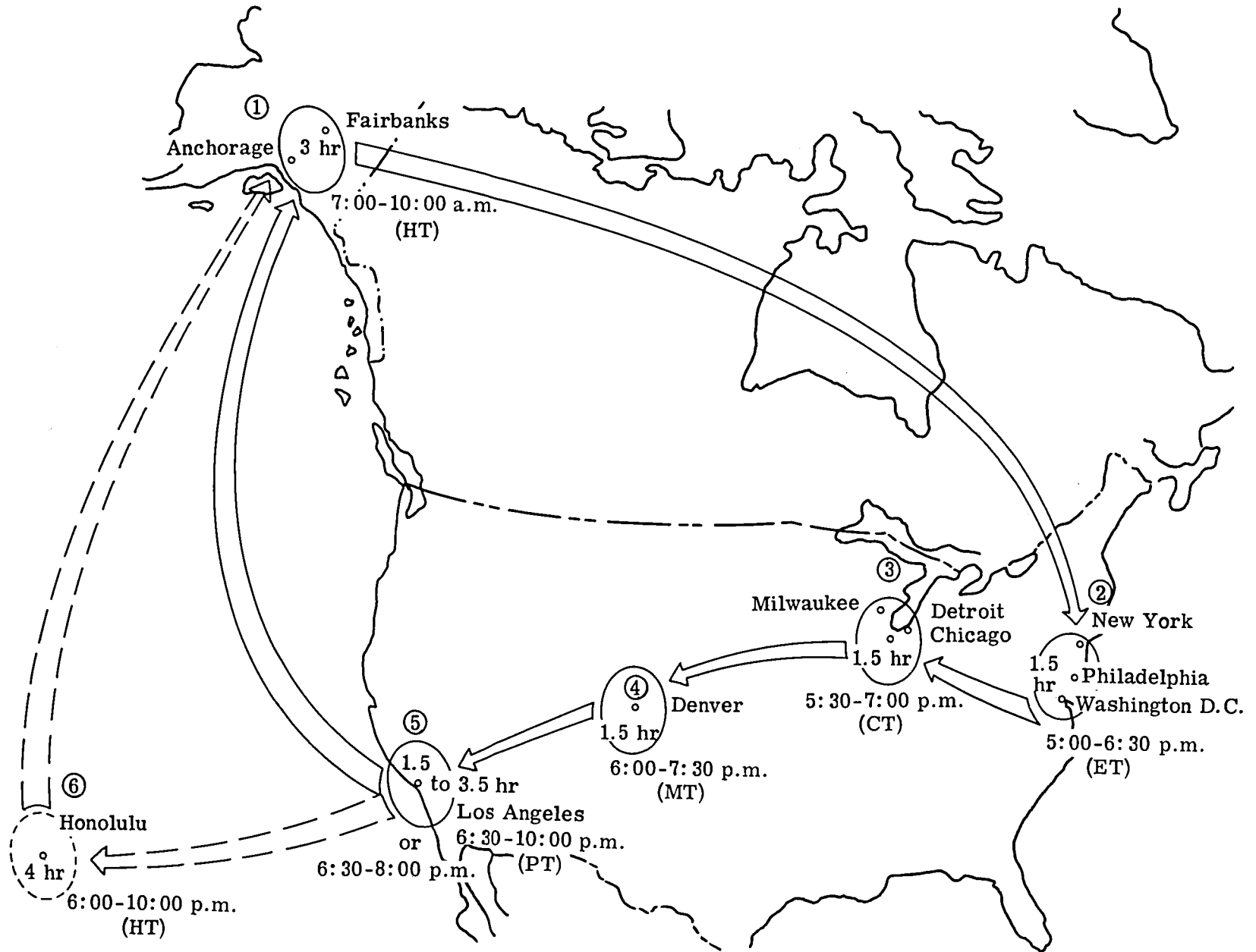


Figure 10.- Scenario for extending daylight hours across country, including Alaska, during wintertime.

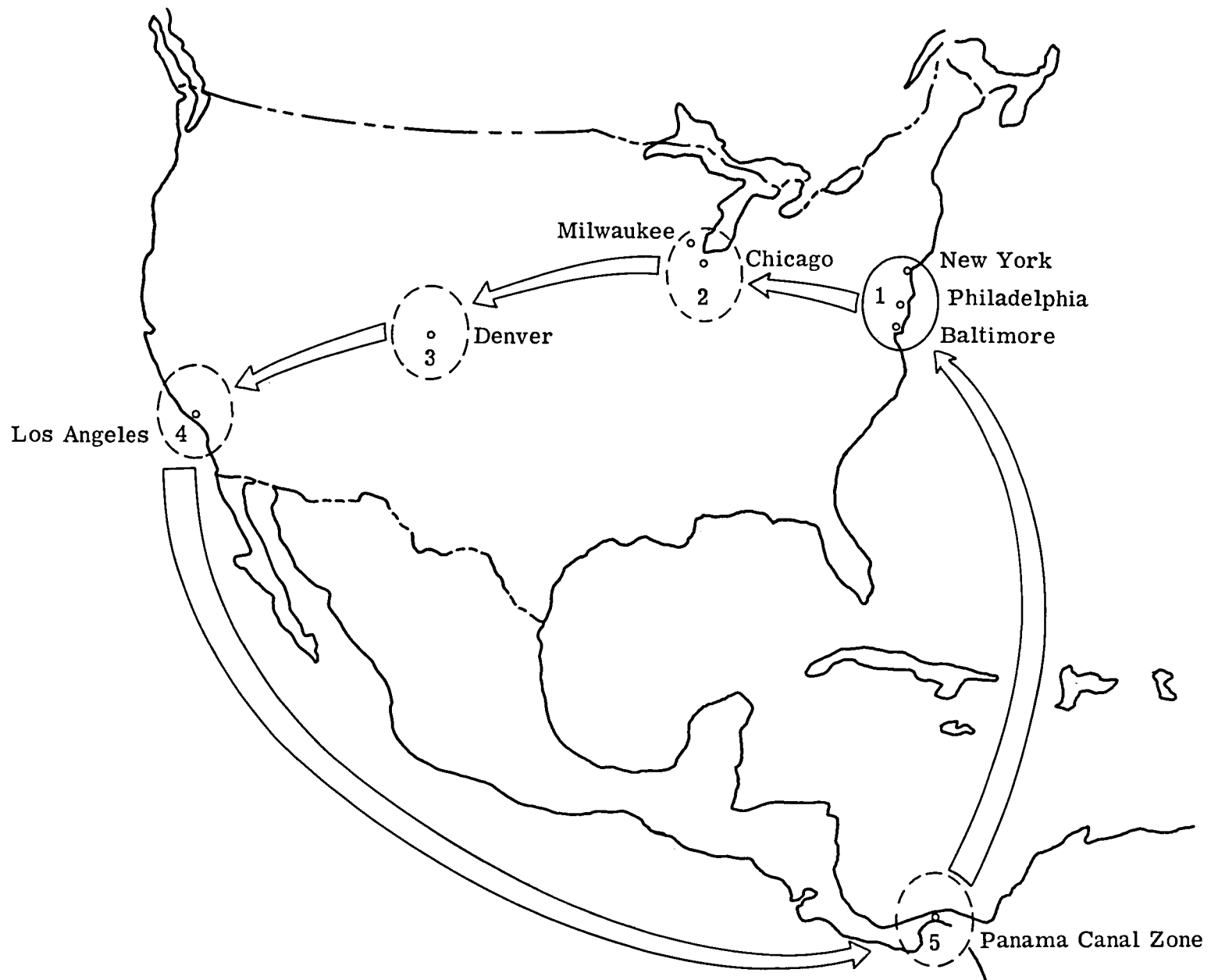
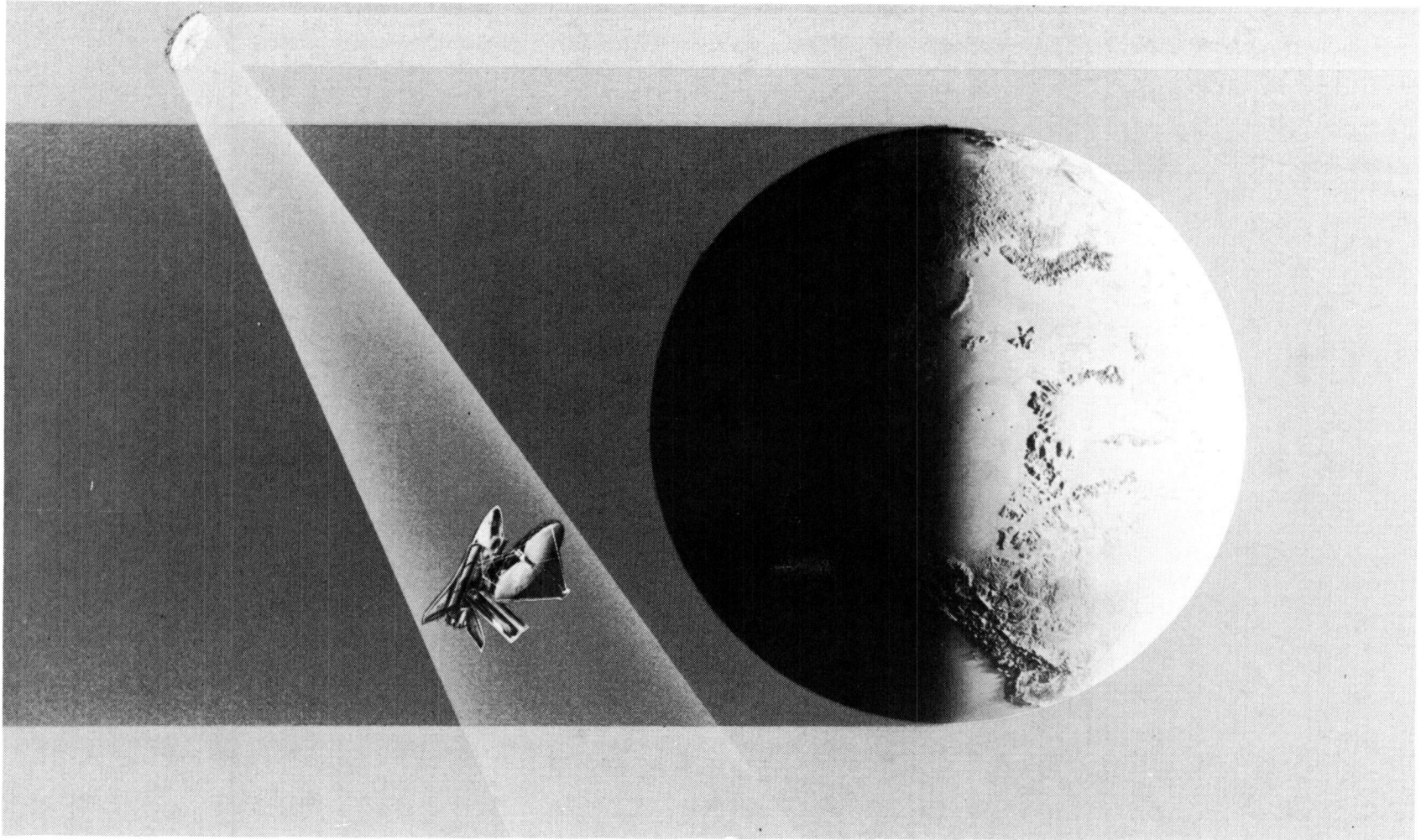


Figure 11.- Scenario for extending daylight hours across country with Panama Canal Zone included.



L-82-166

Figure 12.- Illumination of Shuttle in-orbit operations with 1-km mirror in 6-hour orbit.

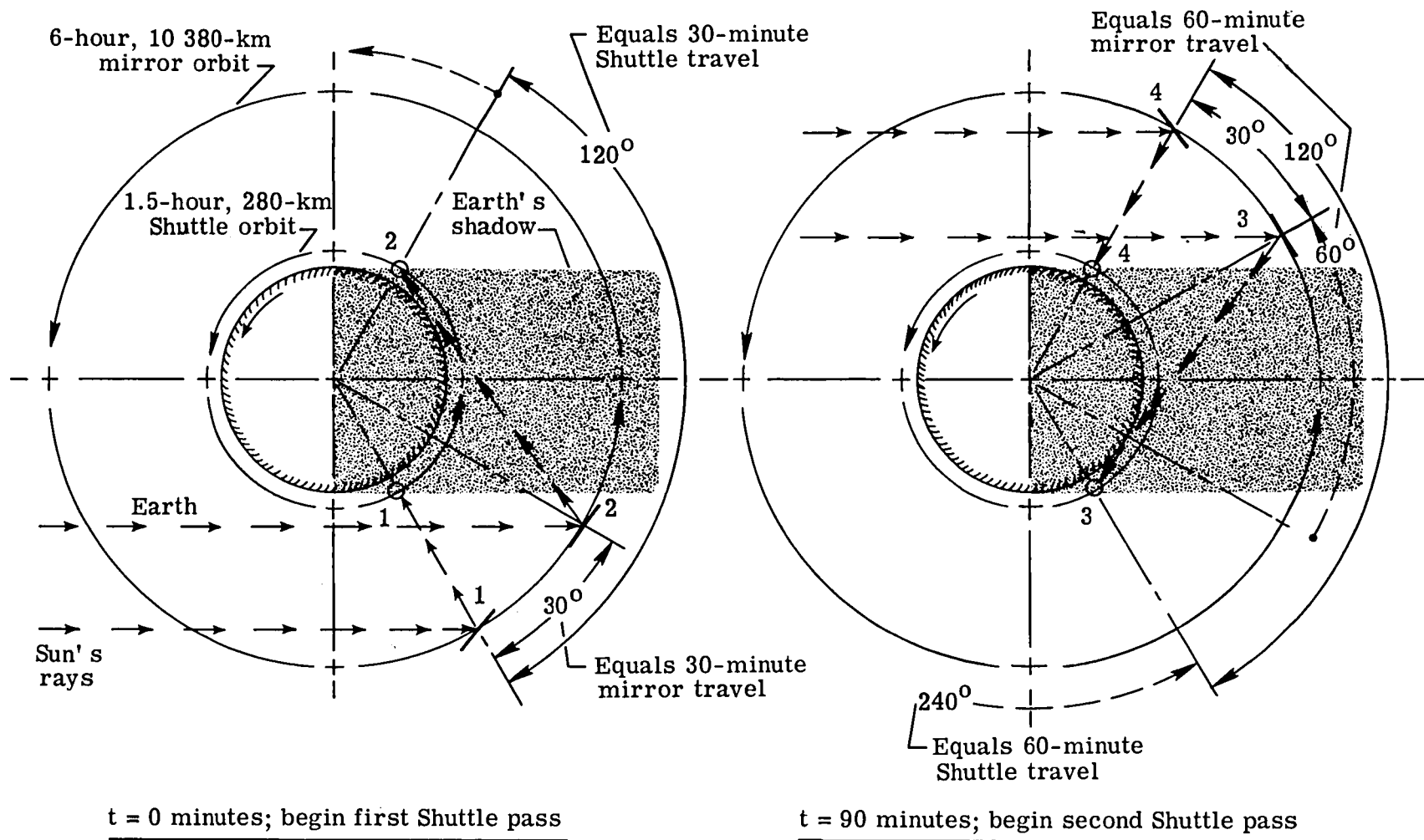


Figure 13.- Illumination of Shuttle in-orbit nighttime operations with single mirror in 6-hour orbit. Single mirror in 6-hour orbit could illuminate 2 of 4 passes of Shuttle in 1.5-hour orbit; 2 mirrors would provide full-time illumination; average intensity of 1-km mirror is 11 lux.

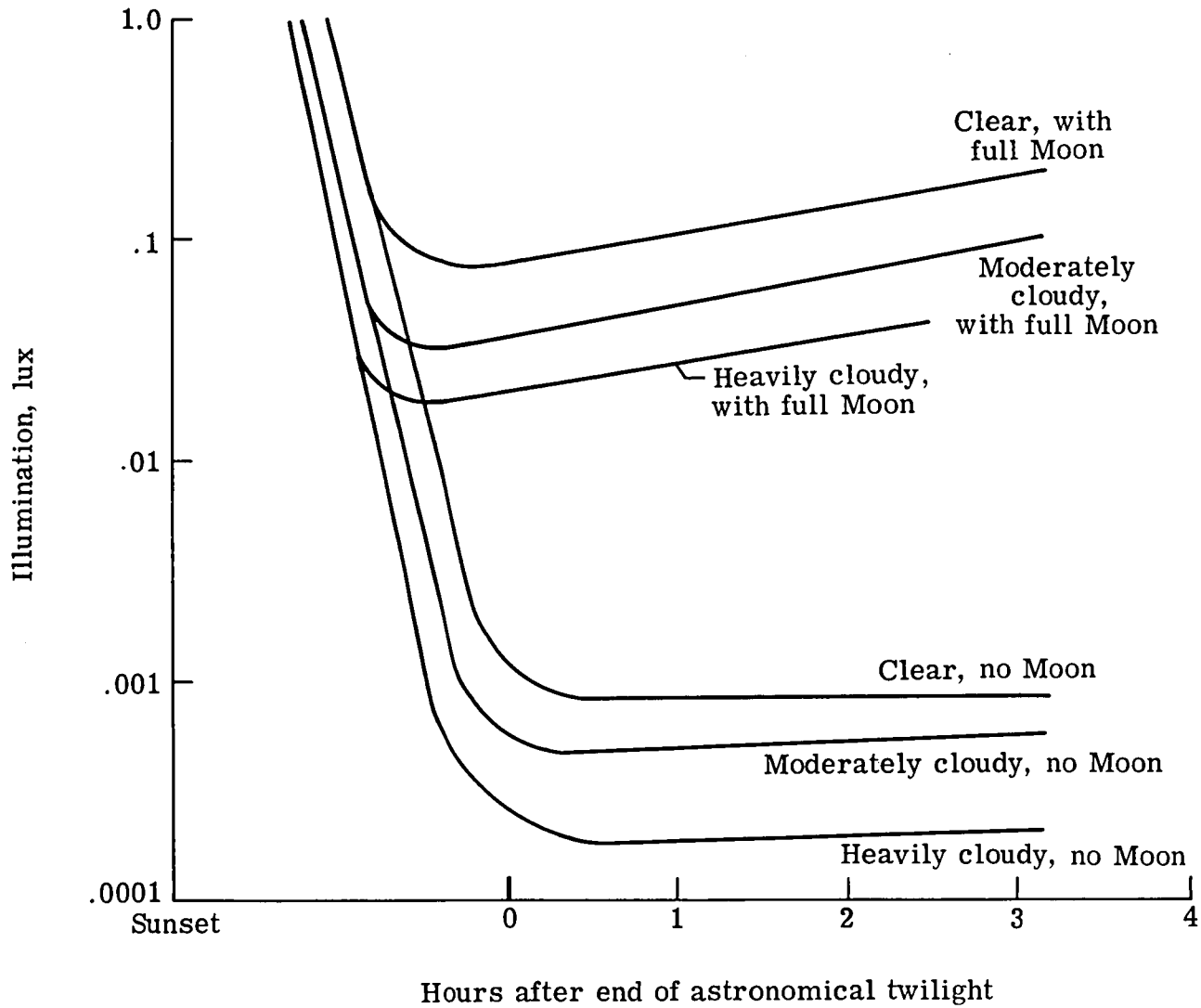


Figure 14.- Effect of cloud cover on illumination (ref. 2). End of astronomical twilight occurs when Sun is  $18^\circ$  below horizon.

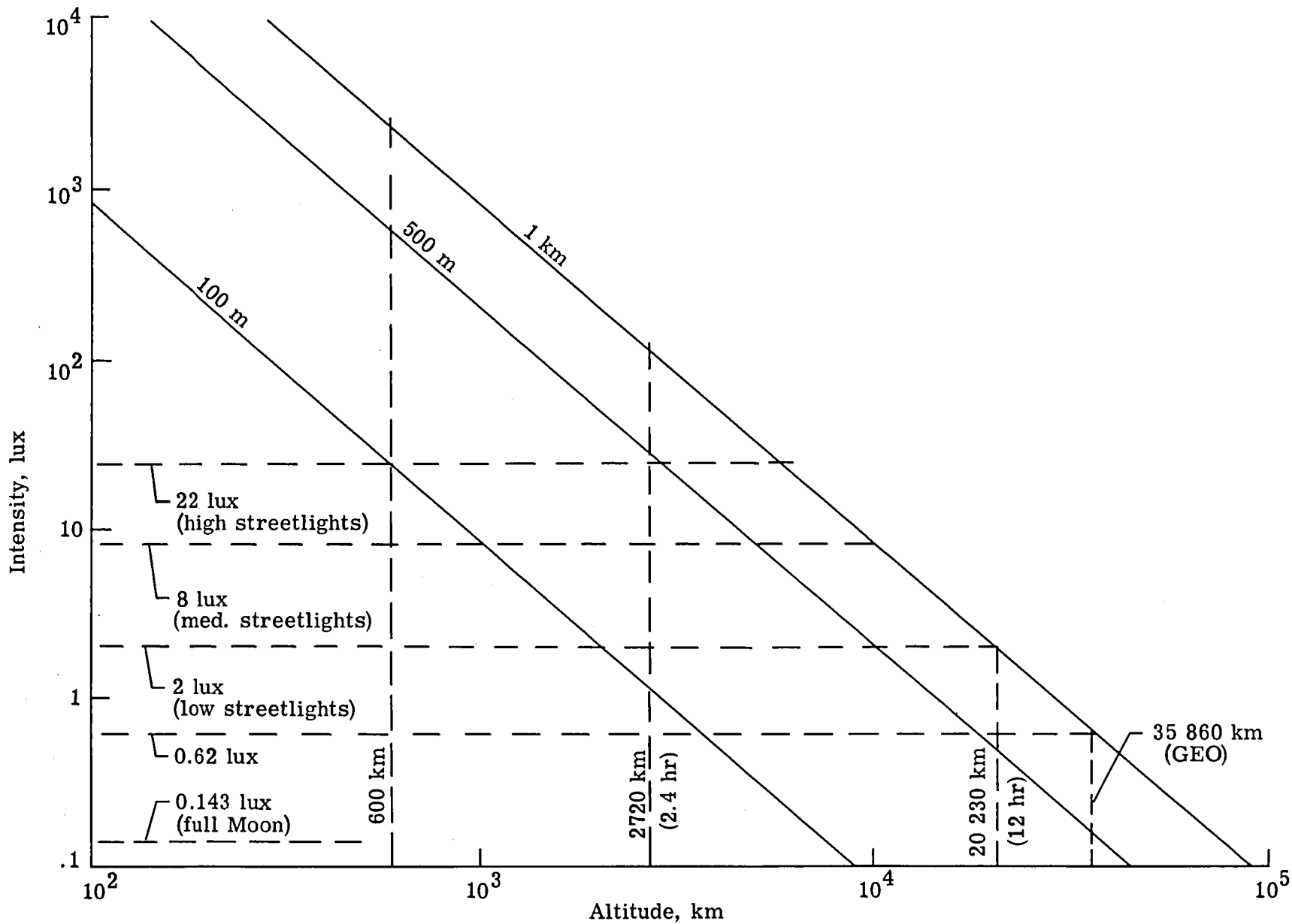


Figure 15.- Intensity versus altitude for 100-m, 500-m, and 1-km reflectors. Assume reflectors at zenith and tilted 45° relative to Sun; assume nominal losses;  $I_0 = 118\,900$  lux.

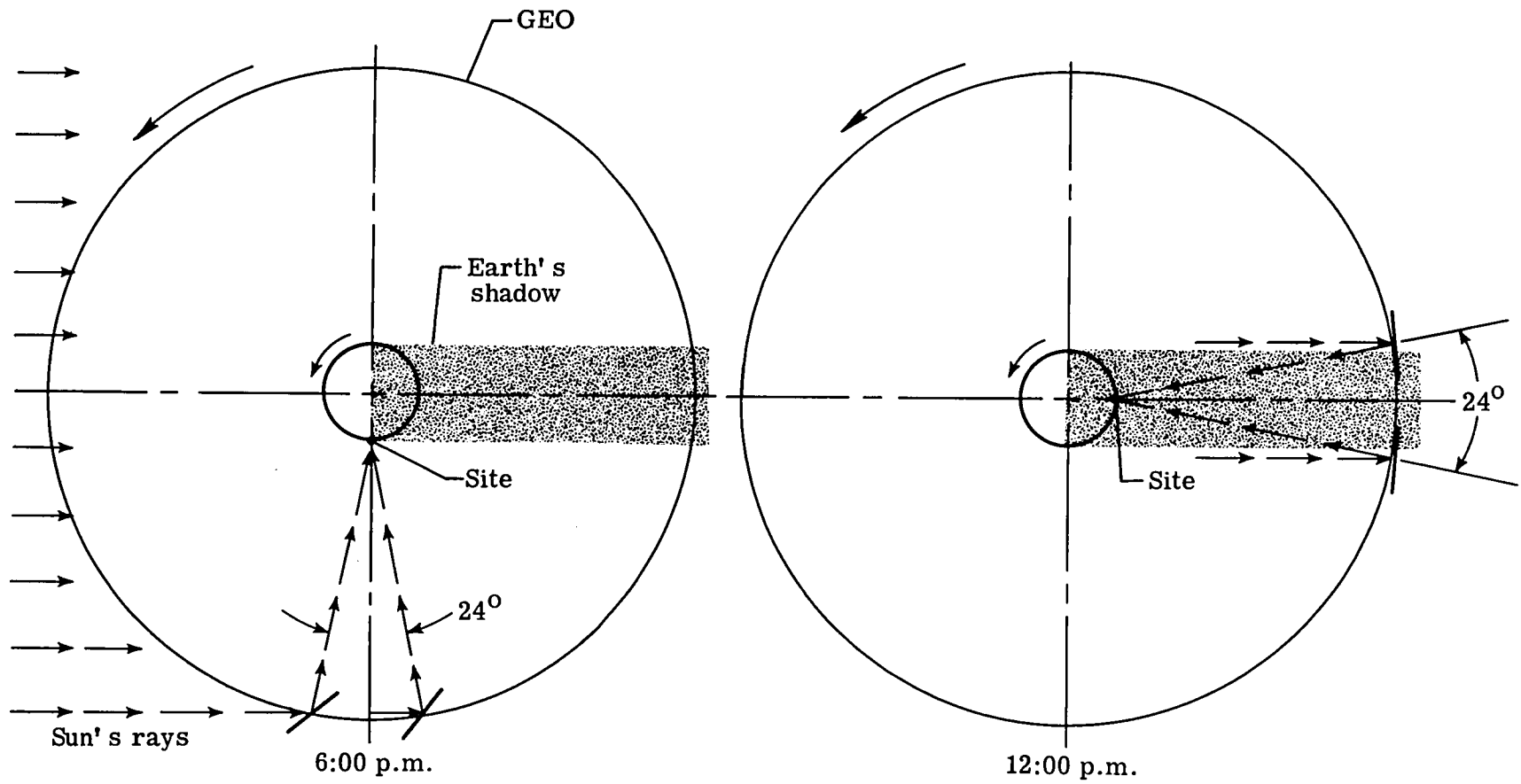


Figure 16.- Earth site illumination from GEO for worst case of  $0^\circ$  inclination at spring and fall equinoxes. Separation of  $24^\circ$  assures only 1 cluster eclipsed at a time.



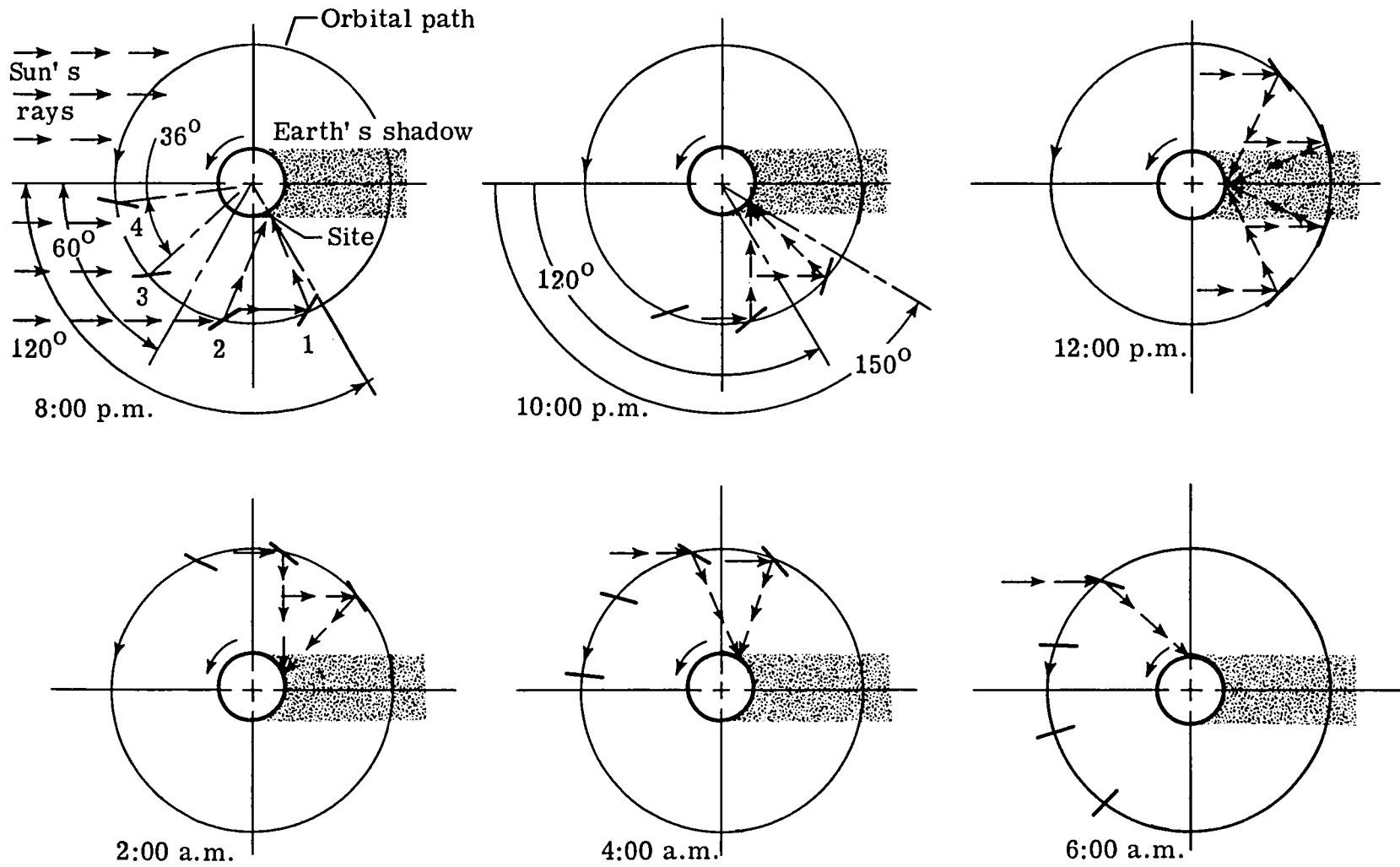


Figure 17.- Earth site illumination from 12-hour orbit. Spacecraft moves 60° and site moves 30° every 2 hours.

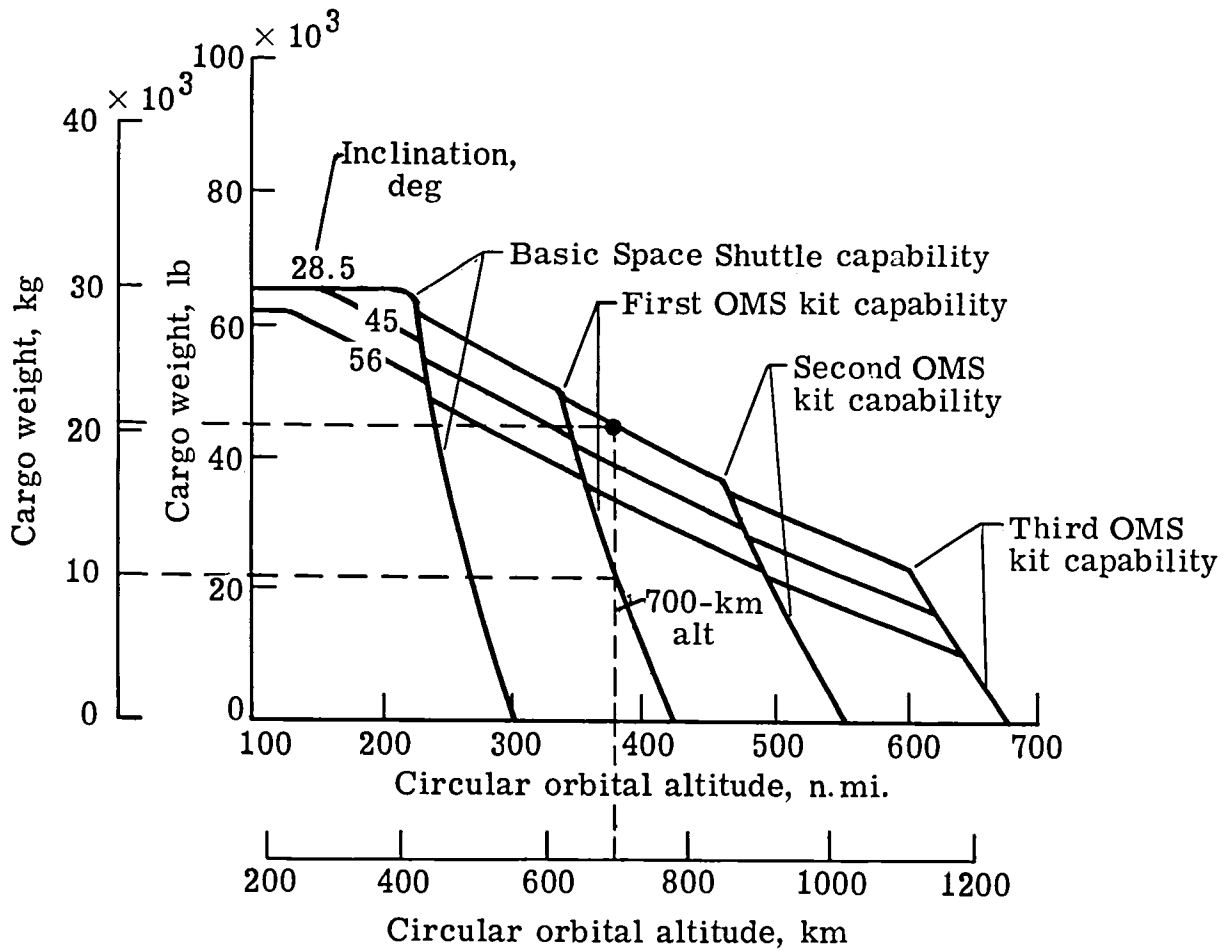


Figure 18.- Maximum cargo weights at various circular orbital altitudes for flights with delivery only (ref. 18).

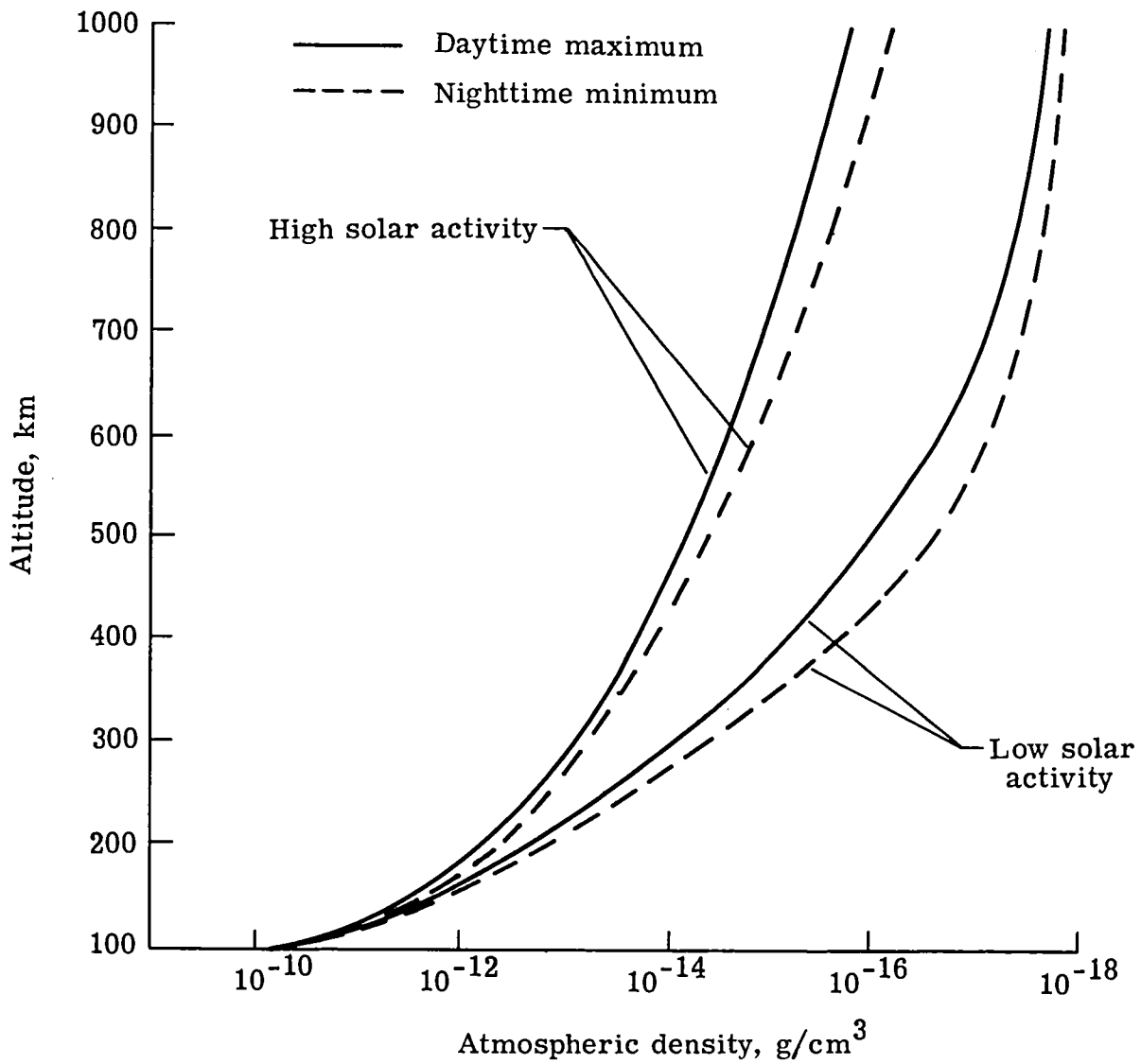


Figure 19.- Typical daytime maximum and nighttime minimum atmospheric density profiles for high and low solar activity (ref. 19).

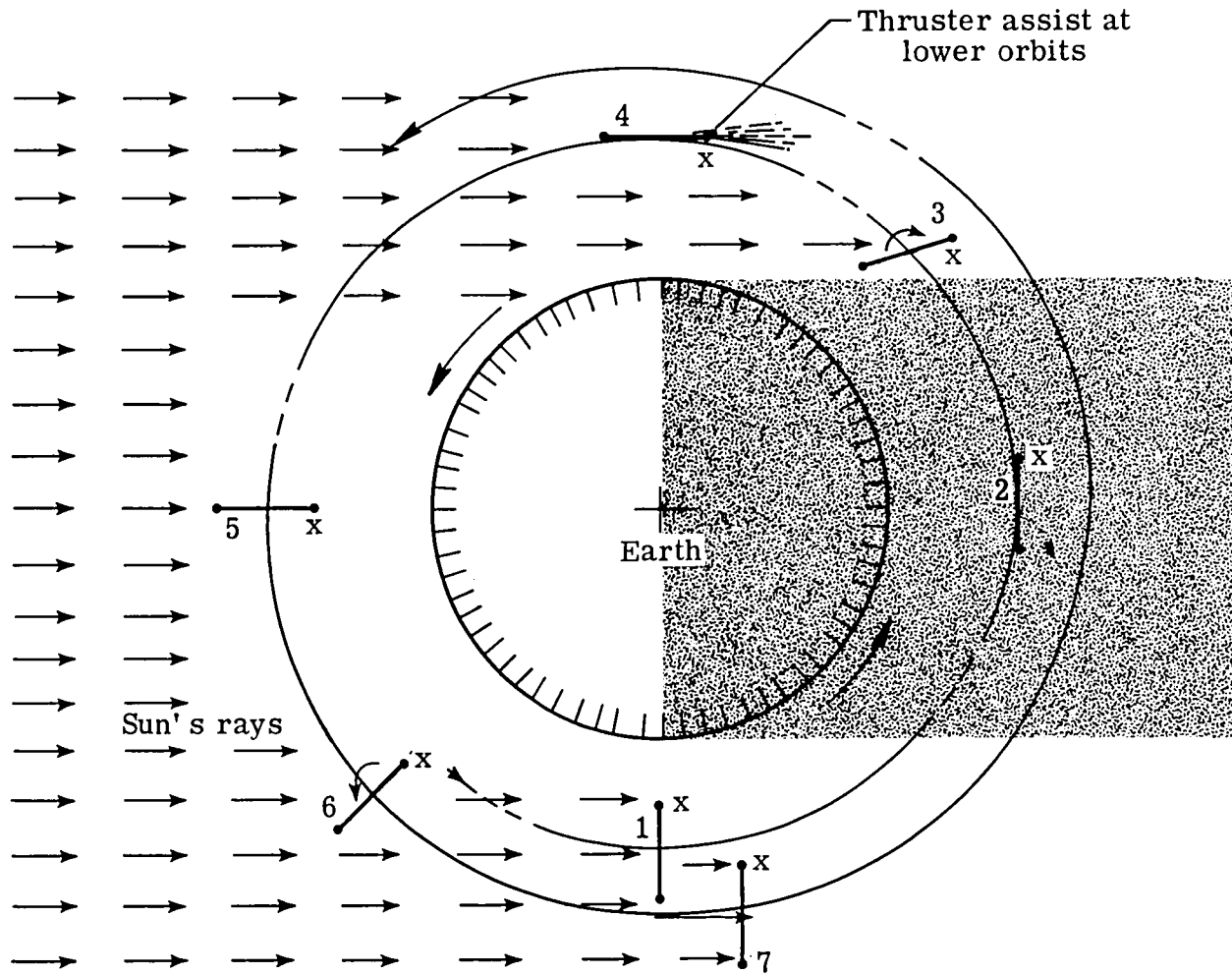


Figure 20.- Solar-sailing technique for solar reflectors. Numerals indicate position relative to Sun while sailing one spiral loop.

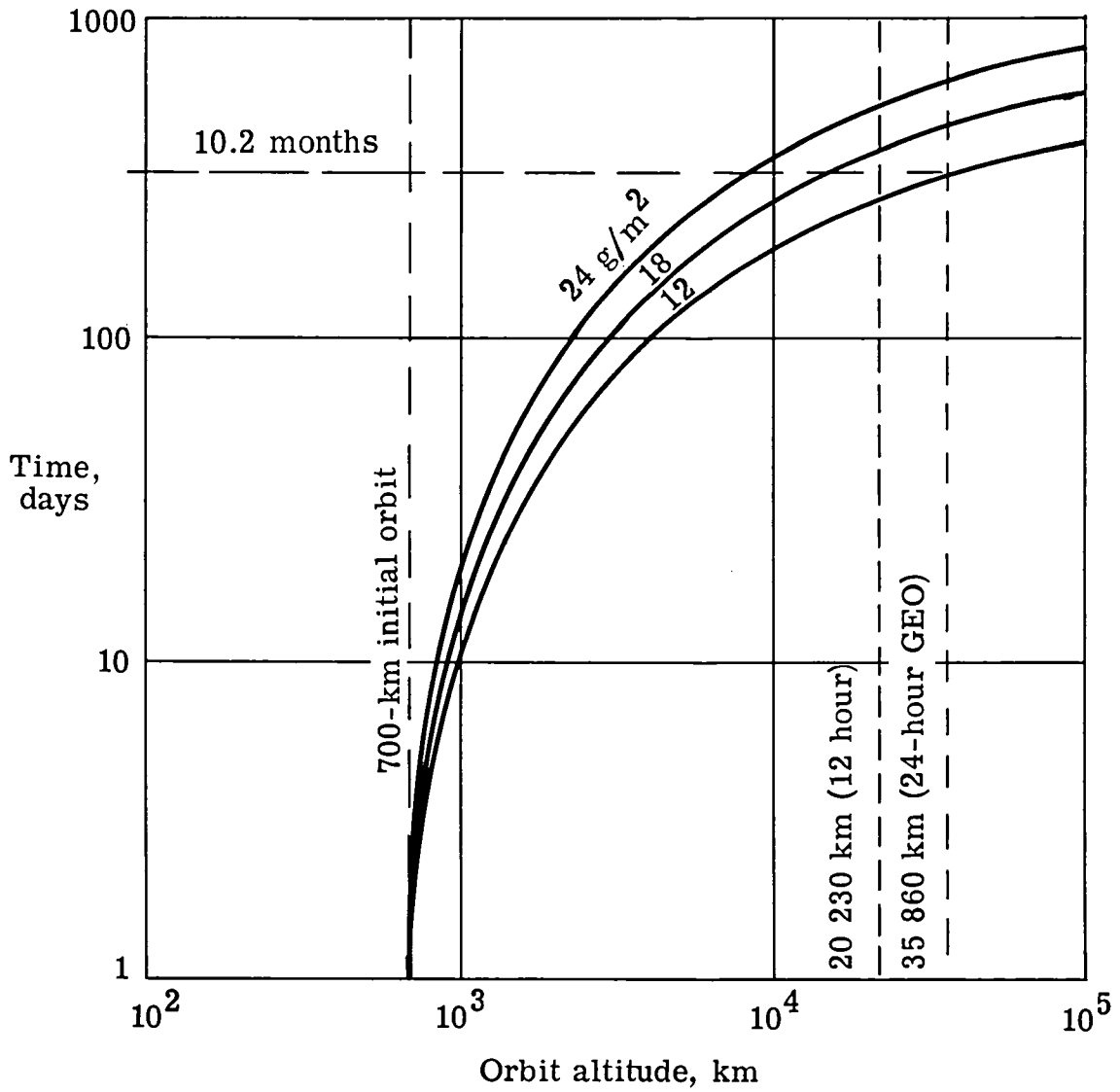


Figure 21.- Time required to solar sail from initial orbit of 700 km for spacecraft specific weights of 12, 18, and 24 g/m<sup>2</sup>. Atmospheric drag effects are not included.

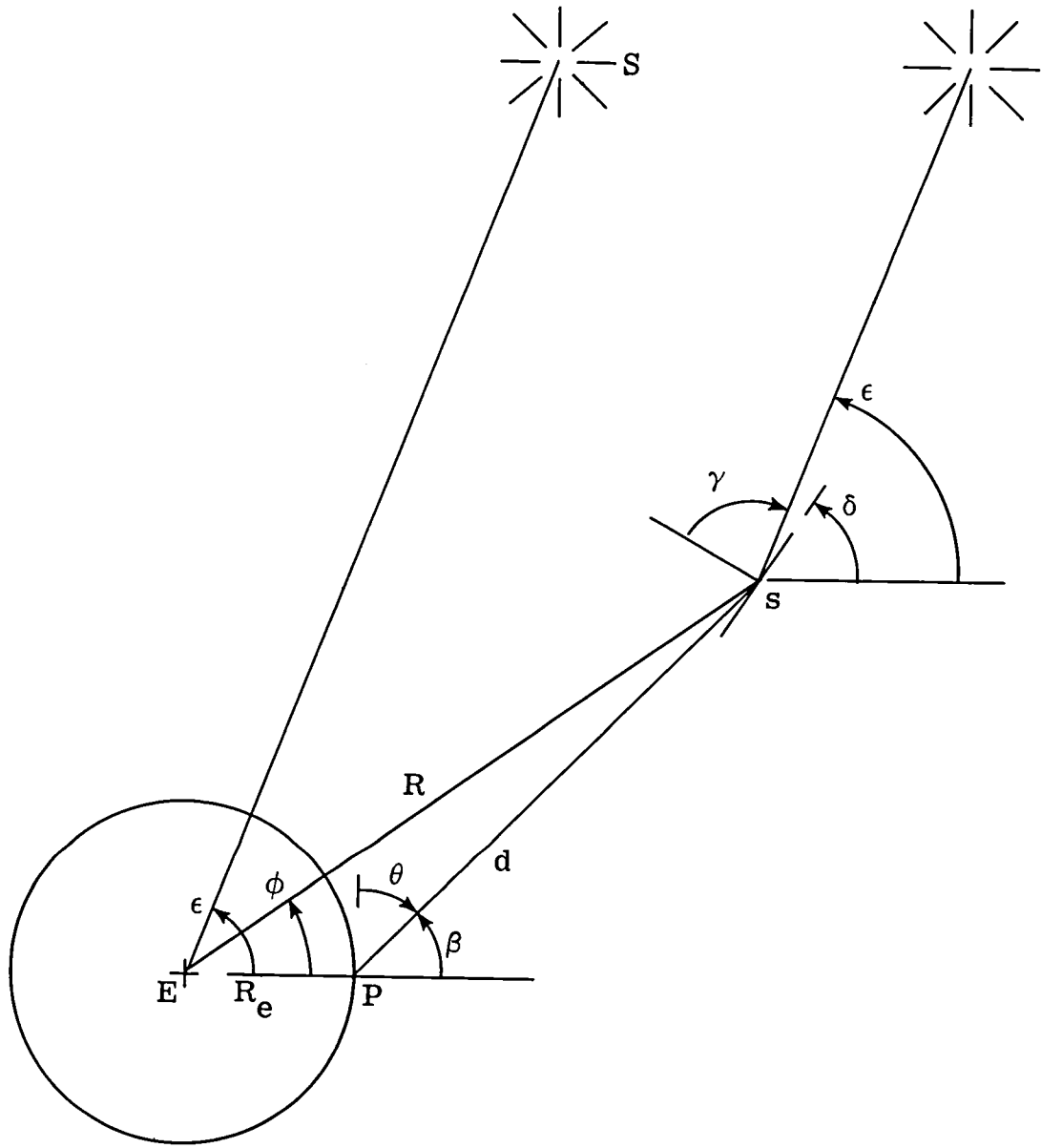


Figure 22.- Geometry of geocentric spacecraft orbit coplanar with Earth and Sun (ref. 17).

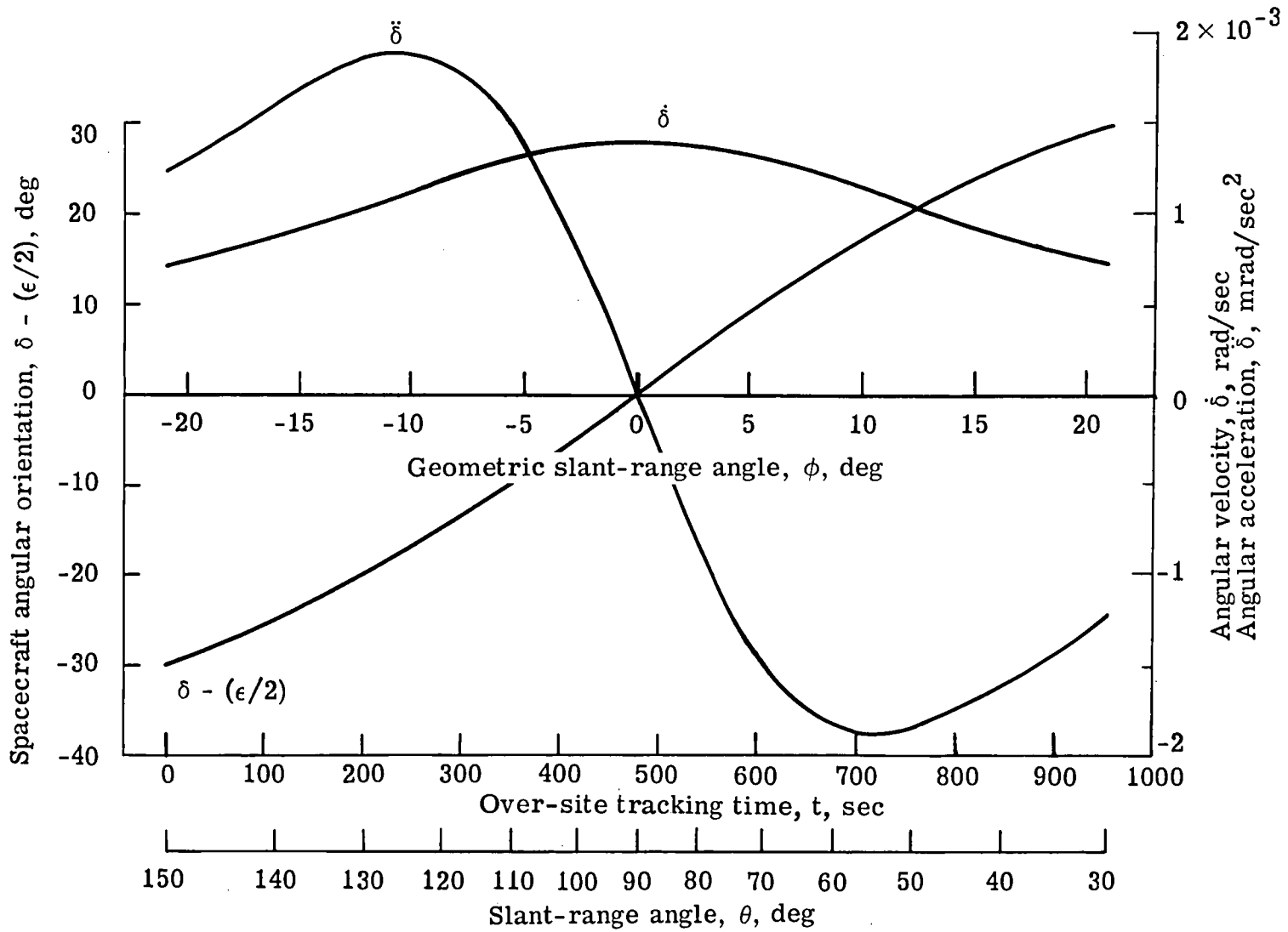


Figure 23.- Kinematics of spacecraft tracking maneuver for an orbital altitude of 2400 km (ref. 17).

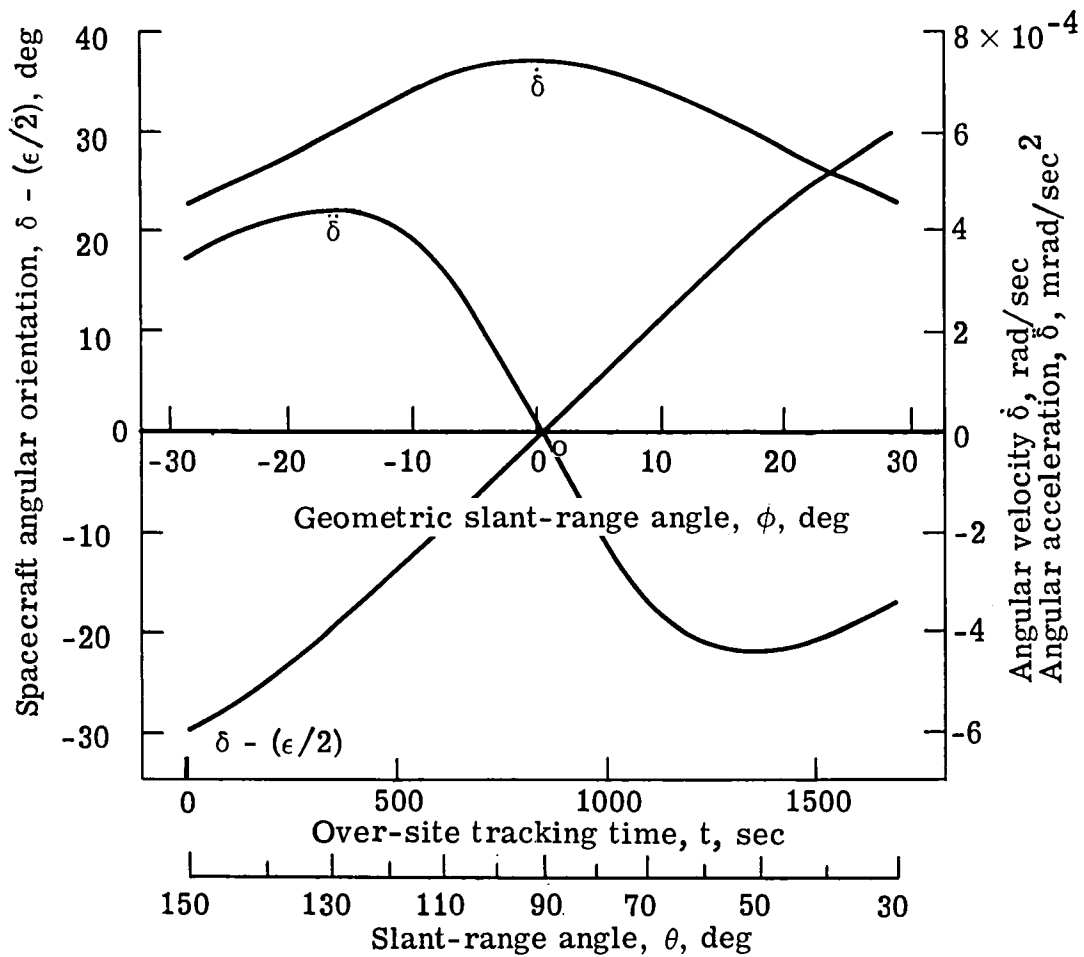


Figure 24.- Kinematics of spacecraft tracking maneuver for an orbital altitude of 4146 km (ref. 17).



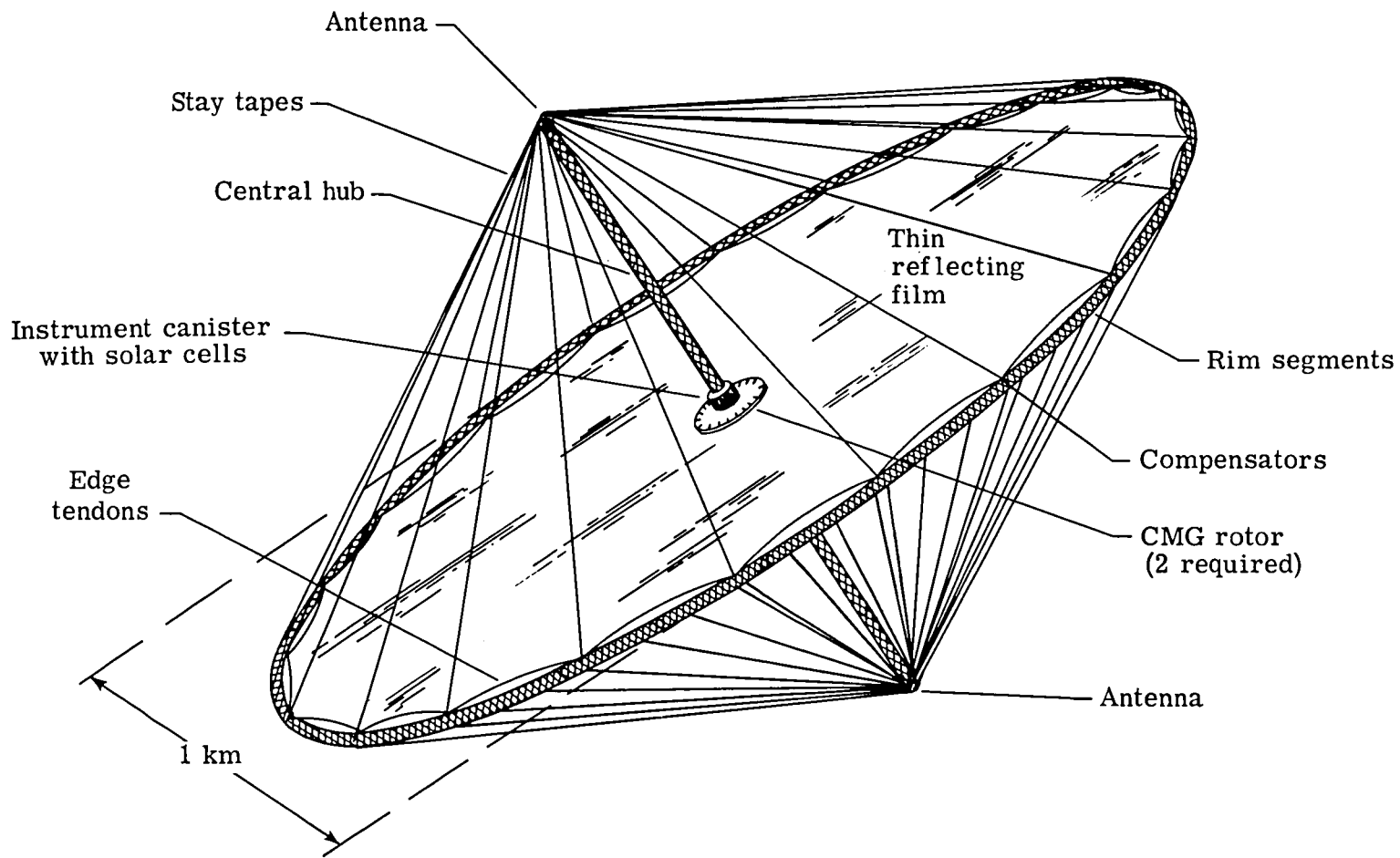


Figure 25.- Hoop-column solar-reflector spacecraft (baseline) concept.

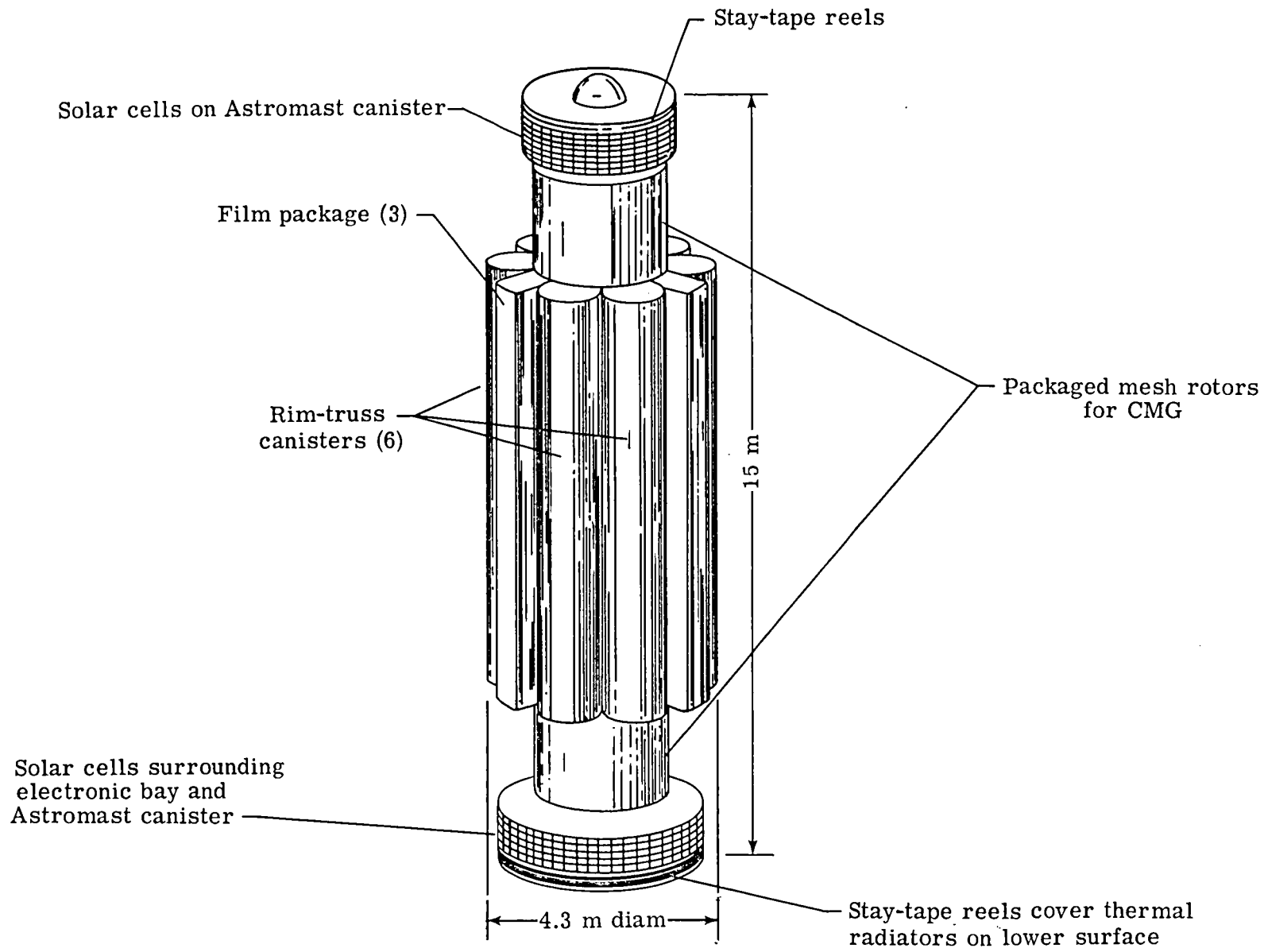


Figure 26.- Configuration of 1-km-diameter reflector spacecraft packaged for Shuttle cargo bay.

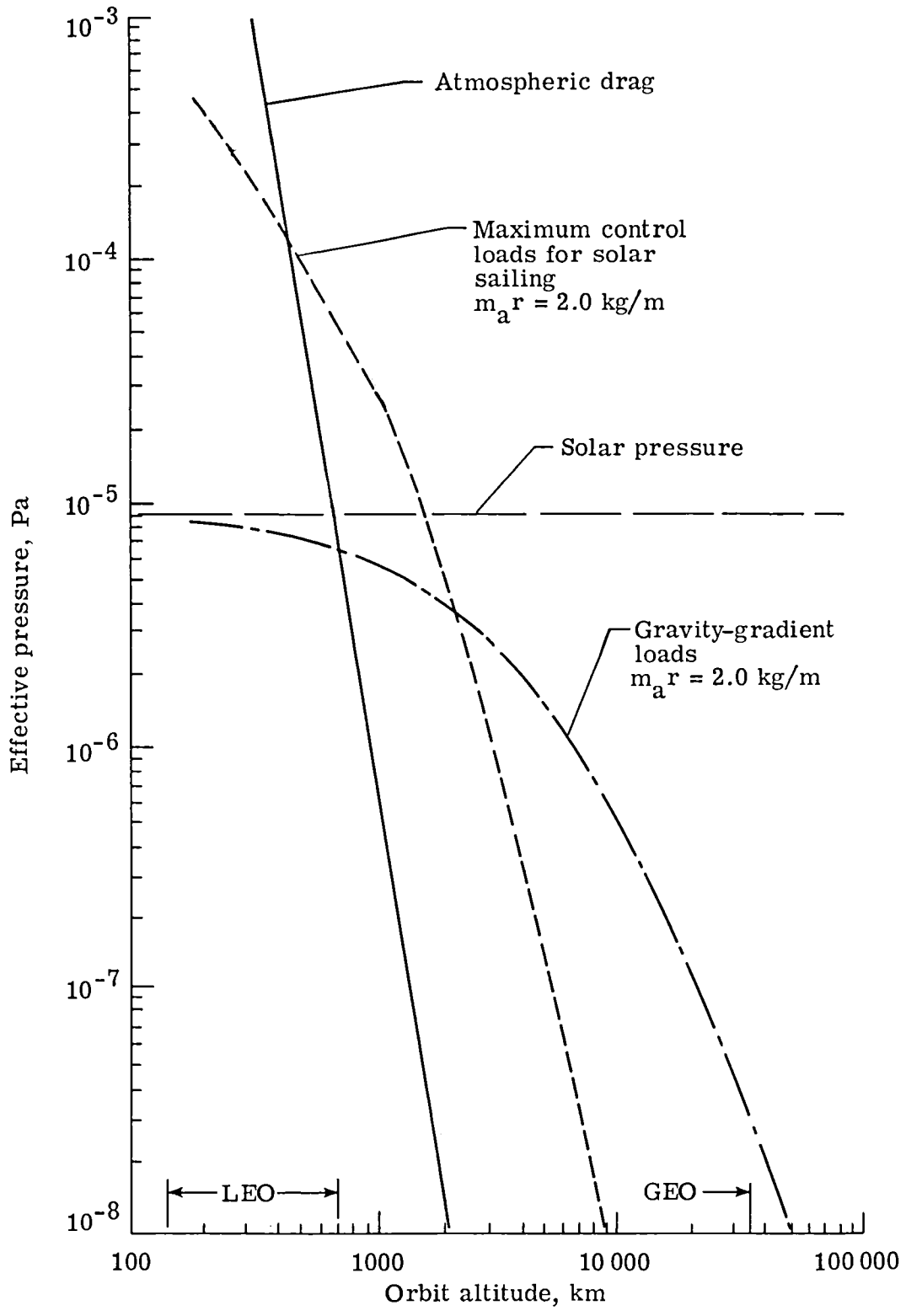
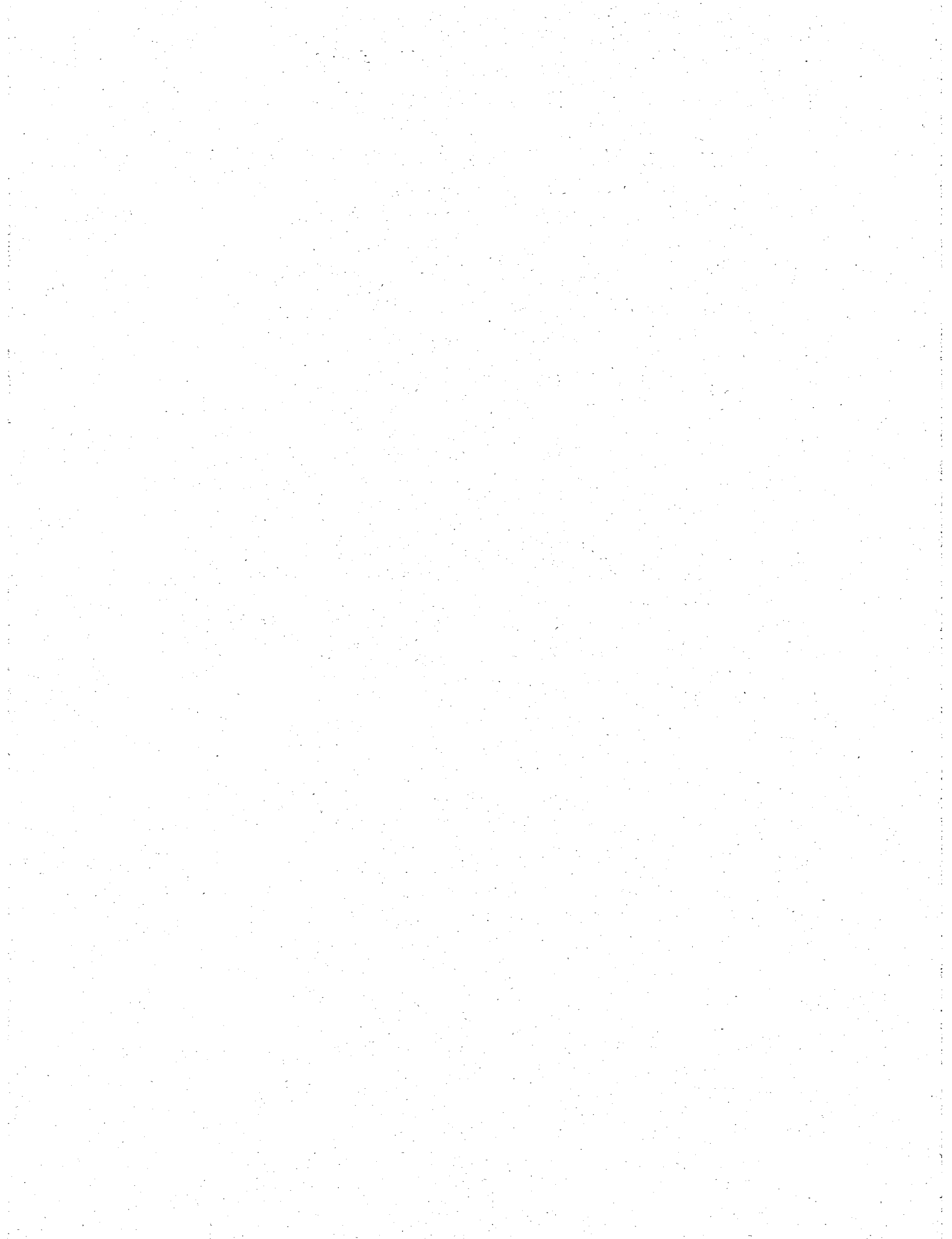


Figure 27.- Maximum loads on reflective membrane of a 1-km spacecraft at different orbit altitudes.





1. Report No. NASA TP-2065		2. Government Accession No.		3. Recipient's Catalog No.	
4. Title and Subtitle ILLUMINATION FROM SPACE WITH ORBITING SOLAR-REFLECTOR SPACECRAFT				5. Report Date September 1982	
				6. Performing Organization Code 506-62-43	
7. Author(s) John E. Canady, Jr., and John L. Allen, Jr.				8. Performing Organization Report No. L-15127	
				10. Work Unit No.	
9. Performing Organization Name and Address  NASA Langley Research Center Hampton, VA 23665				11. Contract or Grant No.	
				13. Type of Report and Period Covered Technical Paper	
12. Sponsoring Agency Name and Address  National Aeronautics and Space Administration Washington, DC 20546				14. Sponsoring Agency Code	
15. Supplementary Notes					
16. Abstract  Studies indicate it is feasible to use orbiting mirrors to reflect sunlight to Earth for several illumination applications. A constellation of sixteen 1-km solar-reflector spacecraft in geosynchronous orbit can illuminate a region 333 km in diameter to 8 lux, which is brighter than most existing expressway lighting systems. This constellation can serve one region all night long or can provide illumination during mornings and evenings to five regions across the United States. Preliminary cost estimates indicate such an endeavor is economically feasible. The studies also explain how two solar reflectors can illuminate the in-orbit nighttime operations of Space Shuttle. Several other mission scenarios are described. An unfurlable, 1-km-diameter solar-reflector spacecraft design concept was derived. This spacecraft can be packaged in the Space Shuttle, transported to low Earth orbit, unfurled, and solar sailed to operational orbits up to geosynchronous. The necessary technical studies and improvements in technology are described, and potential environmental concerns are discussed.					
17. Key Words (Suggested by Author(s)) Illumination from space Solar-reflector spacecraft Solar sailing Deployable gossamer structures			18. Distribution Statement  Unclassified - Unlimited  Subject Category 18		
19. Security Classif. (of this report) Unclassified		20. Security Classif. (of this page) Unclassified		21. No. of Pages 88	22. Price A05



National Aeronautics and  
Space Administration

Washington, D.C.  
20546

Official Business  
Penalty for Private Use, \$300

THIRD-CLASS BULK RATE

Postage and Fees  
National Aeronautics and  
Space Administration  
NASA-451



LANGLEY RESEARCH CENTER



POSTMASTER: If Undeliverable (Section 158  
Postal Manual) Do Not Return

---