

NASA-CR-165,967

**NASA Contractor Report 165967**

NASA-CR-165967  
19820025920

NORSEX 79

MICROWAVE REMOTE SENSING

DATA SUMMARY REPORT

SEPTEMBER 29 - OCTOBER 12, 1979

HAROLD F. HENNIGAR AND SALLY K. SCHAFFNER

THE BIONETICS CORPORATION  
HAMPTON, VIRGINIA 23666

CONTRACT NAS1-16978  
MAY 1982

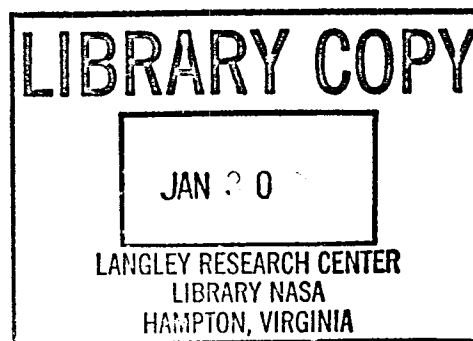

National Aeronautics and  
Space Administration

**Langley Research Center**  
Hampton, Virginia 23665



## TABLE OF CONTENTS

	<u>Page</u>
SUMMARY . . . . .	v
SECTION 1 . . . . .	1
<u>INTRODUCTION</u> . . . . .	1
<u>DATA ORGANIZATION</u> . . . . .	4
SECTION 2 . . . . .	7
<u>SENSOR DESCRIPTIONS</u> . . . . .	7
STEPPED FREQUENCY MICROWAVE RADIOMETER . . . . .	7
AIRBORNE MICROWAVE SCATTEROMETER . . . . .	14
PRECISION RADIATION THERMOMETER . . . . .	23
SECTION 3 . . . . .	25
<u>SENSOR GEOMETRY</u> . . . . .	25
SECTION 4 . . . . .	34
<u>NORSEX DATA SET SUMMARY</u> . . . . .	34
SECTION 5 . . . . .	39
<u>NORSEX DATA EXAMPLE</u> . . . . .	39
BIBLIOGRAPHY . . . . .	44
<u>GENERAL</u> . . . . .	44
<u>INSTRUMENTATION</u> . . . . .	45
<u>NORSEX</u> . . . . .	45
APPENDIX A: AERIAL PHOTOGRAPHY LOG AND ORDERING INFORMATION . . . . .	47
APPENDIX B: NORSEX DATA TAPE DOCUMENTATION . . . . .	52

TABLE OF CONTENTS

	<u>Page</u>
APPENDIX C: NORSEX TIME LINE PLOTS AND FLIGHT LINES . . . . .	60
DAY 272 . . . . .	61
DAY 274 . . . . .	81
DAY 277 . . . . .	111
DAY 281 . . . . .	133
DAY 283 . . . . .	161
DAY 285 . . . . .	190

LIST OF FIGURES

<u>Figure</u>		<u>Page</u>
1	The NASA C-130 Aircraft . . . . .	2
2	Map of the NORSEX Experiment Area . . . . .	3
3	Stepped Frequency Microwave Radiometer . . . . .	8
4	Front Panel View of the Digital Controller for the Stepped Frequency Microwave Radiometer	9
5	Block Diagram of the Stepped Frequency Microwave Radiometer . . . . .	11
6	Simplified Block Diagram of the Airborne Microwave Scatterometer . . . . .	15
7	Scatterometer Gimbal Assembly on C-130 Aircraft . . . . .	16
8	Scatterometer Transmitter/Receiver . . . . .	16
9	Rack-Mounted Electronics for Scatterometer . . . . .	17
10	Arrangement of Sensors on-board the NASA C-130 . . . . .	26
11	SFMR Footprints . . . . .	30
12	Time Line Plot . . . . .	36
13A	Example of Sensor Data . . . . .	40
13B	Example of Sensor Data . . . . .	41

LIST OF TABLES

<u>TABLE</u>		<u>PAGE</u>
1	Summary of Flight Days . . . . .	5
2	AMSCAT Operating Characteristics . . . . .	19
3	PRT-5 Operating Characteristics . . . . .	24

## SUMMARY

This report summarizes the airborne microwave remote sensing measurements obtained by NASA Langley Research Center in support of the 1979 Norwegian Remote Sensing Experiment (NORSEX). The remote sensing objectives of NORSEX were to investigate the capabilities of an active/passive microwave system to measure ice concentration and type in the vicinity of the marginal ice zone near Svalbard, Norway and to apply microwave techniques to the investigation of a thermal oceanic front near Bear Island, Norway. The instruments used during NORSEX include the Stepped Frequency Microwave Radiometer (SFMR), Airborne Microwave Scatterometer (AMSCAT), Precision Radiation Thermometer (PRT-5) and metric aerial photography. Remote sensing data are inventoried, summarized and presented in a user-friendly format. Data summaries are presented as time-history plots which indicate when and where data were obtained as well as the sensor configuration. All data are available on nine-track computer tapes in card-image format upon request to the NASA Langley Technical Library.

## SECTION 1

### INTRODUCTION

This report summarizes the airborne remote sensing data sets obtained by NASA Langley Research Center in support of the 1979 Norwegian Remote Sensing Experiment (NORSEX). The remote sensing objectives of NORSEX are listed below in order of priority:

- (1) Evaluate the capability of an active/passive microwave system to measure ice concentration and type near the Marginal Ice Zone (MIZ) north of Svalbard, Norway.
- (2) Investigate the microwave signature of a quasi-permanent thermal oceanic front (Polar Front) in the vicinity of Bear Island, Norway.

Six flights were conducted over the region during September and October 1979 using the NASA C-130 aircraft shown in Figure 1. The flights were staged from Tromso, Norway with refueling stops at Longyearbyen, located in Svalbard, Norway. The first two flights were made in conjunction with ship-borne microwave measurements performed aboard the Norwegian icebreaker Polar Circle, which was located in the marginal ice zone. Ancillary oceanographic measurements were also obtained by the Polar Circle in the marginal ice zone and in the polar front area. Figure 2 is a map of the region including Tromso, Svalbard, the marginal ice zone and the polar front. A summary of flight days is presented



Figure 1. The NASA C-130 Aircraft (NASA 929)



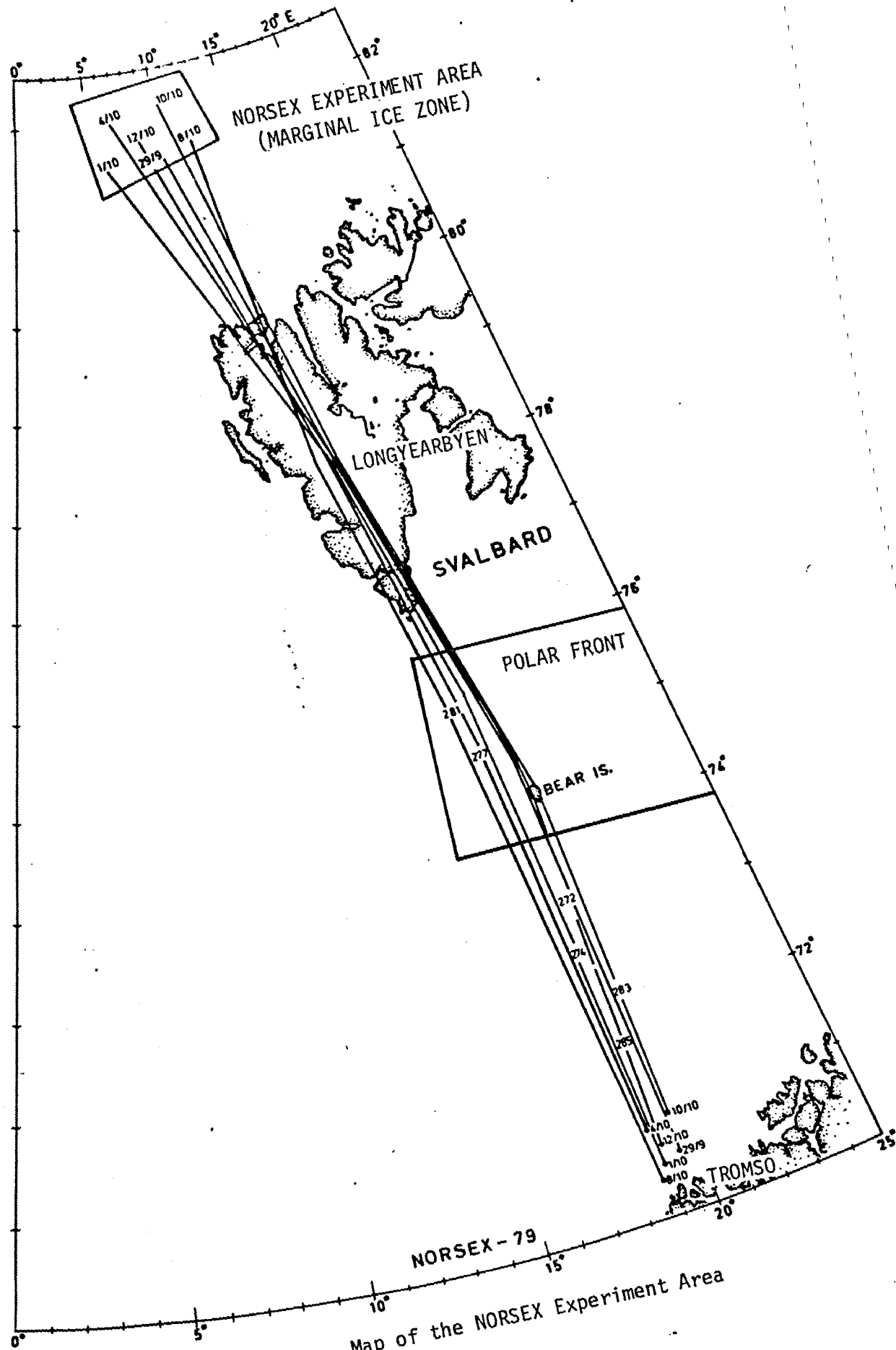

Figure 2. Map of the NORSEX Experiment Area

in Table 1. NASA Langley sensors on board the C-130 aircraft included a 14.6 GHz Airborne Microwave Scatterometer (AMSCAT), and a 4.5 to 7.2 GHz Stepped Frequency Microwave Radiometer (SFMR). A thermal infrared radiometer (PRT-5) and two Zeiss 6-inch focal length metric cameras were also used. Descriptions of these instruments are provided in the next Section.

#### DATA ORGANIZATION

The primary objective of this report is to present the remote sensing data collected on the mission in a user-friendly format. Data are organized by flight day and are referenced to Greenwich Meridian Time (GMT). Data summaries are presented in Section 3 as time-line plots and indicate when and where the data were obtained, as well as the sensor configuration. All data have been inspected and time-corrected, where appropriate, and are available on nine-track computer tapes in card image format upon request to the NASA Langley Technical Library (See Appendix B). Upon inspection of the time-line plots a user can access a specific data segment by searching the tapes for the appropriate start and stop time. Selection of data for detailed analysis will depend upon the requirements of the user. The data have been organized so that selection is easiest if the user has a particular sensor configuration in mind, or is interested in a particular geographic location. No attempt at detailed analyses has been presented in this report, and users are

TABLE 1

<u>JULIAN DAY</u>	<u>CALENDAR DAY</u>	<u>PRINCIPAL TEST SITE</u>
272	Sep. 29, 1979	A, B
274	Oct. 1, 1979	A
277	Oct. 4, 1979	B, A
281	Oct. 8, 1979	A, B
283	Oct. 10, 1979	A
285	Oct. 12, 1979	A

A - Marginal Ice Zone

B - Polar Front

urged to apply their own methods of analysis to the data. It is hoped that by making these data available, many alternative methods of analysis will be developed and applied.

In general, aerial photography serves as ground truth over the marginal ice zone (See Appendix A). Limited oceanographic data, in report form, are also available for the marginal ice zone, the polar front, and certain other areas. A bibliography lists publications of general interest as well as those dealing specifically with NASA Langley instrumentation and the NORSEX experiment.

## SECTION 2

### SENSOR DESCRIPTIONS

#### STEPPED FREQUENCY MICROWAVE RADIOMETER

The Stepped Frequency Microwave Radiometer (SFMR) is a precision, nadir looking, circular polarized radiometer designed, developed and fabricated by Langley Research Center. SFMR is believed to be the first variable frequency microwave radiometer controlled by a digital microprocessor which provides both radiometer control functions and real-time data processing. The radiometer antenna, microwave portion and signal processor are shown in Figure 3. The front panel of the digital controller is shown in Figure 4.

The SFMR is capable of operating at frequencies between 4.5 GHz and 7.2 GHz at bandwidths of 10, 50, 250 or 1000 megahertz with integration times from 0.2 to 20 seconds. The frequency can be varied in incremental steps from approximately 0.2 to 5 times the bandwidth per integration time. During NORSEX, however, SFMR operated only at 6.6 GHz so that results could be compared with data recorded by the 6.6 GHz channel of the Scanning Multi-frequency Microwave Radiometer (SMMR) on board the Nimbus-7 satellite (Reference 6, 8). Analysis has shown that the SFMR exhibits an absolute precision of better than  $2.0^{\circ}$  K. Removal of absolute instrument bias was accomplished through comparison of the physical sea surface temperature calculated

Data Processor, Controller  
(See Figure 4)

Constant Temperature  
Electronic Enclosure

Mixer, LO,  
Filter  
Assembly

Signal  
Processor

Antenna

Figure 3. Stepped frequency microwave radiometer

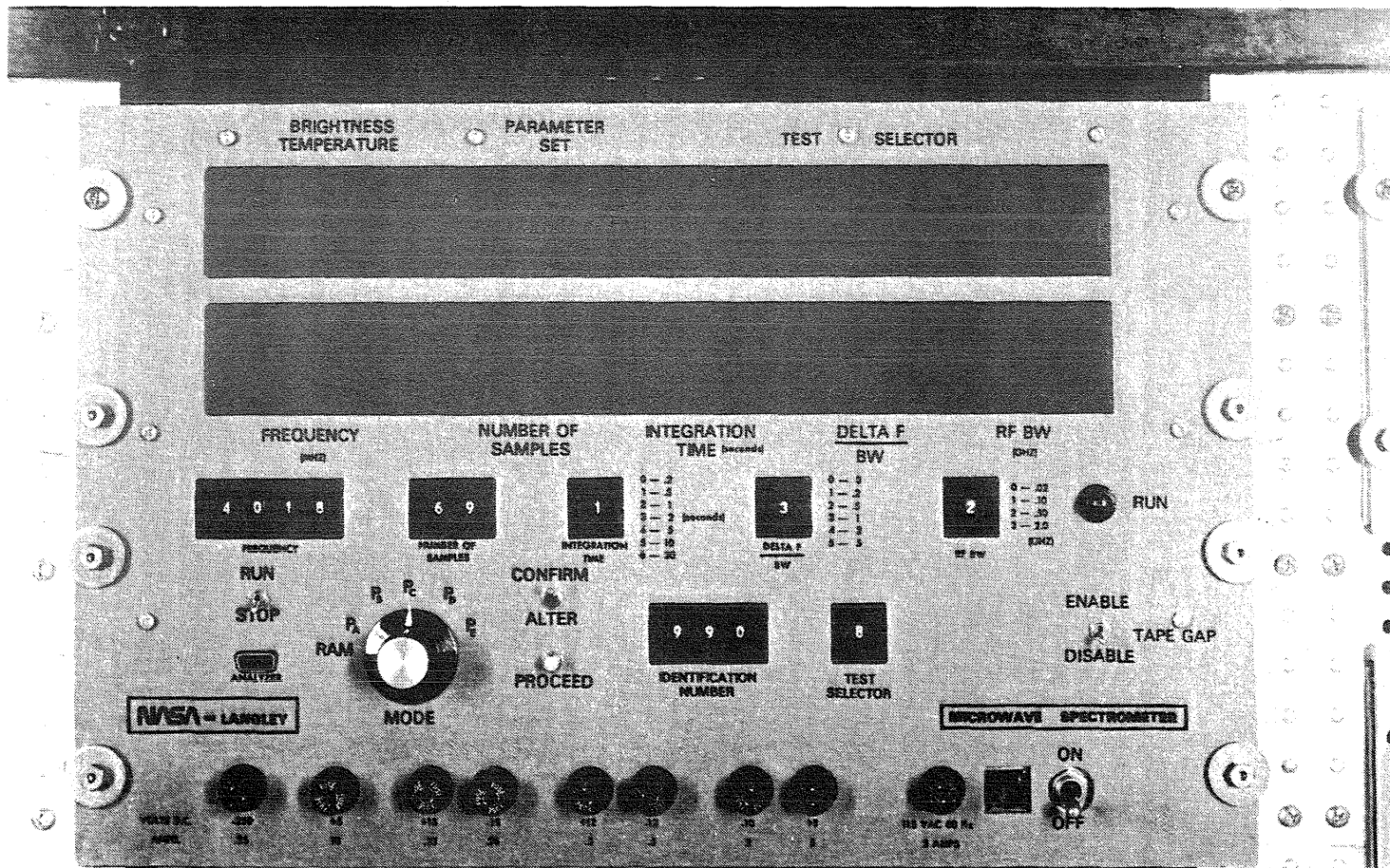

Figure 4. Front panel view of the digital controller for the stepped frequency microwave radiometer

from the brightness temperature observed by the SFMR at the ice edge with the in-situ sea surface temperature. Wind speed and sea surface salinity were taken into account in the calculation of sea surface temperature from brightness temperature. The ideal radiometer brightness temperature sensitivity of the instrument varies between 0.012K and 1.25K depending on the bandwidth and integration time selected for the SFMR. The measured radiometer sensitivity at 6.6 GHz was between 0.69K and 0.88K with a 90% confidence and between 0.65K and 0.94K with a 99% confidence. The ideal radiometer sensitivity for the above case was 0.25K. The radiometer was operating with a 60 MHz pre-detection filter bandwidth, a 0.2 second post detection integration time, with 5 samples averaged during post flight data reduction to achieve a sample period of 1 second.

The SFMR is a balanced Dicke-switched square-wave correlated radiometer. The radiometer utilizes a closed-loop Type I noise feedback circuit to add noise to the received antenna noise, thereby balancing to the Dicke reference noise. The microwave portion of the radiometer, including the broad band tunnel-diode low-noise amplifier is maintained in a constant temperature enclosure at the Dicke reference temperature within  $\pm 0.10\text{K}$ . A block diagram of the radiometer is shown in Figure 5.

The antenna consists of a corrugated wall broadband horn (10 dB Beamwidth for circular polarization  $\sim 20.5^\circ$ ). The antenna has a polarizing radome to provide for circular polarization.



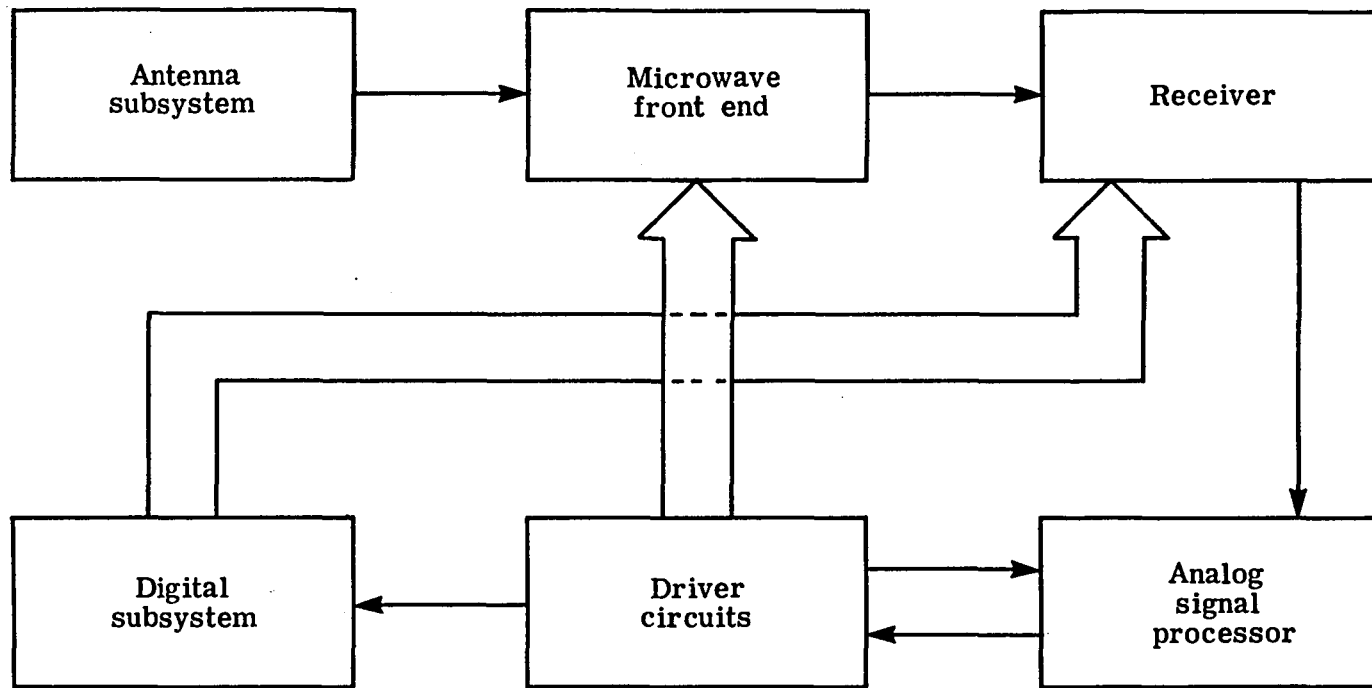

Figure 5. Block diagram of the stepped frequency microwave radiometer.

An 11 layer fiberglass/honeycomb sandwich radome is used over the polarizing radome in pressurized aircraft. The feed of the antenna is located within the constant temperature enclosure. The noise injection circuit consists of a solid-state noise diode, isolator, PIN diode switch and 20 dB directional coupler. The Dicke switch is a broadband latching circulator.

The receiver portion of the radiometer consists of a homodyne mixer, YIG tuned local oscillator and 1 to 1000 megahertz IF amplifier. The frequency of the radiometer is controlled by an eight bit digital word from the digital subsystem that is converted to a 0 to 10 volt dc voltage. This signal controls the voltage tuned microwave oscillator. The frequency can be changed every 200 milliseconds in steps of 16 MHz or greater over the frequency range from 4.018 GHz to 8.098 GHz. However, the antenna limits the useable frequency range to 4.500 GHz to 7.200 GHz. The bandwidth of the radiometer is selected by the digital subsystem using one of four paths through the filter bank.

The 1 to 1000 MHz constant power level noise signal is transformer coupled into a hot-carrier diode square-law detector in the analog signal processor. The detected noise signal is amplified, synchronously detected with the Dicke switching frequency and the resultant error signal is fed to a true integrator. The output of the integrator is filtered to remove the effect of the Dicke switching frequency and used to control the pulse train output of a voltage-to-frequency (V/F) converter.

The V/F converter provides a variable duty cycle 70 micro-second pulse train. The pulse repetition frequency varies from 0 to 10,000 pulses per second linearly with the dc output voltage of the integrator. This pulse train is applied to the noise injection PIN diode switch and controls the number of injected constant amplitude, constant width noise pulses. The digital subsystem measures the duty cycle of the pulse train to determine the noise added to the antenna noise.

The digital subsystem provides both control functions to the radiometer, data processing of the output signal from the radiometer and physical temperature measurements of several locations in the radiometer. It also provides front panel control functions and real-time displays for the operator. The radiometer data are formatted along with time, temperatures and other operational data, and are recorded on a digital tape recorder. An estimate of the brightness temperature is computed by the microprocessor and displayed to the operator (Reference 18). The integration time of the radiometer is determined by the count period of the injection time counters which compute the duty cycle of the radiometer output. The integration time of the closed-loop radiometer noise feedback is several times faster than the minimum integration time allowed by the digital subsystem.

## AIRBORNE MICROWAVE SCATTEROMETER

The Airborne Microwave Scatterometer, AMSCAT, (formerly known as SUS) is an active microwave remote sensor that was developed at the NASA Langley Research Center to measure the absolute normalized radar cross section of ocean, ice, and land targets. The scatterometer operates in a "long-pulse", or interrupted continuous wave, mode at a center frequency of 14.6 GHz. The simplified block diagram is shown in Figure 6. AMSCAT is separated into three major assemblies; gimbal, transmitter/receiver, and rack-mounted electronics.

The gimbal assembly comprises a dual-linear polarized parabolic antenna (3.5 degree beamwidth); a two-axis, servo controlled pedestal (to provide independent elevation and azimuth positioning); and a multi-layer honeycomb/fiberglass radome. For NORSEX, this assembly was mounted on the underside of the fuselage beneath the vertical stabilizer (tail section) of a C-130 aircraft (Figure 7).

The transmitter/receiver assembly (Figure 8) comprises all the microwave hardware including circulator switches, a 1W and a 20W TWT power amplifier, low noise tunnel diode amplifier and a solid state microwave source for generating the transmitter and receiver local oscillator signals. The system operation is digitally controlled by commands generated in the rack-mounted equipment.

The rack-mounted electronics (Figure 9) comprises power

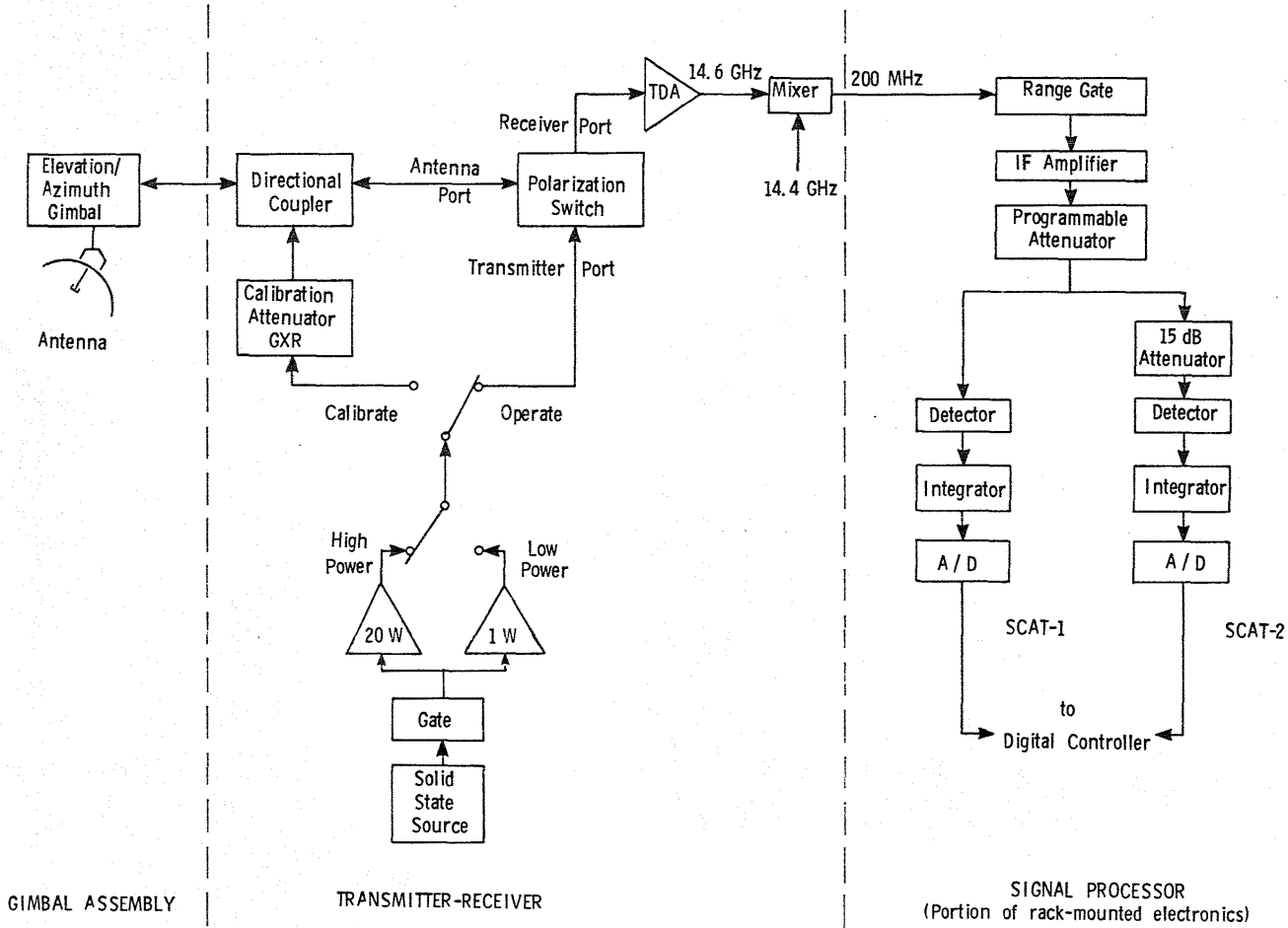

Figure 6. Simplified Block Diagram of the Airborne Microwave Scatterometer

AMSCAT  
Antenna  
(less feed  
and Radome)

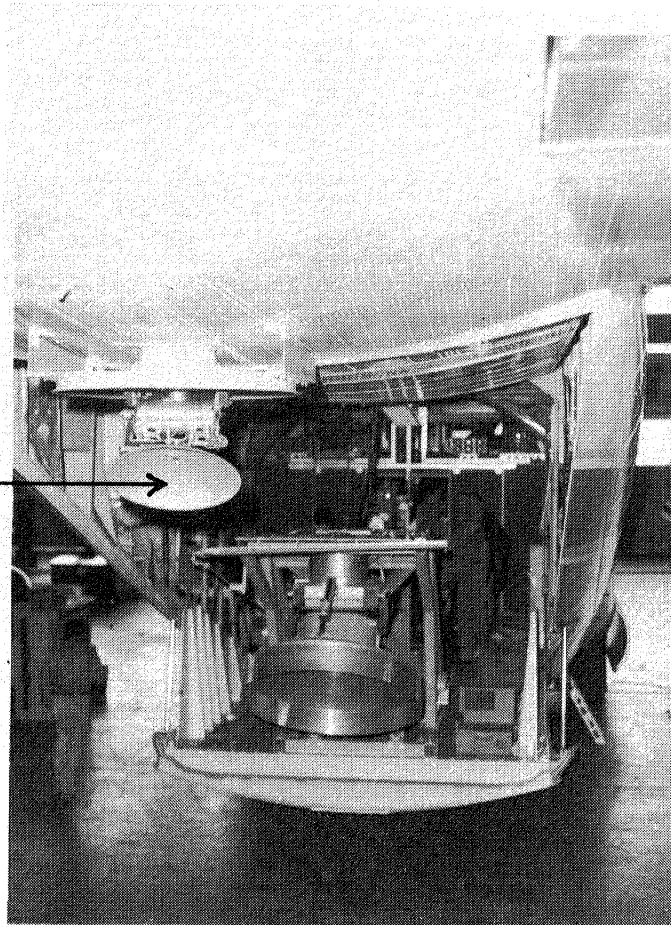

Figure 7. Scatterometer Gimbal  
Assembly on C-130 Aircraft

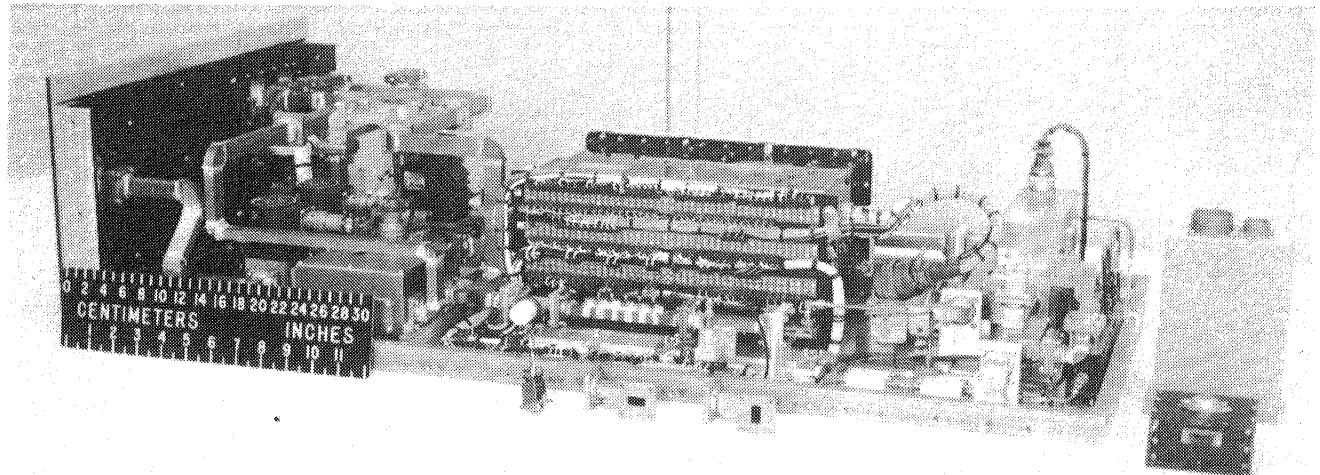

Figure 8. Scatterometer Transmitter/Receiver Assembly

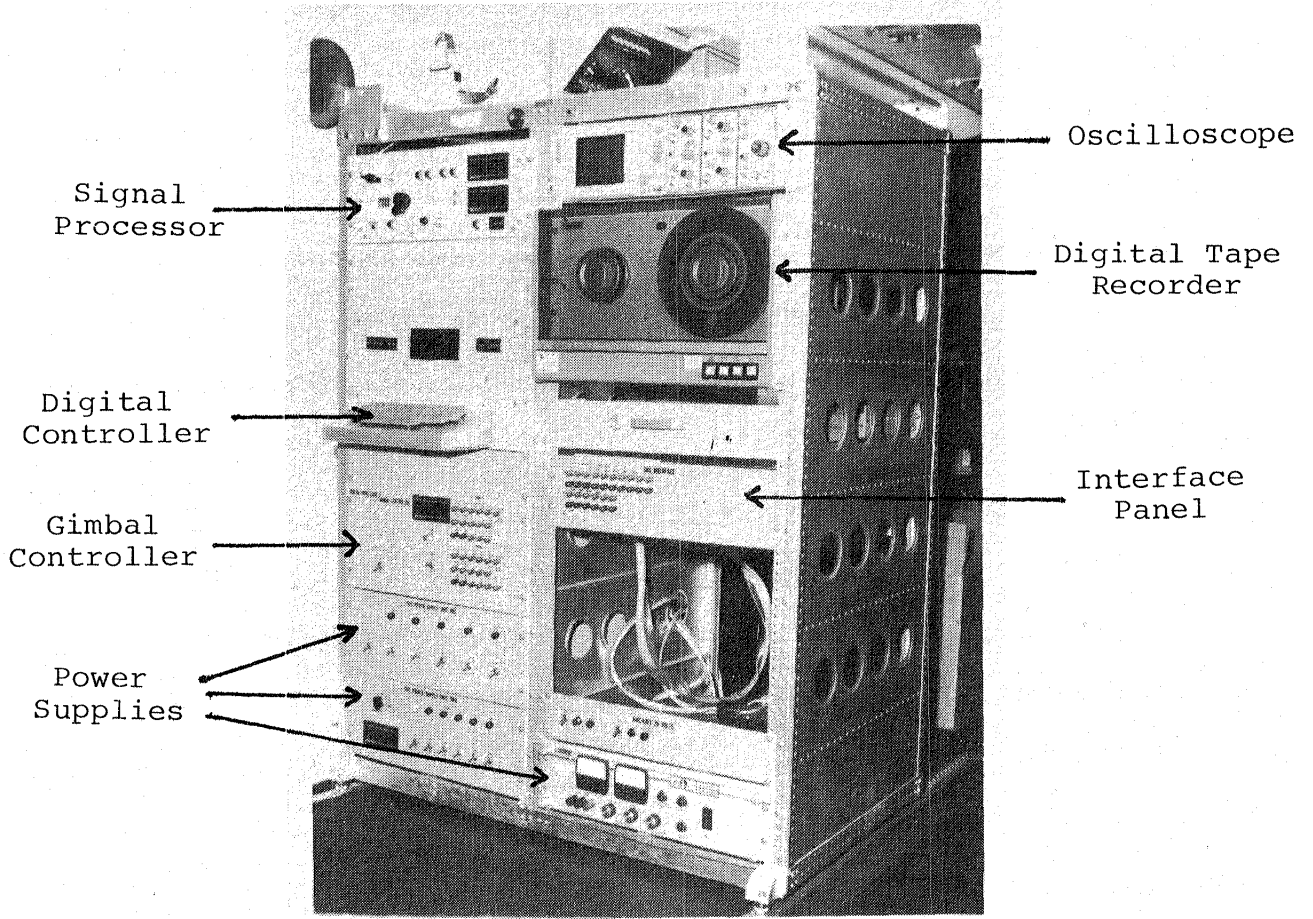

Figure 9. Rack-Mounted Electronics for Scatterometer

supplies, the gimbal controller, the signal processor, digital controller/data system, and an analog strip chart recorder. The signal processor (Figure 6) has two overlapping channels which provide an instantaneous received power range of greater than 40 dB. A programmable attenuator is used as a coarse gain control to provide an additional 60 dB range. In each channel, the signals are square-law detected, integrated for 500 ms, and then A/D converted and recorded with a 7-track digital recorder. The digital controller/data system is a micro-processor which generates the precise timing and control logic needed by the scatterometer to form RF pulses, operate switches, range gates, and to A/D convert SCAT integrator voltages, and format aircraft parameters and radar data for recording. The use of this processor enables considerable flexibility in the selection of radar operating characteristics (Table 2) via an interactive programming mode.

In making scatterometer measurements, the quantity of interest is the scattering coefficient  $\sigma^0$ . This quantity is independent of the type of radar performing the measurement and is defined from the radar equation to be:

$$\sigma^0 = \frac{P_r}{P_t} \frac{(4\pi)^3 R^4}{G^2 \lambda^2 A_T L_S} \quad (1)$$

where  $P_r$  = received power

$P_t$  = transmitted power



TABLE 2. AMSCAT OPERATING CHARACTERISTICS

SELECTABLE CHARACTERISTICS

Polarization	- HH*, HV, VV, VH
Incidence Angle	- 0° to 54°
Azimuth Angle (Relative to Heading)	- 15° to 345°

NON-SELECTABLE CHARACTERISTICS

Frequency	- 14.6 GHz
$\sigma^{\circ}$ Sampling Rate	- 2 sec <sup>-1</sup>
Absolute $\sigma^{\circ}$ Accuracy	- $\pm$ 1.0 dB
$\sigma^{\circ}$ Precision	- $\pm$ 0.1 dB
Antenna Beamwidth	- 3.5°
Total $\sigma^{\circ}$ Range	- + 20 DB to -40 dB

\* Transmit horizontal/receive horizontal. With transmit and receive each either horizontal or vertical, there are four possible combinations. When transmit and receive are of like polarization, the system is said to be in a dominant polarization, and when opposed, in a cross-polarization.

- G = antenna gain
- R = slant range
- L<sub>s</sub> = miscellaneous losses; couplers, waveguide, etc.
- λ = free-space wavelength
- A<sub>T</sub> = effective antenna footprint on surface.

For the AMSCAT case of beam limited conditions:

$$A_T = \frac{\pi}{4} \frac{(\beta_{eq} R)^2}{\cos \theta} \quad (2)$$

where  $\beta_{eq}$  is the effective pencil-beam antenna width (approximately equal to the half power antenna beam width in radians) and  $\theta$  is the incidence angle. The scattering coefficient thus becomes:

$$\sigma^o = \frac{P_r}{P_t} \frac{(16)^2 R^2 \cos \theta}{G^2 \lambda^2 \beta_{eq}^2 L_s} \quad (3)$$

Refer to the block diagram of Figure 6. The  $P_r/P_t$  ratio was measured in two steps. First, a sample of the transmitter power, attenuated by a known value  $GXR$ , was diverted into the receiver. This produced a "calibration" output voltage  $V_{cal}$  in each receiver channel proportional to  $P_t$ . Next, the transmitter was connected to the antenna and an output voltage  $V_{sur}$  proportional to  $P_r$  was obtained in a particular channel. Solving for the received-to-transmitted power ratio (in terms of the voltage from a particular channel) yields:

$$\frac{P_r}{P_t} = \frac{V_{sur}}{V_{cal}} \frac{GXR \alpha_{cal}}{\alpha_{sur}} \quad (4)$$

where  $V$  = output voltage of integrator  
 $\alpha$  = programmable attenuator value  
 $GXR$  = receiver calibration loop attenuation

and subscripts are:

cal = during calibration  
sur = during surface observation.

Finally, in terms of the AMSCAT transfer function, the expression for  $\sigma^0$  is:

$$\sigma^0 = (16)^2 \frac{H^2 V_{sur} \alpha_{cal} GXR}{\lambda^2 V_{cal} \alpha_{sur} G^2 \cos \theta (\beta_{eq})^2 L_s} \quad (5)$$

where  $H$  is the altitude of the aircraft (antenna).

The absolute  $\sigma^0$  value from equation (5) will be in error because of inaccuracies in the determination of the instrument transfer coefficients ( $G$ ,  $\alpha$ ,  $L_s$ ,  $GXR$ ,  $\beta$ ) and the variables ( $H$ ,  $\theta$ ,  $V$ ). This error can be separated into a bias and random component. The accuracy of this bias determination is better than  $\pm 1$  dB.

The major contributor to the random component of  $\sigma^0$  is  $V_{sur}$ . Because of Rayleigh fading of the received power from the surface,  $V_{sur}$  is an imperfect estimate of the mean received power used in the  $\sigma^0$  calculation, equation (1). The normalized

standard deviation of the cross section is approximately:

$$\frac{\Delta\sigma^0}{\sigma^0} = \frac{1}{\sqrt{N}} \quad (6)$$

where  $N$  = number of independent samples,

$$N = \sqrt{\beta_d \tau} \quad (7)$$

where  $\tau$  = integration time

and  $\beta_d$  = Doppler bandwidth of received power,

$$\beta_d = \frac{2Vf}{C} (\sin \theta_{\max} - \sin \theta_{\min}) \quad (8)$$

Here  $V$  = aircraft speed

$f$  = radar frequency

$C$  = speed of light

For the NORSEX mission  $\Delta\sigma^0/\sigma^0$  was less than  $\pm 0.5$  dB

After the conclusion of the field phase of NASA's participation in the NORSEX program, an intermittent contact was found in the polarization change-over switch of the scatterometer. The effect of this condition is that much of the scatterometer data intended as HH (see Table 2) polarization was discovered later to be actually either HV or some mixture of HH and HV. This results in an uncertainty of several dB in absolute level of the HH, HV and VH data. The VV data are not affected.

## PRECISION RADIATION THERMOMETER

The Precision Radiation Thermometer, referred to as the PRT-5, is a nadir-looking infrared radiometer used to remotely measure physical temperature of targets. The output of the PRT-5 is available on the nine-track digital tapes as surface temperature in degrees Celsius. Table 3 summarizes the operating characteristics of the instrument used during the NORSEX mission. The user should consult reference 21 for a complete description of the instrument.

TABLE 3. PRT-5 OPERATING CHARACTERISTICS

Performance Data

Temperature Measurement Range ( $^{\circ}\text{C}$ )	-35 to + 75 $^{\circ}$ C
Accuracy	0.5 $^{\circ}\text{C}$
Sensitivity (@ 25 $^{\circ}\text{C}$ )	0.1 $^{\circ}\text{C}$
Filter Band	8 - 14 microns
Field of view	2 $^{\circ}$

### SECTION 3

#### SENSOR GEOMETRY

In order to make use of the data obtained during NORSEX 79, an understanding of sensor geometry and its effects on temporal and spatial alignment of the data is required. Figure 10 illustrates the arrangement of sensors on board the NASA C-130 aircraft during the NORSEX mission. The Stepped Frequency Microwave Radiometer (SFMR), PRT-5 and aerial cameras are nadir looking instruments, hence, the footprints of these instruments were directly beneath the aircraft. The Airborne Microwave Scatterometer (AMSCAT), however, operated at a variety of incidence angles from  $0^{\circ}$  to  $54^{\circ}$  and was aimed behind the aircraft. For an incidence of  $0^{\circ}$  the AMSCAT was nadir-looking, however, as the incidence angle increases the AMSCAT footprint is translated backward along the flight line. Therefore, the SFMR, PRT-5 and aerial cameras will image an area before the AMSCAT. As stated previously, all sensors have been referenced to Greenwich Meridian Time (GMT). This requires that a temporal correction be applied by the user to the AMSCAT data in order to align the data from all sensors. This correction is as follows:

$$\text{AMSCAT time (GMT)} = \text{NADIR time (GMT)} + \Delta t$$

where  $\Delta t$  is a function of aircraft altitude, speed and the incidence angle of the AMSCAT. The temporal offset ( $\Delta t$ ) can be

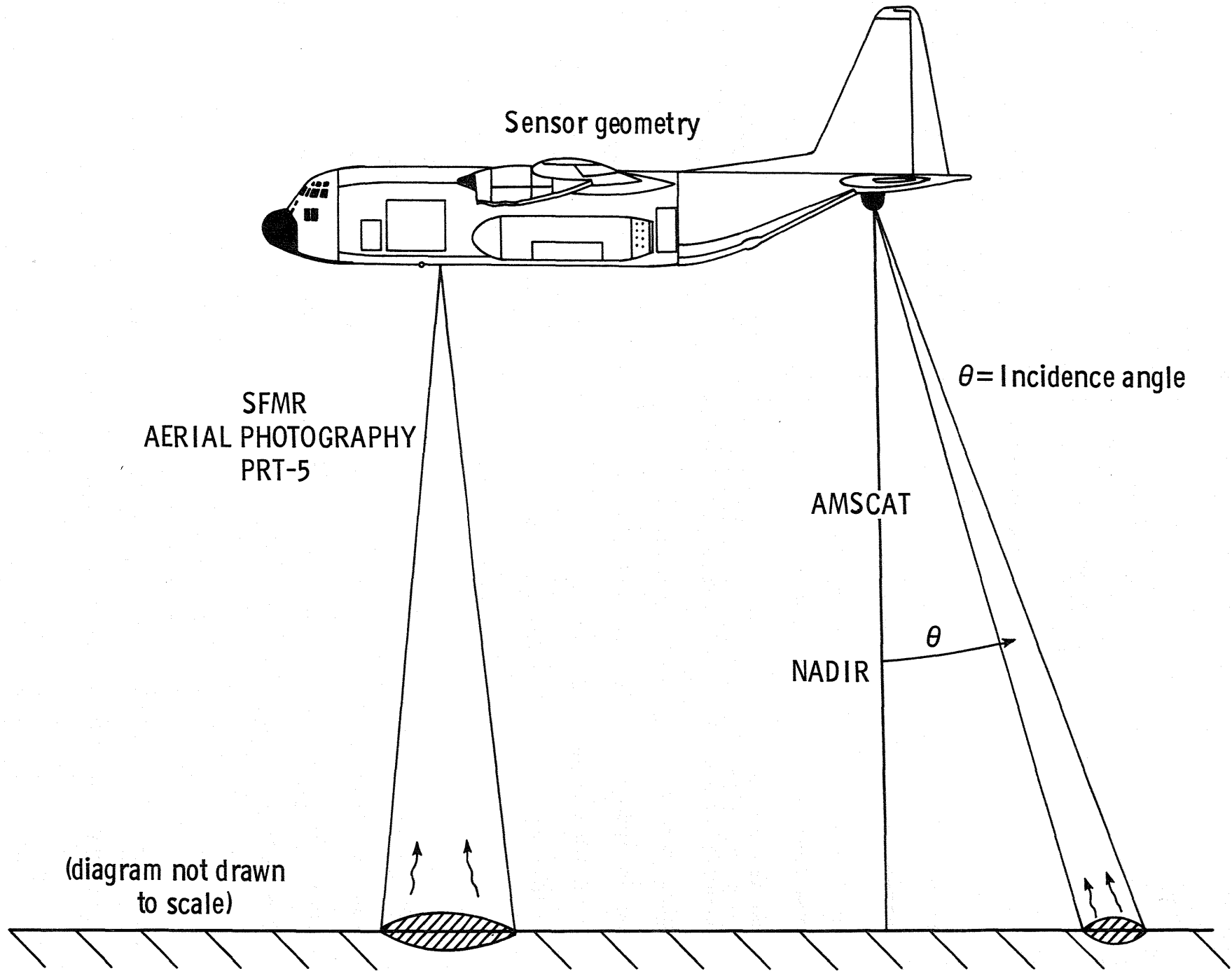

Figure 10. Arrangement of Sensors on board the NASA C-130



calculated using the following equation:

$$\Delta t = \frac{\text{Aircraft Altitude} \times \text{tangent } \theta}{\text{Aircraft Groundspeed}}$$

where  $\theta$  = incidence angle. Altitude and groundspeed must be in the same units (i.e., altitude = meters; groundspeed = meters per second). Location of footprints on the aerial photography requires the calculation of the distance offset between the AMSCAT and the nadir-looking instruments. For the AMSCAT, the time recorded with a sigma-naught value indicates the centroid of the smeared footprint rather than instantaneous footprint. Using the variables described above, the distance offset can be calculated from:

$$\text{Distance offset} = \text{Altitude} \times \text{tangent } \theta$$

The distance offset can be applied to the photography by converting to distance on the aerial photography using the scale of the aerial photograph. For the 152.4 mm focal length camera used during NORSEX:

$$\text{Photographic Scale} = \frac{\text{Altitude}}{\text{Focal Length}}$$

For example, at an altitude of 1600 meters the scale of the aerial photograph is 1:10500. At this scale, one centimeter on the photograph equals 105 meters on the ground.

Footprint sizes of the instruments vary, with the aerial cameras having the largest footprints and the SFMR, AMSCAT, and PRT-5 having successively smaller footprints, all of which are contained within the camera footprint (i.e., photograph). Calculation of footprint sizes for the various sensors is described below.

Instantaneous footprints of all sensors at nadir would be nearly circular. However, due to the fact that the sensors record data over varying integration times (usually 0.5 second) there is a smearing of the footprint in the direction of the flight line. For example, the instantaneous 10 dB footprint (Beamwidth =  $20.5^\circ = 0.37$  rad) of the SFMR can be calculated from:

$$\text{SFMR Footprint Diameter} = 0.37 \times \text{Altitude}$$

At an aircraft altitude of 1000 meters the SFMR instantaneous footprint would be a circle with a diameter of 370 meters. The footprint is smeared, however, along the flight line by the distance the aircraft traveled during the signal integration. At an aircraft speed of  $114 \text{ ms}^{-1}$  the aircraft would have traveled 57 meters for a 0.5 second integration period. Therefore the SFMR footprint would actually be an ellipse with the major axis along the flight line and the minor axis perpendicular to the flight line. For the SFMR, the time recorded with a data value indicated the centroid of the smeared footprint rather than the

instantaneous footprint. Referring to Figure 11, footprint size perpendicular to the flight line is:

$$A = 0.37 \times \text{Altitude}$$

while footprint size along the flight line is:

$$B = A + [\text{Integration time} \times \text{Aircraft Groundspeed}]$$

For an altitude of 1000 meters and a groundspeed of 225 knots, footprint dimensions are as follows:

$$A = 370 \text{ meters}$$

$$B = 427 \text{ meters}$$

Footprints of the PRT-5, for all practical purposes, are circular as the integration time was less than 0.03 second.

For the PRT-5, footprint dimensions are:

$$A = B = .035 \times \text{Altitude}$$

For an altitude of 1000 meters and an aircraft speed of 225 knots, footprint dimensions are:

$$A = B = 35 \text{ meters}$$

Calculation of footprint size for the AMSCAT is slightly different because, in addition to smearing along the flight line, the instrument is not nadir-looking. The instantaneous footprint size of the AMSCAT is described for A (perpendicular to flight line) and B (along flight line) by:

A = 370 M  
B = 427 M

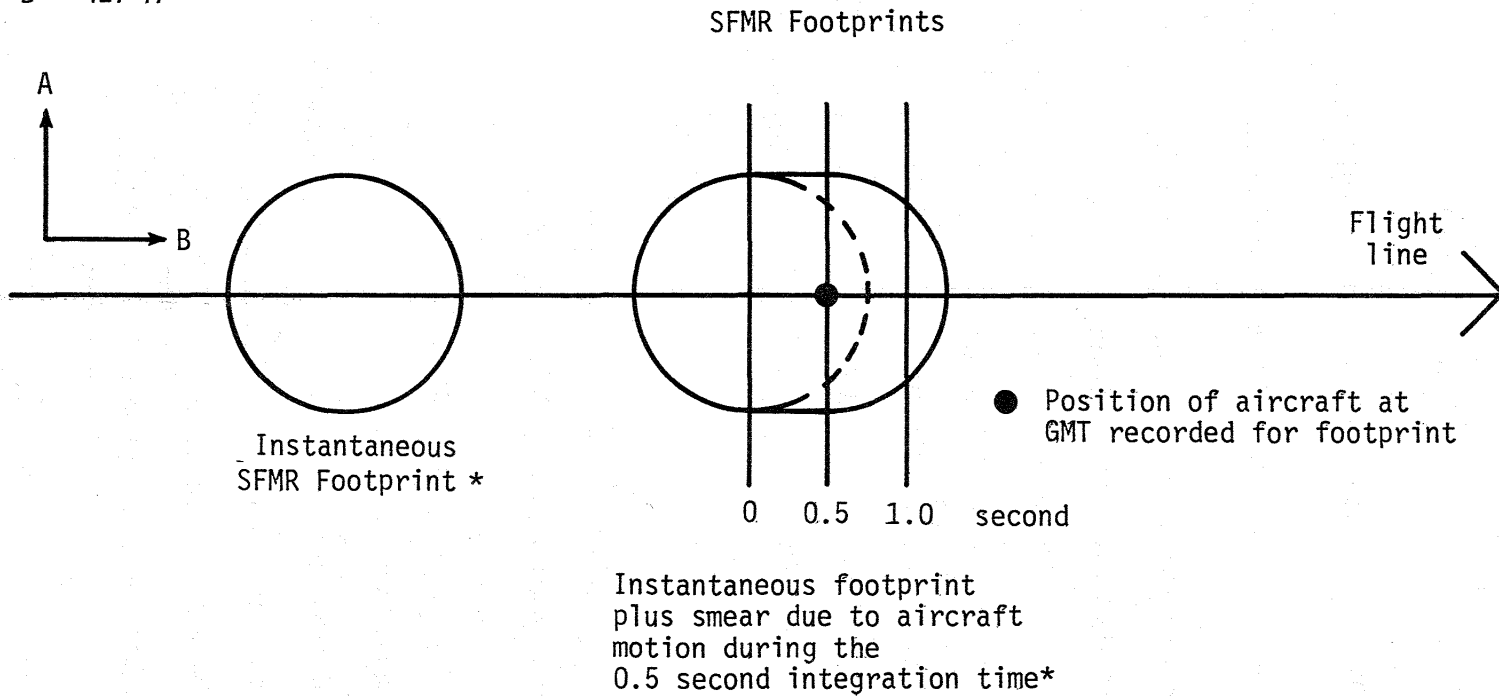

Figure 11. SFMR Footprints

\*Footprints not drawn to scale

$$A = \frac{.0612 \times \text{Aircraft Altitude}}{\cos \theta}$$

$$B = \frac{A}{\cos \theta}$$

where  $\theta$  = Incidence Angle. (The antenna 3.5 dB beamwidth expressed in radians is .0612)

Again, for an aircraft in motion, there is smearing along the flight line and B becomes:

$$B = \frac{A}{\cos \theta} + [\text{Integration time} \times \text{Aircraft Groundspeed}]$$

For an altitude of 1000 meters, an aircraft groundspeed of  $114 \text{ ms}^{-1}$ , and an incidence angle of  $45^\circ$ , AMSCAT footprint size is:

$$A = 86.5 \text{ meters}$$

$$B = 179.3 \text{ meters}$$

It is important to consider that time recorded for each photograph indicates the position of the aircraft over the center of the photograph. If photography was obtained at the same time as a nadir-looking sensor recorded data, the sensor footprints would be located over the exact center of the aerial photograph. This will not always prove to be the case and an adjustment must be made. Given the time of the aerial photograph ( $t = 0$  seconds) and the time the nadir-looking instruments

recorded data ( $t = +1$  seconds), the sensor footprints will be located "ahead" of the center of the aerial photograph, relative to the direction of travel. At a speed of  $114 \text{ ms}^{-1}$ , the center of the nadir-looking sensor footprints would be approximately 114 meters "ahead" of the center of the photograph. At a photographic scale of 1:10500 the footprint would be approximately 1.1 cm "ahead" of the center of the photograph for a 1 second time difference. Likewise, for photograph time = 0 and sensor time = -1 second, the sensor footprint would be located 114 meters "behind" the center of the photograph, again relative to the direction of travel.

After the centers of the nadir-looking sensors have been located on the aerial photograph, the AMSCAT footprints may be located using the distance and time offsets as calculated above.

After footprint sizes have been calculated for the various sensors at the appropriate altitudes, groundspeeds, incidence angles and integration times, templates of the footprints may be drawn at the scale of the photography for that section and transferred to clear acetate sheets. The acetate sheets can then be overlaid on the aerial photography and used to locate footprints.

In summary, the process of locating microwave footprints on aerial photograph is as follows:

- 1) Calculate time and distance offsets for AMSCAT relative to SFMR and PRT-5 (AMSCAT time = Nadir time +  $\Delta t$ ).
- 2) Calculate footprint sizes for SFMR, PRT-5 and AMSCAT.

- 3) Draw template of sensor footprints at scale of appropriate photography.
- 4) Locate center of photograph.
- 5) Determine if nadir-looking sensor footprints (SFMR; PRT-5) are located "behind" or "ahead" of center of photograph.
- 6) Calculate distance offset between center of aerial photograph and sensor footprint.
- 7) Center footprint templates for SFMR and PRT-5 along the flight line.
- 8) Use distance offset calculated for AMSCAT to locate AMSCAT footprint behind SFMR and PRT-5 footprints.
- 9) Identify ice types within each footprint and correlate with remote sensing data.

## SECTION 4

### NORSEX DATA SET SUMMARY

This Section summarizes all of the remote sensing data obtained by NASA Langley Research Center during the 1979 Norwegian Remote Sensing Experiment (NORSEX). These data are available on digital computer tapes (See Appendix B).

Data were obtained for six days during the period of September 29 - October 19, 1979, and are referenced by Julian Day. Flight line plots are presented for each day (Appendix C). The first plot indicates the geographic location of all flight lines for the entire day, which includes the area of the Polar Front and the Marginal Ice Zone. The second plot is an enlarged plot of flight lines only in the vicinity of the Marginal Ice Zone. Because the primary objective of NORSEX 79 was the acquisition of data over sea ice, flight lines corresponding to the annotated flight lines and runs are located only near the Marginal Ice Zone. Data for the Polar Front and other areas were obtained and are also included in the time line plots for each day.

The time-line plots for each day were made showing when sensors were recording data. The time-line plots are referenced to Greenwich Meridian Time (GMT), which is also the local time. The corresponding Latitude and Longitude are also shown. The plots will enable a user to select data for detailed analysis based upon the need for a particular sensor configuration and/or



geographical location. For ease of access to data on the available digital tapes, all sensor data are referenced to Greenwich Meridian Time (GMT). Twelve variables are indicated on these plots. A solid line indicates the presence of data; absence of a solid line indicates that no data are available. The scale of these plots is 120 seconds/inch and data gaps of less than 10 seconds duration are not indicated. The parameters shown for each time-line plot are detailed below and are referenced to Figure 12.

A) Day 272 - This indicates the Julian Day during 1979 which corresponds to the time-line plot. Julian days and their corresponding calendar days are listed below:

<u>Julian Day</u>	<u>Calendar Day</u>
Day 272	September 29, 1979
Day 274	October 1, 1979
Day 277	October 4, 1979
Day 281	October 8, 1979
Day 283	October 10, 1979
Day 285	October 12, 1979

B) Photography - Stereo-coverage 9-inch format black and white aerial photography was obtained for nearly all of the official flight lines. An ellipse on the time-line plot indicates the most accurate estimate of when a photograph was taken. Because of the overlap on adjacent photographs, ground coverage is nearly

NORSEX DATA SET SUMMARY  
DAY 272

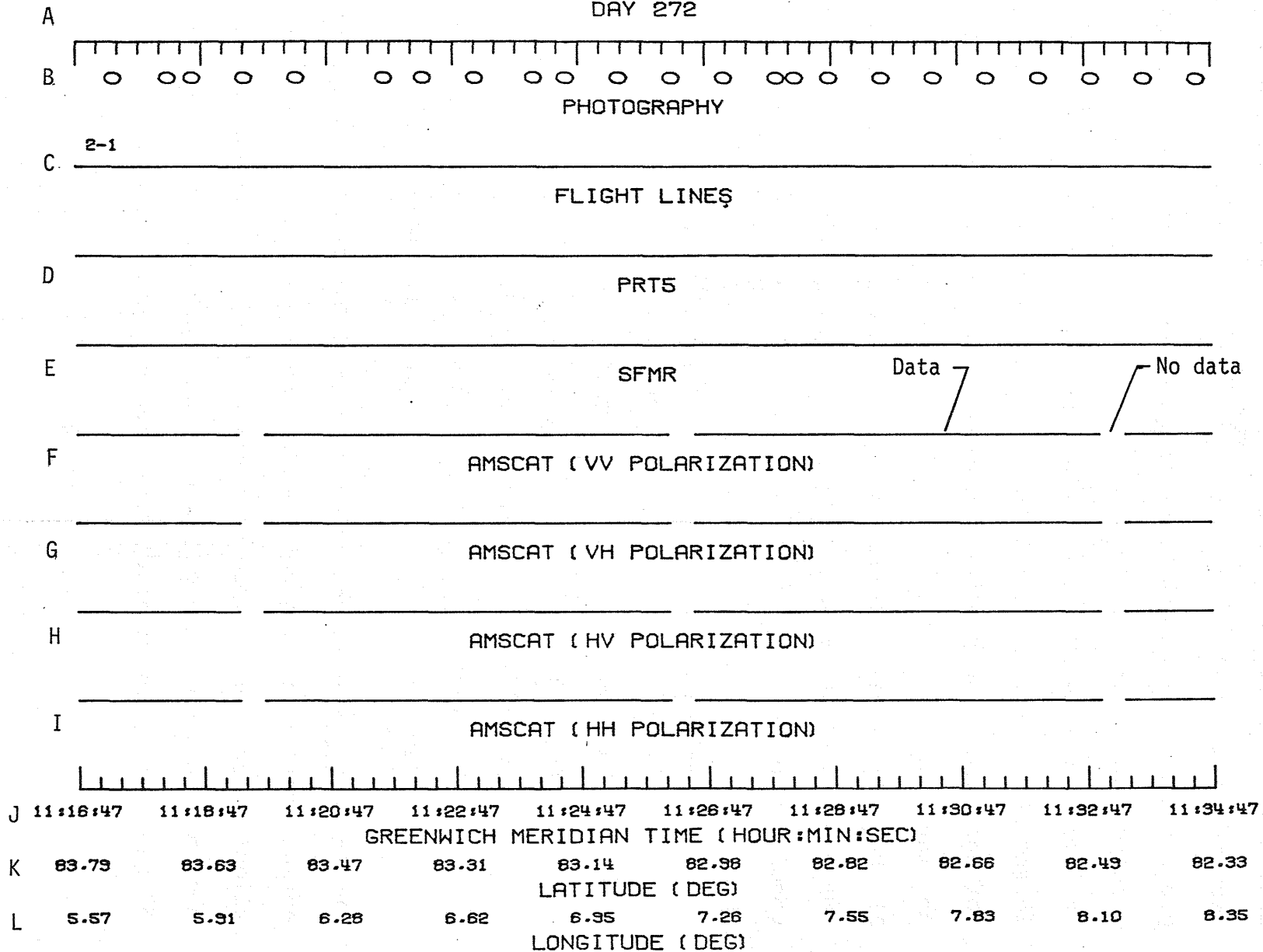

Figure 12. Time Line Plot

continuous, however, during the middle of some flight lines, extensive cloud cover beneath the aircraft prevented the acquisition of usable photography. Since only a limited amount of film was carried on board the aircraft, the camera operator manually turned off the camera over extensive cloud cover and turned it on again when openings appeared. Consequently, there are gaps in the photographic record of some flight lines. A complete inventory of all available aerial photography is presented in Appendix A.

C) Flight Lines - A solid line indicates whether or not the data were obtained during an official flight line. The number i.e., 2-1) refers to the flight line and run number. Geographic locations of the official flight lines for each day are plotted at the beginning of data for each day. Furthermore, aerial photography is inventoried (Appendix A) for each day according to its flight line and run, as well as by GMT. Data obtained other than during an official flight line may not be usable. These data are presented here for the sake of completeness and for their considerable value as an historical data base.

D) PRT-5 - This indicates when the Infrared Radiometer was taking data. This sensor remotely senses the physical temperature of the earth's surface.

E) SFMR - A solid line indicates whether the Stepped Frequency Microwave Radiometer acquired Brightness Temperatures ( $T_B$ ). During this study the SFMR operated only at a frequency of 6.6 GHz.

F - 1) AMSCAT ( X X Polarization) - A solid line shows whether the Airborne Microwave Scatterometer was on, and at what polarizations it was operating. For example, VH Polarization indicates that AMSCAT transmitted at vertical (V) polarization and received at horizontal (H) polarization. Likewise HH Polarization indicates horizontal transmit and horizontal receive.

J) Greenwich Meridian Time (H:M:S) - All data are referenced to GMT. Available computer tapes can be easily accessed by searching for the start and stop times of desired data segments.

K - L) Latitude/Longitude - Approximate latitude and longitude plotted in hundredths of a degree every 2 minutes along the flight line. Flight lines for each day are also plotted.

## SECTION 5

### NORSEX DATA EXAMPLE

Figures 13 A and B are examples of sensor data recorded on digital data tapes. All data can be referenced by Greenwich Meridian Time (GMT) as well as by Latitude and Longitude. Data shown in this example were selected from the time-line plots of NORSEX Day 281, Line 1 - Run 1 and were accessed on the tapes by searching for a given start and stop time. Only four variables are plotted here, however, there are many more variables recorded on the digital tapes (See Appendix B). Choice of variables to examine will depend upon the particular requirements of the user.

This example was selected because it includes remote sensing data obtained for a variety of representative ice and water features. The data were obtained along a transect as the aircraft passed over the open ocean and headed into the Marginal Ice Zone. Aerial photography is available for this example and was used as surface truth to identify ice features which could be correlated to the remote sensing data. Because the data for the sensors have been temporally aligned, statistical techniques could be employed to extract microwave signatures for ice types at various concentrations. As mentioned previously, ancillary oceanographic field data are available to supplement the remote sensing data (See Bibliography). The following section describes

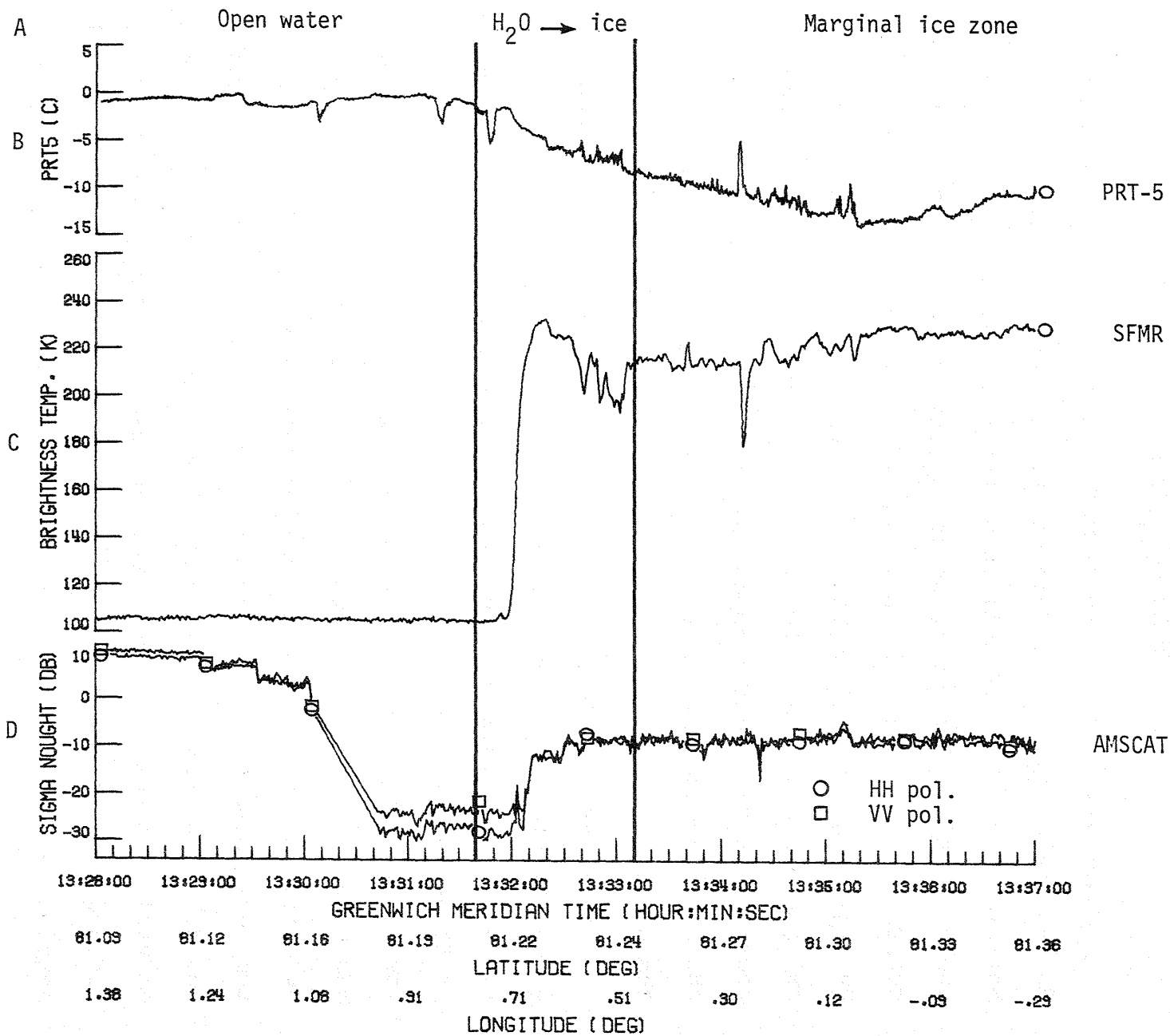
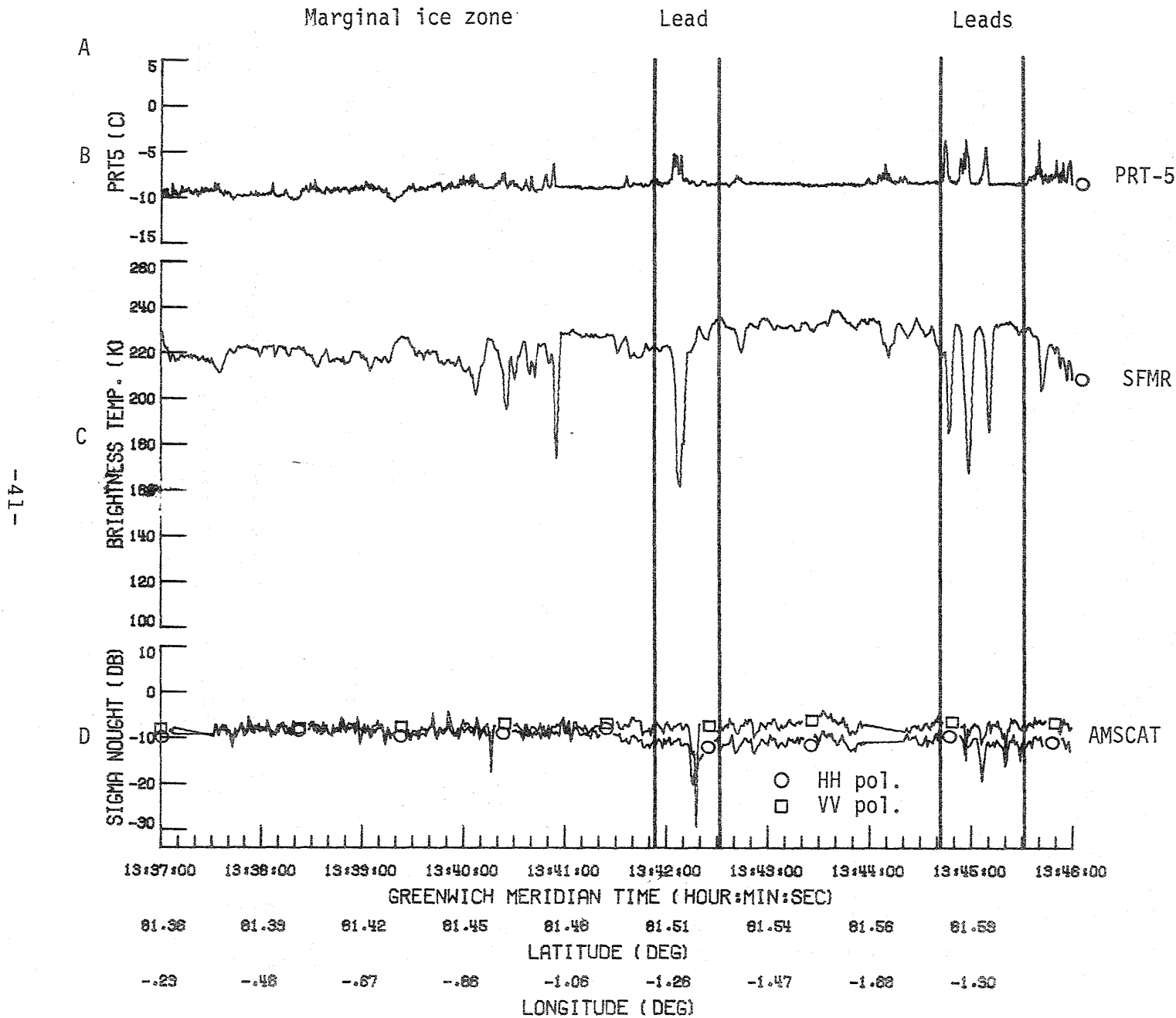

Figure 13A. Example of Sensor Data



-41-

Figure 13B. Example of Sensor Data

the data plotted in Figure 13.

A) Annotations for sea ice features observed on the aerial photography and matched to the remote sensing data.

B) PRT-5 - Physical temperatures of the surface obtained with an infrared radiometer are plotted here in degrees Celsius. Note how surface temperatures decrease as the aircraft passes from an area of open water to an area which is ice-covered. Peaks represent temperatures higher than the surrounding area and correspond to leads, or openings, in the ice cover. Exposed water is warmer than the ice, hence the higher surface temperatures obtained over the leads.

C) Stepped Frequency Microwave Radiometer - Output from the 6.6 GHz microwave radiometer is shown here as Brightness Temperature ( $T_B$ ) in degrees Kelvin. There is a significant increase in Brightness Temperature as the aircraft proceeds from water to ice. Brightness Temperatures are calculated from emitted microwave radiation and appear to be inversely related to physical temperature as recorded by the PRT-5. While physical temperature does affect Brightness Temperature, the tremendous difference between water and ice Brightness Temperatures is primarily due to the difference in microwave emissivity between ice and water.

D) Airborne Microwave Scatterometer - The Scattering Coefficient obtained by the AMSCAT at two polarizations, HH and VV, is shown here. Changes in backscatter ( $\sigma$ -naught) are due to changes



in surface roughness. Generally, low returns indicate a smooth surface while higher returns indicate a surface with some relief. In this example the scatterometer return increased as the aircraft traveled from an area of relatively smooth water to relatively rough ice at the Marginal Ice Zone.

This method of visual feature extraction and correlation with remote sensing data could be performed for other data segments as well. The data and brief qualitative analysis presented here serve only to illustrate one potential use of the data. No doubt, other, more quantitative methods of analysis are appropriate using the digital data available on the computer tapes.

## BIBLIOGRAPHY

### GENERAL

- 1) Campbell, W. J. et al., Beaufort Sea Ice Zones Delineated by Microwave Imagery. J. Geophys. Res. 81 (6), 1103-1110, 1976.
- 2) Campbell, W. J., Ramseier, R. O., Zwally, H. J. and Gloersen, P., Arctic Sea-Ice Variations from Time-Lapse Passive Microwave Imagery. Boundary-Layer Meteorology (18) 99-106, 1980.
- 3) Campbell, W. J., Weeks, W. F., Ramseier, R. O. and Gloersen, P., Geophysical Studies of Floating Ice by Remote Sensing. J. Glaciology 15 (73), 305-328, 1975.
- 4) Campbell, W., Gloersen, P., Zwally, H. J., Ramseier, R. O. and Elachi, C., Simultaneous Passive and Active Microwave Observations of Near-Shore Beaufort Sea Ice. J. Petroleum Technology, 1105-1112, 1980.
- 5) Gloersen, P., Nordberg, P., Schmutge, T. J., Wilheit, T. T. and Campbell, W. J., Microwave Signature of First-Year and Multiyear Ice. NASA TM-X-66006, 22, 1972.
- 6) Gloersen, P. and Baroth, F. T., A Scanning Multichannel Microwave Radiometer for Nimbus-G and Seasat-A. IEEE Jrn. Ocean Engineering, GE-2(2), 172-178, 1977.
- 7) Jackson, B. L., Jones, W. L. and Stanley, W. D., Measure of Arctic Sea Ice Characteristics Using Microwave Scatterometry. Proceedings of the 1979 IEEE Southeast Conference, pp 278-280.
- 8) Onstott, R. G., Moore, R. K. and Weeks, W. F., Surface-Based Scatterometer Results of Arctic Sea Ice. IEEE Trans. Geoscience Electronics. GE-17, (3), 78-85, 1979.
- 9) Parashar, S. K., Horalich, R. M., Moore, R. K. and Biggs, A. W., Radar Scatterometer Discrimination of Sea Ice Types. IEEE Trans. Geoscience Electronics GE-15 (2), 83-87, 1977.
- 10) Rouse, J. W., Arctic Ice Type Identification by Radar. Proc. of the IEEE 57, (4), 605-511, 1969.
- 11) Swift, C. T. et al., Microwave Radar and Radiometric Remote Sensing Measurements of Lake Ice, Geophys. Res. Lett., 7, (4), 243-246, 1980.

- 12) Wadhams, P., The Ice Cover in the Greenland and Norwegian Seas, J. Geophys. Res., 19, (3), 345-393, 1981.
- 13) Walsh, J. E. and Johnson, C. M., Interannual Atmospheric Variability and Associated Fluctuations in Arctic Sea Ice Extent, J. Geophys. Res., 84, (11), 6915-6928, 1979.
- 14) Weeks, W. F., Sea Ice: The Potential of Remote Sensing. Oceanus (33), 39-48, 1981.
- 15) Wilheit, T., Blinn, J., Campbell, W., Edgerton, A. and Nordbert, W., Aircraft Measurements of Microwave Emission from Arctic Sea Ice. NASA-TM-X-65742, 25, 1971.
- 16) Zubov, N. W., Arctic Ice (In Russian) Izdatel' stuo Glavers-morputi, Moscow. (English Translation, U.S. Naval Oceanographic Office, Washington, D.C.), 1943.
- 17) Zwally, H. J. and Gloersen, P., Passive Microwave Images of the Polar Regions and Research Applications. Polar Record 18 (116), 431-450, 1977.

#### INSTRUMENTATION

- 18) Harrington, R. F., The Development of a Stepped Frequency Microwave Radiometer and Its Application to Remote Sensing of the Earth. NASA-TM-81847, 1980.
- 19) Earth Resources Data Format Control Book. NASA TR-543, 1975.
- 20) Instruction Manual for Precision Radiation Thermometer Model PRT-5. Barnes Engineering Company, Stanford, Connecticut.
- 21) Delnore, V. E. et al., AMSCAT Data Archive (NASA TMX in preparation).

#### NORSEX

- 22) Buckley, J. R. Cammelsrod, T., Johannessen, J. A., Johannessen, O. M. and Reed, L. P., Upwelling: Oceanic Structure at the Edge of the Arctic Ice Pack in Winter, Science. 203, 165-167, 1979.

- 23) Campbell, W. J. et al., The Norwegian Remote Sensing Experiment (NORSEX) in a Marginal Ice Zone. ESA SP-167, pp. 113-118, 1981.
- 24) Johannessen, J. A., et al., A CTD-Data Report from the NORSEX Marginal Ice Zone Program North of Svalbard in September-October 1979. Geophysical Institute, University of Bergen, Norway. NORSEX Report 1, 1980.
- 25) Johannessen, O. M. and Foster, L. A., A Note on the Topographically Controlled Oceanic Polar Front in the Barents Sea, J. Geophys. Res., 83, (9), 4567-4571, 1978.
- 26) Matzler, C., et al., Radiation and Surface Observations of Water and Ice Carried Out from the R/V Polarsirkel in the Marginal Sea Ice Zone West of Spitsbergen, September-October 1979. Geophys. Inst., University of Bergen, Norway. NORSEX Report 2, 1980.
- 27) Morrison, J. and Anderson, R., Progress Report of the Analysis of Data Gathered with the Arctic Profiling System During NORSEX 79. Lidar Science Center, University of Washington, Seattle, 1980.
- 28) Savden, S. et al., Current Measurements from a Buoy Drifting with the Ice Pack. Geophys. Inst., University of Bergen, Norway. NORSEX Report 4, 1980.

References 24 - 28 are available from:

Dr. Ola Johannessen  
Geophysical Institute, AVD-D  
University of Bergen  
Allegt 70, N 5014  
Bergen, Norway

APPENDIX A

AERIAL PHOTOGRAPHY LOG  
AND ORDERING INFORMATION

Aerial photography obtained during NORSEX 79 may be purchased as 9 x 9 inch black and white contact prints from NASA Johnson Space Center.

Requests for photography should be addressed to:

Olav Smistad  
Manager - Earth Resources Program  
Code SJ  
NASA Johnson Space Center  
Houston, Texas 77058

When ordering photography please supply the following information:

Mission Number	410
Mission Name:	NORSEX 79
Film Roll Number:	<See Table 3>
Start Frame Number:	<See Table 3>
End Frame Number	<See Table 3>

As of January 1982, the cost of photography is approximately \$1.75 per 9 x 9 inch black and white contact print.

Selection of aerial photography for purchase should be made in conjunction with inspection of the time-line plots. When a particular data segment has been selected for analysis, the flight line and run numbers obtained from the time-line plot can

be referenced to the photography log (Table 4) to identify the first and last frame in that particular run and the film roll number.

EXAMPLE:

Referring to Figure 12, which was used to illustrate the use of time-line plots, one obtains the following information:

Day: 272

Flight Line and Run: 2-1

Using the photographic inventory for Day 272, Line 2 - Run 1, one then obtains the following information:

Mission #: 410

Mission Name: NORSEX 79

Film Roll Number: 1

Start Frame Number: 86

End Frame Number: 123

This information should then be supplied to NASA Johnson Space Center when ordering photography.

## AERIAL PHOTO LOG

DAY	LINE	RUN	ROLL	START FRAME	START FRAME TIME	END FRAME	END FRAME TIME	APPROX. PHOTO SCALE	AIRCRAFT GROUND SPEED (KNOTS)	* LOCATION
272	10	1	1	1	61551.43	27	63446.03	1:5800	154	PF
	15	1	1	28	63716.31	53	65550.00	1:6000	147	PF
	6	1	1	54	70611.53	60	71031.09	1:600	214	PF
	4	1	1	61	102351.16	63	102530.68	1:41000	265	MIZ
	4	2	1	64	104008.09	70	104548.68	1:41000	270	MIZ
	1	1	1	71	104608.12	85	110823.72	1:41000	269	MIZ
	2	1	1	86	114613.42	123	114631.41	1:41000	300	MIZ
274	5	1	1	181	100957.35	190	102235.61	1:19500	164	MIZ
	6	1	1	191	102552.77	199	103418.39	1:19500	188	MIZ
	7	1	1	200	103731.47	215	104819.93	1:19500	157	MIZ
	8	1	1	216	106146.04	233	110127.58	1:19500	184	MIZ
	9	1	1	234	110610.82	247	111506.41	1:19500	159	MIZ
	10	1	1	248	112830.59	254	113159.22	1:19500	185	MIZ
	11	1	1	255	114118.16	266	114834.70	1:19500	159	MIZ
	12	1	1	267	115250.75	276	120018.10	1:19500	184	MIZ
	13	1	1	277	121457.66	330	122214.93	1:3200	171	MIZ
	14	1	1	331	122303.94	365	122750.25	1:3200	155	MIZ
	15	1	1	366	122842.72	421	123649.10	1:3200	129	MIZ
	13	2	1	422	130037.91	516	131157.57	1:3200	124	MIZ
	14	2	1	517	131403.80	533	131557.56	1:3200	175	MIZ
	14	2	2	1	131626.99	36	132058.36	1:3200	136	MIZ
15	2	2	37	132105.32	107	132905.98	1:3300	124	MIZ	





DAY	LINE	RUN	ROLL	START FRAME	START FRAME TIME	END FRAME	END FRAME TIME	APPROX: PHOTO SCALE	AIRCRAFT GROUND SPEED (KNOTS)	* LOCATION
285	1	1	4	194	131837.53	215	132347.48	1:660	209	MIZ
	1	2	4	235	133848.94	316	134956.35	1:2400	144	MIZ
	2	1	4	317	135404.38	361	135958.85	1:2500	145	MIZ
	2	2	4	369	141023.15	469	142951.43	1:2500	122	MIZ
	2	3	4	470	143240.67	555	144449.80	1:2500	146	MIZ
	2	3	5	1	144457.28	22	144802.07	1:2500	146	MIZ

\* MIZ - MARGINAL ICE ZONE

PF - POLAR FRONT

APPENDIX B

NORSEX DATA TAPE DOCUMENTATION

The NASA Langley NORSEX Data Set is available on seven nine-track tapes from the NASA LaRC Technical Library. The first six tapes (one tape for each day of the NORSEX mission) contain NERDAS parameters, camera control information, PRT-5 and environmental information, and AMSCAT information. The file structure for these tapes is:

<u>FILE PORTION</u>	<u>VARIABLE</u>	<u>MEANING</u>	<u>FORMAT</u>
HEADER	MISS	MISSION #	I10
	NDAY	JULIAN DAY	I10
	NFILE	FILE #	I10
	NFEND	END FILE COUNTER	I10
	NTSTRT	START TAPE COUNTER	I10
	NTEND	END TAPE COUNTER	I10
	TSTRT	START TIME, HHMMSS.S	F10.2
	TEND	END TIME, HHMMSS.S	F10.2
SUBRECORD 1	GMT	TIME, HHMMSS.S	F10.2
	SEC	TIME, TOTAL SECONDS	F10.2
	XLAT	LATITUDE, DEGREES	F10.2
	XLON	LONGITUDE, DEGREES	F10.2
	CTIM	CAMERA TIME, SECONDS (GMT)	F10.2
	NCP	CAMERA PULSE	I10
	NFCNT	FILE RECORD COUNTER	I10
	NTCNT	TAPE RECORD COUNTER	I10
	NCP=1	IF A PHOTOGRAPH WAS TAKEN: OTHERWISE NCP = INTEGER DUMMY VALUE (-9999)	
SUBRECORD 2	ALT	ALTITUDE, METERS (M)	F8.2
	HEAD	HEADING, DEGREES	F8.2
	DRIFT	DRIFT, DEGREES	F8.2
	ROLL	ROLL, DEGREES	F8.2
	PITCH	PITCH, DEGREES	F8.2
	GRSP	GROUND SPEED, M/S	F8.2
	WDSP	WIND SPEED, M/S	F8.2
	WDAN	WIND ANGLE, DEGREES	F8.2
	PRT	PRT, °CELSIUS	F8.2
	TAT	TAT, °CELSIUS (TOTAL AIR TEMPERATURE)	F8.2

<u>FILE PORTION</u>	<u>VARIABLE</u>	<u>MEANING</u>	<u>FORMAT</u>
SUBRECORD	SDB	SIGMA NAUGHT, DB (SEE AMSCAT DESCRIPTION)	F8.2
	THETA	INCIDENCE ANGLE, DEGREES	F8.2
	PHI	AZIMUTH ANGLE, DEGREES	F8.2
	DPF	DEPOL FACTOR	F8.4
	DFR	DOPPLER FREQUENCY, GHZ	F8.4
	IPOL	POLARIZATION 0 = HH; 2 = VH; 1 = HV; 3 = VV	I8
	MODE	MODE	I8
	ISET	SET	I8
	ISTIM	SCAT TIMING	I8
	IREC	AMSCAT RECORD NUMBER	I8

The time, latitude, and longitude records within a file are continuous with a sample rate of .5 seconds. Missing parameters are filled in with dummy variables. Real dummy values are 9999.99 or 99.9999. Integer dummy values are -9999. A sample FORTRAN program to read these tapes is shown below:

```

PROGRAM REDTAP (INPUT, OUTPUT, TAPE 1)
10 READ (1, 101) MISS, NDAY, NFILE, NFEND, NTSTRT, NTEND, TSTRT,
TEND
IF (EOF (1).NE.0) STOP
20 READ (1, 201) GMT, SEC, XLAT, XLON, CTTM, NCP, NFCNT, NTCNT
IF (EOF (1).NE.0) GO TO 10
READ (1, 202) ALT, HEAD, DRIFT, ROLL, PITCH, GRSP, WDSP,
WDAN, PRT
1 TAT
READ (1, 203) SDB, THETA, PHI, DPF, DFR, IPOL, MODE, ISET,
ISTIM
1 IREC
GO TO 20
101 FORMAT (6I10, 2F10.2)
201 FORMAT (5F10,2, 3I10)
202 FORMAT (10F8.2)
203 FORMAT (3F8.2, 2F8.4, 5I8)
END

```

The seventh tape in the set contains SFMR data for all six days of the NORSEX mission. The file structure for this tape is:

<u>FILE PORTION</u>	<u>VARIABLE</u>	<u>MEANING</u>	<u>FORMAT</u>
HEADER	MISS	MISSION #	I10
	NDAY	JULIAN DAY	I10
	NFILE	FILE #	I10
	NFEND	END FILE COUNTER	I10

<u>FILE PORTION</u>	<u>VARIABLE</u>	<u>MEANING</u>	<u>FORMAT</u>
HEADER	NTSTRT	START TAPE COUNTER	I10
	NTEND	END TAPE COUNTER	I10
	NSTRT	START TIME, HHMMSS:S	F10.2
	TEND	END TIME, HHMMSS:S	F10.2
SFMR RECORD	GMT	TIME, HHMMSS:S	F10.2
	SEC	TIME, SECONDS	F10.2
	TB	BRIGHTNESS TEMPERATURE, °K *	F10.2
	FREQ	FREQUENCY, MHZ	F10.2
	NFCNT	FILE RECORD COUNTER	I10
	NTCNT	TAPE RECORD COUNTER	I10

\* See reference 18

The sample rate varies for these records and there are no dummy values. A sample FORTRAN program to read this tape is shown below:

```

PROGRAM REDTAP (INPUT, OUTPUT, TAPE 1)
10 READ (1,101) MISS, NDAY, NFILE, NFEND, NTSTRT, NTSTRT,
   NTEND, NSTRT, TEND
   IF (EOF (1).NE.0) STOP
20 READ (1,201) GMT, SEC, IB, FREQ, NFCNT, NTCNT
   IF (EOF (1).NE.0) GO TO 10
   GO TO 20
101 FORMAT (6I10, 2F10.2)
201 FORMAT (4F10.2, 2I10)
END

```

The following table lists tape numbers for the NORSEX data set:

<u>JULIAN DAY</u>	<u>TAPE NUMBER</u>
272	NB0308
274	NA1156
277	NA1157
281	NA1204
283	NA1205
285	NA1206
SFMR (ALL DAYS)	NA1131

The following table lists start and stop times and tape counters and the number of records per file for each file on the first six tapes in the set:

DAY 272

TAPE NUMBER NB0308

<u>FILE</u>	<u>START TIME</u>	<u>STOP TIME</u>	<u>END FILE COUNTER</u>	<u>START TAPE COUNTER</u>	<u>END TAPE COUNTER</u>
1	55226.5	60233.0	1214	1	1214
2	60306.5	61345.5	1279	1215	1493
3	61532.0	65655.0	4967	2494	7460
4	65734.0	71224.5	1782	7461	7242
5	71512.5	73131.0	1958	9243	11200
6	73210.0	74218.0	1217	11201	12417
7	100345.0	101701.5	1594	12918	14011
8	102257.0	110852.0	5511	14012	19522
9	111241.5	114822.0	4282	19523	23804
10	120200.0	121935.0	2111	23805	25915
11	132316.0	140530.0	5069	25916	30984
12	140716.0	145734.5	6038	30985	37022

DAY 274

TAPE NUMBER: NA1156

<u>FILE</u>	<u>START TIME</u>	<u>STOP TIME</u>	<u>END FILE COUNTER</u>	<u>START TAPE COUNTER</u>	<u>END TAPE COUNTER</u>
1	54546.5	54850.0	368	1	368
2	55031.0	62336.5	3972	369	4340
3	63147.5	71825.0	5596	4341	9936
4	71931.5	72823.0	1064	9937	11000
5	72918.5	74226.0	1576	11001	12576
6	90837.5	93642.0	3370	12577	15946
7	93730.5	93955.0	290	15947	16236
8	94049.0	94606.0	635	16237	16871
9	94705.5	95840.5	1391	16872	18262
10	100801.5	110130.5	6491	18263	24681
11	110200.5	111846.0	2012	24862	26693
12	111921.5	120111.0	5020	26694	31713
13	120213.5	124054.5	4643	31713	36356
14	124132.0	125748.5	1954	36357	38310
15	125828.5	133500.5	4385	38311	42695
16	133812.5	141140.0	4016	42696	46711
17	141415.0	142829.0	1710	46712	48421
18	145945.0	151348.0	1637	48422	50108
19	151526.0	160642.5	6154	50109	56262

DAY 277

TAPE NUMBER: NA1157

<u>FILE</u>	<u>START TIME</u>	<u>STOP TIME</u>	<u>END FILE COUNTER</u>	<u>START TAPE COUNTER</u>	<u>END TAPE COUNTER</u>
1	52135.0	52602.0	535	1	535
2	52832.0	53329.0	655	536	1190
3	53430.0	54137.0	855	1191	2045
4	54525.5	55645.5	1361	2046	3406
5	55747.5	60118.5	423	3407	3829
6	60244.0	60923.5	822	3830	4651
7	61012.5	64411.0	4078	4652	8729
8	64521.0	65707.0	1413	8730	10142
9	70526.0	71121.5	712	10143	10854
10	71344.5	71904.0	640	10855	11494
11	84141.5	84804.0	766	11495	12260
12	84905.0	92805.5	4682	12261	16942
13	93415.0	94604.0	1419	16943	18361
14	100352.0	102620.0	1697	18362	21058
15	105900.0	115018.0	6157	21059	27215
16	115137.0	133320.5	12208	27216	39423

DAY 281

TAPE NUMBER: NA1204

<u>FILE</u>	<u>START TIME</u>	<u>STOP TIME</u>	<u>END FILE COUNTER</u>	<u>START TAPE COUNTER</u>	<u>END TAPE COUNTER</u>
1	51242.5	52051.5	979	1	979
2	52125.0	52657.0	665	980	1644
3	52817.5	53713.0	1072	1645	2716
4	55609.5	62600.5	3583	2717	6299
5	63146.5	64814.0	1976	6300	8275
6	64858.5	65932.5	1269	8276	9544
7	71439.5	74015.5	3073	9545	12617
8	74300.5	74525.0	290	12618	12907
9	74701.5	81915.5	3869	12908	16776
10	82002.5	91003.5	6003	16777	22779
11	92248.0	92824.5	674	22780	23453
12	120650.5	121334.5	809	23454	24262
13	121450.0	124313.5	3410	24263	27672
14	124349.0	125133.5	930	27673	28602
15	125231.5	145247.0	14432	28603	43034
16	145336.0	151814.5	2958	43035	45992
17	152042.5	154228.0	2612	45993	48604
18	154729.0	160130.0	1683	48605	50287

DAY 283

TAPE NUMBER: NA1205

<u>FILE</u>	<u>START TIME</u>	<u>STOP TIME</u>	<u>END FILE COUNTER</u>	<u>START TAPE COUNTER</u>	<u>END TAPE COUNTER</u>
1	72605.5	73000.0	471	1	471
2	73052.5	74217.0	1370	472	1841
3	74324.5	75948.5	1969	1842	3810
4	80022.0	92317.0	9951	3811	13751
5	104058.0	110439.0	2843	13762	16604
6	110537.0	112204.0	1975	16605	18579
7	112249.0	131845.5	13914	18580	32493
8	131920.5	145721.0	11762	32494	32493
9	150317.5	171456.0	15798	44256	60053

DAY 285

TAPE NUMBER: NA1206

<u>FILE</u>	<u>START TIME</u>	<u>STOP TIME</u>	<u>END FILE COUNTER</u>	<u>START TAPE COUNTER</u>	<u>END TAPE COUNTER</u>
1	92446.0	94642.5	2631	1	2634
2	94751.0	104930.5	7400	2635	10034
3	121325.0	124808.0	4167	10035	14201
4	125002.5	125239.0	314	14202	14515
5	125317.5	125819.5	605	14516	15120
6	131504.0	143033.0	9059	15121	24179
7	143127.0	145701.5	3070	24180	27249
8	145758.0	152119.0	2803	27250	30052
9	152213.5	161056.5	5847	30053	35899
10	161137.5	180925.0	14136	35900	50035
11	181010.5	183654.5	3209	50036	53244

The following table lists the start and stop times and tape counters and the number of records per file for each file on the SFMR tape:

SFMR DATA

TAPE NUMBER: NAl131

<u>DAY</u>	<u>FILE</u>	<u>START TIME</u>	<u>STOP TIME</u>	<u>END FILE COUNTER</u>	<u>START TAPE COUNTER</u>	<u>END TAPE COUNTER</u>
272	1	52113.6	52858.1	231	1	231
	2	53501.3	65741.6	2447	232	2678
	3	94125.5	94901.0	226	2679	2904
	4	95231.3	145657.6	9008	2905	11912
274	1	53818.9	74242.6	3682	1	3682
	2	91046.5	92343.5	54	3683	3736
	3	92147.9	120835.5	4936	3737	8672
	4	120854.8	133343.0	9923	8673	18595
	5	135304.3	135731.0	522	18596	19117
	6	144125.3	155233.5	2106	19118	21223
	7	155324.6	161320.8	591	21224	21814
277	1	51343.5	72348.1	3850	1	3850
	2	84114.6	124455.9	7211	3851	11061
	3	131946.5	140236.0	1268	11062	12329
281	1	51255.0	51922.0	192	1	192
	2	52000.0	53054.0	324	193	516
	3	53132.9	53723.9	175	517	691
	4	53757.3	54049.7	87	692	778
	5	54147.0	55125.0	286	779	1064
	6	55246.0	73952.3	3170	1065	4234
	7	83359.7	101041.8	2862	4235	7096
	8	121108.6	154308.2	12499	7097	19595
	9	160208.5	162026.8	1080	19596	20675
	10	162109.7	182136.0	3566	20676	24241
283	1	70401.5	70629.0	75	1	75
	2	71353.9	92310.6	3826	76	3901
	3	104416.6	110839.7	722	3902	4623
	4	110923.8	111057.8	48	4624	4671
	5	111145.0	113542.1	710	4672	5381
	6	114142.0	120847.7	803	5382	6184
	7	12910.7	145648.8	9883	6185	16067
	8	151943.2	171446.4	6783	16068	22850
285	1	85844.3	104744.0	3226	1	3226
	2	121150.2	125813.6	2736	3227	5962
	3	131302.2	131447.7	105	5963	6067
	4	132630.1	133538.2	540	6068	6607
	5	133551.9	145712.1	9520	6608	16127
	6	145758.7	161912.9	2405	16128	18532
	7	161932.2	181228.5	6658	18533	25190
	8	181301.7	183631.0	696	25191	25886



The tapes are presently in standard NASA-Langley format. Tapes requested by other installations will have the following characteristics:

- (1) 1/2 inch, 9-track tapes
- (2) Unlabelled
- (3) Density = 1600 characters/inch
- \* (4) Coding mode, ASCII or EBCDIC
- \*\* (5) Block size = 5120 characters/block  
Record size = 10 characters/record

- \* Indicate preferred coding mode
- \*\* Indicate preferred block size and record length, if other than those given.

Copies of digital tapes are available upon request to:

NASA Langley Technical Library  
Attn: Jane Hess  
Mail Stop 185  
Langley Research Center  
Hampton, Virginia 23665

APPENDIX C

NORSEX TIME-LINE PLOTS AND FLIGHT LINES

DAY 272

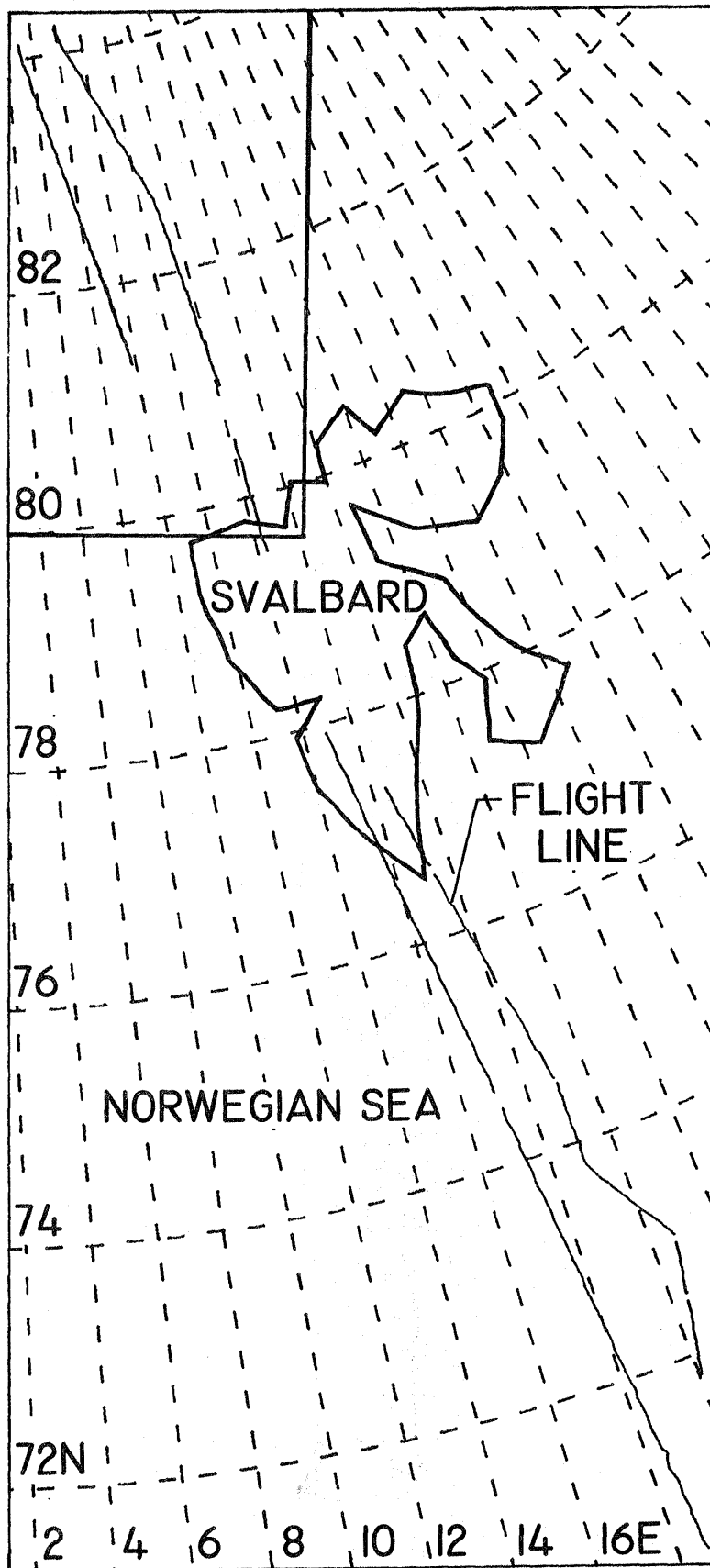

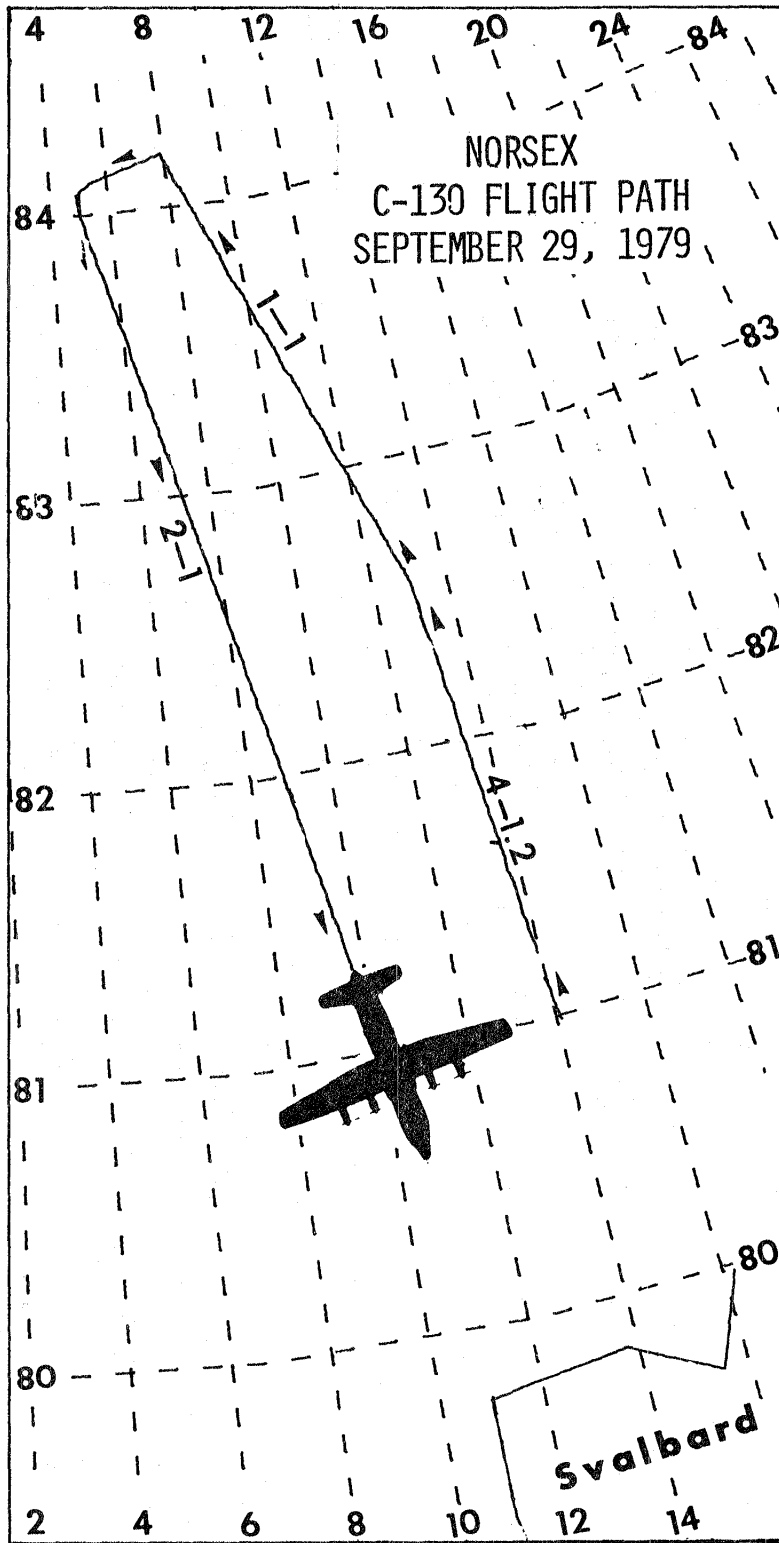

NORSEX DATA SET SUMMARY  
DAY 272

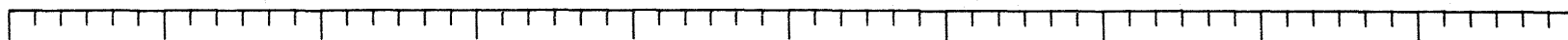

PRTS

SFMR

AMSCAT (VV POLARIZATION)

AMSCAT (HH POLARIZATION)

05:52:26 05:54:26 05:56:26 05:58:26 06:00:26 06:02:26 06:04:26 06:06:26 06:08:26 06:10:26 06:12:26

GREENWICH MERIDIAN TIME (HOUR:MIN:SEC)

71.84 71.98 72.11 72.24 72.37 72.48 72.57 72.65 72.73 72.80

LATITUDE (DEG)

20.08 20.15 20.23 20.31 20.38 20.44 20.50 20.53 20.58 20.63

LONGITUDE (DEG)

NORSEX DATA SET SUMMARY  
DAY 272

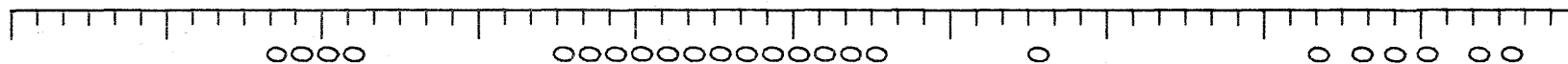

PHOTOGRAPHY

10-1

FLIGHT LINES

PRT5

SFMR

AMSCAT (VV POLARIZATION)

-65-

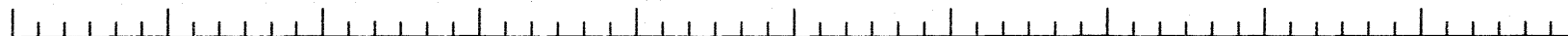

06:12:26 06:14:26 06:16:26 06:18:26 06:20:26 06:22:26 06:24:26 06:26:26 06:28:26 06:30:26 06:32:26

GREENWICH MERIDIAN TIME ( HOUR:MIN:SEC)

72.88                    73.04            73.11            73.18            73.25            73.32            73.39            73.46            73.53

LATITUDE ( DEG)

20.68                    20.67            20.52            20.35            20.21            20.06            19.90            19.74            19.58

LONGITUDE ( DEG)





NORSEX DATA SET SUMMARY  
DAY 272

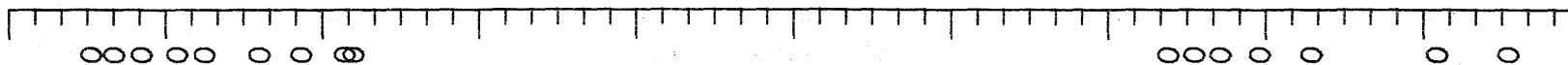

PHOTOGRAPHY

15-1

FLIGHT LINES

PRT5

SFMR

AMSCAT (VV POLARIZATION)

AMSCAT (VH POLARIZATION)

AMSCAT (HV POLARIZATION)

AMSCAT (HH POLARIZATION)

-67-

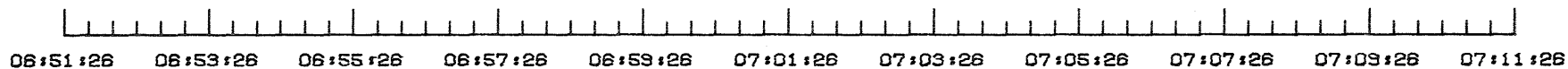

GREENWICH MERIDIAN TIME (HOUR:MIN:SEC)

06:51:26 06:53:26 06:55:26 06:57:26 06:59:26 07:01:26 07:03:26 07:05:26 07:07:26 07:09:26 07:11:26

74.33 74.41 74.49 74.64 74.72 74.83 74.95 75.07 75.19

LATITUDE (DEG)

19.00 19.00 19.00 18.88 18.83 18.76 18.67 18.58 18.49

LONGITUDE (DEG)

NORSEX DATA SET SUMMARY  
DAY 272

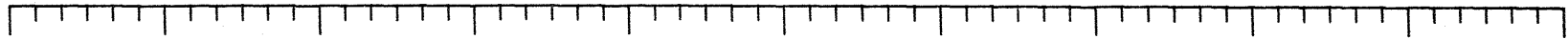

-89-

PRT5

AMSCAT (VV POLARIZATION)

AMSCAT (VH POLARIZATION)

AMSCAT (HV POLARIZATION)

AMSCAT (HH POLARIZATION)

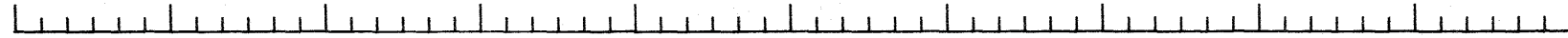

07:11:26	07:13:26	07:15:26	07:17:26	07:19:26	07:21:26	07:23:26	07:25:26	07:27:26	07:29:26	07:31:26
GREENWICH MERIDIAN TIME (HOUR:MIN:SEC)										
75.31		75.53	75.64	75.76	75.88	76.00	76.13	76.27		76.41
LATITUDE (DEG)										
18.39		18.21	18.11	18.01	17.90	17.80	17.68	17.57		17.43
LONGITUDE (DEG)										

NORSEX DATA SET SUMMARY  
 DAY 272

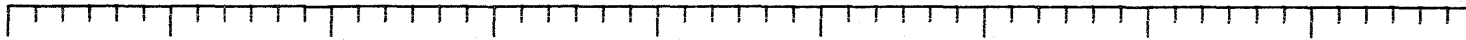

PRT5

SFMR

AMSCAT (VV POLARIZATION)

AMSCAT (VH POLARIZATION)

AMSCAT (HV POLARIZATION)

AMSCAT (HH POLARIZATION)



10:03:45    10:05:45    10:07:45    10:09:45    10:11:45    10:13:45    10:15:45    10:17:45    10:19:45    10:21:45

GREENWICH MERIDIAN TIME ( HOUR:MIN:SEC)

79.54      79.63      79.84      79.93      80.14      80.23      80.44

LATITUDE ( DEG)

14.38      14.35      14.32      14.31      14.27      14.24      14.22

LONGITUDE ( DEG)

NORSEX DATA SET SUMMARY  
DAY 272

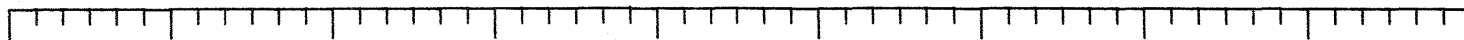

PHOTOGRAPHY  
4-1                      4-2

FLIGHT LINES

PRT5

SFMR

AMSCAT (VV POLARIZATION)

AMSCAT (VH POLARIZATION)

AMSCAT (HV POLARIZATION)

AMSCAT (HH POLARIZATION)

10:20:45    10:22:45    10:24:45    10:26:45    10:28:45    10:30:45    10:32:45    10:34:45    10:36:45    10:38:45

GREENWICH MERIDIAN TIME ( HOUR:MIN:SEC)

81.10      81.25      81.40      81.54      81.69      81.84      81.99      82.14

LATITUDE ( DEG)

14.03      13.96      13.86      13.76      13.66      13.56      13.47      13.37

LONGITUDE ( DEG)

NORSEX DATA SET SUMMARY  
DAY 272

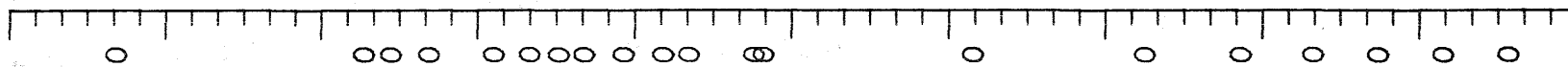

PHOTOGRAPHY

4-2

1-1

FLIGHT LINES

PRTS

SFMR

AMSCAT (VV POLARIZATION)

AMSCAT (VH POLARIZATION)

AMSCAT (HV POLARIZATION)

AMSCAT (HH POLARIZATION)

10:38:46 10:40:46 10:42:46 10:44:46 10:46:46 10:48:46 10:50:46 10:52:46 10:54:46 10:56:46 10:58:46

GREENWICH MERIDIAN TIME (HOUR:MIN:SEC)

82.14 82.29 82.43 82.58 82.72 82.87 83.01 83.15 83.29 83.43 83.57

LATITUDE (DEG)

13.37 13.25 13.12 13.00 12.84 12.69 11.91 11.54 11.11 10.66 10.22

LONGITUDE (DEG)

NORSEX DATA SET SUMMARY  
DAY 272

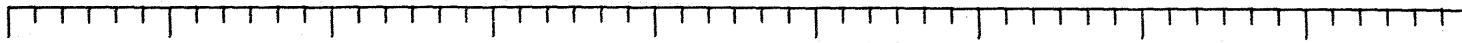

PHOTOGRAPHY

1-1

2-1

FLIGHT LINES

PRT5

SFMR

AMSCAT (VV POLARIZATION)

AMSCAT (VH POLARIZATION)

AMSCAT (HV POLARIZATION)

AMSCAT (HH POLARIZATION)

10:58:46 11:00:46 11:02:46 11:04:46 11:06:46 11:08:46 11:10:46 11:12:46 11:14:46 11:16:46

GREENWICH MERIDIAN TIME (HOUR:MIN:SEC)

83.57 83.70 83.84 83.98 84.11 84.23 84.11 83.96 83.79

LATITUDE (DEG)

10.22 9.76 9.29 8.80 8.24 7.51 4.79 5.13 5.57

LONGITUDE (DEG)

NORSEX DATA SET SUMMARY  
DAY 272

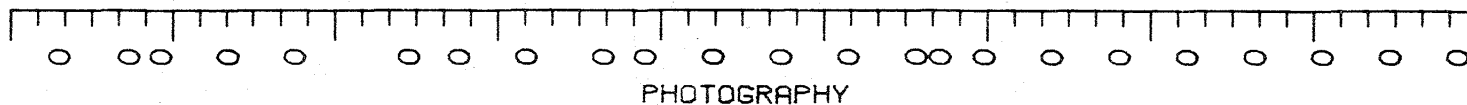

2-1

FLIGHT LINES

PRTS

SFMR

AMSCAT (VV POLARIZATION)

AMSCAT (VH POLARIZATION)

AMSCAT (HV POLARIZATION)

AMSCAT (HH POLARIZATION)

11:16:47	11:18:47	11:20:47	11:22:47	11:24:47	11:26:47	11:28:47	11:30:47	11:32:47	11:34:47
83.79	83.63	83.47	83.31	83.14	82.98	82.82	82.66	82.49	82.33
LATITUDE (DEG)									
5.57	5.91	6.28	6.62	6.95	7.26	7.55	7.83	8.10	8.35
LONGITUDE (DEG)									

-73-

NORSEX DATA SET SUMMARY  
DAY 272

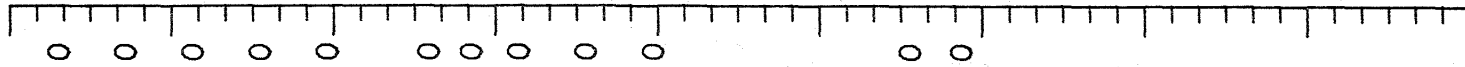

PHOTOGRAPHY

2-1

FLIGHT LINES

PRTS

SFMR

AMSCAT (VV POLARIZATION)

AMSCAT (VH POLARIZATION)

AMSCAT (HV POLARIZATION)

AMSCAT (HH POLARIZATION)

11:34:47 11:36:47 11:38:47 11:40:47 11:42:47 11:44:47 11:46:47 11:48:47 11:50:47 11:52:47

GREENWICH MERIDIAN TIME (HOUR:MIN:SEC)

82.33 82.17 82.01 81.85 81.70 81.53 81.38

LATITUDE (DEG)

8.35 8.53 8.83 9.04 9.24 9.45 9.65

LONGITUDE (DEG)



NORSEX DATA SET SUMMARY  
DAY 272

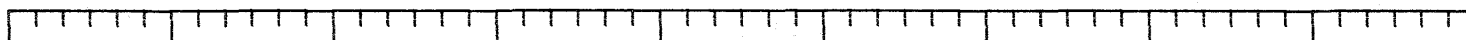

SFMR

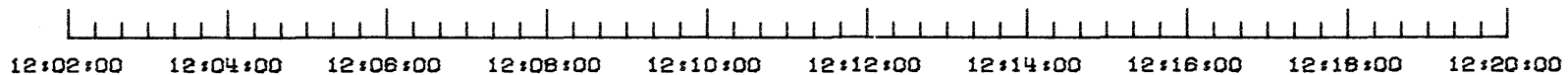

GREENWICH MERIDIAN TIME ( HOUR:MIN:SEC)

81.44	81.53	81.62	81.71	81.80	81.89	81.99	82.08	82.17
LATITUDE ( DEG)								
9.60	9.49	9.39	9.26	9.17	9.08	8.95	8.81	8.62
LONGITUDE ( DEG)								

NORSEX DATA SET SUMMARY  
DAY 272

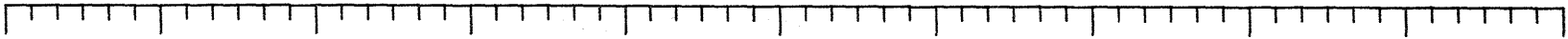

PRT5

SFMR

AMSCAT (VV POLARIZATION)

AMSCAT (HH POLARIZATION)

13:23:16	13:25:16	13:27:16	13:29:16	13:31:16	13:33:16	13:35:16	13:37:16	13:39:16	13:41:16	13:43:16
GREENWICH MERIDIAN TIME ( HOUR:MIN:SEC)										
77.92	77.77	77.62	77.46	77.30	77.14	76.99	76.83	76.67	76.51	76.35
LATITUDE ( DEG)										
14.88	15.00	15.12	15.26	15.37	15.48	15.60	15.72	15.83	15.94	16.04
LONGITUDE ( DEG)										

NORSEX DATA SET SUMMARY  
 DAY 272

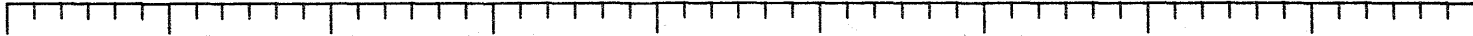

---

PRTS

---



---

SFMR

---



---

AMSCAT (VV POLARIZATION)

---



---

AMSCAT (HH POLARIZATION)

---

13:43:16    13:45:16    13:47:16    13:49:16    13:51:16    13:53:16    13:55:16    13:57:16    13:59:16    14:01:16

GREENWICH MERIDIAN TIME (HOUR:MIN:SEC)

76.35    76.20    76.04    75.89    75.73    75.57    75.41    75.25    75.09

LATITUDE (DEG)

16.04    16.14    16.24    16.34    16.43    16.53    16.62    16.71    16.80

LONGITUDE (DEG)

NORSEX DATA SET SUMMARY  
DAY 272

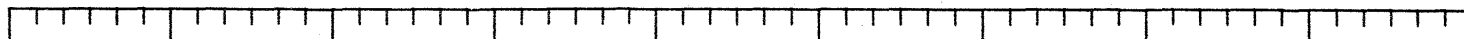

PRT5

SFMR

AMSCAT (VV POLARIZATION)

AMSCAT (HH POLARIZATION)



14:01:16    14:03:16    14:05:16    14:07:16    14:09:16    14:11:16    14:13:16    14:15:16    14:17:16    14:19:16

GREENWICH MERIDIAN TIME ( HOUR:MIN:SEC)

74.94        74.78        74.62        74.47        74.31        74.16        74.00        73.84        73.68

LATITUDE ( DEG)

16.88        16.97        17.05        17.13        17.21        17.29        17.36        17.43        17.50

LONGITUDE ( DEG)

NORSEX DATA SET SUMMARY  
DAY 272

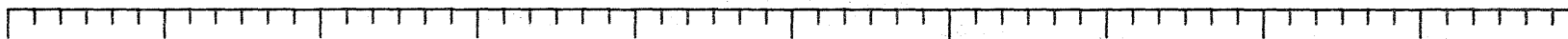

---

PRT5

---



---

SFMR

---



---

AMSCAT (VV POLARIZATION)



14:19:16    14:21:16    14:23:16    14:25:16    14:27:16    14:29:16    14:31:16    14:33:16    14:35:16    14:37:16    14:39:16

GREENWICH MERIDIAN TIME (HOUR:MIN:SEC)

73.53    73.37    73.21    73.06    72.90    72.74    72.59    72.43    72.27    72.12

LATITUDE (DEG)

17.58    17.65    17.73    17.73    17.85    17.92    17.98    18.04    18.11    18.16

LONGITUDE (DEG)

NORSEX DATA SET SUMMARY  
DAY 272

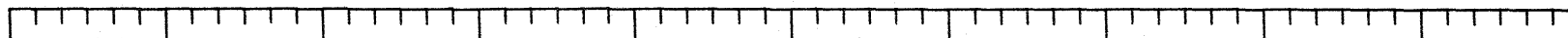

---

PRT5

---



---

SFMR

---

AMSCAT (VV POLARIZATION)

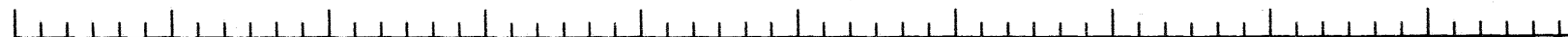

14:39:16    14:41:16    14:43:16    14:45:16    14:47:16    14:49:16    14:51:16    14:53:16    14:55:16    14:57:16    14:59:16

GREENWICH MERIDIAN TIME ( HOUR:MIN:SEC)

71.96    71.82    71.66    71.50    71.32    71.15    70.98    70.81    70.63    70.46

LATITUDE ( DEG)

18.23    18.26    18.34    18.39    18.56    18.51    18.59    18.62    18.66    18.74

LONGITUDE ( DEG)

DAY 274

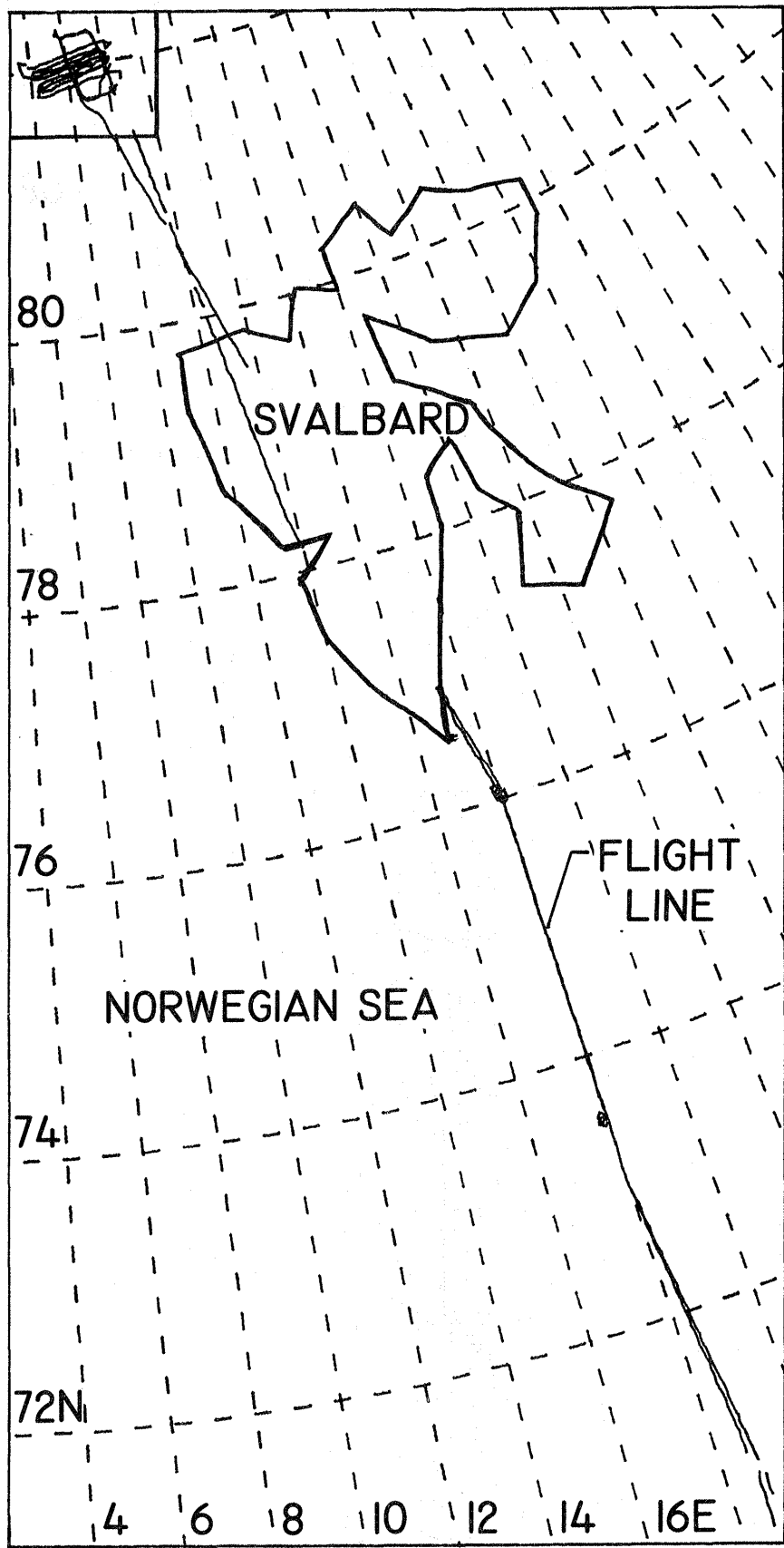



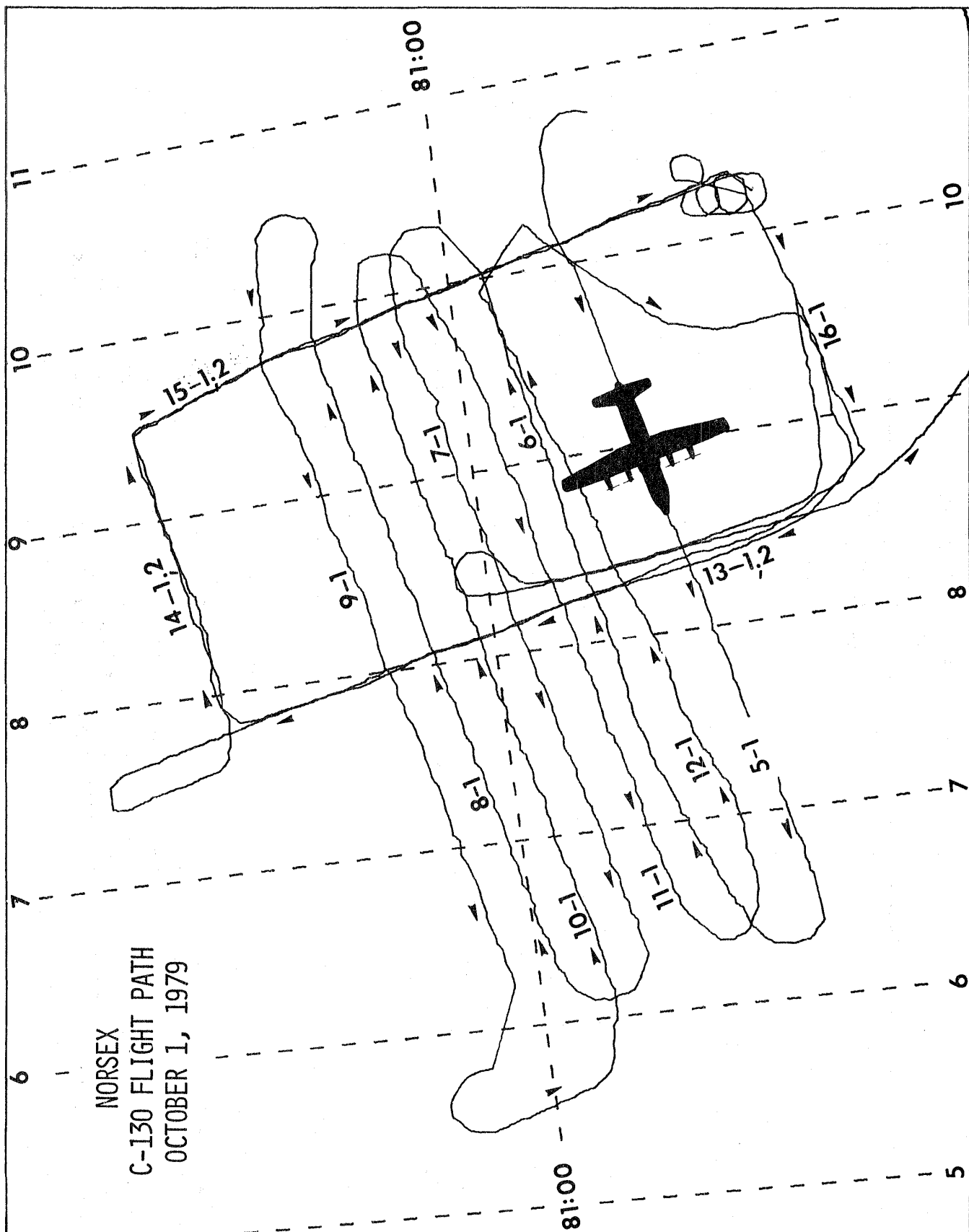

NORSEX DATA SET SUMMARY  
DAY 274

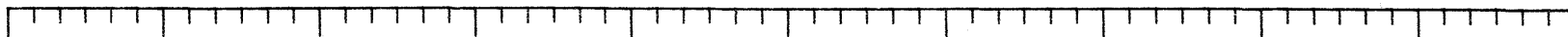

PRT5

\_\_\_\_\_

SFMR



AMSCAT (VV POLARIZATION)

\_\_\_\_\_

AMSCAT (HH POLARIZATION)

\_\_\_\_\_

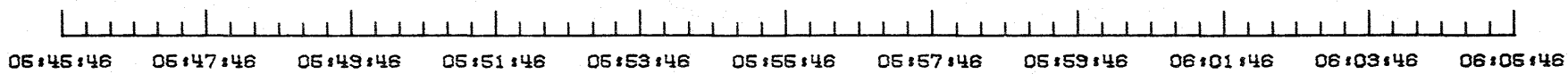

GREENWICH MERIDIAN TIME (HOUR:MIN:SEC)										
06:45:46	06:47:46	06:49:46	06:51:46	06:53:46	06:55:46	06:57:46	06:59:46	06:01:46	06:03:46	06:05:46
70.54	70.66	70.90	71.03	71.16	71.29	71.43	71.56	71.68	71.81	
LATITUDE (DEG)										
18.89	18.87	18.78	18.74	18.70	18.65	18.60	18.56	18.51	18.47	
LONGITUDE (DEG)										

NORSEX DATA SET SUMMARY  
DAY 274

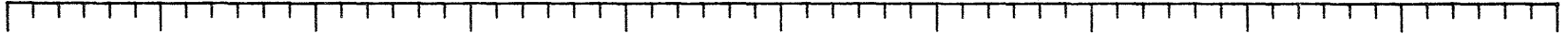

PRT5

SFMR

AMSCAT (VV POLARIZATION)

AMSCAT (HH POLARIZATION)

06:31:47	06:33:47	06:35:47	06:37:47	06:39:47	06:41:47	06:43:47	06:45:47	06:47:47	06:49:47	06:51:47
GREENWICH MERIDIAN TIME ( HOUR:MIN:SEC )										
73.50	73.55	73.54	73.47	73.42	73.52	73.65	73.78	73.91	74.04	74.18
LATITUDE ( DEG )										
17.99	17.74	17.90	17.99	17.89	17.99	17.99	17.98	17.98	17.98	17.99
LONGITUDE ( DEG )										

-85-  
A

NORSEX DATA SET SUMMARY  
 DAY 274

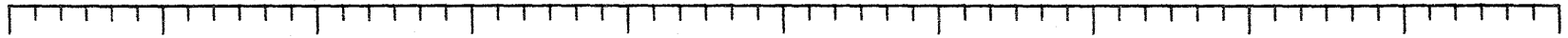

PRT5

SFMR

AMSCAT (VV POLARIZATION)

AMSCAT (HH POLARIZATION)



06:05:47	06:07:47	06:09:47	06:11:47	06:13:47	06:15:47	06:17:47	06:19:47	06:21:47	06:23:47	06:25:47
GREENWICH MERIDIAN TIME (HOUR:MIN:SEC)										
71.82	71.94	72.07	72.20	72.33	72.46	72.59	72.72	72.85		
LATITUDE (DEG)										
18.46	18.42	18.37	18.33	18.27	18.21	18.16	18.12	18.06		
LONGITUDE (DEG)										

NORSEX DATA SET SUMMARY  
 DAY 274

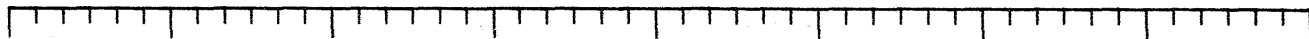

-98-

PRT5

SFMR

AMSCAT (VV POLARIZATION)

AMSCAT (HH POLARIZATION)



07:11:48	07:13:48	07:15:48	07:17:48	07:19:48	07:21:48	07:23:48	07:26:48	07:27:48
GREENWICH MERIDIAN TIME ( HOUR:MIN:SEC)								
75.53	75.66	75.80	75.93	76.07	76.03	76.05	76.04	
LATITUDE ( DEG)								
17.99	17.99	18.00	17.99	17.99	17.84	17.79	17.99	
LONGITUDE ( DEG)								

NORSEX DATA SET SUMMARY  
 DAY 274

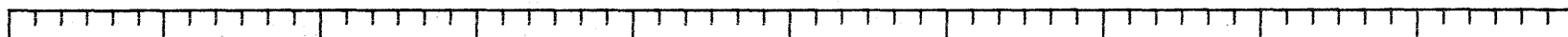

PRT5

SFMR

AMSCAT (VV POLARIZATION)

-87-

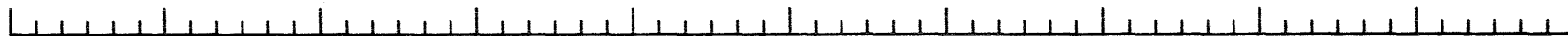

06:51:48	06:53:48	06:55:48	06:57:48	06:59:48	07:01:48	07:03:48	07:05:48	07:07:48	07:09:48	07:11:48
GREENWICH MERIDIAN TIME (HOUR:MIN:SEC)										
74.18	74.31	74.44	74.58	74.72	74.85	74.99	75.12	75.26	75.39	75.53
LATITUDE (DEG)										
17.99	17.99	17.98	17.99	17.99	17.99	17.99	17.99	17.99	18.00	17.99
LONGITUDE (DEG)										

NORSEX DATA SET SUMMARY  
DAY 274

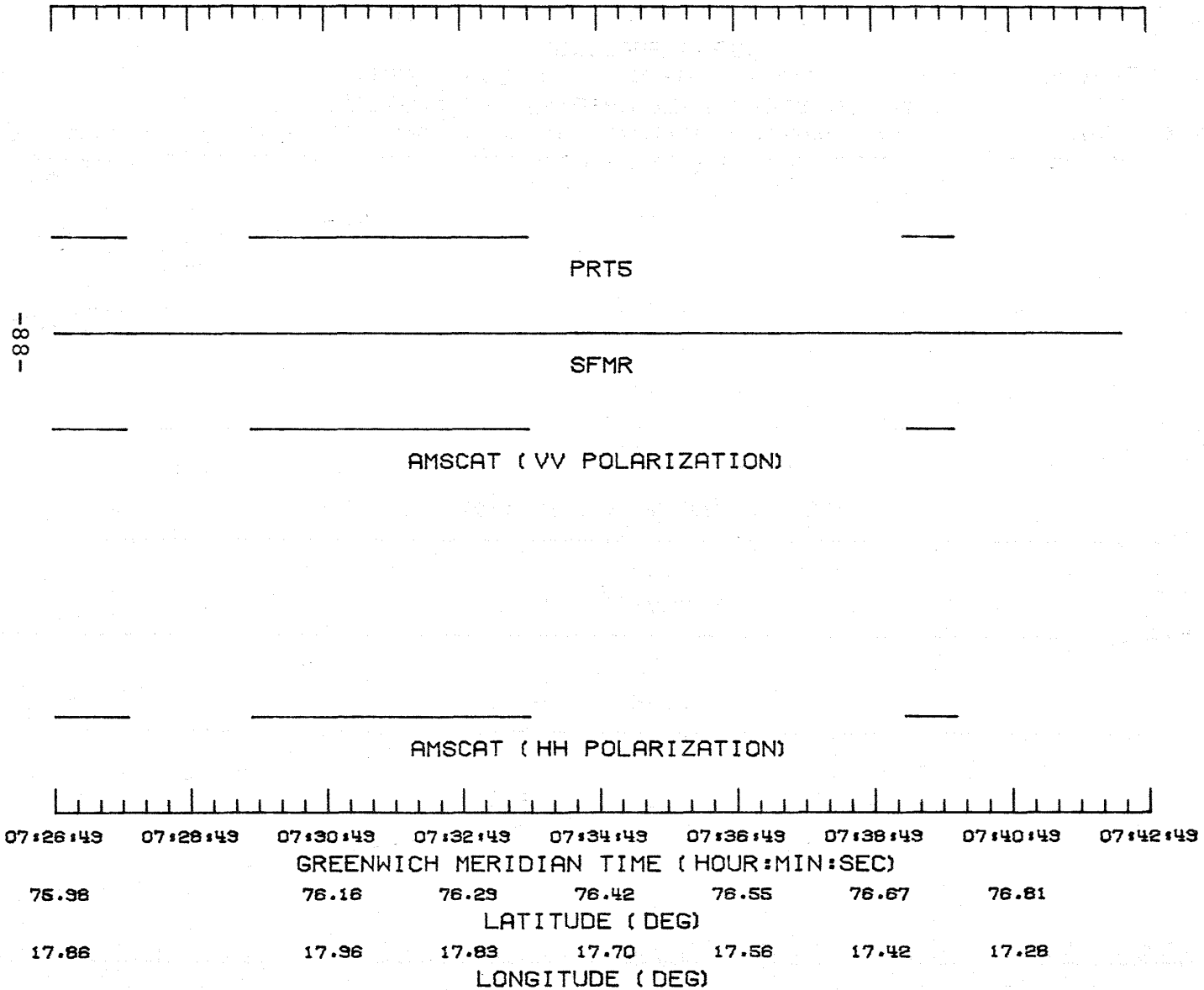

NORSEX DATA SET SUMMARY  
 DAY 274

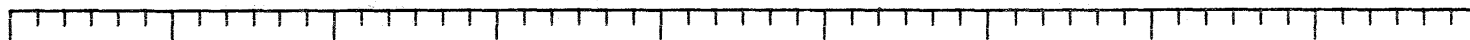

PRTS

SFMR

AMSCAT (VV POLARIZATION)

AMSCAT (VH POLARIZATION)

AMSCAT (HH POLARIZATION)



09:08:37    09:10:37    09:12:37    09:14:37    09:16:37    09:18:37    09:20:37    09:22:37    09:24:37    09:26:37

GREENWICH MERIDIAN TIME (HOUR:MIN:SEC)

78.18    78.29    78.41    78.53    78.65    78.76    78.88    79.00    79.13    79.27

LATITUDE (DEG)

14.01    13.82    13.70    13.62    13.55    13.46    13.37    13.28    13.17    13.07

LONGITUDE (DEG)



NORSEX DATA SET SUMMARY  
DAY 274

-06-

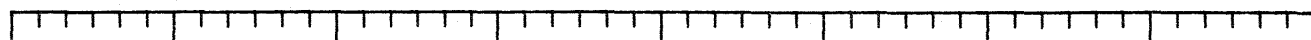

PRTS

SFMR

AMSCAT (VV POLARIZATION)

AMSCAT (VH POLARIZATION)

AMSCAT (HH POLARIZATION)

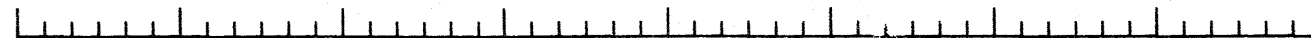

09:26:38 09:28:38 09:30:38 09:32:38 09:34:38 09:36:38 09:38:38 09:40:38 09:42:38

GREENWICH MERIDIAN TIME ( HOUR:MIN:SEC)

79.27 79.41 79.56 79.71 79.85 80.00 80.16 80.47

LATITUDE ( DEG)

13.06 12.94 12.82 12.69 12.56 12.42 12.28 11.96

LONGITUDE ( DEG)

NORSEX DATA SET SUMMARY  
 DAY 274

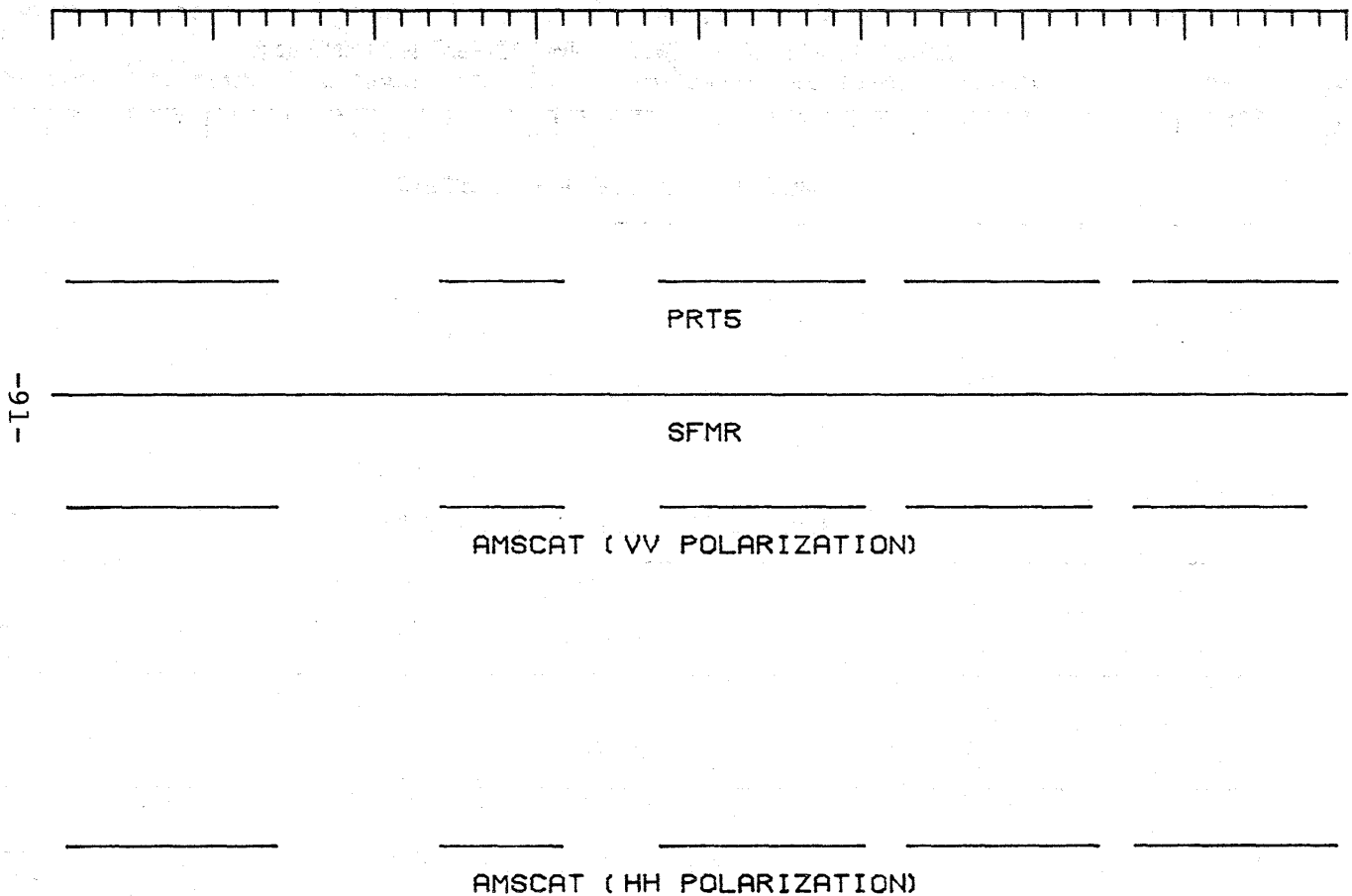

GREENWICH MERIDIAN TIME (HOUR:MIN:SEC)								
09:42:38	09:44:38	09:46:38	09:48:38	09:50:38	09:52:38	09:54:38	09:56:38	09:58:38
80.47	80.63	80.91	81.03	81.15	81.27	81.33	81.43	
LATITUDE (DEG)								
11.96	11.80	11.49	11.35	11.22	11.05	10.91	10.81	
LONGITUDE (DEG)								



NORSEX DATA SET SUMMARY  
DAY 274

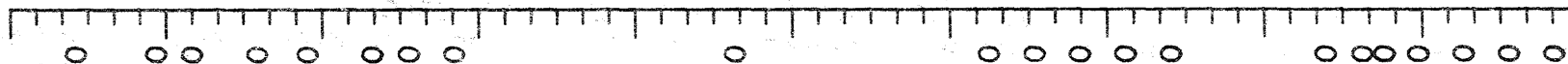

PHOTOGRAPHY

6-1

7-1

FLIGHT LINES

PRT5

SFMR

AMSCAT (VV POLARIZATION)

AMSCAT (HH POLARIZATION)

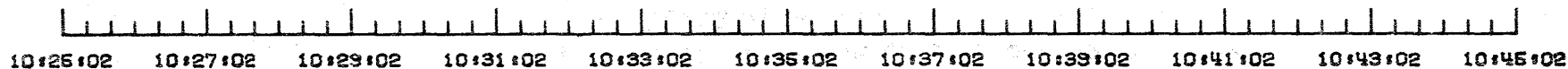

10:26:02	10:27:02	10:29:02	10:31:02	10:33:02	10:35:02	10:37:02	10:39:02	10:41:02	10:43:02	10:45:02
GREENWICH MERIDIAN TIME ( HOUR:MIN:SEC)										
81.85	81.90	81.93	81.95	81.96	81.96	82.04	82.04	82.02	82.00	
LATITUDE ( DEG)										
6.43	7.10	7.83	8.55	9.28	9.99	10.21	9.59	8.96	8.34	
LONGITUDE ( DEG)										

NORSEX DATA SET SUMMARY  
DAY 274



PHOTOGRAPHY

7-1

8-1

FLIGHT LINES

PRTS

SFMR

AMSCAT (VV POLARIZATION)

AMSCAT (HH POLARIZATION)

10:46:01 10:47:01 10:49:01 10:51:01 10:53:01 10:55:01 10:57:01 10:59:01 11:01:01 11:03:01

GREENWICH MERIDIAN TIME ( HOUR:MIN:SEC)

81.98 81.96 81.94 81.97 82.01 82.04 82.07 82.09 82.11

LATITUDE ( DEG)

7.75 7.14 6.63 6.10 6.75 7.48 8.21 8.96 9.70

LONGITUDE ( DEG)

-94-

NORSEX DATA SET SUMMARY  
DAY 274



9-1

FLIGHT LINES

PRTS

SFMR

AMSCAT (VV POLARIZATION)

AMSCAT (HH POLARIZATION)

11:02:00	11:04:00	11:06:00	11:08:00	11:10:00	11:12:00	11:14:00	11:16:00	11:18:00
GREENWICH MERIDIAN TIME (HOUR:MIN:SEC)								
	82.13	82.15	82.13	82.12	82.10	82.08	82.05	82.03
LATITUDE (DEG)								
	10.49	9.87	9.25	8.84	8.01	7.41	6.77	6.14
LONGITUDE (DEG)								

NORSEX DATA SET SUMMARY  
DAY 274

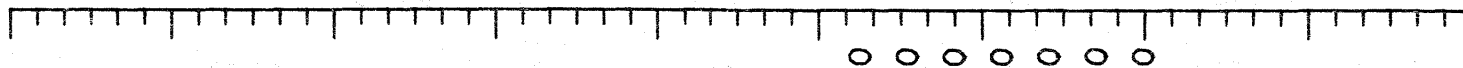

PHOTOGRAPHY

10-1

---

FLIGHT LINES

---

PRTS

---

SFMR

---

AMSCAT (VV POLARIZATION)

---

AMSCAT (HH POLARIZATION)

11:18:01	11:20:01	11:22:01	11:24:01	11:26:01	11:28:01	11:30:01	11:32:01	11:34:01	11:36:01
82.03	82.08	82.03	81.96	81.97	82.00	82.02	82.05	82.06	82.08
GREENWICH MERIDIAN TIME ( HOUR:MIN:SEC)									
LATITUDE ( DEG)									
6.13	5.69	5.51	5.88	6.53	7.30	8.00	8.70	9.42	10.14
LONGITUDE ( DEG)									

NORSEX DATA SET SUMMARY  
DAY 274

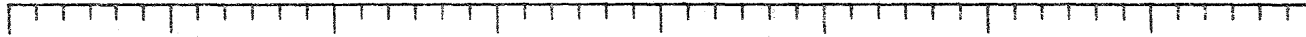

PHOTOGRAPHY

11-1

FLIGHT LINES

PRT5

SFMR

AMSCAT (VV POLARIZATION)

AMSCAT (HH POLARIZATION)

11:36:01 11:38:01 11:40:01 11:42:01 11:44:01 11:46:01 11:48:01 11:50:01 11:52:01

GREENWICH MERIDIAN TIME (HOUR:MIN:SEC)

82.08 82.02 81.99 81.98 81.96 81.93 81.91 81.87

LATITUDE (DEG)

10.14 9.91 9.91 8.69 8.06 7.43 6.82 6.34

LONGITUDE (DEG)

-97-



NORSEX DATA SET SUMMARY  
DAY 274



PHOTOGRAPHY

12-1

FLIGHT LINES

PRT5

SFMR

AMSCAT (VV POLARIZATION)

AMSCAT (HH POLARIZATION)

11:51:02 11:53:02 11:55:02 11:57:02 11:59:02 12:01:02 12:03:02 12:05:02 12:07:02 12:09:02 12:11:02

GREENWICH MERIDIAN TIME ( HOUR:MIN:SEC)

81.84 81.87 81.90 81.93 81.96 81.99 81.94 81.88 81.82 81.75 81.74

LATITUDE ( DEG)

6.58 7.28 7.96 8.63 9.32 10.01 10.20 9.81 9.55 9.53 9.00

LONGITUDE ( DEG)

--86--

NORSEX DATA SET SUMMARY  
DAY 274

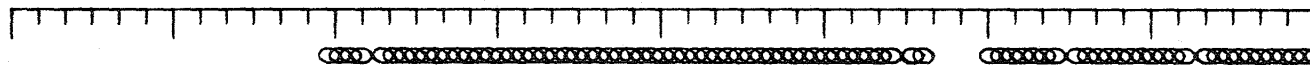

PHOTOGRAPHY

13-1

14-1

FLIGHT LINES

PRT5

SFMR

AMSCAT (VV POLARIZATION)

AMSCAT (HH POLARIZATION)

12:11:02 12:13:02 12:15:02 12:17:02 12:19:02 12:21:02 12:23:02 12:25:02 12:27:02

GREENWICH MERIDIAN TIME (HOUR:MIN:SEC)

81.74 81.77 81.86 81.95 82.04 82.13 82.22 82.23 82.25

LATITUDE (DEG)

9.00 8.54 8.38 8.24 8.08 7.93 7.89 8.48 9.08

LONGITUDE (DEG)

-66-

NORSEX DATA SET SUMMARY  
DAY 274

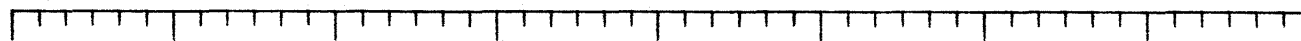

PHOTOGRAPHY

14-1

15-1

FLIGHT LINES

PRTS

SFMR

AMSCAT (VV POLARIZATION)

AMSCAT (HH POLARIZATION)

12:27:03 12:29:03 12:31:03 12:33:03 12:35:03 12:37:03 12:39:03 12:41:03 12:43:03

GREENWICH MERIDIAN TIME ( HOUR:MIN:SEC)

82.25 82.23 82.17 82.10 82.03 81.96 81.89 81.76

LATITUDE ( DEG)

9.08 9.55 9.73 9.83 9.94 10.06 10.17 10.18

LONGITUDE ( DEG)

-100-

NORSEX DATA SET SUMMARY  
DAY 274



16-1

FLIGHT LINES

PRT5

SFMR

AMSCAT (VV POLARIZATION)

-101-

AMSCAT (HH POLARIZATION)



12:43:03 12:45:03 12:47:03 12:49:03 12:51:03 12:53:03 12:55:03 12:57:03 12:59:03

GREENWICH MERIDIAN TIME (HOUR:MIN:SEC)

81.78 81.78 81.80 81.81 81.81 81.76 81.75 81.73

LATITUDE (DEG)

10.17 10.23 10.28 10.29 10.29 9.93 9.40 8.87

LONGITUDE (DEG)

NORSEX DATA SET SUMMARY  
DAY 274

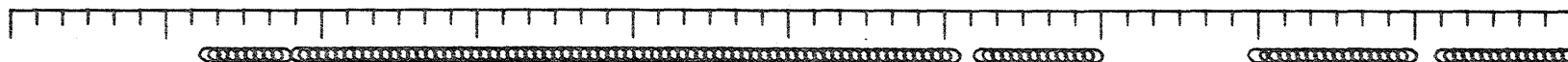

PHOTOGRAPHY

13-2

14-2

FLIGHT LINES

PRTS

SFMR

-102-

AMSCAT (HH POLARIZATION)

12:58:04	13:00:04	13:02:04	13:04:04	13:06:04	13:08:04	13:10:04	13:12:04	13:14:04	13:16:04	13:18:04
GREENWICH MERIDIAN TIME ( HOUR:MIN:SEC)										
	81.81	81.91	82.00	82.09	82.19	82.28	82.29	82.22	82.23	82.24
LATITUDE ( DEG)										
	8.41	8.29	8.14	8.00	7.84	7.67	7.47	7.64	8.20	8.80
LONGITUDE ( DEG)										

NORSEX DATA SET SUMMARY  
DAY 274

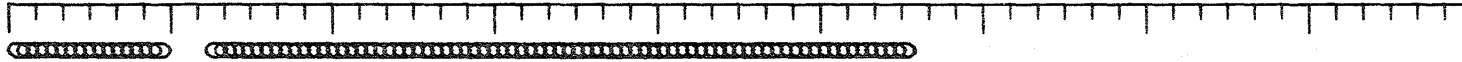

PHOTOGRAPHY

14-2

15-2

FLIGHT LINES

PRT5

SFMR

-103-

AMSCAT (HH POLARIZATION)



13:18:04 13:20:04 13:22:04 13:24:04 13:26:04 13:28:04 13:30:04 13:32:04 13:34:04 13:36:04

GREENWICH MERIDIAN TIME (HOUR:MIN:SEC)

82.24 82.28 82.21 82.14 82.07 82.00 81.93 81.87 81.80

LATITUDE (DEG)

8.80 9.39 9.63 9.79 9.89 10.00 10.10 10.21 10.31

LONGITUDE (DEG)

NORSEX DATA SET SUMMARY  
DAY 274

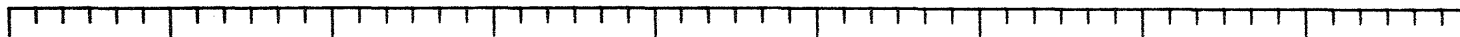

PRT5

SFMR

AMSCAT (VV POLARIZATION)

AMSCAT (HH POLARIZATION)

13:38:12	13:40:12	13:42:12	13:44:12	13:46:12	13:48:12	13:50:12	13:52:12	13:54:12	13:56:12
GREENWICH MERIDIAN TIME ( HOUR:MIN:SEC)									
81.75	81.75	81.83	81.96	82.03	81.93	81.82	81.72	81.64	81.57
LATITUDE ( DEG)									
9.51	8.93	8.48	8.35	8.35	8.37	8.46	8.63	9.04	9.52
LONGITUDE ( DEG)									

NORSEX DATA SET SUMMARY  
DAY 274



PRTS

SFMR

AMSCAT (VV POLARIZATION)

AMSCAT (HH POLARIZATION)

13:56:13	13:58:13	14:00:13	14:02:13	14:04:13	14:06:13	14:08:13	14:10:13	14:12:13
GREENWICH MERIDIAN TIME (HOUR:MIN:SEC)								
81.57	81.47	81.37	81.27	81.16	81.05	80.93	80.81	
LATITUDE (DEG)								
9.52	9.76	10.00	10.25	10.51	10.76	11.01	11.27	
LONGITUDE (DEG)								

-105-



NORSEX DATA SET SUMMARY  
DAY 274

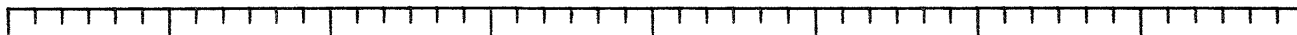

-90I-

PRT5



AMSCAT (VV POLARIZATION)



AMSCAT (HH POLARIZATION)



14:12:13	14:14:13	14:16:13	14:18:13	14:20:13	14:22:13	14:24:13	14:26:13	14:28:13
GREENWICH MERIDIAN TIME (HOUR:MIN:SEC)								
80.43	80.30	80.18	80.02	79.87	79.72	79.55		
LATITUDE (DEG)								
12.06	12.30	12.54	12.80	13.07	13.34	13.61		
LONGITUDE (DEG)								

NORSEX DATA SET SUMMARY  
DAY 274



-107-

PRTS

SFMR

AMSCAT (VV POLARIZATION)

AMSCAT (HH POLARIZATION)



14:59:45	15:01:45	15:03:45	15:05:45	15:07:45	15:09:45	15:11:45	15:13:45	15:15:45	15:17:45	15:19:45
GREENWICH MERIDIAN TIME ( HOUR:MIN:SEC)										
76.91	76.74	76.57	76.40	76.22	76.05	75.88	75.70	75.52	75.34	75.16
LATITUDE ( DEG)										
17.08	17.27	17.43	17.60	17.77	17.95	17.98	17.99	18.00	17.99	17.99
LONGITUDE ( DEG)										

NORSEX DATA SET SUMMARY  
DAY 274

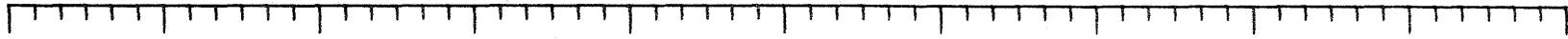

-108-

PRT5

SFMR

AMSCAT (VV POLARIZATION)

AMSCAT (HH POLARIZATION)

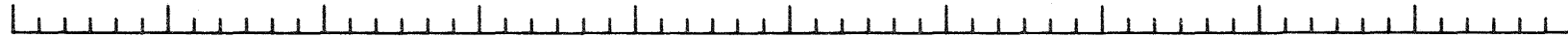

15:19:45	15:21:45	15:23:45	15:25:45	15:27:45	15:29:45	15:31:45	15:33:45	15:35:45	15:37:45	15:39:45
GREENWICH MERIDIAN TIME (HOUR:MIN:SEC)										
75.16	74.99	74.81	74.64	74.46	74.28	74.10	73.92	73.75	73.57	73.39
LATITUDE (DEG)										
17.99	18.00	17.99	17.99	17.99	17.99	17.99	17.99	17.99	18.00	18.00
LONGITUDE (DEG)										

NORSEX DATA SET SUMMARY  
DAY 274

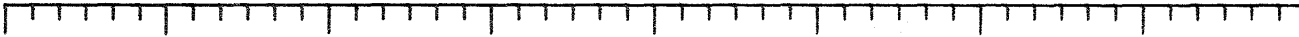

-60T-

PRT5

SFMR

AMSCAT (VV POLARIZATION)

AMSCAT (HH POLARIZATION)

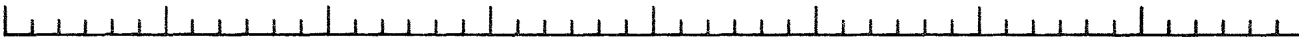

15:39:46	15:41:46	15:43:46	15:45:46	15:47:46	15:49:46	15:51:46	15:53:46	15:55:46
GREENWICH MERIDIAN TIME ( HOUR:MIN:SEC)								
73.39	73.21	73.03	72.85	72.67	72.49	72.31	72.13	71.94
LATITUDE ( DEG)								
18.00	17.99	18.00	18.05	18.11	18.17	18.23	18.29	18.35
LONGITUDE ( DEG)								

NORSEX DATA SET SUMMARY  
 DAY 274

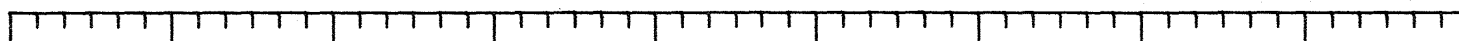

-110-

PRT5

SFMR

AMSCAT (VV POLARIZATION)

AMSCAT (HH POLARIZATION)

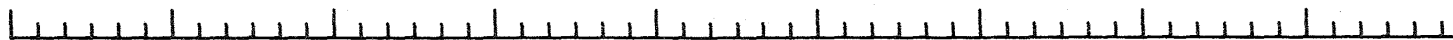

15:55:46 15:57:46 15:59:46 16:01:46 16:03:46 16:05:46 16:07:46 16:09:46 16:11:46 16:13:46

GREENWICH MERIDIAN TIME ( HOUR:MIN:SEC)

71.93	71.73	71.53	71.34	71.14	70.96	70.58	70.41
LATITUDE ( DEG)							
18.35	18.41	18.48	18.54	18.59	18.62	18.71	18.71
LONGITUDE ( DEG)							

DAY 277

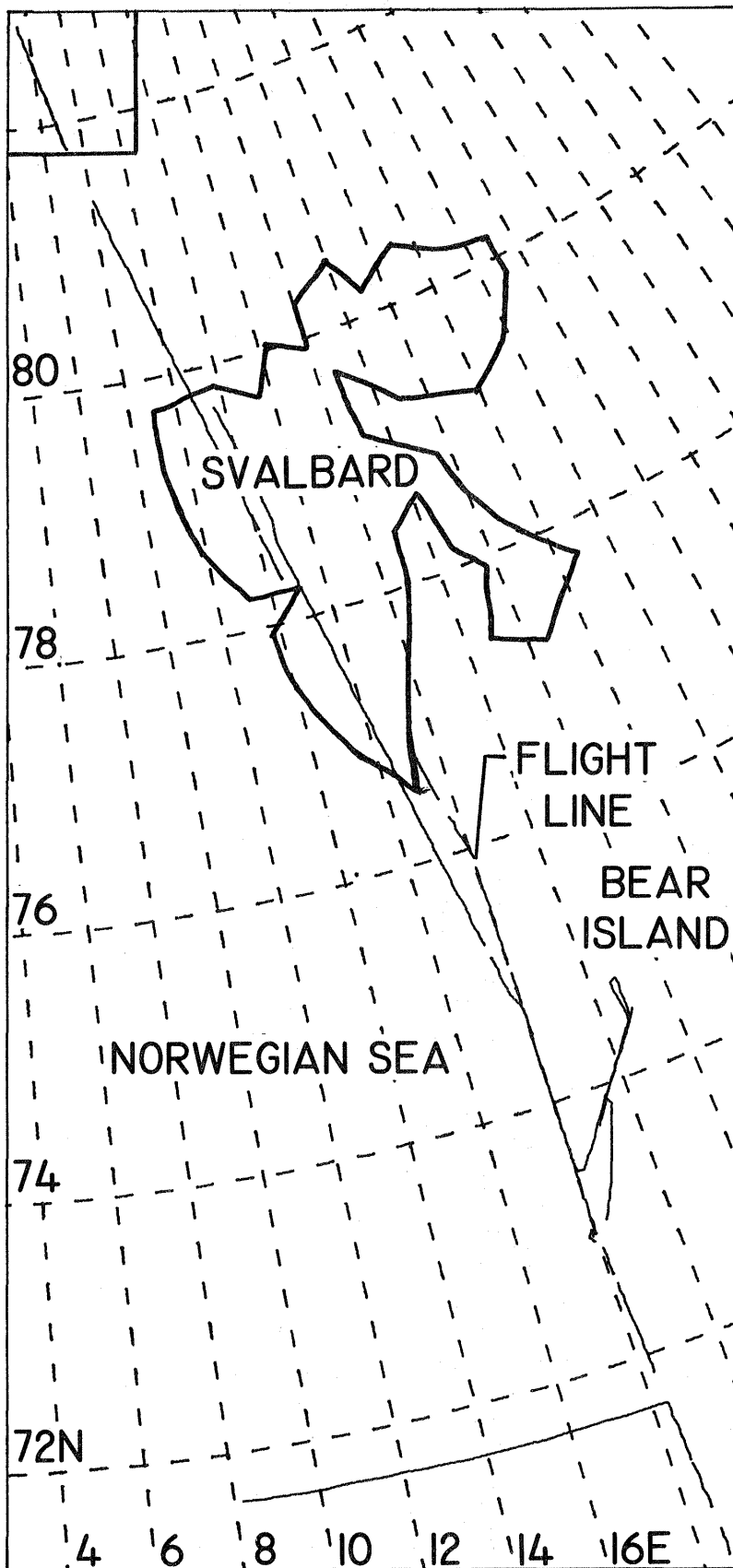

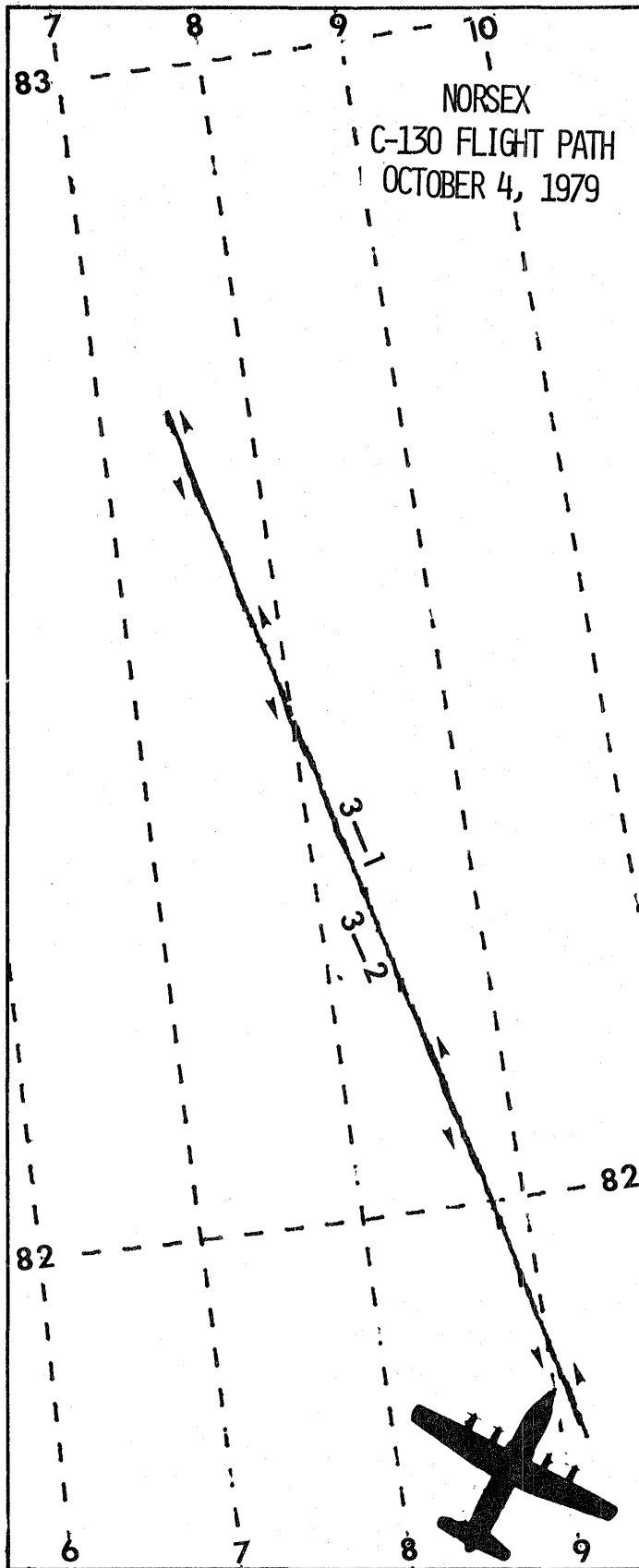



NORSEX DATA SET SUMMARY  
DAY 277

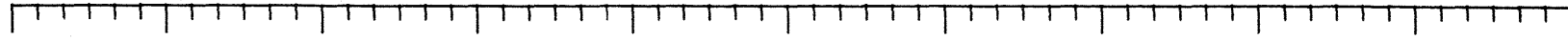

-114-

---

SFMR

06:21:35	06:23:35	06:25:35	06:27:35	06:29:35	06:31:35	06:33:35	06:35:35	06:37:35	06:39:35	06:41:35
GREENWICH MERIDIAN TIME (HOUR:MIN:SEC)										
70.41	70.51	70.62		70.85	70.99	71.12	71.24	71.37	71.50	71.63
LATITUDE (DEG)										
18.62	18.63	18.61		18.55	18.53	18.49	18.46	18.43	18.40	18.14
LONGITUDE (DEG)										

NORSEX DATA SET SUMMARY  
DAY 277

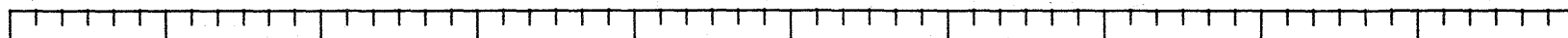

PRT5

SFMR

AMSCAT (VV POLARIZATION)

AMSCAT (HH POLARIZATION)

06:41:35	06:43:35	06:45:35	06:47:35	06:49:35	06:51:35	06:53:35	06:55:35	06:57:35	06:59:35	06:01:35
GREENWICH MERIDIAN TIME ( HOUR:MIN:SEC )										
71.63		71.88	72.01	72.13	72.26	72.39	72.51		72.77	
LATITUDE ( DEG )										
9.66		18.30	18.27	18.24	18.20	18.17	18.14		18.06	
LONGITUDE ( DEG )										

NORSEX DATA SET SUMMARY  
DAY 277

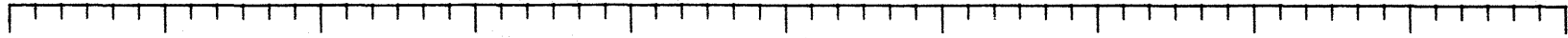

-911-

PRT5

SFMR

AMSCAT (VV POLARIZATION)

AMSCAT (HH POLARIZATION)

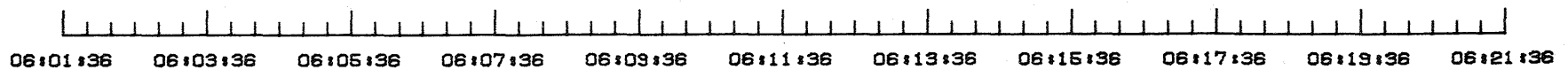

06:01:36	06:03:36	06:05:36	06:07:36	06:09:36	06:11:36	06:13:36	06:15:36	06:17:36	06:19:36	06:21:36
GREENWICH MERIDIAN TIME (HOUR:MIN:SEC)										
73.00	72.97	72.94		73.04	73.15	73.28	73.40	73.53	73.65	
LATITUDE (DEG)										
17.98	17.94	17.91		18.03	17.99	17.99	18.00	18.00	18.00	
LONGITUDE (DEG)										

NORSEX DATA SET SUMMARY  
DAY 277

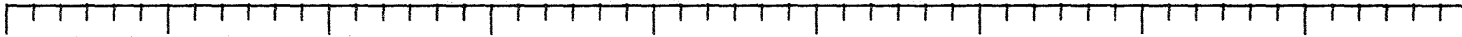

-117-

PRT5

SFMR

AMSCAT (VV POLARIZATION)

AMSCAT (HH POLARIZATION)

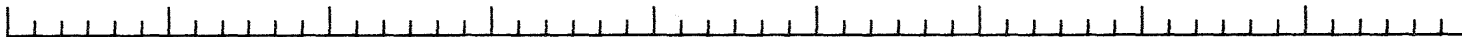

06:21:36	06:23:36	06:25:36	06:27:36	06:29:36	06:31:36	06:33:36	06:35:36	06:37:36	06:39:36
GREENWICH MERIDIAN TIME (HOUR:MIN:SEC)									
73.65	73.78	73.91	74.03	74.15	74.28	74.40	74.52	74.65	74.77
LATITUDE (DEG)									
18.00	18.00	17.99	18.00	17.99	18.00	17.99	17.99	17.99	17.99
LONGITUDE (DEG)									

NORSEX DATA SET SUMMARY  
DAY 277

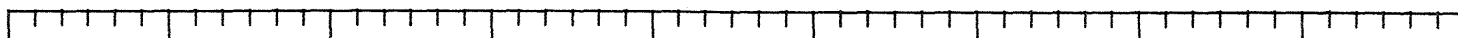

PRTS



SFMR

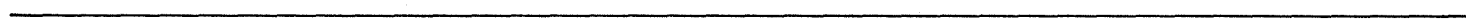

AMSCAT (VV POLARIZATION)



AMSCAT (HH POLARIZATION)



06:39:37 06:41:37 06:43:37 06:45:37 06:47:37 06:49:37 06:51:37 06:53:37 06:55:37 06:57:37

GREENWICH MERIDIAN TIME ( HOUR:MIN:SEC)

74.77 74.89 74.99 75.14 75.26 75.38 75.51 75.64 75.77

LATITUDE ( DEG)

17.99 17.99 17.99 17.99 18.00 18.00 17.99 17.99 18.00

LONGITUDE ( DEG)

NORSEX DATA SET SUMMARY  
 DAY 277

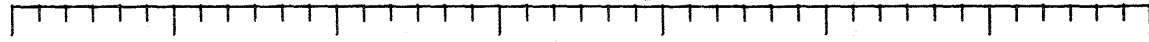

PRT5

SFMR

AMSCAT (VV POLARIZATION)

AMSCAT (HH POLARIZATION)

07:06:26	07:07:26	07:09:26	07:11:26	07:13:26	07:15:26	07:17:26	07:19:26
GREENWICH MERIDIAN TIME ( HOUR:MIN:SEC)							
75.92	76.03	76.15			76.53	76.66	
LATITUDE ( DEG)							
18.02	17.91	17.79			17.43	17.30	
LONGITUDE ( DEG)							

NORSEX DATA SET SUMMARY  
DAY 277



---

PRT5

---

SFMR

---

AMSCAT (VV POLARIZATION)

---

AMSCAT (HH POLARIZATION)

08:41:41	08:43:41	08:45:41	08:47:41	08:49:41	08:51:41	08:53:41	08:55:41	08:57:41
GREENWICH MERIDIAN TIME ( HOUR:MIN:SEC)								
78.32	78.42	78.54	78.65	78.76	78.87	78.98	79.08	
LATITUDE ( DEG)								
14.48	14.35	14.25	14.11	14.06	13.92	13.78	13.65	
LONGITUDE ( DEG)								

NORSEX DATA SET SUMMARY  
DAY 277

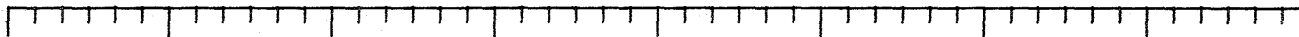

-121-

PRT5

SFMR

AMSCAT (VV POLARIZATION)

AMSCAT (HH POLARIZATION)



08:56:10    08:58:10    09:00:10    09:02:10    09:04:10    09:06:10    09:08:10    09:10:10    09:12:10

GREENWICH MERIDIAN TIME ( HOUR:MIN:SEC)

79.11        79.23        79.37        79.51        79.65        79.79        79.93        80.08

LATITUDE ( DEG)

19.62        19.48        19.30        19.11        12.92        12.73        12.52        12.29

LONGITUDE ( DEG)



NORSEX DATA SET SUMMARY  
DAY 277

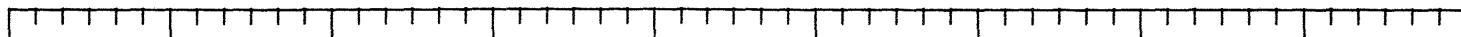

PRT5

SFMR

AMSCAT (VV POLARIZATION)

AMSCAT (HH POLARIZATION)

09:11:05	09:13:05	09:15:05	09:17:05	09:19:05	09:21:05	09:23:05	09:25:05	09:27:05	09:29:05
GREENWICH MERIDIAN TIME ( HOUR:MIN:SEC)									
80.14	80.29	80.43	80.58	80.72	80.87	81.02	81.17	81.33	
LATITUDE ( DEG)									
12.20	11.98	11.74	11.50	11.26	10.99	10.71	10.44	10.14	
LONGITUDE ( DEG)									

NORSEX DATA SET SUMMARY  
DAY 277

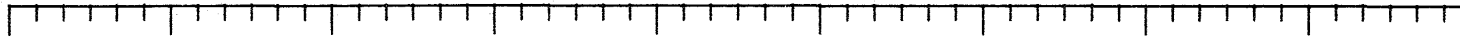

PHOTOGRAPHY

3-1

FLIGHT LINES

PRT5

SFMR

-123-

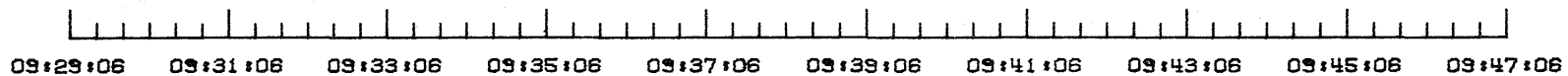

GREENWICH MERIDIAN TIME ( HOUR:MIN:SEC)

81.84      81.96      82.08      82.21      82.34      82.47

LATITUDE ( DEG)

9.05      8.86      8.66      8.42      8.18      7.92

LONGITUDE ( DEG)

NORSEX DATA SET SUMMARY  
DAY 277

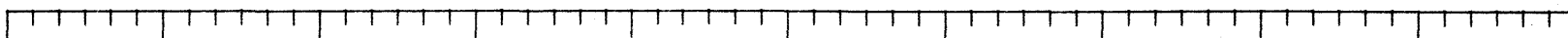

3-2

FLIGHT LINES

PRT5

SFMR

-124-

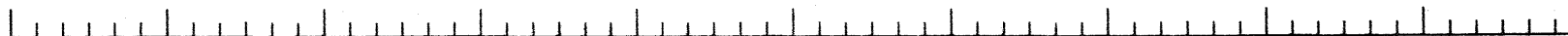

10:03:52	10:05:52	10:07:52	10:09:52	10:11:52	10:13:52	10:15:52	10:17:52	10:19:52	10:21:52	10:23:52
82.77	82.69	82.60	82.51	82.42	82.34	82.25	82.16	82.07	81.98	81.89
LATITUDE (DEG)										
7.30	7.49	7.66	7.83	8.00	8.18	8.35	8.52	8.67	8.84	8.99
LONGITUDE (DEG)										

NORSEX DATA SET SUMMARY  
DAY 277

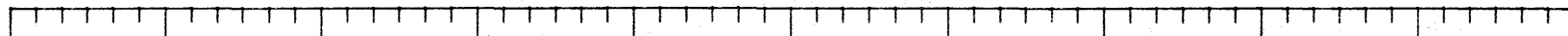

PRT5

SFMR

AMSCAT (VV POLARIZATION)

AMSCAT (HH POLARIZATION)



10:59:00	11:01:00	11:03:00	11:05:00	11:07:00	11:09:00	11:11:00	11:13:00	11:15:00	11:17:00	11:19:00
GREENWICH MERIDIAN TIME (HOUR:MIN:SEC)										
79.68	79.52	79.38	79.21	79.05	78.88	78.72	78.55	78.39	78.21	78.05
LATITUDE (DEG)										
13.51	13.78	14.03	14.20	14.40	14.57	14.63	14.72	14.89	15.05	15.24
LONGITUDE (DEG)										

NORSEX DATA SET SUMMARY  
 DAY 277

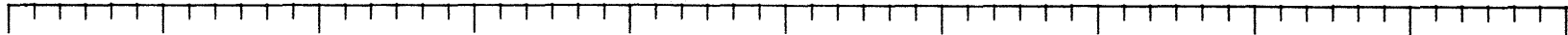

PRT5

SFMR

AMSCAT (VV POLARIZATION)

AMSCAT (HH POLARIZATION)

11:19:00	11:21:00	11:23:00	11:25:00	11:27:00	11:29:00	11:31:00	11:33:00	11:35:00	11:37:00	11:39:00
GREENWICH MERIDIAN TIME ( HOUR:MIN:SEC)										
78.05	77.88	77.71	77.54	77.36	77.19	77.02	76.84	76.67	76.49	76.32
LATITUDE ( DEG)										
15.24	15.41	15.57	15.73	15.88	16.04	16.19	16.34	16.49	16.63	16.75
LONGITUDE ( DEG)										

NORSEX DATA SET SUMMARY  
DAY 277

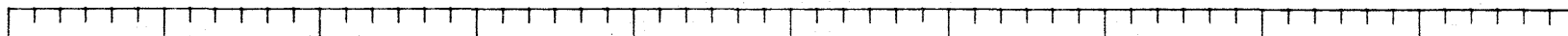

-127-

PRT5

SFMR

AMSCAT (VV POLARIZATION)

AMSCAT (HH POLARIZATION)



11:39:01	11:41:01	11:43:01	11:45:01	11:47:01	11:49:01	11:51:01	11:53:01	11:55:01	11:57:01	11:59:01
GREENWICH MERIDIAN TIME ( HOUR:MIN:SEC)										
76.32	76.14	75.97	75.78	75.59	75.39		75.03	74.89	74.78	74.66
LATITUDE ( DEG)										
16.76	16.89	17.02	17.15	17.29	17.42		17.65	17.76	17.92	18.01
LONGITUDE ( DEG)										

NORSEX DATA SET SUMMARY  
DAY 277

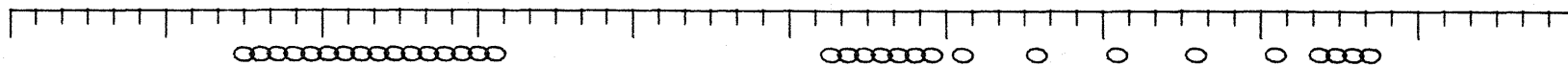

PHOTOGRAPHY

20-1

FLIGHT LINES

PRT5

SFMR

AMSCAT (VV POLARIZATION)

AMSCAT (HH POLARIZATION)

11:59:01	12:01:01	12:03:01	12:05:01	12:07:01	12:09:01	12:11:01	12:13:01	12:15:01	12:17:01	12:19:01
GREENWICH MERIDIAN TIME ( HOUR:MIN:SEC)										
74.66	74.53	74.40	74.27	74.13	74.00	73.86	73.73	73.59	73.46	73.52
LATITUDE ( DEG)										
18.01	18.00	18.00	18.00	18.00	18.00	18.00	18.00	17.99	18.05	18.40
LONGITUDE ( DEG)										

NORSEX DATA SET SUMMARY  
DAY 277

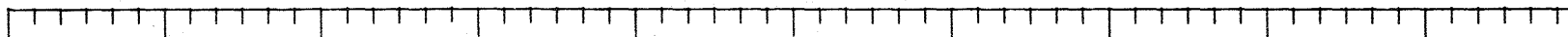

OOOOOOOOOOOOOOOOOOOOOOOOOOOOOOOOOOOO

PHOTOGRAPHY

21-1

FLIGHT LINES

PRT5

SFMR

AMSCAT (VV POLARIZATION)

AMSCAT (HH POLARIZATION)

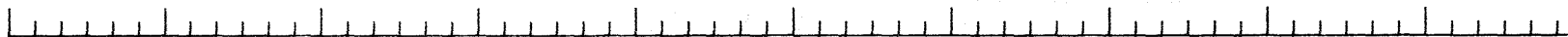

12:19:02	12:21:02	12:23:02	12:25:02	12:27:02	12:29:02	12:31:02	12:33:02	12:35:02	12:37:02	12:39:02
GREENWICH MERIDIAN TIME (HOUR:MIN:SEC)										
73.52	73.62	73.73	73.84	73.95	74.05	74.16	74.27	74.38	74.50	74.64
LATITUDE (DEG)										
18.40	18.65	18.92	19.21	19.49	19.78	20.07	20.36	20.66	20.74	20.75
LONGITUDE (DEG)										



NORSEX DATA SET SUMMARY  
DAY 277

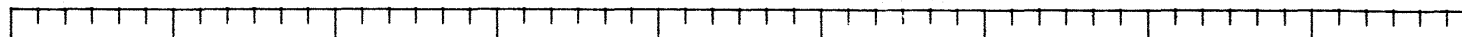

0

PHOTOGRAPHY

21-1

1-1

1-2

FLIGHT LINES

PRT5

SFMR

AMSCAT (VV POLARIZATION)

AMSCAT (HH POLARIZATION)

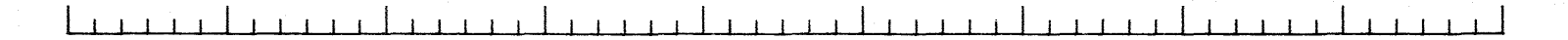

12:39:02 12:41:02 12:43:02 12:45:02 12:47:02 12:49:02 12:51:02 12:53:02 12:55:02 12:57:02

GREENWICH MERIDIAN TIME (HOUR:MIN:SEC)

74.64 74.71 74.59 74.49 74.39 74.30 74.27 74.37 74.46 74.46

LATITUDE (DEG)

20.75 20.57 20.58 20.66 20.65 20.43 20.39 20.65 20.83 20.89

LONGITUDE (DEG)

NORSEX DATA SET SUMMARY  
DAY 277

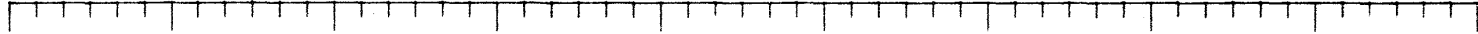

21-2

FLIGHT LINES

PRT5

AMSCAT (VV POLARIZATION)

AMSCAT (HH POLARIZATION)

12:57:03	12:59:03	13:01:03	13:03:03	13:05:03	13:07:03	13:09:03	13:11:03	13:13:03	13:15:03
GREENWICH MERIDIAN TIME ( HOUR:MIN:SEC)									
74.46	74.37	74.28	74.20	74.11	74.02	73.94	73.85	73.77	73.70
LATITUDE ( DEG)									
20.88	20.62	20.39	20.16	19.92	19.70	19.47	19.24	19.01	18.93
LONGITUDE ( DEG)									

NORSEX DATA SET SUMMARY  
DAY 277

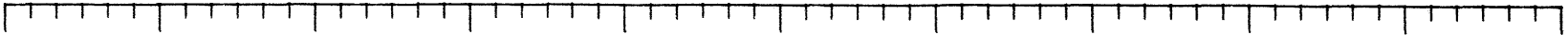

2-1

FLIGHT LINES

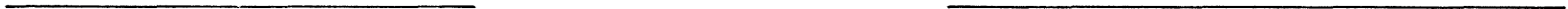

PRT5



SFMR

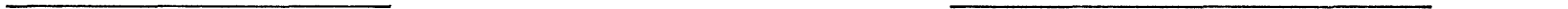

AMSCAT (VV POLARIZATION)

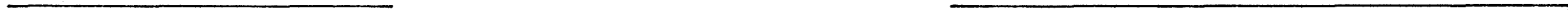

AMSCAT (HH POLARIZATION)

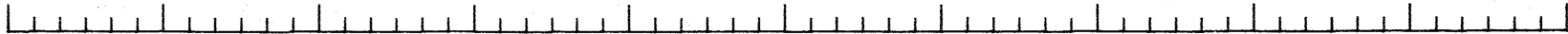

13:15:03	13:17:03	13:19:03	13:21:03	13:23:03	13:25:03	13:27:03	13:29:03	13:31:03	13:33:03	13:35:03
GREENWICH MERIDIAN TIME ( HOUR:MIN:SEC)										
73.70	73.79	73.89	73.81	73.70	73.58	73.46	73.33	73.20	73.07	
LATITUDE ( DEG)										
18.93	19.12	19.37	19.40	19.27	19.13	18.99	18.81	18.61	18.40	
LONGITUDE ( DEG)										

DAY 281

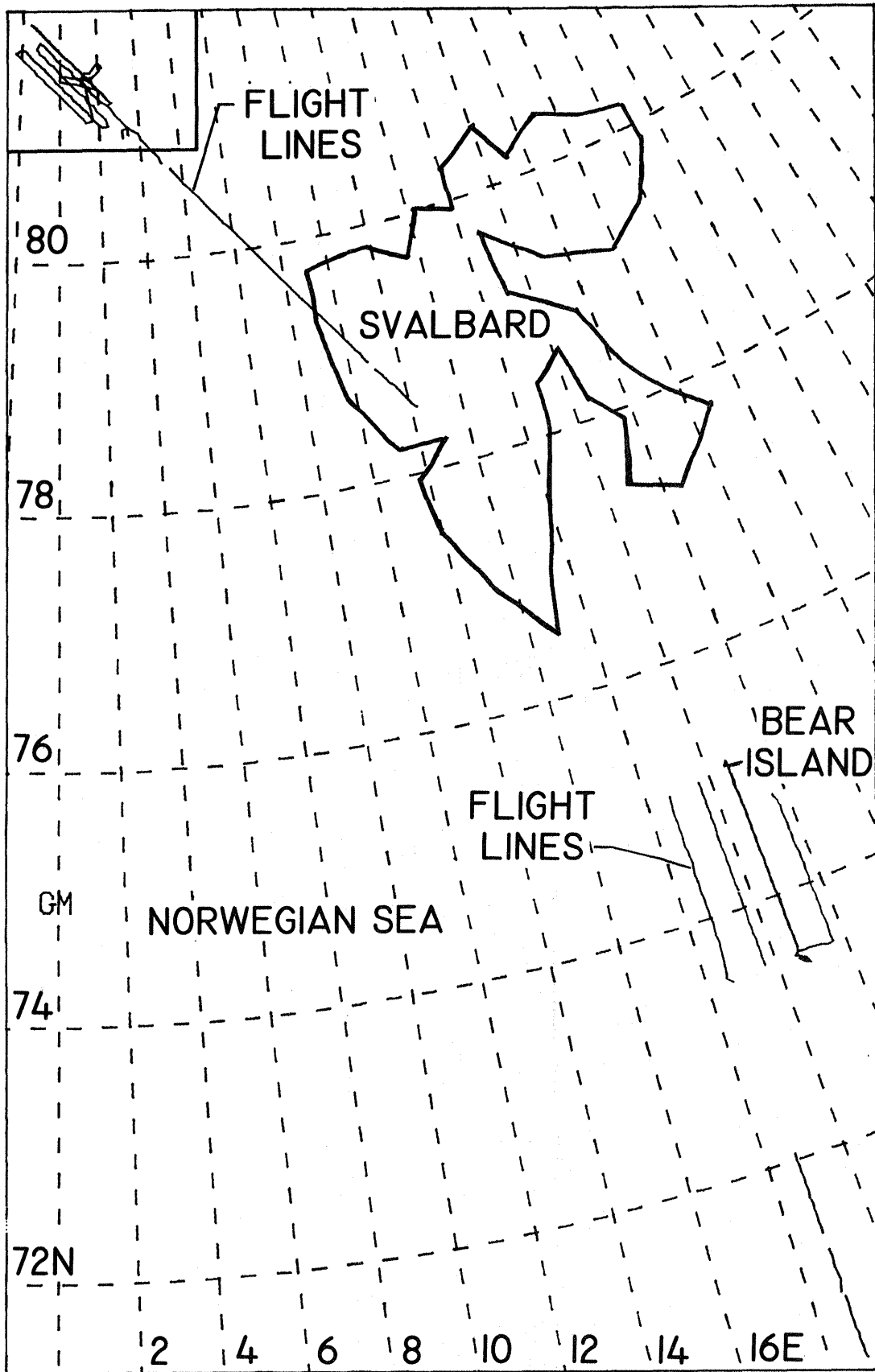

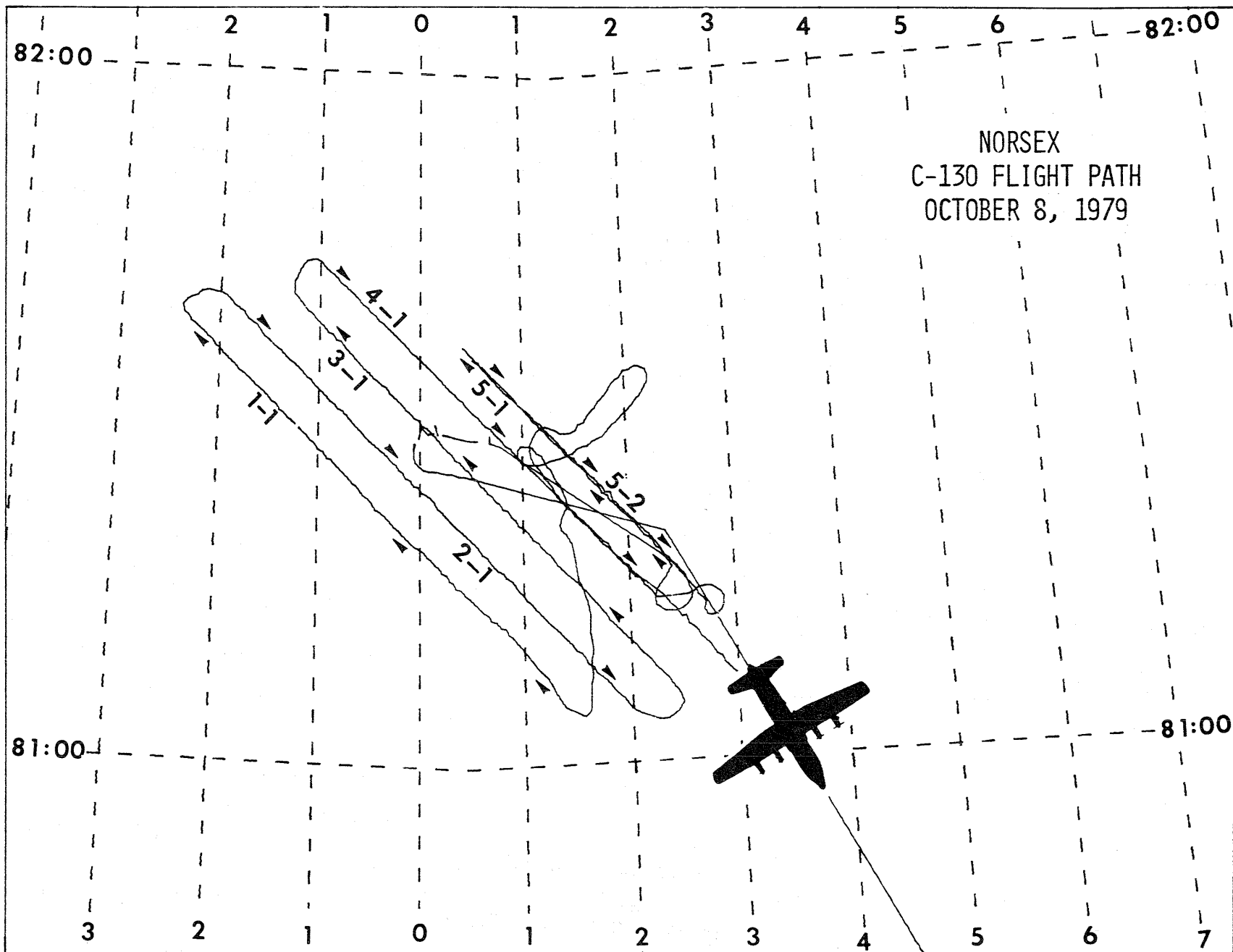

NORSEX DATA SET SUMMARY  
DAY 281

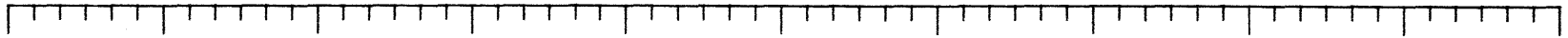

-136-

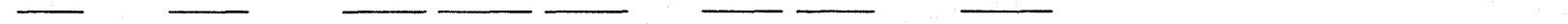

PRT5



SFMR

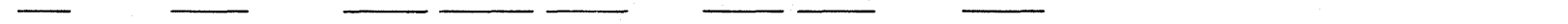

AMSCAT (VV POLARIZATION)



AMSCAT (HH POLARIZATION)

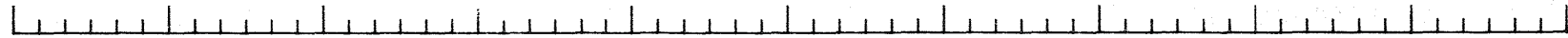

05:12:42	05:14:42	05:16:42	05:18:42	05:20:42	05:22:42	05:24:42	05:26:42	05:28:42	05:30:42	05:32:42
GREENWICH MERIDIAN TIME ( HOUR:MIN:SEC)										
70.38	70.50	70.63	70.75	70.88	71.01	71.14	71.29	71.43	71.57	71.71
LATITUDE ( DEG)										
18.84	18.83	18.82	18.81	18.81	18.83	18.81	18.81	18.81	18.80	18.78
LONGITUDE ( DEG)										

NORSEX DATA SET SUMMARY  
DAY 281

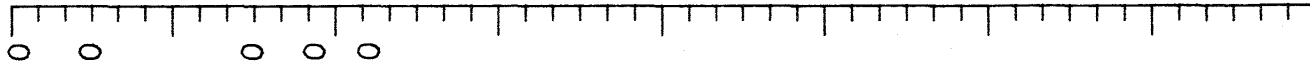

PHOTOGRAPHY

1-4

---

FLIGHT LINES

---

PRTS

---

SFMR

-137-

05:56:09	05:58:09	06:00:09	06:02:09	06:04:09	06:06:09	06:08:09	06:10:09	06:12:09
GREENWICH MERIDIAN TIME (HOUR:MIN:SEC)								
73.48	73.50	73.51	73.54	73.66	73.78	73.90	74.03	
LATITUDE (DEG)								
18.67	18.63	18.57	18.59	18.62	18.68	18.67	18.67	
LONGITUDE (DEG)								





NORSEX DATA SET SUMMARY  
DAY 281

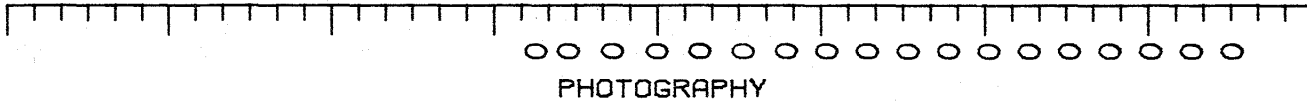

PHOTOGRAPHY

2-1

---

FLIGHT LINES

---

PRTS

---

SFMR

-139-

06:31:46	06:33:46	06:35:46	06:37:46	06:39:46	06:41:46	06:43:46	06:45:46	06:47:46
GREENWICH MERIDIAN TIME ( HOUR:MIN:SEC)								
75.04	74.93	74.82	74.71	74.59	74.48	74.37	74.26	74.14
LATITUDE ( DEG)								
19.66	19.66	19.66	19.66	19.66	19.66	19.66	19.67	19.66
LONGITUDE ( DEG)								

NORSEX DATA SET SUMMARY  
DAY 281

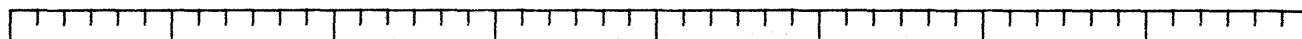

PHOTOGRAPHY

2-1

2-1



FLIGHT LINES

-140-



SFMR



06:47:47	06:49:47	06:51:47	06:53:47	06:55:47	06:57:47	06:59:47	07:01:47	07:03:47
----------	----------	----------	----------	----------	----------	----------	----------	----------

GREENWICH MERIDIAN TIME ( HOUR:MIN:SEC)

74.14	74.09	73.97	73.86	73.73	73.70			
-------	-------	-------	-------	-------	-------	--	--	--

LATITUDE ( DEG)

13.66	13.66	13.66	13.66	13.66	13.66			
-------	-------	-------	-------	-------	-------	--	--	--

LONGITUDE ( DEG)

NORSEX DATA SET SUMMARY  
DAY 281

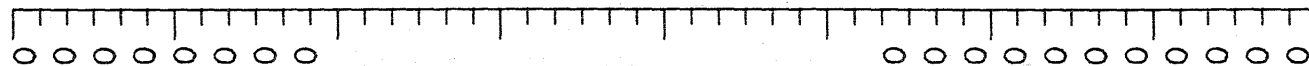

PHOTOGRAPHY

3-1

FLIGHT LINES

-141-

SFMR

07:14:39	07:16:39	07:18:39	07:20:39	07:22:39	07:24:39	07:26:39	07:28:39	07:30:39
GREENWICH MERIDIAN TIME ( HOUR:MIN:SEC)								
73.66	73.67	73.79	73.90	74.02	74.13	74.25	74.37	74.48
LATITUDE ( DEG)								
20.66	20.67	20.67	20.67	20.67	20.67	20.67	20.67	20.67
LONGITUDE ( DEG)								

NORSEX DATA SET SUMMARY  
DAY 281

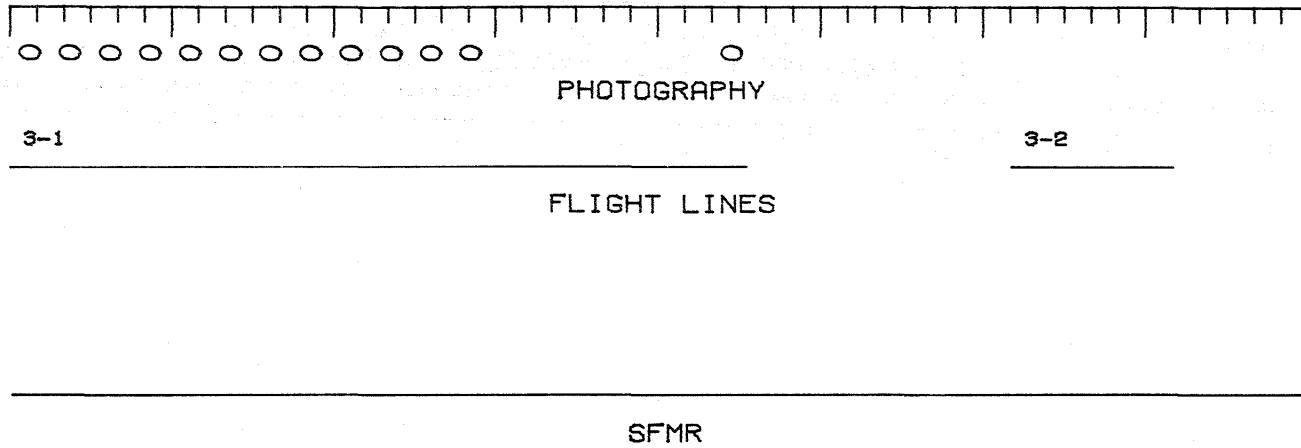

-142-

07:30:40	07:32:40	07:34:40	07:36:40	07:38:40	07:40:40	07:42:40	07:44:40	07:46:40
GREENWICH MERIDIAN TIME ( HOUR:MIN:SEC)								
74.48	74.60	74.71	74.83	74.94			75.07	
LATITUDE ( DEG)								
20.67	20.67	20.67	20.67	20.66			20.91	
LONGITUDE ( DEG)								

NORSEX DATA SET SUMMARY  
 DAY 281

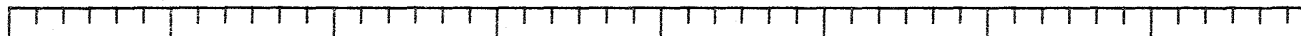

3-3

3-4

FLIGHT LINES

PRT5

AMSCAT (VV POLARIZATION)

AMSCAT (HH POLARIZATION)

-143-



07:46:40    07:48:40    07:50:40    07:52:40    07:54:40    07:56:40    07:58:40    08:00:40    08:02:40

GREENWICH MERIDIAN TIME ( HOUR:MIN:SEC)

75.08        75.13        75.01        74.89        74.78        74.67        74.55        74.43

LATITUDE (DEG)

20.67        20.63        20.65        20.66        20.66        20.67        20.67        20.66

LONGITUDE (DEG)

NORSEX DATA SET SUMMARY  
DAY 281

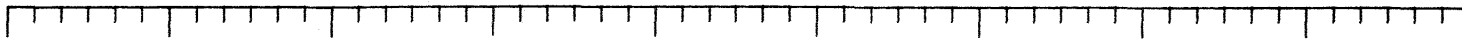

3-4

FLIGHT LINES

PRTS

AMSCAT (VV POLARIZATION)

AMSCAT (HH POLARIZATION)

08:02:41	08:04:41	08:06:41	08:08:41	08:10:41	08:12:41	08:14:41	08:16:41	08:18:41	08:20:41
GREENWICH MERIDIAN TIME ( HOUR:MIN:SEC)									
74.43	74.31	74.20	74.08	73.97	73.86	73.75	73.65	73.54	73.45
LATITUDE ( DEG)									
20.66	20.66	20.65	20.67	20.67	20.66	20.66	20.66	20.64	20.66
LONGITUDE ( DEG)									

NORSEX DATA SET SUMMARY  
DAY 281

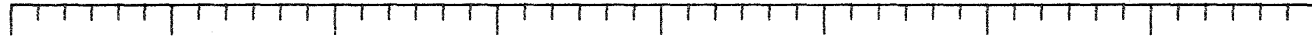

OOOO OOOOO

PHOTOGRAPHY

3-5

3-6

FLIGHT LINES

PRTS

SFMR

AMSCAT (VV POLARIZATION)

AMSCAT (HH POLARIZATION)

-145-

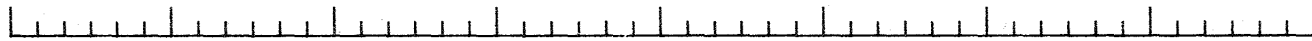

08:26:02 08:28:02 08:30:02 08:32:02 08:34:02 08:36:02 08:38:02 08:40:02 08:42:02

GREENWICH MERIDIAN TIME ( HOUR:MIN:SEC)

73.45 73.41 73.46 73.53 73.53 73.52 73.50 73.54 73.53

LATITUDE ( DEG)

20.57 20.85 20.80 20.45 20.75 21.11 21.45 21.64 21.57

LONGITUDE ( DEG)



NORSEX DATA SET SUMMARY  
DAY 281



PHOTOGRAPHY

5-1

FLIGHT LINES

PRT5

SFMR

AMSCAT (VV POLARIZATION)

AMSCAT (HH POLARIZATION)

08:42:02	08:44:02	08:46:02	08:48:02	08:50:02	08:52:02	08:54:02	08:56:02	08:58:02
GREENWICH MERIDIAN TIME ( HOUR:MIN:SEC)								
73.53	73.52	73.62	73.74	73.86	73.98	74.10	74.22	74.34
LATITUDE ( DEG)								
21.58	21.57	21.66	21.67	21.67	21.66	21.67	21.67	21.67
LONGITUDE ( DEG)								

-146-

NORSEX DATA SET SUMMARY  
DAY 281

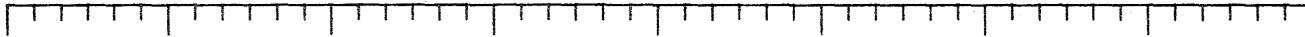

5-1

FLIGHT LINES

PRTS

SFMR

AMSCAT (VV POLARIZATION)

AMSCAT (HH POLARIZATION)

08:58:03	09:00:03	09:02:03	09:04:03	09:06:03	09:08:03	09:10:03	09:12:03	09:14:03
GREENWICH MERIDIAN TIME ( HOUR:MIN:SEC)								
74.34	74.47	74.58	74.71	74.72	74.74	74.75		
LATITUDE ( DEG)								
21.67	21.66	21.66	21.67	21.62	21.61	21.54		
LONGITUDE ( DEG)								

-147-

NORSEX DATA SET SUMMARY  
DAY 281

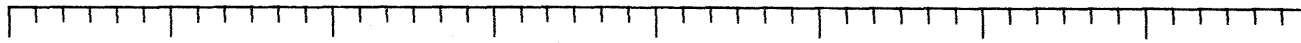

OOOOOOOO OOOOOO

PHOTOGRAPHY

-148-



SFMR

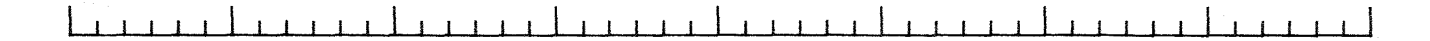

09:14:04 09:16:04 09:18:04 09:20:04 09:22:04 09:24:04 09:26:04 09:28:04 09:30:04

GREENWICH MERIDIAN TIME ( HOUR:MIN:SEC)

	74.97	74.99	75.01
LATITUDE ( DEG)			
	18.68	18.68	18.64
LONGITUDE ( DEG)			

NORSEX DATA SET SUMMARY  
DAY 281

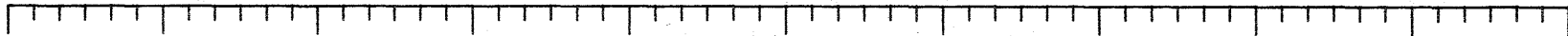

PRT5

SFMR

AMSCAT (VV POLARIZATION)

AMSCAT (HH POLARIZATION)

12:08:50	12:08:50	12:10:50	12:12:50	12:14:50	12:16:50	12:18:50	12:20:50	12:22:50	12:24:50	12:26:50
GREENWICH MERIDIAN TIME ( HOUR:MIN:SEC)										
78.61	78.62	78.73	78.84	78.94	79.06	79.17	79.30	79.43	79.56	79.68
LATITUDE ( DEG)										
14.20	13.85	13.49	13.12	12.74	12.35	11.94	11.49	11.01	10.53	10.02
LONGITUDE ( DEG)										

NORSEX DATA SET SUMMARY  
DAY 281

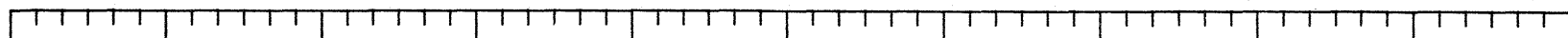

PRT5

SFMR

AMSCAT (VV POLARIZATION)

AMSCAT (HH POLARIZATION)

12:26:51 12:28:51 12:30:51 12:32:51 12:34:51 12:36:51 12:38:51 12:40:51 12:42:51 12:44:51 12:46:51

GREENWICH MERIDIAN TIME ( HOUR:MIN:SEC)

79.68 79.81 79.94 80.06 80.19 80.32 80.45 80.58 80.70 80.83 80.96

LATITUDE (DEG)

10.02 9.50 8.97 8.44 7.85 7.25 6.64 6.01 5.37 4.70 4.13

LONGITUDE (DEG)

-150-

NORSEX DATA SET SUMMARY  
DAY 281

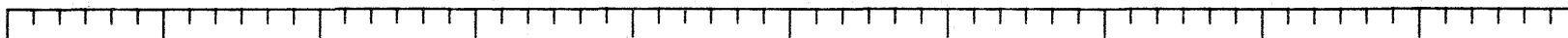

PRT5

SFMR

AMSCAT (VV POLARIZATION)

AMSCAT (HH POLARIZATION)

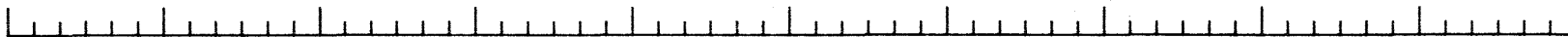

12:46:51 12:48:51 12:50:51 12:52:51 12:54:51 12:56:51 12:58:51 13:00:51 13:02:51 13:04:51 13:06:51

GREENWICH MERIDIAN TIME (HOUR:MIN:SEC)

80.95 81.04 80.99 81.04 81.12 81.20 81.26 81.33 81.40 81.48 81.49

LATITUDE (DEG)

4.13 3.51 3.11 3.44 3.04 2.61 2.22 1.78 1.33 1.06 1.52

LONGITUDE (DEG)

-151-

NORSEX DATA SET SUMMARY  
 DAY 281

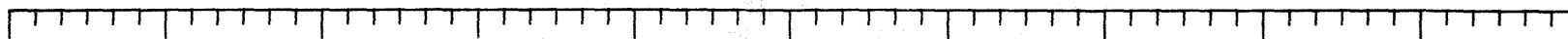

PRT5

SFMR

AMSCAT (VV POLARIZATION)

AMSCAT (HH POLARIZATION)

13:06:52	13:08:52	13:10:52	13:12:52	13:14:52	13:16:52	13:18:52	13:20:52	13:22:52	13:24:52	13:26:52
GREENWICH MERIDIAN TIME (HOUR:MIN:SEC)										
81.49	81.56	81.55	81.48	81.44	81.46	81.40	81.33	81.26	81.17	81.09
LATITUDE (DEG)										
1.52	1.90	2.18	1.76	1.21	1.09	1.39	1.43	1.58	1.63	1.61
LONGITUDE (DEG)										

NORSEX DATA SET SUMMARY  
DAY 281

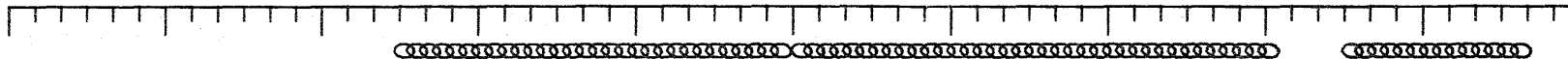

PHOTOGRAPHY

1-1

FLIGHT LINES

PRT5

SFMR

AMSCAT (VV POLARIZATION)

AMSCAT (HH POLARIZATION)

13:28:52	13:28:52	13:30:52	13:32:52	13:34:52	13:36:52	13:38:52	13:40:52	13:42:52	13:44:52	13:46:52
GREENWICH MERIDIAN TIME ( HOUR:MIN:SEC)										
81.09	81.12	81.18	81.24	81.30	81.35	81.42	81.47	81.53	81.59	81.65
LATITUDE ( DEG)										
1.61	1.25	.92	.53	.14	-.26	-.65	-1.04	-1.44	-1.86	-2.28
LONGITUDE ( DEG)										



NORSEX DATA SET SUMMARY  
DAY 281

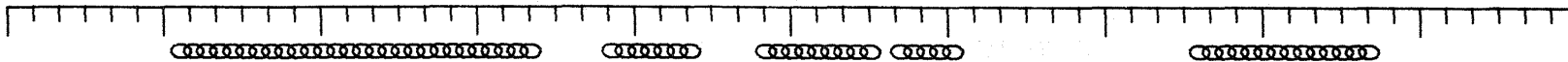

PHOTOGRAPHY

2-1

FLIGHT LINES

PRTS

SFMR

AMSCAT (VV POLARIZATION)

AMSCAT (HH POLARIZATION)

13:46:53	13:48:53	13:50:53	13:52:53	13:54:53	13:56:53	13:58:53	14:00:53	14:02:53	14:04:53	14:06:53
GREENWICH MERIDIAN TIME ( HOUR:MIN:SEC)										
81.65	81.69	81.65	81.59	81.54	81.48	81.43	81.38	81.32	81.26	81.21
LATITUDE ( DEG)										
-2.28	-2.07	-1.65	-1.28	-.90	-.53	-.16	.21	.57	.92	1.27
LONGITUDE ( DEG)										



NORSEX DATA SET SUMMARY  
DAY 281

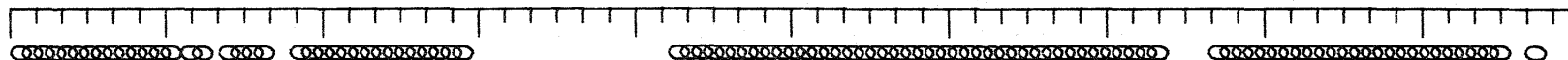

PHOTOGRAPHY

3-1

4-1

FLIGHT LINES

PRTS

SFMR

AMSCAT (VV POLARIZATION)

AMSCAT (HH POLARIZATION)

14:26:54	14:28:54	14:30:54	14:32:54	14:34:54	14:36:54	14:38:54	14:40:54	14:42:54	14:44:54	14:46:54
GREENWICH MERIDIAN TIME ( HOUR:MIN:SEC)										
81.50	81.56	81.62	81.68	81.74	81.69	81.63	81.58	81.52	81.47	81.41
LATITUDE ( DEG)										
-.01	-.40	-.80	-1.20	-1.07	-.67	-.28	.10	.48	.85	1.24
LONGITUDE ( DEG)										

NORSEX DATA SET SUMMARY  
DAY 281

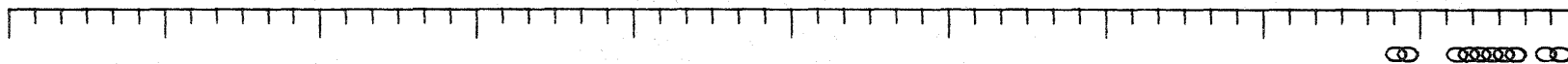

⊙ ⊙⊙⊙⊙⊙⊙ ⊙

PHOTOGRAPHY

4-1

5-1

FLIGHT LINES

PRT5

SFMR

AMSCAT (VV POLARIZATION)

AMSCAT (HH POLARIZATION)

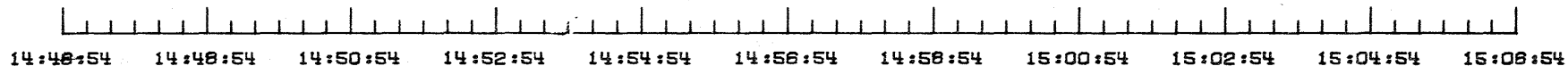

14:46:54 14:48:54 14:50:54 14:52:54 14:54:54 14:56:54 14:58:54 15:00:54 15:02:54 15:04:54 15:06:54

GREENWICH MERIDIAN TIME (HOUR:MIN:SEC)

81.41 81.36 81.30 81.26 81.23 81.29 81.36 81.42 81.48 81.53

LATITUDE (DEG)

1.24 1.58 1.95 2.71 2.70 2.42 2.08 1.70 1.33 .93

LONGITUDE (DEG)

NORSEX DATA SET SUMMARY  
DAY 281

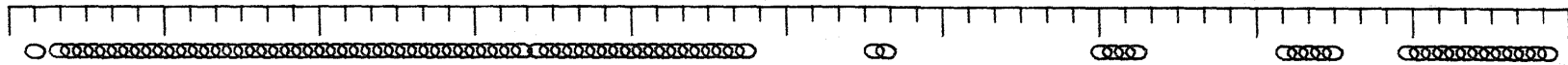

PHOTOGRAPHY

5-1

5-2

FLIGHT LINES

PRT5

SFMR

AMSCAT (VV POLARIZATION)

AMSCAT (HH POLARIZATION)

15:06:55	15:08:55	15:10:55	15:12:55	15:14:55	15:16:55	15:18:55	15:20:55	15:22:55	15:24:55	15:26:55
GREENWICH MERIDIAN TIME (HOUR:MIN:SEC)										
81.53	81.60	81.66	81.72	81.78	81.84	81.89	81.83	81.78	81.72	
LATITUDE (DEG)										
.93	.51	.10	-.32	-.74	-1.18	-1.55	-1.15	-.76	-.36	
LONGITUDE (DEG)										

NORSEX DATA SET SUMMARY  
DAY 281

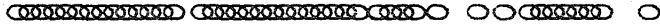
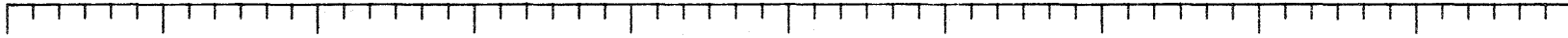

PHOTOGRAPHY

5-2

---

FLIGHT LINES

---

PRTS

---

SFMR

---

-159-

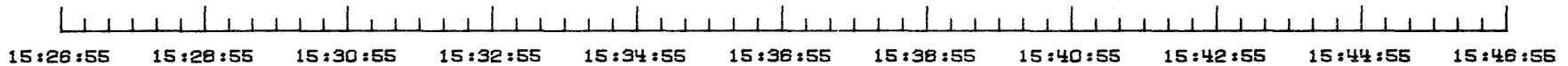

15:26:55	15:28:55	15:30:55	15:32:55	15:34:55	15:36:55	15:38:55	15:40:55	15:42:55	15:44:55	15:46:55
GREENWICH MERIDIAN TIME ( HOUR:MIN:SEC)										
81.72	81.67	81.61	81.55	81.50	81.44	81.38	81.32			
LATITUDE ( DEG)										
-.36	.02	.38	.76	1.14	1.51	1.88	2.25			
LONGITUDE ( DEG)										

NORSEX DATA SET SUMMARY  
DAY 281

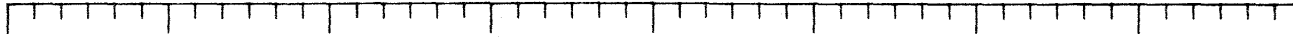

---

PRT5

SFMR

---

-160-



15:46:56    15:48:56    15:50:56    15:52:56    15:54:56    15:56:56    15:58:56    16:00:56    16:02:56

GREENWICH MERIDIAN TIME ( HOUR:MIN:SEC)

81.39    81.45    81.48    81.45    81.42    81.40    81.37

LATITUDE ( DEG)

1.85    1.28    .52    -.05    .53    1.30    2.01

LONGITUDE ( DEG)

DAY 283



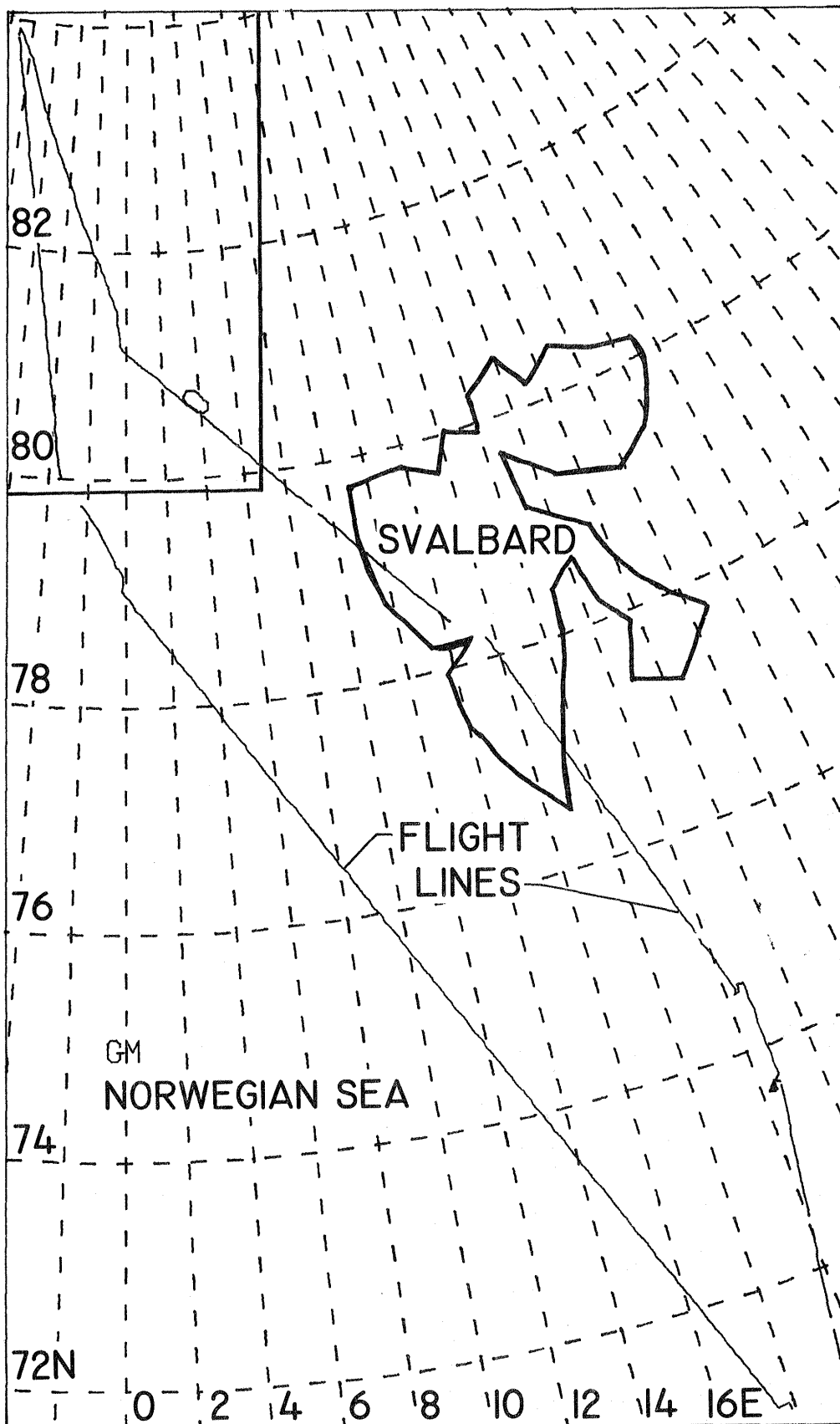

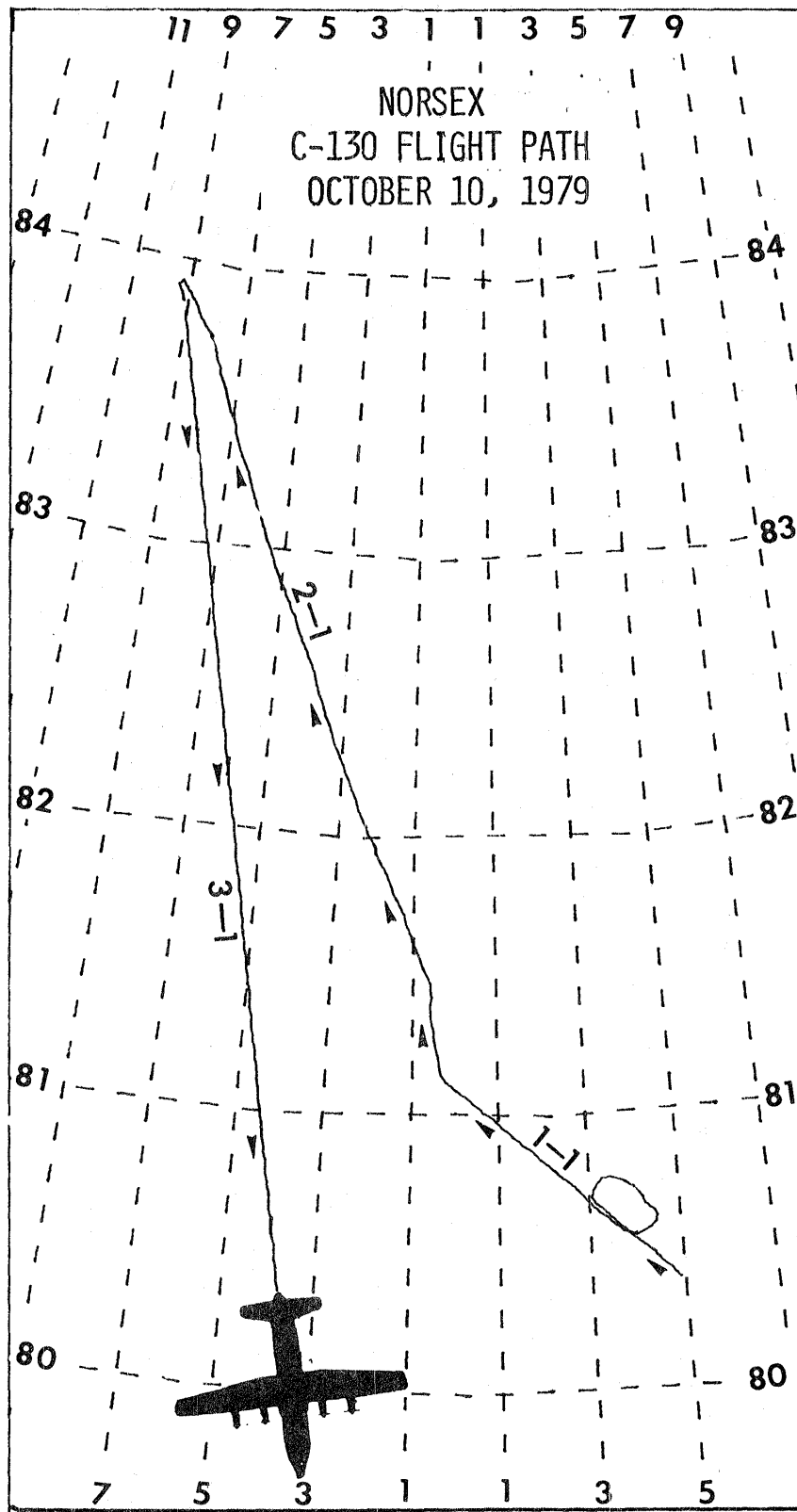

NORSEX DATA SET SUMMARY  
 DAY 283

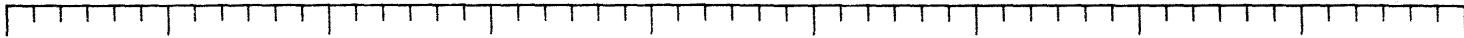

PRT5

SFMR

AMSCAT (VV POLARIZATION)

AMSCAT (VH POLARIZATION)

AMSCAT (HV POLARIZATION)

AMSCAT (HH POLARIZATION)



07:26:05    07:28:05    07:30:05    07:32:05    07:34:05    07:36:05    07:38:05    07:40:05    07:42:05    07:44:05

GREENWICH MERIDIAN TIME ( HOUR:MIN:SEC)

71.21        71.36                    71.66        71.81        71.95        72.10        72.24        72.38        72.52

LATITUDE (DEG)

19.51        19.58                    19.70        19.77        19.83        19.90        19.96        20.03        20.10

LONGITUDE (DEG)

NORSEX DATA SET SUMMARY  
DAY 283

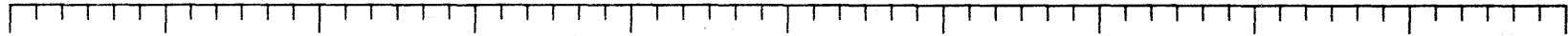

PRT5

SFMR

AMSCAT (VV POLARIZATION)

AMSCAT (VH POLARIZATION)

AMSCAT (HV POLARIZATION)

AMSCAT (HH POLARIZATION)

07:44:06	07:46:06	07:48:06	07:50:06	07:52:06	07:54:06	07:56:06	07:58:06	08:00:06	08:02:06	08:04:06
GREENWICH MERIDIAN TIME (HOUR:MIN:SEC)										
72.52	72.66	72.80	72.94	73.08	73.22	73.36	73.50		73.63	73.66
LATITUDE (DEG)										
20.10	20.16	20.23	20.30	20.37	20.44	20.51	20.59		20.40	20.35
LONGITUDE (DEG)										

NORSEX DATA SET SUMMARY  
DAY 283

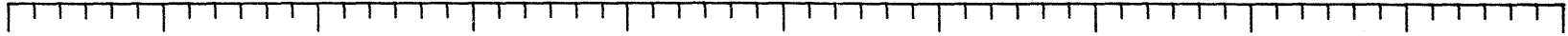

PRT5

SFMR

AMSCAT (VV POLARIZATION)

AMSCAT (HH POLARIZATION)

08:04:06	08:06:06	08:08:06	08:10:06	08:12:06	08:14:06	08:16:06	08:18:06	08:20:06	08:22:06	08:24:06
GREENWICH MERIDIAN TIME (HOUR:MIN:SEC)										
73.65	73.65	73.61	73.71	73.84	73.99	74.13	74.27	74.41	74.55	74.52
LATITUDE (DEG)										
20.35	20.40	20.42	20.65	20.67	20.67	20.67	20.67	20.66	20.67	20.48
LONGITUDE (DEG)										

NORSEX DATA SET SUMMARY  
DAY 263

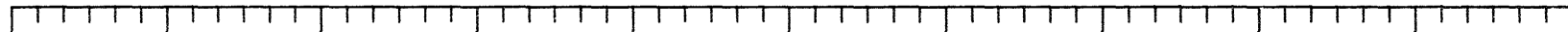

PRT5

SFMR

AMSCAT (VV POLARIZATION)

AMSCAT (VH POLARIZATION)

AMSCAT (HV POLARIZATION)

AMSCAT (HH POLARIZATION)



08:24:07	08:26:07	08:28:07	08:30:07	08:32:07	08:34:07	08:36:07	08:38:07	08:40:07	08:42:07	08:44:07
GREENWICH MERIDIAN TIME ( HOUR:MIN:SEC)										
74.52	74.51	74.52	74.54	74.68	74.81	74.95	75.09	75.23	75.37	75.50
LATITUDE ( DEG)										
20.48	20.33	20.24	20.35	20.22	20.09	19.94	19.79	19.65	19.49	19.34
LONGITUDE ( DEG)										

NORSEX DATA SET SUMMARY  
DAY 283

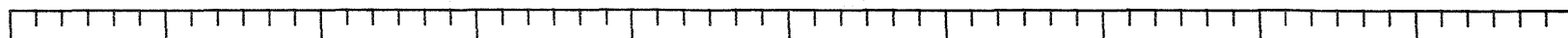

PRT5

SFMR

AMSCAT (VV POLARIZATION)

AMSCAT (HH POLARIZATION)

08:44:07	08:46:07	08:48:07	08:50:07	08:52:07	08:54:07	08:56:07	08:58:07	09:00:07	09:02:07	09:04:07
GREENWICH MERIDIAN TIME ( HOUR:MIN:SEC)										
75.50	75.64	75.78	75.92	76.06	76.19	76.33	76.47	76.61	76.74	76.88
LATITUDE ( DEG)										
18.34	18.18	18.02	18.86	18.69	18.52	18.36	18.18	17.99	17.81	17.62
LONGITUDE ( DEG)										

NORSEX DATA SET SUMMARY  
DAY 283

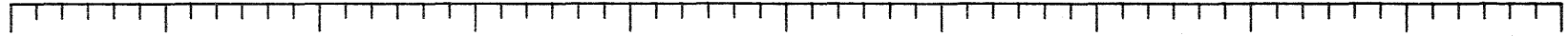

PRT5

SFMR

AMSCAT (VV POLARIZATION)

AMSCAT (HH POLARIZATION)

09:04:08	09:06:08	09:08:08	09:10:08	09:12:08	09:14:08	09:16:08	09:18:08	09:20:08	09:22:08	09:24:08
GREENWICH MERIDIAN TIME ( HOUR:MIN:SEC)										
76.88	77.02	77.16	77.31	77.47	77.62	77.77	77.91	78.04	78.15	
LATITUDE ( DEG)										
17.62	17.42	17.22	17.00	16.78	16.55	16.31	16.09	15.87	15.68	
LONGITUDE ( DEG)										



NORSEX DATA SET SUMMARY  
DAY 283

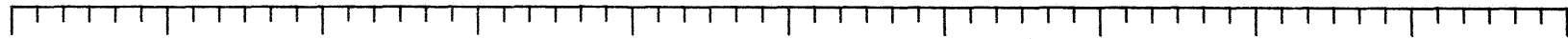

PRT5

SFMR

AMSCAT (VV POLARIZATION)

AMSCAT (VH POLARIZATION)

AMSCAT (HV POLARIZATION)

AMSCAT (HH POLARIZATION)



10:40:58 10:42:58 10:44:58 10:46:58 10:48:58 10:50:58 10:52:58 10:54:58 10:56:58 10:58:58 11:00:58

GREENWICH MERIDIAN TIME (HOUR:MIN:SEC)

78.40 78.50 78.60 78.70 78.80 78.90 79.00 79.10 79.20 79.29 79.39

LATITUDE (DEG)

14.23 13.86 13.48 13.10 12.71 12.31 11.91 11.48 11.06 10.63 10.20

LONGITUDE (DEG)

NORSEX DATA SET SUMMARY  
 DAY 283

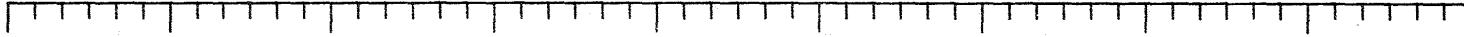

PRTS

SFMR

AMSCAT (VV POLARIZATION)

AMSCAT (VH POLARIZATION)

AMSCAT (HV POLARIZATION)

AMSCAT (HH POLARIZATION)



11:00:58 11:02:58 11:04:58 11:06:58 11:08:58 11:10:58 11:12:58 11:14:58 11:16:58 11:18:58

GREENWICH MERIDIAN TIME (HOUR:MIN:SEC)

79.39 79.49 79.71 79.82 79.92 80.03 80.15 80.26 80.38

LATITUDE (DEG)

10.13 9.74 8.63 8.16 7.61 7.02 6.40 5.73 5.06

LONGITUDE (DEG)

NORSEX DATA SET SUMMARY  
DAY 283

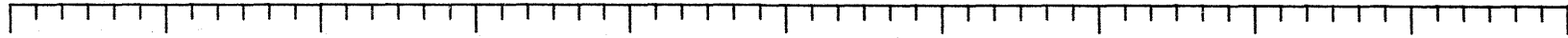

PRT5

SFMR

AMSCAT (VV POLARIZATION)

AMSCAT (VH POLARIZATION)

AMSCAT (HV POLARIZATION)

AMSCAT (HH POLARIZATION)

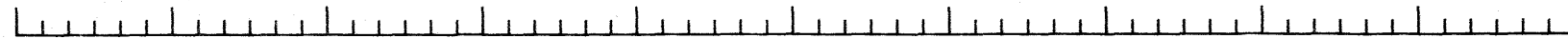

11:18:59	11:20:59	11:22:59	11:24:59	11:26:59	11:28:59	11:30:59	11:32:59	11:34:59	11:36:59	11:38:59
GREENWICH MERIDIAN TIME ( HOUR:MIN:SEC)										
80.38	80.43	80.59	80.70	80.76	80.67	80.61	80.61	80.58	80.57	80.62
LATITUDE ( DEG)										
5.06	4.33	3.73	3.03	3.75	4.23	4.43	4.47	4.13	3.81	3.43
LONGITUDE ( DEG)										

NORSEX DATA SET SUMMARY  
DAY 283

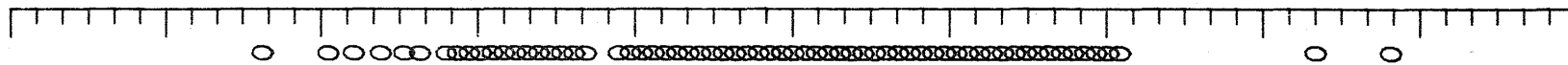

PHOTOGRAPHY

1-1

FLIGHT LINES

PRT5

SFMR

AMSCAT (VV POLARIZATION)

AMSCAT (VH POLARIZATION)

AMSCAT (HH POLARIZATION)

11:38:59	11:40:59	11:42:59	11:44:59	11:46:59	11:48:59	11:50:59	11:52:59	11:54:59	11:56:59	11:58:59
GREENWICH MERIDIAN TIME ( HOUR:MIN:SEC)										
80.62	80.68	80.74	80.79	80.84	80.88	80.93	80.99	81.04	81.08	81.13
LATITUDE ( DEG)										
3.43	3.06	2.73	2.38	2.03	1.68	1.31	.93	.56	.18	-.18
LONGITUDE ( DEG)										

NORSEX DATA SET SUMMARY  
DAY 283

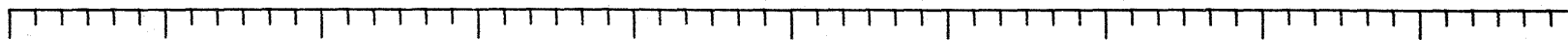

00

PHOTOGRAPHY

1-1

2-1

FLIGHT LINES

PRTS

SFMR

AMSCAT (VV POLARIZATION)

AMSCAT (VH POLARIZATION)

AMSCAT (HH POLARIZATION)

11:59:00 12:01:00 12:03:00 12:05:00 12:07:00 12:09:00 12:11:00 12:13:00 12:15:00 12:17:00 12:19:00

GREENWICH MERIDIAN TIME (HOUR:MIN:SEC)

81.13 81.21 81.30 81.39 81.48 81.56 81.64 81.72 81.79 81.87 81.94

LATITUDE (DEG)

-.18 -.37 -.49 -.56 -.57 -.80 -1.00 -1.23 -1.45 -1.68 -1.94

LONGITUDE (DEG)

NORSEX DATA SET SUMMARY  
DAY 283

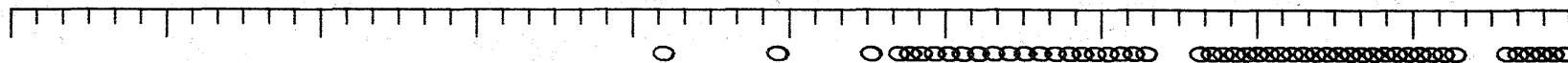

PHOTOGRAPHY

2-1

2-1

FLIGHT LINES

PRT5

SFMR

AMSCAT (VV POLARIZATION)

AMSCAT (VH POLARIZATION)

AMSCAT (HH POLARIZATION)

12:19:00	12:21:00	12:23:00	12:25:00	12:27:00	12:29:00	12:31:00	12:33:00	12:35:00	12:37:00	12:39:00
GREENWICH MERIDIAN TIME (HOUR:MIN:SEC)										
81.94	82.01	82.09	82.16	82.24	82.31	82.39	82.47	82.55	82.62	82.70
LATITUDE (DEG)										
-1.94	-2.18	-2.44	-2.66	-2.88	-3.13	-3.36	-3.58	-3.73	-4.02	-4.28
LONGITUDE (DEG)										

NORSEX DATA SET SUMMARY  
DAY 283

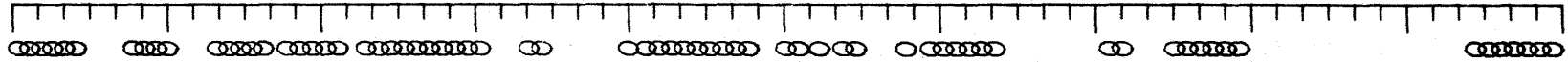

PHOTOGRAPHY

2-1

FLIGHT LINES

PRTS

SFMR

AMSCAT (VV POLARIZATION)

AMSCAT (VH POLARIZATION)

AMSCAT (HH POLARIZATION)

12:39:01	12:41:01	12:43:01	12:45:01	12:47:01	12:49:01	12:51:01	12:53:01	12:55:01	12:57:01	12:59:01
GREENWICH MERIDIAN TIME ( HOUR:MIN:SEC)										
82.70	82.77	82.84	82.91	82.98	83.05	83.12	83.18	83.25	83.32	83.38
LATITUDE ( DEG)										
-4.28	-4.54	-4.80	-5.06	-5.32	-5.56	-5.80	-6.03	-6.26	-6.49	-6.72
LONGITUDE ( DEG)										

NORSEX DATA SET SUMMARY  
DAY 283

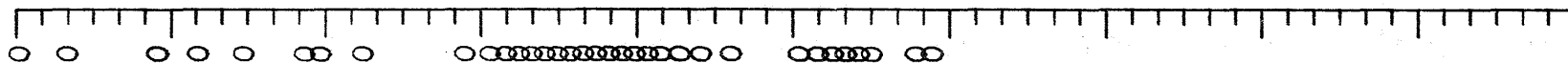

PHOTOGRAPHY

2-1

FLIGHT LINES

PRTS

SFMR

AMSCAT (VV POLARIZATION)

AMSCAT (VH POLARIZATION)

AMSCAT (HH POLARIZATION)

12:59:01	13:01:01	13:03:01	13:05:01	13:07:01	13:09:01	13:11:01	13:13:01	13:15:01	13:17:01	13:19:01
GREENWICH MERIDIAN TIME ( HOUR:MIN:SEC)										
83.38	83.45	83.52	83.58	83.65	83.71	83.77	83.83	83.89	83.93	
LATITUDE (DEG)										
-6.72	-6.95	-7.17	-7.41	-7.67	-7.89	-8.21	-8.56	-8.92	-9.35	
LONGITUDE (DEG)										



NORSEX DATA SET SUMMARY  
DAY 283

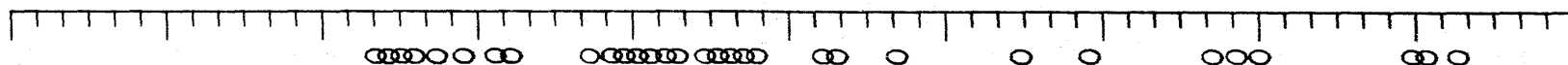

PHOTOGRAPHY

3-1

FLIGHT LINES

PRTS

SFMR

AMSCAT (VV POLARIZATION)

AMSCAT (VH POLARIZATION)

AMSCAT (HH POLARIZATION)

13:19:02 13:21:02 13:23:02 13:25:02 13:27:02 13:29:02 13:31:02 13:33:02 13:35:02 13:37:02 13:39:02

GREENWICH MERIDIAN TIME (HOUR:MIN:SEC)

83.77 83.68 83.59 83.50 83.41 83.32 83.23 83.14 83.06 82.97

LATITUDE (DEG)

-8.88 -8.68 -8.48 -8.29 -8.12 -7.92 -7.74 -7.57 -7.40 -7.24

LONGITUDE (DEG)

NORSEX DATA SET SUMMARY  
DAY 283

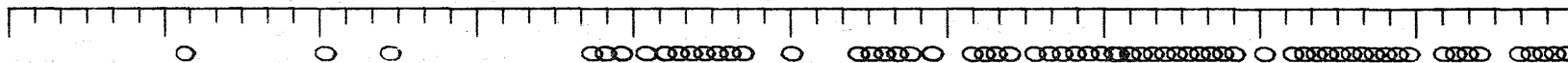

PHOTOGRAPHY

3-1

FLIGHT LINES

PRT5

SFMR

AMSCAT (VV POLARIZATION)

AMSCAT (VH POLARIZATION)

AMSCAT (HH POLARIZATION)

13:39:02 13:41:02 13:43:02 13:45:02 13:47:02 13:49:02 13:51:02 13:53:02 13:55:02 13:57:02 13:59:02

GREENWICH MERIDIAN TIME (HOUR:MIN:SEC)

82.97 82.88 82.79 82.70 82.62 82.54 82.46 82.38 82.30 82.22 82.15

LATITUDE (DEG)

-7.24 -7.07 -6.92 -6.77 -6.62 -6.50 -6.37 -6.26 -6.14 -6.00 -5.83

LONGITUDE (DEG)

NORSEX DATA SET SUMMARY  
DAY 283

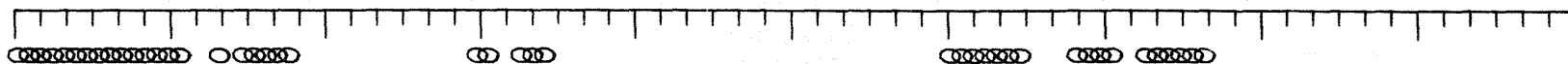

PHOTOGRAPHY

3-1

3-1

FLIGHT LINES

PRT5

SFMR

AMSCAT (VV POLARIZATION)

AMSCAT (VH POLARIZATION)

AMSCAT (HH POLARIZATION)

13:59:03	14:01:03	14:03:03	14:05:03	14:07:03	14:09:03	14:11:03	14:13:03	14:15:03	14:17:03	14:19:03
GREENWICH MERIDIAN TIME ( HOUR:MIN:SEC)										
82.15	82.07	82.00	81.92	81.84	81.76	81.69	81.61	81.54	81.46	81.39
LATITUDE (DEG)										
-5.89	-5.79	-5.69	-5.58	-5.47	-5.37	-5.28	-5.18	-5.09	-4.99	-4.89
LONGITUDE (DEG)										

NORSEX DATA SET SUMMARY  
DAY 283

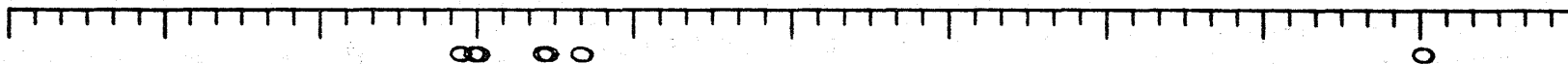

PHOTOGRAPHY

3-1

FLIGHT LINES

PRTS

SFMR

AMSCAT (VV POLARIZATION)

AMSCAT (VH POLARIZATION)

AMSCAT (HH POLARIZATION)

14:19:03	14:21:03	14:23:03	14:25:03	14:27:03	14:29:03	14:31:03	14:33:03	14:35:03	14:37:03	14:39:03
GREENWICH MERIDIAN TIME ( HOUR:MIN:SEC)										
81.33	81.30	81.22	81.14	81.06	80.98	80.90	80.83	80.75	80.67	80.60
LATITUDE ( DEG)										
-4.63	-4.60	-4.70	-4.60	-4.52	-4.43	-4.34	-4.26	-4.17	-4.10	-4.01
LONGITUDE ( DEG)										

NORSEX DATA SET SUMMARY  
DAY 283

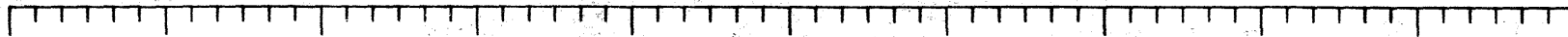

PHOTOGRAPHY

3-1

FLIGHT LINES

PRTS

SFMR

AMSCAT (VV POLARIZATION)

AMSCAT (VH POLARIZATION)

AMSCAT (HH POLARIZATION)

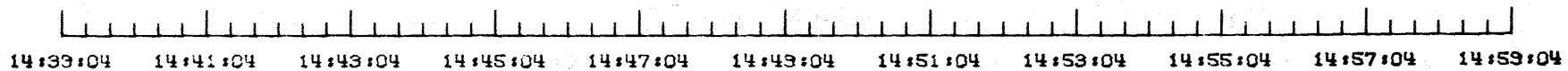

GREENWICH MERIDIAN TIME ( HOUR:MIN:SEC)

80.60 80.53 80.45 80.39 80.32 80.25 80.19 80.12 80.06 80.00

LATITUDE ( DEG)

-4.01 -3.93 -3.88 -3.83 -3.78 -3.68 -3.63 -3.56 -3.50 -3.30

LONGITUDE ( DEG)

NORSEX DATA SET SUMMARY  
DAY 283

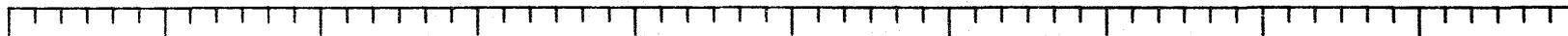

---

PRTS

-183-

14:59:04	15:01:04	15:03:04	15:05:04	15:07:04	15:09:04	15:11:04	15:13:04	15:15:04	15:17:04	15:19:04
GREENWICH MERIDIAN TIME ( HOUR:MIN:SEC )										
79.71	79.61	79.51	79.42	79.32	79.23	79.14	79.04			
LATITUDE ( DEG )										
-1.38	-1.60	-1.30	-.38	-.68	-.45	-.17	-.25			
LONGITUDE ( DEG )										

NORSEX DATA SET SUMMARY  
DAY 283

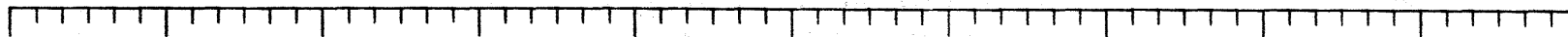

PRTS

SFMR

AMSCAT (VV POLARIZATION)

AMSCAT (VH POLARIZATION)

AMSCAT (HV POLARIZATION)

AMSCAT (HH POLARIZATION)

15:19:05 15:21:05 15:23:05 15:25:05 15:27:05 15:29:05 15:31:05 15:33:05 15:35:05 15:37:05 15:39:05

GREENWICH MERIDIAN TIME ( HOUR:MIN:SEC)

79.04 78.95 78.85 78.75 78.65 78.54 78.42 78.31 78.19 78.07 77.95

LATITUDE ( DEG)

-.25 .06 .48 .30 1.30 1.72 2.15 2.55 2.96 3.38 3.79

LONGITUDE ( DEG)

NORSEX DATA SET SUMMARY  
DAY 283



PRT5

SFMR

AMSCAT (VV POLARIZATION)

AMSCAT (VH POLARIZATION)

AMSCAT (HV POLARIZATION)

AMSCAT (HH POLARIZATION)

15:39:05	15:41:05	15:43:05	15:45:05	15:47:05	15:49:05	15:51:05	15:53:05	15:55:05	15:57:05	15:59:05
GREENWICH MERIDIAN TIME ( HOUR:MIN:SEC)										
77.95	77.83	77.70	77.58	77.45	77.33	77.19	77.06	76.92	76.78	76.63
LATITUDE ( DEG)										
3.73	4.20	4.53	4.98	5.36	5.74	6.12	6.50	6.88	7.27	7.64
LONGITUDE ( DEG)										



NORSEX DATA SET SUMMARY  
DAY 283

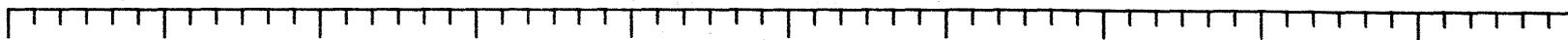

PRT5

SFMR

AMSCAT (VV POLARIZATION)

AMSCAT (VH POLARIZATION)

AMSCAT (HV POLARIZATION)

AMSCAT (HH POLARIZATION)

15:59:06 16:01:06 16:03:06 16:05:06 16:07:06 16:09:06 16:11:06 16:13:06 16:15:06 16:17:06 16:19:06

GREENWICH MERIDIAN TIME (HOUR:MIN:SEC)

76.63 76.49 76.34 76.19 76.05 75.90 75.75 75.60 75.45 75.30 75.15

LATITUDE (DEG)

7.65 8.02 8.33 8.75 9.03 9.44 9.77 10.10 10.43 10.75 11.05

LONGITUDE (DEG)

NORSEX DATA SET SUMMARY  
DAY 283

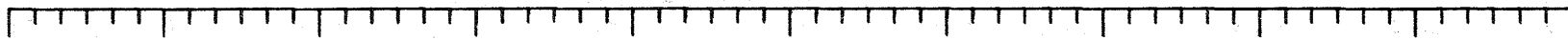

PRTS

SFMR

AMSCAT (VV POLARIZATION)

AMSCAT (VH POLARIZATION)

AMSCAT (HV POLARIZATION)

AMSCAT (HH POLARIZATION)

16:19:06	16:21:06	16:23:06	16:25:06	16:27:06	16:29:06	16:31:06	16:33:06	16:35:06	16:37:06	16:39:06
GREENWICH MERIDIAN TIME ( HOUR:MIN:SEC)										
75.15	75.00	74.85	74.70	74.55	74.40	74.25	74.09	73.94	73.79	73.64
LATITUDE ( DEG)										
11.05	11.35	11.66	11.95	12.24	12.52	12.79	13.05	13.32	13.58	13.83
LONGITUDE ( DEG)										

NORSEX DATA SET SUMMARY  
DAY 283

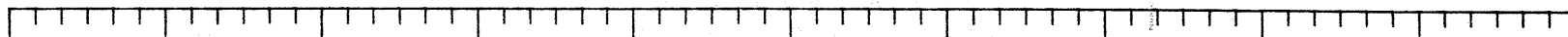

PRT5

SFMR

AMSCAT (VV POLARIZATION)

AMSCAT (VH POLARIZATION)

AMSCAT (HV POLARIZATION)

AMSCAT (HH POLARIZATION)

16:39:07 16:41:07 16:43:07 16:45:07 16:47:07 16:49:07 16:51:07 16:53:07 16:55:07 16:57:07 16:59:07

GREENWICH MERIDIAN TIME (HOUR:MIN:SEC)

73.64 73.49 73.34 73.19 73.04 72.89 72.74 72.59 72.44 72.29 72.14

LATITUDE (DEG)

13.83 14.07 14.31 14.55 14.78 15.01 15.23 15.45 15.67 15.88 16.09

LONGITUDE (DEG)

NORSEX DATA SET SUMMARY  
 DAY 283

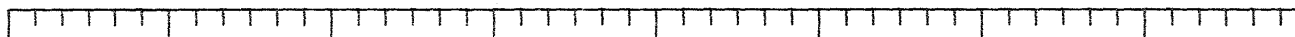

PRT5

SFMR

AMSCAT (VV POLARIZATION)

AMSCAT (VH POLARIZATION)

AMSCAT (HV POLARIZATION)

AMSCAT (HH POLARIZATION)

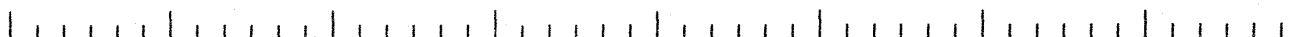

16:59:07	17:01:07	17:03:07	17:05:07	17:07:07	17:09:07	17:11:07	17:13:07	17:15:07
GREENWICH MERIDIAN TIME ( HOUR:MIN:SEC)								
72.14	71.98	71.83	71.67	71.51	71.35	71.19	71.04	
LATITUDE ( DEG)								
16.10	16.30	16.50	16.71	16.31	17.11	17.31	17.50	
LONGITUDE ( DEG)								

DAY 285

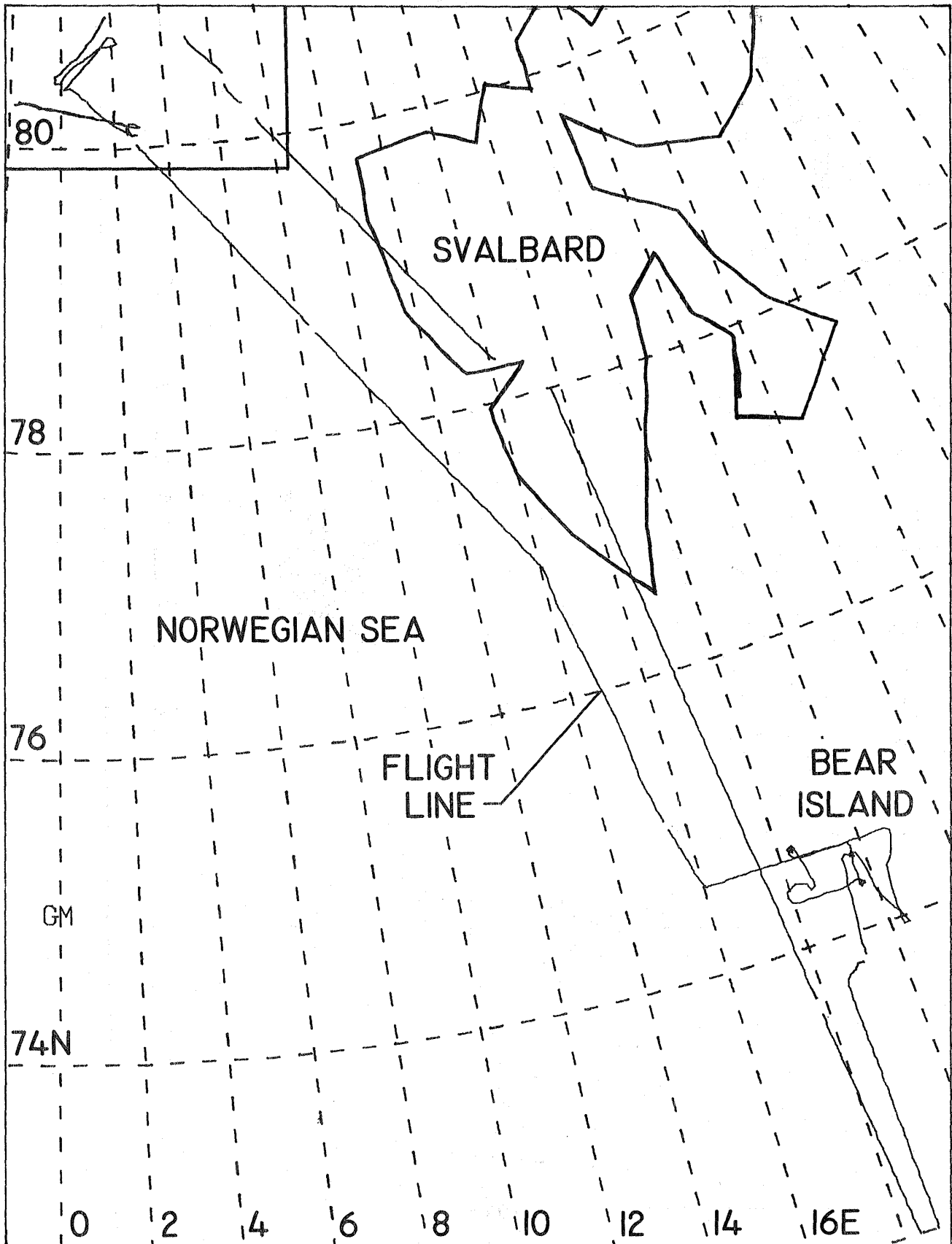

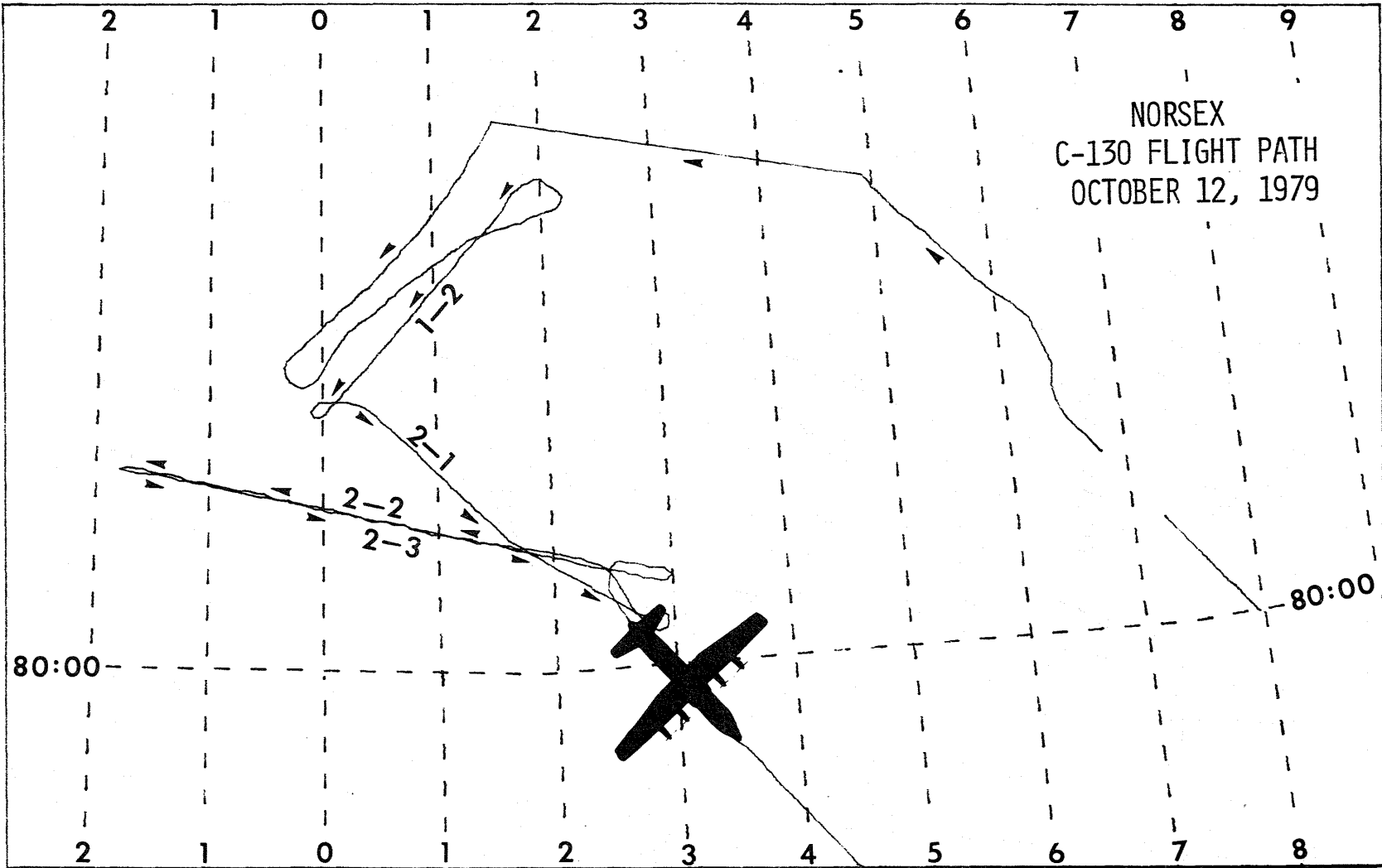

NORSEX DATA SET SUMMARY  
DAY 285

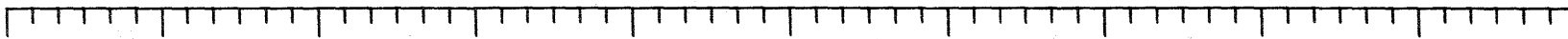

PRT5

SFMR

AMSCAT (VV POLARIZATION)

AMSCAT (VH POLARIZATION)

AMSCAT (HV POLARIZATION)

AMSCAT (HH POLARIZATION)

09:24:46 09:26:46 09:28:46 09:30:46 09:32:46 09:34:46 09:36:46 09:38:46 09:40:46 09:42:46 09:44:46

GREENWICH MERIDIAN TIME ( HOUR:MIN:SEC)

72.00 72.15 72.29 72.43 72.57 72.71 72.86 73.00 73.15 73.30 73.44

LATITUDE ( DEG)

18.34 18.30 18.25 18.22 18.17 18.12 18.07 18.03 17.98 17.92 17.87

LONGITUDE ( DEG)



NORSEX DATA SET SUMMARY  
DAY 285

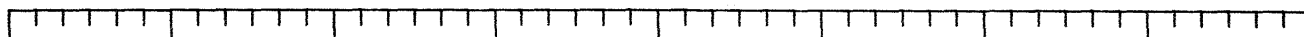

-194-

---

PRT5

---



---

SFMR

---



---

AMSCAT (VV POLARIZATION)

---



---

AMSCAT (VH POLARIZATION)

---



---

AMSCAT (HV POLARIZATION)

---



---

AMSCAT (HH POLARIZATION)

---



09:44:46	09:46:46	09:48:46	09:50:46	09:52:46	09:54:46	09:56:46	09:58:46	10:00:46
GREENWICH MERIDIAN TIME (HOUR:MIN:SEC)								
73.44	73.74	73.83	74.03	74.18	74.32	74.47	74.61	
LATITUDE (DEG)								
17.87	17.77	17.71	17.66	17.60	17.55	17.43	17.42	
LONGITUDE (DEG)								

NORSEX DATA SET SUMMARY  
 DAY 285

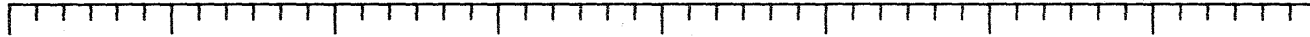

-195-

PRTS

SFMR

AMSCAT (VV POLARIZATION)

AMSCAT (HH POLARIZATION)



10:00:47	10:02:47	10:04:47	10:06:47	10:08:47	10:10:47	10:12:47	10:14:47	10:16:47
GREENWICH MERIDIAN TIME ( HOUR:MIN:SEC)								
74.61	74.76	74.90	75.04	75.19	75.33	75.48	75.62	75.76
LATITUDE ( DEG)								
17.43	17.38	17.31	17.25	17.19	17.13	17.06	16.99	16.93
LONGITUDE ( DEG)								

NORSEX DATA SET SUMMARY  
DAY 285

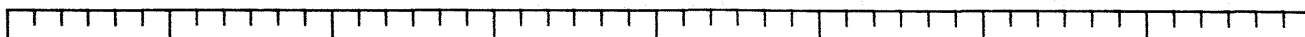

-196-

---

PRTS

---

SFMR

---

AMSCAT (VV POLARIZATION)

---

AMSCAT (HH POLARIZATION)



10:16:47	10:18:47	10:20:47	10:22:47	10:24:47	10:26:47	10:28:47	10:30:47	10:32:47
GREENWICH MERIDIAN TIME (HOUR:MIN:SEC)								
75.76	75.90	76.04	76.18	76.32	76.47	76.62	76.76	76.91
LATITUDE (DEG)								
16.93	16.88	16.79	16.72	16.65	16.58	16.50	16.42	16.34
LONGITUDE (DEG)								

NORSEX DATA SET SUMMARY  
DAY 285

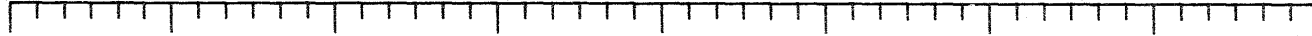

-197-

PRT5

SFMR

AMSCAT (VV POLARIZATION)

AMSCAT (HH POLARIZATION)



10:32:48	10:34:48	10:36:48	10:38:48	10:40:48	10:42:48	10:44:48	10:46:48	10:48:48
GREENWICH MERIDIAN TIME (HOUR:MIN:SEC)								
76.91	77.04	77.18	77.31	77.45	77.58	77.71	77.84	77.97
LATITUDE (DEG)								
16.34	16.27	16.19	16.11	16.03	15.95	15.86	15.78	15.69
LONGITUDE (DEG)								

NORSEX DATA SET SUMMARY  
DAY 285

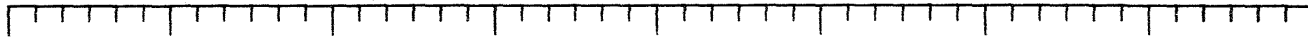

-198-

-----  
PRTS

-----  
SFMR

-----  
AMSCAT (VV POLARIZATION)

-----  
AMSCAT (HH POLARIZATION)

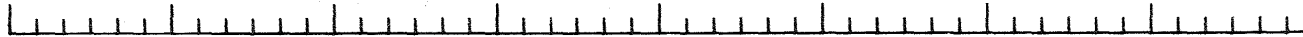

12:13:25	12:15:25	12:17:25	12:19:25	12:21:25	12:23:25	12:25:25	12:27:25	12:29:25
GREENWICH MERIDIAN TIME (HOUR:MIN:SEC)								
78.27	78.36	78.46	78.56	78.66	78.76	78.86	78.96	79.07
LATITUDE (DEG)								
14.18	13.88	13.56	13.25	12.94	12.61	12.27	11.93	11.59
LONGITUDE (DEG)								

NORSEX DATA SET SUMMARY  
DAY 285

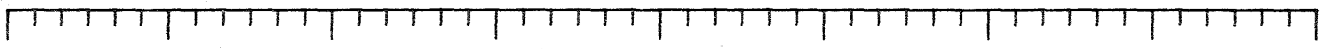

-199-

PRTS

SFMR

AMSCAT (VV POLARIZATION)

AMSCAT (VH POLARIZATION)

AMSCAT (HV POLARIZATION)

AMSCAT (HH POLARIZATION)

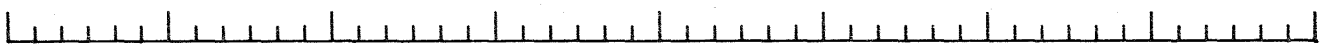

12:29:25	12:31:25	12:33:25	12:35:25	12:37:25	12:39:25	12:41:25	12:43:25	12:45:25
GREENWICH MERIDIAN TIME (HOUR:MIN:SEC)								
79.07	79.17	79.27	79.38	79.49	79.61	79.72	79.83	79.95
LATITUDE (DEG)								
11.58	11.23	10.86	10.46	10.03	9.58	9.13	8.67	8.17
LONGITUDE (DEG)								

NORSEX DATA SET SUMMARY  
DAY 285

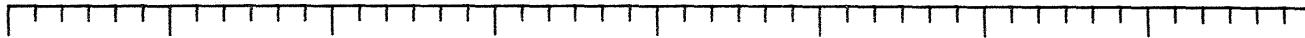

PRT5

SFMR

-200-

AMSCAT (VV POLARIZATION)

AMSCAT (VH POLARIZATION)

AMSCAT (HV POLARIZATION)

AMSCAT (HH POLARIZATION)

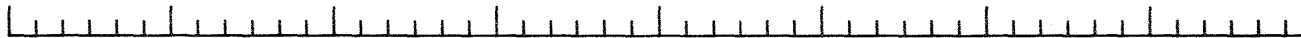

12:45:26    12:47:26    12:49:26    12:51:26    12:53:26    12:55:26    12:57:26    12:59:26    13:01:26

GREENWICH MERIDIAN TIME (HOUR:MIN:SEC)

79.95      80.08                    80.32      80.46      80.56      80.66

LATITUDE (DEG)

8.17      7.64                    6.55      6.34      5.75      5.16

LONGITUDE (DEG)

NORSEX DATA SET SUMMARY  
DAY 285

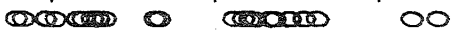

PHOTOGRAPHY

PRTS

SFMR

AMSCAT (VV POLARIZATION)

AMSCAT (HH POLARIZATION)



13:15:04 13:17:04 13:19:04 13:21:04 13:23:04 13:25:04 13:27:04 13:29:04 13:31:04 13:33:04 13:35:04

GREENWICH MERIDIAN TIME (HOUR:MIN:SEC)

80.86 80.76 80.67 80.58 80.51 80.43 80.50 80.55 80.60 80.64 80.66

LATITUDE (DEG)

1.76 1.38 .96 .49 -.01 -.24 .17 .53 .36 1.35 1.82

LONGITUDE (DEG)



NORSEX DATA SET SUMMARY  
DAY 285

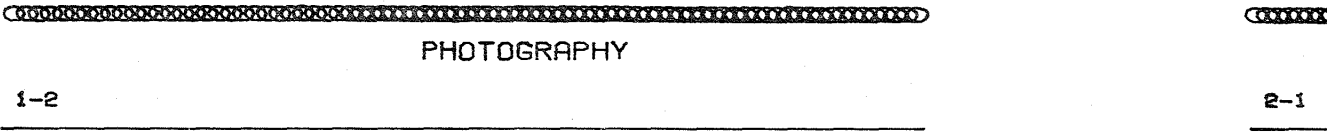
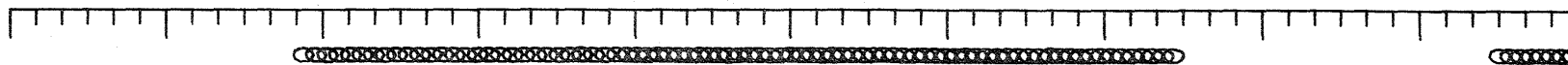

FLIGHT LINES

PRTS

SFMR

AMSCAT (VV POLARIZATION)

AMSCAT (HH POLARIZATION)

13:35:04	13:37:04	13:39:04	13:41:04	13:43:04	13:45:04	13:47:04	13:49:04	13:51:04	13:53:04	13:55:04
GREENWICH MERIDIAN TIME ( HOUR:MIN:SEC)										
80.66	80.70	80.72	80.66	80.60	80.54	80.48	80.42	80.40	80.40	80.34
LATITUDE ( DEG)										
1.82	2.21	1.84	1.50	1.17	.82	.50	.18	-.10	.35	.72
LONGITUDE ( DEG)										

NORSEX DATA SET SUMMARY  
DAY 285

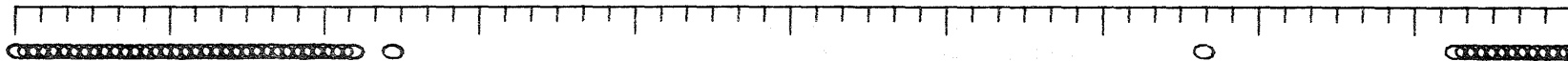

PHOTOGRAPHY

2-1

2-2

FLIGHT LINES

PRT5

SFMR

AMSCAT (VV POLARIZATION)

AMSCAT (VH POLARIZATION)

AMSCAT (HV POLARIZATION)

AMSCAT (HH POLARIZATION)

13:55:05	13:57:05	13:59:05	14:01:05	14:03:05	14:05:05	14:07:05	14:09:05	14:11:05	14:13:05	14:15:05
GREENWICH MERIDIAN TIME (HOUR:MIN:SEC)										
80.34	80.28	80.22	80.17	80.13	80.09	80.06	80.10	80.16	80.18	80.19
LATITUDE (DEG)										
.72	1.08	1.45	1.83	2.24	2.65	2.91	2.62	2.42	2.02	1.62
LONGITUDE (DEG)										

-203-

NORSEX DATA SET SUMMARY  
DAY 285

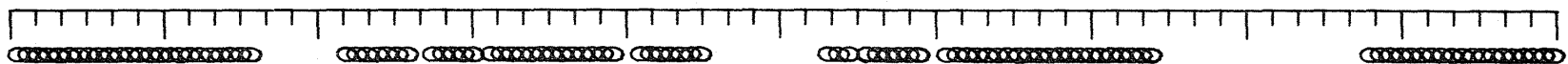

PHOTOGRAPHY

2-2

2-2

2-3

FLIGHT LINES

PRT5

SFMR

AMSCAT (VV POLARIZATION)

AMSCAT (VH POLARIZATION)

AMSCAT (HH POLARIZATION)

14:15:05	14:17:05	14:19:05	14:21:05	14:23:05	14:25:05	14:27:05	14:29:05	14:31:05	14:33:05	14:35:05
GREENWICH MERIDIAN TIME ( HOUR:MIN:SEC)										
80.13	80.20	80.22	80.24	80.25	80.26	80.28	80.29	80.30	80.28	
LATITUDE ( DEG)										
1.62	1.18	.76	.34	-.08	-.50	-.91	-1.33	-1.52	-1.05	
LONGITUDE ( DEG)										

-204-

NORSEX DATA SET SUMMARY  
DAY 265

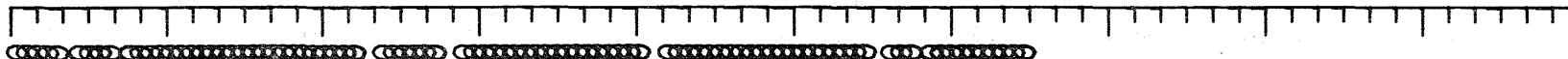

PHOTOGRAPHY

2-3

FLIGHT LINES

PRT5

SFMR

AMSCAT (VV POLARIZATION)

AMSCAT (HH POLARIZATION)

14:35:06	14:37:06	14:39:06	14:41:06	14:43:06	14:45:06	14:47:06	14:49:06	14:51:06	14:53:06	14:55:06
GREENWICH MERIDIAN TIME ( HOUR:MIN:SEC)										
80.28	80.27	80.25	80.23	80.22	80.20	80.18	80.16	80.14	80.15	80.16
LATITUDE ( DEG)										
-1.04	-.57	-.10	.37	.83	1.29	1.75	2.24	2.68	2.93	2.51
LONGITUDE ( DEG)										

NORSEX DATA SET SUMMARY  
DAY 285

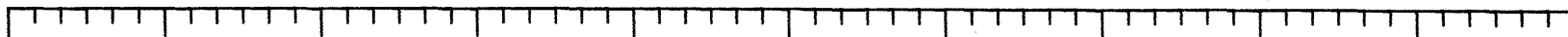

PRTS

SFMR

AMSCAT (VV POLARIZATION)

AMSCAT (HH POLARIZATION)

14:55:06 14:57:06 14:59:06 15:01:06 15:03:06 15:05:06 15:07:06 15:09:06 15:11:06 15:13:06 15:15:06

GREENWICH MERIDIAN TIME ( HOUR:MIN:SEC)

80.16 79.97 79.87 79.77 79.67 79.57 79.46 79.34 79.23 79.11

LATITUDE ( DEG)

2.51 3.08 3.55 4.01 4.49 4.97 5.46 5.95 6.45 6.92

LONGITUDE ( DEG)

NORSEX DATA SET SUMMARY  
 DAY 285

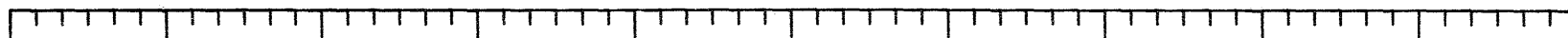

PRTS

SFMR

AMSCAT (VV POLARIZATION)

AMSCAT (HH POLARIZATION)

15:15:07	15:17:07	15:19:07	15:21:07	15:23:07	15:25:07	15:27:07	15:29:07	15:31:07	15:33:07	15:35:07
GREENWICH MERIDIAN TIME ( HOUR:MIN:SEC)										
79.11	78.99	78.86	78.74	78.62	78.48	78.35	78.21	78.07	77.93	77.79
LATITUDE ( DEG)										
6.93	7.40	7.87	8.33	8.78	9.25	9.72	10.18	10.62	11.06	11.49
LONGITUDE ( DEG)										

NORSEX DATA SET SUMMARY  
DAY 285

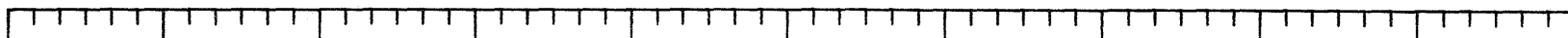

PRTS

SFMR

AMSCAT (VV POLARIZATION)

AMSCAT (HH POLARIZATION)

15:35:07	15:37:07	15:39:07	15:41:07	15:43:07	15:45:07	15:47:07	15:49:07	15:51:07	15:53:07	15:55:07
GREENWICH MERIDIAN TIME (HOUR:MIN:SEC)										
77.79	77.65	77.51	77.37	77.23	77.09	76.95	76.80	76.63	76.46	76.29
LATITUDE (DEG)										
11.49	11.91	12.31	12.71	13.10	13.48	13.85	14.12	14.21	14.40	14.56
LONGITUDE (DEG)										

NORSEX DATA SET SUMMARY  
DAY 285

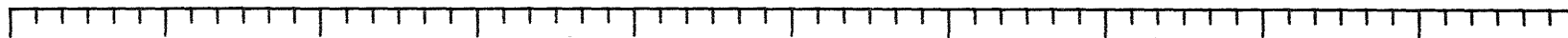

PRTS

SFMR

AMSCAT (VV POLARIZATION)

AMSCAT (HH POLARIZATION)

15:55:08 15:57:08 15:59:08 16:01:08 16:03:08 16:05:08 16:07:08 16:09:08 16:11:08 16:13:08 16:15:08

GREENWICH MERIDIAN TIME (HOUR:MIN:SEC)

76.28 76.12 75.95 75.79 75.63 75.46 75.31 75.17 74.92 74.82

LATITUDE (DEG)

14.56 14.70 14.86 15.00 15.09 15.16 15.24 15.39 15.66 15.77

LONGITUDE (DEG)



NORSEX DATA SET SUMMARY  
DAY 285

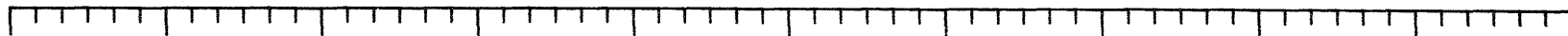

1-1

FLIGHT LINES

PRTS

SFMR

AMSCAT (VV POLARIZATION)

AMSCAT (HH POLARIZATION)

16:15:08 16:17:08 16:19:08 16:21:08 16:23:08 16:25:08 16:27:08 16:29:08 16:31:08 16:33:08 16:35:08

GREENWICH MERIDIAN TIME (HOUR:MIN:SEC)

74.82 74.71 74.61 74.58 74.59 74.59 74.59 74.59 74.59 74.59 74.58

LATITUDE (DEG)

15.76 15.88 16.00 16.34 16.75 17.17 17.58 17.99 18.40 18.81 19.23

LONGITUDE (DEG)

NORSEX DATA SET SUMMARY  
DAY 285

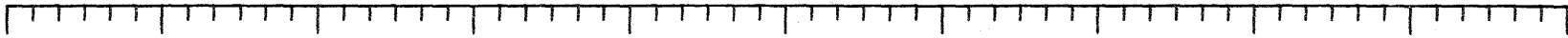

1-1

2-1

3-1

FLIGHT LINES

PRT5

SFMR

AMSCAT (VV POLARIZATION)

AMSCAT (HH POLARIZATION)



16:35:09	16:37:09	16:39:09	16:41:09	16:43:09	16:45:09	16:47:09	16:49:09	16:51:09	16:53:09	16:55:09
GREENWICH MERIDIAN TIME (HOUR:MIN:SEC)										
74.58	74.58	74.48	74.37	74.27	74.28	74.28	74.32	74.32	74.30	74.30
LATITUDE (DEG)										
19.23	19.65	19.69	19.67	19.73	19.72	19.69	19.69	19.51	19.08	18.64
LONGITUDE (DEG)										

NORSEX DATA SET SUMMARY  
DAY 285

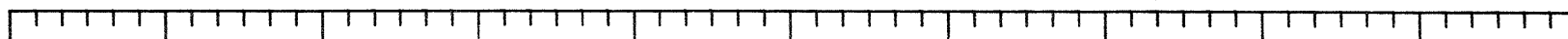

3-1

5-1

FLIGHT LINES

PRT5

SFMR

AMSCAT (VV POLARIZATION)

AMSCAT (HH POLARIZATION)

16:55:09	16:57:09	16:59:09	17:01:09	17:03:09	17:05:09	17:07:09	17:09:09	17:11:09	17:13:09	17:15:09
GREENWICH MERIDIAN TIME ( HOUR:MIN:SEC)										
74.30	74.30	74.36	74.42	74.35	74.43	74.55	74.66	74.66	74.66	74.67
LATITUDE ( DEG)										
18.64	18.19	17.91	18.21	18.48	18.59	18.50	18.35	18.30	18.28	18.29
LONGITUDE ( DEG)										

NORSEX DATA SET SUMMARY  
DAY 285



6-1

7-1

FLIGHT LINES

PRTS

SFMR

AMSCAT (VV POLARIZATION)

AMSCAT (HH POLARIZATION)

17:15:10	17:17:10	17:19:10	17:21:10	17:23:10	17:25:10	17:27:10	17:29:10	17:31:10	17:33:10	17:35:10
GREENWICH MERIDIAN TIME (HOUR:MIN:SEC)										
74.67	74.58	74.58	74.58	74.58	74.58	74.58	74.55	74.44	74.34	74.23
LATITUDE (DEG)										
18.29	18.33	18.76	19.21	19.59	20.01	20.44	20.76	20.64	20.40	20.34
LONGITUDE (DEG)										

NORSEX DATA SET SUMMARY  
DAY 285

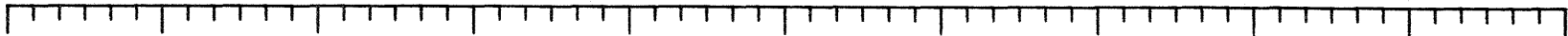

7-1

8-1

FLIGHT LINES

PRT5

SFMR

AMSCAT (VV POLARIZATION)

AMSCAT (HH POLARIZATION)

17:35:10	17:37:10	17:39:10	17:41:10	17:43:10	17:45:10	17:47:10	17:49:10	17:51:10	17:53:10	17:55:10
GREENWICH MERIDIAN TIME ( HOUR:MIN:SEC)										
74.23	74.12	74.01	73.96	74.07	74.17	74.23	74.42	74.43	74.50	74.49
LATITUDE ( DEG)										
20.34	20.31	20.30	20.44	20.25	20.03	19.95	19.88	19.68	19.66	19.64
LONGITUDE ( DEG)										

NORSEX DATA SET SUMMARY  
DAY 285

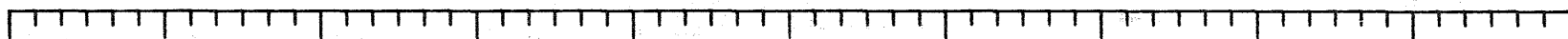

9-1

FLIGHT LINES

PRTS

SFMR

AMSCAT (VV POLARIZATION)

AMSCAT (HH POLARIZATION)

17:55:11	17:57:11	17:59:11	18:01:11	18:03:11	18:05:11	18:07:11	18:09:11	18:11:11	18:13:11	18:15:11
GREENWICH MERIDIAN TIME ( HOUR:MIN:SEC)										
74.49	74.51	74.42	74.30	74.19	74.08	73.96	73.85	73.73	73.70	73.59
LATITUDE ( DEG)										
19.64	19.57	19.43	19.37	19.33	19.29	19.26	19.23	18.91	18.61	18.61
LONGITUDE ( DEG)										

NORSEX DATA SET SUMMARY  
DAY 285

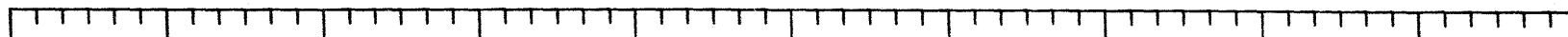

---

PRT5

---



---

SFMR

---



---

AMSCAT (VV POLARIZATION)

---



---

AMSCAT (HH POLARIZATION)

---

18:15:11	18:17:11	18:19:11	18:21:11	18:23:11	18:25:11	18:27:11	18:29:11	18:31:11	18:33:11	18:35:11
GREENWICH MERIDIAN TIME (HOUR:MIN:SEC)										
73.58	73.47	73.34	73.22	73.09	72.94	72.77	72.61	72.44	72.28	72.11
LATITUDE (DEG)										
18.62	18.62	18.64	18.65	18.68	18.67	18.68	18.70	18.72	18.74	18.74
LONGITUDE (DEG)										

1. Report No. NASA CR-165967		2. Government Accession No.		3. Recipient's Catalog No.	
4. Title and Subtitle NORSEX 79 Microwave Remote Sensing Data Summary Report September 29 - October 12, 1979				5. Report Date May 1982	
				6. Performing Organization Code	
7. Author(s) Harold F. Hennigar Sally K. Schaffner				8. Performing Organization Report No.	
				10. Work Unit No.	
9. Performing Organization Name and Address The Bionetics Corporation 18 Research Drive Hampton, Virginia 23666				11. Contract or Grant No. NAS1-16978	
				13. Type of Report and Period Covered Contractor Report	
12. Sponsoring Agency Name and Address National Aeronautics & Space Administration Washington, D. C. 20546				14. Sponsoring Agency Code	
15. Supplementary Notes  Langley Technical Monitor: William L. Grantham					
16. Abstract  A summary is given of the airborne microwave remote sensing measurements obtained by NASA Langley Research Center in support of the 1979 Norwegian Remote Sensing Experiment (NORSEX). The remote sensing objectives of NORSEX were to investigate the capabilities of an active/passive microwave system to measure ice concentration and type in the vicinity of the marginal ice zone near Svalbard, Norway and to apply microwave techniques to the investigation of a thermal oceanic front near Bear Island, Norway. The instruments used during NORSEX include the Stepped Frequency Microwave Radiometer (SFMR), Airborne Microwave Scatterometer (AMSCAT), Precision Radiation Thermometer (PRT-5) and metric aerial photography. Remote sensing data are inventoried, summarized and presented in a user-friendly format. Data summaries are presented as time-history plots which indicate when and where data were obtained as well as the sensor configuration. All data are available on nine-track computer tapes in card-image format upon request to the NASA Langley Technical Library.					
17. Key Words (Suggested by Author(s))  Remote Sensing Microwaves			18. Distribution Statement  Unclassified - Unlimited  Subject Category 43		
19. Security Classif. (of this report) Unclassified	20. Security Classif. (of this page) Unclassified	21. No. of Pages 222	22. Price A10		



**End of Document**