

881088215



National Aeronautics and Space Administration

NASA TM-82491
JULY 1982

George C. Marshall Space Flight Center
Marshall Space Flight Center, Alabama 35812

NASA-TM-82491 19820026439

Shuttle VLBI Experiment

Technical Working Group Summary Report

Edited by:
Samuel H. Morgan
and
David H. Roberts

LIBRARY COPY

AUG 30 1984

LANGLEY RESEARCH CENTER
LIBRARY, NASA
HAMPTON, VIRGINIA

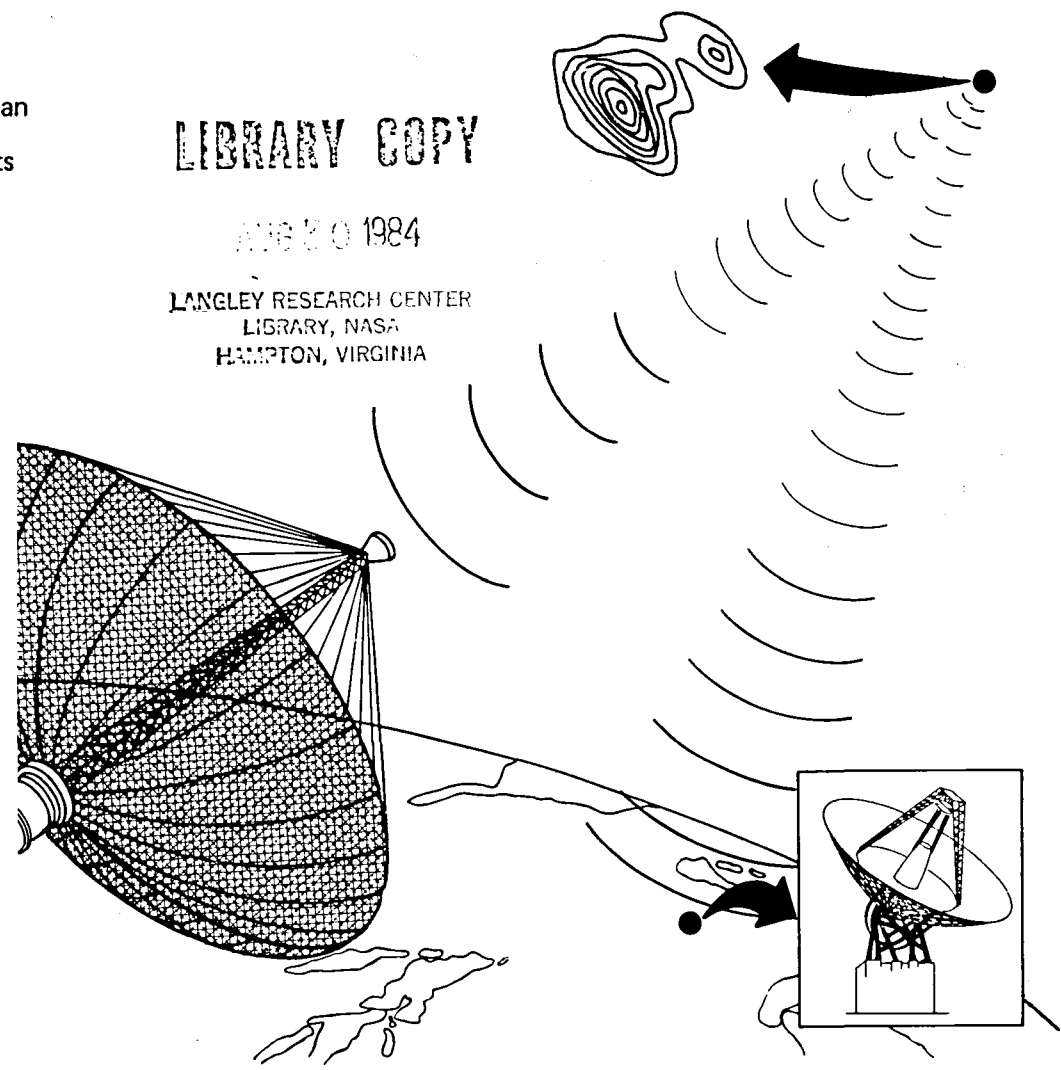

.

.

.

.

1. REPORT NO. NASA TM-82491		2. GOVERNMENT ACCESSION NO.		3. RECIPIENT'S CATALOG NO.	
4. TITLE AND SUBTITLE Shuttle VLBI Experiment: Technical Working Group Summary Report				5. REPORT DATE July 1982	
				6. PERFORMING ORGANIZATION CODE	
7. AUTHOR(S) Samuel H. Morgan and David H. Roberts* (editors)				8. PERFORMING ORGANIZATION REPORT #	
9. PERFORMING ORGANIZATION NAME AND ADDRESS George C. Marshall Space Flight Center Marshall Space Flight Center, AL 35812				10. WORK UNIT NO. RTOP 159-41-03	
				11. CONTRACT OR GRANT NO.	
12. SPONSORING AGENCY NAME AND ADDRESS National Aeronautics and Space Administration Washington, DC 20546				13. TYPE OF REPORT & PERIOD COVERED Technical Memorandum	
				14. SPONSORING AGENCY CODE	
15. SUPPLEMENTARY NOTES Prepared by Advanced Systems Office, Program Development *Brandeis University, Waltham, MA					
16. ABSTRACT <p>This report provides a quantitative description of the gain in interferometric resolution of extragalactic sources at radio frequencies which can be achieved by placing a Very Long Baseline Interferometry (VLBI) antenna in space. The report describes in some detail a VLBI demonstration experiment using a large deployable antenna, which will, if realized, be a very acceptable first venture for VLBI in space. The material presented in this report was compiled by a Shuttle VLBI Experiment Working Group which was chartered in 1981 by the Office of Space Science and Applications to develop the rationale and a technical plan for the experiment. The report also includes a tutorial on VLBI, a summary of the technology available for the experiment and a preliminary mission scenario.</p>					
17. KEY WORDS Very Long Baseline Interferometry Radio Astronomy			18. DISTRIBUTION STATEMENT Unclassified-Unlimited		
19. SECURITY CLASSIF. (of this report) Unclassified		20. SECURITY CLASSIF. (of this page) Unclassified		21. NO. OF PAGES 51	22. PRICE NTIS

N82-34315 #



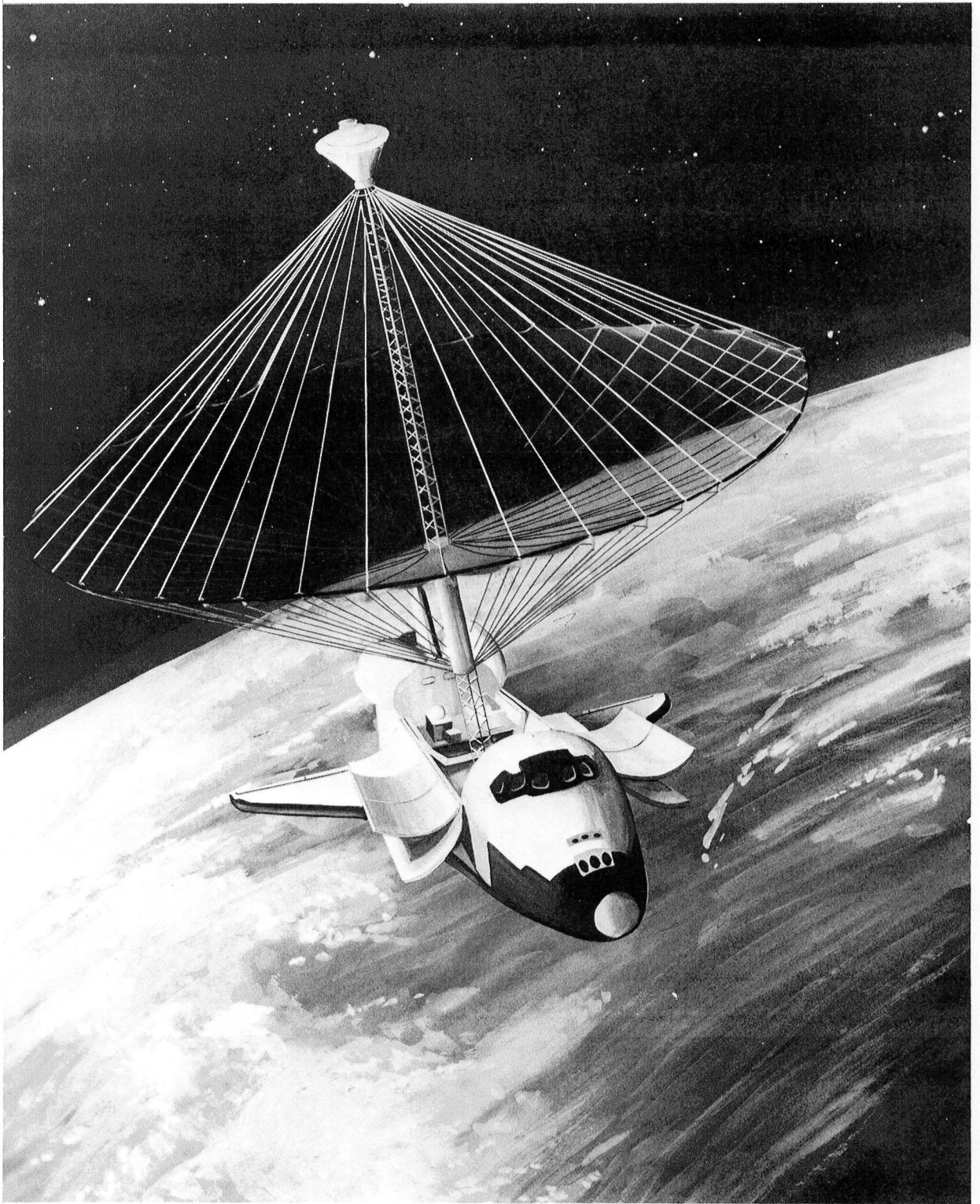



TABLE OF CONTENTS

	PAGE
FOREWORD	v
TECHNICAL WORKING GROUP MEMBERSHIP/ACKNOWLEDGEMENT	vii
1.0 INTRODUCTION	1-1
2.0 SCIENTIFIC OBJECTIVES OF VLBI	2-1
3.0 ADVANTAGES OF VLBI IN SPACE	3-1
4.0 TECHNOLOGY READINESS	4-1
4.1 Antenna	4-3
4.2 Receivers	4-7
4.3 Frequency Standards	4-9
4.4 IF To Digital Electronics	4-9
4.5 Data Recording	4-9
4.6 Summary of Technological Readiness	4-10
5.0 A SHUTTLE-BASED DEMONSTRATION	5-1



FOREWORD

Radio astronomy has a continuous history of uncovering new astrophysical phenomena. Both galactic and extragalactic radio sources emit many orders of magnitude more radio power than had been foreseen by any theory, leading to the realization that high energy processes are commonplace in the universe, occurring in radio sources that range from stellar to galactic dimensions. Quasars and pulsars were discovered by radio methods, leading to new questions of fundamental significance for physics and cosmology. Galactic nuclei have been shown to be centers of activity that have deep astrophysical significance. Interstellar masers demonstrate that dense gas clouds can exhibit phenomena with an entirely unexpected degree of order and coherence. Equipment developments in radio interferometry have led to the techniques of aperture synthesis and very-long-baseline-interferometry (VLBI), which have effected a revolution in the imaging capabilities of radio astronomy. No one predicted that radio telescopes would develop to the present state, in which they surpass the angular resolving power of that of optical telescopes by three orders of magnitude. This extraordinary resolving power has led to a number of surprises, including apparent velocities in quasars that exceed the speed of light, ordered structures in radio galaxies on scales from one to a million parsecs, and interstellar masers with apparent sizes smaller than an astronomical unit. As the body of discoveries from VLBI has grown, problems have been uncovered that now require interferometry baselines greater than an earth diameter, and the era of space VLBI has arrived.

This report provides a quantitative description of the gain in interferometric resolution of extragalactic sources at radio frequencies which can be achieved by placing a VLBI antenna in space. The report describes in some detail a VLBI demonstration experiment using a large deployable antenna, which will, if realized, be a very acceptable first venture for VLBI in space. The material presented in this report was compiled by a Shuttle VLBI Experiment Working Group which was chartered in 1981 by the Office of Space Science and Applications to develop the rationale and a technical plan for the experiment. The report also includes a tutorial on VLBI, a summary of the technology available for the experiment and a preliminary mission scenario.



TECHNICAL WORKING GROUP FOR
SHUTTLE VLBI EXPERIMENT

BERNARD F. BURKE	Massachusetts Institute of Technology	Chairman
SAMUEL H. MORGAN	Marshall Space Flight Center	Executive Secretary
LEE D. BRUNN	Jet Propulsion Laboratory	
ROGER E. DOXSEY	Massachusetts Institute of Technology	
EDWARD C. HAMILTON	Marshall Space Flight Center	
KENNETH J. JOHNSTON	Naval Research Laboratory	
JAMES F. JORDAN	Jet Propulsion Laboratory	
ROBERT A. PRESTON	Jet Propulsion Laboratory	
DAVID H. ROBERTS	Brandeis University/Massachusetts Institute of Technology	
LESTER L. SACKETT	C. S. Draper Laboratory	

ACKNOWLEDGMENT

The Working Group wishes to thank the following individuals for their extensive contributions in support of the study summarized in this report:

Charles Stark Draper Laboratory
STEVE CROOPNICK
CELESTE SATTER

G. C. Marshall Space Flight Center
BOB GOSS
KEN HINKLE
MIKE TUCKER

Massachusetts Institute of Technology
PERRY GREENFIELD

Jet Propulsion Laboratory
GEORGE PURCELL
SCOTT BOLTON

Smithsonian Astrophysical Observatory
R. F. C. VESSOT

1.0 INTRODUCTION

A radio frequency Michelson interferometer of arbitrarily large baseline can be constructed by synchronizing widely separated radio telescopes with the use of atomic frequency standards. The received signals are recorded coherently at each station and are processed later at a central location. In effect, by using several radio telescopes and by using the rotation of the earth to give a large collection of baselines, a radio telescope of enormous size can be synthesized. The technique, known as Very-Long-Baseline Interferometry (VLBI), has achieved angular resolution of tenths of a milli-arc-second, using existing radio telescopes on the surface of the earth. The size of the earth has become a practical limitation, and it is clear that a VLBI system with an element on an orbiting platform would profitably extend the technique to much higher angular resolution.

An ultimate goal for the last decade of this century would be the deployment of a free-flying VLBI observatory, or set of observatories, with large antennas placed in high elliptical Earth orbits. Such a facility, observing in concert with a continental array of ground stations, could in a few years complete a rigorous survey of extragalactic sources over almost the entire celestial sphere, acquiring enough data to facilitate the detailed brightness mapping of most of the known sources and providing temporal studies of the most important ones. To reach this goal one can identify an evolutionary space VLBI program, with three natural phases, which makes use of the expected improved capabilities in space systems.

Figure 1.1 illustrates this program with its three parts: a large deployable antenna demonstration on Space Shuttle, an antenna on a Space Platform, and a Free-Flying Observatory.

The advent of the Space Shuttle makes possible a demonstration of VLBI in space using a large retrievable antenna attached to the Shuttle. This demonstration flight, discussed in more detail in the final section, would provide an on-orbit test of the antenna system (which also has potential applications in defense, communications, and Earth observations, among others), prove the concept of VLBI in space, and provide valuable scientific data. An artist concept of the proposed 50 meter antenna system is shown in Figure 1.2.

The Space Platform is expected to be available by the end of this decade. This Platform is conceived as a multiple payload facility that will supply berthing, pointing, power and data management for a variety of attached payloads. A VLBI station attached to a Space Platform could carry out observations for extended periods using the same science package previously

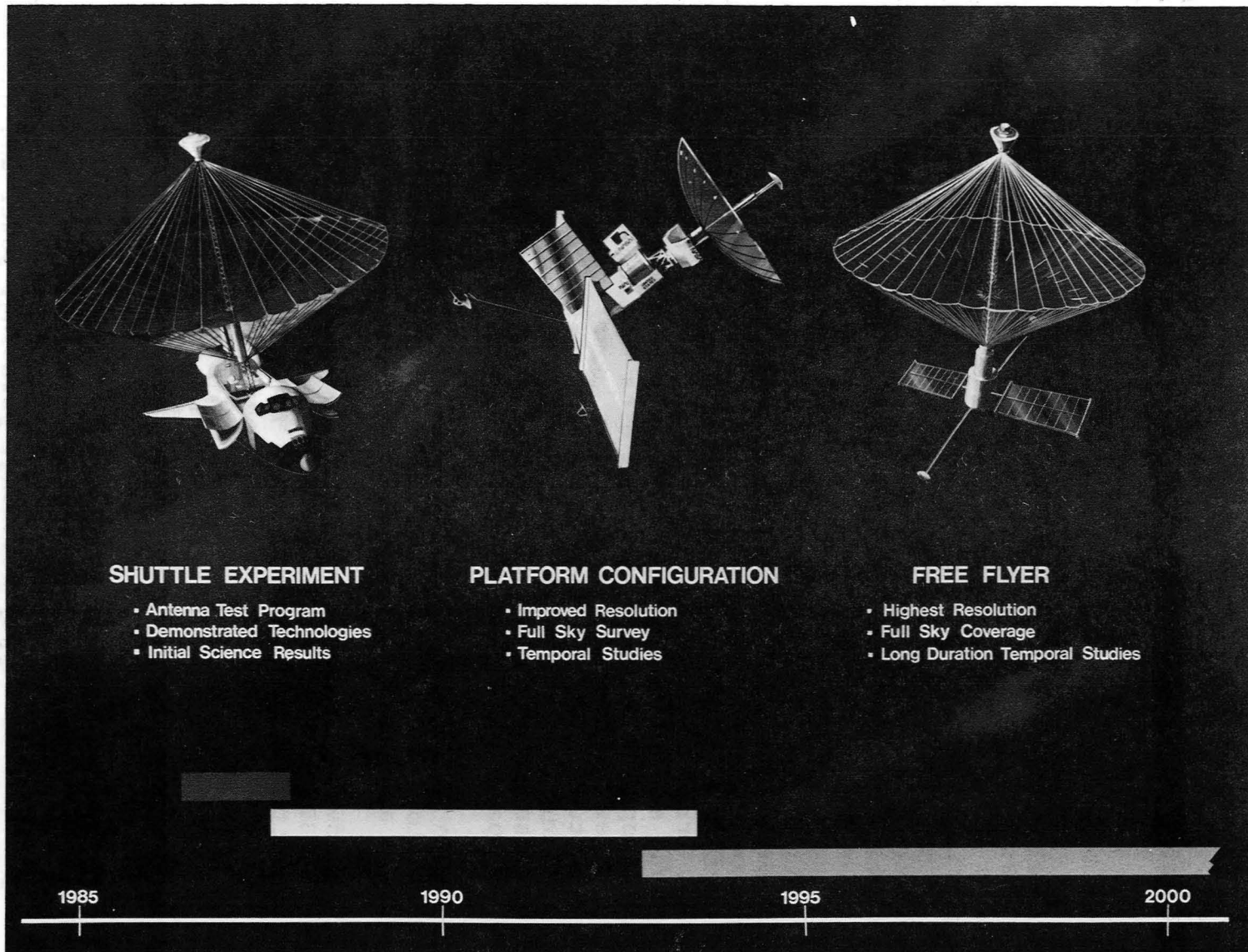

Figure 1.1. A Space VLBI Program: Major Elements

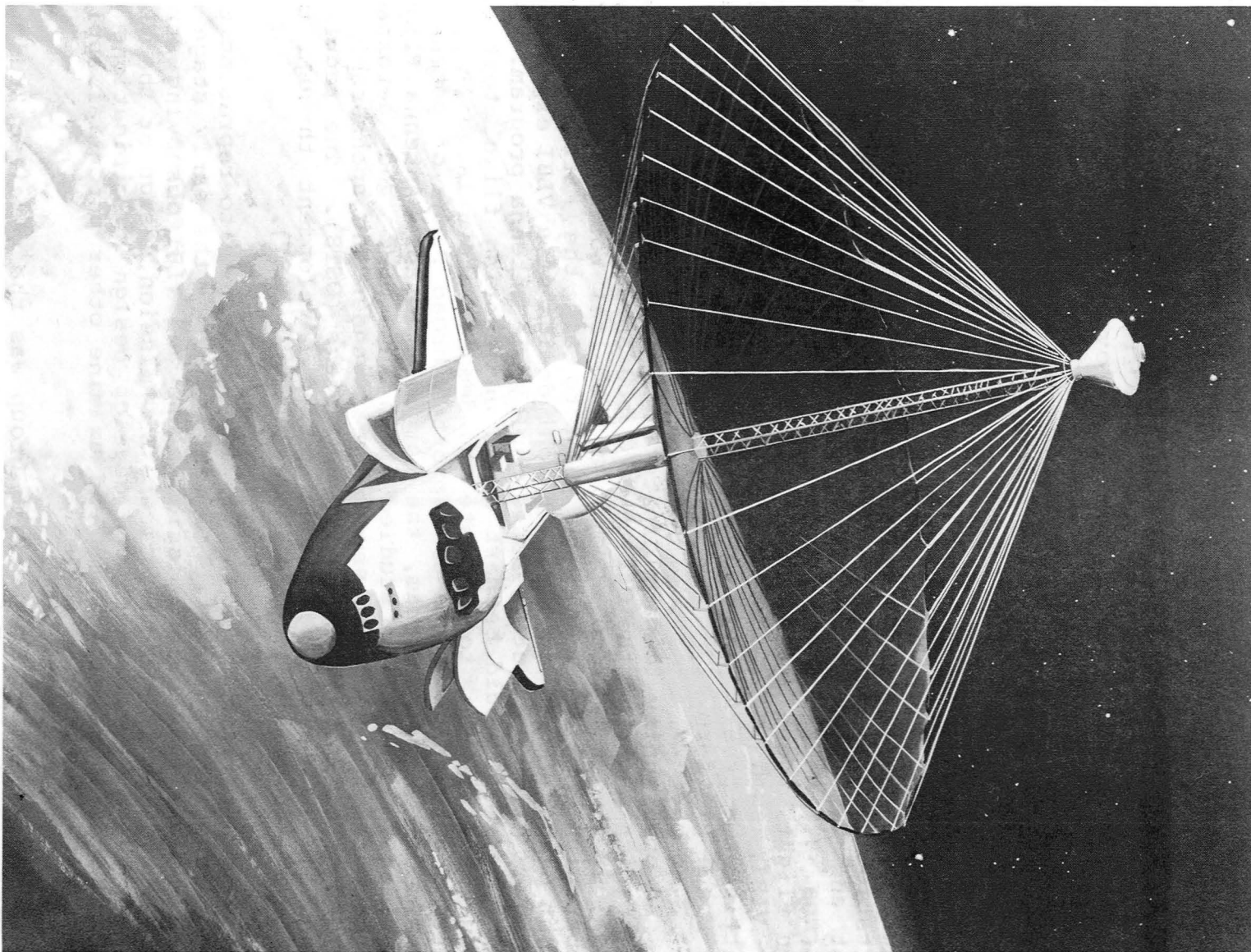

Figure 1.2. 50-Meter Deployable Antenna

demonstrated on the Shuttle. Figure 1.3 illustrates the Platform concept with a VLBI antenna mounted on one of the payload berthing systems.

The Free-Flying Observatory (Figure 1.4) would probably function up to one of the higher VLA frequencies, at least 15 GHz, and would also require a large deployable mesh antenna. The orbital altitude will be high, above 5000 km, with a geocentric inclination greater than 40°. Observation and mapping of a single source would require from one to several days, but with a 2-5 year lifetime, precession of the orbit will allow good viewing coverage over the celestial sphere.

It should be noted that the program plan illustrated in Figure 1.1 is opportunity driven, relying on NASA's Space Transportation System and the agency's high interest in the development and demonstration of large space structures like a large antenna. If NASA abandons or delays the large antenna demonstration flight, there are other acceptable first ventures into space for VLBI, such as a small or medium sized antenna aboard the Shuttle or a free-flying explorer mission or a similar antenna on the Space Platform.

An opportunity to participate in a large antenna Shuttle demonstration prompted the Office of Space Science and Applications (OSSA) in March 1981 to appoint a Technical Working Group (the membership is listed on Page vii) to aid the Marshall Space Flight Center (MSFC) in the technical design of a VLBI experiment within an existing Shuttle-based deployable antenna program. The VLBI experiment would be part of an engineering flight test and measurement program, to evaluate and demonstrate a large (~ 50 m) aperture antenna in space to support a broad range of potential users. The larger program, the Large Deployable Antenna Flight Experiment, has been studied both by MSFC and aerospace contractors over the past several years under the sponsorship of the Office of Space Transportation Systems (OSTS). The required technology has also been under active development through the Office of Aeronautics and Space Technology (OAST).

Major assignments to the working group were to represent the interests of the scientific community during the early stage of mission planning, review mission plans and VLBI observing strategies, assist MSFC in the science and mission design of the VLBI mission, review parameters and develop design specifications of various space VLBI subsystems and examine other potential applications of the system.

A major task of the working group was the detailed study of the VLBI experiment. This experiment has been analyzed in terms of both engineering and scientific requirements. Particular emphasis was placed on utilizing available and modified systems

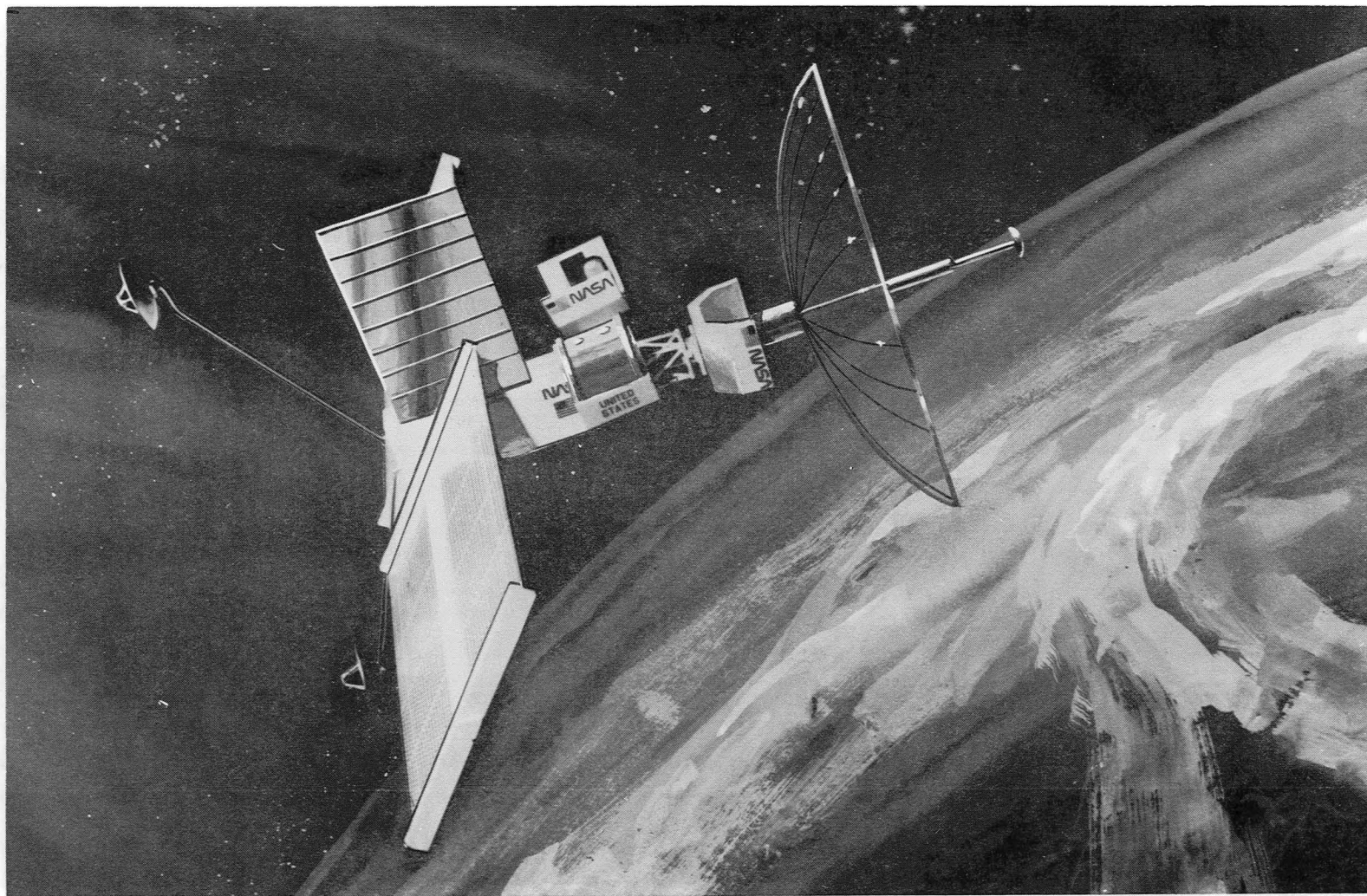

Figure 1.3. Orbiting VLBI: Platform Configuration

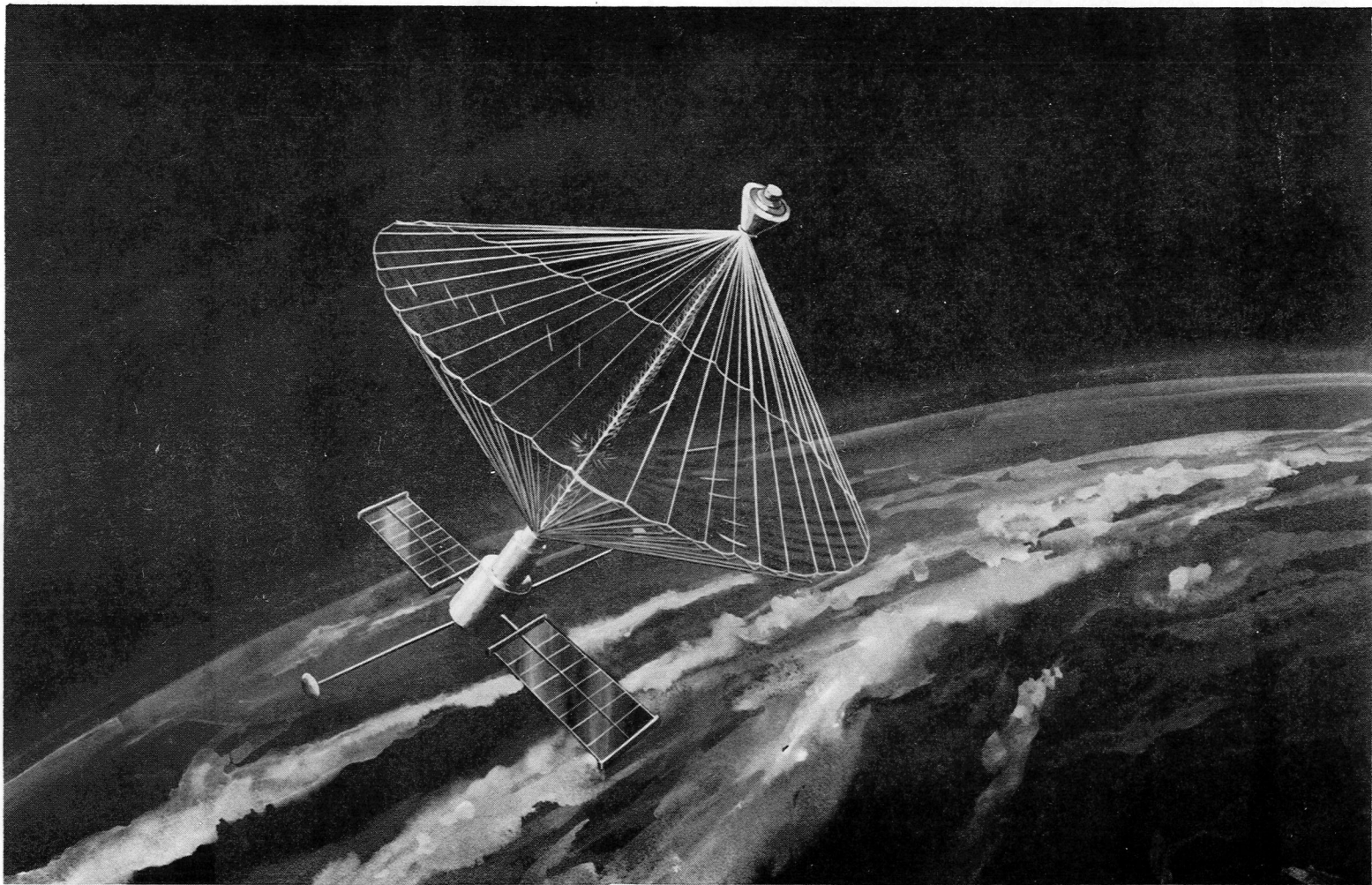

Figure 1.4. Orbiting VLBI: Free Flyer Configuration

where possible to achieve minimum costs, but at the same time requiring the high performance that would assure a successful mission. Except for the large antenna, the technology for an orbiting VLBI mission is available. Adding VLBI systems and observations to the Large Deployable Antenna Flight Experiment will not only demonstrate VLBI in space but will significantly enhance the microwave evaluation part of the engineering flight test.

The next two sections of this document discuss VLBI science objectives and demonstrate the advantages of placing a VLBI terminal in space. The technologies ready for the Shuttle-VLBI demonstration are discussed in Section 4. The Shuttle-based experiment and subsystem requirements are summarized in the final section.

2.0 VLBI SCIENCE OBJECTIVES

The Very-Long-Baseline Interferometry (VLBI) technique is based on the ability to synchronize widely-separated radio telescopes by use of local atomic frequency standards, or by satellite frequency transfer methods. The signal amplitudes are recorded on magnetic tapes, or relayed via satellite, and cross-correlated at a central location, creating a Michelson interferometer that can be used to synthesize a radio telescope whose aperture is limited only by the size of the earth. The extraordinary angular resolution which results from this method (as fine as 10^{-4} seconds of arc) has led to the discovery that quasars often exhibit internal motions that apparently exceed the speed of light, and that virtually every active galactic nucleus has angular structure that is unresolved with the best observations currently available. Within our home galaxy, the powerful molecular masers, often associated with the star-formation process, have been shown to have complex spatial and velocity structure on very small scales. Active binary systems, such as the mass-transfer binary X-ray objects, exhibit outbursts of radio noise. Even the nucleus of our galaxy is sufficiently compact to require study by VLBI techniques.

In nearly every case, there remains spatial structure which is unresolved with the best angular resolution achievable with antennas on the earth, indicating that determination of the true structural picture requires antennas in space. There is now ample experience with earth-based systems to show that there are no technical barriers to space VLBI. It is also clear that such a system offers further advantages: greatly-improved 2-dimensional, high dynamic range maps of complex sources and the ability to achieve high time resolution of rapidly varying objects (such as galactic binary systems and the intriguing SS433).

The famous quasar 3C273, the radio source that was the first example of this class of object, provides an interesting case history. The earliest VLBI data, obtained with only two antennas, revealed that the source structure was changing unexpectedly rapidly. Subsequent observations with more antennas confirmed the apparent "super-light" relative motion of the different parts of the source. A recent sequence of VLBI maps, made using the currently available radio telescopes, is shown in Figure 2.1. The multiple "blobs" of radio emission move in time, and the best fit to the data yields an angular velocity which corresponds to a physical velocity 10 times the speed of light (if the cosmological interpretation of quasar redshifts is correct). This is clearly an interesting puzzle, and the same maps that

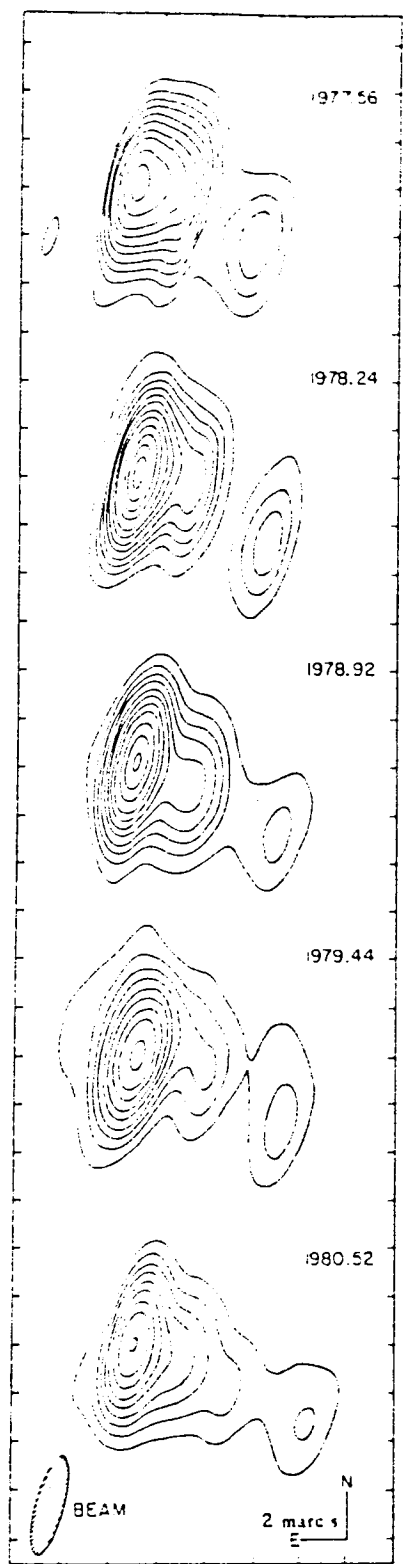

FIGURE 2.1 CONTOUR MAPS OF 3C273 AT 10.65 GHz

demonstrate the effect also show the limitations of the present VLBI system. The radio structures show a N-S elongation that is purely an artifact of the observations - this lack of N-S resolution is caused by the low declination of 3C273 and the location of present radio telescopes in the temperate zone of the Northern Hemisphere. Even a simple, near-earth VLBI system in space would give markedly better resolution, both N-S and E-W, than is currently available.

The operating principle of VLBI is illustrated in Figure 2.2. A pair of antennas form a Michelson interferometer when their phase-coherent outputs are combined vectorially, either in real time (as in conventional radio interferometry) or in post-real time (as in VLBI). The antennas in Figure 2.2 are observing the same source, and if it is effectively point-like the correlated output will vary sinusoidally in time. This signal, the interferometer fringe, represents the sinusoidal sensitivity pattern of the interferometer pair, turned out as the interferometer moves with the rotation of the earth. The fringe is characterized by an amplitude and a phase, which can be combined in a single complex number, the source visibility.

If the radio source is extended, the resulting visibility will have changed amplitude and phase, due to the mutual interference of the various parts of the source. In effect, the visibility is proportional to the Fourier transform of the source brightness distribution. A simple geometrical interpretation can be given for this process. The source brightness distribution $B(x,y)$, is a function of two angular coordinates x,y , which are usually taken to be right ascension and declination. A two-dimensional Fourier transformation yields the Fourier dual $V(u,v)$, where u,v are Fourier conjugate coordinates determined by the following process. Construct a plane perpendicular to the line of sight to the source, as shown in Figure 2.2; let the u and v axes be east-west and north-south in this plane, respectively. Then take the physical baseline vector \vec{D} joining the antennas, measured in wavelengths of the observation, and project it onto the $u-v$ plane to give a vector \vec{D}' . At each instant the interferometer pair measures the value of the Fourier transformation $V(u,v)$ of the brightness distribution $B(x,y)$ for the current values of u and v determined by \vec{D}' .

The complete Fourier transformation V is built up by the technique of earth-rotation aperture synthesis. As the earth rotates the projected baseline \vec{D}' moves in an elliptical locus, permitting measurement of V for a family of values of u,v . When many different antennas are available, each antenna pair corresponds to a different physical baseline, and each traces out a different elliptical locus in the $u-v$ plane. If the baselines are well-chosen, a good sampling of V is obtained. A Fourier

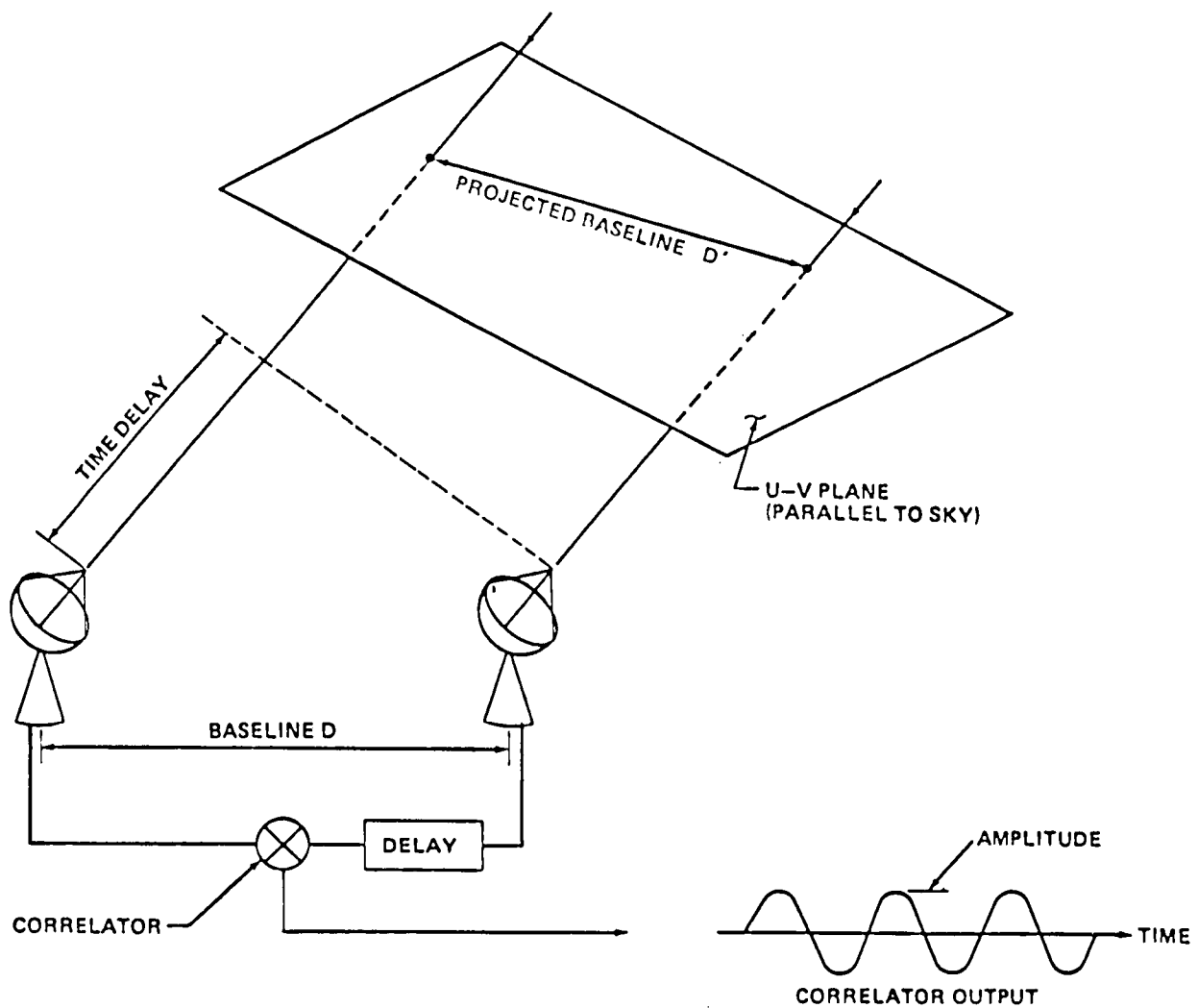

FIGURE 2.2 THE OPERATING PRINCIPLES OF VLBI

inversion of the visibility thus collected yields its Fourier dual, the source brightness distribution $B(x,y)$, convolved with a finite angular spreading function (the "beam") imposed by the lack of measurement of $V(u,v)$ on baselines longer than those available in the observation. The angular resolution (width of the beam) improves with increasing physical baseline and/or decreasing observing wavelength.

The orbiting VLBI technique does not differ conceptually from the case of a ground-based array of radio telescopes. The simplest system uses a simple station in orbit in conjunction with one or more ground stations, as shown in Figure 2.3. The $u-v$ plane is constructed in the same way, and a single orbit of the space antenna results in the $u-v$ locus shown in Figure 2.4a. Because of the rotation of the earth between orbital passes, each orbit results in a different $u-v$ locus, and with a number of successive orbits the $u-v$ coverage builds up as shown in Figure 2.4b. In this way a single ground-space antenna pair can provide considerably more "u-v coverage" than can a single ground-ground antenna pair.

There are two major figures of merit associated with a VLBI observation; the maximum baseline, which determines the angular resolution, and the completeness of the coverage of the $u-v$ plane, which determines the quality of the desired source brightness distribution map. Large "holes" in the $u-v$ coverage generate large sidelobes in the effective beam pattern, and cause artifacts to appear in the derived map. The net effect is to limit one's ability to measure complicated brightness distribution, and in particular, to look at the less intense components of the map. A high quality aperture synthesis system such as the VLA allows one to cover a dynamic range (ratio of brightest to faintest reliable features in the map) of 1000 to 1 or greater, while existing VLBI experiments seldom achieve a dynamic range better than 20 to 1.

The orbiting VLBI system achieves improvement in both figures of merit. The first goal, larger baselines, comes as a natural result of being freed from earth-based restrictions on antenna separations and orientations. The first step, going into near-earth orbit, increases the angular resolution by about a factor of two, and lays the groundwork for extension to much larger baselines. Since nearly every object studied by earth-based VLBI contains unresolved structure on the largest baselines, space baselines are required to achieve the angular resolution to see the additional detail that must exist. The relativistic jets, for example, that are seen at the cores of active galaxies and quasars retain jet-like structure at the resolution of current observations, and we need greater angular resolution to probe, ultimately, the underlying acceleration mechanism.

2-6

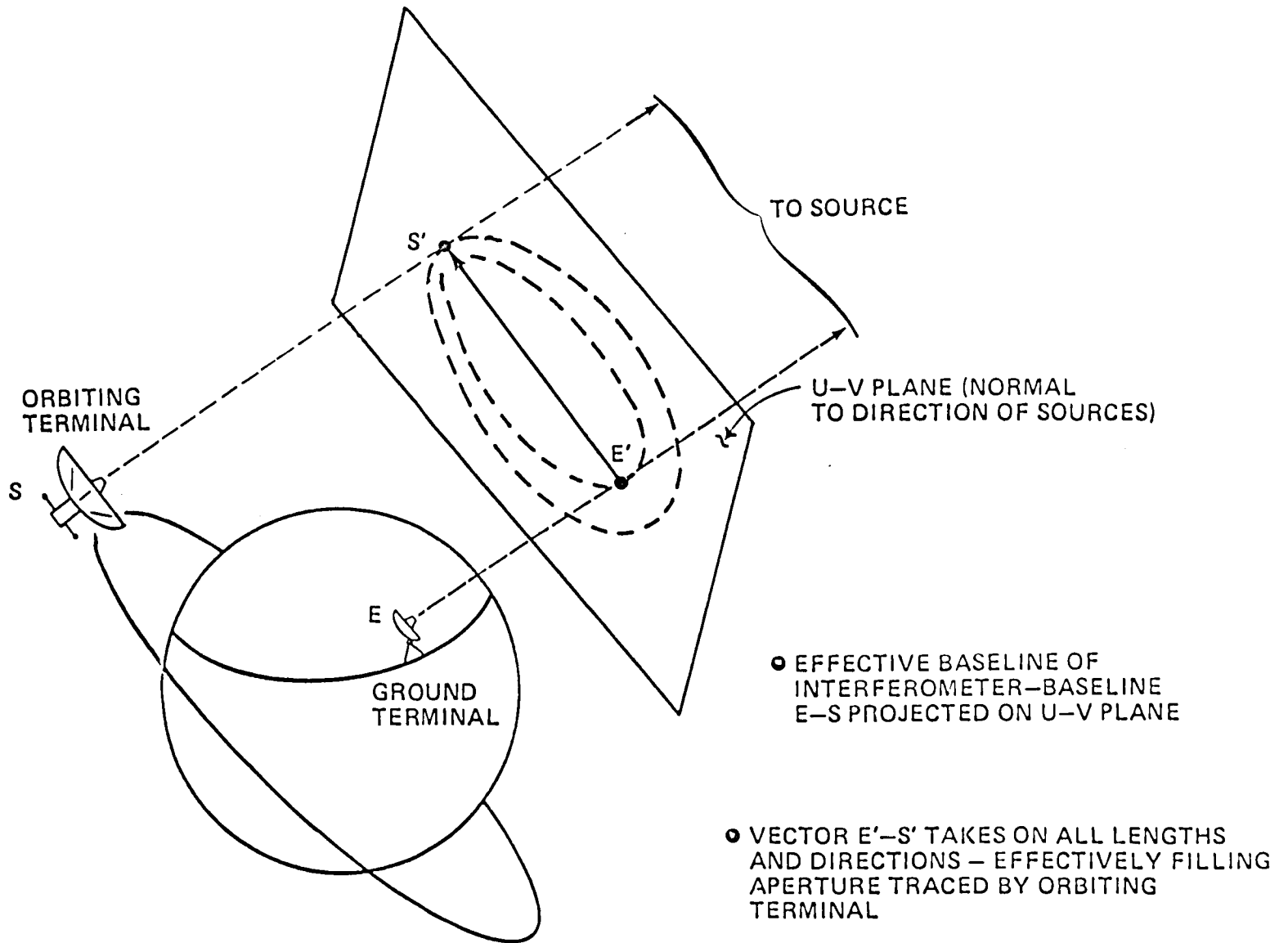
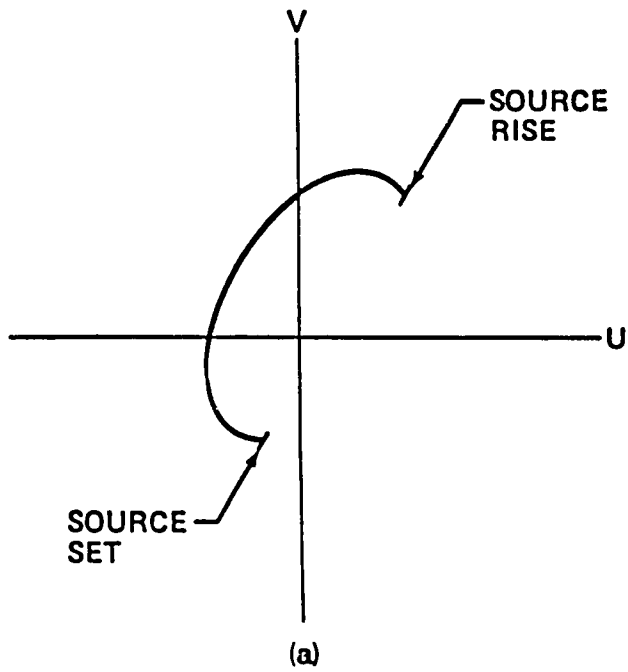
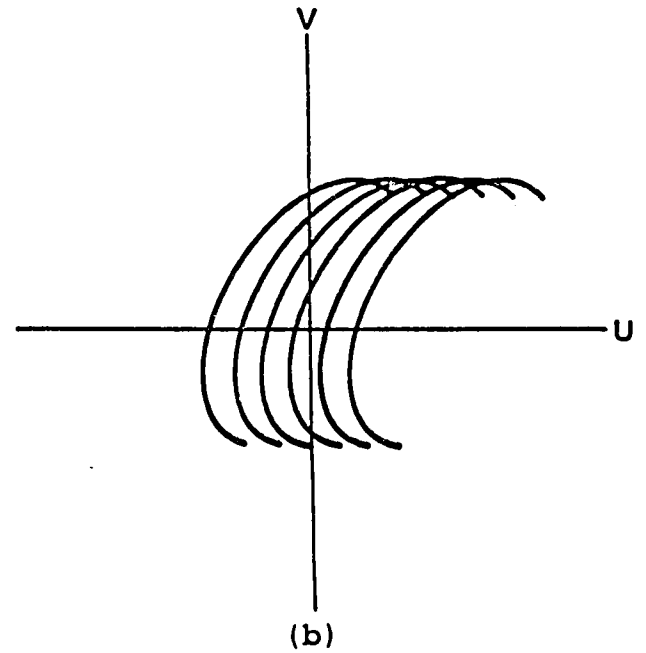

FIGURE 2.3 THE ORBITING VLBI CONCEPT



SINGLE ORBIT



MULTIPLE ORBITS

FIGURE 2.4 FOURIER COVERAGE IN THE U-V PLANE

The second goal, complete Fourier coverage, is an advantage of an orbiting VLBI system. In addition to the generation (for each ground station) of a group of u-v tracks which help cover the u-v plane, space VLBI using a satellite with a modest inclination to the earth's equator automatically generates large N-S Fourier components for sources of any declination, even those near the celestial equator (e.g. 3C273). This results in N-S resolution comparable to E-W resolution, and will alleviate the artificial elongation so apparent in Figure 2.1.

A third capability of the orbiting space VLBI system is the ability to gather data from a wide range of u and v in a short time (one-half of a satellite orbital period). This is in contrast to a ground-based array, for which it takes 12 hours to complete each elliptical track in the u-v plane. Many rapidly-varying sources such as Cygnus X-3 and SS433 change dramatically during the time required for a ground-based VLBI aperture synthesis. However, if an orbiting VLBI station could be used with a suitable ground-based array, a good set of u-v points could be obtained in 45 minutes, a time short enough to freeze the action.

3.0 ADVANTAGES OF VLBI IN SPACE

Current ground-based VLBI suffers from several significant limitations which are due to restrictions on the locations of the antennas used to make the observations. First is the lack of large north-south antenna separations. This constraint, which arises because of the east-west distribution of temperate land masses on the earth, results in poor north-south resolution for celestial objects of low declination. Since half of the sky is located in the equatorial band $|\delta| \leq 30^\circ$, this is a severe problem. A second limitation is that most of the large astronomical telescopes are located in the northern hemisphere, making the southern half of the celestial sphere effectively unobservable by VLBI. This is of course related to the lack of large land masses south of the equator, so it cannot be overcome simply by building southern VLBI stations. The third limitation on Earth-based VLBI is the small number of antennas available. (The current US VLBI Network has only 6 regular and 5 affiliate stations). This results in a relatively small number of baselines, and thus in coarse and sporadic coverage of the fourier transform plane. A corollary to this is that the locations of the existing stations were not chosen to optimize the u-v coverage in any way -- the stations were built for other radio astronomy applications and co-opted into VLBI. No station has ever been built expressly for VLBI; proposals to build a mid-western VLBI station in order to significantly improve u-v coverage have not met with success. Recent proposals by Caltech and NRAO to build a dedicated array of ~ 10 telescopes for VLBI would go part of the way towards solving the u-v coverage problem, but would be limited by the cost of so many new stations. A fourth limitation of ground-based VLBI is the maximum baseline obtainable, approximately the diameter of the Earth. While substantial information has been obtained within this limitation, the ultimate limit on VLBI resolution, set by interstellar scattering, is reached only for baselines which are one to three orders of magnitude larger, depending on the wavelength. Especially important in this context is to obtain higher resolution at long wavelengths, a task which simply requires longer physical baselines than are possible in Earth-based VLBI.

The use of a single satellite-based VLBI station in concert with several ground-based stations would lift most of these restrictions, resulting in a dramatically expanded VLBI capability. A space VLBI station provides a rapidly changing baseline to each ground station being used. Such a space terminal in near-Earth orbit circles the Earth about 16 times a day. The ground stations are in different positions relative to the source for each orbit, and a large number of different space-ground u-v tracks result from each orbit. As we illustrate below, this

results in u-v coverage very different from that obtained using ground stations alone. In particular, with the proper choice of satellite orbit, the north-south u-v coverage is comparable to the east-west coverage, the transform plane is heavily sampled, and the maximum baseline is consistently as large as the diameter of the satellite orbit. With the use of only one or two southern hemisphere ground stations space VLBI works for sources anywhere on the celestial sphere. Finally, extension of the space VLBI concept to include one or more stations in large eccentric orbits could extend the angular resolution of VLBI to the limits set by interstellar scattering.

3.1 Space VLBI Simulations

In order to illustrate the advantages of VLBI with a satellite-based station, we present the results of simulations which include (1) ground-based VLBI as it is presently done, (2) ground-based VLBI with a proposed dedicated VLBI array, (3) near-Earth orbit space VLBI with existing ground stations, (4) space VLBI in combination with a dedicated ground array, and (5) space VLBI with one or more satellites in large elliptical orbits. Examination of the results illustrates clearly the advantage of doing VLBI in space.

Figure 3.1 shows the u-v coverage and equivalent synthesized beam which result from conventional ground-based VLBI observations of the important source 3C84. Figure 3.1a assumes that three ground stations, Haystack (HSTK), NRAO Green Bank (GB), and Owens Valley (OVRO), observe the source for as long as it is above the horizon at any pair of stations. The angular scale assumes a wavelength of 18 cm was used. Figures 3.1b and 3.1c add a midwest antenna (North Liberty) and a European antenna (Bonn), respectively, to the observation. Because 3C84 is at the relatively high declination of $+41^\circ$, the north-south resolution is comparable to the east-west resolution. Note that the inclusion of the midwest station somewhat improves the sidelobe level of the beam, while the inclusion of the Bonn station and the resulting intercontinental baselines improves the resolution by about a factor of two. Somewhat better sidelobe levels and comparable resolution result when the entire US VLBI network is used.

In Figures 3.2a-c, we show the u-v coverage and corresponding synthesized beams which result from horizon-to-horizon observations of the source 3C273, an important low-declination ($\delta = +2^\circ$) source. These figures correspond to those in the previous paragraph -- the first assumes three US stations, the second adds a midwest station, and the third the Bonn station. This dramatically demonstrates the difficulty of doing ground-based VLBI on low declination sources. Although the east-west baseline projections compare with the case of 3C84, the north-south

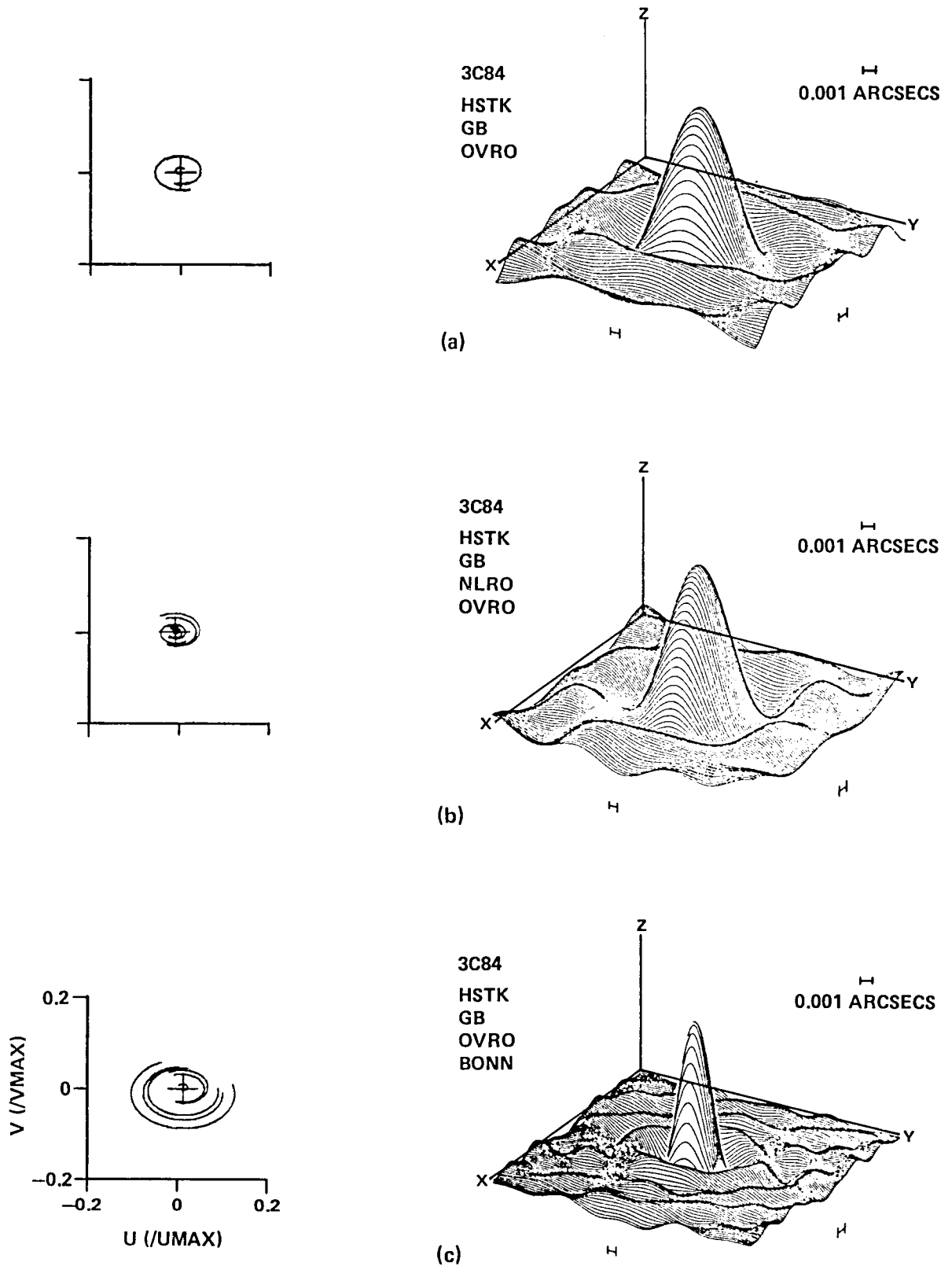

FIGURE 3.1 FOURIER COVERAGE AND EQUIVALENT SYNTHESIZED BEAM FROM GROUND-BASED VLBI OBSERVATORIES

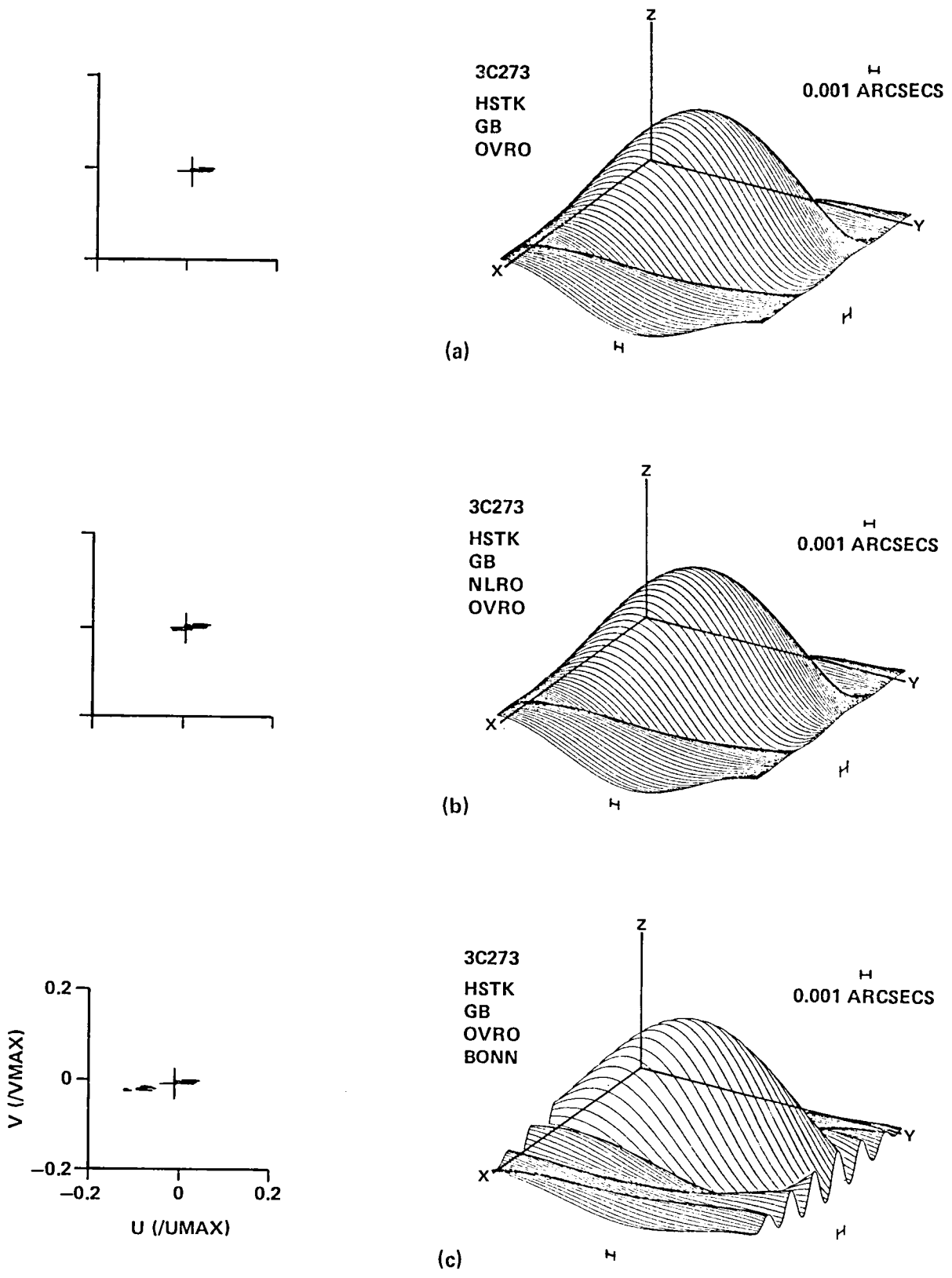

FIGURE 3.2 FOURIER COVERAGE AND EQUIVALENT SYNTHESIZED BEAM FROM GROUND-BASED VLBI OBSERVATORIES

projection of 3C273 is almost zero, with the result that there is almost no north-south resolution of this source.

Combination of a single space-based VLBI station with the modest number of ground-based antennas considered in the two examples above causes a dramatic change in the u-v coverage obtained for sources of all declinations. In Figures 3.3 and 3.4 we show the result of adding a single space VLBI terminal to the three ground stations (Haystack, Green Bank, Owens Valley). Figure 3.3 illustrates the effects of using a space terminal in a nominal orbit to observe 3C84. Both the extent and the density of the fourier plane coverage are improved, and the synthesized beam shows the results -- improved resolution and decreased side-lobe level. Figure 3.4 shows what happens when the same space and ground stations are used to observe the low-declination source 3C273. This example illustrates the third great advantage of using a space terminal -- even for sources near the celestial equator, and ground-based antennas which are oriented predominantly east-west, there are significant north-south baselines. Of course, the extent of the north-south baseline projection depends on the orbit of the spacecraft. In this example we used an orbit with altitude 370 km and inclination 57° ; this is a typical orbit available for the Space Shuttle.

A comparison of space VLBI and ground-based VLBI using a dedicated array shows the two approaches to be complementary rather than competitive. In Figure 3.5 we show the results of a dedicated-array observation of sources at $\delta = +64, +30, \text{ and } +6^\circ$. Here we have used the Caltech Array #13, a set of 10 stations ranging from New England to Hawaii. Note that the objective of a well-filled u-v plane is achieved easily at high declinations, and fairly well at the lowest declinations. For the latter case, the north-south resolution is noticeably poorer than the east-west resolution. Figure 3.6 shows the results of observations of the same sources using a 57° inclination space VLBI terminal with the best possible orbital inclination (longitude of ascending node = right ascension $+90^\circ$), and only three ground stations. The resulting projected baselines are considerably greater than provided by the dedicated array, especially in the case of low declination sources, and are strikingly better in the north-south direction. However, with only 3 ground stations, there are rather large gaps in the u-v coverage and a correspondingly large sidelobe level in the beam.

From the examples above it is clear that the combination of a single space VLBI terminal and a dedicated ground array of 10 antennas would provide the best qualities of each system. This is dramatically illuminated in Figure 3.7 where we show the u-v coverage and beam which result. Even for sources near the celestial equator the u-v coverage is dense and extends to

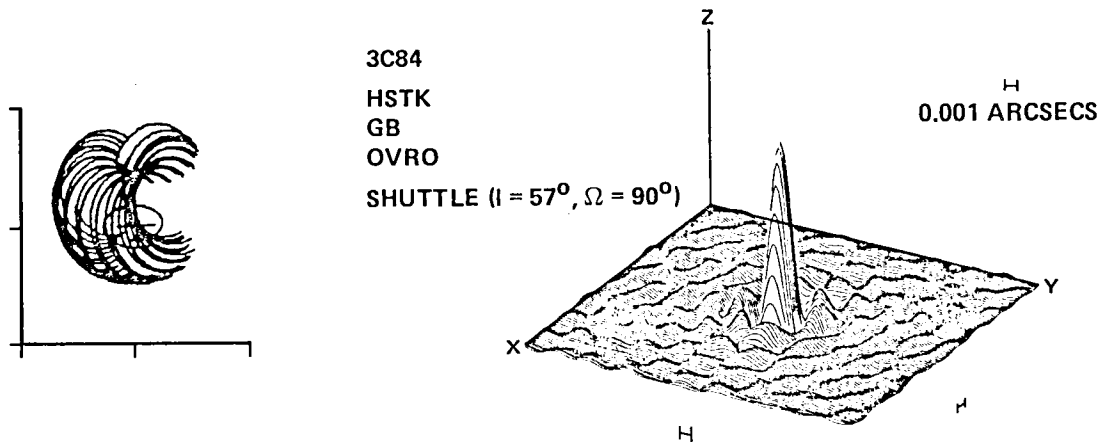

FIGURE 3.3 FOURIER COVERAGE AND EQUIVALENT SYNTHESIZED BEAM FROM GROUND-BASED VLBI OBSERVATORIES AND A SINGLE SPACE-BASED STATION

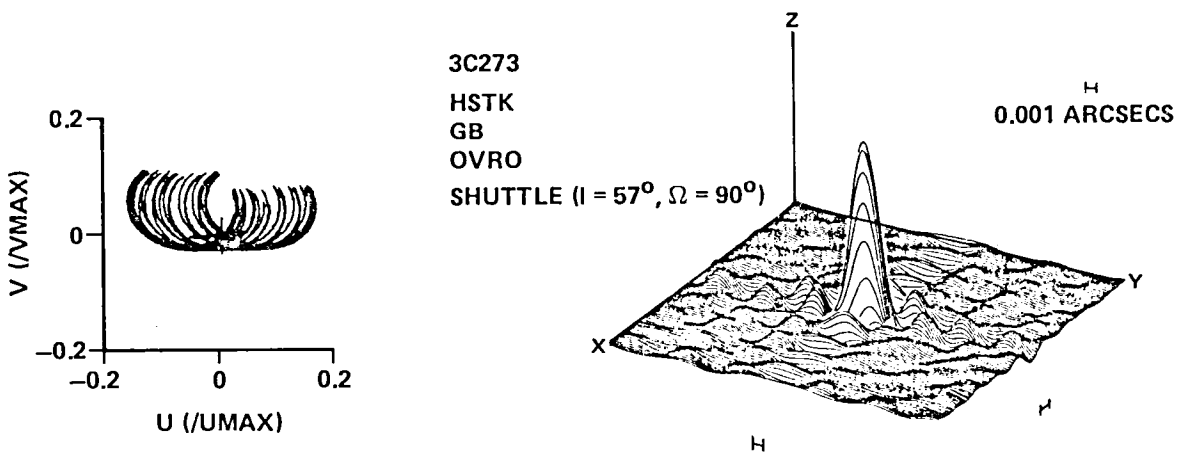

FIGURE 3.4 FOURIER COVERAGE AND EQUIVALENT SYNTHESIZED BEAM FROM GROUND-BASED VLBI OBSERVATORIES AND A SINGLE SPACE-BASED STATION

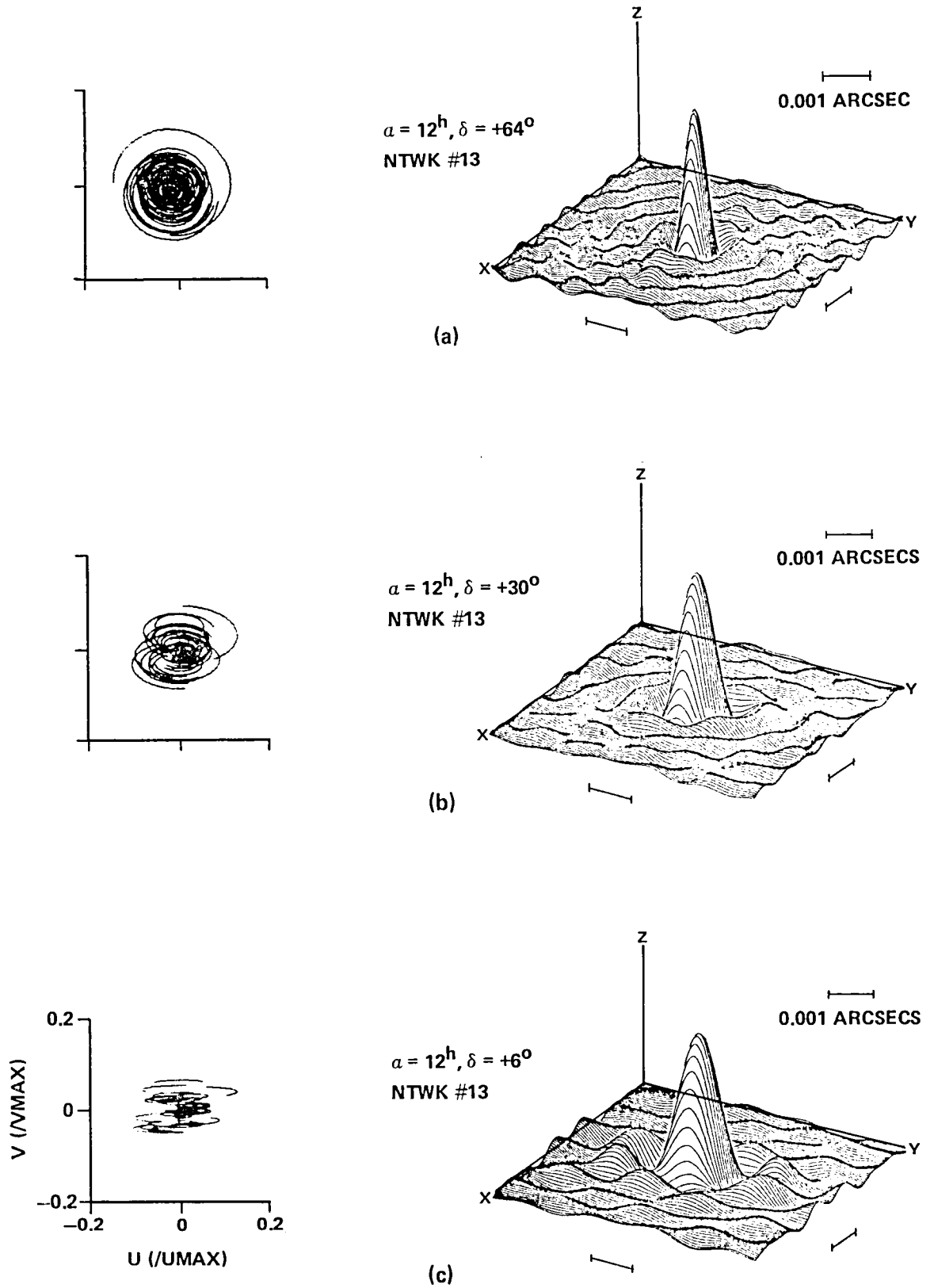

FIGURE 3.5 FOURIER COVERAGE AND EQUIVALENT SYNTHESIZED BEAM FROM A DEDICATED GROUND-BASED ARRAY

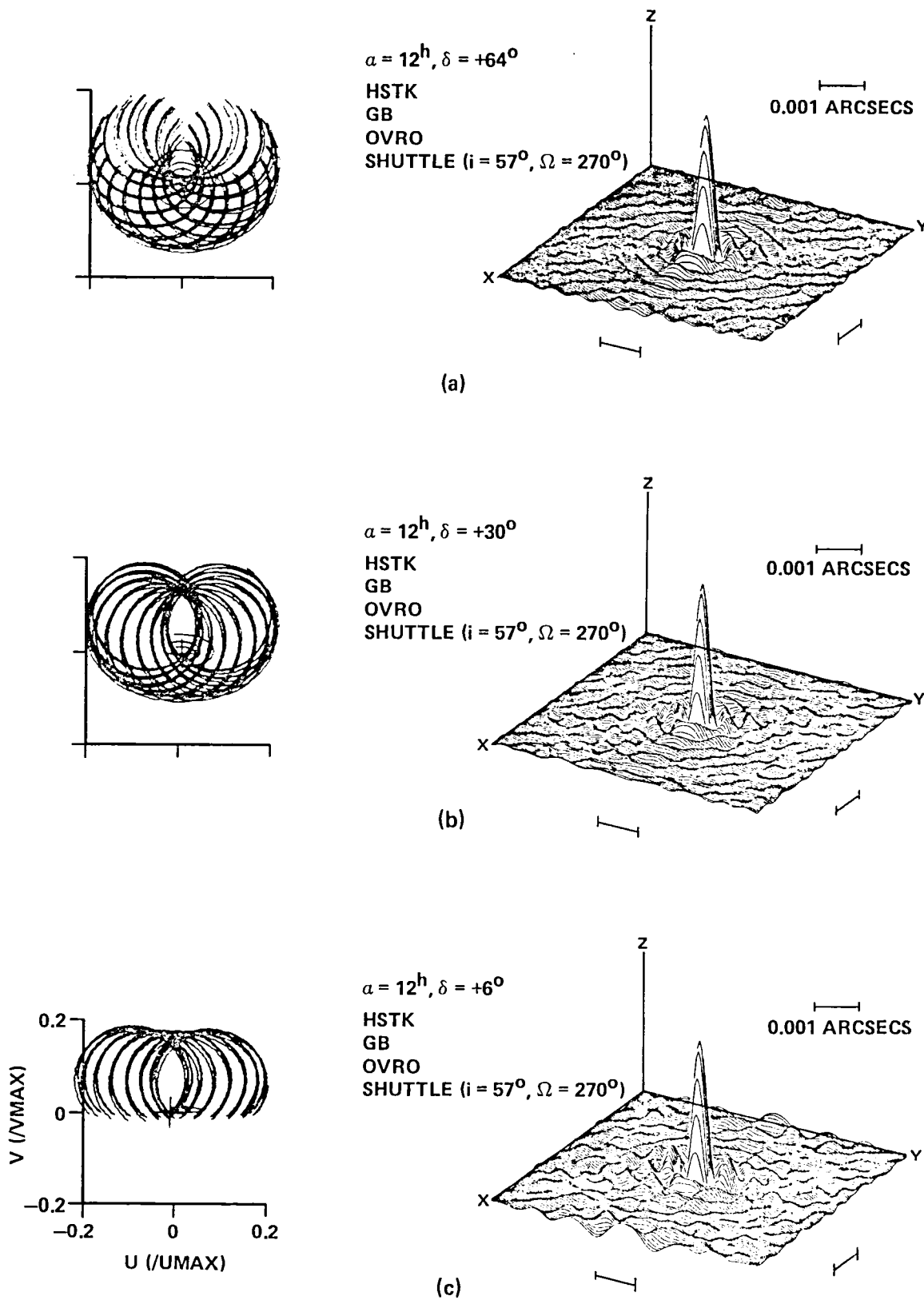

FIGURE 3.6 FOURIER COVERAGE AND EQUIVALENT SYNTHESIZED BEAM FROM THREE GROUND-BASED OBSERVATORIES AND A SINGLE SPACE-BASED STATION.

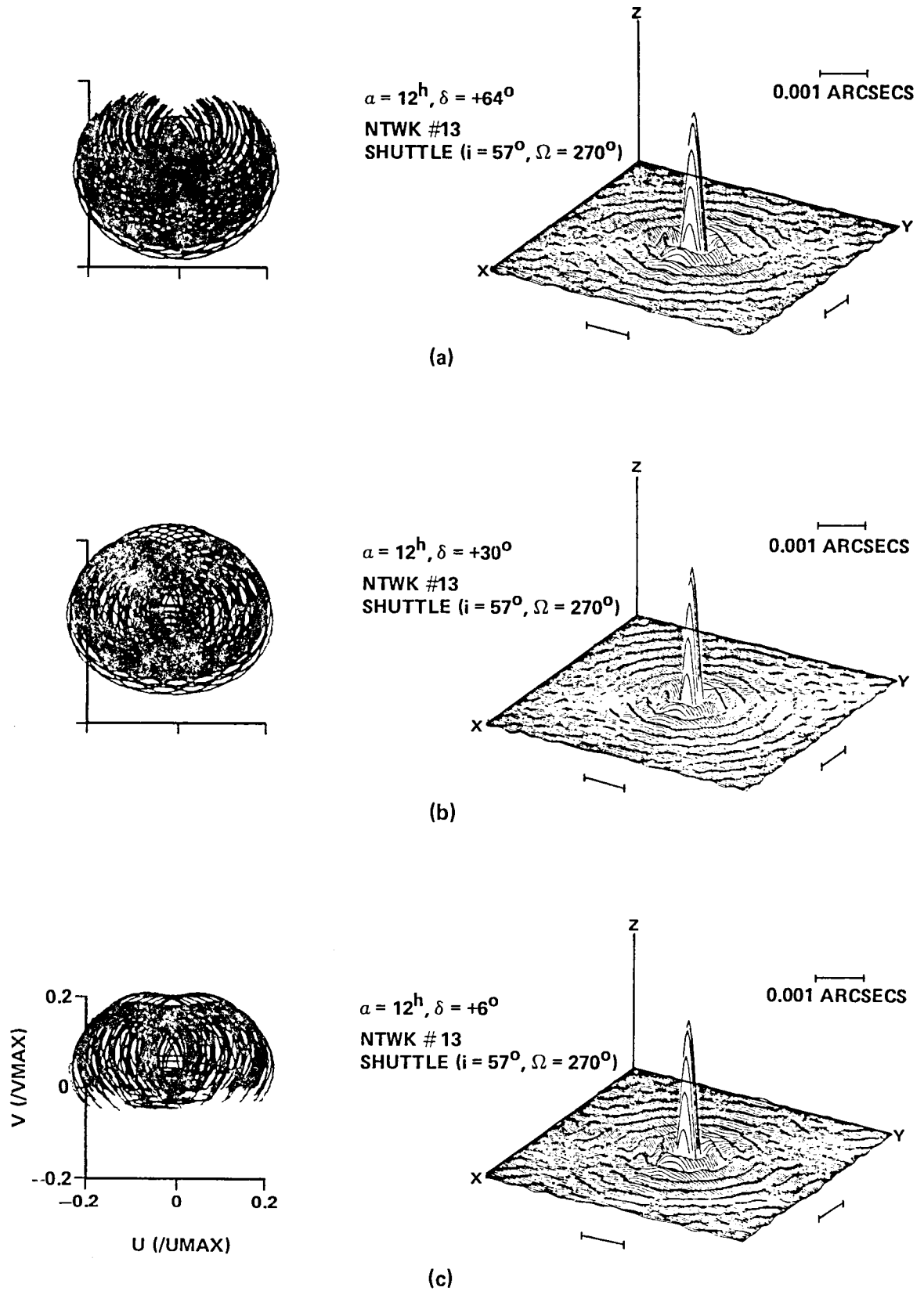

FIGURE 3.7 FOURIER COVERAGE AND EQUIVALENT SYNTHESIZED BEAM FROM A DEDICATED GROUND-BASED ARRAY AND A SINGLE SPACE-BASED VLBI STATION

significant north-south values. There is no doubt that such a system would yield a qualitative improvement in the spatial information provided by VLBI.

A quantitative assessment of the VLBI observations represented in Figures 3.5 through 3.7 can be made using Figures 3.8 through 3.10. These are effectively cross sections of the synthesized beams which result from the various combinations of sources and ground and/or space antennas; in each case the maximum excursion from zero of the beam is plotted for 10 annuli surrounding the central peak. For each source declination (64° , 30° , 6°) it is clear that the combination of the space antenna and only three ground stations provide a substantial improvement in resolution over that available from a dedicated ground-based array alone. In addition, the relatively poor performance of the ground array for a source near the celestial equator may be seen in high distant side lobe levels apparent in Figure 3.10. However, the combination of ground array and a single space antenna works extremely well at all of these declinations, as is evident from these three figures.

Extension of VLBI techniques to include one or more space terminals in a large orbit would lead to greatly improved angular resolution. For example, an orbit with semi-major axis 100,000 km and eccentricity 0.9 provides a maximum baseline to an Earth-based station of about 200,000 km, roughly half the distance to the moon. Figure 3.11 shows the result of using three large elliptical orbits with mutually perpendicular major axes and slightly different periods to observe a source at declination $+45^\circ$. The extensive satellite-satellite orbits yield remarkably complete $u-v$ coverage, and the effective resolution is about 0.20 milliarcseconds at a wavelength of 18 cm. This is a factor of 15 improvement over the best possible $\lambda = 18$ cm resolution involving Earth-based or near-Earth orbiting VLBI stations, yielding more than 200 times as much spatial information.

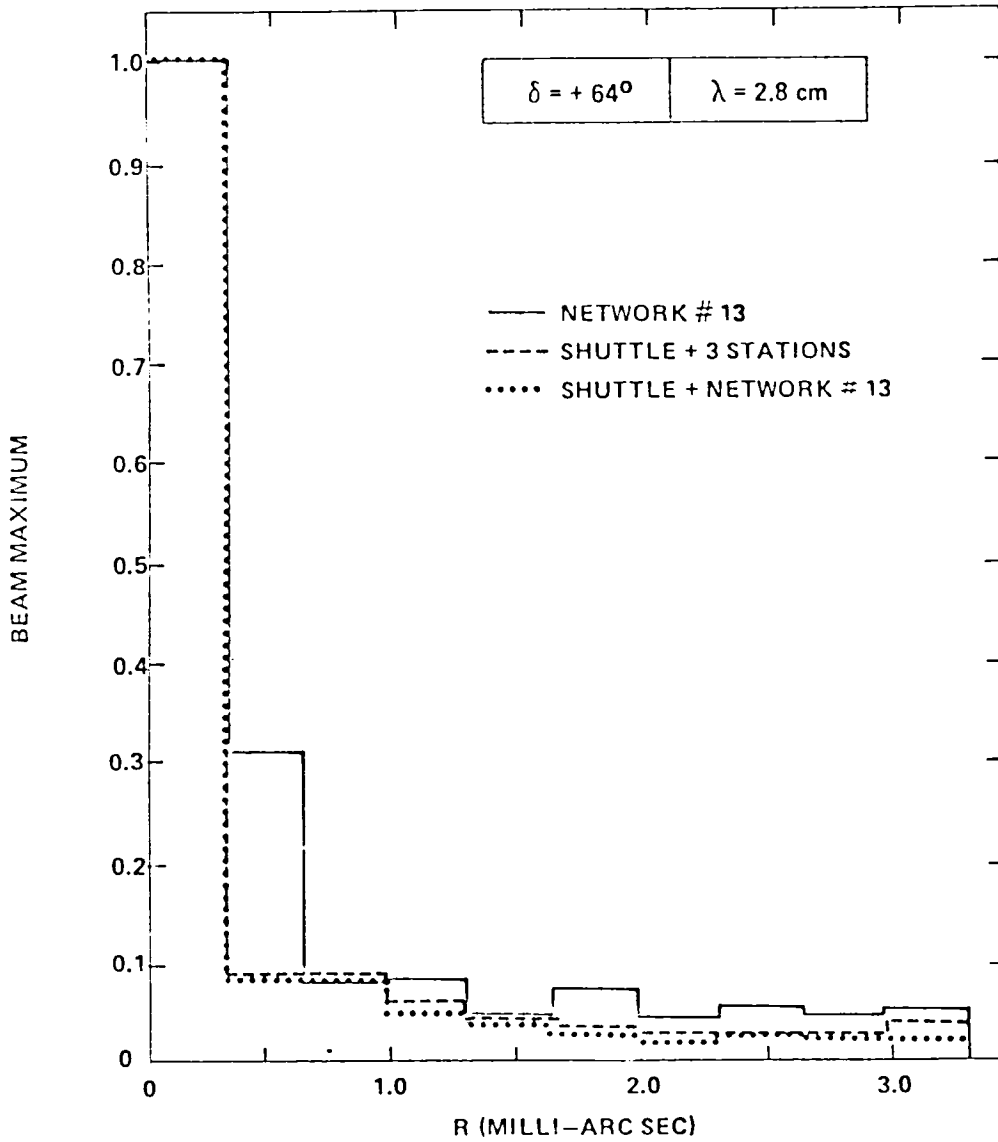

FIGURE 3.8 COMPARISON OF EFFECTIVE CROSS SECTIONS OF SYNTHESIZED BEAMS ($\delta = 64^\circ$)

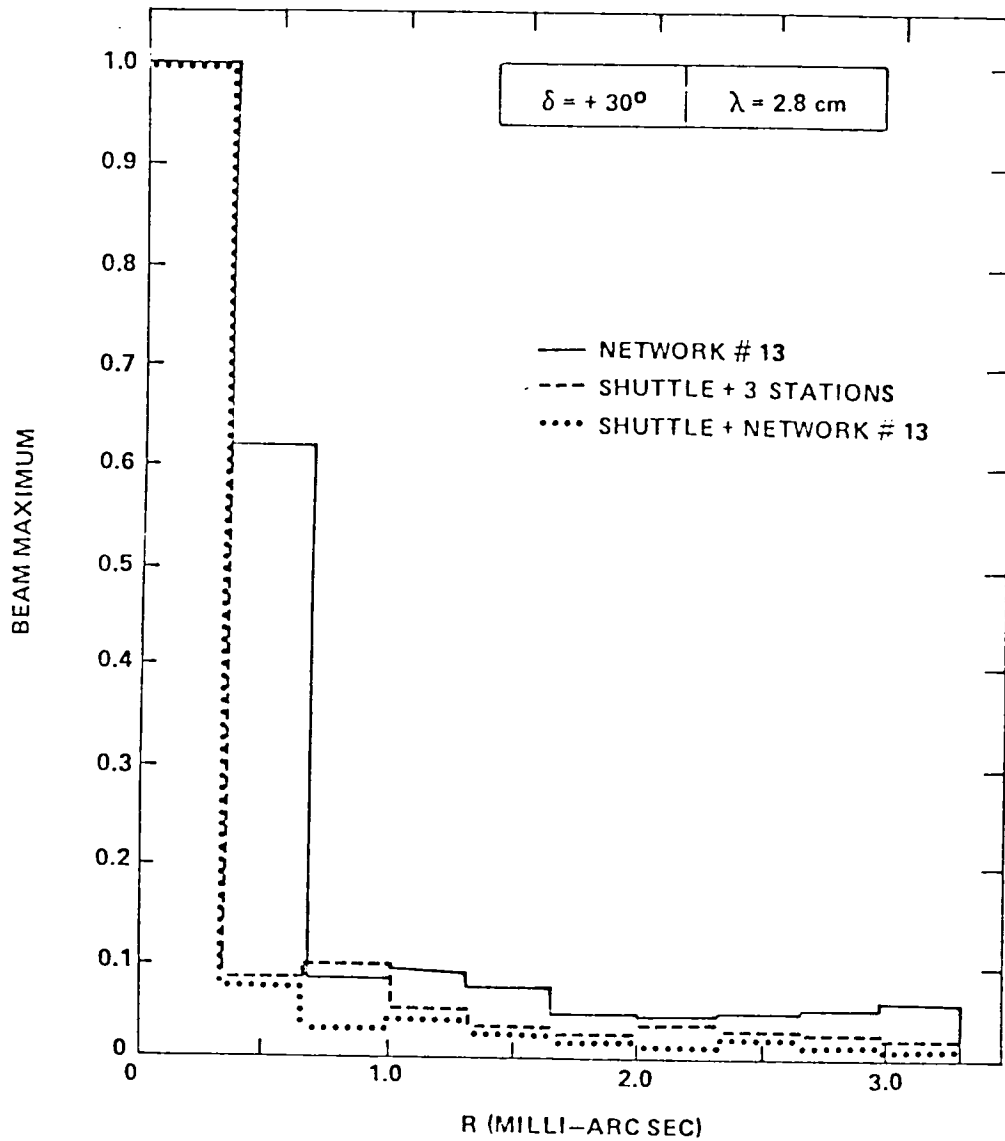

FIGURE 3.9 COMPARISON OF EFFECTIVE CROSS SECTIONS
 OF SYNTHESIZED BEAMS
 ($\delta = 30^\circ$)

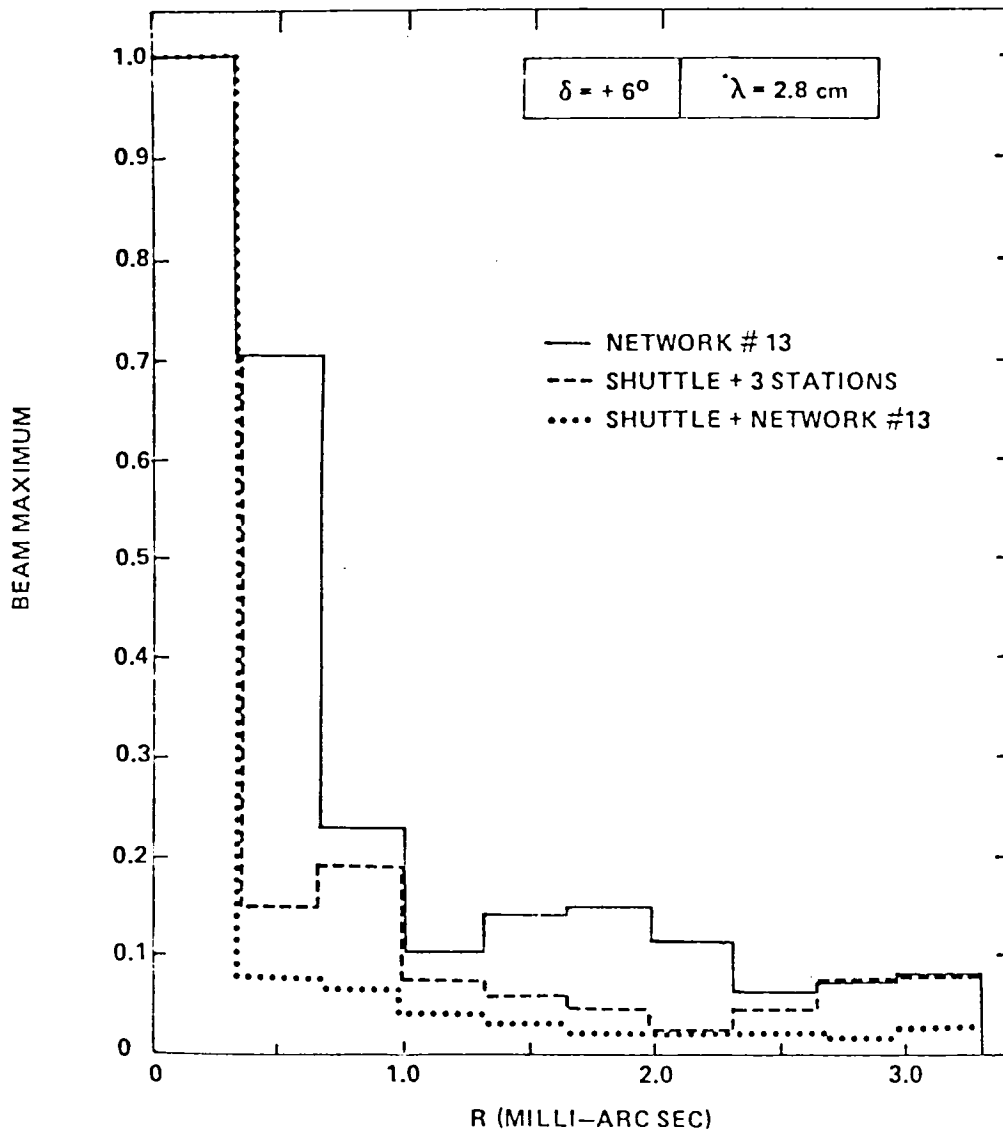

FIGURE 3.10 COMPARISON OF EFFECTIVE CROSS SECTIONS
 OF SYNTHESIZED BEAMS
 ($\delta = 6^\circ$)

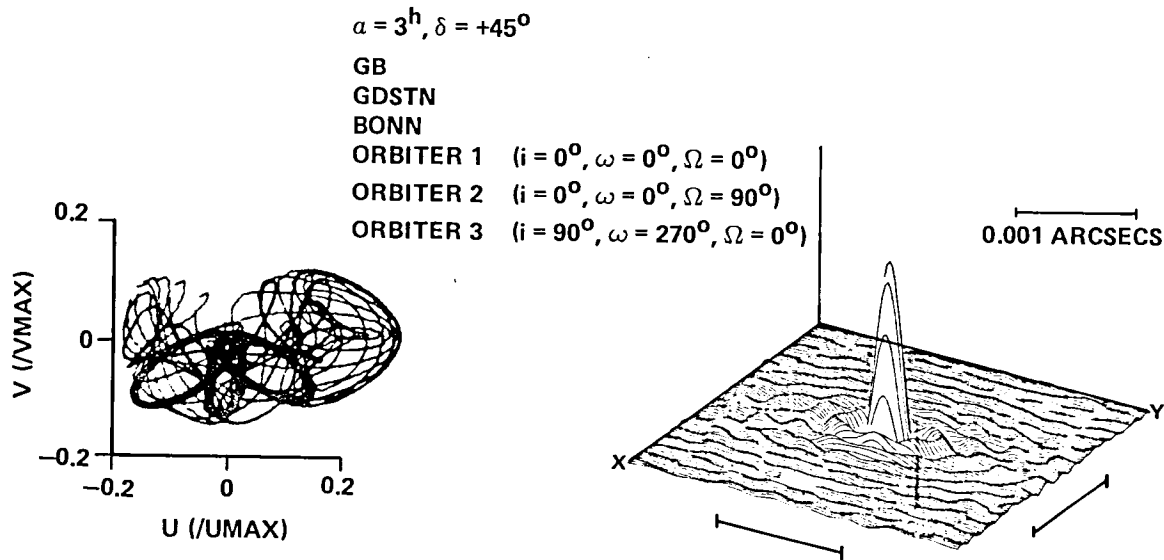

FIGURE 3.11 FOURIER COVERAGE AND EFFECTIVE SYNTHESIZED BEAM FROM THREE GROUND-BASED VLBI OBSERVATORIES AND THREE SPACE-BASED VLBI STATIONS IN LARGE ELLIPTICAL ORBITS

4.0 TECHNOLOGY READINESS

There are no conceptual differences between ground-based and orbital VLBI. In ground-based VLBI the necessary relative motion of the stations is provided by the Earth's rotation; in orbital VLBI it is provided by orbital motion. The question of VLBI technology readiness then reduces to the question of our ability to produce space-based versions of the subsystems necessary to conduct a ground-based VLBI observation. The crucial subsystems are the antenna and its pointing system, receivers, frequency standards, IF to digital electronics and data recording mechanisms. These subsystems are shown in block diagram form in Figure 4.1. It is important to keep in mind that VLBI sensitivity depends on both observing stations. For use in the following discussion the expression for signal to noise ratio (SNR) is:

$$\text{SNR} = k S_c (g_1 g_2)^{\frac{1}{2}} \left[\frac{e_1 e_2}{T_1 T_2} \right]^{\frac{1}{2}} D_1 D_2 (Bt)^{\frac{1}{2}},$$

where $k \approx 2 \times 10^{-4}$, and

S_c = correlated flux in Janskys,

$e_{1,2}$ = antenna efficiencies (1 = ground, 2 = space or ground),

$D_{1,2}$ = antenna diameter, in meters,

$T_{1,2}$ = receiver system temperatures, in ° K,

B = bandwidth in Hz,

t = integration time in seconds,

g_1, g_2 = mispointing coefficient (typically ≈ 1 for ground-based antennas and $\geq \frac{1}{2}$ for space-based antennas).

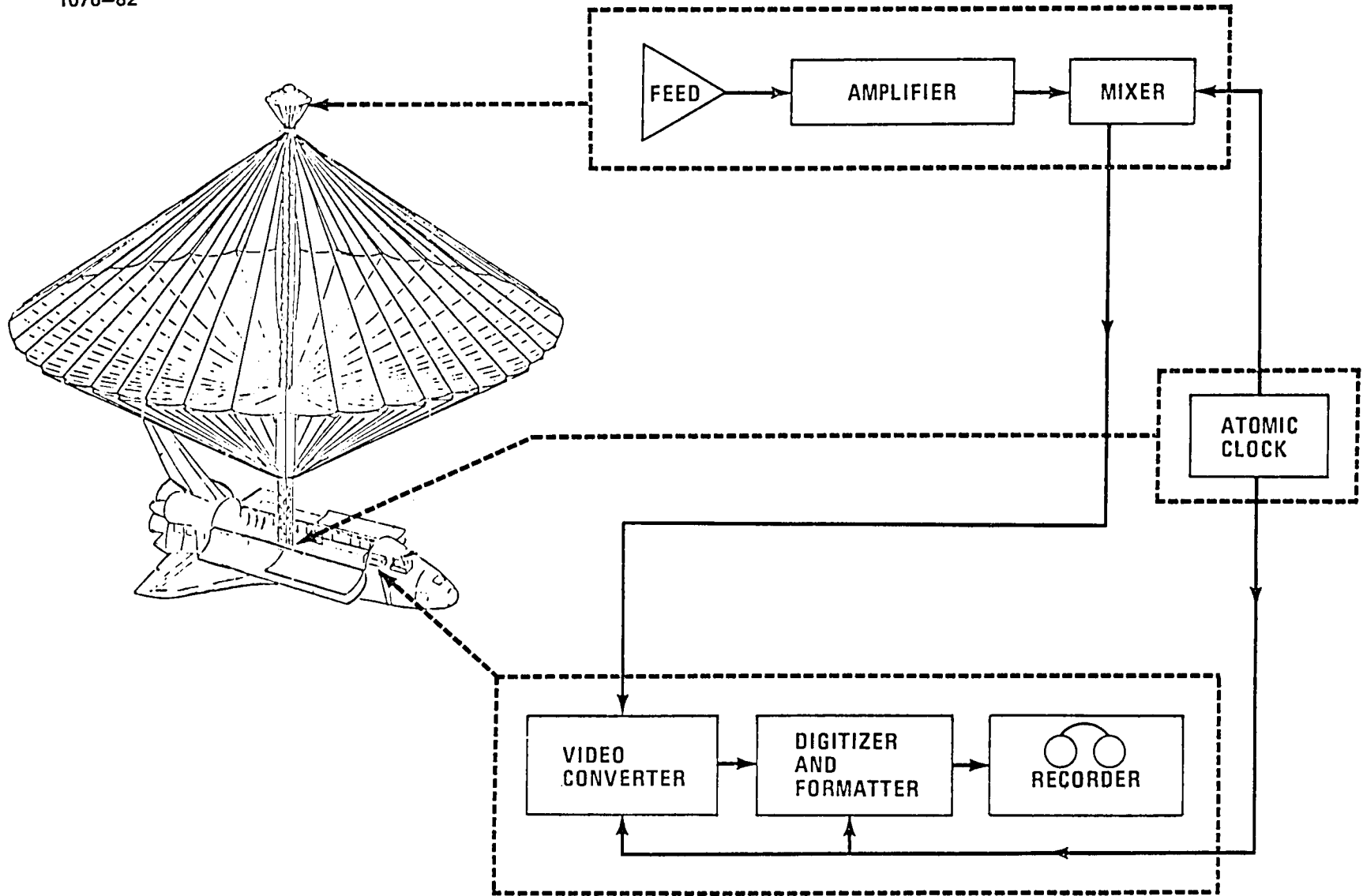

FIGURE 4.1 BLOCK DIAGRAM OF A SPACE VLBI SYSTEM

As an example of a typical ground antenna, the parameters for the Haystack 120 foot antenna at 3.8 cm are $D_1 = 37\text{m}$, $e_1 = 0.4$, $T_1 = 75^\circ\text{K}$. In addition, for continuum sources the bandwidth used in ground-based VLBI observations will typically be 2 to 56 MHz and integration times can range up to 20 minutes.

4.1 Antenna

Antenna parameters enter into the expression for SNR in two ways: efficiency and diameter. Since the SNR varies only as the square root of the efficiency, the diameter is the more important of the two parameters. Ground-based antennas commonly used for VLBI have diameters ranging from 24 to 100 meters. There are several reasons for attempting to gain SNR by making the spaceborne antenna diameter as large as possible. First, the total usable bandwidth is likely to be considerably smaller than routinely available for entirely ground-based observations because of data rate limitations (see below). Secondly, the system temperature may be higher (again, see below). Finally, the price one pays for improved u-v plane coverage is that the time spent in a given u-v plane cell is shorter, and hence the integration times will often be shorter than for ground-based observations. All these effects tend to decrease the SNR; consequently, if the orbiting VLBI system is to be applicable to the full set of astrophysics problems engaged in by ground-based VLBI, it should have an antenna at the large end of the size scale (diameter 50 m). However, an important set of strong sources could be observed with an orbiting VLBI system with antenna diameters as small as 5 or 10 meters, depending on other system parameters.

The first large parabolic reflector antenna to be used in space was the ATS-6 antenna in 1974. This antenna, shown as an insert in Figure 4.2, had a diameter of 9 meters and operated at frequencies up to ~ 2 GHz. Deployable antenna technology has progressed significantly in the intervening decade, but if we desire a 50 meter antenna with 8 GHz capability, a demonstration in space is probably required before a long-duration VLBI mission with such a large aperture can be contemplated. The Shuttle deployable antenna test experiment is intended to test the technology needed for such structures.

The efficiency parameter for the antenna should not be ignored. The efficiency will depend on the mesh size of the surface, an easy parameter to control, and on the surface irregularities, a more difficult parameter to control. The ratio of antenna diameter to rms surface irregularity is often used as a measure of antenna quality. Predicted values of this parameter

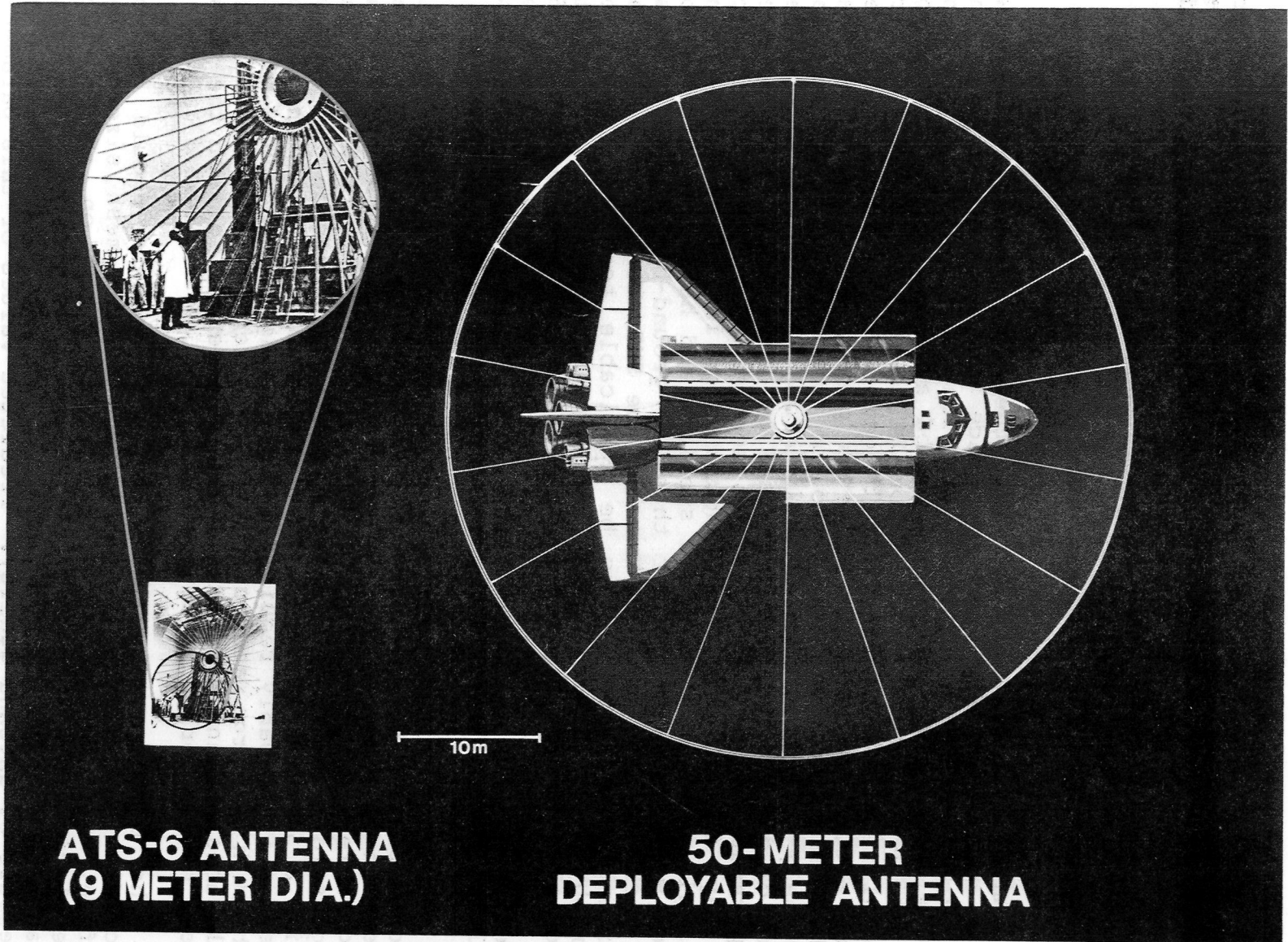

Figure 4.2. 50-Meter Deployable Antenna

for a 50 meter deployable antenna are about 2×10^4 and should allow good performance up to frequencies of about 10 GHz.

The pointing capability of the antenna system will also be an important parameter. The half power beamwidth (HPBW) of an antenna is about λ/D , where λ is the observing wavelength. At $\lambda = 3.8$ cm and $D = 50$ m, the HPBW is 0.05° . It is essential that the source be maintained within this angle. For ground-based antennas, pointing errors at 8 GHz are typically less than 10% of a beamwidth. For a space-based antenna, the antenna pointing system may achieve an accuracy perhaps no better than half a beamwidth, but sky sensors should allow knowledge of the pointing error to about 10% of the HPBW.

Antenna pointing for the Shuttle-based antenna is accomplished through the following three steps:

(1). The Shuttle points the antenna to within $\sim 0.5^\circ$ of the celestial target.

(2). An optical or RF sensor is used to drive the movable subreflector to within $\sim 1/2$ beamwidth of the target.

(3). Knowledge of pointing is recorded from the sensor discussed above to later correct for any residual mispointing of the antenna. This knowledge will permit a posteriori correction for amplitude loss due to mispointing.

The pointing system must be capable of correcting for any gravity gradient or aerodynamic torque influences. In addition, it may have to respond to vibrational modes induced in the large, flexible structure. Initial finite element simulations of a 50 meter deployable antenna attached to the Shuttle have indicated that the antenna structure is quite stable during various Shuttle motions.

A preliminary study of the dynamics and control of the Shuttle-attached antenna was performed at the C. S. Draper Laboratory. The emphasis of the study was on the capability of the Orbiter Flight Control System (FCS) to maintain antenna pointing in the presence of gravity gradient and aerodynamic torques and antenna flexure. The Orbiter could be used to maintain coarse pointing (0.1 - 1.0 deg) while an antenna-based mechanism, such as feed control, performed fine pointing, steering the antenna beam between firings of the vernier Reaction Control System (RCS) jets. VLBI observations would take place during the periods between firings.

A simple finite-element flex model, based on a MSFC deployable antenna design, was used to investigate the effects of RCS jet firings on the flexible antenna. Figure 4.3 illustrates the antenna and Orbiter configuration from the dynamic graphics

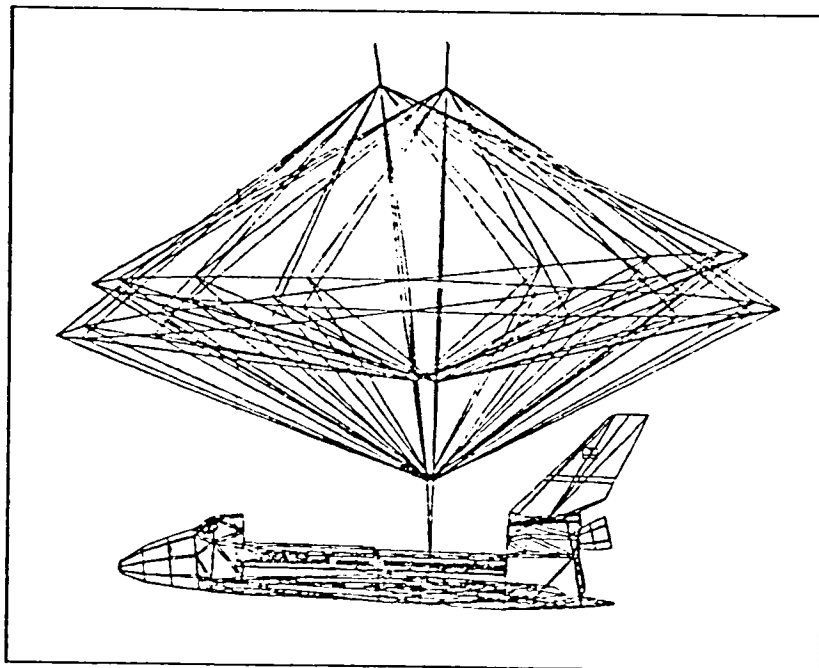
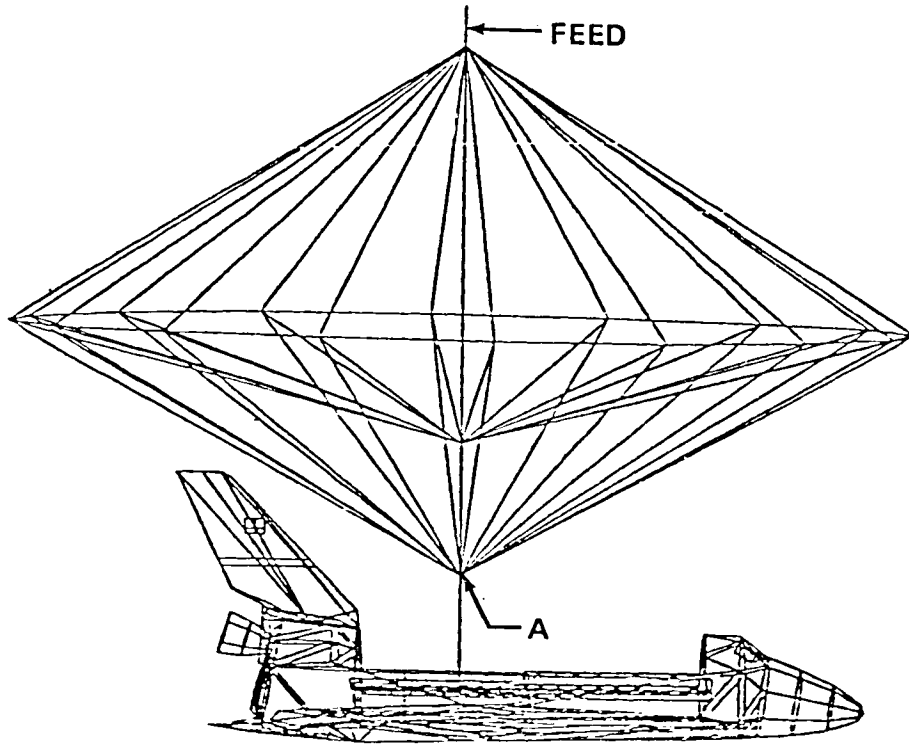

NOTE: ANTENNA MOTION IS GREATLY EXAGGERATED

FIGURE 4.3 FLEX SIMULATION GRAPHICS REPRESENTATION OF ANTENNA AND ORBITER

system output which was used to study the flex motion. The FCS can operate with an attitude deadband as small as 0.1 degree (although absolute pointing uncertainty is greater [≈ 0.5 deg] because of Inertial Measuring Unit (IMU) drift and other error sources). It was found that even with a deadband as small as 0.1 degree there will be frequent periods of one minute or longer without jet firings. A larger deadband may be desirable in order to increase the signal integration time between firings, to reduce antenna flexure, and to reduce consumption of RCS fuel. One simulation included the flexible antenna model and illustrated the limit cycle behavior of the vehicle acted upon by maximum gravity gradient torques in all three axes. Figure 4.4 shows the deflections of the antenna feed along the Orbiter axes. During a 400 second simulation, there were several roll, pitch, and yaw RCS firings. The motion in the x-axis principally shows the effect of firings in pitch, and that in the y-direction the effect of firings in roll. The magnitude of the antenna flex motion was less than one inch, resulting in an antenna physical axis error less than 0.1 degree peak-to-peak. The antenna motion along the z-axis is much smaller than a wavelength and thus will not destroy the coherent interference. For the MSFC antenna design, the significant bending was in the mast below the dish of the antenna (point A in Figure 4.3), the antenna structure itself maintaining its shape. This is displayed graphically in the insert of Figure 4.3 where the bending has been greatly exaggerated in order to qualitatively display the motion. It should be kept in mind that other antenna designs may behave differently.

4.2 Receivers

The recent development of gallium arsenide field effect transistors (GaAs FET) receivers has provided a very suitable technology for use in an orbital VLBI station. These receivers are both considerably simpler in design than parametric amplifiers (or other type receivers previously commonly used in radio astronomy) and are comparable in sensitivity. Their performance can be enhanced considerably with cryogenic cooling. This is routinely being done at ground observatories, but may pose more of a problem for orbital operations. Radiative cooling may be useful in lowering the physical temperature of the receiver package but will not be able to achieve the best physical temperatures obtained on the ground. In any case, for the Shuttle mission the long cool-down time of radiative cooling systems precludes their use.

Consequently, it is likely that the system temperature of the orbital station will be somewhat higher than that attainable at ground observatories. Typical system temperatures of receivers in space might be $\sim 75^\circ$ K at 2 GHz and 160° K at 8 GHz. It should be noted, however, that the system temperatures enter into the SNR under a square root, and hence this degradation will be acceptable.

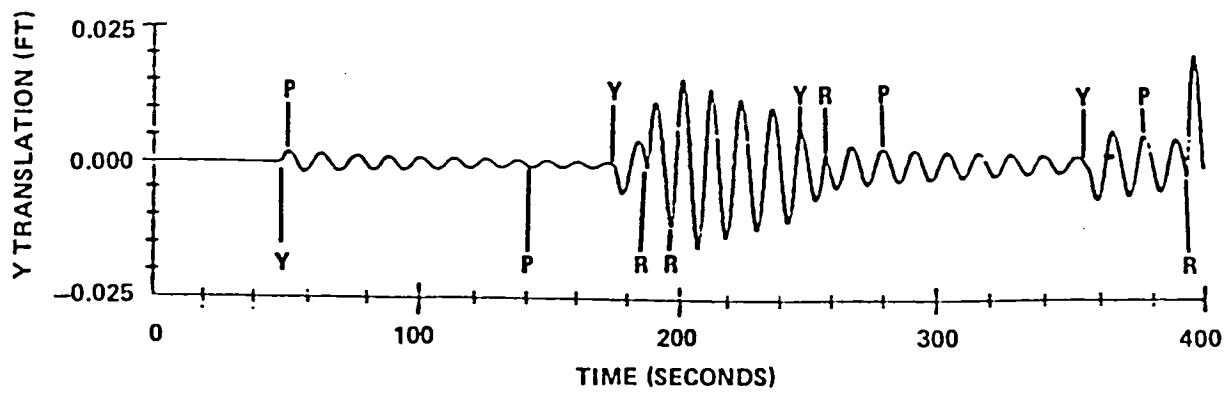
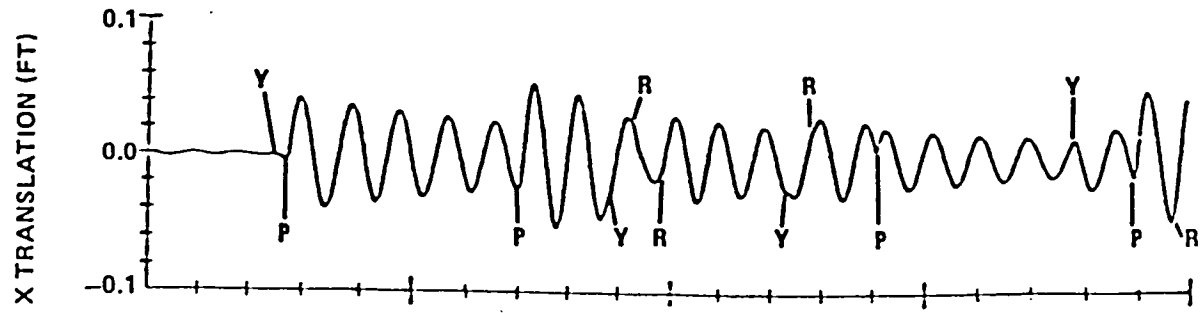

NOTE: TIMES OF ROLL (R), PITCH (P) AND YAW (Y) FIRINGS ARE INDICATED

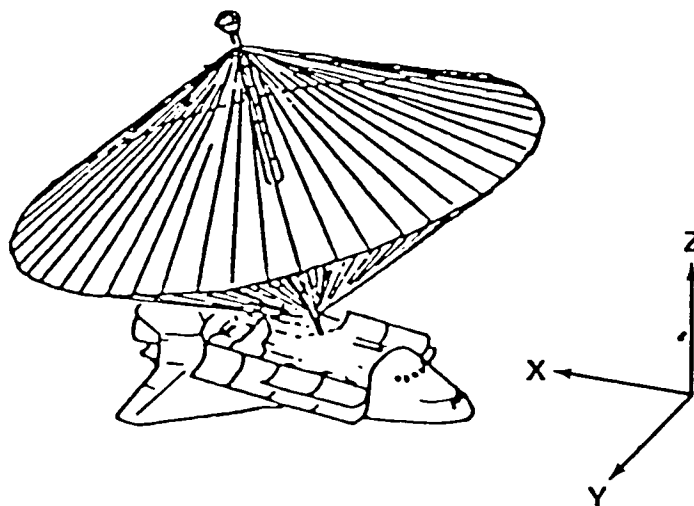

FIGURE 4.4 ANTENNA FEED DEFLECTION DUE TO FLEXURE

4.3 Frequency Standards

In order for a VLBI measurement to succeed, the clock frequencies used in the local oscillators must be stable enough for the accumulated drift over the integration periods to be considerably less than a cycle of RF phase (perhaps 10°). At 8 GHz a 100 second integration (typical of space VLBI) requires a frequency stability of $\sim 3 \times 10^{-14}$. An assessment of present technology indicates a hydrogen maser frequency standard is needed. A hydrogen maser of sufficient stability has been flown on a sub-orbital rocket flight by NASA in the SAO Gravity Probe-A (Redshift) experiment in 1976 and hence the technology is available. Current flight qualified crystal oscillators and cesium or rubidium frequency standards do not have sufficient stability to be used at high frequencies (≥ 5 GHz), but might be used at lower frequencies. For free-flyer VLBI observatories which spend a significant portion of each orbit at altitudes greater than 5000 km, direct line of sight communication to Deep Space Network tracking sites is possible most of the time, allowing the frequency stability of a ground-based hydrogen maser to be transferred to the spacecraft via a self-correcting, two-way Doppler link.

4.4 IF To Digital Electronics

After the signal has been mixed at the receiver with the clock-generated local oscillator signal and converted to an IF signal, it must be down converted again to a video signal and then sampled and digitalized. In addition, time synchronization information must be kept with the data. The Mark III VLBI system developed for NASA by Haystack Observatory has become a standard ground-based VLBI system and is now in use at several observatories. The video converters and data formatter required to perform this function fit in $1/2$ of a standard 19" rack. These electronic modules could be repackaged and qualified for space use, either in the Shuttle, Space Platform or free-flyer environments.

4.5 Data Recording

The Mark III system, as used in ground-based observations, can record a maximum of 28 -2 MHz channels. Each channel has been 1 bit sampled at the Nyquist frequency, twice the bandwidth. Hence, each station can generate as much as $28 \times 2 \times 2 \times 10^6 = 112$ M bits/s. This data is normally recorded on a modified Honeywell instrumentation tape recorder. This large data rate will be one of the primary concerns for orbital VLBI. The Mark III systems are modularized in terms of channels, each of which can generate at most 4 Mb/s of data (2 MHz bandwidth). Clearly, the number of channels included in a given Orbiting VLBI application will depend on the data storage or transmission capability available.

For Shuttle applications, where the data can easily be recorded and carried back to the ground, the most promising solution may be standard cassette video recorders, each of which is capable of recording one 4 Mb/s channel. The use of several recorders (up to 4) would then provide a reasonable total bandwidth. Instrumentation recorders might be possible, but may not be suitable for the Shuttle environment (size, power, dissipation, etc.).

4.6 Summary of Technological Readiness

The subsystems required to support an orbiting VLBI mission are technologically ready. Antennas as large as 50 meters appear to be technically feasible; however, testing in space is probably required. Existing GaAs FET technology provides acceptable system noise temperatures. An appropriate hydrogen maser frequency standard has been built and flown in space, and free-flyer missions may not require on-board frequency standards. The IF to digital electronics are routine. The data volume can be handled either with on-board recording or direct data transmission, depending on the mission.

5.0 A SHUTTLE-BASED DEMONSTRATION

As discussed in the introduction, an acceptable first step in the development of VLBI observatories in space could be to demonstrate the concept and necessary technology with a Shuttle-based experiment. Although the technology required for a free-flying or space platform-based VLBI instrument is considered current state-of-the-art, some of the major technology components, such as large (~ 50 m diameter) deployable antennas have not flown in space. In addition, a Shuttle-based mission would allow all aspects of a space VLBI system to be tested: RF instrumentation, antenna performance, data acquisition systems, data processing, and radio source brightness map construction.

The purpose of a proposed Shuttle mission is actually two-fold:

- (1) to demonstrate the deployment and use of a large deployable antenna in space, and
- (2) to prove that Radio Astronomy science can be done with a space-borne VLBI observatory.

The mission and system parameters to conduct the Shuttle-based VLBI demonstration experiment are summarized in Table 1.

Large deployable antennas in space are being pursued for a number of different uses: VLBI, communications, remote sensing, and DoD applications. Although deployable antennas of the 10 meter class have been flown in space before, a 50 meter antenna would be a significant jump in civilian technology. The construction of such a large scale antenna is considered to be state-of-the-art, but there is no way to test such as antenna on the ground due to effects such as gravitational stresses. Hence, it is prudent to check the deployment, surface quality, operating characteristics, and pointing mechanism of a large deployable antenna on a short Shuttle mission before such a structure is committed to a longer term mission.

A successful Shuttle-based VLBI experiment will provide the confidence to undertake a longer lifetime VLBI mission. The Shuttle experiment by itself will yield important scientific results, but primarily will demonstrate the feasibility of the VLBI technique in space and provide a testing ground for the operational procedures. It will therefore provide a secure base for follow-on VLBI space facilities.

A possible mission plan for a 7-day Shuttle test flight might be to perform tests of the antenna itself for the first half of

TABLE I.
VLBI DEMONSTRATION EXPERIMENT
PARAMETERS

ANTENNA
SYSTEM

SURFACE ACCURACY	FREQ. (GHz)	BEAM TYPE	POLARIZATION	RECEIVER BANDWIDTH	SYSTEM NOISE TEMPERATURE
$> \frac{\lambda}{30}$ @ 1.4 GHz	1.66 2.3 8.4	SINGLE	ONE SENSE - CIRC. POL. TO BE DETECTED	100 MHz	160°K @ FEEDPOINT

5-2

POINTING
REQUIRE-
MENTS OF
ANTENNA
SYSTEM*

ELECTRICAL AXIS	ANT. TRACKING/ POINTING SUBSYS.	KNOWLEDGE OF POINTING	SLEW RATE	INTEG. TIME
POINTED TO WITHIN 1/2 BEAMWIDTH OF TARGET	$\pm 0.025^\circ$	$\pm 0.01^\circ$	3° /MIN	60 SEC (REQUIRED TO TRACK SOURCE FOR 60 SEC WITHOUT VRCS FIRING)
----- 1.66 GHZ - 0.25° 2.3 - 0.18° 8.4 - 0.05°				

ORBIT
REQUIRE-
MENTS

ALTITUDE	INCLINATION	POSITION KNOWLEDGE	VELOCITY KNOWLEDGE
MINIMUM: 350 km	$40^\circ \leq i \leq 57^\circ$	± 10 km	± 1 m/SEC

* ANTENNA SYSTEM POINTING INCLUDES: ORBITER, ANTENNA STRUCTURE, MOVABLE FEED/SUBREFLECTOR AND BEAM STEERING TO REACH REQUIRED ACCURACIES.

the mission, while devoting the second half of the mission to a VLBI demonstration. The option of a second flight is an attractive possibility in case additional data or increased confidence is desired.

One half of the mission duration allows for 3-1/2 days of VLBI data acquisition. This period would be broken down into a series of distinct observations of both northern and southern hemisphere extragalactic radio sources. Each experiment would consist of acquiring, digitizing and recording onboard data, which would later be processed on the ground to yield brightness contour maps of the sources. Data acquisition for each source would take 8 to 12 hours. Allowing an hour or so for pointing slews and source acquisition, seven experiments can be performed in the 3-1/2 days. A few experiments might be repeated at a backup lower frequency.

The optimum orbit for a Shuttle demonstration is one that provides the most complete u-v plane coverage in the least observation time. Brief studies have shown that orbital inclinations between 40 and 57° will permit adequate coverage of northern, southern and equatorial sources. Altitude is not critical for VLBI observations, although higher altitudes (400 km) increase ground station viewing periods which may be desirable for real time interferometer performance verification. The altitude must be high enough, however, to minimize aerodynamic torques on the antenna system. The final observing program selection will be made a few months prior to launch based on the current state of knowledge regarding the various source structures and intensities. In general, orbital requirements imposed by the VLBI and deployable antenna experiment appear to be easily met by the Shuttle.

A preliminary VLBI flight system design capable of meeting the demonstration objectives and utilizing, to the maximum extent, existing capabilities and technologies is shown schematically in Figure 5.1. The baseline system, where data is recorded on-board the Shuttle during the mission and later correlated with data from ground-based observations, is shown in Figure 5.2. The primary observing frequency will be at X-band (8.4 GHz) with S-band (2.3 GHz) serving as backup. The frequency choice is based on the fact that the interferometer resolution improves at shorter wavelengths, therefore making X-band observation more desirable. However, this must be consistent with antenna pointing limitations. The VLBI ground stations now located in the northern hemisphere can provide coverage in both frequency bands. The DSN and Australian VLBI stations provide a similar capability for the southern hemisphere.

110-82

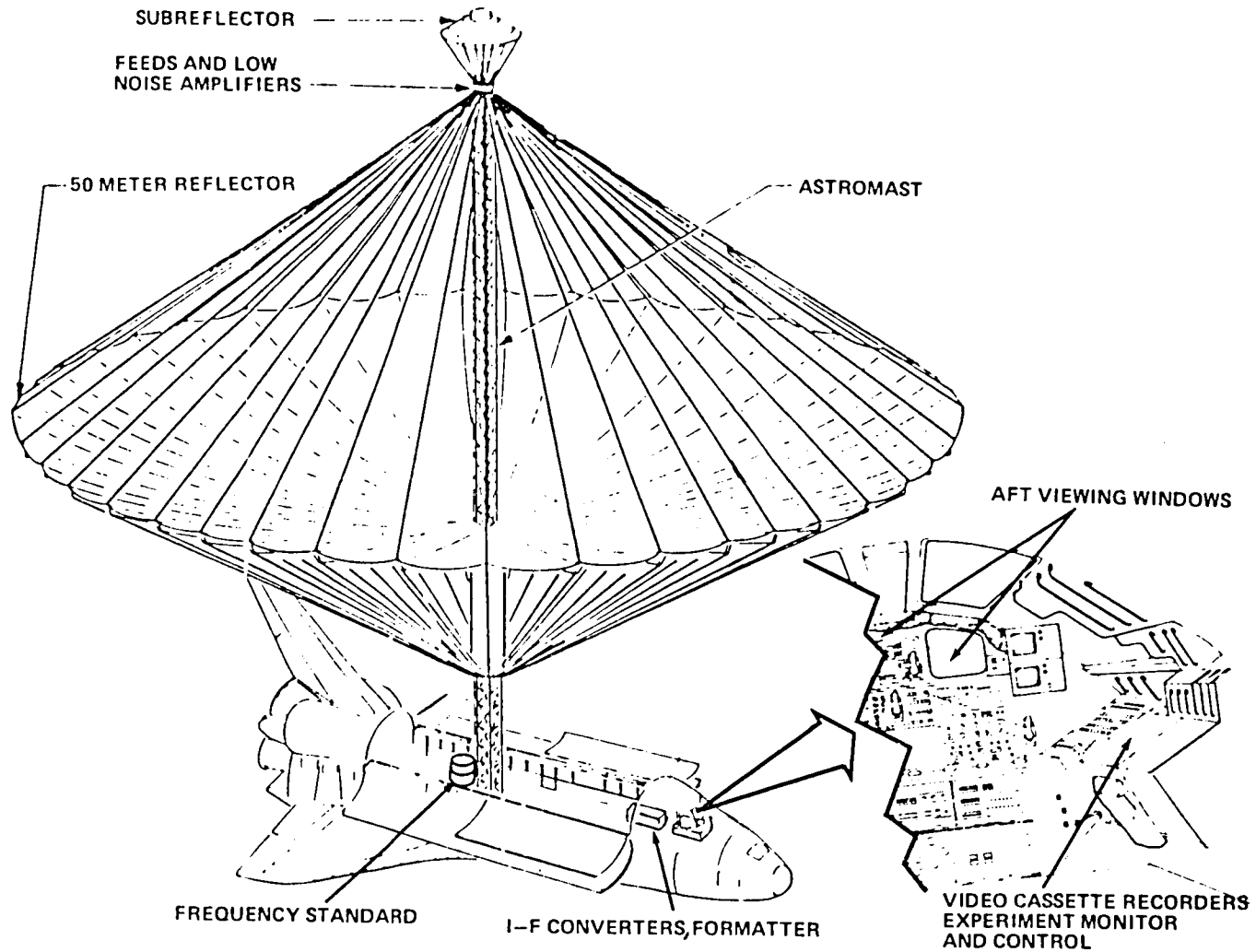

5-4

FIGURE 5.1 SHUTTLE/VLBI FLIGHT SYSTEM

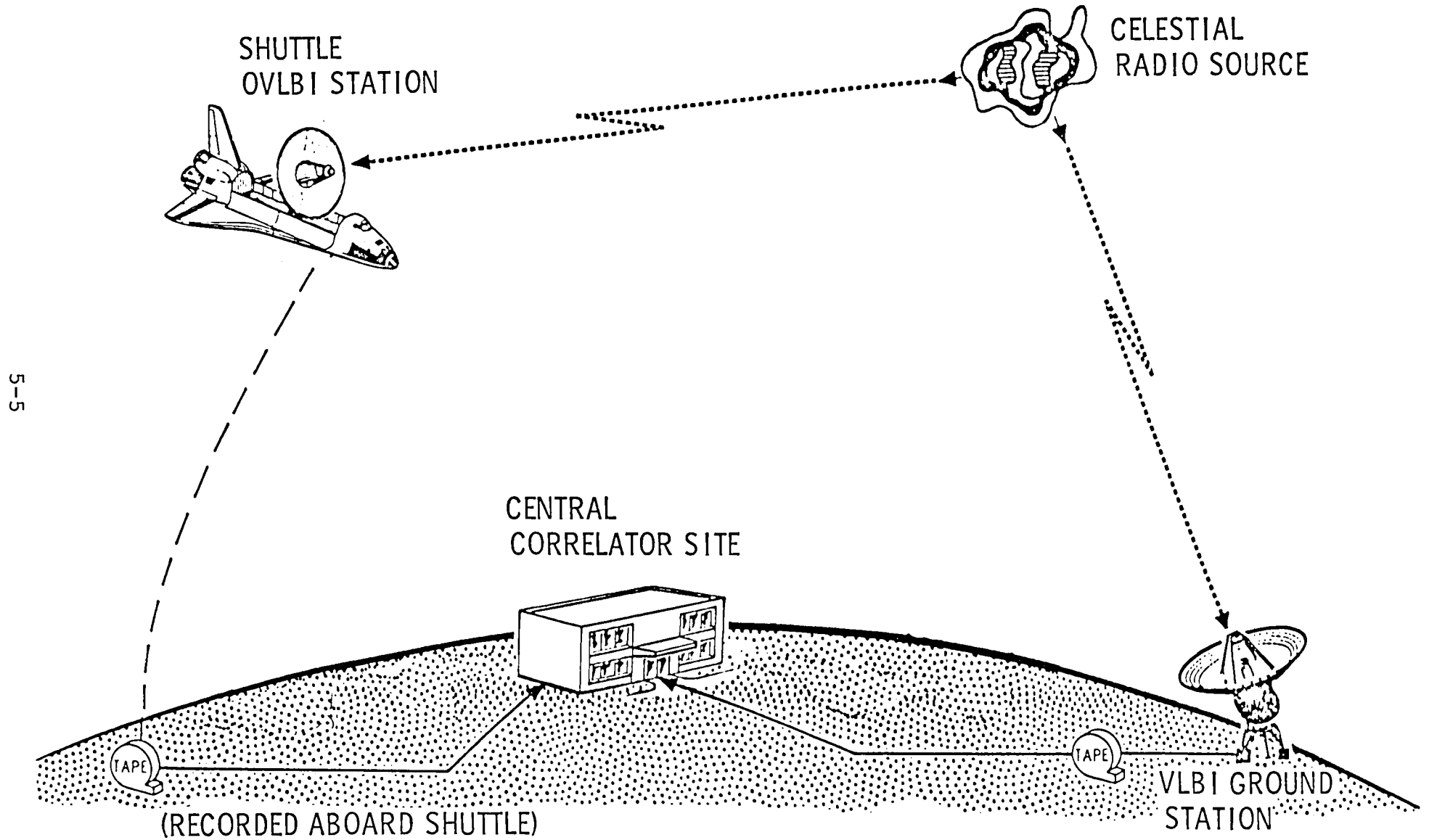

5-5

FIGURE 5.2 SHUTTLE/VLBI DATA MANAGEMENT CONFIGURATION

An essential element of any long baseline interferometer is a highly stable frequency standard. It is necessary to maintain maximum correlation over the period which the data is being integrated. For the Shuttle orbit a maximum integration time of 60-100 seconds is set by the motion of the beam across the U-V plane, i.e. a longer period would result in smearing between cells. This time, coupled with the observing frequency and allowable error, dictates a frequency stability of a few parts in 1×10^{-14} . Such stability is achievable using current operational hydrogen masers for the ground stations. A version of the flight qualified hydrogen maser flown on the NASA/SAO Gravitational Redshift Experiment would suffice for the orbiter frequency standard.

Simultaneously at each ground station the received energy will be down converted, amplified, digitized and recorded, using the Mark III VLBI instrumentation system. A similar process will occur on the orbiter with data being recorded on video cassette recorders (VCR). The use of VCR's permits relatively high bit packing densities, using physically compact recorders. This permits several recorders to be placed in the cabin area, thus enhancing the reliability.

With the exception of occasional tape changes, most operations will be automatic, thereby minimizing crew training requirements. Control and display equipment is provided in the aft-cabin areas to permit status monitoring of the various subsystems.

Most of the electronics equipment can be located in the cargo bay area, using two standard size equipment racks. The microwave low noise amplifiers and down converters are located on the uppermost portion of the antenna to permit close proximity to the antenna feeds. This is necessary in order to achieve low system noise temperatures and consequent high signal to noise ratios.

Probably the most demanding aspect of the experiment, from an engineering viewpoint, is the antenna pointing. For a 50 meter antenna operating at S- and X-bands, the resultant half-power beamwidths are approximately 0.18° and 0.05° respectively. The Shuttle itself cannot maintain absolute pointing to within 0.05° , thus some means is needed to acquire and maintain the source within the halfpower points. A system for maintaining highly accurate antenna pointing using the energy received from a radio source has been developed by the DSN and is now operational in ground antennas. A very preliminary analysis indicates a variant of this technology could provide the necessary pointing accuracy for a flight system. More analysis and simulation work is required in this area to permit selection of the optimum design approach, however results thus far have been encouraging.

In general, the integration of the VLBI experiment with the Shuttle-based deployable antenna experiment appears to be a relatively straightforward application of existing technology and hardware. The additional capability provided by the VLBI equipment may, in fact, enhance the evaluation of the antenna microwave performance. Such a Shuttle-based demonstration would be a very profitable first step for VLBI in space.

APPROVAL

SHUTTLE VLBI EXPERIMENT;
TECHNICAL WORKING GROUP SUMMARY REPORT

Edited by:

Samuel H. Morgan

and

David H. Roberts

The information in this report has been reviewed for technical content. Review of any information concerning Department of Defense or nuclear energy activities or programs has been made by the MSFC Security Classification Officer. This report, in its entirety, has been determined to be unclassified.

Herman P. Gierow
Director
Advanced Systems Office

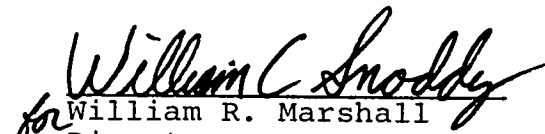
for William R. Marshall
Director
Program Development

1. The first part of the document discusses the importance of maintaining accurate records of all transactions.

2. It is essential to ensure that all entries are supported by appropriate documentation and receipts.

3. Regular audits should be conducted to verify the accuracy of the records and identify any discrepancies.

.

.

.

.

LANGLEY RESEARCH CENTER



3 1176 00181 6066

