

- Panels
1. Sparecraft & Ground Support
  2. Test environment
  3. Sequence of Events
  4. Disassembly activities  
Items removed list



# REPORT OF APOLLO 204 REVIEW BOARD

TO

THE ADMINISTRATOR

NATIONAL AERONAUTICS AND SPACE ADMINISTRATION

**APPENDIX D**

PANELS 1 thru 4

N.A.S.A. HISTORICAL  
ARCHIVES

NO. \_\_\_\_\_

250 pgs

#### **APOLLO SPACECRAFT**

The spacecraft (S/C) consists of a launch escape system (LES) assembly, command module (C/M), service module (S/M), and the spacecraft/lunar module adapter (SLA). The LES assembly provides the means for rapidly separating the C/M from the S/M during pad or suborbital aborts. The C/M forms the spacecraft control center, contains necessary automatic and manual equipment to control and monitor the spacecraft systems, and contains the required equipment for safety and comfort of the crew. The S/M is a cylindrical structure located between the C/M and the SLA. It contains the propulsion systems for attitude and velocity change maneuvers. Most of the consumables used in the mission are stored in the S/M. The SLA is a truncated cone which connects the S/M to the launch vehicle. It also provides the space wherein the lunar module (L/M) is carried on lunar missions.

#### **TEST IN PROGRESS AT TIME OF ACCIDENT**

Spacecraft 012 was undergoing a "Plugs Out Integrated Test" at the time of the accident on January 27, 1967. Operational Checkout Procedure, designated OCP FO-K-0021-1 applied to this test. Within this report this procedure is often referred to as OCP-0021.

#### **TESTS AND ANALYSES**

Results of tests and analyses not complete at the time of publication of this report will be contained in Appendix G, Addenda and Corrigenda.

#### **CONVERSION OF TIME**

Throughout this report, time is stated in Greenwich Mean Time (GMT). To convert GMT to Eastern Standard Time (EST), subtract 17 hours. For example, 23:31 GMT converted is 6:31 p.m. EST.

**REPORT OF PANEL 1  
SPACECRAFT AND GROUND SUPPORT EQUIPMENT  
CONFIGURATION  
APPENDIX D-1  
TO  
FINAL REPORT OF  
APOLLO 204 REVIEW BOARD**



## TABLE OF CONTENTS

- A. TASK ASSIGNMENT
- B. PANEL ORGANIZATION
  - 1. MEMBERSHIP
  - 2. COGNIZANT BOARD MEMBER
- C. PROCEEDINGS
  - 1. INVESTIGATIVE APPROACH
    - a. SPACECRAFT
    - b. SPACECRAFT INTERFACES
    - c. GROUND SYSTEM
  - 2. PRESENTATION OF DATA
    - a. LAUNCH CONFIGURATION
      - (1) SPACECRAFT
      - (2) SPACECRAFT INTERFACES
      - (3) GROUND SYSTEM
    - b. REQUIRED TEST CONFIGURATION
      - (1) SPACECRAFT
      - (2) SPACECRAFT INTERFACES
      - (3) GROUND SYSTEM
    - c. CONFIGURATION AT TIME OF ACCIDENT
      - (1) SPACECRAFT
        - (a) DOCUMENTATION
        - (b) DATA SYNOPSIS
          - 1. SIGNIFICANT CONFIGURATION ITEMS
          - 2. ITEMS WHICH MAY HAVE RELEVANCE TO  
FLAME PROPAGATION
      - (2) SPACECRAFT INTERFACES
        - (a) DOCUMENTATION
        - (b) DATA SYNOPSIS
      - (3) GROUND SYSTEM
        - (a) DOCUMENTATION
        - (b) DATA SYNOPSIS
    - d. POST-ACCIDENT CONFIGURATION

- e. PLUGS IN TEST CONFIGURATION
    - (1) SPACECRAFT
    - (2) SPACECRAFT INTERFACES
    - (3) GROUND SYSTEM
  - f. CONFIGURATION FOR ALTITUDE CHAMBER TEST
    - (1) SPACECRAFT
    - (2) SPACECRAFT INTERFACES
    - (3) GROUND SYSTEM
  - g. SPACECRAFT 008 TEST CONFIGURATION
- D. FINDINGS AND DETERMINATIONS
- E. SUPPORTING DATA

#### ENCLOSURES

- 1-1 SPACECRAFT CONFIGURATION
- 1-2 VIEW OF SPACECRAFT LAUNCH VEHICLE IN SERVICE  
STRUCTURE WITH ACCESS ARM EXTENDED
- 1-3 AERIAL DRAWING OF LAUNCH COMPLEX 34
- 1-4 SCOPE OF INVESTIGATION
- 1-5 CUMULATIVE EO RELEASES SUBSEQUENT TO DELIVERY  
S/C 012
- 1-6 VIEW OF COMMAND MODULE MOCKUP INTERIOR, LESS COUCHES
- 1-7 VIEW OF COMMAND MODULE MOCKUP INTERIOR, COUCHES  
INSTALLED
- 1-8 CREW COMPARTMENT STOWAGE AND LOOSE EQUIPMENT  
CONFIGURATION
- 1-9 SPACECRAFT/GSE INTERFACE DRAWINGS
- 1-10 LIST OF REFERENCES

#### GLOSSARY OF TERMS

# SPACECRAFT AND GROUND SUPPORT EQUIPMENT (GSE) CONFIGURATION PANEL

## A. TASK ASSIGNMENT

The Apollo 204 Review Board established the Spacecraft and Ground Support Equipment (GSE) Configuration Panel 1. The task assigned for accomplishment by Panel 1 was prescribed as follows:

Establish and document physical configuration of spacecraft and GSE immediately prior to and during fire accident including equipment configuration, switch position, and nonflight items in cockpit. By deviation, document configuration differences with respect to expected launch configuration and configurations used in previous testing, (altitude chamber, for example), as pertinent to this problem. To a lower level of detail, document configurational difference between the spacecraft and other spacecraft as pertinent to this problem.

In response to the task assignment, the Panel Chairman presented for Board approval a Statement of Work which further described the individual elements of the task. The Statement of Work defined the term, "Spacecraft and GSE Configuration", as: "The physical state of the Spacecraft and/or supporting systems, including components, ground equipment, facilities, and their interfaces at a specified point in time."

## B. PANEL ORGANIZATION

### 1. MEMBERSHIP:

The assigned task was accomplished by the following members of the Spacecraft and Ground Support Equipment (GSE) Configuration Panel:

Mr. Jesse F. Goree, Jr., Chairman, Manned Spacecraft Center (MSC), NASA  
Mr. Charles D. Gay, Kennedy Space Center (KSC), NASA  
Mr. Carroll R. Rouse, Kennedy Space Center (KSC), NASA  
Mr. Charles R. Haines, Manned Spacecraft Center (MSC), NASA  
Mr. Ronald V. Murad, NASA Headquarters, Office of Manned Space Flight  
Mr. William F. Edson, North American Aviation, Inc., Kennedy Space Center (KSC)  
Mr. Ray F. Larson, North American Aviation, Inc., Kennedy Space Center (KSC)

### 2. COGNIZANT BOARD MEMBER:

Mr. John J. Williams, Kennedy Space Center (KSC), NASA, Board Member, was assigned to monitor the Spacecraft and Ground Support Equipment (GSE) Configuration Panel.

## C. PROCEEDINGS

### 1. INVESTIGATIVE APPROACH

Enclosures 1-1, 1-2, and 1-3 are general representations of the Spacecraft, Launch Vehicle and Launch Complex, and are provided to aid the discussions contained in this section. This Panel pursued the investigation in terms of exceptions to the required launch configuration. For this purpose, the required launch configuration was defined as that documented by engineering data approved (released) for implementation. Identification of the configuration differences existing at the time of the accident was accomplished through review of work records against released engineering data. These differences were analyzed to identify items pertinent to the accident. This approach did not constitute presumptions as to the adequacy of the documented launch configuration. Rather, these data were considered to represent the engineering effort accomplished during the design of the Spacecraft and provided a baseline for comparative analyses. The Spacecraft and supporting systems were identified according to the major hardware elements to permit discrete consideration of each element relative to the accident. Major hardware elements were:

- a. Spacecraft (S/C) -
  - (1) Command Module (C/M) interior
  - (2) General configuration of the Command Module, Service Module (S/M), and Adapter
- b. Spacecraft/Launch Vehicle
  - (1) Spacecraft/Launch Vehicle
  - (2) Spacecraft/ground system
- c. Ground system -
  - (1) Spacecraft Ground Support Equipment (GSE)
  - (2) Supporting facilities
  - (3) Remote monitoring and control equipment, including Acceptance Checkout Equipment (ACE), the Operational Inter-Communications System (OIS), and other Radio Frequency (RF) command, record, or audio links.

Configurations of the hardware elements were defined as of the time immediately prior to and following the accident on January 27, 1967. The time of the accident is described as occurring during the performance of Operational Checkout Procedure (OCP) FO-K-0021-1, "Space Vehicle Plugs Out Integrated Test", at the condition of a countdown hold ten minutes (T-10) prior to simulated launch. The term, "Plugs Out", refers to disconnection of spacecraft/GSE umbilicals. The C/M interior was pressurized with oxygen to approximately sixteen pounds per square inch absolute, (psia) during the Space Vehicle Plugs Out Integrated Test. Relevant Spacecraft 012 configuration differences existing at the time of the accident were also documented with respect to launch, previous Spacecraft 012 tests, and the test configuration of another Apollo spacecraft. Documentation of the first of these cases was accomplished as an integral part of defining the configuration immediately prior to and following the accident. The following conditions were used as the bases for the latter two cases:

- a. Spacecraft 012 configuration during Plugs-In Test at T-10 (hold), January 25, 1967. This test represents the last operation of Spacecraft 012 systems prior to start of the Space Vehicle Plugs Out Integrated Test.
- b. Spacecraft 012 configuration during Altitude Chamber Test at T-10 minutes (hold), December 29, 1966. During this test, the spacecraft exterior was exposed to partial vacuum to simulate high altitude operation. The C/M interior was pressurized with oxygen to approximately 16 psia during final preparations for altitude simulation. Following chamber evacuation, the C/M interior pressure was maintained at approximately five and one-half psia. This test was similar to the Space Vehicle Plugs Out Integrated Test in terms of exposure to an oxygen environment.
- c. Spacecraft 008 configuration during Altitude Chamber Test No. 3 at the Manned Spacecraft Center, October 26, 1966. This test also involved exposure to an oxygen environment. Differences in test configuration between Spacecraft 012 and Spacecraft 008 were identified to determine possible relevance to the Spacecraft 012 accident.

The scope of this Panel's activities in documenting the configuration of the hardware elements is schematically represented in Enclosure 1-4.

Initial efforts were those of compiling all data to identify configuration differences existing at the time of the accident. While compiling these data, the Panel was called upon to supply specific configuration data to other Apollo 204 Review Board Panels. A total of 34 special reports were prepared in response to these requests. These configuration data are included in this report to the extent pertinent to the accident. After assembling the necessary source information, the data were collated according to hardware elements and conditions depicted in Enclosure 1-4. Data elements organized in this manner permitted comparative analyses from which significant differences could then be identified.

## 2. PRESENTATION OF DATA.

Data assembled during the course of this investigation are summarized in the following paragraphs according to the specific conditions and hardware elements considered.

- a. Launch Configuration. The required launch configuration of Spacecraft 012 and its supporting systems is identified by basic documentation. This documentation is described as follows:



(1) Spacecraft. Released engineering drawings listed in the "Spacecraft 012 Configuration Index", January 29, 1967. The individual component parts are identified, by part number, in "Spacecraft 012 Indentured Parts List", January 28, 1967. Note: Configuration Index and Indentured Parts List are computer tabulations for which input data was updated continuously prior to the accident. These data were retrieved on the dates indicated.

(2) Spacecraft Interfaces. Interfaces between the Spacecraft and Launch Vehicle are defined by applicable Interface Control Drawings (ICD's):

(a) "Instrument Unit to Spacecraft Physical Requirements, ICD 13M20408."

(b) "Instrument Unit to Spacecraft Lunar Module Adapter (SLA) Electrical Interface (S/C 012), ICD 40M37508A."

Spacecraft-to-ground system interface connections were specified in the "Launch Complex 34 Checklist, OCP FO-K-10011," and implemented in accordance with the "GSE Functional Integrated System Schematics." Physical provisions for these connections are defined by detailed spacecraft and GSE drawings. The spacecraft-to-launch vehicle and spacecraft-to-ground system interfaces are depicted in Enclosure 1-9, Drawing 1-D-0056-2.

(3) Ground System. The required configuration of the spacecraft GSE is prescribed by the "GSE Functional Integrated System Schematics," according to the particular checkout or servicing operation to be performed. "Operational Checkout Procedure, OCP FO-K-0007," prescribes the sequence of launch operations, referring to the "Launch Complex 34 Checklist, OCP FO-K-10011," for detailed GSE connections, operations, and disconnections. The checklist provides only a narrative statement of the operations; therefore, it must be used in conjunction with the "GSE Functional Integrated System Schematics." Basic design interfaces between the spacecraft GSE, supporting facilities, and remote monitoring and control equipment are defined in numerous ICD's (Reference 1-8). Configuration requirements of these ICD's are reflected in released engineering data.

b. Required Test Configuration. Certain of the released engineering orders (EO's) specify that they are to be accomplished prior to a test which follows the Space Vehicle Plugs Out Integrated Test; for example, Flight Readiness Test (FRT) or Countdown. However, explicit definition of total spacecraft configuration requirements for the Space Vehicle Plugs Out Integrated Test did not exist in the form of released engineering data. The Operational Checkout Procedure for the Space Vehicle Plugs Out Integrated Test, OCP FO-K-0021-1, specified the functional configurations prescribed for the test. These functional configuration requirements include those items required to be different from the launch configuration to permit accomplishment of the simulated launch less the physical event. Both the engineering data and the test documentation leave definition of the required test configuration to inference as opposed to explicit specifications.

The test operation involved a procedure wherein all work not accomplished to meet launch requirements was reviewed to identify those open items which would constrain accomplishment of the test. Therefore, the decision to proceed with the test has been construed by this Panel to mean that all recognized constraints were satisfied. This aspect of configuration requirements was considered in cooperation with Test Procedures Review Panel, 7, and is discussed further in Appendix D-7.

Items required to be different from the launch configuration for reasons of test conditions and procedures are summarized in the following paragraphs:

(1) Spacecraft. Spacecraft configuration differences authorized by OCP FO-K-0021-1 and engineering orders (EO's) for the Space Vehicle Plugs Out Integrated Test were as follows:

(a) Open access panels to permit GSE connections.

(b) Expendables not on board to preclude unnecessary exposure of systems to contamination or hazards to operation.

(c) Fuel cells not activated to preclude partial reduction of useful life.

(d) Electrical circuits to pyrotechnic devices interrupted and shorting plugs installed to prevent actual firing during simulated mission sequence.

(e) Boost Protective Cover installation not completed to permit access to GSE connections.

(f) Circuits from S/M batteries to S/M jettison controller interrupted. This was to prevent

continuous applications of voltage to Reaction Control System (RCS) jet solenoids (simulated by load boxes) following simulated Service Module/Command Module separation.

(g) Installation of test batteries (flight type) to preclude power drain from units assigned (by serial number) for the actual mission.

(h) Those items specifically required to be accomplished as of a planned test subsequent to the Space Vehicle Plugs Out Integrated Test. These items are specified by Engineering Orders which are identified as open EO's (See Reference 1-10).

(2) Spacecraft Interfaces. Differences required for the test operations were:

(a) Facility air supply through C/M access panel to the space between pressure vessel and heat shield to provide humidity control.

(b) Connection of ground-supplied oxygen in absence of on board supplies.

(c) Special umbilical interface for water/glycol circulation to prevent disconnection at time of umbilical separation in planned mission sequence.

(d) Connection of isolated power supply to maintain water/glycol return valve in open position (to continue external conditioning) following planned umbilical separation.

(e) Connections for GSE battery rack to be used as fuel cell substitute following planned simulated transfer to internal power.

(f) Special interfaces for S/C antennas to provide RF link to ground system.

(g) Connection of RCS load boxes (simulators) to permit testing of flight controls, yet preclude exercising RCS jet solenoids.

(h) Installation of fuse boxes in the electrical interface between the spacecraft and the launch vehicle to protect computers in the Instrument Unit from any adverse conditions during the test.

(3) Ground System. The required ground system configuration differences from the launch configuration were those required in support of the interfaces described in paragraph B.3.b(2). The ground system and interface configurations are depicted in the following drawings of Enclosure 1-9.

TITLE	NUMBER
S/C/Range/Launch Vehicle Interfaces, T-10, OCP FO-K-0021-1	1-D-0056-3
S/C/GSE Configuration during T-10 Hold, OCP FO-K-0021-1, Electrical	1-D-0056-4
Launch Complex 34 (LC 34) ECS Airduct	1-D-0056-7
S/C/GSE Configuration during T-10 Hold, OCP FO-K-0021-1, Mechanical	1-D-0056-8

#### c. Configuration at Time of Accident

Data prescribing the configuration at the time of the accident were obtained from configuration management records as supplied by Panel 6 (Historical Data), witness reports, and special reports submitted by other organizations. Pertinent information contained in special reports prepared after the accident was verified by this Panel. Panel 1 also prepared documentation of configuration elements based upon post-accident inspection in those cases where complete data were not otherwise available. These data are discussed in the following paragraphs.

##### (1) Spacecraft.

(a) Documentation: Differences between the launch configuration and the configuration at the time of the accident are documented by the following:

1. "Spacecraft 012 Configuration Verification Record (CVR)," January 28, 1967.

This document identifies the work status of all released EO's effective on Spacecraft 012 which were not accomplished at time of receipt at KSC or were released subsequently. The CVR is a computer tabulation of data inputs as of the start of Space Vehicle Plugs Out Integrated Test which was retrieved on the date indicated. Enclosure 1-5 is a graphical representation of cumulative EO releases and work status subsequent to delivery of Spacecraft 012. While verifying this document, Panel 1 identified several EO's partially accomplished at the time of the accident. These EO's are listed in Reference 1-12. Also, twenty-two EO's listed in Reference 1-13, were released subsequent to closeout of the CVR, and were not accomplished as of the time of the accident. A summary listing of all EO's open at the time of the accident was prepared by the Panel and is contained in Reference 1-10. This listing includes those released for incorporation through normal work schedules as well as those constrained for incorporation at a time subsequent to the Space Vehicle Plugs Out Integrated Test.

2. "Spacecraft 012 Test and Acceptance Inspection Report (TAIR)." This document consists of several volumes (or books) with entries for each work item initiated on the Spacecraft. Entries reflect the part affected, authorizing documents, entry date, closeout date, quality control inspection stamps. Entries pertinent to this Panel's investigation are those of "Parts Installation and Removal Records (PIRR's)," and "Temporary Installation Records (TIR's)." "Discrepancy Reports/Material Review (DR/MR)" actions, Type A "Test Preparation Sheets (TPS's)" and OCP requirements authorize work on the Spacecraft. The PIRR is used to record any work against a previously installed and accepted part or the installation of a new part; for example, removal of a part for rework, removal of a part for access, disconnection of mated connectors, etc. The TIR is used to record temporary installations which must be removed to meet requirements of the launch configuration. Entries in either of these records constitute open items until such time as the affected part is returned to the launch configuration and verified by quality control inspection. DR/MR actions result from discrepancy reports which are dispositioned for correction by minor form or fit changes under authority of the Materials Review Board. Type "A" TPS's authorize work to be accomplished on the Spacecraft in conformance with released EO's. PIRR's and TIR's reflect TPS, DR/MR, or OCP authority. PIRR's and TIR's open at the time of the accident were reviewed by the Panel and are listed in Reference 1-10.

3. "Spacecraft 012 Controls Configuration" (switch and valve positions). This document was prepared by Panel 1 and is provided as Reference 1-15. Data presented in this document relative to the controls configuration before the accident were obtained from the accomplished parts of the OCP. The document also contains comparisons of control configurations at other specified times.

4. "Crew Compartment Stowage and Loose Equipment Configuration." Data contained in Enclosure 1-8 were compiled from Reference 1-16, 1-17 and 1-18. This enclosure identifies the stowed equipment and materials that were in the Spacecraft at the time of the accident. This information was used to configure a mockup of the C/M to portray the configuration of Spacecraft 012 immediately prior to the accident. Enclosure 1-6 is a photograph of this mockup, less crew couches. Enclosure 1-7 is a picture of the mockup with couches and umbilicals installed. The mockup was used by Panel 5 (Origin and Propagation of Fire) to study possible fire propagation paths.

(b) Data Synopsis: Review of the data discussed previously reveals that 80 EO's were outstanding at the time of the test. Of these, 20 were specified to be accomplished subsequent to the Space Vehicle Plugs Out Integrated Test and four were of a nature not affecting configuration. A total of 384 PIRR's /TIR's were open, of which 125 were initiated as requirements of the test. The remaining 259 items reflect incomplete status of further work to have been accomplished prior to launch. Open items represented by these figures were identified through reconciliation of configuration records with witness reports and results of post-accident inspection. Procedures for TAIR entries required that removal of a part be documented by PIRR, and that installation of a temporary replacement be entered on a TIR. In some in-

stances, this resulted in two entries against a single change action. Many of the PIRR's/TIR's were not relevant as they affected items such as Service Module access panels or protective covers on external components. Significant items contained in the referenced data are identified in two categories: Significant configuration items, and items which may have relevance to flame propagation. These items are presented below.

#### 1. Significant Configuration Items

a. Investigation of the released engineering and work orders for the installation of new debris traps has shown that this work was only partially complete. Engineering Order No. 582252 released the debris trap modification kit. This modification provides for the replacement of the fish-net type of debris traps with Raschel net debris traps. All old-type debris traps were removed. Eleven (11) of twenty-five (25) new debris traps were installed prior to start of test. This replacement was documented on the authorizing TPS.

b. Flight items installed in other than normal configurations:

(1) Two 16-mm sequence cameras and a camera power cable were stowed loose on the floor of the gas chromatograph installation area. The normal stowage position of these items is one camera with cable in Scientific Compartment "A" and one camera in Scientific Compartment "G."

(2) A Dew Point Hygrometer Sensor, sensor cable, power cable, and control unit, were stowed loose on the floor of the gas chromatograph installation area. The normal stowage position of these items is scientific compartment "D."

(3) The drinking water dispenser was not connected to the hose.

c. The Spacecraft controls configuration which existed at the time of the accident was in accordance with the planned procedure specified in Operational Checkout Procedure FO-K-0021-1 with the following exceptions:

(1) The crewmen's audio center communications controls configuration which existed at the time of the accident differed from the planned procedure due to the troubleshooting of the communications systems during the tests. The exact configuration of these controls at the time of the accident cannot be determined. The configuration as found after the accident would have permitted all three crewmen to have two-way communication both within the Spacecraft and to the ground.

(2) The switch labeled "VHF ANTENNA" (Very High Frequency Antenna Selector Switch) was specified to be in the "UPPER" position, but was changed to "LOWER" per ground personnel request during the communication troubleshooting. This action switched the active VHF antennas.

(3) The switch labeled "S-BAND ANTENNA" (S-Band Antenna Selector Switch) was specified to be in the "UPPER" position, but was changed to "LOWER" per ground personnel request during the communications troubleshooting. This action switched the active S-Band antennas.

(4) The switch labeled "H<sub>2</sub>O ACCUM AUTO/MAN/AUTO" (Water Accumulator Mode Selector Switch) was specified to be in the "MAN" (Manual) position, but was changed to "AUTO" (Automatic) during the test per flight crew request. In the "AUTO" position, the cyclic accumulator is actuated automatically every ten minutes to remove moisture from the suit loop gases. In the "MAN" position, the cyclic accumulators must be cycled by the crew using the switch labeled "H<sub>2</sub>O ACCUM/ON/OFF/ON" (Manual On-Off Switch) as required.

(5) The switch labeled "AC INVERTER 2 MNB/OFF" (Inverter Number 2 Power Switch) was specified to be in the "OFF" position, but was changed to "MNB" (Main Bus B) by recorded deviation to the OCP during the test. "MNB" is the correct position, supplying the Main Bus B power to Inverter No. 2.

d. Earth Landing System sequence cover panel assembly in right-hand equipment

bay removed on January 23, 1967. Removed per OCP FO-K- 10011 deviation No. 25 for purpose of connecting Acceptance Checkout Equipment (ACE) connectors. (ACE removed prior to Space Vehicle Plugs Out Integrated Test).

e. Cover on connector on Guidance and Navigation (G&N) computer removed to facilitate installation of 100 series test connector cover which was installed for testing purposes and would be removed before flight.

f. Ten connector caps on Power Servo Assembly (PSA) trays were removed on December 30, 1966.

g. Translation Controller ME901-0171-0204, S/N EAC 1024, installed on left-hand couch, left-hand side on January 24, 1967. Authorization for installation was per Test Preparation Sheet S/C 566 Step No. 3. Controller was installed to support OCP FO-K- 0006 (Plugs In Test) and OCP FO-K-0021-1.

h. Rotational Controller, ME901-0172-0204, S/N DAK 1034, installed in left-hand couch, right-hand side on January 24, 1967. Authorization for installation was per Test Preparation Sheet S/C 566 Step No. 4. Controller was installed to support OCP FO-K-0006 and OCP FO-K-0021-1.

i. Carbon dioxide absorber elements ME901-0218-0001, S/N 24172 and 24171, installed on January 27, 1967, as specified in OCP FO-K-10011 deviation No. 140. Absorber elements are a different configuration than the flight articles (ME901-0218-0001 as compared with -0021-1). Elements installed for Space Vehicle Plugs Out Integrated Test did not have by pass provisions and were enclosed in a glass fiber shell as opposed to aluminum.

j. Pyro Panel (No. 150) was temporarily installed prior to the Plugs In Test, (OCP FO-K-0006). Panel was not fully installed and was recorded as a temporary installation. The panel was out approximately 5 to 6 inches from lower equipment bay panel line and was located on aft bulkhead.

k. Engineering Order (EO 507283) released the requirements for replacing the electrical bonding straps for couches with a strap that is less susceptible to damage. Two of four existing straps were removed on Parts Installation Removal Records. New electrical bond straps (P/N MS 25083-3BB8 and MS 25083-2BB8) were to be installed by TPS-SC 012-SC-535, which was not accomplished prior to the Space Vehicle Plugs Out Integrated Test.

l. Gas Chromatograph (P/N R534845-2-A, Serial Number 5) was removed on December 30, 1966. Replacement of gas chromatograph was not a constraint to the conduct of Space Vehicle Plugs Out Integrated Test or Plugs In Test. The power and sensor connector for the chromatograph had voltage present, and was placed on the shelf of the gas chromatograph compartment. (See Appendix B, Witness Statement No. 44).

m. The Data Storage Electronic Assembly (DSEA) Recorder (P/N LSC-360-12, Serial Number 104) was temporarily installed January 27, 1967. Installation was made in accordance with Test Preparation Sheet (TPS SC 012 583, Step 1P). The temporary installation of the DSEA Recorder was accomplished to provide a flight configuration for the Space Vehicle Plugs Out Integrated Test. The power connector to the DSEA was energized during the test. Post-test investigation revealed that the power connector was not hooked up.

## 2. Items Which May have Relevance to Flame Propagation

a. Engineering Order, (EO 226756) released at the Contractor's Downey facility on January 20, 1967, provided direction to inspect the polyurethane foam (Specification MB0130-039) in specified areas and coat with silicone rubber, (Type II, Specification MB0130-019) to meet flammability requirements. This direction was not recorded in the CVR as of start of Space Vehicle Plugs Out Integrated Test (issued at Contractor's Florida Facility on January 27, 1967,) and was not accomplished on S/C 012. This item is of possible significance in terms of fuel for the fire and as a medium for flame propagation.

b. Polyethylene bags were used to cover the hose fitting for the drinking water dispenser and the battery instrumentation cable and connectors (2) and transducer, which were placed on the aft bulkhead near the batteries. These bags are nonflight materials.

c. Two Polyurethane pads, approximately 20 x 24 x 2 inches, covered with Velostat, were stowed over the Z-Z couch struts. The pads were placed in the Spacecraft to protect the struts, wiring, and aft bulkhead during the planned emergency egress at the end of the test. (See Appendix B, Witness Statement Number 3). These items were nonflight materials and were not documented by quality inspection records.

d. Three packages of switching checklists from Operational Checkout Procedure FO K-0021-1 (multilith process) and one package of system malfunction procedures (Xerox and Bruning processes), in a manila folder were stowed on the crew couches and on the girth shelf. These items were on unqualified paper. While required for the test, these items were not documented by quality inspection records.

e. Nylon protective sleeves were covering all three crewmen's oxygen umbilicals. These were nonflight items.

f. Three GSE window covers were temporarily installed. Covers were installed to protect the windows and are nonflight items that were in the Command Module (C/M) at the time of the accident. Another such cover for the side hatch window was removed by the crew and stowed inside the C/M. Covers are nylon fabric where the flight covers are made of aluminized Mylar.

g. Velcro pile MFL-F-21840A installed to protect Velcro hook on C/M floor. Would have been removed before flight.

h. "Remove before flight" streamers installed in C/M interior. Represents additional nonflight items in C/M.

i. Polyethylene zipper tubing installed to protect hand controller cables. Polyethylene tubing cover is a nonflight item and represents additional material in the C/M.

## (2) Spacecraft Interfaces

(a) Documentation: Configuration of Spacecraft interfaces at the time of the accident is defined by the documentation described below:

1. Spacecraft/Launch Vehicle (SC/LV) interfaces are depicted in Enclosure 1-9, Drawing 1-D-0056-3. Also, details of the SC/LV electrical interface functions are defined in Reference 1-19. These data are based upon review of ICD's 40M37508A, 13M20408, changes thereto, and visual inspection to the extent possible.

2. Spacecraft/Ground System interfaces are represented schematically in Enclosure 1-9, Drawings 1-D-0056-3, -4, -7, and -8. Also electrical cable connections and interface functions are identified in Reference 1-19.

(b) Data Synopsis:

Significant interface differences from the required launch configuration were as follows:

1. The fuel cell battery rack assembly (C14-395) was electrically mated to the connectors from which fuel cells 1 and 3 would (in flight) supply direct current (DC) power to the S/C busses. This was accomplished per Checklist FO-K-1011 and was required due to the fact that the fuel cells were not operating in this test. Power was being supplied through the flyaway umbilical from a ground power source. At T-0 minutes, the umbilical would have been dropped to satisfy test requirements. At T-10 minutes, per the Test Procedure, OCP FO-K-0021-1, bus power would have been transferred from external GSE power to C14-395 battery power (Enclosure 1-9, Drawing 1-D-0056-4).

2. The Y00-085 cable and a power supply were connected to the S/C water/glycol drain and vent shutoff valve S23LV1 (Reference 1-D-0056-8). This valve must be held open by a 28 VDC source in order to maintain water glycol circulation during ground testing. During this test, the flyaway umbilical which normally carries the 28 VDC power is disconnected at T-0 minutes and, the valve would close if not separately powered.

3. The ground oxygen (O<sub>2</sub>) source was connected to the S/C. Oxygen to the Space-

craft was supplied (Reference Schematic 1-D-0056-8) from a bottle source through the O<sub>2</sub> Test Set to the O<sub>2</sub> valve box in the S/C. This particular configuration was being used for the first time at LC 34.

4. A thermocouple was taped to the oxidizer "A" isolation valve and was connected to a GSE meter. During this test, the propellant isolation valves were to be energized for a period of approximately 15 minutes. A technician was to monitor the valve temperature during the actuation time in the test.

5. Seven C/M RCS simulator cables were connected from the simulator boxes to the S/C. These cables were connected from the simulator boxes to the RCS Control Boxes through C/M access panels. Each of these cables ran beneath the Boost Protective Cover (BPC) sections that had been installed surrounding the S/C hatch. Post-test observation indicates that the cable interference with the BPC bulged the installed sections of BPC such that the hatch section of the BPC could not be installed properly.

### (3) Ground System

(a) Documentation: The configuration of the ground system at the time of the accident is described by the following:

1. Spacecraft GSE configurations existing at the time of the accident or used earlier in the test are depicted in Enclosure 1-9, Drawings 1-D-0056-1, -4, -5, -7, -8, and -9. These drawings were prepared for Panel 1 based upon visual inspection and reference to GSE Functional Integrated Schematics for internal detail. The individual GSE models used during the test and change actions not accomplished are tabulated in Reference 1-19.

2. Configuration of supporting facilities was documented by a report prepared by the KSC Launch Facilities Division in support of this Panel's investigation. This report is provided as Reference 1-20. Reference 1-21 is an inventory listing of miscellaneous items found on the service structure platforms after the accident.

3. Configuration of remote monitoring and control equipments are briefly described in Reference 1-20. Reference 1-22, prepared by this Panel, contains further data regarding details of the configuration of the Acceptance Checkout Equipment (ACE), Operations Intercommunications System (OIS), and the Mission Control Center, Houston. The overall configuration of remote monitoring and control equipment at the time of the accident is depicted in Enclosure 1-9, Drawing 1-D-0056-3. The configuration of ACE is shown in Enclosure 1-9, Drawing 1-D-0060. OIS configuration is shown in Drawing 1-D-0062.

(b) Data Synopsis: Significance of the ground system configuration is summarized as follows:

1. No further significance is attached to the Spacecraft GSE configuration beyond that previously discussed under the heading "Spacecraft/Ground System Interfaces."

2. The configuration of supporting facilities within the scope of this Panel's investigation is not represented as pertinent to the accident. The safety aspects of the facility configuration were deferred to Panel 13 (Ground Emergency Provisions Review).

3. The remote monitoring and control equipment were configured according to published requirements and operational procedures. Analyses of difficulties experienced in the communications equipments, as mentioned in Reference 1-22, were referred to Panel 9 (Design Reviews).

### d. Post-Accident Configuration

The damage caused by the fire in the Spacecraft is documented by the Apollo 204 Review Board Photographic Files and by the work records of the disassembly accomplished by Panel 4 (Disassembly activities). Panel 1 considered those aspects of the post-accident configuration necessary to verify certain elements of the configuration existing at the time of the accident and to identify changes in control configuration accomplished during the fire. The scope of these considerations was limited to configuration change actions accomplished during and immediately following the fire. Considerations were based upon photographs and visual inspection by members of this Panel. The significant post-accident configuration differences are summarized as follows:

(1) The rotary switch labeled "BMAG POWER" (Body-mounted attitude gyro power switch) was found in the "OFF" position, whereas it should have been in the "AC2 MNB" (Alternating Current Number 2 and Main Bus B) position. A silhouette pointing to the "AC2 MNB" position

indicates the switch was moved to the "OFF" position after sooting occurred.

(2) Thirty-three circuit breakers which were closed prior to the accident were found "OPEN." The shafts exposed by the circuit breakers opening vary from sooted to clean, giving some gross determination of the relative times at which the different breakers opened (Reference 1-15).

(3) Two switches labeled "MAIN BUS TIE-BAT A & C and BAT B & C" (Battery A and C tie to Main Bus A and Battery B and C tie to Main Bus B) apparently were changed from the "AUTO" to the "ON" positions by the crew after the fire was reported. This action placed Spacecraft batteries A and C in parallel onto Main Bus A and batteries B and C in parallel onto Main Bus B; in addition to the ground power being supplied. This action was not a planned procedure in event of rapid or emergency egress. It could have been taken in an attempt to maintain communication or lighting since emergency procedures called for GSE power off.

(4) The Pad Emergency Egress Procedure specified in the Apollo Crew Abbreviated Checklist, page 15-2 (including planned changes), called for: (a) Turning off the switches labeled "MASTER EVENT SEQ CONT PYRO ARM-1 and -2," (Master Event Sequence Controller Pyrotechnic Arming Switches); (b) "SM RCS PROPELLANT A, B, C, AND D," (Service Module Reaction Control System Propellant Switches for Quads A, B, C and D); (c) Placing the CABIN RELIEF VALVE TO "DUMP"; (d) Opening the four circuit breakers labeled "MASTER EVENT SEQ CONT ARM A BAT A, ARM B BAT B, LOGIC A BAT A, and LOGIC B BAT B," (Master Event Sequence Controller Pyrotechnic and Logic Arming Circuit Breakers). One of the circuit breakers, "MASTER EVENT SEQ CONT ARM B BAT B" was found open. All the other controls listed above are in the pre-accident configurations.

(5) The switch labeled "RCS INDICATORS" (Reaction Control System Indicators) was specified to be in the "SM D" position (Service Module Reaction Control System Quad D), but was found in the "SM A" position. OCP FO-K-0021-1 did not specify the normal step of returning this switch to the "SM A" position after use (as specified in the Apollo Crew Abbreviated Checklist and in previous Operational Checkout Procedures). The crew apparently did this in accordance with the abbreviated checklist. This switch selects the inputs to the time-shared RCS displays on Panel 12.

(6) The switch labeled "TAPE RECORDER RECORD/PLAY" was found after the accident to be in the "OFF" position (OCP FO-K-0021-1 specified "RECORD"). There is no record of the crew deviating from the OCP FO-K-0021-1 specified position. The Apollo Crew Abbreviated Checklist specified "OFF" for this switch until immediately prior to launch. The switch might have been set to "OFF" per that procedure (without ground coordination) or knocked off inadvertently. The Tape Recorder (DSE) would not operate in either switch position until enabled by setting the switch labeled "TAPE RECORDER FWD/REV" (Tape Recorder Forward/Reverse Selector Switch) to the forward or reverse position (planned just prior to launch).

(7) The gas chromatograph power sensor connector was found on the aft bulkhead. This connector was placed on the shelf of the chromatograph compartment at time of crew ingress.

#### e. Plugs-In Test Configuration

The Spacecraft 012 Plugs-In Test, OCP FO-K-0006, was initiated at 4:00 a.m. EST, January 25, 1967, and was completed at 2:54 a.m. EST, January 26, 1967. Aside from test set-up, few configuration changes were accomplished between completion of Plugs-In Test and start of the Space Vehicle Plugs Out Integrated Test at 7:00 a.m. EST, on January 27, 1967. Configuration changes were identified from Parts Installation and Removal Records, Temporary Installation Records, and Discrepancy Report/Material Review dispositions. The configuration at the time of the Plugs-In Test relative to the Space Vehicle Plugs Out Integrated Test is summarized as follows:

##### (1) Spacecraft

Difference in the configuration of the Spacecraft at the time of the Plugs-In Test with respect to the Space Vehicle Plugs Out Integrated Test are listed in Reference 1-10. Significant differences were as follows:

(a) Boost Protective Cover (BPC) and splice plate (10 pieces) installed for Space Vehicle Plugs Out Integrated Test. The BPC was partially installed to accommodate the hatch BPC which was necessary for the planned emergency egress exercise.

(b) Main "A," Main "B," and the post-landing test batteries were not installed (used)



during the Plugs-In Test. Jettison controller batteries were used for each test, but were of a different serial number.

(c) Eleven protective dust caps installed on pyrotechnic connectors in the C/M subsequent to Plugs-In Test. Caps placed on non-mated connectors to provide protection and prevent shorting.

(d) The Inertial Measurement Unit (IMU) heater shorting plug was temporarily installed in tray 7 for the Space Vehicle Plugs Out Integrated Test. This provides heater power from the S/C bus rather than from an external source. The installation of this shorting plug represents a configuration difference from the Plugs-In Test; however, this plug had been used previously during the Altitude Chamber Test (OCP FO-K-0034A). The "Launch" configuration also requires that this plug be installed.

(e) Carbon dioxide absorber elements, P/N ME 901-0128-0001, were installed for the Space Vehicle Plugs Out Integrated Test. These absorber elements were not flight configuration.

(f) The same three crewmen umbilical electrical cables (cobra cables) were used in the Plugs-In Test as were used in Space Vehicle Plugs Out Integrated Test. However, two additional cobra cables were stowed on board for this test, one of which was used by the Command Pilot during part of the test.

(g) Noise-limiter adapters were attached to the cobra cables for the Space Vehicle Plugs Out Integrated Test, but not used for Plugs-In. They were checked out in the Spacecraft between the times of the two tests.

(h) An "octopus cable," (Medical Data Acquisition System cable) was installed for the Space Vehicle Plugs Out Integrated Test, but not used for Plugs-In Test.

(i) Flight crew equipment was not stowed for the Plugs-In Test.

## (2) Spacecraft Interfaces

Differences in the Spacecraft interface configurations between the Plugs In and Space Vehicle Plugs Out Integrated Tests are identified in Reference 1-19. The significant differences were:

(a) Pyrotechnic Substitute Units were utilized during the Plugs In Test and were disconnected during the Space Vehicle Plugs Out Integrated Test in an attempt to provide better S/C ground isolation.

(b) Fuel Cell Battery Substitute Unit was utilized during the Space Vehicle Plugs Out Integrated Test. This unit is used to supply S/C bus internal power in the absence of fuel cell operation after the flyaway umbilical has been dropped.

(c) Protective Pressurization Unit was utilized to maintain a pad pressure on the Service Propulsion System (SPS) tanks. This unit was disconnected during the Space Vehicle Plugs Out Integrated Test in an attempt to maintain better ground isolation.

(d) Battery Substitute Unit was used during the Plugs In Test. This unit was utilized in lieu of the S/C entry and post-landing batteries during that test.

(e) Water/glycol shutoff valve control cable and associated power supply was utilized during the Space Vehicle Plugs Out Integrated Test. This requirement exists in order to hold the water/glycol return shutoff valve open after flyaway umbilical ejection, such that continuous water-glycol circulation may be maintained.

(f) Conditioned air was supplied through the access arm White Room and the open Spacecraft hatch for the Plugs-In Test, therefore not requiring external oxygen supply. An oxygen test set was utilized during the Space Vehicle Plugs Out Integrated Test. Oxygen was supplied from two K bottles through this unit to a facility valve box and then to the Spacecraft.

(g) GSE access connectors were connected to the Service Module (S/M) during the Plugs-In Test to monitor fluid system parameters. They were not required for the Space Vehicle Plugs Out Integrated Test.

(h) The ACE carry-on test equipment was utilized during the Plugs-In Test. This equipment is located on Level A8 outside the C/M and is connected to the Spacecraft systems through cables which run through the hatch and connect to the individual Spacecraft systems. This equipment was not required for the Space Vehicle Plugs Out Integrated Test.

## (3) Ground System

The Spacecraft GSE configuration differences between the Plugs In and Space Vehicle

Plugs Out Integrated Test are given in Reference 1-19. No significant differences were identified beyond those discussed above under the heading, "Spacecraft Interfaces." Data presented in Reference 1-22 reflect that no differences existed in the configurations of the ACE and OIS equipment relevant to the accident.

f. Configuration for Altitude Chamber Test

The final run of the Spacecraft 012 Altitude Chamber Test, OCP FO-K-0034A-1, began at 6:00 a.m. EST, on December 29, 1966, in the East Altitude Chamber in the Manned Spacecraft Operations Building (MSOB). The test was completed at 3:30 a.m. EST, December 30, 1966. At the time of the Altitude Chamber Test, configuration records reveal that sixty (60) released EO's had not been accomplished. Test Acceptance Inspection Records reflect that three-hundred-eight (308) work items were open. These records were reviewed to determine configuration actions accomplished or closed out between the completion of the Altitude Chamber Test and the Space Vehicle Plugs Out Integrated Test. Discrepancy Report/Material Review dispositions were screened to identify corrective actions that altered configuration and were accomplished in this time period. Configuration differences are summarized as follows:

(1) Spacecraft

Differences in the spacecraft configuration between the Altitude Chamber Test and the Space Vehicle Plugs Out Integrated Test are presented in Reference 1-10. Enclosure 1-8 reflects differences in crew equipment and loose items stowed in C/M. Significant differences were as follows:

(a) Only the inner hatch was installed for the Altitude Chamber Test. Both inner and outer hatches were installed and latched, and BPC hatch was in place but not latched for Space Vehicle Plugs Out Integrated Test.

(b) Pyrotechnic panel (no. 150) was temporarily installed for Altitude Chamber Test. This panel was removed December 30, 1966, and was temporarily installed prior to the Plugs In Test (OCP FO-K-0006). The panel was not fully installed, being out approximately 5 to 6 inches from the lower equipment bay panel line and located on the C/M aft bulkhead.

(c) Carbon dioxide absorber elements of the correct flight configuration (ME 901-0218-0021) were installed for the Altitude Chamber Test, instead of the non-flight configuration for the Space Vehicle Plugs Out Integrated Test.

(d) Command Module interior panel, P/N V16-441802, covering J-box in left-hand lower equipment bay was removed for DR/MR disposition to relieve interference with wire bundle. The panel was replaced prior to the Space Vehicle Plugs Out Integrated Test.

(e) Spacecraft oxygen tanks were serviced for the Altitude Chamber Test.

(f) Hydrogen tanks were pressurized with nitrogen during the Altitude Chamber Test.

(g) Fuel cell battery substitute unit was not connected for Altitude Chamber Test. Spacecraft was powered by external GSE/facility power.

(h) DC power bus voltage monitor recorder was installed for Altitude Chamber Test.

(i) Additional Velcro was installed after completion of Altitude Chamber Test.

(j) Noise limiters were not installed on cobra cables for Altitude Chamber Test.

(k) The gas chromatograph was installed for the Altitude Chamber Test.

(l) The Data Storage Electronics Assemblies (DSEA's) were installed in flight configuration for Altitude Chamber Test.

(m) The Spacecraft TV camera was on during the Altitude Chamber Test, but not for Space Vehicle Plugs Out Integrated Test (after crew ingress).

(n) Translation and rotation controllers were installed to flight configuration for Altitude Chamber Test.

(o) Floodlight installation was modified subsequent to Altitude Chamber Test.

(p) Crew equipment stowage was approximately flight configuration for Altitude Chamber Test. See Enclosure 1-8 for detailed differences.

(q) Debris traps were modified subsequent to Altitude Chamber Test.

(r) All crew couch ground straps were installed for Altitude Chamber Test.

(2) Spacecraft Interfaces

The Spacecraft/ground system interfaces existing during the Altitude Chamber Test are

depicted in Enclosure 1-9, Drawing 1-D-0056-6. Significant interface differences relative to Space Vehicle Plugs Out Integrated Test were:

(a) During the Altitude Chamber Test, the A-14-062 Launch Vehicle Substitute Unit was installed. During Space Vehicle Plugs Out Integrated Test, the Command and Service Module/Spacecraft to Lunar Module Adapter (CSM/SLA) configuration was mechanically and electrically mated to the LV. The electrical connection to the Instrumentation Unit (IU) was through a separation device.

(b) RCS engine simulators were used for both tests. The X00-075 units were used during the Altitude Chamber run and the A14-275 units were used for the Space Vehicle Plugs Out Integrated Test.

(c) The external Digital Test Command System (DTCSC 14-231) is utilized at LC 34 and is not required in the Altitude Chamber.

(d) The Fuel Cell Battery Substitute Unit (C14-395) was utilized during the Space Vehicle Plugs Out Integrated Test. This unit is used to supply S/C bus internal power after the fly-away umbilical has been dropped.

(e) The Mobile Data Recorder was utilized to record S/C DC bus voltages during the Altitude Chamber Test. It was not utilized during the Space Vehicle Plugs Out Integrated Test.

(f) The water/glycol shutoff valve control cable and associated power supply was utilized during the Space Vehicle Plugs Out Integrated Test. This requirement exists in order to hold the glycol shutoff valve open after flyaway umbilical eject, such that continuous water-glycol circulation may be maintained.

(g) The oxygen test set (Z00-025-401) was used during the Space Vehicle Plugs Out Integrated Test. Oxygen was supplied from one "K" bottles through this unit to a facility valve box and then to the Spacecraft. During the Altitude Chamber Test, oxygen was supplied from the on board tanks, each of which had been loaded with liquid oxygen (LOX). Oxygen, hydrogen, and nitrogen fill, vent, pressurization, and relief lines were connected to the S/C during Altitude Chamber operation.

(h) The Protective Pressurization Unit (S14-099) was used to maintain a pad pressure on the SPS tanks. This unit was disconnected during the Space Vehicle Plugs Out Integrated Test to maintain better ground isolation.

(i) During the Space Vehicle Plugs Out Integrated Test, the Launch Escape System (LES) tower was installed and electrically connected. During the Altitude Chamber Test, neither the LES tower nor the pyrotechnic substitute boxes were installed.

(j) GSE access connectors were connected to the S/M during the Altitude Chamber Test and were not connected during the Space Vehicle Plugs Out Integrated Test.

(k) The access Arm/White Room was mated to the S/C during the Space Vehicle Plugs Out Integrated Test. This configuration does not exist in the Altitude Chamber.

(l) Air was being supplied to a C/M access port to maintain a low humidity condition in the space between the C/M pressure vessel and heat shield during the Space Vehicle Plugs Out Integrated Test.

### (3) Ground System

Configuration of the Spacecraft GSE at the time of the Altitude Chamber Test is defined in Reference 1-19. Configurations of the supporting facilities together with the GSE are shown schematically in Enclosure 1-9, Drawing 1-D-0056-6. Remote monitoring and control equipment configurations are described in Reference 1-22. Significant differences in the ground system configuration relate directly to the interface differences discussed previously; therefore, further discussions are not provided.

### g. Spacecraft 008 Test Configuration

The Spacecraft 008 Thermal Vacuum Test No. 3 was conducted at the Space Environmental Simulation Laboratory (SESL), MSC, from October 26, 1966 through November 1, 1966. The configuration for this test was selected for comparison with the configuration of S/C 012 at the time of the accident. A special computer tabulation was obtained to compare the configuration verification records of the two Spacecraft. Copies of the S/C 008 test reports and supporting data were

obtained. These data were reviewed and a summary report was prepared (Reference 1-24). Significant extracts from the summary report are:

(1) Spacecraft 008 wire harnesses did not have the modification kit (Teflon wrapping) installed which provides additional protection to crew compartment wiring. A special pad protected the wiring on the aft bulkhead during the S/C 008 test.

(2) Spacecraft 008 had additional wiring that was not in S/C 012 to implement limited remote control during unmanned altitude chamber tests. Additional wiring for test instrumentation was installed in S/C 008. The right-hand C/M window of S/C 008 was utilized for an umbilical pressure bulkhead penetration to bring out the additional control circuits and instrumentation.

(3) Command Module floodlights of improved configuration were employed on S/C 012. S/C 008 utilized the basic configuration for all thermal vacuum testing. The provisions for portable floodlights were established as a requirement from the S/C 008 tests and installed on S/C 012, but the portable lights were not aboard for Space Vehicle Plugs Out Integrated Test.

(4) Noise filter adapters for the crewman umbilical electrical cables were not utilized on S/C 008, but were used on S/C 012.

(5) Spacecraft 008 instrumentation and signal conditioners for test monitoring were not flight qualified instruments in all cases, but had been tested to the actual test environment. Flight instrumentation was installed on S/C 012.

(6) Design modifications were incorporated in the Environmental Control Unit (ECU) on the S/C 012 unit as compared to the S/C 008 ECU.

(7) A production prototype mission events sequencer was used on S/C 008. S/C 012 had production sequencers that were flight qualified.

(8) Crew couches were modified for the long duration of thermal vacuum test on S/C 008. Crew compartment stowage and special Teflon covered Sarfoam pads on the aft bulkhead were used on S/C 008, differing from the S/C 012 flight configuration. The crew compartment hatch on S/C 008 thermal vacuum test run No. 3 had the airlock incorporated for scientific experiments.

(9) Beta cloth over Teflon covering was used extensively on the aft bulkhead (covering the special Sarfoam pad) and couches during the Spacecraft 008 test. This is a fire-resistant material. Also, fire extinguishers were available inside the crew compartment during the S/C 008 test.

(10) A large number of differences existed in the GSE and supporting facilities. These differences were not significant to the Spacecraft 012 accident.

## D. FINDINGS AND DETERMINATIONS

Review of data presented in this report results in summary findings and determinations as follows:

### 1. FINDING

One hundred and sixty-four (164) Engineering Orders (EO's) were not accomplished at the time Spacecraft 012 was received at KSC. Six hundred and twenty-three (623) EO's were released subsequent to receipt at KSC. Of these, twenty-two (22) were recent releases which were not recorded in configuration records at KSC at the time of the accident.

### DETERMINATION

Continuing engineering changes indicate progressive development of the Spacecraft configuration through the time of the Space Vehicle Plugs Out Integrated Test. At the time of the test, the configuration could not have been complete with respect to the launch configurations.

### 2. FINDING

The required Space Vehicle Plugs Out Integrated Test configuration was not explicitly defined by design engineering or test documentation. Definition of required test configuration was limited to test set-up and controls configurations specified in OCP FO-K-0021-1.

### DETERMINATION

The absence of explicit definition of Spacecraft test configuration requirements relegated such definition to the test organization. Further, it is the opinion of this Panel that the lack of timely and

explicit design definition of the required test configuration precluded complete assessment of adverse configuration aspects as constraints to the test.

### 3. FINDING

Eighty (80) EO's effective on S/C 012 were not accomplished at the time of the accident. Of these, twenty (20) were specified to be accomplished subsequent to the Space Vehicle Plugs Out Integrated Test. Four (4) of the open EO's were of a nature not affecting configuration. Three hundred and eighty-four (384) Parts Installation and Removal Records (PIRR's) and Temporary Installation Records (TIR's) were open, of which one hundred and twenty-five (125) were in compliance with requirements of the test documentation.

### DETERMINATION

It is concluded that test requirements had no defined relationship to the open status of fifty-six (56) EO's and two hundred and fifty-nine (259) PIRR's/TIR's. It is the opinion of this Panel that all work items and EO's were not closed because of late receipt of changes or further work scheduled to be accomplished prior to launch.

### 4. FINDING

Items were placed on board the Spacecraft during preparation for the Space Vehicle Plugs Out Integrated Test which were not documented by quality inspection records.

### DETERMINATION

Procedures for controlling entry of items into the Spacecraft were not strictly enforced.

This page left blank intentionally.

# SPACECRAFT CONFIGURATION

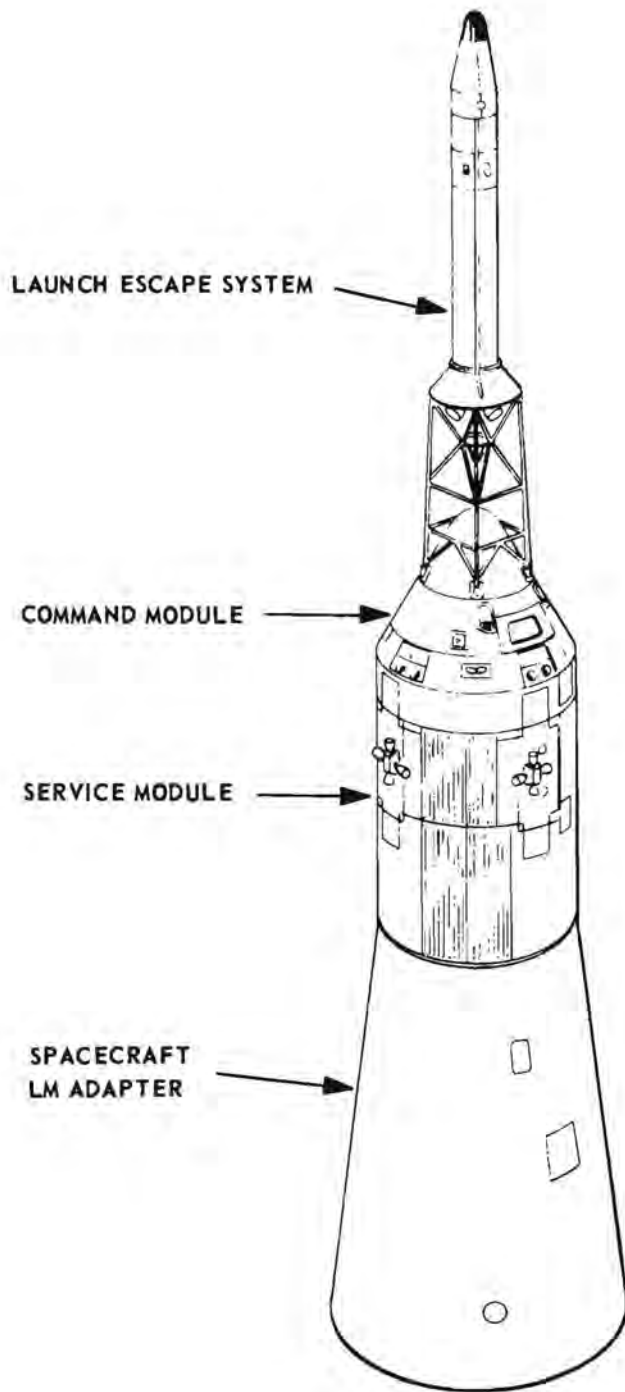

ENCLOSURE 1-1

D-1-21

This page left blank intentionally.



VIEW OF SPACECRAFT LAUNCH VEHICLE IN SERVICE STRUCTURE  
WITH ACCESS ARMS EXTENDED

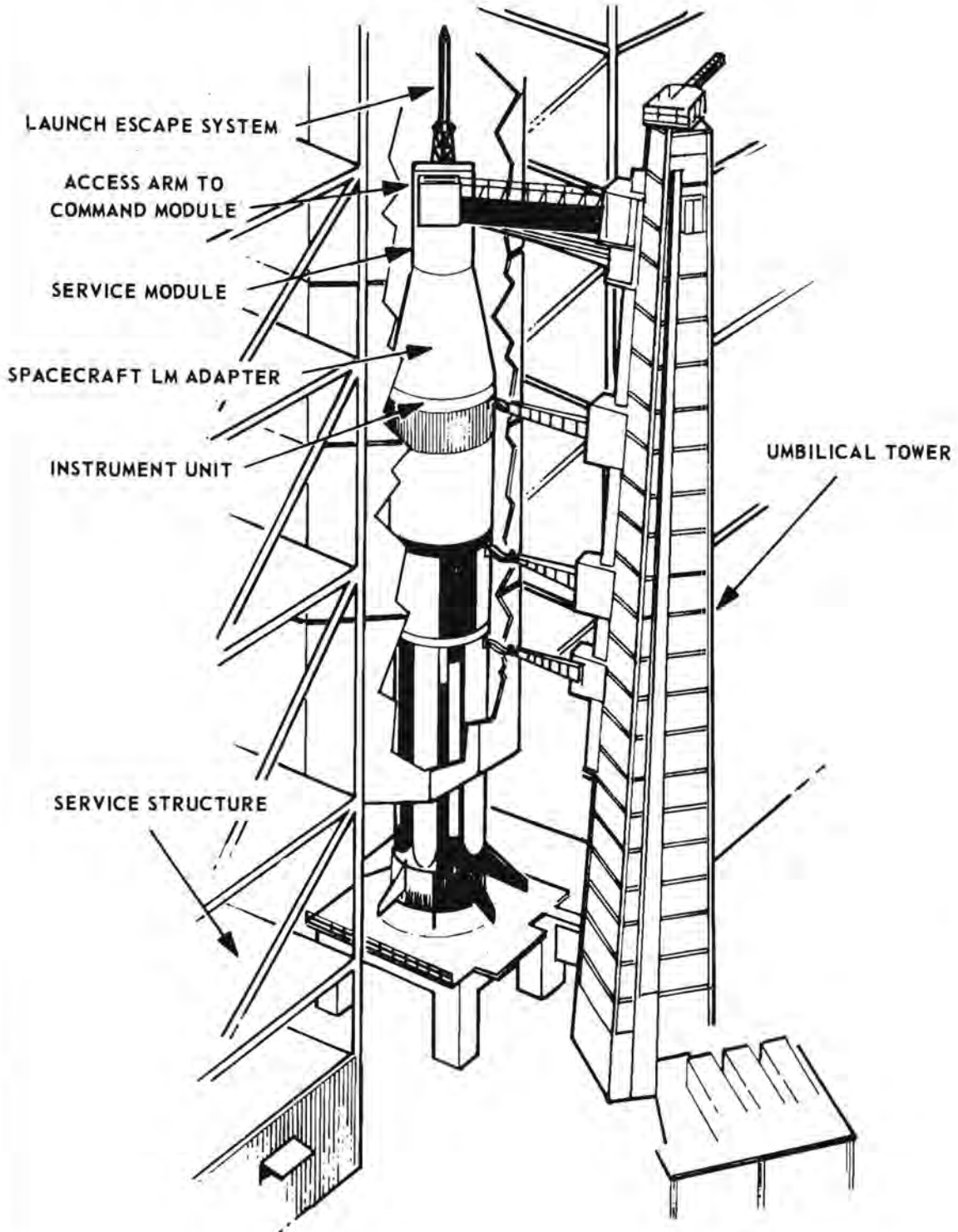

ENCLOSURE 1-2

D-1-23

This page left blank intentionally.

AERIAL DRAWING OF LAUNCH COMPLEX 34

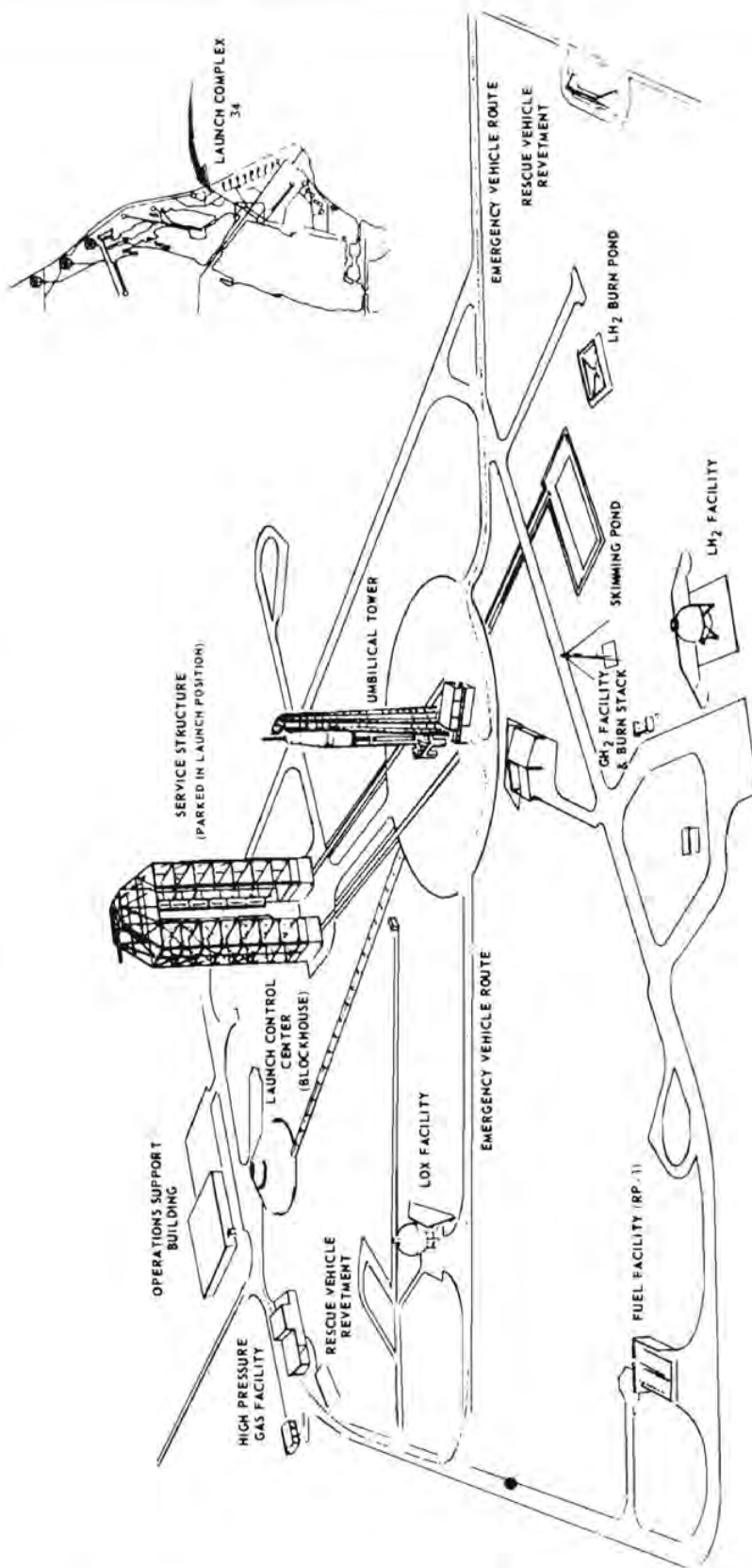

This page left blank intentionally.

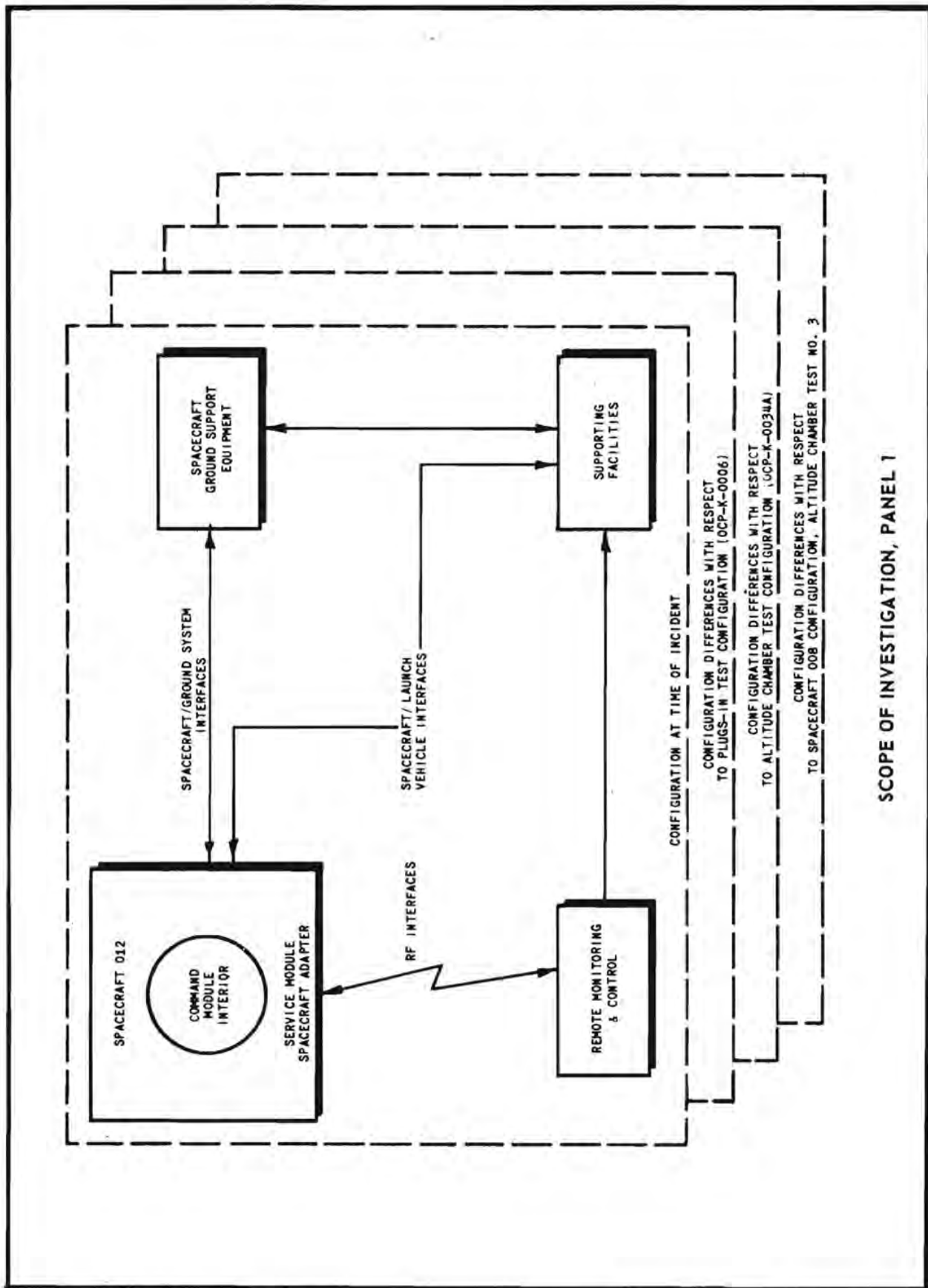

SCOPE OF INVESTIGATION, PANEL 1

This page left blank intentionally.

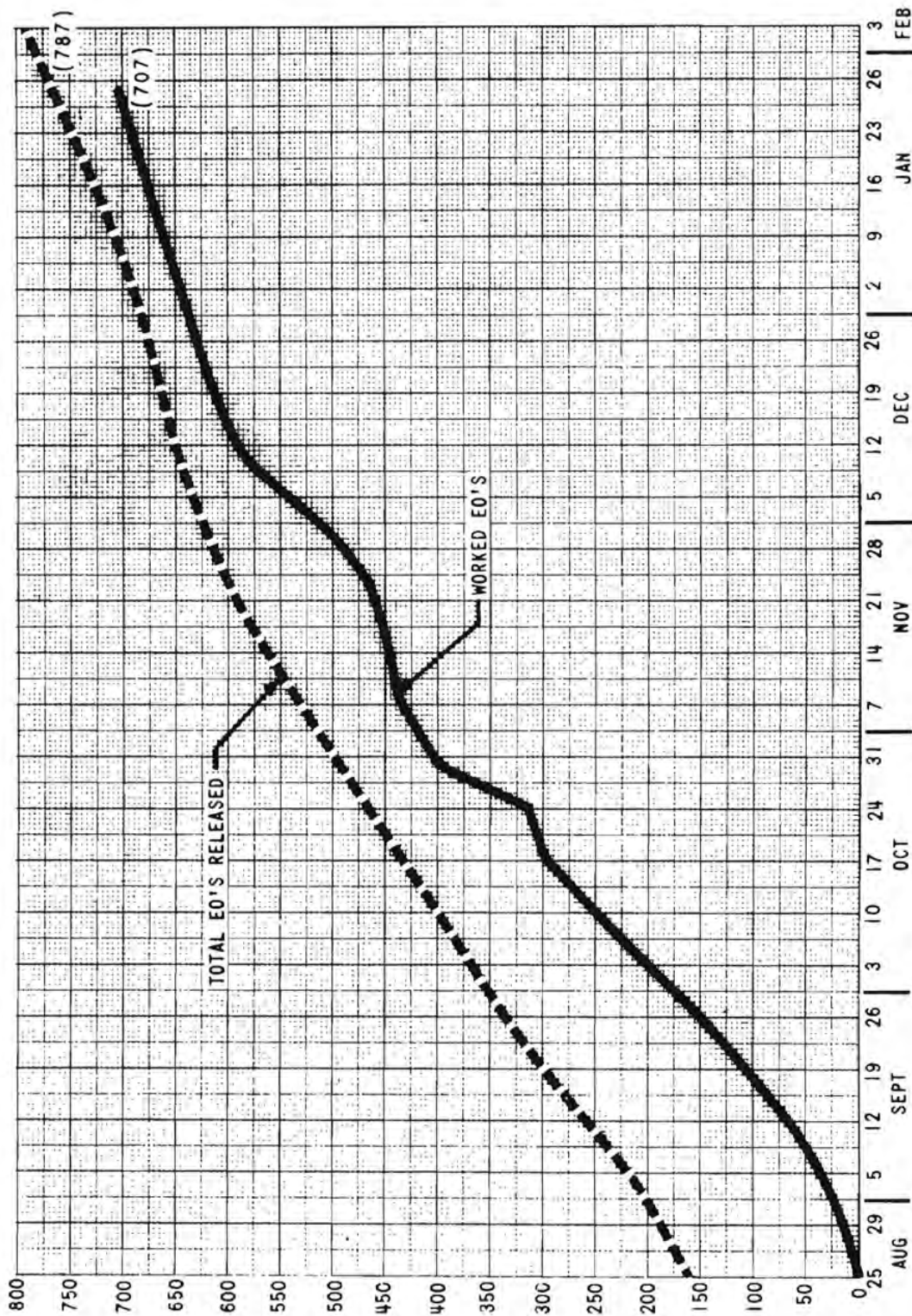

CUMULATIVE EO RELEASE SUBSEQUENT TO DELIVERY, SPACECRAFT 012

This page left blank intentionally.



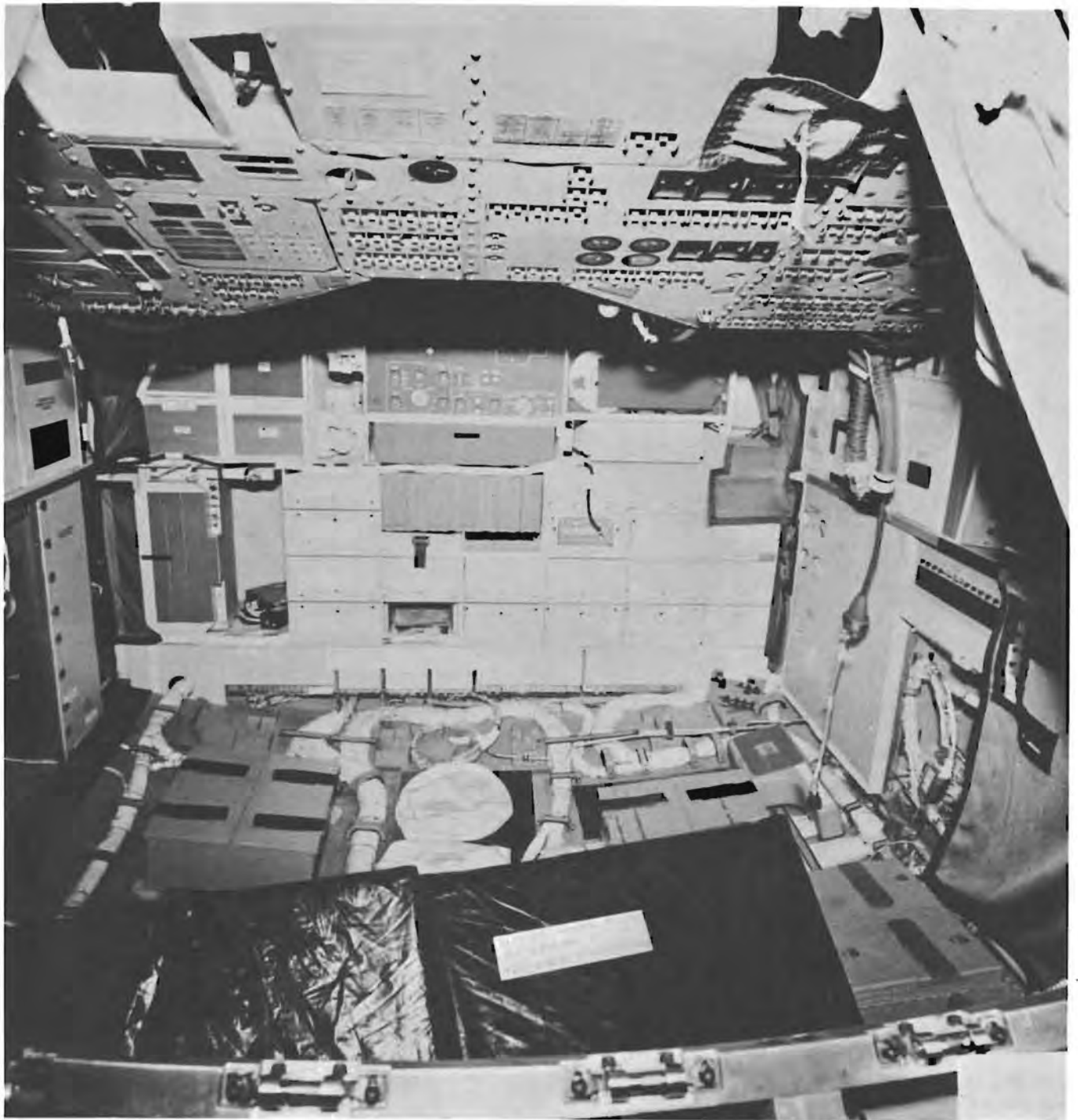

VIEW OF COMMAND MODULE MOCKUP INTERIOR LESS COUCHES

ENCLOSURE 1-6



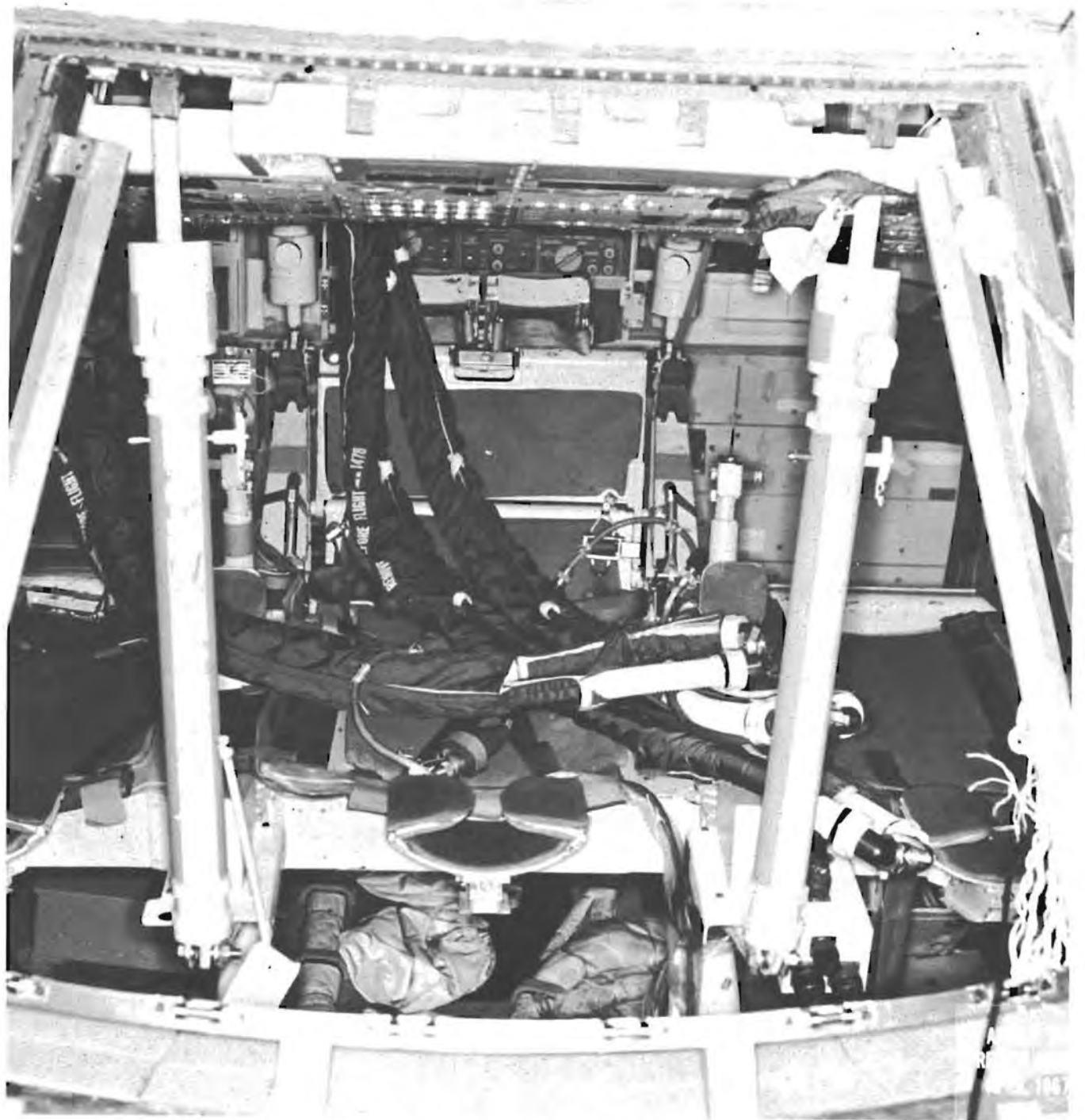

VIEW OF COMMAND MODULE MOCKUP INTERIOR, COUCHES INSTALLED

## SPACECRAFT 012 CREW COMPARTMENT STOWAGE AND LOOSE EQUIPMENT CONFIGURATION

The attached table lists by area the configuration of stowage items and other loose equipment for the Spacecraft 012 Crew Compartment. This information is given for the planned launch, Operational Checkout Procedure (OCP) K-0034A-1-Manned Altitude Chamber Test, and OCP K-0021-1-Plugs-Out Test.

The data for planned launch was taken from the Spacecraft 012 Operational and Experimental GFE/CFG Stowage List. Data for OCP's K-0034A-1 and K-0021-1 were derived from the applicable Test Preparation Sheets, Part Installation or Removal Records, Temporary Installation Records, Stowage OCP's and interviews of ground and flight crew support personnel. In the case of OCP K-0021-1 some data was also derived from physical inspections of the spacecraft after the incident.

The data includes all items loose in the crew compartment, installed in stowage containers, carried on the flight crew's persons, or items subject to removal/displacement by the flight crew. It further includes all non-flight materials known to be on board the spacecraft. All items are listed under their normal launch stowage locations, except that non-flight items are listed where actually stowed for the test. Items stowed in other than normal launch locations or in other than normal launch conditions are identified by notes in the "REMARKS" column.

The "STOWAGE ITEM NUMBER" is a cross index to the Spacecraft 012 Operational and Experimental GFE/CFE Stowage List.

### LEFT HAND EQUIPMENT BAY

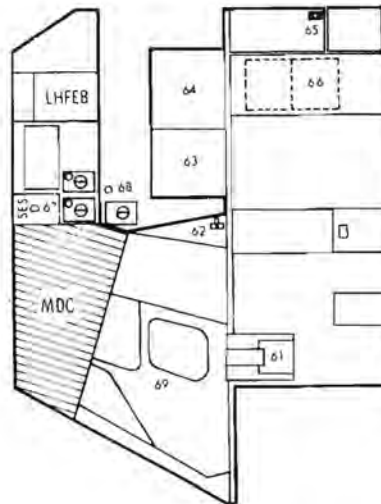

### CREW COMPARTMENT STORAGE AND LOOSE EQUIPMENT CONFIGURATION

MSC FORM 1725 (MAR 87)(01)

STORAGE AREA	QUANTITY			PART NUMBER	NOMENCLATURE	STORAGE ITEM NUMBER	REMARKS
	PLANNED LAUNCH	OCP K-0034A-1	OCP K-0021-1				
67	1	1	-	V16-335050-41	Scientific Container "D"	873	
67	1	1	1	EC32003-1	Dew Pt Hygrometer Sensor	038	- Stowed on floor of area 82 in LEB for 0021-1
67	1	1	1	EC32004	Sensor Cable	039	- (same as above)
67	1	1	1	EC32005	Control Unit	040	- (same as above)
67	1	1	1	SEB11100016-201	Control Pwr Cable	041	- (same as above)
67	1	1	1	SDC18300001	Octopus Cable	213	- Installed across LEB
62	1	1	1	V16-601140-11	Tee Handle	803C	
62	-	-	-	TA44-2	Roll Tape	057	
63	1	-	-	V16-601520	Container (Food Strg Supp)	812	
63	1	-	-	14-0113	Food Set	008	- 15 man-meals food stowed in special container on 0034A-1
64	12	-	-	SEB33100075-200	Plastic Bag	056	
64	3	3	-	A1912-000	CWG	020	
64	3	3	-	A2007-000	In Flt Coveralls (jacket)	021	
64	3	3	-	A2006-000	In Flt Coveralls (pants)	021	
64	-	-	-	ME901-0355	Sandals (3 pr)	805	
64	2	2	-	ME901-0355-0031	Sandals (3 pr)	805	
64	2	2	-	ME901-0355-0032	Sandals (3 pr)	805	
64	1	1	1	ME901-0355-0039	Sandals (3 pr)	805	
64	1	1	1	ME901-0355-0040	Sandals	805	
64	12	-	-	SEB33100075-203	Plastic Bag	061	
61	1	1	-	SDB33100039	Commanders Checklist	012A	
61	1	1	-	SDB33100040	Flight Plan	012D	
61	1	1	-	V16-601391	Container Flt Data File	840	
65	1	1	-	V16-601140-11	Tee Handle	803C	
68	3	-	3	V16-601549	Noise Limiter Adapter Cables		
78	lea	3	3	V16-601201-71,-81,-91	Umbilical Assy	877	
68	3	3	3	4235	O <sub>2</sub> Hose Inlet Nozzle	408	- On umbilicals
68	3	3	3	4236	O <sub>2</sub> Hose Exhaust Nozzle	410	- On umbilicals
68	2	2	2	V16-601263-41	Cobra Cable	878	
68	1	1	1	V16-601263-51	Cobra Cable	878	
68	3	3	1	V16-601396	T-Adapter Elect	1000	- Center Crewman cobra cable ONLY on 0021-1
66	2	2	2	ME901-0218-0001	LiOH Cartridges	868	- Dash numbers -0001 installed for 0021-1.
68	-	-	3	Non-flight	GSE Covers		- Non-flight dash number - On all 3 O <sub>2</sub> umbilicals. Made of nylon. Each had "Remove before flight" streamer.

## LOWER EQUIPMENT BAY

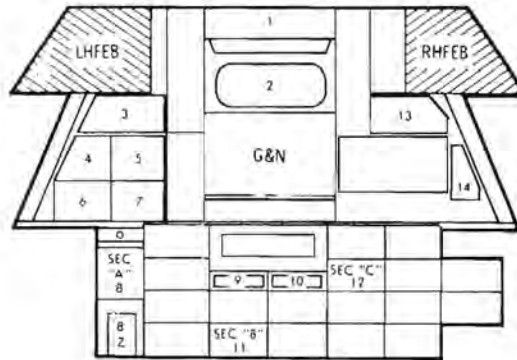

## CREW COMPARTMENT STOWAGE AND LOOSE EQUIPMENT CONFIGURATION

MSC FORM 1775 (MAR 67)(203)

STOWAGE AREA	QUANTITY			PART NUMBER	NOMENCLATURE	STOWAGE ITEM NUMBER	REMARKS
	PLANNED LAUNCH	OCF K-0034A-1	OCF K-0021-1				
1	1	1	1	2012691	G&N Long Eyepiece SCT	019	
1	1	1	1	2012719	G&N SCT Eyepiece	016	
1	1	1	1	1013010	SCT Prism Housing	016A	
1	1	1	1	2012700	G&N SXT Eyepiece	017	
1	1	1	1	2012699	SXT Mirror Housing	017A	
2A	1	1	1	SDB33100065-201	G&N Optics Cover SXT	054	
7B	1	1	1	SEB33100072-201	G&N Optics Cover SCT	055	Found on aft bulkhead after 0021-1
3	1	-	-	V16-601518	Food Container "A"	814	
4	1	-	-	V16-601516	Food Container "B"	816	
5	1	-	-	V16-601517	Food Container "C"	815	
6	1	-	-	V16-601514	Food Container "D"	818	
7	1	-	-	V16-601515	Food Container "E"	817	
8	1	1	-	SEB33100031-201	Ring Sight	008	
8A	1	1	1	SEB33100021-207/208	16 MM Seq Cam with Film	001	Stowed on floor of area 8Z, LEB for 0021-1
8B	1	1	1	SEB33100026-201	16 MM Power Cable	005	Stowed on floor of area 8Z, LEB
8C	1	1	-	SEB33100023-201	18MM Lens	003	
8D	1	1	-	SEB33100054-201	25 MM Lens	202	
8E	1	1	-	SEB33100025-201	100 MM Lens	004	
8F	1	1	-	SEB33100051-201	Mirror Mtg Bracket	037	
8G	4	1	-	SEB33100022-206	16 MM Magazine	002	1 stowed in area 90, crew couch, on 0034A-1
8H	1	1	-	SEB33100029-201	10 MM Camera	006	
8I	1	1	-	SEB33100032-201	250 MM Lens	009	
8J	1	-	-	SEB33100030-201, -202, -203	70 MM Magazine	212	
8K	1	1	-	SEB33100027-201	Exp Dial	011	
8L	1	1	-	SEB33100028-201	Spotmeter	010	
8M	1	1	-	EC30155	Vascular Support	215	
8N	1	1	-	SEB12100037-201	Binoculars	036	
8N	1	1	-	V16-752031	Foam Cushion	1015	
8N	1	1	-	V16-752058-41	Foam Cushion	1016	
8N	1	1	-	V16-753110	Foam Separator	1016A	
8N	1	1	-	SEB33100050-201	Filter (on camera)	053	
8Z	-	-	1	Non-flight	Plastic Dust Cap		On gas chromatograph pyrc connector
8Z	1	1	-		Gas Chromatograph		Not installed on 0021-1
9	1	1	-	V16-334137	Crew Flt Data File Cont.	839	

LOWER EQUIPMENT BAY (CONT.)

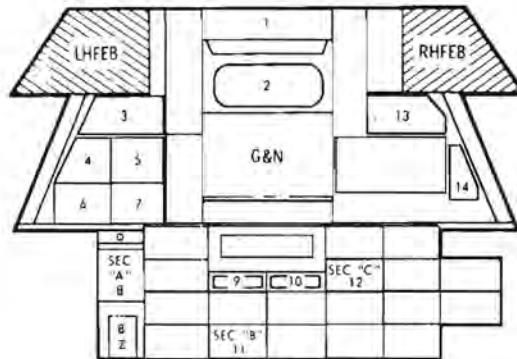

CREW COMPARTMENT STOWAGE AND LOOSE EQUIPMENT CONFIGURATION

MSC FORM 1725 (MAR 67)(01)

STOWAGE AREA	QUANTITY			PART NUMBER	NOMENCLATURE	STOWAGE ITEM NUMBER	REMARKS
	PLATEMOUNT LAUNCH	OCF K-0034A-1	OCF K-0021-1				
9	1	1	-	SDB33100044	Landmark Maps	012F	
9	1	1	2	SDB33100048	S/C Sys Data	012G	One document found on center couch, on on RH girth shelf, area 92 after 0021-1
9	1	1	-	SDB33100047	Exper Checklist	012H	
9	1	1	-	SDB33100045	Star Chart	012I	
9	1	1	-	SDB33100046	Orbital Map	012J	
9	1	1	-	SDB33100043	Navigation Checklist	012B	
10	1	1	-	V16-601125	Tool Workshelf Dwr	803	
10	1	1	-	V16-601145-21	Tool "A"	803A	
10	1	1	-	V16-601480	Tool "B"	803B	
10	2	2	-	V16-601310-21	Tool "F"	803F	
10	1	1	-	V16-601134-11	Tool "H"	803H	
10	1	1	-	V16-601481-11	Tool "J"	803J	
10	1	1	-	V16-601133-11	Tool "L"	803K	
10	1	1	-	V16-601400	Tether	803M	
10	1	1	-	V16-601241-11	Dwr Assy with Workshelf	819	
10	1	1	-	V16-601404	Work/Food Shelf	820	
10	1	1	-	SEB12100049-201	Inspection Mirror	068	
11	1	-	-	EX75036	Goggles	204	
11	3	-	-	EX75037	Mouthpiece	205	
11	8	5	-	SEB33100030-201, -202 or -203	70 MM Magazine	008	
11	7	7	-	SEB33100022-206	16 MM Magazine	002	
12	1	1	1	SD511076	MDAS	600	
13	1	1	-	SEB42100004-201	Physiological Monitoring Kit	024	
13	3	3	-	14-149	UCD Clamps	029	
13	1	1	-	14-0207	Urine Receptacle	035	
13	1	1	-	14-0009	Urine Filter Assy	034	
13	1	1	-	V16-601421-101	Receptacle Assy Relief Tube	861	
13	1	1	-	V16-601526-11	Wrapper Assy Relief Tube	876	
14	14	1	-	14-0112	Towels (Dry Utility)	031	
15	-	-	1	Non-flight	Mounting Hardware for Panel 150		In plastic bag taped to panel
Several LEB Panels	-	-	-	Non-flight	White Room Tape		Over open ACE connectors on 14 panels & over entry battery terminals

## RIGHT HAND EQUIPMENT BAY

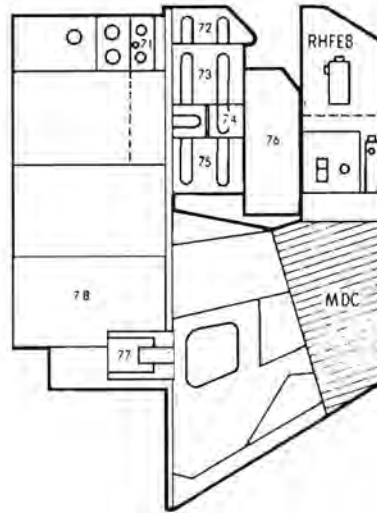

## CREW COMPARTMENT STORAGE AND LOOSE EQUIPMENT CONFIGURATION

MSC FORM 1775 (MAR 67)(01)

STORAGE AREA	QUANTITY			PART NUMBER	NOMENCLATURE	STORAGE ITEM NUMBER	REMARKS
	PLANNED LAUNCH	OCF K-0034A-1	OCF K-0021-1				
71					Vacuum Cleaner Compartment		
71	5	5	-	V16-611238	Vacuum Clnr Ref Stow Bag Assy	834	
71	5	5	-	ME192-0039-0001	Vacuum Clnr Debris Bag	834A	
71	5	5	-	ME901-0736-0001	Fecal Outer Bag	834B	
71	5	5	-	ME393-0001-0001	Vacuum Clnr Germicide Pouch	834C	
71	5	5	-	M7503	Tie Band	834D	
72					Medical Accessories Kit Com		
72	1	1	-	102765	Bio Instrumentation ACC Kit	023	
72	35	35	-	SEB42100011-201	Electrodes	023A	
72	50	50	-	SEB42100012-201	Micropore Disks	023B	
72	8	8	-	14-0228	Wet Wipe Towels	023C	
72	2	2	-	SEB42100014-201	Paste	023D	
72	1	1	-	SEB42100013-201	Stoma Seal Disk	023E	
72	1	1	-	SEB42100005-201	Bio Instr Stowage Bag	023F	
73	1	1	1	V16-611241	Vacuum Cleaner Nozzle	833A	
73	1	1	-	EA35068-1	Nephelometer(Aerosol Particle)	201	
73	10	10	-	V16-601419-101	Sanitation Supply Assy	811	
73	10	10	-	V16-601378-11	Inner Fecal Bag	811A	
73	10	10	-	ME399-0001-0001	Germicide Pouch	811B	
73	10	10	-	ME901-0736-0001	Outer Fecal Bag	811C	
73	10	10	-	V16-601419-3	Outer Tie Band	811D	
73	7	1	-	14-0112	Dry Utility Towels	031	
73	5	5	-	V16-611238	Vacuum Cln Ref Stow Bag Assy	834	
73	5	5	-	ME192-0039-0001	Vacuum Clnr Debris Bag	834A	
73	5	5	-	ME901-0736-0001	Fecal Outer Bag	834B	
73	5	5	-	ME393-0001-0001	Vacuum Clnr Germicide Pouch	834C	
73	5	5	-	M7503	Tie Band	834D	
74	2	2	2	V16-601538	Elect Adapters, Sleep	887	
74	3	3	3	V16-601356	Adapter-CWG-Elect	821	
74	2	2	2	V16-601263-51	Cobra Cable	878	- On 0021-1, both spares removed from stowage by crew, both found on couch
75					Sanitation Supplies Compt.		
75	1	1	-	V16-601112-501	Box San Sup Storage A	806	
75	1	1	-	V16-601112-401	Box San Sup Storage B	808	
75	1	1	-	V16-601112-301	Box San Sup Storage C	809	
75	52	52	-	V16-601419-11	Sanitation Supply Assy	811	
75	52	52	-	V16-601378-11	Inner Fecal Bag	811A	
75	52	52	-	ME399-0001-0001	Germicide Pouch	811B	
75	52	52	-	ME901-0736-0001	Outer Fecal Bag	811C	



RIGHT HAND EQUIPMENT BAY (CON'T)

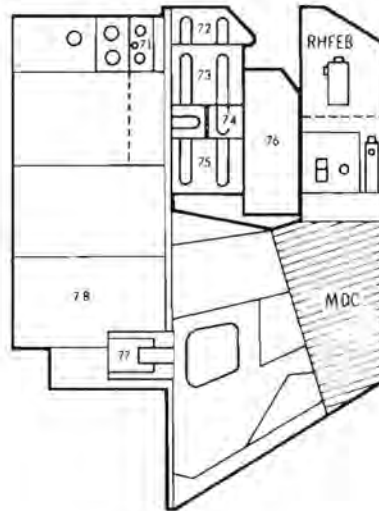

CREW COMPARTMENT STOWAGE AND LOOSE EQUIPMENT CONFIGURATION

MSC FORM 1125 (MAR 87)(01)

STOWAGE AREA	QUANTITY			PART NUMBER	NOMENCLATURE	STOWAGE ITEM NUMBER	REMARKS
	PLANNED LAUNCH	OCF K-0034A-1	OCF K-0021-1				
75	52	52	-	V16-601419-3	Outer Tie Band	811D	
75	2	2	-	V16-601120-51	Cover	810	
75	1	1	-	V16-601120-61	Cover	807	
75	1	-	-	V16-601519	Aux Food Comp RHEB	813	
77	1	1	-	V16-601391	Crew Flt Data File Container	840	
77A	1	1	-	SDB33100041	Sys Eng Checklist	012C	
77B	1	1	2	SDB33100042	Mission Log & Data	012E	Found on LH and center couches after 0021-1.
76A	2	2	1	LSC-360-12	DSEA (Voice Recorder)		Installed in alternate position - Primary installation position taped with "Boat Tape" on 0021-1.
76A	1	1	1		DSEA Adapter Cable		Not connected on 0021-1
78	-	-	8	Non-flight	Plastic Dust Caps		On pyro and circuit interrupter connectors

**FORWARD BULKHEAD, SIDEWALL  
AND HATCH**

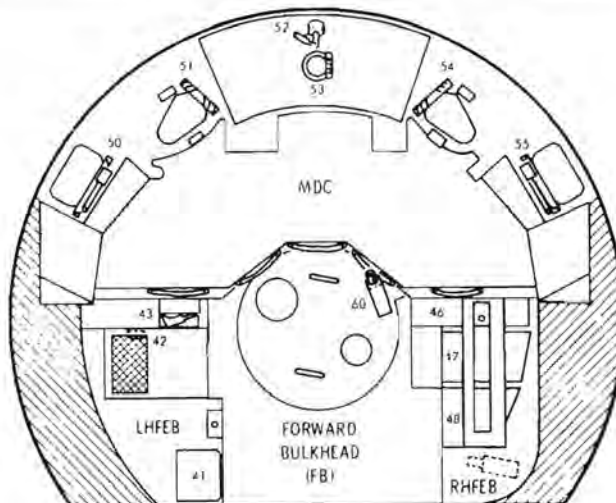

**CREW COMPARTMENT STORAGE AND LOOSE EQUIPMENT CONFIGURATION**

MSC FORM 1775 (MAR 83)(01)

STOWAGE AREA	QUANTITY			PART NUMBER	NOMENCLATURE	STOWAGE ITEM NUMBER	REMARKS
	PLANNED LAUNCH	OCP K-0034A-1	OCP K-0021-1				
41					LHFEB--Loose Parts Comp.		
41A	1	1	1	2014764-011	Short Handhold	013	
41P	1	1	1	2014764-021	Long Handhold	014	
41C	1	1	1	V16-334100	LEP Rot Cont Mount	R31	
41D	1	1	1	1011787-1	C/N Long Eyerelef Eyepiece Set	018	
43	1	1	1	14-0104-02	Metering water Dispenser	409	Not connected to hose on 0021-1. Hose fitting covered by plastic bag
46					RHFEB-Stow. Area - Survival Kits		
46	1	1		V16-601371-101	Container Survival Kit A	847	
46	1	1		SEB40100011-201	Rucksack No. 1	025A	
46A	1	1		SEB40100010-201	Rucksack	025A	
46P	2	2		20538	Combination Survival Assy	025A	
46C	16	16		SEB40100021-001	Desalter Kit Tablets	025A	
46D	2	2		SEB40100021-002	Desalter Kit Process Bag	025A	
46E	2	2		SEB40100021-003	Mending Kit	025A	
46F	3	3		SEB40100020-201	Sunglasses	025A	
46G	1	1		2588218	Radio/Beacon Assy	025A	
46H	1	1		2588254	Radio/Beacon Spare Battery	025A	
46I	1	1		2555952	Radio/Beacon Cable Assy	025A	
46J	2	2		SEB40100004-201	Machete	025A	
46K	2	2		SEB40100001-201	Machete Sheath	025A	
46	1	1		SEB40100013-201	Rucksack No. 2	025B	
46A	1	1		SEB40100012-201	Rucksack	025B	
46P	2	2		SEB40100022-201	Water Container	025B	
46C	1	1		SEB40100052-201	Water Container	025B	
46D	IN	IN			Water	025P	
46E	3	3		SD840100048-201	Water Container Stoppers	025B	
46F	1	1		SEB40100058-201	Medical Kit	025B	
46G	1	1		281SSAR	Filler Material	025B	
47	1	1		ME281-0023-0001	Sea Water Pump	838	
47	1	1		V16-601372-101	Container Survival Kit B	818	
47	1	1		SEP40100017-201	Rucksack No. 3	025C	
47A	1	1		SEB40100016-201	Rucksack	025C	

FORWARD BULKHEAD, SIDEWALL  
AND HATCH (CONT.)

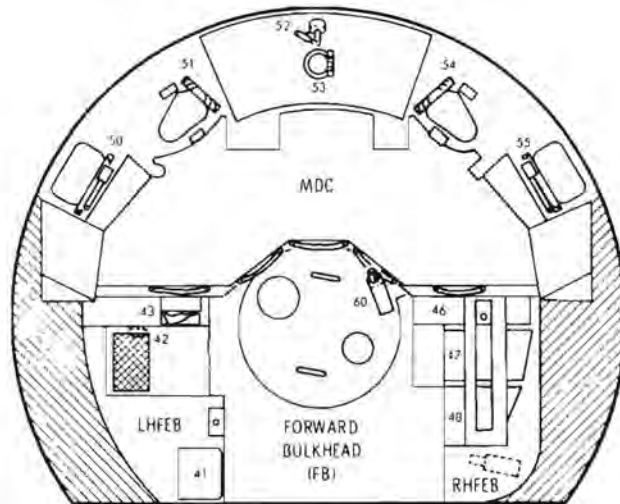

CREW COMPARTMENT STORAGE AND LOOSE EQUIPMENT CONFIGURATION

MSC FORM 1125 (MAR 87)(01)

STOWAGE AREA	QUANTITY			PART NUMBER	NOMENCLATURE	STOWAGE ITEM NUMBER	REMARKS
	PLANNED LAUNCH	OCF K-0034A-1	OCF K-0021-1				
47P	1	1		SEB40100031-201	Life Raft Kit - 3 Man	025C	
47C	1	1		SEP40100030-201	Life Raft Inflation Assy	025C	
47D	3	3		SEB40100023-201	Sea Anchor	025C	
47E	6	6		SEB40100005-201	Sea Dye Marker	025C	
47F	3	3		SEP40100002-201	Sun Bonnet	025C	
47G	3	3		SEB40100014-201	Lanyard	025C	
47H	1	1		SEP40100015-201	Mooring Lanyard	025C	
47I	3	3		SEB40100055-001	Pad	025C	
47J	3	3		SEP40100053-201	Strap Assy	025C	
47K	3	3		SEB40100054-201	Strap Assy	025C	
48	1	1		V16-601373-101	Container Survival Kit C	849	
50	1	1		V16-771339-21	Left Side View Window Shade	867	-GSE Nylon covers installed in lieu of aluminized mylar flight window covers on windows in areas 50, 51, 53, and 55. Hatch window cover (53) removed by crew after ingress and stowed somewhere in the spacecraft.
51	1	1		V16-771341-11	Shade-LH Rendezvous	865	
53	1	1		V16-771340-21	Shade--hatch	864	
55	1	1		V16-771339-21	Rt. side View Window Shade	867	
52	1			V16-601484	Tool "E" Wrench Assy	803	
54	1	1		V16-771341-12	Shade--RH Rendezvous	866	
60	1			ME901-0090-0023	CM TV Camera	826	
48	1	1		SEB40100031-201	3 Man Life Raft		
48	15	10		SEB42100015-201	Urine Storage Bag		
48	6	6		EC30108-1	Urine Receiver		
48	3	3		SEB 42100001-201	Cuff Storage Bag		
48	45	45		EC30094	Roll on Cuff		
MDC			1	Non-flight	FDAI Cover		-Removed from FDAI by Command Pilot and placed on aft bulkhead after crew ingress.

AFT BULKHEAD

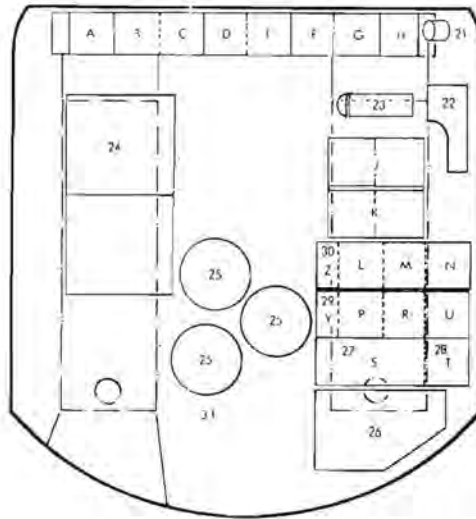

CREW COMPARTMENT STORAGE AND LOOSE EQUIPMENT CONFIGURATION

MSC FORM 1725 (MAR 67)(07)

STOWAGE AREA	QUANTITY			PART NUMBER	NOMENCLATURE	STOWAGE ITEM NUMBER	REMARKS
	PLANNED LAUNCH	OCF K-0034A-1	OCF K-0021-1				
21				EC30004-1	Inflight Exerciser	227	
21	1	1	-	SEB42100025-201	Inflight Exerciser Pouch	228	
22							
22	1	1	1	ME901-0090-0023	TV Optics Container	827	
22	1	1	1	ME901-0090-0023	TV Zoom Lens	828	
23	1	1	-	V16-601418-501	Fecal Cannister	860	
24							
24	1	1	-	V16-331092-51	PGA Stowage Bag	801	
24	3	3	-	V16-601416	Crew Waste Basket	855	
24	1	1	-	V16-601211-131	Crew Restraint	856	
24	1	1	-	V16-601506	Pad Fecal Cannister	882	
25							
25A	1	1	1	A1991-000	Skull Cap Assy	042	
25B	1	1	1	A1991-000	Skull Cap Assy	042	
25C	1	1	1	A1991-000	Skull Cap Assy	042	
25	3	3	3	A2012-000	Head Set	043	
25	3	3	3	A2011-000	Helmet Stowage Container	043	
26							
26	1	1	1	V16-601211-141	Sleep Restraint	857	
26	1	1	-	V16-331126-71	PGA Stowage Bag	802	
27	6	-	-	SEB33100068	70 MM Film Pack	060	
27	1	1	-	SEB33100029-201	70 MM Camera	006	
27	1	1	-	SEB33100031-201	Ring Sight	007	
27	1	1	1	ME331-0017-0032	COAS	850	
27	4	-	-	SEB33100022-206	16 MM Magazine	002	
28	9	-	-	SEB33100022-206	16 MM Magazine	002	
28	2	1	1	434-0097-002	COAS Bulb	850A	
28	1	1	-	V16-753103	16 MM Camera Bracket	1003	
30	9	9	-	EC30115	Pen Lights	032	
29	1	1	-	SEB12100047-201	Tool Kit	068	
31	4	4	-	SEB12100018-201	PPK	033	
	-	-	IN	Non-flight	Velcro pile covering velcro hook over large portion of aft bulkhead		- Installed to protect velcro hook.
A-H	16	16	-	ME901-0218-0021	LiOH Cartridges	868	- Stowage cannisters not installed on 0021-1
J,K	4	4	-	ME901-0218-0021	LiOH Cartridges	868	
L,M,N	3	3	-	ME901-0218-0021	LiOH Cartridges	868	
P,R,U	3	3	-	ME901-0218-0021	LiOH Cartridges	868	
AA-DD	4	-	-	ME901-0218-0021	LiOH Cartridges	868	
D-E	-	-	1	Non-flight	Battery Instrumentation Cable & Transducer		- Stowed in plastic bag on aft bulkhead

### CREW COUCHES GIRTH SHELF

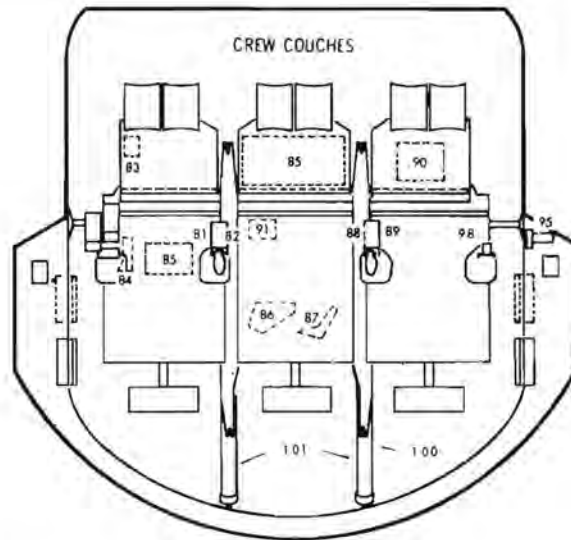

### CREW COMPARTMENT STORAGE AND LOOSE EQUIPMENT CONFIGURATION

NSC FORM 1725 (MAR 87)(01)

STORAGE AREA	QUANTITY			PART NUMBER	NOMENCLATURE	STORAGE ITEM NUMBER	REMARKS
	PLANNED LAUNCH	OCP K-003A-1	OCP K-0021-1				
Crew Couches	2	1	1	V16-601472-152	Couch Pad Assy	879	
	2	2	2	V16-601472-161	Couch Pad Assy	879	
	2	1	1	V16-601472-171	Couch Pad Assy	879	
	2	2	2	V16-601472-181	Couch Pad Assy	879	
	3	1	1	V16-601472-191	Couch Pad Assy	879	
	3	1	1	V16-601472-201	Couch Pad Assy	879	
	3	1	1	V16-601472-211	Couch Pad Assy	879	
	3	3	3	V16-601472-221	Couch Pad Assy	879	
	3	1	1	V16-601472-231	Couch Pad Assy	879	
	1	1	1	V16-601494	Wire Run Cover	880	
	2	2	2	V16-601495	Wire Run Cover	880	
	1	1	1	V16-601496-1	Wire Run Cover	880	
	1	1	1	V16-601496-2	Wire Run Cover	880	
	1	1	1	ME901-0257-0007	Restraint Assy	881	
	1	1	1	ME901-0257-0009	Restraint Assy	881	
1	1	1	ME901-0257-0011	Restraint Assy	881		
-	-	1	Non-flight	OCP K-0021-1 Checklist		- Found on LH couch after O021-1 - Multilith Process Paper	
93	-	-	1	Non-flight	OCP K-0021-1 Checklist		- Multilith process paper
92	-	-	1	Non-flight	OCP K-0021-1 Checklist		- Multilith process paper
92	-	-	1	Non-flight	Malfunction Procedures Document		- Zerox and Bruning process paper in manila folder.
81	1	1	1	V16-531750-2	Arm Rest, crew couch	871	
81	-	-	1	Non-flight	Tubular Cover		- On rotational hand controller harness
81	1	1	1		Rotational Controller		
83	1	1	-	RMK-100A	Emergency Medical Kit	022	- Container only stowed on O021-1
84	1	1	1	V16-880207-21	Translation Cont. Mtg Bkt	869	
84	1	1	-	V16-880207-11	Translation Cont. Adapter	830	
84	2	2	1		Translation Controller	870	
85A	6	6	-	EC33203	Tissue Dispenser	030	
85B	1	1	-	EC33203	Tissue Dispenser	030	
86	1	1	-	V16-331128	TV Camera Mtg Bkt	853A	
87	1	1	-	V16-331160	16MM Camera Mtg Bkt	853	
89	1	1	1	V16-531750-1	Arm Rest, Crew Couch	870	
90							
90	1	1	1	SEB33100021-207/208	16 MM Seq Camera	001	- Stowed on floor of area B2 in LEB for O021-1, loaded w/ loaded magazine for O03A-1

CREW COUCHES GIRTH SHELF (CON'T)

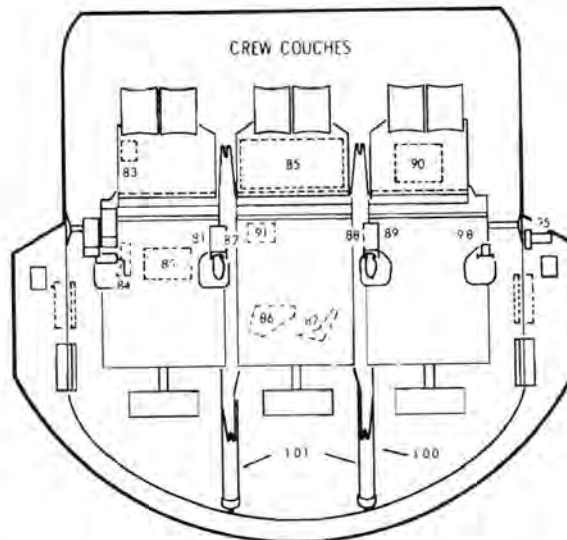

CREW COMPARTMENT STOWAGE AND LOOSE EQUIPMENT CONFIGURATION

MSC FORM 1775 (MAR 57)(01)

STOWAGE AREA	QUANTITY			PART NUMBER	NOMENCLATURE	STOWAGE ITEM NUMBER	REMARKS
	PLANNED LAUNCH	OCP K-0034A-1	OCP K-0021-1				
90	1	1	-	SEB33100055-201	70 MM Super Wide Angle Cam	048	
90	1	1	-	SEB33100056-201	5 MM Lens, 16MM Camera	045	
90	2	-	-	SEB33100030-201, -202 or -203	70 MM Film Magazine	212	
90	1	-	-	SEB33100069-203	Interference Filter	229	
90	1	-	-	SEB33100050-202	Filter	230	
90	1	1	-	V16-754239	Vol "G" Foam Cushion	888	
90	2	2	-	SEB33100050-201	Haze Filter (on camera)	053	
90	2	2	-	EL30170	Goggles Assy	231	
91	1	1	-	ME280-0008-0001	Sensor Unit-Temp Evaporator	884	
95	1	1	-	V16-601501-11	Tool "P" Handle Ext.	803P	
96	1	-	-	V16-771358	Floodlight		-Stowage bag only stowed for 0021-1
96	1	-	-	V16-420394	Floodlight Cable		
97	1	-	-	V16-752080	Camera Brkt (5051)		
98	1	1	1	V16-531750-2	Arm Rest, Crew Couch	871	
98	1	1	-		Rotational Controller		
100	-	-	1	Non-flight	Dust Cap		-Plastic - on SCS junction box connector
101	-	-	2	Non-flight	Foam Rubber Pads		-Covered with velostat, clean room tape, laid over Z-Z struts

CARRIED ON CREWMEN

CREW COMPARTMENT STOWAGE AND LOOSE EQUIPMENT CONFIGURATION

MSC FORM 1125 (MAR 67)(01)

STOWAGE AREA	QUANTITY			PART NUMBER	NOMENCLATURE	STOWAGE ITEM NUMBER	REMARKS
	PLACES ON LAUNCH	OCP K-003/A-1	OCP K-002/B-1				
	3	3	3	A 1936-000	Pressure Garment Assembly	400	-1 per crewman
	3	3	3	A 1912-003	Constant Wear Garment	401	-1 per crewman
	15	15	15	RFB-OP-4-3-002	Passive Dosimeter	402	-5 per crewman
	3	3	3	EC 20115	Penlights	403	-1 per crewman
	3	3	3	SEB12100033-201	Sunglasses	404	-1 per crewman
	3	3	3	SEB12100034-201	Sunglass Puch	404A	-1 per crewman
	3	3	3	SEB40100095-201	Life Vest	405	-1 per crewman
	3	3	3	14-0105	Urine Collection Device	406	-1 per crewman
	1	1	1	RFB-OP-4-3-003	Pocket Dosimeter	414	-On Senior Pilot
	3	3	3	SEB12100029-001	Chronograph	415	-1 per crewman
	3	3	3	SEB12100030-201	Watchband	416	-1 per crewman
	6	6	6	SEB12100031-001	Marking Pen	417	-2 per crewman
	6	6	6	SEB12100032-202	Mechanical Pencil	418	-2 per crewman
	1	1	1	CSD 20542	Scissors	421	-On Command Pilot
	2	2	2	EC 30190	Scissors	419	-On Senior Pilot and Pilot
	3 pr	3 pr	3 pr		Glove Inserts		-1 pair per crewman
	3 pr	3 pr	3 pr		Wrist Dams		-1 pair per crewman
	3	3	3		Neck Vent Dams		-1 per crewman
	3	3	3		Neck Dams		-1 per crewman
	3 pr	3 pr	3 pr	A-1901-001	Heel Plates		-1 pair per crewman
	3 pr	3 pr	3 pr	A-1902-001	Sole Plates		-1 pair per crewman
	1	1	1	EC 30045	Shroud Cutters	422	-On Senior Pilot
	3	3	3		Combination Knife		-1 per crewman
	-	-	1	Non-flight	Ratchet Wrench		-On Command Pilot
	-	3	3	Non-flight	Personal Watchband		-1 per crewman
	3	3	3		Bioinstrumentation System	407	-1 per crewman

SPACECRAFT/GSE INTERFACE DRAWINGS

ATTACHMENTS:

<u>Drawing No.</u>	<u>Title</u>
1-D-0056-1	SC/GSE Status During T-10 Hold - 0021
1-D-0056-2	SC/GSE Configuration During T-10 Hold - 0007
1-D-0056-3	SC Range/Launch Vehicle Interfaces T-10 - 0021 (2 sheets)
1-D-0056-4	SC/GSE Configuration During T-10 Hold - 0021 Electrical
1-D-0056-5	LC-34 EPS/GSE Electrical (General)
1-D-0056-6	Altitude Chamber SC/GSE Configuration - 0034A
1-D-0056-7	LC-34 ECS Airduct
1-D-0056-8	SC/GSE Configuration During T-10 Hold - 0021 Mechanical
1-D-0056-9	LC-34 ECS Water Glycol/Oxygen GSE
1-D-0060	ACE-S/C Uplink (Command) Configuration T-10 Minutes OCP-K-0021 (Sheet 1 of 2)
	ACE-S/C Downlink (Monitor) Configuration T-10 Minutes OCP-K-0021 (Sheet 2 of 2)
1-D-0062	AS-204 Astro Comm Circuits

ENCLOSURE 1-9

D-1-47



SPACECRAFT AND GROUND SUPPORT EQUIPMENT  
CONFIGURATION DURING T-10 HOLD

ELECTRICAL POWER STATUS

MAIN BUSS POWER ----- EXTERNAL  
BATTERY BUSSES ----- ENTRY BATTERIES  
BATTERY RELAY BUSS ----- EXTERNAL  
PYROTECHNIC BUSSES ----- ARMED  
LOGIC BUSSES ----- ARMED  
EMERGENCY DETECTION SYSTEM BUSSES ----- ARMED  
SERVICE MODULE JETTISON CONTROLLERS ----- OPEN CIRCUIT TO  
SM BATTERIES

NON-FLIGHT CONDITIONS

CONDITIONED AIR WAS BEING BLOWN INTO COMMAND MODULE BASE AREA  
CRYOGENIC TANKS EMPTY  
NO PROPELLANTS, HELIUM, OR NITROGEN ON BOARD  
WATER GLYCOL RETURN SHUT OFF VALVE (SM) HELD OPEN BY EXTERNAL  
POWER  
PYROS SHORTED, CONNECTORS TIED BACK  
COMMAND MODULE OXYGEN SUPPLIED THROUGH ONE UMBILICAL LINE

1-D-0056-1

ENCLOSURE 1-9a

D-1-48

L/C 34  
 SPACECRAFT GSE CONFIGURATION DURING T-10 OCP0007

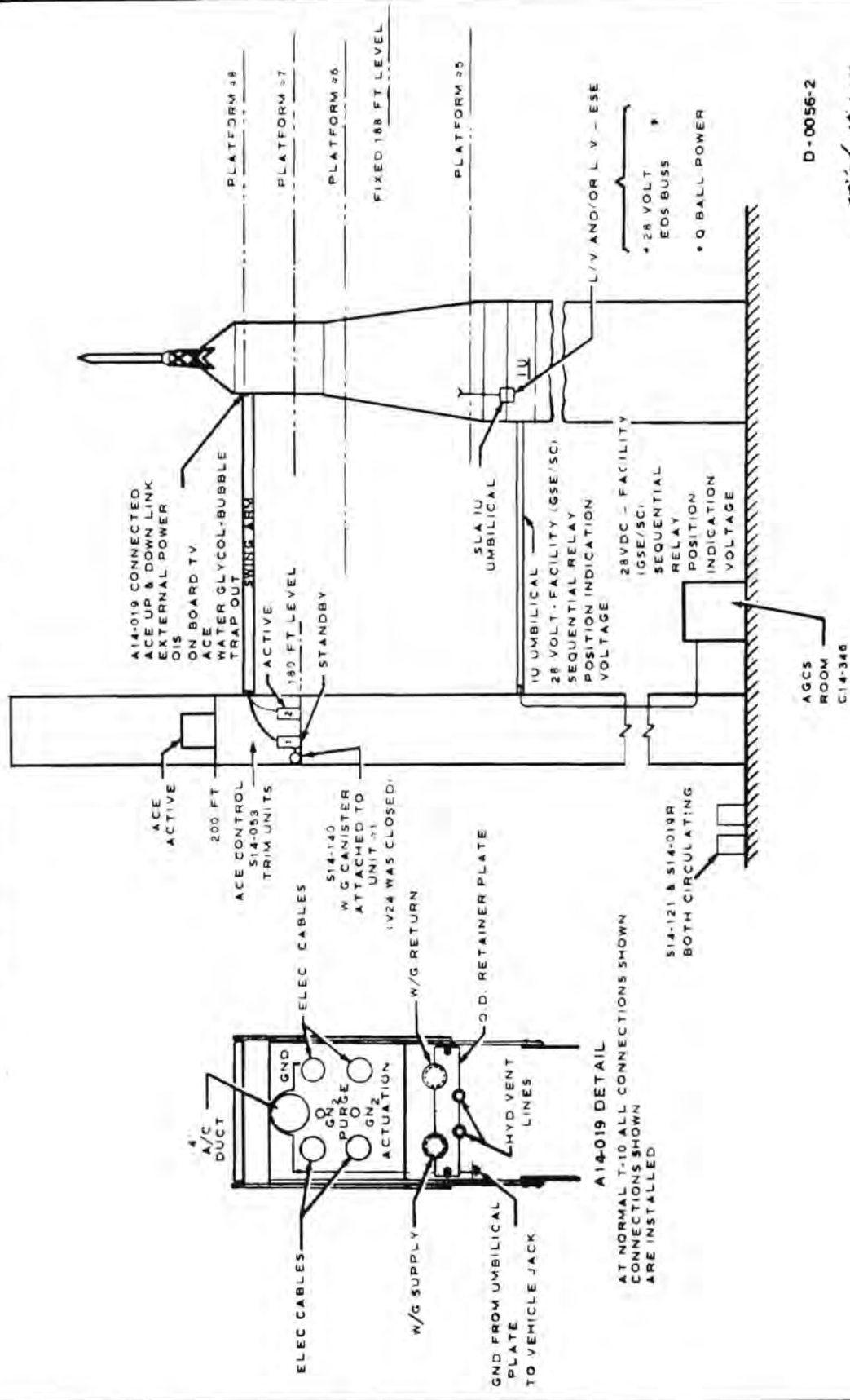

1. 10/10/67  
 2. 10/10/67  
 3. 10/10/67  
 4. 10/10/67  
 5. 10/10/67

D-0056-2





This page left blank intentionally.



S/C - GSE CONFIGURATION DURING T-10 HOLD -0021 ELEC.

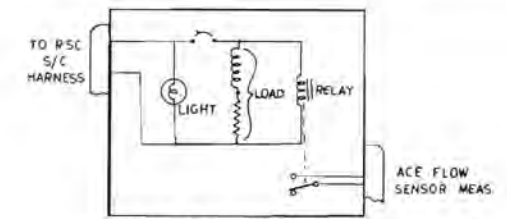
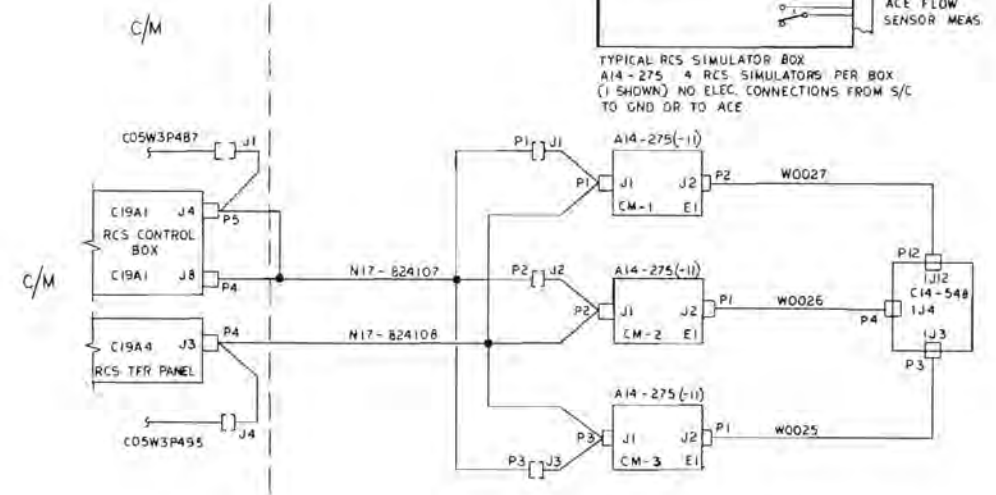
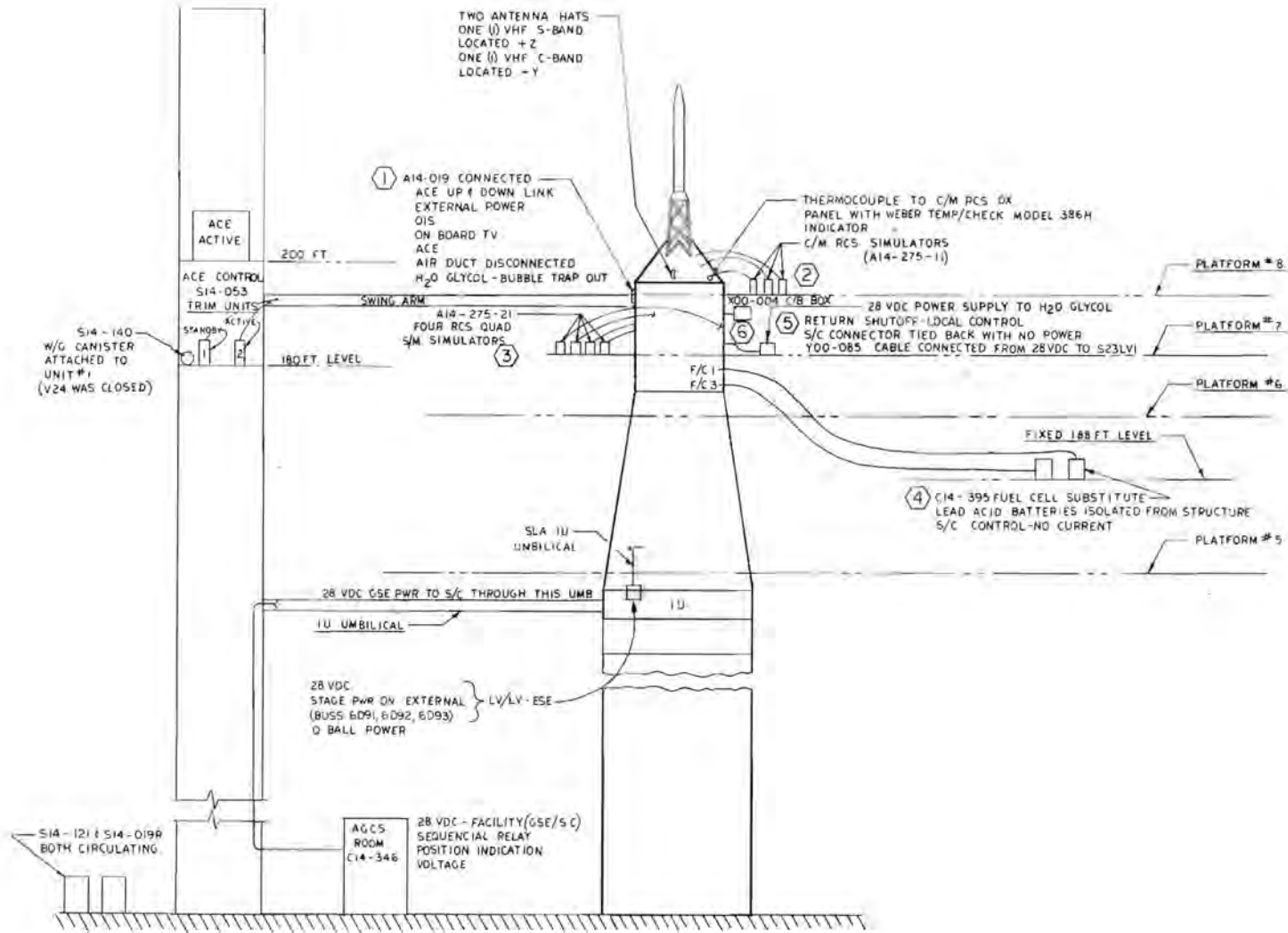

TYPICAL RCS SIMULATOR BOX  
A14-275 4 RCS SIMULATORS PER BOX  
(1 SHOWN) NO ELEC. CONNECTIONS FROM S/C TO GND OR TO ACE

2) DETAIL

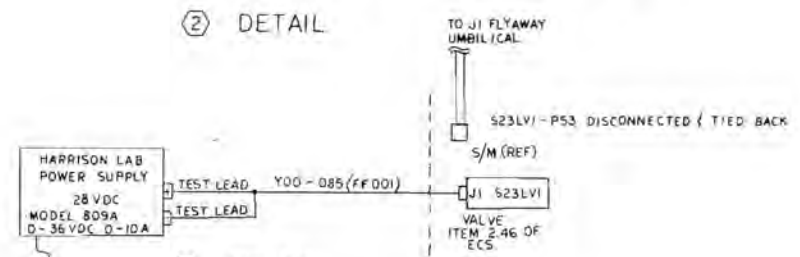

5) DETAIL

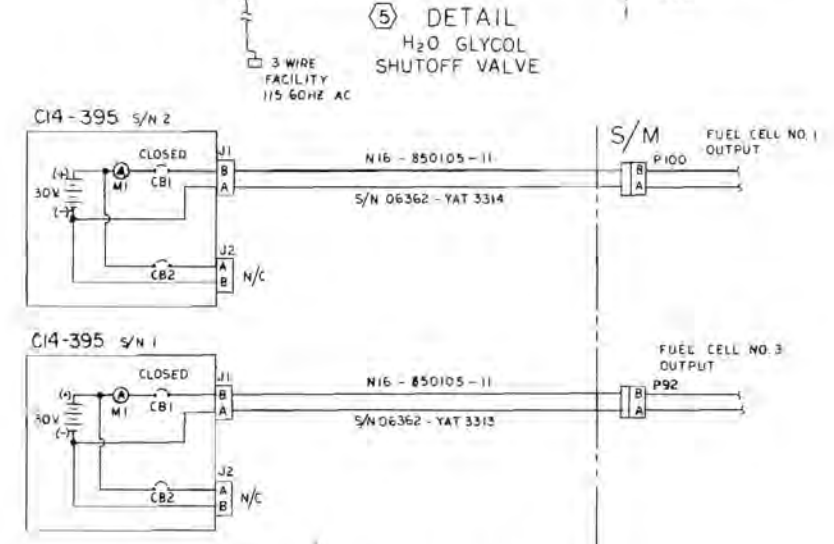

4) DETAIL

NOTE: N16-850105-11 CABLES TO BOTH C14-395 UNITS WERE DISCONNECTED DURING GSE POWER DOWN.

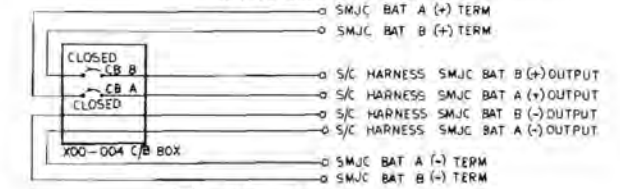

6) DETAIL

- NOTES:
1. ① THRU ③ DEPICT ELECTRICAL GSE CONNECTED TO S/C FOR PLUGS-OUT TEST AT T-10 MIN.
  2. ④ DEPICTS UMBILICAL FLY-AWAY WHICH IS ONLY GSE CONNECTED TO S/C DURING LAUNCH TERMINAL COUNTDOWN.
  3. ALL ITEMS SHOWN WITHIN COMMAND MODULE AND/OR SERVICE MODULE AND/OR IU ARE FOR REF ONLY.

*Handwritten notes:*  
 H. L. ... 2-15-67  
 M. L. ... 2-16-67  
 W. B. ... NASA 2-16-67  
 C. R. ... 2-16-67

# EPS GSE (ELEC.) L/C 34

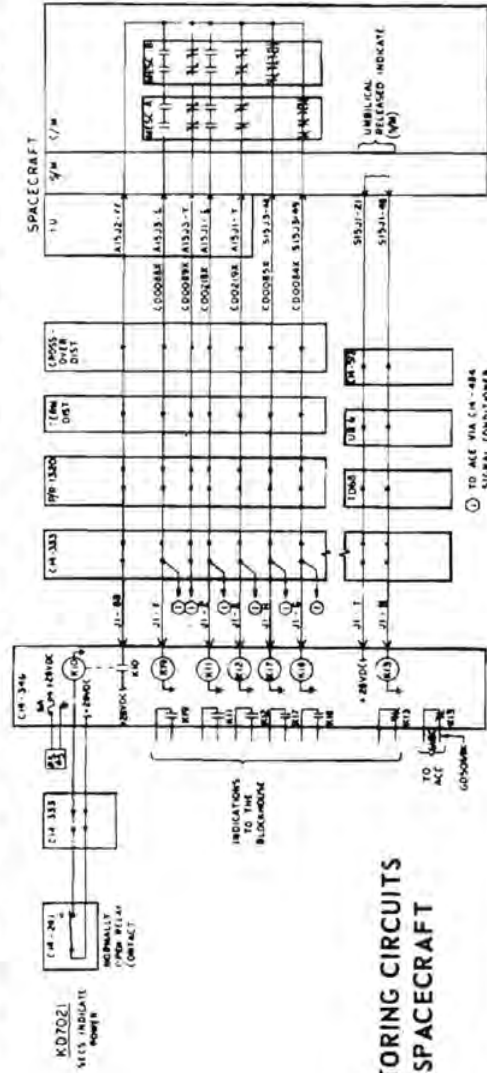
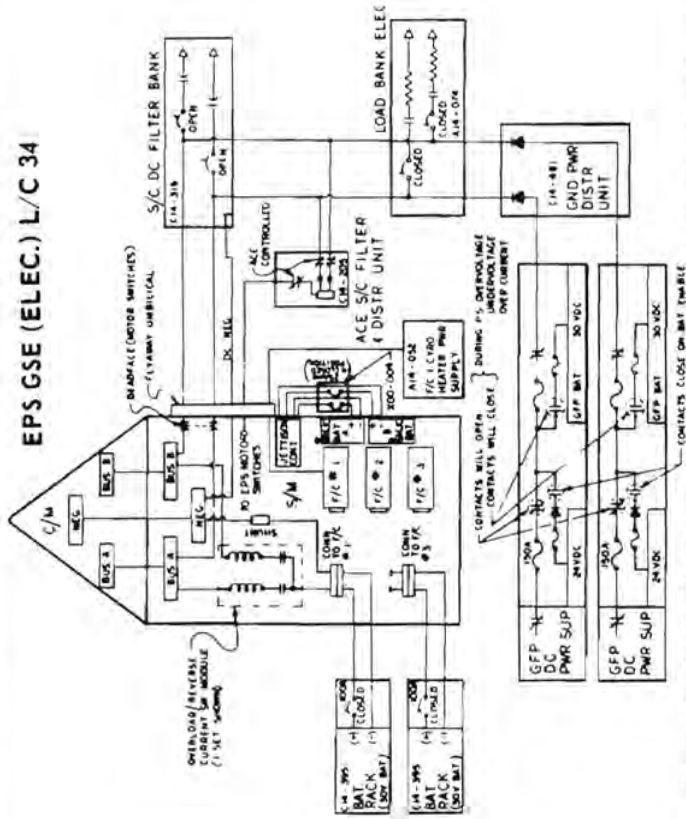

LOGIC BUS INDICATE  
 PYRO BUS INDICATE  
 PYRO FIRING RELAYS SAFE (B)  
 PYRO FIRING RELAYS SAFE (O)

NOTE: SCHEMATIC REFERENCE INFORMATION ONLY  
 & SAME PIN BATTERY AS PYRO BATTERY  
 C14-346 2-1-67  
 C14-347 2-1-67  
 C14-348 2-1-67  
 C14-349 2-1-67  
 C14-350 2-1-67  
 C14-351 2-1-67  
 C14-352 2-1-67  
 C14-353 2-1-67  
 C14-354 2-1-67  
 C14-355 2-1-67  
 C14-356 2-1-67  
 C14-357 2-1-67  
 C14-358 2-1-67  
 C14-359 2-1-67  
 C14-360 2-1-67  
 C14-361 2-1-67  
 C14-362 2-1-67  
 C14-363 2-1-67  
 C14-364 2-1-67  
 C14-365 2-1-67  
 C14-366 2-1-67  
 C14-367 2-1-67  
 C14-368 2-1-67  
 C14-369 2-1-67  
 C14-370 2-1-67  
 C14-371 2-1-67  
 C14-372 2-1-67  
 C14-373 2-1-67  
 C14-374 2-1-67  
 C14-375 2-1-67  
 C14-376 2-1-67  
 C14-377 2-1-67  
 C14-378 2-1-67  
 C14-379 2-1-67  
 C14-380 2-1-67  
 C14-381 2-1-67  
 C14-382 2-1-67  
 C14-383 2-1-67  
 C14-384 2-1-67  
 C14-385 2-1-67  
 C14-386 2-1-67  
 C14-387 2-1-67  
 C14-388 2-1-67  
 C14-389 2-1-67  
 C14-390 2-1-67  
 C14-391 2-1-67  
 C14-392 2-1-67  
 C14-393 2-1-67  
 C14-394 2-1-67  
 C14-395 2-1-67  
 C14-396 2-1-67  
 C14-397 2-1-67  
 C14-398 2-1-67  
 C14-399 2-1-67  
 C14-400 2-1-67

I-D - 0056-5

PYRO & LOGIC MONITORING CIRCUITS  
 SHOWING C14-346 TO SPACECRAFT  
 INTERFACE



This page left blank intentionally.

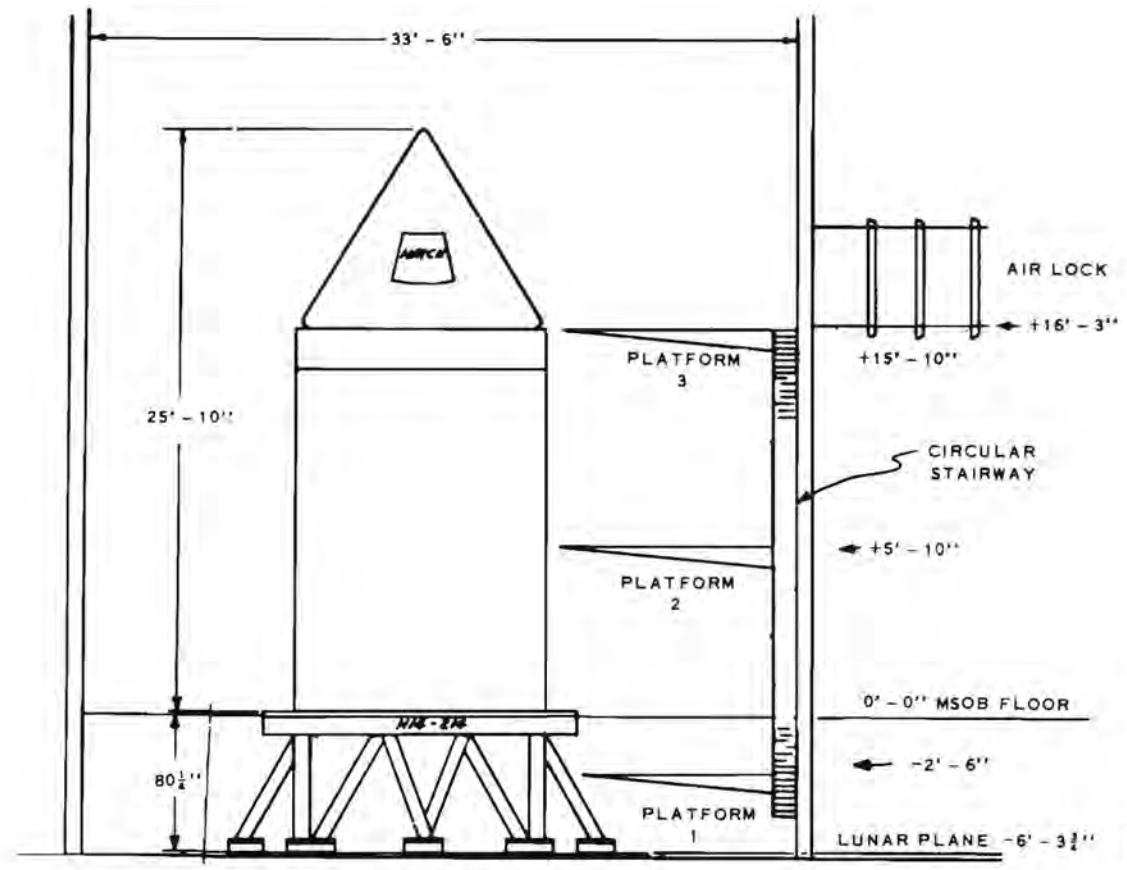
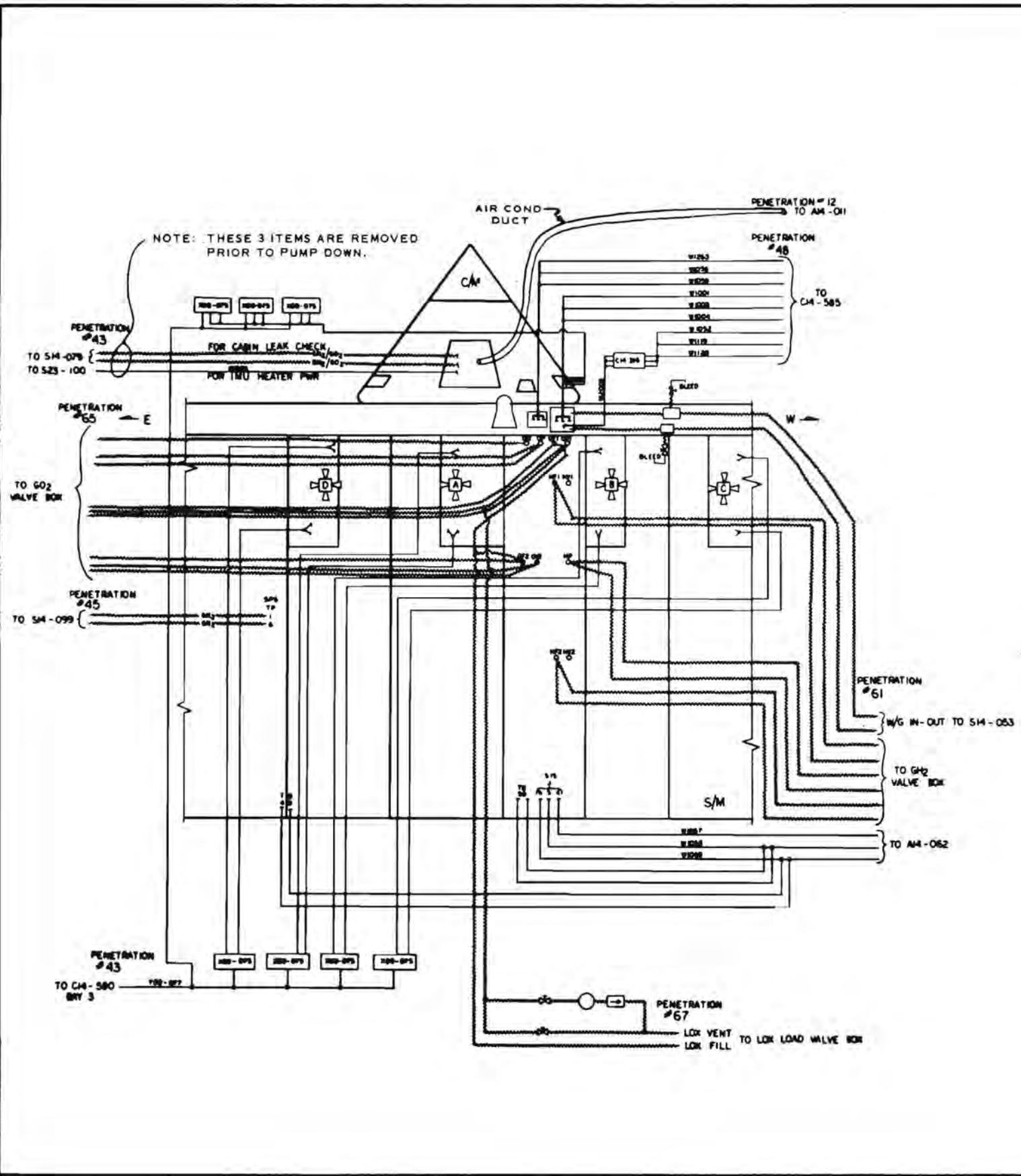

ALTITUDE CHAMBER  
SPACECRAFT/GSE CONFIGURATION  
0034A

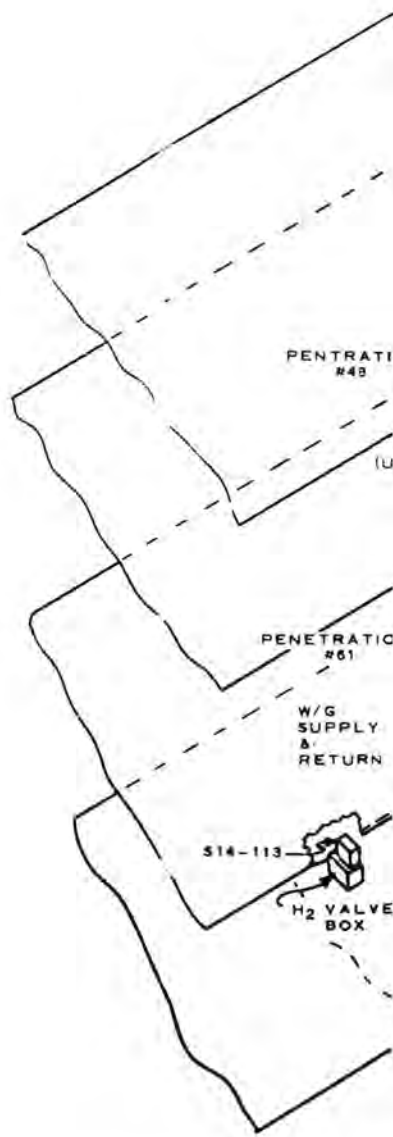

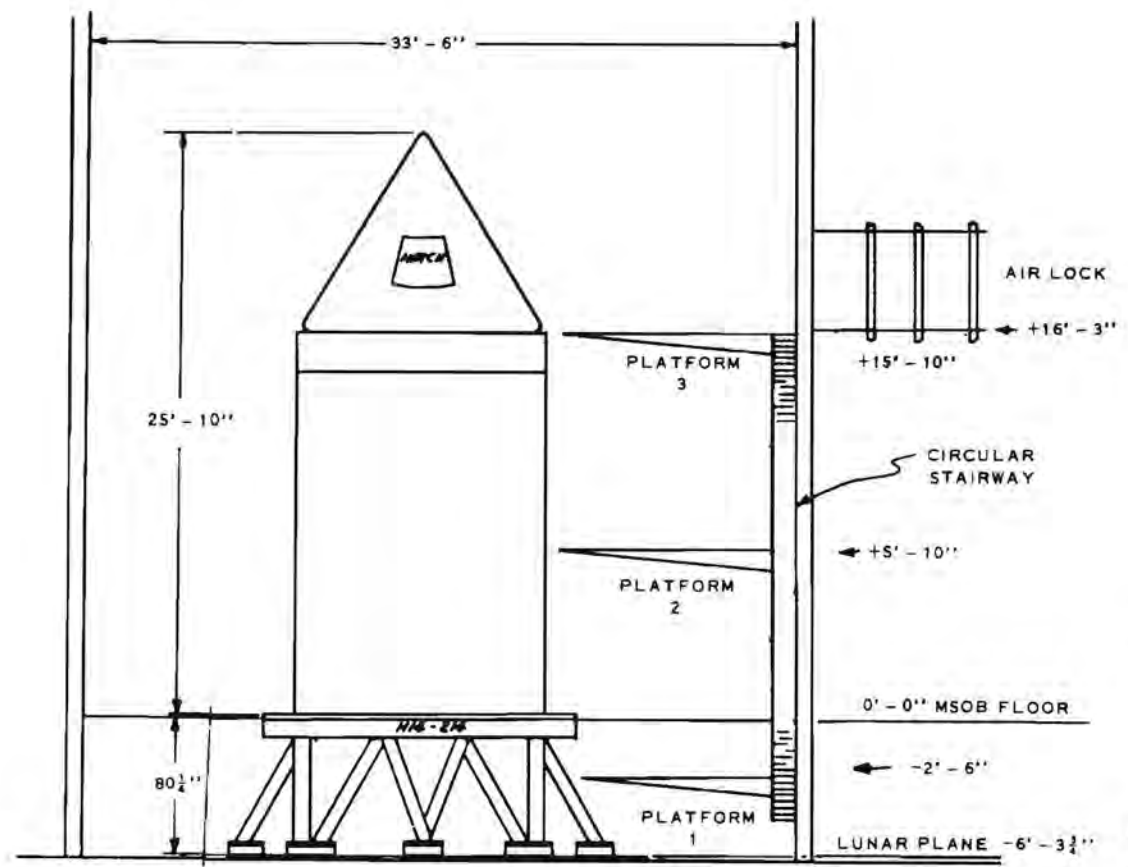
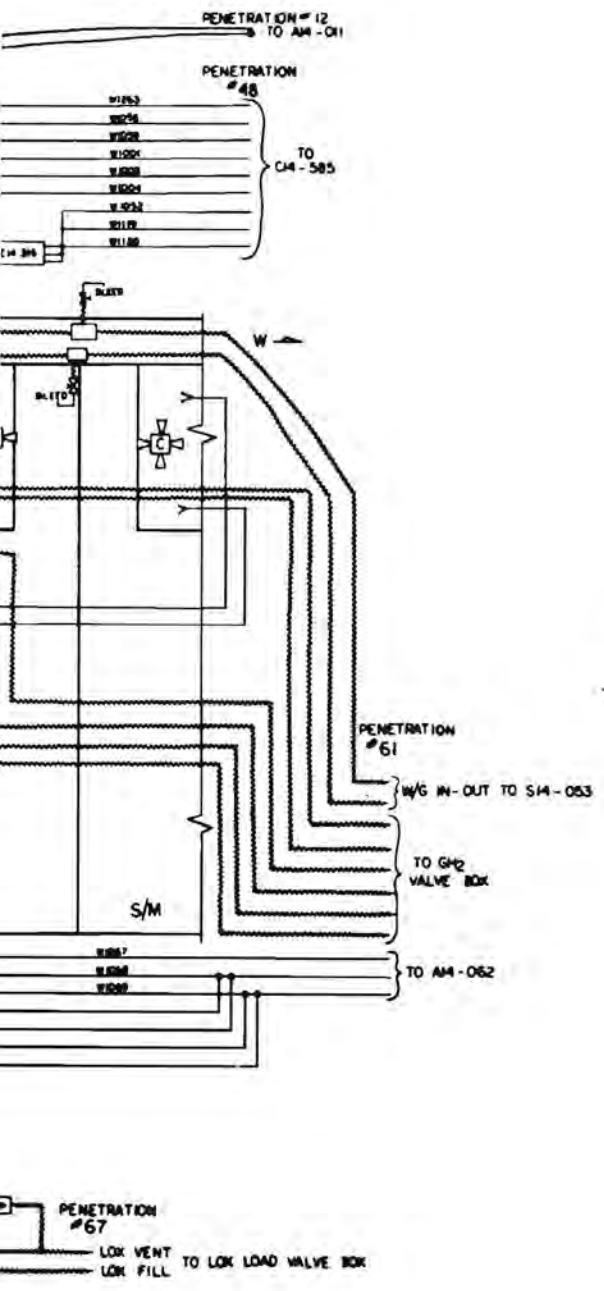

ALTITUDE CHAMBER  
SPACECRAFT/GSE CONFIGURATION  
0034A

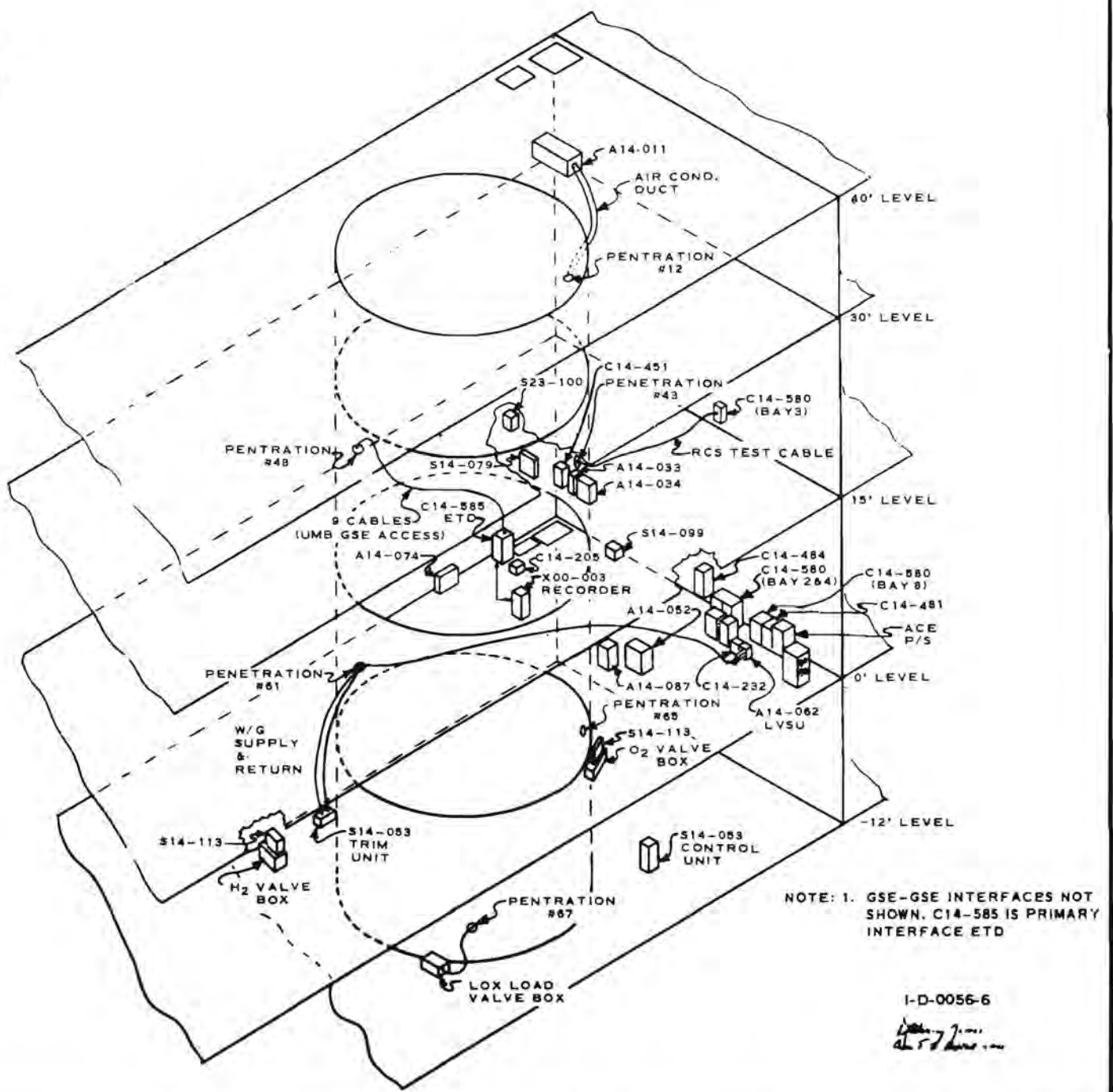

NOTE: 1. GSE-GSE INTERFACES NOT SHOWN. C14-585 IS PRIMARY INTERFACE ETD

I-D-0056-6  
*John J. ...*  
*ALP*

L/C 34  
ECS AIR DUCT

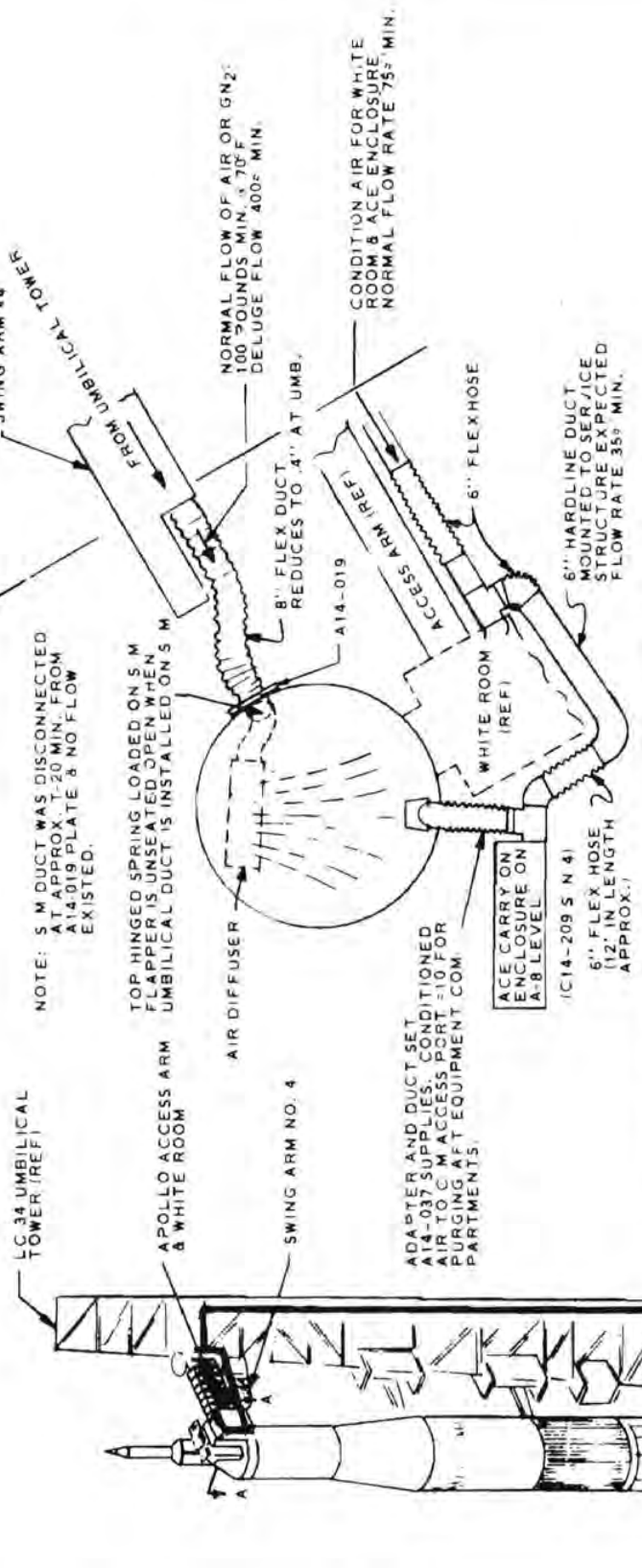

NOTE: S M DUCT WAS DISCONNECTED AT APPROX. T-20 MIN. FROM A14-019 PLATE & NO FLOW EXISTED.

TOP HINGED SPRING LOADED ON S M FLAPPER IS UNSEATED OPEN WHEN UMBILICAL DUCT IS INSTALLED ON S M

ADAPTER AND DUCT SET A14-037 SUPPLIES, CONDITIONED AIR TO C M ACCESS PORT #10 FOR PURGING AFT EQUIPMENT COMPARTMENTS.

ACE CARRY ON ENCLOSURE ON A-8 LEVEL (C14-209 S N 4)

6" FLEX HOSE (12' IN LENGTH APPROX.)

VIEW A-A (8TH LEVEL)

CHRYSLER AIR CONDITIONING UNITS ON TOP OF ECS BUILDING

*Handwritten notes:*  
 2' Above 4th 2-6-67  
 2nd Bell May 2-6-67  
 W.P. Moore NASA 2-6-67  
 C.E. Olson NASA 2-9-67  
 J.P. Murphy NASA 2/10/67

Drawn by  
 Date: 1-2-67

I-D-0056-7

This page left blank intentionally.

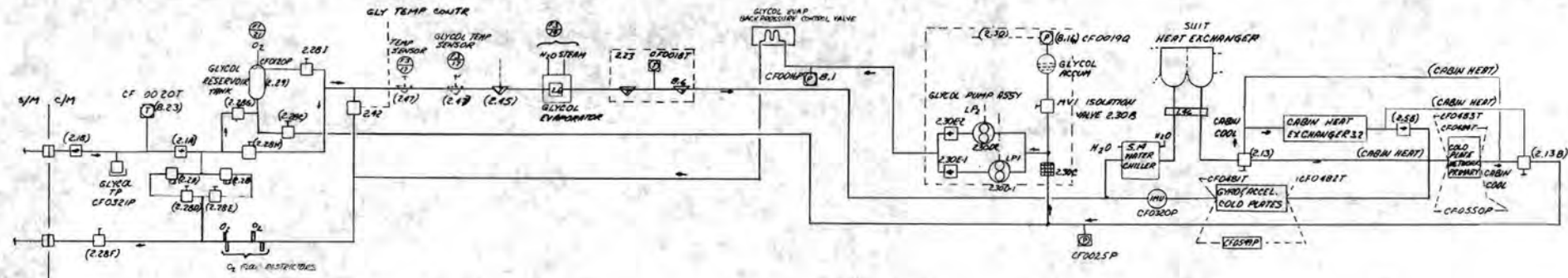

L/C 34

S/C GSE CONFIGURATION DURING T-10 HOLD OCP 0021 MECHANICAL

UNIT INDEX NO.	DESCRIPTION	
1.45	02311213	SUIT EVAPORATOR GLYCOL INLET TEMP SENSOR
1.46	02311213	SUIT EVAPORATOR GLYCOL DIVERSION VALVE
1.47	02311213	CN COOLANT SUPPLY LINE CHECK VALVE
1.48	02311213	CN COOLANT SUPPLY LINE CHECK VALVE
1.49	02311213	OLYCOL BRNDNG HEAT ISOLATION CHECK VALVE
1.50	02311213	SPACE RADIATOR OUTLET CHECK VALVE
1.51	02311213	SPACE RADIATOR OUTLET CHECK VALVE
1.52	02311213	SPACE RADIATOR OUTLET CHECK VALVE
1.53	02311213	SPACE RADIATOR OUTLET CHECK VALVE
1.54	02311213	CABIN TEMP CONTROL VALVE
1.55	02311213	GLYCOL PUMP PRESSURE SWITCH
1.56	02311213	GLYCOL PRESSURE RELIEF VALVE
1.57	02311213	GLYCOL PRESSURE RELIEF VALVE
1.58	02311213	RES RADIATOR ISOLATION VALVE
1.59	02311213	RES RADIATOR ISOLATION VALVE
1.60	02311213	RES RADIATOR ISOLATION VALVE
1.61	02311213	RES RADIATOR ISOLATION VALVE
1.62	02311213	GLYCOL EVAPORATOR LIQUID OUTLET TEMP SENSOR
1.63	02311213	GLYCOL BRNDNG FILL DISCONNECT VALVE
1.64	02311213	GLYCOL BRNDNG FILL DISCONNECT VALVE
1.65	02311213	GLYCOL BRNDNG FILL DISCONNECT VALVE
1.66	02311213	GLYCOL BRNDNG FILL DISCONNECT VALVE
1.67	02311213	MANUAL BYPASS SHUTOFF VALVE
1.68	02311213	MANUAL BYPASS SHUTOFF VALVE
1.69	02311213	RADIATOR SHUT OFF VALVE
1.70	02311213	GLYCOL RESERVOIR TRAP VALVE
1.71	02311213	GLYCOL RESERVOIR TRAP VALVE
1.72	02311213	GLYCOL RESERVOIR TRAP VALVE
1.73	02311213	GLYCOL RESERVOIR TRAP VALVE
1.74	02311213	GLYCOL ACCUMULATOR ISOLATION VALVE
1.75	02311213	GLYCOL PUMP FILTER
1.76	02311213	GLYCOL PUMP
1.77	02311213	GLYCOL PUMP CHECK VALVE
1.78	02311213	GLYCOL PUMP CHECK VALVE
1.79	02311213	GLYCOL TEMPERATURE CONTROL VALVE
1.80	02311213	GLYCOL TEMPERATURE SENSOR
1.81	02311213	GLYCOL DRAIN AND TRAP SHUTOFF VALVE
1.82	02311213	GLYCOL TEMPERATURE SENSOR
1.83	02311213	GLYCOL TEMPERATURE SENSOR
1.84	02311213	GLYCOL TEMPERATURE SENSOR
1.85	02311213	CABIN HEAT EXCHANGER CHECK VALVE
1.86	02311213	GLYCOL BRNDNG FILL LINE CHECK VALVE
1.87	02311213	GLYCOL EVAPORATOR
1.88	02311213	CABIN HEAT EXCHANGER
1.89	02311213	CABIN TEMP OVER-CORRECTION SENSOR
1.90	02311213	WATER CHILLER

02311213	GLYCOL AND LIQ TEMP
02311213	TANKS OUT PRESS
02311213	GLYCOL SWAP LIQ TEMP
02311213	GLYCOL PUMP UP PRESS
02311213	GLYCOL ACCUMULATOR QUANTITY
02311213	PUMP INLET PRESS
02311213	COLD PLATE BRANCH 1 INLET TEMP
02311213	COLD PLATE BRANCH 1 OUTLET TEMP
02311213	COLD PLATE BRANCH 2 INLET TEMP
02311213	COLD PLATE BRANCH 2 INLET TEMP
02311213	COLD PLATE BRANCH 2 INLET TEMP
02311213	COLD PLATE BRANCH 2 INLET TEMP

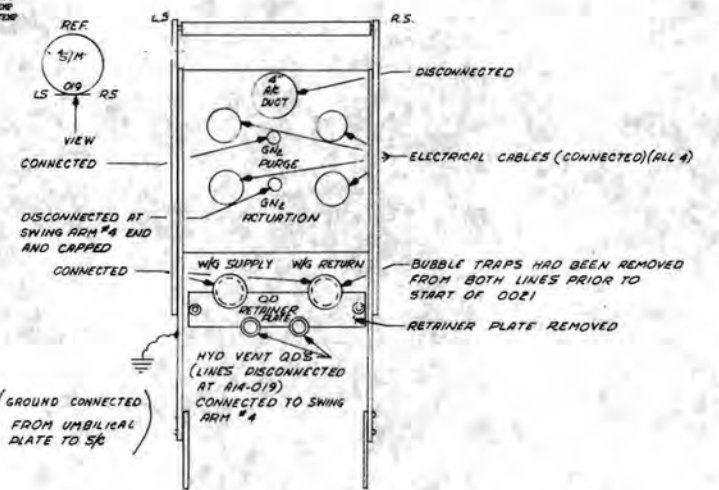
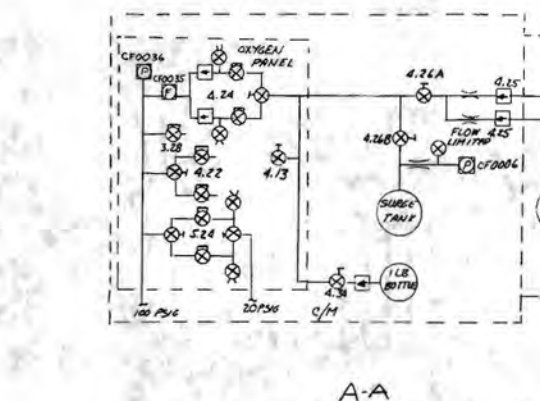
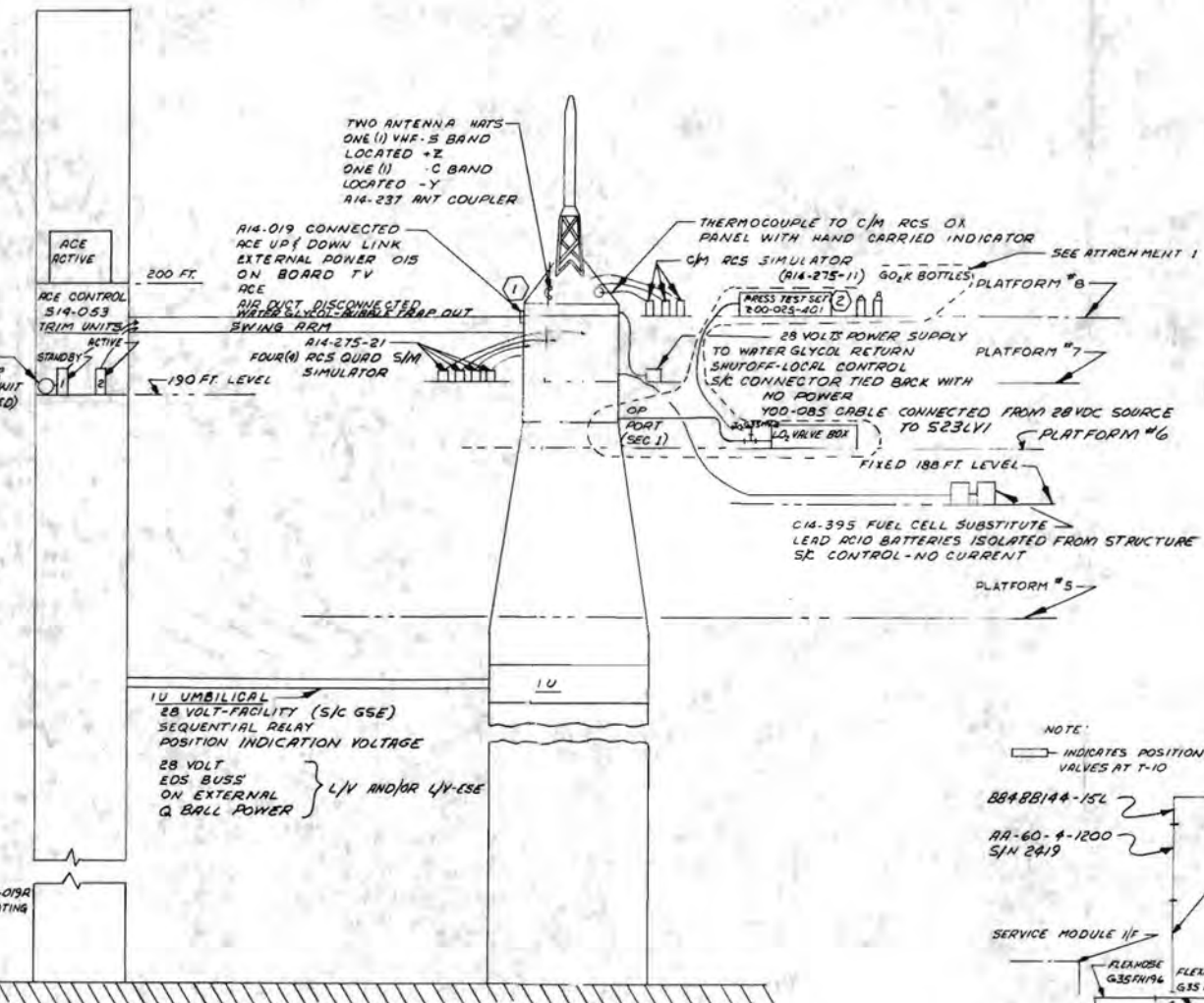
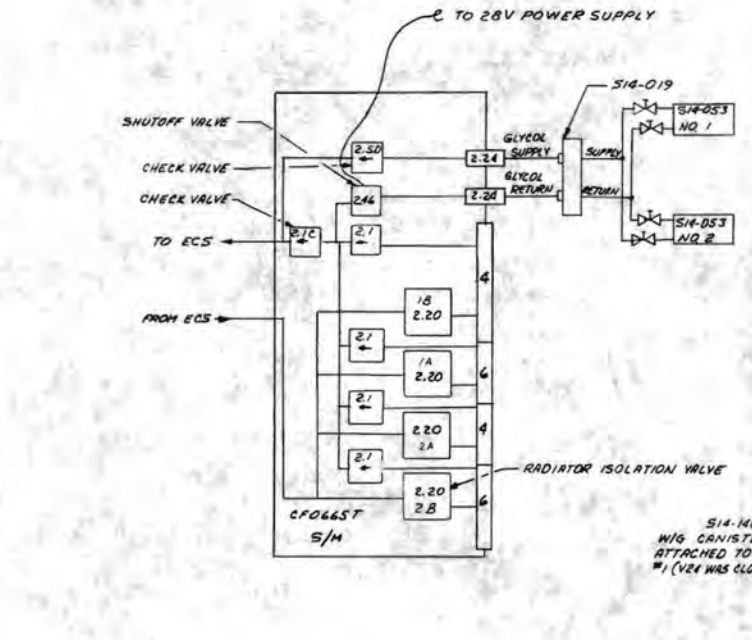

R14-019 CONFIGURATION T-10 (0021) 1/27/67

1 DETAIL

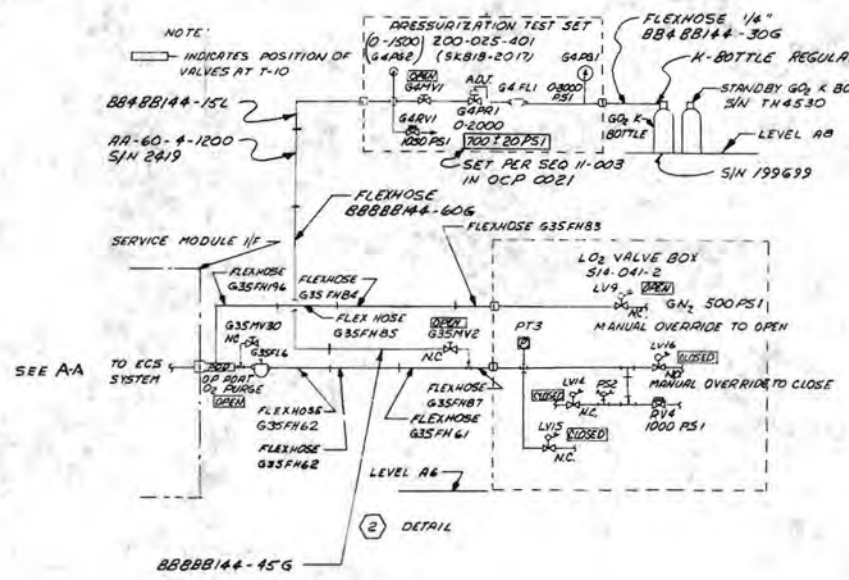

2 DETAIL



L/C 34  
ECS WATER GLYCOL GSE  
OXYGEN GSE

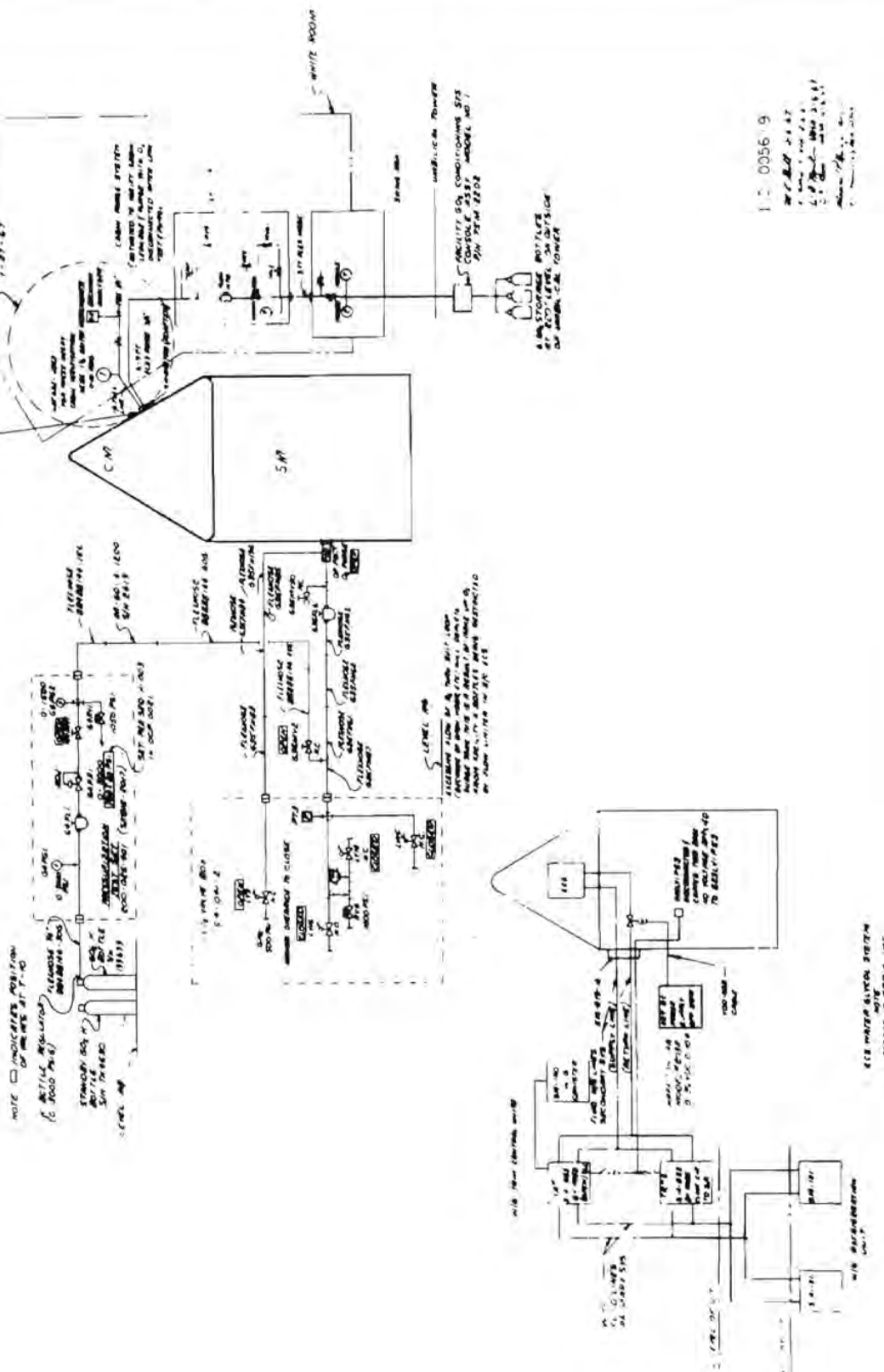

I.C. 0056.9  
 1. 18:00 GRS  
 2. 18:15 GRS  
 3. 18:30 GRS  
 4. 18:45 GRS



This page left blank intentionally.

CONTROL ROOM - DATA ENTRY UPLINK

SIGNAL DISTRIBUTION ROOM - UPLINK

COMPUTER ROOM - UPLINK

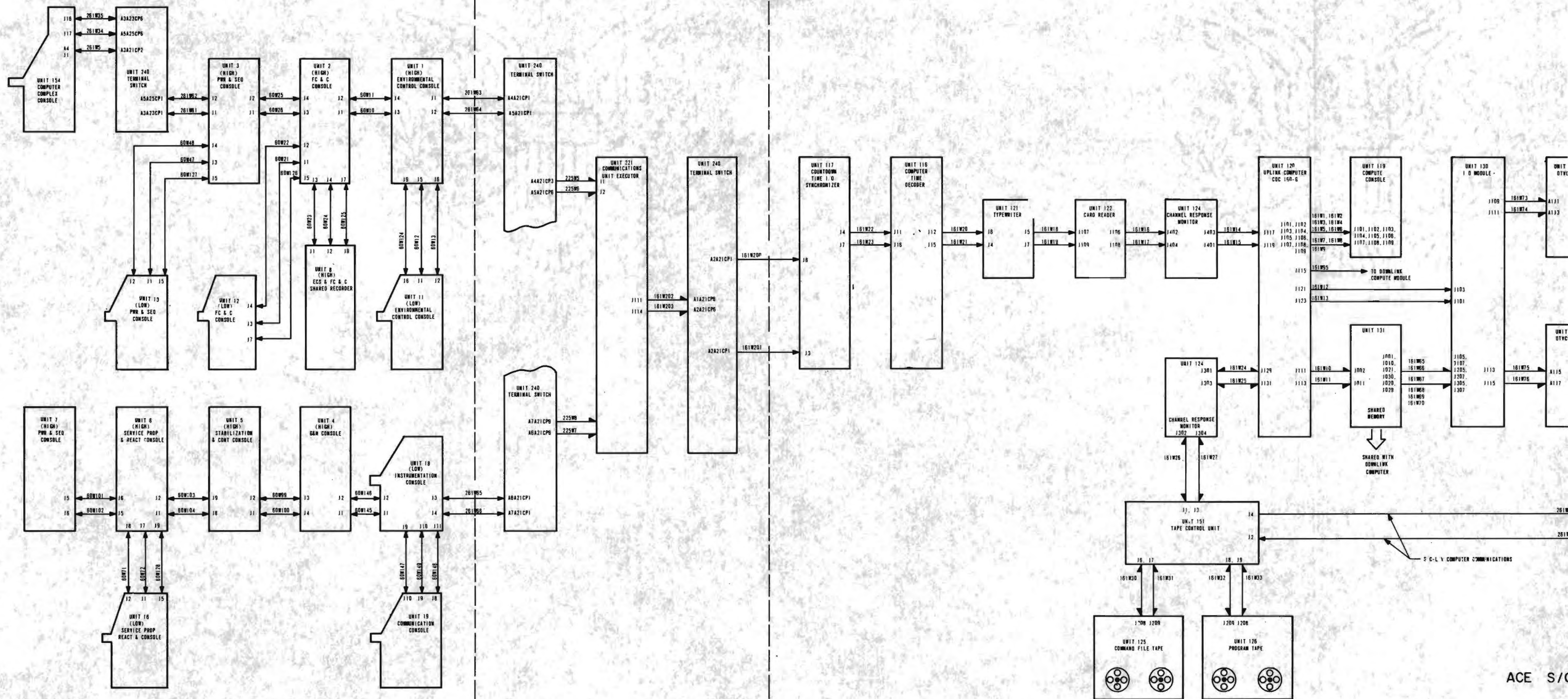

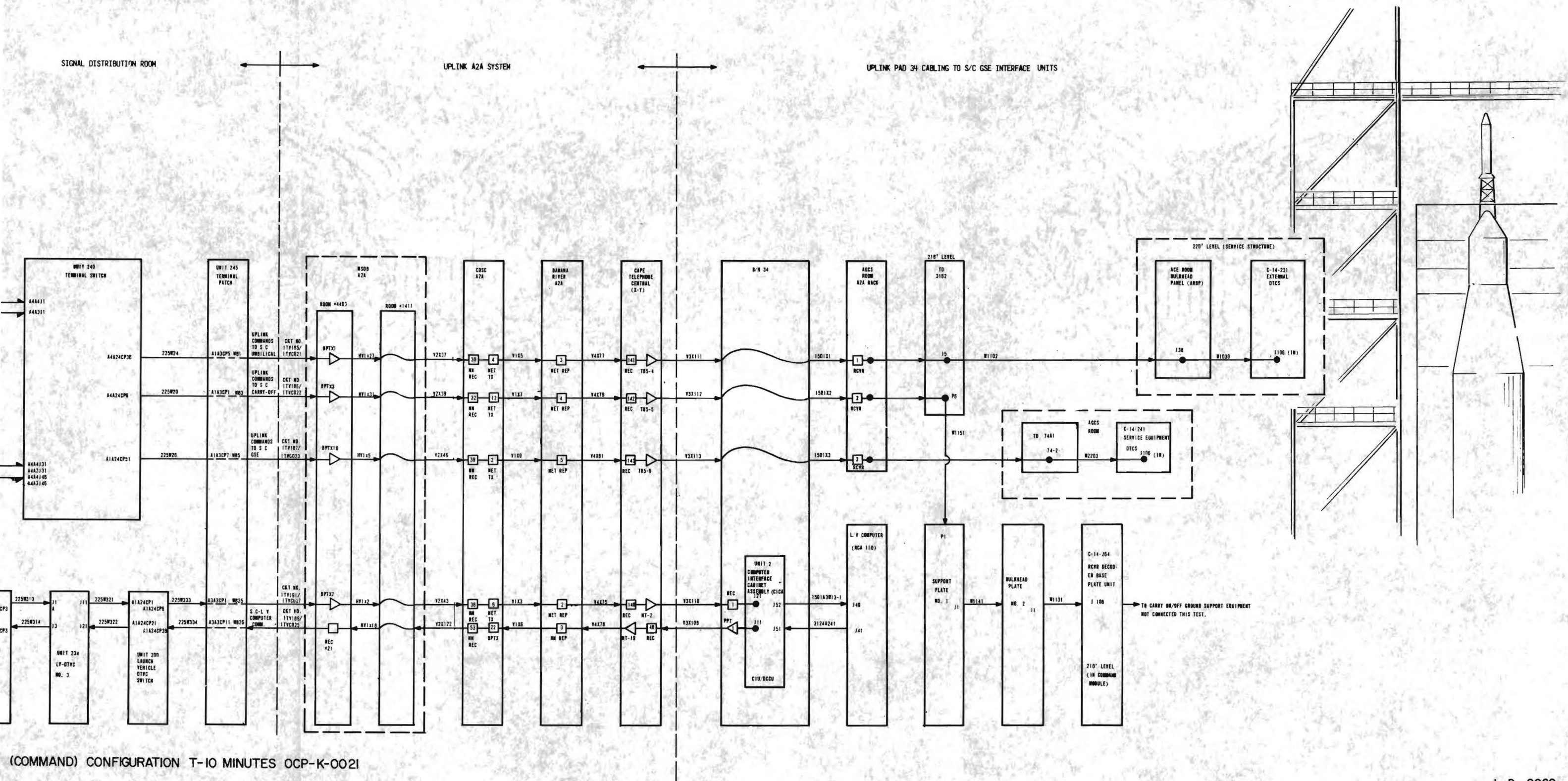

(COMMAND) CONFIGURATION T-10 MINUTES OCP-K-0021

SIGNAL DISTRIBUTION ROOM DOWNLINK

CONTROL ROOM - DOWNLINK

SIGNAL DISTRIBUTION ROOM DOWNLINK

COMPUTER ROOM - DOWNLINK

SIGNAL DISTRIBUTION ROOM - DOWNLINK

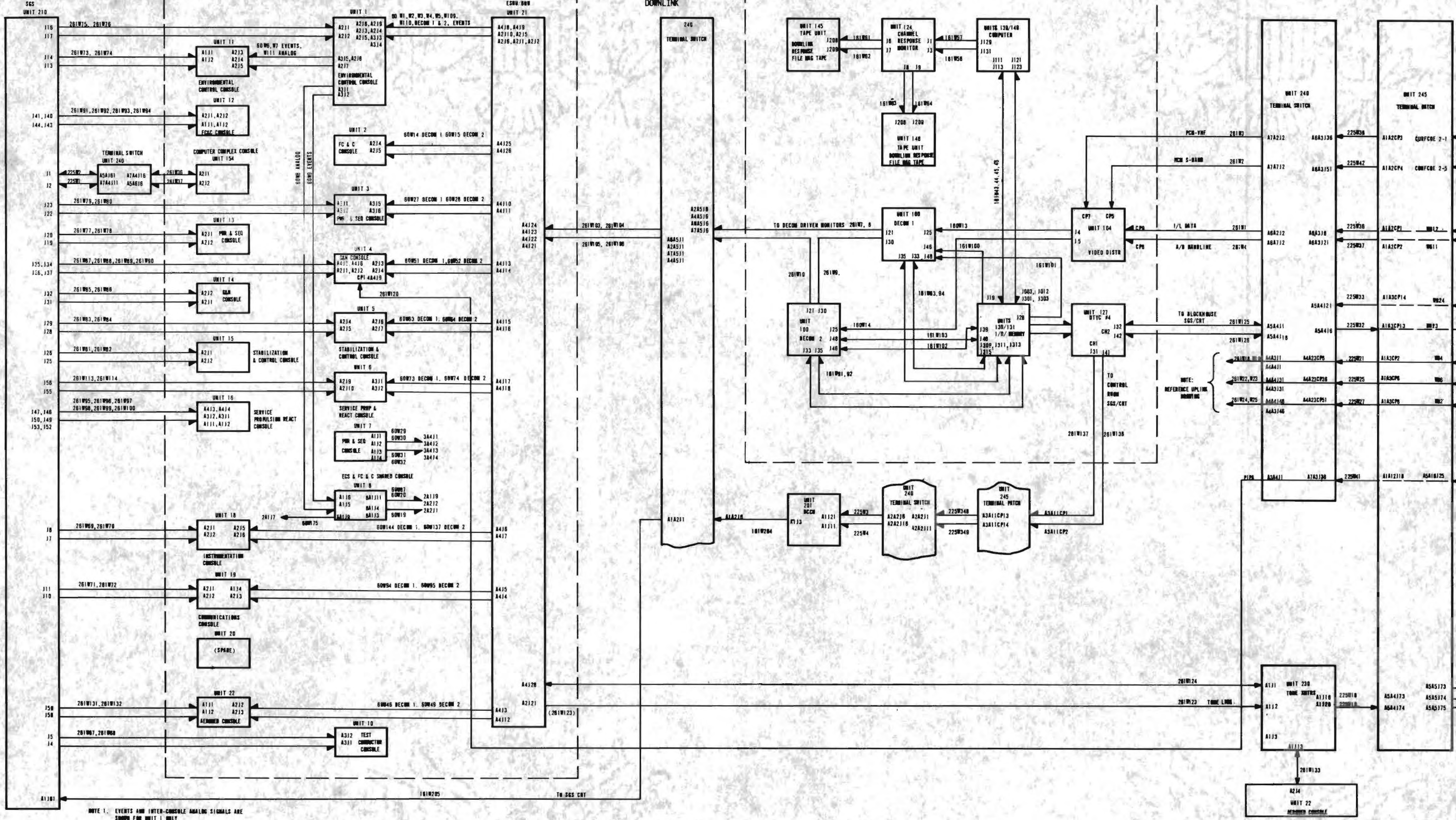

NOTE 1. EVENTS AND INTER-CONSOLE ANALOG SIGNALS ARE SUPPLY FOR UNIT 1 ONLY

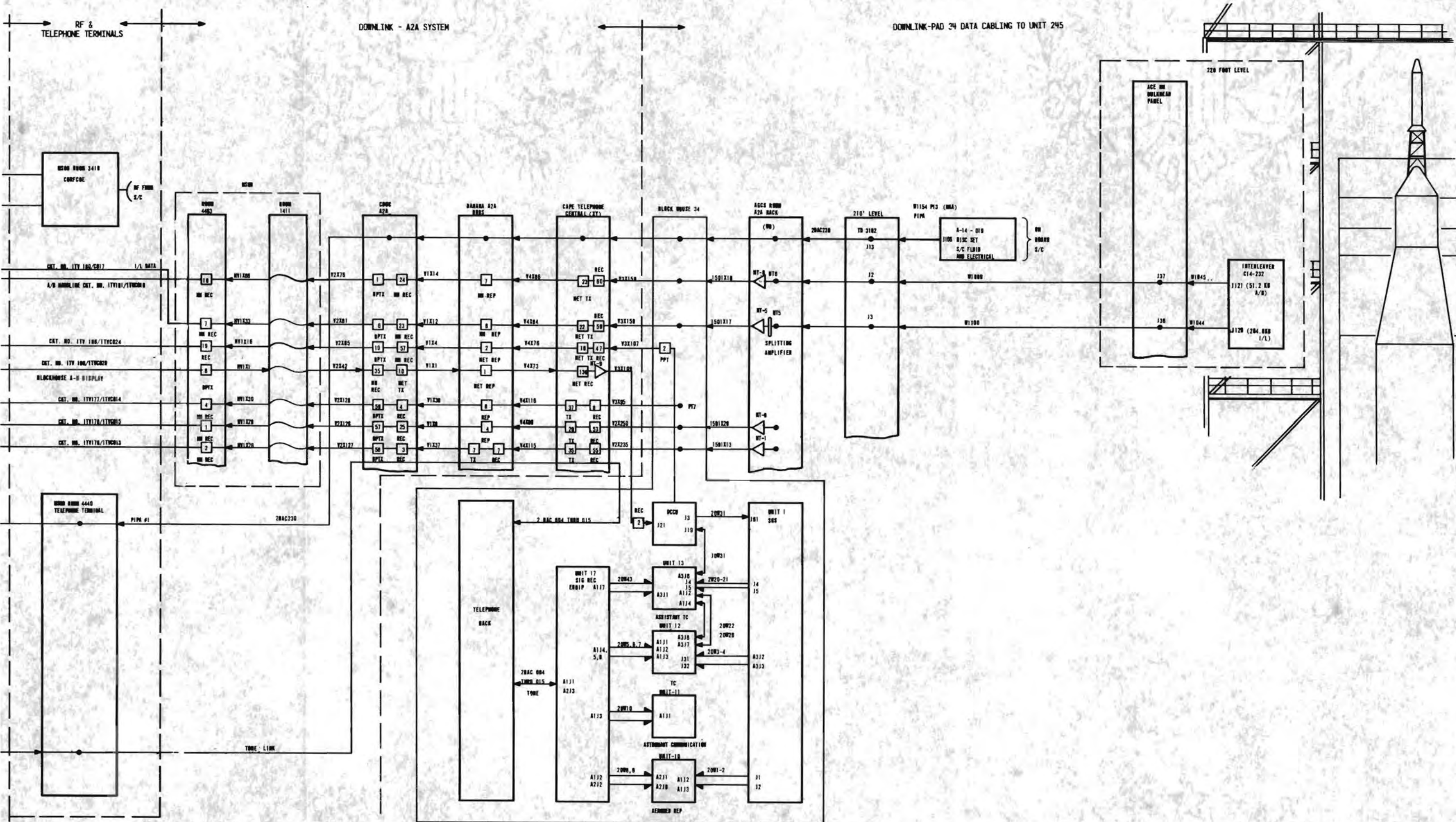

ACE S/C SYSTEM DOWNLINK (MONITOR) CONFIGURATION T-10 MINUTES OCP-K-0021

# AS204 ASTRO COMM CIRCUITS

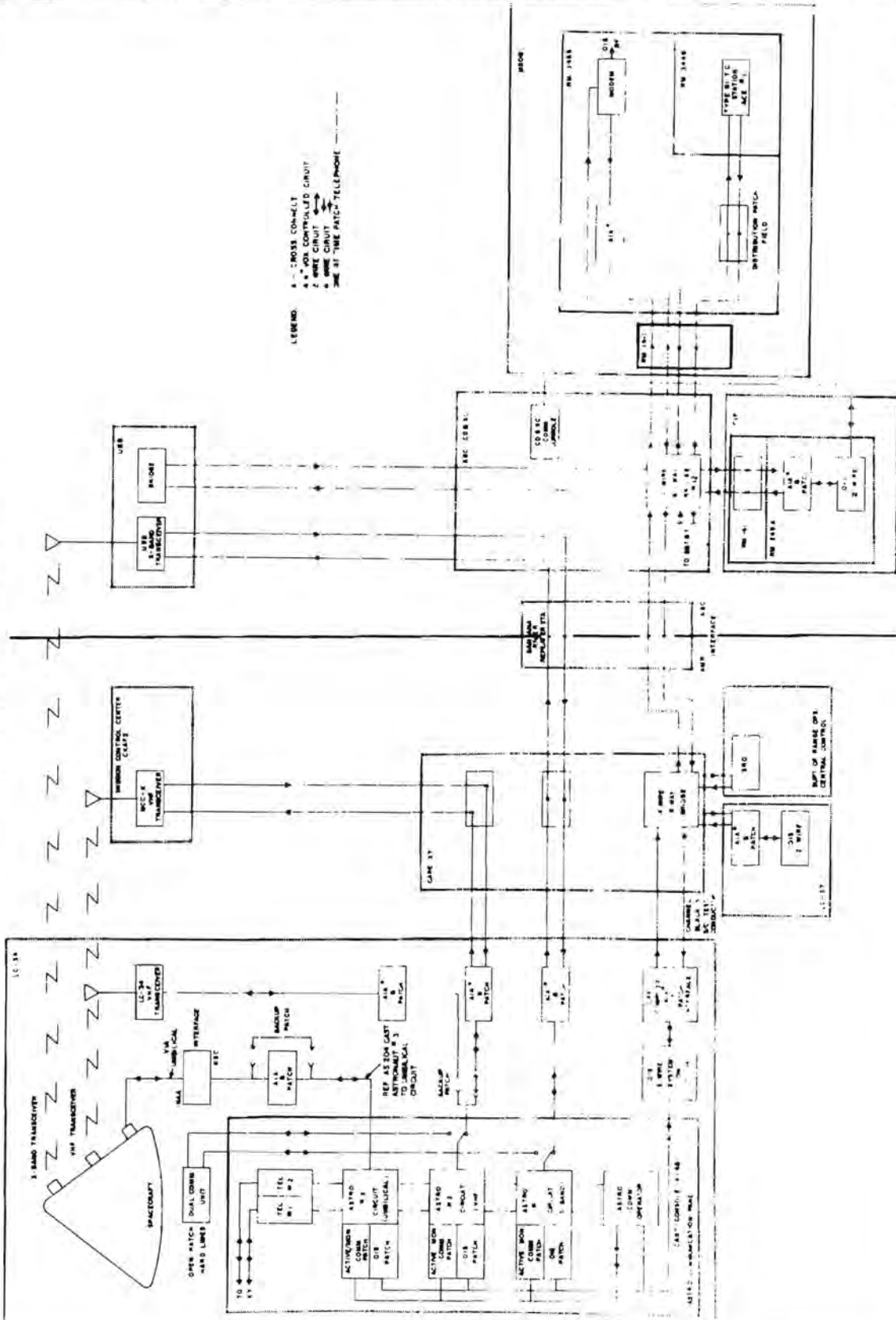

LEGEND:  
 1. CROSS CONNECT  
 2. 4x4 PATCH CONTROLLED CIRCUIT  
 3. 4x8 PATCH CONTROLLED CIRCUIT  
 4. 8x8 PATCH CONTROLLED CIRCUIT  
 5. 4x4 PATCH TELEPHONE  
 6. 4x8 PATCH TELEPHONE  
 7. 8x8 PATCH TELEPHONE

1-0-0062

This page left blank intentionally.

## E. SUPPORTING DATA

### LIST OF REFERENCES

The following documents are referenced in this report and are available from the Apollo 204 Review Board, General File.

Number	Reference
1-1	"Spacecraft 012 Configuration Index", Jan. 29, 1967, North American Aviation, Inc. Process Data Report No. U487-16; Panel 1 Reference No. 1-D-0006.
1-2	"Spacecraft 012 Indentured Parts List", Jan. 28, 1967, North American Aviation, Inc. Process Data Report No. U487-14; Panel 1 Reference No. 1-D-0007.
1-3	"Apollo Interface Document, Instrument Unit to Spacecraft Physical Requirements", Saturn/Apollo Mechanical Integration Panel, ICD 13 M 20108; Panel 1 Reference No. 1-D-0097.
1-4	"Interface Control Document Definition of Saturn SA-204, and Apollo S/C 012 Electrical Interface", Apollo Saturn Electrical Panel, ICD 40 M 37508A; Panel 1 Reference No. 1-D-0096.
1-5	"Launch Complex 34 Checklist, FO-K 10011", Oct. 25, 1966, North American Aviation, Inc.; (Panel 7 Data).
1-6	"GSE Functional Integrated System Schematics, Spacecraft 012 & 014, ETR LC-34", North American Aviation, Inc. Document No. G11-900912; Panel 1 Reference No. 1-D-0094.
1-7	"Launch Countdown, Preliminary Review Document, FO-K-0007", Jan. 17, 1967, North American Aviation, Inc.; Panel 1 Reference No. 1-D-0100.
1-8	"Inter-Center Interface Control Document Log", Monthly Publication, Marshall Space Flight Center, NASA; Panel 1 Reference No. 1-D-0102.
1-9	"Space Vehicle Plugs Out Integrated Test, FO-K-0021-1", Jan. 25, 1967, North American Aviation, Inc.; (Panel 7 Data).
1-10	"Summary of Spacecraft Configuration Differences", Apollo 204 Review Board, Spacecraft and GSE Configuration, Panel 1 Reference No. 1-D-0098.
1-11	"Spacecraft 012 Configuration Verification Record (CVR)", January 28, 1967, North American Aviation, Inc., Florida; Facility CVR; Panel 1 Reference No. 1-D-002.
1-12	"List of EO's Partially Accomplished Spacecraft 012 at Time of Accident", Panel 1 Reference No. 1-D-0020.
1-13	"EO's Outstanding Against S/C 012 Not in Florida Facility CVR Tab Run", Panel 1 Reference No. 1-D-0024.
1-14	"Spacecraft 012 Test and Acceptance Inspection Report (TAIR)", (Panel 6 Data)

ENCLOSURE 1-10



- 1-15 "Spacecraft 012 Controls Configuration", Panel 1 Reference No. 1-D-0058.
- 1-16 "Comparison of S/C 012 Operational and Experimental GFE/CFE Stowed Equipment for K-0034A-1 and K-0021-1, Letter from CF22/Team Leader, Apollo 204, to Chairman, Panel 1, February 21, 1967. Panel 1 Reference No. 1-D-0099.
- 1-17 "Items on Crew at Ingress", R. A. Mitchell, February 6, 1967, Panel 1 Reference No. 1-D-011.
- 1-18 "Initial Report on S/C Configuration", February 1, 1967, by W. F. Edson and C. D. Gay; Panel 1 Reference No. 1-D-0003.
- 1-19 "S/C/GSE Configuration Comparison", Panel 1 Reference No. 1-D-0093.
- 1-20 "Support Operations Investigation, AS-204 Incident, Panel No. 1 GSE and Spacecraft Configuration", submitted by Chief, Launch Facilities Division, KSC, Panel 1 Reference No. 1-D-0095.
- 1-21 "Inventory of Levels A-6, A-7, A-8 (LC 34 Service Structure)", February 23, 1967, Panel 1 Reference No. 1-D-0101.
- 1-22 "Report - Test Configurations of Remote Test Monitoring and Control Equipments", Panel 1, March 9, 1967; Panel 1 Reference No. 1-D-0091.
- 1-23 "Crew Abbreviated Checklist - Mission AS-204", January 23, 1967, NASA Manned Spacecraft Center; (Panel 7 Data).
- 1-24 "Summary Comparison, S/C 008 Thermal Vacuum Test No. 3 and S/C 012 Plugs Out Test (OCP-K-0021)", March 10, 1967, Panel 1; Panel 1 Reference No. 1-D-0092.

ENCLOSURE 1-10

D-1-70

**REPORT OF PANEL 2  
TEST ENVIRONMENTS  
APPENDIX D-2  
TO  
FINAL REPORT OF  
APOLLO 204 REVIEW BOARD**

This page left blank intentionally.

## TEST ENVIRONMENTS PANEL

### A. TASK ASSIGNMENT

The Apollo 204 Review Board established the Test Environments Panel, 2. The task assigned for accomplishment by Panel 2 was prescribed as follows:

Provide history of all test environments encountered by this Spaccraft on a major assembly-total assembly basis which are germane to validation of systems from fire hazard standpoint. Include appropriate qualification testing of systems and subsystems. Particular emphasis should be placed on qualification tests in pure oxygen with regard to pressures, temperature, time of exposure, and simulation of equipment malfunction. Indicate any deficiencies in this test program related to the subject problem. Also, include comparison with previous tests of appropriate flight, house, or boilerplate spacecraft. Any problems encountered related to fire hazard shall be documented.

### B. PANEL ORGANIZATION

#### 1. MEMBERSHIP

The assigned task was accomplished by the following members of the Test Environments Panel:

- Mr. W. F. Hoyler, Chairman, Manned Spacecraft Center (MSC), NASA
- Mr. B. J. McCarty, Manned Spacecraft Center (MSC), NASA
- Mr. C. F. Key, Marshall Space Flight Center (MSFC), NASA
- Mr. C. O. Baker, North American Aviation, Inc. (NAA)
- Mr. A. E. Toelken, North American Aviation, Inc. (NAA)
- Mr. H. J. Dunham, General Electric Company (GE)
- Mr. C. M. Nolen, General Electric Company (GE)

#### 2. COGNIZANT BOARD MEMBER

Mr. G. C. White, Jr., NASA Headquarters, was assigned to monitor the Test Environments Panel.

### C. PROCEEDINGS

#### 1. GENERAL PROCEEDINGS

This Panel planned and implemented a review of all tests for histories pertinent to the investigation. Attention was focused primarily upon oxygen test histories of the crew compartment systems, and arcing and shorting problems experienced during those tests. However, all environments were reviewed for rationale used in original derivation, substantiation by ground and flight vehicle tests, and margins imposed when implemented into component level tests. The other environments were examined as possibly being germane to the cause of the accident from an indirect standpoint. These reviews included the vibration, heating, and humidity environments.

The qualification tests were reviewed at MSC and involved examination of more than 1000 documents. The vehicle level tests were reviewed at NAA, Downey, California, and included a review of another 500 or more related documents. Summaries of these efforts were reviewed by the Panel at Kennedy Space Center (KSC) to seek out any test program deficiencies.

Other related oxygen fires which have occurred in and out of the Apollo Program were investigated to determine areas of similarity.

The difference in qualification, or component level tests, and flight vehicle tests should be pointed out before the discussion of testing which follows. In the qualification tests, the component is subjected to design limit conditions sequentially and/or simultaneously, is essentially worn out by the end of its test program, and is never flown. In vehicle level tests, a considerable amount of functional testing is

performed, but always under nominal conditions, rather than design limit conditions.

## 2. OXYGEN TEST HISTORY

Summaries of oxygen test history are given by Enclosure 2-1, for Spacecraft (S/C) 008, 009, 011, and 012, and by Enclosure 2-2 for component level tests. Details of these histories (References 2-4 and 2-5) are in the Apollo 204 Review Board General File.

The Certification Test Specification (CTS), SID 65-1210, recognized that ground operations would involve short duration high pressure oxygen exposure. It specified 14.7 pounds per square inch absolute (psia) pressure of 95 per cent oxygen for four hours, and 21 psia with 14.7 psia partial pressure oxygen for two hours. Although few subsystems experienced this requirement in the component level tests (Enclosure 2-2), most cabin subsystems were exposed to this environment in the S/C 008 tests (Enclosure 2-1). About half of the components of the Environmental Control System were tested to the MIL-STD 810 exposure proof test, which is a somewhat more positive test against fire hazards than is oxygen exposure per se.

The original CCOH ((combined contaminant, oxygen, and humidity) test was established in early 1965. It was unrealistic, being based upon MIL-STD 810 which is established as an accelerated test of the atmospheric conditions an aircraft would experience under years of service in sea coastal regions. The Apollo S/C is maintained in a controlled atmosphere during manufacture and at KSC. Because of this, early in 1966, the test was established as being 8 hours of salt spray, 50 hours of dry oxygen exposure at 5 psia, and 120 hours of humid oxygen exposure. Cold-plate mounted equipment was temperature cycled during the humid oxygen exposure.

Nearly all of the cabin electrical equipment was subjected to the CCOH test, or to the MIL-STD 810 explosion proof test. Some were not actually tested, but were qualified by being similar in design to another tested component.

## 3. VEHICLE TEST COMPARISON

During S/C 008 testing, the cabin equipment was exposed to approximately 18 hours of oxygen exposure (6.5 hours unmaned, 11.5 hours manned) at concentrations of 90 per cent or higher and pressure of one atmosphere or greater. S/C 012 experienced 8 hours and 30 minutes of manned testing under similar oxygen concentrations and pressures. Neither S/C 009 nor 011 were subjected to oxygen concentrations above 75 percent during either ground testing or flight.

## 4. ETHYLENE GLYCOL LEAKS IN COMMAND MODULE 012

Command Module (C/M) 012 experienced water/ethylene glycol leaks and spillages. This is reported in detail by Panel 8. Panel 2, concerned that the connectors had been broken open during the cleaning process, recommended test requirements to Panel 16 to verify the effectiveness of the cleaning techniques.

## 5. ARCING AND SHORTING PROBLEMS

The evaluation of anomalies considered relevant to possible causes of, or contributors to, a fire was focused on C/M 012 checkout and test experience, and the certification test program. All discrepancy and failure records at NAA and KSC were reviewed to identify arcing and shorting anomalies. The review included both resolved and unresolved anomalies so that the corrective action planned or taken could be reassessed. The significant anomalies were then classified as either likely or remotely possible candidates relative to possible bearing on a spacecraft fire.

Although many hundreds of records were reviewed in the course of this anomaly investigation, only those considered most significant are included in this report. Enclosures 2-4 and 2-5 summarize these anomalies encountered during certification testing and C/M 012 testing, respectively.

## 6. EQUIPMENT USED FOR TEST ONLY

C/M 012 was configured with some equipment which was installed for test only. This equipment,

necessary to monitor test parameters or permit system operation, etc., during ground tests, would be replaced with flight hardware or removed prior to launch. However, investigation disclosed some equipment of this nature remained in the crew compartment during manned ground tests. Equipment falling in this category was reviewed for aspects of test history and failures which might reflect a possible cause of the accident. Two of the items of this type which were on C/M 012 and perhaps relevant to the accident were the Elapsed Time Indicators and the Lithium Hydroxide (LiOH) canisters.

Elapsed Time Indicators (ETI) required to measure the total operating time of selected subsystems were installed on 15 units of cabin equipment. By virtue of their requirement to record total operating time on limited life equipment, they remain installed at all times until just prior to flight. Test history of the ETI's indicated that in one case a fire hazard existed. An ETI on the Caution and Warning System had failed by shorting and was found distorted and cracked due to excessive heat. Subsequent examination of C/M 012 absolved the ETI as an area of concern.

LiOH canisters installed in the Environmental Control System (ECS) were being utilized for test only. This type canister had previously failed certification tests due to powdering of LiOH pellets under vibration.

Equipment which was not required to be on-board during flight did not receive the intense and repeated scrutiny imposed on flight hardware. This was recognized by restricting the use of non-flight hardware.

## 7. OTHER OXYGEN FIRES

Data and documentation on four non-Apollo manned experiments in which there were fires were accumulated and reviewed. Failure and trouble reports on two Apollo ECS explosions and one Apollo ECS fire were reviewed. This review was summarized (Enclosure 2-6) and forwarded to Panel 5.

## 8. ENVIRONMENTAL REQUIREMENTS

Environments, other than oxygen exposure, were reviewed to seek out any possible deficiency that may have contributed indirectly to the accident.

### a. Temperatures

Temperature requirements were derived from wind tunnel data and heat transfer analyses, then later substantiated and/or modified by ground vehicle test data (S/C 008), and flight data. Flight data from S/C 009 and 011 boost conditions indicate Service Module (S/M) shell temperatures of about 200°F which is within the 400°F design temperature.

The S/C 008 vehicle was tested in a vacuum chamber, with solar heat generators and cold walls, to verify orbital temperature distribution. These tests confirmed that the equipment in the C/M will experience temperatures in the +30°F to +90°F range. The equipment is qualified to temperatures from +5°F to +145°F.

### b. Acceleration

Acceleration test levels were defined on the basis of maximum conditions expected during boost, entry, and abort. The peak acceleration during ascent occurs just prior to first stage separation and is 4.9 g along the x axis; lateral accelerations are much lower (1.85 g maximum at lift-off). The peak acceleration for the mission occurs during abort or entry, and is expected to be 10 g. Test conditions are typically 6 g along each of 3 mutually perpendicular axes for S/M equipment and 20 g for C/M equipment. Acceleration levels experienced during the S/M 011 flight were well within expected limits.

### c. Vibration

In this area of testing for the effect of repeated stresses there are trade-offs between the level of stress introduced by vibration and the number of times stresses of a given level are repeated. Thus, a given level for a given time may be a proper simulation of a higher level for a shorter time period and may give a more useful answer than the latter. These facts are reflected in the qualification test program for the 012 Spacecraft components.

### (1) Apollo Program Testing

The vibration levels for qualification testing of components were originally established on the basis of data from other programs. These data were used to define a spectrum of flight vibration levels which would be expected along each axis of the Spacecraft throughout the frequency range of 20 to 2000 cycles per second. The components were qualified by subjecting them to a random vibration throughout this frequency range at the expected flight level. The length of these tests, which was 15 minutes along each axis, was several times the expected duration of vibratory excitation during atmospheric flight. Some component vibration tests were conducted using electromagnetic shakers and the remaining components were tested with acoustic excitation.

Ground test Service Module 006 and Service Module and Command Module 007 were acoustically excited in a reverberation chamber at a level which corresponded to the estimated external vibration levels which would be applied to the complete Spacecraft in actual flight. These tests showed that the interior vibration levels which were experienced by the components were higher than the originally established criteria. New criteria, corresponding to the levels obtained in these ground tests on 006 and 007, were established and all components were requalified to this higher expected flight level. The duration of the new component qualification tests was decreased to one-third, that is, from 16 minutes per axis to 5-1/3 minutes per axis. The 5-1/3 minutes duration is still three times the amount of time the Spacecraft will experience significant vibration levels during the ascent flight out of the atmosphere.

The flight test data from Spacecraft 002, 009, and 011 verified the flight vibration level criteria used in the ground tests of 006 and 007.

Components used in flight spacecraft are given flight acceptance vibration testing which is like the qualification testing except that the vibration level is 25 per cent of the expected flight level and the duration is only about one (1) minute.

No complete flight spacecraft, including 012, was given flight acceptance vibration tests.

### (2) Vibration Test Philosophy

There are two basic philosophies regarding flight acceptance vibration testing. Some believe that flight acceptance vibration tests are an essential tool in verifying that a component or system of proven design (proven in qualification testing) does not have workmanship defects. Others believe that flight acceptance vibration tests of actual flight hardware may degrade the equipment and produce incipient failure. This possibility of potential degradation of flight equipment is very real. A dilemma is presented, therefore, in deciding how to best insure reliability of flight hardware and to balance the risk of having undetected defective hardware against the risk of creating an incipient failure in the acceptance test. This dilemma is particularly acute in manned flight programs.

At the component level, this risk was balanced on the Gemini program by acceptance testing at 75% of the expected flight level and on Apollo by acceptance testing at 25% of the flight level. Both programs tested the components for a duration of one (1) minute in each axis. The reduced levels and durations of the tests were such that defective items would likely be noted but the risk of creating incipient failure was minimized. In Gemini one complete flight spacecraft (No. 2) and the first manned flight spacecraft (No. 3) were subjected to 75% flight level vibration testing. This testing revealed no design or workmanship deficiencies. At that time, it was decided to eliminate testing of the follow-on Gemini Spacecraft. In Apollo, no complete spacecraft intended for flight has been given vibration acceptance tests.

#### d. Shock

Shock levels for the C/M and S/M were determined analytically and then modified by flight and landing impact test vehicles. There are no significant flight shock levels for the S/M and the Service Module/Lunar Module Adapter (SLA). The C/M equipment is tested to shock levels of 78 g's. The maximum shock level measured was 75.8 g's on the main display console during drop number 104 on S/C 2S-1, which represented a "worst-case" water drop.

e. Test Levels on Two ECS Components

As typical examples, the following are some of the specific environmental test levels imposed on two Environmental Control System components during the qualification test program:

	Service Module (Nitrogen Regulator Used as Typical Component)	Command Module (Oxygen Flow Restrictor Utilized as Typical Component)
Temperature	0 - 200° F	Fluid flow governed temperature extremes on this item, rather than the cabin atmospheric temperature
Vibration	0.1 g <sup>2</sup> /cps 90 - 250 cps, decreasing to 0.012 at 2000 cps	0.06 g <sup>2</sup> /cps, 80 - 400 cps, decreasing 3 db-oct. to 2000 cps
Acceleration	7 g's along the longitudinal axis	20 g's, 5 minutes per axis
Shock	Not applicable	78 g's (ECS equipment also receives tumbling abort shock test)

f. Results of Environmental Review

In reviewing the environments, and the manner in which they were implemented into tests, it appears there is a fundamental difference in philosophy in the way Apollo and Gemini programs treated the vibration environment.

There are two prevailing philosophies concerning acceptance vibration. Some feel that vibration is a very effective acceptance "tool" for exposing defective workmanship. They feel that flight hardware should be acceptance tested at expected flight level vibration for a short period, but only if the equipment is qualified to flight levels for long periods. Others feel that if the flight equipment is vibrated at flight levels for acceptance, it will be degraded.

In the Gemini program the former philosophy prevailed. Equipment was qualified to greater than flight level vibration for 15 minutes per axis, which permitted several one minute acceptance vibration tests. The Apollo program qualifies equipment to vibration for only 320 seconds per axis, which permits only limited high level vibration acceptance tests.

High level vibration acceptance tests expose amplitude sensitive faults in wiring connectors, such as cold solder joints. These faults, if not exposed and corrected, can eventually be manifested as failures by subtle combinations of other environments, such as pressure-temperature.

**D. FINDINGS AND DETERMINATIONS**

**1. FINDING**

All crew compartment equipment was not tested to be explosion proof.

**DETERMINATION**

There was insufficient testing of possible ignition sources.



## 2. FINDING

Crew compartment equipment of C/M 012 was exposed to water ethylene glycol contamination. Untested cleaning techniques were employed for that equipment discovered to be wet.

## 3. FINDING

Some of the C/M cabin equipment exhibited arcing or shorting during either certification or S/C 012 testing. There is no positive way to determine from the records reviewed whether S/C anomalies (possibly caused by a short or an arc) are reviewed by systems engineers and the test conductor prior to a test.

### DETERMINATION

Review of possible ignition sources prior to manned testing was inadequate.

## 4. FINDING

Not all equipment installed in C/M 012 at the time of the accident was intended to be flown. Some components were installed for test purposes only.

### DETERMINATION

The suitability of this equipment in the C/M for this test was not established.

## 5. FINDING

Non-certified equipment was installed in the C/M at the time of the accident. The "cobra cable" P/N V16-601263 and "T" adapter P/N V16-601396 are examples.

### DETERMINATION

The suitability of this equipment in the C/M for this test was not established.

## 6. FINDING

The design required the mating and demating of "hot" electrical connectors as normal crew procedure. Changing to a spare "cobra cable" is an example.

### DETERMINATION

The practice of breaking "hot" electrical circuits introduces fire initiation hazards.

## E. SUPPORTING DATA

This section contains the following Enclosures to which Section C refers:

### Enclosure

- 2-1 Vehicle Test Summary
- 2-2 Summary of oxygen test history of component level tests
- 2-3 Not Used
- 2-4 Summary of significant certification test anomalies involving possible ignition sources
- 2-5 Summary of significant C/M 012 anomalies involving possible ignition sources
- 2-6 Summaries of other oxygen fires
- 2-7 Glossary of terms
- 2-8 List of References

**VEHICLE TEST SUMMARY  
(Oxygen Experience)**

Space-craft	Test Name	Test No.	Oxygen Concentration in Cabin, Percent	Cabin Pressure (psia)	Cabin Temperature Degrees	Test Duration, (hr)	Systems Operating
008	SID66 - 475	1 (Unmanned)	90 or greater	14.7 or above	95+	Approx. 6.5	Comm. (up link) Elec-trical Power Environmental Control
				Between 5 and 14.7	64 to 89	72	Comm, Elect. Pwr., Env. Control
		2 (Manned)	90 or greater	14.7 or above	64 to 89	Approx. 4	ECS, EPS, D&C, Comm, G&N & SCS
			90 or greater	Between 5 and 14.7	64 to 89	152	ECS, EPS, D&C, Comm, G&N & SCS
		3 (Manned)	90 or greater	14.7 or above	61 to 81	Approx. 7.5	ECS, EPS, D&C Comm, G&N & SCS
			90 or greater	Between 5 and 14.7	61 to 81	137.5	ECS, EPS, D&C Comm, G&N & SCS

**VEHICLE TEST SUMMARY  
(Oxygen Experience)**

Space-craft	Test Name	Test No.	Oxygen Concentration in Cabin, percent	Cabin Pressure, (psia)	Cabin Temperature Degrees F	Test Duration, (hr)	Systems Operating
009	(No O <sub>2</sub> was used in cabin during CDDT or Pre-launch Test)						
011	Countdown Dem. Test (CDDT)	OCP FO-K-0033	75	15.3	76	6 hrs.	ECP EPS D&C
	Launch Countdown	OCP FO-K-0007	75	15.3	76	6 hrs.	SEQ COMM
012	Mission Run Plugs Out	OCP FO-K-0021	93	16	73	2 hrs. 13 min.	
	CSM Alt. Chamber Test No. 1	OCP FO-K-0034 a) Unmanned Alt. Run (220,000') b) Manned Alt. Run (220,000')	Approx 100 75 Approx 100 95	App. sea lev. 6.2 App. sea lev. 5.5	75 75 - 77	1.2 hrs. 28 hrs. 1 hr. 11 hrs.	FCS EPS D&C SEQ
	ESM Alt. Chamber Test No. 2	OCP FO-K-0034A-1 a) Unmanned Alt. Run (220,000') b) Manned Alt. Run (220,000')	Approx 100 75 Approx 100 95	App. sea lev. 6.2 App. sea lev. 5.5	77 75 - 77	1.5 hrs. 6 hrs. 1.5 hrs. 11 hrs.	COMM

**SUMMARY OF OXYGEN TEST HISTORY OF COMPONENT  
LEVEL TESTS**

Total Equipments in Cabin by Subsystem which Use, Control or Distribute Electricity

SUBSYSTEM	NUMBER	NUMBER RECEIVING EXPLOSION TEST
Pyro Devices	2	0
Sequence Systems	6	0
Environmental Control System (ECS)	68	32 Received MIL-STD 810 Explosion Proof Test 16 Qualified by Similarity
Crew Equipment	3	0
Stabilization & Control System (SCS)	12	11 Received O <sub>2</sub> Test at 14.7 psia
Guidance & Navigation (G&N)	19	18 Received O <sub>2</sub> Test at 14.7 psia
Instrumentation	12	0
Communications	32	14 Received O <sub>2</sub> Test at 14.7 psia
Electrical	47	0
Displays and Cont.	14	0
Subtotal	215	
GFE	15	3 Received MIL-STD 810 Explosion Proof Test 1 Received O <sub>2</sub> Test at 14.7 psia
<b>TOTALS</b>	230	96

35 Equipments received MIL-STD 810 Explosion Proof Test

44 Equipments received Oxygen Tests at 14.7 psia.

G&N Oxygen Test duration was 22 hours. All other Oxygen Tests were 4 hours duration.

Remaining equipments received oxygen tests at 5 psia pressure, with duration varying from one hour to 640 hours. Most of the ECS components were tested for 640 hours.

**ENCLOSURE 2-2**

D-2-11

This page left blank intentionally.

**SUBSYSTEM DISPLAYS AND CONTROLS**

Part Name	Part No.	CTR No.	Certification Test Problem	Problem Disposition
Floodlights	ME484-0045-XXXX	01226316	During both Qualification and S/C Systems Tests, failures occurred involving transient susceptibility of solid state components.	Vendor instituted a redesign and retest.

**SUBSYSTEM - EPS DISTRIBUTION EQUIPMENT**

Part Name	Part No.	CTR No.	Certification Test Problem	Problem Disposition
Static Inverter	ME495-0001-0004	01122702 01222302	Reference Failure Report WE000537. During phase unbalance tests per CTR 01222302, the inverter input shorted. Two pairs of 65 ampere booster transistors were shorted, caused by shorting of a Zener diode in the DC link.	Corrective action was to provide added surge tests for Zener diodes and high current density tested molybdenum transistors for the inverter. The added surge tests and high current density tests have been concluded to be effective. However, sufficient test history has not been accumulated to preclude consideration of this failure as suspect.

**SUBSYSTEM - ENVIRONMENTAL CONTROL**

Part Name	Part No.	CTR No.	Certification Test Problem	Problem Disposition
Waste Manager Blower	Item 40.1 ME901-0030-0001 Vendor #12A1306	01111339 01211314 01211729	(A) Failure Report GL000229 Motor shorted out during Dielectric test due to damaged wire insulation. ( Pre-Qual Functional Test)	(A) The stator molding fixture was modified to allow easier insertion and removal of the stator. Also, in-process dielectric check of the stator assembly immediately after molding was changed from 1000 VAC to 1250 VAC for one minute. New Part No. ME901-0030-0002
			(B) Failure Report GL000241 Motor failed to operate due to a short in an electrical connector. Short was caused by the accumulation of water around the connector terminal pins. ( Qualification Mission Life Test - Oct. 22, 1965)	(B) Blower Connector was redesigned by eliminating sleeving insulation and substituting the use of plotting compound to insulate connector terminals. New Part No. ME901-0030-0003
			(C) Failure Report MA024568 Motor stopped and drew excessive power. Failure was caused by a migration and build up of bearing lubricant between the rotor and stator causing the motor to freeze. ( Qualification Mission Life Test - April 29, 1966)	(C) Motor bearing was redesigned using a Barden Bar-Temp dry lubricant bearing. New Part No. ME901-0030-0004



**SUBSYSTEM - ENVIRONMENTAL CONTROL ( CONTD)**

Part Name	Part No.	CTR No.	Certification Test Problem	Problem Disposition
Waste Management Blower ( Contd)	Item 40.1 ME901-0030-0003 19A1306	01111339 01211314 01211729	(D) Failure Report GL000255 Blower failed to start at the beginning of test. Failure was caused by a migration and build up of bearing lubricant between the rotor and stator causing the motor to freeze. ( Life Cycle Test - Qualification January 6, 1966)	(D) Motor bearing was redesigned using a Barden Bar-Temp dry lubricant bearing. New Part No. ME901-0030-0004
			(E) During S/C 008 testing this blower operated erratically and would cause its circuit breaker to open after 30 seconds of continuous operation. ( S/C 008 Manned Thermal Vacuum Test) August 4, 1966	(E) Failure was due to corrosion caused by a backup of urine into the WMS blower. The backup of urine occurred when a facility urine dump line froze prohibiting removal of urine from the spacecraft. Since this failure was classified as a secondary failure by NAA, no corrective action was implemented.
			(F) Failure Report MA019932 Motor shorted out due to water contamination. ( PostAcceleration Qualification Test) March 23, 1966	(F) Failure was induced by an accumulation of water in the Waste Management System prior to delivery for testing. Since this was a secondary failure, apparently caused by human error, no corrective action was taken.

**SUBSYSTEM - ENVIRONMENTAL CONTROL ( CONTD)**

Part Name	Part No.	DTR No.	Certification Test Problem	Problem Disposition
Waste Management Blower ( contd)	Item 40.1 ME901-0030-0004 19A1306	01111339 01211314 01211729	(G) Failure Report MA024562 Blower developed an internal short during oxidation testing. Failure was caused by moisture contamination in the rotor-stator area. ( Oxidation Qual. Test) April 14, 1966	( G) No corrective action has been implemented for the following reasons: This failure occurred with the blower installed in the old Waste Management System configuration where moisture contamination was possible. The Waste Management System has been redesigned per CCA 827 to provide a direct urine to space dump capability. This change deletes the requirement for blower performance during urine and fecal modes of operation. Therefore, the blower is now needed only for vacuum cleaner operation and under this design the blower should not be subjected to moisture contamination.
			(H) Failure Report M165617. During second spacecraft 008 mated test, blower apparently shorted out and failed to operate.	(H) Analysis indicated failure was due to urine contamination resulting from a previous test. Blower motor did overheat when operated for 3 1/2 hours under deadheaded (no flow) conditions prior to the subject failure. No corrective action was implemented due to the system design change described in Paragraph G.

**SUBSYSTEM - SEQUENTIAL EVENTS CONTROL**

Part Name	Part No.	CTR No.	Certification Test Problem	Problem Disposition
Master Events Sequence Controller	ME901-0567-0008	00909302	An improperly located splice shorted to cover of unit.	Instruction was given to Manufacturing and Inspection by the Failure Review Board to check clearance around wire bundle in accordance with the existing specifications (AA0113-005, AA1113-017 and AAD1130921). The instruction was given by IL 696-704-110-65-800.

**SUBSYSTEM - TELECOMMUNICATIONS**

Part Name	Part No.	CTR No.	Certification Test Problem	Problem Disposition
PCM Telemetry	ME901-0-088-0002 and ME901-0-088-0102	012 21 308 011 21 303 009 21 306	After salt spray test and prior to post-salt spray functional test, 400 Hz line fuse blew. Collins FR 100971 and NAA APS 303-AN apply. After repair of the test article, it was resubmitted to salt spray test, and 400 Hz power was applied this time, whereas it had not been applied during the 48 hr. salt spray test referred to above. Another failure was incurred almost immediately. Collins FR 101187 and NAA APS 304-AN apply.	The "fix" assigned for the first post-salt spray failure (FR 100971) was immediately rendered invalid by the second failure (FR 101187), which occurred during the first salt spray retest. A second, more extensive, corrective action involving potting the capacitor bank with RTV 1538 was evolved. This afforded a better seal for capacitor bank. It also gave better protection to the 400 Hz power-input wiring against workmanship error by lessening the likelihood of pinched or mashed insulation. The test article was potted according to requirements of the second corrective action and was retested again with satisfactory results. There has been no recurrence of this problem to date.

This page left blank intentionally.

**SUMMARY OF SIGNIFICANT S/C 012 ANOMALIES INVOLVING POSSIBLE IGNITION SOURCES**

Part Name	Part No.	Anomaly	Disposition
Caution and Warning System		<p>During OCP K-0034-A, a master alarm occurred when switch S-5 on panel 13 and switch S-5 on panel 23 were placed in the push-to-talk position. (Ref. interim discrepancy report I.D.R. No. 003)</p>	<p>Trouble shooting failed to identify cause of anomaly. This discrepancy was still open at the time of the last test.</p>
Connector	ME0414 - 0265 - 5550	<p>Connector J-288 was identified as "deteriorating" at pins 80-81-82. This is a connector attached to the yaw ECA. (Ref. D. R. 0293)</p>	<p>Material review action determined that the unit was acceptable for flight, with the proviso that it be reexamined each time it was demated. The next demating took place on Oct. 27, 1966, when the yaw ECA was removed. The connector was judged acceptable by inspection.</p>
"T" Adapter	V16-601396	<p>During OCP K-0034A-1, it was noted that when either crewman pushed the push-to-talk, parameter CJO002 (respiration rate) modulated approximately 20% full scale. (Ref. I.D.R. 029)</p>	<p>After extensive trouble shooting (89 steps) failed to disclose the cause of this anomaly, it was decided that RF conditions in the altitude chamber were probably responsible. The DR was held open until after satisfactory completion of sequence 12 of OCP K-0021.</p>

**SUMMARY OF SIGNIFICANT S/C 012 ANOMALIES INVOLVING POSSIBLE IGNITION SOURCES**

Part Name	Part No.	Anomaly	Disposition
DC to DC Converter	130 110	S/N 035 causes intermittent noisy operation of the signal conditioners.	Troubleshooting failed to determine the cause. Item considered acceptable for OCP FO-K-0021-1 (Ref. DR AK-037).
Harness Assy.	V16-420312	Potting was split at end away from pins on connector E01W1J5. (Reference D.R. 0518)	Dispositioned OK for flight because the damaged area was at the end of the potting installation.
Cobra Cable	V16-601263	Insulator chipped out between pins 13 and 14 on "normal" side of connector on Command Pilot's cable.	Accepted for flight after Material Review Board evaluation.
Guidance and Control System		During OCP 6504 a high frequency oscillation was observed on the middle gimbal angle indicator. (Reference NAA P.A.R. MA 019060 and ACED AFR 13432, 13428 and 13429.)	Analysis revealed a burned hole and charring on external potting on tray 2 and tray 3. Failure closeout stated cause to be human error in installing trays.

## SUMMARIES OF OTHER OXYGEN FIRES

A review of one unmanned and four manned experiments in which there were fires shows that the exact ignition source in four of the fires was undetermined. They were believed to be electrical in nature. The only fatalities occurred in the two accidents in which there was a flash fire. In all five fires, inadequate safety precautions had been taken to either prevent or extinguish the fire or to protect the occupants.

### BROOKS AIR FORCE BASE, SEPTEMBER 9, 1962

A fire occurred in the Space Cabin Simulator at Brooks Air Force Base on September 9, 1962. Test conditions were 5 psia 100 percent oxygen and the test had been in progress fourteen days at the time of the fire. The odor removal system used activated charcoal and the Carbon Dioxide (CO<sub>2</sub>) removal system had an aluminum cover and consisted of a 500-pound bed of a mixture of 80-percent calcium hydroxide and 20-percent barium hydroxide. The Environmental Control System circulated cabin air progressively through the hydroxide, the charcoal, through the temperature controller (electric heater and refrigerant evaporator coil), then through an aluminum duct to the circulation fan. From the fan, ducts distributed air over the area behind the electronic test panel (cyclomotor). The air then leaked through openings in the panel back into the cabin. Both occupants wore pressure suits and one was asleep. Immediately upon noticing a glow behind the cyclomotor, one occupant awoke the other, grabbed a CO<sub>2</sub> extinguisher, and fought the fire until he collapsed from smoke inhalation. The awakened occupant immediately opened his face plate with the apparent intention of donning an oxygen mask, but he collapsed from smoke inhalation before he could get a mask or assist in extinguishing the fire. Both occupants were treated for smoke inhalation and neither received burns. There was no flash fire and damage was confined to the end of the chamber in the vicinity of the cyclomotor. Photographs of the aluminum duct immediately downstream of the temperature controller show definite signs of an implosion-explosion in the duct with a three-inch to four-inch diameter hole burned through one duct wall at the center of the imploded area. This was never fully clarified during the investigation and testimony revealed insufficient fuel had been consumed (burned) in the vicinity of the hole to melt the aluminum. Testimony also revealed that a small explosion could have occurred in the duct without being heard by either of the helmeted occupants. The investigating board concluded that the most likely source of ignition was a short or arc in an undetermined electronic component behind the cyclomotor panel.

### BROOKS AIR FORCE BASE, JANUARY 31, 1967

A second fire occurred on January 31, 1967, in the same Brooks Air Force Base facility described in the first accident. Test conditions were 7.2 psia 100-percent oxygen. The test was in the first day of a planned 67-day test to study hematology of 16 rabbits. Two men had been in the simulator 12 minutes at the time of the fire, which was fatal to both. Both men suffered second and third degree burns over 90 percent of their bodies. An outside observer witnessed a flash fire which engulfed the chamber. A final report by the investigating board is at present unavailable and details of the facility design, and its differences with the design at the time of the 1962 fire, are therefore also unavailable. However, progress reports of the investigating board have provided the following information. Examination of the blower motor after the fire showed that the impeller was binding against the motor case and application of power to the motor resulted in blowing the fuses. Relationship of the motor malfunction to start of the fire has not yet been determined. The motor was downstream of the CO<sub>2</sub> absorbent bed. A short has been positively identified in an unspecified electrical fixture. The unanimous opinion of the investigating board and its observers-advisors and consultants is that the most probable cause of the fire was the existence of a combustible atmosphere within the chamber. The combustible atmosphere is believed (by the board) to be primarily hydrogen and possibly included hydrocarbons as a result of the animal experiment. Experiments conducted on-site have conclusively shown that the CO<sub>2</sub> absorbent reacted with water and aluminum and generated hydrogen. The ducting and the CO<sub>2</sub> absorber materials are the same as at the time of the 1962 fire: i.e., 80 percent calcium hydroxide and 20 percent barium hydroxide in aluminum ducting. There is evidence of intense heat in the CO<sub>2</sub> absorbent bed and intense exothermic chemical reactions were present in the air conditioning duct. This



can be explained by an additional reaction which would have resulted from aluminum and iron oxide being reacted in the presence of a hydrogen-oxygen flame which can cause fusing of metals such as stainless steel, chromium, and other metals. This is known as a "thermite reaction" and the AF Materials Laboratory has determined that it can be initiated at 2352°F, the reactants being stainless steel and oxygen. The reaction is self-sustaining and reaches a temperature of 2550 to 2650°F. The reaction is suppressed in the presence of steam or about 35 percent CO<sub>2</sub>. A possible source of the initiating temperature is the burning tape which was around the top of the CO<sub>2</sub> absorber filters. This tape can initiate the oxygen/stainless steel reaction in three seconds in 14.7 psia oxygen, but its burning temperature is as yet unknown in 7 psia oxygen. The CO<sub>2</sub> fire extinguishers were not removed from their holders and examination of the three oxygen regulators show no indication of malfunction. Ignition sources were considered by the investigation board to include an arc from an electrical short, an electrostatic spark, a friction spark, spontaneous oxidation, heated surfaces (particularly those which might have been in the CO<sub>2</sub> absorbent bed), heated surfaces from friction or hot wire, the electrical motor downstream of the CO<sub>2</sub> absorbent bed, clothing which might have ignited on contact with a heated surface or as a result of spontaneous oxidation, or ignition of a sponge, chair cushion, or rabbit fur from either an electrostatic discharge or spontaneous oxidation. A short in a lighting fixture wire was determined to be the most probable source of ignition.

#### NAVY EXPERIMENTAL DIVING UNIT, FEBRUARY 16, 1965

A fire occurred in the decompression chamber of the Navy's Experimental Diving Unit (EDU) at Washington, D.C. on February 16, 1965. Conditions at the time of the fire were 28-percent oxygen 36-percent nitrogen, and 36-percent helium at a total pressure of 55.6 psia (92 feet depth) or an oxygen partial pressure of 15.6 psia. About eleven minutes after entering the chamber (via a lock) from an adjacent chamber at 126 psia (250-foot depth) one of the divers reported the fire. Two observers at a viewing port observed a fire four inches in diameter and two feet high coming from the CO<sub>2</sub> scrubber immediately prior to a flash fire which engulfed the entire chamber. During the next minute, chamber pressure rose to 130 psia (260-foot depth). Attempts to rescue were unsuccessful and both occupants died. The CO<sub>2</sub> scrubber was portable and was designed for use as an emergency device for submarine atmosphere control and consisted of a tub containing six cylindrical tubes. The center tube contained the fan motor and outer tubes contained four CO<sub>2</sub> absorbent canisters and one filter element. Flow of chamber air through the scrubber was down through the four absorber canisters and up and out through the filter unit. The absorber elements consisted of a cylindrical metal can with metal screens on each end. The metal cylinder and screen materials are unidentified. The absorber chemical was the same as that in use at the time of both Brooks' fires; i.e., 80 percent calcium hydroxide and 20-percent barium hydroxide. The "tub" which housed the entire scrubber assembly was made of an unidentified metal. The filter element was made of convoluted paper (probably Kraft) cylinders supported on the inside by a perforated metal (iron) cylinder and at the ends with stamped aluminum covers cemented to cardboard rings which are in turn cemented to the convoluted paper. Each unused unit weighs 2.1 pounds of which paper and cemented end rings comprise 1 pound. Investigation determined that primary use for this filter was in hydraulic systems and in the fuel systems of jet aircraft, and that common practice is to test every single filter element by immersion in an organic liquid and, while submerged, blow air through the filter to see if flaws existed at the seals of the paper. Tests were performed on two unused filter elements identical in design to the accident-involved filter. An acetone extraction on one showed that it probably contained about 0.3 to 0.4 pounds of kerosene-like liquid. This is consistent with the filter specification which lists maximum dry unit weight at 1.8 pounds. This also shows that the dry weight of the paper and end rings is 0.7 pound, arrived at by subtracting total weight of metal (2.1-1.0=1.1) from the 1.8 pounds total dry weight. A second filter was placed in a CO<sub>2</sub> scrubber, without CO<sub>2</sub> absorbent installed and operated for 2 hours. From this test, it was determined that the volatile liquids would be removed from the filter in 5 to 10 hours depending upon temperature and flow rate through the unit. The accident-involved filter was one of two supplied with the scrubber which had 1-1/2 to 2 years of intermittent use and the time logged on each filter is unknown. The used filter not involved in the accident had no "hydrocarbon" odor and an acetone extraction of the paper revealed a weight loss of only 10.2 percent compared to 36 percent loss on an unused filter. Samples from the used filter and an unused filter were subjected to high-frequency

discharge (Tesla coil) in a stream of oxygen. The unused filter ignited easily and the flame spread rapidly whereas the used filter required 5 to 7 seconds of continuous discharge, ignited at the edge of the paper, and did not burn readily. From these tests, it was concluded that most or all of the easily ignitable material (hydrocarbon) had been removed from the filter by use prior to the EDU fire and that a rather strong ignition source would have been required to ignite it. A bench test of the scrubber motor after the fire showed that it ran at a reduced speed and rapidly overheated, the condition being caused by faulty operation of the centrifugal throw-out switch which resulted in the motor running on starting windings. The EDU had no provisions for odor removal (such as activated charcoal). The fire caused extensive damage including complete consumption of untreated cotton terry-cloth bath robes and about twelve feet of flexible air conditioning duct made of fabric-covered spiral wire. Untreated cotton mattresses with flame-proof covers were partially consumed. About five feet of the rubber on the unarmored electric cord to the portable scrubber was consumed as was rubber of armor-covered cables directly above the CO<sub>2</sub> scrubber. A simplified calculation by Naval Research Laboratory personnel showed that the pressure rise experienced during the fire would have caused a 761°F temperature rise and that the temperature rise would require the burning of only about 1.1 pounds of cellulosic material, i.e., cotton or perhaps wood-based paper in the filter. The investigation concluded that the most probable cause of the fire was the overheated scrubber motor causing spontaneous ignition of the filter element in a high-oxygen atmosphere. Fire extinguishing equipment consisted of a bucket of sand and a bucket of water, neither of which was used.

#### NAVY AIR CREW EQUIPMENT LABORATORY, NOVEMBER 17, 1962

A fire occurred in the Navy's Air Crew Equipment Laboratory (ACEL) on November 17, 1962. Test conditions were 100 percent oxygen at 5 psia and the fire occurred on the 17th day of the test. The fire started on the insulation of the ground wire to a light fixture. The ground wire was loose and an arc ignited the insulation. One of the four occupants tried to smother the fire with a towel which also ignited. Further attempts with an asbestos blanket resulted in ignition of the blanket and clothing worn by occupants. Subsequent attempts by all four to extinguish fire on the clothing of others resulted in the ignition of the clothing of all four, generally on the sleeves and pants legs. One occupant's hand caught on fire. All occupants escaped in about 40 seconds after first report of the fire and all were treated for first and second degree burns over 15 to 20 percent of their bodies. Immediately after exit of the occupants the door was closed, the chamber taken to 80,000 feet and purged for 20 minutes with CO<sub>2</sub> to extinguish the fire. There was no flash fire and there were no extinguishers in the chamber.

#### APOLLO ECS FIRE AT AIRESEARCH TORRANCE FACILITY, APRIL 28, 1966

A fire occurred in an unmanned qualification test of the Apollo Environmental Control System at Torrance, California, on April 28, 1966. Test conditions at, and 23.5 hours prior to the fire, were 100 percent oxygen at 5 psia. Prior to bringing the test up to 5 psia, the test had included 2456 hours at 10-4 millimeters of mercury (Torr). The investigating board concluded that the most probable cause of the fire was failure of a commercial quality strip heater used to add heat to the steam duct. The strip heater used polyvinyl chloride (PVC) insulation and the manufacturer's temperature rating was 167°F continuous, 190°F maximum in air. There was a sharp bend in the heater strip bearing against an ECU power lead splice at the heater strip entry into asbestos tape wrapped over the steam duct in the test set-up. Under high temperature conditions, the heater tape wire was demonstrated to extrude through the PVC insulation and a fire was initiated under simulated test conditions. Three other ignition causes were considered as possibilities. Strip heaters of the same type as above, but covered with aluminum foil, were on the potable water and dew point line sensor. Deterioration of insulation could have caused a short between one of the wires and the aluminum foil. Dew point measurements within the cabin showed that some metal surface temperatures were such that water could have condensed on them causing arcing on open terminal strips, unpotted connectors, or the 400-cycle unit, igniting adjacent materials. One of the ECU high pressure oxygen check valves, which use an elastomeric (DPR) seal, was severely damaged and it was theorized that high pressure "impact" of the 900 psia oxygen could have ignited the EPR. AiResearch ran a series of 3000 psi impact tests without ignition, and although the test results were not absolutely conclusive, it was concluded that this was the least probable of the possible

causes presented. Other damage caused by the fire included excessively burned insulation of the test set-up wiring, fusing and burning of ECU wire harness, and burned polyurethane foam insulation on the oxygen and water-glycol lines. The investigating board concluded that, although 16 components had malfunctioned prior to and during the test and 18 had failed due to damage by the fire, the ECS qualification unit was not the direct cause of the fire. Also, test equipment and materials were improper for the environment, there was no fire detection or extinguishing equipment, and there were no emergency procedures. The board also concluded that improvement in the selection of some materials used in the ECS and the Apollo Command Module (C/M) could be made to control fire. Also, the C/M electrical circuits and wiring have potential hazards from arcing or direct short circuits. Also concluded was the fact that AiResearch procedures and documentation were inadequate, that quality control (QC) personnel were provided inadequate direction and that a NASA Test Readiness Review might have precluded the incident. The board recommended that all action necessary be taken to preclude initiation of a fire in the C/M with special emphasis on adequacies of wire bundle derating, circuit breaker/wire compatibility, and elimination of all possible nonmetallic materials in contact with wire bundles. The board also recommended the imposition of nonmetallic materials specification requirements on all contractors and other suppliers of flight equipment, and to strengthen the materials selection and application program.

#### **APOLLO ECS EXPLOSION AT AIRESEARCH, APRIL 13, 1965**

An explosion occurred in an unmanned qualification test of the Apollo ECS at AiResearch on April 13, 1965. The explosion occurred after 127 hours of a planned 141-hour test. Conditions were corrosive contaminants, oxygen, and humidity (CCOH) per qualification test procedure SS-1224-R, paragraph 6.8. Failure reports were prepared for four components; a sensor (P/N 820110-1), a fan (P/N 826310-2-1), a valve (P/N 850028-1-1), and an absolute pressure transducer (P/N 837044-1-1). The explosion was determined to be the result of polyurethane foam swelling underneath a water tank causing a suspended electrical immersion heater to touch the bottom of the tank. Sufficient localized heat was generated to ignite the oxygen-saturated foam. Electrical connections did not indicate evidence of shorting and it was noted that all units were operable after the test was aborted. Corrective action included use of Teflon sheets in place of polyurethane foam and neoprene to isolate the units electrically, connection of the unit mounting frame and tank to a common ground, potting of heater leads, installation of a commercial submersion heater in the water tank by welding a boss.

#### **APOLLO ECS EXPLOSION AT AIRESEARCH, JULY 1, 1964**

An explosion occurred in unmanned qualification test in the explosion proof chamber at AiResearch on or about July 1, 1964. The test had been in progress 30 minutes and test conditions were in accordance with explosion proof test SS-1218-R, paragraph 6.9.2. A cabin air temperature sensor, P/N 820100-1, was damaged to the extent that the glass bead around the thermistor was bubbled and pitted from the heat. Conclusion as to the cause of the explosion was that the insulation around the heater coil broke down from heat inside the explosion chamber while the explosion proof test was in progress. Corrective action was to retest the sensor for temperature versus resistance per SS-1113-R, revision 1, paragraph 4.2. The sensor was retested, witnessed by NAA and Air Force QC, and released for future testing on July 1, 1964

## GLOSSARY OF TERMS

APS	Apollo Problem Summary
AFB	Air Force Base
AS	Apollo/Saturn
BTU	British Thermal Unit
CC	Cubic Centimeter
C/M	Command Module
Cm <sup>2</sup>	Square Centimeter
CO <sub>2</sub>	Carbon Dioxide
cps	Cycles Per Second
CTN	Certification Test Network
CTR	Certification Test Requirement
DR	Discrepancy Report
db	Decibel
ECS	Environmental Control System
EPS	Electrical Power System
ECU	Environmental Control Unit
ECA	Electronic Control Assemblies
FR	Failure Report
°F	Degrees Fahrenheit
g	Acceleration Due to Gravity
g <sup>2</sup> /CPS	Vibration Power Spectral Density
GSE	Ground Support Equipment
GT	Gemini/Titan
H <sub>2</sub> O	Water
HZ	Frequency In Cycles per Second

## GLOSSARY OF TERMS (Continued)

IMU	Inertial Measurement Unit
LB	Pound
LiOH	Lithium Hydroxide
LM	Lunar Module
MA	Mercury/Atlas
MEK	Methel Ethyl Ketone
MIL STD	Military Standard
MSC	Manned Spacecraft Center
MSOB	Manned Spacecraft Operations Building
NA	Not Applicable
N <sub>2</sub>	Nitrogen
OCP	Operational Checkout Procedure
O <sub>2</sub>	Oxygen
P/N	Part Number
PSIA	Pounds Per Square Inch Absolute
QD	Quick Disconnect
S/C	Spacecraft
SLA	Spacecraft/Lunar Module Adapter
S/M	Service Module
S/N	Serial Number
TORR	Millimeters of Mercury Vacuum
VAC	Volts Alternating Current
VDC	Volts Direct Current
W/G	Water Glycol

## LIST OF REFERENCES

- 2-1 Memorandums generated by Panel 2.
- 2-2 Response from MSC concerning:
  - a. Unqualified equipment on S/C 012.
  - b. Significant arcing and shorting anomalies.
  - c. Explosion proof testing.
- 2-3 Discrepancy reports supporting Enclosure 2-7.
- 2-4 Oxygen exposure and failure data of vehicle level tests.
- 2-5 Oxygen exposure history of component level tests.
- 2-6 Discrepancy reports and failure reports regarding water/glycol leaks in the ECS.
- 2-7 Elapsed Time Indicators qualification data.
- 2-8 Failure survey for possible or highly probable fire initiators.
- 2-9 Environmental Control System qualification requirements.
- 2-10 Acceptance Test Procedure AiResearch Rpt. SS-110-R, Rev. 1 dated 10-2-64.  
Interim Change Notice A to above dtd. 12-2-64.
- 2-11 Acceptance Test Procedure AiResearch Rpt. SS-1720-R, dtd. 9-20-65.  
Interim Change Notice E to above dtd. 5-11-66.
- 2-12 Group 1 Qualification Test Procedure AiResearch Rpt. SS-1274-R, Rev. 2 dtd. 10-1-65.
- 2-13 Group 1 Qualification Test Report AiResearch Rpt. SS-1474-R, dtd. 3-21-66.  
Errata to above dtd. 9-7-66.
- 2-14 Group III Qualification Test Procedure AiResearch Rpt. SS-1507-R, Rev. 1 dtd. 8-30-65.
- 2-15 Group III Qualification Test Report AiResearch Rpt. SS-1807-R dtd. 4-12-66.  
Errata to above dtd. 9-29-66.
- 2-16 Environmental Control System Procurement Specification NAA No. MC901-0215, Rev. G, dtd. 8-31-66.
- 2-17 Goodyear Aerospace Rpt. GER-12246 dtd. 8-21-65.
- 2-18 U.S. Naval Research Laboratory Rpt. 6090 dtd. 7-28-64.
- 2-19 U.S. Naval Research Laboratory Ltr. 6130-56 dtd 3-23-65.
- 2-20 U.S. Naval Research Laboratory Ltr. 6130-41 dtd. 2-25-65.
- 2-21 U.S. Naval Research Laboratory Ltr. 6180-39, dtd. 2-25-65.
- 2-22 Fire at High Pressure by J.V. Harter, dtd, 3-24-65.
- 2-23 Preliminary Report AiResearch Fire dtd 4-28-65.
- 2-24 Final Report AiResearch Fire dtd 4-28-66.
- 2-25 Report of Fire at Naval Air Crew Equipment Laboratory undated.
- 2-26 Report of Fire at Air Force Aerospace Medical Division dtd 10-9-62.
- 2-27 13 Photographs of fire at A.F. Aerospace Medical Division undated.
- 2-28 Group of TWX's regarding fire at Brooks AFB on 1-31-67 Progress Rpt. No.'s 5, 6, 7, and 8.
- 2-29 NAA Failure Notification AR-TR-64-242 dtd 2-2-65.
- 2-30 AiResearch Trouble Rpt. 4769 dtd 1-28-65.
- 2-31 Notebook of 40 photographs of S/C 012 in and around LiOH canisters.

ENCLOSURE 2-8

This page left blank intentionally.

**REPORT OF PANEL 3  
SEQUENCE OF EVENTS  
APPENDIX D-3  
TO  
FINAL REPORT OF  
APOLLO 204 REVIEW BOARD**



This page left blank intentionally.

## SEQUENCE OF EVENTS

### A. TASK ASSIGNMENT

Analyze data obtained immediately prior to and during the fire incident including digital, analog, voice communications, photography, etc. Data should display significant events as they occurred with precise time tag. Time histories of all continuous or semi-continuous recorded parameters, correlation of parameter variations and events shall be recorded as well as interpretation of the results of said analysis. Where pertinent, normal expected variations shall be compared with those actually obtained.

### B. PANEL ORGANIZATION

#### 1. MEMBERSHIP:

The assigned task was accomplished by the following members of the Sequence of Events Panel:

- Mr. D. D. Arabian, Chairman, Manned Spacecraft Center (MSC), NASA
- Mr. H. Creighton, Kennedy Space Center (KSC), NASA
- Mr. W. Jewel, Kennedy Space Center (KSC), NASA
- Mr. W. Eckmeier, North American Aviation (NAA), Kennedy Space Center
- Mr. A. Tischler, North American Aviation (NAA), Downey

#### 2. COGNIZANT BOARD MEMBER:

Dr. M. Faget, Manned Spacecraft Center (MSC), NASA, Board Member, was assigned to monitor the Sequence of Events Panel.

#### 3. PANEL CONSOLIDATION:

Panel 3 served as a separate Panel from January 31, 1967 through February 23, 1967. The Panel was dissolved on February 23, 1967 and merged with Panel 18. This merger was accomplished to better support the Apollo 204 Review.

### C. PROCEEDINGS

#### 1. GENERAL DESCRIPTION OF THE DATA SYSTEM

a. The engineering data used in the determination of the sequence of events was obtained from the spacecraft instrumentation system and is presented in Enclosure 3-1. This system consists of the following main elements:

- (1) The instruments in the Command Module which measured about 400 items such as voltages, temperatures and pressures.
- (2) A signal processing system in the Command Module which converts the physical parameters measured into a form suitable for transmission.
- (3) The hard-line and radio transmission links which carry the converted data to the ground.
- (4) The ground system which provides permanent tape records of the data obtained and also provides the various kinds of real-time displays of the data required to conduct the test.
- (5) The instruments in other parts of the Space Vehicle and Ground Support Equipment systems. These instruments provide data to the ground recording stations in a similar manner as for the Command Module.
- (6) A communications network for voice transmission between the various groups associated with the tests including the Command Module crew.

Enclosure 3-2 is a simplified schematic of the data system in use in Spacecraft (S/C) 012 and on the ground during the Plugs Out Test and shows the general elements within the Spacecraft and the radio and hard-line links to the main ground stations at John F. Kennedy Space Center (KSC). Data were also transmitted from the KSC ground stations to other sites such as the Air Force Eastern Test Range (AFETR) and to the Manned Spacecraft Center (MSC) in Houston.

b. Because of the large number of measurements which are made in the Command Module, and in the other systems in the Spacecraft, it is impossible within the present state-of-the-art to provide continuous information on each measurement made. This is true for both ground tests and space flight operations. A system is used, therefore, which provides periodic sampling of each measurement. The sampling system used is the Pulse Code Modulation (PCM) system. This system takes samples of each measurement a predetermined number of times each second. The sampling rate varies from 200 per second on parameters which are expected to vary rapidly sometime during test or flight operations to one per second for parameters not expected to vary rapidly. The final record, therefore, provides samples of data from each measurement permitting a near continuous record to be constructed. This may not be possible if rapid variations in the measured quantity occur. Rapid variations between sampling times are not recorded. However, a change may be detected when the parameter is sampled even though the actual initial variation of the parameter, or the precise time the variation occurred, cannot be determined. This condition may provide clues to the nature of events that are not fully recorded.

c. The signal processing equipment in the Command Module converts the sampled data into a binary code. This code consists of "words" each of which are eight "bits" long. The Command Module PCM system transmits 6400 "words" per second and, therefore, 51,200 "bits" per second.

Each "word" corresponds to a particular value of the parameter being measured. Such a "word" is also called a "count." The full scale range of each measuring instrument is divided into 254 "counts." A change, however, in a "count" (or "word"), does not necessarily correspond to a real change in the parameter being measured. This effect is obtained because "noise" is inherent in information transmission and processing system. The "noise" can cause changes in "counts." Careful examination of records is required to distinguish between real changes in magnitude of the parameters being measured and apparent magnitude changes which are due to "noise." This result is particularly true when the "noise" produces a one "count" change between two adjacent measurement levels. In general, a one "count" change does not reflect a real change in level of the measured parameter, particularly if one "count" fluctuations have occurred for an extended period.

## 2. SEQUENCE OF EVENTS

a. On the morning of January 27, 1967, a test of S/C 012 commenced. The purpose of the test was to verify systems operation in a simulated launch and to exercise countdown procedures in preparation for actual launch. The test was identified as a Space Vehicle Plugs Out Integrated Test OCP FO-K-0021-1 in which the spacecraft would be electrically disconnected from the Ground Support Equipment (GSE) by removing the umbilical connectors normally disconnected at the time of launch.

b. Spacecraft power buses were energized at 12:55 GMT(7:55 a.m. EST) and subsystems were activated and checked in preparation for crew ingress which occurred about five hours later at 18:00 GMT. At the time the Spacecraft Commander changed from the closed-loop ventilator to the Environmental Control System (ECS), he stated there was an odor like "sour milk" in the suit circuit loop. Ingress of the Pilot and Senior Pilot continued and at 18:20 GMT, the countdown was held for Bendix support personnel to obtain a gas sample from the suit circuit loop for later analysis of the odor. The countdown then continued at 19:42 GMT with the normal suit circuit checks, cabin switch checklists, hatch installations, and cabin purge with oxygen followed by the leak check of the sealed cabin. During the cabin leak checks, the Emergency Detection System (EDS) which monitors critical functions within the launch vehicle and indicates to the crew when an emergency situation exists, was checked. By 21:50 GMT, the EDS and the cabin purge and leak checks were finally completed. The boost protective cover which provides thermal protection to the spacecraft outer surface during launch could not be properly latched in place; however, the test continued until 22:30 GMT when a hold of the countdown was called for a communications problem. The crew became aware of the problem, a "live mike" condition, at 22:26:48 GMT, and a series of trouble-shooting exercises was conducted, such as interchanging the communications cables (Cobra Cables) that connect the astronauts' microphones and earphones to the communications equipment within the Spacecraft, and checking the effect of various communication

mode selection of the communications system. The "live mike" condition continued to exist after the troubleshooting exercises and the cause for this condition had not been determined by the time of first voice indication of fire. Another communication problem appeared after troubleshooting; it was in the ground station and involved the distribution of the various voice links. Shortly after the troubleshooting period, decision was made to proceed with the simulated static firing of the Reaction Control System (RCS) thrusters while communications were still possible. By 23:04 GMT the ground station worked around their problem by patching Spacecraft communications to Black 3, a specific communications loop. All test personnel were switched to this loop. By around 23:13 GMT the static firing exercise was completed. Voice check was made between the crew and the ground. The communications from the crew to the ground were somewhat garbled. At 23:22:27 GMT, the ECS engineers noted an appreciable depletion of the oxygen purge tank. The Command Pilot had his face plate open which accounted for the change and by about 23:23 GMT the face plate was closed. Still plagued by poor communication, Astro Communication Console CAST suggested the crew switch to S-band voice link; a communication check with each of the crew was acceptable. However, some undefined difficulty with the communications between the Spacecraft and the ground still existed.

c. At 23:28:00 GMT the count was holding at T-10 minutes and resumption of the count was anticipated momentarily. All the systems being monitored through the PCM system by systems engineers showed normal operation (particularly the electrical and ECS) at this time. Sixteen personnel were standing by at the various floor levels of the gantry to provide technical support as required. Those with specific functions to be performed at T-0 were positioned in the vicinity of assigned stations. Movement was reportedly negligible and no work was being performed on the flight or ground support hardware. Seven persons were positioned within the Saturn S-IV-B aft interstage monitoring assigned communication channels or otherwise engaged in support coordination. The only known anomaly within the Spacecraft was the "live microphone" which was picking up the rhythmic cadence of the Command Pilot's breathing sounds representative of a man at rest. In addition, the Senior Pilot's biomedical parameters showed normal resting levels. During this period, voice transmissions from the Spacecraft confirmed this impression of a relaxed situation. The termination of the last relaxed conversational transcript from the Spacecraft occurred at 23:30:02 GMT.

d. At 23:31:04.7 GMT, the crew call of fire was received over the voice loop. The series of events during the minute preceding the fire call was extracted from an after-the-fact review of the data and observation by personnel involved with the test.

At about 23:30:40 GMT, random sounds other than the normal breathing from the Command Pilot were evident on the "live mike." The sounds were similar to those obtained by tapping or brushing a microphone. The frequency of the noise occurrences was much greater than noted earlier in the test when the mike was "live." The noises subsided several seconds before the crew call of fire. Throughout the one-minute period before the crew call of fire, the oxygen flow to the suit circuits continually increased and reached the upper flow limit of the measuring system at about 23:30:59 GMT. During this period the torquing signals to the Inertial Measuring Unit showed fluctuations which were an indication of movement of the Spacecraft. In addition, biomedical data indicates a slight increase of activity by the Senior Pilot. This indication subsided within the one-minute time period. An assessment of the noises on the voice loop, increasing oxygen flow to the suit circuits, torquing signal variations to the Inertial Measuring Unit and Senior Pilot slight increase in activity between about 23:30:40 GMT and 23:30:59 GMT show that crew activity within the Spacecraft occurred. During the period when the crew was active, the open channel of the gas chromatograph showed fluctuations commencing at about 23:30:50 GMT. This fluctuation may have also indicated crew activity because of the antenna characteristics of the disconnected cable. At about 23:30:55 GMT a momentary dropout of the data being transmitted from the Spacecraft occurred. The C-band beacon also showed an interruption at this time. The AC voltages on the three phases of inverter Number 2 showed a transient, as did one of the phases which supplied power to the hand controller.

e. About six seconds before the call of fire by the crew, all systems appeared to be at a steady or quiescent state, except for the high oxygen flow to the suit circuits. The crew call of fire occurred at 23:31:04.7 GMT.

There were two voice transmissions from the Spacecraft. The first transmission, believed to be that of the Command Pilot, at 23:31:04.7 GMT reported "a fire in the cockpit." This transmission ended at 23:31:10 GMT. The second and last transmission, believed to be the Pilot's, started at 23:31:16.8 GMT and ended at 23:31:21.8 GMT. This transmission reported "a bad fire" followed by two garbled phrases. Coincident with the call of fire, immediate and marked increase in the biomedical measurements from the Senior Pilot occurred. The magnitude of these readings continued to increase until loss of data from the Spacecraft. Those systems sensitive to the Spacecraft movement, including the launch vehicle accelerometers, showed increasing indications of Spacecraft movement. These indications continued until loss of data, which occurred at 23:31:22.40 GMT (6:31:22.40 p.m. EST).

The witnesses on station to support the test heard the call of fire. A muffled explosion was heard next, followed by two loud whooshes of escaping gas as the Spacecraft cabin ruptured from the internal pressure increase caused by the fire. Flames shot from open access panels. Astronaut helmet, arm and back movements were observed through the cabin window. The light intensity from within the cabin increased, and flames filled the view through the window.

f. Ground power was switched from the Spacecraft at 23:32:46.4 GMT. However, internal batteries had been switched on the main buses by the crew at about 23:31:13 GMT so that removal of ground power did not deenergize the electrical systems within the Spacecraft. Between 23:31:15 GMT and 23:33:00 GMT repeated attempts were made by the pad crew to enter the smoke-filled White Room to rescue the astronauts from the Spacecraft. The fires external to the Spacecraft continued to burn as hatch removal progressed. At about 23:36 GMT the hatch was removed and at approximately 23:43:00 GMT, three physicians arrived from the blockhouse.

g. Detailed events from about one minute prior to the fire to the time when ground power was switched from the Spacecraft, are shown in Enclosure 3-3. (Ground power was removed from the Spacecraft after loss of all data transmission from the Spacecraft.) The recorded data from the onboard instrumentation, the ground instrumentation, and the voice transcripts were used to establish the events of the enclosure.

### 3. DATA INDICATION

Some of the more significant data obtained just prior to the crew call of fire is shown in Enclosure 3-4. These data cover a period of one minute before the call of fire until loss of the data signals. The data shown include various parameters indicating Spacecraft motion, the "live mike" audio noises on the Command Pilot's S-band, oxygen flow rate into the suit loop, biomedical indications from the Senior Pilot, AC bus 2 transient and associated effects on the C-band operation and VHF telemetry carrier and the gas chromatograph signal monitor. Each of these subjects is discussed in the Report of Panel 18.

## D. FINDING AND DETERMINATIONS

### 1. FINDING:

The data recorded from the Spacecraft and ground instrumentation system during the Spacecraft Plugs Out Test were found to be valid except for three brief dropouts which occurred around 23:31:17.4 GMT, 23:31:21.0 GMT and 23:31:21.4 GMT. All onboard data transmission ended at about 23:31:22.40 GMT.

### 2. DETERMINATION:

The onboard instrumentation system functioned normally prior to and during the initial phases of the fire. There were no indicated malfunctions in any of the instrumentation sensors during this period.

## E. SUPPORTING DATA

1. Enclosure 3-1 Sequence of Events, Final Summary Report
2. Enclosure 3-2 Flow of Data Information from S/C and Ground Support Equipment

3. Enclosure 3-3 Sequence of Events

4. Enclosure 3-4 Data Indications

This page left blank intentionally.

**ENCLOSURE 3-1**



This page left blank intentionally.

## 1. INTRODUCTION

This report contains the sequence of events from about one minute prior to the crew call of fire to loss of data. The basic data pertinent to the sequence of events are presented in direct-write recorder form. A brief discussion of the data indications for each system is given. The analysis of these data indications are presented in the final report of Panel 18 where additional data is presented to support the discussion.

CR	Cathode Ray
AC	Alternating Current
DC	Direct Current
ECS	Environmental Control System
TVC	Thrust Vector Control
PCM	Pulse Code Modulation
VHF/FM	Very High Frequency/Frequency Modulation
MTVC	Manual Thrust Vector Control
W/G	Water-Glycol
S/C	Spacecraft
IMU	Inertial Measurement Unit
OAT	Over - All Testing
GSE	Ground Support Equipment
SRP	Senior Pilot
EDS	Emergency Detection System
HFLT	Houston Flight
BPC	Boost Protective Cover
CMD	Command Pilot
SM-RCS	Service Module-Reaction Control System
ACE S/C	Acceptance Checkout Equipment Spacecraft
ACE	Acceptance Checkout Equipment
LOS	Loss of Signal
KSC	Kennedy Space Center
ECA	Electronic Control Assembly
ECU	Environmental Control Unit
SPS	Service Propulsion System
F/C	Fuel Cell
G&N	Guidance and Navigation
PIPA	Pulse Integrating Pendulous Accelerometer
LEB	Left Equipment Bay
FHS	Forward Heat Shield
CSM/SLA	Command Service Module/Saturn LM Adapter
LES	Launch Escape System
DSEA	Data Storage Electronic Assembly
MCCH	Mission Control Center Houston
GMT	Greenwich Mean Time

ENCLOSURE 3-1

PSIG	Pounds Per Square Inch Gauge
PSIA	Pounds Per Square Inch Absolute
S/V	Space Vehicle
NRZ PCM	Non-Return to Zero Pulse Code Modulation
TPS	Test Planning Sheet
EPS	Electrical Power System
EDU	Coupling Display Unit
ADA	Angular Differentiating Accelerometer
CW	Continuous Wave
MSOB	Manned Spacecraft Operations Building
MOLC	ACE Open Loop Communication Station
CAST	Astro Communicator Console
PLT	Pilot
MSTC	Manned Spacecraft Operations Building Spacecraft Test Conductor
CGSS	Cryogenic Gas Storage System
PUGS	Propellant Utilization Gaging System
SM-A	Service Module Quad A
SM-D	Service Module Quad D
SM	Service Module
MDAS	Medical Data Acquisition System
VDC	Voltage Direct Current
CG	Gas Chromatograph
C & W	Caution and Warning
PTT	Press to Talk
VHF/AM	Very High Frequency/Amplitude Modulation
CCW	Counterclockwise
RFI	Radio Frequency Interference
CSM	Command Service Module
T/R	Transmit/Receive

## 2. SIGNIFICANT EVENTS PRIOR TO THE START OF THE FINAL TEST

### a. SC ARRIVAL TO START OF PLUGS OUT TEST

August 26, 1966	-	Command Module arrival at KSC.
September 14	-	Start of combined systems test (OCP-FO-0035).
September 17	-	Spacecraft (S/C) power-down for troubleshooting.
September 19	-	S/C power-up for OCP-FO-K0035.
September 23	-	S/C power-down for OCP-FO-K-0035 troubleshooting.
September 27	-	OCP-FO-K0035 ECS leak checks.
September 29	-	Remove electronic control assemblies (ECA) because of water glycol (W/G) leak.
September 30	-	Reinstall ECA's. Environmental control system water glycol leak corrected.

October 1	- S/C power-up and completed OCP-FO-K-0035.
October 7	- W/G spill during transducer change. Remove all ECA's because of W/G wetting.
October 8	- Install new ECA's.
October 10	- Manned sea level run of flight crew altitude chamber test, OCP-FO-K-0034 started.
October 11	- Manned sea level run discontinued due to bent pins in CM-SM umbilical. PCM replaced due to suspected bad transistors.
October 12-13	- Manned sea level run performed.
October 14-15	- Unmanned altitude run performed.
October 18	- First manned (flight crew) altitude run aborted at 13,000 feet due to inverter no. 1 failure. Inverter replaced. Shorted input transistor. (Had not gone through the screening process.) Replacement was of modified and screened type.
October 19	- First manned (flight crew) altitude run completed.
October 21	- Second manned (back-up crew) altitude run initiated but scrubbed due to O <sub>2</sub> regulator failure.
October 27	- Decision received to change ECU. Inverters no. 2 and no. 3 removal started. (These two were of the unmodified type.)
October 28	- ECA's removed for water glycol drain.
October 29	- Demate CSM to pressure test service propulsion system (SPS) tanks. Installed Yaw Axis ECA.
October 31	- C/M moved to integrated no. 1 stand.
November 1	- ECU removed.
November 3	- SPS tank removal from S/M started.
November 4	- Install roll and pitch ECA's. New inverter installed complete.
November 5	- Fuel cell (F/C) no. 2 W/G pump replaced due to leak.
November 6	- Start SPS tank pressure testing at Pad 16.
November 8	- O <sub>2</sub> panel with new O <sub>2</sub> regulator installed. Installation of ECU initiated. Installation of SPS tanks initiated.
November 9	- Drain of fuel cell water-glycol completed. F/C W/G fill initiated.
November 11	- New SPS fuel tanks received. Leak check of ECU completed. Installation of SPS tanks completed.
November 12	- Power-up S/C to support ECS checks.
November 13	- Move S/M to Pad 16 for SPS installed tank pressure checks. G&N computer, S/N 123, removal in work to install flight program memory.
November 14	- ECS W/G servicing started.
November 15	- Install S/M in altitude chamber. ECS W/G servicing complete.

November 16	- G&N computer installed temporarily to perform PIPA test. Corrosion noted on pins. Must be removed.
November 17	- G&N PIPA test complete. Computer S/N 123 removed. Will install new computer S/N 124 due to corrosion on pins of S/N 123.
November 19	- CSM mate started.
November 20	- Installation of new G&N computer S/N 124. Held up by broken bolt. CSM mate complete.
November 21	- Air in ECS W?G system. Must be re-serviced.
November 22	- ECS W/G drain started. Broken bolt in computer removed. Computer removed. Computer removed. Computer bolts found to be too soft.
November 25	- O2 panel removed and -5 O2 regulator installed.
November 26	- G&N computer S/N 124 installed.
November 27	- ECS W/G reservice complete. W/G leak in lower equipment bay (LEB) repaired.
November 29	- S/C power-up and conduct OCP-FO-K-0034.
November 30	- Test scrubbed due to W/G leak in ECU.
December 1	- Decision made to remove ECU.
December 2	- Drain W/G system. Repair W/G leak in LEB.
December 3	- Removed ECU and shipped to AiResearch (A/R).
December 14	- Started ECU installation.
December 16	- Completed installation of forward heat shield (FHS).
December 19	- Completed ECU installation. Started W/G servicing per OCP-FO-K-5518.
December 21	- Completed W/G servicing.
December 27	- Initiated manned (back-up crew) sea level run OCP-FO-K-0034A.
December 28	- Manned sea level run completed. Unmanned altitude run completed.
December 29	- Started manned (back-up crew) altitude run.
December 30	- Manned altitude run completed.
January 3, 1967	- Remove CSM from altitude chamber for SPS nozzle installation and SLA mate.
January 4	- Start CSM/SLA mate
January 6	- New quads "A" and "D" installed due to minor damage in original quad engine nozzle. Moved to LC-34 and mated to launch vehicle.
January 7	- Launch vehicle pull test completed.

- January 10 - Solenoid valve on cyclic accumulator no. 1 replaced.  
Perform OCP-FO-K-0039 GSE interface test.  
Start circuit interrupter test.  
Main DSKY replaced due to burned out light on numeral.
- January 11 - Removed panel 31 and replaced suit pressure meter.
- January 12 - Circuit interrupter test completed.  
Start combined systems test  
OCP-FO-K-0005.
- January 13 - Start F/C cryogenic loading test,  
OCP-FO-K-4736.
- January 14 - OCP-FO-K-0005 completed.
- January 15 - Launch escape system (LES) mate completed.
- January 16 - S/C powered up for trouble shooting.
- January 17 - OCP-FO-K-4736 completed.
- January 18 - Electrical mate, OCP-FO-K-0004, started and completed.
- January 20 - Plugs in, integrated test, OCP-FO-K-0006 dry run without HFLT started and completed.
- January 21 - Potting of panel no. 12 initiated.
- January 23 - O2 purge valve on F/C no. 1 replaced.  
Potting on panel no. 12 reheated. Still not properly cured. Installed for test.  
Circuit interrupters between CM/SM opened in search of missing test spacer which prevents damage to the o-ring in the connector during test (not found in interrupters).  
Repair pyro battery wire.
- January 24 - MCCCH interface test, OCP-FO-K-0045, started and completed.  
Pyro connector repaired.  
Water flush test completed.  
S/C power-on troubleshooting in work.
- January 26 - YAW ECA replaced due to electronic anomaly and new one retested.  
Started replacing DSEA connector.  
OCP-FO-K-0006 completed.
- January 27 - DSEA connector replacement completed.  
Plugs out, OAT, OCP-FO-K-0021-1 started.

### 3. SEQUENCE OF EVENTS

#### a. START OF PLUGS OUT TEST TO 23:30:00 GMT

- The following is the time line for plugs out, OAT, OCP-FO-K-0021-1, January 27, 1967:
- 12:55 GMT - S/C bus power up.
  - 13:20 GMT - S/C subsystems activation and systems test.
  - 14:50 GMT - ECSsystems test started.
  - 16:00 GMT - T-3 hours and hold for 1 hour for ECS.  
ECS had trouble with O2K bottle hookup through GSE into pneumatically operated disconnect at service module.

17:00 GMT	- ECS test completed.
17:05 GMT	- Started pre-ingress switch checklist.
18:00 GMT	- Command Pilot ingress. When Command Pilot changed over from the closed loop ventilator to S/C ECS, he said there was an odor in the systems like "sour milk." Continued with Pilot and Senior Pilot ingress.
18:09:56:5 GMT	- SRP hooks up to communications cables after ingress and biomed data becomes available.
18:30 GMT	- Begin hold for odor in suit loop. Bendix support called for to supply evacuated "watermelon" to take samples of suit circuit loop. Sample taken during hold.
19:25 GMT	- Picked up count and performed suit circuit checks.
19:40 GMT	- Post-ingress switch checklist performed silently by flight crew.
19:45 GMT	- Inner hatch installed and started cabin purge and leak check.
20:00 GMT	- Start emergency detection system (EDS) test.
21:00 GMT	- EDS test complete. Start abort request checks.
21:15 GMT	- Abort request checks complete.
21:50 GMT	- Cabin purge and leak check complete. Start outer hatch and boost protective cover (BPC) installation. Could not properly latch BPC hatch.
22:40 GMT	- Hold for communications problems. Proceed with terminal count functions where communications allowed.
22:45:15:5 GMT	- SRP disconnects his communication cables and gives to CMD. This is done in an effort to isolate the communications problem.
22:45:28 GMT	- CMD hooks up to SRP cables and runs communications check.
22:46:45:9 GMT	- CMD disconnects from SRP cables.
22:46:51:2 GMT	- SRP reconnects to communications cables and re-establishes biomed data.
22:47:33 GMT	- CMD reconnects to his own communications cables.
22:53 GMT	- Approximate time CMD replaced cobra cable.
23:10:00 GMT	- Start simulated SM-RCS static fire.
23:15:00 GMT	- Complete static fire.
23:20 GMT	- Completed all terminal count functions up to transfer to internal power. Hold at T-10 minutes for communications problems.

b. 23:30:00 GMT TO LOSS OF DATA

Figure 3-1 shows the significant sequence of events time line as gathered from the recorded data. Figures 3-2 through 3-8 represent the actual recorded data.

# SEQUENCE OF EVENTS

TIMES SHOWN ARE DERIVED FROM SAMPLED MEASUREMENTS AND ARE UNCERTAIN BY THE SAMPLING RATE OF THE SPECIFIC MEASUREMENT

ONE SECOND SCALE

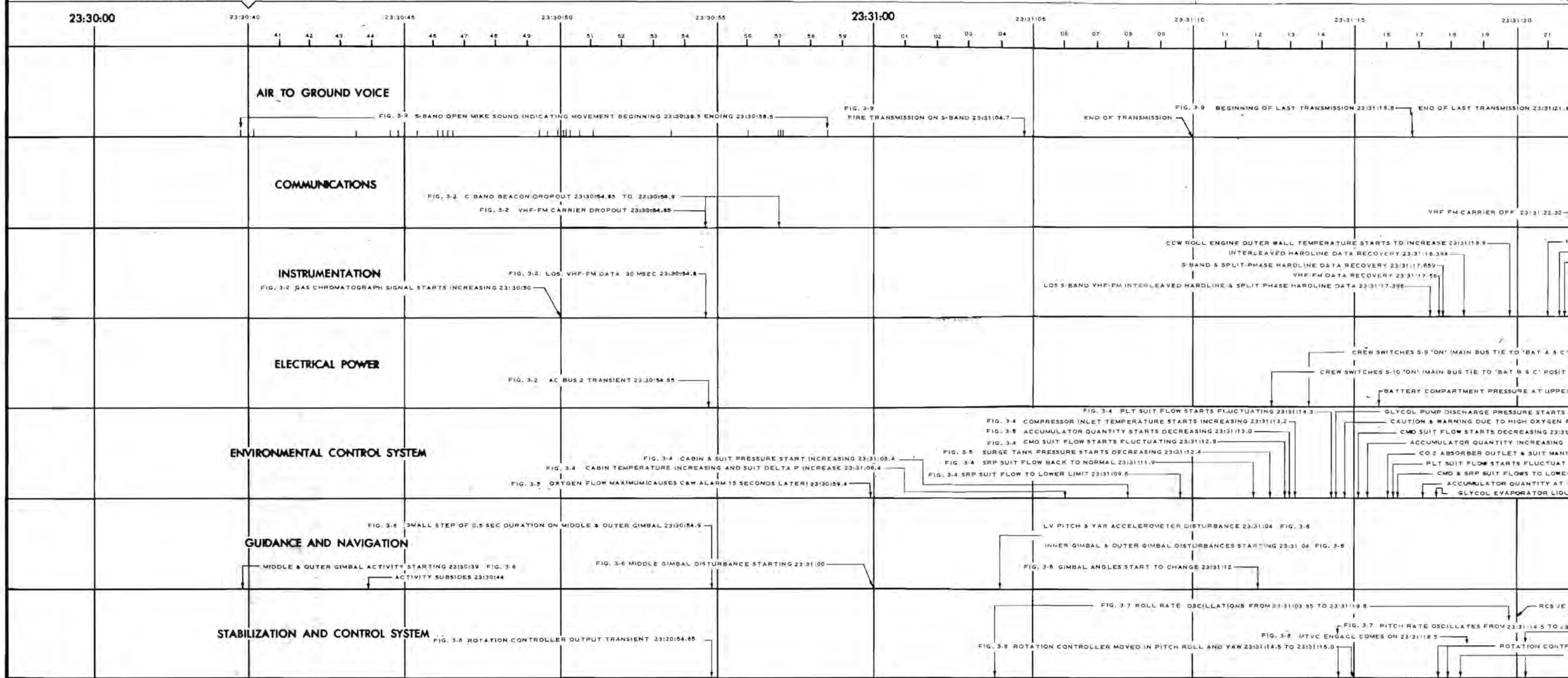



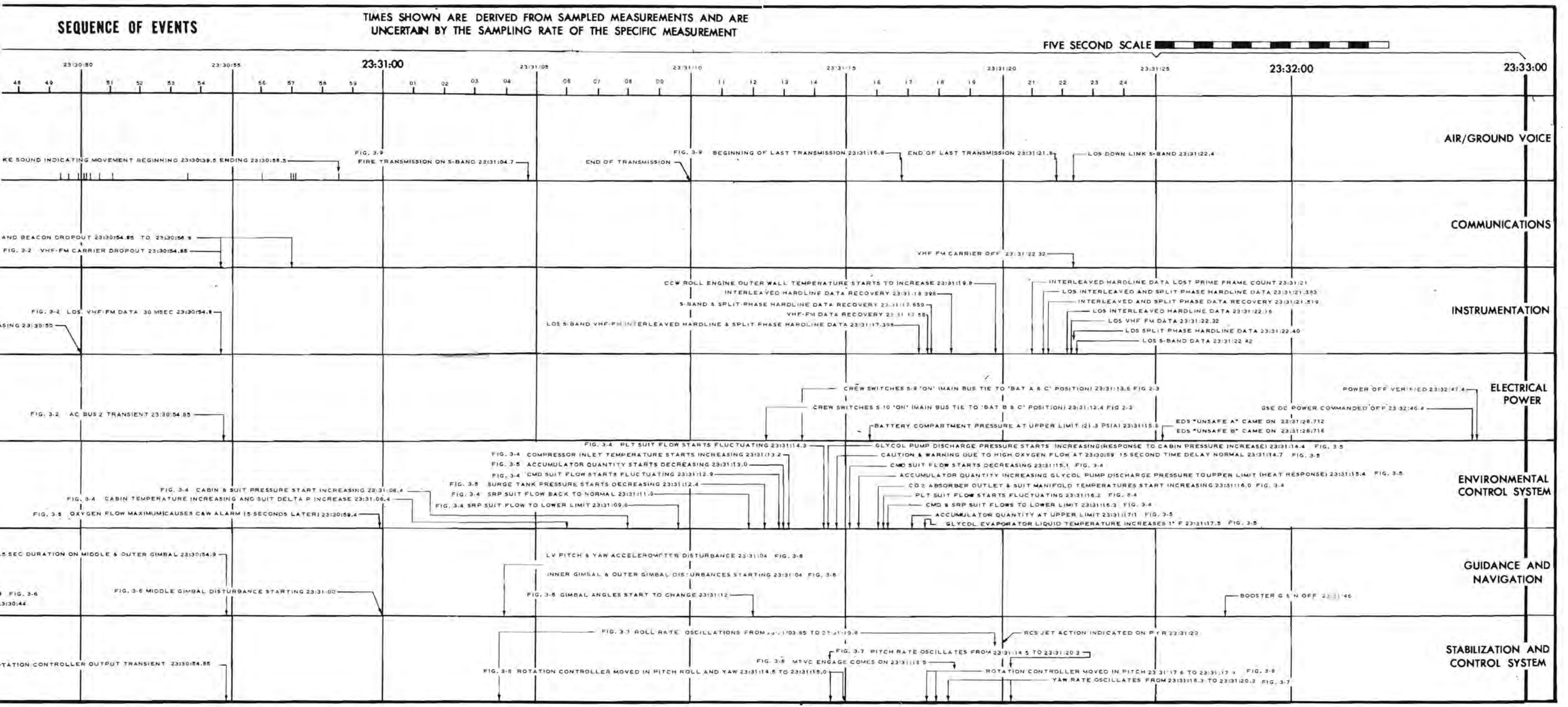
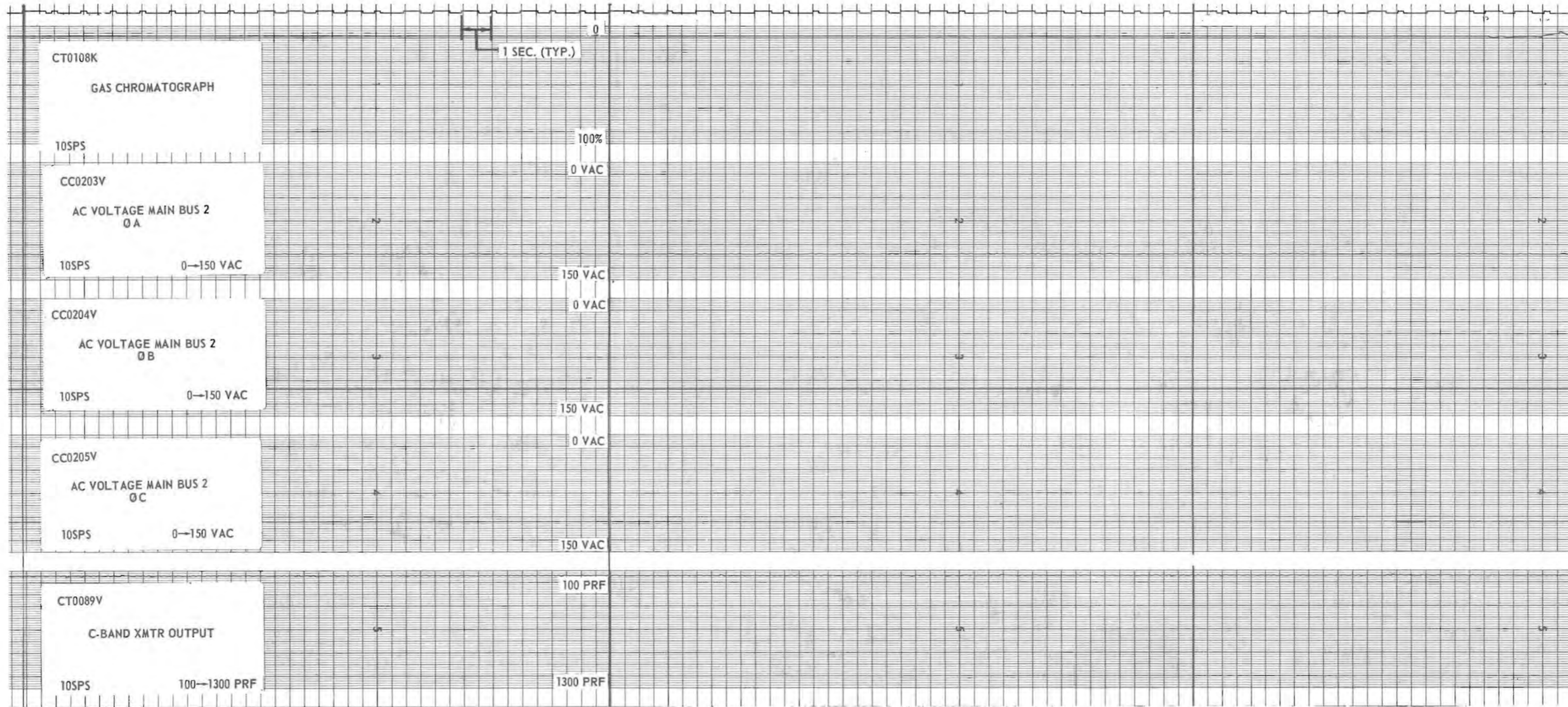

FIGURE 3-1 SEQUENCE OF EVENTS

23:30:00

23:30:20

23:30:40



261-106 O - 87 (Face p. 1 of 2) No. 7

FIGURE 3-2 AC BUS 2 ASSOCIATED MEASUREMENT TRACES

23:30:40

23:31:00

23:31:20

3-6

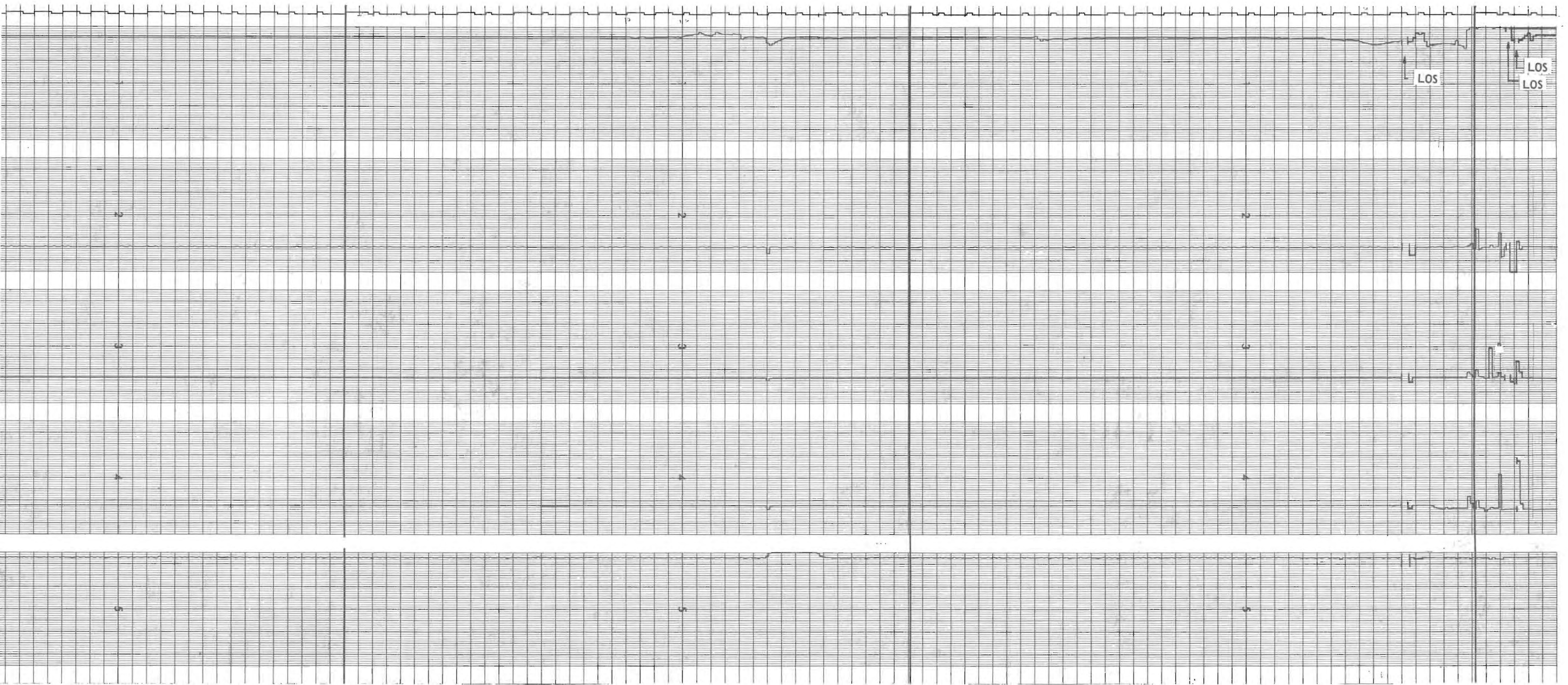

FIGURE 3-2 AC BUS 2 ASSOCIATED MEASUREMENT TRACES

23:30:00

23:30:20

23:30:40

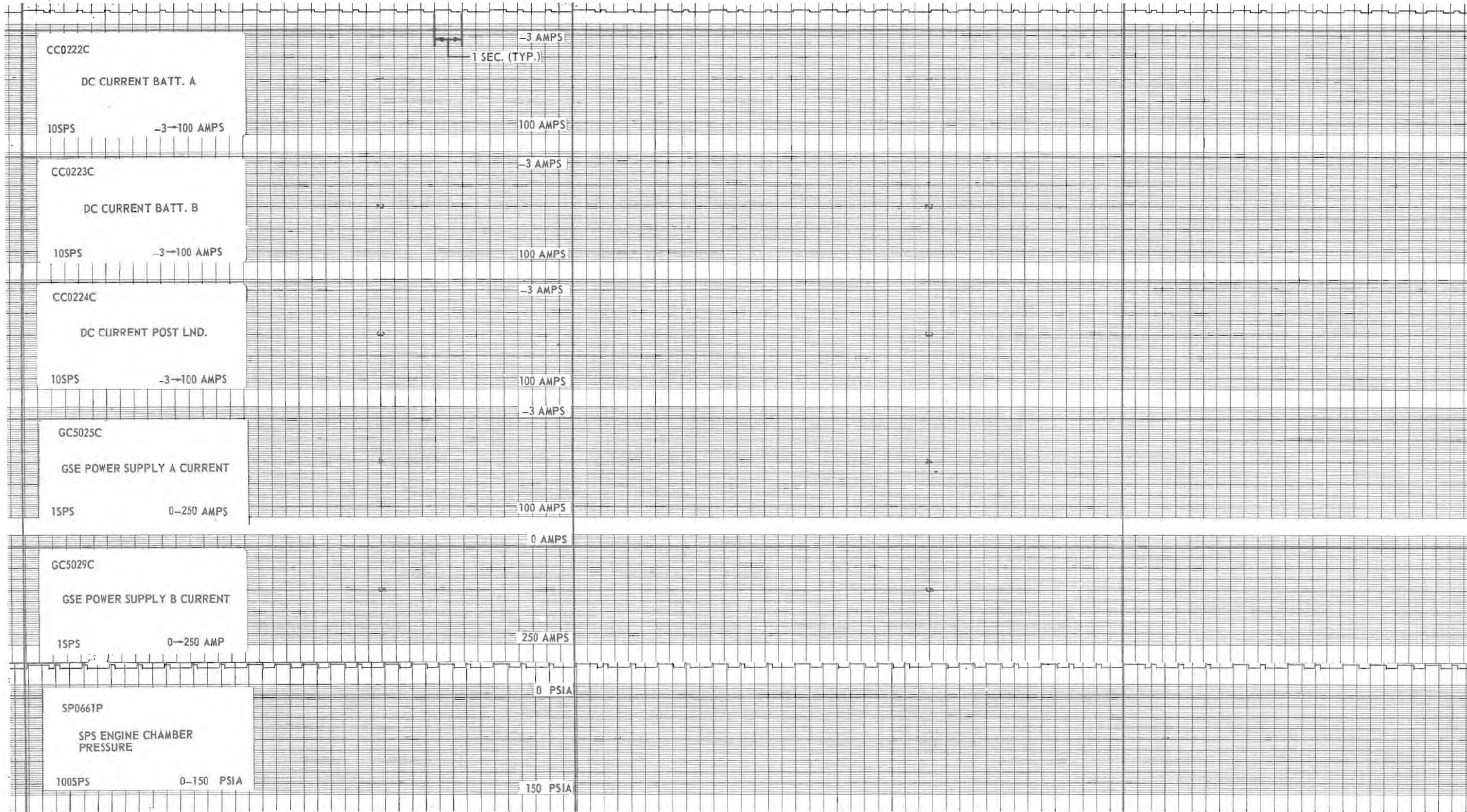

FIGURE 3-3 DC CURRENT AND ASSOCIATED MEASUREMENT TRACES

23:30:40

23:31:00

23:31:20

3-7

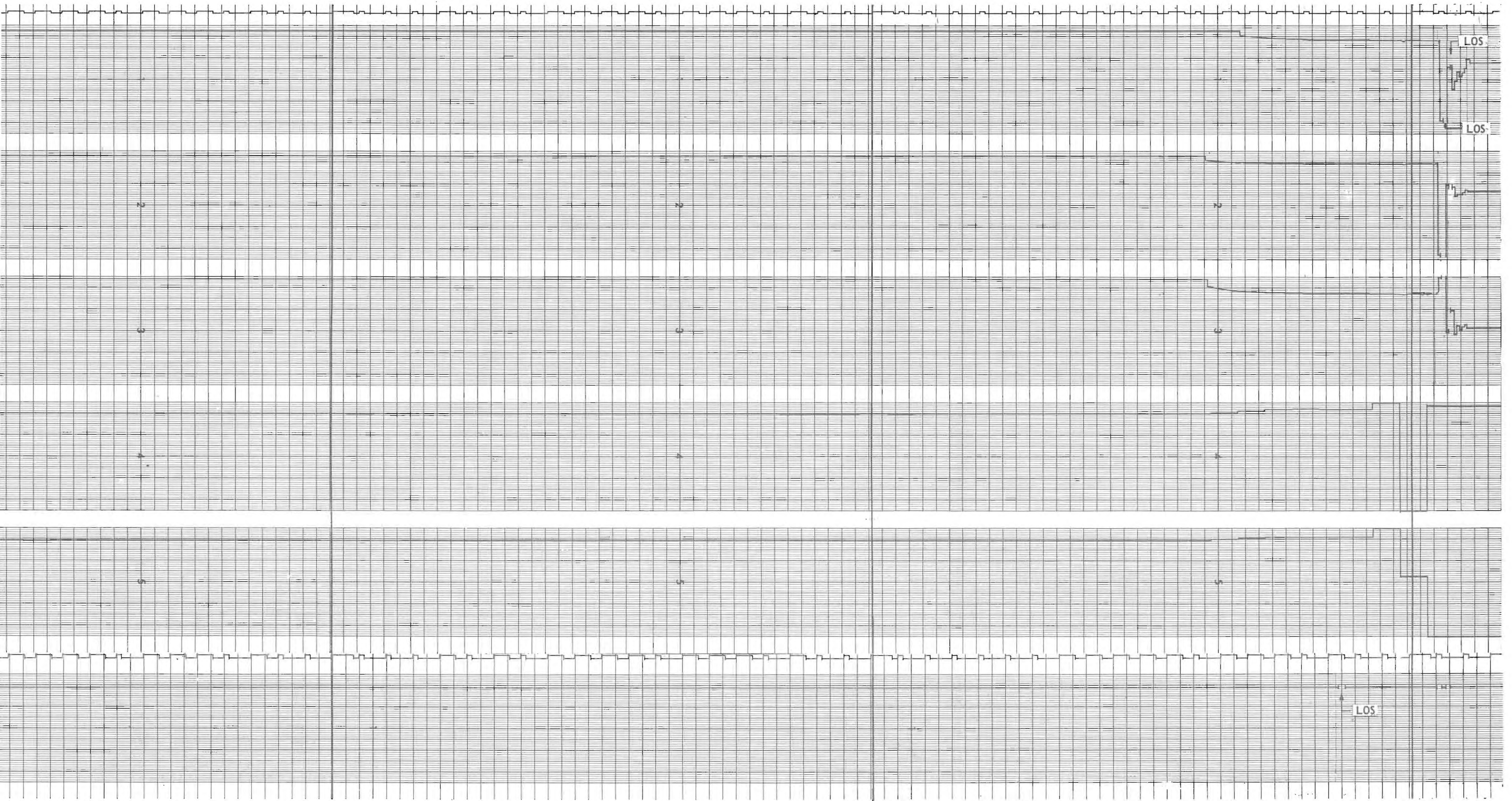

FIGURE 3-3 DC CURRENT AND ASSOCIATED MEASUREMENT TRACES

23:30:00

23:30:20

23:30:40

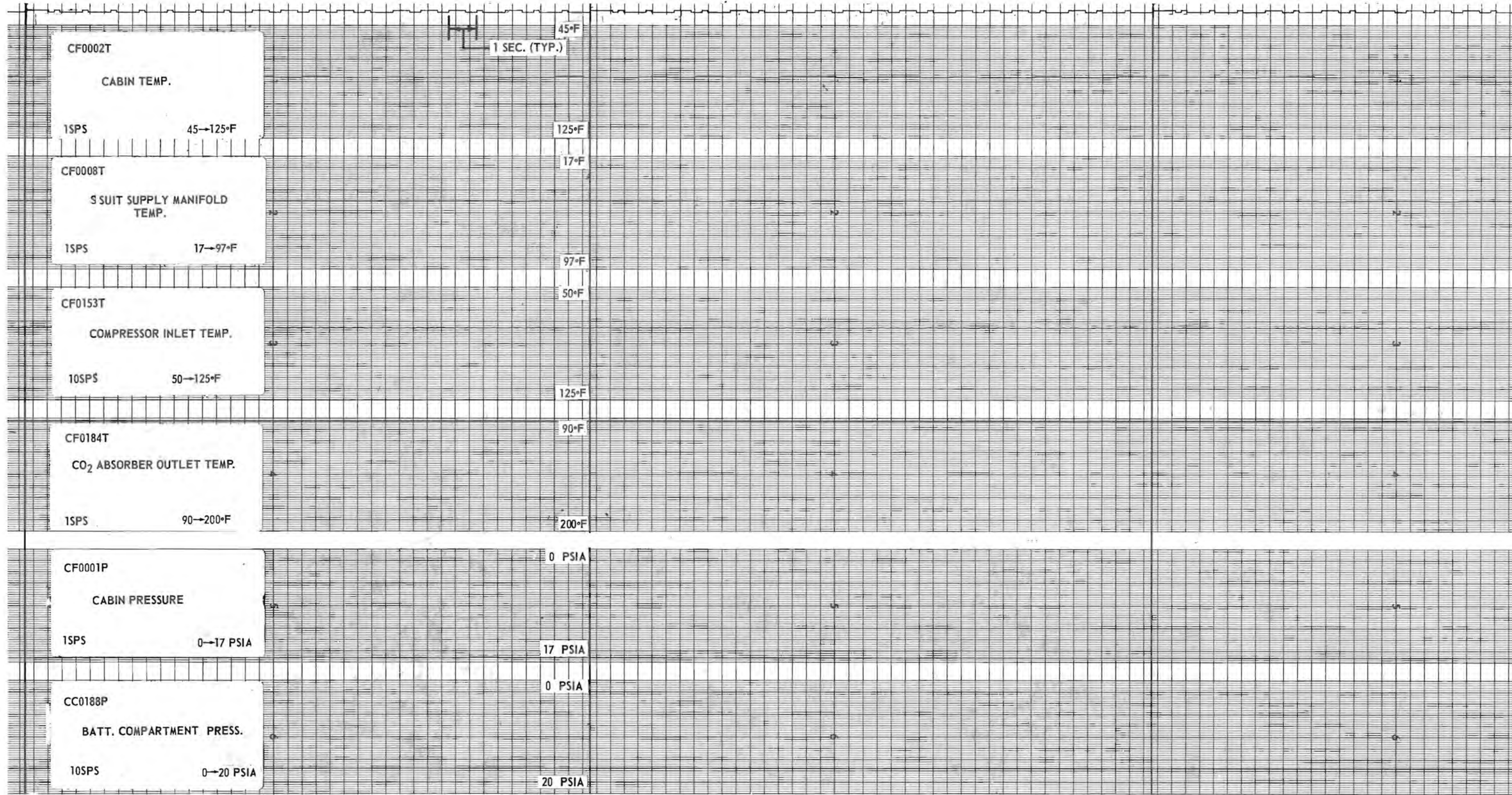

FIGURE 3-4 ECS MEASUREMENT TRACES (SHEET 1 OF 2)

23:30:40

23:31:00

23:31:20

3-8

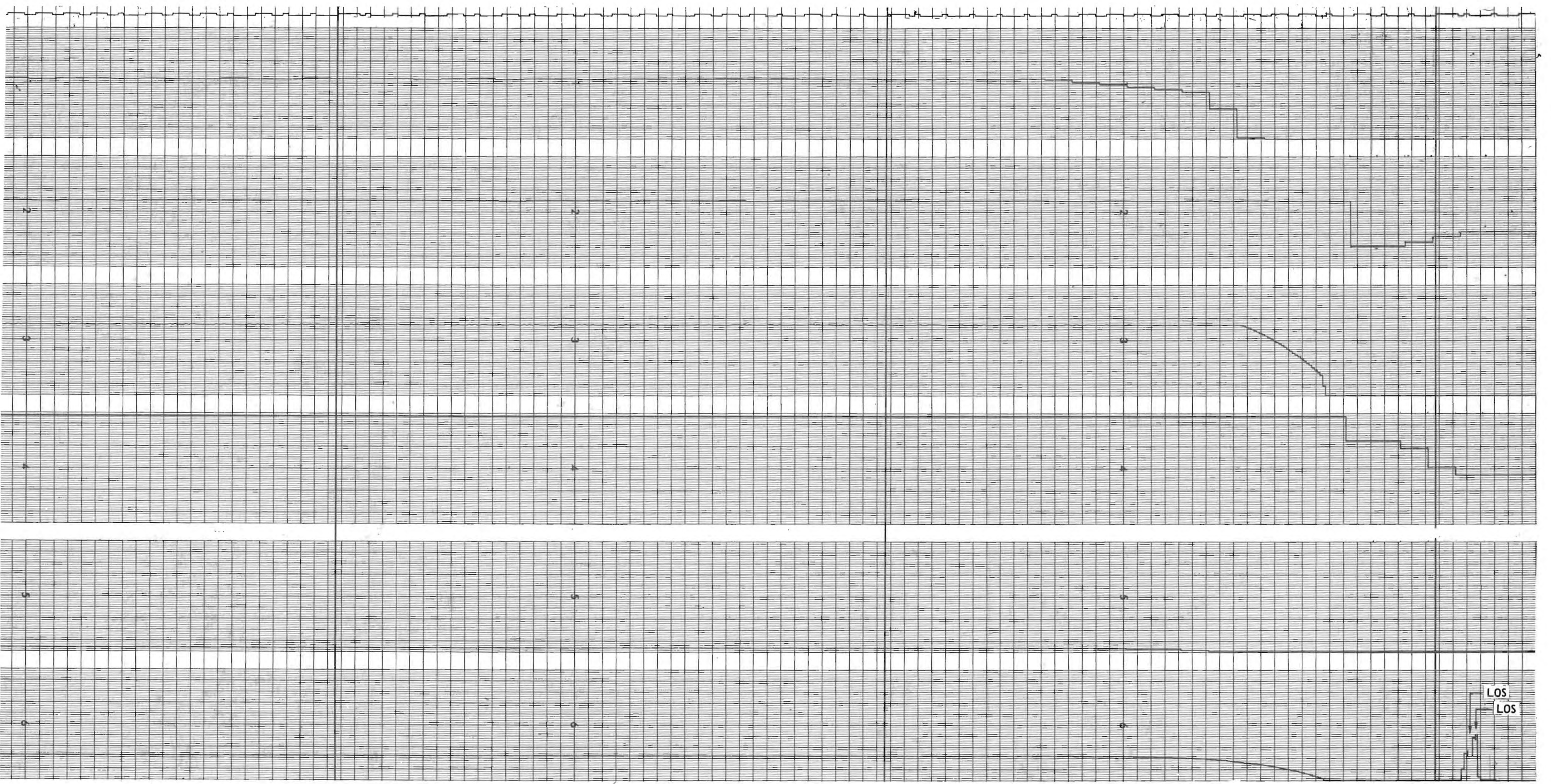

FIGURE 3-4 ECS MEASUREMENT TRACES (SHEET 1 OF 2)

23:30:00

23:30:20

23:30:40

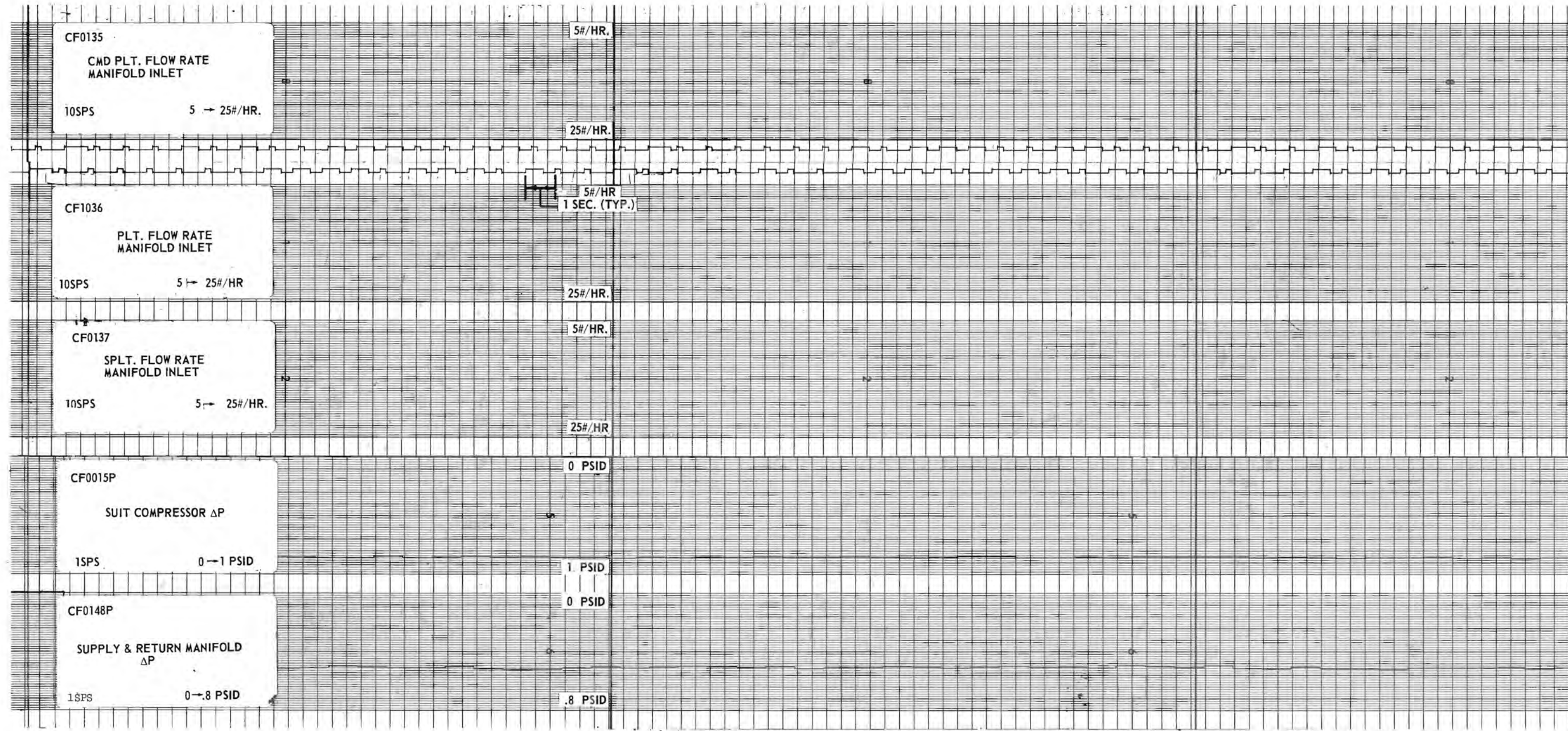

FIG. 3-4 ECS MEASUREMENT TRACES (SHEET 2 OF 2)



23:30:40

23:31:00

23:31:20

3-9

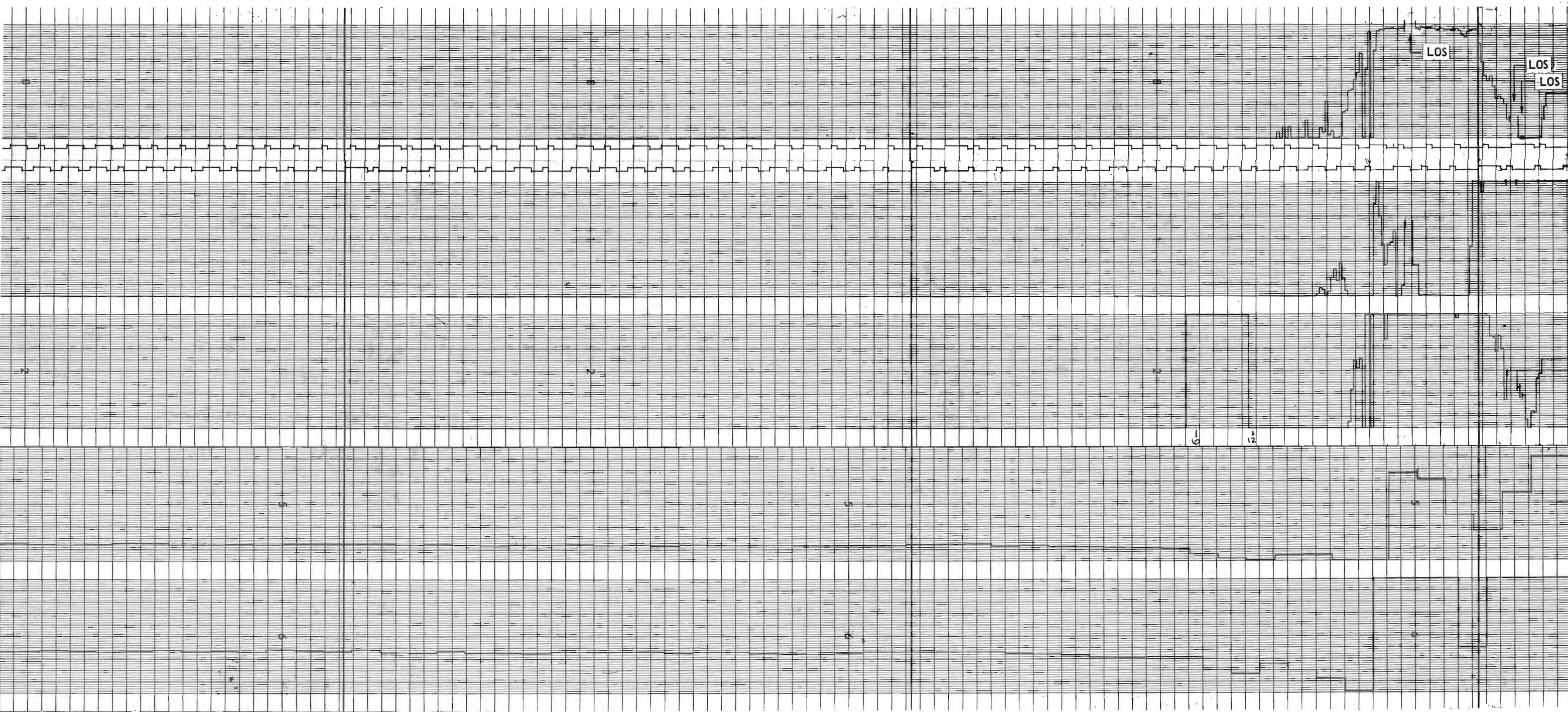

FIG. 3-4 ECS MEASUREMENT TRACES (SHEET 2 OF 2)

23:30:00

23:30:20

23:30:40

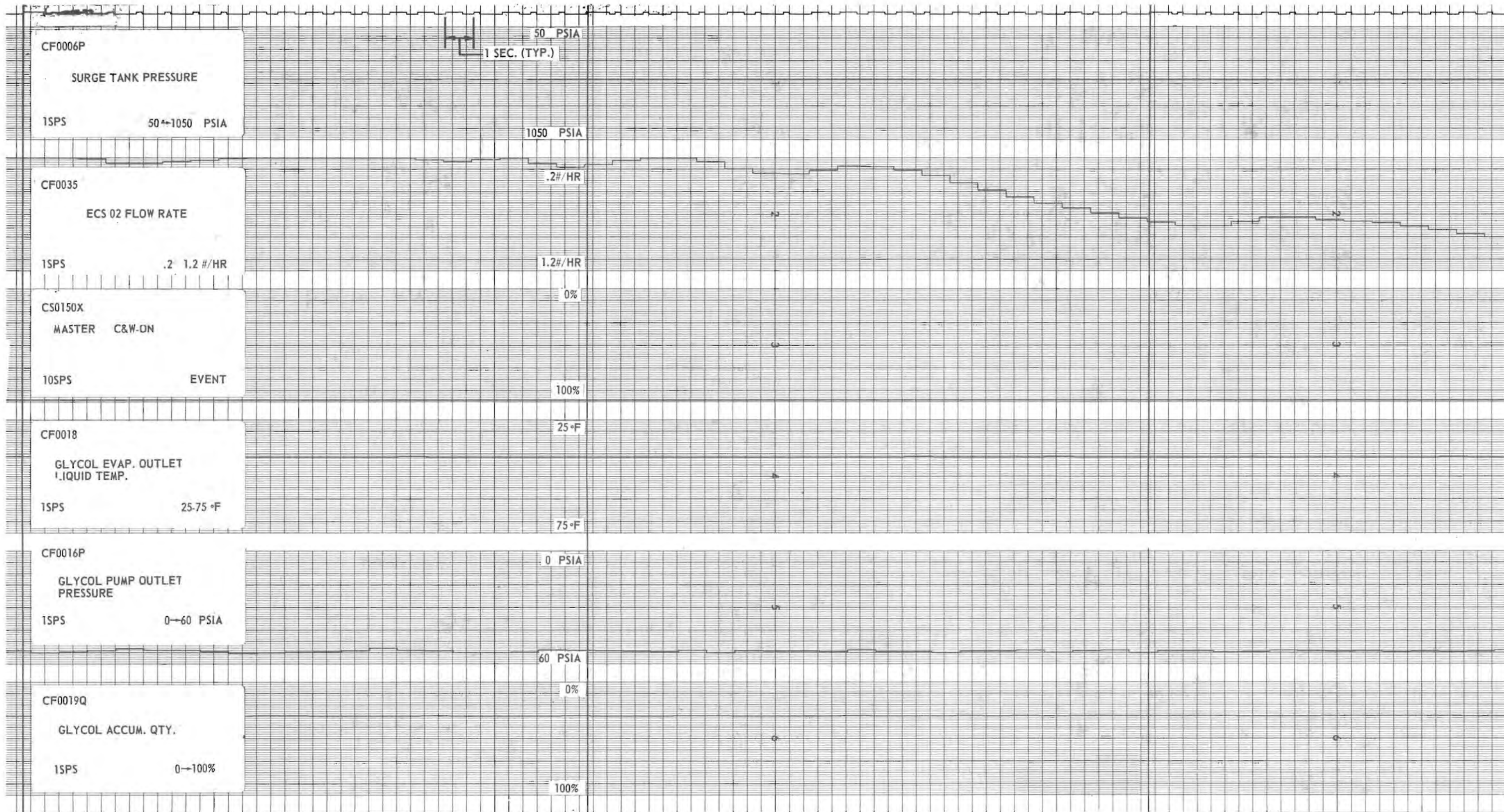

FIGURE 3-5 ECS MEASUREMENT TRACES

23:30:40

23:31:00

23:31:20 3-10

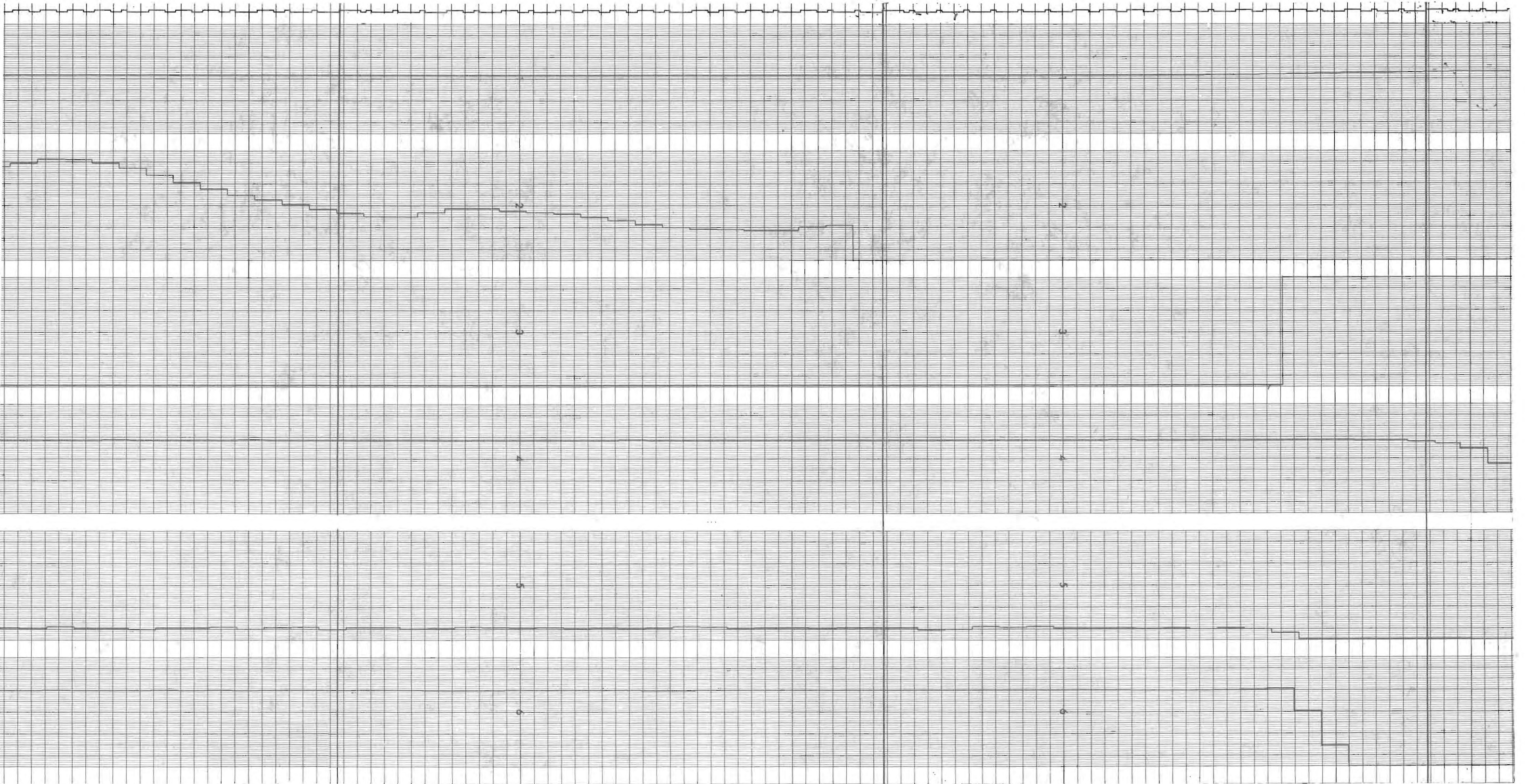

FIGURE 3-5 ECS MEASUREMENT TRACES

23:30:00

23:30:20

23:30:40



FIG 3-6 TORQUE MOTOR INPUT MEASUREMENT TRACES

23:30:40

23:31:00

23:31:20 3-11



FIG 3-6 TORQUE MOTOR INPUT MEASUREMENT TRACES

23:30:00

23:30:20

23:30:40

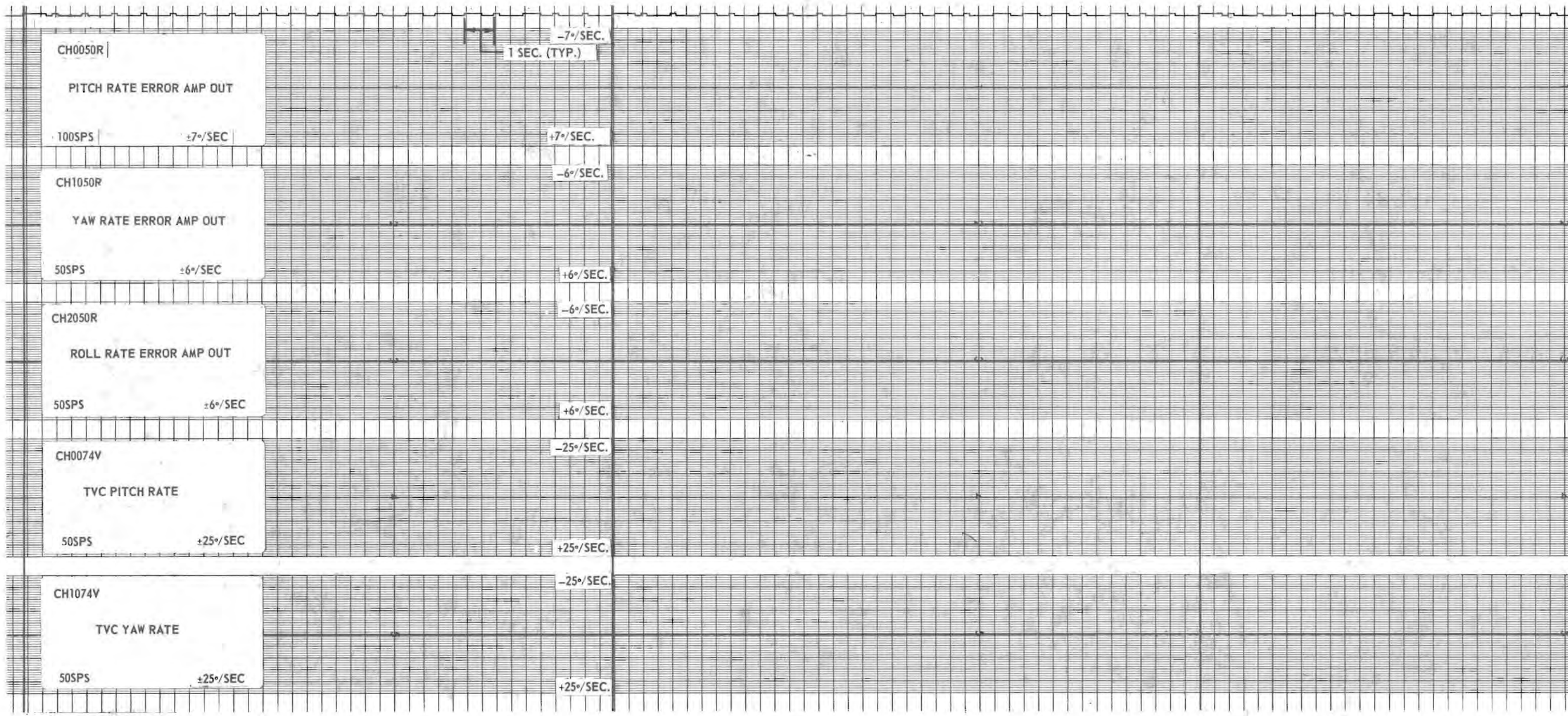

FIGURE 3-7 RATE AND RATE ERROR MEASUREMENT TRACES

23:30:40

23:31:00

23:31:20 3-12

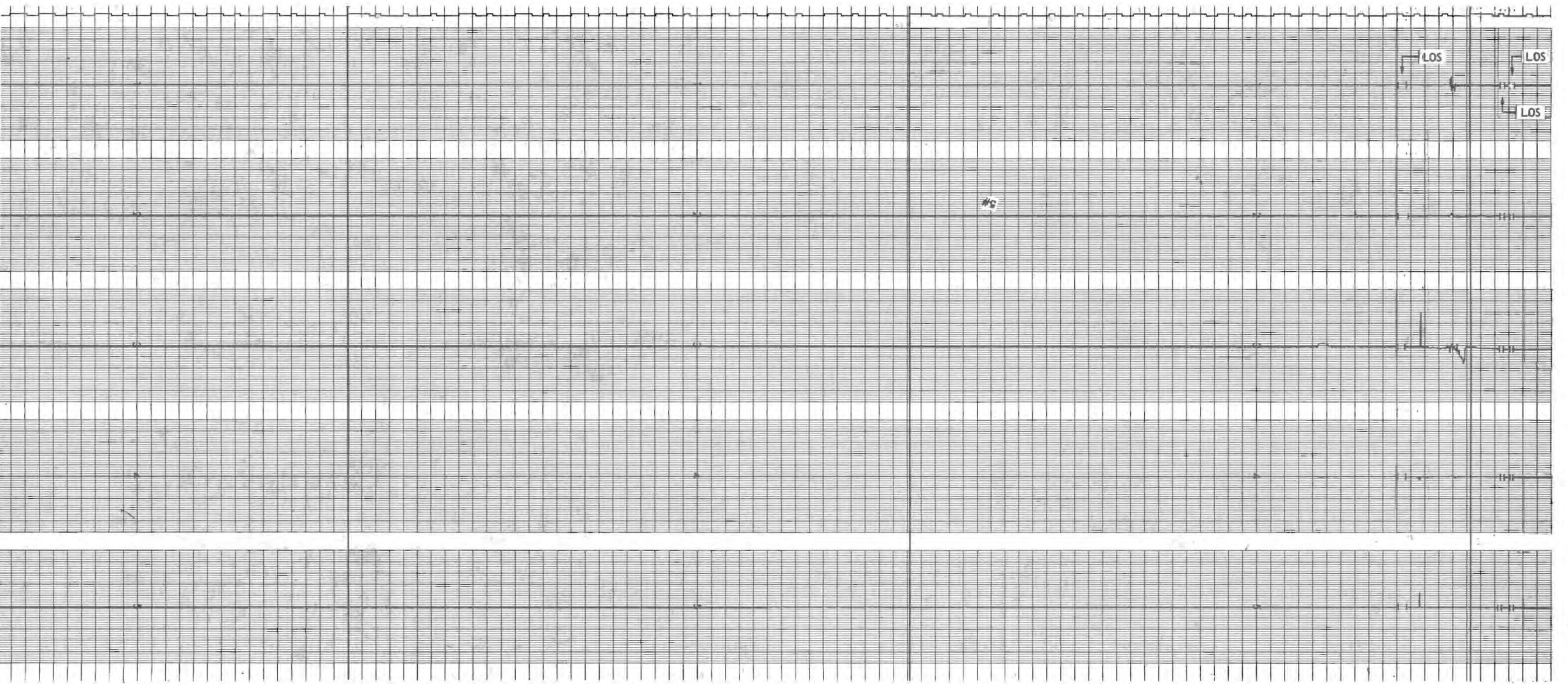
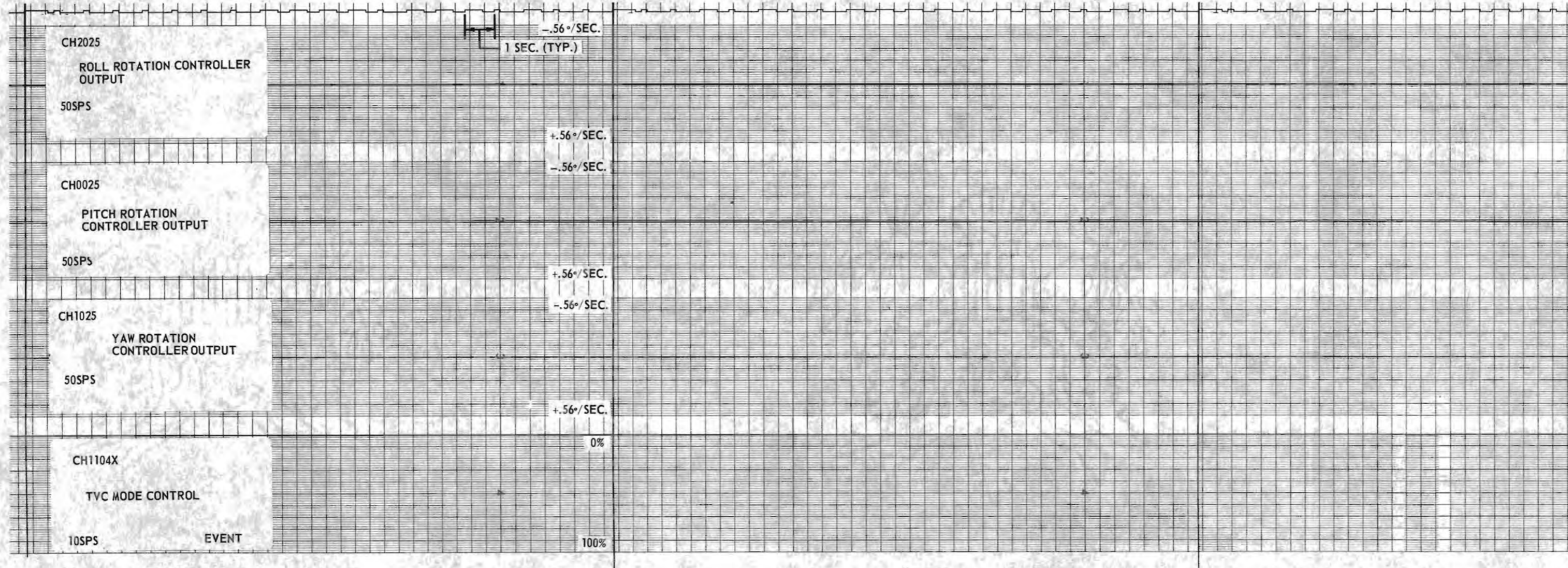

FIGURE 3-7 RATE AND RATE ERROR MEASUREMENT TRACES

23:30:00

23:30:20

23:30:40



281-106 O - 87 (Face p. D-3-16) No. 14

FIGURE 3-8 ROTATION CONTROLLER TVC MODE MEASUREMENT TRACES



23:30:40

23:31:00

23:31:20

3-18

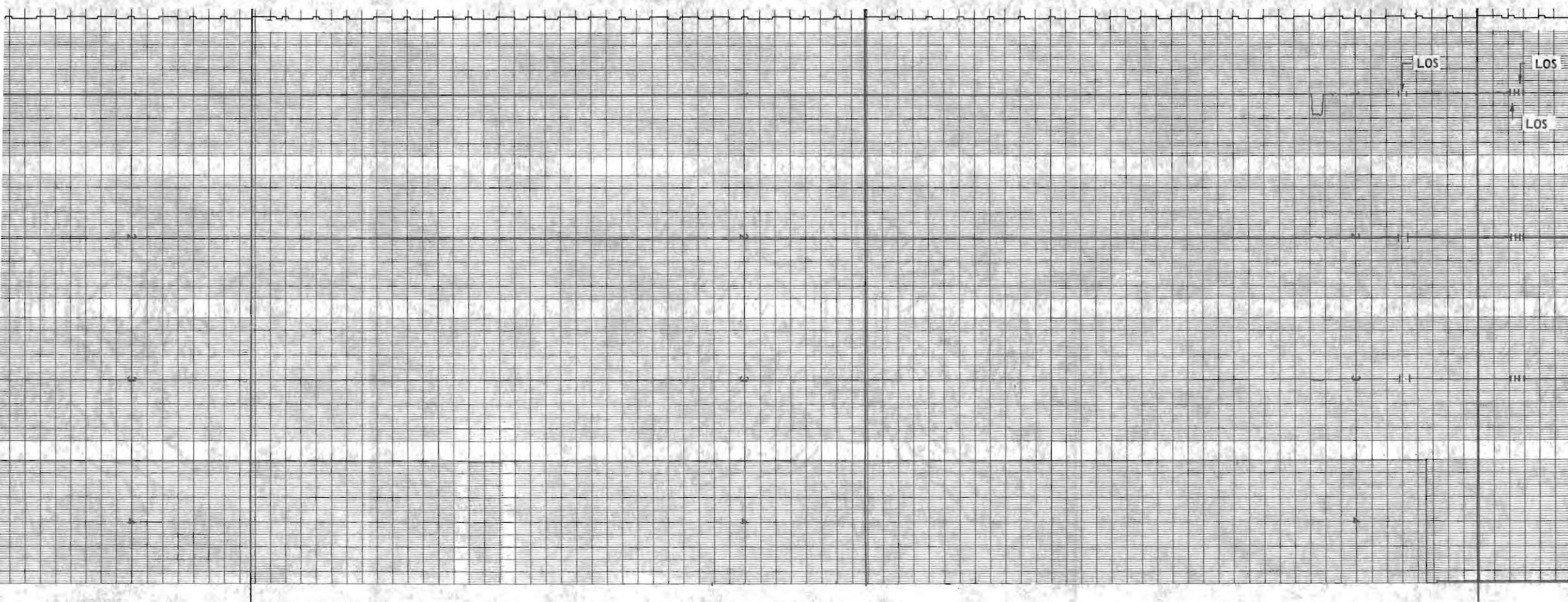

FIGURE 3-8 ROTATION CONTROLLER TVC MODE MEASUREMENT TRACES

The illustrations contained in this section are direct reproductions of the direct-write recordings made through the ACE S/C ground station decommutator. No smoothing techniques have been employed. However, during the last 5 seconds before final LOS three additional losses of data occurred. At these times the PCM wavetrain recovered as much as a second before the ACE decommutator was able to reacquire synchronization. In order to provide information during the portion of this time when the wavetrain was available but the decommutator not in synchronization, manual data reduction was employed.

#### 4. SYSTEM

##### a. INSTRUMENTATION

###### (1). INSTRUMENTATION CONFIGURATION

Deviations from standard launch configuration were as follows:

- (a). The transducer for measuring battery compartment manifold pressure, CC0188P (0 to 21.3 psia), was not installed in the port in the manifold. However, the instrument was electrically connected and stowed, and in this configuration provided a measure of cabin pressure.
- (b). Batteries A and B case temperature measurements, CC0178T and CC0179T, were not connected.
- (c). S/M - adapter separation monitor A, SS0120X, was inoperative at the time of the test. Refer to S/C DR No. 932.
- (d). The gas chromatograph was not installed.
- (e). Elapsed time indicators were installed on the PCM packages, the central timing equipment and the signal conditioning equipment. These indicators were to be removed prior to flight.

###### (2) SYSTEMS DESCRIPTION

(a). The engineering data used for the determination of the sequence of events was extracted via the spacecraft instrumentation system. The mechanism for accomplishing this task involves sensing S/C physical parameters, converting the parameters into varying direct current electrical signals, sequentially sampling the signals and then converting these signals into binary coded words which are transmitted for recording and display (see Figure 4.1-1). The basic hardware used includes sensors, signal conditioners, and the pulse code modulation system.

(b). The pulse code modulation system (PCM) samples the various sensors and signal conditioners in the S/C and encodes the information for transmission. The PCM basically is a number of electronic input switches and an encoder, all of which are controlled by a programmer. The input switches, through programmer control, are sampled sequentially with each sample period being 15 microseconds. The voltage passed through the switch during the sampling time is then converted by the encoder into an 8-bit, binary word of 156.25 microseconds duration. This results in each switch being sampled sequentially in 156.25-microsecond time increments. The number of times per second each input switch is sampled is controlled by the programmer. Programmed sampling rates are 200, 100, 50, 10 and 1 samples per second. The end result of this operation is a serial stream of data consisting of 6400 eight-bit binary words per second. The serial word stream is then transmitted to an area to be decoded, recorded and displayed (see Figure 4.1-2).

(c). A list of all active instrumentation parameters which were being monitored during OCP-FO-K-0021, S/V Plugs Out Integrated Test, is presented in Table 4.1-2 and an explanation is given in Table 4.1-1.

###### (3). COMMENTS ON DATA

Data quality was good except for three confirmed dropouts of the onboard PCM system at the following times (all GMT):

23:31:17.398 to 23:31:17.659

23:31:21.018 to 23:31:21.284

23:31:21.383 to 23:31:21.519

These dropouts were confirmed by prime frame count readouts of computer tabulations and strip chart recordings made from available data sources. Measurements with sampling rates of one and ten per second did not show good data on strip charts for one full second following the 23:31:17.398 GMT dropout, because after system recovery at 23:31:17.659 GMT the PCM prime frame counter picked up one count. Data are read from a digital frame dump in this period by reading the prime frame count and subtracting one for proper prime frame identification.

(a). DATA SOURCES

Four data sources were available (See Figure 4.1-2):

1. 51.2 kilo-bit bi-phase hard line data (S/C PCM)
2. 204.8 kilo-bit interleaved data (S/C and GSE PCM's)
3. 51.2 kilo-bit NRZ PCM data via the S/C very high frequency/frequency modulated (VHF/FM) transmitter (S/C PCM)
  
4. 51.2 kilo-bit NRZ data via the S/C S-band transmitter (S/C PCM). The VHF/FM and 41.2 kilo-bit bi-phase hardline sources were used here for data purposes since those sources showed fewer dropouts and bit errors than the interleaved data, and since trouble with the ground stations made data from the S-band link practically unusable.

(b). CABIN PRESSURE FROM BATTERY MANIFOLD PRESSURE

The pressure sensor for the battery manifold pressure measurement, CCO188P, was electrically connected to a signal conditioner. The sensor was not mounted to the battery manifold to avoid possible damage to the sensor during battery removals and installations. The port of the battery manifold in which the sensor was to be mounted was plugged. The sensor and coiled wire were wrapped in a plastic bag and stowed in an area under the battery mounting shelf between the shelf and the floor of the S/C. In this configuration, the instrument sensed cabin pressure. The upper limit of the sensor, 21.3 psia, was reached at 23:31:18.518 GMT.

(c). BATTERY CASE TEMPERATURES

The battery A and B case temperature measurements, CCO178T (battery A) and CCO179T (battery B), were not active. The sensors are installed only on flight batteries, and since test batteries were used, no sensors were available. The signal conditioners for these measurements and associated wiring were installed. The two sensor connectors were packed in individual plastic bags, the wire coiled and stowed in the same area with the battery manifold pressure sensor. The output of the two measurement points was reviewed and found never to deviate from a full scale reading which, in this case, is normal.

(d). DATA DROP-OUTS

At 23:30:54.85 GMT a drop-out of the detected PCM signal from the S/C VHF/FM transmitter was noted. However, the hardline signal from the PCM system showed no change in any way; this is confirmed by all playback data from the hardline sources. Thus, no data interruption at this time was experienced.

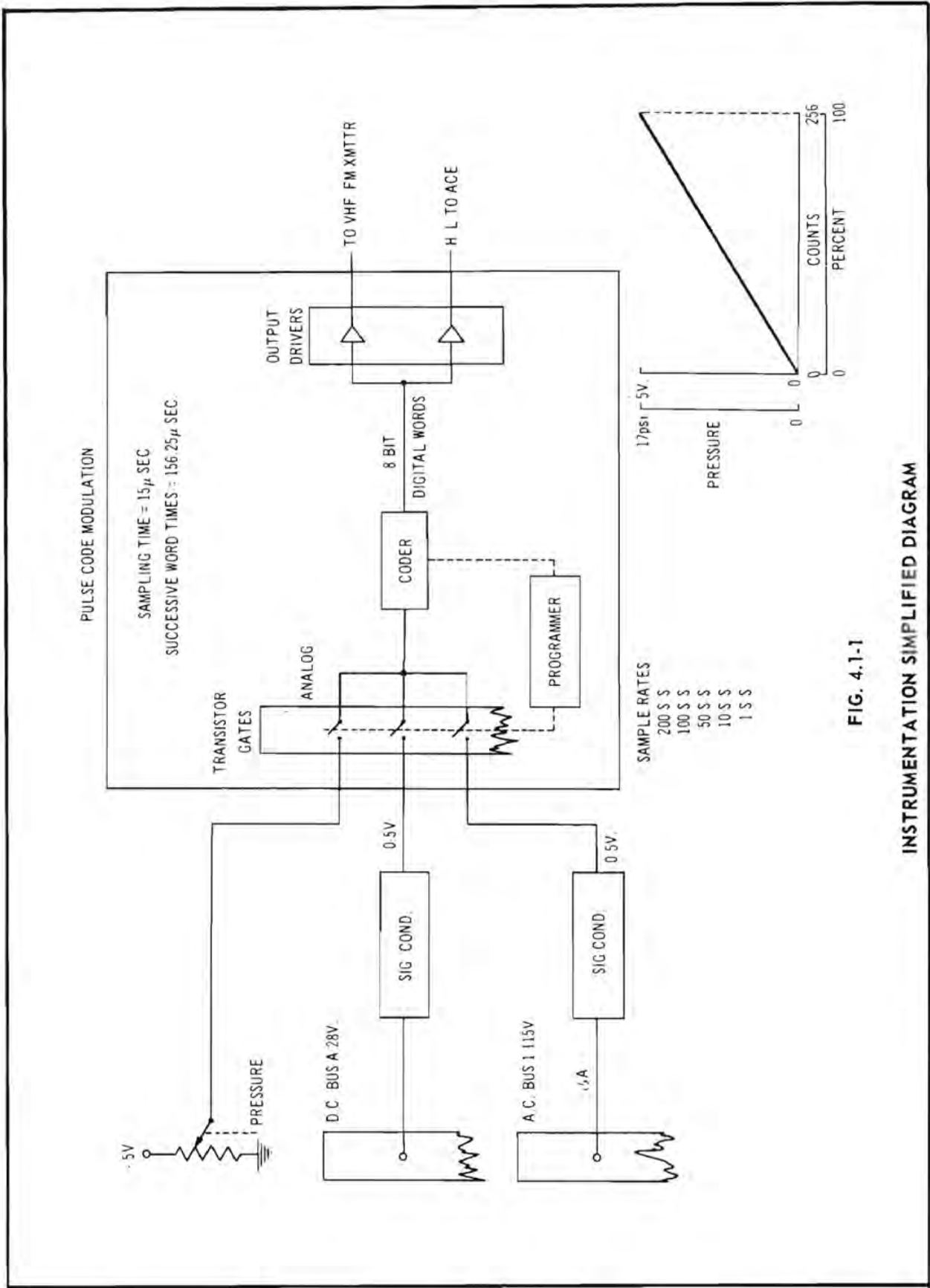

FIG. 4.1-1  
 INSTRUMENTATION SIMPLIFIED DIAGRAM

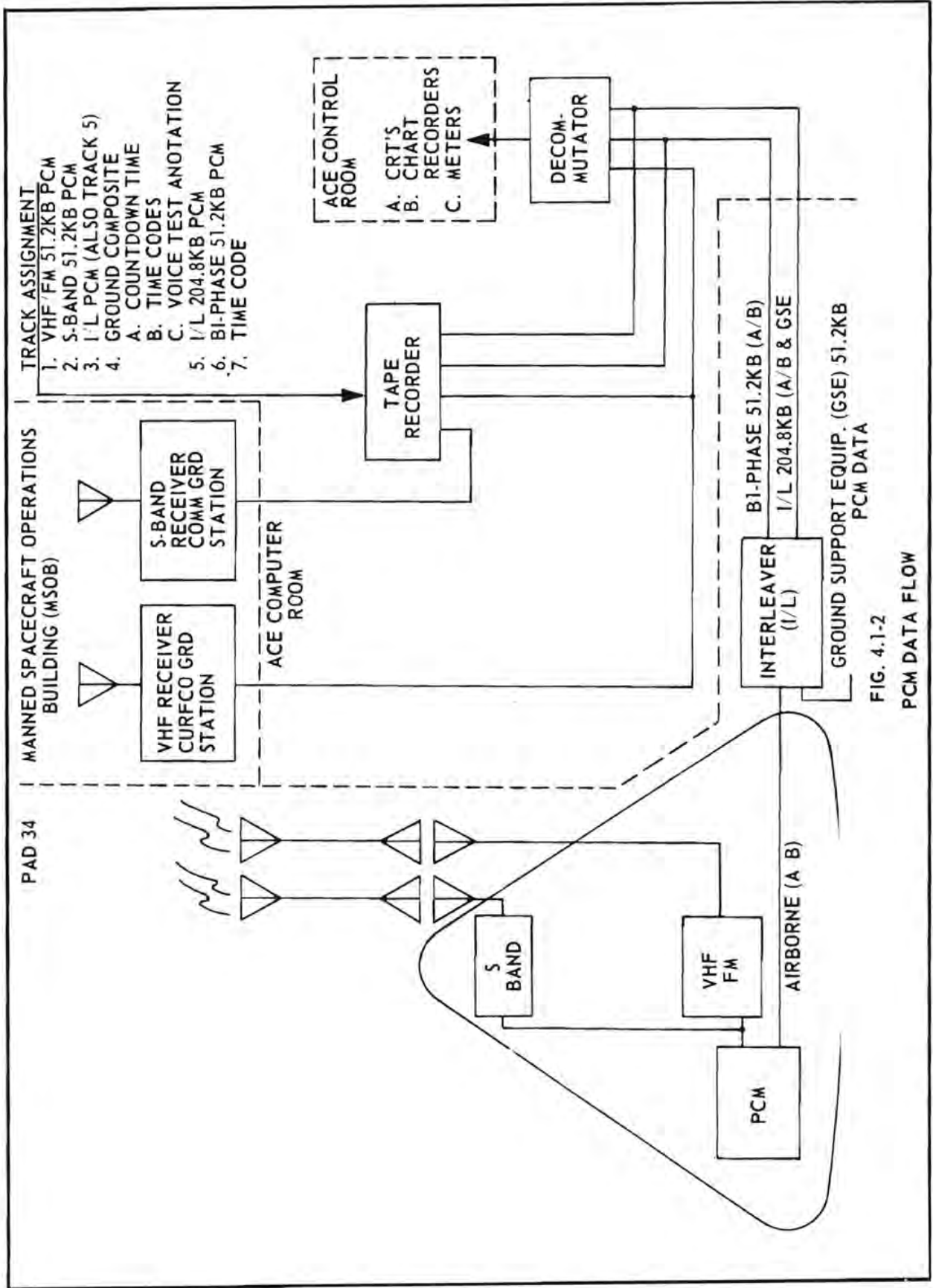
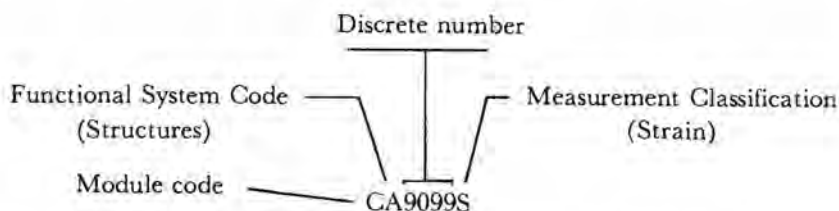

FIG. 4.1-2

PCM DATA FLOW

TABLE 4.1-1  
MEASUREMENT IDENTIFICATION

The measurement identification consists of seven characters: two letters followed by four numbers and one letter.



The first letter (module code) designates the measurement location by module.

- A Adapter
- B Booster
- C Command module
- L Launch escape tower
- S Service module

The second letter (functional subsystem code) denotes the subsystem within which the measurement originates.

- A Structures
- C Electrical power
- D Master events sequence controller
- E Earth landing sequence controller
- F Environmental control
- G Guidance and navigation
- H Stabilization and control
- J Crew equipment
- K Flight technology
- P Service propulsion
- R Reaction control
- S Launch vehicle emergency detection
- T Communications and instrumentation

Characters three through six are numbers assigned sequentially or grouped for clarity within each system. The seventh character, a letter, denotes measurement classification as follows:

- |                     |                  |
|---------------------|------------------|
| A Acceleration      | N Camera         |
| B Phase             | P Pressure       |
| C Current           | Q Quantity       |
| D Vibration         | R Rate           |
| E Power             | S Strain         |
| F Frequency         | T Temperature    |
| G Force             | V Voltage        |
| H Position/Attitude | W Time           |
| J Biomedical        | X Discrete event |
| K Radiation         | Y Acoustical     |
| L Velocity          | Z pH-acidity     |
| M Mass              |                  |

TABLE 4.1-2 ACTIVE PCM MEASUREMENTS FOR S/C 012

SUBSYSTEM STRUCTURES

MEAS. ID	MEASUREMENT DESCRIPTION	SAMPLE RATE	DATA RANGE		UNITS
			LOW	HIGH	
C A1502	T TEMP SIDE HS BOND LOC A	1 S/S	-260	+600	DEG F
C A1505	T TEMP SIDE HS BOND LOC B	1 S/S	-260	+600	DEG F
C A1509	T TEMP SIDE HS BOND LOC C	1 S/S	-260	+600	DEG F
C A5480	T TEMP AFT HS LOC 1-A	1 S/S	-100	+4000	DEG F
C A5481	T TEMP AFT HS LOC 1-B	1 S/S	-100	+4000	DEG F
C A5482	T TEMP AFT HS LOC 1-C	1 S/S	-100	+1600	DEG F
C A5483	T TEMP AFT HS LOC 1-D	1 S/S	-100	+1000	DEG F
C A5484	R FLUX AFT HS LOC 1-4	1 S/S	0+150	B/+150	B/F/S
C A5490	T TEMP AFT HS LOC 2-A	1 S/S	-100	+4000	DEG F
C A5491	T TEMP AFT HS LOC 2-B	1 S/S	-100	+1600	DEG F
C A5492	T TEMP AFT HS LOC 2-C	1 S/S	-100	+900	DEG F
C A5493	T TEMP AFT HS LOC 2-D	1 S/S	-100	+1000	DEG F
C A5494	R FLUX AFT HS LOC 2	1 S/S	0	+100	B/F/S
S A2361	T TEMP SECT 6 IN SURF	1 S/S	-100	+200	DEG F
S A2364	T TEMP SECT 3 FUEL TANK SURF	1 S/S	-100	+200	DEG F
S A2365	T TEMP SECT 6 FUEL TANK SURF	1 S/S	-100	+200	DEG F

SUBSYSTEM ELECTRICAL POWER

C C0175	T TEMP STATIC INVERTER 1	1 S/S	+32	+248	DEG F
C C0176	T TEMP STATIC INVERTER 2	1 S/S	+32	+248	DEG F
C C0177	T TEMP STATIC INVERTER 3	1 S/S	+32	+248	DEG F
C C0178	T TEMP BATTERY A CASE	10 S/S	0	+250	DEG F
C C0179	T TEMP BATTERY B CASE	10 S/S	0	+250	DEG F
C C0188	P PRESS BATT COMPARTMENT (MANIF)	10 S/S	0	+20	PSIA
C C0200	V AC VOLTAGE MAIN BUS 1 PHASE A	10 S/S	0	+150	VAC
C C0201	V AC VOLTAGE MAIN BUS 1 PHASE B	10 S/S	0	+150	VAC
C C0202	V AC VOLTAGE MAIN BUS 1 PHASE C	10 S/S	0	+150	VAC
C C0203	V AC VOLTAGE MAIN BUS 2 PHASE A	10 S/S	0	+150	VAC
C C0204	V AC VOLTAGE MAIN BUS 2 PHASE B	10 S/S	0	+150	VAC
C C0205	V AC VOLTAGE MAIN BUS 2 PHASE C	10 S/S	0	+150	VAC
C C0206	V DC VOLTAGE MAIN BUS A	10 S/S	0	+45	VDC
C C0207	V DC VOLTAGE MAIN BUS B	10 S/S	0	+45	VDC
C C0210	V DC VOLTAGE BATTERY BUS A	10 S/S	0	+45	VDC
C C0211	V DC VOLTAGE BATTERY BUS B	10 S/S	0	+45	VDC
C C0212	V DC VOLTAGE POST LANDING BTRY	10 S/S	0	+45	VDC
C C0213	F FREQUENCY AC BUS 1 PHASE A	1 S/S	+380	+420	CPS
C C0214	V DC VOLTAGE BATT CHARGER OUT	10 S/S	0	+45	VDC
C C0217	F FREQUENCY AC BUS 2 PHASE A	1 S/S	+380	+420	CPS
C C0222	C DC CURRENT BATTERY A	10 S/S	0	+100	AMP
C C0223	C DC CURRENT BATTERY B	1 S/S	0	+100	AMP
C C0224	C DC CURRENT POST LANDING BTRY	10 S/S	0	+100	AMP
C C0232	V DC VOLTAGE BATTERY RELAY BUS	10 S/S	0	+45	VDC
S C2060	P N2 PRESSURE F/C 1 REGULATED	1S/S	0	+75	PSIA
S C2061	P N2 PRESSURE F/C 2 REGULATED	1 S/S	0	+75	PSIA
S C2062	P N2 PRESSURE F/C 3 REGULATED	1 S/S	0	+75	PSIA
S C2066	P O2 PRESSURE F/C 1 REGULATED	10 S/S	0	+75	PSIA
S C2067	P O2 PRESSURE F/C 2 REGULATED	10 S/S	0	+75	PSIA
S C2068	P O2 PRESSURE F/C 3 REGULATED	10 S/S	0	+75	PSIA
S C2069	P H2 PRESSURE F/C 1 REGULATED	10 S/S	0	+75	PSIA
S C2070	P H2 PRESSURE F/C 2 REGULATED	10 S/S	0	+75	PSIA
S C2071	P H2 PRESSURE F/C 3 REGULATED	10 S/S	0	+75	PSIA
S C2081	T TEMP F/C 1 COND EXHAUST	1 S/S	+150	+250	DEG F
S C2082	T TEMP F/C 2 COND EXHAUST	1 S/S	+150	+250	DEG F
S C2083	T TEMP F/C 3 COND EXHAUST	1 S/S	+150	+250	DEG F
S C2084	T TEMP F/C 1 SKIN	1 S/S	+20	+550	DEG F
S C2085	T TEMP F/C 2 SKIN	1 S/S	+20	+550	DEG F
S C2086	T TEMP F/C 3 SKIN	1 S/S	+20	+550	DEG F

S C2087	T TEMP FC 1 RADIATOR OUTLET	1 S/S	-50	+300	DEG F
S C2088	T TEMP FC 2 RADIATOR OUTLET	1 S/S	-50	+300	DEG F
S C2089	T TEMP FC 3 RADIATOR OUTLET	1 S/S	-50	+300	DEG F
S C2113	C DC CURRENT F/C 1 OUTPUT	10 S/S	0	+100	AMP
S C2114	C DC CURRENT F/C 2 OUTPUT	10 S/S	0	+100	AMP
S C2115	C DC CURRENT F/C 3 OUTPUT	10 S/S	0	+100	AMP
S C2120	X FUEL CELL 1 BUS A DISCONNECT	10 S/S	OFF	ON	EVENT
S C2121	X FUEL CELL 2 BUS A DISCONNECT	10 S/S	OFF	ON	EVENT
S C2122	X FUEL CELL 3 BUS A DISCONNECT	10 S/S	OFF	ON	EVENT
S C2125	X FUEL CELL 1 BUS B DISCONNECT	10 S/S	OFF	ON	EVENT
S C2126	X FUEL CELL 2 BUS B DISCONNECT	10 S/S	OFF	ON	EVENT
S C2127	X FUEL CELL 3 BUS B DISCONNECT	10 S/S	OFF	ON	EVENT
S C2139	R FLOW RATE H2 F/C 1	10 S/S	0	+0.2	LB/HR
S C2140	R FLOW RATE H2 F/C 2	10 S/S	0	+0.2	LB/HR
S C2141	R FLOW RATE H2 F/C 3	10 S/S	0	+0.2	LB/HR
S C2142	R FLOW RATE O2 F/C 1	10 S/S	0	+1.6	LB/HR
S C2143	R FLOW RATE O2 F/C 2	10 S/S	0	+1.6	LB/HR
S C2144	R FLOW RATE O2 F/C 3	10 S/S	0	+1.6	LB/HR
S C2160	X PH FACTOR WATER CONDITION F/C 1	10 S/S	NORMAL	HIGH	EVENT
S C2161	X PH FACTOR WATER CONDITION F/C 2	10 S/S	NORMAL	HIGH	EVENT
S C2162	X PH FACTOR WATER CONDITION F/C 3	10 S/S	NORMAL	HIGH	EVENT
S C2323	X FUEL CELL 1 SHUT OFF MON	10 S/S	CLOSE	OPEN	EVENT
S C2324	X FUEL CELL 2 SHUT OFF MON	10 S/S	CLOSE	OPEN	EVENT
S C2325	X FUEL CELL 3 SHUT OFF MON	10 S/S	CLOSE	OPEN	EVENT

### SUBSYSTEM MASTER EVENTS SEQUENCE CONTROLLER

C D0002	X LES ABORT INITIATE SIGNAL A	10 S/S	OFF	ON	EVENT
C D0005	V DC VOLTAGE PYRO BUS A	10 S/S	0	+40	VDC
C D0006	V DC VOLTAGE PYRO BUS B	10 S/S	0	+40	VDC
C D0023	X CM-SM SEP RELAY CLOSE A	10 S/S	OFF	ON	EVENT
C D0024	X CM-SM SEP RELAY CLOSE B	10 S/S	OFF	ON	EVENT
C D0037	X ELS SEQ START RLY CLOSE A	10 S/S	OFF	ON	EVENT
C D0038	X ELS SEQ START RLY CLOSE B	10 S/S	OFF	ON	EVENT
C D0044	X BOOSTER CUT-OFF SIG A	10 S/S	OFF	ON	EVENT
C D0062	X LES ABORT INITIATE SIGNAL B	10 S/S	OFF	ON	EVENT
C D0105	X LES ABORT INITIATE SIGNAL B	10 S/S	OFF	ON	EVENT
C D 0105	X TWR JETTISON A	10 S/S	OFF	ON	EVENT
C D0106	X TWR JETTISON B	10 S/S	OFF	ON	EVENT
C D0120	X CANARD DEPLOY A	10 S/S	OFF	ON	EVENT
C D0121	X CANARD DEPLOY B	10 S/S	OFF	ON	EVENT
C D0125	X ADAPT/SM SEP INITIATE A	10 S/S	OFF	ON	EVENT
C D0126	X ADAPT/SM SEP INITIATE B	10 S/S	OFF	ON	EVENT
C D0127	X ADAPT SEPARATION A	10 S/S	OFF	ON	EVENT
C D0128	X ADAPT SEPARATION B	10 S/S	OFF	ON	EVENT
C D0130	X HAND CONTROLLER INPUT A	10 S/S	OFF	ON	EVENT
C D0131	X HAND CONTROLLER INPUT B	10 S/S	OFF	ON	EVENT
C D0132	X EDS ABORT LOGIC IN NO 1	10 S/S	OFF	ON	EVENT
C D0133	X EDS ABORT LOGIC IN NO 2	10 S/S	OFF	ON	EVENT
C D0134	X EDS ABORT LOGIC IN NO 3	10 S/S	OFF	ON	EVENT
C D0135	X EDS ABORT LOGIC OUT A	10 S/S	OFF	ON	EVENT
C D0136	X EDS ABORT LOGIC OUT B	10 S/S	OFF	ON	EVENT
C D0140	X DIRECT ULLAGE ON A	10 S/S	OFF	ON	EVENT
C D0141	X DIRECT ULLAGE ON B	10 S/S	OFF	ON	EVENT
C D0170	X RCS ACTIVATE SIG A	10 S/S	OFF	ON	EVENT
C D0171	X RCS ACTIVATE SIG B	10 S/S	OFF	ON	EVENT
C D0173	X CM RCS PRESS SIG A	10 S/S	OFF	ON	EVENT
C D0174	X CM RCS PRESS SIG B	10 S/S	OFF	ON	EVENT
C D0200	V DC BOLTAGE LOGIC BUS A	10 S/S	+22	+37	VDC
C D0201	V DC VOLTAGE LOGIC BUS B	10 S/S	+22	+37	VDC
C D0230	X FWD HS JETTISON A	10 S/S	OFF	ON	EVENT
C D0231	X FWD HS JETTISON B	10 S/S	OFF	ON	EVENT
C D0315	X EDS ENABLE A	10 S/S	OFF	ON	EVENT
C D0316	X EDS ENABLE B	10 S/S	OFF	ON	EVENT
C D1006	X LES MOTOR INITIATE A	10 S/S	OFF	ON	EVENT
C D1007	X LES MOTOR INITIATE B	10 S/S	OFF	ON	EVENT



## SUBSYSTEM EARTH LANDING SEQUENCE CONTROLLER

C E0001 X DROGUE DEPLOY RELAY CLOSE A	10 S/S	OFF	ON	EVENT
C E0002 X DROGUE DEPLOY RELAY CLOSE B	10 S/S	OFF	ON	EVENT
C E0003 X MAIN CHUTE DEPL-DRG REL RLY A	10 S/S	OFF	ON	EVENT
C E0004 X MAIN CHUTE DEPL-DRG REL RLY B	10 S/S	OFF	ON	EVENT
C E0007 X BARO SW LOCK-IN RLY CLOSE A	10 S/S	OFF	ON	EVENT
C E0008 X BARO SW LOCK-IN RLY CLOSE B	10 S/S	OFF	ON	EVENT
C E0035 P BAROMETRIC PRESS STATIC REF	1 S/S	0	+15	PSIA
C E0321 X MAIN CHUTE DISCONNECT RELAY A	10 S/S	OFF	ON	EVENT
C E0322 X MAIN CHUTE DISCONNECT RELAY B	10 S/S	OFF	ON	EVENT

## SUBSYSTEM ENVIRONMENTAL CONTROL

C F0001 P PRESSURE CABIN	1 S/S	0	+17	PSIA
C F0002 T TEMP CABIN	1 S/S	+40	+125	DEG F
C F0005 P PRESSURE CO2 PARTIAL	1 S/S	0	+30	MMHG
C F0006 P PRESS SURGE TANK	1 S/S	+50	+1050	PSIA
C F0008 T TEMP SUIT SUPPLY MANIF	1 S/S	+20	+95	DEG F
C F0009 Q QUANTITY WASTE WATER TANK	1 S/S	0	+100	PCNT
C F0010 Q QUAN POTABLE H2O TANK	1 S/S	0	+90	PCNT
C F0012 P PRESS SUIT DEMA ND REG SUPPLY	1 S/S	0	+17	PSIA
C F0015 P PRESS SUIT COMPRESSOR DIFF	1 S/S	0	+1	PSID
C F0016 P PRESS GLYCOL PUMP OUTLET	1 S/S	0	+60	PSIA
C F0017 T TEMP GLYCOL EVAP OUTLET STREAM	1 S/S	+20	+95	DEG
C F0018 T TEMP GLYCOL EVAP OUTLET LIQUID	1 S/S	+25	+75	DEG F
C F0019 Q QUANTITY GLYCOL ACCUM	1 S/S	-10	+100	PCNT
C F0020 T TEMP SPACE RADIATOR OUTLET	1 S/S	-50	+100	DEG F
C F0025 P PRESS PUMP PACKAGE INLET	50 S/S	0	+75	PSIA
S F0030 Q QUANTITY H2 TANK 1	1 S/S	0	+25	LB
S F0031 Q QUANTITY H2 TANK 2	1 S/S	0	+28	LB
S F0032 Q QUANTITY O2 TANK 1	1 S/S	0	+320	LB
S F0033 Q QUANTITY O2 TANK 2	1 S/S	0	+320	LB
C F0034 P BACK PRESS GLYCOL EVAPORATOR	10 S/S	+0.25	+0.25	PSIA
C F0035 R FLOWRATE ECS O2	1 S/S	+0.2	+1.0	LB/HR
C F0036 P PRESS OUTLET O2 REG SUPPLY	1 S/S	0	+150	PSIA
S F0037 P PRESS O2 TANK 1	1 S/S	+50	+1050	PSIA
S F0038 P PRESS O2 TANK 2	1 S/S	+50	+1050	PSIA
S F0039 P PRESS H2 TANK 1	1 S/S	0	+350	PSIA
S F0041 T TEMP O2 TANK 1	1 S/S	-325	+80	DEG F
S F0042 T TEMP O2 TANK 2	1 S/S	-325	+80	DEG F
S F0043 T TEMP H2 TANK 1	1 S/S	-425	-200	DEG F
S F0044 T TEMP H2 TANK 2	1 S/S	-425	-200	DEG F
C F0120 P PRESS H2O AND GLYCOL TANKS	1 S/S	0	+50	PSIA
C F0135 R FLOW RATE MAN INLET TO SUIT 1	1 S/S	0	+25	LB/HR
C F0136 R FLOW RATE MAN INLET TO SUIT 2	1 S/S	0	+25	LB/HR
C F0137 R FLOW RATE MAN INLET TO SUIT 3	1 S/S	0	+25	LB/HR
C F0148 P DP SUPPLY AND RETURN MAN	1 S/S	0	+0.8	PSID
C F0153 T TEMP COMPRESSOR INLET	1 S/S	0	+200	DEG F
C F0184 T TEMP CO2 ABSORBER OUTLET	1 S/S	+90	+200	DEG F
C F0245 T TEMP O2 REG INLET	1 S/S	-50	+150	DEG F
C F0326 P PRESS POTABLE H2O TANK DRAIN	1 S/S	0	+50	PSIA
C F0327 P PRESS WASTE H2O TANK DRAIN	1 S/S	0	+50	PSIA
C F0481 T TEMP CP BR 1 INLET	1 S/S	+40	+150	DEG F
C F0482 T TEMP CP BR 1 OUTLET	1 S/S	+40	+150	DEG F
C F0483 T TEMP CP BR 2 INLET	1 S/S	+40	+150	DEG F
C F0484 T TEMP CP BR 2 INLET	1 S/S	+40	+150	BEG F
C F0549 P DIFF PRESS COLDPLATE BR 1	1 S/S	0	+2.0	PSID
C F0550 P DIFF PRESS COLDPLATE BR 2	1 S/S	0	+10	PSID
S F0665 T TEMP SPACE RADIATOR INLET	1 S/S	+60	+150	DEG F

## SUBSYSTEM GUIDANCE AND NAVIGATION

C G0001 V COMPUTER DIGITAL DATA 40 BITS	50 S/S			
C G1101 V -28 VDC SUPPLY	10 S/S	0	-35	VDC
C G1110 V 2.5 VDC TM BIAS	1 S/S	0	+5	VDC

C G1503 X IMU +28 VDC OPERATE	10 S/S	OFF	ON	EVENT
C G1513 X IMU +28 VDC STANDBY	10 S/S	OFF	ON	EVENT
C G1523 X AGC +28 VDC	10 S/S	OFF	ON	EVENT
C G1533 X OPTX +28 VDC	10 S/S	OFF	ON	EVENT
C G2110 V IGA TORQUE MOTOR INPUT	10 S/S	-8	+8	VDC
C G2112 V IGA 1X RES OUTPUT SINE IN PHASE	10 S/S	0	+50	DEG
C G2113 V IGA 1X RES OUTPUT COS IN PHASE	10 S/S	45 DEG	135	DEG
C G2117 V IGA SERVO ERROR IN PHASE	100 S/S	0	0.5	VRMS
C G2140 V MGA TORQUE MOTOR INPUT	10 S/S	-8	+8	VDC PSA
C G2142 V MGA 1X RES OUTPUT SINE IN PHASE	10 S/S	-45	+45	DEG
C G2143 V MGA 1X RES OUTPUT COS IN PHASE	10 S/S	45	135	DEG
C G2147 V MGA SERVO ERROR IN PHASE	100 S/S	0	0.5	VRMS
C G2170 V OGA TORQUE MOTOR INPUT	10 S/S	-8	+8	VDC
C G2172 V OGA 1X RES OUTPUT SINE IN PHASE	10 S/S	-45	+45	DEG
C G2173 V OGA 1X RES OUTPUT COS IN PHASE	10 S/S	45	135	DEG
C G2177 V OGA SERVO ERROR IN PHASE	100 S/S	-5	+5	VRMS
C G2206 V IGA CDU 1X RES ERROR IN PHASE	10 A/S	-8	+8	VRMS
C G2236 V MGA CDU 1X RES ERROR IN PHASE	10 S/S	-8	+8	VRMS
C G2266 V OGA CDU 1X RES ERROR IN PHASE	10 S/S	-8	+8	VRMS
C G2300 T PIPA TEMP	1 S/S	125	135	DEG F
C G2301 T IRIG TEMP	1 S/S	128	137	DEG F
C G2302 C IMU HEATER CURRENT	1 S/S	0	+5.000	AMP
C G2302 C IMU BLOWER CURRENT	1 S/S	0	+5.000	AMP
C G3102 V SXT TRUN MOTOR DRIVE IN PHASE	10 S/S	-5	+5	VRMS
C G3112 V SXT SHAFT MOTOR DRIVE IN PHASE	10 S/S	-5	+5	VRMS
C G3133 V SCT TRUN MOTOR DRIVE	10 S/S	-5	+5	VRMS
C G3141 V TRUN CDU 16X RES ERROR IN PHASE	10 S/S	-50	+50	MVRMS
C G3200 V TRUN CDU MOTOR DRIVE IN PHASE	10 S/S	-5	+5	VRMS
C G3220 V SHAFT CDU MOTOR DRIVE IN PHASE	10 S/S	-5	+5	VRMS
C G4300 T AGC TEMP MONITOR	1 S/S	20	220	DEG F
C G5000 X PIPA FAIL	10 S/S	OFF	ON	EVENT
C G5001 X IMU FAIL	10 S/S	OFF	ON	EVENT
C G5002 X CDU FAIL	10 S/S	OFF	ON	EVENT
C G5003 X GIMBAL LOCK WARNING	10 S/S	OFF	ON	EVENT
C G5005 X ERROR DETECT	10 S/S	OFF	ON	EVENT
C G5006 X IMU TEMP LIGHT	10 S/S	OFF	ON	EVENT
C G5007 X ZERO ENCODER LIGHT	10 S/S	OFF	ON	EVENT
C G5008 X IMU DELAY LIGHT	10 S/S	OFF	ON	EVENT
C G5020 X AGC ALARM 1 (PROGRAM)	10 S/S	OFF	ON	EVENT
C G5021 X AGC ALARM 2 (AGC ACTIVITY)	10 S/S	OFF	ON	EVENT
C G5022 X AGC ALARM 3 (TM)	10 S/S	OFF	ON	EVENT
C G5023 X AGC ALARM 4 (PROG CK FAIL)	10 S/S	OFF	ON	EVENT
C G5024 X AGC ALARM 5 (SCALAR FAIL)	10 S/S	OFF	ON	EVENT
C G5025 X AGC ALARM 6 (PARITY FAIL)	10 S/S	OFF	ON	EVENT
C G5026 X AGC ALARM 7 (COUNTER FAIL)	10 S/S	OFF	ON	EVENT
C G5027 X AGC ALARM 8 (KEY RELEASE)	10 S/S	OFF	ON	EVENT
C G5028 X AGC ALARM 9 (RUPT LOCK)	10 S/S	OFF	ON	EVENT
C G5029 X AGC ALARM 10 (TC TRAP)	10 S/S	OFF	ON	EVENT
C G5030 X COMPUTER POSER FAIL LIGHT	10 S/S	OFF	ON	EVENT
C G6000 P IMU PRESSURE	1 S/S	0	25	PSIA
C G6020 T PSA TEMP 1 TRAY 3	1 S/S	10	250	DEG F
C G6021 T PSA TEMP 2 TRAY 2	1 S/S	10	250	DEG F
C G6022 T PSA TEMP 3 TRAY 4	1 S/S	10	200	DEG F

### SUBSYSTEM STABILIZATION AND CONTROL

C H0024 R. PITCH RATE	50 S/S	-25	+25	DEG/SEC
C H0025 V PITCH MAN ROTATION CONTROL	50 S/S	-4	+4	VAC
C H0034 H PITCH POS FEEDBACK IN	50 S/S	-10	+10	DEG
C H0047 C PTV DIFF CLUTCH VOLTS COMBINER	50 S/S	-800	+800	MANP
C H0050 R PITCH RATE ERR AMP OUT	100 S/S	-6	+6	DEG/SEC
C H0067 V P INTEGRATOR/ATT ERROR SUMMING	10 S/S	-2.5	+2.5	VDC
C H0074 V MTVC PITCH RATE	50 S/S	-25	+25	DEG/SEC
C H0075 H PITCH SCS ATT ERROR	10 S/S	0	+10	VRMS
C H0087 X +PITCH/+X SOLENOID DRIVER OUT	200 S/S	ON	OFF	EVENT
C H0088 X -PITCH/+X SOLENOID DRIVER OUT	200 S/S	ON	OFF	EVENT

C H0089 X +PITCH/-X SOLENOID DRIVER OUT	200 S/S	ON	OFF	EVENT
C H0090 X -PITCH/-X SOLENOID DRIVER OUT	200 S/S	ON	OFF	EVENT
C H0100 X G-N DV MODE CONTROL	10 S/S		OFF	ON
C H0101 X G-N ATT MODE CONTROL	10 S/S	OFF	ONN	EVENT
C H0102 X G-N ENTRY MODE CONTROL	10 S/S	OFF	ON	EVENT
C H0103 X MONITOR MODE CONTROL	10 S/S	OFF	ON	EVENT
C H1024 R YAW RATE	50 S/S	-25	+25	DEG/SEC
C H1025 V YAW MAN ROTATION CONTROL	50 S/S	0	5.0	VRMS
C H1034 H YAW POS FEEDBACK IN	50 S/S	-8.5	+8.5	VDC
C H1047 C YTV DIFF CLUTCH VOLTS COMBINER	50 S/S	-800	+800	MAMP
C H1050 R YAW RATE ERR AMP OUT	50 S/S	-6	+6	DEG/SEC
C H1067 V Y INTEGRA TOR/ATT SUMMING	10 S/S	-2.5	+2.5	VDC
C H1074 R MTVC YAW RATE	50 S/S	-25	-25	DEG/SEC
C H1075 H YAW SCS ATT ERROR	10 S/S	0	10	VRMS
C H1087 X +YAW/+X SOLENOID DRIVER OUT	200 S/S	ON	OFF	EVENT
C H1088 X -YAW/+X SOLENOID DRIVER OUT	200 S/S	ON	OFF	EVENT
C H1089 X +YAW/-X SOLENOID DRIVER OUT	200 S/S	ON	OFF	EVENT
C H1090 X -YAW/-X SOLENOID DRIVER OUT	200 S/S	ON	OFF	EVENT
C H1100 X SCS DV MODE CONTROL	10 S/S	OFF	ON	EVENT
C H1101 X SCS ATT MODE CONTROL	10 S/S	OFF	ON	EVENT
C H1102 X SCS ENTRY MODE CONTROL	10 S/S	OFF	ON	EVENT
C H1103 X SCS LOCAL VERTICAL MODE	10 S/S	OFF	ON	EVENT
C H1104 X MTVC MODE CONTROL	10 S/S	OFF	ON	EVENT
C H2015 V COMBINED AG SMRD	10 S/S	0	800	CPS
C H2024 R ROLL RATE	50 S/S	-25	+25	DEG/SEC
C H2025 V ROLL MAN ROTATION CONTROL OUT	50 S/S	0	+5	VRMS
C H2026 V COMBINED RG SMRD	10 S/S	0	1600	CPS
C H2030 T COMBINED ATTITUDE GYRO TEMP	1 S/S	0	5	VDC
C H2050 R ROLL RATE ERR AMP OUT	50 S/S	-6	+6	DEG/SEC
C H2070 H ROLL ATTITUDE ERROR AMP OUT	10 S/S	-25	+25	VDC
C H2075 H ROLL SCS ATT ERROR	10 S/S	0	10	VRMS
C H2087 X +ROLL/+Z SOLENOID DRIVER OUT	200 S/S	ON	OFF	EVENT
C H2088 X -ROLL/+Z SOLENOID DRIVER OUT	200 S/S	ON	OFF	EVENT
C H2089 X +ROLL/-Z SOLENOID DRIVER OUT	200 S/S	ON	OFF	EVENT
C H2090 X -ROLL/-Z SOLENOID DRIVER OUT	200 S/S	OFF	ON	EVENT
C H2091 X +ROLL/+Y SOLENOID DRIVER OUT	200 S/S	OFF	ON	EVENT
C H2092 X -ROLL/+Y SOLENOID DRIVER OUT	200 S/S	OFF	ON	EVENT
C H2093 X +ROLL/-Y SOLENOID DRIVER OUT	200 S/S	OFF	ON	EVENT
C H2094 X -ROLL/-Y SOLENOID DRIVER OUT	200 S/S	OFF	ON	EVENT
C H3185 X -05G MANUAL SWITCH	10 S/S	OFF	ON	EVENT
C H3186 V DV REMAINING POTENTIOMETER OUT	10 S/S	0	+3K	FT/SEC
C H4100 H RESOLVER SIN OUT PITCH ATT	10 S/S	-12		+12
C H4101 H RESOLVER COS OUT PITCH ATT	10 S/S	0	160	DEG
C H4102 H RESOLVER SIN OUT YAW ATT	10 S/S	-12	+12	VAC
C H410 H RESOLVER COS OUT YAW ATT	10 S/S	-12	+12	VAC
C H4104 H RESOLVER SIN OUT ROLL ATT	10 S/S	-12	+12	VAC
C H4105 H RESOLVER COS OUT ROLL ATT	10 S/S	-12	+12	VAC
C H4320 X SPS SOLENOID DRIVER OUT 1	50 S/S	OFF	ON	EVENT
C H4321 X SPS SOLENOID DRIVER OUT 2	50 S/S	OFF	ON	EVENT

### SUBSYSTEM CREW EQUIPMENT

C J0002 J PNEUM SLECTOR SW OUTPUT SIG	500 S/S	-5	+5	OHM
C J0066 J EKG AXIS 1 SEL SW OUT SIG	200 S/S	0.1	+5	MV
C J0067 J EKG AXIS 2 SEL SW OUT SIG	200 S/S	0.1	-5	MV
C J0210 X SEL SW POSITION ASTRO 1	10 S/S	OFF	ON	EVENT
C J0211 X SEL SW POSITION ASTRO 2	10 S/S	OFF	ON	EVENT
C J0212 X SEL SW POSITION ASTRO 3	10 S/S	OFF	ON	EVENT

### SUBSYSTEM SERVICE PROPULSION

S P0001 P HE TANK PRESS	10 S/S	0	+5K	PSIA
S P0002 T HE TANK TEMP	1 S/S	-100	+200	DEG F
S P003 P PRESS OXIDIZER TANKS	10 S/S	0	+300	PSIA
S P0005 T TEMP OXIDIZER ENG FEEDLINE	10 S/S	0	+200	DEG F

S P0006	P	PRESS FUEL TANKS	10 S/S	0	+300	PSIA
S P008	T	TEMP FUEL ENG FEEDLINE	10 S/S	0	+200	DEG F
S P0009	P	PRESS MAIN VLV ENG OXIDIZER IN	10 S/S	0	+300	PSIA
S P0010	P	PRESS MA IN VLV ENG FUEL IN	10 S/S	0	+300	PSA
S P0020	T	TEMP CHAMBER OUTER SKIN 1	1 S/S	0	+500	DEG F
S P0022	H	POSITION FUEL/OXIDIZER VLV 1	10 S/S	0	+90	DEG
S P0023	H	POSITION FUEL/OXIDIZER VLV 2	10 S/S	0	+90	DEG
S P0024	H	POSITION FUEL/OXIDIZER VLV 3	10 S/S	0	+90	DEG
S P0025	H	POSITION FUEL/OXIDIZER VLV 4	10 S/S	0	+90	DEG
S P0045	T	TEMP ENG VLV BODY	1 S/S	0	+250	DEG F
S P0048	T	TEMP ENG FUEL FEEDLING	1 S/S	0	+200	DEG F
S P0049	T	TEMP ENG OX FEEDLINE	1 S/S	0	+200	DEG F
S P0050	T	TEMP NOZZLE CUTER SKIN 1	1 S/S	-25	+2500	DEG F
S P0054	T	TEMP 1 OX DIST LINE	1 S/S	0	-250	DEG F
S P0055	T	TEMP 2 OX DIST LINE	50 S/S	0	+250	DEG F
S P0057	T	TEMP 1 FUEL DISTLINE	50 S/S	0	+250	DEG F
S P0058	T	TEMP 2 FUEL DIST LINE	50 S/S	0	+250	DEG F
S P0060	T	TEMP INJECTOR MAN	10 S/S	0	+200	DEG F
S P0600	P	ENG VLV ACT SYS TENK PRESS PRI	1 S/S	-25	+2500	DEG F
S P0601	P	ENG VLV ACT SYS TANK PRESS SEC	10 S/S	0	+5000	PSIA
S P0655	Q	QUAN OX TANK 1 PRI-TOTAL AUX	1 S/S	0	+16K	LB
S P0656	Q	QUAN OX TANK 2	1 S/S	0	+16K	LB
S P0657	Q	QUAN FUEL TANK 1 PRI-TOTAL AUX	1 S/S	0	+8K	LB
S P0658	Q	QUAN FUEL TANK 2	1 S/S	0	+8K	LB
S P0661	P	PRESS ENGINE CHAMBER	100S/S	0	+150	PSIA
S P2054	T	TEMP GIMBAL ACTUATOR CASE (YAW)	10 S/S	0	+200	DEG F
S P2055	T	TEMP GIMBAL ACTUATOR CASE (PITCH)	1 S/S	0	+200	DEG F

### SUBSYSTEM REACTION CONTROL

C R0001	P	HE PRESS TANK A	1 S/S	0	+5K	PSIA
C R0002	P	HE PRESS TANK B	1 S/S	0	+5K	PSIA
C R0003	T	HE TEMP TANKS A	1 S/S	0	+300	DEG F
C R0004	T	HE TEMP TANK B	1 S/S	0	+300	DEG F
C R0005	P	PRESS FUEL TANK A	10 S/S	0	+400	PSIA
C R0006	P	PRESS FUEL TANK B	10 S/S	0	+400	PSIA
C R0011	P	PRESS OXIDIZER TANK A	10 S/S	0	+400	PSIA
C R0012	P	PRESS OXIDIZER	10 S/S	0	+400	PSIA
C R2201	T	TEMP OX VLV CCW ENG SYS A	50 S/S	-50	+250	DEG F
C R2202	T	TEMP OX VLV -Y ENG SYS A	10 S/S	-50	+250	DEG F
C R2203	T	TEMP OX VLV +Y ENG SYS B	1 S/S	-50	+250	DEG F
C R2204	T	TEMP OX VLV -P ENG SYS B	1 S/S	-50	+250	DEG F
C R2205	T	TEMP OX VLV -P ENG SYS A	50 S/S	-50	+250	DEG F
C R2206	T	TEMP OX VLV CW ENG SYS B	1 S/S	-50	+250	DEG F
C R4561	T	TEMP CCW ROLL ENG OUT WALL T3 SYS A	500 S/S	0	+1000	DEG F
C R4582	T	TEMP CCW ROLL ENG OUT WALL T3 SYS B	50 S/S	0	+1000	DEG F
S R5001	P	HE PRESS TANK A	1 S/S	0	+5K	PSIA
S R5002	P	HE PRESS TANK B	1 S/S	0	+5K	PSIA
S R5003	P	HE PRESS TANK C	1 S/S	0	+5K	PSIA
S R5004	P	HE PRESS TANK D	1 S/S	0	+5K	PSIA
S R5013	T	HE TEMP TANK A	200 S/S	0	+150	DEG F
S R5014	T	HE TEMP TANK B	200 S/S	0	+150	DEG F
S R5015	T	HE TEMP TANK C	100 S/S	0	+150	DEG F
S R5016	T	HE TEMP TANK D	1 S/S	0	+150	DEG F
S R5055	Q	QUANTITY SN RCS PROP BITS 1-8	10 S/S	0	+70	LB
S R5056	Q	QUANTITY SN RCS PROP BITS 9-14	10 S/S	0	+140	LB
S R5065	T	TEMP ENGINE PACKAGE A1	1 S/S	0	+300	DEG F
S R5066	T	TEMP ENGINE PACKAGE B1	1 S/S	0	+300	DEG F
S R5067	T	TEMP ENGINE PACKAGE C1	1 S/S	0	+300	DEG F
S R5068	T	TEMP ENGINE PACKAGE D1	1 S/S	0	+300	DEG F
S R5729	P	A HE MANIFOLD PRESS	10 S/S	0	+400	PSIA
S R5733	P	A OXIDIZER MANIFOLD PRESS	100 S/S	0	+300	PSIA
S R5737	P	A FUEL MANIFOLD PRESS	100 S/S	0	+300	PSIA
S R5776	P	B HE MANIFOLD PRESS	10 S/S	0	+400	PSIA
S R5784	P	B FUEL MANIFOLD PRESS	100 S/S	0	+300	PSIA
S R5817	P	C HE MANIFOLD PRESS	10 S/S	0	+400	PSIA

S R5821 P D HE MANIFOLD PRESS	100 S/S	0	+300	PSIA
S R 5822 P C FUEL MANIFOLD PRESS	100 S/S	0	+300	PSIA
S R5823 P D FUEL MANIFOLD PRESS	100 S/S	0	+300	PSIA
S R5830 P D HE MANIFOLD PRESS	10 S/S	0	+400	PSIA
S R7128 T TEMP INJ HEAD +Y ENG SYS B	50 S/S	0	+500	PSIA
S R7134 T TEMP INJ HEAD CCW ENG SYS A		50 S/S	0	+500

#### SUBSYSTEM LAUNCH VEHICLE EMERGENCY DETECTION

B S0016 X LAUNCH VEH GUIDANCE FAIL A	10 S/S	OFF	ON	EVENT
B S0020 X LAUNCH VEH RATE EXCESSIVE A	10 S/S	OFF	ON	EVENT
B S0030 X ENG NO 1 OUT A	10 S/S	OFF	ON	EVENT
B S0032 X ENG NO 2 OUT A	10 S/S	OFF	ON	EVENT
B S0034 X ENG NO 3 OUT A	10 S/S	OFF	ON	EVENT
B S0036 X ENG NO 4 OUT A	10 S/S	OFF	ON	EVENT
B S0038 X ENG NO 5 OUT A	10 S/S	OFF	ON	EVENT
B S0040 X ENG NO 6 OUT A	10 S/S	OFF ON	ON	EVENT
B S0042 X ENG NO 7 OUT A	10 S/S	OFF	ON	EVENT
B S0044 X ENG NO 8 OUT A	10 S/S	OFF	ON	EVENT
B S0060 X LIFT OFF SIGNAL A	10 S/S	OFF	ON	EVENT
B S0061 X LIFT OFF SIGNAL B	10 S/S	OFF	ON	EVENT
C S0080 X EDS ABORT REQUEST A	10 S/S	OFF	ON	EVENT
L S0090 X TOWER PHYS SEPARATION MON A	10 S/S	OFF	ON	EVENT
L S0091 X TOWER PHYS SEPARATION MON B	10 S/S	OFF	ON	EVENT
C S0100 X CM-CM PHYS SEPARATION MON A	10 S/S	OFF	ON	EVENT
C S0101 X CM-SM PHYS SEPARATION MON B	10 S/S	OFF	ON	EVENT
S S0120 X SM/ADAPTER PHYS SEPARATION	10 S/S	OFF	ON	EVENT
S S0121 X SM/ADAPTER PHYS SEPARATION	10 S/S	OFF	ON	EVENT
C S0150 X MASTER CAUTION-WARNING ON	10 S/S	OFF	ON	EVENT

#### SUBSYSTEM COMMUNICATIONS AND INSTRUMENTATION

C T0012 X TAPE MOTION MONITOR OPER	10 S/S	OFF	ON	EVENT
C T0013 X TAPE MOTION MONITOR R AND D	10 S/S	OFF	ON	EVENT
C T0015 V SIG COND POS SUPPLY VOLTS	10 S/S	0	+35	VDC
C T0016 V SIG COND NEG SUPPLY VOLTS	10 S/S	0	-35	VDC
C T0017 V SENSOR EXCITATION 5 VOLTS	10 S/S	0	+8	VDC
C T0018 V SENSOR EXCITATION 10 VOLTS	10 S/S	0	+17	VDC
C T0055 V TV CAMERA TARGET VOLTAGE	10 S/S	0	+500	FT LMB
C T0089 C-BAND XMTR OUTPUT MONITOR	10 S/S	100	1300	PRF
C T0098 F C-BAND DECODER OUT	10 S/S	100	1300	PRF
C T0108 K GAS ANALYXIX-SUIT AND CABIN	10 S/S	0	5	VDC
C T0120 X PCM BIT RATE CHANGE 8 BIT	1 S/S			DIGITAL
C T0125 V PCM HI LEVEL 85 PERCENT REF	10 S/S	0	5.0	VDC
C T0126 V PCM HI LEVEL 15 PERCENT REF	10 S/S	0	5.0	VDC
C T0127 V PCM LO LEVEL 85 PERCENT REF	1 S/S	0	.040	VDC
C T0128 V PCM LO LEVEL 15 PERCENT REF	1 S/S	0	.040	VDC
C T0141 X CTE TIMING MCDE MONITOR	10 S/S	OFF	ON	EVENT
C T0142 F CENTRAL TIMING GMT 32 BIT	10 S/S			DIGITAL
C T0147 V S-BAND REC AGC VOLTAGE	10 S/S	-130	-40	DBM
C T0191 V VHF/AM REC AGC VOLTAGE	10 S/S	-25	-1	DBM
C T0212 V S-BAND REC STATIC PHASE ERROR	10 S/S	-60K	+60K	DEV CPS
C T0215 V S-BAND XMTR DETECTED RF OUTPUT	10 S/S	0	600	MW
C T0261 V UDL REC SIGNAL STRENGTH	10 S/S	-110	-90	DBM
C T0262 V UDL SYS VALIDITY SIGNAL 8-BIT	50 S/S			DIGITAL
C T0320 V VHF/AM XMTR DETECTED RF OUTPUT	100 S/S	0	12	WATTS
C T0330 V VHF/FM XMTR PA DETECTED RF OUT	10 S/S	0	18	WATTS
C T0340 X PCM TIMING SOURCE EXT OR INT	10 S/S	INT	EXT	EVENT

## b. SEQUENTIAL SYSTEMS

### (1) SEQUENTIAL SYSTEM CONFIGURATION

(a) Ordnance was only installed and electrically connected in the forward deck area under the forward heat shield. The forward deck harness was disconnected from pyro continuity verification box and shorting plugs were installed. All other ordnance which was installed did not contain the initiating devices.

(b) The flight connections, which are made to the GSE access connectors of the RCS control boxes in order to reset the 61-second time delays during the terminal count EDS test, were not connected, due to a checklist error.

(c) A circuit breaker box was inserted between the SM pyro batteries and the SM jettison controllers in order to terminate -x translation of the SM at CM/SM separation, to prevent SM jettison battery depletion.

### (2). COMMENTS ON DATA

An analysis of the SC-012 sequential system data for the time period from 23:12:00 GMT through 23:31:17.398 GMT indicates normal system operation during this time.

At approximately 23:31:12 GMT the battery buses were switched on the main buses, which caused the logic buses to drop to the main bus voltage level. Refer to subsequent paragraph c. for further discussion of the switching.

At 23:31:15.5 GMT a master alarm occurred. This condition was caused by O2 high flow, in that O2 flow rate was saturated for the 15 seconds prior to this master alarm (See figure 3-5).

At 23:31:26.712 GMT, hardline data indicates that EDS "unsafe A" came on. This indicates that at this time one of the three EDS buses from the spacecraft to the launch vehicle was lost. Since two of the EDS bus circuit breakers were open when cockpit configuration was established post-incident, the determination is that the first circuit breaker was tripped at this time.

One non-instrumented anomaly was noted by the launch vehicle personnel during the EDS test at 20:52:23 GMT. At this time the launch Vehicle Attitude Reference Fail check was being performed. EDS bus 1 was turned off and astronaut was to verify no change in the panel 5 status light. However, he stated that the "Engine 8 Out" light went off. This light came back on 8 seconds later as reported by the astronaut and verified on the voice tape. Data review shows no switching in the cockpit from the time the EDS bus 1 went off for approximately 39 seconds. No further information is available since this is the "B" side of the light and it is not instrumented. At this time no explanation is available.

## c. ELECTRICAL POWER

### (1). SYSTEM CONFIGURATION

Just prior to the incident, the spacecraft DC buses were being powered from GSE ground power supplies via the S/M GSE flyaway umbilical. Spacecraft batteries were not connected to the main DC buses. The fuel cell (F/C) simulator (C14-395 battery pack) was connected to fuel cell no. 1 and fuel cell no. 3 harnesses (fuel cells 1, 2 and 3 were disconnected) but not tied to the spacecraft buses.

Spacecraft AC bus 1 was powered by inverter 1 which was powered from DC bus A, and AC bus 2 was powered by inverter 2 which was powered from DC bus B. Inverter 3 was not operating since it is used only for backup in the event of failure of inverter no. 1 or 2.

Bus versus equipment configuration is shown in Table 4.3-1.

(2). COMMENTS ON DATA

(a). The electrical power system was operating normally throughout the performance of OCP-FO-K-0021-1 up to approximately 23:30:55 GMT. At that time a small, short duration increase in AC bus 2 voltages (all three phases) was noted. Prior to this time the AC bus 2 voltages were steady to within one bit of information and as follows (see Figure 3-2):

- Phase A (CC0203) - 117.0 to 117.6 VAC
- Phase B (CC0204) - 116.6 VAC
- Phase C (CC0205) - 112.5 VAC

The voltages varied from this steady state value as follows:

TIME (GMT)	AMPLITUDE (VOLTS).	TIME (GMT)	AMPLITUDE (VOLTS)
Phase A 23:30:54.920	125.8	23:30:55.020	117.0
Phase B 23:30:54.920	120.8	23:30:55.026	117.2
Phase C 23:30:54.927	117.2	23:30:55.027	113

The voltages then returned to the values previously recorded (refer to Panel 18 Report, AC bus 2 voltage variations, for further discussion) and remained at those values up to LOS.

The only other unusual indication in the EPS system prior to LOS occurred at 23:31:13 GMT with indications that Bat B&C had been connected to the main DC buses, followed at 23:31:14 GMT by indications that Bat A&C had been connected to the main DC buses (see Figure 2-3). This was accomplished by crew manual connection of these batteries to the main buses. The switches used to accomplish this (panel 22 - main bus tie Bat B&C) were found during post-incident inspection to be in the positions that would connect these batteries to the main buses.

(b). There is no evidence of an electrical short indicated in any of the other EPS parameters.

(3). SYSTEM POWER REMOVAL

Following the incident, removal of external power was begun at 23:32:46 GMT and all external power was removed by 23:33:13 GMT. However, there was no way to remove Bat A, B, and C from the buses, and spacecraft buses remained powered until the batteries were depleted (estimated at approximately 05:30 GMT, 28 January 1967).

d. GUIDANCE AND NAVIGATION SYSTEM

(1). SYSTEM CONFIGURATION

The guidance and navigation system was in the normal launch configuration with the following exceptions:

- (a). The coupling display units (CDU) hermetic sealing panel was not installed.
- (b). The ground test access connector covers were not installed on the power-servo assembly trays.

(2). DATA EVALUATION

Data evaluation of all the instrumented parameters associated with guidance and navigation has not revealed any facts that would indicate a malfunction which might have contributed to the accident. All system operation was normal prior to the incident.

The physical characteristic of the system design lends itself to supplying nonsystem related facts associated with the incident, e.g.:

- (a). Change in navigation base pitch angle correlates with crew compartment pressure changes, as discussed in the Panel 18 report.

TABLE 4.3-1 SC 012 EQUIPMENT VS BUS CONFIGURATION AT 23:30:00 GMT

EQUIPMENT	DC MN A	DC MN B	BAT A	BAT B	PYRO A	PYRO B	AC BUS I	AC BUS 2
<b>EPS</b>								
Entry Bat A	N/C		Conn					
Entry Bat B		N/C		Conn				
Post Land Bat	N/C	N/C						
Pyro Bat A					Conn			
Pyro Bat B						Conn		
Bat Charger							N/C	
Inv 1 DC (Input)	Conn						Conn	
Inv 1 AC (Output)								
Inv 2 DC (Input)		Conn						
Inv 2 AC (Output)								Conn
Inv 3 DC (Input)	N/C	N/C						
Inv 3 AC (Input)							N/C	N/C
Power Factor Corr Box							Conn	Conn
Phase Synch Box							N/C	N/C
AC O/V-U/V Unit							Conn	Conn
DC U/V Unit	Conn	Conn						
<b>FUEL CELL &amp; CRYO</b>								
None								
<b>SEQUENTIAL</b>								
MESC			Conn	Conn	Conn	Conn		
ELSC			Conn	Conn	Conn	Conn		
RSC Contr Box			Conn	Conn	Conn	Conn		
C&W Power Sup/Lights	Conn	Conn						
Dig Event Timers	Conn	Conn						
PCVB			Conn	Conn				
Emerg Det System			Conn	Conn				
<b>SCS AND G/N</b>								
IMU	Conn	Conn						
IMU Heater	Conn	Conn						
Computer	Conn	Conn						
Lighting							Conn	
SCS Partial Power	Conn						Conn	
Rate Gyro							Conn	
Rotation Control								Conn
BMAG		Conn						Conn
TVC (1 & 2)								
RCS Direct Coils	N/C	N/C						
RCS Normal Coils	Conn	Conn						

NC: Not Connected.

Conn: Connected.



TABLE 4.3-1 SC 012 EQUIPMENT VS BUS CONFIGURATION AT 23:30:00 GMT (Continued)

EQUIPMENT	DC MN A	DC MN B	BAT A	BAT B	PYRO A	PYRO B	AC BUS 1	AC BUS 2
<b>INSTRUMENTATION</b>								
PCM							Conn	
SCE	Conn	Conn					Conn	
Central Timing Equip	Conn	Conn						
Flt Qual Rcdr			Conn					N/C
DSE	Conn	Conn						N/C
Panel 204 (Non ESS)		Conn						
Panel 204 (ESS)	Conn	Conn						
CI4A12 Fuse Box		Conn						
MDAS		Conn						
<b>COMMUNICATIONS</b>								
UDL	Conn	Conn						
TV	Conn	Conn						
VHF/FM	Conn	Conn					N/C	Conn
S Band PA	Conn	Conn					Conn	N/C
PMP	Conn	Conn					Conn	N/C
Audio Center	Conn	Conn						
VHF/RCV BCN	N/C	N/C						
HF	N/C	N/C						
DSEA	N/C*	N/C						
VHF/AM	Conn	Conn						
C Band								Conn
*Power connector not hooked up to DSEA. Circuit breaker was on.								
<b>PROPULSION</b>								
None								
<b>ECS</b>								
H <sub>2</sub> O Accum	Conn	Conn						
Cabin Air Fan 1							Conn	
Cabin Air Fan 2								Conn
Suit Compressors							Conn	N/C
Glycol Pumps							Conn	N/C
Waste & Pot H <sub>2</sub> O	Conn	Conn						
Xdcrs, Press GP 1&2	Conn	Conn						
ECS Xdcr, Temp	Conn	Conn						
Radiator Isol Valve 1							Conn	
Radiator Isol Valve 2								N/C
Pot H <sub>2</sub> O	Conn	Conn						

(b). Changes in gimbal torque motor input voltages indicate vehicle movement, as discussed in the Panel 18 report.

Since the G&N system was in the gyrocompassing mode during the test, the system attempted to maintain the inertial platform horizontal to local gravity and the azimuth at a predetermined heading. Any motion that tends to alter these conditions results in a correcting voltage being applied to the platform gimbal torque motors. Crew activity can impart motion to the vehicle, which could result in torque motor voltages which can be discerned from normal signals applied during gyrocompassing.

(3). DATA PECULIARITIES

After the fire started, the Check Fail Alarm CG5005 and Error Detect PGNS alarm CG5023 came on at 23:31:17.3.

e. STABILIZATION CONTROL SYSTEM

(1). SCS CONFIGURATION

The SCS was configured to launch configuration, with the following exceptions:

- (a). Only one (1) rotation controller was installed.
- (b). Only one (1) translation control was installed.
- (c). The A14-275 quad simulators were connected instead of the RCS engines.

(2). COMMENTS ON DATA

Data analysis indicates normal operation of all parameters until loss of data, with the following exceptions:

(a). ROTATION CONTROL OUTPUT SIGNALS

At 23:30:54.85 GMT, a momentary shift in level was noted on the rotation control output pitch (CH0025), yaw (CH1025), and roll (CH2025) measurements. The power for these parameters was supplied by AC bus 2, phase A. This occurrence is associated with the AC transient (see Figure 5.2-1 in the Panel 18 Report for further discussion).

At 23:31:14.6 GMT a signal was noted on the roll rotation control output of approximately 1.75 VAC and the associated signal of the roll error amplifier output which is equivalent to monitoring the controller for position roll. At the same time, small transients were noted on the pitch and yaw rotation control output measurements are proportional to the amount and direction of controller position.

At the time of the incident, the rotational control was pinned in a null position. Physical examination of the rotation controller following the incident showed the handle still pinned and with no apparent damage to the pin. Soot deposits on the pin indicated slight pin motion. Special tests indicate the pin will allow slight movement of the controller with an appreciable output signal.

(b). RATE ERROR AMPLIFIER OUTPUT OSCILLATIONS

Beginning at 23:31:04 GMT, and continuing to loss of signal, small amplitude oscillations were noted on the roll rate error amplifier output. Smaller oscillations and transients were noted on the pitch and yaw rate error outputs (see Figures 3-7 and 3-8). These changes correlate with spacecraft movement.

(c). MTVC ENGAGE

At 23:31:18.2 GMT, following a loss of signal of approximately 800 milliseconds, the event manual thrust vector control (MTVC) engage was noted to have changed state from OFF to ON. This condition continued until loss of signal.

Following this event, pitch and yaw MTVC rate gyro outputs showed activity indicating the MTVC circuits were active (see Figure 4.5-2). MTVC engage is actuated by physically rotating the T-handle on the translation controller to a CW position. Examination of the translation controller following the incident showed the T-handle to be in a MTVC ON position.

(d). Beginning at 23:31:20 GMT, RCS solenoid driver activity was indicated, which could be the result of shorts in spacecraft wiring. This time was just prior to the loss of data.

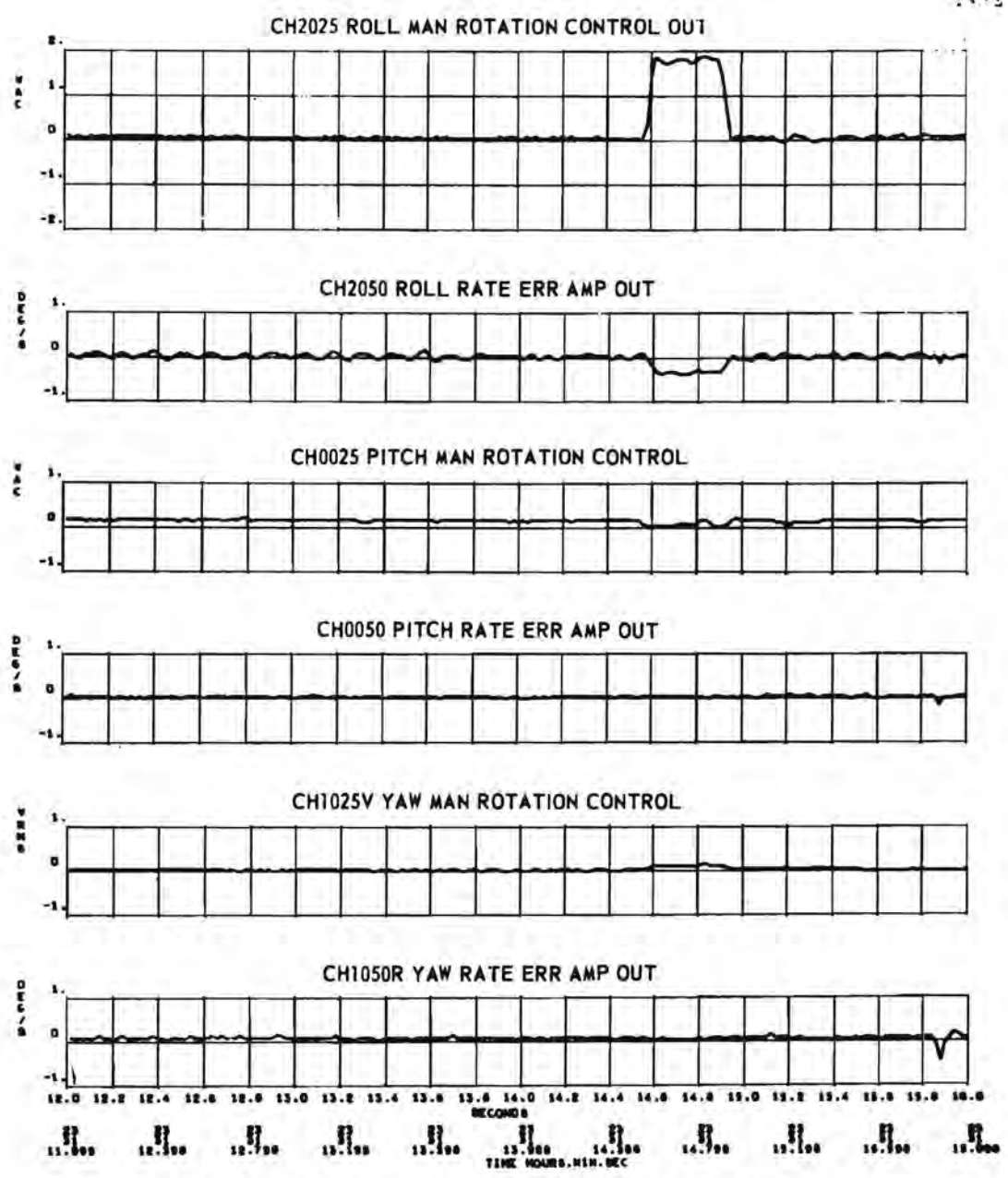

FIGURE 4.5-1 ROTATION CONTROLLER OUTPUT SIGNALS



## f. ENVIRONMENTAL CONTROL SYSTEM

### (1). OXYGEN SUPPLY SUBSYSTEM CONFIGURATION (See Figure 4.6-1)

Gaseous oxygen from K-bottles was utilized for environmental oxygen throughout the test. The following GSE was used for support:-

#### (a). K-Bottle and Regulator

The K-bottle regulator was adjusted at 14:15 GMT and maintained throughout the test at approximately 1000 psig to the gas pressure panel. One K-bottle change was performed at approximately 20:18 GMT.

#### (b). Gas Pressure Panel

The outlet from the K-bottle regulator was regulated down to 650-750 psig in the unit and maintained at this value throughout the test.

#### (c). Oxygen Valve Panel

This panel was used as an isolation interface between gas pressure panel and the service module oxygen pneumatically operated disconnect (POD).

#### (d). Spacecraft Oxygen System Configuration

The oxygen entering the service module was isolated from the cryogenic tanks by check valves. The O<sub>2</sub> entered the command module through one of two available supply lines to the oxygen surge tank, one pound bottle, and regulators for distribution to various O<sub>2</sub> subsystems.

### (2). COMMENTS ON OXYGEN SUBSYSTEM DATA

The oxygen system worked normally both prior to and after the report of the fire, with the exception of the high O<sub>2</sub> flow rate. This is discussed in the Panel 18 Report.

### (3). SUIT CIRCUIT OXYGEN SYSTEM CONFIGURATION

Oxygen at 100 psig was supplied to the suit circuit through the demand pressure regulator (see Figure 4.6-2).

The demand pressure regulator is used for normal makeup, or demands of up to 0.70 lb/min of oxygen. The demand regulator test selector is used to pressurize the suit circuit for suit integrity tests.

### (4). COMMENTS ON SUIT CIRCUIT OXYGEN SYSTEM DATA

The suit circuit oxygen system worked normally both prior to and after the report of the fire. At 23:31:09.6 GMT, the suit flow for the SRP suddenly went to lower limit for 2 seconds and back to full scale in a step function. See Panel 18 Report for further discussion.

### (5). W/G SUBSYSTEM CONFIGURATION (see Figure 4.6-3)

Water glycol was being supplied from GSE (S14-053) and as it would be for normal launch, with one exception, the solenoid-operated valve on the return line in the service module was powered by an auxiliary 28 VDC supply to maintain flow after the umbilical disconnect (Plugs Out). Cold water glycol is supplied to the S/C from the trim control unit (S14-053) at constant pressure, temperature, and flow rate. The final adjustments of these conditions were made immediately following inner hatch installation at 19:45 GMT. Supply pressure was constant at 69.5 psia (FF5062).

Supply temperature was adjusted in order to achieve  $40 \pm 1$  degree F at the glycol evaporator outlet.

Actual value was constant 40.9°F, measured at CFOO18T. Flow rate was adjusted to a constant 196.5 lb/hr (FF5063).

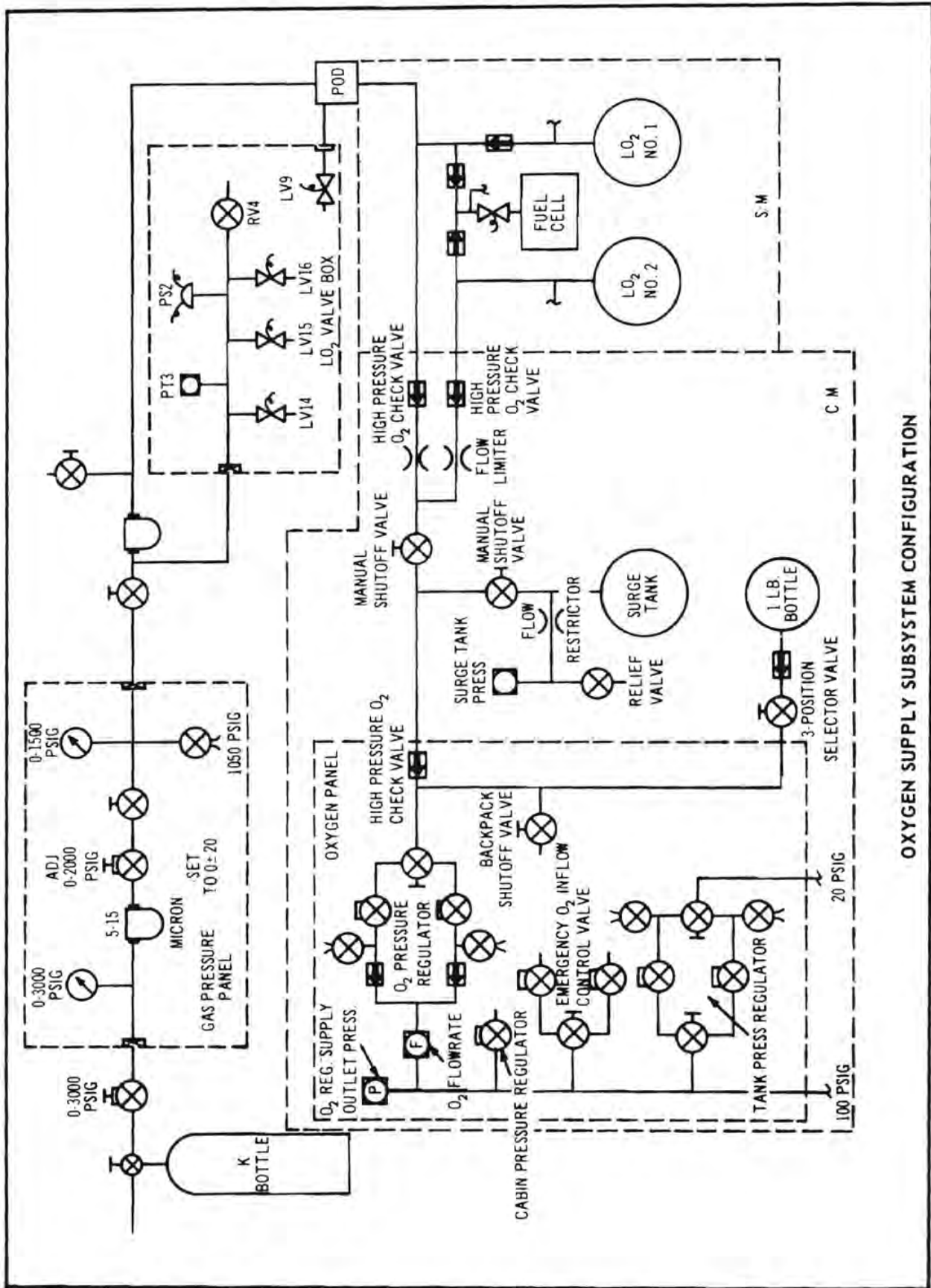

OXYGEN SUPPLY SUBSYSTEM CONFIGURATION

FIG. 4.6-1

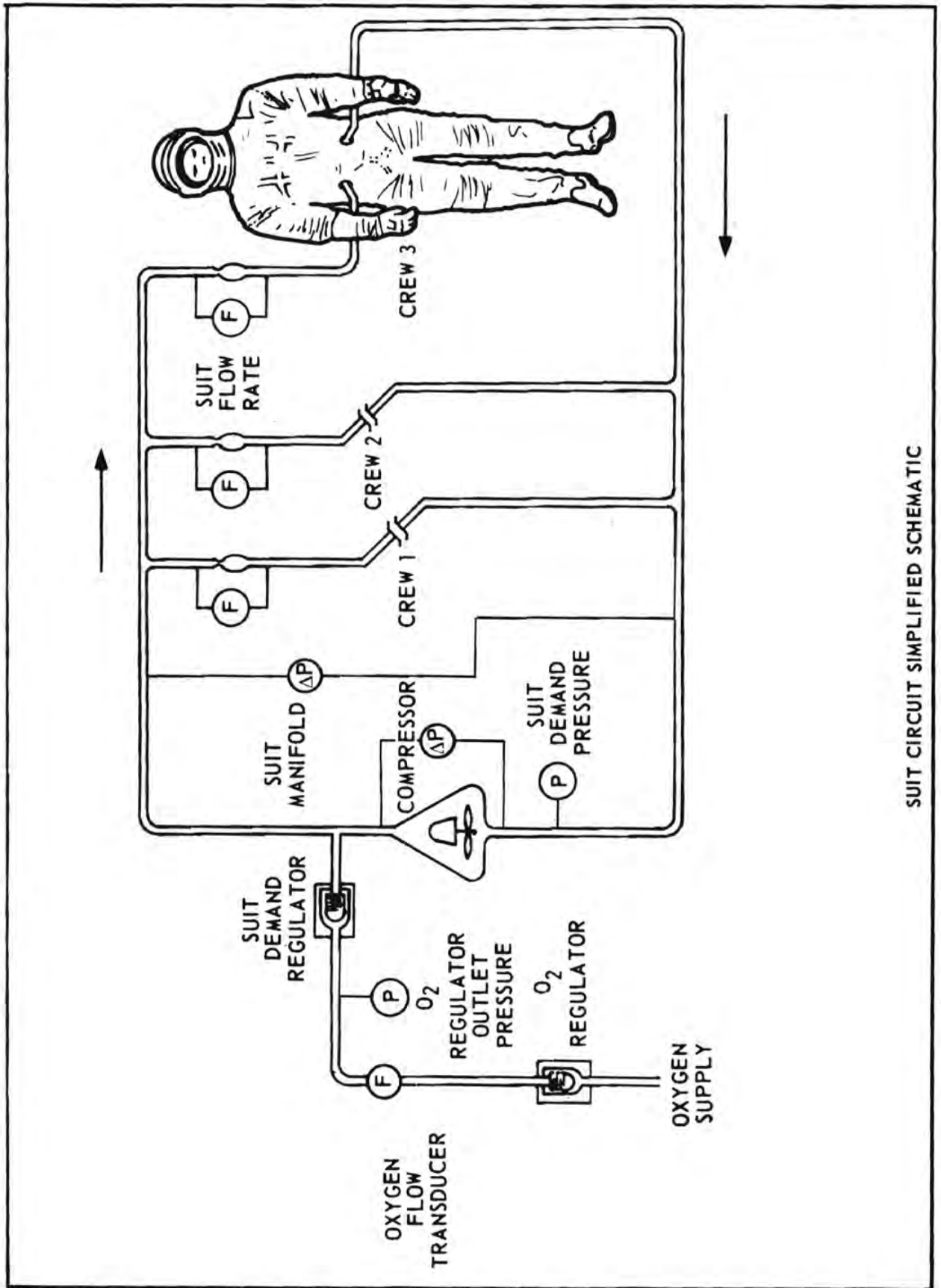

SUIT CIRCUIT SIMPLIFIED SCHEMATIC

FIG. 4.6-2

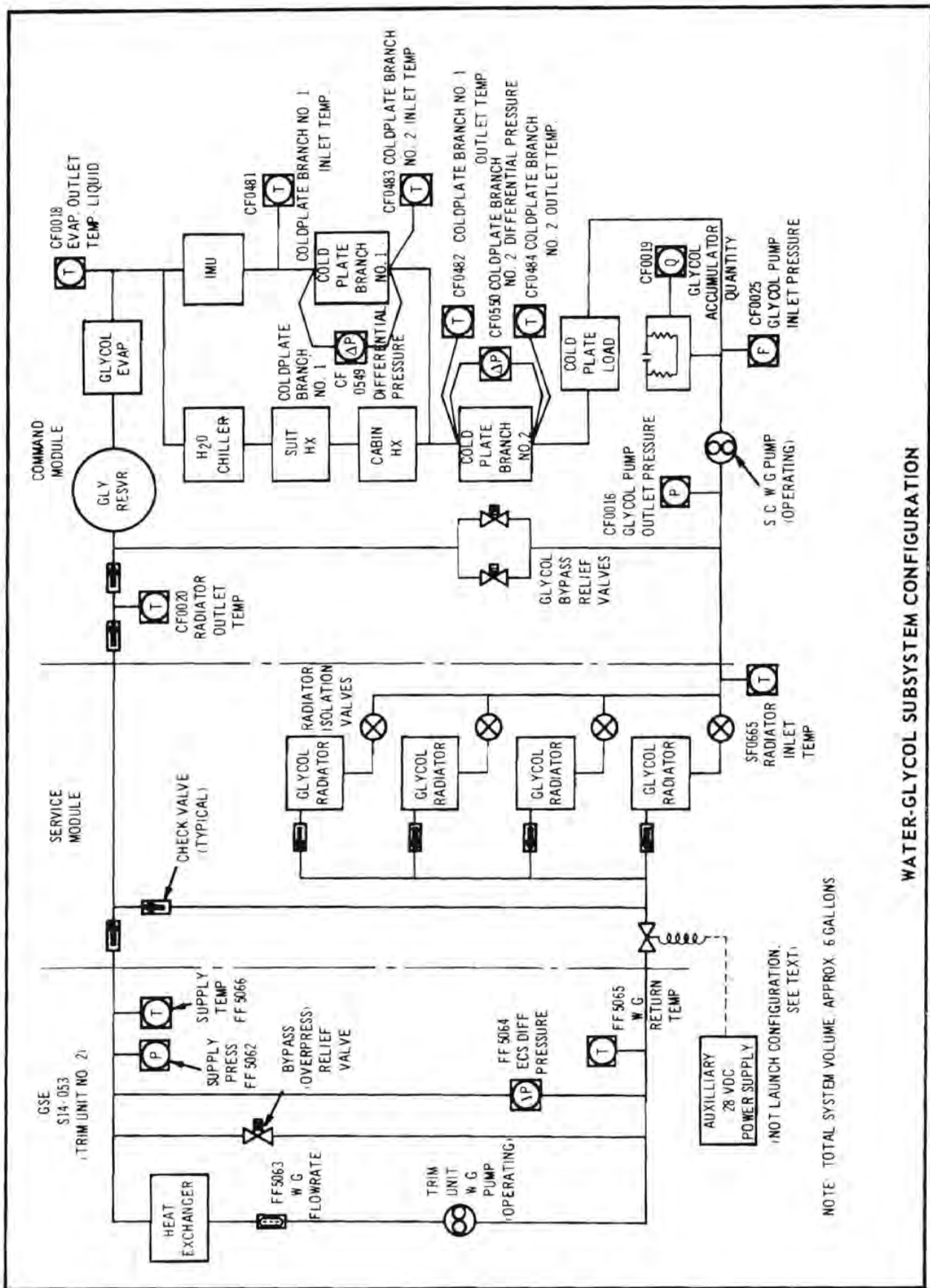

WATER-GLYCOL SUBSYSTEM CONFIGURATION

FIG. 4-6-3



## (6) COMMENTS ON DATA

At about 8 minutes prior to the crew call of fire the accumulator quantity pressure measurement started a gradual decrease which continued to the time when the cabin pressure rose because of the fire. The supply pressure measurement, which also senses changes of pressure within the glycol system, showed an associated change during this period of time. See Panel 18 Report for further discussion.

## g. COMMUNICATION

(1). The communication system was in launch configuration except for the following:

- (a). Only one data storage electronic assembly voice recorder (DSEA) was installed, but was not electrically connected. Two DSEA's are required for launch configuration, with only one connected.
- (b). Only one bio-med tee adapter was installed (SRP position). For flight there would be three.
- (c). CMD Pilot was using a flight-space cobra cable (-51) instead of the normal cable (-41); the cobra cable was changed during the "live mike" troubleshooting.
- (d). Audio control panel and cobra cable switches were in position to facilitate testing as a workaround for the "live mike" problem.
- (e). The USBE was in the "transponder only" mode (power amplifier "off"). The launch configuration transponder power amplifier mode would have been selected at T-10 minutes. Figure 4.7-1 shows the astronaut umbilical communication system cobra cable, tee adapter, etc.

## (2). COMMENTS ON DATA

(a). All data reviewed indicates that the spacecraft communication system performed normally between 23:30:00 GMT and LOS, except for the following:

- (1). VHF/FM DROPOUT - A momentary dropout occurred in the RF detected PCM video wave-train at 23:30:54.85 GMT and lasted for approximately 30 milliseconds. MSOB and the TEL IV signal strength parameters of the VHF/FM carrier had a momentary dropout coincident with the PCM video dropout. See Panel 18 Report for further discussion.
- (2). C-BAND DROPOUT - A C-band dropout occurred at 23:30:54.85 GMT and lasted for 1.7 seconds (see Figure 3-2). The dropout was indicated in the receiver decoder and in the transmitter output. Both are PCM data points which are sampled 10 times per second, and both have RC time constants of 0.1 second. See Panel 18 Report for additional details.
- (3). "LIVE MIKE" CONDITION - Voice tape analysis and PCM data records showed a "live mike" (constant keying) condition existed from the CMD Pilot position during a considerable portion of the final test period. See Panel 18 Report for greater detail.

## (b). VOICE RECORDINGS

Voice recordings were made in the Manned Spacecraft Operations Building (MSOB) ACE Station, MSOB Open Loop Communication Station (MOLC), Blockhouse 34, MCCK at Cape Kennedy, MSC-Houston, and NAA Downey via Houston (see Figure 4.7-2). The data from these tapes were studied in an attempt to determine possible clues to the cause and crew reaction to the fire. A transcript was made of the S-band and VHF/AM tracks of the MOLC voice tape from 23:29:45.5 GMT to LOS. This tape was chosen because it contained the only direct S-band voice from the S/C and was less noisy than the OIS tapes.

## (c). ANALYSIS OF OSCILLOGRAPH RECORDING

The voice transmissions shown in Figure 3-9 were analyzed with the use of MOLC tapes and PCM data. This figure shows the VHF/AM and S-band voice tracks oscillograph readout from 23:29:42.5 GMT to LOS.

### (1). 23:29:42.5 to 23:30:14 GMT

- (a). The CMD was transmitting on S-band. The SRP made a voice transmission on S-band and VHF/AM. There was no voice transmission by the PLT.

# ASTRONAUT COMMUNICATIONS SYSTEMS

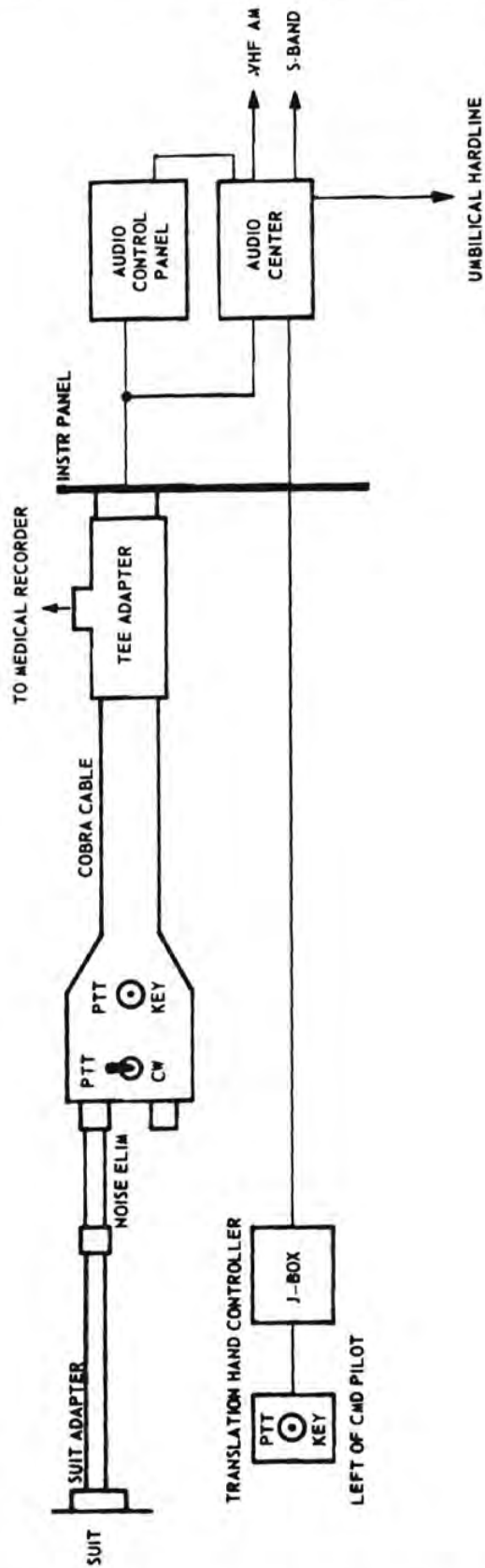

ASTRONAUT COMMUNICATIONS SYSTEM

FIG. 4.7-1

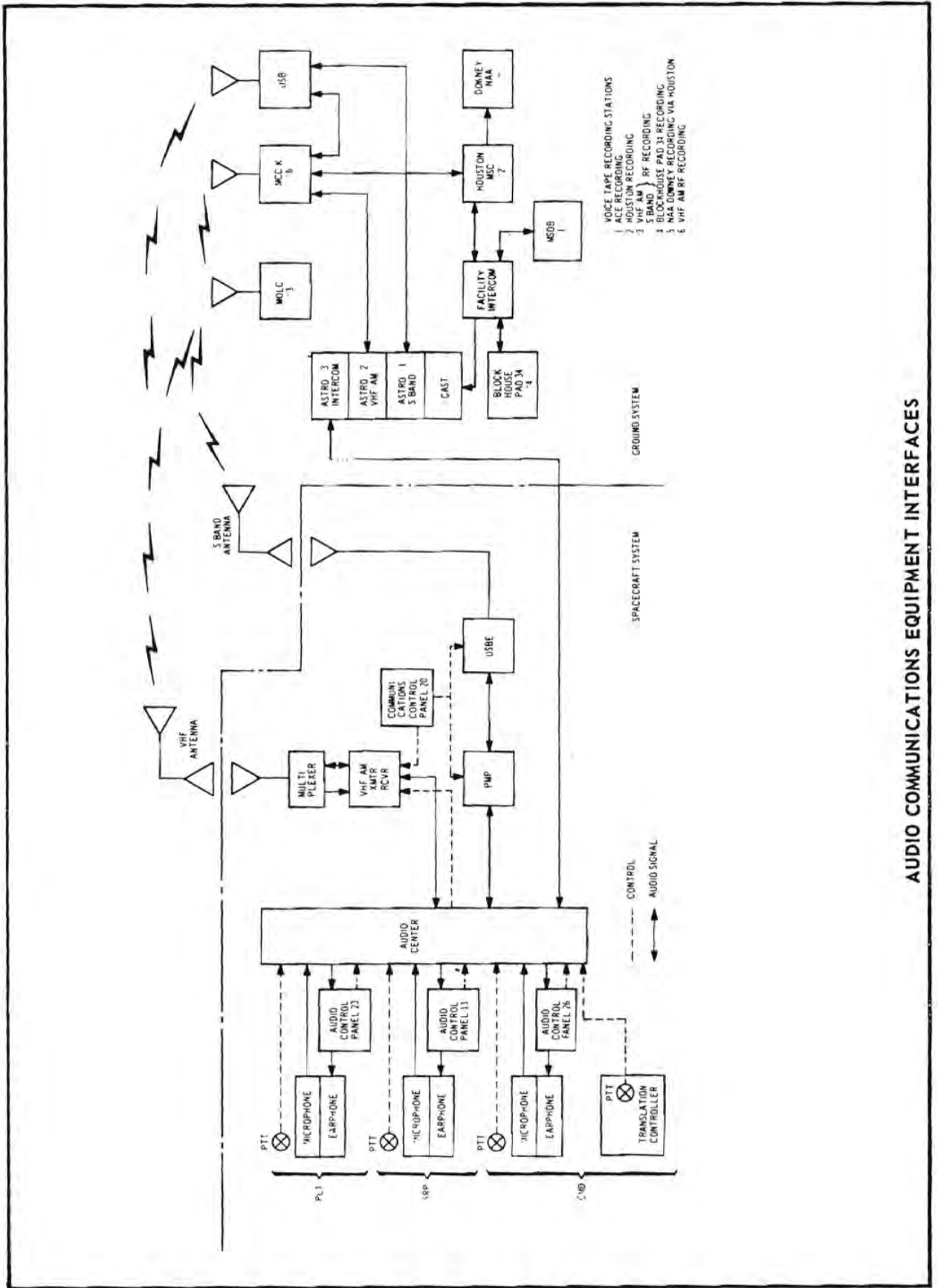

AUDIO COMMUNICATIONS EQUIPMENT INTERFACES

FIG. 4.7-2

(b). The ground personnel were transmitting to the S/C on S-band. The voice of the CMD was being turned around by the CAST (astro communicator console) system and retransmitted to the S/C on VHF.

(c). The "live mike" noises are not evident, probably because of the higher noise level caused by the uplink S-band being patched to the MOLC RF recorder.

(2). 23:30:14 to 23:31:00 GMT

(a). There were no voice transmissions from the S/C.

(b). The ground personnel were not transmitting to the S/C on VHF.

(c). There was no change in the "live mike" condition. Considerable amounts of noise similar to those obtained when a microphone is brushed or tapped, including breathing sounds, were evident. Some of the louder noises appear to have had sufficient amplitude to trigger the uplink VHF/AM via CAST.

(3). 23:31:00 GMT TO LOS

(a). There were two series of voice transmissions on S-band. The times for these two transmissions are detailed in Figure 3-9. No voice communications on VHF were made from the S/C during this time period.

(b). The ground personnel were not transmitting to the S/C on VHF. The voice transmissions from the S/C were being turned around by the CAST system and were retransmitted to the S/C on VHF.

(d). ANALYSIS OF VOICE TAPES DURING THE PERIOD OF FIRE

The tape transcripts of the voice tapes from the Command Module during the time period of the fire (referred to as the first and second transmission, on Table 4.7-1), have been extensively analyzed. This analysis included a review of all transmissions prior to the fire that were made by the crew during the test in an attempt to aid in the determination of who made these last two transmissions and what was said. This analysis was made by NASA personnel familiar with the communication systems, the crew and their voice characteristics, the sequence of events before, during and after the fire as determined during the accident investigation. The Apollo 204 Review Board also reviewed these transmissions. Experts at the Bell Telephone Laboratories also performed extensive analysis of the tape record. Review by other experts, such as Civil Aeronautics Board accident investigation personnel, is currently in progress. Any new findings from these additional reviews will be included in Appendix G of the Final Report.

Except for a portion of the first transmission, which is quite clear, the remainder of the first and second transmission is not clear and it is impossible to define exactly what was said by the crew. Two points made by the Bell Telephone Laboratory experts, however, should be noted:

(1). The present state-of-the-art of analysis of voice records is such that little, if anything, can be determined as to what was said if the recording is not sufficiently clear to be intelligible by listening alone. Analysis, however, can, under these circumstances, provide some clues; but these clues cannot be used to definitely determine which crew member initiated the transmission.

(2). When the recording of the transmission is not clear, there will be nearly as many interpretations of what was said as there are qualified listeners. Many interpretations of what was said have been made. A summary of these interpretations is made in the following paragraphs.

The analysis of the first voice transmitted is as follows:

This transmission began at 23:31:04.7 GMT with an exclamatory remark. This transmission is not clear. Most listeners believe this initial remark was one of the following:

"Hey "

"Fire "

"Break "

Most listeners believe, and laboratory analysis supports this belief, that this transmission was made by the Command Pilot. This remark is followed by a short period of noise (bumping sounds, etc.).

TABLE 4.7-1 TRANSCRIPT OF VOICE CHANNEL FOR LAST 27 SECONDS

<u>MOLC VHF/AM TRACK TRANSCRIPT</u>		<u>MOLC S-BAND TRANSCRIPT</u>	
		23:30:55.5	(Noise)
		23:30:56	(Breathing sound)
		23:30:56.5	(Noise)
		23:30:58.1	(Noise)
23:30:58.5	(Short noise 0.6 sec)		
		23:31:04	(Breathing sound)
23:31:04.7	*(First voice transmission)	23:31:04.7	(First voice transmission of spacecraft problem)
23:31:10.0	(End of first transmission)	23:31:10.0	(End of transmission)
		23:31:16.8	(Second voice transmission of spacecraft problem)
23:31:17.1	(Second voice transmission)		
23:31:21.8	(End of second transmission)	23:31:21.8	(End of second transmission)
		23:31:22.4	(LOS)

\* Analysis of these transmissions appears in paragraph 4.7

The second portion of this first transmission begins at 23:31:06.2 GMT with an unclear word. Most listeners believe the first to be one of the following:

"I've"

"We've"

The remainder of this transmission is quite clear and is: "...Got a fire in the cockpit", followed by a clipped word sounding like "VHEH", which ended at 23:31:10 GMT. Many listeners believed this transmission to have been made by the Pilot. Some believe it could have been made by the Command Pilot or the Senior Pilot. However, laboratory analysis assigns the greatest probability that it was made by the Pilot, but the results of the analysis do not negate the possibility that one of the other crew members could have made the transmission.

The analysis of the second voice transmission is as follows:

Following a 6.8 second period of no transmission the second transmission began at 23:31:16.8 GMT and ended at 23:31:21.8 GMT. The entire second transmission is somewhat garbled. This second transmission, therefore, is subject to wide variation of interpretation as to content and as to who was making the transmission or transmissions. The general content is what appears to be three separate phrases and it has been interpreted several ways by many listeners. The following is a list of some of the interpretations that have been made:

(1). "Fighting a bad fire - Let's get out....

Open 'er up."

(2). "We've got a bad fire - Let's get out....

We're burning up."

"I'm reporting a bad fire....I'm getting out..Oh, AAH." (Scream)

Some people feel that the very end of this second transmission is a scream or the start of one. Many listeners believe this transmission was made by the Pilot.

It should be noted that:

(1). The total time duration of these two transmissions was brief, lasting 17.1 seconds; the first lasted 5.3 seconds and the second lasted 5.0 seconds, with a 6.8 second period of no transmission between.

(2). The transmissions provide evidence only of the time the crew first transmitted a report of the existence of the fire and do not provide any direct information as to the cause of the fire.

## H. FUEL CELL AND CRYOGENIC GAS STORAGE SYSTEM

### (1). FUEL CELLS

Fuel cells were inactive and were not being monitored during the incident. A review of the data from 23:26:00 GMT to the incident indicated no fuel cell anomalies.

### (2). CRYOGENIC GAS STORAGE SYSTEM (CGSS)

The CGSS was inactive during the test. Gas was supplied to the environmental control system from "K" bottles through port OP on the service module. A review of data from 23:26:00 GMT to the incident indicated no anomalies in the CGSS.

## i. PROPULSION (SPS AND RCS)

### (1). SERVICE PROPULSION SYSTEM CONFIGURATION

The differences from the normal launch countdown configuration were as follows:

Propellant tanks, helium storage tanks, and engine actuation system GN2 tanks were not serviced to flight pressures but were at low (normal) blanket pressures (using GN2).

### (2). COMMENTS ON SPS DATA

All data on the SPS remained normal and constant until loss of data.

### (3). REACTION CONTROL SYSTEM CONFIGURATION

CSM RCS was configured for launch with the following exceptions:

(a). The engine simulators were installed in lieu of actual engine circuitry.

(b). No consumables were on board. The scupper supports were in place.

(c). A temperature thermocouple was taped to CM "B" system oxidizer isolation valve to monitor valve temperature rise during plugs out mission run.

(d). The engine throat plugs and flow sensors were partially installed in preparation for flight readiness test. The engine covers were installed on quad engines. CM engines were environmentally sealed with tape.

#### (4). COMMENTS ON RCS DATA

A simulated SM RCS +X engine static firing had been completed at approximately 23:15:00 GMT using Pilot's rotation controller. No anomalies were observed in this test. Following the simulated static firing the CSM RCS system was monitored for remainder of the active test. A review of the data tapes for the period 23:26:00 GMT to 23:31:30 GMT did not disclose any system anomalies. Significant RCS data peculiarities are detailed below:

- (a). A linear rise in temperature from an ambient condition of 70° F to 197° F occurred between 23:31:19.858 GMT and loss of signal at 23:31:22.432 GMT on CR4561T. This transducer is a resistance thermometer type and is spot welded to the upper surface of CM RCS "A" CCW engine between frames No. 21 and 22, (closer to frame 21), and behind panel CM 18. It is also covered with 3/4 inches of insulating Q-felt. A second transducer, CR2201T, mounted on the oxidizer injector valve of the same engine, showed no temperature increase. Although this transducer is of a similar resistance type, it was bonded to and encapsulated in silicon rubber. It was also 90 degrees further around the engine on its outward side and located between frames no. 20 and 21 (closer to frame 21). Although partially covered by the boost protective cover, CR2201T was exposed to ambient conditions (panel CM 19). The sudden rise in temperature of CR4561T is indicative of exposure to flame at the time of cabin pressure vessel rupture. Time correlation with other rupture data points must take into account the fact that the engine and transducer are enclosed with insulating Q-felt as noted above.
- (b). The RCS propellant isolation circuit breakers (CB16 and CB15) on panel 25 were found to be open during post-fire inspection. Further inspection revealed that the circuit breakers' stems were only slightly smutted indicating that the circuit breakers opened after the fire started to subside.
- (c). The RCS selector switch was found in the SM-A position rather than the SM-D position called for by the procedure. This switch selects a particular SM quad for parameter monitoring and has no change-of-state function. The SM-A position is assumed to be a pilot's natural reaction to return to the initial monitoring position instead of leaving it in the final position following simulated static fire.

#### j. CREW SYSTEMS, BIOMED, AND EXPERIMENTS

##### (1). SYSTEM CONFIGURATION

The biomed system was in launch configuration with the following exceptions:

- (a). An E. O. was released to pot the octopus cable connectors to prevent breakage of connector back shells. Planning was also in work to wrap the cable with tefglas and attach Velcro to provide attach points for support of the cable.
- (b). Only one biomed tee adapter was installed and this was in the SRP position. The biomed parameters for the SRP position were being monitored on both PCM and the MDAS recorder and the time of incident.

Only the crew systems equipment required to support OCP-FO-K-0021-1 was stowed in the S/C. The stowed crew systems equipment which has an electrical interface with the S/C (cameras, hygrometer, alignment sight) were not connected to the S/C at the time of the accident.

##### (2). COMMENTS ON DATA

- (a). PCM and MDAS recorder data throughout the test was normal except for several noise glitches which appeared on the biomed data channels. Physicians verified these glitches were not normal biomedical data. The first glitch occurred at 18:28:02 GMT and recurred randomly with the last one at 23:24:00 GMT. These noise spikes are believed to be caused by RFI, which has been duplicated during post-incident bench test by glitching the input power. From the time the MDAS was turned on and the timer reset to zero (17:36:02 GMT) until LOS of the timer (23:31:21.2 GMT), the timer operated normally with no loss of, or change in, timing.
- (b). Based on the PCM and MDAS data available from S/C 012, there is no indication that the biomed system contributed to the case of the incident.

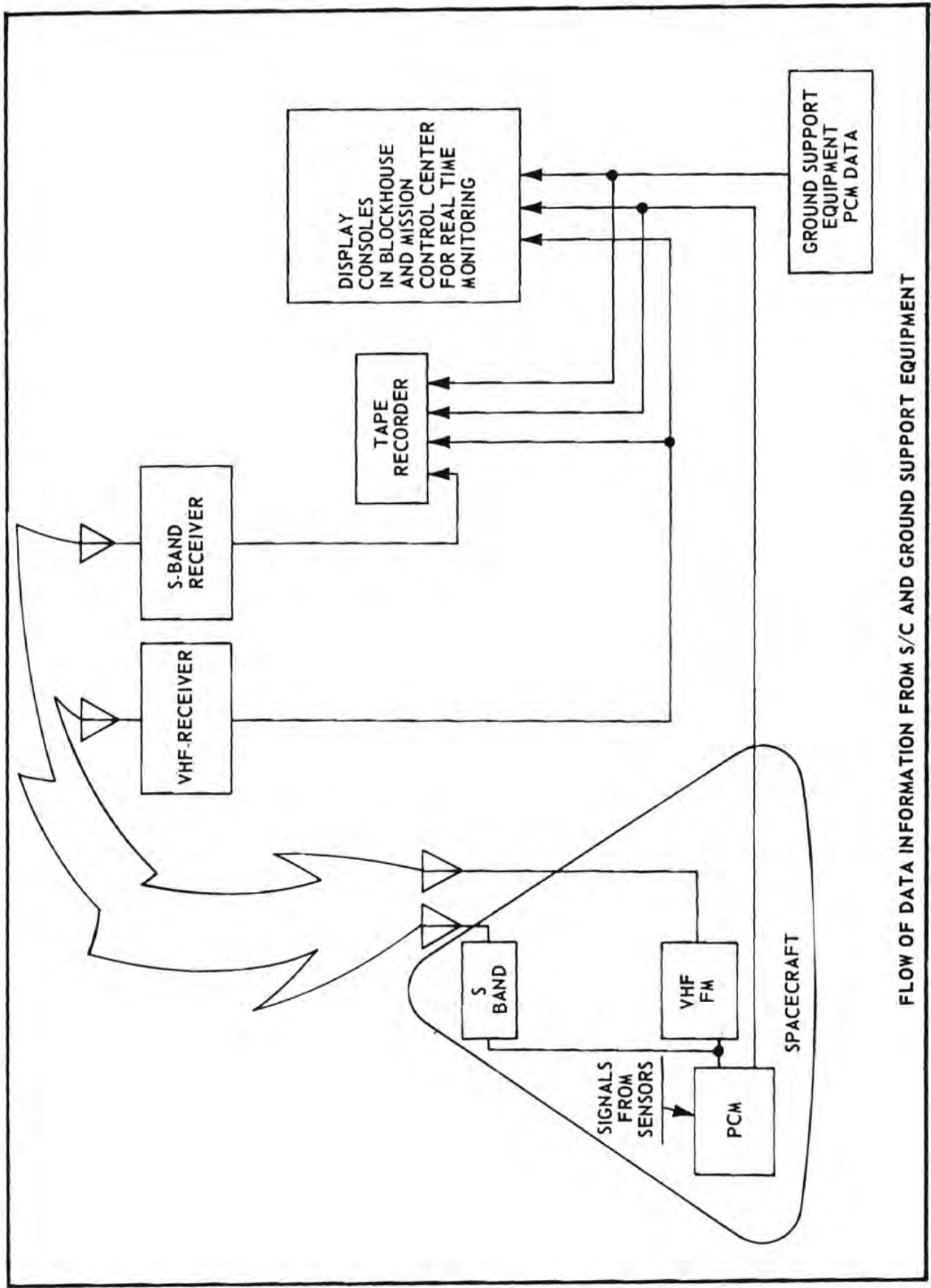

FLOW OF DATA INFORMATION FROM S/C AND GROUND SUPPORT EQUIPMENT



This page left blank intentionally.

# SEQUENCE OF EVENTS

TIMES SHOWN ARE DERIVED FROM SAMPLED MEASUREMENTS AND ARE UNCERTAIN BY THE SAMPLING RATE OF THE SPECIFIC MEASUREMENT

ONE SECOND SCALE 

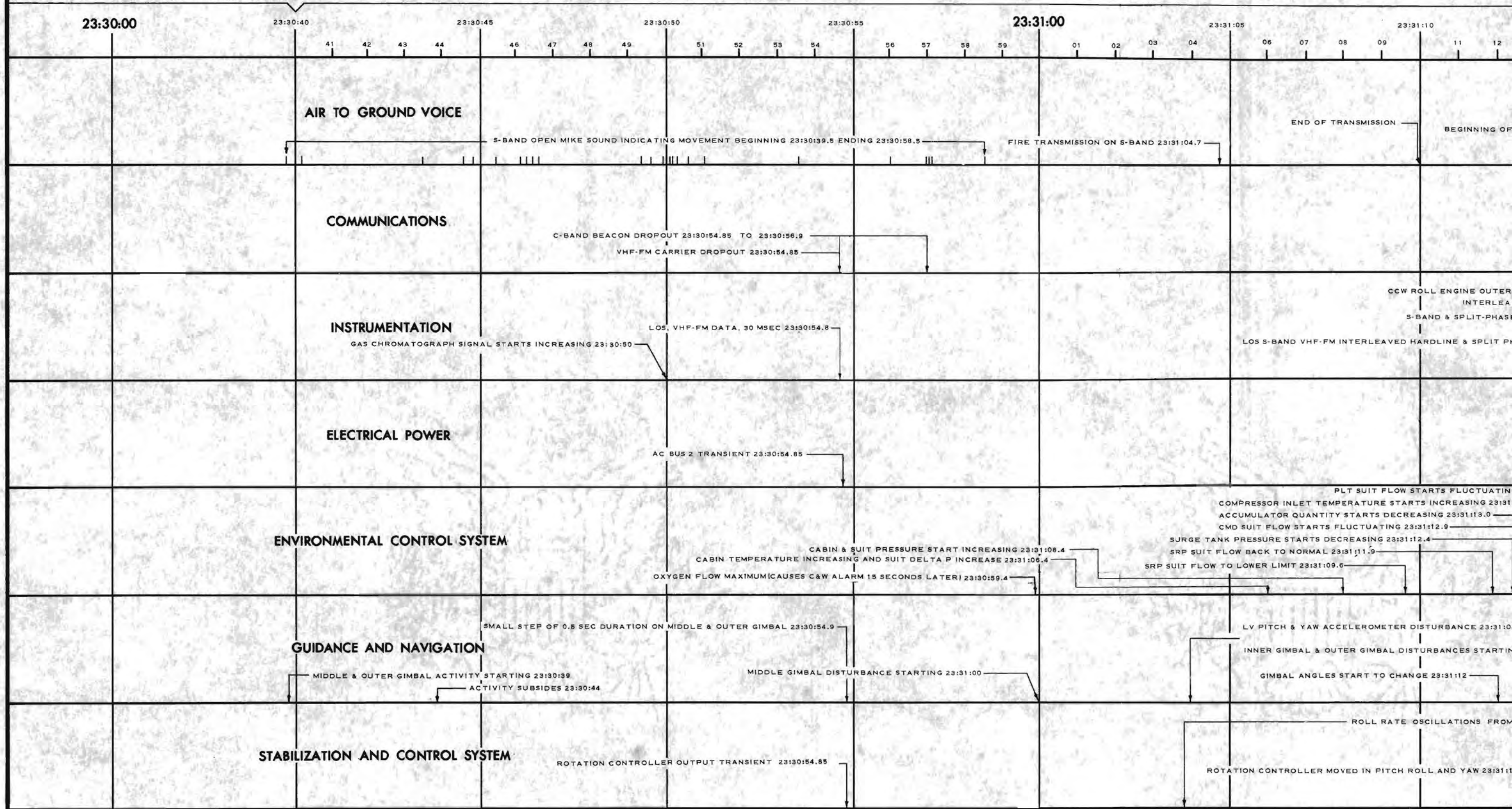

TIMES SHOWN ARE DERIVED FROM SAMPLED MEASUREMENTS AND ARE UNCERTAIN BY THE SAMPLING RATE OF THE SPECIFIC MEASUREMENT

FIVE SECOND SCALE 

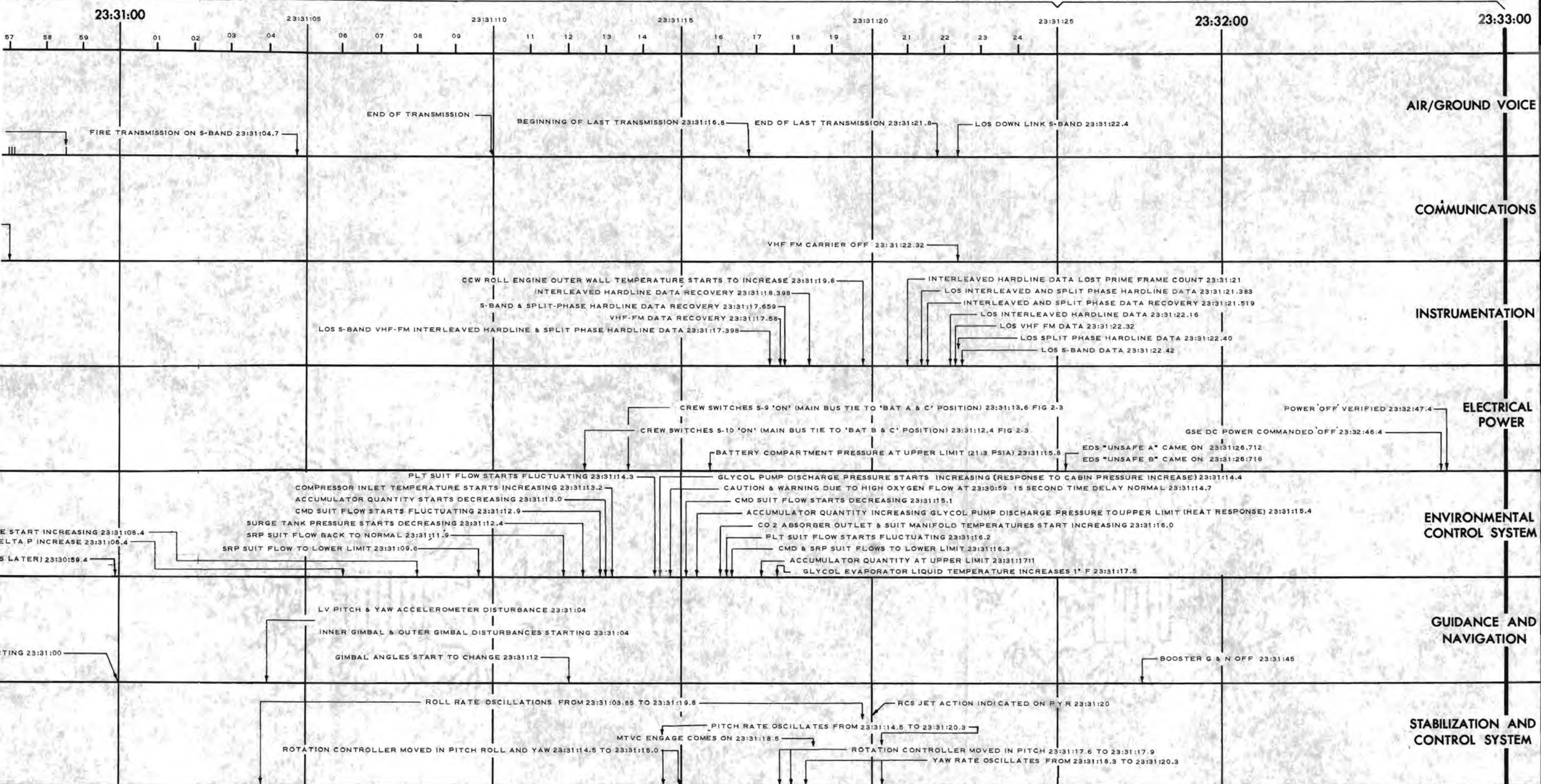

ENCLOSURE 3-3. SEQUENCE OF EVENTS

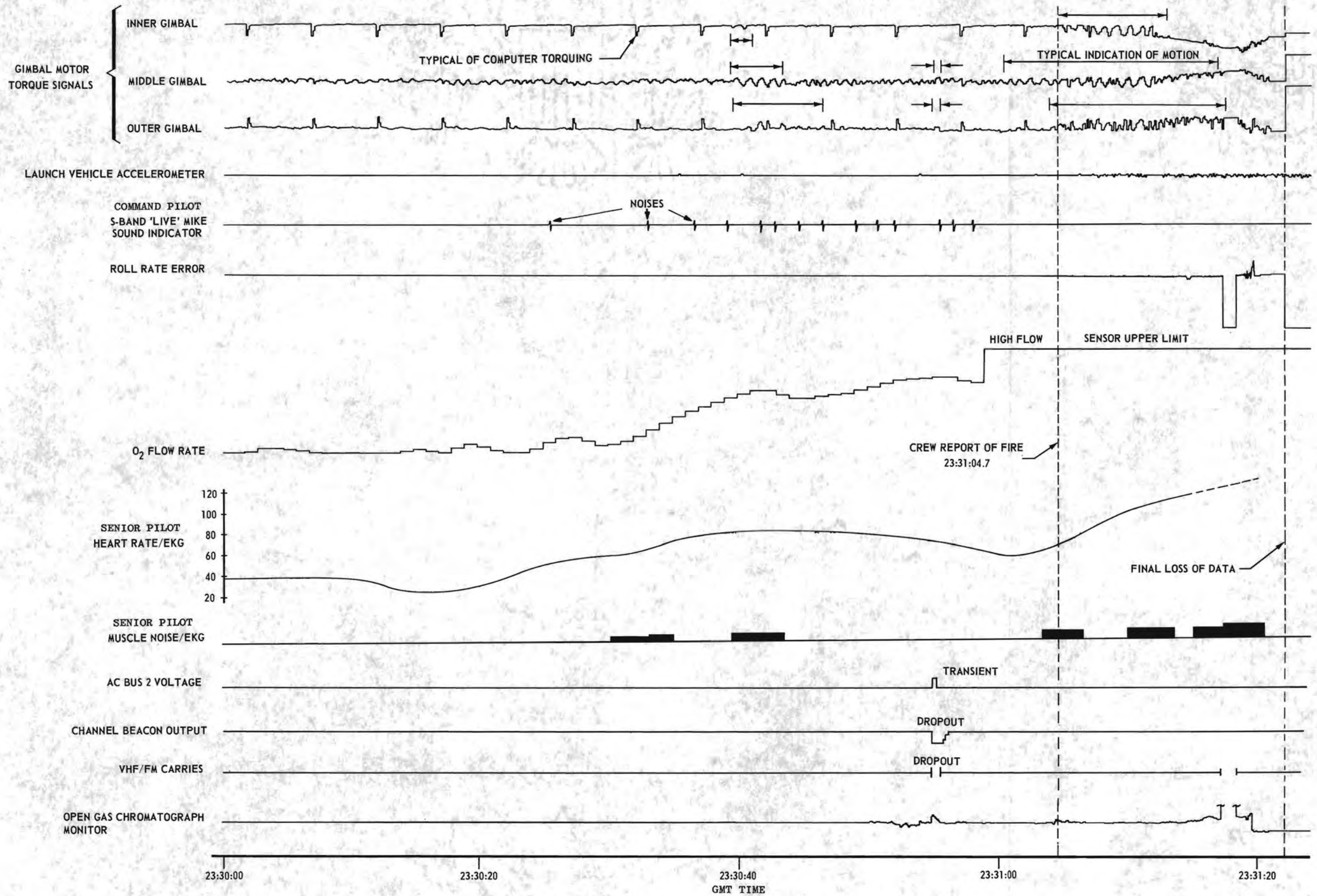

**REPORT OF PANEL 4  
DISASSEMBLY ACTIVITIES PANEL  
APPENDIX D-4  
TO  
FINAL REPORT OF  
APOLLO 204 REVIEW BOARD**

This page left blank intentionally.

# DISASSEMBLY ACTIVITIES PANEL

## A. TASK ASSIGNMENT

The Apollo 204 Review Board established the Disassembly Activities Panel, 4. The task assigned for accomplishment by Panel 4 was prescribed as follows:

Develop plans and procedures for progressive disassembly of Apollo Spacecraft 012 for purposes of inspection and failure analysis. Disassembly should be configured to proceed on a step-by-step basis, in a manner to obtain the maximum amount of information prior to disturbing the evidence. Contents of testing requirements shall also be considered. Disassembly plans should consider both the cockpit and the area outside the pressure hull. Means for cataloging documentary information within the spacecraft and for the display of removed items shall be a part of these plans and procedures.

## B. PANEL ORGANIZATION

### 1. MEMBERSHIP:

The assigned task was accomplished by the following members of the Disassembly Activities Panel:

Mr. Scott H. Simpkinson, Chairman, Manned Spacecraft Center (MSC), NASA  
Mr. Samuel T. Beddingfield, Kennedy Space Center (KSC), NASA  
Mr. Robert G. Covell, Jr., Kennedy Space Center (KSC), NASA  
Mr. Paul J. Graf, Kennedy Space Center (KSC), NASA  
Mr. Robert J. Reed, Kennedy Space Center (KSC), NASA  
Mr. Harry C. Shoaf, Kennedy Space Center (KSC), NASA  
Mr. Charles G. Stevenson, Kennedy Space Center (KSC), NASA  
Mr. Joseph C. Campbell, Manned Spacecraft Center (MSC), NASA  
Mr. Dean F. Grimm, Manned Spacecraft Center (MSC), NASA  
Mr. Patrick J. Hanifin, North American Aviation (NAA), Downey  
Mr. John M. Moore, North American Aviation (NAA), Kennedy Space Center

### 2. COGNIZANT BOARD MEMBER:

Colonel Frank Borman, U. S. Air Force, Board Member, Manned Spacecraft Center (MSC), NASA, was assigned to monitor the Disassembly Activities Panel.

## C. PROCEEDINGS

### 1. INVESTIGATIVE APPROACH

a. SPACECRAFT 012 DISASSEMBLY PROCEDURES. Immediately after the accident, at 6:31 p.m., EST (23:31 GMT) on January 27, 1967, NASA Kennedy Space Center Security placed Launch Complex 34 under additional security. Special guards were assigned to the service structure and to the adjustable-eight (A-8) level at the entrance to the Command Module (C/M). Controls were established for personnel access to the service structure and the C/M. Everything located at the Launch Complex such as Ground Support Equipment (GSE), spare parts, documents and drawings, special clothing, breathing apparatus and fire fighting equipment, etc., was impounded. The NASA Test Supervisor in the blockhouse, in conjunction with NASA Security, controlled all activities on the service structure. Implementation of these directions was coordinated through the NASA Operations Engineer and the NAA Pad Leader at the C/M.

After the fire, prior to disturbing any items in the spacecraft, a series of photographs were taken. Several photographs were made of the surrounding areas on adjustable levels A-7 and A-8. Photographs showing the configuration of the area around the Pad Leader's desk on A-8 and a closeup of the desk may be seen in Enclosures 4-1, 4-2, and 4-3. The step-by-step photography method was established as a standard operating procedure for the entire activity of the Disassembly Activities Panel.

After the last crewman was removed at approximately 2:00 a.m., EST on January 28, 1967, two spacecraft observers entered the C/M at 3:00 a.m. to verify certain panel switch positions. Other than this there was no activity inside the C/M on the day after the accident. Small groups of NASA and NAA management, the Apollo 204 Review Board Members, Representatives, and Consultants and others with a need to know, inspected the exterior of Spacecraft 012. They looked in through the open hatch, but did not enter the C/M.

At 1:00 a.m., EST, Sunday, January 29, 1967, a NASA photographer took additional pictures inside the C/M and an astronaut entered the spacecraft to verify additional switch positions needed to clarify the data. Considerable inspection of the exterior of the spacecraft and the A-8 level was accomplished throughout the day. At 10:00 a.m. EST, a second astronaut entered the C/M and removed a few items of Government-furnished crew equipment after it was determined that they had no relation to the accident. Following this, one member of the Press was escorted to the A-8 level and was permitted to take pictures, with the stipulation that he could not enter the spacecraft. No more activity took place inside the spacecraft on that day.

At noon on Monday, January 30, 1967, a NASA operation engineer entered the C/M to examine the Gas Chromatograph Cable and direct a photographer to take pictures in the vicinity of the cable. At about the same time, the Apollo 204 Review Board created a Hardware Removal and Disposition Panel (later retitled Disassembly Activities) to establish the procedures for disassembly of Spacecraft 012. This Panel immediately established criteria that required a standard Apollo Test Preparation Sheet (TPS) for any work or inspection on Spacecraft 012. Each TPS had to be signed by both NASA and NAA systems engineers and by the Panel Chairman (NASA) or his delegate (NASA) and a NAA member of the Panel. These TPS's were necessary to assure proper coordination and will remain as a permanent record of the work accomplished. All prepared TPS's are contained in the Apollo 204 Review Board General File.

The first step toward an orderly disassembly was to assure safe working conditions at the spacecraft. A meeting was held with KSC and Air Force Eastern Test Range (AFETR) Safety personnel in which it was decided that (1) the Launch Escape System (LES) should be removed and properly stored, (2) the forward heat shield should be removed and all pyrotechnics removed and stored or made safe, (3) the structure should be examined by structural engineers, and (4) all pressure vessels should be declared safe, or the pressure should be relieved. It was also decided that work inside the spacecraft would not be allowed until dust samples were taken and the air declared free from possible harmful concentrations of beryllium dust. (Beryllium is used in the structure of the Guidance and Navigation (G&N) System.) After obtaining Board approval, these tasks were accomplished and Spacecraft 012 was considered safe for investigative purposes by 10:00 p.m. EST on Thursday, February 2, 1967.

The Hardware and Disposition Panel prepared and issued a memorandum which stated the mode of operation for those concerned. It is included as Enclosure 4-4 to this report.

Members of Panel 5, Origin and Propagation of Fire, cleaned the couches in a carefully planned manner and documented all phases of the task. Charred data books and procedure manuals removed from the couches were carefully packed and hand carried to the Federal Bureau of Investigation Laboratory, Washington, D. C., in an attempt to identify any notes that may have been made by the crew.

After a specially constructed plywood cover was installed on the couches, NASA and NAA Quality Control (QC) inspectors entered the spacecraft and recorded all unusual appearances of hardware, including damaged components, but not including superficial damage such as smoke discoloration and other accident effects. After more than four hours of inspection by QC, the systems engineers then entered the spacecraft. Each system engineer was allotted sufficient time to visually



inspect all of the exposed hardware of his system. This was necessary in order to formulate an effective plan for an orderly disassembly and to establish an overall priority for component removal. Following approximately four hours of engineering inspection, a NASA photographer took a series of close-up stereo photographs of the C/M interior, including many special points of interest required by various systems engineers. Before removing the couches, the top egress hatch was removed.

It was recognized that the task of searching the physical evidence would be difficult and time consuming because of the confined area within the C/M and the small hatch through which everything had to enter and leave. In order to remove the components as quickly as possible and keep the members of the investigating team informed of the findings, it was necessary to have an engineer and a technician enter the spacecraft to remove the equipment and then have a photographer take the place of the technician and document the conditions after each removal. With proper distribution of the engineer's findings and the color photographs, all parties with a need to know were informed of the progress and considerable time was saved in the disassembly process.

Removal of the couches posed a unique problem in that it was desirable not to disturb the aft bulkhead (crew compartment floor) in any way. The normal removal requires technicians to lie on the floor and work on the couches from the underside. To accomplish removal of the couches without disturbing evidence, a special platform was built which was supported from the hatch sill at one end and from strut attachment fittings at the other end. The technicians were able to lie on this platform and perform the work necessary to remove the couches.

After the couches were removed, a special false floor, fabricated from aluminum angles supporting removable 18-inch squares of 3/4-inch thick Plexiglass, was suspended from the existing couch strut fittings to provide access to the entire inside of the spacecraft including the floor, without disturbing any of the evidence. The false floor, after a check fitting in Spacecraft 014, is shown installed in Spacecraft 012 in Enclosure 4-5. A NASA photographer then entered the spacecraft and took a series of precision scale photographs of the interior which were later glued to the inside of a one-half scale model for a three dimensional reference. Members of Panel 10, Analysis of Fracture Areas, then entered the spacecraft for an inspection of the structural failures in the aft bulkhead.

At this point, with the couches removed, Panel 5, Origin and Propagation of Fire, with Members and Consultants of the Apollo 204 Review Board, entered the spacecraft to look over the cabin from the vantage provided by the transparent false floor.

A decision was made to repeat investigation inspections by QC and the various systems engineers. In order to disseminate information and to retain a permanent record of important observations during this type of inspection, a TPS was generated requiring a written summary of all significant findings after performing an inspection but before leaving the A-8 level of the service structure. These summary sheets were distributed to all parties with a need to know.

The preparations for disassembly proceeded quite well; however, upon entering the next phase involving the need for closely controlled and coordinated equipment removal, it became obvious that new procedures were required. To implement these procedures, the Board appointed a Panel Coordination Committee (PCC), which included three Board Members and several Consultants.

The first order of business of this Committee was to amend the procedures for accomplishing work in the C/M. Panel 4 was redesignated the Disassembly Activities Panel instead of Hardware Removal and Disposition Panel. Apollo 204 Review Board Administrative Procedure Number 18 concerning the Use and Control of Test Preparation Sheets was published. This procedure covered the plan and control by which spacecraft hardware would be removed, inspected, analyzed or otherwise modified. Under this plan, requirements were reviewed by the PCC and presented to the Board for approval. After approval of a specific requirement by item number, TPS's to implement

the required action were generated by the appropriate NASA/NAA systems engineers and approved by members of:

- NASA-MSC and NASA-KSC Engineering

- NAA Engineering

- Panel 5, Origin and Propagation of Fire

- Panel 18, Integration Analysis

- Materials Analysis Branch, KSC

- Panel Coordination Committee

- Panel 4, Disassembly Activities (only in those cases where execution of the TPS involved work inside or on the C/M)

Concurrently, two new categories of investigation TPS's were established. These were the Component Analysis (CA) for testing a removed component or a component from spares stock and the Material Analysis (MA) for analyzing a sample of material from the spacecraft or from the stockroom.

By February 7, 1967, this system was fully operational. The concentrated effort of organized and coordinated equipment checkout and removals continued on a three-shift seven day a week basis. All unusual or suspect circumstances or conditions were immediately brought to the attention of Panel 5, Origin and Propagation of Fire, and the appropriate systems engineers for any desired change in direction.

During the equipment removal, electrical connectors used to connect large bundles of wires were in general disconnected; however, if any connectors showed physical evidence of damage, the wires were cut at the point where they were the least damaged and were clearly identified with separate tags on each cut end. In the case of tubing, lines were generally cut at a convenient distance from the joints to allow a leak check to be performed on the original joint. Exact interfaces were photographed and marked prior to disassembly, where possible, so that original conditions could be reassembled if desirable.

All interfaces, such as electrical connectors, tubing joints, physical mounting of components, etc., were closely inspected and photographed immediately prior to, during, and after disassembly as shown in Enclosure 4-6. All disconnects were made over clean plastic bags to catch any debris or contamination. Every item removed or taken from the C/M was appropriately tagged, sealed in clean plastic containers and transported under the required security to bonded storage.

On February 17, 1967, the Review Board was satisfied that removal and wiring tests had progressed to the point that moving the spacecraft would not disturb any remaining evidence. The C/M was moved to the Pyrotechnic Installation Building (PIB) at KSC where better working conditions were available. The structural integrity of the damaged C/M was questionable; therefore, a special sling was constructed to be used to remove the C/M and lower it to ground level. This sling consisted of the standard sling designed to hoist the entire stacked Apollo spacecraft (including the Lunar Module) plus two straps at approximately ninety degrees going around the C/M and under the aft heat shield. These added straps were designed to support the entire C/M in case of a structural failure in the spacecraft. The verification test of this sling using a boilerplate Flight Verification Vehicle (C/M), with the structural interconnection points disconnected to simulate a failure, is shown in Enclosure 4-7.

After verification of the sling, it was attached to the 012 Command Module and used to lower it to a mounting ring on a trailer at the base of the service structure. The trailer was used to transport the C/M to the PIB. In order to minimize vibration, the speed was held to below five miles per hour over the 6.6 miles traveled. The moving operation is shown in Enclosures 4-8, 4-9, 4-10, and 4-11. At the PIB, the C/M was placed in the fixture normally used for alignment of the Launch Escape System. This fixture, shown supporting the aft heat shield in Enclosure 4-12, was used for a period of 18 days to support the spacecraft during equipment removal and special testing.

With the improved working conditions in the PIB, it was found that a work plan of two eight-hour shifts per day for six days a week was sufficient to keep pace with the analysis and disassembly planning. The only exception to this was a three-day period of three eight-hour shifts per day, utilized to remove the aft heat shield, move the C/M to a more convenient work station (Enclosure 4-13), and remove the crew-compartment heat shield (foreground of Enclosure 4-12). This activity took place on March 7, 8, and 9, 1967. The planned disassembly of the C/M was completed on March 27, 1967.

In general, non-functional panels and low-suspect hardware were removed from around areas of suspect or heavy damage. This was done to gain better access for inspection and component removal within damaged areas without disturbance of evidence.

#### b. CATALOGING AND DISPLAY OF ITEMS REMOVED FROM THE SPACECRAFT

In accordance with the task assignment for Panel 4, Disassembly Activities, the Panel took immediate action to catalog and place on display, the hundreds of items that would be removed from C/M 012 during the course of the investigation. The KSC PIB was assigned to the Apollo 204 Review Board as an area in which components removed from the C/M could be placed in bonded storage, but be available for inspection by personnel associated with the investigation.

The following areas were established within the PIB:

(1) BOND ROOM — A bonded area to receive components as they were removed from C/M 012. This area was provided with a receiving table; ten storage cabinets for small components, areas for large components and items associated with the investigation, but not from the C/M itself. Enclosures 4-14 and 4-15 show the interior of this room.

(2) ASTRONAUT EQUIPMENT ROOM AND WORK ROOM — An area in which the spacesuits and other Government furnished crew equipment were investigated.

(3) BONDED DISPLAY AREA — An area in which components could be displayed under controlled conditions. The purpose of this area was to permit investigators to make visual examination of C/M 012 components. Work other than visual examination was not permitted in the display area. Enclosure 4-16 shows the components that were on display on February 21, 1967, and Enclosure 4-17 on March 14, 1967.

During the course of the disassembly, there were approximately 1025 items removed from the spacecraft, logged, and either placed on display or held in bonded storage. Enclosure 4-18 is a list of these items by log number. This list does not include nearly 250 items that were logged into the PIB Bond Room from the launch complex and similar areas of concern (not removed from the C/M); however, these items were numbered in the same series, resulting in a total of over 1250 items. A set of C/M drawings was prepared and distributed that was marked with the removed-item log numbers, indicating the area in or on the spacecraft from which each one was removed. In addition to these documents, which were issued weekly as the disassembly progressed, a third document showing the display location of each removed item was prepared daily and distributed weekly, and a fourth document was updated daily and distributed weekly showing the location of all logged items that were carried out of the PIB for further analysis.

(4) COMMAND MODULE 012 WORK AREA - At the PIB, the C/M was placed in a supporting ring within an existing workstand. The C/M remained in this area until the aft heat shield was removed. The C/M was then transferred to a standard support ring in the north end of the building. While in these areas, technicians continued to disassemble the C/M in accordance with approved TPS's. These two work areas are shown in Enclosures 4-12 and 4-13. After a component was removed from C/M 012, it was photographed and then sent to the appropriate bond area.

(5) SPACECRAFT 014 COMMAND MODULE — Spacecraft 014 Command Module was shipped to KSC on February 1, 1967, to assist the Apollo 204 Review Board in the investigation. This C/M was placed in the PIB as shown in the foreground of Enclosure 4-19, and was used as

a vehicle for practicing difficult removals of C/M 012 components.

(6) **MOCK-UP NO. 2** — Mock-up No. 2, a full-scale plywood C/M, was also brought to KSC and placed in the PIB on February 8, 1967, as shown in the background of Enclosure 4-19. This mock-up was configured with Velcro, debris traps, couch positioning, etc., to duplicate the C/M 012 configuration at the time of the fire.

(7) **HALF-SCALE MOCK-UP** — A half-scale mock-up of a C/M interior was placed in the bonded display area on February 8, 1967. This mock-up was used to display half-scale interior surface photographs taken after the fire in C/M 012.

Drawing SCN 311905, Rev. A, indicates the layout of the various areas within the PIB (Enclosure 4-20). Security was maintained within the PIB through the use of access lists, sign in/out lists, and guards stationed at the main entrance and at the entrance to each of the bonded areas within the building. (See guard station A, B, and C on Enclosure 4-20.) Guard station B was discontinued after C/M 012 was moved to the bonded work area at the north end of the PIB. A member of Panel 4 Disassembly Activities was also present in the PIB throughout all work periods.

c. **RELEASE OF IMPOUNDED EQUIPMENT** — Immediately after the accident, all Spacecraft 012 equipment and associated data, and also the Launch Vehicle, at KSC were impounded. This was done to establish the configuration of the spacecraft, associated GSE, documents, personal tools, and miscellaneous items.

A Material Release Record System (MRR) was devised by the Review Board to control the release of all impounded items. The MRR was the method used to classify items in one of three categories as determined by the Apollo 204 Review Board. The three categories were as follows:

(1) **CATEGORY A** — Items which may have a significant influence or bearing on the results or findings of the Apollo 204 Review Board.

(2) **CATEGORY B** — Items other than Category "A" that are considered relevant to the Apollo 204 Review Board investigation.

(3) **CATEGORY C** — Material released from Board jurisdiction.

Impounded items were systematically reviewed and approved on MRR's for release from Category A to Category B or C by the Apollo 204 Review Board. In those cases for which no constraints to release were made, the items were processed for release by TPS's written and signed by the appropriate NASA or NAA systems engineers and signed by the Chairman of the Disassembly Activities Panel. In addition, the TPS's were accompanied by release letters signed by the Disassembly Activities Panel Chairman.

In those cases for which constraints to release were made by the Review Board, TPS's were required to show precisely what steps were to be worked in order to clear the restraints. When the restraints were removed, the items were released by TPS's and release letters.

The Spacecraft 012 C/M, its systems and components, will be retained in bonded storage in Category A or B at KSC. All GSE was appropriately released by MRR. All prepared MRR's are contained in "Schedule of Physical Evidence"; Appendix F to the Final Report of the Apollo 204 Review Board.

#### D. SUPPORTING DATA

##### List of Enclosures

Enclosure	Description	Drawing or Neg. No.
4-1	Level A-8 - looking toward East Wall	B-128-1-C
4-2	Level A-8 - looking toward North Wall	B-128-2-C
4-3	Level A-8 - close-up of Pad Leader's desk	B-128-5-C

(Sheet 6 of 7)

4-4	Hardware removal and disposition panel modus operandi	Memo dated Feb. 2, 1967
4-5	False floor installed in spacecraft	33-72C-3
4-6	Electrical interface photography	139-315C-11
4-7	Special sling verification test	94-205-2
4-8	C/M being moved out of service structure	109-281C-3
4-9	C/M on special sling being lowered to ground	113-276C-1
4-10	C/M being lowered onto trailer	109-282C-6
4-11	C/M moving out of gate at Complex 34	111-286C-4
4-12	Aft heat shield in alignment fixture with crew- compartment heat shield in the foreground	303-651C-2
4-13	C/M in final work station, with all heat shield removed	303-654C-1
4-14	PIB bond room looking toward the North wall	303-654C-2
4-15	PIB bond room looking toward the South wall	303-654C-3
4-16	PIB bonded display area on February 21, 1967	142-322C-3
4-17	PIB bonded display area on March 14, 1967	303-651C-3
4-18	Items removed from S/C 012 and placed on display or in bonded storage.	
4-19	C/M 014 and C/M Mock-up 2	303-651C-5
4-20	AS-204 component arrangement in PIB	SCX 311905

This page left blank intentionally.

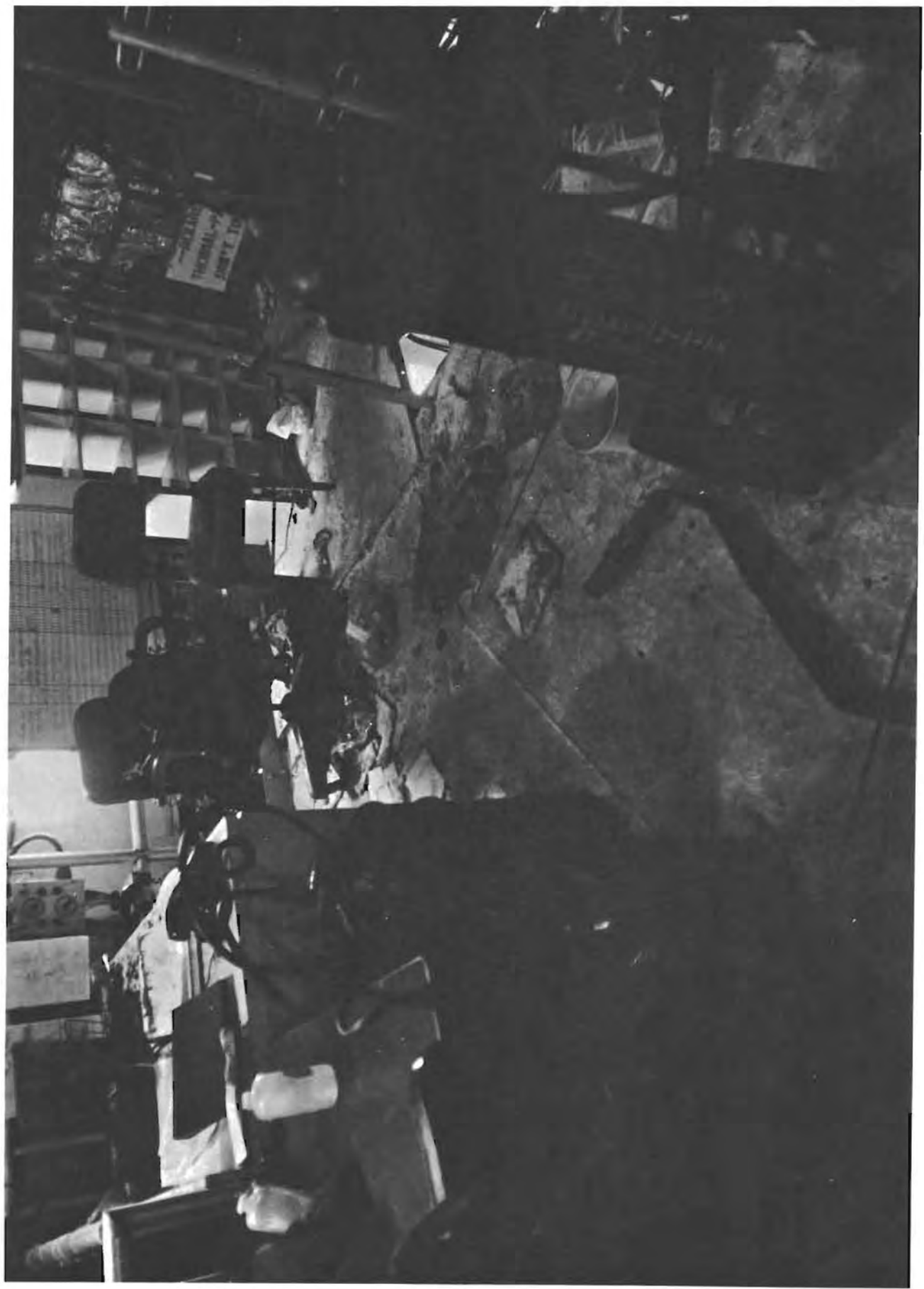

LEVEL A8 LOOKING TOWARD EAST WALL





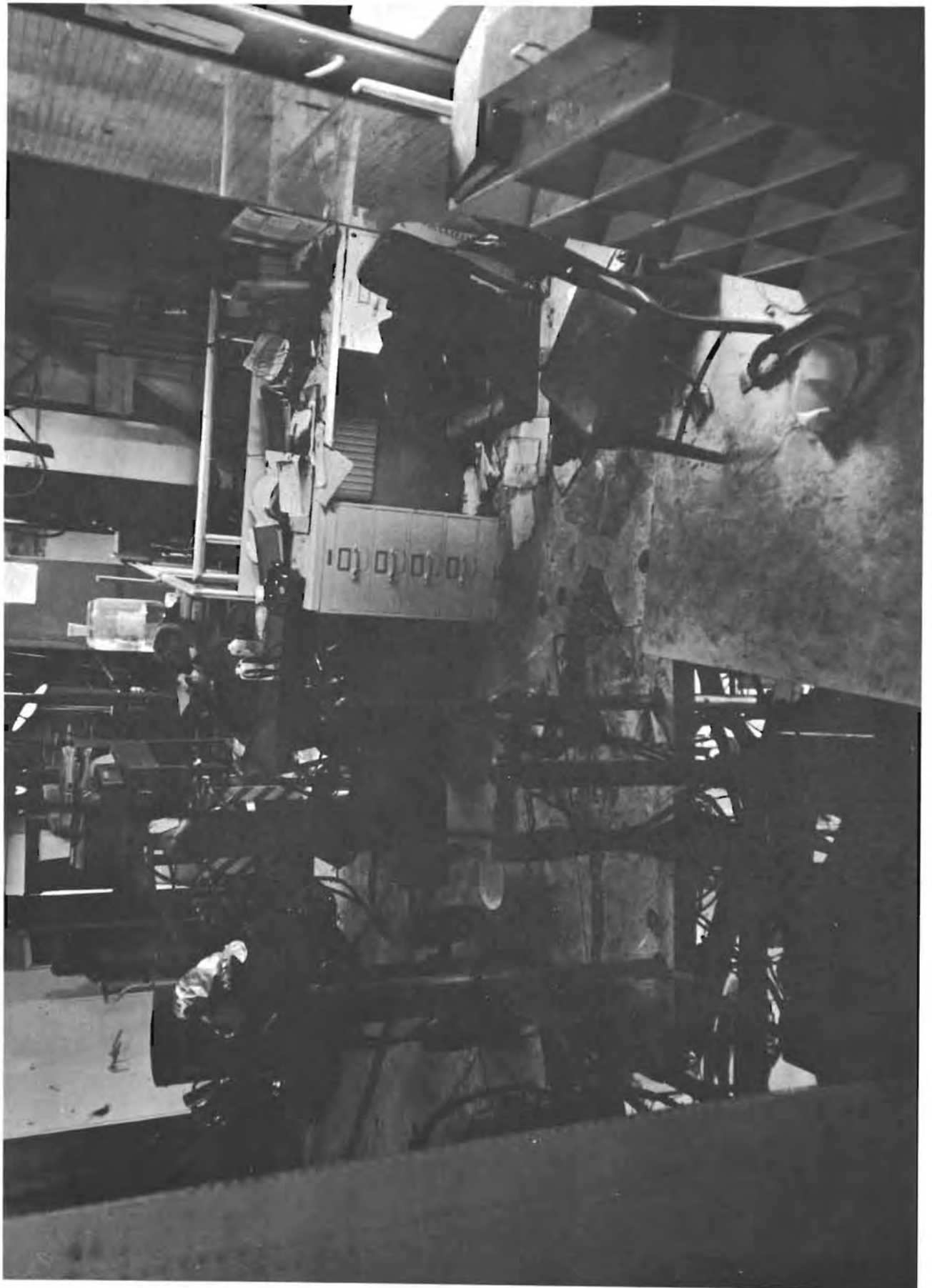

LEVEL A8 LOOKING TOWARD NORTH WALL



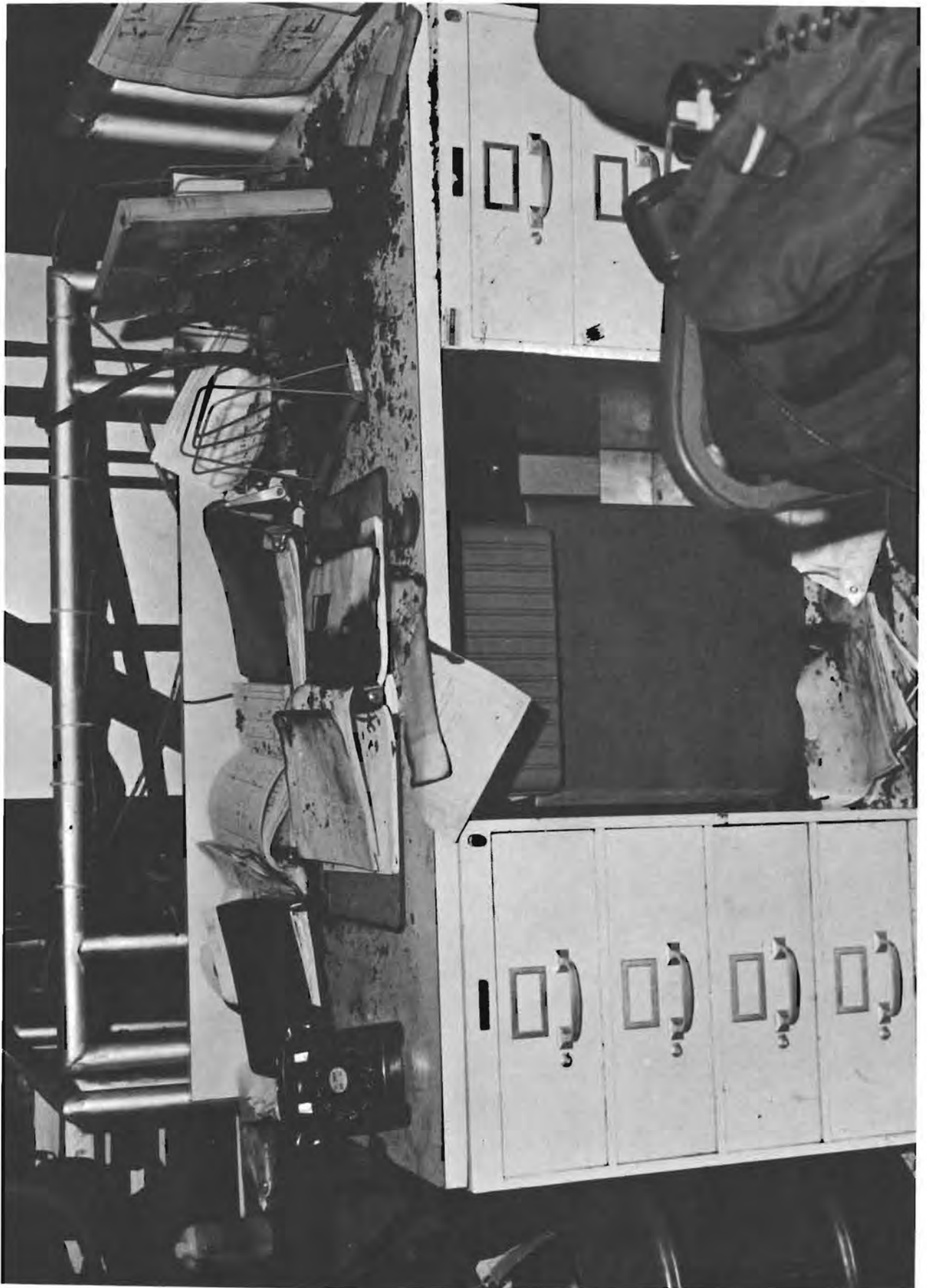

LEVEL A8 CLOSE-UP OF PAD LEADER'S DESK



TO: Those Concerned

SUBJECT: Designation of Hardware Removal and Disposition Panel

A Hardware Removal and Disposition Panel has been established to plan and control the removal and disposition of AS-204 spacecraft hardware. The Chairman of the panel will report to the Chairman of the Board of Inquiry who will approve the plan and be kept informed of all removal and disposition actions. The composition of the panel is as follows:

Scott H. Simpkinson	Chairman
Sam Beddingfield	Member
John Moore	Member
Patrick J. Hanifin	Member

The panel may call upon MSC, KSC and NAA for necessary assistance in accomplishing its assigned task.

After an intended removal and disposition action has been planned and approved by the Chairman of the Board of Inquiry, the actual removal and disposal work within the local KSC area will be executed by the Panel through the normal NASA and NAA pad and industrial area organizations. The Panel will provide written instructions (in accordance with APOP procedures) and broad supervision to designated NASA and NAA operations engineers. The designated operations engineers are Ernie Reyes, NASA, and Bruce Haight, NAA. The two designated engineers will arrange for necessary alternates to act for them during extra shift operations. The operations engineers will arrange for access to the pad and scheduling of their work through the Test Supervisor on duty at Launch Complex 34.

The following will govern the operation of hardware removal and disposition:

#### I. WORK AUTHORIZATION AND DOCUMENTATION

##### a. TEST PREPARATION SHEET

All work on S/C 012 and on the spacecraft GSE that is, or has been connected to the spacecraft, is to be authorized by Test Preparation Sheets (TPS's). The TPS is required to be written and signed by NAA and NASA KSC-SCO Systems Engineering. The TPS is approved by signature of a NASA and a NAA member of the Hardware Removal and Disposition Panel.

(1) A specific and complete statement of the "reason for work" is required on each TPS.

(2) The TPS's are to consist of step-by-step work items written in a detailed manner that will leave no question as to what is specifically required to be done.

(3) No wire bundle electrical connectors are to be disconnected without specific call-out by W/B connector number of the TPS.

(4) All work on the spacecraft is to be accomplished by NAA technicians unless otherwise indicated on the TPS.

(5) All work is to be witnessed by NASA KSC-SCO and NAA Inspection. In addition, it is the responsibility of the HRD panel to make sure that the TPS includes the necessary requirements for official observers when required. Upon completion of each TPS work item, the item is to be stamped by NASA/NAA Inspection indicating completion.

(6) It is required that TPS's which authorized removal of equipment from the spacecraft conclude with the following statement as the last item of work: "Transport equipment to the Pyro Installation Building (PIB) and stock in bonded storage."

(7) Work or examination of the equipment upon removal from the spacecraft must be authorized by a subsequent TPS which is to begin with a statement that authorizes removal of the equipment from the bonded storage room, if required.

(8) Upon completion of work authorized by a TPS, it is required that a summary statement be made on the last TPS mod sheet by the NASA/NAA Systems Engineers. The summary statement is to include all items of a significant nature that were observed during the work activity indicating where follow-up action is needed.

(Sheet 1 of 4)

ENCLOSURE 4-4

D-4-17

#### b. TPS MODIFICATION SHEETS

Whenever a TPS is required to be modified in order to allow continuance of work activity, a TPS mod sheet is required. The TPS mod sheet is required to be written and signed by NAA and NASA KSC-SCO Systems Engineering and the Chairman of the Hardware Removal and Disposition Panel. In addition:

- (1) A specific and complete statement of the reason for the mod sheet is required on each TPS.
- (2) The TPS mod sheet must authorize work that is within the intent of the original TPS.

#### c. PARTS INSTALLATION AND REMOVAL RECORD

All equipment or material removed from the spacecraft must be documented on a Parts Installation and Removal Record (PIRR). The information noted on the PIRR consists of a part number (if available or applicable); a description of the equipment or material; and time and date of removal.

The PIRR is to be used as noted in the APOP, with Q C required to buy off all entries.

#### d. PARTS TAG

All equipment or material removed from the spacecraft must be tagged with a parts tag. The tag is to be attached to the hardware in such a manner that will not affect the condition of the equipment. The tag is to be attached to the container or bag that the material is placed into.

- (1) The parts tag is to accompany the equipment or material at all times.
- (2) Hardware removal tape:

It is required that prior to: removal of spacecraft hardware; spacecraft system components; disconnect of spacecraft electrical connectors; and, disconnect of spacecraft plumbing lines, a short length of silver-gray tape be attached across the mating line between the hardware to be removed and the adjacent hardware remaining in the spacecraft.

An indexing line is to be then marked on the tape with a black ball-point pen at right angles to, and across, the hardware mating line. A number correlating to the spacecraft hardware removal form entry is also to be written on each end of the tape.

The tape is then cut along the hardware mating line and the hardware is removed from the spacecraft.

The purpose of the indexing tape is to provide a capability of duplicating the as-was installation as accurately as possible, if and when necessary.

#### e. APOLLO PRE-FLIGHT OPERATIONS PROCEDURES MANUAL (APOP)

The APOP is the reference document to be used during all work activity on the spacecraft. Where differences exist between this memo and the APOP, this memo is the ruling document.

f. A separate investigation TAIR book has been establishing and all TPS's associated with spacecraft work, including GSE, will be retained in the investigation TAIR book. Copies of completed TPS with all deviations, mod sheets, summaries, and other notations, shall be furnished to the Chairman, one to be distributed to the Board.

### 2. WORK SUPPORT

#### a. OPERATIONS ENGINEERING

It is required that NASA KSC-SCO and NAA Operations Engineers be on duty at the spacecraft on an around-the-clock basis.

- (1) The Operations Engineers represent the HRD Panel at the spacecraft and at the PIB. They are in charge of the operations at the sites.
- (2) The Operations Engineers have the responsibility to schedule the daily spacecraft activity in detail. They also have the authority to stop work on the spacecraft when deemed necessary.
- (3) The Operations Engineers are responsible to maintain a spacecraft log, which documents all activity on the spacecraft on an hourly basis. A copy of the log is to be provided to the HRD Panel and is to be updated on a daily basis.

#### b. SYSTEMS ENGINEERING

It is required that NASA KSC-SCO and NAA SYSTEMS Engineers be on duty on a first shift basis with an evening shift contact specified by name.

c. QUALITY CONTROL

It is required that NASA KSC-SCO and NAA Inspection personnel be assigned at the spacecraft on an around-the-clock basis. It is required that NASA KSC-SCO and NAA Inspection be assigned in the PIB bonded storage room on an around-the-clock basis.

GENERAL

1. No task will be initiated until those individuals assigned to accomplish the task are thoroughly briefed by the responsible engineer and the Accident Investigator. No disassembly task will be performed on S/C 012 until the same task has been performed on S.C. 014 by the same individual.

2. Access to the spacecraft area will be tightly controlled and will be restricted to those individuals who have a specific task associated with the accident investigation. Specific pad access will be controlled by the test supervisor on duty at Launch Complex 34 through the pad leader at the Command Module.

3. Requests for work in the spacecraft or on any equipment attached to the spacecraft will come from only one source, defined as follows:

THE APOLLO 204 REVIEW BOARD. When a specific task has been defined by the Apollo 204 Review Board, the applicable systems group will be directed by the Hardware Removal and Disposition Panel to prepare a TPS of the task for submittal to the Review Board for approval, if indicated in the task request by the Board. The TPS, a more detailed plan of the task to be accomplished, will contain the applicable signatures of the Hardware Removal and Disposition Panel as discussed in paragraph 1 above.

/s/ Scott H. Simpkinson  
Chairman

/s/ John M. Moore  
Member

/s/ J. Janokaitis for S. T. Beddingfield  
Member

/s/ Patrick J. Hanifin  
Member

Modification to Memo "Designation of Hardware Removal and Disposition Panel"

Mr. Dean F. Grimm is assigned as a special representative of the HRD panel to work in the PIB. Mr. Grimm is authorized to sign all TPS and mod sheets for the HRD panel for work in the PIB. The designated operations engineers are Mr. R. G. Covell of NASA, and R. A. Gore of NAA. The two designated engineers will arrange for necessary alternates to act for them during extra shift operations.

Paragraph 1. (a) step 5 is modified to read "All work is to be witnessed by both NASA KSC-SCO and NAA Inspection unless specified otherwise on the TPS".

Paragraph 1. (b) is modified to read "Whenever a TPS is required to be modified in order to allow continuance of work activity, a TPS mod sheet is required. The TPS mod sheet is required to be written and signed by NAA and NASA-KSC-SCO system engineering and the Chairman of the Hardware Removal and Disposition Panel if the Chairman is present. Mr. S. T. Beddingfield is authorized to sign in the chairman's absence. If Mr. Beddingfield is not present then the astronaut on duty can sign."

- (1) A specific and complete statement of the reason for the mod sheet is required on each TPS.
- (2) The TPS mod sheet must authorize work that is within the intent of the original TPS.
- (3) The Chairman of the committee must be appraised of the mod as soon as practical.

The following astronauts will be on duty:

Major Donn Eisele  
Captain Stuart Roosa  
Major Ed Givens  
Captain John F. Swigert

/s/ Scott H. Simpkinson  
Chairman

/s/ S. T. Beddingfield  
Member

/s/ J. M. Moore  
Member

/s/ Patrick J. Hanifin  
Member



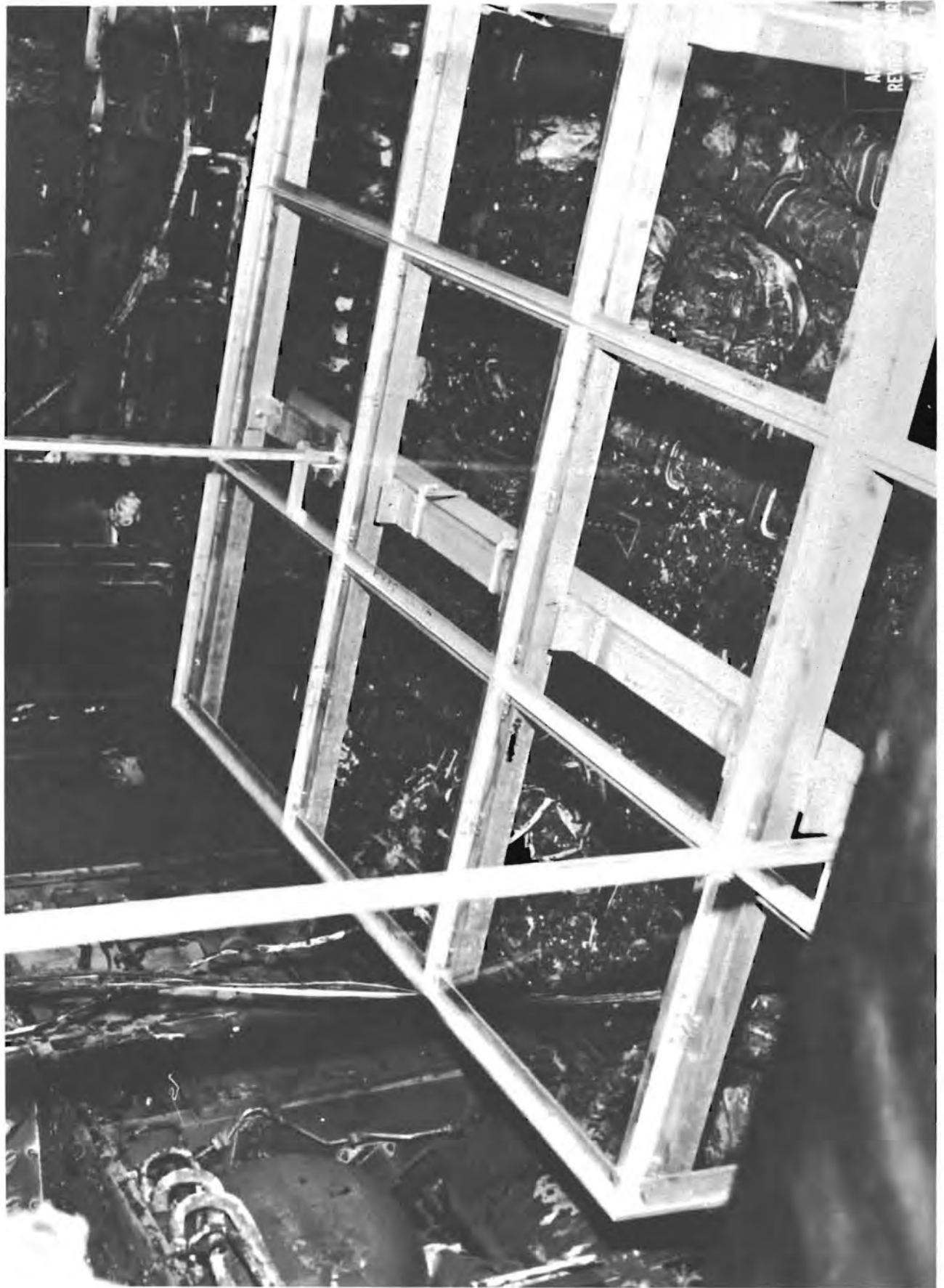

FALSE FLOOR INSTALLED IN SPACECRAFT 012

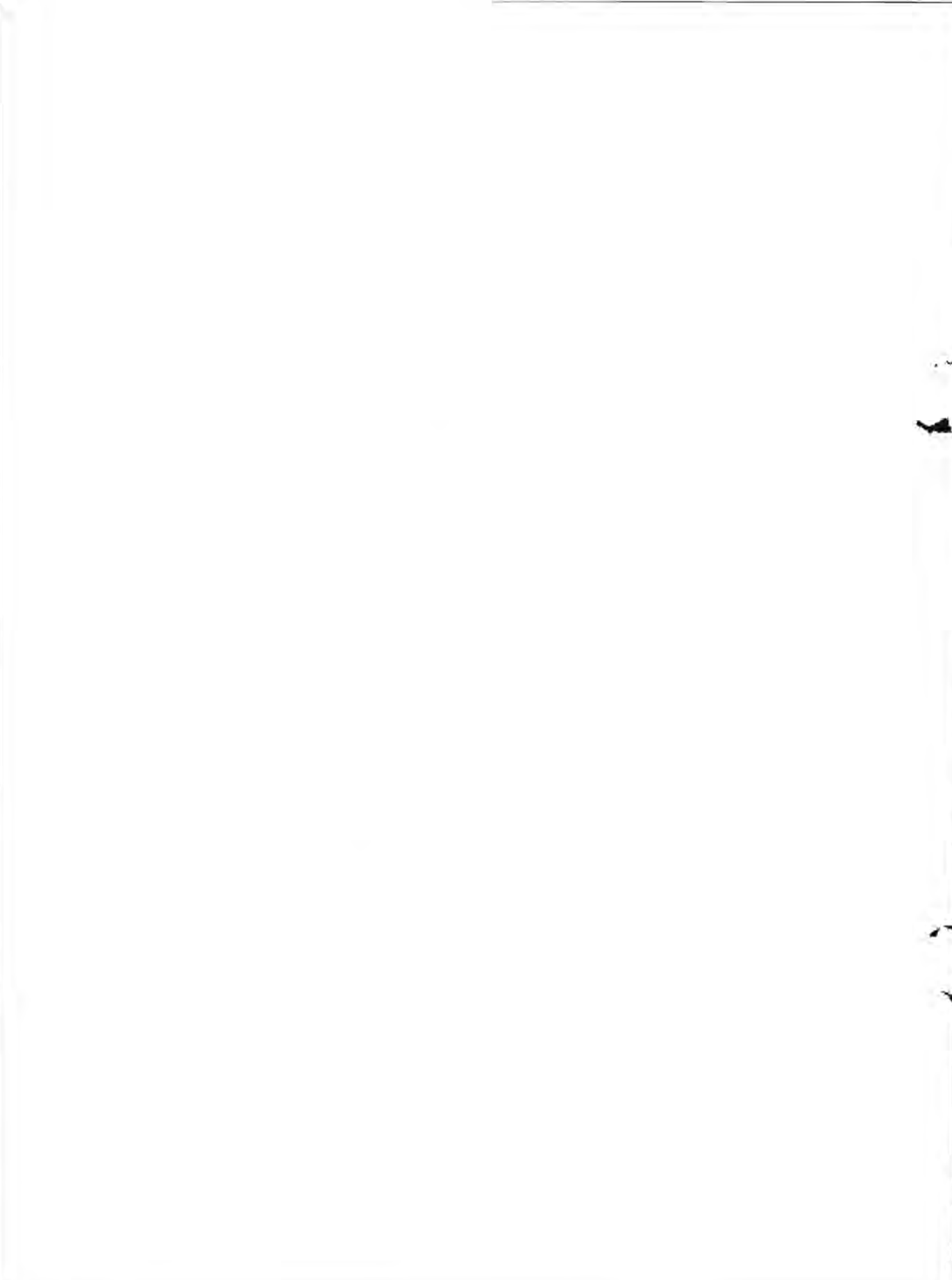



ELECTRICAL INTERFACE PHOTOGRAPHY



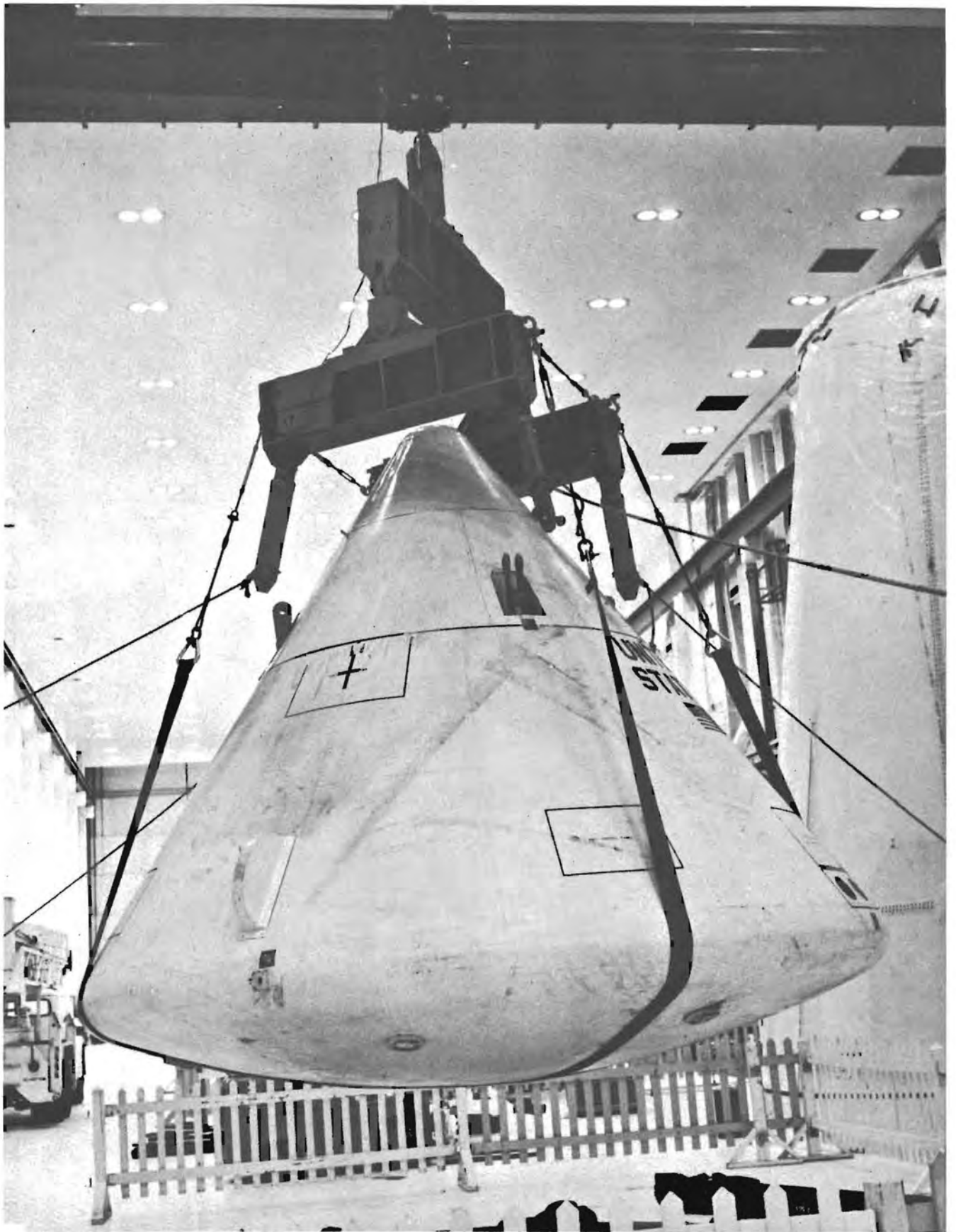

SPECIAL SLING VERIFICATION TEST

ENCLOSURE 4-7





COMMAND MODULE BEING MOVED OUT OF SERVICE STRUCTURE

ENCLOSURE 4-8







COMMAND MODULE OR SPECIAL BEING LOWERED TO GROUND



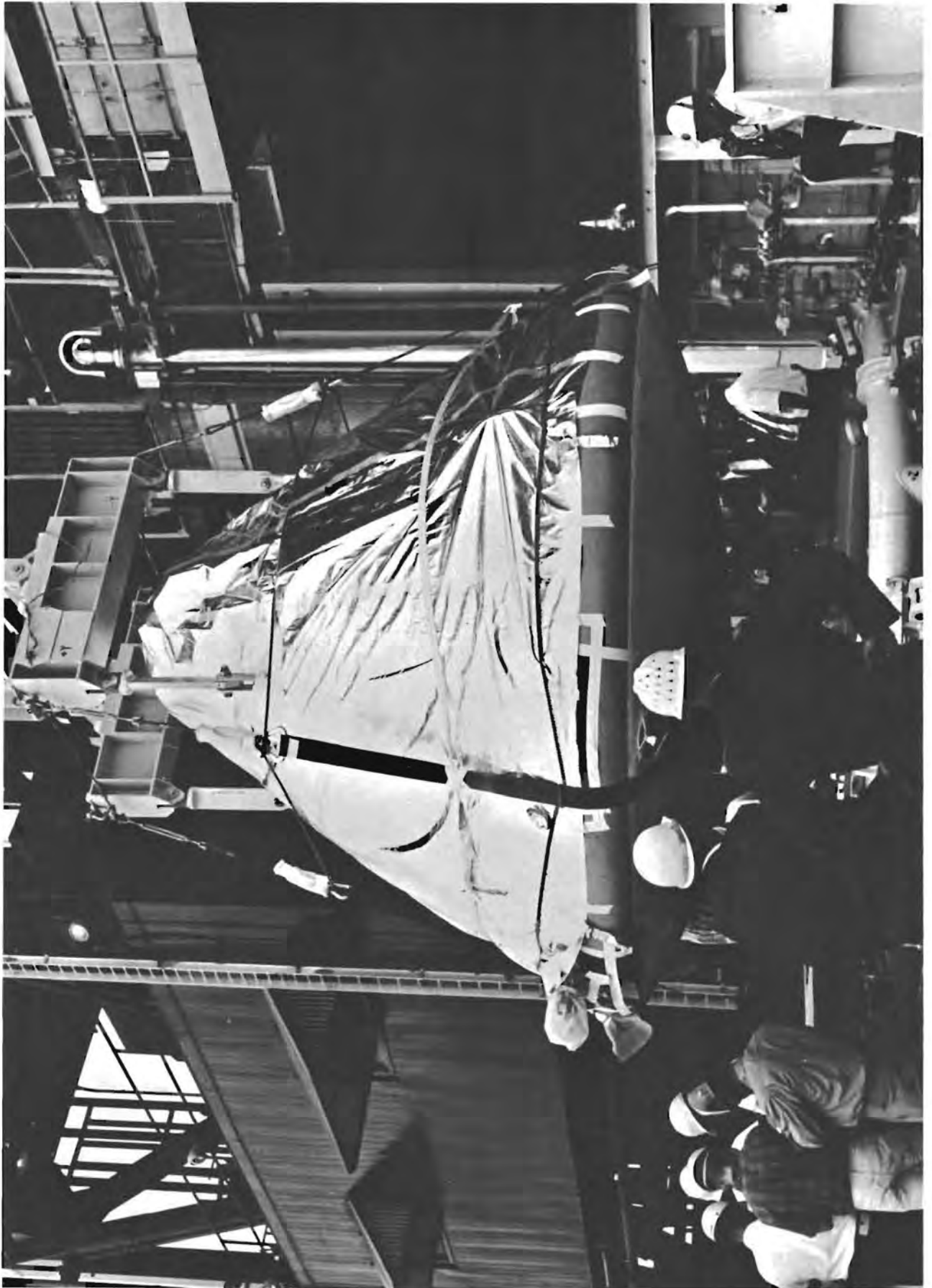

COMMAND MODULE BEING LOWERED ONTO TRAILER



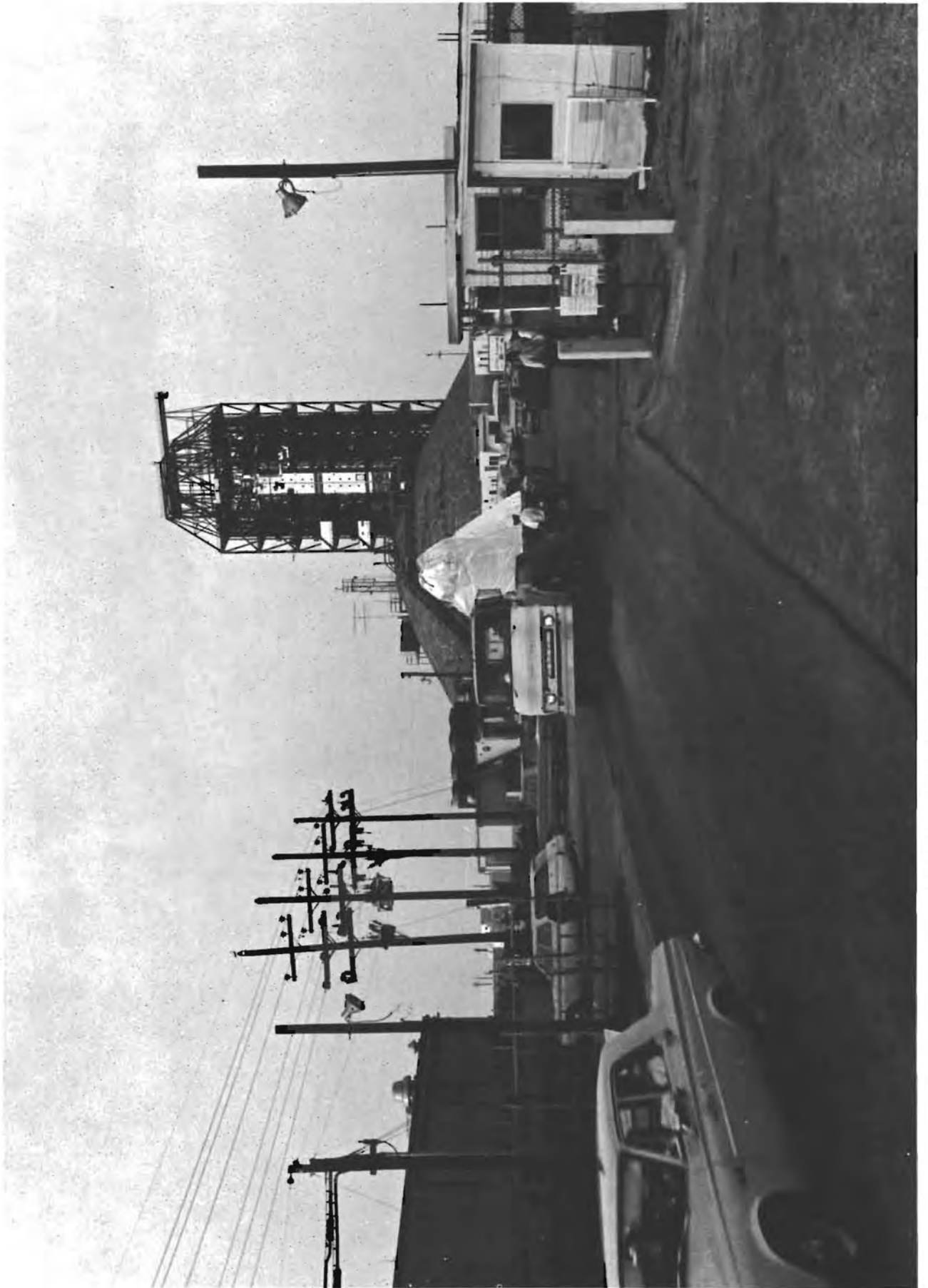

COMMAND MODULE MOVING OUT OF GATE AT COMPLEX 34



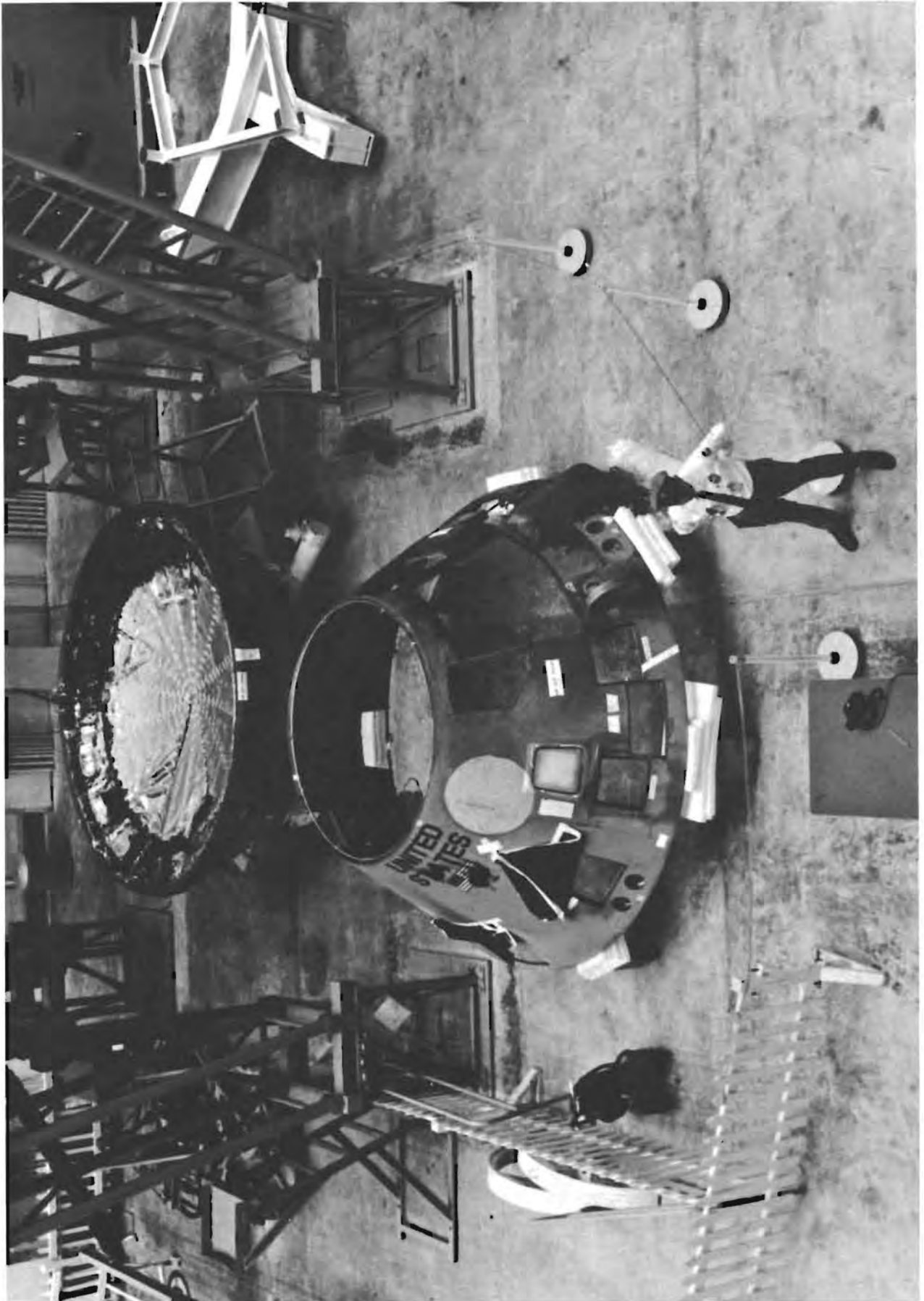

AFT HEAT SHIELD IN ALIGNMENT FIXTURE WITH CREW COMPARTMENT  
HEAT SHIELD IN THE FOREGROUND

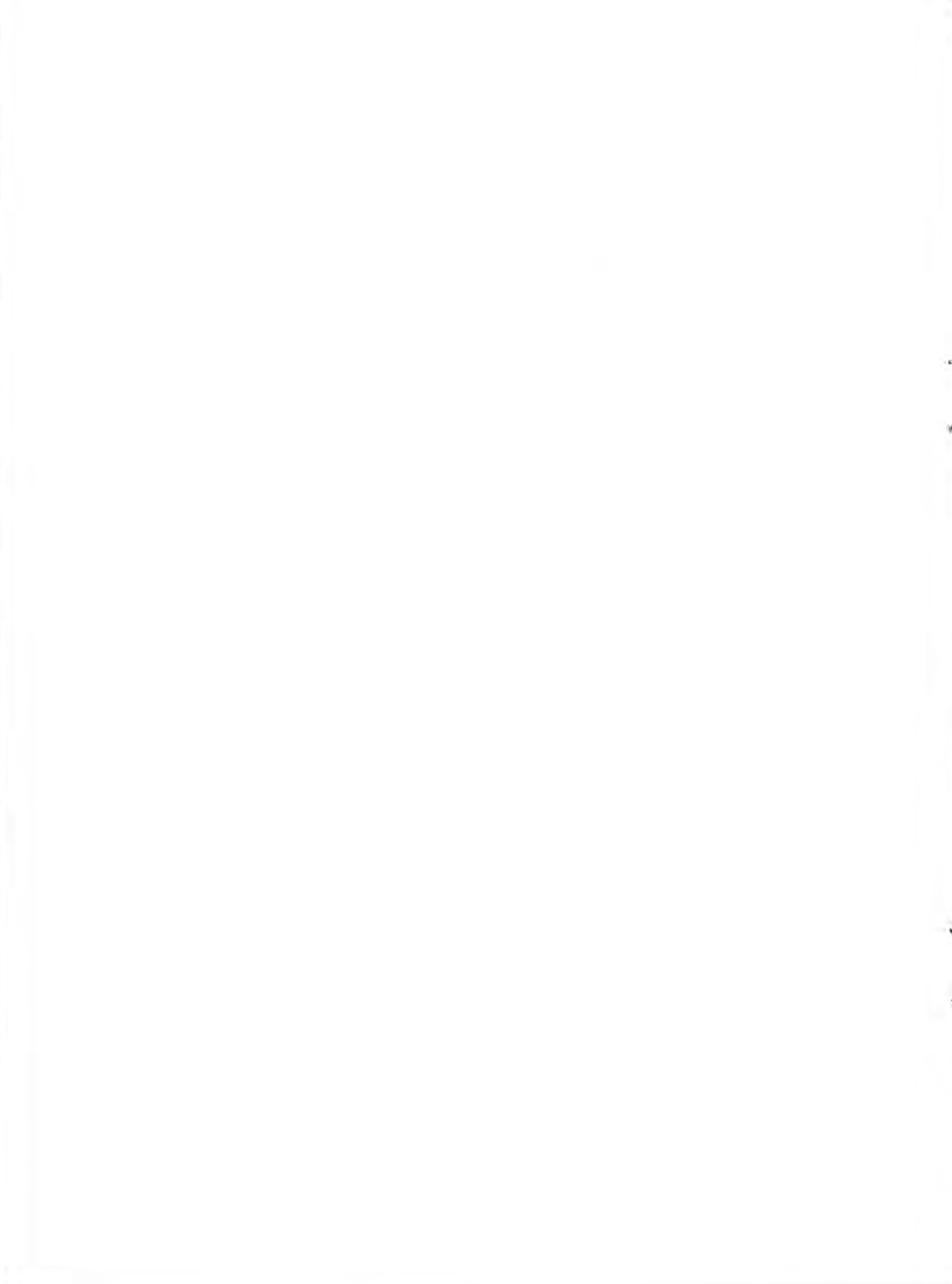



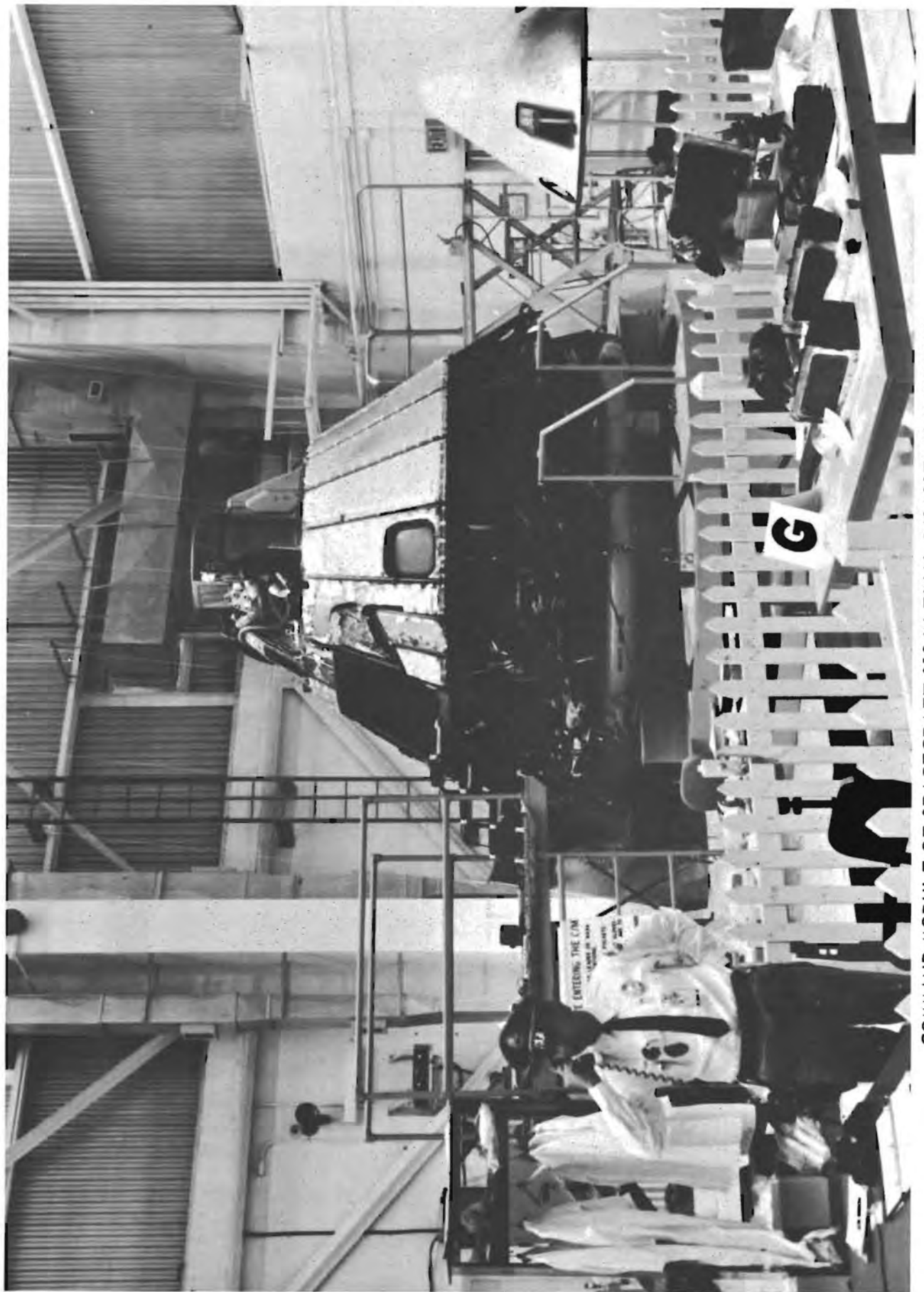

COMMAND MODULE OF SPACECRAFT 012 IN FINAL DISASSEMBLY AT THE PYROTECHNICS INSTALLATION BUILDING



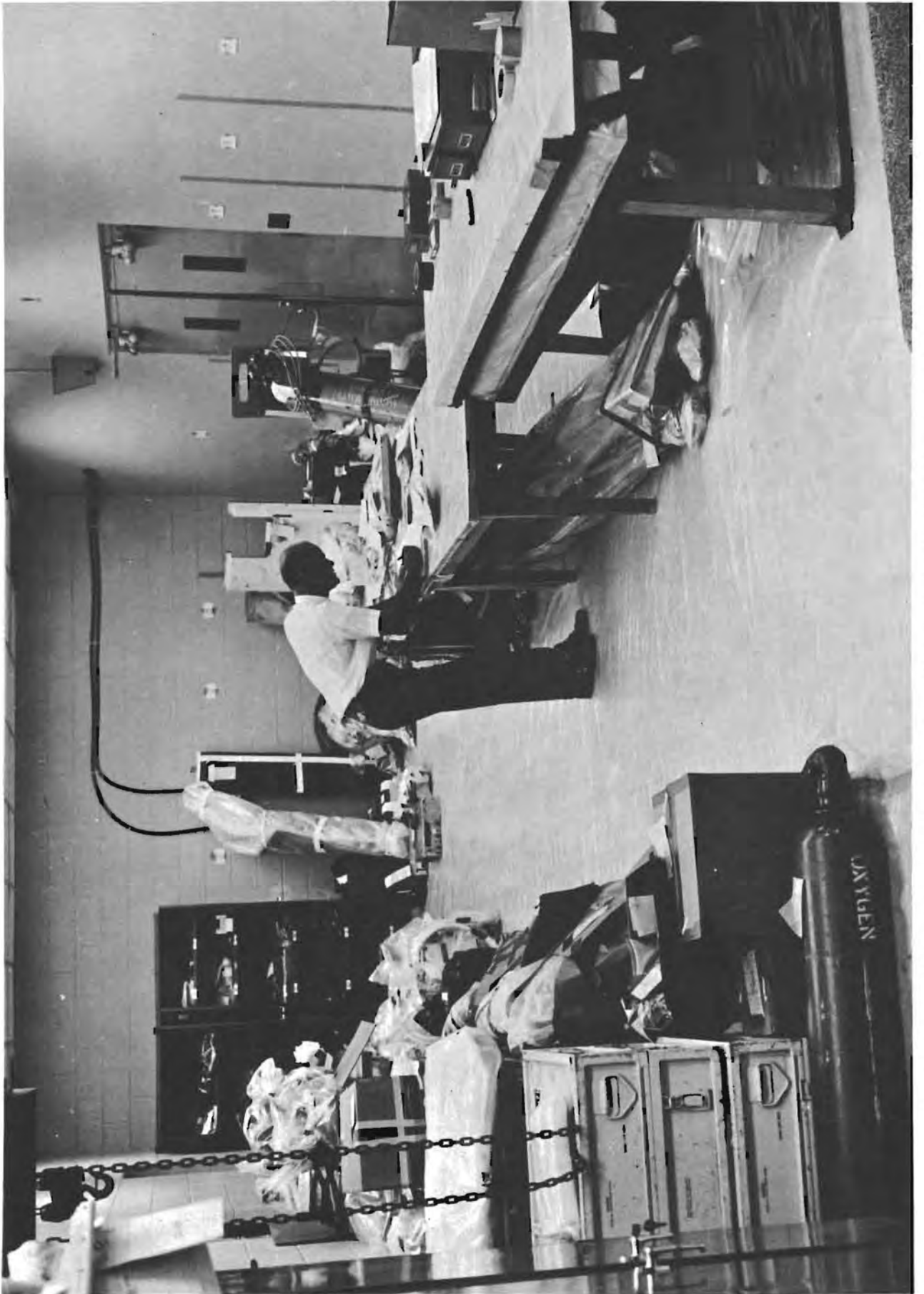

PYROTECHNICS INSTALLATION BUILDING BOND ROOM, LOOKING TOWARD THE NORTH WALL



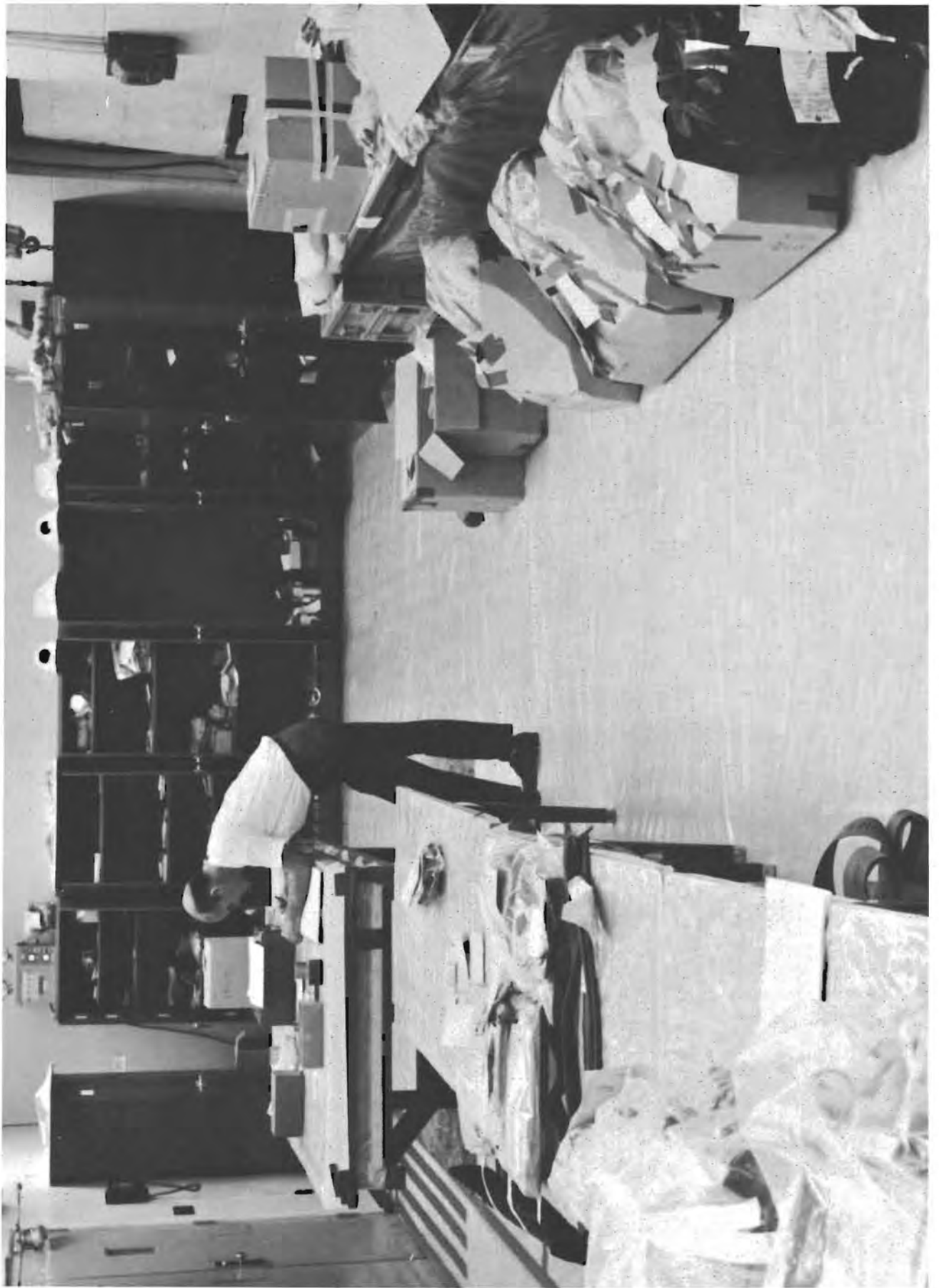

PYROTECHNICS INSTALLATION BUILDING BOND ROOM, LOOKING TOWARD THE SOUTH WALL



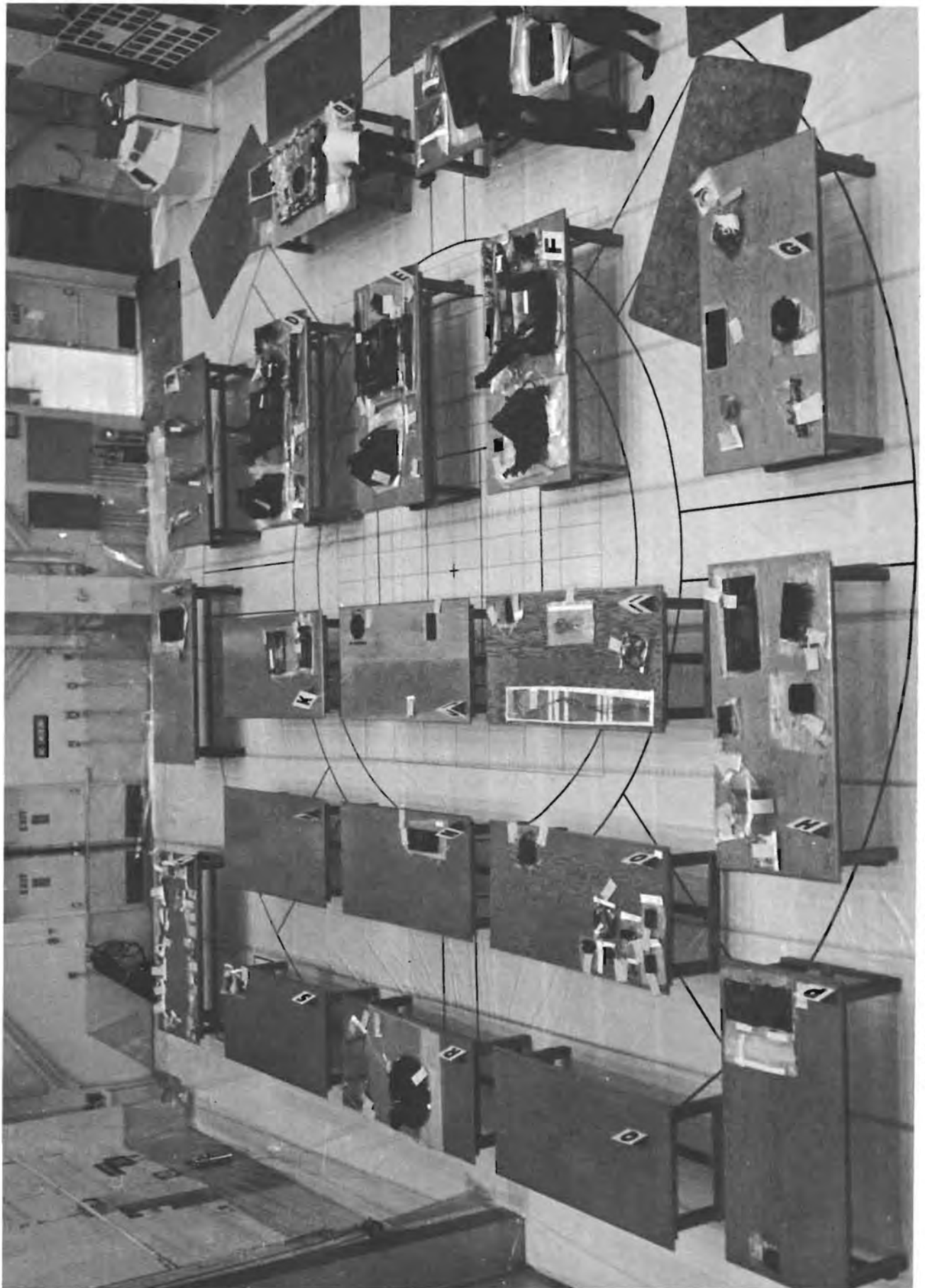

PYROTECHNICS INSTALLATION BUILDING BONDED DISPLAY AREA ON FEBRUARY 21, 1967





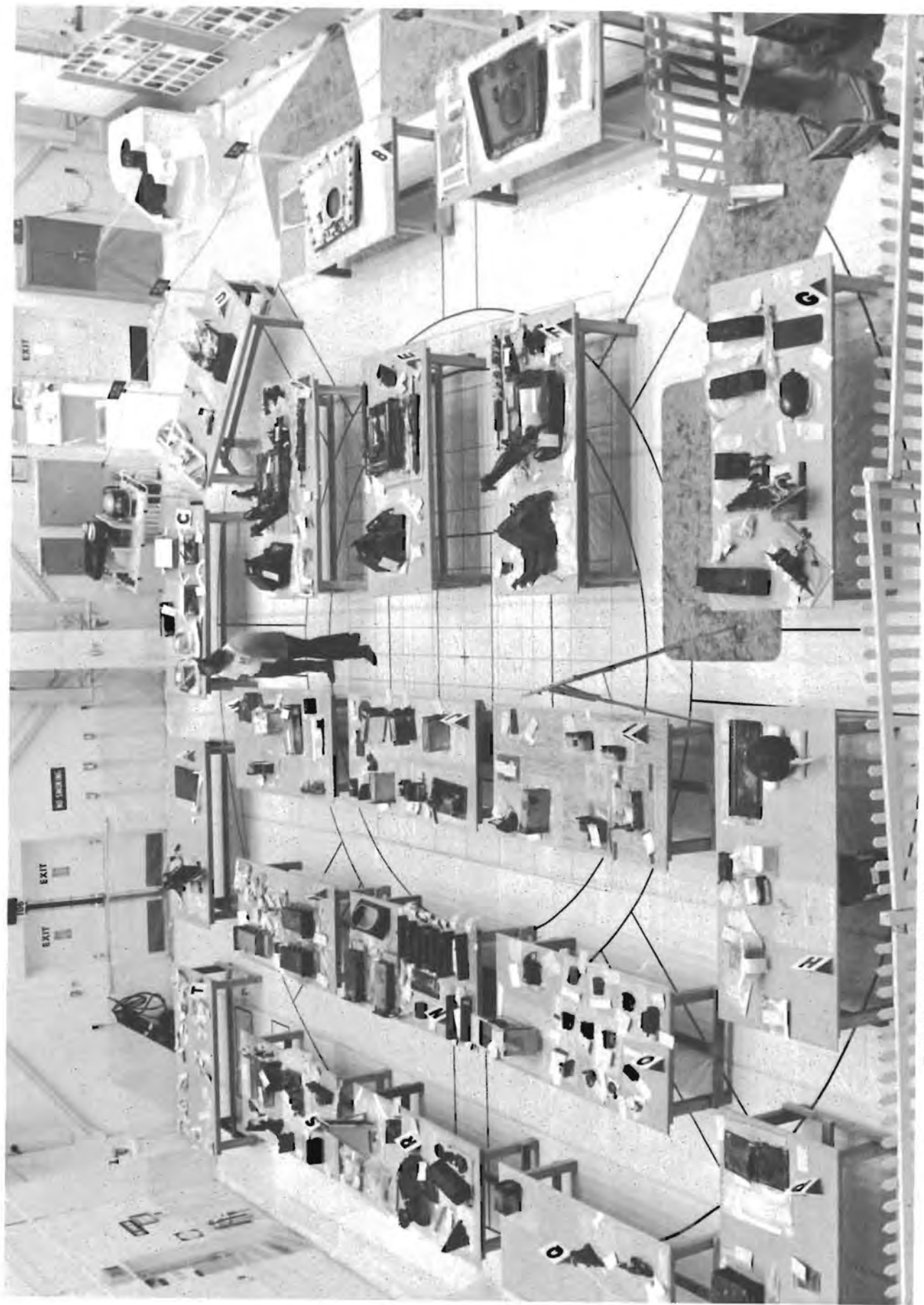

PYROTECHNICS INSTALLATION BUILDING BONDED DISPLAY AREA ON MARCH 14, 1967

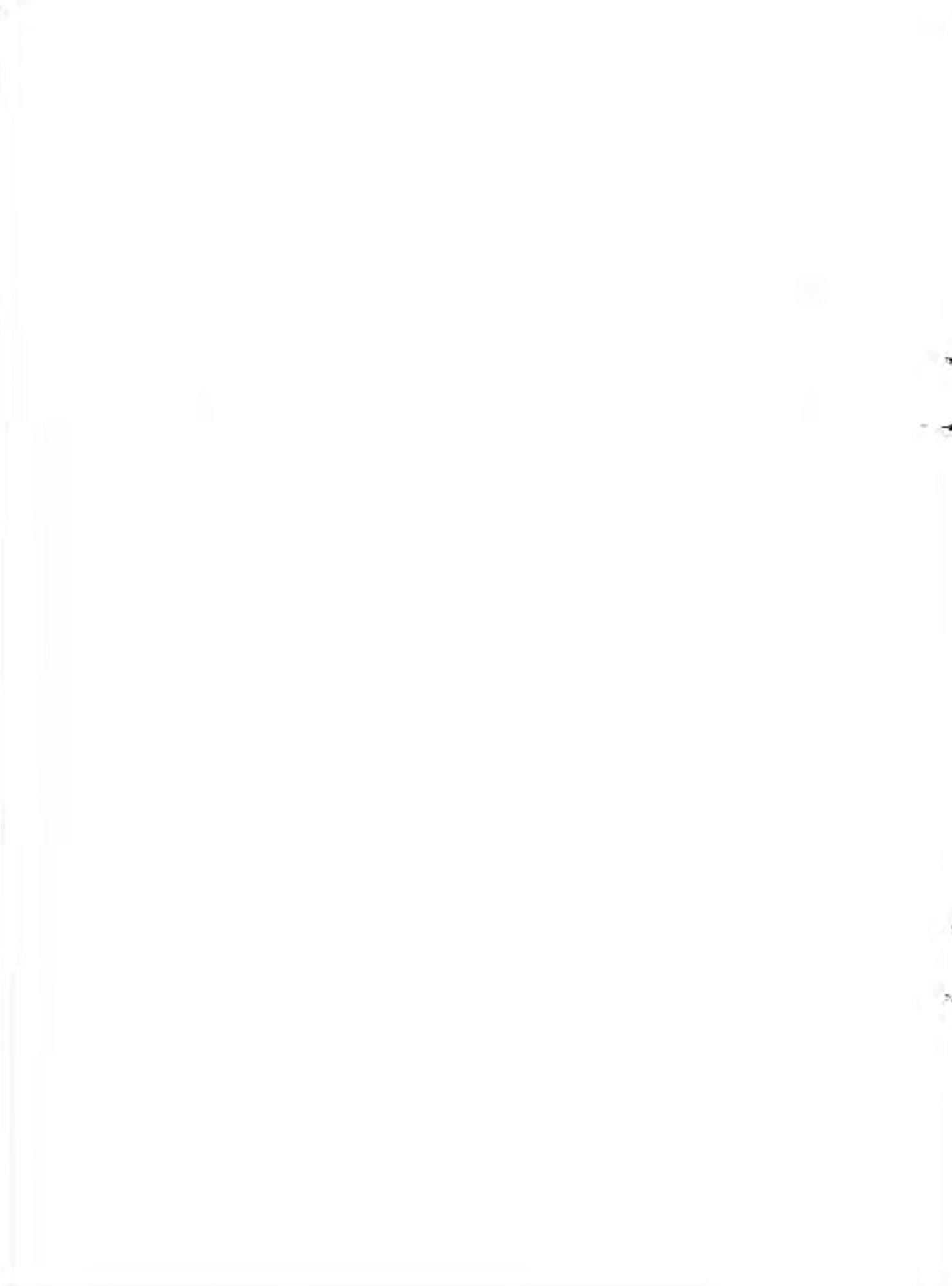

ITEM REMOVED FROM S/C 012 AND PLACED ON DISPLAY OR IN BONDED STORAGE

Revised 3/4/67

LOG No.	NOUN	PIRR No.	TPS
1	Bolt Assy	38	001
2	Bolt Assy	36	001
3	Bolt Assy	39	001
4	Bolt Assy	37	001
5	Screw	21	004
6	Splice	19	004
7	Splice	15	004
8	Splice	17	004
9	Splice	18	004
10	Splice	16	004
11	Splice	13	004
12	Mating Hardware	40	001
13	Mating Hardware	42	001
14	Mating Hardware	44	001
15	Mating Hardware	43	001
16	Switch Lock	N/A	N/A
17	Debris	1	001
18	(Oil) Debris	3	004
19	Debris	5	004
20	(Rubber Finger) Debris	6	004
21	Debris	11	004
22	Debris	12	004
23	Debris	14	004
24	Debris	20	004
25	Debris	23	010
26	Debris	25	010
27	Debris	32	001
28	(Filler) Debris	47	003
29	(Filler) Debris	48	003
30	(Filler) Debris	49	003
31	(Filler) Debris	50	003
32	(Tape) Debris	51	010
33	(QC Note) Hardware	--	--
34	B.P.C. FWD Sect.	36-44	001
35	Boost Protect Hatch	--	--
36	Boost Protect Cover	10	004
37	Boost Protect Cover	9	004
38	Boost Protect Cover	7	004
39	Boost Protect Cover	8	004
40	FWD Heat Shield	105	003
41	Switch Checklist	142	012
42	Pilot Logbook	140	012
43	Djvider	145	012
44	Debris	147	012
45	Debris	150	012
46	Pack Pad	146	012
47	(Cover) Divider	144	012
48	(R.H. Couch) L.H. Arm Rest	139	012

ENCLOSURE 4-18

D-4-47

49	Back Pad	148	012
50	Handbook	141	012
51	(Pilot) Logbook	138	012
52	Debris	149	012
53	Debris	151	012
54	Paper	143	012
55	Cobra Cable	158	012
56	Small Debris	159	012
57	Small Debris	156	012
58	Small Debris	160	012
59	Small Debris	157	012
60	Small Debris	154	012
61	Cable Run	153	012
62	Loose Debris	155	012
63	Debris	137	012
64	Back Pad	152	012
65	Head Rest (Center)	161	015
66	Hardware for Head Rest Center Couch	162 thru 167	015
67	Head Rest L.H. Couch	168	015
68	Hardware for Head Rest L. H. Couch	169 thru 174	015
69	Head Rest R. H.	175	015
70	Head Rest R.H. Hardware	176 thru 181	015
71	Leg Rest R.H. Couch	182	015
72	Hardware Seat Belt	183	015
73	Screw	184	015
76	Inner Hatch	189	016
77	Outer Hatch	190	016
83	Debris	135	004
97	Hand Controller	187	015
99	CTR Couth Leg Rest	191	015
100	L.H. Couch Leg Rest	221	015
101	Debris	225	015
102	L.H. Crew Couch Hardware	222 thru 224	015
103	Bracket	192 thru 194	015
120	Base Assy	226	015
131	SCS Phase Inverter	256	018
136	Translation Controller	268	022
141	Egress Tun. Hatch	276	023
149	1 Bag Debris	271	015
150	1 Bag Debris	272	015
151	1 Bag Debris	273	015
152	1 Head Rest Pad	275	018
159	Debris	292	018
160	Debris	259	018
161	Pip Pin	295	024
162	02 Hose Umbilical	279	023
163	02 Hose Umbilical	278	023
164	02 Hose Umbilical	280	023
165	Torque Tube	293	024
166	Book	336	012
167	Book	335	012
168	Book	337	012

169	L.H. Crew Couch	358	024
170	R.H. Crew Couch	308	024
171	CNTR Crew Couch Back Rest	301	024
172	R/H ZZ Strut	302	024
173	Z Axis L.H. Strut Assy	354	024
174	R.H. Couch Strut Assy Head	307	024
175	L.H. XX Strut	360	024
181	Pitch RCS 8 PC Access	325	018
192	Debris	359	
193	Bolts	299	024
194	Bolts	298	024
195	Loose Debris	300	024
196	Bolt-Nut Washer	357	024
197	Bolt-Nut 2 Washers	353	024
198	Docking Handle	297	024
199	Bolt-Nut 2 Washers	306	024
200	Bolt-Nut Washer	304	024
201	Pip Pin	296	024
202	Bolt-Nut Washer	356	024
203	Bolt-Nut Washer	305	024
204	Bolt-Nut Washer	355	024
229	Panel 319	339	032
230	Atten. Panel Assy	340	032
232	Insulation from Translation Controller	269	022
233	Comp "C" Scientific	351	011
234	MDAS	348	011
235	(For MDAS) Screws	350	011
236	Food Compt. Door	341	033
237	Garment Compt. Door	366	033
238	Disconnect P101 (in S/C)	349	
240	G&N Panel Screws	367	048
241	Screws	352	048
242	Panel	363	048
243	G&N Front Panel (102)	368	048
249	Water Gun	373	050
250	W/G Bracket	374	050
251	Panel	376	050
252	Screws	375	050
254	Panel Assy	383	053
258	Entry "A" Battery	402	060
259	Entry "B" Battery	403	060
260	Post Landing Battery	404	060
261	Batt Mounting Hardware	405	060
262	Suit Ventilator	NA	014
263	Suit Ventilator	NA	014
264	Suit Ventilator	NA	014
265	Suit Ventilator	NA	014
266	Suit Ventilator	NA	014
267	Suit Ventilator	131	014
268	Suit Ventilator	132	014
269	Suit Ventilator	130	014
270	Terminal Board Cover	408	040
272	Screws	409	040
273	Screws	410	040

274	Terminal Board Cover	411	040
275	Terminal Board Cover	413	040
276	Screw	412	040
278	Main Chute	419	067
279	Main Chute	420	067
280	Main Chute	421	067
281	Retention Flap	426	067
282	Retention Flap	424	067
283	Retention Flap	425	067
284	Screws	423	067
285	Screws	422	067
286	Brake Cord	430	067
287	Tyrap's	427	067
288	Nor Mex Cord	429	067
289	02 Analyzer	108	007
290	02 Analyzer	109	007
291	16 mm Sequential Camera	480	081
292	Cable Assy	476	071
293	Spit Cobra Cable	436 & 437	071
294	16 mm Sequential Camera	480	081
295	Sensor Cable & Sensor	483	081
296	Power Cable	484	081
297	Cobra Cable (SS RP)	477 thru 479	071
298	Hydro Meter Control Unit	482	081
299	16 mm Power Cable	481	081
300	Lithium & Charcoal	447	039
301	SCMD Cable Assy	439 & 440	071
302	Sample on Kim Wipe	432	062
303	Attenuation Panel (313)	486	039
304	Bag of LIOH Crystals	450	039
305	Comp. A Odor Absorber	446	039
306	Vacuum Cleaner Bag	485	039
307	Bag of Carbon	449	039
308	Screws	487	039
309	Connector Module	448	069
310	18 ea. Samples	451	079
311	02 Panel	493	063
312	Screws	494	063
313	H2O Panel	491	065
314	Panel R.H. E. B.	489	070
315	Screws	490	070
316	Screws	492	065
317	Metal Chip	506	086
318	L.H. Piece of Wire Switch Guard	507	086
319	R.H. Piece of Wire Switch Guard	508	086
320	Screws (4) Nuts (3) Washers (2)	512	070
321	Cover Plate & Mount Hardware	509	082
322	CO2 Sensor	513	090
323	Bracket CO2 Mount	514	090
324	02 Tank	525	092
325	02 Tank Mounting Hardware	524	092
326	Steam Duct & Mounting Hardware	526 thru 529	094
329	Screws (2 ea.)	558	109
330	Screws (2 ea.)	559	109
331	Tube	555	108

332	Water Glycol in Plastic Bag	622	108
333	Pyro "A" Battery	556	109
334	Pyro "B" Battery	557	109
335	Access Panel	550	100
336	Tube	560	108
340	Screws	644	112
341	Samples	623	079
346	Sector #1 Fairing	652	112
352	Screws	650	112
353	Screws	649	112
354	Screws	670	112
355	Lock	640	112
356	Lock	639	112
357	Lock	638	112
358	Clamps	654	112
359	Elect. Module	651	562
368	Container	656	155
370	Debris Valastat	667	
376	String Tie	665	116
377	Melted Metal	666	116
382	Tension Tie Bolt	668	112
383	Counter Sunk Washer	669	112
384	Spacer	670	112
385	Washer	671	112
386	Nut	672	112
387	Tension Tie Bolt	673	112
388	Counter Sunk Washer	674	112
389	Spacer	675	112
390	Washer	676	112
391	Nut	677	112
392	Tension Tie Bolt	678	112
393	Counter Sunk Washer	679	112
394	Spacer	680	112
395	Washer	681	112
396	Nut	682	112
397	Strap Assy	684	S/C 012/S/C 112
398	Clamp	549	S/C 012/S/C 097
401	Bolt	693	112
402	Ablator Plug	685 thru 687	112
403	Bolt	688	112
405	Panel 24	001	IV S/C 012 C/M 041
406	Panel 24 Hardware 16 Screws	002	IV S/C 012 C/M 041
407	02 Valve Handle	003	IV S/C 012 C/M 041
408	LIOH Canister	007	IV C/M 061
409	Plug Ablator	008	IV C/M 043
410	Shims	012	IV C/M 061
411	Debris	011	IV C/M 061
418	Gas Chromatograph Conn. & Wiring	031	IV S/C 012 C/M 075
419	A-N Tee Bulkhead	019	IV S/C 012 C/M 074
420	Water Line Assy	014	IV S/C 012 C/M 074
421	CO2 Sensor Line	016	IV S/C 012 C/M 074
422	CO2 Sensor Line	017	IV S/C 012 C/M 074
423	Water Line	015	IV S/C 012 C/M 074
424	Delta P Sensor	020 & 023	IV S/C 012 C/M 074

425	Compression Pads	025	S/C 012 C/M 036
426	Diffuser	024	036
427	Bracket	030	036
428	Screws	033	S/C 012 S/C 036
429	Floodlight Hardware	033	032
430	Floodlight Guard Connector	034	032
431	Floodlight Hardware	037	033
432	Floodlight	033	032
433	Floodlight	037	032
434	Watch	046	IV C/M 076
435	Sunglasses	047	IV C/M 076
436	Scissors	048	IV C/M 076
437	Penlight	049	IV C/M 076
438	Survival	050	IV C/M 076
439	Neck Dam & Pocket	051	IV C/M 076
440	Shroud Cutter	052	IV C/M 076
441	Penlight	053	IV C/M 076
442	Inlet Temp. Transducer	045	IV C/M 074
443	Bolts	054	IV C/M 074
444	Debris	061	IV C/M 074
445	Debris	062	IV C/M 074
446	Washers	057	IV C/M 074
447	Debris	065	IV C/M 074
448	Kim Wipes	064	IV C/M 074
449	Debris	063	IV C/M 074
450	ECU	054	IV C/M 074
451	Bolt ECU Mount	055	IV C/M 074
452	Washer ECU	058	IV C/M 074
453	Nuts (ZEA) ECU	059	IV C/M 074
454	Washer ECU	060	IV C/M 074
455	Bolt ECU	066	IV C/M 074
456	Line, Tubing ECU 3/8" OD (Debris)	068	IV C/M 074
457	Line Tubing 1/4" OD (Debris ECU)	069	IV C/M 074
458	LIOH Debris (ECU Removal)	072	IV C/M 074
459	Hardware (ECU Removal)	073	IV C/M 074
460	R.H. (XX Foot) Floodlight	075	IV C/M 059
461	L.H. (XX Foot) Floodlight	074	IV C/M 059
462	Console Floodlight	079	IV 029
463	Console Floodlight	078	IV 028
464	Vial of Liquid (ECU)	082	IV C/M 074
465	Food Compt. B-C-D-E	083	091
466	Plate & Mount Hardware	084	091
467	Panel Assy	087	091
468	Screws, Food Compt. Doubler	085	091
469	Doubler	086	091
470	DSE Recorder	092	046
488	Panel #25	097	IV C/M 025
489	Hardware for Panel #25	102	IV C/M 025
490	R.H. Rendezvous window	108	IV C/M 089
491	Screws, R.H. Rendezvous Window	107	IV C/M 089
492	Ablator Plugs R.H. Rend. Window	103 & 104	IV C/M 089
493	L.H. Rend Window	106	IV C/M 089
494	Screws, L.H. Rend. Window	105	IV C/M 089
495	Ablator Plugs L.H. Rend Window	093 & 094	IV C/M 089



496	Mylar (Small piece in Bag)	111	S/C 012 S/C 090
497	Signal Conditioner Bolts	113	IV S/C 012 C/M 049
498	Dummy Module	121	IV S/C 012 C/M 049
499	Dummy Module	118	IV S/C 012 C/M 049
500	Dummy Module	120	IV S/C 012 C/M 049
501	Dummy Module	117	IV S/C 012 C/M 049
502	Dummy Module	119	IV S/C 012 C/M 049
503	Power Supply	115	IV S/C 012 C/M 049
504	Spacer	116	IV S/C 012 C/M 049
505	Front Retaining Plate	114	IV S/C 012 C/M 049
506	Front Retaining Panel	129	IV S/C 012 C/M 049
507	Attenuator Module	123	IV S/C 012 C/M 049
508	Amplifier	124	IV S/C 012 C/M 049
509	Attenuator Module	127	IV S/C 012 C/M 049
510	Dummy Module	122	IV S/C 012 C/M 049
511	Attenuator Module	125	IV S/C 012 C/M 049
512	Amplifier Module	126	IV S/C 012 C/M 049
513	Attenuator Module	128	IV S/C 012 C/M 049
514	Front Retaining Plate	130	IV S/C 012 C/M 049
515	Dummy Module	135	S/C 049
516	Attenuator Module	133	S/C 049
517	Dummy Module	136	S/C 049
518	Reg. Module	132	S/C 049
519	Reg. Module	131	S/C 049
520	AMP Module	138	S/C 049
521	AMP Module	134	S/C 049
522	AMP Module	137	S/C 049
523	Data File, Door & Hinge Pin	141	IV C/M 106
524	Spacers - Top & Bottom, Sig. Cond.	142 & 143	IV C/M 049
525	J1 Module	152	IV C/M 049
526	J2 Module	151	IV C/M 049
527	J3 Module	150	IV C/M 049
528	J4 Module	149	IV C/M 049
529	J5 Module	148	IV S/C 012 C/M 049
530	J6 Module	147	IV S/C 012 C/M 049
531	J7 Module	146	IV S/C 012 C/M 049
532	J8 Module	145	IV S/C 012 C/M 049
533	J27 Module	153	IV S/C 012 C/M 049
534	J28 Module	154	IV S/C 012 C/M 049
535	J29 Module	155	IV S/C 012 C/M 049
536	J30 Module	156	IV S/C 012 C/M 049
537	J31 Module	157	IV S/C 012 C/M 049
538	J32 Module	158	IV S/C 012 C/M 049
539	J33 Module	159	IV S/C 012 C/M 049
540	J34 Module	160	IV S/C 012 C/M 049
541	J35 Module	168	IV S/C 012 C/M 049
542	J36 Module	167	IV S/C 012 C/M 049
543	J37 Module	166	IV S/C 012 C/M 049
544	J38 Module	165	IV S/C 012 C/M 049
545	J39 Module	164	IV S/C 012 C/M 049
546	J40 Module	163	IV S/C 012 C/M 049
547	J41 Module	162	IV S/C 012 C/M 049
548	J42 Module	161	IV S/C 012 C/M 049
549	Spacer	169	IV S/C 012 C/M 049

550	Spacer	170	IV S/C 012 C/M 049
551	Screws (SCE Base Plate)	176	IV S/C 012 C/M 049
552	Screws (SCE Base Plate)	174	IV C/M 049
553	SCE Base Plate	175	IV C/M 049
554	Hardware, Washers & Screws	178	IV C/M 090
555	Ablator Plugs	110	IV C/M 090
556	Hardware, Screw & Washer	177	IV C/M 090
557	Ablator, Astro-Sextant	109	IV C/M 090
558	Seal	181	IV C/M 090
559	Seal	182	IV C/M 090
560	S-Band X-Ponder	185	IV C/M 125
561	SCT Crown (Lower)	192	IV C/M 090
562	Screws (4 ea.)	200	IV C/M 090
563	Screws (3 ea.)	190	IV C/M 090
564	SCT Crown Half	193	IV C/M 090
565	Screws (4 ea.)	202	IV C/M 090
566	Sextant Crown Upper Half	195	IV C/M 090
567	SCT Crown, Half Lower	194	IV C/M 090
601	Ablator Plugs	201	IV C/M 090
602	Telescope Cover	184	IV C/M 090
603	Sextant Cover	183	IV C/M 090
604	G&N Computer	203	IV C/M 070
605	Screws	204	IV C/M 070
606	Controller	None	P.I. 031
607	Box of Controllers	None	P.I. 031
608	Panel #2	207	018
609	Panel #2 (Howe)	208	018
610	Panel #1	210	019
611	Hardware for Panel #1	209	019
612	Hand-Hold	215	019
613	Hardware for Hand-Hold	216 & 217	019
614	Connector Octopus Cable	219	IV S/C 012 C/M 130
615	Flight Qual. Recorder	212	IV S/C 012 C/M 045
621	Bolts	787	S/C 012 S/C 161
622	Washers	801	S/C 012 S/C 161
623	Barrel Nuts	802	S/C 012 S/C 161
624	Bolts	800	S/C 012 S/C 161
625	Poly Tape	803	S/C 012 S/C 161
626	Ablator Panel	198	IV C/M 090
627	Q. Felt	231	IV C/M 090
628	Nutplate Strips	230	IV C/M 090
629	Z Strip	221	IV C/M 090
630	Ablative Panel Inner	228	IV C/M 090
631	Insulation Strip	220	IV C/M 090
632	Washers (34 ea.)	197	IV C/M 090
633	Yaw ECA	222	IV C/M 052
634	Display ECA	229	IV C/M 051
635	AUX ECA	238	IV C/M 053
636	Roll ECA	243	IV C/M 055
637	Panel 22	257	IV C/M 023
638	Panel 21	254	IV C/M 022
639	Cam Locks	249	IV C/M 055
640	MDP Panel #3	266	IV C/M 015
641	Hardware for Panel #3	265	IV C/M 015
642	D&C Panel #10	269	IV C/M 002

643	Hardware for Panel #10	268	IV C/M 002
644	D&C Panel 11	272	IV C/M 003
645	Hardware, D&C Panel 11	271	IV C/M 003
646	D&C Panel #16	276	IV C/M 010
647	D&C Panel #15	280	IV C/M 011
648	Hardware, Panel #16	275	IV C/M 010
649	Hardware, Panel #15	279	IV C/M 011
650	Pads	SM 077	S/C 012 161
651	Washer	SM 076	S/C 012 161
652	Safety Wire	SM 073	S/C 012 161
653	Screws	SM 064	S/C 012 161
654	Washer	SM 065	S/C 012 161
655	Cotter Pin	SM 068	S/C 012 161
656	Nut	S/M 069	S/C 012 161
657	Washer	S/M 070	S/C 012 161
658	Screw	S/M 071	S/C 012 161
659	Bolt	S/M 074	S/C 012 161
660	Nut	S/M 075	S/C 012 161
661	Washer	S/M 078	S/C 012 161
662	Debris	S/M 083	S/C 012 161
663	Half Ring	S/M 066	S/C 012 161
664	Support	S/M 079	S/C 012 161
665	Ring	S/M 080	S/C 012 161
666	Seal	S/M 081	S/C 012 161
667	Screws, Mount Panel #12	284	C/M 009
668	D&C Panel #12	285	C/M 009
669	PCM #1	287	IV S/C 012 C/M 047
670	Nut (PCM #1) L.H.	289	IV S/C 012 C/M 047
671	Cold Plate Fuzz	297	IV S/C 012 C/M 047
673	PCM #2	290	IV S/C 012 C/M 048
674	VHF Multiplexer	300	IV C/M 127
675	S-Band Pwr. AMP	301	IV C/M 126
676	Pitch ECA	310	IV C/M 054
677	Main DSKY	312	IV C/M 020
678	Mount Screw for Main DSKY	313	IV C/M 020
679	Shock Washers for Main DSKY	315	IV C/M 020
680	Shock Washer Triangle Main	314	IV C/M 124
681	DSKY	319	IV C/M 124
682	Cold-Plate Fuzz	320	IV C/M 124
683	"C" Band	321	IV C/M 132
684	Cold Plate Fuzz	324	IV C/M 132
685	Panel #5	334	IV C/M 017
686	UHF FM Xmitter	325	IV C/M 131
687	UHF AM Recovery Beacon	330	IV C/M-123
688	UHF AM Rec. Cold Plate Fuzz	330	IV C/M 123
689	Nut UHF AM Rec.	340	IV C/M 123
690	Panel #4 FDAI	337	IV C/M 016
691	Cold Plate Fuzz	339	IV C/M 016
692	Pre-Modulation Processor	345	IV C/M 138
693	P&C Panel #7	349	IV C/M 013
694	Panel #6	352	IV C/M 014
695	Door Assy. & Screws	S/M 155	IV S/M 006
696	#2 Inverter	C/M IV 353	IV C/M 085
697	Bolts Inverter	C/M 354	IV C/M 085

698	Panel S/M -4	S/M 170	IV S/M 006
699	Cover Assy.	S/M 165	IV S/M 006
700	Cover Assy.	S/M 167	IV S/M 006
701	Cover Assy.	S/M 164	IV S/M 006
702	Cover Assy.	S/M 166	IV S/M 006
703	Inverter #1	C/M 355	IV C/M 085
704	Mount Bolts	C/M 355	IV C/M 085
706	#3 Inverter & Hardware	357 & 358	IV C/M 085
716	Splice BPC	359	IV C/M 050
717	Audio Center	363	IV C/M 144
727	Panel #8 Display	375	IV S/C 012
728	Screws	371	IV S/C 012 012
729	Debris	372	IV S/C 012, 012
730	Panel 19	373	IV S/C 012 07
731	Screws	375	IV S/C 012 07
732	Blank Panel #17	376	IV S/C 012 C/M 139
733	Mount Screws Panel #17	377	IV C/M 139
734	Hand Hold	380	IV C/M 005
735	Panel #18	378	IV C/M 005
736	Screws Panel #18	379	IV C/M 005
737	Debris	S/M 146	IV S/M 004
738	Burned Paper	See Note on Q11 Tag	See Note on Q11 Tag
739	D&C Panel #20	390	IV C/M 008
740	Panel #20 Screws	389	IV C/M 008
741	AC Control Box	395	IV C/M 135
742	AC Control Box Mount Bolt	396	IV C/M 135
743	AC Cont. Unit Nut Plate Bracket	394	IV C/M 135
744	Separation Monitors	154	S/M IV 008
745	Debris	171	IV S/M 008
746	Debris	172	IV S/M 008
747	Debris	174	IV S/M 008
748	Debris	173	IV S/M 008
749	Biomed. Ext. Cable	244	IV 018
750	Physio Simulator	244	IV 018
751	Battery, Charger & hardware	397	IV 133
752	Motor Switch C14-56	402	IV 134
753	Motor Switch C14-53	404	IV 134
754	Motor Switch & Hardware C14-52	403	IV 134
755	Cable Clamps	400	IV 134
756	Screws	401	IV 134
757	NAV DSKY	422	IV C/M 092
758	Screws	423	IV C/M 093
759	Eye Piece (Unit 103) Stowage Compt.	C/M 425	IV S/C 012 C/M 093
760	G&N Indicator Panel 105	C/M IV 427	IV S/C 012 C/M 094
761	Mounting Bolts for G&N Panel 105	C/M 428	IV S/C 012 C/M 094
762	W/B Assy. Insul. Rotation Cont.		C/M 049 C/A
763	PSA Tray #9	430	IV C/M 103
764	PSA Tray #10	429	IV C/M 104
765	PSA Tray #2	432	IV C/M 102
766	PSA Tray #1	431	IV C/M 101
767	PSA Tray #4	434	IV C/M 096
768	PSA Tray #3	433	IV C/M 095
769	PSA Tray #5	435	IV C/M 097
770	PSA Tray #6	436	IV C/M 098

771	PSA Tray #7	437	IV C/M 099
772	PSA Tray #8	438	IV C/M 100
773	CDU #1	439	IV C/M 112
774	CDU #2	439	IV C/M 112
775	CDU #3	439	IV C/M 112
776	CDU #4	439	IV C/M 112
777	CDU #5	439	IV C/M 112
778	Signal Conditioner	444	IV C/M 119
779	Panel 101 & Hardware	446	IV C/M 113
780	Rate Gyro	448	IV C/M 056
781	Gyro Attitude	449	IV C/M 057
782	Master Event Seq. Cont.	405	IV C/M 062
783	Master Event Seq. Cont.	413	063
784	Debris	204	IV S/M 005
785	Piece of Glass	202	IV S/M 005
786	Panel 150 Conn. Mount Screws	460	IV C/M 149
798	"C" Band Antenna	461	IV C/M 121
799	Panel C/M 5	463	IV C/M 121
800	Clamps	485	IV C/M 174
801	Clamp	492	IV C/M 174
802	Clamps	469	IV C/M 174
803	Cushion	495	IV C/M 174
804	Clamps	488	IV C/M 174
805	Clamp	490	IV C/M 174
806	Clamp	482	IV C/M 174
807	Clamp	483	IV C/M 174
808	Life Preserver	473	IV C/M 174
809	Screws	470	IV C/M 174
810	Screws	489	IV C/M 174
811	Screws	486	IV C/M 174
812	Screws	487	IV C/M 174
813	String Tie	494	IV C/M 174
814	Clamp	491	IV C/M 174
815	Clamp	493	IV C/M 174
816	Unidentified Material	478	IV C/M 174
817	Clamp	484	IV C/M 174
818	Teflon Wrapping	471	IV C/M 174
819	Screw C/M 6	470	IV C/M 121
820	Clamp Set	456	IV C/M 121
821	Metal Bead	465	IV C/M 171
822	Screws	455	IV C/M 171
823	Rod	472	IV C/M 121
824	T/B Cover	481	IV C/M 174

825	Panel 150 String Tie	-	IV C/M 149
826	Screws C/M 18	476	IV C/M 121
827	Felt	499	IV C/M 121
828	G.Felt	498	IV C/M 121
831	Mounting Screws	505	IV C/M 145
832	Mount Screws	500	IV C/M 145
833	Panel 150 Pyro Bat C/B	496	IV C/M 149
834	Adhesive	-	MA 008
835	Sample Bottle	-	S/C 017
836	Stowage Door Vacuum Clean	501	IV C/M 145
837	Panel 201	504	IV C/M 145
838	Panel 202 Waste Management	502	IV C/M 145
839	Screws for Pnl. 202	503	IV C/M 145
840	Bolts, Heat Shield	010	IV C/M 093
841	Scissors & Suit Debris	531	IV C/M 147
842	Suit Debris	530	IV C/M 147
843	Sun Glasses	526	IV C/M 147
844	Case - Sun Glasses	532	IV C/M 147
845	Dosimeter	525	IV C/M 147
846	Molten Metal	533	IV C/M 147
847	Molten Metal & Wire	535	IV C/M 147
848	Molten Metal	534	IV C/M 147
849	Metal	527	IV C/M 147
850	Metal	528	IV C/M 147
851	Tubing	529	IV C/M 147
852	Screws & nuts	524	IV C/M 147
853	Clamps	523	IV C/M 147
854	Asbestos Insulation	544	IV C/M 043
855	Piece of Fiberglass	548	IV C/M 043
856	Shims	541	IV C/M 043
857	Fiberglass Tape	543	IV C/M 043
858	Q.Felt	552	IV C/M 121
859	RF Cable Clamp	555	IV C/M 121
860	J87 Mounting Hardware	557	IV C/M 121
861	AFT. Heat Shield	510	IV C/M 043
862	Cable Clamps	560	IV C/M 121
863	Cable Tray	561	IV C/M 121
864	Bolts for Cable Tray	563	IV C/M 121
865	Bolts for Cable Tray	562	IV C/M 121
866	Samples L/H Crew Couch L/H Foot Rest	405	C/M MA 007
867	Safety Wire	405	IV C/M 062
868	Cable Tray Assy., With Hardware	564,568,569	IV C/M 121
869	Air Diffuser & Cable Tray	559,566,558,567	IV C/M 121
871	Cable Tray & Hardware	596, 565	IV C/M 121
872	Debris from above Cable Tray	C/M 565	IV C/M 121
873	Insulation CM6	570,571,572	IV C/M 140
874	Heat Sink	578	IV C/M 140
875	Bolts-Heat Sink Mounting	577	IV C/M 140
876	Wire Twisted Pair	597	IV C/M 178
877	Roll Engine CW	580	IV C/M 140
878	Panel & Engine Roll CCW	466	IV C/M 121

879	Pencil, Debris Red Matl.	603	C/M 073
880	Q. Felt	601	IV C/M 121
881	Bolts	579	IV C/M 140
882	Q. Felt	584	IV C/M 043
883	Cable Tray & Hardware	605	IV C/M 121
884	Cable Tray & Hardware	602	IV C/M 121
885	Cable Tray & Hardware	598,600	IV C/M 121
886	Cable Tray	595	IV C/M 121
887	Q. Felt	584	IV C/M 043
888	Blanket CCW Engine	606	IV C/M 140
889	Blanket CW Engine	611	IV C/M 140
890	Heat Sink	583	IV C/M 140
891	Engine Bolts	614	IV C/M 140
892	Hardware	599	IV C/M 121
893	Bolts	613	IV C/M 140
894	Blanket "A"	592	IV C/M 140
895	Blanket "B"	593	IV C/M 140
896	Panel & Engine CW Roll	616, 477	IV C/M 140
897	Q. Felt	594	IV C/M 043
898	Engine, Yaw System "B"	590	IV C/M 140
899	Engine, Yaw System "A"	591	IV C/M 140
900	Engine CCW	615	IV C/M 140
901	Bolts	589	IV C/M 589
902	Cable Tray & Hardware	604	IV C/M 121
903	Q. Felt	584	IV C/M 140
904	Cable Tray & Hardware	617	IV C/M 121
905	Blanket & + Yaw	629	IV C/M 140
906	Blanket & + Yaw	628	IV C/M 140
907	Hardware	637	IV C/M 140
908	Nuts & Washers	547, 548	IV C/M 121
909	Engine + Pitch System A	644	IV C/M 140
910	Engine + Pitch System B	645	IV C/M 140
911	Engine + Yaw System A	635	IV C/M 140
912	Engine + Yaw System B	634	IV C/M 140
913	Protective Cover "Pitch"	646	IV C/M 140
914	Bolts & Washers	643	IV C/M 140
915	Steam Duct	549	IV C/M 121
916	Debris	549	IV C/M 121
917	+ Pitch Engine Blankets	638	IV C/M 140
918	RCS Cont. Box C19A1	673	IV C/M 067
919	Screws & Washers	674	IV C/M 067
920	Air Vent	672	IV C/M 121
921	Washer	659	IV C/M 121
922	Nuts	658, 670	IV C/M 121
923	Washer	671	IV C/M 121
924	RCS Cont. Box	669	IV C/M 068
925	RCS Motor SW Assy.	697	IV C/M 069
926	Clamps & Screws	711, 712	IV C/M 069
927	Debris	--	IV C/M 069
928	- Pitch Engines A&B and Mounting Struct	721	IV C/M 140
929	Mounting Hardware - Pitch	720	IV C/M 140
930	Insulation & Blanket	627	IV C/M 140
931	Cable Clamp	715	IV C/M 121

932	Bracket	754	IV C/M 121
933	Screws	753	IV C/M 121
934	Screws for RCS Cont. Box	670	IV C/M 068
935	Screws for H2O Water Panel	492	S/C 012 065
936	Water Glycol	--	IV C/M 121
937	Washers, Bolt, Spacer	750, 751, 752	IV C/M 121
938	Nut Plate Assy.	741	IV C/M 121
939	Bolts Stringer #5	732	IV C/M 121
940	C/C Heat Shield	742	IV C/M 121
941	Q. Felt	648	IV C/M 121
942	Cobra Cable	762	C/M C/A 065
943	Wire	767	IV C/M 179
944	Hardware	764 thru 766	IV C/M 179
945	Hardware	710, 713, 714	IV C/M 121
946	Bonding Jumpers	761	IV C/M 121
947	Cotter Pins	676	IV C/M 121
948	Bolts	624	IV C/M 121
949	Debris	760	IV C/M 121
950	Hardware and Mounting	726	IV C/M 121
951	Washers	626	IV C/M 121
952	Safety Wire Umbilical	763	IV C/M 121
953	Spacer	625	IV C/M 121
954	Scanning Telescope	768	IV C/M 151
955	Optics Shroud Assy.	770	IV C/M 111
956	Screws Optics Mount	769	IV C/M 111
957	D&C Panel G&N	771	IV C/M 118
958	Screws D&C Mount	773	IV C/M 118
959	Samples		IV C/M 099
960	Soot Samples		MA C/M 008
961	Soot Sample		MA C/M 008
962	Ring Phenolic	783	IV C/M 176
963	Ring Teflon	782	IV C/M 176
964	Ring Phenolic	784	IV C/M 176
965	Seal Teflon Sxt.	781	IV C/M 176
966	Bolts	791	IV C/M 126
967	Nav. Base Optics Assy.	795	IV C/M 176
968	IMU	780	IV C/M 176
969	Bolts	785	IV C/M 176
970	Bolts w/washers	796	IV C/M 176
971	Control Elec. Assy.	790	IV C/M 176
972	USBE Front Panel	814	IV C/M 168
973	O <sub>2</sub> Surge Tank	812	S/C 012 S/C 095
975	O <sub>2</sub> Valve Assy.	804	S/C 012 IV C/M 153
976	Hardware Surge Tank	814	IV C/M 153
977	Outlet Line Surge Tank	800	IV C/M 153
978	Surge Tank ISO Valve Inlet Line	799	IV C/M 153
979	Bolts	807	IV C/M 153
980	Tube Assy	816	IV C/M 153
981	O <sub>2</sub> Relief Valve	808	IV C/M 153
982	Water Glycol Valves	834	IV C/M 153
983	Hand Controller Cable	833	IV C/M 122
984	Tee (Adapter)	830	IV C/M 122
985	Valve	826	IV C/M 153
986	Cobra Cable	832	IV C/M 122



987	Cobra Cable	829	IV C/M 122
988	Cobra Cable	831	IV C/M 122
989	Mtg. Brkt. Hardware	828	IV C/M 153
990	CMC "Y" Wire Assy	839	IV C/M 193
991	Press-Xducer 02 Surge Tank	809	IV C/M 153
992	Box Assorted Items		PI 047
993	Panel 316 C23Z2	842	IV C/M 107
994	Hand (Long) Hold Assy	843	IV C/M 084
995	Short Hand Hold Assy	844	IV C/M 084
996	LM Ret. Cont. Mount	846	IV C/M 084
997	G&N Eye Relief	845	IV C/M 084
998	Loop Clamp G&N	817	IV C/M 180
999	Screws Panel 316	840	IV C/M 107
1000	Bracket & Hardware	822	IV C/M 192
1001	Wire Harness Cover	824	IV C/M 192
1002	ELSC	866	IV C/M 064
1003	ELSC	861	IV C/M 065
1004	Shim. Toe Cap	884	IV C/M 120
1005	Screw	880	IV C/M 120
1006	Screw & Nuts	881	IV C/M 120
1007	PSA Toe Plate	883	IV C/M 120
1008	Thermal Interface Mat'l.	847	IV C/M 120
1009	Wire Covering	852	IV C/M 192
1010	Screws	879	IV C/M 180
1011	Connectors w/Screws	879	IV C/M 180
1012	Clamps & Hardware	885	IV C/M 120
1013	CDV Frame Assy	879	IV C/M 180
1014	Stringers		IV C/M 121
1015	PSA & Connector Assy	873	IV C/M 180
1016	Panel 209 Invert Sync	886	IV C/M 183
1017	Bracket for Panel 209 Invert Sync	904	IV C/M 183
1018	Screws Panel 209 Mount	887	IV C/M 183
1019	Panel 208 Invert Sync Box	903	IV C/M 184
1020	Screws Panel 208 Mount	902	IV C/M 184
1021	Plate Below Frame R/H Side	910	IV C/M 179
1022	Panel 203 & Hardware	905 & 907	IV C/M 169
1023	Attenuator Panel	908	IV C/M 169
1024	Atten. Panel Mtg. Screws	909	IV C/M 169
1025	Relay Box (VDL)	913	IV C/M 198
1026	PCVB & Hardware	918	IV C/M 066
1027	Heat Shield Sample	930	IV C/M 191
1028	Aft Heat Shield Sample	928	IV C/M 191
1029	TV Camera	931	IV C/M 082
1030	Wire Harness	934	IV C/M 081
1031	DSEA Voice Tape Recorder	933	IV C/M 081
1032	Film Magazine 16 mm	480	C/M MA 013
1033	Panel 100	936	IV C/M 027
1034	Screw for Pnl 100	934	IV C/M 027
1035	Guard Plate Assy	941	IV C/M 026
1036	Panel 200	940	IV C/M 026
1037	Hardware for Pnl 200	937, 943, 942	IV C/M 026
1038	Guard Plate Assy	947	IV C/M 182
1039	C14A8 Phase Correcting Box	946	IV C/M 182
1040	Screws (C14A8)	944	IV C/M 182

1041	Fuse Box	949	IV C/M 185
1042	Fuse Box Bolts & Tee Bracket	952	IV C/M 185
1043	Fuse Box Mtg. Bolts	948	IV C/M 185
1044	R.H. Control Unit Anti Rotational Casing	958	IV C/M 188
1045	Control Level Knobs	954	IV C/M 188
1046	Anti Rotational Casing	953	IV C/M 188
1047	Cabin Press Control Lever Support	955	IV C/M 188
1048	Cabin Press Control Unit	956	IV C/M 188
1049	R.H. Control Assy	957	IV C/M 188
1050	RIV Cabin Press	960	IV C/M 188
1051	2 Brkts. Cover	927	IV C/M 175
1052	Screws	920	IV C/M 175
1053	Mtg. Hdwr.	925	IV C/M 175
1054	Mtg. Screws	926	IV C/M 175
1055	J185 Plug	961 & 962	IV C/M 179
1056	Hardware	964	IV C/M 179
1057	Harness Brkts.	965	IV C/M 179
1058	Sleep Adapter	983	IV C/M 116
1059	Sleep Adapter	984	IV C/M 116
1060	CWG Adapter Cable	986	IV C/M 116
1061	CWG Adapter Cable	985	IV C/M 116
1062	D.C. Pwr. Control Box	981	IV C/M 195
1063	Screws for D. C. Pwr.	980	IV C/M 195
1064	C14A13 Cont. Box Uprighting	990	IV C/M 194
1065	Screws for C14A13 Mount	989	IV C/M 194
1067	Hatch Tool	1002	IV C/M 072
1068	Vacuum Cleaner Assy	991	IV C/M 078
1069	Louver Cabin Air Valve	1001	IV C/M 189
1070	Xducer Front Cabin Air Valve Louver	1003	IV C/M 189
1071	Suit Hose Connector	1004	IV C/M 189
1072	Suit Hose Connector	1004	IV C/M 189
1073	Heat Exchanger	1010	IV C/M 189
1074	Screws	1011	IV C/M 192
1075	Suit Host Contr.	1016	IV C/M 189
1076	Contr. Hdwre.	1016	IV C/M 189
1077	Access Panel	1022	IV C/M 189
1078	Utilization Panel	1018	IV C/M 181
1079	Clamp & Hardware	1021	IV C/M 181
1080	Honeycomb		IV C/M 191
1081	Cabin Press Xducer	999	IV C/M 189
1082	Screws Cobra Cable	1000	IV C/M 189
1083	Xducer Cabin Temp	1023	IV C/M 189
1084	Closure Valve	1026	IV C/M 189
1085	Amplifier Xducer Cabin Temp.	1013	IV C/M 189
1086	Fans Cabin Air	1025	IV C/M 189
1087	Cabin Temp. Controller	1012	IV C/M 189
1088	Xducer Cabin Temp.	1024	IV C/M 189
1089	Debris	1025	IV C/M 189
1090	Panel #13	1034	IV C/M 004
1091	Panel 13 Hardware	1033	IV C/M 004
1092	Panel 23 Hardware	1035	IV C/M 021
1093	Panel 23	1038	IV C/M 021
1094	Panel 26	1042	IV C/M 024

1095	Panel 26 Hardware	1039	IV C/M 024
1096	Mtg. Brkt. C151A52	1043	IV C/M 205
1097	Cable Clamp	1044	IV C/M 205
1098	Motor SW Panel C14A3	1045	IV C/M 205
1099	Helmet Bag	1047	IV C/M 080
1100	Helmet Bag	1046	IV C/M 080
1101	Helmet Bag	1048	IV C/M 080
1102	Close-Out Panel	1049	IV C/M 001
1103	Potable Water Assy.	1053	IV C/M 001
1104	LEB Hardware	1057	IV C/M 179
1105	Hardware Data Tray	1058	IV C/M 192
1106	Access Panel 206	1059	IV C/M 206
1107	1/4 "Snap On" Socket	1063	IV C/M 192
1108	LEB Hardware & Brackets	1062	IV C/M 192
1109	Wire Harness Wrap	1064	IV C/M 192
1110	Clamps	1065	IV C/M 192
1111	Xducer Mount Hardware	1068 & 1069	IV C/M 201
1112	Press Xducer	1070	IV C/M 201
1113	Press Xducer	1068	IV C/M 201
1114	Press Xducer	1069	IV C/M 201
1115	Signal Cond.	1067	IV C/M 201
1116	Pwr. Dist. Box	1083	IV C/M 187
1117	Hardware Bolts & Nuts Washers	1084	IV C/M 187
1118	Pwr. Dist. Box	1080	IV C/M 187
1119	Accelerometer	1089	IV C/M 202
1120	Accelerometer	1090	IV C/M 202
1121	Panel 204	1094	IV C/M 202
1122	Sig. Conditioner	1072	IV C/M 202
1123	Accelerometer	1092	IV C/M 202
1124	Sig. Conditioner	1075	IV C/M 202
1125	Sig. Conditioner	1071	IV C/M 202
1126	Current Limiter	1086	IV C/M 186
1127	Current Limiter	1087	IV C/M 186
1128	Current Limiter Hardware	1088	IV C/M 186
1129	Washer	1103	IV C/M 192
1130	Hardware Clamps Brackets	1102	IV C/M 192
1131	Hardware	1114	IV C/M 038
1132	Hardware	1111, 1112, 1113,	
		1115	IV C/M 038
1133	Elect. Cable Wrapping	1126	IV C/M 192
1134	Check Valve	1128	IV C/M 038
1135	Relief Valve	1107	IV C/M 038
1136	Shut-Off Valve	1108	IV C/M 038
1137	W/G Line Insulation	1129	IV C/M 038
1138	Shut-Off Valve 2.28DE	1119	IV C/M 038
1139	Relief Valve 2.2AB	1118	IV C/M 038
1140	Water Glycol Sample	1120	IV C/M 038
1141	Water Glycol Sample	1130	IV C/M 038
1142	Temp. Sensor	1110	IV C/M 038
1143	Check Valve 22.1	1109	IV C/M 038
1144	S, TXY Canister	1132	IV C/M 073
1145	Stowage Canister	1134	IV C/M 073
1146	TV Flex Coil Cord	1137	IV C/M 208
1147	Debris	1139	IV C/M 073

1148	Debris	1138	IV C/M 073
1149	COAS	1136	IV C/M 073
1150	COAS Bulb	1135	IV C/M 073
1151	Hardware Cover S & T	1131	IV C/M 073
1152	Hardware Canister	1138	IV C/M 073
1153	Clamps & Screws	1140	IV C/M 209
1154	Storage Box	1141	IV C/M 200
1155	Shelf, Vacuum Cleaner	1099	IV C/M 200
1156	SCS J Box	1148	CA C/M 231
1157	Knobs Cont. WMS Panel	1149	IV C/M 200
1158	Panel & Hardware WMS	1150	IV C/M 200
1159	Panel & Hardware WMS	1151	IV C/M 200
1160	Vert. Angle & Hardware	1142	IV C/M 200
1161	Horiz. "T" & Hardware	1143	IV C/M 200
1162	Back-Up Valve	1154	IV C/M 200
1163	Back-Up Valve	1157	IV C/M 200
1164	UDL Line	1158	IV C/M 200
1165	Line, Fr. WMS Sel. Valve	1160	IV C/M 200
1166	Valve Selector WMS	1161	IV C/M 200
1167	Line Assy	1162	IV C/M 200
1168	Valve Check	1164	IV C/M 200
1169	Clamp	1165	IV C/M 200
1170	Line Assy	1174	IV C/M 200
1171	Line Assy Waste Man.	1171	IV C/M 200
1172	Blower Waste Management	1170	IV C/M 200
1173	Urine Dump Lock	1163	IV C/M 200
1174	Check Valve	1172	IV C/M 200
1175	Check Valve	1173	IV C/M 200
1176	ECU P-33 Connector	1177	IV C/M 209
1177	ECU P-34 Connector	1178	IV C/M 209
1178	Events Conditioner	1179	IV C/M 117
1179	Canister Med. Science	1185	IV C/M 117
1180	Events Conditioner Hardware	1180	IV C/M 117
1181	Bolts for J-80 J Box	1182	IV C/M 117
1182	RF Coax Switch	1186	IV C/M 203
1183	Hardware for RF Coax Switch	1188	IV C/M 203
1184	Dust Cap and Tape	1204	IV C/M 162
1185	Sample W/G	1294	IV C/M 207
1186	Sample W/G	1294	IV C/M 207
1187	Debris	1226	IV C/M 211
1188	Debris	1224	IV C/M 211
1189	Debris	1223	IV C/M 211
1190	Debris	1225	IV C/M 211
1191	Debris	1229	IV C/M 211
1192	Debris	1222	IV C/M 211
1193	Debris	1230	IV C/M 211
1194	Debris	1231	IV C/M 211
1195	Debris	1219	IV C/M 211
1196	Debris	1232	IV C/M 211
1197	Debris	1227	IV C/M 211
1198	Debris	1228	IV C/M 211
1199	Debris	1221	IV C/M 211
1200	Debris	1220	IV C/M 211
1201	Debris	1234	IV C/M 211

1202	Debris	1233	IV C/M 211
1203	Debris	1236	IV C/M 211
1204	RF Conn. Loc. Clamps	1237	IV C/M 203
1205	C and W Detection Unit	1238	IV C/M 006
1206	Hardware for C and W Detection Unit	1203	IV C/M 006
1207	Access Panel	1239	IV C/M 006
1208	J11 Brkt. Hardware	1241	IV C/M 006
1209	J9 Brkt. Hardware	1240	IV C/M 006
1210	Sample #1		MA C/M 026
1211	Sampe #2		MA C/M 026
1212	Sample #3		MA C/M 026
1213	Sample #4		MA C/M 026
1214	Dye Marker	1242	IV C/M 112
1215	Dye Marker Swimmer	1247	IV C/M 112
1216	End Cap Dye Marker	1243	IV C/M 112
1217	Circuit Interrupter	1249	IV C/M 152
1218	Circuit Interrupter	1248	IV C/M 152
1219	Tube Sample	1250	IV C/M 190
1220	Tube Sample	1251	IV C/M 190
1221	Tube Sample	1252	IV C/M 190
1222	Tube Sample	1253	IV C/M 190
1223	Tube Sample	1254	IV C/M 190
1224	Tube Sample	1255	IV C/M 190
1225	Tube Sample	1256	IV C/M 190
1226	Tube Sample	1257	IV C/M 190
1227	Tube Sample	1258	IV C/M 190
1228	Brkt. Bundle Clamp	1259	IV C/M 192
1229	Line End "A"	1264	IV C/M 190
1230	Brkt. Assy. & Hardware	1268	IV C/M 190
1231	Tubing End "B"	1265	IV C/M 190
1232	Tubing H2O Waste Tank	1269	IV C/M 190
1233	Tube End "C"	1266	IV C/M 190
1234	Tube End "D"	1267	IV C/M 190
1235	Bracket	1270	IV C/M 179
1236	Clamp Section	1261	IV C/M 192
1237	Hdwre. & Clamps	1263	IV C/M 192
1238	Teflon & Spot Tie	1262	IV C/M 192
1239	Food Compt. "A"	1271	IV C/M 105
1240	Wire from C28 AR173	1272	IV C/M 179
1241	G & N Loose Equipment	1276	IV C/M 115
1242	Test Panel	1277	IV C/M 115
1243	Door Scientific D	1275	IV C/M 115
1244	Panel	1278	IV C/M 115
1245	Door, Assembly RHEB	1281	IV C/M 141
1246	Door, Assembly RHEB	1280	IV C/M 141
1247	Door, Assembly RHEB	1279	IV C/M 141
1248	Door, Assembly RHEB	1282	IV C/M 141
1249	ECS Restrictor Assembly	1291	IV C/M 086
1250	Filter Assembly	1292	IV C/M 086
1251	Filter Assembly	1293	IV C/M 086
1252	Check Valve	1294	IV C/M 086
1253	Check Valve	1295	IV C/M 086
1254	Line Assembly	1296	IV C/M 086
1255	Line Assembly	1297	IV C/M 086

1256	Line Assembly	1298	IV C/M 086
1257	Line Assembly	1299	IV C/M 086
1258	Clamp	1300	IV C/M 086
1259	Hardware	1301	IV C/M 086
1260	O2 Line	1302	IV C/M 086
1261	Oxygen Restrictor Assembly	1303	IV C/M 086

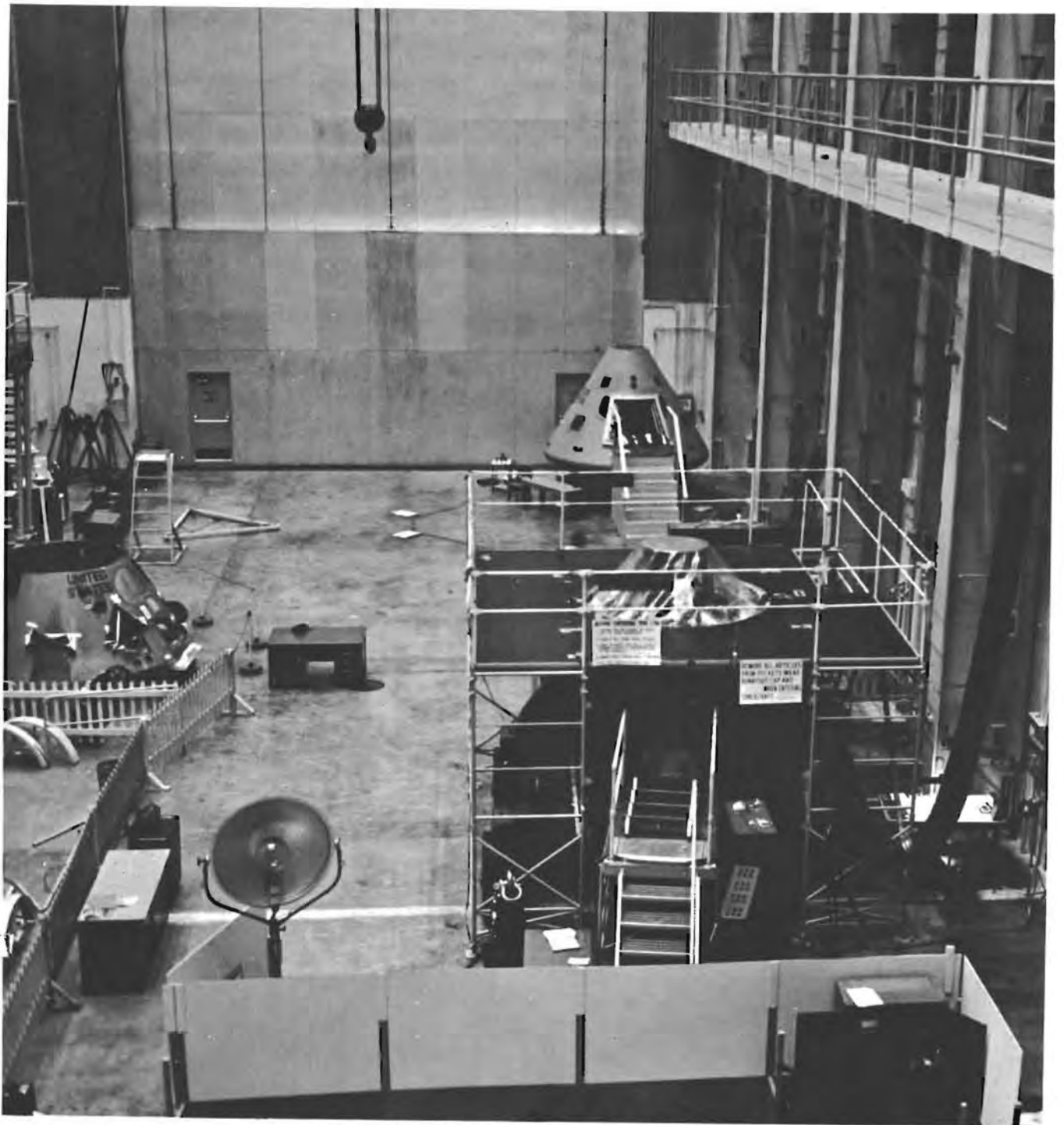

COMMAND MODULE 014 AND COMMAND MODULE MOCKUP #2





PLAN VIEW

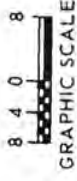
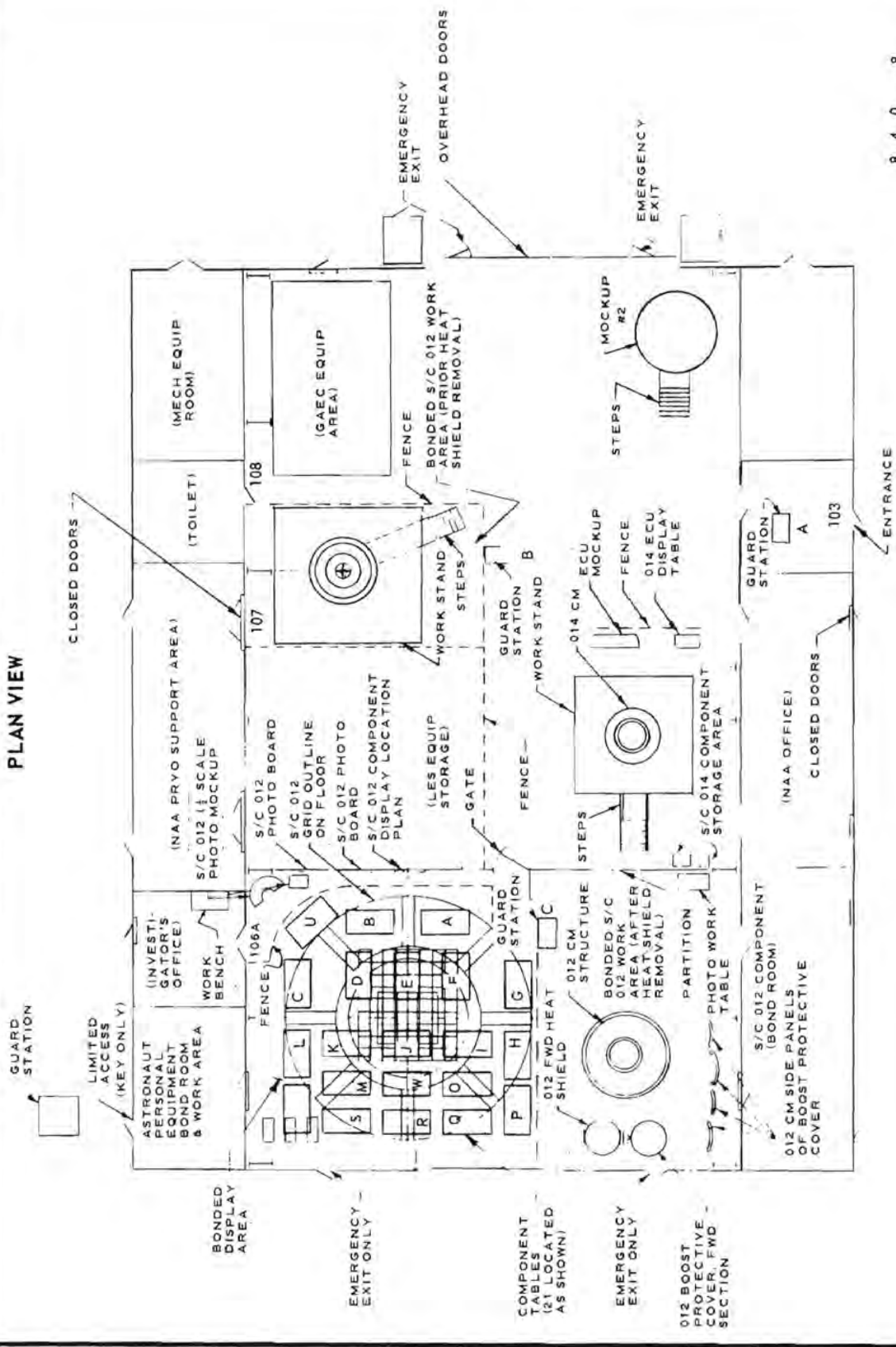

This page left blank intentionally.