

General Disclaimer

One or more of the Following Statements may affect this Document

- This document has been reproduced from the best copy furnished by the organizational source. It is being released in the interest of making available as much information as possible.
- This document may contain data, which exceeds the sheet parameters. It was furnished in this condition by the organizational source and is the best copy available.
- This document may contain tone-on-tone or color graphs, charts and/or pictures, which have been reproduced in black and white.
- This document is paginated as submitted by the original source.
- Portions of this document are not fully legible due to the historical nature of some of the material. However, it is the best reproduction available from the original submission.

NASA CONTRACTOR
REPORT

NASA CR-162080



SPACE APPLICATIONS OF AUTOMATION, ROBOTICS AND MACHINE
INTELLIGENCE SYSTEMS (ARAMIS)
VOLUME 2: SPACE PROJECTS OVERVIEW

By Rene H. Miller, Marvin L. Minsky, and David B. S. Smith
Massachusetts Institute of Technology
Space Systems Laboratory
Artificial Intelligence Laboratory
77 Massachusetts Avenue
Cambridge, Massachusetts 02139

(NASA-CR-162080-Vol-2) SPACE APPLICATIONS
OF AUTOMATION, ROBOTICS AND MACHINE
INTELLIGENCE SYSTEMS (ARAMIS). VOLUME 2:
SPACE PROJECTS OVERVIEW Final Report
(Massachusetts Inst. of Tech.) 182 p

N83-10848

HCA09

Uncias

G3/63 38342

Phase 1, Final Report

August 1982

Prepared for

NASA-GEORGE C. MARSHALL SPACE FLIGHT CENTER
Marshall Space Flight Center, Alabama 35812

1. REPORT NO. NASA CR-162080	2. GOVERNMENT ACCESSION NO.	3. RECIPIENT'S CATALOG NO.	
4. TITLE AND SUBTITLE Space Applications of Automation, Robotics and Machine Intelligence Systems (ARAMIS), Volume 2: Space Projects Overview		5. REPORT DATE August 1982	6. PERFORMING ORGANIZATION CODE
		8. PERFORMING ORGANIZATION REPORT # SSL Report #22-82	
7. AUTHOR(S) Rene H. Miller, Marvin L. Minsky, and David B. S. Smith	9. PERFORMING ORGANIZATION NAME AND ADDRESS Massachusetts Institute of Technology Artificial Intelligence Laboratory 77 Massachusetts Avenue Cambridge, Massachusetts		10. WORK UNIT NO.
12. SPONSORING AGENCY NAME AND ADDRESS National Aeronautics and Space Administration Washington, D. C. 20546		11. CONTRACT OR GRANT NO. NAS8-34381	13. TYPE OF REPORT & PERIOD COVERED Contractor Report Phase I Final
		14. SPONSORING AGENCY CODE	
15. SUPPLEMENTARY NOTES Technical Supervisor: Georg von Tiesenhausen, George C. Marshall Space Flight Center.			
16. ABSTRACT <p>This study explores potential applications of automation, robotics, and machine intelligence systems (ARAMIS) to space activities, and to their related ground support functions, in the years 1985-2000, so that NASA may make informed decisions on which aspects of ARAMIS to develop. The study first identifies the specific tasks which will be required by future space projects. It then defines ARAMIS options which are candidates for those space project tasks, and evaluates the relative merits of these options. Finally, the study identifies promising applications of ARAMIS, and recommends specific areas for further research.</p> <p>The ARAMIS options defined and researched by the study group span the range from fully human to fully machine, including a number of intermediate options (e.g., humans assisted by computers, and various levels of teleoperation). By including this spectrum, the study searches for the optimum mix of humans and machines for space project tasks.</p> <p>This is Volume II of a four-volume set, the fourth volume consisting of two documents, CR-162082, and an appendix, CR-162083.</p>			
17. KEY WORDS Automation Robotics Machine intelligence Space systems		18. DISTRIBUTION STATEMENT Unclassified-Unlimited <i>William C Snoddy</i> William R. Marshall, Director Program Development	
19. SECURITY CLASSIF. (of this report) Unclassified	20. SECURITY CLASSIF. (of this page) Unclassified	21. NO. OF PAGES 181	22. PRICE NTIS

TABLE OF CONTENTS

<u>Section</u>	<u>Page</u>	
<u>VOLUME 1: EXECUTIVE SUMMARY</u>		
1.1	Introduction	
1.1.1	Contractual Background of Study	1.1
1.1.2	Technical Background and Study Objectives	1.1
1.1.3	This Document and the Final Report	1.3
1.2	Brief Review of Study Method	1.5
1.2.1	Overview of Method	1.5
1.2.2	Space Project Tasks	1.5
1.2.3	Organization of ARAMIS	1.8
1.2.4	Definition of ARAMIS Capabilities	1.8
1.2.5	Favorable Sequences of ARAMIS Development	1.10
1.2.6	Evaluation of Candidate Capabilities	1.13
1.2.7	Selection of Promising Applications of ARAMIS	1.17
1.3	Results: Promising Applications of ARAMIS	1.21
1.3.1	Organization of Results	1.21
1.3.2	Power Handling	1.21
1.3.3	Checkout	1.23
1.3.4	Mechanical Actuation	1.24
1.3.5	Data Handling and Communication	1.25
1.3.6	Monitoring and Control	1.27
1.3.7	Computation	1.28
1.3.8	Decision and Planning	1.30
1.3.9	Fault Diagnosis and Handling	1.31
1.3.10	Sensing	1.33
1.4	Conclusions and Recommendations	1.35
1.4.1	Conclusions	1.35
1.4.2	Recommendations	1.36
1.5	Preview of Follow-On Work: Telepresence	1.41
1.5.1	Definition of Telepresence	1.41
1.5.2	Phase II of this Study	1.42

TABLE OF CONTENTS

<u>Section</u>		<u>Page</u>
<u>VOLUME 2: SPACE PROJECTS OVERVIEW</u>		
2.1	Introduction	2.1
	2.1.1 Contractual Background of Study	2.1
	2.1.2 Organization of the Final Report	2.1
	2.1.3 Partial Synopsis of Study Method: Space Project Breakdowns	2.3
2.2	Choice of Space Projects for Study	2.8
	2.2.1 Criteria for Choice	2.8
	2.2.2 Projects Selected for Breakdowns	2.8
2.3	Description of Breakdown Method	2.12
	2.3.1 Levels of Breakdowns	2.12
	2.3.2 Options within Breakdowns	2.14
2.4	The Generic Functional Element List	2.16
	2.4.1 Method of Production	2.16
	2.4.2 Comments on GFE List	2.18
<u>APPENDIX 2.A:</u>		
<u>SPACE PROJECT BREAKDOWNS (ANNOTATED)</u>		
2.A.1	Notes on this Appendix	2A.1
2.A.2	Geostationary Platform	2A.3
2.A.3	Advanced X-Ray Astrophysics Facility (AXAF)	2A.18
2.A.4	Teleoperator Maneuvering System	2A.48
2.A.5	Space Platform	2A.79
<u>APPENDIX 2.B:</u>		
<u>GENERIC FUNCTIONAL ELEMENT LIST</u> <u>(WITH BREAKDOWN CODE NUMBERS)</u>		
2.B.1	Notes on this Appendix	2B.1
<u>APPENDIX 2.C:</u>		
<u>GENERIC FUNCTIONAL ELEMENT LIST</u> <u>(WITHOUT BREAKDOWN CODE NUMBERS)</u>		
2.C.1	Notes on this Appendix	2C.1

TABLE OF CONTENTS

<u>Section</u>		<u>Page</u>
<u>VOLUME 3: ARAMIS OVERVIEW</u>		
3.1	Introduction	3.1
	3.1.1 Contractual Background of Study	3.1
	3.1.2 Organization of the Final Report	3.2
	3.1.3 Partial Synopsis of Study Method: ARAMIS Classification	3.4
3.2	General Discussion of ARAMIS	3.8
	3.2.1 General Comments	3.8
	3.2.2 Issues in Classification of ARAMIS	3.12
	3.2.3 Human and Machine	3.16
3.3	Classification of ARAMIS	3.18
	3.3.1 System Used in this Study: ARAMIS Topics	3.18
	3.3.2 Useful Sources of Information	3.20
3.4	ARAMIS Capabilities	3.25
	3.4.1 Method of Definition	3.25
	3.4.2 Production of ARAMIS Capability General Information Forms	3.29
	3.4.3 Favorable Sequences of R&D: Technology Trees	3.33
	References	3.38
<u>APPENDIX 3.A:</u> <u>ARAMIS TOPICS AND THEIR DEFINITIONS</u>		
3.A.1	Notes on this Appendix	3A.1
<u>APPENDIX 3.B:</u> <u>ARAMIS BIBLIOGRAPHY</u>		
3.B.1	Notes on this Appendix	3B.1
<u>APPENDIX 3.C:</u> <u>ARAMIS CAPABILITY GENERAL INFORMATION FORMS</u>		
3.C.1	Notes on this Appendix	3C.1
<u>APPENDIX 3.D:</u> <u>TECHNOLOGY TREES</u>		
3.D.1	Notes on this Appendix	3D.1

TABLE OF CONTENTS

<u>Section</u>	<u>Page</u>	
<u>VOLUME 4: APPLICATION OF ARAMIS CAPABILITIES TO SPACE PROJECT FUNCTIONAL ELEMENTS</u>		
4.1	Introduction	4.1
4.1.1	Contractual Background of Study	4.1
4.1.2	Contributors to this Study	4.2
4.1.3	Organization of the Final Report	4.5
4.2	Study Objectives and Guidelines	4.7
4.2.1	NASA and ARAMIS: The Problem	4.7
4.2.2	Research Objectives	4.10
4.2.3	Guidelines and Assumptions	4.12
4.3	Synopsis of Study Method	4.15
4.3.1	Overview of Study Method	4.15
4.3.2	Space Project Breakdowns	4.21
4.3.3	ARAMIS Classification	4.22
4.4	Selection of Generic Functional Elements for Study	4.25
4.4.1	Classification of GFE's	4.25
4.4.2	Reduction of GFE List	4.26
4.4.3	Definitions of GFE's	4.28
4.5	Definition of Candidate ARAMIS Capabilities	4.30
4.5.1	Issues in Definition of Capabilities	4.30
4.5.2	Method of Definition Used in Study	4.31
4.5.3	Classification of Capabilities by Topics	4.34
4.5.4	Descriptions of ARAMIS Capabilities	4.36
4.5.5	Development of Technology Trees	4.36
4.6	Evaluation of Candidate Capabilities	4.38
4.6.1	Decision Criteria	4.38
4.6.2	Decision Criteria Comparison Charts and ARAMIS Capability Application Forms	4.43
4.6.3	Limitations of Evaluation Method	4.49
4.7	Promising Applications of ARAMIS	4.55
4.7.1	Selection Method	4.55
4.7.2	Promising Applications of ARAMIS	4.63
4.8	Use of this Report by the Study Recipient	4.88
4.8.1	Suggested Procedure	4.88
4.8.2	Example of Procedure	4.92

TABLE OF CONTENTS

<u>Section</u>	<u>Page</u>	
<u>VOLUME 4: Cont'd</u>		
4.9	Preview of Phase II of this Study: Telepresence	4.103
4.9.1	Definitions and Promising Applications	4.103
4.9.2	Issues in Telepresence	4.106
4.10	Phase I Conclusions and Recommendations	4.108
4.10.1	Conclusions	4.108
4.10.2	Recommendations	4.110
	References	4.114

APPENDIX 4.A:

GENERIC FUNCTIONAL ELEMENT LIST
(GROUPED BY TYPES OF GFE'S)

4.A.1	Notes on this Appendix	4A.1
-------	------------------------	------

APPENDIX 4.B:

REDUCED GENERIC FUNCTIONAL ELEMENT LIST

4.B.1	Notes on this Appendix	4B.1
4.B.2	Nomenclature	4B.6

APPENDIX 4.C:

DEFINITIONS OF GFE'S SELECTED FOR FURTHER STUDY

4.C.1	Notes on this Appendix	4C.1
4.C.2	Nomenclature	4C.2

APPENDIX 4.D:

MATRIX: GENERIC FUNCTIONAL ELEMENTS
AND CANDIDATE ARAMIS CAPABILITIES

4.D.1	Notes on this Appendix	4D.1
-------	------------------------	------

APPENDIX 4.E

[In a separate binding; see
Volume 4 (Supplement) below.]

TABLE OF CONTENTS

<u>Section</u>	<u>Page</u>
<u>VOLUME 4: Cont'd</u>	
<u>APPENDIX 4.F:</u> <u>SUGGESTED DATA MANAGEMENT SYSTEM</u>	
4.F.1 Suggested System for ARAMIS Study Method	4F.1
4.F.2 General Comments on the Computer Method	4F.16
4.F.3 Use of the Computer in this Study	4F.18
4.F.4 Computer Program Listings	4F.25
<u>APPENDIX 4.G:</u> <u>TRANSPOSE MATRIX: ARAMIS CAPABILITIES</u> <u>AND THEIR APPLICATIONS TO GFE'S</u>	
4.G.1 Notes on this Appendix	4G.1
<u>VOLUME 4 (SUPPLEMENT):</u> <u>APPENDIX 4,E:</u> <u>CANDIDATE ARAMIS CAPABILITIES:</u> <u>COMPARISON CHARTS AND APPLICATION FORMS</u>	
4.E.1 Notes on this Appendix	4E,1
Power Handling GFF's	4E.4
Checkout GFE's	4E,47
Mechanical Actuation GFE's	4E,121
Data Handling and Communication GFE's	4E,202
Monitoring and Control GFE's	4E.262
Computation GFE's	4E.333
Decision and Planning GFE's	4E.382
Fault Diagnosis and Handling GFE's	4E.452
Sensing GFE's	4E.515

VOLUME 2: SPACE PROJECTS OVERVIEW

2.1 INTRODUCTION

2.1.1 Contractual Background of Study

On June 10, 1981, NASA Marshall Space Flight Center (MSFC) awarded a twelve month contract (NAS8-34381) to the Space Systems Laboratory and the Artificial Intelligence Laboratory of the Massachusetts Institute of Technology, for a study entitled "Space Applications of Automation, Robotics, and Machine Intelligence Systems (ARAMIS)", Phase I. The Space Systems Laboratory is part of the MIT Department of Aeronautics and Astronautics; the Artificial Intelligence Laboratory is one of MIT's inter-departmental laboratories. Work on the contract began on June 10, 1981, with a termination date for Phase I on June 9, 1982.

Following discussions between MIT and NASA MSFC, the contract was expanded to include several additional tasks specifically concerned with structural assembly in space. This "structural assembly expansion" to the contract started on October 27, 1981, with a termination date also on June 9, 1982.

At NASA's request, separate progress reports were produced for the original contract tasks (called the "main study") and for the structural assembly expansion. Separate final reports were also prepared, though some sections are identical in both.

This document is the final report for Phase I of the ARAMIS main study. The final report for the structural assembly expansion of this study is entitled "Automated Techniques for Large

Space Structures" (also contract number NAS8-34381),

The NASA MSFC Contracting Officer's Representative is Georg F. von Tiesenhausen (205-453-2789). The MIT Principal Investigators are Professor Rene H. Miller (617-253-2263) and Professor Marvin L. Minsky (617-253-5864). The MIT Study Manager is David B.S. Smith (617-253-2298).

2.1.2 Organization of the Final Report

Volume 1 of the final report is the Executive Summary. Volumes 2, 3, and 4 are roughly chronological, in the sense that the data and results presented were developed in that order by the study.

Volume 2: Space Projects Overview describes the space project breakdowns, which are used to identify tasks ("functional elements") which will be required by future space projects.

Volume 3: ARAMIS Overview gathers together the information specifically related to automation, robotics, and machine intelligence systems (ARAMIS). The volume starts with a general discussion of ARAMIS and the organization of this field into "topics." It then presents General Information Forms on ARAMIS "capabilities" which are candidates to perform space project tasks.

Volume 4: Application of ARAMIS Capabilities to Space Project Functional Elements is the pivotal volume in the report, since it deals with the relationships between the space project tasks and the ARAMIS capabilities. Specifically, in Volume 4,

the lists of tasks generated in Volume 2, and the background knowledge on ARAMIS presented in Volume 3, are combined to define "candidate ARAMIS capabilities" for each task. Volume 4 then presents the evaluation of the relative merits of the various candidates to perform the space project tasks, and the selection of the promising options suggested for further study.

Thus Volumes 2 and 3 serve to some extent as preparatory material and appendices to Volume 4, which contains most of the complexities of the research effort. Therefore a complete description of the study's objectives and method is included in Volume 4, while partial synopses of the study method appear in Volumes 2 and 3, specifically explaining the production of the data in those volumes.

The study recipient who wishes to apply the results of this study to a new space project will principally use Volume 4, referring to Volume 2 to check further on the definition of a space project task, and referring to Volume 3 for descriptions of suggested candidate ARAMIS capabilities. In addition, Volume 3 is intended as a general introduction to the field of ARAMIS and to its complex jargon.

2.1.3 Partial Synopsis of Study Method: Space Project Breakdowns

The overall ARAMIS study method is illustrated in schematic form in Figure 2.1. The method concentrates on the production of a matrix relating space project tasks (called "generic functional elements"; on the vertical axis in the figure) to pieces of ARAMIS (called "ARAMIS capabilities"; on the horizontal axis in the

FIGURE 2.1: ARAMIS STUDY METHOD: GENERIC FUNCTIONAL ELEMENT/ARAMIS CAPABILITY MATRIX

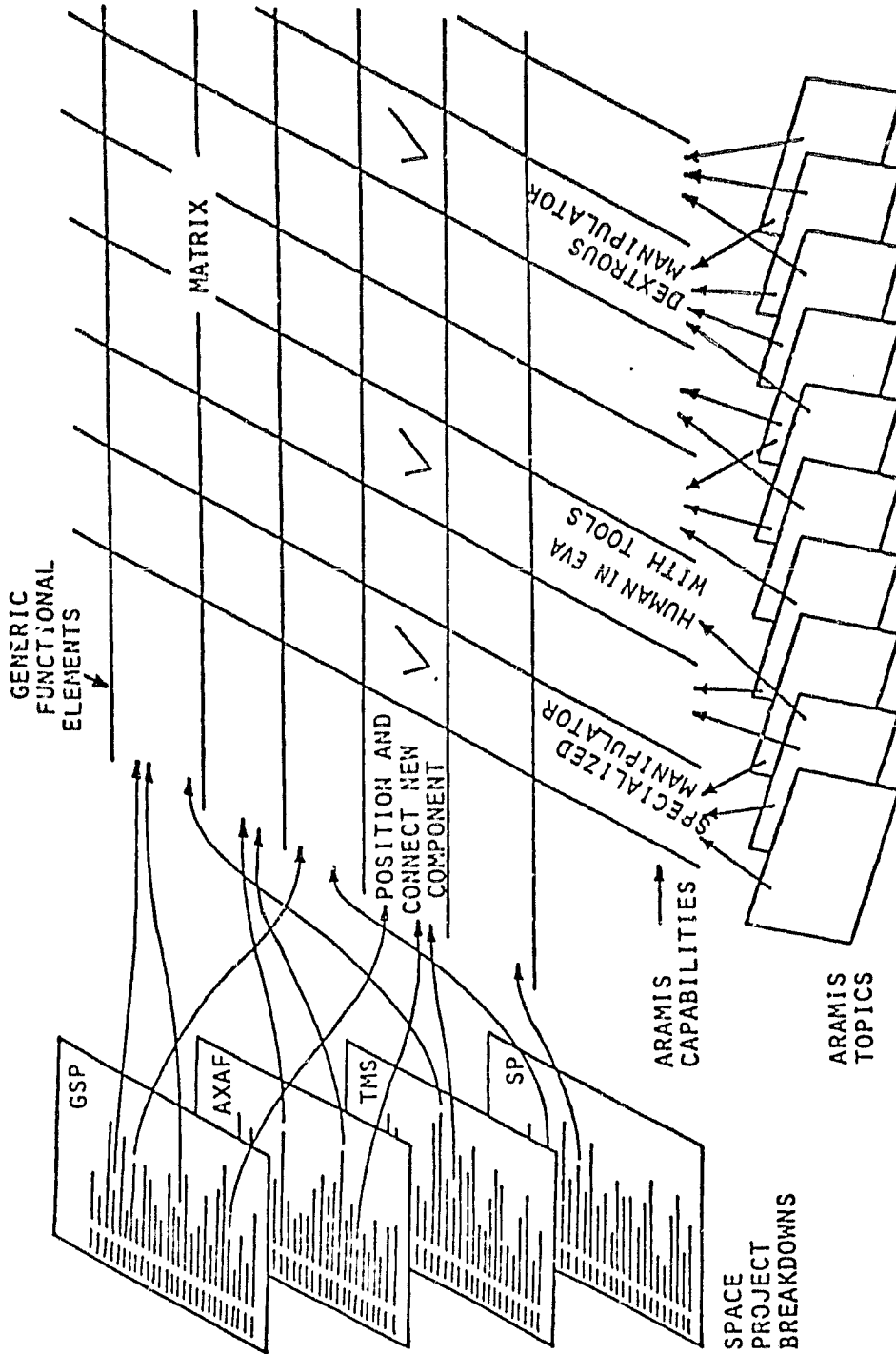

ORIGINAL DRAWING
OF POOR QUALITY

NOTE: EACH CHECKMARK ACTUALLY CONSISTS OF A SERIES OF DECISION CRITERIA VALUES, AND OF COMMENTS ON SPECIAL ASPECTS OF THAT ARAMIS APPLICATION

figure). The example in the figure shows that the generic functional element "Position and Connect New Component" can be satisfied by any of three ARAMIS capabilities: Specialized Manipulator, Human in EVA with Tools, or Dextrous Manipulator. Note that each ARAMIS capability by itself can satisfy the generic functional element.

As illustrated in the figure, the generic functional elements (GFE's) are generated from four space project breakdowns. The choice of the space projects is described in Section 2.2. The breakdown procedure is presented in Section 2.3. The collection of the generic functional elements is described in Section 2.4.

The ARAMIS capabilities are generated by considering each generic functional element in turn, and defining pieces of ARAMIS capable of satisfying the element. These definitions are based on the general background knowledge and organization of ARAMIS developed by this study. Volume 3: ARAMIS Overview describes the methods used to research and organize the field of ARAMIS.

The checkmarks on the matrix grid in the figure are for schematic presentation only. In actuality, each checkmark consists of values of seven decision criteria, with commentary and data sources, on the potential application of that ARAMIS capability to that generic functional element. These criteria are defined and discussed in Section 4.6 (Volume 4).

The ARAMIS study uses a specialized nomenclature, partly adopted from NASA and partly defined specifically for this study. Table 2.1 defines this nomenclature, as well as some acronyms.

TABLE 2.1: ARAMIS STUDY NOMENCLATURE

ARAMIS - <u>A</u> utomation, <u>R</u> obotics, and <u>M</u> achine <u>I</u> ntelligence <u>S</u> ystems
FUNCTIONAL ELEMENT - A small piece of a space project (examples: Open Access Panel, Open Supply Valve), which can be satisfied by a single ARAMIS capability.
GENERIC FUNCTIONAL ELEMENT LIST (GF \bar{E} LIST) - A list of all the functional elements in the four space project breakdowns; a functional element already collected from a previous breakdown is not listed again.
ARAMIS TOPIC - A part of the overall field of ARAMIS (e.g. Manipulators, Machine Vision Techniques, Computer Architecture); the study group identified 28 such topics (with considerable overlap between topics) which collectively cover ARAMIS.
ARAMIS CAPABILITY - A piece of ARAMIS (hardware and/or software) which can by itself satisfy a generic functional element; each capability only involves a small (manageable) part of the wide field of ARAMIS.
DECISION CRITERIA - Indices of the performance of an ARAMIS capability applied to a generic functional element; these indices are evaluated for each candidate ARAMIS capability applied to each generic functional element.
TECHNOLOGY TREES - Favorable sequences of ARAMIS development; i.e. early R&D of certain capabilities enhances later R&D of other capabilities (e.g. prior R&D of tactile sensors and microactuators benefits the development of a dextrous manipulator).
CRITICAL ELEMENT/CAPABILITY (E/C) PAIR - An application of an ARAMIS capability to a generic functional element, for which: the decision criteria values are favorable; and/or the capabilities are important in technology trees. This is therefore a promising application of ARAMIS.
GSP - Geostationary Platform
AXAF - Advanced Xray Astrophysics Facility
TMS - Teleoperator Maneuvering System
SP - Space Platform

Most of the data management functions required by the study method were implemented on a computer, for ease of access and display of the information. The use of the computer in the ARAMIS study is discussed in Appendix 4.F (Volume 4).

2.2 CHOICE OF SPACE PROJECTS FOR STUDY

2.2.1 Criteria for Choice

Three criteria were applied to the selection of space projects:

- 1) The space projects should span the years 1985-2000.

Given an arbitrary technology cutoff date 5 years before launch, this corresponds to projects which have their design phases between now and 1995. The near-term limit was chosen so that study results might have immediate utility. The far-term limit was chosen because the development of ARAMIS would be difficult to predict beyond 1995.

- 2) The space projects should collectively include a wide spectrum of tasks, both in space and on the ground. Therefore if suitable ARAMIS capabilities could be defined to perform these tasks, it was expected that these capabilities could perform the majority of the tasks required by NASA's projects in the next twenty years.

- 3) The number and scope of the projects should be kept low enough to keep the study manageable. Initial discussions suggested that four or five projects would be a likely number.

2.2.2 Projects Selected for Breakdowns

In consultation with NASA MSFC, four space projects were selected for study: the Geostationary Platform (GSP, a communications relay satellite); the Advanced X-ray Astrophysics Facility (AXAF, an X-ray telescope spacecraft); the Teleoperator Maneuvering

System (TMS, a multipurpose free-flying satellite tender); and the Space Platform (SP, a versatile platform for scientific and space applications research). They are sketched in Figure 2.2. These projects were chosen to span the range of space activities expected in the years 1985-2000: communications, astronomy, satellite servicing and support, and science and applications development. For detailed descriptions of these projects, the reader is referred to the reports listed at the beginning of each space project breakdown, in Appendix 2.A.

[Note: as mentioned in Section 2.1.1, this study also included a structural assembly expansion. This research focused on the structural assembly of three projects: the Science and Applications Space Platform, the single-platform version of the Geostationary Platform, and a large radio-frequency antenna. These projects are described and broken down in the structural assembly expansion's final report, "Automated Techniques for Large Space Structures."]

FIGURE 2.2: SPACE PROJECTS SELECTED FOR STUDY

No. 1: Geostationary Platform (GSP)

Communications platform
Constellation version: six
free-flying satellites in
close proximity, with laser
or microwave interlinks (one
unit shown here). Shuttle-
launched to LEO, boosted
to GEO. Scheduled main-
tenance in GEO every 8
years. GSP mass (each
satellite) \sim 6600 kg.

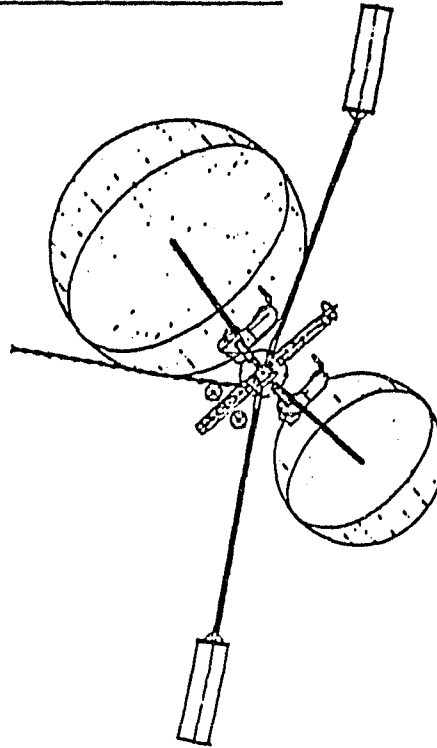

No. 2: Advanced X-ray Astrophysics Facility (AXAF)

1.2-meter diameter X-ray
telescope. Shuttle-
launched, 550 km altitude
orbit. Scheduled main-
tenance in LEO every
3 years. AXAF mass
9000 kg.

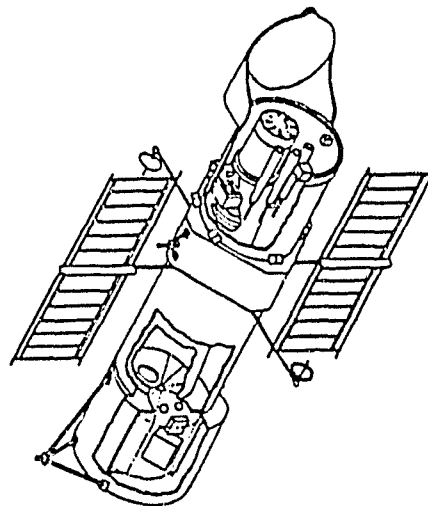

FIGURE 2.2: SPACE PROJECTS SELECTED FOR STUDY (CONTINUED)

No. 3: Teleoperator Maneuvering System (TMS)

Free-flying multipurpose vehicle, with optional kits for:

- in-space inspection and monitoring
- satellite deployment and retrieval
- satellite servicing and repair
- structural assembly of spacecraft

Shuttle-launched to LEO (can be boosted to GEO), returned to Earth for maintenance.
TMS mass \sim 3500 kg (wet).

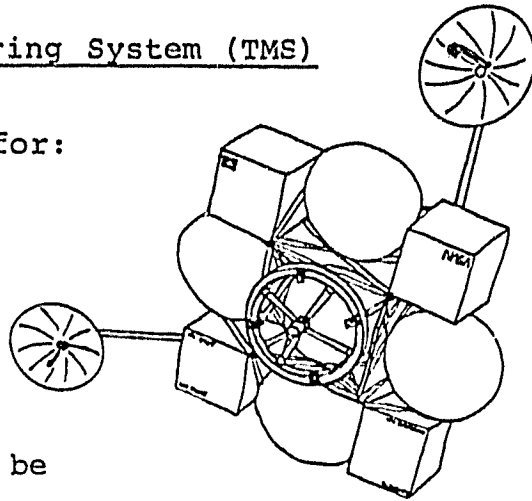

No. 4: Space Platform (SP)

Multipurpose platform, with three principal versions:

- Materials Experiment Carrier (MEC)
- Science and Applications Space Platform (SASP)
- Science and Applications Manned Space Platform (SAMSP)

Shuttle-launched, shuttle-tended (modular payload exchange). Maintenance during Shuttle visits (except SAMSP).

MEC mass \sim 26,300 kg
SASP mass \sim 42,300 kg
SAMSP mass \sim 35,400 kg

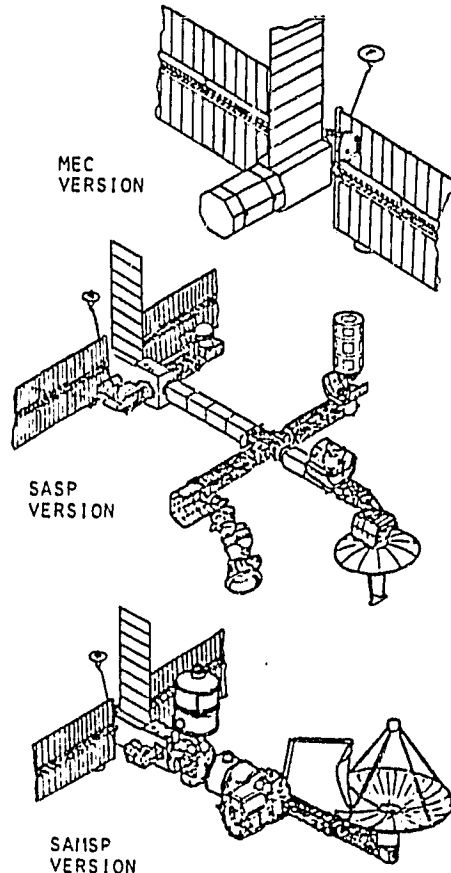

2.3 DESCRIPTION OF BREAKDOWN METHOD

2.3.1 Levels of Breakdowns

Each selected space project was then broken down into successively finer levels: project, missions, sequences, activities, functional elements. At the most detailed level, "functional elements" are small tasks (e.g. Track Nearby Objects, Compute Optimal Consumables Allocation, Position and Connect New Component) required by the space projects, sufficiently small that the same functional element may occur in several space projects, or several times in one space project.

To clarify the structure of the breakdowns, the study group developed a numerical coding system for the levels within the breakdowns. Figure 2.3 shows an example of a functional element's code number.

The project numbers are assigned as follows:

- 1) Geostationary Platform (GSP)
- 2) Advanced X-ray Astrophysics Facility (AXAF)
- 3) Teleoperator Maneuvering System (TMS)
- 4) Space Platform (SP)

The mission numbers may refer to individual flights (e.g. AXAF: the initial launch is a mission; so is each of the later maintenance and repair flights), or to types of missions (e.g. TMS: satellite retrieval, satellite servicing, structure assembly, are all types of missions the TMS can undertake). These distinctions are explained in the comments accompanying the project breakdowns.

FIGURE 2.3: EXAMPLE OF FUNCTIONAL ELEMENT CODE NUMBER

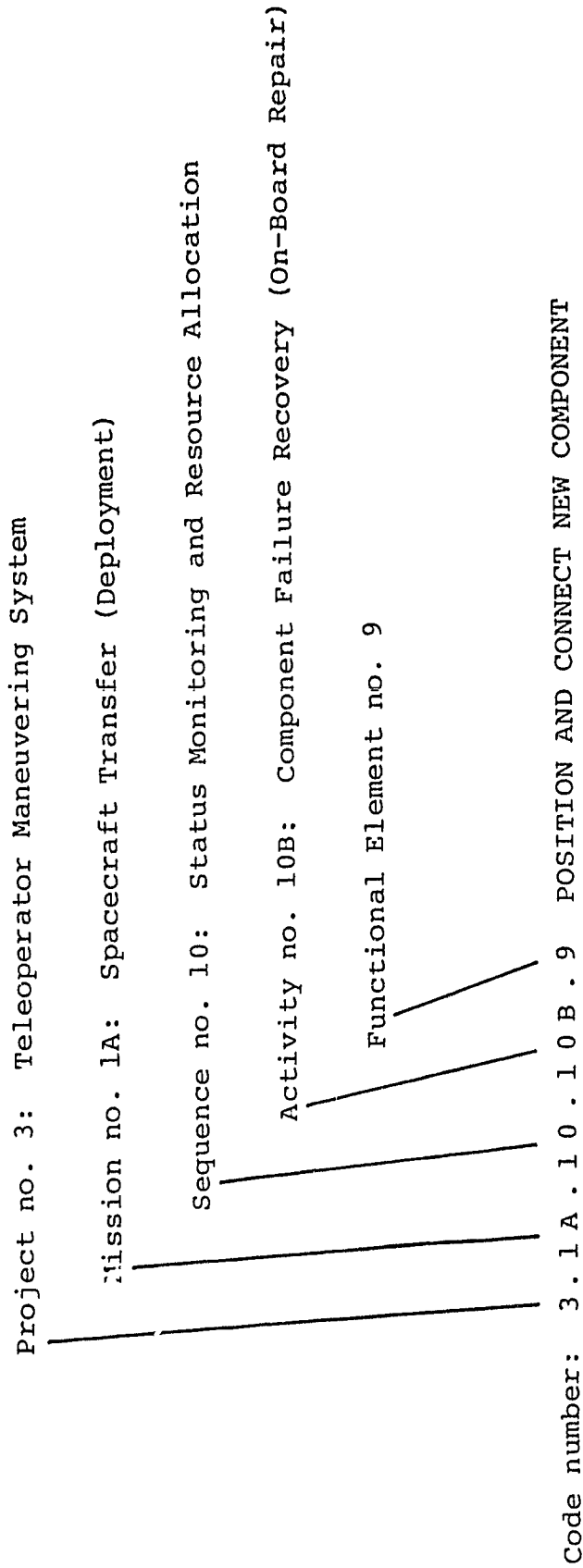

ORIGINAL PAGE IS
OF POOR QUALITY

2.3.2 Options within Breakdowns

"Options" are determined by the listings at the next level down, and identified by letters in the code numbers. In the example in Figure 2.3, mission no. 1A refers to option A (Deployment) within mission 1 (Spacecraft Transfer). Option A denotes a particular set of sequences at the next level down. Mission 1B (Spacecraft Transfer (Retrieval)) would include another set of sequences (different from mission 1A's set in at least one sequence).

For those items with only one option, the code letter is omitted. In the example above, sequence no. 10 (Status Monitoring and Resource Allocation) has only one option. Therefore it contains only one set of activities. However, some of the activities may have options, such as Activity no. 10 (Component Failure Recovery) which has options A (Redundancy) and B (On-Board Repair).

When the literature available to the study group identified a particular "reference" option for a project, then the project breakdown labels that option with the letter "A". In other words, if only the "A" options are considered, the breakdown becomes a listing of the "reference" space project.

Project options are presented as separate missions (e.g. MEC, SASP, and SAMSP (see Figure 2.2) are presented as missions within the Space Platform breakdown). Also, functional elements are not broken down any further, and therefore carry no options.

Thus options can only appear at the mission, sequence, and activity levels.

The four space projects were broken down through literature review, consultation with the MSFC Project Engineers and other experts (e.g. potential AXAF users), and in team brainstorm sessions. Each space project was assigned to one study researcher, who was thus responsible for that project breakdown. The team brainstorm sessions ensured common levels of detail and common nomenclature, so that the same names were given to similar functional elements wherever they appeared in the breakdowns. The project breakdowns were developed and stored as files in a computer, using an extended text editor program. The use of the computer in this study is described in Appendix 4.F (Volume 4).

The four space project breakdowns, including relevant comments, are listed in Appendix 2.A: Space Project Breakdowns (Annotated).

2.4 THE GENERIC FUNCTIONAL ELEMENT LIST

2.4.1 Method of Production

The Generic Functional Element (GFE) List was produced from the four space project breakdowns by a computer program (listed out in Appendix 4.F, in Volume 4). The program scanned through each breakdown in turn, collecting functional elements for the GFE List. A functional element already collected from a previous breakdown (or from earlier in the same breakdown) was not listed again. For example, the functional element Position and Connect New Component occurs in all four breakdowns, and several times in each breakdown, but appears only once in the GFE List.

As each generic functional element is collected for the GFE List, it is assigned a GFE number (prefixed by the letter "g") by the computer program. Since the Geostationary Platform project breakdown was scanned first, GFE's g1 through g170 are in the order of their appearance in the GSP breakdown. (Most of these GFE's appear in other breakdowns also.) GFE's g171 through g238 were added by the scan of the AXAF breakdown; GFE's g239 through g249, by the scan of the TMS breakdown; and GFE's 250 through 330, by the scan of the SP breakdown.

As these numbers suggest, there is considerable commonality of functional elements between breakdowns. Although the GSP breakdown includes 171 separate GFE's, only 28 of these GFE's are GSP-unique (i.e. GFE's which appear only in the GSP breakdown). Similarly, there were 62 AXAF-unique GFE's; 7 TMS-unique GFE's; and 81 SP-unique GFE's (most of which were experiment-specific tasks).

Although each generic functional element is listed only once in the GFE List, the computer program retained the code numbers under which each GFE appeared in the original breakdowns, and listed these code numbers under each GFE. Figure 2.4 presents a partial example of the GFE list, with code numbers.

FIGURE 2.4: PARTIAL EXAMPLE OF GFE LIST (WITH CODE NUMBERS)

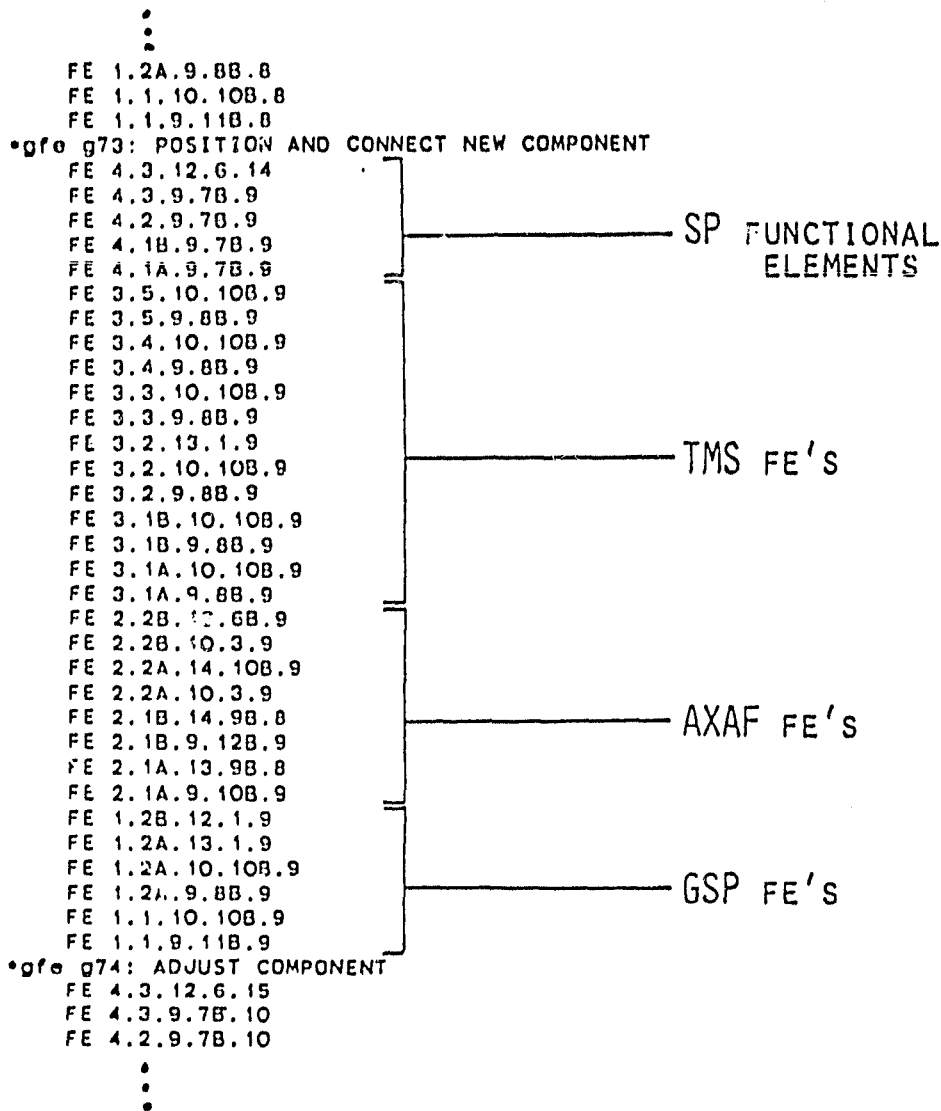

The example shows that Position and Connect New Component is the 73rd GFE identified by the program, and that it occurred in 32 places in the project breakdowns. As the first digits of the code numbers indicate, this GFE occurs in all four breakdowns. (The code numbers are listed in reverse order of appearance in the scan.)

The full GFE List is presented in Appendix 2.B: Generic Functional Element List (with Breakdown Code Numbers). For the study recipient's convenience, a more abbreviated version of the same list is presented in Appendix 2.C: Generic Functional Element List (without Breakdown Code Numbers).

2.4.2 Comments on GFE List

The GSP space project breakdown is 973 lines long; the AXAF breakdown, 1691 lines long; the TMS breakdown, 2079 lines long; the SP breakdown, 1478 lines long. However, the GFE List for all the breakdowns contains only 330 generic functional elements. In other words, each of the four project breakdowns can be entirely assembled from the 330 GFE's. Since the space projects were chosen to span a broad spectrum of activities, it is expected that this list should also contain most (or all) of the elements of a wide variety of space projects. Yet each generic functional element is sufficiently small in scope that any ARAMIS capability which can perform the element only involves a small part of the wide field of ARAMIS.

Since 330 GFE's were collected from 6221 lines of breakdowns, the average GFE occurs in many places in the breakdowns.

Some of these repetitions are between breakdowns, i.e. a task is required in several projects. But most repetitions are within each breakdown: either a task is repeated during the life of the spacecraft; or the same task is listed under several options in a breakdown, the latter situation accounting for most of the repetitions. Therefore, the length of the list of code numbers following a GFE (in Appendix 2.B) is not a direct measure of the number of occurrences of a task; many of those listings indicate the same task in different options (e.g. 3.1A.9.8B.9 and 3.1B.9.8B.9 in Figure 2.4). A more useful indication of a generally needed task is when it appears in all four project breakdowns.

As mentioned in guideline (7) (Section 4.2.3), Phase I of the ARAMIS study considers space project tasks by themselves, outside the context of any specific space projects. Therefore this study concentrates on the Generic Functional Element List. The project breakdowns are only occasionally consulted, to clarify the definition of a generic functional element by checking its context in the source breakdown(s).

The 330-element GFE List also appears in Appendix 4.A (Volume 4), grouped by types of GFE's.

APPENDIX 2.A:
SPACE PROJECT BREAKDOWNS (ANNOTATED)

2.A.1 Notes on this Appendix

Four space projects were selected for this study, and numbered as follows:

- 1) Geostationary Platform (GSP)
- 2) Advanced X-ray Astrophysics Facility (AXAF)
- 3) Teleoperator Maneuvering System (TMS)
- 4) Space Platform (SP)

Each selected space project was broken down into successively finer levels: project, missions, sequences, activities, functional elements. To clarify the breakdown structure, a numerical coding system was developed. It is described in Section 2.3.1. For functional elements, the code numbers are five-segment numbers (e.g. 3.1A.10.10B.9); the first segment identifies the project (e.g. 3: TMS). The code numbers also identify options (described in Section 2.3.2, indicated by letters) at the mission, sequence, and activity levels.

In each breakdown, an initial comment identifies the literature sources used to develop the breakdown. In addition, occasional comments are inserted in the listing, to clarify the items immediately before them.

The project breakdowns were developed through literature review, consultation with the MSFC Project Engineers, and consultation with other experts (e.g. potential AXAF users). Team brainstorm sessions were held to ensure common levels of

detail and nomenclature between the breakdowns. Each project was assigned to one study researcher, who was thus responsible for that breakdown.

The breakdowns were developed and stored as files in a computer, using an extended text editor program. The use of the computer is described in Appendix 4.F (Volume 4). The computer was also used to produce the space project breakdown listings, which follow.

2.A.2:

GEOSTATIONARY PLATFORM

The primary source of information for details of this breakdown was the Geostationary Platform Systems Concepts Definition Study prepared by General Dynamics Convair Division in June 1980.

Additional sources of information were:

- Edelson, B.I. and W.I. Morgan, "Orbital Antenna Farms", *Astronautics and Aeronautics*, Sept. 1977.
- Fordyce, S.W., L. Jaffe, and E.C. Hamilton, "Switchboard in the Sky", *Space Flight*, Vol. 20, No. 6, June 1978.
- Gordan, G.D., and W.L. DeRoucher, "Repairing a Communications Satellite on Orbit", *Comsat Technical Review*, Vol. 6, No. 1, Spring 1976.
- Shrivastava, S.K., "Orbital Perturbations and Stationkeeping of Communication Satellites", *Journal of Spacecraft*, Vol. 15, No. 2, March/April 1978.

1 GEOSTATIONARY PLATFORM

1.1 DEPLOYMENT

1.1.1 DESIGN

- 1.1.1.1 DEFINE REQUIREMENTS
- 1.1.1.2 MISSION ANALYSIS
- 1.1.1.3 PAYLOAD ACCOMODATIONS
- 1.1.1.4 CREATE FUNCTIONAL LAYOUT
- 1.1.1.5 FAILURE MODES ANALYSIS
- 1.1.1.6 ADJUST DESIGN FOR MAINTENANCE AND REPAIR

To ensure access to all parts of the platform for repair in the event of failure or breakdown.

- 1.1.1.7 CREATE MECHANICAL LAYOUT
- 1.1.1.8 SAFETY REVIEW
- 1.1.1.9 DESIGN OF COMPONENTS
- 1.1.1.10 SOFTWARE DEVELOPMENT

This is a longterm activity involving the development of all necessary software associated with the mission.

1.1.2 COMPONENT FABRICATION

1.1.2.1 PROCURE OFF-THE-SHELF COMPONENTS

These are components which require no special design and are readily available.

- 1.1.2.2 PROCURE MATERIALS FOR MANUFACTURED COMPONENTS
- 1.1.2.3 PROCURE MANUFACTURING EQUIPMENT
- 1.1.2.4 MANUFACTURE COMPONENTS

1.1.3 COMPONENT TEST

- 1.1.3.1 SET UP TEST FACILITIES
- 1.1.3.2 STRUCTURAL LOADS TESTS
- 1.1.3.3 DATA PROCESSING AND SOFTWARE TESTS
- 1.1.3.4 ELECTRICAL SYSTEMS TESTS
- 1.1.3.5 THERMAL AND VACUUM TESTS
- 1.1.3.6 THRUSTER TESTS
- 1.1.3.7 SOLAR ARRAY DEPLOYMENT TESTS
- 1.1.3.8 COMPONENT CERTIFICATION

1.1.4 SYSTEM INTEGRATION

1.1.5 SYSTEM TEST

- 1.1.5.1 POWER SUBSYSTEM TESTS
- 1.1.5.2 THERMAL SUBSYSTEM TESTS
- 1.1.5.3 STRUCTURE SUBSYSTEM TESTS
- 1.1.5.4 INFORMATION PROCESSING SUBSYSTEM TESTS
- 1.1.5.5 COMMUNICATIONS SUBSYSTEM TESTS
- 1.1.5.6 ATTITUDE CONTROL SUBSYSTEM TESTS
- 1.1.5.7 PROPULSION SUBSYSTEM TESTS
- 1.1.5.8 TRAFFIC ROUTING SUBSYSTEM TESTS
- 1.1.5.9 INTEGRATED SYSTEMS TESTS
- 1.1.5.10 FAILURE MODES SIMULATION

ORIGINAL PAGE IS
OF POOR QUALITY

- 1.1.5.11 SYSTEM CERTIFICATION
- 1.1.6 SHIPPING TO LAUNCH SITE
 - 1.1.6.1 REMOVE TEST EQUIPMENT
 - 1.1.6.2 PERFORM NECESSARY DISASSEMBLY
 - 1.1.6.3 PACKING
 - 1.1.6.4 TRANSPORT TO LAUNCH SITE
- 1.1.7 PAYLOAD INTEGRATION AND CHECKOUT
 - 1.1.7.1 UNPACKING
 - 1.1.7.2 PERFORM NECESSARY REASSEMBLY
 - 1.1.7.3 INTEGRATED SYSTEMS TESTS
 - 1.1.7.3.1 VERIFY POWER SYSTEM FUNCTION
 - 1.1.7.3.2 VERIFY COMMAND SYSTEM FUNCTION

Commands are sent and the system is checked to ensure that the signals arrive at their appropriate destinations but the system is disarmed.

- 1.1.7.3.3 VERIFY MECHANICAL SYSTEM FUNCTION
- 1.1.7.3.4 VERIFY COMMUNICATIONS SYSTEM FUNCTION

Signals are sent and traced to ensure correct transmission but the communications system is not actually powered up.

- 1.1.7.3.5 MISSION SEQUENCE SIMULATION
- 1.1.7.4 TRANSFER TO VERTICAL PROCESSING FACILITY
 - 1.1.7.4.1 LOAD PAYLOAD INTO CONTAINER
 - 1.1.7.4.2 TRANSPORT CONTAINER TO VERTICAL PROCESSING FACILITY
 - 1.1.7.4.3 UNLOAD CONTAINER
- 1.1.7.5 INTEGRATION WITH BOOSTERS

Cryogenics are loaded on the launch pad.

- 1.1.7.6 PERFORM INTERFACES CHECK
 - 1.1.7.6.1 CHECK SHUTTLE/PAYLOAD MECHANICAL INTERFACES
 - 1.1.7.6.2 CHECK ELECTRICAL INTERFACES
 - 1.1.7.6.3 CHECK PAYLOAD/BOOSTER MECHANICAL INTERFACES
 - 1.1.7.6.4 CHECK ELECTRICAL INTERFACES
- 1.1.7.7 TRANSFER TO LAUNCH PAD
 - 1.1.7.7.1 LOAD PAYLOAD INTO CANISTER
 - 1.1.7.7.2 TRANSPORT TO ROTATING SERVICE STRUCTURE
 - 1.1.7.7.3 LOAD CANISTER INTO ROTATING SERVICE STRUCTURE
 - 1.1.7.7.4 LOAD PAYLOAD INTO ROTATING SERVICE STRUCTURE USING PGHM
 - 1.1.7.7.5 REMOVE CANISTER
- 1.1.7.8 ORBITER/PAYLOAD INTEGRATION (VERTICAL)
 - 1.1.7.8.1 MATE ROTATING SERVICE STRUCTURE TO ORBITER
 - 1.1.7.8.2 EXTEND PAYLOAD INTO ORBITER USING PGHM
 - 1.1.7.8.3 CONNECT ORBITER/PAYLOAD INTERFACES
 - 1.1.7.8.4 CHECK ELECTRICAL INTERFACES
 - 1.1.7.8.5 CLOSE-OUT PAYLOAD BAY
- 1.1.8 COUNTDOWN AND LAUNCH
 - 1.1.8.1 CABIN CLOSEOUT
 - 1.1.8.2 PAYLOAD SERVICING (AS REQUIRED)
 - 1.1.8.3 VEHICLE CLOSEOUT
 - 1.1.8.4 LAUNCH COUNTDOWN
 - 1.1.8.5 LIFTOFF
- 1.1.9 ORBITAL DEPLOYMENT AND CHECKOUT
 - 1.1.9.1 SHUTTLE ATTAINS DELIVERY ORBIT
 - 1.1.9.2 EXTENSION OF PAYLOAD FROM PAYLOAD BAY
 - 1.1.9.2.1 OPEN PAYLOAD BAY DOORS
 - 1.1.9.2.2 ROTATE OTV/GSP PACKAGE OUT OF ORBITER
 - 1.1.9.3 TESTS OF ATTACHED PAYLOAD

It is understood that not all of the equipment to be deployed which is listed below would be carried (and hence deployed) on the first platform of the constellation.

- 1.1.9.3.1 POWER SUBSYSTEM CHECKOUT
- 1.1.9.3.2 INFORMATION PROCESSING SUBSYSTEM CHECKOUT
- 1.1.9.3.3 RAISE CENTRAL MAST
- 1.1.9.3.4 DEPLOY MAIN REFLECTORS
- 1.1.9.3.5 DEPLOY ANTENNA RECEIVER ARRAYS
- 1.1.9.3.6 DEPLOY ANTENNA TRANSMIT ARRAYS
- 1.1.9.3.7 DEPLOY SUBREFLECTOR

- 1.1.9.3.8 DEPLOY INTERFEROMETER
- 1.1.9.3.9 DEPLOY SOLAR ARRAYS
- 1.1.9.3.10 DEPLOY RADIATORS
- 1.1.9.3.11 VERIFY DEPLOYMENT SEQUENCES
- 1.1.9.3.12 RETRACT SOLAR PANELS

Must be retracted for orbital transfer, after which they are redeployed.

- 1.1.9.4 SEPARATION OF PAYLOAD FROM ORBITER
- 1.1.9.5 ORBITAL TRANSFER
 - 1.1.9.5.1 INITIALIZE GUIDANCE SYSTEM
 - 1.1.9.5.2 DETERMINE CURRENT ORBITAL PARAMETERS
 - 1.1.9.5.3 DETERMINE DESIRED ORBITAL PARAMETERS
 - 1.1.9.5.4 CHOOSE OPTIMAL TRAJECTORY
 - 1.1.9.5.5 DETERMINE CURRENT ATTITUDE
 - 1.1.9.5.6 DETERMINE DESIRED ATTITUDE
 - 1.1.9.5.7 FIRE THRUSTERS

This includes firing of main thrusters and RCS thrusters.

- 1.1.9.6 SEPARATION OF GSP FROM OTV
 - 1.1.9.6.1 SEPARATE OTV FROM GSP
 - 1.1.9.6.2 SEPARATION COAST
 - 1.1.9.6.3 FIRE THRUSTERS
 - 1.1.9.6.4 TRANSFER OF OTV TO SUPERSYNCHRONOUS ORBIT

All debris is taken to supersynchronous orbit for disposal where it will not interfere with other existing spacecraft.

- 1.1.9.7 DEPLOYMENT OF SOLAR ARRAYS AND ANTENNAS (IN GEO)
 - 1.1.9.7.1 DEPLOY SOLAR PANELS
 - 1.1.9.7.2 DEPLOY INTER-PLATFORM LINK ANTENNAS
- 1.1.9.8 OPERATIONAL CHECKOUT
 - 1.1.9.8.1 ACTIVATE SUBSYSTEMS
 - 1.1.9.8.2 INFORMATION PROCESSING SUBSYSTEM CHECKOUT
 - 1.1.9.8.3 POWER SUBSYSTEM CHECKOUT
 - 1.1.9.8.4 THERMAL SUBSYSTEM CHECKOUT
 - 1.1.9.8.5 STRUCTURE SUBSYSTEM CHECKOUT
 - 1.1.9.8.6 COMMUNICATIONS SUBSYSTEM CHECKOUT
 - 1.1.9.8.7 ATTITUDE CONTROL SUBSYSTEM CHECKOUT
 - 1.1.9.8.8 PROPULSION SUBSYSTEM CHECKOUT
 - 1.1.9.8.9 TRAFFIC ROUTING SUBSYSTEM CHECKOUT
 - 1.1.9.8.10 CONSUMABLES LEVELS CHECKOUT
 - 1.1.9.8.11 COMPARE MEASURED DATA TO MODEL
- 1.1.9.9 IDENTIFY DEFECTIVE COMPONENT
 - 1.1.9.9.1 DETERMINE ANOMALOUS DATA
 - 1.1.9.9.2 FORM HYPOTHESIS FOR PROBLEM
 - 1.1.9.9.3 DEVISE TEST FOR FAILURE HYPOTHESIS
 - 1.1.9.9.4 PERFORM TEST FOR FAILURE HYPOTHESIS
 - 1.1.9.9.5 IDENTIFY FAULTY COMPONENT
- 1.1.9.10 IDENTIFY DEFECTIVE SOFTWARE
 - 1.1.9.10.1 COMPARE MEASURED DATA TO MODEL
 - 1.1.9.10.2 DETERMINE ANOMALOUS DATA
 - 1.1.9.10.3 FORM HYPOTHESIS FOR PROBLEM
 - 1.1.9.10.4 DEVISE TEST FOR FAILURE HYPOTHESIS
 - 1.1.9.10.5 PERFORM TEST FOR FAILURE HYPOTHESIS
- 1.1.9.11A COMPONENT FAILURE RECOVERY (REDUNDANCY)
 - 1.1.9.11A.1 SWITCH OUT FAULTY COMPONENT
 - 1.1.9.11A.2 SWITCH IN REDUNDANT COMPONENT
 - 1.1.9.11A.3 MAKE DIAGNOSTIC CHECKS
 - 1.1.9.11A.4 UPDATE SPACECRAFT MODEL
- 1.1.9.11B COMPONENT FAILURE RECOVERY (ON-BOARD REPAIR)
 - 1.1.9.11B.1 DEFINE ACCESS SEQUENCE
 - 1.1.9.11B.2 LOCATE ACCESS PANEL
 - 1.1.9.11B.3 TRANSFER REPAIR EQUIPMENT TO REPAIR SITE
 - 1.1.9.11B.4 OPEN ACCESS PANEL
 - 1.1.9.11B.5 OBSERVE/LOCATE DEFECTIVE COMPONENT
 - 1.1.9.11B.6 REMOVE COMPONENT
 - 1.1.9.11B.7 STORE COMPONENT
 - 1.1.9.11B.8 LOCATE NEW COMPONENT
 - 1.1.9.11B.9 POSITION AND CONNECT NEW COMPONENT
 - 1.1.9.11B.10 ADJUST COMPONENT

- 1.1.9.11B.11 MAKE DIAGNOSTIC CHECKS
- 1.1.9.11B.12 CLOSE ACCESS PANEL
- 1.1.9.11B.13 STOW REPAIR EQUIPMENT
- 1.1.9.11B.14 UPDATE SPACECRAFT MODEL
- 1.1.9.12 SOFTWARE FAILURE RECOVERY
 - 1.1.9.12.1 DETERMINE CORRECTION ALGORITHM
 - 1.1.9.12.2 DATA/COMMAND ENCODING
 - 1.1.9.12.3 DATA/COMMAND TRANSMISSION
 - 1.1.9.12.4 COMPUTER FUNCTION CHECKS
- 1.1.10 STATUS MONITORING AND RESOURCE ALLOCATION
 - 1.1.10.1 TEMPERATURE MANAGEMENT
 - 1.1.10.1.1 MEASURE COMPONENT TEMPERATURES
 - 1.1.10.1.2 COMPARE TEMPERATURES TO REQUIRED LIMITS
 - 1.1.10.1.3 ADJUST COOLING/HEATING SYSTEMS
 - 1.1.10.2 POWER MANAGEMENT
 - 1.1.10.2.1 MEASURE CURRENTS AND VOLTAGES
 - 1.1.10.2.2 COMPARE CURRENTS AND VOLTAGES TO REQUIRED LIMITS
 - 1.1.10.2.3 EVALUATE BATTERY CHARGING PERFORMANCE
 - 1.1.10.2.4 ADJUST CURRENTS AND VOLTAGES
 - 1.1.10.2.5 ADJUST BATTERY CHARGING CYCLE
 - 1.1.10.3 DATA/COMMAND PROCESSING
 - 1.1.10.3.1 SHORT-TERM MEMORY STORAGE
 - 1.1.10.3.2 LONG-TERM MEMORY STORAGE
 - 1.1.10.3.3 DATA/COMMAND ENCODING
 - 1.1.10.3.4 DATA/COMMAND DECODING
 - 1.1.10.3.5 NUMERICAL COMPUTATION
 - 1.1.10.3.6 LOGIC OPERATIONS
 - 1.1.10.3.7 COMPUTER LOAD SCHEDULING
 - 1.1.10.3.8 COMPUTER FUNCTION CHECKS
 - 1.1.10.4 CONSUMABLES MANAGEMENT
 - 1.1.10.4.1 MONITOR PROPELLANT SUPPLIES
 - 1.1.10.4.2 MONITOR COOLING SYSTEM SUPPLIES
 - 1.1.10.4.3 PROJECT CONSUMABLES REQUIREMENTS FROM MISSION PROFILE
 - 1.1.10.4.4 COMPUTE OPTIMAL CONSUMABLES ALLOCATION
 - 1.1.10.5 STRUCTURAL MANAGEMENT
 - 1.1.10.5.1 MEASURE STRAINS IN STRUCTURE
 - 1.1.10.5.2 MEASURE RELATIVE DISPLACEMENTS
 - 1.1.10.5.3 COMPUTE STRESS AND VIBRATION PARAMETERS
 - 1.1.10.5.4 COMPARE STRESS AND VIBRATION PARAMETERS TO REQUIRED LIMITS
 - 1.1.10.5.5 APPLY COMPENSATING FORCES

Present mission does not include this; it has been included here in
anticipation of possible additions.

- 1.1.10.5.6 APPLY VIBRATION DAMPING
- 1.1.10.6 HAZARD AVOIDANCE
- 1.1.10.7 OPTIMAL SEQUENCING
 - 1.1.10.7.1 UPDATE SPACECRAFT MODEL
 - 1.1.10.7.2 PROJECT DESIRED FUNCTIONS FROM MISSION PROFILE
 - 1.1.10.7.3 ESTIMATE RISKS FROM DESIRED FUNCTIONS
 - 1.1.10.7.4 PROJECT CONSUMABLES REQUIREMENTS FROM MISSION PROFILE
 - 1.1.10.7.5 DETERMINE CONSTRAINTS AND FIGURES OF MERIT
 - 1.1.10.7.6 COMPUTE OPTIMAL SEQUENCING
- 1.1.10.8 IDENTIFY DEFECTIVE COMPONENT
 - 1.1.10.8.1 DETERMINE ANOMALOUS DATA
 - 1.1.10.8.2 FORM HYPOTHESIS FOR PROBLEM
 - 1.1.10.8.3 DEVISE TEST FOR FAILURE HYPOTHESIS
 - 1.1.10.8.4 PERFORM TEST FOR FAILURE HYPOTHESIS
 - 1.1.10.8.5 IDENTIFY FAULTY COMPONENT
- 1.1.10.9 IDENTIFY DEFECTIVE SOFTWARE
 - 1.1.10.9.1 COMPARE MEASURED DATA TO MODEL
 - 1.1.10.9.2 DETERMINE ANOMALOUS DATA
 - 1.1.10.9.3 FORM HYPOTHESIS FOR PROBLEM
 - 1.1.10.9.4 DEVISE TEST FOR FAILURE HYPOTHESIS
 - 1.1.10.9.5 PERFORM TEST FOR FAILURE HYPOTHESIS
- 1.1.10.10A COMPONENT FAILURE RECOVERY (REDUNDANCY)
 - 1.1.10.10A.1 SWITCH OUT FAULTY COMPONENT
 - 1.1.10.10A.2 SWITCH IN REDUNDANT COMPONENT
 - 1.1.10.10A.3 MAKE DIAGNOSTIC CHECKS
 - 1.1.10.10A.4 UPDATE SPACECRAFT MODEL
- 1.1.10.10B COMPONENT FAILURE RECOVERY (ON-BOARD REPAIR)
 - 1.1.10.10B.1 DEFINE ACCESS SEQUENCE

ORIGINAL PAGE IS
OF POOR QUALITY

- 1.1.10.10B.2 LOCATE ACCESS PANEL
- 1.1.10.10B.3 TRANSFER REPAIR EQUIPMENT TO REPAIR SITE
- 1.1.10.10B.4 OPEN ACCESS PANEL
- 1.1.10.10B.5 OBSERVE/LOCATE DEFECTIVE COMPONENT
- 1.1.10.10B.6 REMOVE COMPONENT
- 1.1.10.10B.7 STORE COMPONENT
- 1.1.10.10B.8 LOCATE NEW COMPONENT
- 1.1.10.10B.9 POSITION AND CONNECT NEW COMPONENT
- 1.1.10.10B.10 ADJUST COMPONENT
- 1.1.10.10B.11 MAKE DIAGNOSTIC CHECKS
- 1.1.10.10B.12 CLOSE ACCESS PANEL
- 1.1.10.10B.13 STOW REPAIR EQUIPMENT
- 1.1.10.10B.14 UPDATE SPACECRAFT MODEL
- 1.1.10.11 SOFTWARE FAILURE RECOVERY
 - 1.1.10.11.1 DETERMINE CORRECTION ALGORITHM
 - 1.1.10.11.2 DATA/COMMAND ENCODING
 - 1.1.10.11.3 DATA/COMMAND TRANSMISSION
 - 1.1.10.11.4 COMPUTER FUNCTION CHECKS
- 1.1.10.12 REPORT SYSTEM STATUS
 - 1.1.10.12.1 DATA/COMMAND ENCODING
 - 1.1.10.12.2 DATA/COMMAND TRANSMISSION
 - 1.1.10.12.3 DATA/COMMAND DECODING
 - 1.1.10.12.4 DATA/COMMAND DISPLAY
- 1.1.11 ATTITUDE CONTROL AND STATIONKEEPING
 - 1.1.11.1 MAINTAIN/CHANGE ATTITUDE
 - 1.1.11.1.1 INITIALIZE GUIDANCE SYSTEM
 - 1.1.11.1.2 DETERMINE CURRENT ATTITUDE
 - 1.1.11.1.3 DETERMINE DESIRED ATTITUDE
 - 1.1.11.1.4 DETERMINE NEW CONFIGURATION FOR SPACECRAFT COMPONENTS
 - 1.1.11.1.5 CHOOSE OPTIMAL TRAJECTORY
 - 1.1.11.1.6 ROTATE SPACECRAFT
 - 1.1.11.2 MAINTAIN/CHANGE ORBIT
 - 1.1.11.2.1 INITIALIZE GUIDANCE SYSTEM
 - 1.1.11.2.2 DETERMINE CURRENT ORBITAL PARAMETERS
 - 1.1.11.2.3 DETERMINE DESIRED ORBITAL PARAMETERS
 - 1.1.11.2.4 CHOOSE OPTIMAL TRAJECTORY
 - 1.1.11.2.5 FIRE THRUSTERS
 - 1.1.11.3 OPTIMAL CONTROL ALLOCATION
 - 1.1.11.3.1 UPDATE SPACECRAFT MODEL
 - 1.1.11.3.2 PROJECT DESIRED FUNCTIONS FROM MISSION PROFILE
 - 1.1.11.3.3 ESTIMATE RISKS FROM DESIRED FUNCTIONS
 - 1.1.11.3.4 PROJECT CONSUMABLES REQUIREMENTS FROM MISSION PROFILE
 - 1.1.11.3.5 DETERMINE CONSTRAINTS AND FIGURES OF MERIT
 - 1.1.11.3.6 CHOOSE OPTIMAL CONTROL MODE
 - 1.1.11.3.7 COMPUTE CONTROL COMMANDS
 - 1.1.11.3.8 EXECUTE CONTROL COMMANDS
- 1.1.12 COMMUNICATIONS OPERATIONS
 - 1.1.12.1 ANTENNA POINTING CONTROL
 - 1.1.12.1.1 RECEIVE INPUT FROM ANTENNA POINTING SENSORS
 - 1.1.12.1.2 TRANSMIT INFORMATION TO ANTENNA POINTING CONTROLLER
 - 1.1.12.1.3 DETERMINE ERROR FROM DESIRED ANTENNA POSITION
 - 1.1.12.1.4 ANTENNA POSITIONER CORRECTS POINTING DIRECTION
 - 1.1.12.2 TRAFFIC ROUTING
 - 1.1.12.2.1 RECEIVE COMMUNICATIONS INPUT
 - 1.1.12.2.2 ENTER COMMUNICATIONS INPUT INTO SWITCH CONTROL
 - 1.1.12.2.3 SWITCH CONTROL ENTERS COMMUNICATIONS INPUT INTO SWITCH MATRIX
 - 1.1.12.2.4 SWITCH MATRIX EXECUTES COMMUNICATIONS OUTPUT

1.2A SERVICING MAINTENANCE AND REPAIR (TMS/DTV)

1.2A.1 DESIGN

1.2A.1.1 DEFINE REQUIREMENTS

This includes determining what is to be repaired.

- 1.2A.1.2 MISSION ANALYSIS
- 1.2A.1.3 PAYLOAD ACCOMMODATIONS
- 1.2A.1.4 CREATE FUNCTIONAL LAYOUT
- 1.2A.1.5 FAILURE MODES ANALYSIS
- 1.2A.1.6 CREATE MECHANICAL LAYOUT
- 1.2A.1.7 SAFETY REVIEW
- 1.2A.1.8 DESIGN OF COMPONENTS
- 1.2A.1.9 SOFTWARE DEVELOPMENT

- 1.2A.2 COMPONENT FABRICATION
 - 1.2A.2.1 PROCURE OFF-THE-SHELF COMPONENTS
 - 1.2A.2.2 PROCURE MATERIALS FOR MANUFACTURED COMPONENTS
 - 1.2A.2.3 PROCURE MANUFACTURING EQUIPMENT
 - 1.2A.2.4 MANUFACTURE COMPONENTS
- 1.2A.3 COMPONENT TEST
 - 1.2A.3.1 SET UP TEST FACILITIES
 - 1.2A.3.2 STRUCTURAL LOADS TESTS
 - 1.2A.3.3 DATA PROCESSING AND SOFTWARE TESTS
 - 1.2A.3.4 ELECTRICAL SYSTEMS TESTS
 - 1.2A.3.5 THERMAL AND VACUUM TESTS
 - 1.2A.3.6 THRUSTER TESTS
 - 1.2A.3.7 SOLAR ARRAY DEPLOYMENT TESTS
 - 1.2A.3.8 COMPONENT CERTIFICATION
- 1.2A.4 SYSTEM INTEGRATION
- 1.2A.5 SYSTEM TESTS
 - 1.2A.5.1 POWER SUBSYSTEM TESTS
 - 1.2A.5.2 THERMAL SUBSYSTEM TESTS
 - 1.2A.5.3 STRUCTURE SUBSYSTEM TESTS
 - 1.2A.5.4 INFORMATION PROCESSING SUBSYSTEM TESTS
 - 1.2A.5.5 COMMUNICATIONS SUBSYSTEM TESTS
 - 1.2A.5.6 ATTITUDE CONTROL SUBSYSTEM TEST
 - 1.2A.5.7 PROPULSION SUBSYSTEM TESTS
 - 1.2A.5.8 INTEGRATED SYSTEMS TESTS
 - 1.2A.5.9 FAILURE MODES SIMULATION
 - 1.2A.5.10 SYSTEM CERTIFICATION
- 1.2A.6 SHIPPING TO LAUNCH SITE
 - 1.2A.6.1 REMOVE TEST EQUIPMENT
 - 1.2A.6.2 PERFORM NECESSARY DISASSEMBLY
 - 1.2A.6.3 PACKING
 - 1.2A.6.4 TRANSPORT TO LAUNCH SITE
- 1.2A.7A PAYLOAD INTEGRATION AND CHECKOUT (HORIZONTAL PAYLOAD)
 - 1.2A.7A.1 UNPACKING
 - 1.2A.7A.2 PERFORM NECESSARY REASSEMBLY
 - 1.2A.7A.3 INTEGRATED SYSTEMS TESTS
 - 1.2A.7A.3.1 VERIFY POWER SYSTEM FUNCTION
 - 1.2A.7A.3.2 VERIFY COMMAND SYSTEM FUNCTION
 - 1.2A.7A.3.3 VERIFY MECHANICAL SYSTEM FUNCTION
 - 1.2A.7A.3.4 VERIFY COMMUNICATIONS SYSTEM FUNCTION
 - 1.2A.7A.3.5 MISSION SEQUENCE SIMULATION
 - 1.2A.7A.4 TRANSFER TO OPERATIONS AND CHECKOUT BUILDING
 - 1.2A.7A.5 INTEGRATE TMS WITH PAYLOAD
 - 1.2A.7A.6 PERFORM INTERFACES CHECK
 - 1.2A.7A.6.1 CHECK TMS/PAYLOAD MECHANICAL INTERFACES
 - 1.2A.7A.6.2 CHECK ELECTRICAL INTERFACES
 - 1.2A.7A.6.3 CHECK SHUTTLE/PAYLOAD MECHANICAL INTERFACES
 - 1.2A.7A.6.4 CHECK ELECTRICAL INTERFACES
 - 1.2A.7A.7 TRANSFER TMS/PAYLOAD TO ORBITER PROCESSING FACILITY
 - 1.2A.7A.7.1 ATTACH STRONGBACK TO PAYLOAD
 - 1.2A.7A.7.2 LOAD PAYLOAD INTO CANISTER
 - 1.2A.7A.7.3 REMOVE STRONGBACK
 - 1.2A.7A.7.4 CLOSE CANISTER
 - 1.2A.7A.7.5 TRANSPORT CANISTER TO ORBITER PROCESSING FACILITY
 - 1.2A.7A.7.6 UNLOAD CANISTER
 - 1.2A.7A.8 ORBITER/PAYLOAD INTEGRATION (HORIZONTAL)
 - 1.2A.7A.8.1 ATTACH STRONGBACK TO PAYLOAD
 - 1.2A.7A.8.2 INSTALL PAYLOAD IN ORBITER
 - 1.2A.7A.8.3 CONNECT ORBITER/PAYLOAD INTERFACES
 - 1.2A.7A.8.4 CHECK ELECTRICAL INTERFACES
 - 1.2A.7A.8.5 REMOVE STRONGBACK
 - 1.2A.7A.8.6 CLOSE-OUT PAYLOAD BAY
 - 1.2A.7A.8.7 INSTALLATION OF ORBITER PAYLOAD STATION CONSOLES
- 1.2A.7B PAYLOAD INTEGRATION AND CHECKOUT (VERTICAL PAYLOAD)
 - 1.2A.7B.1 UNPACKING
 - 1.2A.7B.2 PERFORM NECESSARY REASSEMBLY
 - 1.2A.7B.3 INTEGRATED SYSTEMS TESTS
 - 1.2A.7B.3.1 VERIFY POWER SYSTEM FUNCTION
 - 1.2A.7B.3.2 VERIFY COMMAND SYSTEM FUNCTION
 - 1.2A.7B.3.3 VERIFY MECHANICAL SYSTEM FUNCTION
 - 1.2A.7B.3.4 VERIFY COMMUNICATIONS SYSTEM FUNCTION
 - 1.2A.7B.3.5 MISSION SEQUENCE SIMULATION
 - 1.2A.7B.4 TRANSFER TO VERTICAL PROCESSING FACILITY

- 1.2A.7B.5 INTEGRATE TMS WITH PAYLOAD
- 1.2A.7B.6 PERFORM INTERFACES CHECK
 - 1.2A.7B.6.1 CHECK TMS/PAYLOAD MECHANICAL INTERFACES
 - 1.2A.7B.6.2 CHECK ELECTRICAL INTERFACES
 - 1.2A.7B.6.3 CHECK SHUTTLE/PAYLOAD MECHANICAL INTERFACES
 - 1.2A.7B.6.4 CHECK ELECTRICAL INTERFACES
- 1.2A.7B.7 TRANSFER PAYLOAD TO LAUNCH PAD
 - 1.2A.7B.7.1 LOAD PAYLOAD INTO CANISTER
 - 1.2A.7B.7.2 TRANSPORT TO ROTATING SERVICE STRUCTURE
 - 1.2A.7B.7.3 LOAD CANISTER INTO ROTATING SERVICE STRUCTURE
 - 1.2A.7B.7.4 LOAD PAYLOAD INTO ROTATING SERVICE STRUCTURE USING PGHM
 - 1.2A.7B.7.5 REMOVE CANISTER
- 1.2A.7B.8 ORBITER/PAYLOAD INTEGRATION (VERTICAL)
 - 1.2A.7B.8.1 MATE ROTATING SERVICE STRUCTURE TO ORBITER
 - 1.2A.7B.8.2 EXTEND PAYLOAD INTO ORBITER USING PGHM
 - 1.2A.7B.8.3 CONNECT ORBITER/PAYLOAD INTERFACES
 - 1.2A.7B.8.4 CHECK ELECTRICAL INTERFACES
 - 1.2A.7B.8.5 CLOSE-OUT PAYLOAD BAY
 - 1.2A.7B.8.6 INSTALLATION OF ORBITER PAYLOAD STATION CONSOLES
- 1.2A.8 COUNTDOWN AND LAUNCH
- 1.2A.9 ORBITAL DEPLOYMENT AND CHECKOUT
 - 1.2A.9.1 SHUTTLE ATTAINS DELIVERY ORBIT
 - 1.2A.9.2 TESTS OF ATTACHED PAYLOAD
 - 1.2A.9.2.1 POWER SUBSYSTEM CHECKOUT
 - 1.2A.9.2.2 INFORMATION PROCESSING SUBSYSTEM CHECKOUT
 - 1.2A.9.3 EXTENSION OF PAYLOAD FROM PAYLOAD BAY
 - 1.2A.9.3.1 OPEN PAYLOAD BAY DOORS
 - 1.2A.9.3.2 ACTIVATE RMS
 - 1.2A.9.3.3 LOCATE GRASPING FIXTURE ON TARGET
 - 1.2A.9.3.4 MOVE RMS TO FIXTURE
 - 1.2A.9.3.5 GRASP FIXTURE
 - 1.2A.9.3.6 RELEASE PAYLOAD RESTRAINTS
 - 1.2A.9.3.7 TRANSLATE PAYLOAD OUT OF PAYLOAD BAY
 - 1.2A.9.4 SEPARATION OF PAYLOAD FROM ORBITER
 - 1.2A.9.4.1 RMS RELEASES PAYLOAD
 - 1.2A.9.4.2 SECURE RMS IN PAYLOAD BAY
 - 1.2A.9.5 OPERATIONAL CHECKOUT
 - 1.2A.9.5.1 ACTIVATE SUBSYSTEMS
 - 1.2A.9.5.2 INFORMATION PROCESSING SUBSYSTEM CHECKOUT
 - 1.2A.9.5.3 POWER SUBSYSTEM CHECKOUT
 - 1.2A.9.5.4 THERMAL SUBSYSTEM CHECKOUT
 - 1.2A.9.5.5 STRUCTURAL SUBSYSTEM CHECKOUT
 - 1.2A.9.5.6 COMMUNICATIONS SUBSYSTEM CHECKOUT
 - 1.2A.9.5.7 ATTITUDE CONTROL SUBSYSTEM CHECKOUT
 - 1.2A.9.5.8 PROPULSION SUBSYSTEM CHECKOUT
 - 1.2A.9.5.9 CONSUMABLES LEVELS CHECKOUT
 - 1.2A.9.6 IDENTIFY DEFECTIVE COMPONENT
 - 1.2A.9.6.1 DETERMINE ANOMALOUS DATA
 - 1.2A.9.6.2 FORM HYPOTHESIS FOR PROBLEM
 - 1.2A.9.6.3 DEVISE TEST FOR FAILURE HYPOTHESIS
 - 1.2A.9.6.4 PERFORM TEST FOR FAILURE HYPOTHESIS
 - 1.2A.9.6.5 IDENTIFY FAULTY COMPONENT
 - 1.2A.9.7 IDENTIFY DEFECTIVE SOFTWARE
 - 1.2A.9.7.1 COMPARE MEASURED DATA TO MODEL
 - 1.2A.9.7.2 DETERMINE ANOMALOUS DATA
 - 1.2A.9.7.3 FORM HYPOTHESIS FOR PROBLEM
 - 1.2A.9.7.4 DEVISE TEST FOR FAILURE HYPOTHESIS
 - 1.2A.9.7.5 PERFORM TEST FOR FAILURE HYPOTHESIS
 - 1.2A.9.8A COMPONENT FAILURE RECOVERY (REDUNDANCY)
 - 1.2A.9.8A.1 SWITCH OUT FAULTY COMPONENT
 - 1.2A.9.8A.2 SWITCH IN REDUNDANT COMPONENT
 - 1.2A.9.8A.3 MAKE DIAGNOSTIC CHECKS
 - 1.2A.9.8A.4 UPDATE SPACECRAFT MODEL
 - 1.2A.9.8B COMPONENT FAILURE RECOVERY (ON-BOARD REPAIR)
 - 1.2A.9.8B.1 DEFINE ACCESS SEQUENCE
 - 1.2A.9.8B.2 LOCATE ACCESS PANEL
 - 1.2A.9.8B.3 TRANSFER REPAIR EQUIPMENT TO REPAIR SITE
 - 1.2A.9.8B.4 OPEN ACCESS PANEL
 - 1.2A.9.8B.5 OBSERVE/LOCATE DEFECTIVE COMPONENT
 - 1.2A.9.8B.6 REMOVE COMPONENT
 - 1.2A.9.8B.7 STORE COMPONENT
 - 1.2A.9.8B.8 LOCATE NEW COMPONENT

ORIGINAL COPY
OF POOR QUALITY

- 1.2A.9.8B.9 POSITION AND CONNECT NEW COMPONENT
- 1.2A.9.8B.10 ADJUST COMPONENT
- 1.2A.9.8B.11 MAKE DIAGNOSTIC CHECKS
- 1.2A.9.8B.12 CLOSE ACCESS PANEL
- 1.2A.9.8B.13 STOW REPAIR EQUIPMENT
- 1.2A.9.8B.14 UPDATE SPACECRAFT MODEL
- 1.2A.9.9 SOFTWARE FAILURE RECOVERY
 - 1.2A.9.9.1 DETERMINE CORRECTION ALGORITHM
 - 1.2A.9.9.2 DATA/COMMAND ENCODING
 - 1.2A.9.9.3 DATA/COMMAND TRANSMISSION
 - 1.2A.9.9.4 COMPUTER FUNCTION CHECKS
- 1.2A.9.10 ORBITAL TRANSFER (OF TMS/SPACECRAFT)
 - 1.2A.9.10.1 INITIALIZE GUIDANCE SYSTEM
 - 1.2A.9.10.2 DETERMINE CURRENT ORBITAL PARAMETERS
 - 1.2A.9.10.3 DETERMINE DESIRED ORBITAL PARAMETERS
 - 1.2A.9.10.4 CHOOSE OPTIMAL TRAJECTORY
 - 1.2A.9.10.5 DETERMINE CURRENT ATTITUDE
 - 1.2A.9.10.6 DETERMINE DESIRED ATTITUDE
 - 1.2A.9.10.7 ROTATE SPACECRAFT
 - 1.2A.9.10.8 FIRE THRUSTERS
- 1.2A.9.11 TMS UNDOCK WITH OTV
 - 1.2A.9.11.1 RELEASE DOCKING LATCH
 - 1.2A.9.11.2 RETRACT DOCKING MECHANISM
 - 1.2A.9.11.3 MOVE AWAY FROM PAYLOAD
- 1.2A.10 STATUS MONITORING AND RESOURCE ALLOCATION
 - 1.2A.10.1 TEMPERATURE MANAGEMENT
 - 1.2A.10.1.1 MEASURE COMPONENT TEMPERATURES
 - 1.2A.10.1.2 COMPARE TEMPERATURES TO REQUIRED LIMITS
 - 1.2A.10.1.3 ADJUST COOLING/HEATING SYSTEMS
 - 1.2A.10.2 POWER MANAGEMENT
 - 1.2A.10.2.1 MEASURE CURRENTS AND VOLTAGES
 - 1.2A.10.2.2 COMPARE CURRENTS AND VOLTAGES TO REQUIRED LIMITS
 - 1.2A.10.2.3 ADJUST CURRENTS AND VOLTAGES
 - 1.2A.10.2.4 MONITOR BATTERIES
 - 1.2A.10.3 DATA/COMMAND PROCESSING
 - 1.2A.10.3.1 SHORT-TERM MEMORY STORAGE
 - 1.2A.10.3.2 LONG-TERM MEMORY STORAGE
 - 1.2A.10.3.3 DATA/COMMAND ENCODING
 - 1.2A.10.3.4 DATA/COMMAND DECODING
 - 1.2A.10.3.5 NUMERICAL COMPUTATION
 - 1.2A.10.3.6 LOGIC OPERATIONS
 - 1.2A.10.3.7 COMPUTER LOAD SCHEDULING
 - 1.2A.10.3.8 COMPUTER FUNCTION CHECKS
 - 1.2A.10.4 CONSUMABLES MANAGEMENT
 - 1.2A.10.4.1 MONITOR PROPELLANT SUPPLIES
 - 1.2A.10.4.2 PROJECT CONSUMABLES REQUIREMENTS FROM MISSION PROFILE
 - 1.2A.10.4.3 COMPUTE OPTIMAL CONSUMABLES ALLOCATION
 - 1.2A.10.5 STRUCTURAL MANAGEMENT
 - 1.2A.10.5.1 MEASURE STRAINS IN STRUCTURE
 - 1.2A.10.5.2 COMPUTE STRESS AND VIBRATION PARAMETERS
 - 1.2A.10.5.3 COMPARE STRESS AND VIBRATION PARAMETERS TO REQUIRED LIMITS
 - 1.2A.10.5.4 APPLY COMPENSATING FORCES
 - 1.2A.10.5.5 APPLY VIBRATION DAMPING
 - 1.2A.10.6 HAZARD AVOIDANCE
 - 1.2A.10.7 OPTIMAL SEQUENCING
 - 1.2A.10.7.1 UPDATE SPACECRAFT MODEL
 - 1.2A.10.7.2 PROJECT DESIRED FUNCTIONS FROM MISSION PROFILE
 - 1.2A.10.7.3 ESTIMATE RISKS FROM DESIRED FUNCTIONS
 - 1.2A.10.7.4 PROJECT CONSUMABLES REQUIREMENTS FROM MISSION PROFILE
 - 1.2A.10.7.5 DETERMINE CONSTRAINTS AND FIGURES OF MERIT
 - 1.2A.10.7.6 COMPUTE OPTIMAL SEQUENCING
 - 1.2A.10.8 IDENTIFY DEFECTIVE COMPONENT
 - 1.2A.10.8.1 DETERMINE ANOMALOUS DATA
 - 1.2A.10.8.2 FORM HYPOTHESIS FOR PROBLEM
 - 1.2A.10.8.3 DEVISE TEST FOR FAILURE HYPOTHESIS
 - 1.2A.10.8.4 PERFORM TEST FOR FAILURE HYPOTHESIS
 - 1.2A.10.8.5 IDENTIFY FAULTY COMPONENT
 - 1.2A.10.9 IDENTIFY DEFECTIVE SOFTWARE
 - 1.2A.10.9.1 COMPARE MEASURED DATA TO MODEL
 - 1.2A.10.9.2 DETERMINE ANOMALOUS DATA
 - 1.2A.10.9.3 FORM HYPOTHESIS FOR PROBLEM
 - 1.2A.10.9.4 DEVISE TEST FOR FAILURE HYPOTHESIS

- 1.2A.10.9.5 PERFORM TEST FOR FAILURE HYPOTHESIS
- 1.2A.10.10A COMPONENT FAILURE RECOVERY (REDUNDANCY)
 - 1.2A.10.10A.1 SWITCH OUT FAULTY COMPONENT
 - 1.2A.10.10A.2 SWITCH IN REDUNDANT COMPONENT
 - 1.2A.10.10A.3 MAKE DIAGNOSTIC CHECKS
 - 1.2A.10.10A.4 UPDATE SPACECRAFT MODEL
- 1.2A.10.10B COMPONENT FAILURE RECOVERY (ON-BOARD REPAIR)
 - 1.2A.10.10B.1 DEFINE ACCESS SEQUENCE
 - 1.2A.10.10B.2 LOCATE ACCESS PANEL
 - 1.2A.10.10B.3 TRANSFER REPAIR EQUIPMENT TO REPAIR SITE
 - 1.2A.10.10B.4 OPEN ACCESS PANEL
 - 1.2A.10.10B.5 OBSERVE/LOCATE DEFECTIVE COMPONENT
 - 1.2A.10.10B.6 REMOVE COMPONENT
 - 1.2A.10.10B.7 STORE COMPONENT
 - 1.2A.10.10B.8 LOCATE NEW COMPONENT
 - 1.2A.10.10B.9 POSITION AND CONNECT NEW COMPONENT
 - 1.2A.10.10B.10 ADJUST COMPONENT
 - 1.2A.10.10B.11 MAKE DIAGNOSTIC CHECKS
 - 1.2A.10.10B.12 CLOSE ACCESS PANEL
 - 1.2A.10.10B.13 STOW REPAIR EQUIPMENT
 - 1.2A.10.10B.14 UPDATE SPACECRAFT MODEL
- 1.2A.10.11 SOFTWARE FAILURE RECOVERY
 - 1.2A.10.11.1 DETERMINE CORRECTION ALGORITHM
 - 1.2A.10.11.2 DATA/COMMAND ENCODING
 - 1.2A.10.11.3 DATA/COMMAND TRANSMISSION
 - 1.2A.10.11.4 COMPUTER FUNCTION CHECKS
- 1.2A.10.12 REPORT SYSTEM STATUS
 - 1.2A.10.12.1 DATA/COMMAND ENCODING
 - 1.2A.10.12.2 DATA/COMMAND TRANSMISSION
 - 1.2A.10.12.3 DATA/COMMAND DECODING
 - 1.2A.10.12.4 DATA/COMMAND DISPLAY
- 1.2A.11 DOCK WITH SPACECRAFT
 - 1.2A.11.1 ADJUST ORBIT
 - 1.2A.11.1.1 INITIALIZE GUIDANCE SYSTEM
 - 1.2A.11.1.2 DETERMINE CURRENT ORBITAL PARAMETERS
 - 1.2A.11.1.3 DETERMINE DESIRED ORBITAL PARAMETERS
 - 1.2A.11.1.4 CHOOSE OPTIMAL TRAJECTORY
 - 1.2A.11.1.5 FIRE THRUSTERS
 - 1.2A.11.2 ADJUST ATTITUDE
 - 1.2A.11.2.1 DETERMINE CURRENT ATTITUDE
 - 1.2A.11.2.2 DETERMINE DESIRED ATTITUDE
 - 1.2A.11.2.3 DETERMINE NEW CONFIGURATION FOR SPACECRAFT COMPONENTS
 - 1.2A.11.2.4 CHOOSE OPTIMAL TRAJECTORY
 - 1.2A.11.2.5 ROTATE SPACECRAFT
 - 1.2A.11.3 OPTIMAL CONTROL ALLOCATION
 - 1.2A.11.3.1 UPDATE SPACECRAFT MODEL
 - 1.2A.11.3.2 PROJECT DESIRED FUNCTIONS FROM MISSION PROFILE
 - 1.2A.11.3.3 ESTIMATE RISKS FROM DESIRED FUNCTIONS
 - 1.2A.11.3.4 PROJECT CONSUMABLES REQUIREMENTS FROM MISSION PROFILE
 - 1.2A.11.3.5 DETERMINE CONSTRAINTS AND FIGURES OF MERIT
 - 1.2A.11.3.6 CHOOSE OPTIMAL CONTROL MODE
 - 1.2A.11.3.7 COMPUTE CONTROL COMMANDS
 - 1.2A.11.3.8 EXECUTE CONTROL COMMANDS
 - 1.2A.11.4 DOCK TMS TO SPACECRAFT
 - 1.2A.11.4.1 LOCATE DOCKING TARGET
 - 1.2A.11.4.2 EXTEND DOCKING MECHANISM
 - 1.2A.11.4.3 FASTEN DOCKING LATCH
- 1.2A.12 DIAGNOSTIC CHECK (OF SPACECRAFT)
 - 1.2A.12.1 IDENTIFY DEFECTIVE COMPONENT
 - 1.2A.12.1.1 DETERMINE ANOMALOUS DATA
 - 1.2A.12.1.2 FORM HYPOTHESIS FOR PROBLEM
 - 1.2A.12.1.3 DEVISE TEST FOR FAILURE HYPOTHESIS
 - 1.2A.12.1.4 PERFORM TEST FOR FAILURE HYPOTHESIS
 - 1.2A.12.1.5 IDENTIFY FAULTY COMPONENT
 - 1.2A.12.2 IDENTIFY DEFECTIVE SOFTWARE
 - 1.2A.12.2.1 COMPARE MEASURED DATA TO MODEL
 - 1.2A.12.2.2 DETERMINE ANOMALOUS DATA
 - 1.2A.12.2.3 FORM HYPOTHESIS FOR PROBLEM
 - 1.2A.12.2.4 DEVISE TEST FOR FAILURE HYPOTHESIS
 - 1.2A.12.2.5 PERFORM TEST FOR FAILURE HYPOTHESIS
- 1.2A.13 COMPONENT/SOFTWARE REPLACEMENT
 - 1.2A.13.1 COMPONENT REPLACEMENT

- 1.2A.13.1.1 DEFINE ACCESS SEQUENCE
- 1.2A.13.1.2 LOCATE ACCESS PANEL
- 1.2A.13.1.3 TRANSFER REPAIR EQUIPMENT TO REPAIR SITE
- 1.2A.13.1.4 OPEN ACCESS PANEL
- 1.2A.13.1.5 OBSERVE/LOCATE DEFECTIVE COMPONENT
- 1.2A.13.1.6 REMOVE COMPONENT
- 1.2A.13.1.7 STORE COMPONENT
- 1.2A.13.1.8 LOCATE NEW COMPONENT
- 1.2A.13.1.9 POSITION AND CONNECT NEW COMPONENT
- 1.2A.13.1.10 ADJUST COMPONENT
- 1.2A.13.1.11 MAKE DIAGNOSTIC CHECKS
- 1.2A.13.1.12 CLOSE ACCESS PANEL
- 1.2A.13.1.13 STOW REPAIR EQUIPMENT
- 1.2A.13.1.14 UPDATE SPACECRAFT MODEL
- 1.2A.13.2 SOFTWARE REPLACEMENT
 - 1.2A.13.2.1 DATA/COMMAND ENCODING
 - 1.2A.13.2.2 DATA/COMMAND TRANSMISSION
 - 1.2A.13.2.3 COMPUTER FUNCTION CHECKS
- 1.2A.14 RESUPPLY CONSUMABLES
 - 1.2A.14.1A FLUID REPLACEMENT (UMBILICAL)
 - 1.2A.14.1A.1 LOCATE ACCESS PANEL
 - 1.2A.14.1A.2 OPEN ACCESS PANEL
 - 1.2A.14.1A.3 CLOSE INTERNAL VALVES
 - 1.2A.14.1A.4 EXTEND AND ATTACH UMBILICAL
 - 1.2A.14.1A.5 OPEN SUPPLY VALVE
 - 1.2A.14.1A.6 MONITOR FLUID TRANSFER
 - 1.2A.14.1A.7 CLOSE SUPPLY VALVE
 - 1.2A.14.1A.8 DETACH AND RETRACT UMBILICAL
 - 1.2A.14.1A.9 OPEN INTERNAL VALVES
 - 1.2A.14.1A.10 CHECK FOR LEAKS
 - 1.2A.14.1A.11 CLOSE ACCESS PANEL
 - 1.2A.14.1B FLUID REPLACEMENT (TANK REPLACEMENT)
 - 1.2A.14.1B.1 LOCATE ACCESS PANEL
 - 1.2A.14.1B.2 TRANSFER REPAIR EQUIPMENT TO REPAIR SITE
 - 1.2A.14.1B.3 OPEN ACCESS PANEL
 - 1.2A.14.1B.4 CLOSE INTERNAL VALVES
 - 1.2A.14.1B.5 LOCATE OLD TANK
 - 1.2A.14.1B.6 DISCONNECT OLD TANK
 - 1.2A.14.1B.7 REMOVE OLD TANK
 - 1.2A.14.1B.8 STORE OLD TANK
 - 1.2A.14.1B.9 LOCATE NEW TANK
 - 1.2A.14.1B.10 INSTALL NEW TANK
 - 1.2A.14.1B.11 CONNECT NEW TANK
 - 1.2A.14.1B.12 OPEN INTERNAL VALVES
 - 1.2A.14.1B.13 CHECK FOR LEAKS
 - 1.2A.14.1B.14 CLOSE ACCESS PANEL
 - 1.2A.14.1B.15 STOW REPAIR EQUIPMENT
- 1.2A.15 NON-ROUTINE MAINTENANCE AND REPAIR
- 1.2A.16 REDEPLOY SPACECRAFT
 - 1.2A.16.1 ORBITAL TRANSFER (OF TMS/SPACECRAFT)
 - 1.2A.16.1.1 INITIALIZE GUIDANCE SYSTEM
 - 1.2A.16.1.2 DETERMINE CURRENT ORBITAL PARAMETERS
 - 1.2A.16.1.3 DETERMINE DESIRED ORBITAL PARAMETERS
 - 1.2A.16.1.4 CHOOSE OPTIMAL TRAJECTORY
 - 1.2A.16.1.5 DETERMINE CURRENT ATTITUDE
 - 1.2A.16.1.6 DETERMINE DESIRED ATTITUDE
 - 1.2A.16.1.7 ROTATE SPACECRAFT
 - 1.2A.16.1.8 FIRE THRUSTERS
 - 1.2A.16.2 UNDOCK TMS FROM PAYLOAD
 - 1.2A.16.2.1 RELEASE DOCKING LATCH
 - 1.2A.16.2.2 RETRACT DOCKING MECHANISM
 - 1.2A.16.2.3 MOVE AWAY FROM PAYLOAD
 - 1.2A.16.3 OPERATIONAL CHECKOUT AND ATTITUDE ADJUSTMENT OF SPACECRAFT
- 1.2A.17 DOCK WITH SPACECRAFT
 - 1.2A.17.1 ADJUST ORBIT
 - 1.2A.17.1.1 INITIALIZE GUIDANCE SYSTEM
 - 1.2A.17.1.2 DETERMINE CURRENT ORBITAL PARAMETERS
 - 1.2A.17.1.3 DETERMINE DESIRED ORBITAL PARAMETERS
 - 1.2A.17.1.4 CHOOSE OPTIMAL TRAJECTORY
 - 1.2A.17.1.5 FIRE THRUSTERS
 - 1.2A.17.2 ADJUST ATTITUDE
 - 1.2A.17.2.1 DETERMINE CURRENT ATTITUDE

OPERATIONAL
OF POOR QUALITY.

- 1.2A.17.2.2 DETERMINE DESIRED ATTITUDE
- 1.2A.17.2.3 DETERMINE NEW CONFIGURATION FOR SPACECRAFT COMPONENTS
- 1.2A.17.2.4 CHOOSE OPTIMAL TRAJECTORY
- 1.2A.17.2.5 ROTATE SPACECRAFT
- 1.2A.17.3 OPTIMAL CONTROL ALLOCATION
 - 1.2A.17.3.1 UPDATE SPACECRAFT MODEL
 - 1.2A.17.3.2 PROJECT DESIRED FUNCTIONS FROM MISSION PROFILE
 - 1.2A.17.3.3 ESTIMATE RISKS FROM DESIRED FUNCTIONS
 - 1.2A.17.3.4 PROJECT CONSUMABLES REQUIREMENTS FROM MISSION PROFILE
 - 1.2A.17.3.5 DETERMINE CONSTRAINTS AND FIGURES OF MERIT
 - 1.2A.17.3.6 CHOOSE OPTIMAL CONTROL MODE
 - 1.2A.17.3.7 COMPUTE CONTROL COMMANDS
 - 1.2A.17.3.8 EXECUTE CONTROL COMMANDS
- 1.2A.17.4 DOCK TMS TO SPACECRAFT
 - 1.2A.17.4.1 LOCATE DOCKING TARGET
 - 1.2A.17.4.2 EXTEND DOCKING MECHANISM
 - 1.2A.17.4.3 FASTEN DOCKING LATCH
- 1.2A.18 DEBRIS DISPOSAL
 - 1.2A.18.1 ORBITAL TRANSFER
 - 1.2A.18.1.1 INITIALIZE GUIDANCE SYSTEM
 - 1.2A.18.1.2 DETERMINE CURRENT ORBITAL PARAMETERS
 - 1.2A.18.1.3 DETERMINE DESIRED ORBITAL PARAMETERS
 - 1.2A.18.1.4 CHOOSE OPTIMAL TRAJECTORY
 - 1.2A.18.1.5 DETERMINE CURRENT ATTITUDE
 - 1.2A.18.1.6 DETERMINE DESIRED ATTITUDE
 - 1.2A.18.1.7 FIRE THRUSTERS
 - 1.2A.18.1.8 COAST TO SUPERSYNCHRONOUS ORBIT
 - 1.2A.18.2 DEBRIS DISPOSAL
 - 1.2A.18.2.1 TRANSFER DEBRIS TO DISPOSAL POSITION
 - 1.2A.18.2.2 JETTISON DEBRIS
- 1.2A.19 RENDEZVOUS WITH ORBITER
 - 1.2A.19.1 ORBITAL TRANSFER (OF TMS)
 - 1.2A.19.1.1 INITIALIZE GUIDANCE SYSTEM
 - 1.2A.19.1.2 DETERMINE CURRENT ORBITAL PARAMETERS
 - 1.2A.19.1.3 DETERMINE DESIRED ORBITAL PARAMETERS
 - 1.2A.19.1.4 CHOOSE OPTIMAL TRAJECTORY
 - 1.2A.19.1.5 DETERMINE CURRENT ATTITUDE
 - 1.2A.19.1.6 DETERMINE DESIRED ATTITUDE
 - 1.2A.19.1.7 ROTATE SPACECRAFT
 - 1.2A.19.1.8 FIRE THRUSTERS
 - 1.2A.19.2 SHUTDOWN TMS FOR RETRIEVAL
 - 1.2A.19.2.1 STOW TMS ANTENNA
 - 1.2A.19.2.2 DEACTIVATE TMS SUBSYSTEMS
- 1.2A.20 RETRIEVAL BY ORBITER
 - 1.2A.20.1 ADJUST ORBIT (OF ORBITER)
 - 1.2A.20.1.1 INITIALIZE GUIDANCE SYSTEM
 - 1.2A.20.1.2 DETERMINE CURRENT ORBITAL PARAMETERS
 - 1.2A.20.1.3 DETERMINE DESIRED ORBITAL PARAMETERS
 - 1.2A.20.1.4 CHOOSE OPTIMAL TRAJECTORY
 - 1.2A.20.1.5 FIRE THRUSTERS
 - 1.2A.20.2 ADJUST ATTITUDE (OF ORBITER)
 - 1.2A.20.2.1 DETERMINE CURRENT ATTITUDE
 - 1.2A.20.2.2 DETERMINE DESIRED ATTITUDE
 - 1.2A.20.2.3 DETERMINE NEW CONFIGURATION FOR SPACECRAFT COMPONENTS
 - 1.2A.20.2.4 CHOOSE OPTIMAL TRAJECTORY
 - 1.2A.20.2.5 ROTATE SPACECRAFT
 - 1.2A.20.3 OPTIMAL CONTROL ALLOCATION
 - 1.2A.20.3.1 UPDATE SPACECRAFT MODEL
 - 1.2A.20.3.2 PROJECT DESIRED FUNCTIONS FROM MISSION PROFILE
 - 1.2A.20.3.3 ESTIMATE RISKS FROM DESIRED FUNCTIONS
 - 1.2A.20.3.4 PROJECT CONSUMABLES REQUIREMENTS FROM MISSION PROFILE
 - 1.2A.20.3.5 DETERMINE CONSTRAINTS AND FIGURES OF MERIT
 - 1.2A.20.3.6 CHOOSE OPTIMAL CONTROL MODE
 - 1.2A.20.3.7 COMPUTE CONTROL COMMANDS
 - 1.2A.20.3.8 EXECUTE CONTROL COMMANDS
 - 1.2A.20.4 ORBITER RECOVERY OF TMS
 - 1.2A.20.4.1 ACTIVATE RMS
 - 1.2A.20.4.2 LOCATE GRASPING FIXTURE ON TARGET
 - 1.2A.20.4.3 MOVE RMS TO FIXTURE
 - 1.2A.20.4.4 GRASP FIXTURE
 - 1.2A.20.4.5 LOCATE CRADLE IN PAYLOAD BAY
 - 1.2A.20.4.7 TRANSLATE PAYLOAD TO CRADLE

- 1.2A.20.4.7 LOCATE PAYLOAD RESTRAINTS
- 1.2A.20.4.8 FASTEN PAYLOAD RESTRAINTS
- 1.2A.20.4.9 RMS RELEASES PAYLOAD
- 1.2A.20.4.10 SECURE RMS IN PAYLOAD BAY
- 1.2A.21 REENTRY AND LANDING
- 1.2A.22 POST-FLIGHT OPERATIONS
 - 1.2A.22.1 SAFING OF ORBITER AND HAZARDOUS PAYLOADS
 - 1.2A.22.2 REMOVAL OF PAYLOADS FROM ORBITER

1.2B SERVICING MAINTENANCE AND REPAIR (OIV ONLY)

 This mission involves two possibilities: either an OTV carrying supplies of consumables which would be transferred to the GSP via umbilical, or, in the event that the GSP had its own manipulator with limited capability, an OTV with a repair kit in addition to supplies of consumables.

- 1.2B.1 DESIGN
 - 1.2B.1.1 DEFINE REQUIREMENTS
 - 1.2B.1.2 MISSION ANALYSIS
 - 1.2B.1.3 PAYLOAD ACCOMODATIONS
 - 1.2B.1.4 CREATE FUNCTIONAL LAYOUT
 - 1.2B.1.5 FAILURE MODES ANALYSIS
 - 1.2B.1.6 CREATE MECHANICAL LAYOUT
 - 1.2B.1.7 SAFETY REVIEW
 - 1.2B.1.8 DESIGN OF COMPONENTS
 - 1.2B.1.9 SOFTWARE DEVELOPMENT
- 1.2B.2. COMPONENT FABRICATION
 - 1.2B.2.1 PROCURE OFF-THE-SHELF COMPONENTS
 - 1.2B.2.2 PROCURE MATERIALS FOR MANUFACTURED COMPONENTS
 - 1.2B.2.3 PROCURE MANUFACTURING EQUIPMENT
 - 1.2B.2.4 MANUFACTURE COMPONENTS
- 1.2B.3 COMPONENT TEST
 - 1.2B.3.1 SET UP TEST FACILITIES
 - 1.2B.3.2 STRUCTURAL LOADS TESTS
 - 1.2B.3.3 DATA PROCESSING AND SOFTWARE TESTS
 - 1.2B.3.4 ELECTRICAL SYSTEMS TESTS
 - 1.2B.3.5 THERMAL AND VACUUM TESTS
 - 1.2B.3.6 THRUSTER TESTS
 - 1.2B.3.7 SOLAR ARRAY DEPLOYMENT TESTS
 - 1.2B.3.8 COMPONENT CERTIFICATION
- 1.2B.4 SYSTEM INTEGRATION
- 1.2B.5 SYSTEM TEST
 - 1.2B.5.1 POWER SUBSYSTEM TESTS
 - 1.2B.5.2 THERMAL SUBSYSTEM TESTS
 - 1.2B.5.3 STRUCTURE SUBSYSTEM TESTS
 - 1.2B.5.4 INFORMATION PROCESSING SUBSYSTEM TESTS
 - 1.2B.5.5 COMMUNICATIONS SUBSYSTEM TESTS
 - 1.2B.5.6 ATTITUDE CONTROL SUBSYSTEM TESTS
 - 1.2B.5.7 PROPULSION SUBSYSTEM TESTS
 - 1.2B.5.8 TRAFFIC ROUTING SUBSYSTEM TESTS
 - 1.2B.5.9 INTEGRATED SYSTEMS TESTS
 - 1.2B.5.10 FAILLRE MODES SIMULATION
 - 1.2B.5.11 SYSTEM CERTIFICATION
- 1.2B.6 SHIPPING TO LAUNCH SITE
 - 1.2B.6.1 REMOVE TEST EQUIPMENT
 - 1.2B.6.2 PERFORM NECESSARY DISASSEMBLY
 - 1.2B.6.3 PACKING
 - 1.2B.6.4 TRANSPORT TO LAUNCH SITE
- 1.2B.7 PAYLOAD INTEGRATION AND CHECKOUT
 - 1.2B.7.1 UNPACKING
 - 1.2B.7.2 PERFORM NECESSARY REASSEMBLY
 - 1.2B.7.3 INTEGRATED SYSTEMS TESTS
 - 1.2B.7.3.1 VERIFY POWER SYSTEM FUNCTION
 - 1.2B.7.3.2 VERIFY COMMAND SYSTEM FUNCTION
 - 1.2B.7.3.3 VERIFY MECHANICAL SYSTEM FUNCTION
 - 1.2B.7.3.4 VERIFY COMMUNICATIONS SYSTEM FUNCTION
 - 1.2B.7.3.5 MISSION SEQUENCE SIMULATION
 - 1.2B.7.4 TRANSFER TO VERTICAL PROCESSING FACILITY
 - 1.2B.7.4.1 LOAD PAYLOAD INTO CONTAINER
 - 1.2B.7.4.2 TRANSPORT CONTAINER TO VERTICAL PROCESSING FACILITY
 - 1.2B.7.4.3 UNLOAD CONTAINER
 - 1.2B.7.5 INTEGRATION WITH BOOSTERS

- 1.2B.7.6 PERFORM INTERFACES CHECK
 - 1.2B.7.6.1 CHECK SHUTTLE/PAYLOAD MECHANICAL INTERFACES
 - 1.2B.7.6.2 CHECK ELECTRICAL INTERFACES
 - 1.2B.7.6.3 CHECK PAYLOAD/BOOSTER MECHANICAL INTERFACES
 - 1.2B.7.6.4 CHECK ELECTRICAL INTERFACES
- 1.2B.7.7 TRANSFER TO LAUNCH PAD
 - 1.2B.7.7.1 LOAD PAYLOAD INTO CANISTER
 - 1.2B.7.7.2 TRANSPORT TO ROTATING SERVICE STRUCTURE
 - 1.2B.7.7.3 LOAD CANISTER INTO ROTATING SERVICE STRUCTURE
 - 1.2B.7.7.4 LOAD PAYLOAD INTO ROTATING SERVICE STRUCTURE USING PGHM
 - 1.2B.7.7.5 REMOVE CANISTER
- 1.2B.7.8 ORBITER/PAYLOAD INTEGRATION (VERTICAL)
 - 1.2B.7.8.1 MATE ROTATING SERVICE STRUCTURE TO ORBITER
 - 1.2B.7.8.2 EXTEND PAYLOAD INTO ORBITER USING PGHM
 - 1.2B.7.8.3 CONNECT ORBITER/PAYLOAD INTERFACES
 - 1.2B.7.8.4 CHECK ELECTRICAL INTERFACES
 - 1.2B.7.8.5 CLOSE-OUT PAYLOAD BAY
- 1.2B.8 COUNTDOWN AND LAUNCH
 - 1.2B.8.1 CABIN CLOSEOUT
 - 1.2B.8.2 PAYLOAD SERVICING (AS REQUIRED)
 - 1.2B.8.3 VEHICLE CLOSEOUT
 - 1.2B.8.4 LAUNCH COUNTDOWN
 - 1.2B.8.5 LIFTOFF
- 1.2B.9 ORBITAL DEPLOYMENT AND CHECKOUT
 - 1.2B.9.1 SHUTTLE ATTAINS DELIVERY ORBIT
 - 1.2B.9.2 EXTENSION OF PAYLOAD FROM PAYLOAD BAY
 - 1.2B.9.2.1 OPEN PAYLOAD BAY DOORS
 - 1.2B.9.2.2 ACTIVATE RMS
 - 1.2B.9.2.3 LOCATE GRASPING FIXTURE ON TARGET
 - 1.2B.9.2.4 MOVE RMS TO FIXTURE
 - 1.2B.9.2.5 GRASP FIXTURE
 - 1.2B.9.2.6 RELEASE PAYLOAD RESTRAINTS
 - 1.2B.9.2.7 TRANSLATE PAYLOAD OUT OF PAYLOAD BAY
 - 1.2B.9.3 SEPARATION OF PAYLOAD FROM ORBITER
 - 1.2B.9.3.1 RMS RELEASES PAYLOAD
 - 1.2B.9.3.2 SECURE RMS IN PAYLOAD BAY
 - 1.2B.9.4 ORBITAL TRANSFER
 - 1.2B.9.4.1 INITIALIZE GUIDANCE SYSTEM
 - 1.2B.9.4.2 DETERMINE CURRENT ORBITAL PARAMETERS
 - 1.2B.9.4.3 DETERMINE DESIRED ORBITAL PARAMETERS
 - 1.2B.9.4.4 CHOOSE OPTIMAL TRAJECTORY
 - 1.2B.9.4.5 DETERMINE CURRENT ATTITUDE
 - 1.2B.9.4.6 DETERMINE DESIRED ATTITUDE
 - 1.2B.9.4.7 ROTATE SPACECRAFT
 - 1.2B.9.4.8 FIRE THRUSTERS
- 1.2B.10 DOCK WITH SPACECRAFT (GSP)
 - 1.2B.10.1 ADJUST ORBIT
 - 1.2B.10.1.1 INITIALIZE GUIDANCE SYSTEM
 - 1.2B.10.1.2 DETERMINE CURRENT ORBITAL PARAMETERS
 - 1.2B.10.1.3 DETERMINE DESIRED ORBITAL PARAMETERS
 - 1.2B.10.1.4 CHOOSE OPTIMAL TRAJECTORY
 - 1.2B.10.1.5 FIRE THRUSTERS
 - 1.2B.10.2 ADJUST ATTITUDE
 - 1.2B.10.2.1 DETERMINE CURRENT ATTITUDE
 - 1.2B.10.2.2 DETERMINE DESIRED ATTITUDE
 - 1.2B.10.2.3 DETERMINE NEW CONFIGURATION FOR SPACECRAFT COMPONENTS
 - 1.2B.10.2.4 CHOOSE OPTIMAL TRAJECTORY
 - 1.2B.10.2.5 ROTATE SPACECRAFT
 - 1.2B.10.3 OPTIMAL CONTROL ALLOCATION
 - 1.2B.10.3.1 UPDATE SPACECRAFT MODEL
 - 1.2B.10.3.2 PROJECT DESIRED FUNCTIONS FROM MISSION PROFILE
 - 1.2B.10.3.3 ESTIMATE RISKS FROM DESIRED FUNCTIONS
 - 1.2B.10.3.4 PROJECT CONSUMABLES REQUIREMENTS FROM MISSION PROFILE
 - 1.2B.10.3.5 DETERMINE CONSTRAINTS AND FIGURES OF MERIT
 - 1.2B.10.3.6 CHOOSE OPTIMAL CONTROL MODE
 - 1.2B.10.3.7 COMPUTE CONTROL COMMANDS
 - 1.2B.10.3.8 EXECUTE CONTROL COMMANDS
 - 1.2B.10.4 DOCK TMS TO SPACECRAFT
 - 1.2B.10.4.1 LOCATE DOCKING TARGET
 - 1.2B.10.4.2 EXTEND DOCKING MECHANISM
 - 1.2B.10.4.3 FASTEN DOCKING LATCH
- 1.2B.11 DIAGNOSTIC CHECK (OF SPACECRAFT)

- 1.2B.11.1 IDENTIFY DEFECTIVE COMPONENT
 - 1.2B.11.1.1 DETERMINE ANOMALOUS DATA
 - 1.2B.11.1.2 FORM HYPOTHESIS FOR PROBLEM
 - 1.2B.11.1.3 DEVISE TEST FOR FAILURE HYPOTHESIS
 - 1.2B.11.1.4 PERFORM TEST FOR FAILURE HYPOTHESIS
 - 1.2B.11.1.5 IDENTIFY FAULTY COMPONENT
- 1.2B.11.2 IDENTIFY DEFECTIVE SOFTWARE
 - 1.2B.11.2.1 COMPARE MEASURED DATA TO MODEL
 - 1.2B.11.2.2 DETERMINE ANOMALOUS DATA
 - 1.2B.11.2.3 FORM HYPOTHESIS FOR PROBLEM
 - 1.2B.11.2.4 DEVISE TEST FOR FAILURE HYPOTHESIS
 - 1.2B.11.2.5 PERFORM TEST FOR FAILURE HYPOTHESIS
- 1.2B.12 COMPONENT/SOFTWARE REPLACEMENT
 - 1.2B.12.1 COMPONENT REPLACEMENT
 - 1.2B.12.1.1 DEFINE ACCESS SEQUENCE
 - 1.2B.12.1.2 LOCATE ACCESS PANEL
 - 1.2B.12.1.3 TRANSFER REPAIR EQUIPMENT TO REPAIR SITE
 - 1.2B.12.1.4 OPEN ACCESS PANEL
 - 1.2B.12.1.5 OBSERVE/LOCATE DEFECTIVE COMPONENT
 - 1.2B.12.1.6 REMOVE COMPONENT
 - 1.2B.12.1.7 STORE COMPONENT
 - 1.2B.12.1.8 LOCATE NEW COMPONENT
 - 1.2B.12.1.9 POSITION AND CONNECT NEW COMPONENT
 - 1.2B.12.1.10 ADJUST COMPONENT
 - 1.2B.12.1.11 MAKE DIAGNOSTIC CHECKS
 - 1.2B.12.1.12 CLOSE ACCESS PANEL
 - 1.2B.12.1.13 STOW REPAIR EQUIPMENT
 - 1.2B.12.1.14 UPDATE SPACECRAFT MODEL
 - 1.2B.12.2 SOFTWARE REPLACEMENT
 - 1.2B.12.2.1 DATA/COMMAND ENCODING
 - 1.2B.12.2.2 DATA/COMMAND TRANSMISSION
 - 1.2B.12.2.3 COMPUTER FUNCTION CHECKS
- 1.2B.13 RESUPPLY CONSUMABLES
 - 1.2B.13.1 FLUID REPLACEMENT (UMBILICAL)
 - 1.2B.13.1.1 LOCATE ACCESS PANEL
 - 1.2B.13.1.2 OPEN ACCESS PANEL
 - 1.2B.13.1.3 CLOSE INTERNAL VALVES
 - 1.2B.13.1.4 EXTEND AND ATTACH UMBILICAL
 - 1.2B.13.1.5 OPEN SUPPLY VALVE
 - 1.2B.13.1.6 MONITOR FLUID TRANSFER
 - 1.2B.13.1.7 CLOSE SUPPLY VALVE
 - 1.2B.13.1.8 DETACH AND RETRACT UMBILICAL
 - 1.2B.13.1.9 OPEN INTERNAL VALVES
 - 1.2B.13.1.10 CHECK FOR LEAKS
 - 1.2B.13.1.11 CLOSE ACCESS PANEL
- 1.2B.14 NON-ROUTINE MAINTENANCE AND REPAIR
- 1.2B.15 REDEPLOY SPACECRAFT (DTV)
 - 1.2B.15.1 ORBITAL TRANSFER
 - 1.2B.15.1.1 INITIALIZE GUIDANCE SYSTEM
 - 1.2B.15.1.2 DETERMINE CURRENT ORBITAL PARAMETERS
 - 1.2B.15.1.3 DETERMINE DESIRED ORBITAL PARAMETERS
 - 1.2B.15.1.4 CHOOSE OPTIMAL TRAJECTORY
 - 1.2B.15.1.5 DETERMINE CURRENT ATTITUDE
 - 1.2B.15.1.6 DETERMINE DESIRED ATTITUDE
 - 1.2B.15.1.7 ROTATE SPACECRAFT
 - 1.2B.15.1.8 FIRE THRUSTERS
 - 1.2B.15.2 UNDOCK TMS FROM PAYLOAD
 - 1.2B.15.2.1 RELEASE DOCKING LATCH
 - 1.2B.15.2.2 RETRACT DOCKING MECHANISM
 - 1.2B.15.2.3 MOVE AWAY FROM PAYLOAD
 - 1.2B.15.3 OPERATIONAL CHECKOUT AND ATTITUDE ADJUSTMENT OF SPACECRAFT
- 1.2B.16 RENDEZVOUS WITH ORBITER
 - 1.2B.16.1 ORBITAL TRANSFER (OF DTV)
 - 1.2B.16.1.1 INITIALIZE GUIDANCE SYSTEM
 - 1.2B.16.1.2 DETERMINE CURRENT ORBITAL PARAMETERS
 - 1.2B.16.1.3 DETERMINE DESIRED ORBITAL PARAMETERS
 - 1.2B.16.1.4 CHOOSE OPTIMAL TRAJECTORY
 - 1.2B.16.1.5 DETERMINE CURRENT ATTITUDE
 - 1.2B.16.1.6 DETERMINE DESIRED ATTITUDE
 - 1.2B.16.1.7 ROTATE SPACECRAFT
 - 1.2B.16.1.8 FIRE THRUSTERS
 - 1.2B.16.2 SHUTDOWN TMS FOR RETRIEVAL

ORIGINAL PAGE IS
OF POOR QUALITY

- 1.2B.16.2.1 STOW TMS ANTENNA
- 1.2B.16.2.2 DEACTIVATE TMS SUBSYSTEMS
- 1.2B.17 RETRIEVAL BY ORBITER
 - 1.2B.17.1 ADJUST ORBIT (OF ORBITER)
 - 1.2B.17.1.1 INITIALIZE GUIDANCE SYSTEM
 - 1.2B.17.1.2 DETERMINE CURRENT ORBITAL PARAMETERS
 - 1.2B.17.1.3 DETERMINE DESIRED ORBITAL PARAMETERS
 - 1.2B.17.1.4 CHOOSE OPTIMAL TRAJECTORY
 - 1.2B.17.1.5 FIRE THRUSTERS
 - 1.2B.17.2 ADJUST ATTITUDE (OF ORBITER)
 - 1.2B.17.2.1 DETERMINE CURRENT ATTITUDE
 - 1.2B.17.2.2 DETERMINE DESIRED ATTITUDE
 - 1.2B.17.2.3 DETERMINE NEW CONFIGURATION FOR SPACECRAFT COMPONENTS
 - 1.2B.17.2.4 CHOOSE OPTIMAL TRAJECTORY
 - 1.2B.17.2.5 ROTATE SPACECRAFT
 - 1.2B.17.3 OPTIMAL CONTROL ALLOCATION
 - 1.2B.17.3.1 UPDATE SPACECRAFT MODEL
 - 1.2B.17.3.2 PROJECT DESIRED FUNCTIONS FROM MISSION PROFILE
 - 1.2B.17.3.3 ESTIMATE RISKS FROM DESIRED FUNCTIONS
 - 1.2B.17.3.4 PROJECT CONSUMABLES REQUIREMENTS FROM MISSION PROFILE
 - 1.2B.17.3.5 DETERMINE CONSTRAINTS AND FIGURES OF MERIT
 - 1.2B.17.3.6 CHOOSE OPTIMAL CONTROL MODE
 - 1.2B.17.3.7 COMPUTE CONTROL COMMANDS
 - 1.2B.17.3.8 EXECUTE CONTROL COMMANDS
 - 1.2B.17.4 ORBITER RECOVERY OF TMS
 - 1.2B.17.4.1 ACTIVATE RMS
 - 1.2B.17.4.2 LOCATE GRASPING FIXTURE ON TARGET
 - 1.2B.17.4.3 MOVE RMS TO FIXTURE
 - 1.2B.17.4.4 GRASP FIXTURE
 - 1.2B.17.4.5 LOCATE CRADLE IN PAYLOAD BAY
 - 1.2B.17.4.6 TRANSLATE PAYLOAD TO CRADLE
 - 1.2B.17.4.7 LOCATE PAYLOAD RESTRAINTS
 - 1.2B.17.4.8 FASTEN PAYLOAD RESTRAINTS
 - 1.2B.17.4.9 RMS RELEASES PAYLOAD
 - 1.2B.17.4.10 SECURE RMS IN PAYLOAD BAY
- 1.2B.18 REENTRY AND LANDING
- 1.2B.19 POST-FLIGHT OPERATIONS
 - 1.2B.19.1 SAFING OF ORBITER AND HAZARDOUS PAYLOADS
 - 1.2B.19.2 REMOVAL OF PAYLOADS FROM ORBITER

2.A.3:

ADVANCED X-RAY ASTROPHYSICS FACILITY (AXAF)

ORIGINAL COPY
OF POOR COPY

The main data sources used in preparing this breakdown are: NASA TM-78285
AXAF Science Working Group Report, May 1980; AXAF Phase A Reference Concept,
NASA-MSFC, November 1980.

2 Advanced X-Ray Astrophysics Facility (AXAF)

2.1A INITIAL DEPLOYMENT (SHUTTLE WITH OMS KIT)

2.1A.1 DESIGN

- 2.1A.1.1 DEFINE REQUIREMENTS
- 2.1A.1.2 MISSION ANALYSIS
- 2.1A.1.3 PAYLOAD ACCOMMODATIONS
- 2.1A.1.4 CREATE FUNCTIONAL LAYOUT
- 2.1A.1.5 FAILURE MODES ANALYSIS
- 2.1A.1.6 ADJUST DESIGN FOR MAINTENANCE AND REPAIR
- 2.1A.1.7 CREATE MECHANICAL LAYOUT
- 2.1A.1.8 SAFETY REVIEW
- 2.1A.1.9 DESIGN OF COMPONENTS
- 2.1A.1.10 SOFTWARE DEVELOPMENT

2.1A.2 COMPONENT FABRICATION

- 2.1A.2.1 PROCURE OFF-THE-SHELF COMPONENTS
- 2.1A.2.2 PROCURE MATERIALS FOR MANUFACTURED COMPONENTS
- 2.1A.2.3 PROCURE MANUFACTURING EQUIPMENT
- 2.1A.2.4 MANUFACTURE COMPONENTS
- 2.1A.2.5 MIRROR SURFACE FINISHING

2.1A.3 COMPONENT TEST

- 2.1A.3.1 SET UP TEST FACILITIES
- 2.1A.3.2 STRUCTURAL LOADS TESTS
- 2.1A.3.3 DATA PROCESSING AND SOFTWARE TESTS
- 2.1A.3.4 SOLAR ARRAY DEPLOYMENT TESTS
- 2.1A.3.5 ELECTRICAL SYSTEMS TESTS
- 2.1A.3.6 THERMAL AND VACUUM TESTS
- 2.1A.3.7 DETECTOR ALIGNMENT TESTS
- 2.1A.3.8 MIRROR DRIVE SYSTEMS TESTS
- 2.1A.3.9 MIRROR OPTICAL TESTS
- 2.1A.3.10 COMPONENT CERTIFICATION

2.1A.4 SYSTEM INTEGRATION

2.1A.5 SYSTEM TEST

- 2.1A.5.1 POWER SUBSYSTEM TESTS
- 2.1A.5.2 THERMAL SUBSYSTEM TESTS
- 2.1A.5.3 STRUCTURE SUBSYSTEM TESTS
- 2.1A.5.4 INFORMATION PROCESSING SUBSYSTEM TESTS
- 2.1A.5.5 COMMUNICATIONS SUBSYSTEM TESTS
- 2.1A.5.6 ATTITUDE CONTROL SUBSYSTEM TESTS
- 2.1A.5.7 OPTICAL SUBSYSTEM TESTS
- 2.1A.5.8 INTEGRATED SYSTEMS TESTS
- 2.1A.5.9 FAILURE MODES SIMULATION
- 2.1A.5.10 SYSTEM CERTIFICATION

2.1A.6 SHIPPING TO LAUNCH SITE

- 2.1A.6.1 REMOVE TEST EQUIPMENT
- 2.1A.6.2 PERFORM NECESSARY DISASSEMBLY
- 2.1A.6.3 PACKING
- 2.1A.6.4 TRANSPORT TO LAUNCH SITE

2.1A.7 PAYLOAD INTEGRATION AND CHECKOUT

- 2.1A.7.1 UNPACKING
- 2.1A.7.2 PERFORM NECESSARY REASSEMBLY
- 2.1A.7.3 INTEGRATED SYSTEMS TESTS
 - 2.1A.7.3.1 VERIFY POWER SYSTEM FUNCTION
 - 2.1A.7.3.2 VERIFY COMMAND SYSTEM FUNCTION
 - 2.1A.7.3.3 VERIFY MECHANICAL SYSTEM FUNCTION
 - 2.1A.7.3.4 VERIFY COMMUNICATIONS SYSTEM FUNCTION
 - 2.1A.7.3.5 VERIFY DETECTOR SYSTEM FUNCTION
 - 2.1A.7.3.6 MISSION SEQUENCE SIMULATION
- 2.1A.7.4 TRANSFER TO OPERATIONS AND CHECKOUT BLDG.
 - 2.1A.7.4.1 LOAD PAYLOAD INTO CONTAINER
 - 2.1A.7.4.2 TRANSPORT TO OPERATIONS AND CHECKOUT BLDG.
 - 2.1A.7.4.3 ATTACH STRONGBACK TO PAYLOAD
 - 2.1A.7.4.4 INSTALL PAYLOAD IN HORIZONTAL CITE
- 2.1A.7.5 PERFORM INTERFACES CHECK
 - 2.1A.7.5.1 CHECK SHUTTLE/PAYLOAD MECHANICAL INTERFACES
 - 2.1A.7.5.2 CHECK ELECTRICAL INTERFACES
- 2.1A.7.6 TRANSFER PAYLOAD TO ORBITER PROCESSING FACILITY

- 2.1A.7.6.1 ATTACH STRONGBACK TO PAYLOAD
- 2.1A.7.6.2 LOAD PAYLOAD INTO CANISTER
- 2.1A.7.6.3 REMOVE STRONGBACK
- 2.1A.7.6.4 CLOSE CANISTER
- 2.1A.7.6.5 TRANSPORT CANISTER TO ORBITER PROCESSING FACILITY
- 2.1A.7.7 ORBITER/PAYLOAD INTEGRATION (HORIZONTAL)
 - 2.1A.7.7.1 ATTACH STRONGBACK TO PAYLOAD
 - 2.1A.7.7.2 INSTALL PAYLOAD IN ORBITER
 - 2.1A.7.7.3 CONNECT ORBITER/PAYLOAD INTERFACES
 - 2.1A.7.7.4 CHECK ELECTRICAL INTERFACES
 - 2.1A.7.7.5 INSTALLATION OF OMS KIT
 - 2.1A.7.7.6 CLOSE-OUT PAYLOAD BAY
- 2.1A.8 COUNTDOWN AND LAUNCH
- 2.1A.9 ORBITAL DEPLOYMENT AND CHECKOUT
 - 2.1A.9.1 SHUTTLE ATTAINS DELIVERY ORBIT
 - 2.1A.9.2 EXTENSION OF PAYLOAD FROM PAYLOAD BAY
 - 2.1A.9.2.1 OPEN PAYLOAD BAY DOORS
 - 2.1A.9.2.2 LOCATE GRASPING FIXTURE ON TARGET

The target is AXAF.

- 2.1A.9.2.3 GRASP FIXTURE
- 2.1A.9.2.4 RELEASE PAYLOAD RESTRAINTS
- 2.1A.9.2.5 TILT PAYLOAD TO VERTICAL POSITION

AXAF is mounted on a tilt-table.

- 2.1A.9.3 EXTEND DEPLOYABLE COMPONENTS
 - 2.1A.9.3.1 LOCATE SOLAR ARRAY RESTRAINTS
 - 2.1A.9.3.2 RELEASE SOLAR ARRAY RESTRAINTS
 - 2.1A.9.3.3 LOCATE GRASPING FIXTURE ON TARGET

The target is the AXAF solar array.

- 2.1A.9.3.4 GRASP FIXTURE
- 2.1A.9.3.5 DEPLOY SOLAR ARRAYS
- 2.1A.9.3.6 LOCATE SUNSHADE RESTRAINTS
- 2.1A.9.3.7 RELEASE SUNSHADE RESTRAINTS
- 2.1A.9.3.8 LOCATE GRASPING FIXTURE ON TARGET

The target is the AXAF sunshade.

- 2.1A.9.3.9 GRASP FIXTURE
- 2.1A.9.3.10 OPEN SUNSHADE
- 2.1A.9.3.11 DEPLOY TDRSS ANTENNAS
- 2.1A.9.4 TESTS OF ATTACHED PAYLOAD
 - 2.1A.9.4.1 COMMAND DETECTOR SELECTION

Command to rotate detector carousel is entered from Orbiter.

- 2.1A.9.4.2 OBSERVE DETECTOR SELECTION

Data from AXAF is checked to verify detector selection.

- 2.1A.9.4.3 MONITOR TELEMETRY

AXAF data is monitored by Orbiter.

- 2.1A.9.4.4 EVALUATE SYSTEM PERFORMANCE

Detector and housekeeping data is evaluated to verify correct response to command.

- 2.1A.9.5 SEPARATION OF PAYLOAD FROM ORBITER
 - 2.1A.9.5.1 LOCATE GRASPING FIXTURE ON TARGET

The target is AXAF.

- 2.1A.9.5.2 GRASP FIXTURE
- 2.1A.9.5.3 RELEASE PAYLOAD RESTRAINTS
- 2.1A.9.5.4 TRANSLATE PAYLOAD OUT OF PAYLOAD BAY

2.1A.9.5.5 RMS RELEASES PAYLOAD
2.1A.9.6 OPERATIONAL CHECKOUT
2.1A.9.6.1 ACTIVATE AXAF SUBSYSTEMS

Attitude control, communications, thermal control systems are activated.

2.1A.9.6.2 COMMAND ATTITUDE CHANGE

Command to change pointing is entered.

2.1A.9.6.3 OBSERVE ATTITUDE CHANGE

Orbiter observes results of attitude change command.

2.1A.9.6.4 MONITOR TELEMETRY

AXAF data output is monitored by ground through TDRSS.

2.1A.9.6.5 EVALUATE SYSTEM PERFORMANCE

Detector and housekeeping data is evaluated to verify correct response to command.

2.1A.9.7 STABILIZE AXAF FOR RETRIEVAL

If system performance is not adequate, retrieval may be necessary, for repairs in payload bay or on ground.

2.1A.9.7.1 INITIALIZE GUIDANCE SYSTEM

Update inertial reference system.

2.1A.9.7.2 DETERMINE CURRENT ATTITUDE

2.1A.9.7.3 DETERMINE DESIRED ATTITUDE

2.1A.9.7.4 DETERMINE NEW CONFIGURATION FOR SPACECRAFT COMPONENTS

Main components are solar arrays and radiators.

2.1A.9.7.5 CHOOSE OPTIMAL TRAJECTORY

2.1A.9.7.6 ROTATE SPACECRAFT

Use magnetic torquers for attitude control.

2.1A.9.7.7 DETERMINE DISTURBING TORQUES

2.1A.9.7.8 COMPUTE REQUIRED RESULTANT

2.1A.9.7.9 APPLY COMPENSATING TORQUES

Use magnetic torquers.

2.1A.9.7.10 SHUTDOWN SPACECRAFT SYSTEMS

2.1A.9.8 ATTACH AXAF TO ORBITER

2.1A.9.8.1 MATCH AXAF VELOCITY AND ATTITUDE WITH ORBITER

2.1A.9.8.2 LOCATE GRASPING FIXTURE ON TARGET

The target is AXAF.

2.1A.9.8.3 GRASP FIXTURE

2.1A.9.8.4 TRANSLATE PAYLOAD TO CRADLE

2.1A.9.8.5 FASTEN PAYLOAD RESTRAINTS

2.1A.9.9 IDENTIFY DEFECTIVE COMPONENT

2.1A.9.9.1 DETERMINE ANOMALOUS DATA

2.1A.9.9.2 FORM HYPOTHESIS FOR PROBLEM

2.1A.9.9.3 DEVISE TEST FOR FAILURE HYPOTHESIS

2.1A.9.9.4 PERFORM TEST FOR FAILURE HYPOTHESIS

2.1A.9.9.5 IDENTIFY FAULTY COMPONENT

2.1A.9.10A COMPONENT FAILURE RECOVERY (REDUNDANCY)

2.1A.9.10A.1 SWITCH OUT FAULTY COMPONENT

2.1A.9.10A.2 SWITCH IN REDUNDANT COMPONENT

2.1A.9.10A.3 MAKE DIAGNOSTIC CHECKS

2.1A.9.10A.4 UPDATE SPACECRAFT MODEL

2.1A.9.10B COMPONENT FAILURE RECOVERY (ON-BOARD REPAIR)

ORIGINAL
OF TECHNICAL

- 2.1A.9.10B.1 DEFINE ACCESS SEQUENCE
- 2.1A.9.10B.2 LOCATE ACCESS PANEL
- 2.1A.9.10B.3 TRANSFER REPAIR EQUIPMENT TO REPAIR SITE
- 2.1A.9.10B.4 OPEN ACCESS PANEL
- 2.1A.9.10B.5 OBSERVE/LOCATE DEFECTIVE COMPONENT
- 2.1A.9.10B.6 REMOVE COMPONENT
- 2.1A.9.10B.7 STORE COMPONENT
- 2.1A.9.10B.8 LOCATE NEW COMPONENT
- 2.1A.9.10B.9 POSITION AND CONNECT NEW COMPONENT
- 2.1A.9.10B.10 ADJUST COMPONENT
- 2.1A.9.10B.11 MAKE DIAGNOSTIC CHECKS
- 2.1A.9.10B.12 CLOSE ACCESS PANEL
- 2.1A.9.10B.13 STOW REPAIR EQUIPMENT
- 2.1A.9.11 IDENTIFY DEFECTIVE SOFTWARE
 - 2.1A.9.11.1 COMPARE MEASURED DATA TO MODEL
 - 2.1A.9.11.2 DETERMINE ANOMALOUS DATA
 - 2.1A.9.11.3 FORM HYPOTHESIS FOR PROBLEM
 - 2.1A.9.11.4 DEVISE TEST FOR FAILURE HYPOTHESIS
 - 2.1A.9.11.5 PERFORM TEST FOR FAILURE HYPOTHESIS
 - 2.1A.9.11.6 IDENTIFY FAULTY SOFTWARE
- 2.1A.9.12 SOFTWARE FAILURE RECOVERY
 - 2.1A.9.12.1 DETERMINE CORRECTION ALGORITHM
 - 2.1A.9.12.2 DATA/COMMAND ENCODING
 - 2.1A.9.12.3 DATA/COMMAND TRANSMISSION
 - 2.1A.9.12.4 COMPUTER FUNCTION CHECKS
- 2.1A.10 SECURE PAYLOAD IN ORBITER
 - 2.1A.10.1 RETRACT DEPLOYABLE PAYLOAD COMPONENTS
 - 2.1A.10.1.1 RETRACT TDRSS ANTENNAS
 - 2.1A.10.1.2 LOCATE SUNSHADE RESTRAINTS
 - 2.1A.10.1.3 RELEASE SUNSHADE RESTRAINTS
 - 2.1A.10.1.4 LOCATE GRASPING FIXTURE ON TARGET
 - The target is the AXAF sunshade.

 - 2.1A.10.1.5 GRASP FIXTURE
 - 2.1A.10.1.6 CLOSE SUNSHADE
 - 2.1A.10.1.7 LOCATE SOLAR ARRAY RESTRAINTS
 - 2.1A.10.1.8 RELEASE SOLAR ARRAY RESTRAINTS
 - 2.1A.10.1.9 LOCATE GRASPING FIXTURE ON TARGET
 - The target is the AXAF solar array.

 - 2.1A.10.1.10 GRASP FIXTURE
 - 2.1A.10.1.11 RETRACT SOLAR ARRAYS
 - 2.1A.10.2 RETRACTION OF PAYLOAD INTO PAYLOAD BAY
 - 2.1A.10.2.1 LOCATE GRASPING FIXTURE ON TARGET
 - The target is AXAF.

 - 2.1A.10.2.2 GRASP FIXTURE
 - 2.1A.10.2.3 TILT PAYLOAD TO HORIZONTAL POSITION
 - AXAF is mounted on a tilt-table.

 - 2.1A.10.2.4 FASTEN PAYLOAD RESTRAINTS
 - 2.1A.10.2.5 CLOSE PAYLOAD BAY DOORS
- 2.1A.11 REENTRY AND LANDING
- 2.1A.12 POST-FLIGHT OPERATIONS
 - 2.1A.12.1 SAFING OF ORBITER
 - 2.1A.12.2 REMOVAL OF PAYLOAD FROM ORBITER
 - 2.1A.12.2.1 OPEN PAYLOAD BAY DOORS
 - 2.1A.12.2.2 ATTACH STRONGBACK TO PAYLOAD
 - 2.1A.12.2.3 LOAD PAYLOAD INTO CANISTER
- 2.1A.13 STATUS MONITORING AND RESOURCE ALLOCATION
 - 2.1A.13.1 TEMPERATURE MANAGEMENT
 - 2.1A.13.1.1 MEASURE COMPONENT TEMPERATURES
 - 2.1A.13.1.2 COMPARE TEMPERATURES TO REQUIRED LIMITS
 - 2.1A.13.1.3 ADJUST HEATING/COOLING SYSTEMS
 - 2.1A.13.2 POWER MANAGEMENT
 - 2.1A.13.2.1 MEASURE CURRENTS AND VOLTAGES
 - 2.1A.13.2.2 COMPARE CURRENTS AND VOLTAGES TO REQUIRED LIMITS
 - 2.1A.13.2.3 ADJUST CURRENTS AND VOLTAGES

- 2.1A.13.2.4 EVALUATE BATTERY CHARGING PERFORMANCE
- 2.1A.13.2.5 ADJUST BATTERY CHARGING CYCLE
- 2.1A.13.3 DATA/COMMAND PROCESSING
 - 2.1A.13.3.1 SHORT-TERM MEMORY STORAGE
 - 2.1A.13.3.2 LONG-TERM MEMORY STORAGE
 - 2.1A.13.3.3 DATA/COMMAND ENCODING
 - 2.1A.13.3.4 DATA/COMMAND DECODING
 - 2.1A.13.3.5 NUMERICAL COMPUTATION
 - 2.1A.13.3.6 LOGIC OPERATIONS
 - 2.1A.13.3.7 COMPUTER LOAD SCHEDULING
 - 2.1A.13.3.8 COMPUTER FUNCTION CHECKS
- 2.1A.13.4 CONSUMABLES MANAGEMENT
 - 2.1A.13.4.1 MONITOR BATTERIES
 - 2.1A.13.4.2 MONITOR GAS SUPPLIES
 - 2.1A.13.4.3 MONITOR COOLING SYSTEM SUPPLIES
 - 2.1A.13.4.4 PRESSURIZE DETECTORS WHEN NEEDED
 - 2.1A.13.4.5 DEPRESSURIZE DETECTORS WHEN NOT IN USE
 - 2.1A.13.4.6 PROJECT CONSUMABLES REQUIREMENTS FROM MISSION PROFILE
 - 2.1A.13.4.7 COMPUTE OPTIMAL CONSUMABLES ALLOCATION
- 2.1A.13.5 STRUCTURAL MANAGEMENT
 - 2.1A.13.5.1 MEASURE STRAINS IN STRUCTURE
 - 2.1A.13.5.2 MEASURE RELATIVE DISPLACEMENTS
 - 2.1A.13.5.3 COMPUTE STRESS AND VIBRATION PARAMETERS
 - 2.1A.13.5.4 APPLY COMPENSATING FORCES
 - 2.1A.13.5.5 APPLY VIBRATION DAMPING
- 2.1A.13.6 HAZARD AVOIDANCE
 - 2.1A.13.6.1 COMPUTE POSITIONS OF SUN, EARTH, MOON
 - 2.1A.13.6.2 DETERMINE ANGLES RELATIVE TO TELESCOPE LINE-OF-SIGHT
 - 2.1A.13.6.3 MONITOR BRIGHT OBJECT DETECTOR
 - 2.1A.13.6.4 MONITOR SAA DETECTOR
 - 2.1A.13.6.5 COMPARE DETECTOR OUTPUT TO PRESET LIMITS
 - 2.1A.13.6.6 CLOSE OPTICAL SHUTTERS
 - 2.1A.13.6.7 REDUCE VOLTAGES IN SENSITIVE EQUIPMENT
 - 2.1A.13.6.8 SHUTDOWN DETECTORS
- 2.1A.13.7 OPTIMAL SEQUENCING
 - 2.1A.13.7.1 UPDATE SPACECRAFT MODEL
 - 2.1A.13.7.2 PROJECT DESIRED FUNCTIONS FROM MISSION PROFILE
 - 2.1A.13.7.3 ESTIMATE RISKS FROM DESIRED FUNCTIONS
 - 2.1A.13.7.4 PROJECT CONSUMABLES REQUIREMENTS FROM MISSION PROFILE
 - 2.1A.13.7.5 DETERMINE CONSTRAINTS AND FIGURES OF MERIT
 - 2.1A.13.7.6 COMPUTE OPTIMAL SEQUENCING
- 2.1A.13.8 IDENTIFY DEFECTIVE COMPONENT
 - 2.1A.13.8.1 DETERMINE ANOMALOUS DATA
 - 2.1A.13.8.2 FORM HYPOTHESIS FOR PROBLEM
 - 2.1A.13.8.3 DEVISE TEST FOR FAILURE HYPOTHESIS
 - 2.1A.13.8.4 PERFORM TEST FOR FAILURE HYPOTHESIS
 - 2.1A.13.8.5 IDENTIFY FAULTY COMPONENT
- 2.1A.13.9A COMPONENT FAILURE RECOVERY (REDUNDANCY)
 - 2.1A.13.9A.1 SWITCH OUT FAULTY COMPONENT
 - 2.1A.13.9A.2 SWITCH IN REDUNDANT COMPONENT
 - 2.1A.13.9A.3 MAKE DIAGNOSTIC CHECKS
 - 2.1A.13.9A.4 UPDATE SPACECRAFT MODEL
- 2.1A.13.9B COMPONENT FAILURE RECOVERY (ON-BOARD REPAIR)
 - 2.1A.13.9B.1 DEFINE ACCESS SEQUENCE
 - 2.1A.13.9B.2 LOCATE ACCESS PANEL
 - 2.1A.13.9B.3 TRANSFER REPAIR EQUIPMENT TO REPAIR SITE
 - 2.1A.13.9B.4 OBSERVE/LOCATE DEFECTIVE COMPONENT
 - 2.1A.13.9B.5 REMOVE COMPONENT
 - 2.1A.13.9B.6 STORE COMPONENT
 - 2.1A.13.9B.7 LOCATE NEW COMPONENT
 - 2.1A.13.9B.8 POSITION AND CONNECT NEW COMPONENT
 - 2.1A.13.9B.9 ADJUST COMPONENT
 - 2.1A.13.9B.10 MAKE DIAGNOSTIC CHECKS
 - 2.1A.13.9B.11 CLOSE ACCESS PANEL
 - 2.1A.13.9B.12 STOW REPAIR EQUIPMENT
- 2.1A.13.10 IDENTIFY DEFECTIVE SOFTWARE
 - 2.1A.13.10.1 COMPARE MEASURED DATA TO MODEL
 - 2.1A.13.10.2 DETERMINE ANOMALOUS DATA
 - 2.1A.13.10.3 FORM HYPOTHESIS FOR PROBLEM
 - 2.1A.13.10.4 DEVISE TEST FOR FAILURE HYPOTHESIS
 - 2.1A.13.10.5 PERFORM TEST FOR FAILURE HYPOTHESIS
 - 2.1A.13.10.6 IDENTIFY FAULTY SOFTWARE

ORIGINAL PAGE IS
OF POOR QUALITY

- 2.1A.13.11 SOFTWARE FAILURE RECOVERY
 - 2.1A.13.11.1 DETERMINE CORRECTION ALGORITHM
 - 2.1A.13.11.2 DATA/COMMAND ENCODING
 - 2.1A.13.11.3 DATA/COMMAND TRANSMISSION
 - 2.1A.13.11.4 COMPUTER FUNCTION CHECKS
- 2.1A.13.12 REPORT SYSTEM STATUS
 - 2.1A.13.12.1 DATA/COMMAND ENCODING
 - 2.1A.13.12.2 DATA/COMMAND TRANSMISSION
 - 2.1A.13.12.3 DATA/COMMAND DECODING
 - 2.1A.13.12.4 DATA/COMMAND DISPLAY
- 2.1A.14 ATTITUDE CONTROL & STATIONKEEPING
 - 2.1A.14.1 MAINTAIN/CHANGE ATTITUDE
 - 2.1A.14.1.1 INITIALIZE GUIDANCE SYSTEM
 - Update inertial reference system.
----- - 2.1A.14.1.2 DETERMINE CURRENT ATTITUDE
 - 2.1A.14.1.3 DETERMINE DESIRED ATTITUDE
 - 2.1A.14.1.4 DETERMINE NEW CONFIGURATION FOR SPACECRAFT COMPONENTS
 - Main components are solar arrays and radiators.
----- - 2.1A.14.1.5 CHOOSE OPTIMAL TRAJECTORY
 - 2.1A.14.1.6 ROTATE SPACECRAFT
 - Use magnetic torquers for attitude control.
----- - 2.1A.14.1.7 DETERMINE DISTURBING TORQUES
 - 2.1A.14.1.8 COMPUTE REQUIRED RESULTANT
 - 2.1A.14.1.9 APPLY COMPENSATING TORQUES
 - Use magnetic torquers.
----- - 2.1A.14.2 OPTIMAL CONTROL ALLOCATION
 - 2.1A.14.2.1 UPDATE SPACECRAFT MODEL
 - 2.1A.14.2.2 PROJECT DESIRED FUNCTIONS FROM MISSION PROFILE
 - 2.1A.14.2.3 ESTIMATE RISKS FROM DESIRED FUNCTIONS
 - 2.1A.14.2.4 DETERMINE CONSTRAINTS AND FIGURES OF MERIT
 - 2.1A.14.2.5 COMPUTE CONTROL COMMANDS
 - 2.1A.14.2.6 EXECUTE CONTROL COMMANDS
 - 2.1A.15 OBSERVATION SEQUENCE
 - 2.1A.15.1 IDENTIFY DESIRED ATTITUDE
 - 2.1A.15.1.1 RECEIVE GROUND COMMANDS
 - 2.1A.15.1.2 DATA/COMMAND DECODING
 - 2.1A.15.2 SELECT DETECTOR TO BE USED
 - 2.1A.15.2.1 RECEIVE GROUND COMMANDS
 - 2.1A.15.2.2 DATA/COMMAND DECODING
 - 2.1A.15.2.3 MOVE DETECTOR INTO POSITION
 - 2.1A.15.2.4 DETECTOR POWER ON
 - 2.1A.15.2.5 DETECTOR COOLING ON
 - 2.1A.15.2.6 OPEN DETECTOR APERTURES
 - 2.1A.15.2.7 FINE FOCUS DETECTOR
 - 2.1A.15.3 OPERATE DETECTOR AND ASPECT SYSTEM
 - 2.1A.15.3.1 TAKE DATA FROM DETECTOR
 - 2.1A.15.3.2 TAKE DATA FROM ASPECT SENSORS
 - 2.1A.15.3.3 DATA/COMMAND ENCODING
 - 2.1A.15.3.4 DATA/COMMAND TRANSMISSION
 - 2.1A.16 ON-ORBIT ALIGNMENT OF TELESCOPE SYSTEM
 - 2.1A.16.1 IDENTIFY DESIRED ATTITUDE
 - 2.1A.16.1.1 PICK X-RAY SOURCE WITH KNOWN OPTICAL COUNTERPART
 - 2.1A.16.1.2 DETERMINE DESIRED ATTITUDE
 - 2.1A.16.2 LOCATE X-RAY SOURCE
 - 2.1A.16.2.1 MOVE DETECTOR INTO POSITION
 - 2.1A.16.2.2 DETECTOR POWER ON
 - 2.1A.16.2.3 DETECTOR COOLING ON
 - 2.1A.16.2.4 OPEN DETECTOR APERTURES
 - 2.1A.16.2.5 FINE FOCUS DETECTOR
 - 2.1A.16.2.6 TAKE DATA FROM DETECTOR
 - 2.1A.16.2.7 DATA/COMMAND ENCODING
 - 2.1A.16.2.8 DATA/COMMAND TRANSMISSION
 - 2.1A.16.2.9 DETERMINE IF TARGET IS WITHIN DETECTOR FOV
 - 2.1A.16.3 LOCATE OPTICAL COUNTERPART

- 2.1A.16.3.1 TAKE DATA FROM ASPECT SENSORS
- 2.1A.16.3.2 DATA/COMMAND ENCODING
- 2.1A.16.3.3 DATA/COMMAND TRANSMISSION
- 2.1A.16.3.4 DETERMINE IF TARGET IS WITHIN ASPECT SENSOR FOV
- 2.1A.16.3.5 SELECT NEW TELESCOPE ATTITUDE IF NECESSARY

 If target has not been found, another try must be made.

- 2.1A.16.4 DETERMINE RELATIVE ALIGNMENT
 - 2.1A.16.4.1 TAKE DATA FROM DETECTOR
 - 2.1A.16.4.2 TAKE DATA FROM ASPECT SENSORS
 - 2.1A.16.4.3 DATA/COMMAND ENCODING
 - 2.1A.16.4.4 DATA/COMMAND TRANSMISSION
 - 2.1A.16.4.5 PROCESS IMAGE DATA
 - 2.1A.16.4.6 DETERMINE ALIGNMENT CORRECTION

ORIGINAL PAGE IS
 OF POOR QUALITY

2.1B INITIAL DEPLOYMENT (SHUTTLE WITH TMS UPPER STAGE)

- 2.1B.1 DESIGN
 - 2.1B.1.1 DEFINE REQUIREMENTS
 - 2.1B.1.2 MISSION ANALYSIS
 - 2.1B.1.3 PAYLOAD ACCOMMODATIONS
 - 2.1B.1.4 CREATE FUNCTIONAL LAYOUT
 - 2.1B.1.5 FAILURE MODES ANALYSIS
 - 2.1B.1.6 ADJUST DESIGN FOR MAINTENANCE AND REPAIR
 - 2.1B.1.7 CREATE MECHANICAL LAYOUT
 - 2.1B.1.8 SAFETY REVIEW
 - 2.1B.1.9 DESIGN OF COMPONENTS
 - 2.1B.1.10 SOFTWARE DEVELOPMENT
- 2.1B.2 COMPONENT FABRICATION
 - 2.1B.2.1 PROCURE OFF-THE-SHELF COMPONENTS
 - 2.1B.2.2 PROCURE MATERIALS FOR MANUFACTURED COMPONENTS
 - 2.1B.2.3 PROCURE MANUFACTURING EQUIPMENT
 - 2.1B.2.4 MANUFACTURE COMPONENTS
 - 2.1B.2.5 MIRROR SURFACE FINISHING
- 2.1B.3 COMPONENT TEST
 - 2.1B.3.1 SET UP TEST FACILITIES
 - 2.1B.3.2 STRUCTURAL LOADS TESTS
 - 2.1B.3.3 DATA PROCESSING AND SOFTWARE TESTS
 - 2.1B.3.4 SOLAR ARRAY DEPLOYMENT TESTS
 - 2.1B.3.5 ELECTRICAL SYSTEMS TESTS
 - 2.1B.3.6 THERMAL AND VACUUM TESTS
 - 2.1B.3.7 DETECTOR ALIGNMENT TESTS
 - 2.1B.3.8 THRUSTER TESTS
 - 2.1B.3.9 MIRROR DRIVE SYSTEMS TESTS
 - 2.1B.3.10 MIRROR OPTICAL TESTS
 - 2.1B.3.11 COMPONENT CERTIFICATION
- 2.1B.4 SYSTEM INTEGRATION
- 2.1B.5 SYSTEM TEST
 - 2.1B.5.1 POWER SUBSYSTEM TESTS
 - 2.1B.5.2 THERMAL SUBSYSTEM TESTS
 - 2.1B.5.3 STRUCTURE SUBSYSTEM TESTS
 - 2.1B.5.4 INFORMATION PROCESSING SUBSYSTEM TESTS
 - 2.1B.5.5 COMMUNICATIONS SUBSYSTEM TESTS
 - 2.1B.5.6 ATTITUDE CONTROL SUBSYSTEM TESTS
 - 2.1B.5.7 OPTICAL SUBSYSTEM TESTS
 - 2.1B.5.8 PROPULSION SUBSYSTEM TESTS
 - 2.1B.5.9 INTEGRATED SYSTEMS TESTS
 - 2.1B.5.10 FAILURE MODES SIMULATION
 - 2.1B.5.11 SYSTEM CERTIFICATION
- 2.1B.6 SHIPPING TO LAUNCH SITE
 - 2.1B.6.1 REMOVE TEST EQUIPMENT
 - 2.1B.6.2 PERFORM NECESSARY DISASSEMBLY
 - 2.1B.6.3 PACKING
 - 2.1B.6.4 TRANSPORT TO LAUNCH SITE
- 2.1B.7 PAYLOAD INTEGRATION AND CHECKOUT
 - 2.1B.7.1 UNPACKING
 - 2.1B.7.2 PERFORM NECESSARY REASSEMBLY
 - 2.1B.7.3 INTEGRATED SYSTEMS TESTS
 - 2.1B.7.3.1 VERIFY POWER SYSTEM FUNCTION
 - 2.1B.7.3.2 VERIFY COMMAND SYSTEM FUNCTION
 - 2.1B.7.3.3 VERIFY MECHANICAL SYSTEM FUNCTION
 - 2.1B.7.3.4 VERIFY COMMUNICATIONS SYSTEM FUNCTION

ORIGINAL PAGE 2
OF FOUR QUANTITY

- 2.1B.7.3.5 VERIFY DETECTOR SYSTEM FUNCTION
- 2.1B.7.3.6 MISSION SEQUENCE SIMULATION
- 2.1B.7.4 TRANSFER TO OPERATIONS AND CHECKOUT BLDG.
 - 2.1B.7.4.1 LOAD PAYLOAD INTO CONTAINER
 - 2.1B.7.4.2 TRANSPORT TO OPERATIONS AND CHECKOUT BLDG.
 - 2.1B.7.4.3 ATTACH STRONGBACK TO PAYLOAD
 - 2.1B.7.4.4 INSTALL PAYLOAD IN HORIZONTAL CITE
- 2.1B.7.5 INTEGRATE TMS WITH PAYLOAD
- 2.1B.7.6 PERFORM INTERFACES CHECK
 - 2.1B.7.6.1 CHECK TMS/PAYLOAD MECHANICAL INTERFACES
 - 2.1B.7.6.2 CHECK SHUTTLE/PAYLOAD MECHANICAL INTERFACES
 - 2.1B.7.6.3 CHECK ELECTRICAL INTERFACES
- 2.1B.7.7 TRANSFER TMS/PAYLOAD TO ORBITER PROCESSING FACILITY
 - 2.1B.7.7.1 ATTACH STRONGBACK TO PAYLOAD
 - 2.1B.7.7.2 LOAD PAYLOAD INTO CANISTER
 - 2.1B.7.7.3 REMOVE STRONGBACK
 - 2.1B.7.7.4 CLOSE CANISTER
 - 2.1B.7.7.5 TRANSPORT CANISTER TO ORBITER PROCESSING FACILITY
- 2.1B.7.8 ORBITER/PAYLOAD INTEGRATION (HORIZONTAL)
 - 2.1B.7.8.1 ATTACH STRONGBACK TO PAYLOAD
 - 2.1B.7.8.2 INSTALL PAYLOAD IN ORBITER
 - 2.1B.7.8.3 CONNECT ORBITER/PAYLOAD INTERFACES
 - 2.1B.7.8.4 CHECK ELECTRICAL INTERFACES
 - 2.1B.7.8.5 CLOSE-OUT PAYLOAD BAY
 - 2.1B.7.8.6 INSTALLATION OF ORBITER PAYLOAD STATION CONSOLES
- 2.1B.8 COUNTDOWN AND LAUNCH
- 2.1B.9 ORBITAL DEPLOYMENT AND CHECKOUT
 - 2.1B.9.1 SHUTTLE ATTAINS DELIVERY ORBIT
 - 2.1B.9.2 EXTENSION OF PAYLOAD FROM PAYLOAD BAY
 - 2.1B.9.2.1 OPEN PAYLOAD BAY DOORS
 - 2.1B.9.2.2 LOCATE GRASPING FIXTURE ON TARGET

The target is AXAF.

- 2.1B.9.2.3 GRASP FIXTURE
- 2.1B.9.2.4 RELEASE PAYLOAD RESTRAINTS
- 2.1B.9.2.5 TRANSLATE PAYLOAD OUT OF PAYLOAD BAY
- 2.1B.9.3 OPERATIONAL CHECKOUT OF TMS
 - 2.1B.9.3.1 ACTIVATE TMS SUBSYSTEMS
 - 2.1B.9.3.2 INFORMATION PROCESSING SUBSYSTEM CHECKOUT
 - 2.1B.9.3.3 POWER SUBSYSTEM CHECKOUT
 - 2.1B.9.3.4 THERMAL SUBSYSTEM CHECKOUT
 - 2.1B.9.3.5 STRUCTURAL SUBSYSTEM CHECKOUT
 - 2.1B.9.3.6 COMMUNICATIONS SUBSYSTEM CHECKOUT
 - 2.1B.9.3.7 ATTITUDE CONTROL SUBSYSTEM CHECKOUT
 - 2.1B.9.3.8 PROPULSION SUBSYSTEM CHECKOUT
 - 2.1B.9.3.9 CONSUMABLES LEVELS CHECKOUT
- 2.1B.9.4 ORBITAL TRANSFER (OF TMS/SPACECRAFT)
 - 2.1B.9.4.1 INITIALIZE GUIDANCE SYSTEM

Update inertial reference system.

- 2.1B.9.4.2 DETERMINE CURRENT ORBITAL PARAMETERS
- 2.1B.9.4.3 DETERMINE DESIRED ORBITAL PARAMETERS
- 2.1B.9.4.4 CHOOSE OPTIMAL TRAJECTORY
- 2.1B.9.4.5 DETERMINE CURRENT ATTITUDE
- 2.1B.9.4.6 DETERMINE DESIRED ATTITUDE
- 2.1B.9.4.7 ROTATE SPACECRAFT

Use magnetic torquers for attitude control.

- 2.1B.9.4.8 FIRE THRUSTERS
- 2.1B.9.5 EXTEND DEPLOYABLE COMPONENTS
 - 2.1B.9.5.1 LOCATE SOLAR ARRAY RESTRAINTS
 - 2.1B.9.5.2 RELEASE SOLAR ARRAY RESTRAINTS
 - 2.1B.9.5.3 LOCATE GRASPING FIXTURE ON TARGET

The target is the AXAF solar array.

- 2.1B.9.5.4 GRASP FIXTURE
- 2.1B.9.5.5 DEPLOY SOLAR ARRAYS
- 2.1B.9.5.6 LOCATE SUNSHADE RESTRAINTS

- 2.1B.9.5.7 RELEASE SUNSHADE RESTRAINTS
- 2.1B.9.5.8 LOCATE GRASPING FIXTURE ON TARGET

 The target is the AXAF sunshade.

- 2.1B.9.5.9 GRASP FIXTURE
- 2.1B.9.5.10 OPEN SUNSHADE
- 2.1B.9.5.11 DEPLOY TDRSS ANTENNAS
- 2.1B.9.6 UNDOCK TMS FROM PAYLOAD
 - 2.1B.9.6.1 RELEASE DOCKING LATCH
 - 2.1B.9.6.2 RETRACT DOCKING MECHANISM
 - 2.1B.9.6.3 MOVE AWAY FROM PAYLOAD
- 2.1B.9.7 OPERATIONAL CHECKOUT OF AXAF
 - 2.1B.9.7.1 ACTIVATE AXAF SUBSYSTEMS

 Attitude control, communications, thermal control systems are activated.

- 2.1B.9.7.2 COMMAND ATTITUDE CHANGE

 Command to change pointing is entered.

- 2.1B.9.7.3 OBSERVE ATTITUDE CHANGE

 Orbiter observes results of attitude change command.

- 2.1B.9.7.4 MONITOR TELEMTRY

 AXAF data is monitored by Orbiter.

- 2.1B.9.7.5 EVALUATE SYSTEM PERFORMANCE

 Detector and housekeeping data is evaluated to verify correct response to command.

- 2.1B.9.8 STABILIZE AXAF FOR RETRIEVAL

 If system performance is not adequate, retrieval may be necessary, for repairs in payload bay or on ground.

- 2.1B.9.8.1 INITIALIZE GUIDANCE SYSTEM

 Update inertial reference system.

- 2.1B.9.8.2 DETERMINE CURRENT ATTITUDE
- 2.1B.9.8.3 DETERMINE DESIRED ATTITUDE
- 2.1B.9.8.4 DETERMINE NEW CONFIGURATION FOR SPACECRAFT COMPONENTS

 Main components are solar arrays and radiators.

- 2.1B.9.8.5 CHOOSE OPTIMAL TRAJECTORY
- 2.1B.9.8.6 ROTATE SPACECRAFT

 Use magnetic torquers for attitude control.

- 2.1B.9.8.7 DETERMINE DISTURBING TORQUES
- 2.1B.9.8.8 COMPUTE REQUIRED RESULTANT
- 2.1B.9.8.9 APPLY COMPENSATING TORQUES

 Use magnetic torquers.

- 2.1B.9.8.10 SHUTDOWN SPACECRAFT SYSTEMS
- 2.1B.9.9 DOCK TMS TO SPACECRAFT
 - 2.1B.9.9.1 LOCATE DOCKING TARGET
 - 2.1B.9.9.2 EXTEND DOCKING MECHANISM
 - 2.1B.9.9.3 FASTEN DOCKING LATCH
- 2.1B.9.10 RETRACT DEPLOYABLE PAYLOAD COMPONENTS
 - 2.1B.9.10.1 RETRACT TDRSS ANTENNAS
 - 2.1B.9.10.2 LOCATE SUNSHADE RESTRAINTS
 - 2.1B.9.10.3 RELEASE SUNSHADE RESTRAINTS
 - 2.1B.9.10.4 LOCATE GRASPING FIXTURE ON TARGET

The target is the AXAF sunshade.

- 2.1B.9.10.5 GRASP FIXTURE
- 2.1B.9.10.6 CLOSE SUNSHADE
- 2.1B.9.10.7 LOCATE SOLAR ARRAY RESTRAINTS
- 2.1B.9.10.8 RELEASE SOLAR ARRAY RESTRAINTS
- 2.1B.9.10.9 LOCATE GRASPING FIXTURE ON TARGET

The target is the AXAF solar array.

- 2.1B.9.10.10 GRASP FIXTURE
- 2.1B.9.10.11 RETRACT SOLAR ARRAYS
- 2.1B.9.11 IDENTIFY DEFECTIVE COMPONENT
 - 2.1B.9.11.1 DETERMINE ANOMALOUS DATA
 - 2.1B.9.11.2 FORM HYPOTHESIS FOR PROBLEM
 - 2.1B.9.11.3 DEVISE TEST FOR FAILURE HYPOTHESIS
 - 2.1B.9.11.4 PERFORM TEST FOR FAILURE HYPOTHESIS
 - 2.1B.9.11.5 IDENTIFY FAULTY COMPONENT
- 2.1B.9.12A COMPONENT FAILURE RECOVERY (REDUNDANCY)
 - 2.1B.9.12A.1 SWITCH OUT FAULTY COMPONENT
 - 2.1B.9.12A.2 SWITCH IN REDUNDANT COMPONENT
 - 2.1B.9.12A.3 MAKE DIAGNOSTIC CHECKS
 - 2.1B.9.12A.4 UPDATE SPACECRAFT MODEL
- 2.1B.9.12B COMPONENT FAILURE RECOVERY (ON-BOARD REPAIR)
 - 2.1B.9.12B.1 DEFINE ACCESS SEQUENCE
 - 2.1B.9.12B.2 LOCATE ACCESS PANEL
 - 2.1B.9.12B.3 TRANSFER REPAIR EQUIPMENT TO REPAIR SITE
 - 2.1B.9.12B.4 OPEN ACCESS PANEL
 - 2.1B.9.12B.5 OBSERVE/LOCATE DEFECTIVE COMPONENT
 - 2.1B.9.12B.6 REMOVE COMPONENT
 - 2.1B.9.12B.7 STORE COMPONENT
 - 2.1B.9.12B.8 LOCATE NEW COMPONENT
 - 2.1B.9.12B.9 POSITION AND CONNECT NEW COMPONENT
 - 2.1B.9.12B.10 ADJUST COMPONENT
 - 2.1B.9.12B.11 MAKE DIAGNOSTIC CHECKS
 - 2.1B.9.12B.12 CLOSE ACCESS PANEL
 - 2.1B.9.12B.13 STOW REPAIR EQUIPMENT
- 2.1B.9.13 IDENTIFY DEFECTIVE SOFTWARE
 - 2.1B.9.13.1 COMPARE MEASURED DATA TO MODEL
 - 2.1B.9.13.2 DETERMINE ANOMALOUS DATA
 - 2.1B.9.13.3 FORM HYPOTHESIS FOR PROBLEM
 - 2.1B.9.13.4 DEVISE TEST FOR FAILURE HYPOTHESIS
 - 2.1B.9.13.5 PERFORM TEST FOR FAILURE HYPOTHESIS
 - 2.1B.9.13.6 IDENTIFY FAULTY SOFTWARE
- 2.1B.9.14 SOFTWARE FAILURE RECOVERY
 - 2.1B.9.14.1 DETERMINE CORRECTION ALGORITHM
 - 2.1B.9.14.2 DATA/COMMAND ENCODING
 - 2.1B.9.14.3 DATA/COMMAND TRANSMISSION
 - 2.1B.9.14.4 COMPUTER FUNCTION CHECKS
- 2.1B.10 RENDEZVOUS WITH ORBITER
 - 2.1B.10.1 ORBITAL TRANSFER (OF TMS)
 - 2.1B.10.1.1 INITIALIZE GUIDANCE SYSTEM

Update inertial reference system.

- 2.1B.10.1.2 DETERMINE CURRENT ORBITAL PARAMETERS
- 2.1B.10.1.3 DETERMINE DESIRED ORBITAL PARAMETERS
- 2.1B.10.1.4 CHOOSE OPTIMAL TRAJECTORY
- 2.1B.10.1.5 DETERMINE CURRENT ATTITUDE
- 2.1B.10.1.6 DETERMINE DESIRED ATTITUDE
- 2.1B.10.1.7 ROTATE SPACECRAFT

Use magnetic torquers for attitude control.

- 2.1B.10.1.8 FIRE THRUSTERS
- 2.1B.10.2 SHUTDOWN TMS FOR RETRIEVAL
 - 2.1B.10.2.1 STOW TMS ANTENNA
 - 2.1B.10.2.2 DEACTIVATE TMS SUBSYSTEMS
- 2.1B.11 RETRIEVAL BY ORBITER
 - 2.1B.11.1 ADJUST ORBIT (OF ORBITER)
 - 2.1B.11.1.1 INITIALIZE GUIDANCE SYSTEM

Update inertial reference system.

- 2.1B.11.1.2 DETERMINE CURRENT ORBITAL PARAMETERS
- 2.1B.11.1.3 DETERMINE DESIRED ORBITAL PARAMETERS
- 2.1B.11.1.4 CHOOSE OPTIMAL TRAJECTORY
- 2.1B.11.1.5 FIRE THRUSTERS
- 2.1B.11.2 ADJUST ATTITUDE (OF ORBITER)
 - 2.1B.11.2.1 DETERMINE CURRENT ATTITUDE
 - 2.1B.11.2.2 DETERMINE DESIRED ATTITUDE
 - 2.1B.11.2.3 DETERMINE NEW CONFIGURATION FOR SPACECRAFT COMPONENTS

Main components are solar arrays and radiators.

- 2.1B.11.2.4 CHOOSE OPTIMAL TRAJECTORY
- 2.1B.11.2.5 ROTATE SPACECRAFT

Use magnetic torquers for attitude control.

- 2.1B.11.3 OPTIMAL CONTROL ALLOCATION
 - 2.1B.11.3.1 UPDATE SPACECRAFT MODEL
 - 2.1B.11.3.2 PROJECT DESIRED FUNCTIONS FROM MISSION PROFILE
 - 2.1B.11.3.3 ESTIMATE RISKS FROM DESIRED FUNCTIONS
 - 2.1B.11.3.4 PROJECT CONSUMABLES REQUIREMENTS FROM MISSION PROFILE
 - 2.1B.11.3.5 DETERMINE CONSTRAINTS AND FIGURES OF MERIT
 - 2.1B.11.3.6 CHOOSE OPTIMAL CONTROL MODE
 - 2.1B.11.3.7 COMPUTE CONTROL COMMANDS
 - 2.1B.11.3.8 EXECUTE CONTROL COMMANDS
- 2.1B.11.4 ORBITER RECOVERY OF TMS
 - 2.1B.11.4.1 ACTIVATE RMS
 - 2.1B.11.4.2 LOCATE GRASPING FIXTURE ON TARGET

Target is the TMS.

- 2.1B.11.4.3 MOVE RMS TO FIXTURE
- 2.1B.11.4.4 GRASP FIXTURE
- 2.1B.11.4.5 LOCATE CRADLE IN PAYLOAD BAY
- 2.1B.11.4.6 TRANSLATE PAYLOAD TO CRADLE
- 2.1B.11.4.7 FASTEN PAYLOAD RESTRAINTS
- 2.1B.11.4.8 RMS RELEASES PAYLOAD
- 2.1B.11.4.9 SECURE RMS IN PAYLOAD BAY
- 2.1B.12 REENTRY AND LANDING
- 2.1B.13 POST-FLIGHT OPERATIONS
 - 2.1B.13.1 SAFING OF ORBITER
 - 2.1B.13.2 REMOVAL OF PAYLOAD FROM ORBITER
 - 2.1B.13.2.1 OPEN PAYLOAD BAY DOORS
 - 2.1B.13.2.2 ATTACH STRONGBACK TO PAYLOAD
 - 2.1B.13.2.3 LOAD PAYLOAD INTO CANISTER
- 2.1B.14 STATUS MONITORING AND RESOURCE ALLOCATION
 - 2.1B.14.1 TEMPERATURE MANAGEMENT
 - 2.1B.14.1.1 MEASURE COMPONENT TEMPERATURES
 - 2.1B.14.1.2 COMPARE TEMPERATURES TO REQUIRED LIMITS
 - 2.1B.14.1.3 ADJUST HEATING/COOLING SYSTEMS
 - 2.1B.14.2 POWER MANAGEMENT
 - 2.1B.14.2.1 MEASURE CURRENTS AND VOLTAGES
 - 2.1B.14.2.2 COMPARE CURRENTS AND VOLTAGES TO REQUIRED LIMITS
 - 2.1B.14.2.3 ADJUST CURRENTS AND VOLTAGES
 - 2.1B.14.2.4 EVALUATE BATTERY CHARGING PERFORMANCE
 - 2.1B.14.2.5 ADJUST BATTERY CHARGING CYCLE
 - 2.1B.14.3 DATA/COMMAND PROCESSING
 - 2.1B.14.3.1 SHORT-TERM MEMORY STORAGE
 - 2.1B.14.3.2 LONG-TERM MEMORY STORAGE
 - 2.1B.14.3.3 DATA/COMMAND ENCODING
 - 2.1B.14.3.4 DATA/COMMAND DECODING
 - 2.1B.14.3.5 NUMERICAL COMPUTATION
 - 2.1B.14.3.6 LOGIC OPERATIONS
 - 2.1B.14.3.7 COMPUTER LOAD SCHEDULING
 - 2.1B.14.3.8 COMPUTER FUNCTION CHECKS
 - 2.1B.14.4 CONSUMABLES MANAGEMENT
 - 2.1B.14.4.1 MONITOR BATTERIES
 - 2.1B.14.4.2 MONITOR GAS SUPPLIES
 - 2.1B.14.4.3 MONITOR COOLING SYSTEM SUPPLIES
 - 2.1B.14.4.4 PRESSURIZE DETECTORS WHEN NEEDED

2.1B.14.13
OF POOR QUALITY

- 2.1B.14.4.5 DEPRESSURIZE DETECTORS WHEN NOT IN USE
- 2.1B.14.4.6 PROJECT CONSUMABLES REQUIREMENTS FROM MISSION PROFILE
- 2.1B.14.4.7 COMPUTE OPTIMAL CONSUMABLES ALLOCATION
- 2.1B.14.5 STRUCTURAL MANAGEMENT
 - 2.1B.14.5.1 MEASURE STRAINS IN STRUCTURE
 - 2.1B.14.5.2 MEASURE RELATIVE DISPLACEMENTS
 - 2.1B.14.5.3 COMPUTE STRESS AND VIBRATION PARAMETERS
 - 2.1B.14.5.4 APPLY COMPENSATING FORCES
 - 2.1B.14.5.5 APPLY VIBRATION DAMPING
- 2.1B.14.6 HAZARD AVOIDANCE
 - 2.1B.14.6.1 COMPUTE POSITIONS OF SUN, EARTH, MOON
 - 2.1B.14.6.2 DETERMINE ANGLES RELATIVE TO TELESCOPE LINE-OF-SIGHT
 - 2.1B.14.6.3 MONITOR BRIGHT OBJECT DETECTOR
 - 2.1B.14.6.4 MONITOR SAA DETECTOR
 - 2.1B.14.6.5 COMPARE DETECTOR OUTPUT TO PRESET LIMITS
 - 2.1B.14.6.6 CLOSE OPTICAL SHUTTERS
 - 2.1B.14.6.7 REDUCE VOLTAGES IN SENSITIVE EQUIPMENT
 - 2.1B.14.6.8 SHUTDOWN DETECTORS
- 2.1B.14.7 OPTIMAL SEQUENCING
 - 2.1B.14.7.1 UPDATE SPACECRAFT MODEL
 - 2.1B.14.7.2 PROJECT DESIRED FUNCTIONS FROM MISSION PROFILE
 - 2.1B.14.7.3 ESTIMATE RISKS FROM DESIRED FUNCTIONS
 - 2.1B.14.7.4 PROJECT CONSUMABLES REQUIREMENTS FROM MISSION PROFILE
 - 2.1B.14.7.5 DETERMINE CONSTRAINTS AND FIGURES OF MERIT
 - 2.1B.14.7.6 COMPUTE OPTIMAL SEQUENCING
- 2.1B.14.8 IDENTIFY DEFECTIVE COMPONENT
 - 2.1B.14.8.1 DETERMINE ANOMALOUS DATA
 - 2.1B.14.8.2 FORM HYPOTHESIS FOR PROBLEM
 - 2.1B.14.8.3 DEVISE TEST FOR FAILURE HYPOTHESIS
 - 2.1B.14.8.4 PERFORM TEST FOR FAILURE HYPOTHESIS
 - 2.1B.14.8.5 IDENTIFY FAULTY COMPONENT
- 2.1B.14.9A COMPONENT FAILURE RECOVERY (REDUNDANCY)
 - 2.1B.14.9A.1 SWITCH OUT FAULTY COMPONENT
 - 2.1B.14.9A.2 SWITCH IN REDUNDANT COMPONENT
 - 2.1B.14.9A.3 MAKE DIAGNOSTIC CHECKS
 - 2.1B.14.9A.4 UPDATE SPACECRAFT MODEL
- 2.1B.14.9B COMPONENT FAILURE RECOVERY (ON-BOARD REPAIR)
 - 2.1B.14.9B.1 DEFINE ACCESS SEQUENCE
 - 2.1B.14.9B.2 LOCATE ACCESS PANEL
 - 2.1B.14.9B.3 TRANSFER REPAIR EQUIPMENT TO REPAIR SITE
 - 2.1B.14.9B.4 OBSERVE/LOCATE DEFECTIVE COMPONENT
 - 2.1B.14.9B.5 REMOVE COMPONENT
 - 2.1B.14.9B.6 STORE COMPONENT
 - 2.1B.14.9B.7 LOCATE NEW COMPONENT
 - 2.1B.14.9B.8 POSITION AND CONNECT NEW COMPONENT
 - 2.1B.14.9B.9 ADJUST COMPONENT
 - 2.1B.14.9B.10 MAKE DIAGNOSTIC CHECKS
 - 2.1B.14.9B.11 CLOSE ACCESS PANEL
 - 2.1B.14.9B.12 STOW REPAIR EQUIPMENT
- 2.1B.14.10 IDENTIFY DEFECTIVE SOFTWARE
 - 2.1B.14.10.1 COMPARE MEASURED DATA TO MODEL
 - 2.1B.14.10.2 DETERMINE ANOMALOUS DATA
 - 2.1B.14.10.3 FORM HYPOTHESIS FOR PROBLEM
 - 2.1B.14.10.4 DEVISE TEST FOR FAILURE HYPOTHESIS
 - 2.1B.14.10.5 PERFORM TEST FOR FAILURE HYPOTHESIS
 - 2.1B.14.10.6 IDENTIFY FAULTY SOFTWARE
- 2.1B.14.11 SOFTWARE FAILURE RECOVERY
 - 2.1B.14.11.1 DETERMINE CORRECTION ALGORITHM
 - 2.1B.14.11.2 DATA/COMMAND ENCODING
 - 2.1B.14.11.3 DATA/COMMAND TRANSMISSION
 - 2.1B.14.11.4 COMPUTER FUNCTION CHECKS
- 2.1B.14.12 REPORT SYSTEM STATUS
 - 2.1B.14.12.1 DATA/COMMAND ENCODING
 - 2.1B.14.12.2 DATA/COMMAND TRANSMISSION
 - 2.1B.14.12.3 DATA/COMMAND DECODING
 - 2.1B.14.12.4 DATA/COMMAND DISPLAY
- 2.1B.15 ATTITUDE CONTROL & STATIONKEEPING
 - 2.1B.15.1 MAINTAIN/CHANGE ATTITUDE
 - 2.1B.15.1.1 INITIALIZE GUIDANCE SYSTEM

Update inertial reference system.

- 2.1B.15.1.2 DETERMINE CURRENT ATTITUDE
- 2.1B.15.1.3 DETERMINE DESIRED ATTITUDE
- 2.1B.15.1.4 DETERMINE NEW CONFIGURATION FOR SPACECRAFT COMPONENTS

Main components are solar arrays and radiators.

- 2.1B.15.1.5 CHOOSE OPTIMAL TRAJECTORY
- 2.1B.15.1.6 ROTATE SPACECRAFT

Use magnetic torquers for attitude control.

- 2.1B.15.1.7 DETERMINE DISTURBING TORQUES
- 2.1B.15.1.8 COMPUTE REQUIRED RESULTANT
- 2.1B.15.1.9 APPLY COMPENSATING TORQUES

Use magnetic torquers.

- 2.1B.15.2 OPTIMAL CONTROL ALLOCATION
 - 2.1B.15.2.1 UPDATE SPACECRAFT MODEL
 - 2.1B.15.2.2 PROJECT DESIRED FUNCTIONS FROM MISSION PROFILE
 - 2.1B.15.2.3 ESTIMATE RISKS FROM DESIRED FUNCTIONS
 - 2.1B.15.2.4 DETERMINE CONSTRAINTS AND FIGURES OF MERIT
 - 2.1B.15.2.5 COMPUTE CONTROL COMMANDS
 - 2.1B.15.2.6 EXECUTE CONTROL COMMANDS
- 2.1B.16 OBSERVATION SEQUENCE
 - 2.1B.16.1 IDENTIFY DESIRED ATTITUDE
 - 2.1B.16.1.1 RECEIVE GROUND COMMANDS
 - 2.1B.16.1.2 DATA/COMMAND DECODING
 - 2.1B.16.2 SELECT DETECTOR TO BE USED
 - 2.1B.16.2.1 RECEIVE GROUND COMMANDS
 - 2.1B.16.2.2 DATA/COMMAND DECODING
 - 2.1B.16.2.3 MOVE DETECTOR INTO POSITION
 - 2.1B.16.2.4 DETECTOR POWER ON
 - 2.1B.16.2.5 DETECTOR COOLING ON
 - 2.1B.16.2.6 OPEN DETECTOR APERTURES
 - 2.1B.16.2.7 FINE FOCUS DETECTOR
 - 2.1B.16.3 OPERATE DETECTOR AND ASPECT SYSTEM
 - 2.1B.16.3.1 TAKE DATA FROM DETECTOR
 - 2.1B.16.3.2 TAKE DATA FROM ASPECT SENSORS
 - 2.1B.16.3.3 DATA/COMMAND ENCODING
 - 2.1B.16.3.4 DATA/COMMAND TRANSMISSION
- 2.1B.17 ON-ORBIT ALIGNMENT OF TELESCOPE SYSTEM
 - 2.1B.17.1 IDENTIFY DESIRED ATTITUDE
 - 2.1B.17.1.1 PICK X-RAY SOURCE WITH KNOWN OPTICAL COUNTERPART
 - 2.1B.17.1.2 DETERMINE DESIRED ATTITUDE
 - 2.1B.17.2 LOCATE X-RAY SOURCE
 - 2.1B.17.2.1 MOVE DETECTOR INTO POSITION
 - 2.1B.17.2.2 DETECTOR POWER ON
 - 2.1B.17.2.3 DETECTOR COOLING ON
 - 2.1B.17.2.4 OPEN DETECTOR APERTURES
 - 2.1B.17.2.5 FINE FOCUS DETECTOR
 - 2.1B.17.2.6 TAKE DATA FROM DETECTOR
 - 2.1B.17.2.7 DATA/COMMAND ENCODING
 - 2.1B.17.2.8 DATA/COMMAND TRANSMISSION
 - 2.1B.17.2.9 DETERMINE IF TARGET IS WITHIN DETECTOR FOV
 - 2.1B.17.3 LOCATE OPTICAL COUNTERPART
 - 2.1B.17.3.1 TAKE DATA FROM ASPECT SENSORS
 - 2.1B.17.3.2 DATA/COMMAND ENCODING
 - 2.1B.17.3.3 DATA/COMMAND TRANSMISSION
 - 2.1B.17.3.4 DETERMINE IF TARGET IS WITHIN ASPECT SENSOR FOV
 - 2.1B.17.3.5 SELECT NEW TELESCOPE ATTITUDE IF NECESSARY

If target has not been found, another try must be made.

- 2.1B.17.4 DETERMINE RELATIVE ALIGNMENT
 - 2.1B.17.4.1 TAKE DATA FROM DETECTOR
 - 2.1B.17.4.2 TAKE DATA FROM ASPECT SENSORS
 - 2.1B.17.4.3 DATA/COMMAND ENCODING
 - 2.1B.17.4.4 DATA/COMMAND TRANSMISSION
 - 2.1B.17.4.5 PROCESS IMAGE DATA
 - 2.1B.17.4.6 DETERMINE ALIGNMENT CORRECTION

ORIGINAL PAGE IS
OF POOR QUALITY

- 2.2A SERVICING, MAINTENANCE, AND REPAIR (SHUTTLE WITH OMS KIT)
 - 2.2A.1 DESIGN
 - 2.2A.1.1 DEFINE REQUIREMENTS
 - 2.2A.1.2 MISSION ANALYSIS
 - 2.2A.1.3 PAYLOAD ACCOMMODATIONS
 - 2.2A.1.4 CREATE FUNCTIONAL LAYOUT
 - 2.2A.1.5 FAILURE MODES ANALYSIS
 - 2.2A.1.6 CREATE MECHANICAL LAYOUT
 - 2.2A.1.7 SAFETY REVIEW
 - 2.2A.1.8 DESIGN OF COMPONENTS
 - 2.2A.1.10 SOFTWARE DEVELOPMENT
 - 2.2A.2 COMPONENT FABRICATION
 - 2.2A.2.1 PROCURE OFF-THE-SHELF COMPONENTS
 - 2.2A.2.2 PROCURE MATERIALS FOR MANUFACTURED COMPONENTS
 - 2.2A.2.3 PROCURE MANUFACTURING EQUIPMENT
 - 2.2A.2.4 MANUFACTURE COMPONENTS
 - 2.2A.3 COMPONENT TEST
 - 2.2A.3.1 SET UP TEST FACILITIES
 - 2.2A.3.2 STRUCTURAL LOADS TESTS
 - 2.2A.3.3 DATA PROCESSING AND SOFTWARE TESTS
 - 2.2A.3.4 SOLAR ARRAY DEPLOYMENT TESTS
 - 2.2A.3.5 ELECTRICAL SYSTEMS TESTS
 - 2.2A.3.6 THERMAL AND VACUUM TESTS
 - 2.2A.3.7 DETECTOR ALIGNMENT TESTS
 - 2.2A.3.8 COMPONENT CERTIFICATION
 - 2.2A.4 SYSTEM INTEGRATION
 - 2.2A.5 SYSTEM TEST
 - 2.2A.5.1 POWER SUBSYSTEM TESTS
 - 2.2A.5.2 THERMAL SUBSYSTEM TESTS
 - 2.2A.5.3 STRUCTURE SUBSYSTEM TESTS
 - 2.2A.5.4 INFORMATION PROCESSING SUBSYSTEM TESTS
 - 2.2A.5.5 COMMUNICATIONS SUBSYSTEM TESTS
 - 2.2A.5.6 ATTITUDE CONTROL SUBSYSTEM TESTS
 - 2.2A.5.7 OPTICAL SUBSYSTEM TESTS
 - 2.2A.5.8 INTEGRATED SYSTEMS TESTS
 - 2.2A.5.9 FAILURE MODES SIMULATION
 - 2.2A.5.10 SYSTEM CERTIFICATION
 - 2.2A.6 SHIPPING TO LAUNCH SITE
 - 2.2A.6.1 REMOVE TEST EQUIPMENT
 - 2.2A.6.2 PERFORM NECESSARY DISASSEMBLY
 - 2.2A.6.3 PACKING
 - 2.2A.6.4 TRANSPORT TO LAUNCH SITE
 - 2.2A.7 PAYLOAD INTEGRATION AND CHECKOUT
 - 2.2A.7.1 UNPACKING
 - 2.2A.7.2 PERFORM NECESSARY REASSEMBLY
 - 2.2A.7.3 INTEGRATED SYSTEMS TESTS
 - 2.2A.7.3.1 VERIFY POWER SYSTEM FUNCTION
 - 2.2A.7.3.2 VERIFY COMMAND SYSTEM FUNCTION
 - 2.2A.7.3.3 VERIFY MECHANICAL SYSTEM FUNCTION
 - 2.2A.7.3.4 VERIFY COMMUNICATIONS SYSTEM FUNCTION
 - 2.2A.7.3.5 VERIFY DETECTOR SYSTEM FUNCTION
 - 2.2A.7.3.6 MISSION SEQUENCE SIMULATION
 - 2.2A.7.4 TRANSFER TO OPERATIONS AND CHECKOUT BLDG.
 - 2.2A.7.4.1 LOAD PAYLOAD INTO CONTAINER
 - 2.2A.7.4.2 TRANSPORT TO OPERATIONS AND CHECKOUT BLDG.
 - 2.2A.7.4.3 ATTACH STRONGBACK TO PAYLOAD
 - 2.2A.7.4.4 INSTALL PAYLOAD IN HORIZONTAL CITE
 - 2.2A.7.5 PERFORM INTERFACES CHECK
 - 2.2A.7.5.1 CHECK SHUTTLE/PAYLOAD MECHANICAL INTERFACES
 - 2.2A.7.5.2 CHECK ELECTRICAL INTERFACES
 - 2.2A.7.6 TRANSFER PAYLOAD TO ORBITER PROCESSING FACILITY
 - 2.2A.7.6.1 ATTACH STRONGBACK TO PAYLOAD
 - 2.2A.7.6.2 LOAD PAYLOAD INTO CANISTER
 - 2.2A.7.6.3 REMOVE STRONGBACK
 - 2.2A.7.6.4 CLOSE CANISTER
 - 2.2A.7.6.5 TRANSPORT CANISTER TO ORBITER PROCESSING FACILITY
 - 2.2A.7.7 ORBITER/PAYLOAD INTEGRATION (HORIZONTAL)
 - 2.2A.7.7.1 ATTACH STRONGBACK TO PAYLOAD
 - 2.2A.7.7.2 INSTALL PAYLOAD IN ORBITER
 - 2.2A.7.7.3 CONNECT ORBITER/PAYLOAD INTERFACES
 - 2.2A.7.7.4 CHECK ELECTRICAL INTERFACES
 - 2.2A.7.7.5 INSTALLATION OF OMS KIT

- 2.2A.7.7.6 CLOSE-OUT PAYLOAD BAY
- 2.2A.8 COUNTDOWN AND LAUNCH
- 2.2A.9 ORBITAL RENDEZVOUS AND CAPTURE
 - 2.2A.9.1 SHUTTLE ATTAINS RENDEZVOUS ORBIT
 - 2.2A.9.2 RENDEZVOUS WITH AXAF
 - 2.2A.9.2.1 COMPUTE EXPECTED TARGET POSITION
 - 2.2A.9.2.2 ALIGN ORBITER WITH EXPECTED TARGET POSITION
 - 2.2A.9.2.3 DEPLOY RENDEZVOUS SENSOR
 - 2.2A.9.2.4 ACTIVATE RENDEZVOUS SENSOR
 - 2.2A.9.2.5 TRACK TARGET
 - 2.2A.9.2.6 COMPUTE TERMINAL PHASE OMS BURN
 - 2.2A.9.2.7 FIRE THRUSTERS
 - 2.2A.9.3 OPERATIONAL CHECKOUT
 - 2.2A.9.3.1 COMMAND ATTITUDE CHANGE
 - Command to change pointing is entered.
----- - 2.2A.9.3.2 OBSERVE ATTITUDE CHANGE
 - Orbiter observes results of attitude change command.
----- - 2.2A.9.3.3 MONITOR TELEMETRY
 - AXAF data is monitored by Orbiter.
----- - 2.2A.9.3.4 EVALUATE SYSTEM PERFORMANCE
 - Detector and housekeeping data is evaluated to verify correct response to command.
----- - 2.2A.9.4 STABILIZE AXAF FOR RETRIEVAL
 - If system performance is not adequate, retrieval may be necessary, for repairs in payload bay or on ground.
----- - 2.2A.9.4.1 INITIALIZE GUIDANCE SYSTEM
 - Update inertial reference system.
----- - 2.2A.9.4.2 DETERMINE CURRENT ATTITUDE
 - 2.2A.9.4.3 DETERMINE DESIRED ATTITUDE
 - 2.2A.9.4.4 DETERMINE NEW CONFIGURATION FOR SPACECRAFT COMPONENTS
 - Main components are solar arrays and radiators.
----- - 2.2A.9.4.5 CHOOSE OPTIMAL TRAJECTORY
 - 2.2A.9.4.6 ROTATE SPACECRAFT
 - Use magnetic torquers for attitude control.
----- - 2.2A.9.4.7 DETERMINE DISTURBING TORQUES
 - 2.2A.9.4.8 COMPUTE REQUIRED RESULTANT
 - 2.2A.9.4.9 APPLY COMPENSATING TORQUES
 - Use magnetic torquers.
----- - 2.2A.9.4.10 SHUTDOWN SPACECRAFT SYSTEMS
 - 2.2A.9.5 ATTACH AXAF TO ORBITER
 - 2.2A.9.5.1 MATCH AXAF VELOCITY AND ATTITUDE WITH ORBITER
 - 2.2A.9.5.2 LOCATE GRASPING FIXTURE ON TARGET
 - The target is AXAF.
----- - 2.2A.9.5.3 GRASP FIXTURE
 - 2.2A.9.5.4 TRANSLATE PAYLOAD TO CRADLE
 - 2.2A.9.5.5 FASTEN PAYLOAD RESTRAINTS
 - 2.2A.9.6 TESTS OF ATTACHED PAYLOAD
 - 2.2A.9.6.1 COMMAND DETECTOR SELECTION
 - Command to rotate detector carousel is entered from Orbiter.
----- - 2.2A.9.6.2 OBSERVE DETECTOR SELECTION

Data from AXAF is checked to verify detector selection.

2.2A.9.6.3 MONITOR TELEMETRY

AXAF data is monitored by Orbiter.

2.2A.9.6.4 EVALUATE SYSTEM PERFORMANCE

Detector and housekeeping data is evaluated to verify correct response
to command.

2.2A.9.7 IDENTIFY DEFECTIVE COMPONENT

- 2.2A.9.7.1 DETERMINE ANOMALOUS DATA
- 2.2A.9.7.2 FORM HYPOTHESIS FOR PROBLEM
- 2.2A.9.7.3 DEVISE TEST FOR FAILURE HYPOTHESIS
- 2.2A.9.7.4 PERFORM TEST FOR FAILURE HYPOTHESIS
- 2.2A.9.7.5 IDENTIFY FAULTY COMPONENT

2.2A.9.8 IDENTIFY DEFECTIVE SOFTWARE

- 2.2A.9.8.1 COMPARE MEASURED DATA TO MODEL
- 2.2A.9.8.2 DETERMINE ANOMALOUS DATA
- 2.2A.9.8.3 FORM HYPOTHESIS FOR PROBLEM
- 2.2A.9.8.4 DEVISE TEST FOR FAILURE HYPOTHESIS
- 2.2A.9.8.5 PERFORM TEST FOR FAILURE HYPOTHESIS
- 2.2A.9.8.6 IDENTIFY FAULTY SOFTWARE

2.2A.10 COMPONENT/SOFTWARE REPLACEMENT

2.2A.10.1 REMOVE OLD DETECTOR MODULE

- 2.2A.10.1.1 LOCATE ACCESS PANEL
- 2.2A.10.1.2 OPEN ACCESS PANEL
- 2.2A.10.1.3 MOVE DETECTOR INTO POSITION
- 2.2A.10.1.4 CLOSE INTERNAL VALVES
- 2.2A.10.1.5 DISCONNECT DETECTOR
- 2.2A.10.1.6 REMOVE DETECTOR
- 2.2A.10.1.7 STORE DETECTOR

2.2A.10.2 INSTALL NEW DETECTOR MODULE

- 2.2A.10.2.1 LOCATE DETECTOR
- 2.2A.10.2.2 INSTALL DETECTOR
- 2.2A.10.2.3 CONNECT DETECTOR
- 2.2A.10.2.4 OPEN INTERNAL VALVES
- 2.2A.10.2.5 MAKE DIAGNOSTIC CHECKS
- 2.2A.10.2.6 CLOSE ACCESS PANEL

2.2A.10.3 COMPONENT REPLACEMENT

- 2.2A.10.3.1 DEFINE ACCESS SEQUENCE
- 2.2A.10.3.2 LOCATE ACCESS PANEL
- 2.2A.10.3.3 TRANSFER REPAIR EQUIPMENT TO REPAIR SITE
- 2.2A.10.3.4 OPEN ACCESS PANEL
- 2.2A.10.3.5 OBSERVE/LOCATE DEFECTIVE COMPONENT
- 2.2A.10.3.6 REMOVE COMPONENT
- 2.2A.10.3.7 STORE COMPONENT
- 2.2A.10.3.8 LOCATE NEW COMPONENT
- 2.2A.10.3.9 POSITION AND CONNECT NEW COMPONENT
- 2.2A.10.3.10 ADJUST COMPONENT
- 2.2A.10.3.11 MAKE DIAGNOSTIC CHECKS
- 2.2A.10.3.12 CLOSE ACCESS PANEL
- 2.2A.10.3.13 STOW REPAIR EQUIPMENT

2.2A.10.4 SOFTWARE REPLACEMENT

- 2.2A.10.4.1 DATA/COMMAND ENCODING
- 2.2A.10.4.2 DATA/COMMAND TRANSMISSION
- 2.2A.10.4.3 COMPUTER FUNCTION CHECKS

2.2A.11 RESUPPLY CONSUMABLES

2.2A.11.1A FLUID REPLACEMENT (UMBILICAL)

- 2.2A.11.1A.1 LOCATE ACCESS PANEL
- 2.2A.11.1A.2 OPEN ACCESS PANEL
- 2.2A.11.1A.3 CLOSE INTERNAL VALVES
- 2.2A.11.1A.4 EXTEND AND ATTACH UMBILICAL
- 2.2A.11.1A.5 OPEN SUPPLY VALVE
- 2.2A.11.1A.6 MONITOR FLUID TRANSFER
- 2.2A.11.1A.7 CLOSE SUPPLY VALVE
- 2.2A.11.1A.8 DETACH AND RETRACT UMBILICAL
- 2.2A.11.1A.9 OPEN INTERNAL VALVES
- 2.2A.11.1A.10 CHECK FOR LEAKS
- 2.2A.11.1A.11 CLOSE ACCESS PANEL

ORIGINAL PAGE IS
OF POOR QUALITY

2.2A.11.1B FLUID REPLACEMENT (TANK REPLACEMENT)

- 2.2A.11.1B.1 LOCATE ACCESS PANEL
- 2.2A.11.1B.2 TRANSFER REPAIR EQUIPMENT TO REPAIR SITE
- 2.2A.11.1B.3 OPEN ACCESS PANEL
- 2.2A.11.1B.4 CLOSE INTERNAL VALVES
- 2.2A.11.1B.5 LOCATE OLD TANK
- 2.2A.11.1B.6 DISCONNECT OLD TANK
- 2.2A.11.1B.7 REMOVE OLD TANK
- 2.2A.11.1B.8 STORE OLD TANK
- 2.2A.11.1B.9 LOCATE NEW TANK
- 2.2A.11.1B.10 INSTALL NEW TANK
- 2.2A.11.1B.11 CONNECT NEW TANK
- 2.2A.11.1B.12 OPEN INTERNAL VALVES
- 2.2A.11.1B.13 CHECK FOR LEAKS
- 2.2A.11.1B.14 CLOSE ACCESS PANEL
- 2.2A.11.1B.15 STOW REPAIR EQUIPMENT

2.2A.12 NON-ROUTINE MAINTENANCE AND REPAIR

2.2A.13 SECURE PAYLOAD IN ORBITER

2.2A.13.1 RETRACT DEPLOYABLE PAYLOAD COMPONENTS

- 2.2A.13.1.1 RETRACT TORSS ANTENNAS
- 2.2A.13.1.2 LOCATE SUNSHADE RESTRAINTS
- 2.2A.13.1.3 RELEASE SUNSHADE RESTRAINTS
- 2.2A.13.1.4 LOCATE GRASPING FIXTURE ON TARGET

The target is the AXAF sunshade.

- 2.2A.13.1.5 GRASP FIXTURE
- 2.2A.13.1.6 CLOSE SUNSHADE
- 2.2A.13.1.7 LOCATE SOLAR ARRAY RESTRAINTS
- 2.2A.13.1.8 RELEASE SOLAR ARRAY RESTRAINTS
- 2.2A.13.1.9 LOCATE GRASPING FIXTURE ON TARGET

The target is the AXAF solar array.

- 2.2A.13.1.10 GRASP FIXTURE
- 2.2A.13.1.11 RETRACT SOLAR ARRAYS
- 2.2A.13.2 RETRACTION OF PAYLOAD INTO PAYLOAD BAY
- 2.2A.13.2.1 LOCATE GRASPING FIXTURE ON TARGET

The target is AXAF.

- 2.2A.13.2.2 GRASP FIXTURE
- 2.2A.13.2.3 TILT PAYLOAD TO HORIZONTAL POSITION

AXAF is mounted on a tilt-table.

- 2.2A.13.2.4 FASTEN PAYLOAD RESTRAINTS
- 2.2A.13.2.5 CLOSE PAYLOAD BAY DOORS
- 2.2A.14 ORBITAL DEPLOYMENT AND CHECKOUT
- 2.2A.14.1 SHUTTLE ATTAINS DELIVERY ORBIT
- 2.2A.14.2 EXTENSION OF PAYLOAD FROM PAYLOAD BAY
- 2.2A.14.2.1 OPEN PAYLOAD BAY DOORS
- 2.2A.14.2.2 LOCATE GRASPING FIXTURE ON TARGET

The target is AXAF.

- 2.2A.14.2.3 GRASP FIXTURE
- 2.2A.14.2.4 RELEASE PAYLOAD RESTRAINTS
- 2.2A.14.2.5 TILT PAYLOAD TO VERTICAL POSITION

AXAF is mounted on a tilt-table.

- 2.2A.14.3 EXTEND DEPLOYABLE COMPONENTS
- 2.2A.14.3.1 LOCATE SOLAR ARRAY RESTRAINTS
- 2.2A.14.3.2 RELEASE SOLAR ARRAY RESTRAINTS
- 2.2A.14.3.3 LOCATE GRASPING FIXTURE ON TARGET

The target is the AXAF solar array.

- 2.2A.14.3.4 GRASP FIXTURE
- 2.2A.14.3.5 DEPLOY SOLAR ARRAYS
- 2.2A.14.3.6 LOCATE SUNSHADE RESTRAINTS

2.2A.14.3.7 RELEASE SUNSHADE RESTRAINTS
2.2A.14.3.8 LOCATE GRASPING FIXTURE ON TARGET

The target is the AXAF sunshade.

2.2A.14.3.9 GRASP FIXTURE
2.2A.14.3.10 OPEN SUNSHADE
2.2A.14.3.11 DEPLOY TDRSS ANTENNAS
2.2A.14.4 TESTS OF ATTACHED PAYLOAD
2.2A.14.4.1 COMMAND DETECTOR SELECTION

Command to rotate detector carousel is entered from Orbiter.

2.2A.14.4.2 OBSERVE DETECTOR SELECTION

Data from AXAF is checked to verify detector selection.

2.2A.14.4.3 MONITOR TELEMTRY

AXAF data is monitored by Orbiter.

2.2A.14.4.4 EVALUATE SYSTEM PERFORMANCE

Detector and housekeeping data is evaluated to verify correct response to command.

2.2A.14.5 SEPARATION OF PAYLOAD FROM ORBITER
2.2A.14.5.1 LOCATE GRASPING FIXTURE ON TARGET

The target is AXAF.

2.2A.14.5.2 GRASP FIXTURE
2.2A.14.5.3 RELEASE PAYLOAD RESTRAINTS
2.2A.14.5.4 TRANSLATE PAYLOAD OUT OF PAYLOAD BAY
2.2A.14.5.5 RMS RELEASES PAYLOAD
2.2A.14.6 OPERATIONAL CHECKOUT
2.2A.14.6.1 ACTIVATE AXAF SUBSYSTEMS

Attitude control, communications, thermal control systems are activated.

2.2A.14.6.2 COMMAND ATTITUDE CHANGE

Command to change pointing is entered.

2.2A.14.6.3 OBSERVE ATTITUDE CHANGE

Orbiter observes results of attitude change command.

2.2A.14.6.4 MONITOR TELEMTRY

AXAF data is monitored by Orbiter.

2.2A.14.6.5 EVALUATE SYSTEM PERFORMANCE

Detector and housekeeping data is evaluated to verify correct response to command.

2.2A.14.7 STABILIZE AXAF FOR RETRIEVAL

If system performance is not adequate, retrieval may be necessary, for repairs in payload bay or on ground.

2.2A.14.7.1 INITIALIZE GUIDANCE SYSTEM

Update inertial reference system.

2.2A.14.7.2 DETERMINE CURRENT ATTITUDE
2.2A.14.7.3 DETERMINE DESIRED ATTITUDE
2.2A.14.7.4 DETERMINE NEW CONFIGURATION FOR SPACECRAFT COMPONENTS

Main components are solar arrays and radiators.

- 2.2A.14.7.5 CHOOSE OPTIMAL TRAJECTORY
- 2.2A.14.7.6 ROTATE SPACECRAFT

Use magnetic torquers for attitude control.

- 2.2A.14.7.7 DETERMINE DISTURBING TORQUES
- 2.2A.14.7.8 COMPUTE REQUIRED RESULTANT
- 2.2A.14.7.9 APPLY COMPENSATING TORQUES

Use magnetic torquers.

- 2.2A.14.7.10 SHUTDOWN SPACECRAFT SYSTEMS
- 2.2A.14.8 ATTACH AXAF TO ORBITER
 - 2.2A.14.8.1 MATCH AXAF VELOCITY AND ATTITUDE WITH ORBITER
 - 2.2A.14.8.2 LOCATE GRASPING FIXTURE ON TARGET

The target is AXAF.

- 2.2A.14.8.3 GRASP FIXTURE
- 2.2A.14.8.4 TRANSLATE PAYLOAD TO CRADLE
- 2.2A.14.8.5 FASTEN PAYLOAD RESTRAINTS
- 2.2A.14.9 IDENTIFY DEFECTIVE COMPONENT
 - 2.2A.14.9.1 DETERMINE ANOMALOUS DATA
 - 2.2A.14.9.2 FORM HYPOTHESIS FOR PROBLEM
 - 2.2A.14.9.3 DEVISE TEST FOR FAILURE HYPOTHESIS
 - 2.2A.14.9.4 PERFORM TEST FOR FAILURE HYPOTHESIS
 - 2.2A.14.9.5 IDENTIFY FAULTY COMPONENT
- 2.2A.14.10A COMPONENT FAILURE RECOVERY (REDUNDANCY)
 - 2.2A.14.10A.1 SWITCH OUT FAULTY COMPONENT
 - 2.2A.14.10A.2 SWITCH IN REDUNDANT COMPONENT
 - 2.2A.14.10A.3 MAKE DIAGNOSTIC CHECKS
 - 2.2A.14.10A.4 UPDATE SPACECRAFT MODEL
- 2.2A.14.10B COMPONENT FAILURE RECOVERY (ON-BOARD REPAIR)
 - 2.2A.14.10B.1 DEFINE ACCESS SEQUENCE
 - 2.2A.14.10B.2 LOCATE ACCESS PANEL
 - 2.2A.14.10B.3 TRANSFER REPAIR EQUIPMENT TO REPAIR SITE
 - 2.2A.14.10B.4 OPEN ACCESS PANEL
 - 2.2A.14.10B.5 OBSERVE/LOCATE DEFECTIVE COMPONENT
 - 2.2A.14.10B.6 REMOVE COMPONENT
 - 2.2A.14.10B.7 STORE COMPONENT
 - 2.2A.14.10B.8 LOCATE NEW COMPONENT
 - 2.2A.14.10B.9 POSITION AND CONNECT NEW COMPONENT
 - 2.2A.14.10B.10 ADJUST COMPONENT
 - 2.2A.14.10B.11 MAKE DIAGNOSTIC CHECKS
 - 2.2A.14.10B.12 CLOSE ACCESS PANEL
 - 2.2A.14.10B.13 STOW REPAIR EQUIPMENT
- 2.2A.14.11 IDENTIFY DEFECTIVE SOFTWARE
 - 2.2A.14.11.1 COMPARE MEASURED DATA TO MODEL
 - 2.2A.14.11.2 DETERMINE ANOMALOUS DATA
 - 2.2A.14.11.3 FORM HYPOTHESIS FOR PROBLEM
 - 2.2A.14.11.4 DEVISE TEST FOR FAILURE HYPOTHESIS
 - 2.2A.14.11.5 PERFORM TEST FOR FAILURE HYPOTHESIS
 - 2.2A.14.11.6 IDENTIFY FAULTY SOFTWARE
- 2.2A.14.12 SOFTWARE FAILURE RECOVERY
 - 2.2A.14.12.1 DETERMINE CORRECTION ALGORITHM
 - 2.2A.14.12.2 DATA/COMMAND ENCODING
 - 2.2A.14.12.3 DATA/COMMAND TRANSMISSION
 - 2.2A.14.12.4 COMPUTER FUNCTION CHECKS
- 2.2A.15 REENTRY AND LANDING
- 2.2A.16 POST-FLIGHT OPERATIONS
 - 2.2A.16.1 SAFING OF ORBITER
 - 2.2A.16.2 REMOVAL OF PAYLOAD FROM ORBITER
 - 2.2A.16.2.1 OPEN PAYLOAD BAY DOORS
 - 2.2A.16.2.2 ATTACH STRONGBACK TO PAYLOAD
 - 2.2A.16.2.3 LOAD PAYLOAD INTO CANISTER

2.2B SERVICING, MAINTENANCE, AND REPAIR (SHUTTLE WITH TMS UPPER STAGE)

- 2.2B.1 DESIGN
 - 2.2B.1.1 DEFINE REQUIREMENTS
 - 2.2B.1.2 MISSION ANALYSIS
 - 2.2B.1.3 PAYLOAD ACCOMMODATIONS

- 2.2B.1.4 CREATE FUNCTIONAL LAYOUT
- 2.2B.1.5 FAILURE MODES ANALYSIS
- 2.2B.1.6 CREATE MECHANICAL LAYOUT
- 2.2B.1.7 SAFETY REVIEW
- 2.2B.1.8 DESIGN OF COMPONENTS
- 2.2B.1.10 SOFTWARE DEVELOPMENT
- 2.2B.2 COMPONENT FABRICATION
 - 2.2B.2.1 PROCURE OFF-THE-SHELF COMPONENTS
 - 2.2B.2.2 PROCURE MATERIALS FOR MANUFACTURED COMPONENTS
 - 2.2B.2.3 PROCURE MANUFACTURING EQUIPMENT
 - 2.2B.2.4 MANUFACTURE COMPONENTS
- 2.2B.3 COMPONENT TEST
 - 2.2B.3.1 SET UP TEST FACILITIES
 - 2.2B.3.2 STRUCTURAL LOADS TESTS
 - 2.2B.3.3 DATA PROCESSING AND SOFTWARE TESTS
 - 2.2B.3.4 SOLAR ARRAY DEPLOYMENT TESTS
 - 2.2B.3.5 ELECTRICAL SYSTEMS TESTS
 - 2.2B.3.6 THERMAL AND VACUUM TESTS
 - 2.2B.3.7 DETECTOR ALIGNMENT TESTS
 - 2.2B.3.8 THRUSTER TESTS
 - 2.2B.3.9 COMPONENT CERTIFICATION
- 2.2B.4 SYSTEM INTEGRATION
- 2.2B.5 SYSTEM TEST
 - 2.2B.5.1 POWER SUBSYSTEM TESTS
 - 2.2B.5.2 THERMAL SUBSYSTEM TESTS
 - 2.2B.5.3 STRUCTURE SUBSYSTEM TESTS
 - 2.2B.5.4 INFORMATION PROCESSING SUBSYSTEM TESTS
 - 2.2B.5.5 COMMUNICATIONS SUBSYSTEM TESTS
 - 2.2B.5.6 ATTITUDE CONTROL SUBSYSTEM TESTS
 - 2.2B.5.7 OPTICAL SUBSYSTEM TESTS
 - 2.2B.5.8 PROPULSION SUBSYSTEM TESTS
 - 2.2B.5.9 INTEGRATED SYSTEMS TESTS
 - 2.2B.5.10 FAILURE MODES SIMULATION
 - 2.2B.5.11 SYSTEM CERTIFICATION
- 2.2B.6 SHIPPING TO LAUNCH SITE
 - 2.2B.6.1 REMOVE TEST EQUIPMENT
 - 2.2B.6.2 PERFORM NECESSARY DISASSEMBLY
 - 2.2B.6.3 PACKING
 - 2.2B.6.4 TRANSPORT TO LAUNCH SITE
- 2.2B.7 PAYLOAD INTEGRATION AND CHECKOUT
 - 2.2B.7.1 UNPACKING
 - 2.2B.7.2 PERFORM NECESSARY REASSEMBLY
 - 2.2B.7.3 INTEGRATED SYSTEMS TESTS
 - 2.2B.7.3.1 VERIFY POWER SYSTEM FUNCTION
 - 2.2B.7.3.2 VERIFY COMMAND SYSTEM FUNCTION
 - 2.2B.7.3.3 VERIFY MECHANICAL SYSTEM FUNCTION
 - 2.2B.7.3.4 VERIFY COMMUNICATIONS SYSTEM FUNCTION
 - 2.2B.7.3.5 VERIFY DETECTOR SYSTEM FUNCTION
 - 2.2B.7.3.6 MISSION SEQUENCE SIMULATION
 - 2.2B.7.4 TRANSFER TO OPERATIONS AND CHECKOUT BLDG.
 - 2.2B.7.4.1 LOAD PAYLOAD INTO CONTAINER
 - 2.2B.7.4.2 TRANSPORT TO OPERATIONS AND CHECKOUT BLDG.
 - 2.2B.7.4.3 ATTACH STRONGBACK TO PAYLOAD
 - 2.2B.7.4.4 INSTALL PAYLOAD IN HORIZONTAL CITE
 - 2.2B.7.5 INTEGRATE TMS WITH PAYLOAD
 - 2.2B.7.6 PERFORM INTERFACES CHECK
 - 2.2B.7.6.1 CHECK TMS/PAYLOAD MECHANICAL INTERFACES
 - 2.2B.7.6.2 CHECK SHUTTLE/PAYLOAD MECHANICAL INTERFACES
 - 2.2B.7.6.3 CHECK ELECTRICAL INTERFACES
 - 2.2B.7.7 TRANSFER TMS/PAYLOAD TO ORBITER PROCESSING FACILITY
 - 2.2B.7.7.1 ATTACH STRONGBACK TO PAYLOAD
 - 2.2B.7.7.2 LOAD PAYLOAD INTO CANISTER
 - 2.2B.7.7.3 REMOVE STRONGBACK
 - 2.2B.7.7.4 CLOSE CANISTER
 - 2.2B.7.7.5 TRANSPORT CANISTER TO ORBITER PROCESSING FACILITY
 - 2.2B.7.8 ORBITER/PAYLOAD INTEGRATION (HORIZONTAL)
 - 2.2B.7.8.1 ATTACH STRONGBACK TO PAYLOAD
 - 2.2B.7.8.2 INSTALL PAYLOAD IN ORBITER
 - 2.2B.7.8.3 CONNECT ORBITER/PAYLOAD INTERFACES
 - 2.2B.7.8.4 CHECK ELECTRICAL INTERFACES
 - 2.2B.7.8.5 CLOSE-OUT PAYLOAD BAY
 - 2.2B.7.8.6 INSTALLATION OF ORBITER PAYLOAD STATION CONSOLES

- 2.2B.8 COUNTDOWN AND LAUNCH
- 2.2B.9 ORBITAL RENDEZVOUS AND CAPTURE
 - 2.2B.9.1 SHUTTLE ATTAINS DELIVERY ORBIT
 - 2.2B.9.2 TESTS OF ATTACHED PAYLOAD
 - 2.2B.9.2.1 POWER SUBSYSTEM CHECKOUT
 - 2.2B.9.2.2 INFORMATION PROCESSING SUBSYSTEM CHECKOUT
 - 2.2B.9.3 EXTENSION OF PAYLOAD FROM PAYLOAD BAY
 - 2.2B.9.3.1 OPEN PAYLOAD BAY DOORS
 - 2.2B.9.3.2 ACTIVATE RMS
 - 2.2B.9.3.3 LOCATE GRASPING FIXTURE ON TARGET

The target is the TMS.

- 2.2B.9.3.4 MOVE RMS TO FIXTURE
- 2.2B.9.3.5 GRASP FIXTURE
- 2.2B.9.3.6 RELEASE PAYLOAD RESTRAINTS
- 2.2B.9.3.7 TRANSLATE PAYLOAD OUT OF PAYLOAD BAY
- 2.2B.9.4 SEPARATION OF PAYLOAD FROM ORBITER
 - 2.2B.9.4.1 RMS RELEASES PAYLOAD
 - 2.2B.9.4.2 SECURE RMS IN PAYLOAD BAY
- 2.2B.9.5 OPERATIONAL CHECKOUT OF TMS
 - 2.2B.9.5.1 ACTIVATE TMS SUBSYSTEMS
 - 2.2B.9.5.2 INFORMATION PROCESSING SUBSYSTEM CHECKOUT
 - 2.2B.9.5.3 POWER SUBSYSTEM CHECKOUT
 - 2.2B.9.5.4 THERMAL SUBSYSTEM CHECKOUT
 - 2.2B.9.5.5 STRUCTURAL SUBSYSTEM CHECKOUT
 - 2.2B.9.5.6 COMMUNICATIONS SUBSYSTEM CHECKOUT
 - 2.2B.9.5.7 ATTITUDE CONTROL SUBSYSTEM CHECKOUT
 - 2.2B.9.5.8 PROPULSION SUBSYSTEM CHECKOUT
 - 2.2B.9.5.9 CONSUMABLES LEVELS CHECKOUT
- 2.2B.9.6 ORBITAL TRANSFER
 - 2.2B.9.6.1 INITIALIZE GUIDANCE SYSTEM

Update inertial reference system.

- 2.2B.9.6.2 DETERMINE CURRENT ORBITAL PARAMETERS
- 2.2B.9.6.3 DETERMINE DESIRED ORBITAL PARAMETERS
- 2.2B.9.6.4 CHOOSE OPTIMAL TRAJECTORY
- 2.2B.9.6.5 DETERMINE CURRENT ATTITUDE
- 2.2B.9.6.6 DETERMINE DESIRED ATTITUDE
- 2.2B.9.6.7 ROTATE SPACECRAFT

Use magnetic torquers for attitude control.

- 2.2B.9.6.8 FIRE THRUSTERS
- 2.2B.9.7 OPERATIONAL CHECKOUT OF AXAF
 - 2.2B.9.7.1 COMMAND ATTITUDE CHANGE

Command to change pointing is entered

- 2.2B.9.7.2 OBSERVE ATTITUDE CHANGE

Orbiter observes results of attitude change command.

- 2.2B.9.7.3 MONITOR TELEMETRY

AXAF data is monitored by Orbiter.

- 2.2B.9.7.4 EVALUATE SYSTEM PERFORMANCE

Detector and housekeeping data is evaluated to verify correct response to command.

- 2.2B.9.8 STABILIZE AXAF FOR RETRIEVAL

If system performance is not adequate, retrieval may be necessary, for repairs in payload bay or on ground.

- 2.2B.9.8.1 INITIALIZE GUIDANCE SYSTEM

Update inertial reference system.

- 2.2B.9.8.2 DETERMINE CURRENT ATTITUDE
- 2.2B.9.8.3 DETERMINE DESIRED ATTITUDE
- 2.2B.9.8.4 DETERMINE NEW CONFIGURATION FOR SPACECRAFT COMPONENTS

Main components are solar arrays and radiators.

- 2.2B.9.8.5 CHOOSE OPTIMAL TRAJECTORY
- 2.2B.9.8.6 ROTATE SPACECRAFT

Use magnetic torquers for attitude control.

- 2.2B.9.8.7 DETERMINE DISTURBING TORQUES
- 2.2B.9.8.8 COMPUTE REQUIRED RESULTANT
- 2.2B.9.8.9 APPLY COMPENSATING TORQUES

Use magnetic torquers.

- 2.2B.9.8.10 SHUTDOWN SPACECRAFT SYSTEMS
- 2.2B.9.9 DOCK TMS TO SPACECRAFT
 - 2.2B.9.9.1 LOCATE DOCKING TARGET
 - 2.2B.9.9.2 EXTEND DOCKING MECHANISM
 - 2.2B.9.9.3 FASTEN DOCKING LATCH
- 2.2B.9.10 IDENTIFY DEFECTIVE COMPONENT
 - 2.2B.9.10.1 DETERMINE ANOMALOUS DATA
 - 2.2B.9.10.2 FORM HYPOTHESIS FOR PROBLEM
 - 2.2B.9.10.3 DEVISE TEST FOR FAILURE HYPOTHESIS
 - 2.2B.9.10.4 PERFORM TEST FOR FAILURE HYPOTHESIS
 - 2.2B.9.10.5 IDENTIFY FAULTY COMPONENT
- 2.2B.9.11 IDENTIFY DEFECTIVE SOFTWARE
 - 2.2B.9.11.1 COMPARE MEASURED DATA TO MODEL
 - 2.2B.9.11.2 DETERMINE ANOMALOUS DATA
 - 2.2B.9.11.3 FORM HYPOTHESIS FOR PROBLEM
 - 2.2B.9.11.4 DEVISE TEST FOR FAILURE HYPOTHESIS
 - 2.2B.9.11.5 PERFORM TEST FOR FAILURE HYPOTHESIS
 - 2.2B.9.11.6 IDENTIFY FAULTY SOFTWARE
- 2.2B.10 COMPONENT/SOFTWARE REPLACEMENT
 - 2.2B.10.1 REMOVE OLD DETECTOR MODULE
 - 2.2B.10.1.1 LOCATE ACCESS PANEL
 - 2.2B.10.1.2 OPEN ACCESS PANEL
 - 2.2B.10.1.3 MOVE DETECTOR INTO POSITION
 - 2.2B.10.1.4 CLOSE INTERNAL VALVES
 - 2.2B.10.1.5 DISCONNECT DETECTOR
 - 2.2B.10.1.6 REMOVE DETECTOR
 - 2.2B.10.1.7 STORE DETECTOR
 - 2.2B.10.2 INSTALL NEW DETECTOR MODULE
 - 2.2B.10.2.1 LOCATE DETECTOR
 - 2.2B.10.2.2 INSTALL DETECTOR
 - 2.2B.10.2.3 CONNECT DETECTOR
 - 2.2B.10.2.4 OPEN INTERNAL VALVES
 - 2.2B.10.2.5 MAKE DIAGNOSTIC CHECKS
 - 2.2B.10.2.6 CLOSE ACCESS PANEL
 - 2.2B.10.3 COMPONENT REPLACEMENT
 - 2.2B.10.3.1 DEFINE ACCESS SEQUENCE
 - 2.2B.10.3.2 LOCATE ACCESS PANEL
 - 2.2B.10.3.3 TRANSFER REPAIR EQUIPMENT TO REPAIR SITE
 - 2.2B.10.3.4 OPEN ACCESS PANEL
 - 2.2B.10.3.5 OBSERVE/LOCATE DEFECTIVE COMPONENT
 - 2.2B.10.3.6 REMOVE COMPONENT
 - 2.2B.10.3.7 STORE COMPONENT
 - 2.2B.10.3.8 LOCATE NEW COMPONENT
 - 2.2B.10.3.9 POSITION AND CONNECT NEW COMPONENT
 - 2.2B.10.3.10 ADJUST COMPONENT
 - 2.2B.10.3.11 MAKE DIAGNOSTIC CHECKS
 - 2.2B.10.3.12 CLOSE ACCESS PANEL
 - 2.2B.10.3.13 STOW REPAIR EQUIPMENT
 - 2.2B.10.4 SOFTWARE REPLACEMENT
 - 2.2B.10.4.1 DATA/COMMAND ENCODING
 - 2.2B.10.4.2 DATA/COMMAND TRANSMISSION
 - 2.2B.10.4.3 COMPUTER FUNCTION CHECKS
- 2.2B.11 RESUPPLY CONSUMABLES
 - 2.2B.11.1A FLUID REPLACEMENT (UMBILICAL)
 - 2.2B.11.1A.1 LOCATE ACCESS PANEL

- 2.2B.11.1A.2 OPEN ACCESS PANEL
- 2.2B.11.1A.3 CLOSE INTERNAL VALVES
- 2.2B.11.1A.4 EXTEND AND ATTACH UMBILICAL
- 2.2B.11.1A.5 OPEN SUPPLY VALVE
- 2.2B.11.1A.6 MONITOR FLUID TRANSFER
- 2.2B.11.1A.7 CLOSE SUPPLY VALVE
- 2.2B.11.1A.8 DETACH AND RETRACT UMBILICAL
- 2.2B.11.1A.9 OPEN INTERNAL VALVES
- 2.2B.11.1A.10 CHECK FOR LEAKS
- 2.2B.11.1A.11 CLOSE ACCESS PANEL
- 2.2B.11.1B FLUID REPLACEMENT (TANK REPLACEMENT)
 - 2.2B.11.1B.1 LOCATE ACCESS PANEL
 - 2.2B.11.1B.2 TRANSFER REPAIR EQUIPMENT TO REPAIR SITE
 - 2.2B.11.1B.3 OPEN ACCESS PANEL
 - 2.2B.11.1B.4 CLOSE INTERNAL VALVES
 - 2.2B.11.1B.5 LOCATE OLD TANK
 - 2.2B.11.1B.6 DISCONNECT OLD TANK
 - 2.2B.11.1B.7 REMOVE OLD TANK
 - 2.2B.11.1B.8 STORE OLD TANK
 - 2.2B.11.1B.9 LOCATE NEW TANK
 - 2.2B.11.1B.10 INSTALL NEW TANK
 - 2.2B.11.1B.11 CONNECT NEW TANK
 - 2.2B.11.1B.12 OPEN INTERNAL VALVES
 - 2.2B.11.1B.13 CHECK FOR LEAKS
 - 2.2B.11.1B.14 CLOSE ACCESS PANEL
 - 2.2B.11.1B.15 STOW REPAIR EQUIPMENT
- 2.2B.12 NON-ROUTINE MAINTENANCE AND REPAIR
- 2.2B.13 ORBITAL DEPLOYMENT AND CHECKOUT
 - 2.2B.13.1 ORBITAL TRANSFER (OF TMS/SPACECRAFT)
 - 2.2B.13.1.1 INITIALIZE GUIDANCE SYSTEM

Update inertial reference system.

- 2.2B.13.1.2 DETERMINE CURRENT ORBITAL PARAMETERS
- 2.2B.13.1.3 DETERMINE DESIRED ORBITAL PARAMETERS
- 2.2B.13.1.4 CHOOSE OPTIMAL TRAJECTORY
- 2.2B.13.1.5 DETERMINE CURRENT ATTITUDE
- 2.2B.13.1.6 DETERMINE DESIRED ATTITUDE
- 2.2B.13.1.7 ROTATE SPACECRAFT

Use magnetic torquers for attitude control.

- 2.2B.13.1.8 FIRE THRUSTERS
- 2.2B.13.2 UNDOCK TMS FROM PAYLOAD
 - 2.2B.13.2.1 RELEASE DOCKING LATCH
 - 2.2B.13.2.2 RETRACT DOCKING MECHANISM
 - 2.2B.13.2.3 MOVE AWAY FROM PAYLOAD
- 2.2B.13.3 EXTEND DEPLOYABLE COMPONENTS
 - 2.2B.13.3.1 LOCATE SOLAR ARRAY RESTRAINTS
 - 2.2B.13.3.2 RELEASE SOLAR ARRAY RESTRAINTS
 - 2.2B.13.3.3 LOCATE GRASPING FIXTURE ON TARGET

The target is the AXAF solar array.

- 2.2B.13.3.4 GRASP FIXTURE
- 2.2B.13.3.5 DEPLOY SOLAR ARRAYS
- 2.2B.13.3.6 LOCATE SUNSHADE RESTRAINTS
- 2.2B.13.3.7 RELEASE SUNSHADE RESTRAINTS
- 2.2B.13.3.8 LOCATE GRASPING FIXTURE ON TARGET

The target is the AXAF sunshade.

- 2.2B.13.3.9 GRASP FIXTURE
- 2.2B.13.3.10 OPEN SUNSHADE
- 2.2B.13.3.11 DEPLOY TDRSS ANTENNAS
- 2.2B.13.4 OPERATIONAL CHECKOUT OF AXAF
 - 2.2B.13.4.1 ACTIVATE AXAF SUBSYSTEMS

Attitude control, communications, thermal control systems are activated.

- 2.2B.13.4.2 COMMAND ATTITUDE CHANGE

ORIGINAL PLAN
OF POOR QUALITY

Command to change pointing is entered.

2.2B.13.4.3 OBSERVE ATTITUDE CHANGE

Orbiter observes results of attitude change command.

2.2B.13.4.4 MONITOR TELEMETRY

AXAF data is monitored by Orbiter.

2.2B.13.4.5 EVALUATE SYSTEM PERFORMANCE

Detector and housekeeping data is evaluated to verify correct response to command.

2.2B.13.5 IDENTIFY DEFECTIVE COMPONENT

2.2B.13.5.1 DETERMINE ANOMALOUS DATA

2.2B.13.5.2 FORM HYPOTHESIS FOR PROBLEM

2.2B.13.5.3 DEVISE TEST FOR FAILURE HYPOTHESIS

2.2B.13.5.4 PERFORM TEST FOR FAILURE HYPOTHESIS

2.2B.13.5.5 IDENTIFY FAULTY COMPONENT

2.2B.13.6A COMPONENT FAILURE RECOVERY (REDUNDANCY)

2.2B.13.6A.1 SWITCH OUT FAULTY COMPONENT

2.2B.13.6A.2 SWITCH IN REDUNDANT COMPONENT

2.2B.13.6A.3 MAKE DIAGNOSTIC CHECKS

2.2B.13.6A.4 UPDATE SPACECRAFT MODEL

2.2B.13.6B COMPONENT FAILURE RECOVERY (ON-BOARD REPAIR)

2.2B.13.6B.1 DEFINE ACCESS SEQUENCE

2.2B.13.6B.2 LOCATE ACCESS PANEL

2.2B.13.6B.3 TRANSFER REPAIR EQUIPMENT TO REPAIR SITE

2.2B.13.6B.4 OPEN ACCESS PANEL

2.2B.13.6B.5 OBSERVE/LOCATE DEFECTIVE COMPONENT

2.2B.13.6B.6 REMOVE COMPONENT

2.2B.13.6B.7 STORE COMPONENT

2.2B.13.6B.8 LOCATE NEW COMPONENT

2.2B.13.6B.9 POSITION AND CONNECT NEW COMPONENT

2.2B.13.6B.10 ADJUST COMPONENT

2.2B.13.6B.11 MAKE DIAGNOSTIC CHECKS

2.2B.13.6B.12 CLOSE ACCESS PANEL

2.2B.13.6B.13 STOW REPAIR EQUIPMENT

2.2B.13.7 IDENTIFY DEFECTIVE SOFTWARE

2.2B.13.7.1 COMPARE MEASURED DATA TO MODEL

2.2B.13.7.2 DETERMINE ANOMALOUS DATA

2.2B.13.7.3 FORM HYPOTHESIS FOR PROBLEM

2.2B.13.7.4 DEVISE TEST FOR FAILURE HYPOTHESIS

2.2B.13.7.5 PERFORM TEST FOR FAILURE HYPOTHESIS

2.2B.13.7.6 IDENTIFY FAULTY SOFTWARE

2.2B.13.8 SOFTWARE FAILURE RECOVERY

2.2B.13.8.1 DETERMINE CORRECTION ALGORITHM

2.2B.13.8.2 DATA/COMMAND ENCODING

2.2B.13.8.3 DATA/COMMAND TRANSMISSION

2.2B.13.8.4 COMPUTER FUNCTION CHECKS

2.2B.14 RENDEZVOUS WITH ORBITER

2.2B.14.1 ORBITAL TRANSFER (OF TMS)

2.2B.14.1.1 INITIALIZE GUIDANCE SYSTEM

Update inertial reference system.

2.2B.14.1.2 DETERMINE CURRENT ORBITAL PARAMETERS

2.2B.14.1.3 DETERMINE DESIRED ORBITAL PARAMETERS

2.2B.14.1.4 CHOOSE OPTIMAL TRAJECTORY

2.2B.14.1.5 DETERMINE CURRENT ATTITUDE

2.2B.14.1.6 DETERMINE DESIRED ATTITUDE

2.2B.14.1.7 ROTATE SPACECRAFT

Use magnetic torquers for attitude control.

2.2B.14.1.8 FIRE THRUSTERS

2.2B.14.2 SHUTDOWN TMS FOR RETRIEVAL

2.2B.14.2.1 STOW TMS ANTENNA

2.2B.14.2.2 DEACTIVATE TMS SUBSYSTEMS

- 2.2B.15 RETRIEVAL BY ORBITER
- 2.2B.15.1 ADJUST ORBIT (OF ORBITER)
- 2.2B.15.1.1 INITIALIZE GUIDANCE SYSTEM

 Update inertial reference system

- 2.2B.15.1.2 DETERMINE CURRENT ORBITAL PARAMETERS
- 2.2B.15.1.3 DETERMINE DESIRED ORBITAL PARAMETERS
- 2.2B.15.1.4 CHOOSE OPTIMAL TRAJECTORY
- 2.2B.15.1.5 FIRE THRUSTERS
- 2.2B.15.2 ADJUST ATTITUDE (OF ORBITER)
- 2.2B.15.2.1 DETERMINE CURRENT ATTITUDE
- 2.2B.15.2.2 DETERMINE DESIRED ATTITUDE
- 2.2B.15.2.3 DETERMINE NEW CONFIGURATION FOR SPACECRAFT COMPONENTS

 Main components are solar arrays and radiators.

- 2.2B.15.2.4 CHOOSE OPTIMAL TRAJECTORY
- 2.2B.15.2.5 ROTATE SPACECRAFT

 Use magnetic torquers for attitude control.

- 2.2B.15.3 OPTIMAL CONTROL ALLOCATION
- 2.2B.15.3.1 UPDATE SPACECRAFT MODEL
- 2.2B.15.3.2 PROJECT DESIRED FUNCTIONS FROM MISSION PROFILE
- 2.2B.15.3.3 ESTIMATE RISKS FROM DESIRED FUNCTIONS
- 2.2B.15.3.4 PROJECT CONSUMABLES REQUIREMENTS FROM MISSION PROFILE
- 2.2B.15.3.5 DETERMINE CONSTRAINTS AND FIGURES OF MERIT
- 2.2B.15.3.6 CHOOSE OPTIMAL CONTROL MODE
- 2.2B.15.3.7 COMPUTE CONTROL COMMANDS
- 2.2B.15.3.8 EXECUTE CONTROL COMMANDS
- 2.2B.15.4 ORBITER RECOVERY OF TMS
- 2.2B.15.4.1 ACTIVATE RMS
- 2.2B.15.4.2 LOCATE GRASPING FIXTURE ON TARGET

 Target is the TMS

- 2.2B.15.4.3 MOVE RMS TO FIXTURE
- 2.2B.15.4.4 GRASP FIXTURE
- 2.2B.15.4.5 LOCATE CRADLE IN PAYLOAD BAY
- 2.2B.15.4.6 TRANSLATE PAYLOAD TO CRADLE
- 2.2B.15.4.7 FASTEN PAYLOAD RESTRAINTS
- 2.2B.15.4.8 RMS RELEASES PAYLOAD
- 2.2B.15.4.9 SECURE RMS IN PAYLOAD BAY
- 2.2B.16 REENTRY AND LANDING
- 2.2B.17 POST-FLIGHT OPERATIONS
- 2.2B.17.1 SAFING OF ORBITER
- 2.2B.17.2 REMOVAL OF PAYLOAD FROM ORBITER
- 2.2B.17.2.1 OPEN PAYLOAD BAY DOORS
- 2.2B.17.2.2 ATTACH STRONGBACK TO PAYLOAD
- 2.2B.17.2.3 LOAD PAYLOAD INTO CANISTER

2.3A RECOVERY (SHUTTLE WITH OMS KIT)

- 2.3A.1 DESIGN
- 2.3A.1.1 DEFINE REQUIREMENTS
- 2.3A.1.2 MISSION ANALYSIS
- 2.3A.1.3 PAYLOAD ACCOMMODATIONS
- 2.3A.1.4 CREATE FUNCTIONAL LAYOUT
- 2.3A.1.5 FAILURE MODES ANALYSIS
- 2.3A.1.6 ADJUST DESIGN FOR MAINTENANCE AND REPAIR
- 2.3A.1.7 CREATE MECHANICAL LAYOUT
- 2.3A.1.8 SAFETY REVIEW
- 2.3A.1.9 DESIGN OF COMPONENTS
- 2.3A.1.10 SOFTWARE DEVELOPMENT
- 2.3A.2 COMPONENT FABRICATION
- 2.3A.2.1 PROCURE OFF-THE-SHELF COMPONENTS
- 2.3A.2.2 PROCURE MATERIALS FOR MANUFACTURED COMPONENTS
- 2.3A.2.3 PROCURE MANUFACTURING EQUIPMENT
- 2.3A.2.4 MANUFACTURE COMPONENTS
- 2.3A.3 COMPONENT TEST
- 2.3A.3.1 SET UP TEST FACILITIES
- 2.3A.3.2 STRUCTURAL LOADS TESTS

- 2.3A.9.3 DATA PROCESSING AND SOFTWARE TESTS
 - 2.3A.9.4 SOLAR ARRAY DEPLOYMENT TESTS
 - 2.3A.9.5 ELECTRICAL SYSTEMS TESTS
 - 2.3A.9.6 THERMAL AND VACUUM TESTS
 - 2.3A.9.7 DETECTOR ALIGNMENT TESTS
 - 2.3A.9.8 COMPONENT CERTIFICATION
 - 2.3A.4 SYSTEM INTEGRATION
 - 2.3A.5 SYSTEM TEST
 - 2.3A.5.1 POWER SUBSYSTEM TESTS
 - 2.3A.5.2 THERMAL SUBSYSTEM TESTS
 - 2.3A.5.3 STRUCTURE SUBSYSTEM TESTS
 - 2.3A.5.4 INFORMATION PROCESSING SUBSYSTEM TESTS
 - 2.3A.5.5 COMMUNICATIONS SUBSYSTEM TESTS
 - 2.3A.5.6 ATTITUDE CONTROL SUBSYSTEM TESTS
 - 2.3A.5.7 INTEGRATED SYSTEMS TESTS
 - 2.3A.5.8 FAILURE MODES SIMULATION
 - 2.3A.5.9 SYSTEM CERTIFICATION
 - 2.3A.6 SHIPPING TO LAUNCH SITE
 - 2.3A.6.1 REMOVE TEST EQUIPMENT
 - 2.3A.6.2 PERFORM NECESSARY DISASSEMBLY
 - 2.3A.6.3 PACKING
 - 2.3A.6.4 TRANSPORT TO LAUNCH SITE
 - 2.3A.7 PAYLOAD INTEGRATION AND CHECKOUT
 - 2.3A.7.1 UNPACKING
 - 2.3A.7.2 PERFORM NECESSARY REASSEMBLY
 - 2.3A.7.3 INTEGRATED SYSTEMS TESTS
 - 2.3A.7.3.1 VERIFY POWER SYSTEM FUNCTION
 - 2.3A.7.3.2 VERIFY COMMAND SYSTEM FUNCTION
 - 2.3A.7.3.3 VERIFY MECHANICAL SYSTEM FUNCTION
 - 2.3A.7.3.4 VERIFY COMMUNICATIONS SYSTEM FUNCTION
 - 2.3A.7.3.5 MISSION SEQUENCE SIMULATION
 - 2.3A.7.4 TRANSFER TO OPERATIONS AND CHECKOUT BLDG.
 - 2.3A.7.4.1 LOAD PAYLOAD INTO CONTAINER
 - 2.3A.7.4.2 TRANSPORT TO OPERATIONS AND CHECKOUT BLDG.
 - 2.3A.7.4.3 ATTACH STRONGBACK TO PAYLOAD
 - 2.3A.7.4.4 INSTALL PAYLOAD IN HORIZONTAL CITE
 - 2.3A.7.5 PERFORM INTERFACES CHECK
 - 2.3A.7.5.1 CHECK SHUTTLE/PAYLOAD MECHANICAL INTERFACES
 - 2.3A.7.5.2 CHECK ELECTRICAL INTERFACES
 - 2.3A.7.6 TRANSFER PAYLOAD TO ORBITER PROCESSING FACILITY
 - 2.3A.7.6.1 ATTACH STRONGBACK TO PAYLOAD
 - 2.3A.7.6.2 LOAD PAYLOAD INTO CANISTER
 - 2.3A.7.6.3 REMOVE STRONGBACK
 - 2.3A.7.6.4 CLOSE CANISTER
 - 2.3A.7.6.5 TRANSPORT CANISTER TO ORBITER PROCESSING FACILITY
 - 2.3A.7.7 ORBITER/PAYLOAD INTEGRATION (HORIZONTAL)
 - 2.3A.7.7.1 ATTACH STRONGBACK TO PAYLOAD
 - 2.3A.7.7.2 INSTALL PAYLOAD IN ORBITER
 - 2.3A.7.7.3 CONNECT ORBITER/PAYLOAD INTERFACES
 - 2.3A.7.7.4 CHECK ELECTRICAL INTERFACES
 - 2.3A.7.7.5 INSTALLATION OF OMS KIT
 - 2.3A.7.7.6 CLOSE-OUT PAYLOAD BAY
 - 2.3A.8 COUNTDOWN AND LAUNCH
 - 2.3A.9 ORBITAL DEPLOYMENT AND CHECKOUT
 - 2.3A.10 ORBITAL RENDEZVOUS AND CAPTURE
 - 2.3A.10.1 SHUTTLE ATTAINS RENDEZVOUS ORBIT
 - 2.3A.10.2 RENDEZVOUS WITH AXAF
 - 2.3A.10.2.1 COMPUTE EXPECTED TARGET POSITION
 - 2.3A.10.2.2 ALIGN ORBITER WITH EXPECTED TARGET POSITION
 - 2.3A.10.2.3 DEPLOY RENDEZVOUS SENSOR
 - 2.3A.10.2.4 ACTIVATE RENDEZVOUS SENSOR
 - 2.3A.10.2.5 TRACK TARGET
 - 2.3A.10.2.6 COMPUTE TERMINAL PHASE OMS BURN
 - 2.3A.10.2.7 FIRE THRUSTERS
 - 2.3A.10.3 STABILIZE AXAF FOR RETRIEVAL
 - 2.3A.10.3.1 INITIALIZE GUIDANCE SYSTEM
 - 2.3A.10.3.2 DETERMINE CURRENT ATTITUDE
 - 2.3A.10.3.3 DETERMINE DESIRED ATTITUDE
 - 2.3A.10.3.4 DETERMINE NEW CONFIGURATION FOR SPACECRAFT COMPONENTS
- Update inertial reference system.

Main components are solar arrays and radiators.

- 2.3A.10.3.5 CHOOSE OPTIMAL TRAJECTORY
- 2.3A.10.3.6 ROTATE SPACECRAFT

Use magnetic torquers for attitude control.

- 2.3A.10.3.7 DETERMINE DISTURBING TORQUES
- 2.3A.10.3.8 COMPUTE REQUIRED RESULTANT
- 2.3A.10.3.9 APPLY COMPENSATING TORQUES

Use magnetic torquers.

- 2.3A.10.3.10 SHUTDOWN SPACECRAFT SYSTEMS
- 2.3A.10.4 ATTACH AXAF TO ORBITER
 - 2.3A.10.4.1 MATCH AXAF VELOCITY AND ATTITUDE WITH ORBITER
 - 2.3A.10.4.2 LOCATE GRASPING FIXTURE ON TARGET

The target is AXAF.

- 2.3A.10.4.3 GRASP FIXTURE
- 2.3A.10.4.4 TRANSLATE PAYLOAD TO CRADLE
- 2.3A.10.4.5 FASTEN PAYLOAD RESTRAINTS
- 2.3A.11 SECURE PAYLOAD IN ORBITER
 - 2.3A.11.1 RETRACT DEPLOYABLE PAYLOAD COMPONENTS
 - 2.3A.11.1.1 RETRACT TORSS ANTENNAS
 - 2.3A.11.1.2 LOCATE SUNSHADE RESTRAINTS
 - 2.3A.11.1.3 RELEASE SUNSHADE RESTRAINTS
 - 2.3A.11.1.4 LOCATE GRASPING FIXTURE ON TARGET

The target is the AXAF sunshade.

- 2.3A.11.1.5 GRASP FIXTURE
- 2.3A.11.1.6 CLOSE SUNSHADE
- 2.3A.11.1.7 LOCATE SOLAR ARRAY RESTRAINTS
- 2.3A.11.1.8 RELEASE SOLAR ARRAY RESTRAINTS
- 2.3A.11.1.9 LOCATE GRASPING FIXTURE ON TARGET

The target is the AXAF solar array.

- 2.3A.11.1.10 GRASP FIXTURE
- 2.3A.11.1.11 RETRACT SOLAR ARRAYS
- 2.3A.11.2 RETRACTION OF PAYLOAD INTO PAYLOAD BAY
 - 2.3A.11.2.1 LOCATE GRASPING FIXTURE ON TARGET

The target is AXAF.

- 2.3A.11.2.2 GRASP FIXTURE
- 2.3A.11.2.3 TILT PAYLOAD TO HORIZONTAL POSITION

AXAF is mounted on a tilt-table.

- 2.3A.11.2.4 FASTEN PAYLOAD RESTRAINTS
- 2.3A.11.2.5 CLOSE PAYLOAD BAY DOORS
- 2.3A.12 REENTRY AND LANDING
- 2.3A.13 POST-FLIGHT OPERATIONS
 - 2.3A.13.1 SAFING OF ORBITER
 - 2.3A.13.2 REMOVAL OF PAYLOAD FROM ORBITER
 - 2.3A.13.2.1 OPEN PAYLOAD BAY DOORS
 - 2.3A.13.2.2 ATTACH STRONGBACK TO PAYLOAD
 - 2.3A.13.2.3 LOAD PAYLOAD INTO CANISTER

2.3B RECOVERY (SHUTTLE WITH TMS UPPER STAGE)

- 2.3B.1 DESIGN
 - 2.3B.1.1 DEFINE REQUIREMENTS
 - 2.3B.1.2 MISSION ANALYSIS
 - 2.3B.1.3 PAYLOAD ACCOMMODATIONS
 - 2.3B.1.4 CREATE FUNCTIONAL LAYOUT
 - 2.3B.1.5 FAILURE MODES ANALYSIS
 - 2.3B.1.6 CREATE MECHANICAL LAYOUT
 - 2.3B.1.7 SAFETY REVIEW

- 2.3B.1.8 DESIGN OF COMPONENTS
- 2.3B.1.10 SOFTWARE DEVELOPMENT
- 2.3B.2 COMPONENT FABRICATION
 - 2.3B.2.1 PROCURE OFF-THE-SHELF COMPONENTS
 - 2.3B.2.2 PROCURE MATERIALS FOR MANUFACTURED COMPONENTS
 - 2.3B.2.3 PROCURE MANUFACTURING EQUIPMENT
 - 2.3B.2.4 MANUFACTURE COMPONENTS
- 2.3B.3 COMPONENT TEST
 - 2.3B.3.1 SET UP TEST FACILITIES
 - 2.3B.3.2 STRUCTURAL LOADS TESTS
 - 2.3B.3.3 DATA PROCESSING AND SOFTWARE TESTS
 - 2.3B.3.4 SOLAR ARRAY DEPLOYMENT TESTS
 - 2.3B.3.5 ELECTRICAL SYSTEMS TESTS
 - 2.3B.3.6 THERMAL AND VACUUM TESTS
 - 2.3B.3.7 DETECTOR ALIGNMENT TESTS
 - 2.3B.3.8 THRUSTER TESTS
 - 2.3B.3.9 COMPONENT CERTIFICATION
- 2.3B.4 SYSTEM INTEGRATION
- 2.3B.5 SYSTEM TEST
 - 2.3B.5.1 POWER SUBSYSTEM TESTS
 - 2.3B.5.2 THERMAL SUBSYSTEM TESTS
 - 2.3B.5.3 STRUCTURE SUBSYSTEM TESTS
 - 2.3B.5.4 INFORMATION PROCESSING SUBSYSTEM TESTS
 - 2.3B.5.5 COMMUNICATIONS SUBSYSTEM TESTS
 - 2.3B.5.6 ATTITUDE CONTROL SUBSYSTEM TESTS
 - 2.3B.5.7 OPTICAL SUBSYSTEM TESTS
 - 2.3B.5.8 PROPULSION SUBSYSTEM TESTS
 - 2.3B.5.9 INTEGRATED SYSTEMS TESTS
 - 2.3B.5.10 FAILURE MODES SIMULATION
 - 2.3B.5.11 SYSTEM CERTIFICATION
- 2.3B.6 SHIPPING TO LAUNCH SITE
 - 2.3B.6.1 REMOVE TEST EQUIPMENT
 - 2.3B.6.2 PERFORM NECESSARY DISASSEMBLY
 - 2.3B.6.3 PACKING
 - 2.3B.6.4 TRANSPORT TO LAUNCH SITE
- 2.3B.7 PAYLOAD INTEGRATION AND CHECKOUT
 - 2.3B.7.1 UNPACKING
 - 2.3B.7.2 PERFORM NECESSARY REASSEMBLY
 - 2.3B.7.3 INTEGRATED SYSTEMS TESTS
 - 2.3B.7.3.1 VERIFY POWER SYSTEM FUNCTION
 - 2.3B.7.3.2 VERIFY COMMAND SYSTEM FUNCTION
 - 2.3B.7.3.3 VERIFY MECHANICAL SYSTEM FUNCTION
 - 2.3B.7.3.4 VERIFY COMMUNICATIONS SYSTEM FUNCTION
 - 2.3B.7.3.5 MISSION SEQUENCE SIMULATION
 - 2.3B.7.4 TRANSFER TO OPERATIONS AND CHECKOUT BLDG.
 - 2.3B.7.4.1 LOAD PAYLOAD INTO CONTAINER
 - 2.3B.7.4.2 TRANSPORT TO OPERATIONS AND CHECKOUT BLDG.
 - 2.3B.7.4.3 ATTACH STRONGBACK TO PAYLOAD
 - 2.3B.7.4.4 INSTALL PAYLOAD IN HORIZONTAL SITE
 - 2.3B.7.5 INTEGRATE TMS WITH PAYLOAD
 - 2.3B.7.6 PERFORM INTERFACES CHECK
 - 2.3B.7.6.1 CHECK TMS/PAYLOAD MECHANICAL INTERFACES
 - 2.3B.7.6.2 CHECK SHUTTLE/PAYLOAD MECHANICAL INTERFACES
 - 2.3B.7.6.3 CHECK ELECTRICAL INTERFACES
 - 2.3B.7.7 TRANSFER TMS/PAYLOAD TO ORBITER PROCESSING FACILITY
 - 2.3B.7.7.1 ATTACH STRONGBACK TO PAYLOAD
 - 2.3B.7.7.2 LOAD PAYLOAD INTO CANISTER
 - 2.3B.7.7.3 REMOVE STRONGBACK
 - 2.3B.7.7.4 CLOSE CANISTER
 - 2.3B.7.7.5 TRANSPORT CANISTER TO ORBITER PROCESSING FACILITY
 - 2.3B.7.8 ORBITER/PAYLOAD INTEGRATION (HORIZONTAL)
 - 2.3B.7.8.1 ATTACH STRONGBACK TO PAYLOAD
 - 2.3B.7.8.2 INSTALL PAYLOAD IN ORBITER
 - 2.3B.7.8.3 CONNECT ORBITER/PAYLOAD INTERFACES
 - 2.3B.7.8.4 CHECK ELECTRICAL INTERFACES
 - 2.3B.7.8.5 CLOSE-OUT PAYLOAD BAY
 - 2.3B.7.8.6 INSTALLATION OF ORBITER PAYLOAD STATION CONSOLES
- 2.3B.8 COUNTDOWN AND LAUNCH
- 2.3B.9 ORBITAL RENDEZVOUS AND CAPTURE
 - 2.3B.9.1 SHUTTLE ATTAINS DELIVERY ORBIT
 - 2.3B.9.2 TESTS OF ATTACHED PAYLOAD
 - 2.3B.9.2.1 POWER SUBSYSTEM CHECKOUT

ORIGINAL PLAN
OF POOL OPERATIONS

- 2.3B.9.2.2 INFORMATION PROCESSING SUBSYSTEM CHECKOUT
- 2.3B.9.3 EXTENSION OF PAYLOAD FROM PAYLOAD BAY
 - 2.3B.9.3.1 OPEN PAYLOAD BAY DOORS
 - 2.3B.9.3.2 ACTIVATE RMS
 - 2.3B.9.3.3 LOCATE GRASPING FIXTURE ON TARGET

The target is the TMS.

- 2.3B.9.3.4 MOVE RMS TO FIXTURE
- 2.3B.9.3.5 GRASP FIXTURE
- 2.3B.9.3.6 RELEASE PAYLOAD RESTRAINTS
- 2.3B.9.3.7 TRANSLATE PAYLOAD OUT OF PAYLOAD BAY
- 2.3B.9.4 SEPARATION OF PAYLOAD FROM ORBITER
 - 2.3B.9.4.1 RMS RELEASES PAYLOAD
 - 2.3B.9.4.2 SECURE RMS IN PAYLOAD BAY
- 2.3B.9.5 OPERATIONAL CHECKOUT OF TMS
 - 2.3B.9.5.1 ACTIVATE TMS SUBSYSTEMS
 - 2.3B.9.5.2 INFORMATION PROCESSING SUBSYSTEM CHECKOUT
 - 2.3B.9.5.3 POWER SUBSYSTEM CHECKOUT
 - 2.3B.9.5.4 THERMAL SUBSYSTEM CHECKOUT
 - 2.3B.9.5.5 STRUCTURAL SUBSYSTEM CHECKOUT
 - 2.3B.9.5.6 COMMUNICATIONS SUBSYSTEM CHECKOUT
 - 2.3B.9.5.7 ATTITUDE CONTROL SUBSYSTEM CHECKOUT
 - 2.3B.9.5.8 PROPULSION SUBSYSTEM CHECKOUT
 - 2.3B.9.5.9 CONSUMABLES LEVELS CHECKOUT
- 2.3B.9.6 ORBITAL TRANSFER
 - 2.3B.9.6.1 INITIALIZE GUIDANCE SYSTEM

Update inertial reference system.

- 2.3B.9.6.2 DETERMINE CURRENT ORBITAL PARAMETERS
- 2.3B.9.6.3 DETERMINE DESIRED ORBITAL PARAMETERS
- 2.3B.9.6.4 CHOOSE OPTIMAL TRAJECTORY
- 2.3B.9.6.5 DETERMINE CURRENT ATTITUDE
- 2.3B.9.6.6 DETERMINE DESIRED ATTITUDE
- 2.3B.9.6.7 ROTATE SPACECRAFT

Use magnetic torquers for attitude control.

- 2.3B.9.6.8 FIRE THRUSTERS
- 2.3B.9.7 STABILIZE AXAF FOR RETRIEVAL
 - 2.3B.9.7.1 INITIALIZE GUIDANCE SYSTEM

Update inertial reference system.

- 2.3B.9.7.2 DETERMINE CURRENT ATTITUDE
- 2.3B.9.7.3 DETERMINE DESIRED ATTITUDE
- 2.3B.9.7.4 DETERMINE NEW CONFIGURATION FOR SPACECRAFT COMPONENTS

Main components are solar arrays and radiators.

- 2.3B.9.7.5 CHOOSE OPTIMAL TRAJECTORY
- 2.3B.9.7.6 ROTATE SPACECRAFT

Use magnetic torquers for attitude control.

- 2.3B.9.7.7 DETERMINE DISTURBING TORQUES
- 2.3B.9.7.8 COMPUTE REQUIRED RESULTANT
- 2.3B.9.7.9 APPLY COMPENSATING TORQUES

Use magnetic torquers.

- 2.3B.9.7.10 SHUTDOWN SPACECRAFT SYSTEMS
- 2.3B.9.8 DOCK TMS TO SPACECRAFT
 - 2.3B.9.8.1 LOCATE DOCKING TARGET
 - 2.3B.9.8.2 EXTEND DOCKING MECHANISM
 - 2.3B.9.8.3 FASTEN DOCKING LATCH
- 2.3B.10 RENDEZVOUS WITH ORBITER
 - 2.3B.10.1 ORBITAL TRANSFER (OF TMS/SPACECRAFT)
 - 2.3B.10.1.1 INITIALIZE GUIDANCE SYSTEM

Update inertial reference system.

ORIGINAL PAGE IS
OF POOR QUALITY

- 2.3B.10.1.2 DETERMINE CURRENT ORBITAL PARAMETERS
2.3B.10.1.3 DETERMINE DESIRED ORBITAL PARAMETERS
2.3B.10.1.4 CHOOSE OPTIMAL TRAJECTORY
2.3B.10.1.5 DETERMINE CURRENT ATTITUDE
2.3B.10.1.6 DETERMINE DESIRED ATTITUDE
2.3B.10.1.7 ROTATE SPACECRAFT

Use magnetic torquers for attitude control.

- 2.3B.10.1.8 FIRE THRUSTERS
2.3B.10.2 SHUTDOWN TMS FOR RETRIEVAL
2.3B.10.2.1 STOW TMS ANTENNA
2.3B.10.2.2 DEACTIVATE TMS SUBSYSTEMS
2.3B.11 RETRIEVAL BY ORBITER
2.3B.11.1 ADJUST ORBIT (OF ORBITER)
2.3B.11.1.1 INITIALIZE GUIDANCE SYSTEM

Update inertial reference system.

- 2.3B.11.1.2 DETERMINE CURRENT ORBITAL PARAMETERS
2.3B.11.1.3 DETERMINE DESIRED ORBITAL PARAMETERS
2.3B.11.1.4 CHOOSE OPTIMAL TRAJECTORY
2.3B.11.1.5 FIRE THRUSTERS
2.3B.11.2 ADJUST ATTITUDE (OF ORBITER)
2.3B.11.2.1 DETERMINE CURRENT ATTITUDE
2.3B.11.2.2 DETERMINE DESIRED ATTITUDE
2.3B.11.2.3 DETERMINE NEW CONFIGURATION FOR SPACECRAFT COMPONENTS

Main components are solar arrays and radiators.

- 2.3B.11.2.4 CHOOSE OPTIMAL TRAJECTORY
2.3B.11.2.5 ROTATE SPACECRAFT

Use magnetic torquers for attitude control.

- 2.3B.11.3 OPTIMAL CONTROL ALLOCATION
2.3B.11.3.1 UPDATE SPACECRAFT MODEL
2.3B.11.3.2 PROJECT DESIRED FUNCTIONS FROM MISSION PROFILE
2.3B.11.3.3 ESTIMATE RISKS FROM DESIRED FUNCTIONS
2.3B.11.3.4 PROJECT CONSUMABLES REQUIREMENTS FROM MISSION PROFILE
2.3B.11.3.5 DETERMINE CONSTRAINTS AND FIGURES OF MERIT
2.3B.11.3.6 CHOOSE OPTIMAL CONTROL MODE
2.3B.11.3.7 COMPUTE CONTROL COMMANDS
2.3B.11.3.8 EXECUTE CONTROL COMMANDS
2.3B.11.4 ORBITER RECOVERY OF TMS/SPACECRAFT
2.3B.11.4.1 ACTIVATE RMS
2.3B.11.4.2 LOCATE GRASPING FIXTURE ON TARGET

The target is AXAF+TMS.

- 2.3B.11.4.3 MOVE RMS TO FIXTURE
2.3B.11.4.4 GRASP FIXTURE
2.3B.11.4.5 LOCATE CRADLE IN PAYLOAD BAY
2.3B.11.4.6 TRANSLATE PAYLOAD TO CRADLE
2.3B.11.4.7 FASTEN PAYLOAD RESTRAINTS
2.3B.11.4.8 RMS RELEASES PAYLOAD
2.3B.11.4.9 SECURE RMS IN PAYLOAD BAY
2.3B.12 REENTRY AND LANDING
2.3B.13 POST-FLIGHT OPERATIONS
2.3B.13.1 SAFING OF ORBITER
2.3B.13.2 REMOVAL OF PAYLOAD FROM ORBITER
2.3B.13.2.1 OPEN PAYLOAD BAY DOORS
2.3B.13.2.2 ATTACH STRONGBACK TO PAYLOAD
2.3B.13.2.3 LOAD PAYLOAD INTO CANISTER

2.A.4:

TELEOPERATOR MANEUVERING SYSTEM

The primary information for this breakdown came from the following sources: Teleoperator Maneuvering System Study/Mission Requirements and System Definition Study/Review, April 7, 1981, July 22, 1981, and May 11, 1982; Vought Corporation TMS Design Information Release, September 19, 1980; MSFC's Remote Satellite Services Program/Program Planning Summary, February 1981; Teleoperator Maneuvering System Study/Mission Requirements and System Definition Study (Volume II-Technical Report), May 11, 1982.

3 TELEOPERATOR MANEUVERING SYSTEM

3.1A SPACECRAFT TRANSFER (DEPLOYMENT)

This mission is the deployment option of the more general spacecraft transfer mission. The TMS is used to transfer a spacecraft from the Orbiter to its intended orbit.

3.1A.1 DESIGN

3.1A.1.1 DEFINE REQUIREMENTS

TMS subsystem requirements include communications, viewing, docking, guidance and control, propulsion, power, and environmental subsystems.

3.1A.1.2 MISSION ANALYSIS

3.1A.1.3 PAYLOAD ACCOMODATIONS

3.1A.1.4 CREATE FUNCTIONAL LAYOUT

3.1A.1.5 FAILURE MODES ANALYSIS

3.1A.1.6 ADJUST DESIGN FOR MAINTAINANCE AND REPAIR

3.1A.1.7 CREATE MECHANICAL LAYOUT

3.1A.1.8 SAFETY REVIEW

3.1A.1.9 DESIGN OF COMPONENTS

3.1A.1.10 SOFTWARE DEVELOPMENT

3.1A.2 COMPONENT FABRICATION

3.1A.2.1 PROCURE OFF-THE-SHELF COMPONENTS

3.1A.2.2 PROCURE MATERIALS FOR MANUFACTURED COMPONENTS

3.1A.2.3 PROCURE MANUFACTURING EQUIPMENT

3.1A.2.4 MANUFACTURE COMPONENTS

3.1A.3 COMPONENT TEST

3.1A.3.1 SET UP TEST FACILITIES

3.1A.3.2 STRUCTURAL LOADS TESTS

3.1A.3.3 DATA PROCESSING AND SOFTWARE TESTS

3.1A.3.4 ANTENNA AND ARRAY DEPLOYMENT TESTS

3.1A.3.5 ELECTRICAL SYSTEMS TESTS

3.1A.3.6 THERMAL AND VACUUM TESTS

3.1A.3.7 THRUSTER TESTS

3.1A.3.8 COMPONENT CERTIFICATION

3.1A.4 SYSTEM INTEGRATION

3.1A.5 SYSTEM TEST

3.1A.5.1 POWER SUBSYSTEM TESTS

3.1A.5.2 THERMAL SUBSYSTEM TESTS

3.1A.5.3 STRUCTURE SUBSYSTEM TESTS

3.1A.5.4 INFORMATION PROCESSING SUBSYSTEM TESTS

3.1A.5.5 COMMUNICATIONS SUBSYSTEM TESTS

3.1A.5.6 ATTITUDE CONTROL SUBSYSTEM TESTS

3.1A.5.7 PROPULSION SUBSYSTEM TESTS

3.1A.5.8 INTEGRATED SYSTEMS TESTS

3.1A.5.9 FAILURE MODES SIMULATION

3.1A.5.10 SYSTEM CERTIFICATION

3.1A.6 SHIPPING TO LAUNCH SITE

3.1A.6.1 REMOVE TEST EQUIPMENT

3.1A.6.2 PERFORM NECESSARY DISASSEMBLY

3.1A.6.3 PACKING

3.1A.6.4 TRANSPORT TO LAUNCH SITE

3.1A.7A PAYLOAD INTEGRATION AND CHECKOUT (HORIZONTAL PAYLOAD)

The integration attitude of the TMS will depend upon the payload carried by the TMS. Horizontal integration will be used for a horizontal payload.

3.1A.7A.1 UNPACKING

3.1A.7A.2 PERFORM NECESSARY REASSEMBLY

3.1A.7A.3 INTEGRATED SYSTEMS TESTS

3.1A.7A.3.1 VERIFY POWER SYSTEM FUNCTION

ORIGINAL PAGE IS
OF POOR QUALITY

- 3.1A.7A.3.2 VERIFY COMMAND SYSTEM FUNCTION
- 3.1A.7A.3.3 VERIFY MECHANICAL SYSTEM FUNCTION
- 3.1A.7A.3.4 VERIFY COMMUNICATIONS SYSTEM FUNCTION
- 3.1A.7A.3.5 MISSION SEQUENCE SIMULATION
- 3.1A.7A.4 TRANSFER TO OPERATIONS AND CHECKOUT BLDG.
 - 3.1A.7A.4.1 LOAD PAYLOAD INTO CONTAINER
 - 3.1A.7A.4.2 TRANSPORT TO OPERATIONS AND CHECKOUT BLDG.
 - 3.1A.7A.4.3 ATTACH STRONGBACK TO PAYLOAD
 - 3.1A.7A.4.4 INSTALL PAYLOAD IN HORIZONTAL CITE
- 3.1A.7A.5 INTEGRATE TMS WITH PAYLOAD
- 3.1A.7A.6 PERFORM INTERFACES CHECK
 - 3.1A.7A.6.1 CHECK TMS/PAYLOAD MECHANICAL INTERFACES
 - 3.1A.7A.6.2 CHECK ELECTRICAL INTERFACES
 - 3.1A.7A.6.3 CHECK SHUTTLE/PAYLOAD MECHANICAL INTERFACES
 - 3.1A.7A.6.4 CHECK ELECTRICAL INTERFACES
- 3.1A.7A.7 TRANSFER TMS/PAYLOAD TO ORBITER PROCESSING FACILITY
 - 3.1A.7A.7.1 ATTACH STRONGBACK TO PAYLOAD
 - 3.1A.7A.7.2 LOAD PAYLOAD INTO CANISTER
 - 3.1A.7A.7.3 REMOVE STRONGBACK
 - 3.1A.7A.7.4 CLOSE CANISTER
 - 3.1A.7A.7.5 TRANSPORT CANISTER TO ORBITER PROCESSING FACILITY
 - 3.1A.7A.7.6 UNLOAD CANISTER
- 3.1A.7A.8 ORBITER/PAYLOAD INTEGRATION (HORIZONTAL)
 - 3.1A.7A.8.1 ATTACH STRONGBACK TO PAYLOAD
 - 3.1A.7A.8.2 INSTALL PAYLOAD IN ORBITER
 - 3.1A.7A.8.3 CONNECT ORBITER/PAYLOAD INTERFACES
 - 3.1A.7A.8.4 CHECK ELECTRICAL INTERFACES
 - 3.1A.7A.8.5 REMOVE STRONGBACK
 - 3.1A.7A.8.6 CLOSE-OUT PAYLOAD BAY
 - 3.1A.7A.8.7 INSTALLATION OF ORBITER PAYLOAD STATION CONSOLES
- 3.1A.7B PAYLOAD INTEGRATION AND CHECKOUT (VERTICAL PAYLOAD)

The integration attitude of the TMS will depend upon the payload carried by the TMS. Vertical integration will be used for a vertical payload.

- 3.1A.7B.1 UNPACKING
- 3.1A.7B.2 PERFORM NECESSARY REASSEMBLY
- 3.1A.7B.3 INTEGRATED SYSTEMS TESTS
 - 3.1A.7B.3.1 VERIFY POWER SYSTEM FUNCTION
 - 3.1A.7B.3.2 VERIFY COMMAND SYSTEM FUNCTION
 - 3.1A.7B.3.3 VERIFY MECHANICAL SYSTEM FUNCTION
 - 3.1A.7B.3.4 VERIFY COMMUNICATIONS SYSTEM FUNCTION
 - 3.1A.7B.3.5 MISSION SEQUENCE SIMULATION
- 3.1A.7B.4 TRANSFER TO VERTICAL PROCESSING FACILITY
 - 3.1A.7B.4.1 LOAD PAYLOAD INTO CONTAINER
 - 3.1A.7B.4.2 TRANSPORT CONTAINER TO VERTICAL PROCESSING FACILITY
 - 3.1A.7B.4.3 UNLOAD CONTAINER
- 3.1A.7B.5 INTEGRATE TMS WITH PAYLOAD
- 3.1A.7B.6 PERFORM INTERFACES CHECK
 - 3.1A.7B.6.1 CHECK TMS/PAYLOAD MECHANICAL INTERFACES
 - 3.1A.7B.6.2 CHECK ELECTRICAL INTERFACES
 - 3.1A.7B.6.3 CHECK SHUTTLE/PAYLOAD MECHANICAL INTERFACES
 - 3.1A.7B.6.4 CHECK ELECTRICAL INTERFACES
- 3.1A.7B.7 TRANSFER PAYLOAD TO LAUNCH PAD
 - 3.1A.7B.7.1 LOAD PAYLOAD INTO CANISTER
 - 3.1A.7B.7.2 TRANSPORT TO ROTATING SERVICE STRUCTURE
 - 3.1A.7B.7.3 LOAD CANISTER INTO ROTATING SERVICE STRUCTURE
 - 3.1A.7B.7.4 LOAD PAYLOAD INTO ROTATING SERVICE STRUCTURE USING PGHM
 - 3.1A.7B.7.5 REMOVE CANISTER
- 3.1A.7B.8 ORBITER/PAYLOAD INTEGRATION (VERTICAL)
 - 3.1A.7B.8.1 MATE ROTATING SERVICE STRUCTURE TO ORBITER
 - 3.1A.7B.8.2 EXTEND PAYLOAD INTO ORBITER USING PGHM
 - 3.1A.7B.8.3 CONNECT ORBITER/PAYLOAD INTERFACES
 - 3.1A.7B.8.4 CHECK ELECTRICAL INTERFACES
 - 3.1A.7B.8.5 CLOSE-OUT PAYLOAD BAY
 - 3.1A.7B.8.6 INSTALLATION OF ORBITER PAYLOAD STATION CONSOLES
- 3.1A.8 COUNTDOWN AND LAUNCH
- 3.1A.9 ORBITAL DEPLOYMENT AND CHECKOUT
 - 3.1A.9.1 SHUTTLE ATTAINS DELIVERY ORBIT
 - 3.1A.9.2 TESTS OF ATTACHED PAYLOAD

In these sequences, the "payload" is the TMS mated with its payload.

- 3.1A.9.2.1 POWER SUBSYSTEM CHECKOUT
- 3.1A.9.2.2 INFORMATION PROCESSING SUBSYSTEM CHECKOUT
- 3.1A.9.3 EXTENSION OF PAYLOAD FROM PAYLOAD BAY
 - 3.1A.9.3.1 OPEN PAYLOAD BAY DOORS
 - 3.1A.9.3.2 ACTIVATE RMS
 - 3.1A.9.3.3 LOCATE GRASPING FIXTURE ON TARGET
 - 3.1A.9.3.4 MOVE RMS TO FIXTURE
 - 3.1A.9.3.5 GRASP FIXTURE
 - 3.1A.9.3.6 RELEASE PAYLOAD RESTRAINTS
 - 3.1A.9.3.7 TRANSLATE PAYLOAD OUT OF PAYLOAD BAY
- 3.1A.9.4 SEPARATION OF PAYLOAD FROM ORBITER
 - 3.1A.9.4.1 RMS RELEASES PAYLOAD
 - 3.1A.9.4.2 SECURE RMS IN PAYLOAD BAY
- 3.1A.9.5 OPERATIONAL CHECKOUT

Checkout of the TMS on-orbit.

- 3.1A.9.5.1 ACTIVATE TMS SUBSYSTEMS
- 3.1A.9.5.2 INFORMATION PROCESSING SUBSYSTEM CHECKOUT
- 3.1A.9.5.3 POWER SUBSYSTEM CHECKOUT
- 3.1A.9.5.4 THERMAL SUBSYSTEM CHECKOUT
- 3.1A.9.5.5 STRUCTURAL SUBSYSTEM CHECKOUT
- 3.1A.9.5.6 COMMUNICATIONS SUBSYSTEM CHECKOUT
- 3.1A.9.5.7 ATTITUDE CONTROL SUBSYSTEM CHECKOUT
- 3.1A.9.5.8 PROPULSION SUBSYSTEM CHECKOUT
- 3.1A.9.5.9 CONSUMABLES LEVELS CHECKOUT
- 3.1A.9.6 IDENTIFY DEFECTIVE COMPONENT
 - 3.1A.9.6.1 DETERMINE ANOMALOUS DATA
 - 3.1A.9.6.2 FORM HYPOTHESIS FOR PROBLEM
 - 3.1A.9.6.3 DEVISE TEST FOR FAILURE HYPOTHESIS
 - 3.1A.9.6.4 PERFORM TEST FOR FAILURE HYPOTHESIS
 - 3.1A.9.6.5 IDENTIFY FAULTY COMPONENT
- 3.1A.9.7 IDENTIFY DEFECTIVE SOFTWARE
 - 3.1A.9.7.1 COMPARE MEASURED DATA TO MODEL
 - 3.1A.9.7.2 DETERMINE ANOMALOUS DATA
 - 3.1A.9.7.3 FORM HYPOTHESIS FOR PROBLEM
 - 3.1A.9.7.4 DEVISE TEST FOR FAILURE HYPOTHESIS
 - 3.1A.9.7.5 PERFORM TEST FOR FAILURE HYPOTHESIS
- 3.1A.9.8A COMPONENT FAILURE RECOVERY (REDUNDANCY)
 - 3.1A.9.8A.1 SWITCH OUT FAULTY COMPONENT
 - 3.1A.9.8A.2 SWITCH IN REDUNDANT COMPONENT
 - 3.1A.9.8A.3 MAKE DIAGNOSTIC CHECKS
 - 3.1A.9.8A.4 UPDATE SPACECRAFT MODEL
- 3.1A.9.8B COMPONENT FAILURE RECOVERY (ON-BOARD REPAIR)

This on-board repair might be done by a TMS manipulator.

- 3.1A.9.8B.1 DEFINE ACCESS SEQUENCE
- 3.1A.9.8B.2 LOCATE ACCESS PANEL
- 3.1A.9.8B.3 TRANSFER REPAIR EQUIPMENT TO REPAIR SITE
- 3.1A.9.8B.4 OPEN ACCESS PANEL
- 3.1A.9.8B.5 OBSERVE/LOCATE DEFECTIVE COMPONENT
- 3.1A.9.8B.6 REMOVE COMPONENT
- 3.1A.9.8B.7 STORE COMPONENT
- 3.1A.9.8B.8 LOCATE NEW COMPONENT
- 3.1A.9.8B.9 POSITION AND CONNECT NEW COMPONENT
- 3.1A.9.8B.10 ADJUST COMPONENT
- 3.1A.9.8B.11 MAKE DIAGNOSTIC CHECKS
- 3.1A.9.8B.12 CLOSE ACCESS PANEL
- 3.1A.9.8B.13 STOW REPAIR EQUIPMENT
- 3.1A.9.8B.14 UPDATE SPACECRAFT MODEL
- 3.1A.9.9 SOFTWARE FAILURE RECOVERY
 - 3.1A.9.9.1 DETERMINE CORRECTION ALGORITHM
 - 3.1A.9.9.2 DATA/COMMAND ENCODING
 - 3.1A.9.9.3 DATA/COMMAND TRANSMISSION
 - 3.1A.9.9.4 COMPUTER FUNCTION CHECKS
- 3.1A.9.10 ORBITAL TRANSFER (OF TMS/SPACECRAFT)
 - 3.1A.9.10.1 INITIALIZE GUIDANCE SYSTEM
 - 3.1A.9.10.2 DETERMINE CURRENT ORBITAL PARAMETERS

Current orbital parameters might be determined from Orbiter telemetry.

a GPS receiver, or internal memory.

- 3.1A.9.10.3 DETERMINE DESIRED ORBITAL PARAMETERS
- 3.1A.9.10.4 CHOOSE OPTIMAL TRAJECTORY

This would likely be done before the flight, but could be updated once the TMS was on-orbit.

- 3.1A.9.10.5 DETERMINE CURRENT ATTITUDE
- 3.1A.9.10.6 DETERMINE DESIRED ATTITUDE
- 3.1A.9.10.7 ROTATE SPACECRAFT
- 3.1A.9.10.8 FIRE THRUSTERS
- 3.1A.9.11 UNDOCK TMS FROM PAYLOAD
 - 3.1A.9.11.1 RELEASE DOCKING LATCH
 - 3.1A.9.11.2 RETRACT DOCKING MECHANISM
 - 3.1A.9.11.3 MOVE AWAY FROM PAYLOAD

This would have to be done carefully, to avoid thruster impingement upon the spacecraft being deployed.

- 3.1A.9.12 OPERATIONAL CHECKOUT AND ATTITUDE ADJUSTMENT OF SPACECRAFT

This is probably not a TMS function, although the TMS could be used as a telemetry link.

- 3.1A.10 STATUS MONITORING AND RESOURCE ALLOCATION

This sequence is performed in parallel with other on-orbit operational sequences.

- 3.1A.10.1 TEMPERATURE MANAGEMENT
 - 3.1A.10.1.1 MEASURE COMPONENT TEMPERATURES
 - 3.1A.10.1.2 COMPARE TEMPERATURES TO REQUIRED LIMITS
 - 3.1A.10.1.3 ADJUST COOLING/HEATING SYSTEMS
- 3.1A.10.2 POWER MANAGEMENT
 - 3.1A.10.2.1 MEASURE CURRENTS AND VOLTAGES
 - 3.1A.10.2.2 COMPARE CURRENTS AND VOLTAGES TO REQUIRED LIMITS
 - 3.1A.10.2.3 ADJUST CURRENTS AND VOLTAGES
 - 3.1A.10.2.4 MONITOR BATTERIES
- 3.1A.10.3 DATA/COMMAND PROCESSING
 - 3.1A.10.3.1 SHORT-TERM MEMORY STORAGE
 - 3.1A.10.3.2 LONG-TERM MEMORY STORAGE
 - 3.1A.10.3.3 DATA/COMMAND ENCODING
 - 3.1A.10.3.4 DATA/COMMAND DECODING
 - 3.1A.10.3.5 NUMERICAL COMPUTATION
 - 3.1A.10.3.6 LOGIC OPERATIONS
 - 3.1A.10.3.7 COMPUTER LOAD SCHEDULING
 - 3.1A.10.3.8 COMPUTER FUNCTION CHECKS
- 3.1A.10.4 CONSUMABLES MANAGEMENT
 - 3.1A.10.4.1 MONITOR PROPELLANT SUPPLIES
 - 3.1A.10.4.2 PROJECT CONSUMABLES REQUIREMENTS FROM MISSION PROFILE
 - 3.1A.10.4.3 COMPUTE OPTIMAL CONSUMABLES ALLOCATION
- 3.1A.10.5 STRUCTURAL MANAGEMENT
 - 3.1A.10.5.1 MEASURE STRAINS IN STRUCTURE
 - 3.1A.10.5.2 COMPUTE STRESS AND VIBRATION PARAMETERS
 - 3.1A.10.5.3 COMPARE STRESS AND VIBRATION PARAMETERS TO REQUIRED LIMITS
 - 3.1A.10.5.4 APPLY COMPENSATING FORCES
 - 3.1A.10.5.5 APPLY VIBRATION DAMPING
- 3.1A.10.6 HAZARD AVOIDANCE
 - 3.1A.10.6.1 AVOID TANK OVERPRESSURES
 - 3.1A.10.6.2 MAINTAIN SAFE BATTERY CHARGE LEVELS
 - 3.1A.10.6.3 MAINTAIN COMMUNICATION LINKS
 - 3.1A.10.6.4 AVOID EXPOSING SENSITIVE COMPONENTS TO DIRECT SUNLIGHT
 - 3.1A.10.6.5 TRACK NEARBY OBJECTS
 - 3.1A.10.6.6 AVOID CONFLICTING OBJECTS
- 3.1A.10.7 OPTIMAL SEQUENCING
 - 3.1A.10.7.1 UPDATE SPACECRAFT MODEL
 - 3.1A.10.7.2 PROJECT DESIRED FUNCTIONS FROM MISSION PROFILE
 - 3.1A.10.7.3 ESTIMATE RISKS FROM DESIRED FUNCTIONS
 - 3.1A.10.7.4 PROJECT CONSUMABLES REQUIREMENTS FROM MISSION PROFILE
 - 3.1A.10.7.5 DETERMINE CONSTRAINTS AND FIGURES OF MERIT
 - 3.1A.10.7.6 COMPUTE OPTIMAL SEQUENCING

- 3.1A.10.8 IDENTIFY DEFECTIVE COMPONENT
 - 3.1A.10.8.1 DETERMINE ANOMALOUS DATA
 - 3.1A.10.8.2 FORM HYPOTHESIS FOR PROBLEM
 - 3.1A.10.8.3 DEVISE TEST FOR FAILURE HYPOTHESIS
 - 3.1A.10.8.4 PERFORM TEST FOR FAILURE HYPOTHESIS
 - 3.1A.10.8.5 IDENTIFY FAULTY COMPONENT
- 3.1A.10.9 IDENTIFY DEFECTIVE SOFTWARE
 - 3.1A.10.9.1 COMPARE MEASURED DATA TO MODEL
 - 3.1A.10.9.2 DETERMINE ANOMALOUS DATA
 - 3.1A.10.9.3 FORM HYPOTHESIS FOR PROBLEM
 - 3.1A.10.9.4 DEVISE TEST FOR FAILURE HYPOTHESIS
 - 3.1A.10.9.5 PERFORM TEST FOR FAILURE HYPOTHESIS
- 3.1A.10.10A COMPONENT FAILURE RECOVERY (REDUNDANCY)
 - 3.1A.10.10A.1 SWITCH OUT FAULTY COMPONENT
 - 3.1A.10.10A.2 SWITCH IN REDUNDANT COMPONENT
 - 3.1A.10.10A.3 MAKE DIAGNOSTIC CHECKS
 - 3.1A.10.10A.4 UPDATE SPACECRAFT MODEL
- 3.1A.10.10B COMPONENT FAILURE RECOVERY (ON-BOARD REPAIR)
 - 3.1A.10.10B.1 DEFINE ACCESS SEQUENCE
 - 3.1A.10.10B.2 LOCATE ACCESS PANEL
 - 3.1A.10.10B.3 TRANSFER REPAIR EQUIPMENT TO REPAIR SITE
 - 3.1A.10.10B.4 OPEN ACCESS PANEL
 - 3.1A.10.10B.5 OBSERVE/LOCATE DEFECTIVE COMPONENT
 - 3.1A.10.10B.6 REMOVE COMPONENT
 - 3.1A.10.10B.7 STORE COMPONENT
 - 3.1A.10.10B.8 LOCATE NEW COMPONENT
 - 3.1A.10.10B.9 POSITION AND CONNECT NEW COMPONENT
 - 3.1A.10.10B.10 ADJUST COMPONENT
 - 3.1A.10.10B.11 MAKE DIAGNOSTIC CHECKS
 - 3.1A.10.10B.12 CLOSE ACCESS PANEL
 - 3.1A.10.10B.13 STOW REPAIR EQUIPMENT
 - 3.1A.10.10B.14 UPDATE SPACECRAFT MODEL
- 3.1A.10.11 SOFTWARE FAILURE RECOVERY
 - 3.1A.10.11.1 DETERMINE CORRECTION ALGORITHM
 - 3.1A.10.11.2 DATA/COMMAND ENCODING
 - 3.1A.10.11.3 DATA/COMMAND TRANSMISSION
 - 3.1A.10.11.4 COMPUTER FUNCTION CHECKS
- 3.1A.10.12 REPORT SYSTEM STATUS
 - 3.1A.10.12.1 DATA/COMMAND ENCODING
 - 3.1A.10.12.2 DATA/COMMAND TRANSMISSION
 - 3.1A.10.12.3 DATA/COMMAND DECODING
 - 3.1A.10.12.4 DATA/COMMAND DISPLAY
- 3.1A.11 RENDEZVOUS WITH ORBITER
 - 3.1A.11.1 ORBITAL TRANSFER (OF TMS)
 - 3.1A.11.1.1 INITIALIZE GUIDANCE SYSTEM
 - 3.1A.11.1.2 DETERMINE CURRENT ORBITAL PARAMETERS
 - 3.1A.11.1.3 DETERMINE DESIRED ORBITAL PARAMETERS
 - 3.1A.11.1.4 CHOOSE OPTIMAL TRAJECTORY
 - 3.1A.11.1.5 DETERMINE CURRENT ATTITUDE
 - 3.1A.11.1.6 DETERMINE DESIRED ATTITUDE
 - 3.1A.11.1.7 ROTATE SPACECRAFT
 - 3.1A.11.1.8 FIRE THRUSTERS
 - 3.1A.11.2 SHUTDOWN TMS FOR RETRIEVAL
 - 3.1A.11.2.1 STOW TMS ANTENNA
 - 3.1A.11.2.2 DEACTIVATE TMS SUBSYSTEMS
- 3.1A.12 RETRIEVAL BY ORBITER
 - 3.1A.12.1 ADJUST ORBIT (OF ORBITER)
 - 3.1A.12.1.1 INITIALIZE GUIDANCE SYSTEM
 - 3.1A.12.1.2 DETERMINE CURRENT ORBITAL PARAMETERS
 - 3.1A.12.1.3 DETERMINE DESIRED ORBITAL PARAMETERS
 - 3.1A.12.1.4 CHOOSE OPTIMAL TRAJECTORY
 - 3.1A.12.1.5 FIRE THRUSTERS
 - 3.1A.12.2 ADJUST ATTITUDE (OF ORBITER)
 - 3.1A.12.2.1 DETERMINE CURRENT ATTITUDE
 - 3.1A.12.2.2 DETERMINE DESIRED ATTITUDE
 - 3.1A.12.2.3 DETERMINE NEW CONFIGURATION FOR SPACECRAFT COMPONENTS
 - 3.1A.12.2.4 CHOOSE OPTIMAL TRAJECTORY
 - 3.1A.12.2.5 ROTATE SPACECRAFT
 - 3.1A.12.3 OPTIMAL CONTROL ALLOCATION
 - 3.1A.12.3.1 UPDATE SPACECRAFT MODEL
 - 3.1A.12.3.2 PROJECT DESIRED FUNCTIONS FROM MISSION PROFILE
 - 3.1A.12.3.3 ESTIMATE RISKS FROM DESIRED FUNCTIONS

- 3.1A.12.3.4 PROJECT CONSUMABLES REQUIREMENTS FROM MISSION PROFILE
- 3.1A.12.3.5 DETERMINE CONSTRAINTS AND FIGURES OF MERIT
- 3.1A.12.3.6 CHOOSE OPTIMAL CONTROL MODE
- 3.1A.12.3.7 COMPUTE CONTROL COMMANDS
- 3.1A.12.3.8 EXECUTE CONTROL COMMANDS
- 3.1A.12.4 ORBITER RECOVERY OF TMS
 - 3.1A.12.4.1 ACTIVATE RMS
 - 3.1A.12.4.2 LOCATE GRASPING FIXTURE ON TARGET
 - 3.1A.12.4.3 MOVE RMS TO FIXTURE
 - 3.1A.12.4.4 GRASP FIXTURE
 - 3.1A.12.4.5 LOCATE CRADLE IN PAYLOAD BAY
 - 3.1A.12.4.6 TRANSLATE PAYLOAD TO CRADLE
 - 3.1A.12.4.7 FASTEN PAYLOAD RESTRAINTS
 - 3.1A.12.4.8 RMS RELEASES PAYLOAD
 - 3.1A.12.4.9 SECURE RMS IN PAYLOAD BAY
- 3.1A.13 REENTRY AND LANDING
- 3.1A.14 POST-FLIGHT OPERATIONS
 - 3.1A.14.1 SAFING OF ORBITER AND HAZARDOUS PAYLOADS
 - 3.1A.14.2 REMOVAL OF PAYLOADS FROM ORBITER

3.1B SPACECRAFT TRANSFER (RETRIEVAL)

This is the retrieval option of the spacecraft transfer mission. In this mission, the TMS is deployed to retrieve a spacecraft and return it to the Orbiter.

- 3.1B.1 DESIGN
 - 3.1B.1.1 DEFINE REQUIREMENTS
 - 3.1B.1.2 MISSION ANALYSIS
 - 3.1B.1.3 PAYLOAD ACCOMODATIONS
 - 3.1B.1.4 CREATE FUNCTIONAL LAYOUT
 - 3.1B.1.5 FAILURE MODES ANALYSIS
 - 3.1B.1.6 ADJUST DESIGN FOR MAINTAINANCE AND REPAIR
 - 3.1B.1.7 CREATE MECHANICAL LAYOUT
 - 3.1B.1.8 SAFETY REVIEW
 - 3.1B.1.9 DESIGN OF COMPONENTS
 - 3.1B.1.10 SOFTWARE DEVELOPMENT
- 3.1B.2 COMPONENT FABRICATION
 - 3.1B.2.1 PROCURE OFF-THE-SHELF COMPONENTS
 - 3.1B.2.2 PROCURE MATERIALS FOR MANUFACTURED COMPONENTS
 - 3.1B.2.3 PROCURE MANUFACTURING EQUIPMENT
 - 3.1B.2.4 MANUFACTURE COMPONENTS
- 3.1B.3 COMPONENT TEST
 - 3.1B.3.1 SET UP TEST FACILITIES
 - 3.1B.3.2 STRUCTURAL LOADS TESTS
 - 3.1B.3.3 DATA PROCESSING AND SOFTWARE TESTS
 - 3.1B.3.4 ANTENNA AND ARRAY DEPLOYMENT TESTS
 - 3.1B.3.5 ELECTRICAL SYSTEMS TESTS
 - 3.1B.3.6 THERMAL AND VACUUM TESTS
 - 3.1B.3.7 THRUSTER TESTS
 - 3.1B.3.8 COMPONENT CERTIFICATION
- 3.1B.4 SYSTEM INTEGRATION
- 3.1B.5 SYSTEM TEST
 - 3.1B.5.1 POWER SUBSYSTEM TESTS
 - 3.1B.5.2 THERMAL SUBSYSTEM TESTS
 - 3.1B.5.3 STRUCTURE SUBSYSTEM TESTS
 - 3.1B.5.4 INFORMATION PROCESSING SUBSYSTEM TESTS
 - 3.1B.5.5 COMMUNICATIONS SUBSYSTEM TESTS
 - 3.1B.5.6 ATTITUDE CONTROL SUBSYSTEM TESTS
 - 3.1B.5.7 PROPULSION SUBSYSTEM TESTS
 - 3.1B.5.8 INTEGRATED SYSTEMS TESTS
 - 3.1B.5.9 FAILURE MODES SIMULATION
 - 3.1B.5.10 SYSTEM CERTIFICATION
- 3.1B.6 SHIPPING TO LAUNCH SITE
 - 3.1B.6.1 REMOVE TEST EQUIPMENT
 - 3.1B.6.2 PERFORM NECESSARY DISASSEMBLY
 - 3.1B.6.3 PACKING
 - 3.1B.6.4 TRANSPORT TO LAUNCH SITE
- 3.1B.7A PAYLOAD INTEGRATION AND CHECKOUT (HORIZONTAL PAYLOAD)
 - 3.1B.7A.1 UNPACKING
 - 3.1B.7A.2 PERFORM NECESSARY REASSEMBLY
 - 3.1B.7A.3 INTEGRATED SYSTEMS TESTS

- 3.1B.7A.3.1 VERIFY POWER SYSTEM FUNCTION
- 3.1B.7A.3.2 VERIFY COMMAND SYSTEM FUNCTION
- 3.1B.7A.3.3 VERIFY MECHANICAL SYSTEM FUNCTION
- 3.1B.7A.3.4 VERIFY COMMUNICATIONS SYSTEM FUNCTION
- 3.1B.7A.3.5 MISSION SEQUENCE SIMULATION
- 3.1B.7A.4 TRANSFER TO OPERATIONS AND CHECKOUT BLDG.
 - 3.1B.7A.4.1 LOAD PAYLOAD INTO CONTAINER
 - 3.1B.7A.4.2 TRANSPORT TO OPERATIONS AND CHECKOUT BLDG.
 - 3.1B.7A.4.3 ATTACH STRONGBACK TO PAYLOAD
 - 3.1B.7A.4.4 INSTALL PAYLOAD IN HORIZONTAL CITE
- 3.1B.7A.5 INTEGRATE TMS WITH PAYLOAD
- 3.1B.7A.6 PERFORM INTERFACES CHECK
 - 3.1B.7A.6.1 CHECK TMS/PAYLOAD MECHANICAL INTERFACES
 - 3.1B.7A.6.2 CHECK ELECTRICAL INTERFACES
 - 3.1B.7A.6.3 CHECK SHUTTLE/PAYLOAD MECHANICAL INTERFACES
 - 3.1B.7A.6.4 CHECK ELECTRICAL INTERFACES
- 3.1B.7A.7 TRANSFER TMS/PAYLOAD TO ORBITER PROCESSING FACILITY
 - 3.1B.7A.7.1 ATTACH STRONGBACK TO PAYLOAD
 - 3.1B.7A.7.2 LOAD PAYLOAD INTO CANISTER
 - 3.1B.7A.7.3 REMOVE STRONGBACK
 - 3.1B.7A.7.4 CLOSE CANISTER
 - 3.1B.7A.7.5 TRANSPORT CANISTER TO ORBITER PROCESSING FACILITY
 - 3.1B.7A.7.6 UNLOAD CANISTER
- 3.1B.7A.8 ORBITER/PAYLOAD INTEGRATION (HORIZONTAL)
 - 3.1B.7A.8.1 ATTACH STRONGBACK TO PAYLOAD
 - 3.1B.7A.8.2 INSTALL PAYLOAD IN ORBITER
 - 3.1B.7A.8.3 CONNECT ORBITER/PAYLOAD INTERFACES
 - 3.1B.7A.8.4 CHECK ELECTRICAL INTERFACES
 - 3.1B.7A.8.5 REMOVE STRONGBACK
 - 3.1B.7A.8.6 CLOSE-OUT PAYLOAD BAY
 - 3.1B.7A.8.7 INSTALLATION OF ORBITER PAYLOAD STATION CONSOLES
- 3.1B.7B PAYLOAD INTEGRATION AND CHECKOUT* (VERTICAL PAYLOAD)
 - 3.1B.7B.1 UNPACKING
 - 3.1B.7B.2 PERFORM NECESSARY REASSEMBLY
 - 3.1B.7B.3 INTEGRATED SYSTEMS TESTS
 - 3.1B.7B.3.1 VERIFY POWER SYSTEM FUNCTION
 - 3.1B.7B.3.2 VERIFY COMMAND SYSTEM FUNCTION
 - 3.1B.7B.3.3 VERIFY MECHANICAL SYSTEM FUNCTION
 - 3.1B.7B.3.4 VERIFY COMMUNICATIONS SYSTEM FUNCTION
 - 3.1B.7B.3.5 MISSION SEQUENCE SIMULATION
 - 3.1B.7B.4 TRANSFER TO VERTICAL PROCESSING FACILITY
 - 3.1B.7B.4.1 LOAD PAYLOAD INTO CONTAINER
 - 3.1B.7B.4.2 TRANSPORT CONTAINER TO VERTICAL PROCESSING FACILITY
 - 3.1B.7B.4.3 UNLOAD CONTAINER
 - 3.1B.7B.5 INTEGRATE TMS WITH PAYLOAD
 - 3.1B.7B.6 PERFORM INTERFACES CHECK
 - 3.1B.7B.6.1 CHECK TMS/PAYLOAD MECHANICAL INTERFACES
 - 3.1B.7B.6.2 CHECK ELECTRICAL INTERFACES
 - 3.1B.7B.6.3 CHECK SHUTTLE/PAYLOAD MECHANICAL INTERFACES
 - 3.1B.7B.6.4 CHECK ELECTRICAL INTERFACES
 - 3.1B.7B.7 TRANSFER PAYLOAD TO LAUNCH PAD
 - 3.1B.7B.7.1 LOAD PAYLOAD INTO CANISTER
 - 3.1B.7B.7.2 TRANSPORT TO ROTATING SERVICE STRUCTURE
 - 3.1B.7B.7.3 LOAD CANISTER INTO ROTATING SERVICE STRUCTURE
 - 3.1B.7B.7.4 LOAD PAYLOAD INTO ROTATING SERVICE STRUCTURE USING PGHM
 - 3.1B.7B.7.5 REMOVE CANISTER
 - 3.1B.7B.8 ORBITER/PAYLOAD INTEGRATION (VERTICAL)
 - 3.1B.7B.8.1 MATE ROTATING SERVICE STRUCTURE TO ORBITER
 - 3.1B.7B.8.2 EXTEND PAYLOAD INTO ORBITER USING PGHM
 - 3.1B.7B.8.3 CONNECT ORBITER/PAYLOAD INTERFACES
 - 3.1B.7B.8.4 CHECK ELECTRICAL INTERFACES
 - 3.1B.7B.8.5 CLOSE-OUT PAYLOAD BAY
 - 3.1B.7B.8.6 INSTALLATION OF ORBITER PAYLOAD STATION CONSOLES
- 3.1B.8 COUNTDOWN AND LAUNCH
- 3.1B.9 ORBITAL DEPLOYMENT AND CHECKOUT
 - 3.1B.9.1 SHUTTLE ATTAINS DELIVERY ORBIT
 - 3.1B.9.2 TESTS OF ATTACHED PAYLOAD
 - 3.1B.9.2.1 POWER SUBSYSTEM CHECKOUT
 - 3.1B.9.2.2 INFORMATION PROCESSING SUBSYSTEM CHECKOUT
 - 3.1B.9.3 EXTENSION OF PAYLOAD FROM PAYLOAD BAY
 - 3.1B.9.3.1 OPEN PAYLOAD BAY DOORS
 - 3.1B.9.3.2 ACTIVATE RMS

ORIGINAL PART IS
OF POOR QUALITY

- 3.1B.9.3.3 LOCATE GRASPING FIXTURE ON TARGET
- 3.1B.9.3.4 MOVE RMS TO FIXTURE
- 3.1B.9.3.5 GRASP FIXTURE
- 3.1B.9.3.6 RELEASE PAYLOAD RESTRAINTS
- 3.1B.9.3.7 TRANSLATE PAYLOAD OUT OF PAYLOAD BAY
- 3.1B.9.4 SEPARATION OF PAYLOAD FROM ORBITER
 - 3.1B.9.4.1 RMS RELEASES PAYLOAD
 - 3.1B.9.4.2 SECURE RMS IN PAYLOAD BAY
- 3.1B.9.5 OPERATIONAL CHECKOUT
 - 3.1B.9.5.1 ACTIVATE TMS SUBSYSTEMS
 - 3.1B.9.5.2 INFORMATION PROCESSING SUBSYSTEM CHECKOUT
 - 3.1B.9.5.3 POWER SUBSYSTEM CHECKOUT
 - 3.1B.9.5.4 THERMAL SUBSYSTEM CHECKOUT
 - 3.1B.9.5.5 STRUCTURAL SUBSYSTEM CHECKOUT
 - 3.1B.9.5.6 COMMUNICATIONS SUBSYSTEM CHECKOUT
 - 3.1B.9.5.7 ATTITUDE CONTROL SUBSYSTEM CHECKOUT
 - 3.1B.9.5.8 PROPULSION SUBSYSTEM CHECKOUT
 - 3.1B.9.5.9 CONSUMABLES LEVELS CHECKOUT
- 3.1B.9.6 IDENTIFY DEFECTIVE COMPONENT
 - 3.1B.9.6.1 DETERMINE ANOMALOUS DATA
 - 3.1B.9.6.2 FORM HYPOTHESIS FOR PROBLEM
 - 3.1B.9.6.3 DEVISE TEST FOR FAILURE HYPOTHESIS
 - 3.1B.9.6.4 PERFORM TEST FOR FAILURE HYPOTHESIS
 - 3.1B.9.6.5 IDENTIFY FAULTY COMPONENT
- 3.1B.9.7 IDENTIFY DEFECTIVE SOFTWARE
 - 3.1B.9.7.1 COMPARE MEASURED DATA TO MODEL
 - 3.1B.9.7.2 DETERMINE ANOMALOUS DATA
 - 3.1B.9.7.3 FORM HYPOTHESIS FOR PROBLEM
 - 3.1B.9.7.4 DEVISE TEST FOR FAILURE HYPOTHESIS
 - 3.1B.9.7.5 PERFORM TEST FOR FAILURE HYPOTHESIS
- 3.1B.9.8A COMPONENT FAILURE RECOVERY (REDUNDANCY)
 - 3.1B.9.8A.1 SWITCH OUT FAULTY COMPONENT
 - 3.1B.9.8A.2 SWITCH IN REDUNDANT COMPONENT
 - 3.1B.9.8A.3 MAKE DIAGNOSTIC CHECKS
 - 3.1B.9.8A.4 UPDATE SPACECRAFT MODEL
- 3.1B.9.8B COMPONENT FAILURE RECOVERY (ON-BOARD REPAIR)
 - 3.1B.9.8B.1 DEFINE ACCESS SEQUENCE
 - 3.1B.9.8B.2 LOCATE ACCESS PANEL
 - 3.1B.9.8B.3 TRANSFER REPAIR EQUIPMENT TO REPAIR SITE
 - 3.1B.9.8B.4 OPEN ACCESS PANEL
 - 3.1B.9.8B.5 OBSERVE/LOCATE DEFECTIVE COMPONENT
 - 3.1B.9.8B.6 REMOVE COMPONENT
 - 3.1B.9.8B.7 STORE COMPONENT
 - 3.1B.9.8B.8 LOCATE NEW COMPONENT
 - 3.1B.9.8B.9 POSITION AND CONNECT NEW COMPONENT
 - 3.1B.9.8B.10 ADJUST COMPONENT
 - 3.1B.9.8B.11 MAKE DIAGNOSTIC CHECKS
 - 3.1B.9.8B.12 CLOSE ACCESS PANEL
 - 3.1B.9.8B.13 STOW REPAIR EQUIPMENT
 - 3.1B.9.8B.14 UPDATE SPACECRAFT MODEL
- 3.1B.9.9 SOFTWARE FAILURE RECOVERY
 - 3.1B.9.9.1 DETERMINE CORRECTION ALGORITHM
 - 3.1B.9.9.2 DATA/COMMAND ENCODING
 - 3.1B.9.9.3 DATA/COMMAND TRANSMISSION
 - 3.1B.9.9.4 COMPUTER FUNCTION CHECKS
- 3.1B.9.10 ORBITAL TRANSFER

The TMS orbital transfer here is from the Orbiter to the vicinity of the spacecraft to be retrieved.

- 3.1B.9.10.1 INITIALIZE GUIDANCE SYSTEM
- 3.1B.9.10.2 DETERMINE CURRENT ORBITAL PARAMETERS
- 3.1B.9.10.3 DETERMINE DESIRED ORBITAL PARAMETERS
- 3.1B.9.10.4 CHOOSE OPTIMAL TRAJECTORY
- 3.1B.9.10.5 DETERMINE CURRENT ATTITUDE
- 3.1B.9.10.6 DETERMINE DESIRED ATTITUDE
- 3.1B.9.10.7 ROTATE SPACECRAFT
- 3.1B.9.10.8 FIRE THRUSTERS
- 3.1B.10 STATUS MONITORING AND RESOURCE ALLOCATION
 - 3.1B.10.1 TEMPERATURE MANAGEMENT
 - 3.1B.10.1.1 MEASURE COMPONENT TEMPERATURES
 - 3.1B.10.1.2 COMPARE TEMPERATURES TO REQUIRED LIMITS

- 3.1B.10.1.3 ADJUST COOLING/HEATING SYSTEMS
- 3.1B.10.2 POWER MANAGEMENT
 - 3.1B.10.2.1 MEASURE CURRENTS AND VOLTAGES
 - 3.1B.10.2.2 COMPARE CURRENTS AND VOLTAGES TO REQUIRED LIMITS
 - 3.1B.10.2.3 ADJUST CURRENTS AND VOLTAGES
 - 3.1B.10.2.4 MONITOR BATTERIES
- 3.1B.10.3 DATA/COMMAND PROCESSING
 - 3.1B.10.3.1 SHORT-TERM MEMORY STORAGE
 - 3.1B.10.3.2 LONG-TERM MEMORY STORAGE
 - 3.1B.10.3.3 DATA/COMMAND ENCODING
 - 3.1B.10.3.4 DATA/COMMAND DECODING
 - 3.1B.10.3.5 NUMERICAL COMPUTATION
 - 3.1B.10.3.6 LOGIC OPERATIONS
 - 3.1B.10.3.7 COMPUTER LOAD SCHEDULING
 - 3.1B.10.3.8 COMPUTER FUNCTION CHECKS
- 3.1B.10.4 CONSUMABLES MANAGEMENT
 - 3.1B.10.4.1 MONITOR PROPELLANT SUPPLIES
 - 3.1B.10.4.2 PROJECT CONSUMABLES REQUIREMENTS FROM MISSION PROFILE
 - 3.1B.10.4.3 COMPUTE OPTIMAL CONSUMABLES ALLOCATION
- 3.1B.10.5 STRUCTURAL MANAGEMENT
 - 3.1B.10.5.1 MEASURE STRAINS IN STRUCTURE
 - 3.1B.10.5.2 COMPUTE STRESS AND VIBRATION PARAMETERS
 - 3.1B.10.5.3 COMPARE STRESS AND VIBRATION PARAMETERS TO REQUIRED LIMITS
 - 3.1B.10.5.4 APPLY COMPENSATING FORCES
 - 3.1B.10.5.5 APPLY VIBRATION DAMPING
- 3.1B.10.6 HAZARD AVOIDANCE
 - 3.1B.10.6.1 AVOID TANK OVERPRESSURES
 - 3.1B.10.6.2 MAINTAIN SAFE BATTERY CHARGE LEVELS
 - 3.1B.10.6.3 MAINTAIN COMMUNICATION LINKS
 - 3.1B.10.6.4 AVOID EXPOSING SENSITIVE COMPONENTS TO DIRECT SUNLIGHT
 - 3.1B.10.6.5 TRACK NEARBY OBJECTS
 - 3.1B.10.6.6 AVOID CONFLICTING OBJECTS
- 3.1B.10.7 OPTIMAL SEQUENCING
 - 3.1B.10.7.1 UPDATE SPACECRAFT MODEL
 - 3.1B.10.7.2 PROJECT DESIRED FUNCTIONS FROM MISSION PROFILE
 - 3.1B.10.7.3 ESTIMATE RISKS FROM DESIRED FUNCTIONS
 - 3.1B.10.7.4 PROJECT CONSUMABLES REQUIREMENTS FROM MISSION PROFILE
 - 3.1B.10.7.5 DETERMINE CONSTRAINTS AND FIGURES OF MERIT
 - 3.1B.10.7.6 COMPUTE OPTIMAL SEQUENCING
- 3.1B.10.8 IDENTIFY DEFECTIVE COMPONENT
 - 3.1B.10.8.1 DETERMINE ANOMALOUS DATA
 - 3.1B.10.8.2 FORM HYPOTHESIS FOR PROBLEM
 - 3.1B.10.8.3 DEVISE TEST FOR FAILURE HYPOTHESIS
 - 3.1B.10.8.4 PERFORM TEST FOR FAILURE HYPOTHESIS
 - 3.1B.10.8.5 IDENTIFY FAULTY COMPONENT
- 3.1B.10.9 IDENTIFY DEFECTIVE SOFTWARE
 - 3.1B.10.9.1 COMPARE MEASURED DATA TO MODEL
 - 3.1B.10.9.2 DETERMINE ANOMALOUS DATA
 - 3.1B.10.9.3 FORM HYPOTHESIS FOR PROBLEM
 - 3.1B.10.9.4 DEVISE TEST FOR FAILURE HYPOTHESIS
 - 3.1B.10.9.5 PERFORM TEST FOR FAILURE HYPOTHESIS
- 3.1B.10.10A COMPONENT FAILURE RECOVERY (REDUNDANCY)
 - 3.1B.10.10A.1 SWITCH OUT FAULTY COMPONENT
 - 3.1B.10.10A.2 SWITCH IN REDUNDANT COMPONENT
 - 3.1B.10.10A.3 MAKE DIAGNOSTIC CHECKS
 - 3.1B.10.10A.4 UPDATE SPACECRAFT MODEL
- 3.1B.10.10B COMPONENT FAILURE RECOVERY (ON-BOARD REPAIR)
 - 3.1B.10.10B.1 DEFINE ACCESS SEQUENCE
 - 3.1B.10.10B.2 LOCATE ACCESS PANEL
 - 3.1B.10.10B.3 TRANSFER REPAIR EQUIPMENT TO REPAIR SITE
 - 3.1B.10.10B.4 OPEN ACCESS PANEL
 - 3.1B.10.10B.5 OBSERVE/LOCATE DEFECTIVE COMPONENT
 - 3.1B.10.10B.6 REMOVE COMPONENT
 - 3.1B.10.10B.7 STORE COMPONENT
 - 3.1B.10.10B.8 LOCATE NEW COMPONENT
 - 3.1B.10.10B.9 POSITION AND CONNECT NEW COMPONENT
 - 3.1B.10.10B.10 ADJUST COMPONENT
 - 3.1B.10.10B.11 MAKE DIAGNOSTIC CHECKS
 - 3.1B.10.10B.12 CLOSE ACCESS PANEL
 - 3.1B.10.10B.13 STOW REPAIR EQUIPMENT
 - 3.1B.10.10B.14 UPDATE SPACECRAFT MODEL
- 3.1B.10.11 SOFTWARE FAILURE RECOVERY

ORIGINAL COPY
OF POOR QUALITY

- 3.1B.10.11.1 DETERMINE CORRECTION ALGORITHM
- 3.1B.10.11.2 DATA/COMMAND ENCODING
- 3.1B.10.11.3 DATA/COMMAND TRANSMISSION
- 3.1B.10.11.4 COMPUTER FUNCTION CHECKS
- 3.1B.10.12 REPORT SYSTEM STATUS
 - 3.1B.10.12.1 DATA/COMMAND ENCODING
 - 3.1B.10.12.2 DATA/COMMAND TRANSMISSION
 - 3.1B.10.12.3 DATA/COMMAND DECODING
 - 3.1B.10.12.4 DATA/COMMAND DISPLAY
- 3.1B.11 DOCK WITH SPACECRAFT
 - 3.1B.11.1 ADJUST ORBIT
 - 3.1B.11.1.1 INITIALIZE GUIDANCE SYSTEM
 - 3.1B.11.1.2 DETERMINE CURRENT ORBITAL PARAMETERS
 - 3.1B.11.1.3 DETERMINE DESIRED ORBITAL PARAMETERS
 - 3.1B.11.1.4 CHOOSE OPTIMAL TRAJECTORY
 - 3.1B.11.1.5 FIRE THRUSTERS
 - 3.1B.11.2 ADJUST ATTITUDE
 - 3.1B.11.2.1 DETERMINE CURRENT ATTITUDE
 - 3.1B.11.2.2 DETERMINE DESIRED ATTITUDE
 - 3.1B.11.2.3 DETERMINE NEW CONFIGURATION FOR SPACECRAFT COMPONENTS
 - 3.1B.11.2.4 CHOOSE OPTIMAL TRAJECTORY
 - 3.1B.11.2.5 ROTATE SPACECRAFT
 - 3.1B.11.3 OPTIMAL CONTROL ALLOCATION
 - 3.1B.11.3.1 UPDATE SPACECRAFT MODEL
 - 3.1B.11.3.2 PROJECT DESIRED FUNCTIONS FROM MISSION PROFILE
 - 3.1B.11.3.3 ESTIMATE RISKS FROM DESIRED FUNCTIONS
 - 3.1B.11.3.4 PROJECT CONSUMABLES REQUIREMENTS FROM MISSION PROFILE
 - 3.1B.11.3.5 DETERMINE CONSTRAINTS AND FIGURES OF MERIT
 - 3.1B.11.3.6 CHOOSE OPTIMAL CONTROL MODE
 - 3.1B.11.3.7 COMPUTE CONTROL COMMANDS
 - 3.1B.11.3.8 EXECUTE CONTROL COMMANDS
 - 3.1B.11.4 DOCK TMS TO SPACECRAFT
 - 3.1B.11.4.1 LOCATE DOCKING TARGET
 - 3.1B.11.4.2 EXTEND DOCKING MECHANISM
 - 3.1B.11.4.3 FASTEN DOCKING LATCH
- 3.1B.12 DIAGNOSTIC CHECK (OF SPACECRAFT)
 - 3.1B.12.1 IDENTIFY DEFECTIVE COMPONENT
 - 3.1B.12.1.1 DETERMINE ANOMALOUS DATA
 - 3.1B.12.1.2 FORM HYPOTHESIS FOR PROBLEM
 - 3.1B.12.1.3 DEVISE TEST FOR FAILURE HYPOTHESIS
 - 3.1B.12.1.4 PERFORM TEST FOR FAILURE HYPOTHESIS
 - 3.1B.12.1.5 IDENTIFY FAULTY COMPONENT
 - 3.1B.12.2 IDENTIFY DEFECTIVE SOFTWARE
 - 3.1B.12.2.1 COMPARE MEASURED DATA TO MODEL
 - 3.1B.12.2.2 DETERMINE ANOMALOUS DATA
 - 3.1B.12.2.3 FORM HYPOTHESIS FOR PROBLEM
 - 3.1B.12.2.4 DEVISE TEST FOR FAILURE HYPOTHESIS
 - 3.1B.12.2.5 PERFORM TEST FOR FAILURE HYPOTHESIS
- 3.1B.13 RENDEZVOUS WITH ORBITER
 - 3.1B.13.1 ORBITAL TRANSFER (OF TMS/SPACECRAFT)
 - 3.1B.13.1.1 INITIALIZE GUIDANCE SYSTEM
 - 3.1B.13.1.2 DETERMINE CURRENT ORBITAL PARAMETERS
 - 3.1B.13.1.3 DETERMINE DESIRED ORBITAL PARAMETERS
 - 3.1B.13.1.4 CHOOSE OPTIMAL TRAJECTORY
 - 3.1B.13.1.5 DETERMINE CURRENT ATTITUDE
 - 3.1B.13.1.6 DETERMINE DESIRED ATTITUDE
 - 3.1B.13.1.7 ROTATE SPACECRAFT
 - 3.1B.13.1.8 FIRE THRUSTERS
 - 3.1B.13.2 SHUTDOWN TMS FOR RETRIEVAL
 - 3.1B.13.2.1 STOW TMS ANTENNA
 - 3.1B.13.2.2 DEACTIVATE TMS SUBSYSTEMS
- 3.1B.14 RETRIEVAL BY ORBITER (OF TMS/SATELLITE)
 - 3.1B.14.1 ADJUST ORBIT (OF ORBITER)
 - 3.1B.14.1.1 INITIALIZE GUIDANCE SYSTEM
 - 3.1B.14.1.2 DETERMINE CURRENT ORBITAL PARAMETERS
 - 3.1B.14.1.3 DETERMINE DESIRED ORBITAL PARAMETERS
 - 3.1B.14.1.4 CHOOSE OPTIMAL TRAJECTORY
 - 3.1B.14.1.5 FIRE THRUSTERS
 - 3.1B.14.2 ADJUST ATTITUDE (OF ORBITER)
 - 3.1B.14.2.1 DETERMINE CURRENT ATTITUDE
 - 3.1B.14.2.2 DETERMINE DESIRED ATTITUDE
 - 3.1B.14.2.3 DETERMINE NEW CONFIGURATION FOR SPACECRAFT COMPONENTS

- 3.1B.14.2.4 CHOOSE OPTIMAL TRAJECTORY
- 3.1B.14.2.5 ROTATE SPACECRAFT
- 3.1B.14.3 OPTIMAL CONTROL ALLOCATION
 - 3.1B.14.3.1 UPDATE SPACECRAFT MODEL
 - 3.1B.14.3.2 PROJECT DESIRED FUNCTIONS FROM MISSION PROFILE
 - 3.1B.14.3.3 ESTIMATE RISKS FROM DESIRED FUNCTIONS
 - 3.1B.14.3.4 PROJECT CONSUMABLES REQUIREMENTS FROM MISSION PROFILE
 - 3.1B.14.3.5 DETERMINE CONSTRAINTS AND FIGURES OF MERIT
 - 3.1B.14.3.6 CHOOSE OPTIMAL CONTROL MODE
 - 3.1B.14.3.7 COMPUTE CONTROL COMMANDS
 - 3.1B.14.3.8 EXECUTE CONTROL COMMANDS
- 3.1B.14.4 ORBITER RECOVERY OF TMS
 - 3.1B.14.4.1 ACTIVATE RMS
 - 3.1B.14.4.2 LOCATE GRASPING FIXTURE ON TARGET
 - 3.1B.14.4.3 MOVE RMS TO FIXTURE
 - 3.1B.14.4.4 GRASP FIXTURE
 - 3.1B.14.4.5 LOCATE CRADLE IN PAYLOAD BAY
 - 3.1B.14.4.6 TRANSLATE PAYLOAD TO CRADLE
 - 3.1B.14.4.7 FASTEN PAYLOAD RESTRAINTS
 - 3.1B.14.4.8 RMS RELEASES PAYLOAD
 - 3.1B.14.4.9 SECURE RMS IN PAYLOAD BAY
- 3.1B.15 REENTRY AND LANDING
- 3.1B.16 POST-FLIGHT OPERATIONS
 - 3.1B.16.1 SAFING OF ORBITER AND HAZARDOUS PAYLOADS
 - 3.1B.16.2 REMOVAL OF PAYLOADS FROM ORBITER

3.2 SERVICING, MAINTAINANCE AND REPAIR

 This mission uses the TMS to service a spacecraft on-orbit. A repair kit may be carried by the TMS for this mission. The TMS is deployed from the Orbiter, transfers to the spacecraft, docks and repairs the spacecraft, and then returns to the Orbiter.

- 3.2.1 DESIGN
 - 3.2.1.1 DEFINE REQUIREMENTS
 - 3.2.1.2 MISSION ANALYSIS
 - 3.2.1.3 PAYLOAD ACCOMODATIONS
 - 3.2.1.4 CREATE FUNCTIONAL LAYOUT
 - 3.2.1.5 FAILURE MODES ANALYSIS
 - 3.2.1.6 ADJUST DESIGN FOR MAINTAINANCE AND REPAIR
 - 3.2.1.7 CREATE MECHANICAL LAYOUT
 - 3.2.1.8 SAFETY REVIEW
 - 3.2.1.9 DESIGN OF COMPONENTS
 - 3.2.1.10 SOFTWARE DEVELOPMENT
- 3.2.2 COMPONENT FABRICATION
 - 3.2.2.1 PROCURE OFF-THE-SHELF COMPONENTS
 - 3.2.2.2 PROCURE MATERIALS FOR MANUFACTURED COMPONENTS
 - 3.2.2.3 PROCURE MANUFACTURING EQUIPMENT
 - 3.2.2.4 MANUFACTURE COMPONENTS
- 3.2.3 COMPONENT TEST
 - 3.2.3.1 SET UP TEST FACILITIES
 - 3.2.3.2 STRUCTURAL LOADS TESTS
 - 3.2.3.3 DATA PROCESSING AND SOFTWARE TESTS
 - 3.2.3.4 ANTENNA AND ARRAY DEPLOYMENT TESTS
 - 3.2.3.5 ELECTRICAL SYSTEMS TESTS
 - 3.2.3.6 THERMAL AND VACUUM TESTS
 - 3.2.3.7 THRUSTER TESTS
 - 3.2.3.8 COMPONENT CERTIFICATION
- 3.2.4 SYSTEM INTEGRATION
- 3.2.5 SYSTEM TEST
 - 3.2.5.1 POWER SUBSYSTEM TESTS
 - 3.2.5.2 THERMAL SUBSYSTEM TESTS
 - 3.2.5.3 STRUCTURE SUBSYSTEM TESTS
 - 3.2.5.4 INFORMATION PROCESSING SUBSYSTEM TESTS
 - 3.2.5.5 COMMUNICATIONS SUBSYSTEM TESTS
 - 3.2.5.6 ATTITUDE CONTROL SUBSYSTEM TESTS
 - 3.2.5.7 PROPULSION SUBSYSTEM TESTS
 - 3.2.5.8 INTEGRATED SYSTEMS TESTS
 - 3.2.5.9 FAILURE MODES SIMULATION
 - 3.2.5.10 SYSTEM CERTIFICATION
- 3.2.6 SHIPPING TO LAUNCH SITE
 - 3.2.6.1 REMOVE TEST EQUIPMENT

ORIGINAL PART IS
OF POOR QUALITY

- 3.2.6.2 PERFORM NECESSARY DISASSEMBLY
- 3.2.6.3 PACKING
- 3.2.6.4 TRANSPORT TO LAUNCH SITE
- 3.2.7A PAYLOAD INTEGRATION AND CHECKOUT (HORIZONTAL PAYLOAD)
 - 3.2.7A.1 UNPACKING
 - 3.2.7A.2 PERFORM NECESSARY REASSEMBLY
 - 3.2.7A.3 INTEGRATED SYSTEMS TESTS
 - 3.2.7A.3.1 VERIFY POWER SYSTEM FUNCTION
 - 3.2.7A.3.2 VERIFY COMMAND SYSTEM FUNCTION
 - 3.2.7A.3.3 VERIFY MECHANICAL SYSTEM FUNCTION
 - 3.2.7A.3.4 VERIFY COMMUNICATIONS SYSTEM FUNCTION
 - 3.2.7A.3.5 MISSION SEQUENCE SIMULATION
 - 3.2.7A.4 TRANSFER TO OPERATIONS AND CHECKOUT BLDG.
 - 3.2.7A.4.1 LOAD PAYLOAD INTO CONTAINER
 - 3.2.7A.4.2 TRANSPORT TO OPERATIONS AND CHECKOUT BLDG.
 - 3.2.7A.4.3 ATTACH STRONGBACK TO PAYLOAD
 - 3.2.7A.4.4 INSTALL PAYLOAD IN HORIZONTAL CITE
 - 3.2.7A.5 INTEGRATE TMS WITH PAYLOAD

For this mission the payload will be a servicing kit.

- 3.2.7A.6 PERFORM INTERFACES CHECK
 - 3.2.7A.6.1 CHECK TMS/PAYLOAD MECHANICAL INTERFACES
 - 3.2.7A.6.2 CHECK ELECTRICAL INTERFACES
 - 3.2.7A.6.3 CHECK SHUTTLE/PAYLOAD MECHANICAL INTERFACES
 - 3.2.7A.6.4 CHECK ELECTRICAL INTERFACES
- 3.2.7A.7 TRANSFER TMS/PAYLOAD TO ORBITER PROCESSING FACILITY
 - 3.2.7A.7.1 ATTACH STRONGBACK TO PAYLOAD
 - 3.2.7A.7.2 LOAD PAYLOAD INTO CANISTER
 - 3.2.7A.7.3 REMOVE STRONGBACK
 - 3.2.7A.7.4 CLOSE CANISTER
 - 3.2.7A.7.5 TRANSPORT CANISTER TO ORBITER PROCESSING FACILITY
 - 3.2.7A.7.6 UNLOAD CANISTER
- 3.2.7A.8 ORBITER/PAYLOAD INTEGRATION (HORIZONTAL)
 - 3.2.7A.8.1 ATTACH STRONGBACK TO PAYLOAD
 - 3.2.7A.8.2 INSTALL PAYLOAD IN ORBITER
 - 3.2.7A.8.3 CONNECT ORBITER/PAYLOAD INTERFACES
 - 3.2.7A.8.4 CHECK ELECTRICAL INTERFACES
 - 3.2.7A.8.5 REMOVE STRONGBACK
 - 3.2.7A.8.6 CLOSE-OUT PAYLOAD BAY
 - 3.2.7A.8.7 INSTALLATION OF ORBITER PAYLOAD STATION CONSOLES
- 3.2.7B PAYLOAD INTEGRATION AND CHECKOUT (VERTICAL PAYLOAD)
 - 3.2.7B.1 UNPACKING
 - 3.2.7B.2 PERFORM NECESSARY REASSEMBLY
 - 3.2.7B.3 INTEGRATED SYSTEMS TESTS
 - 3.2.7B.3.1 VERIFY POWER SYSTEM FUNCTION
 - 3.2.7B.3.2 VERIFY COMMAND SYSTEM FUNCTION
 - 3.2.7B.3.3 VERIFY MECHANICAL SYSTEM FUNCTION
 - 3.2.7B.3.4 VERIFY COMMUNICATIONS SYSTEM FUNCTION
 - 3.2.7B.3.5 MISSION SEQUENCE SIMULATION
 - 3.2.7B.4 TRANSFER TO VERTICAL PROCESSING FACILITY
 - 3.2.7B.4.1 LOAD PAYLOAD INTO CONTAINER
 - 3.2.7B.4.2 TRANSPORT CONTAINER TO VERTICAL PROCESSING FACILITY
 - 3.2.7B.4.3 UNLOAD CONTAINER
 - 3.2.7B.5 INTEGRATE TMS WITH PAYLOAD
 - 3.2.7B.6 PERFORM INTERFACES CHECK
 - 3.2.7B.6.1 CHECK TMS/PAYLOAD MECHANICAL INTERFACES
 - 3.2.7B.6.2 CHECK ELECTRICAL INTERFACES
 - 3.2.7B.6.3 CHECK SHUTTLE/PAYLOAD MECHANICAL INTERFACES
 - 3.2.7B.6.4 CHECK ELECTRICAL INTERFACES
 - 3.2.7B.7 TRANSFER PAYLOAD TO LAUNCH PAD
 - 3.2.7B.7.1 LOAD PAYLOAD INTO CANISTER
 - 3.2.7B.7.2 TRANSPORT TO ROTATING SERVICE STRUCTURE
 - 3.2.7B.7.3 LOAD CANISTER INTO ROTATING SERVICE STRUCTURE
 - 3.2.7B.7.4 LOAD PAYLOAD INTO ROTATING SERVICE STRUCTURE USING PGHM
 - 3.2.7B.7.5 REMOVE CANISTER
 - 3.2.7B.8 ORBITER/PAYLOAD INTEGRATION (VERTICAL)
 - 3.2.7B.8.1 MATE ROTATING SERVICE STRUCTURE TO ORBITER
 - 3.2.7B.8.2 EXTEND PAYLOAD INTO ORBITER USING PGHM
 - 3.2.7B.8.3 CONNECT ORBITER/PAYLOAD INTERFACES
 - 3.2.7B.8.4 CHECK ELECTRICAL INTERFACES
 - 3.2.7B.8.5 CLCSE-OUT PAYLOAD BAY

- 3.2.7B.8.6 INSTALLATION OF ORBITER PAYLOAD STATION CONSOLES
- 3.2.8 COUNTDOWN AND LAUNCH
- 3.2.9 ORBITAL DEPLOYMENT AND CHECKOUT
 - 3.2.9.1 SHUTTLE ATTAINS DELIVERY ORBIT
 - 3.2.9.2 TESTS OF ATTACHED PAYLOAD
 - 3.2.9.2.1 POWER SUBSYSTEM CHECKOUT
 - 3.2.9.2.2 INFORMATION PROCESSING SUBSYSTEM CHECKOUT
 - 3.2.9.3 EXTENSION OF PAYLOAD FROM PAYLOAD BAY
 - 3.2.9.3.1 OPEN PAYLOAD BAY DOORS
 - 3.2.9.3.2 ACTIVATE RMS
 - 3.2.9.3.3 LOCATE GRASPING FIXTURE ON TARGET
 - 3.2.9.3.4 MOVE RMS TO FIXTURE
 - 3.2.9.3.5 GRASP FIXTURE
 - 3.2.9.3.6 RELEASE PAYLOAD RESTRAINTS
 - 3.2.9.3.7 TRANSLATE PAYLOAD OUT OF PAYLOAD BAY
 - 3.2.9.4 SEPARATION OF PAYLOAD FROM ORBITER
 - 3.2.9.4.1 RMS RELEASES PAYLOAD
 - 3.2.9.4.2 SECURE RMS IN PAYLOAD BAY
 - 3.2.9.5 OPERATIONAL CHECKOUT
 - 3.2.9.5.1 ACTIVATE TMS SUBSYSTEMS
 - 3.2.9.5.2 INFORMATION PROCESSING SUBSYSTEM CHECKOUT
 - 3.2.9.5.3 POWER SUBSYSTEM CHECKOUT
 - 3.2.9.5.4 THERMAL SUBSYSTEM CHECKOUT
 - 3.2.9.5.5 STRUCTURAL SUBSYSTEM CHECKOUT
 - 3.2.9.5.6 COMMUNICATIONS SUBSYSTEM CHECKOUT
 - 3.2.9.5.7 ATTITUDE CONTROL SUBSYSTEM CHECKOUT
 - 3.2.9.5.8 PROPULSION SUBSYSTEM CHECKOUT
 - 3.2.9.5.9 CONSUMABLES LEVELS CHECKOUT
 - 3.2.9.6 IDENTIFY DEFECTIVE COMPONENT
 - 3.2.9.6.1 DETERMINE ANOMALOUS DATA
 - 3.2.9.6.2 FORM HYPOTHESIS FOR PROBLEM
 - 3.2.9.6.3 DEVISE TEST FOR FAILURE HYPOTHESIS
 - 3.2.9.6.4 PERFORM TEST FOR FAILURE HYPOTHESIS
 - 3.2.9.6.5 IDENTIFY FAULTY COMPONENT
 - 3.2.9.7 IDENTIFY DEFECTIVE SOFTWARE
 - 3.2.9.7.1 COMPARE MEASURED DATA TO MODEL
 - 3.2.9.7.2 DETERMINE ANOMALOUS DATA
 - 3.2.9.7.3 FORM HYPOTHESIS FOR PROBLEM
 - 3.2.9.7.4 DEVISE TEST FOR FAILURE HYPOTHESIS
 - 3.2.9.7.5 PERFORM TEST FOR FAILURE HYPOTHESIS
 - 3.2.9.8A COMPONENT FAILURE RECOVERY (REDUNDANCY)
 - 3.2.9.8A.1 SWITCH OUT FAULTY COMPONENT
 - 3.2.9.8A.2 SWITCH IN REDUNDANT COMPONENT
 - 3.2.9.8A.3 MAKE DIAGNOSTIC CHECKS
 - 3.2.9.8A.4 UPDATE SPACECRAFT MODEL
 - 3.2.9.8B COMPONENT FAILURE RECOVERY (ON-BOARD REPAIR)
 - 3.2.9.8B.1 DEFINE ACCESS SEQUENCE
 - 3.2.9.8B.2 LOCATE ACCESS PANEL
 - 3.2.9.8B.3 TRANSFER REPAIR EQUIPMENT TO REPAIR SITE
 - 3.2.9.8B.4 OPEN ACCESS PANEL
 - 3.2.9.8B.5 OBSERVE/LOCATE DEFECTIVE COMPONENT
 - 3.2.9.8B.6 REMOVE COMPONENT
 - 3.2.9.8B.7 STORE COMPONENT
 - 3.2.9.8B.8 LOCATE NEW COMPONENT
 - 3.2.9.8B.9 POSITION AND CONNECT NEW COMPONENT
 - 3.2.9.8B.10 ADJUST COMPONENT
 - 3.2.9.8B.11 MAKE DIAGNOSTIC CHECKS
 - 3.2.9.8B.12 CLOSE ACCESS PANEL
 - 3.2.9.8B.13 STOW REPAIR EQUIPMENT
 - 3.2.9.8B.14 UPDATE SPACECRAFT MODEL
 - 3.2.9.9 SOFTWARE FAILURE RECOVERY
 - 3.2.9.9.1 DETERMINE CORRECTION ALGORITHM
 - 3.2.9.9.2 DATA/COMMAND ENCODING
 - 3.2.9.9.3 DATA/COMMAND TRANSMISSION
 - 3.2.9.9.4 COMPUTER FUNCTION CHECKS
 - 3.2.9.10 ORBITAL TRANSFER
 - 3.2.9.10.1 INITIALIZE GUIDANCE SYSTEM
 - 3.2.9.10.2 DETERMINE CURRENT ORBITAL PARAMETERS
 - 3.2.9.10.3 DETERMINE DESIRED ORBITAL PARAMETERS
 - 3.2.9.10.4 CHOOSE OPTIMAL TRAJECTORY
 - 3.2.9.10.5 DETERMINE CURRENT ATTITUDE
 - 3.2.9.10.6 DETERMINE DESIRED ATTITUDE

- 3.2.9.10.7 ROTATE SPACECRAFT
- 3.2.9.10.8 FIRE THRUSTERS
- 3.2.10 STATUS MONITORING AND RESOURCE ALLOCATION
 - 3.2.10.1 TEMPERATURE MANAGEMENT
 - 3.2.10.1.1 MEASURE COMPONENT TEMPERATURES
 - 3.2.10.1.2 COMPARE TEMPERATURES TO REQUIRED LIMITS
 - 3.2.10.1.3 ADJUST COOLING/HEATING SYSTEMS
 - 3.2.10.2 POWER MANAGEMENT
 - 3.2.10.2.1 MEASURE CURRENTS AND VOLTAGES
 - 3.2.10.2.2 COMPARE CURRENTS AND VOLTAGES TO REQUIRED LIMITS
 - 3.2.10.2.3 ADJUST CURRENTS AND VOLTAGES
 - 3.2.10.2.4 MONITOR BATTERIES
 - 3.2.10.3 DATA/COMMAND PROCESSING
 - 3.2.10.3.1 SHORT-TERM MEMORY STORAGE
 - 3.2.10.3.2 LONG-TERM MEMORY STORAGE
 - 3.2.10.3.3 DATA/COMMAND ENCODING
 - 3.2.10.3.4 DATA/COMMAND DECODING
 - 3.2.10.3.5 NUMERICAL COMPUTATION
 - 3.2.10.3.6 LOGIC OPERATIONS
 - 3.2.10.3.7 COMPUTER LOAD SCHEDULING
 - 3.2.10.3.8 COMPUTER FUNCTION CHECKS
 - 3.2.10.4 CONSUMABLES MANAGEMENT
 - 3.2.10.4.1 MONITOR PROPELLANT SUPPLIES
 - 3.2.10.4.2 PROJECT CONSUMABLES REQUIREMENTS FROM MISSION PROFILE
 - 3.2.10.4.3 COMPUTE OPTIMAL CONSUMABLES ALLOCATION
 - 3.2.10.5 STRUCTURAL MANAGEMENT
 - 3.2.10.5.1 MEASURE STRAINS IN STRUCTURE
 - 3.2.10.5.2 COMPUTE STRESS AND VIBRATION PARAMETERS
 - 3.2.10.5.3 COMPARE STRESS AND VIBRATION PARAMETERS TO REQUIRED LIMITS
 - 3.2.10.5.4 APPLY COMPENSATING FORCES
 - 3.2.10.5.5 APPLY VIBRATION DAMPING
 - 3.2.10.6 HAZARD AVOIDANCE
 - 3.2.10.6.1 AVOID TANK OVERPRESSURES
 - 3.2.10.6.2 MAINTAIN SAFE BATTERY CHARGE LEVELS
 - 3.2.10.6.3 MAINTAIN COMMUNICATION LINKS
 - 3.2.10.6.4 AVOID EXPOSING SENSITIVE COMPONENTS TO DIRECT SUNLIGHT
 - 3.2.10.6.5 TRACK NEARBY OBJECTS
 - 3.2.10.6.6 AVOID CONFLICTING OBJECTS
 - 3.2.10.7 OPTIMAL SEQUENCING
 - 3.2.10.7.1 UPDATE SPACECRAFT MODEL
 - 3.2.10.7.2 PROJECT DESIRED FUNCTIONS FROM MISSION PROFILE
 - 3.2.10.7.3 ESTIMATE RISKS FROM DESIRED FUNCTIONS
 - 3.2.10.7.4 PROJECT CONSUMABLES REQUIREMENTS FROM MISSION PROFILE
 - 3.2.10.7.5 DETERMINE CONSTRAINTS AND FIGURES OF MERIT
 - 3.2.10.7.6 COMPUTE OPTIMAL SEQUENCING
 - 3.2.10.8 IDENTIFY DEFECTIVE COMPONENT
 - 3.2.10.8.1 DETERMINE ANOMALOUS DATA
 - 3.2.10.8.2 FORM HYPOTHESIS FOR PROBLEM
 - 3.2.10.8.3 DEVISE TEST FOR FAILURE HYPOTHESIS
 - 3.2.10.8.4 PERFORM TEST FOR FAILURE HYPOTHESIS
 - 3.2.10.8.5 IDENTIFY FAULTY COMPONENT
 - 3.2.10.9 IDENTIFY DEFECTIVE SOFTWARE
 - 3.2.10.9.1 COMPARE MEASURED DATA TO MODEL
 - 3.2.10.9.2 DETERMINE ANOMALOUS DATA
 - 3.2.10.9.3 FORM HYPOTHESIS FOR PROBLEM
 - 3.2.10.9.4 DEVISE TEST FOR FAILURE HYPOTHESIS
 - 3.2.10.9.5 PERFORM TEST FOR FAILURE HYPOTHESIS
 - 3.2.10.10A COMPONENT FAILURE RECOVERY (REDUNDANCY)
 - 3.2.10.10A.1 SWITCH OUT FAULTY COMPONENT
 - 3.2.10.10A.2 SWITCH IN REDUNDANT COMPONENT
 - 3.2.10.10A.3 MAKE DIAGNOSTIC CHECKS
 - 3.2.10.10A.4 UPDATE SPACECRAFT MODEL
 - 3.2.10.10B COMPONENT FAILURE RECOVERY (ON-BOARD REPAIR)
 - 3.2.10.10B.1 DEFINE ACCESS SEQUENCE
 - 3.2.10.10B.2 LOCATE ACCESS PANEL
 - 3.2.10.10B.3 TRANSFER REPAIR EQUIPMENT TO REPAIR SITE
 - 3.2.10.10B.4 OPEN ACCESS PANEL
 - 3.2.10.10B.5 OBSERVE/LOCATE DEFECTIVE COMPONENT
 - 3.2.10.10B.6 REMOVE COMPONENT
 - 3.2.10.10B.7 STORE COMPONENT
 - 3.2.10.10B.8 LOCATE NEW COMPONENT
 - 3.2.10.10B.9 POSITION AND CONNECT NEW COMPONENT

- 3.2.10.10B.10 ADJUST COMPONENT
- 3.2.10.10B.11 MAKE DIAGNOSTIC CHECKS
- 3.2.10.10B.12 CLOSE ACCESS PANEL
- 3.2.10.10B.13 STOW REPAIR EQUIPMENT
- 3.2.10.10B.14 UPDATE SPACECRAFT MODEL
- 3.2.10.11 SOFTWARE FAILURE RECOVERY
 - 3.2.10.11.1 DETERMINE CORRECTION ALGORITHM
 - 3.2.10.11.2 DATA/COMMAND ENCODING
 - 3.2.10.11.3 DATA/COMMAND TRANSMISSION
 - 3.2.10.11.4 COMPUTER FUNCTION CHECKS
- 3.2.10.12 REPORT SYSTEM STATUS
 - 3.2.10.12.1 DATA/COMMAND ENCODING
 - 3.2.10.12.2 DATA/COMMAND TRANSMISSION
 - 3.2.10.12.3 DATA/COMMAND DECODING
 - 3.2.10.12.4 DATA/COMMAND DISPLAY
- 3.2.11 DOCK WITH SPACECRAFT
 - 3.2.11.1 ADJUST ORBIT
 - 3.2.11.1.1 INITIALIZE GUIDANCE SYSTEM
 - 3.2.11.1.2 DETERMINE CURRENT ORBITAL PARAMETERS
 - 3.2.11.1.3 DETERMINE DESIRED ORBITAL PARAMETERS
 - 3.2.11.1.4 CHOOSE OPTIMAL TRAJECTORY
 - 3.2.11.1.5 FIRE THRUSTERS
 - 3.2.11.2 ADJUST ATTITUDE
 - 3.2.11.2.1 DETERMINE CURRENT ATTITUDE
 - 3.2.11.2.2 DETERMINE DESIRED ATTITUDE
 - 3.2.11.2.3 DETERMINE NEW CONFIGURATION FOR SPACECRAFT COMPONENTS
 - 3.2.11.2.4 CHOOSE OPTIMAL TRAJECTORY
 - 3.2.11.2.5 ROTATE SPACECRAFT
 - 3.2.11.3 OPTIMAL CONTROL ALLOCATION
 - 3.2.11.3.1 UPDATE SPACECRAFT MODEL
 - 3.2.11.3.2 PROJECT DESIRED FUNCTIONS FROM MISSION PROFILE
 - 3.2.11.3.3 ESTIMATE RISKS FROM DESIRED FUNCTIONS
 - 3.2.11.3.4 PROJECT CONSUMABLES REQUIREMENTS FROM MISSION PROFILE
 - 3.2.11.3.5 DETERMINE CONSTRAINTS AND FIGURES OF MERIT
 - 3.2.11.3.6 CHOOSE OPTIMAL CONTROL MODE
 - 3.2.11.3.7 COMPUTE CONTROL COMMANDS
 - 3.2.11.3.8 EXECUTE CONTROL COMMANDS
 - 3.2.11.4 DOCK TMS TO SPACECRAFT
 - 3.2.11.4.1 LOCATE DOCKING TARGET
 - 3.2.11.4.2 EXTEND DOCKING MECHANISM
 - 3.2.11.4.3 FASTEN DOCKING LATCH
- 3.2.12 DIAGNOSTIC CHECK (OF SPACECRAFT)

 This sequence might be done by the repair kit carried by the TMS.

- 3.2.12.1 IDENTIFY DEFECTIVE COMPONENT
 - 3.2.12.1.1 DETERMINE ANOMALOUS DATA
 - 3.2.12.1.2 FORM HYPOTHESIS FOR PROBLEM
 - 3.2.12.1.3 DEVISE TEST FOR FAILURE HYPOTHESIS
 - 3.2.12.1.4 PERFORM TEST FOR FAILURE HYPOTHESIS
 - 3.2.12.1.5 IDENTIFY FAULTY COMPONENT
- 3.2.12.2 IDENTIFY DEFECTIVE SOFTWARE
 - 3.2.12.2.1 COMPARE MEASURED DATA TO MODEL
 - 3.2.12.2.2 DETERMINE ANOMALOUS DATA
 - 3.2.12.2.3 FORM HYPOTHESIS FOR PROBLEM
 - 3.2.12.2.4 DEVISE TEST FOR FAILURE HYPOTHESIS
 - 3.2.12.2.5 PERFORM TEST FOR FAILURE HYPOTHESIS
- 3.2.13 COMPONENT/SOFTWARE REPLACEMENT
 - 3.2.13.1 COMPONENT REPLACEMENT

 This activity would also include non-repair module replacement activity such as experiment changeout and data cartridge replacement.

- 3.2.13.1.1 DEFINE ACCESS SEQUENCE
- 3.2.13.1.2 LOCATE ACCESS PANEL
- 3.2.13.1.3 TRANSFER REPAIR EQUIPMENT TO REPAIR SITE
- 3.2.13.1.4 OPEN ACCESS PANEL
- 3.2.13.1.5 OBSERVE/LOCATE DEFECTIVE COMPONENT
- 3.2.13.1.6 REMOVE COMPONENT
- 3.2.13.1.7 STORE COMPONENT
- 3.2.13.1.8 LOCATE NEW COMPONENT
- 3.2.13.1.9 POSITION AND CONNECT NEW COMPONENT

- 3.2.13.1.10 ADJUST COMPONENT
 - 3.2.13.1.11 MAKE DIAGNOSTIC CHECKS
 - 3.2.13.1.12 CLOSE ACCESS PANEL
 - 3.2.13.1.13 STOW REPAIR EQUIPMENT
 - 3.2.13.1.14 UPDATE SPACECRAFT MODEL
 - 3.2.13.2 SOFTWARE REPLACEMENT
 - 3.2.13.2.1 DATA/COMMAND ENCODING
 - 3.2.13.2.2 DATA/COMMAND TRANSMISSION
 - 3.2.13.2.3 COMPUTER FUNCTION CHECKS
 - 3.2.14 RESUPPLY CONSUMABLES
 - 3.2.14.1A FLUID REPLACEMENT (UMBILICAL)
 - 3.2.14.1A.1 LOCATE ACCESS PANEL
 - 3.2.14.1A.2 OPEN ACCESS PANEL
 - 3.2.14.1A.3 CLOSE INTERNAL VALVES
 - 3.2.14.1A.4 EXTEND AND ATTACH UMBILICAL
 - 3.2.14.1A.5 OPEN SUPPLY VALVE
 - 3.2.14.1A.6 MONITOR FLUID TRANSFER
 - 3.2.14.1A.7 CLOSE SUPPLY VALVE
 - 3.2.14.1A.8 DETACH AND RETRACT UMBILICAL
 - 3.2.14.1A.9 OPEN INTERNAL VALVES
 - 3.2.14.1A.10 CHECK FOR LEAKS
 - 3.2.14.1A.11 CLOSE ACCESS PANEL
 - 3.2.14.1B FLUID REPLACEMENT (TANK REPLACEMENT)
 - 3.2.14.1B.1 LOCATE ACCESS PANEL
 - 3.2.14.1B.2 TRANSFER REPAIR EQUIPMENT TO REPAIR SITE
 - 3.2.14.1B.3 OPEN ACCESS PANEL
 - 3.2.14.1B.4 CLOSE INTERNAL VALVES
 - 3.2.14.1B.5 LOCATE OLD TANK
 - 3.2.14.1B.6 DISCONNECT OLD TANK
 - 3.2.14.1B.7 REMOVE OLD TANK
 - 3.2.14.1B.8 STORE OLD TANK
 - 3.2.14.1B.9 LOCATE NEW TANK
 - 3.2.14.1B.10 INSTALL NEW TANK
 - 3.2.14.1B.11 CONNECT NEW TANK
 - 3.2.14.1B.12 OPEN INTERNAL VALVES
 - 3.2.14.1B.13 CHECK FOR LEAKS
 - 3.2.14.1B.14 CLOSE ACCESS PANEL
 - 3.2.14.1B.15 STOW REPAIR EQUIPMENT
 - 3.2.15 NON-ROUTINE MAINTAINANCE AND REPAIR
-
- This is repair activity not foreseen during mission planning.

- 3.2.16 REDEPLOY SPACECRAFT
 - 3.2.16.1 ORBITAL TRANSFER (OF TMS/SPACECRAFT)
 - 3.2.16.1.1 INITIALIZE GUIDANCE SYSTEM
 - 3.2.16.1.2 DETERMINE CURRENT ORBITAL PARAMETERS
 - 3.2.16.1.3 DETERMINE DESIRED ORBITAL PARAMETERS
 - 3.2.16.1.4 CHOOSE OPTIMAL TRAJECTORY
 - 3.2.16.1.5 DETERMINE CURRENT ATTITUDE
 - 3.2.16.1.6 DETERMINE DESIRED ATTITUDE
 - 3.2.16.1.7 ROTATE SPACECRAFT
 - 3.2.16.1.8 FIRE THRUSTERS
 - 3.2.16.2 UNDOCK TMS FROM PAYLOAD
 - 3.2.16.2.1 RELEASE DOCKING LATCH
 - 3.2.16.2.2 RETRACT DOCKING MECHANISM
 - 3.2.16.2.3 MOVE AWAY FROM PAYLOAD
 - 3.2.16.3 OPERATIONAL CHECKOUT AND ATTITUDE ADJUSTMENT OF SPACECRAFT
 - 3.2.17 RENDEZVOUS WITH ORBITER
 - 3.2.17.1 ORBITAL TRANSFER (OF TMS)
 - 3.2.17.1.1 INITIALIZE GUIDANCE SYSTEM
 - 3.2.17.1.2 DETERMINE CURRENT ORBITAL PARAMETERS
 - 3.2.17.1.3 DETERMINE DESIRED ORBITAL PARAMETERS
 - 3.2.17.1.4 CHOOSE OPTIMAL TRAJECTORY
 - 3.2.17.1.5 DETERMINE CURRENT ATTITUDE
 - 3.2.17.1.6 DETERMINE DESIRED ATTITUDE
 - 3.2.17.1.7 ROTATE SPACECRAFT
 - 3.2.17.1.8 FIRE THRUSTERS
 - 3.2.17.2 SHUTDOWN TMS FOR RETRIEVAL
 - 3.2.17.2.1 STOW TMS ANTENNA
 - 3.2.17.2.2 DEACTIVATE TMS SUBSYSTEMS
 - 3.2.18 RETRIEVAL BY ORBITER
 - 3.2.18.1 ADJUST ORBIT (OF ORBITER)

- 3.2.18.1.1 INITIALIZE GUIDANCE SYSTEM
- 3.2.18.1.2 DETERMINE CURRENT ORBITAL PARAMETERS
- 3.2.18.1.3 DETERMINE DESIRED ORBITAL PARAMETERS
- 3.2.18.1.4 CHOOSE OPTIMAL TRAJECTORY
- 3.2.18.1.5 FIRE THRUSTERS
- 3.2.18.2 ADJUST ATTITUDE (OF ORBITER)
 - 3.2.18.2.1 DETERMINE CURRENT ATTITUDE
 - 3.2.18.2.2 DETERMINE DESIRED ATTITUDE
 - 3.2.18.2.3 DETERMINE NEW CONFIGURATION FOR SPACECRAFT COMPONENTS
 - 3.2.18.2.4 CHOOSE OPTIMAL TRAJECTORY
 - 3.2.18.2.5 ROTATE SPACECRAFT
- 3.2.18.3 OPTIMAL CONTROL ALLOCATION
 - 3.2.18.3.1 UPDATE SPACECRAFT MODEL
 - 3.2.18.3.2 PROJECT DESIRED FUNCTIONS FROM MISSION PROFILE
 - 3.2.18.3.3 ESTIMATE RISKS FROM DESIRED FUNCTIONS
 - 3.2.18.3.4 PROJECT CONSUMABLES REQUIREMENTS FROM MISSION PROFILE
 - 3.2.18.3.5 DETERMINE CONSTRAINTS AND FIGURES OF MERIT
 - 3.2.18.3.6 CHOOSE OPTIMAL CONTROL MODE
 - 3.2.18.3.7 COMPUTE CONTROL COMMANDS
 - 3.2.18.3.8 EXECUTE CONTROL COMMANDS
- 3.2.18.4 ORBITER RECOVERY OF TMS
 - 3.2.18.4.1 ACTIVATE RMS
 - 3.2.18.4.2 LOCATE GRASPING FIXTURE ON TARGET
 - 3.2.18.4.3 MOVE RMS TO FIXTURE
 - 3.2.18.4.4 GRASP FIXTURE
 - 3.2.18.4.5 LOCATE CRADLE IN PAYLOAD BAY
 - 3.2.18.4.6 TRANSLATE PAYLOAD TO CRADLE
 - 3.2.18.4.7 FASTEN PAYLOAD RESTRAINTS
 - 3.2.18.4.8 RMS RELEASES PAYLOAD
 - 3.2.18.4.9 SECURE RMS IN PAYLOAD BAY
- 3.2.19 REENTRY AND LANDING
- 3.2.20 POST-FLIGHT OPERATIONS
 - 3.2.20.1 SAFING OF ORBITER AND HAZARDOUS PAYLOADS
 - 3.2.20.2 REMOVAL OF PAYLOADS FROM ORBITER

3.3 OPERATIONS SUPPORT

 The TMS can be used as a remote platform for operations support. This might include remote lighting or viewing of a worksite, remote sensing for an experiment, measuring thruster plumes, and observing hazardous activities such as OTV engine firings.

- 3.3.1 DESIGN
 - 3.3.1.1 DEFINE REQUIREMENTS
 - 3.3.1.2 MISSION ANALYSIS
 - 3.3.1.3 PAYLOAD ACCOMODATIONS
 - 3.3.1.4 CREATE FUNCTIONAL LAYOUT
 - 3.3.1.5 FAILURE MODES ANALYSIS
 - 3.3.1.6 ADJUST DESIGN FOR MAINTAINANCE AND REPAIR
 - 3.3.1.7 CREATE MECHANICAL LAYOUT
 - 3.3.1.8 SAFETY REVIEW
 - 3.3.1.9 DESIGN OF COMPONENTS
 - 3.3.1.10 SOFTWARE DEVELOPMENT
- 3.3.2 COMPONENT FABRICATION
 - 3.3.2.1 PROCURE OFF-THE-SHELF COMPONENTS
 - 3.3.2.2 PROCURE MATERIALS FOR MANUFACTURED COMPONENTS
 - 3.3.2.3 PROCURE MANUFACTURING EQUIPMENT
 - 3.3.2.4 MANUFACTURE COMPONENTS
- 3.3.3 COMPONENT TEST
 - 3.3.3.1 SET UP TEST FACILITIES
 - 3.3.3.2 STRUCTURAL LOADS TESTS
 - 3.3.3.3 DATA PROCESSING AND SOFTWARE TESTS
 - 3.3.3.4 ANTENNA AND ARRAY DEPLOYMENT TESTS
 - 3.3.3.5 ELECTRICAL SYSTEMS TESTS
 - 3.3.3.6 THERMAL AND VACUUM TESTS
 - 3.3.3.7 THRUSTER TESTS
 - 3.3.3.8 COMPONENT CERTIFICATION
- 3.3.4 SYSTEM INTEGRATION
- 3.3.5 SYSTEM TEST
 - 3.3.5.1 POWER SUBSYSTEM TESTS
 - 3.3.5.2 THERMAL SUBSYSTEM TESTS
 - 3.3.5.3 STRUCTURE SUBSYSTEM TESTS

ORIGINAL PLANS
OF POOR QUALITY

- 3.3.5.4 INFORMATION PROCESSING SUBSYSTEM TESTS
- 3.3.5.5 COMMUNICATIONS SUBSYSTEM TESTS
- 3.3.5.6 ATTITUDE CONTROL SUBSYSTEM TESTS
- 3.3.5.7 PROPULSION SUBSYSTEM TESTS
- 3.3.5.8 INTEGRATED SYSTEMS TESTS
- 3.3.5.9 FAILURE MODES SIMULATION
- 3.3.5.10 SYSTEM CERTIFICATION
- 3.3.6 SHIPPING TO LAUNCH SITE
 - 3.3.6.1 REMOVE TEST EQUIPMENT
 - 3.3.6.2 PERFORM NECESSARY DISASSEMBLY
 - 3.3.6.3 PACKING
 - 3.3.6.4 TRANSPORT TO LAUNCH SITE
- 3.3.7A PAYLOAD INTEGRATION AND CHECKOUT (HORIZONTAL PAYLOAD)
 - 3.3.7A.1 UNPACKING
 - 3.3.7A.2 PERFORM NECESSARY REASSEMBLY
 - 3.3.7A.3 INTEGRATED SYSTEMS TESTS
 - 3.3.7A.3.1 VERIFY POWER SYSTEM FUNCTION
 - 3.3.7A.3.2 VERIFY COMMAND SYSTEM FUNCTION
 - 3.3.7A.3.3 VERIFY MECHANICAL SYSTEM FUNCTION
 - 3.3.7A.3.4 VERIFY COMMUNICATIONS SYSTEM FUNCTION
 - 3.3.7A.3.5 MISSION SEQUENCE SIMULATION
 - 3.3.7A.4 TRANSFER TO OPERATIONS AND CHECKOUT BLDG.
 - 3.3.7A.4.1 LOAD PAYLOAD INTO CONTAINER
 - 3.3.7A.4.2 TRANSPORT TO OPERATIONS AND CHECKOUT BLDG.
 - 3.3.7A.4.3 ATTACH STRONGBACK TO PAYLOAD
 - 3.3.7A.4.4 INSTALL PAYLOAD IN HORIZONTAL CITE
 - 3.3.7A.5 INTEGRATE TMS WITH PAYLOAD

For this mission the payload might include scientific instruments.

 - 3.3.7A.6 PERFORM INTERFACES CHECK
 - 3.3.7A.6.1 CHECK TMS/PAYLOAD MECHANICAL INTERFACES
 - 3.3.7A.6.2 CHECK ELECTRICAL INTERFACES
 - 3.3.7A.6.3 CHECK SHUTTLE/PAYLOAD MECHANICAL INTERFACES
 - 3.3.7A.6.4 CHECK ELECTRICAL INTERFACES
 - 3.3.7A.7 TRANSFER TMS/PAYLOAD TO ORBITER PROCESSING FACILITY
 - 3.3.7A.7.1 ATTACH STRONGBACK TO PAYLOAD
 - 3.3.7A.7.2 LOAD PAYLOAD INTO CANISTER
 - 3.3.7A.7.3 REMOVE STRONGBACK
 - 3.3.7A.7.4 CLOSE CANISTER
 - 3.3.7A.7.5 TRANSPORT CANISTER TO ORBITER PROCESSING FACILITY
 - 3.3.7A.7.6 UNLOAD CANISTER
 - 3.3.7A.8 ORBITER/PAYLOAD INTEGRATION (HORIZONTAL)
 - 3.3.7A.8.1 ATTACH STRONGBACK TO PAYLOAD
 - 3.3.7A.8.2 INSTALL PAYLOAD IN ORBITER
 - 3.3.7A.8.3 CONNECT ORBITER/PAYLOAD INTERFACES
 - 3.3.7A.8.4 CHECK ELECTRICAL INTERFACES
 - 3.3.7A.8.5 REMOVE STRONGBACK
 - 3.3.7A.8.6 CLOSE-OUT PAYLOAD BAY
 - 3.3.7A.8.7 INSTALLATION OF ORBITER PAYLOAD STATION CONSOLES- 3.3.7B PAYLOAD INTEGRATION AND CHECKOUT (VERTICAL PAYLOAD)
 - 3.3.7B.1 UNPACKING
 - 3.3.7B.2 PERFORM NECESSARY REASSEMBLY
 - 3.3.7B.3 INTEGRATED SYSTEMS TESTS
 - 3.3.7B.3.1 VERIFY POWER SYSTEM FUNCTION
 - 3.3.7B.3.2 VERIFY COMMAND SYSTEM FUNCTION
 - 3.3.7B.3.3 VERIFY MECHANICAL SYSTEM FUNCTION
 - 3.3.7B.3.4 VERIFY COMMUNICATIONS SYSTEM FUNCTION
 - 3.3.7B.3.5 MISSION SEQUENCE SIMULATION
 - 3.3.7B.4 TRANSFER TO VERTICAL PROCESSING FACILITY
 - 3.3.7B.4.1 LOAD PAYLOAD INTO CONTAINER
 - 3.3.7B.4.2 TRANSPORT CONTAINER TO VERTICAL PROCESSING FACILITY
 - 3.3.7B.4.3 UNLOAD CONTAINER
 - 3.3.7B.5 INTEGRATE TMS WITH PAYLOAD
 - 3.3.7B.6 PERFORM INTERFACES CHECK
 - 3.3.7B.6.1 CHECK TMS/PAYLOAD MECHANICAL INTERFACES
 - 3.3.7B.6.2 CHECK ELECTRICAL INTERFACES
 - 3.3.7B.6.3 CHECK SHUTTLE/PAYLOAD MECHANICAL INTERFACES
 - 3.3.7B.6.4 CHECK ELECTRICAL INTERFACES
 - 3.3.7B.7 TRANSFER PAYLOAD TO LAUNCH PAD
 - 3.3.7B.7.1 LOAD PAYLOAD INTO CANISTER
 - 3.3.7B.7.2 TRANSPORT TO ROTATING SERVICE STRUCTURE

- 3.3.7B.7.3 LOAD CANISTER INTO ROTATING SERVICE STRUCTURE
- 3.3.7B.7.4 LOAD PAYLOAD INTO ROTATING SERVICE STRUCTURE USING PGHM
- 3.3.7B.7.5 REMOVE CANISTER
- 3.3.7B.8 ORBITER/PAYLOAD INTEGRATION (VERTICAL)
 - 3.3.7B.8.1 MATE ROTATING SERVICE STRUCTURE TO ORBITER
 - 3.3.7B.8.2 EXTEND PAYLOAD INTO ORBITER USING PGHM
 - 3.3.7B.8.3 CONNECT ORBITER/PAYLOAD INTERFACES
 - 3.3.7B.8.4 CHECK ELECTRICAL INTERFACES
 - 3.3.7B.8.5 CLOSE-OUT PAYLOAD BAY
 - 3.3.7B.8.6 INSTALLATION OF ORBITER PAYLOAD STATION CONSOLES
- 3.3.8 COUNTDOWN AND LAUNCH
- 3.3.9 ORBITAL DEPLOYMENT AND CHECKOUT
 - 3.3.9.1 SHUTTLE ATTAINS DELIVERY ORBIT
 - 3.3.9.2 TESTS OF ATTACHED PAYLOAD
 - 3.3.9.2.1 POWER SUBSYSTEM CHECKOUT
 - 3.3.9.2.2 INFORMATION PROCESSING SUBSYSTEM CHECKOUT
 - 3.3.9.3 EXTENSION OF PAYLOAD FROM PAYLOAD BAY
 - 3.3.9.3.1 OPEN PAYLOAD BAY DOORS
 - 3.3.9.3.2 ACTIVATE RMS
 - 3.3.9.3.3 LOCATE GRASPING FIXTURE ON TARGET
 - 3.3.9.3.4 MOVE RMS TO FIXTURE
 - 3.3.9.3.5 GRASP FIXTURE
 - 3.3.9.3.6 RELEASE PAYLOAD RESTRAINTS
 - 3.3.9.3.7 TRANSLATE PAYLOAD OUT OF PAYLOAD BAY
 - 3.3.9.4 SEPARATION OF PAYLOAD FROM ORBITER
 - 3.3.9.4.1 RMS RELEASES PAYLOAD
 - 3.3.9.4.2 SECURE RMS IN PAYLOAD BAY
 - 3.3.9.5 OPERATIONAL CHECKOUT
 - 3.3.9.5.1 ACTIVATE TMS SUBSYSTEMS
 - 3.3.9.5.2 INFORMATION PROCESSING SUBSYSTEM CHECKOUT
 - 3.3.9.5.3 POWER SUBSYSTEM CHECKOUT
 - 3.3.9.5.4 THERMAL SUBSYSTEM CHECKOUT
 - 3.3.9.5.5 STRUCTURAL SUBSYSTEM CHECKOUT
 - 3.3.9.5.6 COMMUNICATIONS SUBSYSTEM CHECKOUT
 - 3.3.9.5.7 ATTITUDE CONTROL SUBSYSTEM CHECKOUT
 - 3.3.9.5.8 PROPULSION SUBSYSTEM CHECKOUT
 - 3.3.9.5.9 CONSUMABLES LEVELS CHECKOUT
 - 3.3.9.6 IDENTIFY DEFECTIVE COMPONENT
 - 3.3.9.6.1 DETERMINE ANOMALOUS DATA
 - 3.3.9.6.2 FORM HYPOTHESIS FOR PROBLEM
 - 3.3.9.6.3 DEVISE TEST FOR FAILURE HYPOTHESIS
 - 3.3.9.6.4 PERFORM TEST FOR FAILURE HYPOTHESIS
 - 3.3.9.6.5 IDENTIFY FAULTY COMPONENT
 - 3.3.9.7 IDENTIFY DEFECTIVE SOFTWARE
 - 3.3.9.7.1 COMPARE MEASURED DATA TO MODEL
 - 3.3.9.7.2 DETERMINE ANOMALOUS DATA
 - 3.3.9.7.3 FORM HYPOTHESIS FOR PROBLEM
 - 3.3.9.7.4 DEVISE TEST FOR FAILURE HYPOTHESIS
 - 3.3.9.7.5 PERFORM TEST FOR FAILURE HYPOTHESIS
 - 3.3.9.8A COMPONENT FAILURE RECOVERY (REDUNDANCY)
 - 3.3.9.8A.1 SWITCH OUT FAULTY COMPONENT
 - 3.3.9.8A.2 SWITCH IN REDUNDANT COMPONENT
 - 3.3.9.8A.3 MAKE DIAGNOSTIC CHECKS
 - 3.3.9.8A.4 UPDATE SPACECRAFT MODEL
 - 3.3.9.8B COMPONENT FAILURE RECOVERY (ON-BOARD REPAIR)
 - 3.3.9.8B.1 DEFINE ACCESS SEQUENCE
 - 3.3.9.8B.2 LOCATE ACCESS PANEL
 - 3.3.9.8B.3 TRANSFER REPAIR EQUIPMENT TO REPAIR SITE
 - 3.3.9.8B.4 OPEN ACCESS PANEL
 - 3.3.9.8B.5 OBSERVE/LOCATE DEFECTIVE COMPONENT
 - 3.3.9.8B.6 REMOVE COMPONENT
 - 3.3.9.8B.7 STORE COMPONENT
 - 3.3.9.8B.8 LOCATE NEW COMPONENT
 - 3.3.9.8B.9 POSITION AND CONNECT NEW COMPONENT
 - 3.3.9.8B.10 ADJUST COMPONENT
 - 3.3.9.8B.11 MAKE DIAGNOSTIC CHECKS
 - 3.3.9.8B.12 CLOSE ACCESS PANEL
 - 3.3.9.8B.13 STOW REPAIR EQUIPMENT
 - 3.3.9.8B.14 UPDATE SPACECRAFT MODEL
 - 3.3.9.9 SOFTWARE FAILURE RECOVERY
 - 3.3.9.9.1 DETERMINE CORRECTION ALGORITHM
 - 3.3.9.9.2 DATA/COMMAND ENCODING

ORIGINAL QUALITY
OF PAGE QUALITY

- 3.3.9.9.3 DATA/COMMAND TRANSMISSION
- 3.3.9.9.4 COMPUTER FUNCTION CHECKS
- 3.3.9.10 ORBITAL TRANSFER
 - 3.3.9.10.1 INITIALIZE GUIDANCE SYSTEM
 - 3.3.9.10.2 DETERMINE CURRENT ORBITAL PARAMETERS
 - 3.3.9.10.3 DETERMINE DESIRED ORBITAL PARAMETERS
 - 3.3.9.10.4 CHOOSE OPTIMAL TRAJECTORY
 - 3.3.9.10.5 DETERMINE CURRENT ATTITUDE
 - 3.3.9.10.6 DETERMINE DESIRED ATTITUDE
 - 3.3.9.10.7 ROTATE SPACECRAFT
 - 3.3.9.10.8 FIRE THRUSTERS
- 3.3.10 STATUS MONITORING AND RESOURCE ALLOCATION
 - 3.3.10.1 TEMPERATURE MANAGEMENT
 - 3.3.10.1.1 MEASURE COMPONENT TEMPERATURES
 - 3.3.10.1.2 COMPARE TEMPERATURES TO REQUIRED LIMITS
 - 3.3.10.1.3 ADJUST COOLING/HEATING SYSTEMS
 - 3.3.10.2 POWER MANAGEMENT
 - 3.3.10.2.1 MEASURE CURRENTS AND VOLTAGES
 - 3.3.10.2.2 COMPARE CURRENTS AND VOLTAGES TO REQUIRED LIMITS
 - 3.3.10.2.3 ADJUST CURRENTS AND VOLTAGES
 - 3.3.10.2.4 MONITOR BATTERIES
 - 3.3.10.3 DATA/COMMAND PROCESSING
 - 3.3.10.3.1 SHORT-TERM MEMORY STORAGE
 - 3.3.10.3.2 LONG-TERM MEMORY STORAGE
 - 3.3.10.3.3 DATA/COMMAND ENCODING
 - 3.3.10.3.4 DATA/COMMAND DECODING
 - 3.3.10.3.5 NUMERICAL COMPUTATION
 - 3.3.10.3.6 LOGIC OPERATIONS
 - 3.3.10.3.7 COMPUTER LOAD SCHEDULING
 - 3.3.10.3.8 COMPUTER FUNCTION CHECKS
 - 3.3.10.4 CONSUMABLES MANAGEMENT
 - 3.3.10.4.1 MONITOR PROPELLANT SUPPLIES
 - 3.3.10.4.2 PROJECT CONSUMABLES REQUIREMENTS FROM MISSION PROFILE
 - 3.3.10.4.3 COMPUTE OPTIMAL CONSUMABLES ALLOCATION
 - 3.3.10.5 STRUCTURAL MANAGEMENT
 - 3.3.10.5.1 MEASURE STRAINS IN STRUCTURE
 - 3.3.10.5.2 COMPUTE STRESS AND VIBRATION PARAMETERS
 - 3.3.10.5.3 COMPARE STRESS AND VIBRATION PARAMETERS TO REQUIRED LIMITS
 - 3.3.10.5.4 APPLY COMPENSATING FORCES
 - 3.3.10.5.5 APPLY VIBRATION DAMPING
 - 3.3.10.6 HAZARD AVOIDANCE
 - 3.3.10.6.1 AVOID TANK OVERPRESSURES
 - 3.3.10.6.2 MAINTAIN SAFE BATTERY CHARGE LEVELS
 - 3.3.10.6.3 MAINTAIN COMMUNICATION LINKS
 - 3.3.10.6.4 AVOID EXPOSING SENSITIVE COMPONENTS TO DIRECT SUNLIGHT
 - 3.3.10.6.5 TRACK NEARBY OBJECTS
 - 3.3.10.6.6 AVOID CONFLICTING OBJECTS
 - 3.3.10.7 OPTIMAL SEQUENCING
 - 3.3.10.7.1 UPDATE SPACECRAFT MODEL
 - 3.3.10.7.2 PROJECT DESIRED FUNCTIONS FROM MISSION PROFILE
 - 3.3.10.7.3 ESTIMATE RISKS FROM DESIRED FUNCTIONS
 - 3.3.10.7.4 PROJECT CONSUMABLES REQUIREMENTS FROM MISSION PROFILE
 - 3.3.10.7.5 DETERMINE CONSTRAINTS AND FIGURES OF MERIT
 - 3.3.10.7.6 COMPUTE OPTIMAL SEQUENCING
 - 3.3.10.8 IDENTIFY DEFECTIVE COMPONENT
 - 3.3.10.8.1 DETERMINE ANOMALOUS DATA
 - 3.3.10.8.2 FORM HYPOTHESIS FOR PROBLEM
 - 3.3.10.8.3 DEVISE TEST FOR FAILURE HYPOTHESIS
 - 3.3.10.8.4 PERFORM TEST FOR FAILURE HYPOTHESIS
 - 3.3.10.8.5 IDENTIFY FAULTY COMPONENT
 - 3.3.10.9 IDENTIFY DEFECTIVE SOFTWARE
 - 3.3.10.9.1 COMPARE MEASURED DATA TO MODEL
 - 3.3.10.9.2 DETERMINE ANOMALOUS DATA
 - 3.3.10.9.3 FORM HYPOTHESIS FOR PROBLEM
 - 3.3.10.9.4 DEVISE TEST FOR FAILURE HYPOTHESIS
 - 3.3.10.9.5 PERFORM TEST FOR FAILURE HYPOTHESIS
 - 3.3.10.10A COMPONENT FAILURE RECOVERY (REDUNDANCY)
 - 3.3.10.10A.1 SWITCH OUT FAULTY COMPONENT
 - 3.3.10.10A.2 SWITCH IN REDUNDANT COMPONENT
 - 3.3.10.10A.3 MAKE DIAGNOSTIC CHECKS
 - 3.3.10.10A.4 UPDATE SPACECRAFT MODEL
 - 3.3.10.10B COMPONENT FAILURE RECOVERY (ON-BOARD REPAIR)

ORIGINAL COPY OF DATA QUALITY

- 3.3.10.10B.1 DEFINE ACCESS SEQUENCE
- 3.3.10.10B.2 LOCATE ACCESS PANEL
- 3.3.10.10B.3 TRANSFER REPAIR EQUIPMENT TO REPAIR SITE
- 3.3.10.10B.4 OPEN ACCESS PANEL
- 3.3.10.10B.5 OBSERVE/LOCATE DEFECTIVE COMPONENT
- 3.3.10.10B.6 REMOVE COMPONENT
- 3.3.10.10B.7 STORE COMPONENT
- 3.3.10.10B.8 LOCATE NEW COMPONENT
- 3.3.10.10B.9 POSITION AND CONNECT NEW COMPONENT
- 3.3.10.10B.10 ADJUST COMPONENT
- 3.3.10.10B.11 MAKE DIAGNOSTIC CHECKS
- 3.3.10.10B.12 CLOSE ACCESS PANEL
- 3.3.10.10B.13 STOW REPAIR EQUIPMENT
- 3.3.10.10B.14 UPDATE SPACECRAFT MODEL
- 3.3.10.11 SOFTWARE FAILURE RECOVERY
 - 3.3.10.11.1 DETERMINE CORRECTION ALGORITHM
 - 3.3.10.11.2 DATA/COMMAND ENCODING
 - 3.3.10.11.3 DATA/COMMAND TRANSMISSION
 - 3.3.10.11.4 COMPUTER FUNCTION CHECKS
- 3.3.10.12 REPORT SYSTEM STATUS
 - 3.3.10.12.1 DATA/COMMAND ENCODING
 - 3.3.10.12.2 DATA/COMMAND TRANSMISSION
 - 3.3.10.12.3 DATA/COMMAND DECODING
 - 3.3.10.12.4 DATA/COMMAND DISPLAY
- 3.3.11 ATTITUDE CONTROL AND STATIONKEEPING
 - 3.3.11.1 MAINTAIN/CHANGE ATTITUDE
 - 3.3.11.1.1 INITIALIZE GUIDANCE SYSTEM
 - 3.3.11.1.2 DETERMINE CURRENT ATTITUDE
 - 3.3.11.1.3 DETERMINE DESIRED ATTITUDE
 - 3.3.11.1.4 DETERMINE NEW CONFIGURATION FOR SPACECRAFT COMPONENTS
 - 3.3.11.1.5 CHOOSE OPTIMAL TRAJECTORY
 - 3.3.11.1.6 ROTATE SPACECRAFT
 - 3.3.11.2 MAINTAIN/CHANGE ORBIT
 - 3.3.11.2.1 INITIALIZE GUIDANCE SYSTEM
 - 3.3.11.2.2 DETERMINE CURRENT ORBITAL PARAMETERS
 - 3.3.11.2.3 DETERMINE DESIRED ORBITAL PARAMETERS
 - 3.3.11.2.4 CHOOSE OPTIMAL TRAJECTORY
 - 3.3.11.2.5 FIRE THRUSTERS
 - 3.3.11.3 OPTIMAL CONTROL ALLOCATION
 - 3.3.11.3.1 UPDATE SPACECRAFT MODEL
 - 3.3.11.3.2 PROJECT DESIRED FUNCTIONS FROM MISSION PROFILE
 - 3.3.11.3.3 ESTIMATE RISKS FROM DESIRED FUNCTIONS
 - 3.3.11.3.4 PROJECT CONSUMABLES REQUIREMENTS FROM MISSION PROFILE
 - 3.3.11.3.5 DETERMINE CONSTRAINTS AND FIGURES OF MERIT
 - 3.3.11.3.6 CHOOSE OPTIMAL CONTROL MODE
 - 3.3.11.3.7 COMPUTE CONTROL COMMANDS
 - 3.3.11.3.8 EXECUTE CONTROL COMMANDS
 - 3.3.11.4 OPERATE MISSION-SPECIFIC SENSORS/ACTUATORS

This is what the TMS is here for--to watch or monitor some activity.
This might include multi-spectral space environment measurements, observation
of DTV engine firings, providing a remote target, lighting a work area, and
so forth.

- 3.3.12 RENDEZVOUS WITH ORBITER
 - 3.3.12.1 ORBITAL TRANSFER (OF TMS/SPACECRAFT)
 - 3.3.12.1.1 INITIALIZE GUIDANCE SYSTEM
 - 3.3.12.1.2 DETERMINE CURRENT ORBITAL PARAMETERS
 - 3.3.12.1.3 DETERMINE DESIRED ORBITAL PARAMETERS
 - 3.3.12.1.4 CHOOSE OPTIMAL TRAJECTORY
 - 3.3.12.1.5 DETERMINE CURRENT ATTITUDE
 - 3.3.12.1.6 DETERMINE DESIRED ATTITUDE
 - 3.3.12.1.7 ROTATE SPACECRAFT
 - 3.3.12.1.8 FIRE THRUSTERS
 - 3.3.12.2 SHUTDOWN TMS FOR RETRIEVAL
 - 3.3.12.2.1 STOW TMS ANTENNA
 - 3.3.12.2.2 DEACTIVATE TMS SUBSYSTEMS
- 3.3.13 RETRIEVAL BY ORBITER (OF TMS/SATELLITE)
 - 3.3.13.1 ADJUST ORBIT (OF ORBITER)
 - 3.3.13.1.1 INITIALIZE GUIDANCE SYSTEM
 - 3.3.13.1.2 DETERMINE CURRENT ORBITAL PARAMETERS
 - 3.3.13.1.3 DETERMINE DESIRED ORBITAL PARAMETERS

ORIGINAL PAGE IS
OF POOR QUALITY

- 3.3.13.1.4 CHOOSE OPTIMAL TRAJECTORY
- 3.3.13.1.5 FIRE THRUSTERS
- 3.3.13.2 ADJUST ATTITUDE (OF ORBITER)
 - 3.3.13.2.1 DETERMINE CURRENT ATTITUDE
 - 3.3.13.2.2 DETERMINE DESIRED ATTITUDE
 - 3.3.13.2.3 DETERMINE NEW CONFIGURATION FOR SPACECRAFT COMPONENTS
 - 3.3.13.2.4 CHOOSE OPTIMAL TRAJECTORY
 - 3.3.13.2.5 ROTATE SPACECRAFT
- 3.3.13.3 OPTIMAL CONTROL ALLOCATION
 - 3.3.13.3.1 UPDATE SPACECRAFT MODEL
 - 3.3.13.3.2 PROJECT DESIRED FUNCTIONS FROM MISSION PROFILE
 - 3.3.13.3.3 ESTIMATE RISKS FROM DESIRED FUNCTIONS
 - 3.3.13.3.4 PROJECT CONSUMABLES REQUIREMENTS FROM MISSION PROFILE
 - 3.3.13.3.5 DETERMINE CONSTRAINTS AND FIGURES OF MERIT
 - 3.3.13.3.6 CHOOSE OPTIMAL CONTROL MODE
 - 3.3.13.3.7 COMPUTE CONTROL COMMANDS
 - 3.3.13.3.8 EXECUTE CONTROL COMMANDS
- 3.3.13.4 ORBITER RECOVERY OF TMS
 - 3.3.13.4.1 ACTIVATE RMS
 - 3.3.13.4.2 LOCATE GRASPING FIXTURE ON TARGET
 - 3.3.13.4.3 MOVE RMS TO FIXTURE
 - 3.3.13.4.4 GRASP FIXTURE
 - 3.3.13.4.5 LOCATE CRADLE IN PAYLOAD BAY
 - 3.3.13.4.6 TRANSLATE PAYLOAD TO CRADLE
 - 3.3.13.4.7 FASTEN PAYLOAD RESTRAINTS
 - 3.3.13.4.8 RMS RELEASES PAYLOAD
 - 3.3.13.4.9 SECURE RMS IN PAYLOAD BAY
- 3.3.14 REENTRY AND LANDING
- 3.3.15 POST-FLIGHT OPERATIONS
 - 3.3.15.1 SAFING OF ORBITER AND HAZARDOUS PAYLOADS
 - 3.3.15.2 REMOVAL OF PAYLOADS FROM ORBITER

3.4 LARGE SPACE SYSTEMS ASSEMBLY

The TMS may be used as an assembly aid in the construction of a large space structure. Tasks would include transferring material between sites, routing cables, structural alignment and assembly, and equipment installation and servicing.

- 3.4.1 DESIGN
 - 3.4.1.1 DEFINE REQUIREMENTS
 - 3.4.1.2 MISSION ANALYSIS
 - 3.4.1.3 PAYLOAD ACCOMMODATIONS
 - 3.4.1.4 CREATE FUNCTIONAL LAYOUT
 - 3.4.1.5 FAILURE MODES ANALYSIS
 - 3.4.1.6 ADJUST DESIGN FOR MAINTAINANCE AND REPAIR
 - 3.4.1.7 CREATE MECHANICAL LAYOUT
 - 3.4.1.8 SAFETY REVIEW
 - 3.4.1.9 DESIGN OF COMPONENTS
 - 3.4.1.10 SOFTWARE DEVELOPMENT
- 3.4.2 COMPONENT FABRICATION
 - 3.4.2.1 PROCURE OFF-THE-SHELF COMPONENTS
 - 3.4.2.2 PROCURE MATERIALS FOR MANUFACTURED COMPONENTS
 - 3.4.2.3 PROCURE MANUFACTURING EQUIPMENT
 - 3.4.2.4 MANUFACTURE COMPONENTS
- 3.4.3 COMPONENT TEST
 - 3.4.3.1 SET UP TEST FACILITIES
 - 3.4.3.2 STRUCTURAL LOADS TESTS
 - 3.4.3.3 DATA PROCESSING AND SOFTWARE TESTS
 - 3.4.3.4 ANTENNA AND ARRAY DEPLOYMENT TESTS
 - 3.4.3.5 ELECTRICAL SYSTEMS TESTS
 - 3.4.3.6 THERMAL AND VACUUM TESTS
 - 3.4.3.7 THRUSTER TESTS
 - 3.4.3.8 COMPONENT CERTIFICATION
- 3.4.4 SYSTEM INTEGRATION
- 3.4.5 SYSTEM TEST
 - 3.4.5.1 POWER SUBSYSTEM TESTS
 - 3.4.5.2 THERMAL SUBSYSTEM TESTS
 - 3.4.5.3 STRUCTURE SUBSYSTEM TESTS
 - 3.4.5.4 INFORMATION PROCESSING SUBSYSTEM TESTS
 - 3.4.5.5 COMMUNICATIONS SUBSYSTEM TESTS
 - 3.4.5.6 ATTITUDE CONTROL SUBSYSTEM TESTS

- 3.4.5.7 PROPULSION SUBSYSTEM TESTS
- 3.4.5.8 INTEGRATED SYSTEMS TESTS
- 3.4.5.9 FAILURE MODES SIMULATION
- 3.4.5.10 SYSTEM CERTIFICATION
- 3.4.6 SHIPPING TO LAUNCH SITE
 - 3.4.6.1 REMOVE TEST EQUIPMENT
 - 3.4.6.2 PERFORM NECESSARY DISASSEMBLY
 - 3.4.6.3 PACKING
 - 3.4.6.4 TRANSPORT TO LAUNCH SITE
- 3.4.7A PAYLOAD INTEGRATION AND CHECKOUT (HORIZONTAL PAYLOAD)
 - 3.4.7A.1 UNPACKING
 - 3.4.7A.2 PERFORM NECESSARY REASSEMBLY
 - 3.4.7A.3 INTEGRATED SYSTEMS TESTS
 - 3.4.7A.3.1 VERIFY POWER SYSTEM FUNCTION
 - 3.4.7A.3.2 VERIFY COMMAND SYSTEM FUNCTION
 - 3.4.7A.3.3 VERIFY MECHANICAL SYSTEM FUNCTION
 - 3.4.7A.3.4 VERIFY COMMUNICATIONS SYSTEM FUNCTION
 - 3.4.7A.3.5 MISSION SEQUENCE SIMULATION
 - 3.4.7A.4 TRANSFER TO OPERATIONS AND CHECKOUT BLDG.
 - 3.4.7A.4.1 LOAD PAYLOAD INTO CONTAINER
 - 3.4.7A.4.2 TRANSPORT TO OPERATIONS AND CHECKOUT BLDG.
 - 3.4.7A.4.3 ATTACH STRONGBACK TO PAYLOAD
 - 3.4.7A.4.4 INSTALL PAYLOAD IN HORIZONTAL SITE
 - 3.4.7A.5 INTEGRATE TMS WITH PAYLOAD

The TMS might carry manipulators for structural assembly or a cargo rack
for this mission.

- 3.4.7A.6 PERFORM INTERFACES CHECK
 - 3.4.7A.6.1 CHECK TMS/PAYLOAD MECHANICAL INTERFACES
 - 3.4.7A.6.2 CHECK ELECTRICAL INTERFACES
 - 3.4.7A.6.3 CHECK SHUTTLE/PAYLOAD MECHANICAL INTERFACES
 - 3.4.7A.6.4 CHECK ELECTRICAL INTERFACES
- 3.4.7A.7 TRANSFER TMS/PAYLOAD TO ORBITER PROCESSING FACILITY
 - 3.4.7A.7.1 ATTACH STRONGBACK TO PAYLOAD
 - 3.4.7A.7.2 LOAD PAYLOAD INTO CANISTER
 - 3.4.7A.7.3 REMOVE STRONGBACK
 - 3.4.7A.7.4 CLOSE CANISTER
 - 3.4.7A.7.5 TRANSPORT CANISTER TO ORBITER PROCESSING FACILITY
 - 3.4.7A.7.6 UNLOAD CANISTER
- 3.4.7A.8 ORBITER/PAYLOAD INTEGRATION (HORIZONTAL)
 - 3.4.7A.8.1 ATTACH STRONGBACK TO PAYLOAD
 - 3.4.7A.8.2 INSTALL PAYLOAD IN ORBITER
 - 3.4.7A.8.3 CONNECT ORBITER/PAYLOAD INTERFACES
 - 3.4.7A.8.4 CHECK ELECTRICAL INTERFACES
 - 3.4.7A.8.5 REMOVE STRONGBACK
 - 3.4.7A.8.6 CLOSE-OUT PAYLOAD BAY
 - 3.4.7A.8.7 INSTALLATION OF ORBITER PAYLOAD STATION CONSOLES
- 3.4.7B PAYLOAD INTEGRATION AND CHECKOUT (VERTICAL PAYLOAD)
 - 3.4.7B.1 UNPACKING
 - 3.4.7B.2 PERFORM NECESSARY REASSEMBLY
 - 3.4.7B.3 INTEGRATED SYSTEMS TESTS
 - 3.4.7B.3.1 VERIFY POWER SYSTEM FUNCTION
 - 3.4.7B.3.2 VERIFY COMMAND SYSTEM FUNCTION
 - 3.4.7B.3.3 VERIFY MECHANICAL SYSTEM FUNCTION
 - 3.4.7B.3.4 VERIFY COMMUNICATIONS SYSTEM FUNCTION
 - 3.4.7B.3.5 MISSION SEQUENCE SIMULATION
 - 3.4.7B.4 TRANSFER TO VERTICAL PROCESSING FACILITY
 - 3.4.7B.4.1 LOAD PAYLOAD INTO CONTAINER
 - 3.4.7B.4.2 TRANSPORT CONTAINER TO VERTICAL PROCESSING FACILITY
 - 3.4.7B.4.3 UNLOAD CONTAINER
 - 3.4.7B.5 INTEGRATE TMS WITH PAYLOAD
 - 3.4.7B.6 PERFORM INTERFACES CHECK
 - 3.4.7B.6.1 CHECK TMS/PAYLOAD MECHANICAL INTERFACES
 - 3.4.7B.6.2 CHECK ELECTRICAL INTERFACES
 - 3.4.7B.6.3 CHECK SHUTTLE/PAYLOAD MECHANICAL INTERFACES
 - 3.4.7B.6.4 CHECK ELECTRICAL INTERFACES
 - 3.4.7B.7 TRANSFER PAYLOAD TO LAUNCH PAD
 - 3.4.7B.7.1 LOAD PAYLOAD INTO CANISTER
 - 3.4.7B.7.2 TRANSPORT TO ROTATING SERVICE STRUCTURE
 - 3.4.7B.7.3 LOAD CANISTER INTO ROTATING SERVICE STRUCTURE
 - 3.4.7B.7.4 LOAD PAYLOAD INTO ROTATING SERVICE STRUCTURE USING PGHM

ORIGINAL PAGE IS
OF POOR QUALITY

- 3.4.7B.7.5 REMOVE CANISTER
- 3.4.7B.8 ORBITER/PAYLOAD INTEGRATION (VERTICAL)
 - 3.4.7B.8.1 MATE ROTATING SERVICE STRUCTURE TO ORBITER
 - 3.4.7B.8.2 EXTEND PAYLOAD INTO ORBITER USING PGHM
 - 3.4.7B.8.3 CONNECT ORBITER/PAYLOAD INTERFACES
 - 3.4.7B.8.4 CHECK ELECTRICAL INTERFACES
 - 3.4.7B.8.5 CLOSE-OUT PAYLOAD BAY
 - 3.4.7B.8.6 INSTALLATION OF ORBITER PAYLOAD STATION CONSOLES
- 3.4.8 COUNTDOWN AND LAUNCH
- 3.4.9 ORBITAL DEPLOYMENT AND CHECKOUT
 - 3.4.9.1 SHUTTLE ATTAINS DELIVERY ORBIT
 - 3.4.9.2 TESTS OF ATTACHED PAYLOAD
 - 3.4.9.2.1 POWER SUBSYSTEM CHECKOUT
 - 3.4.9.2.2 INFORMATION PROCESSING SUBSYSTEM CHECKOUT
 - 3.4.9.3 EXTENSION OF PAYLOAD FROM PAYLOAD BAY
 - 3.4.9.3.1 OPEN PAYLOAD BAY DOORS
 - 3.4.9.3.2 ACTIVATE RMS
 - 3.4.9.3.3 LOCATE GRASPING FIXTURE ON TARGET
 - 3.4.9.3.4 MOVE RMS TO FIXTURE
 - 3.4.9.3.5 GRASP FIXTURE
 - 3.4.9.3.6 RELEASE PAYLOAD RESTRAINTS
 - 3.4.9.3.7 TRANSLATE PAYLOAD OUT OF PAYLOAD BAY
 - 3.4.9.4 SEPARATION OF PAYLOAD FROM ORBITER
 - 3.4.9.4.1 RMS RELEASES PAYLOAD
 - 3.4.9.4.2 SECURE RMS IN PAYLOAD BAY
 - 3.4.9.5 OPERATIONAL CHECKOUT
 - 3.4.9.5.1 ACTIVATE RMS SUBSYSTEMS
 - 3.4.9.5.2 INFORMATION PROCESSING SUBSYSTEM CHECKOUT
 - 3.4.9.5.3 POWER SUBSYSTEM CHECKOUT
 - 3.4.9.5.4 THERMAL SUBSYSTEM CHECKOUT
 - 3.4.9.5.5 STRUCTURAL SUBSYSTEM CHECKOUT
 - 3.4.9.5.6 COMMUNICATIONS SUBSYSTEM CHECKOUT
 - 3.4.9.5.7 ATTITUDE CONTROL SUBSYSTEM CHECKOUT
 - 3.4.9.5.8 PROPULSION SUBSYSTEM CHECKOUT
 - 3.4.9.5.9 CONSUMABLES LEVELS CHECKOUT
 - 3.4.9.6 IDENTIFY DEFECTIVE COMPONENT
 - 3.4.9.6.1 DETERMINE ANOMALOUS DATA
 - 3.4.9.6.2 FORM HYPOTHESIS FOR PROBLEM
 - 3.4.9.6.3 DEVISE TEST FOR FAILURE HYPOTHESIS
 - 3.4.9.6.4 PERFORM TEST FOR FAILURE HYPOTHESIS
 - 3.4.9.6.5 IDENTIFY FAULTY COMPONENT
 - 3.4.9.7 IDENTIFY DEFECTIVE SOFTWARE
 - 3.4.9.7.1 COMPARE MEASURED DATA TO MODEL
 - 3.4.9.7.2 DETERMINE ANOMALOUS DATA
 - 3.4.9.7.3 FORM HYPOTHESIS FOR PROBLEM
 - 3.4.9.7.4 DEVISE TEST FOR FAILURE HYPOTHESIS
 - 3.4.9.7.5 PERFORM TEST FOR FAILURE HYPOTHESIS
 - 3.4.9.8A COMPONENT FAILURE RECOVERY (REDUNDANCY)
 - 3.4.9.8A.1 SWITCH OUT FAULTY COMPONENT
 - 3.4.9.8A.2 SWITCH IN REDUNDANT COMPONENT
 - 3.4.9.8A.3 MAKE DIAGNOSTIC CHECKS
 - 3.4.9.8A.4 UPDATE SPACECRAFT MODEL
 - 3.4.9.8B COMPONENT FAILURE RECOVERY (ON-BOARD REPAIR)
 - 3.4.9.8B.1 DEFINE ACCESS SEQUENCE
 - 3.4.9.8B.2 LOCATE ACCESS PANEL
 - 3.4.9.8B.3 TRANSFER REPAIR EQUIPMENT TO REPAIR SITE
 - 3.4.9.8B.4 OPEN ACCESS PANEL
 - 3.4.9.8B.5 OBSERVE/LOCATE DEFECTIVE COMPONENT
 - 3.4.9.8B.6 REMOVE COMPONENT
 - 3.4.9.8B.7 STORE COMPONENT
 - 3.4.9.8B.8 LOCATE NEW COMPONENT
 - 3.4.9.8B.9 POSITION AND CONNECT NEW COMPONENT
 - 3.4.9.8B.10 ADJUST COMPONENT
 - 3.4.9.8B.11 MAKE DIAGNOSTIC CHECKS
 - 3.4.9.8B.12 CLOSE ACCESS PANEL
 - 3.4.9.8B.13 STOW REPAIR EQUIPMENT
 - 3.4.9.8B.14 UPDATE SPACECRAFT MODEL
 - 3.4.9.9 SOFTWARE FAILURE RECOVERY
 - 3.4.9.9.1 DETERMINE CORRECTION ALGORITHM
 - 3.4.9.9.2 DATA/COMMAND ENCODING
 - 3.4.9.9.3 DATA/COMMAND TRANSMISSION
 - 3.4.9.9.4 COMPUTER FUNCTION CHECKS

- 3.4.9.10 ORBITAL TRANSFER
 - 3.4.9.10.1 INITIALIZE GUIDANCE SYSTEM
 - 3.4.9.10.2 DETERMINE CURRENT ORBITAL PARAMETERS
 - 3.4.9.10.3 DETERMINE DESIRED ORBITAL PARAMETERS
 - 3.4.9.10.4 CHOOSE OPTIMAL TRAJECTORY
 - 3.4.9.10.5 DETERMINE CURRENT ATTITUDE
 - 3.4.9.10.6 DETERMINE DESIRED ATTITUDE
 - 3.4.9.10.7 ROTATE SPACECRAFT
 - 3.4.9.10.8 FIRE THRUSTERS
- 3.4.10 STATUS MONITORING AND RESOURCE ALLOCATION
 - 3.4.10.1 TEMPERATURE MANAGEMENT
 - 3.4.10.1.1 MEASURE COMPONENT TEMPERATURES
 - 3.4.10.1.2 COMPARE TEMPERATURES TO REQUIRED LIMITS
 - 3.4.10.1.3 ADJUST COOLING/HEATING SYSTEMS
 - 3.4.10.2 POWER MANAGEMENT
 - 3.4.10.2.1 MEASURE CURRENTS AND VOLTAGES
 - 3.4.10.2.2 COMPARE CURRENTS AND VOLTAGES TO REQUIRED LIMITS
 - 3.4.10.2.3 ADJUST CURRENTS AND VOLTAGES
 - 3.4.10.2.4 MONITOR BATTERIES
 - 3.4.10.3 DATA/COMMAND PROCESSING
 - 3.4.10.3.1 SHORT-TERM MEMORY STORAGE
 - 3.4.10.3.2 LONG-TERM MEMORY STORAGE
 - 3.4.10.3.3 DATA/COMMAND ENCODING
 - 3.4.10.3.4 DATA/COMMAND DECODING
 - 3.4.10.3.5 NUMERICAL COMPUTATION
 - 3.4.10.3.6 LOGIC OPERATIONS
 - 3.4.10.3.7 COMPUTER LOAD SCHEDULING
 - 3.4.10.3.8 COMPUTER FUNCTION CHECKS
 - 3.4.10.4 CONSUMABLES MANAGEMENT
 - 3.4.10.4.1 MONITOR PROPELLANT SUPPLIES
 - 3.4.10.4.2 PROJECT CONSUMABLES REQUIREMENTS FROM MISSION PROFILE
 - 3.4.10.4.3 COMPUTE OPTIMAL CONSUMABLES ALLOCATION
 - 3.4.10.5 STRUCTURAL MANAGEMENT
 - 3.4.10.5.1 MEASURE STRAINS IN STRUCTURE
 - 3.4.10.5.2 COMPUTE STRESS AND VIBRATION PARAMETERS
 - 3.4.10.5.3 COMPARE STRESS AND VIBRATION PARAMETERS TO REQUIRED LIMITS
 - 3.4.10.5.4 APPLY COMPENSATING FORCES
 - 3.4.10.5.5 APPLY VIBRATION DAMPING
 - 3.4.10.6 HAZARD AVOIDANCE
 - 3.4.10.6.1 AVOID TANK OVERPRESSURES
 - 3.4.10.6.2 MAINTAIN SAFE BATTERY CHARGE LEVELS
 - 3.4.10.6.3 MAINTAIN COMMUNICATION LINKS
 - 3.4.10.6.4 AVOID EXPOSING SENSITIVE COMPONENTS TO DIRECT SUNLIGHT
 - 3.4.10.6.5 TRACK NEARBY OBJECTS
 - 3.4.10.6.6 AVOID CONFLICTING OBJECTS
 - 3.4.10.7 OPTIMAL SEQUENCING
 - 3.4.10.7.1 UPDATE SPACECRAFT MODEL
 - 3.4.10.7.2 PROJECT DESIRED FUNCTIONS FROM MISSION PROFILE
 - 3.4.10.7.3 ESTIMATE RISKS FROM DESIRED FUNCTIONS
 - 3.4.10.7.4 PROJECT CONSUMABLES REQUIREMENTS FROM MISSION PROFILE
 - 3.4.10.7.5 DETERMINE CONSTRAINTS AND FIGURES OF MERIT
 - 3.4.10.7.6 COMPUTE OPTIMAL SEQUENCING
 - 3.4.10.8 IDENTIFY DEFECTIVE COMPONENT
 - 3.4.10.8.1 DETERMINE ANOMALOUS DATA
 - 3.4.10.8.2 FORM HYPOTHESIS FOR PROBLEM
 - 3.4.10.8.3 DEVISE TEST FOR FAILURE HYPOTHESIS
 - 3.4.10.8.4 PERFORM TEST FOR FAILURE HYPOTHESIS
 - 3.4.10.8.5 IDENTIFY FAULTY COMPONENT
 - 3.4.10.9 IDENTIFY DEFECTIVE SOFTWARE
 - 3.4.10.9.1 COMPARE MEASURED DATA TO MODEL
 - 3.4.10.9.2 DETERMINE ANOMALOUS DATA
 - 3.4.10.9.3 FORM HYPOTHESIS FOR PROBLEM
 - 3.4.10.9.4 DEVISE TEST FOR FAILURE HYPOTHESIS
 - 3.4.10.9.5 PERFORM TEST FOR FAILURE HYPOTHESIS
 - 3.4.10.10A COMPONENT FAILURE RECOVERY (REDUNDANCY)
 - 3.4.10.10A.1 SWITCH OUT FAULTY COMPONENT
 - 3.4.10.10A.2 SWITCH IN REDUNDANT COMPONENT
 - 3.4.10.10A.3 MAKE DIAGNOSTIC CHECKS
 - 3.4.10.10A.4 UPDATE SPACECRAFT MODEL
 - 3.4.10.10B COMPONENT FAILURE RECOVERY (ON-BOARD REPAIR)
 - 3.4.10.10B.1 DEFINE ACCESS SEQUENCE
 - 3.4.10.10B.2 LOCATE ACCESS PANEL

ORIGINAL PAGE IS
OF POOR QUALITY

- 3.4.10.10B.3 TRANSFER REPAIR EQUIPMENT TO REPAIR SITE
- 3.4.10.10B.4 OPEN ACCESS PANEL
- 3.4.10.10B.5 OBSERVE/LOCATE DEFECTIVE COMPONENT
- 3.4.10.10B.6 REMOVE COMPONENT
- 3.4.10.10B.7 STORE COMPONENT
- 3.4.10.10B.8 LOCATE NEW COMPONENT
- 3.4.10.10B.9 POSITION AND CONNECT NEW COMPONENT
- 3.4.10.10B.10 ADJUST COMPONENT
- 3.4.10.10B.11 MAKE DIAGNOSTIC CHECKS
- 3.4.10.10B.12 CLOSE ACCESS PANEL
- 3.4.10.10B.13 STOW REPAIR EQUIPMENT
- 3.4.10.10B.14 UPDATE SPACECRAFT MODEL
- 3.4.10.11 SOFTWARE FAILURE RECOVERY
 - 3.4.10.11.1 DETERMINE CORRECTION ALGORITHM
 - 3.4.10.11.2 DATA/COMMAND ENCODING
 - 3.4.10.11.3 DATA/COMMAND TRANSMISSION
 - 3.4.10.11.4 COMPUTER FUNCTION CHECKS
- 3.4.10.12 REPORT SYSTEM STATUS
 - 3.4.10.12.1 DATA/COMMAND ENCODING
 - 3.4.10.12.2 DATA/COMMAND TRANSMISSION
 - 3.4.10.12.3 DATA/COMMAND DECODING
 - 3.4.10.12.4 DATA/COMMAND DISPLAY

3.5 UNCOOPERATIVE SPACECRAFT/DEBRIS CAPTURE

In this mission the TMS is used to capture and dispose of uncooperative spacecraft or debris on orbit.

- 3.5.1 DESIGN
 - 3.5.1.1 DEFINE REQUIREMENTS
 - 3.5.1.2 MISSION ANALYSIS
 - 3.5.1.3 PAYLOAD ACCOMODATIONS
 - 3.5.1.4 CREATE FUNCTIONAL LAYOUT
 - 3.5.1.5 FAILURE MODES ANALYSIS
 - 3.5.1.6 ADJUST DESIGN FOR MAINTAINANCE AND REPAIR
 - 3.5.1.7 CREATE MECHANICAL LAYOUT
 - 3.5.1.8 SAFETY REVIEW
 - 3.5.1.9 DESIGN OF COMPONENTS
 - 3.5.1.10 SOFTWARE DEVELOPMENT
- 3.5.2 COMPONENT FABRICATION
 - 3.5.2.1 PROCURE OFF-THE-SHELF COMPONENTS
 - 3.5.2.2 PROCURE MATERIALS FOR MANUFACTURED COMPONENTS
 - 3.5.2.3 PROCURE MANUFACTURING EQUIPMENT
 - 3.5.2.4 MANUFACTURE COMPONENTS
- 3.5.3 COMPONENT TEST
 - 3.5.3.1 SET UP TEST FACILITIES
 - 3.5.3.2 STRUCTURAL LOADS TESTS
 - 3.5.3.3 DATA PROCESSING AND SOFTWARE TESTS
 - 3.5.3.4 ANTENNA AND ARRAY DEPLOYMENT TESTS
 - 3.5.3.5 ELECTRICAL SYSTEMS TESTS
 - 3.5.3.6 THERMAL AND VACUUM TESTS
 - 3.5.3.7 THRUSTER TESTS
 - 3.5.3.8 COMPONENT CERTIFICATION
- 3.5.4 SYSTEM INTEGRATION
- 3.5.5 SYSTEM TEST
 - 3.5.5.1 POWER SUBSYSTEM TESTS
 - 3.5.5.2 THERMAL SUBSYSTEM TESTS
 - 3.5.5.3 STRUCTURE SUBSYSTEM TESTS
 - 3.5.5.4 INFORMATION PROCESSING SUBSYSTEM TESTS
 - 3.5.5.5 COMMUNICATIONS SUBSYSTEM TESTS
 - 3.5.5.6 ATTITUDE CONTROL SUBSYSTEM TESTS
 - 3.5.5.7 PROPULSION SUBSYSTEM TESTS
 - 3.5.5.8 INTEGRATED SYSTEMS TESTS
 - 3.5.5.9 FAILURE MODES SIMULATION
 - 3.5.5.10 SYSTEM CERTIFICATION
- 3.5.6 SHIPPING TO LAUNCH SITE
 - 3.5.6.1 REMOVE TEST EQUIPMENT
 - 3.5.6.2 PERFORM NECESSARY DISASSEMBLY
 - 3.5.6.3 PACKING
 - 3.5.6.4 TRANSPORT TO LAUNCH SITE
- 3.5.7A PAYLOAD INTEGRATION AND CHECKOUT (HORIZONTAL PAYLOAD)
 - 3.5.7A.1 UNPACKING

- 3.5.7A.2 PERFORM NECESSARY REASSEMBLY
- 3.5.7A.3 INTEGRATED SYSTEMS TESTS
 - 3.5.7A.3.1 VERIFY POWER SYSTEM FUNCTION
 - 3.5.7A.3.2 VERIFY COMMAND SYSTEM FUNCTION
 - 3.5.7A.3.3 VERIFY MECHANICAL SYSTEM FUNCTION
 - 3.5.7A.3.4 VERIFY COMMUNICATIONS SYSTEM FUNCTION
 - 3.5.7A.3.5 MISSION SEQUENCE SIMULATION
- 3.5.7A.4 TRANSFER TO OPERATIONS AND CHECKOUT BLDG.
 - 3.5.7A.4.1 LOAD PAYLOAD INTO CONTAINER
 - 3.5.7A.4.2 TRANSPORT TO OPERATIONS AND CHECKOUT BLDG.
 - 3.5.7A.4.3 ATTACH STRONGBACK TO PAYLOAD
 - 3.5.7A.4.4 INSTALL PAYLOAD IN HORIZONTAL CITE
- 3.5.7A.5 INTEGRATE TMS WITH PAYLOAD
- 3.5.7A.6 PERFORM INTERFACES CHECK
 - 3.5.7A.6.1 CHECK TMS/PAYLOAD MECHANICAL INTERFACES
 - 3.5.7A.6.2 CHECK ELECTRICAL INTERFACES
 - 3.5.7A.6.3 CHECK SHUTTLE/PAYLOAD MECHANICAL INTERFACES
 - 3.5.7A.6.4 CHECK ELECTRICAL INTERFACES
- 3.5.7A.7 TRANSFER TMS/PAYLOAD TO ORBITER PROCESSING FACILITY
 - 3.5.7A.7.1 ATTACH STRONGBACK TO PAYLOAD
 - 3.5.7A.7.2 LOAD PAYLOAD INTO CANISTER
 - 3.5.7A.7.3 REMOVE STRONGBACK
 - 3.5.7A.7.4 CLOSE CANISTER
 - 3.5.7A.7.5 TRANSPORT CANISTER TO ORBITER PROCESSING FACILITY
 - 3.5.7A.7.6 UNLOAD CANISTER
- 3.5.7A.8 ORBITER/PAYLOAD INTEGRATION (HORIZONTAL)
 - 3.5.7A.8.1 ATTACH STRONGBACK TO PAYLOAD
 - 3.5.7A.8.2 INSTALL PAYLOAD IN ORBITER
 - 3.5.7A.8.3 CONNECT ORBITER/PAYLOAD INTERFACES
 - 3.5.7A.8.4 CHECK ELECTRICAL INTERFACES
 - 3.5.7A.8.5 REMOVE STRONGBACK
 - 3.5.7A.8.6 CLOSE-OUT PAYLOAD BAY
 - 3.5.7A.8.7 INSTALLATION OF ORBITER PAYLOAD STATION CONSOLES
- 3.5.7B PAYLOAD INTEGRATION AND CHECKOUT (VERTICAL PAYLOAD)
 - 3.5.7B.1 UNPACKING
 - 3.5.7B.2 PERFORM NECESSARY REASSEMBLY
 - 3.5.7B.3 INTEGRATED SYSTEMS TESTS
 - 3.5.7B.3.1 VERIFY POWER SYSTEM FUNCTION
 - 3.5.7B.3.2 VERIFY COMMAND SYSTEM FUNCTION
 - 3.5.7B.3.3 VERIFY MECHANICAL SYSTEM FUNCTION
 - 3.5.7B.3.4 VERIFY COMMUNICATIONS SYSTEM FUNCTION
 - 3.5.7B.3.5 MISSION SEQUENCE SIMULATION
 - 3.5.7B.4 TRANSFER TO VERTICAL PROCESSING FACILITY
 - 3.5.7B.4.1 LOAD PAYLOAD INTO CONTAINER
 - 3.5.7B.4.2 TRANSPORT CONTAINER TO VERTICAL PROCESSING FACILITY
 - 3.5.7B.4.3 UNLOAD CONTAINER
 - 3.5.7B.5 INTEGRATE TMS WITH PAYLOAD
 - 3.5.7B.6 PERFORM INTERFACES CHECK
 - 3.5.7B.6.1 CHECK TMS/PAYLOAD MECHANICAL INTERFACES
 - 3.5.7B.6.2 CHECK ELECTRICAL INTERFACES
 - 3.5.7B.6.3 CHECK SHUTTLE/PAYLOAD MECHANICAL INTERFACES
 - 3.5.7B.6.4 CHECK ELECTRICAL INTERFACES
 - 3.5.7B.7 TRANSFER PAYLOAD TO LAUNCH PAD
 - 3.5.7B.7.1 LOAD PAYLOAD INTO CANISTER
 - 3.5.7B.7.2 TRANSPORT TO ROTATING SERVICE STRUCTURE
 - 3.5.7B.7.3 LOAD CANISTER INTO ROTATING SERVICE STRUCTURE
 - 3.5.7B.7.4 LOAD PAYLOAD INTO ROTATING SERVICE STRUCTURE USING PGHM
 - 3.5.7B.7.5 REMOVE CANISTER
 - 3.5.7B.8 ORBITER/PAYLOAD INTEGRATION (VERTICAL)
 - 3.5.7B.8.1 MATE ROTATING SERVICE STRUCTURE TO ORBITER
 - 3.5.7B.8.2 EXTEND PAYLOAD INTO ORBITER USING PGHM
 - 3.5.7B.8.3 CONNECT ORBITER/PAYLOAD INTERFACES
 - 3.5.7B.8.4 CHECK ELECTRICAL INTERFACES
 - 3.5.7B.8.5 CLOSE-OUT PAYLOAD BAY
 - 3.5.7B.8.6 INSTALLATION OF ORBITER PAYLOAD STATION CONSOLES
- 3.5.8 COUNTDOWN AND LAUNCH
- 3.5.9 ORBITAL DEPLOYMENT AND CHECKOUT
 - 3.5.9.1 SHUTTLE ATTAINS DELIVERY ORBIT
 - 3.5.9.2 TESTS OF ATTACHED PAYLOAD
 - 3.5.9.2.1 POWER SUBSYSTEM CHECKOUT
 - 3.5.9.2.2 INFORMATION PROCESSING SUBSYSTEM CHECKOUT
 - 3.5.9.3 EXTENSION OF PAYLOAD FROM PAYLOAD BAY

ORIGINAL FAILURE
OF POOR QUALITY

- 3.5.9.3.1 OPEN PAYLOAD BAY DOORS
- 3.5.9.3.2 ACTIVATE RMS
- 3.5.9.3.3 LOCATE GRASPING FIXTURE ON TARGET
- 3.5.9.3.4 MOVE RMS TO FIXTURE
- 3.5.9.3.5 GRASP FIXTURE
- 3.5.9.3.6 RELEASE PAYLOAD RESTRAINTS
- 3.5.9.3.7 TRANSLATE PAYLOAD OUT OF PAYLOAD BAY
- 3.5.9.4 SEPARATION OF PAYLOAD FROM ORBITER
 - 3.5.9.4.1 RMS RELEASES PAYLOAD
 - 3.5.9.4.2 SECURE RMS IN PAYLOAD BAY
- 3.5.9.5 OPERATIONAL CHECKOUT
 - 3.5.9.5.1 ACTIVATE TMS SUBSYSTEMS
 - 3.5.9.5.2 INFORMATION PROCESSING SUBSYSTEM CHECKOUT
 - 3.5.9.5.3 POWER SUBSYSTEM CHECKOUT
 - 3.5.9.5.4 THERMAL SUBSYSTEM CHECKOUT
 - 3.5.9.5.5 STRUCTURAL SUBSYSTEM CHECKOUT
 - 3.5.9.5.6 COMMUNICATIONS SUBSYSTEM CHECKOUT
 - 3.5.9.5.7 ATTITUDE CONTROL SUBSYSTEM CHECKOUT
 - 3.5.9.5.8 PROPULSION SUBSYSTEM CHECKOUT
 - 3.5.9.5.9 CONSUMABLES LEVELS CHECKOUT
- 3.5.9.6 IDENTIFY DEFECTIVE COMPONENT
 - 3.5.9.6.1 DETERMINE ANOMALOUS DATA
 - 3.5.9.6.2 FORM HYPOTHESIS FOR PROBLEM
 - 3.5.9.6.3 DEVISE TEST FOR FAILURE HYPOTHESIS
 - 3.5.9.6.4 PERFORM TEST FOR FAILURE HYPOTHESIS
 - 3.5.9.6.5 IDENTIFY FAULTY COMPONENT
- 3.5.9.7 IDENTIFY DEFECTIVE SOFTWARE
 - 3.5.9.7.1 COMPARE MEASURED DATA TO MODEL
 - 3.5.9.7.2 DETERMINE ANOMALOUS DATA
 - 3.5.9.7.3 FORM HYPOTHESIS FOR PROBLEM
 - 3.5.9.7.4 DEVISE TEST FOR FAILURE HYPOTHESIS
 - 3.5.9.7.5 PERFORM TEST FOR FAILURE HYPOTHESIS
- 3.5.9.8A COMPONENT FAILURE RECOVERY (REDUNDANCY)
 - 3.5.9.8A.1 SWITCH OUT FAULTY COMPONENT
 - 3.5.9.8A.2 SWITCH IN REDUNDANT COMPONENT
 - 3.5.9.8A.3 MAKE DIAGNOSTIC CHECKS
 - 3.5.9.8A.4 UPDATE SPACECRAFT MODEL
- 3.5.9.8B COMPONENT FAILURE RECOVERY (ON-BOARD REPAIR)
 - 3.5.9.8B.1 DEFINE ACCESS SEQUENCE
 - 3.5.9.8B.2 LOCATE ACCESS PANEL
 - 3.5.9.8B.3 TRANSFER REPAIR EQUIPMENT TO REPAIR SITE
 - 3.5.9.8B.4 OPEN ACCESS PANEL
 - 3.5.9.8B.5 OBSERVE/LOCATE DEFECTIVE COMPONENT
 - 3.5.9.8B.6 REMOVE COMPONENT
 - 3.5.9.8B.7 STORE COMPONENT
 - 3.5.9.8B.8 LOCATE NEW COMPONENT
 - 3.5.9.8B.9 POSITION AND CONNECT NEW COMPONENT
 - 3.5.9.8B.10 ADJUST COMPONENT
 - 3.5.9.8B.11 MAKE DIAGNOSTIC CHECKS
 - 3.5.9.8B.12 CLOSE ACCESS PANEL
 - 3.5.9.8B.13 STOW REPAIR EQUIPMENT
 - 3.5.9.8B.14 UPDATE SPACECRAFT MODEL
- 3.5.9.9 SOFTWARE FAILURE RECOVERY
 - 3.5.9.9.1 DETERMINE CORRECTION ALGORITHM
 - 3.5.9.9.2 DATA/COMMAND ENCODING
 - 3.5.9.9.3 DATA/COMMAND TRANSMISSION
 - 3.5.9.9.4 COMPUTER FUNCTION CHECKS
- 3.5.9.10 ORBITAL TRANSFER
 - 3.5.9.10.1 INITIALIZE GUIDANCE SYSTEM
 - 3.5.9.10.2 DETERMINE CURRENT ORBITAL PARAMETERS
 - 3.5.9.10.3 DETERMINE DESIRED ORBITAL PARAMETERS
 - 3.5.9.10.4 CHOOSE OPTIMAL TRAJECTORY
 - 3.5.9.10.5 DETERMINE CURRENT ATTITUDE
 - 3.5.9.10.6 DETERMINE DESIRED ATTITUDE
 - 3.5.9.10.7 ROTATE SPACECRAFT
 - 3.5.9.10.8 FIRE THRUSTERS
- 3.5.10 STATUS MONITORING AND RESOURCE ALLOCATION
 - 3.5.10.1 TEMPERATURE MANAGEMENT
 - 3.5.10.1.1 MEASURE COMPONENT TEMPERATURES
 - 3.5.10.1.2 COMPARE TEMPERATURES TO REQUIRED LIMITS
 - 3.5.10.1.3 ADJUST COOLING/HEATING SYSTEMS
 - 3.5.10.2 POWER MANAGEMENT

- 3.5.10.2.1 MEASURE CURRENTS AND VOLTAGES
- 3.5.10.2.2 COMPARE CURRENTS AND VOLTAGES TO REQUIRED LIMITS
- 3.5.10.2.3 ADJUST CURRENTS AND VOLTAGES
- 3.5.10.2.4 MONITOR BATTERIES
- 3.5.10.3 DATA/COMMAND PROCESSING
 - 3.5.10.3.1 SHORT-TERM MEMORY STORAGE
 - 3.5.10.3.2 LONG-TERM MEMORY STORAGE
 - 3.5.10.3.3 DATA/COMMAND ENCODING
 - 3.5.10.3.4 DATA/COMMAND DECODING
 - 3.5.10.3.5 NUMERICAL COMPUTATION
 - 3.5.10.3.6 LOGIC OPERATIONS
 - 3.5.10.3.7 COMPUTER LOAD SCHEDULING
 - 3.5.10.3.8 COMPUTER FUNCTION CHECKS
- 3.5.10.4 CONSUMABLES MANAGEMENT
 - 3.5.10.4.1 MONITOR PROPELLANT SUPPLIES
 - 3.5.10.4.2 PROJECT CONSUMABLES REQUIREMENTS FROM MISSION PROFILE
 - 3.5.10.4.3 COMPUTE OPTIMAL CONSUMABLES ALLOCATION
- 3.5.10.5 STRUCTURAL MANAGEMENT
 - 3.5.10.5.1 MEASURE STRAINS IN STRUCTURE
 - 3.5.10.5.2 COMPUTE STRESS AND VIBRATION PARAMETERS
 - 3.5.10.5.3 COMPARE STRESS AND VIBRATION PARAMETERS TO REQUIRED LIMITS
 - 3.5.10.5.4 APPLY COMPENSATING FORCES
 - 3.5.10.5.5 APPLY VIBRATION DAMPING
- 3.5.10.6 HAZARD AVOIDANCE
 - 3.5.10.6.1 AVOID TANK OVERPRESSURES
 - 3.5.10.6.2 MAINTAIN SAFE BATTERY CHARGE LEVELS
 - 3.5.10.6.3 MAINTAIN COMMUNICATION LINKS
 - 3.5.10.6.4 AVOID EXPOSING SENSITIVE COMPONENTS TO DIRECT SUNLIGHT
 - 3.5.10.6.5 TRACK NEARBY OBJECTS
 - 3.5.10.6.6 AVOID CONFLICTING OBJECTS
- 3.5.10.7 OPTIMAL SEQUENCING
 - 3.5.10.7.1 UPDATE SPACECRAFT MODEL
 - 3.5.10.7.2 PROJECT DESIRED FUNCTIONS FROM MISSION PROFILE
 - 3.5.10.7.3 ESTIMATE RISKS FROM DESIRED FUNCTIONS
 - 3.5.10.7.4 PROJECT CONSUMABLES REQUIREMENTS FROM MISSION PROFILE
 - 3.5.10.7.5 DETERMINE CONSTRAINTS AND FIGURES OF MERIT
 - 3.5.10.7.6 COMPUTE OPTIMAL SEQUENCING
- 3.5.10.8 IDENTIFY DEFECTIVE COMPONENT
 - 3.5.10.8.1 DETERMINE ANOMALOUS DATA
 - 3.5.10.8.2 FORM HYPOTHESIS FOR PROBLEM
 - 3.5.10.8.3 DEVISE TEST FOR FAILURE HYPOTHESIS
 - 3.5.10.8.4 PERFORM TEST FOR FAILURE HYPOTHESIS
 - 3.5.10.8.5 IDENTIFY FAULTY COMPONENT
- 3.5.10.9 IDENTIFY DEFECTIVE SOFTWARE
 - 3.5.10.9.1 COMPARE MEASURED DATA TO MODEL
 - 3.5.10.9.2 DETERMINE ANOMALOUS DATA
 - 3.5.10.9.3 FORM HYPOTHESIS FOR PROBLEM
 - 3.5.10.9.4 DEVISE TEST FOR FAILURE HYPOTHESIS
 - 3.5.10.9.5 PERFORM TEST FOR FAILURE HYPOTHESIS
- 3.5.10.10A COMPONENT FAILURE RECOVERY (REDUNDANCY)
 - 3.5.10.10A.1 SWITCH OUT FAULTY COMPONENT
 - 3.5.10.10A.2 SWITCH IN REDUNDANT COMPONENT
 - 3.5.10.10A.3 MAKE DIAGNOSTIC CHECKS
 - 3.5.10.10A.4 UPDATE SPACECRAFT MODEL
- 3.5.10.10B COMPONENT FAILURE RECOVERY (ON-BOARD REPAIR)
 - 3.5.10.10B.1 DEFINE ACCESS SEQUENCE
 - 3.5.10.10B.2 LOCATE ACCESS PANEL
 - 3.5.10.10B.3 TRANSFER REPAIR EQUIPMENT TO REPAIR SITE
 - 3.5.10.10B.4 OPEN ACCESS PANEL
 - 3.5.10.10B.5 OBSERVE/LOCATE DEFECTIVE COMPONENT
 - 3.5.10.10B.6 REMOVE COMPONENT
 - 3.5.10.10B.7 STORE COMPONENT
 - 3.5.10.10B.8 LOCATE NEW COMPONENT
 - 3.5.10.10B.9 POSITION AND CONNECT NEW COMPONENT
 - 3.5.10.10B.10 ADJUST COMPONENT
 - 3.5.10.10B.11 MAKE DIAGNOSTIC CHECKS
 - 3.5.10.10B.12 CLOSE ACCESS PANEL
 - 3.5.10.10B.13 STOW REPAIR EQUIPMENT
 - 3.5.10.10B.14 UPDATE SPACECRAFT MODEL
- 3.5.10.11 SOFTWARE FAILURE RECOVERY
 - 3.5.10.11.1 DETERMINE CORRECTION ALGORITHM
 - 3.5.10.11.2 DATA/COMMAND ENCODING

- 3.5.10.11.3 DATA/COMMAND TRANSMISSION
- 3.5.10.11.4 COMPUTER FUNCTION CHECKS
- 3.5.10.12 REPORT SYSTEM STATUS
 - 3.5.10.12.1 DATA/COMMAND ENCODING
 - 3.5.10.12.2 DATA/COMMAND TRANSMISSION
 - 3.5.10.12.3 DATA/COMMAND DECODING
 - 3.5.10.12.4 DATA/COMMAND DISPLAY
- 3.5.11 CAPTURE UNCOOPERATIVE SPACECRAFT/DEBRIS
 - 3.5.11.1 ADJUST ORBIT
 - 3.5.11.1.1 INITIALIZE GUIDANCE SYSTEM
 - 3.5.11.1.2 DETERMINE CURRENT ORBITAL PARAMETERS
 - 3.5.11.1.3 DETERMINE DESIRED ORBITAL PARAMETERS
 - 3.5.11.1.4 CHOOSE OPTIMAL TRAJECTORY
 - 3.5.11.1.5 FIRE THRUSTERS
 - 3.5.11.2 ADJUST ATTITUDE
 - 3.5.11.2.1 DETERMINE CURRENT ATTITUDE
 - 3.5.11.2.2 DETERMINE DESIRED ATTITUDE
 - 3.5.11.2.3 DETERMINE NEW CONFIGURATION FOR SPACECRAFT COMPONENTS
 - 3.5.11.2.4 CHOOSE OPTIMAL TRAJECTORY
 - 3.5.11.2.5 ROTATE SPACECRAFT
 - 3.5.11.3 OPTIMAL CONTROL ALLOCATION
 - 3.5.11.3.1 UPDATE SPACECRAFT MODEL
 - 3.5.11.3.2 PROJECT DESIRED FUNCTIONS FROM MISSION PROFILE
 - 3.5.11.3.3 ESTIMATE RISKS FROM DESIRED FUNCTIONS
 - 3.5.11.3.4 PROJECT CONSUMABLES REQUIREMENTS FROM MISSION PROFILE
 - 3.5.11.3.5 DETERMINE CONSTRAINTS AND FIGURES OF MERIT
 - 3.5.11.3.6 CHOOSE OPTIMAL CONTROL MODE
 - 3.5.11.3.7 COMPUTE CONTROL COMMANDS
 - 3.5.11.3.8 EXECUTE CONTROL COMMANDS
 - 3.5.11.4 CAPTURE SPACECRAFT/DEBRIS

The TMS is expected to use a dedicated debris capture device for this activity.

- 3.5.11.4.1 OBSERVE TUMBLING SPACECRAFT
- 3.5.11.4.2 DETERMINE SPACECRAFT PRINCIPAL SPIN AXIS
- 3.5.11.4.3 SPIN UP DEBRIS CAPTURE DEVICE

This breakdown assumes a spinnable debris capture device. Other systems for debris detumbling and capture are possible.

- 3.5.11.4.4 GRASP FIXTURE
- 3.5.11.4.5 BRAKE DEBRIS CAPTURE DEVICE
- 3.5.12 INSERT SPACECRAFT/DEBRIS INTO REENTRY TRAJECTORY

This sequence may be omitted if it is desired to return the spacecraft/debris to the Orbiter.

- 3.5.12.1 ORBITAL TRANSFER (OF TMS/SPACECRAFT)
 - 3.5.12.1.1 INITIALIZE GUIDANCE SYSTEM
 - 3.5.12.1.2 DETERMINE CURRENT ORBITAL PARAMETERS
 - 3.5.12.1.3 DETERMINE DESIRED ORBITAL PARAMETERS
 - 3.5.12.1.4 CHOOSE OPTIMAL TRAJECTORY
 - 3.5.12.1.5 DETERMINE CURRENT ATTITUDE
 - 3.5.12.1.6 DETERMINE DESIRED ATTITUDE
 - 3.5.12.1.7 ROTATE SPACECRAFT
 - 3.5.12.1.8 FIRE THRUSTERS
- 3.5.12.2 RELEASE SPACECRAFT/DEBRIS AND REBOOST TMS
 - 3.5.12.2.1 RELEASE SPACECRAFT FROM DEBRIS CAPTURE DEVICE
 - 3.5.12.2.2 INITIALIZE GUIDANCE SYSTEM
 - 3.5.12.2.3 DETERMINE CURRENT ORBITAL PARAMETERS
 - 3.5.12.2.4 DETERMINE DESIRED ORBITAL PARAMETERS
 - 3.5.12.2.5 CHOOSE OPTIMAL TRAJECTORY
 - 3.5.12.2.6 DETERMINE CURRENT ATTITUDE
 - 3.5.12.2.7 DETERMINE DESIRED ATTITUDE
 - 3.5.12.2.8 ROTATE SPACECRAFT
 - 3.5.12.2.9 FIRE THRUSTERS
- 3.5.13 RENDEZVOUS WITH ORBITER
 - 3.5.13.1 ORBITAL TRANSFER (OF TMS)
 - 3.5.13.1.1 INITIALIZE GUIDANCE SYSTEM
 - 3.5.13.1.2 DETERMINE CURRENT ORBITAL PARAMETERS
 - 3.5.13.1.3 DETERMINE DESIRED ORBITAL PARAMETERS

ORIGINAL PAGE IS
OF POOR QUALITY.

- 3.5.13.1.4 CHOOSE OPTIMAL TRAJECTORY
- 3.5.13.1.5 DETERMINE CURRENT ATTITUDE
- 3.5.13.1.6 DETERMINE DESIRED ATTITUDE
- 3.5.13.1.7 ROTATE SPACECRAFT
- 3.5.13.1.8 FIRE THRUSTERS
- 3.5.13.2 SHUTDOWN TMS FOR RETRIEVAL
 - 3.5.13.2.1 STOW TMS ANTENNA
 - 3.5.13.2.2 DEACTIVATE TMS SUBSYSTEMS
- 3.5.14 RETRIEVAL BY ORBITER
 - 3.5.14.1 ADJUST ORBIT (OF ORBITER)
 - 3.5.14.1.1 INITIALIZE GUIDANCE SYSTEM
 - 3.5.14.1.2 DETERMINE CURRENT ORBITAL PARAMETERS
 - 3.5.14.1.3 DETERMINE DESIRED ORBITAL PARAMETERS
 - 3.5.14.1.4 CHOOSE OPTIMAL TRAJECTORY
 - 3.5.14.1.5 FIRE THRUSTERS
 - 3.5.14.2 ADJUST ATTITUDE (OF ORBITER)
 - 3.5.14.2.1 DETERMINE CURRENT ATTITUDE
 - 3.5.14.2.2 DETERMINE DESIRED ATTITUDE
 - 3.5.14.2.3 DETERMINE NEW CONFIGURATION FOR SPACECRAFT COMPONENTS
 - 3.5.14.2.4 CHOOSE OPTIMAL TRAJECTORY
 - 3.5.14.2.5 ROTATE SPACECRAFT
 - 3.5.14.3 OPTIMAL CONTROL ALLOCATION
 - 3.5.14.3.1 UPDATE SPACECRAFT MODEL
 - 3.5.14.3.2 PROJECT DESIRED FUNCTIONS FROM MISSION PROFILE
 - 3.5.14.3.3 ESTIMATE RISKS FROM DESIRED FUNCTIONS
 - 3.5.14.3.4 PROJECT CONSUMABLES REQUIREMENTS FROM MISSION PROFILE
 - 3.5.14.3.5 DETERMINE CONSTRAINTS AND FIGURES OF MERIT
 - 3.5.14.3.6 CHOOSE OPTIMAL CONTROL MODE
 - 3.5.14.3.7 COMPUTE CONTROL COMMANDS
 - 3.5.14.3.8 EXECUTE CONTROL COMMANDS
 - 3.5.14.4 ORBITER RECOVERY OF TMS
 - 3.5.14.4.1 ACTIVATE RMS
 - 3.5.14.4.2 LOCATE GRASPING FIXTURE ON TARGET
 - 3.5.14.4.3 MOVE RMS TO FIXTURE
 - 3.5.14.4.4 GRASP FIXTURE
 - 3.5.14.4.5 LOCATE CRADLE IN PAYLOAD BAY
 - 3.5.14.4.6 TRANSLATE PAYLOAD TO CRADLE
 - 3.5.14.4.7 FASTEN PAYLOAD RESTRAINTS
 - 3.5.14.4.8 RMS RELEASES PAYLOAD
 - 3.5.14.4.9 SECURE RMS IN PAYLOAD BAY
- 3.5.15 REENTRY AND LANDING
- 3.5.16 POST-FLIGHT OPERATIONS
 - 3.5.16.1 SAFING OF ORBITER AND HAZARDOUS PAYLOADS
 - 3.5.16.2 REMOVAL OF PAYLOADS FROM ORBITER

2.A.5:

SPACE PLATFORM

ORIGINAL PLANING OF POOR QUALITY

The primary source of information for the details of this breakdown was the Materials Experiment Carrier Concepts Definition Study, completed in February 1981 by TRW. Volumes III through V contain nearly-identical sections on mission analysis and breakdown. Volume III also supplied useful information on design and on trade-offs.

4 SPACE PLATFORM (SP)

4.1A MATERIALS EXPERIMENT CARRIER (UNSERVICED, SINGLE-SORTIE)

4.1A.1 DESIGN

4.1A.1.1 DEFINE REQUIREMENTS

4.1A.1.2 SELECT EXPERIMENTAL PACKAGES

The Materials Experiment Carrier (MEC) can accept experimental packages within specified size, weight, and service envelopes. Current candidate experiments for MEC missions include containerless metals processes, zero-g crystal growth, metal solidification, float zone processes, and cell cultures. Experiments of similar needs and time duration should be grouped together on missions in order to fully utilize the MEC while on-orbit.

4.1A.1.3 MISSION ANALYSIS

Given the relatively large power needs of materials processing experiments, and the need for MEC servicing and deployment by the Shuttle, optimal orbital characteristics for MEC/Space Platform missions provide both maximum average SP power output and convenient Shuttle access. These two criteria favor orbits of different inclinations (high incl. for power, low incl. for best access) so engineering tradeoffs become necessary. Careful consideration must be made of experiment weight vs. power needs before mission outlines are constructed.

4.1A.1.4 PAYLOAD ACCOMODATIONS

Determine all subsystem interactions such as data transmission, power use, thermal dissipation, and structural loads.

4.1A.1.5 CREATE FUNCTIONAL LAYOUT

The component specifications should be compatible with available technology, should be fabricable within time constraints, and should comply with the functional layout.

4.1A.1.6 CREATE MECHANICAL LAYOUT

4.1A.2 COMPONENT FABRICATION

4.1A.2.1 PROCURE OFF-THE-SHELF COMPONENTS

4.1A.2.2 PROCURE MATERIALS FOR MANUFACTURE OF COMPONENTS

4.1A.2.3 PROCURE MANUFACTURING EQUIPMENT

4.1A.2.4 MANUFACTURE COMPONENTS

4.1A.3 COMPONENT TEST

Verify that when components are grouped into subsystems they can perform all functional layout operations.

4.1A.3.1 SET UP TEST FACILITIES

4.1A.3.2 STRUCTURAL LOADS TESTS

The structure or a functional mockup will be exposed to various vibration loads to verify structural integrity.

4.1A.3.3 DATA PROCESSING AND SOFTWARE TESTS

Verify software by inputting data which simulates expected operational inputs, but has been previously processed so the proper output is known. This nominal output is compared to the output of the flight software to verify its proper operation. Software interfaces may exist between many of the systems onboard, depending on the final design. For instance, the furnace heating system may be directly linked to the temperature control system. These interfaces must be tested for proper operation by actual installation and operation simulation (i.e. simulated thermal input to test the temperature control link) since their failure could be detrimental to several systems. Note that in the event of a fault detected during flight, software can be dumped and new software can

be loaded into the system via ground telemetry.

4.1A.3.4 SOLAR ARRAY DEPLOYMENT TESTS

Simulated solar array power is supplied to the power management/conditioning subsystem. This system is commanded to supply various voltages and currents to other subsystems. These quantities are measured under real or simulated loads and compared against nominal performance.

- 4.1A.3.5 CHECK RF PATTERN
4.1A.3.6 ELECTRICAL SYSTEMS TESTS
4.1A.3.7 THERMAL AND VACUUM TESTS
4.1A.3.8 COMPONENT CERTIFICATION
4.1A.4 SYSTEM INTEGRATION
4.1A.4.1 RECEIVE AND SORT COMPONENTS
4.1A.4.2 POSITION AND ORIENT COMPONENT
4.1A.4.3 ATTACH COMPONENTS
4.1A.5 SYSTEM TEST
4.1A.5.1 POWER SUBSYSTEM TEST
4.1A.5.2 THERMAL SUBSYSTEM TESTS
4.1A.5.3 INFORMATION PROCESSING SUBSYSTEM TESTS

Verify that the data relay and storage systems meet design specifications.

- 4.1A.5.4 STRUCTURE SUBSYSTEM TESTS
4.1A.5.5 COMMUNICATIONS SUBSYSTEM TESTS
4.1A.5.6 INTEGRATED SYSTEMS TEST
4.1A.5.7 FAILURE MODES SIMULATION
4.1A.5.8 SYSTEM CERTIFICATION
4.1A.6 PAYLOAD INSTALLATION AND TRANSPORT
4.1A.6.1 INSTALLATION OF EXPERIMENTAL PACKAGES

Experimental packages will be designed and constructed, separately from the MEC, by the sponsoring researcher or company. Packages will have to meet specified power use, size, weight, interface, environment, and safety criteria. Packages will be integrated and tested with the MEC after the MEC itself has been assembled and checked-out. EP/MEC integration will take place at the MEC contractor's facility.

4.1A.6.2 TESTING AT INTEGRATION SITE

EP/MEC system performance and compatibility checkouts will be done at the MEC contractor's facility.

- 4.1A.6.3 REMOVE TEST EQUIPMENT
4.1A.6.4 PERFORM NECESSARY DISASSEMBLY

The full MEC assembly (including experimental packages) will be safed before partial disassembly for packing. Transportation to launch site will probably be by truck.

- 4.1A.6.5 PACKING
4.1A.6.6 TRANSPORT TO LAUNCH SITE
4.1A.7 ORBITER/PAYLOAD INTEGRATION AND CHECKOUT
4.1A.7.1 UNPACKING
4.1A.7.2 PERFORM NECESSARY REASSEMBLY
4.1A.7.3 INTEGRATED SYSTEMS TESTS
4.1A.7.3.1 VERIFY POWER SYSTEM FUNCTION
4.1A.7.3.2 VERIFY COMMAND SYSTEM FUNCTION
4.1A.7.3.3 VERIFY MECHANICAL SYSTEM FUNCTION
4.1A.7.3.4 VERIFY COMMUNICATIONS SYSTEM FUNCTION
4.1A.7.4 PERFORM INTERFACES CHECK
4.1A.7.4.1 CHECK EXPERIMENTAL PACKAGE INTERFACE
4.1A.7.4.2 CHECK SHUTTLE/PAYLOAD MECHANICAL INTERFACES
4.1A.7.4.3 CHECK ELECTRICAL INTERFACES
4.1A.7.5 TRANSFER PAYLOAD TO ORBITER PROCESSING FACILITY
4.1A.7.5.1 ATTACH STRONGBACK TO PAYLOAD
4.1A.7.5.2 LOAD PAYLOAD INTO CANISTER
4.1A.7.5.3 REMOVE STRONGBACK
4.1A.7.5.4 CLOSE CANISTER
4.1A.7.5.5 TRANSPORT CANISTER TO ORBITER PROCESSING FACILITY

- 4.1A.7.6 ORBITER/PAYLOAD INTEGRATION
 - 4.1A.7.6.1 ATTACH STRONGBACK TO PAYLOAD
 - 4.1A.7.6.2 INSTALL PAYLOAD IN ORBITER
 - 4.1A.7.6.3 CONNECT ORBITER/PAYLOAD INTERFACES
 - 4.1A.7.6.4 CHECK ELECTRICAL INTERFACES
 - 4.1A.7.6.5 CLOSE-OUT PAYLOAD BAY
 - 4.1A.7.6.6 INSTALLATION OF ORBITER PAYLOAD STATION CONSOLES
 - 4.1A.7.6.7 INSTALLATION OF OMS KIT
- 4.1A.8 COUNTDOWN AND LAUNCH
- 4.1A.9 ORBITAL DEPLOYMENT AND CHECKOUT
 - 4.1A.9.1 ORBITER/SP RENDEZVOUS AND CAPTURE
 - 4.1A.9.1.1 DETERMINE CURRENT ORBITAL PARAMETERS
 - 4.1A.9.1.2 DETERMINE CURRENT ATTITUDE
 - 4.1A.9.1.3 DETERMINE DESIRED ORBITAL PARAMETERS
 - 4.1A.9.1.4 CHOOSE OPTIMAL TRAJECTORY

An optimal trajectory for SP/MEC rendezvous with the Shuttle consumes minimum SP propellant, within flight-time constraints. The consequences of micro-gravity levels induced from maneuvers and the possible sun-shielding needs of other SP payloads must also be considered.

4.1A.9.1.5 RETRACT SOLAR ARRAYS

Upon signal, the Space Platform will withdraw its deployable solar arrays and radiators. This action is necessary to prevent damage or loss of these systems during SP orbital maneuvers.

- 4.1A.9.1.6 RETRACT RADIATORS
- 4.1A.9.1.7 ORIENT THRUSTERS
- 4.1A.9.1.8 FIRE THRUSTERS
- 4.1A.9.1.9 ORBITER AND SP VELOCITY AND TRAJECTORY ADJUSTMENTS

Alignment and matching before docking will be accomplished with the attitude control systems on both the SP and the Orbiter.

- 4.1A.9.1.10 OPEN PAYLOAD BAY DOORS
- 4.1A.9.1.11 ACTIVATE DOCKING ADAPTER
- 4.1A.9.1.12 DOCKING OF SHUTTLE ADAPTER TO SPACE PLATFORM

The SP will be secured with the Orbiter docking adapter during payload operations.

- 4.1A.9.1.13 SP BERTHING ON DOCKING ADAPTER
- 4.1A.9.1.14 ACTIVATE RMS
- 4.1A.9.2 REMOVE OLD SP PAYLOAD FROM TARGET BERTH

A payload occupying the Space Platform berth designated for the MEC must be removed and stowed in the Orbiter cargo bay before MEC attachment to the SP.

- 4.1A.9.2.1 OPEN PAYLOAD BAY DOORS
- 4.1A.9.2.2 LOCATE GRASPING FIXTURE ON TARGET
- 4.1A.9.2.3 GRASP FIXTURE
- 4.1A.9.2.4 RELEASE PAYLOAD RESTRAINTS
- 4.1A.9.2.5 STOW OLD PAYLOAD IN ORBITER
- 4.1A.9.3 DEPLOY NEW PAYLOAD FROM PAYLOAD BAY
 - 4.1A.9.3.1 LOCATE NEW PAYLOAD
 - 4.1A.9.3.2 GRASP FIXTURE
 - 4.1A.9.3.3 RELEASE PAYLOAD RESTRAINTS
 - 4.1A.9.3.4 ATTACH NEW PAYLOAD TO SP

After sensory indication of interface alignment, the MEC is mated with the SP docking berth.

4.1A.9.4 OPERATIONAL CHECKOUT

The systems' status is observed after full deployment and systems activation.

- 4.1A.9.4.1 ACTIVATE SUBSYSTEMS
- 4.1A.9.4.2 POWER SUBSYSTEM CHECKOUT
- 4.1A.9.4.3 THERMAL SUBSYSTEM CHECKOUT

- 4.1A.9.4.4 INFORMATION PROCESSING SUBSYSTEM CHECKOUT
- 4.1A.9.4.5 STRUCTURE SUBSYSTEM CHECKOUT
- 4.1A.9.4.6 COMMUNICATIONS SUBSYSTEM CHECKOUT
- 4.1A.9.4.7 SP/PAYLOAD INTERFACE CHECKOUT
- 4.1A.9.4.8 CONSUMABLES LEVELS CHECKOUT
- 4.1A.9.4.9 COMPARE MEASURED DATA TO MODEL
- 4.1A.9.5 IDENTIFY DEFECTIVE COMPONENT
 - 4.1A.9.5.1 DETERMINE ANOMALOUS DATA
 - 4.1A.9.5.2 FORM HYPOTHESIS FOR PROBLEM
 - 4.1A.9.5.3 DEVISE TEST FOR FAILURE HYPOTHESIS
 - 4.1A.9.5.4 PERFORM TEST FOR FAILURE HYPOTHESIS
 - 4.1A.9.5.5 IDENTIFY FAULTY COMPONENT
- 4.1A.9.6 IDENTIFY DEFECTIVE SOFTWARE
 - 4.1A.9.6.1 COMPARE MEASURED DATA TO MODEL
 - 4.1A.9.6.2 DETERMINE ANOMALOUS DATA
 - 4.1A.9.6.3 FORM HYPOTHESIS FOR PROBLEM
 - 4.1A.9.6.4 DEVISE TEST FOR FAILURE HYPOTHESIS
 - 4.1A.9.6.5 PERFORM TEST FOR FAILURE HYPOTHESIS
- 4.1A.9.7A COMPONENT FAILURE RECOVERY (REDUNDANCY)
 - 4.1A.9.7A.1 SWITCH OUT FAULTY COMPONENT
 - 4.1A.9.7A.2 SWITCH IN REDUNDANT COMPONENT
 - 4.1A.9.7A.3 MAKE DIAGNOSTIC CHECKS
 - 4.1A.9.7A.4 UPDATE SPACECRAFT MODEL
- 4.1A.9.7B COMPONENT FAILURE RECOVERY (ON-BOARD REPAIR)
 - 4.1A.9.7B.1 DEFINE ACCESS SEQUENCE
 - 4.1A.9.7B.2 LOCATE ACCESS PANEL
 - 4.1A.9.7B.3 TRANSFER REPAIR EQUIPMENT TO REPAIR SITE
 - 4.1A.9.7B.4 OPEN ACCESS PANEL
 - 4.1A.9.7B.5 OBSERVE/LOCATE DEFECTIVE COMPONENT
 - 4.1A.9.7B.6 REMOVE COMPONENT
 - 4.1A.9.7B.7 STORE COMPONENT
 - 4.1A.9.7B.8 LOCATE NEW COMPONENT
 - 4.1A.9.7B.9 POSITION AND CONNECT NEW COMPONENT
 - 4.1A.9.7B.10 ADJUST COMPONENT
 - 4.1A.9.7B.11 MAKE DIAGNOSTIC CHECKS
 - 4.1A.9.7B.12 CLOSE ACCESS PANEL
 - 4.1A.9.7B.13 STOW REPAIR EQUIPMENT
 - 4.1A.9.7B.14 UPDATE SPACECRAFT MODEL
- 4.1A.9.8 SOFTWARE FAILURE RECOVERY
 - 4.1A.9.8.1 DETERMINE CORRECTION ALGORITHM
 - 4.1A.9.8.2 DATA/COMMAND ENCODING
 - 4.1A.9.8.3 DATA/COMMAND TRANSMISSION
 - 4.1A.9.8.4 COMPUTER FUNCTION CHECKS
- 4.1A.9.9 SEPARATION OF SP FROM ORBITER
 - 4.1A.9.9.1 TRANSFER OPERATIONAL CONTROL FROM MISSION TO PAYLOAD CONTROL
 - 4.1A.9.9.2 UNDOCKING OF ORBITER FROM SP
 - 4.1A.9.9.3 DETERMINE CURRENT ORBITAL PARAMETERS
 - 4.1A.9.9.4 DETERMINE CURRENT ATTITUDE
 - 4.1A.9.9.5 DETERMINE DESIRED ORBITAL PARAMETERS
 - 4.1A.9.9.6 CHOOSE OPTIMAL TRAJECTORY
 - 4.1A.9.9.7 RETRACT SOLAR ARRAYS
 - 4.1A.9.9.8 RETRACT RADIATORS
 - 4.1A.9.9.9 ORIENT THRUSTERS
 - 4.1A.9.9.10 FIRE THRUSTERS
 - 4.1A.9.9.11 ACTIVATE SUBSYSTEMS
 - 4.1A.9.9.12 POWER SUBSYSTEM CHECKOUT
 - 4.1A.9.9.13 THERMAL SUBSYSTEM CHECKOUT
 - 4.1A.9.9.14 INFORMATION PROCESSING SUBSYSTEM CHECKOUT
 - 4.1A.9.9.15 STRUCTURE SUBSYSTEM CHECKOUT
 - 4.1A.9.9.16 COMMUNICATIONS SUBSYSTEM CHECKOUT
 - 4.1A.9.9.17 SP/PAYLOAD INTERFACE CHECKOUT
 - 4.1A.9.9.18 CONSUMABLES LEVELS CHECKOUT
 - 4.1A.9.9.19 COMPARE MEASURED DATA TO MODEL
 - 4.1A.9.9.20 DEPLOY SOLAR ARRAYS
 - 4.1A.9.9.21 DEPLOY RADIATORS
- 4.1A.10 STATUS MONITORING AND RESOURCE ALLOCATION

This is primarily allocation of power and thermal dump capacity.
Experiments provide their own materials, but must share power and thermal
systems. Resource allocation is a scheduling procedure to prevent overload
of the power and thermal subsystems.

- 4.1A.10.1 TEMPERATURE MANAGEMENT
 - 4.1A.10.1.1 MEASURE COMPONENT TEMPERATURES
 - 4.1A.10.1.2 COMPARE TEMPERATURE TO REQUIRED LIMITS
 - 4.1A.10.1.3 ADJUST COOLING/HEATING SYSTEMS
- 4.1A.10.2 POWER MANAGEMENT
 - 4.1A.10.2.1 MEASURE CURRENTS AND VOLTAGES
 - 4.1A.10.2.2 COMPARE CURRENTS AND VOLTAGES TO REQUIRED LIMITS
 - 4.1A.10.2.3 EVALUATE BATTERY CHARGING PERFORMANCE
 - 4.1A.10.2.4 ADJUST CURRENTS AND VOLTAGES
 - 4.1A.10.2.5 ADJUST BATTERY CHARGING CYCLE
- 4.1A.10.3 DATA/COMMAND PROCESSING
 - 4.1A.10.3.1 SHORT-TERM MEMORY STORAGE
 - 4.1A.10.3.2 LONG-TERM MEMORY STORAGE
 - 4.1A.10.3.3 DATA/COMMAND ENCODING
 - 4.1A.10.3.4 DATA/COMMAND DECODING
 - 4.1A.10.3.5 NUMERICAL COMPUTATION
 - 4.1A.10.3.6 LOGIC OPERATIONS
 - 4.1A.10.3.7 COMPUTER LOAD SCHEDULING
 - 4.1A.10.3.8 COMPUTER FUNCTION CHECKS
- 4.1A.10.4 CONSUMABLES MANAGEMENT

Many onboard experiments require supplies of cryogenics or materials for operation which must be periodically replaced. If a supply is depleted faster than expected, its storage-monitoring device signals that the supply is low. It may also predict in advance that a supply will be depleted.

- 4.1A.10.4.1 MONITOR GAS SUPPLIES
- 4.1A.10.4.2 MONITOR PROPELLANT SUPPLIES
- 4.1A.10.4.3 MONITOR COOLING SYSTEM SUPPLIES
- 4.1A.10.4.4 PROJECT CONSUMABLES REQUIREMENTS FROM MISSION PROFILE
- 4.1A.10.4.5 COMPUTE OPTIMAL CONSUMABLES ALLOCATION
- 4.1A.10.5 STRUCTURAL MANAGEMENT
 - 4.1A.10.5.1 MEASURE STRAINS IN STRUCTURE
 - 4.1A.10.5.2 MEASURE RELATIVE DISPLACEMENTS
 - 4.1A.10.5.3 COMPUTE STRESS AND VIBRATION PARAMETERS
 - 4.1A.10.5.4 COMPARE STRESS AND VIBRATION PARAMETERS TO REQUIRED LIMITS
 - 4.1A.10.5.5 APPLY COMPENSATING FORCES
 - 4.1A.10.5.6 APPLY VIBRATION DAMPING
- 4.1A.10.6 HAZARD AVOIDANCE
 - 4.1A.10.6.1 AVOID TANK OVERPRESSURES
 - 4.1A.10.6.2 MAINTAIN SAFE BATTERY CHARGE LEVELS
 - 4.1A.10.6.3 MONITOR MICRO-GRAVITY LEVELS
 - 4.1A.10.6.4 MAINTAIN COMMUNICATION LINKS
 - 4.1A.10.6.5 AVOID EXPOSING SENSITIVE COMPONENTS TO DIRECT SUNLIGHT
- 4.1A.10.7 OPTIMAL SEQUENCING

Progress of each experiment relative to the planned mission should be monitored, and notification given to the principal investigator if time delays caused by mechanical or other problems will cause stationkeeping or other maneuvers to overlap with an experiment in progress. If necessary, experiments may be rescheduled to allow for these problems.

- 4.1A.10.7.1 UPDATE SPACECRAFT MODEL
- 4.1A.10.7.2 PROJECT DESIRED FUNCTIONS FROM MISSION PROFILE
- 4.1A.10.7.3 ESTIMATE RISKS FROM DESIRED FUNCTIONS
- 4.1A.10.7.4 PROJECT CONSUMABLES REQUIREMENTS FROM MISSION PROFILE
- 4.1A.10.7.5 DETERMINE CONSTRAINTS AND FIGURES OF MERIT
- 4.1A.10.7.6 COMPUTE OPTIMAL SEQUENCING
- 4.1A.10.8 IDENTIFY DEFECTIVE COMPONENT
 - 4.1A.10.8.1 DETERMINE ANOMALOUS DATA
 - 4.1A.10.8.2 FORM HYPOTHESIS FOR PROBLEM
- 4.1A.10.9 REPORT SYSTEMS STATUS
 - 4.1A.10.9.1 DATA/COMMAND ENCODING
 - 4.1A.10.9.2 DATA/COMMAND TRANSMISSION
 - 4.1A.10.9.3 DATA/COMMAND DECODING
 - 4.1A.10.9.4 DATA/COMMAND DISPLAY
- 4.1A.11A PRE-EXPERIMENT OPERATIONS (SOLIDS)
 - 4.1A.11A.1 TRANSFER SAMPLE FROM STORAGE TO FURNACE
 - 4.1A.11A.1.1 IDENTIFY SHAPE, SIZE IN BIN

Each EP will include its own uniquely shaped and marked samples.

- 4.1A.11A.1.2 MATCH WITH SAMPLE MODEL
- 4.1A.11A.1.3 POSITION MANIPULATOR (ON RAILS)

The grasping apparatus will be moved to a preset location in the sample storage bay.

- 4.1A.11A.1.4 GRASP SAMPLE
- 4.1A.11A.1.5 TRANSPORT SAMPLE TO EXPERIMENT AREA
- 4.1A.11A.1.6 OPEN HOLDER
- 4.1A.11A.1.7 INSERT SAMPLE
- 4.1A.11A.1.8 CLOSE HOLDER
- 4.1A.11A.2 ACTIVATE PAYLOAD-SPECIFIC INSTRUMENTATION

Examples: high-temperature-rated sound-frequency sensors (for acoustic containerless metals processing), or ultraprecision thermocouples (for solution crystal growth).

- 4.1A.11A.2.1 ACTIVATE FAIL-SAFE SUBSYSTEM(S)
- 4.1A.11A.2.2 CHECK ALIGNMENT WITH ALIGNMENT CRITERIA

Input from contact-sensors in the sample-holder should be compared with the specified "world-model" input.

- 4.1A.11A.2.3 SET (OR EVACUATE) FURNACE ATMOSPHERE

A preset atmosphere (or vacuum) should be achieved in the furnace before experimental operations begin.

- 4.1A.11A.2.4 ACTIVATE EXPERIMENTAL PROCESS SPECIFIC EQUIPMENT
- 4.1A.11A.3 PROVIDE THERMAL CONTROL FOR PROCESSES
 - 4.1A.11A.3.1 MEASURE COMPONENT TEMPERATURE
 - 4.1A.11A.3.2 COMPARE TEMPERATURE TO REQUIRED LIMITS
 - 4.1A.11A.3.3 ACTIVATE FURNACE TEMPERATURE-MAINTAINING UNIT
- 4.1A.11A.4 ANALYZE RESIDUAL GAS

The presence of sample-material molecules and any possible chemical reactants around the sample in the furnace must be confirmed and measured before beginning the experimental process.

- 4.1A.11A.4.1 INITIATE GAS ANALYZER OPERATION
- 4.1A.11A.4.2 RECORDING AND ON-BOARD STORAGE OF DATA
- 4.1A.12A CONDUCT PAYLOAD-SPECIFIC EXPERIMENT (SOLIDS)

Currently, the specific experiment could be one of:

- Advanced Solidification Experiments
- High-Gradient Directional Solidification
- Float Zone processing
- Acoustic Containerless processing
- Electromagnetic Containerless processing
- Electrostatic Containerless processing
- Vapor Crystal Growth
- Solution Crystal Growth
- Unique Payloads

-
- 4.1A.12A.1.1 MEASURE EXPERIMENTAL DATA, WITH SPEC. INSTRUMENTATION
 - 4.1A.12A.1.2 RECORDING AND ON-BOARD STORAGE OF DATA
 - 4.1A.13A POST-EXPERIMENT OPERATIONS (SOLIDS)
 - 4.1A.13A.1 CONCLUDE EXPERIMENT
 - 4.1A.13A.1.1 COOL SAMPLE
 - 4.1A.13A.1.2 ADJUST FURNACE PRESSURE TO SAFE LEVEL
 - 4.1A.13A.2 TRANSFER SAMPLE FROM FURNACE TO STORAGE
 - 4.1A.13A.2.1 GET SAMPLE WITH SAMPLE HOLDER
 - 4.1A.13A.2.2 REMOVE SAMPLE FROM FURNACE
 - 4.1A.13A.2.3 RELEASE SAMPLE FROM SAMPLE HOLDER
 - 4.1A.13A.2.4 REMOVE SAMPLE FROM HOLDER
 - 4.1A.13A.2.5 TRANSPORT SAMPLE TO STORAGE BIN
 - 4.1A.13A.2.6 RELEASE SAMPLE IN BIN
 - 4.1A.13A.3 SHUTDOWN OPERATIONS
 - 4.1A.13A.3.1 PURGE GASES FROM FURNACE
 - 4.1A.13A.3.2 BAKEOUT FURNACE

4.1A.13A.3.3 REPROGRAM PROCESS SET-POINTS AND CONTROLS
4.1A.11B PRE-EXPERIMENT OPERATIONS (FLUIDS)

Each EP will include its own means of identifying (by ph, density, etc.)
fluid sample materials and products.

4.1A.11B.1 PREPARE SAMPLE (AS REQUIRED)

Sample preparation might include heating it to a preset temperature,
pressurizing the sample storage chamber, or injecting a
handling-facilitation agent prior to mixing it with the processing media.

4.1A.11B.2 ENVIRONMENT IS CONTROLLED, CAREFULLY MONITORED

- 4.1A.11B.2.1 DEFROST LIVE CELLS
- 4.1A.11B.2.2 SUPPLY NUTRIENTS AND GASES
- 4.1A.11B.2.3 REMOVE ORGANIC WASTES

4.1A.11B.3 PREPARE SYSTEM FLOW CONDITIONS

Prior to sample injection into the experimental chamber, appropriate
relative pressures must be maintained in the chamber and sample storage
area. System temperatures must be at nominal values, and all necessary
pumps and valves must be activated.

4.1A.11B.4 INJECT SAMPLE INTO CHAMBER

- 4.1A.11B.4.1 PUMP SAMPLE INTO CHAMBER
- 4.1A.11B.4.2 PUMP MEDIA FLUID INTO CHAMBER

4.1A.11B.5 ACTIVATE INSTRUMENTATION

4.1A.12E CONDUCT PAYLOAD-SPECIFIC EXPERIMENT (FLUIDS)

Currently, the specific experiment could be one of:

Vapor Crystal Growth
Solution Crystal Growth
Bioprocessing
Unique payloads

4.1A.12B.1.1 MEASURE EXPERIMENTAL DATA, WITH SPEC. INSTRUMENTATION

4.1A.12B.1.2 RECORDING AND ON-BOARD STORAGE OF DATA

4.1A.13B POST-EXPERIMENT OPERATIONS (FLUIDS)

4.1A.13B.1 COLLECT FRACTIONS

4.1A.13B.2 SAMPLE DATA MANAGEMENT AND MONITORING

4.1A.13B.2.1 TRANSMIT DATA TO GROUND PROCESSING CENTER

4.1A.13B.2.2 WHEN SPECIFIED GROWTH PARAMS. REACHED, PREPARE SAMPLE FOR RETURN

4.1A.13B.3 SHUTDOWN OPERATIONS

4.1A.13B.3.1 STORE PRODUCTS IN A CONTROLLED ENVIRONMENT FOR RETURN

4.1A.13B.3.2 FLUSH SYSTEM WITH BIOCIDE, PRIOR TO NEXT CYCLE

4.1A.14 RETRIEVAL BY ORBITER

4.1A.14.1 ORBITER/SP RENDEZVOUS AND CAPTURE

4.1A.14.1.1 DETERMINE CURRENT ORBITAL PARAMETERS

4.1A.14.1.2 DETERMINE CURRENT ATTITUDE

4.1A.14.1.3 DETERMINE DESIRED ORBITAL PARAMETERS

4.1A.14.1.4 CHOOSE OPTIMAL TRAJECTORY

4.1A.14.1.5 RETRACT SOLAR ARRAYS

4.1A.14.1.6 RETRACT RADIATORS

4.1A.14.1.7 ORIENT THRUSTERS

4.1A.14.1.8 FIRE THRUSTERS

4.1A.14.1.9 ORBITER AND SP VELOCITY AND TRAJECTORY ADJUSTMENTS

4.1A.14.1.10 OPEN PAYLOAD BAY DOORS

4.1A.14.1.11 ACTIVATE DOCKING ADAPTER

4.1A.14.1.12 DOCKING OF SHUTTLE ADAPTER TO SPACE PLATFORM

4.1A.14.1.13 SP BERTHING ON DOCKING ADAPTER

4.1A.14.1.14 ACTIVATE RMS

4.1A.14.2 PAYLOAD WITHDRAWAL FROM SP

4.1A.14.2.1 SP INTERFACE WITH PAYLOAD IS SHUTDOWN

4.1A.14.2.2 PAYLOAD INTERNAL POWER ACTIVATED

4.1A.14.2.3 LOCATE GRASPING FIXTURE ON TARGET

4.1A.14.2.4 GRASP FIXTURE

4.1A.14.2.5 RELEASE PAYLOAD RESTRAINTS

4.1A.14.2.6 TRANSLATE PAYLOAD TO CRADLE

4.1A.14.2.7 FASTEN PAYLOAD RESTRAINTS

4.1A.14.3 SHUTTLE/PAYLOAD INTEGRATION AND TESTING

- 4.1A.14.3.1 ORBITER/PAYLOAD INTEGRATION CHECKOUT
- 4.1A.14.3.2 CLOSE PAYLOAD BAY DOORS
- 4.1A.14.4 SEPARATION OF SP FROM ORBITER
 - 4.1A.14.4.1 TRANSFER OPERATIONAL CONTROL FROM MISSION TO PAYLOAD CONTROL
 - 4.1A.14.4.2 UNDOCKING OF ORBITER FROM SP
 - 4.1A.14.4.3 DETERMINE CURRENT ORBITAL PARAMETERS
 - 4.1A.14.4.4 DETERMINE CURRENT ATTITUDE
 - 4.1A.14.4.5 DETERMINE DESIRED ORBITAL PARAMETERS
 - 4.1A.14.4.6 CHOOSE OPTIMAL TRAJECTORY
 - 4.1A.14.4.7 RETRACT SOLAR ARRAYS
 - 4.1A.14.4.8 RETRACT RADIATORS
 - 4.1A.14.4.9 ORIENT THRUSTERS
 - 4.1A.14.4.10 FIRE THRUSTERS
 - 4.1A.14.4.11 ACTIVATE SUBSYSTEMS
 - 4.1A.14.4.12 POWER SUBSYSTEM CHECKOUT
 - 4.1A.14.4.13 THERMAL SUBSYSTEM CHECKOUT
 - 4.1A.14.4.14 INFORMATION PROCESSING SUBSYSTEM CHECKOUT
 - 4.1A.14.4.15 STRUCTURE SUBSYSTEM CHECKOUT
 - 4.1A.14.4.16 COMMUNICATIONS SUBSYSTEM CHECKOUT
 - 4.1A.14.4.17 SP/PAYLOAD INTERFACE CHECKOUT
 - 4.1A.14.4.18 CONSUMABLES LEVELS CHECKOUT
 - 4.1A.14.4.19 COMPARE MEASURED DATA TO MODEL
 - 4.1A.14.4.20 DEPLOY SOLAR ARRAYS
 - 4.1A.14.4.21 DEPLOY RADIATORS
- 4.1A.15 RE-ENTRY AND LANDING OF ORBITER
- 4.1A.16 POST-FLIGHT OPERATIONS
 - 4.1A.16.1 SAFING OF ORBITER AND HAZARDOUS PAYLOADS
 - 4.1A.16.2 REMOVAL OF PAYLOADS FROM ORBITER
 - 4.1A.16.2.1 OPEN PAYLOAD BAY DOORS
 - 4.1A.16.2.2 PRIORITY REMOVAL OF TIME-CRITICAL ITEMS
 - 4.1A.16.2.3 ATTACH STRONGBACK TO PAYLOAD
 - 4.1A.16.2.4 LOAD PAYLOAD INTO CANISTER
 - 4.1A.16.3 PAYLOAD REMOVAL FROM ORBITER PROCESSING FACILITY
- 4.1B MATERIALS EXPERIMENT CARRIER (SERVICED, MULTI-SORTIE)
 - 4.1B.1 DESIGN
 - 4.1B.1.1 DEFINE REQUIREMENTS
 - 4.1B.1.2 SELECT EXPERIMENTAL PACKAGES
 - 4.1B.1.3 MISSION ANALYSIS
 - 4.1B.1.4 PAYLOAD ACCOMODATIONS
 - 4.1B.1.5 CREATE FUNCTIONAL LAYOUT
 - 4.1B.1.6 CREATE MECHANICAL LAYOUT
 - 4.1B.2 COMPONENT FABRICATION
 - 4.1B.2.1 PROCURE OFF-THE-SHELF COMPONENTS
 - 4.1B.2.2 PROCURE MATERIALS FOR MANUFACTURE OF COMPONENTS
 - 4.1B.2.3 PROCURE MANUFACTURING EQUIPMENT
 - 4.1B.2.4 MANUFACTURE COMPONENTS
 - 4.1B.3 COMPONENT TEST
 - 4.1B.3.1 SET UP TEST FACILITIES
 - 4.1B.3.2 STRUCTURAL LOADS TESTS
 - 4.1B.3.3 DATA PROCESSING AND SOFTWARE TESTS
 - 4.1B.3.4 SOLAR ARRAY DEPLOYMENT TESTS
 - 4.1B.3.5 CHECK RF PATTERN
 - 4.1B.3.6 ELECTRICAL SYSTEMS TESTS
 - 4.1B.3.7 THERMAL AND VACUUM TESTS
 - 4.1B.3.8 COMPONENT CERTIFICATION
 - 4.1B.4 SYSTEM INTEGRATION
 - 4.1B.4.1 RECEIVE AND SORT COMPONENTS
 - 4.1B.4.2 POSITION AND ORIENT COMPONENT
 - 4.1B.4.3 ATTACH COMPONENTS
 - 4.1B.5 SYSTEM TEST
 - 4.1B.5.1 POWER SUBSYSTEM TEST
 - 4.1B.5.2 THERMAL SUBSYSTEM TESTS
 - 4.1B.5.3 INFORMATION PROCESSING SUBSYSTEM TESTS
 - 4.1B.5.4 STRUCTURE SUBSYSTEM TESTS
 - 4.1B.5.5 COMMUNICATIONS SUBSYSTEM TESTS
 - 4.1B.5.6 ANALYZE PERFORMANCE DATA
 - 4.1B.5.7 REPEAT CONSTRUCTION/CHECKOUT CYCLE UNTIL O.K.
 - 4.1B.6 PAYLOAD INSTALLATION AND TRANSPORT
 - 4.1B.6.1 INSTALLATION OF EXPERIMENTAL PACKAGES
 - 4.1B.6.2 TESTING AT INTEGRATION SITE
 - 4.1B.6.3 REMOVE TEST EQUIPMENT

- ORIGINAL PAGE IS
OF POOR QUALITY
- 4.1B.6.4 PERFORM NECESSARY DISASSEMBLY
 - 4.1B.6.5 PACKING
 - 4.1B.6.6 TRANSPORT TO LAUNCH SITE
 - 4.1B.7 ORBITER/PAYLOAD INTEGRATION AND CHECKOUT
 - 4.1B.7.1 UNPACKING
 - 4.1B.7.2 PERFORM NECESSARY REASSEMBLY
 - 4.1B.7.3 INTEGRATED SYSTEMS TESTS
 - 4.1B.7.3.1 VERIFY POWER SYSTEM FUNCTION
 - 4.1B.7.3.2 VERIFY COMMAND SYSTEM FUNCTION
 - 4.1B.7.3.3 VERIFY MECHANICAL SYSTEM FUNCTION
 - 4.1B.7.3.4 VERIFY COMMUNICATIONS SYSTEM FUNCTION
 - 4.1B.7.4 PERFORM INTERFACES CHECK
 - 4.1B.7.4.1 CHECK EXPERIMENTAL PACKAGE INTERFACE
 - 4.1B.7.4.2 CHECK SHUTTLE/PAYLOAD MECHANICAL INTERFACES
 - 4.1B.7.4.3 CHECK ELECTRICAL INTERFACES
 - 4.1B.7.5 TRANSFER PAYLOAD TO ORBITER PROCESSING FACILITY
 - 4.1B.7.5.1 ATTACH STRONGBACK TO PAYLOAD
 - 4.1B.7.5.2 LOAD PAYLOAD INTO CANISTER
 - 4.1B.7.5.3 REMOVE STRONGBACK
 - 4.1B.7.5.4 CLOSE CANISTER
 - 4.1B.7.5.5 TRANSPORT CANISTER TO ORBITER PROCESSING FACILITY
 - 4.1B.7.6 ORBITER/PAYLOAD INTEGRATION
 - 4.1B.7.6.1 ATTACH STRONGBACK TO PAYLOAD
 - 4.1B.7.6.2 INSTALL PAYLOAD IN ORBITER
 - 4.1B.7.6.3 CONNECT ORBITER/PAYLOAD INTERFACES
 - 4.1B.7.6.4 CHECK ELECTRICAL INTERFACES
 - 4.1B.7.6.5 CLOSE-OUT PAYLOAD BAY
 - 4.1B.7.6.6 INSTALLATION OF ORBITER PAYLOAD STATION CONSOLES
 - 4.1B.7.6.7 INSTALLATION OF DMS KIT
 - 4.1B.8 COUNTDOWN AND LAUNCH
 - 4.1B.9 ORBITAL DEPLOYMENT AND CHECKOUT
 - 4.1B.9.1 ORBITER/SP RENDEZVOUS AND CAPTURE
 - 4.1B.9.1.1 DETERMINE CURRENT ORBITAL PARAMETERS
 - 4.1B.9.1.2 DETERMINE CURRENT ATTITUDE
 - 4.1B.9.1.3 DETERMINE DESIRED ORBITAL PARAMETERS
 - 4.1B.9.1.4 CHOOSE OPTIMAL TRAJECTORY
 - 4.1B.9.1.5 RETRACT SOLAR ARRAYS
 - 4.1B.9.1.6 RETRACT RADIATORS
 - 4.1B.9.1.7 ORIENT THRUSTERS
 - 4.1B.9.1.8 FIRE THRUSTERS
 - 4.1B.9.1.9 ORBITER AND SP VELOCITY AND TRAJECTORY ADJUSTMENTS
 - 4.1B.9.1.10 OPEN PAYLOAD BAY DOORS
 - 4.1B.9.1.11 ACTIVATE DOCKING ADAPTER
 - 4.1B.9.1.12 DOCKING OF SHUTTLE ADAPTER TO SPACE PLATFORM
 - 4.1B.9.1.13 SP BERTHING ON DOCKING ADAPTER
 - 4.1B.9.1.14 ACTIVATE RMS
 - 4.1B.9.2 REMOVE OLD SP PAYLOAD FROM TARGET BERTH
 - 4.1B.9.2.1 OPEN PAYLOAD BAY DOORS
 - 4.1B.9.2.2 LOCATE GRASPING FIXTURE ON TARGET
 - 4.1B.9.2.3 GRASP FIXTURE
 - 4.1B.9.2.4 RELEASE PAYLOAD RESTRAINTS
 - 4.1B.9.2.5 STOW OLD PAYLOAD IN ORBITER
 - 4.1B.9.3 DEPLOY NEW PAYLOAD FROM PAYLOAD BAY
 - 4.1B.9.3.1 LOCATE NEW PAYLOAD
 - 4.1B.9.3.2 GRASP FIXTURE
 - 4.1B.9.3.3 RELEASE PAYLOAD RESTRAINTS
 - 4.1B.9.3.4 ATTACH NEW PAYLOAD TO SP
 - 4.1B.9.4 OPERATIONAL CHECKOUT
 - 4.1B.9.4.1 ACTIVATE SUBSYSTEMS
 - 4.1B.9.4.2 POWER SUBSYSTEM CHECKOUT
 - 4.1B.9.4.3 THERMAL SUBSYSTEM CHECKOUT
 - 4.1B.9.4.4 INFORMATION PROCESSING SUBSYSTEM CHECKOUT
 - 4.1B.9.4.5 STRUCTURE SUBSYSTEM CHECKOUT
 - 4.1B.9.4.6 COMMUNICATIONS SUBSYSTEM CHECKOUT
 - 4.1B.9.4.7 SP/PAYLOAD INTERFACE CHECKOUT
 - 4.1B.9.4.8 CONSUMABLES LEVELS CHECKOUT
 - 4.1B.9.4.9 COMPARE MEASURED DATA TO MODEL
 - 4.1B.9.5 IDENTIFY DEFECTIVE COMPONENT
 - 4.1B.9.5.1 DETERMINE ANOMALOUS DATA
 - 4.1B.9.5.2 FORM HYPOTHESIS FOR PROBLEM
 - 4.1B.9.5.3 DEVISE TEST FOR FAILURE HYPOTHESIS
 - 4.1B.9.5.4 PERFORM TEST FOR FAILURE HYPOTHESIS

- 4.1B.9.5.5 IDENTIFY FAULTY COMPONENT
- 4.1B.9.6 IDENTIFY DEFECITIVE SOFTWARE
 - 4.1B.9.6.1 COMPARE MEASURED DATA TO MODEL
 - 4.1B.9.6.2 DETERMINE ANOMALOUS DATA
 - 4.1B.9.6.3 FORM HYPOTHESIS FOR PROBLEM
 - 4.1B.9.6.4 DEVISE TEST FOR FAILURE HYPOTHESIS
 - 4.1B.9.6.5 PERFORM TEST FOR FAILURE HYPOTHESIS
- 4.1B.9.7A COMPONENT FAILURE RECOVERY (REDUNDANCY)
 - 4.1B.9.7A.1 SWITCH OUT FAULTY COMPONENT
 - 4.1B.9.7A.2 SWITCH IN REDUNDANT COMPONENT
 - 4.1B.9.7A.3 MAKE DIAGNOSTIC CHECKS
 - 4.1B.9.7A.4 UPDATE SPACECRAFT MODEL
- 4.1B.9.7B COMPONENT FAILURE RECOVERY (ON-BOARD REPAIR)
 - 4.1B.9.7B.1 DEFINE ACCESS SEQUENCE
 - 4.1B.9.7B.2 LOCATE ACCESS PANEL
 - 4.1B.9.7B.3 TRANSFER REPAIR EQUIPMENT TO REPAIR SITE
 - 4.1B.9.7B.4 OPEN ACCESS PANEL
 - 4.1B.9.7B.5 OBSERVE/LOCATE DEFECTIVE COMPONENT
 - 4.1B.9.7B.6 REMOVE COMPONENT
 - 4.1B.9.7B.7 STORE COMPONENT
 - 4.1B.9.7B.8 LOCATE NEW COMPONENT
 - 4.1B.9.7B.9 POSITION AND CONNECT NEW COMPONENT
 - 4.1B.9.7B.10 ADJUST COMPONENT
 - 4.1B.9.7B.11 MAKE DIAGNOSTIC CHECKS
 - 4.1B.9.7B.12 CLOSE ACCESS PANEL
 - 4.1B.9.7B.13 STOW REPAIR EQUIPMENT
 - 4.1B.9.7B.14 UPDATE SPACECRAFT MODEL
- 4.1B.9.8 SOFTWARE FAILURE RECOVERY
 - 4.1B.9.8.1 DETERMINE CORRECTION ALGORITHM
 - 4.1B.9.8.2 DATA/COMMAND ENCODING
 - 4.1B.9.8.3 DATA/COMMAND TRANSMISSION
 - 4.1B.9.8.4 COMPUTER FUNCTION CHECKS
- 4.1B.9.9 SEPARATION OF SP FROM ORBITER
 - 4.1B.9.9.1 TRANSFER OPERATIONAL CONTROL FROM MISSION TO PAYLOAD CONTROL
 - 4.1B.9.9.2 UNDOCKING OF ORBITER FROM SP
 - 4.1B.9.9.3 DETERMINE CURRENT ORBITAL PARAMETERS
 - 4.1B.9.9.4 DETERMINE CURRENT ATTITUDE
 - 4.1B.9.9.5 DETERMINE DESIRED ORBITAL PARAMETERS
 - 4.1B.9.9.6 CHOOSE OPTIMAL TRAJECTORY
 - 4.1B.9.9.7 RETRACT SOLAR ARRAYS
 - 4.1B.9.9.8 RETRACT RADIATORS
 - 4.1B.9.9.9 ORIENT THRUSTERS
 - 4.1B.9.9.10 FIRE THRUSTERS
 - 4.1B.9.9.11 ACTIVATE SUBSYSTEMS
 - 4.1B.9.9.12 POWER SUBSYSTEM CHECKOUT
 - 4.1B.9.9.13 THERMAL SUBSYSTEM CHECKOUT
 - 4.1B.9.9.14 INFORMATION PROCESSING SUBSYSTEM CHECKOUT
 - 4.1B.9.9.15 STRUCTURE SUBSYSTEM CHECKOUT
 - 4.1B.9.9.16 COMMUNICATIONS SUBSYSTEM CHECKOUT
 - 4.1B.9.9.17 SP/PAYLOAD INTERFACE CHECKOUT
 - 4.1B.9.9.18 CONSUMABLES LEVELS CHECKOUT
 - 4.1B.9.9.19 COMPARE MEASURED DATA TO MODEL
 - 4.1B.9.9.20 DEPLOY SOLAR ARRAYS
 - 4.1B.9.9.21 DEPLOY RADIATORS
- 4.1B.10 STATUS MONITORING AND RESOURCE ALLOCATION
 - 4.1B.10.1 TEMPERATURE MANAGEMENT
 - 4.1B.10.1.1 MEASURE COMPONENT TEMPERATURES
 - 4.1B.10.1.2 COMPARE TEMPERATURE TO REQUIRED LIMITS
 - 4.1B.10.1.3 ADJUST COOLING/HEATING SYSTEMS
 - 4.1B.10.2 POWER MANAGEMENT
 - 4.1B.10.2.1 MEASURE CURRENTS AND VOLTAGES
 - 4.1B.10.2.2 COMPARE CURRENTS AND VOLTAGES TO REQUIRED LIMITS
 - 4.1B.10.2.3 EVALUATE BATTERY CHARGING PERFORMANCE
 - 4.1B.10.2.4 ADJUST CURRENTS AND VOLTAGES
 - 4.1B.10.2.5 ADJUST BATTERY CHARGING CYCLE
 - 4.1B.10.3 DATA/COMMAND PROCESSING
 - 4.1B.10.3.1 SHORT-TERM MEMORY STORAGE
 - 4.1B.10.3.2 LONG-TERM MEMORY STORAGE
 - 4.1B.10.3.3 DATA/COMMAND ENCODING
 - 4.1B.10.3.4 DATA/COMMAND DECODING
 - 4.1B.10.3.5 NUMERICAL COMPUTATION
 - 4.1B.10.3.6 LOGIC OPERATIONS

- 4.1B.10.3.7 COMPUTER LOAD SCHEDULING
- 4.1B.10.3.8 COMPUTER FUNCTION CHECKS
- 4.1B.10.4 CONSUMABLES MANAGEMENT
 - 4.1B.10.4.1 MONITOR GAS SUPPLIES
 - 4.1B.10.4.2 MONITOR PROPELLANT SUPPLIES
 - 4.1B.10.4.3 MONITOR COOLING SYSTEM SUPPLIES
 - 4.1B.10.4.4 PROJECT CONSUMABLES REQUIREMENTS FROM MISSION PROFILE
 - 4.1B.10.4.5 COMPUTE OPTIMAL CONSUMABLES ALLOCATION
- 4.1B.10.5 STRUCTURAL MANAGEMENT
 - 4.1B.10.5.1 MEASURE STRAINS IN STRUCTURE
 - 4.1B.10.5.2 MEASURE RELATIVE DISPLACEMENTS
 - 4.1B.10.5.3 COMPUTE STRESS AND VIBRATION PARAMETERS
 - 4.1B.10.5.4 COMPARE STRESS AND VIBRATION PARAMETERS TO REQUIRED LIMITS
 - 4.1B.10.5.5 APPLY COMPENSATING FORCES
 - 4.1B.10.5.6 APPLY VIBRATION DAMPING
- 4.1B.10.6 HAZARD AVOIDANCE
 - 4.1B.10.6.1 AVOID TANK OVERPRESSURES
 - 4.1B.10.6.2 MAINTAIN SAFE BATTERY CHARGE LEVELS
 - 4.1B.10.6.3 MONITOR MICRO-GRAVITY LEVELS
 - 4.1B.10.6.4 MAINTAIN COMMUNICATION LINKS
 - 4.1B.10.6.5 AVOID EXPOSING SENSITIVE COMPONENTS TO DIRECT SUNLIGHT
- 4.1B.10.7 OPTIMAL SEQUENCING
 - 4.1B.10.7.1 UPDATE SPACECRAFT MODEL
 - 4.1B.10.7.2 PROJECT DESIRED FUNCTIONS FROM MISSION PROFILE
 - 4.1B.10.7.3 ESTIMATE RISKS FROM DESIRED FUNCTIONS
 - 4.1B.10.7.4 PROJECT CONSUMABLES REQUIREMENTS FROM MISSION PROFILE
 - 4.1B.10.7.5 DETERMINE CONSTRAINTS AND FIGURES OF MERIT
 - 4.1B.10.7.6 COMPUTE OPTIMAL SEQUENCING
- 4.1B.10.8 IDENTIFY DEFECTIVE COMPONENT
 - 4.1B.10.8.1 DETERMINE ANOMALOUS DATA
 - 4.1B.10.8.2 FORM HYPOTHESIS FOR PROBLEM
- 4.1B.10.9 REPORT SYSTEMS STATUS
 - 4.1B.10.9.1 DATA/COMMAND ENCODING
 - 4.1B.10.9.2 DATA/COMMAND TRANSMISSION
 - 4.1B.10.9.3 DATA/COMMAND DECODING
 - 4.1B.10.9.4 DATA/COMMAND DISPLAY
- 4.1B.11A PRE-EXPERIMENT OPERATIONS (SOLIDS)
 - 4.1B.11A.1 TRANSFER SAMPLE FROM STORAGE TO FURNACE
 - 4.1B.11A.1.1 IDENTIFY SHAPE, SIZE IN BIN
 - 4.1B.11A.1.2 MATCH WITH SAMPLE MODEL
 - 4.1B.11A.1.3 POSITION MANIPULATOR (ON RAILS)
 - 4.1B.11A.1.4 GRASP SAMPLE
 - 4.1B.11A.1.5 TRANSPORT SAMPLE TO EXPERIMENT AREA
 - 4.1B.11A.1.6 OPEN HOLDER
 - 4.1B.11A.1.7 INSERT SAMPLE
 - 4.1B.11A.1.8 CLOSE HOLDER
 - 4.1B.11A.2 ACTIVATE PAYLOAD-SPECIFIC INSTRUMENTATION
 - 4.1B.11A.2.1 ACTIVATE FAIL-SAFE SUBSYSTEM(S)
 - 4.1B.11A.2.2 CHECK ALIGNMENT WITH ALIGNMENT CRITERIA
 - 4.1B.11A.2.3 SET (OR EVACUATE) FURNACE ATMOSPHERE
 - 4.1B.11A.2.4 ACTIVATE EXPERIMENTAL PROCESS SPECIFIC EQUIPMENT
 - 4.1B.11A.3 PROVIDE THERMAL CONTROL FOR PROCESSES
 - 4.1B.11A.3.1 MEASURE COMPONENT TEMPERATURE
 - 4.1B.11A.3.2 COMPARE TEMPERATURE TO REQUIRED LIMITS
 - 4.1B.11A.3.3 ACTIVATE FURNACE TEMPERATURE-MAINTAINING UNIT
 - 4.1B.11A.4 ANALYZE RESIDUAL GAS
 - 4.1B.11A.4.1 INITIATE GAS ANALYZER OPERATION
 - 4.1B.11A.4.2 RECORDING AND ON-BOARD STORAGE OF DATA
- 4.1B.12A CONDUCT PAYLOAD-SPECIFIC EXPERIMENT (SOLIDS)
 - 4.1B.12A.1.1 MEASURE EXPERIMENTAL DATA, WITH SPEC. INSTRUMENTATION
 - 4.1B.12A.1.2 RECORDING AND ON-BOARD STORAGE OF DATA
- 4.1B.13A POST-EXPERIMENT OPERATIONS (SOLIDS)
 - 4.1B.13A.1 CONCLUDE EXPERIMENT
 - 4.1B.13A.1.1 COOL SAMPLE
 - 4.1B.13A.1.2 ADJUST FURNACE PRESSURE TO SAFE LEVEL
 - 4.1B.13A.2 TRANSFER SAMPLE FROM FURNACE TO STORAGE
 - 4.1B.13A.2.1 GET SAMPLE WITH SAMPLE HOLDER
 - 4.1B.13A.2.2 REMOVE SAMPLE FROM FURNACE
 - 4.1B.13A.2.3 RELEASE SAMPLE FROM SAMPLE HOLDER
 - 4.1B.13A.2.4 REMOVE SAMPLE FROM HOLDER
 - 4.1B.13A.2.5 TRANSPORT SAMPLE TO STORAGE BIN
 - 4.1B.13A.2.6 RELEASE SAMPLE IN BIN

- 4.1B.13A.3 SHUTDOWN OPERATIONS
 - 4.1B.13A.3.1 PURGE GASES FROM FURNACE
 - 4.1B.13A.3.2 BAKEOUT FURNACE
 - 4.1B.13A.3.3 REPROGRAM PROCESS SET-POINTS AND CONTROLS
- 4.1B.11B PRE-EXPERIMENT OPERATIONS (FLUIDS)
 - 4.1B.11B.1 PREPARE SAMPLE (AS REQUIRED)
 - 4.1B.11B.2 ENVIRONMENT IS CONTROLLED, CAREFULLY MONITORED
 - 4.1B.11B.2.1 DEFROST LIVE CELLS
 - 4.1B.11B.2.2 SUPPLY NUTRIENTS AND GASES
 - 4.1B.11B.2.3 REMOVE ORGANIC WASTES
 - 4.1B.11B.3 PREPARE SYSTEM FLOW CONDITIONS
 - 4.1B.11B.4 INJECT SAMPLE INTO CHAMBER
 - 4.1B.11B.4.1 PUMP SAMPLE INTO CHAMBER
 - 4.1B.11B.4.2 PUMP MEDIA FLUID INTO CHAMBER
 - 4.1B.11B.5 ACTIVATE INSTRUMENTATION
- 4.1B.12B CONDUCT PAYLOAD-SPECIFIC EXPERIMENT (FLUIDS)
 - 4.1B.12B.1.1 MEASURE EXPERIMENTAL DATA, WITH SPEC. INSTRUMENTATION
 - 4.1B.12B.1.2 RECORDING AND ON-BOARD STORAGE OF DATA
- 4.1B.13B POST-EXPERIMENT OPERATIONS (FLUIDS)
 - 4.1B.13B.1 COLLECT FRACTIONS
 - 4.1B.13B.2 SAMPLE DATA MANAGEMENT AND MONITORING
 - 4.1B.13B.2.1 TRANSMIT DATA TO GROUND PROCESSING CENTER
 - 4.1B.13B.2.2 WHEN SPECIFIED GROWTH PARAMS. REACHED, PREPARE SAMPLE FOR RETURN
 - 4.1B.13B.3 SHUTDOWN OPERATIONS
 - 4.1B.13B.3.1 STORE PRODUCTS IN A CONTROLLED ENVIRONMENT FOR RETURN
 - 4.1B.13B.3.2 FLUSH SYSTEM WITH BIOCIDES, PRIOR TO NEXT CYCLE
- 4.1B.14 SERVICING AND RESUPPLY
 - 4.1B.14.1 PRE-RENDEZVOUS PREPARATIONS
 - 4.1B.14.1.1 SEND GROUND SIGNAL TO SP TO BEGIN SERV. SEQ.
 - 4.1B.14.1.2 REDUCE POWER TO SUBSYSTEMS

 Power to the MEC's subsystems must be reduced in anticipation of switching to internal battery power from the external power supply, as the Space Platform retracts its solar arrays.

- 4.1B.14 ? ORBITER/SP RENDEZVOUS AND CAPTURE
 - 4.1B.14.2.1 DETERMINE CURRENT ORBITAL PARAMETERS
 - 4.1B.14.2.2 DETERMINE CURRENT ATTITUDE
 - 4.1B.14.2.3 DETERMINE DESIRED ORBITAL PARAMETERS
 - 4.1B.14.2.4 CHOOSE OPTIMAL TRAJECTORY
 - 4.1B.14.2.5 RETRACT SOLAR ARRAYS
 - 4.1B.14.2.6 RETRACT RADIATORS
 - 4.1B.14.2.7 ORIENT THRUSTERS
 - 4.1B.14.2.8 FIRE THRUSTERS
 - 4.1B.14.2.9 ORBITER AND SP VELOCITY AND TRAJECTORY ADJUSTMENTS
 - 4.1B.14.2.10 OPEN PAYLOAD BAY DOORS
 - 4.1B.14.2.11 ACTIVATE DOCKING ADAPTER
 - 4.1B.14.2.12 DOCKING OF SHUTTLE ADAPTER TO SPACE PLATFORM
 - 4.1B.14.2.13 SP BERTHING ON DOCKING ADAPTER
- 4.1B.14.3 REMOVAL AND TRANSFER OF EXPERIMENTAL PACKAGES
 - 4.1B.14.3.1 SHUTDOWN EXPERIMENTAL PACKAGES
 - 4.1B.14.3.2 ACTIVATE RMS
 - 4.1B.14.3.3 LOCATE GRASPING FIXTURE ON TARGET
 - 4.1B.14.3.4 GRASP FIXTURE
 - 4.1B.14.3.5 RELEASE PAYLOAD RESTRAINTS
 - 4.1B.14.3.6 TRANSLATE PAYLOAD TO CRADLE
 - 4.1B.14.3.7 FASTEN PAYLOAD RESTRAINTS
 - 4.1B.14.3.8 ORIENT NEW PAYLOADS
 - 4.1B.14.3.9 ATTACH NEW PAYLOADS
 - 4.1B.14.3.10 ORBITER/PAYLOAD INTEGRATION CHECKOUT
- 4.1B.14.4 NON-SCHEDULED MAINTENANCE
- 4.1B.14.5 OPERATIONAL CHECKOUT
 - 4.1B.14.5.1 ACTIVATE SUBSYSTEMS
 - 4.1B.14.5.2 POWER SUBSYSTEM CHECKOUT
 - 4.1B.14.5.3 THERMAL SUBSYSTEM CHECKOUT
 - 4.1B.14.5.4 INFORMATION PROCESSING SUBSYSTEM CHECKOUT
 - 4.1B.14.5.5 STRUCTURE SUBSYSTEM CHECKOUT
 - 4.1B.14.5.6 COMMUNICATIONS SUBSYSTEM CHECKOUT
 - 4.1B.14.5.7 SP/PAYLOAD INTERFACE CHECKOUT
 - 4.1B.14.5.8 CONSUMABLES LEVELS CHECKOUT
 - 4.1B.14.5.9 COMPARE MEASURED DATA TO MODEL
- 4.1B.14.6 SEPARATION OF ORBITER AND SP

- 4.1B.14.6.1 SECURE RMS IN PAYLOAD BAY
- 4.1B.14.6.2 CLOSE PAYLOAD BAY DOORS
- 4.1B.14.6.3 UNDOCKING OF ORBITER FROM SP
- 4.1B.15 RETRIEVAL BY ORBITER
 - 4.1B.15.1 ORBITER/SP RENDEZVOUS AND CAPTURE
 - 4.1B.15.1.1 DETERMINE CURRENT ORBITAL PARAMETERS
 - 4.1B.15.1.2 DETERMINE CURRENT ATTITUDE
 - 4.1B.15.1.3 DETERMINE DESIRED ORBITAL PARAMETERS
 - 4.1B.15.1.4 CHOOSE OPTIMAL TRAJECTORY
 - 4.1B.15.1.5 RETRACT SOLAR ARRAYS
 - 4.1B.15.1.6 RETRACT RADIATORS
 - 4.1B.15.1.7 ORIENT THRUSTERS
 - 4.1B.15.1.8 FIRE THRUSTERS
 - 4.1B.15.1.9 ORBITER AND SP VELOCITY AND TRAJECTORY ADJUSTMENTS
 - 4.1B.15.1.10 OPEN PAYLOAD BAY DOORS
 - 4.1B.15.1.11 ACTIVATE DOCKING ADAPTER
 - 4.1B.15.1.12 DOCKING OF SHUTTLE ADAPTER TO SPACE PLATFORM
 - 4.1B.15.1.13 SP BERTHING ON DOCKING ADAPTER
 - 4.1B.15.1.14 ACTIVATE RMS
 - 4.1B.15.2 PAYLOAD WITHDRAWAL FROM SP
 - 4.1B.15.2.1 SP INTERFACE WITH PAYLOAD IS SHUTDOWN
 - 4.1B.15.2.2 PAYLOAD INTERNAL POWER ACTIVATED
 - 4.1B.15.2.3 LOCATE GRASPING FIXTURE ON TARGET
 - 4.1B.15.2.4 GRASP FIXTURE
 - 4.1B.15.2.5 RELEASE PAYLOAD RESTRAINTS
 - 4.1B.15.2.6 TRANSLATE PAYLOAD TO CRADLE
 - 4.1B.15.2.7 FASTEN PAYLOAD RESTRAINTS
 - 4.1B.15.3 SHUTTLE/PAYLOAD INTEGRATION AND TEST
 - 4.1B.15.3.1 ORBITER/PAYLOAD INTEGRATION CHECKOUT
 - 4.1B.15.3.2 CLOSE PAYLOAD BAY DOORS
 - 4.1B.15.4 SEPARATION OF SP FROM ORBITER
 - 4.1B.15.4.1 TRANSFER OPERATIONAL CONTROL FROM MISSION TO PAYLOAD CONTROL
 - 4.1B.15.4.2 UNDOCKING OF ORBITER FROM SP
 - 4.1B.15.4.3 DETERMINE CURRENT ORBITAL PARAMETERS
 - 4.1B.15.4.4 DETERMINE CURRENT ATTITUDE
 - 4.1B.15.4.5 DETERMINE DESIRED ORBITAL PARAMETERS
 - 4.1B.15.4.6 CHOOSE OPTIMAL TRAJECTORY
 - 4.1B.15.4.7 RETRACT SOLAR ARRAYS
 - 4.1B.15.4.8 RETRACT RADIATORS
 - 4.1B.15.4.9 ORIENT THRUSTERS
 - 4.1B.15.4.10 FIRE THRUSTERS
 - 4.1B.15.4.11 ACTIVATE SUBSYSTEMS
 - 4.1B.15.4.12 POWER SUBSYSTEM CHECKOUT
 - 4.1B.15.4.13 THERMAL SUBSYSTEM CHECKOUT
 - 4.1B.15.4.14 INFORMATION PROCESSING SUBSYSTEM CHECKOUT
 - 4.1B.15.4.15 STRUCTURE SUBSYSTEM CHECKOUT
 - 4.1B.15.4.16 COMMUNICATIONS SUBSYSTEM CHECKOUT
 - 4.1B.15.4.17 SP/PAYLOAD INTERFACE CHECKOUT
 - 4.1B.15.4.18 CONSUMABLES LEVELS CHECKOUT
 - 4.1B.15.4.19 COMPARE MEASURED DATA TO MODEL
 - 4.1B.15.4.20 DEPLOY SOLAR ARRAYS
 - 4.1B.15.4.21 DEPLOY RADIATORS
- 4.1B.16 RE-ENTRY AND LANDING OF ORBITER
- 4.1B.17 POST-FLIGHT OPERATIONS
 - 4.1B.17.1 SAFING OF ORBITER AND HAZARDOUS PAYLOADS
 - 4.1B.17.2 REMOVAL OF PAYLOADS FROM ORBITER
 - 4.1B.17.2.1 OPEN PAYLOAD BAY DOORS
 - 4.1B.17.2.2 PRIORITY REMOVAL OF TIME-CRITICAL ITEMS
 - 4.1B.17.2.3 ATTACH STRONGBACK TO PAYLOAD
 - 4.1B.17.2.4 LOAD PAYLOAD INTO CANISTER
 - 4.1B.17.3 PAYLOAD REMOVAL FROM ORBITER PROCESSING FACILITY

SCIENCE AND APPLICATIONS SPACE PLATFORM

The SASP specific material in this breakdown was obtained from the following two sources: Final Report for Payloads Requirements/Accommodations Assessment Study for Science and Applications Space Platforms, MSFC Contract No. NAS8-33759 by TRW Inc. November 1980. Conceptual Design Study Science and Applications Space Platform, MSFC Contract No. NAS8-33592 by McDonnell Douglas Astronautics Co. October 1980.

4.2 SCIENCE AND APPLICATIONS SPACE PLATFORM (SASP)

4.2.1 DESIGN

4.2.1.1 DEFINE REQUIREMENTS

4.2.1.2 SELECT PAYLOADS

The SASP can carry many different combinations of experiments. Some have special orbital and viewing requirements, others are not compatible (Materials Experiment Assembly and Life Sciences Modules) due to microgravity requirements. The experiments must be put into compatible groupings so the SASP can be designed to accomodate them.

4.2.1.3 MISSION ANALYSIS

The orbital constraints of the STS system and SASP must be compared to experiment requirements. Some experiments need high inclination orbits, others need higher altitude orbits. Mission requirements determine when and how maneuvers will be made. These must be examined to insure they are feasible and to determine propulsion subsystem requirements.

4.2.1.4 PAYLOAD ACCOMODATIONS

4.2.1.5 CREATE FUNCTIONAL LAYOUT

Determine all subsystem interactions such as data transmission, power use, thermal dissipation, and structural loads. The component specifications should be compatible with present levels of technology and comply with the functional layout.

4.2.1.6 CREATE MECHANICAL LAYOUT

Verify that when components are grouped into subsystems they can perform all functional layout operations.

4.2.2 COMPONENT FABRICATION

4.2.2.1 PROCURE OFF-THE-SHELF COMPONENTS

4.2.2.2 PROCURE MATERIALS FOR MANUFACTURE OF COMPONENTS

4.2.2.3 PROCURE MANUFACTURING EQUIPMENT

4.2.2.4 MANUFACTURE COMPONENTS

4.2.3 COMPONENT TEST

4.2.3.1 SET UP TEST FACILITIES

4.2.3.2 STRUCTURAL LOADS TESTS

4.2.3.3 DATA PROCESSING AND SOFTWARE TESTS

Verify software by inputting data which simulates expected operational inputs, but has been previously processed so the proper output is known. This nominal output is compared to the output of the flight software to verify its proper operation.

4.2.3.4 SOLAR ARRAY DEPLOYMENT TESTS

4.2.3.5 CHECK RF PATTERN

4.2.3.6 ELECTRICAL SYSTEMS TESTS

4.2.3.7 THERMAL AND VACUUM TESTS

4.2.3.8 COMPONENT CERTIFICATION

4.2.4 SYSTEM INTEGRATION

4.2.4.1 RECEIVE AND SORT COMPONENTS

4.2.4.2 POSITION AND ORIENT COMPONENT

4.2.4.3 ATTACH COMPONENTS

4.2.5 SYSTEM TEST

4.2.5.1 POWER SUBSYSTEM TEST

Simulated solar array power is supplied to the power management/conditioning subsystem. This system is commanded to supply various voltages and currents to other subsystems. These quantities are measured under real or simulated load and compared against nominal performance.

4.2.5.2 THERMAL SUBSYSTEM TESTS

4.2.5.3 INFORMATION PROCESSING SUBSYSTEM TESTS

4.2.5.4 STRUCTURE SUBSYSTEM TESTS

The structure or a functional mockup is exposed to various vibration loads

ORIGINAL PLAN
OF PROGRAM QUALITY

to verify structural integrity. Deployment actuators are tested and, if possible, deployable structures go through a full deployment sequence.

4.2.5.5 COMMUNICATIONS SUBSYSTEM TESTS

Verify that the antennas meet design specifications.

- 4.2.5.6 ANALYZE PERFORMANCE DATA
- 4.2.5.7 REPEAT CONSTRUCTION/CHECKOUT CYCLE UNTIL O.K.
- 4.2.6 PAYLOAD INSTALLATION AND TRANSPORT
 - 4.2.6.1 TESTING AT INTEGRATION SITE
 - 4.2.6.2 REMOVE TEST EQUIPMENT
 - 4.2.6.3 PERFORM NECESSARY DISASSEMBLY
 - 4.2.6.4 PACKING
 - 4.2.6.5 TRANSPORT TO LAUNCH SITE
- 4.2.7 ORBITER/PAYLOAD INTEGRATION AND CHECKOUT
 - 4.2.7.1 UNPACKING
 - 4.2.7.2 PERFORM NECESSARY REASSEMBLY
 - 4.2.7.3 INTEGRATED SYSTEMS TESTS
 - 4.2.7.3.1 VERIFY POWER SYSTEM FUNCTION
 - 4.2.7.3.2 VERIFY COMMAND SYSTEM FUNCTION
 - 4.2.7.3.3 VERIFY MECHANICAL SYSTEM FUNCTION
 - 4.2.7.3.4 VERIFY COMMUNICATIONS SYSTEM FUNCTION
 - 4.2.7.4 PERFORM INTERFACES CHECK
 - 4.2.7.4.1 CHECK SHUTTLE/PAYLOAD MECHANICAL INTERFACES
 - 4.2.7.4.2 CHECK ELECTRICAL INTERFACES
 - 4.2.7.5 TRANSFER PAYLOAD TO ORBITER PROCESSING FACILITY
 - 4.2.7.5.1 ATTACH STRONGBACK TO PAYLOAD
 - 4.2.7.5.2 LOAD PAYLOAD INTO CANISTER
 - 4.2.7.5.3 REMOVE STRONGBACK
 - 4.2.7.5.4 CLOSE CANISTER
 - 4.2.7.5.5 TRANSPORT CANISTER TO ORBITER PROCESSING FACILITY
 - 4.2.7.6 ORBITER/PAYLOAD INTEGRATION
 - 4.2.7.6.1 ATTACH STRONGBACK TO PAYLOAD
 - 4.2.7.6.2 INSTALL PAYLOAD IN ORBITER
 - 4.2.7.6.3 CONNECT ORBITER/PAYLOAD INTERFACES
 - 4.2.7.6.4 CHECK ELECTRICAL INTERFACES
 - 4.2.7.6.5 CLOSE-OUT PAYLOAD BAY
 - 4.2.7.6.6 INSTALLATION OF ORBITER PAYLOAD STATION CONSOLES
 - 4.2.7.6.7 INSTALLATION OF OMS KIT
- 4.2.8 COUNTDOWN AND LAUNCH
- 4.2.9 ORBITAL DEPLOYMENT AND CHECKOUT
 - 4.2.9.1 ORBITER/SP RENDEZVOUS AND CAPTURE
 - 4.2.9.1.1 DETERMINE CURRENT ORBITAL PARAMETERS
 - 4.2.9.1.2 DETERMINE CURRENT ATTITUDE
 - 4.2.9.1.3 DETERMINE DESIRED ORBITAL PARAMETERS
 - 4.2.9.1.4 CHOOSE OPTIMAL TRAJECTORY
 - 4.2.9.1.5 RETRACT SOLAR ARRAYS
 - 4.2.9.1.6 RETRACT RADIATORS
 - 4.2.9.1.7 ORIENT THRUSTERS
 - 4.2.9.1.8 FIRE THRUSTERS
 - 4.2.9.1.9 ORBITER AND SP VELOCITY AND TRAJECTORY ADJUSTMENTS
 - 4.2.9.1.10 OPEN PAYLOAD BAY DOORS
 - 4.2.9.1.11 ACTIVATE DOCKING ADAPTER
 - 4.2.9.1.12 DOCKING OF SHUTTLE ADAPTER TO SPACE PLATFORM
 - 4.2.9.1.13 SP BERTHING ON DOCKING ADAPTER
 - 4.2.9.1.14 ACTIVATE RMS
 - 4.2.9.2 REMOVE OLD SP PAYLOAD FROM TARGET BERTH
 - 4.2.9.2.1 OPEN PAYLOAD BAY DOORS
 - 4.2.9.2.2 LOCATE GRASPING FIXTURE ON TARGET
 - 4.2.9.2.3 GRASP FIXTURE
 - 4.2.9.2.4 RELEASE PAYLOAD RESTRAINTS
 - 4.2.9.2.5 STOW OLD PAYLOAD IN ORBITER
 - 4.2.9.3 DEPLOY NEW PAYLOAD FROM PAYLOAD BAY
 - 4.2.9.3.1 LOCATE NEW PAYLOAD
 - 4.2.9.3.2 GRASP FIXTURE
 - 4.2.9.3.3 RELEASE PAYLOAD RESTRAINTS
 - 4.2.9.3.4 ATTACH NEW PAYLOAD TO SP
 - 4.2.9.4 OPERATIONAL CHECKOUT
 - 4.2.9.4.1 ACTIVATE SUBSYSTEMS
 - 4.2.9.4.2 POWER SUBSYSTEM CHECKOUT
 - 4.2.9.4.3 THERMAL SUBSYSTEM CHECKOUT

ORIGINAL PAGE IS
OF POOR QUALITY

- 4.2.9.4.4 INFORMATION PROCESSING SUBSYSTEM CHECKOUT
- 4.2.9.4.5 STRUCTURE SUBSYSTEM CHECKOUT
- 4.2.9.4.6 COMMUNICATIONS SUBSYSTEM CHECKOUT
- 4.2.9.4.7 SP/PAYLOAD INTERFACE CHECKOUT
- 4.2.9.4.8 ATTITUDE CONTROL SUBSYSTEM CHECKOUT
- 4.2.9.4.9 CONSUMABLES LEVELS CHECKOUT
- 4.2.9.4.10 COMPARE MEASURED DATA TO MODEL
- 4.2.9.5 IDENTIFY DEFECTIVE COMPONENT
 - 4.2.9.5.1 DETERMINE ANOMALOUS DATA
 - 4.2.9.5.2 FORM HYPOTHESIS FOR PROBLEM
 - 4.2.9.5.3 DEVISE TEST FOR FAILURE HYPOTHESIS
 - 4.2.9.5.4 PERFORM TEST FOR FAILURE HYPOTHESIS
 - 4.2.9.5.5 IDENTIFY FAULTY COMPONENT
- 4.2.9.6 IDENTIFY DEFECTIVE SOFTWARE
 - 4.2.9.6.1 COMPARE MEASURED DATA TO MODEL
 - 4.2.9.6.2 DETERMINE ANOMALOUS DATA
 - 4.2.9.6.3 FORM HYPOTHESIS FOR PROBLEM
 - 4.2.9.6.4 DEVISE TEST FOR FAILURE HYPOTHESIS
 - 4.2.9.6.5 PERFORM TEST FOR FAILURE HYPOTHESIS
- 4.2.9.7A COMPONENT FAILURE RECOVERY (REDUNDANCY)
 - 4.2.9.7A.1 SWITCH OUT FAULTY COMPONENT
 - 4.2.9.7A.2 SWITCH IN REDUNDANT COMPONENT
 - 4.2.9.7A.3 MAKE DIAGNOSTIC CHECKS
 - 4.2.9.7A.4 UPDATE SPACECRAFT MODEL
- 4.2.9.7B COMPONENT FAILURE RECOVERY (ON-BOARD REPAIR)
 - 4.2.9.7B.1 DEFINE ACCESS SEQUENCE
 - 4.2.9.7B.2 LOCATE ACCESS PANEL
 - 4.2.9.7B.3 TRANSFER REPAIR EQUIPMENT TO REPAIR SITE
 - 4.2.9.7B.4 OPEN ACCESS PANEL
 - 4.2.9.7B.5 OBSERVE/LOCATE DEFECTIVE COMPONENT
 - 4.2.9.7B.6 REMOVE COMPONENT
 - 4.2.9.7B.7 STORE COMPONENT
 - 4.2.9.7B.8 LOCATE NEW COMPONENT
 - 4.2.9.7B.9 POSITION AND CONNECT NEW COMPONENT
 - 4.2.9.7B.10 ADJUST COMPONENT
 - 4.2.9.7B.11 MAKE DIAGNOSTIC CHECKS
 - 4.2.9.7B.12 CLOSE ACCESS PANEL
 - 4.2.9.7B.13 STOW REPAIR EQUIPMENT
 - 4.2.9.7B.14 UPDATE SPACECRAFT MODEL
- 4.2.9.8 SOFTWARE FAILURE RECOVERY
 - 4.2.9.8.1 DETERMINE CORRECTION ALGORITHM
 - 4.2.9.8.2 DATA/COMMAND ENCODING
 - 4.2.9.8.3 DATA/COMMAND TRANSMISSION
 - 4.2.9.8.4 COMPUTER FUNCTION CHECKS
- 4.2.9.9 SEPARATION OF SP FROM ORBITER
 - 4.2.9.9.1 TRANSFER OPERATIONAL CONTROL FROM MISSION TO PAYLOAD CONTROL
 - 4.2.9.9.2 UNDOCKING OF ORBITER FROM SP
 - 4.2.9.9.3 DETERMINE CURRENT ORBITAL PARAMETERS
 - 4.2.9.9.4 DETERMINE CURRENT ATTITUDE
 - 4.2.9.9.5 DETERMINE DESIRED ORBITAL PARAMETERS
 - 4.2.9.9.6 CHOOSE OPTIMAL TRAJECTORY
 - 4.2.9.9.7 RETRACT SOLAR ARRAYS
 - 4.2.9.9.8 RETRACT RADIATORS
 - 4.2.9.9.9 ORIENT THRUSTERS
 - 4.2.9.9.10 FIRE THRUSTERS
 - 4.2.9.9.11 ACTIVATE SUBSYSTEMS
 - 4.2.9.9.12 POWER SUBSYSTEM CHECKOUT
 - 4.2.9.9.13 THERMAL SUBSYSTEM CHECKOUT
 - 4.2.9.9.14 INFORMATION PROCESSING SUBSYSTEM CHECKOUT
 - 4.2.9.9.15 STRUCTURE SUBSYSTEM CHECKOUT
 - 4.2.9.9.16 COMMUNICATIONS SUBSYSTEM CHECKOUT
 - 4.2.9.9.17 SP/PAYLOAD INTERFACE CHECKOUT
 - 4.2.9.9.18 CONSUMABLES LEVELS CHECKOUT
 - 4.2.9.9.19 COMPARE MEASURED DATA TO MODEL
 - 4.2.9.9.20 DEPLOY SOLAR ARRAYS
 - 4.2.9.9.21 DEPLOY RADIATORS
- 4.2.10 STATUS MONITORING AND RESOURCE ALLOCATION

This is primarily allocation of power² and thermal dump capacity.
Experiments provide their own materials, but must share power and thermal
systems. Resource allocation is a scheduling procedure to prevent overload
of the power and thermal subsystems.

CONSEQUENCES
OF POOR QUALITY

-
- 4.2.10.1 TEMPERATURE MANAGEMENT
 - 4.2.10.1.1 MEASURE COMPONENT TEMPERATURES
 - 4.2.10.1.2 COMPARE TEMPERATURE TO REQUIRED LIMITS
 - 4.2.10.1.3 ADJUST COOLING/HEATING SYSTEMS
- 4.2.10.2 POWER MANAGEMENT
 - 4.2.10.2.1 MEASURE CURRENTS AND VOLTAGES
 - 4.2.10.2.2 COMPARE CURRENTS AND VOLTAGES TO REQUIRED LIMITS
 - 4.2.10.2.3 EVALUATE BATTERY CHARGING PERFORMANCE
 - 4.2.10.2.4 ADJUST CURRENTS AND VOLTAGES
 - 4.2.10.2.5 ADJUST BATTERY CHARGING CYCLE
- 4.2.10.3 DATA/COMMAND PROCESSING
 - 4.2.10.3.1 SHORT-TERM MEMORY STORAGE
 - 4.2.10.3.2 LONG-TERM MEMORY STORAGE
 - 4.2.10.3.3 DATA/COMMAND ENCODING
 - 4.2.10.3.4 DATA/COMMAND DECODING
 - 4.2.10.3.5 NUMERICAL COMPUTATION
 - 4.2.10.3.6 LOGIC OPERATIONS
 - 4.2.10.3.7 COMPUTER LOAD SCHEDULING
 - 4.2.10.3.8 COMPUTER FUNCTION CHECKS
- 4.2.10.4 CONSUMABLES MANAGEMENT
-

Many onboard experiments require supplies of cryogenics or materials for operation which must be periodically replaced. If a supply is depleted faster than expected then its storage device signals that the supply is low. It may also predict in advance that a supply will be depleted.

- 4.2.10.4.1 MONITOR GAS SUPPLIES
- 4.2.10.4.2 MONITOR PROPELLANT SUPPLIES
- 4.2.10.4.3 MONITOR COOLING SYSTEM SUPPLIES
- 4.2.10.4.4 PROJECT CONSUMABLES REQUIREMENTS FROM MISSION PROFILE
- 4.2.10.4.5 COMPUTE OPTIMAL CONSUMABLES ALLOCATION
- 4.2.10.5 STRUCTURAL MANAGEMENT
 - 4.2.10.5.1 MEASURE STRAINS IN STRUCTURE
 - 4.2.10.5.2 MEASURE RELATIVE DISPLACEMENTS
 - 4.2.10.5.3 COMPUTE STRESS AND VIBRATION PARAMETERS
 - 4.2.10.5.4 COMPARE STRESS AND VIBRATION PARAMETERS TO REQUIRED LIMITS
 - 4.2.10.5.5 APPLY COMPENSATING FORCES
 - 4.2.10.5.6 APPLY VIBRATION DAMPING
- 4.2.10.6 HAZARD AVOIDANCE
 - 4.2.10.6.1 AVOID TANK OVERPRESSURES
 - 4.2.10.6.2 MAINTAIN SAFE BATTERY CHARGE LEVELS
 - 4.2.10.6.3 MONITOR MICRO-GRAVITY LEVELS
-

Since some materials processing experiments require ultra-low acceleration or "gravity" levels it is necessary to monitor the "g" loads and structural vibration to insure that these experiments are not disturbed. Also, some other SASP payload operations may need schedule adjustment to avoid generating "g" loads. For example: The slewing of a large instrument such as a telescope could induce significant "g" loads. This operation would have to be scheduled when materials processing is not in progress.

- 4.2.10.6.4 MAINTAIN COMMUNICATION LINKS
- 4.2.10.6.5 AVOID EXPOSING SENSITIVE COMPONENTS TO DIRECT SUNLIGHT
- 4.2.10.7 OPTIMAL SEQUENCING
 - 4.2.10.7.1 UPDATE SPACECRAFT MODEL
 - 4.2.10.7.2 PROJECT DESIRED FUNCTIONS FROM MISSION PROFILE
 - 4.2.10.7.3 ESTIMATE RISKS FROM DESIRED FUNCTIONS
 - 4.2.10.7.4 PROJECT CONSUMABLES REQUIREMENTS FROM MISSION PROFILE
 - 4.2.10.7.5 DETERMINE CONSTRAINTS AND FIGURES OF MERIT
 - 4.2.10.7.6 COMPUTE OPTIMAL SEQUENCING
- 4.2.10.8 IDENTIFY DEFECTIVE COMPONENT
 - 4.2.10.8.1 DETERMINE ANOMALOUS DATA
 - 4.2.10.8.2 FORM HYPOTHESIS FOR PROBLEM
- 4.2.10.9 REPORT SYSTEMS STATUS
 - 4.2.10.9.1 DATA/COMMAND ENCODING
 - 4.2.10.9.2 DATA/COMMAND TRANSMISSION
 - 4.2.10.9.3 DATA/COMMAND DECODING
 - 4.2.10.9.4 DATA/COMMAND DISPLAY
- 4.2.11 ATTITUDE CONTROL AND STABILIZATION
 - 4.2.11.1 MAINTAIN ATTITUDE
 - 4.2.11.1.1 INITIALIZE GUIDANCE SYSTEM

- 4.2.11.1.2 DETERMINE CURRENT ATTITUDE
- 4.2.11.1.3 DETERMINE NEW CONFIGURATION FOR SPACECRAFT COMPONENTS
- 4.2.11.1.4 CHOOSE OPTIMAL TRAJECTORY
- 4.2.11.1.5 ROTATE SPACECRAFT
- 4.2.11.2 MAINTAIN ORBIT
 - 4.2.11.2.1 DETERMINE CURRENT ORBITAL PARAMETERS
 - 4.2.11.2.2 DETERMINE DESIRED ORBITAL PARAMETERS
 - 4.2.11.2.3 CHOOSE OPTIMAL TRAJECTORY
 - 4.2.11.2.4 RETRACT SOLAR ARRAYS
 - 4.2.11.2.5 RETRACT RADIATORS
 - 4.2.11.2.6 FIRE THRUSTERS
- 4.2.11.3 OPTIMAL CONTROL ALLOCATION
 - 4.2.11.3.1 UPDATE SPACECRAFT MODEL
 - 4.2.11.3.2 PROJECT DESIRED FUNCTIONS FROM MISSION PROFILE
 - 4.2.11.3.3 PROJECT CONSUMABLES REQUIREMENTS FROM MISSION PROFILE
 - 4.2.11.3.4 DETERMINE CONSTRAINTS AND FIGURES OF MERIT
 - 4.2.11.3.5 CHOOSE OPTIMAL CONTROL MODE
 - 4.2.11.3.6 COMPUTE CONTROL COMMANDS
 - 4.2.11.3.7 EXECUTE CONTROL COMMANDS
- 4.2.12 PRE-EXPERIMENT OPERATIONS
- 4.2.13 CONDUCT PAYLOAD-SPECIFIC EXPERIMENT

Certain experiments may not be possible to run simultaneously because of power, viewing angle, contamination, or other constraints.

4.2.14 POST-EXPERIMENT OPERATIONS

The SASP must provide a means for each instrument or experiment to transmit its status and data. During some experiments data transmission will be a continuous process, during others it will be a discrete process. The control of materials experiments may require real time data transmission to allow experimenters on the ground to interact with their experiments. Earth resources instruments will generate large amounts of data to be transmitted.

- 4.2.15 SERVICING AND RESUPPLY
 - 4.2.15.1 PRE-RENDEZVOUS PREPARATIONS
 - 4.2.15.1.1 SEND GROUND SIGNAL TO SP TO BEGIN SERV. SEQ.
 - 4.2.15.1.2 REDUCE POWER TO SUBSYSTEMS
 - 4.2.15.2 ORBITER/SP RENDEZVOUS AND CAPTURE
 - 4.2.15.2.1 DETERMINE CURRENT ORBITAL PARAMETERS
 - 4.2.15.2.2 DETERMINE CURRENT ATTITUDE
 - 4.2.15.2.3 DETERMINE DESIRED ORBITAL PARAMETERS
 - 4.2.15.2.4 CHOOSE OPTIMAL TRAJECTORY
 - 4.2.15.2.5 RETRACT SOLAR ARRAYS
 - 4.2.15.2.6 RETRACT RADIATORS
 - 4.2.15.2.7 ORIENT THRUSTERS
 - 4.2.15.2.8 FIRE THRUSTERS
 - 4.2.15.2.9 ORBITER AND SP VELOCITY AND TRAJECTORY ADJUSTMENTS
 - 4.2.15.2.10 OPEN PAYLOAD BAY DOORS
 - 4.2.15.2.11 ACTIVATE DOCKING ADAPTER
 - 4.2.15.2.12 DOCKING OF SHUTTLE ADAPTER TO SPACE PLATFORM
 - 4.2.15.2.13 SP BERTHING ON DOCKING ADAPTER
 - 4.2.15.3 REMOVAL AND TRANSFER OF PAYLOADS
 - 4.2.15.3.1 SHUTDOWN PAYLOADS
 - 4.2.15.3.2 ACTIVATE RMS
 - 4.2.15.3.3 LOCATE GRASPING FIXTURE ON TARGET
 - 4.2.15.3.4 GRASP FIXTURE
 - 4.2.15.3.5 RELEASE PAYLOAD RESTRAINTS
 - 4.2.15.3.6 TRANSLATE PAYLOAD TO CRADLE
 - 4.2.15.3.7 FASTEN PAYLOAD RESTRAINTS
 - 4.2.15.3.8 ORIENT NEW PAYLOADS
 - 4.2.15.3.9 ATTACH NEW PAYLOADS
 - 4.2.15.3.10 ORBITER/PAYLOAD INTEGRATION CHECKOUT
 - 4.2.15.4 NON-SCHEDULED MAINTENANCE
 - 4.2.15.5 OPERATIONAL CHECKOUT
 - 4.2.15.5.1 ACTIVATE SUBSYSTEMS
 - 4.2.15.5.2 POWER SUBSYSTEM CHECKOUT
 - 4.2.15.5.3 THERMAL SUBSYSTEM CHECKOUT
 - 4.2.15.5.4 INFORMATION PROCESSING SUBSYSTEM CHECKOUT
 - 4.2.15.5.5 STRUCTURE SUBSYSTEM CHECKOUT
 - 4.2.15.5.6 COMMUNICATIONS SUBSYSTEM CHECKOUT

ORIGINAL PAGE 1,
OF POOR QUALITY

- 4.2.15.5.7 SP/PAYLOAD INTERFACE CHECKOUT
- 4.2.15.5.8 CONSUMABLES LEVELS CHECKOUT
- 4.2.15.5.9 COMPARE MEASURED DATA TO MODEL
- 4.2.15.6 SEPARATION OF ORBITER AND SP
 - 4.2.15.6.1 SECURE RMS IN PAYLOAD BAY
 - 4.2.15.6.2 CLOSE PAYLOAD BAY DOORS
 - 4.2.15.6.3 UNDOCKING OF ORBITER FROM SP
- 4.2.16 RETRIEVAL BY ORBITER
 - 4.2.16.1 ORBITER/SP RENDEZVOUS AND CAPTURE
 - 4.2.16.1.1 DETERMINE CURRENT ORBITAL PARAMETERS
 - 4.2.16.1.2 DETERMINE CURRENT ATTITUDE
 - 4.2.16.1.3 DETERMINE DESIRED ORBITAL PARAMETERS
 - 4.2.16.1.4 CHOOSE OPTIMAL TRAJECTORY
 - 4.2.16.1.5 RETRACT SOLAR ARRAYS
 - 4.2.16.1.6 RETRACT RADIATORS
 - 4.2.16.1.7 ORIENT THRUSTERS
 - 4.2.16.1.8 FIRE THRUSTERS
 - 4.2.16.1.9 ORBITER AND SP VELOCITY AND TRAJECTORY ADJUSTMENTS
 - 4.2.16.1.10 OPEN PAYLOAD BAY DOORS
 - 4.2.16.1.11 ACTIVATE DOCKING ADAPTER
 - 4.2.16.1.12 DOCKING OF SHUTTLE ADAPTER TO SPACE PLATFORM
 - 4.2.16.1.13 SP BERTHING ON DOCKING ADAPTER
 - 4.2.16.1.14 ACTIVATE RMS
 - 4.2.16.2 PAYLOAD WITHDRAWAL FROM SP
 - 4.2.16.2.1 SP INTERFACE WITH PAYLOAD IS SHUTDOWN
 - 4.2.16.2.2 PAYLOAD INTERNAL POWER ACTIVATED
 - 4.2.16.2.3 LOCATE GRASPING FIXTURE ON TARGET
 - 4.2.16.2.4 GRASP FIXTURE
 - 4.2.16.2.5 RELEASE PAYLOAD RESTRAINTS
 - 4.2.16.2.6 TRANSLATE PAYLOAD TO CRADLE
 - 4.2.16.2.7 FASTEN PAYLOAD RESTRAINTS
 - 4.2.16.3 SHUTTLE/PAYLOAD INTEGRATION AND TEST
 - 4.2.16.3.1 ORBITER/PAYLOAD INTEGRATION CHECKOUT
 - 4.2.16.3.2 CLOSE PAYLOAD BAY DOORS
 - 4.2.16.4 SEPARATION OF SP FROM ORBITER
 - 4.2.16.4.1 TRANSFER OPERATIONAL CONTROL FROM MISSION TO PAYLOAD CONTROL
 - 4.2.16.4.2 UNDOCKING OF ORBITER FROM SP
 - 4.2.16.4.3 DETERMINE CURRENT ORBITAL PARAMETERS
 - 4.2.16.4.4 DETERMINE CURRENT ATTITUDE
 - 4.2.16.4.5 DETERMINE DESIRED ORBITAL PARAMETERS
 - 4.2.16.4.6 CHOOSE OPTIMAL TRAJECTORY
 - 4.2.16.4.7 RETRACT SOLAR ARRAYS
 - 4.2.16.4.8 RETRACT RADIATORS
 - 4.2.16.4.9 ORIENT THRUSTERS
 - 4.2.16.4.10 FIRE THRUSTERS
 - 4.2.16.4.11 ACTIVATE SUBSYSTEMS
 - 4.2.16.4.12 POWER SUBSYSTEM CHECKOUT
 - 4.2.16.4.13 THERMAL SUBSYSTEM CHECKOUT
 - 4.2.16.4.14 INFORMATION PROCESSING SUBSYSTEM CHECKOUT
 - 4.2.16.4.15 STRUCTURE SUBSYSTEM CHECKOUT
 - 4.2.16.4.16 COMMUNICATIONS SUBSYSTEM CHECKOUT
 - 4.2.16.4.17 SP/PAYLOAD INTERFACE CHECKOUT
 - 4.2.16.4.18 CONSUMABLES LEVELS CHECKOUT
 - 4.2.16.4.19 COMPARE MEASURED DATA TO MODEL
 - 4.2.16.4.20 DEPLOY SOLAR ARRAYS
 - 4.2.16.4.21 DEPLOY RADIATORS
- 4.2.17 RE-ENTRY AND LANDING OF ORBITER
- 4.2.18 POST-FLIGHT OPERATIONS
 - 4.2.18.1 SAFING OF ORBITER AND HAZARDOUS PAYLOADS
 - 4.2.18.2 REMOVAL OF PAYLOADS FROM ORBITER
 - 4.2.18.2.1 OPEN PAYLOAD BAY DOORS
 - 4.2.18.2.2 PRIORITY REMOVAL OF TIME-CRITICAL ITEMS
 - 4.2.18.2.3 ATTACH STRONGBACK TO PAYLOAD
 - 4.2.18.2.4 LOAD PAYLOAD INTO CANISTER
 - 4.2.18.3 PAYLOAD REMOVAL FROM ORBITER PROCESSING FACILITY

SCIENCE AND APPLICATIONS MANNED SPACE PLATFORM

The SAMSP specific material in this breakdown was obtained from the following two sources: Final Report for Payloads Requirements/Accommodations Assessment

Study for Science and Applications Space Platforms, MSFC Contract No. NAS8-33759 by TRW Inc. November 1980. Conceptual Design Study Science and Applications Space Platform, MSFC Contract No. NAS8-33692 by McDonnell Douglas Astronautics Co. October 1980.

4.3 SCIENCE AND APPLICATIONS MANNED SPACE PLATFORM (SAMSP)

4.3.1 DESIGN

- 4.3.1.1 DEFINE REQUIREMENTS
- 4.3.1.2 SELECT PAYLOADS
- 4.3.1.3 MISSION ANALYSIS
- 4.3.1.4 PAYLOAD ACCOMODATIONS
- 4.3.1.5 CREATE FUNCTIONAL LAYOUT
- 4.3.1.6 CREATE MECHANICAL LAYOUT

4.3.2 COMPONENT FABRICATION

- 4.3.2.1 PROCURE OFF-THE-SHELF COMPONENTS
- 4.3.2.2 PROCURE MATERIALS FOR MANUFACTURE OF COMPONENTS
- 4.3.2.3 PROCURE MANUFACTURING EQUIPMENT
- 4.3.2.4 MANUFACTURE COMPONENTS

4.3.3 COMPONENT TEST

- 4.3.3.1 SET UP TEST FACILITIES
- 4.3.3.2 STRUCTURAL LOADS TESTS
- 4.3.3.3 DATA PROCESSING AND SOFTWARE TESTS
- 4.3.3.4 SOLAR ARRAY DEPLOYMENT TESTS
- 4.3.3.5 CHECK RF PATTERN
- 4.3.3.6 ELECTRICAL SYSTEMS TESTS
- 4.3.3.7 THERMAL AND VACUUM TESTS
- 4.3.3.8 COMPONENT CERTIFICATION

4.3.4 SYSTEM INTEGRATION

- 4.3.4.1 RECEIVE AND SORT COMPONENTS
- 4.3.4.2 POSITION AND ORIENT COMPONENT
- 4.3.4.3 ATTACH COMPONENTS

4.3.5 SYSTEM TEST

- 4.3.5.1 POWER SUBSYSTEM TEST
- 4.3.5.2 THERMAL SUBSYSTEM TESTS
- 4.3.5.3 INFORMATION PROCESSING SUBSYSTEM TESTS
- 4.3.5.4 STRUCTURE SUBSYSTEM TESTS
- 4.3.5.5 COMMUNICATIONS SUBSYSTEM TESTS
- 4.3.5.6 ANALYZE PERFORMANCE DATA
- 4.3.5.7 REPEAT CONSTRUCTION/CHECKOUT CYCLE UNTIL O.K.

4.3.6 PAYLOAD INSTALLATION AND TRANSFER

- 4.3.6.1 TESTING AT INTEGRATION SITE
- 4.3.6.2 REMOVE TEST EQUIPMENT
- 4.3.6.3 PERFORM NECESSARY DISASSEMBLY
- 4.3.6.4 PACKING
- 4.3.6.5 TRANSPORT TO LAUNCH SITE

4.3.7 ORBITER/PAYLOAD INTEGRATION AND CHECKOUT

- 4.3.7.1 UNPACKING
- 4.3.7.2 PERFORM NECESSARY REASSEMBLY
- 4.3.7.3 INTEGRATED SYSTEMS TESTS
 - 4.3.7.3.1 VERIFY POWER SYSTEM FUNCTION
 - 4.3.7.3.2 VERIFY COMMAND SYSTEM FUNCTION
 - 4.3.7.3.3 VERIFY MECHANICAL SYSTEM FUNCTION
 - 4.3.7.3.4 VERIFY COMMUNICATIONS SYSTEM FUNCTION
- 4.3.7.4 PERFORM INTERFACES CHECK
 - 4.3.7.4.1 CHECK SHUTTLE/PAYLOAD MECHANICAL INTERFACES
 - 4.3.7.4.2 CHECK ELECTRICAL INTERFACES
- 4.3.7.5 TRANSFER PAYLOAD TO ORBITER PROCESSING FACILITY
 - 4.3.7.5.1 ATTACH STRONGBACK TO PAYLOAD
 - 4.3.7.5.2 LOAD PAYLOAD INTO CANISTER
 - 4.3.7.5.3 REMOVE STRONGBACK
 - 4.3.7.5.4 CLOSE CANISTER
 - 4.3.7.5.5 TRANSPORT CANISTER TO ORBITER PROCESSING FACILITY
- 4.3.7.6 ORBITER/PAYLOAD INTEGRATION
 - 4.3.7.6.1 ATTACH STRONGBACK TO PAYLOAD
 - 4.3.7.6.2 INSTALL PAYLOAD IN ORBITER
 - 4.3.7.6.3 CONNECT ORBITER/PAYLOAD INTERFACES
 - 4.3.7.6.4 CHECK ELECTRICAL INTERFACES
 - 4.3.7.6.5 CLOSE-OUT PAYLOAD BAY
 - 4.3.7.6.6 INSTALLATION OF ORBITER PAYLOAD STATION CONSOLES
 - 4.3.7.6.7 INSTALLATION OF DMS KIT

4.3.8 COUNTDOWN AND LAUNCH

ORIGINAL PAGE IS
OF POOR QUALITY.

- 4.3.9 ORBITAL DEPLOYMENT AND CHECKOUT
 - 4.3.9.1 ORBITER/SP RENDEZVOUS AND CAPTURE
 - 4.3.9.1.1 DETERMINE CURRENT ORBITAL PARAMETERS
 - 4.3.9.1.2 DETERMINE CURRENT ATTITUDE
 - 4.3.9.1.3 DETERMINE DESIRED ORBITAL PARAMETERS
 - 4.3.9.1.4 CHOOSE OPTIMAL TRAJECTORY
 - 4.3.9.1.5 RETRACT SOLAR ARRAYS
 - 4.3.9.1.6 RETRACT RADIATORS
 - 4.3.9.1.7 SP ON INTERNAL POWER
 - 4.3.9.1.8 ORIENT THRUSTERS
 - 4.3.9.1.9 FIRE THRUSTERS
 - 4.3.9.1.10 ORBITER AND SP VELOCITY AND TRAJECTORY ADJUSTMENTS
 - 4.3.9.1.11 OPEN PAYLOAD BAY DOORS
 - 4.3.9.1.12 ACTIVATE DOCKING ADAPTER
 - 4.3.9.1.13 DOCKING OF SHUTTLE ADAPTER TO SPACE PLATFORM
 - 4.3.9.1.14 SP BERTHING ON DOCKING ADAPTER
 - 4.3.9.1.15 ACTIVATE RMS
 - 4.3.9.2 REMOVE OLD SP PAYLOAD FROM TARGET BERTH
 - 4.3.9.2.1 OPEN PAYLOAD BAY DOORS
 - 4.3.9.2.2 LOCATE GRASPING FIXTURE ON TARGET
 - 4.3.9.2.3 GRASP FIXTURE
 - 4.3.9.2.4 RELEASE PAYLOAD RESTRAINTS
 - 4.3.9.2.5 STOW OLD PAYLOAD IN ORBITER
 - 4.3.9.3 DEPLOY NEW PAYLOAD FROM PAYLOAD BAY
 - 4.3.9.3.1 LOCATE NEW PAYLOAD
 - 4.3.9.3.2 GRASP FIXTURE
 - 4.3.9.3.3 RELEASE PAYLOAD RESTRAINTS
 - 4.3.9.3.4 ATTACH NEW PAYLOAD TO SP
 - 4.3.9.4 OPERATIONAL CHECKOUT
 - 4.3.9.4.1 ACTIVATE SUBSYSTEMS
 - 4.3.9.4.2 POWER SUBSYSTEM CHECKOUT
 - 4.3.9.4.3 THERMAL SUBSYSTEM CHECKOUT
 - 4.3.9.4.4 INFORMATION PROCESSING SUBSYSTEM CHECKOUT
 - 4.3.9.4.5 STRUCTURE SUBSYSTEM CHECKOUT
 - 4.3.9.4.6 COMMUNICATIONS SUBSYSTEM CHECKOUT
 - 4.3.9.4.7 SP/PAYLOAD INTERFACE CHECKOUT
 - 4.3.9.4.8 ATTITUDE CONTROL SUBSYSTEM CHECKOUT
 - 4.3.9.4.9 CONSUMABLES LEVELS CHECKOUT
 - 4.3.9.4.10 COMPARE MEASURED DATA TO MODEL
 - 4.3.9.5 IDENTIFY DEFECTIVE COMPONENT
 - 4.3.9.5.1 DETERMINE ANOMALOUS DATA
 - 4.3.9.5.2 FORM HYPOTHESIS FOR PROBLEM
 - 4.3.9.5.3 DEVISE TEST FOR FAILURE HYPOTHESIS
 - 4.3.9.5.4 PERFORM TEST FOR FAILURE HYPOTHESIS
 - 4.3.9.5.5 IDENTIFY FAULTY COMPONENT
 - 4.3.9.6 IDENTIFY DEFECTIVE SOFTWARE
 - 4.3.9.6.1 COMPARE MEASURED DATA TO MODEL
 - 4.3.9.6.2 DETERMINE ANOMALOUS DATA
 - 4.3.9.6.3 FORM HYPOTHESIS FOR PROBLEM
 - 4.3.9.6.4 DEVISE TEST FOR FAILURE HYPOTHESIS
 - 4.3.9.6.5 PERFORM TEST FOR FAILURE HYPOTHESIS
 - 4.3.9.7A COMPONENT FAILURE RECOVERY (REDUNDANCY)
 - 4.3.9.7A.1 SWITCH OUT FAULTY COMPONENT
 - 4.3.9.7A.2 SWITCH IN REDUNDANT COMPONENT
 - 4.3.9.7A.3 MAKE DIAGNOSTIC CHECKS
 - 4.3.9.7A.4 UPDATE SPACECRAFT MODEL
 - 4.3.9.7B COMPONENT FAILURE RECOVERY (ON-BOARD REPAIR)
 - 4.3.9.7B.1 DEFINE ACCESS SEQUENCE
 - 4.3.9.7B.2 LOCATE ACCESS PANEL
 - 4.3.9.7B.3 TRANSFER REPAIR EQUIPMENT TO REPAIR SITE
 - 4.3.9.7B.4 OPEN ACCESS PANEL
 - 4.3.9.7B.5 OBSERVE/LOCATE DEFECTIVE COMPONENT
 - 4.3.9.7B.6 REMOVE COMPONENT
 - 4.3.9.7B.7 STORE COMPONENT
 - 4.3.9.7B.8 LOCATE NEW COMPONENT
 - 4.3.9.7B.9 POSITION AND CONNECT NEW COMPONENT
 - 4.3.9.7B.10 ADJUST COMPONENT
 - 4.3.9.7B.11 MAKE DIAGNOSTIC CHECKS
 - 4.3.9.7B.12 CLOSE ACCESS PANEL
 - 4.3.9.7B.13 STOW REPAIR EQUIPMENT
 - 4.3.9.7B.14 UPDATE SPACECRAFT MODEL
 - 4.3.9.8 SOFTWARE FAILURE RECOVERY

- 4.3.9.8.1 DETERMINE CORRECTION ALGORITHM
- 4.3.9.8.2 DATA/COMMAND ENCODING
- 4.3.9.8.3 DATA/COMMAND TRANSMISSION
- 4.3.9.8.4 COMPUTER FUNCTION CHECKS
- 4.3.9.9 SEPARATION OF SP FROM ORBITER
 - 4.3.9.9.1 TRANSFER OPERATIONAL CONTROL FROM MISSION TO PAYLOAD CONTROL
 - 4.3.9.9.2 UNDOCKING OF ORBITER FROM SP
 - 4.3.9.9.3 DETERMINE CURRENT ORBITAL PARAMETERS
 - 4.3.9.9.4 DETERMINE CURRENT ATTITUDE
 - 4.3.9.9.5 DETERMINE DESIRED ORBITAL PARAMETERS
 - 4.3.9.9.6 CHOOSE OPTIMAL TRAJECTORY
 - 4.3.9.9.7 RETRACT SOLAR ARRAYS
 - 4.3.9.9.8 RETRACT RADIATORS
 - 4.3.9.9.9 SP ON INTERNAL POWER
 - 4.3.9.9.10 ORIENT THRUSTERS
 - 4.3.9.9.11 FIRE THRUSTERS
 - 4.3.9.9.12 ACTIVATE SUBSYSTEMS
 - 4.3.9.9.13 POWER SUBSYSTEM CHECKOUT
 - 4.3.9.9.14 THERMAL SUBSYSTEM CHECKOUT
 - 4.3.9.9.15 INFORMATION PROCESSING SUBSYSTEM CHECKOUT
 - 4.3.9.9.16 STRUCTURE SUBSYSTEM CHECKOUT
 - 4.3.9.9.17 COMMUNICATIONS SUBSYSTEM CHECKOUT
 - 4.3.9.9.18 SP/PAYLOAD INTERFACE CHECKOUT
 - 4.3.9.9.19 CONSUMABLES LEVELS CHECKOUT
 - 4.3.9.9.20 COMPARE MEASURED DATA TO MODEL
 - 4.3.9.9.21 DEPLOY SOLAR ARRAYS
 - 4.3.9.9.22 DEPLOY RADIATORS
- 4.3.10 STATUS MONITORING AND RESOURCE ALLOCATION

 In addition to standard data acquisition, the SAMSP must also allow data on the spacecraft status to be available for crew use and the crew must be able to enter their observations and data.

- 4.3.10.1 TEMPERATURE MANAGEMENT
 - 4.3.10.1.1 MEASURE COMPONENT TEMPERATURES
 - 4.3.10.1.2 COMPARE TEMPERATURE TO REQUIRED LIMITS
 - 4.3.10.1.3 ADJUST COOLING/HEATING SYSTEMS
- 4.3.10.2 POWER MANAGEMENT
 - 4.3.10.2.1 MEASURE CURRENTS AND VOLTAGES
 - 4.3.10.2.2 COMPARE CURRENTS AND VOLTAGES TO REQUIRED LIMITS
 - 4.3.10.2.3 EVALUATE BATTERY CHARGING PERFORMANCE
 - 4.3.10.2.4 ADJUST CURRENTS AND VOLTAGES
 - 4.3.10.2.5 ADJUST BATTERY CHARGING CYCLE
- 4.3.10.3 DATA/COMMAND PROCESSING
 - 4.3.10.3.1 SHORT-TERM MEMORY STORAGE
 - 4.3.10.3.2 LONG-TERM MEMORY STORAGE
 - 4.3.10.3.3 DATA/COMMAND ENCODING
 - 4.3.10.3.4 DATA/COMMAND DECODING
 - 4.3.10.3.5 NUMERICAL COMPUTATION
 - 4.3.10.3.6 LOGIC OPERATIONS
 - 4.3.10.3.7 COMPUTER LOAD SCHEDULING
 - 4.3.10.3.8 COMPUTER FUNCTION CHECKS
- 4.3.10.4 CONSUMABLES MANAGEMENT
 - 4.3.10.4.1 MONITOR GAS SUPPLIES
 - 4.3.10.4.2 MONITOR PROPELLANT SUPPLIES
 - 4.3.10.4.3 MONITOR COOLING SYSTEM SUPPLIES
 - 4.3.10.4.4 PROJECT CONSUMABLES REQUIREMENTS FROM MISSION PROFILE
 - 4.3.10.4.5 COMPUTE OPTIMAL CONSUMABLES ALLOCATION
- 4.3.10.5 STRUCTURAL MANAGEMENT
 - 4.3.10.5.1 MEASURE STRAINS IN STRUCTURE
 - 4.3.10.5.2 MEASURE RELATIVE DISPLACEMENTS
 - 4.3.10.5.3 COMPUTE STRESS AND VIBRATION PARAMETERS
 - 4.3.10.5.4 COMPARE STRESS AND VIBRATION PARAMETERS TO REQUIRED LIMITS
 - 4.3.10.5.5 APPLY COMPENSATING FORCES
 - 4.3.10.5.6 APPLY VIBRATION DAMPING
- 4.3.10.6 HAZARD AVOIDANCE
 - 4.3.10.6.1 AVOID TANK OVERPRESSURES
 - 4.3.10.6.2 MAINTAIN SAFE BATTERY CHARGE LEVELS
 - 4.3.10.6.3 MONITOR MICRO-GRAVITY LEVELS
 - 4.3.10.6.4 MAINTAIN COMMUNICATION LINKS
 - 4.3.10.6.5 AVOID EXPOSING SENSITIVE COMPONENTS TO DIRECT SUNLIGHT
- 4.3.10.7 OPTIMAL SEQUENCING

ORIGINAL PAGE IS
OF POOR QUALITY

- 4.3.10.7.1 UPDATE SPACECRAFT MODEL
- 4.3.10.7.2 PROJECT DESIRED FUNCTIONS FROM MISSION PROFILE
- 4.3.10.7.3 ESTIMATE RISKS FROM DESIRED FUNCTIONS
- 4.3.10.7.4 PROJECT CONSUMABLES REQUIREMENTS FROM MISSION PROFILE
- 4.3.10.7.5 DETERMINE CONSTRAINTS AND FIGURES OF MERIT
- 4.3.10.7.6 COMPUTE OPTIMAL SEQUENCING
- 4.3.10.8 IDENTIFY DEFECTIVE COMPONENT
 - 4.3.10.8.1 DETERMINE ANOMALOUS DATA
 - 4.3.10.8.2 FORM HYPOTHESIS FOR PROBLEM
- 4.3.10.9 REPORT SYSTEMS STATUS
 - 4.3.10.9.1 DATA/COMMAND ENCODING
 - 4.3.10.9.2 DATA/COMMAND TRANSMISSION
 - 4.3.10.9.3 DATA/COMMAND DECODING
 - 4.3.10.9.4 DATA/COMMAND DISPLAY
- 4.3.11 ATTITUDE CONTROL AND STABILIZATION
 - 4.3.11.1 MAINTAIN ATTITUDE
 - 4.3.11.1.1 INITIALIZE GUIDANCE SYSTEM
 - 4.3.11.1.2 DETERMINE CURRENT ATTITUDE
 - 4.3.11.1.3 DETERMINE NEW CONFIGURATION FOR SPACECRAFT COMPONENTS
 - 4.3.11.1.4 CHOOSE OPTIMAL TRAJECTORY
 - 4.3.11.1.5 ROTATE SPACECRAFT
 - 4.3.11.2 MAINTAIN ORBIT
 - 4.3.11.2.1 DETERMINE CURRENT ORBITAL PARAMETERS
 - 4.3.11.2.2 DETERMINE DESIRED ORBITAL PARAMETERS
 - 4.3.11.2.3 CHOOSE OPTIMAL TRAJECTORY
 - 4.3.11.2.4 RETRACT SOLAR ARRAYS
 - 4.3.11.2.5 RETRACT RADIATORS
 - 4.3.11.2.6 FIRE THRUSTERS
 - 4.3.11.3 OPTIMAL CONTROL ALLOCATION
 - 4.3.11.3.1 UPDATE SPACECRAFT MODEL
 - 4.3.11.3.2 PROJECT DESIRED FUNCTIONS FROM MISSION PROFILE
 - 4.3.11.3.3 PROJECT CONSUMABLES REQUIREMENTS FROM MISSION PROFILE
 - 4.3.11.3.4 DETERMINE CONSTRAINTS AND FIGURES OF MERIT
 - 4.3.11.3.5 CHOOSE OPTIMAL CONTROL MODE
 - 4.3.11.3.6 COMPUTE CONTROL COMMANDS
 - 4.3.11.3.7 EXECUTE CONTROL COMMANDS
- 4.3.12 STATUS MONITORING AND RESOURCE ALLOCATION (LIFE SUPPORT)
 - 4.3.12.1 HABITAT MODULE ENVIRONMENT MANAGEMENT
 - 4.3.12.1.1 MEASURE MODULE ATMOSPHERIC TEMPERATURES
 - 4.3.12.1.2 COMPARE ATMOSPHERIC TEMPERATURES TO REQUIRED LIMITS
 - 4.3.12.1.3 ADJUST COOLING/HEATING SYSTEMS
 - 4.3.12.1.4 MONITOR HABITAT PRESSURE, ATMOSPHERIC COMPOSITION
 - 4.3.12.1.5 COMPARE TO REQUIRED LIFE SUPPORT CONDITIONS
 - 4.3.12.1.6 ADJUST HABITAT-MAINTENANCE SUBSYSTEMS
 - 4.3.12.2 LIFE SUPPORT SYSTEM POWER MANAGEMENT
 - 4.3.12.2.1 MEASURE CURRENTS AND VOLTAGES
 - 4.3.12.2.2 COMPARE CURRENTS AND VOLTAGES TO REQUIRED LIMITS
 - 4.3.12.2.3 EVALUATE SOLAR ARRAY PERFORMANCE
 - 4.3.12.2.4 EVALUATE BATTERY CHARGING PERFORMANCE
 - 4.3.12.2.5 ADJUST CURRENTS AND VOLTAGES
 - 4.3.12.2.6 ADJUST BATTERY CHARGING CYCLE
 - 4.3.12.3 CONSUMABLES MANAGEMENT
 - 4.3.12.3.1 MONITOR GAS SUPPLIES
 - 4.3.12.3.2 MONITOR HABITAT-MAINTENANCE SYSTEMS SUPPLIES
 - 4.3.12.3.3 MONITOR SUPPLIES, CONDITION OF PERISHABLES
 - 4.3.12.3.4 MONITOR EQUIPMENT INVENTORY
 - 4.3.12.3.5 PROJECT CONSUMABLES REQUIREMENTS FROM MISSION PROFILE
 - 4.3.12.3.6 COMPUTE OPTIMAL CONSUMABLES ALLOCATION
 - 4.3.12.4 HAZARD AVOIDANCE
 - 4.3.12.4.1 MAINTAIN EMERGENCY CONSUMABLES RESERVE
 - 4.3.12.4.2 MAINTAIN SAFE BATTERY CHARGE LEVELS
 - 4.3.12.4.3 MONITOR RADIATION LEVELS
 - 4.3.12.4.4 MAINTAIN COMMUNICATION LINKS
 - 4.3.12.4.5 AVOID EXPOSING SENSITIVE COMPONENTS TO DIRECT SUNLIGHT
 - 4.3.12.4.6 MONITOR VITAL SIGNS OF CREW MEMBERS
 - 4.3.12.4.7 MONITOR REST, NUTRITION OF CREW MEMBERS
 - 4.3.12.5 OPTIMAL HABITAT SEQUENCING
 - 4.3.12.5.1 UPDATE HABITAT MODEL
 - 4.3.12.5.2 PROJECT DESIRED FUNCTIONS FROM MISSION PROFILE
 - 4.3.12.5.3 ESTIMATE RISKS FROM DESIRED FUNCTIONS
 - 4.3.12.5.4 PROJECT CONSUMABLES REQUIREMENTS FROM MISSION PROFILE
 - 4.3.12.5.5 DETERMINE CONSTRAINTS AND FIGURES OF MERIT

- 4.3.12.5.6 COMPUTE OPTIMAL SEQUENCING
- 4.3.12.6 FAILURE RECOVERY (ON-BOARD REPAIR)
 - 4.3.12.6.1 COMPARE MEASURED DATA TO MODEL
 - 4.3.12.6.2 DETERMINE ANOMALOUS DATA
 - 4.3.12.6.3 FORM HYPOTHESIS FOR PROBLEM
 - 4.3.12.6.4 DEVISE TEST FOR FAILURE HYPOTHESIS
 - 4.3.12.6.5 PERFORM TEST FOR FAILURE HYPOTHESIS
 - 4.3.12.6.6 DEFINE ACCESS SEQUENCE
 - 4.3.12.6.7 LOCATE ACCESS PANEL
 - 4.3.12.6.8 TRANSFER REPAIR EQUIPMENT TO REPAIR SITE
 - 4.3.12.6.9 OPEN ACCESS PANEL
 - 4.3.12.6.10 OBSERVE/LOCATE DEFECTIVE COMPONENT
 - 4.3.12.6.11 REMOVE COMPONENT
 - 4.3.12.6.12 STORE COMPONENT
 - 4.3.12.6.13 LOCATE NEW COMPONENT
 - 4.3.12.6.14 POSITION AND CONNECT NEW COMPONENT
 - 4.3.12.6.15 ADJUST COMPONENT
 - 4.3.12.6.16 MAKE DIAGNOSTIC CHECKS
 - 4.3.12.6.17 CLOSE ACCESS PANEL
 - 4.3.12.6.18 STOW REPAIR EQUIPMENT
 - 4.3.12.6.19 UPDATE SPACECRAFT MODEL
- 4.3.12.7 FAILURE RECOVERY (REDUNDANCY)
 - 4.3.12.7.1 SWITCH OUT FAULTY COMPONENT
 - 4.3.12.7.2 SWITCH IN REDUNDANT COMPONENT
 - 4.3.12.7.3 MAKE DIAGNOSTIC CHECKS
 - 4.3.12.7.4 UPDATE SPACECRAFT MODEL
- 4.3.13 PRE-EXPERIMENT OPERATIONS
- 4.3.14 CONDUCT PAYLOAD-SPECIFIC EXPERIMENT
- 4.3.15 POST-EXPERIMENT OPERATIONS
- 4.3.16 SERVICING AND RESUPPLY
 - 4.3.16.1 PRE-RENDEZVOUS PREPARATIONS
 - 4.3.16.1.1 SEND GROUND SIGNAL TO SP TO BEGIN SERV. SEQ.
 - 4.3.16.1.2 REDUCE POWER TO SUBSYSTEMS
 - 4.3.16.2 ORBITER/SP RENDEZVOUS AND CAPTURE
 - 4.3.16.2.1 DETERMINE CURRENT ORBITAL PARAMETERS
 - 4.3.16.2.2 DETERMINE CURRENT ATTITUDE
 - 4.3.16.2.3 DETERMINE DESIRED ORBITAL PARAMETERS
 - 4.3.16.2.4 CHOOSE OPTIMAL TRAJECTORY
 - 4.3.16.2.5 RETRACT SOLAR ARRAYS
 - 4.3.16.2.6 RETRACT RADIATORS
 - 4.3.16.2.7 SP ON INTERNAL POWER
 - 4.3.16.2.8 ORIENT THRUSTERS
 - 4.3.16.2.9 FIRE THRUSTERS
 - 4.3.16.2.10 ORBITER AND SP VELOCITY AND TRAJECTORY ADJUSTMENTS
 - 4.3.16.2.11 OPEN PAYLOAD BAY DOORS
 - 4.3.16.2.12 ACTIVATE DOCKING ADAPTER
 - 4.3.16.2.13 DOCKING OF SHUTTLE ADAPTER TO SPACE PLATFORM
 - 4.3.16.2.14 SP BERTHING ON DOCKING ADAPTER
 - 4.3.16.3 REMOVAL AND TRANSFER OF PAYLOADS
 - 4.3.16.3.1 SHUTDOWN PAYLOADS
 - 4.3.16.3.2 ACTIVATE RMS
 - 4.3.16.3.3 LOCATE GRASPING FIXTURE ON TARGET
 - 4.3.16.3.4 GRASP FIXTURE
 - 4.3.16.3.5 RELEASE PAYLOAD RESTRAINTS
 - 4.3.16.3.6 TRANSLATE PAYLOAD TO CRADLE
 - 4.3.16.3.7 FASTEN PAYLOAD RESTRAINTS
 - 4.3.16.3.8 ORIENT NEW PAYLOADS
 - 4.3.16.3.9 ATTACH NEW PAYLOADS
 - 4.3.16.3.10 ORBITER/PAYLOAD INTEGRATION CHECKOUT
 - 4.3.16.3.11 EXCHANGE PERSONNEL, THROUGH DOCKING MODULE
 - 4.3.16.3.12 STORAGE OF CONSUMABLES IN HABITAT MODULE
 - 4.3.16.4 NON-SCHEDULED MAINTENANCE
 - 4.3.16.5 OPERATIONAL CHECKOUT
 - 4.3.16.5.1 ACTIVATE SUBSYSTEMS
 - 4.3.16.5.2 POWER SUBSYSTEM CHECKOUT
 - 4.3.16.5.3 THERMAL SUBSYSTEM CHECKOUT
 - 4.3.16.5.4 INFORMATION PROCESSING SUBSYSTEM CHECKOUT
 - 4.3.16.5.5 STRUCTURE SUBSYSTEM CHECKOUT
 - 4.3.16.5.6 COMMUNICATIONS SUBSYSTEM CHECKOUT
 - 4.3.16.5.7 SP/PAYLOAD INTERFACE CHECKOUT
 - 4.3.16.5.8 CONSUMABLES LEVELS CHECKOUT
 - 4.3.16.5.9 COMPARE MEASURED DATA TO MODEL

- 4.3.16.6 SEPARATION OF ORBITER AND SP
 - 4.3.16.6.1 SECURE RMS IN PAYLOAD BAY
 - 4.3.16.6.2 CLOSE PAYLOAD BAY DOORS
 - 4.3.16.6.3 UNDOCKING OF ORBITER FROM SP
- 4.3.17 RETRIEVAL BY ORBITER
 - 4.3.17.1 ORBITER/SP RENDEZVOUS AND CAPTURE
 - 4.3.17.1.1 DETERMINE CURRENT ORBITAL PARAMETERS
 - 4.3.17.1.2 DETERMINE CURRENT ATTITUDE
 - 4.3.17.1.3 DETERMINE DESIRED ORBITAL PARAMETERS
 - 4.3.17.1.4 CHOOSE OPTIMAL TRAJECTORY
 - 4.3.17.1.5 RETRACT SOLAR ARRAYS
 - 4.3.17.1.6 RETRACT RADIATORS
 - 4.3.17.1.7 ORIENT THRUSTERS
 - 4.3.17.1.8 FIRE THRUSTERS
 - 4.3.17.1.9 ORBITER AND SP VELOCITY AND TRAJECTORY ADJUSTMENTS
 - 4.3.17.1.10 OPEN PAYLOAD BAY DOORS
 - 4.3.17.1.11 ACTIVATE DOCKING ADAPTER
 - 4.3.17.1.12 DOCKING OF SHUTTLE ADAPTER TO SPACE PLATFORM
 - 4.3.17.1.13 SP BERTHING ON DOCKING ADAPTER
 - 4.3.17.1.14 ACTIVATE RMS
 - 4.3.17.2 PAYLOAD WITHDRAWAL FROM SP
 - 4.3.17.2.1 SP INTERFACE WITH PAYLOAD IS SHUTDOWN
 - 4.3.17.2.2 PAYLOAD INTERNAL POWER ACTIVATED
 - 4.3.17.2.3 LOCATE GRASPING FIXTURE ON TARGET
 - 4.3.17.2.4 GRASP FIXTURE
 - 4.3.17.2.5 RELEASE PAYLOAD RESTRAINTS
 - 4.3.17.2.6 TRANSLATE PAYLOAD TO CRADLE
 - 4.3.17.2.7 FASTEN PAYLOAD RESTRAINTS
 - 4.3.17.3 SHUTTLE/PAYLOAD INTEGRATION AND TES
 - 4.3.17.3.1 ORBITER/PAYLOAD INTEGRATION CHECKOUT
 - 4.3.17.3.2 CLOSE PAYLOAD BAY DOORS
 - 4.3.17.4 SEPARATION OF SP FROM ORBITER
 - 4.3.17.4.1 TRANSFER OPERATIONAL CONTROL FROM MISSION TO PAYLOAD CONTROL
 - 4.3.17.4.2 UNDOCKING OF ORBITER FROM SP
 - 4.3.17.4.3 DETERMINE CURRENT ORBITAL PARAMETERS
 - 4.3.17.4.4 DETERMINE CURRENT ATTITUDE
 - 4.3.17.4.5 DETERMINE DESIRED ORBITAL PARAMETERS
 - 4.3.17.4.6 CHOOSE OPTIMAL TRAJECTORY
 - 4.3.17.4.7 RETRACT SOLAR ARRAYS
 - 4.3.17.4.8 RETRACT RADIATORS
 - 4.3.17.4.9 ORIENT THRUSTERS
 - 4.3.17.4.10 FIRE THRUSTERS
 - 4.3.17.4.11 ACTIVATE SUBSYSTEMS
 - 4.3.17.4.12 POWER SUBSYSTEM CHECKOUT
 - 4.3.17.4.13 THERMAL SUBSYSTEM CHECKOUT
 - 4.3.17.4.14 INFORMATION PROCESSING SUBSYSTEM CHECKOUT
 - 4.3.17.4.15 STRUCTURE SUBSYSTEM CHECKOUT
 - 4.3.17.4.16 COMMUNICATIONS SUBSYSTEM CHECKOUT
 - 4.3.17.4.17 SP/PAYLOAD INTERFACE CHECKOUT
 - 4.3.17.4.18 CONSUMABLES LEVELS CHECKOUT
 - 4.3.17.4.19 COMPARE MEASURED DATA TO MODEL
 - 4.3.17.4.20 DEPLOY SOLAR ARRAYS
 - 4.3.17.4.21 DEPLOY RADIATORS
- 4.3.18 RE-ENTRY AND LANDING OF ORBITER
- 4.3.19 POST-FLIGHT OPERATIONS
 - 4.3.19.1 SAFING OF ORBITER AND HAZARDOUS PAYLOADS
 - 4.3.19.2 REMOVAL OF PAYLOADS FROM ORBITER
 - 4.3.19.2.1 OPEN PAYLOAD BAY DOORS
 - 4.3.19.2.2 PRIORITY REMOVAL OF TIME-CRITICAL ITEMS
 - 4.3.19.2.3 PRIORITY REMOVAL OF PERSONNEL
 - 4.3.19.2.4 ATTACH STRONGBACK TO PAYLOAD
 - 4.3.19.2.5 LOAD PAYLOAD INTO CANISTER
 - 4.3.19.3 PAYLOAD REMOVAL FROM ORBITER PROCESSING FACILITY

APPENDIX 2.B:
GENERIC FUNCTIONAL ELEMENT LIST
(WITH BREAKDOWN CODE NUMBERS)

2.B.1 Notes on this Appendix

The Generic Functional Element (GFE) List was collected from the four space project breakdowns by a computer program (see Sections 2.4.1 and 2.4.2 for a description and discussion of this procedure). A functional element collected from a previous breakdown was not repeated again, but the code numbers under which it appeared were stored by the computer.

Thus the resulting GFE List contains 330 generic functional elements, from which all of the four project breakdowns can be assembled. Each GFE is followed by a list of code numbers, indicating the locations in the breakdowns where that GFE appeared as a functional element. This allows the study recipient to trace the contexts in which a GFE appeared in the original breakdowns, to clarify its definition.

The space project breakdowns (presented in Appendix 2.A) were scanned by the computer program in the order: GSP, AXAF, TMS, SP. Therefore the order of the GFE's, and their assigned numbers (g1, g2, etc.) reflect this scan. GFE's g1 through g170 were collected from the GSP breakdown (though most of them appear in other breakdowns as well). GFE's g171 through g238 were added by the scan of the AXAF breakdown; GFE's g239 through g249, by the scan of the TMS breakdown; and GFE's g250 through g330, by the scan of the SP breakdown.

As mentioned in Section 2.3.2, team brainstorm sessions were held to define common nomenclature for functional elements. Despite these precautions, three typographical variations appeared in the listing. Since the computer program uses word-recognition to collect GFE's, these 3 typos appear as separate GFE's: g200, similar to g83; g263, similar to g82; and g277, similar to g81. By the time these were identified, the GFE List had been used extensively in further study tasks; since correcting these typos would have renumbered one-third of the GFE's, the study group left the List unaltered.

This 330-element GFE List is also presented, without the lists of code numbers, in Appendix 2.C. The listing of the Generic Functional Element List, with project breakdown code numbers, follows.

*gfe g1: VERIFY POWER SYSTEM FUNCTION

FE 4.3.7.3.1
FE 4.2.7.3.1
FE 4.1B.7.3.1
FE 4.1A.7.3.1
FE 3.5.7B.3.1
FE 3.5.7A.3.1
FE 3.4.7B.3.1
FE 3.4.7A.3.1
FE 3.3.7B.3.1
FE 3.3.7A.3.1
FE 3.2.7B.3.1
FE 3.2.7A.3.1
FE 3.1B.7B.3.1
FE 3.1B.7A.3.1
FE 3.1A.7B.3.1
FE 3.1A.7A.3.1
FE 2.3B.7.3.1
FE 2.3A.7.3.1
FE 2.2B.7.3.1
FE 2.2A.7.3.1
FE 2.1B.7.3.1
FE 2.1A.7.3.1
FE 1.2B.7.3.1
FE 1.2A.7B.3.1
FE 1.2A.7A.3.1
FE 1.1.7.3.1

*gfe g2: VERIFY COMMAND SYSTEM FUNCTION

FE 4.3.7.3.2
FE 4.2.7.3.2
FE 4.1B.7.3.2
FE 4.1A.7.3.2
FE 3.5.7B.3.2
FE 3.5.7A.3.2
FE 3.4.7B.3.2
FE 3.4.7A.3.2
FE 3.3.7B.3.2
FE 3.3.7A.3.2
FE 3.2.7B.3.2
FE 3.2.7A.3.2
FE 3.1B.7B.3.2
FE 3.1B.7A.3.2
FE 3.1A.7B.3.2
FE 3.1A.7A.3.2
FE 2.3B.7.3.2
FE 2.3A.7.3.2
FE 2.2B.7.3.2
FE 2.2A.7.3.2
FE 2.1B.7.3.2
FE 2.1A.7.3.2
FE 1.2B.7.3.2
FE 1.2A.7B.3.2
FE 1.2A.7A.3.2
FE 1.1.7.3.2

*gfe g3: VERIFY MECHANICAL SYSTEM FUNCTION

FE 4.3.7.3.3

FE 4.2.7.3.3
FE 4.1B.7.3.3
FE 4.1A.7.3.3
FE 3.5.7B.3.3
FE 3.5.7A.3.3
FE 3.4.7B.3.3
FE 3.4.7A.3.3
FE 3.3.7B.3.3
FE 3.3.7A.3.3
FE 3.2.7B.3.3
FE 3.2.7A.3.3
FE 3.1.7B.3.3
FE 3.1.7A.3.3
FE 3.1.7B.3.3
FE 3.1.7A.3.3
FE 2.3.7.3.3
FE 2.3.7.3.3
FE 2.2.7.3.3
FE 2.2.7.3.3
FE 2.1.7.3.3
FE 2.1.7.3.3
FE 1.2.7.3.3
FE 1.2.7.3.3
FE 1.2.7A.3.3
FE 1.1.7.3.3

*gfe g4: VERIFY COMMUNICATIONS SYSTEM FUNCTION

FE 4.3.7.3.4
FE 4.2.7.3.4
FE 4.1.7.3.4
FE 4.1.7.3.4
FE 3.5.7B.3.4
FE 3.5.7A.3.4
FE 3.4.7B.3.4
FE 3.4.7A.3.4
FE 3.3.7B.3.4
FE 3.3.7A.3.4
FE 3.2.7B.3.4
FE 3.2.7A.3.4
FE 3.1.7B.3.4
FE 3.1.7A.3.4
FE 3.1.7B.3.4
FE 3.1.7A.3.4
FE 2.3.7.3.4
FE 2.3.7.3.4
FE 2.2.7.3.4
FE 2.2.7.3.4
FE 2.1.7.3.4
FE 2.1.7.3.4
FE 1.2.7.3.4
FE 1.2.7.3.4
FE 1.2.7A.3.4
FE 1.1.7.3.4

*gfe g5: VERIFY SEQUENCE SIMULATION

FE 3.5.7B.3.5
FE 3.5.7A.3.5

ORIGINAL PAGE IS
OF POOR QUALITY

ORIGINAL FILED
OF POOR QUALITY

FE 3.4.7B.3.5
FE 3.4.7A.3.5
FE 3.3.7B.3.5
FE 3.3.7A.3.5
FE 3.2.7B.3.5
FE 3.2.7A.3.5
FE 3.1B.7B.3.5
FE 3.1B.7A.3.5
FE 3.1A.7B.3.5
FE 3.1A.7A.3.5
FE 2.3B.7.3.5
FE 2.3A.7.3.5
FE 2.2B.7.3.6
FE 2.2A.7.3.6
FE 2.1B.7.3.6
FE 2.1A.7.3.6
FE 1.2B.7.3.5
FE 1.2A.7B.3.5
FE 1.2A.7A.3.5
FE 1.1.7.3.5

*gfe 96: LOAD PAYLOAD INTO CONTAINER
FE 3.5.7B.4.1
FE 3.5.7A.4.1
FE 3.4.7B.4.1
FE 3.4.7A.4.1
FE 3.3.7B.4.1
FE 3.3.7A.4.1
FE 3.2.7B.4.1
FE 3.2.7A.4.1
FE 3.1B.7B.4.1
FE 3.1B.7A.4.1
FE 3.1A.7B.4.1
FE 3.1A.7A.4.1
FE 2.3B.7.4.1
FE 2.3A.7.4.1
FE 2.2B.7.4.1
FE 2.2A.7.4.1
FE 2.1B.7.4.1
FE 2.1A.7.4.1
FE 1.2B.7.4.1
FE 1.1.7.4.1

*gfe 97: TRANSPORT CONTAINER TO VERTICAL PROCESSING FACILITY
FE 3.5.7B.4.2
FE 3.4.7B.4.2
FE 3.3.7B.4.2
FE 3.2.7B.4.2
FE 3.1B.7B.4.2
FE 3.1A.7B.4.2
FE 1.2B.7.4.2
FE 1.1.7.4.2

*gfe 98: UNLOAD CONTAINER
FE 3.5.7B.4.3
FE 3.4.7B.4.3
FE 3.3.7B.4.3
FE 3.2.7B.4.3

FE 3.1B.7B.4.3
FE 3.1A.7B.4.3
FE 1.2B.7.4.3
FE 1.1.7.4.3

*gfe 99: CHECK SHUTTLE/PAYLOAD MECHANICAL INTERFACES
FE 4.3.7.4.1
FE 4.2.7.4.1
FE 4.1B.7.4.2
FE 4.1A.7.4.2
FE 3.5.7B.6.3
FE 3.5.7A.6.3
FE 3.4.7B.6.3
FE 3.4.7A.6.3
FE 3.3.7B.6.3
FE 3.3.7A.6.3
FE 3.2.7B.6.3
FE 3.2.7A.6.3
FE 3.1B.7B.6.3
FE 3.1B.7A.6.3
FE 3.1A.7B.6.3
FE 3.1A.7A.6.3
FE 2.3B.7.6.2
FE 2.3A.7.5.1
FE 2.2B.7.6.2
FE 2.2A.7.5.1
FE 2.1B.7.6.2
FE 2.1A.7.5.1
FE 1.2B.7.6.1
FE 1.2A.7B.6.3
FE 1.2A.7A.6.3
FE 1.1.7.6.1

*gfe 100: CHECK ELECTRICAL INTERFACES
FE 4.3.7.6.4
FE 4.3.7.4.2
FE 4.2.7.6.4
FE 4.2.7.4.2
FE 4.1B.7.6.4
FE 4.1B.7.4.3
FE 4.1A.7.6.4
FE 4.1A.7.4.3
FE 3.5.7B.8.4
FE 3.5.7B.6.4
FE 3.5.7A.8.4
FE 3.5.7A.6.4
FE 3.4.7B.8.4
FE 3.4.7B.6.2
FE 3.4.7A.8.4
FE 3.4.7A.6.4
FE 3.3.7B.8.4
FE 3.3.7B.6.4
FE 3.3.7B.4.3

FE 3.3.7A.8.4
FE 3.3.7A.6.4
FE 3.3.7A.6.2
FE 3.2.7B.8.4
FE 3.2.7B.6.4
FE 3.2.7A.8.4
FE 3.2.7A.6.4
FE 3.2.7A.6.2
FE 3.1B.7B.8.4
FE 3.1B.7B.6.4
FE 3.1B.7B.6.2
FE 3.1B.7A.8.4
FE 3.1B.7A.6.4
FE 3.1B.7A.6.2
FE 3.1A.7B.8.4
FE 3.1A.7B.6.4
FE 3.1A.7A.8.4
FE 3.1A.7A.6.4
FE 2.3B.7.8.4
FE 2.3B.7.6.3
FE 2.3A.7.7.4
FE 2.3A.7.5.2
FE 2.2B.7.8.4
FE 2.2B.7.6.3
FE 2.2A.7.7.4
FE 2.1B.7.8.4
FE 2.1B.7.6.3
FE 2.1A.7.7.4
FE 2.1A.7.5.2
FE 1.2B.7.8.4
FE 1.2B.7.6.4
FE 1.2B.7.6.2
FE 1.2A.7B.8.4
FE 1.2A.7B.6.4
FE 1.2A.7A.8.4
FE 1.2A.7A.6.4
FE 1.2A.7A.6.2
FE 1.1.7.8.4
FE 1.1.7.6.4
FE 1.1.7.6.2
FE 1.1.7.6.3
FE 1.1.7.6.3
*gfe 911: CHECK PAYLOAD/BOOSTER MECHANICAL INTERFACES
FE 4.3.19.2.5
FE 4.3.7.5.2
FE 4.2.18.2.4
FE 4.2.7.5.2
FE 4.1B.17.2.4
FE 4.1B.7.5.2

FE 4.1A.16.2.4
FE 4.1A.7.5.2
FE 3.5.7B.7.1
FE 3.5.7A.7.2
FE 3.4.7B.7.1
FE 3.4.7A.7.2
FE 3.3.7B.7.1
FE 3.3.7A.7.2
FE 3.2.7B.7.1
FE 3.2.7A.7.2
FE 3.1B.7B.7.1
FE 3.1B.7A.7.2
FE 3.1A.7B.7.1
FE 3.1A.7A.7.2
FE 2.3B.13.2.3
FE 2.3B.7.7.2
FE 2.3A.13.2.3
FE 2.3A.7.6.2
FE 2.2B.17.2.3
FE 2.2B.7.7.2
FE 2.2A.16.2.3
FE 2.2A.7.6.2
FE 2.1B.13.2.3
FE 2.1B.7.7.2
FE 2.1A.12.2.3
FE 2.1A.7.6.2
FE 1.2B.7.7.1
FE 1.2A.7B.7.1
FE 1.2A.7A.7.2
FE 1.1.7.7.1
*gfe 913: TRANSPORT TO ROTATING SERVICE STRUCTURE
FE 3.5.7B.7.2
FE 3.4.7B.7.2
FE 3.3.7B.7.2
FE 3.2.7B.7.2
FE 3.1B.7B.7.2
FE 3.1A.7B.7.2
FE 1.2B.7.7.2
FE 1.2A.7B.7.2
FE 1.1.7.7.2
*gfe 914: LOAD CANISTER INTO ROTATING SERVICE STRUCTURE
FE 3.5.7B.7.3
FE 3.4.7B.7.3
FE 3.3.7B.7.3
FE 3.2.7B.7.3
FE 3.1B.7B.7.3
FE 3.1A.7B.7.3
FE 1.2B.7.7.3
FE 1.2A.7B.7.3
FE 1.1.7.7.3
*gfe 915: LOAD PAYLOAD INTO ROTATING SERVICE STRUCTURE USING PGHM
FE 3.5.7B.7.4
FE 3.4.7B.7.4
FE 3.3.7B.7.4
FE 3.2.7B.7.4

FE 3.1B.7B.7.4
FE 3.1A.7B.7.4
FE 1.2B.7.7.4
FE 1.2A.7B.7.4
FE 1.1.7.7.4
*gfe 916: REMOVE CANISTER

FE 3.5.7B.7.5
FE 3.4.7B.7.5
FE 3.3.7B.7.5
FE 3.2.7B.7.5
FE 3.1B.7B.7.5
FE 3.1A.7B.7.5
FE 1.2B.7.7.5
FE 1.2A.7B.7.5
FE 1.1.7.7.5

*gfe 917: MATE ROTATING SERVICE STRUCTURE TO ORBITER

FE 3.5.7B.8.1
FE 3.4.7B.8.1
FE 3.3.7B.8.1
FE 3.2.7B.8.1
FE 3.1B.7B.8.1
FE 3.1A.7B.8.1
FE 1.2B.7.8.1
FE 1.2A.7B.8.1
FE 1.1.7.8.1

*gfe 918: EXTEND PAYLOAD INTO ORBITER USING PGHM

FE 3.5.7B.8.2
FE 3.4.7B.8.2
FE 3.3.7B.8.2
FE 3.2.7B.8.2
FE 3.1B.7B.8.2
FE 3.1A.7B.8.2
FE 1.2B.7.8.2
FE 1.2A.7B.8.2
FE 1.1.7.8.2

*gfe 919: CONNECT ORBITER/PAYLOAD INTERFACES

FE 4.3.7.6.3
FE 4.2.7.6.3
FE 4.1B.7.6.3
FE 4.1A.7.6.3
FE 3.5.7B.8.3
FE 3.5.7A.8.3
FE 3.4.7B.8.3
FE 3.4.7A.8.3
FE 3.3.7B.8.3
FE 3.3.7A.8.3
FE 3.2.7B.8.3
FE 3.2.7A.8.3
FE 3.1B.7B.8.3
FE 3.1B.7A.8.3
FE 3.1A.7B.8.3
FE 3.1A.7A.8.3
FE 2.3B.7.8.3
FE 2.3A.7.7.3
FE 2.2B.7.8.3

FE 2.2A.7.7.3
FE 2.1B.7.8.3
FE 2.1A.7.7.3
FE 1.2B.7.8.3
FE 1.2A.7B.8.3
FE 1.2A.7A.8.3
FE 1.1.7.8.3

*gfe 920: CLOSE-OUT PAYLOAD BAY

FE 4.3.7.6.5
FE 4.2.7.6.5
FE 4.1B.7.6.5
FE 4.1A.7.6.5
FE 3.5.7B.8.5
FE 3.5.7A.8.6
FE 3.4.7B.8.5
FE 3.4.7A.8.6
FE 3.3.7B.8.5
FE 3.3.7A.8.6
FE 3.2.7B.8.5
FE 3.2.7A.8.6
FE 3.1B.7B.8.5
FE 3.1B.7A.8.6
FE 3.1A.7B.8.5
FE 3.1A.7A.8.6
FE 2.3B.7.8.5
FE 2.3A.7.7.6
FE 2.2B.7.8.5
FE 2.2A.7.7.6
FE 2.1B.7.8.5
FE 2.1A.7.7.6
FE 1.2B.7.8.5
FE 1.2A.7B.8.5
FE 1.2A.7A.8.6
FE 1.1.7.8.5

*gfe 921: OPEN PAYLOAD BAY DOORS

FE 4.3.19.2.1
FE 4.3.17.1.10
FE 4.3.16.2.11
FE 4.3.9.2.1
FE 4.3.9.1.11
FE 4.2.18.2.1
FE 4.2.16.1.10
FE 4.2.15.2.10
FE 4.2.9.2.1
FE 4.2.9.1.10
FE 4.1B.17.2.1
FE 4.1B.15.1.10
FE 4.1B.14.2.10
FE 4.1B.9.2.1
FE 4.1B.9.1.10
FE 4.1A.16.2.1
FE 4.1A.14.1.10
FE 4.1A.9.2.1
FE 4.1A.9.1.10
FE 3.5.9.3.1

ORIGINAL: FE 1.9.3.3
OF POOR QUALITY.

FE 3.4.9.3.1
FE 3.3.9.3.1
FE 3.2.9.3.1
FE 3.1B.9.3.1
FE 3.1A.9.3.1
FE 2.3B.13.2.1
FE 2.3B.9.3.1
FE 2.3A.13.2.1
FE 2.2B.17.2.1
FE 2.2B.9.3.1
FE 2.2A.16.2.1
FE 2.2A.14.2.1
FE 2.1B.13.2.1
FE 2.1B.9.2.1
FE 2.1A.12.2.1
FE 2.1A.9.2.1
FE 1.2B.9.2.1
FE 1.2A.9.3.1
FE 1.1.9.2.1
*gfe 922: ROTATE OTV/GSP PACKAGE OUT OF ORBITER
FE 1.1.9.2.2
*gfe 923: POWER SUBSYSTEM CHECKOUT
FE 4.3.17.4.12
FE 4.3.16.5.2
FE 4.3.9.9.13
FE 4.3.9.4.2
FE 4.2.16.4.12
FE 4.2.15.5.2
FE 4.2.9.9.12
FE 4.2.9.4.2
FE 4.1B.15.4.12
FE 4.1B.14.5.2
FE 4.1B.9.9.12
FE 4.1B.9.4.2
FE 4.1A.14.4.12
FE 4.1A.9.9.12
FE 4.1A.9.4.2
FE 3.5.9.5.3
FE 3.5.9.2.1
FE 3.4.9.5.3
FE 3.4.9.2.1
FE 3.3.9.5.3
FE 3.3.9.2.1
FE 3.2.9.5.3
FE 3.2.9.2.1
FE 3.1B.9.5.3
FE 3.1B.9.2.1
FE 3.1A.9.5.3
FE 3.1A.9.2.1
FE 2.3B.9.5.3
FE 2.3B.9.2.1
FE 2.2B.9.5.3
FE 2.1B.9.3.3
FE 1.2A.9.5.3

FE 1.2A.9.2.1
FE 1.1.9.3.3
FE 1.1.9.3.1
*gfe 924: INFORMATION PROCESSING SUBSYSTEM CHECKOUT
FE 4.3.17.4.14
FE 4.3.16.5.4
FE 4.3.9.9.15
FE 4.3.9.4.4
FE 4.2.16.4.14
FE 4.2.15.5.4
FE 4.2.9.9.14
FE 4.2.9.4.4
FE 4.1B.15.4.14
FE 4.1B.14.5.4
FE 4.1B.9.9.14
FE 4.1B.9.4.4
FE 4.1A.14.4.14
FE 4.1A.9.9.14
FE 4.1A.9.4.4
FE 3.5.9.5.2
FE 3.5.9.2.2
FE 3.4.9.5.2
FE 3.4.9.2.2
FE 3.3.9.5.2
FE 3.3.9.2.2
FE 3.2.9.5.2
FE 3.2.9.2.2
FE 3.1B.9.5.2
FE 3.1B.9.2.2
FE 3.1A.9.5.2
FE 3.1A.9.2.2
FE 2.3B.9.5.2
FE 2.3B.9.2.2
FE 2.2B.9.5.2
FE 2.2B.9.2.2
FE 2.1B.9.3.2
FE 1.2A.9.5.2
FE 1.2A.9.2.2
FE 1.1.9.8.2
FE 1.1.9.3.2
*gfe 925: RAISE CENTRAL MAST
FE 1.1.9.3.3
*gfe 926: DEPLOY MAIN REFLECTORS
FE 1.1.9.3.4
*gfe 927: DEPLOY ANTENNA RECEIVER ARRAYS
FE 1.1.9.3.5
*gfe 928: DEPLOY ANTENNA TRANSMIT ARRAYS
FE 1.1.9.3.6
*gfe 929: DEPLOY SUBREFLECTOR
FE 1.1.9.3.7
*gfe 930: DEPLOY INTERFEROMETER
FE 1.1.9.3.8
*gfe 931: DEPLOY SOLAR ARRAYS
FE 4.3.17.4.20
FE 4.3.9.9.21

FE 4.2.16.4.20
FE 4.2.9.9.20
FE 4.1B.15.4.20
FE 4.1B.9.9.20
FE 4.1A.14.4.20
FE 4.1A.9.9.20
FE 2.2B.13.3.5
FE 2.2A.14.3.5
FE 2.1B.9.5.5
FE 2.1A.9.3.5
FE 1.1.9.3.9
*gfe 932: DEPLOY RADIATORS
FE 4.3.17.4.21
FE 4.3.9.9.22
FE 4.2.16.4.21
FE 4.2.9.9.21
FE 4.1B.15.4.21
FE 4.1B.9.9.21
FE 4.1A.14.4.21
FE 4.1A.9.9.21
FE 1.1.9.3.10
*gfe 933: VERIFY DEPLOYMENT SEQUENCES
FE 1.1.9.3.11

*gfe 934: RETRACT SOLAR PANELS

*gfe 935: INITIALIZE GUIDANCE SYSTEM

FE 4.3.11.1.1
FE 4.2.11.1.1
FE 3.5.14.1.1
FE 3.5.13.1.1
FE 3.5.12.2.2
FE 3.5.12.1.1
FE 3.5.11.1.1
FE 3.5.9.10.1
FE 3.4.9.10.1
FE 3.3.13.1.1
FE 3.3.12.1.1
FE 3.3.11.2.1
FE 3.3.11.1.1
FE 3.3.9.10.1
FE 3.2.18.1.1
FE 3.2.17.1.1
FE 3.2.16.1.1
FE 3.2.11.1.1
FE 3.2.9.10.1
FE 3.1B.14.1.1
FE 3.1B.13.1.1
FE 3.1B.11.1.1
FE 3.1B.9.10.1
FE 3.1A.12.1.1
FE 3.1A.11.1.1
FE 3.1A.9.10.1
FE 2.3B.11.1.1
FE 2.3B.10.1.1
FE 2.3B.9.7.1

FE 2.3B.9.6.1
FE 2.3A.10.3.1
FE 2.2B.15.1.1
FE 2.2B.14.1.1
FE 2.2B.13.1.1
FE 2.2B.9.8.1
FE 2.2B.9.6.1
FE 2.2A.14.7.1
FE 2.2A.9.4.1
FE 2.1B.15.1.1
FE 2.1B.11.1.1
FE 2.1B.10.1.1
FE 2.1B.9.8.1
FE 2.1B.9.4.1
FE 2.1A.14.1.1
FE 2.1A.9.7.1
FE 1.2B.17.1.1
FE 1.2B.16.1.1
FE 1.2B.15.1.1
FE 1.2B.10.1.1
FE 1.2B.9.4.1
FE 1.2A.20.1.1
FE 1.2A.19.1.1
FE 1.2A.18.1.1
FE 1.2A.17.1.1
FE 1.2A.16.1.1
FE 1.2A.11.1.1
FE 1.2A.9.10.1
FE 1.1.11.2.1
FE 1.1.11.1.1
FE 1.1.9.5.1

*gfe 936: DETERMINE CURRENT ORBITAL PARAMETERS

FE 4.3.17.4.3
FE 4.3.17.1.1
FE 4.3.16.2.1
FE 4.3.11.2.1
FE 4.3.9.9.3
FE 4.3.9.1.1
FE 4.2.16.4.3
FE 4.2.16.1.1
FE 4.2.15.2.1
FE 4.2.11.2.1
FE 4.2.9.9.3
FE 4.2.5.1.1
FE 4.1B.15.4.3
FE 4.1B.15.1.1
FE 4.1B.14.2.1
FE 4.1B.9.9.3
FE 4.1B.9.1.1
FE 4.1A.14.4.3
FE 4.1A.14.1.1
FE 4.1A.9.9.3
FE 4.1A.9.1.1
FE 3.5.14.1.2
FE 3.5.13.1.2

ORIGINAL DATA
OF POOR QUALITY

FE 4.2.11.2.2
FE 4.2.9.9.5
FE 4.2.9.1.3
FE 4.18.15.4.5
FE 4.18.15.1.3
FE 4.18.14.2.3
FE 4.18.9.9.5
FE 4.18.9.1.3
FE 4.1A.14.4.5
FE 4.1A.14.1.3
FE 4.1A.9.9.5
FE 4.1A.9.1.3
FE 3.5.14.1.3
FE 3.5.13.1.3
FE 3.5.12.2.4
FE 3.5.12.1.3
FE 3.5.11.1.3
FE 3.5.9.10.3
FE 3.4.9.10.3
FE 3.3.13.1.3
FE 3.3.12.1.3
FE 3.3.11.2.3
FE 3.3.9.10.3
FE 3.2.18.1.3
FE 3.2.17.1.3
FE 3.2.16.1.3
FE 3.2.11.1.3
FE 3.2.9.10.3
FE 3.18.14.1.3
FE 3.18.13.1.3
FE 3.18.11.1.3
FE 3.18.9.10.3
FE 3.1A.12.1.3
FE 3.1A.11.1.3
FE 3.1A.9.10.3
FE 2.38.11.1.3
FE 2.38.10.1.3
FE 2.38.9.6.3
FE 2.28.15.1.3
FE 2.28.14.1.3
FE 2.28.13.1.3
FE 2.28.9.6.3
FE 2.18.11.1.3
FE 2.18.10.1.3
FE 2.18.9.4.3
FE 1.28.17.1.3
FE 1.28.16.1.3
FE 1.28.15.1.3
FE 1.28.10.1.3
FE 1.28.9.4.3
FE 1.2A.20.1.3
FE 1.2A.19.1.3
FE 1.2A.18.1.3
FE 1.2A.17.1.3
FE 1.2A.16.1.3

FE 3.5.12.2.3
FE 3.5.12.1.2
FE 3.5.11.1.2
FE 3.5.9.10.2
FE 3.4.9.10.2
FE 3.3.13.1.2
FE 3.3.12.1.2
FE 3.3.11.2.2
FE 3.3.9.10.2
FE 3.2.18.1.2
FE 3.2.17.1.2
FE 3.2.16.1.2
FE 3.2.11.1.2
FE 3.2.9.10.2
FE 3.18.14.1.2
FE 3.18.13.1.2
FE 3.18.11.1.2
FE 3.18.9.10.2
FE 3.1A.12.1.2
FE 3.1A.11.1.2
FE 3.1A.9.10.2
FE 2.38.11.1.2
FE 2.38.10.1.2
FE 2.38.9.6.2
FE 2.28.15.1.2
FE 2.28.14.1.2
FE 2.28.13.1.2
FE 2.28.9.6.2
FE 2.18.11.1.2
FE 2.18.10.1.2
FE 2.18.9.4.2
FE 1.28.17.1.2
FE 1.28.16.1.2
FE 1.28.15.1.2
FE 1.28.10.1.2
FE 1.28.9.4.2
FE 1.2A.20.1.2
FE 1.2A.19.1.2
FE 1.2A.18.1.2
FE 1.2A.17.1.2
FE 1.2A.16.1.2
FE 1.2A.11.1.2
FE 1.2A.9.10.2
FE 1.1.11.2.2
FE 1.1.9.5.2

*gfe 937: DETERMINE DESIRED ORBITAL PARAMETERS

FE 4.3.17.4.5
FE 4.3.17.1.3
FE 4.3.16.2.3
FE 4.3.11.2.2
FE 4.3.9.9.5
FE 4.3.9.1.3
FE 4.2.16.4.5
FE 4.2.16.1.3
FE 4.2.15.2.3

ORIGINAL POINTS
OF POOR QUALITY

FE 1.2A.11.1.3
FE 1.2A.9.10.3
FE 1.1.11.2.3
FE 1.1.9.5.3
*gfe 938: CHOOSE OPTIMAL TRAJECTORY
FE 4.3.17.4.6
FE 4.3.17.1.4
FE 4.3.16.2.4
FE 4.3.11.2.3
FE 4.3.11.1.4
FE 4.3.9.9.6
FE 4.3.9.1.4
FE 4.2.16.4.6
FE 4.2.16.1.4
FE 4.2.15.2.4
FE 4.2.11.2.3
FE 4.2.11.1.4
FE 4.2.9.9.6
FE 4.2.9.1.4
FE 4.1B.15.4.6
FE 4.1B.15.1.4
FE 4.1B.14.2.4
FE 4.1B.9.9.6
FE 4.1B.9.1.4
FE 4.1A.14.1.4
FE 4.1A.14.1.4
FE 4.1A.9.9.6
FE 4.1A.9.1.4
FE 3.5.14.2.4
FE 3.5.14.1.4
FE 3.5.13.1.4
FE 3.5.12.2.5
FE 3.5.12.1.4
FE 3.5.11.2.4
FE 3.5.11.1.4
FE 3.5.9.10.4
FE 3.4.9.10.4
FE 3.3.13.2.4
FE 3.3.13.1.4
FE 3.3.12.1.4
FE 3.3.11.2.4
FE 3.3.11.1.5
FE 3.3.9.10.4
FE 3.2.18.2.4
FE 3.2.18.1.4
FE 3.2.17.1.4
FE 3.2.16.1.4
FE 3.2.11.2.4
FE 3.2.11.1.4
FE 3.2.9.10.4
FE 3.1B.14.2.4
FE 3.1B.14.1.4
FE 3.1B.13.1.4
FE 3.1B.11.2.4
FE 3.1B.11.1.4

FE 3.1B.9.10.4
FE 3.1A.12.2.4
FE 3.1A.12.1.4
FE 3.1A.11.1.4
FE 3.1A.9.10.4
FE 2.3B.11.2.4
FE 2.3B.11.1.4
FE 2.3B.10.1.4
FE 2.3B.9.7.5
FE 2.3B.9.6.4
FE 2.3A.10.3.5
FE 2.2B.15.2.4
FE 2.2B.15.1.4
FE 2.2B.14.1.4
FE 2.2B.13.1.4
FE 2.2B.9.8.5
FE 2.2B.9.6.4
FE 2.2A.14.7.5
FE 2.2A.9.4.5
FE 2.1B.15.1.5
FE 2.1B.11.2.4
FE 2.1B.11.1.4
FE 2.1B.10.1.4
FE 2.1B.9.8.5
FE 2.1B.9.4.4
FE 2.1A.14.1.5
FE 2.1A.9.7.5
FE 1.2B.17.2.4
FE 1.2B.17.1.4
FE 1.2B.16.1.4
FE 1.2B.15.1.4
FE 1.2.10.2.4
FE 1.2B.10.1.4
FE 1.2B.9.4.4
FE 1.2A.20.2.4
FE 1.2A.20.1.4
FE 1.2A.19.1.4
FE 1.2A.18.1.4
FE 1.2A.17.2.4
FE 1.2A.17.1.4
FE 1.2A.16.1.4
FE 1.2A.11.2.4
FE 1.2A.11.1.4
FE 1.2A.9.10.4
FE 1.1.11.2.4
FE 1.1.11.1.5
FE 1.1.9.5.4
*gfe 939: DETERMINE CURRENT ATTITUDE
FE 4.3.17.4.4
FE 4.3.17.1.2
FE 4.3.16.2.2
FE 4.3.11.1.2
FE 4.3.9.9.4
FE 4.3.9.1.2
FE 4.2.16.4.4

ORIGINAL FORM IS
OF POOR QUALITY

FE 2.1A.9.7.2
FE 1.2B.17.2.1
FE 1.2B.16.1.5
FE 1.2B.15.1.5
FE 1.2B.10.2.1
FE 1.2B.9.4.5
FE 1.2A.20.2.1
FE 1.2A.19.1.5
FE 1.2A.18.1.5
FE 1.2A.17.2.1
FE 1.2A.16.1.5
FE 1.2A.11.2.1
FE 1.2A.9.10.5
FE 1.1.11.1.2
FE 1.1.9.5.5

*Gf# Q40: DETERMINE DESIRED ATTITUDE

FE 3.5.14.2.2
FE 3.5.13.1.6
FE 3.5.12.2.7
FE 3.5.12.1.6
FE 3.5.11.2.2
FE 3.5.9.10.6
FE 3.4.9.10.6
FE 3.3.13.2.2
FE 3.3.12.1.6
FE 3.3.11.1.3
FE 3.3.9.10.6
FE 3.2.18.2.2
FE 3.2.17.1.6
FE 3.2.16.1.6
FE 3.2.11.2.2
FE 3.2.9.10.6
FE 3.1B.14.2.2
FE 3.1B.13.1.6
FE 3.1B.11.2.2
FE 3.1B.9.10.6
FE 3.1A.12.2.2
FE 3.1A.11.1.6
FE 3.1A.9.10.6
FE 2.3B.11.2.2
FE 2.3B.10.1.6
FE 2.3B.9.7.3
FE 2.3B.9.6.6
FE 2.3A.10.3.3
FE 2.2B.15.2.2
FE 2.2B.14.1.6
FE 2.2B.13.1.6
FE 2.2B.9.8.3
FE 2.2B.9.6.6
FE 2.2A.14.7.3
FE 2.2A.9.4.3
FE 2.1B.17.1.2
FE 2.1B.15.1.3
FE 2.1B.11.2.2
FE 2.1B.10.1.6

FE 4.2.16.1.2
FE 4.2.15.2.2
FE 4.2.11.1.2
FE 4.2.9.9.4
FE 4.2.9.1.2
FE 4.1B.15.4.4
FE 4.1B.15.1.2
FE 4.1B.14.2.2
FE 4.1B.9.9.4
FE 4.1B.9.1.2
FE 4.1A.14.4.4
FE 4.1A.14.1.2
FE 4.1A.9.9.4
FE 4.1A.9.1.2
FE 3.5.14.2.1
FE 3.5.13.1.5
FE 3.5.12.2.6
FE 3.5.12.1.5
FE 3.5.11.2.1
FE 3.5.9.10.5
FE 3.4.9.10.5
FE 3.3.13.2.1
FE 3.3.12.1.5
FE 3.3.11.1.2
FE 3.3.9.10.5
FE 3.2.18.2.1
FE 3.2.17.1.5
FE 3.2.16.1.5
FE 3.2.11.2.1
FE 3.2.9.10.5
FE 3.1B.14.2.1
FE 3.1B.13.1.5
FE 3.1B.11.2.1
FE 3.1B.9.10.5
FE 3.1A.12.2.1
FE 3.1A.11.1.5
FE 3.1A.9.10.5
FE 2.3B.11.2.1
FE 2.3B.10.1.5
FE 2.3B.9.7.2
FE 2.3B.9.6.5
FE 2.3A.10.3.2
FE 2.2B.15.2.1
FE 2.2B.14.1.5
FE 2.2B.13.1.5
FE 2.2B.9.8.2
FE 2.2B.9.6.5
FE 2.2A.14.7.2
FE 2.2A.9.4.2
FE 2.1B.15.1.2
FE 2.1B.11.2.1
FE 2.1B.10.1.5
FE 2.1B.9.8.2
FE 2.1B.9.4.5
FE 2.1A.14.1.2

FE 2.1B.9.8.3
FE 2.1B.9.4.6
FE 2.1A.16.1.2
FE 2.1A.14.1.3
FE 2.1A.9.7.3
FE 1.2B.17.2.2
FE 1.2B.16.1.6
FE 1.2B.15.1.6
FE 1.2B.10.2.2
FE 1.2B.9.4.6
FE 1.2A.20.2.2
FE 1.2A.19.1.6
FE 1.2A.18.1.6
FE 1.2A.17.2.2
FE 1.2A.16.1.6
FE 1.2A.11.2.2
FE 1.2A.9.10.6
FE 1.1.11.1.3
FE 1.1.9.5.6
*gfe G41: FIRE THRUSTERS
FE 4.3.17.4.10
FE 4.3.17.1.8
FE 4.3.16.2.9
FE 4.3.11.2.6
FE 4.3.9.9.11
FE 4.3.9.1.9
FE 4.2.16.4.10
FE 4.2.16.1.8
FE 4.2.15.2.8
FE 4.2.11.2.6
FE 4.2.9.9.10
FE 4.2.9.1.8
FE 4.1B.15.4.10
FE 4.1B.15.1.8
FE 4.1B.14.2.8
FE 4.1B.9.9.10
FE 4.1B.9.1.8
FE 4.1A.14.4.10
FE 4.1A.14.1.8
FE 4.1A.9.9.10
FE 4.1A.9.1.8
FE 3.5.14.1.5
FE 3.5.13.1.8
FE 3.5.12.2.9
FE 3.5.12.1.8
FE 3.5.11.1.5
FE 3.5.9.10.8
FE 3.4.9.10.8
FE 3.3.13.1.5
FE 3.3.12.1.8
FE 3.3.11.2.5
FE 3.3.9.10.8
FE 3.2.18.1.5
FE 3.2.17.1.8
FE 3.2.16.1.8

FE 3.2.11.1.5
FE 3.2.9.10.8
FE 3.1B.14.1.5
FE 3.1B.13.1.8
FE 3.1B.11.1.5
FE 3.1B.9.10.8
FE 3.1A.12.1.5
FE 3.1A.11.1.8
FE 3.1A.9.10.8
FE 2.3B.11.1.5
FE 2.3B.10.1.8
FE 2.3B.9.6.8
FE 2.3A.10.2.7
FE 2.2B.15.1.5
FE 2.2B.14.1.8
FE 2.2B.13.1.8
FE 2.2B.9.6.8
FE 2.2A.9.2.7
FE 2.1B.11.1.5
FE 2.1B.10.1.8
FE 2.1B.9.4.8
FE 1.2B.17.1.5
FE 1.2B.16.1.8
FE 1.2B.15.1.8
FE 1.2B.10.1.5
FE 1.2B.9.4.8
FE 1.2A.20.1.5
FE 1.2A.19.1.8
FE 1.2A.18.1.7
FE 1.2A.17.1.5
FE 1.2A.16.1.8
FE 1.2A.11.1.5
FE 1.2A.9.10.8
FE 1.1.11.2.5
FE 1.1.9.6.3
FE 1.1.9.5.7
*gfe G42: SEPARATE OTV FROM GSP
FE 1.1.9.6.1
*gfe G43: SEPARATION COAST
FE 1.1.9.6.2
*gfe G44: TRANSFER OF OTV TO SUPERSYNCHRONOUS ORBIT
FE 1.1.9.6.4
*gfe G45: DEPLOY SOLAR PANELS
FE 1.1.9.7.1
*gfe G46: DEPLOY INTER-PLATFORM LINK ANTENNAS
FE 1.1.9.7.2
*gfe G47: ACTIVATE SUBSYSTEMS
FE 4.3.17.4.11
FE 4.3.16.5.1
FE 4.3.9.9.12
FE 4.3.9.4.1
FE 4.2.16.4.11
FE 4.2.15.5.1
FE 4.2.9.9.11
FE 4.2.9.4.1

ORIGINAL...
OF POOR QUALITY

FE 4.1B.15.4.11
FE 4.1B.14.5.1
FE 4.1B.9.9.11
FE 4.1B.9.4.1
FE 4.1A.14.4.11
FE 4.1A.9.9.11
FE 4.1A.9.4.1
FE 1.2A.9.5.1
FE 1.1.9.8.1

*gfe g48: THERMAL SUBSYSTEM CHECKOUT

FE 4.3.17.4.13
FE 4.3.16.5.3
FE 4.3.9.9.14
FE 4.3.9.4.3
FE 4.2.16.4.13
FE 4.2.15.5.3
FE 4.2.9.9.13
FE 4.2.9.4.3
FE 4.1B.15.4.13
FE 4.1B.14.5.3
FE 4.1B.9.9.13
FE 4.1B.9.4.3
FE 4.1A.14.4.13
FE 4.1A.9.9.13
FE 4.1A.9.4.3
FE 3.5.9.5.4
FE 3.4.9.5.4
FE 3.3.9.5.4
FE 3.2.9.5.4
FE 3.1B.9.5.4
FE 3.1A.9.5.4
FE 2.3B.9.5.4
FE 2.2B.9.5.4
FE 2.1B.9.3.4
FE 1.2A.9.5.4
FE 1.1.9.8.4

*gfe g49: STRUCTURE SUBSYSTEM CHECKOUT

FE 4.3.17.4.15
FE 4.3.16.5.5
FE 4.3.9.9.16
FE 4.3.9.4.5
FE 4.2.16.4.15
FE 4.2.15.5.5
FE 4.2.9.9.15
FE 4.2.9.4.5
FE 4.1B.15.4.15
FE 4.1B.14.5.5
FE 4.1B.9.9.15
FE 4.1B.9.4.5
FE 4.1A.14.4.15
FE 4.1A.9.9.15
FE 4.1A.9.4.5
FE 1.1.9.8.5

*gfe g50: COMMUNICATIONS SUBSYSTEM CHECKOUT

FE 4.3.17.4.16

FE 4.3.16.5.6
FE 4.3.9.9.17
FE 4.3.9.4.6
FE 4.2.16.4.16
FE 4.2.15.5.6
FE 4.2.9.9.16
FE 4.2.9.4.6
FE 4.1B.15.4.16
FE 4.1B.14.5.6
FE 4.1B.9.9.16
FE 4.1B.9.4.6
FE 4.1A.14.4.16
FE 4.1A.9.9.16
FE 4.1A.9.4.6
FE 3.5.9.5.6
FE 3.4.9.5.6
FE 3.3.9.5.6
FE 3.2.9.5.6
FE 3.1B.9.5.6
FE 3.1A.9.5.6
FE 2.3B.9.5.6
FE 2.2B.9.5.6
FE 2.1B.9.3.6
FE 1.2A.9.5.6
FE 1.1.9.8.6

*gfe g51: ATTITUDE CONTROL SUBSYSTEM CHECKOUT

FE 4.3.9.4.8
FE 4.2.9.4.8
FE 3.5.9.5.7
FE 3.4.9.5.7
FE 3.3.9.5.7
FE 3.2.9.5.7
FE 3.1B.9.5.7
FE 3.1A.9.5.7
FE 2.3B.9.5.7
FE 2.2B.9.5.7
FE 2.1B.9.3.7
FE 1.2A.9.5.7
FE 1.1.9.8.7

*gfe g52: PROPULSION SUBSYSTEM CHECKOUT

FE 3.5.9.5.8
FE 3.4.9.5.8
FE 3.3.9.5.8
FE 3.2.9.5.8
FE 3.1B.9.5.8
FE 3.1A.9.5.8
FE 2.3B.9.5.8
FE 2.2B.9.5.8
FE 2.1B.9.3.8
FE 1.2A.9.5.8
FE 1.1.9.8.8

*gfe g53: TRAFFIC ROUTING SUBSYSTEM CHECKOUT

FE 1.1.9.8.9

*gfe g54: CONSUMABLES LEVELS CHECKOUT

FE 4.3.17.4.16

FE 4.3.16.5.8
FE 4.3.9.9.19
FE 4.3.9.4.9
FE 4.2.16.4.18
FE 4.2.15.5.8
FE 4.2.9.9.18
FE 4.2.9.4.9
FE 4.18.15.4.18
FE 4.18.14.5.8
FE 4.18.9.9.18
FE 4.18.9.4.8
FE 4.1A.14.4.18
FE 4.1A.9.9.18
FE 4.1A.9.4.8
FE 3.5.9.5.9
FE 3.4.9.5.9
FE 3.3.9.5.9
FE 3.2.9.5.9
FE 3.18.9.5.9
FE 3.1A.9.5.9
FE 2.38.9.5.9
FE 2.28.9.5.9
FE 2.18.9.3.9
FE 1.2A.9.5.9
FE 1.1.9.8.10

*gfe 955: COMPARE MEASURED DATA TO MODEL

FE 4.3.17.4.19
FE 4.3.16.5.9
FE 4.3.12.6.1
FE 4.3.9.9.20
FE 4.3.9.6.1
FE 4.3.9.4.10
FE 4.2.16.4.19
FE 4.2.15.5.9
FE 4.2.9.9.19
FE 4.2.9.6.1
FE 4.2.9.4.10
FE 4.18.15.4.19
FE 4.18.14.5.9
FE 4.18.9.9.19
FE 4.18.9.6.1
FE 4.18.9.4.9
FE 4.1A.14.4.19
FE 4.1A.9.9.19
FE 4.1A.9.6.1
FE 4.1A.9.4.9
FE 3.5.10.9.1
FE 3.5.9.7.1
FE 3.4.10.9.1
FE 3.4.9.7.1
FE 3.3.10.9.1
FE 3.3.9.7.1
FE 3.2.10.9.1
FE 3.2.12.2.1
FE 3.2.10.9.1

*gfe 956: DETERMINE ANOMALOUS DATA

FE 3.18.12.2.1
FE 3.18.10.9.1
FE 3.18.9.7.1
FE 3.1A.10.9.1
FE 3.1A.9.7.1
FE 2.28.13.7.1
FE 2.28.9.11.1
FE 2.2A.14.11.1
FE 2.2A.9.8.1
FE 2.18.14.10.1
FE 2.18.9.13.1
FE 2.1A.13.10.1
FE 2.1A.9.11.1
FE 1.28.11.2.1
FE 1.2A.12.2.1
FE 1.2A.10.9.1
FE 1.2A.9.7.1
FE 1.1.10.9.1
FE 1.1.9.10.1
FE 1.1.9.8.11
FE 4.3.12.6.2
FE 4.3.10.6.1
FE 4.3.9.6.2
FE 4.3.9.5.1
FE 4.2.10.8.1
FE 4.2.9.6.2
FE 4.2.9.5.1
FE 4.18.10.8.1
FE 4.18.9.6.2
FE 4.18.9.5.1
FE 4.1A.10.8.1
FE 4.1A.9.6.2
FE 4.1A.9.5.1
FE 3.5.10.9.2
FE 3.5.10.8.1
FE 3.5.9.7.2
FE 3.5.9.6.1
FE 3.4.10.9.2
FE 3.4.10.8.1
FE 3.4.9.7.2
FE 3.4.9.6.1
FE 3.3.10.9.2
FE 3.3.10.8.1
FE 3.3.9.7.2
FE 3.3.9.6.1
FE 3.2.12.2.2
FE 3.2.12.1.1
FE 3.2.10.9.2
FE 3.2.10.8.1
FE 3.2.9.7.2
FE 3.2.9.6.1
FE 3.18.12.2.2
FE 3.18.12.1.1
FE 3.18.10.9.2

ORIGINAL PAGE IS
OF POOR QUALITY

FE 3.4.9.7.3
FE 3.4.9.6.2
FE 3.3.10.9.3
FE 3.3.10.8.2
FE 3.3.9.7.3
FE 3.3.9.6.2
FE 3.2.12.2.3
FE 3.2.12.1.2
FE 3.2.10.9.3
FE 3.2.10.8.2
FE 3.2.9.7.3
FE 3.2.9.6.2
FE 3.1B.12.2.3
FE 3.1B.12.1.2
FE 3.1B.10.9.3
FE 3.1B.10.8.2
FE 3.1B.9.7.3
FE 3.1B.9.6.2
FE 3.1A.10.9.3
FE 3.1A.10.8.2
FE 3.1A.9.7.3
FE 3.1A.9.6.2
FE 2.2B.13.7.3
FE 2.2B.13.5.2
FE 2.2B.9.11.3
FE 2.2B.9.10.2
FE 2.2A.14.11.3
FE 2.2A.14.9.2
FE 2.2A.9.8.3
FE 2.2A.9.7.2
FE 2.1B.14.10.3
FE 2.1B.14.8.2
FE 2.1B.9.13.3
FE 2.1B.9.11.2
FE 2.1A.13.10.3
FE 2.1A.13.8.2
FE 2.1A.9.11.3
FE 2.1A.9.9.2
FE 1.2B.11.2.3
FE 1.2B.11.1.2
FE 1.2A.12.2.3
FE 1.2A.12.1.2
FE 1.2A.10.9.3
FE 1.2A.10.8.2
FE 1.2A.9.7.3
FE 1.2A.9.6.2
FE 1.1.10.9.3
FE 1.1.10.8.2
FE 1.1.9.10.3
FE 1.1.9.9.2
FE 4.3.12.6.4
FE 4.3.9.6.4
FE 4.3.9.5.3
FE 4.2.9.6.3

*gfe Q58: DEVISE TEST FOR FAILURE HYPOTHESIS

FE 3.1B.10.8.1
FE 3.1B.9.7.2
FE 3.1B.9.6.1
FE 3.1A.10.9.2
FE 3.1A.10.8.1
FE 3.1A.9.7.2
FE 3.1A.9.6.1
FE 2.2B.13.7.2
FE 2.2B.13.5.1
FE 2.2B.9.11.2
FE 2.2B.9.10.1
FE 2.2A.14.11.2
FE 2.2A.14.9.1
FE 2.2A.9.8.2
FE 2.2A.9.7.1
FE 2.1B.14.10.2
FE 2.1B.14.8.1
FE 2.1B.9.13.2
FE 2.1B.9.11.1
FE 2.1A.13.10.2
FE 2.1A.13.8.1
FE 2.1A.9.11.2
FE 2.1A.9.9.1
FE 1.2B.11.2.2
FE 1.2B.11.1.1
FE 1.2A.12.2.2
FE 1.2A.12.1.1
FE 1.2A.10.9.2
FE 1.2A.10.8.1
FE 1.2A.9.7.2
FE 1.2A.9.6.1
FE 1.1.10.9.2
FE 1.1.10.8.1
FE 1.1.9.10.2
FE 1.1.9.9.1
FE 4.3.12.6.3
FE 4.3.10.8.2
FE 4.3.9.6.3
FE 4.3.9.5.2
FE 4.2.10.8.2
FE 4.2.9.6.3
FE 4.2.9.5.2
FE 4.1B.10.8.2
FE 4.1B.9.6.3
FE 4.1B.9.5.2
FE 4.1A.10.8.2
FE 4.1A.9.6.3
FE 4.1A.9.5.2
FE 3.5.10.9.3
FE 3.5.10.8.2
FE 3.5.9.7.3
FE 3.5.9.6.2
FE 3.4.10.9.3
FE 3.4.10.8.2

*gfe Q57: FORM HYPOTHESIS FOR PROBLEM

FE 1.2A.9.7.4
FE 1.2A.9.6.3
FE 1.1.10.9.4
FE 1.1.10.8.3
FE 1.1.9.10.4
FE 1.1.9.9.3
*gfe 959: PERFORM TEST FOR FAILURE HYPOTHESIS
FE 4.3.12.6.5
FE 4.3.9.6.5
FE 4.3.9.5.4
FE 4.2.9.6.5
FE 4.2.9.5.4
FE 4.1B.9.6.5
FE 4.1B.9.5.4
FE 4.1A.9.6.5
FE 4.1A.9.5.4
FE 3.5.10.9.5
FE 3.5.10.8.4
FE 3.5.9.7.5
FE 3.5.9.6.4
FE 3.4.10.9.5
FE 3.4.10.8.4
FE 3.4.9.7.5
FE 3.4.9.6.4
FE 3.3.10.9.5
FE 3.3.10.8.4
FE 3.3.9.7.5
FE 3.3.9.6.4
FE 3.2.12.2.5
FE 3.2.12.1.4
FE 3.2.10.9.5
FE 3.2.10.8.4
FE 3.2.9.7.5
FE 3.2.9.6.4
FE 3.1B.12.2.5
FE 3.1B.12.1.4
FE 3.1B.10.9.5
FE 3.1B.10.8.4
FE 3.1B.9.7.5
FE 3.1B.9.6.4
FE 3.1A.10.9.5
FE 3.1A.10.8.4
FE 3.1A.9.7.5
FE 3.1A.9.6.4
FE 2.2B.13.7.5
FE 2.2B.13.5.4
FE 2.2B.9.11.5
FE 2.2B.9.10.4
FE 2.2A.14.11.5
FE 2.2A.14.9.4
FE 2.2A.9.8.5
FE 2.2A.9.7.4
FE 2.1B.14.10.5
FE 2.1B.14.8.4
FE 2.1B.9.13.5

FE 4.2.9.5.3
FE 4.1B.9.6.4
FE 4.1B.9.5.3
FE 4.1A.9.6.4
FE 4.1A.9.5.3
FE 3.5.10.9.4
FE 3.5.10.8.3
FE 3.5.9.7.4
FE 3.5.9.6.3
FE 3.4.10.9.4
FE 3.4.10.8.3
FE 3.4.9.7.4
FE 3.4.9.6.3
FE 3.3.10.9.4
FE 3.3.10.8.3
FE 3.3.9.7.4
FE 3.3.9.6.3
FE 3.2.12.2.4
FE 3.2.12.1.3
FE 3.2.10.9.4
FE 3.2.10.8.3
FE 3.2.9.7.4
FE 3.2.9.6.3
FE 3.1B.12.2.4
FE 3.1B.12.1.3
FE 3.1B.10.9.4
FE 3.1B.10.8.3
FE 3.1B.9.7.4
FE 3.1B.9.6.3
FE 3.1A.10.9.4
FE 3.1A.10.8.3
FE 3.1A.9.7.4
FE 3.1A.9.6.3
FE 2.2B.13.7.4
FE 2.2B.13.5.3
FE 2.2B.9.11.4
FE 2.2B.9.10.3
FE 2.2A.14.11.4
FE 2.2A.14.9.3
FE 2.2A.9.8.4
FE 2.2A.9.7.3
FE 2.1B.14.10.4
FE 2.1B.14.8.3
FE 2.1B.9.13.4
FE 2.1B.9.11.3
FE 2.1A.13.10.4
FE 2.1A.13.8.3
FE 2.1A.9.11.4
FE 2.1A.9.9.3
FE 1.2B.11.2.4
FE 1.2B.11.1.3
FE 1.2A.12.2.4
FE 1.2A.12.1.3
FE 1.2A.10.9.4
FE 1.2A.10.8.3

FE 4.1A.9.7A.1
FE 3.5.10.10A.1
FE 3.5.9.8A.1
FE 3.4.10.10A.1
FE 3.4.9.8A.1
FE 3.3.10.10A.1
FE 3.3.9.8A.1
FE 3.2.10.10A.1
FE 3.2.9.8A.1
FE 3.1B.10.10A.1
FE 3.1B.9.8A.1
FE 3.1A.10.10A.1
FE 3.1A.9.8A.1
FE 2.2B.13.6A.1
FE 2.2A.14.10A.1
FE 2.1B.14.9A.1
FE 2.1B.9.12A.1
FE 2.1A.13.9A.1
FE 2.1A.9.10A.1
FE 1.2A.10.10A.1
FE 1.2A.9.8A.1
FE 1.1.10.10A.1
FE 1.1.9.11A.1

*gfe 962: SWITCH IN REDUNDANT COMPONENT

FE 4.3.12.7.2
FE 4.3.9.7A.2
FE 4.2.9.7A.2
FE 4.1B.9.7A.2
FE 4.1A.9.7A.2
FE 3.5.10.10A.2
FE 3.5.9.8A.2
FE 3.4.10.10A.2
FE 3.4.9.8A.2
FE 3.3.10.10A.2
FE 3.3.9.8A.2
FE 3.2.10.10A.2
FE 3.2.9.8A.2
FE 3.1B.10.10A.2
FE 3.1B.9.8A.2
FE 3.1A.10.10A.2
FE 3.1A.9.8A.2
FE 2.2B.13.6A.2
FE 2.2A.14.10A.2
FE 2.1B.14.9A.2
FE 2.1B.9.12A.2
FE 2.1A.13.9A.2
FE 2.1A.9.10A.2
FE 1.2A.10.10A.2
FE 1.2A.9.8A.2
FE 1.1.10.10A.2
FE 1.1.9.11A.2

*gfe 963: MAKE DIAGNOSTIC CHECKS

FE 4.3.12.7.3
FE 4.3.12.6.16
FE 4.3.9.7B.11

FE 2.1B.9.11.4
FE 2.1A.13.10.5
FE 2.1A.13.6.4
FE 2.1A.9.11.5
FE 2.1A.9.9.4
FE 1.2B.11.2.5
FE 1.2B.11.1.4
FE 1.2A.12.2.5
FE 1.2A.12.1.4
FE 1.2A.10.9.5
FE 1.2A.10.8.4
FE 1.2A.9.7.5
FE 1.2A.9.6.4
FE 1.1.10.9.5
FE 1.1.10.8.4
FE 1.1.9.10.5
FE 1.1.9.9.4

*gfe 960: IDENTIFY FAULTY COMPONENT

FE 4.3.9.5.5
FE 4.2.9.5.5
FE 4.1B.9.5.5
FE 4.1A.9.5.5
FE 3.5.10.8.5
FE 3.5.9.6.5
FE 3.4.10.8.5
FE 3.4.9.6.5
FE 3.3.10.8.5
FE 3.3.9.6.5
FE 3.2.12.1.5
FE 3.2.10.8.5
FE 3.2.9.6.5
FE 3.1B.12.1.5
FE 3.1B.10.8.5
FE 3.1B.9.6.5
FE 3.1A.10.8.5
FE 3.1A.9.6.5
FE 2.2B.13.5.5
FE 2.2B.9.10.5
FE 2.2A.14.9.5
FE 2.2A.9.7.5
FE 2.1B.14.8.5
FE 2.1B.9.11.5
FE 2.1A.13.8.5
FE 2.1A.9.9.5
FE 1.2B.11.1.5
FE 1.2A.12.1.5
FE 1.2A.10.8.5
FE 1.2A.9.6.5
FE 1.1.10.8.5
FE 1.1.9.9.5

*gfe 961: SWITCH OUT FAULTY COMPONENT

FE 4.3.12.7.1
FE 4.3.9.7A.1
FE 4.2.9.7A.1
FE 4.1B.9.7A.1

FE 1.1.10.10A.3
 OF POOR QUALITY

*gfe 964: UPDATE SPACECRAFT MODEL

- FE 1.1.10.10A.3
- FE 1.1.9.11B.11
- FE 1.1.9.11A.3
- FE 4.3.12.7.4
- FE 4.3.12.6.19
- FE 4.3.11.3.1
- FE 4.3.10.7.1
- FE 4.3.9.7B.14
- FE 4.3.9.7A.4
- FE 4.2.11.3.1
- FE 4.2.10.7.1
- FE 4.2.9.7B.14
- FE 4.2.9.7A.4
- FE 4.1B.10.7.1
- FE 4.1B.9.7B.14
- FE 4.1B.9.7A.4
- FE 4.1A.10.7.1
- FE 4.1A.9.7B.14
- FE 4.1A.9.7A.4
- FE 3.5.14.3.1
- FE 3.5.11.3.1
- FE 3.5.10.10B.14
- FE 3.5.10.10A.4
- FE 3.5.10.7.1
- FE 3.5.9.8B.14
- FE 3.5.9.8A.4
- FE 3.4.10.10B.14
- FE 3.4.10.10A.4
- FE 3.4.10.7.1
- FE 3.4.9.8B.14
- FE 3.4.9.8A.4
- FE 3.3.13.3.1
- FE 3.3.11.3.1
- FE 3.3.10.10B.14
- FE 3.3.10.10A.4
- FE 3.3.10.7.1
- FE 3.3.9.8B.14
- FE 3.3.9.8A.4
- FE 3.2.18.3.1
- FE 3.2.13.1.14
- FE 3.2.11.3.1
- FE 3.2.10.10B.14
- FE 3.2.10.10A.4
- FE 3.2.10.7.1
- FE 3.2.9.8B.14
- FE 3.2.9.8A.4
- FE 3.1B.14.3.1
- FE 3.1B.11.3.1
- FE 3.1B.10.10B.14
- FE 3.1B.10.10A.4
- FE 3.1B.10.7.1
- FE 3.1B.9.8B.14
- FE 3.1B.9.8A.4
- FE 3.1A.12.3.1
- FE 3.1A.10.10B.11
- FE 3.1A.10.10A.3
- FE 3.1A.9.8B.11
- FE 3.1A.9.8A.3
- FE 2.2B.13.6B.11
- FE 2.2B.13.6A.3
- FE 2.2B.10.3.11
- FE 2.2B.10.2.5
- FE 2.2A.14.10B.11
- FE 2.2A.14.10A.3
- FE 2.2A.10.7.11
- FE 2.2A.10.2.J
- FE 2.1B.14.9B.10
- FE 2.1B.14.9A.3
- FE 2.1B.9.12B.11
- FE 2.1B.9.12A.3
- FE 2.1A.13.9B.10
- FE 2.1A.13.9A.3
- FE 2.1A.9.10B.11
- FE 2.1A.9.10A.3
- FE 1.2B.12.1.11
- FE 1.2A.13.1.11
- FE 1.2A.10.10B.11
- FE 1.2A.10.10A.3
- FE 1.2A.9.8B.11
- FE 1.2A.9.8A.3
- FE 1.1.10.10B.11

FE 3.1A.10.10B.14
FE 3.1A.10.10A.4
FE 3.1A.10.7.1
FE 3.1A.9.8B.14
FE 3.1A.9.8A.4
FE 2.3B.11.3.1
FE 2.2B.15.3.1
FE 2.2B.13.6A.4
FE 2.2A.14.10A.4
FE 2.1B.15.2.1
FE 2.1B.14.9A.4
FE 2.1B.14.7.1
FE 2.1B.11.3.1
FE 2.1B.9.12A.4
FE 2.1A.14.2.1
FE 2.1A.13.9A.4
FE 2.1A.13.7.1
FE 2.1A.9.10A.4
FE 1.2B.17.3.1
FE 1.2B.12.1.14
FE 1.2B.10.3.1
FE 1.2A.20.3.1
FE 1.2A.17.3.1
FE 1.2A.13.1.14
FE 1.2A.11.3.1
FE 1.2A.10.10B.14
FE 1.2A.10.10A.4
FE 1.2A.10.7.1
FE 1.2A.9.8B.14
FE 1.2A.9.8A.4
FE 1.1.11.3.1
FE 1.1.10.10B.14
FE 1.1.10.10A.4
FE 1.1.10.7.1
FE 1.1.9.11B.14
FE 1.1.9.11A.4
*gfe 965: DEFINE ACCESS SEQUENCE
FE 4.3.12.6.6
FE 4.3.9.7B.1
FE 4.2.9.7B.1
FE 4.1B.9.7B.1
FE 4.1A.9.7B.1
FE 3.5.10.10B.1
FE 3.5.9.8B.1
FE 3.4.10.10B.1
FE 3.4.9.8B.1
FE 3.3.10.10B.1
FE 3.2.13.1.1
FE 3.2.10.10B.1
FE 3.2.9.8B.1
FE 3.1B.9.12B.2
FE 3.1B.9.8B.2
FE 3.1A.10.10B.2
FE 3.1A.9.8B.2
FE 2.2B.13.6B.2
FE 2.2B.11.1B.1
FE 2.2B.11.1A.1
FE 2.2B.10.3.2
FE 2.2B.10.1.1
FE 2.2A.14.10B.2
FE 2.2A.11.1B.1
FE 2.2A.11.1A.1
FE 2.2A.10.3.2
FE 2.2A.10.1.1
FE 2.1B.14.9B.2
FE 2.1B.9.12B.2
FE 2.1A.13.9B.2
FE 2.1A.9.10B.2
FE 1.2B.13.1.1
FE 1.2B.12.1.2
FE 1.2A.14.1B.1
FE 1.2A.14.1A.1
FE 1.2A.13.1.2
FE 1.2A.10.10B.2

FE 2.2B.13.6B.1
FE 2.2B.10.3.1
FE 2.2A.14.10B.1
FE 2.2A.10.3.1
FE 2.1B.14.9B.1
FE 2.1B.9.12B.1
FE 2.1A.13.9B.1
FE 2.1A.9.10B.1
FE 1.2B.12.1.1
FE 1.2A.13.1.1
FE 1.2A.10.10B.1
FE 1.2A.9.8B.1
FE 1.1.10.10B.1
FE 1.1.9.11B.1
FE 1.1.9.11A.1
*gfe 966: LOCATE ACCESS PANEL
FE 4.3.12.6.7
FE 4.3.9.7B.2
FE 4.2.9.7B.2
FE 4.1B.9.7B.2
FE 4.1A.9.7B.2
FE 3.5.10.10B.2
FE 3.5.9.8B.2
FE 3.4.10.10B.2
FE 3.4.9.8B.2
FE 3.3.10.10B.2
FE 3.3.9.8B.2
FE 3.2.14.1B.1
FE 3.2.14.1A.1
FE 3.2.13.1.2
FE 3.2.10.10B.2
FE 3.2.9.8B.2
FE 3.1B.10.10B.2
FE 3.1B.9.8B.2
FE 3.1A.10.10B.2
FE 3.1A.9.8B.2
FE 2.2B.13.6B.2
FE 2.2B.11.1B.1
FE 2.2B.11.1A.1
FE 2.2B.10.3.2
FE 2.2B.10.1.1
FE 2.2A.14.10B.2
FE 2.2A.11.1B.1
FE 2.2A.11.1A.1
FE 2.2A.10.3.2
FE 2.2A.10.1.1
FE 2.1B.14.9B.2
FE 2.1B.9.12B.2
FE 2.1A.13.9B.2
FE 2.1A.9.10B.2
FE 1.2B.13.1.1
FE 1.2B.12.1.2
FE 1.2A.14.1B.1
FE 1.2A.14.1A.1
FE 1.2A.13.1.2
FE 1.2A.10.10B.2

FE 1.2A.9.88.2
 FE 1.1.10.108.2
 FE 1.1.9.11B.2
 *gfe 967: TRANSFER REPAIR EQUIPMENT TO REPAIR SITE
 FE 4.3.12.6.8
 FE 4.3.9.7B.3
 FE 4.2.9.7B.3
 FE 4.1B.9.7B.3
 FE 4.1A.9.7B.3
 FE 3.5.10.108.3
 FE 3.5.9.88.3
 FE 3.4.10.108.3
 FE 3.4.9.88.3
 FE 3.3.10.108.3
 FE 3.3.9.88.3
 FE 3.2.14.1B.2
 FE 3.2.13.1.3
 FE 3.2.10.108.3
 FE 3.2.9.88.3
 FE 3.1B.10.108.3
 FE 3.1B.9.88.3
 FE 3.1A.10.108.3
 FE 3.1A.9.88.3
 FE 2.2B.13.6B.3
 FE 2.2B.11.1B.2
 FE 2.2B.10.3.3
 FE 2.2A.11.1B.2
 FE 2.2A.14.108.3
 FE 2.2A.10.3.3
 FE 2.1A.13.9B.3
 FE 2.1A.9.108.3
 FE 1.2B.12.1.3
 FE 1.2A.14.1B.2
 FE 1.2A.13.1.3
 FE 1.2A.10.108.3
 FE 1.2A.9.88.3
 FE 1.1.10.108.3
 FE 1.1.9.11B.3
 *gfe 968: OPEN ACCESS PANEL
 FE 4.3.12.6.9
 FE 4.3.9.7B.4
 FE 4.2.9.7B.4
 FE 4.1B.9.7B.4
 FE 4.1A.9.7B.4
 FE 3.5.10.108.4
 FE 3.5.9.88.4
 FE 3.4.10.108.4
 FE 3.4.9.88.4
 FE 3.3.10.108.4
 FE 3.3.9.88.4
 FE 3.2.14.1B.3
 FE 3.2.14.1A.2
 FE 3.2.13.1.4

FE 3.2.10.108.4
 FE 3.2.9.88.4
 FE 3.1B.10.108.4
 FE 3.1B.9.88.4
 FE 3.1A.10.108.4
 FE 3.1A.9.88.4
 FE 2.2B.13.6B.4
 FE 2.2B.11.1B.3
 FE 2.2B.11.1A.2
 FE 2.2B.10.3.4
 FE 2.2B.10.1.2
 FE 2.2A.14.108.4
 FE 2.2A.11.1B.3
 FE 2.2A.11.1A.2
 FE 2.2A.10.3.4
 FE 2.2A.10.1.2
 FE 2.1B.9.12B.4
 FE 2.1A.9.108.4
 FE 1.2B.13.1.2
 FE 1.2B.12.1.4
 FE 1.2A.14.1B.3
 FE 1.2A.14.1A.2
 FE 1.2A.13.1.4
 FE 1.2A.10.108.4
 FE 1.2A.9.88.4
 FE 1.1.10.108.4
 FE 1.1.9.11B.4
 FE 4.3.12.6.10
 FE 4.3.9.7B.5
 FE 4.2.9.7B.5
 FE 4.1B.9.7B.5
 FE 4.1A.9.7B.5
 FE 3.5.10.108.5
 FE 3.5.9.88.5
 FE 3.4.10.108.5
 FE 3.4.9.88.5
 FE 3.3.10.108.5
 FE 3.3.9.88.5
 FE 3.2.13.1.5
 FE 3.2.10.108.5
 FE 3.2.9.88.5
 FE 3.1B.10.108.5
 FE 3.1B.9.88.5
 FE 3.1A.10.108.5
 FE 3.1A.9.88.5
 FE 2.2B.13.6B.5
 FE 2.2B.10.3.5
 FE 2.2A.14.108.5
 FE 2.2A.10.3.5
 FE 2.1B.14.9B.4
 FE 2.1B.9.12B.5
 FE 2.1A.13.9B.4
 FE 2.1A.9.108.5
 FE 1.2B.12.1.5

*gfe 969: OBSERVE/LOCATE DEFECTIVE COMPONENT

ORIGINAL PAGE IS
 OF POOR QUALITY

ORIGINAL PAGE IS
OF POOR QUALITY

FE 1.2A.13.1.5
FE 1.2A.10.10B.5
FE 1.2A.9.8B.5
FE 1.1.10.10B.5
FE 1.1.9.11B.5
*gfe 970: REMOVE COMPONENT
FE 4.3.12.6.11
FE 4.3.9.7B.6
FE 4.2.9.7B.6
FE 4.1B.9.7B.6
FE 4.1A.9.7B.6
FE 3.5.10.10B.6
FE 3.5.9.8B.6
FE 3.4.10.10B.6
FE 3.4.9.8B.5
FE 3.3.10.10B.6
FE 3.3.9.8B.6
FE 3.2.13.1.6
FE 3.2.10.10B.6
FE 3.2.9.8B.6
FE 3.1B.10.10B.6
FE 3.1B.9.8B.6
FE 3.1A.10.10B.6
FE 3.1A.9.8B.6
FE 2.2B.13.6B.6
FE 2.2A.14.10B.6
FE 2.2A.10.3.6
FE 2.1B.14.9B.5
FE 2.1B.9.12B.6
FE 2.1A.13.9B.5
FE 2.1A.9.10B.6
FE 1.2B.12.1.6
FE 1.2A.13.1.6
FE 1.2A.10.10B.6
FE 1.2A.9.8B.6
FE 1.1.10.10B.6
FE 1.1.9.11B.6

*gfe 971: STORE COMPONENT

FE 4.3.12.6.12
FE 4.3.9.7B.7
FE 4.2.9.7B.7
FE 4.1B.9.7B.7
FE 4.1A.9.7B.7
FE 3.5.10.10B.7
FE 3.5.9.8B.7
FE 3.4.10.10B.7
FE 3.4.9.8B.7
FE 3.3.10.10B.7
FE 3.3.9.8B.7
FE 3.2.13.1.7
FE 3.2.10.10B.7
FE 3.2.9.8B.7
FE 3.1B.10.10B.7
FE 3.1B.9.8B.7

FE 3.1A.10.10B.7
FE 3.1A.9.8B.7
FE 2.2B.13.6B.7
FE 2.2B.10.3.7
FE 2.2A.14.10B.7
FE 2.2A.10.3.7
FE 2.1B.14.9B.6
FE 2.1B.9.12B.7
FE 2.1A.13.9B.6
FE 2.1A.9.10B.7
FE 1.2B.12.1.7
FE 1.2A.13.1.7
FE 1.2A.10.10B.7
FE 1.2A.9.8B.7
FE 1.1.10.10B.7
FE 1.1.9.11B.7

*gfe 972: LOCATE NEW COMPONENT

FE 4.3.12.6.13
FE 4.3.9.7B.8
FE 4.2.9.7B.8
FE 4.1B.9.7B.8
FE 4.1A.9.7B.8
FE 3.5.10.10B.8
FE 3.5.9.8B.8
FE 3.4.10.10B.8
FE 3.4.9.8B.8
FE 3.3.10.10B.8
FE 3.3.9.8B.8
FE 3.2.13.1.8
FE 3.2.10.10B.8
FE 3.2.9.8B.8
FE 3.1B.10.10B.8
FE 3.1B.9.8B.8
FE 3.1A.10.10B.8
FE 3.1A.9.8B.8
FE 2.2B.13.6B.8
FE 2.2B.10.3.8
FE 2.2A.14.10B.8
FE 2.2A.10.3.8
FE 2.1B.14.9B.7
FE 2.1B.9.12B.8
FE 2.1A.13.9B.7
FE 2.1A.9.10B.8
FE 1.2B.12.1.8
FE 1.2A.13.1.8
FE 1.2A.10.10B.8
FE 1.2A.9.8B.8
FE 1.1.10.10B.8
FE 1.1.9.11B.8

*gfe 973: POSITION AND CONNECT NEW COMPONENT

FE 4.3.12.6.14
FE 4.3.9.7B.9
FE 4.2.9.7B.9
FE 4.1B.9.7B.9
FE 4.1A.9.7B.9

ORIGINAL PAGE IS
OF POOR QUALITY

FE 3.5.10.10B.9
FE 3.5.9.8B.9
FE 3.4.10.10B.9
FE 3.4.9.8B.9
FE 3.3.10.10B.9
FE 3.3.9.8B.9
FE 3.2.13.1.9
FE 3.2.10.10B.9
FE 3.2.9.8B.9
FE 3.1B.10.10B.9
FE 3.1B.9.8B.9
FE 3.1A.10.10B.9
FE 3.1A.9.8B.9
FE 2.2B.13.6B.9
FE 2.2B.10.3.9
FE 2.2A.14.10B.9
FE 2.1B.14.9B.8
FE 2.1B.9.12B.9
FE 2.1A.13.9B.8
FE 2.1A.9.10B.9
FE 1.2B.12.1.9
FE 1.2A.13.1.9
FE 1.2A.10.10B.9
FE 1.2A.9.8B.9
FE 1.1.10.10B.9
FE 1.1.9.11B.9

*gfe 974: ADJUST COMPONENT

FE 4.3.12.6.15
FE 4.3.9.7B.10
FE 4.2.9.7B.10
FE 4.1B.9.7B.10
FE 4.1A.9.7B.10
FE 3.5.10.10B.10
FE 3.5.9.8B.10
FE 3.4.10.10B.10
FE 3.4.9.8B.10
FE 3.3.10.10B.10
FE 3.3.9.8B.10
FE 3.2.13.1.10
FE 3.2.10.10B.10
FE 3.2.9.8B.10
FE 3.1B.10.10B.10
FE 3.1B.9.8B.10
FE 3.1A.10.10B.10
FE 3.1A.9.8B.10
FE 2.2B.13.6B.6
FE 2.2B.10.3.10
FE 2.2A.14.10B.10
FE 2.2A.10.3.10
FE 2.1B.14.9B.9
FE 2.1B.9.12B.10
FE 2.1A.13.9B.9
FE 2.1A.9.10B.10
FE 1.2B.12.1.10

FE 1.2A.13.1.10
FE 1.2A.10.10B.10
FE 1.2A.9.8B.10
FE 1.1.10.10B.10
FE 1.1.9.11B.10

*gfe 975: CLOSE ACCESS PANEL

FE 4.3.12.6.17
FE 4.3.9.7B.12
FE 4.2.9.7B.12
FE 4.1B.9.7B.12
FE 4.1A.9.7B.12
FE 3.5.10.10B.12
FE 3.5.9.8B.12
FE 3.4.10.10B.12
FE 3.4.9.8B.12
FE 3.3.10.10B.12
FE 3.3.9.8B.12
FE 3.2.14.1B.14
FE 3.2.14.1A.11
FE 3.2.13.1.12
FE 3.2.10.10B.12
FE 3.2.9.8B.12
FE 3.1B.10.10B.12
FE 3.1B.9.8B.12
FE 3.1A.10.10B.12
FE 3.1A.9.8B.12
FE 2.2B.13.6B.12
FE 2.2B.11.1B.14
FE 2.2B.11.1A.11
FE 2.2B.10.3.12
FE 2.2B.10.2.6
FE 2.2A.14.10B.12
FE 2.2A.11.1B.14
FE 2.2A.11.1A.11
FE 2.2A.10.3.12
FE 2.2A.10.2.6
FE 2.1B.14.9B.11
FE 2.1B.9.12B.12
FE 2.1A.13.9B.11
FE 2.1A.9.10B.12
FE 1.2B.13.1.11
FE 1.2B.12.1.12
FE 1.2A.14.1B.14
FE 1.2A.14.1A.11
FE 1.2A.13.1.12
FE 1.2A.10.10B.12
FE 1.2A.9.8B.12
FE 1.1.10.10B.12
FE 1.1.9.11B.12

*gfe 976: STOW REPAIR EQUIPMENT

FE 4.3.12.6.18
FE 4.3.9.7B.13
FE 4.2.9.7B.13
FE 4.1B.9.7B.13
FE 4.1A.9.7B.13

ORIGINAL PAGE IS
OF POOR QUALITY

FE 3.5.10.10B.13
FE 3.5.9.8B.13
FE 3.4.10.10B.13
FE 3.4.9.8B.13
FE 3.3.10.10B.13
FE 3.3.9.8B.13
FE 3.2.14.1B.15
FE 3.2.13.1.13
FE 3.2.10.10B.13
FE 3.2.9.8B.13
FE 3.1B.10.10B.13
FE 3.1B.9.8B.13
FE 3.1A.10.10B.13
FE 3.1A.9.8B.13
FE 2.2B.13.6B.13
FE 2.2B.11.1B.15
FE 2.2B.10.3.13
FE 2.2A.14.10B.13
FE 2.2A.11.1B.15
FE 2.2A.10.3.13
FE 2.1B.14.9B.12
FE 2.1B.9.12B.13
FE 2.1A.13.9B.12
FE 2.1A.9.10B.13
FE 1.2B.12.1.13
FE 1.2A.14.1B.15
FE 1.2A.13.1.13
FE 1.2A.10.10B.13
FE 1.2A.9.8B.13
FE 1.1.10.10B.13
FE 1.1.9.11B.13

*gfe 977: DETERMINE CORRECTION ALGORITHM
FE 4.3.9.8.1
FE 4.2.9.8.1
FE 4.1B.9.8.1
FE 4.1A.9.8.1
FE 3.5.10.11.1
FE 3.5.9.1
FE 3.4.10.11.1
FE 3.4.9.1
FE 3.3.10.11.1
FE 3.3.9.1
FE 3.2.10.11.1
FE 3.2.9.1
FE 3.1B.10.11.1
FE 3.1B.9.1
FE 3.1A.10.11.1
FE 3.1A.9.1
FE 2.2B.13.8.1
FE 2.2A.14.12.1
FE 2.1B.14.11.1
FE 2.1B.9.14.1
FE 2.1A.13.11.1
FE 2.1A.9.12.1
FE 1.2A.10.11.1

*gfe 978: DATA/COMMAND ENCODING
FE 1.2A.9.9.1
FE 1.1.10.11.1
FE 1.1.9.12.1
FE 4.3.10.9.1
FE 4.3.10.3.3
FE 4.3.9.8.2
FE 4.2.10.9.1
FE 4.2.10.3.3
FE 4.2.9.8.2
FE 4.1B.10.9.1
FE 4.1B.10.3.3
FE 4.1B.9.8.2
FE 4.1A.10.9.1
FE 4.1A.10.3.3
FE 4.1A.9.8.2
FE 3.5.10.12.1
FE 3.5.10.11.2
FE 3.5.10.3.3
FE 3.5.9.9.2
FE 3.4.10.12.1
FE 3.4.10.11.2
FE 3.4.10.3.3
FE 3.4.9.9.2
FE 3.3.10.12.1
FE 3.3.10.11.2
FE 3.3.10.3.3
FE 3.3.9.9.2
FE 3.2.13.2.1
FE 3.2.10.12.1
FE 3.2.10.11.2
FE 3.2.10.3.3
FE 3.2.9.9.2
FE 3.1B.10.12.1
FE 3.1B.10.11.2
FE 3.1B.10.3.3
FE 3.1B.9.9.2
FE 3.1A.10.12.1
FE 3.1A.10.11.2
FE 3.1A.10.3.3
FE 3.1A.9.9.2
FE 2.2B.13.8.2
FE 2.2B.10.4.1
FE 2.2A.14.12.2
FE 2.2A.10.4.1
FE 2.1B.17.4.3
FE 2.1B.17.3.2
FE 2.1B.17.2.7
FE 2.1B.16.3.3
FE 2.1B.14.12.1
FE 2.1B.14.11.2
FE 2.1B.14.3.3
FE 2.1B.9.14.2
FE 2.1A.15.4.3
FE 2.1A.15.3.2

FE 2.1A.16.4.4
FE 2.1A.16.3.3
FE 2.1A.16.2.8
FE 2.1A.15.3.4
FE 2.1A.13.12.2
FE 2.1A.13.11.3
FE 2.1A.9.12.3
FE 1.2B.12.2.2
FE 1.2A.13.2.2
FE 1.2A.10.12.2
FE 1.2A.10.11.3
FE 1.2A.9.9.3
FE 1.1.10.12.2
FE 1.1.10.11.3
FE 1.1.9.12.3

*gfe 980: COMPUTER FUNCTION CHECKS

FE 4.3.10.3.8
FE 4.3.9.8.4
FE 4.2.10.3.8
FE 4.2.9.8.4
FE 4.1B.10.3.8
FE 4.1B.9.8.4
FE 4.1A.10.3.8
FE 4.1A.9.8.4
FE 3.5.10.11.4
FE 3.5.10.3.8
FE 3.5.9.9.4
FE 3.4.10.11.4
FE 3.4.10.3.8
FE 3.4.9.9.4
FE 3.3.10.11.4
FE 3.3.10.3.8
FE 3.3.9.9.4
FE 3.2.13.2.3
FE 3.2.10.11.4
FE 3.2.10.3.8
FE 3.2.9.9.4
FE 3.1B.10.11.4
FE 3.1B.10.3.8
FE 3.1B.9.9.4
FE 3.1A.10.11.4
FE 3.1A.10.3.8
FE 3.1A.9.9.4
FE 2.2B.13.8.4
FE 2.2B.10.4.3
FE 2.2A.14.12.4
FE 2.2A.10.4.3
FE 2.1B.14.11.4
FE 2.1B.14.3.8
FE 2.1B.9.14.4
FE 2.1A.13.11.4
FE 2.1A.13.3.8
FE 2.1A.9.12.4
FE 1.2B.12.2.3
FE 1.2A.13.2.3

FE 2.1A.16.2.7
FE 2.1A.15.3.3
FE 2.1A.13.12.1
FE 2.1A.13.11.2
FE 2.1A.13.3.3
FE 2.1A.9.12.2
FE 1.2B.12.2.1
FE 1.2A.13.2.1
FE 1.2A.10.12.1
FE 1.2A.10.11.2
FE 1.2A.10.3.3
FE 1.2A.9.9.2
FE 1.1.10.12.1
FE 1.1.10.11.2
FE 1.1.10.3.3
FE 1.1.9.12.2

*gfe 979: DATA/COMMAND TRANSMISSION

FE 4.3.10.9.2
FE 4.3.9.8.3
FE 4.2.10.9.2
FE 4.2.9.8.3
FE 4.1B.10.9.2
FE 4.1B.9.8.3
FE 4.1A.10.9.2
FE 4.1A.9.8.3
FE 3.5.10.12.2
FE 3.5.10.11.3
FE 3.5.9.9.3
FE 3.4.10.12.2
FE 3.4.10.11.3
FE 3.4.9.9.3
FE 3.3.10.12.2
FE 3.3.10.11.3
FE 3.3.9.9.3
FE 3.2.13.2.2
FE 3.2.10.12.2
FE 3.2.10.11.3
FE 3.2.9.9.3
FE 3.1B.10.12.2
FE 3.1B.10.11.3
FE 3.1B.9.9.3
FE 3.1A.10.12.2
FE 3.1A.10.11.3
FE 3.1A.9.9.3
FE 2.2B.13.8.3
FE 2.2B.10.4.2
FE 2.2A.14.12.3
FE 2.2A.10.4.2
FE 2.1B.17.4.4
FE 2.1B.17.3.3
FE 2.1B.16.3.4
FE 2.1B.14.12.2
FE 2.1B.14.11.3
FE 2.1B.9.14.3

FE 1.2A.10.11.4
FE 1.2A.10.3.8
FE 1.2A.9.9.4
FE 1.1.10.11.4
FE 1.1.10.3.8
FE 1.1.9.12.4
*gfe 981: MEASURE COMPONENT TEMPERATURES
FE 4.3.10.1.1
FE 4.2.10.1.1
FE 4.1B.10.1.1
FE 4.1A.10.1.1
FE 3.5.10.1.1
FE 3.4.10.1.1
FE 3.3.10.1.1
FE 3.2.10.1.1
FE 3.1B.10.1.1
FE 3.1A.10.1.1
FE 2.1B.14.1.1
FE 2.1A.13.1.1
FE 1.2A.10.1.1
FE 1.1.10.1.1
FE 3.5.10.1.2
FE 3.4.10.1.2
FE 3.3.10.1.2
FE 3.2.10.1.2
FE 3.1B.10.1.2
FE 3.1A.10.1.2
FE 2.1B.14.1.2
FE 2.1A.13.1.2
FE 1.2A.10.1.2
FE 1.1.10.1.2

*gfe 982: COMPARE TEMPERATURES TO REQUIRED LIMITS

FE 3.5.10.1.2
FE 3.4.10.1.2
FE 3.3.10.1.2
FE 3.2.10.1.2
FE 3.1B.10.1.2
FE 3.1A.10.1.2
FE 2.1B.14.1.2
FE 2.1A.13.1.2
FE 1.2A.10.1.2
FE 1.1.10.1.2
*gfe 983: ADJUST COOLING/HEATING SYSTEMS
FE 4.3.12.1.3
FE 4.3.10.1.3
FE 4.2.10.1.3
FE 4.1B.10.1.3
FE 4.1A.10.1.3
FE 3.5.10.1.3
FE 3.4.10.1.3
FE 3.3.10.1.3
FE 3.2.10.1.3
FE 3.1B.10.1.3
FE 3.1A.10.1.3
FE 1.2A.10.1.3
FE 1.1.10.1.3
*gfe 984: MEASURE CURRENTS AND VOLTAGES
FE 4.3.12.2.1
FE 4.3.10.2.1
FE 4.2.10.2.1
FE 4.1B.10.2.1
FE 4.1A.10.2.1
FE 3.5.10.2.1
FE 3.4.10.2.1
FE 3.3.10.2.1
FE 3.2.10.2.1
FE 3.1B.10.2.1
FE 3.1A.10.2.1
FE 2.1B.14.2.1
FE 2.1A.13.2.1
FE 1.2A.10.2.1
FE 1.1.10.2.1

*gfe 985: COMPARE CURRENTS AND VOLTAGES TO REQUIRED LIMITS

FE 4.3.12.2.2
FE 4.3.10.2.2
FE 4.2.10.2.2
FE 4.1B.10.2.2
FE 4.1A.10.2.2
FE 3.5.10.2.2
FE 3.4.10.2.2
FE 3.3.10.2.2
FE 3.2.10.2.2
FE 3.1B.10.2.2
FE 3.1A.10.2.2
FE 2.1B.14.2.2
FE 2.1A.13.2.2
FE 1.2A.10.2.2
FE 1.1.10.2.2
*gfe 986: EVALUATE BATTERY CHARGING PERFORMANCE
FE 4.3.12.2.4
FE 4.3.10.2.3
FE 4.2.10.2.3
FE 4.1B.10.2.3
FE 4.1A.10.2.3
FE 2.1B.14.2.4
FE 2.1A.13.2.4
FE 1.1.10.2.3
*gfe 987: ADJUST CURRENTS AND VOLTAGES
FE 4.3.12.2.5
FE 4.3.10.2.4
FE 4.2.10.2.4
FE 4.1B.10.2.4
FE 4.1A.10.2.4
FE 3.5.10.2.3
FE 3.4.10.2.3
FE 3.3.10.2.3
FE 3.2.10.2.3
FE 3.1B.10.2.3
FE 3.1A.10.2.3
FE 2.1B.14.2.3
FE 2.1A.13.2.3
FE 1.2A.10.2.3
FE 1.1.10.2.4

*gfe 988: ADJUST BATTERY CHARGING CYCLE

FE 4.3.12.2.6
FE 4.3.10.2.5
FE 4.2.10.2.5
FE 4.1B.10.2.5
FE 4.1A.10.2.5
FE 3.4.10.2.5
FE 3.3.10.2.5
FE 3.2.10.2.5
FE 3.1B.10.2.5
FE 3.1A.10.2.5
FE 2.1B.14.2.5
FE 2.1A.13.2.5
FE 1.2A.10.2.5
FE 1.1.10.2.5

*gfe g89: SHORT-TERM MEMORY STORAGE

- FE 2.1A.13.2.5
- FE 1.1.10.2.5
- FE 4.3.10.3.1
- FE 4.2.10.3.1
- FE 4.1B.10.3.1
- FE 4.1A.10.3.1
- FE 3.5.10.3.1
- FE 3.4.10.3.1
- FE 3.3.10.3.1
- FE 3.2.10.3.1
- FE 3.1B.10.3.1
- FE 3.1A.10.3.1
- FE 2.1B.14.3.1
- FE 2.1A.13.3.1
- FE 1.2A.10.3.1
- FE 1.1.10.3.1

*gfe g90: LONG-TERM MEMORY STORAGE

- FE 4.3.10.3.2
- FE 4.2.10.3.2
- FE 4.1B.10.3.2
- FE 4.1A.10.3.2
- FE 3.5.10.3.2
- FE 3.4.10.3.2
- FE 3.3.10.3.2
- FE 3.2.10.3.2
- FE 3.1B.10.3.2
- FE 3.1A.10.3.2
- FE 2.1B.14.3.2
- FE 2.1A.13.3.2
- FE 1.2A.10.3.2
- FE 1.1.10.3.2

*gfe g91: DATA/COMMAND DECODING

- FE 4.3.10.3.3
- FE 4.3.10.3.4
- FE 4.2.10.3.3
- FE 4.2.10.3.4
- FE 4.1B.10.3.3
- FE 4.1B.10.3.4
- FE 4.1A.10.3.3
- FE 4.1A.10.3.4
- FE 3.5.10.3.3
- FE 3.5.10.3.4
- FE 3.4.10.3.3
- FE 3.4.10.3.4
- FE 3.3.10.3.3
- FE 3.3.10.3.4
- FE 3.2.10.3.3
- FE 3.2.10.3.4
- FE 3.1B.10.3.3
- FE 3.1B.10.3.4
- FE 3.1A.10.3.3
- FE 3.1A.10.3.4
- FE 2.1B.14.3.3
- FE 2.1B.14.3.4
- FE 2.1A.13.3.3
- FE 2.1A.13.3.4
- FE 1.2A.10.3.3
- FE 1.2A.10.3.4
- FE 1.1.10.3.3
- FE 1.1.10.3.4

- FE 2.1B.14.12.3
- FE 2.1B.14.3.4
- FE 2.1A.15.2.2
- FE 2.1A.15.1.2
- FE 2.1A.13.12.3
- FE 2.1A.13.3.4
- FE 1.2A.10.12.3
- FE 1.2A.10.3.4
- FE 1.1.10.12.3
- FE 1.1.10.3.4

*gfe g92: NUMERICAL COMPUTATION

- FE 4.3.10.3.5
- FE 4.2.10.3.5
- FE 4.1B.10.3.5
- FE 4.1A.10.3.5
- FE 3.5.10.3.5
- FE 3.4.10.3.5
- FE 3.3.10.3.5
- FE 3.2.10.3.5
- FE 3.1B.10.3.5
- FE 3.1A.10.3.5
- FE 2.1B.14.3.5
- FE 2.1A.13.3.5
- FE 1.2A.10.3.5
- FE 1.1.10.3.5

*gfe g93: LOGIC OPERATIONS

- FE 4.3.10.3.6
- FE 4.2.10.3.6
- FE 4.1B.10.3.6
- FE 4.1A.10.3.6
- FE 3.5.10.3.6
- FE 3.4.10.3.6
- FE 3.3.10.3.6
- FE 3.2.10.3.6
- FE 3.1B.10.3.6
- FE 3.1A.10.3.6
- FE 2.1B.14.3.6
- FE 2.1A.13.3.6
- FE 1.2A.10.3.6
- FE 1.1.10.3.6

*gfe g94: COMPUTER LOAD SCHEDULING

- FE 4.3.10.3.7
- FE 4.2.10.3.7
- FE 4.1B.10.3.7
- FE 4.1A.10.3.7
- FE 3.5.10.3.7
- FE 3.4.10.3.7
- FE 3.3.10.3.7
- FE 3.2.10.3.7
- FE 3.1B.10.3.7
- FE 3.1A.10.3.7
- FE 2.1B.14.3.7
- FE 2.1A.13.3.7
- FE 1.2A.10.3.7
- FE 1.1.10.3.7

*gfe 995: MONITOR PROPELLANT SUPPLIES

FE 4.3.10.4.2
FE 4.2.10.4.2
FE 4.1B.10.4.2
FE 4.1A.10.4.2
FE 3.5.10.4.1
FE 3.4.10.4.1
FE 3.3.10.4.1
FE 3.2.10.4.1
FE 3.1B.10.4.1
FE 3.1A.10.4.1
FE 1.2A.10.4.1
FE 1.1.10.4.1

*gfe 996: MONITOR COOLING SYSTEM SUPPLIES

FE 4.3.10.4.3
FE 4.2.10.4.3
FE 4.1B.10.4.3
FE 4.1A.10.4.3
FE 2.1B.14.4.3
FE 2.1A.13.4.3
FE 1.1.10.4.2

*gfe 997: PROJECT CONSUMABLES REQUIREMENTS FROM MISSION PROFILE

FE 4.3.12.5.4
FE 4.3.12.3.5
FE 4.3.11.3.3
FE 4.3.10.7.4
FE 4.3.10.4.4
FE 4.2.11.3.3
FE 4.2.10.7.4
FE 4.2.10.4.4
FE 4.1B.10.7.4
FE 4.1B.10.4.4
FE 4.1A.10.7.4
FE 4.1A.10.4.4
FE 3.5.14.3.4
FE 3.5.11.3.4
FE 3.5.10.7.4
FE 3.5.10.4.2
FE 3.4.10.7.4
FE 3.4.10.4.2
FE 3.3.13.3.4
FE 3.3.11.3.4
FE 3.3.10.7.4
FE 3.3.10.4.2
FE 3.2.18.3.4
FE 3.2.11.3.4
FE 3.2.10.7.4
FE 3.2.10.4.2
FE 3.1B.14.3.4
FE 3.1B.11.3.4
FE 3.1B.10.7.4
FE 3.1B.10.4.2
FE 3.1A.12.3.4
FE 3.1A.10.7.4
FE 3.1A.10.4.2

FE 2.3B.11.3.4
FE 2.2B.15.3.4
FE 2.1B.14.7.4
FE 2.1B.14.4.6
FE 2.1B.11.3.4
FE 2.1A.13.7.4
FE 2.1A.13.4.6
FE 1.2B.17.3.4
FE 1.2B.10.3.4
FE 1.2A.20.3.4
FE 1.2A.17.3.4
FE 1.2A.11.3.4
FE 1.2A.10.7.4
FE 1.2A.10.4.2
FE 1.1.11.3.4
FE 1.1.10.7.4
FE 1.1.10.4.3

*gfe 998: COMPUTE OPTIMAL CONSUMABLES ALLOCATION

FE 4.3.12.3.6
FE 4.3.10.4.5
FE 4.2.10.4.5
FE 4.1B.10.4.5
FE 4.1A.10.4.5
FE 3.5.10.4.3
FE 3.4.10.4.3
FE 3.3.10.4.3
FE 3.2.10.4.3
FE 3.1B.10.4.3
FE 3.1A.10.4.3
FE 2.1B.14.4.7
FE 2.1A.13.4.7
FE 1.2A.10.4.3
FE 1.1.10.4.4

*gfe 999: MEASURE STRAINS IN STRUCTURE

FE 4.3.10.5.1
FE 4.2.10.5.1
FE 4.1B.10.5.1
FE 4.1A.10.5.1
FE 3.5.10.5.1
FE 3.4.10.5.1
FE 3.3.10.5.1
FE 3.2.10.5.1
FE 3.1B.10.5.1
FE 3.1A.10.5.1
FE 2.1B.14.5.1
FE 2.1A.13.5.1
FE 1.2A.10.5.1
FE 1.1.10.5.1

*gfe 1000: MEASURE RELATIVE DISPLACEMENTS

FE 4.3.10.5.2
FE 4.2.10.5.2
FE 4.1B.10.5.2
FE 4.1A.10.5.2
FE 2.1B.14.5.2
FE 2.1A.13.5.2

ORIGINAL PAGE IS
OF POOR QUALITY

CONFIDENTIAL IS
PROPERTY

*gfe g101: COMPUTE STRESS AND VIBRATION PARAMETERS

FE 1.1.10.5.2
FE 4.3.10.5.3
FE 4.2.10.5.3
FE 4.1B.10.5.3
FE 4.1A.10.5.3
FE 3.5.10.5.2
FE 3.4.10.5.2
FE 3.3.10.5.2
FE 3.2.10.5.2
FE 3.1B.10.5.2
FE 3.1A.10.5.2
FE 2.1B.14.5.3
FE 2.1A.13.5.3
FE 1.2A.10.5.2
FE 1.1.10.5.3

*gfe g102: COMPARE STRESS AND VIBRATION PARAMETERS TO REQUIRED LIMITS

FE 4.3.10.5.4
FE 4.2.10.5.4
FE 4.1B.10.5.4
FE 4.1A.10.5.4
FE 3.5.10.5.3
FE 3.4.10.5.3
FE 3.3.10.5.3
FE 3.2.10.5.3
FE 3.1B.10.5.3
FE 3.1A.10.5.3
FE 1.2A.10.5.3
FE 1.1.10.5.4

*gfe g103: APPLY COMPENSATING FORCES

FE 4.3.10.5.5
FE 4.2.10.5.5
FE 4.1B.10.5.5
FE 4.1A.10.5.5
FE 3.5.10.5.4
FE 3.4.10.5.4
FE 3.3.10.5.4
FE 3.2.10.5.4
FE 3.1B.10.5.4
FE 3.1A.10.5.4
FE 2.1B.14.5.4
FE 2.1A.13.5.4
FE 1.2A.10.5.4
FE 1.1.10.5.5

*gfe g104: APPLY VIBRATION DAMPING

FE 4.3.10.5.6
FE 4.2.10.5.6
FE 4.1B.10.5.6
FE 4.1A.10.5.6
FE 3.5.10.5.5
FE 3.4.10.5.5
FE 3.3.10.5.5
FE 3.2.10.5.5
FE 3.1B.10.5.5
FE 3.1A.10.5.5

FE 2.1B.14.5.5
FE 2.1A.13.5.5
FE 1.2A.10.5.5
FE 1.1.10.5.6

*gfe g105: PROJECT DESIRED FUNCTIONS FROM MISSION PROFILE

FE 4.3.12.5.2
FE 4.3.11.3.2
FE 4.3.10.7.2
FE 4.2.11.3.2
FE 4.2.10.7.2
FE 4.1B.10.7.2
FE 4.1A.10.7.2
FE 3.5.14.3.2
FE 3.5.11.3.2
FE 3.5.10.7.2
FE 3.4.10.7.2
FE 3.3.13.3.2
FE 3.3.11.3.2
FE 3.3.10.7.2
FE 3.2.18.3.2
FE 3.2.11.3.2
FE 3.2.10.7.2
FE 3.1B.14.3.2
FE 3.1B.11.3.2
FE 3.1B.10.7.2
FE 3.1A.12.3.2
FE 3.1A.10.7.2
FE 2.3B.11.3.2
FE 2.2B.15.3.2
FE 2.1B.15.2.2
FE 2.1B.14.7.2
FE 2.1B.11.3.2
FE 2.1A.14.2.2
FE 2.1A.13.7.2
FE 1.2B.17.3.2
FE 1.2B.10.3.2
FE 1.2A.20.3.2
FE 1.2A.17.3.2
FE 1.2A.11.3.2
FE 1.2A.10.7.2
FE 1.1.11.3.2
FE 1.1.10.7.2

*gfe g106: ESTIMATE RISKS FROM DESIRED FUNCTIONS

FE 4.3.12.5.3
FE 4.3.10.7.3
FE 4.2.10.7.3
FE 4.1B.10.7.3
FE 4.1A.10.7.3
FE 3.5.14.3.3
FE 3.5.11.3.3
FE 3.5.10.7.3
FE 3.4.10.7.3
FE 3.3.13.3.3
FE 3.3.11.3.3
FE 3.3.10.7.3

C. P. P. PRICE IS QUALITY

FE 3.2.18.3.3
FE 3.2.11.3.3
FE 3.2.10.7.3
FE 3.1B.14.3.3
FE 3.1B.11.3.3
FE 3.1B.10.7.3
FE 3.1A.12.3.3
FE 3.1A.10.7.3
FE 2.3B.11.3.3
FE 2.2B.15.3.3
FE 2.1B.15.2.3
FE 2.1B.14.7.3
FE 2.1B.11.3.3
FE 2.1A.14.2.3
FE 2.1A.13.7.3
FE 1.2B.17.3.3
FE 1.2B.10.3.3
FE 1.2A.20.3.3
FE 1.2A.17.3.3
FE 1.2A.11.3.3
FE 1.2A.10.7.3
FE 1.1.11.3.3
FE 1.1.10.7.3

*gfe g107 DETERMINE CONSTRAINTS AND FIGURES OF MERIT

FE 1.2A.20.3.5
FE 1.2A.17.3.5
FE 1.2A.11.3.5
FE 1.2A.10.7.5
FE 1.1.11.3.5
FE 1.1.10.7.5
FE 4.3.12.5.6
FE 4.3.10.7.6
FE 4.2.10.7.6
FE 4.1B.10.7.6
FE 4.1A.10.7.6
FE 3.5.10.7.6
FE 3.4.10.7.6
FE 3.3.10.7.6
FE 3.2.10.7.6
FE 3.1B.10.7.6
FE 3.1A.10.7.6
FE 2.1B.14.7.6
FE 2.1A.13.7.6
FE 1.2A.10.7.6
FE 1.1.10.7.6

*gfe g109 DATA/COMMAND DISPLAY

FE 4.3.10.9.4
FE 4.2.10.9.4
FE 4.1B.10.9.4
FE 4.1A.10.9.4
FE 3.5.10.12.4
FE 3.4.10.12.4
FE 3.3.10.12.4
FE 3.2.10.12.4
FE 3.1B.10.12.4
FE 3.1A.10.12.4
FE 2.1B.14.12.4
FE 2.1A.13.12.4
FE 1.2A.10.12.4
FE 1.1.10.12.4

*gfe g110: DETERMINE NEW CONFIGURATION FOR SPACECRAFT COMPONENTS

FE 4.3.11.1.3
FE 4.2.11.1.3
FE 3.5.14.2.3
FE 3.5.11.2.3
FE 3.3.13.2.3
FE 3.3.11.1.4
FE 3.2.18.2.3
FE 3.2.11.2.3
FE 3.1B.14.2.3
FE 3.1B.11.2.3
FE 3.1A.12.2.3
FE 2.3B.11.2.3
FE 2.3B.9.7.4
FE 2.3A.10.3.4
FE 2.2B.15.2.3
FE 2.2B.9.8.4
FE 2.2A.14.7.4

ORIGINAL FILED
OF POOR QUALITY

FE 2.2A.9.4.4
FE 2.1B.15.1.4
FE 2.1B.11.2.3
FE 2.1B.9.8.4
FE 2.1A.14.1.4
FE 2.1A.9.7.4
FE 1.2B.17.2.3
FE 1.2B.10.2.3
FE 1.2A.20.2.3
FE 1.2A.17.2.3
FE 1.2A.11.2.3
FE 1.1.11.1.4
*gfe g111: ROTATE SPACECRAFT
FE 4.3.11.1.5
FE 4.2.11.1.5
FE 3.5.14.2.5
FE 3.5.13.1.7
FE 3.5.12.2.8
FE 3.5.12.1.7
FE 3.5.11.2.5
FE 3.5.9.10.7
FE 3.4.9.10.7
FE 3.3.13.2.5
FE 3.3.12.1.7
FE 3.3.11.1.6
FE 3.3.9.10.7
FE 3.2.18.2.5
FE 3.2.17.1.7
FE 3.2.16.1.7
FE 3.2.11.2.5
FE 3.2.9.10.7
FE 3.1B.14.2.5
FE 3.1B.13.1.7
FE 3.1B.11.2.5
FE 3.1B.9.10.7
FE 3.1A.12.2.5
FE 3.1A.11.1.7
FE 3.1A.9.10.7
FE 2.3B.11.2.5
FE 2.3B.10.1.7
FE 2.3B.9.7.6
FE 2.3B.9.6.7
FE 2.3A.10.3.6
FE 2.2B.15.2.5
FE 2.2B.14.1.7
FE 2.2B.13.1.7
FE 2.2B.9.8.6
FE 2.2B.9.6.7
FE 2.2A.14.7.6
FE 2.2A.9.4.6
FE 2.1B.15.1.6
FE 2.1B.11.2.5
FE 2.1B.10.1.7
FE 2.1B.9.8.6
FE 2.1B.9.4.7

FE 2.1A.14.1.6
FE 2.1A.9.7.6
FE 1.2B.17.2.5
FE 1.2B.16.1.7
FE 1.2B.15.1.7
FE 1.2B.10.2.5
FE 1.2B.9.4.7
FE 1.2A.20.2.5
FE 1.2A.19.1.7
FE 1.2A.17.2.5
FE 1.2A.16.1.7
FE 1.2A.11.2.5
FE 1.2A.9.10.7
FE 1.1.11.1.6
*gfe g112: CHOOSE OPTIMAL CONTROL MODE
FE 4.3.11.3.5
FE 4.2.11.3.5
FE 3.5.14.3.6
FE 3.5.11.3.6
FE 3.3.13.3.6
FE 3.3.11.3.6
FE 3.2.18.3.6
FE 3.2.11.3.6
FE 3.1B.14.3.6
FE 3.1B.11.3.6
FE 3.1A.12.3.6
FE 2.3B.11.3.6
FE 2.2B.15.3.6
FE 2.1B.11.3.6
FE 1.2B.17.3.6
FE 1.2B.10.3.6
FE 1.2A.20.3.6
FE 1.2A.17.3.6
FE 1.2A.11.3.6
FE 1.1.11.3.6
*gfe g113: COMPUTE CONTROL COMMANDS
FE 4.3.11.3.6
FE 4.2.11.3.6
FE 3.5.14.3.7
FE 3.5.11.3.7
FE 3.3.13.3.7
FE 3.3.11.3.7
FE 3.2.18.3.7
FE 3.2.11.3.7
FE 3.1B.14.3.7
FE 3.1B.11.3.7
FE 3.1A.12.3.7
FE 2.3B.11.3.7
FE 2.2B.15.3.7
FE 2.1B.15.2.5
FE 2.1B.11.3.7
FE 2.1A.14.2.5
FE 1.2B.17.3.7
FE 1.2B.10.3.7
FE 1.2A.20.3.7

ORIGINAL PAGE IS
OF POOR QUALITY

FE 1.2A.17.3.7
FE 1.2A.11.3.7
FE 1.1.11.3.7
*gfe g114: EXECUTE CONTROL COMMANDS
FE 4.3.11.3.7
FE 4.2.11.3.7
FE 3.5.14.3.8
FE 3.5.11.3.8
FE 3.3.13.3.8
FE 3.3.11.3.8
FE 3.2.18.3.8
FE 3.2.11.3.8
FE 3.1B.14.3.8
FE 3.1B.11.3.8
FE 3.1A.12.3.8
FE 2.3B.11.3.8
FE 2.2B.15.3.8
FE 2.1B.15.2.6
FE 2.1B.11.3.8
FE 2.1A.14.2.6
FE 1.2B.17.3.8
FE 1.2B.10.3.8
FE 1.2A.20.3.8
FE 1.2A.17.3.8
FE 1.2A.11.3.8
FE 1.1.11.3.8
*gfe g115: RECEIVE INPUT FROM ANTENNA POINTING SENSORS
FE 1.1.12.1.1
*gfe g116: TRANSMIT INFORMATION TO ANTENNA POINTING CONTROLLER
FE 1.1.12.1.2
*gfe g117: DETERMINE ERROR FROM DESIRED ANTENNA POSITION
FE 1.1.12.1.3
*gfe g118: ANTENNA POSITIONER CORRECTS POINTING DIRECTION
FE 1.1.12.1.4
*gfe g119: RECEIVE COMMUNICATIONS INPUT
FE 1.1.12.2.1
*gfe g120: ENTER COMMUNICATIONS INPUT INTO SWITCH CONTROL
FE 1.1.12.2.2
*gfe g121: SWITCH CONTROL ENTERS COMMUNICATIONS INPUT INTO SWITCH MATRIX
FE 1.1.12.2.3
*gfe g122: SWITCH MATRIX EXECUTES COMMUNICATIONS OUTPUT
FE 1.1.12.2.4
*gfe g123: CHECK TMS/PAYLOAD MECHANICAL INTERFACES
FE 3.5.7B.6.1
FE 3.5.7A.6.1
FE 3.4.7B.6.1
FE 3.4.7A.6.1
FE 3.3.7B.6.1
FE 3.3.7A.6.1
FE 3.2.7B.6.1
FE 3.2.7A.6.1
FE 3.1B.7B.6.1
FE 3.1B.7A.6.1
FE 3.1A.7B.6.1
FE 3.1A.7A.6.1

FE 2.3B.7.6.1
FE 2.2B.7.6.1
FE 2.1B.7.6.1
FE 1.2A.7B.6.1
FE 1.2A.7A.6.1
*gfe g124: ATTACH STRONGBACK TO PAYLOAD
FE 4.3.19.2.4
FE 4.3.7.6.1
FE 4.3.7.5.1
FE 4.2.18.2.3
FE 4.2.7.6.1
FE 4.2.7.5.1
FE 4.1B.17.2.3
FE 4.1B.7.6.1
FE 4.1B.7.5.1
FE 4.1A.16.2.3
FE 4.1A.7.6.1
FE 4.1A.7.5.1
FE 3.5.7A.8.1
FE 3.5.7A.7.1
FE 3.5.7A.4.3
FE 3.4.7A.8.1
FE 3.4.7A.7.1
FE 3.4.7A.4.3
FE 3.3.7A.8.1
FE 3.3.7A.7.1
FE 3.3.7A.4.3
FE 3.2.7A.8.1
FE 3.2.7A.7.1
FE 3.2.7A.4.3
FE 3.1B.7A.8.1
FE 3.1B.7A.7.1
FE 3.1B.7A.4.3
FE 3.1A.7A.8.1
FE 3.1A.7A.7.1
FE 3.1A.7A.4.3
FE 2.3B.13.2.2
FE 2.3B.7.8.1
FE 2.3B.7.7.1
FE 2.3B.7.4.3
FE 2.3A.13.2.2
FE 2.3A.7.7.1
FE 2.3A.7.6.1
FE 2.3A.7.4.3
FE 2.2B.17.2.2
FE 2.2B.7.8.1
FE 2.2B.7.7.1
FE 2.2B.7.4.3
FE 2.2A.16.2.2
FE 2.2A.7.7.1
FE 2.2A.7.6.1
FE 2.2A.7.4.3
FE 2.1B.13.2.2
FE 2.1B.7.8.1
FE 2.1B.7.7.1

FE 2.1B.7.4.2
FE 2.1A.12.2.2
FE 2.1A.7.7.1
FE 2.1A.7.6.1
FE 2.1A.7.4.3
FE 1.2A.7A.8.1
FE 1.2A.7A.7.1
*gfe 9125 REMOVE STRONGRACK
FE 4.3.7.5.3
FE 4.2.7.5.3
FE 4.1B.7.5.3
FE 4.1A.7.5.3
FE 3.5.7A.8.5
FE 3.5.7A.7.3
FE 3.4.7A.8.5
FE 3.4.7A.7.3
FE 3.3.7A.8.5
FE 3.3.7A.7.3
FE 3.2.7A.8.5
FE 3.2.7A.7.3
FE 3.1B.7A.8.5
FE 3.1B.7A.7.3
FE 3.1A.7A.8.5
FE 3.1A.7A.7.3
FE 2.3B.7.7.3
FE 2.3A.7.6.3
FE 2.2B.7.7.3
FE 2.2A.7.6.3
FE 2.1B.7.7.3
FE 2.1A.7.6.3
FE 1.2A.7A.8.5
FE 1.2A.7A.7.3

*gfe 9126 CLOSE CANISTER
FE 4.3.7.5.4
FE 4.2.7.5.4
FE 4.1B.7.5.4
FE 4.1A.7.5.4
FE 3.5.7A.7.4
FE 3.4.7A.7.4
FE 3.3.7A.7.4
FE 3.2.7A.7.4
FE 3.1B.7A.7.4
FE 3.1A.7A.7.4
FE 2.3B.7.7.4
FE 2.3A.7.6.4
FE 2.2B.7.7.4
FE 2.2A.7.6.4
FE 2.1B.7.7.4
FE 2.1A.7.6.4
FE 1.2A.7A.7.4

*gfe 9127: TRANSPORT CANISTER TO ORBITER PROCESSING FACILITY
FE 4.3.7.5.5
FE 4.2.7.5.5
FE 4.1B.7.5.5
FE 4.1A.7.5.5

FE 3.5.7A.7.5
FE 3.4.7A.7.5
FE 3.3.7A.7.5
FE 3.2.7A.7.5
FE 3.1B.7A.7.5
FE 3.1A.7A.7.5
FE 2.3B.7.7.5
FE 2.3A.7.6.5
FE 2.2B.7.7.5
FE 2.2A.7.6.5
FE 2.1B.7.7.5
FE 2.1A.7.6.5
FE 1.2A.7A.7.5
*gfe 9128 UNLOAD CANISTER
FE 3.5.7A.7.6
FE 3.4.7A.7.6
FE 3.3.7A.7.6
FE 3.2.7A.7.6
FE 3.1B.7A.7.6
FE 3.1A.7A.7.6
FE 1.2A.7A.7.6

*gfe 9129 INSTALL PAYLOAD IN ORBITER
FE 4.3.7.6.2
FE 4.2.7.6.2
FE 4.1B.7.6.2
FE 4.1A.7.6.2
FE 3.5.7A.8.2
FE 3.4.7A.8.2
FE 3.3.7A.8.2
FE 3.2.7A.8.2
FE 3.1B.7A.8.2
FE 3.1A.7A.8.2
FE 2.3B.7.8.2
FE 2.3A.7.7.2
FE 2.2B.7.8.2
FE 2.2A.7.7.2
FE 2.1B.7.8.2
FE 2.1A.7.7.2
FE 1.2A.7A.8.2

*gfe 9130: INSTALLATION OF ORBITER PAYLOAD STATION CONSOLES
FE 4.3.7.6.6
FE 4.2.7.6.6
FE 4.1B.7.6.6
FE 4.1A.7.6.6
FE 3.5.7B.8.6
FE 3.5.7A.8.7
FE 3.4.7B.8.6
FE 3.4.7A.8.7
FE 3.3.7B.8.6
FE 3.3.7A.8.7
FE 3.2.7B.8.6
FE 3.2.7A.8.7
FE 3.1B.7B.8.6
FE 3.1B.7A.8.7
FE 3.1A.7B.8.6

FE 3.2.18.4.2
FE 3.2.9.3.3
FE 3.18.14.4.2
FE 3.18.9.3.3
FE 3.1A.12.4.2
FE 3.1A.9.3.3
FE 2.3B.11.4.2
FE 2.3B.9.3.3
FE 2.3A.11.2.1
FE 2.3A.11.1.9
FE 2.3A.11.1.4
FE 2.3A.10.4.2
FE 2.2B.15.4.2
FE 2.2B.13.3.8
FE 2.2B.13.3.3
FE 2.2B.9.3.3
FE 2.2A.14.8.2
FE 2.2A.14.5.1
FE 2.2A.14.3.8
FE 2.2A.14.3.3
FE 2.2A.14.2.2
FE 2.2A.13.2.1
FE 2.2A.13.1.9
FE 2.2A.13.1.4
FE 2.2A.9.5.2
FE 2.1B.11.4.2
FE 2.1B.9.10.9
FE 2.1B.9.10.4
FE 2.1B.9.5.8
FE 2.1B.9.5.3
FE 2.1B.9.2.2
FE 2.1A.10.2.1
FE 2.1A.10.1.9
FE 2.1A.10.1.4
FE 2.1A.9.8.2
FE 2.1A.9.5.1
FE 2.1A.9.3.8
FE 2.1A.9.3.3
FE 2.1A.9.2.2
FE 1.2B.17.4.2
FE 1.2B.9.2.3
FE 1.2A.20.4.2
FE 1.2A.9.3.3
*gfe 9133: MOVE RMS TO FIXTURE
FE 3.5.14.4.3
FE 3.5.9.3.4
FE 3.4.9.3.4
FE 3.3.13.4.3
FE 3.3.9.3.4
FE 3.2.18.4.3
FE 3.2.9.3.4
FE 3.1B.14.4.3
FE 3.1B.9.3.4
FE 3.1A.12.4.3
FE 3.1A.9.3.4

FE 3.1A.7A.8.7
FE 2.3B.7.8.6
FE 2.2B.7.8.6
FE 2.1B.7.8.6
FE 1.2A.7B.8.6
FE 1.2A.7A.8.7
*gfe 9131: ACTIVATE RMS
FE 4.3.17.1.14
FE 4.3.16.3.2
FE 4.3.9.1.15
FE 4.2.16.1.14
FE 4.2.15.3.2
FE 4.2.9.1.14
FE 4.1B.15.1.14
FE 4.1B.14.3.2
FE 4.1B.9.1.14
FE 4.1A.14.1.14
FE 4.1A.9.1.14
FE 3.5.14.4.1
FE 3.5.9.3.2
FE 3.4.9.3.2
FE 3.3.13.4.1
FE 3.3.9.3.2
FE 3.2.18.4.1
FE 3.2.9.3.2
FE 3.1B.14.4.1
FE 3.1B.9.3.2
FE 3.1A.12.4.1
FE 3.1A.9.3.2
FE 2.3B.11.4.1
FE 2.3B.9.3.2
FE 2.2B.15.4.1
FE 2.2B.9.3.2
FE 2.1B.11.4.1
FE 1.2B.17.4.1
FE 1.2B.9.2.2
FE 1.2A.20.4.1
FE 1.2A.9.3.2
*gfe 9132: LOCATE GRASPING FIXTURE ON TARGET
FE 4.3.17.2.3
FE 4.3.16.3.3
FE 4.3.9.2.2
FE 4.2.16.2.3
FE 4.2.15.3.3
FE 4.2.9.2.2
FE 4.1B.15.2.3
FE 4.1B.14.3.3
FE 4.1B.9.2.2
FE 4.1A.14.2.3
FE 4.1A.9.2.2
FE 3.5.14.4.2
FE 3.5.9.3.3
FE 3.4.9.3.3
FE 3.3.13.4.2
FE 3.3.9.3.3

FE 2.3B.11.4.3
 FE 2.3B.9.3.4
 FE 2.2B.15.4.3
 FE 2.2B.9.3.4
 FE 2.1B.11.4.3
 FE 1.2B.17.4.3
 FE 1.2B.9.2.4
 FE 1.2A.20.4.3
 FE 1.2A.9.3.4
 *gfe 9134: GRASP FIXTURE
 FE 4.3.17.2.4
 FE 4.3.16.3.4
 FE 4.3.9.3.2
 FE 4.3.9.2.3
 FE 4.2.16.2.4
 FE 4.2.15.3.4
 FE 4.2.9.3.2
 FE 4.2.9.2.3
 FE 4.1B.15.2.4
 FE 4.1B.14.3.4
 FE 4.1B.9.3.2
 FE 4.1B.9.2.3
 FE 4.1A.14.2.4
 FE 4.1A.9.3.2
 FE 3.5.14.4.4
 FE 3.5.11.4.4
 FE 3.5.9.3.5
 FE 3.4.9.3.5
 FE 3.3.13.4.4
 FE 3.3.9.3.5
 FE 3.2.18.4.4
 FE 3.2.9.3.5
 FE 3.1B.14.4.4
 FE 3.1A.12.4.4
 FE 3.1A.9.3.5
 FE 2.3B.11.4.4
 FE 2.3B.9.3.5
 FE 2.3A.11.2.2
 FE 2.3A.11.1.10
 FE 2.3A.11.1.5
 FE 2.3A.10.4.3
 FE 2.2B.15.4.4
 FE 2.2B.13.3.9
 FE 2.2B.13.3.4
 FE 2.2B.9.3.5
 FE 2.2A.14.8.3
 FE 2.2A.14.5.2
 FE 2.2A.14.3.9
 FE 2.2A.14.3.4
 FE 2.2A.14.2.3
 FE 2.2A.13.2.2
 FE 2.2A.13.1.10
 FE 2.2A.13.1.5

FE 2.2A.9.5.3
 FE 2.1B.11.4.4
 FE 2.1B.9.10.10
 FE 2.1B.9.10.5
 FE 2.1B.9.5.9
 FE 2.1B.9.5.4
 FE 2.1B.9.2.3
 FE 2.1A.10.2.2
 FE 2.1A.10.1.10
 FE 2.1A.10.1.5
 FE 2.1A.9.8.3
 FE 2.1A.9.5.2
 FE 2.1A.9.3.9
 FE 2.1A.9.3.4
 FE 2.1A.9.2.3
 FE 1.2B.17.4.4
 FE 1.2B.9.2.5
 FE 1.2A.20.4.4
 FE 1.2A.9.3.5
 *gfe 9135: RELEASE PAYLOAD RESTRAINTS
 FE 4.3.17.2.5
 FE 4.3.16.3.5
 FE 4.3.9.3.3
 FE 4.3.9.2.4
 FE 4.2.16.2.5
 FE 4.2.15.3.5
 FE 4.2.9.3.3
 FE 4.2.9.2.4
 FE 4.1B.15.2.5
 FE 4.1B.14.3.5
 FE 4.1B.9.3.3
 FE 4.1B.9.2.4
 FE 4.1A.14.2.5
 FE 4.1A.9.3.3
 FE 4.1A.9.2.4
 FE 3.5.9.3.6
 FE 3.4.9.3.6
 FE 3.3.9.3.6
 FE 3.2.9.3.6
 FE 3.1B.9.3.6
 FE 3.1A.9.3.6
 FE 2.3B.9.3.6
 FE 2.2B.9.3.6
 FE 2.2A.14.5.3
 FE 2.2A.14.2.4
 FE 2.1B.9.2.4
 FE 2.1A.9.5.3
 FE 2.1A.9.2.4
 FE 1.2B.9.2.6
 FE 1.2A.9.3.6
 *gfe 9136: TRANSLATE PAYLOAD OUT OF PAYLOAD BAY
 FE 3.5.9.3.7
 FE 3.4.9.3.7
 FE 3.3.9.3.7
 FE 3.2.9.3.7

ORIGINAL POINTS
OF POINT OF ENTRY

FE 1.2A.9.4.2
*gfe 9139: STRUCTURAL SUBSYSTEM CHECKOUT

FE 3.5.9.5.5
FE 3.4.9.5.5
FE 3.3.9.5.5
FE 3.2.9.5.5
FE 3.1B. .5.5
FE 3.1A.9.5.5
FE 2.3B.9.5.5
FE 2.2B.9.5.5
FE 2.1B.9.3.5
FE 1.2A.9.5.5

*gfe 9140: RELEASE DOCKING LATCH

FE 3.2.16.2.1
FE 3.1A.9.11.1
FE 2.2B.13.2.1
FE 2.1B.9.6.1
FE 1.2B.15.2.1
FE 1.2A.16.2.1
FE 1.2A.9.11.1
FE 3.2.16.2.2

*gfe 9141: RETRACT DOCKING MECHANISM

FE 3.1A.9.11.2
FE 2.2B.13.2.2
FE 2.1B.9.6.2
FE 1.2B.15.2.2
FE 1.2A.16.2.2
FE 1.2A.9.11.2

*gfe 9142: MOVE AWAY FROM PAYLOAD

FE 3.2.16.2.3
FE 3.1A.9.11.3
FE 2.2B.13.2.3
FE 2.1B.9.6.3
FE 1.2B.15.2.3
FE 1.2A.16.2.3
FE 1.2A.9.11.3

*gfe 9143: MONITOR BATTERIES

FE 3.5.10.2.4
FE 3.4.10.2.4
FE 3.3.10.2.4
FE 3.2.10.2.4
FE 3.1B.10.2.4
FE 3.1A.10.2.4
FE 2.1B.14.4.1
FE 2.1A.13.4.1
FE 1.2A.10.2.4

*gfe 9144: LOCATE DOCKING TARGET

FE 3.2.11.4.1
FE 3.1B.11.4.1
FE 2.3B.9.8.1
FE 2.2B.9.9.1
FE 2.1B.9.9.1
FE 1.2B.10.4.1
FE 1.2A.17.4.1
FE 1.2A.11.4.1

FE 3.1B.9.3.7
FE 3.1A.9.3.7
FE 2.3B.9.3.7
FE 2.2B.9.3.7
FE 2.2A.14.5.4
FE 2.1B.9.2.5
FE 2.1A.9.5.4
FE 1.2B.9.2.7
FE 1.2A.9.3.7
*gfe 9137: RMS RELEASES PAYLOAD

FE 3.5.14.4.8
FE 3.5.9.4.1
FE 3.4.9.4.1
FE 3.3.13.4.8
FE 3.3.9.4.1
FE 3.2.18.4.8
FE 3.2.9.4.1
FE 3.1B.14.4.8
FE 3.1B.9.4.1
FE 3.1A.12.4.8
FE 3.1A.9.4.1
FE 2.3B.11.4.8
FE 2.3B.9.4.1
FE 2.2B.15.4.8
FE 2.2B.9.4.1
FE 2.1B.11.4.8
FE 2.1A.9.5.5
FE 1.2B.17.4.9
FE 1.2B.9.3.1
FE 1.2A.20.4.9
FE 1.2A.9.4.1

*gfe 9138: SECURE RMS IN PAYLOAD BAY

FE 4.3.16.6.1
FE 4.2.15.6.1
FE 4.1B.14.6.1
FE 3.5.14.4.9
FE 3.5.9.4.2
FE 3.4.9.4.2
FE 3.3.13.4.9
FE 3.3.9.4.2
FE 3.2.18.4.9
FE 3.2.9.4.2
FE 3.1B.14.4.9
FE 3.1B.9.4.2
FE 3.1A.12.4.9
FE 3.1A.9.4.2
FE 2.3B.11.4.9
FE 2.3B.9.4.2
FE 2.2B.15.4.9
FE 2.2B.9.4.2
FE 2.1B.11.4.9
FE 1.2B.17.4.10
FE 1.2B.9.3.2
FE 1.2A.20.4.10

ORIGIN
OF PROGRAM

*gfe 9143: EXTEND DOCKING MECHANISM

FE 3.2.11.4.2
FE 3.1B.11.4.2
FE 2.3B.9.8.2
FE 2.2B.9.9.2
FE 2.1B.9.9.2
FE 1.2B.10.4.2
FE 1.2A.17.4.2
FE 1.2A.11.4.2
FE 3.2.11.4.3
FE 3.1B.11.4.3
FE 2.3B.9.8.3
FE 2.2B.9.9.3
FE 2.1B.9.9.3
FE 1.2B.10.4.3
FE 1.2A.17.4.3
FE 1.2A.11.4.3

*gfe 9146: FASTEN DOCKING LATCH

FE 3.2.11.4.3
FE 3.1B.11.4.3
FE 2.3B.9.8.3
FE 2.2B.9.9.3
FE 2.1B.9.9.3
FE 1.2B.10.4.3
FE 1.2A.17.4.3
FE 1.2A.11.4.3

*gfe 9147: CLOSE INTERNAL VALVES

FE 3.2.14.1B.4
FE 3.2.14.1A.3
FE 2.2B.11.1B.4
FE 2.2B.11.1A.3
FE 2.2B.10.1.4
FE 2.2A.11.1B.4
FE 2.2A.11.1A.3
FE 2.2A.10.1.4
FE 1.2B.13.1.3
FE 1.2A.14.1B.4
FE 1.2A.14.1A.3

*gfe 9148: EXTEND AND ATTACH UMBILICAL

FE 3.2.14.1A.4
FE 2.2B.11.1A.4
FE 2.2A.11.1A.4
FE 1.2B.13.1.4
FE 1.2A.14.1A.4

*gfe 9149: OPEN SUPPLY VALVE

FE 3.2.14.1A.5
FE 2.2B.11.1A.5
FE 2.2A.11.1A.5
FE 1.2B.13.1.5
FE 1.2A.14.1A.5

*gfe 9150: MONITOR FLUID TRANSFER

FE 3.2.14.1A.6
FE 2.2B.11.1A.6
FE 2.2A.11.1A.6
FE 1.2B.13.1.6
FE 1.2A.14.1A.6

*gfe 9151: CLOSE SUPPLY VALVE

FE 3.2.14.1A.7
FE 2.2B.11.1A.7
FE 2.2A.11.1A.7
FE 1.2B.13.1.7
FE 1.2A.14.1A.7

*gfe 9152: DETACH AND RETRACT UMBILICAL

FE 3.2.14.1A.8
FE 2.2B.11.1A.8
FE 2.2A.11.1A.8
FE 1.2B.13.1.8
FE 1.2A.14.1A.8

*gfe 9153: OPEN INTERNAL VALVES

FE 3.2.14.1B.12
FE 3.2.14.1A.9
FE 2.2B.11.1B.12
FE 2.2B.11.1A.9
FE 2.2B.10.2.4
FE 2.2A.11.1B.12
FE 2.2A.11.1A.9
FE 2.2A.10.2.4
FE 1.2B.13.1.9
FE 1.2A.14.1B.12
FE 1.2A.14.1A.9

*gfe 9154: CHECK FOR LEAKS

FE 3.2.14.1B.13
FE 3.2.14.1A.10
FE 2.2B.11.1B.13
FE 2.2B.11.1A.10
FE 2.2A.11.1B.13
FE 2.2A.11.1A.10
FE 1.2B.13.1.10
FE 1.2A.14.1B.13
FE 1.2A.14.1A.10

*gfe 9155: LOCATE OLD TANK

FE 3.2.14.1B.5
FE 2.2B.11.1B.5
FE 2.2A.11.1B.5
FE 1.2A.14.1B.5

*gfe 9156: DISCONNECT OLD TANK

FE 3.2.14.1B.6
FE 2.2B.11.1B.6
FE 2.2A.11.1B.6
FE 1.2A.14.1B.6

*gfe 9157: REMOVE OLD TANK

FE 3.2.14.1B.7
FE 2.2B.11.1B.7
FE 2.2A.11.1B.7
FE 1.2A.14.1B.7

*gfe 9158: STORE OLD TANK

FE 3.2.14.1B.8
FE 2.2B.11.1B.8
FE 2.2A.11.1B.8
FE 1.2A.14.1B.8

*gfe 9159: LOCATE NEW TANK

FE 3.2.14.1B.9
FE 2.2B.11.1B.9
FE 2.2A.11.1B.9
FE 1.2A.14.1B.9

*gfe 9160: INSTALL NEW TANK

FE 3.2.14.1B.10
FE 2.2B.11.1B.10

FE 2.2A.11.1B.10
FE 1.2A.14.1B.10
*gfe g161: CONNECT NEW TANK
FE 3.2.14.1B.11
FE 2.2B.11.1B.11
FE 2.2A.11.1B.11
FE 1.2A.14.1B.11
*gfe g162: COAST TO SUPERSYNCHRONOUS ORBIT
FE 1.2A.18.1.8
*gfe g163: TRANSFER DEBRIS TO DISPOSAL POSITION
FE 1.2A.18.2.1
*gfe g164: JETTISON DEBRIS
FE 1.2A.18.2.2
*gfe g165: STOW TMS ANTENNA
FE 3.5.13.2.1
FE 3.3.12.2.1
FE 3.2.17.2.1
FE 3.1B.13.2.1
FE 3.1A.11.2.1
FE 2.3B.10.2.1
FE 2.2B.14.2.1
FE 2.1B.10.2.1
FE 1.2B.16.2.1
FE 1.2A.19.2.1
*gfe g166: DEACTIVATE TMS SUBSYSTEMS
FE 3.5.13.2.2
FE 3.3.12.2.2
FE 3.2.17.2.2
FE 3.1B.13.2.2
FE 3.1A.11.2.2
FE 2.3B.10.2.2
FE 2.2B.14.2.2
FE 2.1B.10.2.2
FE 1.2B.16.2.2
FE 1.2A.19.2.2
*gfe g167: LOCATE CRADLE IN PAYLOAD BAY
FE 3.5.14.4.5
FE 3.3.13.4.5
FE 3.2.18.4.5
FE 3.1B.14.4.5
FE 3.1A.12.4.5
FE 2.3B.11.4.5
FE 2.2B.15.4.5
FE 2.1B.11.4.5
FE 1.2B.17.4.5
FE 1.2A.20.4.5
*gfe g168: TRANSLATE PAYLOAD TO CRADLE
FE 4.3.17.2.6
FE 4.3.16.3.6
FE 4.2.16.2.6
FE 4.2.15.3.6
FE 4.1B.15.2.6
FE 4.1B.14.3.6
FE 4.1A.14.2.6
FE 3.5.14.4.6
FE 3.3.13.4.6
FE 3.2.18.4.6
FE 3.1A.12.4.6
FE 2.3B.11.4.6
FE 2.3A.10.4.4
FE 2.2B.15.4.6
FE 2.2A.14.8.4
FE 2.2A.9.5.4
FE 2.1B.11.4.6
FE 2.1A.9.8.4
FE 1.2B.17.4.6
FE 1.2A.20.4.7
*gfe g169: LOCATE PAYLOAD RESTRAINTS
FE 1.2B.17.4.7
FE 1.2A.20.4.7
*gfe g170: FASTEN PAYLOAD RESTRAINTS
FE 4.3.17.2.7
FE 4.3.16.3.7
FE 4.2.16.2.7
FE 4.2.15.3.7
FE 4.1B.15.2.7
FE 4.1B.14.3.7
FE 4.1A.14.2.7
FE 3.5.14.4.7
FE 3.3.13.4.7
FE 3.2.18.4.7
FE 3.1B.14.4.7
FE 3.1A.12.4.7
FE 2.3B.11.4.7
FE 2.3A.11.2.4
FE 2.3A.10.4.5
FE 2.2B.15.4.7
FE 2.2A.14.8.5
FE 2.2A.13.2.4
FE 2.2A.9.5.5
FE 2.1B.11.4.7
FE 2.1A.10.2.4
FE 2.1A.9.8.5
FE 1.2B.17.4.8
FE 1.2A.20.4.8
*gfe g171: VERIFY DETECTOR SYSTEM FUNCTION
FE 2.2B.7.3.5
FE 2.2A.7.3.5
FE 2.1B.7.3.5
FE 2.1A.7.3.5
*gfe g172: TRANSPORT TO OPERATIONS AND CHECKOUT BLDG.
FE 3.5.7A.4.2
FE 3.4.7A.4.2
FE 3.3.7A.4.2
FE 3.2.7A.4.2
FE 3.1B.7A.4.2
FE 3.1A.7A.4.2
FE 2.3B.7.4.2
FE 2.3A.7.4.2

FE 2.2B.7.4.2
 FE 2.2A.7.4.2
 FE 2.1B.7.4.2
 FE 2.1A.7.4.2
 *gfe g173: INSTALL PAYLOAD IN HORIZONTAL CITE
 FE 3.5.7A.4.4
 FE 3.4.7A.4.4
 FE 3.3.7A.4.4
 FE 3.2.7A.4.4
 FE 3.1B.7A.4.4
 FE 3.1A.7A.4.4
 FE 2.3B.7.4.4
 FE 2.3A.7.4.4
 FE 2.2B.7.4.4
 FE 2.2A.7.4.4
 FE 2.1B.7.4.4
 FE 2.1A.7.4.4
 *gfe g174: INSTALLATION OF OMS KIT
 FE 4.3.7.6.7
 FE 4.2.7.6.7
 FE 4.1B.7.6.7
 FE 4.1A.7.6.7
 FE 2.3A.7.7.5
 FE 2.2A.7.7.5
 FE 2.1A.7.7.5
 *gfe g175: TILT PAYLOAD TO VERTICAL POSITION
 FE 2.2A.14.2.5
 FE 2.1A.9.2.5
 *gfe g176: LOCATE SOLAR ARRAY RESTRAINTS
 FE 2.3A.11.1.7
 FE 2.2B.13.3.1
 FE 2.2A.14.3.1
 FE 2.2A.13.1.7
 FE 2.1B.9.10.7
 FE 2.1B.9.5.1
 FE 2.1A.10.1.7
 FE 2.1A.9.3.1
 *gfe g177: RELEASE SOLAR ARRAY RESTRAINTS
 FE 2.3A.11.1.8
 FE 2.2B.13.3.2
 FE 2.2A.14.3.2
 FE 2.2A.13.1.8
 FE 2.1B.9.10.8
 FE 2.1B.9.5.2
 FE 2.1A.10.1.8
 FE 2.1A.9.3.2
 *gfe g178: LOCATE SUNSHADE RESTRAINTS
 FE 2.3A.11.1.2
 FE 2.2B.13.3.6
 FE 2.2A.14.3.6
 FE 2.2A.13.1.2
 FE 2.1B.9.10.2
 FE 2.1B.9.5.6
 FE 2.1A.10.1.2
 FE 2.1A.9.3.6

*gfe g179: RELEASE SUNSHADE RESTRAINTS
 FE 2.3A.11.1.3
 FE 2.2B.13.3.7
 FE 2.2A.14.3.7
 FE 2.2A.13.1.3
 FE 2.1B.9.10.3
 FE 2.1A.10.1.3
 FE 2.1A.9.3.7
 *gfe g180: OPEN SUNSHADE
 FE 2.2B.13.3.10
 FE 2.2A.14.3.10
 FE 2.1B.9.5.10
 FE 2.1A.9.3.10
 *gfe g181: DEPLOY TDRSS ANTENNAS
 FE 2.2B.13.3.11
 FE 2.2A.14.3.11
 FE 2.1B.9.5.11
 FE 2.1A.9.3.11
 *gfe g182: COMMAND DETECTOR SELECTION
 FE 2.2A.14.4.1
 FE 2.2A.9.6.1
 FE 2.1A.9.4.1
 *gfe g183: OBSERVE DETECTOR SELECTION
 FE 2.2A.14.4.2
 FE 2.2A.9.6.2
 FE 2.1A.9.4.2
 *gfe g184: MONITOR TELEMETRY
 FE 2.2B.13.4.4
 FE 2.2B.9.7.3
 FE 2.2A.14.6.4
 FE 2.2A.14.4.3
 FE 2.2A.9.6.3
 FE 2.2A.9.3.3
 FE 2.1B.9.7.4
 FE 2.1A.9.6.4
 FE 2.1A.9.4.3
 *gfe g185: EVALUATE SYSTEM PERFORMANCE
 FE 2.2B.13.4.5
 FE 2.2B.9.7.4
 FE 2.2A.14.6.5
 FE 2.2A.14.4.4
 FE 2.2A.9.6.4
 FE 2.2A.9.3.4
 FE 2.1B.9.7.5
 FE 2.1A.9.6.5
 FE 2.1A.9.4.4
 *gfe g186: ACTIVATE AXAF SUBSYSTEMS
 FE 2.2B.13.4.1
 FE 2.2A.14.6.1
 FE 2.1B.9.7.1
 FE 2.1A.9.6.1
 *gfe g187: COMMAND ATTITUDE CHANGE
 FE 2.2B.13.4.2
 FE 2.2B.9.7.1

FE 2.2A.14.6.2
FE 2.2A.9.3.1
FE 2.1B.9.7.2
FE 2.1A.9.6.2
*gfe g188: OBSERVE ATTITUDE CHANGE
FE 2.2B.13.4.3
FE 2.2B.9.7.2
FE 2.2A.14.6.3
FE 2.2A.9.3.2
FE 2.1B.9.7.3
FE 2.1A.9.6.3
*gfe g189: DETERMINE DISTURBING TORQUES
FE 2.3B.9.7.7
FE 2.3A.10.3.7
FE 2.2B.9.8.7
FE 2.2A.14.7.7
FE 2.2A.9.4.7
FE 2.1B.15.1.7
FE 2.1B.9.8.7
FE 2.1A.14.1.7
FE 2.1A.9.7.7
*gfe g190: COMPUTE REQUIRED RESULTANT
FE 2.3B.9.7.8
FE 2.3A.10.3.8
FE 2.2B.9.8.8
FE 2.2A.14.7.8
FE 2.2A.9.4.8
FE 2.1B.15.1.8
FE 2.1B.9.8.8
FE 2.1A.14.1.8
FE 2.1A.9.7.8
*gfe g191: APPLY COMPENSATING TORQUES
FE 2.3B.9.7.9
FE 2.3A.10.3.9
FE 2.2B.9.8.9
FE 2.2A.14.7.9
FE 2.2A.9.4.9
FE 2.1B.15.1.9
FE 2.1B.9.8.9
FE 2.1A.14.1.9
FE 2.1A.9.7.9
*gfe g192: SHUTDOWN SPACECRAFT SYSTEMS
FE 2.3B.9.7.10
FE 2.3A.10.3.10
FE 2.2B.9.8.10
FE 2.2A.14.7.10
FE 2.2A.9.4.10
FE 2.1B.9.8.10
FE 2.1A.9.7.10
*gfe g193: MATCH AXAF VELOCITY AND ATTITUDE WITH ORBITER
FE 2.3A.10.4.1
FE 2.2A.14.8.1
FE 2.2A.9.5.1
FE 2.1A.9.8.1
*gfe g194: IDENTIFY FAULTY SOFTWARE
FE 2.2B.13.7.6
FE 2.2B.9.11.6
FE 2.2A.14.11.6
FE 2.2A.9.8.6
FE 2.1B.14.10.6
FE 2.1B.9.13.6
FE 2.1A.13.10.6
FE 2.1A.9.11.6
*gfe g195: RETRACT TDRSS ANTENNAS
FE 2.3A.11.1.1
FE 2.2A.13.1.1
FE 2.1B.9.10.1
FE 2.1A.10.1.1
*gfe g196: CLOSE SUNSHADE
FE 2.3A.11.1.6
FE 2.2A.13.1.6
FE 2.1B.9.10.6
FE 2.1A.10.1.6
*gfe g197: RETRACT SOLAR ARRAYS
FE 4.3.17.4.7
FE 4.3.17.1.5
FE 4.3.16.2.5
FE 4.3.11.2.4
FE 4.3.9.9.7
FE 4.3.9.1.5
FE 4.2.16.4.7
FE 4.2.16.1.5
FE 4.2.15.2.5
FE 4.2.11.2.4
FE 4.2.9.9.7
FE 4.2.9.1.5
FE 4.1B.15.4.7
FE 4.1B.15.1.5
FE 4.1B.14.2.5
FE 4.1B.9.9.7
FE 4.1B.9.1.5
FE 4.1A.14.4.7
FE 4.1A.14.1.5
FE 4.1A.9.9.7
FE 4.1A.9.1.5
FE 2.3A.11.1.11
FE 2.2A.13.1.11
FE 2.1B.9.10.11
FE 2.1A.10.1.11
*gfe g198: TILT PAYLOAD TO HORIZONTAL POSITION
FE 2.3A.11.2.3
FE 2.2A.13.2.3
FE 2.1A.10.2.3
*gfe g199: CLOSE PAYLOAD BAY DOORS
FE 4.3.17.3.2
FE 4.3.16.6.2
FE 4.2.16.3.2
FE 4.2.15.6.2
FE 4.1B.15.3.2
FE 4.1B.14.6.2

FE 4.1A.14.3.2
 FE 2.3A.11.2.5
 FE 2.2A.13.2.5
 FE 2.1A.10.2.5
 *gfe g200: ADJUST HEATING/COOLING SYSTEMS
 FE 2.1B.14.1.3
 FE 2.1A.13.1.3
 *gfe g201: MONITOR GAS SUPPLIES
 FE 4.3.12.3.1
 FE 4.3.10.4.1
 FE 4.2.10.4.1
 FE 4.1B.10.4.1
 FE 4.1A.10.4.1
 FE 2.1B.14.4.2
 FE 2.1A.13.4.2
 *gfe g202: PRESSURIZE DETECTORS WHEN NEEDED
 FE 2.1B.14.4.4
 FE 2.1A.13.4.4
 *gfe g203: DEPRESSURIZE DETECTORS WHEN NOT IN USE
 FE 2.1B.14.4.5
 FE 2.1A.13.4.5
 *gfe g204: COMPUTE POSITIONS OF SUN, EARTH, MOON
 FE 2.1B.14.6.1
 FE 2.1A.13.6.1
 FE 2.1B.14.6.2
 FE 2.1A.13.6.2
 *gfe g205: DETERMINE ANGLES RELATIVE TO TELESCOPE LINE-OF-SIGHT
 FE 2.1B.14.6.3
 FE 2.1A.13.6.3
 *gfe g206: MONITOR BRIGHT OBJECT DETECTOR
 FE 2.1B.14.6.4
 FE 2.1A.13.6.4
 *gfe g207: MONITOR SAA DETECTOR
 FE 2.1B.14.6.5
 FE 2.1A.13.6.5
 *gfe g208: COMPARE DETECTOR OUTPUT TO PRESET LIMITS
 FE 2.1B.14.6.6
 FE 2.1A.13.6.6
 *gfe g209: CLOSE OPTICAL SHUTTERS
 FE 2.1B.14.6.7
 FE 2.1A.13.6.7
 *gfe g210: REDUCE VOLTAGES IN SENSITIVE EQUIPMENT
 FE 2.1B.14.6.8
 FE 2.1A.13.6.8
 *gfe g211: SHUTDOWN DETECTORS
 FE 2.1B.16.2.1
 FE 2.1B.16.1.1
 FE 2.1A.15.2.1
 FE 2.1A.15.1.1
 *gfe g212: RECEIVE GROUND COMMANDS
 FE 2.2B.10.1.3
 FE 2.2A.10.1.3
 FE 2.1B.17.2.1
 FE 2.1B.16.2.3

FE 2.1A.16.2.1
 FE 2.1A.15.2.3
 *gfe g214: DETECTOR POWER ON
 FE 2.1B.17.2.2
 FE 2.1B.16.2.4
 FE 2.1A.16.2.2
 FE 2.1A.15.2.4
 *gfe g215: DETECTOR COOLING ON
 FE 2.1B.17.2.3
 FE 2.1B.16.2.5
 FE 2.1A.16.2.3
 FE 2.1A.15.2.5
 *gfe g216: OPEN DETECTOR APERTURES
 FE 2.1B.17.2.4
 FE 2.1B.16.2.6
 FE 2.1A.16.2.4
 FE 2.1A.15.2.6
 *gfe g217: FINE FOCUS DETECTOR
 FE 2.1B.17.2.5
 FE 2.1B.16.2.7
 FE 2.1A.16.2.5
 FE 2.1A.15.2.7
 *gfe g218: TAKE DATA FROM DETECTOR
 FE 2.1B.17.4.1
 FE 2.1B.17.2.6
 FE 2.1B.16.3.1
 FE 2.1A.16.4.1
 FE 2.1A.16.2.6
 FE 2.1A.15.3.1
 *gfe g219: TAKE DATA FROM ASPECT SENSORS
 FE 2.1B.17.4.2
 FE 2.1B.17.3.1
 FE 2.1B.16.3.2
 FE 2.1A.16.4.2
 FE 2.1A.16.3.1
 FE 2.1A.15.3.2
 *gfe g220: PICK X-RAY SOURCE WITH KNOWN OPTICAL COUNTERPART
 FE 2.1B.17.1.1
 FE 2.1A.16.1.1
 *gfe g221: DETERMINE IF TARGET IS WITHIN DETECTOR FOV
 FE 2.1B.17.2.9
 FE 2.1A.16.2.9
 *gfe g222: DETERMINE IF TARGET IS WITHIN ASPECT SENSOR FOV
 FE 2.1B.17.3.4
 FE 2.1A.16.3.4
 *gfe g223: SELECT NEW TELESCOPE ATTITUDE IF NECESSARY
 FE 2.1B.17.3.5
 FE 2.1A.16.3.5
 *gfe g224: PROCESS IMAGE DATA
 FE 2.1B.17.4.5
 FE 2.1A.16.4.5
 *gfe g225: DETERMINE ALIGNMENT CORRECTION
 FE 2.1B.17.4.6
 FE 2.1A.16.4.6
 *gfe g226: ACTIVATE TMS SUBSYSTEMS

*gfe g247: SPIN UP DEBRIS CAPTURE DEVICE
 FE 3.5.11.4.3
 *gfe g248: BRAKE DEBRIS CAPTURE DEVICE
 FE 3.5.11.4.5
 *gfe g249: RELEASE SPACECRAFT FROM DEBRIS CAPTURE DEVICE
 FE 3.5.12.2.1
 *gfe g250: CHECK EXPERIMENTAL PACKAGE INTERFACE
 FE 4.1B.7.4.1
 FE 4.1A.7.4.1

*gfe g251: RETRACT RADIATORS
 FE 4.3.17.4.8
 FE 4.3.17.1.6
 FE 4.3.16.2.6
 FE 4.3.11.2.5
 FE 4.3.9.9.8
 FE 4.3.9.1.6
 FE 4.2.16.4.8
 FE 4.2.16.1.6
 FE 4.2.15.2.6
 FE 4.2.11.2.5
 FE 4.2.9.9.8
 FE 4.2.9.1.6
 FE 4.1B.15.4.8
 FE 4.1B.15.1.6
 FE 4.1B.14.2.6
 FE 4.1B.9.9.0
 FE 4.1B.9.1.6
 FE 4.1A.14.4.8
 FE 4.1A.14.1.6
 FE 4.1A.9.9.8
 FE 4.1A.9.1.6

*gfe g252: ORIENT THRUSTERS
 FE 4.3.17.4.9
 FE 4.3.17.1.7
 FE 4.3.16.2.8
 FE 4.3.9.9.10
 FE 4.3.9.1.8
 FE 4.2.16.4.9
 FE 4.2.16.1.7
 FE 4.2.15.2.7
 FE 4.2.9.9.9
 FE 4.2.9.1.7
 FE 4.1B.15.4.9
 FE 4.1B.15.1.7
 FE 4.1B.14.2.7
 FE 4.1B.9.9.9
 FE 4.1B.9.1.7
 FE 4.1A.14.4.9
 FE 4.1A.14.1.7
 FE 4.1A.9.9.9
 FE 4.1A.9.1.7

*gfe g253: ORBITER AND SP VELOCITY AND TRAJECTORY ADJUSTMENTS
 FE 4.3.17.1.9
 FE 4.3.16.2.10
 FE 4.3.9.1.10

FE 4.2.16.1.9
 FE 4.2.15.2.9
 FE 4.2.9.1.9
 FE 4.1B.15.1.9
 FE 4.1B.14.2.9
 FE 4.1B.9.1.9
 FE 4.1A.14.1.9
 FE 4.1A.9.1.9

*gfe g254: ACTIVATE DOCKING ADAPTER
 FE 4.3.17.1.11
 FE 4.3.16.2.12
 FE 4.3.9.1.12
 FE 4.2.16.1.11
 FE 4.2.15.2.11
 FE 4.2.9.1.11
 FE 4.1B.15.1.11
 FE 4.1B.14.2.11
 FE 4.1B.9.1.11
 FE 4.1A.14.1.11
 FE 4.1A.9.1.11

*gfe g255: DOCKING OF SHUTTLE ADAPTER TO SPACE PLATFORM
 FE 4.3.17.1.12
 FE 4.3.13.2.13
 FE 4.3.9.1.13
 FE 4.2.16.1.12
 FE 4.2.15.2.12
 FE 4.2.9.1.12
 FE 4.1B.15.1.12
 FE 4.1B.14.2.12
 FE 4.1B.9.1.12
 FE 4.1A.14.1.12
 FE 4.1A.9.1.12

*gfe g256: SP BERTHING ON DOCKING ADAPTER
 FE 4.3.17.1.13
 FE 4.3.16.2.14
 FE 4.3.9.1.14
 FE 4.2.16.1.13
 FE 4.2.15.2.13
 FE 4.2.9.1.13
 FE 4.1B.15.1.13
 FE 4.1B.14.2.13
 FE 4.1B.9.1.13
 FE 4.1A.14.1.13
 FE 4.1A.9.1.13

*gfe g257: STOW OLD PAYLOAD IN ORBITER
 FE 4.3.9.2.5
 FE 4.2.9.2.5
 FE 4.1B.9.2.5
 FE 4.1A.5.2.5

*gfe g258: LOCATE NEW PAYLOAD
 FE 4.3.9.3.1
 FE 4.2.9.3.1
 FE 4.1B.9.3.1
 FE 4.1A.9.3.1

*gfe g259: ATTACH NEW PAYLOAD TO SP

- FE 4.3.9.3.4
- FE 4.2.9.3.4
- FE 4.18.9.3.4
- FE 4.1A.9.3.4
- *gfe 9260: SP/PAYLOAD INTERFACE CHECKOUT
- FE 4.3.17.4.17
- FE 4.3.16.5.7
- FE 4.3.9.9.18
- FE 4.3.9.4.7
- FE 4.2.16.4.17
- FE 4.2.15.5.7
- FE 4.2.9.9.17
- FE 4.2.9.4.7
- FE 4.18.15.4.17
- FE 4.18.14.5.7
- FE 4.18.9.9.17
- FE 4.18.9.4.7
- FE 4.1A.14.4.17
- FE 4.1A.9.9.17
- FE 4.1A.9.4.7
- *gfe 9261: TRANSFER OPERATIONAL CONTROL FROM MISSION TO PAYLOAD CONTROL
- FE 4.3.17.4.1
- FE 4.3.9.9.1
- FE 4.2.16.4.1
- FE 4.2.9.9.1
- FE 4.18.15.4.1
- FE 4.18.9.9.1
- FE 4.1A.14.4.1
- FE 4.1A.9.9.1
- *gfe 9262: UNDOCKING OF ORBITER FROM SP
- FE 4.3.17.4.2
- FE 4.3.16.6.3
- FE 4.3.9.9.2
- FE 4.2.16.4.2
- FE 4.2.15.6.3
- FE 4.2.9.9.2
- FE 4.18.15.4.2
- FE 4.18.14.6.3
- FE 4.18.9.9.2
- FE 4.1A.14.4.2
- FE 4.1A.9.9.2
- *gfe 9263: COMPARE TEMPERATURE TO REQUIRED LIMITS
- FE 4.3.10.1.2
- FE 4.2.10.1.2
- FE 4.18.11A.3.2
- FE 4.18.10.1.2
- FE 4.1A.11A.3.2
- FE 4.1A.10.1.2
- *gfe 9264: MONITOR MICRO-GRAVITY LEVELS
- FE 4.3.10.6.3
- FE 4.2.10.6.3
- FE 4.18.10.6.3
- FE 4.1A.10.6.3
- *gfe 9265: IDENTIFY SHAPE. SIZE IN BIN
- FE 4.18.11A.1.1
- FE 4.1A.11A.1.1
- FE 4.18.11A.1.2
- FE 4.1A.11A.1.2
- FE 4.18.11A.1.3
- FE 4.1A.11A.1.3
- *gfe 9268: GRASP SAMPLE
- FE 4.18.11A.1.4
- FE 4.1A.11A.1.4
- *gfe 9269: TRANSPORT SAMPLE TO EXPERIMENT AREA
- FE 4.18.11A.1.5
- FE 4.1A.11A.1.5
- *gfe 9270: OPEN HOLDER
- FE 4.18.11A.1.6
- FE 4.1A.11A.1.6
- *gfe 9271: INSERT SAMPLE
- FE 4.18.11A.1.7
- FE 4.1A.11A.1.7
- *gfe 9272: CLOSE HOLDER
- FE 4.18.11A.1.8
- FE 4.1A.11A.1.8
- *gfe 9273: ACTIVATE FAIL-SAFE SUBSYSTEM(S)
- FE 4.18.11A.2.1
- FE 4.1A.11A.2.1
- *gfe 9274: CHECK ALIGNMENT WITH ALIGNMENT CRITERIA
- FE 4.18.11A.2.2
- FE 4.1A.11A.2.2
- *gfe 9275: SET (OR EVACUATE) FURNACE ATMOSPHERE
- FE 4.18.11A.2.3
- FE 4.1A.11A.2.3
- *gfe 9276: ACTIVATE EXPERIMENTAL PROCESS SPECIFIC EQUIPMENT
- FE 4.18.11A.2.4
- FE 4.1A.11A.2.4
- *gfe 9277: MEASURE COMPONENT TEMPERATURE
- FE 4.18.11A.3.1
- FE 4.1A.11A.3.1
- *gfe 9278: ACTIVATE FURNACE TEMPERATURE-MAINTAINING UNIT
- FE 4.18.11A.3.3
- FE 4.1A.11A.3.3
- *gfe 9279: INITIATE GAS ANALYZER OPERATION
- FE 4.18.11A.4.1
- FE 4.1A.11A.4.1
- *gfe 9280: RECORDING AND ON-BOARD STORAGE OF DATA
- FE 4.18.12B.1.2
- FE 4.18.12A.1.2
- FE 4.18.11A.4.2
- FE 4.1A.12B.1.2
- FE 4.1A.11A.4.2
- *gfe 9281: MEASURE EXPERIMENTAL DATA, WITH SPEC. INSTRUMENTATION
- FE 4.18.12B.1.1
- FE 4.18.12A.1.1
- FE 4.1A.12B.1.1
- FE 4.1A.12A.1.1
- *gfe 9282: COOL SAMPLE

FE 4.1B.13A.1.1
 FE 4.1A.13A.1.1
 *gfe g283: ADJUST FURNACE PRESSURE TO SAFE LEVEL
 FE 4.1B.13A.1.2
 FE 4.1A.13A.1.2
 *gfe g284: GET SAMPLE WITH SAMPLE HOLDER
 FE 4.1B.13A.2.1
 FE 4.1A.13A.2.1
 *gfe g285: REMOVE SAMPLE FROM FURNACE
 FE 4.1B.13A.2.2
 FE 4.1A.13A.2.2
 *gfe g286: RELEASE SAMPLE FROM SAMPLE HOLDER
 FE 4.1B.13A.2.3
 FE 4.1A.13A.2.3
 *gfe g287: REMOVE SAMPLE FROM HOLDER
 FE 4.1B.13A.2.4
 FE 4.1A.13A.2.4
 *gfe g288: TRANSPORT SAMPLE TO STORAGE BIN
 FE 4.1B.13A.2.5
 FE 4.1A.13A.2.5
 *gfe g289: RELEASE SAMPLE IN BIN
 FE 4.1B.13A.2.6
 FE 4.1A.13A.2.6
 *gfe g290: PURGE GASES FROM FURNACE
 FE 4.1B.13A.3.1
 FE 4.1A.13A.3.1
 *gfe g291: BAKEOUT FURNACE
 FE 4.1B.13A.3.2
 FE 4.1A.13A.3.2
 *gfe g292: REPROGRAM PROCESS SET-POINTS AND CONTROLS
 FE 4.1B.13A.3.3
 FE 4.1A.13A.3.3
 *gfe g293: DEFROST LIVE CELLS
 FE 4.1B.11B.2.1
 FE 4.1A.11B.2.1
 *gfe g294: SUPPLY NUTRIENTS AND GASES
 FE 4.1B.11B.2.2
 FE 4.1A.11B.2.2
 *gfe g295: REMOVE ORGANIC WASTES
 FE 4.1B.11B.2.3
 FE 4.1A.11B.2.3
 *gfe g296: PUMP SAMPLE INTO CHAMBER
 FE 4.1B.11B.4.1
 FE 4.1A.11B.4.1
 *gfe g297: PUMP MEDIA FLUID INTO CHAMBER
 FE 4.1B.11B.4.2
 FE 4.1A.11B.4.2
 *gfe g298: TRANSMIT DATA TO GROUND PROCESSING CENTER
 FE 4.1B.13B.2.1
 FE 4.1A.13B.2.1
 *gfe g299: WHEN SPECIFIED GROWTH PARAMS. REACHED, PREPARE SAMPLE FOR RETURN
 FE 4.1B.13B.2.2
 FE 4.1A.13B.2.2
 *gfe g300: STORE PRODUCTS IN A CONTROLLED ENVIRONMENT FOR RETURN
 FE 4.1B.13B.3.1

FE 4.1A.13B.3.1
 *gfe g301: FLUSH SYSTEM WITH BIOCIDES, PRIOR TO NEXT CYCLE
 FE 4.1B.13B.3.2
 FE 4.1A.13B.3.2
 *gfe g302: SP INTERFACE WITH PAYLOAD IS SHUTDOWN
 FE 4.3.17.2.1
 FE 4.2.16.2.1
 FE 4.1B.15.2.1
 FE 4.1A.14.2.1
 *gfe g303: PAYLOAD INTERNAL POWER ACTIVATED
 FE 4.3.17.2.2
 FE 4.2.16.2.2
 FE 4.1B.15.2.2
 FE 4.1A.14.2.2
 *gfe g304: ORBITER/PAYLOAD INTEGRATION CHECKOUT
 FE 4.3.17.3.1
 FE 4.3.16.3.10
 FE 4.2.16.3.1
 FE 4.2.15.3.10
 FE 4.1B.15.3.1
 FE 4.1B.14.3.10
 FE 4.1A.14.3.1
 *gfe g305: PRIORITY REMOVAL OF TIME-CRITICAL ITEMS
 FE 4.3.19.2.2
 FE 4.2.18.2.2
 FE 4.1B.17.2.2
 FE 4.1A.16.2.2
 *gfe g306: PAYLOAD REMOVAL FROM ORBITER PROCESSING FACILITY
 FE 4.3.19.3
 FE 4.2.18.3
 FE 4.1B.17.3
 FE 4.1A.16.3
 *gfe g307: SEND GROUND SIGNAL TO SP TO BEGIN SERV. SEQ.
 FE 4.3.16.1.1
 FE 4.2.15.1.1
 FE 4.1B.14.1.1
 *gfe g308: REDUCE POWER TO SUBSYSTEMS
 FE 4.3.16.1.2
 FE 4.2.15.1.2
 FE 4.1B.14.1.2
 *gfe g309: SHUTDOWN EXPERIMENTAL PACKAGES
 FE 4.1B.14.3.1
 *gfe g310: ORIENT NEW PAYLOADS
 FE 4.3.16.3.8
 FE 4.2.15.3.8
 FE 4.1B.14.3.8
 *gfe g311: ATTACH NEW PAYLOADS
 FE 4.3.16.3.9
 FE 4.2.15.3.9
 FE 4.1B.14.3.9
 *gfe g312: SHUTDOWN PAYLOADS
 FE 4.3.16.3.1
 FE 4.2.15.3.1
 *gfe g313: SP ON INTERNAL POWER
 FE 4.3.16.2.7

OF 12

ORIGINAL FILED
OF POOR QUALITY

FE 4.3.9.9.9
FE 4.3.9.1.7
*gfe g314: MEASURE MODULE ATMOSPHERIC TEMPERATURES
FE 4.3.12.1.1
*gfe g315: COMPARE ATMOSPHERIC TEMPERATURES TO REQUIRED LIMITS
FE 4.3.12.1.2
*gfe g316: MONITOR HABITAT PRESSURE, ATMOSPHERIC COMPOSITION
FE 4.3.12.1.4
*gfe g317: COMPARE TO REQUIRED LIFE SUPPORT CONDITIONS
FE 4.3.12.1.5
*gfe g318: ADJUST HABITAT-MAINTENANCE SUBSYSTEMS
FE 4.3.12.1.6
*gfe g319: EVALUATE SOLAR ARRAY PERFORMANCE
FE 4.3.12.2.3
*gfe g320: MONITOR HABITAT-MAINTENANCE SYSTEMS SUPPLIES
FE 4.3.12.3.2
*gfe g321: MONITOR SUPPLIES, CONDITION OF PERISHABLES
FE 4.3.12.3.3
*gfe g322: MONITOR EQUIPMENT INVENTORY
FE 4.3.12.3.4
*gfe g323: MAINTAIN EMERGENCY CONSUMABLES RESERVE
FE 4.3.12.4.1
*gfe g324: MONITOR RADIATION LEVELS
FE 4.3.12.4.3
*gfe g325: MONITOR VITAL SIGNS OF CREW MEMBERS
FE 4.3.12.4.6
*gfe g326: MONITOR REST, NUTRITION OF CREW MEMBERS
FE 4.3.12.4.7
*gfe g327: UPDATE HABITAT MODEL
FE 4.3.12.5.1
*gfe g328: EXCHANGE PERSONNEL, THROUGH DOCKING MODULE
FE 4.3.16.3.11
*gfe g329: STORAGE OF CONSUMABLES IN HABITAT MODULE
FE 4.3.16.3.12
*gfe g330: PRIORITY REMOVAL OF PERSONNEL
FE 4.3.19.2.3

APPENDIX 2.C:
GENERIC FUNCTIONAL ELEMENT LIST
(WITHOUT BREAKDOWN CODE NUMBERS)

2.C.1 Notes on this Appendix

This appendix repeats the Generic Functional Element (GFE) List presented in Appendix 2.B, but omits the lists of functional element code numbers after each GFE. The GFE List was collected from the four space project breakdowns by a computer program (see Sections 2.4.1 and 2.4.2 for a description and discussion of this procedure). A functional element collected from a previous breakdown was not listed again. The resulting GFE List contains 330 generic functional elements, from which all of the four project breakdowns can be assembled.

The space project breakdowns (presented in Appendix 2.A) were scanned by the computer program in the order: GSP, AXAF, TMS, SP. Therefore the order of the GFE's, and their assigned numbers (g1, g2, etc.) reflect this scan. GFE's g1 through g170 were collected from the GSP breakdown (though most of them appear in other breakdowns as well). GFE's g171 through g238 were added by the scan of the AXAF breakdown; GFE's g239 through g249, by the scan of the TMS breakdown; and GFE's g250 through g330, by the scan of the SP breakdown.

As mentioned in Section 2.3.2, team brainstorm sessions were held to define common nomenclature for functional elements. Despite these precautions, three typographical variations

appeared in the listing. Since the computer program uses word-recognition to collect GFE's, these 3 typos appear as separate GFE's: g200, similar to g83; g263, similar to g82; and g277, similar to g81. By the time these were identified, the GFE List had been used extensively in further study tasks; since correcting these typos would have renumbered one-third of the GFE's, the study group left the List unaltered.

GENERIC FUNCTIONAL ELEMENT LIST (330 GFE'S)

- *gfe g1: VERIFY POWER SYSTEM FUNCTION
- *gfe g2: VERIFY COMMAND SYSTEM FUNCTION
- *gfe g3: VERIFY MECHANICAL SYSTEM FUNCTION
- *gfe g4: VERIFY COMMUNICATIONS SYSTEM FUNCTION
- *gfe g5: MISSION SEQUENCE SIMULATION
- *gfe g6: LOAD PAYLOAD INTO CONTAINER
- *gfe g7: TRANSPORT CONTAINER TO VERTICAL PROCESSING FACILITY
- *gfe g8: UNLOAD CONTAINER
- *gfe g9: CHECK SHUTTLE/PAYLOAD MECHANICAL INTERFACES
- *gfe g10: CHECK ELECTRICAL INTERFACES
- *gfe g11: CHECK PAYLOAD/BOOSTER MECHANICAL INTERFACES
- *gfe g12: LOAD PAYLOAD INTO CANISTER
- *gfe g13: TRANSPORT TO ROTATING SERVICE STRUCTURE
- *gfe g14: LOAD CANISTER INTO ROTATING SERVICE STRUCTURE
- *gfe g15: LOAD PAYLOAD INTO ROTATING SERVICE STRUCTURE USING PGHM
- *gfe g16: REMOVE CANISTER
- *gfe g17: MATE ROTATING SERVICE STRUCTURE TO ORBITER
- *gfe g18: EXTEND PAYLOAD INTO ORBITER USING PGHM
- *gfe g19: CONNECT ORBITER/PAYLOAD INTERFACES
- *gfe g20: CLOSE-OUT PAYLOAD BAY
- *gfe g21: OPEN PAYLOAD BAY DOORS
- *gfe g22: ROTATE OTV/GSP PACKAGE OUT OF ORBITER
- *gfe g23: POWER SUBSYSTEM CHECKOUT
- *gfe g24: INFORMATION PROCESSING SUBSYSTEM CHECKOUT
- *gfe g25: RAISE CENTRAL MAST
- *gfe g26: DEPLOY MAIN REFLECTORS
- *gfe g27: DEPLOY ANTENNA RECEIVER ARRAYS
- *gfe g28: DEPLOY ANTENNA TRANSMIT ARRAYS
- *gfe g29: DEPLOY SUBREFLECTOR
- *gfe g30: DEPLOY INTERFEROMETER
- *gfe g31: DEPLOY SOLAR ARRAYS
- *gfe g32: DEPLOY RADIATORS
- *gfe g33: VERIFY DEPLOYMENT SEQUENCES
- *gfe g34: RETRACT SOLAR PANELS
- *gfe g35: INITIALIZE GUIDANCE SYSTEM
- *gfe g36: DETERMINE CURRENT ORBITAL PARAMETERS
- *gfe g37: DETERMINE DESIRED ORBITAL PARAMETERS
- *gfe g38: CHOOSE OPTIMAL TRAJECTORY
- *gfe g39: DETERMINE CURRENT ATTITUDE
- *gfe g40: DETERMINE DESIRED ATTITUDE
- *gfe g41: FIRE THRUSTERS
- *gfe g42: SEPARATE OTV FROM GSP
- *gfe g43: SEPARATION COAST
- *gfe g44: TRANSFER OF OTV TO SUPERSYNCHRONOUS ORBIT
- *gfe g45: DEPLOY SOLAR PANELS
- *gfe g46: DEPLOY INTER-PLATFORM LINK ANTENNAS
- *gfe g47: ACTIVATE SUBSYSTEMS
- *gfe g48: THERMAL SUBSYSTEM CHECKOUT
- *gfe g49: STRUCTURE SUBSYSTEM CHECKOUT
- *gfe g50: COMMUNICATIONS SUBSYSTEM CHECKOUT
- *gfe g51: ATTITUDE CONTROL SUBSYSTEM CHECKOUT
- *gfe g52: PROPULSION SUBSYSTEM CHECKOUT
- *gfe g53: TRAFFIC ROUTING SUBSYSTEM CHECKOUT
- *gfe g54: CONSUMABLES LEVELS CHECKOUT
- *gfe g55: COMPARE MEASURED DATA TO MODEL
- *gfe g56: DETERMINE ANOMALOUS DATA
- *gfe g57: FORM HYPOTHESIS FOR PROBLEM
- *gfe g58: DEVISE TEST FOR FAILURE HYPOTHESIS
- *gfe g59: PERFORM TEST FOR FAILURE HYPOTHESIS
- *gfe g60: IDENTIFY FAULTY COMPONENT
- *gfe g61: SWITCH OUT FAULTY COMPONENT
- *gfe g62: SWITCH IN REDUNDANT COMPONENT
- *gfe g63: MAKE DIAGNOSTIC CHECKS
- *gfe g64: UPDATE SPACECRAFT MODEL
- *gfe g65: DEFINE ACCESS SEQUENCE
- *gfe g66: LOCATE ACCESS PANEL
- *gfe g67: TRANSFER REPAIR EQUIPMENT TO REPAIR SITE
- *gfe g68: OPEN ACCESS PANEL
- *gfe g69: OBSERVE/LOCATE DEFECTIVE COMPONENT
- *gfe g70: REMOVE COMPONENT

ORIGINAL FILED
OF FOUR

*gfe g71: STORE COMPONENT
*gfe g72: LOCATE NEW COMPONENT
*gfe g73: POSITION AND CONNECT NEW COMPONENT
*gfe g74: ADJUST COMPONENT
*gfe g75: CLOSE ACCESS PANEL
*gfe g76: STOW REPAIR EQUIPMENT
*gfe g77: DETERMINE CORRECTION ALGORITHM
*gfe g78: DATA/COMMAND ENCODING
*gfe g79: DATA/COMMAND TRANSMISSION
*gfe g80: COMPUTER FUNCTION CHECKS
*gfe g81: MEASURE COMPONENT TEMPERATURES
*gfe g82: COMPARE TEMPERATURES TO REQUIRED LIMITS
*gfe g83: ADJUST COOLING/HEATING SYSTEMS
*gfe g84: MEASURE CURRENTS AND VOLTAGES
*gfe g85: COMPARE CURRENTS AND VOLTAGES TO REQUIRED LIMITS
*gfe g86: EVALUATE BATTERY CHARGING PERFORMANCE
*gfe g87: ADJUST CURRENTS AND VOLTAGES
*gfe g88: ADJUST BATTERY CHARGING CYCLE
*gfe g89: SHORT-TERM MEMORY STORAGE
*gfe g90: LONG-TERM MEMORY STORAGE
*gfe g91: DATA/COMMAND DECODING
*gfe g92: NUMERICAL COMPUTATION
*gfe g93: LOGIC OPERATIONS
*gfe g94: COMPUTER LOAD SCHEDULING
*gfe g95: MONITOR PROPELLANT SUPPLIES
*gfe g96: MONITOR COOLING SYSTEM SUPPLIES
*gfe g97: PROJECT CONSUMABLES REQUIREMENTS FROM MISSION PROFILE
*gfe g98: COMPUTE OPTIMAL CONSUMABLES ALLOCATION
*gfe g99: MEASURE STRAINS IN STRUCTURE
*gfe g100: MEASURE RELATIVE DISPLACEMENTS
*gfe g101: COMPUTE STRESS AND VIBRATION PARAMETERS
*gfe g102: COMPARE STRESS AND VIBRATION PARAMETERS TO REQUIRED LIMITS
*gfe g103: APPLY COMPENSATING FORCES
*gfe g104: APPLY VIBRATION DAMPING
*gfe g105: PROJECT DESIRED FUNCTIONS FROM MISSION PROFILE
*gfe g106: ESTIMATE RISKS FROM DESIRED FUNCTIONS
*gfe g107: DETERMINE CONSTRAINTS AND FIGURES OF MERIT
*gfe g108: COMPUTE OPTIMAL SEQUENCING
*gfe g109: DATA/COMMAND DISPLAY
*gfe g110: DETERMINE NEW CONFIGURATION FOR SPACECRAFT COMPONENTS
*gfe g111: ROTATE SPACECRAFT
*gfe g112: CHOOSE OPTIMAL CONTROL MODE
*gfe g113: COMPUTE CONTROL COMMANDS
*gfe g114: EXECUTE CONTROL COMMANDS
*gfe g115: RECEIVE INPUT FROM ANTENNA POINTING SENSORS
*gfe g116: TRANSMIT INFORMATION TO ANTENNA POINTING CONTROLLER
*gfe g117: DETERMINE ERROR FROM DESIRED ANTENNA POSITION
*gfe g118: ANTENNA POSITIONER CORRECTS POINTING DIRECTION
*gfe g119: RECEIVE COMMUNICATIONS INPUT
*gfe g120: ENTER COMMUNICATIONS INPUT INTO SWITCH CONTROL
*gfe g121: SWITCH CONTROL ENTERS COMMUNICATIONS INPUT INTO SWITCH MATRIX
*gfe g122: SWITCH MATRIX EXECUTES COMMUNICATIONS OUTPUT
*gfe g123: CHECK TMS/PAYLOAD MECHANICAL INTERFACES
*gfe g124: ATTACH STRONGBACK TO PAYLOAD
*gfe g125: REMOVE STRONGBACK
*gfe g126: CLOSE CANISTER
*gfe g127: TRANSPORT CANISTER TO ORBITER PROCESSING FACILITY
*gfe g128: UNLOAD CANISTER
*gfe g129: INSTALL PAYLOAD IN ORBITER
*gfe g130: INSTALLATION OF ORBITER PAYLOAD STATION CONSOLES
*gfe g131: ACTIVATE RMS
*gfe g132: LOCATE GRASPING FIXTURE ON TARGET
*gfe g133: MOVE RMS TO FIXTURE
*gfe g134: GRASP FIXTURE
*gfe g135: RELEASE PAYLOAD RESTRAINTS
*gfe g136: TRANSLATE PAYLOAD OUT OF PAYLOAD BAY
*gfe g137: RMS RELEASES PAYLOAD
*gfe g138: SECURE RMS IN PAYLOAD BAY
*gfe g139: STRUCTURAL SUBSYSTEM CHECKOUT
*gfe g140: RELEASE DOCKING LATCH

*gfe g141: RETRACT DOCKING MECHANISM
 *gfe g142: MOVE AWAY FROM PAYLOAD
 *gfe g143: MONITOR BATTERIES
 *gfe g144: LOCATE DOCKING TARGET
 *gfe g145: EXTEND DOCKING MECHANISM
 *gfe g146: FASTEN DOCKING LATCH
 *gfe g147: CLOSE INTERNAL VALVES
 *gfe g148: EXTEND AND ATTACH UMBILICAL
 *gfe g149: OPEN SUPPLY VALVE
 *gfe g150: MONITOR FLUID TRANSFER
 *gfe g151: CLOSE SUPPLY VALVE
 *gfe g152: DETACH AND RETRACT UMBILICAL
 *gfe g153: OPEN INTERNAL VALVES
 *gfe g154: CHECK FOR LEAKS
 *gfe g155: LOCATE OLD TANK
 *gfe g156: DISCONNECT OLD TANK
 *gfe g157: REMOVE OLD TANK
 *gfe g158: STORE OLD TANK
 *gfe g159: LOCATE NEW TANK
 *gfe g160: INSTALL NEW TANK
 *gfe g161: CONNECT NEW TANK
 *gfe g162: COAST TO SUPERSYNCHRONOUS ORBIT
 *gfe g163: TRANSFER DEBRIS TO DISPOSAL POSITION
 *gfe g164: JETTISON DEBRIS
 *gfe g165: STOW TMS ANTENNA
 *gfe g166: DEACTIVATE TMS SUBSYSTEMS
 *gfe g167: LOCATE CRADLE IN PAYLOAD BAY
 *gfe g168: TRANSLATE PAYLOAD TO CRADLE
 *gfe g169: LOCATE PAYLOAD RESTRAINTS
 *gfe g170: FASTEN PAYLOAD RESTRAINTS
 *gfe g171: VERIFY DETECTOR SYSTEM FUNCTION
 *gfe g172: TRANSPORT TO OPERATIONS AND CHECKOUT BLDG.
 *gfe g173: INSTALL PAYLOAD IN HORIZONTAL CITE
 *gfe g174: INSTALLATION OF OMS KIT
 *gfe g175: TILT PAYLOAD TO VERTICAL POSITION
 *gfe g176: LOCATE SOLAR ARRAY RESTRAINTS
 *gfe g177: RELEASE SOLAR ARRAY RESTRAINTS
 *gfe g178: LOCATE SUNSHADE RESTRAINTS
 *gfe g179: RELEASE SUNSHADE RESTRAINTS
 *gfe g180: OPEN SUNSHADE
 *gfe g181: DEPLOY TDRSS ANTENNAS
 *gfe g182: COMMAND DETECTOR SELECTION
 *gfe g183: OBSERVE DETECTOR SELECTION
 *gfe g184: MONITOR TELEMETRY
 *gfe g185: EVALUATE SYSTEM PERFORMANCE
 *gfe g186: ACTIVATE AXAF SUBSYSTEMS
 *gfe g187: COMMAND ATTITUDE CHANGE
 *gfe g188: OBSERVE ATTITUDE CHANGE
 *gfe g189: DETERMINE DISTURBING TORQUES
 *gfe g190: COMPUTE REQUIRED RESULTANT
 *gfe g191: APPLY COMPENSATING TORQUES
 *gfe g192: SHUTDOWN SPACECRAFT SYSTEMS
 *gfe g193: MATCH AXAF VELOCITY AND ATTITUDE WITH ORBITER
 *gfe g194: IDENTIFY FAULTY SOFTWARE
 *gfe g195: RETRACT TDRSS ANTENNAS
 *gfe g196: CLOSE SUNSHADE
 *gfe g197: RETRACT SOLAR ARRAYS
 *gfe g198: TILT PAYLOAD TO HORIZONTAL POSITION
 *gfe g199: CLOSE PAYLOAD BAY DOORS
 *gfe g200: ADJUST HEATING/COOLING SYSTEMS
 *gfe g201: MONITOR GAS SUPPLIES
 *gfe g202: PRESSURIZE DETECTORS WHEN NEEDED
 *gfe g203: DEPRESSURIZE DETECTORS WHEN NOT IN USE
 *gfe g204: COMPUTE POSITIONS OF SUN, EARTH, MOON
 *gfe g205: DETERMINE ANGLES RELATIVE TO TELESCOPE LINE-OF-SIGHT
 *gfe g206: MONITOR BRIGHT OBJECT DETECTOR
 *gfe g207: MONITOR SAA DETECTOR
 *gfe g208: COMPARE DETECTOR OUTPUT TO PRESET LIMITS
 *gfe g209: CLOSE OPTICAL SHUTTERS
 *gfe g210: REDUCE VOLTAGES IN SENSITIVE EQUIPMENT

ORIGINAL PAGE IS
OF POOR QUALITY

*gfe g211: SHUTDOWN DETECTORS
*gfe g212: RECEIVE GROUND COMMANDS
*gfe g213: MOVE DETECTOR INTO POSITION
*gfe g214: DETECTOR POWER ON
*gfe g215: DETECTOR COOLING ON
*gfe g216: OPEN DETECTOR APERTURES
*gfe g217: FINE FOCUS DETECTOR
*gfe g218: TAKE DATA FROM DETECTOR
*gfe g219: TAKE DATA FROM ASPECT SENSOR
*gfe g220: PICK X-RAY SOURCE WITH KNOWN OPTICAL COUNTERPART
*gfe g221: DETERMINE IF TARGET IS WITHIN DETECTOR FOV
*gfe g222: DETERMINE IF TARGET IS WITHIN ASPECT SENSOR FOV
*gfe g223: SELECT NEW TELESCOPE ATTITUDE IF NECESSARY
*gfe g224: PROCESS IMAGE DATA
*gfe g225: DETERMINE ALIGNMENT CORRECTION
*gfe g226: ACTIVATE TMS SUBSYSTEMS
*gfe g227: COMPUTE EXPECTED TARGET POSITION
*gfe g228: ALIGN ORBITER WITH EXPECTED TARGET POSITION
*gfe g229: DEPLOY RENDEZVOUS SENSOR
*gfe g230: ACTIVATE RENDEZVOUS SENSOR
*gfe g231: TRACK TARGET
*gfe g232: COMPUTE TERMINAL PHASE GMS BURN
*gfe g233: DISCONNECT DETECTOR
*gfe g234: REMOVE DETECTOR
*gfe g235: STORE DETECTOR
*gfe g236: LOCATE DETECTOR
*gfe g237: INSTALL DETECTOR
*gfe g238: CONNECT DETECTOR
*gfe g239: AVOID TANK OVERPRESSURES
*gfe g240: MAINTAIN SAFE BATTERY CHARGE LEVELS
*gfe g241: MAINTAIN COMMUNICATION LINKS
*gfe g242: AVOID EXPOSING SENSITIVE COMPONENTS TO DIRECT SUNLIGHT
*gfe g243: TRACK NEARBY OBJECTS
*gfe g244: AVOID CONFLICTING OBJECTS
*gfe g245: OBSERVE TUMBLING SPACECRAFT
*gfe g246: DETERMINE SPACECRAFT PRINCIPAL SPIN AXIS
*gfe g247: SPIN UP DEBRIS CAPTURE DEVICE
*gfe g248: BRAKE DEBRIS CAPTURE DEVICE
*gfe g249: RELEASE SPACECRAFT FROM DEBRIS CAPTURE DEVICE
*gfe g250: CHECK EXPERIMENTAL PACKAGE INTERFACE
*gfe g251: RETRACT RADIATORS
*gfe g252: ORIENT THRUSTERS
*gfe g253: ORBITER AND SP VELOCITY AND TRAJECTORY ADJUSTMENTS
*gfe g254: ACTIVATE DOCKING ADAPTER
*gfe g255: DOCKING OF SHUTTLE ADAPTER TO SPACE PLATFORM
*gfe g256: SP BERTHING ON DOCKING ADAPTER
*gfe g257: STOW OLD PAYLOAD IN ORBITER
*gfe g258: LOCATE NEW PAYLOAD
*gfe g259: ATTACH NEW PAYLOAD TO SP
*gfe g260: SP/PAYLOAD INTERFACE CHECKOUT
*gfe g261: TRANSFER OPERATIONAL CONTROL FROM MISSION TO PAYLOAD CONTROL
*gfe g262: UNDOCKING OF ORBITER FROM SP
*gfe g263: COMPARE TEMPERATURE TO REQUIRED LIMITS
*gfe g264: MONITOR MICRO-GRAVITY LEVELS
*gfe g265: IDENTIFY SHAPE, SIZE IN BIN
*gfe g266: MATCH WITH SAMPLE MODEL
*gfe g267: POSITION MANIPULATOR (ON RAILS)
*gfe g268: GRASP SAMPLE
*gfe g269: TRANSPORT SAMPLE TO EXPERIMENT AREA
*gfe g270: OPEN HOLDER
*gfe g271: INSERT SAMPLE
*gfe g272: CLOSE HOLDER
*gfe g273: ACTIVATE FAIL-SAFE SUBSYSTEM(S)
*gfe g274: CHECK ALIGNMENT WITH ALIGNMENT CRITERIA
*gfe g275: SET (OR EVACUATE) FURNACE ATMOSPHERE
*gfe g276: ACTIVATE EXPERIMENTAL PROCESS SPECIFIC EQUIPMENT
*gfe g277: MEASURE COMPONENT TEMPERATURE
*gfe g278: ACTIVATE FURNACE TEMPERATURE-MAINTAINING UNIT
*gfe g279: INITIATE GAS ANALYZER OPERATION
*gfe g280: RECORDING AND ON-BOARD STORAGE OF DATA

CRITERIA
OF POOR

*gfe g281: MEASURE EXPERIMENTAL DATA, WITH SPEC. INSTRUMENTATION
*gfe g282: COOL SAMPLE
*gfe g283: ADJUST FURNACE PRESSURE TO SAFE LEVEL
*gfe g284: GET SAMPLE WITH SAMPLE HOLDER
*gfe g285: REMOVE SAMPLE FROM FURNACE
*gfe g286: RELEASE SAMPLE FROM SAMPLE HOLDER
*gfe g287: REMOVE SAMPLE FROM HOLDER
*gfe g288: TRANSPORT SAMPLE TO STORAGE BIN
*gfe g289: RELEASE SAMPLE IN BIN
*gfe g290: PURGE GASES FROM FURNACE
*gfe g291: BAKEOUT FURNACE
*gfe g292: REPROGRAM PROCESS SET-POINTS AND CONTROLS
*gfe g293: DEFROST LIVE CELLS
*gfe g294: SUPPLY NUTRIENTS AND GASES
*gfe g295: REMOVE ORGANIC WASTES
*gfe g296: PUMP SAMPLE INTO CHAMBER
*gfe g297: PUMP MEDIA FLUID INTO CHAMBER
*gfe g298: TRANSMIT DATA TO GROUND PROCESSING CENTER
*gfe g299: WHEN SPECIFIED GROWTH PARAMS. REACHED, PREPARE SAMPLE FOR RETURN
*gfe g300: STORE PRODUCTS IN A CONTROLLED ENVIRONMENT FOR RETURN
*gfe g301: FLUSH SYSTEM WITH BIOCIDES, PRIOR TO NEXT CYCLE
*gfe g302: SP INTERFACE WITH PAYLOAD IS SHUTDOWN
*gfe g303: PAYLOAD INTERNAL POWER ACTIVATED
*gfe g304: ORBITER/PAYLOAD INTEGRATION CHECKOUT
*gfe g305: PRIORITY REMOVAL OF TIME-CRITICAL ITEMS
*gfe g306: PAYLOAD REMOVAL FROM ORBITER PROCESSING FACILITY
*gfe g307: SEND GROUND SIGNAL TO SP TO BEGIN SERV. SEQ.
*gfe g308: REDUCE POWER TO SUBSYSTEMS
*gfe g309: SHUTDOWN EXPERIMENTAL PACKAGES
*gfe g310: ORIENT NEW PAYLOADS
*gfe g311: ATTACH NEW PAYLOADS
*gfe g312: SHUTDOWN PAYLOADS
*gfe g313: SP ON INTERNAL POWER
*gfe g314: MEASURE MODULE ATMOSPHERIC TEMPERATURES
*gfe g315: COMPARE ATMOSPHERIC TEMPERATURES TO REQUIRED LIMITS
*gfe g316: MONITOR HABITAT PRESSURE, ATMOSPHERIC COMPOSITION
*gfe g317: COMPARE TO REQUIRED LIFE SUPPORT CONDITIONS
*gfe g318: ADJUST HABITAT-MAINTENANCE SUBSYSTEMS
*gfe g319: EVALUATE SOLAR ARRAY PERFORMANCE
*gfe g320: MONITOR HABITAT-MAINTENANCE SYSTEMS SUPPLIES
*gfe g321: MONITOR SUPPLIES, CONDITION OF PERISHABLES
*gfe g322: MONITOR EQUIPMENT INVENTORY
*gfe g323: MAINTAIN EMERGENCY CONSUMABLES RESERVE
*gfe g324: MONITOR RADIATION LEVELS
*gfe g325: MONITOR VITAL SIGNS OF CREW MEMBERS
*gfe g326: MONITOR REST, NUTRITION OF CREW MEMBERS
*gfe g327: UPDATE HABITAT MODEL
*gfe g328: EXCHANGE PERSONNEL, THROUGH DOCKING MODULE
*gfe g329: STORAGE OF CONSUMABLES IN HABITAT MODULE
*gfe g330: PRIORITY REMOVAL OF PERSONNEL