

N O T I C E

THIS DOCUMENT HAS BEEN REPRODUCED FROM
MICROFICHE. ALTHOUGH IT IS RECOGNIZED THAT
CERTAIN PORTIONS ARE ILLEGIBLE, IT IS BEING RELEASED
IN THE INTEREST OF MAKING AVAILABLE AS MUCH
INFORMATION AS POSSIBLE

✓
NASA Technical Memorandum 82988
AHS-RWP-19

Experimental Program for the Evaluation of Turbofan/Turboshaft Conversion Technology

✓
J. G. McArdle and L. M. Wenzel
*Lewis Research Center
Cleveland, Ohio*

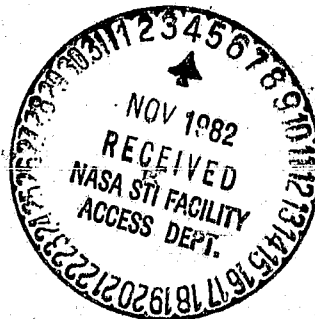

(NASA-TM-82988) EXPERIMENTAL PROGRAM FOR
THE EVALUATION OF TURBOFAN/TURBOSHAFT C
CONVERSION TECHNOLOGY (NASA) 25 p
HC A02/MF A01

N83-11130

CSSL 21E

Unclas

G3/07 01016

Prepared for the
Rotary Wing Propulsion System Specialist Meeting
sponsored by the American Helicopter Society
Williamsburg, Virginia, November 16-18, 1982

NASA

EXPERIMENTAL PROGRAM FOR THE EVALUATION OF TURBOFAN/TURBOSHAFT CONVERSION TECHNOLOGY

J. G. McArdle and L. M. Wenzel
National Aeronautics and Space Administration
Lewis Research Center
Cleveland, Ohio 44135

SUMMARY

E-1420

A TF34 turbofan engine is being modified to produce shaft power from an output coupling on the fan disk when variable inlet guide vanes are closed to reduce fan airflow. The engine, called a convertible engine, could be used on advanced rotorcraft such as X-wing, ABC (Advancing Blade Concept), and Folding Tilt Rotor, and on V/STOL craft in which two engines are cross-coupled. The engine will be tested on an outdoor static test stand at NASA Lewis Research Center. Steady-state tests will be made to measure performance in turbofan, turboshaft, and combined power output modes. Transient tests will be made to determine the response of the engine and a new digital engine control system for several types of rapid changes in thrust and shaft load. The paper describes the engine modifications, the test facility equipment, proposed testing techniques for several types of tests, and typical test results predicted from engine performance computer programs.

INTRODUCTION

Engines which can convert between turbofan and turboshaft power output modes, called convertible engines, could be used to power high-speed rotorcraft and V/STOL airplanes. For rotorcraft, the engine would drive a lifting rotor (shaft power output mode) for vertical and low-speed horizontal flight, and a thrust fan (turbofan power output mode) for high-speed horizontal flight. For a jet powered V/STOL airplane, the convertible feature could be used to cross-couple the fans in a two-engine configuration for safety in case one engine failed.

In a convertible engine, the power turbine drives both the fan and an output shaft connected to some other load. For turbofan power, the shaft load is removed or reduced, as by releasing a clutch. For turboshaft power, the fan is unloaded aerodynamically. Two general methods have been proposed to unload the fan (ref. 1). One method is based on variable-pitch fan blades - fan power is reduced as pitch is made "flatter". This method has been demonstrated in tests of engines such as QCSEE (ref. 2) and Q-FAN (ref. 3). The other method is based on variable inlet guide vanes (VIGV's) which can be deflected to change the fan airflow and inflow swirl - fan power is reduced as the flow and the pressure rise through the fan are made less. This method has been demonstrated in tests such as those reported in reference 4. Figure 1 (based on data in ref. 4) shows that over 50 percent thrust attenuation was obtained by closing the VIGV's 50 degrees.

Although the methods of varying the fan and shaft power loads have been demonstrated successfully, conversion between output modes while the engine is running has not yet been attempted. In recognition of the potential installation and performance advantages of convertible engines, the Defense Advanced

Research Project Agency (DARPA) and the National Aeronautics and Space Administration (NASA) have joined in a Convertible Engine System Technology (CEST) Program to establish the feasibility of the convertible engine concept. This program is intended to expand base technology, generate design criteria, and provide data and experience applicable to engines and controls for future convertible propulsion systems. The program includes defining requirements for convertible engine systems, and evaluating an engine system which could be used on advanced rotorcraft such as X-wing, ABC (Advancing Blade Concept), and Folding Tilt Rotor. The experimental work, the subject of this paper, will be done at the NASA Lewis Research Center with a modified TF34-400B engine. Major modifications will be the addition of VIGV's, a coupling on the fan disk for shaft power output, and controls to work in conjunction with the standard TF34 engine control system in shaft power output mode and during power output mode changes. Additional apparatus, such as variable fan exit guide vanes (VEGV's) and a core bleed valve, also will be installed so the engine can perform efficiently over its full operating range.

The experimental program was reported previously in reference 1, and has progressed in all areas since that paper was written. The present report will describe more details of the modified engine and test facility equipment, discuss proposed testing techniques, and show typical test results predicted from engine performance computer programs.

APPARATUS

Engine

A production TF34-400 engine is being modified for the CEST tests by the manufacturer, General Electric Company Aircraft Engine Business Group. The purpose of the modifications is to build a versatile research engine using as many existing parts as feasible. The resulting configuration is not intended to become a production engine. The major modifications are shown in figure 2. The fan will be unloaded aerodynamically by deflecting part-span variable inlet guide vanes (VIGV's) to change the flow rate and swirl angle of air entering the fan tip. The vanes are called "part-span" because they reach only from the outer duct wall to the core/bypass flow splitter, and thus have little effect on core flow when they are deflected. With the fan load reduced, the power turbine will drive an external load through a shaft coupled to the fan disk. The fan blades are the same as the standard TF34 blades except for the addition of a full-chord shroud, which becomes part of the flow splitter, now extended forward to the VIGV's. Variable exit guide vanes (VEGV's) will be used to improve fan stage efficiency, and to reduce metal stress and flow instability caused by increases in stator incidence angle when fan airflow is decreased. A valve will be built into the engine case between the fan hub and the core compressor to bleed air as necessary to maintain fan hub stall margin when hub and core engine flows are not matched (e.g., high shaft speed with low power and thrust). Bay cooling air will be drawn from the core flow just downstream of the bleed valve. Further description of the new CEST TF34 hardware is given in following paragraphs in this section.

Expected performance of the modified engine, herein called the CEST TF34 engine, is compared to the standard TF34 engine in Table I. Some important characteristics of the CEST TF34 engine are brought out in the tabulations. One characteristic is that significant thrust also is produced at maximum shaft

power, even though the VIGV's are in the most closed position. This thrust is caused by the core engine exhaust and by a small flow through the fan due to vane leakage. The thrust could be used for rotorcraft control, such as anti-torque or thrust vectoring. In addition, the estimated fan windage power is high in shaft power output mode. This power is consumed in churning the relatively stagnant air in the fan space, and might cause localized heating and material problems if the leakage flow is not sufficient for adequate cooling. Also, note that maximum thrust is less than the standard TF34. This is the result of locating the core/bypass flow splitter so that full core flow is attained at design shaft speed, thus permitting maximum shaft power. But as a consequence, the fan tip (bypass) flow area is decreased by the splitter frontal area, so total airflow, maximum thrust, and turbine power needed to drive the fan (indicated by $T_{4.5}$) are reduced. This situation would not be encountered in a new engine, as the fan design would be adjusted to size the core and bypass flows properly.

Variable Inlet Guide Vanes - A set of 30 vanes, previously used in the Propulsion Engine Technology (PET) program described in reference 4, will be mounted in front of the fan. Each vane will consist of a fixed forward strut and a movable rear flap. The flaps were altered after the PET program to pivot through 85 degrees, and are deflected together by a hydraulic actuator and a unison ring outside the fan case. When fully closed, bypass airflow is reduced about 90 percent.

Flow Splitter and Shrouded Blades - The core/bypass flow splitter will be extended forward of the VIGV's to provide VIGV structural support and to reduce core inlet radial distortion when the vanes are deflected (ref. 4). This modification requires addition of an integral full-chord shroud to the standard TF34 fan blades to act as part of the flow splitter. A sharp-edge, non-contacting seal is built into the front of the shroud to minimize hot gas leakage into the core when the VIGV's are closed. No seals are used at the aft or side edges of the shroud.

Variable Exit Guide Vanes (VEGV's) - The standard TF34 set of 44 fixed exit guide vanes will be replaced with a set of the same number of variable vanes. Each of the new vanes will consist of two shorter-chord airfoils in tandem, the front piece being movable and the rear piece fixed. The movable airfoils are deflected together through 60 degrees by a hydraulic actuator and a unison ring outside the fan case.

Shaft Extension - The fan shaft will be extended forward from the fan disk for shaft power output. The extension includes a flexible coupling and a bearing supported by a spider in a section of the inlet ducting. The duct section is mounted from a strongback which is also rigidly attached to the fan case. This arrangement will keep the shaft in factory alignment during engine transportation and operation at the NASA test stand. Dynamic analyses predict a shaft critical speed of 7650 rpm, which is safely above the maximum expected shaft speed during testing.

Core Bleed Valve - An annular sliding ring valve will be installed just aft of the VEGV's to bypass fan hub airflow not needed by the core engine during part-power operation. The valve will be moved by three hydraulic actuators evenly spaced around the engine. Maximum valve stroke will be 4.7 cm (1.85 in.).

Bay Cooling Air - Bay cooling air will be bled from the core engine inlet duct through orifice holes just downstream of the core bleed valve. The air is collected in a manifold and then distributed as needed to ventilate and cool the engine inside the core cowling. The core engine inlet temperature sensor will be mounted in the manifold to get an accurate measurement for the engine control system.

Inlet and Exhaust - All testing will be done with the standard TF34 separate-flow exhaust system, and with a bellmouth and long inlet duct having a combined flow straightener and FOD screen.

Engine Control System

The production standard TF34 hydromechanical engine control will be supplemented by a new digital control system. The controls, working together, will keep engine operation stable and safely within design limits and will enable the engine to respond to rapid thrust and shaft power demands. The controls operate on fuel flow, VIGV position, VEGV position, and core bleed valve position.

The efficacy of the control system will be evaluated in some of the tests by measuring the engine performance during simulated flight maneuvers. For these tests, the pilot's inputs to the engine control system will be effected by time-varying signals from programmable function generators. When the convertible engine is used for rotorcraft propulsion, these inputs are presumed to be as follows:

	<u>Rotorcraft</u>	<u>Test Stand</u>
Shaft Speed:	Reference speed ("Beeper")	Same as rotorcraft
Thrust:	Thrust lever or autopilot	Programmed thrust command
Shaft Load:	Collective pitch plus load from auxiliary equipment (circulation control compressors, hydraulics, etc.)	Programmed torque command

When the convertible engine is used for fixed wing propulsion (i.e., principally turbofan power output), these inputs are presumed to be as follows:

	<u>Aircraft</u>	<u>Test Stand</u>
Thrust (preferred method; requires "mode" switch):	Power lever (varies fan speed, VIGV's full open)	Same as aircraft
Thrust (alternate method):	Thrust lever or autopilot (fixed fan speed, VIGV position varies)	Programmed thrust command
Shaft Load:	Load from auxiliary equipment	Programmed torque command

The CEST TF34 engine control system, configured for rotorcraft propulsion, is shown in simplified block diagram form in figure 3. Shaft speed is held constant by a closed loop control system. The speed error signal is modified by torque and thrust anticipation signals to reduce speed droop during fast transients, and goes to the production control to operate the fuel valve. The shaft speed error signal also goes to a power priority bias circuit, which closes the VIGV's if the reference shaft speed cannot be maintained at limiting fuel flow. The thrust demand signal sets VIGV deflection position without reference to engine operating conditions. A VIGV position feedback signal is used to set VEGV vane position according to a pre-determined schedule, and to influence the core bleed valve schedule. The core bleed valve position is scheduled principally on shaft and core corrected speeds.

For fixed wing propulsion, the preferred control method is to lock the VIGV's in full-open position, then control thrust by varying fan speed (i.e., conventional turbofan practice), as stated previously. This method would require a "mode" switch to change control logic, but the same control system hardware could be used. An alternate control method uses the same control logic as for rotorcraft propulsion; for that, thrust would be varied by changing VIGV closure at constant shaft speed. This method may be desirable if the shaft load is intolerant to speed changes; however, the thrust specific fuel consumption is higher than with the variable fan speed control method for fixed wing propulsion.

Test Stand

The test site at the Lewis Research Center consists of an outdoor static test stand, a service shelter which is moved away on tracks before testing, and a control room about 120 meters (400 ft) from the engine inlet. A sketch of the engine mounted on the test stand is shown in figure 4. The engine (on a strongback as described previously) will be suspended from an overhead thrust system capable of measuring up to 44 500 newtons (10 000 lb) thrust. A drivetrain on the engine centerline will connect the dynamometer to the engine fan shaft extension, and contains a torque meter plus provision to mount a flywheel. The optional flywheel could be used to simulate the inertia of a flight rotor and transmission system.

Alignment and balance of the whole drivetrain from engine fan to dynamometer is critical to the success of this installation. The drivetrain is a complex assembly consisting of several bearings, spindles, and floating shafts connected by crowned gear-tooth couplings. Two of the couplings are oil lubricated and the remainder are grease lubricated. Each coupling is designed to tolerate up to 0.2 degrees of misalignment. The shaft will be balanced in parts and as an assembly before testing begins. With the dynamometer connected, the driveshaft will be spun up to full speed by an auxiliary motor from the engine end to assure satisfactory operation. The shaft will not be disassembled after that, and alignment will be checked periodically to assure that it remains within allowable limits.

Power Absorber System

The engine shaft load will be provided by the power absorber system. Load power is shaft torque multiplied by shaft speed. Torque, which simulates rotorcraft rotor torque plus all other shaft loads, will be developed by a

perforated disk waterbrake dynamometer. The dynamometer characteristics are shown in figure 5. At any given speed, torque is increased by increasing the water flow rate through an inlet valve. The absorbed power is converted to heat, and raises the water exit temperature. The waterbrake can absorb up to 7450 kilowatts (10 000 HP) at 10 000 rpm, corresponding to 7120 newton-meters (64 000 in.-lb) torque. This capability is adequate for the TF34 CEST test program.

A schematic of the power absorber system is shown in figure 6. Filtered cooling tower water will be supplied to the system at constant flow rate and constant pressure through a long 20-centimeter (8-in.) pipe. Shaft torque, measured by a torquemeter in the power driveline, is compared to a torque command signal to produce a torque error signal. A three-way inlet water valve, responding to the error signal, will direct the required flow into the waterbrake and the excess into a bypass line. Both flows will be collected in an open sump for return to the cooling tower. In this design, the system will respond more quickly to torque command changes because the waterbrake is isolated effectively from water inertia effects in both the supply and return lines.

For steady-state tests the desired constant dynamometer torque can be set by manually adjusting the inlet water valve. For transient tests, however, manual operation is not feasible because the torque must be varied with time to simulate loads from flight maneuvers. Examples of transient loads to be simulated are pilot induced loads from collective pitch changes, conversion between fixed wing and rotary modes, and unexpected load changes such as sudden wind gusts. For these transient tests, shaft power will be set by the waterbrake operating with a closed loop torque control.

A simplified block diagram of the systems used to generate torque command signals is presented in figure 7. A programmable function generator is used to provide a time varying signal, $TRQ(t)$, representing all the torque requirements imposed on the engine except load perturbations caused by deviations from the reference speed setting. An anticipation signal is directed to the engine control system for simulated transients initiated by pilot command, such as collective pitch changes, so that the fuel control can begin to accommodate a forthcoming shaft speed change before it actually occurs. For simulated transients other than X-wing conversions, the $TRQ(t)$ output is adjusted for rotor system damping and inertial effects. These adjustments are based on the 15.2 meter (50 ft) diameter X-wing rotor system described in reference 6. The rotor damping effect, following the "propeller law", is proportional to the square of measured shaft speed times a damping coefficient related to the rotor characteristics. The rotor inertia effect is calculated from the rate of change of measured shaft speed and a constant representing the polar moment of inertia for the engine shaft load (principally the rotor and speed reducing transmission in the rotor drive system). For X-wing conversion maneuvers it is assumed that the clutch in the rotor power transmission system will be programmed to keep the rotor speed changing at a constant rate. This assumption, plus the fact that the conversion is a slow engine transient, makes adjustments for rotor system damping and inertia effects unnecessary. Thus, for the X-wing conversion transient tests, all the shaft load requirements are contained in the programmed $TRQ(t)$.

The dynamic capability, i.e., the rapidity with which torque can be changed, of the power absorber system has been examined. An analysis indicated that the maximum rate of change of torque attainable was 9500 newton-meter/sec (7000 ft-lb/sec). This limit, compared with the rates of change of torque required for typical maneuvers and transients, is shown in figure 8. The line shows the calculated capability of the system; the system will respond satisfactorily to torque commands having time rates of change less than the limit defined by the line. The symbols represent demands from the most important transient tests. It is judged that the overall response of the power absorber system is fast enough to determine accurately the performance and dynamic characteristics of the engine and control for simulated critical flight maneuvers.

Instrumentation

For the steady-state CEST TF34 tests, the measurement capability will be as follows:

Digital Data

- a. Up to 360 scani-valve pressure measurements
- b. Up to 288 thermocouple temperature measurements
- c. Up to 100 other measurements (e.g., thrust, torque, speeds, etc.)

Dynamic Analog Data

- a. Ten strain gages and 12 thermocouples on fan blades (data via telemetry)
- b. Fourteen strain gages on variable vanes
- c. Photo-electric scanner system for blade vibration or flutter (see ref. 5 for description)
- d. Seven fast-response wall pressure transducers for stall detection and propagation characteristics
- e. Twenty vibration pickups to detect unbalance or misalignment

The most important performance data, such as thrust, torque, speed, etc, will be measured several times in the sampling pattern to obtain good time averaged data.

For the transient tests, the same instrumentation generally will be used because load changes will not be sufficiently rapid to require high-frequency-response transducers. The prime data records, however, will be analog recordings that can be displayed as time based graphs.

Digital data will be acquired on the laboratory's central data system and batch processed on an IBM 370 computer. Dynamic analog data will be recorded on strip charts and magnetic tape in the control room.

TESTS

Three types of tests will be performed with the CEST TF34 engine at Lewis Research Center: steady-state performance tests, transient load tests, and simulated X-wing conversion tests.

For the steady-state performance tests data will be obtained throughout the useful operating range of the engine in turbofan, turboshaft, and combined power output modes. These tests also will expose any undesirable character-

istics, such as stall or flutter, which might unexpectedly limit operation of this engine. Additionally, the data will improve understanding of the unusual fan flow processes and mechanical stresses that occur when the VIGV's are deflected. The final results will be used to estimate the performance of future aircraft powered by convertible engines, and to aid design of new convertible engines.

For the transient load tests the response of the engine with the new digital control system will be measured for several types of rapid changes in thrust and shaft load. The required transient loads were determined by X-wing study contractors. The transients will represent typical flight maneuvers. In addition, some more severe transient loads will be tested to investigate the engine control system capability. Control system parameters may be changed to improve performance, and to explore potential control problems and effects on engine behavior.

For the simulated X-wing conversion tests, stable conversion from each power output mode to the other will be demonstrated using the new engine control system. The power mode requirements will be based on the contractors' studies. (The X-wing, figure 9, is a proposed new type of V/STOL craft which takes off and lands vertically with a lifting rotor, and flies horizontally at high speed using fan thrust with the rotor stopped. The rotor utilizes circulation control lift augmentation powered by large air compressors. Conversion between flight modes takes place at 1500 meters (5000 ft) altitude, 250 knots airspeed. A complete description of the X-wing and its propulsion requirements, including use of a convertible engine, is given in ref. 6).

Before delivery to Lewis, the CEST TF34 engine will be checked out in turbofan power mode in a factory test cell. The first runs at Lewis will be made without the dynamometer, and will repeat some of the factory tests to validate the installation and data systems, and to calibrate some of the air-flow measuring stations. Then the engine will be connected to the dynamometer for checkout of the power absorber system and its controls.

Steady-State Performance Tests

The steady-state performance tests will not require the new CEST TF34 digital electronic control. The standard TF34 engine control (see fig. 3) will be used, along with auxiliary controls to maintain a manually set reference shaft speed. The power lever, dynamometer torque command, VIGV position, VEGV position, and core bleed valve will be operated manually.

Performance data will be obtained throughout the useful operating range of the engine in turbofan, turboshaft, and combined power output modes. The VEGV angular position will be varied with VIGV closure angle for optimum performance according to relationships developed from fan aerodynamic analyses. These relationships will be checked to determine if they are essentially correct for at least one shaft speed setting by measuring thrust changes and/or metal stress changes (strain gage data) when the VEGV angle is moved away from the analytical optimum position. The core bleed valve will be adjusted as necessary to keep the fan hub always on the design operating line.

A meaningful way to display convertible engine data is by means of graphs of the type shown in figure 10. This figure shows the predicted engine performance for constant corrected shaft speed and for core bleed needed to maintain the fan hub design operating line. The graph indicates that the engine

can develop almost any combination of thrust and shaft power by appropriate adjustment of the VIGV closure angle and the core bleed valve. Plots for other shaft speeds show similar performance trends. Experimental data will be obtained to compare the measured performance at selected speeds with the analytical predictions. Maximum shaft speed (turboshaft mode) is of most present interest, so performance will be studied most extensively at that speed. If the experimental performance trends deviate significantly from the expected trends, additional data may be obtained to investigate the differences, and to revise the computer program.

Data from the steady-state performance tests will be used to set up the limits and control schedules for the transient load tests.

Transient Load Tests for Rotorcraft Propulsion Systems

For all the transient tests, the new CEST TF34 engine control system (fig. 3) will be used, with torque and thrust command programs, $TRQ(t)$ and $F_N(t)$ respectively, entered by the programmable function generators. Examples of transient propulsive loads expected from typical flight maneuvers will be discussed here. Computer studies show that the engine will also be stable for more severe transients.

Thrust and torque command programs to simulate a thrust transient are illustrated in figure 11. This type of transient might occur during X-wing acceleration to conversion speed after take-off. In this transient the engine thrust increases to a significantly higher level in 1.5 seconds, while the shaft load remains constant at relatively low power. The engine response to this input, predicted by a dynamic performance computer program, is shown in figure 12. With no time lag, the VIGV closure angle changes in accordance with the command signal. Fuel flow increases, and the core engine accelerates to raise the engine power level. Shaft speed dips slightly, but quickly returns to the original reference speed. Shaft load oscillates somewhat as the transient proceeds because of the lightly damped torsional resonance of the rotor/shaft system in the rotorcraft which is simulated in the computer program. These oscillations will not occur during the tests, but that is not important in determining the behavior of the engine and control system. The net result of the transient is a prompt and smooth increase in thrust, which continues to rise to the desired value (after the final VIGV position has been attained) as the core engine speed increases to its new steady-state value. These results were obtained with a thrust anticipation signal (see fig. 3). Without anticipation, calculations show that shaft speed undershoot and overshoot during rapid transients would be about twice the amounts shown in figure 12 and in the other transient performance figures in this report.

Thrust and torque command programs for a simulated shaft load transient, rotorcraft take-off, are shown in figure 13. In this transient both thrust and shaft load increase significantly in 1.5 seconds. The computed engine response is shown in figure 14. As in the previous example, the VIGV closure angle changes with no time lag, causing fuel flow to increase and the core engine to accelerate. The shaft speed slightly undershoots, then overshoots, the reference speed. Both the thrust and shaft load increase promptly with little or no overshoot.

Transient Load Tests for Fixed Wing Propulsion System

As described previously, the preferred control strategy for fixed wing propulsion requires a "mode" switch that sets the VIGV's to full open position. Then, thrust is varied by changing shaft speed in the same manner as conventional turbofan engines. For transient tests in this mode, thrust demands will be simulated by power lever changes such as snap (less than one second) accelerations and decelerations. As the thrust and shaft speed change during the transient, the shaft torque could be held constant by means of a constant command from the programmable function generator. Or, shaft power could be held constant using an additional feedback circuit based on measured shaft speed.

For the "alternate" engine control system described previously, transient tests will be done using programmable function generators for both thrust and torque commands, as in the transient load tests for rotorcraft propulsion systems.

Simulated X-Wing Conversion Tests

These tests are similar to the transient load tests for rotorcraft propulsion systems previously discussed, and will use the same control system and test equipment. The X-wing rotorcraft characteristics and conversion requirements are from reference 6.

Typical flight propulsion demands for a two-engine X-wing craft during a rotor-start conversion are shown in figure 15. Conversion is actually a relatively slow maneuver, taking 18 seconds to accomplish. For that reason, conversion is not expected to strain the engine. The total shaft load is made up of main rotor system torque and circulation control compressor load torque. The main rotor system torque consists of rotor aerodynamic torque, which is only about 135 newton-meters (100 ft-lbs) at full rotor speed, and rotor and transmission system acceleration torque. The acceleration torque requirement assumes that rotor acceleration is constant throughout conversion. The slopes at the beginning and end of the main rotor load curve are associated with clutch engagement times. The compressor load is high because a large quantity of air is needed to blow the rotor leading and trailing edges. Thrust increases during conversion for control purposes, and to counteract parasitic drag and aft tilt of the main rotor. Aft tilt is used in X-wing rotary mode flight for partial auto-rotation, which reduces shaft power requirements.

The conversion maneuver will take place at 1500 meters (5000 ft) altitude, 250 knots airspeed. At those flight conditions, engine performance is significantly different than at static test stand conditions, chiefly because of the reduction in net thrust from inlet momentum. This performance difference complicates conversion simulation in a test stand. Engine performance graphs at the flight and test stand conditions are shown in figure 16. For a rotor-start conversion, the engine operating point traverses in 18 seconds from A to B in figure 16(a). For the same shaft powers and net thrusts at test stand conditions, indicated by points A' and B' in figure 16(b), the simulation is not satisfactory because of large discrepancies in VIGV closure angles and core engine power levels. Duplication of internal performance, rather than thrust and shaft load, is desired for the most meaningful tests of engine and

control system behavior. On this basis, the engine operating point will traverse from C to D for a simulated rotor-start conversion. VIGV angles, corrected core speed, power turbine inlet temperature, and other important internal performance parameters are acceptably similar to the flight conversion parameters, although the thrust and shaft power changes are greater.

The thrust and torque command programs for a simulated rotor-start conversion are shown in figure 17. The TRQ(t) spike at 18 seconds is allowance for the possibility that the clutch "grabs" at lockup because the rotor has not attained programmed speed.

Engine response during the simulated conversion is shown in figure 18. As in the other tests, the thrust increase at nominally constant shaft speed requires a change in VIGV closure angle. This change, plus the sudden torque changes at conversion start, results in shaft speed undershoot, then overshoot, from the reference speed. Other engine parameters behave in the expected manner throughout conversion.

CONCLUDING REMARKS

A joint NASA-DARPA program to establish the feasibility of the convertible engine concept has been described. The program includes evaluation of an engine system which could be used on advanced rotorcraft such as X-wing, ABC (Advancing Blade Concept), and Folding Tilt Rotor. The experimental work will be done at NASA Lewis Research Center with a modified TF34-400B engine. Major modifications will be the addition of variable inlet guide vanes, a coupling on the fan disk for shaft power output, and controls to work in conjunction with the standard TF34 engine control system in shaft power output mode and during power output mode changes. Planned tests include steady-state performance tests, transient load tests in both power output modes, and simulated X-wing conversion maneuvers. Results of typical tests, as predicted by digital computer programs, have been shown. The engine is expected to operate stably in both power output modes and in all transient load tests.

Engine delivery is scheduled for February, 1983. Engine and facility preparation work is underway and progressing well in all areas. No large unexpected problems have been encountered. Test operations are expected to start in May, 1983.

REFERENCES

1. Abdalla, K.L.; and Brooks, A.: TF34 Convertible Engine System Technology Program. Presented at the 38th Annual Forum of the American Helicopter Society, (Anaheim, CA), May 1982.
2. Under-the-Wing (UTW) Engine Composite Nacelle Test Report, Detailed Engine Performance. (R78AEG573-Vol-1, General Electric Co., NASA Contract NAS3-18021.) NASA CR-159471, 1979.
3. Schaefer, J.W.; Sagerser, D.A.; and Stakolich, E.G.: Dynamics of High-Bypass-Engine Thrust Reversal Using a Variable-Pitch Fan. NASA TM X-3524, 1977.
4. Bobula, G.A.; Soeder, R.H.; and Burkardt, L.A.: Effect of a Part-Span Variable Inlet Guide Vane on the Performance of a High-Bypass Turbofan Engine. NASA TM 82617, 1981.
5. Nieberding, W. C.; and Pollack, J. L.: Optical Detection of Blade Flutter. ASME Paper 77-GT-66, March, 1977.
6. Williams, R.M.; and Boyd, T.H.: Preliminary X-Wing Characteristics and Propulsion Interface Document, DTNSRDC/TM-16-81/06, David W. Taylor Naval Ship Research and Development Center, 1981.

**ORIGINAL PAGE IS
OF POOR QUALITY**

TABLE I. - COMPARISON OF CEST TF34 AND TF34-400 ENGINES AT MAXIMUM
POWER RATING, SEA-LEVEL-STATIC, STANDARD-DAY CONDITIONS

	CEST TF34		Standard TF34-400
	Shaft power output mode	Fan power output mode	
Fan diameter, cm (in.)	112 (44.0)	112 (44.0)	112 (44.0)
Fan blades, number	28	28	28
Shaft speed, rpm	6890*	6890*	6890*
Fan tip pressure ratio	-	1.44	1.48
Inlet corrected air- flow, kg/sec (lb/sec)	33.4 (73.6)	146 (322)	154 (340)
Bypass ratio	0.53	6.22	6.26
Thrust, N (lb)	7730 (1740)	36 600 (8220)	41 300 (9280)
Shaft power, kW (hp)	3930 (5270)**	0	-
Power turbine inlet temperature, T _{4.5} , K (°R)	1078 (1940)*	1042 (1876)	1078 (1940)*
VIGV angle, deg	85*	0	-

*Design or operating limit

**Estimated fan windage power = 1040 kW (1400 hp)

ORIGINAL PAGE
BLACK AND WHITE PHOTOGRAPH

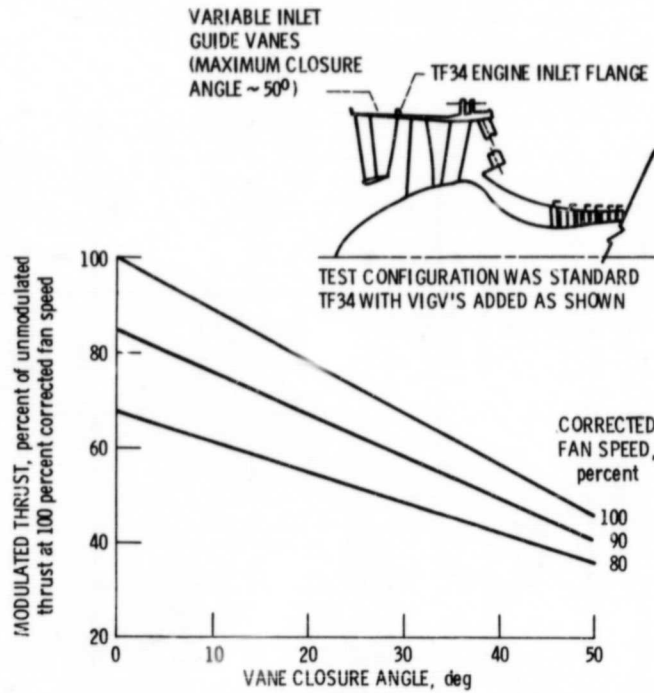

Figure 1. - Thrust modulation with variable inlet guide vanes. Data from reference 4.

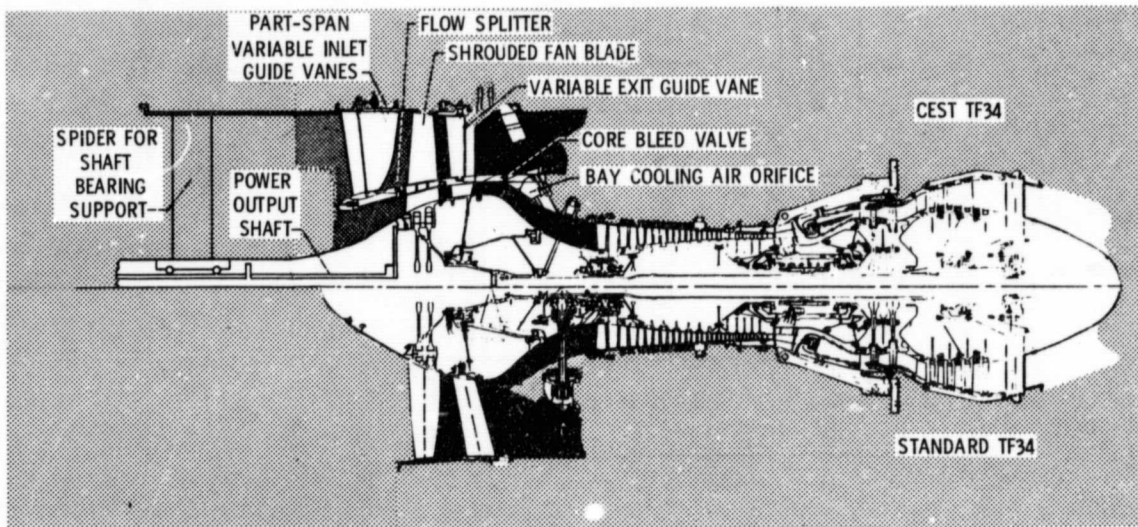

Figure 2. - CEST TF34 compared to standard TF34 engine.

ORIGINAL PAGE IS
OF POOR QUALITY

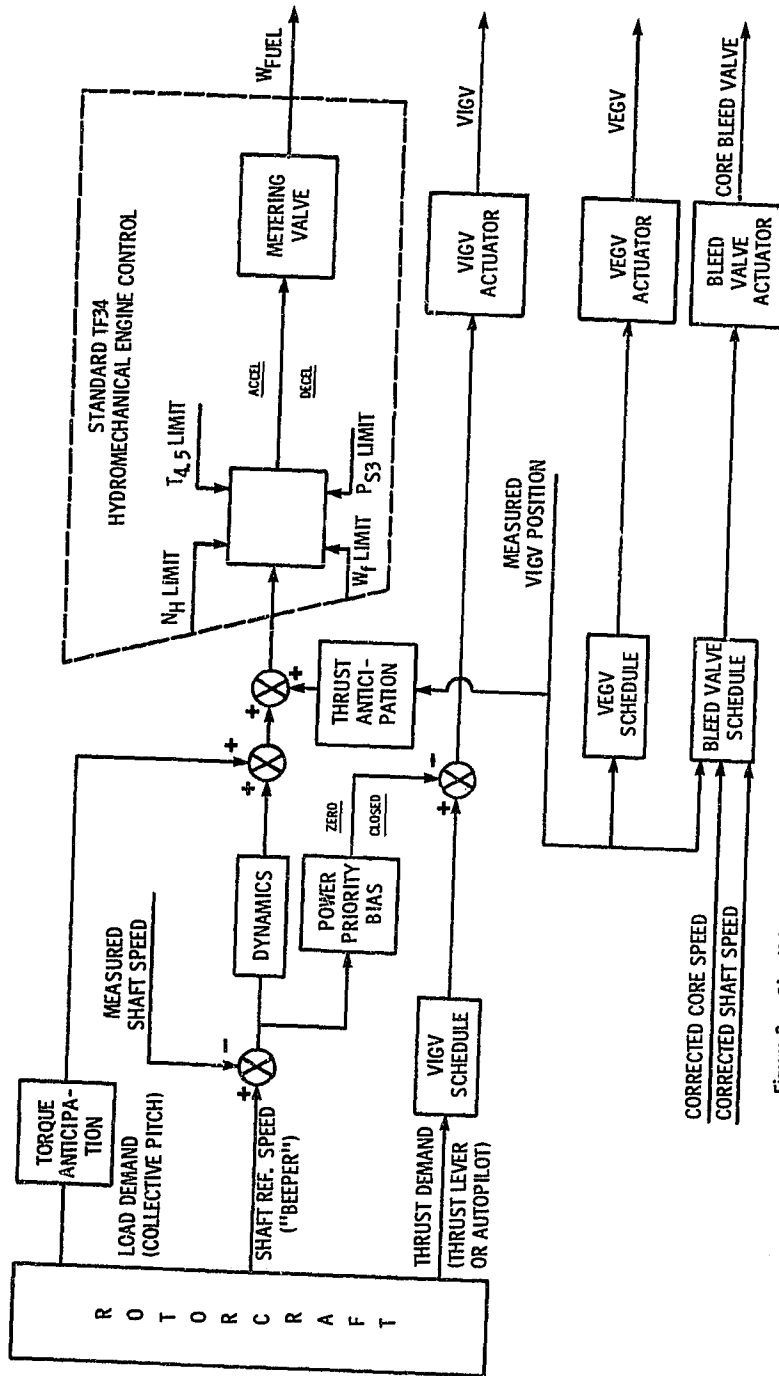

Figure 3. - Simplified CEST TF34 engine control system configured for rotorcraft propulsion.

ORIGINAL PAGE IS
OF POOR QUALITY

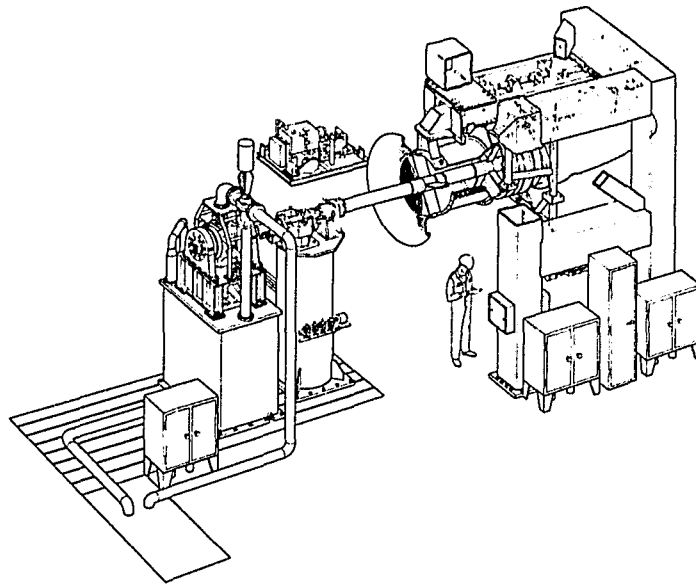

Figure 4. - CEST TF 34 on test stand at NASA Lewis Research Center.

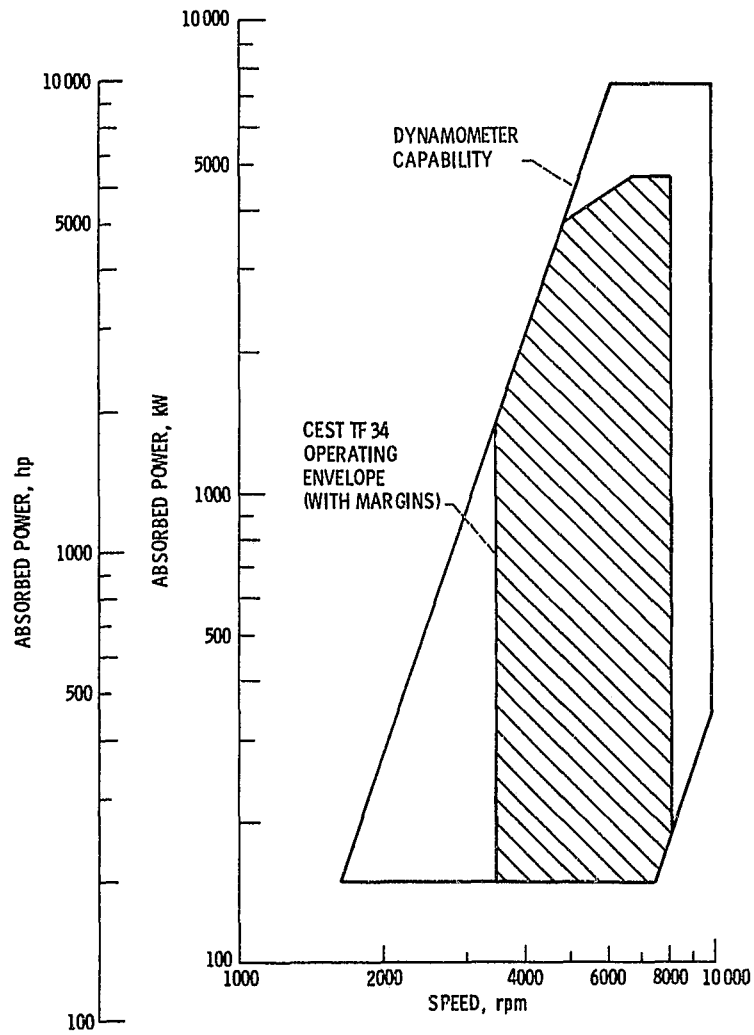

Figure 5. - Waterbrake dynamometer capability.

ORIGINAL PAGE IS
OF POOR QUALITY

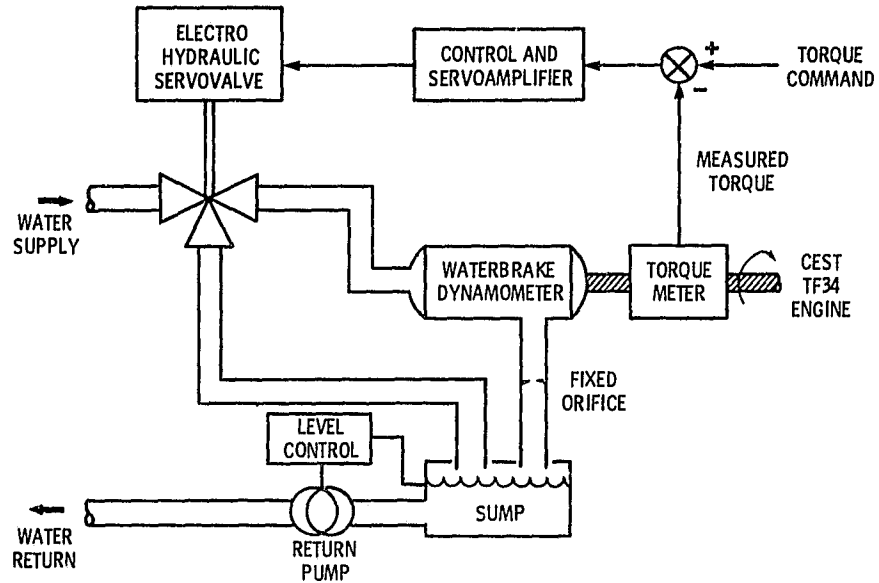

Figure 6. - Power absorber system.

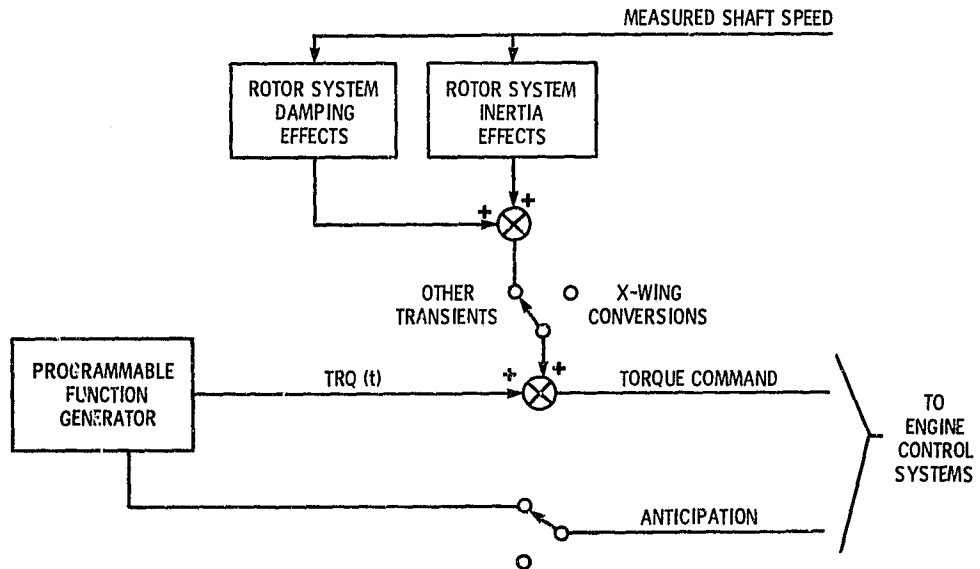

Figure 7. - Simplified block diagram of torque command system.

ORIGINAL PAGE IS
OF POOR QUALITY

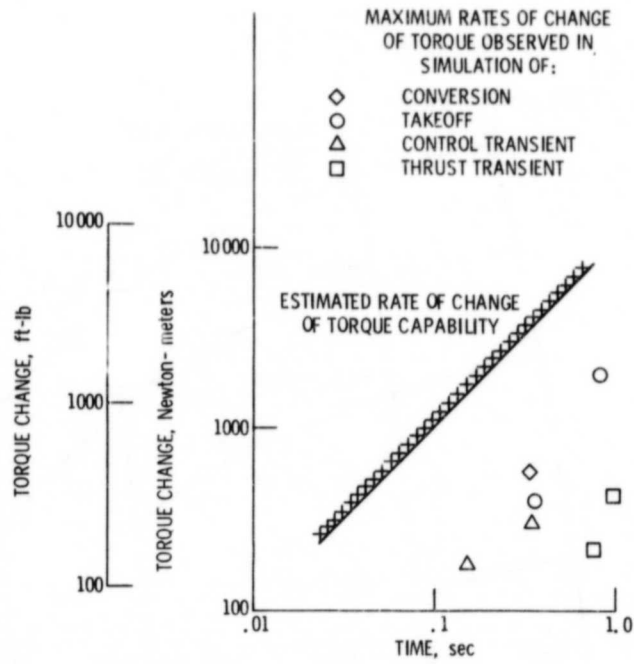

Figure 8. - Dynamic capability of power absorber system.

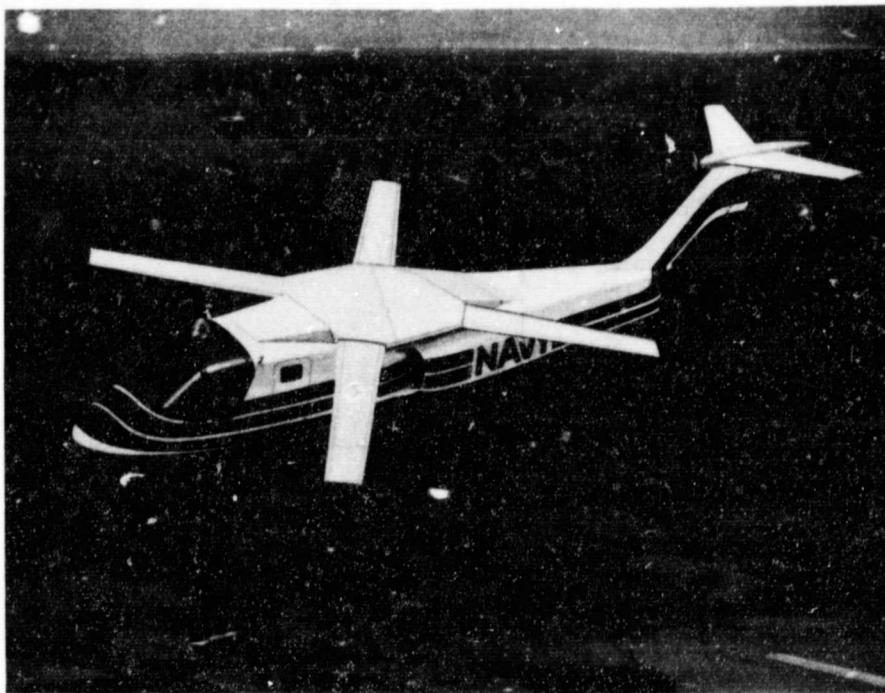

Figure 9. - X-wing rotorcraft studied by DARPA.

ORIGINAL PAGE IS
OF POOR QUALITY

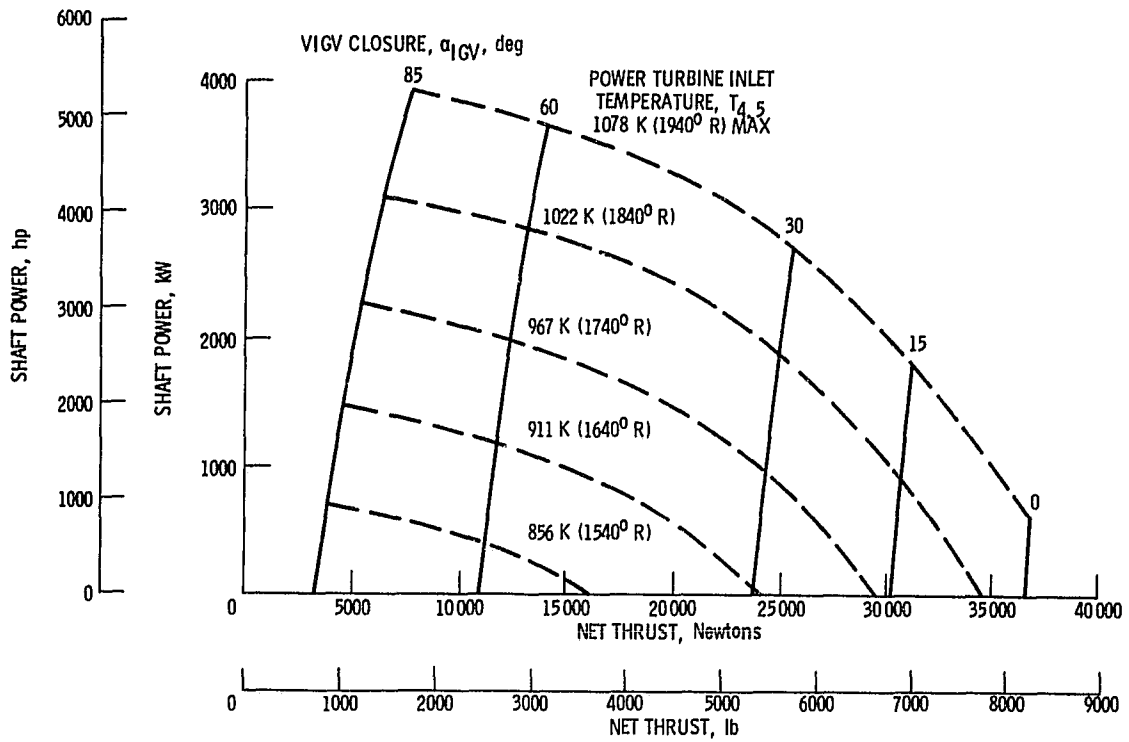

Figure 10. - Predicted CEST TF 34 engine performance at sea-level static conditions, 6890 rpm shaft speed.

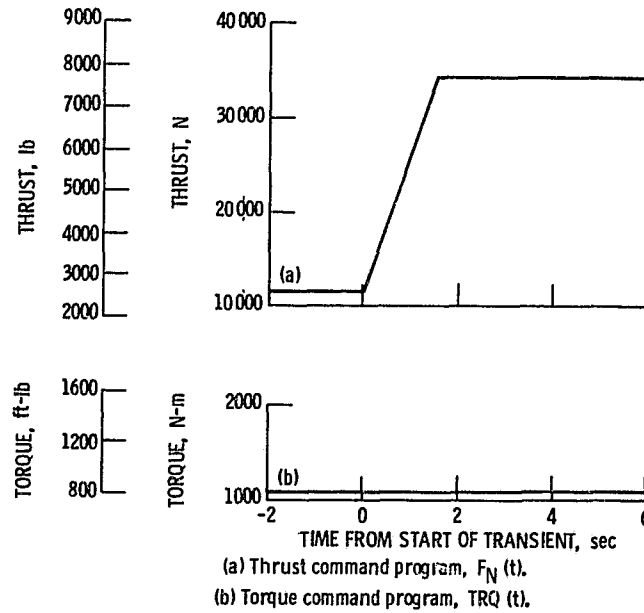

Figure 11. - Thrust and torque command programs for simulation of rotorcraft thrust transient at 6890 rpm shaft speed.

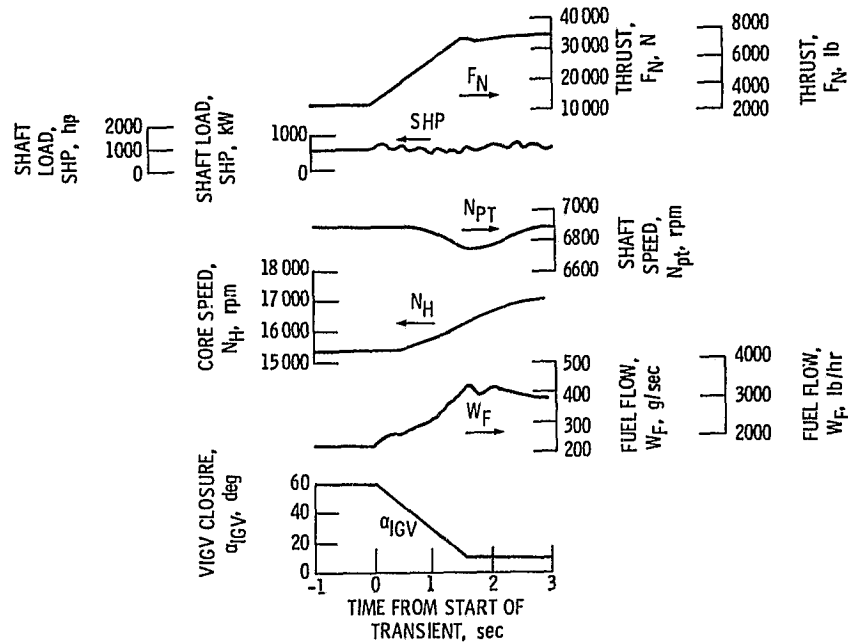

Figure 12. - Engine response to rotorcraft thrust transient.

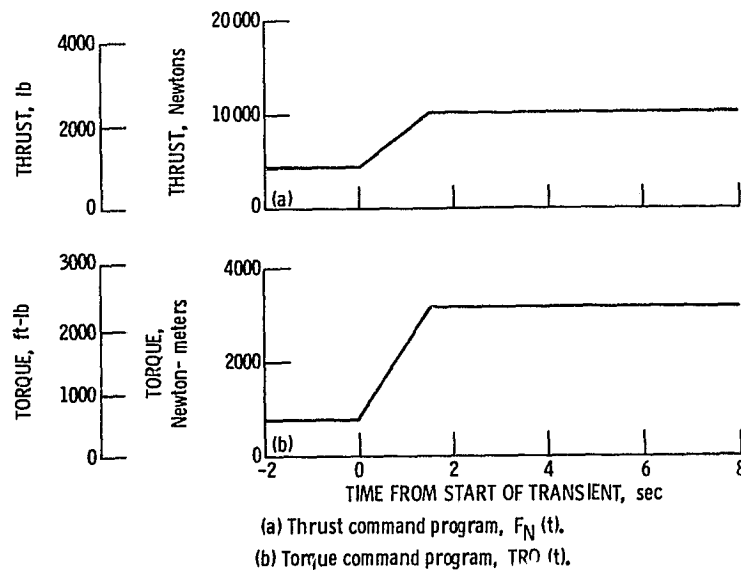

Figure 13. - Thrust and torque command programs for simulation of rotorcraft take-off at 6890 rpm shaft speed.

ORIGINAL PAGE IS
OF POOR QUALITY

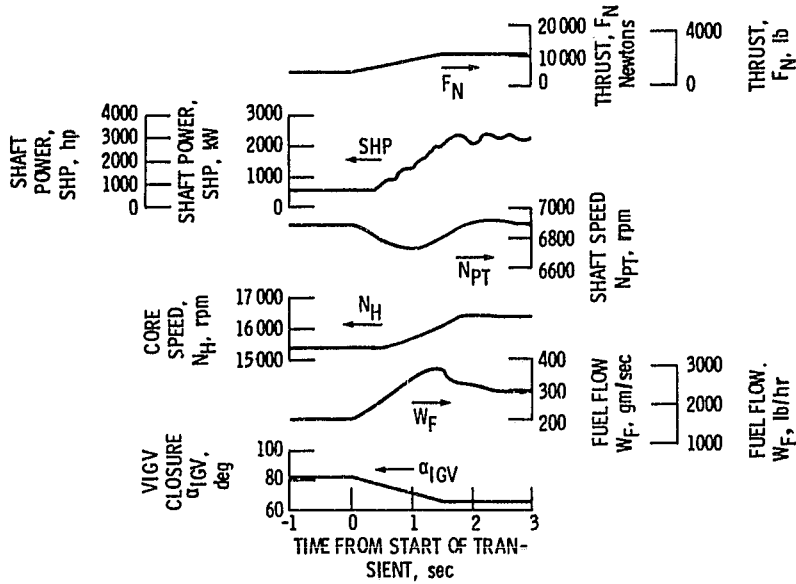

Figure 14. - Engine response to rotorcraft take-off transient.

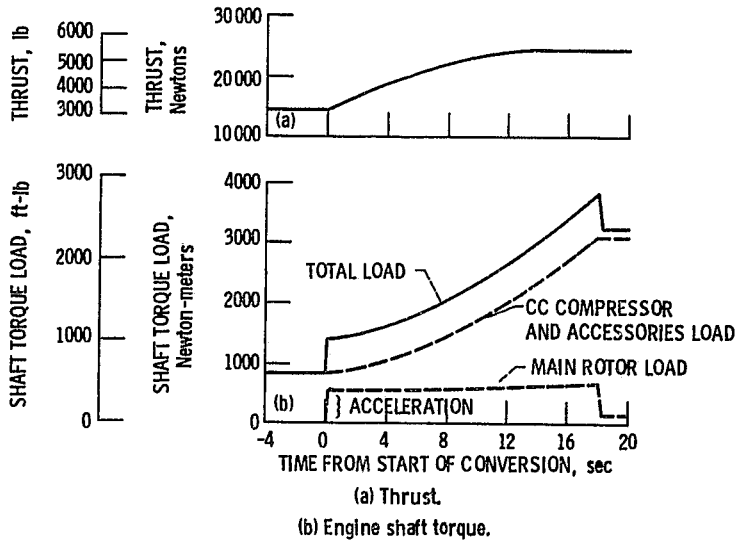

Figure 15. - X-wing rotorcraft total demand during rotor-start conversion. 13 600-kg (30 000-lb) craft; 15.2-m (50 ft) diameter rotor; 1500-m (5000 ft) altitude; 250 kn airspeed.

ORIGINAL PAGE IS
OF POOR QUALITY

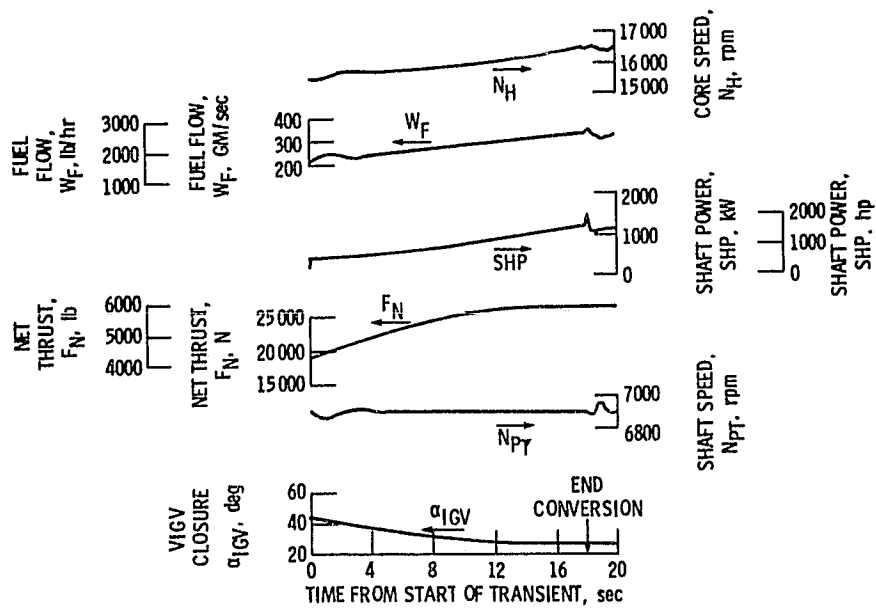
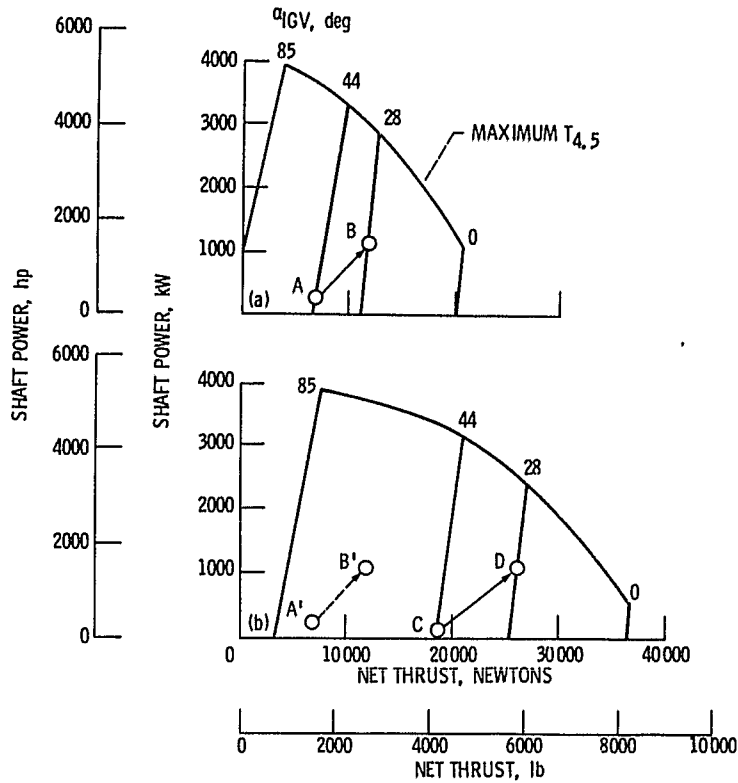

Figure 18. - Engine response to simulated X-wing rotor-start conversion.

ORIGINAL PAGE IS
OF POOR QUALITY



(a) X-wing conversion at 1500 m (5000 ft) altitude, 250 Kn air-speed (each of two engines).

(b) Sea-level-static test stand simulation of conversion.

Figure 16. - Test stand simulation of X-wing rotor-start conversion, shaft speed 6890 rpm.

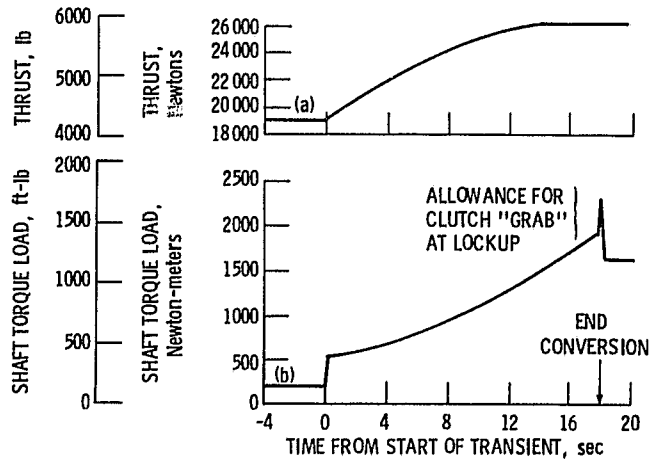

(a) Thrust command program, $F_N(t)$.

(b) Torque command program, $TRQ(t)$.

Figure 17. - Thrust and torque command programs for test stand simulation of X-wing rotor-start conversion.