

General Disclaimer

One or more of the Following Statements may affect this Document

- This document has been reproduced from the best copy furnished by the organizational source. It is being released in the interest of making available as much information as possible.
- This document may contain data, which exceeds the sheet parameters. It was furnished in this condition by the organizational source and is the best copy available.
- This document may contain tone-on-tone or color graphs, charts and/or pictures, which have been reproduced in black and white.
- This document is paginated as submitted by the original source.
- Portions of this document are not fully legible due to the historical nature of some of the material. However, it is the best reproduction available from the original submission.

COMMUNICATIONS SATELLITE NO. 2
(CS-2)

Communications and Broadcasting
Satellite Organization

(NASA-TM-76950) COMMUNICATIONS SATELLITE
NO. 2 (CS-2) (National Aeronautics and Space
Administration) 69 p HC A04/MF A0A CSCL 17B

N83-11406

Unclas
G3/32 01054

Translation of "Tsushin eisei 2 go", Japanese Report
Communications and Broadcasting Satellites Organization,
Tokyo, Japan, January, 1982, pp. 1-49.



ORIGINAL PAGE 13
OF POOR QUALITY

STANDARD TITLE PAGE

1. Report No. NASA TM-76950		2. Government Accession No.		3. Recipient's Catalog No.	
4. Title and Subtitle COMMUNICATIONS SATELLITE No. 2				5. Report Date OCTOBER 1982	
				6. Performing Organization Code	
7. Author(s) Communications and Broadcasting Satellite Organization				8. Performing Organization Report No.	
				10. Work Unit No.	
9. Performing Organization Name and Address SCITRAN Box 5456 Santa Barbara, CA 93108				11. Contract or Grant No. NASw- 3542	
				12. Type of Report and Period Covered Translation	
12. Sponsoring Agency Name and Address National Aeronautics and Space Administration Washington, D.C. 20546				14. Sponsoring Agency Code	
				15. Supplementary Notes Translation of "Tsushin eisei 2 go". Japanese Report Communications and Broadcasting Satellites Organization, Tokyo, Japan, January, 1982, pp. 1-49.	
16. Abstract The communications satellite (CS-2) was developed as the most recent practical communications satellite in Japan as a result of developing the practical medium size geostationary communications satellite (CS). The purpose of the CS-2 is to provide national communications and industrial communications, such as special emergency and remote communications, and to contribute to the development of technology pertaining to communications satellites. Description and operating parameters of the following satellite components are presented: structure, communications system, telemetry/command system, electric power system, attitude and antenna control system, secondary propulsion system, apogee motor, framework, and heat control system.					
17. Key Words (Selected by Author(s))			18. Distribution Statement UNLIMITED		
19. Security Classif. (of this report) Unclassified		20. Security Classif. (of this page) Unclassified		21. No. of Pages 68	22. Price

Table of Contents

Main Purpose	1
System Outline	4
CS-2 Structure	8
Communications System	20
Telemetry/Command System (TT&C)	28
Electric Power System (EPS)	31
Attitude and Antenna Control System (AACS)	33
Secondary Propulsion System (RCE)	36
Apogee Motor (AKM)	40
Framework	42
Heat Control System	46
Mission Operation	49
Lift-off and Entrance into Transfer Orbit	51
Entrance into the Geostationary Orbit and Station Keeping	57

Main Purpose

/1*

The communications satellite (CS-2) was developed as the most recent practical communications satellite in Japan as a result of developing the practical medium size geostationary communications satellite (CS).

The purpose of the CS-2 is to provide national communications and industrial communications, such as special emergency communications and remote communications, and to contribute to the development of technology pertaining to communications satellites.

The main satellite (CS-2a) will be launched during the winter of 1982 with an N-II rocket and the tracking reserve satellite (CS-2b) will be launched during the summer of 1983 with an NH-rocket. These satellites will be positioned at stationary positions of, respectively, the 130th degree of east longitude and the 135th degree of east longitude.

*Translator's note: the numbers in margins refer to the foreign text page.

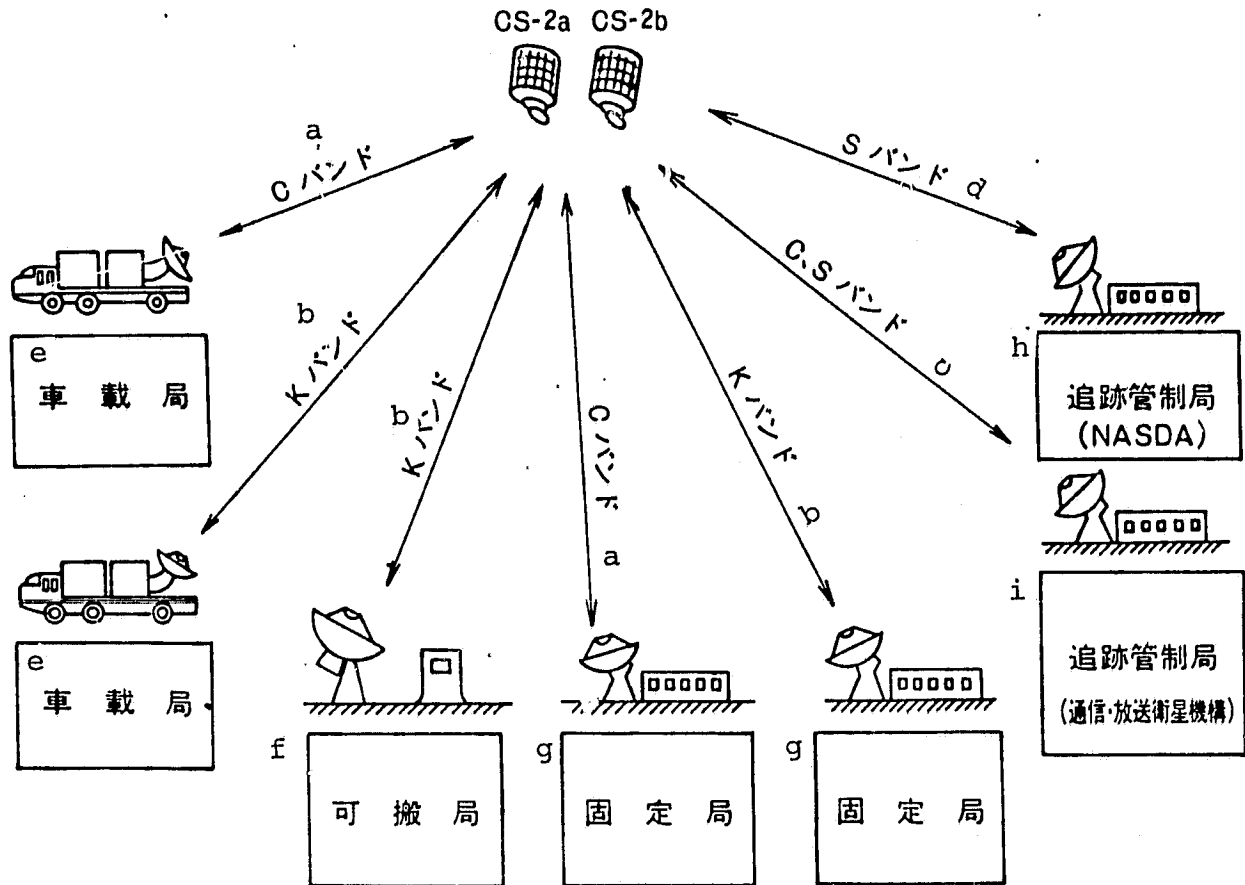

- Key: a. C band b. K band c. C,S band d. S band
 e. mobile station f. portable station
 g. permanent station h. tracking control station (NASDA)
 i. tracking control station
 (communications - transmission satellite (illegible))

System Outline

/3

The CS-2 was developed by the National Space Development Agency (NASDA) with the objective of launching the main satellite and reserve orbiting satellite in 1983. The satellite was manufactured with Mitsubishi Electric Corporation acting as the main contractor. Assistance was obtained from the Ford Aerospace and Communications Corporation of the United States. Furthermore, a communications antenna and communications relay were developed by, respectively, Mitsubishi Electric Corporation and Nippon Telegraph and Telephone Public Corporation based on the development results of Nippon Telegraph and Telephone Public Corporation.

The CS-2 will be launched from the NASDA Tanegashima Space Center with an N-Hirocket. The rocket will be controlled by the NASDA until the satellite enters the transfer orbit.

After the satellite becomes stationary it will be checked by the NASDA once it has entered the drift and geostationary orbits. Then it will be used by Telestat Japan and related agencies while in this geostationary satellite orbit.

The CS-2 has the communications channels of 6 K band channels and 2 C band channels. Communications will be supplied to the Japanese mainland with the K band and to the Japanese mainland including remote islands with the C band.

Communications Map

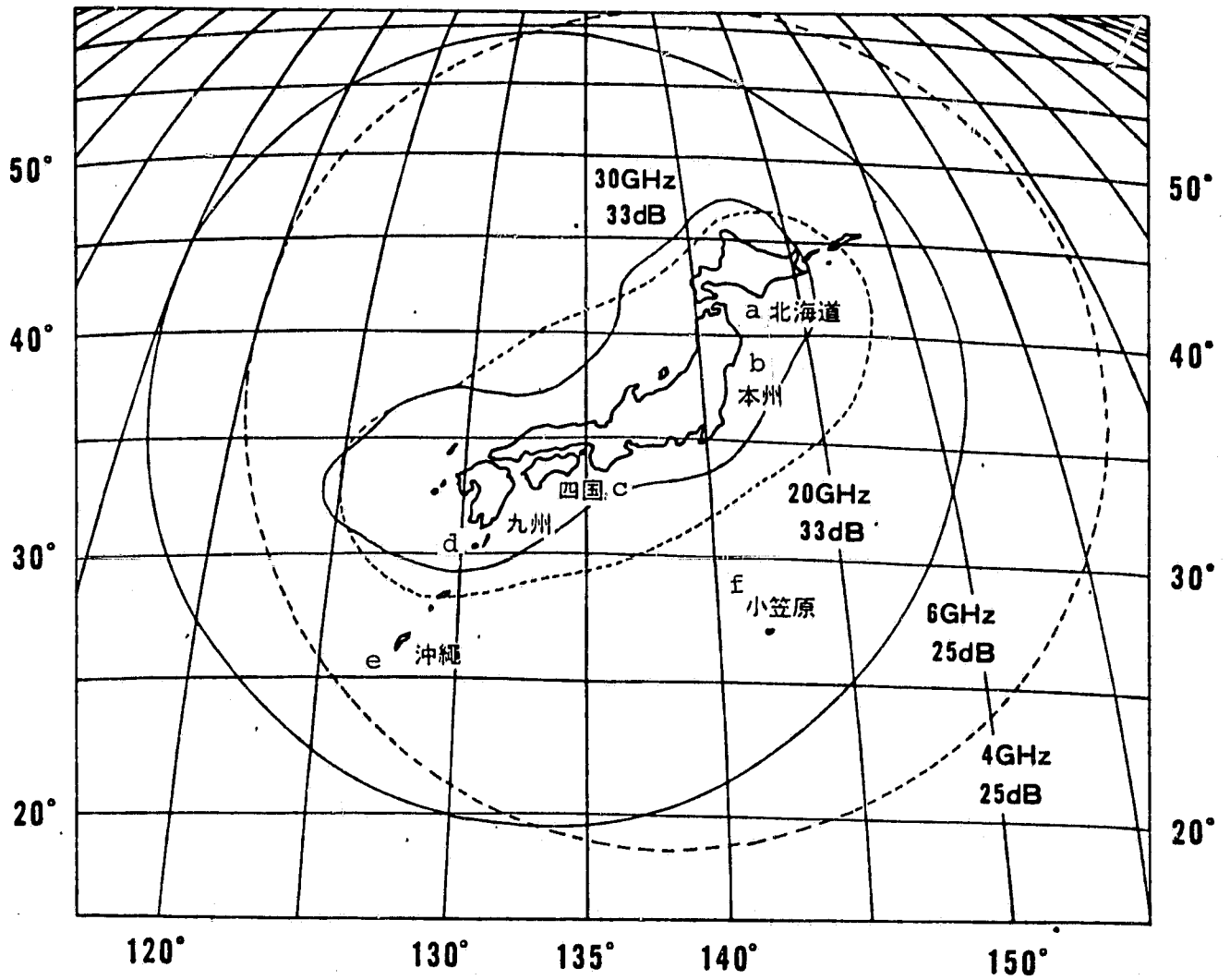

Key: a. Hokkaido b. Honshu c. Shikoku d. Kyushu
e. Okinawa f. Ogasawara

Main Satellite Parameters

Stationary position	130th degree of east longitude (CS-2a) and 135th degree of east longitude (CS-2b)
station keeping	within North-South $\pm 0.1^\circ$, within East-West $\pm 0.1^\circ$
antenna direction accuracy	within 0.3° (semi-vertical angle)
satellite life span	more than 3 years, 5 years standard
launching rocket	N-II rocket
ground station (TT&C)	S band and C band from NASDA and related agency ground stations

Main Communications System Parameters

	K band	C band
frequency used		
ascending circuit	27.5-29.25 GHz	5.925-6.425 GHz
descending circuit	17.7-19.45 GHz	3.7-4.2 GHz
number of channels	6	2
channels employed in shade	(illegible)	1
antenna irradiation region	Japanese mainland	all of Japan
EIRP	37.0 dBW	29.5 dBW
G/ T	-3.8 dB/K	-6.0 dB/K

Frequency Allocation

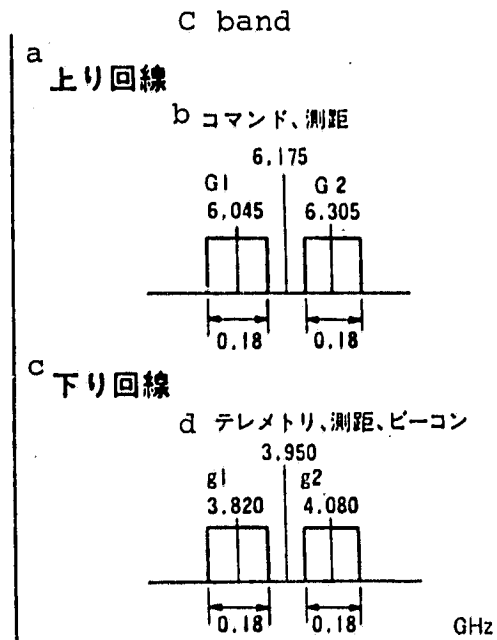

Key: a. ascending circuit b. command, range
c. descending circuit d. telemetry, range, beacon

K band

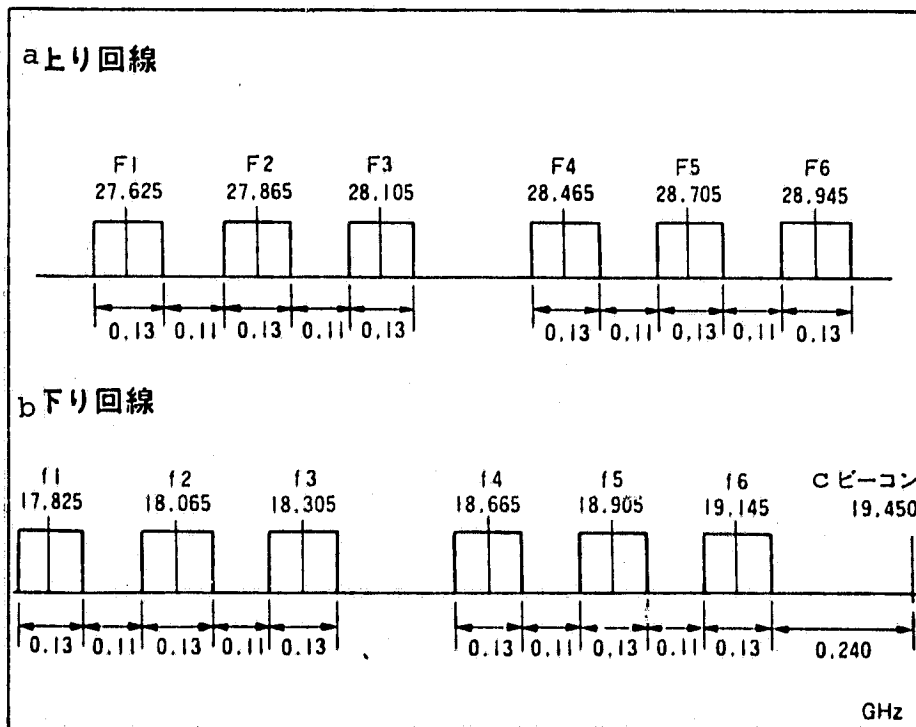

Key: a. ascending circuit b. descending circuit c. beacon

The CS-2 is a spin-stable satellite which carries a mechanical despun antenna. Its structure is the result of a trade off between the basic necessities of communications region, necessary life span, launching rocket, etc. and the many necessities of weight, stable (illegible) heat control, hardware for space performance, etc. The satellite itself is a cylinder with a diameter of 218.4 cm and height of 204.5 cm. The total height from the AKM nozzle at the base to the top of the despun antenna is 328.8 cm. This structure is suitable for N-II rocket firing.

The solar array that generates electricity is attached to the outside of the satellite. The majority of the equipment riding on the satellite is situated on a single equipment platform. A drive motor assembly (DMA) is supported on top of the center of the cylinder. The bottom of the center of the cylinder is attached to the launching rocket with an attachment foot. The K band and C band antenna anchors are connected to the rotating portion of the DMA housing. The S band antenna is arranged in bands in the center of the cylinder surface.

The CS-2 consists of the following subsystems.

- communications system (communications antenna and communications relay)
- telemetry/command system (TT&C)
- electrical power system (EPS)
- attitude and antenna control system (AACS)
- secondary propulsion system (RCE)
- apogee motor (AKM)
- framework
- heat control system

ORIGINAL PAGE IS
OF POOR QUALITY

CS-2 System Distribution
Diagram*

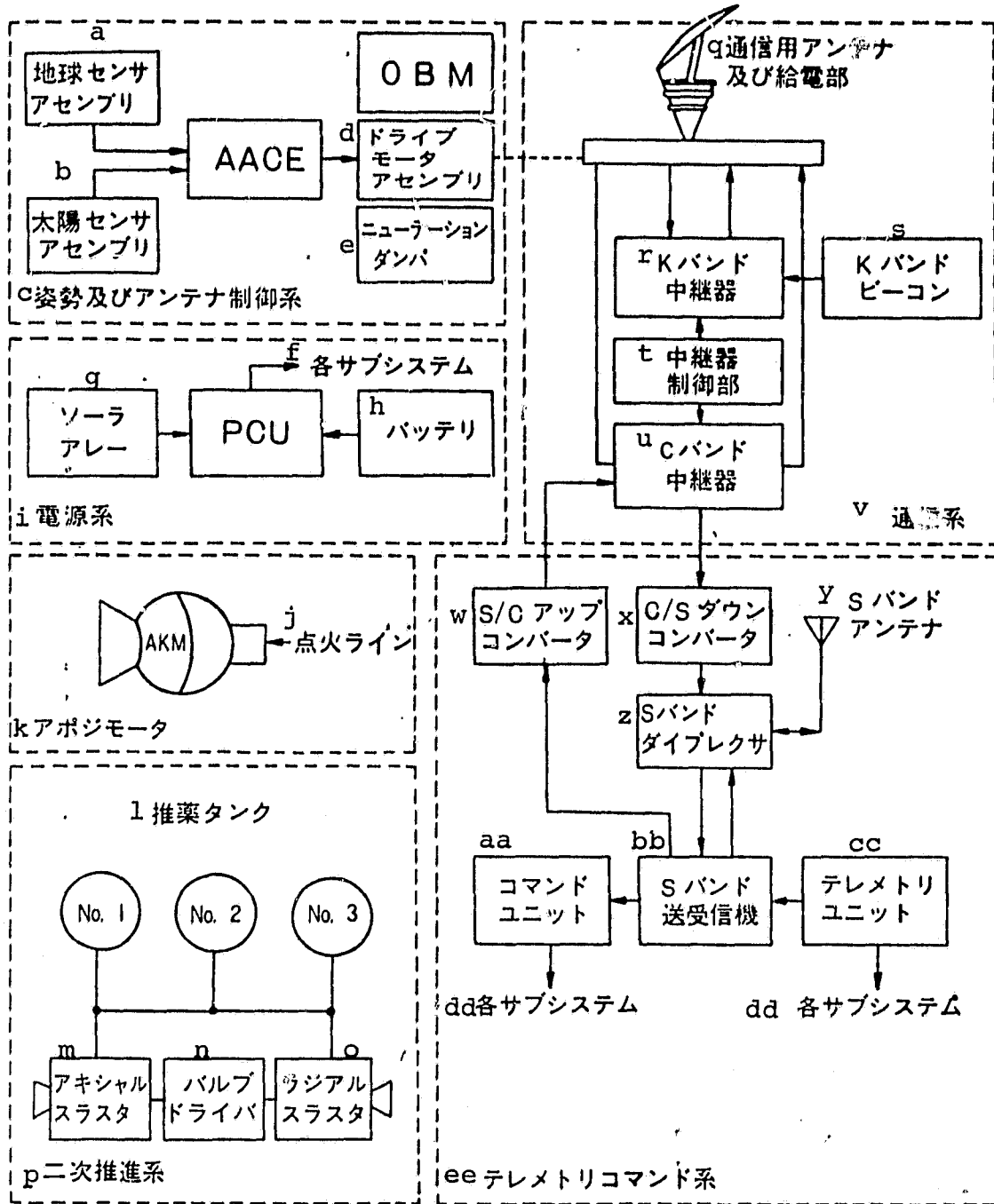

*Translator's note: please refer to key on page 10.

CS-2 System Distribution Diagram [Page 9]

- Key:
- a. earth sensor assembly
 - b. solar sensor assembly
 - c. attitude and antenna control system
 - d. drive motor assembly
 - e. nutation damper
 - f. each subsystem
 - g. solar array
 - h. battery
 - i. electrical power system
 - j. ignition line
 - k. apogee motor
 - l. fuel tank
 - m. axial thruster
 - n. valve drive
 - o. radial thruster
 - p. secondary propulsion system
 - q. communications antenna and electrical accessories
 - r. K band relay
 - s. K band beacon
 - t. relay control
 - u. C band relay
 - v. communications system
 - w. S/C up converter
 - x. C/S down converter
 - y. S band antenna
 - z. S band diplexer
 - aa. command unit
 - bb. S band transmitter-receiver
 - cc. telemetry unit
 - dd. each subsystem
 - ee. telemetry command system

General Diagram of the Satellite *

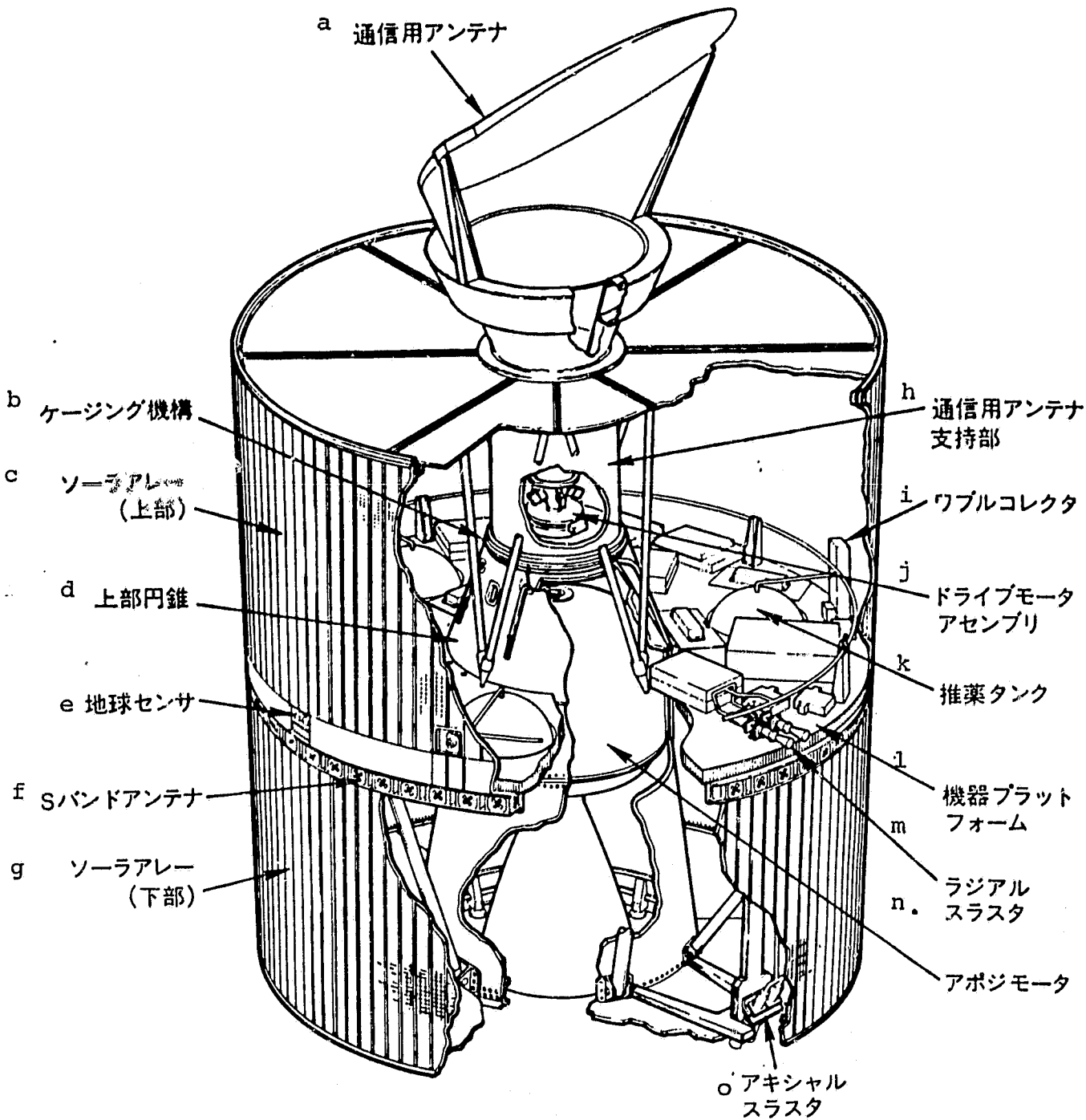

*Translator's note: please refer to key on page 12.

General Diagram of the Satellite

Key: a. communications antenna support b. casing c. solar array (top)
d. top cone e. earth sensor
f. S band antenna g. solar array (bottom)
h. communications (illegible) support (illegible)
i. wobble (illegible) j. drive assembly
k. fuel tank l. equipment platform
m. radial thruster n. apogee motor
o. axial thruster

Equipment Arrangement

Top

**ORIGINAL PAGE IS
OF POOR QUALITY**

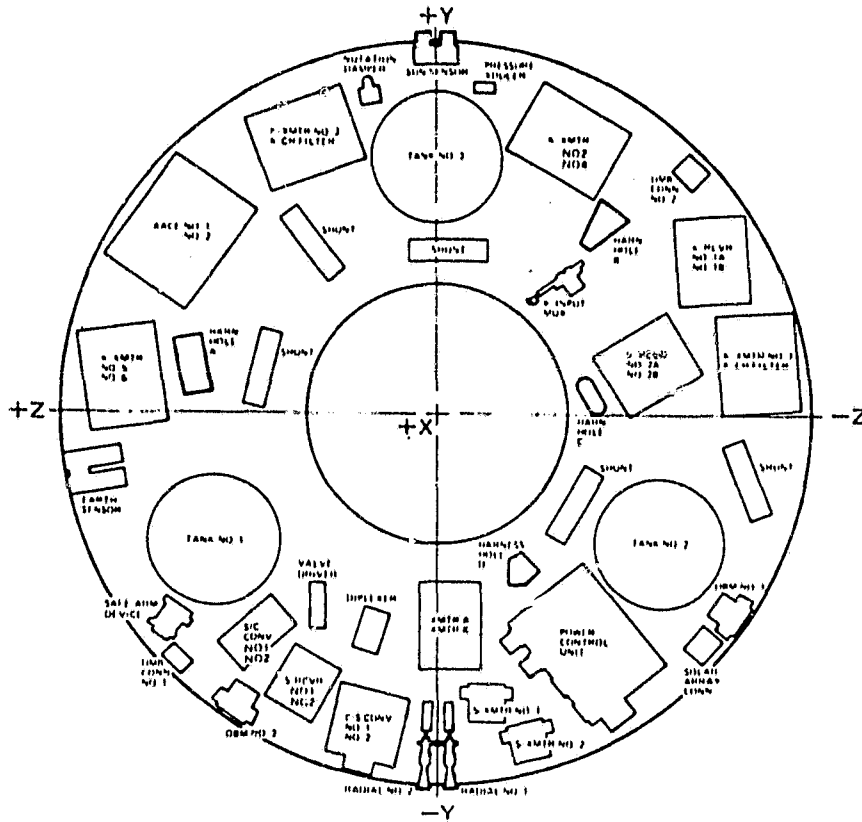

Important Parameters

<u>item</u>	<u>function</u>	<u>properties</u>
shape	cylinder with a diameter of 218.4 cm and height of 204.5 cm height including the communications mechanical despun antenna is 328.8 cm.	suitable for N-II rocket
weight	N-II rocket launching possible	670 kg during lift off
attitude stability	spin stability system	spin rate: 90±9 rpm moment of inertia ratio: 1.05 or more
communications system	multifrequency feed system despun antenna	noise out-band index put (dB) (dBm) (MHz)
	K band 6 channel	K band 12 34 130
	C band 2 channel	C band 6.2 34.5 180
	K band beacon	
	K band ascending/descending circuit frequency	30/20 GHz band
	C band ascending/descending circuit frequency	6/4 GHz band
	antenna gain	K band 33 dB or more C band 25 dB or more
telemetry/ command system (TT&C)	S band transmitter and receiver and S band omni antenna STDN	transmitting output 1 W receiving frequency 2.1108 GHz transmitting frequency 2.2865 GHz receiving frequency 6.175 GHz 3.950 GHz
	C band signals converted to S band signals (command and range)	
	S band signals converted to C band signals (telemetry and range) range system	noncoherent, side tone ranging system
	telemetry data	64 watt/main frame

Main Parameters

<u>item</u>	<u>function</u>	<u>properties</u>
	command data	128 bits/second command tone 1:8,600 Hz 0:7,400 Hz
electric power system (EPS)	cylindrical solar array divided into 2 parts, top and bottom separate battery charging control array NiCd battery-2 main bus voltage stabilized with a shunt set	fall equinox summer solstice initial life 543 W 477 W after 3 years 479 W 423 W after 5 years 462 W 409 W discharge depth less than 55% bus voltage 29.4±0.2V DC
attitude and antenna control system (AACS)	attitude determination information from latitude of earth, spin rate, and angle of the sun. earth and solar sensors employed adjustment range of main axis of inertia with wobble corrector control of main antenna direction axis with drive motor and control electronics	angle of the sun: ±87° latitude of earth: 4 ~ 23° 0.2° antenna bias ±4° (East-west) step angle ±0.03° attenuation constant 15 min.
secondary propulsion system (RCE)	hydrazine monopropellant system thruster used for attitude control and station keeping (approved power 2.3 kg)	fuel tank capacity 52.2 kg 90 msec pulse mode or series mode jet propulsion (60 sec)
apogee motor (AKM)	STAR-27 individual motor	total power about 951,919 N-sec (maximum capability)
housing	single equipment platform monocock shell structure	

<u>item</u>	<u>function</u>	<u>properties</u>
heat control system	employs casing equipment in DMA passive, partial heater employed	
antenna		within 0.3° (semi-vertical angle)
directional accuracy		
orbit maintenance		longitude: within $\pm 0.1^\circ$ latitude: within $\pm 0.1^\circ$
life span		more than 3 years, 5 years standard

Reliability Distribution
(3 years)

	reliability
communications relay*	0.76
communications antenna	0.99
telemetry/command system	0.98
electric power system	0.98
attitude and antenna control system	0.98
secondary propulsion system	0.99
apogee motor	0.96
framework and heat control system	0.99
<u>total reliability</u>	<u>0.67</u>

* remaining reliability of 4K, 2C band channels

Weight Distribution

	weight (kg)
communications antenna	16
communication relay	66
<u>mission equipment</u>	<u>82</u>
telemetry/command system	27.1
electric power system	67.9
attitude and antenna control system	21.3
secondary propulsion system	9.7
apogee motor (after combustion)	26.5
framework	36.0
heat control system	15.5
electrical gauges	14.7
mechanical gauges	10.2
<u>Dry weight</u>	<u>228.9</u>
secondary propulsion system fuel/pressurizing agents	37.8
AKM fuel	317.6
<u>Fuel</u>	<u>355.4</u>
margin	3.7
<u>weight at lift off</u>	<u>670</u>

Fuel Distribution (3 years)

/14

attitude/orbit control	amount of control	amount of fuel necessary (kg)
AKM jet propulsion attitude	132.4	2.14
spin axis reverse perpendicular attitude	65.7	0.97
station aquisition	72.3 m/s	11.75
North-south orbit maintenance	2.56	21.12
east-west orbit maintenance	5.5 m/s	1.21
attitude maintenance	14.4	0.43
<u>subtotal</u>		<u>37.62</u>
pressurizing agents		0.14
<u>total</u>		<u>37.76</u>

Electrical Power Distribution

	electrical power consumed (W)
communications relay**	276.0
telemetry/command system	39.8
attitude and antenna control system	19.1
electrical power control	9.0
heat control system (maximum)	69.6
secondary propulsion system	0.3
harness loss	4.0
<u>total</u>	<u>417.8</u>
battery charging	26.1
<u>required electrical power</u>	<u>443.9</u>
margin	35.1
<u>solar array-generated power*</u>	<u>479.0</u>

* values are after 3 years (fall equinox)

** 6K, 2C band channels and beacon

The CS-2 communications system consists of a communications antenna and communications relay. This system makes possible the establishment of communications circuits between permanent stations, portable stations, and mobile stations on the Japanese mainland and her islands.

The frequency used for 6 channels of the K band is 27.5-29.25 GHz (ascending) and 17.7-19.45 GHz (descending). The transmitting band width of each channel is 130 MHz. This band width can be used for telephone, television, and data transmission on the Japanese mainland.

The frequency used for the 2 channels of the C band is 5.925-6.425 GHz (ascending) and 3.7- 4.2 GHz (descending). The transmission band width of each channel is 180 MHz. This band width can be used for telephone, color T.V., etc. transmission on the Japanese mainland and her islands.

K bands are transmitted to the mainland and C bands are transmitted to all of Japan, including the remote islands. Antenna gain is 33 dB or more with the K bands and 25 dB or more with the C bands within this beam irradiation region.

Moreover, the output power of each channel of the communications relay is 34 dB or more with the K band and 34.5 dBm or more with the C band.

Communications System Distribution Diagram*

a 通信用アンテナ

1 通信用中継器

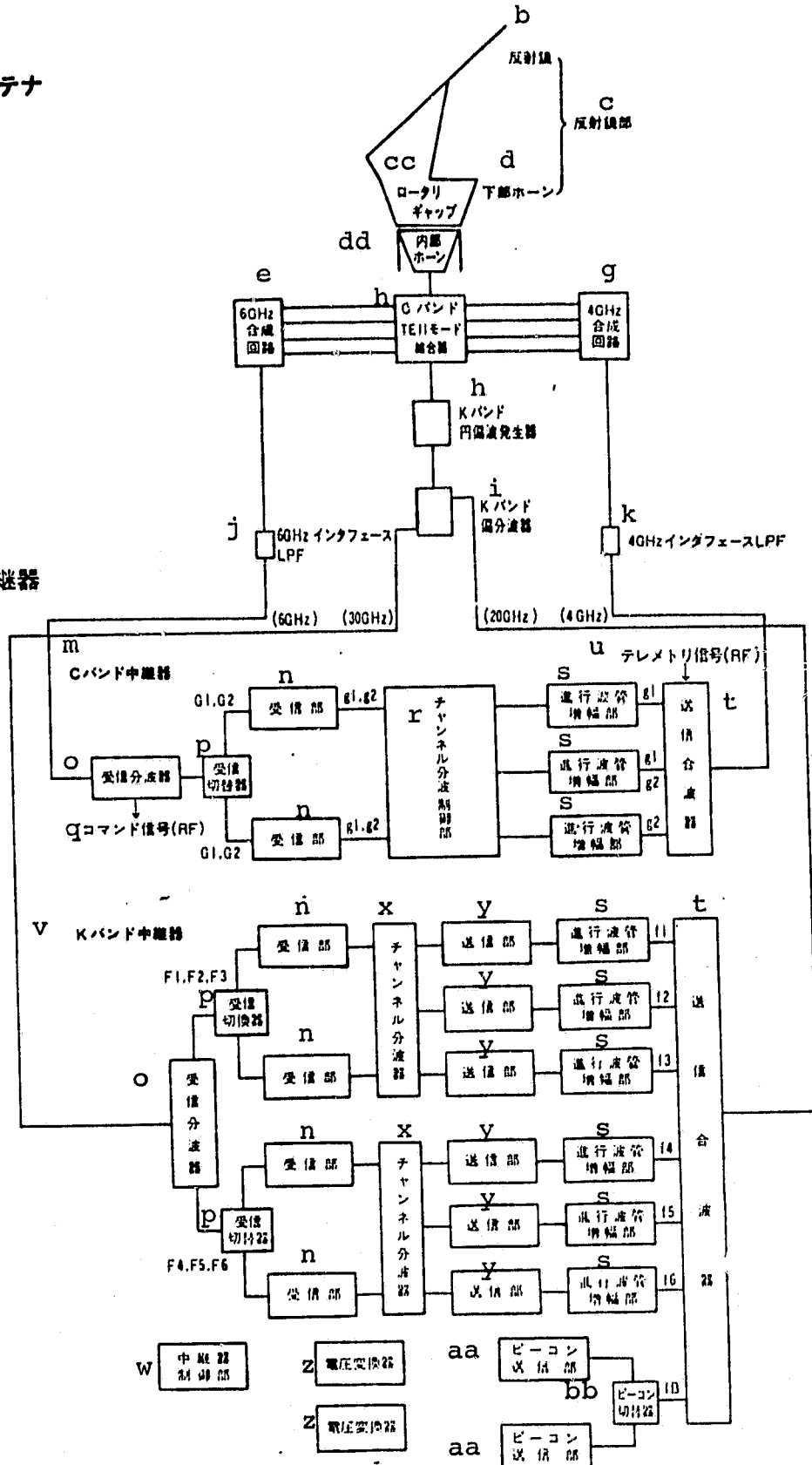

*Translator's note: please refer to key on page 22.

Communications System Distribution Diagram

- Key:
- a. communications antenna
 - b. reflection mirror
 - c. reflection mirror section
 - d. lower horn
 - e. 6 GHz circuit
 - f. C band
 - g. 4 GHz circuit
 - TEH mode adapter
 - h. K band circularly polarized wave generator
 - i. K band polarizer
 - j. 60 Hz interface LPF
 - k. 4 GHz interface LPF
 - l. Communications relay
 - m. C band relay
 - n. receiving section
 - o. receiver branching section
 - p. receiver switching section
 - q. command signal (RF)
 - r. channel filter control section
 - s. traveling wave tube multiplexer
 - t. transmission wave combining device
 - u. telemetry signals (RF)
 - v. K band relay
 - w. relay control
 - x. Channel filter
 - y. transmitting section
 - z. voltage converter
 - aa. beacon transmitting section
 - bb. beacon switching device
 - cc. (illegible) cap
 - dd. internal horn

The communications antenna is a beam horn reflector antenna that uses 4 frequency receiving and transmitting K bands and C bands. It uses circularly polarized waves. K band signals are converted to polarized waves with a circularly polarized wave generator and the transmitting and receiving waves are made into branched waves with a 30/20 GHz band polarizer. C band signals are polarized and transmitted and received with a coupler set up at the horn tube wall and a hybrid circuit.

The reflecting mirror of the antenna is set up so that a specific beam irradiation region will be efficiently reached.

Main Properties of the Communications Antenna

item	K band	C band
frequency	30/20 GHz	6/4 GHz
beam irradiation region	Japanese mainland	all of Japan
gain	33 dB or more	25 dB or more
polarization	circular polarization (levorotation/dextrorotation)	circular polarization (levorotation/dextrorotation)
directional accuracy (3 (illegible))	within 0.3° (semi-vertical angle)	within 0.3° (semi-vertical angle)

ORIGINAL PAGE IS
OF POOR QUALITY

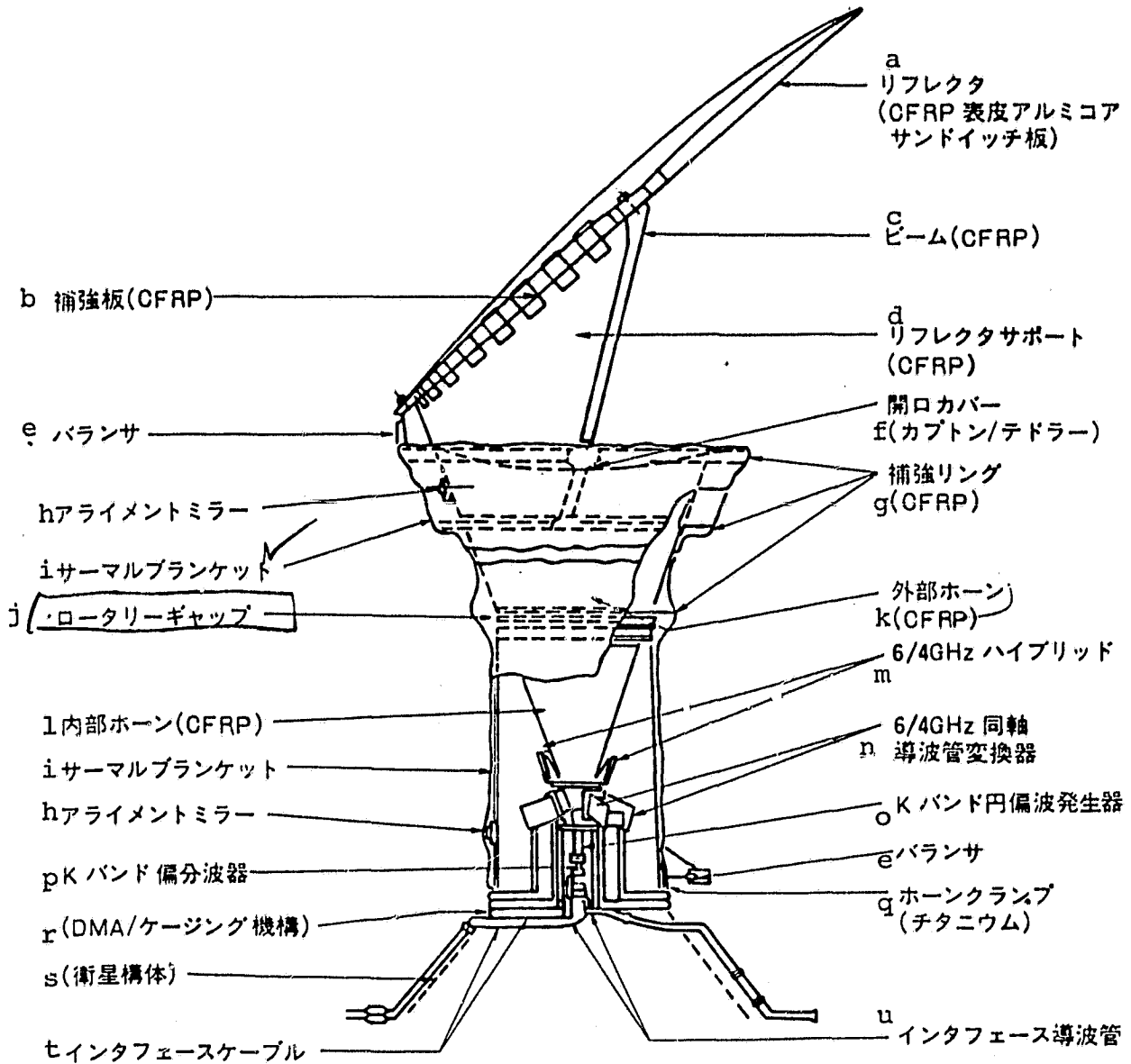

*Translator's note: please refer to key on page 25 .

Communications Antenna

- Key:
- | | |
|---|--|
| a. reflector (CFRP topmost layer aluminum core sandwich plates) | |
| b. reinforcing plates (CFRP) | c. beam (CFRP) |
| d. reflector support (CFRP) | e. balance |
| f. open cover (kaputon/tedora*) | g. reinforcing ring (CFRP) |
| h. alignment mirror | i. thermal blanket |
| j. rotary gap | k. outer horn (CFRP) |
| l. inner horn (CFRP) | m. 6/4 GHz hybrid |
| n. 6/4 GHz coaxial waveguide
switch | o. K band circularly polarized
wave generator |
| p. K band polarizer | q. horn clamp
(titanium) |
| r. (DMA/casing construction) | s. (satellite) |
| t. interface cable | u. interface waveguide |

*Translator's note: terms unknown; transliteration of Japanese phonetic characters.

The communications relay consists of a 6 channel k Band relay and 2 channel C band relay, a K band beacon, and a relay control.

The K band relay and C band relay each possess the function whereby signals from the communication satellite are branched into each channel signals with an input-putput branching filter and the function whereby signals from each channel are combined with an input-output wave combining device prior to transmission to the communication antenna.

K Band Relay

The K band channel converts the reception signals of intermediate frequency 27.625 (F 1), 27.865 (F 2), 28.105 (F 3), 28.465 (F 4), 28.705(F5), and 28.945 GHz (F 6) into transmission frequency and then transmits (9.8GHz) each as a transmission signal of 17.825-19.145 GHz (f1-f6). The beacon frequency is 19.45 GHz.

K band signals received from the communications antenna are branched into F1-F3 and F4-F6 with the input-output branching filter. The F1-F3 and F4-F6 channels are frequency converted into 3 channels at the receiving section. After being amplified and branched with a channel branching filter at the intermediate frequency range, the channels are amplified at the transmitting section, frequency converted and electrically amplified at the traveling wave tube amplification section (TWTA). It is possible to switch all of the K band relays to amplification control modes or linear amplifications modes with commands from the ground.

The 6 channel K band output and K band beacon output are made with an ouput wave combining device. These are then transmitted to the communications antenna.

C band signals received by the communications antenna are branched into command signals of 6.175 GHz and communications signals of 6.045 GHz (G 1) and 6.305 GHz (G 2) with the input branching filter. After the G1 and G2 channel signals are converted into transmission frequency (2.225 GHz) at the receiving section, filtering and amplification are carried out at the channel branching control section. These signals are then electrically amplified by the TWTA.

Signals filtered to 3.820 GHz (g1) and 4.080 GHz (g2) are transmitted to the TWTA at the channel branching control section. Moreover, they can be attenuated to 8 dB at the channel branching control section.

C band transmission signals (g1, g2, and telemetry signals) are synthesized by the C band output wave combining device and are transmitted to the communications antenna.

Relay Control Section

The relay control system takes in the TT&C subsystem and the communications relay and its interface. It consists of a switching circuit and logic circuit. The relay control system has the following properties.

- Selection of the operation mode of the K band relay (amplification control mode and linear amplification mode)
- TWTA selection and operation control
- Guarantees primary/secondary isolation during command execution
- Channel selection and component selection
- C band relay G1 and G2 channel gain adjustment
- telemetry of component operation conditions

Main Properties of Communications Relay

Item	K band	C band
frequency	30/20 GHz	6/4 GHz
channels	6	2
band width (3 dB base)	130 MHz	180 MHz
output power/channel	34 dBm or more	34.5 dBm or more
noise index	12 dB or less	6.2 dB or less
beacon output power	15 dBm or more	

The TT&C consists of the S band antenna assembly, the S band diplexer, the S band transmitter, the RF switch, the command unit, the telemetry units, the S/S down converter, and the S/C up converter. TT&C with the C band is carried out with the C/S down converter, S/C up converter, and communications antenna.

CS-2 is controlled with the S band in the transfer orbit and drift orbit. It can also be controlled with the C band using the communications antenna in the geostationary orbit.

The up link includes the command or range signals (2.1108 GHz) and the down link includes the telemetry or (illegible) signals (2.2865 GHz). After the command signals are received by the S band receiver, they are decoded by the command unit and transmitted to each subsystem. The telemetry sensed at each section of the satellite is transmitted with the S band transmitter through the telemetry unit. After the signals are demodulated into tone signals inside the S band transmitter and receiver, they are remodulated and transmitted.

The S band antenna assembly consists of 64 (illegible) dipoles arranged in a circle in the middle of the satellite. The antenna direction is a toroidal pattern that moves up and down from the surface perpendicular to the spin axis.

The S band transmitter and receiver consists of a receiver and transmitter. Each are a redundant structure. The receiver receives S band command signals, or C band command signals and range signals through the C/S down converter with a redundant structure and PM demodulates these signals. PCM/FSK/AM command signals are supplied to the command unit and range tone signals are supplied to the transmitter. The (illegible) carries out K modulation of the PCM telemetry signals from the telemetry unit with a 256 KHz carrier wave. These are then PM modulated with the range tone signals from the receiver. This output is connected to the S band antenna assembly and redundant S/C up converter.

The command unit is a redundant structure. The unit input is (illegible) the command signals of two S band receivers. The command unit demodulates and (illegible) command signals and supplies these signals to each unit of the satellite.

The telemetry unit encodes telemetry data from each unit of the satellite and carries out (illegible) editing. It then supplies this information to the S band transmitter in the form of PCM signals. A cross connection is made between the telemetry unit and the transmitter.

/22

Main Properties of the TT&C

item	down link	up link	range
carrier wave			
frequency			
S band	2.2865 GHz	2.1108 GHz	2.1108 GHz/2.2865 GHz
C band	3.950 GHz	6.175 GHz	6.175 GHz/3.950 GHz
modulation			
system	PCM/PSK/PM	PCM/FSK-AM/PM	tone/PM
modulation			
index	0.8 rad (O-P)	0.4 rad (O-P)	0.56 rad (O-P)
bit rate	250 bps	128 bps	tone frequency
			100 kHz (maximum)
capacity	64 words/frame	168 command	<hr/>

ORIGINAL PAGE IS
OF POOR QUALITY

ORIGINAL PAGE IS
OF POOR QUALITY

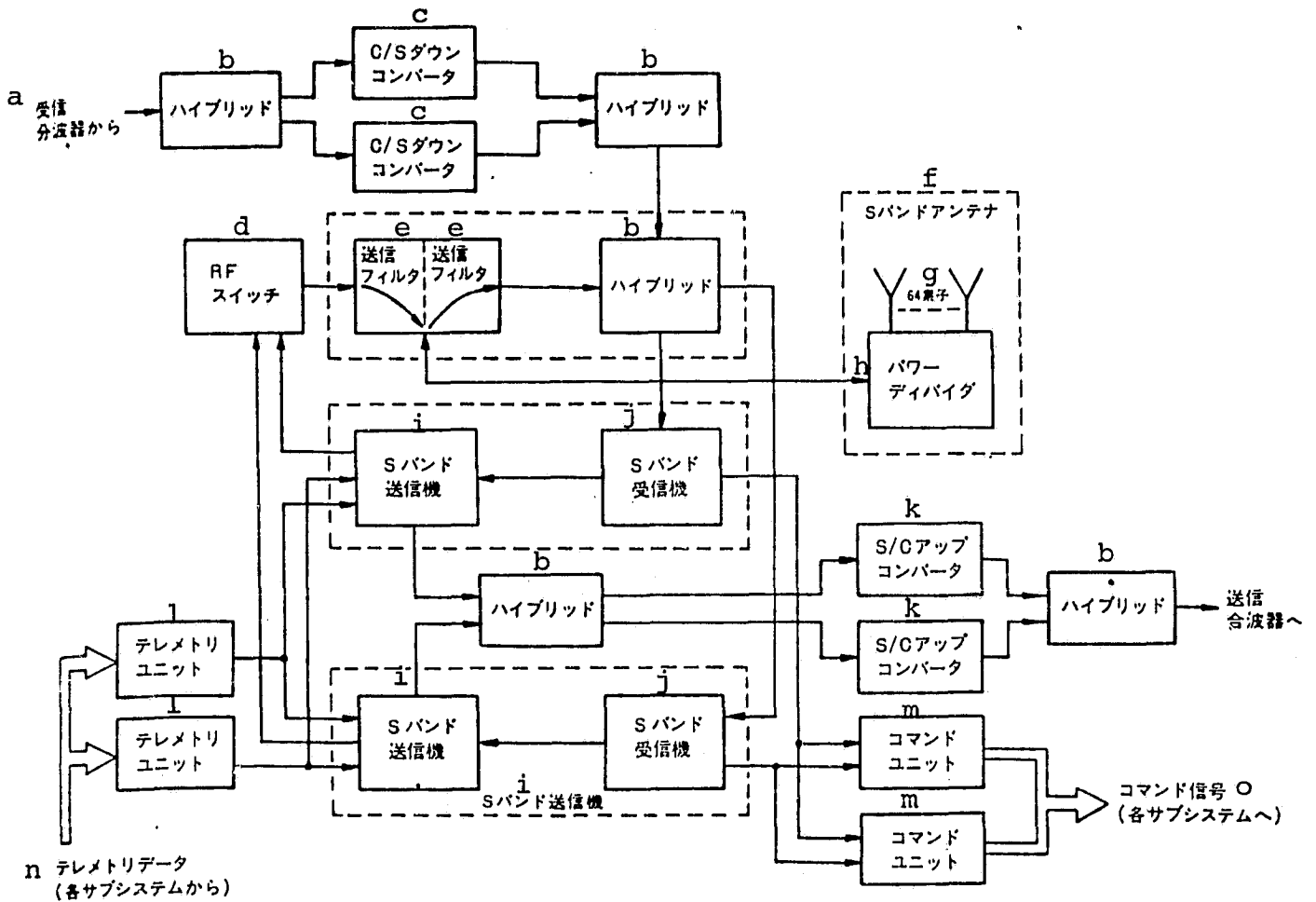

- Key:
- | | | |
|---|------------------------|-----------------------|
| a. from reception filter | b. hybrid | c. C/S down converter |
| d. RF switch | e. transmission filter | |
| f. S band antenna | g. 64 elements | |
| h. power divider | i. S band transmitter | |
| j. S band receiver | k. S/C up converter | |
| l. telemetry unit | m. command unit | |
| n. telemetry data (from each subsystem) | | |
| o. command signals (each subsystem) | | |

Electrical power necessary for satellite usage is supplied for the life span of the satellite by the EPS after the satellite disengages. The EPS consists of the solar array, battery, power control unit (PCU) and shunt set assembly.

The solar array consists of the main array of 18,224 N/P silicon solar batteries that are 2 cm x 3.15 cm and 140 battery charging control arrays. The solar array is located on the outside of the cylindrical satellite. Each array supplies the necessary electrical power to each load, including battery charging, for the life span of the satellite. Voltage control is carried out by a partial shunt regulator. Full battery charging electrical power is supplied during the spring equinox and fall equinox. Trickle charge is supplied during the other seasons.

There are two batteries made of 20 linearly connected Ni-Cd cells with a capacity of 12 AH. They supply electrical power of about 220 W in shade for 88 years. The batteries temporarily supply electrical power at a peak load that exceeds the capacity of the solar array. Moreover, the batteries make possible the use of communications relays of 1 channel from both the K band and C band in shade.

The PCU supplies power to the battery reconditioning unit and electric ignition device (EED) as well as carrying out satellite power control. Moreover, it supplies stabilized electrical power from the solar array and batteries to each load. The main bus voltage is held at 29.4 ± 0.2 V during daylight by the partial shunt regulator. 6 shunt set assemblies consume the excess power from the solar array. Main bus power stabilized in shade is carried out by 2 parallel redundant burst converters. Battery charging control is carried out by command with the charging control array and battery reconditioning is carried out by command using reconditioning resistance. Switching of the charging current is carried out in accordance with the battery temperature and amount of electric power generated by the solar array. Battery reconditioning is discontinued on command using the minimum voltage control circuit.

Main Properties of the EPS

/24

electrical power generated by the solar array (spring and fall equinox) maximum load	3 years 479 W
bus voltage	3 years 444W
maximum discharge depth	29.4±0.2 V dc
	55%

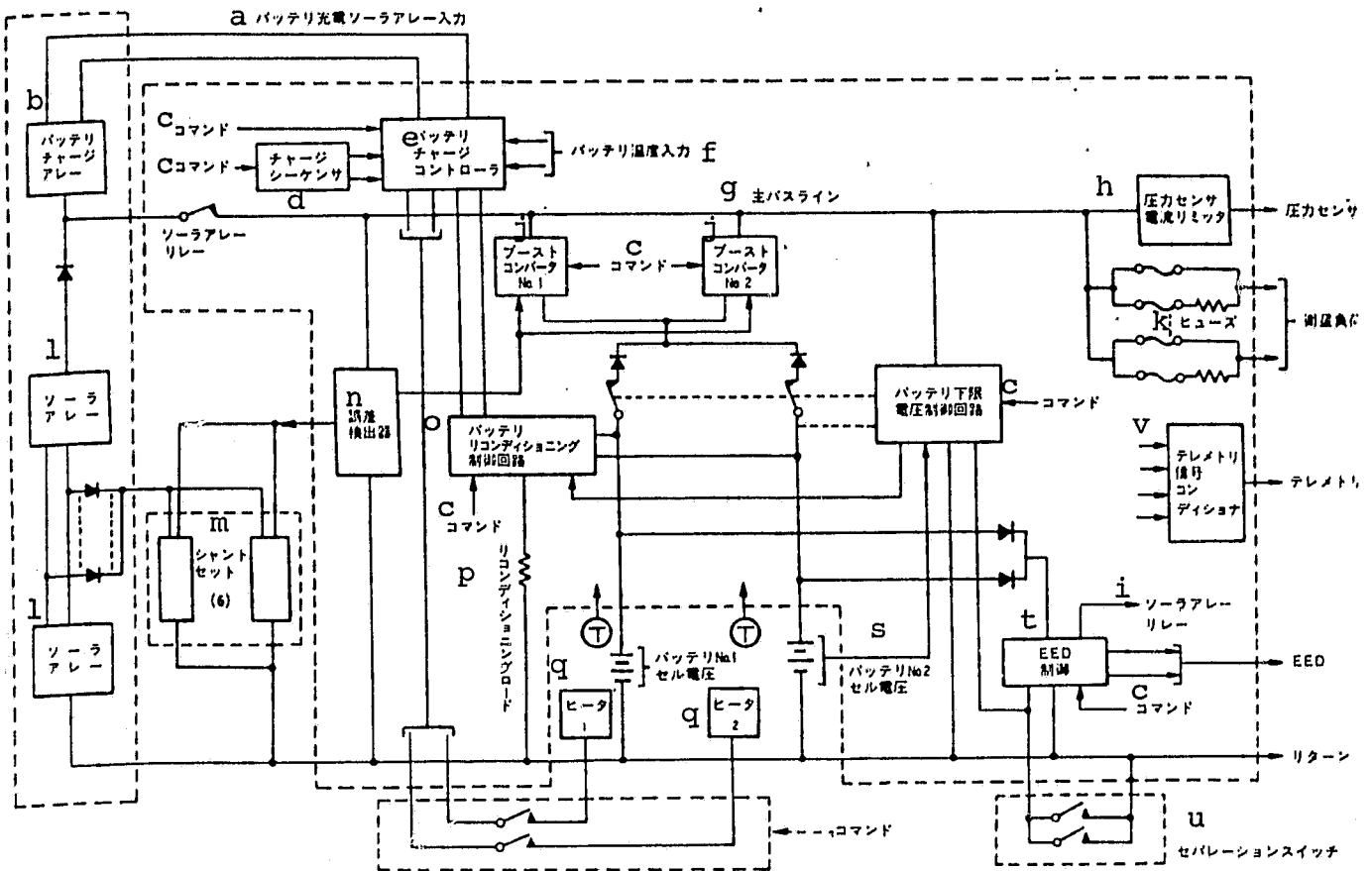

- Key:
- | | |
|---|------------------------------------|
| a. battery charging solar array input | b. battery charging array |
| c. command | d. charging sequence |
| e. battery charging control | f. battery temperature input |
| g. main bus line | h. pressure sensor current limiter |
| i. solar array relay | j. burst converter |
| k. fuse | l. solar array |
| m. shunt set | n. error detector |
| o. battery reconditioning control circuit | p. reconditioning path |
| q. heater | |

- r. battery No. 1 cell voltage
- s. battery No. 2 cell voltage
- t. EED control
- u. separator
- v. telemetry signal conditioner

Attitude and Antenna Control System (AACS)

/25

In addition to carrying out azimuthal control of the communications antenna, the AACS also supplies the necessary information for carrying out attitude control of the satellite. The AACS consists of the earth sensor assembly, solar sensor assembly, nutation damper, drive motor assembly (DMA), wobble corrector (OBM), and attitude and antenna control electronics (AACE).

The earth sensor assembly is made up of 2 infrared sensors with a visual field angle of 1° . They are connected at the respective directions of collimation of $+4^\circ$ and -4° to the spin surface of the satellite. They are used for satellite attitude determination from measurement of the width of the earth, spin rate determinations in shade, and thruster synchronization as a backup for the solar sensor in addition to generating the earth edge pulse as a standard signal for antenna azimuthal control.

The solar sensor assembly consists of a sensor having a visual field of $+87^\circ$ to -30° to the surface perpendicular to the spin axis and a sensor having a visual field of $+30^\circ$ to -87° to the surface perpendicular to the spin axis. The sensor selected by command generates a pulse with each spin of the satellite and measures the solar angle with the pulse width data. The solar sensor assembly also supplies signals for measurement of the solar angle and spin rate and for thruster synchronization.

2 wobble correctors(OBM) are positioned 90° apart. They can adjust the main axis of inertia of the satellite by 0.2° during geostationary orbiting.

The nutation damper is passive and consists of a bending tube filled with neon gas and a steel ball that moves within this tube. Attenuation results are obtained from the gas viscosity in the spaces between the walls of the tube and the ball.

The drive motor assembly consists of a shunt attached to the rotating section of the satellite, housing attached to the despun antenna, and 2 bearings. The electrical equipment and accessories include a brushless torque motor, a brushless resolver, magnetic pick up for 3 speed and position detection, a slip ring between the housing and shunt, etc. The shunt and housing of the DMA are fixed with the casing (illegible) during lift off and the transfer orbit, and the bearings therefore are not affected by direct lift off weight. The despun antenna can be operated with the DMA by dismantling the casing with commands from earth during the geostationary orbit.

The attitude and antenna control electronics (AACE) are made up of 2 redundant units. A cross connection is made between the solar sensor input, earth sensor input, and magnetic pick up input to the AACE unit. The AACE carries out operation and control of the DMA resolver and motor. The AACE is made up of electric circuits that carry out earth and solar sensor data processing, communications antenna offset biasing, despinning, etc. control.

Main Properties of the AACS

/26

Antenna bias: range	$\pm 4^\circ$
accuracy	0.03°
aquisition time	less than 15 minutes
solar angle measurement: range	$\pm 87^\circ$ ($\pm 30^\circ$ redundancy)
: accuracy	$\pm 0.47^\circ$
spin rate measurement accuracy	
solar sensor	± 0.07 RPM
earth sensor	± 0.15 RPM
nutation damping	
time constant	15 minutes or less
threshold	0.05° or less
thruster synchronization pulse	
primary mode (solar sensor)	$\pm 0.15^\circ$
shade mode (earth sensor)	$\pm 0.25^\circ$
earth width measurement: range	$4^\circ - 23^\circ$
accuracy	$\pm 0.534^\circ$

ORIGINAL PAGE IS
OF POOR QUALITY

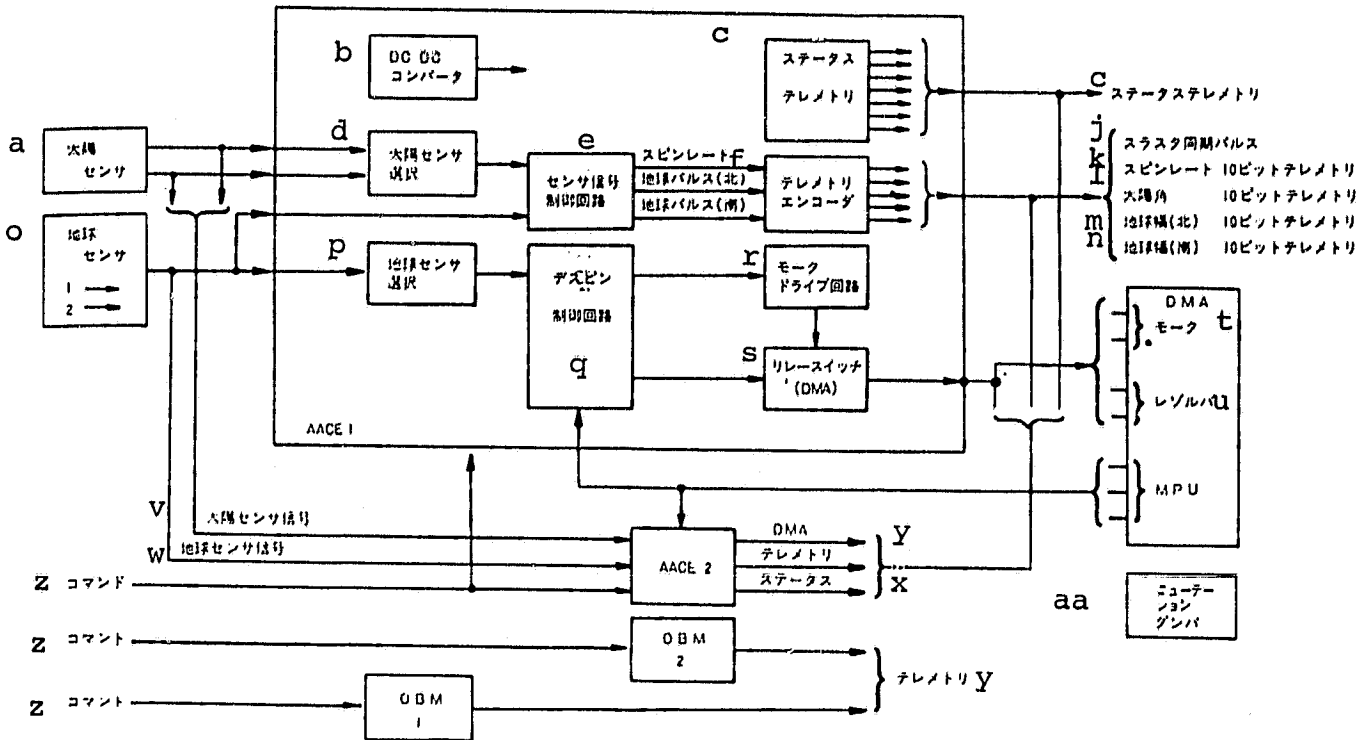

Key: a. solar sensor b. DC DC converter c. status telemetry
d. solar sensor selection e. sensor signal control circuit
f. spin rate g. earth pulse (north) h. earth pulse (south)
i. telemetry encoder j. thruster synchronization pulse
k. spin rate 10 bit telemetry l. solar angle 10 bit telemetry
m. earth width (south) 10 bit telemetry n. earth width (south) 10 bit telemetry
o. earth sensor p. earth sensor selection q. despinning control circuit
r. motor drive circuit s. relay switch (DMA)
t. motor u. resolver v. solar sensor signals
w. earth sensor signals x. status y. telemetry z. command
aa. nutation damper

The RCE is used to correct AKM jet propulsion attitude in transfer orbiting, to correct attitude in order to make the satellite perpendicular to the orbit surface during drift orbiting, to correct orbit entrance errors, for station acquisition, and to maintain orbiting attitude in the geostationary orbit.

The RCE consists of 3 fuel tanks and 4 thrusters (approved power of 2.3 kg). It is a monopropellant hydrazine system. The pulse jet propulsion time of each thruster is 90 msec (approved). East-west orbit correction is carried out using 2 (redundant) radial thrusters attached to the rim of an equipment platform. The thrust axis is almost perpendicular to the satellite spin axis and passes through the center of gravity of the satellite. 2 (redundant) axial thrusters are attached to the bottom of the inside of the satellite solar array. The thrust axes are inclined 6° from the direction parallel to the spin axis. The pulse mode is used during satellite attitude correction and the continuous mode (60 seconds) is used to correct the inclination to the orbit surface.

The operations of the RCE are divided into the 2 types of speed modification and attitude modification. 1 of the 2 (redundant) radial thrusters is employed to increase speed. In order to obtain the necessary acceleration, the thruster carries out jet propulsion of 1 pulse during 1 rotation after the satellite spin is synchronized. Attitude modification is carried out using 1 of the 2 (redundant) axial thrusters. Jet propulsion timing, which standardizes the number of pulses and (illegible) pulse during each operation is determined on command from the earth station.

Main Properties of the RCE

fuel	hydrazine, low carbon monopropellant
fuel tanks	round, 3
fuel supply system	blow down system
pressurizing agent	{illegible} (Hc)
operation pressure range	initial of 241 N/cm ² a to final of 48.3 N/cm ² a
fuel capacity	52.2 kg, maximum (at time of maximum blow down ratio)
fuel temperature	(illegible) 4° C-60° C
maximum operation pressure	276 N/cm ² a (400 PSIA)

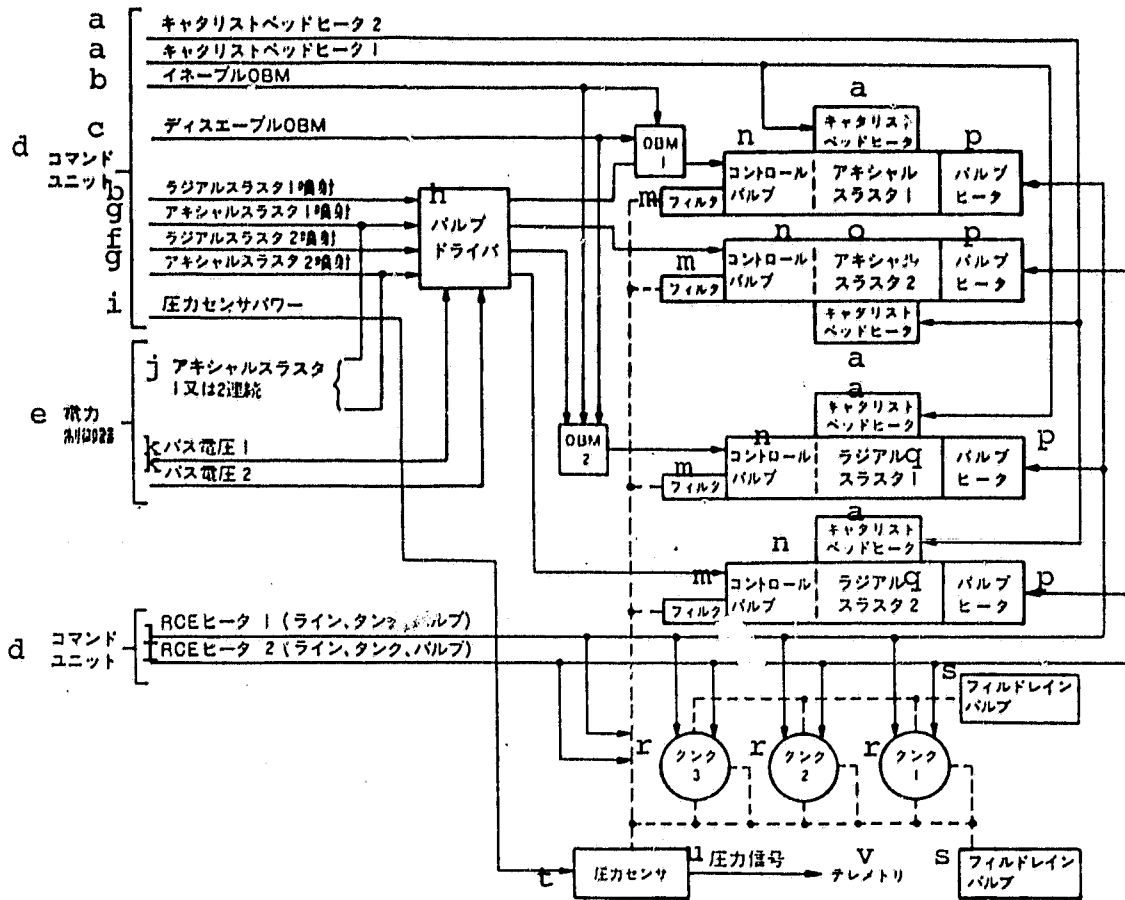

- Key:
- a. catalytic bend heater
 - b. enabling OBM
 - c. disabling OBM
 - d. command unit
 - e. electric power control device
 - f. radial thruster/jet propulsion
 - g. axial thruster/jet propulsion
 - h. valve driver
 - i. pressure sensor power
 - j. axial thruster
 - k. bus voltage
 - l or 2 connections
 - l. RCE heater (line, tank, valve)
 - m. filter
 - n. control valve
 - o. axial thruster
 - p. valve heater
 - q. radial thruster
 - r. tank
 - s. fill drain valve
 - t. pressure sensor
 - u. power signals
 - v. telemetry

ORIGINAL PAGE IS
OF POOR QUALITY

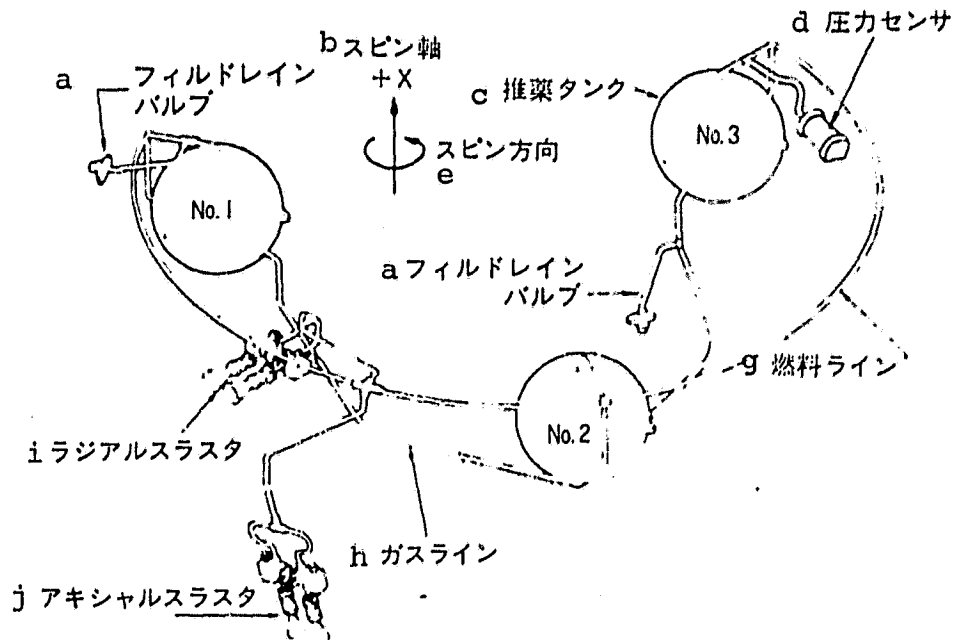

- Key: a. fill drain value b. spin axis c. fuel tank
 d. pressure sensor e. spin direction
 g. fuel line h. gas line
 i. radial thruster j. axial thruster

The STAR-27 solid fuel motor made by Thiokol is used as the AKM. The satellite enters the drift orbit by jet propulsion to a distant point in the transfer orbit. The amount of fuel is adjusted against the satellite weight so that after AKM ignition the orbiting inclination will be close to an angle of 0° . The AKM consists of the 5 essential parts shown below.

- 1) fuel (star-shaped grains)/liner/insulator
- 2) motor casing (titanium)
- 3) nozzle
- 4) ignition system (tunneled bulkhead initiator (TBI) and ignitor)
- 5) explosion transfer apparatus (ETA) and remote safe/arm* device

Main AKM Properties*

/30

	*maximum capability
weight before ignition	350 kg
: fuel	320.2 kg
: inert weight	
before combustion	29.8 kg
weight after combustion	26.5 kg
driving level	45434 N
efficiency ratio power	287.7 sec
power	951,919 N-sec
combustion time	43 seconds

*Translator's note: transliterations of the Japanese phonetic characters sēfu and āmu.

ORIGINAL PAGE IS
OF POOR QUALITY

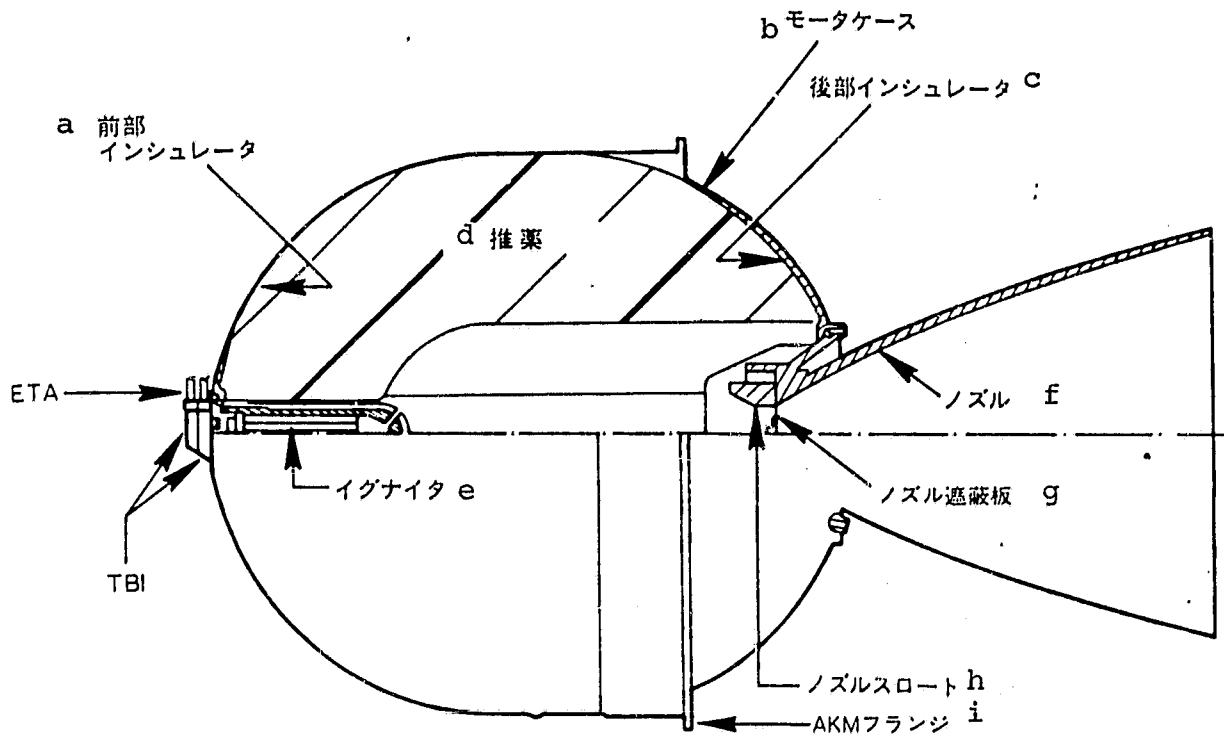

Key: a. front insulator b. motor casing c. back insulator
 d. fuel e. ignitor f. nozzle
 g. nozzle cover h. nozzle slot i. AKM flange

The CS-2 framework is treated on earth to have strength to resist environmental conditions during take off, orbit entrance and geostationary orbiting.

The primary framework consists of the center cylinder and equipment attached to this cylinder. The center cylinder is made from a lower cone, center cylinder, and upper cone. The lower part is the rocket interface, the center section holds the equipment platform, and the drive motor assembly is connected to the upper part. The equipment platform is held to the outside of the cylinder by 8 pipes and the lower end of these supports is attached to the ring of the rocket surface.

The cylindrical solar array is divided into 2 parts, the top and bottom. These are attached to the rim of the equipment platform so that the majority of the weight will not be exerted on the base of the solar array. 8 secondary structural components are attached in radial pattern to support the solar array base at the bottom and top of the satellite.

A casing is located at the top of the center cylinder. The casing protects the DMA from the weight during lift off. The spin section ring and despun section ring are fixed with a 1 V band clamp in this cased condition. This clamp is disconnected by command with a firing bolt.

The center cylinder is fixed to the attachment fitting of the take off rocket by a V band clamp at its lower end. It can be separated with a firing bolt.

Framework Design Conditions

critical load (3 value)		
during lift off	+ 2.8G/-1.4G	vertical direction
	<u>±</u> 2.4 G	horizontal direction
main engine cut off	+12.1 G	vertical direction
	<u>±</u> 1.0 G	horizontal direction
completion of 3rd jet propulsion stage	+10.0 G	vertical direction
AKM combustion	+8.7 G	vertical direction
Rigidity		
minimum number of vibrations in horizontal direction		15 Hz or more
minimum number of vibrations in vertical direction (fixed rocket surface)		35 Hz or more
stability coefficient		1.25 or more

Satellite Framework*

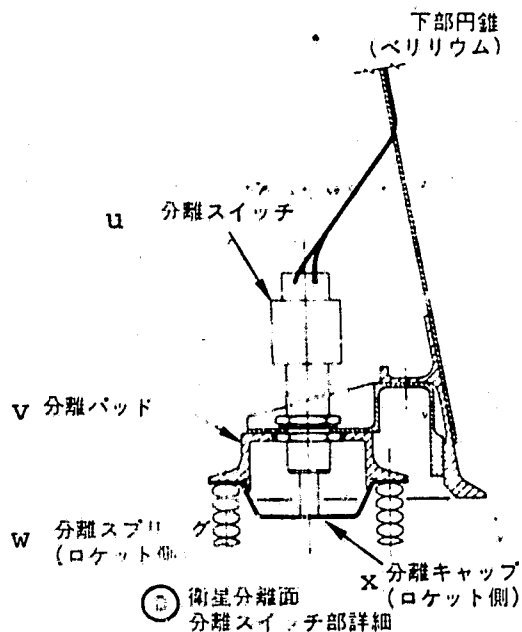
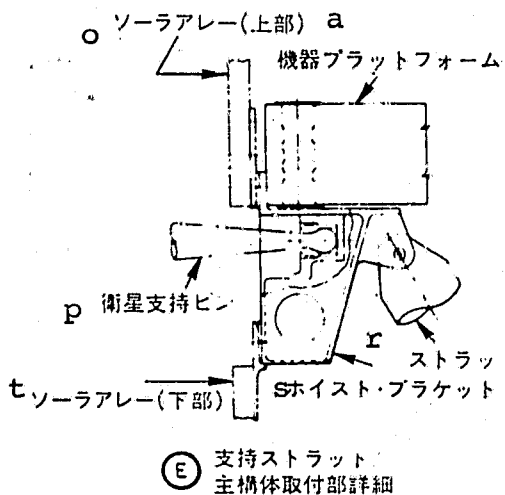
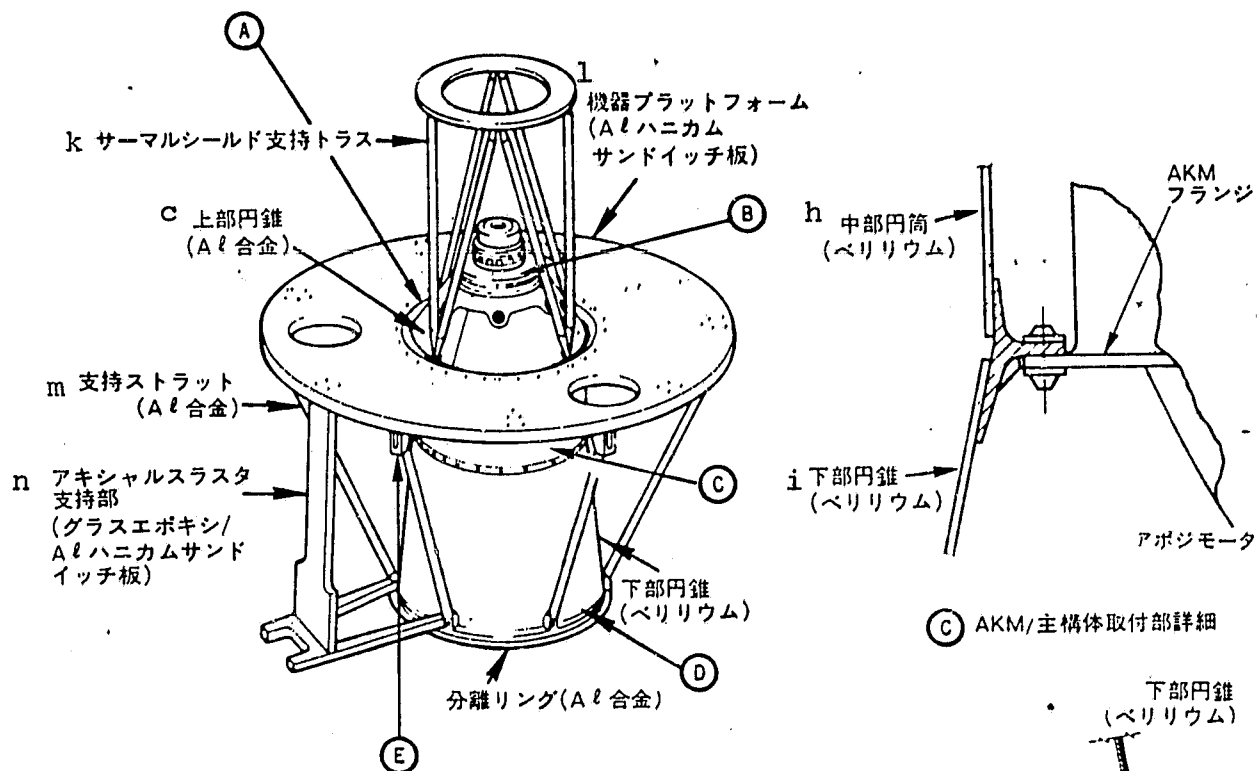
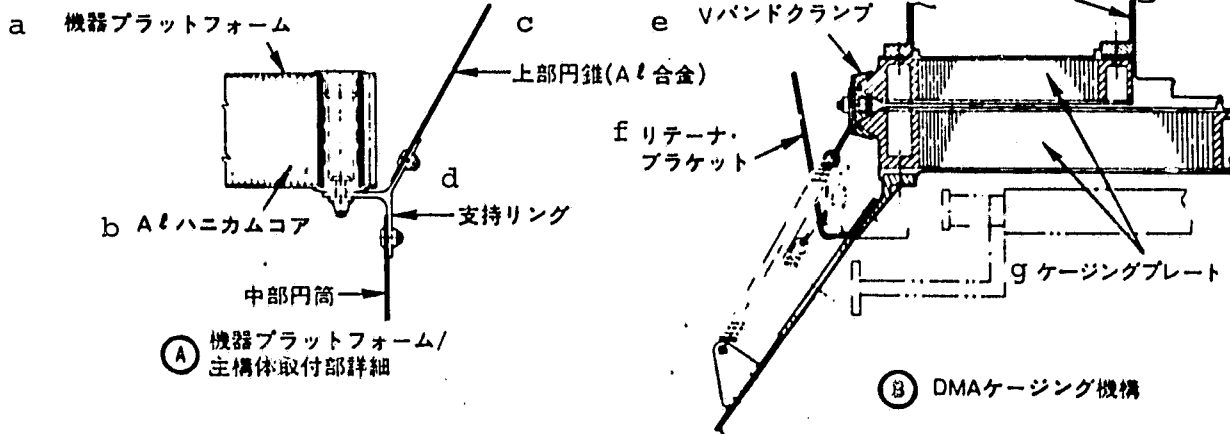

Satellite Framework

- Key:
- A. details of equipment platform/main attachments
 - B. DMA casings structure
 - C. AKM/main attachments
 - D. satellite disengagement surface and disengagement switch
 - E. support struts/main attachments
 - a. equipment platform
 - b. Al hanikamu* core
 - c. upper cone (Al alloy)
 - d. support ring
 - e. V band clamp
 - f. retainer placket
 - g. casing (illegible)
 - h. center cylinder (beryllium)
 - i. lower cone (beryllium)
 - j. disengagement ring (Al alloy)
 - k. thermal shield support truss
 - l. equipment platform
(Al hanikam* sandwich plates)
 - m. support strut (Al alloy)
 - n. axial thruster support
(glass epoxy/Al hanicam* sandwich plates)
 - o. solar array (top)
 - p. satellite support pin
 - r. strut
 - s. hoist placket
 - t. solar array (bottom)
 - u. disengagement switch
 - v. disengagement pad
 - w. disengagement spring
(rocket side)
 - x. (illegible)

* Translator's note: transliteration of Japanese phonetic characters. This term may be honeycomb, which is sometimes used for a porous structure.

The heat control system of the CS-2 is designed so that the temperature of the satellite framework and equipment can be maintained at $\pm 10^{\circ}$ C within the prescribed temperature range during the entire mission.

The majority of the heat control system operates passively using coatings, shields, heat transfer materials, insulation, etc. However, heaters are employed in the batteries, RCE, AKM, DMA, and TWTA when power is off. The heat sink for TWTA is attached to the equipment platform. Thermal energy produced above the platform is radiated to the thermal shields and solar array at the top and bottom of the satellite. This energy is then reradiated into space as infrared energy.

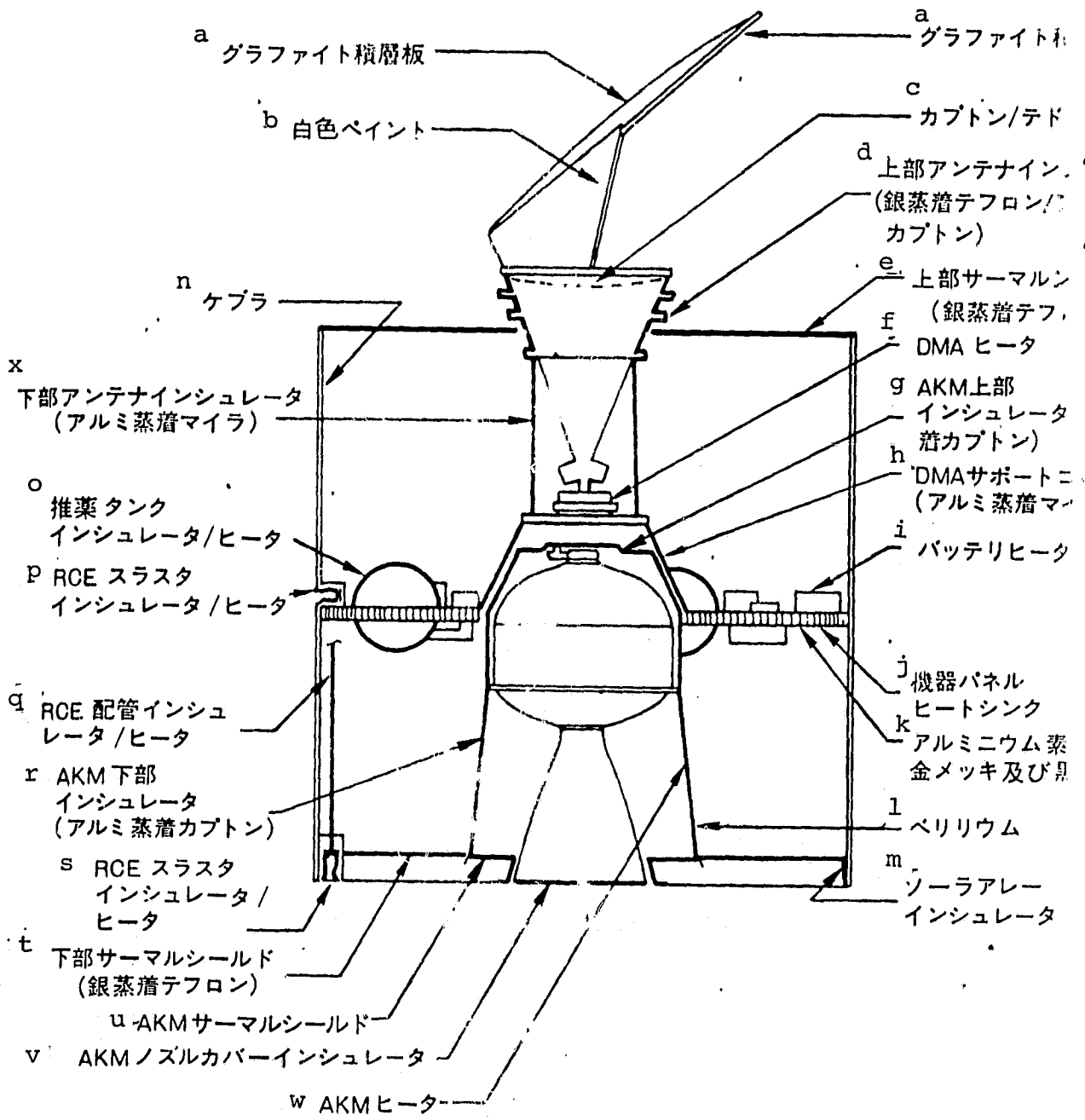

*Translator's note: please refer to key on page 48.

Heat Control System

- Key:
- | | |
|--|---|
| a. graphite laminated plate | b. white paint |
| c. kaputon/tedora* | d. top antenna insulator
(silver-vaporized teflon/
aluminum-vaporized kaputon*) |
| e. top thermal shield
(silver-vaporized teflon) | f. DMA heater |
| g. AKM top insulator
aluminum- vaporized kaputon* | h. DMA support (aluminum -
vaporized maira*) |
| i. battery heater | j. equipment panel heat sink |
| k. aluminum (illegible) plated
and (illegible) | l. beryllium |
| m. solar array insulator | n. cable |
| o. fuel tank insulator/heater | p. RCE thruster insulator/heater |
| q. RCE piping insulator/heater | r. AKM bottom insulator
(aluminum-vaporized kaputon*) |
| s. RCE thruster insulator/heater | t. bottom thermal shield
(silver-vaporized teflon) |
| u. AKM thermal shield | v. AKM nozzle cover insulator |
| w. AKM heater | x. bottom antenna insulator
(aluminum-vaporized maira*) |

*Translator's note: terms unknown; transliteration of Japanese phonetic characters.

Satellite orbit determination, attitude determination, and satellite performance spot checks will be carried out by the NASDA after the satellite has entered the transfer orbit using telemetry/command and range data at the NADS and NASA stations.

Satellite attitude control and apogee motor ignition will be carried out by command from earth. The satellite then will enter the drift orbit. Attitude control for final positioning and orbit control for geostationary orbiting will be carried out in the drift orbit.

During the initial 3 month stage after take off, the functions and properties of the satellite will be spot checked by the NASDA. Afterwards the satellite will be used by the Communications and Broadcasting Satellites Organization and related agencies.

a サブシステム	軌道						
	b フェーズ	c 遷移軌道		e ドリフト軌道	i 静止衛星軌道		
		d アポジモータ点火			f 日照	g 日陰	h 日照
j TT&C系							
k コマンド		—————					
l テレメトリ		—————					
m ビーコン							
n Sバンド		—————					
o Cバンド				—————			
p Kバンド				—————			
q アンテナ							
r Sバンドアンテナ		—————					
s 通信用アンテナ				—————			
t 姿勢制御		—————					
u 二次推進系		▬▬▬▬▬▬▬▬▬▬		▬▬▬▬▬▬▬▬▬▬			▬▬▬▬▬▬▬▬▬▬
v アポジモータ			▬▬▬▬▬▬▬▬▬▬				
w 通信用中継器 o Cバンド p Kバンド					Y 2 系統	X 1 系統	Y 2 系統
					Z 6 系統*	X 1 系統	Z 6 系統*

/36

aa 連続使用 cc * 3年後はKバンド4系統の運用が可能。

bb 間欠使用 ▬▬▬▬▬▬▬▬▬▬

- Key: a. subsystem b. rocket phase c. transfer orbit d. apogee motor ignition
- e. drift orbit f. sunlight g. shade h. day
- i. geostationary orbit j. TT&C system k. command
- l. telemetry m. beacon n. S band o. C band p. K band
- q. antenna r. S band antenna s. communications antenna
- t. attitude control u. secondary propulsion system
- v. apogee motor w. communication relay x. 1st system
- y. 2nd system z. 6th system* aa. continuous use
- bb. intermittent use cc.* K band 4th system can be used after 3 years.
- dd. orbit

The CS-2 will lift off from the NASDA Tanegashima Space Center with an N-II rocket. The satellite will automatically operate on electrical power after disengaging from the rocket's 3rd stage.

The satellite will enter the stand-by orbit while connected to the 3rd and 2nd stage of the rocket by 1 cycle of jet propulsion from the 2nd stage engine, with propulsion of the main engine of the N-II rocket's 1st stage continuing. Spin acceleration will occur at nominal 90(illegible) rpm in the 3rd stage after a 2nd cycle of jet propulsion of the 2nd stage engine. After the 2nd stage engine is given up, the satellite will enter a transfer orbit with a nominal perigee point height of 170 km, nominal apogee point height of 36,716 km, and orbit inclination of 28.8 by jet propulsion with the 3rd stage engine. After 3rd stage combustion is completed, the satellite will disengage from the 3rd stage with the disengagement spring and enter the transfer orbit.

Lift-off Rocket*

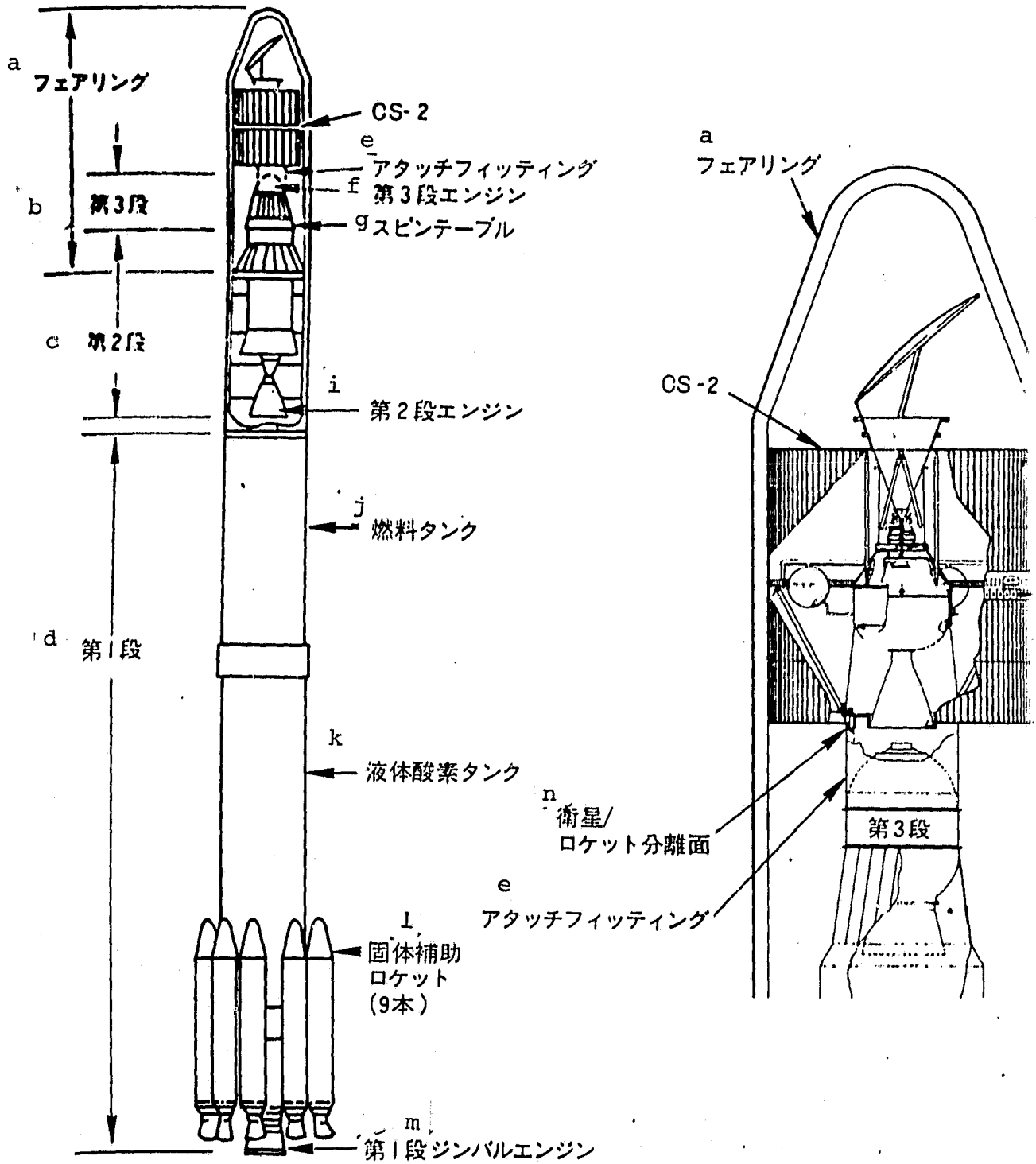

Lift-off Rocket

Key: a. firing b. 3rd stage c. 2nd stage d. 1st stage
e. attachment f. 3rd stage engine g. spin table
i. 2nd stage engine j. fuel tank k. liquid oxygen tank
l. solid reinforcing rockets (9) m. 1st stage gimbal engine
n. satellite/rocket disengagement surface

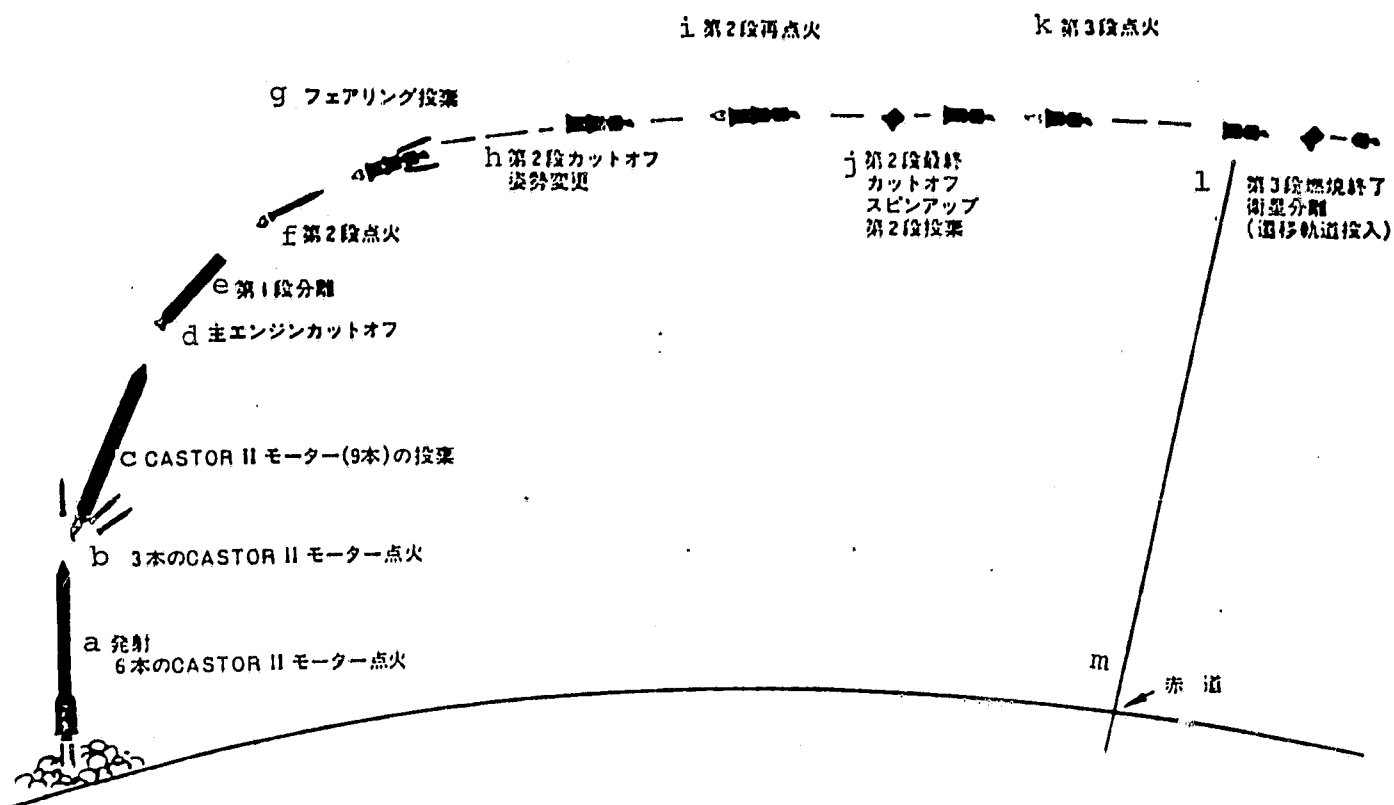

- Key:
- a. firing: ignition of 6 Castor II motors
 - b. ignition of 3 Castor II motors
 - c. Castor II motors (9) are given up
 - d. main engine cut off
 - e. 1st stage disengagement
 - f. 2nd stage ignition
 - g. firing given up
 - h. 2nd stage cut off attitude modification
 - i. 2nd stage reignition
 - j. 2nd stage final cut off spin acceleration 2nd stage given up
 - k. 3rd stage ignition
 - l. 3rd stage (illegible) satellite (illegible) (transfer((illegible)))
 - m. equator

ORIGINAL PAGE IS
OF POOR QUALITY

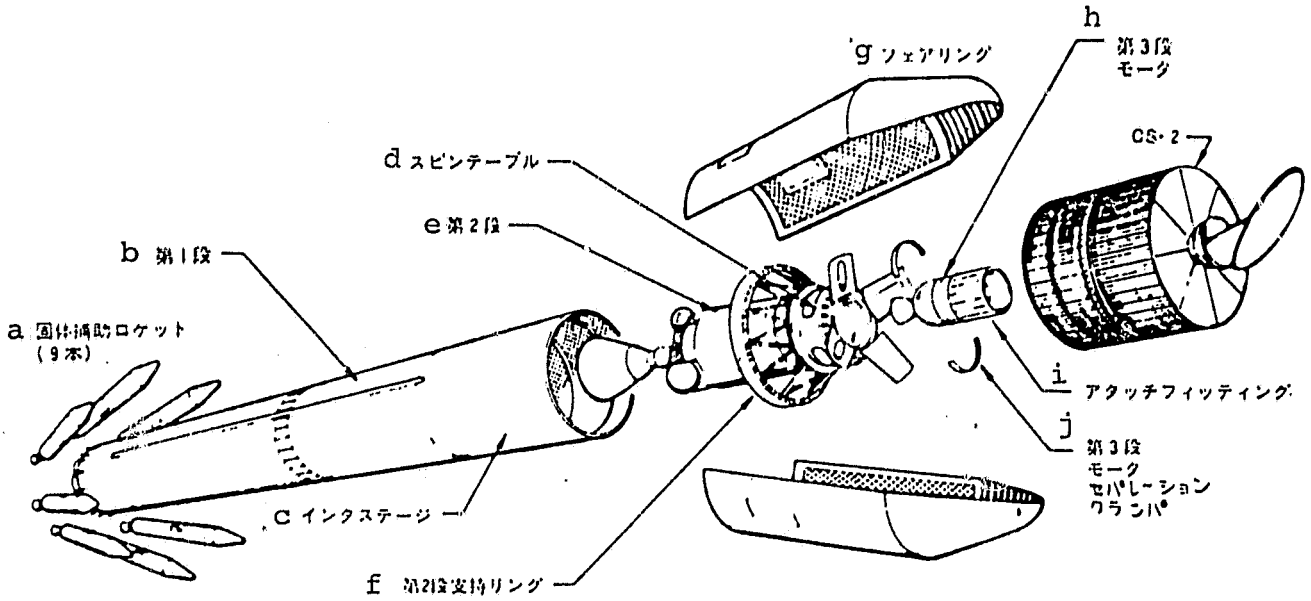

Key: a. solid reinforcing rockets (9) b. 1st stage
 c. interstage d. spin table e. 2nd stage
 f. 2nd stage support ring g. firing
 h. 3rd stage motor i. attachment j. 3rd stage motor
 separation

Transfer Orbit

/40

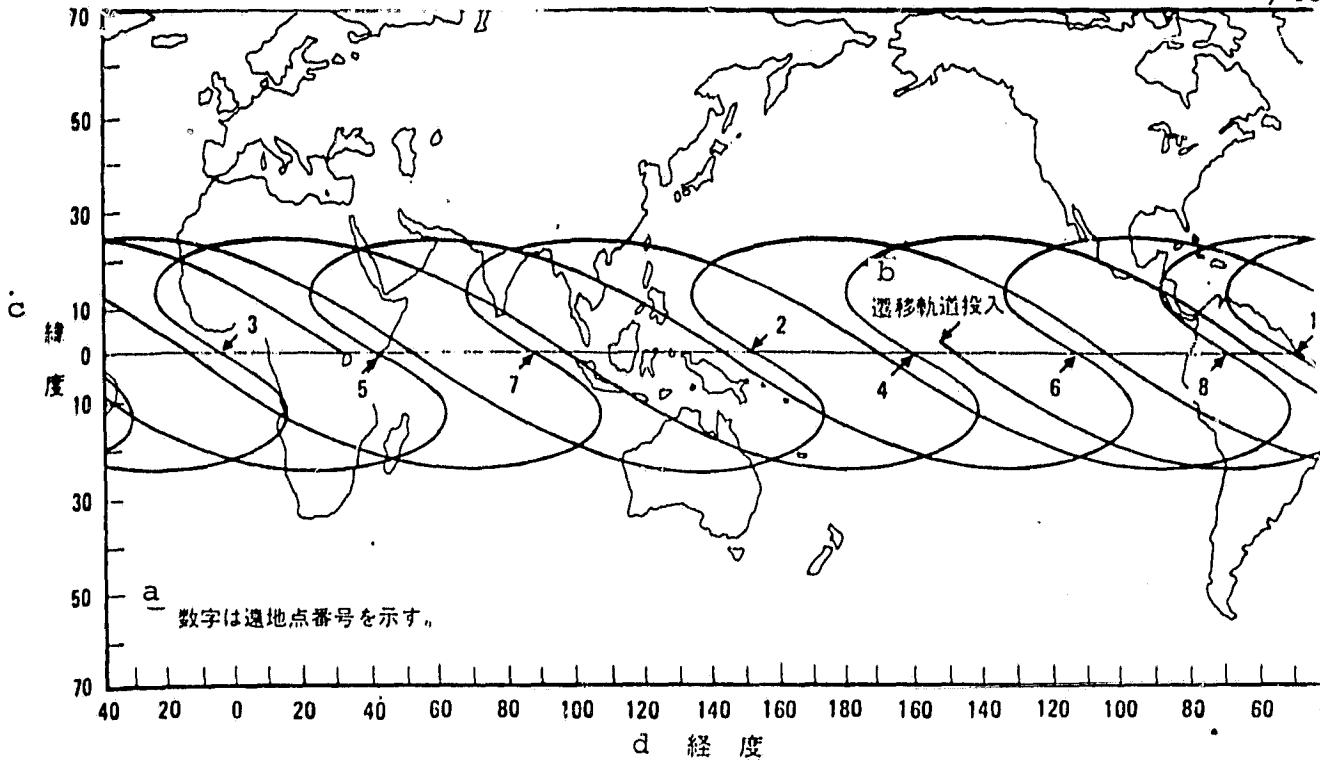

- Key: a. numbers indicate the apogee point number.
b. transfer orbit entrance
c. latitude
d. longitude

ORIGINAL PAGE IS
OF POOR QUALITY

The CS-2 is attitude controlled for AKM ignition after transfer orbit entrance. The satellite then enters the drift orbit from the transfer orbit by apogee motor ignition at the 7th apogee point.

The CS-2, which has entered the drift orbit, is orbit-controlled for geostationary orbiting and positioning with the speed control of the secondary propulsion system.

The satellites are controlled so that the CS-2a will be held at a north-east direction of within $\pm 0.1^\circ$ from the standard location above the equator and the orbit angle of inclination will be within $\pm 0.1^\circ$ with CS-2a being at the 130th degree of longitude and the CS-2b being at the 135th degree of longitude.

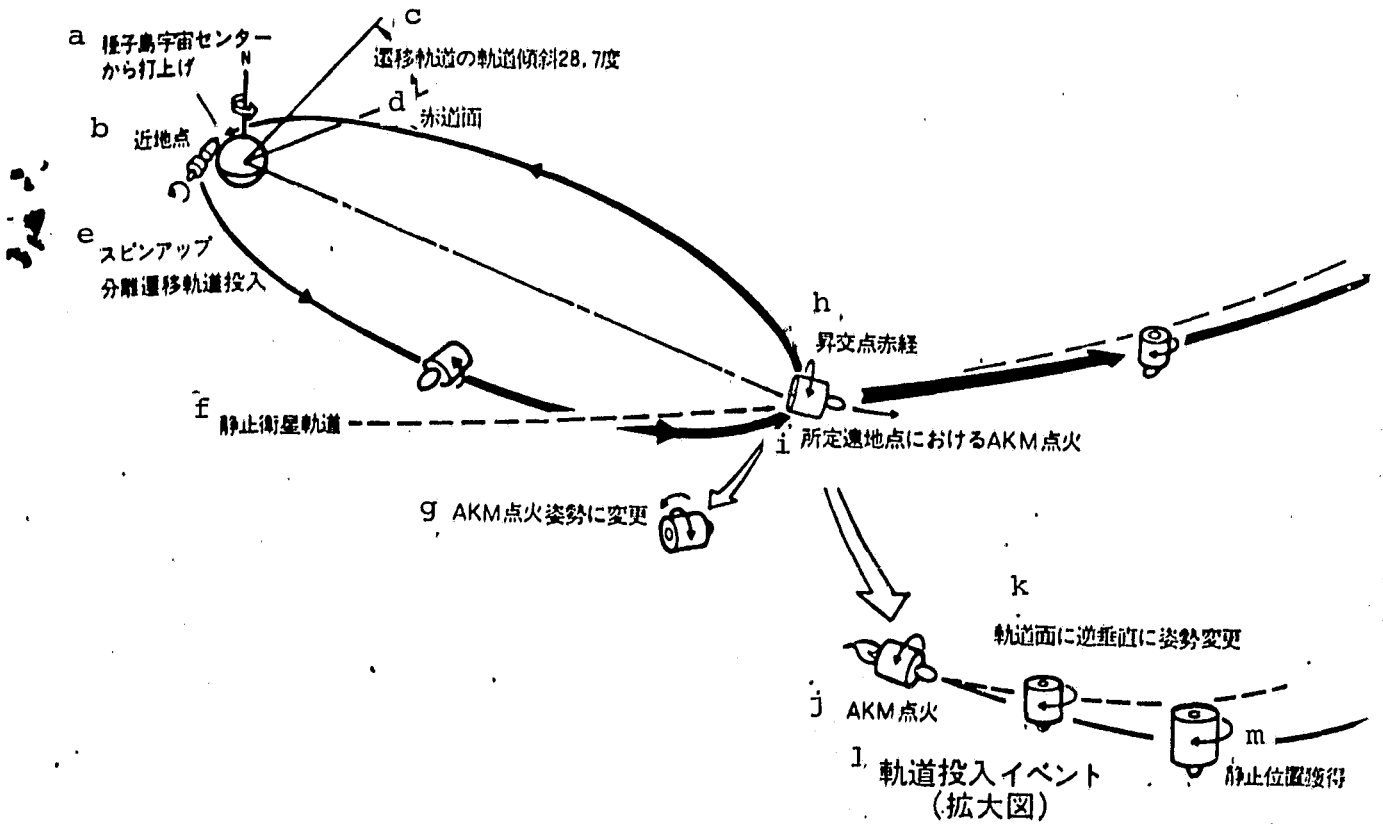

- Key:
- a. lift-off from Tanegashima Space Center
 - b. perigee point
 - c. transfer orbit angle of inclination of 28.7
 - d. equatorial surface
 - e. spin acceleration enters the disengagement orbit
 - f. geostationary satellite orbit
 - g. Modification to AKM ignition attitude
 - h. ascending node equator line
 - i. AKM ignition at fixed apogee point
 - j. AKM ignition
 - k. attitude modification perpendicular to orbit surface
 - l. orbit entrance event (magnification)
 - m. geostationary positioning

ORIGINAL PAGE IS
OF POOR QUALITY

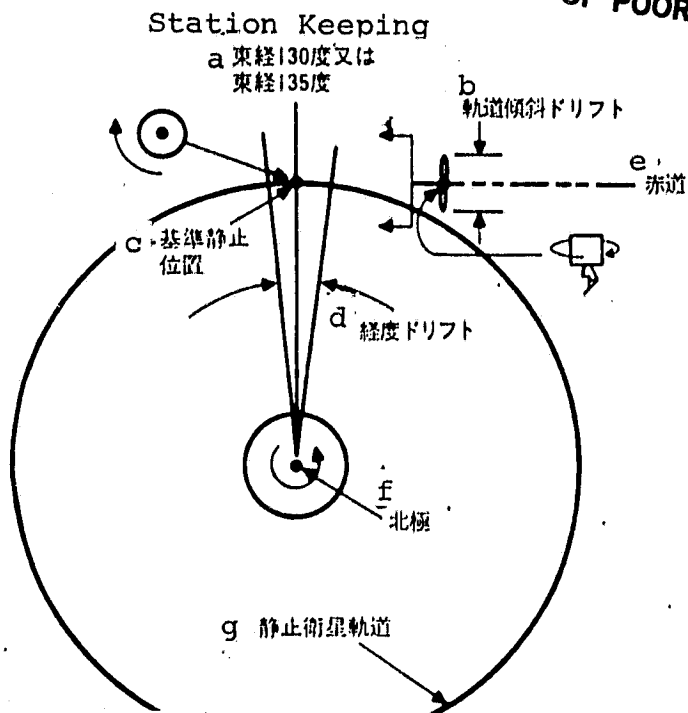

- Key:
- a. 130th degree of east longitude or 135 degree of east longitude
 - b. orbit inclination drift
 - c. standard geostationary position
 - d. longitudinal drift
 - e. equator
 - f. north pole
 - g. geostationary satellite orbit

ORIGINAL PAGE IS
OF POOR QUALITY

EXCISE FRAME

a 通信衛星2号(C)

b 項目	c 期日	d 昭和54年度												e 昭和55年度												f 昭和56年度													
		4	5	6	7	8	9	10	11	12	1	2	3	4	5	6	7	8	9	10	11	12	1	2	3	4	5	6	7	8	9	10							
(1) 主要イベント																																							
(2) CS-2a																																							
^s PFMバス機器製作・試験																																							
^t PFMアンテナ製作・試験																																							
^u PFMトランスポンダ製作・試験																																							
^v PFMインタグレーション																																							
^w PFM認定試験																																							
^x PFM改修及び試験																																							
^y 輸送(米国〜日本)																																							
^z PFM射場搬入後試験																																							
(3) CS-2b																																							
^{aa} FMバス機器製作・試験																																							
^{bb} FMアンテナ製作・試験																																							
^{cc} FMトランスポンダ製作・試験																																							
^{dd} FMインタグレーション																																							
^{ee} FM受入試験																																							
^{ff} 輸送(鎌倉〜種子島)																																							
^{gg} FM射場搬入後試験																																							

i. ↑ 契約(56.3.31)
 j. ↑ 基本設計 (55.4.15 ~ 4.21)
 k. ↑ 詳細設計 (56.1.20 ~ 1.27)

f 昭和56年度					g 昭和57年度												h 昭和58年度																																															
1	2	3	4	5	6	7	8	9	10	11	12	1	2	3	4	5	6	7	8	9	10	11	12	1	2	3	4	5	6	7	8	9	10	11	12	1	2	3																										
↑ k 審査 計 56.1.20 ~ 1.27					↑ l 認定試験後 審査(57.4)												↑ m PFM 去存前審査 (57.10)												↑ n PFM 引渡前審査 (57.12)												↑ p FM 去存前審査 (58.4)												↑ q FM 引渡前審査 (58.6)											
					hh 納入 ↑												hh 納入 ↑																																															

- Key:
- a. Schedule for Communications Satellite 2 (CS-2)
 - b. item c. date d. 1979 e. 1980 f. 1981
 - g. 1982 h. 1983 i. contracted (March 31, 1980)
 - j. basic plans (April 15-April 21, 1980)
 - k. gauges inspected (January 20-27, 1981)
 - l. tests after inspections (March, 1982)
 - m. inspection before PFM load (October, 1982)
 - n. inspection before PFM delivery (December, 1982)
 - o. CS-2a lift off
 - p. inspection before FM load (April, 1983)
 - q. inspection before FM delivery (June, 1983)
 - r. CS-2b lift off
 - s. PFM bus equipment production and testing
 - t. PFM antenna production and testing
 - u. PFM transponder production and testing
 - v. PFM integration
 - w. PFM inspection
 - x. PFM improvements and testing
 - y. shipped (U.S. to Japan)
 - z. testing after PFM installation
 - aa. FM bus equipment production and testing
 - bb. FM antenna production and testing
 - cc. RM transponder production and testing
 - dd. FM integration
 - ee. FM inspection
 - ff. shipped (Kamakura to Tanegashima)
 - gg. FM installation and testing
 - hh. delivery
 - (l) Main Event

Main Conditions for SC-3 Preliminary Designs (Draft)

1. Basic Conditions

The CS-3 will advance research and development as a result of the development of the CS (illegible), etc. as part of the Fixed Communications Satellites Series. Preliminary designs were carried out in accordance with the following conditions in (illegible).

- (1) continuity of services from CS-2
- (2) improvement of communications properties
- (3) economic improvement
- (4) improvement of reliability
- (5) improvement of national technology

2. General Essential Conditions

The following essential design conditions were satisfied in this test.

(1) Number of satellites

There are 3 basic satellites, including 2 orbiting satellites (CS-3a and CS-3b) and 1 reserve satellite on earth.

(2) Lift-off time

The CS-3a will lift-off in the winter of 1987 and the CS-3b will lift-off in the summer of 1988.

(3) Lift-off rocket

The H-I rocket will be used.

(4) Orbits

a. Orbit Position

130th degree east longitude (CS-3a) and 135th degree east longitude (CS-3b)

b. Orbit Maintenance Precision

within +0.05 for both east-west and north-south

(5) Life span and Reliability

a. Lift Span

7 years or more after lift-off

b. Reliability

The probability that the satellite will remain 7 years after lift-off (excluding communications equipment) is 80% or more.

(6) Shape and Weight

a. Shape

The shape and dimensions are suitable for H-I rocket firing.

b. Weight

The initial weight during geostationary orbiting is about 550 kg.

(7) Conditions for Use

It is possible to use all communications equipment during all seasons.

(8) Generated Electrical Power

/46

Sufficient electrical power can be supplied to each part of the satellite, even at the end of its life span.

(9) Communications System Accessories

The following communications devices will be carried.

a. Relays

microwave relays	2 systems
standard milliwave relay	10 systems

The systems have suitable redundancy.

b. Communications Antenna

The communications antenna has the following properties.

(a) microwave band

Irradiates all of Japan, including Okinawa and Ogasawara, with a gain of 25 dB or more.

(b) Standard Milliwave Band

Irradiates to Honshu, Shikoku, Kyushu, and Hokkaido with a gain of 33 dB or more. The gain to Okinawa is 27 dB or more.

(c) Antenna Directional Probability

Changes from the standard direction of the main directional axis of the communications antenna are with a cone with a semi-vertical angle of 0.2° during normal applications. /47

(10) TT&C Frequency

The frequency for TT&C is the same frequency band used for the CS-2. The frequency of the milliwave band beacon is the same as that used for the CS-2.

(11) Others

a. There will be sufficient testing of properties, weight, reliability, economics, precision, etc. and comparison with existing information in order to develop new technologies.

b. There will be sufficient comparison of properties, weight, reliability, economics, precision, etc. in order to further advance national technology.

c. Orbit control, attitude control, and application of control during any season will be verified. The necessity of improving or adding to the TT&C facility and software of the National Space Development Agency and the Communications and Broadcasting Satellites Organization will be determined. When necessary, the expense involved in improvements and additions will be assessed and the details will be made clear.

d. The possibility of lift-off with techniques other than the N-I rocket, such as the space shuttle, Arian, etc., will be tested. When possible, the conditions for application of these other techniques will be clarified.

Information on Communications Satellites

Communications Satellite 2 (CS-2): (illegible) of CS-2
Basic Conditions for Preliminary Designs for CS-3:
 pertains to CS-3 satellite
 (illegible)

Suitable information on conventional technology has been obtained. The following technological information was (illegible) from the Japan Space Institute.

(1) (illegible) communications system:
data communications: 1.54 Mb/s data transmission to computer
 64 Kb/s information transmission (illegible)
 to computer
video communications: 6.3 Mb/s video transmission test
 1.5 Mb/s still picture transmission test
 256 Kb/s audio transmission test
Packet (illegible): 64 Kb/s transmission test with 3 packet
 switching devices.
High speed facsimile: high speed facsimile transmission test at
 1.544 Mb/s.

(2) (illegible) Communications System
on-board-ship equipment: total weight of 15 kg of shot back fai-
 anrame* (28 cm ϕ) (includes 5 kg radome)
transmitter: trial production of 2.6/2.5 GHz band
 FET relay

(3) Multibeam transmission Communications System
TOMA device: trial production of 200 Mb/s transmitter with 30/20 GHz.
Transmitter relay: 30/20 GHz band using GaAs FET switch.

*Translator's note: term unknown; transliteration of Japanese phonetic characters.

multibeam antenna: trial production of antenna that irradiates with 4 beams to the Japanese mainland.

All production by Japan was done in the NASDA buildings. The following is an (illegible).

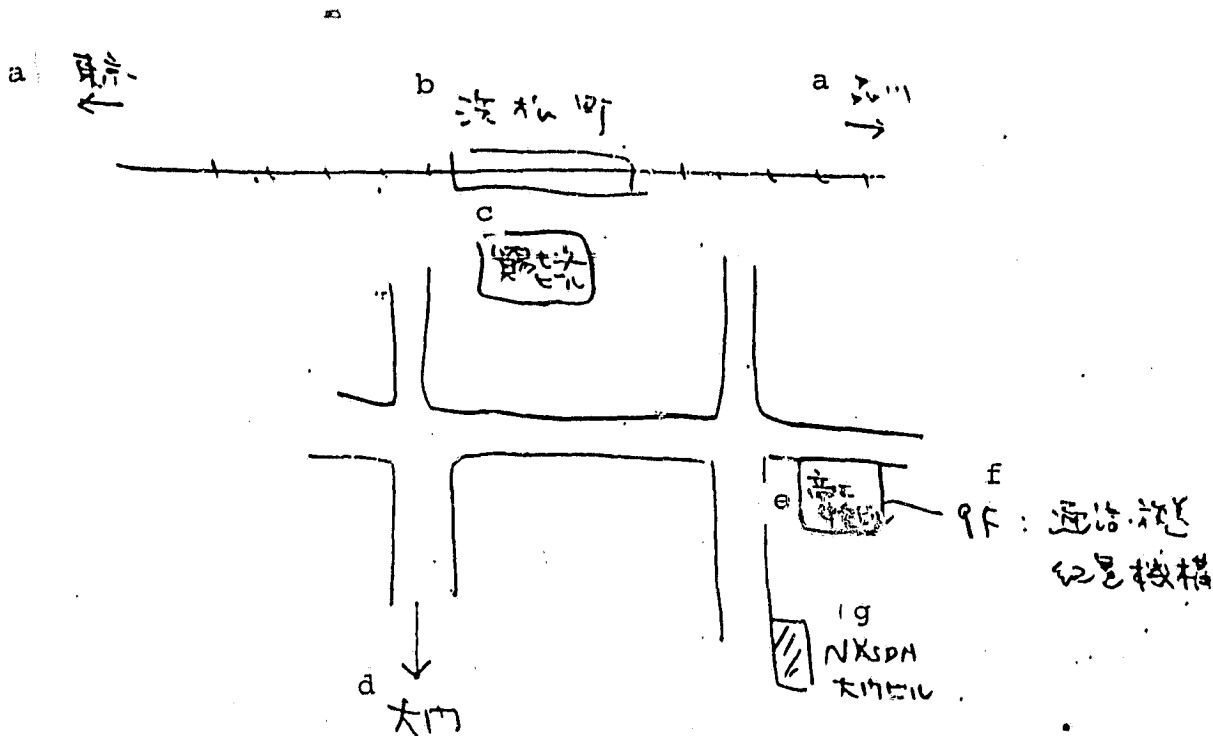

- Key: a. (illegible) b. Senmatsu-cho c. data building
 d. Okado e. Advanced Technology Building
 f. 9F: Communications and Broadcasting Satellites Organization
 g. NASDA main building