

NASA-CR-167954  
19830005857

*NASACR-167954*

NASA CR-167954  
PWA-5523-122



ROTOR REDESIGN FOR A HIGHLY LOADED 1800 FT/SEC  
TIP SPEED FAN  
III. LASER DOPPLER VELOCIMETER REPORT

BY

W.B. HARVEY, D.E. HOBBS, D. LEE, M.C. WILLIAMS AND K.F. WILLIAMS

April 1982

**LIBRARY COPY**

SEP 26 1983

LANGLEY RESEARCH CENTER  
LIBRARY, NASA  
HAMPTON, VIRGINIA

UNITED TECHNOLOGIES CORPORATION  
Pratt & Whitney Aircraft Group  
Commercial Products Division

Prepared for



NATIONAL AERONAUTICS AND SPACE ADMINISTRATION  
NASA-Lewis Research Center  
Contract NAS3-20591

1. Report No. <b>NASA-CR-167954</b>		2. Government Accession No.		3. Recipient's Catalog No.	
4. Title and Subtitle <b>Rotor Redesign for a Highly Loaded 1800 ft/sec Tip Speed Fan, III. Laser Doppler Velocimeter Report</b>				5. Report Date <b>April 1982</b>	
				6. Performing Organization Code	
7. Author(s) <b>W.B. Harvey, D.E. Hobbs, D. Lee, M.C. Williams and K.F. Williams</b>				8. Performing Organization Report No. <b>PWA-5523-122</b>	
9. Performing Organization Name and Address <b>United Technologies Corporation Pratt &amp; Whitney Aircraft Group, CPD East Hartford, Connecticut 06108</b>				10. Work Unit No.	
				11. Contract or Grant No. <b>NAS3-20591</b>	
				13. Type of Report and Period Covered <b>Contractor Report</b>	
12. Sponsoring Agency Name and Address <b>National Aeronautics and Space Administration Washington, D.C. 20546</b>				14. Sponsoring Agency Code	
15. Supplementary Notes <b>NASA Project Manager: Mr. L.J. Herrig, Fluid Mechanics and Acoustics Division, Fan and Compressor Branch, NASA-Lewis Research Center, Cleveland, Ohio 44135. P&amp;WAG Program Manager: Mr. N.T. Monsarrat</b>					
16. Abstract <p>Laser Doppler velocimeter (LDV) techniques were employed for testing a highly loaded, 550 m/sec (1800 ft/sec) tip speed, test fan stage, the objective to provide detailed mapping of the upstream, intrablade, and downstream flowfields of the rotor. Intrablade LDV measurements of velocity and flow angle were obtained along four streamlines passing through the leading edge at 45%, 69%, 85%, and 95% span measured from hub to tip, at 100% of design speed, peak efficiency; 100% speed, near surge; and 95% speed, peak efficiency. At the design point, most passages appeared to have a strong leading edge shock, which moved forward with increasing strength near surge and at part speeds. The flow behind the shock was of a complex mixed subsonic and supersonic form. The intrablade flowfields were found to be significantly nonperiodic at 100% design speed, peak efficiency.</p>					
17. Key Words (Suggested by Author(s)) <b>Laser Doppler Velocimeter Supersonic, Single-Stage Fan Rotor Intrblade Flowfields Nonperiodicity</b>			18. Distribution Statement <b>Unclassified - Unlimited</b>		
19. Security Classif. (of this report) <b>Unclassified</b>		20. Security Classif. (of this page) <b>Unclassified</b>		21. No. of Pages	22. Price*

\* For sale by the National Technical Information Service, Springfield, Virginia 22161

## FOREWORD

The work described herein was performed under NASA Contract NAS-3-20591 by Pratt & Whitney Aircraft Group, Commercial Products Division, United Technologies Corporation, Hartford, Connecticut under the direction of Mr. N. T. Monsarrat, Program Manager. The NASA Project Manager was Mr. L.J. Herrig, NASA-Lewis Research Center, Fluid Mechanics and Acoustics Division.

## TABLE OF CONTENTS

Section	Title	Page
1.0	SUMMARY	1
2.0	INTRODUCTION	1
3.0	APPARATUS	2
	3.1 Fan Stage	2
	3.2 Test Facility	3
4.0	LASER VELOCIMETER INSTRUMENTATION	3
	4.1 Overall System Description	3
	4.2 LDV Optical Head and Traverse System	4
	4.3 Data Acquisition and Processing System	4
5.0	PROCEDURES	4
	5.1 Test Procedure	4
	5.2 Data Reduction Procedure	5
	5.3 Data Analysis Procedure	5
	5.4 Test Conditions and Data Description	7
	5.5 Selection of Laser Fringe Orientations	8
	5.6 Flow Periodicity	9
6.0	DISCUSSION OF RESULTS	10
	6.1 Mach Number Profiles and Flowfield Interpretation	10
	6.2 Periodicity	12
	6.3 Wakes	13
	6.4 Spanwise Traverses	14
7.0	CONCLUSIONS	14
8.0	REFERENCES	16
	APPENDICES	87
	A Symbols and Abbreviations	89
	B Definition of Performance Parameters	91
	C Overall and Blade Element Performance Tabulations	95
	D Laser Doppler Velocimeter Data Measured Flowfield Tabulations	105
	E A Possible Flow Instability	241
	F Blade Coordinates	243
	DISTRIBUTION LIST	245



## LIST OF ILLUSTRATIONS

Figure	Title	Page
1	Cross Section of 1800 Ft/Sec Tip Speed Fan Test Rig	17
2	Rotor Assembly Installed in Test Rig	18
3	Redesigned 1800 Ft/Sec Tip Speed Fan Blade	19
4	Test Stand Schematic	20
5	Optical Layout of Laser Doppler Velocimeter	21
6	Photograph of 1800 Ft/Sec Tip Speed Fan Test Rig, Left Side View Showing Laser Equipment	22
7	Laser Doppler Velocimeter High Speed Data Acquisition System	23
8	Computer-Controlled Data Acquisition System Schematic Diagram	24
9	Laser Doppler Velocimeter Sample Data Set	25
10	Velocity Data Tabulation Sample	26
11	Sample of "Carpet Plot" Type Velocity Histogram	27
12	Velocity Histogram	28
13	Diagram Defining Velocity Vector Terms	29
14	Rotor Performance Map	30
15	Laser Doppler Velocimeter Data Stations	31
16	Aerodynamic Results at 85 Percent Span, 95 Percent Design Speed, $x/b = 0.39$ No Significant Angle Biasing Indicated	32
17	Aerodynamic Results at 85 Percent Span, 100 Percent Design Speed, Near Surge, $x/b = 0.26$ , Passage No. 1 Results Have Been Affected by Angle Biasing	33
18	Mach Number Vs Percent Gap for Passages No. 1, 15, and 31, 85 Percent Span, 100 Percent Design Speed, Peak Efficiency, $x/b = 0.26$	34

LIST OF ILLUSTRATIONS (Cont'd)

Figure	Title	Page
19	Mach Number Contours at 85 Percent Span, 100 Percent Design Speed, Peak Efficiency Passage No. 1	35
20	Mach Number Profiles at 85 Percent Span, 100 Percent Design Speed, Peak Efficiency Passage No. 1	36
21	Mach Number Contours at 85 Percent Span, 95 Percent Design Speed, Peak Efficiency Passage No. 1	40
22	Mach Number Profiles at 85 Percent Span, 95 Percent Design Speed, Peak Efficiency Passage No. 1	41
23	Mach Number Contours at 85 Percent Span, 100 Percent Design Speed, Near Surge Passage No. 1	44
24	Mach Number Profiles at 85 Percent Span, 100 Percent Design Speed, Near Surge Passage No. 1	45
25	Mach Number Contours at 95 Percent Span, 100 Percent Design Speed, Peak Efficiency Passage No. 1	48
26	Mach Number Profiles at 95 Percent Span, 100 Percent Design Speed, Peak Efficiency Passage No. 1	49
27	Mach Number Contours at 95 Percent Span, 95 Percent Design Speed, Peak Efficiency Passage No. 1	54
28	Mach Number Profiles at 95 Percent Span, 95 Percent Design Speed, Peak Efficiency Passage No. 1	55
29	Mach Number Contours at 95 Percent Span, 100 Percent Design Speed, Near Surge Passage No. 1	58
30	Mach Number Profiles at 95 Percent Span, 100 Percent Design Speed, Near Surge Passage No. 1	59

## LIST OF ILLUSTRATIONS (Cont'd)

Figure	Title	Page
31	Mach Number Contours at 69 Percent Span, 100 Percent Design Speed, Peak Efficiency Passage No. 1	64
32	Mach Number Profiles at 69 Percent Span, 100 Percent Design Speed, Peak Efficiency Passage No. 1	65
33	Mach Number Profiles at 45 Percent Span, 100 Percent Design Speed, Peak Efficiency Passage No. 1	68
34	Mach Number Profiles at 45 Percent Span, 95 Percent Design Speed, Peak Efficiency Passage No. 1	69
35	Mach Number Profiles at 45 Percent Span, 100 Percent Design Speed, Near Surge Passage No. 1	70
36	Mach Number Contours From Design Calculations for 95 Percent Span, 100 Percent Design Speed	71
37	Mach Number Contours From Design Calculations for 85 Percent Span, 100 Percent Design Speed	72
38	Mach Number Contours at 85 Percent Span, 100 Percent Design Speed, Peak Efficiency Passage No. 15	73
39	Mach Number Contours at 85 Percent Span, 100 Percent Design Speed, Peak Efficiency Passage No. 31	74
40	Mach Number Contours at 85 Percent Span, 95 Percent Design Speed, Peak Efficiency Passage No. 15	75
41	Mach Number Contours at 85 Percent Span, 95 Percent Design Speed, Peak Efficiency Passage No. 31	76
42	Mach Number Contours at 85 Percent Span, 100 Percent Design Speed, Near Surge Passage No. 15	77

## LIST OF ILLUSTRATIONS (Cont'd)

Figure	Title	Page
43	Mach Number Contours at 85 Percent Span, 100 Percent Design Speed, Near Surge Passage No. 31	78
44	Relative Mach Number for Wakes at $x/b = 1.1$ 95 Percent Span, 100 Percent Design Speed, Peak Efficiency	79
45	Relative Mach Number for Wakes at $x/b = 1.1$ 95 Percent Span, 95 Percent Design Speed, Peak Efficiency	79
46	Relative Mach Number for Wakes at $x/b = 1.1$ 95 Percent Span, 100 Percent Design Speed, Near Surge	80
47	Relative Mach Number for Wakes at $x/b = 1.1$ 85 Percent Span, 100 Percent Design Speed, Peak Efficiency	80
48	Relative Mach Number for Wakes at $x/b = 1.1$ 85 Percent Span, 95 Percent Design Speed, Peak Efficiency	81
49	Relative Mach Number for Wakes at $x/b = 1.1$ 85 Percent Span, 100 Percent Design Speed, Near Surge	81
50	Relative Mach Number for Wakes at $x/b = 1.1$ 69 Percent Span, 100 Percent Design Speed, Peak Efficiency	82
51	Laser Doppler Velocimeter Traverse at Inlet Instrumentation Plane (Station 11) 100 Percent Design Speed, Peak Efficiency	83
52	Laser Doppler Velocimeter Traverse at Leading Edge Plane (Station 13) 100 Percent Design Speed, Peak Efficiency	84
53	Laser Doppler Velocimeter Traverse at Trailing Edge Plane (Station 14) 100 Percent Design Speed, Peak Efficiency	85
54	Velocity Histograms for Passages 1 and 15 at $x/b = 0.52$ - 85 Percent Span, 100 Percent Design Speed, Peak Efficiency Laser Fringe Orientation Angle: ZETA = $60^\circ$	86

ROTOR REDESIGN FOR A HIGHLY LOADED 1800 FT/SEC  
TIP SPEED FAN  
III. LASER DOPPLER VELOCIMETER REPORT

BY

W.B. Harvey, D.E. Hobbs, D. Lee, M.C. Williams and K.F. Williams

PRATT & WHITNEY AIRCRAFT GROUP

1.0 SUMMARY

A highly loaded, 550 m/sec (1800 ft/sec) tip speed, test fan stage was designed, built, and tested by Pratt & Whitney Aircraft under NASA contract NAS3-20591. The stage was first tested using conventional instrumentation, followed by a test employing laser Doppler velocimeter (LDV) techniques. This report provides the results of the LDV test, the results of the conventional instrumentation test having been reported earlier.

The objective of the LDV test was to provide detailed mapping of the upstream, intrablade, and downstream flowfields of the rotor. Intrablade LDV measurements of velocity and flow angle were obtained along four streamlines passing through the leading edge at 45%, 69%, 85%, and 95% span measured from hub to tip. The data were acquired at: (1) 100% of design speed, peak efficiency, (2) 100% speed, near surge, and (3) 95% speed, peak efficiency. Spanwise traverse data at 100% speed, peak efficiency were also obtained at three axial stations located at the inlet instrumentation plane, the rotor leading edge plane, and the rotor trailing edge plane.

Analyses of the data indicated that most passages were characterized by a strong leading edge shock at the design point. The shock moved forward with increasing strength near surge and at part speeds. In all cases the flowfield behind the shock was of a complex mixed subsonic and supersonic form. In a few passages at the design point, the flow was different from the flow in the other passages. The flow in these passages may be nearly shock free or contain multiple shocks of the sort found in some duct flows. At offdesign points, the flow in these passages was closer to that in the others.

2.0 INTRODUCTION

An increased understanding of the flowfield within blade passages is required to improve currently available methods for designing aircraft engine fan/compressor blades. These advances would result in increased fan/compressor efficiency.

Three-dimensional flow calculation procedures have in recent years become available for analysis of a mixed subsonic and supersonic flowfield within a transonic rotor. Validating these computational techniques and developing them

into advanced design procedures requires experimental data obtained within blade passages, data that can be acquired by means of laser Doppler velocimeter (LDV) techniques.

To satisfy this need, intrablade LDV measurements were made as part of the NASA contract NAS3-20591, in which Pratt & Whitney Aircraft designed, built, and tested a highly loaded, 550 m/sec (1800 ft/sec) tip speed, test fan stage. This fan, a revised version of an earlier model and designed using a quasi three-dimensional procedure, was first tested using conventional instrumentation, followed by the LDV measurements, providing the opportunity for comparing the results of intrapassage measurements with flowfield calculations. The details of the design are presented in reference 1, and the standard aerodynamic performance results in reference 2. The results of the LDV measurements are the subject of this report.

### 3.0 APPARATUS

#### 3.1 FAN STAGE

The NAS3-20591, 550 m/sec fan stage (Figures 1 and 2) is a single-stage, axial-flow fan without inlet guide vanes. The stage design parameters are summarized in Table I.

TABLE I

#### DESIGN PARAMETERS

Corrected Speed, rpm	12464
Rotor Tip Speed, m/sec (ft/sec)	550 (1800)
Corrected Flow, kg/sec (lbm/sec)	78.8 (173.8)
Corrected Weight Flow Per Unit Annulus Area, kg/m <sup>2</sup> -sec (lbm/ft <sup>2</sup> -sec)	188.9 (38.7)
Rotor Total Pressure Ratio	2.34
Stage Total Pressure Ratio	2.28
Rotor Adiabatic Efficiency	0.868
Stage Adiabatic Efficiency	0.838
Tip Diameter, meters (in.)	0.8409 (33.108)
Hub/Tip Ratio at Rotor Inlet	0.50
Rotor Tip Solidity	1.635
Rotor Aspect Ratio (average span/axial chord at hub)	2.87
Stator Hub Solidity	2.204
Stator Aspect Ratio (average span/axial chord at hub)	2.22
Stage Average Exit Flow Angle, degrees	0
Number of Rotor Blades	38
Number of Stator Vanes	60

The fan blade (Figure 3) consists of a standard two-part multiple-circular-arc section from the hub to 20 percent span and a four-part, multiple-circular-arc section from 34 percent span to the tip. The region between 20 and 34 percent span provides a smooth transition from the standard multiple-circular-arc section to the four-part section. Details of the rotor design are given in reference 1.

### 3.2 TEST FACILITY

The test program was conducted in the facility shown in Figure 4. This facility was equipped with a synchronous motor and gearbox to provide speed range capability. The inlet air flowed through a flat-plate orifice and through an inlet plenum to provide a uniform total pressure and temperature profile to the test rig. The air flowed from the rig into a toroidal collector, through a set of valves that provided coarse and fine discharge pressure adjustment for the test compressor, and then through exhausters.

Seeding apparatus, consisting of a screen supported by twelve struts, between the plenum and the rotor (Figure 1) provided particles for LDV viewing. The screen, consisting of a square mesh of 0.635 cm (0.25 in.) diameter tubes with 3.81 cm (1.5 in.) pitch, caused a radially nonuniform total pressure loss of about three percent. The organic oil liquid droplet seed particles were injected through a portion of the screen which could be rotated circumferentially to permit alignment of the seeded flow with the LDV measurement volume.

## 4.0 LASER VELOCIMETER INSTRUMENTATION

### 4.1 OVERALL SYSTEM DESCRIPTION

Laser Doppler velocimetry permits the velocity of air to be measured without introducing aerodynamic blockage. The measurements are obtained at the intersection of two nearly parallel laser beams, the laser providing monochromatic light that produces interference fringes at the intersection of the two beams. The light that is scattered by the particles passing through the fringes is detected. The fluid velocity can be calculated from the Doppler shift of the reflected light, the particles being small enough--1.6 microns ( $6.3 \times 10^{-7}$  in.)--to closely follow the flow. The instrument measures the component of velocity in the plane perpendicular to the bisector of the two beams. It is capable of measuring flow velocities from about 1 to 5000 m/sec with an uncertainty of less than one percent.

The laser and optics were mounted adjacent to the rig on a numerically controlled Bridgeport milling machine, which provided remote control traverse capability in three directions. Two optically flat, circular quartz windows, each 7.62 cm (3.0 in.) in diameter and 0.95 cm (0.375 in.) thick, afforded optical access to the rotor and flowfields. The windows, which could occupy any two of three available ports at a time, provided excellent coverage of the upstream and intrablade flows but permitted viewing to only ten percent of chord downstream of the trailing edge. Both windows were equipped with window washing capabilities, using acetone, methanol, and distilled water that could be actuated from the control room.

## 4.2 LDV OPTICAL HEAD AND TRAVERSE SYSTEM

The LDV optical package consisted of a single component fringe system with remotely controlled fringe rotation capability. Two collection lenses with focal lengths of 19.1 cm (7.5 in.) and 31.75 cm (12.5 in.) were used for access to various areas of flow. A simplified drawing of the system is presented in Figure 5, and a photograph is presented in Figure 6. The optical configuration is described in detail in reference 3.

## 4.3 DATA ACQUISITION AND PROCESSING SYSTEM

Data acquisition and processing was accomplished by the computer-controlled system shown in Figures 7 and 8. The computer provided the means of recording the flow velocities and corresponding angular assignments over the entire circumference of the fan at particular axial and radial locations--angular assignment is the circumferential measurement location relative to a fixed reference point on the shaft. A shaft angle encoder provided 1000 angular assignment locations per revolution. All LDV velocity data and corresponding angular assignment data were recorded on magnetic tape at the end of each data acquisition.

Prior to acquisition of data, the LDV coordinate system was aligned with the fan rotor axial center line. Optical correction factors were calculated for each window orientation in order to ensure proper location of the measurement volume within the rig.

## 5.0 PROCEDURES

### 5.1 TEST PROCEDURE

#### 5.1.1 Shakedown Tests

A shakedown test was conducted to verify the mechanical integrity of the rig when operating with the LDV seeding equipment and to assess any impact of the seeding grid on rig performance. The fan was accelerated to 50, 70, 80, 95, and 100 percent of design speed along the wide open operating line. Steady state data were acquired at each speed. Rotor and stator vibratory stresses and rig vibration levels were recorded. Strain gage signals from the rotor were transmitted to the recording equipment by means of telemetry.

#### 5.1.2 LDV Performance Tests

Overall and blade element performance data were taken over a range of flows between wide open throttle and stall at 95 and 100 percent of design speed. These data were compared with the performance results obtained without the seeding grid. A one percent reduction in rotor efficiency was identified, which has been attributed to the seeding grid which caused a radially nonuniform total pressure loss of 2.9 to 3.5 percent. There was no change in surge margin.



LDV data were acquired at three conditions: 100% speed peak efficiency, 100% speed near surge, and 95% speed peak efficiency. In order to monitor rig operation, fixed instrumentation and radial (stator) wake rake traverses were taken between LDV data acquisitions.

## 5.2 DATA REDUCTION PROCEDURE

All LDV data were reduced to single-component, absolute-frame, circumferential velocity profiles for each axial and radial measurement location. A sample data set is shown in Figure 9. The profiles were produced by collation of the raw velocity data into probability densities for each of the 1000 angular locations (clicks). The average velocity for each location was plotted at the bottom, while the total number of measurements making up each velocity was displayed at the top. The top profile was useful in determining whether a sufficient number of measurements was used to make the average velocity statistically meaningful. The center graph (Figure 9) shows the standard deviation of the data divided by its mean velocity. This ratio is usually closely related to the turbulence of the flow. Tabulations of the number of measurements (hits), standard deviation over mean (S/A), and average velocity for each of the 1000 angular locations were produced in matrix form. An example of a velocity matrix is shown in Figure 10.

The individual probability densities for some of the angular locations were examined to investigate the possibility of bimodal velocity distributions in regions of flow where average values did not conform to expectations. More detailed evaluations of data in specific passages of interest were obtained by displaying all velocity measurements from a passage in a graphical form called a "carpet plot". This reduction procedure displays velocity histograms of up to 40 sequential angular locations. The mean of each location is displayed by the "X" on each graph (see Figure 11). When a more detailed examination and possible refinement was required, a histogram of the velocity component distribution for a single angular location was obtained (see Figure 12). It was possible to remove noise, questionable data points, and the weaker of two modes in bimodal distributions such as occurred in the vicinity of shocks.

## 5.3 DATA ANALYSIS PROCEDURE

The laser Doppler velocimeter provides absolute frame velocity components that have to be vectorially combined to determine the resultant flow velocity as shown in Figure 13. All data were taken with the laser pointing horizontally along a radius of the rig so that the plane of the measurements was a tangential-axial plane of the fan. The interference fringe orientation angles, ZETA1 and ZETA2, were the angles that the measured velocity components C1 and C2 made with the tangential. The resultant velocity V is the vector whose tip lies at the intersection of the normals to C1 and C2, as shown in Figure 13. The axial and tangential components of velocity ( $V_z$  and  $V_u$ ) have to be calculated from the measured components C1 and C2. Referring to Figure 13

$$C1 = V_z \sin ZETA1 + V_u \cos ZETA1$$

$$C2 = V_z \sin ZETA2 + V_u \cos ZETA2$$

Which are solved simultaneously to give

$$V_Z = \frac{C1 \cos ZETA2 - C2 \cos ZETA1}{\sin (ZETA1 - ZETA2)}$$

$$V_U = \frac{C2 \sin ZETA1 - C1 \sin ZETA2}{\sin (ZETA1 - ZETA2)}$$

The LDV system measures velocity components in the plane perpendicular to the bisector of the twin laser beams. Any component parallel to the beams (i.e., any radial component) has to be inferred. An aerodynamic throughflow calculation procedure defines the local cone angle PHI, which allows the computation of the radial component by

$$V_R = V_Z \tan PHI$$

The largest absolute value of  $\tan PHI$ , 0.33, occurs at 95% span.

Since holding the inlet temperature constant is not possible, these results are corrected to standard day conditions--viz:  $V_Z$ ,  $V_U$ , and  $V_R$  are divided by the square root of the ratio of the upstream absolute frame stagnation temperature to its standard day value, 288.2K (518.7°R). The relative Mach number,  $M'$ , is then found from the relative flow velocity,  $V'$

$$(V')^2 = (U - V_U)^2 + V_Z^2 + V_R^2$$

$$(M')^2 = \frac{(V')^2 / (\gamma R_{gas} T'_T)}{1 - \frac{(\gamma - 1)}{2} (V')^2 / (\gamma R_{gas} T'_T)}$$

Where the corrected wheel speed,  $U$ , at the radius of the measurement has been corrected in the same way as the velocity components discussed above.  $T'_T$  is the standard day stagnation temperature in the relative frame where uniform rothalpy is assumed.

$$\text{rothalpy} = \text{constant} = C_p (T'_T) - \frac{U^2}{2}$$

The static temperature is computed from

$$T_s = T'_T / (1 + \frac{\gamma - 1}{2} (M')^2)$$

So that the absolute Mach number can be found from

$$V^2 = V_U^2 + V_Z^2 + V_R^2$$

$$M^2 = V^2 / (\gamma R_{\text{gas}} T_s)$$

The relative flow angle BETA PRIME is given by

$$\text{BETA PRIME} = \arcsin \frac{(U - V_U)}{V}$$

and the conventional absolute flow angle BETA, by

$$\text{BETA} = \arcsin (V_U/V)$$

The measured velocity components, fringe orientation angles, corrected axial velocity, the relative and absolute flow angles, and Mach numbers are tabulated in Appendix D. The BETA in the appendix is the flow angle in the measurement plane which is tangent to a cylinder as shown in Figure 13. It differs slightly (less than 1.5 degrees) from the conventional BETA, which can be estimated from the tabulated BETA and PHI angles. The tabulated BETA PRIME, which includes the radial component, is defined above.

#### 5.4 TEST CONDITIONS AND DATA DESCRIPTION

Laser Doppler velocimeter data were acquired at the three test conditions defined in Figure 14: (1) the 100% speed peak efficiency point, (2) the 100% speed near surge point, and (3) the 95% speed peak efficiency point.

Two types of LDV data were acquired. The first type, gapwise data, comprising most of the sets, consists of detailed velocities at 1000 positions covering the entire circumference of the rotor. The second type, spanwise data, consists of spanwise traverses at three axial stations. For these fixed radial and axial positions, data from all around the rotor were combined and an overall average calculated. The data acquisition stations are shown in Figure 15.

Data were not taken at all of these locations for each performance point. The exact locations and operating conditions for which detailed LDV data were acquired are defined in Table II together with the number of velocity components measured at each point. Three components of velocity were measured in many cases. The purpose was to have at least two components reasonably well aligned with the flow whenever large air angle variations occurred. This is discussed in the next section.

TABLE II  
 AXIAL AND SPAN LOCATIONS FOR LDV DATA  
 Operating Conditions

Axial Location (x/bx)	100% Speed, Peak Eff.				100% Speed, Near Surge			95% Speed, Peak Eff.		
	% Span, Hub to Tip				% Span, Hub to Tip			% Span, Hub to Tip		
	95	85	69	45	95	85	45	95	85	45
-0.3	2	2	WL	WL	2	2	WL	2	2	WL
-0.2	2	2	2	WL	-	-	WL	-	-	WL
-0.1	2	2	2	2	2	2	-	2	2	-
0	2	2	2	-	2	2	-	2	2	-
0.13	3*	2	3	-	3+	2	-	2	3	3
0.26	3+	2	3	3+	3	3	3	3+	3	3
0.39	3	2	3	SB	3+	3	SB	3	3	SB
0.52	3	3	SB	SB	3	3	SB	3+	3	SB
0.65	3	3	SB	SB	-	-	SB	-	-	SB
0.78	2	3	SB	SB	2	2	SB	2	3	SB
0.91	2	3	SB	SB	-	-	SB	-	-	SB
1.0	2	2	3	2	-	-	-	-	-	-
1.1	3	3	3	WL	2	2	WL	2	2	WL

Notes:

- 2 Two velocity components are available
- 3 Three components are available, making 3 pairs possible
- 3+ Three components are available, selecting which to use was difficult because of noise
- SB Shroud blocked the view
- WL Window limited view
- Data not taken
- \* Data actually at x/bx = 0.18

The detailed velocity measurements across a typical rotor gap were used to define the Mach number and air angle in both the absolute and relative reference frames and are tabulated in Appendix D. The blade element data for these three test conditions produced from conventional instrumentation are given in Appendix C.

### 5.5 SELECTION OF LASER FRINGE ORIENTATIONS

In laser velocimetry the probability that a given particle passing through the measurement volume will produce a valid velocity signal depends on the angle between the normal to the fringe system and the velocity vector of the particle. The nature of this dependence is determined by the optical and electronic design of the instrument. Generally, the probability of a valid measurement is near unity until the angle between these two vectors exceeds 45 degrees. The effect of this angular dependence on the computation of mean velocities is called angle biasing.

At axial stations for which the flow angle in the absolute frame varies little across the gap, it is ordinarily easy to select two laser fringe orientations that give results having negligible bias. Much of the present data is of this kind. At axial stations where the absolute angle changes radically, such as across shocks and in wakes, more than two fringe orientations should be used. This was done (see Table II) for some of the data presented here. In most of these cases, the velocity was substantially the same when computed from any two of the three measured components, indicating little angle biasing.

Figures 16 and 17 illustrate the data interpretation procedure. Figure 16, which shows some results at 85% span, indicates no significant angle biasing, the three pairings giving nearly identical results. The rule adopted in this analysis was to choose the pair of components derived from the fringe normal orientations closest to the flow direction. In this example there is a shock at about 65% gap that causes a rapid change in the absolute flow angle, BETA. Below 68% gap, BETA is greater than  $30^\circ$ , and the ZETA =  $105^\circ$  (corresponding to BETA =  $-15^\circ$ ) component has been excluded because its direction lies farthest from the flow direction. Above 68% gap, the ZETA =  $15^\circ$  component was ignored for the same reason. Notice that even with this large angle change, the angle bias effects on the misaligned component are quite small, implying that low turbulence levels are present both upstream and downstream of the shock.

This rule was also applied to the data shown in Figure 17 where the three pairings give significantly different results at some gap locations. The difference in relative Mach number is as much as 0.2 near the shock at midgap, indicating that proper fringe orientations are important.

Of the 76 data points defined in Table II, three components were available for analysis in 35 cases. The analyses in twenty-eight of these data sets were straightforward. The remaining six data sets included data taken from regions of the window that contained significant levels of contaminants. The resulting "noise" in the data sets made analysis of these locations somewhat more problematical. The contaminants on the window appeared to be liquids (probably seed) slung radially outward by the blading and moved forward by flow recirculation at the blade tip. A circumferential beading of this liquid occurred at approximately 26% chord and was clearly visible in closed circuit television images of the window. Unfortunately, as a consequence, the flow occurring at 95% span, 26% chord was somewhat masked. However, the data from these somewhat questionable points have been included. Also, it was necessary in one case to take data at 18% chord instead of 13%.

## 5.6 FLOW PERIODICITY

Although data were taken for all the 38 rotor passages, it was impractical to show the flow through every passage and unreasonable to combine passages to provide some sort of average, in view of the variations observed from passage to passage. Instead, the flowfield of passage 1, originally believed to be typical, was evaluated.

Subsequent detailed consideration of the periodicity lead to the analysis of two additional full passages at 85% span. Figure 18 shows the Mach number

variation across the gap at 26% chord for all three passages at the 100% speed, peak efficiency point. Passages 1 and 15 are close to the extremes of the data. Passage 31 data, lying between these, is more typical of the majority of passages in the rotor. The dissimilarities among passages are smaller at the other operating conditions. These passages were chosen to show the range of flowfields present.

## 6.0 DISCUSSION OF RESULTS

### 6.1 MACH NUMBER PROFILES AND FLOWFIELD INTERPRETATION

Figures 19 to 35 show the constant Mach number contours for passage 1, originally thought typical, and the gapwise Mach number profiles from which the contours were derived. Each gapwise figure depicts the flow at a series of axial positions for a single span location and operating condition. These data are tabulated in Appendix D. Gapwise positions were based upon the running blade geometry as calculated in the design process. Contours are given for 95% and 85% span at all three operating conditions and for 69% span at the 100% speed, peak efficiency point. The 45% span results, shown in Figures 33 to 35, are not presented as Mach number contours because of insufficient data. The points shown on the individual Mach number contours correspond to points interpolated from the Mach number profiles.

#### 6.1.1 Eighty-Five Percent Span, One Hundred Percent Speed, Peak Efficiency

The constant Mach number contour plot for the flow at 85% span for the 100% speed, peak efficiency point is shown in Figure 19, which was derived from the gapwise profiles given in Figure 20. The points shown on the contour plot were linearly interpolated from the gapwise profiles. A shock appears at  $x/b$  of 0.13, 0.26, and 0.39 in Figure 20. It shows up as a rapid change in Mach number, which is recognized in the flowfield diagram by the close spacing of the contours. This shock is fairly distinct and nearly normal to the flow. The fall off in Mach number near the pressure side at  $x/b$  of 0.78 and 0.91 is evidence of a boundary layer at these locations. This low momentum fluid from the pressure side boundary layer made up a surprisingly large portion of the total viscous loss. The wakes on either side of the passage are clearly visible at  $x/b$  of 1.1.

The results at  $x/b$  of -0.3 and 0.52 were not used in constructing the Mach number contours. The results at  $x/b$  of -0.3 would have produced implausibly sharp bends in the contours. The unusual results at  $x/b$  of 0.52 are discussed in Appendix E.

#### 6.1.2 Eighty-Five Percent Span, Ninety-Five Percent Speed, Peak Efficiency

Figures 21 and 22 show the Mach number results at the 85% span, 95% speed, peak efficiency point. There was a nearly normal shock across the front of the passage which was stronger than that seen at 100% speed because of the two degree higher incidence angle at 95% speed.

### 6.1.3 Eighty-Five Percent Span, One Hundred Percent Speed, Near Surge

Figures 23 and 24 present Mach number data at the 85% span, 100% speed, near surge point. The shock was nearly normal and moved forward with increased strength and somewhat smeared at 39% chord. The boundary layers are clearly in evidence in the figures. As in the above case, the data behaved erratically at  $x/b$  of 0.13. Because of the anomalies, which were probably caused by window contamination, these data were not used.

### 6.1.4 Ninety-Five Percent Span, One Hundred Percent Speed, Peak Efficiency

The flowfield at 95% span for the 100% speed, peak efficiency point is shown in Figures 25 and 26. Mach number behaved quite erratically at  $x/b$  of 0.18 and 0.26, and in these and some other instances it was necessary to smooth out the results. This was required at 95% span but not at 85%. The revised Mach number vs. percent gap relation was then used to plot the points on the flowfield diagrams; an example is shown in Figure 26b.

Evidence of a shock appears at  $x/b$  of 0.18, 0.26, and 0.39 in Figure 26. The considerable fall off in Mach number near the blade surfaces further back in the passage is evidence of large boundary layers. The inferred blade surface velocity profiles indicate a reacceleration of the flow on the suction surface which is accompanied by a thinning of the boundary layer while the pressure surface shows a flow deceleration. It is doubtful that these boundary layers can be explained by two-dimensional considerations alone. The very thick region of low Mach number flow on the pressure side is probably due to the rotor scraping off the inlet endwall boundary layer. The pressure side boundary layer reaches a maximum thickness at  $x/b$  of 0.65. A comparison of the Mach number profiles at  $x/b$  of 1.0 and 1.1 (Figure 26e) indicates that the low momentum wake fluid observed at 95% span arrived predominantly from the pressure surface. The low momentum flow on the suction side behind the shock may indicate shock-boundary layer interaction. The low momentum wake fluid from the suction surface was less than would be expected. The suction side boundary layer at  $x/b$  of 0.52 and 0.65 (near the shock) was much larger than that seen downstream, indicating that the low momentum fluid downstream of the shock boundary layer interaction may have moved radially away from the region in which it was produced.

These results at 95% span may be misleading because of the complicated nature of the flowfield. The curved region of high Mach number gradient may be interpreted as an S-shaped shock. But a part of this shock is nearly parallel to the flow, an implausible situation. This problem has not been resolved, and the reader is warned that these unusual "shock" patterns may not be what they seem.

### 6.1.5 Ninety-Five Percent Span, Ninety-Five Percent Speed, Peak Efficiency

Figures 27 and 28 show the results at 95% span for the 95% speed, peak efficiency point. Figure 27 shows some similarity to Figure 25. What appears to be a shock moving across the passage can be seen. The flowfield diagram, Figure 27, shows an S-shaped "shock".

Comparison of Figure 27 with Figure 25 indicates that the forward shock was stronger at 95% speed than at the 100% speed, peak efficiency point. The pressure side boundary layer downstream of the  $x/b$  of 0.52 location again seems to contain a large momentum deficit.

#### 6.1.6 Ninety-Five Percent Span, One Hundred Percent Speed, Near Surge

The 95% span data at the near surge point (Figures 29 and 30) show a very strong but more smeared shock structure that moved forward relative to its position at peak efficiency.

#### 6.1.7 Sixty-Nine Percent Span, One Hundred Percent Speed, Peak Efficiency

The Mach number results at the 69% span, 100% speed, peak efficiency point are shown in Figures 31 and 32. There was a large region where data could not be taken because of the partspan shroud. The downstream flow contained some of the shroud wake. The shocks, nearly normal and originating at the leading edge, were similar to those at 85% span. There was a compression-expansion region extending upstream from the leading edge, like that found at 85% span for the same performance point.

#### 6.1.8 Forty-Five Percent Span

Figures 33, 34, and 35 show the limited quantity of Mach number results obtained at the three operating conditions for 45% span.

#### 6.1.9 Calculated Flowfields

The calculated Mach number contours in Figures 36 and 37 represent the design intent flowfield at 95% and 85% span. These flowfields are more characteristic of a maximum flow operating condition than the peak efficiency flowfields in Figures 19 and 29. The importance of secondary flows at 95% span is evident from a comparison of the figures. The major difference between design intent and the LDV results at 85% span lies in the shock structures. The design intent figures show a weak oblique forward shock and a shock at the rear of the passage. The data show a single, nearly normal forward shock, which implies a greater shock loss than the design intent. Since the performance of the rotor was lower than the design intent, as shown in Figure 15, this difference was not surprising.

### 6.2 PERIODICITY

Figures 38 through 43 show the Mach number results for passages 15 and 31 at 85% span for all three operating conditions. Notice that these passages for the 95% and 100% speed, near surge points are very similar to passage 1. In each case there is a shock forward of the leading edge of the blade; however, at the 100% speed, peak efficiency point, passage 15 is markedly different from the others. The flow decelerates gradually, apparently without a shock.



Two possible explanations are:

- 1) Since flows near Mach 1 are very sensitive to area change, there may have been a shock induced change in the displacement thickness of the boundary layer on the blade that was large enough to reaccelerate the flow to supersonic speed. This would have permitted another shock to form, causing another increase in blockage and another reacceleration. This type of behavior has been observed in internal flows (ref. 4). The inability of seed particles to closely follow the flow through shocks could make a multiple shock structure of this sort appear as a gradual Mach number decline.
- 2) Another possibility is that the flow in passage 15 was shock free. In this case, the absence of shock loss should have given a higher Mach number at the back of the passage. While the Mach number for passage 15 at  $x/b$  of 1.0 was slightly higher than in the other passages, the difference was not great enough to be convincing evidence.

It is fairly certain that the passage 15 Mach contours are not just the smeared out results one would expect from using LDV in an unsteady flow. If the flow had been unsteady with, say, a shock jumping from one place to another, the histograms would show bimodality. Their failure to do so indicates that the flow was not unsteady.

### 6.3 WAKES

Figures 44 through 50 show the relative Mach number results for the wakes at 95% and 85% span for all three operating conditions and for 69% span for the 100% speed, peak efficiency point. The wakes are defined at  $x/b$  of 1.1. Six adjacent wakes are shown, and an inspection of the wakes indicates that the six are representative of the full set.

The wakes for the 95% span, 100% speed, peak efficiency point are shown in Figure 44. Assuming a constant gapwise static pressure, the total pressure loss due to viscosity was computed to be approximately six percent with significant variation among the wakes. The relative Mach number gradient between wakes with a peak near the suction surface can also be observed in Figures 45 and 46, which show the wakes at 95% span for the 95% speed and the 100% speed, near surge conditions. At both of these points, the losses indicated by the wakes appear to be less than those indicated by the 100% speed peak efficiency wakes. The data from the near surge point were much less smooth over the entire gap than at the peak efficiency conditions.

The 85% span wakes at 100% speed, peak efficiency appear in Figure 47. These wakes indicate a boundary layer total pressure loss of approximately 3.6%, which is much less than observed at 95% span. The variation in magnitude between wakes is also noticeably less than at 95% span. The Mach number profile is nearly flat between the wakes. Figures 48 and 49 show the 85% span wakes at the 95% speed, and near surge conditions. The magnitude of these wakes appears to be similar to that at the 100% speed, peak efficiency condition, but the Mach number gradient between wakes, observed at 95% span,

can also be seen here. As a result, definition of the wake edges and the calculation of the wake loss are more difficult than for the 100 percent speed, peak efficiency point (Figure 47).

The 69% span wakes at the 100% speed, peak efficiency point, presented in Figure 50, are within the influence of the shroud wake and are extremely nonperiodic. And the edges of the airfoil wakes are unclear.

#### 6.4 SPANWISE TRAVERSES

Figures 51, 52, and 53 show the LDV spanwise traverse data at the instrumentation plane one chord ahead of the rotor, at the rotor leading edge, and at the rotor trailing edge. These data are compared with calculated flow properties obtained from the standard data reduction procedure described in reference 2. The calculations were made with the LDV seeding grid inlet total pressure profile.

The LDV measured values of Mach number and angle ahead of the rotor are in agreement with the calculated values up to the extremity of the measurement at 20% span.

The measured relative Mach number behind the rotor was higher than the calculated relative Mach number, and the measured absolute exit air angle was lower than the calculated value. This discrepancy has not been resolved. It should be recognized, however, that the LDV spanwise data were particle averages rather than mass averages. A portion of the particles in the viscous region of the flow was eliminated from the sample by trailing edge interference, and there was a nonuniform seed particle distribution that could have further biased the measurements. The combination of these two effects resulted in some places where the particle rate was only about ten percent of the peak rate.

The maximum discrepancy in Figure 53 occurs at 85% span. At this position the blade element data calculation indicated that the rotor recovery was 0.806 at the 100% speed, peak efficiency point. The recovery deduced from the LDV measurements by combining the loss appropriate to the passage shock with the deduced mixed-out wake loss (at 1.1 chord) was 0.869, a significantly higher value of recovery. The measured Mach number of 1.02 was also greater than the calculated blade element Mach number, which is consistent with recovery being greater than the calculated value. The LDV result suggests that the loss at the rotor trailing edge was actually smaller than deduced from data taken at the conventional stator exit location. This calls into question the assumptions made concerning what happens to the losses between the rotor trailing edge and the usual instrumentation station. Further study of this wake mixing problem is called for.

#### 7.0 CONCLUSIONS

1. The laser Doppler velocimeter demonstrated an ability to obtain high quality measurements of velocities and flow angles through a rotating blade row.

2. Comprehensive intrablade data were obtained at sections outboard of the shroud. Inboard of the shroud, the data were limited by the presence of the shroud.
3. The rotor wakes were clearly defined and were amenable to qualitative analysis except where the shroud wake was also present. The laser Doppler velocimeter proved to be a nonintrusive method to measure fan performance close behind the rotor. The deduced rotor wake plus shock losses, however, were significantly smaller than those computed from the conventional instrumentation plane at the stator exit. Further studies of the wake mixing problem are required.
4. Neither the measured shock structure nor the wakes were periodic from blade to blade. The magnitude of this nonperiodicity was such that a mean passage analysis constructed from several blade passages would have introduced significant artificial shock smearing and thus would not have been representative of the flow.
5. The individual blade passage measurements were of sufficient quality for use in verifying numerical solutions. It is, however, fundamental to the numerical calculation that the flow be periodic from blade to blade. The nonperiodicity, therefore, makes such verification debatable. Further work is required to determine the cause of this nonperiodicity.
6. The rotor flowfield for most passages was characterized by a strong leading edge shock at the design point. The shock moved forward with increasing strength near surge and at part speed. In all cases the flow behind the shock was of a complex mixed subsonic and supersonic form.
7. The flow in a few passages at the design point was different from the flow in the other passages. The flow in these passages may be nearly shock free or contain multiple shocks of the sort found in some duct flows. At other operating points, the flow in these passages was similar to the others.
8. Angle biasing occurred in high turbulence regions and near shocks. The need to carefully select fringe orientations to eliminate or minimize this effect was demonstrated.
9. The laser Doppler velocimeter particle seed apparatus upstream of the rotor proved to be intrusive. An inlet radial total pressure distortion was introduced which affected the rotor performance. Comparison of test data with design intent was inconclusive for this reason.
10. Secondary flow close to the rotor endwall contaminated a small region of the window. This contamination, probably seed material, could not be removed while the rig was running. Data from this region contained significant levels of scatter that could not be eliminated.

## 8.0 REFERENCES

1. Norton, J.M.; Tari, U.; and Weber, R.M.: "Rotor Redesign for a Highly Loaded 1800 ft/sec Tip Speed Fan - I. Aerodynamic and Mechanical Design," NASA CR-159596, PWA-5523-42, 1979.
2. Bolt, C.R.; Lee, D.; and McDonald, P.W.: "Rotor Redesign for a Highly Loaded 1800 ft/sec Fan - II. Final Performance Report," NASA-CR-159879, PWA-5523-92, 1980.
3. Walker, D.A.; Williams, M.C.; and House, R.D.: "Intrablade Velocity Measurements in a Transonic Fan Utilizing a Laser Doppler Velocimeter," Proceedings of the Minnesota Symposium on Laser Anemometry, Oct. 22-24, 1975.
4. Shapiro, A.H.: The Dynamics and Thermodynamics of Compressible Fluid Flow, The Ronald Press Company, New York, 1953

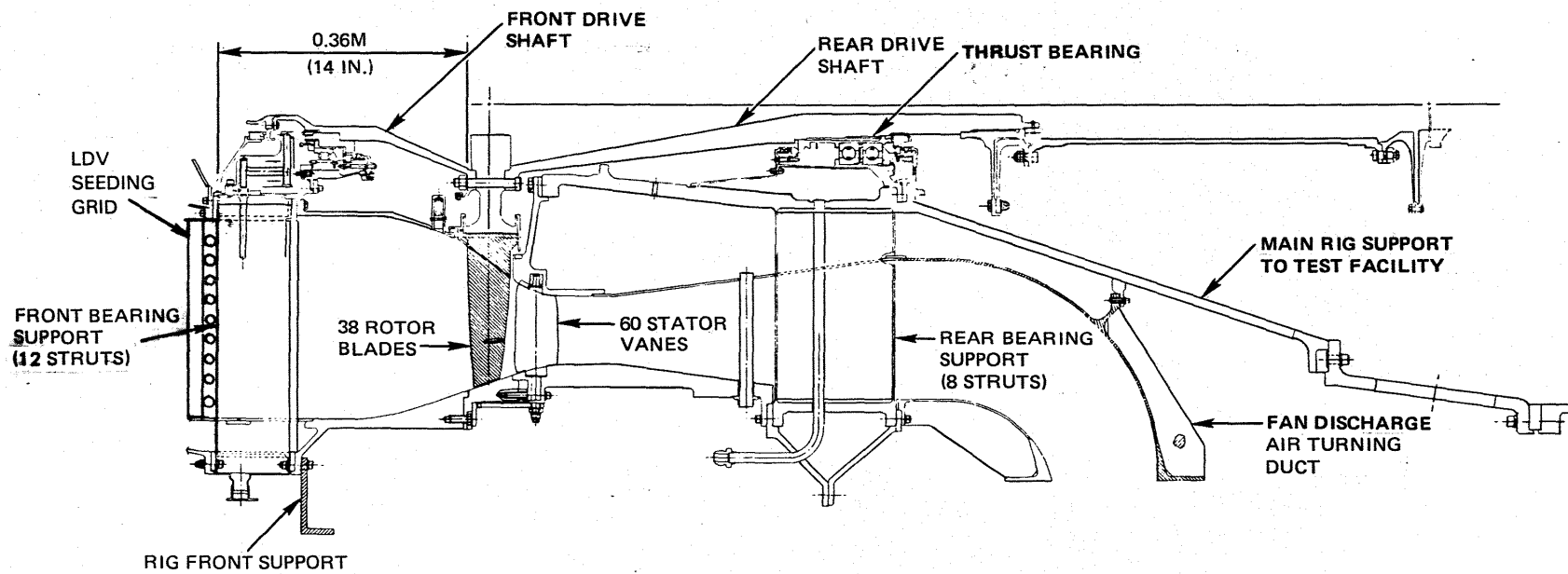

Figure 1 Cross Section of 1800 Ft/Sec Tip Speed Fan Test Rig

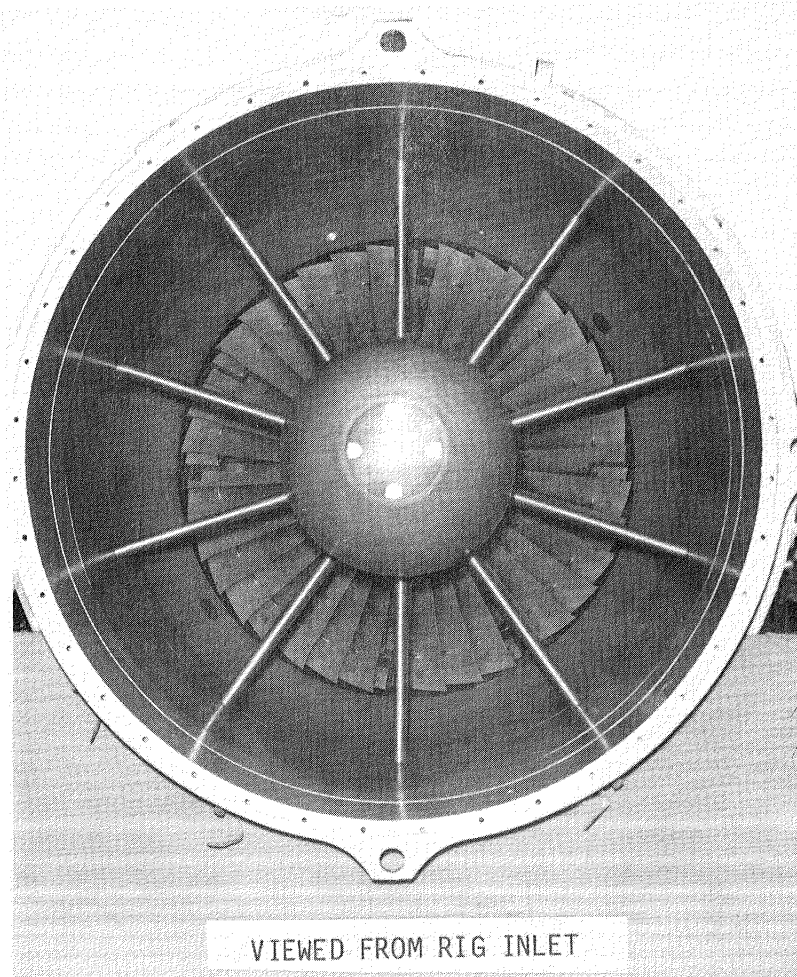

Figure 2 Rotor Assembly Installed in Test Rig

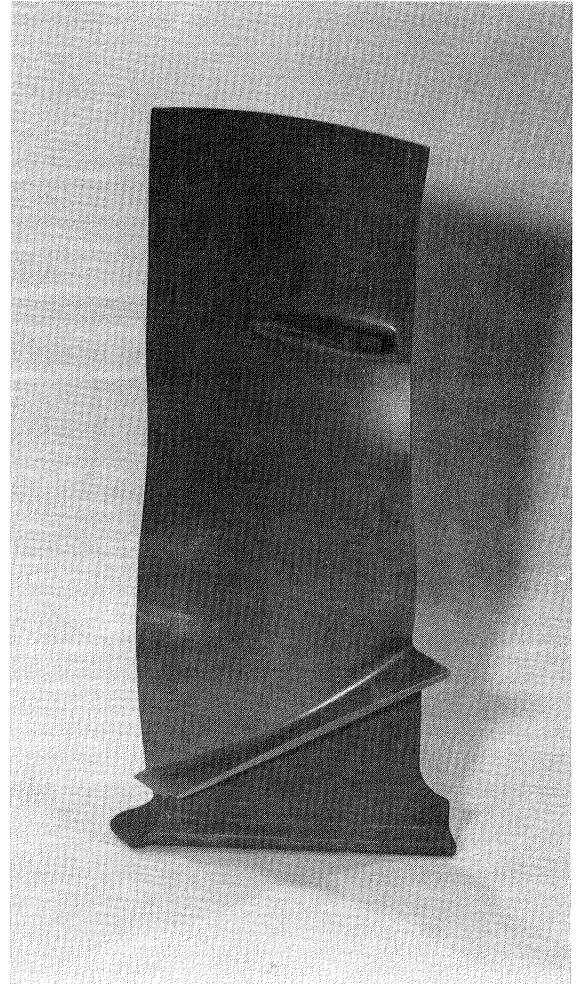
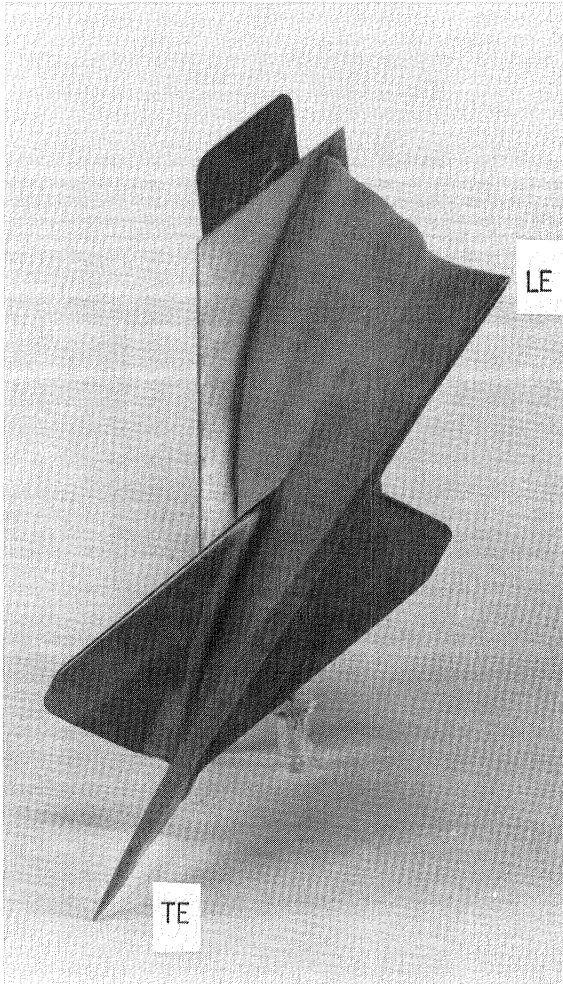

Figure 3      Redesigned 1800 Ft/Sec Tip Speed Fan Blade

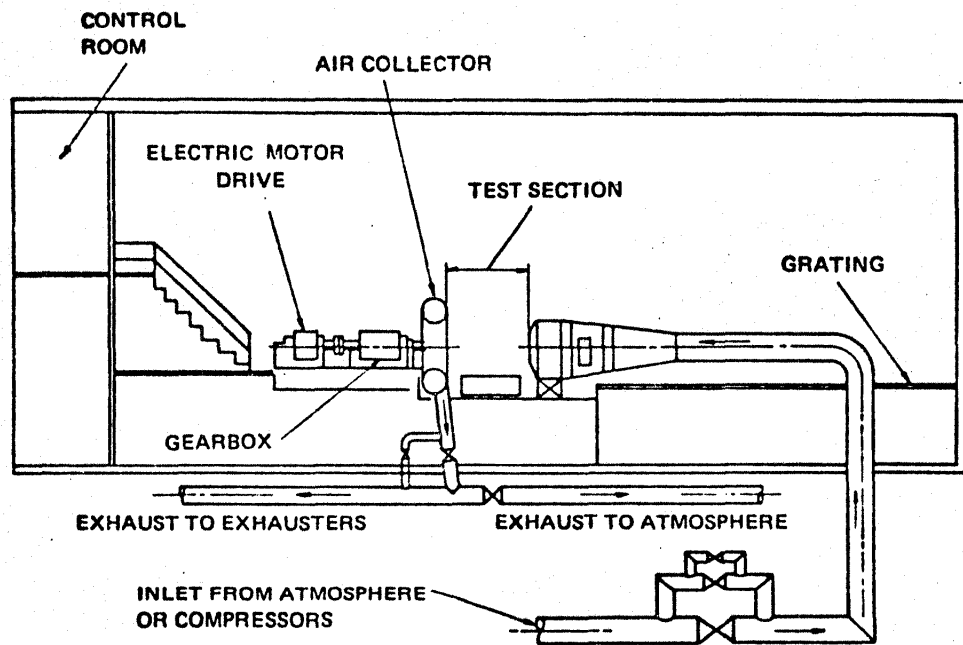

Figure 4 Test Stand Schematic



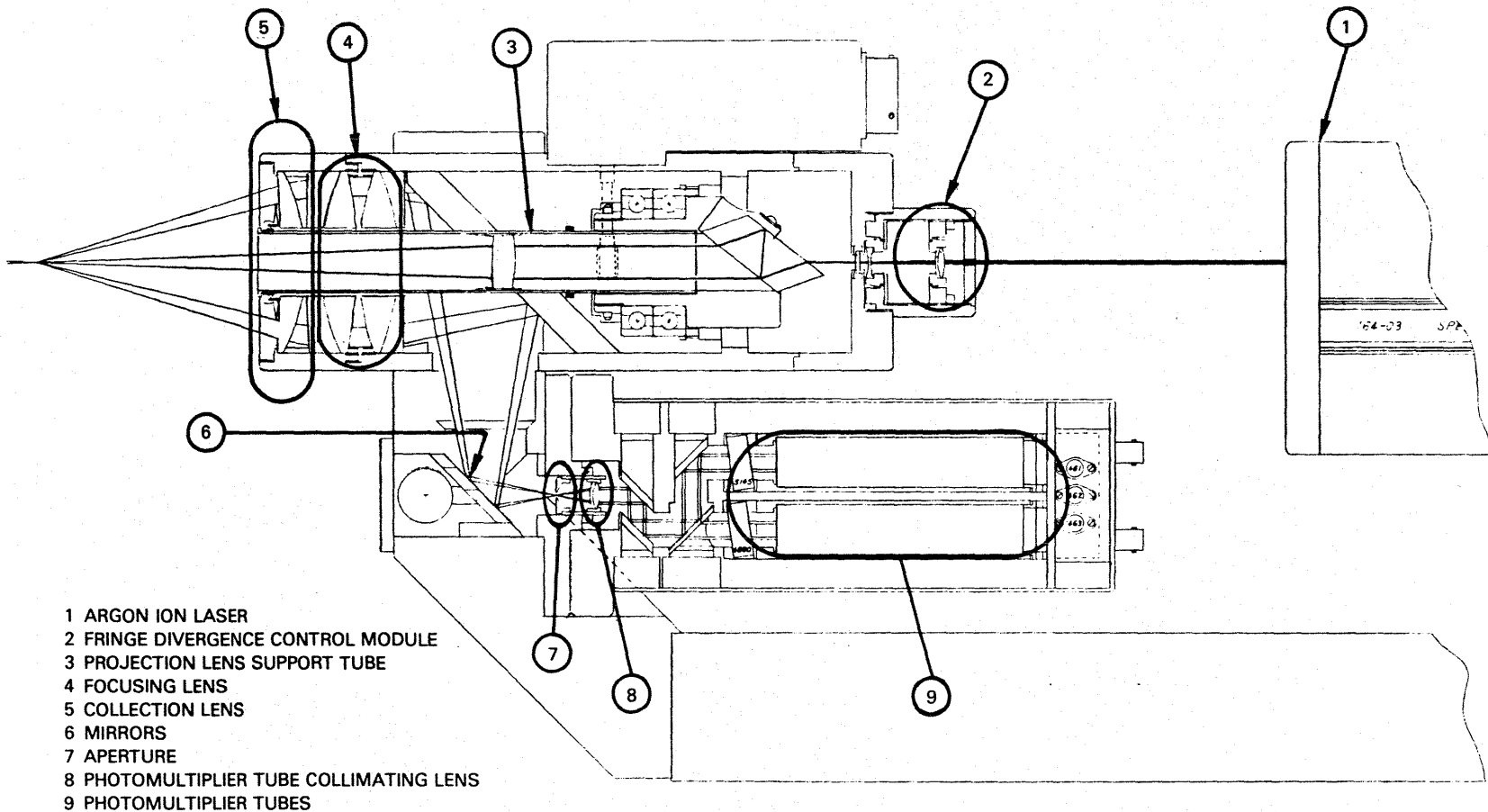

Figure 5 Optical Layout of Laser Doppler Velocimeter

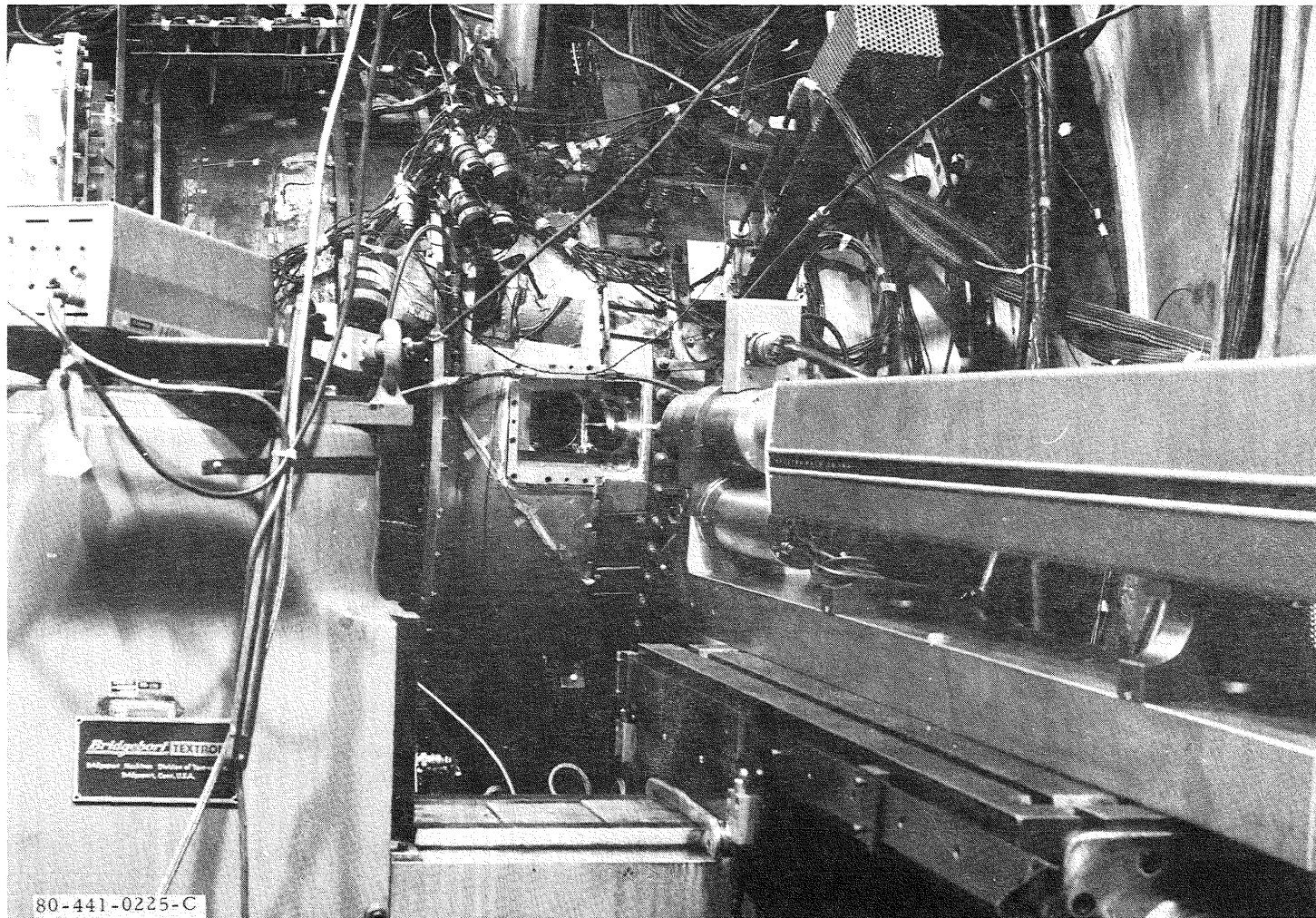

Figure 6 Photograph of 1800 Ft/Sec Tip Speed Fan Test Rig, Left Side View Showing Laser Equipment



Figure 7 Laser Doppler Velocimeter High Speed Data Acquisition System

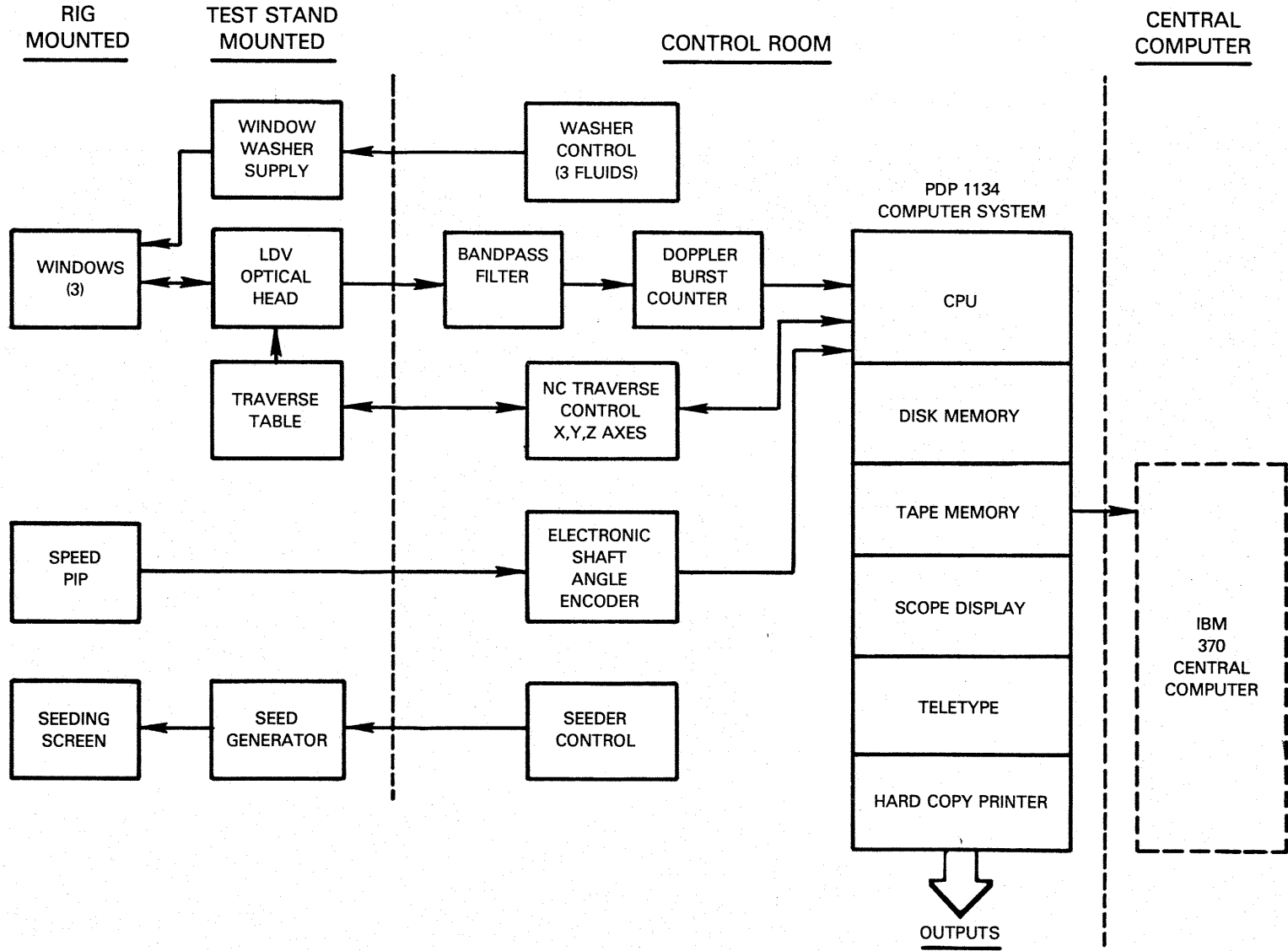

Figure 8 Computer-Controlled Data Acquisition System - Schematic Diagram

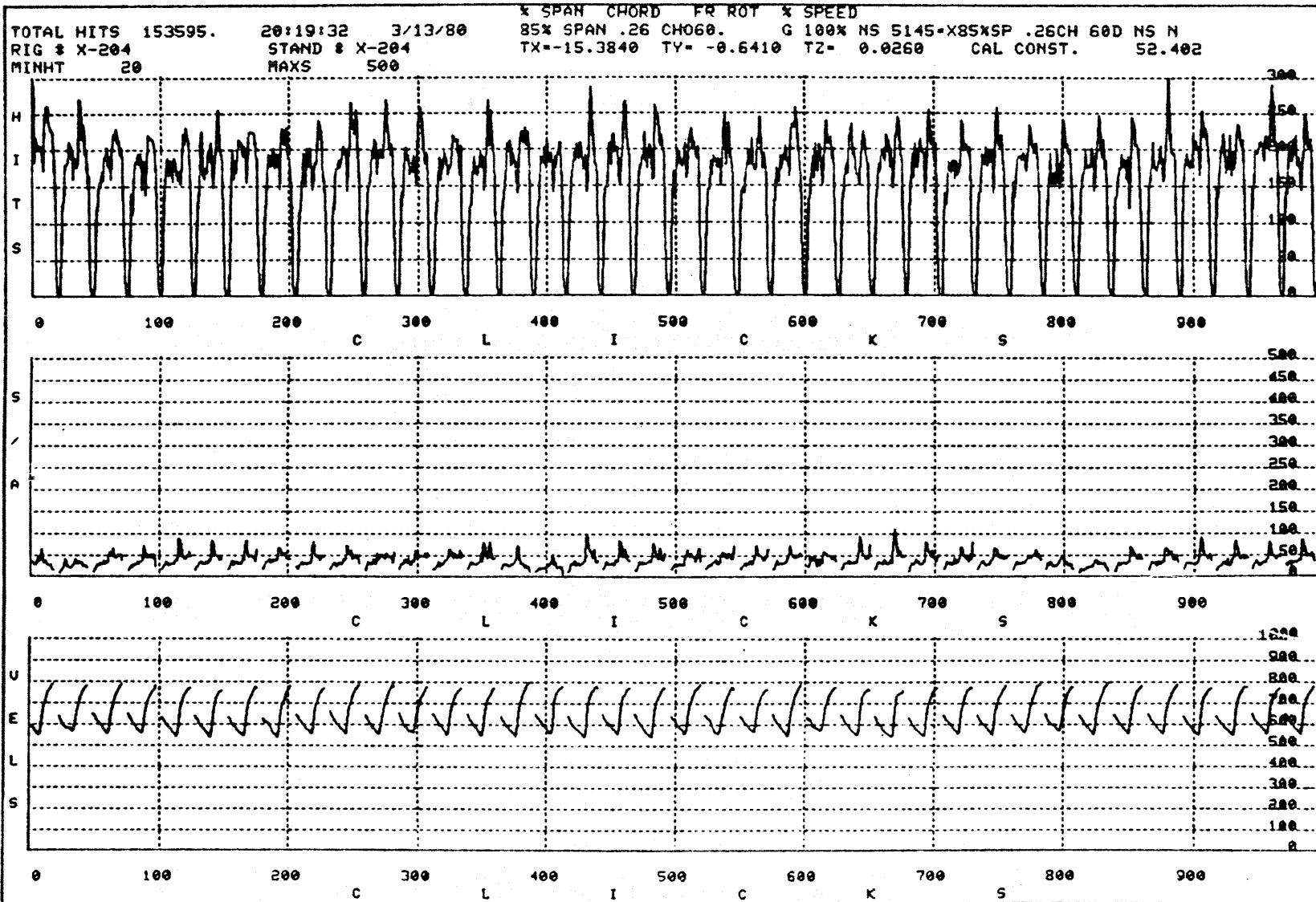

Figure 9 Laser Doppler Velocimeter Sample Data Set

85X SPAN .26 CH060. G 100X MS 5145-X85XSP .26CH 60D MS NASA EDIT1,15,31  
 Y COMPONENT TABLE POSITIONS ARE -15.3840 -0.6410 0.0260  
 ACQUISITION TIME 20:19:32 DATE 3/13/80 RIG # X-204 STAND # X-204 CAL CONST. 52.402

VEL AVE PER CLICK																				
	0	1	2	3	4	5	6	7	8	9	10	11	12	13	14	15	16	17	18	19
0	593	584	578	570	563	554	549	551	604	655	685	700	725	745	757	765	779	787	0	0
20	0	0	638	620	611	597	585	585	577	578	580	574	566	568	598	636	671	693	717	734
40	752	762	772	780	0	0	0	0	850	640	630	616	611	604	595	585	577	567	560	555
60	569	621	662	681	710	728	746	757	770	778	787	0	0	0	0	646	638	623	615	603
80	595	586	577	570	564	557	560	612	656	687	706	723	738	748	759	762	780	0	0	0
100	0	633	623	615	603	596	588	581	573	563	557	551	541	544	602	673	694	718	737	749
120	755	762	766	768	0	0	0	638	624	617	603	595	587	580	573	566	557	553	543	537
140	593	655	695	718	729	742	752	753	761	0	0	0	0	620	623	610	599	591	586	578
160	570	566	557	553	545	540	585	645	689	708	725	738	753	763	776	772	0	0	0	0
180	626	612	608	609	602	589	582	562	555	551	543	536	571	636	667	695	708	725	747	758
200	764	778	0	0	0	0	644	636	622	614	605	598	590	583	575	570	564	555	558	621
220	670	696	712	730	748	754	762	770	0	0	0	0	656	641	630	617	611	605	596	587
240	582	573	567	556	555	614	663	694	709	731	745	756	770	774	785	0	0	0	0	643
260	630	620	610	601	592	581	575	572	558	553	556	599	638	666	695	714	732	752	763	776
280	784	776	0	0	0	651	634	618	604	584	588	578	567	566	567	563	560	592	634	658
300	686	706	726	738	750	761	775	773	0	0	0	650	639	631	619	607	599	592	585	577
320	569	562	550	560	615	659	687	710	724	739	748	760	762	771	0	0	0	0	645	633
340	621	614	603	593	588	580	572	561	549	545	580	644	682	708	726	730	743	757	768	767
360	0	0	0	0	634	621	613	601	593	589	582	571	568	560	557	544	572	634	675	705
380	727	743	760	771	785	794	800	0	0	0	0	646	637	629	619	613	602	594	587	581
400	573	565	561	560	587	700	727	748	755	765	772	772	778	0	0	0	636	629	610	604
420	593	585	582	574	569	563	557	551	544	539	572	667	710	731	745	760	759	773	779	770
440	0	0	0	646	632	619	610	606	598	592	587	576	573	566	557	554	605	672	714	732
460	738	751	762	768	769	0	0	647	634	620	608	601	589	584	576	565	560	551	545	545
480	539	543	608	661	689	712	727	734	752	765	767	768	0	0	0	0	638	625	618	608
500	604	594	586	580	574	566	554	558	608	658	685	707	725	743	759	765	771	775	786	0
520	0	0	644	635	627	624	612	599	581	566	558	557	555	565	600	629	660	683	709	727
540	744	756	767	774	762	0	0	0	638	628	620	610	604	597	589	581	574	569	562	593
560	566	617	667	692	716	728	744	749	760	764	762	0	0	0	650	632	622	610	604	593
580	584	578	570	562	555	543	549	608	652	683	707	726	744	754	767	777	784	0	0	0
600	0	628	620	626	606	588	589	581	578	576	577	572	573	598	643	678	700	715	734	746
620	757	766	771	776	0	0	0	644	634	622	609	602	590	586	575	570	564	556	553	545
640	551	628	692	726	735	746	754	756	763	756	0	0	0	636	624	609	601	594	589	577
660	570	565	560	552	547	539	539	550	637	699	729	742	742	747	750	757	0	0	0	633
680	619	609	599	589	582	577	568	564	558	553	547	541	574	643	683	704	720	735	753	761
700	772	770	0	0	0	641	628	618	613	606	597	590	582	574	567	562	552	560	623	623
720	664	695	721	734	751	763	763	777	768	0	0	643	632	621	611	603	600	591	585	585
740	577	568	564	555	549	611	661	683	709	725	738	747	763	772	778	0	0	0	0	641
760	630	620	605	603	592	586	579	572	566	561	581	613	643	674	699	718	738	753	774	780
780	788	788	0	0	0	648	628	615	609	596	596	592	589	583	577	568	568	603	632	669
800	694	724	748	755	763	775	776	0	0	0	0	642	630	624	612	604	596	588	579	574
820	564	562	549	559	623	663	685	715	728	750	763	776	780	791	0	0	0	0	641	634
840	621	612	605	598	586	580	569	567	559	553	605	644	681	707	723	745	756	765	772	780
860	0	0	0	0	647	635	622	615	606	598	589	581	572	567	557	553	575	642	676	700
880	720	730	745	760	769	775	785	0	0	0	0	637	625	613	603	596	587	581	572	567
900	561	555	547	552	636	686	718	732	742	752	758	765	770	0	0	0	637	625	613	607
920	598	589	583	579	571	568	560	556	546	548	614	677	705	731	743	754	765	776	773	777
940	0	0	0	647	629	622	612	606	600	592	587	578	569	567	551	556	622	672	706	721
960	736	748	757	766	772	0	0	0	0	0	645	635	623	611	607	598	591	583	579	574
980	556	551	580	655	697	716	728	744	754	761	772	776	0	0	0	0	634	618	611	607

\*\*\* ENTER NEXT COMMAND

Figure 10 Velocity Data Tabulation Sample



TOTAL HITS 153595.    20:19:32    3/13/80    X SPAN CHORD FR ROT X SPEED  
 RIG # X-204    STAND # X-204    85% SPAN .26 CH060.    G 100% NS 5145-X85XSP .26CH 60D NS NASA EDIT1,15  
 MINHT 20    MAXS 500    TX=-15.3840 TY=-0.6410 TZ= 0.0260    CAL CONST.    52.402

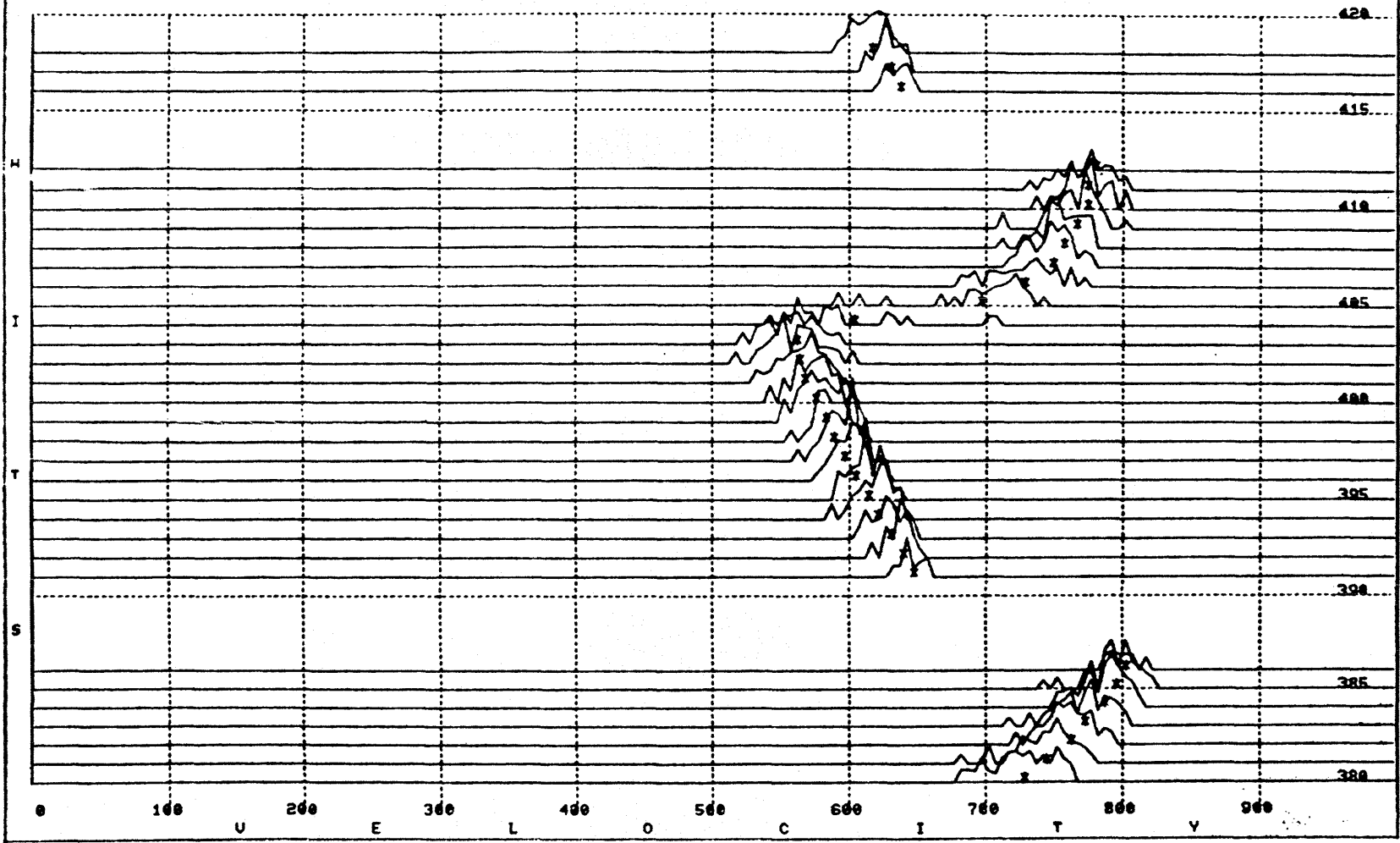

Figure 11    Sample of "Carpet Plot" Type Velocity Histogram  
 X Indicates Mean of Each Location

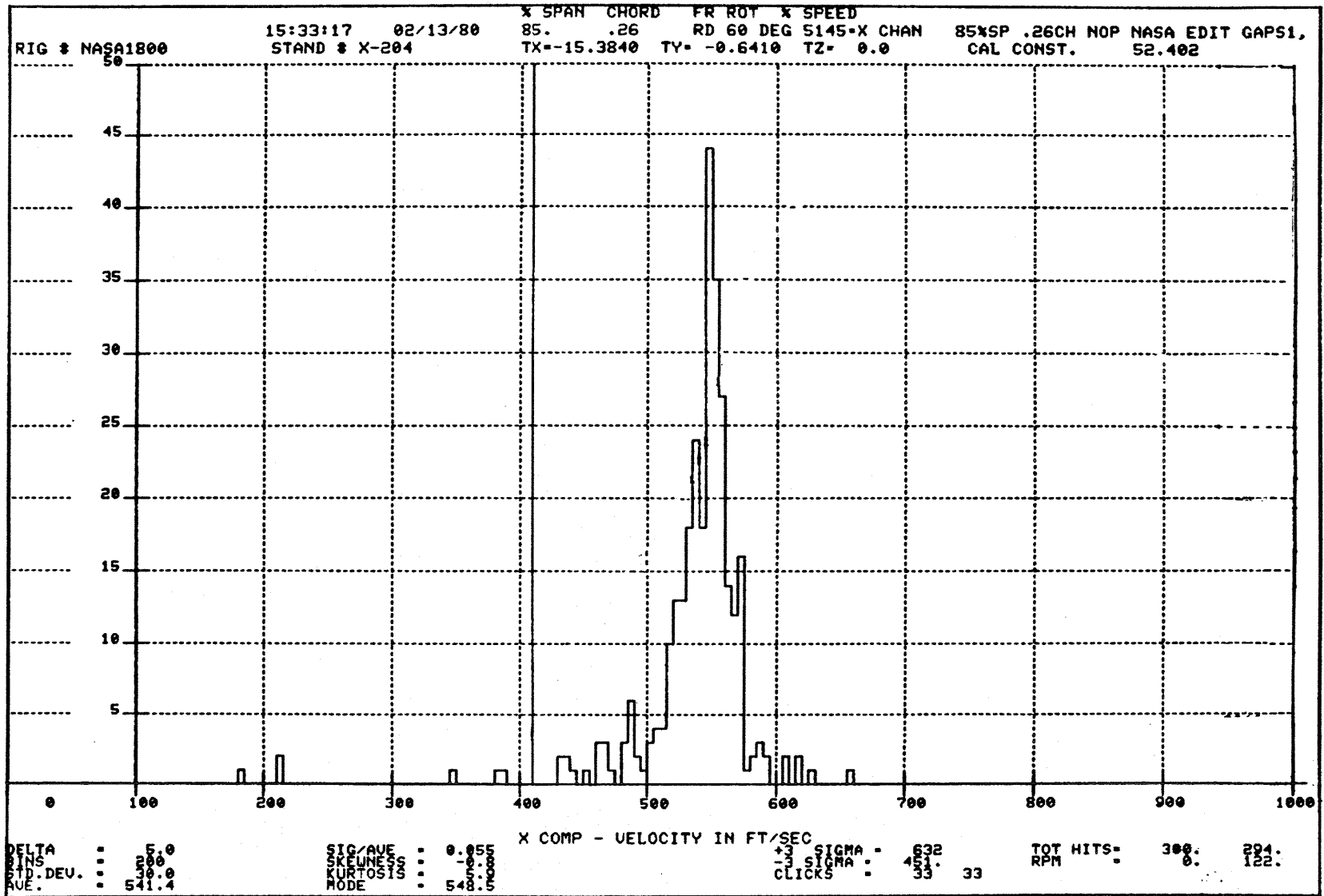

Figure 12 Velocity Histogram



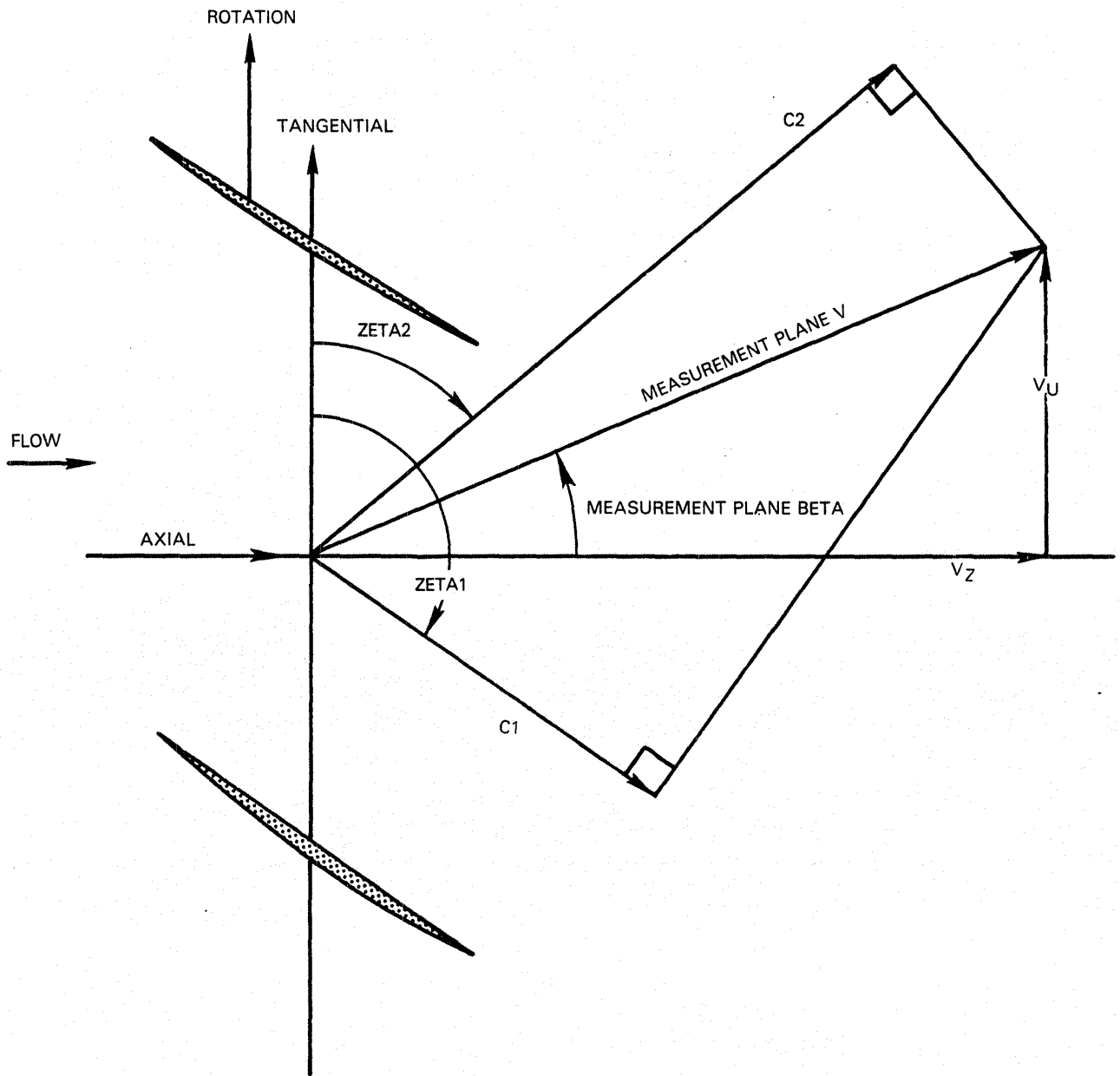

Figure 13 Diagram Defining Velocity Vector Terms

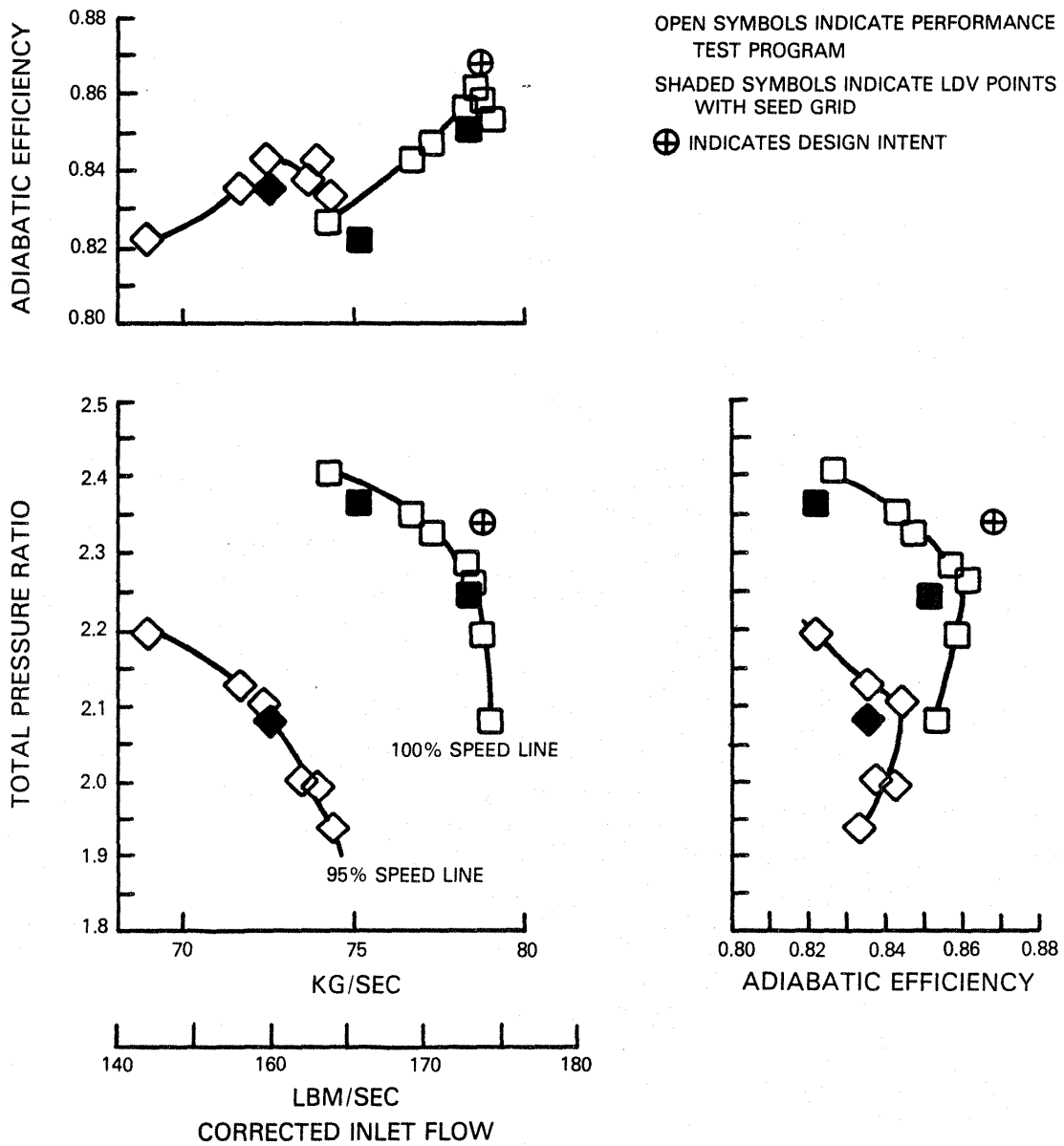
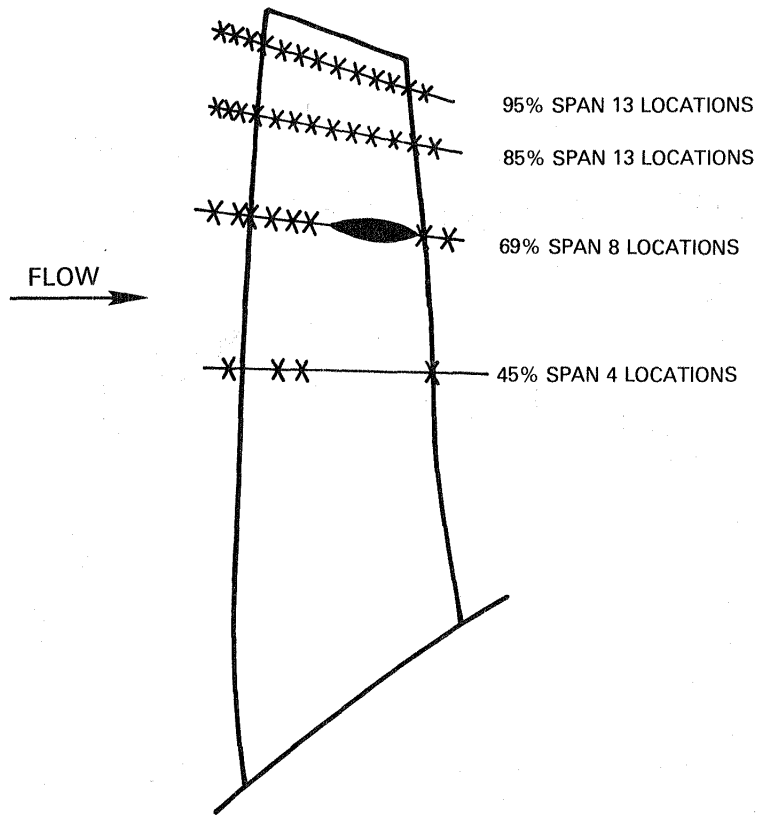

Figure 14 Rotor Performance Map

GAPWISE DATA



SPANWISE TRAVERSE DATA

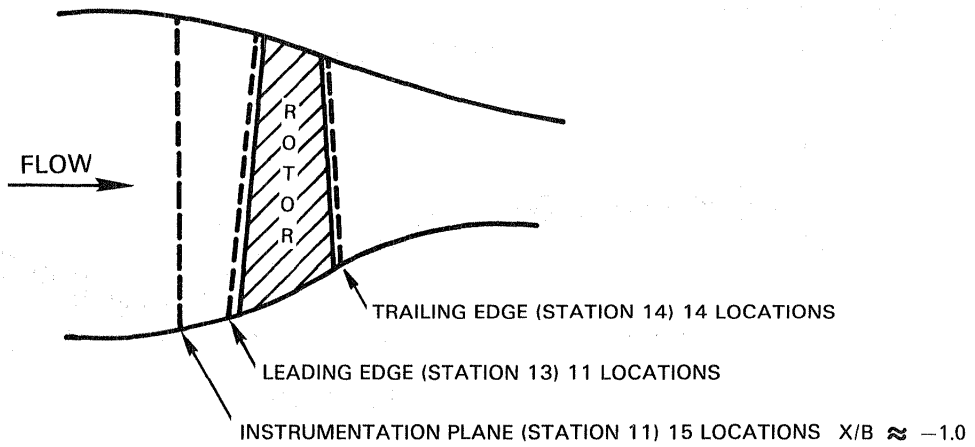

Figure 15 Laser Doppler Velocimeter Data Stations

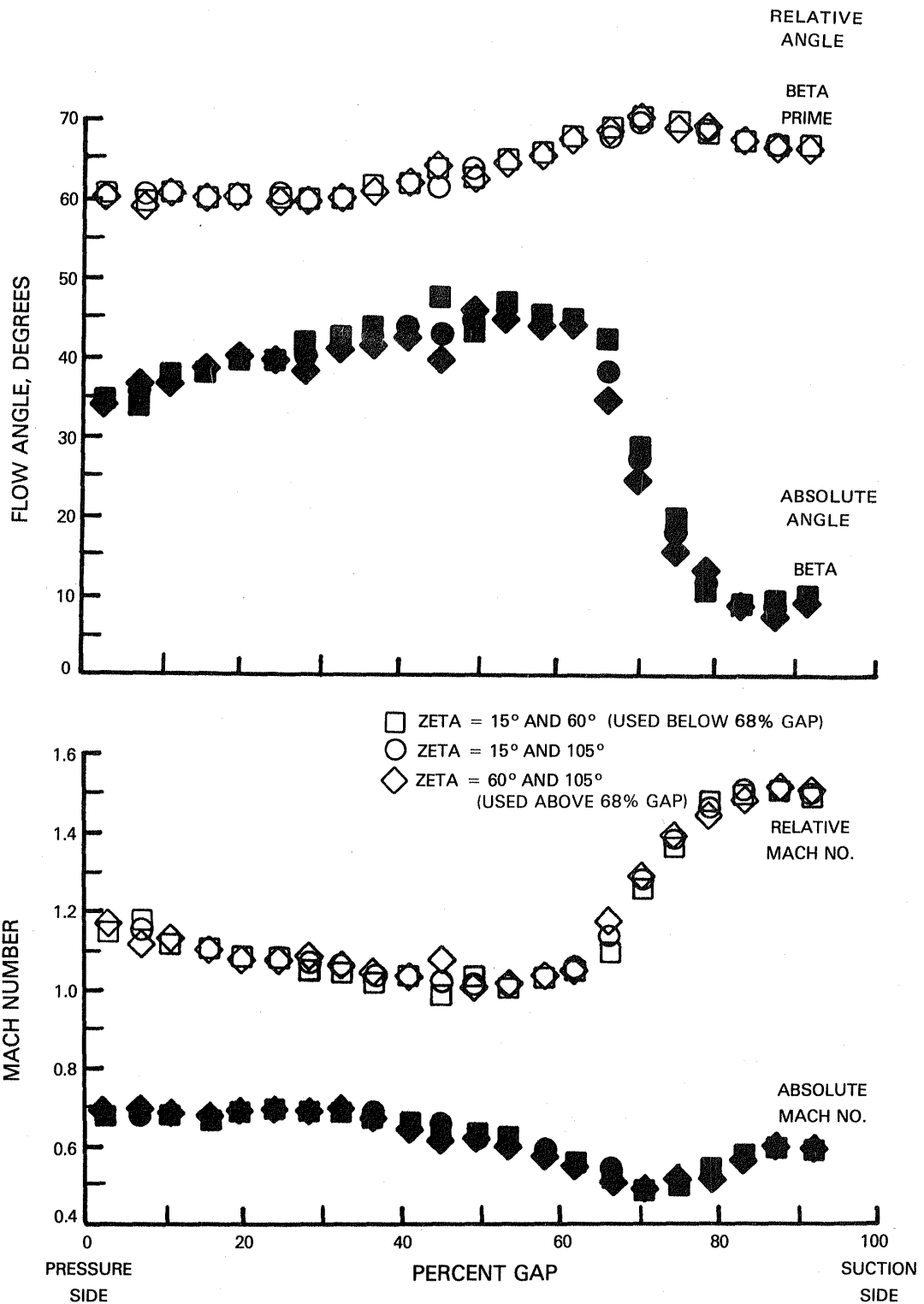

Figure 16 Aerodynamic Results at 85 Percent Span, 95 Percent Design Speed,  $x/b = 0.39$  - No Significant Angle Biasing Indicated

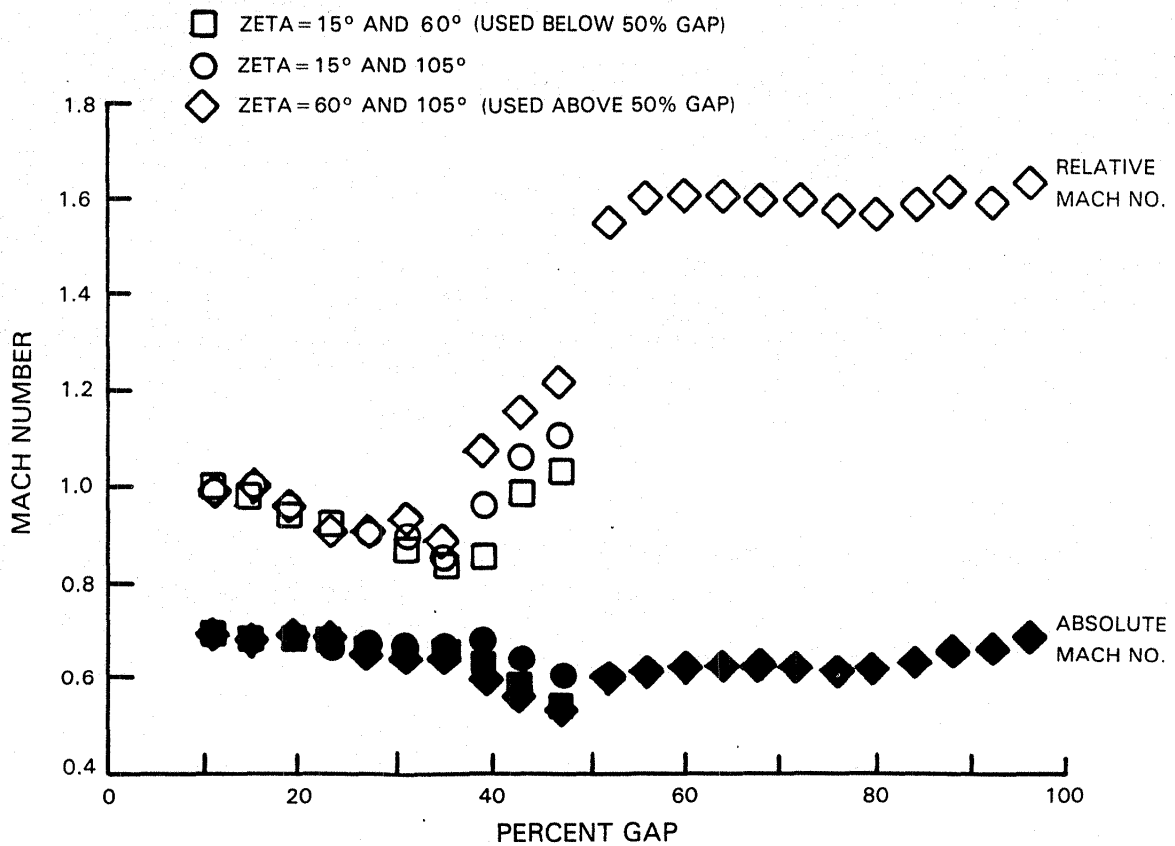
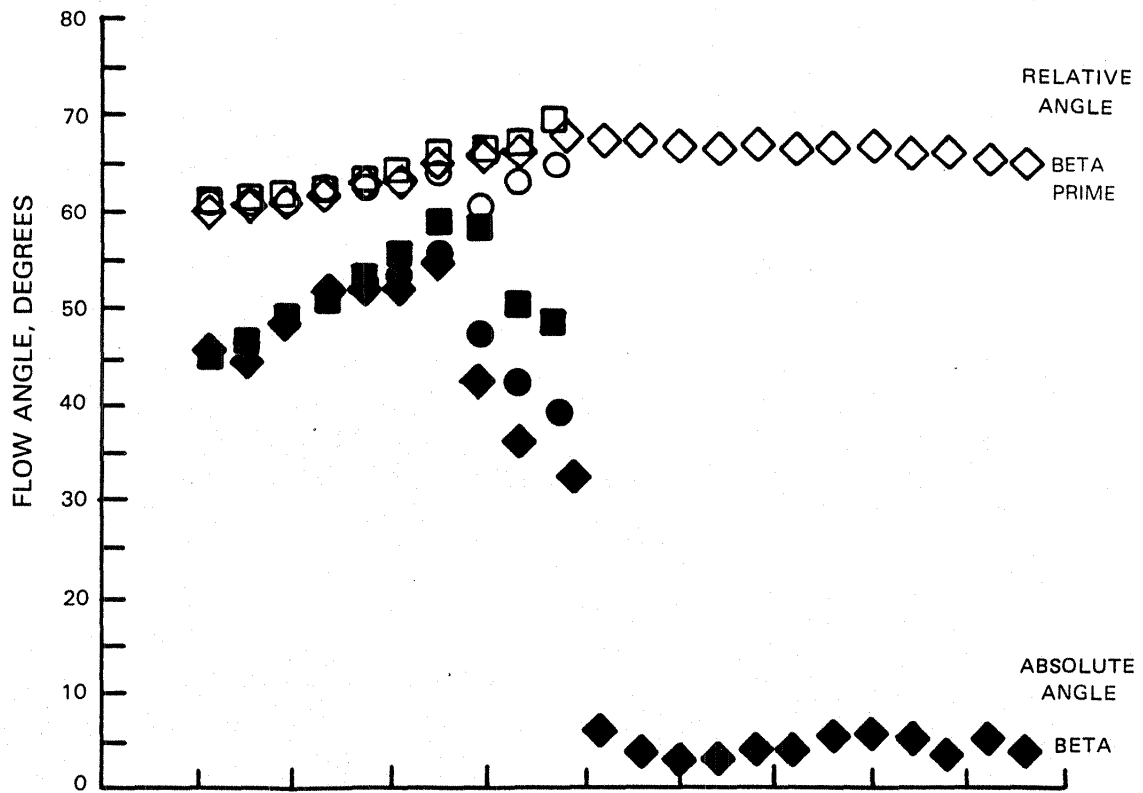

Figure 17 Aerodynamic Results at 85 Percent Span, 100 Percent Design Speed, Near Surge,  $x/b = 0.26$ , Passage No. 1 - Results Have Been Affected by Angle Biasing

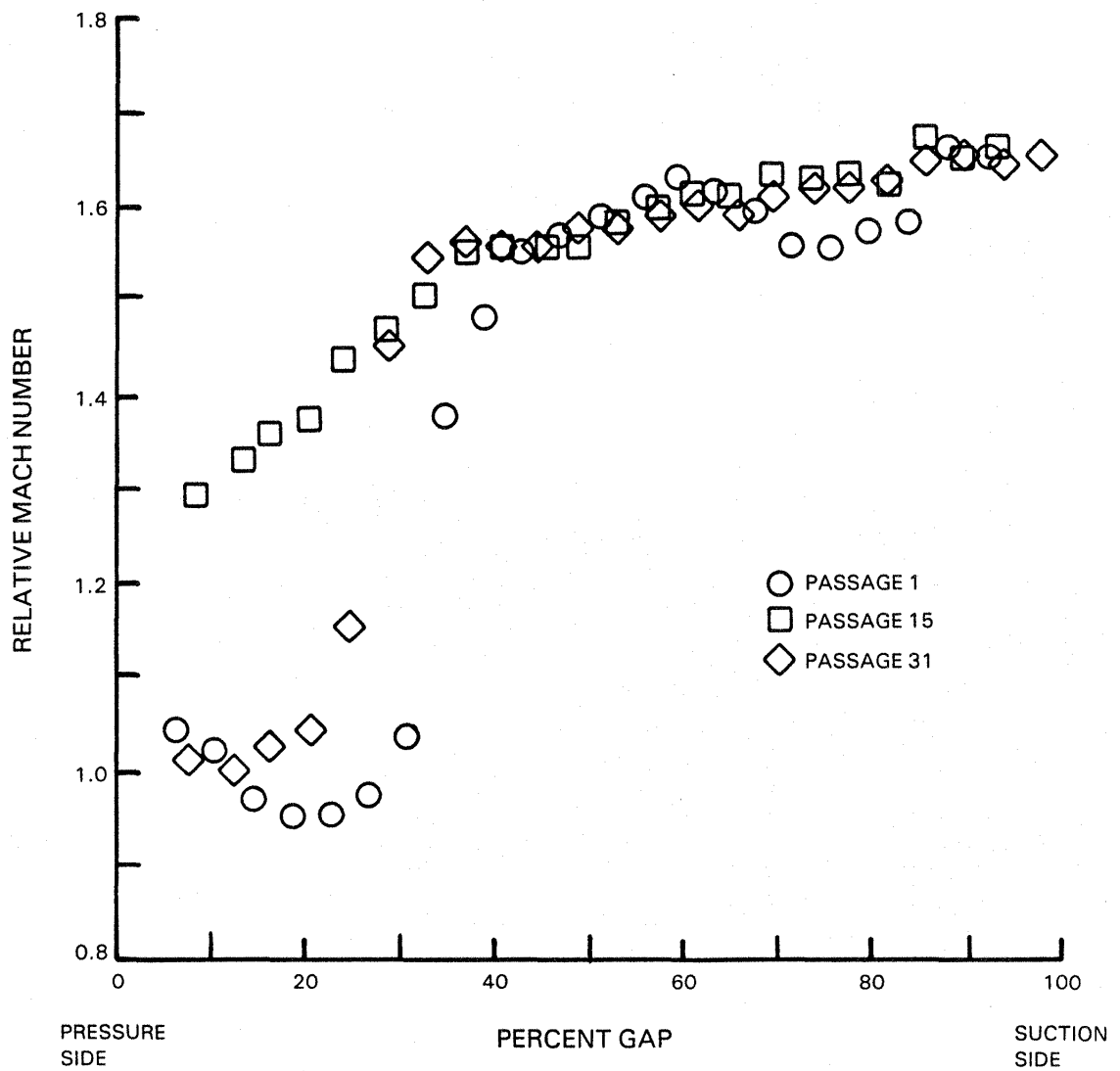

Figure 18 Mach Number Vs Percent Gap for Passages No. 1, 15, and 31  
 - 85 Percent Span, 100 Percent Design Speed, Peak Efficiency,  
 $x/b = 0.26$

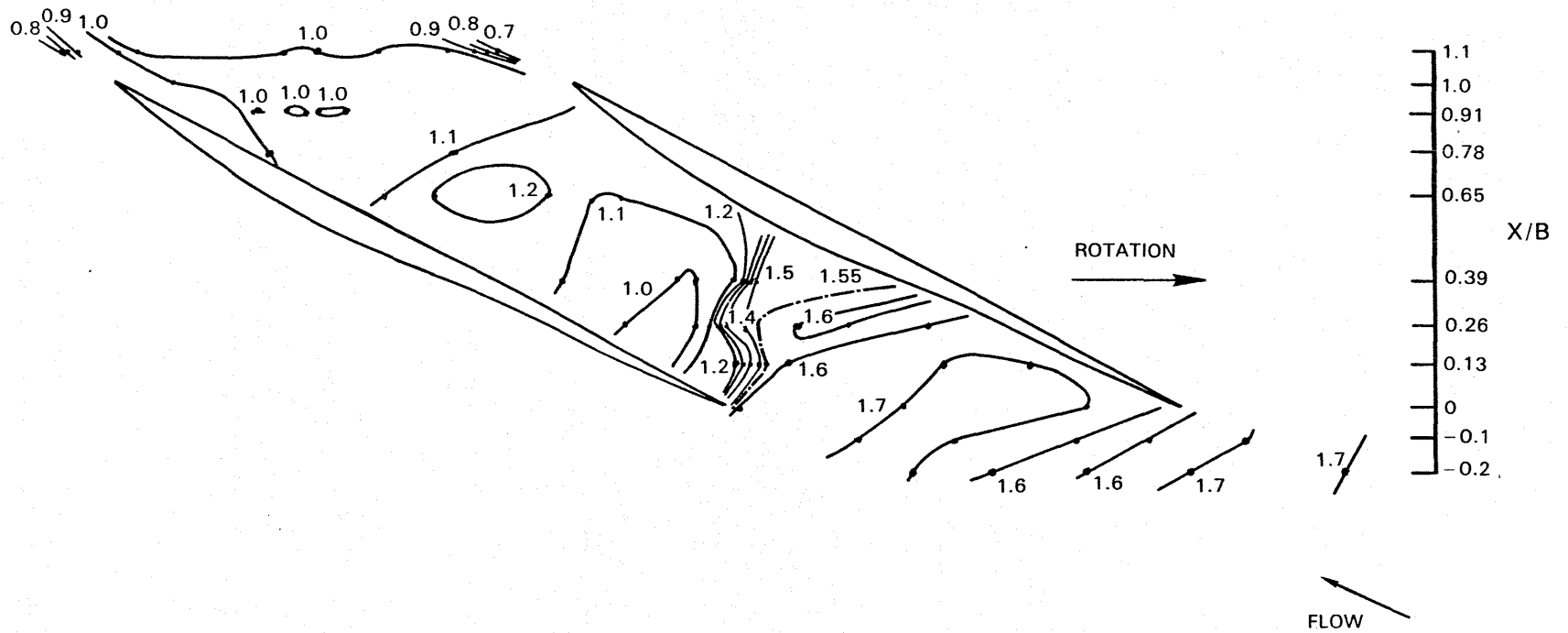

Figure 19 Mach Number Contours at 85 Percent Span, 100 Percent Design Speed, Peak Efficiency - Passage No. 1

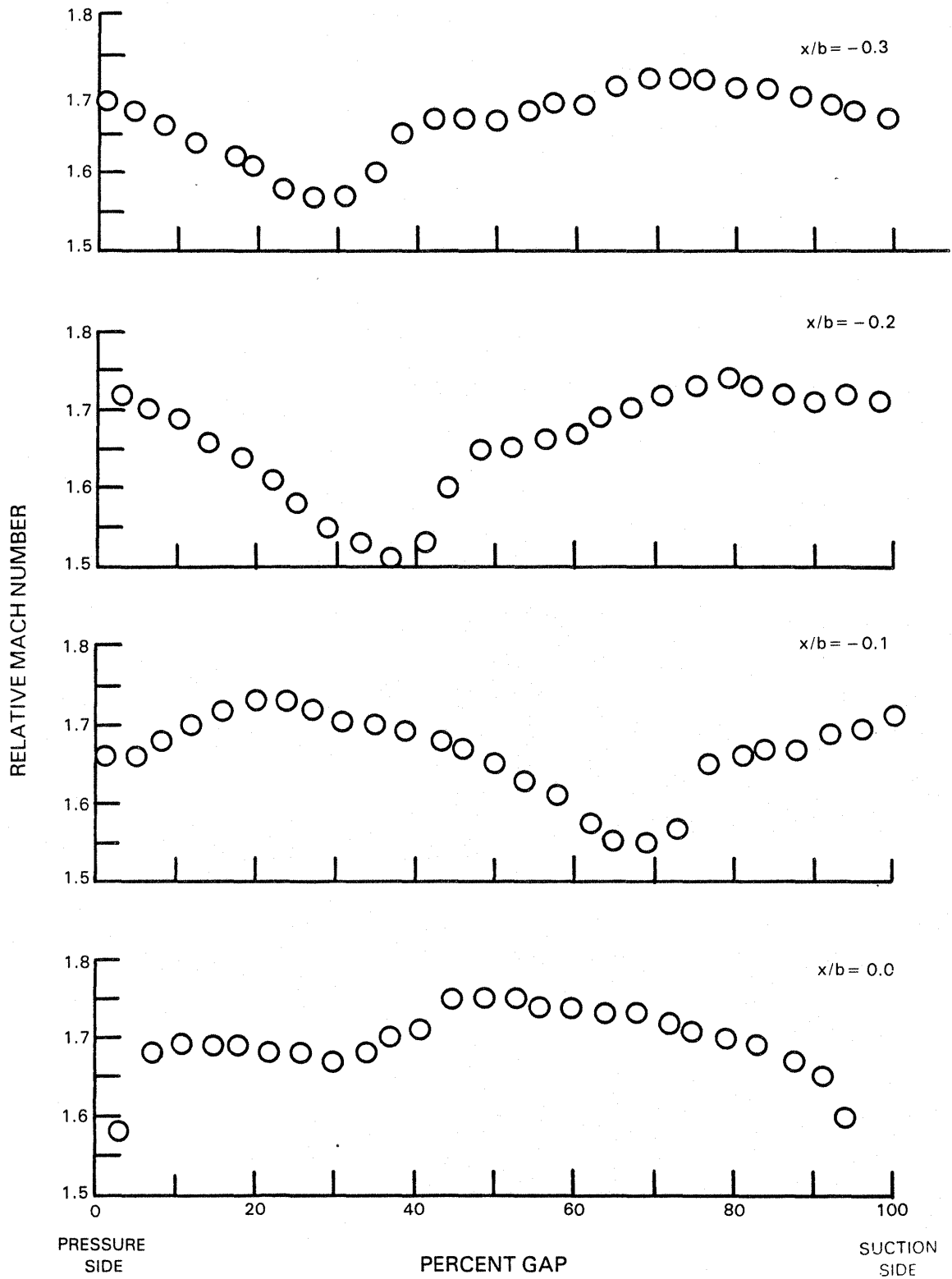

Figure 20a Mach Number Profiles at 85 Percent Span, 100 Percent Design Speed, Peak Efficiency - Passage No. 1



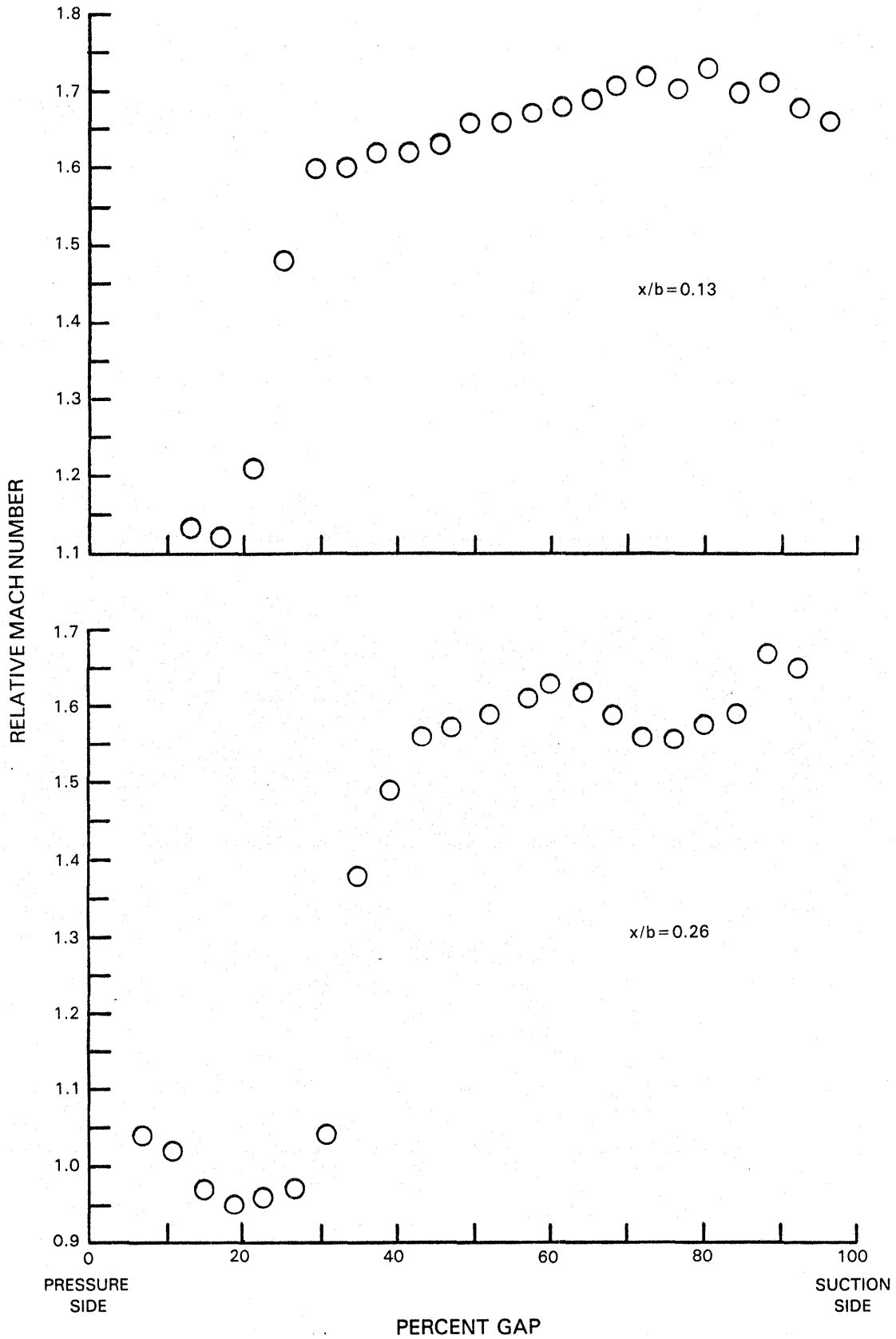

Figure 20b Mach Number Profiles at 85 Percent Span, 100 Percent Design Speed, Peak Efficiency - Passage No. 1

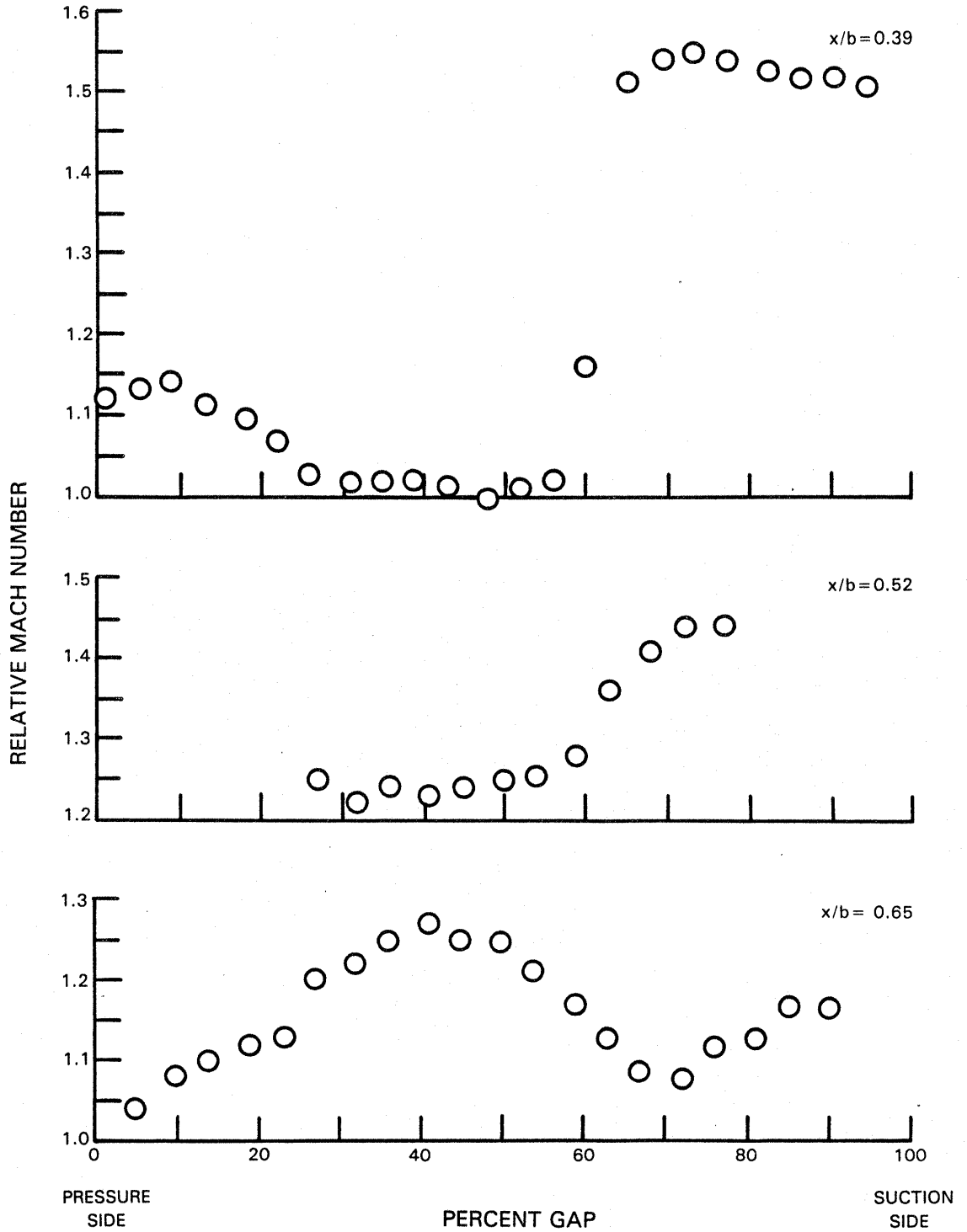

Figure 20c Mach Number Profiles at 85 Percent Span, 100 Percent Design Speed, Peak Efficiency - Passage No. 1

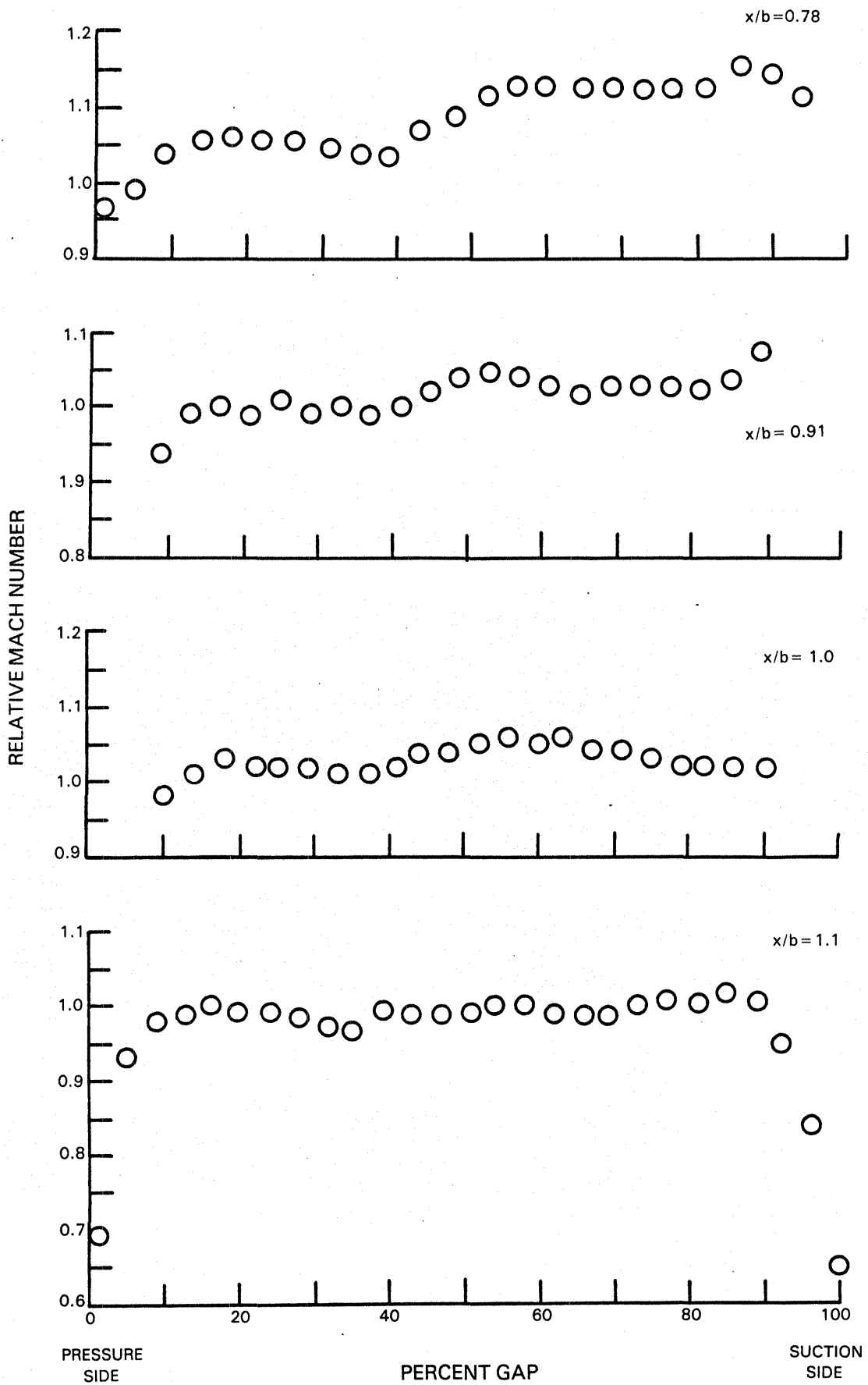

Figure 20d Mach Number Profiles at 85 Percent Span, 100 Percent Design Speed, Peak Efficiency - Passage No. 1

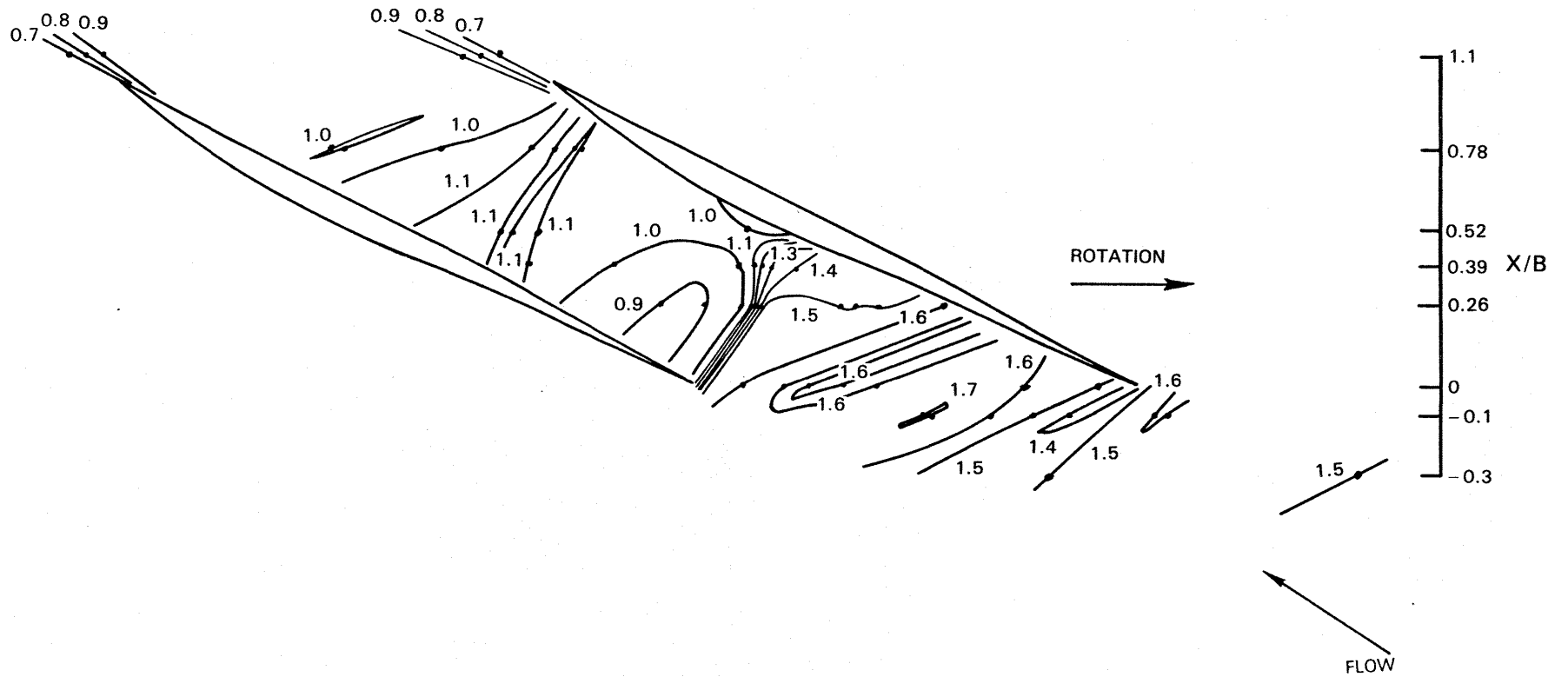

Figure 21 Mach Number Contours at 85 Percent Span, 95 Percent Design Speed, Peak Efficiency - Passage No. 1

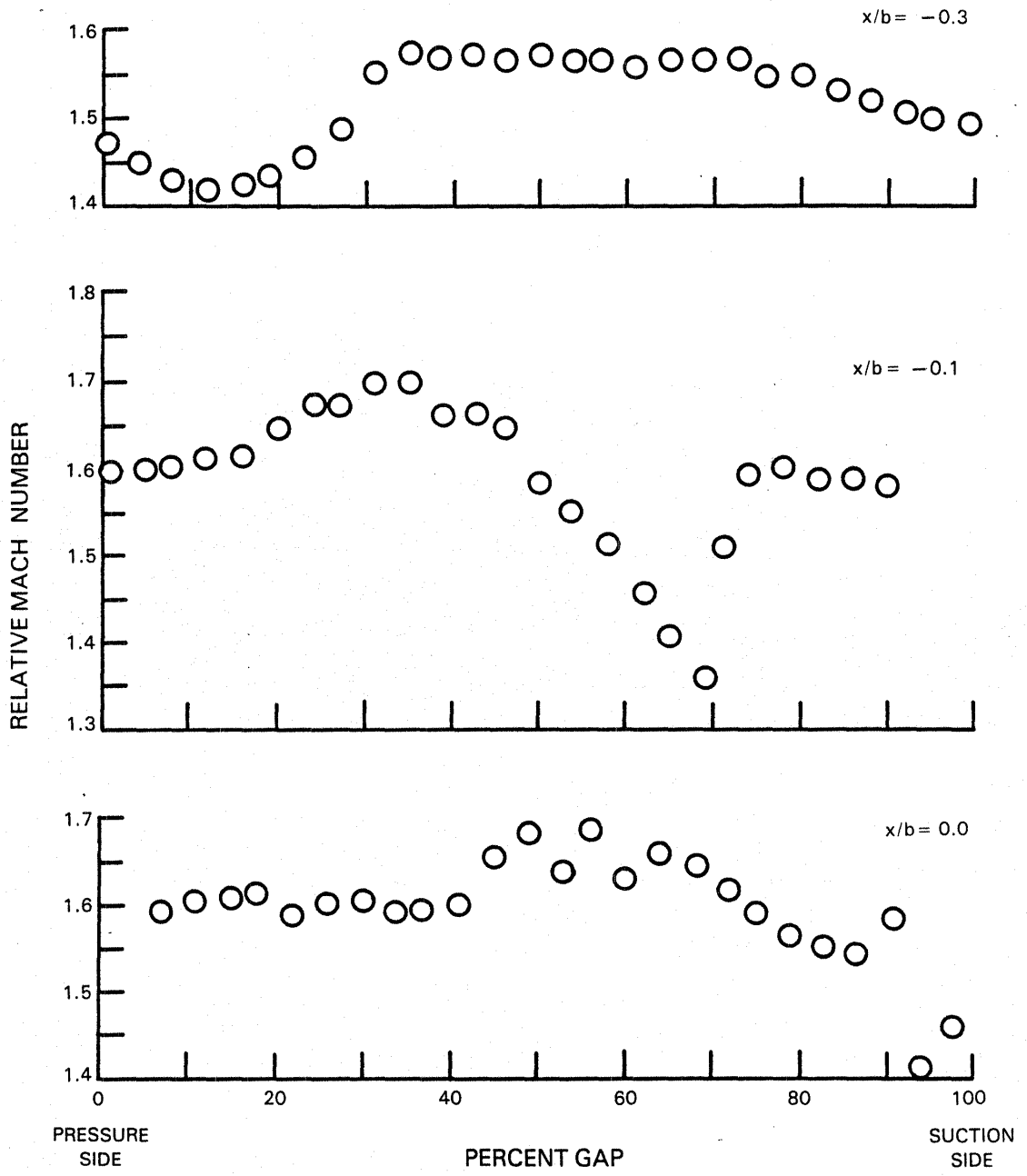

Figure 22a Mach Number Profiles at 85 Percent Span, 95 Percent Design Speed, Peak Efficiency - Passage No. 1

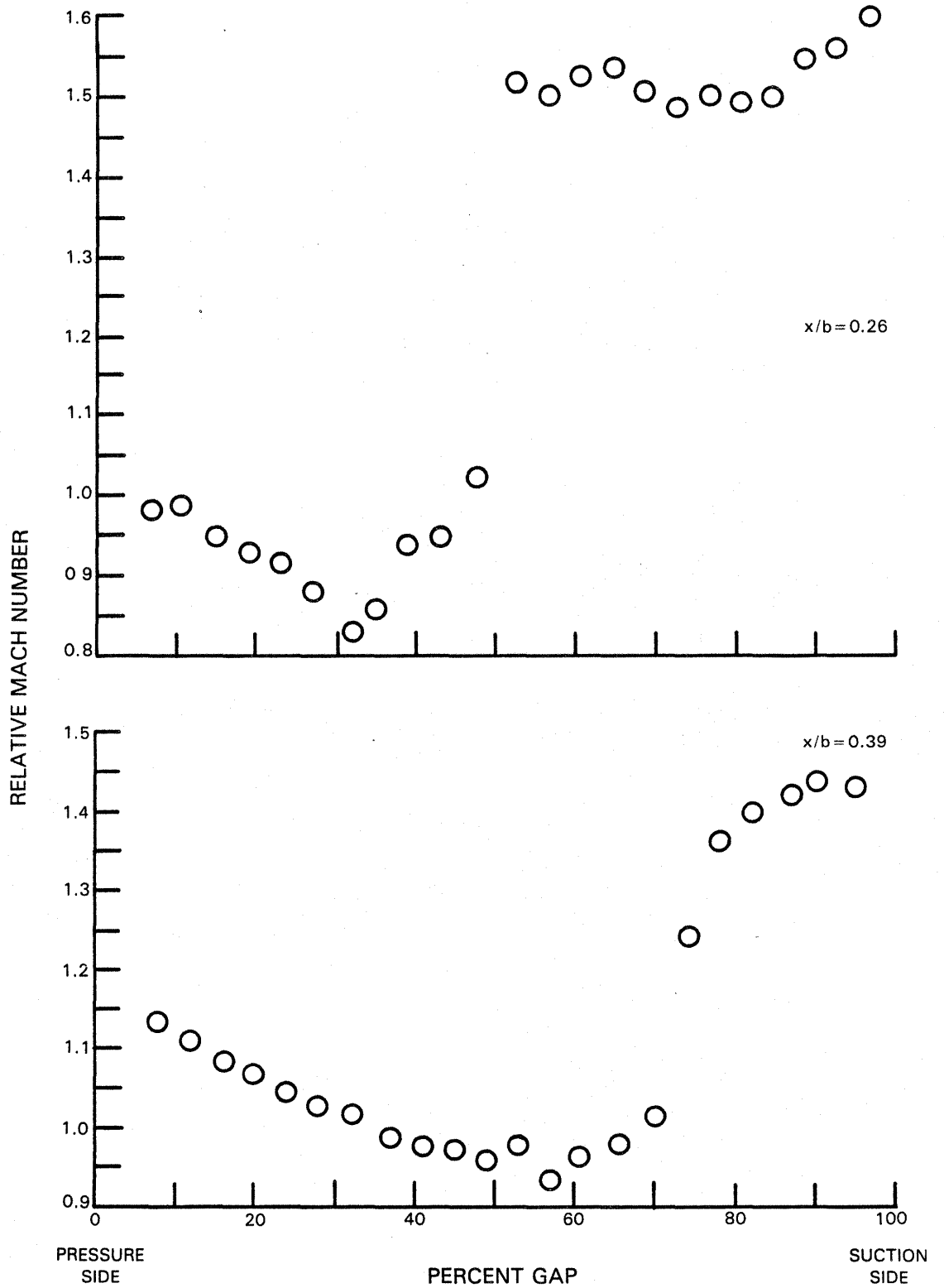

Figure 22b Mach Number Profiles at 85 Percent Span, 95 Percent Design Speed, Peak Efficiency - Passage No. 1

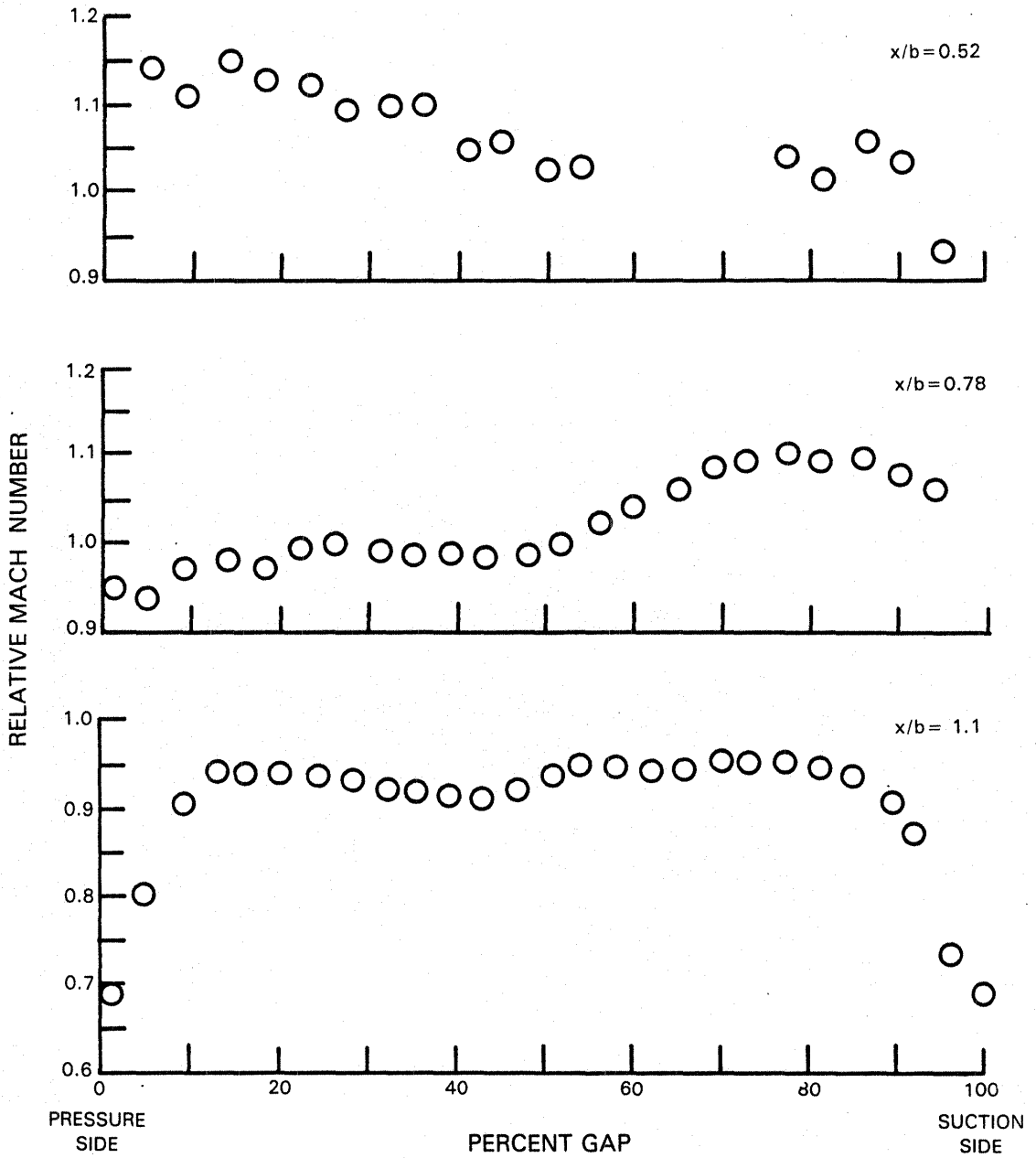

Figure 22c Mach Number Profiles at 85 Percent Span, 95 Percent Design Speed, Peak Efficiency - Passage No. 1

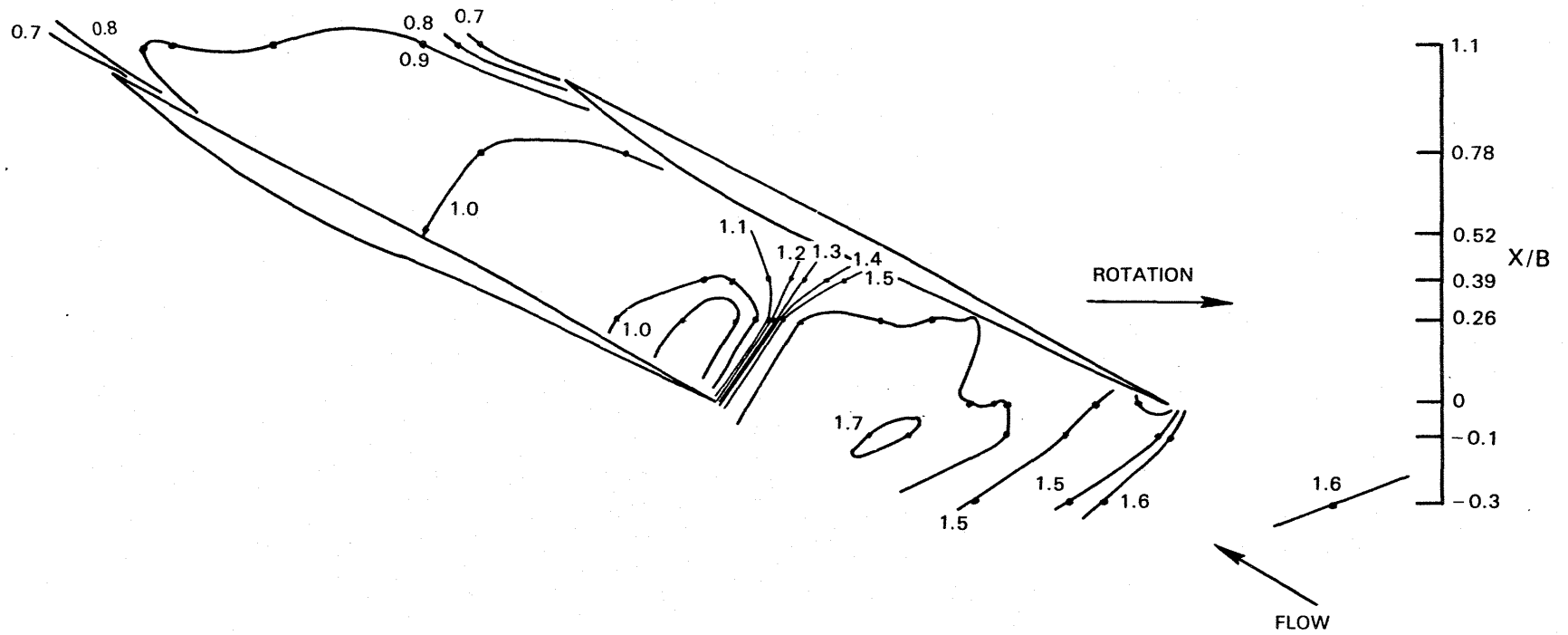

Figure 23 Mach Number Contours at 85 Percent Span, 100 Percent Design Speed, Near Surge - Passage No. 1



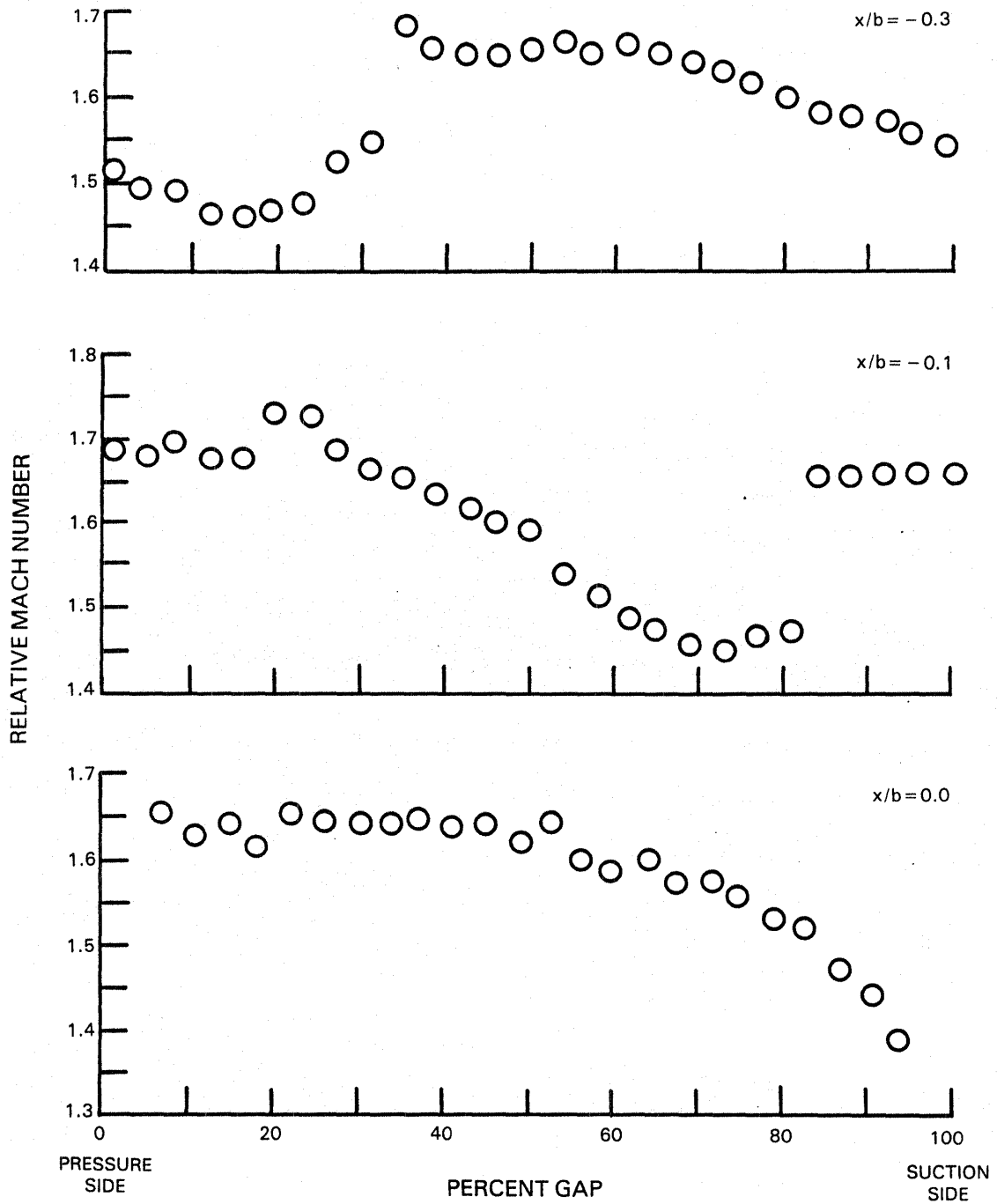

Figure 24a Mach Number Profiles at 85 Percent Span, 100 Percent Design Speed, Near Surge - Passage No. 1

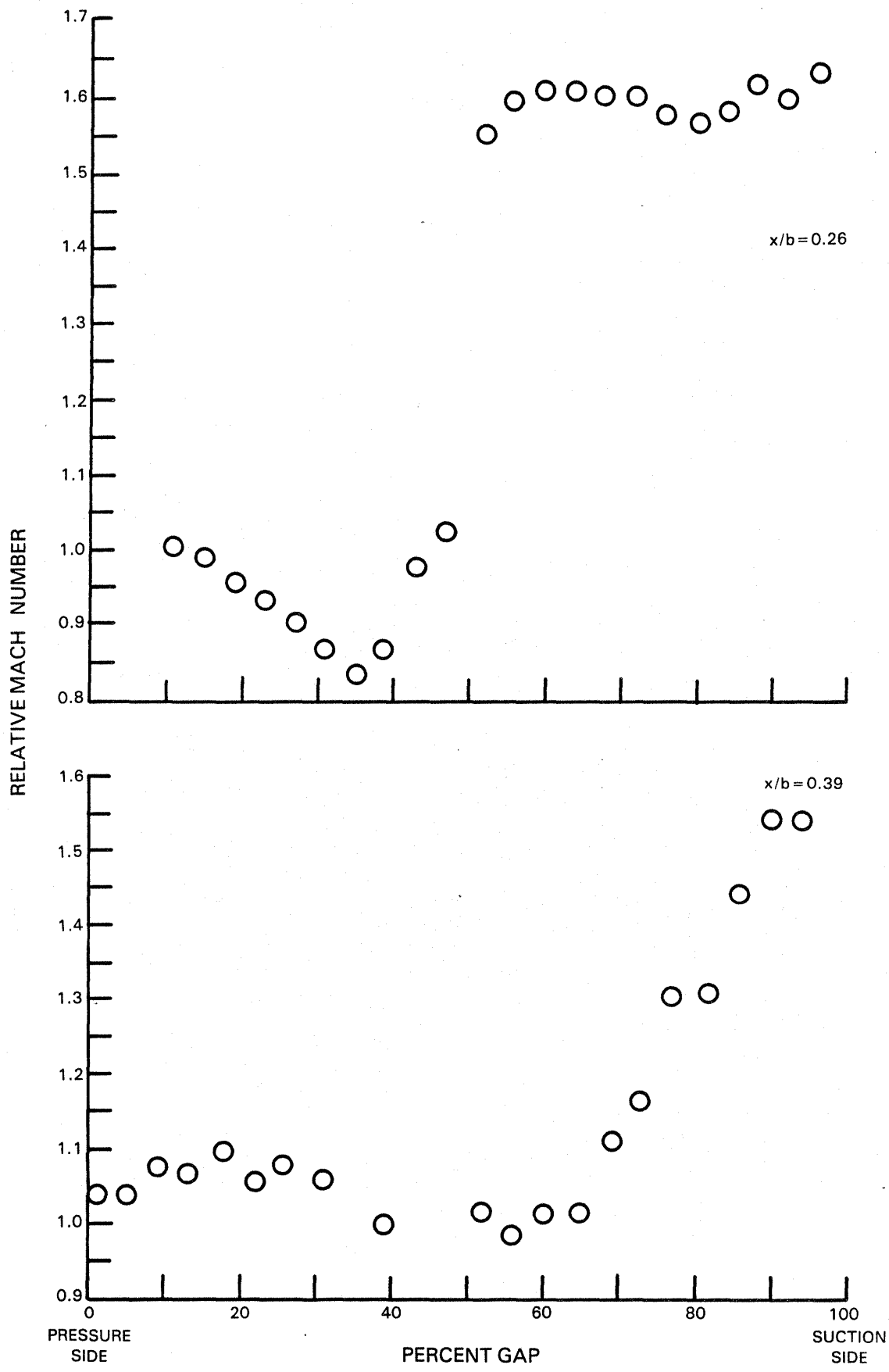

Figure 24b Mach Number Profiles at 85 Percent Span, 100 Percent Design Speed, Near Surge - Passage No. 1

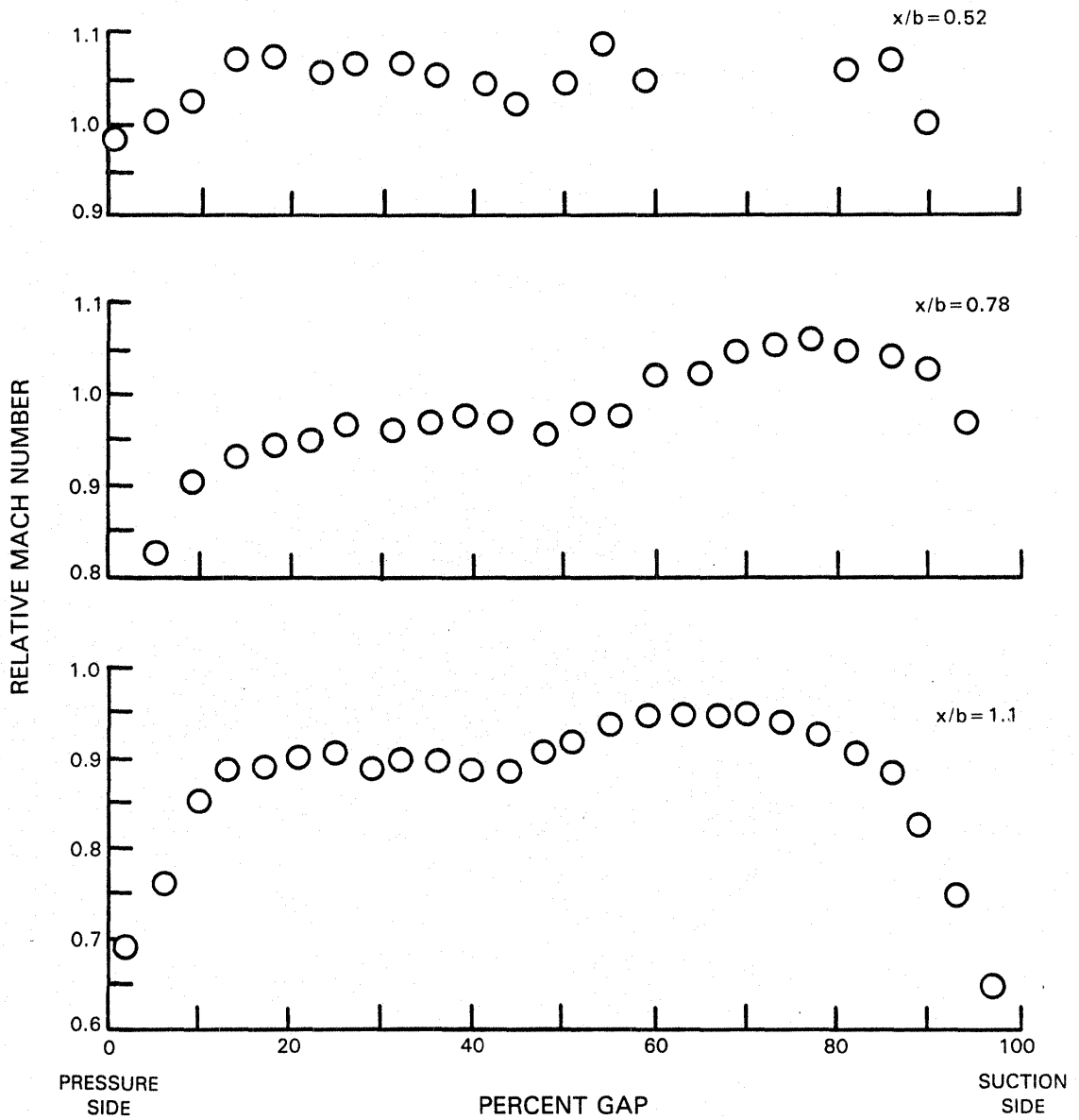

Figure 24c Mach Number Profiles at 85 Percent Span, 100 Percent Design Speed, Near Surge - Passage No. 1

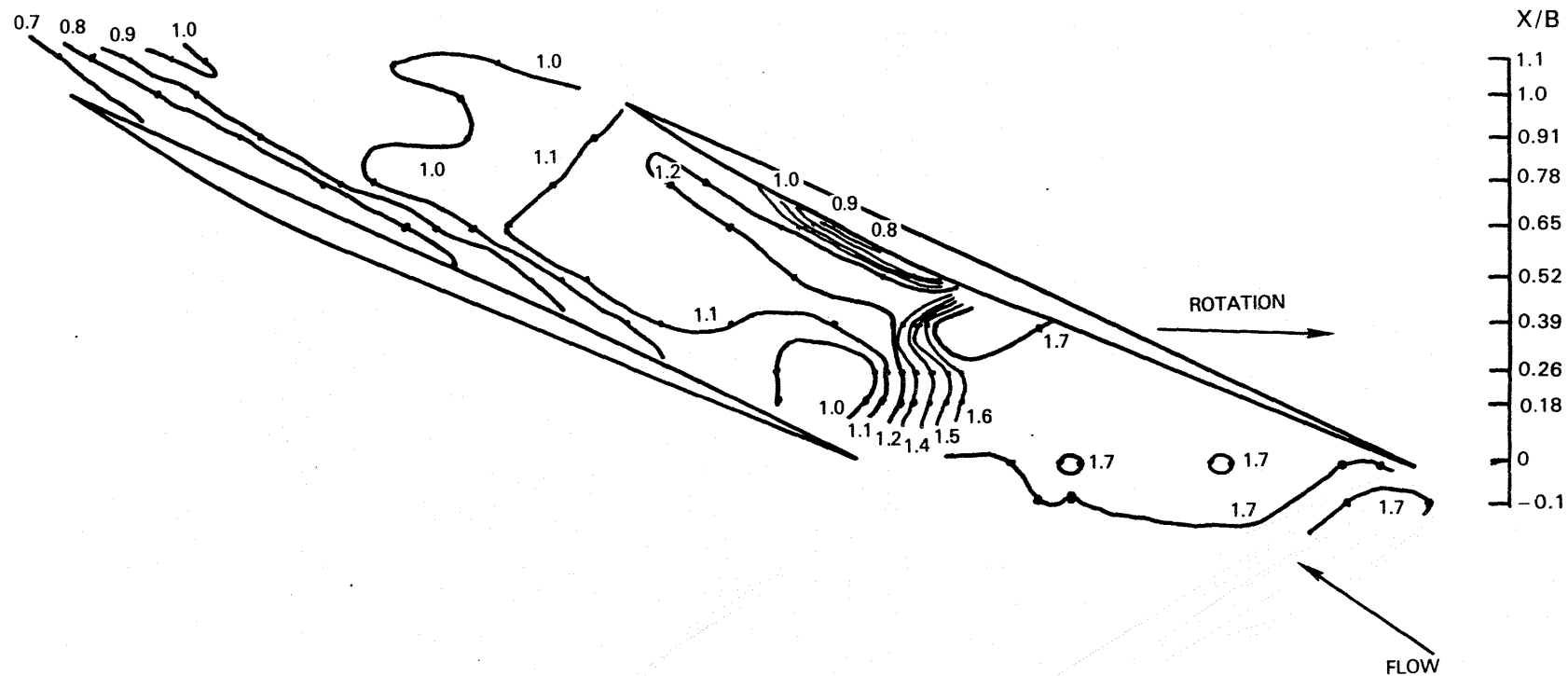

Figure 25

Mach Number Contours at 95 Percent Span, 100 Percent Design Speed, Peak Efficiency - Passage No. 1

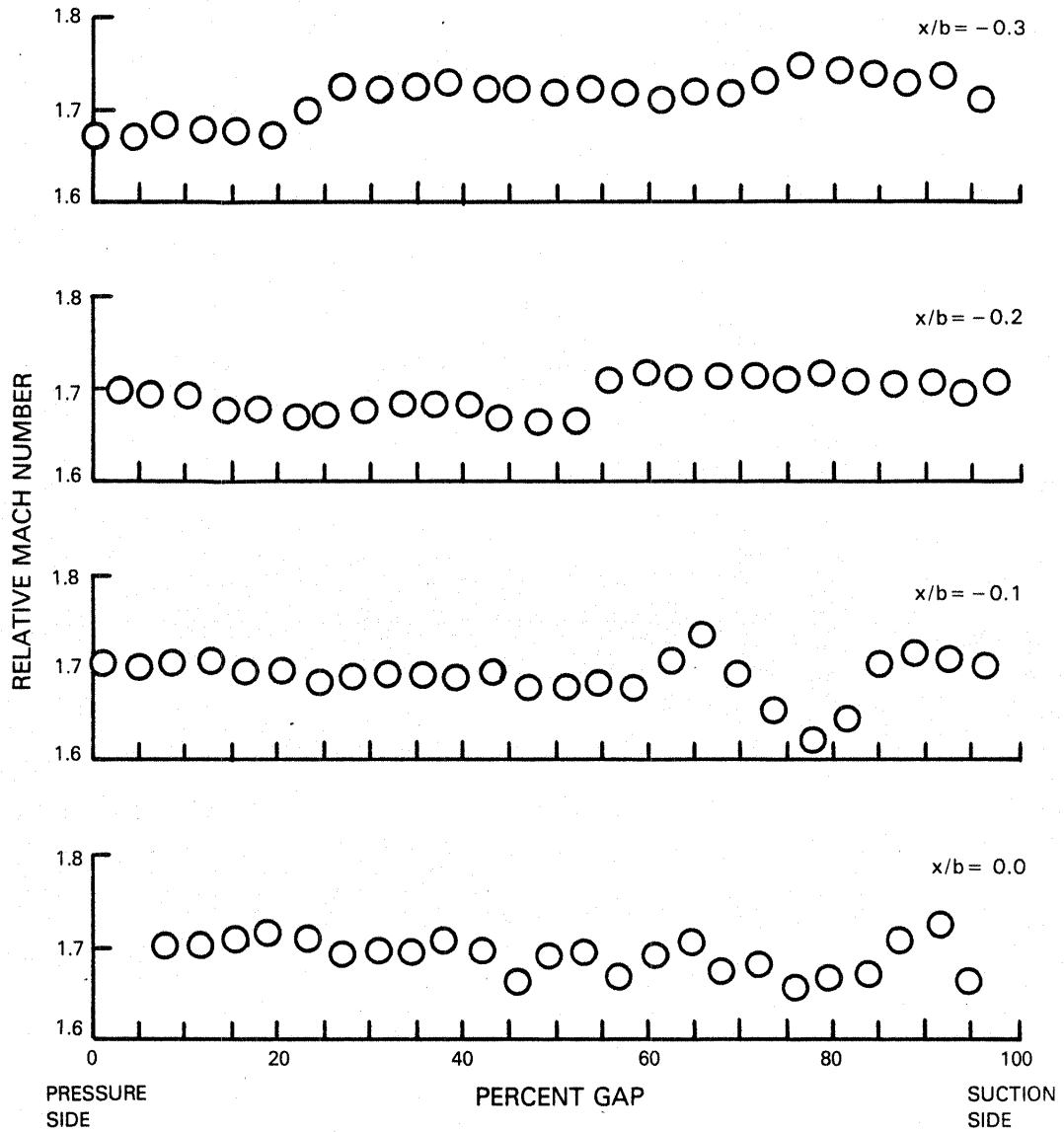

Figure 26a Mach Number Profiles at 95 Percent Span, 100 Percent Design Speed, Peak Efficiency - Passage No. 1

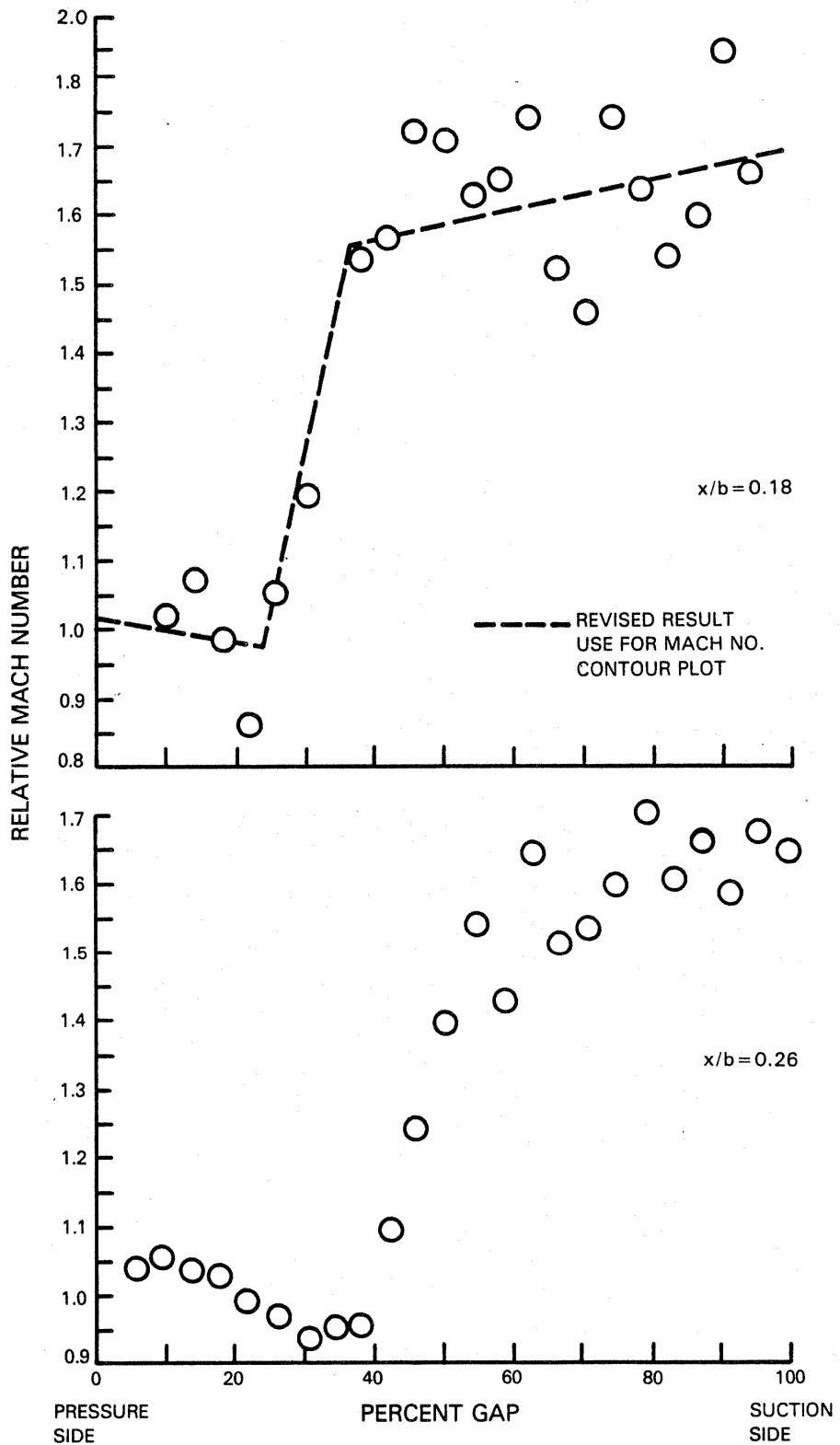

Figure 26b

Mach Number Profiles at 95 Percent Span, 100 Percent Design Speed, Peak Efficiency - Passage No. 1

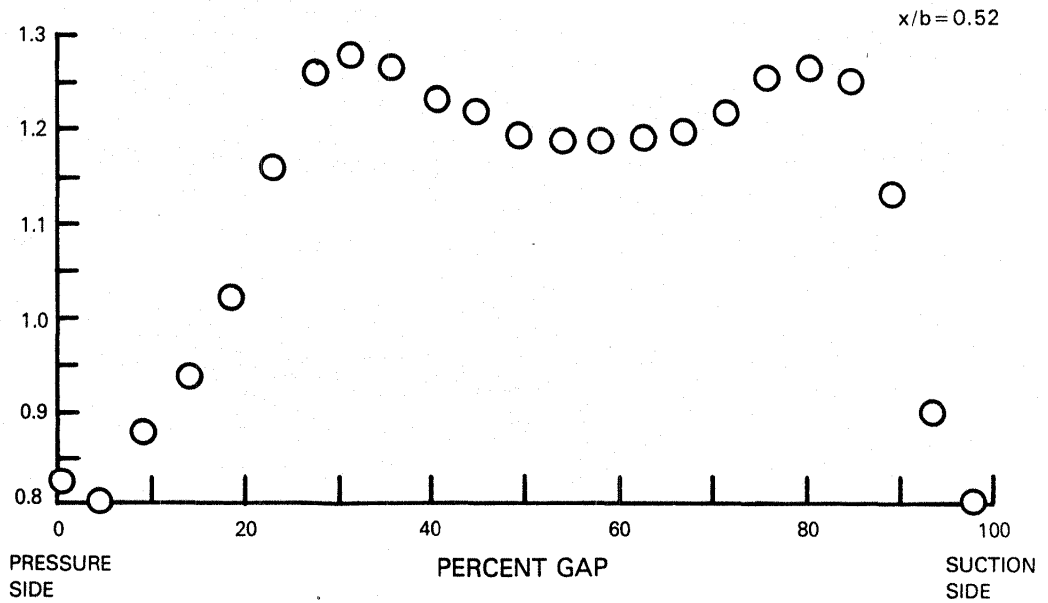
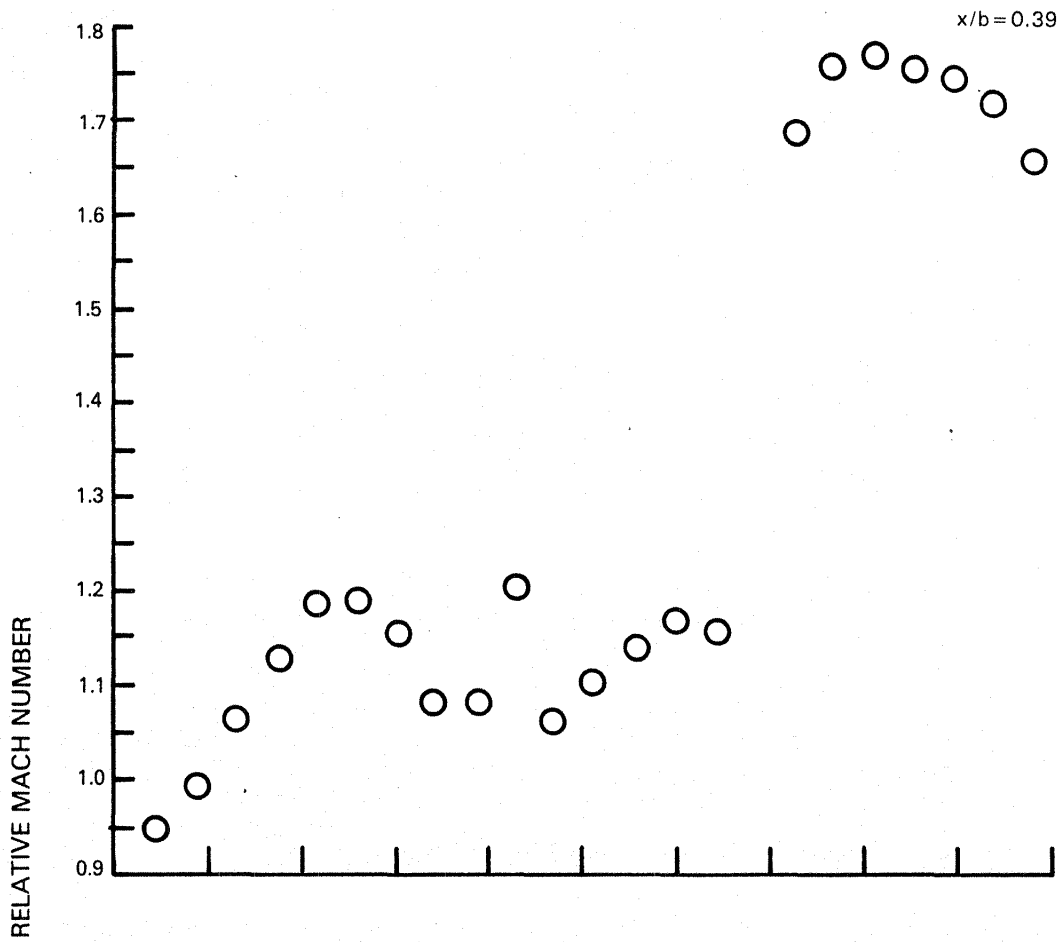

Figure 26c Mach Number Profiles at 95 Percent Span, 100 Percent Design Speed, Peak Efficiency - Passage No. 1

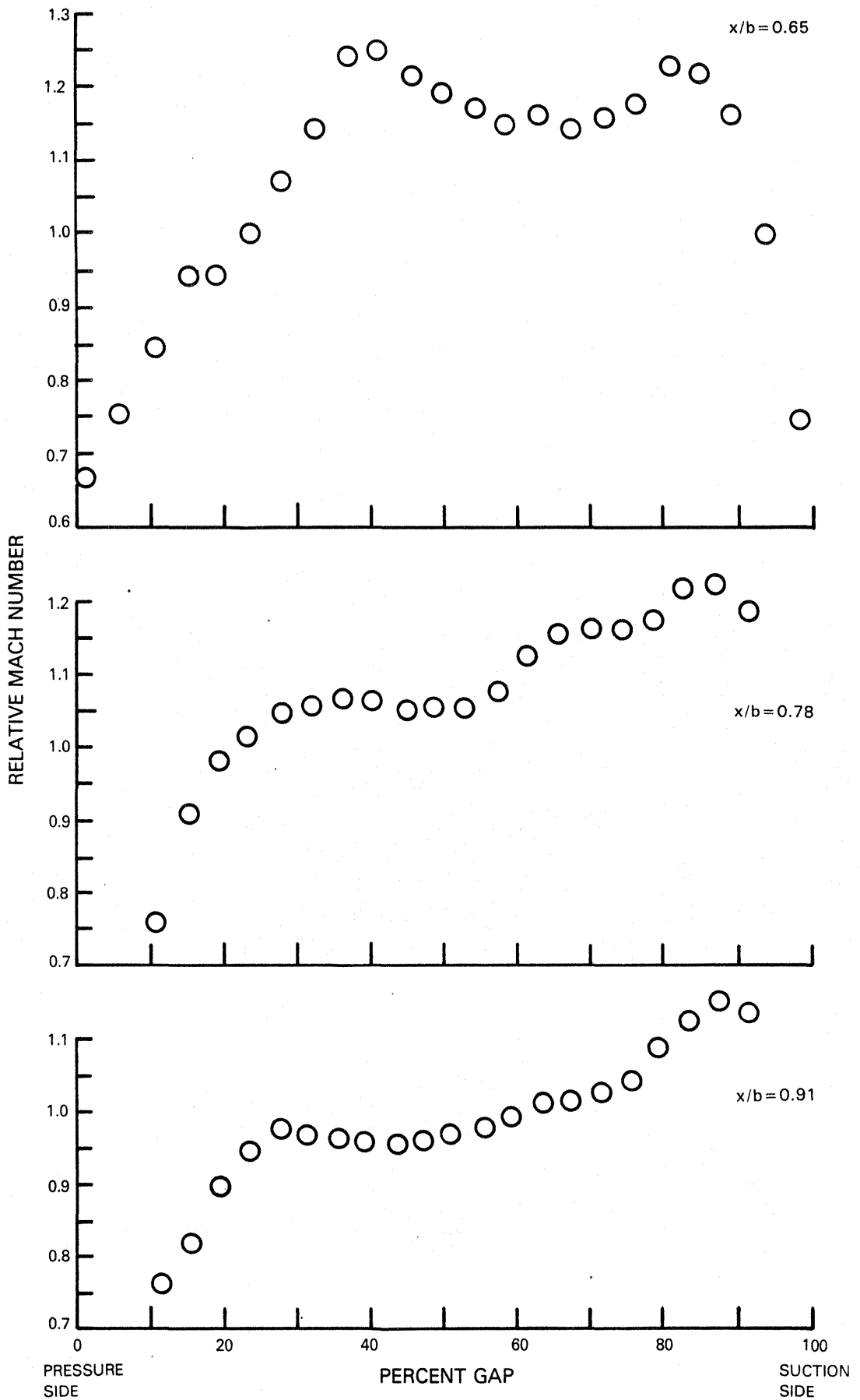

Figure 26d Mach Number Profiles at 95 Percent Span, 100 Percent Design Speed, Peak Efficiency - Passage No. 1



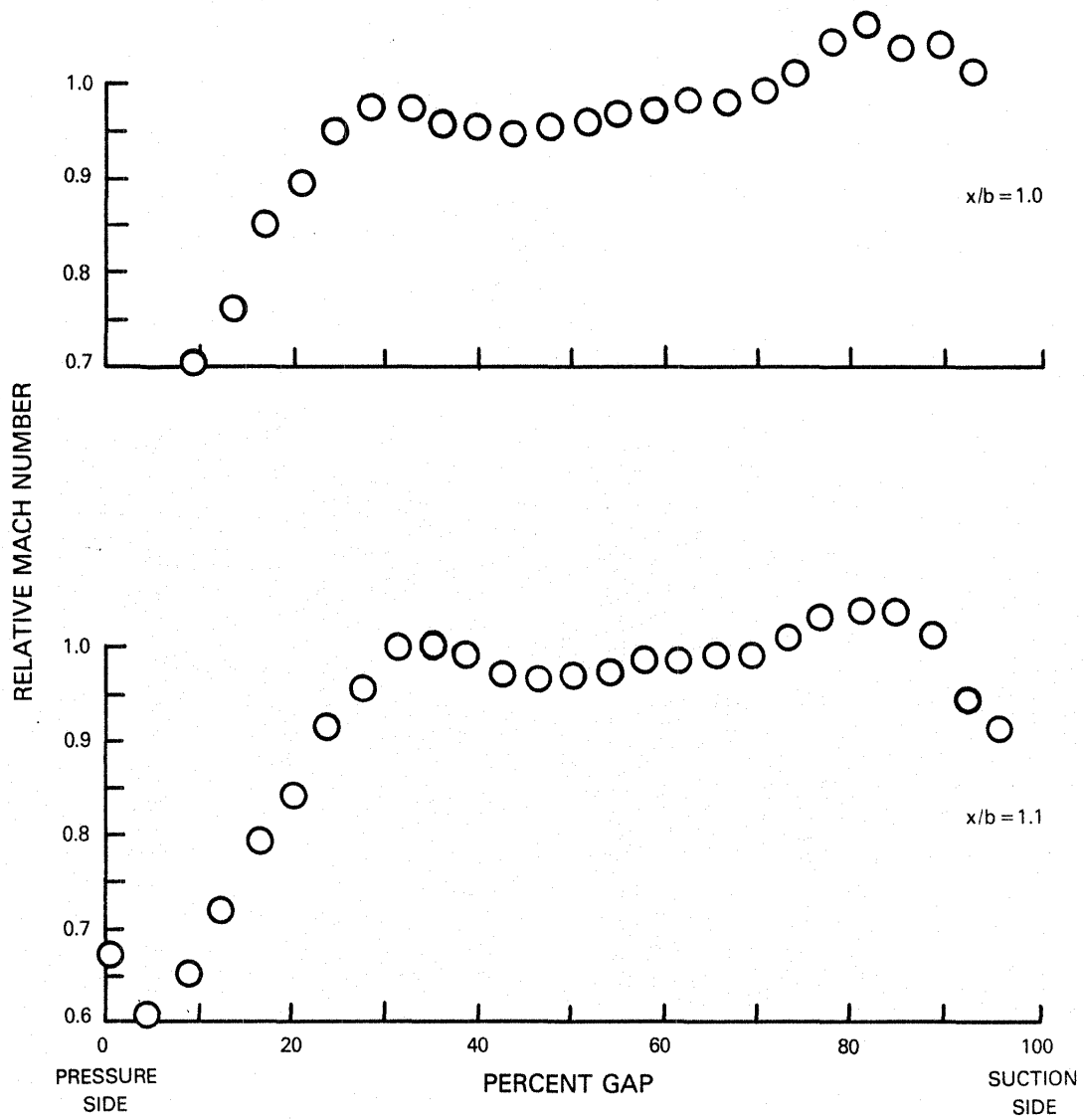

Figure 26e Mach Number Profiles at 95 Percent Span, 100 Percent Design Speed, Peak Efficiency - Passage No. 1

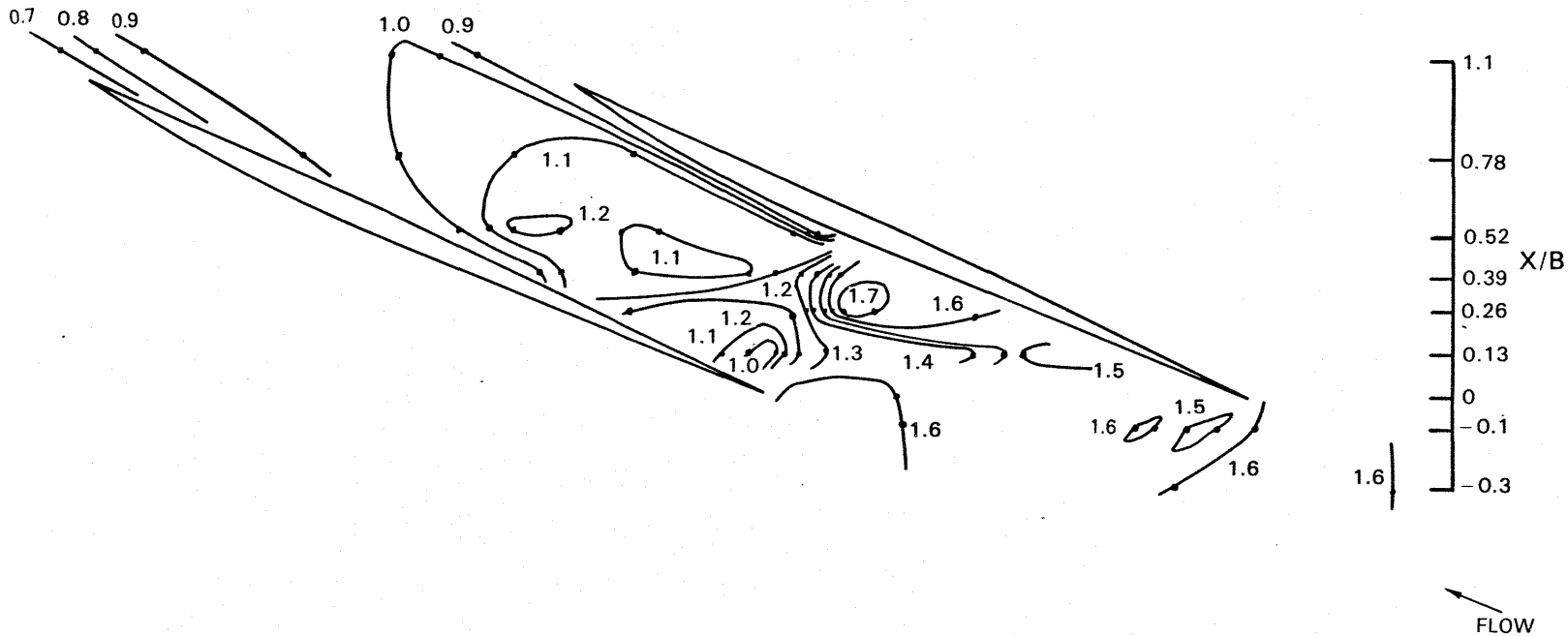

Figure 27 Mach Number Contours at 95 Percent Span, 95 Percent Design Speed, Peak Efficiency - Passage No. 1

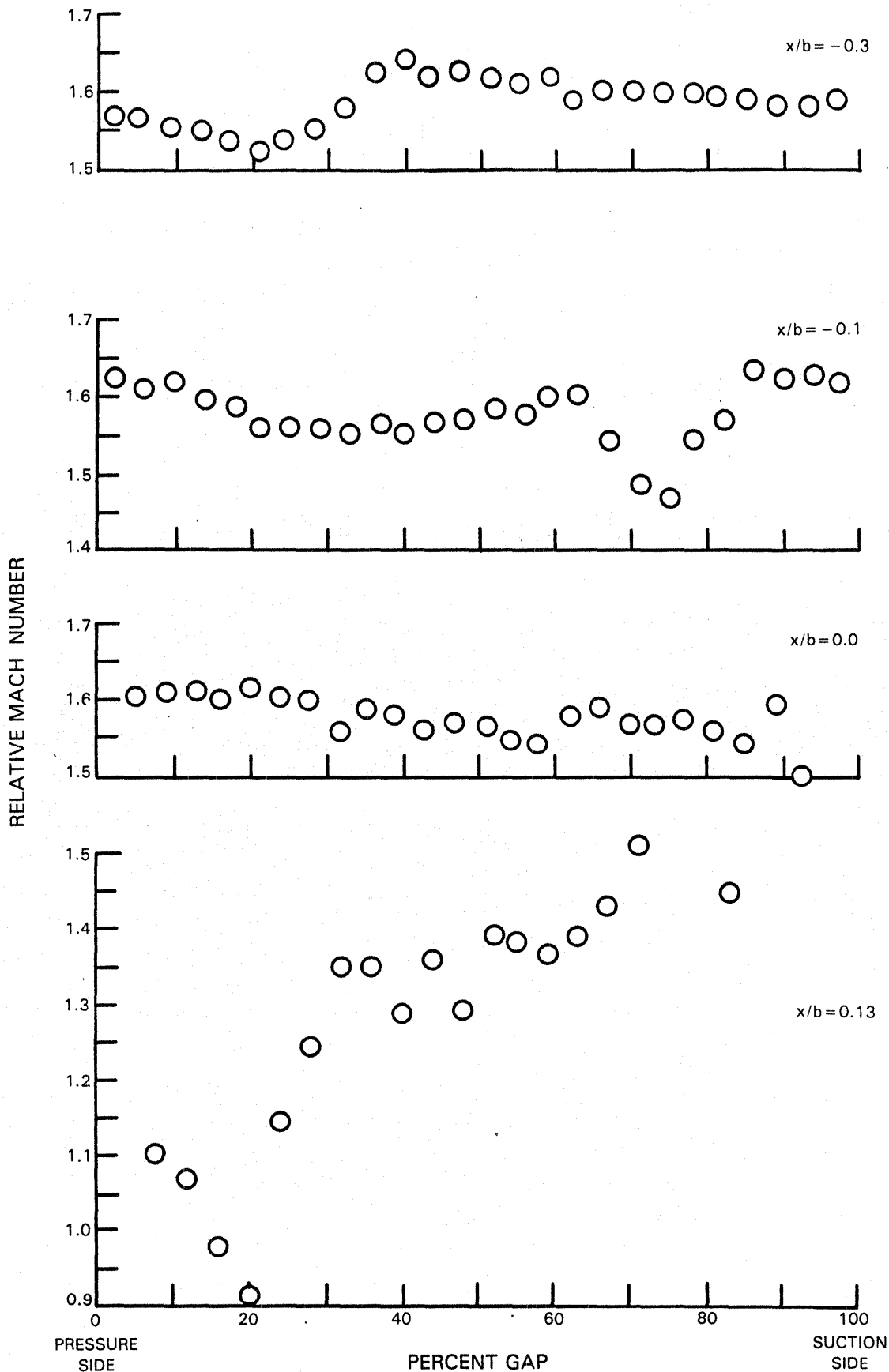

Figure 28a Mach Number Profiles at 95 Percent Span, 95 Percent Design Speed, Peak Efficiency - Passage No. 1

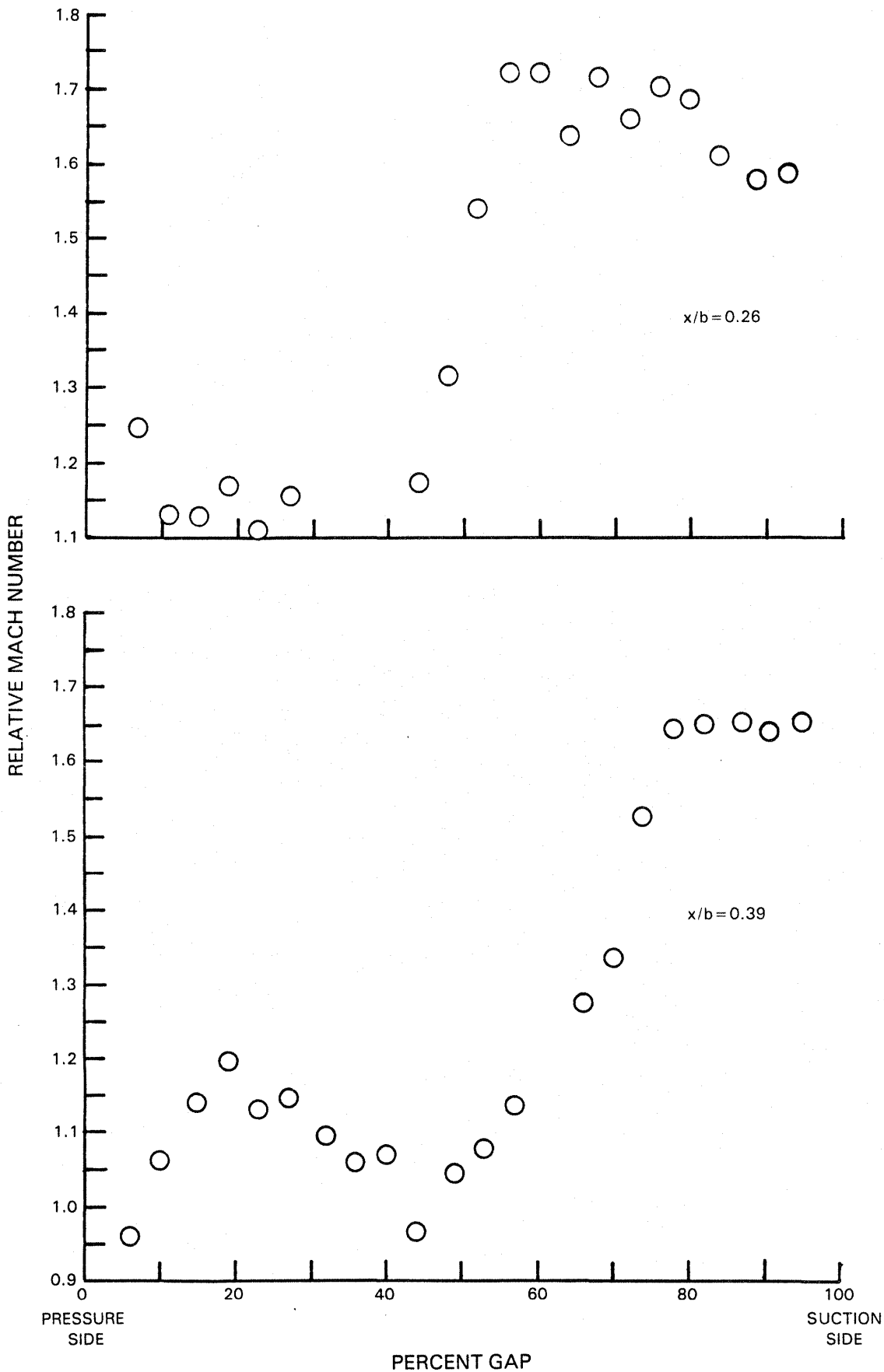

Figure 28b Mach Number Profiles at 95 Percent Span, 95 Percent Design Speed, Peak Efficiency - Passage No. 1

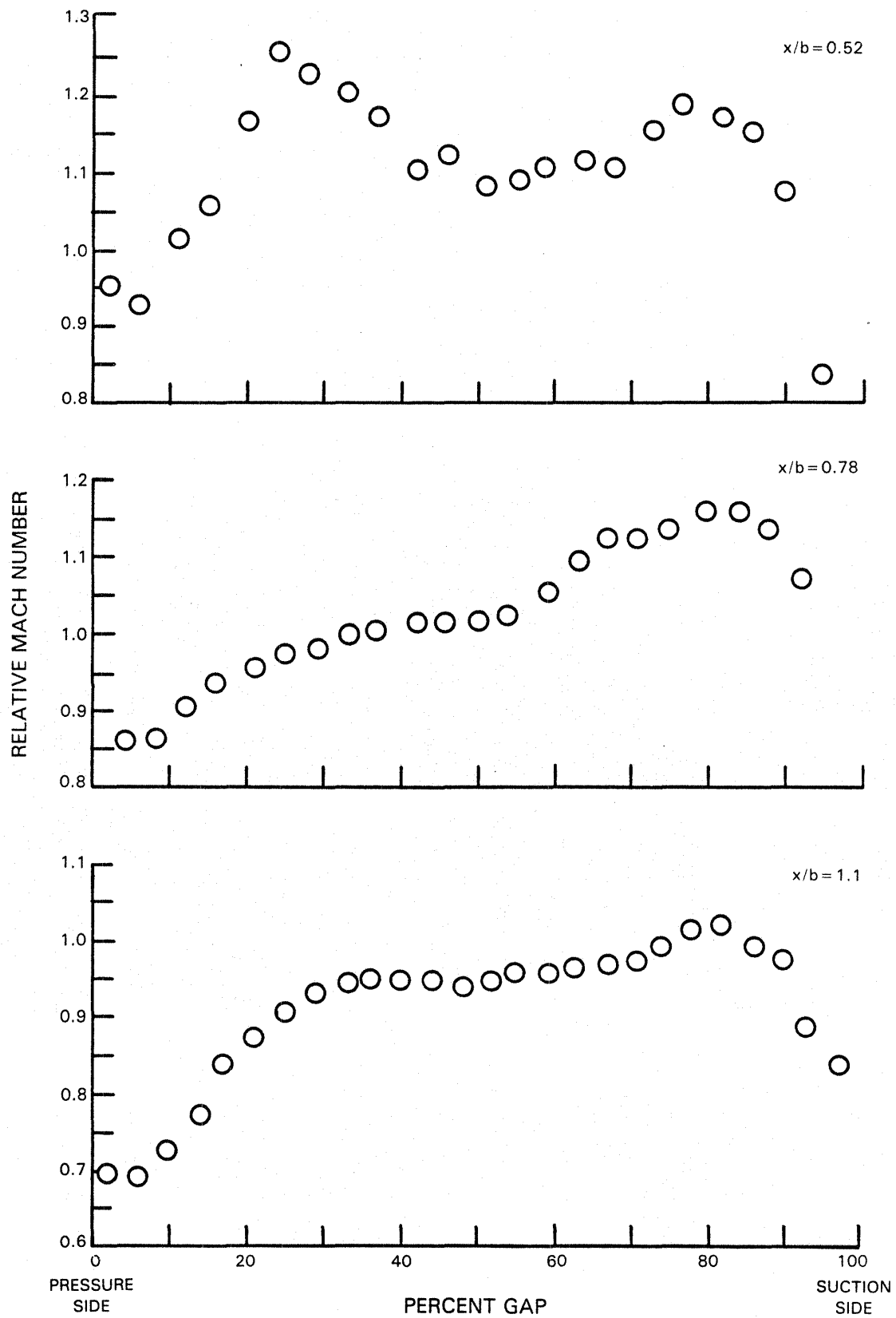

Figure 28c Mach Number Profiles at 95 Percent Span, 95 Percent Design Speed, Peak Efficiency - Passage No. 1

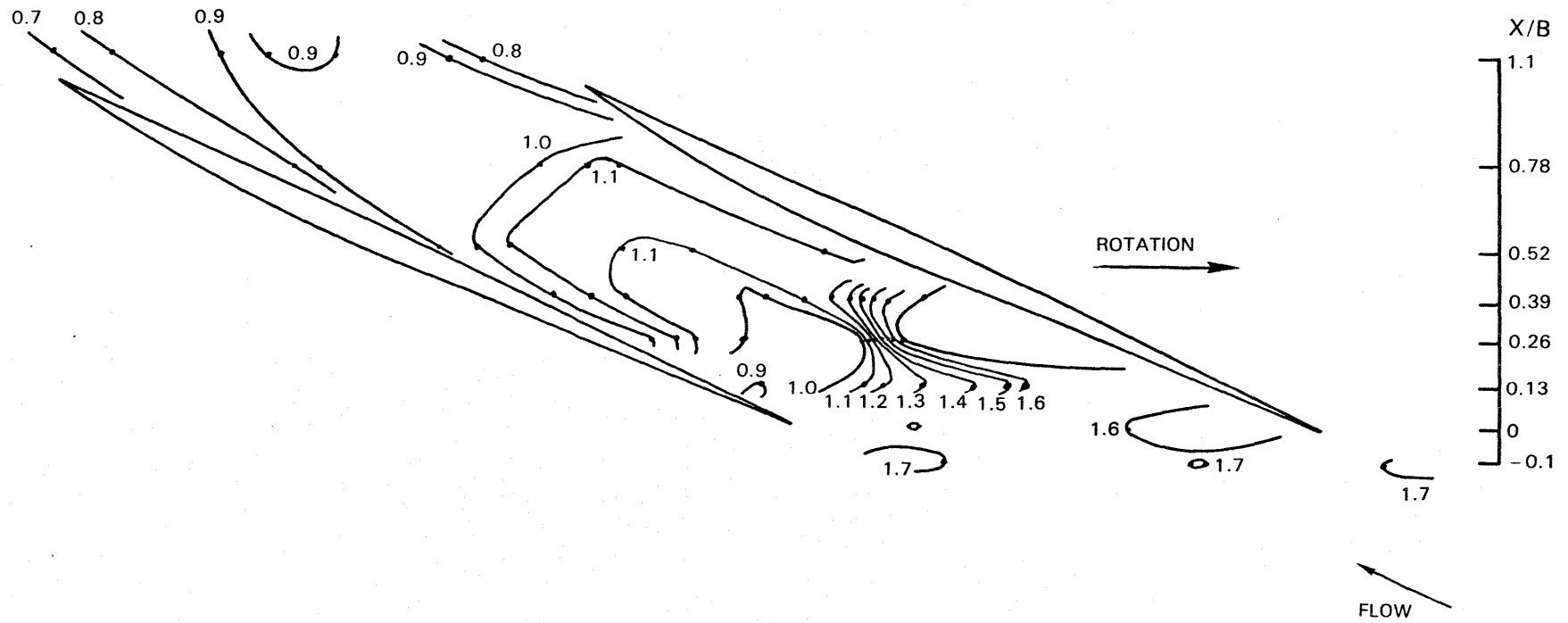

Figure 29 Mach Number Contours at 95 Percent Span, 100 Percent Design Speed, Near Surge - Passage No. 1

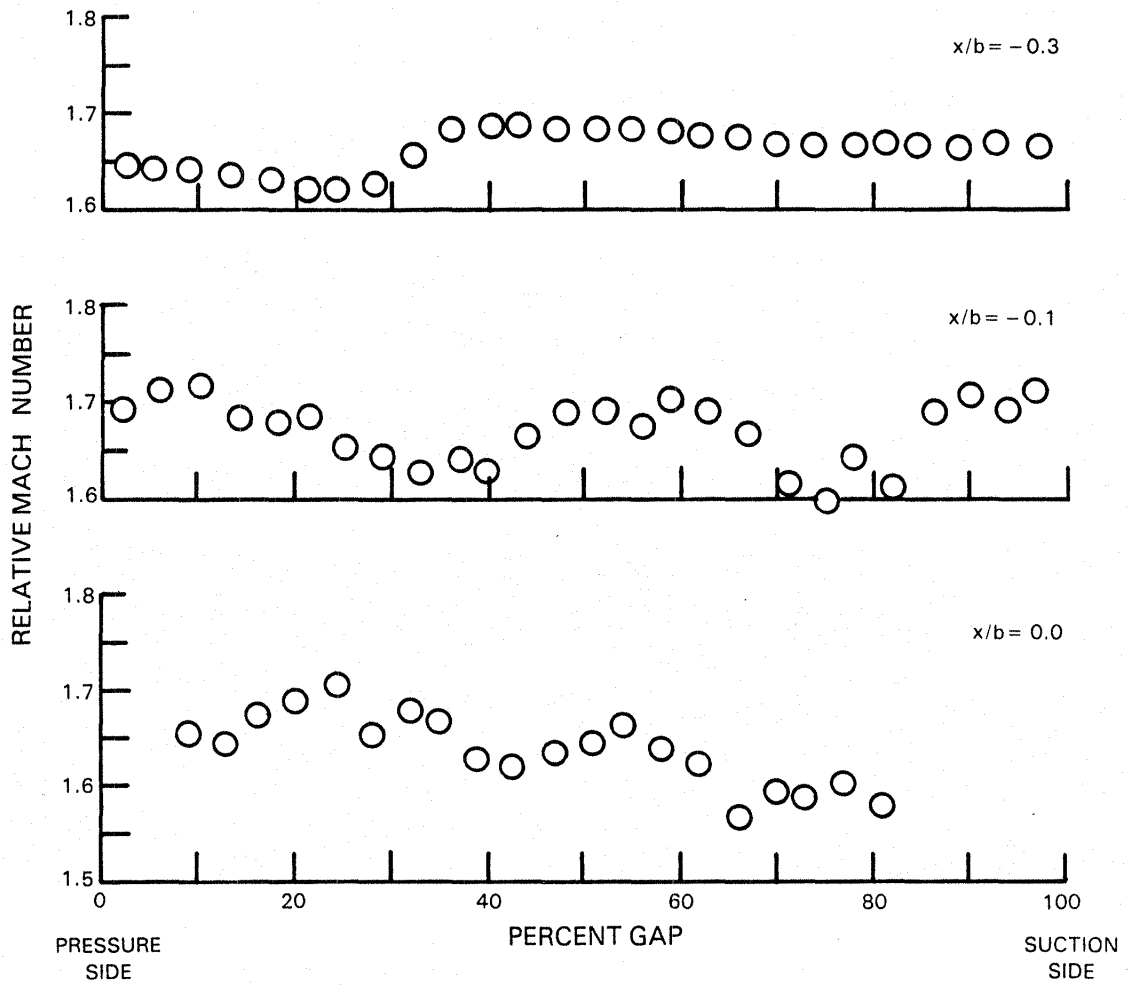

Figure 30a Mach Number Profiles at 95 Percent Span, 100 Percent Design Speed, Near Surge - Passage No. 1

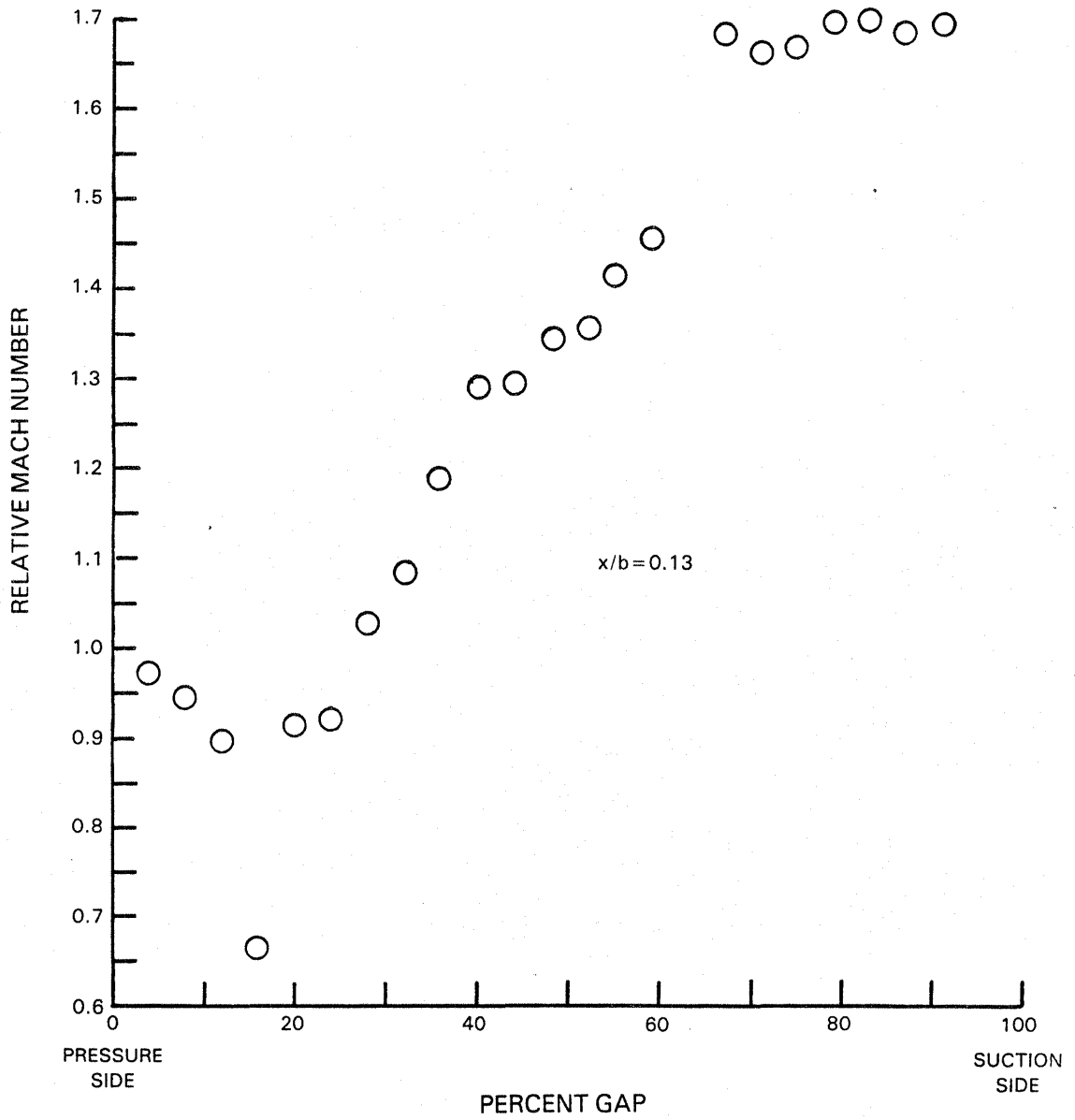

Figure 30b Mach Number Profiles at 95 Percent Span, 100 Percent Design Speed, Near Surge - Passage No. 1



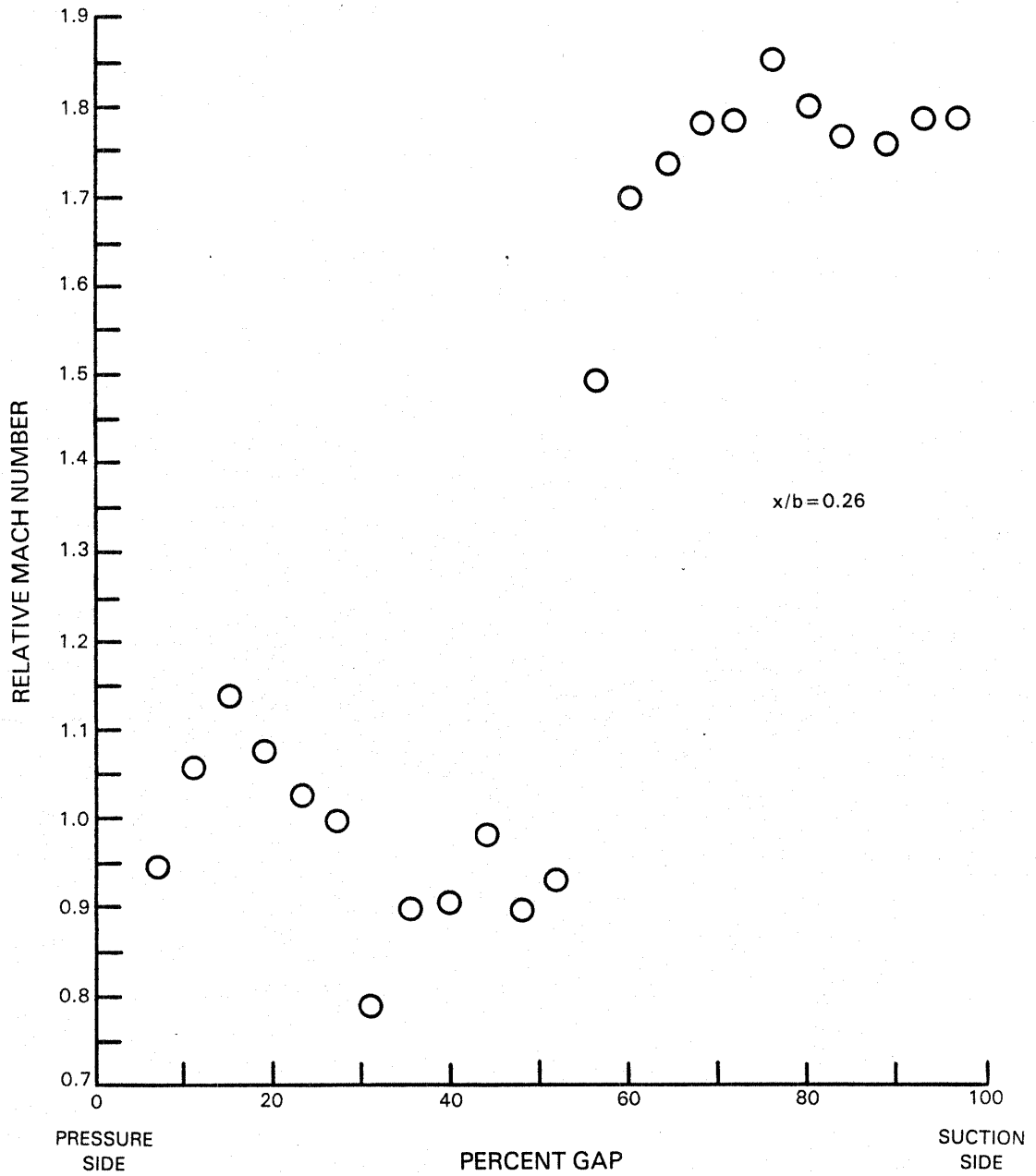

Figure 30c Mach Number Profiles at 95 Percent Span, 100 Percent Design Speed, Near Surge - Passage No. 1

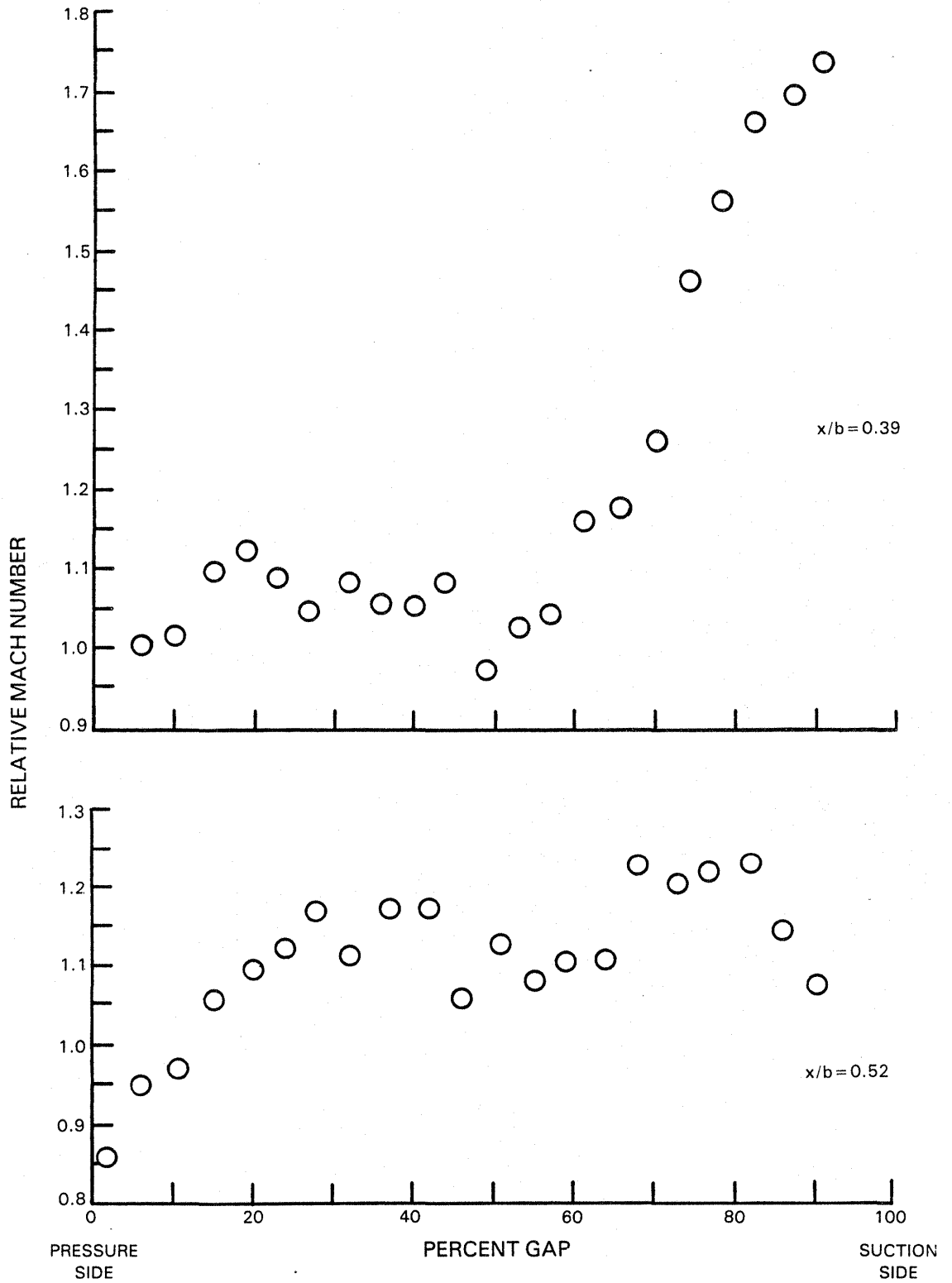

Figure 30d Mach Number Profiles at 95 Percent Span, 100 Percent Design Speed, Near Surge - Passage No. 1

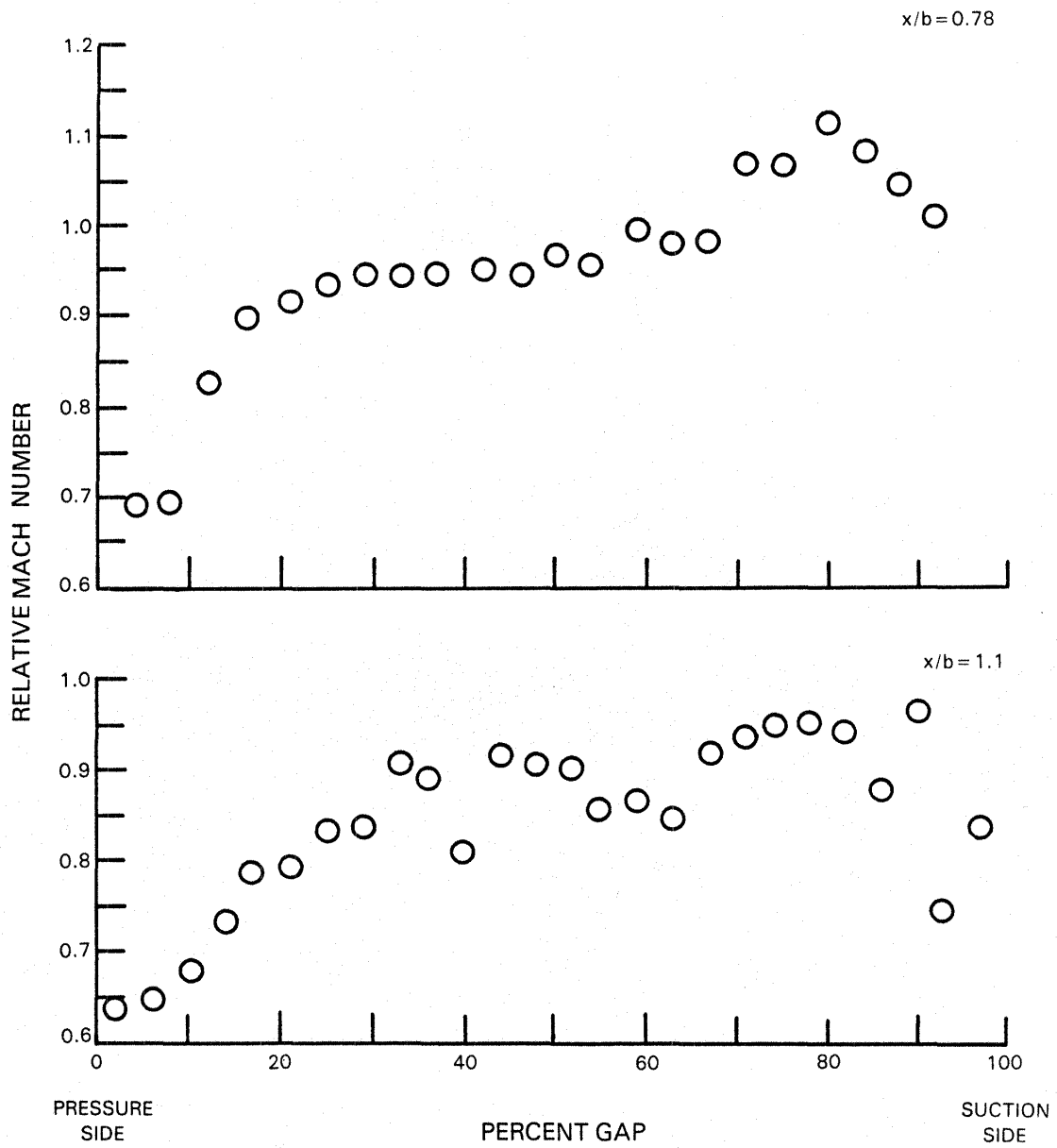

Figure 30e Mach Number Profiles at 95 Percent Span, 100 Percent Design Speed, Near Surge - Passage No. 1

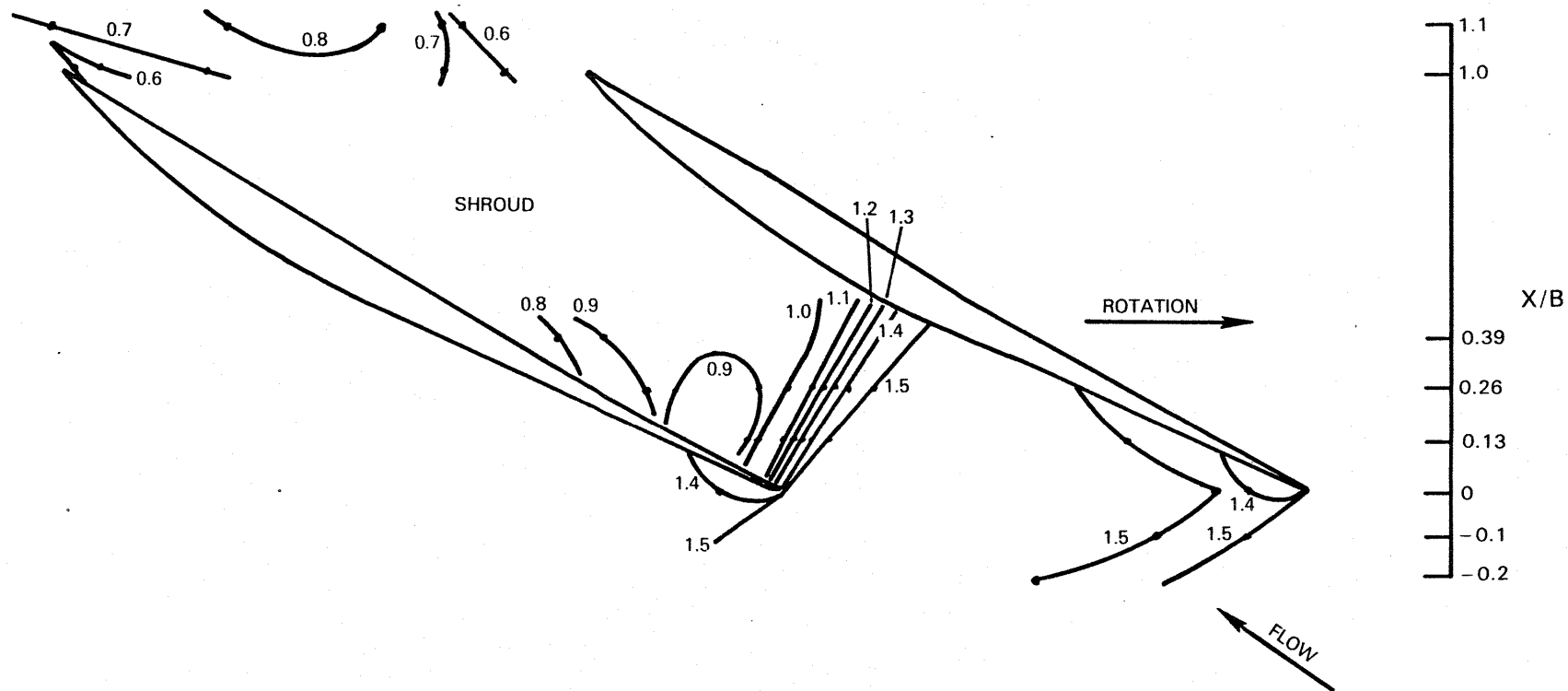

Figure 31 Mach Number Contours at 69 Percent Span, 100 Percent Design Speed, Peak Efficiency - Passage No. 1

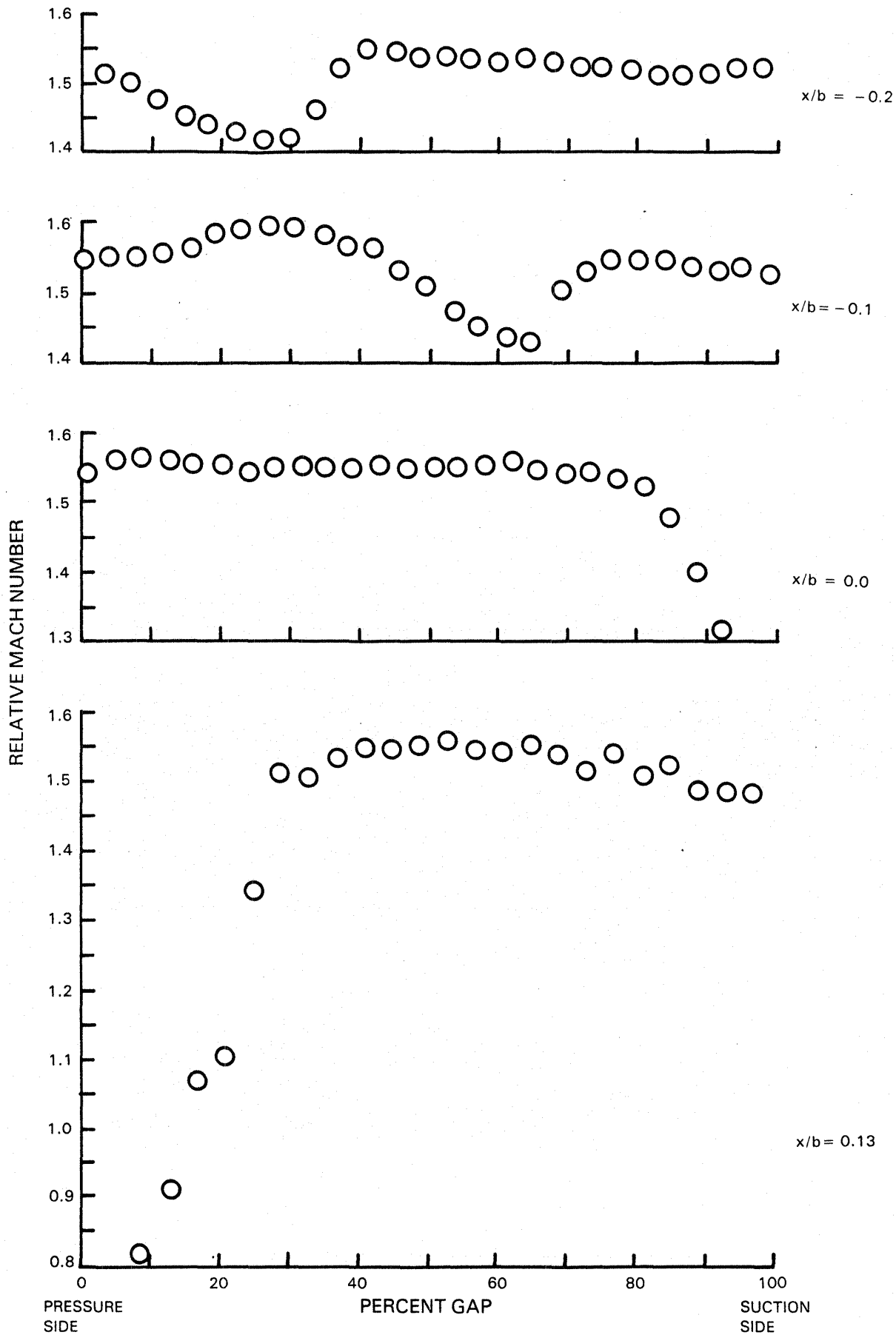

Figure 32a Mach Number Profiles at 69 Percent Span, 100 Percent Design Speed, Peak Efficiency - Passage No. 1

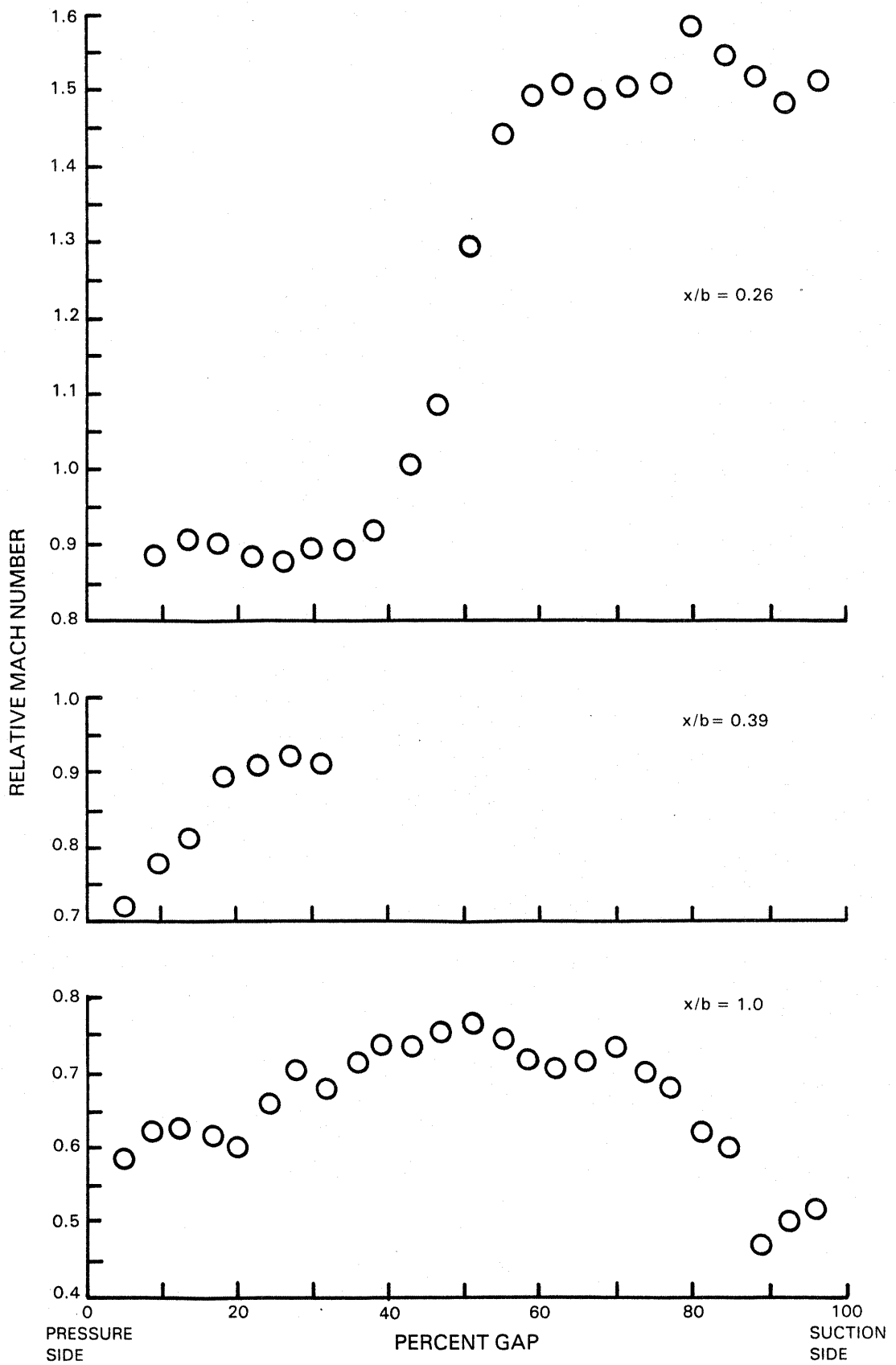

Figure 32b Mach Number Profiles at 69 Percent Span, 100 Percent Design Speed, Peak Efficiency - Passage No. 1

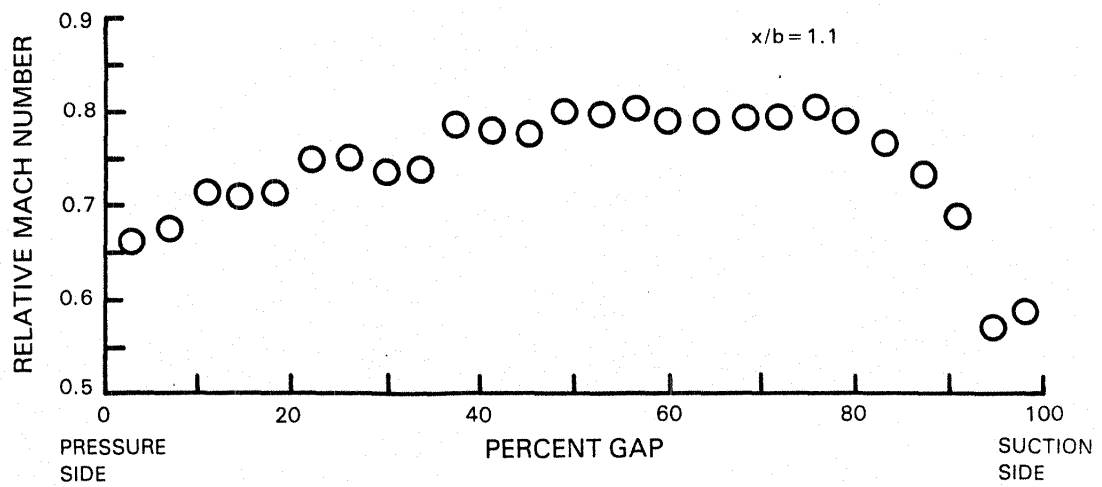

Figure 32c Mach Number Profiles at 69 Percent Span, 100 Percent Design Speed, Peak Efficiency - Passage No. 1

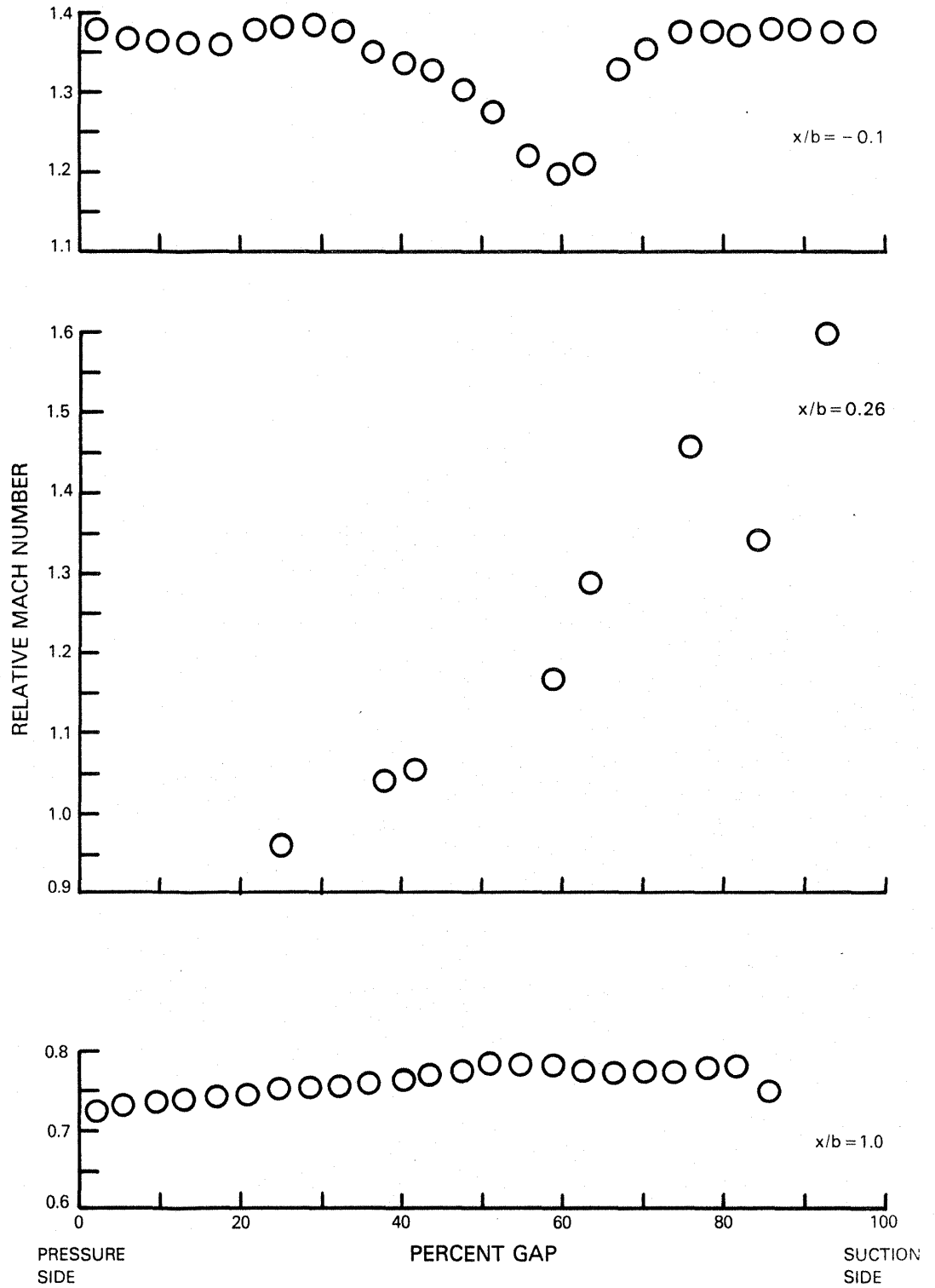

Figure 33 Mach Number Profiles at 45 Percent Span, 100 Percent Design Speed, Peak Efficiency - Passage No. 1



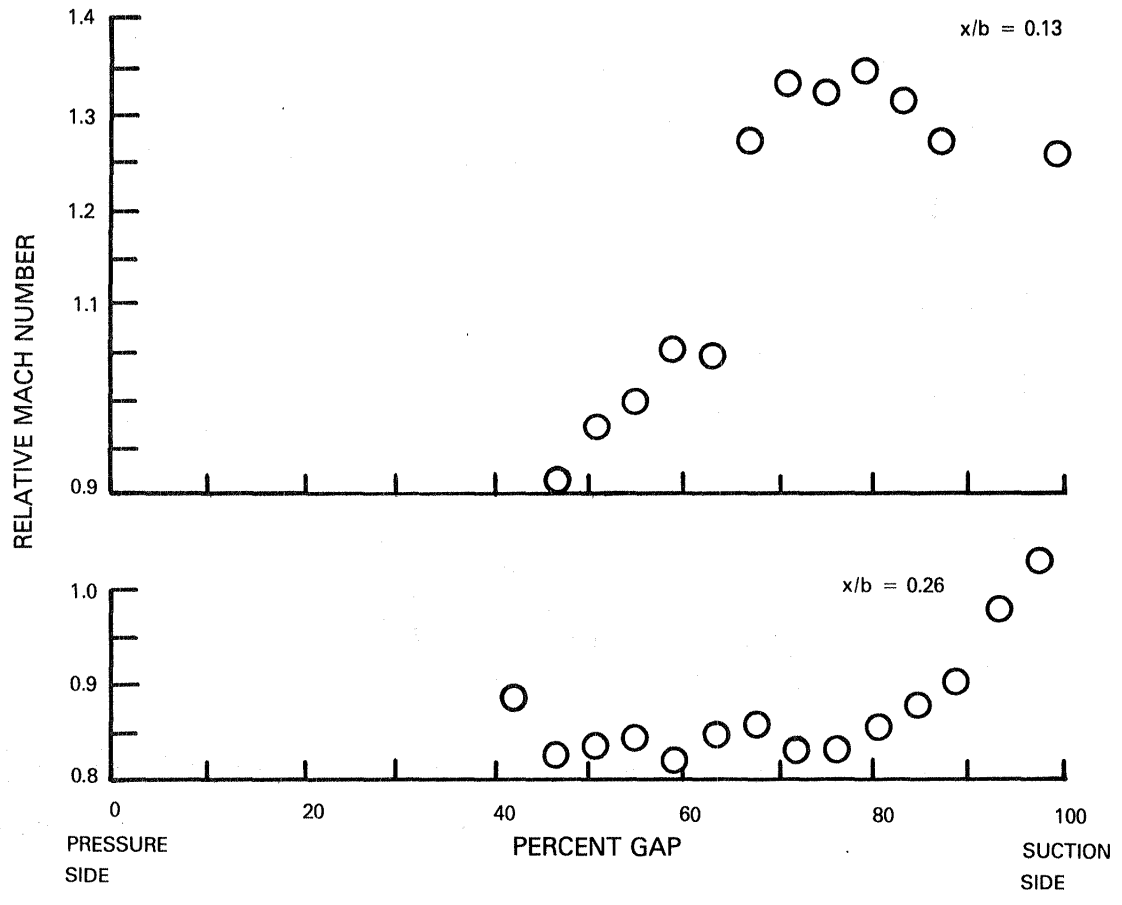

Figure 34 Mach Number Profiles at 45 Percent Span, 95 Percent Design Speed, Peak Efficiency - Passage No. 1

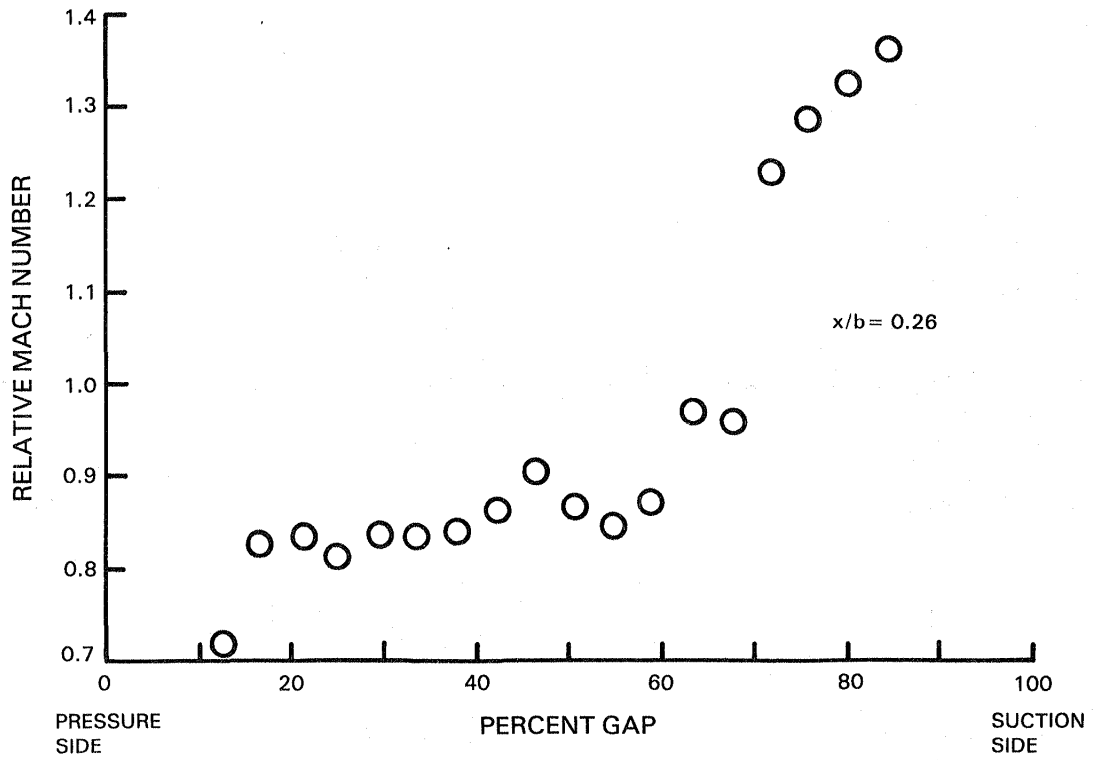

Figure 35 Mach Number Profiles at 45 Percent Span, 100 Percent Design Speed, Near Surge - Passage No. 1

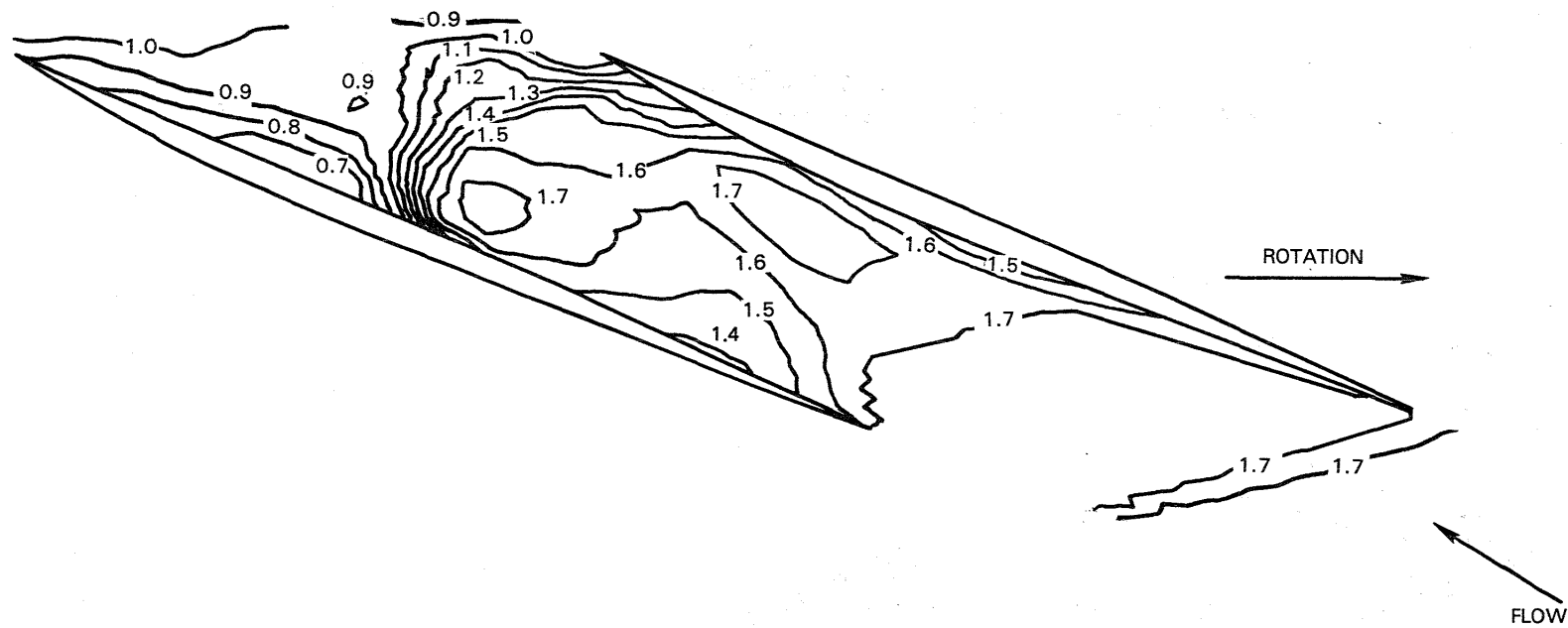

Figure 36 Mach Number Contours From Design Calculations for 95 Percent Span, 100 Percent Design Speed

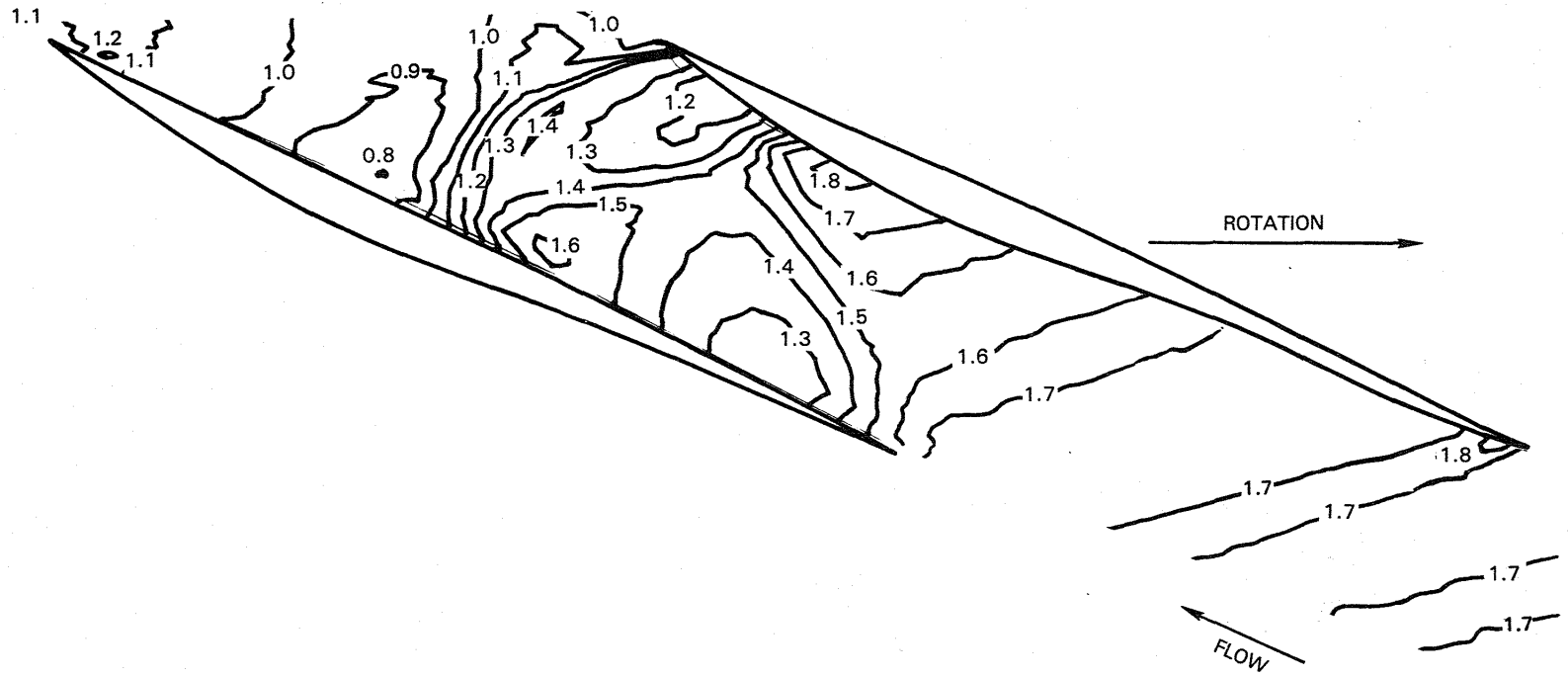

Figure 37 Mach Number Contours From Design Calculations for 85 Percent Span, 100 Percent Design Speed

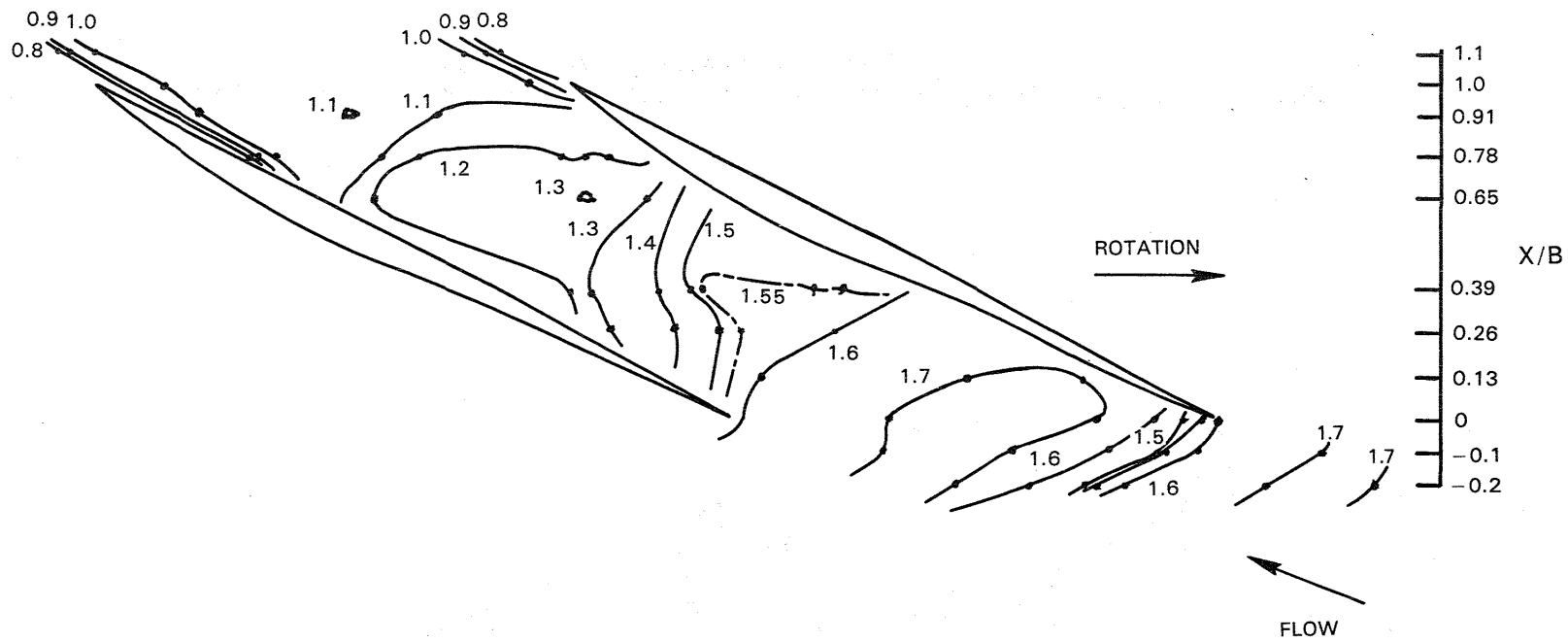

Figure 38

Mach Number Contours at 85 Percent Span, 100 Percent Design Speed, Peak Efficiency - Passage No. 15

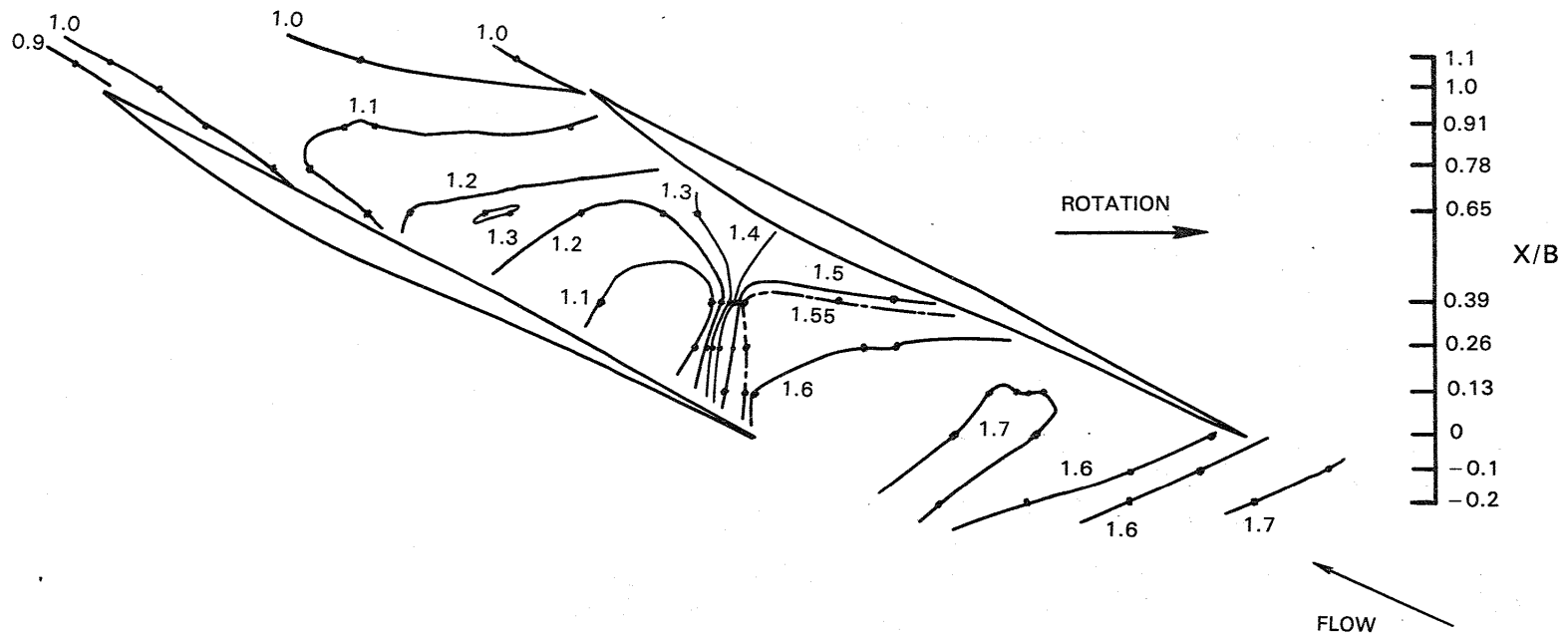

Figure 39 Mach Number Contours at 85 Percent Span, 100 Percent Design Speed, Peak Efficiency - Passage No. 31

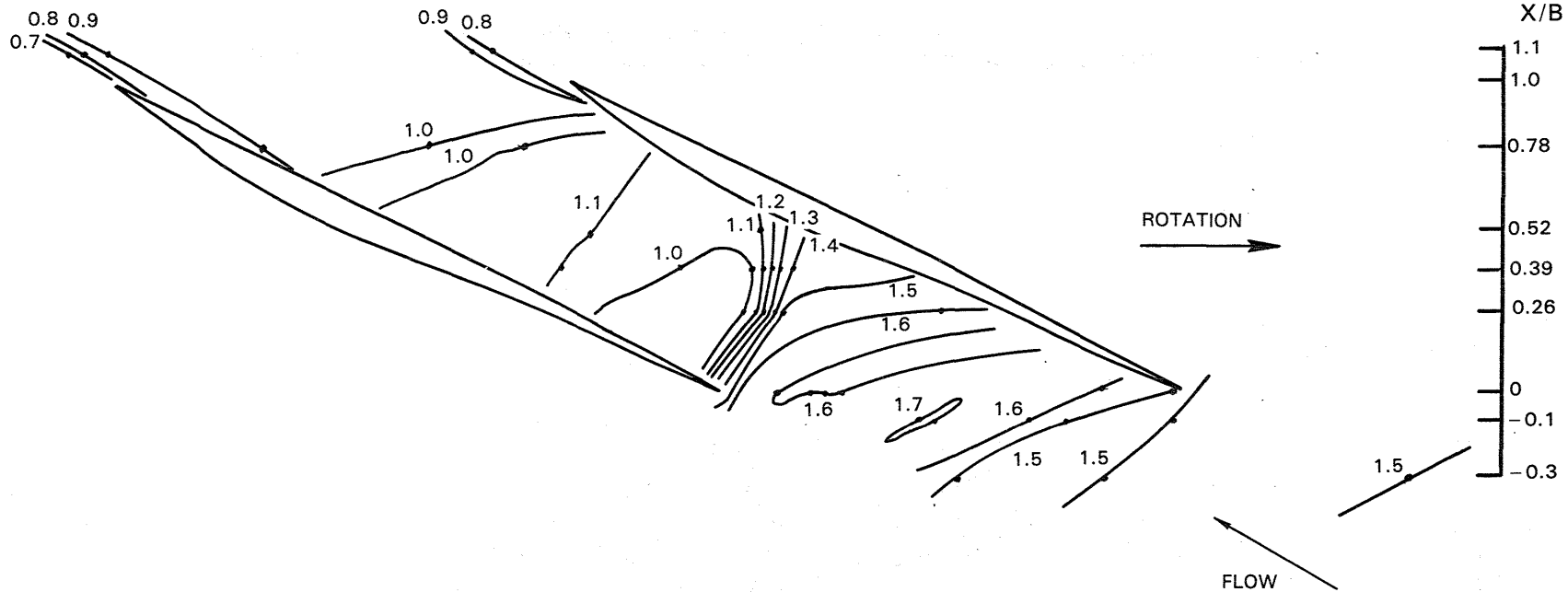

Figure 40 Mach Number Contours at 85 Percent Span, 95 Percent Design Speed, Peak Efficiency - Passage No. 15

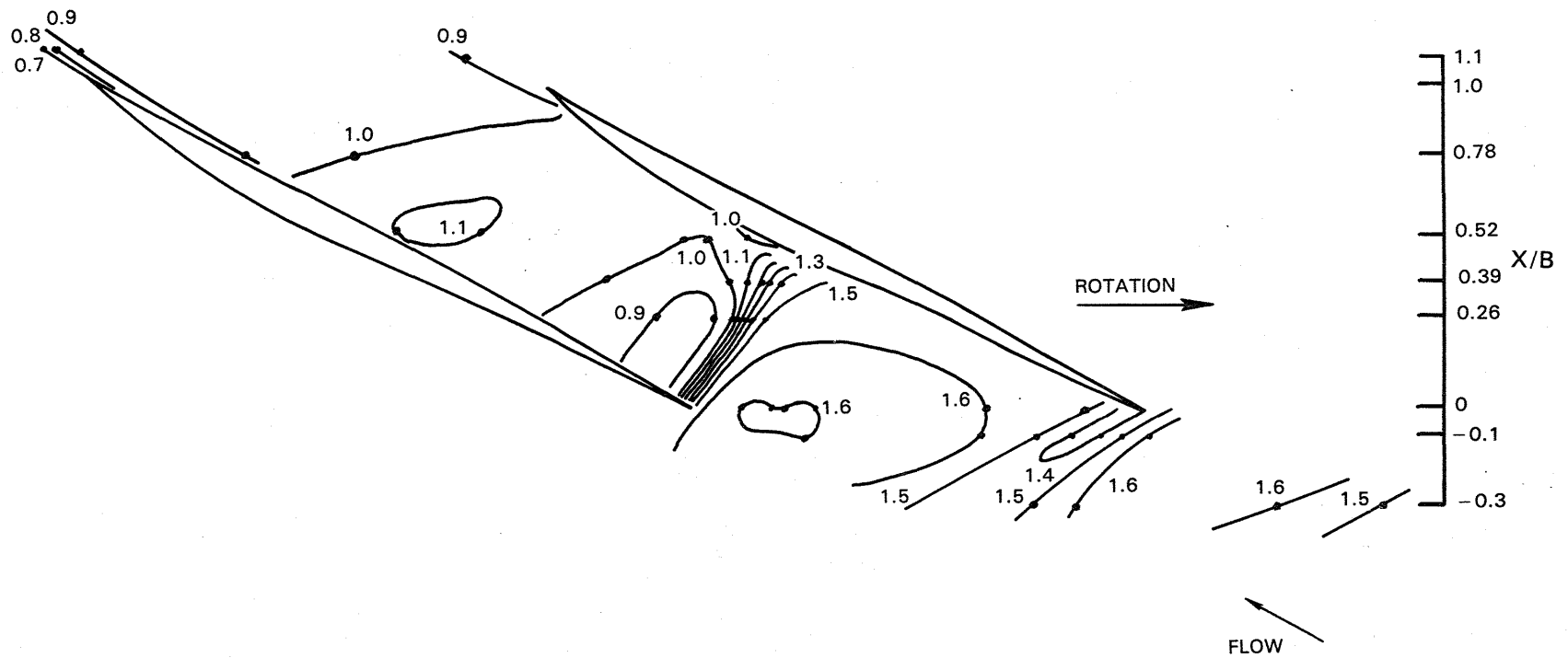

Figure 41 Mach Number Contours at 85 Percent Span, 95 Percent Design Speed, Peak Efficiency - Passage No. 31



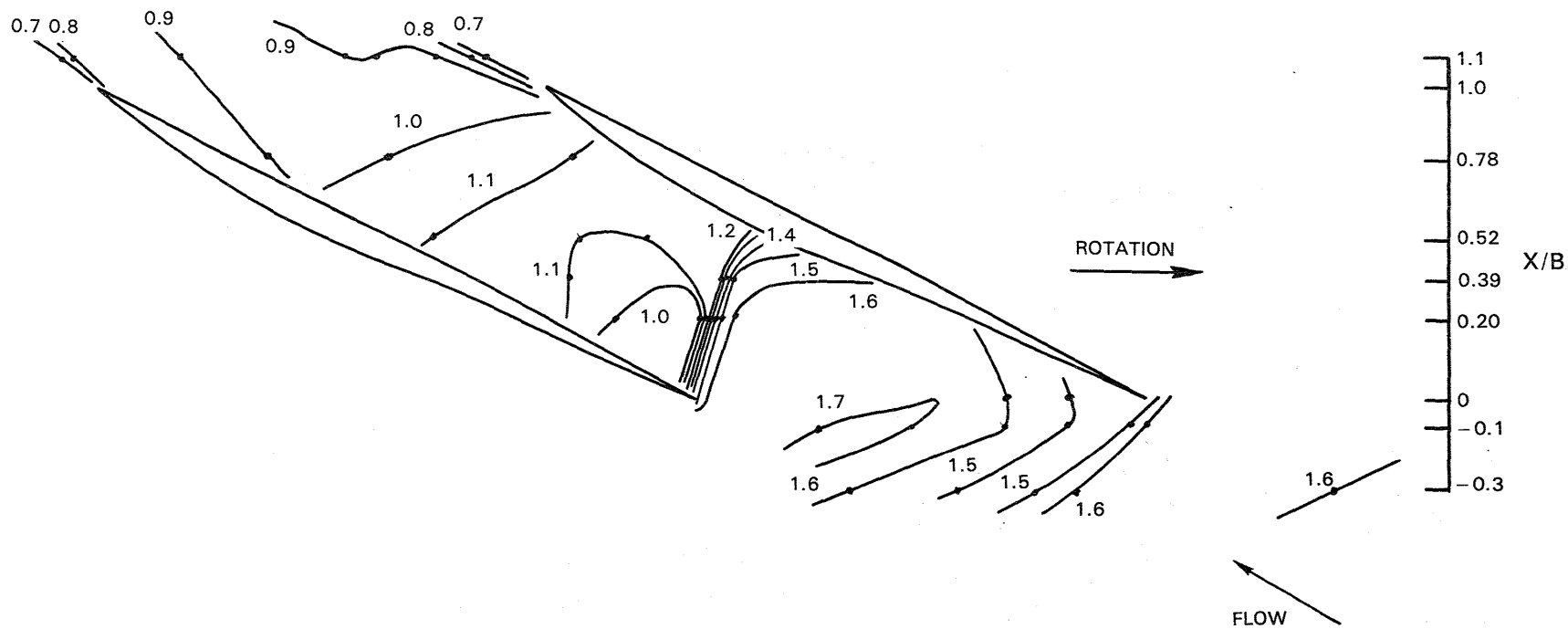

Figure 42 Mach Number Contours at 85 Percent Span, 100 Percent Design Speed, Near Surge - Passage No. 15

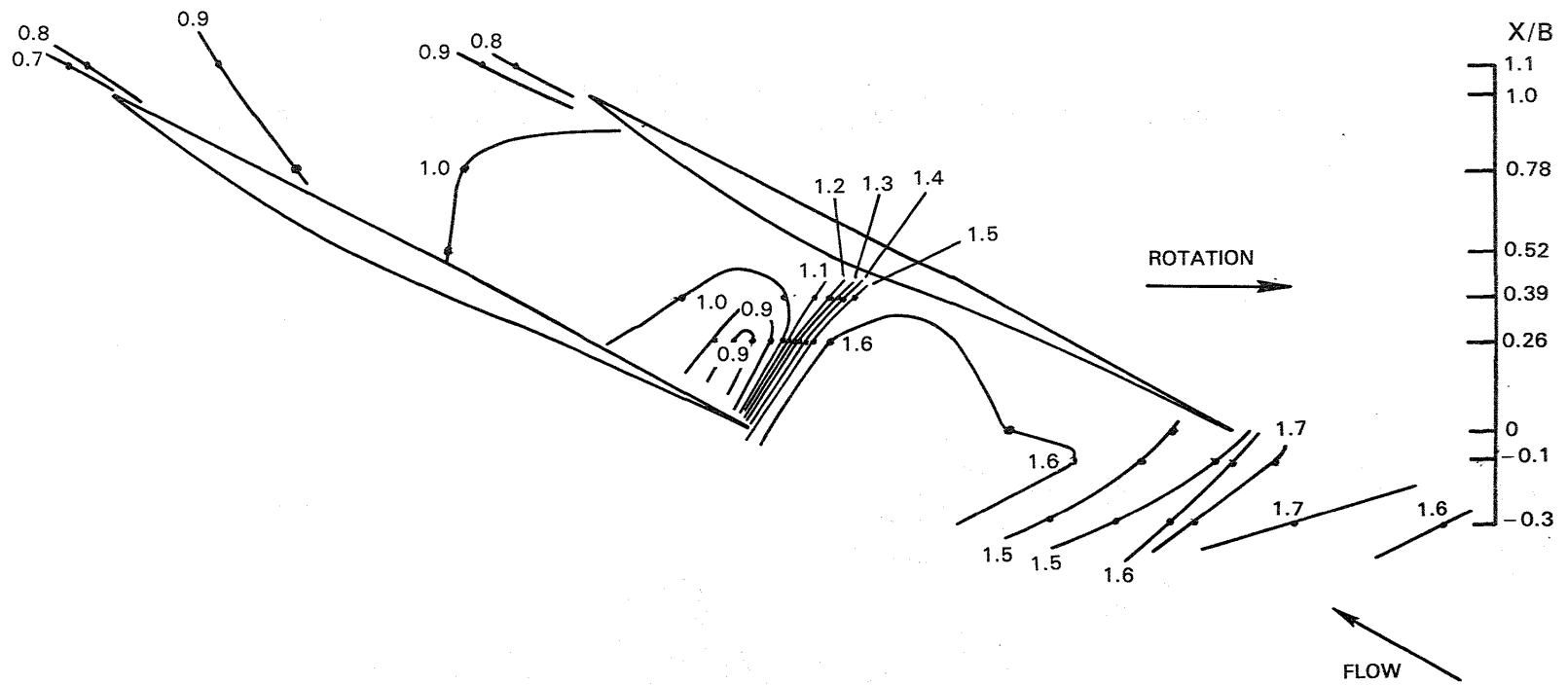

Figure 43 Mach Number Contours at 85 Percent Span, 100 Percent Design Speed, Near Surge - Passage No. 31

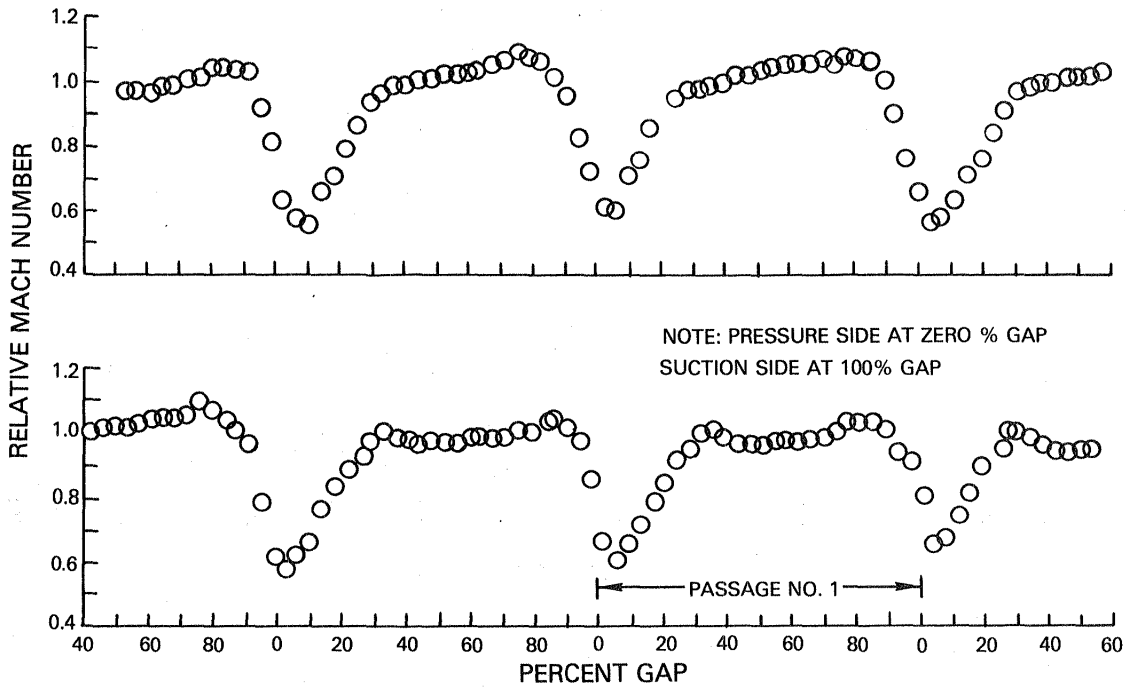

Figure 44 Relative Mach Number for Wakes at  $x/b = 1.1$  - 95 Percent Span, 100 Percent Design Speed, Peak Efficiency

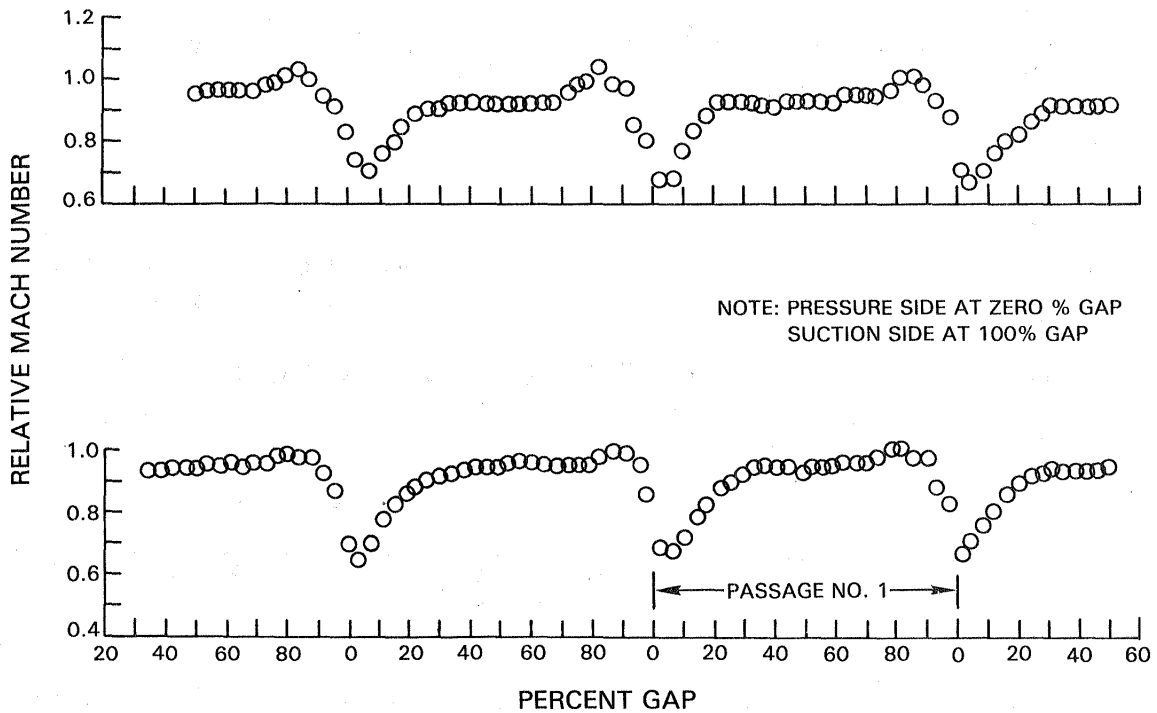

Figure 45 Relative Mach Number for Wakes at  $x/b = 1.1$  - 95 Percent Span, 95 Percent Design Speed, Peak Efficiency

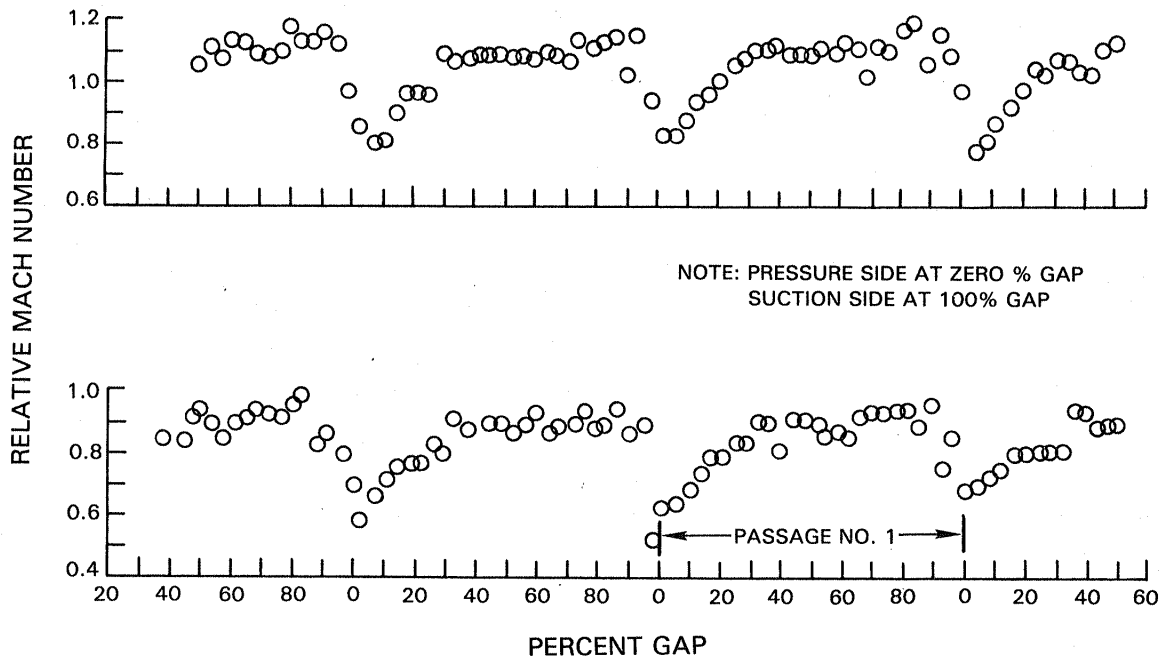

Figure 46 Relative Mach Number for Wakes at  $x/b = 1.1$  - 95 Percent Span, 100 Percent Design Speed, Near Surge

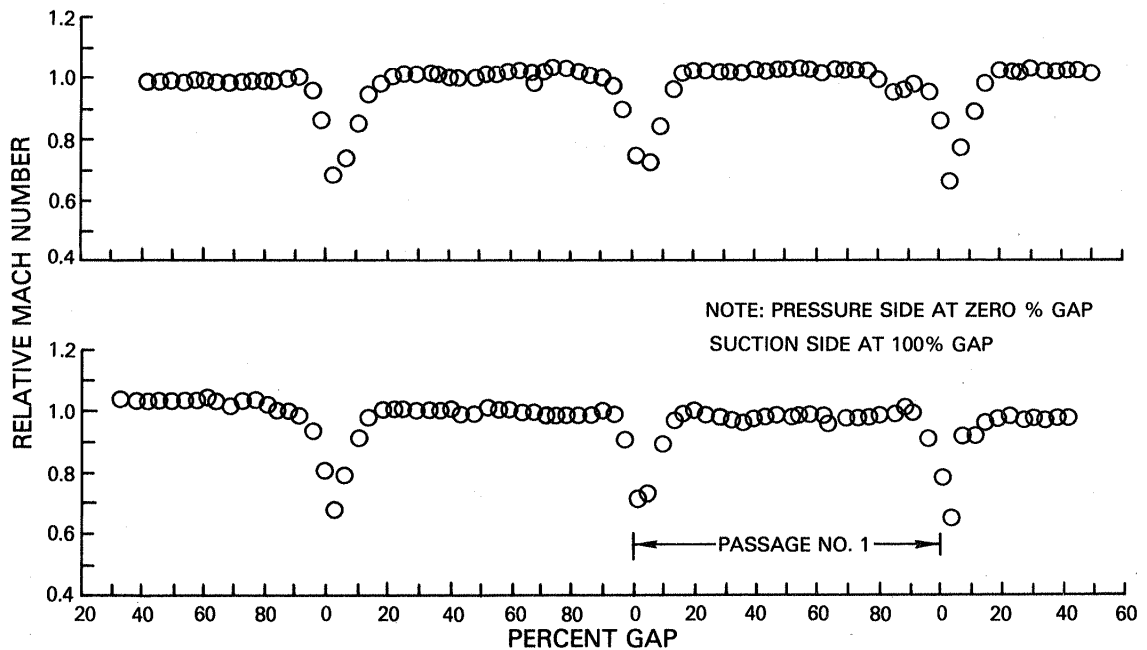

Figure 47 Relative Mach Number for Wakes at  $x/b = 1.1$  - 85 Percent Span, 100 Percent Design Speed, Peak Efficiency

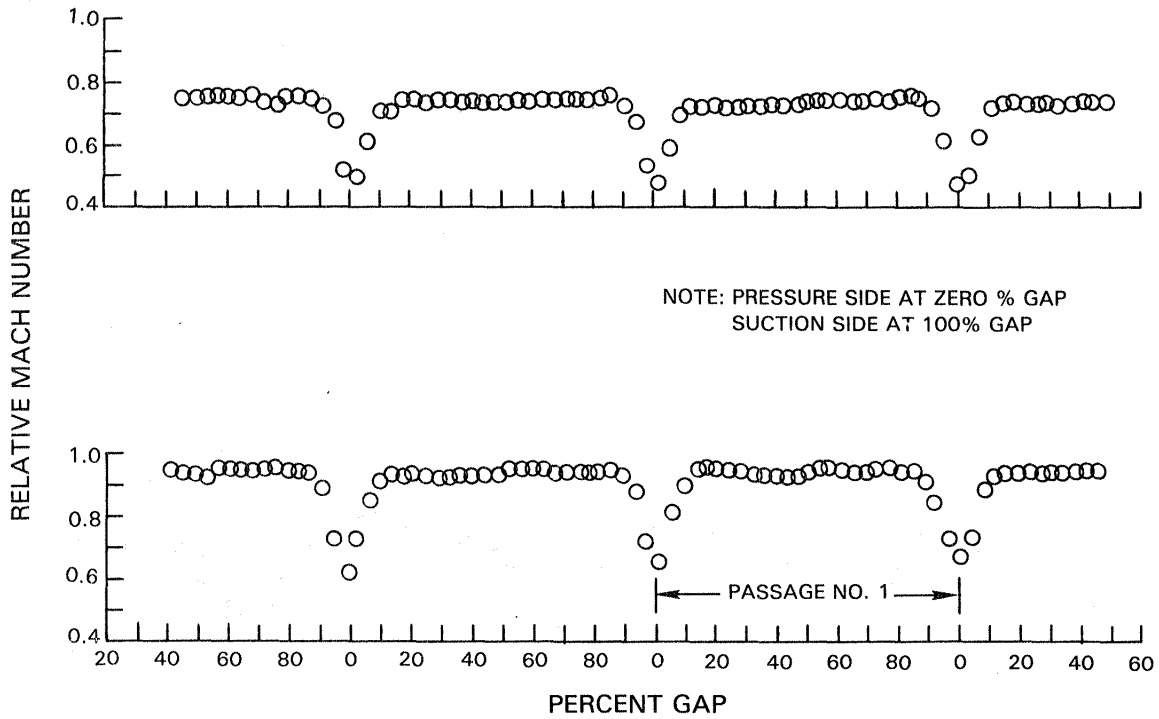

Figure 48 Relative Mach Number for Wakes at  $x/b = 1.1$  - 85 Percent Span, 95 Percent Design Speed, Peak Efficiency

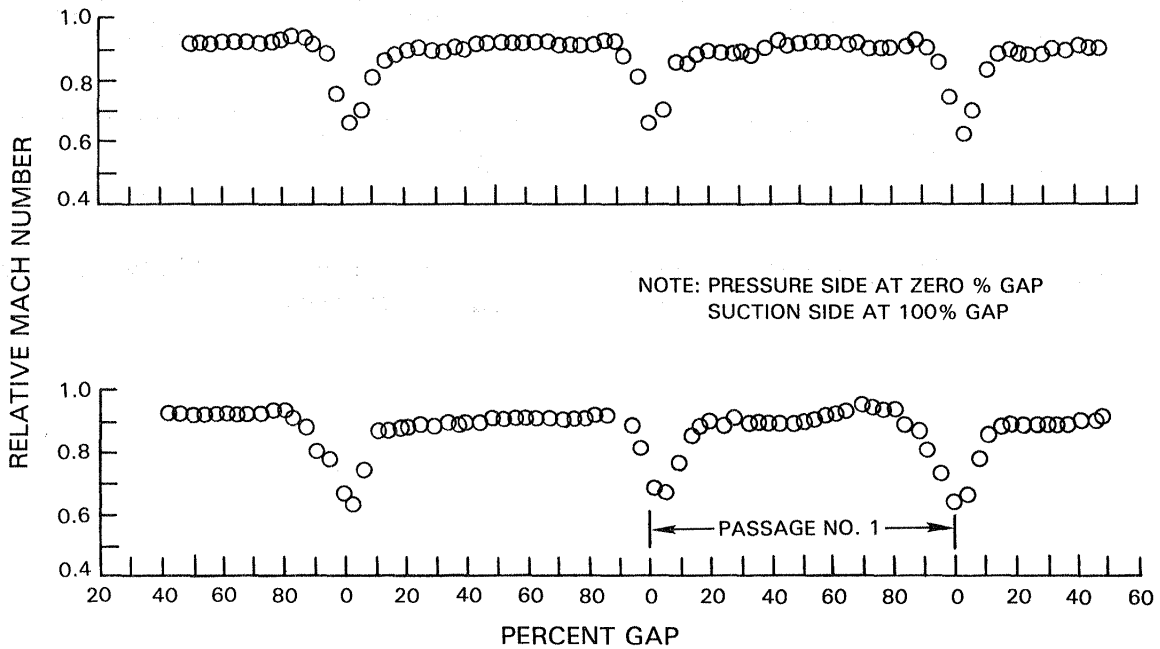

Figure 49 Relative Mach Number for Wakes at  $x/b = 1.1$  - 85 Percent Span, 100 Percent Design Speed, Near Surge

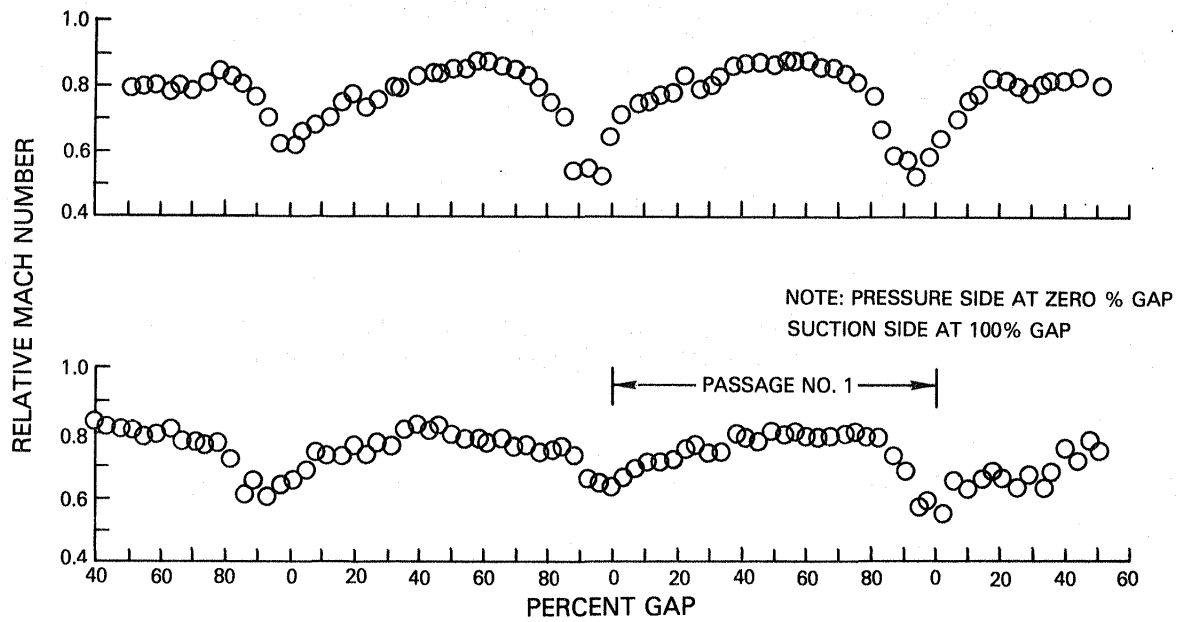

Figure 50 Relative Mach Number for Wakes at  $x/b = 1.1$  - 69 Percent Span, 100 Percent Design Speed, Peak Efficiency

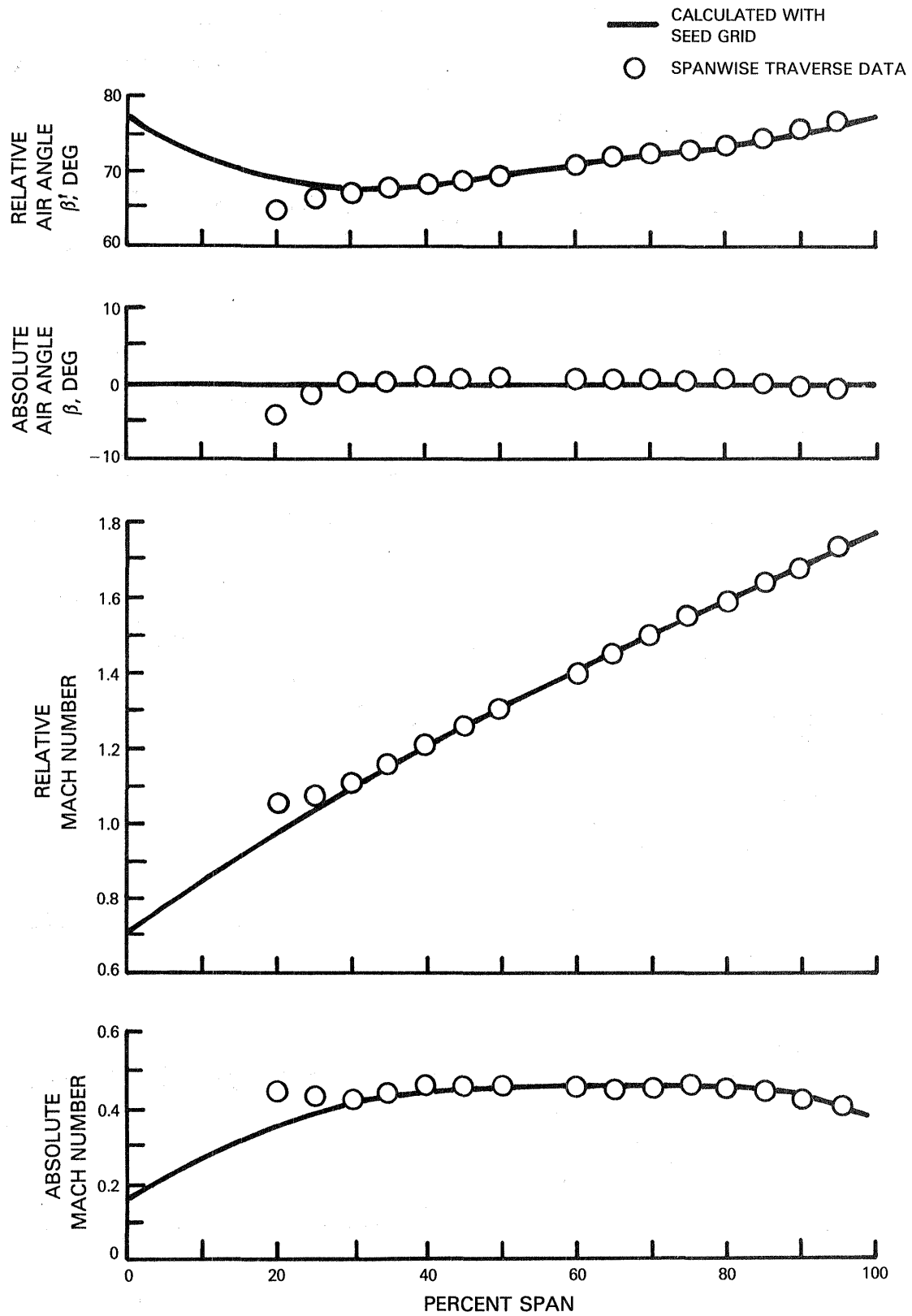

Figure 51

Laser Doppler Velocimeter Traverse at Inlet Instrumentation Plane (Station 11) - 100 Percent Design Speed, Peak Efficiency

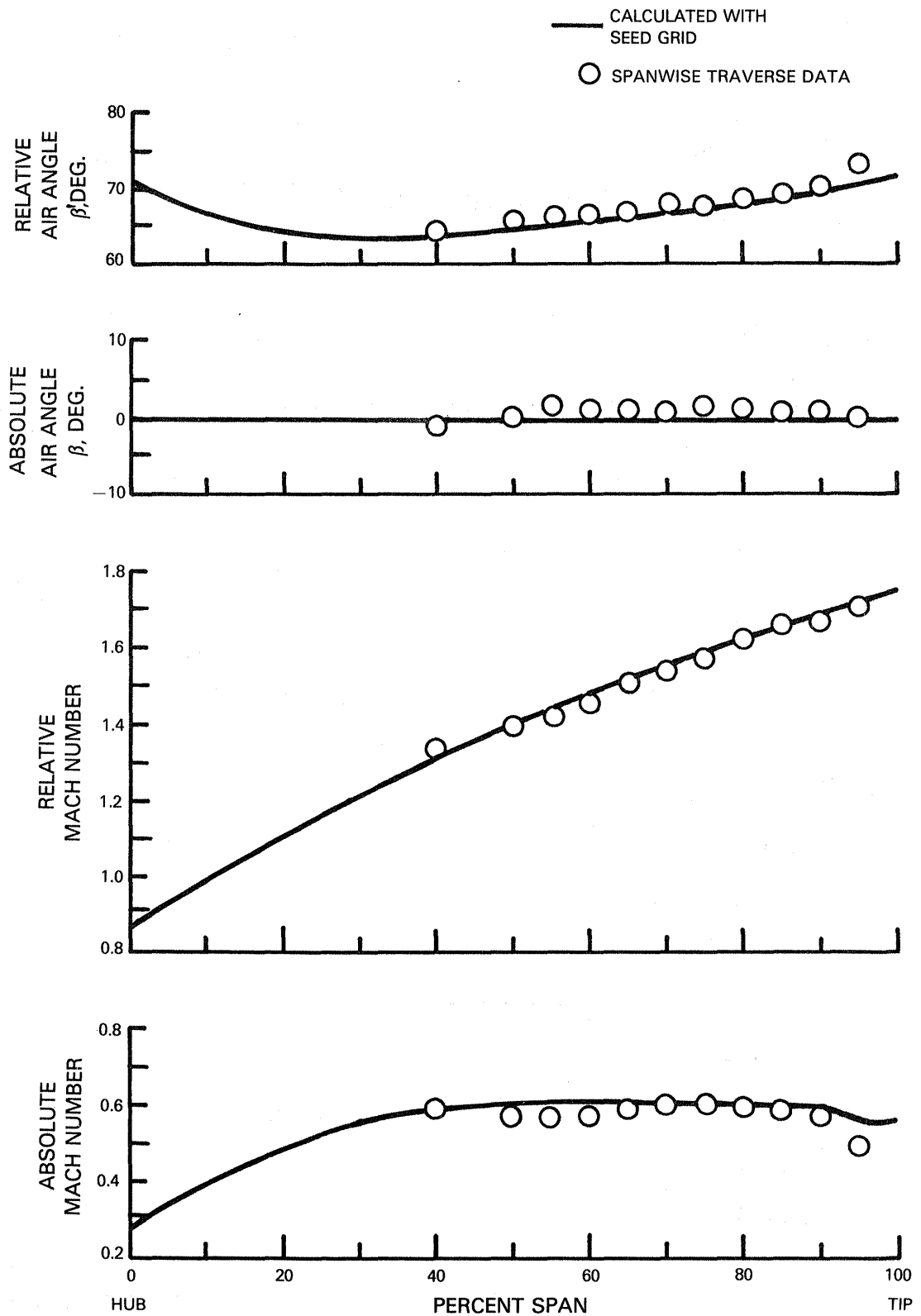

Figure 52 Laser Doppler Velocimeter Traverse at Leading Edge Plane (Station 13) - 100 Percent Design Speed, Peak Efficiency



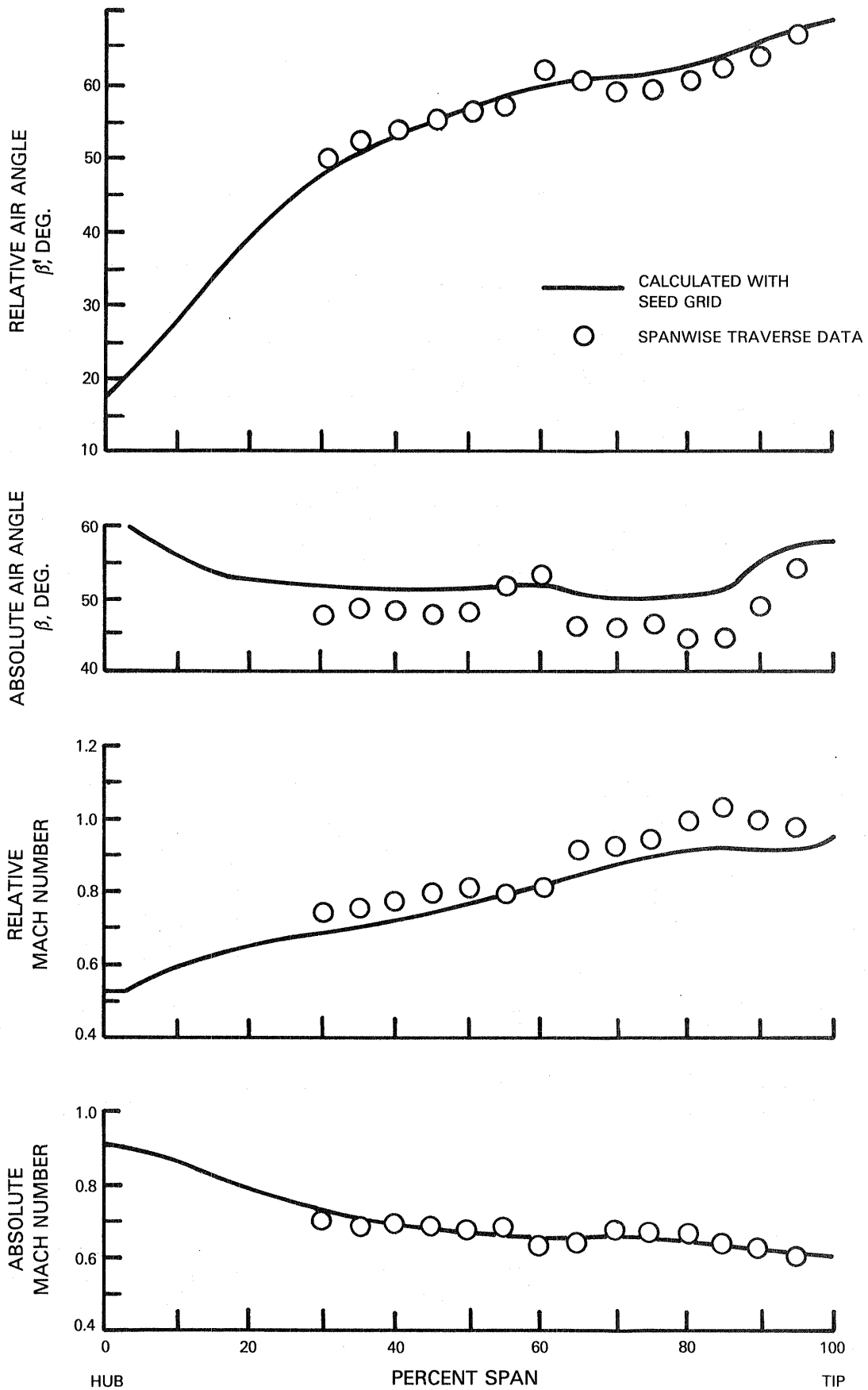
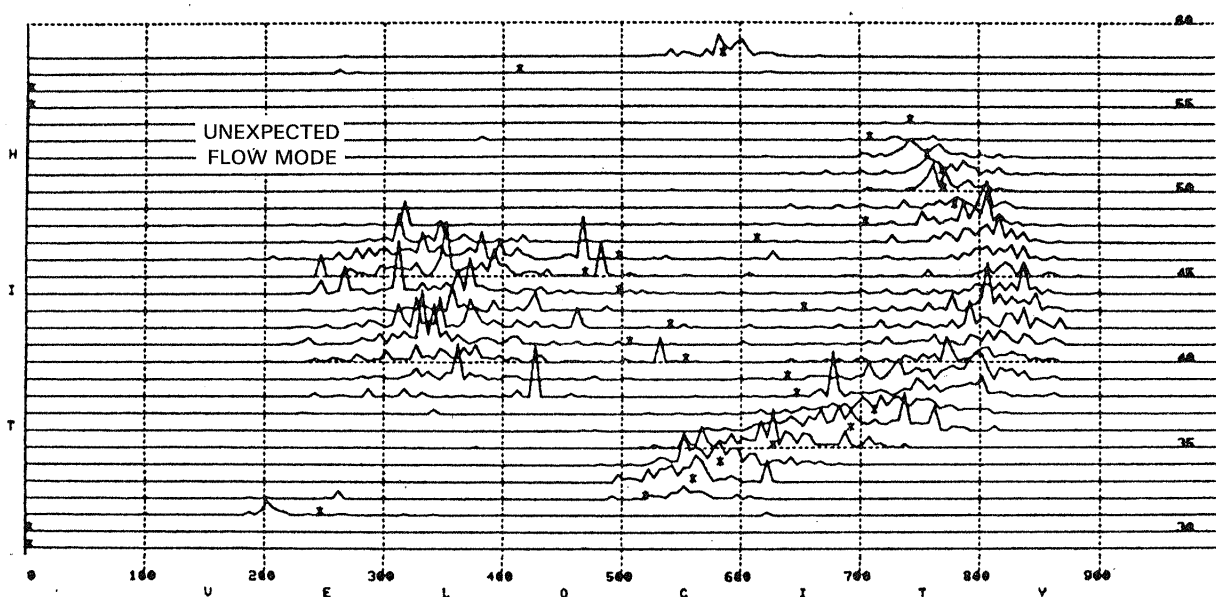
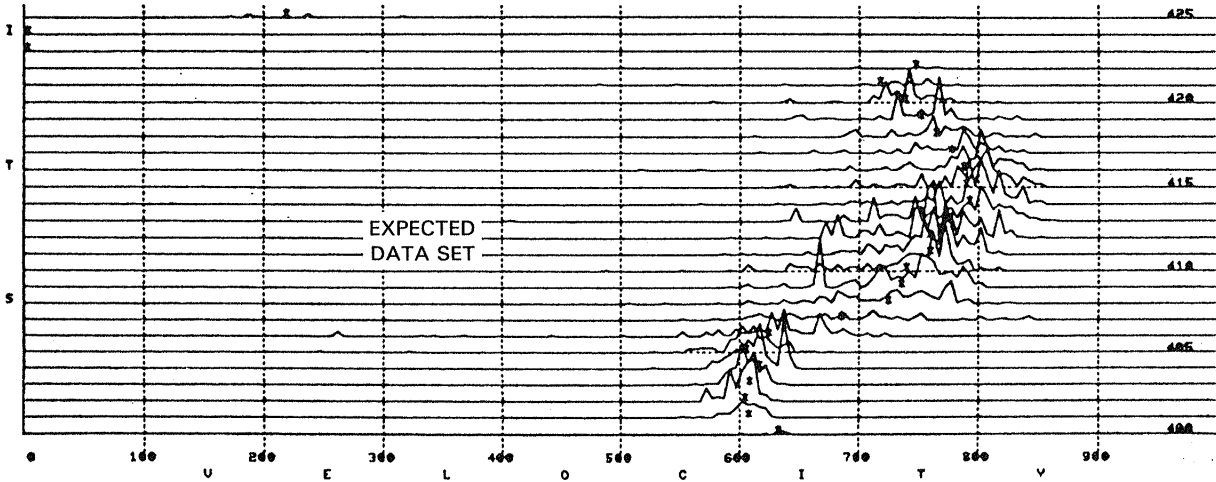

Figure 53 Laser Doppler Velocimeter Traverse at Trailing Edge Plane (Station 14) - 100 Percent Design Speed, Peak Efficiency



PASSAGE NUMBER  
1



PASSAGE NUMBER  
15

Figure 54 Velocity Histograms for Passages 1 and 15 at  $x/b = 0.52$   
 85 Percent Span, 100 Percent Design Speed, Peak Efficiency  
 Laser Fringe Orientation Angle: ZETA = 60°

**APPENDICES  
A through F  
pages 89 to 243**

**This Page Intentionally Left Blank**

## APPENDIX A

### SYMBOLS AND ABBREVIATIONS

A	area - $m^2$ (ft <sup>2</sup> )
b, b <sub>x</sub> , B	blade axial chord - cm (in.)
BETA, $\beta$	absolute air angle, $\arcsin(V_U/V)$ - degrees
BETA, measurement plane	absolute air angle, $\arctan(V_U/V_Z)$ - degrees
BETA PRIME, $\beta'$	relative air angle, $\arcsin[(U - V_U)/V']$ - degrees
C1, C2	velocity components measured by LDV - m/sec (ft/sec)
C <sub>p</sub>	specific heat at constant pressure for air - $\frac{m^2}{sec^2-K}$ (ft <sup>2</sup> /sec <sup>2</sup> -°R)
D	diffusion factor
$i_m$	incident angle, angle between inlet air direction and line tangent to blade mean camber line at leading edge - degrees
$i_{ss}$	incident angle, angle between inlet air direction and line tangent to blade suction surface at leading edge - degrees
M	absolute Mach number
M'	relative Mach number
P <sub>S</sub>	static pressure - N/m <sup>2</sup> (lbf/ft <sup>2</sup> )
P <sub>T</sub>	total pressure - N/m <sup>2</sup> (lbf/ft <sup>2</sup> )
PHI	cone angle of the flow, $\arctan(V_R/V_Z)$ - degrees
R <sub>gas</sub>	gas constant for air - $m^2/sec^2-K$ (ft <sup>2</sup> /sec <sup>2</sup> -°R)
r	radius of rig - m (ft)
T <sub>S</sub>	static temperature - K (°R)
T <sub>T</sub>	total temperature - K (°R)
T' <sub>T</sub>	stagnation temperature relative frame, varies with radius - K (°R)
U	tangential velocity of rotor blade - m/sec (ft/sec)
V	velocity in the absolute frame - m/sec (ft/sec)
V'	velocity in the relative frame - m/sec (ft/sec)

APPENDIX A (Cont'd)

$V_R$	radial flow velocity - m/sec (ft/sec)
$V_U$	tangential flow velocity - m/sec (ft/sec)
$V_Z$	axial flow velocity - m/sec (ft/sec)
$V_\theta$	tangential velocity - m/sec (ft/sec)
$W$	mass flow rate - kg/sec (lbm/sec)
$x$	axial distance from blade leading edge - cm (in.)
ZETA, ZETA1, ZETA2	fringe orientation angles measured from tangential - degrees (see Figure 13)
$\beta^*$	blade metal angle measured from axial - degrees
$\gamma$	ratio of specific heats for air
$\delta$	ratio of total pressure to standard pressure
$\delta^\circ$	deviation angle - degrees
$\eta$	efficiency
$\theta$	ratio of total temperature to standard temperature
$\sigma$	solidity
$\bar{\omega}$	total pressure loss coefficient (see Appendix B, eq. e)
SUBSCRIPTS	
RLE	rotor leading edge
RTE	rotor trailing edge
SLE	stator leading edge
STE	stator trailing edge

APPENDIX B

PERFORMANCE PARAMETERS

a) Relative Total Temperature

$$T'_{T,RLE} = T_{S,RLE} \left[ 1 + \frac{\gamma - 1}{2} (M'_{RLE})^2 \right] \quad (\text{rotor}) \text{ IN}$$

$$T'_{T,RTE} = T'_{T,RLE} + \left[ \frac{U_{RTE}^2 - U_{RLE}^2}{2C_p} \right] \quad (\text{rotor}) \text{ OUT}$$

b) Incidence angle based on mean camber line

$$i_m = \beta'_{RLE} - \beta^*_{RLE} \quad (\text{rotor})$$

$$i_m = \beta_{SLE} - \beta^*_{SLE} \quad (\text{statot})$$

Incidence angle based on suction surface metal angle

$$i_{ss} = \beta'_{RLE} - \beta^*_{ss,RLE} \quad (\text{rotor})$$

$$i_{ss} = \beta_{SLE} - \beta^*_{ss,SLE} \quad (\text{stator})$$

c) Deviation angle

$$\delta^\circ = \beta'_{RTE} - \beta^*_{RTE} \quad (\text{rotor})$$

$$\delta^\circ = \beta_{STE} - \beta^*_{STE} \quad (\text{stator})$$

d) Diffusion factor

$$D = 1 - \frac{V'_{RTE}}{V'_{RLE}} + \frac{r_{RTE} V_{\theta RTE} - r_{RLE} V_{\theta RLE}}{(r_{RTE} + r_{RLE}) \sigma V'_{RLE}} \quad (\text{rotor})$$

$$D = 1 - \frac{V_{STE}}{V_{SLE}} + \frac{r_{SLE} V_{\theta SLE} - r_{STE} V_{\theta STE}}{(r_{SLE} + r_{STE}) V_{SLE}} \quad (\text{stator})$$

APPENDIX B

PERFORMANCE PARAMETERS (Cont'd)

e) Loss coefficient

$$\bar{\omega} = \frac{P'_{T,RLE} \left[ \frac{T'_{T,RTE}}{T'_{T,RLE}} \right]^{\frac{\gamma}{\gamma-1}} - P'_{T,RTE}}{P'_{T,RLE} - P_{S,RLE}} \quad (\text{rotor})$$

$$\bar{\omega} = \frac{P_{T,SLE} - P_{T,STE}}{P_{T,SLE} - P_{S,SLE}} \quad (\text{stator})$$

f) Loss parameter

$$\frac{\bar{\omega} \cos \beta'_{RTE}}{2\sigma} \quad (\text{rotor})$$

$$\frac{\bar{\omega} \cos \beta_{STE}}{2\sigma} \quad (\text{stator})$$

g) Polytropic efficiency

$$\eta_p = \frac{\frac{\gamma-1}{\gamma} \ln \frac{P_{T,RTE}}{P_{T,RLE}}}{\ln \frac{T_{T,RTE}}{T_{T,RLE}}} \quad (\text{rotor})$$

$$\eta_p = \frac{\frac{\gamma-1}{\gamma} \ln \frac{P_{T,STE}}{P_{T,RLE}}}{\ln \frac{T_{T,STE}}{T_{T,RLE}}} \quad (\text{stage})$$



## APPENDIX B

### PERFORMANCE PARAMETERS (Cont'd)

#### h) Adiabatic Efficiency

$$\eta_{ad} = \frac{\left[ \frac{P_{T,RTE}}{P_{T,RLE}} \right]^{\frac{\gamma-1}{\gamma}} - 1}{\left[ \frac{T_{T,RTE}}{T_{T,RLE}} \right] - 1} \quad (\text{rotor})$$

$$\eta_{ad} = \frac{\left[ \frac{P_{T,STE}}{P_{T,RLE}} \right]^{\frac{\gamma-1}{\gamma}} - 1}{\left[ \frac{T_{T,STE}}{T_{T,RLE}} \right] - 1} \quad (\text{stage})$$

#### i) Surge margin

$$SM = \left[ \left( \frac{P_{T,STE}/P_{T,RLE}}{W\sqrt{\theta}/\delta} \right)_{\text{Stall}} \left( \frac{W\sqrt{\theta}/\delta}{P_{T,STE}/P_{T,RLE}} \right)_{\text{Reference or operating point}} - 1 \right]$$

**This Page Intentionally Left Blank**

## APPENDIX C

### OVERALL AND BLADE ELEMENT PERFORMANCE TABULATIONS

100 Percent Design Speed, Peak Efficiency	- Rotor Performance
100 Percent Design Speed, Peak Efficiency	- Stator Performance
95 Percent Design Speed, Peak Efficiency	- Rotor Performance
95 Percent Design Speed, Peak Efficiency	- Stator Performance
100 Percent Design Speed, Near Surge	- Rotor Performance
100 Percent Design Speed, Near Surge	- Stator Performance

APPENDIX C (cont'd)

Symbol Identification

Symbols appearing in the tables are defined as follows:

-1	condition at the airfoil leading edge.
-2	condition at the airfoil trailing edge.
SL	streamline number
V	velocity
VM	meridional velocity
VO	tangential velocity ( $V_\theta$ )
U	tangential velocity of rotor blade
RHOVM	product of density and meridional velocity
EPSI	cone angle of the flow (PHI)
B	air angle measured from axial (BETA)
M	Mach number
INCS	incident angle referenced from suction surface ( $i_s$ )
INCM	incident angle referenced from mean camber line ( $i_m$ )
DEV	deviation angle ( $\delta^\circ$ )
TURN	turning angle ( $B'-1$ minus $B'-2$ , see footnote below)
D FAC	diffusion factor (see Appendix B)
OMEGA-B TOTAL	total pressure loss coefficient ( $\bar{\omega}$ , see Appendix B)
LOSS-P TOTAL	loss parameter (see Appendix B)
P02/P01	ratio of total pressures at trailing and leading edges
T02/T01	ratio of total temperatures at trailing and leading edges
%EFF-A TOTAL	rotor adiabatic efficiency, percent (see Appendix B)

---

Prime symbols indicate a quantity in the rotating frame. Nonprimed symbols indicate the stationary frame.

### Symbol Identification (Cont'd)

%EFF-P TOTAL	rotor polytropic efficiency, percent (see Appendix B)
PO/PO STAGE	ratio of total pressures at stator trailing edge and rotor leading edge
TO/TO STAGE	ratio of total temperatures at stator trailing edge and rotor leading edge
%EFF-A TOT-STG	stage adiabatic efficiency (see Appendix B)
%EFF-P TOT-STG	stage polytropic efficiency (see Appendix B)
PCT TE SPAN	percent span at trailing edge measured from hub to tip
NCORR INLET	corrected rotor angular velocity (viz, actual RPM divided by the square root of upstream $T_T$ over 288.2K)
WCORR INLET	corrected flow (viz, actual mass flow divided by the square root of upstream $T_T$ over 288.2K)
WC1/A1	corrected flow per unit area at rotor leading edge

Spanwise mass averages for a few of these quantities are given at the bottom of the tables.

## AIRFOIL AERODYNAMIC SUMMARY PRINT

100 PERCENT DESIGN SPEED, PEAK EFFICIENCY (ROTOR PERFORMANCE)

RUN NO 114 SPEED CODE 10 POINT NO 14

SL	V-1	V-2	VM-1	VM-2	VO-1	VO-2	U-1	U-2	V'-1	V'-2	VO'-1	VO'-2	RHOVM-1	RHOVM-2	EPSI-1	EPSI-2
	M/SEC	M/SEC	M/SEC	M/SEC	M/SEC	M/SEC	M/SEC	M/SEC	M/SEC	M/SEC	M/SEC	M/SEC	KG/M2 SEC	KG/M2 SEC	RADIAN	RADIAN
1	118.0	314.5	118.0	177.7	0.0	259.5	286.3	332.4	309.6	192.1	-286.3	-72.9	103.97	229.16	0.4777	0.5083
2	138.5	305.9	138.5	184.0	0.0	244.4	304.6	341.9	334.6	208.2	-304.6	-97.4	121.05	241.14	0.3808	0.4399
3	156.7	292.3	156.7	182.2	0.0	228.6	322.5	351.3	358.6	219.7	-322.5	-122.8	135.48	241.19	0.2948	0.3690
4	185.7	257.8	185.7	160.5	0.0	201.7	369.6	379.8	413.6	239.8	-369.6	-178.1	155.48	214.08	0.0997	0.1828
5	193.0	239.8	193.0	149.6	0.0	187.4	422.1	417.7	464.1	274.7	-422.1	-230.3	159.37	199.30	-0.0759	0.0094
6	194.3	234.2	194.3	144.7	0.0	184.2	445.7	436.7	486.2	291.0	-445.7	-252.5	160.51	192.38	-0.1381	-0.0664
7	194.6	235.0	194.6	148.7	0.0	182.0	456.9	446.2	496.6	303.2	-456.9	-264.2	160.89	198.35	-0.1666	-0.1040
8	194.2	236.4	194.2	152.1	0.0	181.0	468.1	455.7	506.8	314.0	-468.1	-274.7	160.91	203.57	-0.1974	-0.1411
9	190.3	234.4	190.3	147.9	0.0	181.9	500.9	484.1	535.9	336.5	-500.9	-302.3	159.61	198.13	-0.2828	-0.2519
10	185.8	232.1	185.8	138.0	0.0	186.6	511.2	493.6	543.9	336.6	-511.2	-307.0	156.18	183.68	-0.3051	-0.2852
11	179.7	228.8	179.7	127.5	0.0	190.0	520.9	503.1	551.1	338.1	-520.9	-313.1	151.11	168.83	-0.3193	-0.3145

SL	B-1	B-2	B'-1	B'-2	M-1	M-2	M'-1	M'-2	INCS	INCM	DEV	TURN	D FAC	OMEGA-B	LOSS-P	PO2/	%EFF-A	%EFF-P
	DEGREE	DEGREE	DEGREE	DEGREE					DEGREE	DEGREE	DEGREE	DEGREE		TOTAL	TOTAL	PO1	TOTAL	TOTAL
1	0.0	55.2	66.98	22.01	0.3638	0.8982	0.9548	0.5485	1.90	5.99	10.07	44.96	0.5783	0.0221	0.0043	2.6181	98.97	99.10
2	0.0	53.0	64.95	27.86	0.4293	0.8739	1.0371	0.5948	1.22	4.93	10.07	37.09	0.5607	0.0222	0.0044	2.5457	98.76	98.91
3	0.0	51.5	63.57	34.05	0.4883	0.8338	1.1172	0.6267	1.13	4.52	10.60	29.52	0.5540	0.0407	0.0079	2.4377	97.35	97.66
4	0.0	51.6	63.19	48.14	0.5840	0.7284	1.3012	0.6776	1.29	3.57	12.34	15.05	0.5574	0.1104	0.0196	2.2307	90.71	91.69
5	0.0	51.3	65.44	56.93	0.6088	0.6713	1.4640	0.7687	1.27	3.12	11.36	8.51	0.5279	0.1575	0.0254	2.1594	84.75	86.29
6	0.0	51.6	66.43	59.98	0.6132	0.6521	1.5345	0.8102	1.29	3.02	9.69	6.45	0.5159	0.1858	0.0285	2.1375	81.28	83.15
7	0.0	50.5	66.90	60.39	0.6142	0.6536	1.5676	0.8432	1.45	3.13	8.01	6.51	0.5014	0.1842	0.0283	2.1491	81.15	83.05
8	0.0	49.6	67.42	60.73	0.6129	0.6566	1.5995	0.8720	1.90	3.45	7.13	6.69	0.4904	0.1860	0.0286	2.1647	80.73	82.69
9	0.0	50.5	69.09	63.60	0.5997	0.6452	1.6886	0.9262	1.95	3.37	5.13	5.49	0.4771	0.2242	0.0316	2.1751	76.16	78.59
10	0.0	53.2	69.89	65.51	0.5845	0.6345	1.7110	0.9200	1.79	3.16	4.98	4.39	0.4864	0.2543	0.0331	2.1837	73.20	75.94
11	0.0	55.9	70.83	67.66	0.5640	0.6215	1.7297	0.9182	1.79	3.12	5.05	3.17	0.4912	0.2753	0.0325	2.1999	71.28	74.24

SL	V-1	V-2	VM-1	VM-2	VO-1	VO-2	U-1	U-2	V'-1	V'-2	VO'-1	VO'-2	RHOVM-1	RHOVM-2	EPSI-1	EPSI-2	PCT TE
	FT/SEC	FT/SEC	FT/SEC	FT/SEC	FT/SEC	FT/SEC	FT/SEC	FT/SEC	FT/SEC	FT/SEC	FT/SEC	FT/SEC	LBM/FT2SEC	LBM/FT2SEC	DEGREE	DEGREE	SPAN
1	387.0	1031.9	387.0	583.0	0.0	851.4	939.3	1090.5	1015.9	630.1	-939.3	-239.1	21.29	46.93	27.372	29.124	0.0500
2	454.5	1003.8	454.5	603.8	0.0	801.9	999.5	1121.6	1097.9	683.2	-999.5	-319.7	24.79	49.39	21.816	25.204	0.1000
3	514.3	959.1	514.3	597.8	0.0	750.0	1058.3	1152.7	1176.6	720.8	-1058.3	-402.7	27.75	49.40	16.893	21.145	0.1500
4	609.1	845.7	609.1	526.6	0.0	661.7	1212.8	1246.1	1357.2	786.7	-1212.8	-584.4	31.84	43.85	5.714	10.476	0.3000
5	633.2	786.9	633.2	491.0	0.0	614.9	1384.8	1370.6	1522.7	901.2	-1384.8	-755.7	32.64	40.82	-4.347	0.540	0.5000
6	637.5	768.6	637.5	474.8	0.0	604.3	1462.3	1432.8	1595.3	954.9	-1462.3	-828.5	32.87	39.40	-7.911	-3.807	0.6000
7	638.5	771.0	638.5	487.8	0.0	597.1	1499.2	1464.0	1629.5	994.7	-1499.2	-866.9	32.95	40.62	-9.548	-5.961	0.6500
8	637.2	775.7	637.2	499.1	0.0	593.8	1536.0	1495.1	1662.9	1030.2	-1536.0	-901.2	32.96	41.69	-11.309	-8.083	0.7000
9	624.4	769.2	624.4	485.4	0.0	596.7	1643.5	1588.5	1758.2	1104.2	-1643.5	-991.8	32.69	40.58	-16.204	-14.433	0.8500
10	609.6	761.6	609.6	452.9	0.0	612.3	1677.1	1619.6	1784.5	1104.4	-1677.1	-1007.3	31.99	37.62	-17.481	-16.343	0.9000
11	589.6	750.8	589.6	418.3	0.0	623.5	1709.2	1650.7	1808.0	1109.2	-1709.2	-1027.3	30.95	34.58	-18.294	-18.021	0.9500

	WCI/A1	WCI/A1	T02/T01	P02/P01	%EFF-A	%EFF-P
	LBM/SEC	KG/SEC			ROTOR	ROTOR
	SQFT	SQM				
	38.73	188.99	1.3062	2.2486	85.09	86.67

AIRFOIL AERODYNAMIC SUMMARY PRINT

100 PERCENT DESIGN SPEED, PEAK EFFICIENCY (STATOR PERFORMANCE)

RUN NO 114 SPEED CODE 10 POINT NO 14

SL	V-1 M/SEC	V-2 M/SEC	VM-1 M/SEC	VM-2 M/SEC	VO-1 M/SEC	VO-2 M/SEC	RHOVM-1 KG/M2 SEC	RHOVM-2 KG/M2 SEC	EPSI-1 RADIAN	EPSI-2 RADIAN
1	324.2	253.1	201.6	253.1	254.0	0.0	253.40	342.93	0.4707	0.0807
2	315.1	250.2	203.8	250.2	240.3	0.0	260.98	346.64	0.4207	0.0681
3	301.5	241.2	200.6	241.2	225.1	0.0	259.77	339.89	0.3618	0.0585
4	269.2	209.9	180.7	209.9	199.5	0.0	235.36	300.32	0.2075	0.0305
5	251.5	192.9	168.2	192.9	186.9	0.0	219.00	274.60	0.0496	-0.0086
6	246.5	188.6	163.4	188.6	184.5	0.0	212.30	266.17	-0.0288	-0.0279
7	247.9	192.0	167.6	192.0	182.6	0.0	218.38	270.71	-0.0658	-0.0371
8	249.9	197.5	171.2	197.5	182.1	0.0	223.48	277.89	-0.0987	-0.0468
9	251.3	204.8	170.9	204.8	184.3	0.0	221.80	282.06	-0.1984	-0.0745
10	251.3	205.2	164.7	205.2	189.8	0.0	211.52	278.05	-0.2293	-0.0848
11	250.6	205.3	158.7	205.3	193.9	0.0	202.15	273.82	-0.2677	-0.0951

SL	B-1 DEGREE	B-2 DEGREE	M-1	M-2	INCS DEGREE	INCM DEGREE	DEV DEGREE	TURN DEGREE	D-FAC	OMEGA-B TOTAL	LOSS-P TOTAL	PO2/ PO1	PO/PO STAGE	TO/TO STAGE	%EFF-A TOT-STG	%EFF-P TOT-STG
1	53.7	0.0	0.9307	0.7033	-0.78	2.18	13.86	53.67	0.3934	0.1982	0.0457	0.9152	2.3925	1.3192	88.66	89.96
2	51.4	0.0	0.9040	0.6976	-0.98	2.14	11.97	51.44	0.3767	0.1555	0.0364	0.9363	2.3746	1.3087	90.79	91.83
3	49.6	0.0	0.8638	0.6735	-2.21	1.16	10.84	49.57	0.3709	0.1096	0.0262	0.9580	2.3245	1.2969	91.77	92.68
4	48.2	0.0	0.7644	0.5829	-4.75	-0.50	10.00	48.23	0.4028	0.0476	0.0120	0.9848	2.1923	1.2842	88.48	89.67
5	48.0	0.0	0.7069	0.5313	-5.93	-0.57	10.07	48.04	0.4324	0.0331	0.0089	0.9907	2.1352	1.2912	83.13	84.82
6	48.5	0.0	0.6892	0.5172	-5.34	0.40	10.10	48.46	0.4440	0.0470	0.0131	0.9872	2.1089	1.2990	79.47	81.49
7	47.5	0.0	0.6927	0.5265	-6.32	-0.45	10.15	47.47	0.4356	0.0566	0.0160	0.9845	2.1180	1.3015	79.32	81.36
8	46.8	0.0	0.6976	0.5415	-7.00	-1.01	10.26	46.80	0.4205	0.0525	0.0151	0.9854	2.1342	1.3062	78.98	81.08
9	47.4	0.0	0.6958	0.5582	-8.51	-2.29	12.36	47.42	0.4068	0.0752	0.0225	0.9792	2.1299	1.3264	73.88	76.47
10	49.4	0.0	0.6914	0.5560	-8.84	-2.60	13.78	49.41	0.4149	0.0926	0.0281	0.9747	2.1282	1.3412	70.58	73.50
11	51.2	0.0	0.6858	0.5535	-12.41	-6.27	16.43	51.21	0.4215	0.1101	0.0338	0.9703	2.1348	1.3545	68.22	71.38

SL	V-1 FT/SEC	V-2 FT/SEC	VM-1 FT/SEC	VM-2 FT/SEC	VO-1 FT/SEC	VO-2 FT/SEC	RHOVM-1 LBM/FT2SEC	RHOVM-2 LBM/FT2SEC	PCT TE SPAN	EPSI-1 DEGREE	EPSI-2 DEGREE
1	1063.8	830.3	661.3	830.3	833.3	0.0	51.90	70.24	0.0430	26.969	4.626
2	1033.8	820.9	668.6	820.9	788.5	0.0	53.45	71.00	0.0901	24.106	3.901
3	989.3	791.3	658.2	791.3	738.5	0.0	53.20	69.61	0.1410	20.729	3.351
4	883.2	688.7	593.0	688.7	654.5	0.0	48.20	61.51	0.2989	11.891	1.747
5	825.0	632.8	551.9	632.8	613.2	0.0	44.85	56.24	0.5086	2.843	-0.494
6	808.6	618.7	536.2	618.7	605.3	0.0	43.48	54.51	0.6103	-1.652	-1.599
7	813.3	629.9	549.9	629.9	599.2	0.0	44.73	55.44	0.6598	-3.769	-2.128
8	820.1	648.0	561.8	648.0	597.4	0.0	45.77	56.92	0.7107	-5.653	-2.684
9	824.6	672.0	560.7	672.0	604.7	0.0	45.43	57.77	0.8620	-11.366	-4.266
10	824.5	673.2	540.3	673.2	622.8	0.0	43.32	56.95	0.9101	-13.138	-4.859
11	822.3	673.6	520.8	673.6	636.3	0.0	41.40	56.08	0.9571	-15.340	-5.447

NCORR INLET RPM	WCORR INLET LBM/SEC	WCORR INLET KG/SEC	TO/10 STAGE	PO2/PO1	PO/PO STAGE	%EFF-A STAGE	%EFF-P STAGE
12459.20	172.70	78.32	1.3062	0.9736	2.1893	81.95	83.81

## AIRFOIL AERODYNAMIC SUMMARY PRINT

95 PERCENT DESIGN SPEED, PEAK EFFICIENCY (ROTOR PERFORMANCE)

RUN NO 117 SPEED CODE 95 POINT NO 17

SL	V-1 M/SEC	V-2 M/SEC	VM-1 M/SEC	VM-2 M/SEC	VO-1 M/SEC	VO-2 M/SEC	U-1 M/SEC	U-2 M/SEC	V'-1 M/SEC	V'-2 M/SEC	VO'-1 M/SEC	VO'-2 M/SEC	RHOVM-1 KG/M2 SEC	RHOVM-2 KG/M2 SEC	EPSI-1 RADIAN	EPSI-2 RADIAN
1	105.4	300.1	105.4	172.0	0.0	245.9	272.5	316.4	292.2	185.9	-272.5	-70.5	95.93	220.01	0.4704	0.5029
2	126.1	292.7	126.1	180.7	0.0	230.2	290.0	325.4	316.2	204.2	-290.0	-95.2	114.11	234.70	0.3727	0.4321
3	144.2	281.2	144.2	181.2	0.0	215.0	307.0	334.5	339.2	217.0	-307.0	-119.4	129.34	237.43	0.2863	0.3625
4	170.7	250.1	170.7	159.5	0.0	192.6	351.9	361.6	391.1	232.4	-351.9	-168.9	149.56	208.47	0.0877	0.1782
5	174.9	232.1	174.9	144.4	0.0	181.6	401.8	397.7	438.2	259.9	-401.8	-216.0	152.08	186.23	-0.0849	0.0066
6	175.4	228.6	175.4	139.8	0.0	180.8	424.3	415.7	459.1	273.3	-424.3	-234.9	152.83	179.25	-0.1419	-0.0680
7	175.4	229.9	175.4	144.7	0.0	178.7	435.0	424.8	469.0	285.5	-435.0	-246.1	153.04	186.17	-0.1682	-0.1051
8	174.9	231.0	174.9	147.1	0.0	178.1	445.6	433.8	478.7	295.0	-445.6	-255.7	152.92	189.55	-0.1966	-0.1418
9	171.3	225.1	171.3	140.8	0.0	175.6	476.9	460.9	506.7	318.1	-476.9	-285.2	151.39	181.80	-0.2724	-0.2490
10	167.6	222.3	167.6	130.8	0.0	179.7	486.6	469.9	514.6	318.3	-486.6	-290.2	148.43	167.91	-0.2898	-0.2802
11	161.2	218.7	161.2	121.0	0.0	182.2	495.9	478.9	521.4	320.4	-495.9	-296.7	142.77	154.71	-0.2992	-0.3071

SL	B-1 DEGREE	B-2 DEGREE	B'-1 DEGREE	B'-2 DEGREE	M-1	M-2	M'-1	M'-2	INCS DEGREE	INCM DEGREE	DEV DEGREE	TURN DEGREE	D FAC	OMEGA-B TOTAL	LOSS-P TOTAL	PO2/ PO1	%EFF-A TOTAL	%EFF-P TOTAL
1	0.0	54.6	68.19	21.95	0.3233	0.8607	0.8963	0.5332	3.11	7.20	10.00	46.24	0.5661	0.0067	0.0013	2.4127	99.68	99.72
2	0.0	51.7	65.84	27.64	0.3887	0.8405	0.9745	0.5865	2.11	5.83	9.86	38.20	0.5403	-0.0014	-0.0003	2.3511	100.07	100.06
3	0.0	49.9	64.29	33.40	0.4463	0.8071	1.0502	0.6229	1.85	5.24	9.95	30.89	0.5298	0.0139	0.0027	2.2629	99.03	99.13
4	0.0	50.5	63.96	46.78	0.5328	0.7109	1.2207	0.6605	2.05	4.34	10.98	17.17	0.5465	0.1103	0.0201	2.0778	90.45	91.38
5	0.0	51.4	66.51	56.18	0.5466	0.6524	1.3696	0.7306	2.34	4.19	10.61	10.33	0.5314	0.1853	0.0305	1.9921	81.68	83.35
6	0.0	52.1	67.53	59.04	0.5482	0.6388	1.4351	0.7640	2.40	4.13	8.75	8.50	0.5246	0.2206	0.0348	1.9766	77.50	79.53
7	0.0	50.7	68.01	59.29	0.5483	0.6422	1.4661	0.7975	2.57	4.25	6.91	8.72	0.5084	0.2171	0.0345	1.9886	77.52	79.56
8	0.0	50.1	68.52	59.79	0.5465	0.6441	1.4962	0.8226	3.00	4.56	6.20	8.73	0.4989	0.2215	0.0350	1.9992	76.80	78.93
9	0.0	50.9	70.09	63.38	0.5347	0.6230	1.5817	0.8803	2.95	4.37	4.91	6.70	0.4795	0.2510	0.0357	1.9898	72.74	75.22
10	0.0	53.5	70.79	65.42	0.5225	0.6113	1.6046	0.8754	2.68	4.06	4.89	5.37	0.4883	0.2806	0.0366	1.9905	69.78	72.52
11	0.0	56.1	71.75	67.59	0.5016	0.5982	1.6225	0.8764	2.71	4.04	4.98	4.16	0.4911	0.2980	0.0353	2.0037	68.23	71.14

SL	V-1 FT/SEC	V-2 FT/SEC	VM-1 FT/SEC	VM-2 FT/SEC	VO-1 FT/SEC	VO-2 FT/SEC	U-1 FT/SEC	U-2 FT/SEC	V'-1 FT/SEC	V'-2 FT/SEC	VO'-1 FT/SEC	VO'-2 FT/SEC	RHOVM-1 LBM/FT2SEC	RHOVM-2 LBM/FT2SEC	EPSI-1 DEGREE	EPSI-2 DEGREE	PCT SPAN	TE
1	345.8	984.5	345.8	564.3	0.0	806.8	894.1	1038.1	958.6	609.8	-894.1	-231.3	19.65	45.06	26.950	28.815	0.0500	
2	413.8	960.3	413.8	592.9	0.0	755.4	951.4	1067.7	1037.5	670.1	-951.4	-312.3	23.37	48.07	21.354	24.758	0.1000	
3	473.0	922.6	473.0	594.5	0.0	705.5	1007.4	1097.3	1112.9	712.1	-1007.4	-391.9	26.49	48.63	16.402	20.770	0.1500	
4	560.1	820.5	560.1	523.4	0.0	631.9	1154.5	1186.3	1283.2	762.4	-1154.5	-554.3	30.63	42.70	5.024	10.210	0.3000	
5	573.8	761.4	573.8	473.9	0.0	595.9	1318.3	1304.7	1437.7	852.6	-1318.3	-708.8	31.15	38.14	-4.865	0.378	0.5000	
6	575.4	749.9	575.4	458.6	0.0	593.3	1392.1	1364.0	1506.3	896.8	-1392.1	-770.7	31.30	36.71	-8.129	-3.896	0.6000	
7	575.5	754.3	575.5	474.8	0.0	586.2	1427.1	1393.6	1538.8	936.7	-1427.1	-807.4	31.34	38.13	-9.640	-6.023	0.6500	
8	573.7	757.8	573.7	482.6	0.0	584.3	1462.1	1423.2	1570.7	967.9	-1462.1	-838.9	31.32	38.82	-11.262	-8.125	0.7000	
9	562.0	738.7	562.0	462.1	0.0	576.3	1564.6	1512.1	1662.4	1043.7	-1564.6	-935.9	31.01	37.23	-15.608	-14.269	0.8500	
10	549.8	729.3	549.8	429.3	0.0	589.6	1596.5	1541.8	1688.5	1044.5	-1596.5	-952.2	30.40	34.39	-16.606	-16.056	0.9000	
11	529.0	717.6	529.0	396.8	0.0	597.8	1627.0	1571.4	1710.9	1051.3	-1627.0	-973.6	29.24	31.69	-17.140	-17.598	0.9500	
	WC1/A1 LBM/SEC SQFT	WC1/A1 KG/SEC SQM							T02/T01	P02/PO1	%EFF-A ROTOR	%EFF-P ROTOR						
	35.91	175.24							1.2789	2.0802	83.47	85.07						



AIRFOIL AERODYNAMIC SUMMARY PRINT

95 PERCENT DESIGN SPEED, PEAK EFFICIENCY (STATOR PERFORMANCE)

RUN NO 117 SPEED CODE 95 POINT NO 17

SL	V-1 M/SEC	V-2 M/SEC	VM-1 M/SEC	VM-2 M/SEC	VO-1 M/SEC	VO-2 M/SEC	RHOVM-1 KG/M2 SEC	RHOVM-2 KG/M2 SEC	EPSI-1 RADIAN	EPSI-2 RADIAN
1	310.0	250.0	195.5	250.0	240.6	0.0	243.89	326.16	0.4680	0.0827
2	301.9	249.0	199.7	249.0	226.3	0.0	253.67	333.00	0.4172	0.0714
3	290.3	241.0	198.6	241.0	211.7	0.0	254.78	328.15	0.3623	0.0621
4	261.1	209.7	178.6	209.7	190.5	0.0	228.24	289.27	0.2187	0.0348
5	243.3	189.6	162.4	189.6	181.1	0.0	205.05	259.65	0.0628	-0.0047
6	240.3	186.7	158.0	186.7	181.1	0.0	198.22	253.24	-0.0184	-0.0250
7	242.2	190.4	162.9	190.4	179.2	0.0	204.89	258.13	-0.0565	-0.0350
8	243.9	195.0	165.6	195.0	179.1	0.0	208.33	263.67	-0.0910	-0.0453
9	241.3	196.0	163.1	196.0	177.9	0.0	204.41	259.86	-0.1964	-0.0742
10	240.6	194.8	156.5	194.8	182.7	0.0	194.47	254.45	-0.2297	-0.0846
11	239.4	193.1	150.9	193.1	185.9	0.0	186.15	248.43	-0.2701	-0.0947

SL	B-1 DEGREE	B-2 DEGREE	M-1	M-2	INCS DEGREE	INCM DEGREE	DEV DEGREE	TURN DEGREE	D-FAC	OMEGA-B TOTAL	LOSS-P TOTAL	PO2/ PO1	PO/PO STAGE	TO/TO STAGE	%EFF-A TOT-STG	%EFF-P TOT-STG
1	53.0	0.0	0.8937	0.7018	-1.46	1.50	13.86	52.99	0.3658	0.2157	0.0497	0.9128	2.1992	1.2865	88.17	89.39
2	50.3	0.0	0.8707	0.7020	-2.15	0.98	11.97	50.27	0.3436	0.1627	0.0381	0.9367	2.1958	1.2756	91.46	92.35
3	48.1	0.0	0.8368	0.6805	-3.66	-0.29	10.84	48.12	0.3373	0.1184	0.0283	0.9566	2.1571	1.2648	92.77	93.50
4	47.3	0.0	0.7457	0.5874	-5.66	-1.41	10.00	47.32	0.3771	0.0571	0.0144	0.9824	2.0375	1.2572	87.70	88.87
5	48.2	0.0	0.6869	0.5256	-5.81	-0.45	10.07	48.16	0.4214	0.0300	0.0081	0.9919	1.9739	1.2677	80.14	81.93
6	48.9	0.0	0.6745	0.5147	-4.91	0.83	10.10	48.89	0.4344	0.0412	0.0115	0.9892	1.9557	1.2779	76.02	78.15
7	47.7	0.0	0.6795	0.5250	-6.05	-0.18	10.15	47.74	0.4249	0.0452	0.0128	0.9880	1.9660	1.2804	75.99	78.14
8	47.3	0.0	0.6833	0.5375	-6.53	-0.54	10.26	47.27	0.4129	0.0412	0.0118	0.9889	1.9779	1.2854	75.39	77.61
9	47.7	0.0	0.6715	0.5372	-8.19	-1.97	12.36	47.74	0.4111	0.0743	0.0222	0.9806	1.9512	1.2987	70.45	73.06
10	49.8	0.0	0.6657	0.5313	-8.49	-2.25	13.78	49.76	0.4230	0.0980	0.0297	0.9748	1.9403	1.3115	66.94	69.83
11	51.5	0.0	0.6594	0.5239	-12.15	-6.01	16.43	51.47	0.4353	0.1279	0.0392	0.9676	1.9392	1.3222	64.65	67.74

SL	V-1 FT/SEC	V-2 FT/SEC	VM-1 FT/SEC	VM-2 FT/SEC	VO-1 FT/SEC	VO-2 FT/SEC	RHOVM-1 LBM/FT2SEC	RHOVM-2 LBM/FT2SEC	PCT TE SPAN	EPSI-1 DEGREE	EPSI-2 DEGREE
1	1017.1	820.4	641.4	820.4	789.4	0.0	49.95	66.80	0.0430	26.815	4.740
2	990.4	817.1	655.4	817.1	742.6	0.0	51.95	68.20	0.0901	23.905	4.091
3	952.5	790.8	651.7	790.8	694.6	0.0	52.18	67.21	0.1410	20.756	3.556
4	856.8	688.1	586.1	688.1	625.0	0.0	46.75	59.25	0.2989	12.528	1.996
5	798.2	622.2	532.9	622.2	594.2	0.0	42.00	53.18	0.5086	3.601	-0.268
6	788.5	612.5	518.3	612.5	594.2	0.0	40.60	51.87	0.6103	-1.056	-1.433
7	794.6	624.7	534.3	624.7	588.1	0.0	41.96	52.87	0.6598	-3.239	-2.003
8	800.2	639.9	543.2	639.9	587.6	0.0	42.67	54.00	0.7107	-5.212	-2.597
9	791.7	643.0	535.0	643.0	583.6	0.0	41.87	53.22	0.8620	-11.250	-4.249
10	789.3	639.3	513.6	639.3	599.3	0.0	39.83	52.11	0.9101	-13.162	-4.850
11	785.6	633.4	495.0	633.4	610.0	0.0	38.12	50.88	0.9571	-15.473	-5.428

	NCORR INLET RPM	WCORR INLET LBM/SEC	WCORR INLET KG/SEC	TO/TO STAGE	PO2/PO1	PO/PO STAGE	%EFF-A STAGE	%EFF-P STAGE
	11831.10	160.00	72.56	1.2789	0.9735	2.0251	80.09	81.95

## AIRFOIL AERODYNAMIC SUMMARY PRINT

100 PERCENT DESIGN SPEED, NEAR SURGE (ROTOR PERFORMANCE)

RUN NO 118 SPEED CODE 10 POINT NO 6

SL	V-1 M/SEC	V-2 M/SEC	VM-1 M/SEC	VM-2 M/SEC	VO-1 M/SEC	VO-2 M/SEC	U-1 M/SEC	U-2 M/SEC	V'-1 M/SEC	V'-2 M/SEC	VO'-1 M/SEC	VO'-2 M/SEC	RHOVM-1 KG/M2 SEC	RHOVM-2 KG/M2 SEC	EPSI-1 RADIAN	EPSI-2 RADIAN
1	110.0	319.0	110.0	164.6	0.0	273.2	289.8	336.4	309.9	176.3	-289.8	-63.2	97.36	210.34	0.4734	0.5042
2	130.8	314.2	130.8	175.9	0.0	260.3	308.3	346.0	334.9	195.7	-308.3	-85.7	115.05	229.39	0.3763	0.4340
3	149.1	299.9	149.1	174.6	0.0	243.9	326.5	355.6	358.9	207.3	-326.5	-111.7	129.92	230.62	0.2915	0.3620
4	177.1	269.1	177.1	154.0	0.0	220.7	374.1	384.4	414.0	224.8	-374.1	-163.7	150.28	206.16	0.0999	0.1799
5	184.6	255.5	184.6	146.5	0.0	209.4	427.2	422.8	465.4	258.8	-427.2	-213.4	154.56	197.00	-0.0768	0.0091
6	185.7	254.6	185.7	144.8	0.0	209.4	451.1	442.0	487.8	274.0	-451.1	-232.6	155.64	194.57	-0.1434	-0.0668
7	185.7	256.6	185.7	147.4	0.0	210.0	462.5	451.6	498.4	283.0	-462.5	-241.6	155.86	198.37	-0.1746	-0.1050
8	185.0	256.5	185.0	145.7	0.0	211.1	473.8	461.2	508.7	289.5	-473.8	-250.1	155.70	195.99	-0.2057	-0.1429
9	181.6	254.0	181.6	136.8	0.0	214.1	507.0	490.0	538.6	308.0	-507.0	-276.0	154.47	183.92	-0.2805	-0.2519
10	177.3	253.1	177.3	132.0	0.0	216.0	517.4	499.6	546.9	312.9	-517.4	-283.7	151.02	177.54	-0.2998	-0.2840
11	171.1	250.4	171.1	125.5	0.0	216.7	527.3	509.2	554.3	318.3	-527.3	-292.5	145.69	168.89	-0.3155	-0.3132

SL	B-1 DEGREE	B-2 DEGREE	B'-1 DEGREE	B'-2 DEGREE	M-1	M-2	M'-1	M'-2	INCS DEGREE	INCM DEGREE	DEV DEGREE	TURN DEGREE	D FAC	OMEGA-B TOTAL	LOSS-P TOTAL	P02/ P01	%EFF-A TOTAL	%EFF-P TOTAL
1	0.0	58.5	68.58	20.68	0.3343	0.8951	0.9420	0.4947	3.50	7.59	8.74	47.90	0.6379	0.0966	0.0191	2.6293	95.67	96.22
2	0.0	55.8	66.39	25.87	0.3996	0.8821	1.0228	0.5494	2.67	6.38	8.08	40.53	0.6081	0.0730	0.0146	2.5957	96.16	96.64
3	0.0	54.4	64.94	32.62	0.4574	0.8408	1.1012	0.5811	2.50	5.89	9.17	32.32	0.5981	0.0838	0.0165	2.4885	94.85	95.46
4	0.0	55.2	64.53	46.89	0.5483	0.7465	1.2812	0.6234	2.63	4.91	11.09	17.64	0.6055	0.1460	0.0266	2.3194	88.54	89.81
5	0.0	55.0	66.65	55.48	0.5727	0.7010	1.4440	0.7101	2.48	4.33	9.92	11.17	0.5769	0.1872	0.0314	2.2871	83.26	85.08
6	0.0	55.1	67.63	57.89	0.5764	0.6940	1.5144	0.7469	2.49	4.22	7.60	9.73	0.5685	0.2171	0.0353	2.2932	79.94	82.12
7	0.0	54.7	68.12	58.35	0.5764	0.6977	1.5471	0.7695	2.67	4.35	5.97	9.77	0.5616	0.2260	0.0369	2.3127	78.89	81.20
8	0.0	55.1	68.65	59.48	0.5742	0.6949	1.5787	0.7841	3.13	4.69	5.88	9.18	0.5595	0.2418	0.0386	2.3197	77.17	79.68
9	0.0	57.1	70.18	63.32	0.5630	0.6801	1.6694	0.8246	3.03	4.46	4.84	6.86	0.5513	0.2880	0.0410	2.3334	72.20	75.26
10	0.0	58.2	70.93	64.74	0.5489	0.6747	1.6928	0.8339	2.82	4.20	4.22	6.18	0.5492	0.3004	0.0402	2.3558	71.07	74.29
11	0.0	59.7	71.87	66.59	0.5285	0.6645	1.7122	0.8447	2.83	4.16	3.97	5.29	0.5445	0.3071	0.0379	2.3819	70.50	73.83

SL	V-1 FT/SEC	V-2 FT/SEC	VM-1 FT/SEC	VM-2 FT/SEC	VO-1 FT/SEC	VO-2 FT/SEC	U-1 FT/SEC	U-2 FT/SEC	V'-1 FT/SEC	V'-2 FT/SEC	VO'-1 FT/SEC	VO'-2 FT/SEC	RHOVM-1 LBM/FT2SEC	RHOVM-2 LBM/FT2SEC	EPSI-1 DEGREE	EPSI-2 DEGREE	PCT TE SPAN
1	360.9	1046.6	360.9	539.9	0.0	896.5	950.7	1103.8	1016.9	578.4	-950.7	-207.2	19.94	43.08	27.126	28.891	0.0500
2	429.3	1030.8	429.3	577.2	0.0	854.1	1011.6	1135.3	1098.9	642.0	-1011.6	-281.2	23.56	46.98	21.562	24.865	0.1000
3	489.1	984.1	489.1	572.9	0.0	800.2	1071.2	1166.8	1177.5	680.1	-1071.2	-366.6	26.61	47.23	16.702	20.742	0.1500
4	581.2	883.1	581.2	505.4	0.0	724.2	1227.6	1261.3	1358.2	737.5	-1227.6	-537.1	30.78	42.22	5.722	10.306	0.3000
5	605.5	838.4	605.5	480.5	0.0	687.1	1401.7	1387.3	1526.9	849.2	-1401.7	-700.2	31.65	40.35	-4.400	0.522	0.5000
6	609.2	835.3	609.2	475.0	0.0	687.0	1480.1	1450.3	1600.6	899.0	-1480.1	-763.2	31.88	39.85	-8.216	-3.825	0.6000
7	609.3	841.9	609.3	483.7	0.0	689.2	1517.4	1481.8	1635.2	928.5	-1517.4	-792.6	31.92	40.63	-10.006	-6.018	0.6500
8	607.1	841.6	607.1	478.1	0.0	692.7	1554.7	1513.3	1669.0	949.7	-1554.7	-820.6	31.89	40.14	-11.785	-8.189	0.7000
9	595.9	833.5	595.9	448.7	0.0	702.4	1663.5	1607.8	1767.0	1010.5	-1663.5	-905.5	31.64	37.67	-16.069	-14.434	0.8500
10	581.8	830.5	581.8	433.2	0.0	708.7	1697.5	1639.3	1794.5	1026.5	-1697.5	-930.7	30.93	36.36	-17.177	-16.272	0.9000
11	561.4	821.6	561.4	411.7	0.0	711.0	1730.0	1670.8	1818.8	1044.4	-1730.0	-959.8	29.84	34.59	-18.078	-17.947	0.9500
	WC1/A1 LBM/SEC	WC1/A1 KG/SEC								T02/T01	P02/P01	%EFF-A ROTOR	%EFF-P ROTOR				
	37.13	181.18								1.3389	2.3658	82.24	84.24				

AIRFOIL AERODYNAMIC SUMMARY PRINT

100 PERCENT DESIGN SPEED, NEAR SURGE (STATOR PERFORMANCE)

RUN NO 118 SPEED CODE 10 POINT NO 6

SL	V-1 M/SEC	V-2 M/SEC	VM-1 M/SEC	VM-2 M/SEC	VO-1 M/SEC	VO-2 M/SEC	RHOVM-1 KG/M2 SEC	RHOVM-2 KG/M2 SEC	EPSI-1 RADIAN	EPSI-2 RADIAN
1	326.6	221.8	187.4	221.8	267.4	0.0	235.00	322.31	0.4632	0.0828
2	321.2	220.4	194.3	220.4	255.8	0.0	248.92	325.76	0.4113	0.0712
3	307.1	211.3	191.4	211.3	240.1	0.0	248.56	316.58	0.3515	0.0633
4	278.1	187.8	172.3	187.8	218.3	0.0	226.30	284.24	0.2030	0.0380
5	265.0	175.1	163.1	175.1	208.9	0.0	215.27	263.12	0.0543	0.0012
6	264.7	176.2	161.5	176.2	209.8	0.0	212.81	262.28	-0.0170	-0.0177
7	267.3	180.7	164.3	180.7	210.9	0.0	216.61	268.04	-0.0507	-0.0273
8	268.0	184.5	163.5	184.5	212.4	0.0	215.03	272.04	-0.0834	-0.0377
9	268.8	192.4	158.8	192.4	216.9	0.0	207.71	277.21	-0.1965	-0.0696
10	269.9	195.0	156.9	195.0	219.6	0.0	204.44	278.12	-0.2314	-0.0812
11	269.4	198.2	154.0	198.2	221.1	0.0	200.06	279.86	-0.2699	-0.0932

SL	B-1 DEGREE	B-2 DEGREE	M-1	M-2	INCS DEGREE	INCM DEGREE	DEV DEGREE	TURN DEGREE	D-FAC	OMEGA-B TOTAL	LOSS-P TOTAL	PO2/ PO1	PO/PO STAGE	TO/TO STAGE	%EFF-A TOT-STG	%EFF-P TOT-STG
1	56.9	0.0	0.9200	0.5983	2.46	5.41	13.86	56.91	0.5035	0.1642	0.0378	0.9309	2.4455	1.3320	87.61	89.06
2	54.4	0.0	0.9050	0.5963	1.94	5.06	11.97	54.35	0.4926	0.1496	0.0351	0.9387	2.4260	1.3242	88.81	90.10
3	52.6	0.0	0.8636	0.5726	0.80	4.17	10.84	52.58	0.4920	0.1110	0.0265	0.9575	2.3731	1.3129	89.45	90.64
4	52.1	0.0	0.7743	0.5066	-0.89	3.36	10.00	52.09	0.5202	0.0463	0.0117	0.9849	2.2833	1.3071	86.57	88.03
5	52.1	0.0	0.7295	0.4685	-1.92	3.44	10.07	52.06	0.5517	0.0537	0.0145	0.9840	2.2498	1.3204	81.33	83.31
6	52.4	0.0	0.7243	0.4689	-1.40	4.34	10.10	52.40	0.5555	0.0682	0.0190	0.9799	2.2468	1.3343	77.80	80.15
7	52.1	0.0	0.7297	0.4801	-1.73	4.14	10.15	52.06	0.5468	0.0737	0.0209	0.9780	2.2599	1.3418	76.68	79.17
8	52.4	0.0	0.7291	0.4888	-1.39	4.61	10.26	52.42	0.5397	0.0739	0.0212	0.9780	2.2680	1.3505	75.13	77.79
9	54.0	0.0	0.7236	0.5055	-1.91	4.31	12.36	54.03	0.5278	0.0936	0.0280	0.9724	2.2685	1.3780	69.68	72.92
10	54.8	0.0	0.7235	0.5107	-3.45	2.80	13.78	54.81	0.5262	0.1085	0.0329	0.9681	2.2789	1.3890	68.12	71.54
11	55.7	0.0	0.7197	0.5177	-7.97	-1.83	16.43	55.66	0.5195	0.1127	0.0346	0.9671	2.3034	1.3985	67.46	70.99

SL	V-1 FT/SEC	V-2 FT/SEC	VM-1 FT/SEC	VM-2 FT/SEC	VO-1 FT/SEC	VO-2 FT/SEC	RHOVM-1 LBM/FT2SEC	RHOVM-2 LBM/FT2SEC	PCT TE SPAN	EPSI-1 DEGREE	EPSI-2 DEGREE
1	1071.5	727.6	614.9	727.6	877.5	0.0	48.13	66.01	0.0430	26.542	4.747
2	1053.9	723.2	637.5	723.2	839.2	0.0	50.98	66.72	0.0901	23.564	4.078
3	1007.4	693.3	628.1	693.3	787.7	0.0	50.91	64.84	0.1410	20.142	3.626
4	912.5	616.1	565.4	616.1	716.3	0.0	46.35	58.21	0.2989	11.628	2.179
5	869.4	574.6	535.0	574.6	685.3	0.0	44.09	53.89	0.5086	3.112	0.067
6	868.5	578.1	529.8	578.1	688.2	0.0	43.58	53.72	0.6103	-0.972	-1.015
7	877.1	593.0	539.2	593.0	691.8	0.0	44.36	54.90	0.6598	-2.905	-1.563
8	879.3	605.2	536.3	605.2	696.8	0.0	44.04	55.72	0.7107	-4.779	-2.159
9	882.1	631.1	521.1	631.1	711.7	0.0	42.54	56.77	0.8620	-11.257	-3.991
10	885.4	639.9	514.6	639.9	720.5	0.0	41.87	56.96	0.9101	-13.261	-4.652
11	883.9	650.3	505.1	650.3	725.3	0.0	40.97	57.32	0.9571	-15.463	-5.337
	NCORR INLET RPM	WCORR INLET LBM/SEC	WCORR INLET KG/SEC				TO/TO STAGE	PO2/PO1 STAGE	PO/PO STAGE	%EFF-A STAGE	%EFF-P STAGE
	12454.60	165.60	75.10				1.3389	0.9715	2.2983	79.14	81.41

**This Page Intentionally Left Blank**

## APPENDIX D

### LASER DOPPLER VELOCIMETER DATA

#### MEASURED FLOWFIELD TABULATIONS

Appendix D presents the LDV data in tabular form. The flowfield data are presented first, in the order given below. Within flowfields the data appear in streamwise order with one chord location per table. The spanwise traverse results are provided next, one per table.

95% Span	100% Speed	Peak Efficiency	Passage No. 1
95% Span	95% Speed	Peak Efficiency	Passage No. 1
95% Span	100% Speed	Near Surge	Passage No. 1
85% Span	100% Speed	Peak Efficiency	Passage No. 1
85% Span	95% Speed	Peak Efficiency	Passage No. 1
85% Span	100% Speed	Near Surge	Passage No. 1
69% Span	100% Speed	Peak Efficiency	Passage No. 1
45% Span	100% Speed	Peak Efficiency	Passage No. 1
45% Span	95% Speed	Peak Efficiency	Passage No. 1
45% Span	100% Speed	Near Surge	Passage No. 1
85% Span	100% Speed	Peak Efficiency	Passage No. 15
85% Span	95% Speed	Peak Efficiency	Passage No. 15
85% Span	100% Speed	Near Surge	Passage No. 15
85% Span	100% Speed	Peak Efficiency	Passage No. 31
85% Span	95% Speed	Peak Efficiency	Passage No. 31
85% Span	100% Speed	Near Surge	Passage No. 31

Spanwise Traverse at Instrumentation Plane	100% Speed	Peak Efficiency
Spanwise Traverse at Leading Edge Plane	100% Speed	Peak Efficiency
Spanwise Traverse at Trailing Edge Plane	100% Speed	Peak Efficiency

#### DEFINITION OF ANGLES

The angles appearing in the tables are BETA, which is shown in Figure 13 as "measurement plane BETA" and defined by

$$\text{BETA} = \arctan (V_U/V_Z)$$

and BETA PRIME which includes the radial component and is given by

$$\text{BETA PRIME} = \arcsin \frac{(U - V_U)}{V'}$$

APPENDIX D (Cont')

LASER DOPPLER VELOCIMETER DATA

95% SPAN 100% SPEED PEAK EFF X/B = -.3 PASSAGE NO. 1

STD DAY RPM = 12470.4, RADIUS = 41.420 CM, PHI = -18.3 DEG, STD DAY TTREL = 433. DEG K, UPSTREAM TTABS = 276. DEG K  
 16.307 IN 780. DEG R 496. DEG R

PERCENT GAP	C1 MPS	C1 FPS	ZETA1 DEG	C2 MPS	C2 FPS	ZETA2 DEG	VZ--CORRECTED MPS	VZ--CORRECTED FPS	BETA DEG	ABSOLUTE MACH NO	BETA PRIME DEG	RELATIVE MACH NO
PRESSURE SIDE												
0.7	97.	317.	135.	99.	324.	45.	141.	464.	0.6	0.446	74.6	1.676
4.5	95.	312.	135.	97.	319.	45.	139.	456.	0.6	0.439	74.8	1.673
8.3	98.	323.	135.	97.	319.	45.	141.	464.	-0.4	0.447	74.6	1.687
12.1	97.	317.	135.	97.	317.	45.	140.	458.	-0.0	0.441	74.8	1.681
15.9	97.	318.	135.	97.	318.	45.	140.	460.	-0.0	0.443	74.7	1.681
19.7	96.	315.	135.	98.	320.	45.	140.	459.	0.5	0.442	74.7	1.676
23.5	103.	337.	135.	100.	327.	45.	146.	480.	-0.9	0.464	74.2	1.700
27.3	111.	363.	135.	102.	336.	45.	154.	505.	-2.2	0.492	73.5	1.728
31.1	110.	362.	135.	104.	340.	45.	155.	508.	-1.8	0.493	73.4	1.724
34.9	111.	363.	135.	102.	335.	45.	154.	505.	-2.3	0.491	73.5	1.728
38.7	111.	364.	135.	102.	334.	45.	154.	505.	-2.5	0.491	73.5	1.730
42.5	110.	362.	135.	103.	338.	45.	154.	506.	-2.0	0.492	73.4	1.725
46.3	109.	358.	135.	101.	331.	45.	152.	498.	-2.2	0.484	73.7	1.724
50.1	109.	356.	135.	101.	333.	45.	152.	498.	-1.9	0.484	73.7	1.720
53.9	109.	359.	135.	100.	329.	45.	152.	497.	-2.5	0.484	73.7	1.727
57.7	108.	354.	135.	100.	328.	45.	150.	493.	-2.2	0.479	73.8	1.721
61.5	107.	352.	135.	101.	331.	45.	151.	494.	-1.8	0.479	73.8	1.716
65.3	109.	358.	135.	100.	329.	45.	151.	497.	-2.4	0.483	73.8	1.726
69.1	109.	359.	135.	102.	334.	45.	153.	501.	-2.1	0.487	73.6	1.724
72.9	114.	375.	135.	105.	344.	45.	158.	520.	-2.5	0.507	73.1	1.738
76.7	118.	387.	135.	107.	351.	45.	163.	534.	-2.8	0.522	72.7	1.750
80.5	117.	383.	135.	106.	349.	45.	161.	529.	-2.7	0.517	72.8	1.746
84.3	117.	384.	135.	109.	356.	45.	163.	535.	-2.2	0.522	72.6	1.742
88.1	114.	375.	135.	107.	350.	45.	160.	524.	-2.0	0.511	72.9	1.734
91.9	115.	376.	135.	104.	340.	45.	158.	518.	-2.9	0.506	73.2	1.742
95.7	110.	361.	135.	104.	341.	45.	155.	508.	-1.6	0.493	73.4	1.721
SUCTION SIDE												

APPENDIX D (Cont'd)

LASER DOPPLER VELOCIMETER DATA

95% SPAN 100% SPEED PEAK EFF X/B = -.2 PASSAGE NO. 1

STD DAY RPM = 12470.4, RADIUS = 41.283 CM, PHI = -18.3 DEG, STD DAY TTREL = 433. DEG K, UPSTREAM TTABS = 279. DEG K  
 16.253 IN 779. DEG R 502. DEG R

PERCENT GAP	C1 MPS	C1 FPS	ZETA1 DEG	C2 MPS	C2 FPS	ZETA2 DEG	VZ--CORRECTED MPS	FPS	BETA DEG	ABSOLUTE MACH NO	BETA PRIME DEG	RELATIVE MACH NO
PRESSURE SIDE												
3.1	108.	353.	135.	107.	350.	45.	154.	505.	-0.2	0.488	73.3	1.697
6.9	107.	351.	135.	107.	351.	45.	154.	505.	-0.0	0.487	73.3	1.694
10.7	108.	355.	135.	107.	351.	45.	155.	507.	-0.3	0.491	73.2	1.699
14.5	104.	340.	135.	108.	353.	45.	152.	498.	1.1	0.480	73.4	1.678
18.3	104.	340.	135.	106.	347.	45.	151.	494.	0.6	0.476	73.6	1.682
22.1	101.	330.	135.	104.	341.	45.	147.	482.	0.9	0.464	73.9	1.673
25.9	101.	330.	135.	103.	339.	45.	147.	481.	0.8	0.463	74.0	1.675
29.7	101.	331.	135.	102.	334.	45.	146.	478.	0.3	0.460	74.1	1.679
33.5	101.	333.	135.	100.	329.	45.	145.	476.	-0.3	0.459	74.2	1.685
37.3	103.	338.	135.	102.	336.	45.	148.	484.	-0.2	0.467	73.9	1.687
41.1	102.	336.	135.	101.	331.	45.	146.	479.	-0.4	0.462	74.1	1.688
44.9	96.	315.	135.	97.	317.	45.	138.	454.	0.2	0.437	74.9	1.671
48.7	95.	311.	135.	95.	312.	45.	136.	448.	0.1	0.430	75.1	1.669
52.5	96.	316.	135.	97.	317.	45.	139.	455.	0.1	0.437	74.8	1.672
56.3	108.	355.	135.	102.	335.	45.	151.	496.	-1.7	0.481	73.7	1.710
60.1	113.	370.	135.	106.	347.	45.	157.	515.	-1.8	0.501	73.1	1.721
63.9	112.	366.	135.	105.	346.	45.	156.	512.	-1.6	0.497	73.2	1.717
67.7	112.	366.	135.	105.	345.	45.	156.	511.	-1.7	0.496	73.2	1.717
71.5	110.	361.	135.	104.	341.	45.	154.	505.	-1.6	0.490	73.4	1.714
75.3	110.	361.	135.	104.	341.	45.	154.	505.	-1.6	0.490	73.4	1.714
79.1	110.	362.	135.	104.	340.	45.	154.	505.	-1.8	0.490	73.4	1.716
82.9	108.	355.	135.	102.	336.	45.	151.	497.	-1.6	0.481	73.6	1.709
86.7	109.	358.	135.	104.	342.	45.	153.	503.	-1.3	0.488	73.4	1.709
90.5	107.	351.	135.	104.	341.	45.	152.	497.	-0.8	0.481	73.6	1.700
94.3	107.	351.	135.	105.	344.	45.	152.	500.	-0.6	0.483	73.5	1.698
98.1	110.	362.	135.	105.	343.	45.	154.	507.	-1.5	0.492	73.3	1.713
SUCTION SIDE												

APPENDIX D (Cont'd)

LASER DOPPLER VELOCIMETER DATA

95% SPAN 100% SPEED PEAK EFF X/B = -.1 PASSAGE NO. 1

STD DAY RPM = 12470.4, RADIUS = 41.143 CM, PHI = -18.3 DEG, STD DAY TTREL = 432. DEG K, UPSTREAM TTABS = 280. DEG K  
 16.198 IN 777. DEG R 504. DEG R

PERCENT GAP	C1 MPS	C1 FPS	ZETA1 DEG	C2 MPS	C2 FPS	ZETA2 DEG	VZ--CORRECTED MPS	VZ--CORRECTED FPS	BETA DEG	ABSOLUTE MACH NO	BETA PRIME DEG	RELATIVE MACH NO
PRESSURE SIDE												
1.7	111.	363.	135.	106.	348.	45.	155.	510.	-1.2	0.495	73.1	1.706
5.5	110.	362.	135.	107.	351.	45.	156.	511.	-0.9	0.496	73.1	1.703
9.3	112.	366.	135.	107.	350.	45.	157.	514.	-1.3	0.498	73.0	1.709
13.1	111.	363.	135.	107.	350.	45.	156.	511.	-1.0	0.496	73.1	1.705
16.9	109.	359.	135.	108.	355.	45.	156.	512.	-0.3	0.496	73.0	1.696
20.7	110.	361.	135.	108.	353.	45.	156.	512.	-0.6	0.496	73.0	1.700
24.5	108.	354.	135.	108.	355.	45.	155.	509.	0.1	0.491	73.1	1.689
28.3	108.	355.	135.	107.	352.	45.	155.	507.	-0.2	0.490	73.2	1.693
32.1	109.	359.	135.	109.	357.	45.	157.	514.	-0.2	0.497	73.0	1.695
35.9	109.	359.	135.	111.	365.	45.	158.	519.	0.5	0.502	72.7	1.689
39.7	110.	360.	135.	111.	364.	45.	158.	519.	0.3	0.502	72.7	1.691
43.5	109.	357.	135.	108.	353.	45.	155.	509.	-0.3	0.493	73.1	1.695
47.3	107.	351.	135.	109.	359.	45.	155.	509.	0.6	0.491	73.0	1.683
51.1	106.	348.	135.	108.	354.	45.	153.	504.	0.5	0.486	73.2	1.682
54.9	107.	350.	135.	108.	353.	45.	154.	504.	0.2	0.487	73.2	1.686
58.7	107.	351.	135.	111.	365.	45.	157.	514.	1.1	0.495	72.8	1.679
62.5	115.	376.	135.	110.	361.	45.	161.	529.	-1.2	0.514	72.6	1.714
66.3	119.	392.	135.	109.	359.	45.	164.	539.	-2.5	0.526	72.4	1.737
70.1	109.	359.	135.	108.	353.	45.	156.	511.	-0.5	0.494	73.1	1.697
73.9	96.	316.	135.	102.	334.	45.	142.	466.	1.6	0.447	74.3	1.655
77.7	88.	290.	135.	100.	327.	45.	135.	443.	3.4	0.423	75.0	1.627
81.5	92.	302.	135.	98.	320.	45.	136.	446.	1.7	0.427	75.0	1.647
85.3	111.	365.	135.	106.	347.	45.	156.	511.	-1.4	0.496	73.1	1.709
89.1	114.	373.	135.	106.	348.	45.	158.	517.	-2.0	0.503	73.0	1.719
92.9	114.	373.	135.	107.	351.	45.	158.	519.	-1.7	0.505	72.9	1.717
96.7	112.	367.	135.	108.	354.	45.	158.	517.	-1.0	0.502	72.9	1.707
SUCTION SIDE												



APPENDIX D (Cont'd)

LASER DOPPLER VELOCIMETER DATA

95% SPAN 100% SPEED PEAK EFF X/B = 0.0 PASSAGE NO. 1

STD DAY RPM = 12470.4, RADIUS = 41.006 CM, PHI = -18.3 DEG, STD DAY TTREL = 431. DEG K, UPSTREAM TTABS = 281. DEG K  
 16.144 IN 775. DEG R 506. DEG R

PERCENT GAP	C1 MPS	C1 FPS	ZETA1 DEG	C2 MPS	C2 FPS	ZETA2 DEG	VZ--CORRECTED MPS	VZ--CORRECTED FPS	BETA DEG	ABSOLUTE MACH NO	BETA PRIME DEG	RELATIVE MACH NO
PRESSURE SIDE												
8.0	112.	369.	135.	108.	355.	45.	158.	518.	-1.1	0.503	72.8	1.704
11.8	111.	364.	135.	106.	349.	45.	156.	510.	-1.2	0.495	73.1	1.701
15.6	114.	373.	135.	107.	350.	45.	158.	518.	-1.8	0.504	72.9	1.713
19.4	115.	376.	135.	106.	349.	45.	158.	519.	-2.1	0.506	72.9	1.717
23.2	113.	370.	135.	107.	351.	45.	157.	516.	-1.5	0.502	72.9	1.708
27.0	111.	364.	135.	108.	353.	45.	156.	513.	-0.9	0.498	73.0	1.699
30.8	111.	365.	135.	109.	357.	45.	158.	517.	-0.6	0.501	72.8	1.697
34.6	112.	369.	135.	112.	368.	45.	161.	528.	-0.1	0.511	72.5	1.695
38.4	115.	376.	135.	111.	365.	45.	162.	531.	-0.9	0.515	72.4	1.707
42.2	114.	375.	135.	116.	381.	45.	165.	541.	0.5	0.524	72.0	1.695
46.0	109.	357.	135.	118.	388.	45.	163.	533.	2.4	0.514	72.1	1.667
49.8	115.	378.	135.	119.	390.	45.	168.	550.	0.9	0.532	71.7	1.693
53.6	116.	381.	135.	121.	397.	45.	170.	557.	1.2	0.539	71.4	1.692
57.4	113.	371.	135.	126.	412.	45.	171.	561.	3.0	0.541	71.1	1.670
61.2	118.	386.	135.	125.	409.	45.	173.	569.	1.7	0.551	71.0	1.692
65.0	119.	392.	135.	123.	402.	45.	173.	568.	0.7	0.552	71.1	1.704
68.8	115.	378.	135.	124.	407.	45.	171.	562.	2.1	0.543	71.2	1.682
72.6	116.	381.	135.	125.	410.	45.	173.	566.	2.1	0.548	71.0	1.684
76.4	111.	363.	135.	125.	410.	45.	169.	553.	3.5	0.533	71.3	1.661
80.2	112.	369.	135.	124.	406.	45.	169.	555.	2.7	0.535	71.3	1.671
84.0	116.	379.	135.	126.	415.	45.	173.	568.	2.6	0.549	70.9	1.679
87.8	124.	408.	135.	129.	422.	45.	181.	594.	1.0	0.578	70.3	1.713
91.6	127.	418.	135.	129.	424.	45.	184.	603.	0.4	0.588	70.1	1.726
95.4	115.	376.	135.	130.	425.	45.	175.	573.	3.5	0.553	70.7	1.668
SUCTION SIDE												



APPENDIX D (Cont'd)

LASER DOPPLER VELOCIMETER DATA

95% SPAN 100% SPEED PEAK EFF X/B = .26 PASSAGE NO. 1

STD DAY RPM = 12470.4, RADIUS = 40.648 CM, PHI = -18.3 DEG, STD DAY TTREL = 428. DEG K, UPSTREAM TTABS = 281. DEG K  
 16.003 IN 771. DEG R 505. DEG R

PERCENT GAP	C1 MPS	C1 FPS	ZETA1 DEG	C2 MPS	C2 FPS	ZETA2 DEG	VZ--CORRECTED MPS	VZ--CORRECTED FPS	BETA DEG	ABSOLUTE MACH NO	BETA PRIME DEG	RELATIVE MACH NO
PRESSURE SIDE												
6.1	111.	363.	105.	229.	750.	60.	164.	538.	47.5	0.662	63.8	1.042
10.2	119.	392.	105.	236.	774.	60.	173.	568.	45.8	0.680	62.6	1.059
14.2	124.	408.	105.	250.	819.	60.	182.	596.	46.5	0.719	60.6	1.036
18.3	130.	427.	105.	261.	855.	60.	190.	623.	46.4	0.749	58.9	1.027
22.4	127.	417.	105.	267.	877.	60.	190.	624.	48.1	0.770	57.8	0.992
26.5	126.	412.	105.	273.	895.	60.	191.	627.	49.2	0.787	56.9	0.969
30.6	120.	395.	105.	276.	904.	60.	188.	618.	50.9	0.798	56.4	0.938
34.6	119.	389.	105.	268.	879.	60.	184.	605.	50.5	0.776	57.7	0.952
38.7	118.	386.	105.	264.	867.	60.	182.	598.	50.3	0.766	58.3	0.959
42.8	138.	454.	105.	252.	827.	60.	193.	632.	42.6	0.723	60.1	1.094
46.9	161.	527.	105.	242.	794.	60.	205.	672.	33.5	0.703	61.4	1.241
50.9	175.	574.	105.	223.	732.	60.	208.	683.	23.8	0.675	63.5	1.394
55.0	200.	655.	105.	222.	729.	60.	225.	740.	14.9	0.718	63.2	1.546
59.1	179.	588.	105.	221.	726.	60.	211.	691.	21.7	0.678	63.6	1.427
63.2	210.	688.	105.	215.	706.	60.	230.	755.	9.3	0.734	63.8	1.644
67.3	188.	616.	105.	214.	701.	60.	214.	701.	16.4	0.680	64.3	1.511
71.3	188.	616.	105.	209.	685.	60.	212.	696.	14.8	0.673	64.8	1.534
75.4	193.	632.	105.	202.	664.	60.	213.	699.	10.9	0.676	65.4	1.595
79.5	207.	678.	105.	199.	654.	60.	222.	728.	5.0	0.711	65.4	1.704
83.6	187.	612.	105.	192.	629.	60.	205.	672.	9.4	0.648	66.5	1.609
87.6	192.	629.	105.	188.	616.	60.	207.	679.	6.1	0.659	66.8	1.663
91.7	176.	578.	105.	183.	602.	60.	194.	638.	10.3	0.614	67.6	1.584
95.8	187.	614.	105.	180.	589.	60.	201.	659.	4.6	0.639	67.7	1.676
99.9	183.	602.	105.	180.	592.	60.	198.	651.	6.3	0.629	67.7	1.647
SUCTION SIDE												



APPENDIX D (Cont'd)

LASER DOPPLER VELOCIMETER DATA

95% SPAN 100% SPEED PEAK EFF X/B = .52 PASSAGE NO. 1

STD DAY RPM = 12470.4, RADIUS = 40.287 CM, PHI = -18.3 DEG, STD DAY TTREL = 426. DEG K, UPSTREAM TTABS = 281. DEG K  
 15.861 IN 766. DEG R 505. DEG R

PERCENT GAP	C1 MPS	C1 FPS	ZETA1 DEG	C2 MPS	C2 FPS	ZETA2 DEG	VZ--CORRECTED MPS	VZ--CORRECTED FPS	BETA DEG	ABSOLUTE MACH NO	BETA PRIME DEG	RELATIVE MACH NO
PRESSURE SIDE												
0.9	237.	777.	60.	264.	866.	15.	139.	455.	60.0	0.724	63.0	0.829
5.4	243.	798.	60.	273.	897.	15.	141.	462.	60.5	0.746	61.8	0.808
9.8	255.	838.	60.	265.	868.	15.	164.	538.	54.9	0.756	59.4	0.883
14.2	266.	874.	60.	259.	851.	15.	183.	600.	50.7	0.774	57.5	0.942
18.6	272.	891.	60.	245.	804.	15.	200.	657.	45.4	0.780	56.8	1.026
23.1	279.	915.	60.	222.	727.	15.	227.	746.	37.0	0.804	56.0	1.167
27.5	287.	941.	60.	209.	685.	15.	247.	812.	31.7	0.840	55.1	1.265
31.9	292.	958.	60.	210.	688.	15.	254.	833.	30.9	0.858	54.4	1.282
36.3	286.	939.	60.	208.	681.	15.	247.	812.	31.5	0.838	55.2	1.269
40.8	283.	930.	60.	212.	696.	15.	240.	789.	33.3	0.825	55.5	1.234
45.2	281.	921.	60.	212.	695.	15.	237.	777.	33.8	0.815	55.8	1.224
49.6	273.	897.	60.	212.	695.	15.	227.	744.	35.5	0.791	56.8	1.195
54.0	268.	878.	60.	208.	684.	15.	221.	725.	35.8	0.773	57.6	1.190
58.5	258.	848.	60.	201.	660.	15.	214.	701.	35.7	0.747	58.8	1.192
62.9	247.	812.	60.	194.	635.	15.	204.	669.	36.0	0.715	60.4	1.190
67.3	240.	788.	60.	187.	612.	15.	199.	652.	35.6	0.695	61.4	1.200
71.7	230.	755.	60.	175.	574.	15.	193.	634.	34.3	0.668	62.7	1.223
76.2	215.	704.	60.	158.	519.	15.	184.	603.	32.4	0.627	64.7	1.256
80.6	202.	663.	60.	148.	486.	15.	174.	570.	32.1	0.592	66.3	1.266
85.0	190.	622.	60.	143.	469.	15.	160.	525.	33.8	0.554	68.1	1.252
89.4	178.	585.	60.	159.	523.	15.	133.	435.	44.8	0.521	70.5	1.135
93.9	176.	577.	60.	209.	686.	15.	94.	307.	64.3	0.568	73.4	0.903
98.3	193.	634.	60.	242.	794.	15.	94.	309.	67.6	0.641	71.6	0.806
SUCTION SIDE												



APPENDIX D (Cont'd)

LASER DOPPLER VELOCIMETER DATA

95% SPAN 100% SPEED PEAK EFF X/B = .78 PASSAGE NO. 1

STD DAY RPM = 12470.4, RADIUS = 39.929 CM, PHI = -18.3 DEG, STD DAY TTREL = 423. DEG K, UPSTREAM TTABS = 281. DEG K  
 15.720 IN 762. DEG R 505. DEG R

PERCENT GAP	C1 MPS	C1 FPS	ZETA1 DEG	C2 MPS	C2 FPS	ZETA2 DEG	VZ--CORRECTED MPS	FPS	BETA DEG	ABSOLUTE MACH NO	BETA PRIME DEG	RELATIVE MACH NO
PRESSURE SIDE												
11.3	128.	421.	90.	254.	834.	0.	130.	427.	63.2	0.747	62.6	0.761
15.5	140.	460.	90.	205.	674.	0.	142.	466.	55.7	0.671	64.5	0.909
19.7	147.	483.	90.	183.	600.	0.	149.	490.	51.2	0.644	64.9	0.983
23.9	150.	492.	90.	173.	567.	0.	152.	499.	49.1	0.632	65.2	1.016
28.2	153.	501.	90.	164.	538.	0.	155.	508.	47.0	0.623	65.4	1.046
32.4	156.	511.	90.	160.	526.	0.	158.	518.	45.8	0.624	65.1	1.062
36.6	159.	523.	90.	159.	521.	0.	162.	530.	44.9	0.630	64.7	1.072
40.8	163.	536.	90.	163.	535.	0.	166.	543.	44.9	0.645	63.9	1.065
45.0	163.	535.	90.	166.	544.	0.	165.	542.	45.5	0.649	63.8	1.056
49.3	168.	551.	90.	166.	546.	0.	170.	558.	44.7	0.661	63.1	1.062
53.5	173.	566.	90.	170.	558.	0.	175.	574.	44.6	0.677	62.2	1.059
57.7	177.	580.	90.	166.	545.	0.	179.	588.	43.2	0.681	61.9	1.078
61.9	187.	612.	90.	156.	511.	0.	189.	620.	39.9	0.690	61.3	1.125
66.1	194.	637.	90.	149.	490.	0.	197.	646.	37.6	0.701	60.7	1.158
70.4	198.	650.	90.	151.	494.	0.	201.	659.	37.2	0.713	60.2	1.162
74.6	198.	651.	90.	151.	494.	0.	201.	660.	37.2	0.713	60.1	1.162
78.8	202.	662.	90.	148.	484.	0.	204.	671.	36.2	0.719	59.9	1.178
83.0	209.	686.	90.	139.	457.	0.	212.	695.	33.7	0.729	59.6	1.217
87.2	210.	690.	90.	139.	457.	0.	213.	699.	33.5	0.733	59.4	1.220
91.5	209.	687.	90.	148.	486.	0.	212.	696.	35.3	0.740	59.0	1.191
SUCTION SIDE												

## APPENDIX D (Cont'd)

## LASER DOPPLER VELOCIMETER DATA

95% SPAN 100% SPEED PEAK EFF X/B = .91 PASSAGE NO. 1

STD DAY RPM = 12470.4, RADIUS = 39.748 CM, PHI = -18.3 DEG, STD DAY TTREL = 422. DEG K, UPSTREAM TTABS = 281. DEG K  
 15.649 IN 760. DEG R 505. DEG R

PERCENT GAP	C1 MPS	C1 FPS	ZETA1 DEG	C2 MPS	C2 FPS	ZETA2 DEG	VZ--CORRECTED MPS	VZ--CORRECTED FPS	BETA DEG	ABSOLUTE MACH NO	BETA PRIME DEG	RELATIVE MACH NO
PRESSURE SIDE												
11.5	132.	432.	90.	251.	824.	0.	133.	438.	62.3	0.747	62.0	0.769
15.5	139.	456.	90.	234.	769.	0.	141.	462.	59.3	0.725	62.2	0.823
19.5	147.	481.	90.	210.	688.	0.	149.	487.	55.0	0.691	63.0	0.901
23.5	149.	489.	90.	194.	638.	0.	151.	496.	52.5	0.668	63.7	0.947
27.5	148.	485.	90.	183.	601.	0.	150.	492.	51.1	0.646	64.7	0.978
31.5	143.	470.	90.	183.	599.	0.	145.	476.	51.9	0.636	65.4	0.973
35.5	141.	461.	90.	183.	599.	0.	142.	467.	52.4	0.630	65.8	0.969
39.5	139.	457.	90.	185.	606.	0.	141.	463.	53.0	0.632	65.9	0.961
43.5	139.	457.	90.	186.	611.	0.	141.	463.	53.2	0.635	65.8	0.957
47.5	143.	468.	90.	184.	604.	0.	145.	474.	52.2	0.637	65.4	0.968
51.5	146.	479.	90.	184.	605.	0.	148.	485.	51.6	0.644	64.9	0.971
55.5	150.	493.	90.	183.	600.	0.	152.	500.	50.6	0.650	64.3	0.982
59.5	154.	506.	90.	179.	588.	0.	156.	513.	49.3	0.652	64.0	0.998
63.5	159.	522.	90.	175.	574.	0.	161.	529.	47.7	0.655	63.6	1.018
67.5	163.	536.	90.	176.	578.	0.	166.	543.	47.2	0.666	62.9	1.021
71.5	166.	546.	90.	174.	571.	0.	169.	553.	46.3	0.670	62.6	1.032
75.5	172.	563.	90.	172.	563.	0.	174.	571.	45.0	0.677	62.0	1.048
79.5	178.	585.	90.	161.	529.	0.	181.	593.	42.1	0.678	61.8	1.090
83.5	186.	610.	90.	152.	500.	0.	188.	618.	39.3	0.684	61.4	1.129
87.5	196.	644.	90.	151.	494.	0.	199.	653.	37.5	0.708	60.2	1.153
91.5	200.	656.	90.	158.	518.	0.	203.	665.	38.3	0.727	59.3	1.138
SUCTION SIDE												



APPENDIX D (Cont'd)

LASER DOPPLER VELOCIMETER DATA

95% SPAN 100% SPEED PEAK EFF X/B = 1.0 PASSAGE NO. 1

STD DAY RPM = 12470.4, RADIUS = 39.624 CM, PHI = -18.3 DEG, STD DAY TTREL = 421. DEG K, UPSTREAM TTABS = 281. DEG K  
 15.600 IN 758. DEG R 505. DEG R

PERCENT GAP	C1 MPS	C1 FPS	ZETA1 DEG	C2 MPS	C2 FPS	ZETA2 DEG	VZ--CORRECTED MPS	VZ--CORRECTED FPS	BETA DEG	ABSOLUTE MACH NO	BETA PRIME DEG	RELATIVE MACH NO
PRESSURE SIDE												
9.7	113.	371.	90.	265.	871.	0.	115.	376.	66.9	0.752	64.1	0.704
13.5	134.	439.	90.	255.	835.	0.	136.	445.	62.3	0.757	61.2	0.761
17.3	144.	472.	90.	224.	734.	0.	146.	478.	57.3	0.713	62.2	0.856
21.1	148.	485.	90.	211.	693.	0.	150.	492.	55.0	0.697	62.5	0.896
24.9	155.	509.	90.	194.	637.	0.	157.	516.	51.4	0.680	62.7	0.954
28.7	155.	507.	90.	186.	610.	0.	157.	514.	50.3	0.664	63.4	0.976
32.5	150.	491.	90.	183.	599.	0.	152.	498.	50.7	0.649	64.3	0.979
36.3	143.	468.	90.	185.	608.	0.	145.	474.	52.4	0.640	65.2	0.961
40.1	142.	465.	90.	186.	610.	0.	144.	471.	52.7	0.639	65.3	0.958
43.9	139.	457.	90.	187.	612.	0.	141.	463.	53.3	0.636	65.6	0.953
47.7	142.	466.	90.	185.	607.	0.	144.	472.	52.5	0.638	65.3	0.961
51.5	140.	459.	90.	184.	603.	0.	142.	465.	52.7	0.632	65.7	0.961
55.3	144.	473.	90.	181.	595.	0.	146.	479.	51.5	0.636	65.2	0.974
59.1	142.	465.	90.	180.	590.	0.	144.	471.	51.8	0.628	65.7	0.975
62.9	149.	488.	90.	180.	591.	0.	151.	495.	50.5	0.643	64.6	0.985
66.7	147.	482.	90.	179.	588.	0.	149.	488.	50.7	0.637	65.0	0.985
70.5	153.	503.	90.	174.	571.	0.	155.	510.	48.6	0.642	64.4	1.009
74.3	156.	513.	90.	172.	563.	0.	158.	520.	47.7	0.644	64.1	1.021
78.1	166.	545.	90.	166.	545.	0.	168.	552.	45.0	0.657	63.1	1.052
81.9	159.	523.	90.	158.	517.	0.	162.	530.	44.7	0.629	64.6	1.067
85.7	163.	534.	90.	168.	552.	0.	165.	541.	45.9	0.653	63.4	1.040
89.5	172.	565.	90.	171.	562.	0.	175.	573.	44.8	0.679	61.9	1.047
93.3	175.	573.	90.	181.	595.	0.	177.	581.	46.1	0.700	60.8	1.022
SUCTION SIDE												

## APPENDIX D (Cont'd)

## LASER DOPPLER VELOCIMETER DATA

95% SPAN 100% SPEED PEAK EFF X/B = 1.1 PASSAGE NO. 1

STD DAY RPM = 12470.4, RADIUS = 39.487 CM, PHI = -18.3 DEG, STD DAY TTREL = 421. DEG K, UPSTREAM TTABS = 281. DEG K  
 15.546 IN 757. DEG R 505. DEG R

PERCENT GAP	C1 MPS	C1 FPS	ZETA1 DEG	C2 MPS	C2 FPS	ZETA2 DEG	VZ--CORRECTED MPS	FPS	BETA DEG	ABSOLUTE MACH NO	BETA PRIME DEG	RELATIVE MACH NO
PRESSURE SIDE												
1.4	215.	704.	60.	266.	874.	0.	95.	312.	70.6	0.732	67.8	0.674
5.2	221.	726.	60.	289.	948.	0.	90.	295.	72.9	0.776	67.0	0.611
9.0	228.	748.	60.	277.	909.	0.	105.	343.	69.6	0.765	64.8	0.658
12.8	235.	772.	60.	261.	856.	0.	123.	403.	65.1	0.752	62.8	0.722
16.6	235.	770.	60.	239.	784.	0.	135.	442.	60.9	0.725	62.6	0.796
20.4	232.	761.	60.	223.	732.	0.	141.	462.	58.1	0.704	62.9	0.846
24.2	231.	759.	60.	203.	666.	0.	152.	499.	53.6	0.685	62.7	0.917
28.0	233.	763.	60.	193.	634.	0.	159.	522.	50.9	0.682	62.3	0.955
31.8	232.	762.	60.	180.	591.	0.	166.	546.	47.7	0.675	62.2	1.004
35.6	232.	760.	60.	179.	588.	0.	166.	545.	47.5	0.673	62.3	1.006
39.4	228.	747.	60.	182.	596.	0.	160.	525.	49.0	0.664	63.0	0.990
43.2	223.	730.	60.	184.	605.	0.	152.	500.	50.8	0.654	64.0	0.970
47.0	219.	720.	60.	184.	604.	0.	149.	489.	51.4	0.646	64.5	0.966
50.8	218.	716.	60.	182.	596.	0.	149.	489.	51.0	0.642	64.7	0.973
54.6	216.	710.	60.	180.	590.	0.	148.	486.	50.9	0.637	64.9	0.977
58.4	215.	707.	60.	178.	583.	0.	148.	486.	50.5	0.633	65.1	0.984
62.2	216.	709.	60.	177.	581.	0.	149.	490.	50.2	0.635	64.9	0.987
66.0	216.	710.	60.	176.	579.	0.	150.	492.	50.0	0.635	64.9	0.990
69.8	217.	712.	60.	175.	575.	0.	151.	497.	49.6	0.636	64.7	0.995
73.6	220.	721.	60.	172.	563.	0.	157.	514.	48.0	0.641	64.2	1.014
77.4	218.	716.	60.	165.	542.	0.	159.	521.	46.5	0.634	64.4	1.036
81.2	218.	715.	60.	164.	538.	0.	159.	522.	46.3	0.633	64.4	1.040
85.0	219.	720.	60.	165.	540.	0.	161.	527.	46.1	0.637	64.1	1.040
88.8	225.	737.	60.	173.	566.	0.	162.	531.	47.2	0.653	63.4	1.019
92.6	226.	741.	60.	193.	632.	0.	152.	497.	52.2	0.666	63.5	0.946
96.4	232.	761.	60.	203.	667.	0.	152.	500.	53.5	0.687	62.6	0.917
SUCTION SIDE												

APPENDIX D (Cont'd)

LASER DOPPLER VELOCIMETER DATA

95% SPAN 95% SPEED PEAK EFF X/B = -.3 PASSAGE NO. 1

STD DAY RPM = 11846.9, RADIUS = 41.420 CM, PHI = -18.3 DEG, STD DAY TTREL = 419. DEG K, UPSTREAM TTABS = 270. DEG K  
 16.307 IN 755. DEG R 486. DEG R

PERCENT GAP	C1 MPS	C1 FPS	ZETA1 DEG	C2 MPS	C2 FPS	ZETA2 DEG	VZ--CORRECTED MPS	FPS	BETA DEG	ABSOLUTE MACH NO	BETA PRIME DEG	RELATIVE MACH NO
PRESSURE SIDE												
1.5	84.	276.	135.	87.	287.	45.	125.	411.	1.1	0.393	75.5	1.573
5.3	82.	270.	135.	86.	283.	45.	123.	404.	1.3	0.386	75.8	1.569
9.1	78.	257.	135.	84.	277.	45.	119.	390.	2.1	0.372	76.2	1.557
12.9	76.	248.	135.	82.	268.	45.	115.	377.	2.2	0.359	76.6	1.553
16.7	73.	239.	135.	83.	272.	45.	114.	373.	3.7	0.355	76.7	1.539
20.5	68.	224.	135.	81.	267.	45.	109.	359.	5.0	0.341	77.1	1.525
24.3	73.	240.	135.	82.	269.	45.	113.	372.	3.3	0.354	76.8	1.543
28.1	77.	252.	135.	85.	278.	45.	118.	387.	2.8	0.369	76.3	1.551
31.9	89.	292.	135.	91.	299.	45.	132.	432.	0.7	0.414	74.9	1.585
35.7	103.	339.	135.	96.	315.	45.	146.	478.	-2.1	0.463	73.5	1.633
39.5	106.	349.	135.	96.	315.	45.	148.	485.	-2.9	0.472	73.4	1.646
43.3	101.	333.	135.	97.	319.	45.	145.	476.	-1.2	0.460	73.5	1.623
47.1	101.	333.	135.	94.	310.	45.	143.	470.	-2.0	0.455	73.8	1.629
50.9	99.	326.	135.	94.	310.	45.	142.	465.	-1.4	0.449	73.9	1.620
54.7	97.	317.	135.	94.	308.	45.	139.	457.	-0.8	0.440	74.1	1.610
58.5	99.	326.	135.	94.	308.	45.	141.	463.	-1.6	0.448	74.0	1.621
62.3	92.	303.	135.	93.	305.	45.	135.	444.	0.2	0.427	74.5	1.594
66.1	96.	314.	135.	92.	303.	45.	137.	451.	-1.0	0.434	74.3	1.609
69.9	94.	309.	135.	92.	302.	45.	136.	446.	-0.7	0.430	74.5	1.604
73.7	93.	305.	135.	91.	298.	45.	134.	440.	-0.7	0.424	74.7	1.601
77.5	94.	309.	135.	92.	303.	45.	136.	447.	-0.6	0.430	74.4	1.603
81.3	92.	301.	135.	91.	298.	45.	133.	438.	-0.3	0.421	74.7	1.596
85.1	92.	301.	135.	92.	301.	45.	134.	440.	-0.0	0.422	74.6	1.594
88.9	91.	298.	135.	92.	303.	45.	134.	439.	0.5	0.421	74.6	1.589
92.7	90.	296.	135.	93.	305.	45.	134.	439.	0.9	0.421	74.6	1.585
96.5	91.	300.	135.	92.	301.	45.	134.	439.	0.1	0.422	74.7	1.593
SUCTION SIDE												



APPENDIX D (Cont'd)

LASER DOPPLER VELOCIMETER DATA

95% SPAN 95% SPEED PEAK EFF X/B = 0.0 PASSAGE NO. 1

STD DAY RPM = 11846.9, RADIUS = 41.006 CM, PHI = -18.3 DEG, STD DAY TTREL = 417. DEG K, UPSTREAM TTABS = 270. DEG K  
 16.144 IN 751. DEG R 486. DEG R

PERCENT GAP	C1 MPS	C1 FPS	ZETA1 DEG	C2 MPS	C2 FPS	ZETA2 DEG	VZ--CORRECTED MPS	VZ--CORRECTED FPS	BETA DEG	ABSOLUTE MACH NO	BETA PRIME DEG	RELATIVE MACH NO
PRESSURE SIDE												
5.0	100.	329.	135.	94.	308.	45.	142.	465.	-1.9	0.450	73.8	1.609
8.8	98.	321.	135.	89.	292.	45.	136.	448.	-2.7	0.433	74.4	1.610
12.6	97.	318.	135.	85.	280.	45.	133.	437.	-3.6	0.423	74.8	1.614
16.4	98.	323.	135.	92.	302.	45.	139.	457.	-1.9	0.441	74.1	1.605
20.2	98.	321.	135.	87.	285.	45.	135.	443.	-3.4	0.429	74.6	1.615
24.0	96.	315.	135.	87.	287.	45.	134.	440.	-2.7	0.425	74.7	1.606
27.8	96.	315.	135.	89.	292.	45.	135.	443.	-2.2	0.428	74.5	1.602
31.6	91.	299.	135.	99.	324.	45.	139.	455.	2.3	0.436	73.8	1.561
35.4	96.	314.	135.	94.	308.	45.	138.	454.	-0.6	0.437	74.0	1.590
39.2	97.	319.	135.	100.	329.	45.	144.	473.	0.9	0.455	73.3	1.582
43.0	96.	314.	135.	107.	351.	45.	148.	486.	3.2	0.465	72.7	1.562
46.8	98.	320.	135.	107.	350.	45.	149.	489.	2.6	0.469	72.6	1.570
50.6	99.	324.	135.	110.	361.	45.	153.	500.	3.1	0.480	72.2	1.568
54.4	96.	314.	135.	115.	377.	45.	154.	505.	5.2	0.483	71.9	1.546
58.2	96.	315.	135.	115.	377.	45.	154.	506.	5.1	0.484	71.8	1.547
62.0	104.	342.	135.	115.	378.	45.	160.	526.	2.9	0.506	71.4	1.581
65.8	104.	342.	135.	111.	363.	45.	157.	515.	1.7	0.496	71.8	1.590
69.6	103.	337.	135.	116.	381.	45.	160.	525.	3.5	0.504	71.3	1.572
73.4	102.	334.	135.	115.	377.	45.	158.	519.	3.5	0.499	71.5	1.571
77.2	105.	346.	135.	119.	391.	45.	164.	538.	3.5	0.518	70.9	1.578
81.0	101.	330.	135.	117.	384.	45.	159.	522.	4.3	0.500	71.4	1.562
84.8	98.	323.	135.	120.	395.	45.	160.	525.	5.7	0.502	71.1	1.546
88.6	109.	359.	135.	119.	389.	45.	167.	546.	2.3	0.527	70.7	1.596
92.4	87.	285.	135.	119.	389.	45.	150.	492.	8.8	0.470	72.0	1.503
SUCTION SIDE												

## APPENDIX D (Cont'd)

## LASER DOPPLER VELOCIMETER DATA

95% SPAN 95% SPEED PEAK EFF X/B = .13 PASSAGE NO. 1

STD DAY RPM = 11846.9, RADIUS = 40.825 CM, PHI = -18.3 DEG, STD DAY TTREL = 416. DEG K, UPSTREAM TTABS = 270. DEG K  
 16.073 IN, 749. DEG R, 486. DEG R

PERCENT GAP	C1 MPS	C1 FPS	ZETA1 DEG	C2 MPS	C2 FPS	ZETA2 DEG	VZ--CORRECTED MPS	VZ--CORRECTED FPS	BETA DEG	ABSOLUTE MACH NO	BETA PRIME DEG	RELATIVE MACH NO
PRESSURE SIDE												
7.8	151.	496.	60.	140.	459.	15.	111.	365.	47.2	0.457	73.2	1.101
11.8	170.	559.	60.	157.	516.	15.	126.	412.	47.0	0.512	70.4	1.070
15.8	149.	489.	60.	165.	540.	15.	90.	296.	59.3	0.478	75.0	0.980
19.7	122.	399.	60.	166.	544.	15.	51.	166.	72.9	0.455	81.2	0.917
23.7	113.	372.	60.	111.	365.	15.	79.	258.	51.2	0.353	78.5	1.146
27.7	116.	382.	60.	92.	302.	15.	97.	318.	36.7	0.351	76.7	1.249
31.6	119.	391.	60.	74.	243.	15.	114.	374.	23.1	0.371	75.3	1.353
35.6	121.	397.	60.	75.	246.	15.	116.	381.	22.9	0.376	75.0	1.353
39.6	129.	422.	60.	91.	297.	15.	115.	379.	29.7	0.390	74.6	1.291
43.5	130.	427.	60.	79.	258.	15.	126.	414.	21.7	0.407	73.8	1.360
47.5	142.	465.	60.	97.	318.	15.	129.	424.	28.1	0.431	72.7	1.295
51.5	141.	463.	60.	78.	257.	15.	142.	466.	17.9	0.451	72.0	1.397
55.4	144.	474.	60.	82.	270.	15.	144.	472.	19.0	0.458	71.7	1.385
59.4	143.	468.	60.	84.	275.	15.	140.	460.	20.4	0.449	72.0	1.370
63.4	158.	519.	60.	89.	291.	15.	158.	520.	18.3	0.504	69.8	1.394
67.3	160.	524.	60.	83.	273.	15.	165.	540.	15.3	0.520	69.4	1.432
71.3	166.	543.	60.	74.	242.	15.	180.	590.	9.7	0.566	68.3	1.512
83.2	130.	427.	60.	63.	206.	15.	138.	452.	12.4	0.432	73.0	1.452
SUCTION SIDE												

APPENDIX D (Cont'd)

LASER DOPPLER VELOCIMETER DATA

95% SPAN 95% SPEED PEAK EFF X/B = .26 PASSAGE NO. 1

STD DAY RPM = 11846.9, RADIUS = 40.648 CM, PHI = -18.3 DEG, STD DAY TTREL = 415. DEG K, UPSTREAM TTABS = 267. DEG K  
 16.003 IN 747. DEG R 480. DEG R

PERCENT GAP	C1 MPS	C1 FPS	ZETA1 DEG	C2 MPS	C2 FPS	ZETA2 DEG	VZ--CORRECTED MPS	FPS	BETA DEG	ABSOLUTE MACH NO	BETA PRIME DEG	RELATIVE MACH NO
PRESSURE SIDE												
6.9	165.	540.	105.	231.	757.	60.	209.	685.	29.5	0.700	60.3	1.246
11.0	155.	507.	105.	247.	812.	60.	208.	682.	36.7	0.736	58.0	1.132
15.1	168.	550.	105.	268.	880.	60.	225.	739.	36.6	0.797	54.8	1.131
19.1	173.	568.	105.	265.	868.	60.	228.	748.	34.3	0.790	55.5	1.171
23.2	159.	521.	105.	260.	853.	60.	216.	708.	37.8	0.771	56.0	1.112
27.3	165.	540.	105.	256.	841.	60.	219.	717.	35.3	0.764	56.7	1.154
43.6	147.	481.	105.	224.	734.	60.	193.	633.	34.2	0.669	61.4	1.176
47.7	174.	570.	105.	226.	740.	60.	214.	701.	24.9	0.699	61.0	1.317
51.8	204.	669.	105.	216.	709.	60.	232.	762.	11.5	0.741	61.9	1.542
55.8	225.	739.	105.	209.	687.	60.	245.	805.	2.5	0.799	62.4	1.723
59.9	221.	726.	105.	205.	671.	60.	240.	789.	2.1	0.783	62.9	1.719
64.0	213.	700.	105.	209.	685.	60.	236.	775.	6.0	0.760	62.6	1.641
68.1	219.	718.	105.	201.	661.	60.	238.	779.	1.8	0.773	63.3	1.718
72.1	207.	679.	105.	196.	644.	60.	227.	744.	3.8	0.730	64.0	1.660
76.2	206.	677.	105.	187.	614.	60.	223.	731.	0.8	0.723	64.9	1.704
80.3	200.	656.	105.	182.	598.	60.	216.	710.	1.1	0.699	65.5	1.685
84.4	190.	622.	105.	182.	598.	60.	209.	685.	4.8	0.666	65.7	1.613
88.5	182.	596.	105.	178.	583.	60.	201.	660.	6.0	0.639	66.3	1.583
92.5	183.	599.	105.	178.	583.	60.	202.	662.	5.6	0.642	66.3	1.589
SUCTION SIDE												





APPENDIX D (Cont'd)

LASER DOPPLER VELOCIMETER DATA

95% SPAN 95% SPEED PEAK EFF X/B = .52 PASSAGE NO. 1

STD DAY RPM = 11846.9, RADIUS = 40.287 CM, PHI = -18.3 DEG, STD DAY TTREL = 413. DEG K, UPSTREAM TTABS = 268. DEG K  
 15.861 IN 743. DEG R 482. DEG R

PERCENT GAP	C1 MPS	C1 FPS	ZETA1 DEG	C2 MPS	C2 FPS	ZETA2 DEG	VZ--CORRECTED MPS	VZ--CORRECTED FPS	BETA DEG	ABSOLUTE MACH NO	BETA PRIME DEG	RELATIVE MACH NO
PRESSURE SIDE												
1.8	215.	705.	60.	205.	674.	15.	154.	505.	49.4	0.646	63.2	0.959
6.2	217.	712.	60.	213.	699.	15.	151.	496.	51.2	0.656	62.9	0.931
10.7	217.	711.	60.	195.	640.	15.	164.	538.	45.3	0.645	62.7	1.015
15.1	217.	712.	60.	186.	609.	15.	171.	562.	41.8	0.644	62.5	1.062
19.5	216.	710.	60.	163.	536.	15.	187.	613.	33.9	0.647	62.3	1.173
23.9	230.	753.	60.	157.	515.	15.	210.	689.	28.1	0.699	60.3	1.257
28.4	234.	769.	60.	166.	545.	15.	210.	690.	30.1	0.708	59.6	1.226
32.8	234.	769.	60.	170.	559.	15.	207.	680.	31.6	0.705	59.6	1.204
37.2	234.	769.	60.	176.	576.	15.	203.	667.	33.4	0.701	59.6	1.176
41.6	231.	758.	60.	187.	612.	15.	191.	625.	38.1	0.685	60.2	1.107
46.1	239.	785.	60.	190.	623.	15.	200.	655.	37.0	0.710	58.9	1.120
50.5	228.	747.	60.	189.	621.	15.	184.	603.	40.0	0.675	60.8	1.081
54.9	227.	744.	60.	187.	613.	15.	184.	605.	39.4	0.672	60.9	1.090
59.3	220.	723.	60.	179.	586.	15.	181.	595.	38.3	0.654	61.8	1.109
63.8	218.	714.	60.	175.	574.	15.	180.	591.	37.8	0.647	62.2	1.117
68.2	204.	668.	60.	167.	548.	15.	166.	545.	39.1	0.605	64.4	1.109
72.6	195.	639.	60.	152.	499.	15.	164.	539.	36.0	0.581	65.5	1.156
77.0	188.	617.	60.	141.	461.	15.	163.	536.	33.2	0.564	66.3	1.193
81.5	177.	582.	60.	137.	451.	15.	151.	494.	35.5	0.531	68.0	1.174
85.9	171.	561.	60.	137.	451.	15.	141.	464.	37.8	0.511	69.1	1.154
90.3	176.	577.	60.	156.	511.	15.	135.	443.	44.2	0.527	68.9	1.077
94.7	186.	611.	60.	215.	704.	15.	107.	349.	62.2	0.605	69.4	0.834
SUCTION SIDE												



APPENDIX D (Cont'd)

LASER DOPPLER VELOCIMETER DATA

95% SPAN 95% SPEED PEAK EFF X/B = 1.1 PASSAGE NO. 1

STD DAY RPM = 11846.9, RADIUS = 39.487 CM, PHI = -18.3 DEG, STD DAY TTREL = 408. DEG K, UPSTREAM TTABS = 269. DEG K  
 15.546 IN 734. DEG R 484. DEG R

PERCENT GAP	C1 MPS	C1 FPS	ZETA1 DEG	C2 MPS	C2 FPS	ZETA2 DEG	VZ--CORRECTED MPS	FPS	BETA DEG	ABSOLUTE MACH NO	BETA PRIME DEG	RELATIVE MACH NO
PRESSURE SIDE												
2.1	215.	704.	60.	240.	787.	0.	113.	371.	65.5	0.713	63.7	0.697
5.9	215.	704.	60.	242.	794.	0.	112.	367.	65.9	0.716	63.8	0.690
9.7	219.	717.	60.	235.	770.	0.	121.	397.	63.5	0.712	62.7	0.721
13.5	213.	700.	60.	217.	713.	0.	125.	411.	60.9	0.682	63.5	0.774
17.3	212.	695.	60.	199.	653.	0.	134.	440.	56.9	0.659	63.5	0.837
21.1	212.	696.	60.	190.	622.	0.	140.	460.	54.4	0.651	63.3	0.872
24.9	215.	705.	60.	182.	596.	0.	148.	487.	51.7	0.652	62.6	0.906
28.7	213.	698.	60.	174.	572.	0.	150.	492.	50.2	0.642	62.9	0.930
32.5	205.	671.	60.	167.	547.	0.	145.	475.	50.0	0.618	64.3	0.944
36.3	201.	661.	60.	164.	538.	0.	143.	469.	49.9	0.609	64.8	0.949
40.1	202.	663.	60.	165.	541.	0.	143.	469.	50.0	0.611	64.7	0.947
43.9	200.	655.	60.	165.	540.	0.	140.	460.	50.5	0.605	65.2	0.944
47.7	198.	651.	60.	166.	543.	0.	138.	454.	51.1	0.603	65.4	0.938
51.5	197.	647.	60.	163.	534.	0.	138.	454.	50.6	0.598	65.6	0.947
55.3	197.	647.	60.	160.	526.	0.	140.	459.	49.9	0.596	65.5	0.956
59.1	198.	650.	60.	161.	529.	0.	140.	461.	49.9	0.599	65.4	0.954
62.9	198.	650.	60.	159.	521.	0.	142.	466.	49.2	0.598	65.3	0.964
66.7	199.	654.	60.	158.	519.	0.	144.	472.	48.7	0.600	65.1	0.968
70.5	200.	656.	60.	158.	517.	0.	145.	475.	48.4	0.602	65.0	0.971
74.3	199.	654.	60.	152.	500.	0.	147.	483.	47.0	0.598	65.0	0.990
78.1	200.	657.	60.	148.	485.	0.	151.	495.	45.4	0.598	64.7	1.010
81.9	204.	670.	60.	148.	487.	0.	155.	510.	44.7	0.609	64.0	1.015
85.7	209.	686.	60.	158.	520.	0.	155.	509.	46.6	0.625	63.4	0.984
89.5	215.	705.	60.	164.	537.	0.	159.	522.	46.8	0.642	62.4	0.974
93.3	213.	699.	60.	187.	613.	0.	143.	469.	53.5	0.651	63.1	0.883
97.1	218.	714.	60.	203.	665.	0.	139.	456.	56.5	0.675	62.4	0.833
SUCTION SIDE												



APPENDIX D (Cont'd)

LASER DOPPLER VELOCIMETER DATA

95% SPAN      100% SPEED      NEAR SURGE      X/B = -.1      PASSAGE NO. 1

STD DAY RPM = 12470.4,      RADIUS = 41.143 CM,      PHI = -18.3 DEG,      STD DAY TTREL = 432. DEG K,      UPSTREAM TTABS = 271. DEG K  
 16.198 IN      777. DEG R      488. DEG R

PERCENT GAP	C1 MPS	C1 FPS	ZETA1 DEG	C2 MPS	C2 FPS	ZETA2 DEG	VZ--CORRECTED MPS      FPS	BETA DEG	ABSOLUTE MACH NO	BETA PRIME DEG	RELATIVE MACH NO	
PRESSURE SIDE												
2.4	101.	333.	135.	95.	311.	45.	143.	469.	-2.0	0.455	74.5	1.696
6.2	105.	344.	135.	94.	310.	45.	145.	477.	-3.0	0.463	74.3	1.711
10.0	105.	346.	135.	94.	307.	45.	145.	476.	-3.4	0.463	74.4	1.716
13.8	97.	317.	135.	91.	300.	45.	137.	450.	-1.6	0.434	75.1	1.683
17.6	96.	315.	135.	92.	303.	45.	137.	451.	-1.1	0.434	75.0	1.678
21.4	96.	314.	135.	91.	299.	45.	136.	447.	-1.4	0.431	75.1	1.680
25.2	89.	293.	135.	92.	302.	45.	132.	434.	0.9	0.416	75.4	1.651
29.0	89.	293.	135.	95.	312.	45.	134.	441.	1.8	0.422	75.1	1.644
32.8	85.	278.	135.	94.	309.	45.	130.	428.	3.0	0.409	75.5	1.627
36.6	87.	287.	135.	93.	306.	45.	132.	432.	1.8	0.414	75.4	1.641
40.4	87.	287.	135.	97.	317.	45.	134.	440.	2.8	0.421	75.1	1.633
44.2	95.	313.	135.	96.	316.	45.	140.	459.	0.3	0.441	74.7	1.666
48.0	102.	334.	135.	97.	318.	45.	145.	475.	-1.4	0.460	74.2	1.692
51.8	103.	337.	135.	99.	325.	45.	147.	483.	-1.0	0.467	74.0	1.691
55.6	100.	327.	135.	100.	328.	45.	146.	478.	0.1	0.460	74.1	1.676
59.4	106.	347.	135.	98.	323.	45.	149.	488.	-2.1	0.474	73.9	1.706
63.2	100.	328.	135.	95.	311.	45.	142.	466.	-1.5	0.450	74.5	1.690
67.0	91.	299.	135.	88.	290.	45.	131.	429.	-0.9	0.413	75.7	1.667
70.8	78.	256.	135.	86.	283.	45.	120.	393.	2.9	0.374	76.6	1.619
74.6	73.	239.	135.	86.	283.	45.	116.	381.	4.8	0.362	77.0	1.598
78.4	84.	276.	135.	87.	284.	45.	124.	408.	0.8	0.391	76.2	1.643
82.2	82.	268.	135.	96.	314.	45.	129.	424.	4.5	0.404	75.5	1.611
86.0	100.	328.	135.	94.	308.	45.	141.	464.	-1.8	0.448	74.6	1.692
89.8	101.	332.	135.	92.	303.	45.	141.	463.	-2.6	0.449	74.7	1.701
93.6	100.	329.	135.	93.	305.	45.	141.	462.	-2.2	0.447	74.7	1.695
97.4	104.	341.	135.	93.	304.	45.	143.	470.	-3.3	0.457	74.5	1.712
SUCTION SIDE												

APPENDIX D (Cont'd)

LASER DOPPLER VELOCIMETER DATA

95% SPAN    100% SPEED    NEAR SURGE    X/B = 0.0    PASSAGE NO. 1

STD DAY RPM = 12470.4,    RADIUS = 41.006 CM,    PHI = -18.3 DEG,    STD DAY TTREL = 431. DEG K,    UPSTREAM TTABS = 292. DEG K  
 16.144 IN    776. DEG R    525. DEG R

PERCENT GAP	C1 MPS	C1 FPS	ZETA1 DEG	C2 MPS	C2 FPS	ZETA2 DEG	VZ--CORRECTED MPS	VZ--CORRECTED FPS	BETA DEG	ABSOLUTE MACH NO	BETA PRIME DEG	RELATIVE MACH NO
PRESSURE SIDE												
8.8	109.	356.	135.	120.	394.	45.	161.	527.	2.9	0.507	72.2	1.656
12.6	95.	312.	135.	99.	326.	45.	137.	448.	1.3	0.430	74.9	1.646
16.4	101.	330.	135.	96.	314.	45.	138.	453.	-1.4	0.437	74.9	1.676
20.2	99.	324.	135.	89.	291.	45.	132.	432.	-3.1	0.418	75.7	1.685
24.0	109.	357.	135.	98.	321.	45.	145.	477.	-3.0	0.463	74.3	1.705
27.8	98.	323.	135.	101.	333.	45.	141.	461.	0.9	0.443	74.5	1.655
31.6	98.	320.	135.	88.	290.	45.	131.	429.	-2.8	0.414	75.7	1.681
35.4	102.	334.	135.	101.	330.	45.	142.	467.	-0.3	0.449	74.4	1.670
39.2	94.	309.	135.	104.	340.	45.	139.	456.	2.7	0.436	74.5	1.633
43.0	97.	318.	135.	113.	370.	45.	147.	484.	4.3	0.462	73.5	1.624
46.8	98.	321.	135.	109.	359.	45.	146.	478.	3.2	0.457	73.8	1.635
50.6	101.	331.	135.	111.	363.	45.	149.	488.	2.6	0.468	73.5	1.645
54.4	106.	348.	135.	112.	367.	45.	153.	503.	1.5	0.483	73.1	1.663
58.2	102.	336.	135.	116.	379.	45.	153.	503.	3.4	0.482	73.0	1.640
62.0	104.	340.	135.	126.	414.	45.	162.	530.	5.6	0.507	71.9	1.624
65.8	94.	309.	135.	133.	435.	45.	159.	523.	9.6	0.500	71.7	1.573
69.6	98.	320.	135.	127.	417.	45.	158.	518.	7.5	0.495	72.1	1.597
73.4	95.	313.	135.	126.	414.	45.	156.	511.	7.9	0.488	72.3	1.591
77.2	97.	319.	135.	123.	404.	45.	155.	508.	6.7	0.485	72.5	1.604
81.0	90.	294.	135.	119.	391.	45.	147.	481.	8.1	0.459	73.3	1.582
SUCTION SIDE												

APPENDIX D (Cont'd)

LASER DOPPLER VELOCIMETER DATA

95% SPAN    100% SPEED    NEAR SURGE    X/B = .13    PASSAGE NO. 1

STD DAY RPM = 12470.4,    RADIUS = 40.825 CM,    PHI = -18.3 DEG,    STD DAY TTREL = 429. DEG K,    UPSTREAM TTABS = 292. DEG K  
 16.073 IN    773. DEG R    525. DEG R

PERCENT GAP	C1 MPS	C1 FPS	ZETA1 DEG	C2 MPS	C2 FPS	ZETA2 DEG	VZ--CORRECTED MPS	VZ--CORRECTED FPS	BETA DEG	ABSOLUTE MACH NO	BETA PRIME DEG	RELATIVE MACH NO
PRESSURE SIDE												
3.9	214.	701.	60.	220.	723.	15.	135.	444.	54.6	0.625	67.4	0.974
7.8	233.	766.	60.	239.	784.	15.	149.	489.	54.1	0.677	64.4	0.949
11.8	238.	780.	60.	253.	831.	15.	145.	475.	56.9	0.699	63.9	0.900
15.8	230.	753.	60.	306.	1003.	15.	97.	317.	71.5	0.769	67.4	0.665
19.7	214.	703.	60.	235.	770.	15.	126.	413.	58.8	0.641	67.8	0.914
23.7	194.	637.	60.	221.	725.	15.	108.	355.	61.4	0.596	71.2	0.921
27.7	183.	602.	60.	190.	622.	15.	116.	380.	54.8	0.542	71.7	1.031
31.6	173.	568.	60.	172.	564.	15.	114.	375.	52.0	0.507	72.7	1.084
35.6	178.	585.	60.	152.	500.	15.	135.	443.	41.8	0.509	71.0	1.190
39.6	184.	604.	60.	135.	444.	15.	155.	508.	32.3	0.529	69.5	1.293
43.5	189.	620.	60.	138.	453.	15.	160.	523.	31.9	0.543	68.8	1.294
47.5	209.	685.	60.	141.	463.	15.	184.	605.	27.5	0.608	66.1	1.344
51.5	207.	679.	60.	137.	450.	15.	185.	606.	26.4	0.606	66.2	1.359
55.4	218.	716.	60.	134.	441.	15.	202.	662.	22.7	0.652	64.7	1.415
59.4	222.	727.	60.	130.	425.	15.	210.	688.	20.2	0.672	64.1	1.456
67.3	146.	480.	135.	226.	741.	60.	240.	786.	8.1	0.768	63.2	1.687
71.3	142.	466.	135.	226.	742.	60.	238.	780.	9.1	0.760	63.2	1.666
75.3	141.	461.	135.	216.	708.	60.	229.	752.	7.9	0.733	64.3	1.673
79.2	141.	463.	135.	204.	669.	60.	221.	725.	5.8	0.707	65.5	1.695
83.2	140.	460.	135.	198.	650.	60.	216.	710.	5.1	0.692	66.1	1.700
87.2	137.	449.	135.	195.	639.	60.	212.	696.	5.3	0.677	66.5	1.689
91.1	137.	451.	135.	193.	632.	60.	211.	692.	4.8	0.673	66.7	1.696
SUCTION SIDE												

## APPENDIX D (Cont'd)

## LASER DOPPLER VELOCIMETER DATA

95% SPAN 100% SPEED NEAR SURGE X/B = .26 PASSAGE NO. 1

STD DAY RPM = 12470.4, RADIUS = 40.648 CM, PHI = -18.3 DEG, STD DAY TTREL = 428. DEG K, UPSTREAM TTABS = 292. DEG K  
 16.003 IN 771. DEG R 525. DEG R

PERCENT GAP	C1 MPS	C1 FPS	ZETA1 DEG	C2 MPS	C2 FPS	ZETA2 DEG	VZ--CORRECTED MPS	VZ--CORRECTED FPS	BETA DEG	ABSOLUTE MACH NO	BETA PRIME DEG	RELATIVE MACH NO
PRESSURE SIDE												
6.9	250.	819.	60.	249.	818.	15.	164.	537.	52.4	0.717	61.5	0.947
11.0	280.	919.	60.	248.	813.	15.	206.	676.	44.1	0.787	56.7	1.055
15.1	317.	1039.	60.	259.	851.	15.	248.	813.	39.0	0.890	51.7	1.139
19.1	312.	1023.	60.	269.	881.	15.	235.	770.	42.3	0.874	52.1	1.076
23.2	313.	1027.	60.	280.	919.	15.	228.	749.	44.9	0.877	51.6	1.027
27.3	323.	1059.	60.	294.	964.	15.	232.	760.	46.0	0.905	50.0	1.003
31.4	314.	1029.	60.	337.	1105.	15.	189.	621.	57.4	0.912	49.7	0.787
35.4	310.	1018.	60.	307.	1007.	15.	206.	674.	51.7	0.881	51.3	0.899
39.5	310.	1017.	60.	306.	1003.	15.	206.	676.	51.5	0.879	51.4	0.904
43.6	305.	1000.	60.	283.	930.	15.	215.	704.	47.5	0.857	52.7	0.982
47.7	284.	931.	60.	286.	937.	15.	185.	606.	52.9	0.812	55.8	0.899
51.8	276.	907.	60.	272.	894.	15.	184.	603.	51.5	0.788	57.1	0.932
55.8	218.	715.	105.	258.	846.	60.	247.	810.	19.0	0.794	59.7	1.498
59.9	245.	804.	105.	251.	824.	60.	264.	865.	9.2	0.851	60.4	1.701
64.0	241.	792.	105.	238.	782.	60.	256.	841.	6.6	0.830	61.7	1.738
68.1	245.	805.	105.	235.	772.	60.	258.	847.	4.6	0.840	61.9	1.781
72.1	244.	799.	105.	232.	762.	60.	256.	839.	4.2	0.832	62.3	1.784
76.2	246.	806.	105.	223.	731.	60.	254.	832.	0.8	0.836	63.1	1.850
80.3	230.	755.	105.	211.	692.	60.	238.	782.	1.5	0.778	64.4	1.800
84.4	219.	718.	105.	202.	662.	60.	227.	745.	1.9	0.736	65.4	1.768
88.5	212.	694.	105.	193.	634.	60.	219.	718.	1.3	0.708	66.3	1.763
92.5	208.	681.	105.	184.	604.	60.	213.	698.	-0.7	0.692	67.2	1.785
96.6	205.	672.	105.	180.	590.	60.	209.	687.	-1.4	0.681	67.6	1.790
SUCTION SIDE												



APPENDIX D (Cont'd)

LASER DOPPLER VELOCIMETER DATA

95% SPAN, 100% SPEED, NEAR SURGE, X/B = .39 PASSAGE NO. 1

STD DAY RPM = 12470.4, RADIUS = 40.467 CM, PHI = -18.3 DEG, STD DAY TTREL = 427. DEG K, UPSTREAM TTABS = 292. DEG K  
 15.932 IN 769. DEG R 525. DEG R

PERCENT GAP	C1 MPS	C1 FPS	ZETA1 DEG	C2 MPS	C2 FPS	ZETA2 DEG	VZ--CORRECTED MPS	VZ--CORRECTED FPS	BETA DEG	ABSOLUTE MACH NO	BETA PRIME DEG	RELATIVE MACH NO
PRESSURE SIDE												
6.1	236.	774.	60.	227.	744.	15.	161.	528.	49.8	0.674	63.4	1.000
10.4	254.	832.	60.	236.	775.	15.	178.	585.	47.6	0.718	60.6	1.014
14.6	221.	724.	60.	196.	642.	15.	162.	532.	44.3	0.625	65.3	1.097
18.8	232.	761.	60.	198.	649.	15.	176.	577.	41.6	0.655	63.5	1.123
23.1	237.	778.	60.	208.	682.	15.	176.	577.	43.5	0.670	62.9	1.091
27.3	230.	755.	60.	212.	695.	15.	164.	537.	46.8	0.653	64.1	1.051
31.6	249.	816.	60.	217.	712.	15.	185.	608.	43.2	0.701	61.2	1.086
35.8	237.	776.	60.	215.	704.	15.	170.	559.	45.8	0.670	63.1	1.058
40.0	229.	751.	60.	210.	690.	15.	163.	535.	46.7	0.650	64.2	1.054
44.3	221.	725.	60.	199.	653.	15.	160.	525.	45.3	0.627	65.3	1.082
48.5	201.	660.	60.	211.	691.	15.	125.	410.	55.7	0.594	69.1	0.973
52.8	209.	685.	60.	203.	666.	15.	141.	462.	50.6	0.602	67.5	1.028
57.0	196.	644.	60.	192.	629.	15.	132.	432.	50.9	0.568	69.3	1.044
61.2	203.	666.	60.	171.	561.	15.	155.	510.	40.8	0.576	67.4	1.161
65.5	187.	613.	60.	158.	519.	15.	143.	468.	41.2	0.532	69.6	1.175
69.7	185.	606.	60.	140.	458.	15.	153.	501.	33.9	0.529	69.3	1.261
73.9	155.	508.	105.	180.	589.	60.	174.	571.	17.6	0.553	68.8	1.464
78.2	170.	557.	105.	176.	579.	60.	184.	602.	10.2	0.578	68.7	1.568
82.4	180.	590.	105.	171.	560.	60.	188.	618.	3.9	0.598	68.9	1.662
86.7	187.	614.	105.	173.	569.	60.	195.	639.	2.3	0.621	68.5	1.695
90.9	196.	642.	105.	176.	577.	60.	202.	661.	0.2	0.649	68.1	1.740
SUCTION SIDE												

## APPENDIX D (Cont'd)

## LASER DOPPLER VELOCIMETER DATA

95% SPAN 100% SPEED NEAR SURGE X/B = .52 PASSAGE NO. 1

STD DAY RPM = 12470.4, RADIUS = 40.287 CM, PHI = -18.3 DEG, STD DAY TTREL = 426. DEG K, UPSTREAM TTABS = 292. DEG K  
 15.861 IN 767. DEG R 525. DEG R

PERCENT GAP	C1 MPS	C1 FPS	ZETA1 DEG	C2 MPS	C2 FPS	ZETA2 DEG	VZ--CORRECTED MPS	VZ--CORRECTED FPS	BETA DEG	ABSOLUTE MACH NO	BETA PRIME DEG	RELATIVE MACH NO
PRESSURE SIDE												
1.8	208.	682.	60.	240.	787.	15.	114.	373.	62.3	0.640	68.9	0.860
6.2	229.	750.	60.	232.	760.	15.	148.	484.	53.4	0.663	64.6	0.952
10.7	228.	747.	60.	226.	742.	15.	150.	493.	52.0	0.657	64.6	0.973
15.1	230.	753.	60.	209.	687.	15.	164.	540.	46.2	0.651	64.0	1.055
19.5	232.	760.	60.	203.	665.	15.	172.	565.	43.4	0.655	63.5	1.093
23.9	239.	785.	60.	202.	662.	15.	183.	601.	40.9	0.675	62.3	1.122
28.4	250.	819.	60.	200.	657.	15.	198.	650.	37.7	0.705	60.8	1.165
32.8	246.	806.	60.	208.	683.	15.	187.	614.	41.2	0.693	61.4	1.113
37.2	250.	820.	60.	199.	653.	15.	199.	654.	37.2	0.707	60.7	1.172
41.6	253.	829.	60.	201.	661.	15.	201.	661.	37.3	0.714	60.3	1.170
46.1	236.	774.	60.	213.	700.	15.	170.	559.	45.6	0.668	63.0	1.057
50.5	249.	816.	60.	208.	682.	15.	192.	629.	40.3	0.701	61.0	1.125
54.9	242.	794.	60.	212.	697.	15.	179.	588.	43.6	0.683	62.0	1.081
59.3	221.	726.	60.	194.	636.	15.	164.	539.	43.4	0.627	65.0	1.102
63.8	210.	689.	60.	185.	608.	15.	155.	508.	43.9	0.596	66.6	1.108
68.2	214.	703.	60.	163.	535.	15.	176.	579.	34.4	0.611	65.4	1.231
72.6	198.	648.	60.	157.	515.	15.	158.	518.	37.1	0.562	67.8	1.207
77.0	192.	631.	60.	151.	496.	15.	155.	508.	36.4	0.548	68.4	1.220
81.5	189.	620.	60.	148.	485.	15.	153.	501.	36.1	0.539	68.8	1.227
85.9	198.	650.	60.	170.	558.	15.	149.	490.	42.1	0.563	68.1	1.145
90.3	211.	691.	60.	193.	632.	15.	151.	494.	46.4	0.600	66.7	1.075
SUCTION SIDE												

APPENDIX D (Cont'd)

LASER DOPPLER VELOCIMETER DATA

95% SPAN 100% SPEED NEAR SURGE X/B = .78 PASSAGE NO. 1

STD DAY RPM = 12470.4, RADIUS = 39.929 CM, PHI = -18.3 DEG, STD DAY TTREL = 423. DEG K, UPSTREAM TTABS = 292. DEG K  
 15.720 IN 762. DEG R 525. DEG R

PERCENT GAP	C1 MPS	C1 FPS	ZETA1 DEG	C2 MPS	C2 FPS	ZETA2 DEG	V7--CORRECTED MPS	FPS	BETA DEG	ABSOLUTE MACH NO	BETA PRIME DEG	RELATIVE MACH NO
PRESSURE SIDE												
3.7	225.	739.	60.	272.	893.	0.	102.	336.	69.3	0.739	66.8	0.693
7.9	228.	747.	60.	273.	895.	0.	105.	344.	68.9	0.743	66.2	0.695
12.1	229.	752.	60.	235.	772.	0.	128.	420.	61.3	0.697	64.9	0.820
16.3	228.	749.	60.	213.	700.	0.	140.	458.	56.6	0.674	64.6	0.895
20.6	226.	740.	60.	205.	674.	0.	141.	463.	55.4	0.662	64.9	0.918
24.8	220.	722.	60.	198.	650.	0.	139.	456.	54.8	0.645	65.7	0.936
29.0	222.	727.	60.	196.	643.	0.	142.	465.	53.9	0.646	65.4	0.946
33.2	215.	707.	60.	193.	632.	0.	137.	449.	54.5	0.631	66.4	0.948
37.4	215.	707.	60.	193.	632.	0.	137.	449.	54.5	0.631	66.4	0.948
41.7	218.	716.	60.	193.	632.	0.	140.	459.	53.8	0.637	65.9	0.952
45.9	221.	726.	60.	195.	640.	0.	142.	466.	53.8	0.645	65.5	0.948
50.1	226.	741.	60.	191.	627.	0.	150.	491.	51.8	0.652	64.6	0.970
54.3	226.	742.	60.	195.	639.	0.	148.	485.	52.6	0.655	64.6	0.957
58.5	232.	762.	60.	187.	612.	0.	160.	523.	49.3	0.664	63.4	0.998
62.8	221.	726.	60.	186.	610.	0.	147.	483.	51.4	0.639	65.3	0.982
67.0	233.	766.	60.	191.	626.	0.	158.	520.	50.1	0.669	63.3	0.984
71.2	232.	760.	60.	166.	546.	0.	170.	559.	44.2	0.656	63.2	1.072
75.4	235.	770.	60.	169.	553.	0.	173.	566.	44.1	0.665	62.8	1.069
79.6	242.	794.	60.	161.	527.	0.	186.	609.	40.7	0.684	61.6	1.114
83.9	243.	798.	60.	170.	557.	0.	182.	596.	42.9	0.687	61.5	1.081
88.1	246.	808.	60.	180.	590.	0.	179.	589.	44.9	0.697	61.1	1.048
92.3	262.	861.	60.	198.	649.	0.	188.	616.	46.3	0.742	58.7	1.012
SUCTION SIDE												

## APPENDIX D (Cont'd)

## LASER DOPPLER VELOCIMETER DATA

95% SPAN    100% SPEED    NEAR SURGE    X/B = 1.1    PASSAGE NO. 1

STD DAY RPM = 12470.4,    RADIUS = 39.487 CM,    PHI = -18.3 DEG,    STD DAY TTREL = 421. DEG K,    UPSTREAM TTABS = 292. DEG K  
15.546 IN    757. DEG R    525. DEG R

PERCENT GAP	C1 MPS	C1 FPS	ZETA1 DEG	C2 MPS	C2 FPS	ZETA2 DEG	VZ--CORRECTED MPS	VZ--CORRECTED FPS	BETA DEG	ABSOLUTE MACH NO	BETA PRIME DEG	RELATIVE MACH NO
PRESSURE SIDE												
2.1	213.	698.	60.	282.	924.	0.	83.	271.	73.6	0.741	69.7	0.635
5.9	225.	737.	60.	283.	930.	0.	95.	312.	71.3	0.757	66.8	0.644
9.7	227.	746.	60.	274.	899.	0.	104.	340.	69.2	0.746	65.8	0.678
13.5	224.	734.	60.	256.	840.	0.	110.	360.	66.7	0.716	66.1	0.731
17.3	220.	722.	60.	238.	782.	0.	116.	380.	64.0	0.687	66.4	0.784
21.1	215.	707.	60.	234.	767.	0.	113.	371.	64.0	0.674	67.2	0.793
24.9	217.	712.	60.	223.	731.	0.	121.	398.	61.3	0.664	66.5	0.833
28.7	201.	659.	60.	217.	711.	0.	106.	348.	63.8	0.630	69.6	0.832
32.5	211.	691.	60.	199.	654.	0.	127.	418.	57.3	0.628	67.1	0.905
36.3	208.	681.	60.	203.	665.	0.	122.	400.	58.8	0.625	67.8	0.889
40.1	189.	620.	60.	220.	722.	0.	91.	297.	67.5	0.617	72.2	0.807
43.9	198.	650.	60.	191.	627.	0.	118.	386.	58.2	0.596	69.2	0.916
47.7	198.	651.	60.	194.	636.	0.	116.	382.	58.8	0.600	69.2	0.907
51.5	211.	691.	60.	201.	658.	0.	127.	415.	57.6	0.629	67.1	0.900
55.3	208.	682.	60.	212.	695.	0.	117.	384.	60.9	0.636	68.0	0.857
59.1	197.	647.	60.	205.	671.	0.	109.	358.	61.8	0.609	69.8	0.869
62.9	196.	644.	60.	212.	695.	0.	104.	340.	63.8	0.617	70.3	0.843
66.7	195.	639.	60.	190.	623.	0.	115.	376.	58.7	0.589	69.7	0.916
70.5	208.	681.	60.	190.	623.	0.	129.	424.	55.6	0.614	67.4	0.934
74.3	199.	652.	60.	183.	601.	0.	123.	403.	56.0	0.590	68.8	0.945
78.1	205.	671.	60.	184.	604.	0.	129.	424.	54.8	0.603	67.8	0.950
81.9	206.	676.	60.	188.	616.	0.	129.	422.	55.4	0.609	67.6	0.939
85.7	195.	640.	60.	201.	661.	0.	108.	355.	61.6	0.602	70.1	0.876
89.5	196.	644.	60.	177.	581.	0.	124.	406.	54.9	0.580	69.0	0.964
93.3	190.	622.	60.	239.	784.	0.	80.	264.	71.3	0.647	73.1	0.746
97.1	196.	644.	60.	213.	700.	0.	103.	337.	64.1	0.619	70.4	0.837
SUCTION SIDE												

APPENDIX D (Cont'd)

LASER DOPPLER VELOCIMETER DATA

85% SPAN 100% SPEED PEAK EFF X/B = -.3 PASSAGE NO. 1

STD DAY RPM = 12470.4, RADIUS = 39.306 CM, PHI = -14.6 DEG, STD DAY TTREL = 419. DEG K, UPSTREAM TTABS = 271. DEG K  
 15.475 IN 754. DEG R 487. DEG R

PERCENT GAP	C1 MPS	C1 FPS	ZETA1 DEG	C2 MPS	C2 FPS	ZETA2 DEG	VZ--CORRECTED MPS	VZ--CORRECTED FPS	BETA DEG	ABSOLUTE MACH NO	BETA PRIME DEG	RELATIVE MACH NO
PRESSURE SIDE												
0.4	135.	443.	135.	133.	436.	45.	196.	641.	-0.5	0.617	68.6	1.690
4.2	132.	433.	135.	132.	434.	45.	193.	633.	0.1	0.607	68.8	1.677
8.0	126.	413.	135.	129.	424.	45.	186.	611.	0.8	0.584	69.4	1.656
11.8	122.	399.	135.	126.	415.	45.	181.	594.	1.1	0.566	69.8	1.642
15.6	116.	380.	135.	125.	409.	45.	175.	576.	2.1	0.546	70.3	1.621
19.4	110.	361.	135.	120.	394.	45.	168.	551.	2.5	0.521	71.1	1.605
23.2	103.	337.	135.	116.	382.	45.	160.	525.	3.6	0.494	71.8	1.582
27.0	98.	323.	135.	113.	371.	45.	154.	506.	4.0	0.476	72.4	1.571
30.8	99.	324.	135.	112.	368.	45.	154.	505.	3.6	0.475	72.5	1.574
34.6	105.	346.	135.	114.	373.	45.	160.	525.	2.2	0.496	72.0	1.599
38.4	121.	397.	135.	121.	396.	45.	176.	579.	-0.1	0.552	70.5	1.651
42.2	128.	420.	135.	125.	409.	45.	184.	605.	-0.8	0.580	69.7	1.674
46.0	128.	419.	135.	126.	413.	45.	185.	607.	-0.4	0.582	69.6	1.671
49.8	128.	419.	135.	126.	413.	45.	185.	607.	-0.4	0.582	69.6	1.671
53.6	129.	422.	135.	125.	411.	45.	185.	608.	-0.8	0.583	69.6	1.676
57.4	131.	431.	135.	127.	416.	45.	188.	618.	-1.0	0.594	69.4	1.685
61.2	134.	440.	135.	129.	422.	45.	192.	629.	-1.2	0.606	69.0	1.694
65.0	138.	452.	135.	130.	428.	45.	196.	642.	-1.6	0.621	68.7	1.707
68.8	141.	461.	135.	131.	431.	45.	198.	651.	-1.9	0.631	68.5	1.718
72.6	141.	462.	135.	131.	431.	45.	199.	652.	-2.0	0.632	68.5	1.720
76.4	141.	463.	135.	133.	436.	45.	200.	656.	-1.7	0.635	68.3	1.718
80.2	140.	458.	135.	134.	438.	45.	199.	654.	-1.3	0.632	68.3	1.710
84.0	138.	453.	135.	131.	431.	45.	197.	645.	-1.4	0.623	68.6	1.707
87.8	136.	446.	135.	130.	427.	45.	194.	637.	-1.2	0.614	68.8	1.700
91.6	134.	439.	135.	130.	426.	45.	192.	631.	-0.9	0.608	68.9	1.690
95.4	131.	431.	135.	127.	418.	45.	189.	620.	-0.9	0.596	69.3	1.684
99.2	128.	421.	135.	127.	416.	45.	186.	611.	-0.3	0.585	69.5	1.671
SUCTION SIDE												



APPENDIX D (Cont'd)

LASER DOPPLER VELOCIMETER DATA

85% SPAN 100% SPEED PEAK EFF X/B = -.1 PASSAGE NO. 1

STD DAY RPM = 12470.4, RADIUS = 39.050 CM, PHI = -14.6 DEG, STD DAY TTREL = 417. DEG K, UPSTREAM TTABS = 274. DEG K  
 15.374 IN 751. DEG R 493. DEG R

PERCENT GAP	C1 MPS	C1 FPS	ZETA1 DEG	C2 MPS	C2 FPS	ZETA2 DEG	VZ--CORRECTED MPS	VZ--CORRECTED FPS	BETA DEG	ABSOLUTE MACH NO	BETA PRIME DEG	RELATIVE MACH NO
PRESSURE SIDE												
0.8	134.	439.	135.	137.	451.	45.	197.	646.	0.8	0.619	68.2	1.664
4.6	134.	439.	135.	140.	458.	45.	198.	651.	1.2	0.623	67.9	1.660
8.4	137.	451.	135.	141.	461.	45.	202.	661.	0.6	0.636	67.7	1.675
12.2	144.	472.	135.	143.	470.	45.	208.	683.	-0.1	0.660	67.1	1.699
16.0	148.	484.	135.	144.	471.	45.	211.	693.	-0.8	0.672	67.0	1.716
19.8	151.	496.	135.	143.	470.	45.	214.	701.	-1.5	0.682	66.8	1.734
23.6	149.	490.	135.	143.	468.	45.	212.	695.	-1.3	0.675	67.0	1.726
27.4	148.	485.	135.	143.	468.	45.	211.	691.	-1.0	0.671	67.0	1.719
31.2	144.	472.	135.	141.	464.	45.	207.	679.	-0.5	0.656	67.3	1.703
35.0	142.	466.	135.	139.	456.	45.	204.	669.	-0.6	0.646	67.6	1.699
38.8	141.	461.	135.	139.	457.	45.	203.	666.	-0.2	0.642	67.7	1.691
42.6	138.	452.	135.	137.	448.	45.	199.	653.	-0.3	0.629	68.1	1.684
46.4	133.	436.	135.	135.	442.	45.	194.	637.	0.4	0.611	68.5	1.665
50.2	128.	421.	135.	133.	437.	45.	190.	622.	1.1	0.595	68.8	1.647
54.0	122.	401.	135.	130.	427.	45.	183.	601.	1.8	0.572	69.4	1.627
57.8	116.	381.	135.	127.	416.	45.	176.	578.	2.5	0.548	70.1	1.607
61.6	105.	346.	135.	122.	400.	45.	165.	541.	4.1	0.510	71.1	1.571
65.4	98.	322.	135.	119.	391.	45.	158.	517.	5.5	0.486	71.8	1.547
69.2	97.	317.	135.	117.	384.	45.	155.	508.	5.5	0.477	72.1	1.545
73.0	103.	337.	135.	118.	388.	45.	160.	526.	4.0	0.495	71.6	1.567
76.8	126.	412.	135.	125.	410.	45.	182.	596.	-0.1	0.570	69.8	1.651
80.6	130.	428.	135.	130.	427.	45.	189.	620.	-0.1	0.594	69.1	1.663
84.4	132.	432.	135.	131.	430.	45.	191.	625.	-0.1	0.600	68.9	1.666
88.2	133.	437.	135.	131.	430.	45.	192.	629.	-0.5	0.604	68.8	1.673
92.0	136.	447.	135.	132.	433.	45.	195.	638.	-0.9	0.615	68.6	1.685
95.8	139.	455.	135.	134.	438.	45.	197.	648.	-1.1	0.625	68.3	1.694
99.6	143.	470.	135.	135.	442.	45.	202.	661.	-1.8	0.641	68.0	1.712
SUCTION SIDE												

APPENDIX D (Cont'd)

LASER DOPPLER VELOCIMETER DATA

85% SPAN 100% SPEED PEAK EFF X/B = 0.0 PASSAGE NO. 1

STD DAY RPM = 12470.4, RADIUS = 38.923 CM, PHI = -14.6 DEG, STD DAY TTREL = 417. DEG K, UPSTREAM TTABS = 274. DEG K  
 15.324 IN 750. DEG R 493. DEG R

PERCENT GAP	C1 MPS	C1 FPS	ZETA1 DEG	C2 MPS	C2 FPS	ZETA2 DEG	VZ--CORRECTED MPS	VZ--CORRECTED FPS	BETA DEG	ABSOLUTE MACH NO	BETA PRIME DEG	RELATIVE MACH NO
PRESSURE SIDE												
3.1	119.	389.	135.	143.	470.	45.	190.	623.	5.4	0.590	68.2	1.581
6.9	138.	454.	135.	140.	458.	45.	202.	661.	0.3	0.636	67.7	1.675
10.7	141.	464.	135.	140.	460.	45.	204.	670.	-0.2	0.646	67.5	1.688
14.5	141.	464.	135.	141.	462.	45.	205.	672.	-0.1	0.648	67.4	1.687
18.3	142.	465.	135.	141.	462.	45.	205.	672.	-0.2	0.649	67.4	1.688
22.1	140.	459.	135.	142.	465.	45.	204.	670.	0.4	0.645	67.4	1.678
25.9	140.	459.	135.	143.	469.	45.	205.	673.	0.6	0.648	67.3	1.676
29.7	140.	459.	135.	144.	473.	45.	206.	676.	0.9	0.650	67.1	1.674
33.5	142.	467.	135.	145.	476.	45.	208.	684.	0.5	0.659	67.0	1.683
37.3	145.	477.	135.	146.	479.	45.	211.	693.	0.1	0.670	66.7	1.696
41.1	148.	487.	135.	145.	477.	45.	213.	699.	-0.6	0.678	66.7	1.711
44.9	156.	511.	135.	145.	477.	45.	218.	717.	-2.0	0.700	66.4	1.746
48.7	156.	513.	135.	146.	479.	45.	219.	720.	-2.0	0.703	66.3	1.748
52.5	157.	514.	135.	145.	477.	45.	219.	719.	-2.1	0.703	66.3	1.750
56.3	155.	508.	135.	145.	476.	45.	218.	714.	-1.9	0.697	66.4	1.742
60.1	154.	506.	135.	145.	475.	45.	217.	712.	-1.8	0.694	66.5	1.740
63.9	153.	501.	135.	145.	476.	45.	216.	709.	-1.5	0.690	66.5	1.732
67.7	153.	501.	135.	144.	472.	45.	215.	706.	-1.7	0.688	66.6	1.734
71.5	150.	493.	135.	143.	470.	45.	213.	698.	-1.4	0.679	66.8	1.724
75.3	148.	487.	135.	144.	472.	45.	212.	696.	-0.9	0.675	66.8	1.714
79.1	145.	476.	135.	145.	477.	45.	211.	691.	0.1	0.668	66.8	1.695
82.9	143.	469.	135.	144.	472.	45.	208.	683.	0.2	0.658	67.1	1.688
86.7	139.	456.	135.	143.	469.	45.	204.	671.	0.8	0.645	67.3	1.672
90.5	135.	442.	135.	143.	469.	45.	201.	661.	1.7	0.633	67.5	1.652
94.3	124.	407.	135.	145.	476.	45.	195.	640.	4.5	0.608	67.8	1.602
SUCTION SIDE												



APPENDIX D (Cont'd)

LASER DOPPLER VELOCIMETER DATA

85% SPAN 100% SPEED PEAK EFF X/B = .13 PASSAGE NO. 1

STD DAY RPM = 12470.4, RADIUS = 38.755 CM, PHI = -14.6 DEG, STD DAY TTREL = 416. DEG K, UPSTREAM TTABS = 274. DEG K  
 15.258 IN 748. DEG R 493. DEG R

PERCENT GAP	C1 MPS	C1 FPS	ZETA1 DEG	C2 MPS	C2 FPS	ZETA2 DEG	VZ--CORRECTED		BETA DEG	ABSOLUTE MACH NO	BETA PRIME DEG	RELATIVE MACH NO
							MPS	FPS				
PRESSURE SIDE												
13.0	129.	423.	105.	213.	699.	60.	174.	569.	38.2	0.617	64.1	1.125
17.0	130.	426.	105.	217.	711.	60.	176.	576.	38.7	0.628	63.6	1.116
20.9	138.	454.	105.	203.	666.	60.	177.	579.	32.1	0.594	65.2	1.213
24.9	164.	538.	105.	176.	576.	60.	185.	606.	12.2	0.572	67.7	1.478
28.9	174.	572.	105.	165.	542.	60.	188.	618.	3.8	0.587	68.5	1.596
32.8	176.	579.	105.	167.	547.	60.	191.	625.	3.6	0.594	68.3	1.602
36.8	180.	591.	105.	168.	552.	60.	194.	636.	2.8	0.606	68.0	1.618
40.7	183.	600.	105.	171.	562.	60.	197.	646.	3.0	0.616	67.7	1.620
44.7	187.	612.	105.	175.	573.	60.	201.	659.	3.0	0.629	67.3	1.626
48.7	193.	633.	105.	176.	579.	60.	206.	676.	1.4	0.650	67.0	1.660
52.6	196.	642.	105.	180.	591.	60.	210.	688.	1.8	0.660	66.6	1.659
56.6	200.	657.	105.	183.	602.	60.	214.	703.	1.5	0.677	66.2	1.673
60.5	202.	662.	105.	185.	607.	60.	216.	708.	1.5	0.682	66.0	1.675
64.5	205.	672.	105.	186.	611.	60.	218.	717.	1.0	0.693	65.8	1.690
68.4	209.	685.	105.	188.	618.	60.	222.	729.	0.4	0.707	65.5	1.706
72.4	210.	689.	105.	188.	617.	60.	223.	731.	-0.1	0.711	65.5	1.717
76.4	208.	683.	105.	188.	617.	60.	222.	727.	0.5	0.705	65.6	1.704
80.3	211.	692.	105.	187.	612.	60.	223.	732.	-0.9	0.713	65.7	1.732
84.3	208.	683.	105.	188.	618.	60.	222.	727.	0.6	0.705	65.5	1.702
88.2	208.	683.	105.	188.	616.	60.	221.	727.	0.4	0.704	65.6	1.705
92.2	205.	672.	105.	187.	615.	60.	219.	718.	1.4	0.693	65.7	1.683
96.2	204.	669.	105.	191.	627.	60.	220.	721.	3.0	0.692	65.3	1.658
SUCTION SIDE												

APPENDIX D (Cont'd)

LASER DOPPLER VELOCIMETER DATA

85% SPAN 100% SPEED PEAK EFF X/B = .26 PASSAGE NO. 1

STD DAY RPM = 12470.4, RADIUS = 38.590 CM, PHI = -14.6 DEG, STD DAY TTREL = 414. DEG K, UPSTREAM TTABS = 276. DEG K  
 15.193 IN 746. DEG R 497. DEG R

PERCENT GAP	C1 MPS	C1 FPS	ZETA1 DEG	C2 MPS	C2 FPS	ZETA2 DEG	VZ--CORRECTED MPS	VZ--CORRECTED FPS	BETA DEG	ABSOLUTE MACH NO	BETA PRIME DEG	RELATIVE MACH NO
PRESSURE SIDE												
6.8	129.	423.	105.	236.	773.	60.	181.	595.	42.7	0.679	60.9	1.041
10.9	123.	404.	105.	233.	765.	60.	176.	578.	44.2	0.673	61.3	1.022
15.0	114.	374.	105.	235.	771.	60.	170.	558.	47.4	0.683	61.1	0.973
19.0	108.	354.	105.	232.	762.	60.	165.	541.	48.9	0.678	61.6	0.954
23.1	104.	342.	105.	227.	744.	60.	160.	525.	49.3	0.663	62.5	0.955
27.1	106.	349.	105.	224.	735.	60.	161.	527.	48.2	0.654	62.9	0.974
31.2	113.	371.	105.	214.	703.	60.	162.	531.	44.2	0.621	64.2	1.040
35.3	163.	535.	105.	194.	636.	60.	190.	624.	19.3	0.598	65.8	1.382
39.3	170.	557.	105.	180.	591.	60.	190.	623.	11.6	0.589	67.1	1.485
43.4	171.	562.	105.	168.	551.	60.	187.	612.	6.1	0.578	68.3	1.555
47.4	174.	571.	105.	168.	552.	60.	189.	619.	5.2	0.586	68.2	1.571
51.5	179.	587.	105.	171.	560.	60.	193.	633.	4.2	0.601	67.8	1.590
55.6	184.	603.	105.	173.	566.	60.	197.	647.	3.1	0.617	67.5	1.612
59.6	187.	613.	105.	172.	565.	60.	199.	654.	1.9	0.626	67.5	1.634
63.7	184.	604.	105.	172.	564.	60.	197.	647.	2.8	0.617	67.6	1.617
67.7	181.	593.	105.	172.	565.	60.	195.	640.	4.2	0.608	67.6	1.594
71.8	176.	579.	105.	173.	568.	60.	192.	631.	6.2	0.597	67.7	1.561
75.9	178.	585.	105.	176.	577.	60.	195.	638.	6.5	0.604	67.3	1.559
79.9	181.	595.	105.	176.	577.	60.	197.	646.	5.4	0.613	67.3	1.579
84.0	185.	608.	105.	179.	588.	60.	201.	659.	5.2	0.626	66.9	1.588
88.1	202.	663.	105.	186.	609.	60.	215.	707.	1.6	0.681	65.9	1.667
92.1	203.	666.	105.	189.	621.	60.	217.	713.	2.7	0.685	65.5	1.654
SUCTION SIDE												

APPENDIX D (Cont'd)

LASER DOPPLER VELOCIMETER DATA

85% SPAN 100% SPEED PEAK EFF X/B = .39 PASSAGE NO. 1

STD DAY RPM = 12470.4, RADIUS = 38.423 CM, PHI = -14.6 DEG, STD DAY TTREL = 413. DEG K, UPSTREAM TTABS = 276. DEG K  
 15.127 IN 744. DEG R 497. DEG R

PERCENT GAP	C1 MPS	C1 FPS	ZETA1 DEG	C2 MPS	C2 FPS	ZETA2 DEG	VZ--CORRECTED MPS	VZ--CORRECTED FPS	BETA DEG	ABSOLUTE MACH NO	BETA PRIME DEG	RELATIVE MACH NO
PRESSURE SIDE												
0.7	149.	489.	105.	239.	785.	60.	197.	647.	36.8	0.690	60.1	1.122
4.9	150.	491.	105.	238.	781.	60.	197.	647.	36.3	0.687	60.3	1.130
9.2	152.	498.	105.	238.	782.	60.	199.	652.	35.7	0.689	60.2	1.139
13.4	149.	489.	105.	242.	795.	60.	198.	651.	37.4	0.699	59.7	1.112
17.7	147.	481.	105.	243.	798.	60.	197.	646.	38.4	0.701	59.5	1.096
22.0	140.	460.	105.	242.	793.	60.	192.	629.	40.2	0.696	59.8	1.070
26.2	134.	441.	105.	245.	803.	60.	189.	619.	42.6	0.705	59.3	1.032
30.5	130.	428.	105.	243.	796.	60.	185.	607.	43.5	0.700	59.6	1.020
34.7	129.	422.	105.	241.	792.	60.	183.	601.	43.8	0.697	59.8	1.016
39.0	124.	406.	105.	235.	770.	60.	177.	581.	44.3	0.678	60.9	1.015
43.2	119.	389.	105.	230.	756.	60.	172.	564.	45.2	0.667	61.6	1.005
47.5	112.	366.	105.	225.	738.	60.	165.	540.	46.6	0.654	62.5	0.990
51.8	111.	363.	105.	218.	716.	60.	162.	530.	45.8	0.634	63.6	1.009
56.0	101.	333.	105.	205.	671.	60.	150.	491.	46.6	0.597	65.7	1.015
60.3	122.	401.	105.	193.	633.	60.	160.	526.	35.9	0.560	66.7	1.160
64.5	169.	556.	105.	173.	567.	60.	187.	614.	8.9	0.579	67.8	1.513
68.8	170.	558.	105.	168.	550.	60.	186.	609.	6.5	0.575	68.3	1.543
73.0	172.	563.	105.	169.	553.	60.	187.	613.	6.3	0.580	68.1	1.548
77.3	171.	562.	105.	170.	559.	60.	187.	615.	7.1	0.581	68.0	1.537
81.6	172.	564.	105.	172.	565.	60.	189.	619.	7.6	0.584	67.8	1.531
85.8	173.	566.	105.	175.	573.	60.	190.	623.	8.4	0.589	67.5	1.523
90.1	174.	570.	105.	177.	582.	60.	192.	629.	8.9	0.595	67.2	1.517
94.3	173.	569.	105.	180.	589.	60.	192.	631.	9.9	0.596	67.0	1.505
SUCTION SIDE												

APPENDIX D (Cont'd)

LASER DOPPLER VELOCIMETER DATA

85% SPAN 100% SPEED PEAK EFF X/B = .52 PASSAGE NO. 1

STD DAY RPM = 12470.4, RADIUS = 38.257 CM, PHI = -14.6 DEG, STD DAY TTREL = 412. DEG K, UPSTREAM TTABS = 276. DEG K  
 15.062 IN 742. DEG R 496. DEG R

PERCENT GAP	C1 MPS	C1 FPS	ZETA1 DEG	C2 MPS	C2 FPS	ZETA2 DEG	VZ--CORRECTED		BETA DEG	ABSOLUTE MACH NO	BETA PRIME DEG	RELATIVE MACH NO
							MPS	FPS				
PRESSURE SIDE												
27.2	175.	575.	105.	164.	538.	15.	217.	710.	28.1	0.709	59.8	1.252
31.7	176.	577.	105.	176.	577.	15.	220.	723.	30.0	0.730	58.6	1.222
36.3	174.	571.	105.	168.	552.	15.	216.	710.	29.0	0.713	59.5	1.237
40.8	172.	563.	105.	170.	558.	15.	215.	704.	29.7	0.710	59.5	1.226
45.3	171.	561.	105.	163.	535.	15.	212.	696.	28.6	0.697	60.3	1.242
49.8	170.	557.	105.	161.	528.	15.	210.	690.	28.5	0.690	60.6	1.245
54.3	170.	557.	105.	158.	517.	15.	209.	687.	27.9	0.685	60.9	1.254
58.8	171.	561.	105.	151.	496.	15.	209.	685.	26.5	0.678	61.4	1.275
63.3	179.	588.	105.	128.	419.	15.	211.	692.	20.5	0.667	62.6	1.364
67.8	192.	630.	105.	124.	406.	15.	222.	730.	17.8	0.700	61.8	1.412
72.3	200.	656.	105.	121.	397.	15.	230.	753.	16.2	0.721	61.3	1.444
76.8	195.	640.	105.	119.	390.	15.	224.	735.	16.4	0.703	61.9	1.436
SUCTION SIDE												

APPENDIX D (Cont'd)

LASER DOPPLER VELOCIMETER DATA

85% SPAN 100% SPEED PEAK EFF X/R = .65 PASSAGE NO. 1

STD DAY RPM = 12470.4, RADIUS = 38.090 CM, PHI = -14.6 DEG, STD DAY TTREL = 411. DEG K, UPSTREAM TTABS = 273. DEG K  
 14.996 IN 740. DEG R 492. DEG R

PERCENT GAP	C1 MPS	C1 FPS	ZETA1 DEG	C2 MPS	C2 FPS	ZETA2 DEG	VZ--CORRECTED MPS	FPS	BETA DEG	ABSOLUTE MACH NO	BETA PRIME DEG	RELATIVE MACH NO
PRESSURE SIDE												
5.1	119.	391.	105.	218.	716.	60.	169.	553.	42.8	0.635	63.0	1.039
9.6	130.	426.	105.	221.	725.	60.	177.	582.	39.6	0.642	62.4	1.082
14.0	137.	448.	105.	225.	738.	60.	184.	603.	38.1	0.653	61.8	1.101
18.5	141.	461.	105.	226.	741.	60.	187.	613.	36.9	0.656	61.6	1.117
22.9	145.	476.	105.	229.	750.	60.	191.	627.	35.8	0.665	61.2	1.130
27.4	160.	525.	105.	231.	757.	60.	203.	666.	31.1	0.678	60.8	1.200
31.8	168.	552.	105.	236.	774.	60.	211.	692.	29.5	0.697	60.1	1.224
36.3	176.	579.	105.	241.	790.	60.	219.	717.	27.9	0.716	59.4	1.250
40.7	181.	595.	105.	242.	793.	60.	223.	730.	26.5	0.723	59.3	1.273
45.2	183.	602.	105.	251.	825.	60.	228.	747.	28.2	0.747	57.9	1.249
49.6	183.	601.	105.	250.	819.	60.	227.	744.	27.8	0.742	58.2	1.254
54.1	181.	593.	105.	258.	848.	60.	228.	749.	30.6	0.761	56.9	1.209
58.5	175.	575.	105.	263.	863.	60.	226.	742.	33.3	0.768	56.2	1.165
63.0	168.	551.	105.	263.	863.	60.	221.	724.	35.5	0.764	56.1	1.128
67.4	162.	533.	105.	265.	869.	60.	217.	714.	37.6	0.767	55.8	1.094
71.9	159.	523.	105.	265.	868.	60.	215.	706.	38.4	0.766	55.8	1.080
76.3	159.	523.	105.	254.	833.	60.	211.	693.	36.4	0.737	57.4	1.115
80.8	163.	534.	105.	256.	840.	60.	214.	703.	35.8	0.744	57.1	1.125
85.3	167.	548.	105.	250.	821.	60.	215.	706.	33.2	0.731	58.0	1.166
89.7	163.	534.	105.	244.	799.	60.	210.	688.	33.1	0.711	59.0	1.168
SUCTION SIDE												

APPENDIX D (Cont'd)

LASER DOPPLER VELOCIMETER DATA

85% SPAN 100% SPEED PEAK EFF X/B = .78 PASSAGE NO. 1

STD DAY RPM = 12470.4, RADIUS = 37.925 CM, PHI = -14.6 DEG, STD DAY TTREL = 410. DEG K, UPSTREAM TTABS = 274. DEG K  
 14.931 IN 738. DEG R 493. DEG R

PERCENT GAP	C1 MPS	C1 FPS	ZETA1 DEG	C2 MPS	C2 FPS	ZETA2 DEG	VZ--CORRECTED MPS FPS	BETA DEG	ABSOLUTE MACH NO	BETA PRIME DEG	RELATIVE MACH NO
PRESSURE SIDE											
0.8	219.	717.	60.	203.	667.	15.	159. 521.	47.5	0.641	63.0	0.970
5.1	218.	715.	60.	197.	646.	15.	163. 533.	45.5	0.636	63.0	0.999
9.3	217.	713.	60.	189.	619.	15.	168. 550.	42.8	0.632	63.0	1.036
13.6	219.	717.	60.	185.	608.	15.	172. 564.	41.3	0.635	62.7	1.056
17.8	219.	717.	60.	184.	605.	15.	172. 566.	40.9	0.635	62.7	1.060
22.0	221.	724.	60.	185.	608.	15.	175. 573.	40.6	0.640	62.4	1.063
26.3	224.	736.	60.	188.	617.	15.	178. 584.	40.5	0.651	61.8	1.062
30.5	228.	749.	60.	193.	632.	15.	180. 591.	40.9	0.662	61.2	1.053
34.8	230.	753.	60.	197.	647.	15.	179. 586.	42.1	0.666	61.1	1.035
39.0	233.	763.	60.	199.	652.	15.	182. 596.	41.8	0.674	60.6	1.038
43.3	235.	772.	60.	195.	640.	15.	188. 618.	39.8	0.682	60.1	1.066
47.5	237.	779.	60.	191.	627.	15.	194. 637.	37.9	0.688	59.8	1.093
51.7	240.	789.	60.	189.	619.	15.	200. 657.	36.2	0.698	59.3	1.116
56.0	245.	805.	60.	189.	620.	15.	207. 678.	35.1	0.714	58.6	1.132
60.2	251.	822.	60.	194.	635.	15.	211. 691.	35.3	0.728	57.8	1.129
64.5	253.	830.	60.	195.	641.	15.	213. 698.	35.3	0.735	57.5	1.129
68.7	256.	841.	60.	198.	649.	15.	216. 708.	35.2	0.745	57.0	1.129
72.9	258.	845.	60.	199.	653.	15.	217. 710.	35.3	0.748	56.8	1.128
77.2	258.	848.	60.	200.	656.	15.	217. 712.	35.4	0.751	56.7	1.126
81.4	261.	855.	60.	200.	657.	15.	220. 721.	35.0	0.758	56.4	1.133
85.7	263.	863.	60.	197.	647.	15.	226. 740.	33.4	0.768	56.1	1.158
89.9	265.	869.	60.	200.	657.	15.	226. 741.	34.0	0.772	55.8	1.150
94.2	264.	867.	60.	205.	674.	15.	221. 726.	35.7	0.767	55.8	1.121
SUCTION SIDE											

APPENDIX D (Cont'd)

LASER DOPPLER VELOCIMETER DATA

85% SPAN 100% SPEED PEAK EFF X/B = .91 PASSAGE NO. 1

STD DAY RPM = 12470.4, RADIUS = 37.757 CM, PHI = -14.6 DEG, STD DAY TTREL = 409. DEG K, UPSTREAM TTABS = 274. DEG K  
 14.865 IN 736. DEG R 493. DEG R

PERCENT GAP	C1 MPS	C1 FPS	ZETA1 DEG	C2 MPS	C2 FPS	ZETA2 DEG	VZ--CORRECTED MPS FPS	BETA DEG	ABSOLUTE MACH NO	BETA PRIME DEG	RELATIVE MACH NO
PRESSURE SIDE											
8.7	222.	727.	60.	212.	695.	15.	157. 515.	49.4	0.654	62.4	0.936
12.7	220.	723.	60.	200.	656.	15.	164. 537.	45.8	0.644	62.5	0.987
16.7	220.	723.	60.	197.	646.	15.	166. 545.	44.8	0.643	62.4	1.002
20.7	222.	728.	60.	198.	651.	15.	167. 548.	44.8	0.647	62.2	0.999
24.7	222.	729.	60.	197.	646.	15.	169. 553.	44.2	0.647	62.1	1.008
28.7	222.	729.	60.	200.	655.	15.	167. 546.	45.1	0.648	62.1	0.995
32.7	221.	726.	60.	198.	648.	15.	167. 547.	44.7	0.645	62.3	1.002
36.7	221.	726.	60.	199.	654.	15.	165. 543.	45.3	0.646	62.3	0.993
40.7	223.	730.	60.	199.	652.	15.	168. 550.	44.7	0.649	62.1	1.000
44.7	225.	738.	60.	197.	647.	15.	172. 565.	43.5	0.654	61.7	1.015
48.7	226.	743.	60.	192.	631.	15.	178. 583.	41.4	0.657	61.4	1.044
52.7	228.	748.	60.	191.	628.	15.	181. 593.	40.6	0.661	61.1	1.054
56.7	229.	752.	60.	194.	637.	15.	180. 592.	41.2	0.665	60.9	1.044
60.7	230.	756.	60.	198.	649.	15.	179. 589.	42.1	0.669	60.8	1.031
64.7	232.	762.	60.	201.	658.	15.	180. 590.	42.5	0.674	60.5	1.024
68.7	236.	773.	60.	202.	664.	15.	183. 602.	42.1	0.683	59.9	1.027
72.7	238.	782.	60.	204.	668.	15.	186. 611.	41.8	0.691	59.5	1.030
76.7	242.	793.	60.	206.	676.	15.	189. 621.	41.6	0.700	59.0	1.030
80.7	247.	810.	60.	209.	687.	15.	194. 637.	41.3	0.715	58.1	1.033
84.7	253.	830.	60.	212.	694.	15.	201. 660.	40.3	0.732	57.2	1.044
88.7	257.	844.	60.	207.	678.	15.	211. 691.	37.7	0.745	56.6	1.084
SUCTION SIDE											

APPENDIX D (Cont'd)

LASER DOPPLER VELOCIMETER DATA

85% SPAN 100% SPEED PEAK EFF X/B = 1.0 PASSAGE NO. 1

STD DAY RPM = 12470.4, RADIUS = 37.643 CM, PHI = -14.6 DEG, STD DAY TTREL = 408. DEG K, UPSTREAM TTABS = 274. DEG K  
 14.820 IN 735. DEG R 494. DEG R

PERCENT GAP	C1 MPS	C1 FPS	ZETA1 DEG	C2 MPS	C2 FPS	ZETA2 DEG	VZ--CORRECTED MPS	VZ--CORRECTED FPS	BETA DEG	ABSOLUTE MACH NO	BETA PRIME DEG	RELATIVE MACH NO
PRESSURE SIDE												
10.1	111.	364.	105.	200.	655.	15.	163.	534.	45.9	0.641	62.5	0.983
13.9	117.	385.	105.	195.	640.	15.	168.	551.	44.0	0.643	62.2	1.009
17.7	124.	407.	105.	194.	636.	15.	174.	572.	42.4	0.653	61.6	1.028
21.5	122.	400.	105.	195.	639.	15.	172.	565.	43.0	0.650	61.7	1.020
25.3	124.	407.	105.	195.	641.	15.	175.	573.	42.6	0.656	61.4	1.024
29.1	122.	401.	105.	195.	641.	15.	173.	567.	43.0	0.652	61.6	1.020
32.9	122.	401.	105.	198.	651.	15.	174.	570.	43.4	0.659	61.3	1.012
36.7	120.	394.	105.	197.	647.	15.	171.	562.	43.7	0.652	61.7	1.010
40.5	123.	403.	105.	195.	641.	15.	173.	569.	42.8	0.653	61.6	1.021
44.3	127.	416.	105.	192.	630.	15.	176.	579.	41.6	0.654	61.5	1.039
48.1	129.	422.	105.	191.	628.	15.	178.	584.	41.1	0.656	61.3	1.044
51.9	128.	421.	105.	191.	626.	15.	178.	583.	41.1	0.654	61.4	1.045
55.7	132.	433.	105.	190.	625.	15.	181.	594.	40.3	0.661	61.0	1.055
59.5	133.	435.	105.	193.	633.	15.	182.	598.	40.5	0.667	60.7	1.050
63.3	134.	440.	105.	192.	631.	15.	184.	603.	40.1	0.669	60.6	1.056
67.1	133.	435.	105.	197.	646.	15.	183.	602.	41.0	0.675	60.3	1.041
70.9	135.	442.	105.	200.	656.	15.	186.	611.	41.0	0.685	59.7	1.039
74.7	134.	439.	105.	202.	663.	15.	186.	610.	41.5	0.688	59.6	1.031
78.5	132.	433.	105.	204.	669.	15.	185.	606.	42.1	0.688	59.6	1.023
82.3	132.	433.	105.	203.	667.	15.	185.	605.	42.0	0.687	59.6	1.024
86.1	132.	432.	105.	205.	671.	15.	185.	606.	42.2	0.689	59.5	1.021
89.9	136.	445.	105.	208.	683.	15.	189.	622.	41.9	0.704	58.7	1.022
SUCTION SIDE												



APPENDIX D (Cont'd)

LASER DOPPLER VELOCIMETER DATA

85% SPAN 100% SPEED PEAK EFF X/B = 1.1 PASSAGE NO. 1  
 STD DAY RPM = 12470.4, RADIUS = 37.516 CM, PHI = -14.6 DEG, STD DAY TTREL = 407. DEG K, UPSTREAM TTABS = 276. DEG K  
 14.770 IN 733. DEG R 497. DEG R

PERCENT GAP	C1 MPS	C1 FPS	ZETA1 DEG	C2 MPS	C2 FPS	ZETA2 DEG	VZ--CORRECTED MPS	FPS	BETA DEG	ABSOLUTE MACH NO	BETA PRIME DEG	RELATIVE MACH NO
PRESSURE SIDE												
1.1	222.	728.	60.	267.	877.	15.	117.	382.	65.1	0.722	63.2	0.691
4.9	225.	738.	60.	214.	702.	15.	159.	523.	49.0	0.661	61.7	0.931
8.7	228.	748.	60.	205.	673.	15.	170.	558.	45.2	0.663	61.1	0.982
12.5	228.	749.	60.	202.	662.	15.	173.	567.	44.0	0.662	61.0	0.999
16.3	230.	753.	60.	202.	662.	15.	175.	573.	43.7	0.665	60.8	1.003
20.1	229.	752.	60.	203.	667.	15.	173.	568.	44.3	0.665	60.9	0.995
23.9	228.	748.	60.	203.	666.	15.	172.	563.	44.5	0.662	61.1	0.992
27.7	227.	744.	60.	205.	674.	15.	168.	551.	45.7	0.660	61.3	0.977
31.5	228.	748.	60.	207.	679.	15.	169.	553.	45.8	0.663	61.1	0.974
35.3	226.	743.	60.	206.	677.	15.	167.	548.	46.1	0.660	61.4	0.971
39.1	228.	748.	60.	203.	667.	15.	171.	562.	44.6	0.662	61.1	0.991
42.9	227.	745.	60.	202.	664.	15.	171.	560.	44.6	0.659	61.3	0.992
46.7	227.	746.	60.	201.	661.	15.	172.	564.	44.2	0.660	61.2	0.997
50.5	226.	741.	60.	201.	660.	15.	170.	557.	44.6	0.656	61.5	0.994
54.3	227.	744.	60.	200.	656.	15.	172.	564.	43.9	0.658	61.3	1.003
58.1	228.	747.	60.	201.	660.	15.	172.	566.	44.0	0.661	61.1	1.000
61.9	229.	752.	60.	204.	669.	15.	173.	566.	44.5	0.665	60.9	0.992
65.7	230.	753.	60.	204.	668.	15.	173.	568.	44.3	0.666	60.9	0.994
69.5	229.	752.	60.	203.	665.	15.	173.	569.	44.1	0.665	60.9	0.998
73.3	229.	752.	60.	202.	663.	15.	174.	571.	43.9	0.665	60.9	1.001
77.1	231.	758.	60.	202.	663.	15.	176.	579.	43.3	0.669	60.6	1.007
80.9	234.	769.	60.	206.	675.	15.	178.	586.	43.6	0.679	60.1	1.001
84.7	235.	772.	60.	203.	665.	15.	182.	597.	42.3	0.681	59.9	1.018
88.5	237.	777.	60.	206.	676.	15.	182.	596.	43.0	0.685	59.7	1.008
92.3	240.	789.	60.	220.	723.	15.	176.	579.	46.5	0.700	59.1	0.953
96.1	243.	796.	60.	247.	810.	15.	160.	526.	53.7	0.723	58.6	0.840
99.9	224.	734.	60.	279.	914.	15.	111.	364.	67.3	0.743	63.0	0.650
SUCTION SIDE												

## APPENDIX D (Cont'd)

## LASER DOPPLER VELOCIMETER DATA

85% SPAN

95% SPEED PEAK EFF

X/B = -.3 PASSAGE NO. 1

STD DAY RPM = 11846.9, RADIUS = 39.306 CM, PHI = -14.6 DEG, STD DAY TTREL = 407. DEG K, UPSTREAM TTABS = 273. DEG K  
15.475 IN 732. DEG R 492. DEG R

PERCENT GAP	C1 MPS	C1 FPS	ZETA1 DEG	C2 MPS	C2 FPS	ZETA2 DEG	VZ--CORRECTED MPS	VZ--CORRECTED FPS	BETA DEG	ABSOLUTE MACH NO	BETA PRIME DEG	RELATIVE MACH NO
PRESSURE SIDE												
0.4	85.	280.	135.	99.	324.	45.	134.	439.	4.2	0.410	73.9	1.474
4.2	80.	261.	135.	98.	322.	45.	129.	423.	6.0	0.395	74.3	1.453
8.0	73.	240.	135.	97.	317.	45.	123.	404.	7.9	0.378	74.9	1.432
11.8	70.	230.	135.	96.	315.	45.	121.	396.	8.9	0.370	75.1	1.422
15.6	71.	234.	135.	96.	315.	45.	121.	399.	8.4	0.372	75.0	1.427
19.4	73.	240.	135.	95.	313.	45.	122.	401.	7.5	0.375	75.0	1.435
23.2	80.	263.	135.	98.	323.	45.	130.	425.	5.8	0.397	74.2	1.455
27.0	91.	299.	135.	101.	332.	45.	140.	458.	3.0	0.430	73.3	1.492
30.8	110.	362.	135.	106.	349.	45.	157.	516.	-1.0	0.490	71.7	1.558
34.6	117.	384.	135.	112.	366.	45.	166.	545.	-1.4	0.519	70.8	1.576
38.4	116.	379.	135.	111.	365.	45.	165.	540.	-1.1	0.514	70.9	1.570
42.2	118.	386.	135.	113.	371.	45.	168.	550.	-1.1	0.524	70.6	1.576
46.0	116.	379.	135.	111.	365.	45.	165.	540.	-1.1	0.514	70.9	1.570
49.8	116.	382.	135.	111.	363.	45.	165.	541.	-1.5	0.516	70.9	1.575
53.6	116.	382.	135.	112.	366.	45.	166.	543.	-1.2	0.518	70.8	1.573
57.4	117.	383.	135.	112.	369.	45.	166.	546.	-1.1	0.520	70.7	1.573
61.2	115.	378.	135.	114.	374.	45.	166.	546.	-0.3	0.519	70.6	1.563
65.0	116.	382.	135.	113.	370.	45.	166.	546.	-0.9	0.520	70.7	1.571
68.8	117.	384.	135.	114.	375.	45.	168.	551.	-0.7	0.525	70.5	1.571
72.6	116.	380.	135.	111.	365.	45.	165.	541.	-1.2	0.515	70.9	1.571
76.4	111.	364.	135.	111.	365.	45.	161.	529.	0.1	0.502	71.1	1.551
80.2	111.	363.	135.	111.	363.	45.	161.	527.	-0.0	0.500	71.2	1.551
84.0	106.	347.	135.	109.	357.	45.	156.	511.	0.8	0.483	71.7	1.535
87.8	101.	332.	135.	105.	344.	45.	150.	491.	1.0	0.463	72.3	1.524
91.6	97.	318.	135.	103.	339.	45.	145.	477.	1.8	0.449	72.7	1.510
95.4	94.	310.	135.	102.	335.	45.	143.	468.	2.2	0.440	73.0	1.503
99.2	91.	300.	135.	100.	327.	45.	139.	455.	2.5	0.427	73.4	1.496
SUCTION SIDE												

APPENDIX D (Cont'd)

LASER DOPPLER VELOCIMETER DATA

85% SPAN

95% SPEED PEAK EFF

X/B = -.1 PASSAGE NO. 1

STD DAY RPM = 11846.9, RADIUS = 39.050 CM, PHI = -14.6 DEG, STD DAY TTREL = 405. DEG K, UPSTREAM TTABS = 273. DEG K  
 15.374 IN 729. DEG R 491. DEG R

PERCENT GAP	C1 MPS	C1 FPS	ZETA1 DEG	C2 MPS	C2 FPS	ZETA2 DEG	VZ--CORRECTED MPS	VZ--CORRECTED FPS	BETA DEG	ABSOLUTE MACH NO	BETA PRIME DEG	RELATIVE MACH NO
PRESSURE SIDE												
0.8	132.	433.	135.	128.	420.	45.	189.	620.	-0.9	0.595	68.2	1.601
4.6	132.	433.	135.	128.	420.	45.	189.	620.	-0.9	0.595	68.2	1.601
8.4	133.	437.	135.	130.	428.	45.	192.	629.	-0.6	0.604	67.9	1.602
12.2	136.	446.	135.	131.	430.	45.	194.	637.	-1.0	0.613	67.7	1.613
16.0	137.	450.	135.	132.	432.	45.	195.	641.	-1.2	0.618	67.5	1.617
19.8	145.	475.	135.	134.	439.	45.	202.	664.	-2.3	0.645	67.0	1.648
23.6	151.	497.	135.	135.	442.	45.	208.	682.	-3.4	0.667	66.6	1.677
27.4	151.	494.	135.	134.	441.	45.	207.	680.	-3.2	0.664	66.7	1.673
31.2	155.	509.	135.	134.	441.	45.	210.	690.	-4.1	0.678	66.5	1.695
35.0	157.	515.	135.	135.	444.	45.	212.	697.	-4.2	0.686	66.3	1.702
38.8	148.	484.	135.	134.	440.	45.	205.	672.	-2.7	0.654	66.8	1.660
42.6	149.	488.	135.	134.	441.	45.	206.	675.	-2.9	0.658	66.7	1.665
46.4	144.	471.	135.	130.	428.	45.	199.	653.	-2.7	0.634	67.4	1.648
50.2	130.	425.	135.	130.	428.	45.	189.	620.	0.2	0.593	68.0	1.586
54.0	119.	392.	135.	126.	413.	45.	178.	585.	1.5	0.556	69.0	1.551
57.8	110.	362.	135.	123.	403.	45.	169.	556.	3.1	0.525	69.8	1.518
61.6	94.	307.	135.	120.	393.	45.	155.	509.	7.0	0.477	71.0	1.456
65.4	79.	259.	135.	116.	380.	45.	142.	464.	10.7	0.436	72.3	1.407
69.2	64.	211.	135.	112.	366.	45.	128.	419.	15.0	0.396	73.6	1.362
80.6	109.	357.	135.	122.	399.	45.	167.	549.	3.2	0.519	70.0	1.514
84.4	128.	421.	135.	125.	409.	45.	184.	603.	-0.8	0.578	68.7	1.591
88.2	131.	431.	135.	125.	409.	45.	186.	610.	-1.5	0.587	68.5	1.604
92.0	128.	421.	135.	125.	409.	45.	184.	603.	-0.8	0.578	68.7	1.591
95.8	129.	423.	135.	125.	411.	45.	185.	606.	-0.8	0.581	68.6	1.592
99.6	127.	416.	135.	125.	410.	45.	183.	600.	-0.4	0.574	68.7	1.584
SUCTION SIDE												

APPENDIX D (Cont'd)

LASER DOPPLER VELOCIMETER DATA

85% SPAN      95% SPEED PEAK EFF      X/B = 0.0      PASSAGE NO. 1

STD DAY RPM = 11846.9,      RADIUS = 38.923 CM,  
15.324 IN      PHI = -14.6 DEG,      STD DAY TTREL = 404. DEG K,  
728. DEG R      UPSTREAM TTABS = 273. DEG K  
491. DEG R

PERCENT GAP	C1 MPS	C1 FPS	ZETA1 DEG	C2 MPS	C2 FPS	ZETA2 DEG	VZ--CORRECTED MPS	FPS	BETA DEG	ABSOLUTE MACH NO	BETA PRIME DEG	RELATIVE MACH NO
PRESSURE SIDE												
6.9	133.	435.	135.	130.	428.	45.	191.	627.	-0.5	0.602	67.8	1.594
10.7	134.	441.	135.	129.	423.	45.	191.	628.	-1.2	0.604	67.9	1.605
14.5	137.	448.	135.	132.	432.	45.	195.	640.	-1.0	0.616	67.5	1.609
18.3	137.	449.	135.	130.	427.	45.	194.	637.	-1.4	0.614	67.7	1.613
22.1	132.	434.	135.	134.	440.	45.	194.	635.	0.4	0.608	67.4	1.586
25.9	137.	448.	135.	135.	443.	45.	197.	648.	-0.3	0.623	67.2	1.603
29.7	137.	449.	135.	135.	444.	45.	198.	649.	-0.3	0.624	67.1	1.604
33.5	136.	447.	135.	138.	454.	45.	200.	655.	0.4	0.629	66.8	1.596
37.3	136.	445.	135.	137.	448.	45.	198.	649.	0.2	0.623	67.0	1.597
41.1	138.	452.	135.	139.	457.	45.	201.	661.	0.3	0.635	66.6	1.601
44.9	150.	491.	135.	137.	450.	45.	208.	684.	-2.5	0.666	66.4	1.659
48.7	155.	508.	135.	139.	455.	45.	213.	700.	-3.2	0.685	66.0	1.680
52.5	147.	482.	135.	141.	462.	45.	209.	686.	-1.2	0.665	66.1	1.640
56.3	157.	514.	135.	140.	460.	45.	216.	708.	-3.2	0.694	65.7	1.686
60.1	146.	478.	135.	142.	467.	45.	209.	687.	-0.7	0.664	66.0	1.632
63.9	151.	496.	135.	142.	466.	45.	213.	699.	-1.8	0.680	65.8	1.658
67.7	149.	489.	135.	144.	472.	45.	213.	698.	-1.0	0.678	65.7	1.645
71.5	143.	468.	135.	140.	460.	45.	206.	674.	-0.5	0.651	66.3	1.622
75.3	137.	450.	135.	142.	466.	45.	203.	666.	1.0	0.639	66.4	1.594
79.1	134.	441.	135.	151.	496.	45.	208.	681.	3.4	0.651	65.5	1.567
82.9	130.	428.	135.	150.	491.	45.	204.	668.	3.9	0.637	65.8	1.552
86.7	129.	422.	135.	148.	484.	45.	201.	658.	3.9	0.627	66.2	1.548
90.5	137.	448.	135.	146.	479.	45.	205.	674.	1.9	0.646	66.0	1.585
94.3	94.	309.	135.	144.	473.	45.	173.	568.	11.8	0.536	68.2	1.411
98.1	110.	360.	135.	152.	500.	45.	191.	625.	9.2	0.590	66.5	1.460
SUCTION SIDE												

## APPENDIX D (Cont'd)

## LASER DOPPLER VELOCIMETER DATA

85% SPAN

95% SPEED PEAK EFF

X/B = .26 PASSAGE NO. 1

STD DAY RPM = 11846.9,

RADIUS = 38.590 CM,  
15.193 IN

PHI = -14.6 DEG,

STD DAY TTREL = 402. DEG K,  
724. DEG RUPSTREAM TTABS = 271. DEG K  
488. DEG R

PERCENT GAP	C1 MPS	C1 FPS	ZETA1 DEG	C2 MPS	C2 FPS	ZETA2 DEG	VZ--CORRECTED MPS	VZ--CORRECTED FPS	BETA DEG	ABSOLUTE MACH NO	BETA PRIME DEG	RELATIVE MACH NO
PRESSURE SIDE												
6.8	221.	726.	60.	195.	639.	15.	170.	557.	43.8	0.649	61.0	0.983
10.9	222.	728.	60.	195.	639.	15.	171.	559.	43.6	0.651	60.9	0.985
15.0	219.	717.	60.	200.	656.	15.	162.	532.	46.4	0.645	61.5	0.949
19.0	213.	699.	60.	201.	659.	15.	154.	504.	48.4	0.633	62.5	0.927
23.1	210.	690.	60.	201.	660.	15.	150.	491.	49.4	0.627	63.1	0.917
27.1	208.	684.	60.	208.	682.	15.	142.	466.	52.3	0.629	63.5	0.881
31.2	200.	656.	60.	213.	700.	15.	126.	414.	57.0	0.620	65.4	0.831
35.3	197.	645.	60.	205.	674.	15.	127.	417.	55.5	0.605	65.9	0.857
39.3	189.	619.	60.	181.	595.	15.	134.	438.	49.8	0.566	66.7	0.943
43.4	178.	583.	60.	173.	569.	15.	124.	406.	50.8	0.537	68.6	0.948
47.4	171.	560.	60.	153.	502.	15.	129.	423.	45.0	0.507	69.2	1.025
51.5	170.	559.	105.	160.	525.	60.	185.	606.	3.2	0.575	67.8	1.522
55.6	169.	556.	105.	163.	534.	60.	185.	607.	4.7	0.575	67.6	1.503
59.6	174.	571.	105.	164.	538.	60.	189.	619.	3.4	0.588	67.4	1.526
63.7	176.	578.	105.	164.	538.	60.	190.	624.	2.6	0.594	67.3	1.539
67.7	174.	572.	105.	167.	548.	60.	190.	624.	4.5	0.592	67.0	1.512
71.8	170.	559.	105.	166.	546.	60.	187.	614.	5.9	0.581	67.2	1.490
75.9	172.	565.	105.	166.	545.	60.	188.	618.	5.0	0.585	67.2	1.503
79.9	173.	568.	105.	168.	552.	60.	190.	622.	5.5	0.590	66.9	1.498
84.0	177.	582.	105.	172.	565.	60.	194.	637.	5.5	0.605	66.4	1.506
88.1	187.	612.	105.	175.	575.	60.	202.	663.	3.2	0.633	65.9	1.550
92.1	191.	628.	105.	179.	586.	60.	207.	679.	2.7	0.650	65.5	1.565
96.2	198.	650.	105.	180.	592.	60.	213.	697.	1.1	0.672	65.2	1.600
SUCTION SIDE												

APPENDIX D (Cont'd)

LASER DOPPLER VELOCIMETER DATA

85% SPAN      95% SPEED PEAK EFF      X/B = .39      PASSAGE NO. 1

STD DAY RPM = 11846.9,      RADIUS = 38.423 CM,  
 15.127 IN      PHI = -14.6 DEG,      STD DAY TTREL = 401. DEG K,  
 722. DEG R      UPSTREAM TTABS = 271. DEG K  
 488. DEG R

PERCENT GAP	C1 MPS	C1 FPS	ZETA1 DEG	C2 MPS	C2 FPS	ZETA2 DEG	VZ--CORRECTED MPS      FPS	BETA DEG	ABSOLUTE MACH NO	BETA PRIME DEG	RELATIVE MACH NO
PRESSURE SIDE											
7.6	226.	743.	60.	167.	547.	15.	197.      648.	32.4	0.668	59.9	1.136
11.8	224.	735.	60.	170.	558.	15.	192.      628.	34.2	0.659	60.3	1.110
15.9	226.	740.	60.	176.	576.	15.	190.      622.	35.8	0.662	60.0	1.087
20.0	224.	734.	60.	179.	586.	15.	185.      607.	37.4	0.655	60.3	1.066
24.2	227.	746.	60.	185.	608.	15.	185.      607.	38.7	0.665	59.8	1.045
28.3	227.	745.	60.	189.	620.	15.	182.      597.	40.0	0.664	59.8	1.026
32.4	228.	749.	60.	192.	630.	15.	182.      596.	40.7	0.668	59.7	1.016
36.6	224.	736.	60.	195.	640.	15.	174.      570.	42.9	0.658	60.3	0.987
40.7	218.	714.	60.	192.	631.	15.	166.      546.	44.0	0.640	61.5	0.978
44.9	214.	703.	60.	191.	628.	15.	162.      532.	44.8	0.631	62.0	0.971
49.0	211.	691.	60.	191.	628.	15.	157.      515.	45.9	0.622	62.7	0.959
53.1	209.	685.	60.	187.	613.	15.	158.      518.	44.9	0.615	63.0	0.975
57.3	197.	645.	60.	188.	618.	15.	140.      458.	49.5	0.588	65.3	0.930
61.4	187.	615.	60.	176.	576.	15.	136.      446.	48.0	0.559	66.7	0.962
65.5	178.	583.	60.	166.	544.	15.	129.      424.	47.7	0.531	68.2	0.979
69.7	165.	540.	60.	151.	495.	15.	122.      400.	46.5	0.492	70.1	1.013
73.8	119.	391.	105.	155.	507.	60.	145.      476.	24.8	0.468	69.9	1.243
77.9	139.	455.	105.	151.	496.	60.	158.      519.	13.4	0.490	69.6	1.367
82.1	148.	484.	105.	155.	509.	60.	166.      545.	11.0	0.513	68.9	1.400
86.2	157.	514.	105.	162.	530.	60.	175.      575.	9.6	0.542	68.0	1.424
90.4	163.	535.	105.	166.	545.	60.	182.      596.	8.8	0.562	67.3	1.441
94.5	162.	532.	105.	166.	546.	60.	181.      594.	9.3	0.560	67.3	1.434
SUCTION SIDE											

APPENDIX D (Cont'd)

LASER DOPPLER VELOCIMETER DATA

85% SPAN      95% SPEED      PEAK EFF      X/B = .52      PASSAGE NO. 1

STD DAY RPM = 11846.9,      RADIUS = 38.257 CM,      PHI = -14.6 DEG,      STD DAY TTREL = 401. DEG K,      UPSTREAM TTABS = 271. DEG K  
 15.062 IN      721. DEG R      488. DEG R

PERCENT GAP	C1 MPS	C1 FPS	ZETA1 DEG	C2 MPS	C2 FPS	ZETA2 DEG	VZ--CORRECTED MPS	VZ--CORRECTED FPS	BETA DEG	ABSOLUTE MACH NO	BETA PRIME DEG	RELATIVE MACH NO
PRESSURE SIDE												
4.7	210.	688.	60.	153.	502.	15.	184.	603.	31.8	0.620	62.2	1.140
9.2	219.	717.	60.	164.	539.	15.	188.	617.	33.6	0.643	60.9	1.114
13.7	221.	726.	60.	159.	522.	15.	196.	642.	31.0	0.655	60.5	1.151
18.2	219.	720.	60.	162.	533.	15.	191.	625.	32.7	0.647	60.8	1.127
22.7	223.	732.	60.	165.	541.	15.	194.	637.	32.6	0.658	60.2	1.128
27.2	223.	731.	60.	171.	560.	15.	189.	621.	34.8	0.654	60.3	1.097
31.7	226.	742.	60.	171.	562.	15.	194.	635.	34.1	0.665	59.8	1.106
36.3	224.	735.	60.	170.	559.	15.	191.	628.	34.3	0.659	60.1	1.103
40.8	226.	743.	60.	183.	601.	15.	185.	608.	38.2	0.663	59.8	1.047
45.3	232.	760.	60.	184.	605.	15.	192.	629.	37.2	0.678	59.0	1.060
49.8	220.	723.	60.	183.	600.	15.	177.	581.	39.8	0.645	60.8	1.028
54.3	224.	736.	60.	185.	606.	15.	181.	595.	39.3	0.656	60.1	1.032
76.8	201.	658.	60.	166.	546.	15.	161.	529.	39.8	0.589	63.9	1.042
81.3	201.	658.	60.	172.	564.	15.	157.	516.	42.0	0.589	64.0	1.015
85.8	197.	645.	60.	160.	524.	15.	160.	526.	38.5	0.577	64.5	1.062
90.4	193.	633.	60.	163.	534.	15.	153.	502.	40.9	0.567	65.2	1.035
94.9	192.	629.	60.	183.	600.	15.	137.	448.	49.2	0.574	65.9	0.935
SUCTION SIDE												









APPENDIX D (Cont'd)

LASER DOPPLER VELOCIMETER DATA

85% SPAN 100% SPEED NEAR SURGE X/B = -.1 PASSAGE NO. 1

STD DAY RPM = 12470.4, RADIUS = 39.050 CM, PHI = -14.6 DEG, STD DAY TTREL = 417. DEG K, UPSTREAM TTABS = 275. DEG K  
 15.374 IN 751. DEG R 495. DEG R

PERCENT GAP	C1 MPS	C1 FPS	ZETA1 DEG	C2 MPS	C2 FPS	ZETA2 DEG	VZ--CORRECTED MPS	VZ--CORRECTED FPS	BETA DEG	ABSOLUTE MACH NO	BETA PRIME DEG	RELATIVE MACH NO
PRESSURE SIDE												
0.8	138.	452.	135.	134.	441.	45.	197.	646.	-0.7	0.623	68.3	1.687
4.6	137.	450.	135.	137.	450.	45.	199.	651.	-0.0	0.627	68.1	1.679
8.4	142.	465.	135.	137.	451.	45.	202.	663.	-0.9	0.641	67.9	1.699
12.2	137.	449.	135.	139.	455.	45.	199.	654.	0.4	0.629	67.9	1.675
16.0	137.	449.	135.	137.	449.	45.	198.	650.	-0.0	0.625	68.1	1.678
19.8	149.	489.	135.	139.	455.	45.	208.	683.	-2.1	0.665	67.4	1.731
23.6	148.	486.	135.	139.	456.	45.	208.	682.	-1.8	0.663	67.4	1.726
27.4	140.	458.	135.	138.	453.	45.	201.	659.	-0.3	0.636	67.9	1.688
31.2	134.	441.	135.	137.	450.	45.	197.	645.	0.6	0.619	68.2	1.667
35.0	132.	434.	135.	137.	451.	45.	195.	641.	1.1	0.613	68.3	1.656
38.8	126.	415.	135.	137.	448.	45.	190.	625.	2.2	0.595	68.6	1.632
42.6	122.	399.	135.	134.	439.	45.	185.	607.	2.7	0.576	69.1	1.616
46.4	117.	385.	135.	132.	432.	45.	180.	591.	3.3	0.560	69.6	1.602
50.2	114.	374.	135.	130.	427.	45.	177.	580.	3.8	0.548	69.9	1.591
54.0	101.	332.	135.	127.	418.	45.	165.	543.	6.5	0.510	70.8	1.543
57.8	94.	308.	135.	126.	414.	45.	159.	523.	8.4	0.491	71.3	1.516
61.6	86.	281.	135.	121.	398.	45.	150.	491.	9.8	0.461	72.3	1.493
65.4	80.	262.	135.	119.	391.	45.	144.	473.	11.2	0.443	72.8	1.475
69.2	73.	241.	135.	116.	380.	45.	137.	450.	12.6	0.422	73.5	1.457
73.0	72.	235.	135.	114.	373.	45.	134.	440.	12.8	0.413	73.9	1.454
76.8	77.	254.	135.	117.	384.	45.	141.	462.	11.5	0.433	73.2	1.469
80.6	84.	275.	135.	127.	416.	45.	152.	500.	11.5	0.470	71.8	1.475
84.4	129.	422.	135.	130.	425.	45.	187.	613.	0.2	0.587	69.2	1.655
88.2	128.	420.	135.	128.	421.	45.	186.	609.	0.1	0.583	69.4	1.655
92.0	130.	427.	135.	130.	425.	45.	188.	617.	-0.1	0.591	69.2	1.662
95.8	130.	428.	135.	130.	426.	45.	188.	618.	-0.1	0.593	69.1	1.663
99.6	130.	428.	135.	130.	428.	45.	189.	620.	-0.0	0.594	69.1	1.662
SUCTION SIDE												

APPENDIX D (Cont'd)

LASER DOPPLER VELOCIMETER DATA

85% SPAN 100% SPEED NEAR SURGE X/B = 0.0 PASSAGE NO. 1

STD DAY RPM = 12470.4, RADIUS = 38.923 CM, PHI = -14.6 DEG, STD DAY TTREL = 417. DEG K, UPSTREAM TTABS = 274. DEG K  
 15.324 IN 750. DEG R 493. DEG R

PERCENT GAP	C1 MPS	C1 FPS	ZETA1 DEG	C2 MPS	C2 FPS	ZETA2 DEG	VZ--CORRECTED MPS	FPS	BETA DEG	ABSOLUTE MACH NO	BETA PRIME DEG	RELATIVE MACH NO
PRESSURE SIDE												
6.9	125.	411.	135.	119.	391.	45.	177.	582.	-1.4	0.557	70.3	1.656
10.7	120.	395.	135.	120.	394.	45.	174.	572.	-0.1	0.545	70.5	1.633
14.5	124.	407.	135.	120.	395.	45.	177.	582.	-0.9	0.556	70.3	1.648
18.3	118.	386.	135.	121.	397.	45.	173.	568.	0.8	0.540	70.5	1.619
22.1	124.	406.	135.	117.	384.	45.	175.	573.	-1.6	0.549	70.6	1.654
25.9	122.	401.	135.	116.	380.	45.	173.	566.	-1.5	0.542	70.8	1.649
29.7	123.	405.	135.	119.	392.	45.	176.	578.	-0.9	0.553	70.4	1.647
33.5	124.	406.	135.	122.	399.	45.	178.	584.	-0.5	0.558	70.2	1.644
37.3	124.	407.	135.	118.	387.	45.	176.	576.	-1.4	0.551	70.5	1.653
41.1	122.	400.	135.	119.	389.	45.	174.	572.	-0.8	0.547	70.6	1.642
44.9	122.	400.	135.	119.	391.	45.	175.	574.	-0.7	0.548	70.5	1.641
48.7	118.	387.	135.	119.	389.	45.	172.	563.	0.1	0.536	70.8	1.625
52.5	123.	405.	135.	119.	392.	45.	176.	578.	-0.9	0.553	70.4	1.647
56.3	115.	376.	135.	124.	406.	45.	173.	567.	2.2	0.537	70.4	1.601
60.1	111.	365.	135.	122.	399.	45.	169.	554.	2.5	0.524	70.8	1.591
63.9	114.	373.	135.	119.	390.	45.	169.	553.	1.3	0.525	70.9	1.606
67.7	107.	352.	135.	123.	403.	45.	167.	548.	3.9	0.516	70.9	1.572
71.5	110.	361.	135.	126.	414.	45.	171.	562.	3.9	0.531	70.4	1.577
75.3	106.	349.	135.	127.	418.	45.	170.	556.	5.1	0.524	70.4	1.559
79.1	100.	327.	135.	128.	419.	45.	165.	541.	7.0	0.508	70.7	1.531
82.9	98.	320.	135.	129.	422.	45.	164.	538.	7.8	0.505	70.8	1.521
86.7	91.	298.	135.	141.	462.	45.	168.	551.	12.2	0.519	69.8	1.472
90.5	86.	282.	135.	148.	485.	45.	170.	556.	14.8	0.526	69.3	1.440
94.3	72.	237.	135.	146.	480.	45.	159.	520.	18.7	0.496	70.2	1.391
SUCTION SIDE												

APPENDIX D (Cont'd)

LASER DOPPLER VELOCIMETER DATA

85% SPAN 100% SPEED NEAR SURGE X/B = .26 PASSAGE NO. 1

STD DAY RPM = 12470.4, RADIUS = 38.590 CM, PHI = -14.6 DEG, STD DAY TTREL = 414. DEG K, UPSTREAM TTABS = 275. DEG K  
 15.193 IN 746. DEG R 495. DEG R

PERCENT GAP	C1 MPS	C1 FPS	ZETA1 DEG	C2 MPS	C2 FPS	ZETA2 DEG	VZ--CORRECTED MPS	VZ--CORRECTED FPS	BETA DEG	ABSOLUTE MACH NO	BETA PRIME DEG	RELATIVE MACH NO
PRESSURE SIDE												
10.9	238.	780.	60.	213.	700.	15.	178.	584.	45.1	0.688	60.5	1.005
15.0	235.	772.	60.	215.	704.	15.	174.	570.	46.2	0.683	60.9	0.991
19.0	232.	762.	60.	220.	723.	15.	165.	542.	48.9	0.679	61.5	0.954
23.1	229.	752.	60.	223.	732.	15.	159.	522.	50.6	0.675	62.1	0.932
27.1	224.	734.	60.	226.	742.	15.	149.	489.	53.2	0.667	63.1	0.901
31.2	219.	717.	60.	230.	753.	15.	139.	458.	55.9	0.661	64.2	0.871
35.3	211.	693.	60.	232.	762.	15.	127.	417.	59.0	0.653	65.8	0.838
39.3	205.	671.	60.	222.	728.	15.	125.	411.	58.1	0.630	66.8	0.864
43.4	194.	636.	60.	189.	621.	15.	134.	440.	50.8	0.576	67.8	0.981
47.4	182.	598.	60.	172.	565.	15.	130.	427.	48.6	0.539	69.3	1.027
51.5	175.	575.	105.	173.	568.	60.	192.	629.	6.7	0.595	67.6	1.554
55.6	181.	595.	105.	173.	566.	60.	196.	643.	4.0	0.611	67.6	1.597
59.6	186.	610.	105.	175.	574.	60.	200.	657.	3.3	0.626	67.2	1.614
63.7	187.	613.	105.	177.	580.	60.	201.	661.	3.7	0.630	67.0	1.611
67.7	185.	608.	105.	176.	578.	60.	200.	657.	4.0	0.625	67.1	1.604
71.8	185.	607.	105.	176.	577.	60.	200.	656.	4.0	0.624	67.2	1.603
75.9	184.	603.	105.	178.	585.	60.	200.	656.	5.4	0.623	66.9	1.583
79.9	182.	598.	105.	178.	585.	60.	199.	652.	6.0	0.618	67.0	1.573
84.0	187.	614.	105.	182.	597.	60.	204.	668.	5.6	0.635	66.5	1.586
88.1	196.	643.	105.	186.	611.	60.	212.	694.	4.0	0.664	65.9	1.623
92.1	194.	638.	105.	189.	620.	60.	212.	694.	5.5	0.661	65.7	1.599
96.2	204.	668.	105.	194.	638.	60.	220.	723.	4.3	0.692	65.0	1.632
SUCTION SIDE												

APPENDIX D (Cont'd)

LASER DOPPLER VELOCIMETER DATA

85% SPAN 100% SPEED NEAR SURGE X/B = .39 PASSAGE NO. 1

STD DAY RPM = 12470.4, RADIUS = 38.423 CM, PHI = -14.6 DEG, STD DAY TTREL = 413. DEG K, UPSTREAM TTABS = 275. DEG K  
 15.127 IN 744. DEG R 495. DEG R

162

PERCENT GAP	C1 MPS	C1 FPS	ZETA1 DEG	C2 MPS	C2 FPS	ZETA2 DEG	VZ--CORRECTED MPS	VZ--CORRECTED FPS	BETA DEG	ABSOLUTE MACH NO	BETA PRIME DEG	RELATIVE MACH NO
PRESSURE SIDE												
0.7	240.	787.	60.	207.	678.	15.	186.	610.	42.3	0.693	60.0	1.039
4.9	236.	773.	60.	204.	670.	15.	182.	596.	42.7	0.681	60.7	1.036
9.2	243.	797.	60.	202.	664.	15.	193.	634.	40.1	0.701	59.5	1.070
13.4	240.	789.	60.	201.	660.	15.	191.	626.	40.4	0.694	59.9	1.068
17.7	243.	798.	60.	197.	647.	15.	197.	648.	38.3	0.702	59.5	1.097
22.0	240.	786.	60.	202.	664.	15.	189.	618.	41.0	0.691	60.0	1.059
26.2	243.	798.	60.	200.	657.	15.	195.	640.	39.3	0.702	59.5	1.082
30.5	241.	792.	60.	204.	669.	15.	190.	623.	41.0	0.696	59.7	1.058
39.0	239.	784.	60.	215.	704.	15.	179.	587.	45.1	0.692	60.2	0.998
51.8	213.	700.	60.	193.	633.	15.	159.	521.	45.6	0.621	64.2	1.017
56.0	202.	663.	60.	192.	629.	15.	144.	472.	48.9	0.595	66.2	0.988
60.3	201.	661.	60.	186.	610.	15.	147.	483.	47.0	0.590	66.2	1.014
64.5	188.	617.	60.	177.	582.	15.	135.	442.	48.5	0.555	68.3	1.014
68.8	170.	557.	60.	147.	483.	15.	131.	429.	42.8	0.497	70.5	1.106
73.0	151.	496.	60.	125.	410.	15.	121.	397.	39.6	0.443	72.7	1.164
77.3	102.	335.	105.	136.	446.	60.	125.	410.	26.4	0.406	73.6	1.301
81.6	126.	413.	105.	163.	535.	60.	152.	499.	24.8	0.489	70.0	1.305
85.8	150.	492.	105.	163.	535.	60.	170.	557.	13.3	0.525	69.2	1.442
90.1	168.	551.	105.	166.	543.	60.	184.	602.	6.5	0.569	68.5	1.540
94.3	175.	573.	105.	174.	571.	60.	192.	629.	7.3	0.594	67.5	1.540
SUCTION SIDE												

APPENDIX D (Cont'd)

LASER DOPPLER VELOCIMETER DATA

85% SPAN 100% SPEED NEAR SURGE X/B = .52 PASSAGE NO. 1

STD DAY RPM = 12470.4, RADIUS = 38.257 CM, PHI = -14.6 DEG, STD DAY TTREL = 412. DEG K, UPSTREAM TTABS = 275. DEG K  
 15.062 IN 742. DEG R 495. DEG R

PERCENT GAP	C1 MPS	C1 FPS	ZETA1 DEG	C2 MPS	C2 FPS	ZETA2 DEG	VZ--CORRECTED MPS FPS	BETA DEG	ABSOLUTE MACH NO	BETA PRIME DEG	RELATIVE MACH NO	
PRESSURE SIDE												
0.2	227.	746.	60.	208.	682.	15.	167.	550.	46.3	0.662	61.9	0.987
4.7	226.	743.	60.	204.	670.	15.	169.	554.	45.4	0.658	62.0	1.001
9.2	230.	754.	60.	201.	659.	15.	176.	577.	43.3	0.665	61.4	1.028
13.7	231.	759.	60.	193.	634.	15.	184.	602.	40.3	0.668	61.1	1.070
18.2	233.	764.	60.	194.	635.	15.	186.	609.	39.9	0.673	60.9	1.074
22.7	235.	770.	60.	198.	650.	15.	185.	606.	41.0	0.678	60.6	1.058
27.2	237.	778.	60.	198.	651.	15.	188.	617.	40.4	0.685	60.2	1.065
31.7	241.	790.	60.	201.	658.	15.	192.	628.	40.1	0.695	59.7	1.067
36.3	237.	776.	60.	200.	657.	15.	186.	610.	41.2	0.683	60.3	1.054
40.8	240.	788.	60.	205.	671.	15.	188.	616.	41.5	0.694	59.8	1.046
45.3	242.	793.	60.	211.	692.	15.	185.	608.	43.2	0.699	59.6	1.021
49.8	237.	778.	60.	203.	665.	15.	185.	607.	41.8	0.685	60.3	1.044
54.3	244.	800.	60.	198.	651.	15.	197.	647.	38.6	0.704	59.2	1.089
58.8	244.	800.	60.	207.	678.	15.	191.	628.	41.2	0.704	59.2	1.049
81.3	212.	696.	60.	183.	601.	15.	164.	538.	42.5	0.615	64.1	1.055
85.8	211.	692.	60.	179.	587.	15.	165.	543.	41.3	0.611	64.2	1.072
90.4	215.	704.	60.	196.	643.	15.	158.	519.	46.3	0.626	63.9	1.002
SUCTION SIDE												





APPENDIX D (Cont'd)

LASER DOPPLER VELOCIMETER DATA

85% SPAN 100% SPEED NEAR SURGE X/B = 1.1 PASSAGE NO. 1

STD DAY RPM = 12470.4, RADIUS = 37.516 CM, PHI = -14.6 DEG, STD DAY TTREL = 407. DEG K, UPSTREAM TTABS = 275. DEG K  
 14.770 IN 733. DEG R 495. DEG R

PERCENT GAP	C1 MPS	C1 FPS	ZETA1 DEG	C2 MPS	C2 FPS	ZETA2 DEG	VZ--CORRECTED MPS	FPS	BETA DEG	ABSOLUTE MACH NO	BETA PRIME DEG	RELATIVE MACH NO
PRESSURE SIDE												
2.0	216.	710.	60.	244.	799.	0.	112.	367.	65.8	0.711	64.3	0.691
5.8	219.	718.	60.	223.	733.	0.	127.	415.	61.0	0.688	63.4	0.763
9.6	225.	738.	60.	201.	661.	0.	147.	482.	54.6	0.677	61.9	0.851
13.4	226.	743.	60.	193.	633.	0.	154.	504.	52.1	0.674	61.5	0.885
17.2	228.	749.	60.	192.	629.	0.	157.	514.	51.4	0.677	61.2	0.892
21.0	228.	747.	60.	189.	620.	0.	157.	517.	50.9	0.674	61.2	0.901
24.8	227.	746.	60.	188.	618.	0.	157.	517.	50.8	0.673	61.3	0.903
28.6	226.	743.	60.	190.	622.	0.	156.	511.	51.3	0.671	61.5	0.897
32.4	227.	744.	60.	190.	624.	0.	156.	511.	51.4	0.673	61.4	0.895
36.2	227.	745.	60.	190.	625.	0.	156.	511.	51.4	0.673	61.4	0.895
40.0	225.	738.	60.	191.	627.	0.	153.	502.	52.0	0.669	61.8	0.889
43.8	225.	737.	60.	191.	627.	0.	153.	501.	52.0	0.668	61.8	0.888
47.6	226.	742.	60.	187.	614.	0.	157.	514.	50.7	0.669	61.5	0.905
51.4	225.	738.	60.	184.	603.	0.	157.	516.	50.1	0.664	61.7	0.916
55.2	224.	736.	60.	179.	586.	0.	160.	524.	48.9	0.660	61.8	0.934
59.0	226.	743.	60.	176.	578.	0.	164.	537.	47.8	0.664	61.4	0.947
62.8	226.	743.	60.	176.	576.	0.	164.	538.	47.6	0.663	61.4	0.949
66.6	229.	750.	60.	177.	582.	0.	165.	543.	47.7	0.669	61.0	0.946
70.4	228.	748.	60.	177.	582.	0.	165.	540.	47.8	0.668	61.1	0.945
74.2	227.	744.	60.	178.	585.	0.	163.	534.	48.3	0.665	61.3	0.940
78.0	227.	746.	60.	182.	598.	0.	161.	528.	49.2	0.669	61.3	0.926
81.8	231.	758.	60.	190.	623.	0.	161.	528.	50.4	0.682	60.6	0.904
85.6	237.	778.	60.	199.	654.	0.	162.	533.	51.5	0.702	59.6	0.881
89.4	233.	765.	60.	213.	699.	0.	150.	491.	55.5	0.705	60.4	0.824
93.2	238.	781.	60.	238.	781.	0.	141.	462.	60.0	0.739	59.4	0.745
97.0	227.	744.	60.	262.	858.	0.	113.	372.	67.0	0.752	62.2	0.647
SUCTION SIDE												

## APPENDIX D (Cont'd)

## LASER DOPPLER VELOCIMETER DATA

69% SPAN

100% SPEED

PEAK EFF X/B = -.2

PASSAGE NO. 1

STD DAY RPM = 12470.4,

RADIUS = 35.687 CM,  
14.050 IN

PHI = -7.4 DEG,

STD DAY TTREL = 396. DEG K,  
712. DEG RUPSTREAM TTABS = 275. DEG K  
495. DEG R

PERCENT GAP	C1 MPS	C1 FPS	ZETA1 DEG	C2 MPS	C2 FPS	ZETA2 DEG	VZ--CORRECTED MPS	VZ--CORRECTED FPS	BETA DEG	ABSOLUTE MACH NO	BETA PRIME DEG	RELATIVE MACH NO
PRESSURE SIDE												
3.2	127.	418.	135.	130.	426.	45.	186.	611.	0.5	0.569	68.0	1.519
7.0	123.	403.	135.	127.	418.	45.	181.	594.	1.0	0.552	68.5	1.504
10.8	116.	380.	135.	125.	411.	45.	175.	573.	2.2	0.530	69.0	1.479
14.6	108.	355.	135.	123.	403.	45.	167.	549.	3.6	0.506	69.7	1.453
18.4	104.	342.	135.	121.	396.	45.	163.	534.	4.2	0.491	70.1	1.441
22.2	101.	333.	135.	119.	391.	45.	160.	524.	4.6	0.481	70.4	1.433
26.0	99.	325.	135.	119.	390.	45.	158.	518.	5.2	0.475	70.6	1.424
29.8	100.	328.	135.	121.	397.	45.	160.	525.	5.4	0.482	70.3	1.424
33.6	111.	364.	135.	120.	393.	45.	167.	548.	2.2	0.506	69.9	1.469
37.4	128.	420.	135.	127.	417.	45.	185.	606.	-0.2	0.566	68.2	1.526
41.2	136.	445.	135.	131.	431.	45.	193.	634.	-0.9	0.595	67.4	1.551
45.0	135.	444.	135.	132.	433.	45.	193.	635.	-0.7	0.595	67.4	1.548
48.8	134.	439.	135.	132.	434.	45.	193.	632.	-0.3	0.592	67.4	1.541
52.6	134.	438.	135.	132.	433.	45.	192.	630.	-0.3	0.590	67.5	1.541
56.4	133.	435.	135.	132.	432.	45.	191.	628.	-0.2	0.587	67.5	1.537
60.2	131.	431.	135.	132.	434.	45.	191.	626.	0.2	0.585	67.5	1.531
64.0	132.	433.	135.	132.	432.	45.	191.	626.	-0.1	0.586	67.6	1.535
67.8	132.	433.	135.	132.	432.	45.	191.	626.	-0.1	0.586	67.6	1.535
71.6	131.	429.	135.	132.	433.	45.	190.	624.	0.3	0.583	67.6	1.529
75.4	130.	426.	135.	132.	433.	45.	190.	622.	0.5	0.580	67.6	1.525
79.2	129.	424.	135.	130.	427.	45.	188.	616.	0.2	0.575	67.9	1.526
83.0	126.	415.	135.	130.	426.	45.	186.	609.	0.7	0.567	68.0	1.515
86.8	126.	414.	135.	129.	424.	45.	185.	607.	0.7	0.565	68.1	1.515
90.6	127.	416.	135.	129.	422.	45.	185.	607.	0.4	0.565	68.1	1.518
94.4	129.	423.	135.	129.	424.	45.	187.	613.	0.1	0.572	68.0	1.526
98.2	130.	425.	135.	130.	425.	45.	188.	615.	-0.0	0.575	67.9	1.528
SUCTION SIDE												











APPENDIX D (Cont'd)

LASER DOPPLER VELOCIMETER DATA

69% SPAN

100% SPEED

PEAK EFF

X/B = 1.0

PASSAGE NO. 1

STD DAY RPM = 12470.4,

RADIUS = 34.925 CM,  
13.750 IN

PHI = -7.4 DEG,

STD DAY TTREL = 391. DEG K,  
704. DEG R

UPSTREAM TTABS = 275. DEG K  
495. DEG R

PERCENT GAP	C1 MPS	C1 FPS	ZETA1 DEG	C2 MPS	C2 FPS	ZETA2 DEG	VZ--CORRECTED MPS	VZ--CORRECTED FPS	BETA DEG	ABSOLUTE MACH NO	BETA PRIME DEG	RELATIVE MACH NO
PRESSURE SIDE												
1.3	191.	628.	60.	235.	772.	0.	87.	286.	70.1	0.670	67.8	0.608
5.1	183.	601.	60.	239.	783.	0.	75.	248.	72.8	0.667	70.2	0.587
8.9	189.	621.	60.	230.	753.	0.	88.	289.	69.4	0.658	68.1	0.624
12.7	192.	629.	60.	230.	754.	0.	91.	298.	68.9	0.661	67.5	0.626
16.5	181.	594.	60.	228.	749.	0.	79.	259.	71.3	0.646	70.3	0.618
20.3	197.	645.	60.	239.	785.	0.	91.	298.	69.6	0.683	66.5	0.601
24.1	201.	658.	60.	223.	733.	0.	105.	345.	65.3	0.663	65.0	0.660
27.9	203.	667.	60.	212.	696.	0.	115.	377.	62.1	0.651	64.1	0.702
31.7	194.	635.	60.	214.	703.	0.	102.	335.	65.0	0.639	66.5	0.681
35.5	179.	587.	60.	198.	651.	0.	94.	309.	65.1	0.594	69.4	0.716
39.3	187.	612.	60.	195.	641.	0.	105.	345.	62.3	0.601	67.5	0.736
43.1	172.	563.	60.	190.	624.	0.	90.	297.	65.1	0.571	70.8	0.735
46.9	180.	589.	60.	188.	616.	0.	101.	332.	62.2	0.579	68.8	0.753
50.7	177.	581.	60.	183.	600.	0.	101.	332.	61.6	0.569	69.2	0.767
54.5	168.	551.	60.	186.	611.	0.	88.	290.	65.1	0.560	71.4	0.745
58.3	169.	554.	60.	194.	637.	0.	85.	278.	66.9	0.573	71.6	0.719
62.1	193.	633.	60.	206.	676.	0.	106.	349.	63.3	0.626	66.4	0.708
65.9	189.	619.	60.	202.	664.	0.	103.	339.	63.5	0.614	67.3	0.715
69.7	190.	623.	60.	198.	649.	0.	108.	353.	62.0	0.610	66.8	0.732
73.5	181.	594.	60.	204.	668.	0.	94.	307.	65.8	0.605	69.1	0.701
77.3	204.	668.	60.	219.	717.	0.	112.	366.	63.5	0.660	64.2	0.681
81.1	198.	651.	60.	233.	766.	0.	97.	317.	68.0	0.676	65.8	0.623
84.9	191.	628.	60.	238.	780.	0.	86.	281.	70.6	0.675	67.9	0.600
88.7	199.	652.	60.	281.	921.	0.	69.	226.	76.5	0.762	67.6	0.471
92.5	221.	724.	60.	279.	916.	0.	96.	314.	71.5	0.780	60.4	0.506
96.3	203.	667.	60.	266.	874.	0.	83.	272.	73.1	0.739	65.5	0.522
SUCTION SIDE												



**Pages 173 – 174**  
**Missing**  
**in Original Document**

APPENDIX D (Cont'd)

LASER DOPPLER VELOCIMETER DATA

45% SPAN      100% SPEED      PEAK EFF      X/B = .26      PASSAGE NO. 1

STD DAY RPM = 12470.4,      RADIUS = 30.701 CM,  
12.087 IN      PHI = 4.6 DEG,      STD DAY TTREL = 367. DEG K, UPSTREAM TTABS = 294. DEG K  
661. DEG R      530. DEG R

PERCENT GAP	C1 MPS	C1 FPS	ZETA1 DEG	C2 MPS	C2 FPS	ZETA2 DEG	VZ--CORRECTED MPS      FPS	BETA DEG	ABSOLUTE MACH NO	BETA PRIME DEG	RELATIVE MACH NO
PRESSURE SIDE											
25.4	140.	458.	105.	200.	657.	45.	172.      564.	32.2	0.577	59.5	0.963
38.1	159.	523.	105.	199.	654.	45.	188.      616.	25.9	0.601	58.7	1.041
42.3	151.	496.	105.	183.	599.	45.	176.      578.	24.3	0.558	61.2	1.057
59.2	165.	541.	105.	162.	532.	45.	181.      594.	14.2	0.551	62.9	1.173
63.5	179.	588.	105.	146.	479.	45.	188.      617.	5.0	0.568	63.9	1.287
76.2	223.	731.	105.	155.	508.	45.	226.      741.	-2.3	0.704	61.1	1.455
84.6	201.	660.	105.	158.	520.	45.	209.      687.	3.4	0.639	61.6	1.341
93.1	247.	810.	105.	150.	491.	45.	244.      799.	-8.0	0.790	60.7	1.597
SUCTION SIDE											

APPENDIX D (Cont'd)

LASER DOPPLER VELOCIMETER DATA

45% SPAN      100% SPEED      PEAK EFF      X/B = 1.0      PASSAGE NO. 1

STD DAY RPM = 12470.4,      RADIUS = 31.016 CM,      PHI = 4.6 DEG,      STD DAY TTREL = 369. DEG K,      UPSTREAM TTABS = 294. DEG K  
 12.211 IN      664. DEG R      530. DEG R

PERCENT GAP	C1 MPS	C1 FPS	ZETA1 DEG	C2 MPS	C2 FPS	ZETA2 DEG	VZ--CORRECTED MPS	VZ--CORRECTED FPS	BETA DEG	ABSOLUTE MACH NO	BETA PRIME DEG	RELATIVE MACH NO
PRESSURE SIDE												
2.0	142.	467.	90.	180.	592.	0.	141.	462.	51.7	0.622	58.1	0.729
5.8	162.	531.	90.	194.	635.	0.	160.	525.	50.1	0.683	53.1	0.730
9.6	168.	550.	90.	194.	637.	0.	166.	544.	49.2	0.695	52.0	0.739
13.4	168.	552.	90.	194.	636.	0.	166.	546.	49.0	0.696	51.9	0.741
17.2	168.	551.	90.	192.	630.	0.	166.	545.	48.8	0.692	52.2	0.745
21.0	166.	544.	90.	189.	621.	0.	164.	538.	48.8	0.683	52.9	0.748
24.8	164.	539.	90.	186.	609.	0.	163.	533.	48.5	0.673	53.6	0.754
28.6	164.	537.	90.	185.	607.	0.	162.	531.	48.5	0.671	53.8	0.754
32.4	165.	541.	90.	184.	604.	0.	163.	535.	48.1	0.672	53.7	0.759
36.2	166.	546.	90.	184.	604.	0.	165.	540.	47.9	0.675	53.5	0.761
40.0	168.	552.	90.	184.	605.	0.	166.	546.	47.6	0.679	53.1	0.764
43.8	170.	557.	90.	183.	599.	0.	168.	551.	47.1	0.679	53.1	0.771
47.6	172.	564.	90.	182.	596.	0.	170.	558.	46.6	0.681	52.9	0.777
51.4	175.	574.	90.	180.	592.	0.	173.	568.	45.9	0.686	52.5	0.786
55.2	176.	578.	90.	182.	597.	0.	174.	572.	45.9	0.691	52.2	0.784
59.0	177.	581.	90.	183.	601.	0.	175.	575.	46.0	0.695	51.9	0.783
62.8	178.	583.	90.	186.	611.	0.	176.	577.	46.3	0.701	51.4	0.777
66.6	179.	587.	90.	187.	615.	0.	177.	581.	46.3	0.706	51.0	0.777
70.4	180.	590.	90.	189.	620.	0.	178.	584.	46.4	0.711	50.7	0.775
74.2	182.	596.	90.	191.	626.	0.	180.	590.	46.4	0.718	50.2	0.774
78.0	186.	609.	90.	191.	626.	0.	184.	602.	45.8	0.726	49.6	0.782
81.8	188.	616.	90.	192.	631.	0.	186.	609.	45.7	0.733	49.1	0.783
85.6	185.	607.	90.	203.	665.	0.	183.	600.	47.6	0.745	48.1	0.753
SUCTION SIDE												



APPENDIX D (Cont'd)

LASER DOPPLER VELOCIMETER DATA

45% SPAN    95% SPEED    PEAK EFF    X/B = .26    PASSAGE NO. 1

STD DAY RPM = 11846.9,    RADIUS = 30.701 CM,    PHI = 4.6 DEG,    STD DAY TTREL = 361. DEG K,    UPSTREAM TTABS = 292. DEG K  
 12.087 IN    649. DEG R    525. DEG R

PERCENT GAP	C1 MPS	C1 FPS	ZETA1 DEG	C2 MPS	C2 FPS	ZETA2 DEG	VZ--CORRECTED MPS    FPS	BETA DEG	ABSOLUTE MACH NO	BETA PRIME DEG	RELATIVE MACH NO	
PRESSURE SIDE												
42.3	207.	678.	60.	158.	520.	15.	169.	555.	34.8	0.584	57.2	0.885
46.6	206.	675.	60.	171.	562.	15.	159.	522.	40.1	0.583	57.2	0.824
50.8	204.	670.	60.	168.	551.	15.	159.	522.	39.3	0.578	57.5	0.834
55.0	204.	669.	60.	166.	544.	15.	160.	526.	38.5	0.577	57.6	0.842
59.2	200.	655.	60.	168.	551.	15.	153.	502.	40.7	0.566	58.3	0.819
63.5	197.	645.	60.	160.	525.	15.	154.	507.	38.6	0.556	59.0	0.844
67.7	190.	623.	60.	153.	502.	15.	150.	493.	37.9	0.537	60.2	0.854
71.9	195.	639.	60.	162.	532.	15.	150.	494.	40.1	0.552	59.3	0.829
76.2	190.	625.	60.	159.	522.	15.	147.	482.	40.3	0.540	60.1	0.829
80.4	181.	594.	60.	148.	484.	15.	142.	466.	38.7	0.513	61.9	0.851
84.6	179.	587.	60.	141.	464.	15.	144.	471.	36.7	0.506	62.3	0.873
88.8	176.	578.	60.	134.	440.	15.	145.	476.	34.4	0.498	62.7	0.898
93.1	141.	461.	105.	126.	413.	15.	167.	549.	26.9	0.539	60.5	0.976
97.3	151.	496.	105.	116.	379.	15.	175.	574.	22.4	0.548	60.4	1.027
SUCTION SIDE												

APPENDIX D (Cont'd)

LASER DOPPLER VELOCIMETER DATA

45% SPAN    100% SPEED    NEAR SURGE    X/B = .26    PASSAGE NO. 1

STD DAY RPM = 12470.4,    RADIUS = 30.701 CM,  
12.087 IN    PHI = 4.6 DEG,    STD DAY TTREL = 368. DEG K,  
663. DEG R    UPSTREAM TTABS = 292. DEG K  
525. DEG R

PERCENT GAP	C1 MPS	C1 FPS	ZETA1 DEG	C2 MPS	C2 FPS	ZETA2 DEG	VZ--CORRECTED MPS	FPS	BETA DEG	ABSOLUTE MACH NO	BETA PRIME DEG	RELATIVE MACH NO
PRESSURE SIDE												
12.7	193.	633.	60.	208.	684.	30.	125.	410.	53.2	0.571	61.8	0.725
16.9	216.	710.	60.	212.	695.	30.	162.	532.	42.7	0.613	57.1	0.830
21.2	217.	713.	60.	212.	695.	30.	164.	537.	42.3	0.615	57.0	0.835
25.4	214.	701.	60.	211.	693.	30.	158.	518.	43.8	0.606	57.6	0.818
29.6	214.	703.	60.	209.	685.	30.	161.	529.	42.2	0.606	57.5	0.837
33.9	211.	692.	60.	206.	676.	30.	158.	519.	42.5	0.597	58.2	0.836
38.1	210.	688.	60.	204.	670.	30.	158.	519.	42.2	0.593	58.4	0.840
42.3	208.	681.	60.	198.	650.	30.	160.	526.	40.0	0.585	58.8	0.867
46.6	200.	656.	60.	185.	608.	30.	160.	525.	36.9	0.563	60.2	0.907
50.8	199.	652.	60.	190.	625.	30.	153.	501.	40.5	0.561	60.5	0.867
55.0	188.	618.	60.	184.	605.	30.	141.	463.	42.7	0.535	62.4	0.849
59.2	185.	607.	60.	178.	584.	30.	142.	465.	40.9	0.523	63.0	0.872
63.5	175.	573.	60.	154.	506.	30.	147.	484.	32.0	0.493	64.4	0.971
67.7	171.	562.	60.	153.	502.	30.	143.	469.	33.1	0.484	65.0	0.960
71.9	168.	551.	105.	172.	563.	60.	180.	592.	9.0	0.544	64.1	1.228
76.2	184.	605.	105.	180.	591.	60.	195.	640.	5.9	0.590	62.8	1.283
80.4	182.	598.	60.	112.	369.	30.	202.	663.	3.5	0.613	62.4	1.324
84.6	209.	687.	105.	196.	643.	60.	218.	717.	2.9	0.668	60.6	1.361
SUCTION SIDE												

APPENDIX D (Cont'd)

LASER DOPPLER VELOCIMETER DATA

85% SPAN      100% SPEED      PEAK EFF      X/B = -.3      PASSAGE NO. 15

STD DAY RPM = 12470.4,      RADIUS = 39.306 CM,  
15.475 IN      PHI = -14.6 DEG,      STD DAY TTREL = 419. DEG K,  
754. DEG R      UPSTREAM TTABS = 271. DEG K  
487. DEG R

PERCENT GAP	C1 MPS	C1 FPS	ZETA1 DEG	C2 MPS	C2 FPS	ZETA2 DEG	VZ--CORRECTED MPS      FPS	BETA DEG	ABSOLUTE MACH NO	BETA PRIME DEG	RELATIVE MACH NO	
PRESSURE SIDE												
2.0	134.	440.	135.	130.	425.	45.	192.	631.	-1.0	0.608	69.0	1.692
5.8	130.	425.	135.	128.	421.	45.	188.	617.	-0.3	0.592	69.3	1.674
9.6	126.	414.	135.	127.	417.	45.	185.	606.	0.2	0.580	69.6	1.661
13.4	121.	396.	135.	125.	410.	45.	179.	588.	1.0	0.560	70.0	1.641
17.2	114.	373.	135.	122.	399.	45.	172.	563.	1.9	0.534	70.7	1.618
21.0	106.	349.	135.	118.	388.	45.	164.	538.	3.0	0.508	71.4	1.593
24.8	100.	328.	135.	115.	378.	45.	157.	515.	4.1	0.485	72.1	1.573
28.6	95.	311.	135.	112.	369.	45.	151.	496.	4.9	0.466	72.7	1.557
32.4	95.	312.	135.	111.	364.	45.	150.	493.	4.4	0.463	72.8	1.562
36.2	100.	328.	135.	114.	374.	45.	156.	512.	3.7	0.482	72.2	1.575
40.0	119.	392.	135.	122.	400.	45.	176.	578.	0.6	0.551	70.4	1.642
43.8	125.	409.	135.	126.	412.	45.	183.	599.	0.2	0.573	69.8	1.658
47.6	125.	409.	135.	125.	411.	45.	182.	598.	0.1	0.572	69.8	1.658
51.4	124.	407.	135.	126.	414.	45.	183.	599.	0.5	0.572	69.8	1.654
55.2	126.	412.	135.	127.	416.	45.	184.	604.	0.3	0.578	69.6	1.659
59.0	127.	416.	135.	126.	415.	45.	185.	606.	-0.1	0.581	69.6	1.665
62.8	128.	421.	135.	128.	420.	45.	187.	614.	-0.1	0.588	69.4	1.669
66.6	132.	433.	135.	130.	426.	45.	191.	627.	-0.5	0.602	69.0	1.682
70.4	137.	448.	135.	132.	433.	45.	196.	643.	-1.0	0.620	68.6	1.699
74.2	138.	454.	135.	134.	439.	45.	199.	652.	-1.0	0.629	68.3	1.704
78.0	140.	458.	135.	135.	443.	45.	200.	658.	-1.0	0.635	68.2	1.707
81.8	138.	452.	135.	134.	439.	45.	198.	650.	-0.8	0.627	68.4	1.701
85.6	135.	444.	135.	132.	434.	45.	195.	641.	-0.7	0.617	68.6	1.693
89.4	134.	441.	135.	131.	430.	45.	194.	636.	-0.7	0.612	68.8	1.691
93.2	132.	434.	135.	130.	428.	45.	192.	629.	-0.4	0.604	68.9	1.682
97.0	129.	423.	135.	128.	421.	45.	188.	616.	-0.1	0.590	69.3	1.671
SUCTION SIDE												

APPENDIX D (Cont'd)

LASER DOPPLER VELOCIMETER DATA

85% SPAN

100% SPEED

PEAK EFF

X/B = -.2

PASSAGE NO. 15

STD DAY RPM = 12470.4,

RADIUS = 39.179 CM,  
15.425 IN

PHI = -14.6 DEG,

STD DAY TTREL = 418. DEG K,  
753. DEG R

UPSTREAM TTABS = 271. DEG K  
487. DEG R

PERCENT GAP	C1 MPS	C1 FPS	ZETA1 DEG	C2 MPS	C2 FPS	ZETA2 DEG	VZ--CORRECTED MPS	VZ--CORRECTED FPS	BETA DEG	ABSOLUTE MACH NO	BETA PRIME DEG	RELATIVE MACH NO
PRESSURE SIDE												
0.3	147.	483.	135.	135.	442.	45.	206.	675.	-2.5	0.657	67.8	1.738
4.1	144.	472.	135.	134.	438.	45.	202.	664.	-2.1	0.645	68.1	1.724
7.9	142.	465.	135.	133.	435.	45.	200.	657.	-1.9	0.636	68.2	1.716
11.7	135.	442.	135.	129.	423.	45.	192.	631.	-1.3	0.608	68.9	1.691
15.5	128.	421.	135.	127.	416.	45.	186.	611.	-0.3	0.585	69.4	1.666
19.3	123.	405.	135.	124.	407.	45.	181.	593.	0.1	0.566	69.9	1.650
23.1	114.	373.	135.	121.	397.	45.	171.	562.	1.8	0.533	70.7	1.613
26.9	105.	345.	135.	116.	382.	45.	162.	531.	2.9	0.500	71.6	1.586
30.7	95.	312.	135.	113.	371.	45.	152.	498.	4.9	0.468	72.5	1.552
34.5	85.	280.	135.	110.	360.	45.	142.	467.	7.1	0.437	73.4	1.520
38.3	78.	256.	135.	108.	354.	45.	136.	445.	9.1	0.416	74.0	1.495
42.1	84.	275.	135.	109.	358.	45.	141.	462.	7.5	0.432	73.6	1.515
45.9	116.	380.	135.	119.	391.	45.	171.	563.	0.8	0.535	70.8	1.626
49.7	122.	401.	135.	124.	406.	45.	180.	589.	0.4	0.562	70.0	1.645
53.5	122.	399.	135.	123.	405.	45.	179.	587.	0.4	0.559	70.1	1.643
57.3	122.	399.	135.	124.	407.	45.	179.	588.	0.6	0.561	70.0	1.642
61.1	121.	396.	135.	124.	408.	45.	179.	587.	0.9	0.559	70.0	1.637
64.9	124.	406.	135.	126.	412.	45.	182.	597.	0.4	0.570	69.8	1.648
68.7	127.	418.	135.	127.	418.	45.	186.	610.	-0.0	0.584	69.4	1.661
72.5	134.	440.	135.	130.	427.	45.	193.	633.	-0.9	0.609	68.8	1.685
76.3	142.	466.	135.	133.	437.	45.	201.	659.	-1.8	0.638	68.2	1.716
80.1	144.	474.	135.	135.	442.	45.	204.	668.	-2.0	0.649	67.9	1.725
83.9	144.	473.	135.	135.	442.	45.	204.	668.	-1.9	0.648	67.9	1.723
87.7	142.	466.	135.	135.	442.	45.	202.	663.	-1.5	0.641	68.0	1.713
91.5	143.	468.	135.	134.	439.	45.	202.	662.	-1.8	0.642	68.1	1.718
95.3	140.	459.	135.	134.	438.	45.	200.	655.	-1.3	0.633	68.2	1.706
99.1	136.	447.	135.	132.	433.	45.	196.	642.	-0.9	0.619	68.5	1.692
SUCTION SIDE												



APPENDIX D (Cont'd)

LASER DOPPLER VELOCIMETER DATA

85% SPAN

100% SPEED

PEAK EFF

X/B = -.1

PASSAGE NO. 15

STD DAY RPM = 12470.4,

RADIUS = 39.050 CM,  
15.374 IN

PHI = -14.6 DEG,

STD DAY TTREL = 417. DEG K,  
751. DEG R

UPSTREAM TTABS = 274. DEG K  
493. DEG R

PERCENT GAP	C1 MPS	C1 FPS	ZETA1 DEG	C2 MPS	C2 FPS	ZETA2 DEG	VZ--CORRECTED MPS	VZ--CORRECTED FPS	BETA DEG	ABSOLUTE MACH NO	BETA PRIME DEG	RELATIVE MACH NO
PRESSURE SIDE												
2.4	138.	452.	135.	139.	455.	45.	201.	658.	0.2	0.633	67.9	1.680
6.2	139.	456.	135.	139.	456.	45.	202.	661.	-0.0	0.637	67.8	1.685
10.0	140.	460.	135.	141.	463.	45.	204.	669.	0.2	0.645	67.5	1.686
13.8	144.	474.	135.	142.	467.	45.	208.	683.	-0.4	0.660	67.2	1.704
17.6	150.	492.	135.	143.	468.	45.	212.	696.	-1.4	0.677	66.9	1.729
21.4	154.	505.	135.	145.	476.	45.	217.	712.	-1.7	0.694	66.5	1.743
25.2	153.	502.	135.	143.	470.	45.	215.	705.	-1.9	0.688	66.8	1.742
29.0	151.	495.	135.	142.	465.	45.	212.	696.	-1.8	0.678	67.0	1.735
32.8	149.	490.	135.	141.	461.	45.	210.	690.	-1.7	0.671	67.2	1.730
36.6	145.	476.	135.	140.	458.	45.	206.	677.	-1.1	0.656	67.5	1.712
40.4	140.	460.	135.	136.	447.	45.	201.	658.	-0.8	0.635	68.0	1.695
44.2	137.	448.	135.	136.	446.	45.	198.	648.	-0.1	0.624	68.2	1.679
48.0	131.	431.	135.	134.	441.	45.	193.	632.	0.7	0.606	68.6	1.659
51.8	126.	412.	135.	132.	434.	45.	187.	614.	1.5	0.585	69.1	1.637
55.6	121.	398.	135.	129.	424.	45.	182.	596.	1.8	0.567	69.6	1.624
59.4	112.	369.	135.	127.	416.	45.	174.	569.	3.4	0.538	70.3	1.591
63.2	103.	339.	135.	122.	399.	45.	163.	535.	4.6	0.504	71.3	1.563
67.0	93.	306.	135.	118.	388.	45.	153.	503.	6.7	0.472	72.1	1.529
70.8	83.	273.	135.	114.	375.	45.	143.	470.	8.9	0.440	73.1	1.497
74.6	90.	296.	135.	117.	384.	45.	150.	493.	7.4	0.462	72.4	1.519
78.4	123.	402.	135.	126.	415.	45.	181.	593.	0.9	0.565	69.8	1.635
82.2	127.	418.	135.	130.	428.	45.	187.	614.	0.7	0.586	69.2	1.649
86.0	128.	419.	135.	130.	428.	45.	187.	614.	0.6	0.587	69.1	1.650
89.8	129.	422.	135.	131.	429.	45.	188.	617.	0.5	0.591	69.1	1.653
93.6	130.	426.	135.	131.	431.	45.	189.	622.	0.3	0.595	69.0	1.658
97.4	132.	434.	135.	133.	437.	45.	193.	632.	0.2	0.606	68.7	1.665
SUCTION SIDE												

APPENDIX D (Cont'd)

LASER DOPPLER VELOCIMETER DATA

85% SPAN      100% SPEED      PEAK EFF      X/B = 0.0      PASSAGE NO. 15

STD DAY RPM = 12470.4,      RADIUS = 38.923 CM,  
 15.324 IN      PHI = -14.6 DEG,      STD DAY TTREL = 417. DEG K,  
 750. DEG R      UPSTREAM TTABS = 274. DEG K  
 493. DEG R

PERCENT GAP	C1 MPS	C1 FPS	ZETA1 DEG	C2 MPS	C2 FPS	ZETA2 DEG	VZ--CORRECTED MPS      FPS	BETA DEG	ABSOLUTE MACH NO	BETA PRIME DEG	RELATIVE MACH NO	
PRESSURE SIDE												
4.7	141.	463.	135.	141.	461.	45.	204.	670.	-0.1	0.646	67.5	1.686
8.5	142.	466.	135.	141.	461.	45.	205.	672.	-0.3	0.649	67.4	1.690
12.3	144.	473.	135.	142.	465.	45.	207.	680.	-0.5	0.658	67.2	1.698
16.1	145.	475.	135.	142.	467.	45.	208.	683.	-0.5	0.661	67.1	1.700
19.9	145.	475.	135.	144.	472.	45.	209.	687.	-0.2	0.664	67.0	1.697
23.7	145.	477.	135.	144.	473.	45.	210.	689.	-0.2	0.666	66.9	1.699
27.5	144.	474.	135.	144.	473.	45.	209.	687.	-0.1	0.663	67.0	1.695
31.3	145.	476.	135.	145.	477.	45.	211.	691.	0.1	0.668	66.8	1.695
35.1	148.	484.	135.	144.	473.	45.	212.	694.	-0.7	0.673	66.8	1.709
38.9	153.	501.	135.	147.	482.	45.	217.	713.	-1.1	0.694	66.3	1.729
42.7	159.	521.	135.	147.	481.	45.	222.	727.	-2.3	0.712	66.1	1.758
46.5	160.	524.	135.	147.	483.	45.	223.	730.	-2.3	0.716	66.0	1.762
50.3	158.	518.	135.	146.	479.	45.	220.	723.	-2.2	0.708	66.2	1.755
54.1	157.	514.	135.	145.	475.	45.	219.	717.	-2.3	0.702	66.4	1.751
57.9	155.	510.	135.	145.	475.	45.	218.	714.	-2.0	0.698	66.4	1.746
61.7	154.	504.	135.	145.	476.	45.	217.	711.	-1.6	0.693	66.5	1.736
65.5	153.	502.	135.	145.	477.	45.	216.	710.	-1.5	0.692	66.5	1.733
69.3	151.	495.	135.	144.	472.	45.	214.	701.	-1.4	0.682	66.7	1.725
73.1	148.	485.	135.	147.	482.	45.	214.	701.	-0.2	0.679	66.5	1.706
76.9	145.	476.	135.	145.	476.	45.	210.	690.	-0.0	0.667	66.8	1.696
80.7	139.	456.	135.	145.	476.	45.	206.	676.	1.2	0.649	67.1	1.668
84.5	133.	435.	135.	146.	479.	45.	202.	663.	2.8	0.633	67.3	1.637
88.3	122.	400.	135.	146.	479.	45.	194.	638.	5.1	0.605	67.8	1.591
92.1	109.	357.	135.	147.	482.	45.	185.	609.	8.5	0.574	68.3	1.534
95.9	89.	292.	135.	151.	494.	45.	174.	570.	14.4	0.539	68.8	1.448
SUCTION SIDE												

## APPENDIX D (Cont'd)

## LASER DOPPLER VELOCIMETER DATA

85% SPAN

100% SPEED

PEAK EFF

X/B = .13

PASSAGE NO. 15

STD DAY RPM = 12470.4,

RADIUS = 38.755 CM,  
15.258 IN

PHI = -14.6 DEG,

STD DAY TTREL = 416. DEG K,  
748. DEG RUPSTREAM TTABS = 274. DEG K  
493. DEG R

PERCENT GAP	C1 MPS	C1 FPS	ZETA1 DEG	C2 MPS	C2 FPS	ZETA2 DEG	VZ--CORRECTED MPS	VZ--CORRECTED FPS	BETA DEG	ABSOLUTE MACH NO	BETA PRIME DEG	RELATIVE MACH NO
PRESSURE SIDE												
14.7	187.	614.	105.	188.	617.	60.	206.	677.	7.8	0.642	65.9	1.562
18.7	185.	606.	105.	181.	594.	60.	202.	663.	6.1	0.629	66.7	1.581
22.6	182.	597.	105.	175.	573.	60.	198.	648.	4.7	0.616	67.4	1.596
26.6	186.	609.	105.	174.	570.	60.	200.	656.	2.9	0.626	67.4	1.625
30.5	187.	613.	105.	177.	581.	60.	202.	663.	3.8	0.632	67.0	1.616
34.5	191.	626.	105.	179.	586.	60.	205.	674.	2.9	0.644	66.8	1.634
38.4	193.	633.	105.	180.	590.	60.	207.	681.	2.6	0.652	66.6	1.642
42.4	197.	645.	105.	181.	594.	60.	211.	691.	1.8	0.664	66.5	1.661
46.4	199.	654.	105.	183.	601.	60.	213.	700.	1.7	0.673	66.2	1.668
50.3	199.	653.	105.	183.	602.	60.	213.	700.	1.9	0.673	66.2	1.664
54.3	202.	662.	105.	186.	611.	60.	216.	710.	2.0	0.683	65.9	1.669
58.2	202.	663.	105.	186.	610.	60.	216.	710.	1.8	0.684	65.9	1.672
62.2	203.	667.	105.	187.	614.	60.	218.	714.	1.8	0.688	65.7	1.674
66.2	204.	669.	105.	187.	615.	60.	218.	716.	1.7	0.690	65.7	1.677
70.1	205.	673.	105.	189.	619.	60.	220.	721.	1.7	0.695	65.6	1.679
74.1	210.	689.	105.	191.	626.	60.	224.	735.	0.9	0.712	65.3	1.702
78.0	212.	697.	105.	192.	630.	60.	226.	742.	0.6	0.720	65.1	1.712
82.0	214.	702.	105.	190.	623.	60.	226.	743.	-0.7	0.725	65.3	1.735
86.0	212.	696.	105.	189.	620.	60.	225.	738.	-0.4	0.718	65.4	1.727
89.9	211.	691.	105.	192.	629.	60.	225.	737.	1.0	0.714	65.2	1.701
93.9	206.	676.	105.	196.	642.	60.	223.	731.	3.9	0.702	64.9	1.648
SUCTION SIDE												

APPENDIX D (Cont'd)

LASER DOPPLER VELOCIMETER DATA

85% SPAN

100% SPEED

PEAK EFF

X/B = .26

PASSAGE NO. 15

STD DAY RPM = 12470.4,

RADIUS = 38.590 CM,  
15.193 IN

PHI = -14.6 DEG,

STD DAY TIREL = 414. DEG K,  
746. DEG R

UPSTREAM TTABS = 276. DEG K  
497. DEG R

PERCENT GAP	C1 MPS	C1 FPS	ZETA1 DEG	C2 MPS	C2 FPS	ZETA2 DEG	VZ--CORRECTED MPS	VZ--CORRECTED FPS	BETA DEG	ABSOLUTE MACH NO	BETA PRIME DEG	RELATIVE MACH NO
PRESSURE SIDE												
8.6	173.	566.	105.	226.	742.	60.	209.	686.	25.5	0.675	61.9	1.299
12.6	173.	569.	105.	219.	720.	60.	207.	680.	23.3	0.662	62.7	1.331
16.7	173.	568.	105.	212.	694.	60.	204.	670.	21.1	0.646	63.6	1.363
20.7	173.	569.	105.	209.	685.	60.	203.	667.	20.1	0.641	63.9	1.376
24.8	174.	570.	105.	196.	642.	60.	199.	652.	15.7	0.620	65.4	1.436
28.9	172.	564.	105.	187.	612.	60.	194.	636.	13.1	0.602	66.4	1.467
32.9	171.	561.	105.	177.	582.	60.	190.	623.	10.0	0.588	67.4	1.506
37.0	170.	558.	105.	167.	549.	60.	185.	608.	6.4	0.575	68.4	1.550
41.0	170.	559.	105.	167.	549.	60.	186.	609.	6.3	0.575	68.4	1.552
45.1	172.	565.	105.	169.	555.	60.	188.	616.	6.3	0.582	68.1	1.554
49.2	174.	571.	105.	171.	560.	60.	190.	622.	6.2	0.588	67.9	1.558
53.2	180.	590.	105.	173.	568.	60.	195.	639.	4.9	0.606	67.6	1.583
57.3	184.	603.	105.	176.	576.	60.	198.	651.	4.3	0.619	67.2	1.596
61.3	188.	618.	105.	178.	584.	60.	203.	665.	3.6	0.634	66.9	1.614
65.4	191.	626.	105.	181.	593.	60.	205.	674.	3.8	0.643	66.6	1.616
69.5	194.	636.	105.	181.	593.	60.	208.	681.	2.7	0.652	66.5	1.636
73.5	196.	642.	105.	184.	604.	60.	210.	690.	3.3	0.660	66.2	1.631
77.6	198.	650.	105.	187.	612.	60.	213.	698.	3.3	0.669	65.9	1.635
81.6	199.	654.	105.	189.	621.	60.	215.	705.	3.9	0.674	65.6	1.629
85.7	204.	669.	105.	187.	612.	60.	217.	712.	1.4	0.687	65.8	1.674
89.8	207.	679.	105.	195.	640.	60.	222.	730.	3.4	0.701	64.9	1.650
93.8	210.	689.	105.	197.	646.	60.	225.	739.	3.1	0.712	64.7	1.662
SUCTION SIDE												



APPENDIX D (Cont'd)

LASER DOPPLER VELOCIMETER DATA

85% SPAN

100% SPEED

PEAK EFF

X/B = .52

PASSAGE NO. 15

STD DAY RPM = 12470.4,

RADIUS = 38.257 CM,  
15.062 IN

PHI = -14.6 DEG,

STD DAY TTREL = 412. DEG K,  
742. DEG R

UPSTREAM TTABS = 276. DEG K  
496. DEG R

PERCENT GAP	C1 MPS	C1 FPS	ZETA1 DEG	C2 MPS	C2 FPS	ZETA2 DEG	VZ--CORRECTED MPS	VZ--CORRECTED FPS	BETA DEG	ABSOLUTE MACH NO	BETA PRIME DEG	RELATIVE MACH NO
PRESSURE SIDE												
24.6	176.	576.	105.	164.	539.	15.	217.	712.	28.1	0.710	59.7	1.252
29.1	176.	578.	105.	176.	578.	15.	221.	724.	30.0	0.731	58.5	1.222
33.6	174.	572.	105.	169.	553.	15.	217.	711.	29.0	0.714	59.4	1.237
38.1	172.	564.	105.	170.	559.	15.	215.	705.	29.7	0.711	59.5	1.226
42.7	171.	562.	105.	163.	536.	15.	212.	697.	28.6	0.698	60.2	1.242
47.2	170.	558.	105.	161.	529.	15.	211.	691.	28.5	0.691	60.5	1.245
51.7	170.	558.	105.	158.	518.	15.	210.	688.	27.9	0.686	60.8	1.254
56.2	171.	562.	105.	151.	497.	15.	209.	687.	26.5	0.679	61.3	1.274
60.7	180.	589.	105.	128.	420.	15.	211.	693.	20.5	0.668	62.6	1.364
65.2	192.	631.	105.	124.	407.	15.	223.	731.	17.8	0.701	61.7	1.412
69.7	200.	657.	105.	121.	398.	15.	230.	754.	16.2	0.722	61.2	1.444
SUCTION SIDE												

APPENDIX D (Cont'd)

LASER DOPPLER VELOCIMETER DATA

85% SPAN

100% SPEED

PEAK EFF

X/B = .65

PASSAGE NO. 15

STD DAY RPM = 12470.4,

RADIUS = 38.090 CM,  
14.996 IN

PHI = -14.6 DEG,

STD DAY TTREL = 411. DEG K,  
740. DEG R

UPSTREAM TTABS = 273. DEG K  
492. DEG R

PERCENT GAP	C1 MPS	C1 FPS	ZETA1 DEG	C2 MPS	C2 FPS	ZETA2 DEG	VZ--CORRECTED MPS	FPS	BETA DEG	ABSOLUTE MACH NO	BETA PRIME DEG	RELATIVE MACH NO
PRESSURE SIDE												
7.0	136.	445.	105.	221.	725.	60.	182.	596.	37.5	0.642	62.4	1.110
11.4	151.	495.	105.	223.	733.	60.	194.	635.	32.6	0.654	61.9	1.179
15.9	161.	528.	105.	222.	729.	60.	200.	657.	28.6	0.658	61.9	1.237
20.3	169.	553.	105.	224.	735.	60.	207.	678.	26.3	0.670	61.6	1.271
24.8	171.	561.	105.	227.	746.	60.	210.	688.	26.4	0.680	61.2	1.271
29.3	172.	565.	105.	233.	764.	60.	213.	697.	27.4	0.693	60.4	1.257
33.7	173.	568.	105.	236.	775.	60.	214.	704.	27.9	0.702	60.0	1.249
38.2	176.	576.	105.	240.	789.	60.	218.	715.	28.1	0.714	59.4	1.246
42.6	179.	587.	105.	244.	801.	60.	222.	727.	27.9	0.726	58.9	1.251
47.1	184.	605.	105.	250.	819.	60.	228.	747.	27.4	0.744	58.2	1.260
51.5	188.	618.	105.	255.	837.	60.	233.	763.	27.5	0.760	57.4	1.262
56.0	190.	624.	105.	256.	839.	60.	234.	768.	27.0	0.764	57.4	1.270
60.4	192.	629.	105.	253.	831.	60.	234.	769.	26.0	0.760	57.7	1.287
64.9	192.	631.	105.	251.	822.	60.	234.	767.	25.1	0.755	58.1	1.301
69.3	188.	617.	105.	248.	813.	60.	230.	754.	25.8	0.744	58.4	1.287
73.8	184.	604.	105.	243.	798.	60.	225.	738.	26.0	0.729	59.0	1.283
78.2	178.	584.	105.	234.	767.	60.	217.	712.	25.6	0.702	60.3	1.285
82.7	173.	566.	105.	210.	689.	60.	204.	670.	20.8	0.646	63.3	1.351
87.1	165.	540.	105.	200.	655.	60.	195.	638.	20.6	0.615	64.7	1.350
SUCTION SIDE												

APPENDIX D (Cont'd)

LASER DOPPLER VELOCIMETER DATA

85% SPAN 100% SPEED PEAK EFF X/B = .78 PASSAGE NO. 15

STD DAY RPM = 12470.4, RADIUS = 37.925 CM, PHI = -14.6 DEG, STD DAY TTREL = 410. DEG K, UPSTREAM TTABS = 274. DEG K  
 14.931 IN 738. DEG R 493. DEG R

PERCENT GAP	C1 MPS	C1 FPS	ZETA1 DEG	C2 MPS	C2 FPS	ZETA2 DEG	VZ--CORRECTED MPS	FPS	BETA DEG	ABSOLUTE MACH NO	BETA PRIME DEG	RELATIVE MACH NO
PRESSURE SIDE												
2.6	217.	713.	60.	254.	834.	15.	120.	394.	63.2	0.696	64.3	0.742
6.9	217.	712.	60.	211.	691.	15.	151.	496.	50.4	0.643	63.4	0.932
11.1	217.	711.	60.	184.	605.	15.	170.	557.	41.5	0.630	63.0	1.054
15.4	218.	714.	60.	180.	589.	15.	175.	573.	39.5	0.632	62.8	1.081
19.6	218.	716.	60.	177.	581.	15.	177.	582.	38.4	0.634	62.7	1.095
23.8	219.	720.	60.	180.	589.	15.	177.	582.	38.9	0.637	62.5	1.088
28.1	223.	730.	60.	181.	594.	15.	180.	592.	38.6	0.646	62.0	1.090
32.3	226.	743.	60.	184.	604.	15.	184.	603.	38.5	0.657	61.4	1.089
36.6	229.	751.	60.	180.	589.	15.	191.	625.	36.2	0.665	61.0	1.120
40.8	230.	756.	60.	169.	553.	15.	201.	658.	32.0	0.675	60.7	1.182
45.0	233.	765.	60.	157.	516.	15.	213.	698.	27.4	0.694	60.3	1.252
49.3	242.	793.	60.	163.	535.	15.	220.	723.	27.4	0.720	59.1	1.254
53.5	246.	808.	60.	168.	551.	15.	223.	733.	28.0	0.732	58.5	1.246
57.8	252.	826.	60.	173.	567.	15.	227.	746.	28.3	0.747	57.8	1.242
62.0	256.	840.	60.	178.	584.	15.	230.	753.	29.0	0.758	57.2	1.231
66.2	262.	858.	60.	183.	599.	15.	234.	768.	29.3	0.773	56.4	1.229
70.5	266.	874.	60.	187.	615.	15.	237.	779.	29.7	0.787	55.7	1.223
74.7	266.	872.	60.	190.	623.	15.	235.	770.	30.6	0.782	55.8	1.207
79.0	265.	870.	60.	193.	632.	15.	232.	761.	31.6	0.778	55.8	1.190
83.2	262.	860.	60.	186.	611.	15.	232.	762.	30.3	0.772	56.3	1.212
87.5	259.	851.	60.	187.	615.	15.	227.	746.	31.3	0.762	56.6	1.194
91.7	257.	843.	60.	190.	623.	15.	222.	729.	32.6	0.751	57.0	1.172
SUCTION SIDE												





## APPENDIX D (Cont'd)

## LASER DOPPLER VELOCIMETER DATA

85% SPAN

100% SPEED

PEAK EFF

X/B= 1.0

PASSAGE NO. 15

STD DAY RPM = 12470.4,

RADIUS = 37.643 CM,  
14.820 IN

PHI = -14.6 DEG,

STD DAY TTREL = 408. DEG K,  
735. DEG RUPSTREAM TTABS = 274. DEG K  
494. DEG R

PERCENT GAP	C1 MPS	C1 FPS	ZETA1 DEG	C2 MPS	C2 FPS	ZETA2 DEG	VZ--CORRECTED MPS	VZ--CORRECTED FPS	BETA DEG	ABSOLUTE MACH NO	BETA PRIME DEG	RELATIVE MACH NO
PRESSURE SIDE												
11.7	115.	376.	105.	205.	672.	15.	168.	550.	45.8	0.659	61.5	0.979
15.5	123.	402.	105.	197.	645.	15.	173.	569.	43.1	0.655	61.5	1.017
19.3	123.	405.	105.	194.	635.	15.	174.	569.	42.5	0.651	61.7	1.027
23.1	126.	413.	105.	192.	631.	15.	176.	576.	41.8	0.653	61.5	1.036
26.9	123.	403.	105.	191.	628.	15.	172.	565.	42.3	0.645	62.0	1.031
30.7	126.	413.	105.	185.	607.	15.	174.	570.	40.8	0.638	62.3	1.054
34.5	130.	428.	105.	185.	606.	15.	178.	584.	39.8	0.646	61.8	1.065
38.3	129.	422.	105.	185.	608.	15.	176.	579.	40.2	0.644	62.0	1.060
42.1	133.	436.	105.	186.	611.	15.	181.	594.	39.5	0.654	61.4	1.068
45.9	135.	443.	105.	187.	614.	15.	183.	601.	39.2	0.660	61.0	1.070
49.7	134.	441.	105.	186.	611.	15.	182.	599.	39.2	0.657	61.2	1.071
53.5	141.	461.	105.	182.	597.	15.	187.	615.	37.3	0.662	61.0	1.097
57.3	141.	463.	105.	182.	598.	15.	188.	617.	37.3	0.663	60.9	1.098
61.1	136.	446.	105.	186.	610.	15.	184.	603.	38.8	0.660	61.1	1.076
64.9	140.	459.	105.	186.	609.	15.	188.	616.	38.0	0.667	60.7	1.086
68.7	140.	460.	105.	189.	621.	15.	189.	620.	38.5	0.675	60.2	1.078
72.5	141.	462.	105.	183.	600.	15.	188.	616.	37.4	0.664	60.8	1.095
76.3	145.	476.	105.	186.	609.	15.	193.	633.	37.0	0.678	60.1	1.099
80.1	143.	468.	105.	194.	636.	15.	193.	632.	38.7	0.689	59.5	1.073
83.9	139.	456.	105.	203.	665.	15.	191.	628.	40.6	0.699	58.9	1.043
87.7	137.	448.	105.	206.	677.	15.	190.	623.	41.5	0.702	58.8	1.028
91.5	130.	425.	105.	213.	699.	15.	185.	606.	43.7	0.703	58.8	0.996
SUCTION SIDE												

## APPENDIX D (Cont'd)

## LASER DOPPLER VELOCIMETER DATA

85% SPAN 100% SPEED PEAK EFF X/B = 1.1 PASSAGE NO. 15

STD DAY RPM = 12470.4, RADIUS = 37.516 CM, PHI = -14.6 DEG, STD DAY TTREL = 407. DEG K, UPSTREAM TTABS = 276. DEG K  
 14.770 IN 733. DEG R 497. DEG R

PERCENT GAP	C1 MPS	C1 FPS	ZETA1 DEG	C2 MPS	C2 FPS	ZETA2 DEG	VZ--CORRECTED MPS FPS	BETA DEG	ABSOLUTE MACH NO	BETA PRIME DEG	RELATIVE MACH NO
PRESSURE SIDE											
2.7	225.	738.	60.	267.	876.	15.	121. 397.	64.2	0.724	62.5	0.701
6.5	227.	745.	60.	244.	799.	15.	141. 462.	57.3	0.693	61.7	0.807
10.3	231.	757.	60.	207.	678.	15.	173. 567.	44.9	0.670	60.7	0.984
14.1	230.	754.	60.	201.	658.	15.	176. 577.	43.2	0.666	60.8	1.010
17.9	230.	753.	60.	200.	657.	15.	176. 576.	43.2	0.665	60.8	1.010
21.7	229.	751.	60.	198.	649.	15.	177. 579.	42.5	0.663	60.9	1.020
25.5	227.	744.	60.	196.	643.	15.	175. 574.	42.5	0.657	61.3	1.021
29.3	226.	741.	60.	194.	636.	15.	175. 575.	42.1	0.654	61.4	1.029
33.1	226.	742.	60.	194.	636.	15.	176. 576.	42.0	0.655	61.3	1.030
36.9	226.	742.	60.	193.	633.	15.	176. 578.	41.7	0.655	61.3	1.034
40.7	227.	746.	60.	191.	628.	15.	179. 587.	40.8	0.658	61.1	1.046
44.5	227.	746.	60.	192.	630.	15.	179. 586.	41.0	0.658	61.1	1.043
48.3	228.	749.	60.	193.	634.	15.	179. 587.	41.1	0.660	61.0	1.040
52.1	229.	750.	60.	191.	627.	15.	181. 594.	40.3	0.661	60.9	1.051
55.9	229.	751.	60.	192.	629.	15.	181. 594.	40.5	0.662	60.9	1.049
59.7	230.	753.	60.	194.	636.	15.	180. 591.	41.0	0.664	60.8	1.041
63.5	230.	756.	60.	194.	638.	15.	181. 594.	41.0	0.666	60.7	1.041
67.3	231.	757.	60.	196.	643.	15.	180. 592.	41.4	0.667	60.6	1.035
71.1	230.	754.	60.	191.	627.	15.	183. 599.	40.0	0.665	60.7	1.055
74.9	232.	761.	60.	194.	635.	15.	184. 603.	40.2	0.671	60.4	1.051
78.7	236.	775.	60.	202.	664.	15.	183. 602.	42.0	0.683	59.7	1.023
82.5	238.	782.	60.	206.	675.	15.	184. 604.	42.4	0.689	59.4	1.014
86.3	241.	791.	60.	209.	686.	15.	185. 608.	42.8	0.697	59.0	1.008
90.1	245.	805.	60.	214.	703.	15.	188. 616.	43.2	0.710	58.3	0.998
93.9	254.	834.	60.	226.	740.	15.	192. 629.	44.3	0.735	56.8	0.976
97.7	241.	791.	60.	271.	888.	15.	141. 462.	60.4	0.749	58.9	0.734
SUCTION SIDE											

## APPENDIX D (Cont'd)

## LASER DOPPLER VELOCIMETER DATA

85% SPAN 95% SPEED PEAK EFF X/B = -.3 PASSAGE NO.15  
 STD DAY RPM = 11846.9, RADIUS = 39.306 CM, PHI = -14.6 DEG, STD DAY TTREL = 407. DEG K, UPSTREAM TTABS = 273. DEG K  
 15.475 IN 732. DEG R 492. DEG R

PERCENT GAP	C1 MPS	C1 FPS	ZETA1 DEG	C2 MPS	C2 FPS	ZETA2 DEG	VZ--CORRECTED MPS	FPS	BETA DEG	ABSOLUTE MACH NO	BETA PRIME DEG	RELATIVE MACH NO
PRESSURE SIDE												
2.0	85.	280.	135.	98.	322.	45.	133.	437.	4.0	0.409	73.9	1.475
5.8	78.	257.	135.	97.	317.	45.	127.	417.	6.0	0.389	74.5	1.452
9.6	74.	243.	135.	97.	317.	45.	124.	407.	7.5	0.380	74.8	1.436
13.4	69.	226.	135.	95.	312.	45.	119.	391.	9.1	0.365	75.3	1.420
17.2	67.	221.	135.	94.	310.	45.	118.	386.	9.5	0.360	75.5	1.416
21.0	70.	230.	135.	96.	315.	45.	121.	396.	8.9	0.370	75.1	1.422
24.8	78.	256.	135.	98.	321.	45.	128.	419.	6.4	0.391	74.4	1.448
28.6	94.	308.	135.	104.	340.	45.	143.	470.	2.8	0.442	72.9	1.497
32.4	114.	375.	135.	109.	356.	45.	162.	531.	-1.5	0.506	71.2	1.571
36.2	118.	387.	135.	112.	368.	45.	167.	548.	-1.4	0.523	70.7	1.579
40.0	116.	379.	135.	111.	365.	45.	165.	540.	-1.1	0.514	70.9	1.570
43.8	114.	373.	135.	112.	367.	45.	164.	537.	-0.5	0.511	70.9	1.561
47.6	114.	373.	135.	112.	368.	45.	164.	538.	-0.4	0.511	70.9	1.561
51.4	113.	370.	135.	112.	368.	45.	163.	536.	-0.2	0.509	70.9	1.557
55.2	112.	366.	135.	112.	369.	45.	163.	534.	0.2	0.506	71.0	1.551
59.0	115.	377.	135.	113.	370.	45.	165.	542.	-0.5	0.516	70.8	1.565
62.8	115.	377.	135.	113.	372.	45.	166.	544.	-0.4	0.517	70.7	1.563
66.6	115.	377.	135.	113.	370.	45.	165.	542.	-0.5	0.516	70.8	1.565
70.4	112.	368.	135.	114.	374.	45.	164.	539.	0.5	0.511	70.8	1.551
74.2	113.	372.	135.	113.	370.	45.	164.	539.	-0.2	0.512	70.8	1.558
78.0	111.	363.	135.	114.	373.	45.	163.	534.	0.8	0.506	70.9	1.545
81.8	109.	356.	135.	112.	369.	45.	160.	526.	1.0	0.498	71.1	1.539
85.6	106.	348.	135.	109.	356.	45.	156.	511.	0.7	0.483	71.7	1.536
89.4	100.	328.	135.	106.	347.	45.	149.	490.	1.6	0.462	72.3	1.517
93.2	97.	318.	135.	104.	341.	45.	146.	478.	2.0	0.450	72.7	1.509
97.0	93.	304.	135.	102.	334.	45.	141.	463.	2.7	0.435	73.1	1.496
SUCTION SIDE												



APPENDIX D (Cont'd)

LASER DOPPLER VELOCIMETER DATA

85% SPAN 95% SPEED PEAK EFF X/B = 0.0 PASSAGE NO. 15

STD DAY RPM = 11846.9, RADIUS = 38.923 CM, PHI = -14.6 DEG, STD DAY TTREL = 404. DEG K, UPSTREAM TTABS = 273. DEG K  
 15.324 IN 728. DEG R 491. DEG R

PERCENT GAP	C1 MPS	C1 FPS	ZETA1 DEG	C2 MPS	C2 FPS	ZETA2 DEG	VZ--CORRECTED MPS	VZ--CORRECTED FPS	BETA DEG	ABSOLUTE MACH NO	BETA PRIME DEG	RELATIVE MACH NO
PRESSURE SIDE												
4.7	138.	452.	135.	130.	428.	45.	195.	640.	-1.6	0.617	67.6	1.617
8.5	139.	457.	135.	136.	446.	45.	200.	656.	-0.7	0.632	66.9	1.614
12.3	134.	440.	135.	135.	442.	45.	195.	641.	0.1	0.615	67.3	1.593
16.1	134.	440.	135.	136.	445.	45.	196.	643.	0.3	0.617	67.2	1.591
19.9	138.	453.	135.	136.	447.	45.	199.	654.	-0.4	0.629	67.0	1.608
23.7	137.	448.	135.	137.	450.	45.	199.	653.	0.1	0.627	66.9	1.600
27.5	138.	453.	135.	136.	447.	45.	199.	654.	-0.4	0.629	67.0	1.608
31.3	138.	453.	135.	137.	449.	45.	200.	656.	-0.3	0.631	66.9	1.607
35.1	141.	464.	135.	138.	452.	45.	203.	666.	-0.8	0.642	66.6	1.620
38.9	140.	459.	135.	138.	453.	45.	202.	663.	-0.4	0.639	66.7	1.613
42.7	147.	481.	135.	141.	462.	45.	209.	685.	-1.2	0.664	66.1	1.639
46.5	158.	518.	135.	137.	448.	45.	214.	702.	-4.1	0.691	66.1	1.699
50.3	155.	508.	135.	139.	457.	45.	214.	701.	-3.0	0.686	65.9	1.679
54.1	158.	519.	135.	139.	455.	45.	216.	708.	-3.8	0.696	65.8	1.696
57.9	151.	495.	135.	140.	459.	45.	211.	693.	-2.2	0.675	66.0	1.660
61.7	151.	495.	135.	140.	459.	45.	211.	693.	-2.2	0.675	66.0	1.660
65.5	149.	488.	135.	139.	456.	45.	209.	686.	-1.9	0.667	66.2	1.652
69.3	145.	476.	135.	140.	460.	45.	207.	680.	-1.0	0.658	66.2	1.633
73.1	149.	488.	135.	148.	484.	45.	215.	706.	-0.2	0.684	65.3	1.637
76.9	147.	482.	135.	148.	485.	45.	214.	703.	0.2	0.679	65.3	1.628
80.7	146.	478.	135.	149.	488.	45.	214.	702.	0.6	0.678	65.3	1.621
84.5	122.	400.	135.	149.	489.	45.	197.	646.	5.7	0.613	66.3	1.516
88.3	134.	440.	135.	144.	473.	45.	202.	664.	2.1	0.635	66.3	1.577
92.1	136.	446.	135.	143.	469.	45.	203.	665.	1.4	0.637	66.3	1.587
95.9	125.	409.	135.	132.	434.	45.	187.	613.	1.7	0.583	68.0	1.556
99.7	104.	341.	135.	124.	408.	45.	166.	544.	5.1	0.512	69.9	1.484
SUCTION SIDE												



APPENDIX D (Cont'd)

LASER DOPPLER VELOCIMETER DATA

85% SPAN 95% SPEED PEAK EFF X/B = .39 PASSAGE NO. 15

STD DAY RPM = 11846.9, RADIUS = 38.423 CM, PHI = -14.6 DEG, STD DAY TTREL = 401. DEG K, UPSTREAM TTABS = 271. DEG K  
 15.127 IN 722. DEG R 488. DEG R

PERCENT GAP	C1 MPS	C1 FPS	ZETA1 DEG	C2 MPS	C2 FPS	ZETA2 DEG	VZ--CORRECTED MPS	VZ--CORRECTED FPS	BETA DEG	ABSOLUTE MACH NO	BETA PRIME DEG	RELATIVE MACH NO
PRESSURE SIDE												
5.2	219.	717.	60.	166.	543.	15.	187.	614.	34.1	0.643	61.1	1.113
9.4	219.	719.	60.	166.	544.	15.	188.	616.	34.0	0.645	61.0	1.114
13.5	220.	721.	60.	167.	547.	15.	188.	617.	34.2	0.646	60.9	1.111
17.6	222.	729.	60.	172.	564.	15.	188.	616.	35.4	0.652	60.6	1.094
21.8	223.	731.	60.	175.	575.	15.	186.	610.	36.4	0.653	60.5	1.079
25.9	225.	738.	60.	181.	593.	15.	185.	607.	37.8	0.659	60.2	1.059
30.0	221.	726.	60.	182.	598.	15.	179.	587.	39.4	0.648	60.8	1.039
34.2	222.	729.	60.	183.	599.	15.	180.	590.	39.2	0.650	60.6	1.041
38.3	221.	725.	60.	186.	610.	15.	176.	576.	40.8	0.647	60.8	1.020
42.5	220.	722.	60.	187.	615.	15.	173.	568.	41.6	0.645	61.0	1.009
46.6	220.	723.	60.	192.	630.	15.	170.	559.	43.1	0.647	61.0	0.988
59.0	187.	615.	60.	182.	598.	15.	131.	430.	50.6	0.565	66.9	0.931
63.1	186.	609.	60.	173.	568.	15.	135.	444.	47.7	0.554	66.9	0.968
67.3	125.	410.	105.	177.	580.	60.	158.	518.	30.0	0.526	67.1	1.179
71.4	148.	484.	105.	160.	525.	60.	168.	551.	13.1	0.520	68.4	1.377
75.6	160.	526.	105.	162.	530.	60.	178.	583.	8.0	0.550	67.9	1.447
79.7	161.	528.	105.	164.	537.	60.	179.	588.	8.7	0.554	67.6	1.440
83.8	164.	539.	105.	165.	542.	60.	182.	597.	7.9	0.564	67.4	1.453
88.0	161.	528.	105.	167.	548.	60.	180.	592.	10.1	0.558	67.3	1.424
92.1	169.	555.	105.	170.	558.	60.	188.	615.	7.9	0.581	66.7	1.459
SUCTION SIDE												





APPENDIX D (Cont'd)

LASER DOPPLER VELOCIMETER DATA

85% SPAN 95% SPEED PEAK EFF X/B = .78 PASSAGE NO. 15

STD DAY RPM = 11846.9, RADIUS = 37.925 CM, PHI = -14.6 DEG, STD DAY TTREL = 398. DEG K, UPSTREAM TTABS = 271. DEG K  
 14.931 IN 717. DEG R 488. DEG R

PERCENT GAP	C1 MPS	C1 FPS	ZETA1 DEG	C2 MPS	C2 FPS	ZETA2 DEG	VZ--CORRECTED MPS	VZ--CORRECTED FPS	BETA DEG	ABSOLUTE MACH NO	BETA PRIME DEG	RELATIVE MACH NO
PRESSURE SIDE												
2.6	203.	666.	60.	181.	593.	0.	134.	440.	54.3	0.620	64.0	0.845
6.9	203.	665.	60.	162.	530.	0.	145.	476.	48.9	0.605	63.7	0.916
11.1	201.	661.	60.	152.	498.	0.	149.	490.	46.3	0.597	63.8	0.951
15.4	202.	664.	60.	148.	486.	0.	153.	501.	45.0	0.598	63.6	0.966
19.6	201.	661.	60.	147.	481.	0.	153.	501.	44.7	0.595	63.7	0.971
23.8	203.	665.	60.	143.	469.	0.	156.	512.	43.3	0.597	63.5	0.987
28.1	204.	668.	60.	141.	463.	0.	158.	520.	42.6	0.599	63.3	0.996
32.3	204.	669.	60.	141.	464.	0.	159.	520.	42.6	0.600	63.2	0.995
36.6	208.	682.	60.	142.	467.	0.	163.	534.	42.0	0.611	62.6	0.999
40.8	210.	690.	60.	142.	466.	0.	166.	544.	41.4	0.618	62.1	1.005
45.0	211.	693.	60.	141.	461.	0.	168.	551.	40.8	0.620	62.0	1.012
49.3	215.	705.	60.	139.	457.	0.	173.	567.	39.7	0.630	61.3	1.024
53.5	218.	714.	60.	136.	447.	0.	178.	584.	38.3	0.638	60.9	1.042
57.8	223.	733.	60.	130.	427.	0.	189.	618.	35.4	0.656	59.9	1.079
62.0	229.	751.	60.	127.	418.	0.	197.	645.	33.7	0.674	59.1	1.102
66.2	234.	767.	60.	129.	422.	0.	202.	662.	33.3	0.689	58.3	1.108
70.5	239.	783.	60.	128.	419.	0.	208.	683.	32.3	0.705	57.6	1.122
74.7	242.	793.	60.	128.	420.	0.	212.	694.	32.0	0.715	57.1	1.128
79.0	241.	791.	60.	125.	410.	0.	213.	698.	31.2	0.715	57.3	1.140
83.2	243.	797.	60.	124.	408.	0.	215.	706.	30.8	0.721	57.0	1.147
87.5	242.	794.	60.	126.	414.	0.	213.	699.	31.4	0.717	57.1	1.137
91.7	246.	806.	60.	132.	432.	0.	214.	702.	32.4	0.726	56.5	1.122
SUCTION SIDE												

APPENDIX D (Cont'd)

LASER DOPPLER VELOCIMETER DATA

85% SPAN 95% SPEED PEAK EFF X/B = 1.1 PASSAGE NO. 15

STD DAY RPM = 11846.9, RADIUS = 37.516 CM, PHI = -14.6 DEG, STD DAY TTREL = 396. DEG K, UPSTREAM TTABS = 271. DEG K  
 14.770 IN 713. DEG R 487. DEG R

PERCENT GAP	C1 MPS	C1 FPS	ZETA1 DEG	C2 MPS	C2 FPS	ZETA2 DEG	VZ--CORRECTED MPS	VZ--CORRECTED FPS	BETA DEG	ABSOLUTE MACH NO	BETA PRIME DEG	RELATIVE MACH NO
PRESSURE SIDE												
2.7	216.	709.	60.	228.	747.	0.	122.	400.	62.6	0.699	61.3	0.689
6.5	215.	706.	60.	197.	645.	0.	139.	457.	55.5	0.662	61.3	0.797
10.3	213.	700.	60.	169.	556.	0.	153.	503.	48.8	0.637	61.4	0.893
14.1	213.	700.	60.	163.	536.	0.	157.	515.	47.1	0.634	61.4	0.916
17.9	215.	704.	60.	163.	535.	0.	159.	520.	46.7	0.637	61.1	0.920
21.7	215.	706.	60.	163.	536.	0.	159.	522.	46.7	0.638	61.0	0.920
25.5	215.	704.	60.	162.	533.	0.	159.	521.	46.5	0.636	61.1	0.922
29.3	213.	698.	60.	159.	523.	0.	159.	520.	46.1	0.630	61.4	0.930
33.1	212.	695.	60.	158.	520.	0.	158.	518.	46.0	0.628	61.6	0.932
36.9	211.	692.	60.	157.	515.	0.	158.	518.	45.7	0.625	61.7	0.936
40.7	211.	693.	60.	157.	515.	0.	158.	519.	45.7	0.625	61.7	0.937
44.5	212.	694.	60.	157.	514.	0.	159.	521.	45.5	0.626	61.6	0.938
48.3	211.	692.	60.	156.	512.	0.	158.	520.	45.5	0.624	61.7	0.940
52.1	211.	691.	60.	156.	511.	0.	158.	519.	45.5	0.623	61.8	0.940
55.9	210.	690.	60.	155.	509.	0.	158.	519.	45.3	0.622	61.8	0.942
59.7	211.	693.	60.	155.	507.	0.	160.	524.	45.0	0.625	61.7	0.946
63.5	213.	700.	60.	158.	517.	0.	160.	526.	45.4	0.631	61.3	0.938
67.3	215.	704.	60.	158.	520.	0.	161.	529.	45.4	0.635	61.1	0.937
71.1	215.	707.	60.	160.	525.	0.	161.	530.	45.6	0.638	60.9	0.933
74.9	217.	712.	60.	160.	525.	0.	163.	536.	45.3	0.642	60.7	0.936
78.7	216.	709.	60.	159.	522.	0.	163.	534.	45.3	0.639	60.8	0.938
82.5	218.	716.	60.	158.	517.	0.	166.	545.	44.4	0.644	60.4	0.948
86.3	220.	721.	60.	158.	518.	0.	168.	551.	44.2	0.648	60.2	0.950
90.1	222.	727.	60.	163.	535.	0.	167.	548.	45.2	0.655	59.9	0.933
93.9	226.	740.	60.	182.	597.	0.	160.	526.	49.5	0.674	59.2	0.870
97.7	219.	718.	60.	223.	731.	0.	128.	420.	60.9	0.698	60.7	0.710
SUCTION SIDE												

APPENDIX D (Cont'd)

LASER DOPPLER VELOCIMETER DATA

85% SPAN 100% SPEED NEAR SURGE X/B = -.3 PASSAGE NO. 15

STD DAY RPM = 12470.4, RADIUS = 39.306 CM, PHI = -14.6 DEG, STD DAY TTREL = 419. DEG K, UPSTREAM TTABS = 275. DEG K  
 15.475 IN 754. DEG R 495. DEG R

PERCENT GAP	C1 MPS	C1 FPS	ZETA1 DEG	C2 MPS	C2 FPS	ZETA2 DEG	VZ--CORRECTED MPS	VZ--CORRECTED FPS	BETA DEG	ABSOLUTE MACH NO	BETA PRIME DEG	RELATIVE MACH NO
PRESSURE SIDE												
2.0	73.	239.	135.	97.	317.	45.	123.	402.	8.0	0.376	75.7	1.504
5.8	69.	228.	135.	94.	310.	45.	119.	389.	8.7	0.364	76.1	1.496
9.6	67.	220.	135.	94.	307.	45.	116.	381.	9.4	0.356	76.3	1.489
13.4	61.	201.	135.	93.	305.	45.	112.	366.	11.6	0.343	76.8	1.469
17.2	68.	222.	135.	93.	306.	45.	116.	382.	9.0	0.357	76.3	1.492
21.0	64.	209.	135.	95.	311.	45.	115.	376.	11.1	0.352	76.4	1.474
24.8	88.	290.	135.	97.	319.	45.	134.	441.	2.7	0.413	74.7	1.563
28.6	92.	301.	135.	105.	343.	45.	142.	466.	3.7	0.437	73.8	1.561
32.4	116.	381.	135.	116.	382.	45.	168.	552.	0.1	0.525	71.3	1.637
36.2	123.	404.	135.	113.	372.	45.	171.	562.	-2.4	0.539	71.2	1.673
40.0	123.	404.	135.	116.	379.	45.	173.	567.	-1.8	0.543	71.0	1.669
43.8	123.	403.	135.	116.	379.	45.	173.	566.	-1.8	0.542	71.0	1.668
47.6	123.	405.	135.	115.	376.	45.	172.	565.	-2.1	0.542	71.1	1.672
51.4	118.	386.	135.	113.	370.	45.	167.	547.	-1.2	0.522	71.6	1.651
55.2	121.	397.	135.	113.	372.	45.	170.	557.	-1.9	0.533	71.3	1.664
59.0	122.	399.	135.	113.	372.	45.	170.	558.	-2.0	0.535	71.3	1.667
62.8	123.	403.	135.	112.	368.	45.	170.	558.	-2.6	0.536	71.4	1.675
66.6	123.	403.	135.	112.	366.	45.	170.	557.	-2.8	0.535	71.4	1.676
70.4	122.	399.	135.	109.	359.	45.	167.	549.	-3.0	0.527	71.7	1.675
74.2	117.	384.	135.	109.	357.	45.	163.	536.	-2.1	0.513	72.0	1.657
78.0	114.	374.	135.	107.	352.	45.	160.	526.	-1.7	0.501	72.3	1.647
81.8	110.	361.	135.	105.	344.	45.	156.	510.	-1.4	0.485	72.7	1.635
85.6	103.	337.	135.	103.	337.	45.	149.	488.	-0.0	0.461	73.3	1.609
89.4	96.	315.	135.	100.	329.	45.	142.	466.	1.2	0.439	73.9	1.587
93.2	92.	303.	135.	98.	321.	45.	138.	452.	1.7	0.425	74.4	1.578
97.0	86.	283.	135.	97.	318.	45.	133.	435.	3.3	0.407	74.8	1.555
SUCTION SIDE												

## APPENDIX D (Cont'd)

## LASER DOPPLER VELOCIMETER DATA

85% SPAN    100% SPEED    NEAR SURGE    X/B = -.1    PASSAGE NO. 15

STD DAY RPM = 12470.4,    RADIUS = 39.050 CM,  
15.374 IN    PHI = -14.6 DEG,    STD DAY TTREL = 417. DEG K,    UPSTREAM TTABS = 275. DEG K  
751. DEG R    495. DEG R

PERCENT GAP	C1 MPS	C1 FPS	ZETA1 DEG	C2 MPS	C2 FPS	ZETA2 DEG	VZ--CORRECTED MPS	VZ--CORRECTED FPS	BETA DEG	ABSOLUTE MACH NO	BETA PRIME DEG	RELATIVE MACH NO
PRESSURE SIDE												
2.4	138.	453.	135.	133.	437.	45.	196.	644.	-1.0	0.621	68.4	1.691
6.2	137.	449.	135.	135.	444.	45.	197.	646.	-0.3	0.622	68.3	1.681
10.0	141.	464.	135.	135.	444.	45.	200.	657.	-1.3	0.636	68.1	1.702
13.8	152.	499.	135.	139.	456.	45.	211.	691.	-2.6	0.675	67.3	1.745
17.6	150.	491.	135.	138.	454.	45.	208.	684.	-2.2	0.666	67.4	1.735
21.4	145.	477.	135.	136.	447.	45.	204.	669.	-1.9	0.649	67.8	1.719
25.2	145.	476.	135.	136.	446.	45.	203.	667.	-1.9	0.648	67.9	1.718
29.0	142.	466.	135.	137.	448.	45.	202.	662.	-1.1	0.640	67.9	1.702
32.8	134.	440.	135.	136.	446.	45.	195.	641.	0.4	0.615	68.3	1.667
36.6	133.	436.	135.	132.	433.	45.	192.	629.	-0.2	0.604	68.8	1.670
40.4	133.	437.	135.	135.	444.	45.	194.	638.	0.5	0.612	68.4	1.665
44.2	127.	417.	135.	131.	430.	45.	187.	613.	0.9	0.586	69.2	1.646
48.0	123.	403.	135.	129.	423.	45.	182.	598.	1.4	0.569	69.6	1.631
51.8	113.	372.	135.	128.	419.	45.	175.	573.	3.4	0.542	70.2	1.593
55.6	106.	347.	135.	125.	411.	45.	167.	549.	4.8	0.517	70.8	1.566
59.4	97.	319.	135.	123.	403.	45.	159.	523.	6.6	0.491	71.5	1.536
63.2	89.	292.	135.	118.	386.	45.	150.	491.	7.9	0.460	72.5	1.513
67.0	77.	251.	135.	115.	378.	45.	139.	455.	11.4	0.427	73.4	1.470
70.8	73.	239.	135.	111.	365.	45.	133.	437.	11.8	0.410	74.1	1.464
74.6	77.	251.	135.	112.	369.	45.	137.	449.	10.8	0.421	73.7	1.475
78.4	87.	284.	135.	116.	380.	45.	146.	481.	8.2	0.450	72.8	1.507
82.2	116.	380.	135.	129.	422.	45.	177.	581.	3.0	0.550	69.9	1.601
86.0	131.	431.	135.	127.	418.	45.	187.	615.	-0.9	0.590	69.3	1.672
89.8	133.	435.	135.	128.	419.	45.	188.	618.	-1.1	0.594	69.2	1.676
93.6	130.	428.	135.	128.	420.	45.	187.	614.	-0.5	0.589	69.3	1.666
97.4	129.	423.	135.	128.	421.	45.	186.	611.	-0.1	0.585	69.3	1.659
SUCTION SIDE												

APPENDIX D (Cont'd)

LASER DOPPLER VELOCIMETER DATA

85% SPAN    100% SPEED    NEAR SURGE    X/B = 0.0    PASSAGE NO. 15

STD DAY RPM = 12470.4,    RADIUS = 38.923 CM,    PHI = -14.6 DEG,    STD DAY TTREL = 417. DEG K,    UPSTREAM TTABS = 274. DEG K  
 15.324 IN    750. DEG R    493. DEG R

PERCENT GAP	C1 MPS	C1 FPS	ZETA1 DEG	C2 MPS	C2 FPS	ZETA2 DEG	VZ--CORRECTED MPS      FPS	BETA DEG	ABSOLUTE MACH NO	BETA PRIME DEG	RELATIVE MACH NO
PRESSURE SIDE											
0.9	106.	347.	135.	128.	420.	45.	170.	556.	5.4	70.4	1.555
4.7	121.	397.	135.	119.	389.	45.	174.	570.	-0.6	70.6	1.639
8.5	124.	407.	135.	123.	402.	45.	179.	587.	-0.4	70.1	1.644
12.3	124.	408.	135.	122.	399.	45.	178.	585.	-0.6	70.1	1.647
16.1	126.	415.	135.	123.	403.	45.	181.	593.	-0.8	69.9	1.654
19.9	128.	420.	135.	117.	384.	45.	178.	583.	-2.6	70.4	1.672
23.7	127.	416.	135.	118.	388.	45.	178.	583.	-2.0	70.4	1.665
27.5	124.	408.	135.	121.	396.	45.	178.	583.	-0.9	70.2	1.649
31.3	131.	430.	135.	115.	376.	45.	178.	585.	-3.8	70.5	1.691
35.1	128.	419.	135.	116.	381.	45.	177.	580.	-2.7	70.5	1.673
38.9	126.	412.	135.	111.	365.	45.	172.	564.	-3.5	71.1	1.674
42.7	127.	418.	135.	117.	383.	45.	177.	581.	-2.5	70.5	1.670
46.5	121.	397.	135.	115.	377.	45.	171.	561.	-1.5	71.0	1.646
50.3	122.	400.	135.	117.	383.	45.	173.	568.	-1.2	70.7	1.646
54.1	117.	383.	135.	115.	378.	45.	168.	552.	-0.4	71.2	1.627
57.9	115.	378.	135.	117.	384.	45.	168.	553.	0.5	71.1	1.617
61.7	112.	367.	135.	116.	379.	45.	165.	541.	0.9	71.4	1.606
65.5	120.	394.	135.	121.	397.	45.	175.	574.	0.2	70.4	1.630
69.3	111.	364.	135.	116.	381.	45.	165.	540.	1.3	71.4	1.600
73.1	108.	354.	135.	124.	408.	45.	168.	553.	4.1	70.7	1.571
76.9	105.	346.	135.	123.	404.	45.	166.	544.	4.4	70.9	1.564
80.7	100.	328.	135.	133.	436.	45.	169.	554.	8.0	70.2	1.523
84.5	94.	309.	135.	136.	447.	45.	167.	548.	10.3	70.1	1.493
88.3	90.	294.	135.	149.	489.	45.	173.	568.	14.0	69.0	1.453
92.1	84.	276.	135.	150.	492.	45.	170.	557.	15.7	69.1	1.430
SUCTION SIDE											



APPENDIX D (Cont'd)

LASER DOPPLER VELOCIMETER DATA

85% SPAN 100% SPEED NEAR SURGE X/B = .39 PASSAGE NO. 15

STD DAY RPM = 12470.4, RADIUS = 38.423 CM, PHI = -14.6 DEG, STD DAY TTREL = 413. DEG K, UPSTREAM TTARS = 275. DEG K  
 15.127 IN 744. DEG R 495. DEG R

PERCENT GAP	C1 MPS	C1 FPS	ZETA1 DEG	C2 MPS	C2 FPS	ZETA2 DEG	VZ--CORRECTED MPS FPS	BETA DEG	ABSOLUTE MACH NO	BETA PRIME DEG	RELATIVE MACH NO
PRESSURE SIDE											
6.7	237.	778.	60.	179.	586.	15.	202. 664.	33.7	0.689	60.3	1.169
11.0	239.	785.	60.	179.	587.	15.	205. 673.	33.3	0.696	60.0	1.175
15.2	239.	784.	60.	184.	604.	15.	201. 659.	35.1	0.693	60.1	1.147
19.5	241.	790.	60.	194.	637.	15.	196. 644.	38.0	0.695	59.8	1.103
23.8	243.	797.	60.	194.	638.	15.	199. 653.	37.5	0.702	59.5	1.110
28.0	241.	790.	60.	200.	656.	15.	192. 630.	39.9	0.695	59.8	1.075
32.3	242.	794.	60.	202.	664.	15.	192. 630.	40.4	0.698	59.7	1.067
36.5	235.	770.	60.	205.	673.	15.	180. 590.	43.3	0.679	60.8	1.029
40.8	240.	789.	60.	206.	677.	15.	187. 613.	42.0	0.694	59.9	1.043
62.1	187.	614.	60.	157.	515.	15.	148. 486.	40.5	0.544	67.8	1.110
66.3	174.	572.	105.	174.	571.	60.	191. 628.	7.4	0.594	67.5	1.538
70.6	172.	563.	105.	168.	552.	60.	187. 614.	6.1	0.581	68.1	1.550
74.8	175.	573.	105.	170.	559.	60.	190. 624.	5.8	0.591	67.8	1.558
79.1	173.	569.	105.	172.	565.	60.	190. 624.	7.0	0.589	67.7	1.541
83.4	172.	564.	105.	173.	568.	60.	189. 621.	8.0	0.587	67.6	1.527
87.6	176.	578.	105.	174.	571.	60.	193. 632.	6.7	0.598	67.4	1.550
91.9	175.	575.	105.	176.	578.	60.	193. 633.	7.9	0.598	67.2	1.533
96.1	173.	567.	105.	178.	583.	60.	192. 629.	9.4	0.594	67.1	1.510
SUCTION SIDE											





APPENDIX D (Cont'd)

LASER DOPPLER VELOCIMETER DATA

85% SPAN 100% SPEED NEAR SURGE X/B = .78 PASSAGE NO. 15

STD DAY RPM = 12470.4, RADIUS = 37.925 CM, PHI = -14.6 DEG, STD DAY TTREL = 410. DEG K, UPSTREAM TTABS = 275. DEG K  
 14.931 IN 738. DEG R 495. DEG R

PERCENT GAP	C1 MPS	C1 FPS	ZETA1 DEG	C2 MPS	C2 FPS	ZETA2 DEG	VZ--CORRECTED MPS	VZ--CORRECTED FPS	BETA DEG	ABSOLUTE MACH NO	BETA PRIME DEG	RELATIVE MACH NO
PRESSURE SIDE												
2.6	217.	713.	60.	210.	688.	0.	133.	436.	58.2	0.669	63.9	0.820
6.9	216.	708.	60.	199.	652.	0.	138.	452.	55.9	0.655	64.0	0.857
11.1	218.	714.	60.	182.	597.	0.	150.	491.	51.2	0.645	63.4	0.921
15.4	216.	709.	60.	179.	588.	0.	150.	491.	50.8	0.640	63.6	0.928
19.6	217.	711.	60.	176.	578.	0.	152.	499.	49.9	0.639	63.5	0.941
23.8	217.	712.	60.	172.	563.	0.	155.	509.	48.6	0.637	63.4	0.958
28.1	220.	722.	60.	173.	568.	0.	158.	518.	48.3	0.646	62.9	0.958
32.3	223.	730.	60.	169.	555.	0.	163.	535.	46.7	0.650	62.4	0.977
36.6	224.	734.	60.	166.	543.	0.	167.	547.	45.5	0.651	62.1	0.994
40.8	227.	745.	60.	166.	543.	0.	171.	560.	44.8	0.660	61.6	1.000
45.0	228.	749.	60.	165.	540.	0.	173.	566.	44.3	0.663	61.4	1.006
49.3	231.	759.	60.	167.	549.	0.	175.	573.	44.5	0.672	60.9	1.001
53.5	237.	778.	60.	165.	541.	0.	183.	600.	42.7	0.686	59.9	1.022
57.8	237.	776.	60.	169.	553.	0.	180.	590.	43.8	0.685	60.0	1.006
62.0	243.	798.	60.	168.	551.	0.	188.	618.	42.4	0.703	59.0	1.022
66.2	247.	811.	60.	174.	570.	0.	190.	622.	43.2	0.715	58.3	1.008
70.5	244.	800.	60.	171.	560.	0.	187.	615.	43.0	0.705	58.9	1.013
74.7	248.	813.	60.	167.	549.	0.	194.	637.	41.4	0.716	58.3	1.034
79.0	252.	827.	60.	160.	526.	0.	203.	667.	38.9	0.728	57.6	1.071
83.2	251.	823.	60.	158.	519.	0.	203.	666.	38.6	0.725	57.8	1.077
87.5	253.	831.	60.	151.	497.	0.	210.	689.	36.5	0.733	57.5	1.110
91.7	258.	847.	60.	155.	508.	0.	214.	701.	36.6	0.747	56.8	1.107
SUCTION SIDE												



APPENDIX D (Cont'd)

LASER DOPPLER VELOCIMETER DATA

85% SPAN 100% SPEED PEAK EFF X/B = -.3 PASSAGE NO. 31

STD DAY RPM = 12470.4, RADIUS = 39.306 CM, PHI = -14.6 DEG, STD DAY TTREL = 419. DEG K, UPSTREAM TTABS = 271. DEG K  
 15.475 IN 754. DEG R 487. DEG R

PERCENT GAP	C1 MPS	C1 FPS	ZETA1 DEG	C2 MPS	C2 FPS	ZETA2 DEG	VZ--CORRECTED MPS	VZ--CORRECTED FPS	BETA DEG	ABSOLUTE MACH NO	BETA PRIME DEG	RELATIVE MACH NO
PRESSURE SIDE												
2.2	130.	426.	135.	132.	432.	45.	191.	626.	0.4	0.600	68.9	1.669
6.0	127.	417.	135.	131.	429.	45.	188.	617.	0.8	0.590	69.2	1.658
9.8	123.	403.	135.	129.	422.	45.	184.	602.	1.3	0.574	69.6	1.643
13.6	120.	393.	135.	125.	411.	45.	179.	587.	1.3	0.558	70.1	1.637
17.4	115.	378.	135.	124.	407.	45.	175.	573.	2.1	0.543	70.4	1.619
21.2	110.	361.	135.	121.	398.	45.	169.	554.	2.8	0.524	70.9	1.603
25.0	107.	350.	135.	118.	388.	45.	164.	539.	2.9	0.508	71.4	1.595
28.8	106.	348.	135.	118.	386.	45.	163.	536.	3.0	0.506	71.5	1.593
32.6	112.	368.	135.	120.	393.	45.	169.	555.	1.9	0.526	71.0	1.615
36.4	123.	404.	135.	126.	414.	45.	182.	597.	0.7	0.570	69.8	1.650
40.2	135.	442.	135.	131.	431.	45.	194.	637.	-0.7	0.613	68.7	1.692
44.0	135.	444.	135.	132.	434.	45.	195.	641.	-0.7	0.617	68.6	1.693
47.8	135.	444.	135.	133.	437.	45.	196.	643.	-0.5	0.619	68.5	1.691
51.6	136.	445.	135.	134.	441.	45.	197.	647.	-0.3	0.622	68.4	1.690
55.4	138.	453.	135.	134.	440.	45.	199.	652.	-0.8	0.629	68.3	1.702
59.2	139.	457.	135.	136.	445.	45.	201.	658.	-0.8	0.635	68.1	1.704
63.0	142.	465.	135.	137.	451.	45.	204.	668.	-0.9	0.646	67.8	1.712
66.8	144.	471.	135.	139.	457.	45.	206.	677.	-0.9	0.656	67.6	1.717
70.6	145.	476.	135.	142.	467.	45.	210.	688.	-0.5	0.666	67.2	1.719
74.4	151.	496.	135.	147.	481.	45.	217.	713.	-0.9	0.694	66.5	1.740
78.2	157.	516.	135.	149.	489.	45.	224.	733.	-1.5	0.718	66.0	1.765
82.0	160.	524.	135.	151.	496.	45.	227.	744.	-1.6	0.730	65.7	1.773
85.8	159.	522.	135.	150.	493.	45.	226.	741.	-1.6	0.726	65.8	1.772
89.6	155.	508.	135.	146.	480.	45.	220.	721.	-1.6	0.704	66.4	1.758
93.4	153.	501.	135.	144.	471.	45.	216.	709.	-1.8	0.692	66.8	1.753
97.2	148.	485.	135.	139.	457.	45.	210.	687.	-1.7	0.669	67.4	1.738
SUCTION SIDE												



## APPENDIX D (Cont'd)

## LASER DOPPLER VELOCIMETER DATA

85% SPAN    100% SPEED    PEAK EFF    X/B = -.1    PASSAGE NO. 31

STD DAY RPM = 12470.4,    RADIUS = 39.050 CM,    PHI = -14.6 DEG,    STD DAY TTREL = 417. DEG K,    UPSTREAM TTABS = 274. DEG K  
15.374 IN    751. DEG R    493. DEG R

PERCENT GAP	C1 MPS	C1 FPS	ZETA1 DEG	C2 MPS	C2 FPS	ZETA2 DEG	VZ--CORRECTED MPS      FPS	BETA DEG	ABSOLUTE MACH NO	BETA PRIME DEG	RELATIVE MACH NO
PRESSURE SIDE											
2.6	130.	426.	135.	134.	439.	45.	191.    627.	0.9	0.600	68.7	1.653
6.4	131.	429.	135.	135.	444.	45.	193.    633.	1.0	0.606	68.5	1.654
10.2	133.	436.	135.	136.	445.	45.	195.    639.	0.6	0.613	68.4	1.663
14.0	134.	441.	135.	137.	449.	45.	197.    646.	0.5	0.620	68.2	1.668
17.8	138.	454.	135.	137.	450.	45.	200.    656.	-0.3	0.632	68.0	1.685
21.6	141.	462.	135.	138.	452.	45.	202.    663.	-0.6	0.640	67.8	1.695
25.4	140.	460.	135.	137.	448.	45.	201.    659.	-0.8	0.636	68.0	1.695
29.2	138.	454.	135.	137.	449.	45.	200.    655.	-0.3	0.631	68.0	1.686
33.0	136.	447.	135.	138.	452.	45.	199.    652.	0.3	0.627	68.0	1.674
36.8	136.	446.	135.	137.	451.	45.	198.    651.	0.3	0.625	68.1	1.674
40.6	133.	437.	135.	137.	448.	45.	196.    642.	0.7	0.615	68.3	1.663
44.4	131.	429.	135.	137.	448.	45.	194.    636.	1.2	0.609	68.4	1.652
48.2	129.	422.	135.	134.	440.	45.	191.    625.	1.2	0.597	68.7	1.647
52.0	125.	410.	135.	134.	438.	45.	187.    615.	1.9	0.586	69.0	1.632
55.8	119.	391.	135.	130.	426.	45.	181.    593.	2.5	0.563	69.6	1.614
59.6	114.	375.	135.	127.	416.	45.	175.    574.	3.0	0.543	70.2	1.599
63.4	109.	356.	135.	123.	405.	45.	168.    552.	3.7	0.521	70.8	1.581
67.2	105.	345.	135.	122.	399.	45.	164.    540.	4.2	0.509	71.2	1.571
71.0	105.	346.	135.	123.	402.	45.	165.    543.	4.3	0.511	71.0	1.570
74.8	126.	415.	135.	129.	423.	45.	185.    608.	0.5	0.581	69.4	1.648
78.6	138.	452.	135.	137.	449.	45.	199.    653.	-0.2	0.629	68.0	1.683
82.4	139.	456.	135.	138.	453.	45.	201.    659.	-0.2	0.635	67.9	1.686
86.2	140.	460.	135.	138.	454.	45.	202.    663.	-0.4	0.639	67.8	1.691
90.0	141.	463.	135.	140.	458.	45.	204.    668.	-0.3	0.645	67.6	1.693
93.8	142.	465.	135.	141.	462.	45.	205.    672.	-0.2	0.649	67.5	1.694
97.6	143.	469.	135.	141.	464.	45.	206.    677.	-0.3	0.654	67.4	1.698
SUCTION SIDE											

APPENDIX D (Cont'd)

LASER DOPPLER VELOCIMETER DATA

85% SPAN 100% SPEED PEAK EFF X/B = 0.0 PASSAGE NO. 31

STD DAY RPM = 12470.4, RADIUS = 38.923 CM, PHI = -14.6 DEG, STD DAY TTREL = 417. DEG K, UPSTREAM TTABS = 274. DEG K  
 15.324 IN 750. DEG R 493. DEG R

PERCENT GAP	C1 MPS	C1 FPS	ZETA1 DEG	C2 MPS	C2 FPS	ZETA2 DEG	VZ--CORRECTED MPS	FPS	BETA DEG	ABSOLUTE MACH NO	BETA PRIME DEG	RELATIVE MACH NO
PRESSURE SIDE												
1.1	134.	438.	135.	135.	444.	45.	195.	640.	0.4	0.613	68.3	1.661
4.9	134.	438.	135.	137.	450.	45.	196.	644.	0.8	0.617	68.1	1.658
8.7	136.	445.	135.	138.	453.	45.	199.	651.	0.5	0.625	68.0	1.665
12.5	135.	442.	135.	138.	453.	45.	198.	649.	0.7	0.623	68.0	1.661
16.3	136.	446.	135.	139.	457.	45.	200.	655.	0.7	0.629	67.8	1.665
20.1	137.	449.	135.	140.	460.	45.	201.	659.	0.7	0.633	67.7	1.667
23.9	137.	451.	135.	139.	456.	45.	201.	658.	0.3	0.632	67.8	1.672
27.7	138.	453.	135.	140.	459.	45.	202.	661.	0.4	0.636	67.7	1.673
31.5	139.	456.	135.	141.	462.	45.	203.	666.	0.4	0.640	67.5	1.676
35.3	141.	462.	135.	141.	462.	45.	204.	670.	-0.0	0.646	67.4	1.684
39.1	142.	467.	135.	141.	461.	45.	205.	673.	-0.4	0.650	67.4	1.692
42.9	147.	481.	135.	142.	465.	45.	209.	686.	-1.0	0.665	67.1	1.709
46.7	150.	493.	135.	141.	464.	45.	212.	694.	-1.7	0.675	67.0	1.727
50.5	148.	485.	135.	142.	466.	45.	210.	690.	-1.1	0.669	67.0	1.714
54.3	146.	479.	135.	141.	461.	45.	208.	682.	-1.1	0.661	67.3	1.709
58.1	144.	473.	135.	141.	464.	45.	207.	680.	-0.6	0.657	67.2	1.698
61.9	142.	465.	135.	143.	470.	45.	207.	678.	0.3	0.653	67.2	1.684
65.7	142.	465.	135.	142.	467.	45.	206.	676.	0.1	0.652	67.3	1.685
69.5	140.	460.	135.	143.	468.	45.	205.	673.	0.5	0.648	67.3	1.678
73.3	138.	452.	135.	143.	469.	45.	204.	668.	1.1	0.641	67.4	1.666
77.1	137.	448.	135.	143.	468.	45.	203.	664.	1.3	0.637	67.4	1.661
80.9	136.	445.	135.	143.	468.	45.	202.	662.	1.4	0.635	67.5	1.657
84.7	132.	434.	135.	143.	470.	45.	200.	656.	2.3	0.627	67.6	1.641
88.5	128.	420.	135.	142.	466.	45.	196.	643.	3.0	0.612	67.9	1.624
92.3	121.	396.	135.	142.	467.	45.	191.	626.	4.7	0.593	68.2	1.592
96.1	109.	359.	135.	143.	469.	45.	183.	601.	7.6	0.566	68.7	1.543
SUCTION SIDE												

APPENDIX D (Cont'd)

LASER DOPPLER VELOCIMETER DATA

85% SPAN 100% SPEED PEAK EFF X/B = .13 PASSAGE NO. 31

STD DAY RPM = 12470.4, RADIUS = 38.755 CM, PHI = -14.6 DEG, STD DAY TTREL = 416. DEG K, UPSTREAM TTABS = 274. DEG K  
 15.258 IN 748. DEG R 493. DEG R

PERCENT GAP	C1 MPS	C1 FPS	ZETA1 DEG	C2 MPS	C2 FPS	ZETA2 DEG	VZ--CORRECTED MPS	VZ--CORRECTED FPS	BETA DEG	ABSOLUTE MACH NO	BETA PRIME DEG	RELATIVE MACH NO
PRESSURE SIDE												
10.9	178.	585.	105.	190.	625.	60.	201.	659.	12.1	0.624	65.9	1.494
14.9	179.	586.	105.	182.	596.	60.	198.	649.	8.7	0.614	66.8	1.539
18.9	181.	594.	105.	169.	554.	60.	195.	639.	2.7	0.609	68.0	1.620
22.8	182.	598.	105.	169.	555.	60.	196.	642.	2.4	0.613	67.9	1.627
26.8	184.	603.	105.	170.	559.	60.	197.	647.	2.3	0.618	67.8	1.631
30.7	186.	610.	105.	172.	565.	60.	200.	655.	2.2	0.626	67.5	1.635
34.7	188.	618.	105.	173.	567.	60.	202.	661.	1.6	0.633	67.4	1.649
38.7	191.	626.	105.	174.	571.	60.	204.	668.	1.2	0.642	67.2	1.659
42.6	193.	633.	105.	176.	577.	60.	206.	676.	1.1	0.649	67.0	1.663
46.6	195.	640.	105.	178.	583.	60.	208.	683.	1.1	0.657	66.8	1.668
50.5	196.	642.	105.	179.	588.	60.	209.	686.	1.4	0.660	66.7	1.664
54.5	198.	651.	105.	181.	593.	60.	212.	695.	1.1	0.669	66.5	1.675
58.4	199.	653.	105.	181.	595.	60.	212.	697.	1.1	0.672	66.4	1.676
62.4	201.	660.	105.	182.	598.	60.	214.	703.	0.7	0.679	66.3	1.686
66.4	204.	668.	105.	184.	603.	60.	217.	711.	0.5	0.688	66.1	1.695
70.3	206.	676.	105.	184.	604.	60.	219.	717.	-0.2	0.696	66.0	1.710
74.3	205.	671.	105.	184.	605.	60.	218.	714.	0.4	0.691	66.0	1.698
78.2	205.	671.	105.	184.	603.	60.	217.	713.	0.2	0.691	66.0	1.701
82.2	204.	669.	105.	185.	607.	60.	217.	713.	0.8	0.689	65.9	1.690
86.2	202.	663.	105.	185.	607.	60.	216.	709.	1.4	0.683	66.0	1.677
90.1	201.	658.	105.	186.	609.	60.	215.	706.	2.2	0.679	65.9	1.664
94.1	194.	638.	105.	186.	610.	60.	211.	692.	4.4	0.660	66.0	1.621
98.0	193.	634.	105.	187.	613.	60.	210.	690.	5.2	0.658	66.0	1.608
SUCTION SIDE												



APPENDIX D (Cont'd)

LASER DOPPLER VELOCIMETER DATA

85% SPAN    100% SPEED    PEAK EFF    X/B = .26    PASSAGE NO. 31

STD DAY RPM = 12470.4,    RADIUS = 38.590 CM,    PHI = -14.6 DEG,    STD DAY TTREL = 414. DEG K,    UPSTREAM TTARS = 276. DEG K  
 15.193 IN    746. DEG R    497. DEG R

PERCENT GAP	C1 MPS	C1 FPS	ZETA1 DEG	C2 MPS	C2 FPS	ZETA2 DEG	VZ--CORRECTED MPS    FPS	BETA DEG	ABSOLUTE MACH NO	BETA PRIME DEG	RELATIVE MACH NO	
PRESSURE SIDE												
8.8	122.	400.	105.	234.	768.	60.	176.	576.	44.8	0.677	61.2	1.013
12.8	120.	395.	105.	235.	771.	60.	175.	574.	45.4	0.680	61.1	1.003
16.9	120.	394.	105.	228.	747.	60.	172.	564.	44.3	0.658	62.2	1.026
21.0	123.	402.	105.	225.	738.	60.	173.	566.	42.9	0.650	62.5	1.047
25.0	130.	428.	105.	206.	676.	60.	171.	562.	36.0	0.597	65.0	1.155
29.1	168.	550.	105.	185.	606.	60.	190.	624.	14.2	0.591	66.7	1.450
33.1	166.	546.	105.	164.	537.	60.	181.	595.	6.4	0.562	68.8	1.546
37.2	167.	547.	105.	161.	529.	60.	181.	593.	5.2	0.560	69.0	1.560
41.3	168.	551.	105.	163.	536.	60.	182.	598.	5.6	0.565	68.8	1.557
45.3	170.	557.	105.	165.	542.	60.	184.	605.	5.6	0.572	68.6	1.559
49.4	172.	565.	105.	165.	542.	60.	186.	611.	4.6	0.578	68.5	1.575
53.4	174.	572.	105.	167.	548.	60.	188.	618.	4.5	0.586	68.3	1.579
57.5	177.	581.	105.	169.	555.	60.	191.	627.	4.3	0.595	68.0	1.586
61.6	181.	593.	105.	171.	561.	60.	195.	638.	3.7	0.607	67.8	1.600
65.6	183.	601.	105.	176.	576.	60.	198.	650.	4.6	0.617	67.3	1.592
69.7	187.	612.	105.	176.	578.	60.	201.	658.	3.6	0.627	67.1	1.611
73.7	189.	621.	105.	178.	583.	60.	203.	667.	3.1	0.636	66.9	1.622
77.8	192.	631.	105.	181.	595.	60.	207.	678.	3.4	0.648	66.5	1.623
81.9	195.	640.	105.	183.	602.	60.	210.	687.	3.3	0.658	66.2	1.630
85.9	198.	650.	105.	184.	603.	60.	212.	695.	2.3	0.667	66.2	1.649
90.0	202.	664.	105.	188.	616.	60.	216.	710.	2.3	0.683	65.7	1.657
94.0	205.	672.	105.	193.	633.	60.	220.	722.	3.4	0.693	65.1	1.647
98.1	207.	680.	105.	195.	639.	60.	223.	730.	3.2	0.702	64.9	1.654
SUCTION SIDE												

APPENDIX D (Cont'd)

LASER DOPPLER VELOCIMETER DATA

85% SPAN    100% SPEED    PEAK EFF    X/B = .39    PASSAGE NO. 31

STD DAY RPM = 12470.4,    RADIUS = 38.423 CM,    PHI = -14.6 DEG,    STD DAY TTREL = 413. DEG K,    UPSTREAM TTABS = 276. DEG K  
 15.127 IN    744. DEG R    497. DEG R

PERCENT GAP	C1 MPS	C1 FPS	ZETA1 DEG	C2 MPS	C2 FPS	ZETA2 DEG	VZ--CORRECTED MPS      FPS	BETA DEG	ABSOLUTE MACH NO	BETA PRIME DEG	RELATIVE MACH NO	
PRESSURE SIDE												
2.7	159.	523.	105.	243.	796.	60.	206.	675.	34.1	0.703	59.6	1.163
7.0	163.	534.	105.	244.	802.	60.	209.	686.	33.3	0.709	59.3	1.174
11.2	161.	527.	105.	246.	806.	60.	208.	682.	34.3	0.711	59.2	1.158
15.5	157.	514.	105.	245.	808.	60.	205.	673.	35.7	0.711	59.1	1.136
19.7	153.	501.	105.	247.	811.	60.	203.	665.	37.2	0.713	58.9	1.113
24.0	146.	479.	105.	247.	812.	60.	198.	650.	39.4	0.712	58.9	1.079
28.2	140.	459.	105.	243.	797.	60.	192.	630.	40.5	0.699	59.6	1.065
32.5	133.	435.	105.	244.	799.	60.	187.	613.	43.0	0.702	59.5	1.027
36.8	127.	416.	105.	234.	769.	60.	179.	588.	43.2	0.676	60.9	1.030
41.0	123.	402.	105.	231.	758.	60.	175.	574.	44.0	0.668	61.5	1.021
45.3	120.	395.	105.	220.	723.	60.	169.	556.	42.8	0.637	63.1	1.048
49.5	135.	444.	105.	201.	659.	60.	173.	567.	32.7	0.585	65.4	1.196
53.8	173.	568.	105.	166.	546.	60.	187.	614.	4.8	0.582	68.3	1.568
58.0	173.	568.	105.	165.	542.	60.	187.	613.	4.3	0.581	68.4	1.575
62.3	172.	564.	105.	166.	544.	60.	186.	611.	5.0	0.578	68.4	1.564
66.6	171.	562.	105.	166.	545.	60.	186.	610.	5.4	0.577	68.4	1.558
70.8	171.	561.	105.	168.	550.	60.	186.	611.	6.1	0.577	68.2	1.548
75.1	172.	563.	105.	167.	547.	60.	186.	611.	5.5	0.578	68.3	1.557
79.3	172.	563.	105.	169.	556.	60.	187.	615.	6.6	0.581	68.0	1.543
83.6	172.	565.	105.	171.	562.	60.	188.	618.	7.1	0.584	67.8	1.538
87.8	172.	565.	105.	173.	566.	60.	189.	620.	7.6	0.585	67.7	1.532
92.1	172.	563.	105.	176.	579.	60.	190.	623.	9.4	0.588	67.3	1.508
96.4	172.	563.	105.	179.	588.	60.	191.	627.	10.5	0.592	67.1	1.495
SUCTION SIDE												

APPENDIX D (Cont'd)

LASER DOPPLER VELOCIMETER DATA

85% SPAN 100% SPEED PEAK EFF X/B = .52 .PASSAGE NO. 31

STD DAY RPM = 12470.4, RADIUS = 38.257 CM, PHI = -14.6 DEG, STD DAY TTREL = 412. DEG K, UPSTREAM TTABS = 276. DEG K  
 15.062 IN 742. DEG R 496. DEG R

PERCENT GAP	C1 MPS	C1 FPS	ZETA1 DEG	C2 MPS	C2 FPS	ZETA2 DEG	VZ--CORRECTED MPS	VZ--CORRECTED FPS	BETA DEG	ABSOLUTE MACH NO	BETA PRIME DEG	RELATIVE MACH NO
PRESSURE SIDE												
33.9	175.	575.	105.	166.	546.	15.	217.	712.	28.5	0.713	59.5	1.245
38.4	176.	577.	105.	176.	576.	15.	220.	722.	30.0	0.730	58.6	1.223
42.9	174.	571.	105.	172.	565.	15.	217.	714.	29.7	0.719	59.1	1.227
47.4	172.	563.	105.	172.	564.	15.	215.	705.	30.1	0.713	59.4	1.221
51.9	171.	561.	105.	166.	546.	15.	213.	699.	29.2	0.702	60.0	1.233
56.4	170.	557.	105.	162.	532.	15.	211.	691.	28.7	0.692	60.5	1.241
60.9	170.	557.	105.	159.	521.	15.	210.	688.	28.1	0.687	60.8	1.250
65.4	171.	561.	105.	153.	503.	15.	209.	687.	26.9	0.681	61.2	1.269
69.9	179.	588.	105.	138.	452.	15.	213.	700.	22.5	0.680	61.8	1.335
74.5	192.	630.	105.	124.	408.	15.	223.	730.	17.9	0.700	61.7	1.411
79.0	200.	656.	105.	124.	406.	15.	230.	755.	16.8	0.724	61.1	1.436
SUCTION SIDE												

APPENDIX D (Cont'd)

LASER DOPPLER VELOCIMETER DATA

85% SPAN 100% SPEED PEAK EFF X/B = .65 PASSAGE NO. 31

STD DAY RPM = 12470.4, RADIUS = 38.090 CM, PHI = -14.6 DEG, STD DAY TTREL = 411. DEG K, UPSTREAM TTABS = 273. DEG K  
 14.996 IN 740. DEG R 492. DEG R

PERCENT GAP	C1 MPS	C1 FPS	ZETA1 DEG	C2 MPS	C2 FPS	ZETA2 DEG	YZ--CORRECTED		BETA DEG	ABSOLUTE MACH NO	BETA PRIME DEG	RELATIVE MACH NO
							MPS	FPS				
PRESSURE SIDE												
2.8	107.	352.	105.	217.	711.	60.	159.	523.	46.7	0.635	63.4	0.988
7.2	129.	424.	105.	219.	719.	60.	176.	578.	39.4	0.636	62.7	1.085
11.7	142.	467.	105.	223.	732.	60.	187.	614.	35.6	0.649	62.0	1.136
16.1	149.	488.	105.	225.	737.	60.	192.	631.	33.6	0.656	61.7	1.164
20.6	161.	529.	105.	226.	741.	60.	202.	663.	29.4	0.667	61.4	1.225
25.0	170.	557.	105.	228.	747.	60.	209.	685.	26.9	0.679	61.1	1.264
29.5	178.	584.	105.	231.	758.	60.	216.	709.	24.9	0.696	60.7	1.296
33.9	182.	596.	105.	240.	788.	60.	222.	729.	26.0	0.720	59.5	1.281
38.4	194.	636.	105.	247.	812.	60.	234.	767.	23.9	0.751	58.5	1.321
42.8	197.	646.	105.	259.	849.	60.	240.	788.	25.6	0.778	57.0	1.296
47.3	197.	645.	105.	263.	864.	60.	242.	793.	26.8	0.788	56.4	1.277
51.7	198.	648.	105.	260.	854.	60.	241.	791.	25.8	0.782	56.8	1.294
56.2	194.	638.	105.	271.	889.	60.	243.	797.	29.1	0.803	55.2	1.239
60.6	188.	618.	105.	273.	895.	60.	239.	785.	31.3	0.802	54.9	1.201
65.1	182.	597.	105.	275.	903.	60.	236.	773.	33.7	0.803	54.4	1.159
69.6	173.	569.	105.	270.	886.	60.	227.	746.	35.2	0.785	55.1	1.133
74.0	163.	536.	105.	252.	827.	60.	213.	700.	34.8	0.734	57.7	1.141
78.5	163.	535.	105.	238.	781.	60.	208.	682.	31.8	0.698	59.8	1.189
82.9	169.	553.	105.	232.	761.	60.	210.	688.	28.4	0.688	60.6	1.241
87.4	163.	535.	105.	210.	689.	60.	197.	647.	24.4	0.633	63.4	1.297
91.8	155.	508.	105.	190.	622.	60.	184.	603.	21.2	0.581	66.0	1.338
SUCTION SIDE												



APPENDIX D (Cont'd)

LASER DOPPLER VELOCIMETER DATA

85% SPAN 100% SPEED PEAK EFF X/B = .91 PASSAGE NO. 31

STD DAY RPM = 12470.4, RADIUS = 37.757 CM, PHI = -14.6 DEG, STD DAY TTREL = 409. DEG K, UPSTREAM TTABS = 274. DEG K  
 14.865 IN 736. DEG R 493. DEG R

PERCENT GAP	C1 MPS	C1 FPS	ZETA1 DEG	C2 MPS	C2 FPS	ZETA2 DEG	VZ--CORRECTED MPS	VZ--CORRECTED FPS	BETA DEG	ABSOLUTE MACH NO	BETA PRIME DEG	RELATIVE MACH NO
PRESSURE SIDE												
6.6	221.	726.	60.	207.	679.	15.	160.	525.	47.9	0.650	62.4	0.958
10.6	220.	722.	60.	193.	633.	15.	168.	553.	43.5	0.641	62.4	1.020
14.6	222.	727.	60.	191.	628.	15.	172.	563.	42.5	0.644	62.2	1.032
18.6	223.	730.	60.	190.	623.	15.	174.	571.	41.7	0.646	62.0	1.042
22.6	222.	728.	60.	187.	615.	15.	175.	574.	41.0	0.644	62.1	1.052
26.6	223.	731.	60.	183.	601.	15.	179.	588.	39.2	0.647	61.9	1.076
30.6	222.	727.	60.	182.	598.	15.	178.	585.	39.3	0.643	62.1	1.076
34.6	222.	729.	60.	182.	598.	15.	179.	588.	39.1	0.645	62.0	1.079
38.6	223.	732.	60.	180.	592.	15.	182.	596.	38.2	0.648	61.8	1.091
42.6	225.	737.	60.	179.	586.	15.	185.	608.	37.1	0.653	61.5	1.105
46.6	226.	743.	60.	183.	601.	15.	184.	605.	38.2	0.657	61.3	1.089
50.6	229.	750.	60.	188.	617.	15.	184.	603.	39.3	0.663	61.0	1.072
54.6	229.	751.	60.	194.	638.	15.	180.	590.	41.4	0.664	61.0	1.042
58.6	230.	755.	60.	198.	648.	15.	179.	588.	42.1	0.668	60.8	1.031
62.6	231.	757.	60.	198.	648.	15.	180.	591.	41.9	0.670	60.7	1.033
66.6	233.	766.	60.	196.	643.	15.	185.	607.	40.6	0.677	60.3	1.050
70.6	239.	785.	60.	197.	647.	15.	192.	631.	39.4	0.693	59.3	1.065
74.6	244.	801.	60.	204.	670.	15.	194.	636.	40.4	0.707	58.6	1.048
78.6	248.	815.	60.	210.	689.	15.	196.	642.	41.1	0.719	57.9	1.035
82.6	255.	836.	60.	214.	703.	15.	202.	661.	40.7	0.737	56.9	1.038
86.6	260.	853.	60.	213.	700.	15.	210.	687.	39.1	0.753	56.1	1.061
90.6	265.	869.	60.	207.	678.	15.	221.	726.	35.9	0.769	55.5	1.113
SUCTION SIDE												



APPENDIX D (Cont'd)

LASER DOPPLER VELOCIMETER DATA

85% SPAN 100% SPEED PEAK EFF X/B = 1.1 PASSAGE NO. 31

STD DAY RPM = 12470.4, RADIUS = 37.516 CM, PHI = -14.6 DEG, STD DAY TTREL = 407. DEG K, UPSTREAM TTABS = 276. DEG K  
 14.770 IN 733. DEG R 497. DEG R

PERCENT GAP	C1 MPS	C1 FPS	ZETA1 DEG	C2 MPS	C2 FPS	ZETA2 DEG	VZ--CORRECTED MPS	VZ--CORRECTED FPS	BETA DEG	ABSOLUTE MACH NO	BETA PRIME DEG	RELATIVE MACH NO
PRESSURE SIDE												
2.9	228.	748.	60.	234.	767.	15.	149.	490.	54.2	0.684	61.4	0.852
6.7	229.	751.	60.	221.	724.	15.	160.	525.	50.0	0.674	61.1	0.913
10.5	230.	755.	60.	207.	679.	15.	172.	563.	45.2	0.669	60.8	0.981
14.3	230.	755.	60.	201.	658.	15.	176.	578.	43.1	0.667	60.7	1.011
18.1	230.	754.	60.	197.	645.	15.	179.	586.	41.8	0.665	60.8	1.029
21.9	229.	750.	60.	194.	638.	15.	179.	586.	41.5	0.661	60.9	1.035
25.7	227.	746.	60.	192.	629.	15.	179.	587.	40.9	0.658	61.1	1.044
29.5	227.	745.	60.	191.	627.	15.	179.	587.	40.8	0.657	61.2	1.046
33.3	229.	750.	60.	192.	629.	15.	181.	592.	40.5	0.661	60.9	1.048
37.1	229.	751.	60.	193.	633.	15.	180.	591.	40.9	0.662	60.9	1.043
40.9	229.	751.	60.	194.	635.	15.	180.	589.	41.1	0.662	60.9	1.040
44.7	229.	750.	60.	195.	640.	15.	178.	584.	41.7	0.662	61.0	1.032
48.5	228.	748.	60.	197.	645.	15.	176.	578.	42.4	0.660	61.1	1.023
52.3	228.	747.	60.	198.	649.	15.	175.	574.	42.9	0.660	61.1	1.016
56.1	229.	750.	60.	200.	656.	15.	175.	573.	43.3	0.663	61.0	1.009
59.9	230.	755.	60.	202.	663.	15.	175.	575.	43.6	0.667	60.7	1.004
63.7	230.	755.	60.	203.	665.	15.	175.	573.	43.8	0.667	60.7	1.001
67.5	231.	757.	60.	204.	668.	15.	175.	574.	43.9	0.669	60.7	0.999
71.3	231.	757.	60.	205.	671.	15.	174.	572.	44.2	0.669	60.7	0.994
75.1	233.	764.	60.	208.	682.	15.	175.	574.	44.7	0.676	60.3	0.986
78.9	235.	772.	60.	213.	698.	15.	175.	573.	45.6	0.684	59.9	0.971
82.7	237.	778.	60.	215.	707.	15.	175.	575.	45.9	0.689	59.6	0.964
86.5	237.	779.	60.	214.	703.	15.	177.	579.	45.4	0.690	59.6	0.971
90.3	240.	786.	60.	210.	688.	15.	183.	600.	43.4	0.693	59.2	1.000
94.1	242.	794.	60.	215.	704.	15.	183.	599.	44.2	0.701	58.8	0.985
97.9	244.	801.	60.	236.	773.	15.	171.	559.	50.0	0.717	58.4	0.896
SUCTION SIDE												



APPENDIX D (Cont'd)

LASER DOPPLER VELOCIMETER DATA

85% SPAN 95% SPEED PEAK EFF X/B = -.3 PASSAGE NO. 31

STD DAY RPM = 11846.9, RADIUS = 39.306 CM, PHI = -14.6 DEG, STD DAY TTREL = 407. DEG K, UPSTREAM TTARS = 273. DEG K,  
15.475 IN 732. DEG R 492. DEG R

PERCENT GAP	C1 MPS	C1 FPS	ZETA1 DEG	C2 MPS	C2 FPS	ZETA2 DEG	VZ--CORRECTED MPS	VZ--CORRECTED FPS	BETA DEG	ABSOLUTE MACH NO	BETA PRIME DEG	RELATIVE MACH NO
PRESSURE SIDE												
2.2	88.	288.	135.	99.	324.	45.	135.	444.	3.4	0.416	73.7	1.484
6.0	85.	278.	135.	99.	326.	45.	134.	439.	4.5	0.410	73.9	1.470
9.8	80.	262.	135.	98.	323.	45.	129.	425.	6.0	0.397	74.2	1.454
13.6	84.	277.	135.	100.	328.	45.	134.	439.	4.8	0.411	73.8	1.468
17.4	83.	273.	135.	101.	333.	45.	134.	440.	5.7	0.411	73.7	1.460
21.2	90.	296.	135.	104.	340.	45.	141.	462.	4.0	0.433	73.1	1.483
25.0	103.	339.	135.	109.	356.	45.	154.	505.	1.4	0.476	71.8	1.525
28.8	119.	390.	135.	114.	374.	45.	169.	555.	-1.2	0.529	70.4	1.579
32.6	126.	415.	135.	119.	390.	45.	178.	584.	-1.8	0.560	69.5	1.602
36.4	128.	420.	135.	118.	386.	45.	178.	585.	-2.4	0.562	69.6	1.611
40.2	129.	422.	135.	117.	384.	45.	178.	585.	-2.7	0.563	69.6	1.615
44.0	127.	418.	135.	119.	390.	45.	179.	587.	-2.0	0.563	69.5	1.606
47.8	127.	418.	135.	118.	388.	45.	178.	585.	-2.1	0.562	69.6	1.607
51.6	128.	419.	135.	119.	389.	45.	179.	587.	-2.1	0.563	69.5	1.608
55.4	129.	424.	135.	122.	399.	45.	182.	598.	-1.7	0.574	69.1	1.609
59.2	133.	435.	135.	118.	388.	45.	182.	598.	-3.3	0.577	69.3	1.630
63.0	132.	434.	135.	120.	394.	45.	183.	601.	-2.8	0.580	69.1	1.625
66.8	129.	423.	135.	117.	384.	45.	179.	586.	-2.8	0.564	69.6	1.616
70.6	127.	417.	135.	117.	384.	45.	177.	582.	-2.4	0.559	69.7	1.608
74.4	123.	405.	135.	115.	378.	45.	173.	568.	-2.0	0.545	70.1	1.596
78.2	121.	397.	135.	113.	371.	45.	170.	558.	-1.9	0.533	70.4	1.590
82.0	116.	379.	135.	111.	363.	45.	164.	539.	-1.2	0.513	70.9	1.571
85.8	112.	367.	135.	109.	358.	45.	160.	526.	-0.7	0.500	71.3	1.559
89.6	109.	359.	135.	105.	345.	45.	156.	511.	-1.1	0.485	71.8	1.557
93.4	100.	327.	135.	104.	342.	45.	148.	486.	1.3	0.458	72.5	1.519
97.2	92.	303.	135.	102.	336.	45.	141.	464.	3.0	0.435	73.1	1.494
SUCTION SIDE												

APPENDIX D (Cont'd)

LASER DOPPLER VELOCIMETER DATA

85% SPAN 95% SPEED PEAK EFF X/R = -.1 PASSAGE NO. 31

STD DAY RPM = 11846.9, RADIUS = 39.050 CM, PHI = -14.6 DEG, STD DAY TTREL = 405. DEG K, UPSTREAM TTARS = 273. DEG K  
 15.374 IN 729. DEG R 491. DEG R

PERCENT GAP	C1 MPS	C1 FPS	ZETA1 DEG	C2 MPS	C2 FPS	ZETA2 DEG	VZ--CORRECTED MPS	VZ--CORRECTED FPS	BETA DEG	ABSOLUTE MACH NO	BETA PRIME DEG	RELATIVE MACH NO
PRESSURE SIDE												
2.6	131.	430.	135.	125.	411.	45.	186.	611.	-1.3	0.587	68.5	1.602
6.4	131.	431.	135.	126.	413.	45.	187.	613.	-1.2	0.589	68.4	1.602
10.2	131.	429.	135.	126.	412.	45.	186.	611.	-1.2	0.587	68.5	1.600
14.0	132.	433.	135.	126.	412.	45.	187.	614.	-1.4	0.590	68.4	1.605
17.8	133.	435.	135.	127.	417.	45.	189.	619.	-1.2	0.595	68.2	1.605
21.6	137.	448.	135.	127.	418.	45.	192.	629.	-2.0	0.607	68.0	1.622
25.4	139.	455.	135.	129.	422.	45.	194.	637.	-2.2	0.616	67.8	1.629
29.2	143.	470.	135.	128.	419.	45.	197.	646.	-3.3	0.628	67.7	1.652
33.0	143.	470.	135.	128.	419.	45.	197.	646.	-3.3	0.628	67.7	1.652
36.8	139.	455.	135.	128.	420.	45.	194.	636.	-2.3	0.615	67.9	1.630
40.6	135.	443.	135.	128.	420.	45.	191.	627.	-1.5	0.604	68.0	1.614
44.4	135.	442.	135.	128.	421.	45.	191.	627.	-1.4	0.604	68.0	1.612
48.2	134.	439.	135.	129.	423.	45.	191.	626.	-1.1	0.602	68.0	1.607
52.0	123.	403.	135.	127.	418.	45.	182.	597.	1.0	0.568	68.7	1.562
55.8	114.	374.	135.	126.	413.	45.	174.	572.	2.8	0.541	69.3	1.528
59.6	107.	351.	135.	123.	404.	45.	167.	549.	4.0	0.517	69.9	1.504
63.4	93.	304.	135.	120.	393.	45.	154.	507.	7.3	0.475	71.1	1.453
67.2	76.	249.	135.	116.	380.	45.	139.	457.	11.8	0.429	72.5	1.396
71.0	67.	221.	135.	112.	368.	45.	130.	428.	14.0	0.403	73.4	1.371
74.8	82.	269.	135.	112.	367.	45.	141.	462.	8.8	0.433	72.5	1.427
82.4	129.	424.	135.	125.	411.	45.	185.	607.	-0.9	0.582	68.6	1.594
86.2	136.	446.	135.	130.	427.	45.	193.	634.	-1.2	0.611	67.8	1.614
90.0	135.	442.	135.	129.	424.	45.	192.	629.	-1.2	0.606	67.9	1.610
93.8	135.	442.	135.	130.	428.	45.	193.	632.	-0.9	0.608	67.8	1.608
97.6	134.	439.	135.	130.	428.	45.	192.	630.	-0.7	0.606	67.8	1.604
SUCTION SIDE												



APPENDIX D (Cont'd)

LASER DOPPLER VELOCIMETER DATA

85% SPAN 95% SPEED PEAK EFF X/B = .26 PASSAGE NO. 31

STD DAY RPM = 11846.9, RADIUS = 38.590 CM, PHI = -14.6 DEG, STD DAY TTREL = 402. DEG K, UPSTREAM TTABS = 271. DEG K  
 15.193 IN 724. DEG R 488. DEG R

PERCENT GAP	C1 MPS	C1 FPS	ZETA1 DEG	C2 MPS	C2 FPS	ZETA2 DEG	VZ--CORRECTED MPS	FPS	BETA DEG	ABSOLUTE MACH NO	BETA PRIME DEG	RELATIVE MACH NO
PRESSURE SIDE												
8.8	224.	736.	60.	200.	656.	15.	170.	558.	44.6	0.659	60.5	0.968
12.8	221.	726.	60.	205.	672.	15.	162.	533.	47.2	0.654	61.1	0.935
16.9	215.	705.	60.	201.	660.	15.	156.	512.	47.9	0.637	62.2	0.932
21.0	216.	709.	60.	206.	677.	15.	154.	505.	49.3	0.643	62.1	0.912
25.0	212.	696.	60.	203.	665.	15.	151.	495.	49.4	0.632	62.7	0.916
29.1	206.	675.	60.	210.	689.	15.	137.	448.	53.9	0.626	64.1	0.863
33.1	198.	650.	60.	214.	701.	15.	123.	404.	57.7	0.618	65.8	0.825
37.2	191.	626.	60.	205.	672.	15.	119.	392.	57.4	0.595	67.1	0.843
41.3	186.	610.	60.	191.	627.	15.	123.	402.	54.4	0.570	67.6	0.891
45.3	173.	566.	60.	160.	525.	15.	126.	414.	47.3	0.515	69.1	0.996
49.4	152.	500.	105.	161.	529.	60.	172.	564.	11.4	0.532	68.2	1.405
53.4	169.	555.	105.	155.	508.	60.	182.	596.	1.4	0.568	68.4	1.541
57.5	169.	553.	105.	158.	517.	60.	182.	598.	2.9	0.568	68.1	1.523
61.6	173.	569.	105.	160.	525.	60.	187.	613.	2.0	0.584	67.8	1.542
65.6	173.	568.	105.	163.	534.	60.	188.	616.	3.2	0.585	67.5	1.526
69.7	177.	582.	105.	166.	543.	60.	192.	629.	2.7	0.599	67.1	1.540
73.7	179.	587.	105.	168.	551.	60.	194.	636.	3.1	0.605	66.8	1.537
77.8	182.	596.	105.	170.	559.	60.	197.	645.	3.1	0.615	66.5	1.543
81.9	183.	602.	105.	173.	567.	60.	199.	653.	3.4	0.622	66.2	1.542
85.9	187.	615.	105.	175.	575.	60.	203.	665.	2.9	0.636	65.9	1.556
90.0	190.	624.	105.	178.	583.	60.	206.	675.	2.8	0.646	65.6	1.561
94.0	190.	624.	105.	180.	591.	60.	207.	678.	3.7	0.647	65.3	1.549
98.1	187.	615.	105.	182.	598.	60.	205.	674.	5.6	0.641	65.2	1.521
SUCTION SIDE												

APPENDIX D (Cont'd)

LASER DOPPLER VELOCIMETER DATA

85% SPAN 95% SPEED PEAK EFF X/B = .39 PASSAGE NO. 31

STD DAY RPM = 11846.9, RADIUS = 38.423 CM, PHI = -14.6 DEG, STD DAY TTREL = 401. DEG K, UPSTREAM TTABS = 271. DEG K  
 15.127 IN 722. DEG R 488. DEG R

PERCENT GAP	C1 MPS	C1 FPS	ZETA1 DEG	C2 MPS	C2 FPS	ZETA2 DEG	VZ--CORRECTED MPS	VZ--CORRECTED FPS	BETA DEG	ABSOLUTE MACH NO	BETA PRIME DEG	RELATIVE MACH NO
PRESSURE SIDE												
5.4	226.	741.	60.	176.	577.	15.	190.	623.	35.8	0.663	60.0	1.087
9.6	227.	744.	60.	183.	599.	15.	186.	611.	37.9	0.664	59.9	1.057
13.7	224.	735.	60.	184.	604.	15.	181.	595.	39.2	0.656	60.3	1.039
17.8	225.	739.	60.	187.	612.	15.	181.	595.	39.7	0.659	60.1	1.032
22.0	227.	745.	60.	187.	613.	15.	184.	602.	39.3	0.664	59.8	1.037
26.1	228.	748.	60.	189.	619.	15.	184.	602.	39.7	0.667	59.7	1.031
30.3	231.	757.	60.	188.	616.	15.	188.	617.	38.6	0.675	59.3	1.045
34.4	221.	724.	60.	189.	619.	15.	173.	568.	41.8	0.647	60.9	1.006
38.5	219.	720.	60.	194.	638.	15.	167.	549.	44.2	0.645	61.2	0.974
42.7	221.	724.	60.	196.	644.	15.	168.	550.	44.5	0.649	61.0	0.969
46.8	217.	712.	60.	195.	641.	15.	163.	535.	45.3	0.639	61.6	0.961
50.9	212.	696.	60.	194.	637.	15.	157.	516.	46.4	0.627	62.5	0.951
55.1	201.	660.	60.	193.	632.	15.	143.	469.	49.5	0.601	64.5	0.924
59.2	190.	623.	60.	185.	607.	15.	133.	435.	50.7	0.572	66.5	0.925
63.4	180.	592.	60.	177.	582.	15.	125.	409.	51.3	0.546	68.1	0.933
67.5	169.	556.	60.	155.	510.	15.	125.	411.	46.6	0.506	69.4	1.005
71.6	167.	549.	60.	130.	425.	15.	141.	463.	35.4	0.494	68.8	1.125
75.8	157.	514.	60.	91.	300.	15.	154.	505.	20.1	0.486	69.3	1.293
79.9	158.	519.	105.	159.	523.	60.	175.	576.	8.0	0.543	68.1	1.444
84.0	159.	521.	105.	160.	525.	60.	176.	578.	8.0	0.545	68.1	1.445
88.2	159.	522.	105.	162.	531.	60.	177.	581.	8.7	0.548	67.9	1.438
92.3	160.	526.	105.	163.	534.	60.	178.	585.	8.5	0.552	67.7	1.441
96.5	161.	528.	105.	167.	547.	60.	180.	591.	9.9	0.558	67.3	1.425
SUCTION SIDE												

APPENDIX D (Cont'd)

LASER DOPPLER VELOCIMETER DATA

85% SPAN 95% SPEED PEAK EFF X/B = .52 PASSAGE NO. 31

STD DAY RPM = 11846.9, RADIUS = 38.257 CM, PHI = -14.6 DEG, STD DAY TTREL = 401. DEG K, UPSTREAM TTARS = 271. DEG K  
 15.062 IN 721. DEG R 488. DEG R

PERCENT GAP	C1 MPS	C1 FPS	ZETA1 DEG	C2 MPS	C2 FPS	ZETA2 DEG	VZ--CORRECTED MPS	VZ--CORRECTED FPS	BETA DEG	ABSOLUTE MACH NO	BETA PRIME DEG	RELATIVE MACH NO
PRESSURE SIDE												
2.3	212.	697.	60.	165.	542.	15.	179.	586.	35.7	0.624	61.9	1.088
6.8	218.	716.	60.	155.	510.	15.	194.	637.	30.4	0.647	60.9	1.159
11.3	214.	702.	60.	160.	525.	15.	185.	606.	33.3	0.630	61.6	1.119
20.4	224.	735.	60.	170.	559.	15.	191.	628.	34.3	0.659	60.1	1.103
24.9	223.	731.	60.	171.	561.	15.	189.	621.	34.9	0.654	60.3	1.095
29.4	225.	737.	60.	173.	567.	15.	190.	625.	35.0	0.660	60.0	1.093
38.4	232.	762.	60.	182.	597.	15.	194.	638.	36.2	0.681	58.9	1.074
42.9	230.	754.	60.	184.	603.	15.	190.	622.	37.5	0.673	59.2	1.056
47.4	227.	746.	60.	193.	633.	15.	180.	589.	41.3	0.666	59.6	1.003
51.9	234.	767.	60.	187.	614.	15.	193.	633.	37.5	0.684	58.6	1.054
56.4	230.	753.	60.	192.	630.	15.	183.	601.	40.4	0.671	59.3	1.015
60.9	227.	744.	60.	186.	610.	15.	184.	603.	39.1	0.663	59.7	1.035
83.5	204.	668.	60.	177.	582.	15.	157.	516.	43.1	0.599	63.6	0.998
88.0	185.	607.	60.	164.	539.	15.	141.	462.	44.3	0.547	66.7	1.003
92.5	179.	586.	60.	149.	489.	15.	143.	469.	40.2	0.526	67.4	1.057
97.0	178.	583.	60.	163.	536.	15.	131.	430.	46.7	0.529	68.0	0.985
SUCTION SIDE												

APPENDIX D (Cont'd)

LASER DOPPLER VELOCIMETER DATA

85% SPAN 95% SPEED PEAK EFF X/B = .78 PASSAGE NO. 31

STD DAY RPM = 11846.9, RADIUS = 37.925 CM, PHI = -14.6 DEG, STD DAY TTREL = 398. DEG K, UPSTREAM TTABS = 271. DEG K  
 14.931 IN 717. DEG R 488. DEG R

PERCENT GAP	C1 MPS	C1 FPS	ZETA1 DEG	C2 MPS	C2 FPS	ZETA2 DEG	VZ--CORRECTED MPS	FPS	BETA DEG	ABSOLUTE MACH NO	BETA PRIME DEG	RELATIVE MACH NO
PRESSURE SIDE												
2.9	208.	682.	60.	170.	558.	0.	146.	480.	50.2	0.623	62.9	0.892
7.1	205.	672.	60.	159.	522.	0.	149.	489.	47.7	0.609	63.3	0.928
11.3	205.	672.	60.	151.	495.	0.	154.	505.	45.3	0.605	63.2	0.960
15.6	204.	669.	60.	149.	489.	0.	154.	505.	44.9	0.602	63.3	0.965
19.8	201.	661.	60.	145.	476.	0.	153.	504.	44.3	0.595	63.7	0.976
24.1	201.	661.	60.	143.	469.	0.	155.	508.	43.6	0.594	63.7	0.985
28.3	203.	667.	60.	143.	470.	0.	157.	514.	43.3	0.599	63.4	0.987
32.5	208.	682.	60.	142.	467.	0.	163.	534.	42.0	0.611	62.6	0.999
36.8	209.	685.	60.	141.	463.	0.	165.	540.	41.5	0.613	62.4	1.005
41.0	214.	701.	60.	140.	459.	0.	171.	561.	40.1	0.627	61.5	1.019
45.3	214.	703.	60.	141.	461.	0.	171.	562.	40.2	0.629	61.5	1.018
49.5	219.	718.	60.	140.	458.	0.	177.	582.	39.0	0.642	60.7	1.031
53.7	221.	724.	60.	139.	457.	0.	180.	590.	38.6	0.647	60.4	1.036
58.0	226.	743.	60.	137.	450.	0.	188.	617.	37.0	0.664	59.5	1.056
62.2	232.	762.	60.	134.	440.	0.	197.	645.	35.1	0.683	58.5	1.081
66.5	235.	770.	60.	137.	448.	0.	198.	650.	35.4	0.689	58.2	1.077
70.7	238.	780.	60.	139.	455.	0.	200.	658.	35.5	0.698	57.7	1.075
75.0	242.	794.	60.	138.	452.	0.	206.	676.	34.6	0.712	57.0	1.088
79.2	242.	795.	60.	142.	467.	0.	204.	668.	35.8	0.711	57.0	1.070
83.4	241.	790.	60.	140.	459.	0.	203.	667.	35.3	0.707	57.2	1.077
SUCTION SIDE												

228

APPENDIX D (Cont'd)

LASER DOPPLER VELOCIMETER DATA

85% SPAN 95% SPEED PEAK EFF X/B = 1.1 PASSAGE NO. 31

STD DAY RPM = 11846.9, RADIUS = 37.516 CM, PHI = -14.6 DEG, STD DAY TTREL = 396. DEG K, UPSTREAM TTABS = 271. DEG K  
 14.770 IN 713. DEG R 487. DEG R

PERCENT GA'	C1 MPS	C1 FPS	ZETA1 DEG	C2 MPS	C2 FPS	ZETA2 DEG	VZ--CORRECTED MPS	VZ--CORRECTED FPS	BETA DEG	ABSOLUTE MACH NO	BETA PRIME DEG	RELATIVE MACH NO
PRESSURE SIDE												
2.9	206.	677.	60.	220.	723.	0.	115.	376.	63.3	0.673	63.5	0.698
6.7	211.	692.	60.	185.	607.	0.	141.	463.	53.5	0.643	62.0	0.831
10.5	211.	693.	60.	166.	543.	0.	153.	502.	48.1	0.630	61.8	0.904
14.3	212.	697.	60.	163.	534.	0.	156.	512.	47.1	0.631	61.5	0.917
18.1	214.	703.	60.	161.	529.	0.	159.	523.	46.3	0.635	61.2	0.926
21.9	214.	703.	60.	160.	526.	0.	160.	524.	46.0	0.635	61.2	0.930
25.7	213.	700.	60.	159.	521.	0.	160.	524.	45.8	0.632	61.3	0.934
29.5	211.	692.	60.	158.	518.	0.	157.	516.	46.0	0.625	61.8	0.933
33.3	211.	693.	60.	156.	512.	0.	159.	521.	45.4	0.625	61.7	0.940
37.1	211.	693.	60.	155.	509.	0.	159.	523.	45.2	0.625	61.7	0.944
40.9	212.	695.	60.	157.	514.	0.	159.	522.	45.5	0.627	61.6	0.939
44.7	211.	693.	60.	155.	510.	0.	159.	522.	45.2	0.625	61.7	0.943
48.5	210.	690.	60.	155.	509.	0.	158.	519.	45.3	0.622	61.8	0.942
52.3	210.	689.	60.	154.	504.	0.	159.	521.	45.0	0.621	61.9	0.947
56.1	209.	686.	60.	152.	498.	0.	159.	521.	44.6	0.618	62.0	0.953
59.9	212.	694.	60.	153.	501.	0.	161.	529.	44.4	0.625	61.6	0.954
63.7	215.	705.	60.	155.	509.	0.	164.	537.	44.4	0.634	61.0	0.951
67.5	217.	711.	60.	158.	517.	0.	164.	539.	44.7	0.640	60.7	0.945
71.3	216.	709.	60.	158.	520.	0.	163.	535.	45.1	0.639	60.8	0.940
75.1	217.	711.	60.	160.	524.	0.	163.	535.	45.3	0.641	60.7	0.937
78.9	218.	715.	60.	161.	527.	0.	164.	538.	45.3	0.644	60.5	0.935
82.7	218.	715.	60.	159.	522.	0.	165.	541.	44.9	0.644	60.5	0.941
86.5	220.	721.	60.	158.	520.	0.	167.	549.	44.3	0.648	60.2	0.947
90.3	221.	724.	60.	162.	531.	0.	167.	546.	45.1	0.652	60.0	0.936
94.1	224.	735.	60.	173.	568.	0.	164.	537.	47.5	0.665	59.4	0.900
97.9	222.	727.	60.	196.	644.	0.	147.	483.	54.0	0.675	60.0	0.809
SUCTION SIDE												



## APPENDIX D (Cont'd)

## LASER DOPPLER VELOCIMETER DATA

85% SPAN 100% SPEED NEAR SURGE X/B = -.3 PASSAGE NO. 31

STD DAY RPM = 12470.4, RADIUS = 39.304 CM, PHI = -14.6 DEG, STD DAY TTREL = 419. DEG K, UPSTREAM TTABS = 275. DEG K  
 15.474 IN 754. DEG R 495. DEG R

PERCENT GAP	C1 MPS	C1 FPS	ZETA1 DEG	C2 MPS	C2 FPS	ZETA2 DEG	VZ--CORRECTED MPS	VZ--CORRECTED FPS	BETA DEG	ABSOLUTE MACH NO	BETA PRIME DEG	RELATIVE MACH NO
PRESSURE SIDE												
2.2	77.	251.	135.	98.	322.	45.	126.	415.	7.1	0.387	75.3	1.515
6.0	70.	231.	135.	98.	321.	45.	122.	400.	9.3	0.373	75.7	1.492
9.8	65.	214.	135.	96.	315.	45.	117.	383.	10.8	0.358	76.2	1.477
13.6	67.	220.	135.	97.	319.	45.	119.	390.	10.4	0.365	76.0	1.481
17.4	69.	227.	135.	99.	324.	45.	122.	399.	10.0	0.373	75.7	1.486
21.2	77.	253.	135.	99.	326.	45.	128.	419.	7.2	0.391	75.1	1.514
25.0	75.	245.	135.	100.	328.	45.	126.	415.	8.2	0.387	75.2	1.504
28.8	80.	261.	135.	109.	356.	45.	136.	447.	8.8	0.418	74.1	1.504
32.6	110.	360.	135.	116.	380.	45.	163.	536.	1.5	0.507	71.7	1.610
36.4	132.	434.	135.	121.	397.	45.	183.	602.	-2.5	0.580	70.0	1.698
40.2	135.	443.	135.	125.	409.	45.	188.	617.	-2.3	0.596	69.5	1.703
44.0	137.	451.	135.	125.	410.	45.	190.	623.	-2.7	0.603	69.4	1.714
47.8	138.	452.	135.	124.	407.	45.	190.	622.	-3.0	0.603	69.5	1.717
51.6	137.	451.	135.	121.	396.	45.	187.	613.	-3.7	0.595	69.8	1.722
55.4	130.	428.	135.	121.	396.	45.	182.	596.	-2.2	0.574	70.1	1.691
59.2	128.	419.	135.	119.	391.	45.	179.	586.	-2.0	0.564	70.4	1.681
63.0	128.	421.	135.	118.	388.	45.	178.	586.	-2.3	0.563	70.5	1.686
66.8	127.	416.	135.	117.	384.	45.	177.	579.	-2.3	0.557	70.7	1.682
70.6	124.	407.	135.	114.	375.	45.	173.	566.	-2.3	0.543	71.1	1.675
74.4	119.	391.	135.	115.	376.	45.	169.	555.	-1.1	0.530	71.3	1.653
78.2	115.	376.	135.	111.	364.	45.	163.	536.	-0.9	0.510	71.9	1.641
82.0	109.	356.	135.	109.	356.	45.	157.	515.	-0.0	0.489	72.5	1.621
85.8	108.	355.	135.	106.	349.	45.	155.	510.	-0.5	0.484	72.7	1.624
89.6	99.	325.	135.	105.	343.	45.	147.	484.	1.5	0.456	73.4	1.590
93.4	94.	309.	135.	103.	338.	45.	143.	468.	2.6	0.440	73.8	1.574
97.2	85.	280.	135.	101.	331.	45.	135.	442.	4.8	0.414	74.5	1.543
SUCTION SIDE												

APPENDIX D (Cont'd)

LASER DOPPLER VELOCIMETER DATA

85% SPAN 100% SPEED NEAR SURGE X/B = -.1 PASSAGE NO. 31

STD DAY RPM = 12470.4, RADIUS = 39.050 CM, PHI = -14.6 DEG, STD DAY TTREL = 417. DEG K, UPSTREAM TTABS = 275. DEG K  
 15.374 IN 751. DEG R 495. DEG R

PERCENT GAP	C1 MPS	C1 FPS	ZETA1 DEG	C2 MPS	C2 FPS	ZETA2 DEG	YZ--CORRECTED MPS	YZ--CORRECTED FPS	BETA DEG	ABSOLUTE MACH NO	BETA PRIME DEG	RELATIVE MACH NO
PRESSURE SIDE												
2.6	133.	437.	135.	130.	428.	45.	191.	626.	-0.6	0.602	68.9	1.674
6.4	134.	438.	135.	131.	429.	45.	191.	628.	-0.6	0.603	68.9	1.675
10.2	134.	440.	135.	131.	431.	45.	192.	630.	-0.6	0.606	68.8	1.676
14.0	135.	444.	135.	133.	437.	45.	194.	638.	-0.5	0.613	68.6	1.678
17.8	133.	437.	135.	133.	435.	45.	192.	631.	-0.1	0.606	68.7	1.670
21.6	137.	449.	135.	132.	434.	45.	195.	639.	-1.0	0.616	68.6	1.687
25.4	135.	444.	135.	132.	434.	45.	194.	636.	-0.7	0.612	68.7	1.680
29.2	129.	423.	135.	134.	440.	45.	190.	625.	1.1	0.597	68.8	1.648
33.0	132.	432.	135.	133.	436.	45.	192.	628.	0.3	0.602	68.8	1.662
36.8	125.	411.	135.	134.	441.	45.	188.	617.	2.0	0.588	68.9	1.631
40.6	124.	407.	135.	134.	440.	45.	187.	613.	2.2	0.584	69.0	1.626
44.4	119.	390.	135.	132.	432.	45.	181.	595.	2.9	0.565	69.5	1.609
48.2	118.	386.	135.	132.	432.	45.	180.	592.	3.2	0.561	69.5	1.603
52.0	105.	345.	135.	130.	426.	45.	170.	558.	6.0	0.526	70.3	1.554
55.8	102.	335.	135.	128.	420.	45.	167.	546.	6.4	0.514	70.7	1.545
59.6	94.	310.	135.	125.	411.	45.	159.	522.	8.0	0.490	71.4	1.520
63.4	84.	275.	135.	123.	402.	45.	149.	490.	10.6	0.460	72.2	1.483
67.2	76.	248.	135.	119.	392.	45.	141.	463.	12.7	0.435	73.0	1.458
71.0	79.	260.	135.	118.	387.	45.	143.	468.	11.1	0.439	73.0	1.475
74.8	73.	240.	135.	118.	386.	45.	138.	453.	13.1	0.426	73.4	1.452
78.6	90.	296.	135.	122.	399.	45.	153.	503.	8.4	0.472	72.0	1.510
82.4	124.	406.	135.	130.	428.	45.	184.	604.	1.5	0.575	69.4	1.632
86.2	131.	429.	135.	134.	441.	45.	192.	630.	0.8	0.603	68.6	1.655
90.0	142.	467.	135.	137.	450.	45.	202.	664.	-1.1	0.642	67.9	1.703
93.8	141.	464.	135.	135.	443.	45.	200.	657.	-1.3	0.635	68.1	1.703
97.6	144.	474.	135.	137.	449.	45.	204.	668.	-1.6	0.648	67.8	1.713
SUCTION SIDE												

APPENDIX D (Cont'd)

LASER DOPPLER VELOCIMETER DATA

85% SPAN 100% SPEED NEAR SURGE X/B = 0.0 PASSAGE NO. 31

STD DAY RPM = 12470.4, RADIUS = 38.923 CM, PHI = -14.6 DEG, STD DAY TTREL = 417. DEG K, UPSTREAM TTABS = 274. DEG K  
 15.324 IN 750. DEG R 493. DEG R

PERCENT GAP	C1 MPS	C1 FPS	ZETA1 DEG	C2 MPS	C2 FPS	ZETA2 DEG	VZ--CORRECTED MPS	VZ--CORRECTED FPS	BETA DEG	ABSOLUTE MACH NO	BETA PRIME DEG	RELATIVE MACH NO
PRESSURE SIDE												
8.7	119.	390.	135.	116.	379.	45.	170.	558.	-0.8	0.532	71.0	1.635
12.5	121.	396.	135.	116.	382.	45.	172.	564.	-1.0	0.539	70.8	1.642
16.3	122.	401.	135.	119.	392.	45.	175.	575.	-0.7	0.549	70.5	1.642
20.1	119.	392.	135.	115.	377.	45.	170.	558.	-1.1	0.532	71.0	1.639
23.9	120.	395.	135.	120.	395.	45.	175.	573.	-0.0	0.546	70.5	1.632
27.7	117.	384.	135.	116.	381.	45.	169.	555.	-0.2	0.528	71.1	1.626
31.5	122.	400.	135.	123.	402.	45.	177.	582.	0.1	0.555	70.2	1.635
35.3	123.	404.	135.	122.	399.	45.	178.	582.	-0.4	0.556	70.2	1.642
39.1	122.	399.	135.	119.	391.	45.	175.	573.	-0.6	0.547	70.5	1.640
42.9	124.	407.	135.	119.	392.	45.	177.	580.	-1.1	0.554	70.4	1.650
46.7	120.	394.	135.	114.	373.	45.	170.	556.	-1.6	0.532	71.1	1.645
50.5	117.	383.	135.	119.	392.	45.	171.	562.	0.7	0.534	70.7	.618
54.3	112.	369.	135.	122.	399.	45.	170.	557.	2.2	0.527	70.7	1.596
58.1	110.	362.	135.	120.	393.	45.	167.	548.	2.4	0.518	71.0	1.590
61.9	113.	370.	135.	121.	396.	45.	169.	556.	1.9	0.526	70.8	1.599
65.7	111.	364.	135.	121.	398.	45.	168.	553.	2.6	0.523	70.8	1.590
69.5	111.	363.	135.	123.	402.	45.	169.	555.	2.9	0.524	70.7	1.586
73.3	107.	350.	135.	125.	410.	45.	168.	551.	4.5	0.519	70.7	1.565
77.1	105.	345.	135.	123.	403.	45.	165.	543.	4.4	0.511	71.0	1.563
80.9	102.	335.	135.	128.	421.	45.	167.	548.	6.5	0.516	70.6	1.540
84.7	99.	326.	135.	126.	414.	45.	164.	537.	6.8	0.504	70.9	1.533
88.5	89.	293.	135.	132.	432.	45.	160.	526.	10.9	0.494	70.9	1.482
92.3	87.	286.	135.	140.	459.	45.	165.	540.	13.1	0.509	70.1	1.459
96.1	77.	252.	135.	148.	487.	45.	163.	536.	17.6	0.510	69.7	1.404
SUCTION SIDE												

APPENDIX D (Cont'd)

LASER DOPPLER VELOCIMETER DATA

85% SPAN 100% SPEED NEAR SURGE X/B = .26 PASSAGE NO. 31

STD DAY RPM = 12470.4, RADIUS = 38.590 CM, PHI = -14.6 DEG, STD DAY TTREL = 414. DEG K, UPSTREAM TTABS = 275. DEG K  
 15.193 IN 746. DEG R 495. DEG R

PERCENT GAP	C1 MPS	C1 FPS	ZETA1 DEG	C2 MPS	C2 FPS	ZETA2 DEG	VZ--CORRECTED MPS	FPS	BETA DEG	ABSOLUTE MACH NO	BETA PRIME DEG	RELATIVE MACH NO
PRESSURE SIDE												
8.8	241.	791.	60.	221.	726.	15.	177.	581.	46.6	0.700	60.0	0.979
12.8	238.	780.	60.	224.	734.	15.	171.	559.	48.3	0.693	60.6	0.956
16.9	237.	776.	60.	223.	730.	15.	170.	557.	48.3	0.690	60.8	0.958
21.0	233.	763.	60.	226.	742.	15.	161.	530.	50.6	0.684	61.5	0.928
25.0	229.	750.	60.	228.	747.	15.	155.	508.	52.2	0.677	62.3	0.909
29.1	222.	728.	60.	229.	751.	15.	145.	474.	54.7	0.666	63.5	0.883
33.1	218.	715.	60.	219.	717.	15.	147.	481.	52.7	0.648	64.1	0.918
37.2	210.	689.	60.	221.	726.	15.	133.	438.	56.1	0.637	65.7	0.882
41.3	202.	663.	60.	210.	689.	15.	131.	428.	55.2	0.611	66.9	0.910
45.3	142.	466.	105.	190.	623.	60.	174.	571.	26.7	0.565	66.7	1.281
49.4	172.	564.	105.	170.	559.	60.	188.	618.	6.9	0.584	68.0	1.547
53.4	179.	587.	105.	167.	549.	60.	192.	631.	2.9	0.600	68.1	1.608
57.5	182.	597.	105.	171.	562.	60.	196.	643.	3.3	0.612	67.7	1.607
61.6	186.	609.	105.	172.	564.	60.	199.	652.	2.2	0.623	67.5	1.628
65.6	187.	615.	105.	175.	574.	60.	201.	660.	2.7	0.631	67.2	1.624
69.7	189.	619.	105.	176.	579.	60.	203.	665.	2.9	0.635	67.0	1.625
73.7	191.	628.	105.	179.	588.	60.	206.	675.	3.0	0.645	66.7	1.629
77.8	193.	633.	105.	182.	596.	60.	208.	682.	3.3	0.651	66.4	1.626
81.9	194.	638.	105.	184.	604.	60.	210.	688.	3.7	0.658	66.2	1.624
85.9	197.	646.	105.	187.	612.	60.	212.	697.	3.8	0.667	65.9	1.627
90.0	196.	642.	105.	190.	624.	60.	213.	699.	5.5	0.666	65.5	1.600
94.0	200.	656.	105.	192.	630.	60.	217.	711.	4.7	0.680	65.3	1.619
98.1	203.	666.	105.	196.	642.	60.	220.	723.	5.0	0.691	64.9	1.621
SUCTION SIDE												

## APPENDIX D (Cont'd)

## LASER DOPPLER VELOCIMETER DATA

85% SPAN 100% SPEED NEAR SURGE X/B = .39 PASSAGE NO. 31

STD DAY RPM = 12470.4, RADIUS = 38.423 CM, PHI = -14.6 DEG, STD DAY TTREL = 413. DEG K, UPSTREAM TTABS = 275. DEG K  
 15.127 IN 744. DEG R 495. DEG R

PERCENT GAP	C1 MPS	C1 FPS	ZETA1 DEG	C2 MPS	C2 FPS	ZETA2 DEG	VZ--CORRECTED MPS	FPS	BETA DEG	ABSOLUTE MACH NO	BETA PRIME DEG	RELATIVE MACH NO
PRESSURE SIDE												
2.7	237.	779.	60.	198.	651.	15.	188.	618.	40.3	0.685	60.3	1.071
7.0	243.	797.	60.	200.	655.	15.	195.	640.	39.2	0.701	59.5	1.084
11.2	239.	785.	60.	204.	668.	15.	187.	614.	41.5	0.691	60.1	1.052
15.5	245.	803.	60.	206.	675.	15.	193.	634.	40.7	0.706	59.2	1.061
19.7	244.	801.	60.	206.	676.	15.	192.	631.	41.0	0.704	59.3	1.057
24.0	243.	796.	60.	209.	686.	15.	188.	617.	42.3	0.700	59.6	1.037
28.2	243.	797.	60.	205.	673.	15.	191.	627.	41.0	0.701	59.5	1.057
32.5	240.	787.	60.	212.	695.	15.	182.	597.	44.0	0.694	60.0	1.014
36.8	239.	783.	60.	209.	687.	15.	182.	598.	43.5	0.690	60.2	1.022
41.0	236.	773.	60.	215.	705.	15.	174.	571.	46.2	0.684	60.7	0.986
45.3	234.	769.	60.	219.	719.	15.	169.	555.	47.9	0.684	61.0	0.962
58.0	214.	702.	60.	208.	684.	15.	148.	487.	50.7	0.632	64.5	0.947
62.3	189.	621.	60.	187.	612.	15.	130.	425.	51.5	0.565	68.4	0.975
66.6	183.	599.	60.	171.	560.	15.	132.	432.	47.9	0.539	69.1	1.030
70.8	167.	549.	60.	143.	468.	15.	131.	429.	41.6	0.489	70.7	1.122
75.1	117.	385.	105.	159.	521.	60.	144.	474.	27.4	0.472	70.7	1.278
79.3	163.	536.	105.	164.	539.	60.	180.	590.	7.9	0.556	68.7	1.518
83.6	165.	542.	105.	167.	548.	60.	182.	598.	8.3	0.563	68.4	1.516
87.8	166.	544.	105.	170.	557.	60.	184.	602.	9.1	0.568	68.1	1.506
92.1	169.	554.	105.	173.	566.	60.	187.	613.	9.0	0.579	67.8	1.511
96.4	171.	562.	105.	176.	576.	60.	190.	623.	9.2	0.588	67.4	1.511
SUCTION SIDE												

APPENDIX D (Cont'd)

LASER DOPPLER VELOCIMETER DATA

85% SPAN 100% SPEED NEAR SURGE X/B = .52 PASSAGE NO. 31

STD DAY RPM = 12470.4, RADIUS = 38.257 CM, PHI = -14.6 DEG, STD DAY TTREL = 412. DEG K, UPSTREAM TTABS = 275. DEG K  
 15.062 IN 742. DEG R 495. DEG R

PERCENT GAP	C1 MPS	C1 FPS	ZETA1 DEG	C2 MPS	C2 FPS	ZETA2 DEG	VZ--CORRECTED MPS	VZ--CORRECTED FPS	BETA DEG	ABSOLUTE MACH NO	BETA PRIME DEG	RELATIVE MACH NO
PRESSURE SIDE												
2.3	224.	734.	60.	211.	692.	15.	160.	525.	48.4	0.655	62.6	0.961
6.8	227.	744.	60.	198.	649.	15.	174.	571.	43.2	0.657	61.9	1.033
11.3	229.	752.	60.	196.	643.	15.	179.	586.	41.8	0.663	61.5	1.050
15.8	233.	766.	60.	197.	647.	15.	184.	603.	41.0	0.675	60.8	1.058
20.4	232.	762.	60.	198.	651.	15.	181.	594.	41.8	0.671	61.0	1.048
24.9	239.	783.	60.	195.	640.	15.	193.	632.	38.9	0.689	60.0	1.087
29.4	242.	793.	60.	201.	660.	15.	192.	631.	40.0	0.698	59.5	1.068
33.9	242.	793.	60.	201.	660.	15.	192.	631.	40.0	0.698	59.5	1.068
38.4	243.	797.	60.	204.	669.	15.	192.	630.	40.6	0.701	59.4	1.059
42.9	244.	801.	60.	205.	673.	15.	193.	633.	40.7	0.705	59.2	1.057
47.4	245.	805.	60.	202.	664.	15.	197.	645.	39.5	0.708	59.0	1.075
51.9	243.	798.	60.	202.	663.	15.	194.	636.	39.9	0.702	59.3	1.069
56.4	239.	784.	60.	204.	669.	15.	187.	612.	41.7	0.690	60.0	1.045
60.9	237.	779.	60.	203.	666.	15.	185.	607.	41.8	0.686	60.2	1.044
65.4	242.	793.	60.	201.	659.	15.	193.	632.	39.9	0.698	59.5	1.069
88.0	205.	673.	60.	170.	558.	15.	164.	537.	39.8	0.595	65.0	1.097
92.5	196.	642.	60.	169.	553.	15.	152.	497.	42.3	0.569	66.6	1.074
SUCTION SIDE												

## APPENDIX D (Cont'd)

## LASER DOPPLER VELOCIMETER DATA

85% SPAN 100% SPEED NEAR SURGE X/R = .78 PASSAGE NO. 31

STD DAY RPM = 12470.4, RADIUS = 37.925 CM, PHI = -14.6 DEG, STD DAY TTREL = 410. DEG K, UPSTREAM TTARS = 275. DEG K  
 14.931 IN 738. DEG R 495. DEG R

PERCENT GAP	C1 MPS	C1 FPS	ZETA1 DEG	C2 MPS	C2 FPS	ZETA2 DEG	VZ--CORRECTED MPS	FPS	BETA DEG	ABSOLUTE MACH NO	BETA PRIME DEG	RELATIVE MACH NO
PRESSURE SIDE												
2.9	220.	721.	60.	205.	671.	0.	139.	456.	56.4	0.668	63.3	0.842
7.1	219.	720.	60.	192.	630.	0.	146.	479.	53.4	0.657	63.2	0.887
11.3	217.	711.	60.	183.	601.	0.	148.	485.	51.7	0.644	63.6	0.915
15.6	217.	712.	60.	181.	594.	0.	150.	491.	51.1	0.643	63.5	0.923
19.8	218.	715.	60.	177.	582.	0.	153.	501.	49.9	0.643	63.3	0.938
24.1	220.	723.	60.	176.	577.	0.	157.	514.	49.0	0.648	62.8	0.948
28.3	223.	730.	60.	174.	572.	0.	160.	525.	48.1	0.652	62.4	0.958
32.5	225.	737.	60.	174.	570.	0.	163.	534.	47.5	0.657	62.1	0.964
36.8	223.	733.	60.	171.	561.	0.	163.	535.	47.0	0.653	62.3	0.972
41.0	226.	743.	60.	167.	548.	0.	169.	554.	45.3	0.659	61.7	0.993
45.3	226.	740.	60.	168.	550.	0.	168.	550.	45.7	0.657	61.9	0.989
49.5	234.	769.	60.	168.	552.	0.	178.	583.	44.1	0.680	60.4	1.003
53.7	238.	781.	60.	169.	556.	0.	181.	595.	43.7	0.690	59.8	1.006
58.0	241.	790.	60.	172.	564.	0.	183.	600.	43.9	0.697	59.4	1.002
62.2	246.	806.	60.	172.	564.	0.	189.	619.	43.0	0.711	58.6	1.012
66.5	247.	809.	60.	170.	557.	0.	191.	627.	42.3	0.713	58.4	1.022
70.7	250.	821.	60.	172.	565.	0.	194.	637.	42.3	0.723	57.9	1.020
75.0	255.	835.	60.	172.	563.	0.	199.	654.	41.4	0.735	57.2	1.032
79.2	265.	871.	60.	163.	534.	0.	218.	714.	37.4	0.767	55.6	1.092
SUCTION SIDE												

APPENDIX D (Cont'd)

LASER DOPPLER VELOCIMETER DATA

85% SPAN 100% SPEED NEAR SURGE X/B = 1.1 PASSAGE NO. 31

STD DAY RPM = 12470.4, RADIUS = 37.516 CM, PHI = -14.6 DEG, STD DAY TTREL = 407. DEG K, UPSTREAM TTABS = 275. DEG K  
 14.770 IN 733. DEG R 495. DEG R

PERCENT GAP	C1 MPS	C1 FPS	ZETA1 DEG	C2 MPS	C2 FPS	ZETA2 DEG	VZ--CORRECTED MPS	VZ--CORRECTED FPS	BETA DEG	ABSOLUTE MACH NO	BETA PRIME DEG	RELATIVE MACH NO
PRESSURE SIDE												
0.0	221.	726.	60.	257.	842.	0.	110.	361.	67.3	0.737	63.4	0.654
3.8	215.	706.	60.	234.	768.	0.	116.	381.	64.2	0.696	64.4	0.721
7.6	222.	728.	60.	210.	688.	0.	138.	454.	57.2	0.679	62.6	0.816
11.4	223.	733.	60.	197.	645.	0.	148.	485.	53.7	0.670	62.1	0.866
15.2	225.	737.	60.	194.	638.	0.	151.	494.	52.9	0.671	61.9	0.876
19.0	226.	740.	60.	194.	635.	0.	152.	499.	52.5	0.672	61.7	0.881
22.8	226.	743.	60.	193.	634.	0.	153.	504.	52.2	0.674	61.5	0.884
26.6	226.	743.	60.	192.	630.	0.	154.	506.	51.9	0.673	61.5	0.888
30.4	227.	745.	60.	192.	630.	0.	155.	508.	51.8	0.674	61.4	0.889
34.2	229.	750.	60.	191.	626.	0.	157.	517.	51.1	0.677	61.1	0.896
38.0	227.	745.	60.	188.	616.	0.	157.	517.	50.7	0.672	61.3	0.905
41.8	226.	741.	60.	187.	614.	0.	156.	513.	50.8	0.668	61.6	0.905
45.6	225.	737.	60.	185.	608.	0.	156.	512.	50.6	0.664	61.8	0.909
49.4	225.	737.	60.	185.	608.	0.	156.	512.	50.6	0.664	61.8	0.909
53.2	226.	742.	60.	185.	606.	0.	158.	519.	50.1	0.668	61.5	0.914
57.0	227.	746.	60.	187.	614.	0.	158.	519.	50.5	0.672	61.3	0.908
60.8	229.	751.	60.	187.	612.	0.	160.	526.	50.0	0.675	61.0	0.913
64.6	229.	752.	60.	187.	613.	0.	161.	527.	50.0	0.676	61.0	0.912
68.4	231.	758.	60.	187.	613.	0.	163.	534.	49.6	0.680	60.6	0.916
72.2	230.	755.	60.	185.	608.	0.	162.	533.	49.4	0.677	60.8	0.920
76.0	228.	748.	60.	183.	600.	0.	161.	530.	49.2	0.671	61.1	0.925
79.8	229.	750.	60.	182.	596.	0.	163.	534.	48.8	0.672	61.0	0.930
83.6	231.	759.	60.	183.	601.	0.	165.	542.	48.6	0.679	60.6	0.930
87.4	232.	761.	60.	188.	616.	0.	163.	535.	49.7	0.683	60.5	0.914
91.2	231.	759.	60.	197.	646.	0.	157.	515.	52.1	0.687	60.6	0.879
95.0	233.	765.	60.	212.	697.	0.	150.	492.	55.4	0.704	60.4	0.826
98.8	237.	776.	60.	246.	806.	0.	134.	441.	61.9	0.746	59.8	0.716
SUCTION SIDE												



APPENDIX D (Cont'd)

LASER DOPPLER VELOCIMETER TRAVERSE AT INSTRUMENTATION PLANE

100% SPEED PEAK EFFICIENCY

STD DAY RPM = 12470.4,

INNER RADIUS = 18.119 CM,  
7.134 IN

OUTER RADIUS = 44.319 CM,  
17.449 IN

UPSTREAM TTARS = 289. DEG K  
520. DEG R

PERCENT SPAN	RADIUS CM	RADIUS IN	C1 MPS	C1 FPS	ZETA1 DEG	C2 MPS	C2 FPS	ZETA2 DEG	PHI DEG	STD DAY DEG K	TTREL DEG R
95.0	43.010	16.933	90.	295.	135.	88.	290.	45.	-15.3	445.	801.
90.0	41.699	16.417	95.	312.	135.	95.	311.	45.	-13.8	436.	785.
85.0	40.389	15.901	98.	321.	135.	99.	324.	45.	-12.2	427.	768.
80.0	39.080	15.386	101.	330.	135.	103.	338.	45.	-10.8	418.	752.
75.0	37.770	14.870	104.	340.	135.	105.	344.	45.	-9.3	409.	736.
70.0	36.459	14.354	102.	335.	135.	104.	340.	45.	-7.9	401.	721.
65.0	35.149	13.838	104.	340.	135.	105.	345.	45.	-6.1	393.	707.
60.0	33.840	13.323	105.	346.	135.	107.	350.	45.	-4.5	384.	692.
50.0	31.219	12.291	106.	348.	135.	109.	358.	45.	-1.0	370.	666.
45.0	29.908	11.775	106.	349.	135.	108.	353.	45.	0.8	363.	654.
40.0	28.600	11.260	106.	347.	135.	107.	350.	45.	2.5	357.	643.
35.0	27.290	10.744	104.	342.	135.	104.	342.	45.	4.3	352.	633.
30.0	25.979	10.228	101.	333.	135.	100.	328.	45.	6.0	346.	622.
25.0	24.668	9.712	101.	331.	135.	98.	321.	45.	7.6	340.	612.
20.0	23.360	9.197	97.	318.	135.	94.	310.	45.	9.4	335.	603.

PERCENT SPAN	VZ--CORRECTED		BETA DEG	ABSOLUTE MACH NO	BETA PRIME DEG	RELATIVE MACH NO
	MPS	FPS				
95.0	126.	413.	-0.5	0.390	76.9	1.726
90.0	134.	440.	-0.1	0.413	75.8	1.679
85.0	139.	456.	0.3	0.425	74.9	1.631
80.0	144.	472.	0.7	0.438	73.9	1.583
75.0	147.	483.	0.3	0.447	73.1	1.542
70.0	145.	477.	0.4	0.439	72.8	1.489
65.0	147.	484.	0.4	0.444	72.1	1.442
60.0	150.	492.	0.3	0.451	71.2	1.398
50.0	152.	499.	0.8	0.456	69.5	1.299
45.0	151.	496.	0.3	0.454	68.8	1.254
40.0	150.	492.	0.2	0.450	68.1	1.205
35.0	147.	483.	-0.0	0.442	67.5	1.155
30.0	142.	467.	-0.4	0.428	67.2	1.105
25.0	140.	460.	-0.9	0.424	66.4	1.059
20.0	135.	444.	-0.7	0.409	65.9	1.004

APPENDIX D (Cont'd)

LASER DOPPLER VELOCIMETER TRAVERSE AT LEADING EDGE PLANE

100% SPEED PEAK EFFICIENCY

STD DAY RPM = 12470.4,

INNER RADIUS = 21.219 CM,  
8.354 IN

OUTER RADIUS = 42.047 CM,  
16.554 IN

UPSTREAM TTARS = 289. DEG K  
520. DEG R

PERCENT SPAN	RADIUS CM	RADIUS IN	C1 MPS	C1 FPS	ZETA1 DEG	C2 MPS	C2 FPS	ZETA2 DEG	PHI DEG	STD DAY DEG K	TTR L DEG R
95.0	41.006	16.144	113.	370.	135.	110.	360.	45.	-16.5	431.	776.
90.0	39.964	15.734	126.	415.	135.	130.	425.	45.	-15.5	424.	763.
85.0	38.923	15.324	131.	430.	135.	133.	435.	45.	-13.6	417.	750.
80.0	37.882	14.914	133.	437.	135.	137.	450.	45.	-11.8	410.	738.
75.0	36.840	14.504	135.	443.	135.	142.	465.	45.	-9.5	403.	726.
70.0	35.799	14.094	134.	439.	135.	138.	453.	45.	-7.8	396.	713.
65.0	34.757	13.684	134.	439.	135.	137.	448.	45.	-5.9	390.	702.
60.0	33.716	13.274	130.	427.	135.	134.	441.	45.	-3.8	384.	691.
55.0	32.675	12.864	130.	426.	135.	134.	441.	45.	-1.5	378.	680.
50.0	31.633	12.454	131.	431.	135.	130.	428.	45.	0.5	372.	670.
40.0	29.550	11.634	137.	448.	135.	131.	430.	45.	6.0	362.	652.

PERCENT SPAN	VZ--CORRECTED MPS	FPS	BETA DEG	ABSOLUTE MACH NO	BETA PRIME DEG	RELATIVE MACH NO
95.0	157.	516.	-0.8	0.494	73.0	1.695
90.0	181.	593.	0.7	0.568	70.1	1.672
85.0	186.	611.	0.3	0.581	69.3	1.645
80.0	191.	626.	0.8	0.592	68.4	1.605
75.0	195.	641.	1.4	0.601	67.4	1.564
70.0	192.	630.	0.9	0.589	67.4	1.528
65.0	191.	626.	0.6	0.583	67.0	1.491
60.0	187.	613.	0.9	0.567	66.8	1.441
55.0	187.	612.	1.0	0.566	66.2	1.402
50.0	185.	607.	-0.2	0.561	65.9	1.376
40.0	189.	620.	-1.2	0.579	64.0	1.320

APPENDIX D (Cont'd)

LASER DOPPLER VELOCIMETER TRAVERSE AT TRAILING EDGE PLANE

100% SPEED PEAK EFFICIENCY

STD DAY RPM = 12470.4,

INNER RADIUS = 25.639 CM,  
10.094 IN

OUTER RADIUS = 40.703 CM,  
16.025 IN

UPSTREAM TTABS = 289. DEG K  
520. DEG R

PERCENT SPAN	RADIUS CM	RADIUS IN	C1 MPS	C1 FPS	ZETA1 DEG	C2 MPS	C2 FPS	ZETA2 DEG	PHI DEG	STD DAY DEG K	TTRFL DEG R
95.0	39.949	15.728	175.	573.	75.	210.	688.	15.	-17.8	423.	762.
90.0	39.197	15.432	193.	632.	75.	207.	680.	15.	-15.8	419.	754.
85.0	38.443	15.135	206.	675.	75.	204.	669.	15.	-13.8	413.	744.
80.0	37.691	14.839	212.	694.	75.	209.	687.	15.	-12.0	409.	736.
75.0	36.937	14.542	213.	700.	75.	219.	719.	15.	-9.9	404.	727.
70.0	36.185	14.246	213.	698.	75.	217.	711.	15.	-7.9	399.	718.
65.0	35.430	13.949	201.	659.	75.	205.	674.	15.	-6.0	394.	709.
60.0	34.679	13.653	184.	604.	75.	218.	714.	15.	-3.8	389.	701.
55.0	33.924	13.356	204.	668.	75.	232.	761.	15.	-1.5	385.	693.
50.0	33.172	13.060	209.	687.	75.	222.	729.	15.	0.5	381.	685.
45.0	32.418	12.763	209.	685.	75.	221.	726.	15.	2.8	377.	678.
40.0	31.664	12.466	208.	684.	75.	223.	730.	15.	5.2	372.	670.
35.0	30.912	12.170	209.	685.	75.	223.	732.	15.	7.8	368.	663.
30.0	30.157	11.873	253.	829.	45.	187.	612.	0.	10.5	365.	657.

PERCENT SPAN	VZ--CORRECTED MPS	FPS	BETA DEG	ABSOLUTE MACH NO	BETA PRIME DEG	RELATIVE MACH NO
95.0	132.	433.	54.0	0.604	67.8	0.971
90.0	153.	501.	48.6	0.627	64.9	0.998
85.0	168.	552.	44.6	0.647	62.7	1.021
80.0	173.	568.	44.5	0.663	61.2	0.992
75.0	172.	565.	46.3	0.677	59.9	0.939
70.0	172.	565.	45.9	0.673	59.4	0.925
65.0	162.	533.	46.1	0.638	60.9	0.913
60.0	140.	460.	53.2	0.630	62.1	0.807
55.0	158.	517.	51.4	0.681	57.3	0.786
50.0	167.	548.	47.9	0.678	56.1	0.814
45.0	167.	546.	47.9	0.678	55.1	0.795
40.0	166.	544.	48.2	0.682	53.8	0.772
35.0	166.	545.	48.3	0.687	52.4	0.753
30.0	171.	560.	47.5	0.701	50.1	0.744

## APPENDIX E

### POSSIBLE FLOW INSTABILITY

At one time during the LDV evaluation of the 100% speed, peak efficiency point, an unusual velocity pattern was recorded for passages 1 and 31. At 0.52 chord, 85% span, both the 60° and the 105° LDV measurements indicated a strongly bimodal velocity distribution in these passages while gap 15 maintained a single, well behaved flow vector that aligned well with data obtained at both upstream and downstream locations. The data from gaps 1 and 31 have been carefully examined and it is believed that the data suggest a strong oscillatory flow in these passages. A check of the remaining passages indicated this phenomenon existed in varying degrees in ninety percent of the passages.

The possibility that the bimodality was in fact produced by noise has been examined and, although it cannot be completely ruled out, the evidence strongly suggests the data is real since: (1) the passages are not uniformly affected, (2) the condition does not occur at any other locations during running at 100% speed, peak efficiency, nor (3) does it appear again at the same location for the offdesign portions of the test program. Assuming then that the data sets were indicative of real flow variations, what oscillation would be indicated?

An exact determination of the secondary flow direction is difficult to ascertain because the instrument orientations used to optimize the readings for the expected flow directions may have been less than optimum for flow components occurring 30 degrees or more from the expected directions. Given these limitations, an analysis of the data was attempted and it has been tentatively concluded that in the absolute reference frame, the flow oscillated from the usual flow direction toward the direction of wheel rotation. At the angular location chosen for analysis, number 40, one resultant, 240 m/sec (780 ft/sec), was 56° from the tangential direction. The flow spent approximately thirty percent of the time at this condition--this direction and amplitude is consistent with upstream and downstream data sets--and spent the remainder of the time at 135 m/sec (440 ft/sec), flowing 20° to 30° from tangential. This condition persists for 3/4 of the blade gap, see Figure 54. The carpet plot of the data from the 60° fringe orientation for passage 1 clearly shows the region of bimodality in question. A similar plot of gap 15 has been included in Figure 54 for comparison.

**This Page Intentionally Left Blank**

APPENDIX F

BLADE COORDINATES

Blade cross-section coordinates, representing calculated running geometry for 95% and 85% span, are presented below in extended line form. Coordinates are in centimeters. Applicable aerodynamic information appears in Appendix C.

95% Span

Leading Edge: (0.0000, 0.0000)  
 Leading Edge Radius = 41.0060cm

Trailing Edge: (4.7577, 9.5626)  
 Cone Angle = -18.3 Degrees

Pressure Surface - Axial Coordinates

0.0000	0.2205	0.4427	0.6668	0.8920	1.1194	1.3480
1.5784	1.8105	2.0450	2.2812	2.5197	2.7602	3.0033
3.2482	3.4950	3.7437	3.9942	4.2461	4.4996	4.7544

Pressure Surface - Tangential Coordinates

-0.0462	0.4348	0.9114	1.3823	1.8461	2.3040	2.7600
3.2195	3.6853	4.1580	4.6383	5.1262	5.6198	6.1196
6.6190	7.1153	7.6076	8.0955	8.5776	9.0515	9.5184

Suction Surface - Axial Coordinates

0.0000	0.2212	0.4445	0.6703	0.8981	1.1278	1.3602
1.5951	1.8331	2.0744	2.3178	2.5616	2.8054	3.0495
3.2936	3.5377	3.7818	4.0264	4.2710	4.5156	4.7605

Suction Surface - Tangential Coordinates

0.0561	0.6091	1.1552	1.6927	2.2207	2.7462	3.2812
3.8316	4.3998	4.9893	5.5585	6.0810	6.5646	7.0162
7.4392	7.8372	8.2169	8.5827	8.9350	9.2735	9.5997

85% Span

Leading Edge: (0.0000, 0.0000)  
 Leading Edge Radius = 39.6131cm

Trailing Edge: (4.7470, 8.9835)  
 Cone Angle = -14.58 Degrees

Pressure Surface - Axial Coordinates

0.0000	0.2248	0.4506	0.6777	0.9060	1.1351	1.3655
1.5972	1.8303	2.0650	2.3015	2.5400	2.7800	3.0218
3.2647	3.5085	3.7536	4.0000	4.2471	4.4953	4.7445

Pressure Surface - Tangential Coordinates

-0.0437	0.4089	0.8539	1.2893	1.7140	2.1265	2.5390
2.9616	3.3975	3.8481	4.3177	4.8019	5.2880	5.7727
6.2489	6.7158	7.1750	7.6274	8.0711	8.5077	8.9413

Suction Surface - Axial Coordinates

0.0000	0.2253	0.4521	0.6805	0.9101	1.1412	1.3741
1.6093	1.8473	2.0884	2.3312	2.5740	2.8164	3.0584
3.3000	3.5413	3.7823	4.0236	4.2652	4.5070	4.7490

Suction Surface - Tangential Coordinates

0.0533	0.5745	1.0846	1.5801	2.0584	2.5329	3.0256
3.5469	4.1036	4.7026	5.2809	5.7996	6.2611	6.6810
7.0668	7.4252	7.7648	8.0919	8.4089	8.7175	9.0193

**This Page Intentionally Left Blank**

## DISTRIBUTION LIST

1. NASA-Lewis Research Center  
 21000 Brookpark Road  
 Cleveland, OH 44135  
 Attn:
 

Report Control Office	MS 5-5	1
Technical Utilization Office	MS 7-3	1
Library	MS 60-3	2
Fluid Mechanics & Acoustics Div.	MS 5-3	1
Fan & Compressor Branch	MS 5-9	5
C. L. Ball	MS 5-9	1
T. F. Gelder	MS 5-9	1
L. Reid	MS 5-9	1
W. A. Rostafinski	MS 5-9	1
D. M. Sandercock	MS 5-9	1
Acquisition Division	MS 500-305	1
N. T. Musial	MS 500-318	1
W. R. Britsch	MS 301-2	1
R. D. Hager	MS 301-2	1
C. C. Ciepluch	MS 301-4	1
J. W. Schaefer	MS 301-4	1
  
2. NASA Scientific and Technical Information Facility  
 P. O. Box 8757  
 Baltimore/Washington International Airport  
 Maryland 21240  
 Attn: Accessioning Dept. 25
  
3. NASA Headquarters  
 Washington, D.C. 20546  
 Attn: RTP-6/G. Banerian 1
  
4. NASA-Langley Research Center  
 Hampton, VA 23665  
 Attn: S. J. Morris MS 249B 1  
       L. Hasel MS 407 1
  
5. U.S. Army Research & Technology Laboratories  
 Director Applied Technology Laboratory  
 Fort Eustis, VA 23604  
 Attn: DAVDL-EU-TA, J. White 1



- |     |   |       |   |
|-----|---|-------|---|
| 6.  | Headquarters<br>Wright-Patterson AFB, OH 45433  |       |   |
|     | Attn: E. E. Bailey, AFAPL/DO  |       | 1 |
|     | R. P. Carmichael, ASD/XRHI  |       | 1 |
|     | S. Kobelak, AFAPL/TBP   |       | 1 |
|     | A. J. Wennerstrom, AFAPL/TBX  |       | 1 |
|     | M. A. Stibich, AFAPL/TBC  |       | 1 |
| 7.  | Naval Air Systems Command<br>NASAIR/52022<br>Technical Support Branch<br>Washington, D. C. 20362        |       |   |
|     | Attn: R. A. Retta   |       | 1 |
| 8.  | U.S. Navy Ship/Engineering Center<br>Code 6141<br>Washington, D. C. 20362                               |       |   |
|     | Attn: G. L. Graves  |       | 1 |
| 9.  | Naval Air Propulsion Test Center<br>Trenton, NJ 08628   |       |   |
|     | Attn: V. Labosky  | PE-7  | 1 |
|     | J. Pichtelberger  | PE-7  | 1 |
|     | P. Piscopo  | PE-42 | 1 |
| 10. | Pratt & Whitney Aircraft<br>Government Products Division<br>P. O. Box 2691<br>West Palm Beach, FL 33402 |       |   |
|     | Attn: W. R. Alley   |       | 1 |
|     | J. Brent  |       | 1 |
|     | R. E. Davis   |       | 1 |
|     | J. A. Fligg   |       | 1 |
|     | B. A. Jones   |       | 1 |
|     | R. W. Rockenbach  |       | 1 |
|     | H. D. Stetson   |       | 1 |
| 11. | Pratt & Whitney Aircraft<br>400 Main Street<br>East Hartford, CT 06108                                  |       |   |
|     | Attn: T. J. Gillespie   | E2H   | 1 |
|     | N. T. Monsarrat   | E2H   | 1 |
|     | R. E. Pallatine   | E2H   | 1 |
|     | A. W. Stubner   | E2H   | 1 |
|     | H. D. Weingold  | E2H   | 1 |
|     | D. J. Hopwood   | E2H   | 1 |
|     | W. M. Foley (UTRC)  |       | 1 |
|     | Library (CPD)   |       | 1 |
|     | Library (UTRC)  |       | 1 |

12. Detroit Diesel Allison Division, GMC  
 Department 8894, Plant 8  
 P. O. Box 894  
 Indianapolis, IN 46206  
 Attn: R. F. Alverson U-28 1  
 J. L. Dettner U-28 1  
 R. L. Jay W-16 1  
 G. E. Holbrook T-22 1  
 P. Tramm U-27 1  
 Library S-5 1
13. Northern Research and Engineering  
 219 Vassar Street  
 Cambridge, MA 02139  
 Attn: K. Ginwala 1
14. General Electric Company  
 Flight Propulsion Division  
 Cincinnati, OH 45215  
 Attn: J. F. Klapproth K-221 1  
 C. C. Koch H-43 1  
 J. W. McBride E-198 1  
 Marlen Miller K-69 1  
 D. E. Parker H-43 1  
 D. Prince H-48 1  
 L. H. Smith H-43 1  
 J. B. Taylor J-40 1  
 J. S. Keith H-4 1  
 D. C. Wisler H-4 1  
 Technical Information Center N-32 1
15. General Electric Company  
 1000 Western Avenue  
 Lynn, MA 01910  
 Attn: D. P. Edkins M.D. 24048 1  
 F. F. Ehrich M.D. 24505 1  
 L. H. King M.D. 2406 1  
 R. E. Neitzel M.D. 24502 1
16. Curtiss-Wright Corporation  
 Wright Aeronautical  
 Wood-Ridge, NJ 07075  
 Attn: R. Cole 1  
 S. Lombardo 1
17. AiResearch Manufacturing Company  
 P. O. Box 5217  
 Phoenix, AZ 85010  
 Attn: J. Dodge 1  
 G. L. Perrone 1  
 D. Seyler 1  
 J. Switzer 1

18. AiResearch Manufacturing Company  
 2525 West 190th Street  
 Torrance, CA 90509  
 Attn: R. Carmody 1  
       R. Jackson 1  
       L. W. Pearson 1  
       Library 1
19. Union Carbide Corporation  
 Nuclear Division  
 Oak Ridge Gaseous Diffusion Plant  
 P. O. Box P  
 Oak Ridge, TN 37830  
 Attn: J. L. Petty, K1401 MS 385 1
20. AVCO Corporation  
 Lycoming Division  
 550 South Main Street  
 Stratford, CT 06497  
 Attn: C. Kuintzle 1  
       Library 1
21. Teledyne, CAE  
 1330 Laskey Road  
 Toledo, OH 43612  
 Attn: Eli H. Benstein 1  
       Howard C. Walch 1
22. Solar  
 2200 Pacific Highway  
 San Diego, CA 92138  
 Attn: P. A. Pitt A-5 1  
       J. Watkins C-5 1
23. Goodyear Atomic Corporation  
 Box 628  
 Piketon, OH 45661  
 Attn: C. O. Langebrake 1
24. Hamilton Standard Division of  
 United Technologies Corporation  
 Windsor Locks, CT 06096  
 Attn: Mr. C. Rohrback, Chief,  
       Aerodynamics & Hydrodynamics MS 1A-3-6 1
25. Westinghouse Electric Corporation  
 Combustion Turbine System Division  
 Lester, PA 19113  
 Attn: S. M. DeCorso MS A703 1

26. Williams Research Corporation  
P. O. Box 95  
Walled Lake, MI 48088  
Attn: J. Richard Joy 1  
R. A. Horn, Jr. 1
27. Eaton Research Center  
P. O. Box 766  
Southfield, MI 48037  
Attn: Librarian 1
28. Chrysler Corporation  
Research Office  
Department 9510  
P. O. Box 1118  
Detroit, MI 48288  
Attn: Ronald Pampreen CIMS 418-37-18 1
29. Elliott Company  
Jeannette, PA 15644  
Attn: John W. Schlirf 1  
Vice President of Engineering
30. Caterpillar Tractor Company  
Research Dept. Technical Center, Bldg. F  
Peoria, IL 61629  
Attn: J. Wiggins 1
31. BMAD  
Boeing Aerospace Co.  
P. O. Box 3999  
Seattle, WA 98124  
Attn: A. D. Welliver MS 41-52 1
32. Douglas Aircraft Company  
3855 Lakewood Blvd.  
Long Beach, CA 90801  
Attn: Dr. Albert C. Munson, 3557 1
33. Lockheed Missile and Space Company  
P. O. Box 504  
Sunnyvale, CA 94088  
Attn: Technical Information Center 1  
Dept. 52-50, Bldg. 106
34. California Institute of Technology  
Pasadena, CA 91125  
Attn: Professor Duncan Rannie 205-45 1  
Dr. Frank Marble 205-45 1

35. Iowa State University of Science and Technology  
Ames, IA 50010  
Attn: Professor G. K. Serovy  
Dept. of Mech. Engrg. 1
36. Massachusetts Institute of Technology  
Cambridge, MA 02139  
Attn: Dr. J. McCune 1
37. University of Notre Dame  
Notre Dame, IN 46556  
Attn: Engineering Library 1
38. Penn State University  
Department of Aerospace Engineering  
233 Hammond Building  
University Park, PA 16802  
Attn: Prof. B. Lakshminarayana 1
39. Texas A&M University  
Department of Mechanical Engineering  
College Station, TX 77843  
Attn: Dr. Meherwan P. Boyce 1
40. University of Tennessee Space Institute  
Tullahoma, TN 37388  
Attn: Dr. M. Kurosaka 1  
Dr. J. Caruthers 1
41. University of Delaware  
Newark, DE 19711  
Attn: Prof. Barry Seidel  
Dept. of Mech. & Aero. Engrg. 1
42. Naval Postgraduate School  
Monterey, CA 93940  
Attn: R. P. Shreeve, Director  
Turbopropulsion Laboratory 1

**End of Document**