

N83 14335

TDA Progress Report 42-71

July - September 1982

# Electronic Simulation of a Barometric Pressure Sensor for the Meteorological Monitor Assembly

C. N. Guiar and L. W. Duff  
DSN Engineering Section

*This article presents an analysis of the electronic simulation of barometric pressure used to self-test the counter electronics of the digital barometer. The barometer is part of the Meteorological Monitor Assembly that supports navigation in deep space communication. The theory of operation of the digital barometer, the design details, and the verification procedure used with the barometric pressure simulator are presented.*

## I. Introduction

The Meteorological Monitor Assembly (MMA) is one of the subsystems in the Deep Space Network's technical facility which provide the meteorological information necessary for calibrating radiometric data in support of navigational requirements for various deep space communication projects. The assembly as shown in Fig. 1 includes equipment required for the measurement, data processing, and handling of the following major types of data:

- (1) Barometric pressure.
- (2) Rainfall/water precipitation rate.
- (3) Dewpoint temperature of ambient air.
- (4) Azimuth and elevation angles of the large, 64-m antenna.
- (5) Faraday rotation.
- (6) Polarization angle.
- (7) Ground level solar radiation.
- (8) Dry bulb temperature of ambient air.

In supporting field operators, a need evolved for verification of the operation of the barometric pressure instrumentation (digital barometer) using self-test electronics. The barometric pressure simulator was developed for this purpose and is presented by the block diagram in Fig. 2. This article reports on the design details and verification procedures incorporated in the barometric pressure simulator development.

## II. Barometer Functional Description

Schematic diagrams of the Bell & Howell digital barometer (P/N 4-461-004) are shown in Figs. 3 and 4. The digital barometer basically consists of a digital pressure transducer and a front panel light-emitting diode (LED) display. The barometric pressure to be measured is received at the rear panel connector, where it is applied to the input of the transducer. The transducer converts the pressure into a frequency which varies linearly with pressure. This signal is fed into a presettable counter where it is converted to a digital data signal. The digital output signal is applied to the rear panel connector as a parallel binary coded decimal (BCD) output, and also to the front panel LED assembly, which produces a five-digit display.

A precision dual-capacitor pressure-sensing element generates two variable frequencies, one varying directly and the other varying inversely with the pressure applied to the input fitting. The mixer accepts these two frequencies as input and provides an output signal which has a frequency that is the difference between the two input frequencies and varies linearly with pressure change. The purpose of processing the signal in this manner is to provide a more stable and accurate frequency input for the counter electronics. The frequency signal is fed to a digital counter that is programmed to sample the output frequency of the sensing element. The time period of the sample count can be varied by setting the span-adjust switches which will provide a readout in the desired units.

The digital barometer is currently equipped with a capability to self-test the display. When the test switch on the front panel is momentarily pressed to the ON position, all segments of the digital display are lit, producing a display of 88888. Any LED failure in the display will thus be revealed. This was the only self-test feature available with this type of barometer.

In the event that any counter circuit in the group U1-U5 as shown in Fig. 4 fails (e.g., bit malfunction), there is no self-contained means of determining this failure. The counter circuits can be tested by providing a known frequency  $f_0$  to the counter inputs, producing a BCD output that should correspond with  $f_0$ . Therefore, if the BCD output does not correspond properly to the input frequency, it can be assumed that the counter electronics within the barometer have malfunctioned.

### III. Barometric Pressure Simulator

The barometric pressure simulator provides known frequencies to the inputs of counters U1-U5 (Fig. 4) to determine if they are counting correctly. Frequency-generating circuitry and delay, latch, and flag electronics as shown in Fig. 5 comprise the barometric pressure simulator. Details of these electronics are given in the remainder of this section.

#### A. Frequency and Barometric Pressure Relationship

In determining the factor by which the circuit scales simulated barometric pressure according to frequency, a frequency generator was connected directly to the input of the barometer counter electronics (U13) in parallel with a frequency counter measuring system as shown in Fig. 6. Several barometric pressure readings were taken for various frequency values. The resulting test data given in Table 1 indicate that a change in frequency of approximately 7.4 kHz produced a 1.0 mbar<sup>1</sup> change in barometric pressure. The linear frequency-

pressure relationship can be assumed to take the form:

$$f = mp + b \quad (1)$$

where  $f$  is the frequency in kHz,  $p$  is the pressure in mbars,  $m$  is the slope in kHz/mbar, and  $b$  is the ordinate intercept in kHz. If frequency is zero, the pressure is zero; therefore,  $b$  is zero. The average slope, determined using the data in Table 1, is  $7.4 \pm 0.5$  kHz/mbar.

A resolution of 12 bits was chosen to provide a suitable range of frequencies for use in barometric pressure simulation. The 12-bit word, transferred through the latching network from the HP9821A calculator, is used as the input for three cascaded, synchronous, 4-bit counters as shown in Fig. 5. The least significant bit output (LSB) provides the necessary frequency and is determined by:

$$f_{LSB} = \frac{\text{clock frequency}}{(16 - b_1)(16 - b_2)(16 - b_3)} \quad (2)$$

where  $b_1$  is the input bit value for first counter,  $b_2$  is the input bit value for second counter, and  $b_3$  is the input bit value for third counter.

The value 16, used in the denominator, corresponds to the number of increments from binary 0000 to 1111.

A 6-MHz crystal-controlled oscillator provides a constant, stable clock signal for control of the digital electronics. The actual frequency used for barometric pressure simulation ( $f_0$ ) is generated by subtracting the LSB frequency from the clock frequency. Table 2 shows a few examples for various 12-bit inputs and their corresponding simulated barometric pressure.

#### B. Handshake

A simplified block diagram of the HP11202A I/O interface is shown in Fig. 7. The interface provides 8-bit data exchange between the HP9821A calculator and the barometric pressure simulator. Data bits D0-D5 are used for data information and D6 and D7 for control.

Data is transferred in a "half-duplex" mode, meaning data can be either input or output, but not both at the same time. All data and control lines are compatible with standard TTL levels.

When the calculator is given a WRITE command a Select Code Signal is output. The Select Code Signal is used to address the correct device. The status of the Service Interrupt line (SIO) is then checked by the calculator. If a low signal is detected on the SIO line the interface is not busy, allowing data to be held low on the chosen calculator output lines

<sup>1</sup> One millibar (mbar) is equal to 0.0147 psi or 0.101 kPa.

(D00-D07). The Calculator Status Line (S03) signal then sets the I/O line low to indicate that an output operation has been initiated. Next, the Control Enable Line (CEO) and SELECT code signals are output. The CEO signal provides the correct timing for interface operations. If the Select Code Signal addresses the correct device, data is ready to be transferred to the output lines. The device control line ( $\overline{\text{CTL}}$ ) is transmitted to the barometric pressure simulator 5  $\mu\text{sec}$  later, indicating data has been transferred to the output lines (D0-D7). All data will be held on these lines until the barometric pressure simulator returns the Device Ready ( $\overline{\text{FLG}}$ ) signal, indicating data have been accepted.

### C. Latch and Delay

The six data bits (D0-D5) are connected to three 4-bit bistable latches. These latches are used as temporary storage for binary information between HP9821A calculator and frequency generating electronics. Since 12 data bits are needed in the frequency-generating circuitry, data transfer takes place in two segments. The first segment involves sending six bits through one-half of the latch electronics, with the second transfer sending six more data bits through the remaining half.

Data bits D6 and D7 are used for the interchange of data and control of the transfer of data through the latching electronics and into the barometer. Timing between control commands and data inputs is very important if latching is to take place in the correct sequence. Once a FLG signal is returned

to the calculator at the end of each WRITE command, all data on the calculator output lines is cleared. Delay circuitry is provided which allows the control commands to reach the latching network only when data information (D0-D5) is present.

### D. Verification of Simulator Operation

The final function of the barometric pressure simulator provides a means for data verification. Since a known frequency is provided, the BCD output of the barometer can be checked by transferring this data back to the HP9821A calculator for comparison. If the calculated frequency does not agree with the BCD output frequency by approximately  $\pm 0.5$  mbar, it can be assumed that the counter electronics of the barometer have malfunctioned and correction measures should be applied.

## IV. Summary

The barometric pressure simulator provides a method for self-testing the counter electronics of the Bell & Howell digital barometer using electronic simulation of barometric pressure. A prototype model of the simulator has been built and tested and will soon be integrated into the digital barometer for placement in the MMA, thus supporting field operators in the area of barometric data verification. Operating instructions, theory of operation, and associated software for the barometric pressure simulator will be published in an operation and maintenance manual.

ORIGINAL PAGE IS  
OF POOR QUALITY

**Table 1. Test data for determination of scale factor for pressure vs frequency**

Barometer reading, mbars	Frequency reading, MHz	$\frac{\Delta \text{ Pressure,}}{\Delta \text{ Frequency}}$ kHz/mbar
606.8	4.509	
596.8	4.435	7.4
506.0	3.763	7.44
406.7	3.031	7.38
306.7	2.292	7.38
206.9	1.556	7.35

Average = 7.4 kHz/mbar

**Table 2. Sample 12-bit inputs and their corresponding simulated barometric pressure**

12-bit input	(1)	(2)	(3)
0111 1001 1111	95.24	797.9	795.4
0111 1010 1111	111.1	795.8	793.3
0111 1000 1111	83.3	799.5	797.5
0111 0000 1111	41.7	805.2	802.7
0100 1001 1111	71.4	801.2	798.7
0101 1111 1111	545.4	737.1	734.6
0111 1111 1111	666.7	720.7	718.2

$$(1) \text{ Frequency at LSB} = \frac{6 \text{ MHz}}{(16 - b_1)(16 - b_2)(16 - b_3)}$$

$$(2) \text{ Simulated barometric pressure} = P' = \frac{6 \text{ MHz} - f_{LSB}}{7.4 \text{ kHz/mbar}}$$

$$(3) \text{ Corrected barometric pressure} = (P' - 2.5) \text{ mbars}$$

ORIGINAL PAGE IS  
OF POOR QUALITY

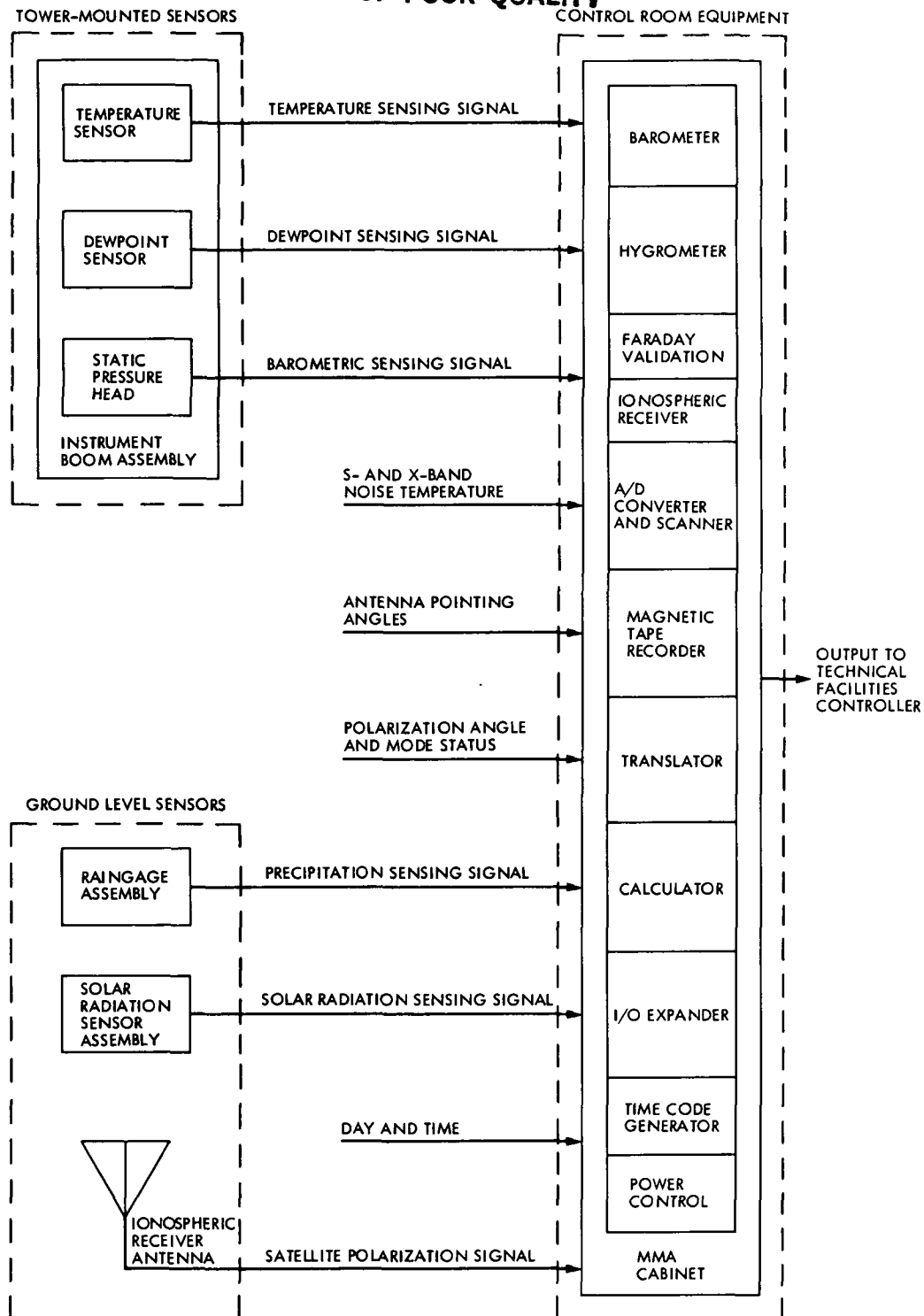

Fig. 1. Overall block diagram of MMA

ORIGINAL PAGE IS  
OF POOR QUALITY

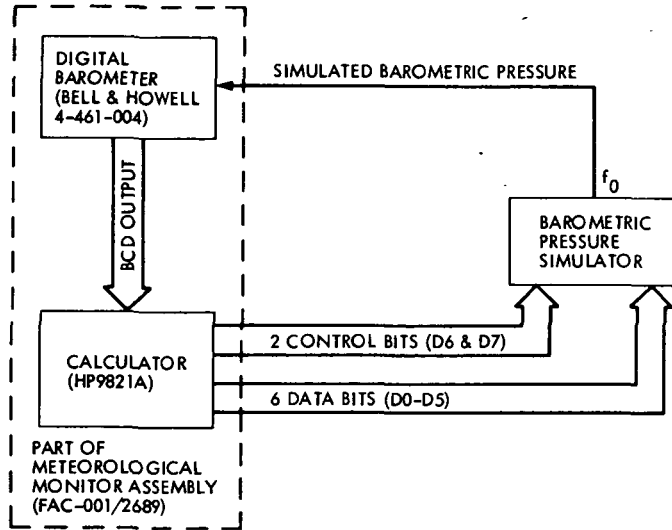

Fig. 2. Barometric self-test electronics block diagram

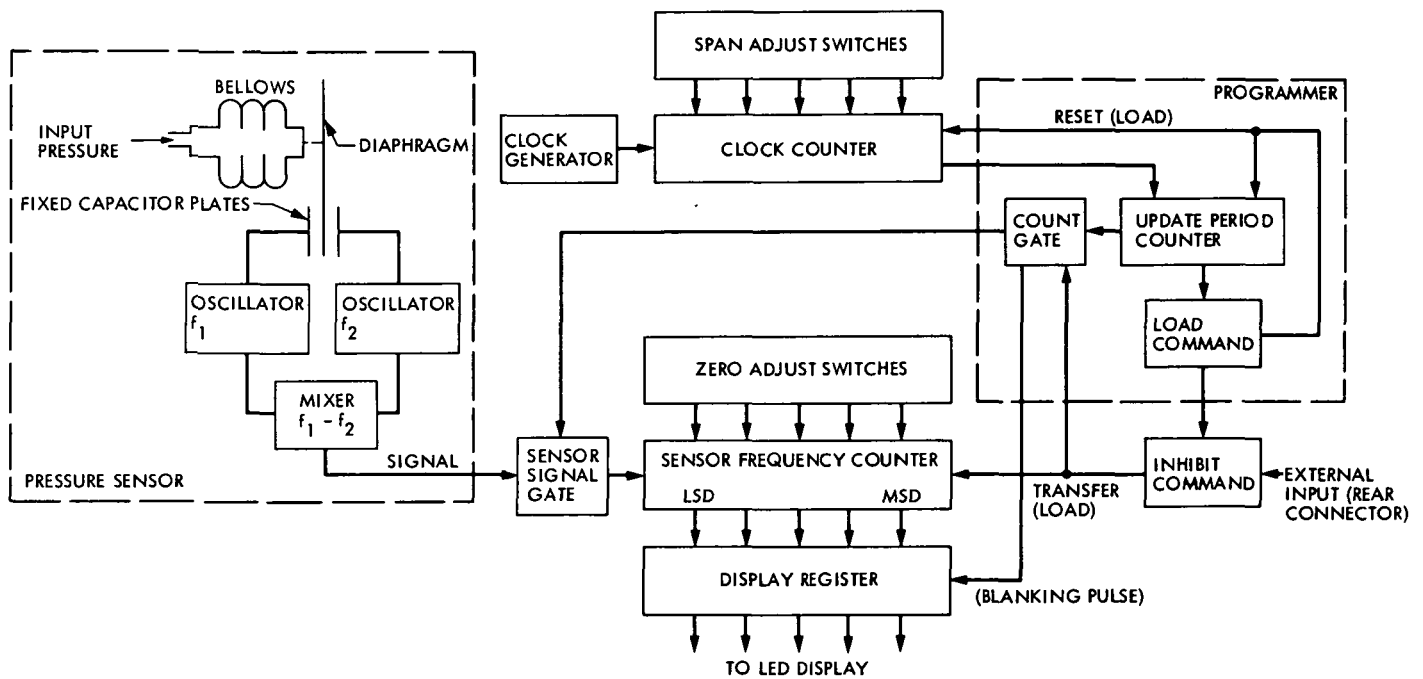

Fig. 3. Functional block diagram for Bell & Howell digital barometer (P/N 4-461-004)

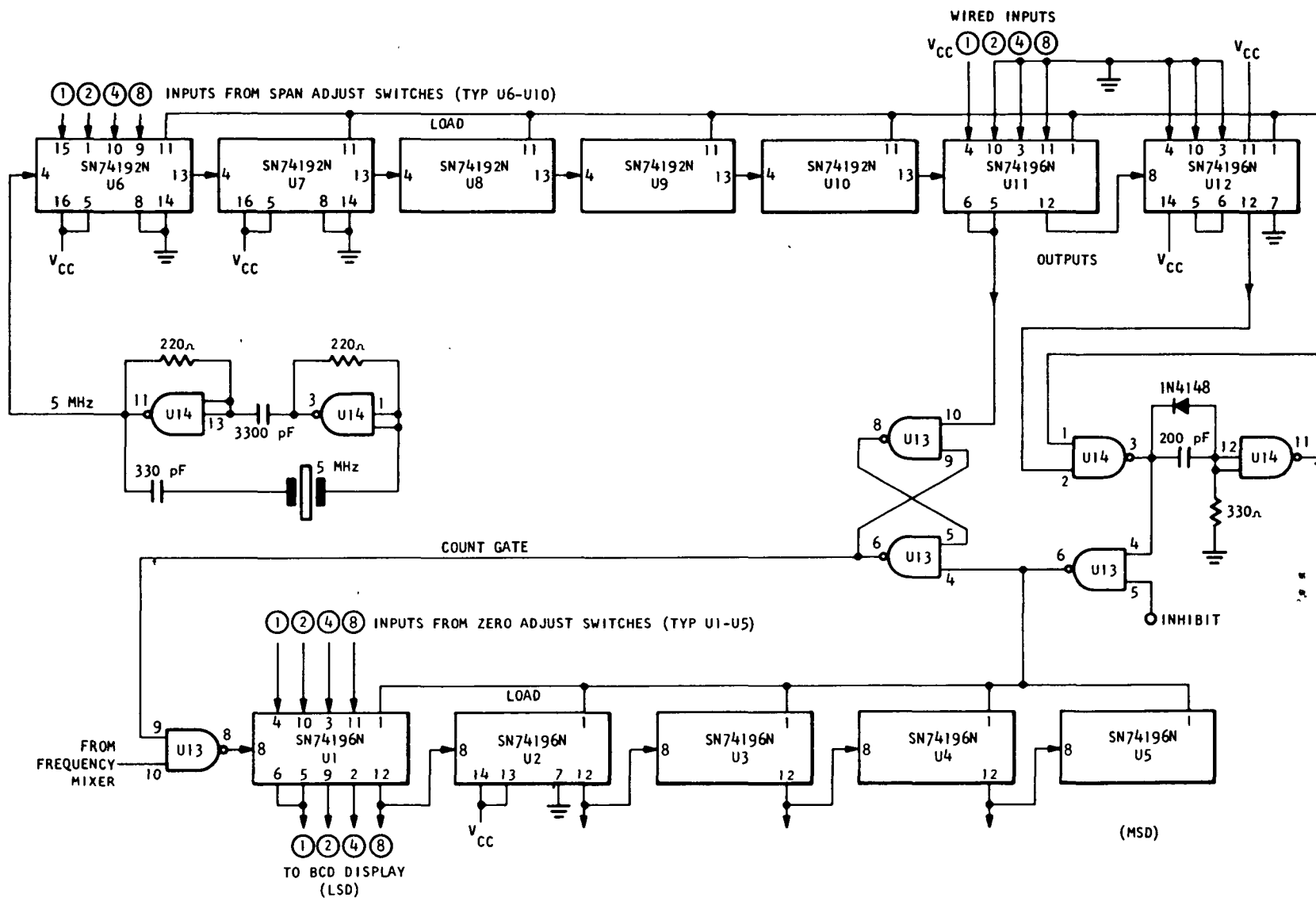

Fig. 4. Simplified schematic diagram of digital electronics for Bell & Howell digital barometer (P/N 4-461-004)

ORIGINAL PAGE IS  
OF POOR QUALITY

ORIGINAL PAGE IS  
OF POOR QUALITY

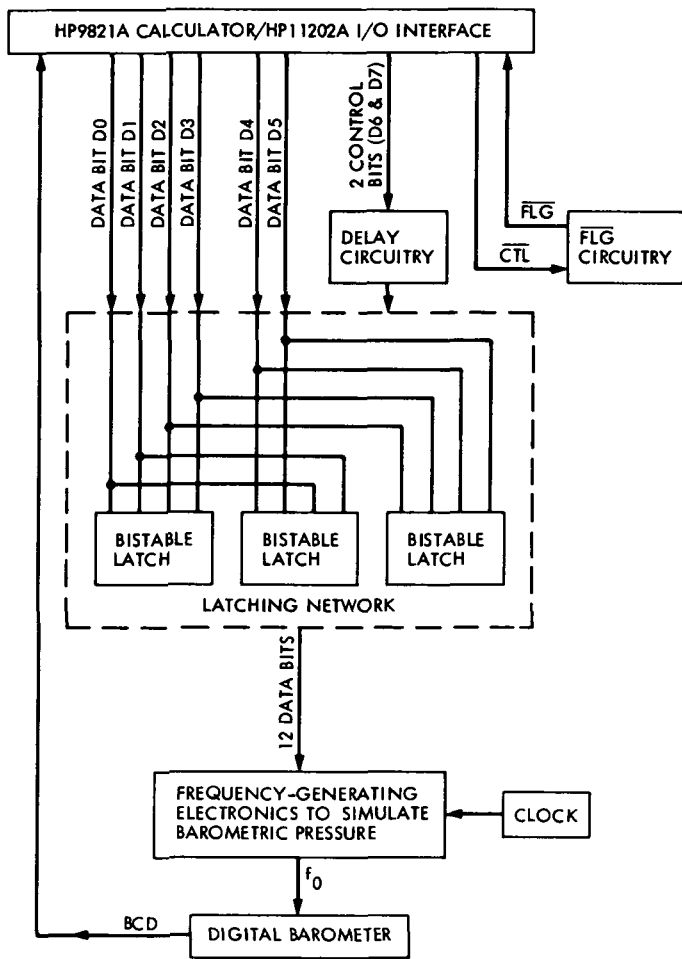

Fig. 5. Block diagram for barometric pressure simulator

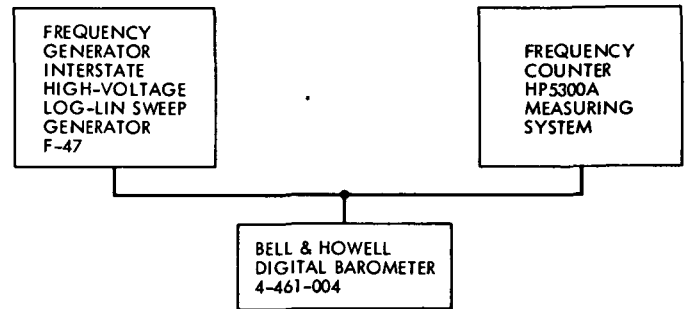

Fig. 6. Test setup for frequency vs simulated barometric pressure scale factor determination



ORIGINAL PAGE IS  
OF POOR QUALITY

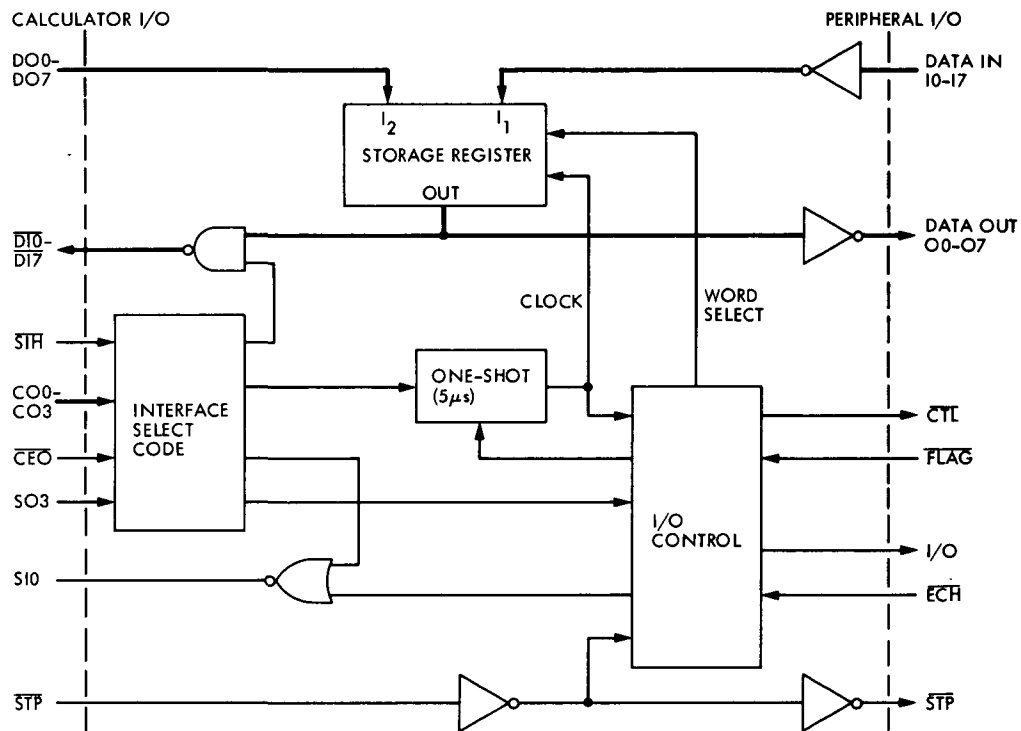

Fig. 7. Simplified block diagram of the HP11202A I/O Interface