

General Disclaimer

One or more of the Following Statements may affect this Document

- This document has been reproduced from the best copy furnished by the organizational source. It is being released in the interest of making available as much information as possible.
- This document may contain data, which exceeds the sheet parameters. It was furnished in this condition by the organizational source and is the best copy available.
- This document may contain tone-on-tone or color graphs, charts and/or pictures, which have been reproduced in black and white.
- This document is paginated as submitted by the original source.
- Portions of this document are not fully legible due to the historical nature of some of the material. However, it is the best reproduction available from the original submission.

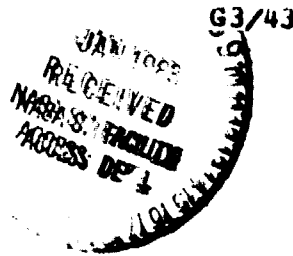

TOPEX ORBIT DETERMINATION USING GPS SIGNALS PLUS A SIDETONE RANGING SYSTEM

Peter L. Bender* and Douglas R. Larden
Joint Institute for Laboratory Astrophysics
National Bureau of Standards and University of Colorado
Boulder, CO 80309

ABSTRACT

One reason for carrying out our GPS orbit determination study was to see how well the radial coordinate for altimeter satellites such as TOPEX could be found by on-board measurements of GPS signals, including the reconstructed carrier phase. Preliminary results are very encouraging. However, the inclusion on altimeter satellites of an additional high accuracy tracking system seems desirable. A suggestion is made for using a sidetone ranging system in conjunction with TRANET 2 beacons.

INTRODUCTION

The accuracy of the altimeter on the proposed TOPEX (Topographic Experiment) satellite is high enough so that 3 cm accuracy for determining the radial coordinate would be very desirable if it can be achieved. One attractive approach is to use signals from the GPS (Global Positioning System) satellites to determine the orbit. However, until the schedule for launching the necessary number of GPS satellites is definite and there are assurances that dithering of the satellite signals or other factors will not degrade the achievable accuracy, a combination of two approaches must be planned for. The redundancy provided by a dual approach would be helpful in any case, if the cost is not too high.

Preliminary results for the GPS method are given briefly in the next section. This is followed by discussion of a possible sidetone ranging system, probably at S-band, which could be used to provide accurate ranges to TOPEX from a number of ground stations. TRANET 2 tracking data would be used also to determine the ionospheric correction and for ambiguity resolution. The sidetone ranging system could be developed by modifying a pair of USB (Unified S-Band) transponders if desired.

*Staff Member, Quantua Physics Division, National Bureau of Standards, Boulder, Colorado.

GPS APPROACH FOR TOPEX ORBIT DETERMINATION

One of the two purposes in our study of the GPS orbit determination problem has been to investigate how accurately GPS signals can be used to determine the orbits of altimeter satellites (Larden and Bender, 1982a). Geometrical arguments indicated that the radial coordinate for TOPEX could be solved for accurately if the horizontal coordinates of the GPS satellites were known to about 20 cm. Our results (Larden and Bender, 1981, 1982b) indicate that this GPS orbit accuracy can be achieved with 2 to 6 hours of tracking from 20 well-distributed ground stations, even when reasonable allowances for uncertainties in the nongravitational forces on the satellite and in the low degree terms of the gravitational field are made. Although measurements of the GPS signals actually would be made nearly continuously at the ground stations, we have assumed in the simulations that measurements are made only infrequently in order to avoid unreasonably large reductions in the measurement errors due to averaging. For the 4 hour case (Larden and Bender, 1982b), a set of measurements was included every 30 minutes. This interval might correspond roughly to the time scale for changes in the errors of water vapor corrections obtained with water vapor radiometers.

As a preliminary case, we added single differences in range between TOPEX and a reference ground station for each GPS satellite visible to TOPEX at the middle of our 4 hour run. TOPEX was taken to be at 2° south latitude, 97° east longitude, and 1300 km altitude. Eleven GPS satellites could be observed with elevation angles of greater than -27°. The uncertainty in each single difference was assumed to be 1.4 cm. Clock offsets for TOPEX at its one observing time and for all but one of the 20 assumed ground stations at each measurement time were solved for. The results for the TOPEX coordinate uncertainties are given in Table 1. Most of the total uncertainty comes from the assumed 3 cm uncertainty in each coordinate for each of the ground stations.

Results of a somewhat different approach to simulating the TOPEX orbit determination problem using GPS signals have been reported recently by Ondrasik (1981, and personal communication, 1981). In particular, the TOPEX radial coordinate uncertainty was calculated based on one set of measurements per minute over only a 10 min observing period, with the uncertainties in the positions of three ground stations located at DSN (Deep Space Net) sites taken to be 10 cm in

Table 1

TOPEX COORDINATE UNCERTAINTIES

Spherical coordinate	Formal error (cm)	Total uncertainty (cm)
Latitude	1.0	3.1
Longitude	1.0	2.7
Radial position	1.3	3.0

each coordinate. The positions of up to ten additional ground stations at TRANET 2 sites were solved for, as well as the GPS satellite positions. The TOPEX orbit was determined, rather than just the instantaneous position. It is interesting that the TOPEX radial coordinate uncertainty increased by less than 80% for a particular 10 min arc involving only two DSN sites when the other nine ground stations for this case were left out. This result appears to indicate that a smaller number of GPS tracking stations than the 20 we have initially assumed may be sufficient when data are also available from an additional satellite which can see many of the GPS satellites.

SIDETONE RANGING SYSTEM APPROACH

Despite the encouraging results of simulations based on observing GPS signals with TOPEX, we believe that an additional accurate orbit determination method is needed, as discussed in the introduction. One fairly obvious approach would be to add an S-band or X-band sidetone ranging transponder to the TRANET 2 beacon on TOPEX, and range to it from a substantial number of ground stations. Some of these would be at existing or planned TRANET 2 stations. Others could be at fixed laser ranging or VLBI sites used in crustal dynamics measurements, but some additional stations in particularly desirable sites probably would be needed.

An example of the type of sidetone ranging system which might be used is shown in Figure 1. It is derived from standard USB transponders, with the input frequencies ν_1 and ν_2 received from the ground being roughly 2100 and 2030 MHz respectively. Transponder #1 would be essentially unmodified. It operates by taking the output from a voltage controlled oscillator (VCO), multiplying it by a fixed ratio of integers (M_1/N_1) to obtain the same frequency as ν_1 , and then phase locking the VCO with a phase sensitive detector so that the two inputs to the phase sensitive detector maintain a fixed phase relationship. The output from the locked VSO is then multiplied by another ratio of integers (M_2/N_2) and sent to a transmitter for rebroadcast to the ground. The integer ratios are chosen so that the output frequency ν_3 of about 2280 MHz is just (240/221) times ν_1 .

For transponder #2, the modifications are more substantial. The VCO in it is locked so that (M_1/N_1) times its frequency is phase locked to the received frequency ν_2 of about 2030 MHz. However, a third VCO is added. Its frequency is multiplied by (M_2/N_2) and sent through the transmitter in transponder #2 to the ground. The frequency of the third VCO is chosen so that the transmitted frequency ν_4 is about 2210 MHz. Some of the signals at frequencies ν_1 and ν_2 going to the phase sensitive detectors in the two transponders are taken out and mixed to give a roughly 70 MHz reference signal, and a similar 70 MHz beat frequency is generated by mixing ν_3 and ν_4 . An additional phase sensitive detector operating at 70 MHz is then used to adjust the third VCO so that the two 70 MHz signals have a fixed phase relationship. To the extent that phase delays within the system remain constant, the phase difference between the two output frequencies ν_3 and ν_4 will be fixed with respect to the phase difference between the received frequencies ν_1 and ν_2 .

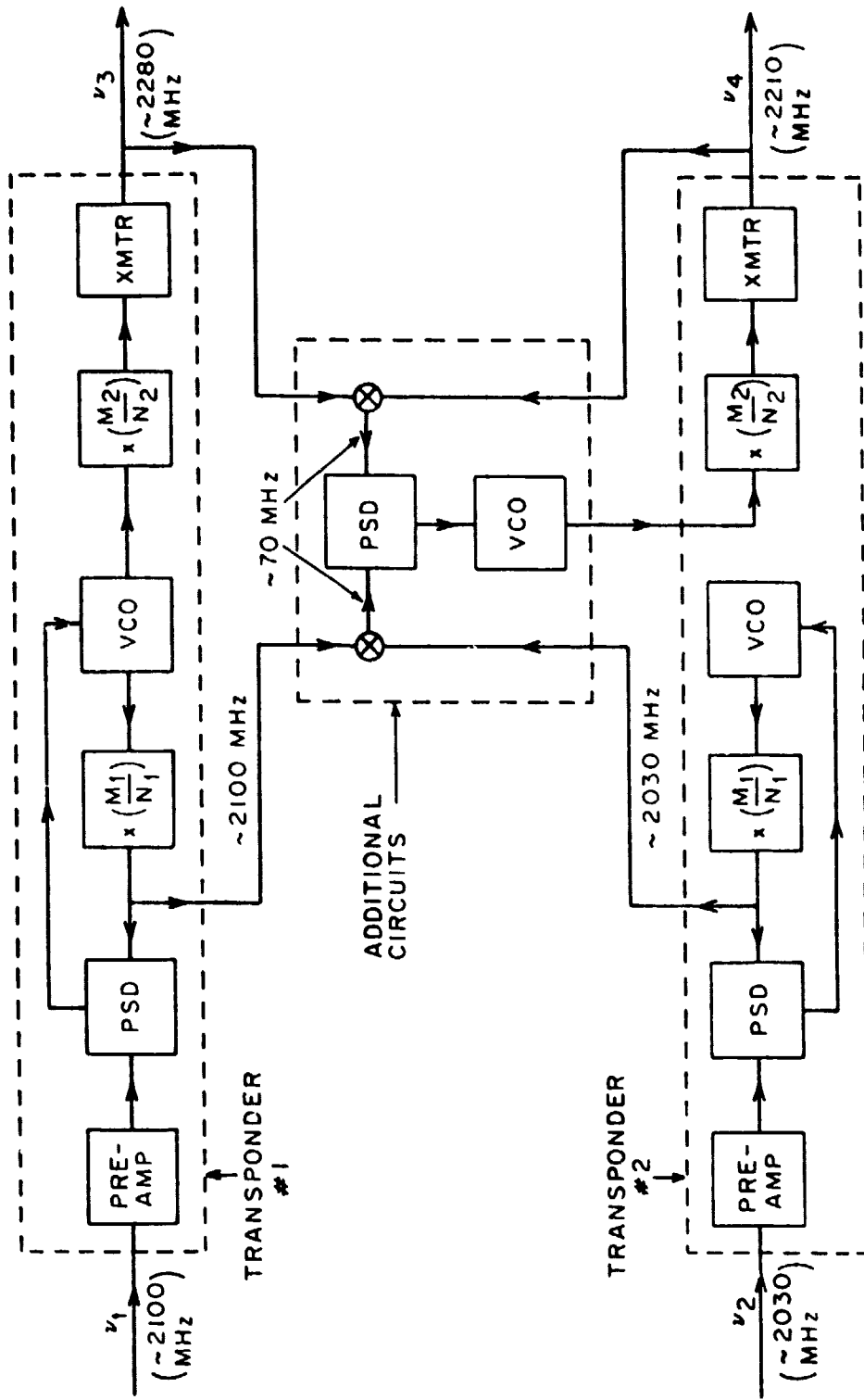

Figure 1. Sidetone Ranging System. PSD = phase sensitive detector; VCO = voltage-controlled oscillator; XMTR = transmitter.

One reason for discussing the example of a possible sidetone ranging system derived from USB transponders is that there is a substantial amount of information on the phase stability of such transponders. In particular, a USB transponder was used in Gravity Probe A, which was a test of the gravitational frequency shift for a hydrogen maser flown in a rocket to an altitude of about 10,000 km (Vessot and Levine, 1979; Vessot et al., 1980). The frequency of the hydrogen maser as a function of time during the flight was compared with that of a second hydrogen maser on the ground using a three-frequency S-band system. It appears from analysis of the results, reversing the original point of view and assuming general relativity is correct, that the time delay stability of the USB transponder used for one uplink and one downlink frequency was 10 picosec per day (Allan et al., 1982). In addition, thermal tests carried out at the Marshall Space Flight Center on two similar transponders indicated a phase shift at S-band with temperature of only 13° per Kelvin. Also, if the temperature coefficient of the initial preamplifiers and phase sensitive detectors for the two parts of the sidetone ranging system were similar, the temperature coefficient for the phase shift of the 70 MHz beat between ν_3 and ν_4 with respect to that between ν_1 and ν_2 should be quite small.

In the example discussed, the range from the ground station to the satellite would be measured in terms of the wavelength for the 70 MHz beat between the two S-band frequencies used. This means that the ambiguity length for the one-way distance would be 2.1 meters, and the ambiguity could be resolved from the TRANET 2 tracking data. It appears likely that the combination of TRANET 2 information on the ionospheric delays from the same ground stations with S-band ranges would be sufficient to accurately determine the ionospheric correction. However, careful studies of this question would be needed before deciding between S-band and X-band for the sidetone ranging system. If an X-band system is not necessary, the S-band phase could be used to improve the precision of the range measurements, with the ambiguity resolved by the 70 MHz beat frequency.

The additional equipment needed at a ground station to make sidetone range measurements has not yet been investigated. However, semi-automatic operation seems quite possible. A water vapor radiometer looking along the line of sight to the satellite will be needed in any case to achieve high accuracy. This requirement appears to preclude operation at unmanned sites because of maintenance requirements. Thus the number of ground stations needed is an important question, which should be studied carefully.

CONCLUSIONS

Both the GPS approach and the use of a sidetone ranging system along with TRANET 2 data appear to be attractive possibilities for tracking TOPEX and other satellites for which accurate orbits are required. Because of present uncertainties concerning possible modifications of the GPS signals and the completion date for the system, as well as to provide redundancy, we believe that the inclusion of a sidetone ranging system on TOPEX and the development of prototype ground station equipment should be pursued. Studies of the number and distribution of ground stations required with the sidetone ranging system also are needed. It would be particularly desirable if most of them

could be at TRANSIT 2 sites or at any additional sites needed for GPS satellite orbit determination.

ACKNOWLEDGMENTS

We wish to thank R. F. C. Vessot of the Smithsonian Astrophysical Observatory for valuable conversations concerning Gravity Probe A. Information from V. J. Ondrasik and S. C. Wu on the Jet Propulsion Laboratory simulations of the TOPEX orbit determination problem using GPS signals also is appreciated. This work was partially supported under NASA order No. W-15, 068.

REFERENCES

- Allan, D. W., C. O. Alley, N. Ashby, R. Decher, R. F. C. Vessot, and G. M. R. Winkler, Ultra-accurate international time and frequency comparison via an orbiting hydrogen-maser clock, in Proc. Third Int. Symposium on Frequency Standards and Metrology, 5-7 October, 1981, Aussois, France (C. Audoin, ed., Editions de Physique, Orsay, France, 1982).
- Larden, D. R., and P. L. Bender, Achievable accuracy of GPS orbit determination from worldwide tracking data, Trans. Amer. Geophys. Union 62, 840 (1981).
- Larden, D. R., and P. L. Bender, Predicted future GPS orbit determination accuracy, in Abstracts, Fourth Annual Conference on the NASA Geodynamics Program, Greenbelt, MD, January 26-29, 1982, p. 33 (1982a).
- Larden, D. R., and P. L. Bender, Preliminary study of GPS orbit determination accuracy achievable from worldwide tracking data, in Proc. Third Int. Geodetic Symposium on Satellite Doppler Positioning, Las Cruces, NM, February 8-12, 1982 (1982b).
- Ondrasik, J., Nearly instantaneous subdecimeter orbit and station location determinations using receive only radiometric data and low precision clocks, Postdeadline paper, Fall Meeting, Amer. Geophys. Union, December 7 (1981); abstract published in Trans. Amer. Geophys. Union 63, 156 (1982).
- Vessot, R. F. C., and M. W. Levine, A test of the equivalence principle using a space-borne clock, General Relativity and Gravitation 10, 181-204 (1979).
- Vessot, R. F. C., M. W. Levine, E. M. Mattison, E. L. Blomberg, T. E. Hoffman, G. V. Nystrom, B. F. Farrell, R. Decker, P. B. Eby, C. R. Baugher, J. W. Watts, D. L. Teuber, and F. D. Wills, Test of relativistic gravitation with a space-borne hydrogen maser, Phys. Rev. Lett. 45, 2081-2084 (1980).