

THE EVOLUTION OF A KU-BAND SATELLITE NETWORK

prepared by the
Public Service Satellite Consortium

for the
National Aeronautics & Space Administration

NASW-4220
3492

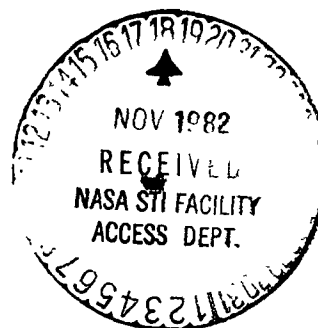

CORPORATE HEADQUARTERS
1660 L Street, N W Suite 907
Washington D C 20036 • (202) 331-1154
ITT TELEX 4991315

TECHNICAL CENTER
2480 West 26th Avenue
Denver, Colorado 80211 • (303) 458-7273
TWX (PSSCTG DVR) 910 931-2686

November, 1982

1. Report No.	2. Government Accession No.	3. Recipient's Catalog No.	
4. Title and Subtitle THE EVOLUTION OF A KU-BAND SATELLITE NETWORK		5. Report Date November, 1982	6. Performing Organization Code
7. Author(s) Louis A. Bransford, Mary Diebler, Stephen C. Dutka and Daniel W. Gorton		8. Performing Organization Report No. NA	10. Work Unit No.
9. Performing Organization Name and Address Public Service Satellite Consortium 1660 L Street, N.W., Suite 907 Washington, D.C. 20036		11. Contract or Grant No. NASW-4220	13. Type of Report and Period Covered Final May 1981-October 1982
12. Sponsoring Agency Name and Address Office of Space and Terrestrial Applications NASA Headquarters Washington, D.C. 20546		14. Sponsoring Agency Code EC-4	
15. Supplementary Notes			
16. Abstract The purpose of this study was to undertake the management and deployment of previously acquired CTS terminals, procure time on appropriate Ku-Band satellites, develop a community of public service users who have readily addressable needs and resources to pay for services on an ad hoc Ku-Band network, and manage a test network for selected users.			
17. Key Words (Suggested by Author(s)) CTS Denver Satellite Access Facility Ku-Band Public service satellite networks Telecommunications planning		18. Distribution Statement Unlimited	
19. Security Class. (of this report) Unclassified	20. Security Class. (of this page) Unclassified	21. No. of Pages 87	22. Price NA

THE EVOLUTION OF A KU-BAND SATELLITE NETWORK

prepared by the
Public Service Satellite Consortium

for the
National Aeronautics & Space Administration

NASW-4220



CORPORATE HEADQUARTERS

1660 L Street, N W . Suite 907
Washington, D C 20036 • (202) 331-1154
ITT TELEX 4991315

TECHNICAL CENTER

2480 West 26th Avenue
Denver, Colorado 80211 • (303) 458-7273
TWX (PSSCTG DVR) 910 931-2686

November, 1982

TABLE OF CONTENTS

Introduction.....	1
Purpose of Study.....	1
Scope of Work: Preparatory Phase.....	2
Scope of Work: Demonstration Phase.....	2
Methodology of Study.....	3
Summary of Individual Task Results.....	3
Task 2.1.1: Determine Available Satellites And Transponders That Operate At Ku-Band.....	4
Task 2.1.2: Determine What Modifications Are Necessary To Make The Denver Satellite Access Facility (DSAF) Operational At Ku-Band.....	16
Task 2.1.3: Determine Ku-Band Capabilities And Limitations Of PSSC's Transportable Earth Station (TES).....	25
Task 2.1.4: Determine What Modifications Are Necessary To Make The CTS Terminals Operational With Existing Ku-Band Satellites.....	29
Task 2.1.5: Determine Which Existing U.S. Networks For Public Service Could Be Served By Existing Canadian Suppliers Of Public Service Programming.....	35
Task 2.1.6: Determine Which PSSC Members, Former CTS Users And Other Public Service Users Could Be Benefitted And Could Be Ready To Test Ku-Band Technology.....	39
Task 2.1.7: Assist Ready Users, If Required, In Gaining Additional Resources To Use A Ku-Band Network.....	44
Task 2.2.1: Arrange For Uplinking of Required Programming And Software For Participating User Organizations.....	47
Task 2.2.2: Supervise And Manage All Other Supplemental Technical System Components.....	47
Task 2.2.3: Handle All Billings Associated With The Network.....	47
Task 2.2.4: Conduct Technical Evaluations Of The Complete Ku-Band System.....	53
Task 2.2.5: Conduct Management Evaluations Of The Efficacy Of The Network In Relation To Costs, Operational Requirements, Software And User Acceptance.....	68
Summary Statements.....	69
Appendix 1: Ku-Band Propagation Impairments By Rain Attenuation On Earth/Space Links.....	72

THE EVOLUTION OF A KU-BAND-SATELLITE NETWORK

Technology transfer and commitment to public service has been evident from NASA's inception. In particular, the Applications Technology Satellites (ATS) and Communications Technology Satellite (CTS) experiments best illustrate NASA's continued interest in redirecting the \$50 billion plus investment in space technology back to earth.

The early demise of both ATS-6 and CTS, however, left an unfilled void in public service use of satellite telecommunications. The hypothesis that commercial satellite services would accommodate the public service was postulated when NASA opted to curtail user experimental satellite activity in the mid-1970's. Commercial C-Band utilization has been well established. Ku-Band applications, on the otherhand, have yet to be proven in the public sector. Additional study was suggested in 1981 to re-examine public service interest in Ku-Band.

Two Ku-Band satellites, SBS and ANIK B, launched in 1981 and 1982, afforded an opportunity to validate Ku-Band utilization in the public sector. Existing and supposedly available (some never used) Ku-Band equipment from the CTS experiment added another dimension to the proposed study.

Essentially, user needs and interest, existing Ku-Band CTS earth stations, expected Ku-Band satellite capacity on SBS, ANIK, G-SAT and SPACENET, in consort with NASA's commitment to public service, motivated this study.

Purpose of Study

The purpose of this NASA-funded study was to undertake the management and deployment of previously acquired CTS terminals, procure time on appropriate Ku-Band satellites, develop a community of public service users who have readily addressable needs and resources to pay for services on an ad hoc Ku-Band network, and manage a test network for selected users.

This study was conducted in two phases: preparatory and demonstration. The preparatory phase was a determination of

available Ku-Band satellite services and the associated costs to develop and manage the proposed public service satellite network. Installation of government earth terminals and acquisition and relocation of other Ku-Band equipment deemed usable would be accomplished in this time period.

In the demonstration phase, actual network services were to be initiated. PSSC would arrange, coordinate, manage and evaluate all aspects of the network, if such a network were deemed feasible.

Scope of Work: Preparatory Phase

The intent of the preparatory phase was to determine the availability of Ku-Band satellite services and the economic feasibility of establishing a compatible network. Seven tasks were undertaken to accomplish this phase:

2.1.1: Determine available satellites and transponders that operate at Ku-Band

2.1.2: Determine what modifications are necessary to make the the Denver Satellite Access Facility (DSAF) operational at Ku-Band

2.1.3: Determine Ku-Band capabilities and limitations of PSSC's Transportable Earth Station (TES)

2.1.4: Determine what modifications are necessary to make the CTS earth stations operational with existing Ku-Band satellites

2.1.5: Determine which existing U.S. networks for public service could be served by existing Canadian suppliers of public service programming

2.1.6: Determine which PSSC members, former CTS users and other public service users could be benefitted and could be ready to test Ku-Band technology

2.1.7: Assist ready users, if required, in gaining additional resources to use a Ku-Band network

Scope of Work: Demonstration Phase

The intent of the demonstration phase was to assist public service organizations in using the Ku-Band network

for their own satellite applications and to technically evaluate the performance of the Ku-Band network components. Six tasks were to be undertaken to accomplish this phase:

2.2.1: Arrange for uplinking of required programming and software for participating user organizations

2.2.2: Supervise and manage all other supplemental technical system components

2.2.3: Handle all billings associated with the network

2.2.4: Conduct technical evaluations of the complete Ku-Band system

2.2.5: Conduct management evaluations of the efficacy of the network in relation to costs, operational requirements, software and user acceptance

2.2.6: Prepare and distribute appropriate reports

Methodology of Study

The methods of information collection and analysis used in this study were straightforward. Public service organizations and members of the Ku-Band satellite industry were directly contacted through telephone interviews, site visits and written communications in fulfillment of study tasks. From this data, PSSC staff were able to extrapolate to the future and analyze probable outcomes regarding network use and users. In addition, PSSC engineering staff technically tested and evaluated Ku-Band ground hardware through formal experimental interface with Ku-Band satellites. Finally, PSSC designed a hypothetical network management plan complete with procedural models to guide operation of subsequent public service satellite networks.

Summary of Individual Task Results

The following section reports the findings and observations for each of the preparatory and demonstration phase tasks listed in the scope of work.

TASK 2.1.1: DETERMINE AVAILABLE SATELLITES AND TRANSPONDERS THAT OPERATE AT KU-BAND

PSSC established contact with the Canadian Department of Communications, Telesat Canada and Satellite Business Systems concerning the technical parameters and transponder availability of ANIK B, ANIK C and SBS I and II respectively in response to task 2.1.1. In addition, a review of the technical characteristics of proposed Ku-Band satellites was conducted in conjunction with this study. A technical abstract of each operating and proposed Ku-Band satellite system follows.

Our investigations revealed a lack of standardization in the utilization of the Ku-Band among the carriers. Differing factors included the sub-division of the band, channel spacing between transponders and service area coverage.

Transponder usage varies as well. Some Ku-Band spacecraft will carry one video signal on one transponder (as is common in C-Band), while others will carry two simultaneous video signals allowing duplex transmission. Future spacecraft may handle numerous video signals in a single transponder; however, the channel bandwidth of that transponder will be greater.

Selected characteristics of operating and proposed Ku-Band satellites are presented below:

<u>KU-BAND</u>	<u>FOOTPRINT</u>	<u>CONTOURS</u>	<u>CHANNEL</u>	<u>USABLE</u>
<u>SATELLITE</u>	<u>MAX. EIRP</u>	<u>MIN. EIRP</u>	<u>SPACING</u>	<u>BANDWIDTH</u>
SBS	43.7 dBW	37 dBW	49 MHz	43 MHz
GSTAR	48	44	61	54
ADV. WESTAR*	48/52	40/49	275	225
ANIK B**	51	48	80	72
ANIK C	-	47	-	54
SPACENET	-	48	80	72

Notes:

- *. 48 dBW is the regional coverage footprint.
52 dBW is the spot-beam (local coverage) footprint.
- ** . These are ANIK B values along the Canadian border over four beams.

There is a trade-off between the published footprint power and the number of independent video signals that may be passed through a single transponder. The published footprint power of a given satellite represents the maximum, or saturated, power output of an individual transponder. When a transponder is used by a single signal, that signal may utilize the saturated power output. When more than one signal shares a single transponder, the saturated power cannot be devoted to any one signal. The signals must share the power, and, as a result, the published EIRP footprint power will be higher than the actual power given to an individual signal. Constraints on inter-signal interference impose this reduction of power to prevent serious mutual distortions between signals. The transponder is then said to be "backed off" by a number of dB; that is, backed down from the saturated output levels.

SATELLITE BUSINESS SYSTEMS (SBS)

SBS currently has two operational Ku-Band satellites in use: SBS I and SBS II. SBS III will be the first U.S. communications satellite launched from the space shuttle in late 1982. SBS IV will follow with a 1983 launch. Each SBS satellite has ten transponders. The primary thrust of SBS satellite services has been digital. However, demonstrations of the video capacity of the SBS satellites were conducted in the summer of 1981. As a result, SBS has been actively marketing its transponders to video users but with limited success.

SBS coverage is divided into six regions with the eastern U.S. being the primary focus. The footprint of the SBS spacecraft (illustrated below in Figure 1) may be used directly (no back-off) for video.

FIGURE 1

EIRP AND G/T: WEIGHTED COVERAGE OF CONUS

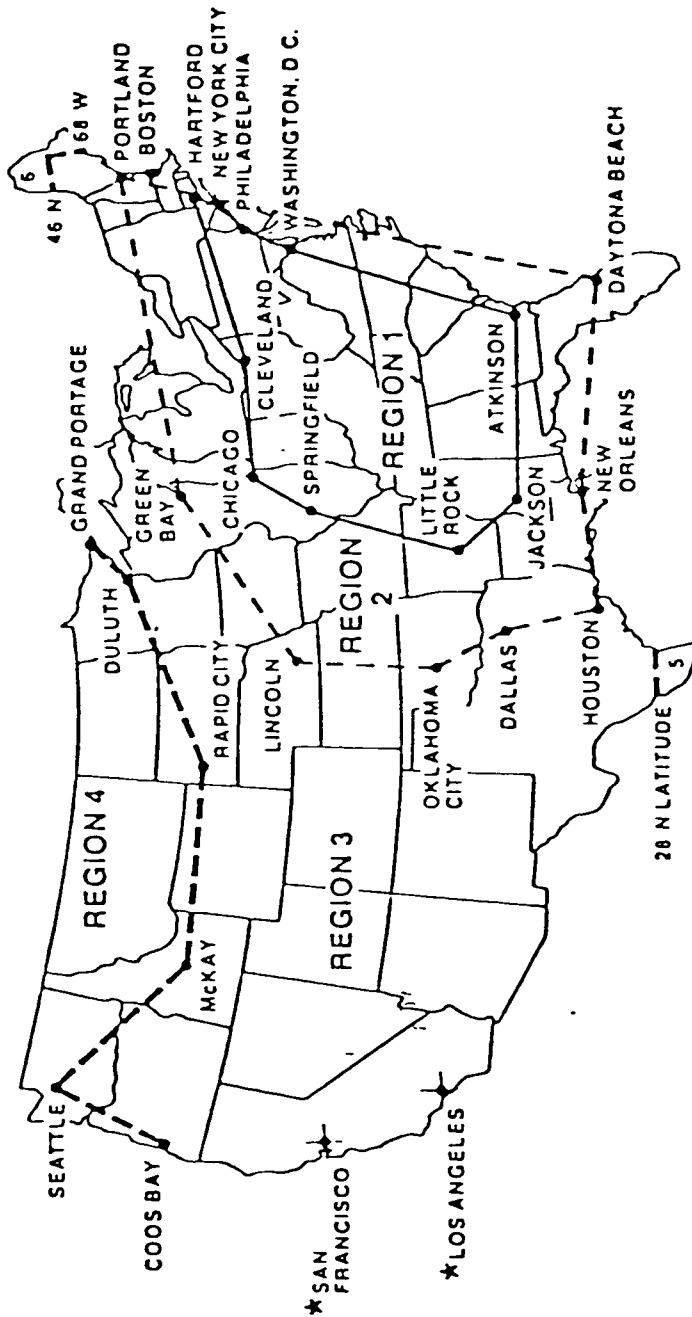

*Comparable to Region 2

	REGIONS					
	1	2	3	4	5	6
EIRP (dBW)	43.7	42.7	40	37	38	39
G/T (dB/K)	2	0	-2.5	-5.5	-4.5	-5.5

Low power transmission and footprint geographical variation were major obstacles to the use of SBS satellites with CTS terminals.

GENERAL TELEPHONE AND ELECTRONICS (GTE)

GTE Satellite Corporation (G-SAT) is preparing G-STAR I and II for 1984 launches. Each satellite will have sixteen transponders. The wider transponder bandwidth may be utilized to handle two video signals simultaneously (constituting back-off).

G-STAR coverage (shown below in Figure 2) indicates more uniform coverage of the continental U.S. (CONUS).

WESTERN UNION (WU)

The Advanced WESTAR spacecraft, scheduled for a 1983 launch, is planned to be a hybrid satellite operating at S, C, and Ku-Bands with shared use by NASA. Very wide (225 MHz) bandwidths will be used enabling Advanced WESTAR to handle 33 video signals simultaneously on one transponder. Six Ku-Band transponders will be available on the satellite.

As illustrated in Figure 3, three beams cover the CONUS. Each has two wideband transponders. The weakest signal appears to lie over El Paso, Texas. Polarization and frequency differs between beams. The spot beams on east and west coasts are circularly polarized (the radio signal rotates). Thus, polarization and frequency must be considered when using this footprint. It has been suggested that the surplus C-Band capacity on the TDRSS at 171 degrees West be utilized to serve the Pacific Basin.

TELESAT CANADA

Telesat Canada has primary responsibility for the ANIK series of Canadian domestic communications satellites. The ANIK A, B, and D series are currently operational, while ANIK C awaits a late 1982 launch. ANIK B and C have Ku-Band capacity.

RELATIVE ELEVATION ANGLE AS VIEWED FROM THE SATELLITE

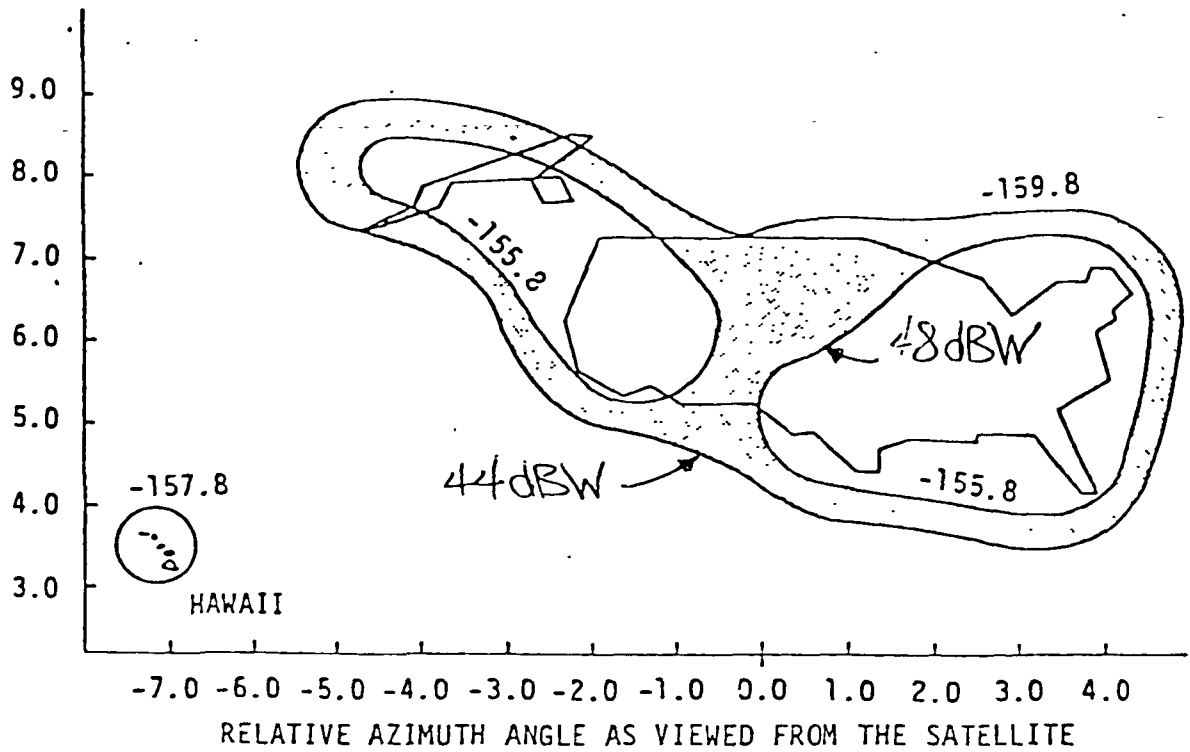

NOTE: FLUX DENSITY VALUES ARE EXPRESSED IN $\text{dBw/m}^2/4\text{kHz}$

MAXIMUM SURFACE FLUX DENSITY CONTOURS FOR COMBINED CONUS AND OFFSHORE COVERAGE FOR A SATELLITE AT 100° OR 103° WEST LONGITUDE

RELATIVE ELEVATION ANGLE AS VIEWED FROM THE SATELLITE

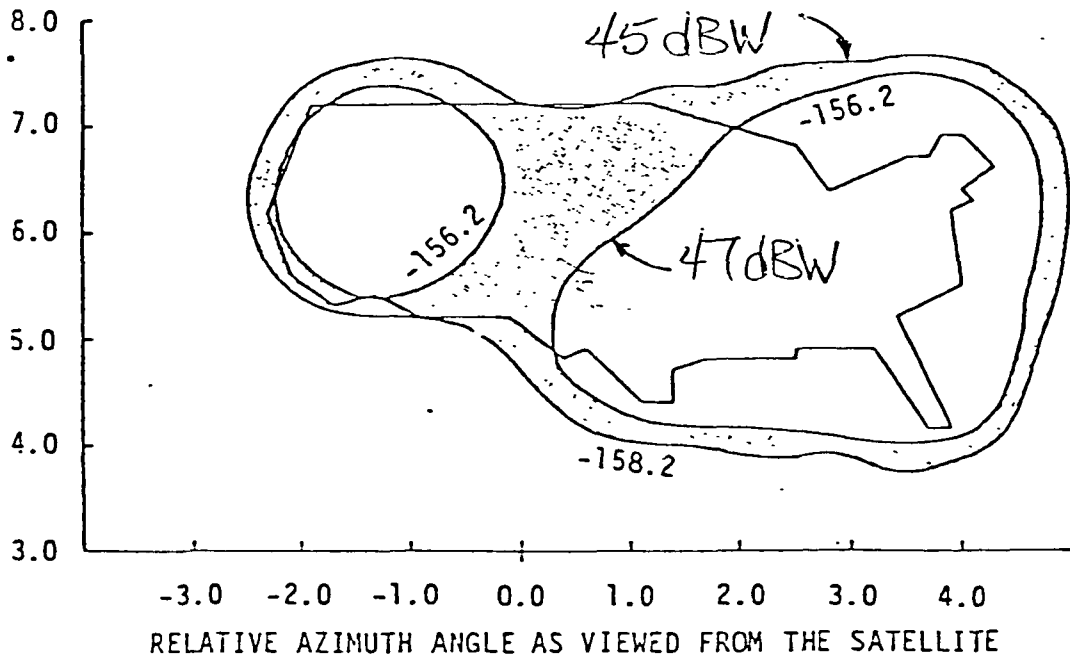

NOTE: FLUX DENSITY VALUES ARE EXPRESSED IN $\text{dBw/m}^2/4\text{kHz}$

MAXIMUM SURFACE FLUX DENSITY CONTOURS FOR CONUS COVERAGE FOR A SATELLITE AT 100° OR 103° WEST LONGITUDE

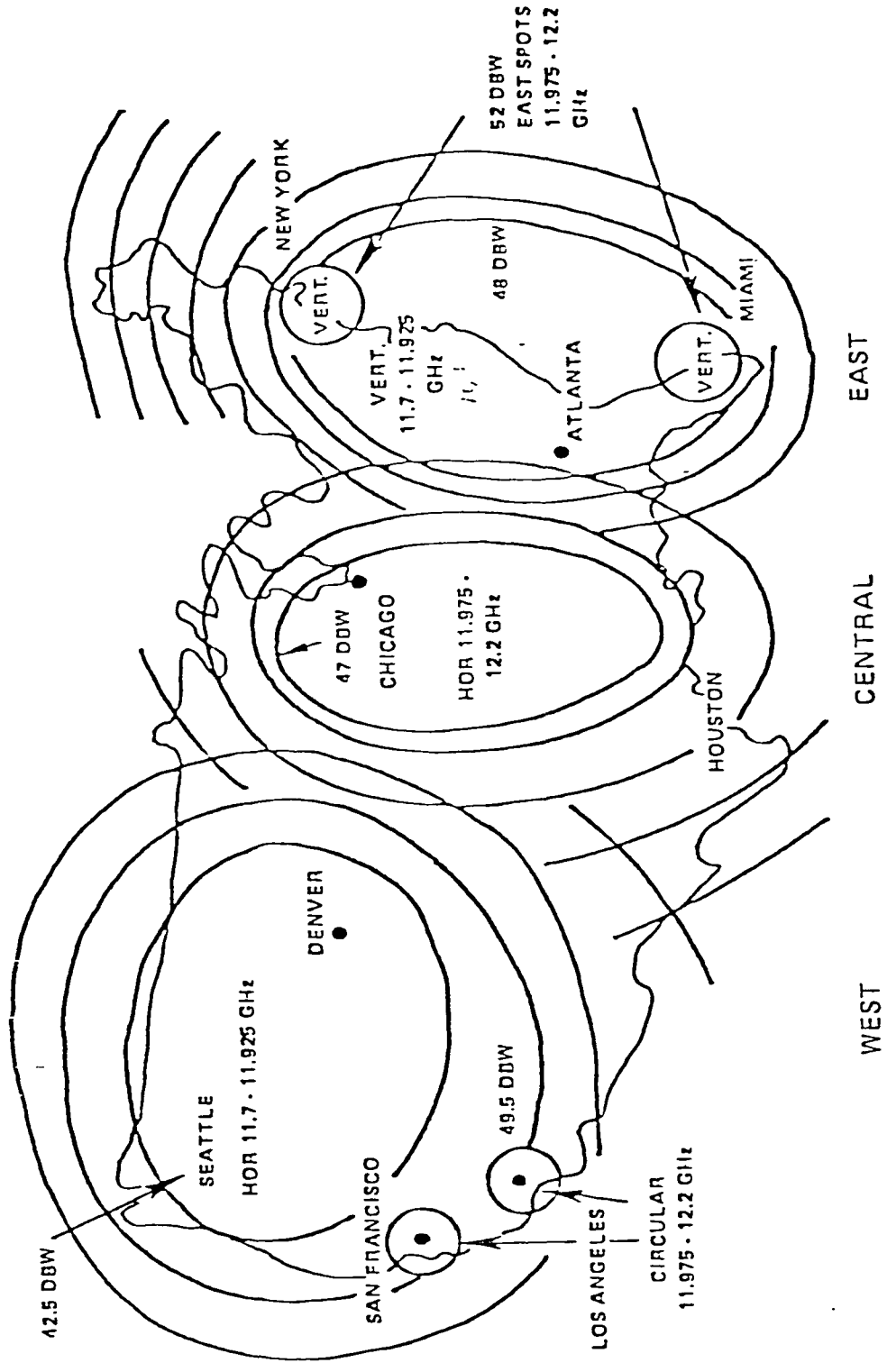

ADVANCED WESTAR KU-BAND COVERAGE
WITH SATELLITE AT 99° WEST LONGITUDE

ANIK B

ANIK B is a hybrid satellite with twelve C-Band transponders and six Ku-Band transponders. The Canadian Department of Communications is the major user of ANIK B. The DOC, from recent conversations, has indicated that they normally carry two video signals per transponder. Accordingly, the "back-off" must be taken into account so that the EIRP is adjusted downward by about 5 dB for use with Canadian earth stations.

The ANIK B spacecraft covers Canada in four beams with only one transponder available per beam. (See Figure 4 below.) The footprints of ANIK B do not extend deeply into the U.S. before losing significant strength. Coupled with unsettled regulatory constraints, this limited U.S. coverage is the most fundamental obstacle for using ANIK B for U.S. domestic services. If a single video signal were to be occasionally carried by an ANIK B transponder, the technical potential exists for limited video transmission to northern U.S. regions.

ANIK C

ANIK C will have sixteen transponders, all in Ku-Band. ANIK C has supposedly been designed with beam-tilt agility. The beams may be steered over a limited North-South range to cover the upper region of CONUS. ANIK C is similar to ANIK B, but has less usable bandwidth available per transponder. ANIK C coverage is shown in Figure 5 below.

Telesat Canada's marketing of ANIK C emphasizes its "two-video" transponder capability. Thus, as with ANIK B, there is limited CONUS potential using ANIK C. There are two exceptions: (1) a transponder carries one video signal; and (2) the beam(s) are tilted into the U.S. Nevertheless, ANIK C transponders are being sold to U.S. users, including GTE.

Anik B Antenna Patterns

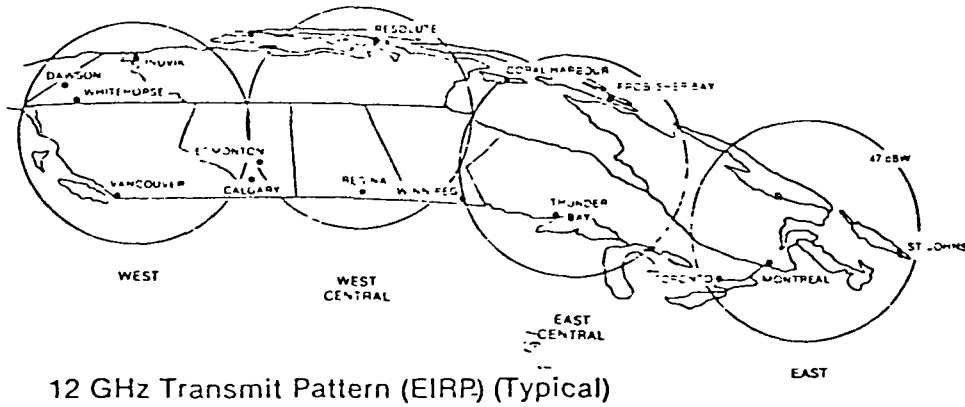
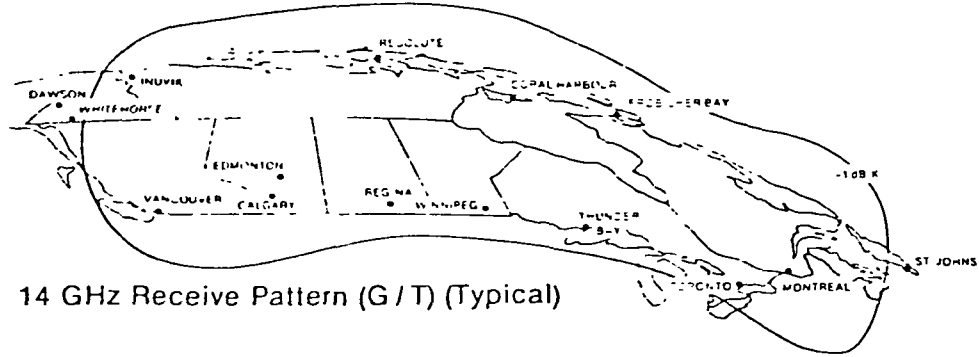

Anik C 12 GHz Transmit Pattern (EIRP) (Typical)

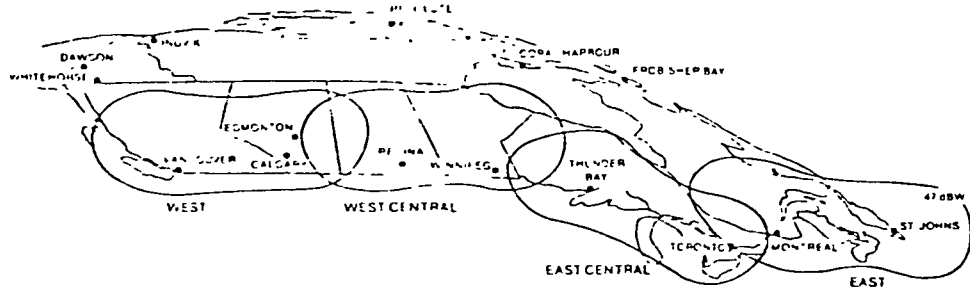

Anik C 14/12 GHz Communications Subsystem

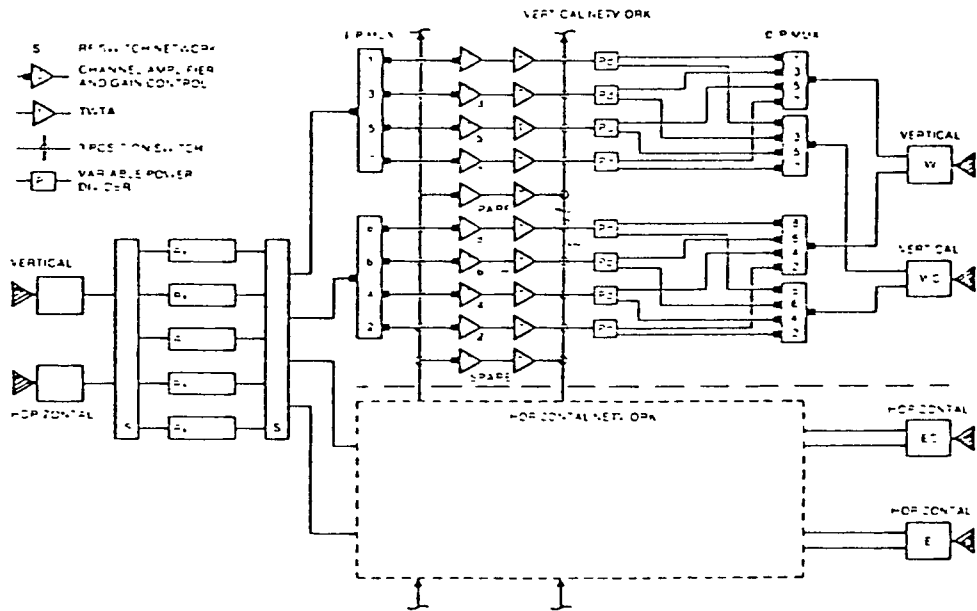

SOUTHERN PACIFIC COMMUNICATIONS CORPORATION (SPCC)

Scheduled for 1984 launches, SPCC's three SPACENET twenty-four transponder hybrid satellites will have at least 6 transponders available in the Ku-Band. SPCC indicates the possibility of SPACENET 72 MHz transponders carrying two video signals each. Ku-Band transponders are to be interconnected thus:

- o East beam up to West beam down
- o West beam up to East beam down
- o East beam up to East beam down
- o West beam up to West beam down

Ku-Band activity will be concentrated on the Northeastern and Southwestern, dense-population regions of the U.S.

Another factor to be watched and weighed is the recent acquisition of SPCC and SP Satellite Corporation by GTE. SPACENET footprints are given below in Figure 6.

Technical characteristics and parameters of all operational and proposed Ku-Band satellite systems must be evaluated thoroughly before any selections could be made for a public service satellite network. On the surface, SBS and GTE characteristics seem to be within range of use with CTS terminals, but not limited thereto. It is noted that SBS, GTE and SPCC base "typical" video performance on clear sky conditions and antennas of 4.5 meters in diameter or larger.

To fulfill part two of this task, PSSC examined Ku-Band transponder availability on SBS and ANIK B satellites.

Transponders for U.S. public service transborder occasional use were not readily available on ANIK B. Section 2.1.4 details the parameters encountered in PSSC discussions with Telesat Canada and DOC.

PSSC also made numerous attempts to obtain SBS transponder time for a Ku-Band demonstration and test directly from SBS. While SBS has the transponder time, corporate policies and procedures inhibited their ability to lease time for occasional, "experimental" use. SBS is looking long and hard instead for regular users. In addition, SBS officials felt it would not be in their own

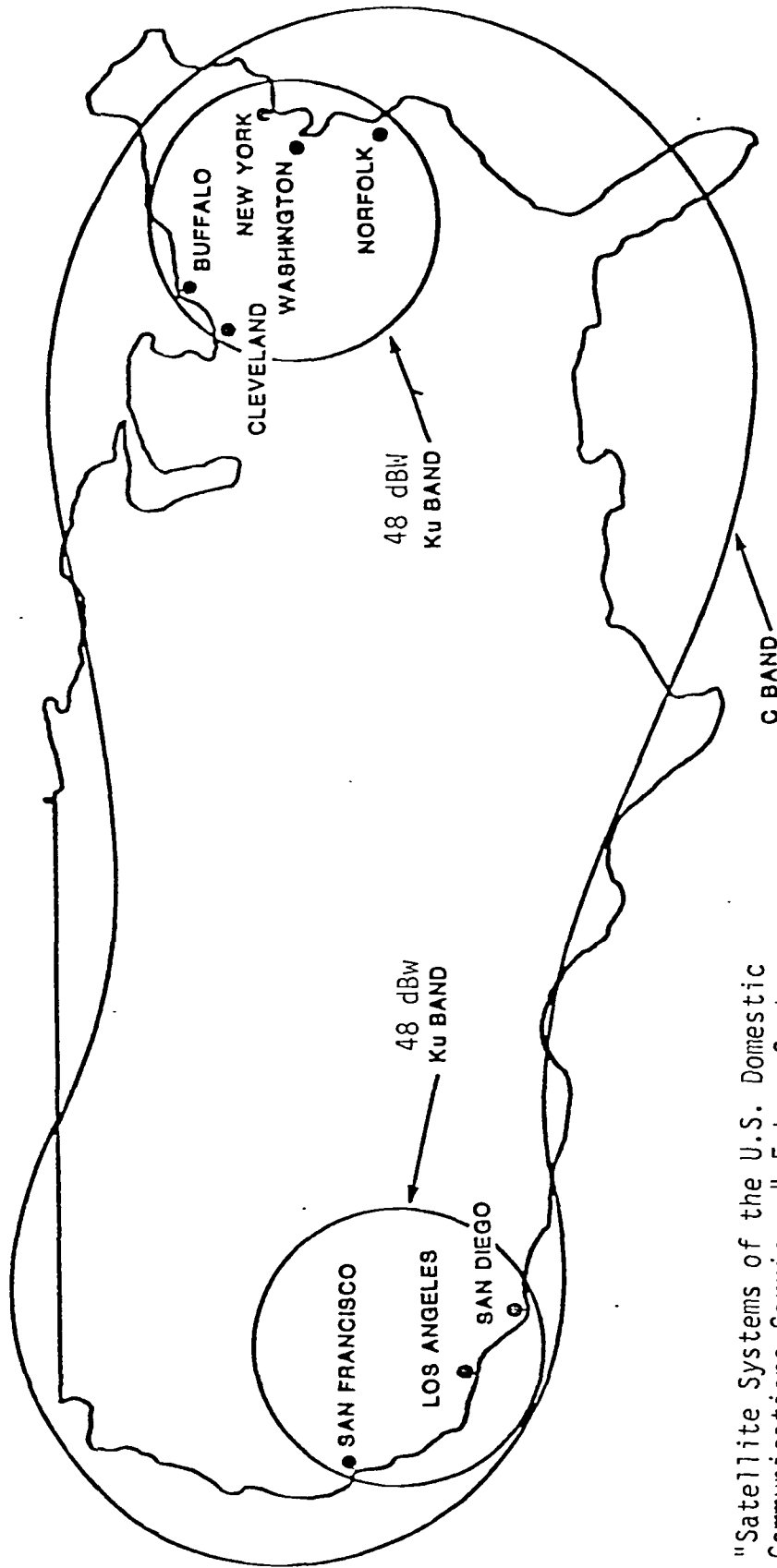

"Satellite Systems of the U.S. Domestic Communications Carriers," Future Systems Incorporated, FSI Report No. 109, July 1980.

ANTENNA COVERAGE PATTERN

Note: Coverage of Alaska and Hawaii is accomplished by means of coupled spot beams.

best interests to participate in a demonstration they believed would result in sub-standard quality video transmission.

Consequently, PSSC circumvented SBS through contact with SBS transponder lessees. G-SAT, who had acquired an SBS transponder last summer, offered free transponder time to PSSC, enabling a test of Ku-Band ground system equipment. The results of the tests, found in detail in Section 2.2.4, were not encouraging for this study.

What is evident today is that Ku-Band capacity will be readily available in 1984. In the interim, it is PSSC's opinion the two existing Ku-Band systems, SBS and ANIK B, due to their inherent design, cannot provide adequate Ku-Band satellite service to the public service sector.

TASK 2.1.2: DETERMINE WHAT MODIFICATIONS ARE NECESSARY TO MAKE THE DENVER SATELLITE ACCESS FACILITY (DSAF) OPERATIONAL AT KU-BAND

The Denver Satellite Access Facility was envisioned as the backbone uplink terminal for the proposed public service Ku-Band network. Additional capability to include basic environmental support factors, necessary radio equipment, radio frequency coordination and personnel to accommodate Ku-Band network requirements are discussed in this section.

The Denver Uplink Terminal (DUT) is the center of PSSC earth-space satellite transmission. It is also the terrestrial terminal for the Network Control Center (NCC) which is linked to DUT via terrestrial microwave radio. NCC and DUT comprise the Denver Satellite Access Facility (DSAF). However, for the purposes of this study, only DUT satellite facilities will be reviewed. No consideration is being afforded the terrestrial connections as the microwave link can support Ku-Band DUT capability as well as C-Band.

The existing environmental factors at DUT and possible Ku-Band implementations, temporary and permanent, were the primary focus of this study.

The DUT is a developed radio site currently operational on C-Band satellite links. The facility also includes a shelter for the equipment with moderate work space and limited human-need resources, such as a small food storage/preparation area, waste disposal and floor space for several cots. Heating and cooling benefits are shared between radio and personnel. The remaining floor space is occupied by equipment racks and spare module/miscellaneous equipment storage.

It has been suggested that the shelter (a permanently installed house trailer) be used to house the Ku-Band radios at the expense of some or all of the work bench area and/or at the cost of reduced access to the additional equipment. System integrity and functional arrangement are the primary reasons for installing the additional racks in the existing shelter as opposed to separate sheltering. Primary power

and air conditioning are assumed adequate to support operation of Ku-Band radios. It is further assumed that either simultaneous C- and Ku-Band uplinks will not occur or that adequate power and air conditioning are available to sustain a dual situation.

The shelter is located in close proximity to a sharp rise in the terrain to the south of DUT. The 11-meter C-Band antenna is positioned just southwest of the shelter, while a CTS 10-foot antenna exists just south of the shelter. The surrounding terrain is composed of foothills which provide natural RFI shielding for the antennas, particularly in the southern directions where interference is more likely to occur. Terrestrial microwave signals are greatly reduced in traversing the rugged terrain around DUT. Shelter proximity keeps line losses at a minimum. A parking area is to the north of the shelter and the fence line to the east. There is ample room to expand to the east.

PSSC proposes two options for DSAF Ku-Band expansion. The first option examines temporary alternatives, while the second details permanent steps.

OPTION A: TEMPORARY KU-BAND ARRANGEMENTS AT DSAF

One possible temporary arrangement to permit Ku-Band uplinking at DUT would be to install the radios in the existing shelter at the aforementioned loss in the work area.

The CTS antenna might also be used for Ku-Band transmission. However, two drawbacks are associated with its use: singular feed and gain.

The terminal's one-port feed permits only one polarization. Simultaneous transmit and receive functions on the same polarity are not typically practiced by SBS or GTE. This means that an uplink on vertical polarity is received on horizontal polarity in most instances and requires that the antenna be equipped with a dual-polarized (or two-port) feed. PSSC's Transportable Earth Station (TES) Ku-Band feed cannot be used with the CTS antenna because of mechanical and optical incompatibility.

Insufficient gain is the other potential problem. A

serious shortfall of power occurs if the 200-watt travelling wave tube amplifier (TWTA) from TES is used with the CTS antenna for uplinking. Currently available Ku-Band high power amplifiers (HPA) operate at about two kilowatts of RF rated power. This power used in conjunction with the CTS antenna would fall short of saturating a transponder on SBS or GTE spacecraft by nearly 1.3 dB under clear sky conditions. The TES TWTA will serve as driver for the HPA at a savings of approximately \$10,000.

The following compromise arrangement makes the best use of existing equipment. The CTS antenna, fitted with receive equipment, may function as a Ku-Band TVRO, (keeping in mind the constraints previously discussed of small aperture antennas on Ku-Band.) The reader is reminded that the CTS terminal will operate on one polarity. Concurrently, a NASA antenna with its one-port feed will be utilized as the transmitting antenna on the opposite polarity. The NASA antenna has a somewhat larger aperture than the CTS and, although a two kilowatt HPA is still required, an advantage of 1.6 dB toward saturation of the transponder is achieved. In fact, if the CTS antenna cannot be pointed, the receive dish could also be a NASA antenna.

There are no known interference-related limitations on antenna aperture for uplinking on Ku-Band under today's standards. Frequency coordination services can verify this through their interference studies and downlink coordination. It is important to note that the Ku uplink band is exclusive, while the downlink band is shared only with remote television pickup service operated predominantly by American Telephone and Telegraph. Thus, it will be necessary to perform downlink coordination only.

This "two-dish" solution is ostensibly temporary in nature. It obviously lacks in cosmetics, system integrity and design finality. The radiated power leaves no margin for weather-related propagation losses. The antennas are undersized. Yet, used as an experimental unit, it is a viable approach. Below are a series of illustrations of this proposed configuration.

CONFIGURATION - OPTION A - EXPERIMENTAL

I. RECEIVING

- A. Vitalink
- B. Hughes

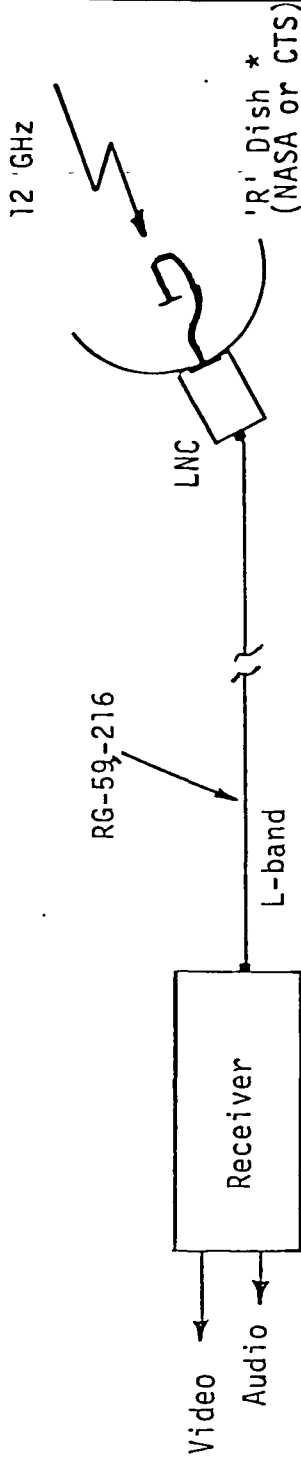

II. TRANSMITTING

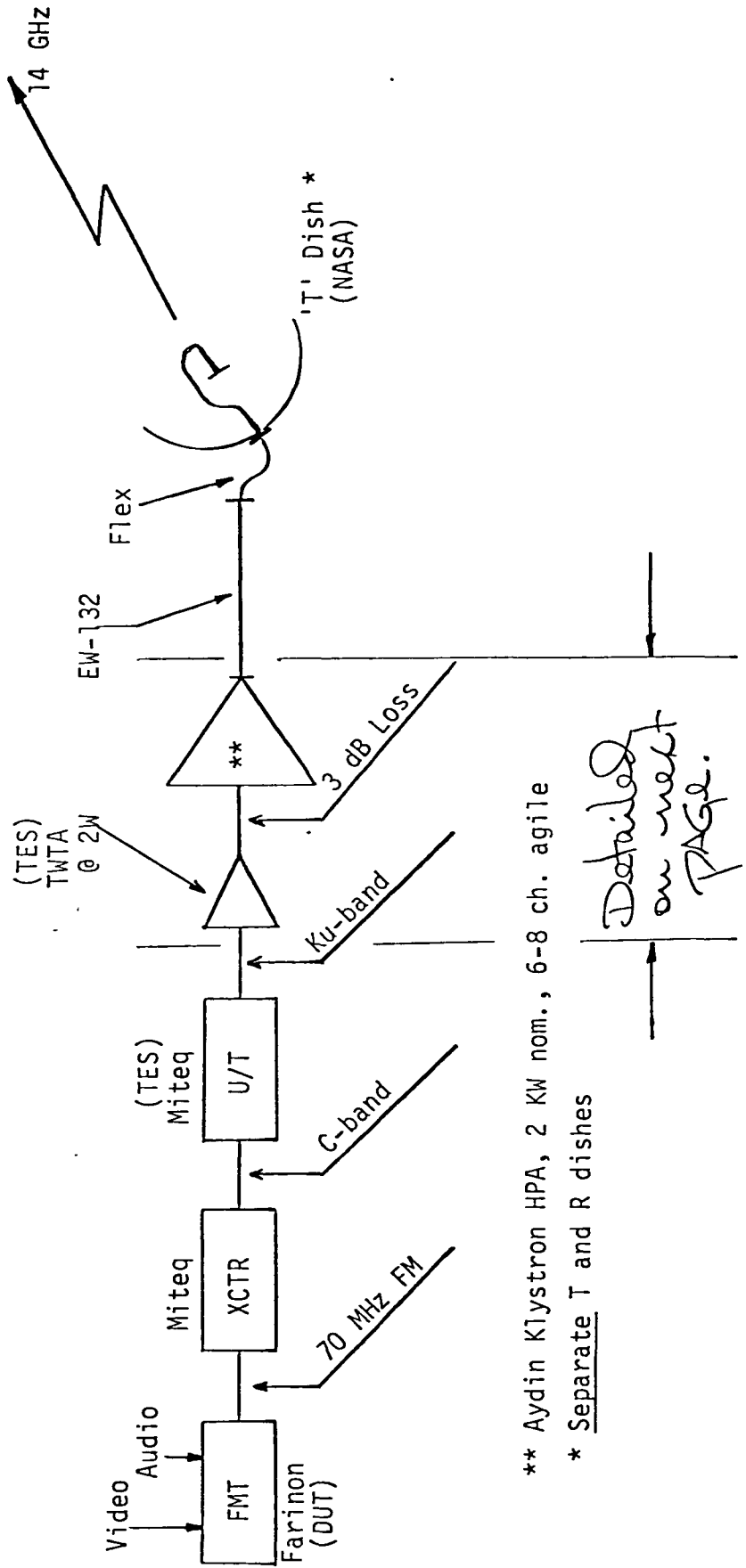

** Aydin Klystron HPA, 2 KW nom., 6-8 ch. agile

* Separate T and R dishes

Detailed on next PAGE.

2KW Ku HPA DRIVE ARRANGEMENT

Aydin
TWT Amplifier
200 watt, maximum
[20 dB back-off]

Aydin
Klystron HPA
Model 1042
2 kW, nom.

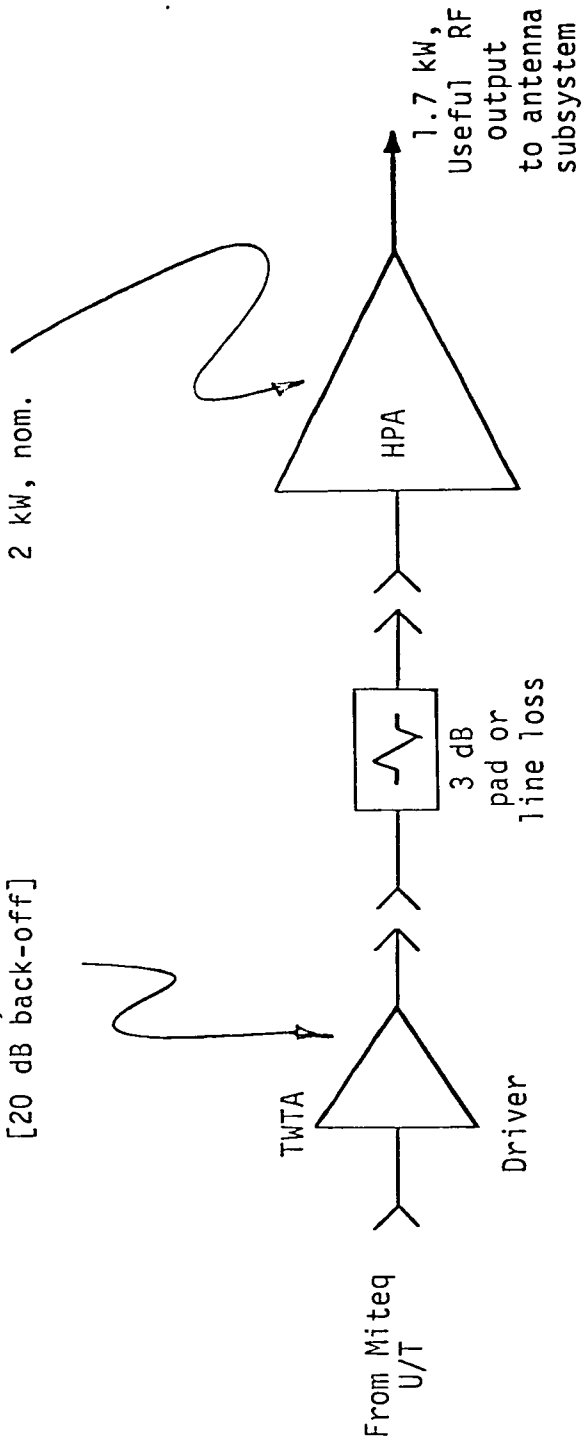

HPA Power Output = 32.2 dBW

Gain @ rated power = 32 dB

Required input = $\frac{0.2 \text{ dBW}}{[1-\text{watt}]}$

Determination of required transmitter power vs. antenna aperture at DUT.

1. Required Flux-density to Saturate	=	-82 dBW/m ²	
2. Volumetric Loss	=	163 dB/m ²	
3. Earth Station EIRP	=	<u>81 dBW</u>	
4. Antenna Gain	=	-G dBi	
5. Line Loss	=	3 dB	(1)
6. Transmitter power	=	<u><u>P dBW</u></u>	

Antenna	Diameter	G	P	
CTS	10'	50.4 dBi	2300 W	
NASA	12'	52.0	1584	
TES	16.4'	54.7	645	(2)

Allowing nominal transmitter power of 1.7 kW output, the CTS configuration is short of saturation by 1.3 dB.

(1) 40' of EW-132 @ 5 dB/100' + 1.0 dB total misc.

(2) TES' present configuration.

OPTION B: PERMANENT KU-BAND ARRANGEMENTS AT DSAF

A plan based on permanency and ample power for uplinks utilizes a 5-meter antenna or larger with a two kilowatt klystron HPA. This configuration would be capable of saturating an SBS or GTE transponder with some margin for weather.

This permanent option would have the antenna installed to the east of the existing shelter to keep line loss at a minimum. Additional permanency/efficiency considerations are to locate the Ku-Band radios as far to the east end of the shelter as possible to further reduce line losses. The existing feed used on TES may be used on this new antenna permanently.

It would be prudent to select an antenna under this option that meets or exceeds the FCC's proposed antenna radiation mask, so that the antenna may be used with spacecraft situated in two-degree orbital slot spacing. Under this configuration, it will be necessary to evaluate the current environmental support (space, power, air conditioning and cosmetics) to assign a value to its adequacy.

Andrew Corporation markets an 8-meter Ku-Band antenna, whose performance is said to adhere to two degree spacing as well as 10 dB cross-polarized discrimination over a significant range of angles off boresight. It is 85% efficient, exhibiting gains of 59.2 and 60.4 dBi on 12 and 14 GHz respectively. Using this antenna in close proximity of the transmitter (to minimize line losses not greater than 2 dB), the 200-watt TWTA from TES would provide ample power to saturate the transponder under clear sky conditions.

The value of such an investment depends on a thorough cost analysis including an evaluation of the market potential. Andrew informally has quoted a cost of \$125,000 for the basic antenna.

Pricing is broken down into three categories: Environment, Equipment and Personnel. The budget assumes Option A implementation. A series of notes details further assumptions.

COST SUMMARY

1. Environment	\$ 400
2. Equipment	87,966
3. Personnel	<u>2,880</u>
	\$91,246

ENVIRONMENT ANALYSIS LIST

<u>Item Description</u>	<u>Supplier</u>	<u>Cost</u>
1. Equipment Space	DUT	\$-0-
2. Primary Power	DUT	-0-
3. Heating/Air Conditioning	DUT	-0-
4. Fence	SCN	-0-
5. Frequency Coordination	Comsearch	<u>400</u>
	TOTAL	\$400

EQUIPMENT LIST

<u>Item Description</u>	<u>Supplier</u>	<u>Cost</u>
1. Ku-Band Receiver, 1 ea. (Rx and LNC no redundancy/spares) 4 audio demods	Vitalink	\$ 3,000
2. FMT, 70 MHz, equipped accept video/audio, including clamp,A/C PS	Farinon	4,238
3. Exciter, C-Band, agile in 0.125 MHz steps	Miteq	12,500
4. Up-translator, C-Band to Ku-Band (TES)	TES	-0-
5. Driver, 1-watt to HPA (TES TWTA) Ku-Band	TES	-0-
6. HPA, 2 kw rated, klystron 6, 8 channel agile Ku-Band	Aydin	65,000
7. Rack, 7', equipment, wired	Farinon	700

8.	Waveguide	Andrew	1,328
9.	Pressure window	M/A	700
10.	Cables, connectors, misc. hardware to include primary power wiring, outlets	various	500
		TOTAL	<u>\$87,966</u>

PERSONNEL LIST

<u>Item Description</u>	<u>Persondays</u>	<u>Cost</u>
1. Set up NASA antenna and feed	2	\$ 360
2. Waveguide installation	3	540
3. Radio/racks installation	3	540
4. Primary power installation	1	180
5. Equipment cabling installation	5	900
6. Test/alignment	2	<u>360</u>
	TOTAL	16 \$2880

Notes:

- o Environment, Item 4: It is assumed that fencing will be installed to encompass the 5-meter antenna by Satellite Communications Network (SCN) under previous agreement to extend the fence line.
- o Equipment, Item 2: FMT may be deleted if shared use of existing FMT at DUT approved.
- o Equipment, Item 7: Bare rack cost is approximately \$250.
- o Equipment, Item 8: Quoted from Andrew current price list with no discount. Recommend factory assembly of parts to greatest extent possible. Andrew advises there is no charge to assemble.
- o Personnel, Item 3: Includes removal of applicable equipment from TES and installation in DUT shelter.

TASK 2.1.3: DETERMINE KU-BAND CAPABILITIES AND LIMITATIONS OF PSSC'S TRANSPORTABLE EARTH STATION (TES)

Acceptance and full utilization of the proposed public service Ku-Band satellite network was predicated on existing and available CTS earth stations to transmit and receive. It was understood that certain modifications would be necessary to enable experimenters to use CTS earth stations with commercial Ku-Band satellites.

DSAF, as discussed in 2.1.2, was perceived as the principal uplink facility for this network. PSSC's TES, designed initially, but never used, to transmit and receive at Ku-Band with CTS, was to complement and supplement DSAF for uplinking of network programs. After the early demise of CTS, TES was reconfigured to transmit and receive at C-Band and is used regularly as a mobile uplink facility. Since the Ku-Band capability on TES had never been used, it was necessary to ascertain its performance, capability and limitations with the SBS and ANIK B satellites. Accordingly, PSSC added a task to the present Ku-Band study to examine TES utilization in conjunction with the proposed Ku-Band public service satellite network.

Prior to the present study, TES had not been used to provide a Ku-Band transmission link other than cursory testing with questionable results. SBS monitored TES transmissions in mid-1981 and reported on the signal quality. A problem was discovered in the antenna feed which has since been corrected. Additionally, the receiver in TES did not perform properly in the preliminary tests. Due to the inconclusive results of these earlier tests, further technical evaluations were conducted as part of the present study. (Details of these later tests appear in Section 2.2.4.)

Absent transponder time for real testing, PSSC engineers indicated that TES was capable of transmitting, but with some shortfall of power. On paper, the analysis revealed that only 63% of the available power would be radiated out of SBS when using TES. This power shortfall on

TES cannot provide the additional brute-force power required to maintain transmission in rainfall. TES may be used in applications which are insensitive to high reliability, since outage time due to rain is expected. The stand-by power needed in rain varies as a function of climate, being low in Colorado and high in Florida.

Table 1 is a footprint of SBS/TES performance showing the calculated minimum receiving antenna apertures against each of the six SBS regions. The 200-watt amplifier and 5-meter antenna can generate nearly the maximum power on SBS spacecraft. Under the limitations of clear skies at both ends of the link, TES can provide uplink video on Ku-Band. A block diagram appears as Table 2 and is a simplified representation of the Ku-Band equipment within TES.

Summarily, the TES design at Ku-Band is ample depending on application and climate. The power shortfall can be virtually ignored in cases where reliability is not of major importance and/or the climate is dry. Until the recent tests, reported in Section 2.2.4, TES had never been proven, and the previous tests had never allowed a proof-of-performance to any level of confidence.

SBS/TES 200-watt PERFORMANCE

MINIMUM RECEIVING ANTENNA APERTURE

(PRELIMINARY)

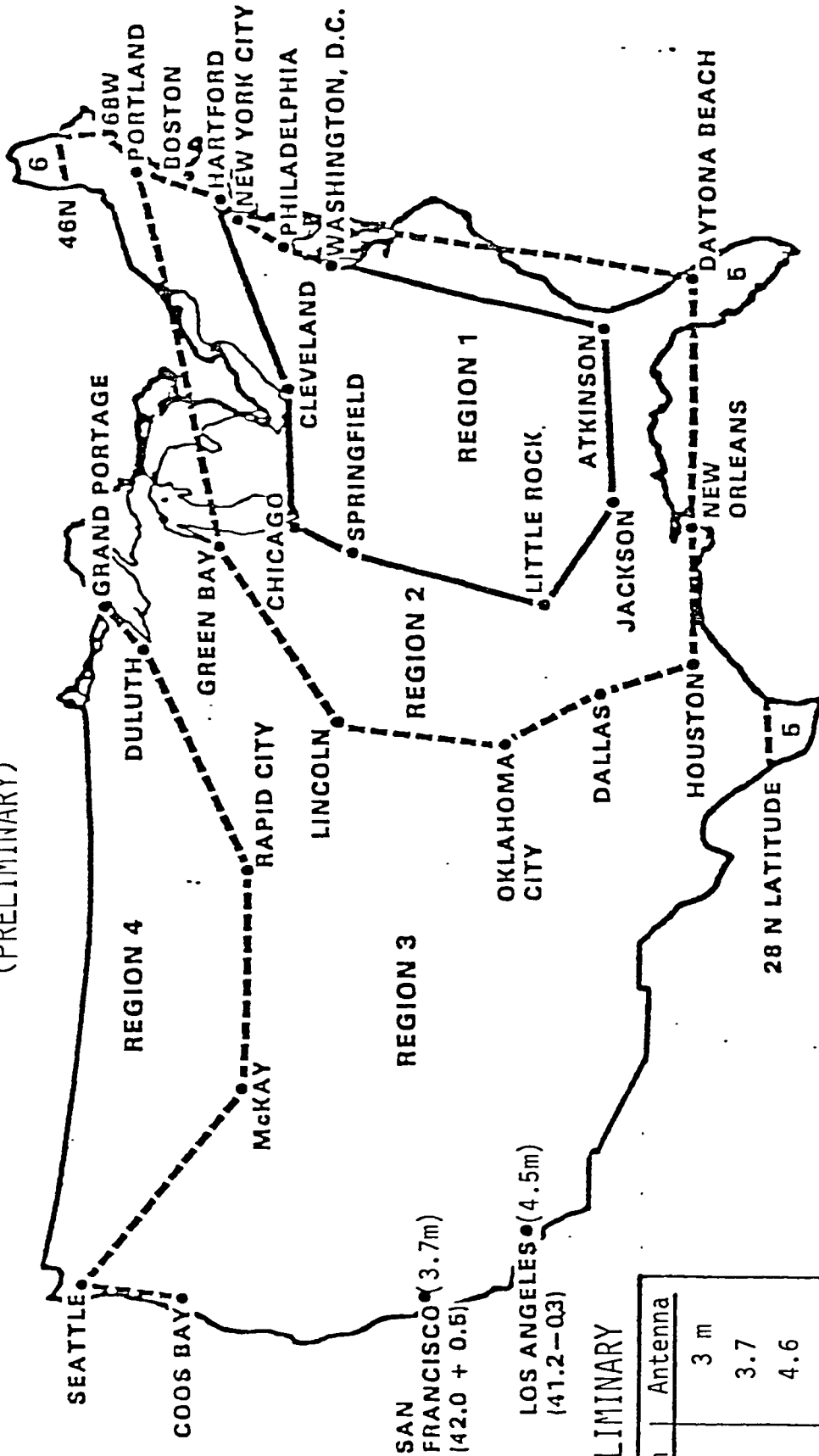

SAN FRANCISCO (3.7m)
(42.0 + 0.5)

LOS ANGELES (4.5m)
(41.2 - 0.3)

PRELIMINARY

Region	Antenna
1	3 m
2	3.7
3	4.6
4	5-7
5	5
6	5

Limitations:

- a. Expected results - testing necessary.
- b. Clear sky - no rain margin.
- c. TES Uplink - Calculated.
- d. SATCOM Inc. receiver.
- e. 48 dB video S/N.

TES CONCEPTUAL BLOCK DIAGRAM

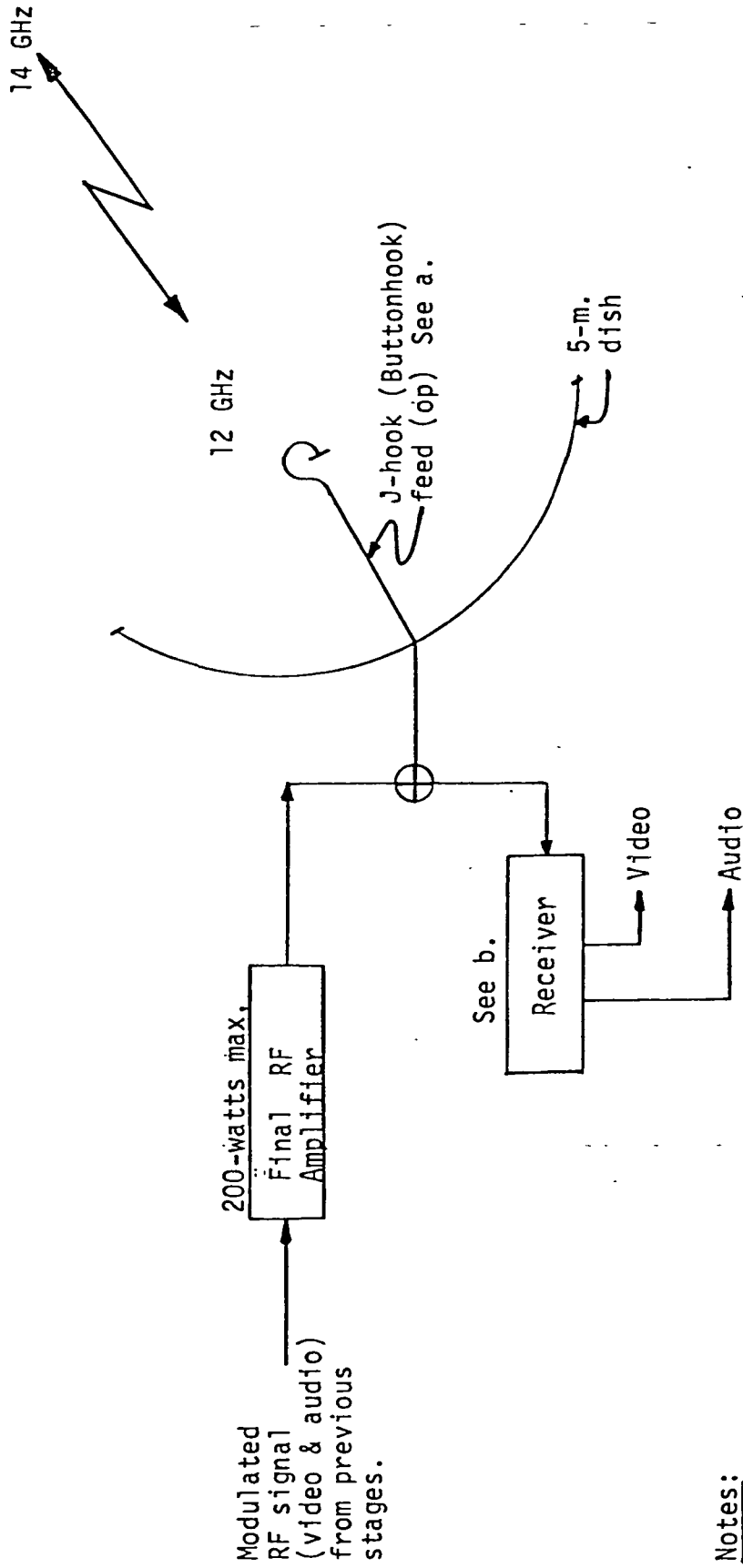

Notes:

- a. Feed recently repaired; it has not been tested.
- b. Receiver - possible types
 - 1: TES own ?
 - 2: SATCOM o.k., expected.
 - 3: Vitalink o.k., expected.
- c. Final amplifier o.k., may be underpowered for certain applications.

TASK 2.1.4: DETERMINE WHAT MODIFICATIONS ARE NECESSARY TO MAKE THE CTS TERMINALS OPERATIONAL WITH EXISTING KU-BAND SATELLITES

In ascertaining the feasibility of using CTS terminals with modern Ku-Band communications satellites, various system parameters have been collated for comparative analysis. Section 2.1.1 addressed spacecraft and operating parameters among several carriers. This section focuses on the feasibility of using CTS terminals based on their technical characteristics. It also determines the range of expected values of existing equipment and condenses the findings into a tabular form for rapid access.

An outline of CTS terminal characteristics as compiled from written and/or verbal sources are summarized in Table 1 below.

Generally, the CTS terminals were custom designed and do not lend themselves to adaptation without some expenditure. Most CTS-type antennas have only limited steering ability. The pedestals would have to be re-positioned to be utilized in different configurations. The transmitters could be required to undergo a refurbishing to bring them into operational status. Refurbishment would include frequency tuning, usually a factory procedure. Similarly, the receivers may not be field tunable. Some are crystal-controlled, and while the crystal can be easily changed, other alignment may be necessary. Unlike the transmitters, the receivers would not necessarily be required to undergo a refurbishment. The cost-effectiveness of re-tuning existing receivers (the Hughes unit in particular) must be weighed against the purchase of state-of-the-art 12 GHz commercial receivers. Accordingly, PSSC evaluated several advertised Ku-Band products in conjunction with the study.

The manufacturers/products surveyed were:

- o SATCOM, Inc. (12 GHz TVRO system)
- o SED Systems, Inc. (12 GHz TVRO system)
- o Vitalink (Ku-Band receiver)

The first two manufacturers and their products presented problems in interfacing with CTS terminals. SATCOM, Inc. is addressing the high volume, total system direct broadcast satellite (DBS) market. SED Systems is Canadian-based, and their U.S. representatives are facing marketing and import problems.

Vitalink, on the otherhand, offers a versatile product which will easily interface with typical Ku-Band antennas and provides moderately easy field-tuning capability. Table 2, which follows, lists pertinent qualities of the receiver. The Vitalink product offers an improvement (as much as 3.5 dB) to existing CTS earth stations at reasonable cost.

Table 2: Characteristics of Vitalink 12 GHz Receiver

- o 24-channel agility
- o 30/20 MHz receiver bandwidth
- o switch selectable
- o 360 degree K LNC mounts on WR-75 flange
- o 4 audio subcarrier demodulators
- o futuristic design
- o flexible bandwidth allows full or half transponder video
- o \$3,000 complete (without cables);
less than Ku-Band LNA alone

Based upon data outlined in Table 1, the usual range of earth station quality or G-over-T (G/T) values is clustered about the 21.7 dBi/degrees K level. Nominal receiver bandwidths are 30-36 MHz. Using these typical values, Table 3 below may now be used to determine required satellite EIRP for operation.

From Table 3, the minimum EIRP required is 41.1 dBW under optimum propagation conditions. The information in this table contains no margin for poorer propagation due to the effects of rain, fog, etc. With a respectable margin, the required minimum EIRP mathematically becomes $41.1 + 6 =$

Earth Station G-over-T
VS.
Spacecraft EIRP

G/T, dBi/°K

EIRP, dBW

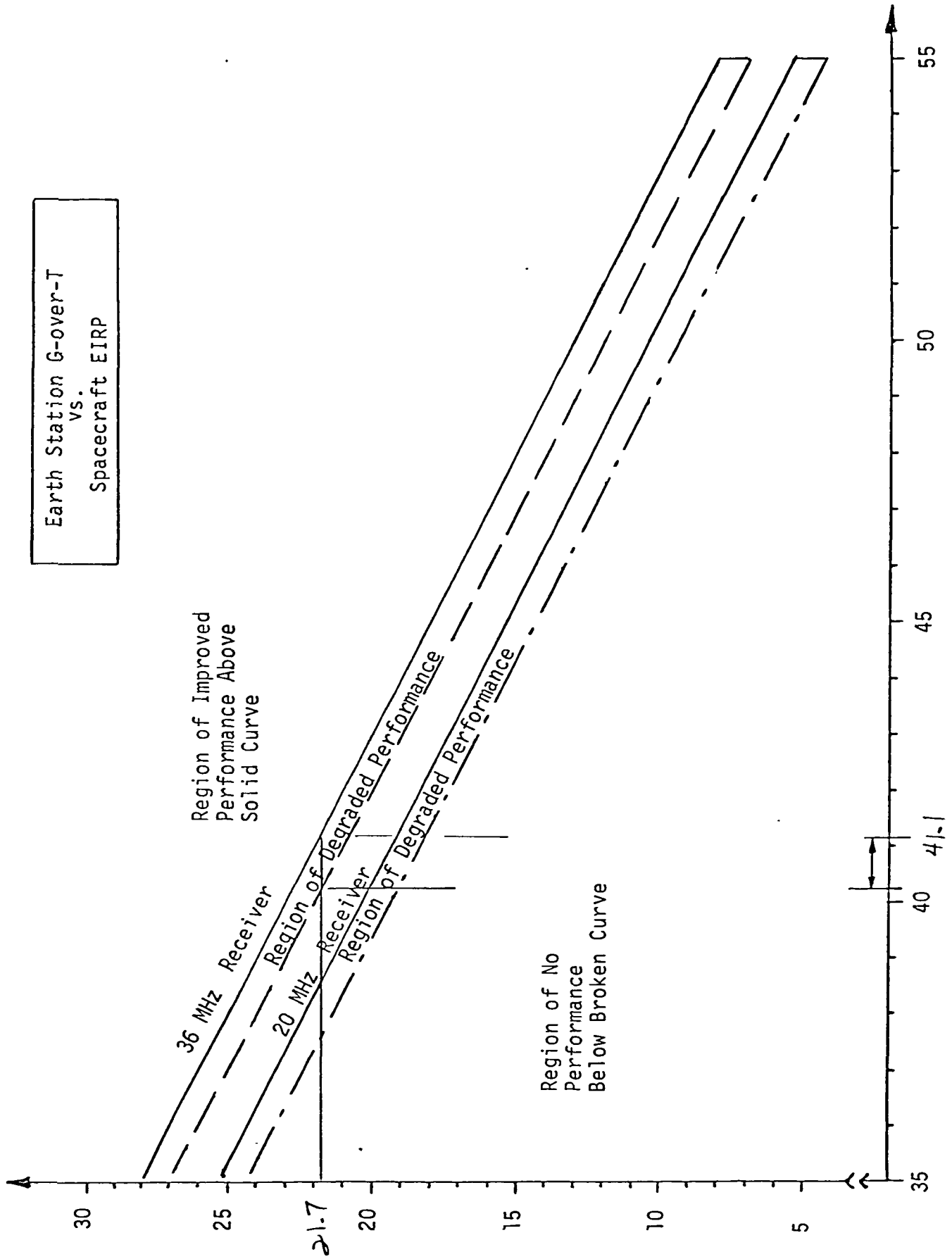

Region of Improved
Performance Above
Solid Curve

36 MHz Receiver

Region of Degraded Performance

20 MHz Receiver

Region of Degraded Performance

Region of No
Performance
Below Broken Curve

21.7

30

25

20

15

10

5

35

40

41.1

45

50

55

47.1 dBW for an earth station G/T of 21.7 dBi/degrees K to overcome the effects of rain and the like. In comparison, this is higher than the SBS satellite delivers. The signal, however, becomes unusable in the presence of rain and in the absence of a large enough G/T.

Table 4, which follows, gives typical values of G/T for various antenna apertures, LNA noise and sky conditions of clear or cloudy. The values are predicated on an antenna efficiency of 55%, 0.3 dB mismatch loss at the antenna/LNA flange and downstream noise contributors totalling 5 degrees K. Antenna noise temperature under clear skies is taken as 30 degrees K while cloudy skies cause the the number to rise to 150 degrees K. The EIRP must necessarily account for transponder utilization as mentioned in Section 2.1.1.

Consulting this table, if the user encounters an earth station having an eight foot antenna and 4dB noise figure LNA, a G/T of 19.9 under clear skies and 19.0 when skies are cloudy will be found. The 19.9 dBi/degrees K is found to require a minimum EIRP of 43 dBW. Conversely, the user may determine earth station G/T required, given spacecraft EIRP. Identically, adding 6 dB to the table value will greatly improve reliability.

There are built-in tolerances in the table, i.e., a degraded region in which operation is possible and, for experimentation, can be valuable in data collection. The regions above and below the degraded region are "improved quality" and "failure" of the FM system, respectively (e.g., an EIRP of 42 dBW and an earth station G/T of 10 dBi/degrees K is not an operational system.)

Overall, information collected indicates that the CTS terminals were designed for specific experimental purposes, using very narrow "tunability" criteria, an exceedingly high-powered satellite (about twenty times higher than SBS), and a fixed orbital position (116 degrees West longitude). These terminals were generally equipped with specialized radios having two channels. The possibility exists for re-tuning the CTS two-channel equipment to new frequencies, but they will still be limited to two channels. In

The following tables list typical values of earth station G-over-T, given the (1) antenna diameter, (2) LNA noise figure or effective input temperature and (3) clear or cloudy sky conditions.

Ku-band (12 GHz)

G/T - Clear Sky

Antenna Diameter	$\frac{3.5}{360}$	$\frac{4}{438}$	$\frac{4.5}{527}$	$\frac{5}{627}$	$\frac{6}{865}$	← NF, dB ← Te, °K
6'	18.2	17.4	16.7	16.0	14.7	
8'	20.7	19.9	19.2	18.5	17.2	
10'	22.6	21.8	21.1	20.4	19.1	
12'	24.2	23.7	22.7	22.0	20.7	
15'	26.3	25.5	24.8	24.1	22.8	

G/T - Cloudy Sky

6'	17.1	16.5	15.9	15.3	14.2
8'	19.6	19.0	18.4	17.8	16.7
10'	21.5	20.9	20.3	19.7	18.6
12'	23.1	22.5	21.9	21.3	20.2
15'	25.2	24.6	24.0	23.4	22.3

addition, if different frequencies are subsequently required, the re-tuning process would have to occur again. Frequency agility over the entire Ku-Band and individual adjustment of the channel frequency is certainly an ideal. The Vitalink receiver presents one ideal alternative in this respect. Increasing the frequency agility of the transmitters is probably unreasonable. More than likely, a new multi-channel unit would need to be purchased. Extending the number of channels on existing transmitters most often require replacement of some part of the equipment. If specific, fixed frequencies are to be used for a period of time commensurate with the cost involved in re-tuning, the user may find it worthwhile to pursue this alternative.

The ability to point the existing CTS antennas to other orbital positions than 116 degrees West longitude may present a problem for given applications. For example, the SECA terminals are extremely limited in pointing adjustment range, while the VA terminals are adjustable over a greater range. Thus, potential pointing constraints do exist and must be considered.

One last limitation PSSC encountered was the small size of the CTS terminal antennas. Most antennas were less than fifteen feet in diameter; a constraint which cannot be modified in and of itself.

The bottom line clearly indicates that CTS terminals cannot be used with existing Ku-Band satellite systems without extensive modification at a cost estimated to be higher than a new state-of-the-art Ku-Band terminal.

TASK 2.1.5: DETERMINE WHICH EXISTING U.S. NETWORKS FOR PUBLIC SERVICE COULD BE SERVED BY EXISTING CANADIAN SUPPLIERS OF PUBLIC SERVICE PROGRAMMING

In the performance of this task, PSSC discovered three major problems in the Ku-Band satellite distribution of U.S./Canadian public service programming: limited antenna coverage of ANIK B, incompatibility of CTS earth stations with ANIK B and transborder protocol restrictions. Despite these problems, PSSC did meet and discuss potential transborder programming arrangements with several Canadian entities.

The Ontario Educational Communications Authority was identified by PSSC as the major Canadian public service programmer using satellites for program distribution. In a meeting with OECA, PSSC was informed that OECA transmits 8-12 hours of daily educational programming to 46 Canadian earth stations via ANIK B on the East Central Beam. This would limit coverage in the U.S. to northern Michigan, Wisconsin and Minnesota.

If technical problems could be circumvented, OECA suggested the distribution of its children's program, Galaxy. They also recommended cable distribution in order for Galaxy to compete with other cable children's program fare including Nickelodeon and Calliope. While the OECA showed interest in the possibility of extending their programming to a U.S. audience through Ku-Band technology, they outlined four problems inherent in such a plan:

1. Technical Limitations. Limited ANIK B U.S. coverage and the transmission of OECA programming using a half transponder would severely restrict the number of U.S. locations able to receive the programming.

2. U.S./Canadian Protocols. There has been a history between the U.S. and Canada of the preclusion of transborder reception.

3. OECA Rights and Clearances. In order for OECA to sanction use of their programs in the U.S., they must obtain rights and clearances for the entire U.S. which is an

expensive proposition.

4. Transborder Marketing. OECA does market programming in the U.S. and would be competing with itself in transborder satellite distribution.

The U.S. marketplace for Canadian programming was never established. At best, only isolated expressions of interest were received. For example, PSSC uncovered an Illinois High School with its own satellite earth station wishing to receive OECA programming. OECA response was negative. The bottom line regarding reception and use of Canadian programming in the U.S. still revolves around financial, legal and technical questions which must continue to be pursued.

In addition to Canadian programmers, PSSC also met with the Canadian Department of Communications and Telesat Canada concerning their interest in cooperating with us in Ku-Band demonstrations by making ANIK B transponder time available. Telesat has leased all Ku-Band capacity on ANIK B to the DOC who found they could not accommodate all Canadian users. Thus, the issue of leasing satellite time for non-Canadian use is a sensitive one. Nevertheless, both DOC and Telesat indicated a willingness to help PSSC plan a transborder teleconference contingent upon these conditions:

1. The teleconference must have a Canadian sponsor/co-sponsor.
2. The teleconference cannot be commercial as regulatory agencies will not approve.
3. The teleconference should be under government auspices.
4. ANIK B time must be available.
5. The teleconference must be experimental and of short term duration.
6. The teleconference must not compromise any Canadian project.
7. Earth stations must be available in Canada.

With these policies in mind, PSSC began planning a transborder teleconference involving the Institute for Career and Vocational Training in the U.S. and the Alberta

Native Communications Society in Canada. The teleconference was to link American and Canadian Indian youth and their leaders to discuss ways in which the American organization could assist the Canadian group in starting similar Indian youth-oriented programs throughout the country.

The event was plagued with problems from the beginning. Internal political problems hampered ANCS participation. FCC delay in transborder event approval stalled planning. But, the incompatibility of the CTS terminal at Montana State University in Bozeman with ANIK B brought about the event's technical end. Consequently, PSSC was not able to coordinate a Ku-Band public service transborder teleconference.

While technical limitations prohibit the use of CTS terminals in Ku-Band demonstrations, there has been a subsequent move by U.S. and Canadian officials to open the transborder gates to satellite teleconferencing. The FCC, with reciprocal authorization from the Canadian government, has approved over a dozen individual transborder events in the past year. As a result, the U.S. and Canada recently reached an agreement on the provision of transborder satellite services by means of domestic satellites. Under the new agreement, domestic satellites may be used to provide a wide range of transborder satellite services subject to certain limitations, including the continued obligation to coordinate with INTELSAT prior to the initiation of transborder service and to obtain Canadian government authorization.

U.S. companies, such as GTE, have also made transponder leasing arrangements on ANIK C. Their plans at this time call for use of the Canadian satellite for delivering U.S. programming within the U.S. only.

It is clear there are transborder teleconferencing needs and interests. U.S. and Canadian organizations are becoming more vocal in their desire to share programming across the border, and steps are being taken to initiate transborder satellite events using domestic satellites. Unfortunately for this study, PSSC discovered the current

generation of commercial domestic Ku-Band satellites are not able to interface with CTS ground stations, which halted PSSC's efforts to conduct U.S./Canadian Ku-Band demonstrations.

TASK 2.1.6: DETERMINE WHICH PSSC MEMBERS, FORMER CTS USERS AND OTHER PUBLIC SERVICE USERS COULD BE BENEFITED AND COULD BE READY TO TEST KU-BAND TECHNOLOGY

In determining which organizations in the public service could benefit from a Ku-Band network, PSSC's first step was to examine public service markets to ascertain their potential for use of satellite communications. Through PSSC research and experience, the following market segment ranking was derived:

- 01: Education/Libraries
- 02: Government
- 03: Communications
- 04: Health/Medicine
- 05: Special Interest and Ethnic Groups
- 06: Science and Technology
- 07: Business
- 08: Social and Human Services
- 09: Finance
- 10: Religion
- 11: Agriculture
- 12: Transportation
- 13: Legal, Protection and Emergency Relief
- 14: Recreation

The primary concern of most of these organizations was the use of satellite communications as a more cost-effective transmission medium for the delivery of programming, both real time and taped, to various intra- and inter-organizational groups and individuals.

In order to determine which public service organizations within these top ranking market segments could become potential users of a Ku-Band public service satellite network, PSSC surveyed its membership, former CTS users, and other members of the public service community with national interests. Criteria were then formulated to select serious candidates from this universe of potential users. These criteria were based on the availability of resources to support participation; communications needs and requirements; network sharing potential; user facilities; and geographic location of user network nodes. Regional distribution, area populations, presence/absence of existing satellite hardware, and popularity of sites for shared use

were also taken into consideration as secondary criteria.

Former CTS users were contacted and interviewed concerning their possible involvement in the proposed Ku-Band public service network. PSSC determined their ownership, status, number and locations of dormant CTS terminals; their willingness to resurrect and share their satellite facilities with other public service groups; and costs and arrangements for acquiring their terminals if not interested in or able to afford network participation. These user interviews uncovered a common obstacle: lack of resources and programming to operate and maintain a national network. Even with the CTS terminals in their possession, the financial burden associated with use and operation of a dedicated satellite network was still too great. Many of the former experimenters were not prepared to use such a network even if it were available at a reasonable cost and on a convenient basis.

Subsequent interviews with other public service entities returned similar results: high interest, low resources. PSSC staff then re-examined market segment findings and hypothesized several special potential Ku-Band networks. The following are working examples:

o State Library Satellite Network: Network is based on the location of Ku-Band terminals at each of the state libraries in the 50 capital cities. The SLSN would serve library, government, educational and community service interests directly, while being readily available for use by other public service organizations. The SLSN would constitute the first satellite network with nodes available for shared use in all 50 states and their capitals. The potential for growth is evidenced by the ability to add any number of the more than 100,000 U.S. libraries as expansion sites.

o National Community Access Network: Network is based on the location of Ku-Band terminals at either cable system head-ends or on the premises of local community access centers with satellite programming delivered on an access channel or directly within the access center facility. The

NCAN would primarily be a community service-oriented network, but open as well to any public sector community organization. As cable service continues to expand, so does the potential for the growth of the NCAN. Currently, nearly 5,000 CATV systems are operational throughout all 50 states, most with some type of access center provisions. Often times, the local access center is the public library which could institute a link between this network and the SLSN.

o State Departments of Education Network: Network configuration is very similar to the SLSN only Ku-Band terminals are located at each State Department of Education facility in all state capital cities. Educational and governmental services would be the primary focus of this network although other public service groups would be welcomed. Other educational organizations, especially the National Education Association and its thousands of affiliates, could enhance and expand the SDEN. (See 2.1.7. for more detail on NEA.) As many State Libraries are divisions of State Education Departments, there is a potential link between this network and the SLSN--most probably through the sharing of satellite facilities.

o American College of Radiology Network: Network is based on the location of Ku-Band terminals at ACR-selected radiological medical schools. ACRN would offer a more specialized medical satellite service, but would be willing to share its facilities with other public groups with communications needs within the ACRN node locations. Expansion is predicated on the incorporation of additional medical facilities and organizations with radiological interests.

o American Indian Satellite Network: Network is based on the location of Ku-Band terminals at selected Indian reservations throughout the U.S. Programming by and about American Indians would comprise the majority of transmissions and could indirectly impact on other phases of public service. Outreach to urban Indians and other off-reservation Indian organizations could add more popular network nodes for greater shared use. PSSC has identified

the Institute for Career and Vocational Training, who ministers to American Indian youth, as one potential aggregator and programming agent. ICVT also expressed an interest in transborder satellite events between American and Canadian Indian youth and their leaders. PSSC worked with ICVT in an attempt to conduct a transborder teleconference demonstration, but hardware and transborder political limitations caused the event to be cancelled.

o Rural Satellite Network (RuralSat): Network is based on the location of Ku-Band terminals in selected rural, isolated areas. RuralSat would enable any type of public service organization to deliver informational/educational programming to previously inaccessible areas, such as areas in the Rocky Mountains, Appalachia, Alaska and the Pacific Northwest. Experimental satellite demonstrations in the 1970's verified the need and usefulness of a rural network. RuralSat would be an expanded, integrated national approach to rural satellite communications.

o Continuing Legal Education Network: Network is based on the location of Ku-Band terminals at sites nationwide selected by the American Law Institute - American Bar Association. Network also has international implications, specifically the exchange of law programming with Canadian legal counterparts. While the main thrust of the network would be law-driven, ALI-ABA would be eager to share facilities with other public service organizations. Collegiate law schools, law firms, and associated institutions could expand CLEN in subsequent years. Section 2.1.7 describes ALI-ABA's interest in establishing a dedicated Ku-Band network.

o PBS Ku-Band Network: Network is based on the location of Ku-Band terminals at interested public broadcasting stations nationwide. Several PBS stations, including those who participated in CTS experimentation under SECA sponsorship, told PSSC they would be interested in acquiring the terminals for the delivery of instructional television. Expansion of network can grow to incorporate

the entire PBS network as well as any educational facilities interested in program reception. Facilities could be shared with other entities in much the same fashion as the Public Television Satellite System does now with its C-Band equipment/services.

o Oregon State System of Higher Education Network: Moving to a narrower scale, this network is based on the location of Ku-Band terminals at major institutions of higher education throughout the state of Oregon. Major network use would revolve around a higher education programming project. Other Oregon-based public service organizations could also utilize these facilities. Unless the statewide network decided to expand into a national scope, linking academic institutions across the nation, its growth potential is somewhat restricted.

Other organizations expressed an interest in having access to a public service satellite network for occasional telecasts. Many public sector groups do not have the funds or the programming to necessitate routine or regular use of a satellite network. Nearly 750 inquiries for teleconferencing service were handled by PSSC during the period from June, 1981 through May, 1982. Only 58 of those ever came to fruition. The failure of the other 692 to convert their inquiries to satellite events can largely be traced to the lack of access to an available, convenient and affordable network. If the public service Ku-Band network could have been created, it would have presented the teleconferencing alternative badly needed by the majority of public service organizations.

TASK 2.1.7: ASSIST READY USERS, IF REQUIRED, IN GAINING
ADDITIONAL RESOURCES TO USE A KU-BAND NETWORK

This task assumed "ready users" would be found, willing and able to absorb expenses for programming, network management, Ku-Band space segment and all associated CTS terminal costs. PSSC identified a number of interested public service groups, but none "ready" to test a Ku-Band network without major subsidy. Groups in the process were made aware of the extensive (as well expensive) technical modifications required to convert CTS terminals to usable Ku-Band earth stations, the lack of convenient and available Ku-Band uplinks and downlinks and the unavailability of satellite time on commercial Ku-Band satellites. Additionally, program rights and transborder legalities, as detailed in Section 2.1.5, adversely affected potential U.S./Canadian "ready users."

PSSC, however, identified and worked with two public service organizations with more serious dedicated network intentions: the National Education Association and the American Law Institute-American Bar Association. Each group is profiled below.

THE NATIONAL EDUCATION ASSOCIATION

1201 16th Street, N.W.
Washington, DC 20036
(202)833-4484

Contact: Robert E. Harmon, Director, Communications
Services

NEA is interested in establishing a nationwide telecommunications network linking the national headquarters with most, if not all, of its 53 state affiliates. Most of these state affiliates are located in or near state capital cities. Together NEA and its affiliates represent 1.7 million members who live throughout the country. NEA envisions a network used for training, organizing and disseminating general information among the local, state and national representatives. Sessions from national and regional conferences would also be transmitted via an NEA network. NEA is also amenable to sharing the network with

other public service organizations.

With these thoughts, PSSC assisted NEA in determining the feasibility of establishing a nationwide video telecommunications network. PSSC identified the technical requirements and associated costs for creating a Ku-Band satellite-based network. Financial considerations were studied and recommendations were made. While technically an NEA network is feasible and communications needs warrant a dedicated system, funding presents a principle roadblock. NEA may have to create a private subsidiary and/or seek outside venture capital to establish a system.

AMERICAN LAW INSTITUTE-AMERICAN BAR ASSOCIATION

4025 Chestnut Street
Philadelphia, PA 19104
(215)243-1600

Contact: Paul A. Wolkin, Executive Director, Committee on Continuing Professional Education

The CCPE division of ALI-ABA is responsible for attending to the professional education needs of its law members and bar groups. CCPE has utilized satellite video-teleconferencing for more than a dozen educational programs. Most recently, CCPE completed a series of ten continuing education teleconferences and are planning an upcoming series of five more. One of CCPE's primary concerns in these teleconferences is the high expense for renting the receive site facilities, some of which can individually cost \$1000. A strong desire to continue ALI-ABA continuing education via satellite at affordable costs motivated a hard look at the feasibility of a Lawyer Satellite Video Receiving Network.

PSSC presented the concept to the Executive Board of ALI-ABA CCPE. Board response indicated an interest in studying the requirements and prospects for the creation of such a network. This group was especially interested in the merits of a Ku-Band system as many bar associations are located in metropolitan areas already saturated in C-Band.

Neither of these two organizations are able to move forth at this time with their network plans, but planning and interest still continue at high levels. Other public service organizations have not advanced beyond occasional use status and cannot justify a dedicated satellite network.

With the right financial assistance, either NEA or ALI-ABA have a better chance of supporting a full-time dedicated network. Had a public service Ku-Band network based on CTS terminals been found feasible, NEA and ALI-ABA would have been prime candidates as potential regular users.

TASK 2.2.1: ARRANGE FOR UPLINKING OF REQUIRED PROGRAMMING AND SOFTWARE FOR PARTICIPATING USER ORGANIZATIONS

TASK 2.2.2: SUPERVISE AND MANAGE ALL OTHER SUPPLEMENTAL TECHNICAL SYSTEM COMPONENTS

TASK 2.2.3: HANDLE ALL BILLINGS ASSOCIATED WITH THE NETWORK

These three tasks were to have been incorporated into an overall network management plan for the Ku-Band public service satellite network demonstration phase. This plan would have defined operational procedures as they impact on network coordination for satellite-delivered events using the ground segment network described in the preparatory phase.

Even though findings from the preparatory phase determined that a Ku-Band public service satellite network is not feasible at this time, the following network management plan, patterned after PSSC's National Satellite Network plan, can serve as a valid step-by-step guide for subsequent attempts at forming and operating a public service network.

ELEMENTS OF NETWORK COORDINATION

Before the management plan is outlined in detail, the general elements of network coordination are given for task definition:

1. Acquisition of Services Specified

Custom networking arrangements to meet the needs of individual clients includes the acquisition of transponder time on the appropriate Ku-Band satellite, use of selected earth stations for transmit and receive (fixed and/or transportable), production facilities and personnel, terrestrial interconnects ("local loops"), audio hookups for program interaction, and viewing accommodations. Arrangements are finalized through the issuance of service orders or purchase orders as appropriate.

2. Configuration Analysis for Compatibility of Technical Distribution System

The analysis includes investigation into technical

possibilities for usage of existing systems; review of distribution alternatives based on user requirements, earth station orientation and operational capabilities, frequency coordination, and requirements for supplemental terrestrial networking; and development of cost estimates for accessing a proposed distribution network to meet the technical, economical and programmatic requirements of the individual client.

3. Operations Plan

The essence of the operations plan is a written description of the service requirements, technical and legal, which is distributed to each supplier of the network.

4. Coordination of Purchase Orders and Payments

A purchase order summary, which includes services ordered and invoices to be received, is developed for each client service and distributed to the PSSC Financial Affairs Department. Billings by suppliers are cross-checked against purchase and/or service orders issued prior to payment.

5. Factsheet of Contacts/Phones for Real-Time Program

Factsheet includes information concerning specifics on viewing locations developed for the client and deemed useful for program participants.

6. Status Report

Report consists of verbal and/or written communication between client and network coordinator to keep client informed on progress of finalizing specified services.

7. Monitoring of Program

Each program coordinated by PSSC is monitored for technical quality (video and audio) by the responsible PSSC Network Coordinator and for troubleshooting any problems which might arise with any supplier of the technical distribution network.

KU-BAND PUBLIC SERVICE SATELLITE NETWORK MANAGEMENT PLAN

1. Establish preliminary communication with client.

o Client and PSSC determine network is appropriate for need.

- o Client submits technical/programmatic parameters via special Preliminary Client Information Form (PCIF).
- o Based on PCIF parameters, PSSC produces cost estimate for event and discusses with client.
- 2. Finalize agreement with client.
 - o Client decides to proceed with event planning and network services.
 - o PSSC develops a Service Agreement, outlining complete event details including client/PSSC responsibilities, service technical specifications and all related costs.
 - o Client signs and returns Service Agreement.
- 3. Obtain Ku-Band transponder time.
 - o Information on all Ku-Band satellites is entered and continually updated in PSSC data base, retrievable by satellite owner/operator, transponder lessee and transponder broker, if applicable.
 - o PSSC determines which Ku-Band transponders are available for date and duration of event.
 - o PSSC secures appropriate transponder time through submission of transponder purchase order on behalf of the client.
- 4. Develop receive site network configuration.
 - o PSSC consults data base to determine receive site options.
 - o PSSC sends Request for Quote (RFQ) to potential network receive sites as identified in Service Agreement.
 - o Individual network nodes respond with bid to PSSC.
 - o PSSC, in consultation with client, selects final receive sites for event and sends Service Orders contracting their participation at the cost quoted (or negotiated).
 - o Receive sites sign and return Service Orders.
- 5. Determine transmission/origination arrangements.
 - o Based on client's programmatic parameters, PSSC consults data base to determine origination facility (studio or remote) options.
 - o PSSC sends RFQs concerning event services to

these origination facilities.

- o Origination facilities respond with bids to PSSC.

- o PSSC, in consultation with client, selects appropriate origination facility and sends a Service Order contracting its participation at the cost quoted (or negotiated).

- o PSSC consults data base to determine the nearest usable Ku-Band uplink for event transmission services.

- o PSSC contracts for satellite transmission services for event on behalf of client.

- o Once origination and transmission facilities are contracted. PSSC determines all "local loop" arrangements necessary to get the signal to the appropriate satellite uplink.

- o PSSC contracts for all necessary "local loop" arrangements as needed for event on behalf of client.

6. Determine audio interaction arrangements.

- o PSSC discusses alternatives with client.

- o PSSC, in consultation with client, selects audio interaction services.

- o PSSC contracts for all audio interaction services needed for event on behalf of client.

7. Ascertain production support.

- o In discussions with client. PSSC assesses production needs and recommends appropriate production support, including personnel, equipment, graphics, etc.

- o PSSC contracts for all required production support for the event on behalf of client.

8. Determine peripheral support arrangements.

- o In discussions with client, PSSC determines the need for peripheral support services, including special video display units for viewing locations, site facilitation, event evaluation, promotion, registration, refreshments, etc.

- o PSSC contracts for all required peripheral support services for the event on behalf of client.

9. Coordinate distribution of technical information

among participating facilities.

- o PSSC prepares troubleshooting list of all participating contacts, including transmission, origination, "local loop" and receive site facilities; client and transponder lease contacts and distribute to all parties.

- o PSSC contacts transmission facility with confirmation of transponder assignment for event.

- o PSSC reconfirms all technical services ordered several days before the event.

10. Coordinate audience participation arrangements.

- o PSSC acquires from client a brief outline of promotional campaign and/or distribution lists of promotional literature.

- o PSSC acquires from client samples of all promotional materials that will be disseminated to prospective audiences.

- o PSSC confirms client contact who will be responsible for inquiries regarding the event at receive site locations.

- o PSSC disseminates promotional materials to all network participants prior to the event for their information.

- o If requested by client, PSSC does a complete promotional package for the event and disseminates as outlined above.

- o If requested by client, PSSC coordinates the participant registration process prior to the event.

- o If applicable and requested by client, PSSC coordinates catering services to participating facilities.

- o If applicable, PSSC acquires samples of informational kits to be distributed to event audience participants.

- o If applicable, PSSC disseminates informational kits to appropriate network participants.

11. Brief all non-technical program participants on their responsibilities for the event.

- o PSSC provides all receive site facilitators with a guide outlining a run down of the event and defining their

responsibilities at the viewing locations.

- o PSSC, in conjunction with production personnel, ensures that event talent is aware of scheduled pre-production, rehearsals and meetings with production personnel, as well as the extent of their responsibilities on the day of the event.

12. Monitor event.

- o On day of event, PSSC troubleshoots teleconference for technical problems.

- o If needed, PSSC determines the source of a technical problem and contacts that technical facility.

13. Coordinate post-event activities.

- o If requested, PSSC submits evaluation of event to client, summarizing both technical and non-technical quality.

- o If requested, PSSC arranges for all post-production event requirements.

- o PSSC collects, organizes and confirms validity of bills from all contracted facilities and personnel for event services.

- o PSSC submits one final bill to client for total event expenses.

- o Client remits payment to PSSC for event expenses.

- o PSSC remits payment to individual event service suppliers.

Steps may vary for each event, but in the aggregate, the guidelines listed above will assist PSSC and public service planners in the organization and management of individual teleconferences with adequate flexibility.

TASK 2.2.4: CONDUCT TECHNICAL EVALUATIONS OF THE COMPLETE KU-BAND SYSTEM

In partial fulfillment of task 2.2.4, PSSC's TES was operated on Ku-Band and transmitted video via SBS-I, Transponder 4 on July 15 and 16, 1982 from DUT. Test time was arranged through GTE Satellite Corporation (GSAT), the contractual party with SBS for the transponder used in the test. A summary of the operating parameters is outlined below:

Uplink Frequency:	14.172 GHz
Downlink Frequency:	11.872 GHz
Flux Density to Saturate:	-82.7 dBW/m ²
Saturated EIRP:	43.2 dBW
S/C Orbital Position:	100 degrees W Long

Measured values of flux density and EIRP were provided by the SBS Tracking, Telemetry and Control (TTC) station in Castle Rock, Colorado and follow this section as Attachment E-1.

The PSSC TES is equipped as a video modem, with dual-conversion C/Ku frequency translation equipment, a 200-watt TWT amplifier, an independent receiver and a 5-meter antenna. Interconnecting RF hardware includes rigid and flexible sections of WR-75 waveguide. A summary of the TES specifications is as follows:

Antenna Gain:	53.0 dBi at 12 GHz 54.7 dBi at 14 GHz
Antenna Feed:	Linear, orthogonal polarization, two-port
Estimated W/G Loss:	1.7 dB
TWT Power:	23.0 dBW
Resultant EIRP:	76.0 dBW
TES Normal Receiver:	Miteq
Independent Receiver:	Vitalink

(See Attachment E-2 for a detailed block diagram of the TES configuration.)

The transmit power from TES is continuously adjustable by two means. The TWT power can be varied coarsely by means

of drive level variation. A fine power adjustment is achieved by variable attenuator on the second stage of conversion. Typical C-Band satellite transmission parameters (10.75 peak deviation, 36 MHz bandwidth, etc.) were utilized. Transmission of video and two audio channels on 6.2 and 6.8 MHz constituted the major portion of actual testing. Various video test signals, audio test-tone and program audio were used.

The Vitalink receiver is designed for Ku-Band operation with twelve discrete push-button channels, each tunable over a range extending into adjacent channels, specified by the manufacturer. The receiver is equipped with audio sub-carrier demodulators tuned to 6.2 and 6.8 MHz. There are also two associated low noise converters with the PSSC receiver.

Downlinks were established using the TES and a 3.7-meter antenna. Both systems were co-located at DUT. Compucon provided frequency clearance services.

Since two antennas and two low noise converters were available, one LNC was connected to each antenna. The interconnecting cable was then moved between LNCs to facilitate comparison of the two antennas. Because it was necessary to remove the TES low noise amplifier and install the Vitalink LNC on the TES antenna, switching between Miteq and Vitalink receivers was not rapid.

TES is also equipped with a spectrum analyzer, power meter and waveform monitor for signal evaluation.

The tests ran from noon to 4 pm EDT on both days. It had been agreed that transmission could be sporadic, depending upon initial results, desired internal measurements, power variation, etc. The only fixed operating parameters during transmission were center frequency, peak modulation and bandwidth.

Representatives from GSAT, SBS and PSSC, named below, were present to observe the tests:

GSAT: Mr. Ming Louie
Engineering Supervisor
Communication Systems
(203)965-3565

SBS: Mr. John Hewitt
Manager, Beacon Station
Satellite Control Engineering
(303)688-5066

PSSC: Dan Gorton, Director, Systems Engineering
Bill Lane, Director, Operational Engineering
Steve Dutka, Senior Systems Engineer
Tom Morrison, Engineering Coordinator
Gene Glasunow, Senior Operations/Maintenance
Engineer
Don Christensen, Operations/Maintenance
Engineer

In addition, John Moravich provided the test signal and measurements of TES performance from the SBS monitoring station in Clarksburg, Maryland.

The TES antenna was pointed toward SBS-I using the spectrum analyzer and signal strength meter on the Miteq receiver. A saturated carrier was produced by the Clarksburg station on Transponder 4 to assist in the fine adjustment of TES pointing and polarization.

At the conclusion of this test, the TES began transmission at very low power and, following Clarksburg's direction, slowly increased power to maximum output. Clarksburg verified that the TES transmission was within prescribed transponder bandwidth, that it did not overdrive the transponder or cause interference to adjacent transponders or satellite, and that it was on frequency.

PSSC monitored the transmission using only the normal TES receiver. The Miteq unit failed to produce a usable signal on either the waveform or video monitors. At this point, all modulation was removed from the TES carrier, leaving only a single carrier wave signal centered on the transponder. Clarksburg measured the signal level produced by TES and determined that the spacecraft was being illuminated 10 dB below saturation. The resulting spacecraft EIRP was 38 dBW, 5.2 dB below the maximum. Given the conditions, TES transmissions were halted to make

internal measurements.

The power output of the Ku-Band TWT amplifier was made by connecting a power meter to the RF sample port, a 50 dB coupler. The following meter reading was taken:

+5.0 dBm,	full-scale
-1.8 dB,	reading
+50 dB,	coupling
<u>-30 dB,</u>	conversion to dBW
23.2 dBW	

This results in a transmitter power of just over 200 watts.

The transmit waveguide was removed at the antenna flange and terminated in a WR-75 to N adaptor and power meter. The waveguide was terminated in a WR-75 to SMA adaptor at the TWT, just past the RF coupler, and power was introduced from the second conversion stage. The insertion loss was identified using the calculations below:

-14.2 dBm,	sending end
-(-18.0) dBm,	receiving end
<u>- 1.0 dB,</u>	adaptor losses
2.8 dB, insertion loss	

Nearly half (47.5%) of RF power is lost in the waveguide. This may be compared with the TES specification of 1.7 dB insertion loss (32.4% loss).

Microwave Specialty Corporation advised PSSC that the focal length of the 5-meter antenna is 75.8 inches. The measured focal length between feed opening and center plate is 75.75 inches. This constitutes less than 0.1% error and is considered to be in adjustment.

The TES LNA was removed from the antenna and the Vitalink LNC installed. TES transmissions resulted in a well-defined, albeit noisy, video signal from the Vitalink receiver. Audio test-tone was introduced on both sub-carriers and received with similar high noise. However, when compared with the Miteq receiver, the Vitalink performance was superior.

Conventional video signal-to-noise measurements were deemed meaningless since noise was predominantly impulsive. Instead, a signal-to-impulsive noise measurement was made in

accordance with the procedure set forth in Report No. 7, Section 3.17, Network Transmission Committee of the Video Transmission Engineering Advisory Committee, Revised January, 1976. The resulting levels are tabulated below:

<u>Antenna</u>	<u>(S/Ni)v</u>
5.0-m	14-16 dB
3.7-m	3 dB, estimated

It is important to note that using the Vitalink 5-meter antenna, a transmit power reduction of nearly 1 dB resulted in the same signal as the Vitalink 3.7-meter combination at full power. Presumably, the difference in antenna gains is about 1 dB since the transponder was being operated in its linear (dB-for-dB) region. However, a large amount of subjectivity enters into these measurements considering the receiver and observers functioned at unusually low operating points.

PSSC learned that the Vitalink receiver is designed for different modulation peaks on 4 and 12 GHz. The video level increased beyond the usual 100 over 40 IRE video-sync level in the 12 GHz position. Thus, a higher discriminator sensitivity was found in the Ku-Band receiver than in C-Band.

Insufficient literature is available on the Vitalink equipment, but marketing representatives claim it has an effective manual threshold extension by switching between 4 and 12 GHz positions. PSSC, however, does not feel this to be a valid claim.

Given identical audio material and levels on both subcarriers, the Vitalink produced a noisier signal on 6.2 MHz than on 6.8 MHz. This is contrary to usual FM noise mechanisms with no explanation available. Audio noise level was not measured, but observers noted aurally that video level affected audio quality, considered usual behavior for an FM system.

PSSC was surprised to learn of TES' measured EIRP shortfall. Engineering staff have accounted for about 1 dB of 5.7 dB in the waveguide. The antenna gain, SBS measurement and transmitter power comprise the major

unknowns and uncertainties. No means are readily available to check the antenna gain accurately. Routine wear and tear have taken their toll on the antenna ears and most probably are the source of reduced gain. SBS offered to assist PSSC in making antenna gain measurements.

As a point of reference, the estimated carrier-to-noise ratio of the TES, given its EIRP and respective satellite EIRP, should have been on the downlink 12.5 dB. Such a level would have delivered a much improved video signal-to-noise ratio. Instead, the receiver is estimated to be operating at 8-9 dB C/N.

The actual antenna gain of TES on Ku-Band is the outstanding question. Link calculations for TES are presented in Attachment E-3.

PSSC staff also discussed the resurrection of the CTS transmitter as a means of increasing TES' EIRP. Major inhibiting factors included:

- o Time expenditure to re-tune
- o Lack of tuning/test equipment
- o Interconnection with TES
- o Overall, temporary one-time solution
- o TES floor space

In summary, TES' performance is at 10 dB below saturation. Paper estimates placed the shortfall at 5 dB. As a result, this shortfall caused the received signal at DUT to be very poor. PSSC operations and systems engineering staff made measurements on TES and found a portion of the power loss in the waveguide. Antenna gain and SBS measurement techniques are the other unknown factors. Routine use of the antenna has reduced the surface accuracy and resultant Ku-Band gain. Potentially, the antenna gain may be measured indirectly at a later time using a saturated carrier on SBS.

The results from the technical evaluation were generally negative, and caution has been suggested in the use of TES for Ku-Band video transmissions requiring a broadcast quality signal.

Attachment E-0, Page 1 of 4

CTS Terminal Type: National Institutes of Health

Source: Biomedical Communications Experiments using the
Communications Technology Satellites, George R. Thoma,
August 1979, National Library of Medicine, #LHNCBC 79-13.

Antenna Size: 10' diameter; Gain: 49.2 dBi

Steering Ability: unknown

Low-noise Amplifier: Noise Figure: 5.5 dB, stage 2

Noise Temperature: 106°K, stage 1

Gain: Unknown

G/T: 23.2 dBi/°K (400°K System)

I.F. Bandwidth: 36 MHz, measured

Frequency Agility: CTS Two-Frequency Plan

Attachment E-0
Page 2 of 4

CTS Terminal Type: Veterans Administration

Source: Operation and Service Manual CTS-Video Receiver-Only
Terminal, Westinghouse Electric Corporation, August 1977,
#FIS-77-4032

Antenna Size: 10' diameter; Gain: 48.3 dBi, mid-band

Steering Ability: $\pm 20^\circ$ azimuth, 0 - 70° elevation

Low-Noise Converter: Noise Figure: < 5dB

Noise Temperature: < 627°K

Gain (RF/IF): 42 dB

G/T: 20.0 dBi/°K, Clear Sky

19.2 dBi/°K, Cloudy Sky

I.F. Bandwidth: > 30 MHz

Frequency Agility: Tuned to 12.0805 GHz

Attachment E-0
Page 3 of 4

CTS Terminal Type: NASA ROT/Hughes

Source: Operation and Maintenance Manual 12 GHz Satellite
Video Receiver, Hughes Aircraft Company - Electron
Dynamics Division, 1979.

Antenna Size: 12' diameter, Gain: 50.3 dBi, Calculated
midband, 55% efficiency

Steering Ability: Limited

Low-Noise Converter: Noise Figure: 4 dB, maximum

Noise Temperature: 438°K

Gain: 44 ± 6 dB

G/T: 23.4 dBi/°K, Clear Sky

22.2 dBi/°K, Cloudy Sky

I.F. Bandwidth: 30 MHz, 3 dB points, Figure 5 - 8, P. 5 - 13

Frequency Agility: The Hughes receivers are 12-channel agile.
Individual fine-tuning of a channel to a
given frequency is not a field-level task.
Worthiness of the receiver will be compared
against the Vitalink during DUT Ku tests.

Attachment E-0
Page 4 of 4

CTS Terminal Type: Southeastern Educational Communications
Association (SECA)

Source: Verbal contact with selected members of SECA
through Bob Kline - Lexington, KY

Antenna Size: 10' and 15' diameter

Gains: 49.2 and 52.4 dBi, respectively (calculated)

Steering Ability: Extremely limited (Designed to track
variations in CTS position only 116° W Longitude)

Low-Noise Amplifier: Noise Figure: 5 dB

Noise Temperature: 627°K

Gain: Unknown

G/T: 10' - 20.9 dBi/°K clear, 20.2 dBi/°K cloudy

15' - 24.1 dBi/°K clear, 23.4 dBi/°K cloudy

I.F. Bandwidth: 36 MHz

Frequency Agility: CTS Frequency Plan, Crystal-controlled,
two frequencies only.

S/C E.I.R.P. & FLUX DENSITY

E/S: CASTLE ROCK, S/C: F3
 DATE :7/13/1982
 TIME 23:51:30 GMT
 E/S is 1.24N Deg. of S/C Tx Foresight
 E/S is .64W Deg. of Sub Satellite Point
 S/C Longitude :259.995E Deg. (Sub. Sat. point)
 S/C Latitude :.003S Deg. (Sub. Sat. point)
 E/S Antenna Azimuth :172.44 Deg.
 E/S Antenna Elevation :44.26 Deg.
 RECEIVER #4

Rx Temperature :91F Deg.
 Rx Gain is set at :LOW
 TUBES 4:4

COMMENTS :WX CLOUDY
 WD 61=0220 NO CXR, 3500 SAT
 GGP

Data in Disk File: E495

CHANNEL	PLATFORM POSITION (Deg.)	U/L FREQ. (GHz)	U/L P.A. (dBm)	Inj P.A. (dBm)	N/A (dB)	U/L Cal. (dB)	D/L Cal. (dB)	U/L S.F. (dB)	D/L P.L. (dB)	U/L S.F. (dB/M ²)	D/L P.L. (dB)	TIME GMT
4	0	14.17200	+8.4	-5.6	+3.3	+71.4	-159.9	+162.5	+205.4	+82.7	+43.2	23:51:21

Data Stored in File: E495

TRANSFER CHARACTERISTICS for CH-4 Tube 4

ATTACHMENT
E-1
PAGE 2 OF 2



5781 CRESTLE ROCK, B/C 1 F3
 E28 to 11.34° N of S/C Tx Borelight
 E28 to 1.84° N of Sub-Borelight point
 Date: 7/14/1982, 11:00:00, 18, 18, 04
 Re: 04 Temp: 19.51 F, Gain: LOK
 B/C Long: 12581885 E, Lat: 11.88318 (Sub-Borelight)
 E28 Azimuth: 172.14°, EL: 14.26°
 COMMENTS: CLOUDY
 GCR

DISK FILE: 1495

+28 -83
+33 -88
+38 -78
+43

Link Calculations

A. Uplink

The level of excitation of the SBS-I transponder as reported by SBS is related to TES EIRP by

$$\begin{aligned}
 \text{EIRP} &= (\text{Flux density}) + 162.5 \\
 &\quad (\text{@ spacecraft}) \\
 &= -92.7 + 162.5 \\
 &= 69.8 \text{ dBW} \qquad (1)
 \end{aligned}$$

The TES antenna gain is determined from transmitter power and waveguide loss by

$$\begin{aligned}
 &69.8 \text{ dBW} \quad \text{EIRP} \\
 &- 23.2 \text{ dBW} \quad \text{transmitter power} \\
 &+ \underline{2.8 \text{ dB}} \quad \text{LL} \\
 &49.4 \text{ dBi} \quad \text{Antenna gain} \qquad (2)
 \end{aligned}$$

Compare this against the 54.7 dBi specification. PSSC operations staff is not surprised by this value.

B. Downlink

On the basis of a 38 dBW spacecraft EIRP, the calculated C/N in the Vitalink receiver using TES is,

$$\begin{aligned}
 &38 \text{ dBW} \quad \text{EIRP} \\
 &- 206 \text{ dB} \quad \text{path loss @ 23,304 mi.} \\
 &+ 53 \text{ dBi} \quad \text{antenna gain} \\
 &- 26.1 \text{ dB}^\circ\text{k} \quad \text{system noise temperature} \\
 &+ 228.6 \text{ dBW} \cdot \text{sec}/^\circ\text{k} \quad \text{Boltzman's constant} \\
 &- \underline{74.7 \text{ dBHz}} \quad \text{Receiver IF bandwidth} \\
 &12.8 \text{ dB} \quad \text{C/N} \qquad (3)
 \end{aligned}$$

The value given in (3) would have produced a good video picture. Instead, values 3.5-4 dB lower were observed with LNC's interchanged. The variables here are

- Antenna gain
- LNC noise temperature

It is believed that antenna gain is the major cause - a logical extension of the reduced uplink EIRP. While it is possible that two Vitalink LNC's are of higher noise temperature than specification, its likelihood seems remote.

System noise temperature (given clear skies during the tests) is based on

- a. Antenna noise temperature: 25°k.
- b. 0.3 dB reject filter insertion loss and mismatches.
- c. 360°k LNC noise temperature
- d. 7.3°k downstream contributors.

TASK 2.2.5: CONDUCT MANAGEMENT EVALUATIONS OF THE EFFICACY OF THE NETWORK IN RELATION TO COSTS, OPERATIONAL REQUIREMENTS, SOFTWARE AND USER ACCEPTANCE

No formal management evaluation of a Ku-Band public service satellite network was conducted. The results from the technical evaluation as reported in Section 2.2.4 negatively affected proposed management evaluation activities. The aborted demonstrations described in Section 2.1.5 compounded the problem.

In lieu of the management evaluation, and with concurrence from the NASA program officer, PSSC conducted and submits a computer study: Ku-Band Propagation Impairments by Rain Attenuation on Earth/Space Links. The report follows as Appendix 1.

SUMMARY STATEMENTS

1. CTS Earth Stations

The costs to acquire, remove, modify and install dormant CTS earth stations are relatively high, estimated at \$13,000 each not including acquisition costs. Extenuating circumstances (i.e., available satellite time and uplink services) compound the problem. It may be just as economical to purchase new Ku-Band earth stations with more built-in capacity than the units designed for CTS interface only.

2. Ku-Band Satellites and Transponder Availability

Occasional use Ku-Band transponder time is limited through 1982. Availability of ANIK B Ku-Band transponder time for non-Canadian applications presented a problem in the course of the study. Prospects improve when transponder requests include a Canadian component; however, the limited U.S. coverage by ANIK B inhibits its use. ANIK C, scheduled for launch in late 1982, shows some promise in the U.S. Recently, G-SAT acquired ten transponders on ANIK C. The availability of ANIK C Ku-Band transponder time for U.S. transmissions could relieve the current shortage until G-SAT and SPACENET become available. Occasional use transponder time on SBS is not presently available. SBS has not made business provisions for the lease of occasional use time on their satellites, including the allocation of a tariff. Access to SBS transponders would present less of a problem if the public service could justify leasing a full transponder. PSSC research also indicates that difficulties can be expected with three meter or less CTS earth stations within SBS antenna coverage regions three and four.

3. Ku-Band Video Uplink Service

The nonexistence of Ku-Band analog video uplinks in the U.S. that can interface with SBS contributes to the dilemma. The only two operating Ku-Band video uplinks are PSSC's Transportable Earth Station (TES) and COMSAT Lab's

Gaithersburg modified CTS uplink. The latter is not readily available for commercial service. The former unit, although unique by design, has, as noted in Section 2.1.3, some inherent limitations with both SBS and ANIK B. TES performance at Ku-Band was not deemed to be video broadcast quality on test conducted as part of the study. It is, however, reasonable to expect that many public service user organizations would not require a broadcast quality signal. Accordingly, until PSSC can upgrade TES to ensure a transmission of high quality Ku-Band signals, the decision has been made at PSSC not to promote TES as a Ku-Band uplink facility.

4. Regulatory Issues

Regulatory barriers also exist which have limited Ku-Band demonstrations considerably with ANIK B. Transborder video transmissions between the U.S. and Canada are currently prohibited and must be approved on a case-by-case basis by both U.S. and Canadian authorities. Although the FCC has ruled favorably on recent transborder requests, and future prospects for non-INTELSAT transborder video transmissions look good, the process is still cumbersome and slow. Even if the transborder transmission is approved, it is still necessary to have the programs cleared for transborder distribution, should this be desired. The costs to clear the rights for transborder distribution can be significant. Several exciting prospects for Ku-Band transborder demonstrations were stymied because of a combination of regulatory and technical problems. (See Section 2.1.5.)

5. Public Service Resources

The present study verified the continuing interest on the part of public service organizations in acquiring improved telecommunications. What continues to be evident are the limited resources to support programming, promotion and technical services. It was indicated that even if the network existed, many public service organizations could not

use it, because the programming to transmit over the network does not exist. People and money to produce appropriate programming are not readily available within the public sector although in the aggregate the volume does exist. The probability of establishing a dedicated public service satellite network improves when planned in collaboration with a private sector network. In turn, a Ku-Band network offers the most viable opportunities consistent with public service requirements.

Ku-Band

Propagation Impairments
by Rain Attenuation
on Earth/Space Links

KPGN.FOR (Fortran)
Computer Program Description
and User Guide

NASA Account No. 4220

August 1982

KPGN.For
Propagation Program
August 1982

Table of Contents	Page
Introduction	3
-purpose	
-sources	
Program Design	3
-stored data	
-input	
-manipulation	
-output	
Flow Chart	6
Program Listing	8
Sample Execution	13
User Entry Summary	14
Figure 6.3-2	15

INTRODUCTION

The need to rapidly determine Ku-band link parameters such as rain attenuation, availability and required margin is especially great in the operation of a transportable earth station.

While a method of calculating rain attenuation exists, it requires substantial manual data manipulation. Its results are susceptible to error caused by repetitive calculations and are thus generally suspect. The manipulation requires a relatively great amount of time to accomplish the end result, a simple graph of statistical probability versus attenuation. From such a graph, the availability and required link margin can be quickly determined.

The computer program, written in Fortran, will generate the statistical attenuation due to rain in only a fraction of the time required by hand, with substantial confidence in the calculations and returned data. The program can be executed for any location to which a transportable unit may be sent in the continental US. The program can also be exercised in such a way that design criteria for earth stations in general would be generated.

The program will perform rain attenuation statistical data for the entire range of frequencies, 10-100 GHz, and will not be limited to any particular band(s).

Creation of the program is based on the technical data contained in "A Propagation Effects Handbook for Satellite Systems Design," A Summary of Propagation Impairments on 10-100 GHz Satellite Links, with Techniques for System Design, R. Kaul, et al, NASA Publication ORI-TR-1679, NASA Headquarters - Washington, D.C., March 1980, Section 6.3.2. This work covers the Ku- and K_v-bands, those of interest in common carrier and DBS applications.

PROGRAM DESIGN

In order to computerize the technical data given in Section 6.3.2 of the NASA Publication, it has had to be reduced to a form on which logical operations can be performed.

Accordingly, the rain rate distribution values of Table 6.3-1 and rain attenuation parameters, a and b, of Table 6.3-2 have been entered into program matrices directly. Interpolation of the attenuation parameters was studied and found to be logarithmic for values of a and linear for values of b.

The probabilities of rain rates (percent-of-year exceeded) in Table 6.3-1 and frequencies of Table 6.3-2 were entered directly into program matrices as well as the latitudes 10-70° north in Figure 6.3-4, dependence of latitude on isotherm height.

Reduction of the data in Figure 6.3-4 required a two-stage process. Figure 6.3-4 is a parametric relationship, the parameter being probability of occurrence. The individual curves were modeled by piece-wise linearization over segments. Matrices relating isotherm height, for a given probability, with latitude were then generated. Interpolation for any given latitude is thus performed linearly.

The second stage of the process involves interpolation of probabilities. The figure gives curves for probabilities an order of magnitude apart only. The interpolation process here must find the intermediate values of probability corresponding to those in Table 6.3-1, twice and five times the lower value.

Studies showed the typical relation between probability and height for given latitudes 20, 35, 50 and 60° to have very slight curvatures overall when plotted on log-lin scales. Thus, a logarithmic interpolation of probabilities results in isotherm heights of acceptably-small error.

The graphical figure, 6.3-2, a map of the continental US showing rain rate regions was not reduced into computer form owing to the complexity of such task and the slight benefit that could accrue by alleviating the rain rate look-up from the user.

Remaining data reduction involved the translation of mathematical equations into Fortran source code.

The program is designed to be immediately accessible to the user; i.e., he need not prepare any computer-stored data files prior to execution, but simply have the input data available at time of execution. Accordingly, the user is prompted by the program to enter the appropriate data as the program runs. Each prompt is accompanied by a format guide to show the user the entry format such as length, decimal location and type, alpha or numeric.

The user is prompted to enter the following data for each run:

- Station name
- Geographical Coordinates
- Ground Elevation in ft, AMSL
- Operating frequency in GHz
- Rain Rate Climate Region
- Antenna Elevation Angle, degrees

and is expected to have these data collated at run time.

These data are then pre-processed to insure they are within range. Latitude, frequency and rain climate are tested for in-range condition to prevent generation of useless output. Further, the user is informed of any particular out-of-range value by message so that he is immediately aware of the problem spot and doesn't have to search it out; the execution then stops. Any data entered in error may be corrected prior to machine acceptance (a carriage return); the program execution may be forced to cease in the event of an unnoticed fatal error in other input data.

When in-range, formatted data are entered, the program processes the data according to the flow chart presented herein.

Output data includes the user's own entries for verification and documentation as well as calculated values of statistical attenuation. For availabilities other than 1, 2 and 5 in a decade, the user would plot the data and connect the points with a smooth curve. Any intermediate values can be read from the graph.

FLOW-CHART GUIDE

Initialization - Matrices moved to computer memory

User Data Entry - User prompts generated and input accepted. Input converted to proper units of measurement. Rain climate and latitude checked for "in-range".

Isotherm Height Probability - Interpolate isotherm height vs. probability at given latitude.

Isotherm Height Interpolation - Determine intermediate 2 and 5 times values.

Path Length - Determine path length as a function of elevation. Check for 90° elevation. Frequency "in-range" condition checked.

Point Rain Rate Values - Interpolate a and b values, both high and low ranges.

Total Attenuation - Check path length high elevation angles, compare path length against parameter Z, correct the probability for long paths and calculate the total path attenuation.

Print-out - Print a table of probability vs. attenuation along with user entries.

SUBROUTINES

Linear Interpolation - A simple slope/intercept calculation.

Logarithmic Interpolation - A log-lin slope/intercept calculation.

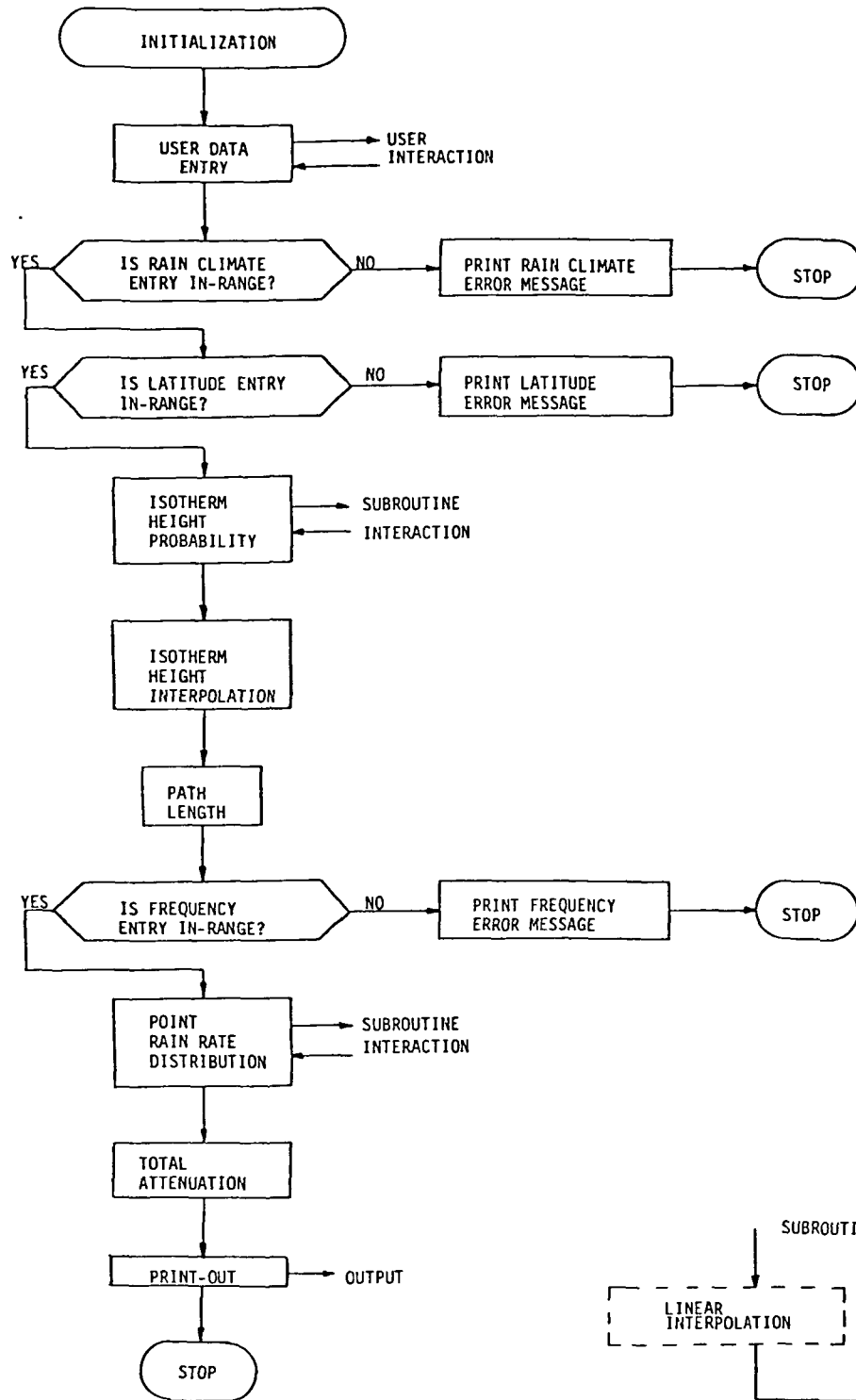

KPGN.FOR
Flow Chart
August 1982

C
C
C

DATA ENTRY

```
WRITE(1,200)
WRITE(1,205)
READ(1,206)(ESTA(N),N=1,3)
WRITE(1,210)
WRITE(1,212)
READ(1,214)(LAT(N),N=1,3)
WRITE(1,216)
READ(1,218)(LON(N),N=1,3)
WRITE(1,225)
READ(1,226)EL
WRITE(1,230)
READ(1,232)FREQ
WRITE(1,240)
READ(1,242)CLMT
WRITE(1,250)
READ(1,232)THETA
```

C

```
WRITE(2,200)
WRITE(2,300)(ESTA(N),N=1,3)
WRITE(2,305)(LAT(N),N=1,3),(LON(N),N=1,3)
WRITE(2,315)EL
WRITE(2,320)FREQ
WRITE(2,325)CLMT
WRITE(2,330)THETA
```

C

```
ELEV=FLOAT(EL)/5280.*1.609347
THETA=THETA/(180.)*3.14159
DLAT=LAT(1)+LAT(2)/60.+LAT(3)/3600.
```

C
C
C

RAIN RATE CLIMATE REGIONS

```
K=0
IF(CLMT.EQ.1HA) K=1
IF(CLMT.EQ.1HB) K=2
IF(CLMT.EQ.1HC) K=3
IF(CLMT.EQ.2HD1)K=4
IF(CLMT.EQ.2HD2)K=5
IF(CLMT.EQ.2HD3)K=6
IF(CLMT.EQ.1HE) K=7
IF(CLMT.EQ.1HF) K=8
IF(CLMT.EQ.1HG) K=9
IF(CLMT.EQ.1HH) K=10
IF(K.EQ.0)WRITE(1,900)
IF(K.EQ.0)STOP
```

C
C
C

ISOTHERM HEIGHT, PROBABILITY = F(LATITUDE)

```
DO 1 I=1,7
IF(DLAT.GE.HLAT(I).AND.DLAT.LE.HLAT(I+1)) GOTO 2
1 CONTINUE
WRITE(1,905)
STOP
2 J=I+1
CALL LININT(HLAT(I),HLAT(J),HM1(I),HM1(J),DLAT,H(1))
CALL LININT(HLAT(I),HLAT(J),HM4(I),HM4(J),DLAT,H(4))
```

```
CALL LININT(HLAT(I),HLAT(J),HM7(I),HM7(J),DLAT,H(7))
CALL LININT(HLAT(I),HLAT(J),HM10(I),HM10(J),DLAT,H(10))
```

C
C
C

ISOTHERM INTERPOLATED PROBABILITIES

```
DO 3 I=1,7,3
  J=I+3
  H(I+1)=H(I)+(H(J)-H(I))*ALOG10(2.)
  H(I+2)=H(I)+(H(J)-H(I))*ALOG10(5.)
3 CONTINUE
```

C
C
C

PATH LENGTH

```
DO 5 J=1,10
  PATH(J)=0.
  IF(THETA.LT.(1.5707))PATH(J)=(H(J)-ELEV)/TAN(THETA)
5 CONTINUE
```

C
C
C

POINT RAIN RATE DISTRIBUTION VALUES, A AND B

```
DO 8 I=1,14
  IF(FREQ.GE.ABFREQ(I).AND.FREQ.LE.ABFREQ(I+1)) GOTO9
8 CONTINUE
  WRITE(1,910)
  STOP
9 J=I+1
  CALL LOGINT(ABFREQ(I),ABFREQ(J),A(I),A(J),FREQ,ARAINL)
  CALL LOGINT(ABFREQ(I),ABFREQ(J),A(I+15),A(J+15),FREQ,ARAINH)
  CALL LININT(ABFREQ(I),ABFREQ(J),B(I),B(J),FREQ,BRAINL)
  CALL LININT(ABFREQ(I),ABFREQ(J),B(I+15),B(J+15),FREQ,BRAINH)
```

C
C
C

TOTAL ATTENUATION,ATTEN AND EMPIRICALS X,Y,Z,U.

```
DO 10 L=1,10
  LK=L+(K-1)*10
  A1=ARAINL
  B1=BRAINL
  IF(RP(LK).GE.30.)A1=ARAINH
  IF(RP(LK).GE.30.)B1=BRAINH
  IF(PATH(L).EQ.0.) GOTO15
  X=2.3+RP(LK)**(-.17)
  Y=.026-(.03*ALOG(RP(LK)))
  Z=3.8-(.6*ALOG(RP(LK)))
  U=(ALOG(X*EXP(Y*Z)))/Z
  IF(PATH(L).LT.Z) GOTO 12

  ATT=(EXP(U*Z*B1)-1.)/(U*B1)
  ATT=ATT-((X**B1)*EXP(Y*Z*B1))/(Y*B1)
  ATT=ATT+((X**B1)*EXP(Y*PATH(L)*B1))/(Y*B1)

  ATTEN(L)=ATT*A1*(RP(LK)**B1)/COS(THETA)
  GO TO 18

12 ATTEN(L)=A1*(RP(LK)**B1)/COS(THETA)*((EXP(U*PATH(L)*B1)-1.)
  +/(U*B1))
  GO TO 18

15 ATTEN(L)=A1*(RP(LK)**B1)*(H(L)-ELEV)
```

```
18 IF(PATH(L).GT.(22.5)) PCT(L)=PCT(L)*PATH(L)/22.5
10 CONTINUE
```

C
C
C

PRINT-OUT OF STATISTICAL DATA

```
WRITE(2,125)
WRITE(2,150)
DO 20 L=1,10
WRITE(2,152)PCT(L),ATTEN(L)
20 CONTINUE
WRITE(2,400)
WRITE(2,400)
WRITE(2,400)
STOP
```

C
C

```
125 FORMAT(/////10X,'EARTH-SPACE PROPAGATION IMPAIRMENTS-STAT. DATA')
150 FORMAT(///20X,'%-OF-THE-TIME',7X,'ATTENUATION'/20X,'ATTEN',1X,
+ 'EXCEEDED',11X,'DB')
152 FORMAT(22X,F6.3,17X,F4.1)
```

C

```
200 FORMAT(///10X,'10-100 GHZ PROPAGATION IMPAIRMENTS')
205 FORMAT(//10X,'ENTER E.S. IDENTIFIER, 12 CHAR. MAX.: ')
206 FORMAT(3A4)
210 FORMAT(//10X,'ENTER ES COORDINATES AS FOLLOWS:')
212 FORMAT(15X,'LATITUDE DD,MM,SS: ')
214 FORMAT(3F3.0)
216 FORMAT(13X,'LONGITUDE DDD,MM,SS: ')
218 FORMAT(F4.0,2F3.0)
225 FORMAT(/10X,'ENTER ES ELEVATION FT AMSL EEEEE: ')
226 FORMAT(I5)
230 FORMAT(/10X,'ENTER ES OPERATING FREQUENCY GHZ FF.FFFF: ')
232 FORMAT(F7.4)
240 FORMAT(/10X,'ENTER ES RAIN RATE CLIMATE REGION CC: ')
242 FORMAT(A2)
250 FORMAT(/10X,'ENTER ES ANTENNA ELEVATION ANGLE DEG DD.DD: ')
```

C

```
300 FORMAT(//12X,'EARTH STATION ',3A4)
305 FORMAT(/12X,'NL: ',3F3.0,' WL: ',F4.0,2F3.0)
315 FORMAT(//12X,'GROUND ELEVATION: ',I5,' FT AMSL')
320 FORMAT(/12X,'OPERATING FREQUENCY: ',F7.4,' GHZ')
325 FORMAT(/12X,'RAIN RATE CLIMATE REGION: ',A2)
330 FORMAT(/12X,'EARTH STATION ANTENNA ELEVATION: ',F5.2,' DEG')
```

C

```
400 FORMAT('1'/)
```

C

```
900 FORMAT(20X,'RAIN RATE CLIMATE INVALID')
905 FORMAT(20X,'LATITUDE OUTSIDE OF 10-70 DEG RANGE')
910 FORMAT(20X,'FREQUENCY OUTSIDE OF 10-100 GHZ RANGE')
```

C

C

END

C

C

C

C

C

SUBRTNE LININT (LINEAR INTERPOLATION)

SUBROUTINE LININT (X1,X2,Y1,Y2,X,Y)

C

SM=(Y2-Y1)/(X2-X1)

BB=(Y1-SM*X1)

Y=SM*X+BB

RETURN

END

C

C

C

SUBRTNE LOGINT (LOGARITHMIC INTERPOLATION)

C

C

SUBROUTINE LOGINT (X1,X2,Y1,Y2,X,Y)

C

SM=(ALOG10(Y2)-ALOG10(Y1))/(X2-X1)

BB=ALOG10(Y1)-SM*X1

Y=10**(SM*X+BB)

RETURN

END

C

C

10-100 GHZ PROPAGATION IMPAIRMENTS

EARTH STATION DVR U/L TERM

NL: 39.38. 4. WL: 105.10.55.

GROUND ELEVATION: 5600 FT AMSL

OPERATING FREQUENCY: 11.8750 GHZ

RAIN RATE CLIMATE REGION: B

EARTH STATION ANTENNA ELEVATION: 43.80 DEG

EARTH-SPACE PROPAGATION IMPAIRMENTS-STAT. DATA

%-OF-THE-TIME ATTEN EXCEEDED	ATTENUATION DB
.001	18.1
.002	11.7
.005	6.2
.010	3.7
.020	2.1
.050	1.0
.100	.5
.200	.3
.500	.1
1.000	.0

KPGN.FOR

SAMPLE EXECUTION

Ku-band
Propagation Program
August 1982

USER ENTRY SUMMARY

Station Name

Geographical Coordinates

Ground Elevation (Ft.) AMSL

Operating Frequency (GHz)

Rain Rate Climate Region
(See Figure 6.3-2, next page)

Antenna Elevation Angle (Degrees)

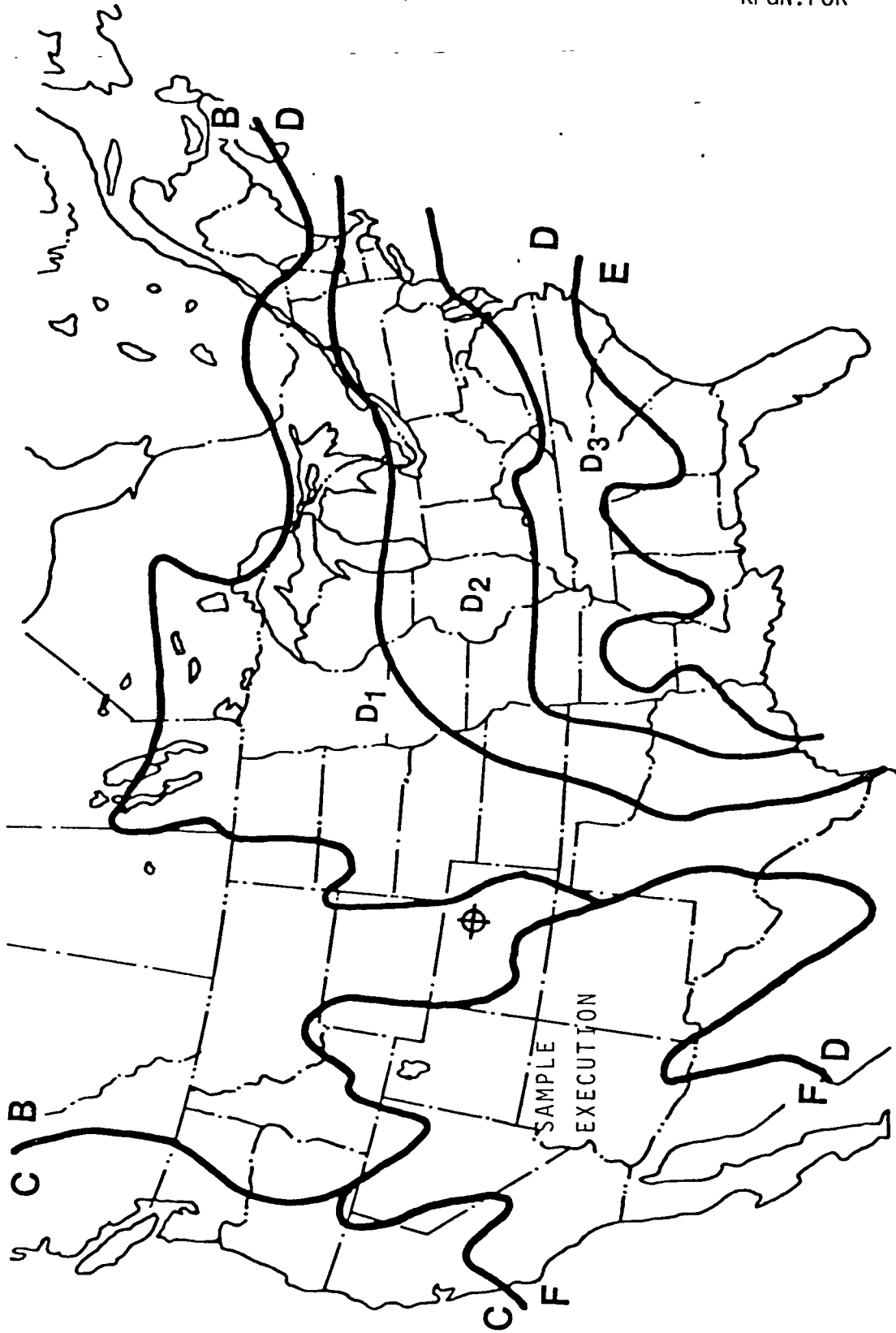

Figure 6.3-2 Rain Rate Climate Regions for Global Prediction Model