

## **General Disclaimer**

### **One or more of the Following Statements may affect this Document**

- This document has been reproduced from the best copy furnished by the organizational source. It is being released in the interest of making available as much information as possible.
- This document may contain data, which exceeds the sheet parameters. It was furnished in this condition by the organizational source and is the best copy available.
- This document may contain tone-on-tone or color graphs, charts and/or pictures, which have been reproduced in black and white.
- This document is paginated as submitted by the original source.
- Portions of this document are not fully legible due to the historical nature of some of the material. However, it is the best reproduction available from the original submission.

(NASA-CR-165770) PROGRAM FOR ESTABLISHING  
LONG-TIME FLIGHT SERVICE PERFORMANCE OF  
COMPOSITE MATERIALS IN THE CENTER WING  
STRUCTURE OF C-130 AIRCRAFT. PHASE 5:  
FLIGHT SERVICE AND (Lockheed-Georgia Co.,

N83-17600

Unclass  
08699

G3/24

**NASA Contractor Report 165770**



**PROGRAM FOR ESTABLISHING LONG-TIME  
FLIGHT SERVICE PERFORMANCE OF  
COMPOSITE MATERIALS IN THE CENTER  
WING STRUCTURE OF C-130 AIRCRAFT**

**PHASE V — FLIGHT SERVICE AND  
INSPECTION**

J. A. KIZER

LOCKHEED-GEORGIA COMPANY  
Marietta, Georgia 30063

Contract NAS1-11100  
OCTOBER 1981

**NASA**

National Aeronautics and  
Space Administration

**Langley Research Center**  
Hampton, Virginia 23665



PROGRAM FOR ESTABLISHING LONG-TIME FLIGHT SERVICE  
PERFORMANCE OF COMPOSITE MATERIALS IN THE  
CENTER WING STRUCTURE OF C-130 AIRCRAFT  
PHASE V - FLIGHT SERVICE AND INSPECTION

By

J. A. Kizer

Prepared under Contract No. NAS1-11100 by  
LOCKHEED-GEORGIA COMPANY  
Marietta, Georgia

for

Langley Research Center  
NATIONAL AERONAUTICS AND SPACE ADMINISTRATION

## FOREWORD

This Phase V - Final Technical Report is submitted in fulfillment of the requirements of Contract NAS1-11100 and reports contract effort from October 1974 through July 1981. Phase V consisted of an in-service evaluation of the center wing boxes that were selectively reinforced with boron-epoxy composites and installed on two C-130H aircraft, AF73-01592 and AF73-01594. A total of 12 inspections were conducted on each of the 2 composite-reinforced center wings during Phase V. Completion of Phase V concludes all activities under contract NAS1-11100, and inspection procedures and calibration standards have been transmitted to the Air Force for use in additional inspections.

This contract is conducted under the sponsorship of the Materials Processing and Applications Branch of the Materials Division of the NASA Langley Research Center. Mr. H. Benson Dexter is the NASA Project Monitor. Mr. J. A. Kizer is the Lockheed-Georgia Company Program Manager. Messrs. D. H. Dysart, W. P. Lanier, and H. H. Woods of Lockheed-Georgia Company's Quality Assurance Organization made major contributions to the technical activities in Phase V.

Use of commercial products or names of manufacturers in this report does not constitute official endorsement of such products or manufacturers, either expressed or implied, by the National Aeronautics and Space Administration.

PRECEDING PAGE BLANK NOT FILLED

## ABSTRACT

One of the most advantageous structural uses of advanced filamentary composites has been shown, in previous studies, to be in areas where selective reinforcement of conventional metallic structure can improve static strength/fatigue endurance at lower weight than that possible if metal reinforcement were used. These advantages have been demonstrated by design, fabrication, and test of three boron-epoxy reinforced C-130H center wing boxes. This structural component was previously redesigned using an aluminum build-up to satisfy the increased severity of fatigue loadings.

All phases of this five-phase NASA program to demonstrate the long-time flight service performance of a selectively reinforced center wing box have been completed. During Phase I, the advanced development work necessary to support detailed design of the composite-reinforced C-130H center wing box was conducted. Activities included the development of a basis for structural design selection and verification of materials and processes, manufacturing and tooling development, and fabrication and test of full-scale portions of the center wing box. Phase I activities are documented in NASA CR-112126.

Phase II activities consisted of preparing detailed design drawings, and conducting necessary analytical structural substantiation including static strength, fatigue endurance, flutter, and weight analyses. Some additional component testing was conducted to verify the design for panel buckling, and to evaluate specific local design areas. Development of the "cool tool" restraint concept was completed, and bonding capabilities were evaluated using full-length skin panel and stringer specimens. Phase II activities are reported in NASA CR-112272.

Phase III activities consisted of the fabrication of three C-130H center wing boxes, selectively reinforced with boron-epoxy composites. The first of the center wing boxes was delivered to the Structural Test Laboratory for fatigue testing. The remaining two center wing boxes were installed on Air Force C-130 aircraft Serial Numbers AF73-01592 and AF73-01594 to demonstrate the long-time flight worthiness of advanced-composite-reinforced aluminum alloy structures. Phase III activities are reported in NASA CR-132495.

Phase IV activities principally consisted of ground and acceptance tests of the three C-130 center wing boxes. Fatigue testing of the center wing test article was completed through four simulated lifetimes with no failures in boron-epoxy laminates or their bondlines. After completion of the fatigue test, an additional proof load test was successfully conducted on the center wing test article applying the limit load upbending condition. Artificial damage was inflicted in the center wing test article at 12 locations after completion of the proof load test, and a crack growth test was conducted using the same cyclic loads spectrum applied in the 4 lifetimes of fatigue testing. Upon completion of the crack growth test, a residual strength test was performed on the center wing test article. The first of the C-130H aircraft, Serial Number AF73-01592, on which the composite-reinforced center wing was installed, was ground vibrated to establish that existing flutter speeds had not been affected by the wing modification. Also, flight acceptance tests were conducted on both C-130H aircraft on which the composite-reinforced center wings are installed. Phase IV activities are reported in NASA CR-145043.

PRECEDING PAGE BLANK NOT FILMED

During Phase V, inspections of the composite-reinforced center wings were conducted over the flight service monitoring period of more than 6 years by Lockheed Quality Assurance personnel. Twelve inspections were conducted on each of the two C-130H airplanes having composite-reinforced center wing boxes. One of the 12 inspections was conducted coincident with a periodic depot maintenance (PDM) inspection. No defects were detected in any of the inspections, and the program was judged to be highly successful.

## TABLE OF CONTENTS

	<u>Page</u>	
1.0	SUMMARY	1
2.0	INTRODUCTION	4
3.0	ORIENTATION MEETING ON IN-SERVICE EVALUATIONS	7
4.0	IN-SERVICE INSPECTION PROCEDURES	8
	4.1 General	8
	4.2 Preparation of Airplane	8
	4.3 Safety Precautions	11
	4.4 Visual Inspections	11
	4.5 Contact Ultrasonic Inspections	11
	4.5.1 Ultrasonic Equipment	11
	4.5.2 Calibration of Equipment	13
	4.5.3 Inspection Procedures	17
5.0	SUMMARY OF INSPECTION RESULTS	23
6.0	CONCLUSIONS	27
	REFERENCES	28

## LIST OF FIGURES

<u>No.</u>		<u>Page</u>
1	Program Schedule	4
2	C-130 Center Wing Box Locations	5
3	Composite Reinforcement Concept	5
4	Exterior Areas of Boron-Epoxy Reinforced Center Wing to be Inspected	9
5	Interior Areas of Boron-Epoxy Reinforced Center Wing to be Inspected	10
6	Sonic Mark I Flaw Detector	12
7	Sperry UM715 Reflectoscope	12
8	Calibration Standards for Contact Ultrasonic Equipment	13
9	Calibration Standard for Boron-Epoxy Reinforcement/Aluminum Skin Bondlines	14
10	Calibration Standard For Boron-Epoxy Reinforcement/Aluminum Stringer Crown Bondlines	15
11	CRT Signal Presentations for Bondline Conditions	16
12	Definition of Nearside and Farside Disbonds	17
13	Center Wing Upper Surface Bondline Locations	18
14	Cross Sections of Center Wing Upper Surface Bondline Locations	19
15	Center Wing Lower Surface Bondline Locations	20
16	Typical Wing Station 220 Joint Area Configuration	22

## LIST OF TABLES

<u>No.</u>		<u>Page</u>
I.	C-130H Composite-Reinforced Center Wing Inspections - AF73-01592	24
II.	C-130H Composite-Reinforced Center Wing Inspections - AF73-01594	25



**PROGRAM FOR ESTABLISHING LONG-TIME FLIGHT SERVICE PERFORMANCE  
OF COMPOSITE MATERIALS IN THE CENTER WING STRUCTURE OF C-130 AIRCRAFT**

**PHASE V - FLIGHT SERVICE AND INSPECTION**

By J. A. Kizer

**1.0 SUMMARY**

One of the most advantageous structural uses of advanced filamentary composites is in areas where selective reinforcement of conventional metallic structure can improve static strength/fatigue endurance at lower weight than would be possible if metal reinforcement were used. A five-phase program was conducted to demonstrate the long-time flight service performance of selectively reinforced center wing boxes for C-130H aircraft. Composite-reinforced wing boxes were installed on two C-130H aircraft, and excellent performance was achieved in a flight service program which was begun in October 1974. In that time period no defects of any kind were detected during periodic inspections of the composite-reinforced center wings.

During the first phase of program activity, the advanced development work necessary to support detailed design of a composite-reinforced C-130H center wing box was conducted. Activities included the development of a basis for structural design, selection and verification of materials and processes, manufacturing and tooling development, and fabrication and test of full-scale portions of the center wing box. Phase I activities have been previously documented in NASA CR-112126, Reference 1.

During Phase II, the basic C-130E aluminum center wing box design was changed by removing aluminum and adding unidirectional boron-epoxy reinforcing laminates bonded to the crown of the hat stiffeners and to the skin under the stiffeners. The laminates were added in a nominal 80/20 area ratio of aluminum to boron/epoxy. A weight savings of 205 kg (450 lb) was achieved which is approximately nine percent of the weight of the production aluminum center wing box.

Sufficient material was provided to meet ultimate load requirements of the C-130E wing box and the fatigue life of the C-130 B/E Wing Box.\* Detailed

\* NOTE: The terminology "C-130 B/E" or "B/E" refers to the existing metallic center wing box which is installed in Model C-130B, C-130-E, and C-130H aircraft. The C-130H is the designation of the aircraft model currently in production. This aircraft has the metal-reinforced center wing which has been retrofitted to a sizeable part of the total C-130 fleet. The two composite-reinforced center wing boxes (flight articles) were installed in C-130H aircraft. In this report, the "B/E" designation always refers to an aircraft model and never means boron-epoxy. Where boron-epoxy is discussed, the words are not abbreviated.

substantiating structural, fatigue, and flutter analyses were conducted to assure structural integrity of the reinforced center wing box. Phase II activities are fully reported in NASA CR-112272, Reference 2.

In Phase III three composite-reinforced center wing boxes were fabricated, one for ground tests, and two for installation on C-130H aircraft for flight evaluation. During fabrication of the wing boxes, boron-epoxy laminates were laid up, cured, and bonded to the metal adherends to form subassemblies. These subassemblies along with fabricated metal parts were assembled into complete wing boxes in the normal C-130 production flow. Throughout the fabrication and assembly activity, thorough inspections were conducted by both Lockheed and Air Force inspectors to assure a high-quality flight product. First Article Configuration Inspections (FACI) were conducted on both flight articles to verify that all requirements had been satisfied. The first flight article was installed in C-130H Serial No. AF73-01592 (Lockheed Serial No. 4557) in June 1974, and the second flight article was installed in C-130H Serial No. AF73-01594 (Lockheed Serial No. 4563) in July 1974. Phase III activities have been previously documented in NASA CR-132495, Reference 3.

During Phase IV, the ground and flight acceptance tests were conducted. The ground tests consisted of proof load tests, a four-lifetime fatigue test, a crack growth test, and a residual strength test. In the residual strength test, the damaged wing test article was static tested to 133 percent design limit load at which time the test was suspended because the stroke on a major hydraulic loading jack was exhausted.

Ground vibration tests were conducted on C-130H (Serial No. AF73-01592) aircraft on which the first composite-reinforced center wing was installed. The purpose of these tests was to verify that existing C-130 aircraft flutter speeds had not been affected by the wing modification. One set of measurements was taken with shakers mounted at each wing tip and another set taken with the shakers mounted at the aft end of each external fuel tank. Plots of output acceleration versus frequency were made to identify the resonant frequencies. The resonant frequencies obtained from these vibration tests were compared with similar results from an aircraft with an all-metal center wing. It was concluded from the comparative results that the vibration characteristics of the aircraft with the composite-reinforced center wing are essentially the same as those for the aircraft with the all-metal center wing.

Flight acceptance tests were conducted on both C-130H aircraft on which the composite-reinforced center wings were installed. After pre-flight functional tests, flight tests were conducted which consisted of the normal flight activities associated with delivery of C-130H aircraft to the United States Air Force. No specific problems associated with the composite-reinforced center wings occurred in either of the C-130H aircraft during the flight acceptance tests. Upon delivery of the first C-130H having a composite-reinforced center wing, one and a half lifetimes of fatigue loads had been applied to the ground test article. The Phase IV activities have been previously documented in NASA CR-145043, Reference 4.

In the fifth phase of the program, the two C-130H airplanes with the composite-reinforced center wings were used in the same operational environment

as other C-130H aircraft assigned to the same airlift wing. Periodic inspections were conducted on the composite-reinforced center wings coincident with phased or isochronal inspections of the aircraft. Twelve inspections were performed to each of the two composite-reinforced center wings which included one inspection that was conducted coincident with a periodic depot maintenance (PDM) inspection on the aircraft. The inspections were accomplished over a period of approximately 6-1/2 years and no defects were detected during the entire period.

2.0 INTRODUCTION

Application studies and Advanced Development tests (References 5 and 1, respectively), conducted for NASA by Lockheed, have shown that boron-epoxy composite laminates bonded to the skin and stiffeners of the C-130 aircraft center wing box can significantly improve the overall fatigue endurance of the structure, at a lower weight than that possible if metal reinforcements were used to achieve the same endurance levels. These advantages have been demonstrated by designing, fabricating, ground testing and flight service evaluating 3 boron-epoxy reinforced C-130H center wing boxes, in a 5-phase program extending over 10 years. The program phases and associated schedules are presented on Figure 1. Successful flight service experience allowed 2 Phase V extensions which increased the program span from 5 1/2 years to 10 years. Documentation of program activities is included in this report and in References 1 through 4.

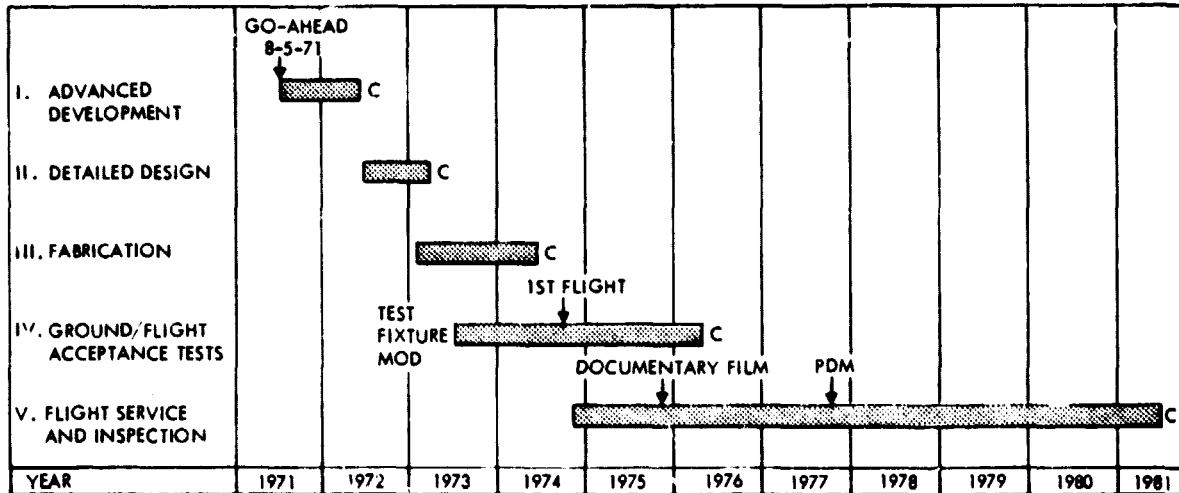

Figure 1. Program Schedule

The center wing box size and location in the C-130 aircraft are illustrated in Figure 2. It is 11.2 m (440 in.) in length, 2.03 m (80 in.) in chord and, in the all-metal configurations, weighs approximately 2243 kg (4944 lb). The center wing box consists of upper and lower surfaces that are reinforced with hat-shaped stringers, the forward and aft wing beams, and truss-type ribs.

During Phase I, the advanced development work necessary to support detailed design of a composite-reinforced C-130 center wing box was conducted. Activities included the development of a basis for structural design, selection of materials and processes, manufacturing and tooling development, and fabrication and test of full-scale portions of the center wing box. The Phase I results further confirmed that, with boron-epoxy reinforcements as shown in Figure 3, equivalent static strength and fatigue endurance could be provided with a significant weight savings. The aluminum skins and stringers have thicknesses less than those of the existing metallic center wing box in Model C-130B/E aircraft. Equivalent strength is provided by the unidirectional boron-epoxy composite.

ORIGINAL PAGE IS  
OF POOR QUALITY

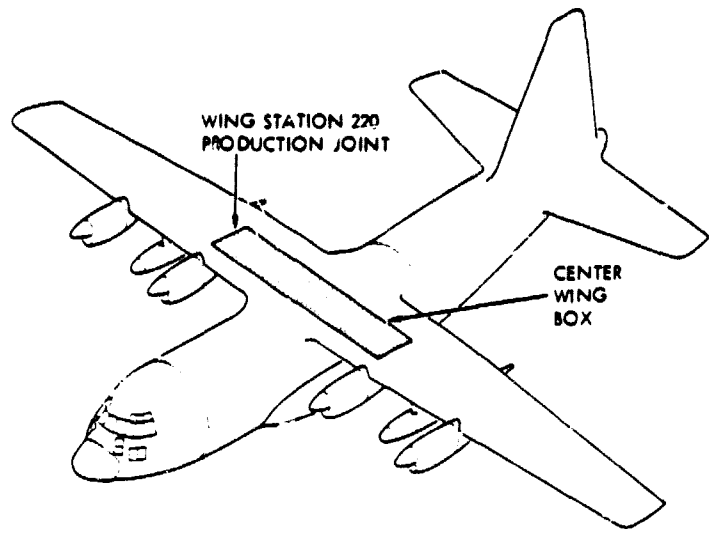

Figure 2. C-130 Center Wing Box Locations

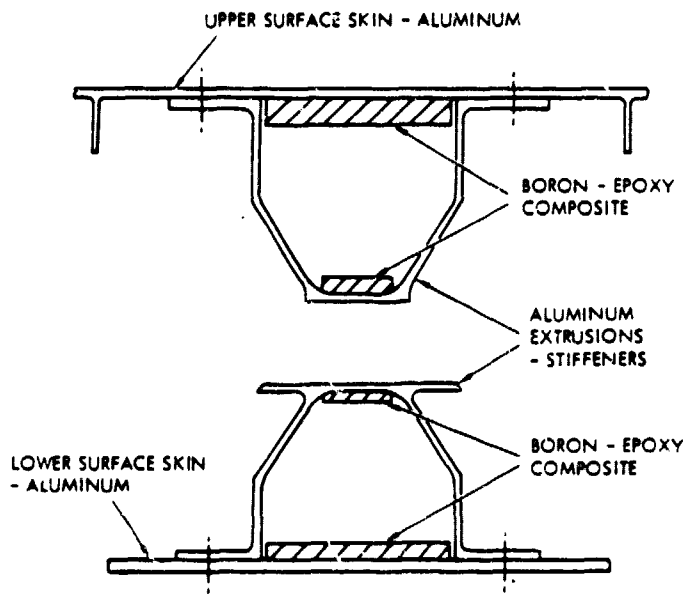

Figure 3. Composite Reinforcement Concept

Phase II activities consisted of preparing detailed design drawings and conducting the substantiating static strength, fatigue endurance, flutter, and weight analyses required for proceeding into Phase III wing box fabrication. Some additional component testing was conducted to complete the panel buckling evaluation and to evaluate specific local design concepts. Tooling development activities were continued to further refine the "cool tool" concept and to evaluate residual stresses with full-length skin panels and stringers. The final design configuration is structurally and functionally interchangeable with the production C-130B/E wing box.

In Phase III, fabrication and assembly of three composite-reinforced center wing boxes were completed. The first of the wing boxes was fabricated for ground testing. After a joint USAF-NASA-Lockheed configuration review, the remaining two center wing boxes were released for installation in two Air Force C-130H aircraft to be flight evaluated in regular operational service by the Military Airlift Command. During fabrication and assembly of the composite-reinforced center wing boxes, thorough visual and ultrasonic inspections were conducted by Lockheed and Air Force inspectors to assure that the final product was of high quality. In addition, the reliability and quality assurance program, continued in Phase III, concluded that a high degree of hardware conformance to detail design was achieved.

During Phase IV, the ground and flight acceptance tests were conducted. The ground tests consisted of proof load tests, a fatigue test, a crack growth test, and a residual strength test on the composite-reinforced wing box test article. Also, the first wing box to be flight evaluated was ground vibrated for comparison of resonant frequencies with those of the all-metal production wing boxes. The purpose of the ground vibration tests was to establish that existing C-130 aircraft flutter speeds had not been affected by the wing modification. Also, flight acceptance tests were conducted on both C-130 aircraft on which the composite-reinforced center wings were installed. In addition, baseline inspections were conducted on each of the composite-reinforced center wings installed on the two C-130H airplanes prior to delivery of the airplanes to the Air Force. A reliability and quality assurance program was continued in accordance with the approved program plan. No disbonds were detected in four lifetimes of fatigue testing of the ground test article.

During Phase V, the two C-130H aircraft with the composite-reinforced center wings were evaluated in an operational environment after delivery of the airplanes to Little Rock Air Force Base in late 1974. Periodic inspection of the composite-reinforced center wings were performed by Lockheed Quality Assurance personnel using inspection procedures and calibration standards developed during the earlier phases of the program. The center wing inspections were conducted coincident with aircraft phased and isochronal inspections. A total of 12 inspections were conducted on each of the 2 composite-reinforced center wings over a period of approximately 6-1/2 years. One of the 12 inspections was conducted coincident with a periodic depot maintenance (PDM) inspection at Warner Robins Air Logistics Command, Robins AFB, Georgia. Air Force maintenance personnel provided assistance in preparation of the airplane for each inspection. After each inspection, letter-type inspection reports were prepared and copies were distributed to the various governmental agencies.

### 3.0 ORIENTATION MEETING ON IN-SERVICE EVALUATIONS

Prior to the first inspection of the composite-reinforced center wing installed on C-130H aircraft, Serial No. AF73-01592, Air Force maintenance and operations personnel at Little Rock Air Force Base, Jacksonville, Arkansas, were briefed on both developmental (Phases I, II, III, and IV) and flight service (Phase V) phases of the C-130 composite-reinforced center wing box program. The organizations participating in the orientation meeting consisted of representatives from the NASA-Langley Research Center, Tactical Air Command Headquarters, 314th Tactical Airlift Wing at Little Rock Air Force Base, Air Force Systems Command, and the Lockheed-Georgia Company. The Lockheed-Georgia Company program manager made a presentation covering the significant areas of the program developmental and flight service phases. During this presentation, necessary support by Air Force maintenance personnel to Lockheed inspection personnel in accomplishing the inspections was delineated. Subsequent to the briefing, a coordination meeting was held at which agreements were reached on the support required from the Air Force during each inspection. The following is a list of those items upon which agreements were reached.

1. Notification of Lockheed-Georgia Company and NASA-Langley Research Center at least five working days prior to a scheduled inspection to allow sufficient time to make travel arrangements.
2. Make the aircraft available to Lockheed inspection personnel at Little Rock Air Force Base for a period of two days and one night prior to the regular aircraft inspection for conducting visual and ultrasonic inspections of the composite-reinforced center wing box.
3. Wash the exterior surfaces of the aircraft center wing prior to inspecting it by Lockheed inspection personnel.
4. Remove and reinstall access doors over the dry bay regions of the center wing box and insulation blankets on the lower surface of the center wing box in the interior of the aircraft.
5. Furnish appropriate work stands, lighting, and electrical power sources as required.
6. Supply portable x-ray equipment if required.

## 4.0 IN-SERVICE INSPECTION PROCEDURES

In-service inspection procedures were developed in the developmental phases of the program, and they are documented in Service Manual Publication (SMP) No. 881 (Reference 6). Copies of SMP No. 881 were furnished to WR/ALC, Robins Air Force Base, and the Military Airlift Command, Scott Air Force Base. In addition, copies of SMP No. 881 were furnished to the Maintenance Control Unit of the 314 Tactical Airlift Wing, Little Rock Air Force Base, for inclusion in the logs of the two C-130 aircraft. Both inspection procedures and repair instructions are included in SMP No. 881 for use in inspection and repair of the boron-epoxy reinforced center wing surface panels by Air Force maintenance and repair depot centers.

The inspection procedures in SMP No. 881 are documented herein for record purposes.

### 4.1 General

All accessible boron-epoxy reinforcement bondlines in the center wing box section will be inspected using contact ultrasonic equipment. Visual inspections will be made over 100 percent of the accessible surfaces of the center wing box section concurrent with the ultrasonic inspection.

Cross-sections of the boron-epoxy reinforced center wing structure are shown in Figure 3 for both upper and lower wing surface panels. Note that the boron-epoxy reinforcements will not be visible to the inspector and that the contact ultrasonic inspection will be performed with the ultrasonic equipment transducer in contact with the aluminum structure (i.e., aluminum skin or aluminum hat-section stringer). The boron-epoxy reinforcements are located at stringers number 1 through number 11 of the center wing upper surface and at stringers number 12 through number 24 of the center wing lower surface. All boron-epoxy reinforcement straps are unidirectional laminates that were cured before they were bonded to the aluminum wing surface skins and aluminum hat-section stringers.

Figures 4 and 5 show the areas of the boron-epoxy reinforced center wing section to be inspected. Figure 4 shows the exterior surface areas to be inspected, and Figure 5 shows accessible interior areas to be inspected. Note that the access door located on the upper surface of the center wing will have to be removed to gain access to the dry bay area to inspect the hat-section stiffener/boron-epoxy reinforcement bondlines. It is further noted that fuel bladder cells have to be removed to have total access to all boron-epoxy reinforcements.

### 4.2 Preparation of Airplane

The airplane center wing will be prepared for inspection as described in the following paragraphs:

1. Thoroughly wash center wing exterior surfaces to remove all foreign materials, such as dirt or grit, which could prevent intimate contact between the ultrasonic equipment transducer and the surfaces of the



ORIGINAL PAGE IS  
OF POOR QUALITY

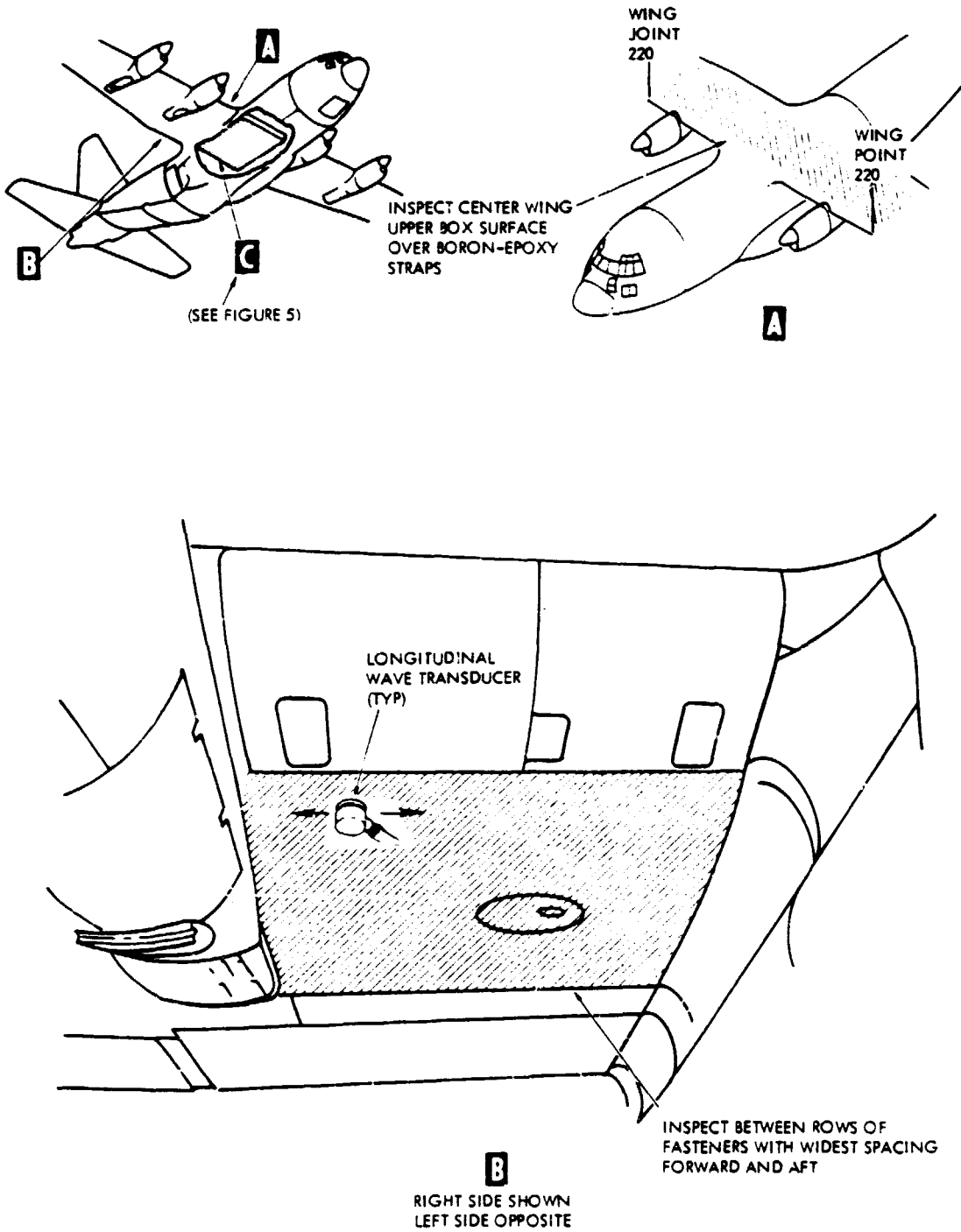

Figure 4. Exterior Areas of Boron-Epoxy Reinforced Center Wing to be Inspected

ORIGINAL PAGE IS  
OF POOR QUALITY.

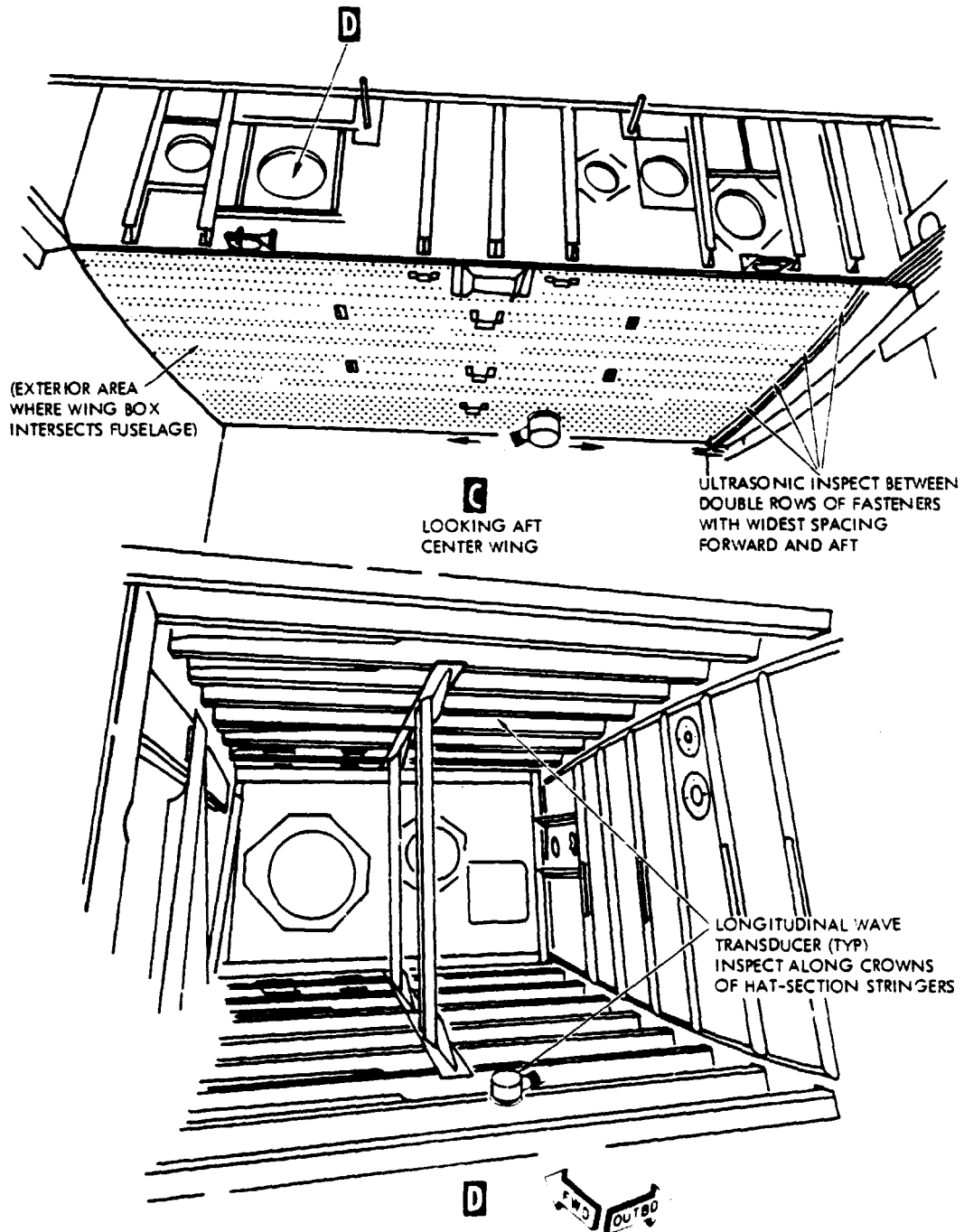

Figure 5. Interior Areas of Boron-Epoxy Reinforced Center Wing to be Inspected

wing. Refer to Air Force Technical Order 1C-130B-2-2 for washing procedures.

2. Turn off electrical power in the aircraft except the lighting circuits required to illuminate the cargo compartment in the vicinity of the center wing.
3. Remove access doors located on the upper surface of the center wing to gain access to the dry bay areas beneath.
4. Remove insulation blankets from the lower surface of the center wing inside the cargo compartment.

#### 4.3 Safety Precautions

Air Force Technical Order 1C-130A-36, Section I, is to be referred to for safety precautions, and Technical Order 33B-1-1 defines the precautions to be observed during nondestructive inspection procedures.

#### 4.4 Visual Inspections

The exterior surfaces and accessible interior surfaces of the boron-epoxy reinforced center wing will be visually inspected. All of these surfaces will be inspected for cracks in the surface finishes and for evidence of corrosion.

#### 4.5 Contact Ultrasonic Inspections

The following paragraphs describe the ultrasonic equipment, calibration of equipment, and inspection procedures for conducting the contact ultrasonic inspections.

##### 4.5.1 Ultrasonic Equipment

The Sonic Mark I Flaw Detector or the Sperry UM715 Reflectoscope, or equivalent, may be used to ultrasonically inspect the boron-epoxy reinforced center wing structure. The Sonic Mark I Flaw Detector is shown in Figure 6, and the UM715 Reflectoscope is depicted in Figure 7. In the early inspections conducted on the boron-epoxy reinforced center wing boxes, the Magnaflux PS702 Flaw Detector was used. However, later inspections were conducted with the newer Sonic Mark I and Sonic Mark IV Flaw Detectors.

A 5-mHz 0.635-cm (0.250-inch) diameter, longitudinal, SFZ transducer was used with all models of the contact ultrasonic equipment. A transducer produced by Automation Industries, Part Number 57A2214, or equivalent is acceptable for conducting the ultrasonic inspections.

Calibration standards for calibrating the contact ultrasonic equipment are shown in Figure 8.

The smaller of the two standards in Figure 8 was used for calibrating the contact ultrasonic equipment for inspecting the boron-epoxy-laminate/hat-section stringer crown bondlines. The larger of the two standards shown in Figure 8 was

ORIGINAL PAGE IS  
OF POOR QUALITY



Figure 6. Sonic Mark I Flaw Detector



Figure 7. Sperry UM715 Reflectoscope

ORIGINAL PAGE IS  
OF POOR QUALITY

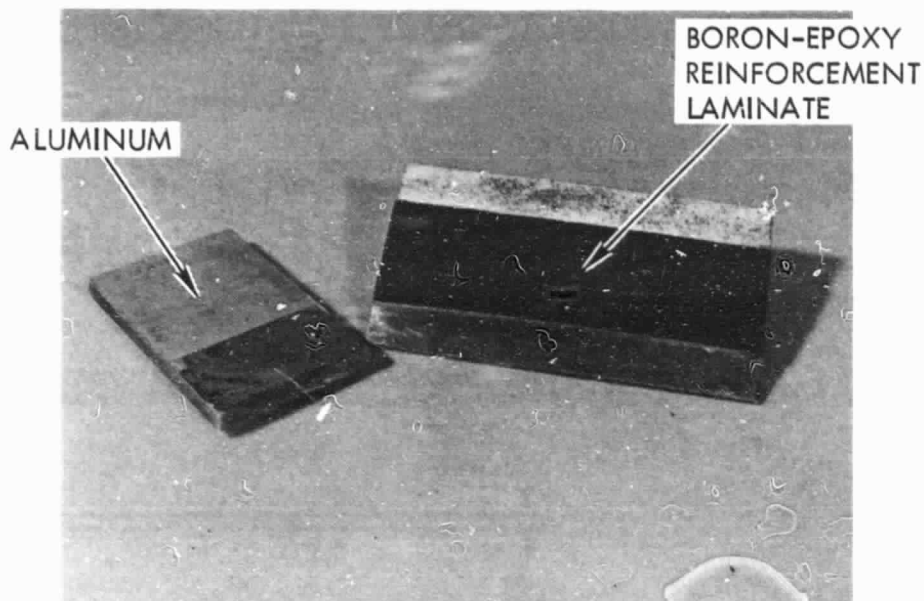

Figure 8. Calibration Standards for Contact Ultrasonic Equipment

used for calibrating the contact ultrasonic equipment for inspecting the boron-epoxy laminate/aluminum wing surface skin bondlines. This larger standard includes an area for calibration of the ultrasonic equipment for inspection of the walkway region of the upper wing surface as that region includes a non-skid coating that is thicker than the finish systems in other areas of the exterior wing surfaces. Figures 9 and 10 are engineering drawings of the two calibration standards shown in Figure 8. In Figure 9, the dimensions and materials are defined for fabricating the calibration standard for the boron-epoxy reinforcement laminate/aluminum wing surface skin bondlines. Figure 10 gives the dimensions and materials required for fabricating the calibration standard for the boron-epoxy reinforcement laminate/hat-section stringer crown bondlines.

#### 4.5.2 Calibration of Equipment

Calibration of the ultrasonic inspection equipment will be accomplished with the appropriate calibration standard shown in either Figures 9 or 10. The calibration standard shown in Figure 9 may be used to calibrate for either painted or unpainted single bondlines. The contact ultrasonic equipment will be calibrated as follows:

1. Apply a water-based couplant (Aerosol OT or mild commercial detergent) on appropriate area of the calibration standard.
2. Place the transducer on the known quality bondline area of the calibration standard.

**ORIGINAL PAGE IS  
OF POOR QUALITY**

**NOTE**

- ⚠ FOR ALUMINUM PARTS; SULFURIC ACID ANODIZE PER MIL-A-8625, TYPE II. SPRAY ONE COAT WASH PRIMER, MIL-C-8514, AND 2 COATS ZINC CHROMATE PRIMER, TT-P-1757.
- ⚠ ON PART 1; BRUSH APPLY WALKWAY COATING, MIL-W-5044 IN AREA "A". (COLOR NOT IMPORTANT).
- ⚠ BOND BORON-EPOXY TO ALUMINUM WITH AF127-3 ADHESIVE FOR A MINIMUM CURE CYCLE OF FOUR HOURS AT  $366^{\circ} \pm 5.6$  K ( $200^{\circ} \pm 10^{\circ}$  F)

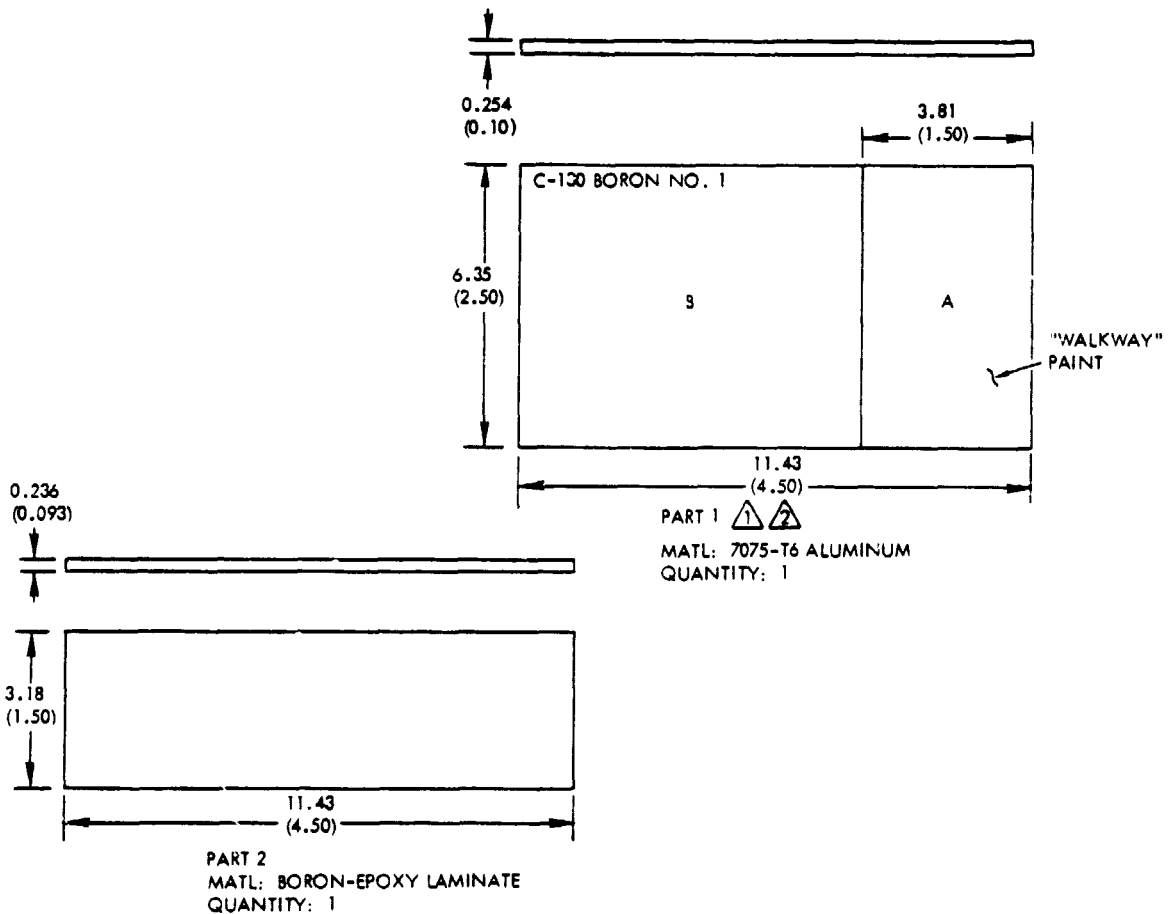
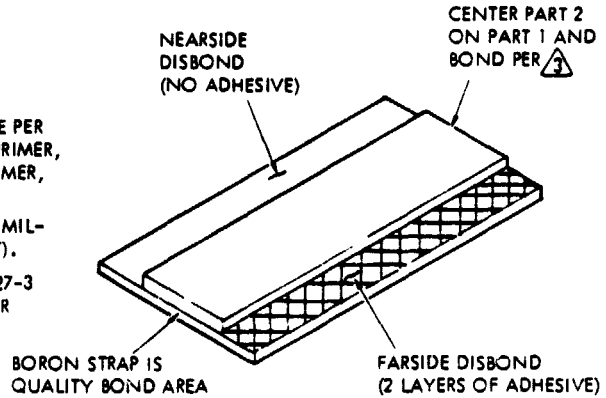
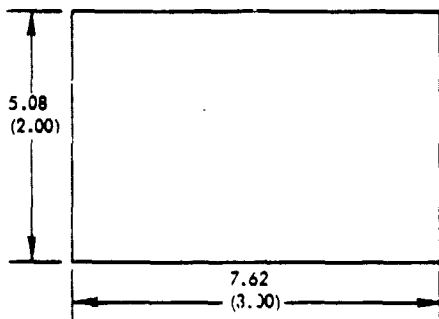
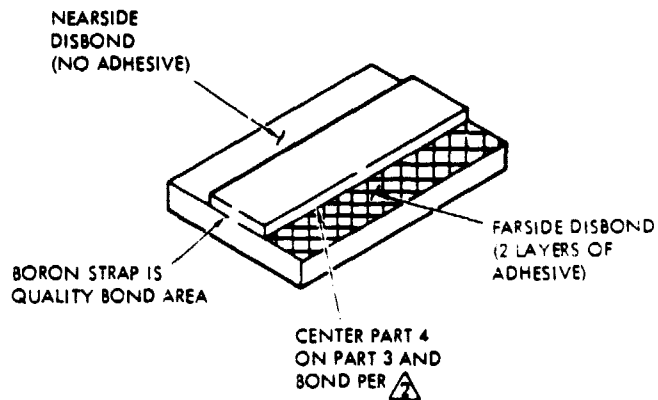
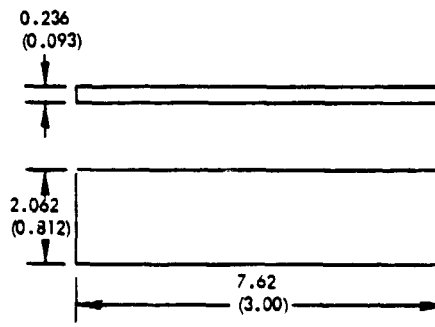

Figure 9. Calibration Standard for Boron-Epoxy Reinforcement/Aluminum Skin Bondlines

ORIGINAL PAGE IS  
OF POOR QUALITY



PART 3   
MATL: 7075-T6 ALUM.  
QUANTITY: 1



PART 4  
MATL: BORON-EPOXY  
LAMINATE  
QUANTITY: 1

**NOTE**

FOR ALUMINUM PARTS; SULFURIC ACID ANODIZE PER MIL-A-8625, TYPE II. SPRAY ONE COAT WASH PRIMER, MIL-C-8514, AND 2 COATS ZINC CHROMATE PRIMER, TT-P-1757.

BOND BORON-EPOXY TO ALUMINUM WITH AF127-3 ADHESIVE FOR A MINIMUM CURE CYCLE OF FOUR HOURS AT  $366^{\circ} \pm 5.6$  K ( $200^{\circ} \pm 10^{\circ}$  F).

Figure 10. Calibration Standard For Boron-Epoxy Reinforcement/Aluminum Stringer Crown Bondlines

**ORIGINAL PAGE IS  
OF POOR QUALITY**

3. Adjust sweep of the ultrasonic flaw detector to obtain a signal occupying approximately 50 percent of the cathode ray tube (CRT) screen. The signal for a quality bondline is shown in CRT Presentation No. 1 of Figure 11.
4. Place transducer over the nearside disbond area of the calibration standard.
5. Adjust the sweep delay/length controls of the flaw detector unit to obtain a ringing signal as shown in CRT Presentation No. 2 of Figure 11.
6. Place transducer over the farside disbond area of the calibration standard.
7. Adjust the sweep delay/length controls of the flaw detector unit to move all signals off the CRT screen as shown in CRT Presentation No. 3 of Figure 11.
8. Balance the gain and sweep controls until the nearside disbond rings out 100 percent, the good quality area covers approximately 50 percent of the CRT screen, and no signal is apparent on the CRT screen for farside disbonds, as illustrated in Figure 11.

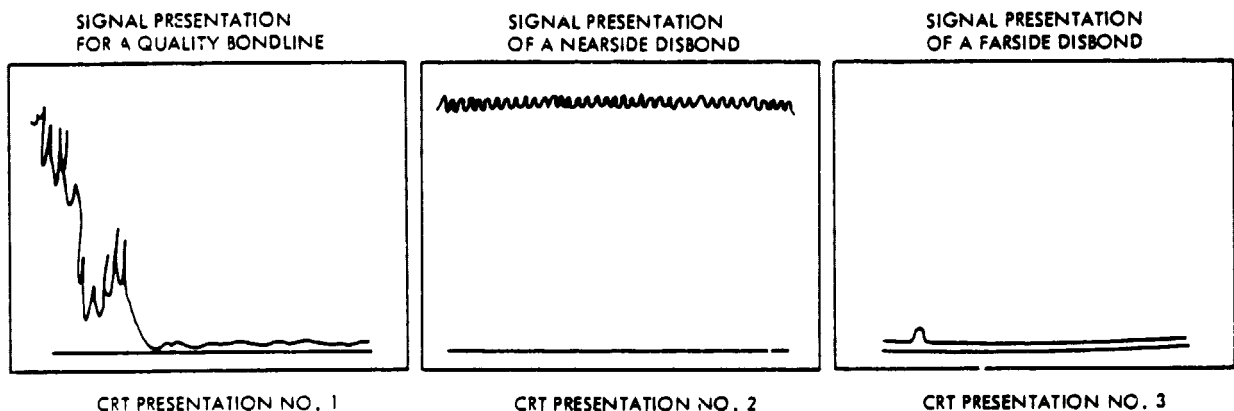

**Figure 11. CRT Signal Presentations for Bondline Conditions**

It is noted that attenuation by sealant, paint, finishes, material differences, etc., may cause a difference in sensitivity between the calibration standard and assembly being inspected. These differences will be determined and compensated for by adjustment of the flaw detector's gain control knob prior to conducting the inspection.

Definitions of nearside and farside disbonds are presented in Figure 12. The terminology of "nearside" and "farside" relates to the location of the flaw detector transducer in relation to the location of the disbond.



ORIGINAL PAGE IS  
OF POOR QUALITY

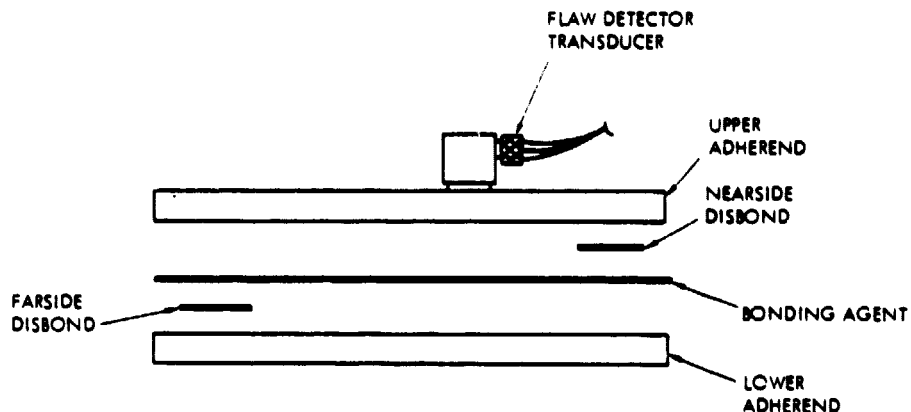
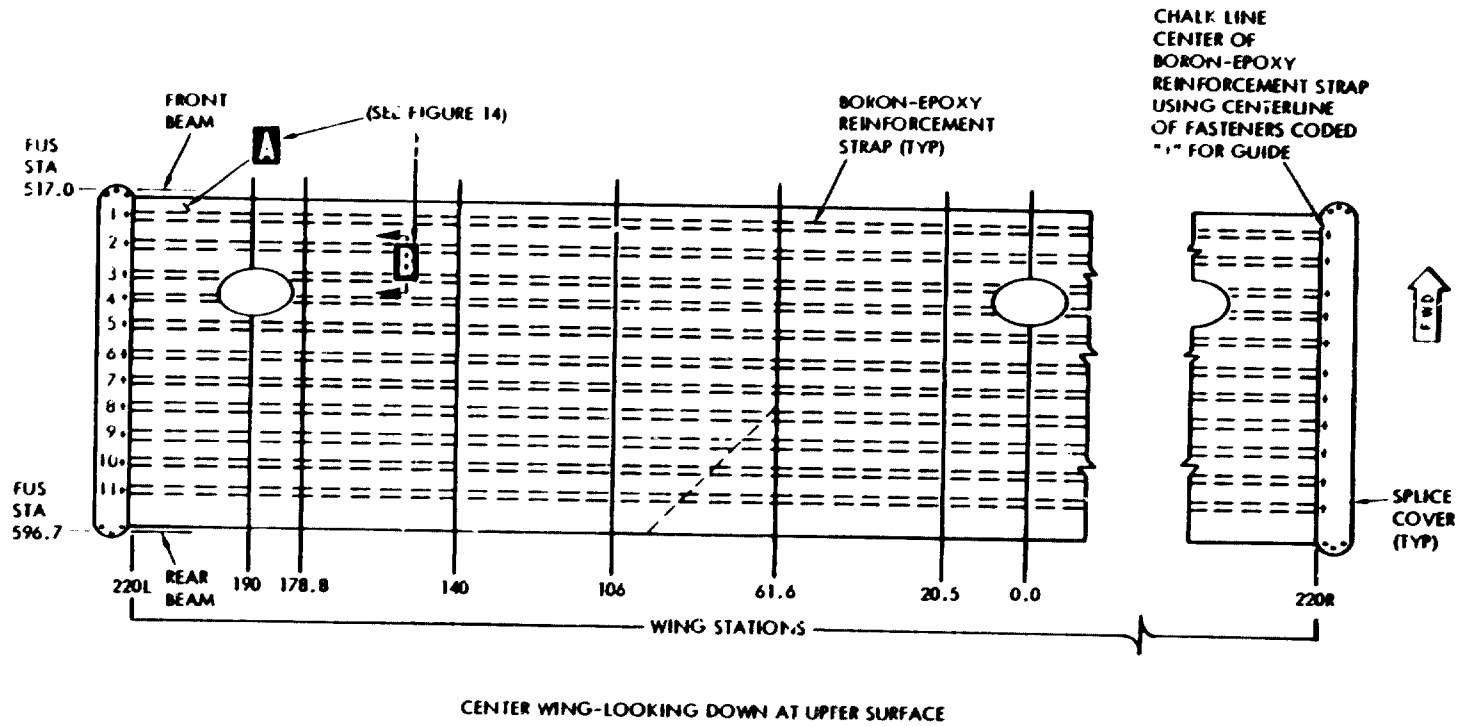

Figure 12. Definition of Nearside and Farside Disbonds

#### 4.5.3 Inspection Procedures

After the boron-epoxy reinforced center wing surfaces have been cleaned, the calibrated ultrasonic inspection equipment will be used to inspect the boron-epoxy reinforcement to metal surface bondlines as follows:

1. Locate the boron-epoxy reinforcement to upper wing surface bondlines and mark exterior wing surface with chalk lines as shown in Figure 13.
2. Apply couplant to the exterior surface of the upper center wing skin on areas along chalk lines as shown in Figure 14. Also, apply couplant to the accessible exterior surfaces of the crowns of the hat-section stringers as shown in Figure 14.
3. Scan the bonded areas of the boron-epoxy reinforced center wing, slowly moving the transducer over the bonded areas while observing the signal presentations on the CRT screen of the flaw detector. It is noted that while inspecting the boron-epoxy reinforced center wing, it is possible to check the calibration of the ultrasonic equipment. This may be accomplished by scanning several areas of the wing surface and observing the signal presentations on the CRT screen. For example, when the transducer is located over wing surface skin between hat-section stringers, the signal presentation on the CRT screen should appear as a nearside disbond as shown in Figure 11. When the transducer is located over an adhesive "squeeze out" area as depicted in Figure 14, the signal presentation on the CRT screen should appear as a farside disbond as shown in Figure 11.
4. Locate the boron-epoxy reinforcement to lower wing surface bondlines by identifying the widest spaces between double rows of fasteners as shown in Figure 15.



ORIGINAL PAGE IS  
OF POOR QUALITY

Figure 13. Center Wing Upper Surface Bondline Locations

ORIGINAL PAGE 13  
OF POOR QUALITY

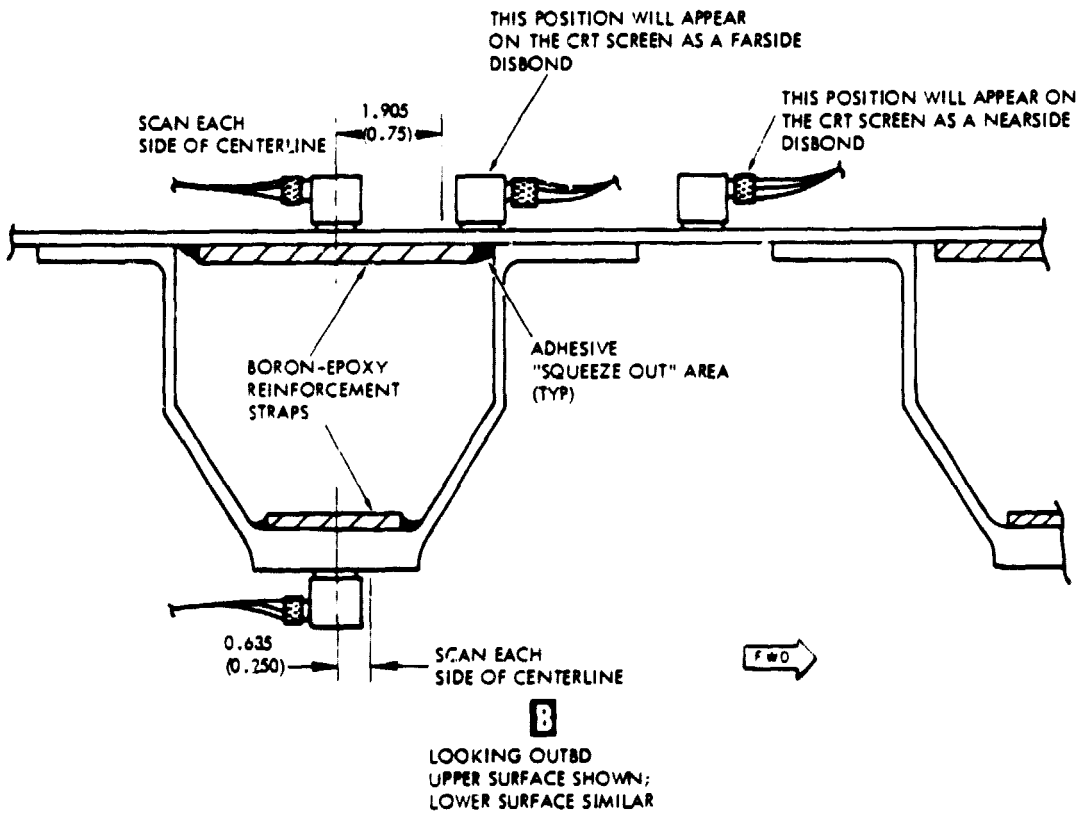
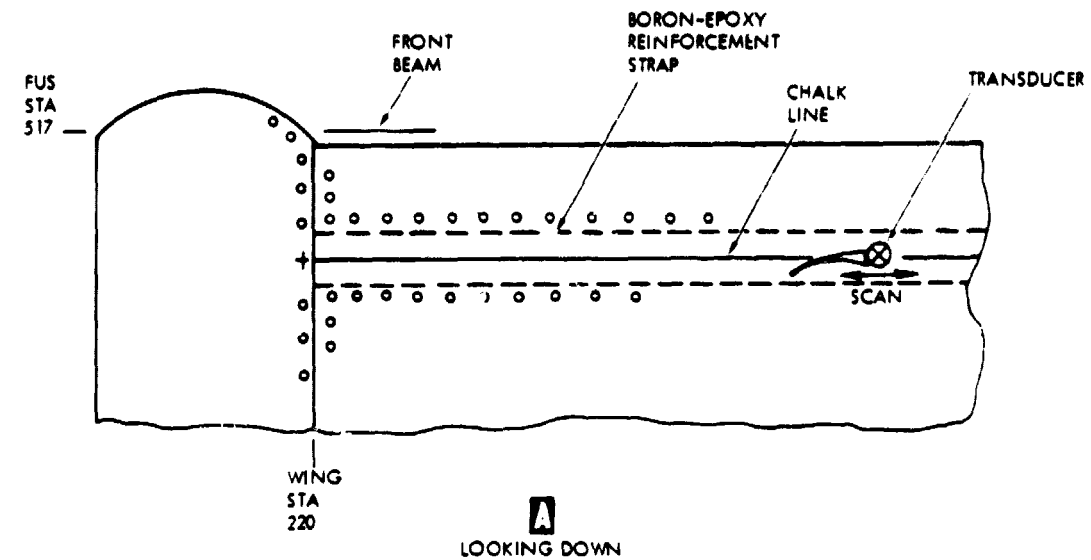

Figure 14. Cross Sections of Center Wing Upper Surface Bondline Locations

ORIGINAL PAGE IS  
OF POOR QUALITY

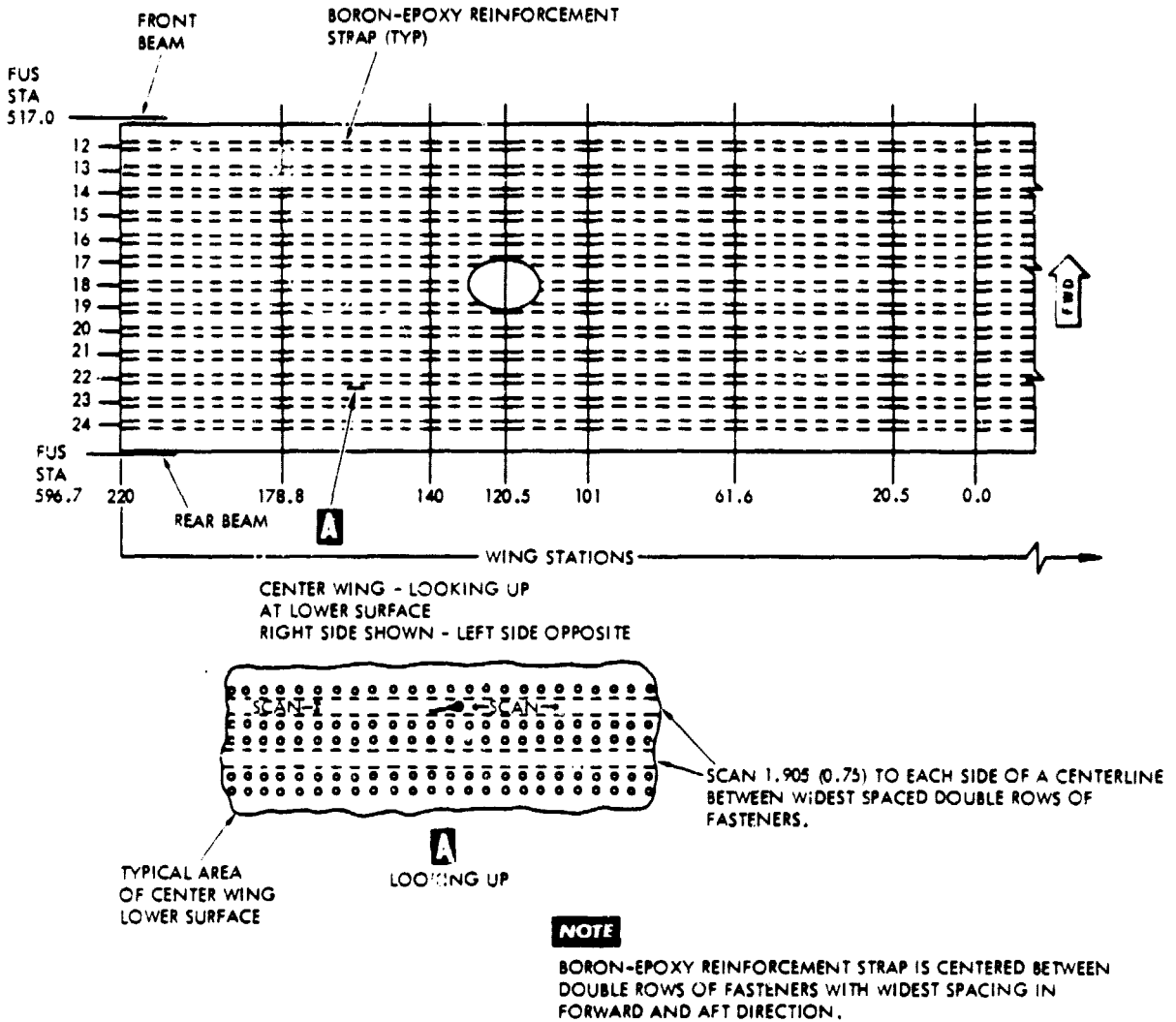

Figure 15. Center Wing Lower Surface Bondline Locations

5. Apply couplant to the exterior surface of the lower wing skin on the areas between rows of fasteners described in 4 above. Also apply couplant to the accessible exterior surfaces of the crowns of the hat-section stringers attached to the lower center wing skin.
6. Scan the bonded areas of the lower center wing surface assembly slowly moving the transducer over the bonded areas while observing the signal presentations on the CRT screen of the flaw detector.

The boron-epoxy reinforcement straps (laminates) are reduced in thickness at the ends of each strap. The reductions in thickness are accomplished by using subsequent boron-epoxy laminate plies of shorter lengths. In these reduced regions, the boron-epoxy laminate plies are interleaved with titanium shims as shown in Figure 16. The reduced cross-sectional areas at the ends of the boron-epoxy reinforcement straps will have a slight effect on the quality signal obtained during the ultrasonic inspection. As the reinforcement strap tapers in thickness, movement of the ultrasonic transducers along the tapered strap will result in a gradual change in the amplitude of the CRT signal. Thus, a different calibration standard is not required as comparison between the slightly changed quality signal and the disbond signal may be made along the tapered strap with the appropriate CRT presentations in Figure 11. Fasteners are installed in the boron-epoxy reduced thickness regions as shown in Figure 16 to resist any peeling force on boron-epoxy reinforcement strap to metal surface bondlines. The installation of fasteners in these regions has no effect on the ultrasonic inspection of the boron-epoxy reinforcement strap/aluminum structure bondlines other than reducing the area of the bondlines. In summary, both reduced area boron-epoxy reinforcement straps and fastener installations were evaluated during development of the ultrasonic inspection procedures and it was determined that the slight variations in CRT signal did not warrant fabrication of additional calibration standards.

7. Locate and mark all flaws and disbonds detected during inspections.
8. Repair flaws and/or disbanded areas using methods described in Section II of SMP 881 (Reference 6).

ORIGINAL PAGE IS  
OF POOR QUALITY

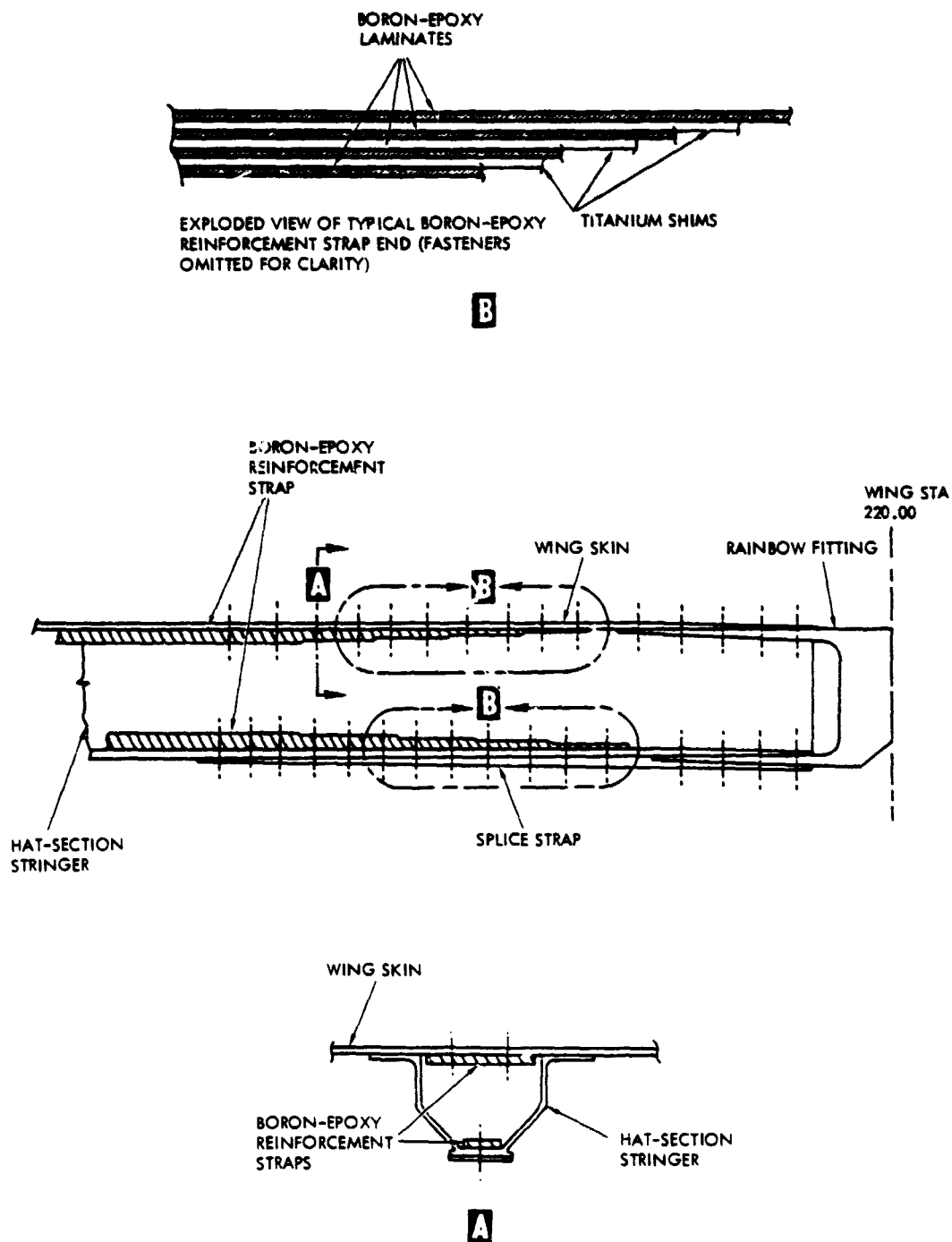

Figure 16. Typical Wing Station 220 Joint Area Configuration

## 5.0 SUMMARY OF INSPECTION RESULTS

Inspection results from inspection of the composite-reinforced center wing boxes installed on C-130H airplanes, Serial Nos. AF73-01592 and AF73-01594, are summarized in Tables I and II, respectively. All inspections were conducted at Little Rock Air Force Base, Jacksonville, Arkansas, with the exception of the inspections conducted coincident with the PDM inspections of the aircraft. The PDM inspections on both C-130H airplanes were conducted at WR/ALC, Robins Air Base, Georgia. In the 24 inspections (12 on each aircraft) conducted by Lockheed inspection teams, Air Force maintenance personnel performed all of the tasks agreed to in the coordination meeting held in the early days of Phase V in a timely and efficient manner. The tasks performed by Air Force maintenance personnel prior to and after each inspection, with the exception of the PDM inspections, are delineated in Section 3.0 of this report. The following additional tasks were performed by Air Force maintenance personnel during the inspections of the boron-epoxy reinforced center wings that were conducted coincident with the aircraft PDM inspections.

1. Removed and reinstalled access doors in the center wing lower surface at Wing Station 120, left and right, to provide access to the auxiliary fuel tanks.
2. Removed and reinstalled the six bladder fuel cells from the auxiliary fuel tanks, three cells on each side of the aircraft, and the backing boards on which the fuel cells rest.
3. Removed and reinstalled the aft nacelle fairings on Engines #2 and #3 nacelles.
4. Removed and reinstalled the lower wing-to-fuselage fairing on both sides of the fuselage.

In each of the 24 inspections, the same contact ultrasonic techniques employed in the baseline inspections were applied in each in-service inspection. In the first 8 in-service inspections of each aircraft, the Sperry UM715 Reflectoscope and the Magnaflux PS702 Flaw Detector, each with a 5 MHz 0.635-cm (0.250-inch) diameter transducer, were used in conducting the ultrasonic inspections. The more powerful UM715 Reflectoscope was used exclusively to inspect the upper wing surface bondlines because of the relatively thick non-skid finish on a significant portion of the upper wing surface area. All other bondlines were inspected using the PS702 Flaw Detector and the UM715 Reflectoscope. The remaining four inspections accomplished on each aircraft were conducted with the newer Sonic Mark I and the Sonic Mark IV equipment.

Upon completion of the 24 inspections, no bondline disbonds or voids were detected that exceeded the specification limits. The specification limits for adhesive bond quality are as follows:

1. The maximum allowable area of any individual disbond is  $0.323\text{-cm}^2$  ( $0.05\text{ inch}^2$ ).

TABLE 1. C-130H COMPOSITE-REINFORCED CENTER WING INSPECTIONS - AF73-01592

INSPECT. NO.	INSPECTION DATE		INSPECTION LOCATION	FLIGHT HOURS ACCUM.	RESULTS/COMMENTS
	PLANNED	ACTUAL			
1	Jan., 1975	1/9-10/75	L.R.A.F.B.*	162	No disbonds and surface finish breaks detected.
2	June, 1975	6/17-18/75	L.R.A.F.B.	551	No disbonds and surface finish breaks detected.
3	Oct., 1975	10/16-17/75	L.R.A.F.B.	826	No disbonds and surface finish breaks detected.
4	Mar., 1976	3/24-25/76	L.R.A.F.B.	1120	No disbonds and surface finish breaks detected.
5	Sept., 1976	9/23-24/76	L.R.A.F.B.	1581	No disbonds and surface finish breaks detected.
6	April, 1977	4/5-6/77	L.R.A.F.B.	1924	No disbonds and surface finish breaks detected.
7 (PDM)	Mar., 1978	3/13-17/78	R.A.F.B.**	2515	No disbonds and surface finish breaks detected.
8	Nov., 1978	11/29-30/78	L.R.A.F.B.	3021	No disbonds and surface finish breaks detected.
9	June, 1979	6/20-21/79	L.R.A.F.B.	3355	No disbonds and surface finish breaks detected.
10	Jan., 1980	1/22-23/80	L.R.A.F.B.	3965	No disbonds and surface finish breaks detected.
11	Aug., 1980	8/20-21/80	L.R.A.F.B.	4512	No disbonds and surface finish breaks detected.
12	Mar., 1981	3/17-18/81	L.R.A.F.B.	4889	No disbonds and surface finish breaks detected.

\* Little Rock Air Force Base, Jacksonville, Arkansas

\*\* Robins Air Force Base, Warner Robins, Georgia

ORIGINAL PAGE IS  
OF POOR QUALITY



TABLE II. C-130H COMPOSITE-REINFORCED CENTER WING INSPECTIONS - AF73-01594

INSPECT. NO.	INSPECTION DATE		INSPECTION LOCATION	FLIGHT HOURS ACCUM.	RESULTS/COMMENTS
	PLANNED	ACTUAL			
1	Feb., 1975	2/18-19/75	L.R.A.F.B. *	187	No disbonds or surface finish breaks detected.
2	July, 1975	7/29-30/75	L.R.A.F.B.	499	No disbonds or surface finish breaks detected.
3	Dec., 1975	12/4-5/75	L.R.A.F.B.	727	No disbonds or surface finish breaks detected.
4	May, 1976	5/19-20/76	L.R.A.F.B.	1064	No disbonds or surface finish breaks detected.
5	Nov., 1976	11/17-18/76	L.R.A.F.B.	1421	No disbonds or surface finish breaks detected.
6	June, 1977	6/14-15/77	L.R.A.F.B.	1913	No disbonds or surface finish breaks detected.
7 (PDM)	Mar., 1978	3/27-30/78	R.A.F.B. **	2522	No disbonds or surface finish breaks detected.
8	Feb., 1979	2/21-22/79	L.R.A.F.B.	3233	No disbonds or surface finish breaks detected.
9	Aug., 1979	8/29-30/79	L.R.A.F.B.	3714	No disbonds or surface finish breaks detected.
10	Apr., 1980	4/9-10/80	L.R.A.F.B.	4194	No disbonds or surface finish breaks detected.
11	Nov., 1980	11/4-5/80	L.R.A.F.B.	4734	No disbonds or surface finish breaks detected.
12	June, 1981	6/16-17/81	L.R.A.F.B.	5109	No disbonds or surface finish breaks detected.

ORIGINAL PAGE IS  
OF POOR QUALITY

\* Little Rock Air Force Base, Jacksonville, Arkansas

\*\* Robins Air Force Base, Warner Robins, Georgia

2. Disbonded areas shall not exceed 5 percent of the total bonded area of each detail assembly.
3. The distance between two adjacent disbonds shall not be less than four times the largest dimension of the largest disbond.
4. No detectable disbonded areas shall be within 0.318-cm (0.125 inch) of any bondline edge.

Visual inspection of all accessible composite-reinforced center wing box surfaces in all 24 inspections did not reveal any surface finish breaks or evidence of corrosion.

During the in-service evaluation period of more than 6-1/2 years, both aircraft were attached to the 314th Tactical Airlift Wing at Little Rock Air Force Base, Jacksonville, Arkansas. Both aircraft were rotated to West Germany on an assignment for several months in addition to performing frequent missions out of the contiguous continental limits of the United States of America. The aircraft were used for basic and proficiency training as well as cargo missions similar to other C-130H aircraft assigned to the 314th Tactical Airlift Wing. Each aircraft had accumulated more than 5000 flight hours upon completion of the in-service evaluation period.

## 6.0 CONCLUSIONS

In this five-phase program, it is concluded that selective reinforcement of metallic wing structures using filamentary composites can improve static strength/fatigue endurance. In addition, a significant weight savings of 205 kg (450 lb) was achieved. This concept was proven through design, manufacturing, ground testing, and flight service evaluations. The flight service evaluation phase, reported herein, was extremely successful. During a period of more than 6-1/2 years the two C-130H aircraft with composite-reinforced center wings accumulated more than 10,000 flight hours collectively without experiencing any problems. Twelve inspections were conducted on each of the two composite-reinforced center wings during the flight service period and no defects were detected by either visual or contact ultrasonic inspection. The successful performance of the C-130H aircraft with the composite-reinforced center wings allowed the transfer of the responsibilities of inspecting and maintaining these two aircraft to the U.S. Air Force user commands and depot maintenance centers. Written inspection procedures and repair techniques have been documented, and inspection procedures were demonstrated for the U.S. Air Force during one of the final inspections during the flight service evaluation phase.

## REFERENCES

1. Harvill, W. E., et al., "Program for Establishing Long-Time Flight Service Performance of Composite Materials in the Center Wing Structure of C-130 Aircraft: Phase I - Advanced Development," NASA CR-112126, Lockheed-Georgia Company, November 1972.
2. Harvill, W. E., et al., "Program for Establishing Long-Time Flight Service Performance of Composite Materials in the Center Wing Structure of C-130 Aircraft: Phase II - Detailed Design," NASA CR-112272, Lockheed-Georgia Company, April 1973.
3. Harvill, W. E., and Kays, A. O., "Program for Establishing Long-Time Flight Service Performance of Composite Materials in the Center Wing Structure of C-130 Aircraft: Phase III - Fabrication," NASA CR-132495, Lockheed-Georgia Company, September 1974.
4. Harvill, W. E., and Kizer, J. A., "Program for Establishing Long-Time Flight Service Performance of Composite Materials in the Center Wing Structure of C-130 Aircraft: Phase IV - Ground/Flight Acceptance Tests," NASA CR-145043, Lockheed-Georgia Company, September 1976.
5. Petit, P. H., "An Application Study of Advanced Composite Materials to the C-130 Center Wing Box," NASA CR-66979, Lockheed-Georgia Company, June 1970.
6. Service Manual Publication No. 881, "Structural Repair Instructions and Inspection Procedures for Boron-Reinforced Center Wing Skin Panels Installed on USAF C-130H Airplanes, Serial Nos. AF73-01592 and AF73-01594," Lockheed-Georgia Company, 1 June 1981.