

**NASA
Technical
Paper
2126**

March 1983

NASA
TP
2126
c.1

**Determination of Airplane
Model Structure From
Flight Data Using Splines
and Stepwise Regression**



Vladislav Klein and
James G. Batterson

LOAN COPY: RETURN TO
AFWL TECHNICAL LIBRARY
KIRTLAND AFB, N. M.

**NASA
Technical
Paper
2126**

1983

TECH LIBRARY KAFB, NM



0067650

Determination of Airplane Model Structure From Flight Data Using Splines and Stepwise Regression

Vladislav Klein

The George Washington University

Joint Institute for Advancement of Flight Sciences

Langley Research Center

Hampton, Virginia

James G. Batterson

Langley Research Center

Hampton, Virginia

NASA

National Aeronautics
and Space Administration

Scientific and Technical
Information Branch

SUMMARY

A procedure for the determination of airplane model structure from flight data is presented. The model is based on a polynomial spline representation of the aerodynamic coefficients, and the procedure is implemented by use of a stepwise regression. First, a form of the aerodynamic force and moment coefficients amenable to the utilization of splines is developed. Next, expressions for splines in one and two variables are introduced. Then the steps in the determination of an aerodynamic model structure and the estimation of parameters are discussed briefly. The focus of the paper is on the application to flight data of the techniques developed. Here, the parameters estimated from large-amplitude maneuvers are compared with a baseline set of parameter estimates from standard small-amplitude maneuvers and steady-state measurements. The model is further validated by comparing the predicted airplane motion with actual measured time histories. It is thus shown that the procedure represents a further step toward the determination of a global model of an airplane from flight data.

INTRODUCTION

A procedure is outlined in reference 1 for the determination of airplane model structure from flight data, including nonlinear aerodynamic effects. This procedure focuses on finding the form of and parameters in aerodynamic model equations using a modified stepwise regression and several decision criteria. The aerodynamic functions are approximated by polynomials in airplane response and input variables. The procedure described was successfully applied to small-amplitude maneuvers. When applied to large-amplitude longitudinal maneuvers, the data were first partitioned into subsets as a function of angle of attack. Then, each subset was analyzed separately. This approach, however, has only limited application. First, each data subset must have a sufficient number of data points for successful model determination. Second, for longitudinal maneuvers, the angle-of-attack intervals for individual subsets must not be so small that the functions vary so little that accurate parameter estimation would not be possible.

In large-amplitude and high-angle-of-attack maneuvers the behavior of aerodynamic functions in one region of angle of attack may be quite different from and totally unrelated to their behavior in another region. In these cases, the polynomial approximation for some aerodynamic nonlinearities would be inadequate. Polynomials are determined everywhere by their values in any interval, no matter how small. They can, therefore, follow a curve in one interval but depart from a curve or even oscillate widely elsewhere. Even if a higher-order polynomial approximates the aerodynamic function sufficiently, the increase in the number of terms can lead to large covariances of their estimates.

To avoid the disadvantages of the polynomial representation, spline functions can be used. Splines avoid some difficulties of polynomials because they are defined on preselected intervals and because the low-order terms may approximate various nonlinearities quite well. The application of splines to airplane model structure determination was first suggested in reference 2. Their use in real flight data analysis was then investigated, and the results are presented in references 3 to 6.

The purpose of this investigation was to examine the use of polynomial splines in one and two variables for postulating the aerodynamic model equations and for determining a model structure by using a stepwise regression. This report is an extension of the research reported in references 1, 5, and 6. The formulation of aerodynamic model equations and the definition of polynomial splines are discussed, followed by a discussion of model structure determination. The entire procedure is tested on several examples.

SYMBOLS AND ABBREVIATIONS

A_0, A_1	coefficients of polynomial $P(x_2)$
B_0	coefficient of polynomial $Q(x_1)$
b	wing span, m
C_a	general aerodynamic force and moment coefficient
C_h	coefficient of x^h in spline function of x
C_{hs}	coefficient of $x_1^h x_2^s$ in spline function of x_1, x_2
C_l	rolling-moment coefficient, $M_x / \bar{q} S b$
C_m	pitching-moment coefficient, $M_y / \bar{q} S \bar{c}$
C_n	yawing-moment coefficient, $M_z / \bar{q} S b$
C_x	longitudinal-force coefficient, $F_x / \bar{q} S$
C_y	lateral-force coefficient, $F_y / \bar{q} S$
C_z	vertical-force coefficient, $F_z / \bar{q} S$
\bar{c}	wing mean aerodynamic chord, m
D_i	coefficient of $(x_1 - x_{1i})_+^m$ in spline function of x_1
D_{ij}	coefficient of $(x_1 - x_{1i})_+^m (x_2 - x_{2j})_+^n$ in spline function of x_1, x_2
$D_{\alpha i}, D_{q i}, D_{\delta e, i}$	coefficients in spline function of $C_z(\alpha)$, $C_{z_q}(\alpha)$, and $C_{z_{\delta e}}(\alpha)$, respectively
F	F-statistic
F_x, F_y, F_z	forces along longitudinal, lateral, and vertical body axes, respectively, N
g	number of unknown parameters
h	lag number
k	number of spline knots over range of x_1
l	number of spline knots over range of x_2
2	

M	maximum lag number
M_X, M_Y, M_Z	rolling, pitching, and yawing moments, respectively, N-m
m	degree of polynomial spline in x_1
N	number of data points
n	degree of polynomial spline in x_2
$P(x_2)$	polynomial in x_2 of degree n
p	roll rate, rad/sec or deg/sec
$Q(x_1)$	polynomial in x_1 of degree m
q	pitch rate, rad/sec or deg/sec
\bar{q}	$= \frac{1}{2}\rho V^2$, kinetic pressure, Pa
R^2	squared multiple correlation coefficient
r	yaw rate, rad/sec or deg/sec
S	wing area, m^2
$S_m(x)$	polynomial spline in x of degree m
$S_{mn}(x_1, x_2)$	polynomial spline in x_1, x_2 of degree m in x_1 and degree n in x_2
s^2	estimated variance
t	time, sec
V	airspeed, m/sec
$W(h)$	autocorrelation function at lag h
x	general independent variable in one-variable spline approximation
$x(i)$	independent variable at time t_i
$(x_j - x_{ji})_+^m$	$= \begin{cases} 0 & \text{if } x_j < x_{ji} \\ (x_j - x_{ji})^m & \text{if } x_j > x_{ji} \end{cases}$
y	general dependent variable
$y(i)$	dependent variable at time t_i
α	angle of attack, rad or deg
$\bar{\alpha}$	midpoint of the α -interval of subset of partitioned data, rad or deg

β	angle of sideslip, rad or deg
δ_a	aileron deflection, rad or deg
δ_e	elevator deflection, rad or deg
δ_r	rudder deflection, rad or deg
$\epsilon(i)$	equation error at time t_i
θ_j	coefficient of general independent variable x_j
$v(i)$	residual value at time t_i
ρ	air density, kg/m ³
$\hat{\sigma}$	standard error of aerodynamic coefficient

Superscripts:

h, s	degree of a polynomial
\cdot	derivative with respect to time
$\hat{}$	estimate

Subscripts:

crit	critical
i or j	value at which spline knots occur
max	maximum value
p	partial

Abbreviations:

ML	maximum likelihood
MSR	modified stepwise regression

Aerodynamic derivatives referenced to a system of body axes with the origin at the airplane center of gravity:

$$C_{l_p} = \frac{\partial C_l}{\partial \frac{pb}{2V}}$$

$$C_{l_r} = \frac{\partial C_l}{\partial \frac{rb}{2V}}$$

$$C_{l_\beta} = \frac{\partial C_l}{\partial \beta}$$

$$C_{l_{\delta a}} = \frac{\partial C_l}{\partial \delta_a}$$

$$C_{l_{\delta r}} = \frac{\partial C_l}{\partial \delta_r}$$

$$C_{m_q} = \frac{\partial C_m}{\partial \frac{qc}{2V}}$$

$$C_{m_\alpha} = \frac{\partial C_m}{\partial \alpha} \quad C_{m_{\delta e}} = \frac{\partial C_m}{\partial \delta_e} \quad C_{n_p} = \frac{\partial C_n}{\partial \frac{pb}{2V}}$$

$$C_{n_r} = \frac{\partial C_n}{\partial \frac{rb}{2V}} \quad C_{n_\beta} = \frac{\partial C_n}{\partial \beta} \quad C_{n_{\delta a}} = \frac{\partial C_n}{\partial \delta_a}$$

$$C_{n_{\delta r}} = \frac{\partial C_n}{\partial \delta_r} \quad C_{x_q} = \frac{\partial C_x}{\partial \frac{qc}{2V}} \quad C_{x_\alpha} = \frac{\partial C_x}{\partial \alpha}$$

$$C_{x_{\delta e}} = \frac{\partial C_x}{\partial \delta_e} \quad C_{y_p} = \frac{\partial C_y}{\partial \frac{pb}{2V}} \quad C_{y_r} = \frac{\partial C_y}{\partial \frac{rb}{2V}}$$

$$C_{y_\beta} = \frac{\partial C_y}{\partial \beta} \quad C_{y_{\delta a}} = \frac{\partial C_y}{\partial \delta_a} \quad C_{y_{\delta r}} = \frac{\partial C_y}{\partial \delta_r}$$

$$C_{z_q} = \frac{\partial C_z}{\partial \frac{qc}{2V}} \quad C_{z_\alpha} = \frac{\partial C_z}{\partial \alpha} \quad C_{z_{\delta e}} = \frac{\partial C_z}{\partial \delta_e}$$

AERODYNAMIC MODEL EQUATIONS

For the determination of model structure and estimation of aerodynamic parameters, the analytical form of the aerodynamic model equations must be postulated. The expressions for coefficients of aerodynamic forces and moments used in this report are based on the following principal assumptions:

1. The instantaneous aerodynamic forces and moments depend only on the instantaneous values of response and input variables. That is, no unsteady aerodynamic effects are considered.
2. The dependence of longitudinal and lateral coefficients on response and input variables can be expressed as

$$C_a = C_a(\beta, \alpha, q, \delta_e) \quad (a = x, z, \text{ or } m)$$

and

$$C_a = C_a(\beta, \alpha, p, r, \delta_a, \delta_r) \quad (a = y, \ell, \text{ or } n)$$

3. The resulting aerodynamic coefficients are obtained as sums of contributions due to (α, β) , and $p, q, r, \delta_a, \delta_e,$ and δ_r . The second group of these contributions is, in general, α -dependent.

Considering the preceding assumptions, the aerodynamic model equations can be written as

$$C_a = C_a(\alpha, \beta)_{q=\delta_e=0} + C_{a_q}(\alpha) q\bar{c}/2V + C_{a_{\delta_e}}(\alpha) \delta_e \quad (a = X, Z, \text{ or } m) \quad (1)$$

and

$$C_a = C_a(\alpha, \beta)_{p=r=\delta_a=\delta_r=0} + C_{a_p}(\alpha) pb/2V + C_{a_r}(\alpha) rb/2V + C_{a_{\delta_a}}(\alpha) \delta_a + C_{a_{\delta_r}}(\alpha) \delta_r \quad (a = Y, \ell, \text{ or } n) \quad (2)$$

The expressions for the aerodynamic coefficients are similar to those used in wind-tunnel testing practice. The first terms on the right-hand side of equations (1) and (2) represent "static" parts with controls fixed at zero deflections. The remaining terms represent contributions of dynamic stability derivatives and control derivatives and their dependence on α . In equations (1) and (2), no $\dot{\alpha}$ and $\dot{\beta}$ terms are explicitly introduced because of their near-linear dependence on the remaining variables. The effects of $\dot{\alpha}$ and $\dot{\beta}$ are included primarily in contributions due to angular velocities.

The form of equations (1) and (2) indicates that each term in these equations can be approximated by a spline either in (α, β) variables or in the α variable. In longitudinal maneuvers with small lateral coupling, equation (1) can be further simplified by replacing the two-dimensional terms in (α, β) by two terms in α . These equations then take the form

$$C_a = C_a(\alpha)_{\beta=q=\delta_e=0} + C_{a_{\beta^2}}(\alpha) \beta^2 + C_{a_q}(\alpha) q\bar{c}/2V + C_{a_{\delta_e}}(\alpha) \delta_e \quad (a = X, Z, \text{ or } m) \quad (3)$$

Equations (2) and (3) represent fairly general formulation of aerodynamic coefficients. In each particular case, however, the postulated aerodynamic model equations should reflect any available a priori knowledge, based on wind-tunnel and/or theoretical aerodynamic data.

POLYNOMIAL SPLINES IN ONE AND TWO VARIABLES

Spline functions are defined as piecewise polynomials of degree m . When continuity restrictions are considered, the function values and derivatives agree at the points where the piecewise polynomials join. These points are called "knots" and are defined by the value of their projection onto the plane (or axis) of independent

variables. A polynomial spline of degree m with continuous derivatives up to degree $m - 1$ approximating a function $f(x)$ for $x \in [x_0, x_{\max}]$, can be expressed as

$$S_m(x) = \sum_{h=0}^m C_h x^h + \sum_{i=1}^k D_i (x - x_i)_+^m \quad (4)$$

where

$$(x - x_i)_+^m = \begin{cases} (x - x_i)^m & (x \geq x_i) \\ 0 & (x < x_i) \end{cases}$$

The values x_1, x_2, \dots, x_k are knots which obey the condition, $x_0 < x_1 < x_2 < \dots < x_k < x_{\max}$, and C_h and D_i are constants. The special case of equation (4) for $m = 0$ (a spline of degree zero) represents an approximation by piecewise constants.

The problem of multidimensional splines is addressed in reference 7. A space of these splines is constructed by taking the tensor product of one-dimensional spaces of polynomial splines. Because of the tensor nature of the resulting space, many of the simple algebraic properties of ordinary polynomial splines in one dimension are carried over. A spline in two variables x_1 and x_2 can be introduced for the approximation of a function $f(x_1, x_2)$ for $x_1 \in [x_{10}, x_{1\max}]$ and $x_2 \in [x_{20}, x_{2\max}]$. Then, as in the one-dimensional case, the two ranges $[x_{10}, x_{1\max}]$ and $[x_{20}, x_{2\max}]$ are subdivided by sets of knots x_{1i} and x_{2i} where

$$x_{10} < x_{11} < \dots < x_{1k} < x_{1\max}$$

$$x_{20} < x_{21} < \dots < x_{2\ell} < x_{2\max}$$

The points (x_{1i}, x_{2i}) partition the above rectangle into rectangular panels. A polynomial spline of degree m for x_1 and of degree n for x_2 with continuous partial derivatives up to $(m - 1) + (n - 1)$ degree on the rectangle defined by the intervals $[x_{10}, x_{1\max}]$ and $[x_{20}, x_{2\max}]$ can be formulated as

$$S_{mn}(x_1, x_2) = \sum_{h=0}^m \sum_{s=0}^n C_{hs} x_1^h x_2^s + \sum_{i=1}^k P_i(x_2) (x_1 - x_{1i})_+^m + \sum_{j=1}^{\ell} Q_j(x_1) (x_2 - x_{2j})_+^n + \sum_{i=1}^k \sum_{j=1}^{\ell} D_{ij} (x_1 - x_{1i})_+^m (x_2 - x_{2j})_+^n \quad (5)$$

where $P_i(x_2)$ and $Q_j(x_1)$ are polynomials of degree n and m , respectively, and C_{hs} and D_{ij} are constants.

As examples of using splines in the approximation of aerodynamic functions, the vertical-force coefficient C_Z and yawing-moment coefficient C_n are considered. In the first case, the form of $C_Z(\alpha, q, \delta_e)$ based on splines can be, according to equation (3), written as

$$C_Z(\alpha, q, \delta_e) = C_Z(\alpha)_{q=\delta_e=0} + C_{Z_q}(\alpha) \frac{q\bar{c}}{2V} + C_{Z_{\delta_e}}(\alpha) \delta_e \quad (6)$$

where

$$\left. \begin{aligned} C_Z(\alpha) &= C_Z(0) + C_{Z_\alpha} \alpha + \sum_{i=1}^k D_{\alpha i} (\alpha - \alpha_i)_+ \\ C_{Z_q}(\alpha) &= C_{Z_q} + \sum_{i=1}^k D_{qi} (\alpha - \alpha_i)_+^0 \\ C_{Z_{\delta_e}}(\alpha) &= C_{Z_{\delta_e}} + \sum_{i=1}^k D_{\delta_e, i} (\alpha - \alpha_i)_+^0 \end{aligned} \right\} \quad (7)$$

Equation (7) indicates that $C_Z(\alpha)$ is approximated by piecewise linear polynomials (the first-degree spline), whereas the remaining two functions are approximated by piecewise constants (the zero-degree splines).

In the second case,

$$\begin{aligned} C_n(\alpha, \beta, p, r, \delta_a, \delta_r) &= C_n(\alpha, \beta)_{p=r=\delta_a=\delta_r=0} + C_{n_p}(\alpha) \frac{pb}{2V} \\ &+ C_{n_r}(\alpha) \frac{rb}{2V} + C_{n_{\delta_a}}(\alpha) \delta_a + C_{n_{\delta_r}}(\alpha) \delta_r \end{aligned} \quad (8)$$

Using equation (5) for $x_1 = \alpha$ and $x_2 = \beta$, and selecting $m = 0$ and $n = 1$, the function $C_n(\alpha, \beta)$ can be approximated as

$$\begin{aligned} C_n(\alpha, \beta) &= C_0 + C_1 \beta + \sum_{i=1}^k (A_{0i} + A_{1i} \beta) (\alpha - \alpha_i)_+^0 \\ &+ \sum_{j=1}^l B_{0j} \beta \left(1 - \frac{\beta_j}{|\beta|}\right)_+ + \sum_{i=1}^k \sum_{j=1}^l D_{ij} \beta \left(1 - \frac{\beta_j}{|\beta|}\right)_+ (\alpha - \alpha_i)_+^0 \end{aligned} \quad (9)$$

where

$$\beta \left(1 - \frac{\beta_j}{|\beta|} \right)_+ = \begin{cases} 0 & (|\beta| < \beta_j) \\ \beta - \beta_j & (\beta > \beta_j) \\ \beta + \beta_j & (\beta < -\beta_j) \end{cases}$$

There is always a positive value for β_j . In this approximation of $C_n(\alpha, \beta)$, it is assumed that $C_n(\beta)$ is an odd function. The remaining functions in equation (8) are then represented by splines in α .

MODEL STRUCTURE DETERMINATION

The determination of an adequate model using the stepwise regression includes three steps: the postulation of terms which might enter the final model, the selection of an adequate model, and the verification of the model selected.

As shown in the previous section, the general form of aerodynamic model equations can be written as

$$y(t) = \theta_0 + \theta_1 x_1 + \dots + \theta_{g-1} x_{g-1} \quad (10)$$

In this equation, $y(t)$ represents the resultant coefficient of aerodynamic force or moment (the dependent variable), θ_0 to θ_{g-1} are the constants in spline representation of the aerodynamic functions, and x_1 to x_{g-1} are the airplane response and input variables and their combinations (the independent variables). When the aerodynamic model equations are postulated, the determination of significant terms among the candidate variables (determination of model structure) and estimation of corresponding parameters follow.

Assuming that a sequence of N observations of y and of x at times t_1, t_2, \dots, t_N has been made, the measured values denoted by $y(i)$ and $x(i)$, where $i = 1, 2, \dots, N$, are related by the following set of N linear equations:

$$y(i) = \theta_0 + \theta_1 x_1(i) + \dots + \theta_{g-1} x_{g-1}(i) + \epsilon(i) \quad (11)$$

where $\epsilon(i)$ represents the equation error. An adequate model for the aerodynamic coefficients can be determined by applying the stepwise regression. The stepwise regression technique is described in references 1 and 8, and its main features are summarized in the appendix.

When formulating spline functions in expressions for an aerodynamic coefficient, the degree of spline and the number and location of knots must be specified. A set of knots is fixed in advance. The number of candidate knots for each spline

is limited only by the available computer memory. The stepwise regression procedure then selects only the knots which are associated with statistically significant parameters. In this way, a suboptimal number of knots and their locations are obtained. A more detailed discussion on the application of statistical variable selection technique to fit splines is contained in reference 9. The selection of degree of spline is influenced by the form of an aerodynamic function which is to be approximated. With little or no knowledge of that form, the model postulation can start with splines of a low degree, that is, the zero degree or first degree. After a tentative model structure is determined, the procedure can be repeated with higher-degree splines for better approximation of the data.

Because of the combination of spline representation with the stepwise regression technique, the number of knots for each spline in the postulated model structure is limited only by practical considerations, that is, the available computer memory. The knots can be positioned arbitrarily within the range of independent variables. The estimation technique then selects only those knots associated with the important terms in the model equation.

As explained in references 1 and 4, the regression analysis for model structure determination and parameter estimation provides the opportunity to use subsets of measured data rather than the whole data set. This approach can, for example, simplify the analysis of maneuvers for obtaining the lateral parameters in equations for the coefficients C_Y , C_l , and C_n . The measured data can be partitioned as a function of α , and it can be assumed that for each subset the coefficients are functions of $\alpha = \bar{\alpha}_i$, where $\bar{\alpha}_i$ is the midpoint of an α -interval of the i th subset. Then, for each subset, equation (2) can be simplified to

$$C_a(\bar{\alpha}, \beta, p, r, \delta_a, \delta_r) = C_a(\bar{\alpha}, \beta)_{p=r=\delta_a=\delta_r=0} + C_{a_p}(\bar{\alpha}) pb/2V + C_{a_r}(\bar{\alpha}) rb/2V + C_{a_{\delta a}}(\bar{\alpha}) \delta_a + C_{a_{\delta r}}(\bar{\alpha}) \delta_r \quad (a = Y, l, \text{ or } n) \quad (12)$$

Thus, the spline functions in two variables (α, β) are replaced by splines in β , and the remaining splines are replaced in α by constants.

The last step in model structure determination and parameter estimation is model verification. The parameter estimates must have realistic values and should be compared with wind-tunnel results and theoretical predictions. Wherever possible, the least-squares estimates should be also compared with the estimates using different techniques, that is, the maximum-likelihood estimation method. Ultimately, the model should be a good predictor of airplane motion within the region of its assumed validity.

EXAMPLES

In the following examples the technique for model structure determination and parameter estimation was applied to measured data of a single-engine, low-wing research airplane. The basic characteristics of the airplane and instrumentation system are presented in reference 10. This airplane had undergone certain wing leading-edge modification which allowed the airplane to be trimmed at angles of

attack up to approximately 24° . The measured data were available in the form of input and output time histories sampled at 0.05-second intervals. The input variables included the directly measured control-surface deflections. The variables α and β were measured by wind vanes, and the airspeed was measured by an anemometer. These measurements were corrected for the local airflow and offset with respect to the airplane center of gravity. The remaining output variables included angular rates and linear accelerations. These variables, together with the airspeed, were used to compute the aerodynamic coefficients (ref. 1), for which the angular accelerations were obtained by differentiation of spline fits of measured angular rates. These data included basically three different sets of maneuvers. For the first set, small-amplitude longitudinal and lateral maneuvers were excited by control-surface deflections at trimmed conditions within the range of α between 4° and 24° . From these maneuvers local models of aerodynamic coefficients were estimated. The second set included the data from longitudinal quasi-steady flights. These flights were represented by slow deceleration-acceleration maneuvers from which static parameters were determined. Finally, the third set of data consisted of large-amplitude longitudinal maneuvers and large-amplitude combined longitudinal and lateral maneuvers with the α variation between 0° and 30° . The large-amplitude maneuvers were analyzed for determining the parameters of an extended model, that is, a model valid over an extended range of α . The combined maneuvers were intended for the determination of the parameters of a model which would be valid within the flight envelope containing prestall and stall maneuvers.

In figure 1, the three important longitudinal stability parameters estimated from 30 small-amplitude maneuvers are plotted against the angle of attack corresponding to the trimmed conditions. All these maneuvers were analyzed by the modified stepwise regression (MSR) described in reference 1. Although the definition of "best model" is subjective and an exhaustive search of all candidate models is prohibitive in both cost and time, experience has shown that the MSR gives an adequate model. For the verification of results obtained, the maximum likelihood (ML) estimation technique of reference 11 was applied to nine test runs. In this analysis, the model structure was the same as determined by MSR. The ML estimates are represented in figure 1 by closed circles. Also plotted in figure 1 are the parameters obtained from quasi-steady flight using expressions from reference 10.

The values of three lateral parameters obtained from 30 small-amplitude lateral maneuvers are given in figure 2. In this case the yawing-moment derivatives were selected. These parameters exhibit large scatter mainly in the stall and post-stall region. This scatter is caused by small excitation of yawing motion of the tested airplane. The estimates of the remaining lateral parameters are shown subsequently to be more consistent. As in the previous case, some runs were also analyzed by the ML method, and the results are presented in figure 2. The estimates of longitudinal and lateral parameters from small-amplitude maneuvers were assembled as a data base for the comparison with the results from large-amplitude maneuvers.

Parameters From Large-Amplitude Longitudinal Maneuver

A large-amplitude longitudinal maneuver was analyzed using the polynomial spline representation of aerodynamic force and moment coefficients. The time histories of the input and response variables in this maneuver are presented in figure 3. From these time histories the aerodynamic functions C_x , C_z , and C_m were computed, and they are plotted in figure 4 against α rather than time. In figure 5, the variation of rate of pitch q and elevator deflection δ_e with α is also shown. Both figures indicate the range of dependent and independent variables available for use

in the regression equations and the distribution of measured points within the α -range. This information can be utilized for the selection of knots and degree of splines in the postulated model structure.

For the spline approximation of all three aerodynamic coefficients, the form of equation (6) was used, first with the first-degree spline for $C_X(\alpha)$, $C_Z(\alpha)$, and $C_m(\alpha)$, and then with the zero-degree splines for the remaining terms. (See eqs. (7) for approximation of C_Z coefficient.) Seventeen knots for each spline were postulated as $\alpha_1 = 6^\circ$, $\alpha_2 = 7^\circ$, ..., $\alpha_{17} = 22^\circ$. The resulting estimates showed that the zero-degree spline approximation of q-terms was rather coarse. Therefore, the first-degree and second-degree splines were introduced instead. The second-degree spline was then considered as the final approximation. As an example of options used in the q-terms representation, the $C_{mq}(\alpha)$ estimates are presented in figure 6. The

different spline approximations of all q-terms had only a small effect on the fit to the data and on the estimated parameters in the remaining terms. The final estimates of polynomial spline terms representing the three aerodynamic coefficients are plotted against α in figure 7. The aerodynamic function estimates are compared with the estimates from small-amplitude maneuvers and show very good agreement with those results. The fit of the polynomial and spline models to the data and the usefulness of the terms in those models can be revealed by the comparison of standard error of aerodynamic coefficient $\hat{\sigma}$ and the squared multiple correlation coefficient R^2 . (See appendix for more detailed explanation.) The values of both coefficients are summarized in table I. For small-amplitude maneuvers, the low values of $\hat{\sigma}$ and high values of R^2 correspond to low-angle-of-attack regimes; conversely, $\hat{\sigma}$ is larger and R^2 smaller for values of α between 20° and 24° .

In figure 8, the spline terms of $C_Z(\alpha)$ and $C_m(\alpha)$ functions are compared with the measurement of these relationships in the quasi-steady flight. This measurement resulted in a double-value function $C_Z(\alpha)$ and $C_m(\alpha)$ for values of α between 10° and 22° , depending on increasing or decreasing values of α . This phenomenon can be caused by the aerodynamic hysteresis and by the hysteresis in the control system. Because of the relatively small differences in both branches of $C_Z(\alpha)$ and $C_m(\alpha)$ curves with respect to the accuracy of these estimates, the hysteresis was not modeled in equation (6).

Even if the agreement between the results from small- and large-amplitude maneuvers is very good, the resulting model is further verified by simulating the airplane longitudinal response. This is done by using the extended model approximated by splines and by using the elevator deflection time history from a selected independent maneuver. The time histories of input and response variables are presented in figure 9, and the response variables V , α , and q are compared with those predicted by the model. The comparison reveals good prediction capabilities for the model.

Parameters From Large-Amplitude Combined Maneuvers

The time histories of one of the combined maneuvers are given in figure 10. The response variables exhibit a persistently excited lateral motion due to the rudder and aileron and longitudinal motion due to elevator deflections and coupling between lateral and longitudinal modes. From this particular maneuver, the variation of aerodynamic coefficients with α is shown in figure 11, and the variation of lateral variables is shown in figure 12. Both figures indicate the amount of excitation of dependent and independent variables in regression equations.

In the first step of data analysis, simplified models for the lateral coefficients were formulated. For the coefficient C_n , the aerodynamic model equation had the form

$$C_n = C_{n\beta}(\alpha) \beta + C_{np}(\alpha) pb/2V + C_{nr}(\alpha) rb/2V + C_{n\delta a}(\alpha) \delta_a + C_{n\delta r}(\alpha) \delta_r \quad (13)$$

with zero-degree splines for all terms included. The equations for C_y and C_l had a similar form. In the next step of the analysis, more complicated models with two-variable splines in α and β were used. This formulation is expressed by equations (8) and (9) for the coefficient C_n . The main differences in the results of the two approaches were found in parameters of the yawing-moment equation. This might indicate that the most pronounced nonlinearities in β are in the coefficient C_n . Figure 13 presents the estimates of $C_{n\beta}$ within the range of β from -4°

to 4° from the three combined maneuvers. Each maneuver covered a different range of α and used a $C_{n\beta}(\alpha)$ and $C_n(\alpha, \beta)$ spline in the model. Both sets of estimates are

compared with those obtained from small-amplitude maneuvers. As shown in figure 13, the second approach gives more consistent estimates which also agree better with the data base than the results of the first approach. The only difference remains in the region of α from 16° to 24° . In this area, the spline approximation of $C_n(\alpha, \beta)$ resulted in directional instability, whereas the small-amplitude data have essentially positive values. Exclusion of the two-dimensional spline $C_n(\alpha, \beta)$ from the model also had an effect on the remaining parameters, mainly the damping in yaw C_{nr} .

The estimates of this parameter are given in figure 14. The second model improved the consistency of the estimates and the agreement with the results of small-amplitude maneuvers.

The estimates of three parameters in the rolling-moment equation with the spline $C_l(\alpha, \beta)$ in the model are shown in figure 15. Consistent results were obtained for parameters $C_{l\beta}$ and C_{lp} , but some scatter is apparent in the estimates of C_{lr} .

From the remaining lateral parameters, the values of $C_{y\beta}$, $C_{y\delta r}$, $C_{l\delta a}$, and $C_{n\delta r}$ were estimated with good confidence, but rather larger scatter was observed in the estimates of the other parameters.

For the verification of previous results and for obtaining more accurate estimates of lateral parameters, the measurements from 12 combined maneuvers were joined together into one set of data. The resulting ensemble of about 13 000 data points was then partitioned into 22 subsets according to the values of α . The modeling of the lateral parameters was conducted mostly on 1° subspaces of the 0° to 30° α -space. As an example, the model for C_n was postulated as

$$C_n(\bar{\alpha}, \beta, p, r, \delta_a, \delta_r) = C_{n\beta} \beta + \sum_{i=1}^5 C_{n\beta i} \beta \left(1 - \frac{\beta_i}{|\beta|} \right)_+ + C_{np} pb/2V + C_{nr} rb/2V + C_{n\delta a} \delta_a + C_{n\delta r} \delta_r \quad (14)$$

where $\bar{\alpha}$ denotes the midpoint of an α -interval. The knots of the spline in β were selected at 4°, 8°, 12°, 16°, and 20°. The estimates of parameters from partitioned data are presented in figure 16. In general, these estimates are more consistent than those from individual maneuvers and are closer to the results from small-amplitude maneuvers. The nonlinear variation of the lateral coefficients with β for $\alpha = \bar{\alpha}$, and with the remaining lateral variables equal to zero, is demonstrated in figure 17 for three different values of $\bar{\alpha}$. Finally, the values of $C_n(\alpha, \beta)$ for $\beta > 0$ and all remaining independent variables equal to zero are plotted in figure 18. The results from the partitioned data have confirmed the previous conclusion about the most pronounced nonlinearities in C_n with β and about the small nonlinear variation of the remaining two coefficients with this variable.

For the additional comparison of results from small- and large-amplitude maneuvers and from individual runs and partitioned data, the values of standard error $\hat{\sigma}$ and squared multiple correlation coefficient R^2 for all cases are summarized in table II. For small-amplitude maneuvers and partitioned data the minimum values of $\hat{\sigma}$ and maximum value of R^2 correspond to low values of α , and the other values correspond to high values of α . From the values of $\hat{\sigma}$ and R^2 , it could be concluded that at high angles of attack only the model for C_n was not able to fully explain all the variation in the measured data. This conclusion indicates that some additional terms in the model should be considered. Models for C_n used in large-amplitude maneuvers without partitioning brought some improvements in R^2 and $\hat{\sigma}$ over the same values from previous maneuvers.

The combined maneuvers were primarily intended for the estimation of lateral parameters. However, an attempt was also made to estimate the parameters in the pitching-moment equation from these data. A possibility of aerodynamic coupling was considered and the model was postulated as

$$\begin{aligned}
 C_m(\bar{\alpha}, p, q, r, \delta_a, \delta_e, \delta_r) = & C_{m_{p=q=r=\delta_a=\delta_e=\delta_r=0}} + C_{m_q} q\bar{c}/2V + C_{m_{\delta_e}} \delta_e \\
 & + C_{m_{\delta_e^3}} \delta_e^3 + C_{m_\beta} |\beta| + \sum_{i=1}^4 C_{m_{\beta_i}} |\beta - \beta_i|_+ \\
 & + C_{m_p} |pb/2V| + C_{m_r} |rb/2V| + C_{m_{\delta_a}} |\delta_a| + C_{m_{\delta_r}} |\delta_r|
 \end{aligned} \tag{15}$$

where

$$|\beta - \beta_i|_+ = \begin{cases} 0 & (|\beta| < \beta_i) \\ \beta - \beta_i & (\beta \geq \beta_i) \\ |\beta + \beta_i| & (\beta \leq -\beta_i) \end{cases}$$

The estimates of the most significant parameters in the model are presented in figure 19. Their comparisons with the estimates from small- and large-amplitude longitudinal maneuvers indicate good estimates of C_m and $C_{m_{\delta_e}}$ terms. Some discrepan-

cies with previous results are visible in the estimates of C_{m_q} . For the values of C_m from partitioned data, R^2 varied between 63 percent and 37 percent. This indicates a strong possibility of modeling error in equation (15). The low values of R^2 are in contrast with values of R^2 in table I for both small- and large-amplitude longitudinal maneuvers.

For the verification of the estimated lateral parameters, the aerodynamic model from partitioned data was used. The equations of motion for $\alpha = 22.5^\circ$ were integrated with the initial conditions and control time histories from a flight trimmed at $\alpha \approx 20^\circ$. The control input for this independent maneuver consisted of a doublet in aileron followed by a doublet in rudder. The predicted time histories are plotted against the actual flight data in figure 20. The comparison of these time histories shows an acceptable agreement between them.

CONCLUDING REMARKS

The application of polynomial splines and stepwise regression for the determination of airplane model structure from flight data has been demonstrated. First, a form of the aerodynamic force and moment coefficients compatible with the utilization of splines in one (angle of attack) and two (angles of attack and sideslip) variables was developed. Then, the model postulated for the analysis of flight data from large-amplitude maneuvers was discussed. The procedure of model determination was used in several examples. Whenever possible, the resulting parameters were verified by comparison with a baseline formed by the estimates from small-amplitude maneuvers and steady-state measurements. The airplane equations of motion, employing the model obtained, were numerically integrated to simulate the airplane responses to actual flight inputs. These responses were then compared with the measured flight time histories of response to that input.

The main conclusions from the research reported can be summarized as follows:

1. In order to obtain a global aerodynamic model from flight data, it was advantageous to use large-amplitude longitudinal and combined maneuvers in which the longitudinal and lateral motion were excited over an extended range of angle of attack.
2. When postulating the aerodynamic model with little or no a priori knowledge of its form, the approximating splines can be of low degree (zero or first). After a tentative model structure is determined, the procedure can be repeated with higher-degree splines for better approximation of the data.
3. Because of the combination of spline representation with the stepwise regression, the knots can be positioned arbitrarily within the range of independent variables. The number of candidate knots for each spline is limited only by the available computer memory.
4. A set of one-dimensional splines in the angle of attack can closely approximate uncoupled longitudinal maneuvers. For the combined maneuvers, however, two-dimensional splines in the angle of attack and sideslip must, in general, be considered. To avoid the complexity of two-dimensional splines, the data from combined maneuvers can be partitioned into subsets according to the values of angle of attack. The lateral parameters from partitioned data were more consistent and closer to the baseline than results from individual large maneuvers.

The procedure presented represents another step towards the determination of a global model of an airplane from flight data. It can provide valuable information about aerodynamic forces and moments acting upon the airplane in large-amplitude maneuvers and/or maneuvers in high-angle-of-attack regions.

Langley Research Center
National Aeronautics and Space Administration
Hampton, VA 23665
January 17, 1983

APPENDIX

STEPWISE REGRESSION

This appendix describes the basic principles and features of the stepwise regression which is used to determine aerodynamic model structure from flight data. This procedure begins with the assumption that there are no variables in the postulated regression equation other than the bias term θ_0 . An effort is then made to find an optimal subset of variables by inserting independent variables into the model one at a time. The first independent variable selected for entry into the equation is the one that has the largest correlation with the dependent variable y . Suppose that this variable is x_1 . This is also the variable that produces the largest value of the F-statistic for testing the significance of regression. The variable is entered if the partial F-statistic exceeds a preselected critical F-value

$$F_p = \frac{\hat{\theta}_1^2}{s^2(\hat{\theta}_1)} > F_{crit}$$

where $\hat{\theta}_1$ is the estimated parameter associated with x_1 and $s^2(\hat{\theta}_1)$ is the variance estimate of θ_1 .

The second variable chosen for entry is the one that now has the largest correlation with y after adjusting for the effect on y of the first variable entered, x_1 in this case. These correlations are referred to as partial correlations. In general, at each step, the independent variable having the highest partial correlation with y is added to the model if its partial F-statistic exceeds the preselected F_{crit} . At each step of the procedure, all variables entered into the model previously are also reassessed by examining their partial F-statistics. A variable added at an earlier step may be redundant because the relationship between it and the remaining variables now in the equation has reduced its value of F_p to less than F_{crit} . If this happens, the significant variable is deleted from the regression model. The procedure terminates when all significant terms have been included in the model.

As a new variable enters the model, several useful quantities are calculated at each stage of the stepwise regression. All these quantities should be examined for the final model selection. First, the user can consider the total F-value for a given model of Q variables calculated as the ratio of the mean square due to the regression to the mean square of the residual. This ratio is given as

$$F = \frac{\sum_{i=1}^N [\hat{y}(i) - \bar{y}]^2}{\sum_{i=1}^N [y(i) - \hat{y}(i)]^2} \frac{N - g}{g - 1}$$

where

$$\bar{y} = \frac{1}{N} \sum_{i=1}^N y(i)$$

APPENDIX

This number usually increases to some maximum value as new variables enter the regression, but then decreases slightly as the new terms are less effective in reducing the residuals. Heuristically, the maximum F-value represents a model which best fits the data with a minimum number of parameters. Second, the squared multiple correlation coefficient R^2 is calculated. This number, expressed as a percentage, is a measure of the usefulness of the terms, other than θ_0 , in the model. The value of R^2 would be 100 percent for a model that perfectly fit the data. Third, at each stage, the partial F-values F_p for each parameter are printed. The user should look for consistency in the values of F_p . For example, if one value of F_p is only slightly greater than F_{crit} and all other values of F_p are much greater, the user may not want to include the variable with the small value of F_p in the model. The fourth aid in model selection is the estimated normalized autocorrelation function for the residuals. The estimate of the autocorrelation function at lag h is given by

$$\hat{W}(h) = \frac{1}{N-h} \sum_{i=1}^{N-h} v(i) v(i+h) \quad (h = 0, 1, \dots, M)$$

where h is the lag number and M is the maximum lag number, which is usually 10 percent of N . The normalized autocorrelation function is calculated as $\hat{W}(h)/\hat{W}(0)$. This function should approach that for white noise with a value of 1 at zero lag and values of 0 at lag for 1 to M . In applications, when the value of F_p for a parameter makes the utility of an independent variable questionable, the contribution of that variable to the actual model structure can be assessed by observing the effect of the variable on the autocorrelation function of residuals. The fifth number that aids the user is the standard error in the residuals $\hat{\sigma}$, which is printed at each stage of the regression.

One learns from experience that not all of the five criteria listed above are "optimally" satisfied for any single model. However, the stepwise regression and its associated information criteria do significantly reduce the number of possible models from which the user must choose. Moreover, as the model structure is determined, so are the parameter estimates. Finally, ambiguity in the model selection can also be resolved by requiring that the estimated parameters make sense physically and that the selected model have good prediction capability.

The selection of a set of candidate model variables from which the stepwise regression can build a model should rely on the user's a priori knowledge of the physical system that is to be modeled. For the airplane, such assumptions as the most influential variables and symmetry considerations have led to the following logic for selection of candidate model variables for a spline analysis of the longitudinal maneuver. (See eqs. (6) and (7) for C_z .) Though it appears lengthy and awkward, this formulation of the FORTRAN code allows for simple deletion, addition, and/or change in candidate model variables.

```

DO 910 I=1,NPTS
X(1,I)=ALPH(I)
X(2,I)=C/(2*VEL(I))*Q(I)
X(3,I)=DELE(I)
DO 911 III=4,39
911 X(III,I)=0.
IF(ALPH(I).GE.XKNOT(1)) X(4,I)=ALPH(I)-XKNOT(1)
IF(ALPH(I).GE.XKNOT(1)) X(5,I)=X(2,I)

```

APPENDIX

```

IF(ALPH(I).GE.XKNOT(2)) X(6,I)=ALPH(I)-XKNOT(2)
IF(ALPH(I).GE.XKNOT(2)) X(7,I)=X(2,I)
IF(ALPH(I).GE.XKNOT(3)) X(8,I)=ALPH(I)-XKNOT(3)
IF(ALPH(I).GE.XKNOT(3)) X(9,I)=X(2,I)
IF(ALPH(I).GE.XKNOT(4)) X(10,I)=ALPH(I)-XKNOT(4)
IF(ALPH(I).GE.XKNOT(4)) X(11,I)=X(2,I)
IF(ALPH(I).GE.XKNOT(5)) X(12,I)=ALPH(I)-XKNOT(5)
IF(ALPH(I).GE.XKNOT(5)) X(13,I)=X(2,I)
IF(ALPH(I).GE.XKNOT(6)) X(14,I)=ALPH(I)-XKNOT(6)
IF(ALPH(I).GE.XKNOT(6)) X(15,I)=X(2,I)
IF(ALPH(I).GE.XKNOT(7)) X(16,I)=ALPH(I)-XKNOT(7)
IF(ALPH(I).GE.XKNOT(7)) X(17,I)=X(2,I)
IF(ALPH(I).GE.XKNOT(8)) X(18,I)=ALPH(I)-XKNOT(8)
IF(ALPH(I).GE.XKNOT(8)) X(19,I)=X(2,I)
IF(ALPH(I).GE.XKNOT(9)) X(20,I)=ALPH(I)-XKNOT(9)
IF(ALPH(I).GE.XKNOT(9)) X(21,I)=X(2,I)
IF(ALPH(I).GE.XKNOT(10)) X(22,I)=ALPH(I)-XKNOT(10)
IF(ALPH(I).GE.XKNOT(10)) X(23,I)=X(2,I)
IF(ALPH(I).GE.XKNOT(11)) X(24,I)=ALPH(I)-XKNOT(11)
IF(ALPH(I).GE.XKNOT(11)) X(25,I)=X(2,I)
IF(ALPH(I).GE.XKNOT(12)) X(26,I)=ALPH(I)-XKNOT(12)
IF(ALPH(I).GE.XKNOT(12)) X(27,I)=X(2,I)
IF(ALPH(I).GE.XKNOT(13)) X(28,I)=ALPH(I)-XKNOT(13)
IF(ALPH(I).GE.XKNOT(13)) X(29,I)=X(2,I)
IF(ALPH(I).GE.XKNOT(14)) X(30,I)=ALPH(I)-XKNOT(14)
IF(ALPH(I).GE.XKNOT(14)) X(31,I)=X(2,I)
IF(ALPH(I).GE.XKNOT(15)) X(32,I)=ALPH(I)-XKNOT(15)
IF(ALPH(I).GE.XKNOT(15)) X(33,I)=X(2,I)
IF(ALPH(I).GE.XKNOT(16)) X(34,I)=ALPH(I)-XKNOT(16)
IF(ALPH(I).GE.XKNOT(16)) X(35,I)=X(2,I)
IF(ALPH(I).GE.XKNOT(17)) X(36,I)=ALPH(I)-XKNOT(17)
IF(ALPH(I).GE.XKNOT(17)) X(37,I)=X(2,I)
IF(ALPH(I).GE.XKNOT(7)) X(38,I)=X(3,I)
IF(ALPH(I).GE.XKNOT(13)) X(39,I)=X(3,I)

```

910 CONTINUE

In the preceding printout, $VEL(I)$ = Airspeed V at t_i , Q = Pitch rate q , $NPTS$ = Number of data points N , C = Wing mean aerodynamic chord \bar{c} , and $X(J,I)$ = Value of j th model variable at t_i . The symbols $XKNOT()$ indicate knots for specific values of α . The table actually gives the logic for creating the $(39 \times N)$ matrix containing the time histories of each of the 39 candidate independent variables. The 17 knots in angle of attack can be set at any value the user deems adequate for the data by setting $XKNOT(I)$ in the program with $I = 1,17$. Changing the candidate model variables can easily be accomplished by substituting the new variable for any of the 39 candidates listed. The number of candidate variables is limited only by the size of the computer memory.

REFERENCES

1. Klein, Vladislav; Batterson, James G.; and Murphy, Patrick C.: Determination of Airplane Model Structure From Flight Data by Using Modified Stepwise Regression. NASA TP-1916, 1981.
2. Gupta, Narendra K.; and Hall, W. Earl, Jr.: Model Structure Determination and Test Input Selection for Identification of Nonlinear Regimes. ONR-CR215-213-5, U.S. Navy, Feb. 1976. (Available from DTIC as AD A037 831.)
3. Vincent, J. H.; Gupta, N. K.; and Hall, W. E., Jr.: Recent Results in Parameter Identification for High Angle-of-Attack Stall Regimes. AIAA Paper 79-1640, Aug. 1979.
4. Stalford, H. L.: High-Alpha Aerodynamic Model Identification of T-2C Aircraft Using the EBM Method. J. Aircr., vol. 18, no. 10, Oct. 1981, pp. 801-809.
5. Klein, V.; Batterson, J. G.; and Smith, P. L.: On the Determination of Airplane Model Structure From Flight Data. Identification and System Parameter Estimation - Sixth IFAC Symposium, Volume 2, George A. Bekey and George N. Saridis, eds., Pergamon Press, Inc., c.1982, pp. 1034-1039.
6. Klein, V.; and Batterson, J. G.: Determination of Airplane Aerodynamic Parameters From Flight Data at High Angles of Attack. Proceedings of the 13th Congress of the International Council of the Aeronautical Sciences, Volume 1, B. Laschka and R. Staufenbiel, eds., 1982, pp. 467-474. (Available as ICAS-82-6.3.3.)
7. Schumaker, Larry L.: Spline Functions: Basic Theory. John Wiley & Sons, Inc., c.1981.
8. Draper, N. R.; and Smith, H.: Applied Regression Analysis. John Wiley & Sons, Inc., c.1966.
9. Smith, Patricia L.: Curve Fitting and Modeling With Splines Using Statistical Variable Selection Techniques. NASA CR-166034, 1982.
10. Klein, Vladislav: Determination of Stability and Control Parameters of a Light Airplane From Flight Data Using Two Estimation Methods. NASA TP-1306, 1979.
11. Grove, Randall D.; Bowles, Roland L.; and Mayhew, Stanley C.: A Procedure for Estimating Stability and Control Parameters From Flight Test Data by Using Maximum Likelihood Methods Employing a Real-Time Digital System. NASA TN D-6735, 1972.

TABLE I.- COMPARISON OF STANDARD ERRORS AND SQUARED MULTIPLE CORRELATION COEFFICIENTS FROM DIFFERENT MANEUVERS FOR LONGITUDINAL DATA

Aerodynamic coefficient	Small-amplitude maneuvers				Large-amplitude maneuvers	
	$\hat{\sigma}$		R^2		$\hat{\sigma}$	R^2
	Min.	Max.	Min.	Max.		
C_X	0.0011	0.020	71.5	99.9	0.014	96.5
C_Z	.0064	.042	88.3	99.9	.039	98.6
C_m	.0052	.028	89.1	99.5	.033	93.5

TABLE II.- COMPARISON OF STANDARD ERRORS AND SQUARED MULTIPLE CORRELATION COEFFICIENTS FROM DIFFERENT MANEUVERS FOR LATERAL DATA

Aerodynamic coefficient	Small-amplitude maneuvers				Large-amplitude maneuvers							
	$\hat{\sigma}$		R^2		Separate runs				Partitioned data			
	$\hat{\sigma}$		R^2		$\hat{\sigma}$		R^2		$\hat{\sigma}$		R^2	
	Min.	Max.	Min.	Max.	Min.	Max.	Min.	Max.	Min.	Max.	Min.	Max.
C_Y	0.0026	0.0120	94.3	99.9	0.0072	0.0390	96.4	99.1	0.0066	0.0360	81.6	99.3
C_l	.0014	.0062	88.9	96.5	.0049	.0084	93.7	94.5	.0026	.0095	86.1	97.4
C_n	.0008	.0040	60.6	99.3	.0032	.0057	88.9	96.4	.0027	.0064	78.5	96.6

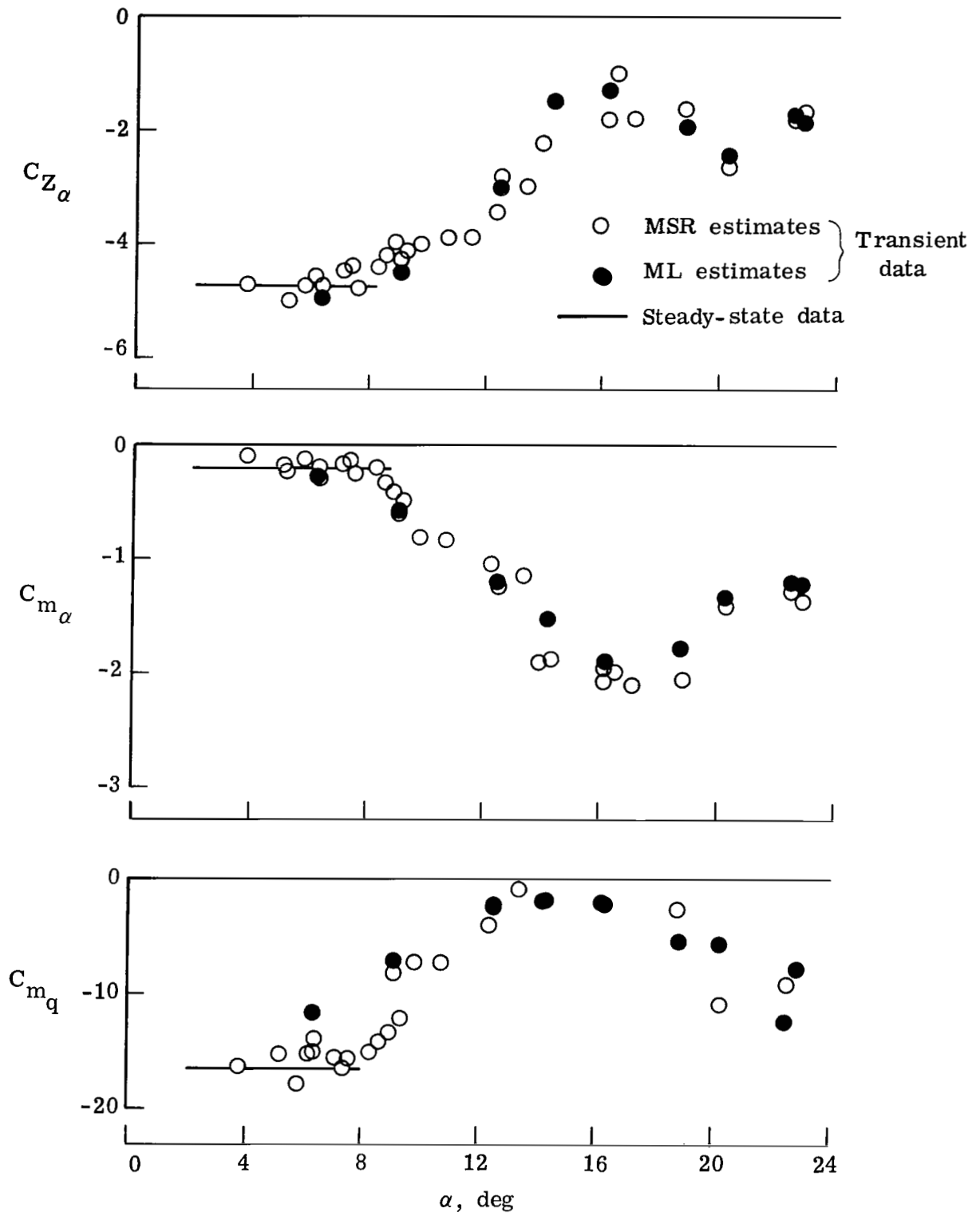

Figure 1.- Estimated longitudinal parameters from quasi-steady and small-amplitude maneuvers.

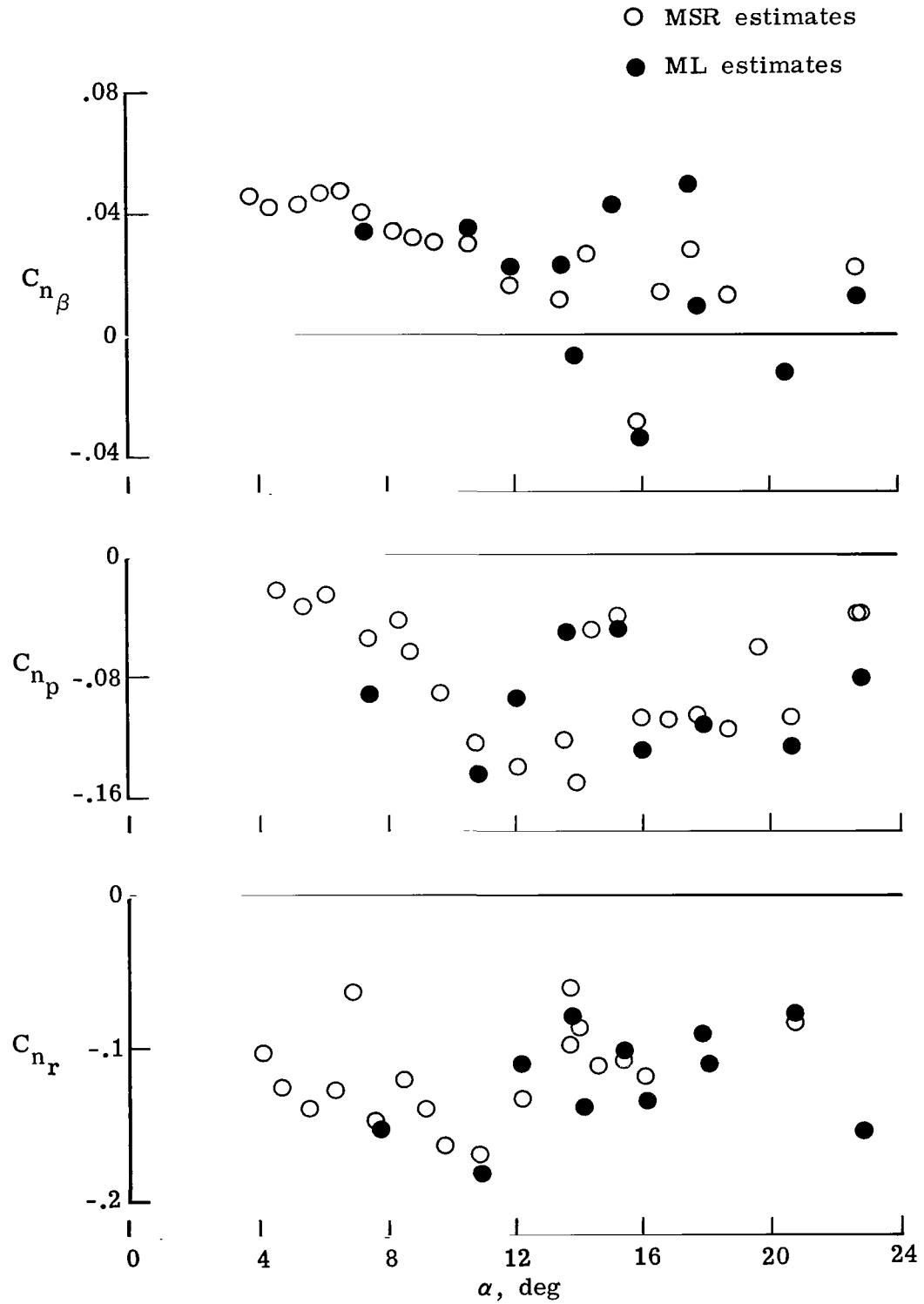

Figure 2.- Estimated lateral parameters from small-amplitude maneuvers. Transient data.

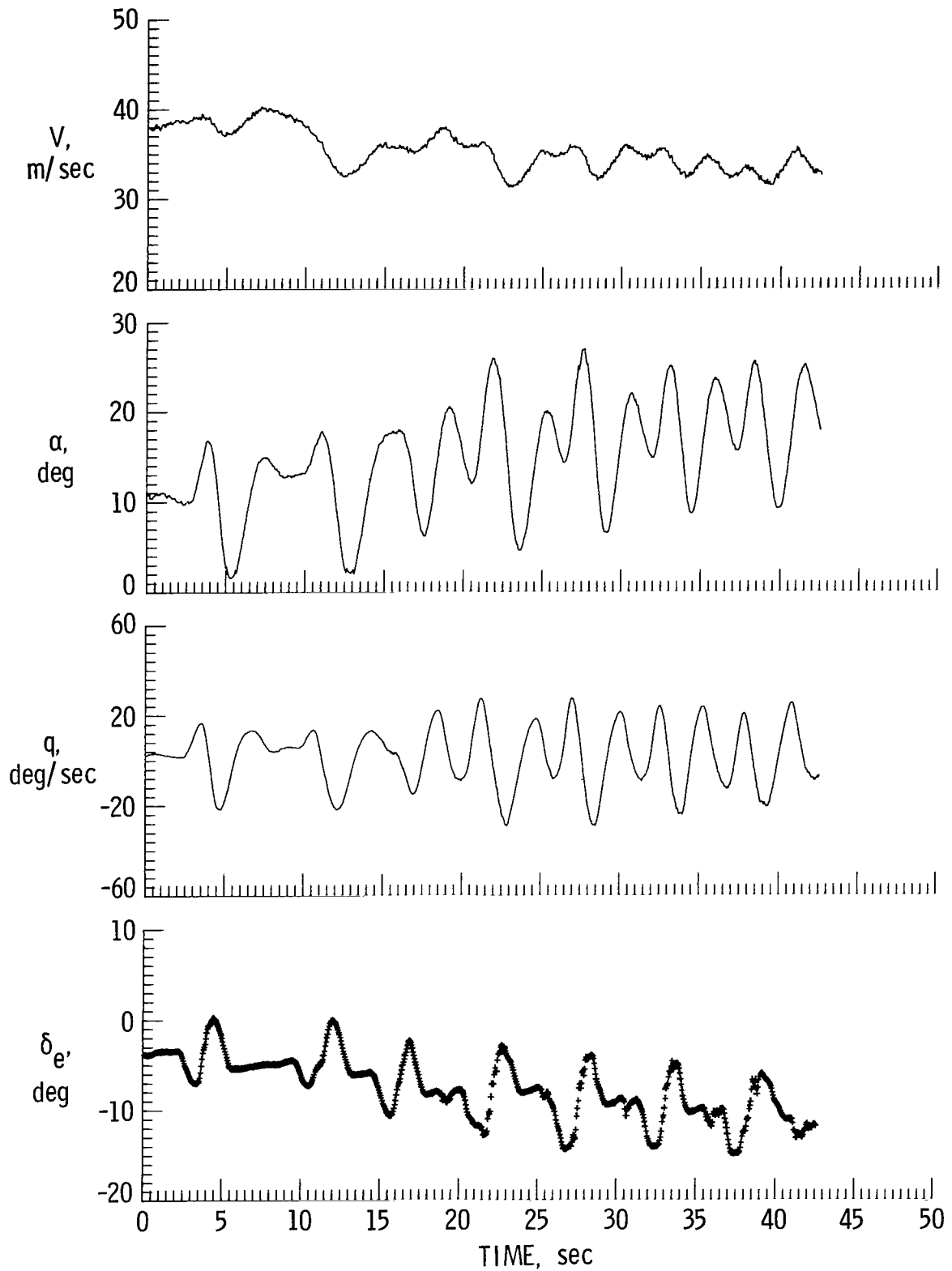

Figure 3.- Time histories of measured longitudinal variables in large-amplitude maneuver.

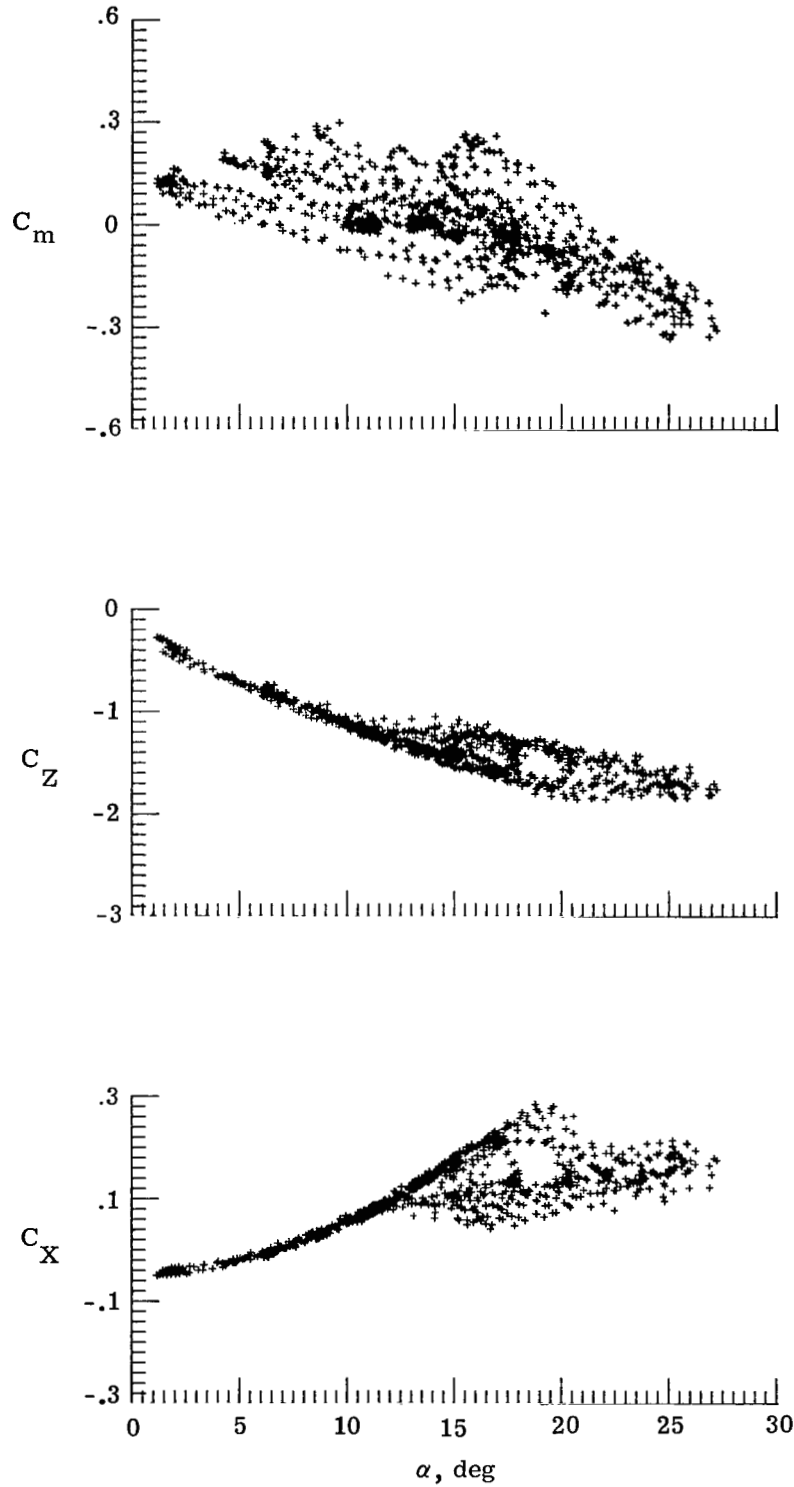

Figure 4.- Time histories of longitudinal aerodynamic coefficients in large-amplitude maneuver plotted against angle of attack.

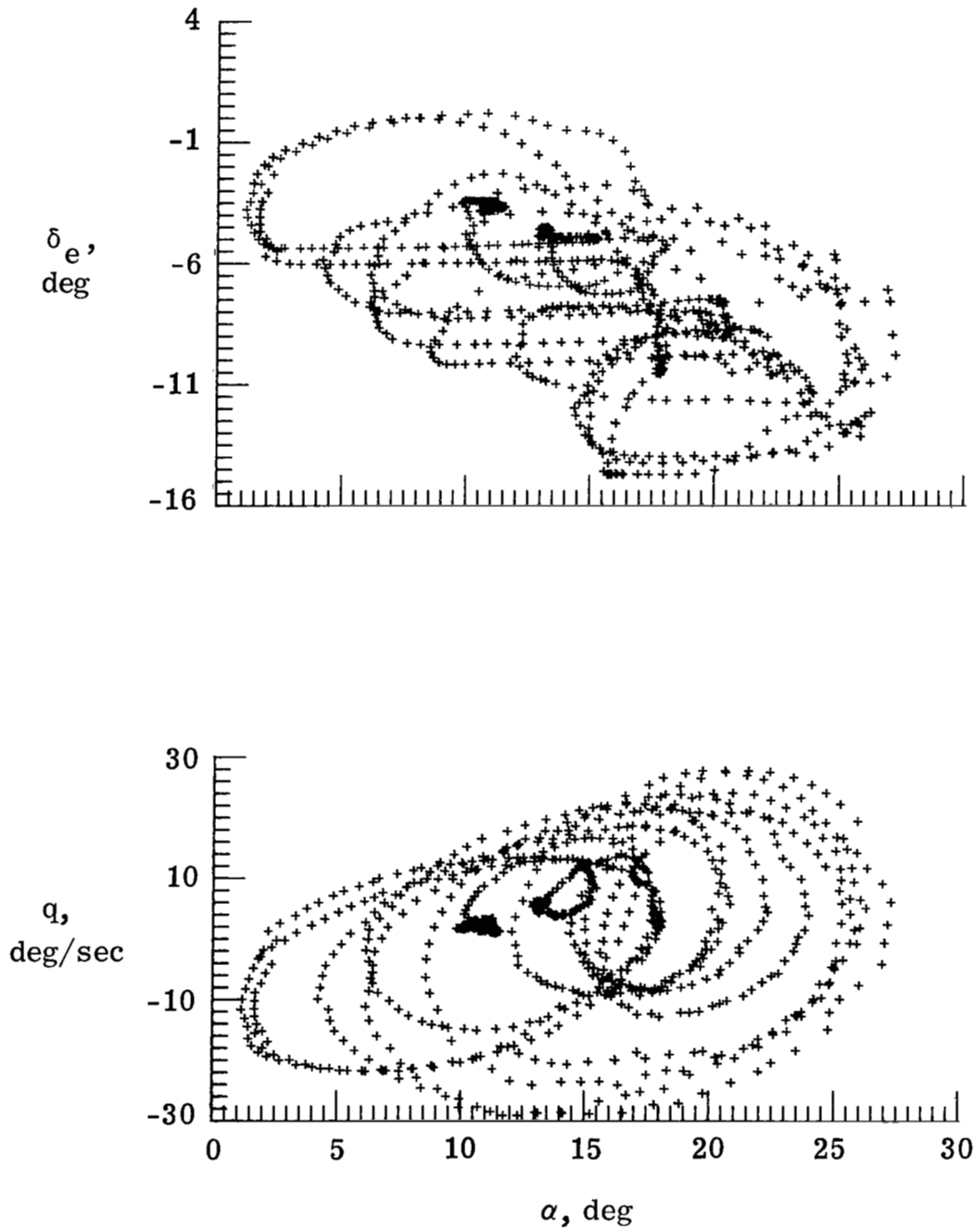

Figure 5.- Variation of two longitudinal variables with angle of attack in large-amplitude maneuver.

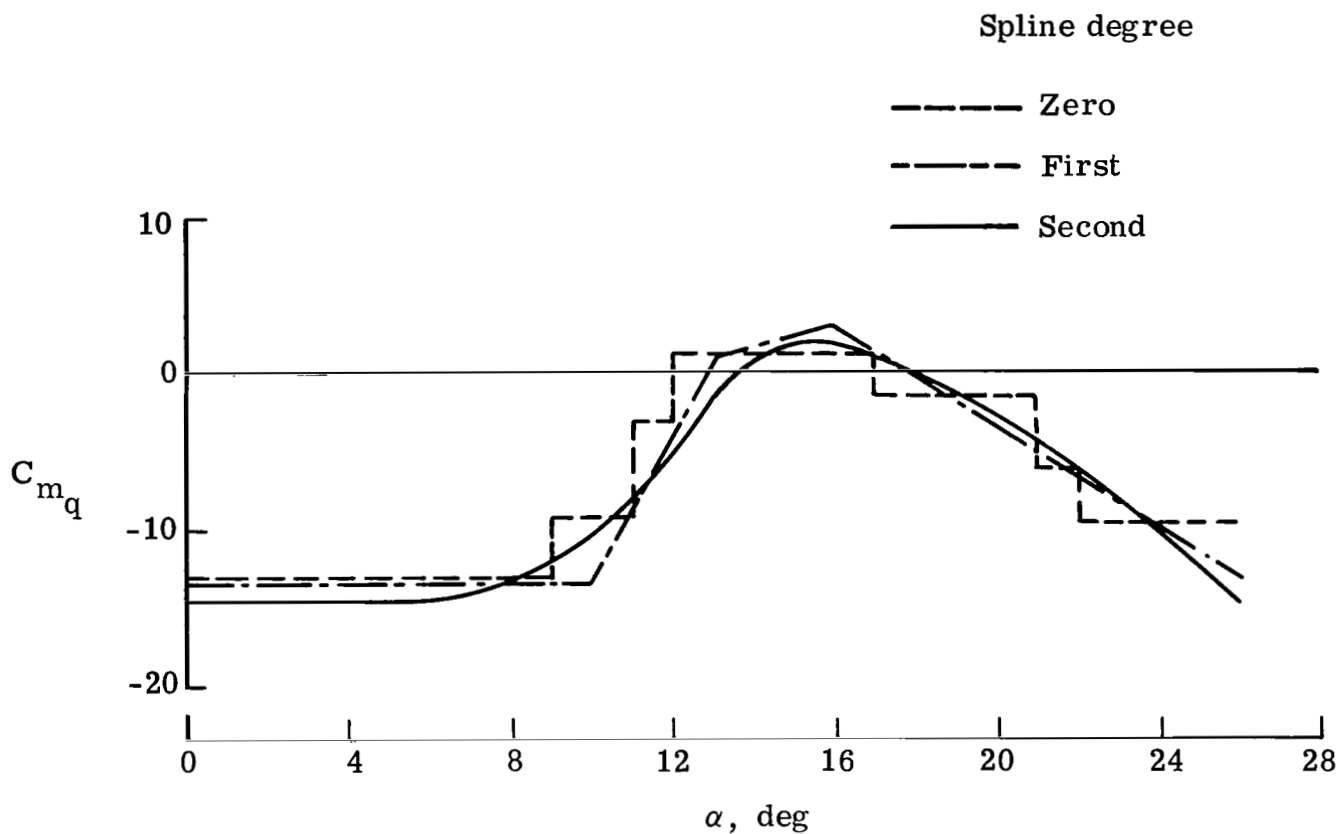

Figure 6.- Estimated damping-in-pitch variation with angle of attack from large-amplitude maneuver using splines of different degrees.

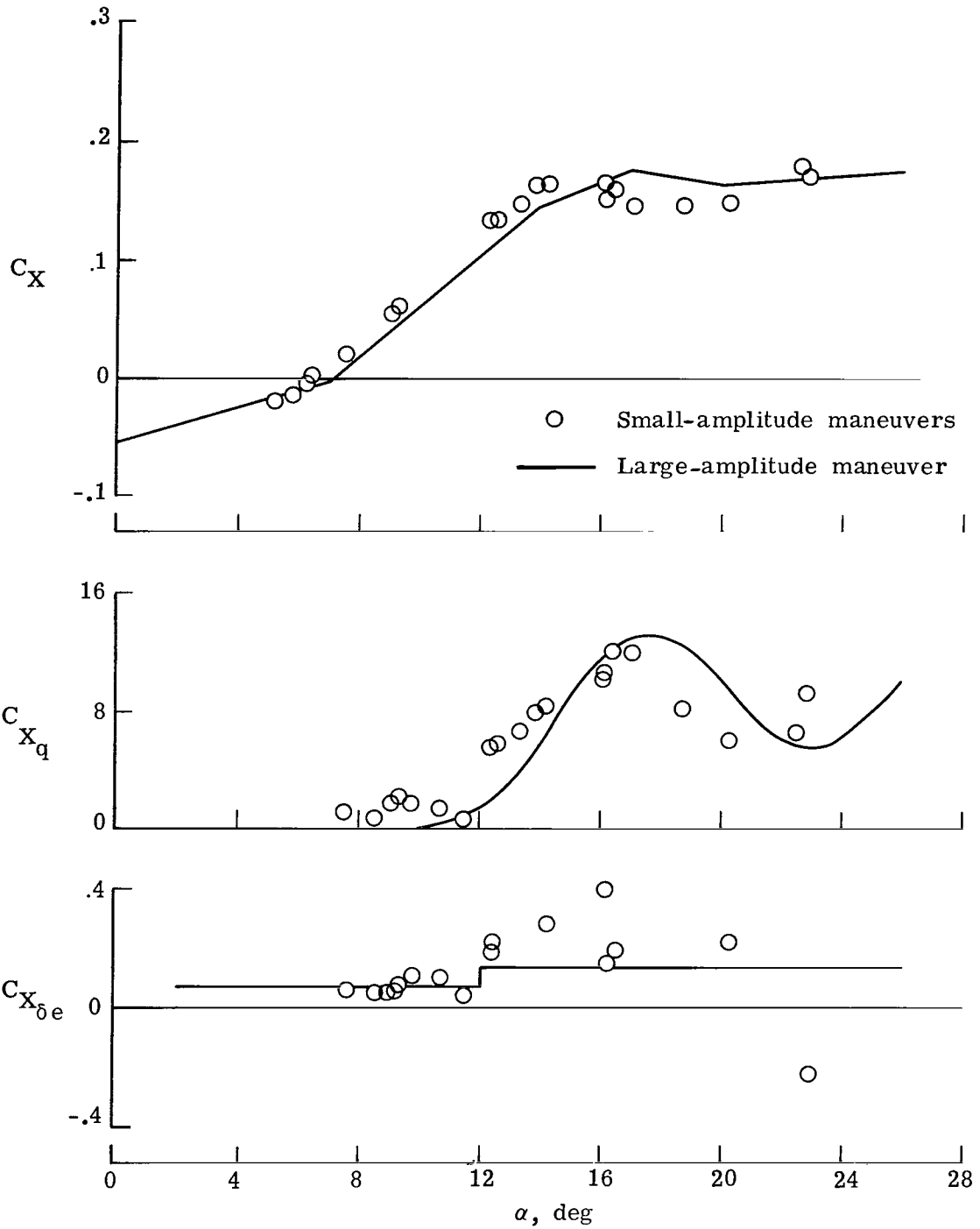

Figure 7.- Comparison of longitudinal parameters estimated from different maneuvers.

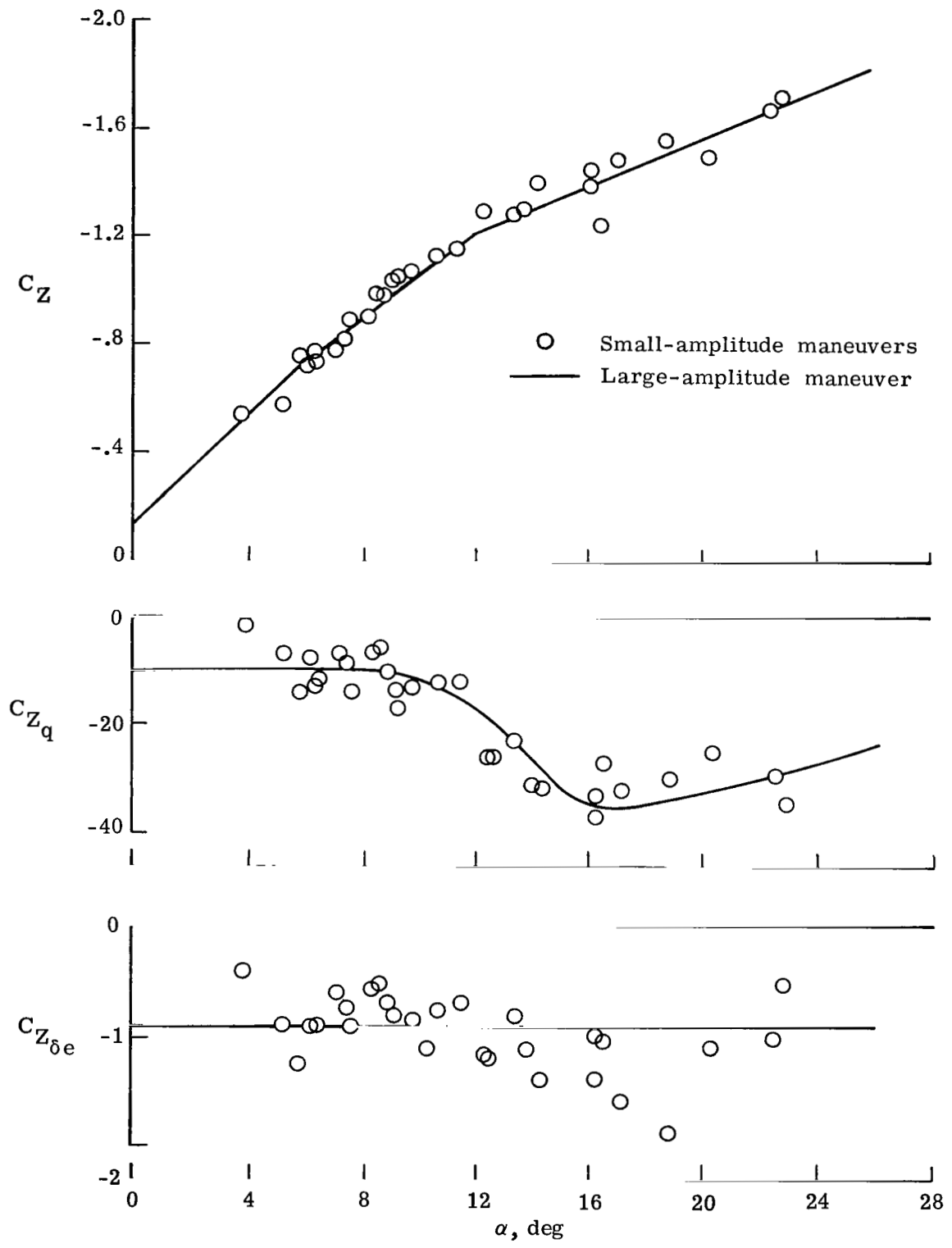

Figure 7.- Continued.

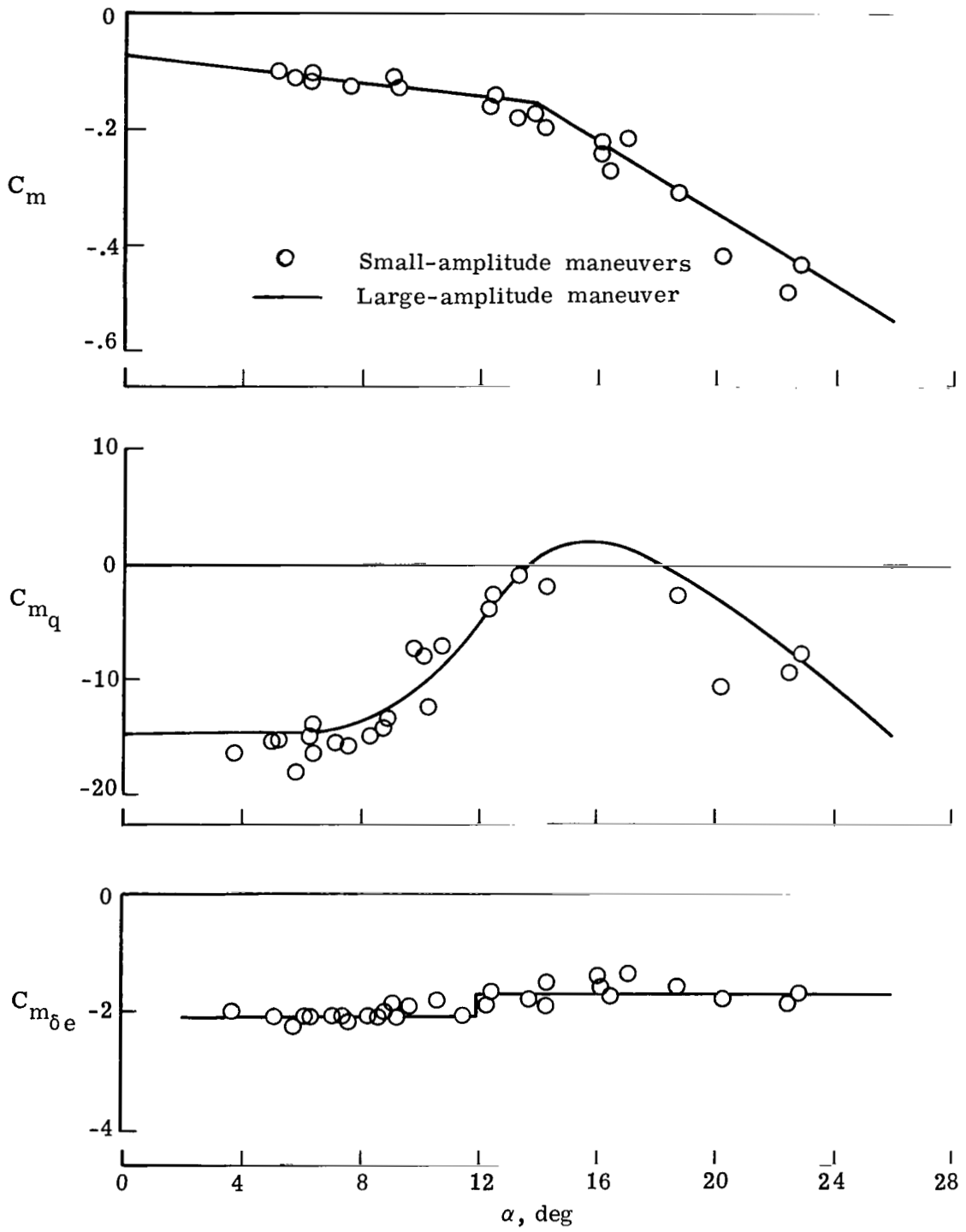

Figure 7.- Concluded.

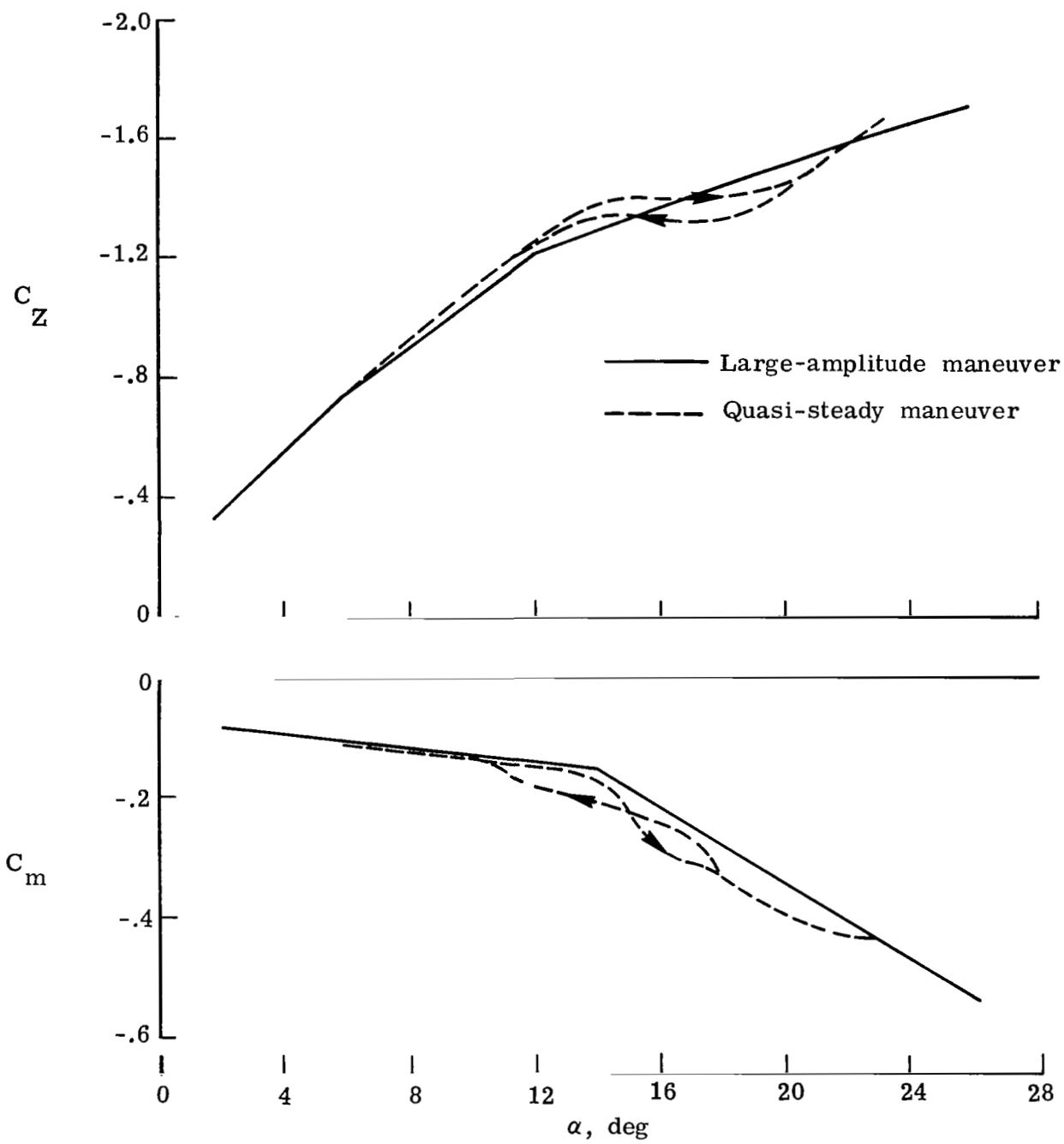

Figure 8.- Comparison of vertical-force and pitching-moment coefficient in steady-state conditions estimated from different maneuvers.

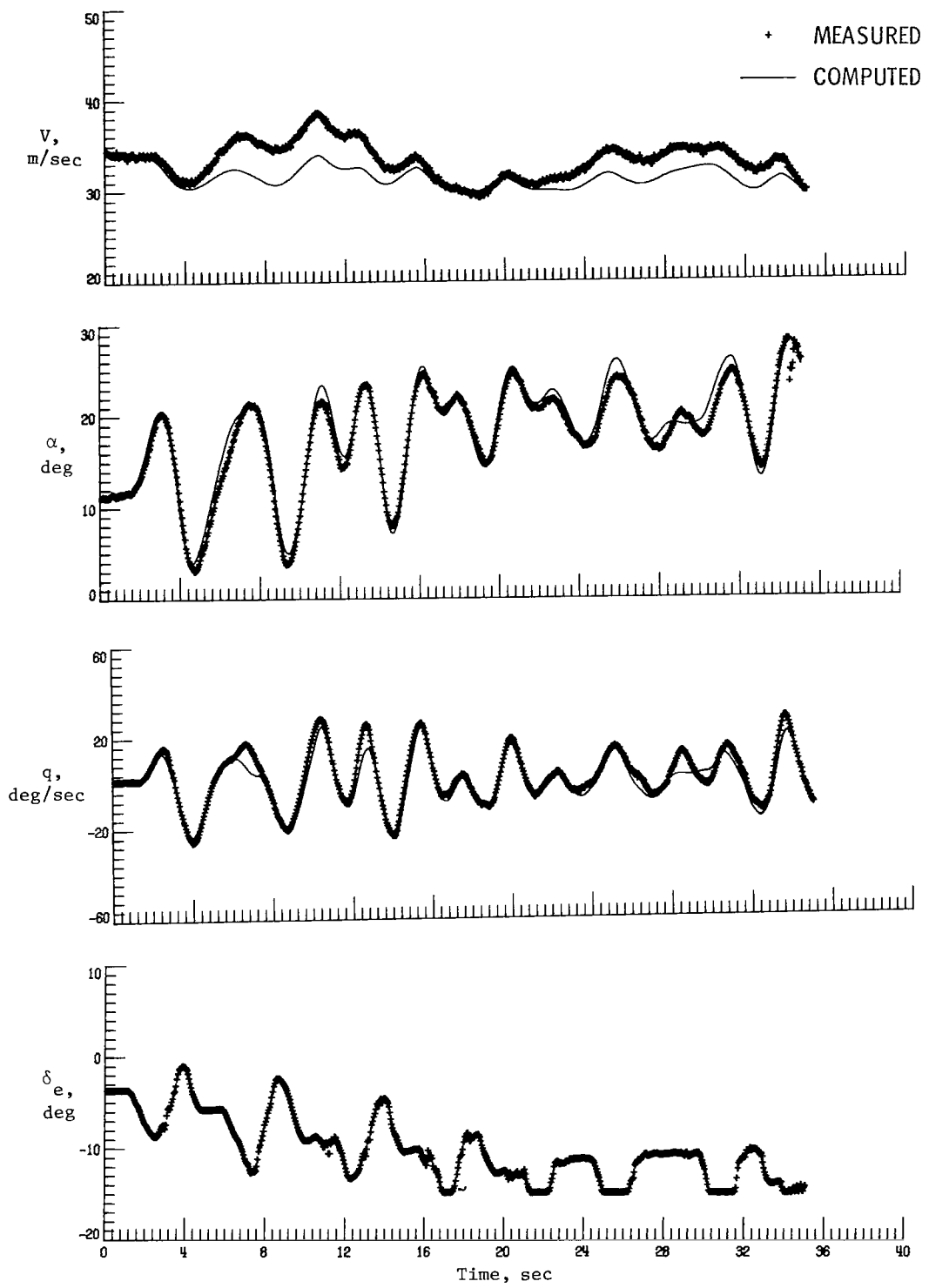

Figure 9.- Time histories of measured longitudinal flight data and those computed by using parameters obtained by stepwise regression with spline approximation.

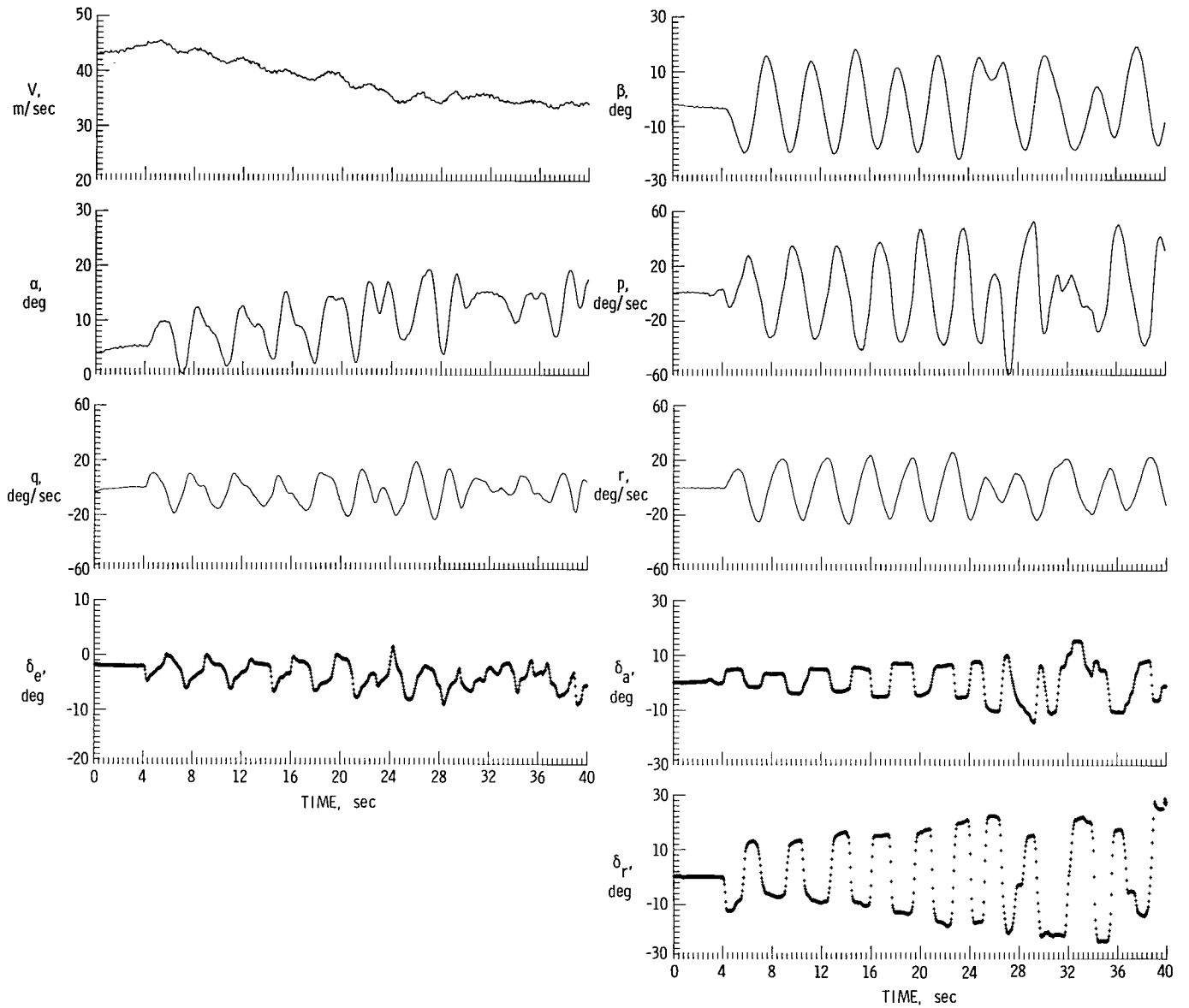

Figure 10.- Time histories of measured input and response variables in large-amplitude maneuver.

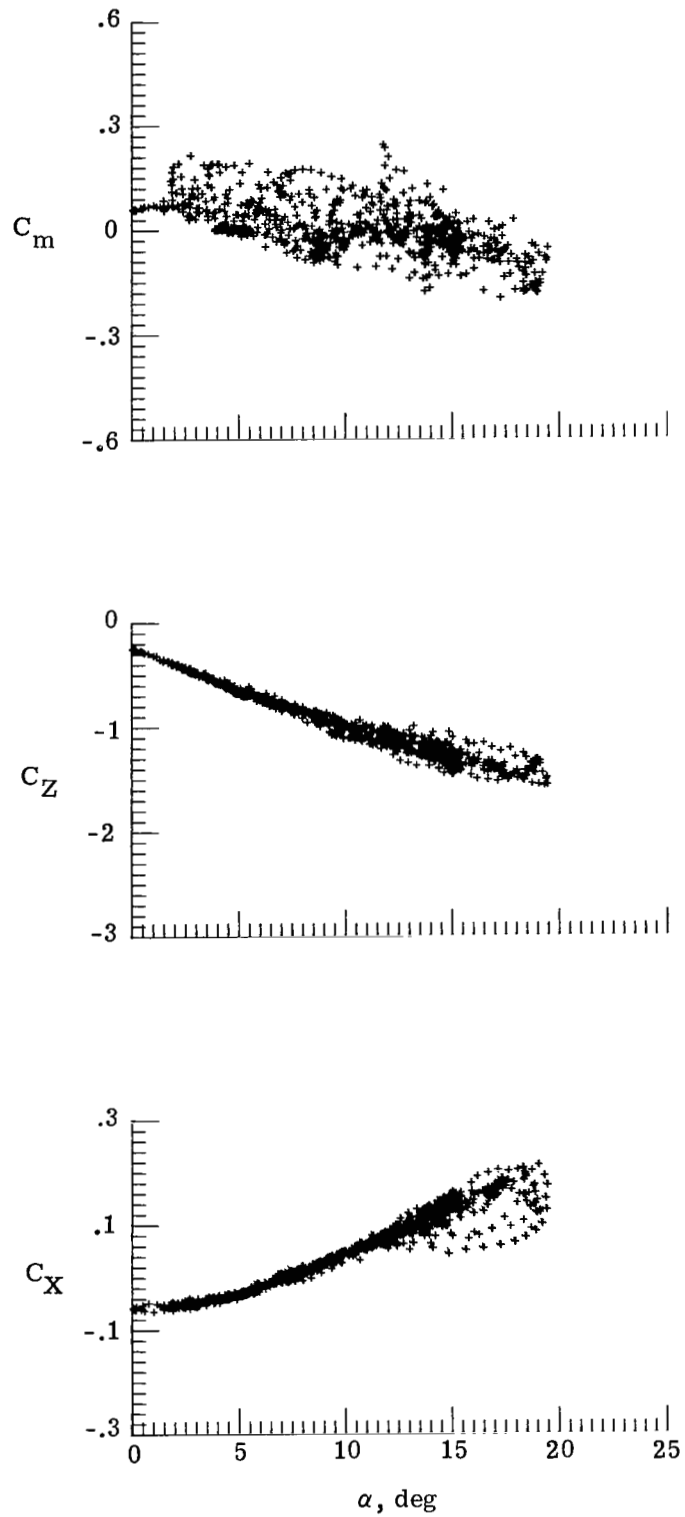

Figure 11.- Time histories of aerodynamic coefficients in large-amplitude maneuver plotted against angle of attack.

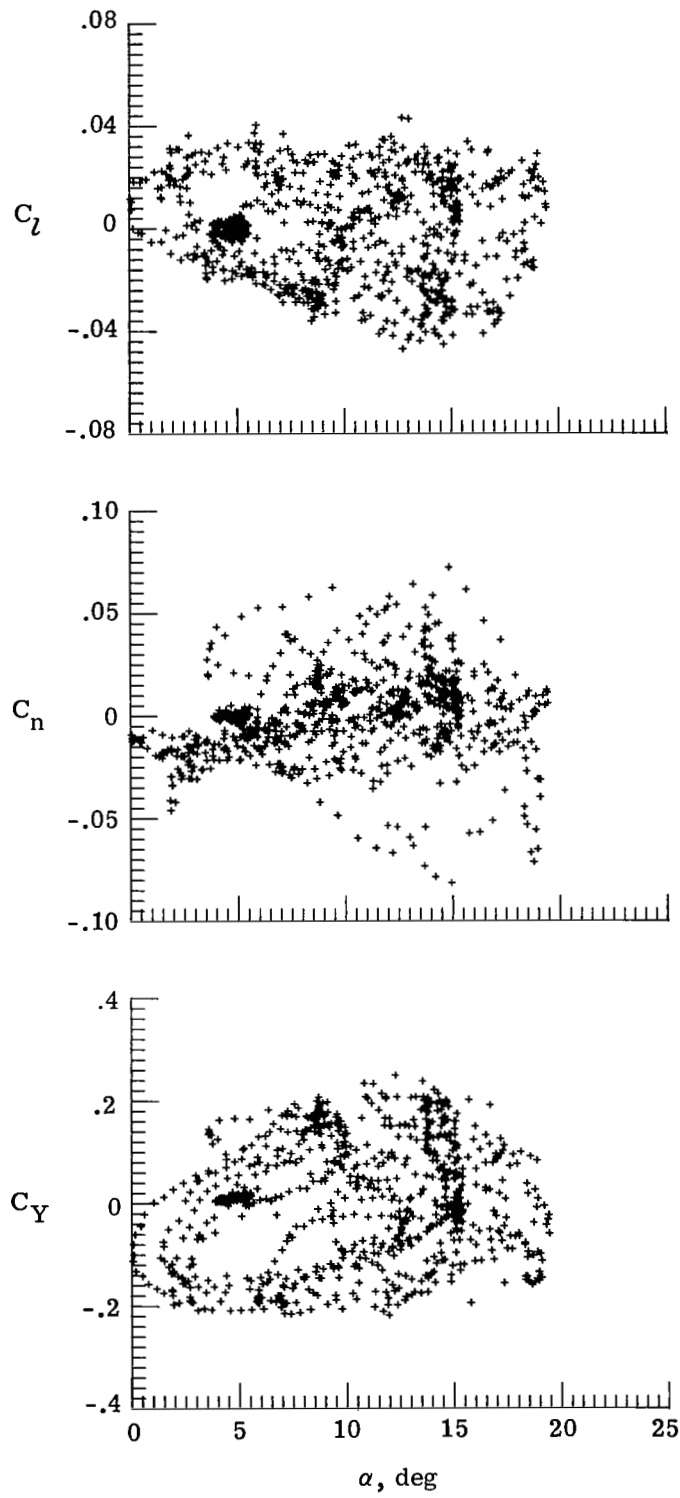

Figure 11.- Concluded.

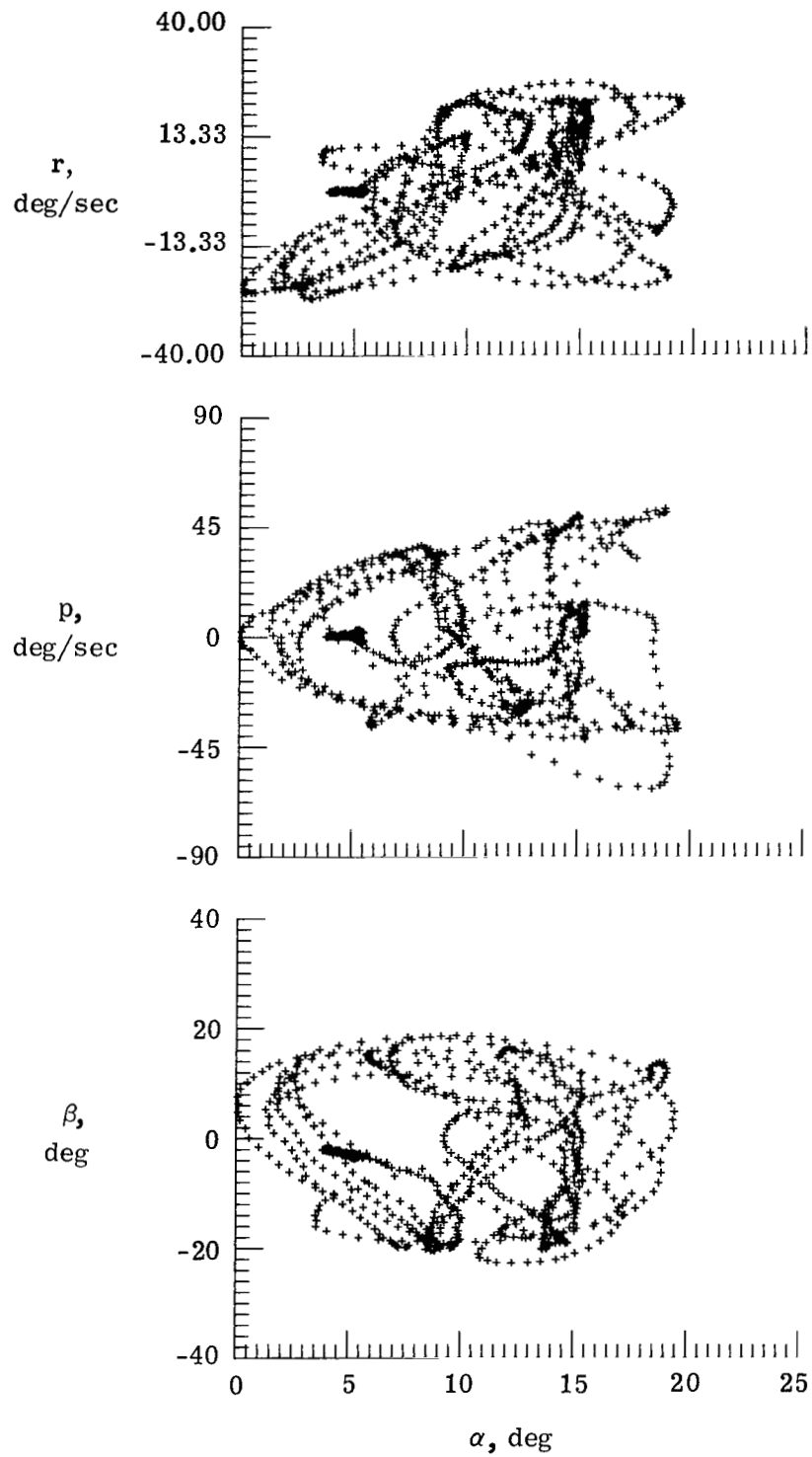

Figure 12.- Variation of lateral variables with angle of attack in large-amplitude maneuver.

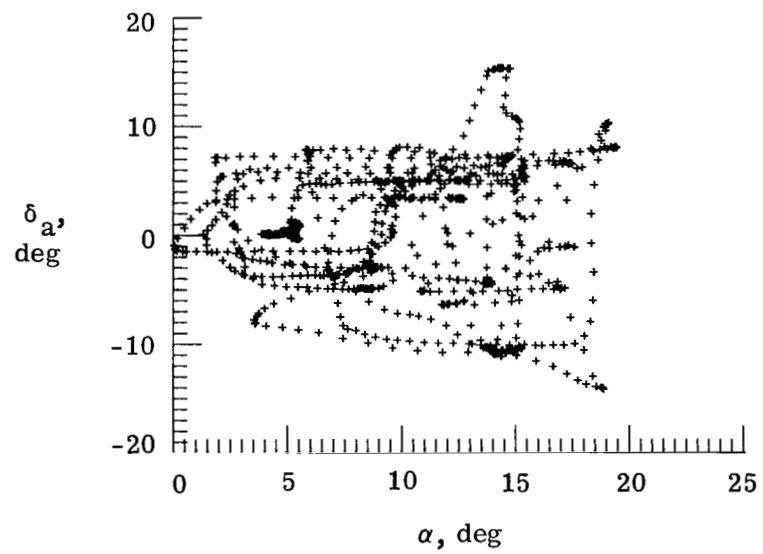
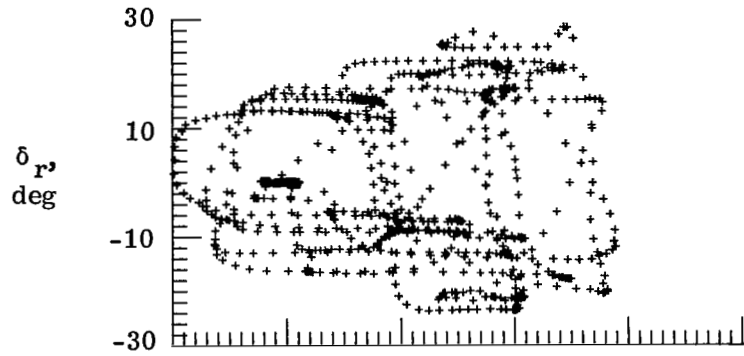

Figure 12.- Concluded.

- Small-amplitude maneuvers
- ≡≡≡ Large-amplitude maneuvers

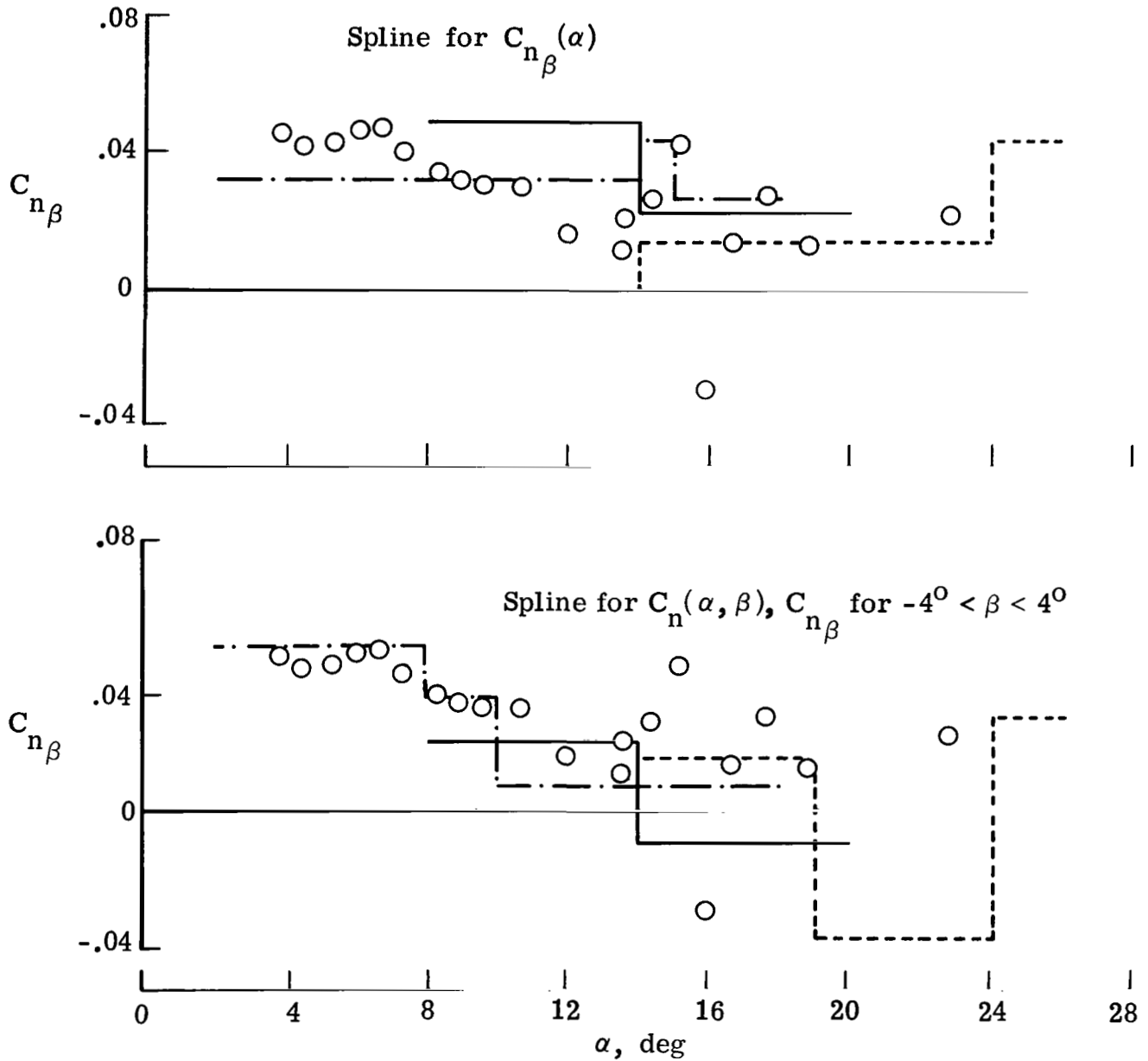

Figure 13.- Comparison of derivative of yawing moment due to sideslip estimated from different maneuvers and using different spline approximations.

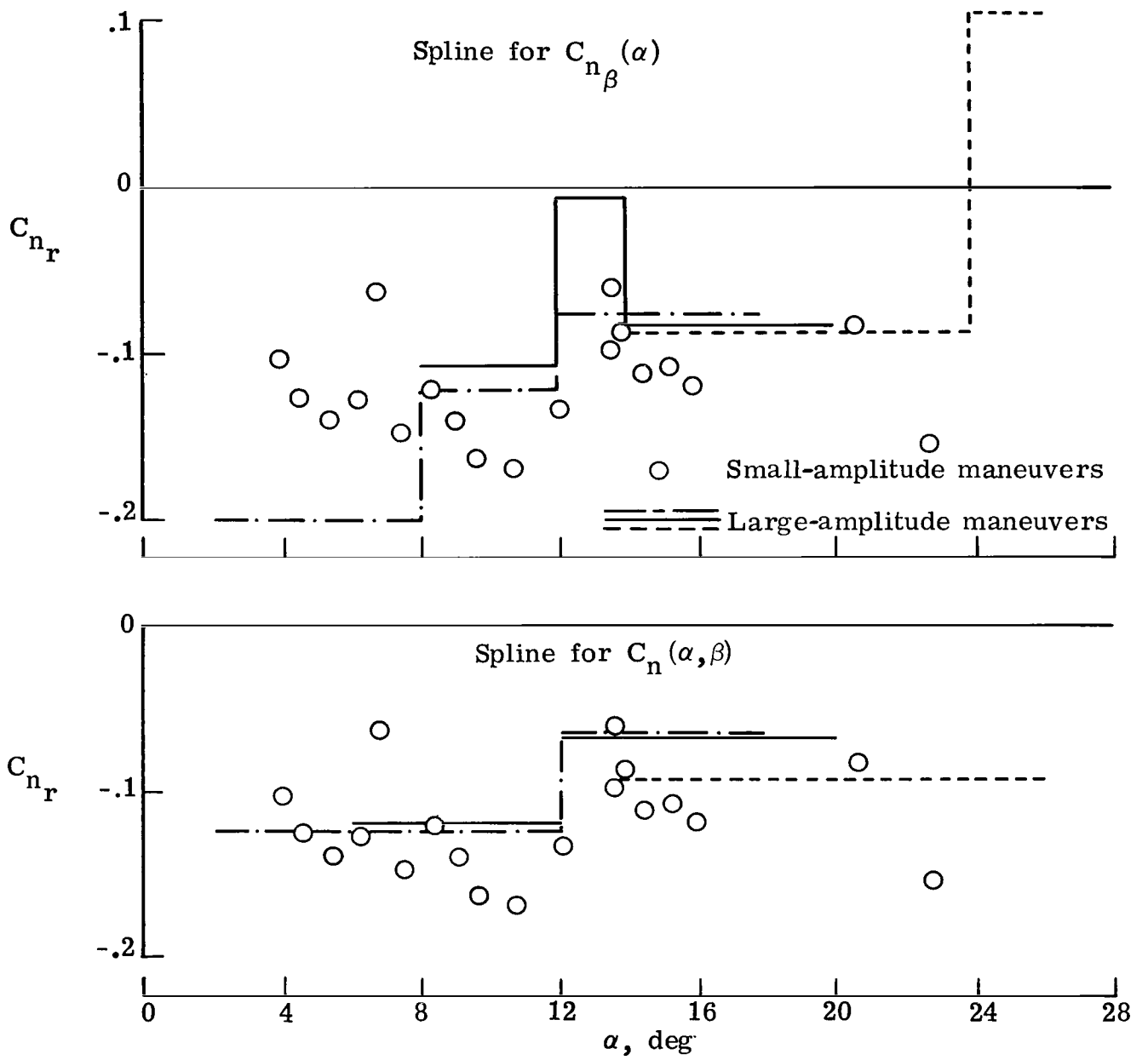

Figure 14.- Comparison of damping-in-yaw derivative estimated from different maneuvers and using different spline approximations.

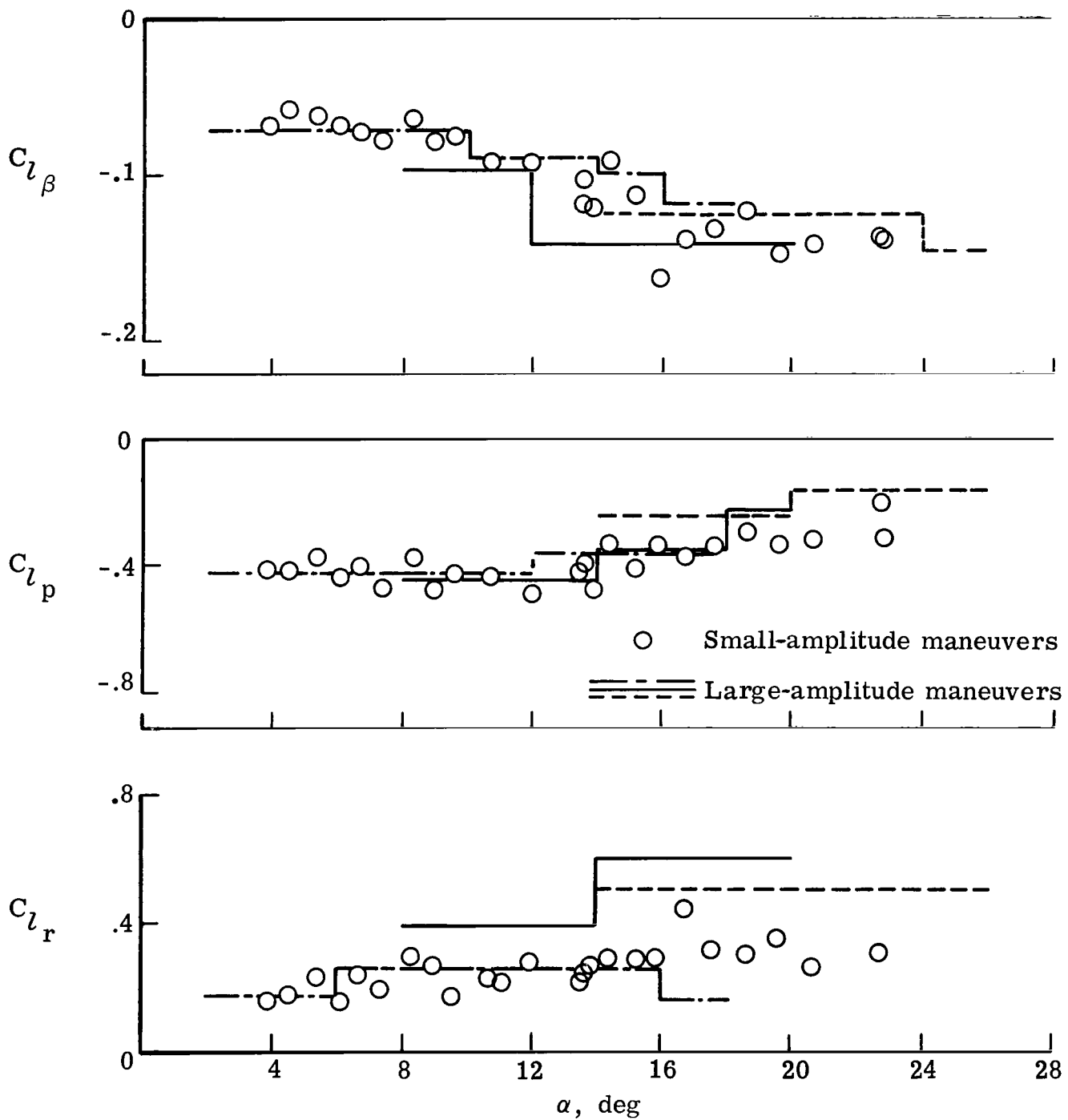

Figure 15.- Comparison of lateral parameters estimated from small- and large-amplitude maneuvers.

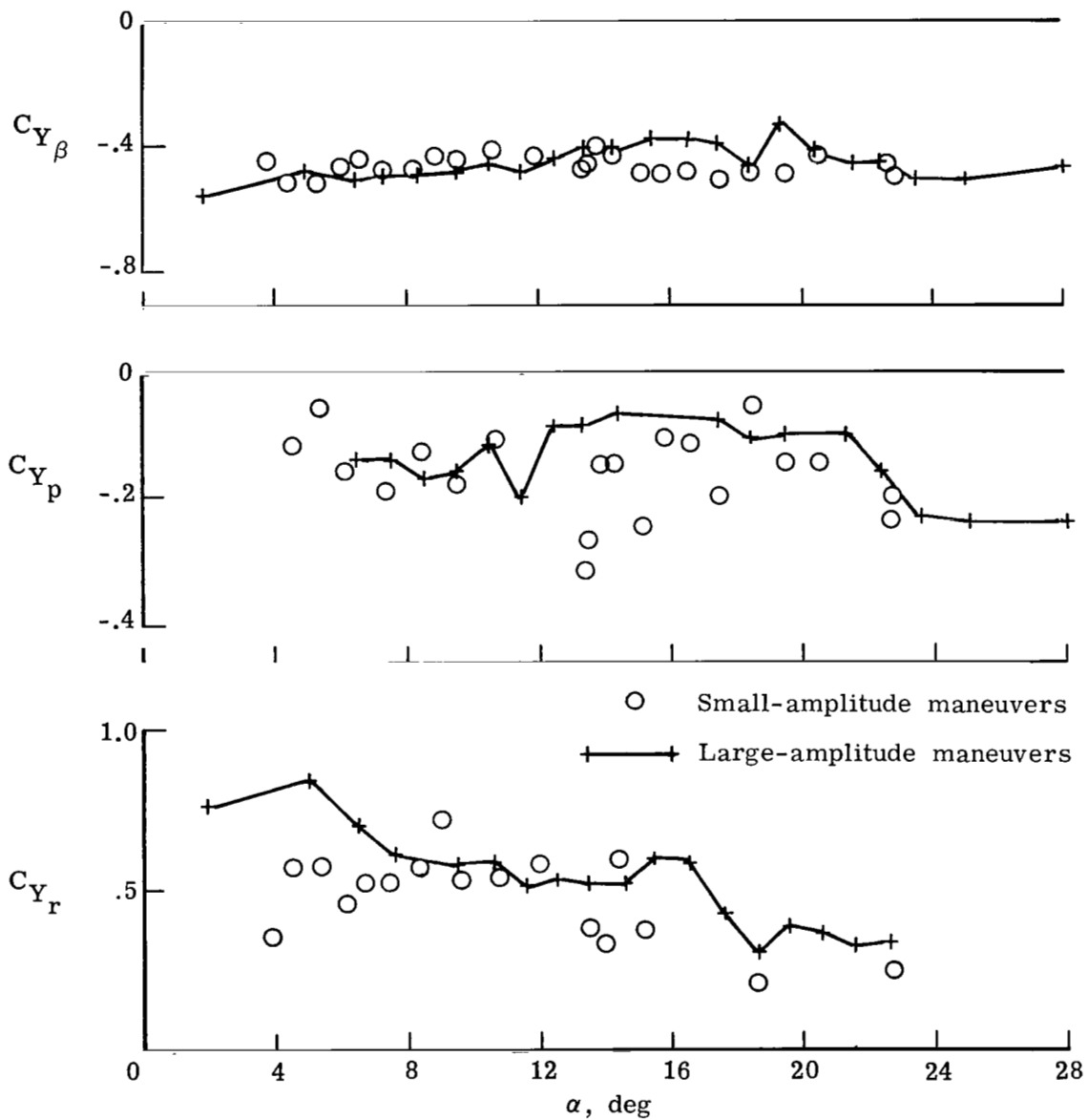

Figure 16.- Comparison of lateral parameters estimated from small- and large-amplitude maneuvers with partitioned data.

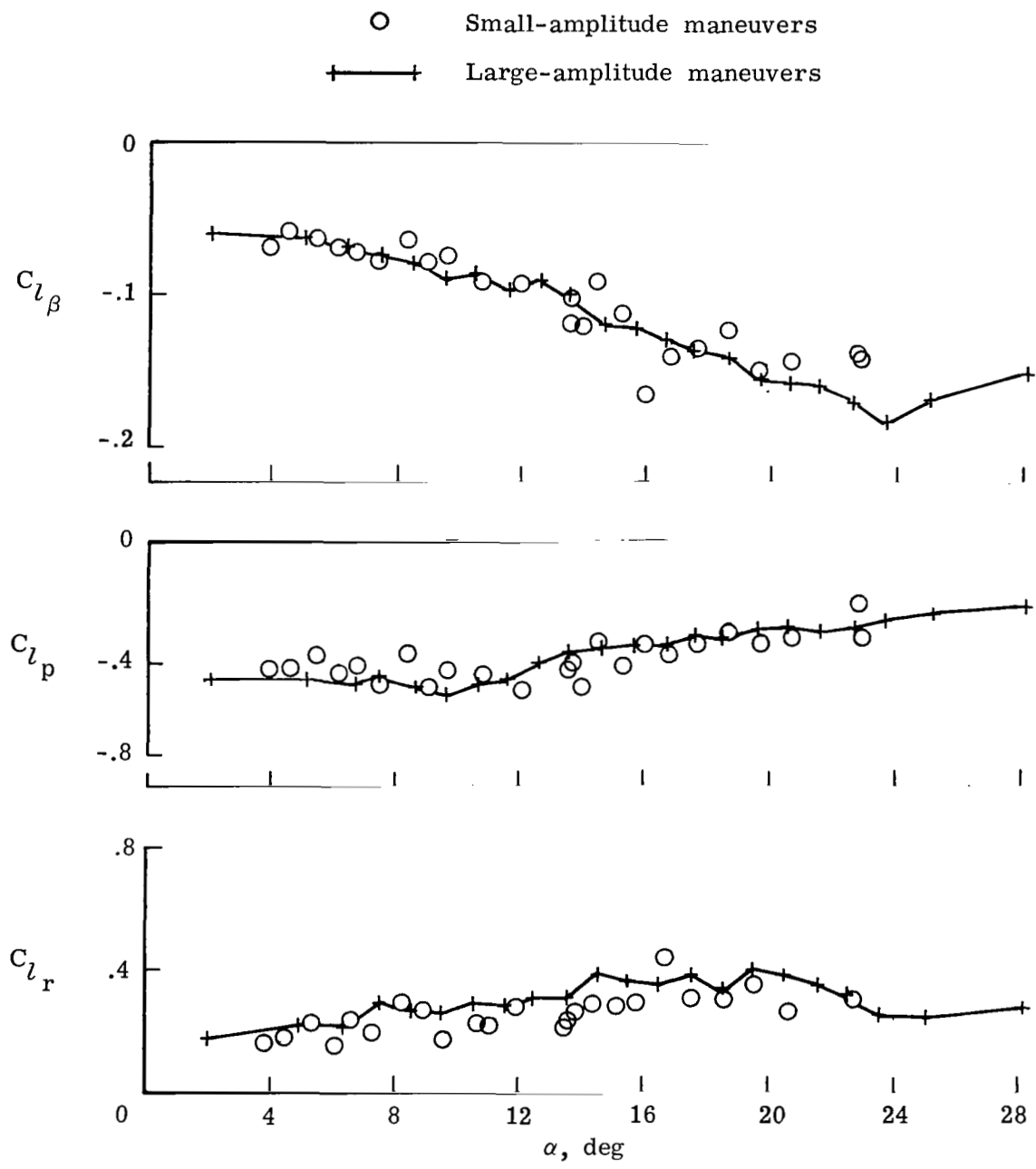

Figure 16.- Continued.

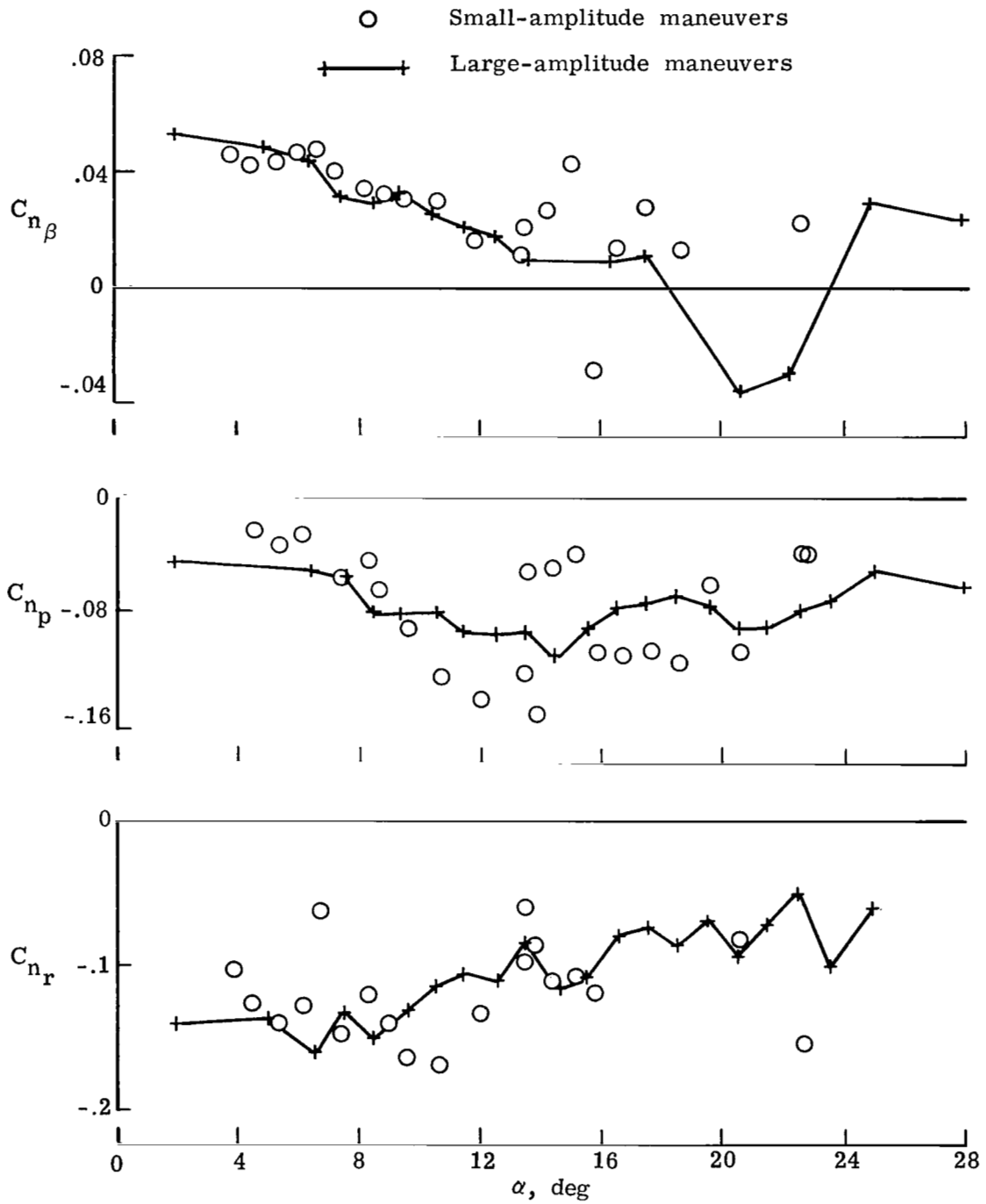

Figure 16.- Continued.

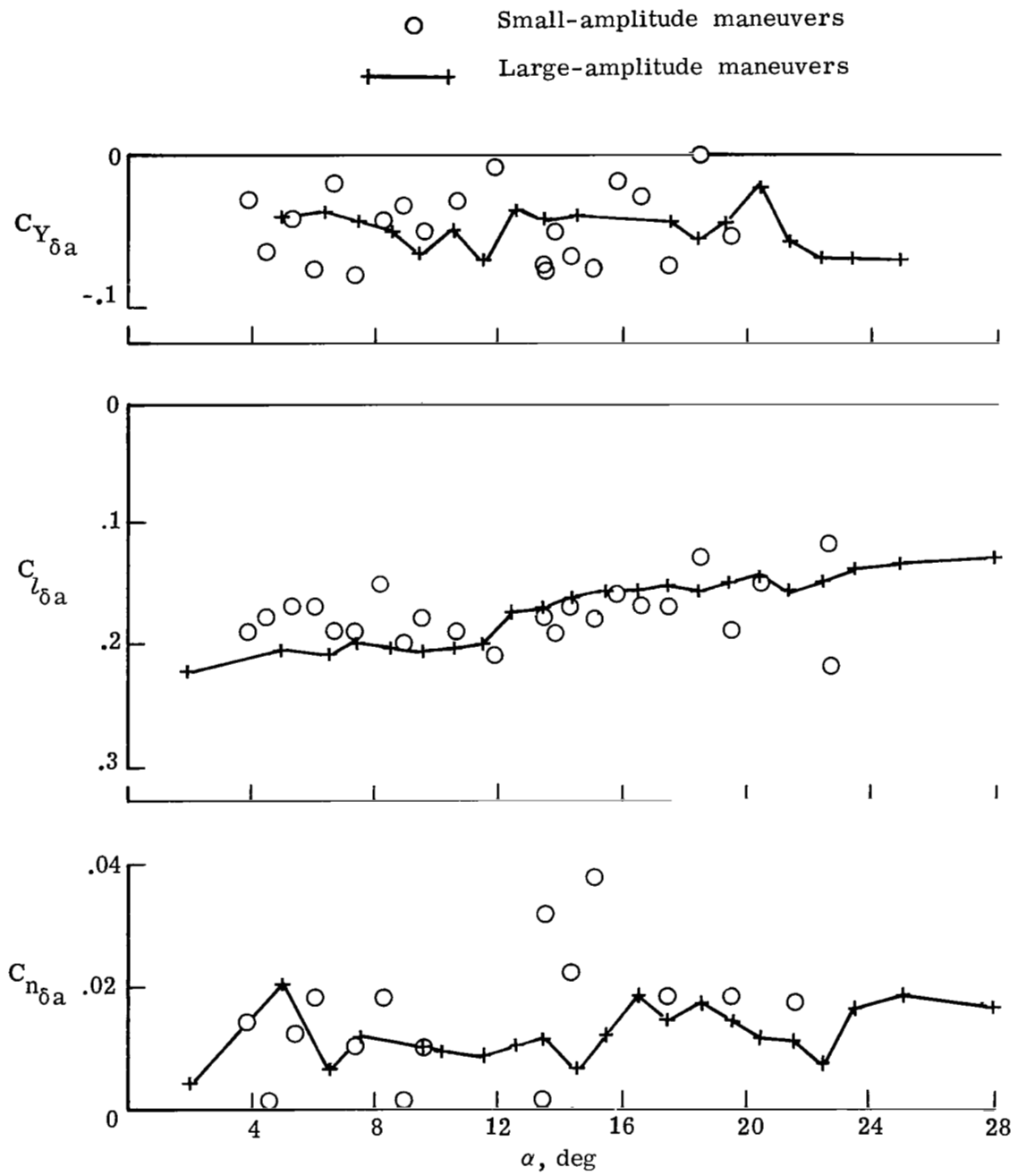

Figure 16.- Continued.

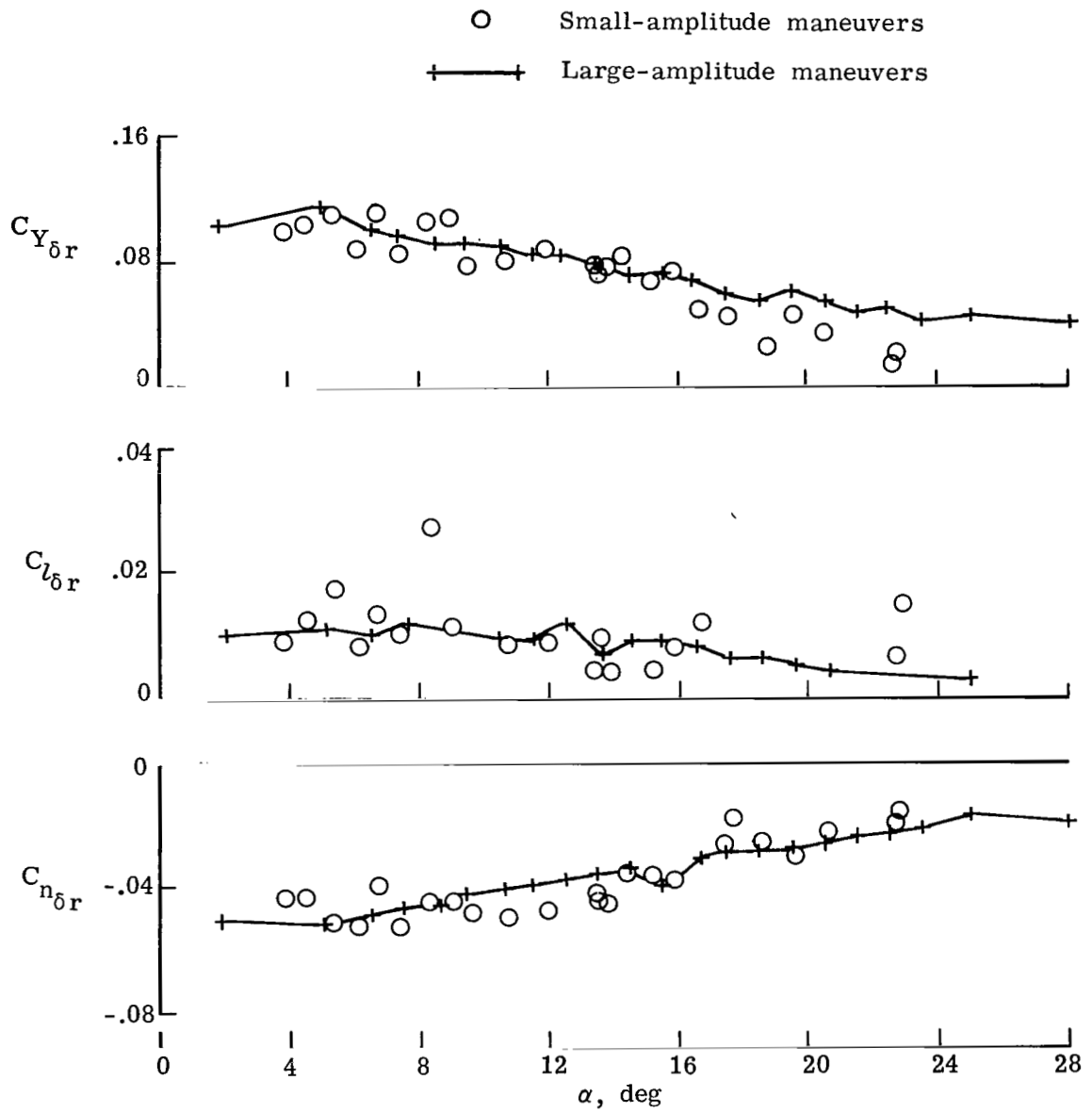

Figure 16.- Concluded.

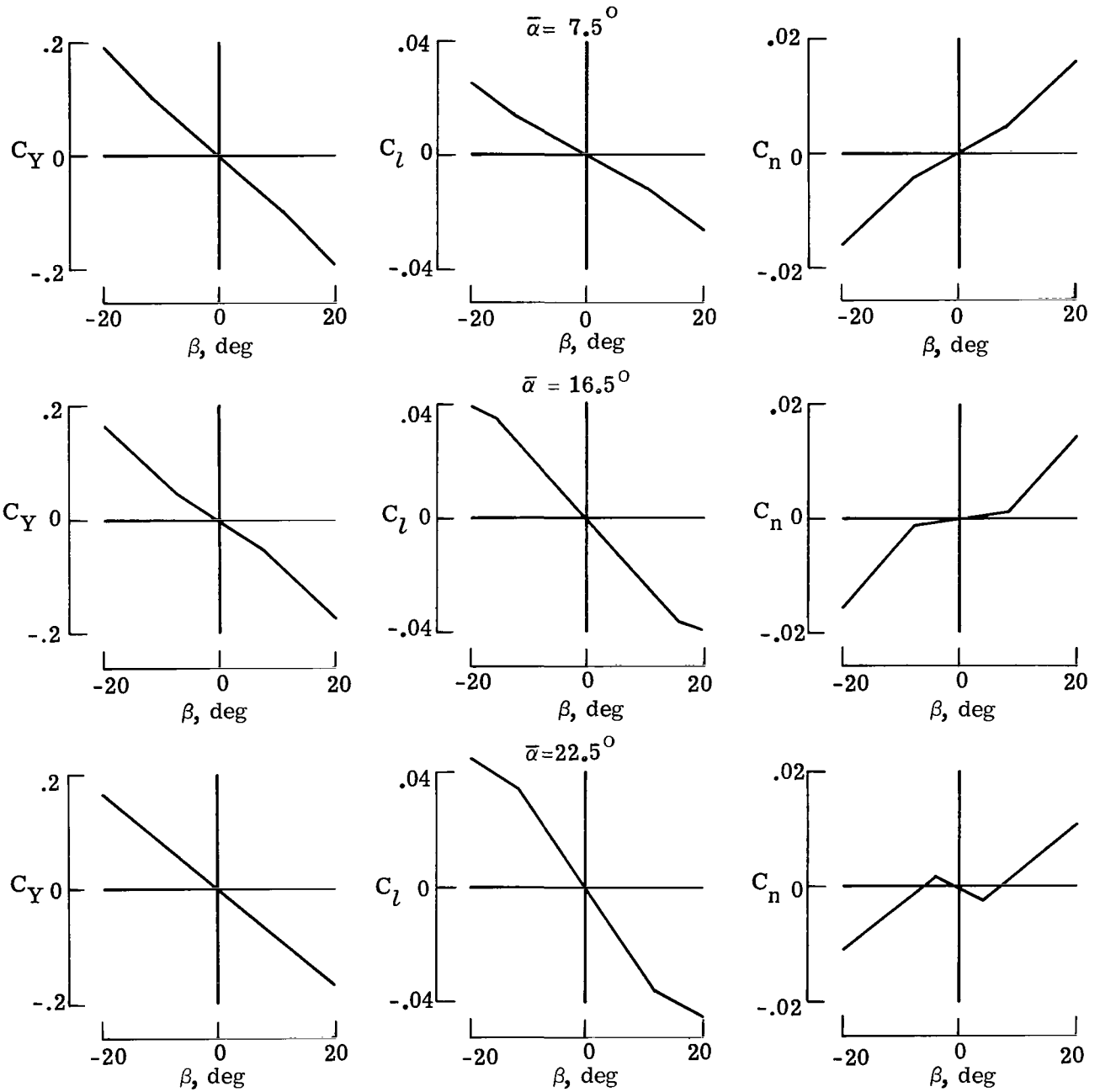

Figure 17.- Steady-state values of lateral coefficients estimated from large-amplitude maneuvers. Partitioned data.

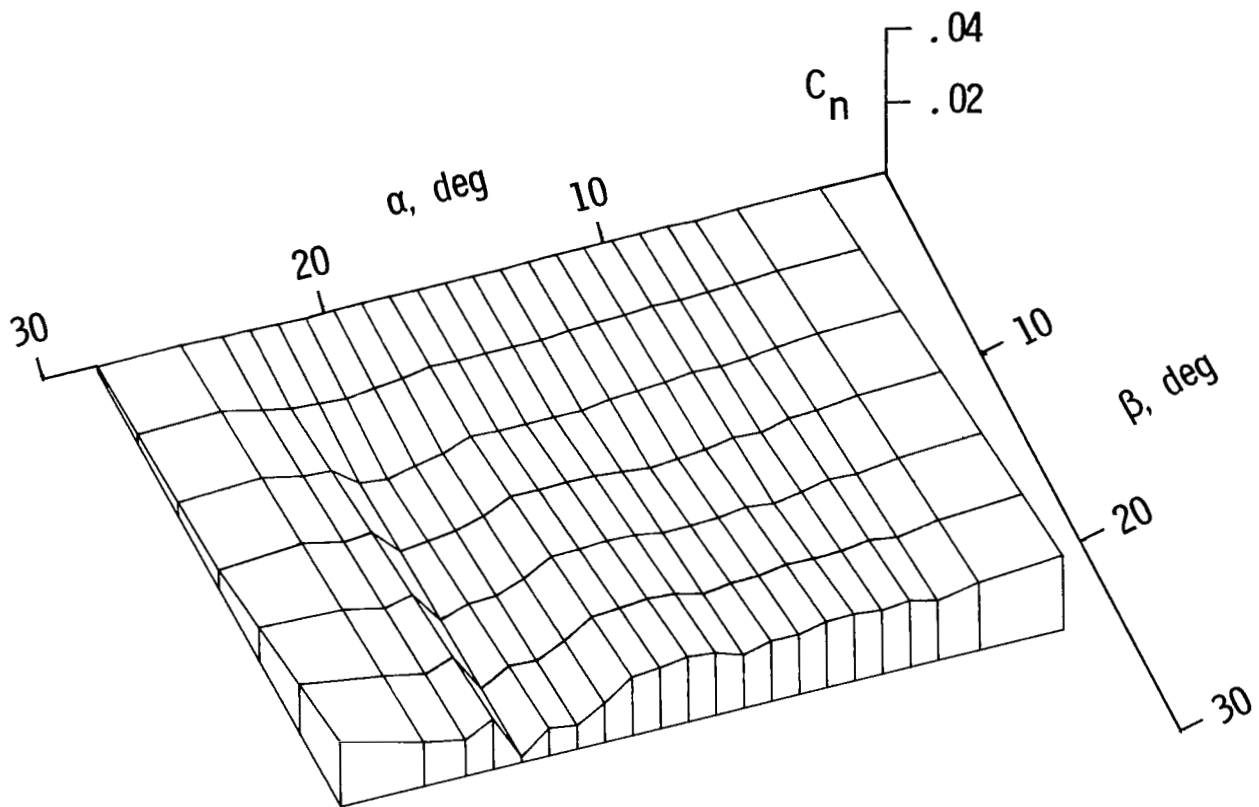

Figure 18.- Steady-state values of yawing-moment coefficients estimated from large-amplitude maneuvers. Partitioned data.

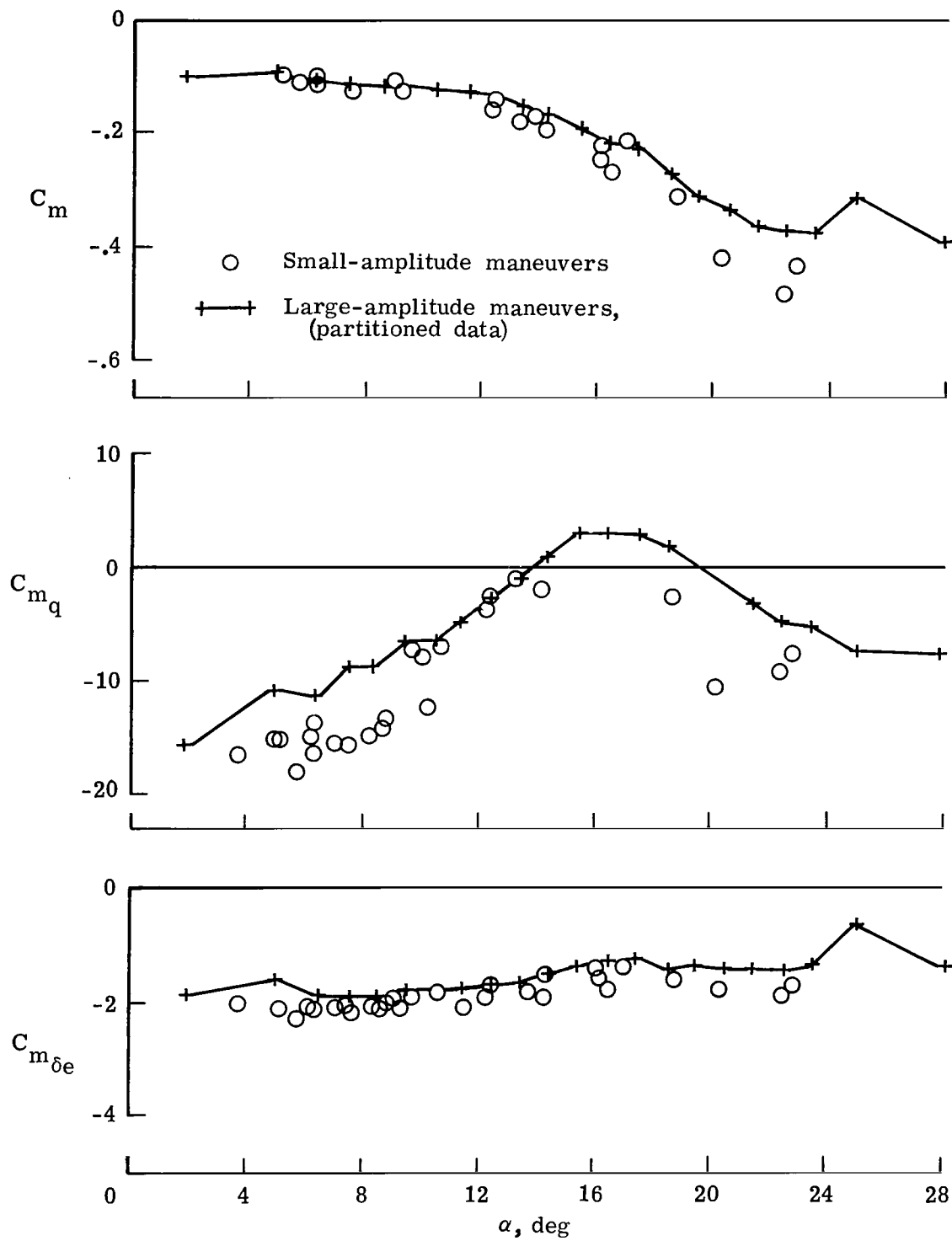

Figure 19.- Comparison of longitudinal parameters estimated from different maneuvers.

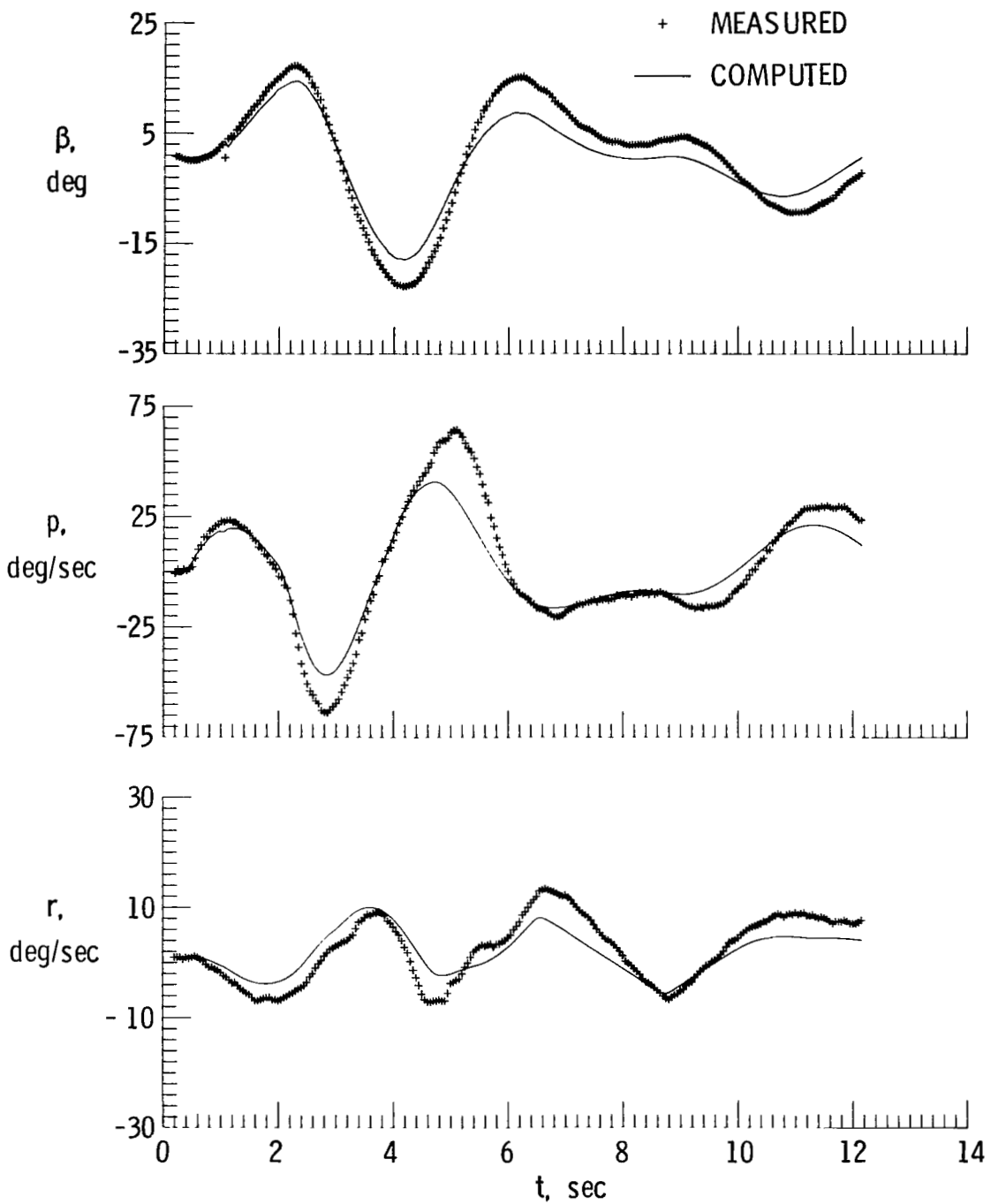

Figure 20.- Time histories of measured lateral flight data and those computed by using parameters obtained by stepwise regression from partitioned data.

1. Report No. NASA TP-2126		2. Government Accession No.		3. Recipient's Catalog No.	
4. Title and Subtitle DETERMINATION OF AIRPLANE MODEL STRUCTURE FROM FLIGHT DATA USING SPLINES AND STEPWISE REGRESSION				5. Report Date March 1983	
7. Author(s) Vladislav Klein and James G. Batterson				6. Performing Organization Code 505-34-03-06	
9. Performing Organization Name and Address NASA Langley Research Center Hampton, VA 23665				8. Performing Organization Report No. L-15541	
12. Sponsoring Agency Name and Address National Aeronautics and Space Administration Washington, DC 20546				10. Work Unit No.	
15. Supplementary Notes Vladislav Klein: Joint Institute for Advancement of Flight Sciences, The George Washington University, Hampton, Virginia. James G. Batterson: Langley Research Center.				11. Contract or Grant No.	
16. Abstract <p>A procedure for the determination of airplane model structure from flight data is presented. The model is based on a polynomial spline representation of the aerodynamic coefficients, and the procedure is implemented by use of a stepwise regression. First, a form of the aerodynamic force and moment coefficients amenable to the utilization of splines is developed. Next, expressions for the splines in one and two variables are introduced. Then the steps in the determination of an aerodynamic model structure and the estimation of parameters are discussed briefly. The focus of the paper is on the application to flight data of the techniques developed.</p>				13. Type of Report and Period Covered Technical Paper	
17. Key Words (Suggested by Author(s)) Aerodynamic model equations Model structure determination Parameter estimation Polynomial splines Stepwise regression				14. Sponsoring Agency Code	
18. Distribution Statement Unclassified - Unlimited				Subject Category 08	
19. Security Classif. (of this report) Unclassified	20. Security Classif. (of this page) Unclassified	21. No. of Pages 50	22. Price A03		

National Aeronautics and
Space Administration

Washington, D.C.
20546

Official Business

Penalty for Private Use, \$300

THIRD-CLASS BULK RATE

Postage and Fees Paid
National Aeronautics and
Space Administration
NASA-451



6 1 10, A, 330304 S0090303
DEPT OF THE AIR FORCE
AF WEAPONS LABORATORY
ATTN: TECHNICAL LIBRARY (SUL)
KIRTLAND AFB MS 37117

NASA

S

POSTMASTER: If Undeliverable (Section 158
Postal Manual) Do Not Return