

NASA Technical Memorandum 84637

AVRADCOM Technical Report TR-83-B-1

FLIGHT SERVICE EVALUATION OF COMPOSITE COMPONENTS
ON BELL 206L AND SIKORSKY S-76 HELICOPTERS

NASA-TM-84637 19830011544

DONALD J. BAKER

MARCH 1983

LIBRARY COPY

MAR 18 1983

LANGLEY RESEARCH CENTER
LIBRARY, NASA
HAMPTON, VIRGINIA

NASA
National Aeronautics and
Space Administration
Langley Research Center
Hampton, Virginia 23665



FLIGHT SERVICE EVALUATION OF COMPOSITE
COMPONENTS ON BELL 206L AND SIKORSKY S-76 HELICOPTERS

Donald J. Baker

Structures Laboratory
U.S. Army Research and Technology Laboratories (AVRADCOM)
Langley Research Center
Hampton, VA 23665

Abstract

Progress on two programs to evaluate composite structural components in flight service on commercial helicopters is described. Thirty-six ship sets of composite components that include the litter door, baggage door, forward fairing, and vertical fin have been installed on Bell Model 206L helicopters that are operating in widely different climatic areas. Four horizontal stabilizers and ten tail rotor spars that are production components on the S-76 helicopter will be tested after prescribed periods of service to determine the effects of the operating environment on their performance. Concurrent with the flight evaluation, specimens from materials used to fabricate the components are being exposed in ground racks and tested at specified intervals to determine the effects of outdoor environments. Results achieved from 14,000 hours of accumulated service on the 206L components, tests on a S-76 horizontal stabilizer after 1600 hours of service, tests on a S-76 tail rotor spar after 2300 hours service, and two years of ground based exposure of material coupons are reported.

Introduction

Over the past ten years, NASA has sponsored programs to build a data base and establish confidence in the long term durability of advanced composite materials in transport aircraft structures (reference 1). Primary and secondary components have been installed on commercial aircraft and world-wide flight service experience is being obtained. Flight environments for transport aircraft and the helicopter are quite different and the behavior of composite components in the two environments may differ substantially. Therefore, in 1978 NASA and the U.S. Army Research and Technology Laboratory initiated the first major program to evaluate composite helicopter components in flight service.

A contract was awarded to design, fabricate, certificate, and install forty ship sets of composite litter doors, baggage doors, forward fairings and vertical fins on Bell 206L helicopters. The specific objective is to determine the durability of composite airframe structures in the environment of light commercial helicopters. Such helicopters often operate for extended periods in remote areas with primitive maintenance facilities and near unimproved areas where damage from tree limbs, rocks, sand and other debris is commonly encountered.

In 1979 NASA and the U.S. Army Research and Technology Laboratory initiated a research program to determine the degradation in strength of composite helicopter components that results from flight service. A contract was awarded to track the flight service performance of four horizontal stabilizers and ten tail rotor paddles on Sikorsky S-76 helicopters and to determine the residual strength of each composite component after prescribed periods of time. The composite components are production parts for the S-76.

The S-76 composite components were chosen to compare real-time in-service environmental effects with accelerated laboratory test results and analytical predictions for both static and dynamic loaded primary structures. The tail rotor is designed primarily for cyclic fatigue loading whereas the horizontal stabilizer is designed for static loading. Environmental factors established through flight service of these components will allow more efficient design of composite components for future helicopters.

Concurrent with the two flight service programs, specimens from the materials used to fabricate the components are being exposed in ground racks at seven sites and will be tested at prescribed intervals to determine the effects of outdoor environments.

This paper describes the design, certification and flight service experience of each composite component and ground based exposure of material specimens. Residual strength of components after flight service and strength of specimens after outdoor exposure are reported and compared with baseline values.

Use of commercial products or names of manufacturers in this report does not constitute official endorsement of such products or manufacturers, either expressed or implied, by the National Aeronautics and Space Administration or the U.S. Army Research and Technology Laboratories.

Bell 206L Components

A total of forty-five (45) ship sets of litter doors, baggage doors, forward fairings and vertical fins were manufactured for the Bell 206L helicopter (figure 1). To date, thirty-six sets have been installed on helicopters for commercial service. A detailed description of the design, fabrication and certification of each component is reported in reference 2. A brief description of each component follows.

Component Description

Litter Door - The litter door is located on the left side of the aircraft as shown in figure 1. The door is 0.7 m (26.0 in.) wide by 1.2 m (46.0 in.) high. A photograph and schematic of the litter door are shown in figure 2. The door consists of outer and inner skins of Kevlar-49 fabric/Hexcel F-185 epoxy composite material. Each skin contains areas that are reinforced with unidirectional Kevlar-49/Hexcel F-560 epoxy composite material. Each skin was fabricated separately and then the two skins were secondarily bonded together to form the door. A plexiglass window was bonded directly to the door with 3M-EC3549 adhesive.

Design of the litter door was controlled primarily by two loading conditions required for FAA certification: An outward aerodynamic load and the weight of the litter door and cabin door plus a 222N (50 lbf) downward force at the rear of the cabin door. The latter loading condition simulates a person pulling on the cabin door when both doors are open and hereafter is labeled cantilever door loading. The aerodynamic loading was simulated by applying a uniform pressure to the interior of the door with water bags. The litter door was supported at the forward hinges and the upper and lower latch pins that are located near the trailing edge of the door. Aerodynamic loads from the

cabin door were simulated by applying concentrated loads at the litter door to cabin door hinges. The cantilever door loading condition was simulated by supporting the litter door at the forward hinges and applying concentrated loads at the litter door-to-cabin door hinges.

Baggage Door - The baggage door is also located on the left side of the aircraft as shown in figure 1. The door is 0.9 m (37.5 in.) long by 0.6 m (23.4 in.) wide. A photograph of the baggage door is shown in figure 3. The door consists of Kevlar-49 fabric/Brunswick LRF-277 epoxy composite face sheets bonded on 49.7 kg/m³ (3.1 lbf/ft³) Nomex honeycomb core. Areas around the hinges and latches were reinforced with additional plies of Kevlar-49 fabric/LRF-277 epoxy.

Design of the baggage door was based primarily on two loading conditions required for FAA certification: an outward aerodynamic load and a downward load caused by pulling on the door in the opened position. The latter loading is hereafter labeled cantilever door loading.

Forward Fairing - Location of the forward fairing on the aircraft is shown in figure 1. The fairing is 0.9 m (35.9 in.) long, 0.7 m (29.0 in.) wide and 0.3 m (13.0 in.) high at the aft end (figure 4). Most of the fairing consists of single-ply Kevlar-49 fabric/Ferro CE 306 epoxy composite skin that was cured on a 72 kg/m³ (4.5 lbf/ft³) Klegecell foam core. Areas around the hinges and latches were reinforced with additional plies of Kevlar-49 fabric/CE 306 epoxy. Design and certification tests of the fairing were based on an outward aerodynamic pressure load. The aerodynamic loading was simulated by locking the fairing in place in a box and applying a vacuum to the exterior surface while the interior of the fairing was maintained at atmospheric pressure.

Vertical Fin - The vertical fin is used for directional stability in forward flight and is located on the aircraft as shown in figure 1. A photograph of the fin is shown in figure 5. The fin is 2.0m (79.0 in.) high and the chord varies between 0.3 m (12.0 in.) and 0.5 m (18.0 in.). The fin is a conventional sandwich structure with T-300/U.S. Polymeric E-788 epoxy composite facesheets on a Fibertruss core. Fibertruss is a high strength fiberglass core manufactured by Hexcel Corporation. A 200 x 200 mesh aluminum alloy screen was bonded to the exterior surface of each facesheet to provide lightning protection. The tail skid is a tapered filament-wound S-glass/epoxy tube

with a short length of steel tubing and standard abrasion pad attached at the tip.

Three FAA certification tests were required for the vertical fin. Two of the tests were static loadings. One static test simulated aerodynamic loading. The fin was supported at the fuselage attach points and loaded with lead shot bags to failure. The second static load test simulated an aircraft landing in the tail down attitude and is defined as the reserve energy condition. A fin was supported at the fuselage attach points and concentrated load was applied to the tail skid until failure occurred. The fatigue tests were conducted on specimens that simulate the fin-to-fuselage attachment structure of the fin. Each specimen was supported at the attach points and a concentrated load was applied at point "P" (figure 6). The concentrated load was statically equivalent to the aerodynamic load on the top part of the fin. The fatigue tests were conducted at room temperature after the specimens had been conditioned at 49°C (120°F) and 95 percent relative humidity for 42 days (1000 hours).

Ground Exposure Specimens

Concurrent with the flight service program, material test specimens are being exposed at five locations on the North American Continent (figure 7). The selected locations, which have varying environmental conditions, are in the general areas where the composite components are being flown. Each location contains one rack as shown in figure 8. A rack contains 120 each of tension, short-beam-shear, IITRI compression specimens and twenty 5.1 cm (2.0 in.) wide specimens manufactured from the skin materials used in the 206L components. The tension, short-beam-shear, and compression specimens were painted with a polyurethane paint that was used on the helicopters. The remaining specimens were left unpainted to determine the effect of weathering on bare composites. One fifth of the specimens are scheduled to be removed from each rack and returned to the Langley Research Center for testing after 1, 3, 5, 7, and 10 years of exposure.

Flight Service Evaluation

A total of forty (40) ship sets of composite components have been supplied to operators for installation on aircraft that are located in the four geographical areas shown in figure 9. Each component will be inspected annually for evidence of damage, repair, excessive wear or weathering. At the conclusion of the

first, third and fifth year of flight service, six ship sets of components will be removed and returned to Bell Helicopter for static testing. Prior to testing, each component will receive the same non-destructive inspection that was applied during manufacturing. Based upon test results achieved after 5 years of flight service, the program may be extended to 10 years with components scheduled for removal after 7 and 10 years. At the end of the flight service program, nine additional components will be randomly selected for testing to determine the static strength distribution. Test results will be compared to design strength requirements.

Results and Discussion

The average weight of each type of Bell 206L composite component is listed in Table 1 and compared with the weight of production metal components. The weight savings ranges from zero to 37 percent and the average value is 23 percent. Design of the baggage door was driven by a stiffness requirement and no weight saving was achieved for the concept chosen.

Static test results for Bell 206L composite components are listed in Table 2 and compared with the design ultimate loads and the FAA certification requirements. Failure of the litter door, that occurred at approximately 96 percent of the aerodynamic load requirement, was caused by a latch pin slipping out of the latch. Composite material in the door did not fail. The door loaded as a cantilever reached the maximum deflection allowed by the test fixture at 0.7 kN (146 lbf) and did not fail. Based on these two tests, the door was certified. The baggage door was loaded to 333.6 N (75 lbf) in the cantilever door test without failure. The aerodynamic load produced a failure in the metal hinge at 113 percent of the FAA required load. Failure loads for two forward fairings were more than three times the required FAA load. Examination of the failed parts revealed a possible knife cut in the failed area on the first fairing and a faulty latch on the second fairing. This finding was supported by subsequent tests on composite production fairings which failed at higher loads. The vertical fin failed at 1.39 times the FAA required value for aerodynamic pressure loading and 1.9 times the value required for reserve energy loading. The four vertical fin specimens tested in fatigue met the requirement of 10 million cycles without failure. Based on the noted static and fatigue tests, FAA certified the components for unrestricted service.

Five litter doors, four baggage doors, five forward fairings and five vertical fins were randomly selected and subjected to static tests to establish baseline strengths. The components were tested in the as-fabricated condition and in an ambient laboratory environment. Test results are compared with the corresponding Design Ultimate Load (DUL) requirements in Table 3. Failure loads for all components exceeded their design ultimate load requirements. The average failure load for the forward fairing was approximately two times the failure load for FAA certification (Table 2). This result verified that the suspected damage discussed previously caused a lower failure load for the two fairings tested for FAA certification.

The average baseline strengths for the as-fabricated ground exposure specimens are given in Table 4. The average strength retention ratios of the ground based exposure specimens after 1 year of exposure are reported in Table 5. The strength retention ratio is the strength of an exposed specimen divided by the baseline strength. The specimens fabricated from the litter door material (Kevlar/epoxy), that were exposed at Ft. Greeley, AK retained 93 percent of their short-beam-shear (SBS) strength and 90 percent of their compression strength. The remainder of the litter door material specimens did not indicate a significant change in strength. The average strength retention values for compression and SBS specimens fabricated from the baggage door material (Kevlar/epoxy) were 90 and 93 percent, respectively. Strength retention for SBS specimens fabricated from the baggage door material ranged from a low value of 88 percent for specimens exposed at Ft. Greeley, AK to a high value of 97 percent for specimens exposed at Hampton, VA. The compression specimens fabricated from the baggage door material and exposed at Ft. Greeley, AK retained only 85 percent of their strength. The specimens fabricated from the forward fairing material (Kevlar/epoxy) and exposed at Ft. Greeley, AK also retained a lower percentage of their initial strength than specimens exposed at other locations. The specimens fabricated from the vertical fin material (graphite/epoxy) did not exhibit a significant change in strength. All Kevlar-49/epoxy SBS and compression specimens exposed at Ft. Greeley, AK had lower strength retention than specimens exposed at other locations. This trend will be monitored during the remainder of the test program.

Installation of the composite components began in March 1981. Aircraft have accumulated 14,000 hours of flight service with composite components. The high time

aircraft has 1308 hours of service. The litter doors have not been damaged in service. One baggage door was damaged when closed on an oversize cargo and was subsequently repaired with fiberglass/epoxy. The forward fairings have not been damaged in service. Four vertical fins have been damaged in service. A 5.1 cm x 5.1 cm (2.0 in. x 2.0 in.) area was broken out of the trailing edge of one vertical fin when the aircraft, equipped with floats, autorotated into a river. A second fin was damaged on both the leading and trailing edges and the tail skid was broken when hit by another helicopter while on the ground. The leading edge had cracks over a 30.5 cm (12.0 in.) length and the trailing edge was disbanded over an 45.7 cm (18.0 in.) length. These two vertical fins were repaired with fiberglass/epoxy. The tail skid was removed and replaced with a new skid. Damage to the third vertical fin resulted from wind blown debris while the helicopter was on the ground and is shown in figure 10. The damaged area was removed, an epoxy filler was applied, and an external titanium patch was bonded in place. The fourth fin was destroyed in a ground transportation accident.

Two ship sets of composite components with one year of flight service have been removed and tested to failure. One set of components had accumulated 870 hours of flight service in Canada. Three months of the flight service was in Alberta and the remaining 9 months of flight service was in the Montreal area. Test results from these components are compared with the baseline strengths and the design ultimate loads in Table 6. The residual strength of all components exceeded the DUL requirements. Average failure load for the litter doors was approximately 1.6 times the DUL and 82 percent of the baseline strength. Both doors failed by the latch pins slipping from the fixture. The baggage door from the Gulf Coast failed at 1.8 times the DUL and 1.3 times the baseline strength. The baggage door from Canada failed at 1.08 times the DUL and at 77 percent of the baseline strength. Failure loads for the forward fairings were over 6 times the DUL and 60 percent of the baseline strength. Failure loads for the vertical fins were over two times the DUL and approximately 1.1 times the baseline average load.

Sikorsky S-76 Components

Four horizontal stabilizers and ten tail rotor spars, that are production S-76 composite material components, are in flight service and will be tested after prescribed periods of time to determine the effects of the operating equipment.

The location of each type of component on the S-76 is shown in figure 11. A detailed description of the program is given in reference 3. A brief description of each component follows.

Component Description

Horizontal Stabilizer - A sketch of the left half of the horizontal stabilizer is shown in figure 12. Full depth sandwich structure with crossplied Kevlar-49 fabric/Du Pont-American Cyanamid 5143 epoxy composite skins and Nomex honeycomb core were used. The torque tube that joins the left and right sides of the stabilizer is full depth aluminum honeycomb construction with unidirectional AS-1 Graphite/Ciba-Geigy 6350 epoxy composite in spar caps. The torque tube is overwrapped with cross plies of Kevlar-49 fabric/5143 epoxy to provide additional torsional rigidity. The composite horizontal stabilizer weighs 18.1 kg (40.0 lbm).

Design of the stabilizer was controlled primarily by static load requirement. All production parts are proof load tested at room temperature prior to installation. For proof load testing the stabilizer is supported at ± 0.6 m (25.0 in.) from centerline and a 10.7 kN (2400 lbf) downward load is applied at the centerline. The deflection of the torque tube is measured and recorded. FAA certification and baseline strengths were achieved by supporting the stabilizer at the aircraft attachment points and applying load through pads bonded to the stabilizer skin at ± 1.0 m (40.0 in.) from the centerline. This test was performed with the structure at 71°C (160°F).

Tail Rotor Spar - The tail rotor spar is a solid laminate constructed with AS-1 graphite/Ciba-Geigy 6350 epoxy composite material. The spar is shown in figure 13 and is 1.3 m (52.9 in.) long by 0.09 m (3.5 in.) wide. Weight of the spar is 6.6 kg (14.6 lbm). Two glass/epoxy blades are attached to the spar to form the tail rotor paddle as shown in figure 14.

The tail rotor spar was designed to withstand a high number of cyclic loads. The tail rotor spar was fatigue tested using the edgewise moment, flatwise moment, torsion, and centrifugal loads shown in figure 15.

Ground Exposure Panels

Panels of AS-1/6350 and Kevlar-49/5143 are being subjected to outdoor ground based exposure at Stratford, CT and West Palm Beach, FL. The Kevlar-49/epoxy

panels are 5-ply thick and the graphite/epoxy panels are 6, 14, and 33-ply thick. Each year, three panels of each material and thickness combination are removed for evaluation. Sizes of panels are 20.3 cm (8.0 in.) x 55.8 cm (22.0 in.), 15.3 cm (6.0 in.) x 20.3 cm (8.0 in.), and 5.1 cm (2.0 in.) x 15.3 cm (6.0 in.). The 5.1 cm x 15.3 cm panels were left unpainted for determining the effects of weathering on bare composites and the other panels were painted with a polyurethane aircraft paint. The 14 and 33-ply graphite/epoxy panels will be machined into compression, SBS static, flexure and SBS fatigue specimens. The 6-ply graphite/epoxy panel will be machined into compression and flexure specimens. The 5-ply Kevlar-49/epoxy panel will be machined into tension specimens. All exposed specimens will be tested at room temperature and the test data will be compared with baseline data for room temperature dry specimens. Moisture content will be determined by cutting the 15.3 cm x 20.3 cm panel into four specimens and drying at 65°C (150°F).

Flight Service Evaluation

Four horizontal stabilizers and ten tail rotor spars are scheduled to be removed from aircraft in service over an eight year period as shown in Table 7. Since these components are production parts, they receive the normal maintenance inspection for surface damage every 100 flight hours and inspection for structural damage annually or 1000 hours. Two of the stabilizers will be static tested and the remaining stabilizers will be fatigue tested and then subjected to residual strength tests. Six of the tail rotor spars will be fatigue tested and the remaining four spars will be cut into SBS specimens that will be subjected to the following tests: (1) Room temperature static, (2) 77°C (170°F) static and (3) room temperature fatigue.

Results and Discussion

The environmental panels were removed from the Stratford, CT and West Palm Beach, FL (WPB) locations after 2 years of exposure. Data on moisture absorption are presented in Table 8 and figure 16. The 5-ply Kevlar-49/epoxy panel absorbed the most moisture (1.6 percent) whereas a 33-ply graphite/epoxy panel absorbed the least amount of moisture (.18 percent). The average monthly weather data for both locations and predicted moisture content are given in reference 3. Moisture absorption data for the 6-ply graphite/epoxy specimens are compared with predicted moisture absorption in figure 16.

The measured data is approximately midway between the two predicted curves which differentiate the effect of solar radiation.

Static and fatigue tests were conducted on specimens to measure strength retention and the results are presented in Table 9. The 6-ply graphite/epoxy SBS and flexure specimens exposed at West Palm Beach had the lowest strength retention, approximately 85 percent of baseline strength. The same types of specimens exposed at Stratford retained approximately 88 percent of their baseline strengths. The other materials retained between 90 and 105 percent of their baseline strengths.

The first horizontal stabilizer removed from service had accumulated 1600 flight hours over a 17 month period in the Lake Charles, LA area. No defects were found during inspection of the stabilizer. Deflection from the proof load was the same as in the initial acceptance test. Plots of strain as a function of limit load are shown in figure 17. The tension strain response was linear up to 160 percent of design limit load (DLL) and then increased at a reduced slope until the maximum applied load of 220 percent of DLL was reached. The compression strain response was linear to 120 percent of DLL and then increased at a reduced slope until 170 percent of DLL was reached. There was no increase in compression strain after 170 percent of DLL. At 220 percent of DLL a loud "snap" was heard and the load dropped to 150 percent of DLL. Attempts to increase the load beyond the 150 percent DLL resulted in deflection until the test fixture limit was reached. Visual inspection of the stabilizer indicated a buckle in the splice plate on the left hand leading edge of the spar. Teardown of the component indicated a loss of shear transfer capabilities between the composite material and the metal honeycomb (figure 18). At 220 percent of DLL, the shear load had been transferred to the Kevlar/epoxy torque box and eventually buckled the splice plate. The structure still supported 150 percent of DLL but with reduced rigidity. The stabilizer tested for certification did not fail but reached the maximum deflection allowed by the fixture at 268 percent of DLL. Additional tests will be necessary to determine if the change in failure mode is the result of environmental degradation of the composite

materials. Kevlar/epoxy coupons removed from the forward face, at centerline, of the torque box contained 0.8 percent moisture by weight.

The first tail rotor spar (Serial Number 00094) removed from service had accumulated 2390 flight hours over a 29 month period in the Lake Charles, LA area. No defects were found during the inspection of the spar. The spar was fatigue tested and the results are given in figure 19 along with data from spars labeled serial numbers 00046 and 00064 (reference 3). These spars were removed from a Sikorsky flight test aircraft that was at West Palm Beach, FL. The points designated "A" represent the first fracture on one side of the spar. Testing was continued on the other side until fracture occurred and the results are designated "B". The data indicate a 94 percent retention in fatigue strength for the spars exposed 2 to 2 1/2 years compared to the strength of dry spars tested at room temperature for FAA certification. Four coupons were machined from the failed spar (No. 00094) and dried. The average moisture content was 0.26 percent. The two spars (S/N 00046 and 00064) removed from a flight test helicopter had 150 hours of service each and contained .29 percent (S/N 00046) and .32 percent (S/N 00064) of moisture, respectively. The 94 percent strength retention for the spars with 2 to 2 1/2 years service compares well with the 95 percent strength retention projected from laboratory conditioned specimens (reference 3).

Concluding Remarks

206L Program

A total of 14,000 hours of flight service has been accumulated. The high time aircraft has 1308 hours. The only damage to the components has been from ground handling. Residual strength of all components exceeded design ultimate load.

Results of one year of ground exposure indicates the Kevlar/epoxy used in the baggage door retained 85 percent of the baseline strength. Exposure at Ft. Greeley, AK caused the most decrease in strength.

S-76 Program

The horizontal stabilizer that had accumulated 1600 hours of service, failed at 220 percent of design ultimate load.

The tail rotor spar retained 94 percent of the baseline fatigue strength after two years of service.

The predicted moisture absorption compares well with the measured moisture absorption.

References

1. Dexter, H. Benson, "Durability of Aircraft Composite Materials" in Advanced Materials Technology," NASA CP 2251, December 1982, p. 335-355.
2. Zinberg, H., "Flight Service Evaluation of Composite Components on the Bell Helicopter Model 206L: Design, Fabrication, and Testing," NASA CR 166002, November 1982.
3. Rich, M. J. and Lowry, D. W., "Flight Service Evaluation of Composite Helicopter Components First Annual Report March 1981 through April 1982," NASA CR 165952, June 1982.

Table 1. Weight Comparison of Bell 206L Composite and Metal Components.

COMPONENT	COMPONENT WEIGHT, kg (lbm)		WEIGHT SAVING, percent
	METAL	COMPOSITE	
LITTER DOOR	5.94 (13.10)	3.72 (8.20)	37.4
BAGGAGE DOOR	1.32 (2.90)	1.32 (2.90)	0
FORWARD FAIRING	3.90 (8.60)	3.29 (7.26)	15.6
VERTICAL FIN	6.94 (15.30)	5.58 (12.30)	19.6
TOTAL	18.10 (39.90)	13.91 (30.66)	23.2

Table 2. Static Test Results For Bell 206L Composite Components Used to Achieve FAA Certification.

COMPONENT	TYPE OF LOAD SIMULATED	DESIGN ULTIMATE LOAD	LOAD REQUIRED TO MEET FAA CERTIFICATION	FAILURE LOAD
LITTER DOOR	AERODYNAMIC	2.8 kN (634 lbf)	5.5 kN (1230 lbf)	5.2 kN (1176 lbf)
	CANTILEVER DOOR	.34 kN (75 lbf)	.65 kN (146 lbf)	1.9 kN (415 lbf)
BAGGAGE DOOR	AERODYNAMIC	1.94 kN (440 lbf)	2.7 kN (612 lbf)	3.1 kN (695 lbf)
	CANTILEVER DOOR	.22 kN (54 lbf)	.3 kN (75 lbf)	.3 kN (75 lbf)
FORWARD FAIRING	AERODYNAMIC	2.1 kPa (0.3 psi)	3.4 kPa (1.49 psi)	11.9 kPa (1.73 psi)
VERTICAL FIN	AERODYNAMIC	4.6 kN (1040 lbf)	6.5 kN (1456 lbf)	9.0 kN (2025 lbf)
	RESERVE ENERGY	1.6 kN (352 lbf)	2.2 kN (493 lbf)	4.1 kN (927 lbf)

Table 3. Static Test Results for Bell 206L Composite Components Used to Determine Baseline Strength.

COMPONENT	FAILURE LOAD FOR 5 COMPONENTS			DESIGN ULTIMATE LOAD
	MIN.	MAX.	AVG.	
LITTER DOOR	4.8 kN (1070 lbf)	6.0 kN (1347 lbf)	5.4 kN (1215 lbf)	2.8 kN (634 lbf)
BAGGAGE DOOR	2.5 kN (550 lbf)	3.1 kN (700 lbf)	2.7 kN (613 lbf)	1.94 kN (440 lbf)
FORWARD FAIRING	15.2 kPa (2.20 psi)	23.4 kPa (3.40 psi)	21.6 kPa (3.13 psi)	2.1 kPa (0.3 psi)
VERTICAL FIN	8.3 kN (1872 lbf)	9.7 kN (2177 lbf)	9.3 kN (2097 lbf)	4.6 kN (1040 lbf)

*RESULTS OF 4 TESTS

Table 4. Strengths of As-Fabricated Ground Exposure Specimens Materials Used in 206L Composite Components.

COMPONENT	MATERIAL	FIBER ORIENTATION	STRENGTH, MPa (ksi)		
			SBS.	COMP.	TEN.
LITTER DOOR	KEVLAR-49/EPOXY STYLE 281 CLOTH	0/45/0	41.5 (6.0)	139.1 (20.2)	395.5 (57.4)
BAGGAGE DOOR	KEVLAR-49/EPOXY STYLE 120 CLOTH	0/90/±45	26.7 (3.9)	154.2 (22.4)	576.8 (83.7)
FORWARD FAIRING	KEVLAR-49/EPOXY STYLE 281 CLOTH	0/90	36.4 (5.3)	125.9 (18.3)	421.2 (61.1)
VERTICAL FIN	T300/EPOXY TAPE	0/±45/0	77.4 (11.2)	871.1 (126.3)	872.0 (126.5)

Table 5. Effect of One Year Ground Based Exposure on Strength of Composite Materials Used to Fabricate Bell 206L Components.

COMPONENT	MATERIALS AND FIBER ORIENTATION	EXPOSURE LOCATION	STRENGTH RETENTION RATIO *		
			SBS	COMP	TEN
LITTER DOOR	KEVLAR-49/EPOXY STYLE 281 CLOTH 0/45/0	CAMERON, LA OIL PLATFORM ** HAMPTON, VA TORONTO, CANADA FT. GREELEY, AK	0.98	1.01	1.02
			0.95	0.99	1.00
			1.02	0.97	1.05
			0.96	1.00	1.04
BAGGAGE DOOR	KEVLAR-49/EPOXY STYLE 120 CLOTH 0/90/±45	CAMERON, LA OIL PLATFORM ** HAMPTON, VA TORONTO, CANADA FT. GREELEY, AK	0.93	0.94	1.03
			0.90	0.93	0.99
			0.97	0.89	1.00
			0.95	0.89	1.04
FORWARD FAIRING	KEVLAR-49/EPOXY STYLE 281 CLOTH 0/90	CAMERON, LA OIL PLATFORM ** HAMPTON, VA TORONTO, CANADA FT. GREELEY, AK	0.98	0.98	1.00
			0.98	0.98	1.00
			1.02	1.05	1.05
			1.04	0.96	1.04
VERTICAL FIN	T300/EPOXY 0/±45/0	CAMERON, LA OIL PLATFORM ** HAMPTON, VA TORONTO, CANADA FT. GREELEY, AK	1.01	1.03	0.97
			1.02	1.00	0.97
			1.02	1.01	1.01
			1.00	1.01	1.08
			0.97	1.02	1.00

* STRENGTH RETENTION RATIO = STRENGTH (EXPOSED) / STRENGTH (BASELINE)

**GULF OF MEXICO

Table 6. Effect of One Year Flight Service on Static Strength of Bell 206L Composite Components Simulated Aerodynamic Load.

COMPONENT	BASELINE STRENGTH	STRENGTH AFTER FLIGHT SERVICE		DESIGN ULTIMATE LOAD
		810 hr IN GULF COAST	870 hr IN CANADA	
LITTER DOOR	5.4 kN (1215 lbf)	4.5 kN (1009 lbf)	4.4 kN (980 lbf)	2.8 kN (634 lbf)
BAGGAGE DOOR	2.7 kN (613 lbf)	3.6 kN (795 lbf)	2.1 kN (473 lbf)	1.94 kN (440 lbf)
FORWARD FAIRING	21.6 kPa (3.13 psi)	12.4 kPa (1.8 psi)	17.2 kPa (2.5 psi)	2.1 kPa (0.3 psi)
VERTICAL FIN	9.3 kN (2097 lbf)	11.1 kN (2497 lbf)	9.9 kN (2219 lbf)	4.6 kN (1040 lbf)

Table 9. Effect of Two Years Ground Based Exposure on Strength of Composite Materials Used to Fabricate S-76 Components

MATERIAL	NUMBER OF PLYS	EXPOSURE LOCATION	STRENGTH RETENTION FACTOR*			
			SBS STATIC	SBS FATIGUE	FLEX STATIC	TENSION STATIC
GRAPHITE/EPOXY	6	STRATFORD CONN.	.89		.88	
GRAPHITE/EPOXY	14		.90		.95	
GRAPHITE/EPOXY	33		.96	1.05	1.04	
KEVLAR/EPOXY	5		--	--	--	1.05
GRAPHITE/EPOXY	6	WEST PALM BEACH, FL	.86		.84	
GRAPHITE/EPOXY	33		.97	1.02	1.03	
KEVLAR/EPOXY	5		--	--	--	1.00

*STRENGTH RETENTION FACTOR = $\frac{\text{STRENGTH (EXPOSED)}}{\text{STRENGTH (UNEXPOSED)}}$

Table 7. Schedule for Removal of S-76 Components from Service.

COMPONENT	YEARS OF SERVICE								
	2	3	4	5	6	7	8	9	
HORIZONTAL STABILIZER	X		X		X		X		
TAIL ROTOR SPAR	X	X	X	X	X	X	X	X	

Table 8. Summary of Moisture Absorption on Kevlar/Epoxy and Graphite/Epoxy Panels Exposed at Stratford, CT and West Palm Beach, FL

MATERIAL	NUMBER OF PLYS	EXPOSURE CONDITIONS		* MOISTURE CONTENT, percent
		LOCATION	TIME, months	
AS-1/6350 GRAPHITE/EPOXY	6	STRATFORD	25	.86
	6	WPB	26	1.02
	14	STRATFORD	25	.37
	33	STRATFORD	25	.18
	33	WPB	26	.27
KEVLAR/EPOXY	5	STRATFORD	26	1.60
	5	STRATFORD	26	1.46
	5	WPB	26	1.60

*AVERAGE OF FOUR COUPONS

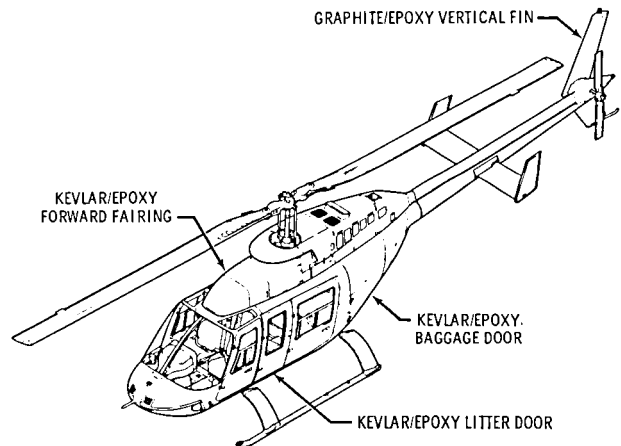
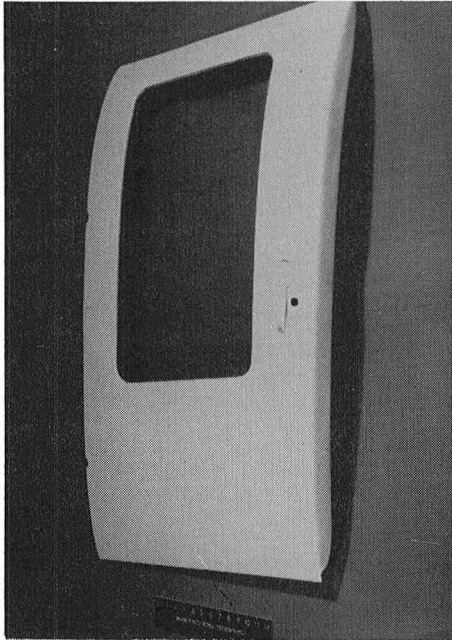

Figure 1. Composite Components in Flight Service on Bell 206L Helicopter.



a) Photograph of door

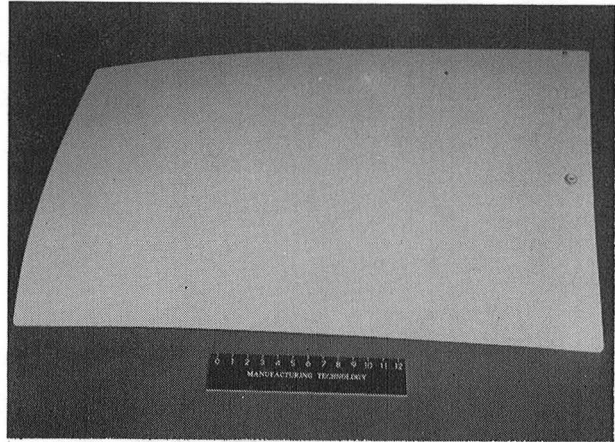
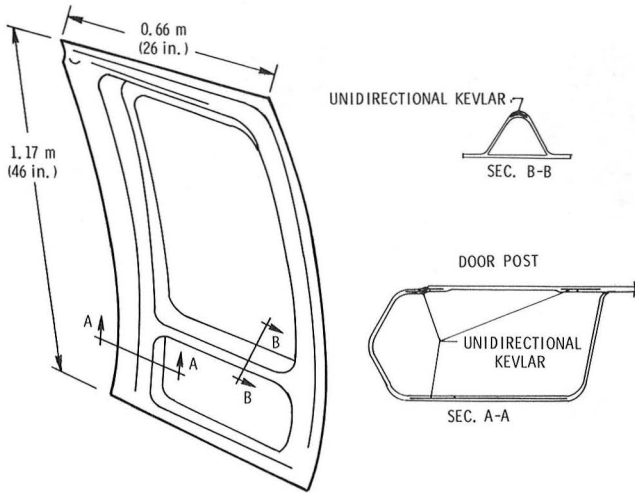

Figure 3. Bell 206L Kevlar/Epoxy Baggage Door.



b) Schematic of door

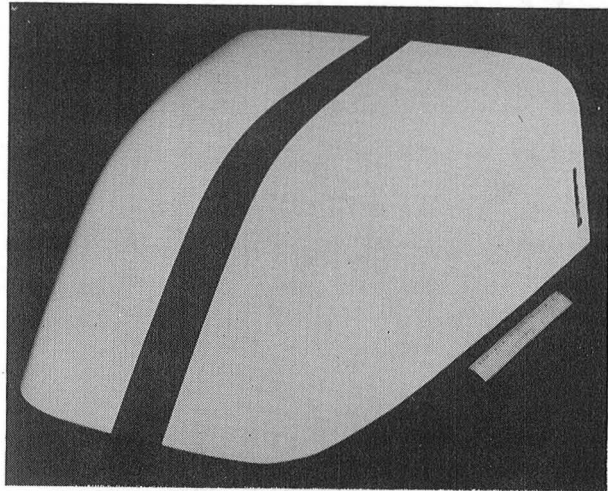

Figure 4. Bell 206L Kevlar/Epoxy Forward Fairing.

Figure 2. Bell 206L Kevlar/Epoxy Litter Door.

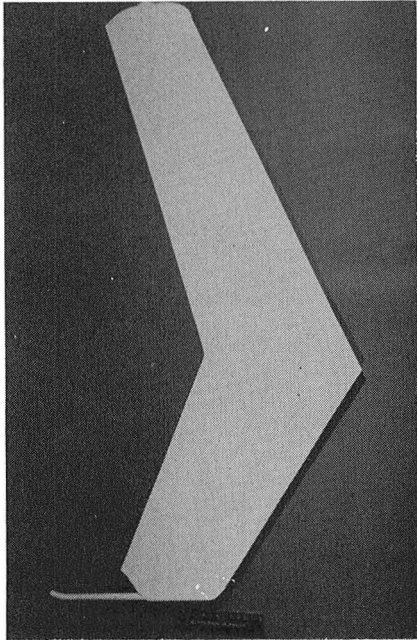

Figure 5. Bell 206L Graphite/Epoxy Vertical Fin.

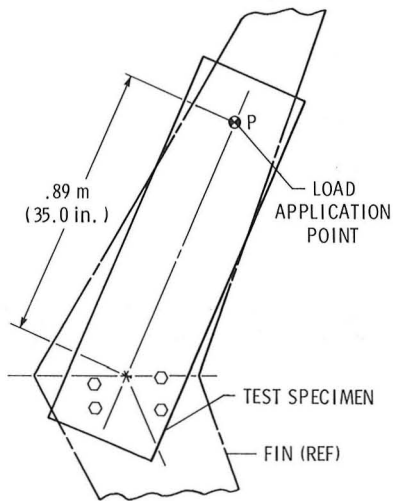

Figure 6. Fatigue Test Specimen for Vertical Fin.

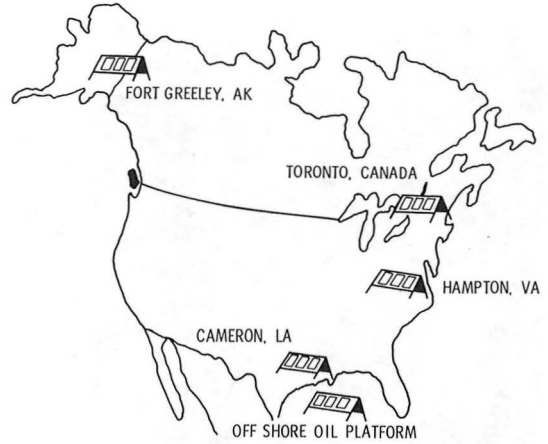

Figure 7. Location of Environmental Specimen Exposure Racks for Materials Used in Bell 206L Components.

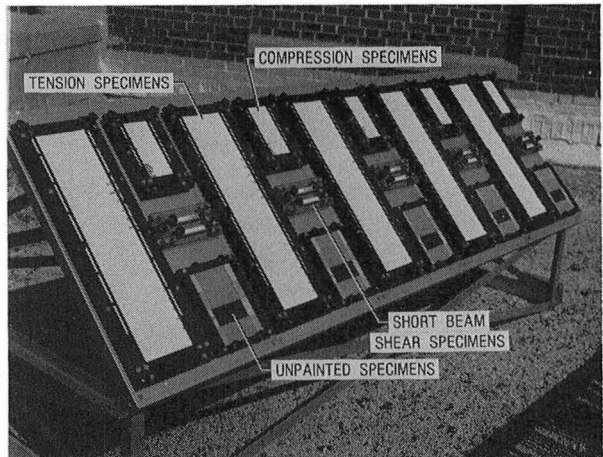

Figure 8. Environmental Exposure Rack with Specimens Installed.

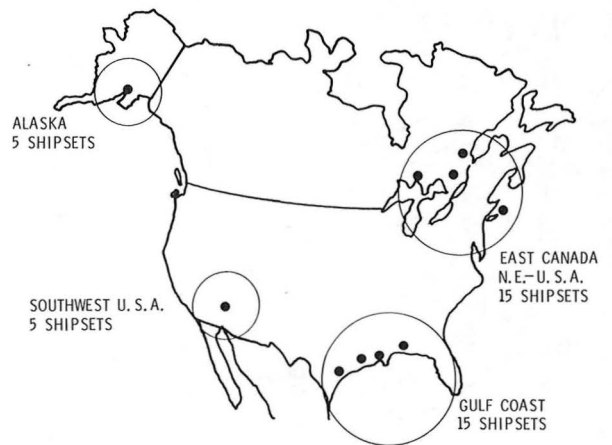

Figure 9. Distribution of Bell 206L Helicopters with Composite Components.

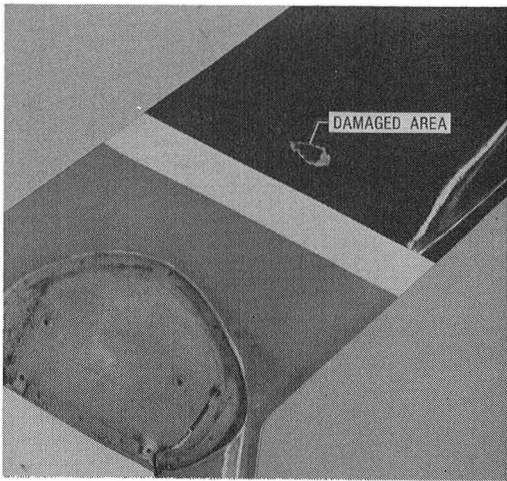

Figure 10. Damaged Bell 206L Graphite/Epoxy Composite Vertical Fin.

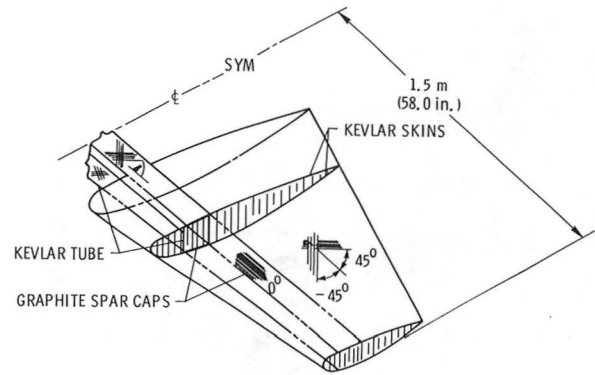

Figure 12. Composite Horizontal Stabilizer for S-76.

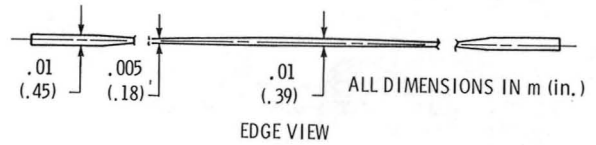
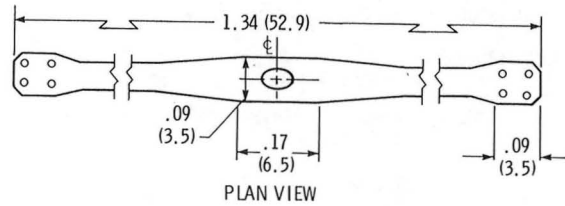

Figure 13. Composite Tail Rotor for S-76

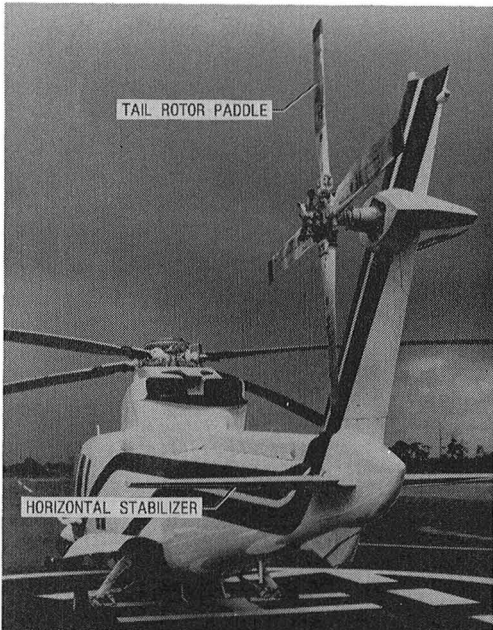

Figure 11. Composite Components in Flight Service on Sikorsky S-76 Helicopter

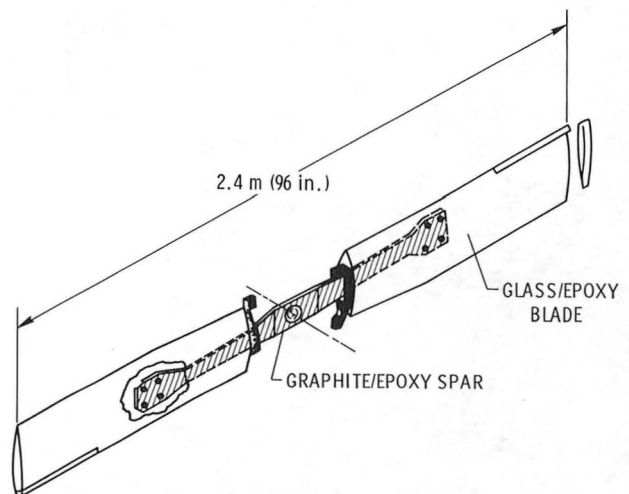

Figure 14. Sikorsky S-76 Tail Rotor Paddle

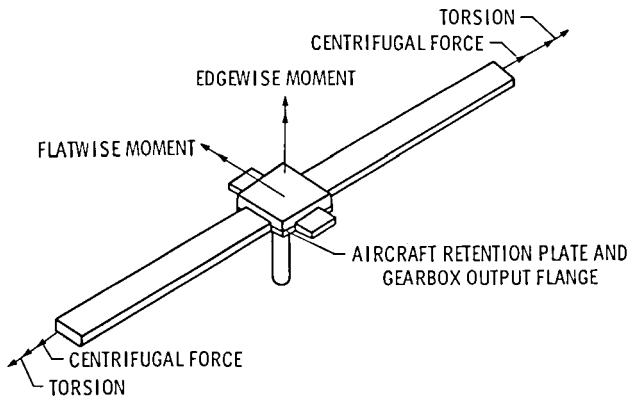

Figure 15. Schematic Diagram of S-76 Tail Rotor Spar Loadings.

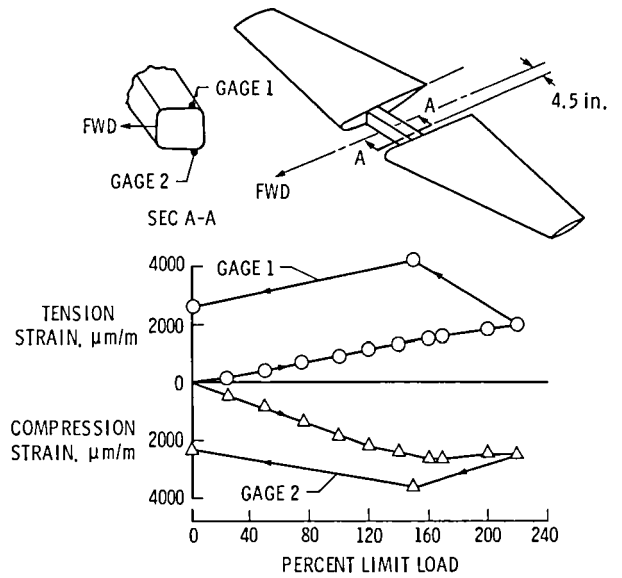

Figure 17. Strain as a Function of Percent Limit Load on S-76 Horizontal Stabilizer Spar, .1 m (4.5 in.) from Centerline.

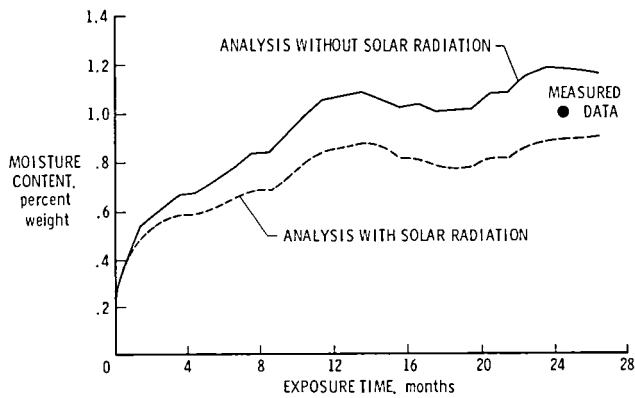

Figure 16. Moisture Absorption of a 6-ply Graphite/Epoxy Panel Exposed At West Palm Beach FL.

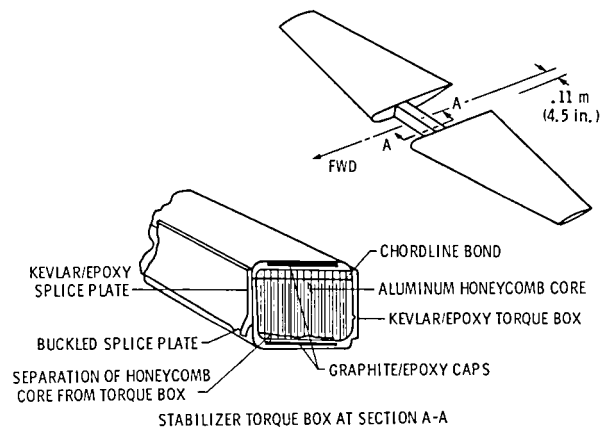

Figure 18. Schematic of S-76 Composite Stabilizer Static Fracture Modes.

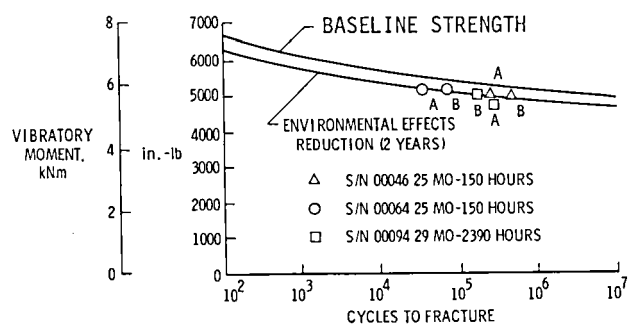

Figure 19. S-76 Tail Rotor Spar, Moment-Cycle Fatigue Curve.

1. Report No. NASA TM-84637 AVRADCOM TR-83-B-1		2. Government Accession No.		3. Recipient's Catalog No.	
4. Title and Subtitle Flight Service Evaluation of Composite Components on Bell 206L and Sikorsky S-76 Helicopters				5. Report Date March 1983	
				6. Performing Organization Code 505-42-23-03	
7. Author(s) Donald J. Baker				8. Performing Organization Report No.	
				10. Work Unit No.	
9. Performing Organization Name and Address Structures Laboratory, USARTL (AVRADCOM) NASA Langley Research Center Hampton, VA 23665				11. Contract or Grant No.	
				13. Type of Report and Period Covered Technical Memorandum	
12. Sponsoring Agency Name and Address National Aeronautics and Space Administration Washington, DC 20546 and U.S. Army Aviation Research & Development Command St. Louis, MO 63166				14. Sponsoring Agency Code	
				15. Supplementary Notes The author is employed by the Structures Laboratory, USARTL (AVRADCOM). This paper was presented at the AHS National Specialist's Meeting - Composite Structures, March 23-25, 1983, Philadelphia, PA.	
16. Abstract Progress on two programs to evaluate composite structural components in flight service on commercial helicopters is described. Thirty-six ship sets of composite components that include the litter door, baggage door, forward fairing, and vertical fin have been installed on Bell Model 206L helicopters that are operating in widely different climatic areas. Four horizontal stabilizers and ten tail rotor spars that are production components on the S-76 helicopter will be tested after prescribed periods of service to determine the effects of the operating environment on their performance. Concurrent with the flight evaluation, specimens from materials used to fabricate the components are being exposed in ground racks and tested at specified intervals to determine the effects of outdoor environments. Results achieved from 14,000 hours of accumulated service on the 206L components, tests on a S-76 horizontal stabilizer after 1600 hours of service, tests on a S-76 tail rotor spar after 2300 hours service, and two years of ground based exposure of material coupons are reported.					
17. Key Words (Suggested by Author(s)) Composite Materials Environmental Evaluation Flight Service			18. Distribution Statement Unclassified-Unlimited Subject Category - 24		
19. Security Classif. (of this report) Unclassified		20. Security Classif. (of this page) Unclassified		21. No. of Pages 13	22. Price* A02

* For sale by the National Technical Information Service, Springfield, Virginia 22161

NASA-Langley, 1983

