

DEB-TR-82-02

APPLICATION GUIDE FOR WASTE HEAT RECOVERY WITH ORGANIC RANKINE CYCLE EQUIPMENT

PHILIP I. MOYNIHAN
JET PROPULSION LABORATORY
CALIFORNIA INSTITUTE OF TECHNOLOGY
PASADENA, CALIFORNIA 91109

JPL Publication 83-7

JANUARY 1983

FINAL REPORT
MAY - DEC 1982



(NASA-CR-170121) APPLICATIONS GUIDE FOR WASTE HEAT RECOVERY Final Report, May - Dec. 1982 (Jet Propulsion Lab.) 81 p HC A95/MF 101

N83-21511

CSCL 10B

Unclass

83/44 03187

APPROVED FOR PUBLIC RELEASE: DISTRIBUTION UNLIMITED



ENERGY GROUP
AIR FORCE ENGINEERING & SERVICES CENTER
TYNDALL AIR FORCE BASE, FLORIDA 32403

REPORT DOCUMENTATION PAGE

**READ INSTRUCTIONS
BEFORE COMPLETING FORM**

1. REPORT NUMBER DEB-TR-82-02		2. GOVT ACCESSION NO.	3. RECIPIENT'S CATALOG NUMBER												
4. TITLE (and Subtitle) APPLICATIONS GUIDE FOR WASTE HEAT RECOVERY		5. TYPE OF REPORT & PERIOD COVERED FINAL REPORT MAY-DEC 1982													
7. AUTHOR(s) Philip I. Moynihan		6. PERFORMING ORG. REPORT NUMBER JPL Publication 83-7													
9. PERFORMING ORGANIZATION NAME AND ADDRESS Jet Propulsion Laboratory California Institute of Technology Pasadena, California 91109		8. CONTRACT OR GRANT NUMBER(s) MIPR NO. N-82-52													
11. CONTROLLING OFFICE NAME AND ADDRESS HQ AFESC/DEB Tyndall AFB, FL 32403		10. PROGRAM ELEMENT, PROJECT, TASK AREA & WORK UNIT NUMBERS NASA TASK RE-152, AMENDMENT 339													
14. MONITORING AGENCY NAME & ADDRESS (if different from Controlling Office)		12. REPORT DATE January 83													
		13. NUMBER OF PAGES 72													
		15. SECURITY CLASS. (of this report)													
		15a. DECLASSIFICATION/DOWNGRADING SCHEDULE													
16. DISTRIBUTION STATEMENT (of this Report) Approved for public release, distribution unlimited															
17. DISTRIBUTION STATEMENT (of the abstract entered in Block 20, if different from Report)															
18. SUPPLEMENTARY NOTES															
19. KEY WORDS (Continue on reverse side if necessary and identify by block number)															
<table border="0"> <tr> <td>Heat Recovery</td> <td>Waste Heat</td> <td>Equipment Costs</td> </tr> <tr> <td>Rankine Cycles</td> <td>Waste-Heat Recovery</td> <td></td> </tr> <tr> <td>Organic Rankine Cycles</td> <td>Recuperators</td> <td></td> </tr> <tr> <td>Power Production</td> <td>Nomograms</td> <td></td> </tr> </table>				Heat Recovery	Waste Heat	Equipment Costs	Rankine Cycles	Waste-Heat Recovery		Organic Rankine Cycles	Recuperators		Power Production	Nomograms	
Heat Recovery	Waste Heat	Equipment Costs													
Rankine Cycles	Waste-Heat Recovery														
Organic Rankine Cycles	Recuperators														
Power Production	Nomograms														
20. ABSTRACT (Continue on reverse side if necessary and identify by block number) This report assesses the state-of-the-art of commercially available organic Rankine cycle (ORC) hardware from a literature search and industry survey. Engineering criteria for applying ORC technology are established, and a set of nomograms to enable the rapid sizing of the equipment is presented. A comparison of an ORC system with conventional heat recovery techniques can be made with a nomogram developed for a recuperative heat exchanger. A graphical technique for evaluating the economic aspects of an ORC system and conventional heat recovery method is discussed; also included is a description of anticipated future trends in organic Rankine cycle R&D.															

**ORIGINAL PAGE IS
OF POOR QUALITY**

PREFACE

**ORIGINAL PAGE
COLOR PHOTOGRAPH**

This report was prepared by the Jet Propulsion Laboratory (JPL) under MIPR NO. N-82-52 for the Air Force Engineering and Services Center, Tyndall AFB, Florida. JPL's principal investigator was Philip I. Moynihan.

This report summarizes work done between May 1982 and December 1982. Freddie L. Beason was the project officer.

The author would like to express his appreciation to Mr. Richard Caputo for his insight and support to the development of the cost-effectiveness portion of this study.

This report has been reviewed by the Public Affairs Office (PA) and is releasable to the National Technical Information Service (NTIS). At NTIS it will be available to the general public, including foreign nations.

This technical report has been reviewed and is approved for publication.

Freddie L. Beason
FREDDIE L. BEASON, P.E.
Mechanical Engineer/Energy

Richard T. Aldinger
RICHARD T. ALDINGER
Lt Col, USAF
Chief, Energy Group

CONTENTS

I.	INTRODUCTION	1-1
II.	BACKGROUND	2-1
	A. LITERATURE SEARCH	2-1
	B. INDUSTRY SURVEY	2-1
	C. SUMMARY OF RESPONSES TO INDUSTRY SURVEY	2-3
	1. Barber-Nichols Engineering Co.	2-3
	2. Mechanical Technology, Inc.	2-4
	3. Ormat Systems, Inc.	2-4
	4. SPS, Inc.	2-5
	5. Sundstrand Energy Systems	2-7
	D. VISITS TO AIR FORCE BASES	2-7
III.	EQUIPMENT SIZING	3-1
	A. SELECTION CRITERIA	3-1
	B. ORC EQUIPMENT LIST	3-4
	C. NOMOGRAMS FOR SIZING ORGANIC RANKINE CYCLE EQUIPMENT	3-9
	D. NOMOGRAM FOR SIZING RECUPERATOR	3-16
IV.	EQUIPMENT COST	4-1
	A. ORC EQUIPMENT INSTALLED COST	4-1
	B. OPERATION AND MAINTENANCE COSTS FOR THE ORC	4-5
	C. ESTIMATE OF ANNUAL SAVINGS FOR THE ORC	4-5
	D. ESTIMATE OF THE COST-EFFECTIVENESS FOR THE ORC	4-8
	E. RECUPERATOR INSTALLED COST	4-19
	F. OPERATION AND MAINTENANCE COSTS FOR RECUPERATORS	4-23
	G. ESTIMATE OF COST-EFFECTIVENESS FOR A RECUPERATOR	4-23

H.	COMPARISON OF ORC COST-EFFECTIVENESS WITH THAT OF CONVENTIONAL HEAT RECOVERY	4-26
V.	R&D PERSPECTIVES FOR ORGANIC RANKINE CYCLE EQUIPMENT	5-1
A.	IMPROVED PERFORMANCE	5-1
B.	IMPROVED HARDWARE	5-2
VI.	CONCLUSIONS	6-1
VII.	REFERENCES	7-1

Figures

1-1.	Comparison of Organic Rankine Cycle with Carnot Efficiency as a Function of Peak Temperature	1-2
3-1.	Schematic Diagram of a Typical Organic Rankine Cycle System with Temperature-Entropy Display	3-2
3-2.	Schematic Diagram of Steam Plant Depicting Possible Locations of Recuperators	3-3
3-3.	Nomogram for Determining Overall Cycle Efficiency for Organic Rankine Cycle Equipment	3-10
3-4.	Nomogram for Determining Net Power Delivered by an Organic Rankine Cycle Powered by a Sensible Waste Heat Medium	3-11
3-5.	Nomogram for Determining Net Power Delivered by an Organic Rankine Cycle Fed from a Condensing Steam Waste Heat Source	3-12
3-6.	Graphical Method for Estimating Volume and Area of an Organic Rankine Bottoming Cycle Unit	3-13
3-7.	Nomogram for Determining Net Heat Recovered by a Recuperative Heat Exchanger from a Waste Heat Source	3-17
4-1.	Capital Costs in 1982 Dollars as a Function of Net Power Output for Organic Rankine Bottoming Cycle Equipment from Various Manufacturers	4-2
4-2.	Recommended Curve for Estimating Installed Cost for Organic Rankine Bottoming Cycle Equipment	4-3
4-3.	Installed Costs in 1978 Dollars for Organic Rankine Bottoming Cycle Equipment with Comparison Between New Installation and Retrofit	4-4

4-4.	Estimated Installed Cost for Rankine Cycles	4-6
4-5.	Range of Rankine Cycle Equipment Installed Costs for Both Organic and Steam Rankine Systems	4-7
4-6.	Graphical Method for Estimating Annual Energy Bill Savings	4-10
4-7.	Determination of Savings-to-Investment Ratio for the Displacement of Electricity Through Waste Heat Recovery with Organic Rankine Bottoming Cycle Equipment	4-17
4-8.	Estimation of Installed Cost for Recuperative Heat Exchanger as a Function of the Total Quantity of Heat Transferred	4-20
4-9.	Graphical Method for Estimating Piping Costs in $\$/kW_c$. . .	4-21
4-10.	Determination of Savings-to-Investment Ratio for the Displacement of Oil Through Waste Heat Recovery With a Recuperative Heat Exchanger	4-28
4-11.	Determination of Savings-to-Investment Ratio for the Displacement of Natural Gas Through Waste Heat Recovery With a Recuperative Heat Exchanger	4-29
4-12.	Break-even Costs of Waste Heat Recovery With an Organic Rankine Bottoming Cycle vs. a Recuperator for and ORC Installation Cost of $\$2000/kW_e$ When Natural Gas is Displaced by Recuperator	4-31
4-13.	Break-even Costs of Waste Heat Recovery With an Organic Rankine Bottoming Cycle vs. a Recuperator for an ORC Installation Cost of $\$1500/kW_e$ When Natural Gas is Displaced by the Recuperator	4-32
4-14.	Break-even Costs of Waste Heat Recovery With an Organic Rankine Bottoming Cycle vs. a Recuperator for an ORC Installation Cost of $\$1000/kW_e$ When Natural Gas is Displaced by the Recuperator	4-33
4-15.	Break-even Costs of Waste Heat Recovery With an Organic Rankine Bottoming Cycle vs. a Recuperator for an ORC Installation Cost of $\$1000/kW_e$ When Oil is Displaced by the Recuperator	4-34
4-16.	Break-even Cost for ORC Equipment and Recuperator/Piping When Recuperator Displaces Natural Gas	4-36
4-17.	Break-even Cost for ORC Equipment and Recuperator/Piping When Recuperator Displaces Oil	4-37

Tables

2-1. ENGINE PRICE LIST FOR SPS ORC HARDWARE. 2-6

3-1. KEY PARAMETERS FOR SELECTION OF ORGANIC RANKINE
BOTTOMING CYCLE EQUIPMENT 3-5

3-2. RANKINE CYCLE ORGANIC WORKING FLUIDS. 3-6

3-3. AVAILABLE ORGANIC RANKINE CYCLE EQUIPMENT:
MANUFACTURERS AND PERFORMANCE CHARACTERISTICS 3-7

3-4. ESTIMATE OF GEOMETRY FOR AN ORGANIC RANKINE
CYCLE UNIT AS SUGGESTED BY AFI. 3-16

4-1. HISTORICAL PERSPECTIVE OF INSTALLED COSTS FOR
ORGANIC RANKINE CYCLE EQUIPMENT 4-8

4-2. CHRONOLOGY OF OPERATION AND MAINTENANCE COST FOR
ORGANIC RANKINE CYCLE EQUIPMENT 4-9

SECTION I

INTRODUCTION

The objective of this study is to determine the feasibility of applying organic Rankine cycle technology to recover waste heat from heat plants on Air Force bases. The substance of the task is to establish a data base for the ORC hardware, to develop a technique for determining its size and cost-effectiveness for a given application, and to devise a method for comparing it with conventional heat recovery techniques, which for this study were identified as recuperative heat exchangers. The product of this effort will be used by the Air Force to identify practical and cost-effective opportunities for waste-heat recovery.

Throughout its bases in the United States, the Air Force has a significant amount of low- to moderate-grade energy. In some cases this energy is recovered by conventional recovery techniques, such as boiler stack economizers; in other instances it is lost altogether. The established waste heat recovery techniques save considerable energy, but they are often restricted in their use by energy conversion and transportation problems. The application of organic Rankine cycle technology could greatly expand waste heat recovery opportunities because of its ability to produce mechanical or electrical work. Electrical power requirements now constitute nearly 56 percent of the total energy consumed by all of the Air Force installations. Bases capable of generating electricity could attain a small measure of energy self-sufficiency for critical operations.

One of the fundamental disadvantages of generating power from low-temperature sources is that the maximum theoretical efficiency, the Carnot efficiency, is itself low. (For example, the Carnot efficiency of an engine receiving heat from a 200°F source and rejecting to a 70°F sink is only 19.7 percent). The organic Rankine cycle offers a significant advantage. By using a working fluid with a high molecular weight, it can obtain efficiencies that are a relatively high percentage of Carnot. A graphical example of this has been extracted from Reference 1 and is presented in Figure 1-1.

Implicit in this study is the assumption that the organic Rankine bottoming cycle would recover waste heat to generate electricity, which subsequently reduces the demand for an equivalent amount of purchased power. The recuperator with which the organic Rankine cycle is compared recovers waste heat by transferring it from a waste energy steam to a useful energy steam. In doing so, it displaces, and thus conserves, a quantity of fuel equivalent to the amount transferred. Consuming fuel solely for operating an organic Rankine cycle to generate electricity is not addressed.

ORIGINAL PAGE IS
OF POOR QUALITY

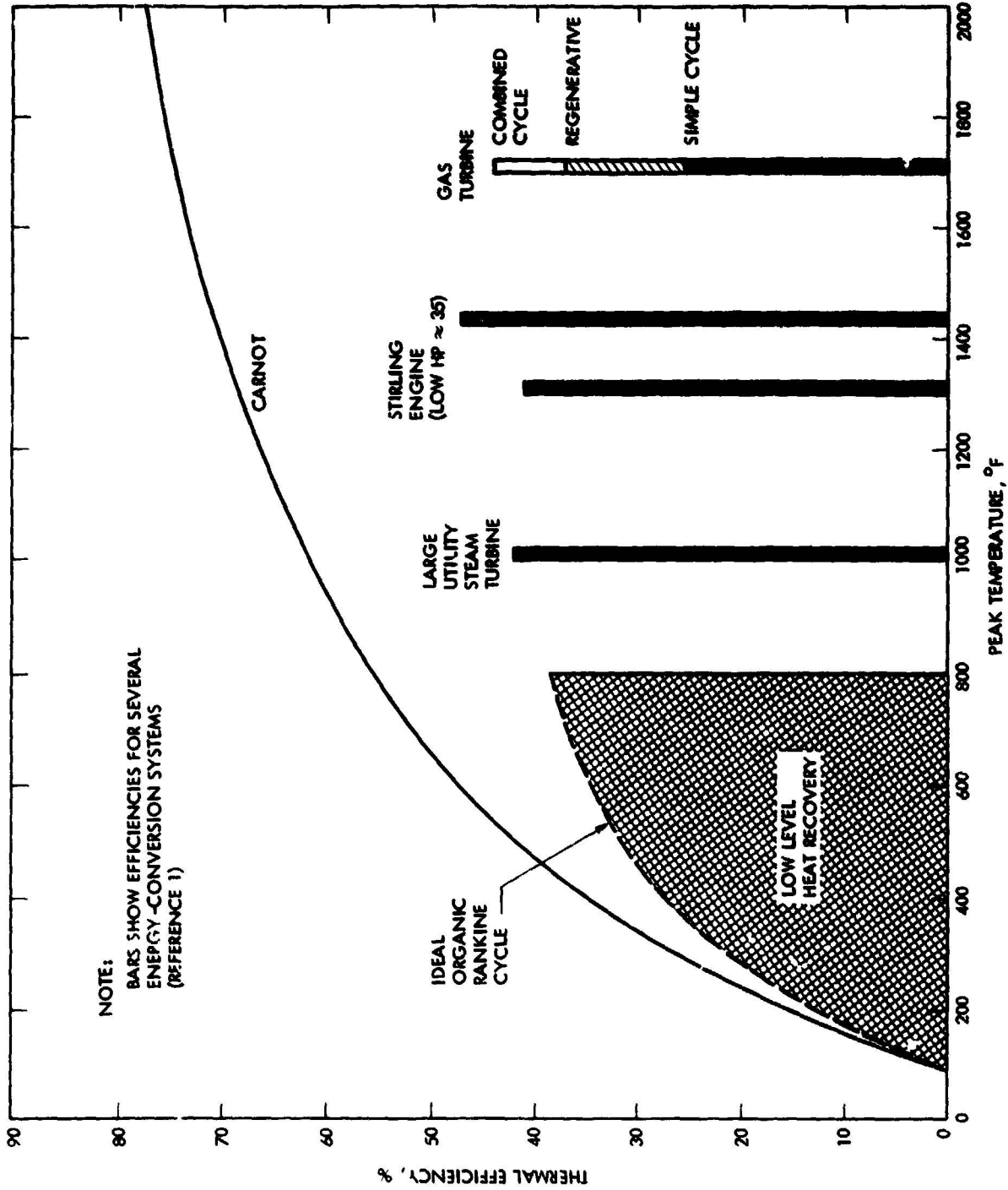

Figure 1-1. Comparison of Organic Rankine Cycle with Carnot Efficiency as a Function of Peak Temperature

SECTION II

BACKGROUND

A. LITERATURE SEARCH

This study was initiated with an extensive literature search to ascertain the status of organic Rankine cycle technology, specifically its application to scavenging waste heat in industrial applications. Considerable effort has been invested in energy conservation since the 1974 energy crisis, and publications since then are rich in studies on waste-heat recovery. Hence, the information sought from the literature search was scoped specifically to heat plants, and the results have been reviewed, condensed, and integrated into the text of this report. Further detail can be obtained directly from the references themselves.

B. INDUSTRY SURVEY

In support of this study, a questionnaire was developed and sent as a form letter to seven of the leading manufacturers of organic Rankine cycle equipment and to two who are not as well known, but who looked promising. These companies were selected from the literature search as representing the widest experience with organic Rankine applications. As an aggregate, they constitute the nucleus of available knowledge on this subject and have developed most of the existing hardware. The emphasis was on low-temperature equipment (on the order of 200°F), although data on applications at other temperatures were encouraged and received. The letter requested marketing information about their developed hardware, along with the following specific items:

- (1) Equipment physical constraint.
 - (a) Schematic diagram of system
 - (b) Working fluid selected
 - (c) Recommended temperature limitations of the working fluid
 - (d) Volume of equipment in terms of floor area and height
 - (e) Weight of individual components (or subsystems), if available
 - (f) Type of expander (i.e., turbine, piston)
 - (g) Silencing requirements, if any.
- (2) Performance
 - (a) Design power output
 - (b) Vaporizer maximum and minimum temperature range

- (c) Condenser maximum and minimum temperature range
 - (d) Flow rate of working fluid
 - (e) Design turbine inlet temperature/pressure
 - (f) Required parasitic units and their power demands (e.g., pumps, valves, etc.)
 - (g) Individual component efficiencies (i.e., turbine, gearbox, generator, etc.)
 - (h) Overall cycle efficiency (or heat rate) of overall unit at specified heat source temperature, condenser temperature, ambient temperature, net power output, and total power available
 - (i) Estimate of part-load performance.
- (3) Mechanical/electrical interfaces
- (a) Required control circuitry
 - (b) Electrical support equipment.
- (4) Operation and maintenance
- (a) Fixed operation and maintenance (O&M) cost in \$/kW-yr
 - (b) Variable O&M cost in mills/kW-hr
 - (c) Personnel required for operation and maintenance
 - (d) Reliability
 - (e) Experience with lifetimes of components
 - (f) Estimated downtime as a function of type of failure
 - (g) Time equipment has been in the field or under development
 - (h) Locations and power levels of operating field units.
- (4) Costs
- (a) Estimate of present capital equipment costs of existing equipment (\$/kW installed or total dollars for discreet units in 1982 dollars)
 - (b) Estimate of improved capital costs as a function of increased production rates (\$/kW installed in 1982 dollars). For example, 10 units, 50 units, 100 units per year

- (c) Estimate of capital equipment costs as a function of net power output (\$/kW in 1982 dollars). In other words, does the capital cost go down as the size of the unit goes up?
- (d) Estimate of installation costs both for a new installation and as a retrofit.

Information was received from all but two of the leading manufacturers who were contacted. The letters to the two lesser-known firms were returned undelivered.

C. SUMMARY OF RESPONSES TO INDUSTRY SURVEY

The responses to the questionnaire sent to the various manufacturers of organic-Rankine-cycle equipment are summarized below. The emphasis in this summary is on the cost information, since technical detail is presented in Section III.

1. Barber-Nichols Engineering Co.

Barber-Nichols is located at 6325 West 55th Avenue, Arvada, Colorado 80002 (telephone 303-421-8111). They have been more actively involved with the development of low-temperature Rankine engines than have most other firms in the United States. They have recently developed engines for the Department of Energy (DOE) that could produce both power and air conditioning as part of the DOE solar-cooling program. These engines were designed to produce 3, 25, 77, and 100 tons of air conditioning or 2, 16, 50, and 66 kW of power. Barber-Nichols included several papers with their information packet (References 2 through 5) wherein many of their units are described. All of their units are either prototypes or especially designed for a particular application.

They included the following order-of-magnitude cost estimates:

Existing Designs		
2 kW	\$ 65,000	\$32,000/kW
16 kW	\$120,000	\$ 7,500/kW
50 kW	\$250,000	\$ 5,000/kW
Special Designs		
500 kW	\$1,000,000	\$ 2,000/kW
1000 kW	\$1,500,000	\$ 1,500/kW

They expressed a strong desire to work with the Air Force in a waste-heat recovery application if the need should arise.

2. Mechanical Technology, Inc.

The Energy Systems Division of Mechanical Technology, Inc. (MTI) is located at 20 Plains Road, Ballston Spa, New York, 12020 (Telephone 518-899-2976). Their information packet included a sales brochure on their organic Rankine systems (Reference 6) and a paper detailing a turbogenerator designed for power outputs from 0.75 MW to 2.5 MW that uses R-113 as the working fluid and operates at turbine inlet temperatures from 170°F to 260°F from waste-heat source temperatures of 180°F to 400°F (Reference 7).

As a means of quantifying order-of-magnitude cost data, they offered the following example. A heat source of 200°F condensing steam flowing at 50,000 lbm/hr supplies an organic Rankine bottoming cycle at a turbine inlet temperature of 190°F. The inlet temperature of the water to the condenser is 80°F. The following parameters were estimated for these conditions:

Heat Input:	48.9 x 10 ⁶ Btu/hr
Power Output:	1230 kW
Condensing Water Required:	6000 gpm
Hardware Costs:	
Vaporizer:	\$490,000
Condenser:	\$365,000
Machinery Package:	\$1,445,000
Total Hardware:	\$2,300,000

MTI cautioned that the high capital cost of the hardware (\$1870/kW) is caused by the low temperature available from the heat source. However, they do have two units of the above capacity currently in production for installation at a Mobil refinery in Torrance, California. The shipment date is scheduled for early 1983.

3. Ormat Systems, Inc.

Ormat Systems, Inc. is located at 98 South Street, Hopkinton, Massachusetts 01748 (Telephone 617-653-6300 or 617-620-0950). They responded to the questionnaire with a letter outlining some of their recent experience and a rough order-of-magnitude of their equipment costs.

Ormat has been producing waste-heat recovery units, primarily for geothermal and industrial waste-heat applications, for the last four years. These units are designed to operate from liquid and condensing-vapor heat sources that include waste streams and hot condensate. Minimum temperatures required are on the order of 200°F although lower temperatures are possible, depending upon the characteristics of the heat source. The power range of their recent units is 300 to 600 kW although smaller units were developed in the past. They indicate that a 5000 kW unit is currently under production for solar-pond applications and is expected to be operative by the end of 1982. It is designed for 185°F turbine inlet temperature.

Units up to the 600 kW size are skid-mounted for container shipment and require minimal effort to install and maintain. They are delivered equipped with either a synchronous or an asynchronous generator per U.S. standards.

The cost of these units will vary depending upon the design power output and the volume of the order. As would be expected, costs are also heavily dependent upon the quality of the heat source. As an estimate, Ormat submitted that the purchase of one 300 kW unit will require an investment of \$1300 per kilowatt. If the desired power output is doubled, then the price will decrease by approximately 10 to 15 percent. A price reduction is also allowed for volume orders of at least 10 units per year. A purchase price of \$1000/kW is anticipated for an order of 100 units per year.

4. SPS, Inc.

SPS, Inc. can be contacted at P. O. Box 380006, Miami, Florida 33138 (Telephone 305-754-7766 or 305-940-7446). They responded directly to each item on the questionnaire, and a summary of this information is presented below. The motive power for their organic Rankine bottoming cycle equipment is provided by a rotary screw expander (Reference 8) driven by Freon 12 or 114, depending upon the temperature of the waste-heat stream. The vaporizer is designed to operate between a temperature range of 150°F and 250°F, and the condenser temperature range is from 40°F to 100°F. In reference to mechanical/electrical interfaces, SPS indicates that the standard package includes all control circuitry required by utility standards and that no electrical support equipment is necessary.

SPS has had equipment under development since 1949 and in production since 1968. They indicate that some units have been running continuously since 1976. They presently have units in the field that operate at power levels ranging from 10 to 400 kW_e.

The SPS information also contained some quantitative comments about their operation and maintenance (O&M) experience. They indicated that the O&M costs would be similar to that of an air conditioning system of the same horsepower, and that no equipment failure has resulted in down time of more than one week. A failure can usually be rectified within a few hours. No personnel are required for operation. The life expectancy for the heat exchangers used is 15 years, whereas it is five years plus for the expander and generator.

They provided cost information in the form of a price list that also included dimensions, shipping weight, and delivery time. This information is summarized and presented in Table 2-1. Although they made a very strong point that because of previous bad experience they are not particularly interested in government business, they would sell equipment to the Air Force under their standard commercial terms.

Table 2-1. ENGINE PRICE LIST FOR SPS ORC HARDWARE (JUNE 1, 1981)

HP	KVA OUTPUT	ORC GEN SET FOR HEAT SOURCE OVER 2050P	ORC GEN SET FOR HEAT SOURCE UNDER 2050P	DIMENSIONS L x W x H	SHIPPING WEIGHT IN 1,000 LB	DELIVERY
14	10	\$ 14,391	\$ 16,118	8'x4'x4'	2.6	90 Days
28	20	\$ 24,155	\$ 27,054	9'x4'x4'	4.2	90 Days
42	30	\$ 36,246	\$ 40,595	12'x4'x4'	5.4	90 Days
56	40	\$ 46,705	\$ 52,310	14'x5'x5'	7.2	120 Days
70	50	\$ 58,395	\$ 65,402	16'x5'x5'	10.0	120 Days
84	60	\$ 70,057	\$ 78,463	16 x5'x5'	12.0	120 Days
112	80	\$ 90,201	\$101,035	16'x5'x5'	14.0	120 Days
140	100	\$112,724	\$126,250	20'x6'x6'	16.0	180 Days
280	200	\$225,449	\$252,502	20'x8'x8'	25.0	180 Days
420	300	\$338,173	\$378,753	22'x8'x8'	29.5	180 Days
560	400	\$414,909	\$463,780	24'x8'x8'	38.0	180 Days

ORIGINAL PAGE IS OF POOR QUALITY

Systems over 800 KVA are assembled on site at approximately \$ 900 per KVA (over 2050P)
 \$1000 per VA (under 2050P)

All prices are F.O.B. factory.

5. Sundstrand Energy Systems

Sundstrand Energy Systems is a unit of Sundstrand Corporation and is located at 4747 Harrison Avenue, Rockford, Illinois, 61101 (Telephone 815-226-6000). Their information package (References 9 through 11) included not only a sales brochure and papers but also several drawings. The Sundstrand waste-heat recovery unit is designed for a nominal rating of 750 kW_e and can accommodate gaseous waste-heat streams above 600° and condensing streams above 500°F, both with sufficient flow. A jointly funded cooperative agreement between Sundstrand and DOE has provided for the installation of four field units at municipal utilities in Beloit, Kansas, Easton, Maryland, and Homestead, Florida, and at a ceramic kiln in Ferguson, Kentucky. An additional unit was modified with DOE funds to generate 200 kW and was installed in Coolidge, Arizona, as part of a solar irrigation project.

The operation and maintenance costs for the Sundstrand 750 kW_e unit are estimated to range from \$10,000 to \$20,000 per year for a fully loaded unit that is operated nearly continuously. They cautioned that the actual costs will vary as a function of site-specific conditions related to the type and number of heat sources and to the general complexity of the installation. These costs include maintenance personnel although no additional personnel are required for operation.

The capital costs for the equipment were estimated to be \$1000/kW based on a 750 kW_e unit with a single heat source. They expect that increased production can reduce equipment costs by up to 25 percent. The installation cost estimate is \$300/kW, again based on a 750 kW_e unit with a single heat source and with no unusually long runs of heat duct or power cable. The total installed cost for a 750 kW_e unit is estimated, then, to be \$1300/kW. However, installation costs can easily double with multiple heat sources and complex site conditions.

D. VISITS TO AIR FORCE BASES

During this study, Kirtland Air Force Base in Albuquerque, New Mexico, and Hill Air Force Base in Ogden, Utah, were visited. Their heat plants were inspected and photographed, and discussions were held with their operations personnel to learn what constitutes a typical Air Force heat plant, where some of the waste-heat sources may be, and what, if anything, is already being done to use the waste heat. A questionnaire requesting performance and cost data specific to each heat plant was sent to the responsible plant engineer at each Air Force Base prior to the visit. In addition, copies of boiler logs were also obtained. The resulting data were used as representative of Air Force Bases in general.

On the whole, the people responsible for the operation of the heat plants are very sensitive to energy savings and either have already implemented, or are in the process of implementing, many energy-saving measures. However, two observations relevant to this study were made. First, with the exception of where the steam may become contaminated, as is the case with the plating operation at Hill Air Force Base, all process steam systems are closed cycles, and the fluid returns as hot water. There are no condensers

in these systems, as all condensation takes place at the load. The steam from the plating operation is condensed separately and the energy from the latent heat is recovered, but the condensate is discarded. Although low grade (~200°F), there is some potential here for additional waste-heat recovery. On the other hand, the potential generally does not exist for recovering waste heat when the returning hot water is to be reused since all energy removed from the hot water must be added back through the combustion of fuel.

In general, there is no provision to recover energy from the vented stack gases, and in some instances these temperatures may be as high as 500°F. The plant personnel were all aware of this loss. Further potential for waste heat recovery exists here.

As a supplement to the information obtained from the visits to Kirtland and Hill Air Force Bases, data from the heat plants at Lowry, MacDill, and Tinker Air Force Bases were obtained (Reference 12), and a boiler log from Robbins Air Force Base, Georgia, was provided by the Air Force Program Manager. This additional information was very useful in scoping the magnitude of the parameters involved over a range of Air Force heat plants.

SECTION III

EQUIPMENT SIZING

Nomograms that enable one to size the hardware that is to be considered for waste-heat recovery are presented in this section. Although the primary candidate for this application is the organic Rankine bottoming cycle, its comparison with conventional means of heat recovery, a recuperative heat exchanger, is a requirement of this study. The essential difference between the two contenders is that the ORC takes energy from the waste-heat stream and converts it to useful work, while the recuperator transfers the energy from the waste stream to a useful stream.

A schematic diagram depicting the major components of an organic Rankine cycle is presented as Figure 3-1. A temperature-entropy diagram representing a typical organic working fluid has also been included to identify the approximate state locations of the points indicated along the cycle.

An indication of how a recuperator could be integrated into a steam plant is presented in Figure 3-2. The two examples cited are representative of a common heat-recovery technique whereby the recuperator preheats the returning boiler feedwater by transferring the waste heat to it, and the waste stream is rejected.

A. SELECTION CRITERIA

The criteria that should be considered when sizing and selecting an organic Rankine system for bottoming-cycle applications are identified and discussed in this section. The key parameters necessary for selecting an organic Rankine cycle for waste-heat recovery can be grouped into two general categories: the overall capability for the combined heat-source and bottoming-cycle system to lend itself to waste-heat recovery, and the specific characteristics that enable cost-effective power conversion to take place. In regard to the former, first it must be ascertained whether or not the heat source is truly waste. For example, the returning hot water to the boiler is not necessarily a waste-heat source. Every unit of energy taken from returning hot water must be made up by consuming additional fuel. This is not cost-effective for either an organic Rankine bottoming cycle or for a recuperator.

Having identified a waste-heat source, one should then make a first-order judgment as to the quality of the heat in regard to the availability of the energy. If the quality of the waste heat is too low, it may not be practical to extract useful work from it. Although availability is implicit in Second Law analysis, a low quality manifests itself very clearly when cost per unit output is considered. Since low output results in high cost per unit output, such conditions are rarely cost-effective. Heat sources with temperatures that are not far from ambient are typical examples.

Of the more specific characteristics governing the establishment of equipment size for cost-effective power conversion, the key criteria are the

ORIGINAL PAGE IS
OF POOR QUALITY

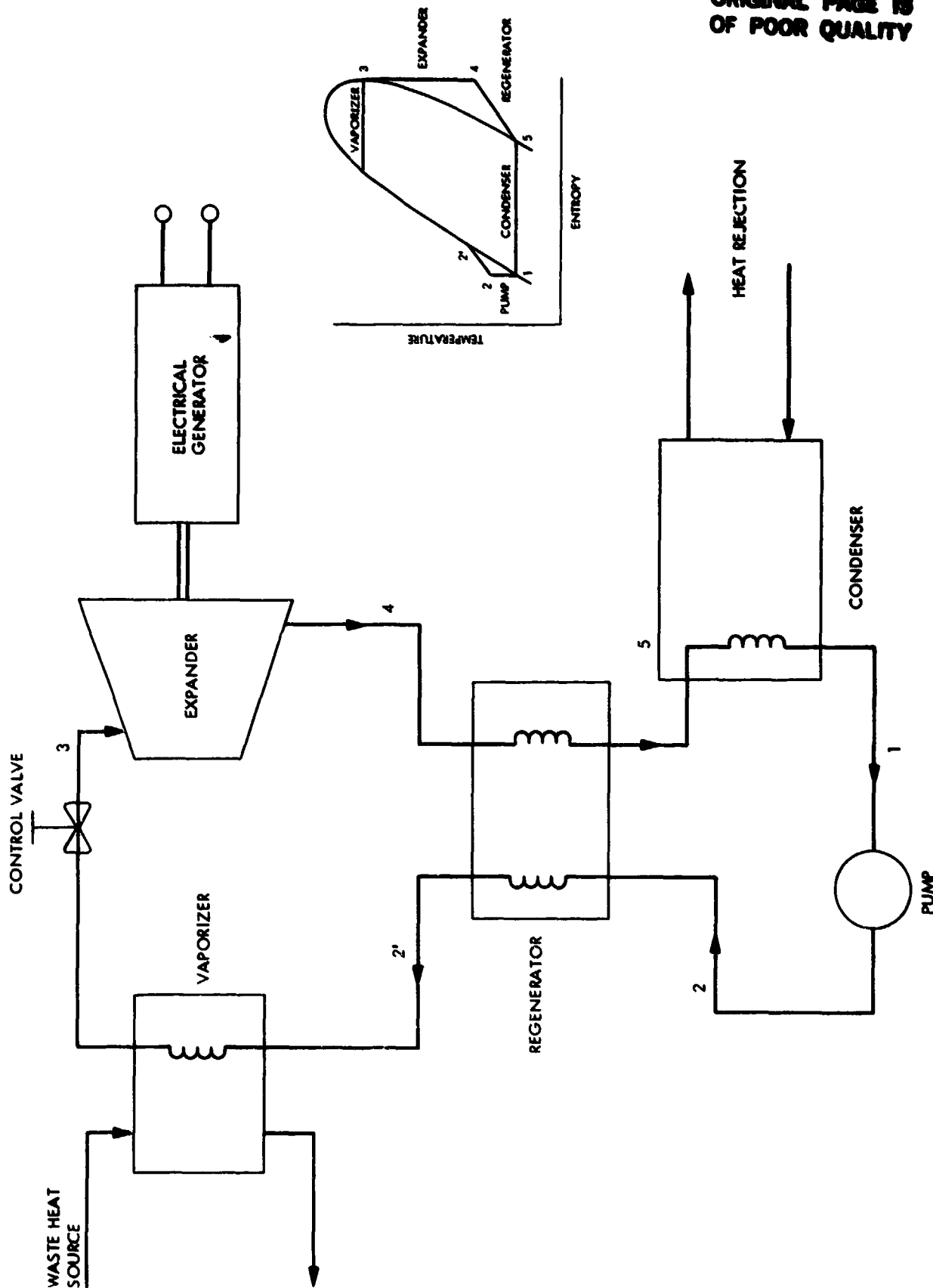

Figure 3-1. Schematic Diagram of a Typical Organic Rankine Cycle System with Temperature-Entropy Display

ORIGINAL PAGE IS
OF POOR QUALITY

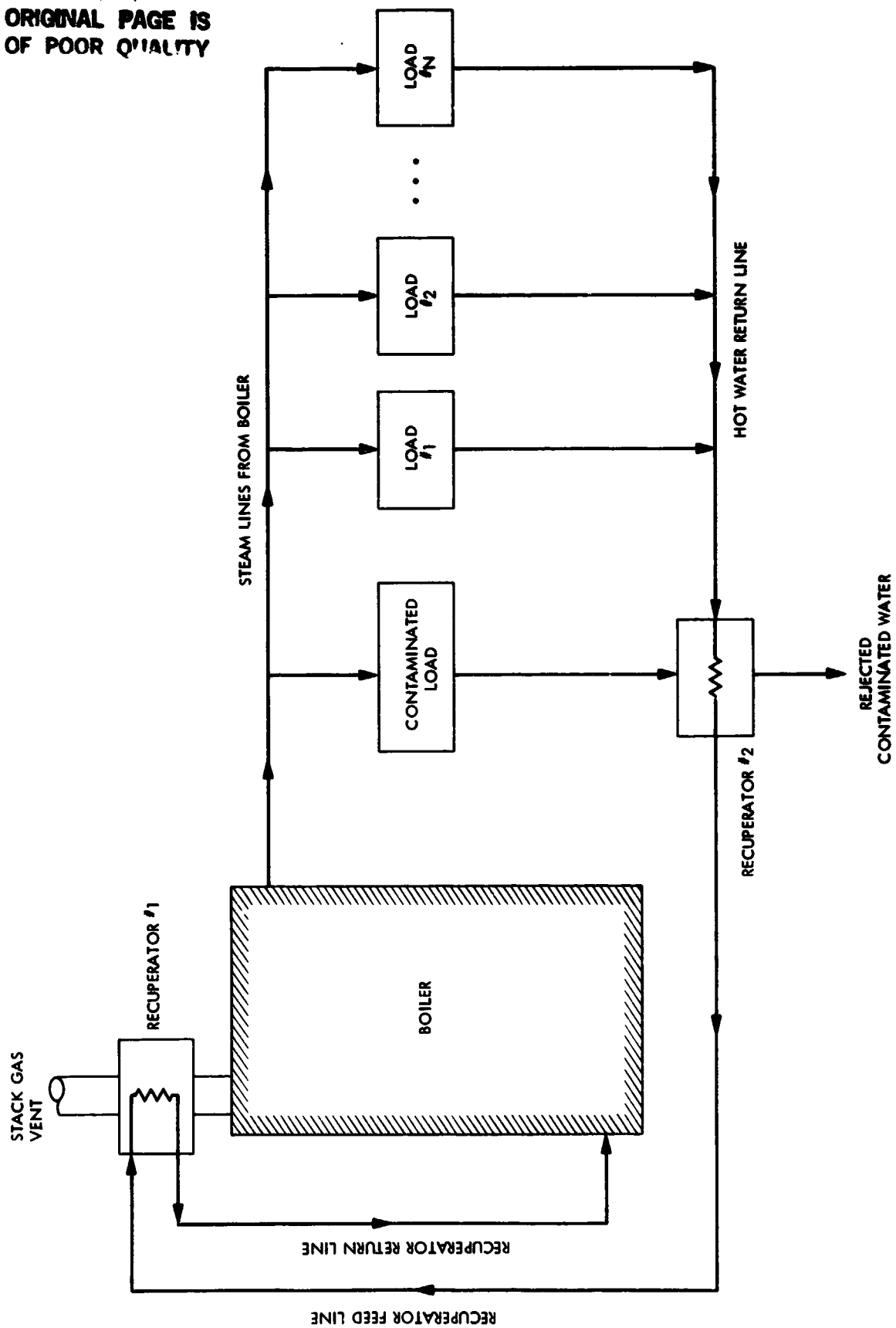

Figure 3-2. Schematic Diagram of Steam Plant Depicting Possible Locations of Recuperators

composition, thermodynamic state, and contaminants (if any) of the waste-heat source; the flow rate of the source medium; the working fluid employed in the Rankine cycle; the thermodynamic and transport properties of the working fluid; the overall cycle efficiency; the specified end use for the bottoming cycle equipment, such as type of power delivered (electrical or mechanical) and power requirements; the necessary floor area and required system volume; the required auxiliary or parasitic equipment (its influence is implicit in the overall cycle efficiency); the capital and installed costs of the equipment; and the operation and maintenance costs.

From information about Air Force heat plants obtained during the visits to the bases and from Reference 12, there appear to be three principal sources of waste heat: stack gases, hot water that is normally discarded, and condensing steam from special processes from which the condensate is not returned. Once the waste-heat source has been identified, the size and cost-effectiveness of an organic Rankine bottoming cycle can be calculated, using the parameters outlined in Table 3-1. Although the necessary auxiliary or parasitic equipment is listed separately as one of the key parameters, it contributes to reducing the overall cycle efficiency and is thus an implicit part of that parameter. The reference to parasitic equipment was identified separately to alert the designer or user to evaluate its influence. However, its effect is implied wherever overall cycle efficiency is referenced in this report.

Three of the more important parameters in this analysis are the total mass flow rate of the heat source, the maximum temperature available, and the minimum temperature allowable. These parameters not only tell how much energy is potentially available, but also the maximum temperature suggests what may be a permissible working fluid for the organic Rankine cycle. The various organic compounds are all subject to thermal decomposition at varying rates and temperatures, depending on their molecular structure. This must be considered if one is to specify specific performance criteria for given temperatures. An excellent summary of organic working fluids and their maximum acceptable temperatures is given in Reference 13. A summary of the critical states and the upper temperature limits for the more common organic working fluids was extracted from Reference 13 and is presented in Table 3-2.

If the waste-heat source is other than water or combustion gases, then the thermodynamic properties of the new medium must be known. To a first order, equipment size can be adequately approximated from knowledge of the heat capacity alone.

B. ORC EQUIPMENT LIST

Performance data on organic Rankine cycle equipment have been compiled and tabulated in Table 3-3. These data summarize the responses to the industry survey and the information on specific hardware derived from the literature search. This table presents as much technical data as possible about commercially available hardware, portraying the state of the art of existing equipment to the designer and conveying the sensitivity of the parameters. This table can and should be used in conjunction with the nomograms when sizing the organic Rankine cycle equipment. For example, if

Table 3-1. KEY PARAMETERS FOR SELECTION OF ORGANIC RANKING BOTTOMING CYCLE EQUIPMENT

Information necessary to size power output of ORC equipment

- o Temperature of source medium
- o Desired final temperature of source medium
- o Flow rate of source medium
- o Overall cycle efficiency of ORC equipment
- o Necessary auxiliary or parasitic equipment

Information necessary to estimate overall cycle efficiency of ORC equipment

- o Temperature of source medium
- o Working fluid of ORC equipment
- o Condensing temperature of working fluid
- o ORC expander efficiency

or

- o Data on actual hardware of the desired size and operating temperatures

Information necessary to determine cost-effectiveness

- o Installed cost of the ORC equipment, \$/kW
- o Operation and maintenance cost
- o Anticipated operating hours per year
- o Cost of electricity displaced
- o Standardized costing parameters and methodology

Information necessary to estimate required floor area and system volume

- o Power output from ORC equipment

Information necessary to compare ORC equipment with a recuperator

- o Installed cost of the recuperator
 - o Heat exchanger effectiveness
 - o Cost of fuel displaced
 - o Same standardized costing parameters and methodology
-

Table 3-2. RANKINE CYCLE ORGANIC WORKING FLUIDS

FLUID	CHEMICAL FORMULA*	MOLECULAR WEIGHT	CRITICAL PT. OF/PSIA	FREEZING PT. OF	APPROX. THERMAL STABILITY LIMIT OF	VAPOR PRESS. AT 104.9P, PSIA	SAT. TEMP. AT 1.5 PSIA, OF	WETTING(W) DRYING(D) NEITHER(N)
R-11	CCl3F	137	383.4/639.9	-167.8	248.0	23.1		N
R-21	CHCl2F	103	352.4/739.8	-211.0		40.0		W
R-22	CHClF2	86	204.8/721.8	-256.0	392.0	211.0		W
R-113	C2Cl3F3	187	417.2/499.0	-31.0	347.0	11.0		D
R-114	C2Cl2F4	171	294.8/472.8	-137.2	347.0	46.0		D
R-113a	C2H2ClF3	118	305.6/589.9	-158.8	392.0	45.0		N
CP-9(a)	C15H16	196	971.6/355.0	-67.0	698.0		392.0	D
CP-25(b)	C7H8	92	609.8/616.8	-139.0	896.0	1.0		D
CP-27(c)	C6H5Cl	113	678.2/655.8	-67.0	608.0	1.0		D
CP-32(d)	C5H5N	79	656.6/816.8	-43.6	698.0	1.0		D
CP-32/. Water(e)	0.23 C5H5N 0.77 H2O	33	690.8/1299.8	-0.4	752.0	2.0		D
CP-34(f)	C4H4S	84	584.6/791.8	-40.0	554.0	3.0		<66C:W >66C:D
FC-75(g)	C8F16O	416	440.6/233.0	-79.6	608.0	1.0		D
FC-88(h)	C5F12	288	302.0/309.0	-175.0	392.0	20.3		D
F-85(i)	0.55 CF3CH2OH 0.1 H2O	88	464.0/929.7		554.0	3.0		W
Dowtherm A(j)	0.245 (C6H5)2 0.755 (C6H5)2O	66	930.2/469.9	-54.4	698.0		284.0	D
Biphenyl	(C6H5)2	154	928.4/476.5	156.2	698.0		284.0	D
Allied P-1 D	C10F22O2	570	469.4/172.0	-121.0	698.0	0.3	167.0	D

*Mixture fractions on mole basis

(a) Monoisopropyl biphenyl (C6H5)(C6H4)-CH(CH3)2

(b) Toluene

(c) Monochlorobenzene

(d) Pyridine

(e) Azeotrope of pyridine and water

(f) Thiophene

(g) Perfluoro-2-butyltetrahydrofuran

(h) Perfluoropentane

(i) Fluorinol (Trifluoroethanol/water mixture)

(j) Eutectic of biphenyl and phenyl ether

ORIGINAL PAGE IS
OF POOR QUALITY

ORIGINAL PAGE IS
OF POOR QUALITY

ORIGIN
OF PG

ORGANIC RANKINE CYCLE (ORC) MANUFACTURER	ADDRESS OF MANUFACTURER	ORC GROSS POWER OUTPUT, KW	ORC NET POWER OUTPUT, KW	WORKING FLUID	OVERALL ORC CYCLE EFFICIENCY, %	HEAT SOURCE ^a	HEAT SOURCE PARAMETERS				TYPE
							FLOWRATE, lb _m /h	INLET TEMP. °F	EXIT TEMP. °F	POWER TO VAPORIZER, KW (10 ⁶ Btu/h)	
AFI ^b	Livingston, NJ	650	560	R-11	9.9	Sulphuric acid	927,700	240	183	5,684 (19.4)	Turbine
AFI	Livingston, NJ	-	500	R-11	12.6	Saturated steam	12,800	304	167	3,955 (13.5)	Turbine
AFI	Livingston, NJ	-	3800	R-11	12.4	Xylene vapors	683,000	223-307	156-307	30,765 (105.0)	Turbine
AFI	Livingston, NJ	-	190	R-11	13.5	Saturated steam	4,400	316	167	1,406 (4.8)	Turbine
AFI	Livingston, NJ	-	475	R-11	12.8	Wet steam	11,900	266	131	3,721 (12.7)	Turbine
AiResearch	Phoenix, AZ	1.7	1.4	R-11	8.0	Solar	-	200	-	17.5 (0.06)	-
AiResearch ^c	Phoenix, AZ	12	11.3	R-11	10.0	Solar	-	190	-	113 (0.386)	-
AiResearch	Phoenix, AZ	37	33	R-11	9.0	Solar	-	200	-	367 (1.25)	-
Barber-Nichols ^d	Arvada, CO	-	500	Isobutane	13.2	Brine (geothermal)	98,000	340	145	5,599 (19.11)	Turbine
Barber-Nichols	Arvada, CO	-	60	R-114	-	Hot water (geothermal)	-	300	-	-	-
Barber-Nichols	Arvada, CO	34	32.9	R-11	10.0	Solar	-	200	-	329 (1.12)	Turbine
Carrier	-	20	19	R-113	14.0	Solar	-	300	-	136 (0.464)	-
General Electric	-	2.3	1.9	FC-88	13.0	Solar	-	300	-	15 (0.05)	-
General Electric	-	7.9	7.1	FC-88	15.0	Solar	-	300	-	47 (0.16)	-
Honeywell	-	1.7	1.6	R-113	8.0	Solar	-	195	-	20 (0.068)	-
Honeywell	-	15	14.6	R-113	8.0	Solar	-	195	-	183 (0.625)	-
Mechanical Technology Inc. (MTI) ^e	Ballston Spa, NY	-	1000	R-113	-	-	-	-	-	-	Turbine
MTI	Ballston Spa, NY	-	1230	R-113	8.6	Condensing steam	50,000	200	200	14,328 (48.9)	Turbine
MTI	Ballston Spa, NY	500	470	Water/R-11	10.0	Diesel exhaust	-	520 (Steam) 245 (R-11)	333 (Steam) 215 (R-11)	-	Turbine
MTI	Ballston Spa, NY	1250	1125	-	11.5	Petrochemical	-	300	212	9,757 (33.3)	Turbine
Ormat Turbines, Ltd. ^f	Hopkinton, MA	-	1 - 6	Trichlorobenzene	-	Gas, oil combustion	-	-	-	-	Turbine
SPS Inc. ^g	Miami, FL	10 - 700	-	R-12, R-114	7 - 15	Hot water, steam	-	250 max 150 min	-	-	Rotary Screw
Sundstrand ^h	Rockford, IL	600	570	Toluene	20.0	Diesel exhaust	-	600-1400	-	-	Turbine
Sundstrand	Rockford, IL	750	-	Toluene	22.1	Hot gas	94,237 (Beloit, KS) 99,932 (Easton, MD) 128,229 (Homestead, FL)	821 752 752	-	-	Turbine
Thermo Electron ⁱ	Waltham, MA	500	385.6	Fluorinol-85	22.8	Diesel exhaust	50,988	683	231	1,688 (5.75)	Turbine
United Technology	-	16	14.8	R-11	13	Solar	-	300	-	114 (0.389)	-

^aThe "heat source" is the source from which the ORC unit, as referenced, derives its power. It is not necessarily limited to this source of energy.

^bComplete address (not referenced in text): AFI Energy Systems
110 S. Orange Ave.
Livingston, NJ 07039
(201) 533-2091

^cThe high-rpm AiResearch expanders are probably turbines.

^dVaporizer heat exchange is accomplished by direct contact of the isobutane with the brine. Also, Barber-Nichols is developing or has developed ORC units in sizes of 2, 16, 50, and 66 kW, as well as 4.33 MW, but details are not available.

^eUnits available in modules up to 2.5 MW.

^fOrmat has nearly 3000 various ORC units in the field (see Ref. generally available).

^gSPS has a wide variety of sizes, but specific details are not available.

^hSundstrand has wide experience in ORC hardware and has developed the nominal 600 kW units are presently in field test programs.

ⁱSandia National Laboratories, Albuquerque, NM.

^jComplete address (not referenced in text):

Thermo Electron Corp.
101 First Avenue
Waltham, MA 02154
(617) 890-8700

ROLLOUT FRAME

ORIGINAL PAGE IS
OF POOR QUALITY

ORIGINAL PAGE IS
OF POOR QUALITY

POWER TO VAPORIZER, (10 ⁶ Btu/h)	EXPANDER PARAMETERS					WORKING FLUID MASS FLOWRATE, lb _m /h	WORKING FLUID CONDENSER PARAMETERS			CONDENSER COOLING WATER PARAMETERS			UNIT SIZE, ft L x W x H	SOURCE OF DATA
	TYPE	SPEED, rpm	EFF, %	INLET TEMP, °F	INLET PRES., psia		INLET TEMP, °F	INLET PRES., psia	EXIT TEMP, °F	INLET TEMP, °F	EXIT TEMP, °F	FLOW- RATE, gpm		
4 (19.4)	Turbine	9,590	-	-	-	-	-	-	-	63	73	-	30 20 25	Ref. 16
5 (13.5)	Turbine	10,370	-	-	-	-	-	-	-	79	91.4	-	30 20 25	Ref. 16
765 (105.0)	Turbine	5,280	-	-	-	-	-	-	-	-	-	-	40 45 30	Ref. 16
406 (4.8)	Turbine	15,500	-	-	-	-	-	-	-	89.6	98.6	-	30 20 25	Ref. 16
721 (12.7)	Turbine	8,700	-	-	-	-	-	-	-	89.6	98.6	-	30 20 25	Ref. 16
7.5 (0.06)	-	60,000	81	190	86	660	-	-	96	84	-	-	-	SNLA ¹
(0.386)	-	30,000	85	190	85	4,450	-	-	96	84	-	-	-	SNLA ¹
7 (1.25)	-	18,000	85	190	86	13,240	-	-	96	84	-	-	-	SNLA ¹
599 (19.11)	Turbine	-	-	255	450	-	-	-	64	-	-	-	80 60 25	Ref. 4 & 5
-	-	-	-	180	-	-	-	-	-	-	-	-	-	Ref. 5
329 (1.12)	Turbine	11,950	75	186	85	12,200	-	-	78	-	-	-	-	SNLA ¹
136 (0.464)	-	20,100	80	273	132	4,780	-	-	120	95 (air-cooled)	-	-	-	SNLA ¹
15 (0.05)	-	1,725	83	290	200	1,100	-	-	109	95 (air-cooled)	-	-	-	SNLA ¹
47 (0.16)	-	1,725	83	290	225	3,400	-	-	109	95 (air-cooled)	-	-	-	SNLA ¹
20 (0.068)	-	35,000	72	176	38	1,080	-	-	95	85	-	-	-	SNLA ¹
183 (0.625)	-	24,000	80	176	38	8,490	-	-	95	85	-	-	-	SNLA ¹
-	Turbine	3,640	84	230	79.6	325,000	94	9.3	-	-	-	-	-	Ref. 7
328 (48.9)	Turbine	-	-	190	-	-	-	-	-	80	-	6,000	-	Sales Info.
-	Turbine	42,200 (Steam)	80 (Steam)	430 (Steam) 190 (R-11)	50 (Steam) 90 (R-11)	-	87 (R-11)	16.5 (R-11)	81 (R-11)	61	67	-	-	Ref. 20 & 33
757 (33.3)	Turbine	-	-	230	-	-	145	-	94	81	68	4,500	-	Ref. 32
-	Turbine	18,000	-	392	-	-	-	-	-	-	-	-	-	Ref. 13 & 31
-	Rotary Screw	-	75-90	-	-	-	-	-	-	100 (max) 40 (min)	-	-	(See Table 1)	Sales Info.
-	Turbine	-	-	550	300	41,200	379	3.15	290	86	111	650	-	Ref. 20
-	Turbine	-	-	524	323	52,000	350	3.8	261	86	110	826	-	Drawings & Sales Info.
688 (5.75)	Turbine	12,500	80.8	550	700	21,500	113	2.8	77	58.2	67.6	936	-	Ref. 20
114 (0.389)	-	42,000	76	285	246	4,140	-	-	114	95 (air-cooled)	-	-	-	SNLA ¹

In the field (see Ref. 13 and 31); however, detailed information is not

specific details are not available.

hardware and has developed several sized for varied applications. Four of
in field test programs.

que, NH.

(1):

2 FOLDOUT FRAME

TABLE 3-3. AVAILABLE ORGANIC RANKINE CYCLE EQUIPMENT, MANUFACTURERS
AND PERFORMANCE CHARACTERISTICS

the nomogram should suggest a size near that for which an existing unit is available, using the existing unit will avoid the additional development cost of a non-standard size. The parameters relevant to the existing hardware, such as cycle efficiency, could then also be used. As a word of caution, however, if the waste-heat source temperature is near or above the thermal stability limit of the working fluid used in the commercial unit, then it may be necessary to change working fluids, which will change the performance characteristics. Such an occurrence, of course, would have to be investigated in greater detail.

C. NOMOGRAMS FOR SIZING ORGANIC RANKINE CYCLE EQUIPMENT

A series of nomograms has been developed to enable one estimate organic Rankine cycle (ORC) equipment for waste-heat recovery applications. The intention is to provide a technique whereby the field engineer can determine quickly and easily by a graphical method the approximate power output that could be realized from the ORC equipment.

For ease of application, the graphs required for the equipment sizing are divided into four parts: a nomogram for estimating the overall cycle efficiency (Figure 3-3), a nomogram for determining the net power delivered by the ORC equipment when driven from a sensible heat source (Figure 3-4), a similar nomogram for deriving power from a condensing steam source (Figure 3-5), and a graphical aid for approximating the volume and area of the equipment itself (Figure 3-6).

Perhaps the most difficult curves to derive in a sufficiently general form, yet with adequate accuracy to give representative results, are those designed to predict the overall cycle efficiency. Figure 3-3, which depicts such curves, was derived largely from earlier work done by Barber-Nichols (Reference 14). For this figure, the expander efficiency has been factored out and shown separately, although it was implicitly incorporated in the original figure from Reference 14. Information from the literature search has indicated that the expander efficiency may vary by several percentage points, and its influence on the overall cycle efficiency can readily be seen. However, if the expander efficiency is not known, a value of 80 percent should be assumed. Also, the generalized curve presented in Reference 14 has been expanded to include a range of condensing temperatures for the organic working fluid from 70°F to 100°F in order to provide a feel for the sensitivity of condensing temperature on cycle efficiency. Properties of R-113 were used to obtain this range. A condensing temperature of 95°F should be assumed if no other information is available.

Ideally, to obtain the greatest accuracy from Figure 3-3 one should know the expander inlet temperature, the working fluid species, the condensing temperature of the working fluid, and the expander efficiency. In the reality of a field situation, little, if any, of this information will be available. Therefore, this nomogram was designed to enable one to estimate the cycle efficiency, given only the maximum temperature of the source medium and the implicit assumptions of a 95°F condensing temperature for the organic fluid and an 80 percent expander efficiency. However, if the specific working fluid and its properties are not known, one would not know the location of the

ORIGINAL PAGE IS
OF POOR QUALITY

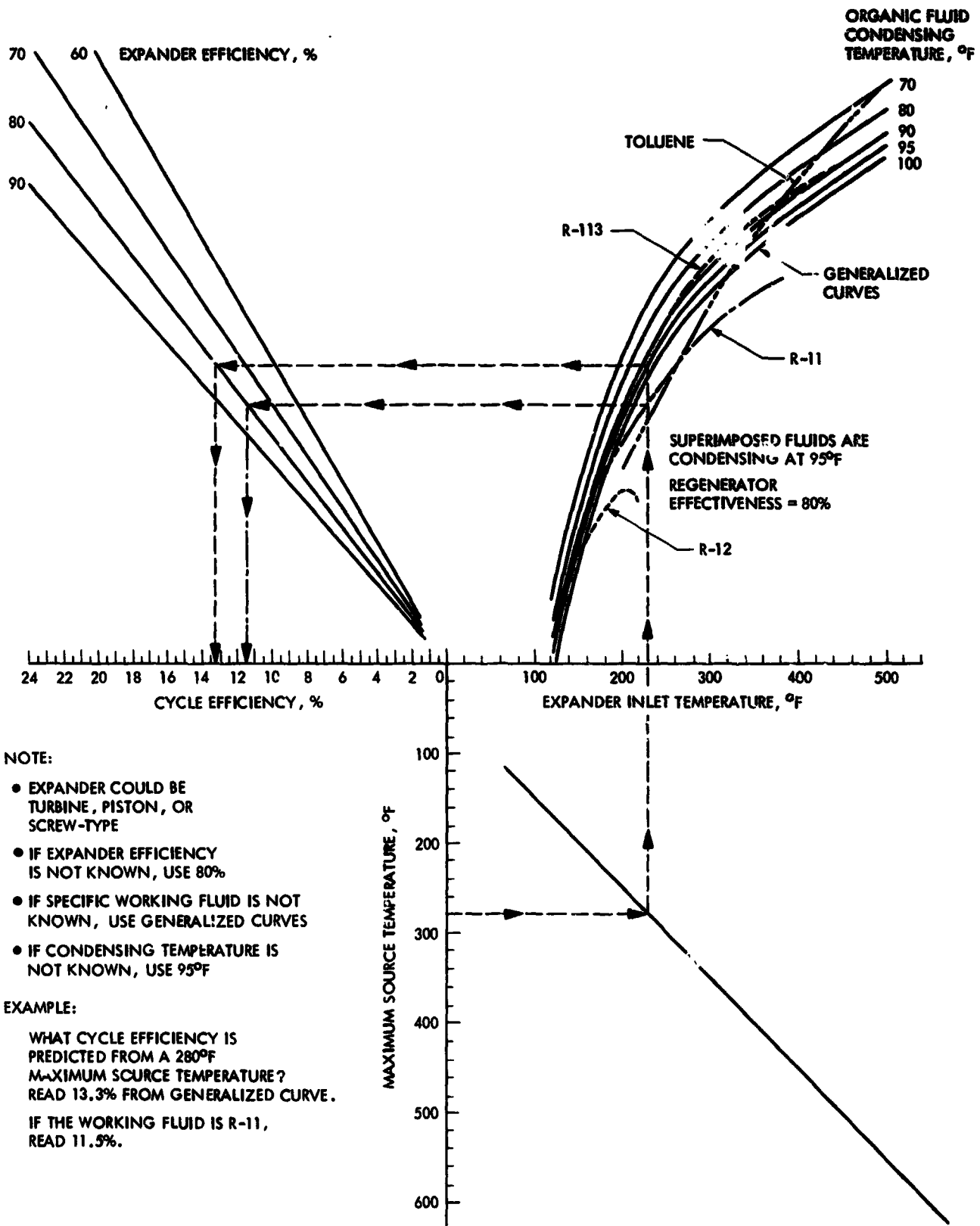
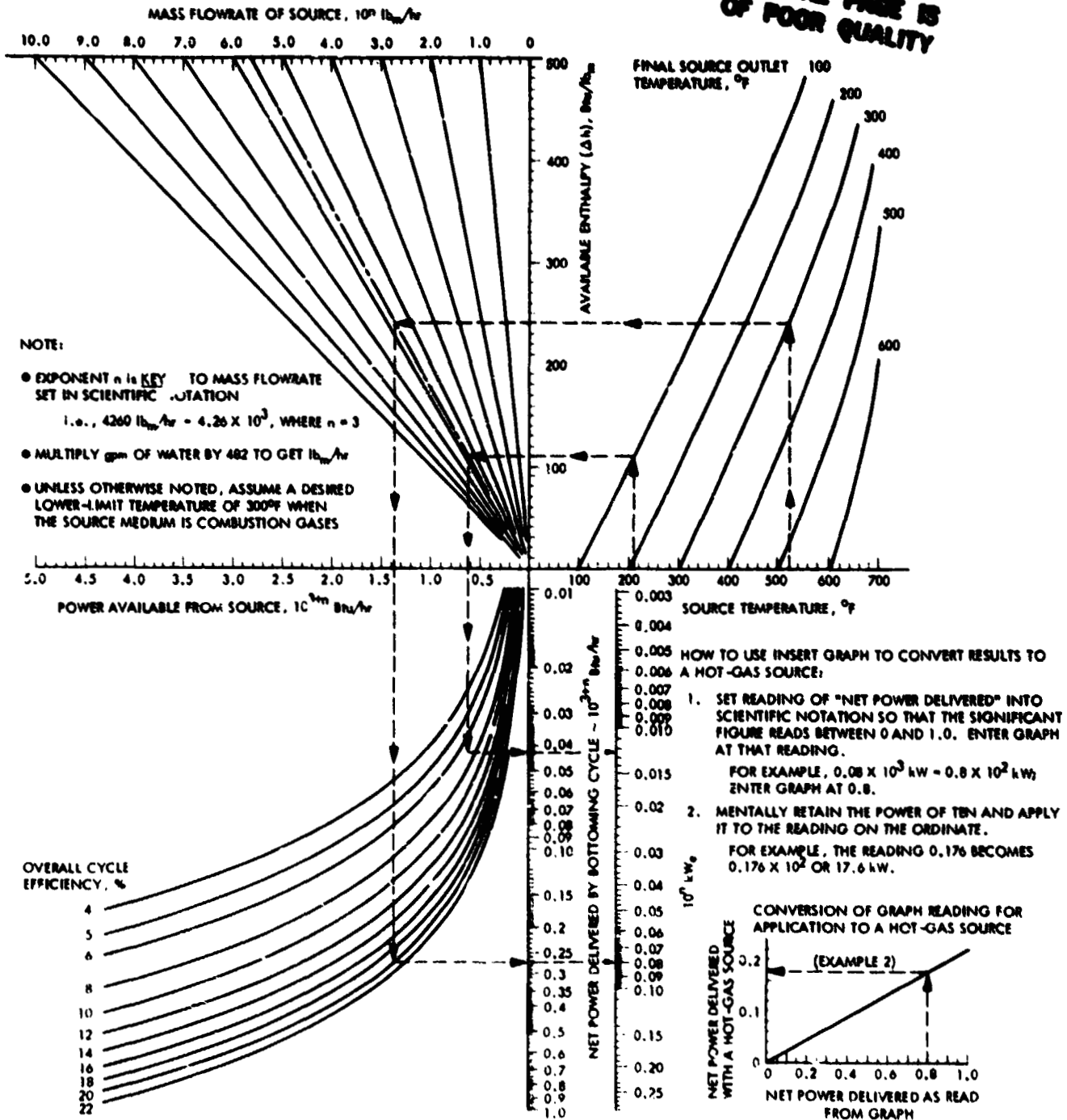

Figure 3-3. Nomogram for Determining Overall Cycle Efficiency for Organic Rankine Cycle Equipment

ORIGINAL PAGE IS
OF POOR QUALITY



EXAMPLE:

1. 210°F WATER FLOWING AT $5640 \text{ lb}_m/\text{hr}$ POWERS AN ORC BOTTOMING CYCLE THAT HAS 7% CYCLE EFFICIENCY. FIND THE NET POWER DELIVERED.
 $\dot{m} = 5640 \text{ lb}_m/\text{hr} = 5.64 \times 10^3 \text{ lb}_m/\text{hr}$, $n = 3$
READ $0.0425 \times 10^6 \text{ Btu}/\text{hr}$ OR 12.5 kW.
(CALCULATE $0.04369 \times 10^6 \text{ Btu}/\text{hr}$ OR 12.74 kW)

2. 520°F STACK GAS AT THE SAME FLOWRATE POWERS AN ORC UNIT THAT IS 20% EFFICIENT. LOWER TEMPERATURE LIMIT OF STACK GAS IS 300°F . FIND THE NET POWER DELIVERED. AS ABOVE, $n = 3$.
READ $0.2545 \times 10^6 \text{ Btu}/\text{hr}$ OR $0.08 \times 10^3 \text{ kW}$,
MULTIPLY BY 0.22 AND OBTAIN $0.056 \times 10^6 \text{ Btu}/\text{hr}$
AND 17.6 kW.
(CALCULATE $0.0608 \times 10^6 \text{ Btu}/\text{hr}$ AND 17.81 kW)
OR READ 0.176 ON THE ORDINATE, CORRECTING kW TO 17.6 kW.

Figure 3-4. Nomogram for Determining Net Power Delivered by an Organic Rankine Cycle Powered by a Sensible Heat Source

ORIGINAL PAGE IS
OF POOR QUALITY

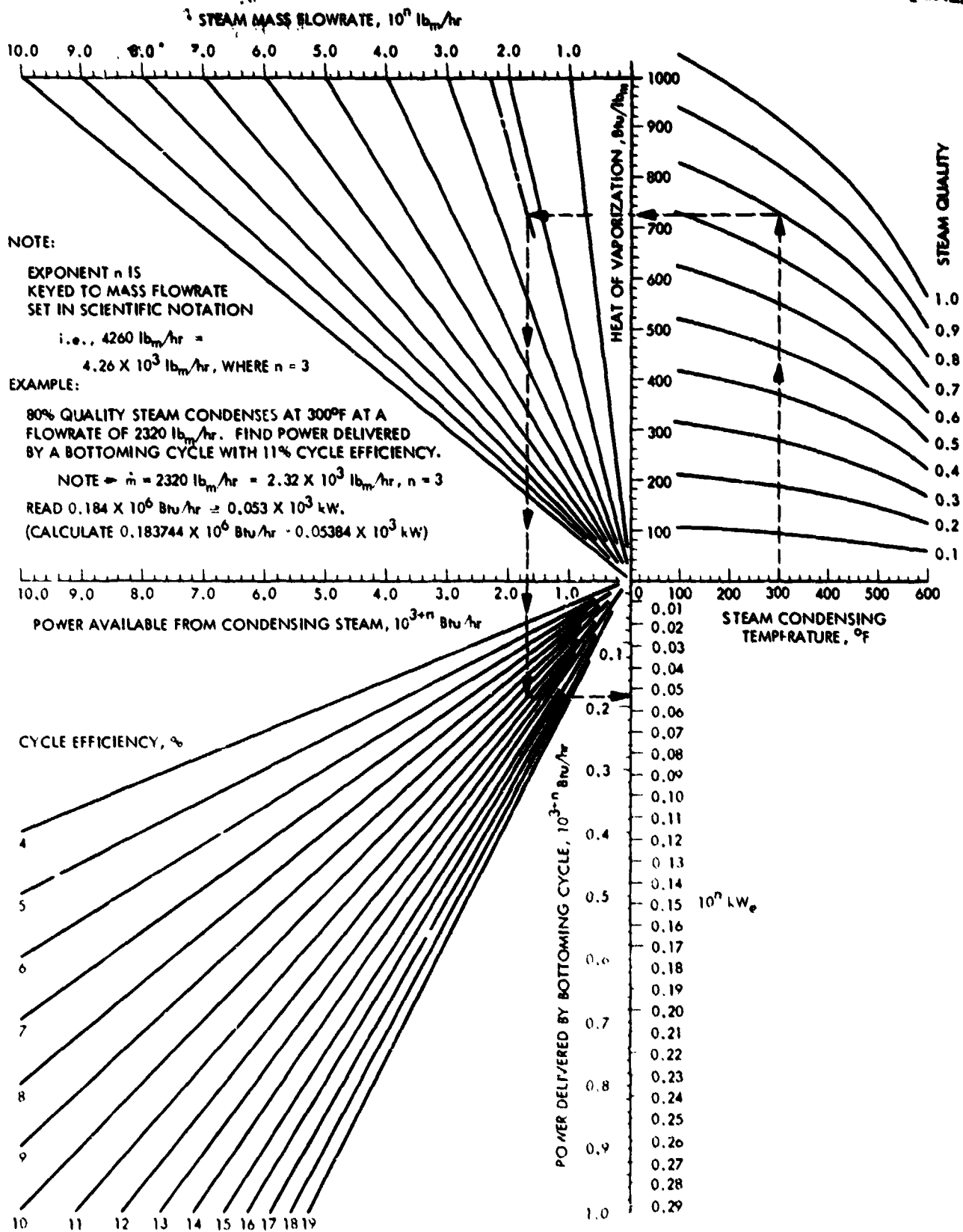

Figure 3-5. Nomogram for Determining Net Power Delivered by an Organic Rankine Cycle Fed from a Condensing Steam Waste Heat Source

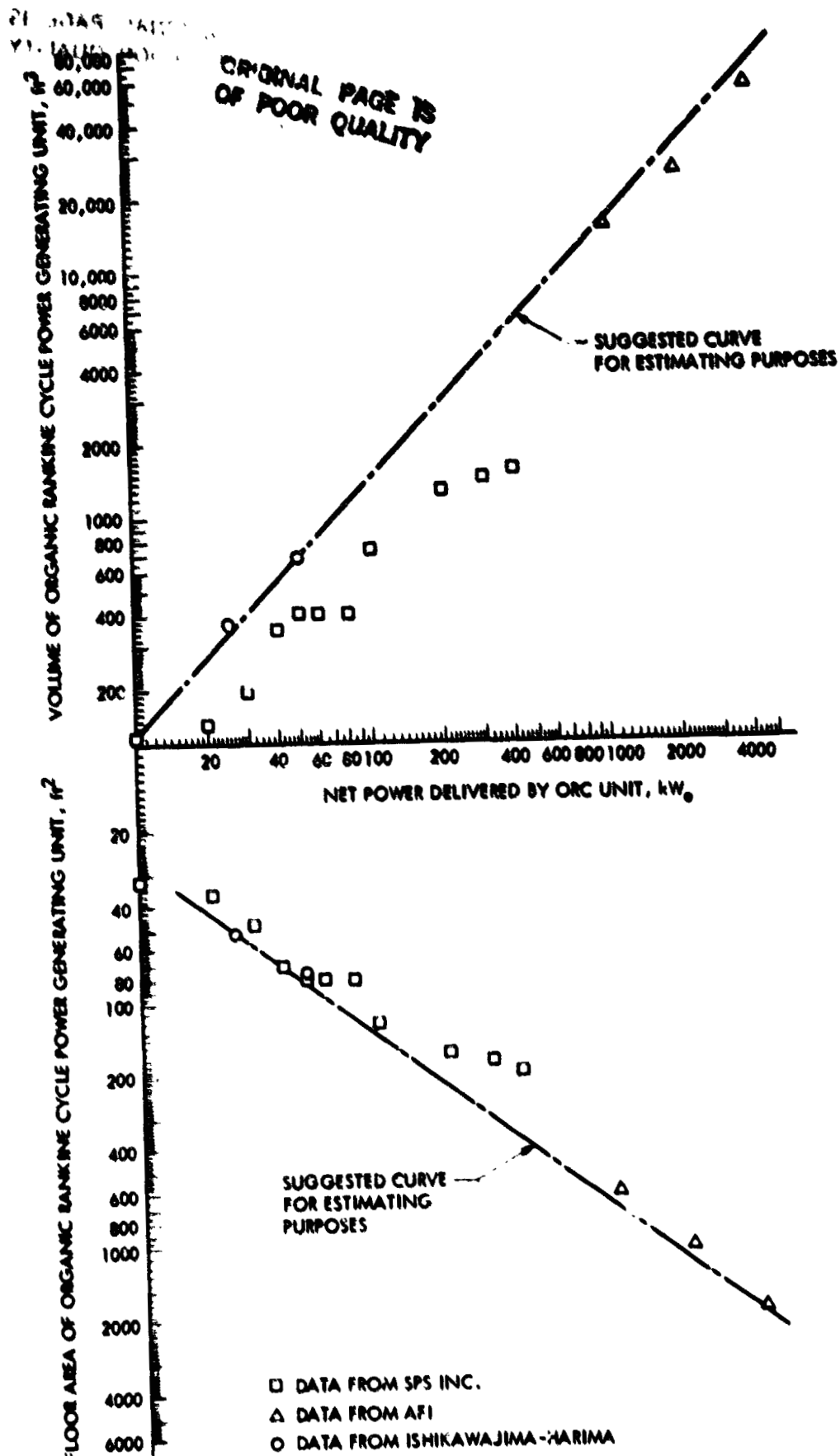

Figure 1-6. Graphical Method for Estimating Volume and Area of an Organic Rankine Bottoming Cycle Unit

ORIGINAL PAGE IS
OF POOR QUALITY

"pinch point" where the organic fluid changes phase or the temperature at which the phase change occurs. An assumed temperature difference of 50°F between the maximum source temperature and the expander inlet temperature was found to predict cycle efficiencies that fell within the data scatter of the information available from the literature and the manufacturers. This assumption was therefore incorporated into Figure 3-3.

With the implicit assumptions above, Figure 3-3 is quite straightforward to use as demonstrated by the example shown in the figure where a predicted overall cycle efficiency of 13.3 percent results from a 280°F maximum source temperature, when read from the generalized curves.

The energy that is potentially recoverable from a sensible waste heat source (i.e., no condensation of the source medium takes place) with an organic Rankine cycle can be determined from Figure 3-4. This figure solves the following equation:

$$q = \eta_{cyc} \dot{m} c_p \Delta T.$$

where

η_{cyc} = overall cycle efficiency

\dot{m} = mass flow rate of the source medium, lbm/hr

c_p = heat capacity of source medium, Btu/lbm °F

ΔT = temperature difference between the available and final temperatures of the source medium, °F

q = net power delivered by the bottoming cycle, Btu/hr or kW_e

Although these curves were derived for water, they can also be used for hot gas sources like stack gases by multiplying the final power derived by 0.22. (This factor is the approximate ratio of the heat capacities of the stack gases and hot water). For sources other than water or combustion gases, the available power for this new source can be estimated to within 10 percent by multiplying the net power output read from the nomogram by the heat capacity of the source medium. This is allowable because the heat capacity for water is approximately equal to 1.0.

To simplify these curves, and still effectively account for the different orders of magnitude of the flow rates and the powers derived, the scales for the flow rate, the power available, and the power derived are presented with a variable exponent, n , that is keyed to the mass flow rate written in scientific notation. Once the variable n is determined, it is used throughout the nomogram. For example, a mass flow rate of 4260 lbm/hr is written in scientific notation as 4.26×10^3 lbm/hr. Here, n becomes 3, and because of this, the scales for the power available and the net power delivered become 10^{3+3} or 10^6 Btu/hr and 10^3 kW_e, respectively. Therefore, when reading this figure (as well as Figure 3-5), one must first determine the mass flow rate so as to set the order of magnitude for the scales.

**ORIGINAL PAGE IS
OF POOR QUALITY**

To estimate ORC power delivery from Figure 3-4, one needs the mass flow rate of the source, the maximum source temperature, the final temperature desired for the source medium after the heat is extracted, and the overall cycle efficiency derived from Figure 3-3. If hot water is the source medium, then a practical lower limit for the desired final temperature (for example, 100°F) can be assumed for the specific case being studied. However, if the source medium is combustion gases, then the desired lower limit of the source temperature should not be less than 300°F unless otherwise specified (see References 10 and 15). This constraint is imposed to prevent the condensation of sulphuric acid, which is present in varying amounts in combustion gases because of the presence of sulphur in the fuels.

This curve is designed for easy use. Once the source mass flow rate has been identified and the magnitude of the scales established, enter the nomogram at the temperature of the source medium and move vertically until the desired final temperature of the source is reached. Then move horizontally to the left until coming to the mass flow rate identified earlier. Next, descend vertically to the value of the overall cycle efficiency that was read from Figure 3-3, then move horizontally to the right and read the net power delivered. If the source medium is hot water, the final value for the net power is the number just read. However, if the source medium is combustion gases, then multiply the number obtained from the nomogram by 0.22 to get the net power delivered. An insert has been provided in Figure 3-4 to allow the user to calculate this graphically. To use this insert, adjust the location of the decimal point so that the significant figures fall between zero and 1.0. For example, if 710 kW_e were read directly from the nomogram, then for a combustion gas source one would rewrite this as 0.71 x 10³ kW_e, enter the insert at 0.71 while mentally retaining the 10³, and read 0.156. Hence, for this example the net power delivered is 0.156 x 10³ or 156 kW_e.

The gross power available from the waste-heat source can also be estimated from Figure 3-4, if desired. It can be read on the horizontal axis between the flow rate and the cycle efficiency.

The net power delivered by an organic Rankine cycle from a condensing steam source can be found from Figure 3-5. This graph is designed to solve the following equation:

$$q = \eta_{cyc} \dot{m} h_{fg}$$

where

h_{fg} = heat of vaporization of water, Btu/lbm

and the remaining parameters are as defined earlier.

As with Figure 3-4, the mass flow rate is identified first and written in scientific notation so as to establish the order of magnitude of the parameter scales. Next, it is necessary to have some estimate of the steam quality (or the heat of condensation) of the source stream. If the heat is normally rejected through a condenser, then the quality can be accurately determined from the knowledge of the heat rejected, which can be calculated from the condenser inlet and outlet temperatures and the flow rate of the cooling water through it. If a condenser is not part of the system from which

waste heat is to be recovered from condensing steam, then the steam quality will have to be determined by another means, possibly by the temporary installation of an instrumented, water-cooled heat exchanger.

However, a review of sample Air Force heat plants revealed very few opportunities for waste-heat recovery from condensing steam, with the possible exception of some specific operation like a plating process. Because of this, Figure 3-5 may find few applications, but it is included here for completeness.

Once an estimate of the net power delivered by an ORC unit has been determined, the volume and the floor area of the system can be approximated with the aid of Figure 3-6. As an example, an ORC unit that delivers 100 kW is contained within an 1400 ft³ volume and covers a 140 ft² floor area. Very little geometry data were found in the literature or offered by the manufacturers. Those data that were acquired are plotted in Figure 3-6 and show a definite trend. Information from AFI (References 16 and 17) suggests that heat recovery systems normally require a clear area of 500 to 1500 ft² adjacent to the waste-heat stream. A supplemental aid for approximating the geometry was also suggested in Reference 16 and is presented in Table 3-4 below.

Table 3-4. ESTIMATE OF GEOMETRY FOR AN ORGANIC RANKINE CYCLE UNIT AS SUGGESTED BY AFI

Power Range, kW _e	Length, ft	Width, ft	Height, ft	Volume, ft ³	Area, ft ²
Up to 1000	30	20	25	15,000	600
1000 - 2000	40	25	25	25,000	1000
2000 - 4000	40	45	30	54,000	1800

D. NOMOGRAM FOR SIZING RECUPERATOR

The conventional technique for recovering waste heat from thermal process facilities is with a recuperative heat exchanger. Since the performance and, ultimately, the cost-effectiveness of an organic Rankine bottoming cycle should be compared with that of a heat exchanger, trade-offs with a recuperative heat exchanger must be made. For this comparison, a nomogram has been developed to estimate the waste heat that could be recovered by a recuperator if it were fed from the same source as is the ORC. This nomogram is presented as Figure 3-7 from which the net heat recovered can be read either as Btu/hr or as kilowatts thermal (kW_t).

Figure 3-7 is designed to be used in conjunction with either Figure 3-4 or Figure 3-5, depending upon whether a sensible or latent heat source is

ORIGINAL PAGE IS
OF POOR QUALITY

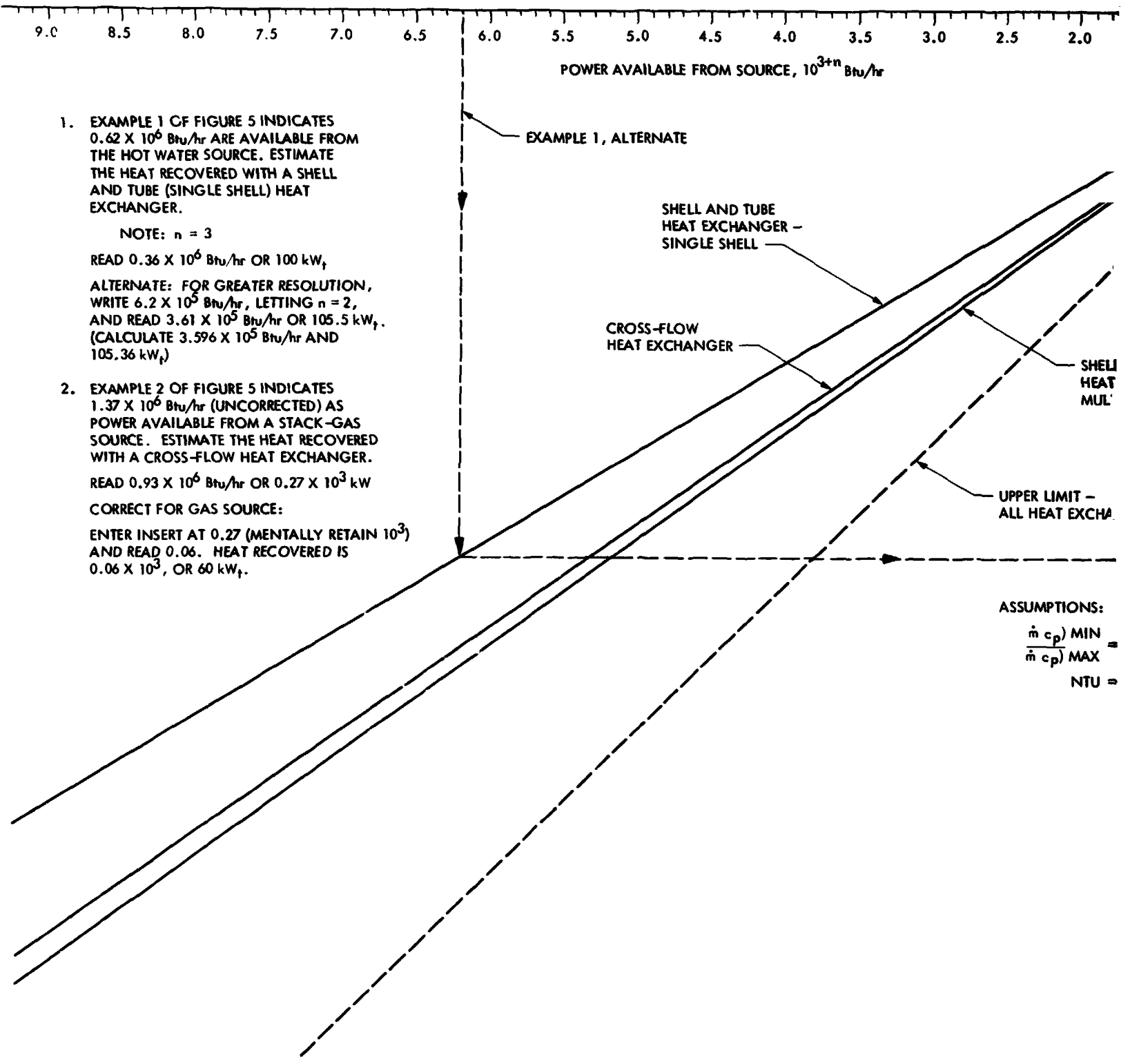

- EXAMPLE 1 OF FIGURE 5 INDICATES 0.62×10^6 Btu/hr ARE AVAILABLE FROM THE HOT WATER SOURCE. ESTIMATE THE HEAT RECOVERED WITH A SHELL AND TUBE (SINGLE SHELL) HEAT EXCHANGER.

NOTE: $n = 3$

READ 0.36×10^6 Btu/hr OR 100 kW_f

ALTERNATE: FOR GREATER RESOLUTION, WRITE 6.2×10^5 Btu/hr, LETTING $n = 2$, AND READ 3.61×10^5 Btu/hr OR 105.5 kW_f. (CALCULATE 3.596×10^5 Btu/hr AND 105.36 kW_f)

- EXAMPLE 2 OF FIGURE 5 INDICATES 1.37×10^6 Btu/hr (UNCORRECTED) AS POWER AVAILABLE FROM A STACK-GAS SOURCE. ESTIMATE THE HEAT RECOVERED WITH A CROSS-FLOW HEAT EXCHANGER.

READ 0.93×10^6 Btu/hr OR 0.27×10^3 kW

CORRECT FOR GAS SOURCE:

ENTER INSERT AT 0.27 (MENTALLY RETAIN 10^3) AND READ 0.06. HEAT RECOVERED IS 0.06×10^3 , OR 60 kW_f.

ASSUMPTIONS:

$$\frac{\dot{m} c_p}{\dot{m} c_p} \text{ MIN} =$$

$$\frac{\dot{m} c_p}{\dot{m} c_p} \text{ MAX} =$$

$$\text{NTU} =$$

OLDOUT ERASER

ORIGINAL PAGE IS
OF POOR QUALITY

ORIGINAL PAGE IS
OF POOR QUALITY

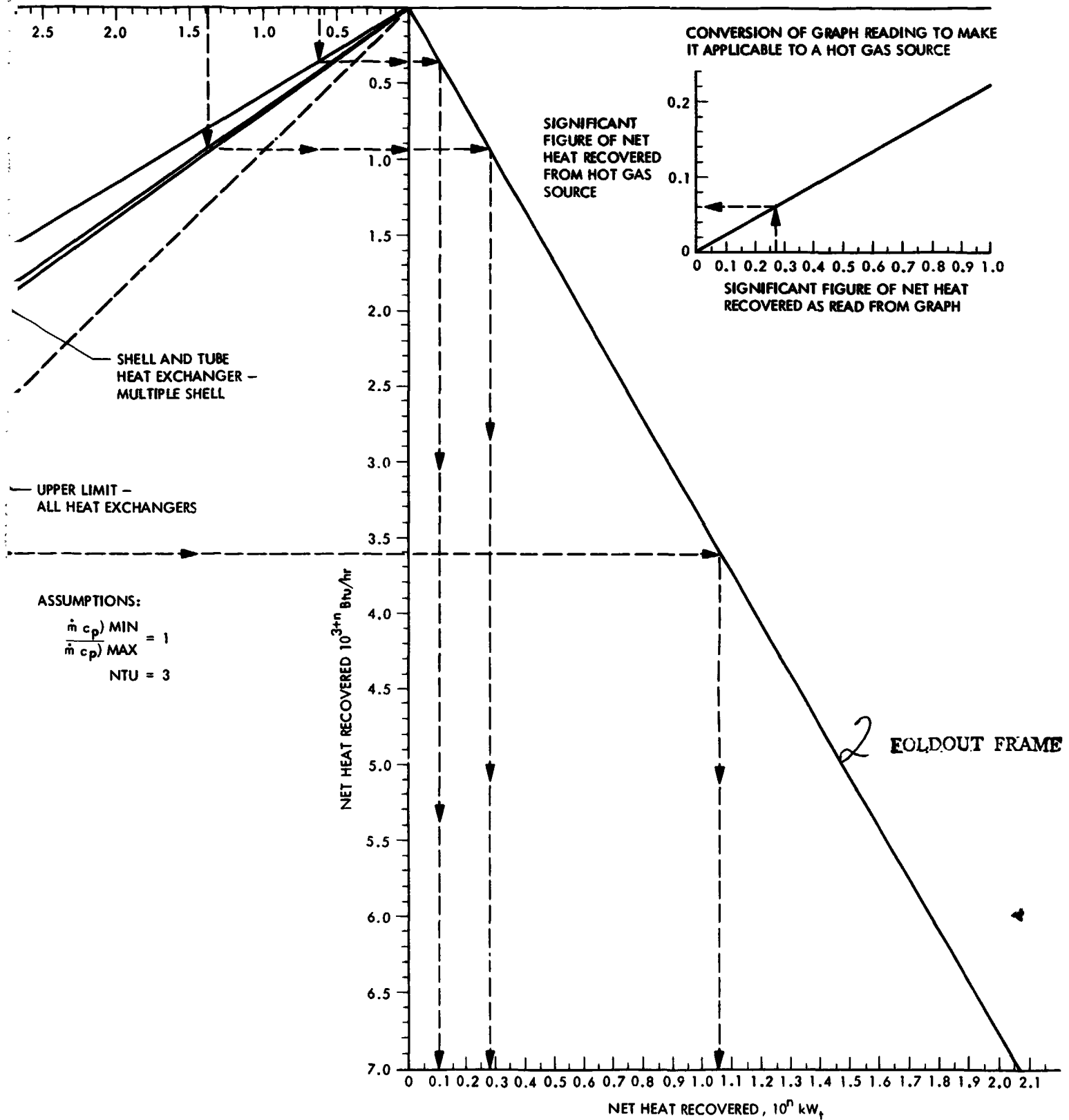

Figure 3-7. Nomogram for Determining Net Heat Recovered by a Recuperative Heat Exchanger from a Waste Heat Source

available. The quantity of waste heat ready to be transferred (in other words, the power available from the source) is determined from the top half of Figures 3-4 and 3-5, and is brought over to Figure 3-7, which substitutes for the bottom half of either of the other two figures. Obviously, the value for n is also carried along.

To maximize the ease with which this figure may be used, three of the most common heat exchangers are identified as the variable curves instead of a more conventional parameter like heat-exchanger effectiveness. This simplification necessitated a compromise in generality that was felt to be minor because a conservative result will generally be predicted for states that deviate from the assumed conditions. A slightly larger heat exchanger will be sized than is actually required. A dashed line depicting the practical upper limit for all heat exchangers is displayed for comparison.

It is assumed that the heat exchangers are sized according to the techniques defined by Kays and London (Reference 18) wherein the number of heat transfer units (NTU) is used in conjunction with the capacity-rate ratio $[(\dot{m} c_p)_{\min}/(\dot{m} c_p)_{\max}]$ to determine the heat exchanger effectiveness. The selection of a capacity-rate ratio of one in the derivation of this curve predicts a lower limit for heat exchanger effectiveness. An NTU of three was selected as being an achievable value consistent with good heat exchanger design practice.

The two examples given are identical with those of Figure 3-4, except that now a heat exchanger replaces the organic Rankine bottoming cycle. The results obtained are self-explanatory on the figure itself. Note that for the case where the heat source is stack gases (Example 2) the value for the power available from the source is transferred directly from Figure 3-4; the correction for a gaseous source is accomplished as the last step with the use of the insert. The insert for Figure 3-7 has the same function as that shown in Figure 3-4, which is to provide the final conversion for waste heat recovered from a combustion gas heat source. Adjust the significant figures of the number obtained from the scale of net heat transferred to fall between zero and one, and note the resulting order of magnitude. Then enter the insert with that significant figure and apply the retained order of magnitude to the number read. For example, in Example 2 the 270 kW_t read as net heat recovered is written as 0.27 x 10³ kW_t, the insert is entered at 0.27 while 10³ is mentally retained, and 0.06 is read to which the 10³ is applied, yielding 60 kW_t.

Once the performance of the recuperator has been estimated, its cost-effectiveness will be determined and the final result will be compared with that derived for the ORC.

PRECEDING PAGE BLANK NOT FILMED

SECTION IV

EQUIPMENT COST

Once the ORC equipment has been sized for a specific application, the next step is to evaluate its cost-effectiveness, for unless there are other overriding considerations, such as a need for self-sufficiency, any new system must be shown to be cost-competitive if it is to replace a conventional process. In this section the equipment installed cost, its savings-to-investment ratio, and a comparison of the break-even costs are presented for both the organic Rankine bottoming cycle and for a recuperator. From these data the cost-effectiveness of the various options can be compared.

A. ORC EQUIPMENT INSTALLED COST

Much information on the installed cost of equipment was obtained from both the literature search and the industry survey. For this study, equipment installed cost is defined as the capital cost of the equipment plus its installation cost. With the exception of Sundstrand, which differentiated the capital cost from the installation cost, the manufacturers responding to the questionnaire quoted cost data in terms of capital costs only. All of these data have been plotted in Figure 4-1 in units of $\$/kW_e$ as a function of net power output in kW_e .

In Figure 4-1, the dashed curve that represents the suggested installed cost to be used for estimating purposes was derived from the assumption that the equipment installation is 40 percent of the total cost. (See, for example, Reference 19). For ease of estimating installed costs in a field environment, a simplified version of Figure 4-1 that displays only the recommended installed cost curve is presented as Figure 4-2 and the figure should be used for all subsequent cost estimates.

Although considerable cost information has been obtained for this study, it was felt that because of the influence of inflation over the past few years that it would be more appropriate to report the latest cost data as representative of a 1982 market and show earlier costs as a depiction of trends, rather than to extrapolate all cost data into 1982 dollars.

The 1978 cost description presented by Burns-McDonnell (Reference 20) was more thorough than any other ORC cost information obtained from the literature search and, therefore, warrants a separate display. Obtaining their baseline data from Sundstrand and Thermo Electron, they have extrapolated it over a range of power ratings and have also shown the influence of a new versus a retrofit installation. Their results have been extracted from Reference 20 and are presented as Figure 4-3.

One would expect to see an inverse relationship between installed cost and maximum cycle temperature for any given power output because temperature-related components like heat exchangers must be larger to extract the same power from a smaller temperature gradient; hence they would be more expensive. With the exception of the data from SPS, Inc., the data obtained

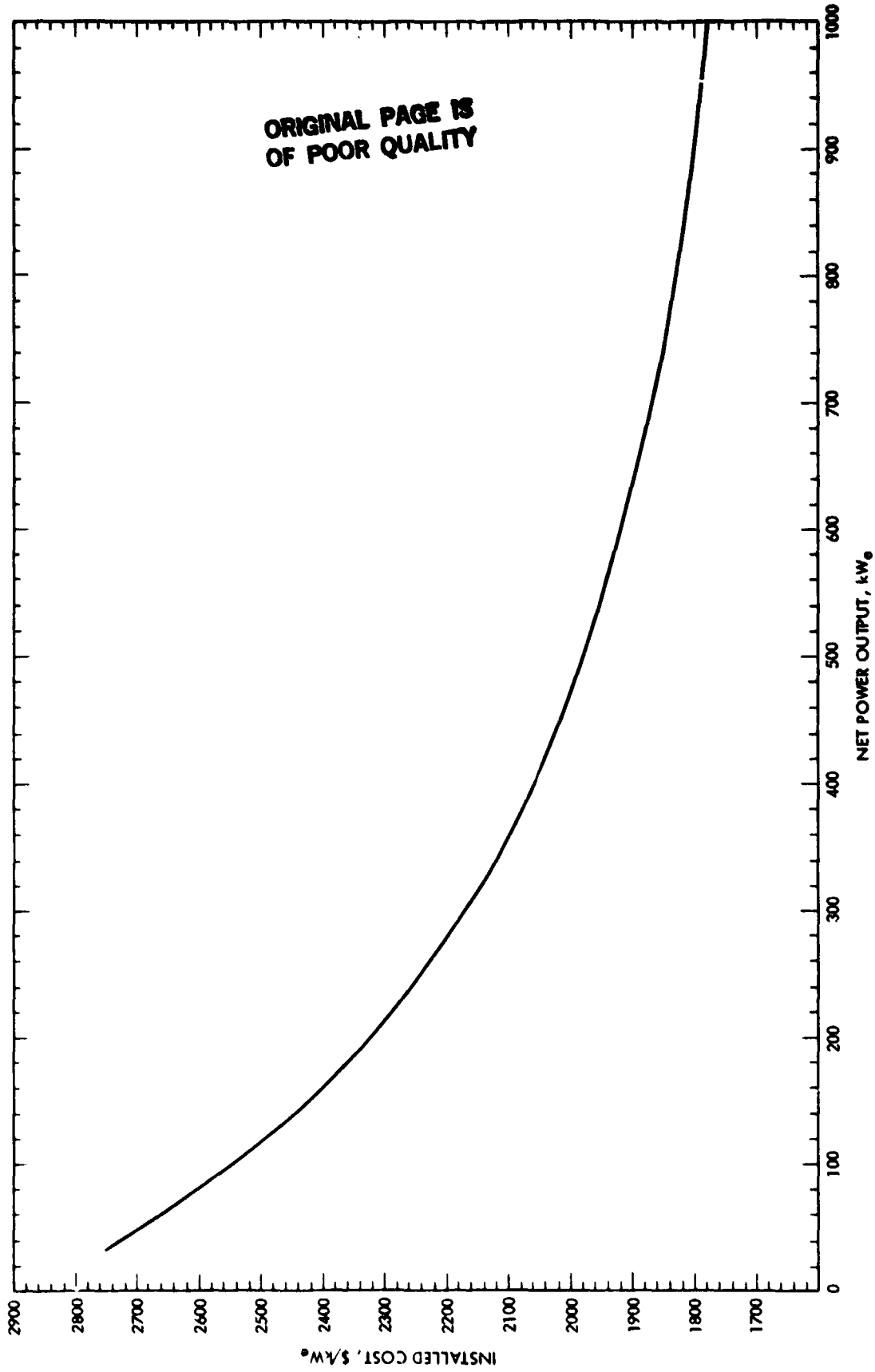

Figure 4-2. Recommended Curve for Estimating Installed Cost for Organic Rankine Bottoming Cycle Equipment (1982 \$)

ORIGINAL PAGE IS
OF POOR QUALITY

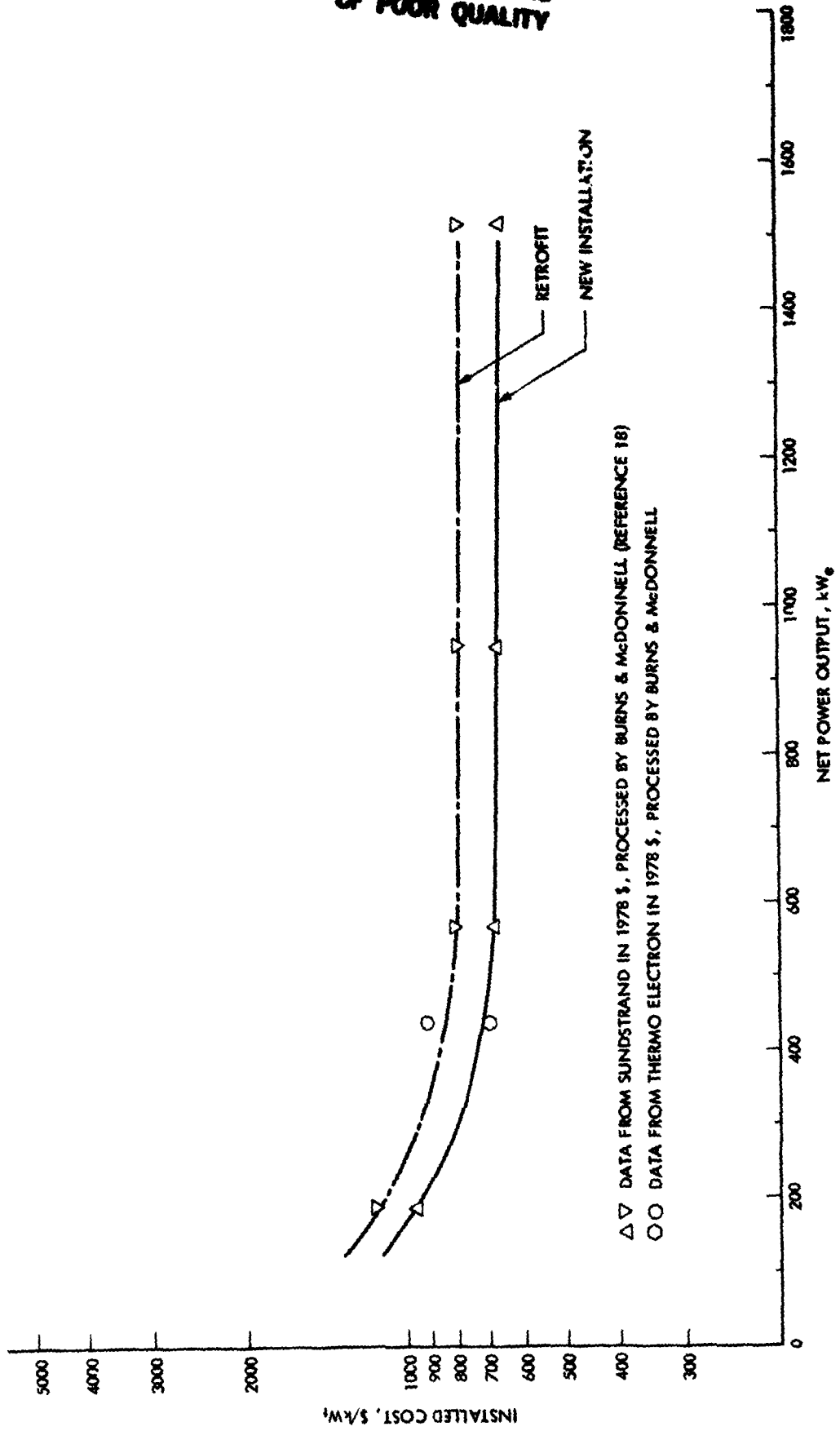

Figure 4-3. Installed Costs in 1978 \$ for Organic Rankine Bottoming Cycle Equipment with Comparison Between New Installation and Retrofit

from the industry survey were not sufficient to display this relation rigorously. However, a graph extracted from Reference 21 and presented as Figure 4-4 does just that. Note that the data in Figure 4-4, although in 1977 dollars, agree well with the 1978 Burus-McDonnell data in Figure 4-3.

An additional comparison of installed costs can be made in 1978 dollars from Figure 4-5, which was obtained from Reference 22. The range of values given for organic Rankine equipment costs compares favorably with those in the other two figures; a range of steam Rankine system costs is also given, but steam Rankine cycles were not investigated for this study.

An historical perspective of the evolution of installed cost for organic Rankine cycle equipment is presented as Table 4-1.

B. OPERATION AND MAINTENANCE COSTS FOR THE ORC

Because of the relatively short history of organic Rankine cycle equipment, well-quantified operation and maintenance (O&M) data are difficult to determine. However, as a result of the literature search, certain trends and consistencies in O&M data became apparent, which were verified by the occasional ORC equipment manufacturer who offered an estimate based on his experience.

Table 4-2 presents a chronological evolution of O&M information that was produced by the literature search and industry survey. It is not surprising to see a decrease in O&M cost with time, as this represents a maturation of the hardware. Operation and maintenance costs tend to lessen as an item of equipment becomes more developed.

C. ESTIMATE OF ANNUAL SAVINGS FOR THE ORC

Once the net power available from the organic Rankine bottoming cycle has been derived, it then becomes possible to estimate the annual energy bill savings, which is the dollars per year of electricity that are displaced by the power recovered from the waste heat. A graphical technique for estimating this savings is presented as Figure 4-6. The net power delivered by the bottoming cycle that was determined from Figure 3-4 or Figure 3-5 is the entry point for this graph. The number of operating hours per year and the local cost of electricity must also be estimated. As the example displayed in Figure 4-6 indicates, if the bottoming cycle had been sized at 150 kW_e net output from either Figure 3-4 or Figure 3-5 and if it were anticipated to operate for 6000 hours per year where electricity costs 80 mills/kw-hr, then an annual energy bill savings of \$72,000 could be realized.

The actual quantity of energy saved for the same conditions is also available from Figure 4-6 and is 9×10^5 kW-hr for this example.

It is important to note in Figure 4-6 that, like Figures 3-4 and 3-5, the scales have been generalized for maximum flexibility. The net power delivered by the ORC equipment must be known in order to enter Figure 4-6. The value for the net power delivered is read from either Figure 3-4 or Figure 3-5

ORIGINAL PAGE IS
OF POOR QUALITY

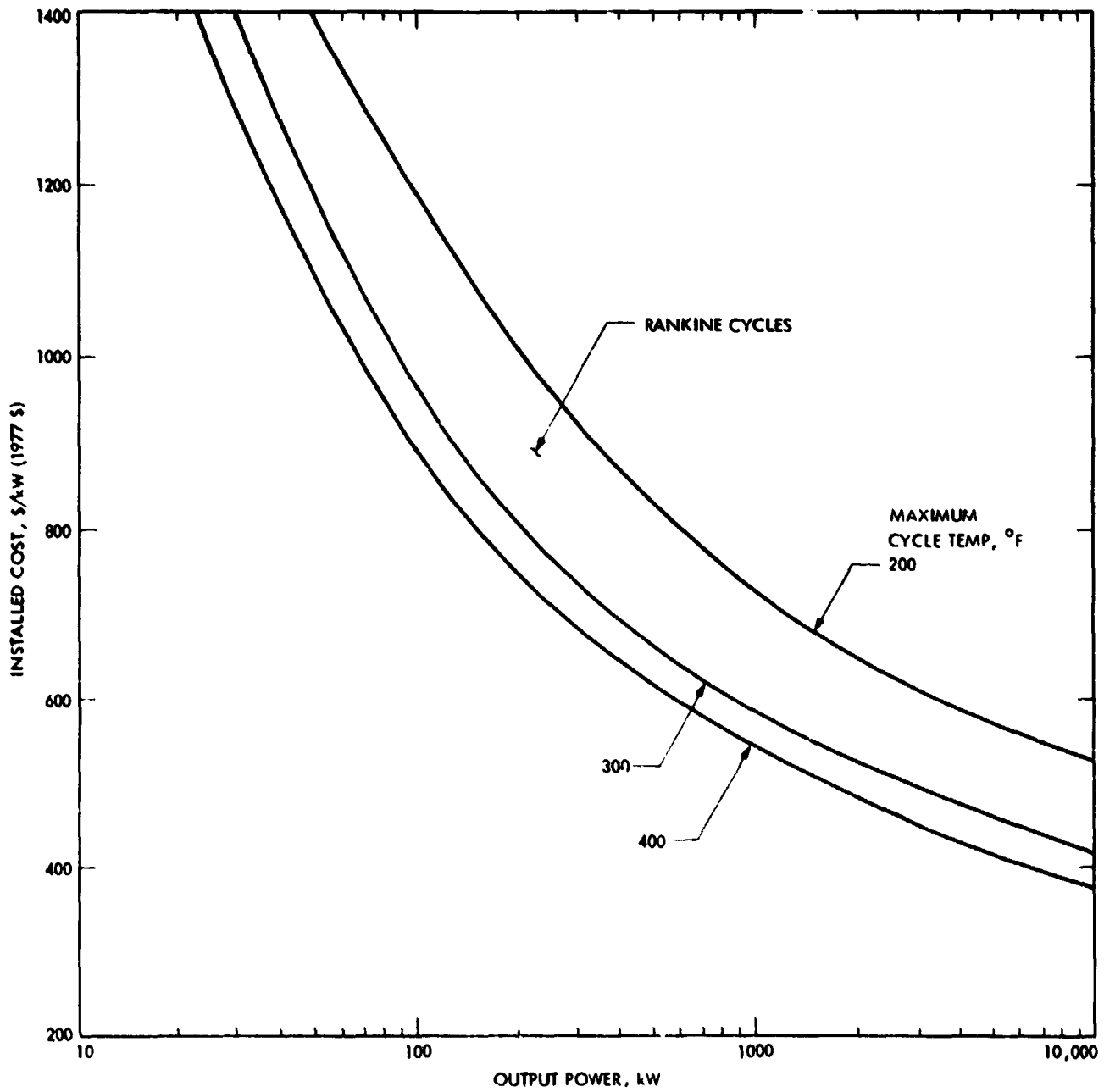

Figure 4-4. Estimated Installed Cost for Rankine Cycles

ORIGINAL PAGE IS
OF POOR QUALITY

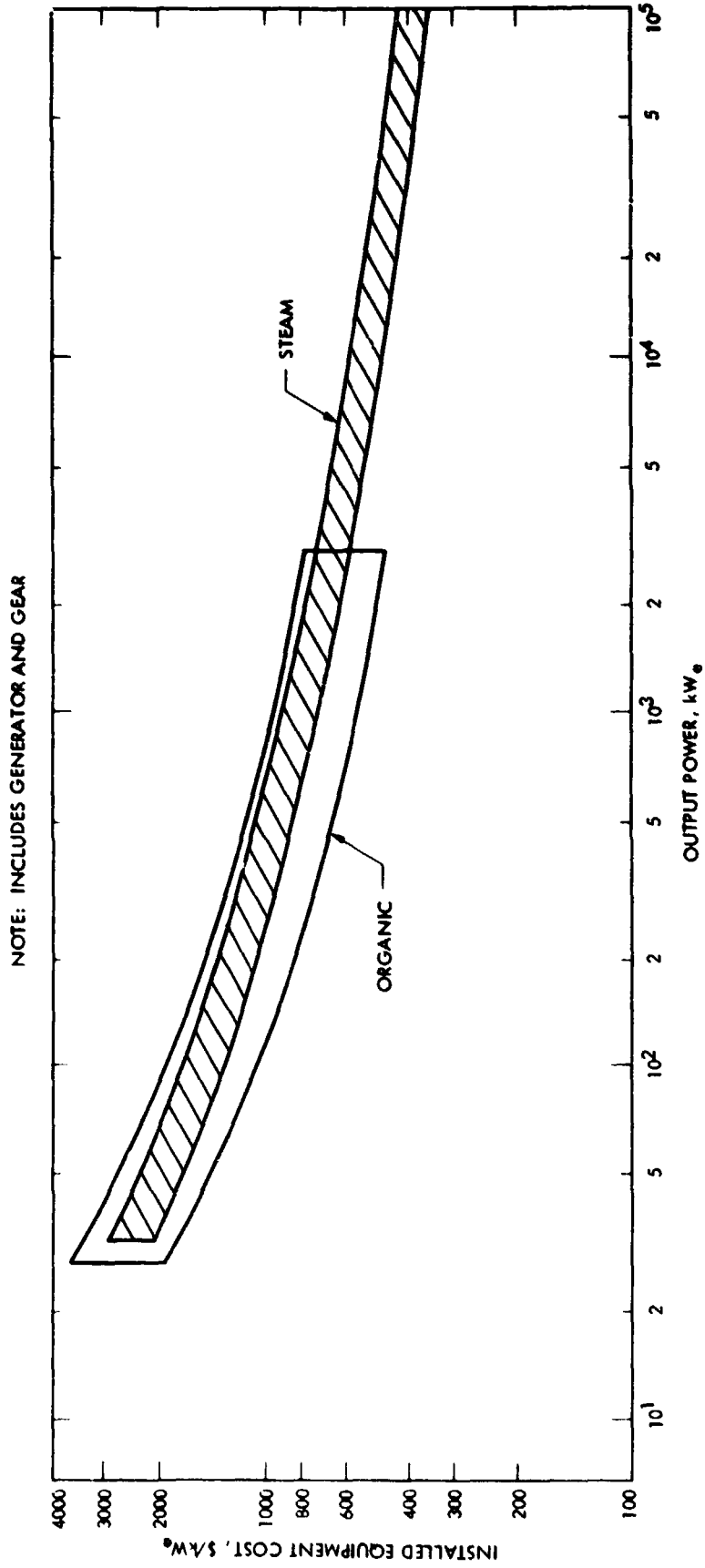

Figure 4-5. Range of Rankine Cycle Equipment Installed Costs for Both Organic and Steam Rankine Systems (1978 \$)

Table 4-1. HISTORICAL PERSPECTIVE OF INSTALLED COSTS FOR ORGANIC RANKINE CYCLE EQUIPMENT

SOURCE	YEAR DOLLARS	INSTALLED COST	REFERENCE
Thermo Electron	1973	\$150/kW _e	23
Barber-Nichols	1974	\$200 to \$300/kW _e	2
Mechanical Technology, Inc.	1974	\$350 to \$1000/kW _e at 50 units/year (10 kW minimum)	24
Automotive Engineering	1978	\$1000 to \$1300/kW _e	25

and is written in scientific notation with the significant figure falling between 1.0 and 10.0. As with the earlier nomograms, the exponent of the ten establishes the variable scale factor, n, which is then used throughout the remainder of the graph.

D. ESTIMATE OF THE COST-EFFECTIVENESS FOR THE ORC

The Energy Conservation Investment Program (ECIP) economics for organic Rankine bottoming cycle equipment was derived utilizing instructions contained in OSD (MRA&L) letter 31 Aug 1982 and instructions from AFESC/DEB.

The savings-to-investment ratio (SIR) is defined as

$$SIR = \Sigma S / \Sigma I \quad (1)$$

where

ΣS = Total net discounted dollar savings

ΣI = Total dollar investment

and

$$\Sigma S = S_E + S_{\bar{E}} \quad (2)$$

where

S_E = Present worth of dollar savings (or cost if negative) due to energy items

$S_{\bar{E}}$ = Present worth of dollar savings (or cost if negative) due to non-energy items

Table 4-2. CHRONOLOGY OF OPERATION AND MAINTENANCE COST FOR ORGANIC RANKINE CYCLE EQUIPMENT

SOURCE	YEAR DOLLARS	O&M COST ESTIMATE	REFERENCE
Thermo Electron	1973	\$0.0005/kW-hr	23
Barber-Nichols	1974	\$0.0003/kW-hr	2
Thermo Electron	1974	$0.0027 + \frac{0.000384}{C_p}$, \$/kW-hr	26
Where C_p = Capacity Factor = $\frac{\text{Annual Hours Of Operation}}{8760}$			
Automotive Engineering	1976	\$0.0015/kW-hr	25
Burns-McDonnell	1978	Fixed O&M = 7.0 \$/kW-yr	20
		Variable O&M = 0.0011 \$/kW-hr	
		Required Annual Maintenance = 1 wk/yr	
Sundstrand	1979	\$0.0015/kW-hr	27
Sundstrand	1982	"...\$10,000 to \$20,000 per year for a fully loaded unit operating nearly continuously..."	Letter dated 2 June 1982
		For a 750 kW _e unit: \$0.0015/kW-hr - \$0.0030/kW-hr	

ORIGINAL PAGE IS
OF POOR QUALITY

ORIGINAL PAGE IS
OF POOR QUALITY

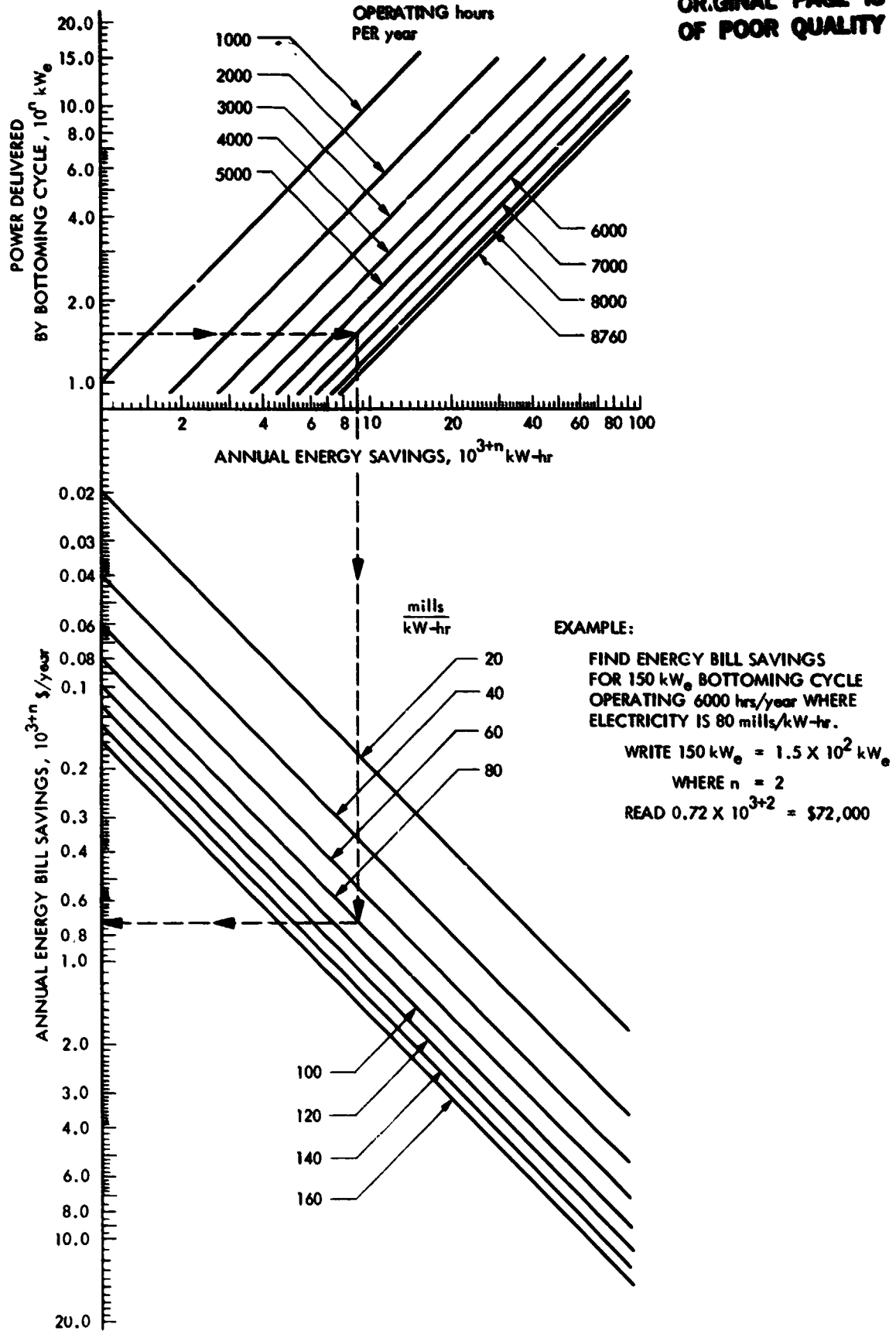

Figure 4-6. Graphical Method for Estimating Annual Energy Bill Savings

and

$$SE = UPW^* \times \Delta E \times C_E \quad (3)$$

where

UPW* = Federal uniform present worth factor at 7% adjusted for energy price escalation by DOE region

ΔE = Energy savings in source MBtu

C_E = Today's cost of energy at the source in dollars per MBtu and the subscript E refers to energy items

and

$$S_{\bar{E}} = (UPW \times C_{\bar{E}R}) + (PW \times C_{\bar{E}R})_1 + \dots + (PW \times C_{\bar{E}R})_n \quad (4)$$

where

UPW = Uniform present worth factor for annual recurring savings or cost, at 7%

$C_{\bar{E}R}$ = Dollar savings (or cost if negative) for annual recurring items

PW = Present worth factor for non-recurring savings or cost at 7% at the appropriate "n" number of years

$C_{\bar{E}R}$ = Dollar savings (or cost if negative) for non-recurring items at the appropriate "n" number of years.

The subscripts \bar{E} and \bar{R} refer to non-energy items and to non-recurring items, respectively.

Also,

$$\Sigma I = (C_C + C_D + C_M) 0.9 - C_S \quad (5)$$

where

C_C = The cost of construction in today's dollars excluding contingencies normally added for future programs (from Figure 4-1 or actual cost estimate)

C_D = The cost of design in today's dollars, generally 6%

C_M = The cost of managing the construction -- supervision, inspection, and overhead (SIOH) -- in today's dollars, generally 5.5%

0.9 = An artificial tax-credit allowable in ECIP calculations to more closely approximate applications in the private-sector

C_S = The cost of salvage -- dollars flowing back to the government -- if not already included in the contract cost

**ORIGINAL PAGE IS
OF POOR QUALITY**

The uniform present worth and present worth factors can be derived from a progression such as

$$UPW^* = \left(\frac{1+e}{d-e} \right) \left[1 - \left(\frac{1+e}{1+d} \right)^n \right] \quad (6)$$

and

$$UPW = \frac{(1+d)^n - 1}{d(1+d)^n} \quad (7)$$

where

d = Discount rate = 0.07

e = Escalation rate

n = System life

However, it is easy to take these factors from Reference 28 wherein the data for suggested fuel escalation rates have been tabulated for use in DoD analysis.

For the purpose of the discussion and demonstrated equations in this section, the UPW* factor was for the United States average. Since a 25-year life was assumed for all equipment, the following UPW* values are used:

	UPW*	Approximate Escalation
Electricity	14.19	2%
Distillate oil	17.79	4%
Residual oil	18.09	4.5%
Natural gas	17.84	4%
Coal	20.76	5.5%

A value for UPW of 11.65 was used for 25 years.

Another important ECIP criterion is the "ECIP Qualification Test." A project must demonstrate that at least 75 percent of the total discounted savings (ΣS) are derived from energy savings.

From Equation (2) ΣS was defined as

$$\Sigma S = S_E + S_E^-$$

But

$$S_E^- \leq (0.25 \Sigma S)$$

**ORIGINAL PAGE IS
OF POOR QUALITY**

Hence,

$$\begin{aligned} S_{\bar{E}} &\leq 0.25 (S_E + S_{\bar{E}}) \\ 0.75 S_{\bar{E}} &\leq 0.25 S_E \\ S_{\bar{E}} &\leq 0.33 S_E \end{aligned} \quad (8)$$

Also,

$$SIR = \frac{\sum S}{\sum I} \geq 1.0 ,$$

then

$$\frac{S_E + S_{\bar{E}}}{\sum I} \geq 1.0$$

or

$$\frac{S_E + 0.33 S_E}{\sum I} \geq 1.0$$

$$1.33 S_E \geq \sum I \quad (9)$$

Other important factors necessary for calculating both the savings-to-investment ratio and the energy-to-cost ratio were extracted from Reference 28 and are tabulated below.

Purchased electric power	11,600 Btu/kWh
Distillate fuel oil	138,700 Btu/gal
Residual fuel oil	Use average thermal content of residual fuel oil at each specific location
Natural gas	1,031,000 Btu/1000 ft ³
LPG, propane, butane	95,500 Btu/gal
Bituminous coal	24,580,000 Btu/short ton
Anthracite coal	28,300,000 Btu/short ton
Purchased steam	1,390 Btu/lb

Purchased energy is defined as being generated off-site. For special cases where electric power or steam is purchased from on-site sources, the actual average gross energy input to the generating plant plus distribution losses may be used, but in no case should the power rate be less than 10,000 Btu/kWh or the steam rate be less than 1200 Btu/lb.

The term "coal" does not include lignite. Where lignite is involved, the Bureau of Mines average value for the source field must be used.

**ORIGINAL PAGE IS
OF POOR QUALITY**

The basic assumptions implicit in establishing the cost-effectiveness for both an ORC unit and the conventional recuperative methods of heat recovery is that the ORC recovers waste heat to displace electrical cost at the expense of its capital, installation, and O&M costs, while the recuperator recovers waste heat to displace fuel costs at the expense of the recuperator capital, installation, and O&M costs. No additional fuel is consumed.

The calculation of savings-to-investment ratio specific to the ORC displacement of electricity proceeded as described below.

The estimated annual energy savings, ΔE , from Equation (3) was written as follows:

$$\begin{aligned}\Delta E &= P_r \times C_f \times \frac{8760 \text{ hr/yr}}{10^6 \text{ Btu/MBtu}} \times 11,600, \frac{\text{Btu}}{\text{kW-hr}} \\ &= 101.6 P_r \times C_f, \frac{\text{MBtu}}{\text{yr}}\end{aligned}\quad (10)$$

where

P_r = Rated power, kW_e

C_f = Annual capacity factor, or hours at operation per 8760 hours

The energy cost term, C_E (source energy cost) was expressed as

$$\begin{aligned}C_{E_{\text{elect}}} &= \mu \frac{\text{¢}}{\text{kW-hr}} \times \frac{10^6 \text{ Btu/MBtu}}{\frac{100\text{¢}}{\$}} \times 11,600, \frac{\text{Btu}}{\text{kW-hr}} \\ &= 0.086\mu, \frac{\$}{\text{MBtu}}\end{aligned}\quad (11)$$

where

μ = today's cost of electricity at the site in cents per kWh.

The present worth for electrical energy then becomes

$$\begin{aligned}S_E &= 14.19 (101.6 \times P_r \times C_f) (0.086\mu) \\ &= 124 P_r \times C_f \times \mu, \frac{\$}{\text{yr}}\end{aligned}\quad (12)$$

The total investment (ΣI) was defined as

$$\Sigma I = (C_C + C_D + C_M) 0.9 - C_S$$

In terms of the size of the device, ΣI can also be defined as

$$\Sigma I = P_r \times C_{ie} \times 0.9 - C_S \quad (13)$$

**ORIGINAL PAGE IS
OF POOR QUALITY**

where

C_{ie} = Total installed cost of the ORC, \$/kW_e (considers construction cost, SIOM, and design in today's dollars).

As for the other associated costs identified by Equation (4) the other individual savings or costs, C_{ER} , were assumed zero for this study. The recurring costs, C_{ER} , were assumed to be the ORC O&M costs, and the values derived by Burns-McDonnell and presented in Table 4-2 were used for the analysis. The recurring costs were expressed as follows:

$$\bar{C}_{ER} = - (a P_r + b P_r \times C_f \times 8760)$$

where

a = Fixed O&M component = \$7/kW-yr

b = Variable O&M component = \$0.0011/kW-hr.

Hence,

$$\bar{C}_{ER} = - (7 + 9.64 C_f) P_r \quad (14)$$

and the other associated costs become

$$\bar{E} = - 11.65 (7 + 9.64 C_f) P_r. \quad (15)$$

Therefore, the net present worth from Equation (2) becomes the sum of Equations (12) and (15), or

$$\Sigma S = 124 P_r \times C_f \times \mu - 11.65 (7 + 9.64 C_f) P_r. \quad (16)$$

A quick review of Equation (16) will show that the O&M contribution is a small percent of the present worth.

The savings-to-investment ratio, Equation (1), is now Equation (16) divided by Equation (13). For this study it is assumed there is no salvage value; therefore, the relationship becomes

$$SIR = \frac{123 P_r \times C_f \times \mu - 11.65 (7 + 9.64 C_f) P_r}{0.9 P_r \times C_T}$$

or

$$SIR = \frac{137.78 C_f \mu}{C_T} - \frac{12.94 (7.964 C_f)}{C_T} \quad (17)$$

Equation (17) is in a format that can be conveniently displayed graphically as a function of electricity cost, ORC installed cost, and total operating hours per year, and it is presented as Figure 4-7.

Because the O&M contribution (non-energy savings) is but a few percentage points of the present worth, it is assumed for this study that the ECIP Qualification test will always be met.

ORIGINAL PAGE IS
OF POOR QUALITY

OR
OF

ASSUMPTIONS:
25-YEAR LIFE
= 2% DIFFERENTIAL ESCALATION
11,600 Btu/kWh HEAT RATE FOR
PURCHASED ELECTRIC POWER
7% DISCOUNT RATE

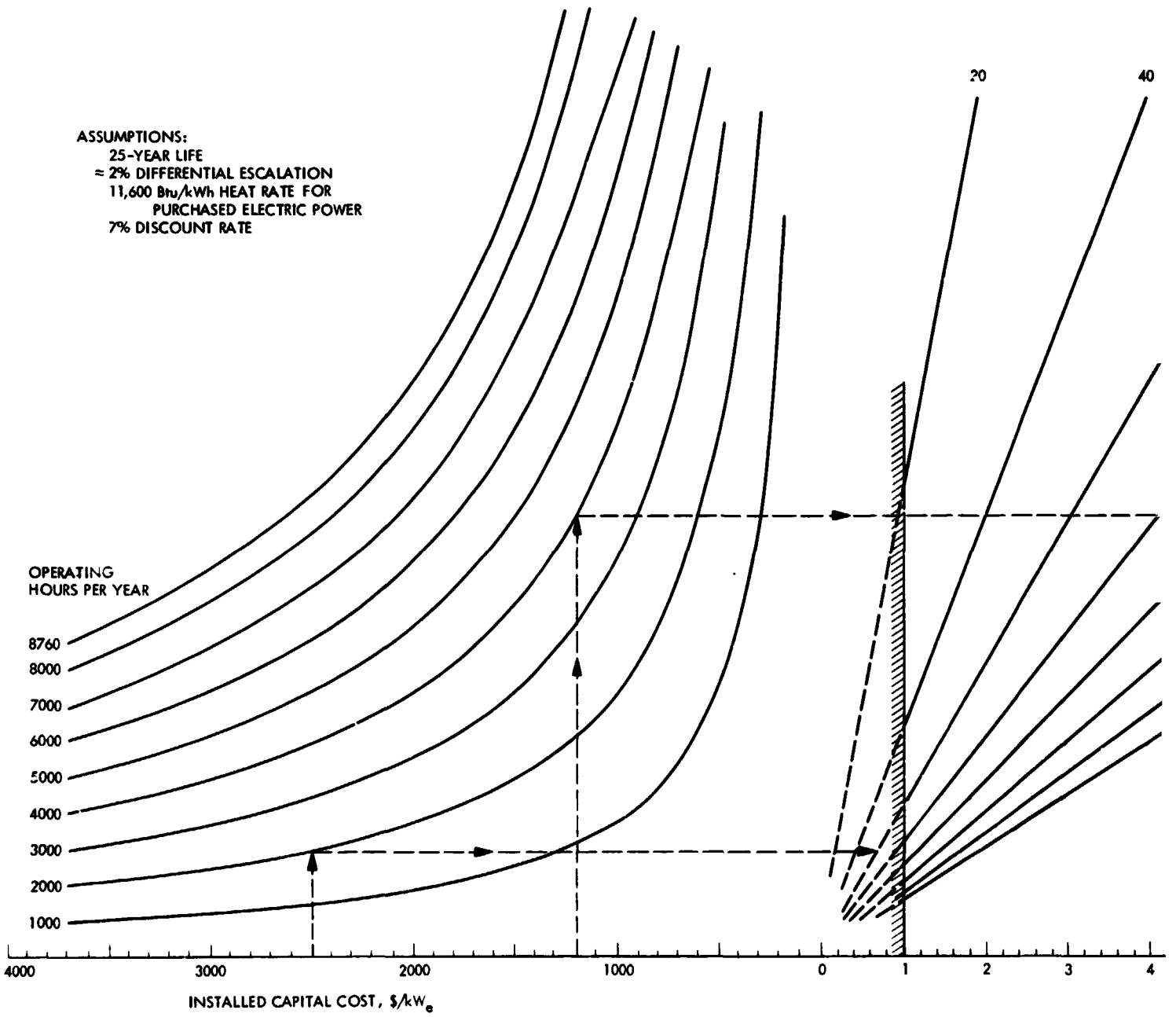

FOLDOUT FRAME

ORIGINAL PAGE IS
OF POOR QUALITY

ORIGINAL PAGE IS
OF POOR QUALITY

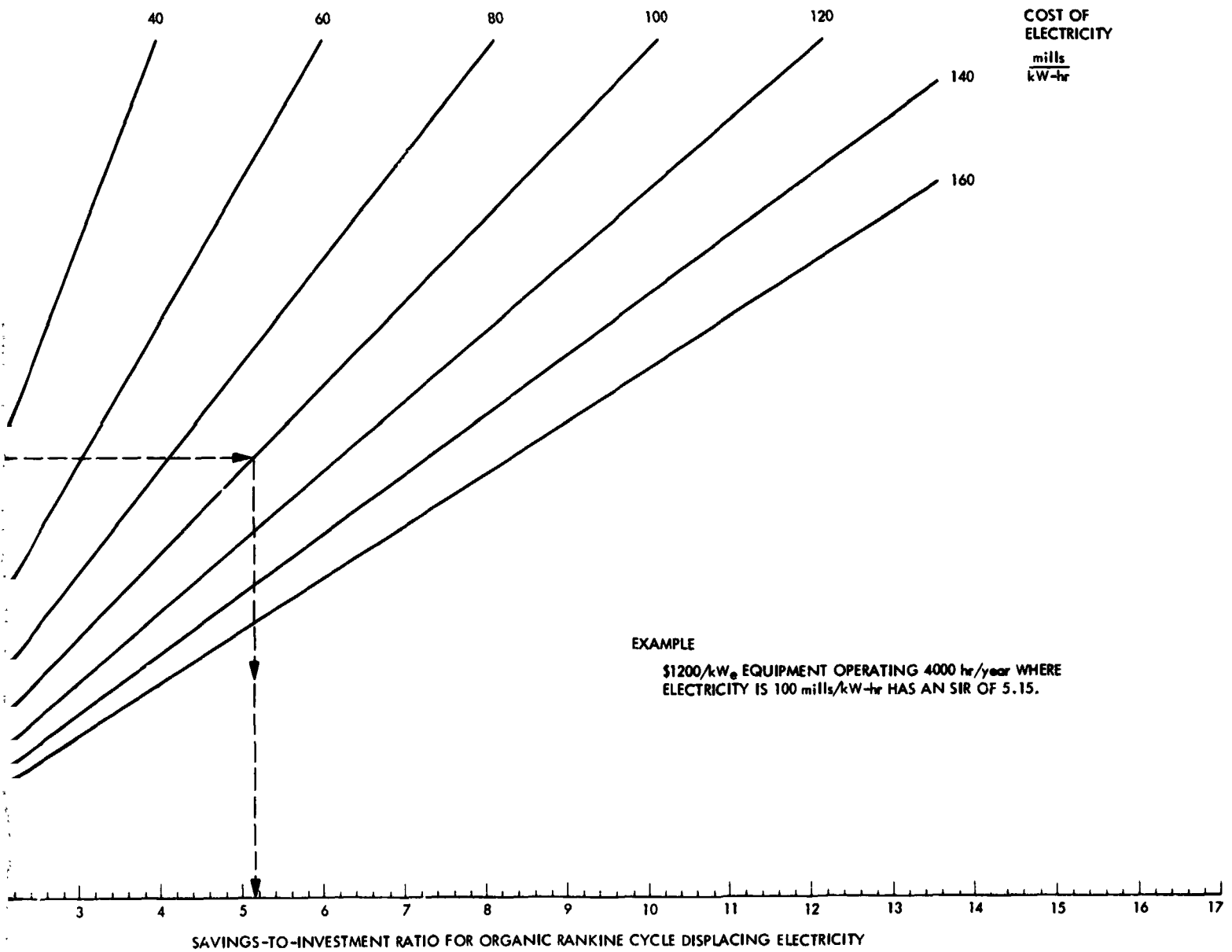

PRECEDING PAGE BLANK NOT FILMED

2 KOLDOUT FRAME

Figure 4-7. Determination of Savings-to-Investment Ratio for the Displacement of Electricity Through Waste Heat Recovery with Organic Rankine Bottoming Cycle Equipment

Figure 4-7 is used in conjunction with Figure 4-2. Once the net power output of the bottoming cycle has been sized, one enters Figure 4-2 to determine an estimate (or estimates) of the installed equipment cost in $\$/kW_e$. One then enters Figure 15 with this value and, along with an estimate of the annual operating hours and the cost of electricity, obtains the savings-to-investment ratio. Multiple cases can be readily compared on the same graph since the relative cost-effectiveness is the difference of the savings-to-investment ratios.

E. RECUPERATOR INSTALLED COST

It is very difficult to develop a generalized curve for the installed cost of heat exchangers since heat exchanger designs are dependent upon so many different parameters - all of which influence the cost to varying degrees. As an example, the capital cost for heat exchangers decreases as both the heat-source temperature and the required quantity of heat transferred increase because of increased thermodynamic efficiency and economies of scale. The opposite is experienced if the heat source temperature is low. Yet, some method of estimating this installed cost is necessary to conduct an adequate trade-off of cost-effectiveness.

A very detailed analysis of the installed costs for heat exchangers is presented in Reference 29, and Figure 4-8 was extracted from this reference for the case where the heat exchange is from gas to liquid. Only the upper limit of the range of values presented in the reference is repeated here, so a conservative answer is obtained for a gas-to-liquid heat exchanger, and the same curve applies to a liquid-to-liquid heat exchange. However, one must be cautioned that each installation is site-specific and that the installation costs obtained from Figure 4-8 are only estimates.

Also, one should note that the units used on the two axes in Figure 4-8 are slightly different from those shown in Figure 4-1 in that the heat transfer rate for heat exchangers is referred to in kilowatts thermal. The units in Figure 4-1 are in kilowatts electric, which implies that a conversion from thermal to electric output has taken place. All other aspects about Figure 4-8 are similar to those of Figure 4-1.

After determining the quantity of heat transferred from Figure 3-7, enter Figure 4-8 with this value and read the installed cost of the recuperator in $\$/kW_t$ from the ordinate. The installation cost of a complete system involving a heat exchanger must also include piping cost, which is a separate parameter. If the lengths of pipe runs are short, then this cost may be small when compared with that of the heat exchanger. However, long pipelines could have a significant cost impact that should be investigated. An estimate of the installed cost of insulated piping was obtained from Reference 30 and is presented below as Figure 4-9. Schedule 40, carbon-steel pipe is assumed in this figure.

As with earlier graphs, Figure 4-9 has been plotted with generic scales for ease of reading. However, for this figure the generalized parameter, m , is the exponent of the 10 that results from writing the net heat transfer reading from Figure 3-7 in scientific notation, as seen in the two examples. (The decimal point may be positioned wherever it gives the greatest resolution

ORIGINAL PAGE IS
OF POOR QUALITY

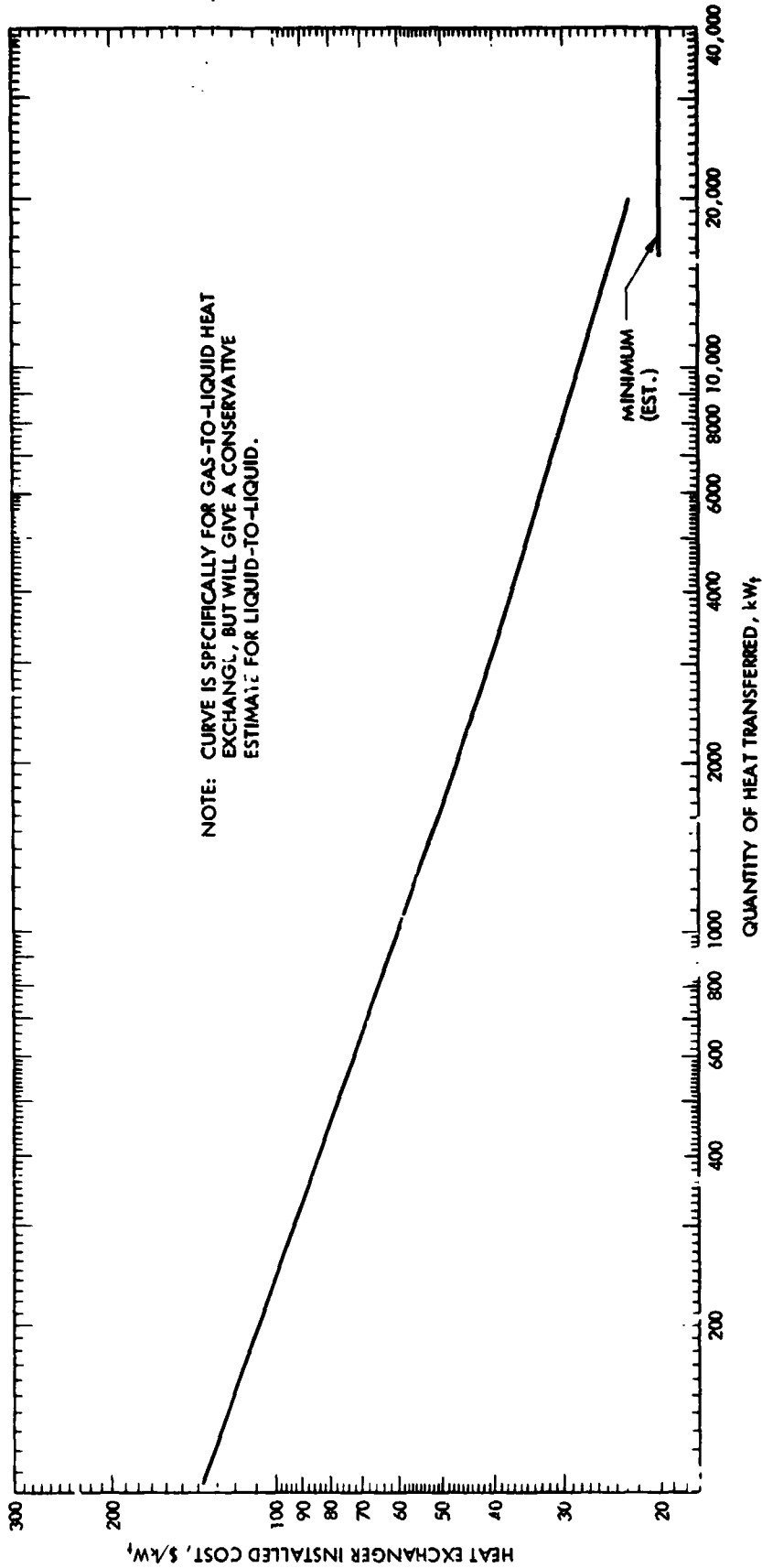
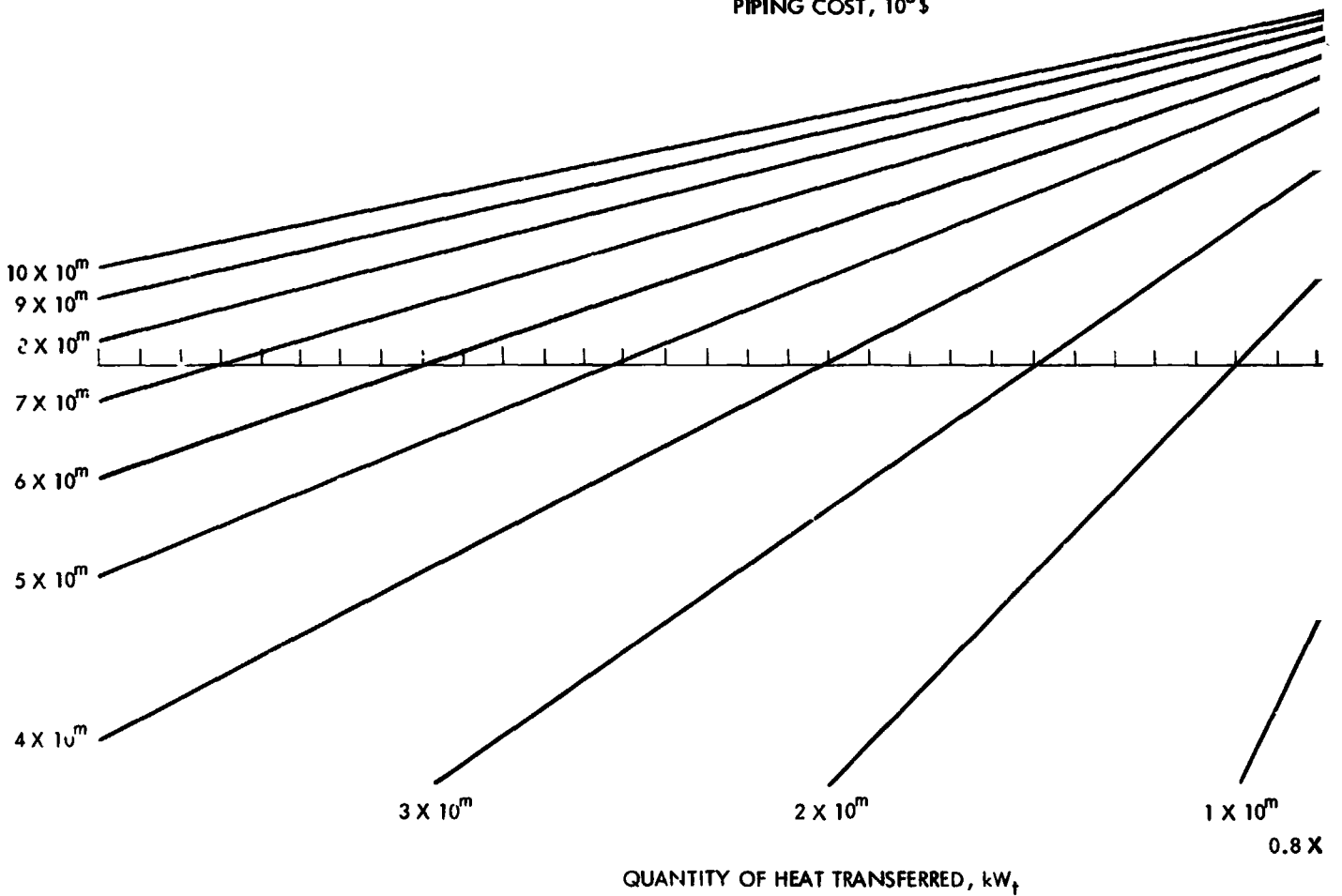
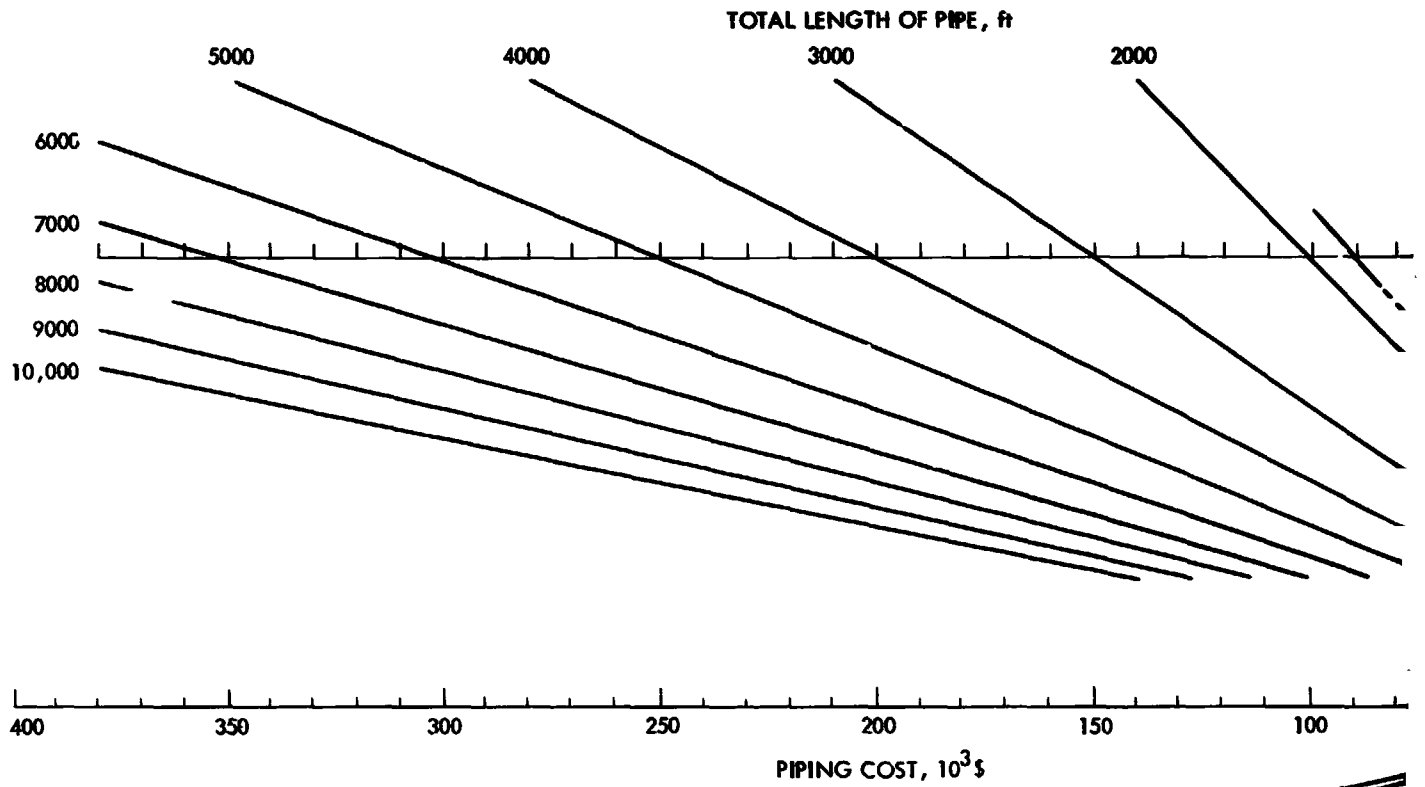

Figure 4-8. Estimation of Installed Cost for Recuperative Heat Exchanger as a Function of the Total Quantity of Heat Transferred (1982 \$)

ORIGINAL PAGE IS
OF POOR QUALITY

ORIGINAL
OF POC



FOLDOUT FRAME

ORIGINAL PAGE IS
OF POOR QUALITY

ORIGINAL PAGE IS
OF POOR QUALITY

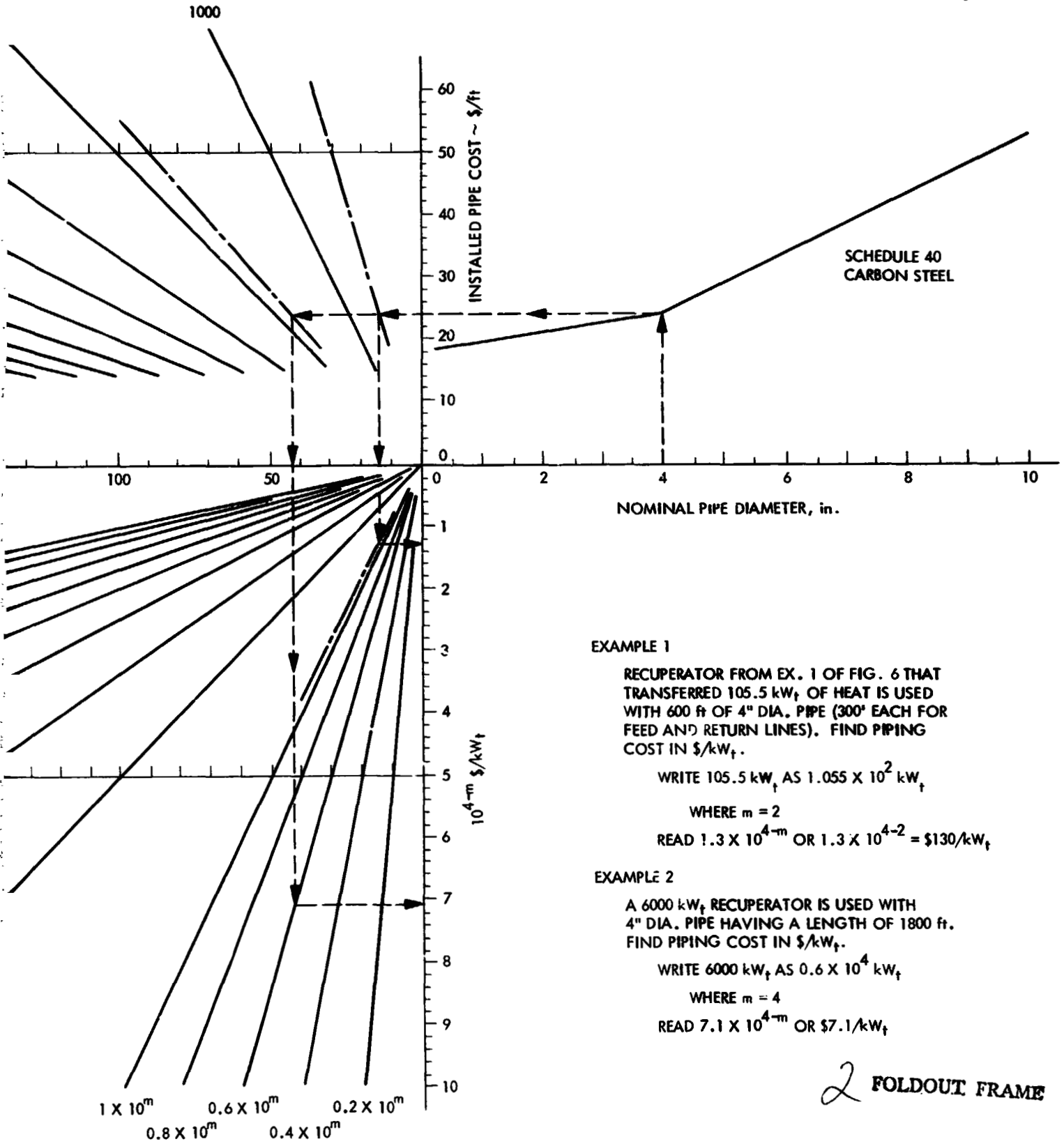

EXAMPLE 1

RECUPERATOR FROM EX. 1 OF FIG. 6 THAT TRANSFERRED 105.5 kW_t OF HEAT IS USED WITH 600 ft OF 4" DIA. PIPE (300' EACH FOR FEED AND RETURN LINES). FIND PIPING COST IN \$/kW_t.

WRITE 105.5 kW_t AS 1.055 X 10² kW_t

WHERE m = 2

READ 1.3 X 10^{4-m} OR 1.3 X 10⁴⁻² = \$130/kW_t

EXAMPLE 2

A 6000 kW_t RECUPERATOR IS USED WITH 4" DIA. PIPE HAVING A LENGTH OF 1800 ft. FIND PIPING COST IN \$/kW_t.

WRITE 6000 kW_t AS 0.6 X 10⁴ kW_t

WHERE m = 4

READ 7.1 X 10^{4-m} OR \$7.1/kW_t

2 FOLDOUT FRAME

Figure 4-9. Graphical Method for Estimating Piping Costs in \$/kW_t

in reading. To obtain a reading of $\$/kW_t$ for piping from Figure 4-9, one needs to know the quantity of heat transferred from Figure 3-7, an estimate of the total length of pipe, and the nominal pipe diameter. The total length of pipe includes both the feed and return lines to and from the recuperator. Since the final cost parameter is in $\$/kW_t$ of heat transferred, one can readily see that recuperator systems with very long pipe lengths associated with relatively small heat transfer rates could be prohibitively expensive.

The final value for $\$/kW_t$, then, is the sum of the reading obtained from Figures 4-8 and 4-9. From Example 1 of Figure 4-9, a value of $\$130/kW_t$ was read for a heat transfer rate of $105.5 kW_t$. Figure 4-8 predicts a heat exchanger installed cost of $\$135/kW_t$ for this same rate. Hence, the total cost of the recuperator and pipe for this example is $\$265/kW_t$. One should also note that for this specific case the cost per kilowatt of the piping and the recuperator are essentially equal, and neglecting the piping cost would result in a serious error.

However, for Example 2 of Figure 4-9, where the piping cost is only $\$7.1/kW_t$, the heat exchanger installed cost for $6000 kW_t$ of heat transferred is $\$33/kW_t$. The total cost is $\$40.1/kW_t$ of which the piping cost is only 18 percent.

F. OPERATION AND MAINTENANCE COSTS FOR RECUPERATORS

Since recuperators are basically passive devices, one would expect that their operation and maintenance costs would generally be low, and information acquired tended to verify this. Therefore, for the purpose of this study, it was assumed that the O&M costs were within the error of the knowledge of the installed cost. However, the O&M costs of heat exchangers are affected by the power requirements of any parasitic units, such as pumps, fans, or other required auxiliaries, and by the quantity and species of contaminants found in the heat source medium. If frequent cleaning is required, then the O&M costs of the recuperator may be significant. All of these factors would have to be evaluated on an individual basis.

G. ESTIMATE OF COST-EFFECTIVENESS FOR A RECUPERATOR

As with the organic Rankine bottoming cycle equipment, the cost-effectiveness of a recuperator/piping system is estimated by the savings-to-investment ratio, which was derived by methods very similar to those presented earlier. Specific variations from the previous method are presented below.

Since the heat transferred by the recuperator is assumed to reduce the amount of energy that must be added back by fuel combustion, then the annual energy savings, ΔE , can be expressed in terms of the energy displaced. Therefore,

$$\Delta E = \frac{q_f \times C_f \times 8760}{10^6}, \frac{\text{MBtu}}{\text{yr}}$$

where

$$q_f = \text{Energy of fuel displaced}$$

ORIGINAL PAGE IS
OF POOR QUALITY

$$= \frac{\dot{m}_b c_p \Delta T_{rec}}{\eta_b} \times C_f \times \frac{8760}{10^6}$$

where

\dot{m}_b = Mass flow rate of water to the boiler

ΔT_{rec} = Heat capacity of water = $1 \frac{\text{Btu}}{\text{lbm}^\circ \text{F}}$

η_b = Boiler efficiency

The annual energy savings can now be written as

$$\Delta E = \frac{\dot{m}_b c_p \Delta T_{rec} C_f}{\eta_b} \times \frac{8760}{10^6}$$

or in terms of rated power in kilowatts,

$$\Delta E = \frac{8760 (3413) P_r C_f}{10^6 \eta_b}$$

or

$$\Delta E = \frac{29.9 P_r C_f}{\eta_b}, \frac{\text{MBtu}}{\text{yr}} \quad (18)$$

The project cost is similar to that of Equation (13), but now the hardware installed cost, C_{it} , is in \$/kW_t. Hence,

$$\Sigma I = P_r \times C_{it} \times 0.9 - C_g, \$ \quad (19)$$

For this study, the recuperator/piping O&M costs have been assumed sufficiently small that they are within the error of knowledge of the hardware installed cost. Therefore, the C_{ER} term from Equation (4) was set equal to zero. A derivation similar to that for Equation (16) results in a ΣS for a recuperator as

$$\Sigma S = UPW^* \times EC \times \Delta E$$

from which, for an assumed zero salvage value,

$$SIR = \frac{UPW^* \times EC \times \Delta E}{0.9 \times P_r \times C_{it}}$$

**ORIGINAL PAGE IS
OF POOR QUALITY**

or

$$SIR = \frac{D. \times EC \times 29.9 P_r C_f}{0.9 \eta_b C_{it}}$$

Hence

$$SIR = \frac{33.22 UPW^* \times EC \times C_f}{\eta_b C_{it}} \quad (20)$$

Equation (20) was then specialized for the specific fuel that was to be displaced. For all cases, a boiler efficiency of 80 percent and a 25-year life were assumed in addition to the parameters identified earlier from Reference 28. For oil with an approximate percent differential inflation factor of 4.25 percent (average of distillate and residual oil), the savings-to-investment ratio became

$$SIR_{oil} = 5372.2 \frac{C_g C_f}{C_{it}} \quad (21)$$

where

$$C_g = \text{Cost per gallon of oil, \$/gal}$$

For natural gas with an appropriate differential inflation of 4 percent, the savings-to-investment ratio was found to be

$$SIR_{ng} = 740.8 \frac{C_m C_f}{C_{it}} \quad (22)$$

where

$$C_m = \text{Cost per million Btu of natural gas, \$/MBtu}$$

Equations (21) and (22) are displayed graphically as Figures 4-10 and 4-11, respectively, in a manner identical to that described for Figure 4-7, except that here the entrance parameter (the equipment installed cost) is the sum of the recuperator and related piping costs. The scale selected for the installed capital cost of the recuperator was that which might be realistically expected. The lower bound in each of these figures were established by setting the savings-to-investment ratio equal to one. The savings-to-investment ratio scales differ in these figures, as well as in Figure 4-7, because of differences in other costing parameters specified by the Air Force that were outlined earlier (Reference 28). These figures are interpreted in the same way as was discussed for Figure 4-7; the higher the savings-to-investment ratio, the better the payoff of the investment.

A cursory review of Figures 4-10 and 4-11 shows that without exception there is a higher savings-to-investment ratio return for the equivalent installed costs and operating times to displace oil than there is to displace natural gas. This conclusion is consistent with the practice in the field, since the bases identified in this study all burn natural gas as the primary source of fuel for their steam plants and store oil for emergency backup.

The comparison of the cost-effectiveness of the recuperator/piping system with ORC equipment is more involved and is covered in the next section.

H. COMPARISON OF ORC COST-EFFECTIVENESS WITH THAT OF CONVENTIONAL HEAT RECOVERY

The comparison of the cost-effectiveness of an organic Rankine bottoming cycle with that of conventional recuperative heat recovery is presented in the form of break-even costs in Figures 4-12 through 4-15. These graphs were derived for heat plants fired with either natural gas or oil. A similar curve could be developed for coal but was not, as no Air Force coal-fired heat plants were identified.

For this analysis the cost-effectiveness of the installation of ORC equipment was assumed equal to that of a recuperated system if the savings-to-investment ratio of each were equal. Hence, the following two equations were developed (one for oil and one for natural gas) to relate the installation cost of the ORC, the installation cost of the recuperator/piping assembly, the fuel cost, and the cost of electricity:

For natural gas

$$C_{it} = 5.362 C_m C_{ie} \quad (23)$$

For oil

$$C_{it} = 38.9 C_g C_{ie} \quad (24)$$

where the parameters are as defined earlier. These equations have been greatly simplified with an error of only a few percent by neglecting the O&M costs, which amount to generally less than 5 percent of the present worth.

As one would expect, the equation for oil is different from that for natural gas because of the difference in other economic parameters, such as escalation rate, that are implicit in the derivation of savings-to-investment ratio. The energy recovered from waste heat with an organic Rankine bottoming cycle displaces electricity and saves electrical cost at the expense of the ORC equipment and installation, while the energy recovered with a recuperator displaces fuel and, therefore, fuel cost at the expense of the recuperator/piping hardware and installation. A comparison of the cost-effectiveness of each, then, is essentially a comparison of the recovered value of these energy sources for the respective investments in equipment.

ORIGINAL PAGE IS
OF POOR QUALITY

PRECEDING PAGE BLANK NOT FILMED

ORIGINAL
OF POOR

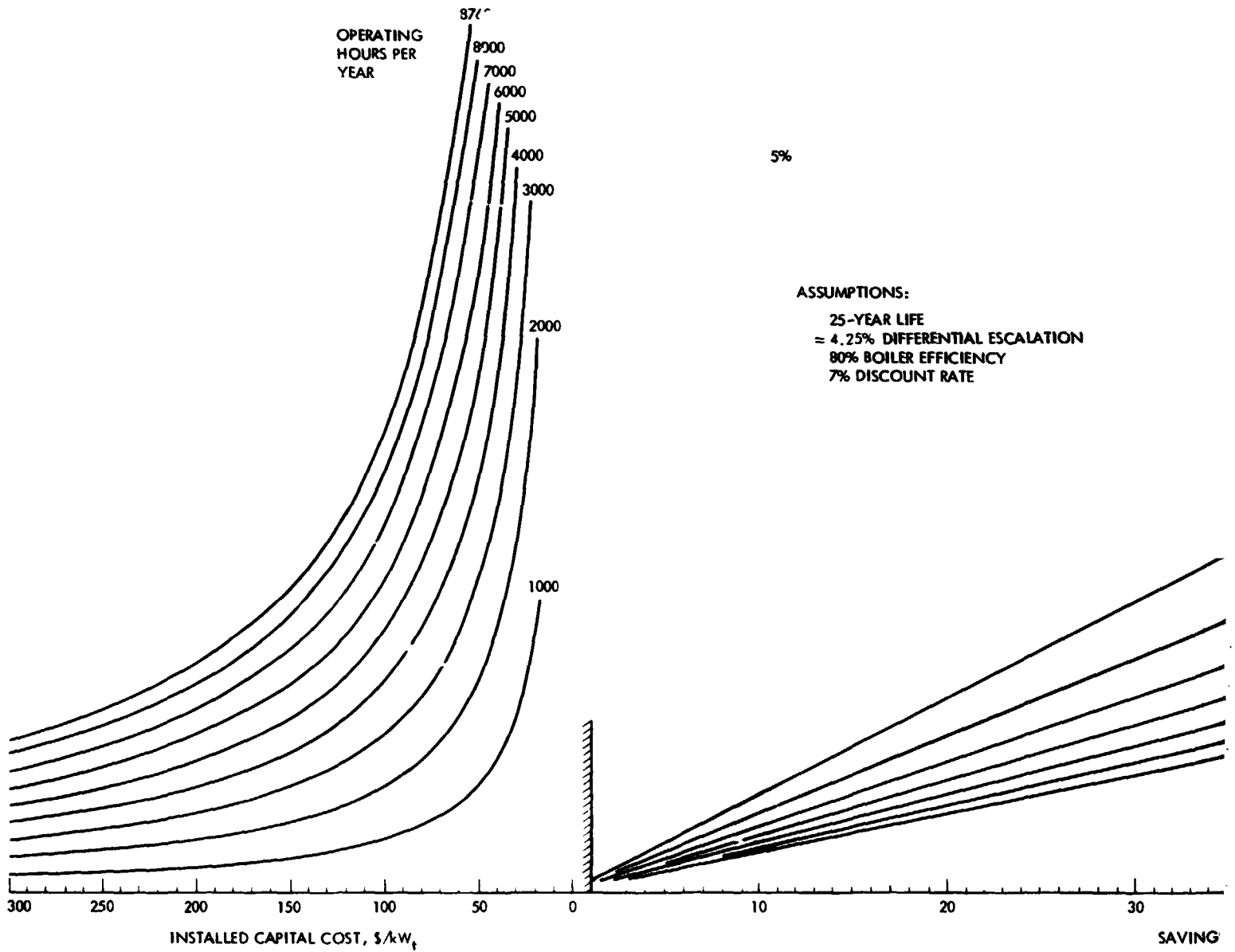

OLDOUT FRAME

PRECEDING PAGE BLANK NOT FILMED

Figure 4-10. Determination of Savings-to-Investment Ratio for the Displacement of Oil Through Waste Heat Recovery With a Recuperative Heat Exchanger

ORIGINAL PAGE IS
OF POOR QUALITY

ORIGINAL PAGE IS
OF POOR QUALITY

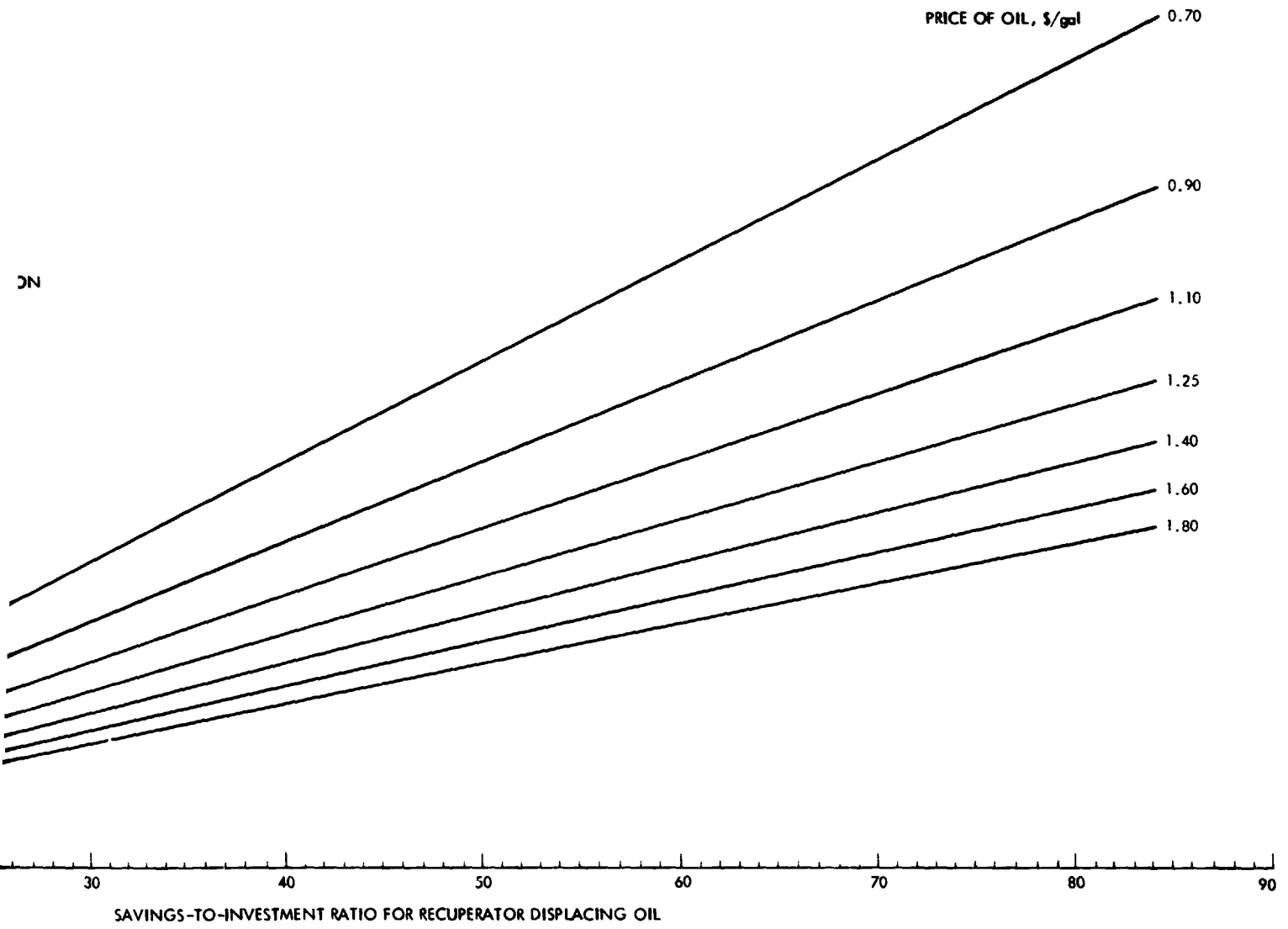

2 FOLDOUT FRAME

ORIGINAL PAGE IS
OF POOR QUALITY

ORR
OF

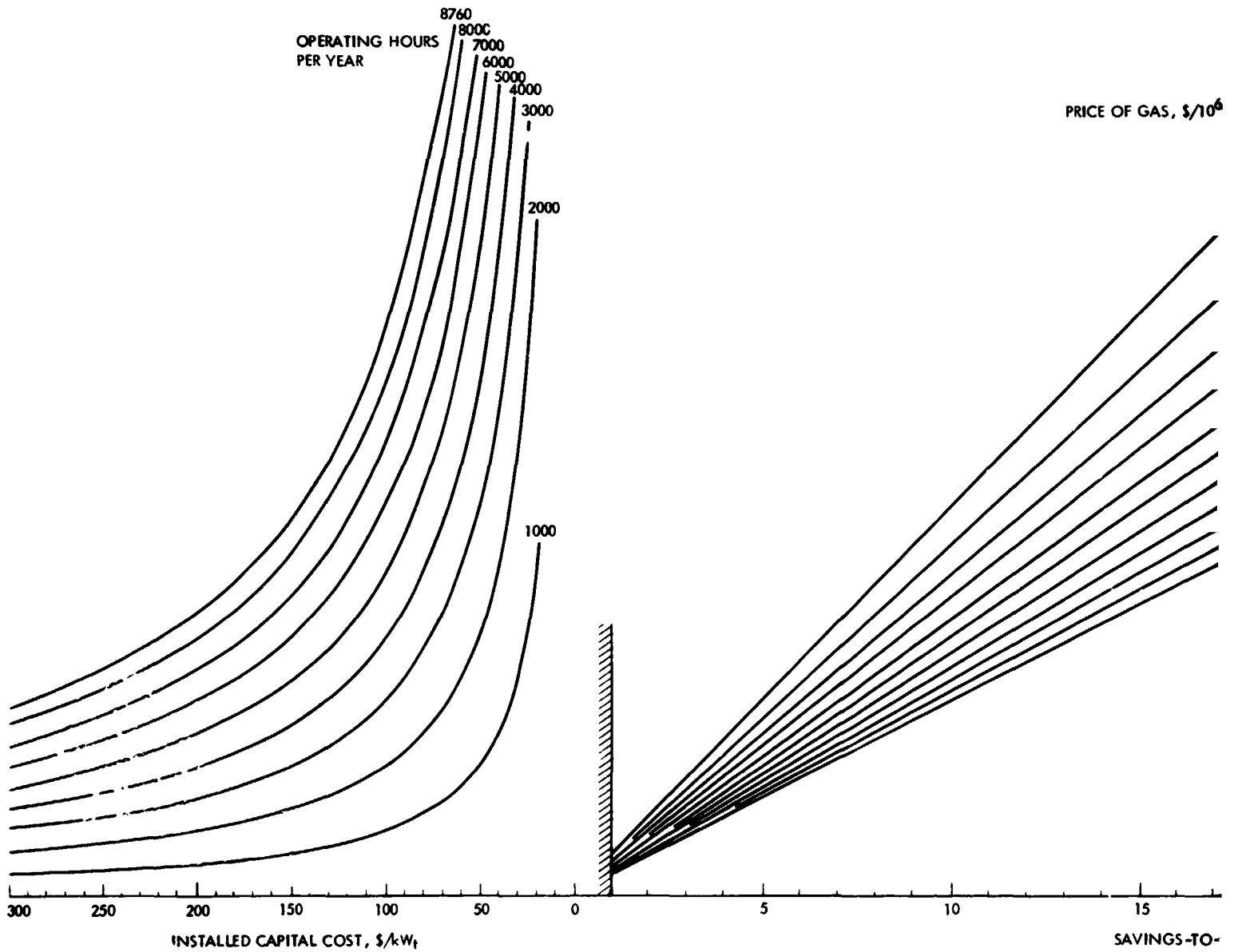

FORNIA

ORIGINAL PAGE IS
OF POOR QUALITY

ORIGINAL PAGE IS
OF POOR QUALITY

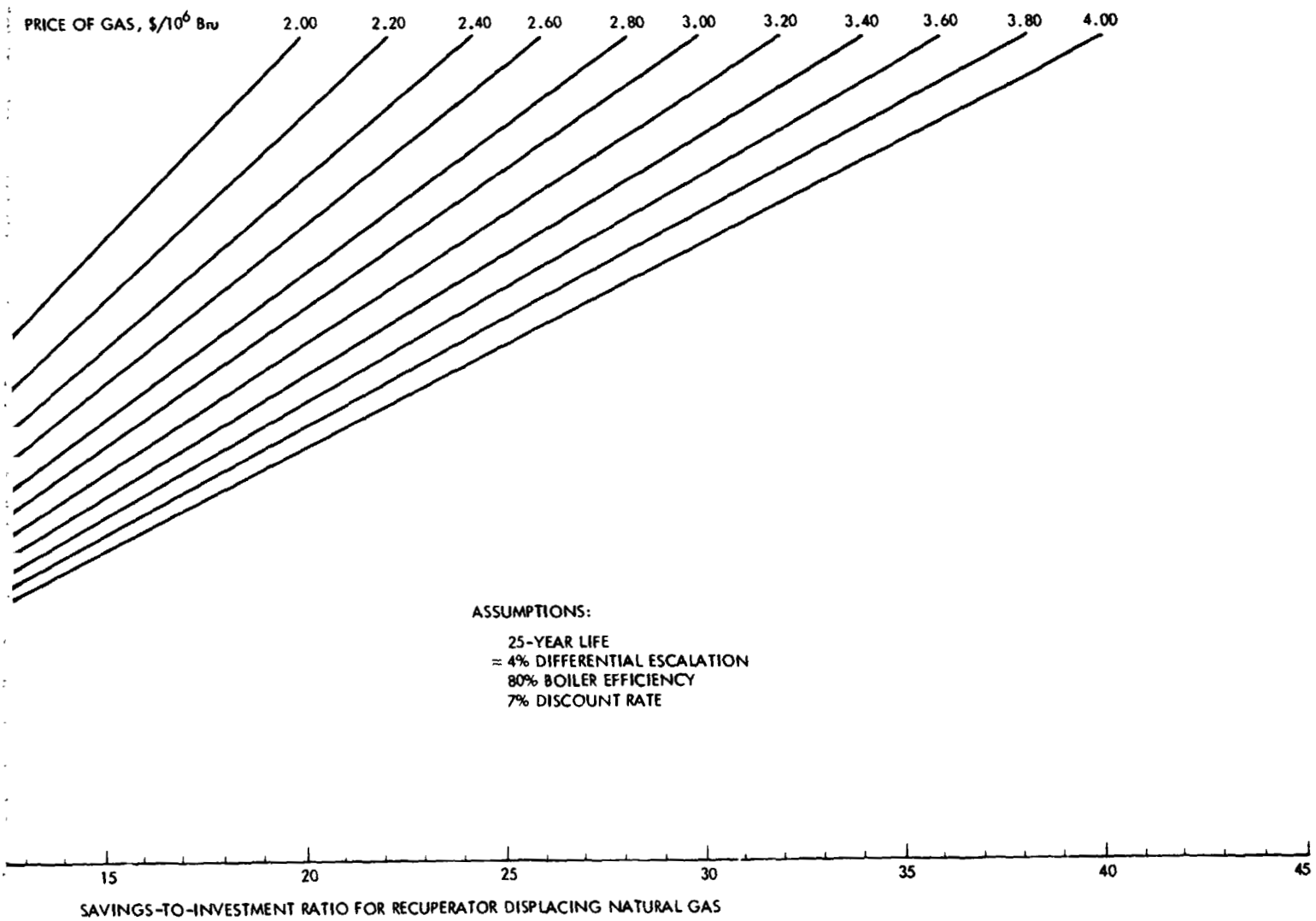

FOLDOUT FRAME 2

PRECEDING PAGE BLANK NOT FILMED

Figure 4-11. Determination of Savings-to-Investment Ratio for the Displacement of Natural Gas Through Waste Heat Recovery With a Recuperative Heat Exchanger

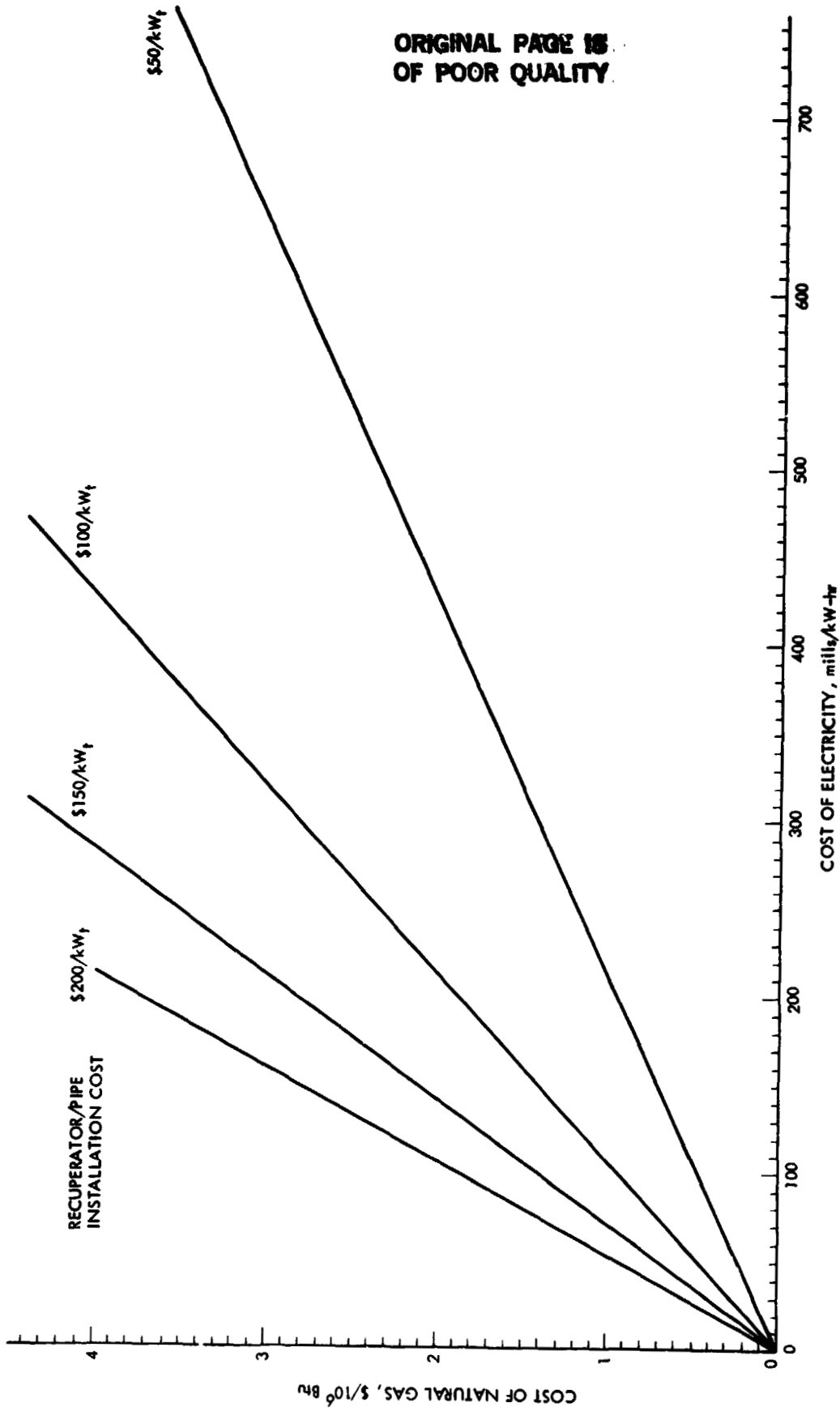

ORIGINAL PAGE IS
OF POOR QUALITY

Figure 4-12. Break-even Costs of Waste Heat Recovery With an Organic Rankine Bottoming Cycle vs. a Recuperator for and ORC Installation Cost of \$2000/kW_e When Natural Gas is Displaced by Recuperator

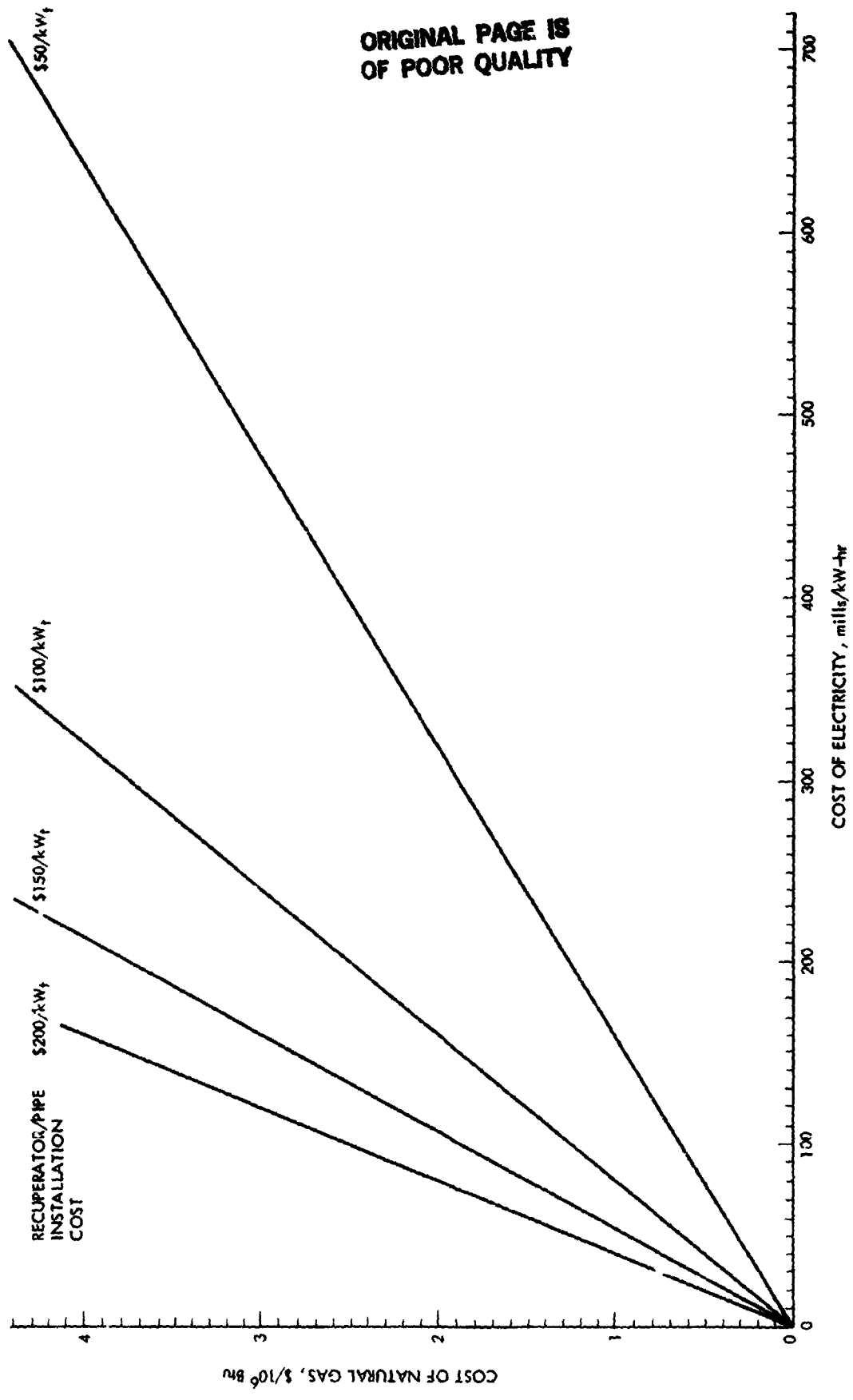

Figure 4-13. Break-even Costs of Waste Heat Recovery with an Organic Rankine Bottoming Cycle vs. a Recuperator for an ORC Installation Cost of \$1500/kW_e When Natural Gas is Displaced by the Recuperator

ORIGINAL PAGE IS
OF POOR QUALITY

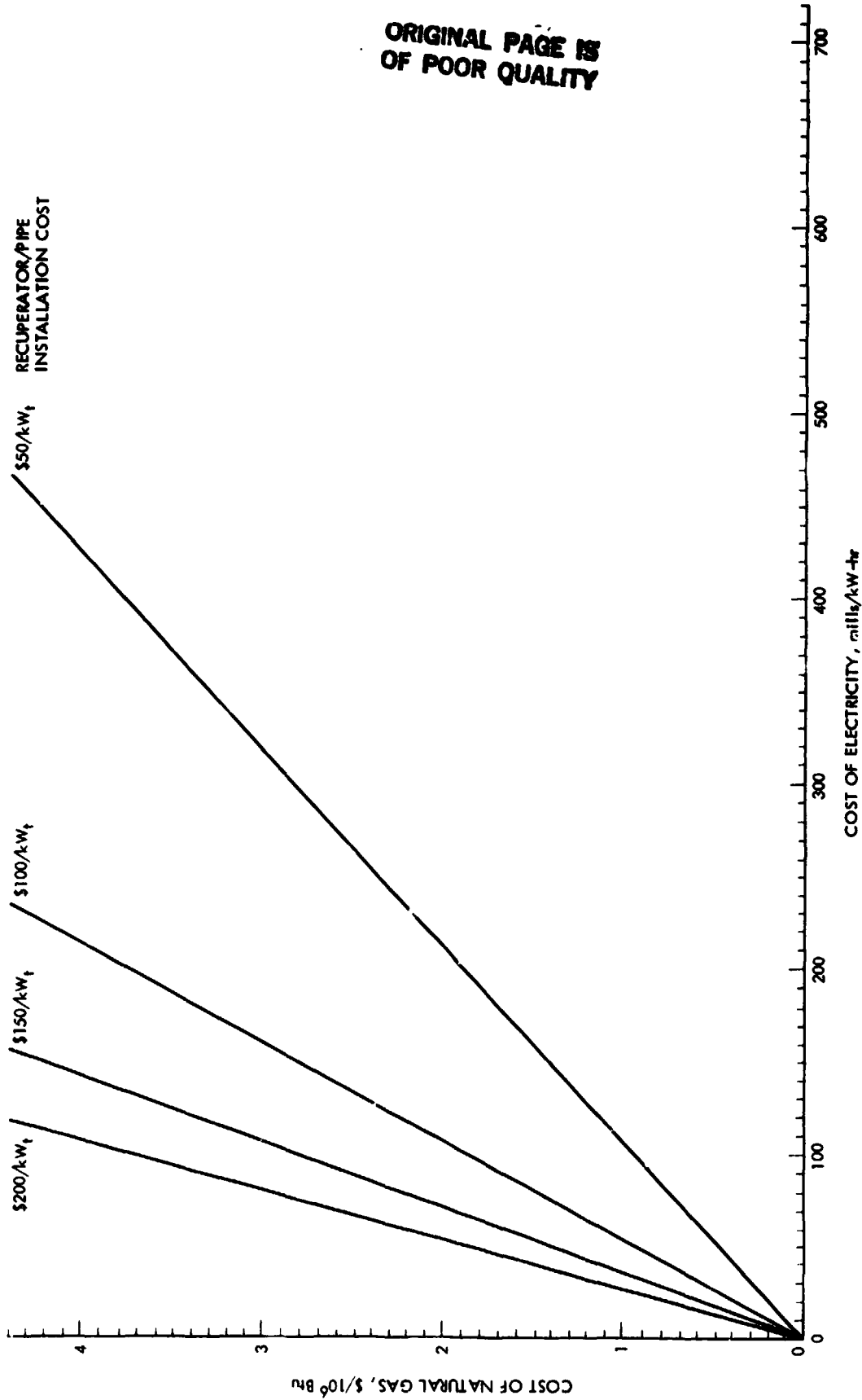

Figure 14. Break-even Costs of Waste Heat Recovery with an Organic Rankine Bottoming Cycle vs. a Recuperator for an ORC Installation Cost of \$100/kW_e When Natural Gas is Displaced by the Recuperator

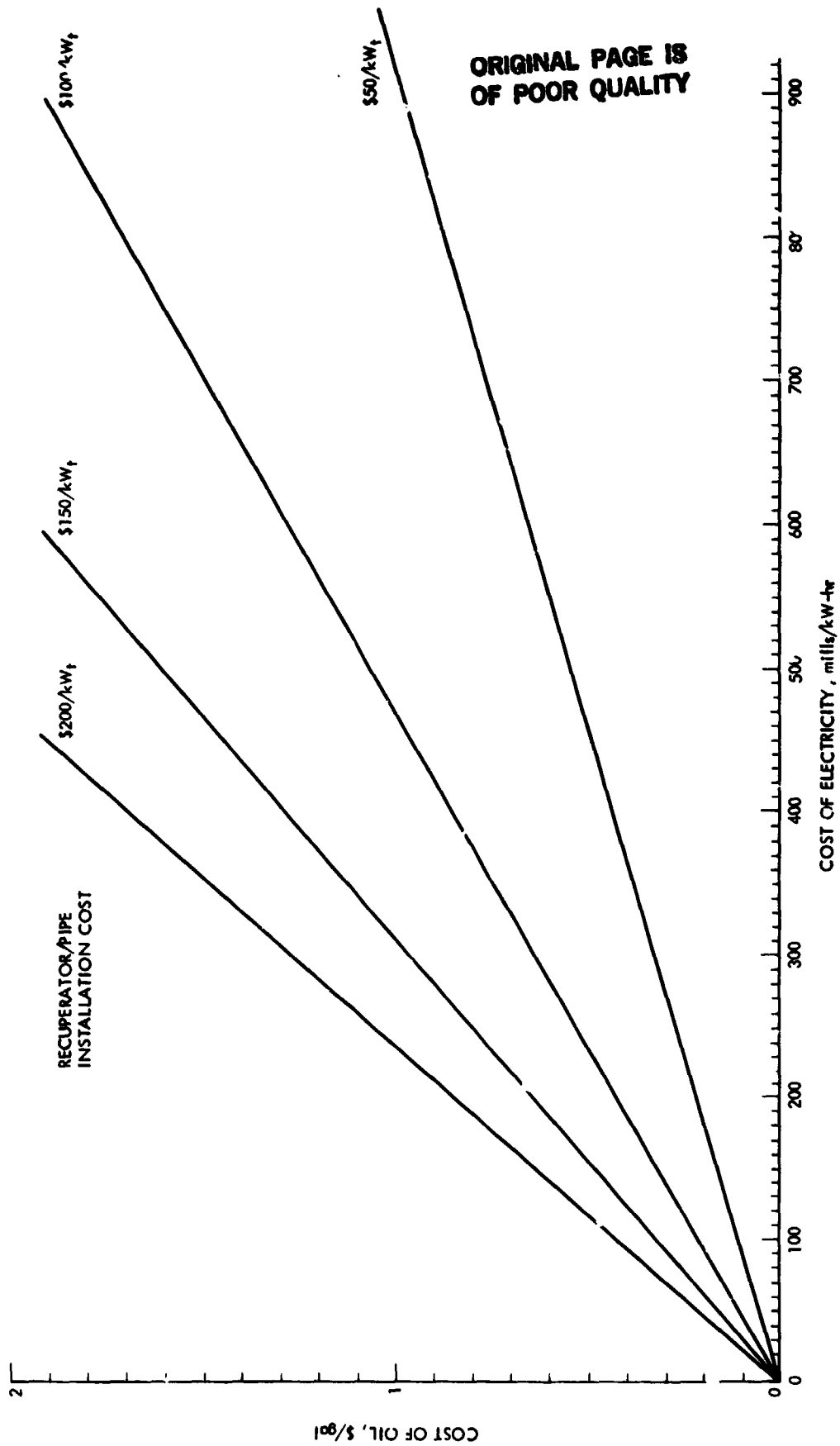

Figure 4-15. Break-even Costs of Waste Heat Recovery with an Organic Rankine Bottoming Cycle vs. a Recuperator for an ORC Installation Cost of \$1000/kW_e When Oil is Displaced by the Recuperator

The break-even costs for an ORC unit and a recuperator when the recuperator is displacing natural gas are shown in Figures 4-12 through 4-14 for ORC installation costs of \$2000/kW_e, \$1500/kW_e, and \$1000/kW_e, respectively. Although \$1000/kW_e is below the minimum depicted in Figure 4-2, it was chosen as a lower limit in case a manufacturer might quote a similar cost for a specific installation. The range of the recuperator/piping costs was selected from a review of Figures 4-8 and 4-9.

As an example of how to interpret these figures, an ORC unit costing \$2000/kW_e can be compared with a recuperator in Figure 4-12. If the recuperator/piping installation cost were \$100/kW_t in an area where the price of electricity is 180 mills/kW-hr, then the price of natural gas must be \$1.70/10⁶ Btu to break even. If the cost of gas is more expensive, for example, \$2.20/10⁶ Btu, then the recuperator is more cost-effective because the ORC will not break even until electricity costs 235 mills/kW-hr since the ORC is displacing a less valuable resource. This is found by following the \$100/kW_t line from the \$1.70 value to the \$2.20 number. If the gas is less expensive, then the ORC is more cost-effective because now the recuperator is displacing a less valuable energy source.

As another example, for a recuperator/piping installation cost of \$150/kW_t in a region where the cost of natural gas is \$2.40/10⁶ Btu, the price of electricity must be 170 mills/kW-hr to break even. Again, if electricity is more expensive, for example, 200 mills/kW-hr, then the price of gas must be \$2.84/10⁶ Btu to break even, and hence the ORC is more cost-effective as it displaces a more valuable resource.

Another, perhaps more simple, interpretation of break-even costs is presented in Figures 4-16 and 4-17 where a recuperator and ORC can be traded off directly, given the price of electricity and fuel. Figure 4-16 depicts the equipment break-even costs where heat exchange from the recuperator displaces natural gas, while Figure 4-17 is a display of that for oil. If the ultimate objective were to determine whether to install a recuperator or an ORC unit, then one could initiate his tradeoff with these graphs. For example, with modest fuel and electricity prices and a low recuperator/piping cost, the required break-even ORC installed cost would fall short of the lower limit of the present-day range of equipment cost, and the ORC could be eliminated a priori. In terms of a specific example, if the recuperator/piping installed cost were \$100/kW_t in an area where the price of electricity were 40 mills/kW-hr and natural gas were \$2.00/10⁶ Btu, then from Figure 4-16 the break-even ORC installed cost would be \$370/kW_e, which is far short of the \$1500/kW_e minimum. On the other hand, if the recuperator/piping installed cost were \$280/kW_t in a region where electricity was 100 mills/kW-hr and natural gas was \$2.00/10⁶ Btu, then again from Figure 4-16, the break-even ORC cost would be \$1580/kW_e, which falls within the range of present-day ORC equipment cost -- thereby indicating that a more detailed study is warranted.

Simply stated, if the fuel source is in reality more expensive than the indicated break-even cost, then the recuperator is more cost-effective; if the actual cost of electricity is more expensive than the break-even value, then the ORC is more cost-effective. As a case in point, for a recuperator/piping installation cost of \$150/kW_t at Hill Air Force Base where natural gas is

ORIGINAL PAGE IS
OF POOR QUALITY

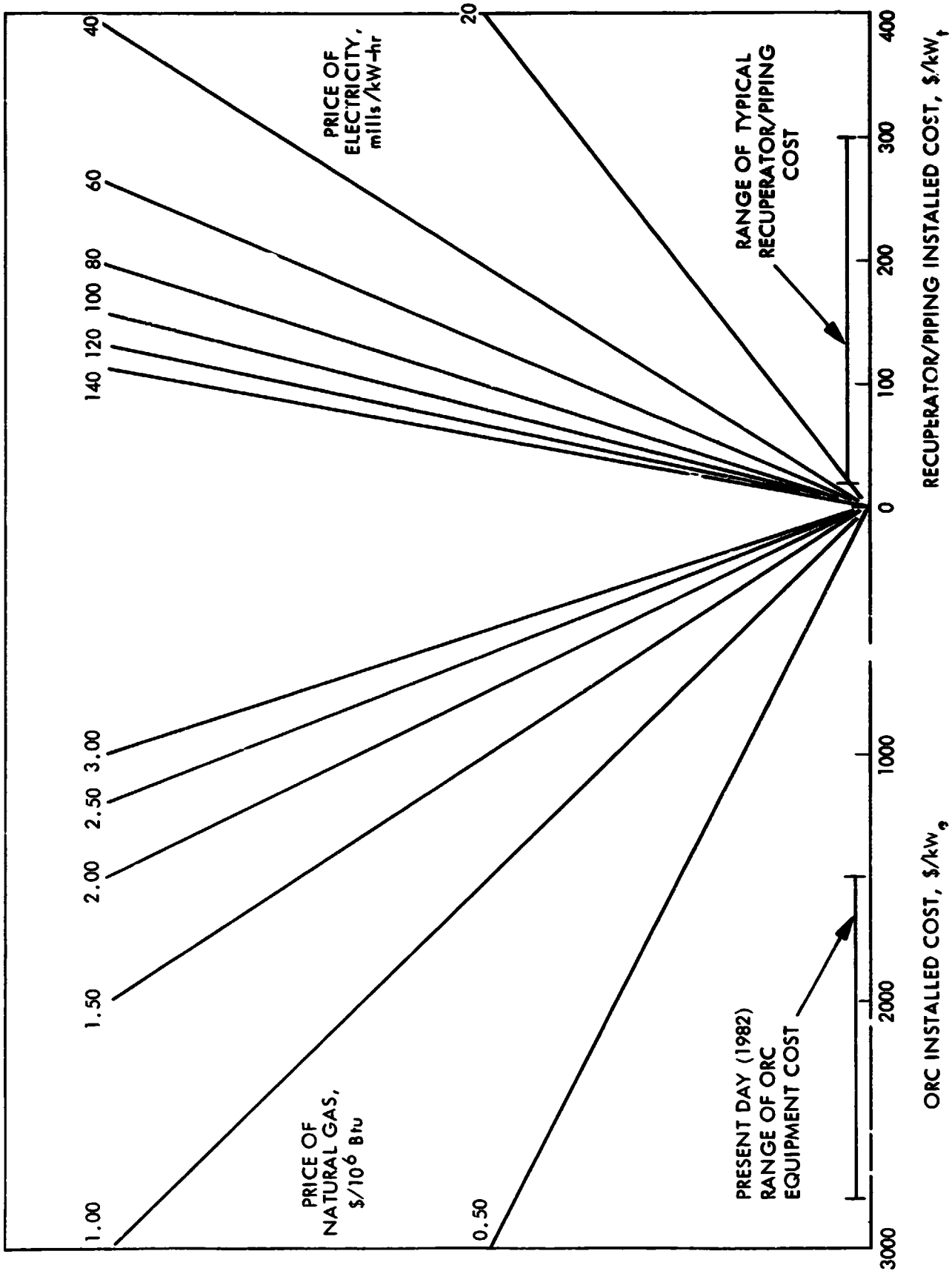

Figure 4-16. Break-even Cost for ORC Equipment and Recuperator/Piping When Recuperator Displaces Natural Gas

ORIGINAL PAGE IS
OF POOR QUALITY

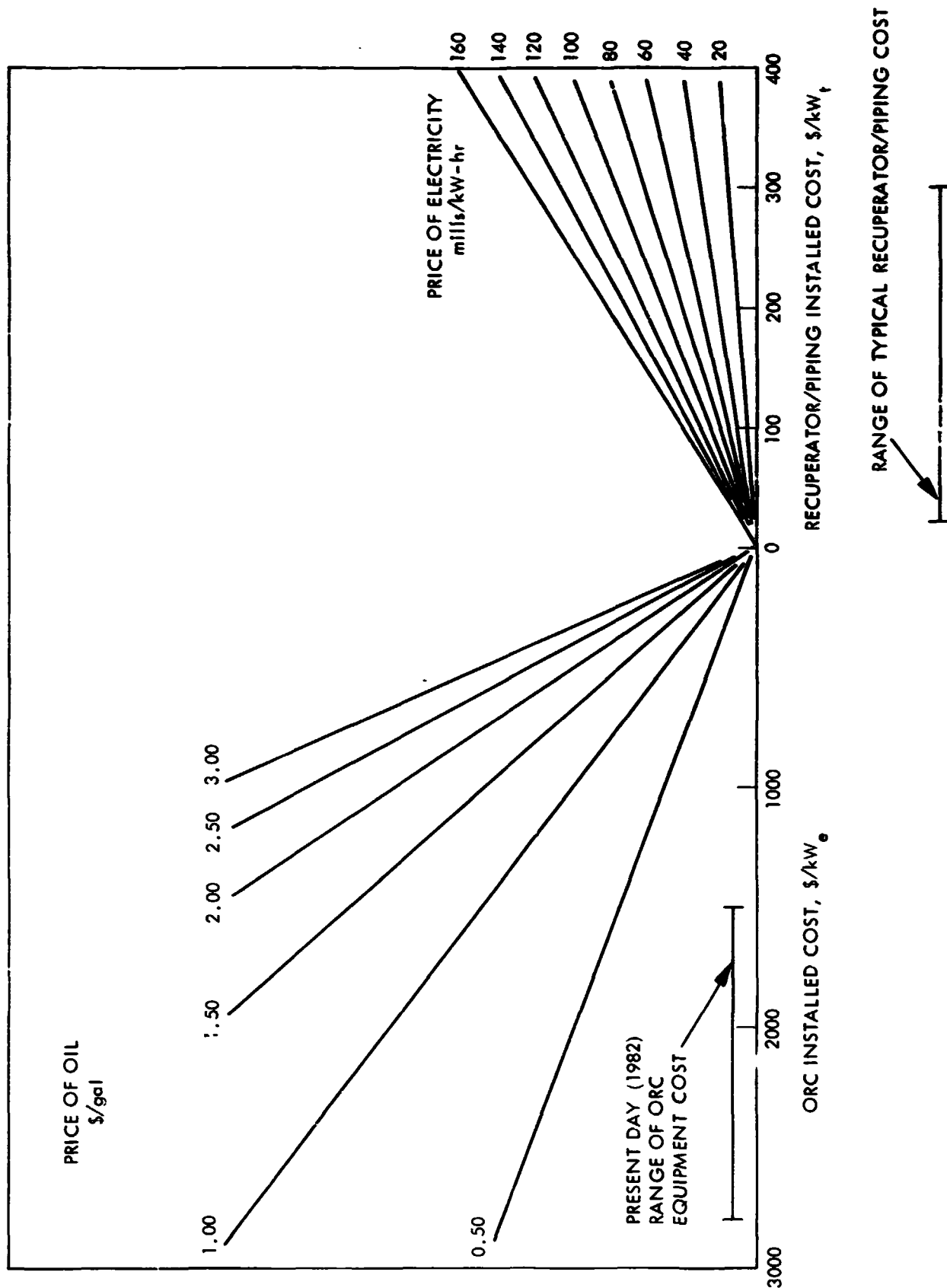

Figure 4-17. Break-even Cost for ORC Equipment and Recuperator/Piping When Recuperator Displaces Oil

\$2.18/10⁶ Btu but electricity is only 24.8 mills/kW-hr, an ORC unit would not be cost-effective until electricity were nearly three times more expensive - even if the ORC installation cost were as low as \$1000/kW_e (Figure 4-14).

Except for possible isolated extreme cases, such as a very expensive recuperator/piping installation, an ORC will probably never be cost-effective if oil is being displaced. This can be seen in both Figures 4-15 and 4-16. Breaking even with today's price of electricity will not even come into range until the price of oil drops below \$0.50/gal. More expensive ORC installation costs only worsen the situation.

A comparison of the cost-effectiveness of an organic Rankine bottoming cycle with that of a recuperator/piping system in light of Figures 4-12 through 4-15 leads to one general conclusion: With today's cost of natural gas in excess of \$2.00/10⁶ Btu and the prices of oil greater than \$1.00/gal, while electricity remains for the most part below 80 mills/kW-hr, recovering waste heat with a recuperator will generally be more cost-effective than would recovering it with an organic Rankine bottoming cycle. This conclusion is not surprising, as there is cost-performance leverage in favor of the recuperator. The hardware for the recuperator/piping assembly is simpler than that for the ORC; as a result, it is only 10 to 50 percent as expensive. Furthermore, because of the nature of the thermodynamics, the heat exchanger effectiveness is four to eight times the conversion efficiency of the ORC. Therefore, with a recuperator, more useful energy is made available to displace a more valuable resource at a lower investment cost. The installation of an organic Rankine bottoming cycle would be considered where electricity is truly expensive or non-existent, where long pipe lengths cause excessive recuperator installation costs, where there is a desire or need for grid independence, or where there is a need to gain firsthand experience with ORC equipment.

SECTION V

R&D PERSPECTIVES FOR ORGANIC RANKINE CYCLE EQUIPMENT

Because of the continued interest in conservation induced by higher fuel costs, the various applications of Rankine cycles for waste heat recovery are expected to increase significantly by the end of the century. To meet this increased demand, emphasis will be toward producing equipment that will deliver higher efficiency at lower capital cost. The anticipated improvements in the technology of organic Rankine cycle hardware are discussed in this section.

A. IMPROVED PERFORMANCE

A strong contributor to the overall cycle efficiency of organic Rankine systems is the efficiency at which the expander is designed to operate. Taken as an individual component, a higher-efficiency expander is within the present state of the art. However, in an attempt to minimize operational problems, manufacturers often compromise its performance potential by limiting its rotational speed to relax the requirements of other components, like bearings. Improved bearing designs, especially for applications where the bearings use the working fluid as a lubricant, will contribute greatly toward reaching the full potential of the expander efficiency.

Considerable work remains in the improvement of the part-load performance of the turbomachinery. For Brayton-cycle applications, much effort has been expended in the use of variable-inlet guide vanes as a more precise way to control flow to the turbine inlet than the conventional throttling method. Although considerable R&D has been accomplished in this area, the hardware is not yet commercially available. However, because of the similarity of equipment, the technology developed for the Brayton cycle will be directly applicable to the organic Rankine cycle.

At first glance, the most obvious way to improve cycle efficiency is to allow the working fluid to run at a higher temperature. However, this approach is very limited with organic fluids, which are subject to increased molecular dissociation as the temperature increases. At present, operating temperatures are limited by how much dissociation can be tolerated with an acceptable buildup of noncondensibles that does not impact performance. (Monomolecular reaction rates are normally displayed as Arrhenius plots, which depict the rate of dissociation of a fluid as a function of the reciprocal of the absolute temperature, and these plots indicate that some dissociation, although very small, is occurring during normal operation.) It was found during the literature search that many manufacturers have voluntarily limited the maximum temperature of the working fluid to avoid the problem of noncondensibles during the normal equipment lifetimes. As an example, toluene temperatures are often limited to approximately 600°F, although experience has shown that it can be operated up to 750°F with an acceptable dissociation rate. Higher cycle efficiencies pay off directly in smaller component sizes and lower capital costs. However, long-term operations at these elevated temperatures will necessitate a design provision for eliminating the noncondensibles, as well as the polymer and carbon deposition.

B. IMPROVED HARDWARE

As ORC equipment becomes more universally applied, refinements in both component designs and their manufacturing processes should result in increased performance and lower capital costs for the final product. For instance, R&D work is being done with radial flow turbines that promise improved performance for small sizes. Although this effort is primarily focused on steam as the working fluid, the final product might be modified for organic fluids. Also, several manufacturers have estimated that merely increasing the production quantities would lower the capital cost of individual ORC units by as much as 25 percent.

With the more extensive use of ORC equipment, operation and maintenance costs will be lower. Not only will the required O&M itself be better defined, but also sources of early failures will have been addressed and corrected.

SECTION VI

CONCLUSIONS

Although a wide variety of waste-heat recovery applications is available to organic Rankine cycle equipment, there are practical bounds within which this equipment should be constrained to operate. Not only should the organic working fluid be selected to fit the temperature of the waste-heat stream, but caution also must be exercised if the source temperature is excessive because of the increased rate of thermal decomposition of the working fluid with higher temperature. For design purposes, it is wise to limit the upper bound of the working fluid temperature to 750°F for which toluene, one of the most stable of the organic fluids, is acceptable.

The establishment of an acceptable lower bound for the waste heat is constrained by the lower operational limit of the equipment and the temperature of the waste-heat stream. Given the minimum equipment performance and the waste-heat temperature, the nomograms can be used to estimate the minimum mass flow rate that the waste-heat source must deliver. If the waste-heat stream can not deliver the minimum required flow rate, then heat recovery by organic Rankine cycle equipment would not be feasible. As a further limitation of the lower bound, applications for temperatures much below 200°F should be investigated carefully, as they may not be cost-effective. If the quality of the waste heat is very low, then useful work extraction may not be practical.

If an application is planned to recover heat from a combustion gas source, then unless there is additional information available, the lower bound for the temperature should be limited to 300°F to avoid condensation of sulphuric acid present in combustion gases from sulphur in the fuel.

Although the primary purpose of this study was to establish a data base for organic Rankine cycle equipment and to develop a technique for estimating its size, the comparison of the ORC with a recuperator has suggested some conclusions specific to the economics of waste-heat recovery that are worth noting.

In regions where electricity costs are high, for example, 80 to 100 mills/kW-hr, the installation of ORC equipment will be cost-effective if the unit is operated more than 20 percent of the year. However, the cost-effectiveness trades off inversely with electricity cost. For cases where the price of electricity is especially low, such as at Hill Air Force Base, wherein early 1982 it was only 24.8 mills/kW-hr, the ORC equipment would have to be on-line greater than 75 percent of the time to be cost-effective. Even though the displacement of electricity with an ORC unit through the recovery of waste heat can be made cost-effective, if the installation of a recuperator is a possible alternative, it should be investigated. For regions where electricity remains relatively inexpensive (for example, below 80 mills/kW-hr), the recovery of waste heat with a recuperator will nearly always be more cost-effective than would its recovery with an organic Rankine bottoming cycle unit. The simple, less expensive recuperator displaces valuable fuel, while the more complex, more expensive ORC equipment displaces electricity, a less expensive resource.

The lower electricity prices are heavily influenced by cheaper power sources, such as hydro, coal, and nuclear, while the prices of oil and natural gas have been rapidly escalating. If no other factors are involved, a recuperator will generally make more useful energy available to displace a more valuable resource at a lower investment cost. However, it should be pointed out that the economics presented in this report represent only a single-point, steady-state snapshot of the dynamic world of electricity and fuel supply. It was beyond the scope of this study to consider such influences as variable rate structures and unstable fuel supplies. The analysis and figures presented represent only a first cut and do not take these factors into account. A detailed economic analysis of the energy needs of an Air Force base must be base specific, energy-supply specific, and utility specific. Short-term effects such as normal and emergency operations must be considered, as well as such long-term influences as fuel availability and flexibility. A detailed consideration of all of these aspects could alter the conclusions.

Another variable that may warrant further investigation is that recently enacted legislation relating to taxes and energy may permit the Air Force to enter into a third-party energy-providing agreement wherein the producers may be allowed to take advantage of the tax laws in a way that could change the economic results from the perspective of the Air Force. The near-term impact could be a lower apparent cost of capital.

As the performance and cost of ORC equipment improve with future development, its economic advantage will most likely improve considerably. However, the selection of one energy recovery method over another from the strictly economic perspective of lowest cost may be in conflict with more vital issues like vulnerability concerns of the base. Cost alone may not be the prime criterion. For example, the installation of ORC equipment should be considered where electricity is non-existent or very expensive; where recuperator installation costs are excessive; where there is a desire to gain hands-on knowledge of ORC equipment for future applications; where there is a need for grid independence, such as for remote siting or for peak shaving to favorably influence the rate structure; or where its installation could reduce base vulnerability.

SECTION VII

REFERENCES

1. Sternlicht, B., "Low-Level Heat Recovery Takes on Added Meaning as Fuel Costs Justify Investment," Power, pp. 84-87, April 1975.
2. Barber, R. E., "Rankine-Cycle Systems for Waste Heat Recovery," Chemical Engineering, pp. 101-106, November 25, 1974.
3. Barber, R. E., "Solar and Geothermal Rankine Cycle Engines Can Convert Petroleum Industry Waste Heat into Electrical Power," ASME 80-Pet-27, Energy Technology Conference and Exhibition, New Orleans, Louisiana, February 3-7, 1980.
4. Nichols, K. E., "A 500 kW Direct Contact Pilot Plant for East Mesa," Geothermal Resources Council, Transactions, Vol 3., September 1979.
5. Prigmore, D. and Nichols, K., "Recent Developments in the Organic Rankine Cycle Heat Engine Field," 15th Intersociety Energy Conversion Engineering Conference, Seattle, Washington, August 18-22, 1980.
6. Mechanical Technology Inc., Organic Rankine Cycle Systems, sales brochure.
7. Meacher, J.S., "Organic Rankine Cycle Systems for Waste Heat Recovery in Refineries and Chemical Process Plants," Mechanical Technology, Inc.
8. S.P.S. Inc., Power Without Fuel, sales brochure.
9. Sundstrand, Power Generation Through Waste Heat Recovery, sales brochure.
10. Niggemann, R.E., Greenlee, W.J., Lacey, P.D., "Fluid Selection and Optimization of an Organic Rankine Cycle Waste Heat Power Conversion System," ASME 78-WA/Ener-6, Winter Annual Meeting, San Francisco, California, December 10-15, 1978.
11. Prasad, A., "Power Generation from Waste Heat Using Organic Rankine Cycle Systems," Sundstrand publication 9021185/0681, June 1981.
12. USAF Solar Thermal Applications Case Studies, Applied Concepts Corporation Technical Report J01-02-81, Contract No. 955887, September 18, 1981.
13. Curran, H.M., "The Use of Organic Working Fluids in Rankine Engines," 809194, 15th Intersociety Energy Conversion Engineering Conference, Seattle, Washington, August 18-22, 1980.
14. Barber, R.E., "Solar Powered Organic Rankine Cycle Engines--Characteristics and Costs," 769200, 11th IECEC meeting.
15. Angelino, G., Moroni, V., "Perspectives for Waste Heat Recovery by Means of Organic Fluid Cycles," Journal of Engineering for Power, ASME 72-WA/Pwr-2, April 1973.

16. AFI, Organic Rankine Cycle Systems for Energy Recovery from Waste Heat, sales brochure.
17. Ichikawa, S. and Watanabe, M., "Organic Rankine Cycle Development and Its Application to Solar Energy Utilization," Ishikawajima-Harima Heavy Industries Co., Ltd. (AFI), International Congress of COMPLES on Solar Energy, Dhahran, Saudi-Arabia, November 2-6, 1975.
18. Kays, W., London, A. L., Compact Heat Exchangers, Second Edition, McGraw-Hill Book Company, 1964.
19. Marciniak, T.J., et al, Comparison of Rankine-Cycle Power Systems: Effects of Seven Working Fluids, Argonne National Laboratory, ANL/CNSV-TM-87 DE82 005599, June 1981.
20. Steitz, P., Mayo, G., An Assessment of the Role of Organic Rankine Cycle Bottoming Systems in Small Utilities, Burns-McDonnell Engineering Co., Project No. 77-810-4-006, Final Report, July 1979, DOE Contract EC-77-C-02-4536.
21. Purcupile, J.C. and Stas, J.D., Energy Conservation in Coal Conversion - Energy Conservation Potential in Heat Recovery Techniques, A Case Study, International Conference on Energy Use Management, pp. 601-610, 1977.
22. Waste Energy Recovery Systems Technology Characterization and Evaluation, Interim Report, Technology Characterization Task 1 through Task 5, United Technologies Research Center, East Hartford, Connecticut, R78-954219-10, February 1979.
23. Morgan, D.T. and Davis, J.P., "High Efficiency Gas Turbine/Organic Rankine Cycle Combined Power Plant," Gas Turbine Conference and Products Show, Zurich, Switzerland, 30 March - 4 April 1974.
24. Sternlicht, B., "The Equipment Side of Low-Level Heat Recovery," Power, pp. 71-77, June 1975.
25. "Marine Diesel Bottoming Cycle May Save Fuel," Automotive Engineering (NY), Vol 87, No. 7, pp. 35-40, July 1979.
26. Morgan, D.T., et al, "High Efficiency Diesel/Organic Rankine Cycle Combined Power Plant," 75-DGP-13, ASME Diesel and Gas Engine Power Conference and Exhibit, New Orleans, Louisiana, April 6-10, 1975.
27. Adam, A.W., 600 kW Organic Rankine Cycle Waste Heat Recovery Power Conversion System, Sundstrand Energy Systems, Rockford, Illinois, 9018265.
28. "Rules and Regulations, Industrial Sector," Federal Register, Vol 46, No. 222; Appendix B, pp. 56721-56728, November 16, 1981.
29. Brown, H.L., et al, Industrial Applications Study, Volume III, Technology Data Base Evaluation of Waste Recovery Systems. Final Report, HCP/T2862-03 UC-95e, Prepared for DOE under contract E(11-1) 2862, March 1978.

30. Biddle, J., et al, "Low-Cost Thermal Transport Piping Networks for Solar Industrial Process Heat Applications," 5th Annual Solar Industrial Process Heat Conference, Houston, Texas, December 16-19, 1980.
31. Bronicki, L. Y., "Twenty Years of Experience with Organic Rankine Cycle Turbines - Their Applicability and Use in Energy Conservation and Alternative Energy Systems," 829190, Proceedings of 17th IECEC Conference, August 1982.
32. Rose, R. K. and Colosimo, D. D., "Organic Rankine Cycles for the Petro-Chemical Industry," Mechanical Technology Inc., Proceedings of Conference on Industrial Energy Conservation Technology, pp. 918-931, 1979.
33. Rhinehart, H. L., Ketler, C. P., Rose, R. K., "Development Status: Binary Rankine Cycle Waste Heat Recovery System," 779175, Proceedings of the 12th IECEC, pp. 1090-1094, 1977.