

NASA-TM-84571 19830013459

NASA Technical Memorandum 84571

Greenland 1979 Microwave Remote Sensing Data Catalog Report - October 14 and 15, 1979

**Harold F. Hennigar, William S. Hirstein,
Sally K. Schaffner, Victor E. Delnore,
and William L. Grantham**

MARCH 1983



**25th Anniversary
1958-1983**

NASA



NASA Technical Memorandum 84571

Greenland 1979 Microwave Remote Sensing Data Catalog Report - October 14 and 15, 1979

Harold F. Hennigar
Deepsea Ventures, Inc.
Gloucester Point, Virginia

William S. Hirstein
Bionetics Corporation
Hampton, Virginia

Sally K. Schaffner
OAO Corporation
Hampton, Virginia

Victor E. Delnore
Kentron Technical Center
Kentron International, Inc.
Hampton, Virginia

William L. Grantham
Langley Research Center
Hampton, Virginia

NASA

National Aeronautics
and Space Administration

**Scientific and Technical
Information Branch**

1983

CONTENTS

SUMMARY	1
INTRODUCTION	1
DATA ORGANIZATION	1
SENSOR DESCRIPTIONS	2
Stepped Frequency Microwave Radiometer	2
Airborne Microwave Scatterometer	3
Precision Radiation Thermometer	6
Sensor Geometry	7
GREENLAND DATA CATALOG	8
APPENDIX A - GREENLAND DATA TAPE DOCUMENTATION	10
APPENDIX B - GREENLAND TIME-LINE PLOTS AND FLIGHT LINES	15
DAY 287	16
DAY 288	30
REFERENCES	49
TABLES	50
FIGURES	51

SUMMARY

This report catalogs the airborne microwave remote sensing measurements obtained by NASA Langley Research Center in support of the 1979 Greenland Remote Sensing Experiment. The remote sensing objective of this experiment was to investigate the microwave properties of the Greenland ice cap using an active and passive microwave system. The instruments used during the Greenland Remote Sensing Experiment include the stepped frequency microwave radiometer (SFMR), airborne microwave scatterometer (AMSCAT), and precision radiation thermometer (PRT-5). Remote sensing data are inventoried and cataloged in a user-friendly format. The data catalog is presented as time-history plots of when and where data were obtained as well as the sensor configuration. All data are available on 9-track computer tapes in card-image format upon request to the National Technical Information Service (NTIS).

INTRODUCTION

This report catalogs the airborne remote sensing data set obtained by NASA Langley Research Center in support of the 1979 Greenland Remote Sensing Experiment. The remote sensing objective of this experiment was to investigate microwave properties of the Greenland ice cap.

Two flights were conducted over the region during October 1979 using the NASA C-130 aircraft shown in figure 1. The flights were staged from Sondrestrom Air Base, Greenland, during transit from Tromsø, Norway, to the Langley Research Center. A summary of data flight days is presented in table I. NASA Langley sensors onboard the C-130 aircraft included a 14.6-GHz airborne microwave scatterometer (AMSCAT), a 4.5- to 7.2-GHz stepped frequency microwave radiometer (SFMR), and a precision radiation thermometer (PRT-5). These instruments are described in the next section.

DATA ORGANIZATION

The primary objective of this report is to present in a user-friendly format what remote sensing data were collected on the mission. Data are organized by flight day and are referenced to Greenwich mean time (GMT). The data catalog is presented as time-line plots indicating when and where the data were obtained as well as the sensor configuration. All data have been inspected and time corrected, where appropriate, and are available on 9-track computer tapes in card-image format upon request to the National Technical Information Service (see appendix A). Upon inspection of the time-line plots, a user can access a specific data segment by searching the tapes for the appropriate start and stop times. Selection of data for detailed analysis will depend upon the requirements of the user. The data have been organized so that selection is easiest if the user has a particular sensor configuration in mind or is interested in a particular geographic location. No detailed analysis has been attempted in this report, and users are urged to apply their own methods of analysis to the data. It is hoped that by making these data available, many alternative methods of analysis will be developed and applied.

SENSOR DESCRIPTIONS

Stepped Frequency Microwave Radiometer

The stepped frequency microwave radiometer (SFMR) is a precision, nadir-looking, circular polarized radiometer designed, developed, and fabricated by Langley Research Center. The SFMR is believed to be the first variable-frequency microwave radiometer controlled by a digital microprocessor, which provides both radiometer control functions and data formatting. The radiometer antenna, microwave section, and signal processor are shown in figure 2. The front panel of the digital controller is shown in figure 3.

The SFMR is capable of operating at frequencies between 4.5 and 7.2 GHz at intermediate frequency (IF) bandwidths of 10, 50, 250, or 1000 MHz and integration times from 0.2 to 20 seconds. The frequency can be varied in incremental steps from approximately 0.2 to 5 times the bandwidth per integration time. During the Greenland mission, however, the SFMR was operated only at 6.6 GHz. Analysis has shown that the SFMR exhibits an absolute precision of better than 2.0 K. The ideal radiometer brightness temperature sensitivity of the instrument varies between 0.012 K and 1.25 K depending on the bandwidth and integration time selected for the SFMR.

The measured radiometer sensitivity at 6.6 GHz was between 0.69 K and 0.88 K with 90-percent confidence and between 0.65 K and 0.94 K with 99-percent confidence. The ideal radiometer sensitivity at 6.6 GHz was 0.25 K. The radiometer was operating with a 50-MHz predetection filter bandwidth and a 0.2-second postdetection integration time, with five samples averaged during postflight data reduction to achieve a sample period of 1 second.

The SFMR is a balanced Dicke-switched square-wave correlated radiometer. The radiometer utilizes a closed-loop Type I noise feedback circuit to add noise to the received antenna noise and thereby balance to the Dicke reference noise. The microwave section of the radiometer, including the broadband tunnel-diode low-noise amplifier, is maintained in a constant-temperature enclosure at the Dicke reference temperature within ± 0.10 K. A block diagram of the radiometer is shown in figure 4.

The antenna consists of a corrugated-wall broadband horn with a 10-dB beam width of approximately 20.5° . The antenna has a meander line polarizer to provide reception to circular polarization only. An 11-layer fiberglass honeycomb-sandwich radome is used as a pressure seal over the polarizing radome. The feed is located within the constant-temperature enclosure, as is the noise injection circuit, which consists of a solid-state noise diode, isolator, PIN diode switch, and 20-dB directional coupler. The Dicke switch is a broadband latching circulator.

The receiver portion of the radiometer consists of a homodyne mixer, YIG-tuned local oscillator, and 1- to 1000-MHz IF amplifier. The microwave frequency of the radiometer is controlled by an 8-bit digital word from the digital subsystem that is converted to 0 to 10 volts dc. This signal controls the voltage-tuned microwave oscillator. The frequency can be changed every 200 ms in steps of 16 MHz or greater over the frequency range from 4.018 GHz to 8.098 GHz. However, the antenna limits the usable frequency range from 4.500 GHz to 7.200 GHz. The bandwidth of the radiometer is selected by the digital subsystem using one of four paths through the filter bank.

The 1- to 1000-MHz constant-power-level noise signal is transformer coupled into a hot-carrier diode square-law detector in the analog signal processor. The detected noise signal is amplified and synchronously detected with the Dicke switching frequency. The resultant error signal is fed to a true integrator. The output of the integrator is filtered to remove the effect of the Dicke switching frequency and used to control the pulse train output of a voltage-to-frequency (V/F) converter.

The V/F converter provides a variable-duty-cycle 70- μ s-pulse train. The pulse repetition frequency, from 0 to 10 000 pulses per second, varies linearly with the dc output voltage of the integrator. This pulse train is applied to the noise-injection PIN diode switch and controls the number of injected constant-amplitude, constant-width noise pulses added to signals from the antenna. The digital subsystem measures the duty cycle of the pulse train to determine the noise added to the antenna noise.

The digital subsystem provides both control functions to the radiometer and data processing of the output signal from the radiometer. The subsystem measures physical temperature at several locations in the radiometer, and it also provides front panel control functions and real-time displays for the operator. The radiometer data are formatted along with time, temperatures, and other operational data and are recorded on a digital tape recorder. An estimate of the brightness temperature is computed by the microprocessor and displayed to the operator (ref. 1). The integration time of the radiometer is determined by the count periods of the injection time counters which compute the duty cycle of the radiometer output. The integration time of the closed-loop radiometer noise feedback is several times faster than the minimum integration time allowed by the digital subsystem.

Airborne Microwave Scatterometer

The airborne microwave scatterometer, AMSCAT (formerly known as SUS), is an active microwave remote sensor that W. L. Jones, Jr.¹ developed at the NASA Langley Research Center to measure the normalized radar cross section of ocean, ice, and land targets. The scatterometer operates in a "long-pulse," or interrupted continuous wave, mode at a center frequency of 14.6 GHz. A simplified block diagram is shown in figure 5. AMSCAT is separated into three major assemblies: gimbal assembly, transmitter-receiver assembly, and rack-mounted electronics.

The gimbal assembly consists of a dual-linear polarized parabolic antenna (3.5° beam width), a two-axis servo-controlled pedestal (to provide independent elevation and azimuth positioning), and a multilayer fiberglass honeycomb radome. For Greenland, this assembly was mounted on the underside of the fuselage beneath the vertical stabilizer (tail section) of the NASA C-130 aircraft (fig. 6).

The transmitter-receiver assembly (fig. 7) consists of all the microwave hardware including circulator switches, a 1-W and a 20-W traveling wave tube (TWT) power amplifier, low-noise tunnel-diode amplifier (TDA), and a solid-state microwave source for generating the transmitter and receiver local oscillator signals. The system operation is digitally controlled by commands generated in the rack-mounted equipment (fig. 8).

¹AMSCAT Data Archive. NASA report, as yet unpublished.

The rack-mounted electronics consists of power supplies, the gimbal controller, the signal processor, digital controller and data system, and an analog strip chart recorder. The signal processor (fig. 5) has two overlapping channels that provide a received power range of greater than 40 dB. A programmable attenuator is used as a coarse gain control to provide an additional 60-dB range. In each channel, the signals are square-law detected, integrated for 500 ms, and then analog-to-digital (A/D) converted and recorded with a 7-track digital recorder. The digital controller and data system is a microcomputer that generates the precise timing and control logic needed by the scatterometer to form radio frequency (RF) pulses, operate switches and range gates, and A/D convert scatterometer integrator voltages. The microcomputer also formats aircraft parameters and radar data for recording. The use of this computer enables considerable adaptability of radar operating characteristics (table II) via an interactive programming mode.

In making scatterometer measurements, the quantity of interest is the scattering coefficient σ^0 . This quantity is independent of the type of radar performing the measurement and is defined from the radar equation as

$$\sigma^0 = \frac{P_r}{P_t} \frac{(4\pi)^3 R^4}{G^2 \lambda^2 A_T L_s} \quad (1)$$

where

P_r	received power
P_t	transmitted power
G	antenna gain
R	slant range
L_s	miscellaneous losses due to couplers, waveguide, etc.
λ	free-space wavelength
A_T	effective antenna footprint on surface

For the AMSCAT case of beam-limited conditions,

$$A_T = \frac{\pi}{4} \frac{(\beta_{eq} R)^2}{\cos \theta} \quad (2)$$

where β_{eq} is the effective pencil-beam antenna width (approximately equal to the half-power antenna beam width in radians) and θ is the incidence angle. The scattering coefficient thus becomes

$$\sigma^0 = \frac{P_r}{P_t} \frac{(16\pi)^2 R^2 \cos \theta}{G^2 \lambda^2 \beta_{eq}^2 L_s} \quad (3)$$

Refer to the block diagram of figure 5. The ratio P_r/P_t is measured in two steps. A sample of the transmitter power, attenuated by a known value GXR , when switched into the receiver produces a "calibration" output voltage V_{cal} proportional to P_t in each receiver channel. When the transmitter is connected to the antenna, an output voltage V_{sur} proportional to P_r is obtained in a particular channel. Solving for the received-to-transmitted power ratio (in terms of the voltage from a particular channel) yields

$$\frac{P_r}{P_t} = \frac{V_{sur}}{V_{cal}} \frac{(GXR)\alpha_{cal}}{\alpha_{sur}} \quad (4)$$

where

- V output voltage of integrator
- α programmable attenuator value
- GXR receiver calibration loop attenuation

and the subscripts denote

- cal during calibration
- sur during surface observation

Finally, in terms of the AMSCAT transfer function, the expression for σ° is

$$\sigma^\circ = (16\pi)^2 \frac{H^2 V_{sur}^2 \alpha_{cal} (GXR)}{\lambda^2 V_{cal}^2 \alpha_{sur}^2 G_{eq}^2 L_s^2 \cos \theta} \quad (5)$$

where H is the altitude of the aircraft.

The σ° value from equation (5) is in error because of inaccuracies in the determination of the instrument transfer coefficients (G , α , L_s , GXR , and β_{eq}) and the variables (H , θ , and V). This error can be separated into a bias and a random component. The accuracy of this bias determination is better than ± 1 dB.

The major contributor to the random component of σ° is V_{sur} . Because of Rayleigh fading of the received power from the surface, V_{sur} is an imperfect estimate of the mean received power used in the σ° calculation (eq. (1)). The normalized standard deviation of the cross section is approximately

$$\frac{\Delta\sigma^\circ}{\sigma^\circ} = \frac{1}{\sqrt{N}} \quad (6)$$

The number of independent samples N is

$$N = \sqrt{\beta_d \tau} \quad (7)$$

where τ is integration time and β_d is the Doppler bandwidth of received power,

$$\beta_d = \frac{2V_{gr}f}{c}(\sin \theta_{\max} - \sin \theta_{\min}) \quad (8)$$

where

V_{gr} aircraft ground speed
 f radar frequency
 c speed of light

For the Greenland mission, $\Delta\sigma^\circ/\sigma^\circ$ was less than ± 0.5 dB.

After the Greenland flights, an intermittent contact was found in the polarization switch of the scatterometer. Thus, much of the scatterometer data intended as HH polarization (see table II) was discovered later to be actually either HV or some mixture of HH and HV. This results in an uncertainty of several dB in the absolute level of the HH, HV, and VH data. The VV data are not affected.

There are two partially overlapping channels in the AMSCAT signal processor, as shown in figure 5. The archived data tapes contain the calculated values of σ° for both channels. The value for either channel was set to -99.00 or $+99.00$ if the integrator voltage for that channel was either too low (noise-dominated) or too high (saturated), respectively. For the data flights over Greenland, the more sensitive channel was on scale 52 percent of the time and the less sensitive channel was on scale 48 percent of the time. Both channels were on scale simultaneously 8 percent of the time. The mean difference between the calculated values of σ° for the two channels, near the saturation point of the more sensitive channel, was about 0.3 dB with a standard deviation of about 1.1 dB. The total number of data points (0.5-second integration time) was 21 756. (These statistics pertain only to the VV polarization.)

Precision Radiation Thermometer

The precision radiation thermometer, referred to as the PRT-5, is a nadir-looking infrared radiometer used to remotely measure physical temperature. The output of the PRT-5 is available on the 9-track digital tapes as surface temperature in degrees Celsius. Table III summarizes the operating characteristics of the instrument used during the Greenland mission. The user should consult reference 2 for a complete description of the instrument. The temperature range of the instrument was adjusted to satisfy the expected measurement range.

Sensor Geometry

To use the data obtained during the Greenland mission, sensor geometry and its effects on alignment of the data must be understood. Figure 9 illustrates the arrangement of sensors onboard the NASA C-130 aircraft during the Greenland mission. The stepped frequency microwave radiometer (SFMR) and PRT-5 are nadir-looking instruments; hence, the footprints of these instruments were directly beneath the aircraft. The airborne microwave scatterometer (AMSCAT), however, operated at a variety of incidence angles from 0° to 54° and was aimed behind the aircraft. For an incidence of 0°, the AMSCAT was nadir looking, but as incidence angle increased, the AMSCAT footprint translated backward along the flight line. Therefore, the SFMR and PRT-5 imaged an area before the AMSCAT. As stated previously, all sensors have been referenced to Greenwich mean time (GMT). This requires that a temporal correction be applied by the user to the AMSCAT data in order to align the data from all sensors on the same target. This correction is as follows:

$$\text{AMSCAT time (GMT)} = \text{NADIR time (GMT)} + \Delta t$$

where Δt is a function of aircraft altitude H , ground speed V_{gr} , and incidence angle θ of the AMSCAT. The temporal offset (Δt) can be calculated from the following equation:

$$\Delta t = \frac{H \tan \theta}{V_{gr}}$$

Altitude and ground speed must be in the same units.

Footprint sizes of the instruments vary, with the SFMR, AMSCAT, and PRT-5 having successively smaller footprints. Calculation of footprint sizes for the various sensors is described in the following paragraphs.

Footprints of all sensors at nadir would be nearly circular if there were no smearing of the footprints in the direction of the flight line due to sensor data integration times. For example, given a beam width of 0.37 rad, the instantaneous footprint of the SFMR can be calculated from

$$\text{SFMR footprint diameter} = 0.37H$$

At an aircraft altitude of 1000 m, the SFMR instantaneous footprint would be circular, with a diameter of 370 m. The footprint is smeared, however, along the flight line by the distance the aircraft traveled during the signal integration time τ . At an aircraft speed of 114 m/s, the aircraft would have traveled 57 m over a 0.5-second integration period. Therefore the SFMR footprint would actually be an ellipse (fig. 10) with the major axis along the flight line and the minor axis perpendicular to the flight line. Referring to figure 10, the footprint dimension perpendicular to the flight line is

$$A = 0.37H = 370 \text{ m}$$

while the footprint dimension along the flight line is

$$B = A + \tau V_{gr} = 427 \text{ m}$$

Footprints of the PRT-5, for all practical purposes, are circular since the integration time was less than 0.03 second. The PRT-5 has a 2° field of view, so that for an aircraft altitude of 1000 m, footprint dimensions are

$$A = B = 0.035 \times 1000 = 35 \text{ m}$$

Calculation of footprint size for the AMSCAT is slightly different because, in addition to smearing along the flight line, the instrument is not nadir looking. The AMSCAT instantaneous footprint dimensions perpendicular to flight line A and along flight line B are given by

$$A = \frac{(\text{Field of view})H}{\cos \theta}$$

$$B = \frac{A}{\cos \theta}$$

where field of view is 0.0612 rad for AMSCAT and θ is incidence angle.

Again, for an aircraft in motion, there is smearing along the flight line and B becomes

$$B = \frac{A}{\cos \theta} + \tau V_{gr}$$

For an altitude of 1000 m, an aircraft ground speed of 114 m/s, and an incidence angle of 45°, the AMSCAT footprint size is

$$A = 86.5 \text{ m}$$

$$B = 179.3 \text{ m}$$

GREENLAND DATA CATALOG

This section catalogs all of the remote sensing data obtained by NASA Langley Research Center during the 1979 Greenland Remote Sensing Experiment. These data are available on digital computer tapes (see appendix A).

Data were obtained on October 14 and 15, 1979, and are referenced by Julian Day 287 and 288, respectively. Flight line plots, presented for each day, indicate the geographic location of all data for the entire day. (Aerial photographs were

not obtained over Greenland because the lack of contrast of the snow-covered surface would have severely limited their usefulness.)

Time-line plots in Greenwich mean time (GMT) for each day show when sensors were recording data; corresponding latitude and longitude are also shown. The plots enable selection of data for detailed analysis based upon the user's need for a particular sensor configuration and/or geographical location. For ease of access to data on the available digital tapes, all sensor data are referenced to Greenwich mean time (GMT). Ten variables are indicated on each time-line plot. A solid line indicates the presence of data; absence of a solid line indicates the absence of data. Data gaps of less than 10 seconds are not indicated. The parameters shown for each time-line plot are labeled in figure 11 and described as follows:

(A) Day 288 - The Julian Day during 1979 corresponding to the time-line plot. Julian Days and their corresponding calendar days are listed in table I.

(B) PRT-5 - Solid line indicating when the precision radiation thermometer was taking data. This sensor remotely senses the physical temperature of the Earth's surface.

(C) SFMR - Solid line indicating whether the stepped frequency microwave radiometer acquired radiometric temperature (T_A). During this experiment, the SFMR operated only at a frequency of 6.6 GHz.

(D-G) AMSCAT (XX Polarization) - Solid lines showing whether the airborne microwave scatterometer was taking data and its polarizations. For example, VH polarization indicates that AMSCAT transmitted at vertical polarization and received at horizontal polarization. Likewise HH polarization indicates horizontal transmission and horizontal reception.

(H) Greenwich mean time (hour:min:sec) - All data are referenced to GMT. Available computer tapes can be easily accessed by searching for the start and stop times of desired data segments.

(I-J) Latitude and Longitude - Approximate latitude and longitude plotted in hundredths of a degree every 2 minutes along the flight line. Some latitudes and longitudes are missing from the time-line plots because of gaps in the data record. If necessary, flight lines may be plotted using latitude and longitude obtained by linear interpolation from recorded values.

Flight lines for each day and the time-line plots are presented in appendix B.

Langley Research Center
National Aeronautics and Space Administration
Hampton, VA 23665
January 28, 1983

APPENDIX A

GREENLAND DATA TAPE DOCUMENTATION

The NASA Langley Greenland Data Set is available on five 9-track tapes from the National Technical Information Service, Springfield, Va. The data for Julian Day 287 are recorded on an AMSCAT output tape and an SFMR tape. The data for Julian Day 288 are recorded on three tapes, two containing NERDAS parameters, PRT-5 data, and AMSCAT data and one containing SFMR data.

In standard AMSCAT output tape format, data are contained in two unformatted arrays, ARY and IARY, as follows:

Array number	Variable	Meaning
ARY(1)	GMT	Time, HHMMSS.S*
ARY(2)	THETA	Incidence angle, deg
ARY(3)	PHI	Azimuth angle, deg
ARY(4)	SIGMA1	Channel one radar backscatter
ARY(5)	SIGMA2	Channel two radar backscatter
ARY(6)	SIGMADB1	Channel one radar backscatter, dB
ARY(7)	SIGMADB2	Channel two radar backscatter, dB
ARY(8)	ALT	Altitude, m
ARY(9)	XLAT	Latitude, deg
ARY(10)	XLON	Longitude, deg
ARY(11)	DPF	Depolarization factor
ARY(12)	SRANG	Slant range
ARY(13)	DFR	Doppler frequency, GHz
ARY(14)	TAT	Total air temperature, °C
ARY(15)	PRT5L	PRT-5 low channel, °C
ARY(16)	PRT5M	PRT-5 mid channel, °C
ARY(17)	WDSP	Wind speed, knots
ARY(18)	WDAN	Wind angle, deg
ARY(19)	HEAD	Heading, deg
ARY(20)	GRSP	Ground speed, m/s
IARY(1)	MODE	AMSCAT operating mode
IARY(2)	ISET	AMSCAT setting
IARY(3)	ITPOL	Transmit polarization: 0 = Horizontal, 1 = Vertical
IARY(4)	IRPOL	Receive polarization: 0 = Horizontal, 1 = Vertical
IARY(5)	INVALID	
IARY(6)	ITIM	Time, total seconds from midnight
IARY(7)	JDAY	Julian Day
IARY(8)	ILIN	AMSCAT line number
IARY(9)	IRUN	AMSCAT run number
IARY(10)	IREC	Sequential record counter
IARY(11)	IAVGFL	Channel flag
IARY(12)	ISCTM	Range gate timing
IARY(13)	ISET2	AMSCAT setting
IARY(14)	ISAMP	Sample number

*HHMMSS.S indicates that the first two digits of the variable are hours, the next two digits are minutes, and the next three digits are seconds to the nearest tenth.

APPENDIX A

A sample FORTRAN program to read this tape is as follows:

```

PROGRAM REDTAP (INPUT, OUTPUT, TAPE 1)
DIMENSION IHD(7), ARY(20), IARY(14)
10 READ (1) IHD
   IF (EOF (1).NE.0) STOP
20 READ (1), ARY, IARY
   IF (EOF (1).NE.0) GO TO 10
GO TO 20
END
    
```

Two tapes for Julian Day 288 contain NERDAS parameters, PRT-5 and environmental information, and AMSCAT information (see ref. 3). They have a file structure as follows:

File portion	Variable	Meaning	Format
HEADER	MISS	Mission number	I10
	NDAY	Julian Day	I10
	NFILE	File number	I10
	NFEND	End file counter	I10
	NTSTRT	Start tape counter	I10
	NTEND	End tape counter	I10
	TSTRT	Start time, HHMMSS.S*	F10.2
	TEND	End time, HHMMSS.S*	F10.2
SUBRECORD 1	GMT	Time, HHMMSS.S*	F10.2
	SEC	Time, total s	F10.2
	XLAT	Latitude, deg	F10.2
	XLON	Longitude, deg	F10.2
	NFCNT	File record counter	I10
	NTCNT	Tape record counter	I10
SUBRECORD 2	ALT	Altitude, m	F8.2
	HEAD	Heading, deg	F8.2
	DRIFT	Drift, deg	F8.2
	ROLL	Roll, deg	F8.2
	PITCH	Pitch, deg	F8.2
	GRSP	Ground speed, m/s	F8.2
	WDSP	Wind speed, m/s	F8.2
	WDAN	Wind angle, deg	F8.2
	PRT	PRT temperature, °C	F8.2
	TAT	Total air temperature, °C	F8.2
SUBRECORD 3	SDB	Scattering coefficient, dB (see AMSCAT description)	F8.2
	THETA	Incidence angle, deg	F8.2
	PHI	Azimuth angle, deg	F8.2
	DPF	Depolarization factor	F8.4
	DFR	Doppler frequency, GHz	F8.4
	IPOL	Polarization: 0 = HH, 2 = VH, 1 = HV, 3 = VV	I8
	MODE	Mode	I8
	ISET	Set	I8
	ISTIM	Scatterometer timing	I8
	IREC	AMSCAT record number	I8

*HHMMSS.S indicates that the first two digits of the variable are hours, the next two digits are minutes, and the next three digits are seconds to the nearest tenth.

APPENDIX A

The time, latitude, and longitude records within a file are continuous with a sample rate of 0.5 second. Missing parameters are filled in with dummy variables. Real dummy values are 9999.99 or 99.9999. Integer dummy values are -9999. A sample FORTRAN program to read these tapes is as follows:

```

PROGRAM REDTAP (INPUT, OUTPUT, TAPE1)
10 READ (1,101) MISS, NDAY, NFILE, NFEND, NTSTRT, NTEND, TSTRT,
    1TEND
    IF (EOF (1).NE.0) STOP
20 READ (1,201) GMT, SEC, XLAT, XLON, NFCNT, NTCNT
    IF (EOF (1).NE.0) GO TO 10
    READ (1,202) ALT, HEAD, DRIFT, ROLL, PITCH, GRSP, WDSP,
    1WDAN, PRT, TAT
    READ (1,203) SDB, THETA, PHI, DPF, DFR, IPOL, MODE, ISET,
    1ISTIM, IREC
    GO TO 20
101 FORMAT (6I10, 2F10.2)
201 FORMAT (4F10.2, 2I10)
202 FORMAT (10F8.2)
203 FORMAT (3F8.2, 2F8.4, 5I8)
    END

```

For the tapes containing SFMR data for Julian Days 287 and 288, the file structure for these tapes is

File portion	Variable	Meaning	Format
HEADER	MISS	Mission number	I10
	NDAY	Julian Day	I10
	NFILE	File number	I10
	NFEND	End file counter	I10
	NTSTRT	Start tape counter	I10
	NTEND	End tape counter	I10
	TSTRT	Start time, HHMMSS.S*	F10.2
	TEND	End time, HHMMSS.S*	F10.2
SFMR RECORD	GMT	Time, HHMMSS.S*	F10.2
	SEC	Time, s	F10.2
	TA	Radiometric temperature, K	F10.2
	FREQ	Frequency, MHz	F10.2
	NFCNT	File record counter	I10
	NTCNT	Tape record counter	I10

*HHMMSS.S indicates that the first two digits of the variable are hours, the next two digits are minutes, and the next three digits are seconds to the nearest tenth.

APPENDIX A

The sample rate varies for these records and there are no dummy values. A sample FORTRAN program to read this tape is as follows:

```

PROGRAM REDTAP (INPUT, OUTPUT, TAPE 1)
10 READ (1,101) MISS, NDAY, NFILE, NFEND, NTSTRT, NTSTRT, NTEND, 1NSTRT, TEND
   IF (EOF (1).NE.0) STOP
20 READ (1,201) GMT, SEC, TA, FREQ, NFCNT, NTCNT
   IF (EOF (1).NE.0) GO TO 10
   GO TO 20
101 FORMAT (6I10, 2F10.2)
201 FORMAT (4F10.2, 2I10)
END
    
```

The following table lists tape numbers for the Greenland data set:

Julian Day	Tape number
287 (AMSCAT ONLY)	NN0901
287 (SFMR)	NP0955
288 (PART 1)	NF0808
288 (PART 2)	NF0811
288 (SFMR)	NP0962

The following table lists start and stop times, tape counters, and the number of records per file for each file:

File	Start time	Stop time	Number of records	Start tape counter	End tape counter
Tape number NN0901 (Day 287)					
1	46619.5	49478.5	5153	1	5153
2	49479.0	52546.0	6042	5154	11196
3	52546.5	54083.0	3025	11197	14222
4	54083.5	58943.0	9057	14223	23280
5	58943.5	62054.0	5408	23281	28689
Tape number NF0808 (Day 288)					
1	45300.0	47107.0	3615	1	3615
2	47110.5	50879.5	7539	3616	11154
3	50880.5	52645.0	3531	11155	14684
4	52686.0	54399.5	3416	14685	18112
5	54400.5	56599.5	4399	18113	22511
6	56600.5	58620.0	4040	22512	26551
Tape number NF0811 (Day 288)					
7	58620.5	61750.0	6260	1	6260
8	61751.0	64035.0	4569	6261	10829
9	64089.5	65150.0	2122	10830	12951
10	65151.0	67290.0	4279	12952	17230

APPENDIX A

SFMR DATA

File	Start time	Stop time	End file counter	Start tape counter	End tape counter
Tape number NP0955 (Day 287)					
1	41904.7	52022.0	4990	1	4990
2	52044.0	61739.0	4782	4991	9772
Tape number NP0962 (Day 288)					
1	44054.8	52737.8	8533	1	8533
2	53338.1	64023.0	10498	8543	19031
3	64041.2	65540.2	4412	19032	23443

Copies of digital tapes are available upon request to

National Technical Information Service (NTIS)
 5285 Port Royal Road
 Springfield, VA 22161

APPENDIX B

GREENLAND TIME-LINE PLOTS AND FLIGHT LINES

GREENLAND FLIGHT LINE
DAY 287

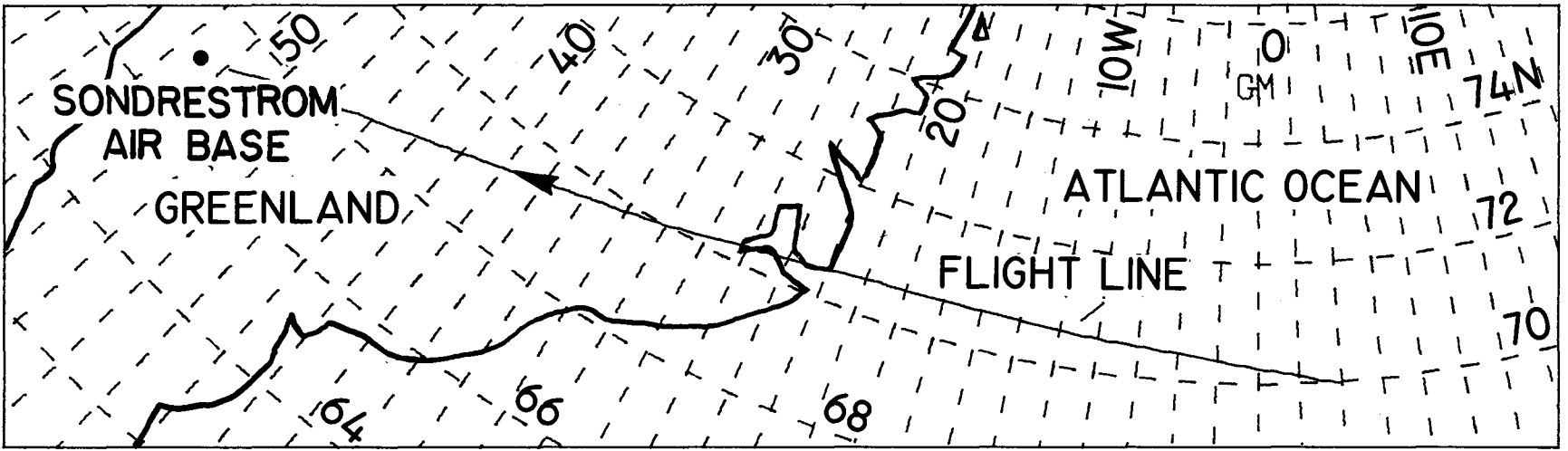

GREENLAND DATA SUMMARY
 DAY 287



SFMR

AMSCAT (VV POLARIZATION)

AMSCAT (VH POLARIZATION)

AMSCAT (HV POLARIZATION)

AMSCAT (HH POLARIZATION)

12:50:00	12:52:00	12:54:00	12:56:00	12:58:00	13:00:00	13:02:00	13:04:00	13:06:00	13:08:00	13:10:00	
GREENWICH MEAN TIME (HOUR:MIN:SEC)											
69.99			70.06			70.09			70.15		70.18
LATITUDE (DEG)											
9.61			2.79			2.37			1.55		1.14
LONGITUDE (DEG)											

APPENDIX B

GREENLAND DATA SUMMARY
DAY 287

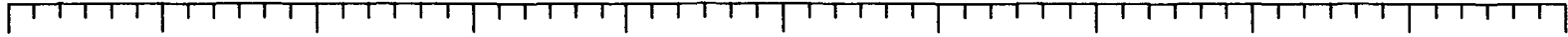

SFMR

AMSCAT (VV POLARIZATION)

AMSCAT (HH POLARIZATION)

13:10:01	13:12:01	13:14:01	13:16:01	13:18:01	13:20:01	13:22:01	13:24:01	13:26:01	13:28:01	13:30:01
GREENWICH MEAN TIME (HOUR:MIN:SEC)										
70.18	70.20	70.23	70.26	70.28		70.33	70.35			
LATITUDE (DEG)										
1.13	.72	.31	-.11	-.52		-1.37	-1.73			
LONGITUDE (DEG)										

GREENLAND DATA SUMMARY
DAY 287

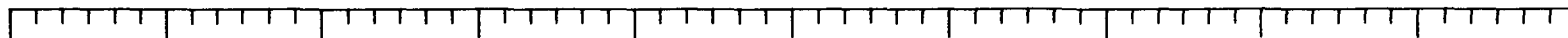

SFMR

AMSCAT (VV POLARIZATION)

AMSCAT (HH POLARIZATION)

13:30:01	13:32:01	13:34:01	13:36:01	13:38:01	13:40:01	13:42:01	13:44:01	13:46:01	13:48:01	13:50:01
GREENWICH MEAN TIME (HOUR:MIN:SEC)										
	70.45		70.48	70.49			70.53	70.54	70.55	
LATITUDE (DEG)										
	-3.93		-4.73	-5.22			-6.52	-6.96	-7.40	
LONGITUDE (DEG)										

APPENDIX B

GREENLAND DATA SUMMARY
DAY 287

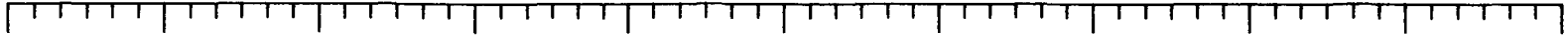

SFMR

AMSCAT (VV POLARIZATION)

AMSCAT (HH POLARIZATION)

13:50:02	13:52:02	13:54:02	13:56:02	13:58:02	14:00:02	14:02:02	14:04:02	14:06:02	14:08:02	14:10:02
GREENWICH MEAN TIME (HOUR:MIN:SEC)										
70.55	70.56	70.56	70.57		70.58	70.58	70.60	70.61	70.62	70.62
LATITUDE (DEG)										
-7.40	-7.83	-8.27	-8.71		-9.60	-10.05	-10.49	-10.93	-11.37	-11.81
LONGITUDE (DEG)										

GREENLAND DATA SUMMARY
DAY 287

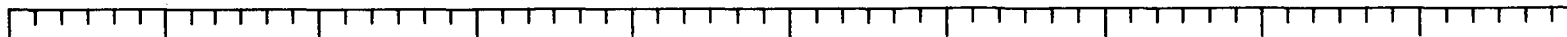

SFMR

AMSCAT (VV POLARIZATION)

AMSCAT (HH POLARIZATION)

14:10:02	14:12:02	14:14:02	14:16:02	14:18:02	14:20:02	14:22:02	14:24:02	14:26:02	14:28:02	14:30:02
GREENWICH MEAN TIME (HOUR:MIN:SEC)										
70.62	70.63	70.64	70.64	70.65	70.65	70.65	70.65	70.65	70.65	70.64
LATITUDE (DEG)										
-11.81	-12.24	-12.68	-13.12	-13.55	-13.99	-14.42	-14.86	-15.29	-15.73	-16.16
LONGITUDE (DEG)										

APPENDIX B

GREENLAND DATA SUMMARY
DAY 287

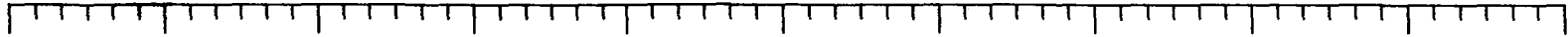

SFMR

AMSCAT (VV POLARIZATION)

AMSCAT (HH POLARIZATION)

14:30:03	14:32:03	14:34:03	14:36:03	14:38:03	14:40:03	14:42:03	14:44:03	14:46:03	14:48:03	14:50:03
GREENWICH MEAN TIME (HOUR:MIN:SEC)										
70.64		70.64	70.64	70.63	70.62	70.61	70.60	70.59	70.58	70.57
LATITUDE (DEG)										
-16.16		-17.04	-17.48	-17.92	-18.36	-18.80	-19.23	-19.66	-20.10	-20.54
LONGITUDE (DEG)										

GREENLAND DATA SUMMARY
DAY 287

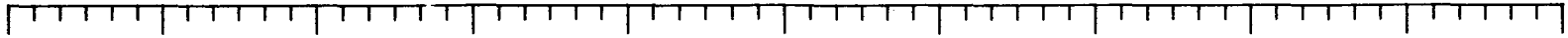

SFMR

AMSCAT (VV POLARIZATION)

AMSCAT (HH POLARIZATION)

14:50:03	14:52:03	14:54:03	14:56:03	14:58:03	15:00:03	15:02:03	15:04:03	15:06:03	15:08:03	15:10:03
GREENWICH MEAN TIME (HOUR:MIN:SEC)										
70.57	70.55		70.62	70.50	70.48		70.44	70.42	70.40	70.37
LATITUDE (DEG)										
-20.54	-20.38		-21.86	-22.23	-22.73		-23.60	-24.03	-24.46	-24.83
LONGITUDE (DEG)										

GREENLAND DATA SUMMARY
DAY 287

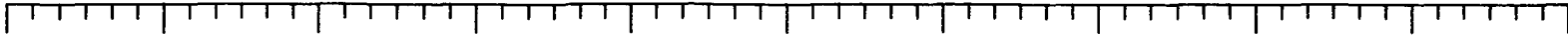

SFMR

AMSCAT (VV POLARIZATION)

AMSCAT (HH POLARIZATION)

15:10:04	15:12:04	15:14:04	15:16:04	15:18:04	15:20:04	15:22:04	15:24:04	15:26:04	15:28:04	15:30:04
GREENWICH MEAN TIME (HOUR:MIN:SEC)										
70.37	70.34	70.32	70.30	70.27		70.21	70.18	70.15	70.11	70.08
LATITUDE (DEG)										
-24.30	-25.32	-25.74	-26.16	-26.58		-27.41	-27.83	-28.24	-28.65	-29.06
LONGITUDE (DEG)										

GREENLAND DATA SUMMARY
DAY 287



SFMR

AMSCAT (VV POLARIZATION)

AMSCAT (VH POLARIZATION)

AMSCAT (HH POLARIZATION)



15:30:04	15:32:04	15:34:04	15:36:04	15:38:04	15:40:04	15:42:04	15:44:04	15:46:04	15:48:04	15:50:04
GREENWICH MEAN TIME (HOUR:MIN:SEC)										
70.08	70.05	70.01	69.98	69.95	69.92	69.89	69.86			69.76
LATITUDE (DEG)										
-29.06	-29.46	-29.86	-30.27	-30.69	-31.10	-31.52	-31.93			-33.16
LONGITUDE (DEG)										

APPENDIX B

GREENLAND DATA SUMMARY
DAY 287

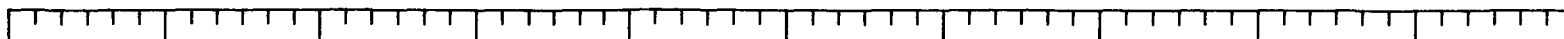

SFMR

AMSCAT (VV POLARIZATION)

AMSCAT (VH POLARIZATION)

AMSCAT (HH POLARIZATION)

15:50:05	15:52:05	15:54:05	15:56:05	15:58:05	16:00:05	16:02:05	16:04:05	16:06:05	16:08:05	16:10:05
GREENWICH MEAN TIME (HOUR:MIN:SEC)										
69.76	69.72	69.68	69.64		69.56	69.52	69.48	69.43	69.39	69.34
LATITUDE (DEG)										
-33.16	-33.57	-33.98	-34.40		-35.22	-35.64	-36.06	-36.47	-36.90	-37.31
LONGITUDE (DEG)										

GREENLAND DATA SUMMARY
DAY 287

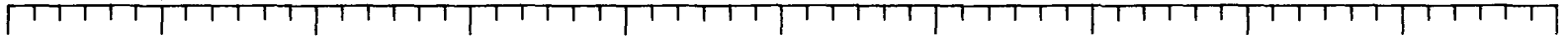

SFMR

AMSCAT (VV POLARIZATION)

AMSCAT (VH POLARIZATION)

AMSCAT (HH POLARIZATION)

16:10:05	16:12:05	16:14:05	16:16:05	16:18:05	16:20:05	16:22:05	16:24:05	16:26:05	16:28:05	16:30:05
GREENWICH MEAN TIME (HOUR:MIN:SEC)										
69.34	69.29	69.24	69.19	69.14		69.03	68.98		68.87	68.82
LATITUDE (DEG)										
-37.31	-37.73	-38.14	-38.56	-38.97		-39.79	-40.20		-41.01	-41.41
LONGITUDE (DEG)										

APPENDIX B

GREENLAND DATA SUMMARY
DAY 287

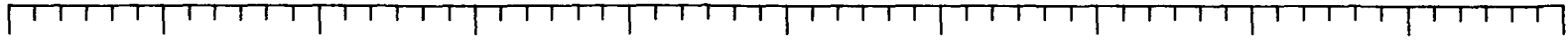

SFMR

AMSCAT (VV POLARIZATION)

AMSCAT (VH POLARIZATION)

AMSCAT (HH POLARIZATION)

16:30:06	16:32:06	16:34:06	16:36:06	16:38:06	16:40:06	16:42:06	16:44:06	16:46:06	16:48:06	16:50:06
GREENWICH MEAN TIME (HOUR:MIN:SEC)										
68.82	68.76	68.71	68.65	68.59	68.53	68.47		68.34	68.27	68.21
LATITUDE (DEG)										
-41.41	-41.81	-42.21	-42.61	-43.00	-43.41	-43.80		-44.60	-45.00	-45.39
LONGITUDE (DEG)										

GREENLAND DATA SUMMARY
DAY 287

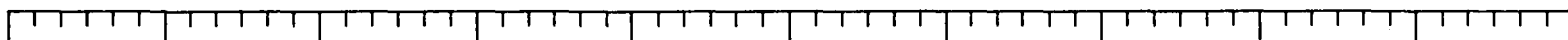

SFMR



AMSCAT (VV POLARIZATION)



AMSCAT (VH POLARIZATION)



AMSCAT (HH POLARIZATION)

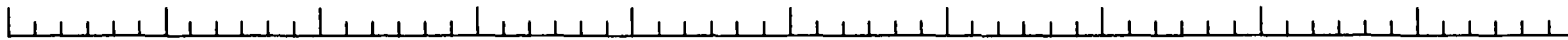

16:50:08	16:52:08	16:54:08	16:56:08	16:58:08	17:00:08	17:02:08	17:04:08	17:06:08	17:08:08	17:10:08
GREENWICH MEAN TIME (HOUR:MIN:SEC)										
68.21	68.14	68.00			67.86	67.79		67.64	67.55	
LATITUDE (DEG)										
-46.40	-46.80	-46.58			-47.35	-47.74		-48.50	-48.88	
LONGITUDE (DEG)										

APPENDIX B

GREENLAND FLIGHT LINE DAY 288

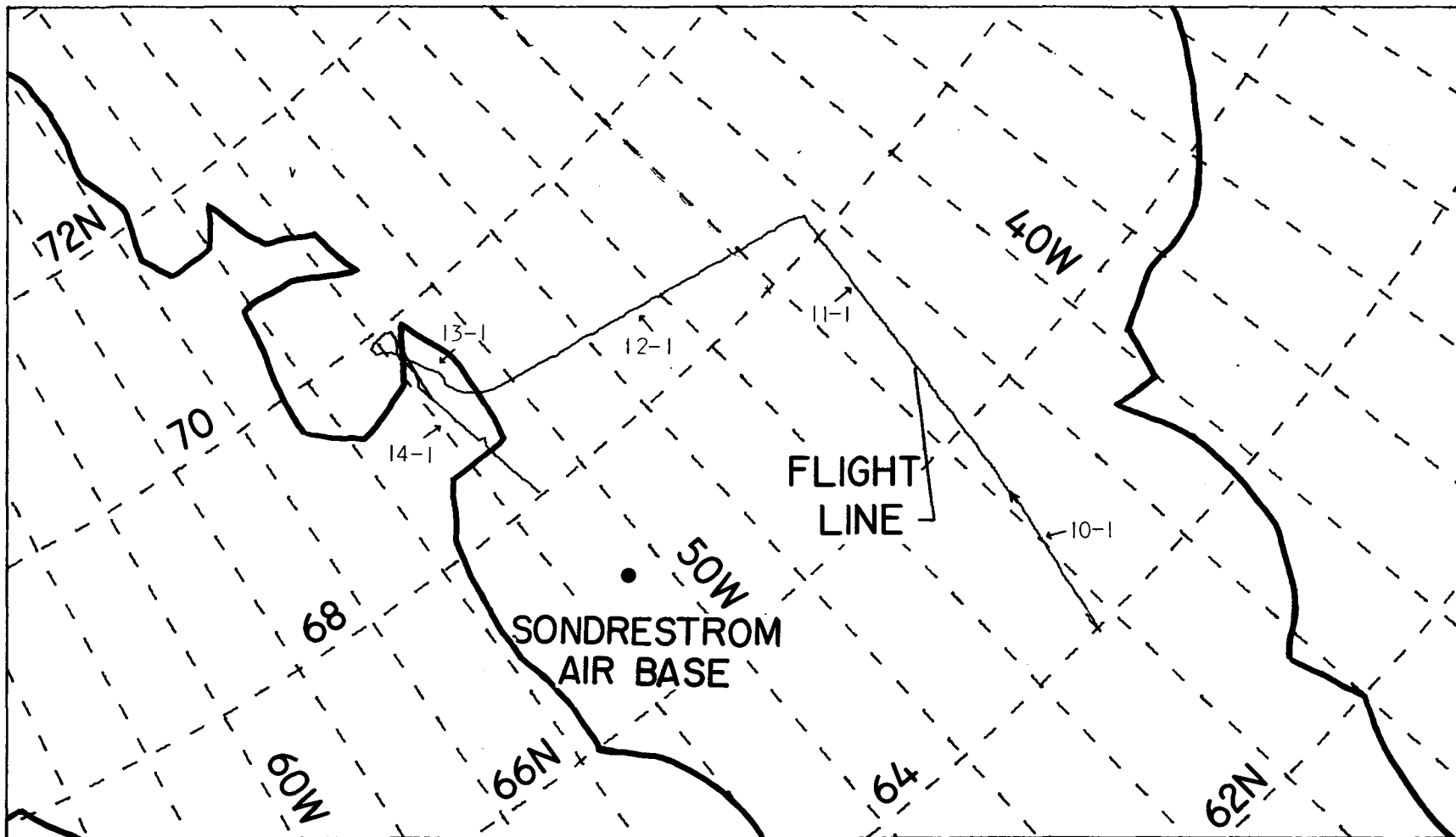

GREENLAND FLIGHT LINE
DAY 288

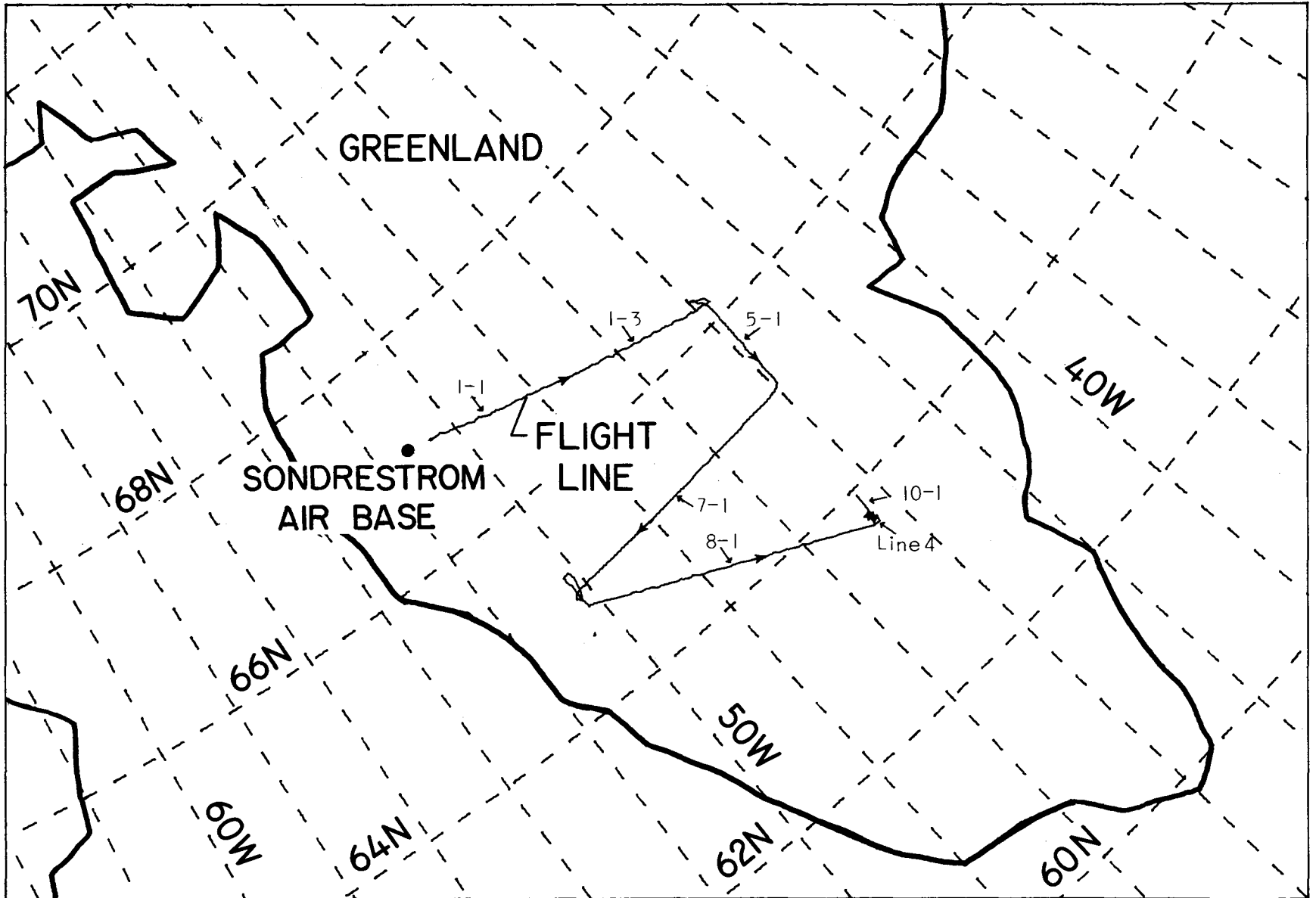

GREENLAND DATA SUMMARY
DAY 288

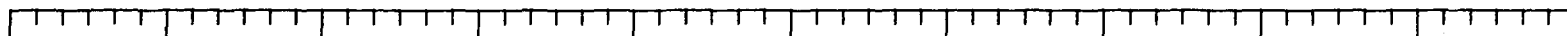

PRT5

SFMR

AMSCAT (VV POLARIZATION)

AMSCAT (VH POLARIZATION)

AMSCAT (HV POLARIZATION)

AMSCAT (HH POLARIZATION)

12:31:40	12:33:40	12:35:40	12:37:40	12:39:40	12:41:40	12:43:40	12:45:40	12:47:40	12:49:40	12:51:40
GREENWICH MEAN TIME (HOUR:MIN:SEC)										
	66.98	66.96	66.93	66.90	66.87	66.85	66.82	66.80		
LATITUDE (DEG)										
	-60.55	-50.31	-50.10	-49.88	-49.65	-49.42	-49.19	-48.97		
LONGITUDE (DEG)										

GREENLAND DATA SUMMARY
DAY 288

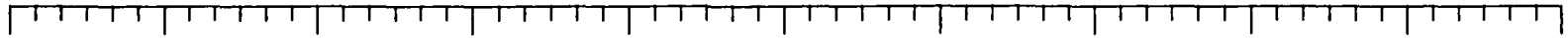

PRT5

SFMR

AMSCAT (VV POLARIZATION)

AMSCAT (VH POLARIZATION)

AMSCAT (HV POLARIZATION)

AMSCAT (HH POLARIZATION)

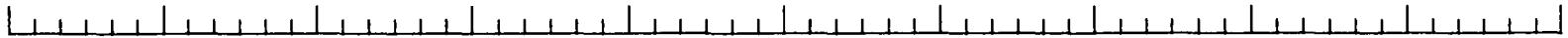

12:51:40	12:53:40	12:55:40	12:57:40	12:59:40	13:01:40	13:03:40	13:05:40	13:07:40	13:09:40	13:11:40
GREENWICH MEAN TIME (HOUR:MIN:SEC)										
66.77	66.74	66.72	66.69	66.66	66.64	66.61	66.58	66.55	66.52	
LATITUDE (DEG)										
-48.74	-48.52	-48.29	-48.07	-47.85	-47.63	-47.40	-47.18	-46.96	-46.75	
LONGITUDE (DEG)										

APPENDIX B

GREENLAND DATA SUMMARY
DAY 288

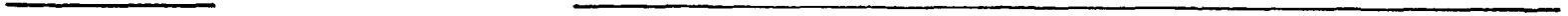
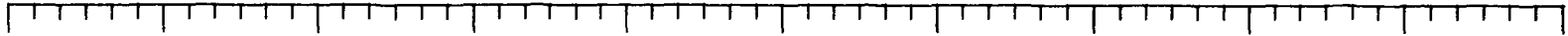

PRT5

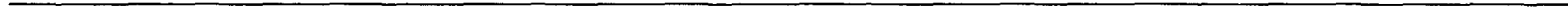

SFMR

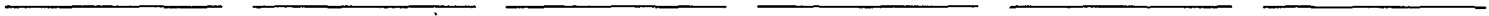

AMSCAT (VV POLARIZATION)



AMSCAT (VH POLARIZATION)



AMSCAT (HH POLARIZATION)

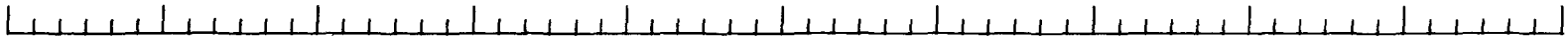

13:11:40	13:13:40	13:15:40	13:17:40	13:19:40	13:21:40	13:23:40	13:25:40	13:27:40	13:29:40	13:31:40
GREENWICH MEAN TIME (HOUR:MIN:SEC)										
66.50	66.48	66.44	66.42	66.40	66.37	66.35	66.32	66.30	66.27	66.24
LATITUDE (DEG)										
-46.53	-46.31	-46.12	-45.90	-45.68	-45.47	-45.24	-45.03	-44.80	-44.58	-44.36
LONGITUDE (DEG)										

GREENLAND DATA SUMMARY
DAY 288

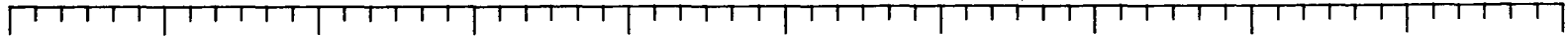

PRT5

SFMR

AMSCAT (VV POLARIZATION)

AMSCAT (VH POLARIZATION)

AMSCAT (HV POLARIZATION)

AMSCAT (HH POLARIZATION)

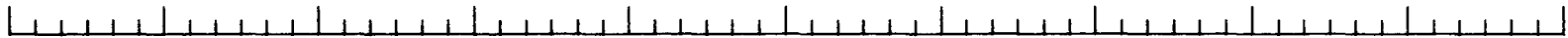

13:31:41	13:33:41	13:35:41	13:37:41	13:39:41	13:41:41	13:43:41	13:45:41	13:47:41	13:49:41	13:51:41
GREENWICH MEAN TIME (HOUR:MIN:SEC)										
66.24	66.22	66.19	66.16	66.23	66.28	66.35	66.30	66.24	66.19	66.12
LATITUDE (DEG)										
-44.36	-44.15	-43.93	-43.72	-43.70	-43.94	-44.00	-43.91	-43.86	-43.75	-43.73
LONGITUDE (DEG)										

GREENLAND DATA SUMMARY
DAY 288

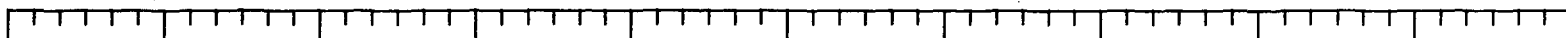

PRT5

SFMR

AMSCAT (VV POLARIZATION)

AMSCAT (VH POLARIZATION)

AMSCAT (HV POLARIZATION)

AMSCAT (HH POLARIZATION)

13:51:41	13:53:41	13:55:41	13:57:41	13:59:41	14:01:41	14:03:41	14:05:41	14:07:41	14:09:41	14:11:41
GREENWICH MEAN TIME (HOUR:MIN:SEC)										
66.12	66.05	65.98	65.90	65.83	65.75	65.68	65.60	65.53	65.45	65.38
LATITUDE (DEG)										
-43.73	-43.74	-43.76	-43.78	-43.80	-43.81	-43.82	-43.84	-43.86	-43.87	-43.89
LONGITUDE (DEG)										

GREENLAND DATA SUMMARY
DAY 288

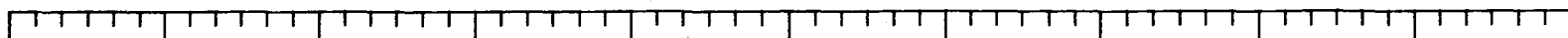

PRT5

SFMR

AMSCAT (VV POLARIZATION)

AMSCAT (VH POLARIZATION)

AMSCAT (HH POLARIZATION)

14:11:42	14:13:42	14:15:42	14:17:42	14:19:42	14:21:42	14:23:42	14:25:42	14:27:42	14:29:42	14:31:42
GREENWICH MEAN TIME (HOUR:MIN:SEC)										
65.38	65.30	65.23	65.16	65.15	65.14	65.14	65.14	65.13	65.13	65.13
LATITUDE (DEG)										
-43.89	-43.90	-43.92	-43.98	-44.22	-44.47	-44.74	-45.00	-45.26	-45.53	-45.78
LONGITUDE (DEG)										

APPENDIX B

GREENLAND DATA SUMMARY
DAY 288

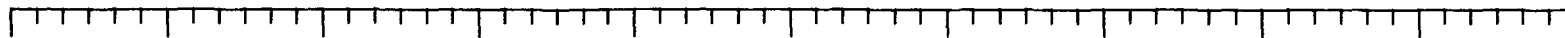

PRT5

SFMR

AMSCAT (VV POLARIZATION)

AMSCAT (VH POLARIZATION)

AMSCAT (HV POLARIZATION)

AMSCAT (HH POLARIZATION)

14:31:42	14:33:42	14:35:42	14:37:42	14:39:42	14:41:42	14:43:42	14:45:42	14:47:42	14:49:42	14:51:42
GREENWICH MEAN TIME (HOUR:MIN:SEC)										
65.13	65.13	65.12		65.11	65.11	65.10	65.10	65.09	65.08	65.08
LATITUDE (DEG)										
-45.76	-46.03	-46.28		-46.62	-47.00	-47.34	-47.60	-47.87	-48.14	-48.37
LONGITUDE (DEG)										

GREENLAND DATA SUMMARY
DAY 288

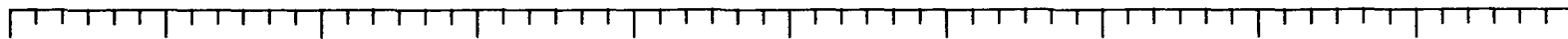

PRT5

SFMR

AMSCAT (VV POLARIZATION)

AMSCAT (VH POLARIZATION)

AMSCAT (HV POLARIZATION)

AMSCAT (HH POLARIZATION)

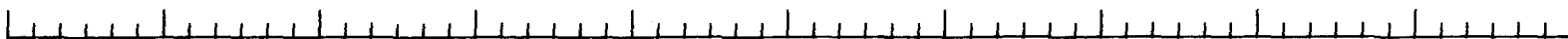

14:51:43	14:53:43	14:55:43	14:57:43	14:59:43	15:01:43	15:03:43	15:05:43	15:07:43	15:09:43	15:11:43
GREENWICH MEAN TIME (HOUR:MIN:SEC)										
85.08	85.08	85.07	85.06	85.05	85.05	85.04	85.03	85.01	84.94	85.02
LATITUDE (DEG)										
-48.37	-48.60	-48.85	-49.10	-49.37	-49.61	-49.86	-50.12	-50.36	-50.31	-50.21
LONGITUDE (DEG)										

APPENDIX B

GREENLAND DATA SUMMARY
DAY 288

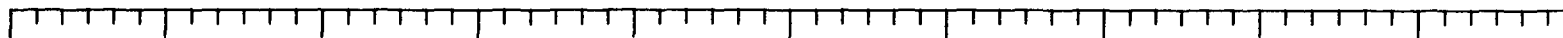

PRT5

SFMR

AMSCAT (VV POLARIZATION)

AMSCAT (VH POLARIZATION)

AMSCAT (HV POLARIZATION)

AMSCAT (HH POLARIZATION)



15:11:43	15:13:43	15:15:43	15:17:43	15:19:43	15:21:43	15:23:43	15:25:43	15:27:43	15:29:43	15:31:43
GREENWICH MEAN TIME (HOUR:MIN:SEC)										
65.02	65.12	65.21	65.13	65.02	64.91	64.84	64.80	64.75	64.68	64.62
LATITUDE (DEG)										
-50.21	-50.15	-50.21	-50.31	-50.29	-50.90	-50.15	-49.93	-49.66	-49.36	-49.07
LONGITUDE (DEG)										

GREENLAND DATA SUMMARY
DAY 288

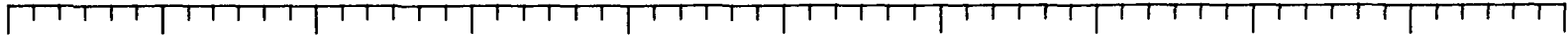

PRT5

SFMR

AMSCAT (VV POLARIZATION)

AMSCAT (VH POLARIZATION)

AMSCAT (HH POLARIZATION)

15:31:44	15:33:44	15:35:44	15:37:44	15:39:44	15:41:44	15:43:44	15:45:44	15:47:44	15:49:44	15:51:44
GREENWICH MEAN TIME (HOUR:MIN:SEC)										
64.62	64.56	64.50	64.43	64.37	64.30	64.24	64.17	64.11	64.04	63.98
LATITUDE (DEG)										
-49.06	-48.75	-48.45	-48.14	-47.83	-47.53	-47.24	-46.96	-46.66	-46.35	-46.08
LONGITUDE (DEG)										

APPENDIX B

GREENLAND DATA SUMMARY
DAY 288

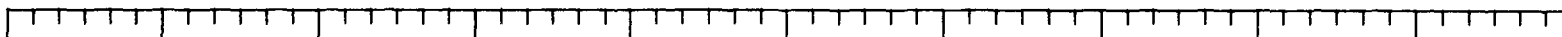

PRT5

SFMR

AMSCAT (VV POLARIZATION)

AMSCAT (VH POLARIZATION)

AMSCAT (HV POLARIZATION)

AMSCAT (HH POLARIZATION)

15:51:44	15:53:44	15:55:44	15:57:44	15:59:44	16:01:44	16:03:44	16:05:44	16:07:44	16:09:44	16:11:44
GREENWICH MEAN TIME (HOUR:MIN:SEC)										
63.98	63.90	63.84	63.77	63.70	63.62	63.70	63.68	63.67	63.74	63.75
LATITUDE (DEG)										
-46.08	-45.76	-45.50	-45.21	-44.93	-44.61	-44.56	-44.50	-44.63	-44.66	-44.55
LONGITUDE (DEG)										

GREENLAND DATA SUMMARY
DAY 288

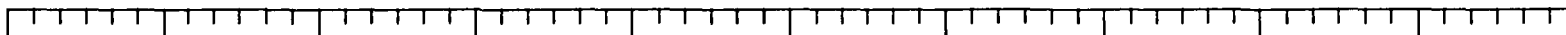

PRT5

SFMR

AMSCAT (VV POLARIZATION)

AMSCAT (VH POLARIZATION)

AMSCAT (HH POLARIZATION)

16:31:45	16:33:45	16:35:45	16:37:45	16:39:45	16:41:45	16:43:45	16:45:45	16:47:45	16:49:45	16:51:45
GREENWICH MEAN TIME (HOUR:MIN:SEC)										
65.10	65.25	65.42	65.58	65.74	65.91	66.08	66.24	66.41	66.58	66.75
LATITUDE (DEG)										
-43.83	-43.75	-43.69	-43.62	-43.56	-43.49	-43.41	-43.34	-43.27	-43.19	-43.12
LONGITUDE (DEG)										

APPENDIX B

GREENLAND DATA SUMMARY
DAY 288

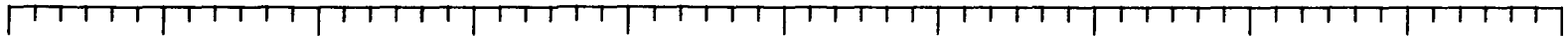

PRT5

SFMR

AMSCAT (VV POLARIZATION)

AMSCAT (VH POLARIZATION)

AMSCAT (HH POLARIZATION)

16:51:46	16:53:46	16:55:46	16:57:46	16:59:46	17:01:46	17:03:46	17:05:46	17:07:46	17:09:46	17:11:46
GREENWICH MEAN TIME (HOUR:MIN:SEC)										
66.75	66.92	67.07	67.25	67.42	67.59	67.76	67.92	68.09	68.24	68.30
LATITUDE (DEG)										
-43.12	-43.04	-42.96	-42.88	-42.81	-42.72	-42.64	-42.56	-42.47	-42.40	-42.30
LONGITUDE (DEG)										

GREENLAND DATA SUMMARY
DAY 288

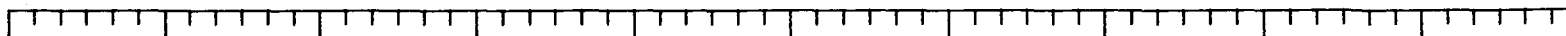

PRT5

SFMR

AMSCAT (VV POLARIZATION)

AMSCAT (VH POLARIZATION)

AMSCAT (HH POLARIZATION)

17:11:46	17:13:46	17:15:46	17:17:46	17:19:46	17:21:46	17:23:46	17:25:46	17:27:46	17:29:46	17:31:46
GREENWICH MEAN TIME (HOUR:MIN:SEC)										
68.30	68.34	68.39	68.43	68.48	68.52	68.56	68.60	68.65	68.68	68.72
LATITUDE (DEG)										
-42.88	-43.30	-43.73	-44.15	-44.58	-45.00	-45.43	-45.86	-46.30	-46.72	-47.16
LONGITUDE (DEG)										

APPENDIX B

GREENLAND DATA SUMMARY
DAY 288

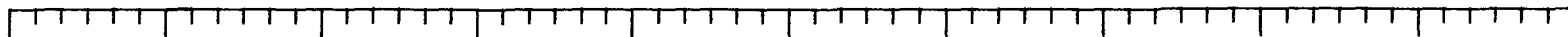

PRT5

SFMR

AMSCAT (VV POLARIZATION)

AMSCAT (VH POLARIZATION)

AMSCAT (HV POLARIZATION)

AMSCAT (HH POLARIZATION)

17:31:47	17:33:47	17:36:47	17:37:47	17:39:47	17:41:47	17:43:47	17:45:47	17:47:47	17:49:47	17:51:47
GREENWICH MEAN TIME (HOUR:MIN:SEC)										
68.72	68.76	68.79	68.83	68.86	68.89	68.92	68.95		69.08	69.20
LATITUDE (DEG)										
-47.16	-47.59	-48.02	-48.46	-48.90	-49.33	-49.77	-50.21		-51.00	-51.24
LONGITUDE (DEG)										

GREENLAND DATA SUMMARY
DAY 288

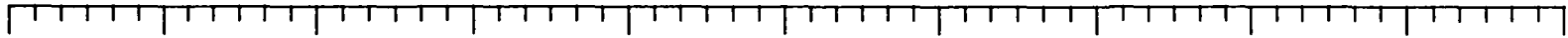

PRT5

SFMR

AMSCAT (VV POLARIZATION)

AMSCAT (HH POLARIZATION)

17:51:47	17:53:47	17:55:47	17:57:47	17:59:47	18:01:47	18:03:47	18:05:47	18:07:47	18:09:47	18:11:47
GREENWICH MEAN TIME (HOUR:MIN:SEC)										
69.20	69.33	69.44	69.53	69.61	69.68	69.78	69.82	69.89	69.93	69.93
LATITUDE (DEG)										
-51.24	-51.23	-51.38	-51.52	-51.64	-51.76	-51.89	-52.11	-52.22	-51.97	-51.69
LONGITUDE (DEG)										

GREENLAND DATA SUMMARY
DAY 288

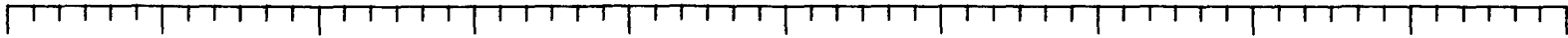

PRT5

SFMR

AMSCAT (VV POLARIZATION)

AMSCAT (VH POLARIZATION)

AMSCAT (HH POLARIZATION)

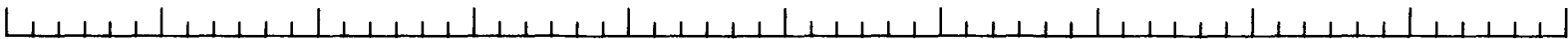

10:11:40	10:13:40	10:15:40	10:17:40	10:19:40	10:21:40	10:23:40	10:25:40	10:27:40	10:29:40	10:31:40
GREENWICH MEAN TIME (HOUR:MIN:SEC)										
69.93	69.84	69.73	69.61	69.48	69.36	69.26	69.12	68.99	68.87	68.74
LATITUDE (DEG)										
-51.66	-51.59	-51.77	-51.76	-51.72	-51.66	-51.79	-51.72	-51.66	-51.59	-51.52
LONGITUDE (DEG)										

REFERENCES

1. Harrington, Richard F.: The Development of a Stepped Frequency Microwave Radiometer and Its Application to Remote Sensing of the Earth. NASA TM-81847, 1980.
2. Instruction Manual for Precision Radiation Thermometer Model PRT-5. Barnes Eng. Co.
3. Hennigar, Harold F.; and Schaffner, Sally K.: NORSEX 79 Microwave Remote Sensing Data Summary Report September 29 - October 12, 1979. NASA CR-165967, 1982.

TABLE I.- SUMMARY OF DATA FLIGHT DAYS

Flight information	Julian Day	
	287	288
Calendar day	Oct. 14, 1979	Oct. 15, 1979
Origin	Tromsø, Norway	Sondrestrom Air Base, Greenland
Test site	Central Greenland ice cap	South Greenland ice cap
Destination	Sondrestrom Air Base, Greenland	Sondrestrom Air Base, Greenland

TABLE II.- AMSCAT OPERATING CHARACTERISTICS

Selectable characteristics:

Polarization HH*, HV, VV, VH
 Incidence angle, deg 0 to 54
 Azimuth angle (relative to heading), deg 15 to 345

Nonselectable characteristics:

Frequency, GHz 14.6
 σ° sampling rate, s^{-1} 2
 Absolute σ° accuracy, dB ± 1.0
 σ° precision, dB ± 0.1
 Antenna beam width, deg 3.5
 Total σ° range, dB 15 to -30

*Transmit horizontal and receive horizontal. With transmit and receive each either horizontal or vertical, there are four possible combinations. When transmit and receive are of like polarization, the system is said to be in dominant polarization, and when opposed, in cross-polarization.

TABLE III.- PRT-5 OPERATING CHARACTERISTICS

Temperature measurement range, $^\circ C$ -35 to +75
 Accuracy, $^\circ C$ 0.5
 Sensitivity (at 25 $^\circ C$), $^\circ C$ 0.1
 Filter band, μm 8 to 14
 Field of view, deg 2



L-82-12,487

Figure 1.- The NASA C-130 aircraft (NASA 929).

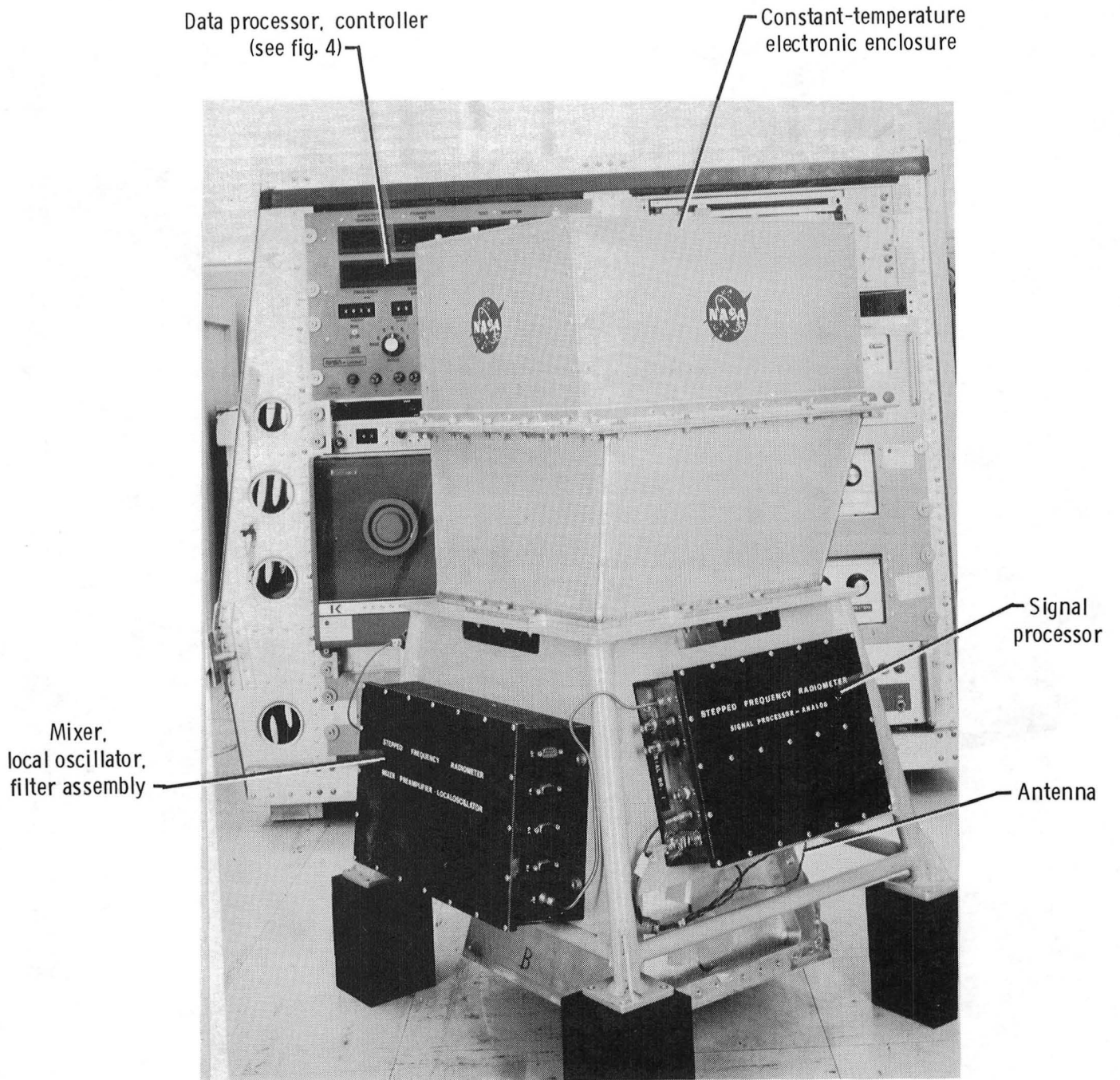

L-83-35

Figure 2.- Stepped frequency microwave radiometer.

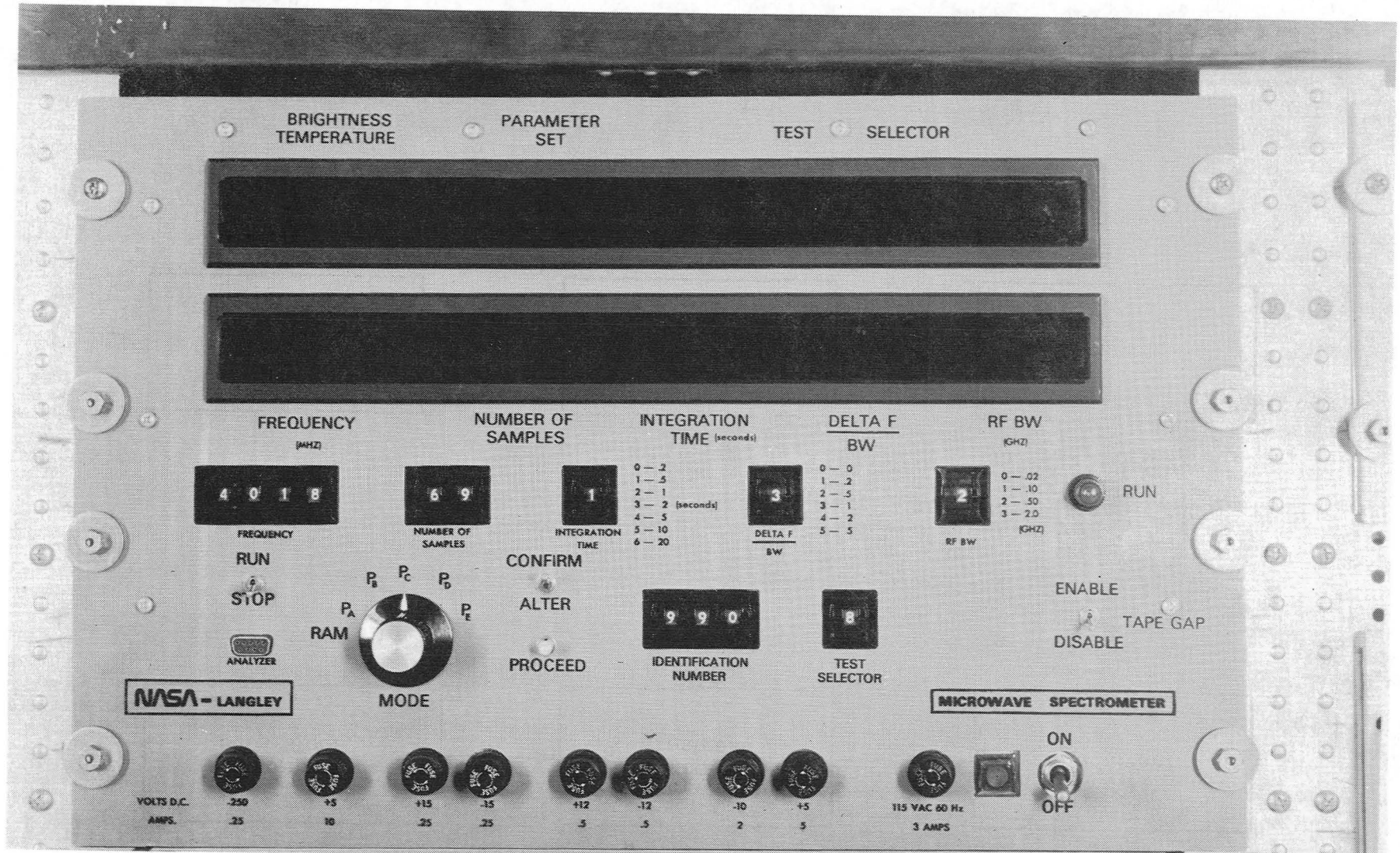

L-77-4488

Figure 3.- Front panel of the digital controller for the stepped frequency microwave radiometer (SFMR).

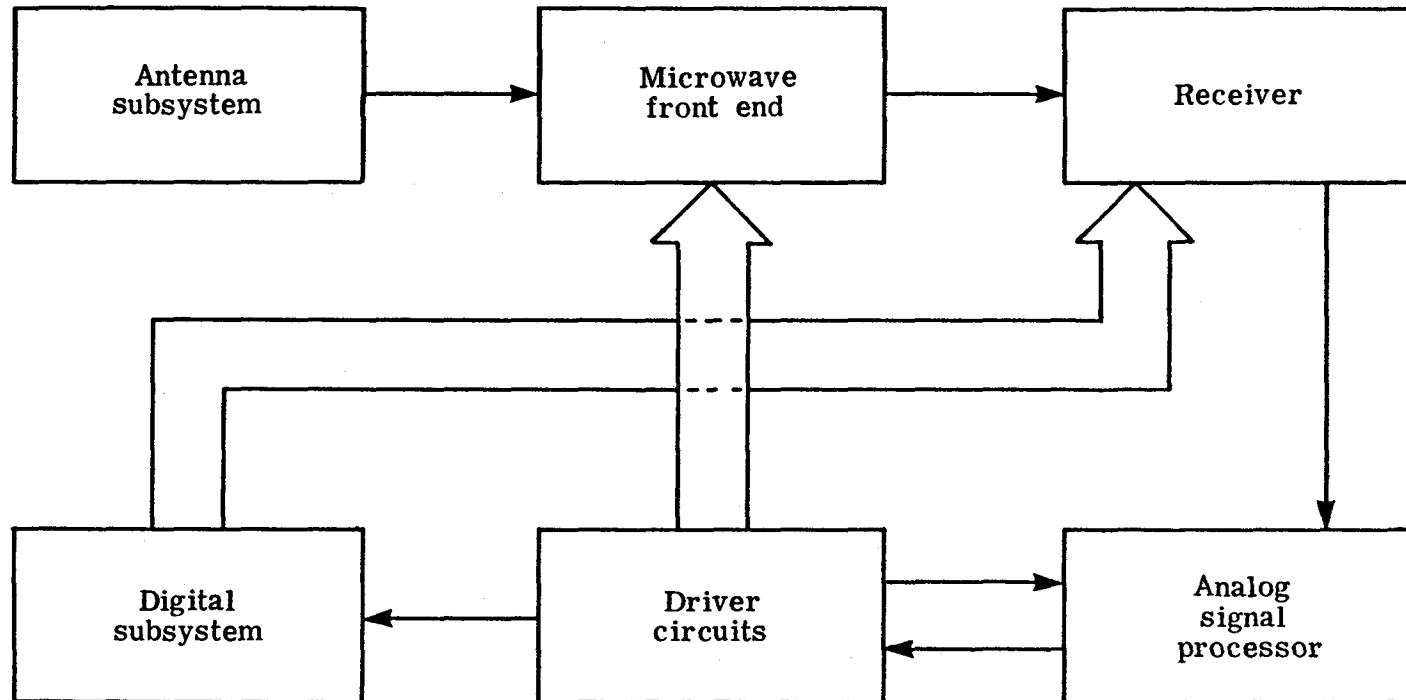

Figure 4.- Block diagram of the stepped frequency microwave radiometer (SFMR).

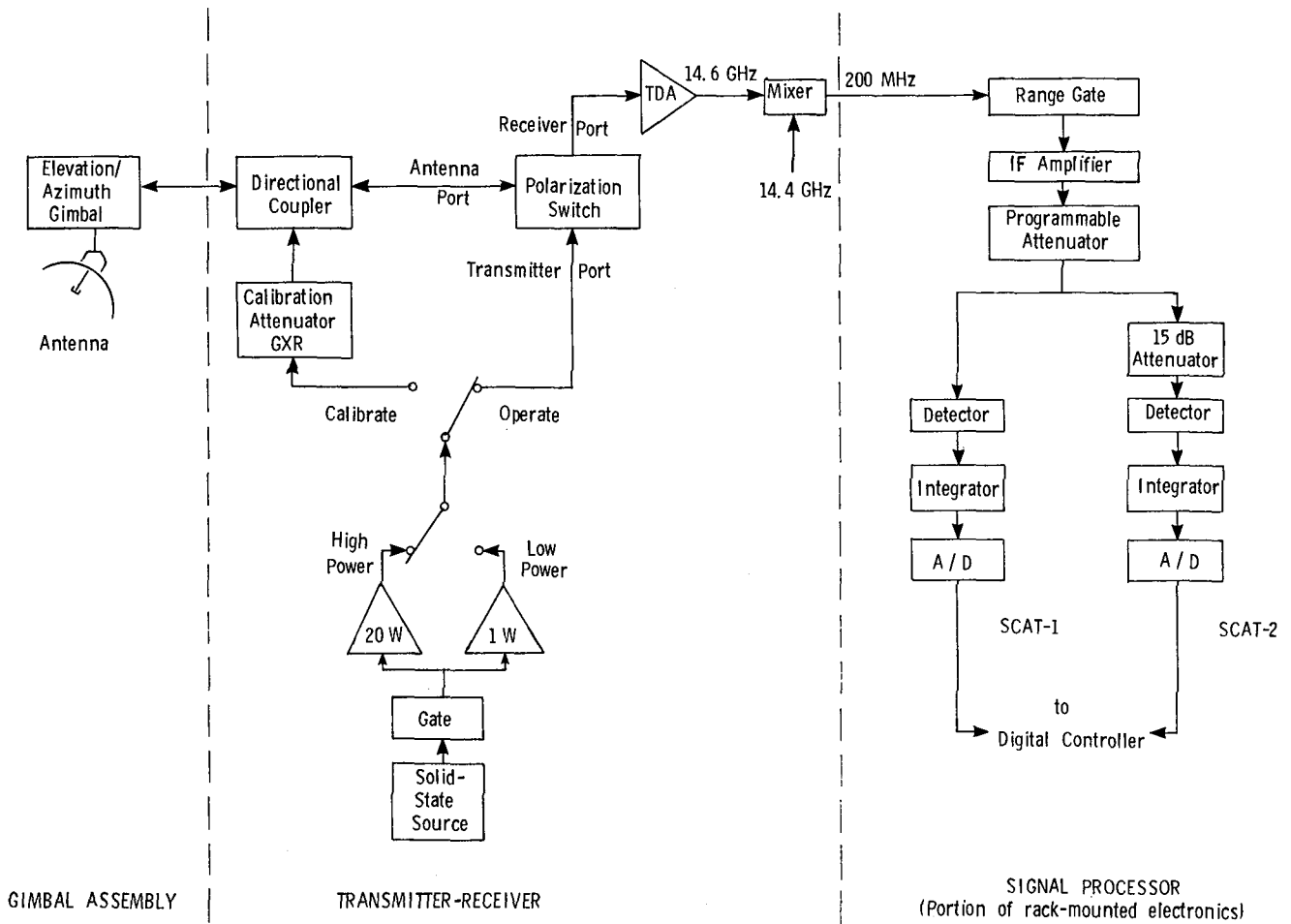

Figure 5.- Simplified block diagram of the airborne microwave scatterometer (AMSCAT).

AMSCAT
Antenna
(less feed
and Radome)

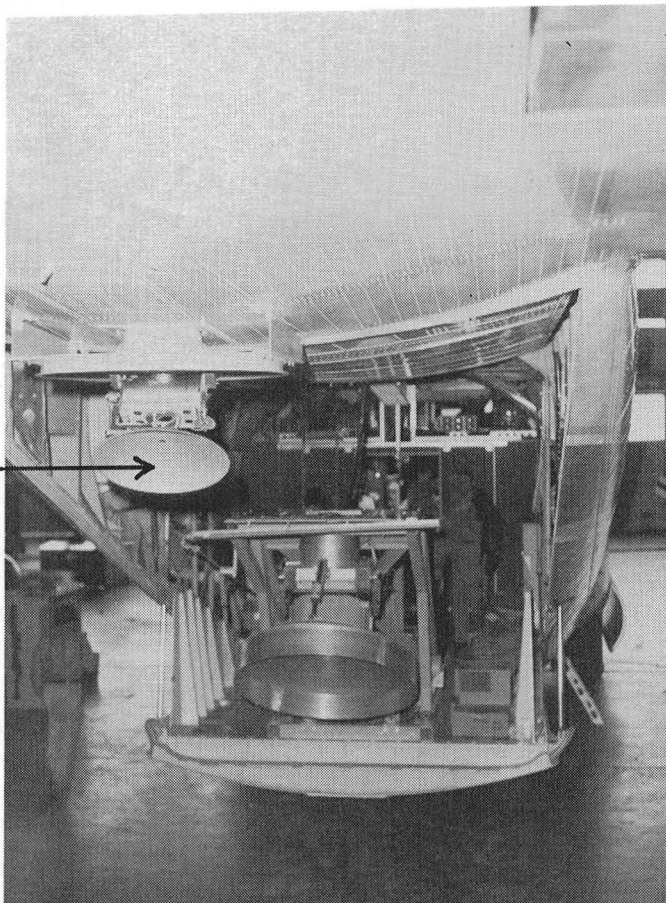

Figure 6.- AMSCAT gimbal assembly on C-130 aircraft.

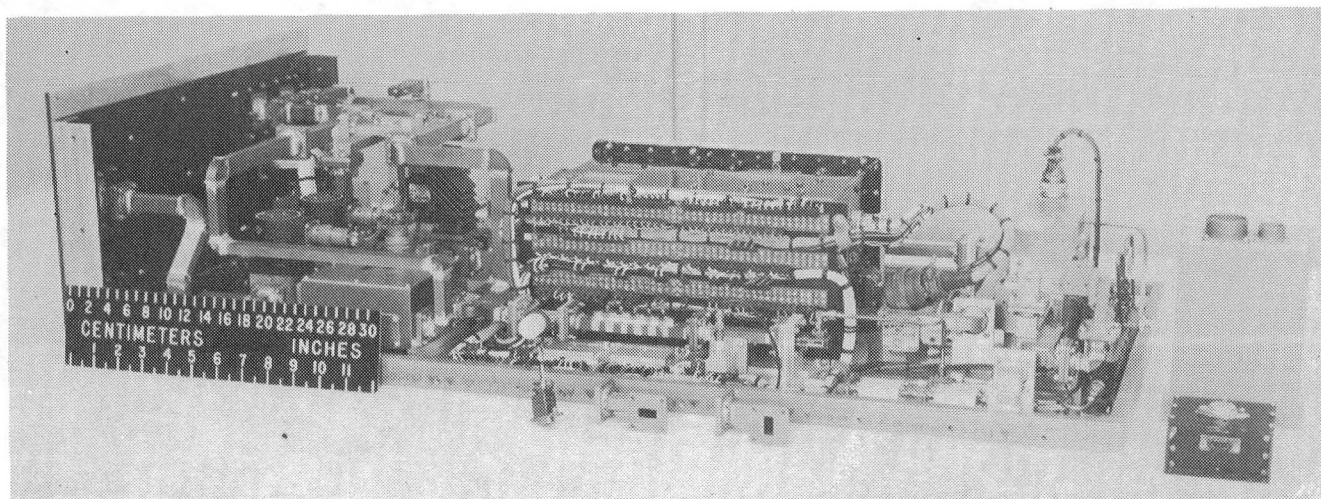

Figure 7.- AMSCAT transmitter-receiver assembly.

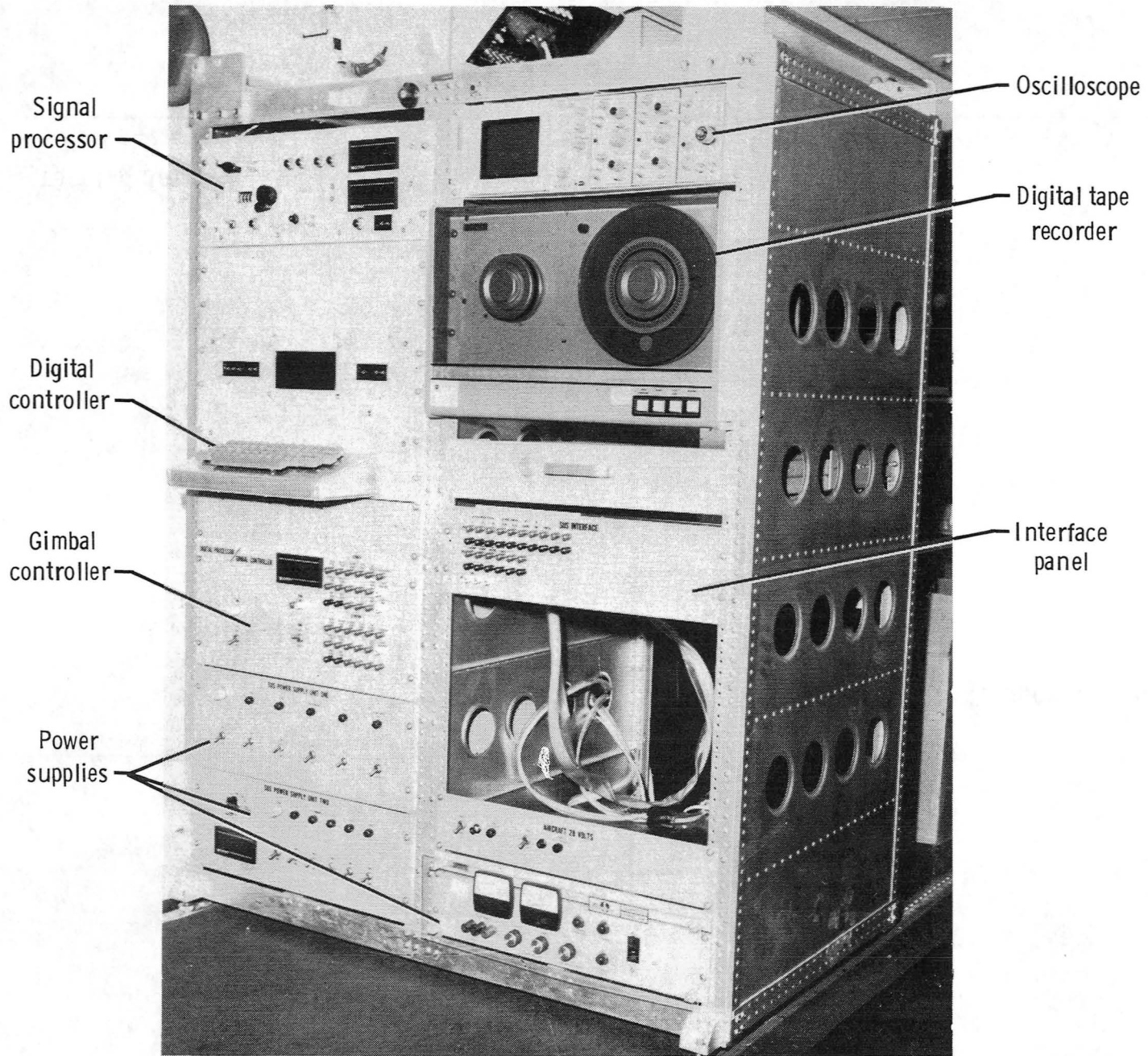

Figure 8.- Rack-mounted electronics for AMSCAT.

L-83-36

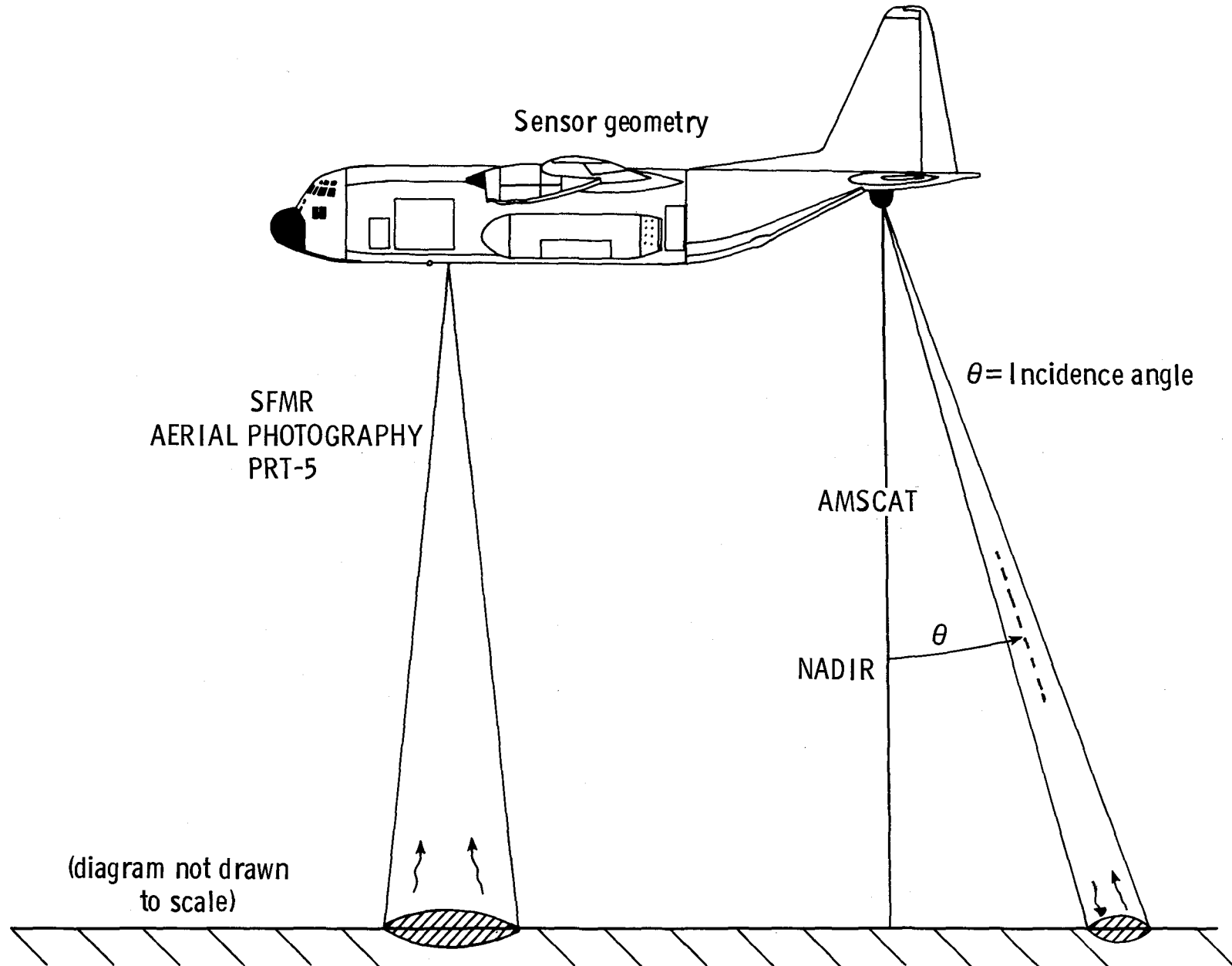

Figure 9.- Arrangement of sensors onboard the NASA C-130.

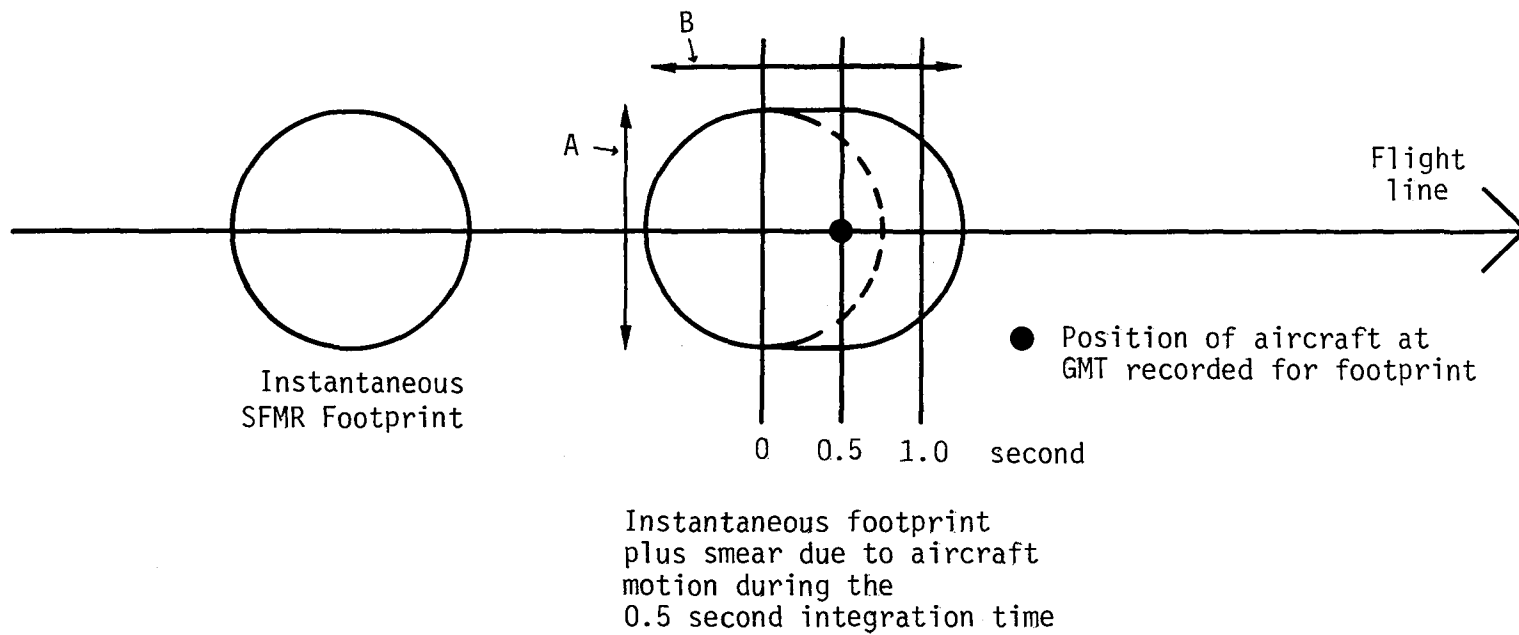

Figure 10.- SFMR footprints. (Not drawn to scale.)

GREENLAND DATA SUMMARY
A DAY 288

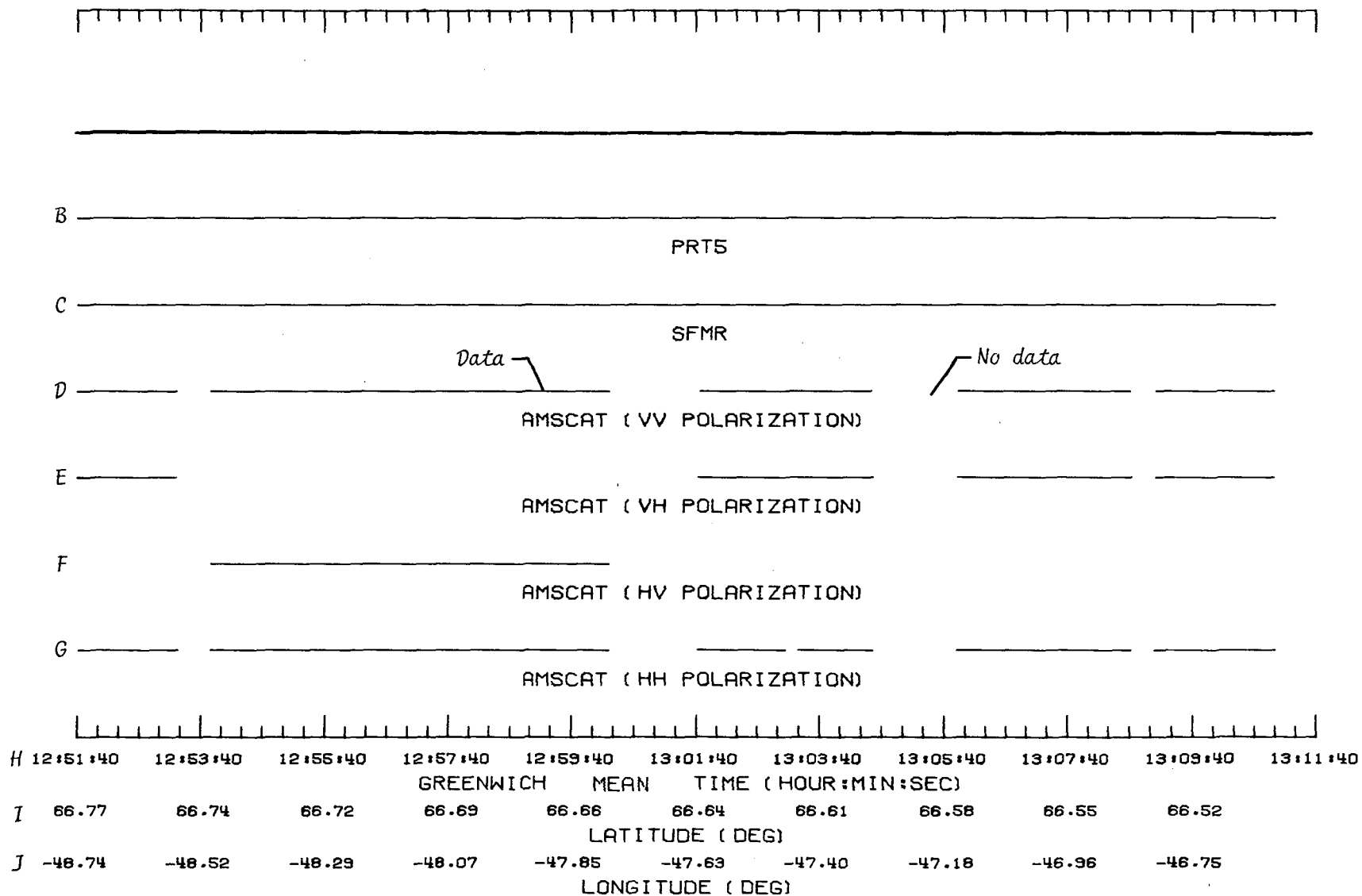

Figure 11.- Sample time-line plot.

1. Report No. NASA TM-84571		2. Government Accession No.		3. Recipient's Catalog No.	
4. Title and Subtitle GREENLAND 1979 MICROWAVE REMOTE SENSING DATA CATALOG REPORT - OCTOBER 14 AND 15, 1979				5. Report Date March 1983	
				6. Performing Organization Code 506-58-23-01	
7. Author(s) Harold F. Hennigar, William S. Hirstein, Sally K. Schaffner, Victor E. Delnore, and William L. Grantham				8. Performing Organization Report No. L-15529	
9. Performing Organization Name and Address NASA Langley Research Center Hampton, VA 23665				10. Work Unit No.	
				11. Contract or Grant No.	
12. Sponsoring Agency Name and Address National Aeronautics and Space Administration Washington, DC 20546				13. Type of Report and Period Covered Technical Memorandum	
				14. Sponsoring Agency Code	
15. Supplementary Notes Harold F. Hennigar: Deepsea Ventures, Inc., Gloucester Point, Virginia. William S. Hirstein: Bionetics Corp., Hampton, Virginia. Sally K. Schaffner: OAO Corp., Hampton, Virginia. Victor E. Delnore: Kentron International, Inc., Hampton, Virginia. William L. Grantham: Langley Research Center, Hampton, Virginia.					
16. Abstract Microwave remote sensing measurements are cataloged for active and passive instruments in support of the 1979 Greenland Remote Sensing Experiment. The Langley Research Center instruments used in this field experiment include the stepped frequency microwave radiometer (4 to 8 GHz) and the airborne microwave scatterometer (14.6 GHz). The microwave signature data are inventoried and cataloged in a user-friendly format and are available on 9-track computer-compatible tapes upon request.					
17. Key Words (Suggested by Author(s)) Microwave Remote sensing Radar signatures			18. Distribution Statement Unclassified - Unlimited Subject Category 48		
19. Security Classif. (of this report) Unclassified	20. Security Classif. (of this page) Unclassified	21. No. of Pages 63	22. Price A04		

National Aeronautics and
Space Administration

Washington, D.C.
20546

Official Business

Penalty for Private Use, \$300

TH



Postage and Fees Paid
National Aeronautics and
Space Administration
NASA-451



POSTMASTER: If Undeliverable (Section 158
Postal Manual) Do Not Return

LIBRARY MATERIAL SLIP		
DO NOT REMOVE SLIP FROM MATERIAL		
Delete your name from this slip when returning material to the library.		
NAME	DATE	MS
JOHNSON, JAMES W	" / 13 / 00	473

NASA Langley Form 474 (Rev. Oct. 1999)