

N83 22296

ORBITER CARGO BAY THERMAL ENVIRONMENT DATA

R. G. Brown
Johnson Space Center

**ORIGINAL PAGE IS
OF POOR QUALITY**

**ORBITER CARGO BAY
THERMAL ENVIRONMENT DATA**

**ROBERT G. BROWN
SEPTEMBER 1982**



ORBITAL FLIGHT TEST THERMAL APPROACH

- **CONSERVATIVE FLIGHT TEST TIMELINE**
- **FIRST FLIGHT THERMALLY BENIGN AS POSSIBLE**
- **EACH ADDITIONAL FLIGHT INCREASING IN
THERMAL DIFFICULTY**
- **MEASUREMENT LOCATIONS DEFINED FOR ORBITER
PERFORMANCE**
- **ORBITER MODEL PREDICTION COMPARISON FOR
STS-1**
- **ORBITER MODEL CORRELATION BASED ON STS-2,
STS-3 AND STS-4**

ORBITAL FLIGHT TEST PROGRAM

	STS-1	STS-2	STS-3	STS-4
DATE	APRIL 12, 1981	NOVEMBER 12, 1981	MARCH 22, 1982	JUNE 27, 1982
BETA ANGLE	-26° TO -19°	-45° TO -51°	-23° TO -36°	-1 TO +20°
MAJOR ATTITUDES FLOWN	SERIES OF SHORT HOLD ATTITUDES EXCEPT FOR TWO 9-9.5 HRS OF +ZLV	BASICALLY +ZLV	24 HRS TAIL SUN TOP TO SPACE ORB RATE 11 HRS PTC 80 HRS XSI (NOSE TO SUN 2 REV PER ORBIT ABOUT X-AXIS) 27 HRS +ZSI (TOP 3-AXIS SI) 12 HRS PTC	10 HRS -ZSI (BOTTOM 3-AXIS SI) 7 HRS GRAVITY 12 HRS +ZLV (TOP 3-AXIS SI) 4½ HRS +ZSI 22 HRS -ZSI (BOTTOM 3-AXIS SI) 10 HRS PTC 61 HRS +XSI (TAIL 3-AXIS SI) 12 HRS PTC
END OF MISSION ATTITUDES	2 ORBITS TAIL TO SUN OPENED DOOR 2 ORBITS TOP TO SUN CLOSED DOOR	2 ORBITS TAIL TO SUN OPENED DOOR 2 ORBITS TOP TO SUN CLOSED DOOR	2 ORBITS TAIL TO SUN OPENED DOOR 2 ORBITS TOP TO SUN CLOSED DOOR	2 ORBITS TAIL TO SUN OPENED DOOR 2 ORBITS TOP TO SUN CLOSED DOOR

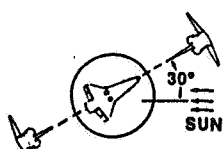
ORBITER ATTITUDES

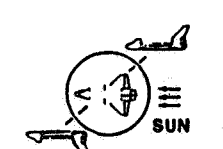
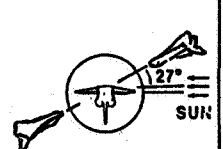
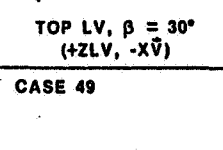
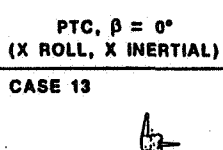
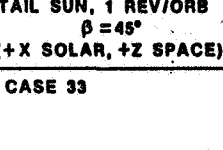
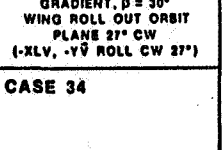
 <p>TOP LV, $\beta = 30^\circ$ (+ZLV, -XV)</p>	 <p>PTC, $\beta = 0^\circ$ (X ROLL, X INERTIAL)</p>	 <p>TAIL SUN, 1 REV/ORB $\beta = 45^\circ$ (+X SOLAR, +Z SPACE)</p>	 <p>NOSE LV, GRAVITY GRADIENT, $\beta = 30^\circ$ WING ROLL OUT ORBIT PLANE 27° CW (-XLV, -YV ROLL CW 27°)</p>
 <p>NOSE SUN, $\beta = 0^\circ$ (-X SI, Y POP)</p>	 <p>TOP SI, $\beta = 60^\circ$ (+Z SI)</p>	 <p>TAIL SI, $\beta = 0^\circ$ (+X SI, Z POP)</p>	 <p>BOTTOM SI, $\beta = 0^\circ$ (-Z SI, Y POP)</p>

ORIGINAL PAGE IS
OF POOR QUALITY

CARGO BAY MEASUREMENTS

- 14 CARGO BAY INSULATION SURFACE TEMPERATURES
- 2 WIRE TRAY SURFACE TEMPERATURES
- 12 SILL LONGERON TEMPERATURES
- 4 GAS TEMPERATURES
- 1 RADIATOR TEMPERATURE
- 1 GAS PRESSURE

CARGO BAY MEASUREMENT LOCATIONS

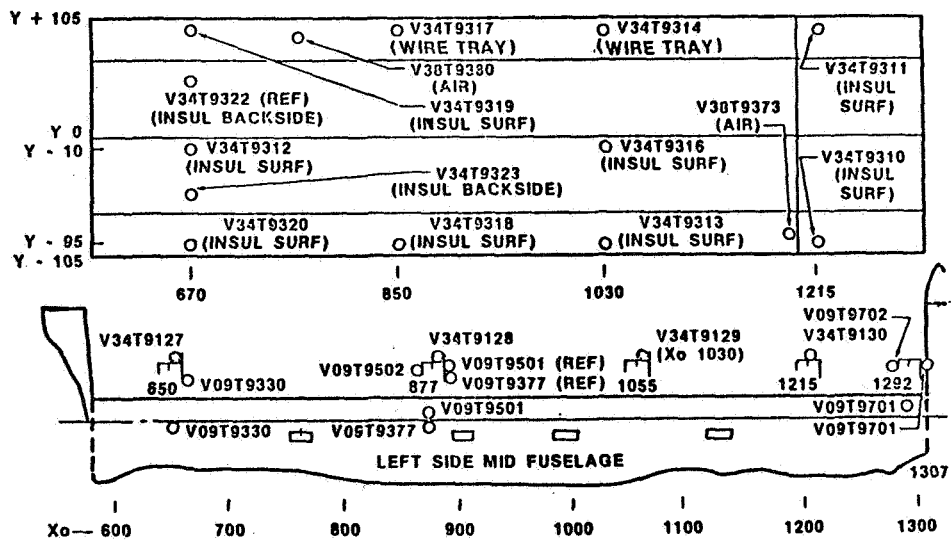

ORIGINAL PAGE IS
OF POOR QUALITY

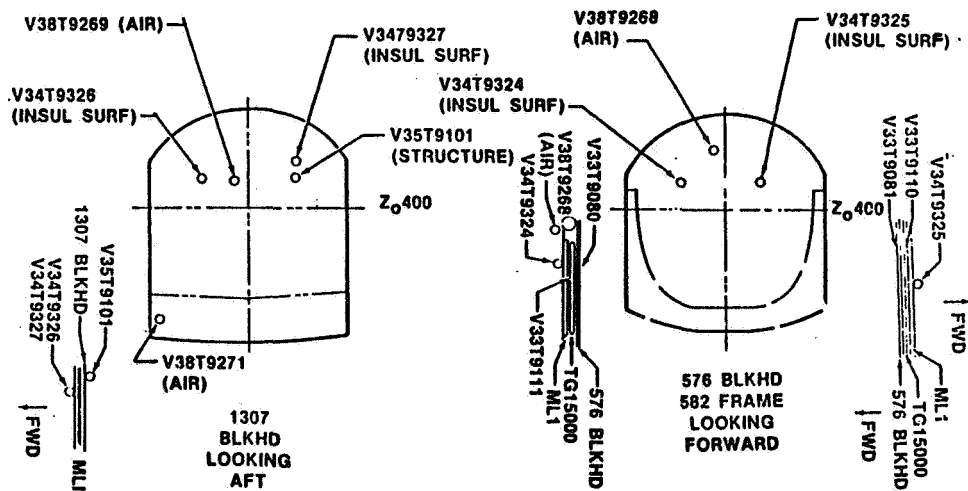
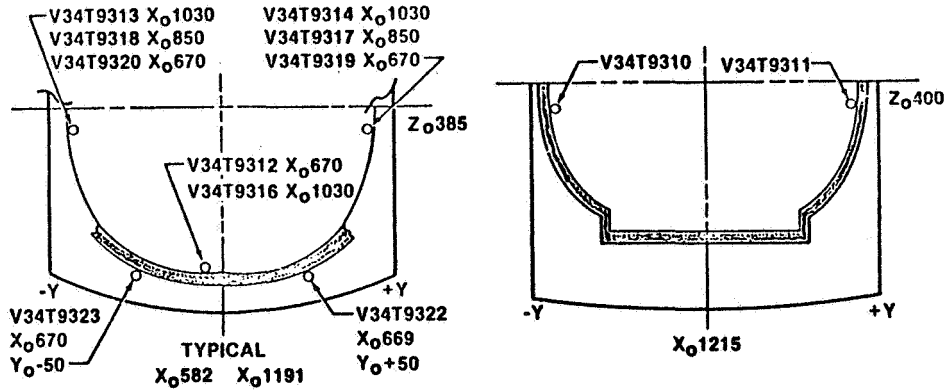

ORBITER PAYLOAD BAY
PRELAUNCH TEMPERATURES

ORIGINAL PAGE IS
OF POOR QUALITY

	STS-1		STS-2		STS-3		STS-4	
	DATA °F	PREDICTION °F	DATA °F	PREDICTION °F	DATA °F	PREDICTION °F	DATA °F	PREDICTION °F
PURGE	80	80	70	70	70	70	70	70
AIR	80	80	70	70	70	70	70	70
LINER	80	80	70	70	70	70	70	70
LONGERON	75	70	70	70	70	70	70	70
FITTING	-	-	-	-	70	70	70	70
RADIATOR	75	75	70	70	70	70	70	70
BULKHEAD	80	80	70	70	70	70	70	70

ORBITER PAYLOAD BY
ASCENT TEMPERATURES
LIFTOFF/MIH/MAX

	STS-1		STS-2		STS-3		STS-4	
	DATA °F	PREDICTION °F	DATA °F	PREDICTION °F	DATA °F	PREDICTION °F	DATA °F	PREDICTION °F
LINER	80/62/84	80/36/97	70/50/65	70/24/80	70/50/65	70/24/80	70/50/65	70/24/80
LONGERON	75	70	70	70	70	70	70	70
FITTING	--	--	--	--	70	70	70	70
RADIATOR	75/65/70	75/65/75	70/57/60	70/60/70	70/57/60	70/60/70	70/57/60	70/60/70
BULKHEAD	80/50/70	80/30/80	70/50/70	70/30/80	70/50/70	70/30/80	70/50/70	70/30/80

ORBITER PAYLOAD BAY
ON-ORBIT TEMPERATURES
MIN/MAX

ORIGINAL PAGE IS
OF POOR QUALITY

	STS-1 +ZLV $\beta \approx -30^\circ$		STS-2 +ZLV $\beta \approx -60^\circ$			
	DATA °F	PREDICTION °F	PORT		STBD	
			DATA °F	PREDICTION °F	DATA °F	PREDICTION °F
LINER	5/80	0/75	25/65	15/75	10/35	5/40
LONGERON	15/20	18/30	40/45	35/50	15/20	15/30
FITTING	-	-	-	-		
BULKHEAD	-10/+120	-25/+120	0/100	-10/115		

ORBITER PAYLOAD BAY
ON-ORBIT TEMPERATURES
MIN/MAX

	STS-3						STS-4		
	TAIL SUN ORB RATE		NOSE SUN 2 ORB RATE		TOP SUN		BOTTOM SUN	TAIL SUN	TOP SUN
	DATA °F	PRED °F	DATA °F	PRED °F	DATA °F	PRED °F	DATA °F	DATA °F	DATA °F
LINER	-153	-190	50/-100	50/-150	30/260*	0/200	30/-80	20/-100	210
LONGERON	-95/-50 ⁺	-90/-60	-40/-20 ⁺	-54/-30	100	115	-20	-40	-30
FITTING	-50	-60	-20	-35	125	140	-10	-35	110
BULKHEAD	-120	-55	20/-100	30/-130	0/100	-10/120	0/-80	30/-100	0/100

+ FWD/AFT LONGERON TEMPERATURE
* MEASUREMENT SUSPECT

ORBITER PAYLOAD BAY
ENTRY AND POSTLANDING TEMPERATURES
E1/TD/MAX*

ORIGINAL PAGE 13
OF POOR QUALITY

	STS-1		STS-2		STS-3		STS-4	
	DATA °F	PRED °F	DATA °F	PRED °F	DATA °F	PRED °F	DATA °F	PRED °F
PURGE**	55/65		55/65		55/65		55/65	
AIR ^A	- /45/80	- /50/80	- /70/80	- /105/105	- /60/85	- /105/105	- /70/80	
LINER	20/60/70	20/48/86	20/65/70	20/68/90	15/68/75	15/75/90	0/70/75	
LONGERON	3/30/75	3/25/70	10/40/70	10/30/60	5/60/70	5/45/65	0/50/75	
FITTING	-	-	-	-	15/65/70	-	10/60/75	
RADIATOR	10/32/80 ^B	10/35/100	15/80/85 ^C	15/85/95	20/80/85 ^C	20/85/90	-5/75/80 ^C	
BULKHEAD	20/50/65	20/42/87	20/60/65	20/42/87	15/60/70	15/65/80	0/65/75	

- * MAXIMUM TEMPERATURES OCCUR AFTER TOUCHDOWN
- ** PURGE WAS 55°F INITIALLY, THEN INCREASED TO 65°F AFTER A FEW HOURS
- A AIR MEASUREMENT APPEARS TO BE ENVIRONMENT TEMPERATURE
- B RADIATOR FLOW FROM TD TO TD +15 MIN.
- C RADIATOR FLOW FROM TD -6 MIN. TO TD +15 MIN.

TMM/FLIGHT DATA COMPARISON
ORBIT AVERAGE TEMPERATURES
STS-3 TAIL SUN (22 HOURS)
FWD (X₀ = 584 - 919)

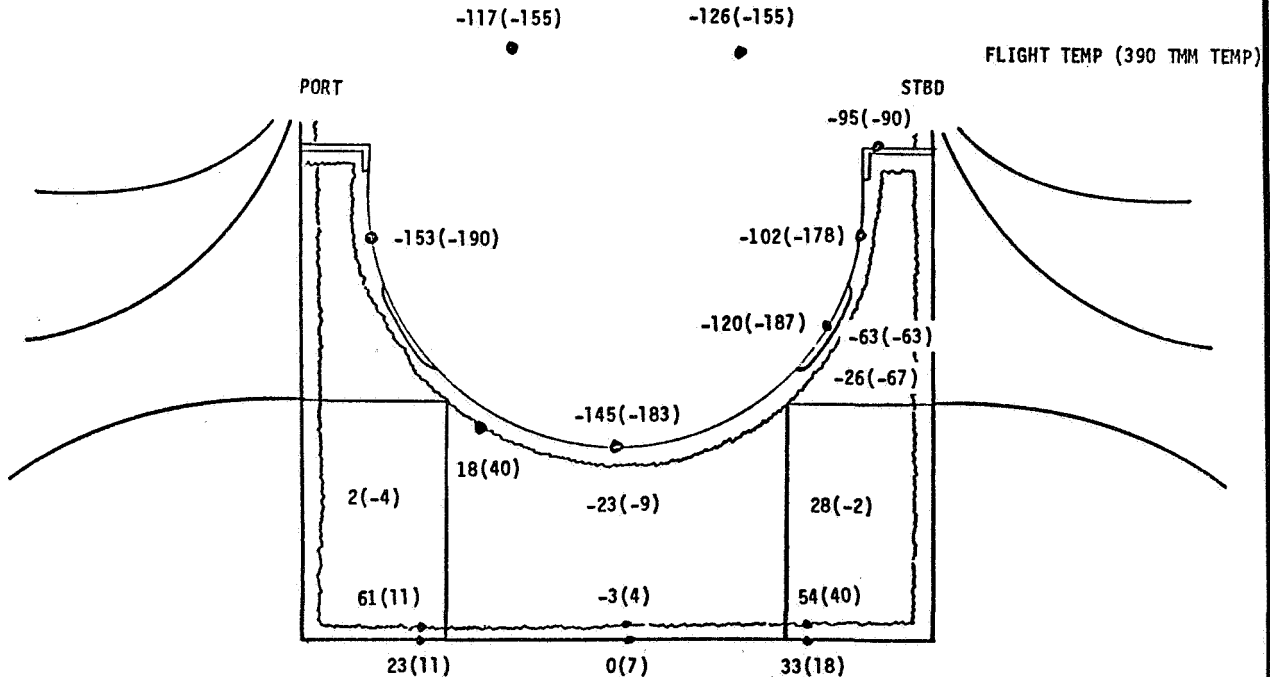

TMM/FLIGHT DATA COMPARISON
 ORBIT AVERAGE TEMPERATURES
 STS-3 TAIL SUN (22 HOURS)
 AFT ($X_0 = 919 - 1307$)

ORIGINAL PAGE IS
 OF POOR QUALITY

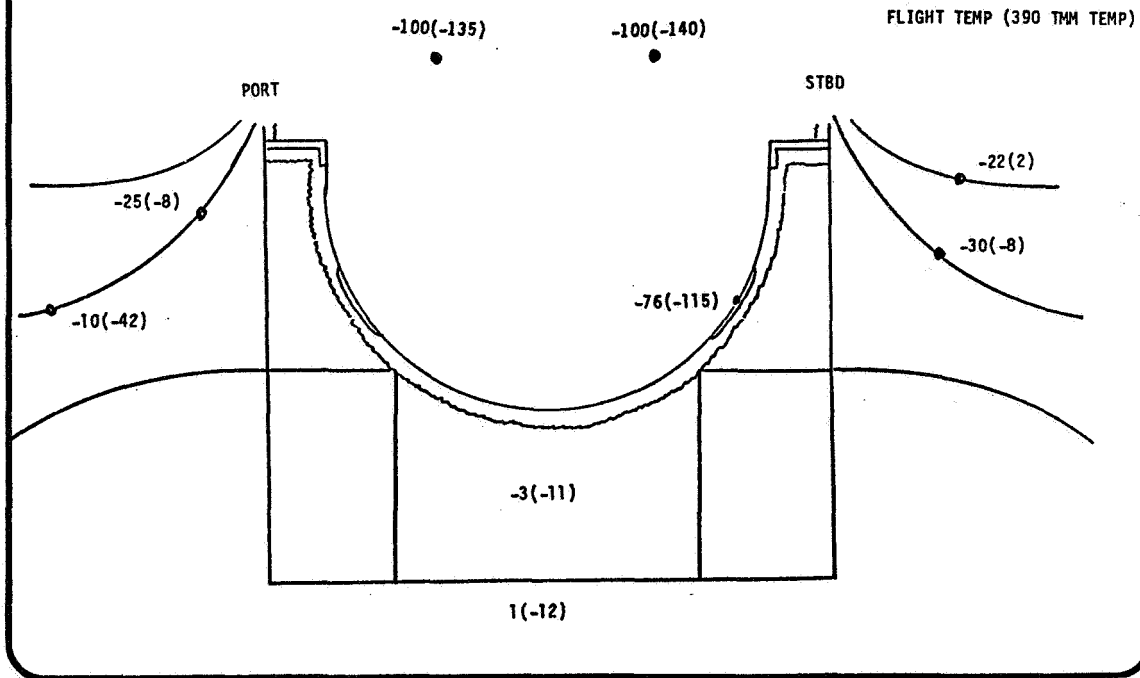

TMM/FLIGHT DATA COMPARISON
 ORBIT AVERAGE TEMPERATURES
 (STS-3 NOSE-SUN (78 HOURS)
 FWD ($X_0 = 584 - 919$)

FLIGHT TEMP (390 TMM TEMP)

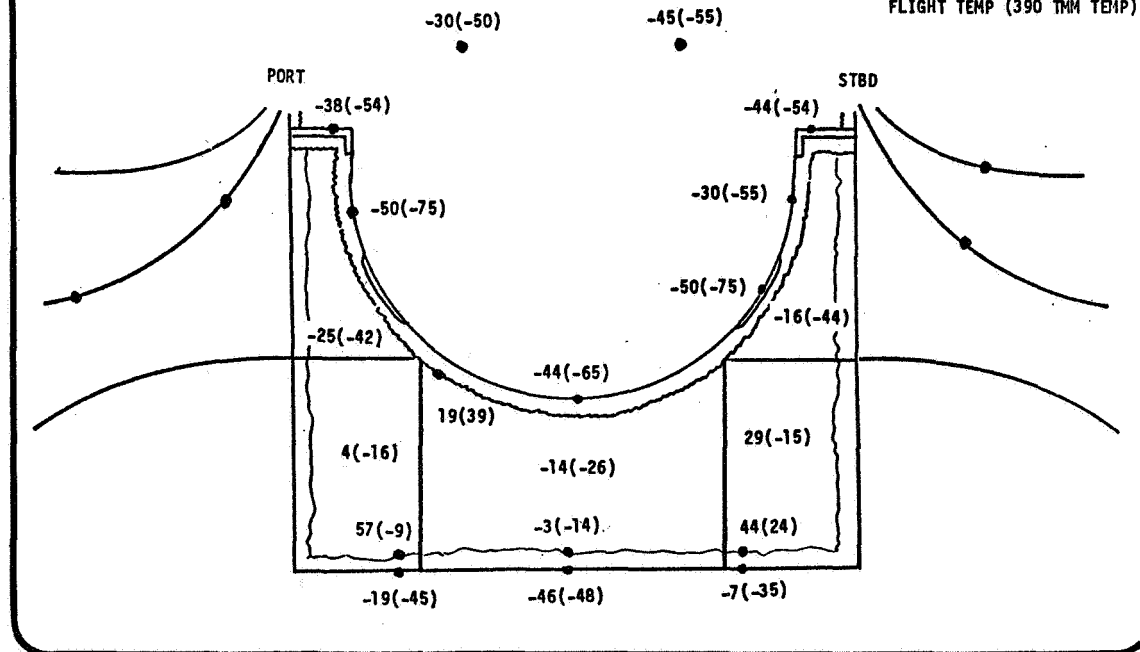

ORIGINAL PAGE IS
OF POOR QUALITY

TMM/FLIGHT DATA COMPARISON
ORBIT AVERAGE TEMPERATURES
STS-3 NOSE-SUN (78 HOURS)
AFT ($X_0 = 919 - 1307$)

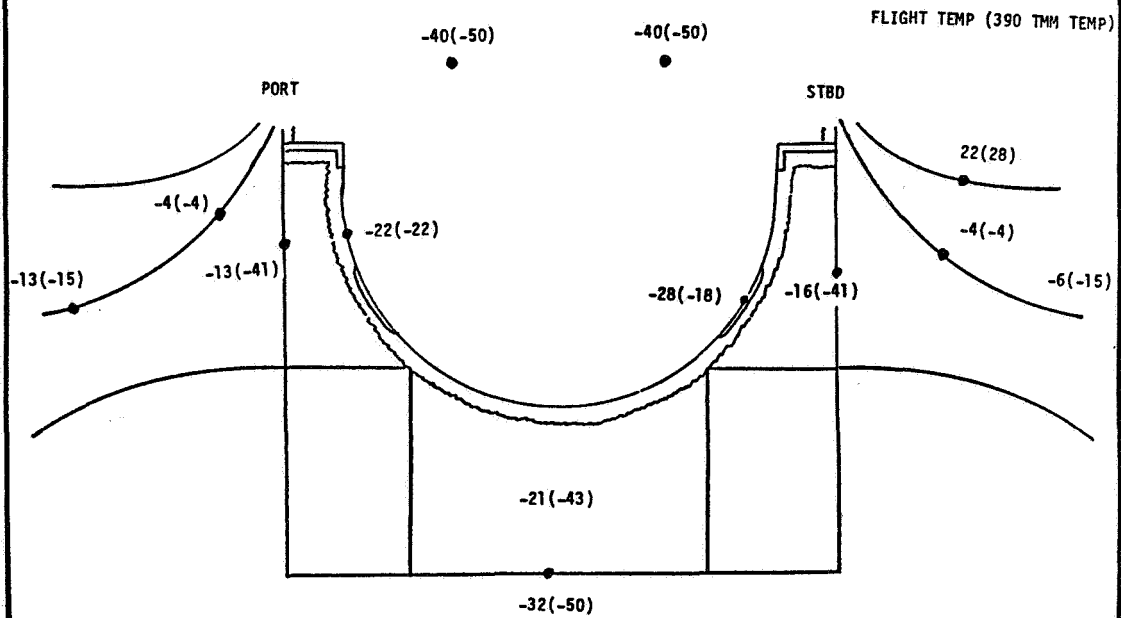

FLIGHT DATA
ORBIT MAXIMUM TEMPERATURES
STS-3 TOP SUN (24 HOURS)
FWD ($X_0 = 584 - 919$)

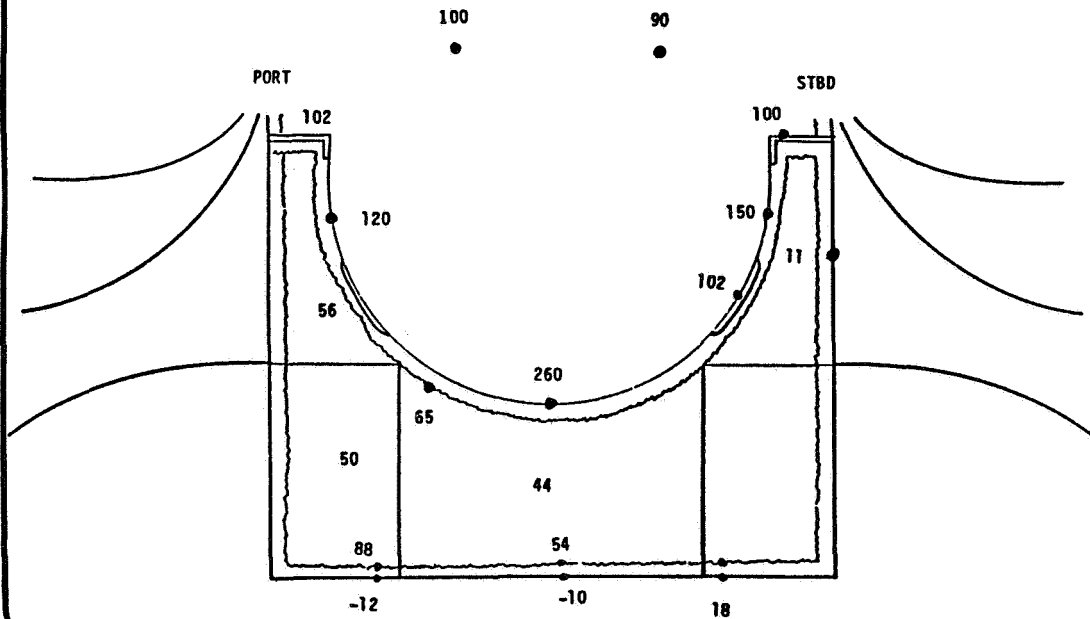

FLIGHT DATA
 ORBIT MAXIMUM TEMPERATURES
 STS-3 TOP SUN (24 HOURS)
 AFT ($X_0 = 919 - 1307$)

ORIGINAL PAGE IS
 OF POOR QUALITY

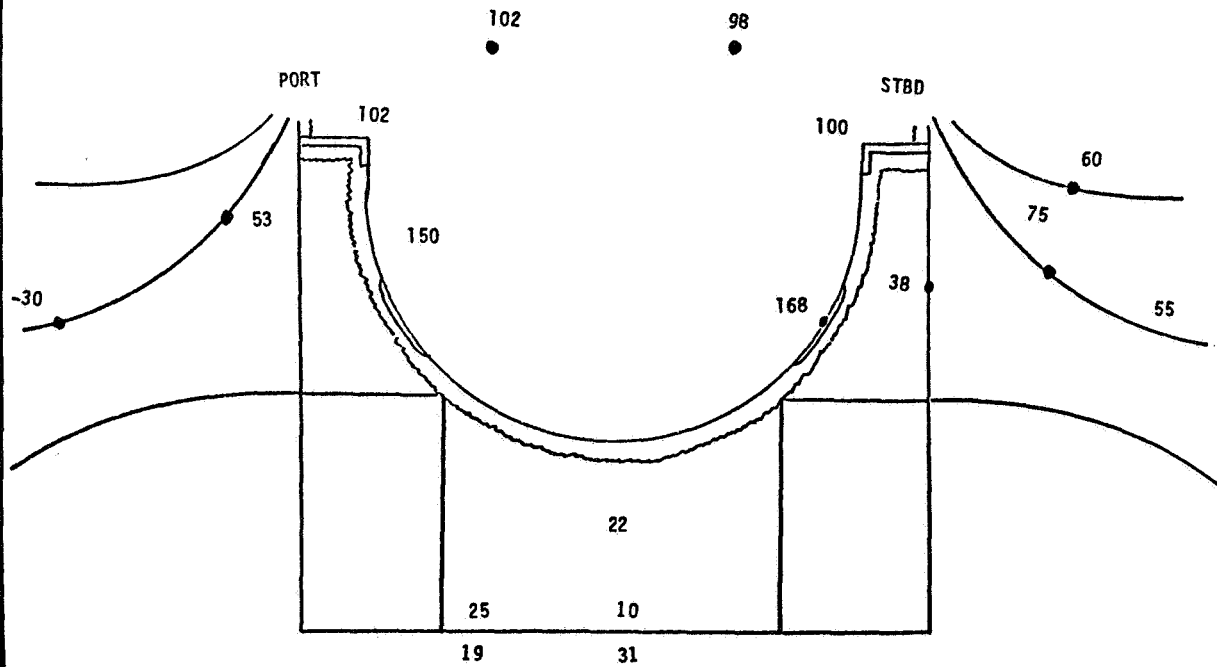

TMM/FLIGHT DATA COMPARISON
 STS-2 ASCENT

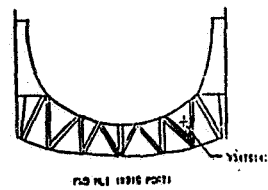
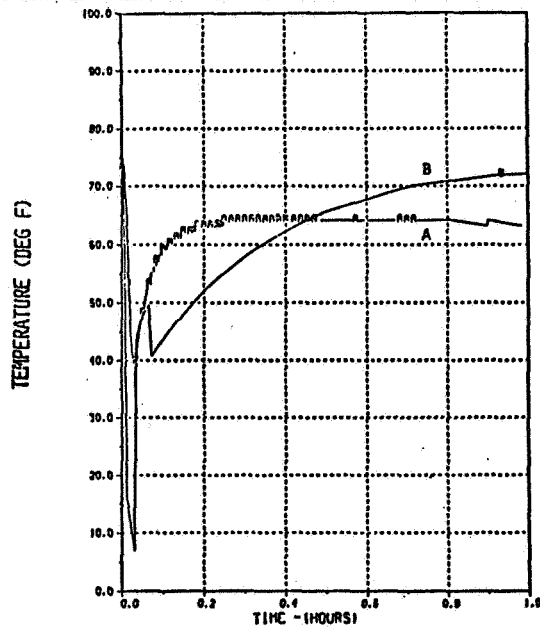

A - STS-2 FLIGHT DATA (V34T9142)
 B - NODE 1268 PREDICTIONS

X_0 919 NLI CLOSEOUT (FNU)

CURRENT MISSION STS-3DF1
LIFT-OFF: 3/22/82 16:00:0
REQ DATE: 4/28/82 14:46:3

ORIGINAL PAGE IS
OF POOR QUALITY

PAYLOAD BAY INSULATION SURFACE FWD

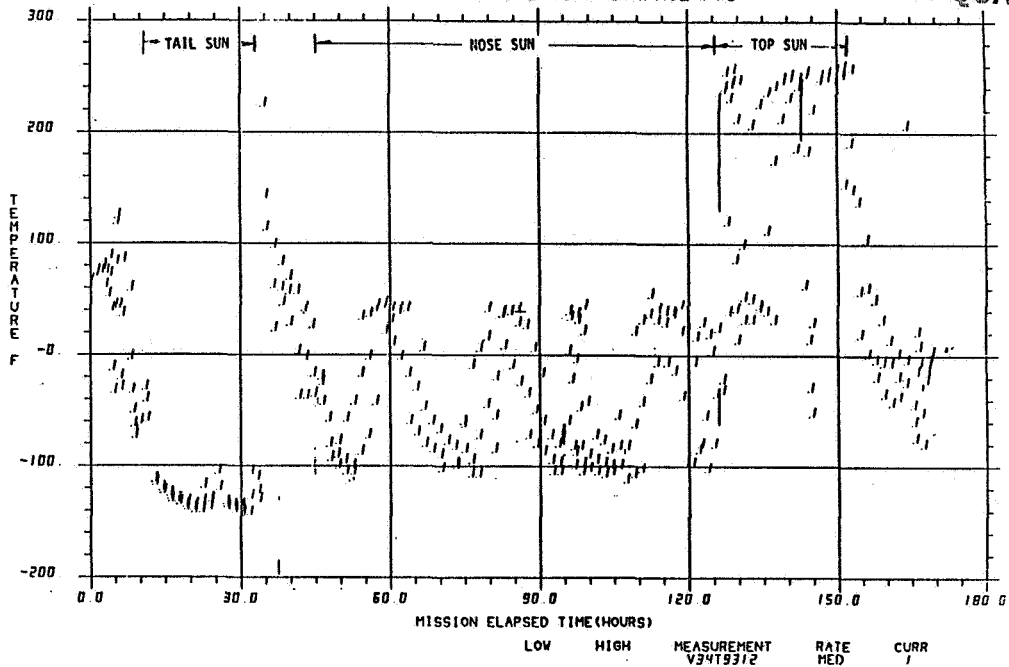

CURRENT MISSION STS-3
LIFT-OFF: 3/22/82 16:00:0
REQ DATE: 4/5/82 15:29:16

PORT LONGERONS

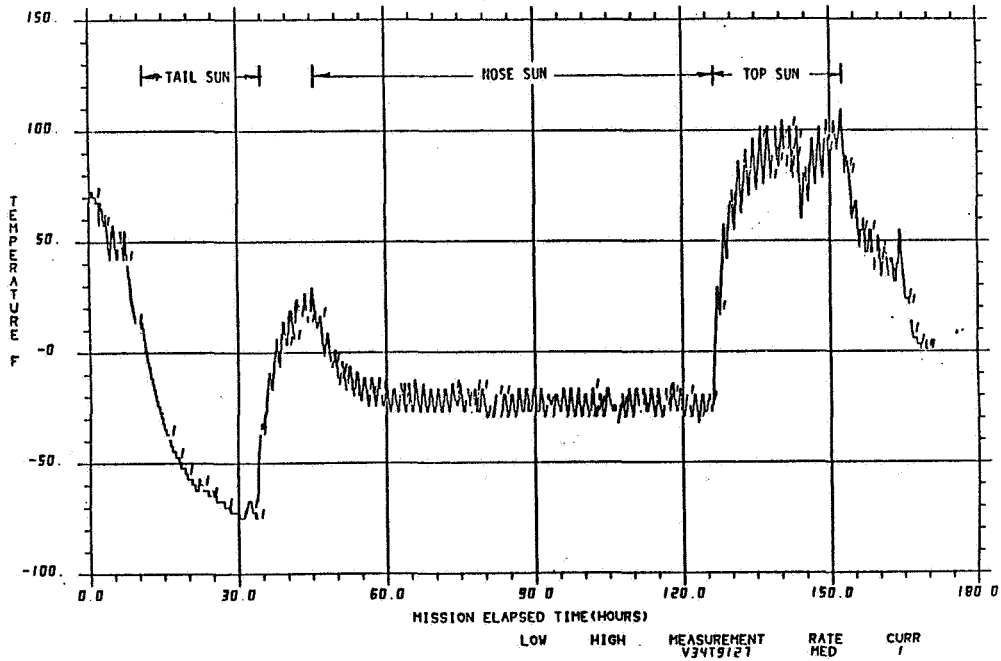

ORIGINAL PAGE IS
OF POOR QUALITY

DFI LONGERON RETENTION FITTING
- LATCH TEMPERATURE -

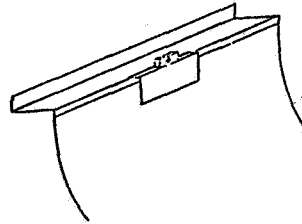
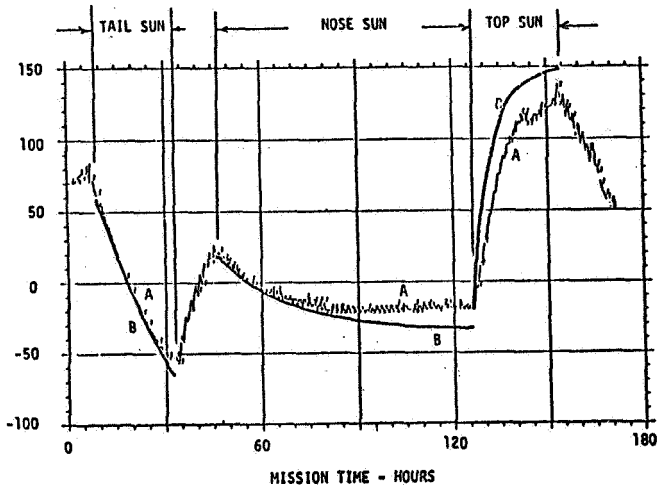

TM/FLIGHT DATA COMPARISON

DFI LONGERON RETENTION FITTING
- LATCH TEMPERATURE -

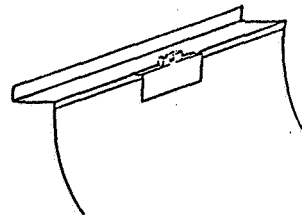
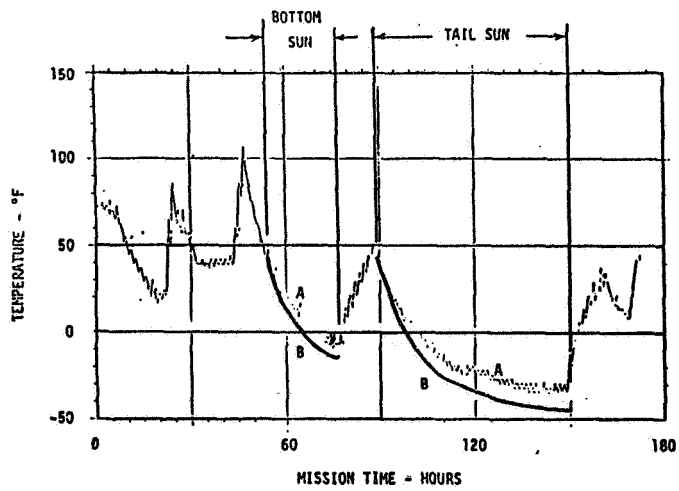

TIME/FLIGHT DATA COMPARISON

ORIGINAL PAGE IS
OF POOR QUALITY

STS-3 ENTRY
FWD LINER (X₀=670)

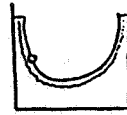
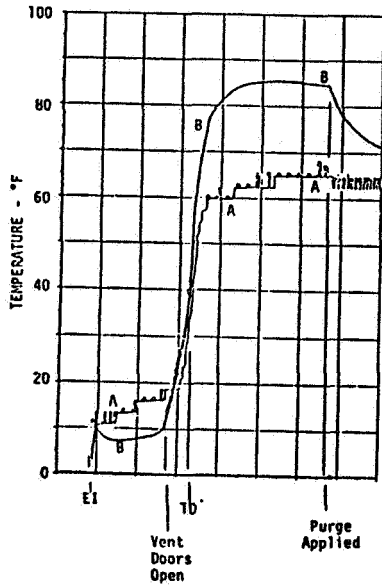

A - STS-3 FLIGHT DATA
B - 390 TMI

STS-1 POSTLANDING TEMPERATURES

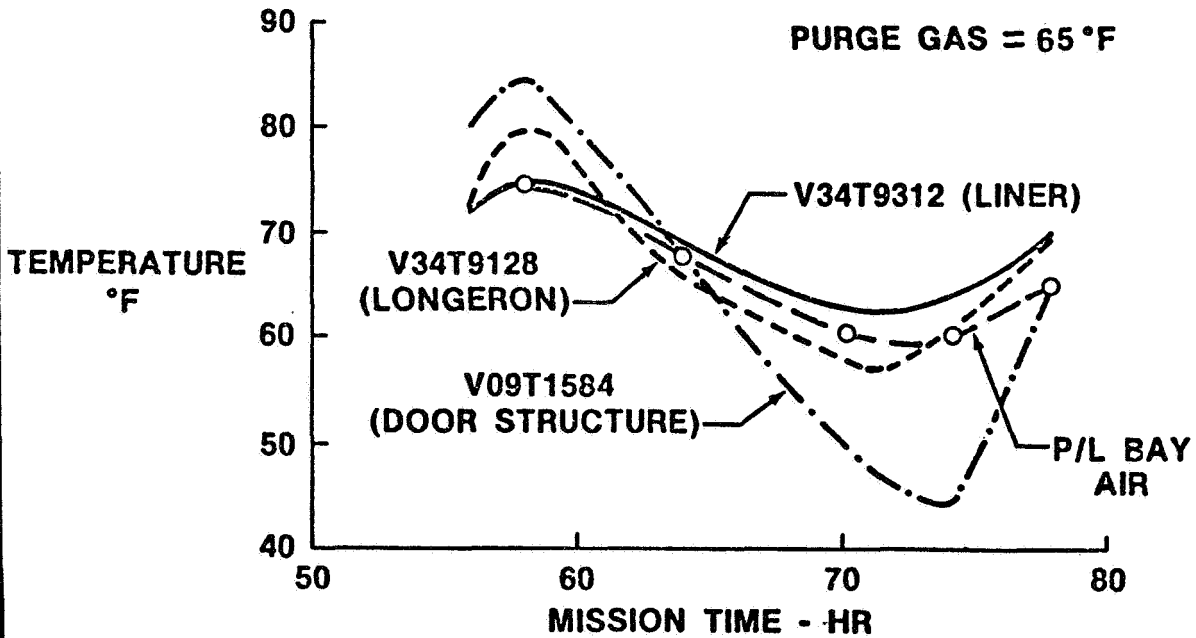

CONCLUSION

ORIGINAL PAGE IS
OF POOR QUALITY

- IN GENERAL THE FLIGHT THERMAL ENVIRONMENT IS LESS SEVERE THAN PREDICTIONS EXCEPT FOR POSSIBLY TOP SUN.
- NO ADVERSE THERMAL EFFECT ON THE ORBITER OR PAYLOAD AS A RESULT OF INTERACTION FOR PAYLOADS FLOWN ON THE FIRST FOUR FLIGHTS.