

**NASA
Technical
Paper
2150**

1983

Performance of an Ablator for Space Shuttle In-Orbit Repair in an Arc-Plasma Airstream

David A. Stewart,
Melanie Cuellar,
and Orvel Flowers
*Ames Research Center
Moffett Field, California*

NASA

National Aeronautics
and Space Administration

Scientific and Technical
Information Branch

NOTATION

A activation constant, sec

E activation energy, kcal/mole

H enthalpy

m mass loss rate, kg/sec

P pressure, atm

r radius, cm

T temperature, K

Subscripts

b base

bp backplate

c corner

t isentropic stagnation condition

w model wall condition

PERFORMANCE OF AN ABLATOR FOR SPACE SHUTTLE IN-ORBIT REPAIR IN AN ARC PLASMA AIRSTREAM

David A. Stewart, Melanie Cuellar,* and Orvel Flowers

Ames Research Center

An ablator patch material performed well in an arc-plasma environment simulating nominal earth-entry conditions for the Space Shuttle. Ablation tests, using vacuum molded cones, provided data to optimize the formulation of a two-part polymer system for application under space conditions. The blunt cones were made using a Teflon mold and a state-of-the-art caulking gun. Char stability of formulations with various amounts of catalyst and diluent were investigated. The char was found to be unstable in formulations with low amounts of catalyst and high amounts of diluent. The best polymer system determined by these tests was evaluated using a half-tile patch in a multiple High-Temperature Reusable Surface Insulation tile model. It was demonstrated that this ablator could be applied in a space environment using a state-of-the-art caulking gun, would maintain the outer mold line of the thermal protection system during entry, and would keep the bond line temperature at the aluminum-tile interface below the design limit.

The thermal protection system (TPS) over most of the Space Shuttle surfaces consists of primarily fibrous silica tiles, ranging in thickness from 2.5 cm to 10.2 cm, with a borosilicate glass coating for emissivity control. The tiles are bonded to the vehicle with a room-temperature vulcanizing elastomer (RTV 560) via a Nomex† strain isolation pad (SIP) between the tile and the aluminum skin (ref. 1). The tiles that cover the lower surface of the Space Shuttle (Orbiter) are roughly 15-cm square and have a black, reaction-cured glass (RCG) coating. These tiles are called High-Temperature Reusable Surface Insulation (HRSI) tiles. The upper surfaces of the Orbiter use tiles 20-cm square with a white glass coating which are called Low-Temperature Reusable Surface Insulation (LRSI) tiles.

During early missions, damage has occurred to both tile systems. Therefore, the possibility does exist, though remote, that damage could occur to an area of the Orbiter's TPS during ascent, which could jeopardize the vehicle's mission. In the development of any repair procedure one must consider that the repair can only be accomplished by the astronaut from the exterior of the Orbiter in space. Past experience with manned space programs such as the Mercury, Gemini, and Apollo suggested that an epoxy-polysulfide-copolymer-based ablator could provide the desired thermal protection to the Space Shuttle during its relatively mild entry environment (refs. 2-5). Based on individual Space Shuttle conditions, specific requirements were established for the ablator (Refs. 6-8):

1. It must harden in a reasonable time in a space environment without external thermal treatment.
2. It must be simple to apply to accommodate the capabilities of a suited astronaut.
3. It must have nonvolatile components.
4. It must adhere to the various Space Shuttle TPS materials.
5. It must maintain the outer mold line of the TPS while surviving one Orbiter Earth entry.

Preliminary arc-plasma tests showed that NASA Ex439, formulated as a mastic by Riccitiello and Flowers of Ames Research Center, met most of the requirements for an in-orbit repair material. The formulation of this ablator is listed in table 1. The two-part ablator is an epoxy/polysulfide copolymer with microquartz fibers in one part (A) and a catalyst along with silica microballoons in the other part (B). The microballoons were incorporated into the formulation to give a finished density of about 640 kg/m³ (40 lb/ft³).

Experiments indicated that the mastic would be difficult to apply by a suited astronaut. The high viscosity of the NASA Ex439 prevented the material from being applied to damaged areas by a state-of-the-art caulking gun. The objective of this study was to optimize the ablator system for space application without sacrificing its thermal/mechanical performance during Earth entry. This paper describes arc-plasma experimental results used to optimize the polymer system and evaluate its thermal performance on a full-scale model in convectively heated environments.

FACILITIES

Arc-plasma tests used for system optimization and evaluation were conducted in the Ames Aerodynamic Heating

*Student Associate, San Jose State University, San Jose, Calif., working under Contract No. NSG2329.

†The use of trade names of manufacturers in this report does not constitute an official endorsement of such products or manufacturers, either expressed or implied by the National Aeronautics and Space Administration.

and 20-MW Pilot Test Facilities. Both facilities used constricted arc-heaters to produce high-enthalpy airstreams.

Aerodynamic Heating Facility

The Aerodynamic Heating Facility provides high-energy hypersonic flow (total enthalpies 7 to 23 MJ/kg) by passing air between concentric toroidal electrodes and expanding it through a 30° total-angle conical nozzle. For this investigation, the geometric-area ratio of the nozzle was 400. The free-stream Mach number was $M = 6.0$.

Blunt bodies were exposed to the high-enthalpy hypersonic airflow for test durations up to 420 sec. The models were located 28 cm downstream of the conical nozzle on water-cooled supports. Thermocouple and pyrometer measurements were made during each test. Impact pressure and stagnation point heat-transfer rates were measured. The nozzle flow properties were estimated from the ratio of measured impact to total pressures, from calculated total enthalpy, and by assuming equilibrium flow from the reservoir to an arbitrary point where chemical reactions and molecular vibrations become frozen (ref. 9).

20-MW Pilot Test Facility

High-enthalpy air from the constricted heater of the 20-MW Pilot Test Facility expands through a semielliptical nozzle with a throat aspect ratio of 4:1 and across a 48.3- by 50.8-cm flat-plate multiple HRSI tile configuration. A silica plate, 25.4-cm long and 40-cm wide, is located at the nozzle exit to ensure a smooth hot-wall flow transition from the nozzle to the test-article surface. Thermocouple and pyrometer measurements are recorded during each exposure. The total enthalpy of the stream can be determined within 15% from sonic flow measurements (ref. 10). These measurements include total pressure, mass flow, and electrical power input. Exposures of about 420 sec and a free-stream Mach number of 4 were used during these tests.

MATERIAL FORMULATION

The Ex439 mastic process was modified to reduce its viscosity and to obtain equal-volume parts in the formulation. The viscosity was reduced by changing the blending process and replacing part of the epoxy resin (Epon 826) in part A with a low-viscosity reactive diluent (Epon 815). This required modifying the method of dispersion from a simple blending of the fiber and resin to include the use of a three-roll mill. Dispersion with a three-roll mill appears to enhance fiber distribution within the resin matrix and improve fiber wetting. Figure 1 shows scanning electron micrographs of

the microquartz fibers (at 200X) as received and after dispersion with the three-roll mill. The process does not reduce the fiber length but improves the mixture uniformity. The reactive diluent added to part A was varied from 15 to 25% by weight in the formulations used in this study. Also, since the magnitude of the polymer exotherm is mass-dependent and rate-of-cure-catalyst-dependent (ref. 11), the repair volume was limited to $2.36 \times 10^{-6} \text{ m}^3$ and the amount of catalyst added to these formulations was limited between 3 and 15% by weight of part B. Variation of the catalysts are designated by the numbers 1, 2, and 3 and the amount of diluent by the letters A, B, and C (see table 4). Equal volumes of parts A and B were obtained by distributing the microquartz fiber and microballoons in both parts.

Thermal and physical properties of the selected material were obtained using a thermogravimetric analysis (TGA) in air and a pull test. Figure 2 shows the weight loss of this material as a function of temperature. Initial decomposition of the material occurred at about 523 K with a char yield, as defined by carbon residues minus fillers, of about 14.5% in an anerobic environment. This is typical of an epoxy/polysulfide resin system cured at ambient (298 K) temperature. The data from the TGA analysis was examined using the procedure of reference 12 to determine the kinetic parameters of the two distinct reactions that are apparent from the weight-loss curve. The first reaction, which takes place between 300 and 523 K, is very complex and the method of data reduction and subsequent curve fitting gives values listed in table 2. The second reaction taking place, from 523 to 723 K, is more straightforward, and the kinetic parameters listed in table 2 are what one would expect for this type of polymer decomposition.

One concern with the use of any material as a repair for the Space Shuttle heat shield is adhesion to the various potential substrates. When a complete tile is lost, the surface most likely to be encountered is a cured RTV 560 silicone adhesive, which is used to bond the fibrous silica tiles to an SIP. If a tile is only damaged, the surface encountered would be the fibrous silica insulation. Table 3 gives the adhesion data of various substrates based on pull tests for the epoxy system. The selected material will adhere to all surfaces except a smooth, pristine RTV 560 surface. Therefore, to use the material for Space Shuttle heat shield repair, any pristine RTV 560 surface will have to be roughened before a repair is made to ensure adhesion.

MODELS

Blunt cones were made using formulations varying in amount of diluent and catalyst and length of cure time. The arc-plasma test matrix for these cones are shown in table 4. The Ex439-B3 refers to a *modified* Ex439 basic formulation

with 15% diluent added and with the catalyst increased by a factor of two. The cure time was varied from $6 \leq t \leq 72$ hr.

These models were made using a vacuum mold (fig. 3). A state-of-the-art caulking gun was used to insert the polymer into the Teflon mold at a pressure of $p = 10^{-3}$ atm. Weep holes and a Teflon piston in the cavity ensured even distribution of the polymer during insertion. The blunt cones had a base diameter of 7.6 cm, a half-angle of 5° , and a flat-face diameter of 6.5 cm. The corner-radius-to-base-radius ratio for the cones was $r_c/r_b = 0.17$. These models were tested in the Aerodynamic Heating Facility.

A multiple-tile flat plate configuration (48 cm by 50 cm) was used in the 20-MW Pilot Test Facility (fig. 4). Each 15-cm-square tile had a platinum-platinum/13% rhodium thermocouple installed at the center and in contact with the RCG surface coating. The 3.8-cm-thick tiles were bonded to an SIP which in turn was bonded to a 0.081-cm-thick aluminum plate. The aluminum plate was mechanically attached to a perforated aluminum sheet (0.08-cm thick) supported only at its outer edges. The tiles were positioned so that their leading edges were swept 45° to the flow; there were gaps of about 0.15 cm between the tiles. A half-patched tile was installed at a location across the centerline near the back of the flat-plate configuration. Chromel-constant thermocouples (0.03-cm diameter) were spot-welded into the 0.08-cm-thick aluminum plate beneath the patch.

Half-patch tiles were used to evaluate the selected formulation in the 20-MW Pilot Test Facility. These patch tiles were constructed either by hand-packing or by using a state-of-the-art caulking gun. Hand-packed patches for the mastic Ex439 were formed at atmospheric conditions. Patches constructed using the caulking gun were formed under vacuum. The half-patches were made in the following manner: A 15-cm-square HRSI tile 5-cm thick was cut in half and mounted to an aluminum plate with an SIP. The half-tile was placed in a wooden mold (fig. 5(a)). The sides of the cavity formed by the wooden mold were lined with stripes of Fibrous Refractory Composite Insulation (FRCI) 0.05-cm thick. A Plexiglas cover was placed over a thin plastic hardback and attached to the wooden mold. The Teflon nozzle was then inserted into a 0.0635-cm-diameter hole in the Plexiglas at the center of the cavity. Twenty-four vent holes (1.27-cm diameter) were equally spaced along the sides of the wooden frame to ensure even distribution of the ablator throughout the cavity during filling. The model was filled with ablator after being placed inside a bell jar and evacuated to 10^{-3} atm. After an appropriate cure time (72 hr), the wooden mold was removed from the bell jar and the Plexiglas cover were removed from the thin plastic hardback (fig. 5(b)).

ARC-JET TEST PROCEDURE

The ablation properties obtained from the vacuum-molded cones were used to select the best polymer

formulation. Tests were conducted using a dual support system in the Aerodynamic Heating Facility (fig. 6). A test cone made with a modified Ex439 formulation was mounted on one struct and a geometrically identical cone made with HRSI was mounted on the other struct as a reference. A platinum-platinum/13% rhodium thermocouple was installed beneath and in contact with the RCG coating of the reference cone. The test conditions were established by the surface temperature on the face of the reference cone. The test cone was exposed to the arc-plasma airstream for a single simulated Space Shuttle Earth entry (420 sec). After each exposure, char thickness, core thickness, and mass-loss measurements were obtained from the cone. A typical post-test model is illustrated in figure 7.

Stagnation-point pressure and heating rates to 1.59-cm-diameter hemisphere-cylinders (mounted at the center of the support system) were measured during each test. The surface temperature on the reference cone was varied from 1394 to 1644 K. The surface pressure was varied from 0.008 atm to 0.019 atm. Total enthalpy of 19 MJ/kg and 20 MJ/kg were calculated from measured stagnation-point pressure and heat-transfer rates.

The patch material selected on the basis of the blunt-cone test series was compared with the basic Ex439 formulation using the full-scale multiple-tile model. A molded half-tile patch (using Ex439-B3) and a hand-packed mastic patch (using the basic Ex439 formulation) were tested. Morphological and thermal response of these materials were compared in a simulated Orbiter Earth entry in the 20-MW Pilot Test Facility. A 420-sec heating pulse was used for the simulation. The test conditions were total enthalpy $H_t = 12.9$ MJ/kg, surface pressure $P_s = 0.01$ atm and surface temperature $T_s = 1255$ K. The airflow out of the semielliptical nozzle was near turbulent at $M_\infty = 4$.

RESULTS AND DISCUSSION

Material Selection

The ablation data from the arc-plasma tests are shown in figs. 8-10. Figure 8 shows char thickness and mass-loss rate as a function of diluent added to part A. Data obtained from a model made with the basic Ex439 formulation are shown by the solid symbol. These blunt cones were cured for 72 hr. In general, at the lower surface temperature (fig. 8(a)), the modified polymer system, with up to 25% Epon 815 diluent added to part A and with equivalent or greater catalyst content than the basic Ex439 formulation, was stable during the arc-plasma exposure. Stability was indicated by a mass-loss rate, $m = 6.0 \times 10^{-3}$ kg/sec \cdot atm $^{0.8}$, and a high char-thickness-to-core-thickness ratio of roughly 0.20. No measurable recession of the front face of the blunt cones was observed. The blunt cone with 20% diluent added to part B of the modified

polymer system was unstable, as indicated by the loss of the char layer and the excessive mass-loss rate ($m = 2.0 \times 10^{-2} \text{ kg/sec} \cdot \text{atm}^{0.8}$). Formulations with half the amount of catalyst of the basic formulation had char layers that were increasingly more unstable with increased amount of diluent. At the higher surface-temperature condition, $T_s = 1664 \text{ K}$, the char layer was unstable for all the formulations except the modified Ex439-A3 and Ex439-B3 (fig. 8(b)). These two formulations show maximum char thickness and minimum mass-loss rates at 10 and 15% diluent added.

Figure 9 shows the relationship between the surface temperature of the HRSI cone and the mass-loss rate of the blunt cones made from various formulations. The RCG surface temperature was used as a convenient reference to correlate these data with an Orbiter Earth entry environment. These data show that the modified polymer system containing up to 15% diluent and twice the catalyst content of the basic formulation was stable over the surface temperature range tested. All other formulations showed an increased mass-loss rate with increased surface temperature. The cone study indicates that the modified NASA Ex439-B3 polymer system would be the most stable of these formulations during an Orbiter Earth entry. The formulation and thermal properties for the modified Ex439-B3 are listed in Table 5.

If Ex439-B3 is to be an effective patch material for the Orbiter TPS, then its char stability, as indicated by mass-loss rate, should be relatively independent of cure time. Mass-loss rate as a function of cure time is plotted in figure 10 at RCG reference surface temperatures from $1349 \text{ K} \leq T_s \leq 1644 \text{ K}$. Cones were cured from 6 hr to 72 hr. The modified Ex-439-B3 cured for 6 hr showed char instability during an arc-plasma exposure at $T_s = 1644 \text{ K}$. The char stability was relatively independent of cure time for all other compositions tested as shown by the small mass-loss rate ($6.0 \times 10^{-3} \text{ kg/sec} \cdot \text{atm}^{0.8}$).

Material Evaluation

The selected Ex439-B3 ablator formulation was compared with the original NASA Ex439 formulation using full-scale tiles. Post-test photographs of the arc-plasma-exposed NASA Ex439-B3 patches are shown in figure 11. Neither patch had a forward-facing step; some surface material was removed from the basic Ex439 (a result of delamination created from being hand packed into the cavity); and the Ex439-B3 surface was smoother than the Ex439 surface after arc-plasma exposure. The aluminum-backplate temperature for the half-tile patches in the multiple tile model are shown in figure 12. The data show that the backplate temperature rise using NASA Ex439-B3 formulation was lower than that obtained using the basic NASA Ex439 formulation and was well within the Space Shuttle design limit (450 K).

CONCLUSIONS

The following conclusions have been reached from this study:

A polymeric system cured at ambient temperature can be formulated and processed to provide an in-orbit repair of the RSI tile heat shield of the Space Shuttle vehicle for a one-time entry; the material can be applied easily with a state-of-the-art caulking gun in a vacuum environment; the in-orbit repair material, as formulated, provides adequate bond strength to most surfaces to survive the entry environment; and the in-orbit repair material maintains the outer mold line with little recession during ablation.

Ames Research Center

National Aeronautics and Space Administration

Moffett Field, California 94035, December 13, 1982

REFERENCES

1. Tischler, A. P.: Defining a Giant Step in Space Transportation, *J. of Astronautics and Aeronautics*, vol. 9, Feb. 1978, pp. 22-25.
2. Cury, D. M.; and Stephens, E. W.: Apollo Ablator Thermal Performance at Suborbital Entry Velocities, NASA TN D-5969, 1970.
3. Sawko, P. M.: Polymer Vehicles as Carriers for Sulfonic Acid Salt of Nitrosubstituted Aromatic Amines. U.S. Patent 3663464, May 1972.
4. Sawko, P. M.; Fontes, E. J.; and Riccitiello, S. R.: An Intumescent Coating for Improved Fuel Fire Protection of Heat-Sensitive Articles, *J. of Paint Tech.*, Aug. 1972, pp. 51-55.
5. Riccitiello, S. R.; and Sawko, P. M.: Fire Protection Covering for Small Diameter Missiles. U.S. Patent 4156752, May 1979.
6. Lundell, J. H.; Wakefield, R. M.; and Jones, J. W.: Experimental Investigation of a Charring Ablative Material Exposed to Combined Convective and Radiative Heating, *AIAA J.*, vol. 3, no. 2, Nov. 1965, pp. 2087-2095.
7. Parker, J. A.; and Winkler, E. L.: The Effects of Molecular Structure on the Thermochemical Properties of Phenolics and Related Polymers, NASA TR R-276, 1967.
8. Pope, R. B.; Riccitiello, S. R.; Goldstein, H. E.; and Parker, J. A.: Ablative Thermal Protection at Low Heating Rates, *Materials J.*, vol. 1, Jan. 1969, p. 1.
9. Yoshikawa, K. K.; and Katzen, E. D.: Charts for Air-Flow Properties in Equilibrium and Frozen Flows in Hypervelocity Nozzles, NASA TN D-693, 1961.
10. Winovich, W.: On the Equilibrium Sonic-Flow Method for Evaluating Electric Arc Heater Performance, NASA TN D-2132, 1964.
11. Lee and Neville: Handbook of Epoxy Resins, McGraw-Hill Book Co., Inc., N.Y., 1967.
12. Cagliostro, D.; Riccitiello, S. R.; and Parker, J.: Acid Catalyzed Decomposition of Delrin, *J. of Macromolecular*, vol. A3, Dec. 1969, pp. 1601-1616.

TABLE 1.— FORMULATION OF
NASA Ex439

NASA Ex439	
Material	Amount, g
Part A	
Epon 826	90.8
Microquartz fiber	30.3
Part B	
Polysulfide LP3	60.6
Catalyst DMP30	7.58
Silica microballoons	30.3
Silicon carbide	1.82

TABLE 2.— KINETIC PARAMETERS OF NASA
Ex439-B3

Reaction	Order	Activation Energy, E*, Kcal/mole	Constant A, sec ⁻¹
1st	3	12.987	4.7 * 10 ⁶
2nd	2	34.930	9.5 * 10 ¹¹

TABLE 3.— ADHESION PROPERTIES
OF NASA Ex439-B3^a

RTV 560	Failed at Bondline
HRSI	Failed in RSI
Aluminum	Failed at 60.8 kg in Ex439-B3

^aShelf life of mixed parts A and B approximately 1 hr.

TABLE 4.— ARC-PLASMA TEST MATRIX FOR O. R. MATERIAL
VARIATIONS

Test	Models tested	Catalyst content, Xstd ^a	Diluent, % ^b	RCG surface temperature, K	Cure time, hr
A	3	0.5	10, 15, 25	1394	>72
	3	1	10, 15, 25	1394	>72
	2	2	10, 15, 25	1394	>72
	1	1	None	1394	>72
B	3	0.5	10, 15, 25	1644	>72
	3	1	10, 15, 25	1644	>72
	3	2	10, 15, 25	1644	>72
	1	1	None	1644	>72
C	2	2.0	15	1394	6, 20
	3	2.0	15	1504	6, 20, >72
	2	2.0	15	1644	6, 20

^aCatalyst content: 1 - 0.5; 2 - 1; 3 - 2.

^bDiluent: A - 10%; B - 15%; and C - 25%.

TABLE 5.— FORMULATION OF
NASA Ex439-B3

NASA Ex439-B3 ^a	
Material	Amount, g
Part A	
Epon 826	72.6
Microquartz fiber	12.1
Epon 815	18.2
Silica microballoons	7.85
Silicon Carbide	.6
Part B	
Polysulfide LP3	60.6
Catalist DMP30	12.1
Silica Microballoons	12.35
Silicon carbide	.6
Microquartz fiber	12.1
^a Thermal properties:	
density: 480–640 kg/m ³	
charyield: 33–34% at 873 K	
softening temperature: 413 K	
linear expansion of ambient -	
348 K: 65 ±10×10 ⁻⁶ m/m K;	
linear expansion of 353 K - 423 K:	
90 ±10×10 ⁻⁶ m/m K;	
specific heat: 1.59×10 ⁻³ J/kg K;	
thermal conductivity:	
2.5×10 ⁻⁴ W/m K;	
heat of reaction: 75.3 J/g	

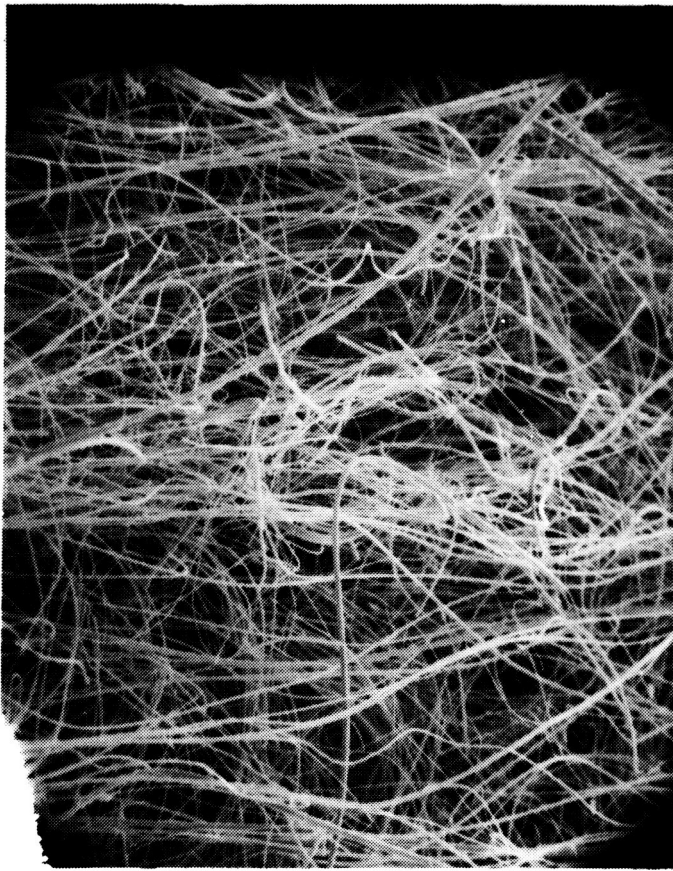

AS RECEIVED



AFTER THREE-ROLL MILL PROCESS

Figure 1.— Microstructure of microquartz fibers before and after dispersion with three-roll mill.

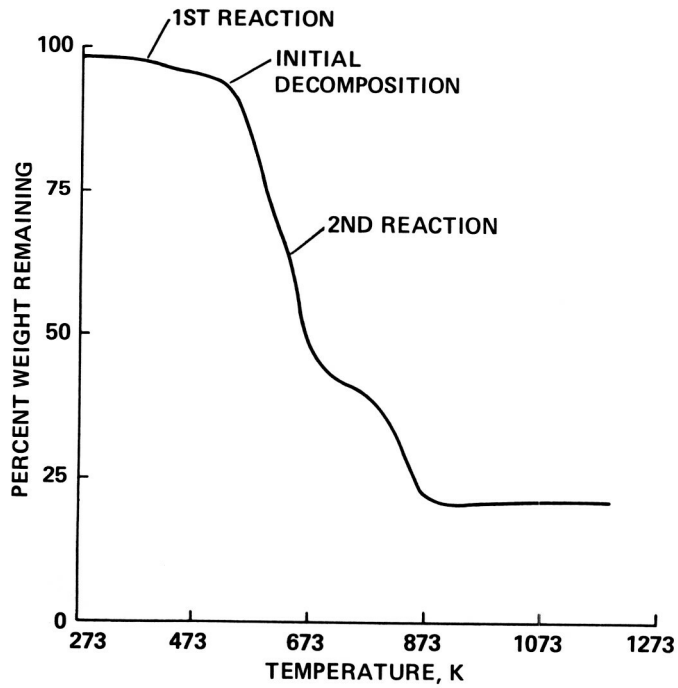

Figure 2.— Weight change of Ex439-B3 ablator during a thermogravimetric analysis in air.

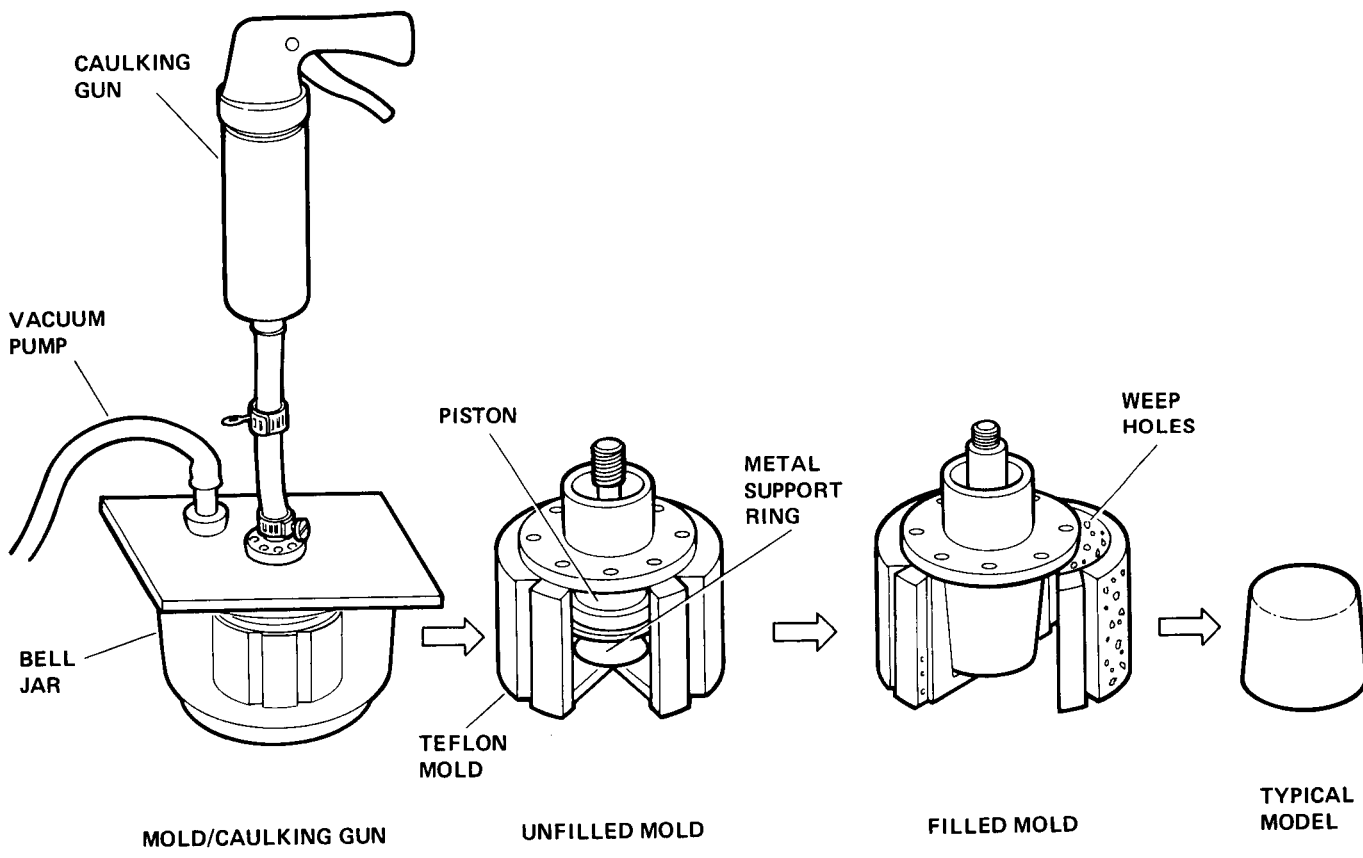

Figure 3.— Molded blunt cone.

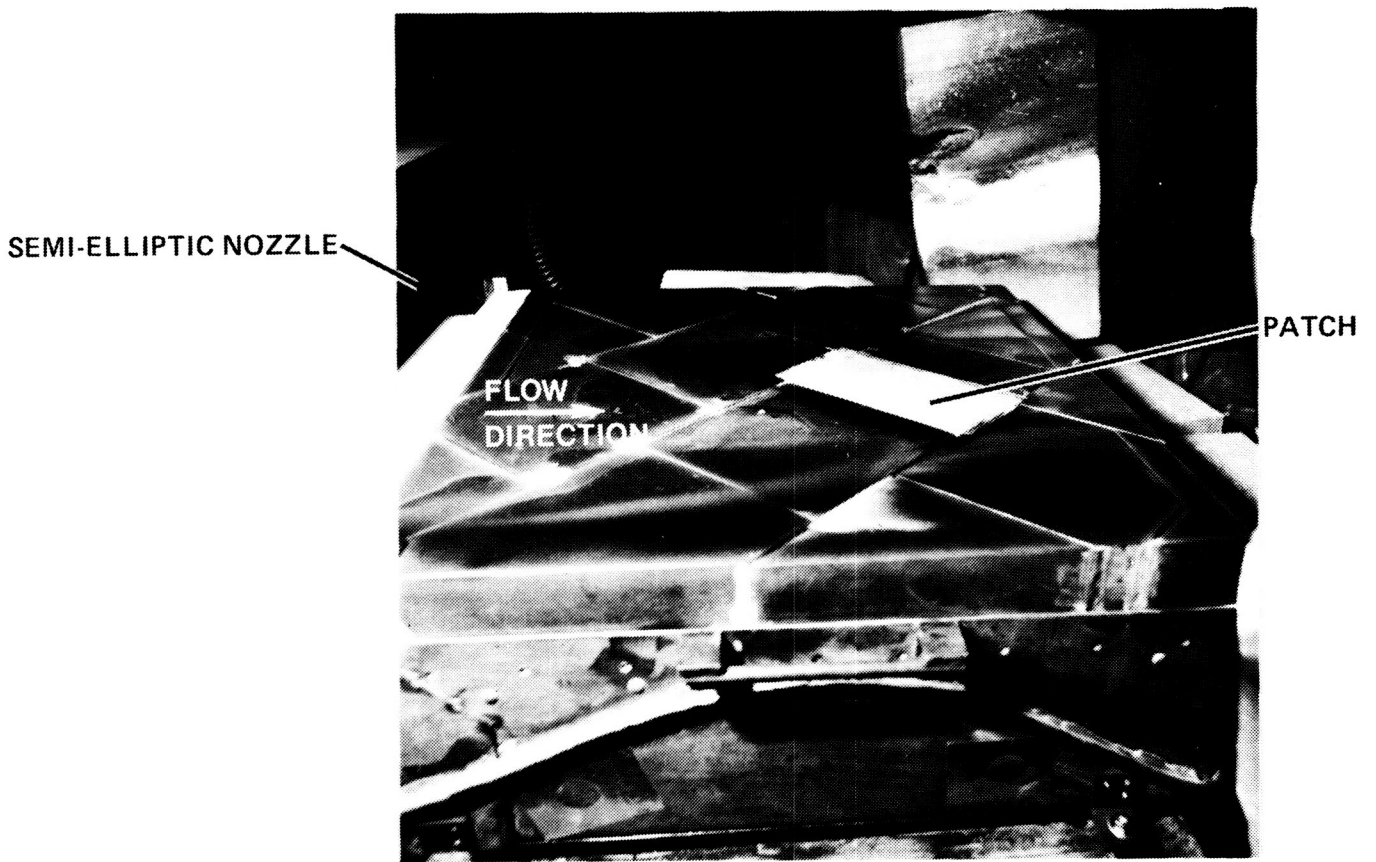
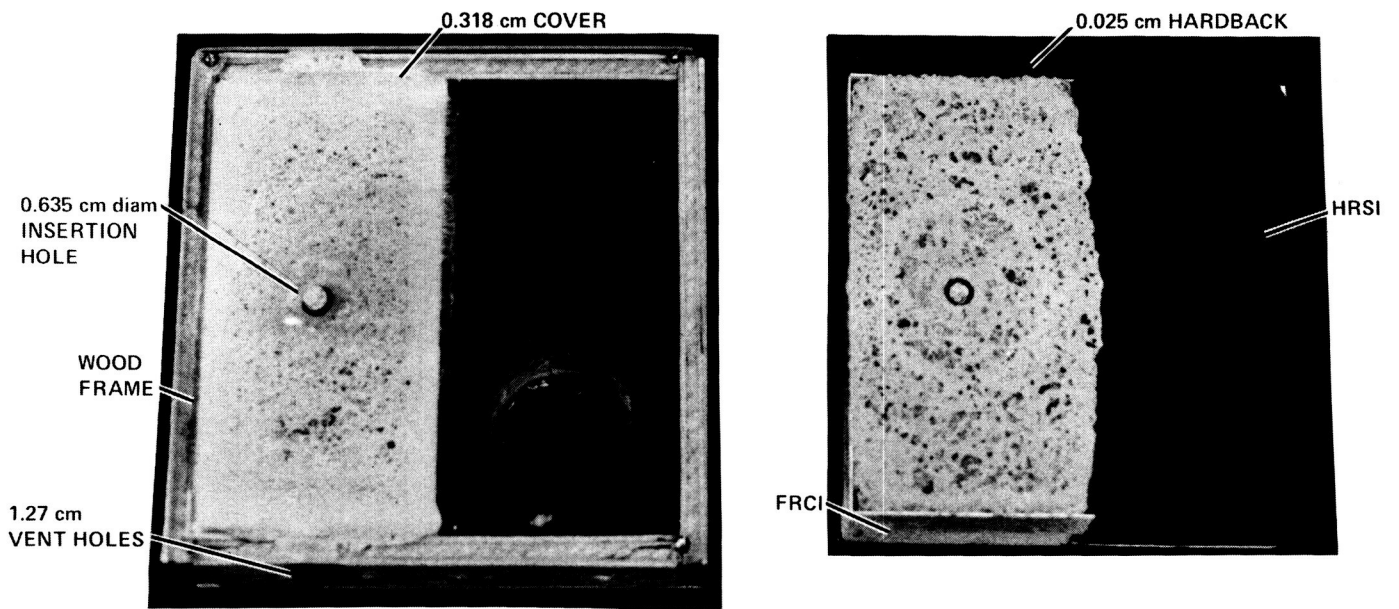

Figure 4.— Test model with half-tile patch in 20-MW Pilot Test Facility.



(a) Ablator in wood mold.

(b) Patch ready for model installation.

Figure 5.— Half-tile patch.

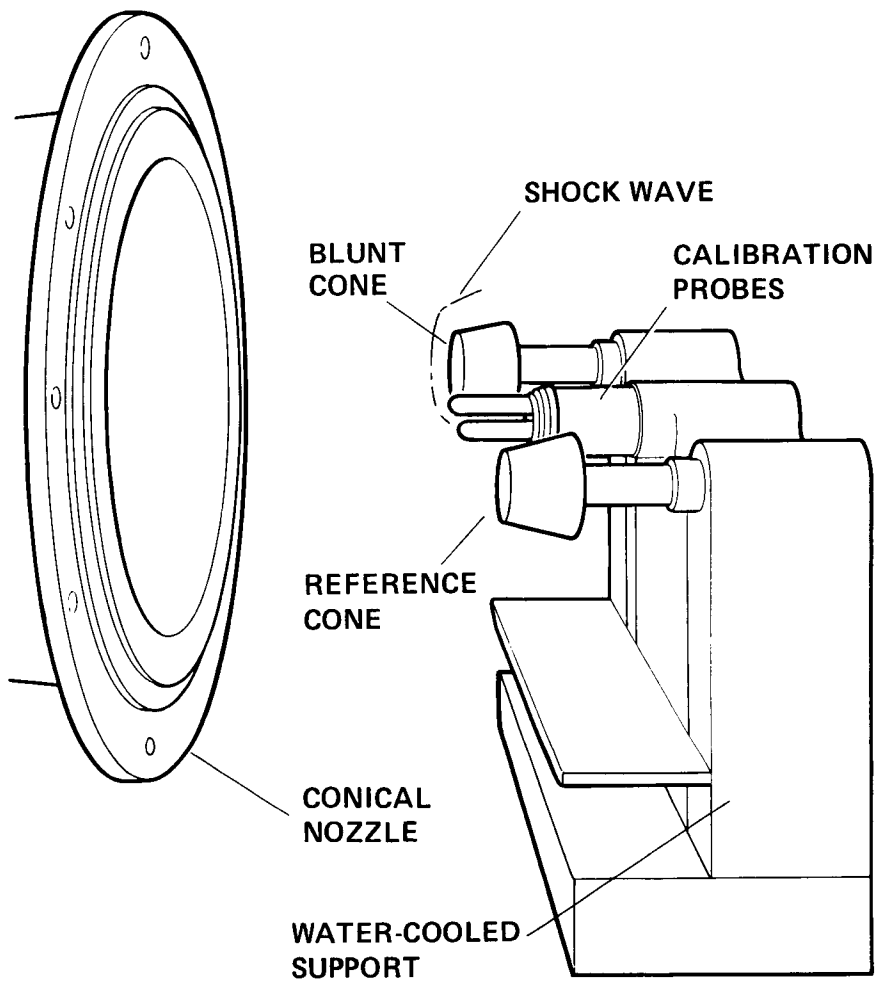

Figure 6.— Test arrangement in Aerodynamic Heating Facility.

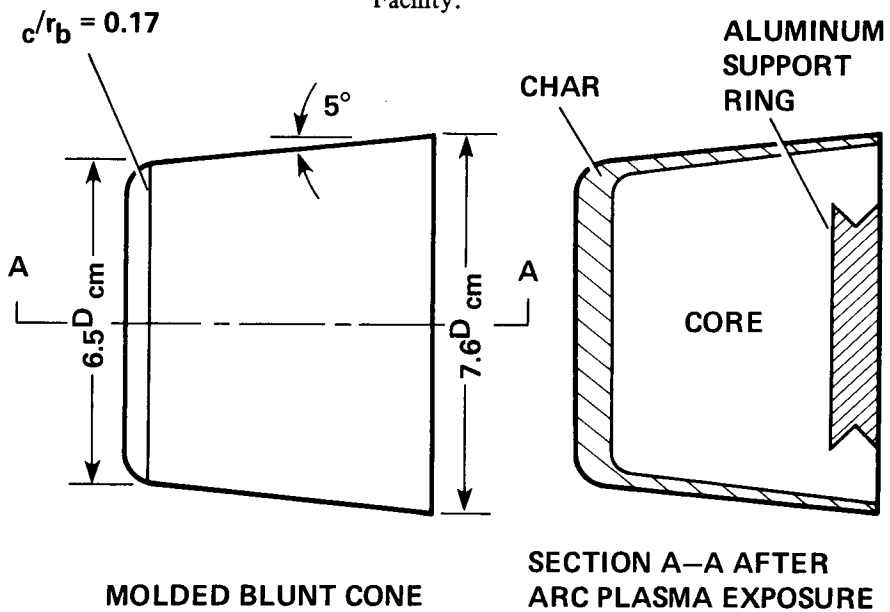
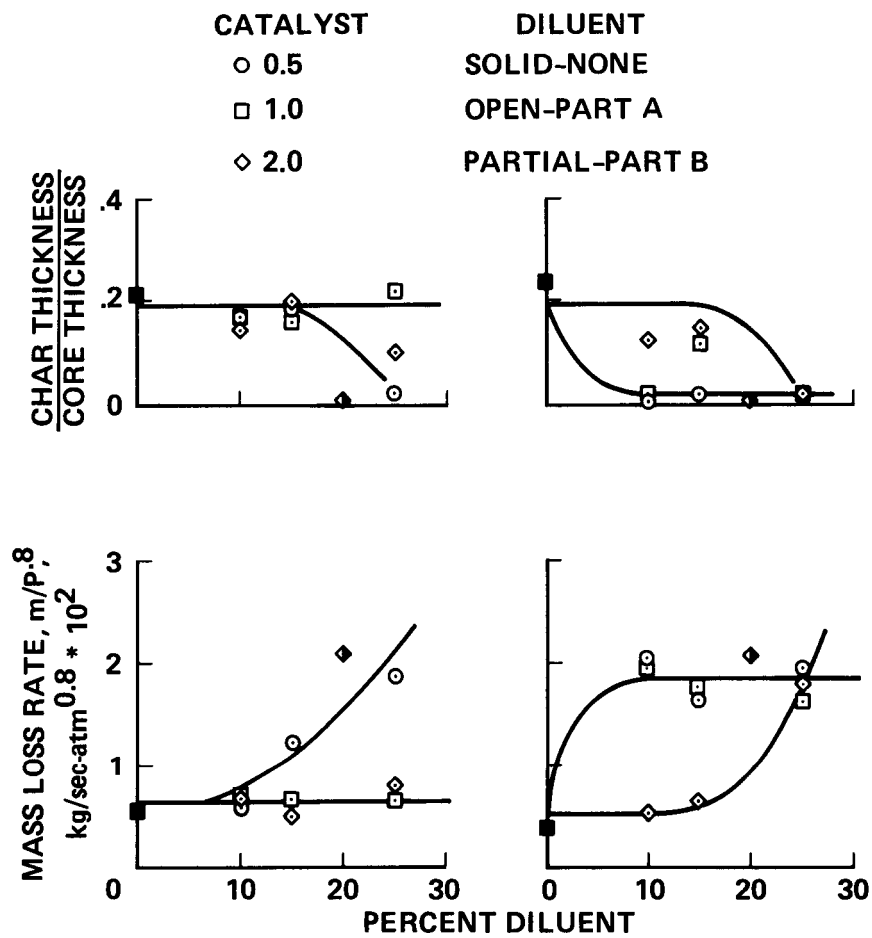

Figure 7.— Typical blunt cone after arc-plasma exposure.



(a) $T_w = 1394 \text{ K}$, $P_w = 0.008 \text{ atm}$.

(b) $T_w = 1644 \text{ K}$, $P_w = 0.018 \text{ atm}$.

Figure 8.— Thermal response of modified Ex439 formulations during arc-plasma exposure in air.

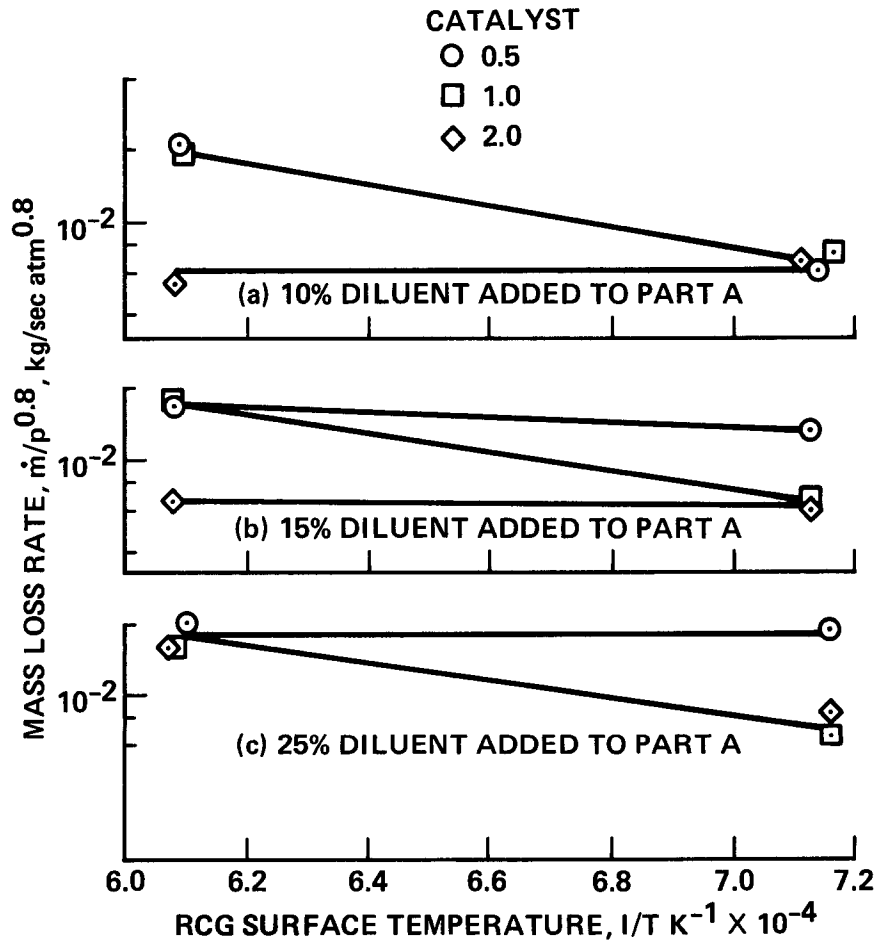

Figure 9.— Mass-loss rate of modified Ex439 formulations as a function of RCG wall temperature during arc-plasma exposure in air.

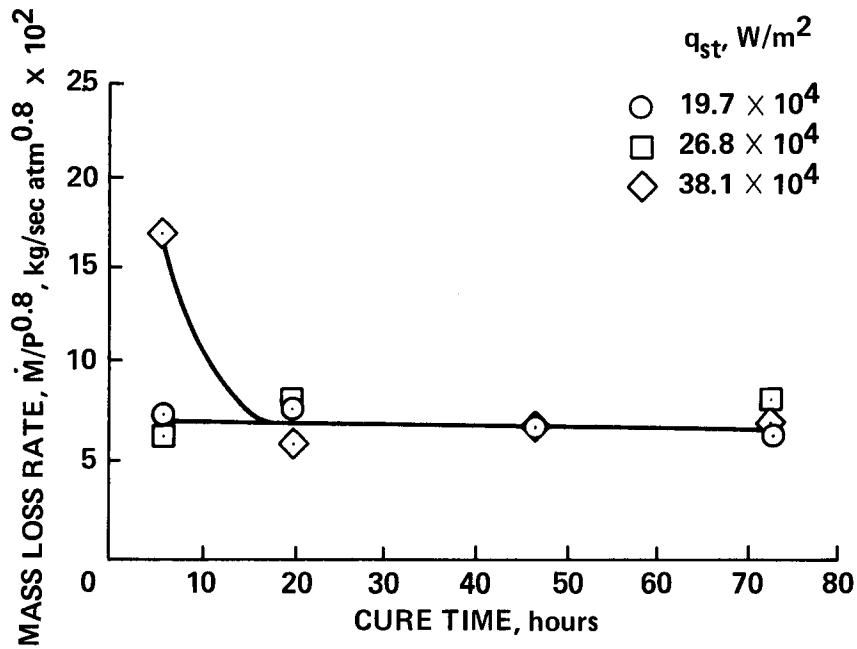
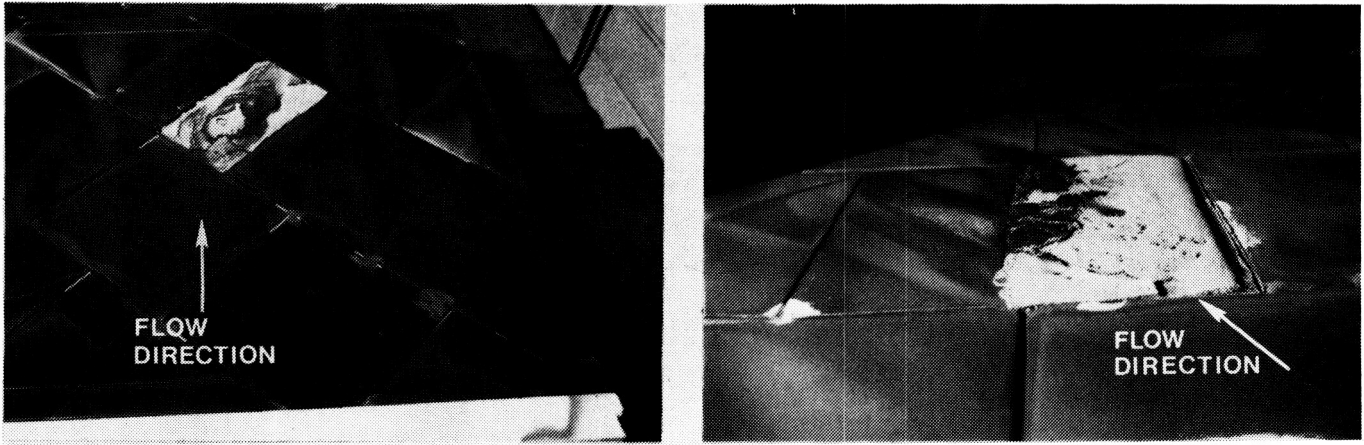

Figure 10.— Mass-loss of Ex439-B3 formulation with cure time during arc-plasma exposure in air.

$T_s = 1256^\circ \text{ K}$
 $P_s = 0.01 \text{ atm}$
 AIR ENVIRONMENT



(a) NASA Ex439 mastic.

(b) NASA Ex439-B3 ablator.

Figure 11.— Post-test photographs of half-tile patches after 420 sec of arc-plasma exposure.

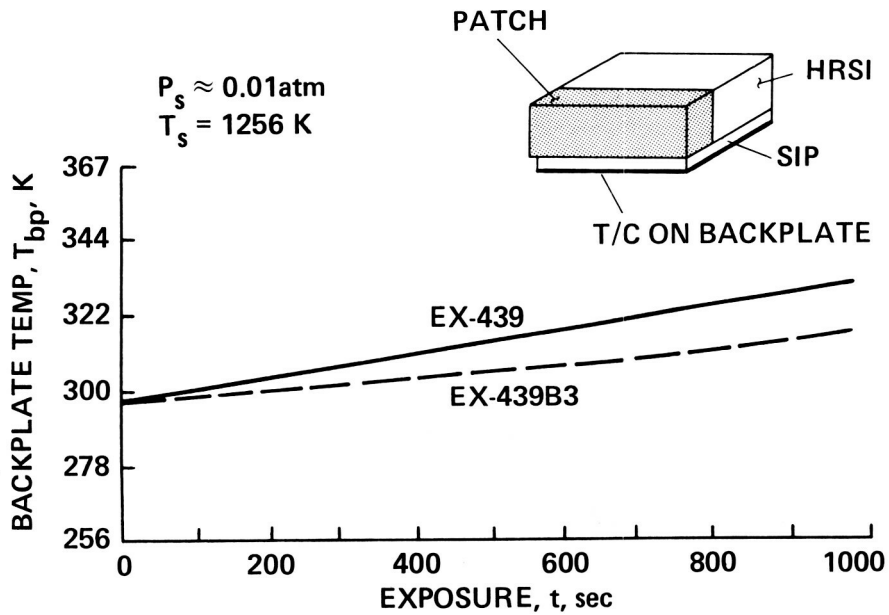

Figure 12.— Comparison of backplate temperature responses between repaired tiles using NASA Ex439 and Ex439-B3 during arc-plasma exposure.

1. Report No. NASA TP-2150	2. Government Accession No.	3. Recipient's Catalog No.	
4. Title and Subtitle PERFORMANCE OF AN ABLATOR FOR SPACE SHUTTLE IN-ORBIT REPAIR IN AN ARC-PLASMA AIRSTREAM		5. Report Date April 1983	6. Performing Organization Code
		8. Performing Organization Report No. A-9112	10. Work Unit No. T-4203
7. Author(s) David A. Stewart, Melanie Cuellar,* and Orvel Flowers		11. Contract or Grant No.	
9. Performing Organization Name and Address NASA Ames Research Center Moffett Field, Calif. 94035		13. Type of Report and Period Covered Technical Paper	
		14. Sponsoring Agency Code 506-53-41-04	
12. Sponsoring Agency Name and Address National Aeronautics and Space Administration Washington, D.C. 20546		15. Supplementary Notes Point of contact: David A. Stewart, Ames Research Center, Mail Stop: 234-1, Moffett Field, Calif. 94035 (415)965-6614 or FTS 448-6085 *Student associate, San Jose State University, working under contract no. NSG2329.	
16. Abstract An ablator patch material performed well in an arc-plasma environment simulating nominal Earth-entry conditions for the Space Shuttle. Ablation tests, using vacuum molded cones, provided data to optimize the formulation of a two-part polymer system for application under space conditions. The blunt cones were made using a Teflon mold and a state-of-the-art caulking gun. Char stability of formulations with various amounts of catalyst and diluent were investigated. The char was found to be unstable in formulations with low amounts of catalyst and high amounts of diluent. The best polymer system determined by these tests was evaluated using a half-tile patch in a multiple High-Temperature Reusable surface Insulation tile model. It was demonstrated that this ablator could be applied in a space environment using a state-of-the-art caulking gun, would maintain the outer mold line of the thermal protection system during entry, and would keep the bond line temperature at the aluminum-tile interface below the design limit.			
17. Key Words (Suggested by Author(s)) In-orbit repair Orbiter TPS ablative repair Orbiter TPS response		18. Distribution Statement Unclassified - Unlimited Subject category - 18	
19. Security Classif. (of this report) Unclassified	20. Security Classif. (of this page) Unclassified	21. No. of Pages 18	22. Price* A02